

# THE RADIO CONSTRUCTOR

Vol. 23 No. 12

JULY 1970

3/6

## *Communications Receiver*

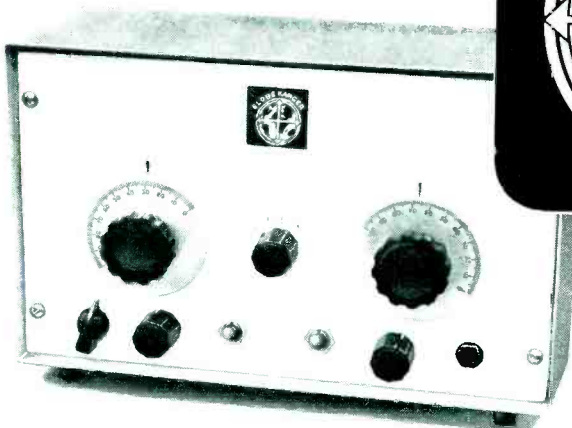

**GLOBE RANGER**



**Explore  
the World**

## **THE GLOBE RANGER 4-BAND SUPERHET**

- ★ 2 Short Wave Bands
- ★ Medium & Long Wave Bands
- ★ BFO & IF Gain Controls
- ★ Ready Wired Coilpack

*Special*  
**IN THIS ISSUE**

**SOLID STATE A.C.  
MILLIVOLTMETER  
UNUSUAL NULL INDICATOR**

**FREE**

**INDEX VOLUME 23  
Aug. 1968 - July 1970**

# New 95 Electronic Components Ltd.

AC107	14.6	BF115	5	NKT129	6	OC84	5	2N186	12	2N3416	7	25320	9		
AC126	5	BF152	13	NKT141	7	OC123	7	2N385A	15	2N3436	15	25321	6		
AC127	5/6	BF154	9	NKT142	6	OC139	5	2N388A	15	2N3525	21	25323	10		
AC127Z	9/6	BF159	15	NKT143	8	OC140	7	2N404	4	6	2N3528	19	25701	8	
AC128	5	BF163	9	NKT144	5	OC171	6	2N410	5	2N4606	5	25703	12		
AC176	5	BF167	8	NKT166	6	OC171	6	2N458A	25	2N3607	4	25720	25		
AC187	12	BF173	6	NKT166	6	OC200	6	3N511A	49	6	2N3702	3	25732	8	
AC188	12	BF178	10	NKT163	5	OC201	9	6	2N513A	3	2N3703	3	251002	10	
ACY17	5	BF179	12	NKT164	5	OC202	18	2	2N3704	3	3	3			
ACY18	3/6	BF180	6	NKT165	6	OC203	19	6	2N599	10	2	2N3705	3		
ACY19	4/5	BF181	7	NKT171	6	OC204	8	2	2N601	25	2	2N3706	2		
ACY20	3/7	BF184	6	NKT172	6	OC205	9	2	2N657	20	2	2N3707	1		
ACY21	4	BF185	8	NKT213	4	OC206	10	6	2N696	4	2	2N3708	2		
ACY22	2/9	BF194	3	NKT214	4	OC207	7	6	2N697	4	2	2N3709	3		
ACY40	3/1	BF195	3/1	NKT215	4	OC309	12	2	2N698	6	2	2N3710	3		
AD140	4/4	BF200	10	NKT216	10	OC371	19	6	2N699	2	6	2N3711	3		
AD141	8	BF213	5	NKT217	13	ORP12	9	6	2N706A	2	6	2N3819	8		
AD140	11	BF229	8	NKT218	5	ORP60	8	2	2N708	4	2	2N3820	18		
AD149	11	BF244	8	NKT219	6	ORP61	8	2	2N711	7	6	2N3826	6		
AD161	6	BF284	7	NKT221	5	ORP63	9	2	2N711A	7	6	2N3854	5		
AD162	6	BF285	9	NKT222	4	P346A	5	2	2N715	7	6	2N3854A	5		
ADT140	3	BF286	6	NKT223	3	RAS310AF	6	2	2N716	7	6	2N3855	5		
AF102	12	BF288	6	NKT224	3	6	2	2N743	4	6	2	2N3855A	6		
AF106	7	BF288	5	NKT225	3	RS580BAF	2	2	2N744	6	2	2N3856	6		
AF114	5	BF350	4	NKT226	10	S1M	15	2	2N753	5	6	2N3856A	6		
AF115	5	BF351	3	NKT227	5	3	19	2	2N914	7	6	2N3901	6		
AF116	5	BF352	3	NKT228	6	3	33	6	2N918	7	6	2N3858A	6		
AF117	5	BF353	3	NKT229	6	5	4	3	2N929	5	6	2N3859	5		
AF118	12	BFW57	6	NKT262	4	5	5	2	2N930	7	6	2N3859A	6		
AF121	6	BFW58	5	NKT264	4	5	9	9	2N930	6	6	2N3860	6		
AF124	4	BFW59	5	NKT271	4	4	9	9	2N930	6	6	2N3860	6		
AF126	3/4	BFX13	5	NKT272	4	4	19	6	2N930	6	6	2N3860	6		
AF127	3/6	BSX19	3	NKT273	5	4	22	6	2N930	6	6	2N3860	6		
AF139	7	BSX20	3	NKT274	4	4	17	6	2N930	6	6	2N3860	6		
AF178	9	BSX21	7	NKT275	5	4	19	2	2N930A	4	2	2N3900A	10		
AF179	11	BSX76	4	NKT276	3	4	3	3	2N303	5	2	2N3903	7		
AF180	12	BSX77	6	NKT279A	2	4	3	3	2N305	5	2	2N3904	7		
AF181	8	BSX78	6	NKT281	4	3	3	3	2N306	5	2	2N3904	7		
AF186V	9	BSY27	4	NKT301	16	4	3	3	2N307	5	2	2N3905	7		
AF186G	9	BSY29	5	NKT302	11	4	3	3	2N308	7	6	2N3906	7		
AF239	7	BSY32	5	NKT303	10	4	5	6	2N309	5	6	2N4037	15		
AFY19	22	BSY36	5	NKT304	9	6	2	2	2N496	3	4	2N4058	4		
AS231	8	BSY37	5	NKT305	9	6	2	2	2N507	4	8	2N4059	5		
AS276	5	BSY38	4	NKT307	7	6	2	6	2N513	5	6	2N4060	5		
AS277	6	BSY95A	3	NKT401	17	6	2	6	2N516	6	2	2N4061	4		
AS278	5	BSW47	8	NKT402	24	4	7	2	2N1711	6	6	2N4284	3		
AS279	6	BSW70	6	NKT403	15	3	2	2	2N1712	6	6	2N4284	3		
AY100	7	BTX19	6	NKT453	10	6	2	2	2N1893	10	2	2N4285	3		
AUY10	30	120	120	NKT405	15	2	2	2	2N2147	17	2	2N4286	3		
B2M	12	BTX40	600	NKT406	15	4	9	3	2N2152	27	6	2N4287	3		
B3M	15	120	120	NKT451	12	6	2	2	2N2148	12	6	2N4288	3		
BC107	2	BYT87	150R	NKT452	12	6	2	2	2N2160	18	2	2N4289	3		
BC108	2	9	31	NKT453	10	6	2	2	2N2243	26	2	2N4290	3		
BC109	2	OC10F1	9	NKT613F	5	5	2	2	2N2368	5	2	2N4291	3		
BC113	5	C111	18	NKT674F	5	5	2	2	2N2369	5	2	2N4292	3		
BC115	6	C111E	12	NKT675	5	5	2	2	2N2369A	6	2	2N4293	3		
BC116	8	C400	9	NKT676	5	5	2	2	2N2370	19	6	2N4293	3		
BC118	5	C426	8	NKT677F	5	4	2	2	2N2484	8	6	2N5028	11		
BC125	11	C444	9	NKT703	5	4	2	2	2N2613	7	6	2N5029	9		
BC126	11	D1371	10	NKT713	7	6	4	2	2N2614	4	2	2N5030	8		
BC134	5	GET102	6	NKT773	5	4	2	2	2N2646	10	2	2N5172	3		
BC135	6	GET103	4	NKT10339	6	4	2	2	2N271	6	2	2N5174	11		
BC136	8	GET113	4	NKT10419	6	6	4	2	2N2712	6	2	2N5175	10		
BC137	8	GET114	4	NKT10419	6	6	4	2	2N2713	5	6	2N5176	9		
BC138	12	GET120	6	NKT10429	4	4	2	2	2N2904	8	6	2N5232	5		
BC140	13	GET880	9	NKT10429	4	4	2	2	2N2904A	8	6	2N5249	13		
BC147	2	GET887	4	NKT10519	6	6	4	2	2N2905	15	2	2N5249A	13		
BC148	3	GET890	6	NKT10519	6	6	4	2	2N2923	4	2	2N5305	7		
BC149	3	GET896	4	NKT16229	6	6	4	2	2N2924	4	2	2N5306	8		
BC154	12	GET899	4	NKT16229	6	6	4	2	2N2925	3	6	2N5309	12		
BC167	3	GET899	4	NKT20329	2	2	2	2	2N2926	7	6	2N5354	5		
BC168	3	GET898	6	NKT20329	2	2	2	2	2N2926	7	6	2N5355	5		
BC169	3	GEX45	3	OC20	19	6	2	2	2N2926	7	6	2N5356	5		
BC182L	2	MAT100	5	OC22	8	3	2	2	2N2926	7	6	2N5356	5		
BC183L	2	MAT110	5	OC23	8	3	2	2	2N2926	7	6	2N5356	5		
BC184L	3	MAT121	5	OC24	8	3	2	2	2N2926	7	6	2N5356	5		
BC121L	3	MAT121	5	OC24	8	3	2	2	2N2926	7	6	2N5356	5		
BCY10	10	M1400	21	OC25	7	6	4	2	2N2926	7	6	2N5356	5		
BCY12	10	M1420	22	OC26	6	4	2	2	2N2926	7	6	2N5356	5		
BCY30	5	M421	22	OC28	12	4	2	2	2N3070	8	6	2N3142	16		
BCY31	5	M430	20	OC35	9	4	2	2	2N3036	39	3	2N3152	24		
BCY32	10	M440	19	OC36	12	6	4	2	2N3053	5	2	25001	10		
BCY33	4	M480	26	OC41	4	6	4	2	2N3054	12	6	25002	12		
BCY34	5	M481	27	OC42	6	4	2	2	2N3055	15	2	25003	12		
BCY38	6	M490	22	OC43	4	6	4	2	2N3133	6	2	25004	15		
BCY40	10	M491	29	OC44	3	2	2	2	2N3135	6	2	25005	15		
BCY42	4	MPF102	8	OC45	3	2	2	2	2N3136	6	2	25006	15		
BCY43	4	MPF103	7	OC70	2	6	2	2	2N325	28	6	25012	25		
BCY54	4	MPF104	7	OC71	2	6	2	2	2N3271	3	2	2N3234	27		
BCY70	4	MPF105	8	OC72	4	6	2	2	2N3391A	6	2	25017	22		
BCY71	8	MPS3638	6	OC75	4	6	2	2	2N3392	5	2	25018	17		
BCY72	4	NKT1003	9	OC76	2	6	2	2	2N3393	5	2	25019	16		
BC187	86	NKT121	11	OC77	5	6	2	2	2N3394	5	2	25104	12		
BCZ11	8	NKT122	8	OC81	3	6	2	2	2N109	11	2	2N3402	5		
BD119	21	NKT123	8	OC81B	3	2	2	2	2N174	16	2	2N3403	5		
BD121	21	NKT125	5	OC82	2	2	2	2	2N217	7	6	2N3404	7		
BD123	18	NKT127	5	OC82D	3	2	2	2	2N370	15	2	2N3414	5		
BD124	12	NKT128	5	OC83	4	6	2	2	2N384	17	2	2N3415	6		

## LOWEST I.C. PRICES YET!

IC10	59.6	Sinclair IC amp.
PA230	20	IC Pre-amplifier
PA234	20	1 watt audio amp.
PA237	32.6	2 watt audio amp.
PA246	52.6	5 watt audio amp.
SL403A	42.6	3 watt Plessey amp.
TAA263	15	Mullard linear amp.
TAD100	45	IC receiver
TAA293	20	Mullard gen. purp. amp.
TAA310	30	Record/Playback preamp.
TAA320	13	MOS LF amplifier
SL702C	29.6	Plessey linear amplifier
3N8A	26	Silicon controlled switch

Data sheets available on request—1/- per copy

PLEASE NOTE Only new—full specification into varied circuits, no below-specification types

### FAIRCHILD MICRO-LOGIC

ul 900	9.9	9/-	8/-
ul 914	9.9	9/-	8/-
ul 923	12.6	11/9	11/-
ul 925	12.6	11/9	11/-

Prices for 100 + and

# A NEW BOOK LOW COST PROPORTIONAL

Over 160 pages. Size  $8\frac{1}{4} \times 5\frac{7}{8}$  in.  
The theory and practice of simple proportional control systems for models, plus:

- Over a dozen special circuits.
- Theoretical diagrams.
- Component lists.
- Full-size and twice-size practical diagrams.
- Full-size and twice-size Printed Circuit designs.
- Clear description of operation of each.
- Practical application gen.

Build yourself —

- Transmitter
- Receiver
- Pulsers
- Coders
- De-coders
- Switchers

Plus a wealth of ancillary electro-mechanical items

A really practical book on the updating of single channel control systems to proportional, from the simple rudder-only, to full dual proportional, plus engine control.

ALL THIS GEN FOR ONLY

**21/-**

Plus 1/- post and packing

Order now from  
**RADIO MODELLER,**  
64 Wellington Road, Hampton Hill, Middx.

And be first in the queue for expected late-June delivery.

## Never Built a Kit Before?

Why not prove how easy it is the HEATHKIT way.  
Build one of these beginner kits.

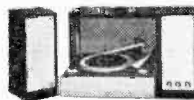

### Stereo Record Player

Exciting sound; budget price. Kit: K/SRP-1.  
£27-6-0 Carr. 5/-

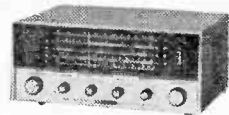

### Economy SW Receiver

World-wide reception, 1 to 30 MHz plus 550-1620 kHz. Kit: K/GR-64.  
£24-16-0 Carr. 9/-



### Deluxe Car Radio

Heathkit value; powerful output. Kit: K/CR-1 (less speakers).  
£12-12-0 Carr. 5/-

### Versatile Service VVM

7AC, 7DC, 7ohm ranges. Kit: K/IM-18U  
£16-14-0 Carr. 5/-

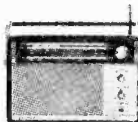

### 'Severn' AM/FM Radio

Beautiful looks; luxury sound. Kit: K/Severn.  
£18-18-0 Carr. 5/-

### Portable VVM

For hobbyists — householders. Kit: K/IM-17.  
£14-8-0 Carr. 6/-



### Model Builders' Tacho

Low cost; accurate. Kit: K/GD-69.  
£11-0-0. Carr. paid



### D.I.Y. Speaker Set

As SSU-1 (less cabinet). Kit: K/SCM-1. £6-10-0. Carr. 5/-

Many more kits in the FREE Catalogue

Please rush me a copy of your FREE Catalogue.

Name.....

Address.....

53/7

Post Code.....



**HEATH**  
(Gloucester) Ltd.  
Dept. 53/7

A Schlumberger Company

**Gloucester GL2 6EE**

# BOUND VOLUME No. 22

of

## "The Radio Constructor" FOR YOUR LIBRARY

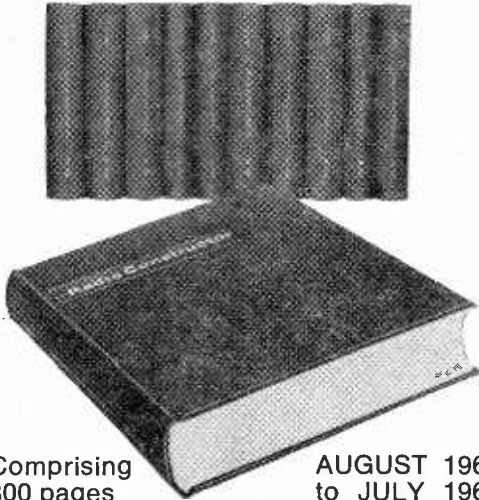

Comprising  
800 pages  
plus index

AUGUST 1968  
to JULY 1969

PRICE **35/-** Postage 4/6

### Special discount of 10/- for regular readers

Just cut the heading from each month's contents page, including title and month of issue, and this will be sufficient evidence of readership to qualify for the discount.

Thus regular readers will still retain their copies for workbench use, while having a splendid bound volume containing issues in mint condition.

PRICE 25/- Postage 4/6

We regret all earlier volumes now  
completely sold out.

Available only from:-

**Data Publications Ltd.**  
57 Maida Vale London W9

## BI-PAK=LOW COST IC'S

BI-PAK Semiconductors now offer you the largest and most popular range of I.C.'s available at these Exclusive Low Prices. T.T.L. Digital SN 74N Series fully coded, brand new to manufacturers specifications. Dual In-Line plastic 14 & 16 pin packages.



BI-PAK ORDER NO.	DESCRIPTION	PRICE AND QTY. PRICES		
		1-24	25-99	100 up
BP 00 = SN 7400N	Quad 2-Input NAND GATE	6/6	5/6	4/6
BP 01 = SN 7401N	Quad 2-Input NAND GATE - OPEN COLLECTOR	6/6	5/6	4/6
BP 04 = SN 7404N	HEX INVERTER	6/6	5/6	4/6
BP 10 = SN 7410N	Triple 3-Input NAND GATE	6/6	5/6	4/6
BP 20 = SN 7420N	Dual 4-Input NAND GATE	6/6	5/6	4/6
BP 30 = SN 7430N	Single 8-Input NAND GATE	6/6	5/6	4/6
BP 40 = SN 7440N	Dual 4-Input BUFFER GATE	6/6	5/6	4/6
BP 41 = SN 7441AN	BCD to decimal decoder and N.I.T. Driver	22/6	20/-	17/6
BP 42 = SN 7442N	BCD to decimal decoder (TTL O/P)	22/6	20/-	17/6
BP 50 = SN 7450N	Dual 2-Input AND/OR/NOT GATE expandable	6/6	5/6	4/6
BP 53 = SN 7453N	Single 8-Input AND/OR/NOT GATE - expandable	6/6	5/6	4/6
BP 60 = SN 7460N	Dual 4-Input - expandable	6/6	5/6	4/6
BP 70 = SN 7470N	Single JK Flip-Flop - edge triggered	9/-	8/-	7/-
BP 72 = SN 7472N	Single Master Slave JK Flip-Flop	9/-	8/-	7/-
BP 73 = SN 7473N	Dual Master Slave JK Flip-Flop	10/-	9/-	8/6
BP 74 = SN 7474N	Dual D Flip-Flop	10/-	9/-	8/6
BP 75 = SN 7475N	Quad Bistable Latch	11/-	10/-	9/6
BP 76 = SN 7476N	Dual Master Slave Flip-Flop with preset and clear	11/-	10/-	9/6
BP 83 = SN 7483N	Four Bit Binary Adder	26/-	22/6	20/-
BP 90 = SN 7490N	BCD Decade Counter	22/6	20/-	17/6
BP 92 = SN 7492N	Divide by 12 4 Bit Binary Counter	22/6	20/-	17/6
BP 93 = SN 7493N	Divide by 16 4 Bit Counter	22/6	20/-	17/6
BP 94 = SN 7494N	Dual Entry 4 Bit Shift Register	22/6	20/-	17/6
BP 95 = SN 7495N	4 Bit Up-Down Shift Register	22/6	20/-	17/6
BP 96 = SN 7496N	5 Bit Shift Register	24/-	21/-	18/6

Brand new. Full to manufacturers specification.

### BP 709 OPERATIONAL AMPLIFIER

Dual in-line 14 pin package. = SN 72709 and similar to MIC 709 & ZLD 709C. PRICE EACH 1-24 25-99 100 up

10/6 9/- 8/-

This is a high performance operational Amplifier with high impedance differential inputs and low impedance output.

### INTEGRATED CIRCUITS

Manufacturers "Fall outs" - out of spec devices including functional units and part functional but classed as out of spec from the manufacturers very rigid specifications. Ideal for learning about I.C.'s and experimental work, on testing some will be found perfect.

PAK NO.	PAK NO.
UIC 00 = 5 x 7400N . . . 10/-	UIC 50 = 5 x 7450 . . . 10/-
UIC 01 = 5 x 7401N . . . 10/-	UIC 53 = 5 x 7453 . . . 10/-
UIC 10 = 5 x 7410N . . . 10/-	UIC 72 = 5 x 7472 . . . 10/-
UIC 20 = 5 x 7420N . . . 10/-	UIC 74 = 5 x 7474 . . . 10/-
UIC 30 = 5 x 7430N . . . 10/-	UIC 75 = 5 x 7475 . . . 10/-
UIC 40 = 5 x 7440N . . . 10/-	UIC 90 = 5 x 7490 . . . 10/-
UIC 41 = 5 x 7441AN . . . 10/-	UIC XI = 20 x As'd 74's 30/-

Packs cannot be split but 20 assorted pieces (our mix) is available as Pak UIC XI. Every Pak carries our Bi-Pak Satisfaction or money back Guarantee.

Motorola Digital I.C.'s MDTL Dual In-line Package  
Type MC 844P Expandable dual 4-input Nand Power Gate 10/- each  
Type MC 845P Clocked Flip-Flop . . . 15/- each  
Full Data supplied with Units.

Data is available for the SN 74N Series of Integrated Circuits in booklet form. Price 2/6.

Please send all orders direct to our Warehouse and despatch department, postal address:

**BI-PAK Semiconductors, P.O. BOX 6, WARE, AERIALS.**  
Postage and packing add 1/-. Overseas add extra for H.M.S. Minimum order 10/- Cash with order please.



# VALUE ALL THE WAY

## QUALITY-TESTED PAKS

6 Matched Trans. OC44/45/81/81D	10/-
20 Re ct AF Trans. PNP	10/-
16 White Spot RF Trans. PNP	10/-
5 Silicon Rects. 3A 100-400 PIV	10/-
2 10 A Silicon Rects. 100 PIV	10/-
2 OC1 140 Trans. NPN Switching	10/-
1 12 A SCR 100 PIV	10/-
3 Sil. Trans. 25303 PNP	10/-
2 200 Mc/s Sil. Trans. NPN BSY26/27	10/-
3 Zener Diodes. 1W 33V 5% Tol.	10/-
4 High Current Trans. OC42 Evt.	10/-
2 Power Transistors 1 OC26 1 OC35	10/-
5 Silicon Rects., 400 PIV 250mA	10/-
4 OC75 Transistors	10/-
1 Power Trans. OC20 100V	10/-
10 OA202 Sil. Diodes Sub-min.	10/-
2 Low Noise Trans. NPN 2N929/30	10/-
1 Sil. Trans. NPN VCB 100 ZT86	10/-
8 OA81 Diodes	10/-
4 OC72 Transistors	10/-
4 OC77 Transistors	10/-
3 Sil. Rects. 400 PIV 500mA	10/-
5 GET884 Trans. Evt. OC44	10/-
5 GET883 Trans. Evt. OC45	10/-
2 2N708 Sil. Trans. 300Mc/s NPN	10/-
3 GT31 LF Low Noise Germ Trans.	10/-
6 IN914 Sil. Diodes 75 PIV 75mA	10/-
8 OA95 Germ. Diodes Sub-min. IN69	10/-
3 NPN Germ. Trans. NKT773 Evt.	10/-
2 OC22 Power Trans. Germ.	10/-
2 OC25 Power Trans. Germ.	10/-
4 AC128 Trans. PNP High Gain	10/-
4 AC127/128 Comp. pair PNP/NPN	10/-
2 2N1307 NPN Switching Trans.	10/-
7 CG52H Germ. Diode Evt. OA71	10/-
3 AF116 Type Trans.	10/-
12 Assorted Germ. Diodes Marked	10/-
4 AC126 Germ. PNP Trans.	10/-
4 Silicon Rect. 100 PIV 750mA	10/-
3 AF117 Trans.	10/-
7 OC81 17 Trans.	10/-
3 OC171 Trans.	10/-
5 2N2926 Sil. Epoxy Trans.	10/-
7 OC71 Type Trans.	10/-
2 25701 Sil. Trans. Texas	10/-
2 10 A 600 PIV Sil. Rects. 1545R	10/-
3 BC108 Sil. NPN High Gain Trans.	10/-
1 2N910 NPN Sil. Trans. VCB 100	10/-
2 1000 PIV Sil. Rect. 1.5 A R53310 AF	10/-
3 BSY95A Sil. Trans. NPN 200Mc/s	10/-
3 OC200 Sil. Trans.	10/-
2 GET890 Low Noise Germ. Trans.	10/-
1 AF139 PNP High Freq. Trans.	10/-
3 NPN Trans. 1 ST141 & 2 ST140	10/-
4 Mad's 2 MAT100 & 2 MAT120	10/-
4 Mad's 2 MAT101 & 1 MAT121	10/-
4 OC44 Germ. Trans. AF	10/-
3 AC127 NPN Germ. Trans.	10/-
1 2N3906 Sil. PNP Trans. Motorola	10/-
2 Sil. Power Rects. BYZ13	15/-
1 Sil. Power Trans. NPN 100Mc/s	15/-
TK201A	15/-
2 2N132 PNP Epitaxial Planar Sil.	10/-
3 2N697 Epitaxial Planar Trans. Sil.	15/-
4 Germ. Power Trans. Evt. OC16	15/-
1 Unijunction Trans. 2N2646	15/-
2 Sil. Trans. 200Mc/s 60Vc ZT83/84	15/-
20 NKT Trans. AF. RF. VHF. Coded	10/-
Eqvt. Ltrs.	10/-
2 2N712 Sil. Epitaxial Planar HFE225	15/-
8 BY100 Type Sil. Rects.	20/-
25 Sil. and Germ. Trans. Mixed, all	20/-
marked, New	20/-

## SEMICONDUCTORS FOR "P.E." 50+50 AMP.

TYPE	EACH	TYPE	EACH
2N1613	4/6	IN914	1/-
2N3055	12/9	OA200	1/-
2N3703	3/-	BFY51	3/6
2N3704	3/6	BYZ13	4/6
2N3707	4/6	40632	1/4
2N3819	8/-	22V1 WZener	3/6

GIRO No. 388-7006



**BI-PAK**

500, Chesham House,  
150 Regent St.  
LONDON, W.1.

## KING OF THE PAKS Unequalled Value and Quality SUPER PAKS NEW BI-PAK UNTESTED SEMICONDUCTORS

Satisfaction GUARANTEED in Every Pak, or money back.

Pak No.	Description	Price
U1	120 Glass Sub-min. General Purpose Germanium Diodes	10/-
U2	60 Mixed Germanium Transistors AF/RF	10/-
U3	75 Germanium Gd Bonded Diodes sim. OA5, OA47	10/-
U4	40 Germanium Transistors like OC81, AC128	10/-
U5	60 200mA Sub-min. Sil. Diodes	10/-
U6	30 Silicon Planar Transistors NPN sim. BSY95A, 2N706	10/-
U7	16 Silicon Rectifiers Top-Hat 750mA up to 1,000V	10/-
U8	50 Sil. Planar Diodes 250mA OA/200/202	10/-
U9	20 Mixed Volts 1 watt Zener Diodes	10/-
U11	25 PNP Silicon Planar Transistors TO-5 sim. 2N1132	10/-
U13	30 PNP-NPN Sil. Transistors OC200 & 25104	10/-
U14	150 Mixed Silicon and Germanium Diodes	10/-
U15	25 NPN Silicon Planar Transistors TO-5 sim. 2N697	10/-
U16	10 3-Amp Silicon Rectifiers Stud Type up to 1000 PIV	10/-
U17	30 Germanium PNP AF Transistors TO-5 like ACY 17-22	10/-
U18	8 6-Amp Silicon Rectifiers BYZ13 Type up to 600 PIV	10/-
U19	25 Silicon NPN Transistors like BC108	10/-
U20	12 1.5-Amp Silicon Rectifiers Top-Hat up to 1,000 PIV	10/-
U21	10 A.F. Germanium alloy Transistors 2G300 Series & OC71	10/-
U23	30 Mad's Like MAT Series PNP Transistors	10/-
U24	20 Germanium 1-amp Rectifiers GJM up to 300 PIV	10/-
U25	25 300 Mc/s NPN Silicon Transistors 2N708, BSY27	10/-
U26	30 Fast Switching Silicon Diodes like IN914 Micro-min	10/-
U28	Experimenters' Assortment of Integrated Circuits, untested, Gates, Flip-Flops, Registers, etc., 8 Assorted Pieces	20/-
U29	10 1 amp SCR's TO-5 can up to 600 PIV CR51/25-600	20/-
U31	20 Sil. Planar NPN trans. low noise Amp 2N3707	10/-
U32	25 Zener diodes 400mW D07 case mixed Volts, 3-18	10/-
U33	15 Plastic case 1 amp Silicon Rectifiers IN4000 series	10/-
U34	30 Sil. PNP alloy trans. TO-5 BCY26, 25302/4	10/-
U35	25 Sil. Planar trans. PNP TO-18 2N2906	10/-
U36	25 Sil. Planar NPN trans. TO-5 BFY50/51/52	10/-
U37	30 Sil. alloy trans. SO-2 PNP, OC200 25322	10/-
U38	20 Fast Switching Sil. trans. NPN 400Mc/s 2N3011	10/-
U39	30 RF Germ. PNP trans. 2N1303/5 TO-5	10/-
U40	10 Dual trans. 6 lead TO-5 2N2060	10/-
U41	25 RF Germ. trans. TO-1 OC45 NKT72	10/-
U42	10 VHF Germ. PNP trans. TO-1 NKT667 AF117	10/-

Code Nos. mentioned above are given as a guide to the type of device in the Pak. The devices themselves are normally unmarked.

## NEW LOW PRICE TESTED S.C.R.'S

1A	3A	7A	16A	30A
(TO-5 case)	(TO-66 case)	(TO-48 case)	(TO-48 case)	(TO-48 case)
50	4/6	5/-	9/6	10/6
100	5/-	6/6	10/6	12/6
200	7/-	7/6	11/6	15/-
400	8/6	9/6	13/6	18/6
600	10/6	11/6	15/6	25/-
800	12/6	14/-	18/-	30/-

## 2 Amp POTTED BRIDGE RECTIFIERS

200V. 10/-, 600V. 15/-, 800V. 20/-

## TRANSISTOR EQUIVALENT & SPECIFICATION BOOK

(German publication). A complete cross reference and equivalent book for European, American and Japanese Transistors. Exclusive to BI-PAK. 15/- each.

## PRINTED CIRCUITS EX-COMPUTER

Packed with semiconductor components and components, 10 boards give a guaranteed 30 trans. and 30 diodes. Our price 10 boards 10/-, Plus 2/- P. & P.

**PLEASE NOTE.** To avoid any further Increased Postal Charges to our Customers and enable us to keep our "By Return Postal service" which is second to none, we have re-organized, postal and streamlined our Despatch Order Department and we now request you to send all your orders together with your remittance, direct to our Warehouse and Despatch Department. postal address: BI-PAK SEMICONDUCTORS, Despatch Dept., P.O. BOX 6, WARE, HERTS. Postage and packing still 1/- per order. Minimum order 10/-.

## SIL. RECTS. TESTED

PIV 750mA	3A	10A	30A
50	1/-	2/9	4/3
100	1/3	3/3	4/6
200	1/9	4/-	4/9
300	2/3	4/6	6/6
400	2/6	5/6	7/6
500	3/-	6/-	8/6
600	3/3	6/9	9/37
800	3/6	7/6	11/-
1000	5/-	9/3	12/6
1200	6/6	11/6	15/-

## TRIACS

VBOM 2A	6A	10A
(TO-1)	(TO-66)	(TO-48)
100	14/-	15/-
200	17/6	20/-
400	20/-	24/-
600	22/-	35/-

VBOM = Blocking voltage in either direction.  
**LUCAS 35A SILICON RECTIFIERS**  
Branded. 400 PIV. Special Price stud type, flying lead, 22/6 each.

## UNIUNION

UT46. Evt. 2N2646, Evt. TI543. BEN3000  
**5/6 EACH**  
25-99 5/- 100 UP 4/-

## NPN SILICON PLANAR

BC107/8/9, 2/- each; 50-99, 1/10; 100 up, 1/8 each; 1,000 off, 1/6 each. Fully tested and coded TO-18 case.

## SILICON HIGH VOLTAGE RECTIFIERS

10-Amp 3-K.V. (3000 P.I.V.) Stud Type with Flying Leads. 16/- each

## ADI161 ADI162

MATCHED COMPLEMENTARY PAIRS OF GERMANIUM POWER TRANSISTORS.  
For mains driven output stages of Amplifiers and Radio receivers. OUR LOWEST PRICE OF 12/6 PER PAIR.

HIGH POWER SILICON PLANAR TRANSISTORS TO-3.  
Ferranti ZT1487 NPN VCB60 1c 6A I.T. 1M/c. VCE 40 Prot. 75W VEB8 HFE 15-45  
Price 15/- each

2N3055 115 W. SIL PWR NPN  
OUR PRICE 12/6 each

FULL RANGE OF ZENER DIODES VOLT. RANGE 2-16V 400mW (DO-7 Case) 2/6 1.5W (Top Hat) 3/6 10W (SO-10 Stud) 5/- AUL (Fully tested 5% tol. and marked. State voltage required.

## BRAND NEW TEXAS GERM. TRANSISTORS

Coded and Guaranteed EQVT.  
T1 82G371A OC71  
T2 82G374 OC75  
T3 82G374A OC81D  
T4 82G381A OC81  
T5 82G382T OC82  
T6 82G344A OC44  
T7 82G345A OC45  
T8 82G378 OC78  
T9 82G399A 2N1302  
T10 82G417 AF117  
All 10/- each pack

## 2N2060 PNP SIL. DIODE TRANS. CODE D1999 TEXAS.

OUR PRICE 5/- each.

120 VCB NIXIE DRIVER TRANSISTOR Sim. BSX21 & C407. 2N1893 FULLY TESTED AND CODED ND120. 1-24 3/6 each. TO-5 NPN 25 up 3/- each

Sil. trans. suitable for P.E. Organ. Metal TO-18 Evt. ZTX300 1/- each. Any Qty.

FREE One 10/- Pack of your own choice free with orders valued £4 or over.

NPN DIFFUSED SILICON PHOTO-DUO-DIODE TYPE I5701 (2N1275) for Tape Readout, high switching and measurement indication. 50V. 250mW. OUR PRICE 10/- EACH, 50 OR OVER 8/6. EACH. FULL DETAILS.

## FET'S

2N3819..... 10/-  
2N3820..... 25/-  
MPF105..... 8/-

LOW COST F.E.T.s Fully Tested, Guaranteed Parameters eqvt. to 2N3819, MPF102, 2N5459. 1-24 7/6 each; 25-99 6/3 each; 100 up 5/6 each. Coded FE19. Full data sent, TO-72 case.

## CADMIUM CELLS

ORP12 8/6  
ORP60, ORP61 8/- each  
PHOTO TRANS. OCP71 Type. 8/6

## INTEGRATED CIRCUITS

### BI-PAK MONOLITHIC AMPLIFIERS

BP709C, Operational amplifier, 15/- each.  
BP701C, Operational amplifier (with Zener output), 12/6 each.  
BP702C, Operational amplifier (with direct output), 12/6 each.  
BP501, Wide band amplifier, 18/- each.  
BP521, Logarithmic wide band amp., 14/- each.  
BP201C, General purpose amplifier (TO-5 lead), (voltage or current amp.), 12/6 each.  
I.C. Operational Amplifier with Zener output. Type 70. Ideal for P.E. Projects. 8 Lead TO-5 case. Full data.

Our price 12/6 each 5 off 11/- each. Large Qty. Prices quoted for

### AMPLIFIER for 'P.E.' projects



Identical encapsulation and pin configuration to the following: ICL402-3, IC10 and IC403. Each circuit incorporates a pre-amp and class A.B. Power amp stage capable of delivering up to 3 watts RMS. Fully tested and guaranteed. Supplied complete with circuit details and data. CODED BP.1010. OUR LOWEST PRICE 30/- each. 10 up 25/- each.

### OTHER MONOLITHIC DEVICES

DI13D1 Silicon Unilateral switch 10/- each.  
A Silicon Planar, monolithic integral circuit having thyristor electrical characteristics, but with an anode gate and a built-in "Zener" diode between gate and cathode. Full data and application circuits available on request.

### FAIRCHILD (U.S.A.) RTUL MICROLOGIC INTEGRATED CIRCUITS

Epoxy case TB-5 lead temp. range 15°C to 55°C. UL900, Buffer, 9/9 each.  
UL914 Dual two-input gate, 9/9 each.  
UL923 J-K-flip-flop, 13/6 each.  
Complete data and circuits for the Fairchild IC's available in booklet form priced 1/6.

### MULLARD I.C. AMPLIFIERS

TA A243, Operational amplifier, 70/- each.  
TA A263, Linear AF amplifier, 18/6 each.  
TA A293, General purpose amplifier, 21/- each.  
CA3020 RCA (U.S.A.) LINEAR INTEGRATED CIRCUITS

Audio Power Ampifier, 30/- each.  
**MONOLIT C DIGITAL CIRCUITS** (10 lead TO-5)  
BP305, 6-Input AND gate, 9/6 each.  
BP314A, 7-Input NOR gate, 9/6 each.  
BP315A, Dual 3-Input NOR gate, 9/6 each.  
BP316, Dual 2-Input NOR gate (expandable), 9/6 each.  
BP320A, J-K-Binary element, 11/6 each.  
BP332A, Dual 3-Input OR gate, 9/6 each.

# THE MODERN BOOK CO

**20 Solid State Projects for the Home**  
by R. M. Marston. 18/- Postage 1/-

**PAL-D Colour Receiver Questions & Answers**  
by K. J. Bohlman. 13/6 Postage 1/-

**Transistor Audio and Radio Circuits**  
by Mullard. 30/- Postage 1/-

**Colour Television PAL System**  
by G. N. Patchett. 50/- Postage 1/-

**Basic Theory and Application of Transistors.**  
17/- Postage 1/6

**Servicing with the Oscilloscope**  
by Gordon J. King. 28/- Postage 1/-

**VHF-UHF Manual**  
by G. R. Jessop. 21/- Postage 1/6

**Radio, Illustrated Teach Yourself**  
by David Gibson. 12/6 Postage 1/-

**The Radio Amateur's Handbook**  
by A.R.R.L. 48/- Postage 4/6

**The Hi-Fi and Tape Recorder Handbook**  
by Gordon J. King. 40/- Postage 2/-

**Radio Servicing Problems**  
by W. A. L. Smith. 9/- Postage 1/-

**The Practical Aerial Handbook**  
by Gordon J. King. 54/- Postage 2/-

**Circuits for Audio and Tape Recording**  
by F. C. Judd. 7/6 Postage 1/-

**Radio Communication Handbook**  
by R.S.G.B. 63/- Postage 4/6

**Amateur Radio Call Book 1970**  
by R.S.G.B. 6/6 Postage 6d.

**Radio Handbook**  
by William I. Orr. 105/- Postage 4/6

We have the Finest Selection of English and American Radio Books in the Country

**19-21 PRAED STREET (Dept RC) LONDON W2**

Telephone PADDington 4185

## JACKSONS

Radio & Electronic Components

(Made in England)

### CAPACITORS

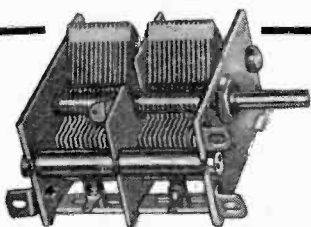

**Type E Gang Capacitor**  
Cat. No. 4507

Robust general purpose model. Mid-line E Law. Capacitance swings 310 pF, 354pF, 399pF, 487pF and 532pF. Air gap .012 inches 750 VDC tested. Pos. T.C. approx. 100 ppm/°C. Length: 1 gang 1 7/32". 2 gang 2 21/64". 3 gang 3 7/16". 4 gang 4 35/64". Front area: 2 3/4" x 2 1/32". Insulation: Ceramic.



Write for literature:

**JACKSON BROS. (London) LIMITED**  
Dept. RC, KINGSWAY-WADDON, CROYDON, CR9 4DG  
Phone Croydon 2754-5 (01-688) Grams Walfilco, Croydon  
U.S. Office: M. Swedgal, 258 Broadway, N. York. N.Y. 10007

### THE WILSIC MK II REVERBERATION UNIT KIT

A new, all silicon version of our self-contained, 6 transistor, reverberation chamber to which microphones, instruments, tuners or tape recorders may be connected for added dimensional effect. The output is suitable for most amplifiers and the unit is especially suitable for use with electronic organs. A ready-built spring and transducer assembly is used. (58/11 if bought separately).

Complete easy-to-build kit, with constructional notes and circuits: £7.10.0. Pre-drilled and printed case 34/- extra. All parts available separately. Send 1/- for circuit and construction details.

**THE IMPROVED WILSIC SIGNAL INJECTOR.** Now all-silicon circuit for extra high frequency harmonics. Light and compact, measuring only 3 1/2" x 1/2" (excluding probe). Price ready for use, including battery 32/6 post free.

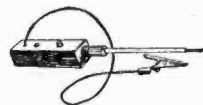

### THE WILSIC WAH-WAH PEDAL KIT

**SELECTIVE AMPLIFIER MODULE.** The basis of the Wah-Wah pedal. Kit contains all the components to build a 2-transistor circuit module, also the sockets, control, etc., required for the constructor to assemble his own design. 35/- Assembled and tested module 42/6.

**FOOT VOLUME CONTROL PEDAL.** Foot pedal unit in very strong fawn plastic. Fitted with output lead and plug for connection to guitar amplifier. May be used for volume control or converted to Wah-Wah by adding the module. Pedal unit only £5.12.6.

Complete kit for Wah-Wah pedal £7.0.0. All post free. Send 1/6 for our catalogue of components, testmeters, musical electronics and more details of the above items. Callers welcome.

**WILSIC ELECTRONICS LIMITED**  
6 COPLEY ROAD, DONCASTER, YORKSHIRE

# BI-PRE-PAK LIMITED

## FULLY TESTED AND MARKED

AC107	3/-	OC170	3/-
AC126	2/6	OC171	4/-
AC127	3/6	OC200	3/6
AC128	2/6	OC201	7/-
AC176	5/-	2C301	2/6
ACY17	3/-	2C303	2/6
AF114	4/-	2N711	10/-
AF115	3/6	2N1302-3	4/-
AF116	3/6	2N1304-5	5/-
AF117	3/6	2N1306-7	6/-
AF186	10/-	2N1308-9	8/-
AF139	10/-	2N3819	9/-
AF239	12/6	Power Transistors	
BFY50	4/-	OC20	10/-
BSY25	7/6	OC23	10/-
BSY26	3/-	OC25	8/-
BSY27	3/-	OC25	8/-
BSY28	3/-	OC26	5/6
BSY29	3/-	OC28	5/6
BSY95A	3/-	OC35	5/6
OC41	2/6	OC36	7/6
OC44	2/6	AD149	10/-
OC45	2/6	AUY10	30/-
OC71	2/6	2N3055	15/-
OC72	2/6	2S034	10/-
OC73	3/6	Diodes	
OC81	2/6	AA42	2/-
OC81D	2/6	OA95	2/-
OC83	4/-	OA79	1/9
OC139	2/6	OA81	1/9
OC140	3/6	IN914	1/6

## ANOTHER SCOOP FOR BI-PRE-PAK

JUST RELEASED FROM STOCK, A.E.I. INTEGRATED CIRCUITS

These are brand new genuine surplus stocks, marked and guaranteed to full makers specification and not remarked rejects.

NE808A	Single 8 1/P Nand Gate TTL	7/-
NE816A	Dual 4 1/P Nand Gate TTL	7/-
NE825A	D.C. Clocked J-K Flip-Flop TTL	17/6
NE840A	Dual 4 1/P Exclusive OR Gate TTL	7/-
NE855A	Dual 4 Power Gate TTL	7/-
NE870A	Triple 3 1/P Nand TTL	7/-
NE880A	Quad 2 Nand TTL	7/-
SP616A	Dual 4 Nand Gate DTL	7/-
SP631A	Quad 2 1/P Gate Expander DTL	7/-
SP670A	Triple 3 Nand Gate DTL	7/-
SP806A	Dual 1/P Expander TTL	7/-
SP808A	Single 8 1/P Nand Gate TTL	7/-
SP816A	Dual 4 1/P Nand Gate TTL	7/-
SP825A	D.C. Clocked J-K Flip-Flop TTL	17/6
SP840A	Dual 4 1/P Exclusive OR Gate TTL	7/-
SP855A	Dual 4 Power Gate TTL	7/-
SP870A	Triple 3 1/P Nand TTL	7/-
SP880A	Quad 2 1/P Nand TTL	7/-
NE500K	Video Amplifier	40/-
NE501K	Video Amplifier 40 MHz	40/-
NE806J	Dual 4 1/P Expander TTL	7/-
NE808J	Single 8 1/P Nand Gate TTL	7/-
NE816J	Dual 1/P Nand Gate TTL	7/-
NE825J	D.C. Clocked J-K Flip-Flop TTL	17/6
NE840J	Dual 4 1/P Exclusive OR Gate TTL	7/-
NE855J	Dual 4 Power Driver TTL	7/-
NE880J	Quad 2 1/P Nand TTL	7/-
ST620A	J-K Flip-Flop DTL	17/6
ST659A	Dual 4 Buffer/Driver DTL	7/-

Suffix: A=DIP 14 lead K=10 lead TO.5 J=Flat Pack

## NEW TESTED & GUARANTEED PAKS

B2	4 Photo Cells, Sun Batteries. .3 to .5V, .5 to 2mA.	10/-
B77	2 AD161-AD162 NPN/PNP Trans. Comp. output. Pair	10/-
B81	10 Reed Switches. Mixed types large and small.	10/-
B89	2 5P5 Light Sensitive Cells. Light res. 400Ω, Dark 1MΩ.	10/-
B91	8 NKT163/164 PNP Germ. to -5. Equiv. to OC44, OC45.	10/-
B92	4 NPN Sil. Trans. A06=BSX20, 2N2369, 500 MHz, 360 mW.	10/-
B93	5 ACY17-21 PNP Germ. GET113 Trans. equivalent to	10/-
B96	5 2N3136 PNP Sil. Trans. TO-18. HFE100-300. IC.600mA. 200 MHz.	10/-
B98	10 XB112 & XB102 equiv. to AC126, AC156, OC81/2, OC71/2, NKT271, etc.	10/-
H4	250 Mixed Resistors. Post & packing 2/-.	10/-
H7	40 Wirewound resistors. Mixed values. Postage 1/6.	10/-
H8	4 BY127 Sil. Recs. 1000 PIV, 1 amp. Plastic.	10/-
H9	2 OCP71 Light sensitive photo-transistors.	10/-

**FREE!** Packs of your own choice up to the value of 10/- with orders over £4.

## LOOK! TRANSISTORS ONLY 6d. EACH

TYPE A	TYPE B	TYPE D
PNP SILICON ALLOY TO-5 CAN	PNP SILICON PLASTIC ENCAPSULATION	NPN SILICON PLANAR PLASTIC PACKAGE
Spec:- hFE 15-100. ICER at VCE=20V 1mA Max. These are of the 2S300 range which is a direct equivalent to the OC200-205 range.	Spec:- hFE 10-200 ICER at VCE=10V 1mA Max. These are of the 2N3702-3 and 2N4059-62 range.	Spec:- VCB 10v VCE 10v Ptot 500 mW hFE 50 min. Audio Preamplifier Transistor, similar to BC 113/4/5.

## NEW UNMARKED UNTESTED PAKS

B78	12 Integrated Circuits, Data & Circuits of types, supplied with orders.	10/-
B80	8 Dual Trans. Matched O/P pairs NPN. Sil. in TO-5 can.	10/-
B82	10 OC45, OC810 & OC81 Trans. Mullard glass type.	10/-
B83	200 Trans. Makers rejects. NPN/ PNP. Sil. & Germ.	10/-
B84	100 Silicon Diodes DO-7 glass equiv. to OA200, OA202.	10/-
B66	150 High quality Germ. Diodes. Min. glass type.	10/-
B86	50 Sil. Diodes sub. min. IN914 & IN916 types.	10/-
B87	100 Germ. PNP Trans. equiv. to OC44, OC45, OC81, etc.	10/-
B88	50 Sil. Trans. NPN, PNP. equivalent to OC200/1, 2N706A, BSY95A, etc.	10/-
B60	10 7 Watt Zener Diodes. Mixed voltages.	10/-
H5	16 1 Amp. Plastic Diodes. 50-1000 Volts.	10/-
H6	40 250mW. Zener Diodes DO-7 min. Glass Type.	10/-

## Return of the unbeatable P.1 Pak. Now greater value than ever.

Full of short lead semiconductors and electronic components, approx. 170. We guarantee at least 30 really high quality factory marked Transistors; PNP and NPN, and a host of diodes and rectifiers. Mounted on printed circuit panels. Identification chart supplied to give some information on the transistors.

**P.1 PLEASE ASK FOR PAK P.1 ONLY 10/-**  
2/- P & P on this Pak.

**MAKE A REV. COUNTER for your Car. The 'TACHO BLOCK'.** This encapsulated block will turn any 0-1mA meter into a perfectly linear and accurate rev. counter for **20/- each** any car.

## FREE CATALOGUE AND LISTS for:- ZENER DIODES TRANSISTORS, RECTIFIERS FULL PRE-PAK LISTS & SUBSTITUTION CHART

MINIMUM ORDER 10/-. CASH WITH ORDER PLEASE. Add 1/- post and packing per order. OVERSEAS ADD EXTRA FOR AIRMAIL.

**P.O. RELAYS 8 FOR 20/-**  
Various Contacts and Coil Resistances. No individual selection. Post & Packing 5/-

**SPECIAL OFFER**  
**Germanium Bridge Rectifiers**  
GEX 541 Finned  
Single phase 12 amp 48v  
Three phase 18 amp 74v  
Ideal for battery chargers or power units. OFFERED AT FRACTION OF MAKERS COST  
**ONLY 12/6 EACH**  
POST & PACKING 2/6

**FREE! A WRITTEN GUARANTEE WITH ALL OUR TESTED SEMICONDUCTORS**

**BI-PRE-PAK LTD** DEPT. C, 222-224 WEST ROAD, WESTCLIFF-ON-SEA, ESSEX  
TELEPHONE: SOUTHEND (0702) 46344



IF YOU'RE BUYING A HOUSE

# Mortgage Protection

is the best Policy for you

If you're buying your house with the help of a Building Society or a private loan, a "Yorkshire" Mortgage Protection Policy will take care of your outstanding payment in the event of your premature death. And, if you wish, you can arrange a Protection "Plus" Policy, which

gives you a substantial cash return at the end of the mortgage term. It costs so little yet means so much to your dependants. Leave them a home not a mortgage!

Please send for further details, without any obligation, of course.

## THE YORKSHIRE INSURANCE COMPANY LIMITED

Becket House, 36-37 Old Jewry, LONDON, E.C.2.

It pays to be protected by a **General Accident** company

Please send me further particulars of the Mortgage Protection Policy

Name.....

Address.....

.....

.....

5304



# AMATRONIX LTD.

39 Selsdon Road,  
South Croydon,  
Surrey, CR2 0DE

MAIL ORDER ONLY. PROMPT SERVICE.  
Orders over 10/- UK post paid. Discounts  
Orders over £3, 10%; over £10, 15%.

## NEW & PERFECT TRANSISTORS

AD161-2	12/-	HK041	2/6	2N3704	3/6
AF239	10/-	HK601	2/6	2N3707	3/6
B5000G	11/3	IS44	1/4	2N3794	3/-
BD121	18/-	MEM564C	16/-	2N3983	6/6
BC107	3/-	OA90	1/3	2N4058	4/-
BC168	2/3	SF115	3/-	2N4284	3/-
BC169	2/6	TI407	6/6	2N4289	3/-
BF167	5/3	TIS60M	4/8	2N4291	3/-
BF178	9/-	TIS61M	4/11	25B187	2/-
BF225	5/-	2N706	2/7	25B405	5/-
BFY51	4/6	2N2926G	2/6	25D72	5/-
GET693	1/3	2N3702	3/-	40468A	7/6

## RECTIFIERS:

800piv, 500mA Si. IS557, 3/-; 50piv, 100mA. 1/- Submin. Selenium Bridge, 30Vrms, 150mA dc, 3/6; Contact-cooled Sel. Bridge, 30Vrms, 700mA dc, 6/- Silicon Bridge, 80Vrms, 1Adc, 10/- All new and perfect.

## NEW!

"IDENTICAL RESONATORS": new Brush Cleveite Transfilters for do-it-yourself ceramic i.f. filters. Four of these plus seven fixed capacitors give razor-sharp selectivity to superhets with 455kHz i.f. Kit of 4 resonators and all capacitors, plus notes on use, 35/- Single resonators, 10/- each, 4 for 30/-

"R.C." MILLIVOLTMETER (Jan., p. 342). Our AX10 Printed Circuit accommodates the main part of the circuit (not TR1). With layout drawing and hints, 15/-

## COMPONENT KITS

AMPLIFIER PACKAGES. Reliable and efficient, and still far cheaper than i.c.'s!

AX2 9V, up to 300mW 12/6

AX3 9V, up to 800mW in 8 ohms 22/6

AX4 24V, 5W, 8 ohms, 3W, 15 ohms 30/-

AX5 12-15V, 3W, 3-5 ohms. NEW! 35/-

**2N3819 . . . 7/- !**

**SPECIAL OFFER FOR ONE MONTH ONLY**

N-Channel Texas junction f.e.t. for a.f. and r.f. New and perfect.

## BUILD A MINI MAINS PACK



Components as shown, and hints 17/6.

## Mini Mains Transformers 30x30x37 mm

MT7	7-0-7V	120mA	13/6
MT9	9-0-9V	80mA	12/6
MT12	12-0-12V	50mA	13/6

## CAPACITORS

Polystyrene: 160V, small, low-loss, tol. 1pF or 2 1/2%. New prices: 10-1500pF, 1/-; 2200-22,000pF, 1/6. In stock: 10, 12, 15, 18, 22, 27, 33, 39, 47, 56, 68, 82, 100, 120, 150, 180, 220, 270, 330, 390, 560, 680, 820, 1000, 1500, 2200, 3300, 4700, 6800, 8200, 10,000, 15,000, 22,000pF.

Miniature Metallised Polyester: .01uF, 8d; .1uF, 10d; .22uF, 1/- 250V wkg. Tuning: 300pF max. Jacksons Dilemin sub-min single tuner, 10/-.

## RESISTORS

Carbon Film, 1/4W, miniature, low noise. 10, 12, 15, 18, 22, 27, 33, 39, 47, 56, 68, 82Ω and so on to 10M. Tol. ± 5% to 1M, 10% above 1M. All 4d. each.

Carbon Skeleton Presets. Submin., vertical, linear, 100mW, 50, 150, 500Ω and so on to 1.5M Egen Type 467, 1/6 each. Volume Control, 10K log. with d.p. switch and long aluminium spindle with flat. Standard size, Egen, 5/6 each.

R. F. CHOKES. Repanco: CH1, 2.5mH, 2/6; CH2, 5mH, 3/-; CH3, 7.5mH, 3/-; CH4, 10mH, 3/-; CH5, 1.5mH, 2/6. All small, ferrite-cored.

FERRITE RODS: 4in. or 4 1/2in. x 1/2in., wound for MW (300pF), 5/-; unwound, 2/-; oval, unwound, 2 x 1/2 x 1/2in., with data, 2/6.

TRANSFORMERS, MINI. A.F.: Eagle LT700, 1200Ω c.t. to 3Ω, 200mW, 5/-; Repanco TT47 driver for single ended push-pull, 4.5 to (1) + (1), 6/-.

TELESCOPIC AERIAL: 7 1/2in. opening to 47in., 9/-.

BATTERY HOLDER BH2 for two 1.5V pen cells, with snap connector, 2/6.

EARPIECES, all 3.5mm plugged, crystal. 4/9; magnetic, 8Ω, 2/6.

# DENCO (CLACTON) LIMITED

355-7-9 OLD ROAD, CLACTON-ON-SEA, ESSEX

Our components are chosen by Technical Authors and Constructors throughout the World for their performance and reliability, every coil being inspected twice plus a final test and near spot-on alignment as a final check.

Our General Catalogue showing full product range	...	...	2s. 6d.
DTB4 Transistor & Valve circuitry for D.P. Coils	...	...	2s. 6d.
DTB9 Valve Type Coil Pack Application circuitry	...	...	2s. 6d.
MD.1 Decoder Circuitry for Stereo Reception	...	...	4s. 0d.

All post paid, but please enclose S.A.E. with all other requests in the interests of retaining lowest possible prices to actual consumers.

# The ABC of obtaining components - SIMPLY! QUICKLY!



**A**

**PURCHASE A HOME RADIO CATALOGUE,** using the Coupon below. Please enclose a cheque or postal order for 12/6 (8/6 plus 4/- packing & postage). Your catalogue will be sent by return of post.

**B**

**CHOOSE YOUR COMPONENTS.** In the Home Radio Catalogue over 8,000 components are listed and more than 1,500 illustrated. A comprehensive index helps you to locate your requirements easily.

**C**

**JOIN OUR CREDIT ACCOUNT SERVICE.** Full details are enclosed with every catalogue.

**D**

**ORDER YOUR COMPONENTS.** Having joined our Credit Account Service, you may order either by phone or post. If you phone out of office hours, a recording machine takes your message.

**E**

**GET STARTED ON THAT PROJECT!** Whether it's constructing or servicing work, the fact that you can obtain the right components easily, without having to chase from shop to shop, will put you in the right frame of mind to make a better job of it.

Whether or not you want to use the Credit Account Service mentioned above, you certainly need the Home Radio Components Catalogue, if you construct or repair radio, television and electronic gadgets. By the way, the catalogue contains six vouchers, each worth a shilling when used as instructed, and with the catalogue we supply a 30-page Price Supplement and a Bookmark giving electronic abbreviations.

**Post the Coupon today, with cheque or P.O. for 12/6.**

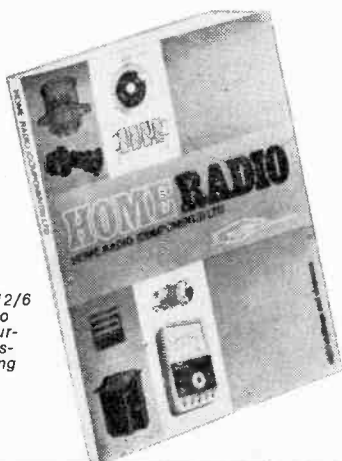

The price of 12/6 applies only to catalogues purchased by customers residing in the U.K.

Please write your Name and Address in block capitals

Name.....

Address.....

.....

.....

HOME RADIO (Components) LTD., Dept RC,  
234-240 London Road, Mitcham, Surrey CR4 3HD



# THE Radio Constructor



Incorporating THE RADIO AMATEUR

JULY 1970

Vol. 23 No. 12

CONTENTS

Published Monthly (1st of Month)  
First Published 1947

Editorial and Advertising Offices  
57 MAIDA VALE LONDON W9

Telephone 01-286 6141      Telegrams Databux, London

© Data Publications Ltd., 1970. Contents may only be reproduced after obtaining prior permission from the Editor. Short abstracts or references are allowable provided acknowledgement of source is given.

Annual Subscription 48s. (U.S.A. and Canada \$6) including postage. Remittances should be made payable to "Data Publications Ltd.". Overseas readers please pay by cheque or International Money Order.

Queries. We regret that we are unable to answer queries other than those arising from articles appearing in this magazine nor can we advise on modifications to equipment described. Queries should be submitted in writing and accompanied by a stamped addressed envelope for reply.

Correspondence should be addressed to the Editor, Advertising Manager, Subscription Manager or the Publishers as appropriate.

Opinions expressed by contributors are not necessarily those of the Editor or proprietors.

Production.—Letterpress.

FURTHER NOTES ON THE DISCOVERY SHORT WAVE RECEIVER	722
TRADE REVIEW	725
CURRENT PROTECTION AND TRIP CIRCUIT (Suggested Circuit No. 236)	726
VENI, VIDI, VICI	729
NOW HEAR THESE	729
NEWS AND COMMENT	730
QSX	732
UNUSUAL NULL INDICATOR	733
SOLID-STATE A.C. MILLIVOLTMETER	736
CYBERNETIC CYNTHIA (PART 2)	743
THE 'GLOBE RANGER' 4-BAND SUPERHET	744
CURRENT SCHEDULES	750
CAN ANYONE HELP ?	753
UNDERSTANDING TAPE RECORDING (Part 3)	754
IN YOUR WORKSHOP	758
LIQUID CRYSTAL DISPLAYS	764
LATE NEWS	765
WORLD DX CLUB CONVENTION	765
LAST LOOK ROUND	765
INDEX VOLUME 23, AUGUST 1969 - JULY 1970	773
RADIO CONSTRUCTOR'S DATA SHEET No. 40 (The Hartley Oscillator)	iii

Published in Great Britain by the Proprietors and Publishers, Data Publications Ltd, 57 Maida Vale, London, W.9.

The Radio Constructor is printed by Kent Paper Company Ltd, London and Ashford, Kent.

**AUGUST ISSUE WILL BE PUBLISHED  
ON AUGUST 1st**

# FURTHER NOTES ON The Discovery SHORT WAVE RECEIVER

by

FRANK A. BALDWIN

The 'Discovery' 2-valve, 4-stage short wave receiver was featured in our issue dated March 1970 and proved to be a popular design for beginner constructors. In this short article, the author describes a few simple modifications which result in the addition of bandspread and headphone reception facilities

THE 'DISCOVERY' 2-VALVE, 4-stage short wave receiver was featured in the March 1970 issue of this journal.\* Due to the grounded-grid input stage, the receiver proved to be the most efficient, simple 'straight' design ever handled by the author

It is known that many 'Discovery' receivers were constructed by beginners, indeed the component supplier several times tem-

porarily ran out of stock of some of the specified parts soon after publication. It is for the beginner constructors who built this receiver that this article has been prepared and if the few simple modifications described are carried out, the owner will find himself equipped with a sensitive, selective and more versatile receiver.

The modifications include the addition of a variable 25pF bandspread capacitor, a headphone jack and a new front panel. Both the bandspread capacitor and the head-

phone jack are mounted on the front panel and in order to accommodate these added controls without giving the receiver a cramped appearance, a new panel is required. This imparts to the receiver a longer and lower styling, as may be seen from the front panel illustration.

The addition of the bandspread capacitor provides the operator with the facility of greater ease of tuning over the various bands, in that stations are more spread out and further apart in terms of rotation than is the case with the bandset capacitor. Thus, with the bandset capacitor set at the high frequency end of a particular band, rotation of the bandspread capacitor from minimum capacitance to maximum capacitance will result in the band being tuned from the high to the low frequency end.

## NEW FRONT PANEL

The first task is to completely remove the old panel. When this has been done, offer it up to the new panel - taking care not to scratch the surface - and position the old atop the new panel such that the two bottom edges are level and there is a  $\frac{1}{2}$ in. overhang at each end of the new panel. Clamp the panels together and, with a centre-punch, mark out the centre points of holes 1, 2, 3, and that for the bandset variable capacitor C8. See Fig. 1. Drill holes 1, 2, 3 and that for C8 to a diameter of  $\frac{1}{8}$ in.

Remove the old panel and, with the aid of a small round or half-round file, slightly enlarge hole 3 in the new panel. It will be remembered that variable capacitor C1, which fits into hole 3, must *not* touch the metalwork at any point, otherwise incoming signal voltages will be short-circuited to chassis.

Next, drill holes 4 and 5 (see Fig. 1) to a diameter of  $\frac{1}{8}$ in. Also, drill the hole for PL1  $\frac{1}{8}$ in. Drill the hole for the motif to a diameter of  $\frac{1}{8}$ in.

Again present the old panel to the new as previously described and mark with a centre-punch the fixing holes for the dial assembly and drill the three holes required to the same diameter as in the old panel.

The drilling of the front panel is now complete. Spray or paint the panel and allow to dry.

When the paint or cellulose is both dry and hardened, secure the front panel to the chassis by means of the securing nuts for the volume control R12 (hole 1); reaction capacitor C9 (hole 2) and input capacitor C1 (hole 3).

Ensure that the spindle of C1 does not make contact with the metalwork by securing it into position with insulating washers moun-

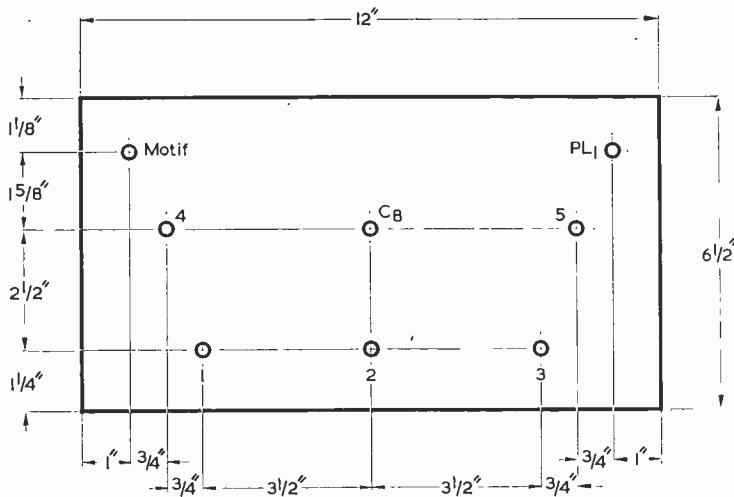

Fig. 1. The drilling details for the new front panel

ted on both sides of the metalwork and by then checking with a simple continuity tester or ohmmeter. If a short circuit exists, adjust the position of C1 within the enlarged hole until the short-circuit clears and then finally secure by tightening the fixing nut. Recheck for a short-circuit to be doubly sure.

Position the headphone jack in hole 4 and secure such that the tags of this component point inwards towards C8.

Position and secure the bandspread capacitor to hole 5 such that the stator (fixed) vanes are nearest C8.

Secure the panel lamp assembly PL1 to the front panel.

With both valves removed from their respective holders and with the moving vanes (rotors) of the bandspread capacitor C8 fully enmeshed, drill a  $\frac{1}{8}$ in. hole through the chassis deck at a point approximately  $\frac{1}{2}$ in. from the rear end plate of C8 and towards the mains transformer. This hole is later fitted with a rubber grommet through which the various leads are taken to the headphone jack. The position of this hole can clearly be seen from the illustration of the above-chassis view reproduced herewith. When centre-punching the mark for this hole ensure that a clear space exists *below* the chassis deck so that the subsequent drilling will not damage any component. Fit a rubber grommet to the hole.

This completes the necessary work prior to wiring-up the bandspread capacitor and modifying the output stage for the addition of the headphone jack.

### WIRING-UP (BANDSPREAD)

1. Deal firstly with wiring into circuit the bandspread capacitor. Remove the coil from its holder and **solder** one end of a short length of p.v.c. covered wire to the capacitor fixed vanes solder tag nearest the chassis deck and **solder** the other end to the fixed vanes tag of C8 nearest the chassis deck. Ensure that this length of wire is well clear of the coil when this latter component is replaced in its holder. This completes the wiring-up required for the bandspread capacitor.

### HEADPHONE JACK

Before the headphone jack can be wired-up, some modifications require to be made at the speaker output tags on the rear apron of the chassis. The eventual result of the following modifications is that the receiver will operate with the loudspeaker in circuit in the usual manner but when the headphone plug is inserted into the jack mounted on the front panel, the audio output is via the phones and the

JULY 1970

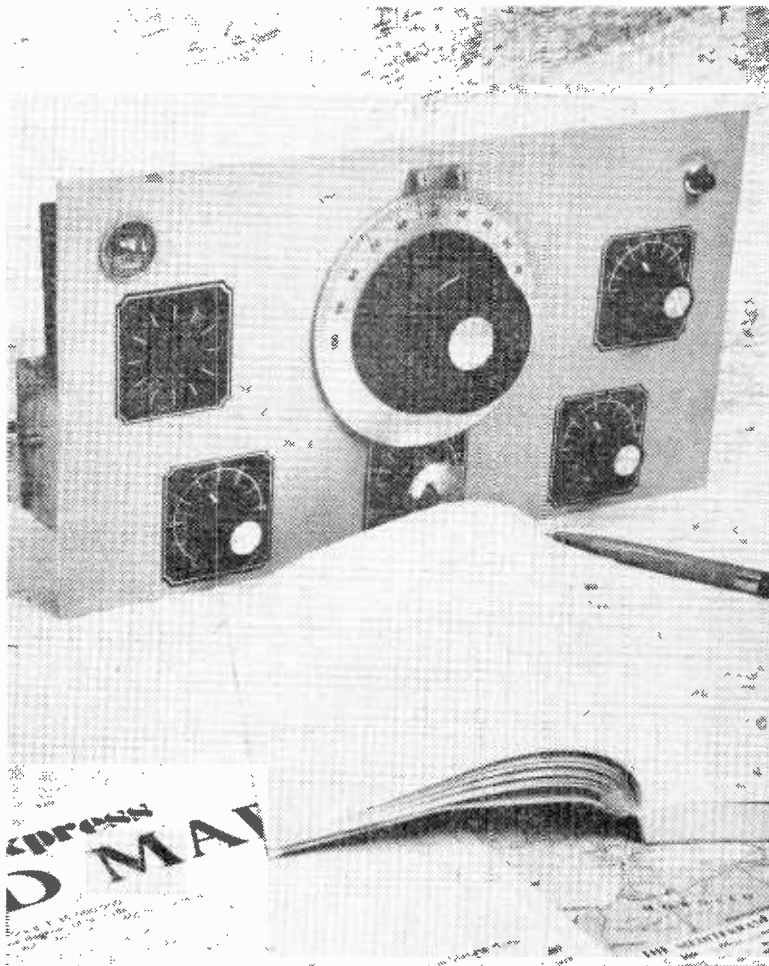

Front panel view of the modified 'Discovery' receiver. Note the use of Panel Signs transfers from Set. No. 6 and the spun aluminium knob fitted to the reaction capacitor C9

speaker is automatically muted. The switching circuit is shown in Fig. 2. When the headphone plug is removed from the jack the reverse process takes place, thus the

operator has the choice of either headphone or loudspeaker operation.

2. Turn the receiver over such that the chassis underside is upper-

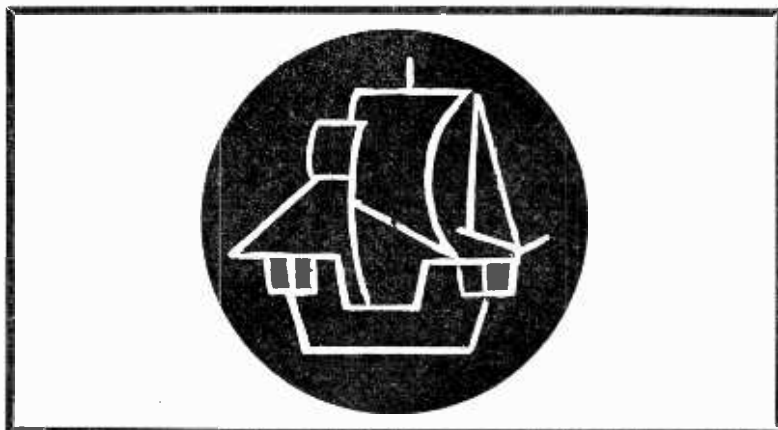



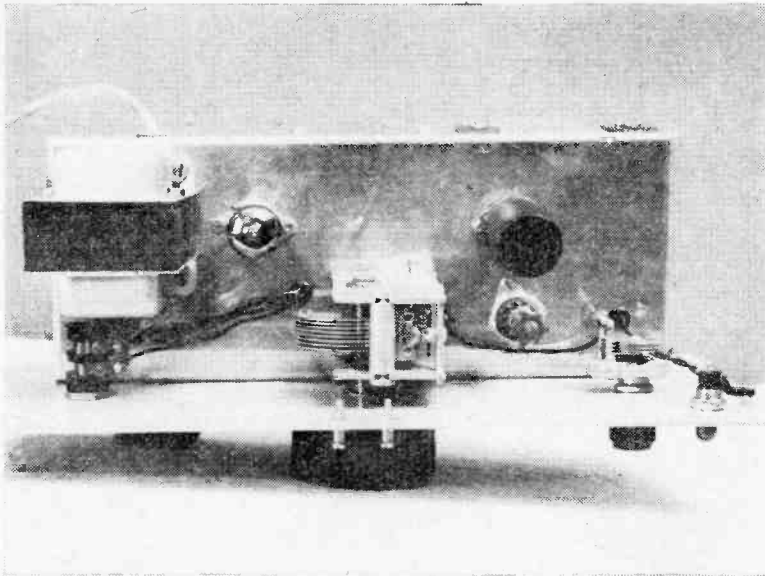

Above-chassis view of the modified receiver. Note the position of the rubber grommet through which are fed all wires to the headphone jack. The orientations of the added bandsread capacitor and headphone jack are clearly shown

## COMPONENTS

### Capacitors

Bandsread - 25 pF variable (Jackson Bros Ltd., type C804)

Headphone Jack - 0.1 $\mu$ F, tubular, (Mullard) 400V wkg.

### Headphone Jack

Jack with 2 'break' contacts (Igranite)

### Headphones

2,000 $\Omega$  impedance (complete with jack plug)

### Panel

12 x 6 $\frac{1}{2}$ in. (H. L. Smith & Co. Ltd.)

### Knob

Spun Aluminium (for reaction control) (H. L. Smith & Co. Ltd.)

### Miscellaneous

Wire (p.v.c. covered), Panel Signs Set No. 6,  $\frac{3}{16}$ in. grommet

most - it will be necessary here to rest the chassis deck on some books.

Refer to the point-to-point diagram published on page 499 of the March 1970 issue and also to Fig. 3 shown here.

3. Identify the existing wire connecting the lower socket of the speaker socket strip to the 6BA chassis tag at the Aerial-Earth socket strip. Unsolder and remove this wire. Ensure that the wire between the 6BA chassis tag and the receiver Earth socket is still connected. Ensure also that the wire from the lower speaker output socket on tag 3 of the output transformer is still connected.

4. Completely remove the wire connecting tag 4 of the output transformer to the speaker output socket nearest the chassis deck.

5. Refer to Fig. 3 in which, for convenience of presentation of connections, the headphone jack is shown with the flat side uppermost.

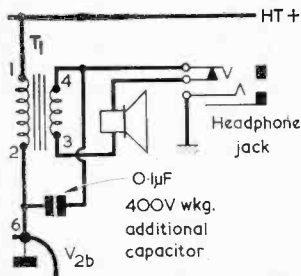

Fig. 2. The altered output circuit resulting from the addition of the headphone jack

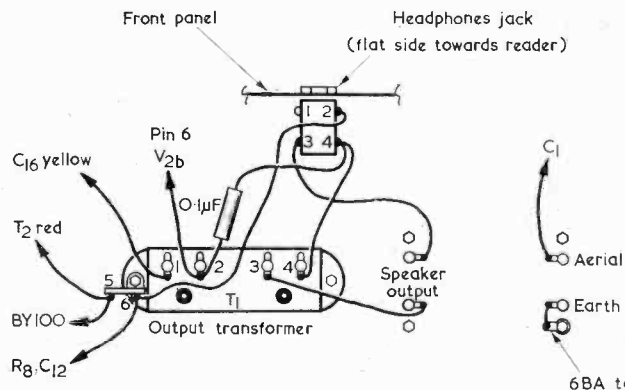

Fig. 3. Point-to-point wiring diagram of the added headphone jack. Note that all wiring is shown in exploded form for purposes of clarity and that, in the receiver, the jack is mounted on the front panel with all leads to it being fed through an additional rubber grommet in the chassis deck - see illustration of the above-chassis view

Obtain an appropriate length of p.v.c. covered wire, pass it through the grommet just fitted and solder one end to tag 2 of the jack and solder the other end to tag 6 of Tagstrip 2 mounted alongside the output transformer. Ensure that the other connection to tag 6 of Tagstrip 2 (R8 and C12) has not been disturbed.

6. Passing an appropriate length of p.v.c. covered wire through the grommet just fitted, solder one end to tag 3 of the headphone jack and solder the other end to the now blank speaker output socket nearest the chassis deck.

7. Passing an appropriate length of p.v.c. covered wire through the grommet just fitted, connect (without soldering) one end to tag 4 of the headphone jack and solder the other end to tag 4 of the output transformer.

8. Take up the additional 0.1 $\mu$ F 400V wkg. capacitor and, fitting sleeving, solder one of its lead-outs to tag 2 of the output transformer. Solder a length of p.v.c. covered wire to its other lead-out, employing sleeving and insulating tape as necessary to ensure that there is no possibility of this connection or the lead-out short-circuiting to

chassis or any other connection. Pass the p.v.c. covered wire through the grommet just fitted and connect it to tag 4 of the headphone jack. Solder both the wires now connected to tag 4 of the headphone jack. As will be gathered from these instructions, the 0.1 $\mu$ F capacitor is below the chassis.

This completes the wiring-up of the headphone jack. The headphones required for use with this receiver should be 2,000 $\Omega$  types. Since an appreciable level of power is available from the output valve, it is preferable to keep a.f. gain control R12, at a fairly low setting for all but very weak signals when using headphones.

#### A FURTHER MODIFICATION

There is a further modification that may be carried out to this receiver and this consists of slightly bending one end corner of the rear rotor vane of C1 such that, when the vanes are fully enmeshed, this makes contact with the stator vanes. In this condition, C1 is short-circuited and signals from the aerial will pass straight through to the cathode of V1(a). The result is maximum sensitivity but minimum selectivity - a condition some may prefer when listening to local amateurs on Top Band.

Care should be taken however when bending the capacitor vane.

Contact between the stator and rotor vanes should only be made at the fully enmeshed position, and rough handling will easily damage the capacitor.

#### PANEL APPEARANCE

To ensure a neat final appearance, the Eagle type KB3 knob which is now fitted to reaction capacitor C9 should be removed, and re-fitted to the new 25pF band-spread capacitor. A spun aluminium knob (see Components List) is then fitted instead to C9. As may be seen from the accompanying illustration, a final neat finish is given by the application of transfers from Panel-Signs Set No. 6.

## TRADE REVIEW . . .

To meet the highest standards of advanced audio-frequency a new range of line-matching and microphone transformers is announced by Gardners Transformers Limited, of Christchurch, Hampshire, England.

Five years of intensive research and development have gone into the new high-performance transformers which will be available to specialist users this month.

The latest Gardners transformers complement the existing high quality range introduced in 1961 which has been so successful that it now represents the standard specified by broadcasting, recording and telephone companies throughout the world.

The existing Gardners transformers come in two basic sizes using International Octal, British 7-pin, or Screen Flying Lead connections. They are ideal for general purposes applications at both low and high signal levels.

Some of the new types, which are similar in size, performance and application to the existing transformers, have the added advantages of a 2,000 volt capability to meet the British Post Office requirement and a wider frequency bandwidth.

The new transformers exploit new metals and materials. In place of the normal oil - or air-filling, they have a closed-cell epoxide resin foam compound

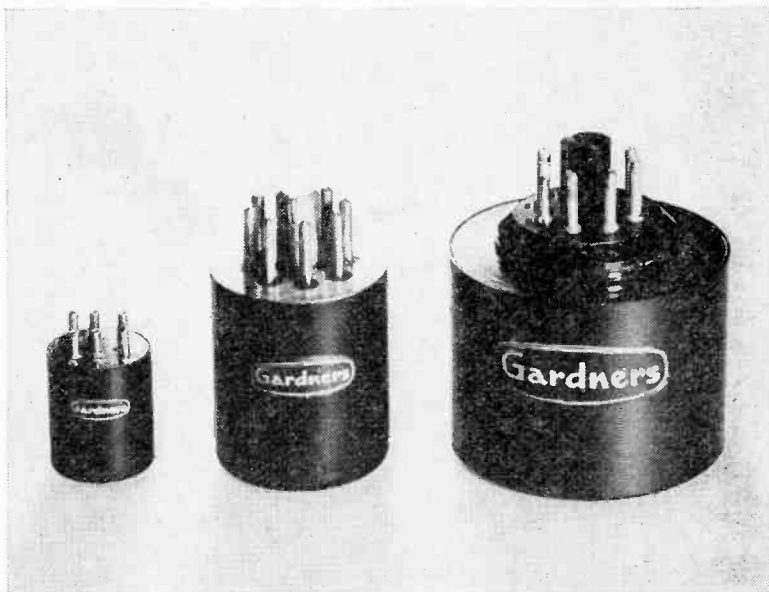

*Examples of the new range of line-matching and microphone transformers announced by Gardners Transformers Limited of Christchurch, Hampshire, England (left to right): Sub-miniature transformer for printed circuit or microphone stick mounting; wide band audio-transformer for high quality studio recording; and wide band transformer to meet British Post Office high voltage test requirement*

to obtain a high degree of acoustic damping.

This filling also gives increased protection to the sensitive core against bumps, vibration and normal mechanical hazards.

The smaller types are vacuum-impregnated with a micro-crystalline wax which remains soft in low temperatures and has little or no effect on the materials forming the sensitive core.

Full specifications of the new range will be contained in **A Manual of Audio-frequency Line-matching Transformers**, an authoritative work of reference on design considerations, to be published this month.

Advance technical data sheets AT.15, AT.16 and AT.17 may be obtained from Gardners Transformers Limited.

# CURRENT PROTECTION AND TRIP CIRCUIT

by G. A. FRENCH

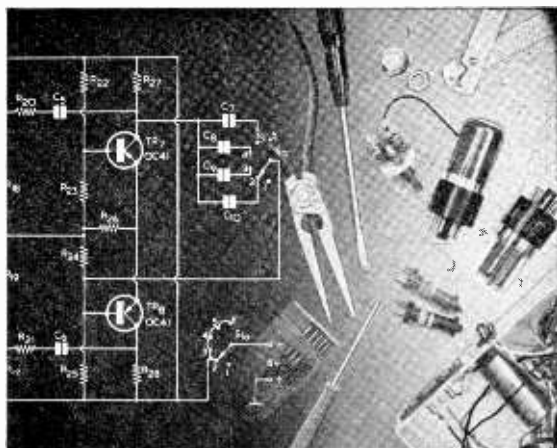

CONSTANT CURRENT TRANSISTOR circuits offer a number of useful and valuable applications in electronics including, in particular, the limiting of current flow to a preset value. In the circuit to be described here a constant current transistor limits the output of any low voltage d.c. power supply unit to a safe value, and also provides a trip function which ensures that load current is cut off if, for any reason, the load attempts to draw a current higher than the limiting value. This trip, once activated, can only be removed by switching off the power supply and switching it on again. Should the load still attempt to draw too high a current

when the supply is once more switched on the circuit trips again. Thus, not only does the protection circuit offer an overload trip but it also ensures that, even under load short-circuit conditions, excessive current cannot flow.

The prototype protection circuit was set up for a limiting current of 150mA, and was found to function satisfactorily over a power supply range of 9 to 20 volts. It should not be employed for higher power supply voltages unless the constant current transistor is changed for a type having a higher V<sub>CEO</sub> than that employed in the prototype. The circuit is capable of being set up to operate at any limiting current

from some 100 to 300mA, whilst the operating principle may be retained (with suitable alteration in some of the components and component values) for currents higher than this.

The protection circuit causes a voltage drop of approximately 0.9 to 1.1 volt to appear in the output from the power supply unit, this voltage drop increasing to about 4 volts (at which the circuit trips) when the output current closely approaches the limiting value.

As may be gathered from the above description, the protection circuit can be a particularly useful addition to a bench power supply, since it ensures that no damage due to excess current flow can occur either to the supply or to its load under fault conditions. The protection circuit may also be incorporated as part of a new power supply if the construction of such a supply is being contemplated. If desired, the protection circuit may be fitted with a variable resistor or a switch selecting a number of different limiting currents.

## THE CIRCUIT

The circuit of the current protection unit appears in Fig. 1. The two input points at the left in this diagram connect to the output of any low voltage d.c. power supply whose output voltage is in the range of 9 to 20 volts. To meet the requirements of circuits within the protection unit itself, the supply must be capable of providing a current in excess of the desired limiting current, the excess current being of the order of 80mA at 20 volts, dropping proportionately to 40mA at 10 volts. The load to be supplied is connected to the output terminals at the right. In series with the negative output from the power

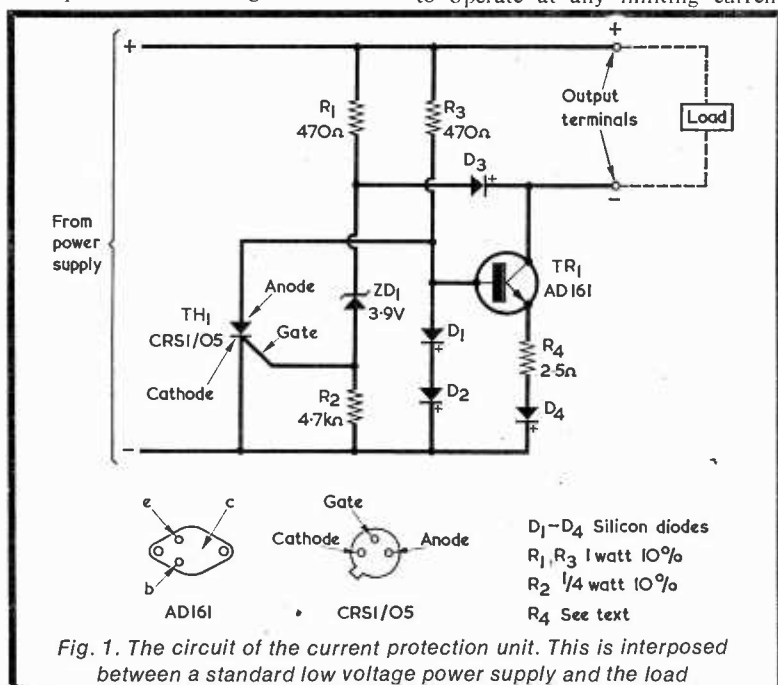

supply is the forward biased diode D4, resistor R4 and transistor TR1.

TR1 is operated in the grounded base mode, its base being held at a constant potential by the two forward biased silicon diodes D1 and D2, these being held conductive by the current flowing from the positive supply rail via R3. TR1 is, in consequence, capable of functioning as a constant current device, the constant current being available at its collector and having an amplitude dependent on the value of R4 in its emitter circuit. Constant current circuits using a transistor connected in the basic mode illustrated in Fig. 1 have appeared, together with detailed technical descriptions of their functioning, in this journal in previous articles (including 'In Your Workshop' in last month's issue) and it is felt that it is unnecessary to offer a full discussion of operation here once more. Suffice it to say that, in the present circuit, the voltage across TR1 remains virtually unaltered for load currents in its collector circuit up to those approaching the constant current value. TR1 then changes over to constant current operation and tends to allow only the constant current to flow, the voltage between its collector and emitter varying according to the effective resistance offered by the load. In practice, TR1 does not offer the almost 'ideal' constant current performance given by smaller transistors with higher gain figures, but its performance is nevertheless more than adequate for the present requirement.

In Fig. 1 R4 has a value which allows the constant current to be of the order of 150mA. For load currents below this figure the protection circuit merely causes approximately 1 volt to be dropped between the negative output of the power supply and the negative output terminal of the protection circuit. Under these conditions, the cathode of diode D3 (connected to the collector of TR1) is therefore 1 volt positive of the lower negative supply rail. This diode is forward biased by R1, and its anode is, in consequence, approximately 1.7 volts positive of the lower negative supply rail.

If, now, the load current is gradually and continually increased it will reach a level which closely approaches the constant current figure, whereupon the voltage at the collector of TR1 commences to go positive. So also, due to the presence of R1, does the anode of D3. The increasing positive voltage at this anode is applied to the 3.9 volt zener diode ZD1 and, when it has reached a sufficiently high level, causes zener current to flow in this diode. The zener current allows a positive voltage to appear at the upper end of R2, this being applied to the gate of thyristor TH1. Gate

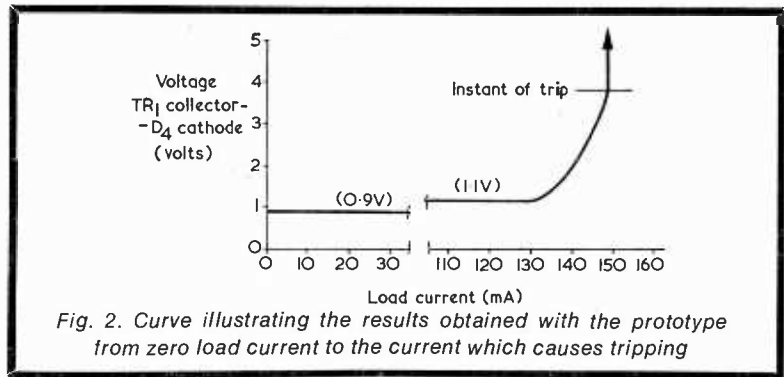

Fig. 2. Curve illustrating the results obtained with the prototype from zero load current to the current which causes tripping

current flows in the thyristor and, when it has risen to the requisite value, causes the thyristor to fire.

As soon as the thyristor fires its anode takes up a potential which is about 0.7 volts positive of its cathode, and the thyristor becomes effectively equivalent to a single forward biased silicon diode. The voltage at the base of TR1 now drops dramatically from that offered by D1 and D2 in series to that offered by TH1 on its own. In consequence TR1 cuts off and no further current (apart from leakage current) flows in its collector circuit. It will be noted that it is impossible, now, for any significant base-emitter current to flow in TR1 because its base is held at the voltage dictated by the effective silicon diode given by TH1. At the same time, silicon diode D4 does not permit any significant emitter current to flow because it can only become conductive at about the same forward voltage as that across TH1.

There is now no collector current in TR1, and the load, if resistive, will cause the negative output terminal to take up the same potential as the positive output terminal. The only component apart from TR1 which is connected to this negative output terminal is D3, and the positive excursion of the negative output terminal merely causes this diode to be reverse biased, its anode being held at the potential given by zener conduction drop in ZD1 plus gate-cathode drop in TH1. If, due say to the application of a charged electrolytic capacitor to the output terminals, D3 is caused to conduct again, it will merely allow forward current to pass with R1 functioning as a limiting resistor. The consequent lack of gate current will not affect the condition of TH1, which requires only an initial gate current pulse to fire and then remain conductive.

The protection circuit will remain tripped until the power supply is switched off, whereupon the lack of voltage between the anode and cathode of the thyristor enables this component to return to its previous non-conductive state. On switching

on again, the protection circuit will function as before until an overload causes it to trip once more. Should the power supply be switched on again whilst the load is still in the condition which caused the circuit to trip, TR1 will, firstly, ensure that excessive current cannot flow in any case whilst, secondly, TH1 will at once re-trip the circuit.

It will be noted that trip operation is wholly electronic in nature and is virtually instantaneous. No mechanical devices, such as relays, are employed. A further point is that although no current flows in the load after the circuit has tripped a current is still drawn from the

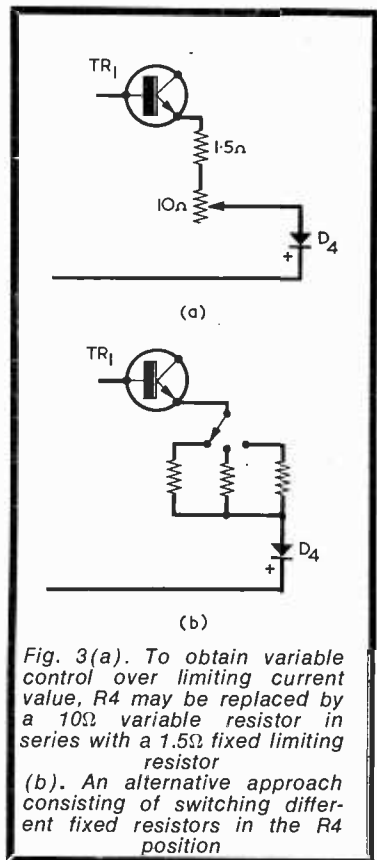

Fig. 3(a). To obtain variable control over limiting current value, R4 may be replaced by a 10Ω variable resistor in series with a 1.5Ω fixed limiting resistor  
(b). An alternative approach consisting of switching different fixed resistors in the R4 position

power supply. This is the current which flows through R1 to ZD1 and the gate of TH1, and through R3 to the anode of TH1.

## PERFORMANCE

The performance of the prototype circuit can be judged from the curve shown in Fig. 2. To obtain this curve, a load made up of a variable resistor in series with a 0-200mA current reading meter was connected across the protection circuit output terminals. A power supply consisting of a stabilised unit set up for an output of 16 volts was connected to the input terminals of the protection circuit, whilst voltage conditions were monitored by a voltmeter connected between the collector of TR1 and the cathode of D4. The voltmeter registered, therefore, the voltage drop in the negative line due to the protection circuit.

At low currents the voltage reading was about 0.9 volt, this increasing gradually to 1.1 volt as current increased to some 80mA. The voltage then remained steady up to approximately 130mA, after which it commenced to rise sharply. At around 3.8 volts the circuit suddenly tripped, whereupon no further current was available from TR1 and its collector assumed the potential of the positive supply rail.

Further runs showed that the circuit tripped reliably at the same voltage and current figures and, also, that it tripped again immediately on switching on if the load resistance had previously been just sufficiently low to cause tripping.

The fact that tripping occurred at about 3.8 volts indicates that the voltage on the upper terminal of ZD1 would, at the instant of tripping, be about 4.4 volts, the extra 0.6 volt being due to forward voltage drop in D3. This figure appears reasonable in view of the nominal voltage rating of the zener diode.

The circuit was checked at power supply output voltages down to 9 volts, and satisfactory tripping was still achieved. Obviously, at these lower supply voltage figures a greater proportion of the supply voltage has to appear across TR1, R4 and D4 for tripping to take place.

## COMPONENTS

Diodes D1 to D4 in the circuit are normal silicon diodes. D4 has to be capable of passing the output current, whilst D1 and D2 should be able to pass the 40mA or so which flows through them via R3 at a power supply voltage of 20. The current in D3 can approach a similar figure. Provided that forward current requirements are met the choice of diodes is not critical. In the prototype the author used BY100's in all the four positions.

The thyristor is an S.T.C. CRS 1/05. This is a small component in a TO5 can and is available from Henry's Radio Ltd. A suitable 250 mW 3.9 volt 5% zener diode, for ZD1, is also available from this firm.

Transistor TR1 is employed well below its maximum current and wattage ratings and requires little more than a small heat sink. It is only required to dissipate any significant power under circuit conditions which closely approach overload. In the instance illustrated in Fig. 2, where about 2.7 volts will be dropped across the transistor on its own at the instant of tripping, maximum dissipation is less than half a watt.

Resistor R4 is shown as 2.5Ω in Fig. 1, this being the value required for a limiting current of 150mA with the prototype. However, some slight adjustment of this value might be necessary to suit individual transistors and diodes, the value of R4 being reduced to increase the con-

stant current limiting value and vice versa. Some constructors may prefer to make these adjustments experimentally by means of different series/parallel combinations of low-value fixed resistors. Alternatively, a variable resistor could be used, a suitable component being the Bulgin 10Ω 3 watt wirewound potentiometer List No. I.V.C.1 (Home Radio Cat. No. VR22A), the track of which can carry currents up to 550mA. If this potentiometer were used in the R4 position it should be connected up as shown in Fig. 3(a), where a 1.5Ω fixed resistor is wired in series to prevent too low a resistance being accidentally inserted in the emitter circuit. If desired, the variable resistor could be provided with a pointer and scale, the latter being calibrated in terms of the corresponding constant current it causes to flow. An alternative switched approach consists of having switched fixed resistors, as in Fig. 3(b), each switch position corresponding to a particular constant current. In all these cases the final value of resistance required is found empirically by measuring the constant current. This process is carried out by connecting a suitable current reading meter across the output terminals of the protection circuit, the trip being temporarily put out of action by short-circuiting R2. The meter then reads the constant current directly. Care should be taken to ensure that R4 is not, under these conditions, accidentally given too low a value, as very heavy currents may then flow.

Some constructors may care to use the basic circuit for currents considerably in excess of the values mentioned earlier. A larger transistor than the AD161 may then be required in the TR1 position. It should be borne in mind that the base current available via R3 should be comfortably in excess of the constant current figure required divided by the gain of the transistor. This fact may necessitate a reduction in the value of R3. D1, D2 and D4 will also be required to pass the larger currents which then flow.

A final point is concerned with the fact that the anode-cathode voltage available for the thyristor before it fires has the rather low value (of around 1.3 volts) which appears across the two forward biased diodes D1 and D2. No trouble due to this low voltage was encountered with the prototype, in which thyristor operation was completely reliable on all occasions. If, nevertheless, it is felt desirable to have a somewhat higher thyristor anode voltage, this may be achieved by inserting resistance between the transistor base and the thyristor anode, as in Fig. 4. The value of the added resistor should be such that about 0.5 to 1 volt extra is available for the thyristor anode. ■

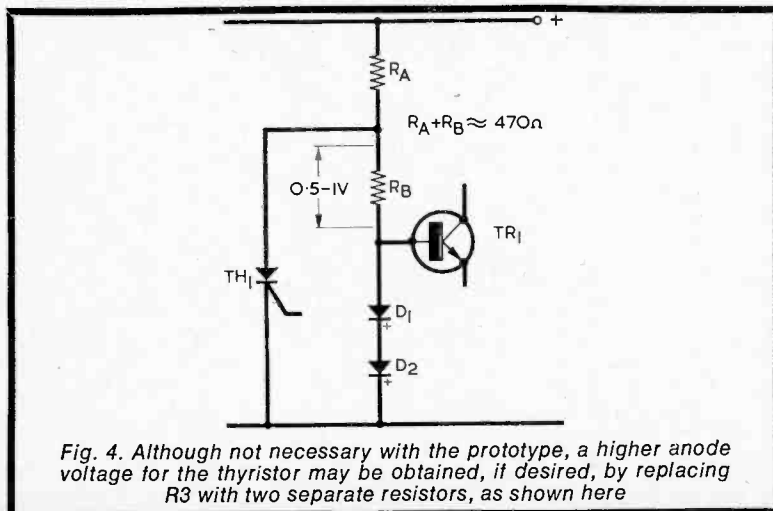

Fig. 4. Although not necessary with the prototype, a higher anode voltage for the thyristor may be obtained, if desired, by replacing R3 with two separate resistors, as shown here



# VENI, VIDI, VICI

These words, spoken by Julius Caesar after his easy victory over Pharnaces II at Pontus, are interpreted "I came, I saw, I conquered". This month, July, is named after Julius Caesar who, you will recall, is famous for the Julian Calendar, organising the First Triumvirate, victory in the Gallic Wars, his feud with Pompey, crossing the Rubicon to win the Civil War and his subsequent leadership of Rome. Apart from his military gifts he also has other claims to fame – writing *Gallic Wars* and *Civil War* – both long acknowledged to be literary masterpieces. Upon divorcing his second wife, Pompeia, who had been involved in a scandal with Clodius, Caesar uttered the oft quoted "Caesar's wife must be above suspicion" and went on to marry his third wife, Calpurnia. Subsequently he indulged in certain 'goings on' with the Temptress of the Nile, Cleopatra. By all accounts his domestic life was anything but blissful. Perhaps this was occasioned by his obsession with interests other than those of the domestic hearth.

The point at issue is – do you indulge in radio to such an extent that most other considerations of life, including the hearth and home, are relegated to a back seat? This sad state of affairs is not uncommon, for it is sometimes the case with particular individuals that, once the bug of radio bites, it bites deep – often to the exclusion of the life partner and her interests, wellbeing and happiness. Unlike Caesar, such a rabid enthusiast would do well to beware the Ides of March!

Golf widows became a music-hall joke, but in many instances such stories could equally well apply to radio widows. In real life the results of such fanaticism are far from jocular, often resulting in domestic unhappiness and upheaval. Just occasionally, however, one hears of a tragi-comedy as the following story illustrates.

Many years ago now, a world-famous Broadcast bands listener, whose monthly reports appeared in many journals both in this country and abroad, went to the seaside on holiday with his long-suffering spouse. Sweltering in a promenade shelter on a hot sunny day, hubby decided to make out his reports and also some QSL cards. He became utterly engrossed in his task. The by now ignored wife, bored to the extreme by the lack of normal conversation and interest, became engaged in a chat with a chance male acquaintance sitting nearby. In final desperation she agreed to a "walk-along-the-front" request, the male intruder into this scene of domestic bliss (sic) being completely unaware that the fanatic seated alongside her was her better-half.

The subsequent enjoyable walk along the promenade with the attentive companion, together with some pleasant non-radio conversation and the gift of a large ice cream cornet ended somewhat abruptly when she indicated that she must now rejoin her husband!

Returning in an elated frame of mind to the shelter after some twenty minutes contact with normal *human* behaviour – she had almost forgotten what this was like – was to find her partner completely engrossed in his self-imposed holiday task. Moreover, he was completely unaware that she had even been absent!

You don't believe it? Well, I can assure you it is absolutely true and actually happened. If you are going on holiday during this, or any other month, forget radio and vow that, in future, more attention will be paid to your partner. She deserves your full-time interest – radio being relegated to a part-time pastime. Radio as a hobby is all very fine and dandy, but it should never, if domestic bliss is to ensue, replace the family and home from the premier position these should occupy in one's mind.

Remember – "Veni, Vidi, Vici"; when you met her you came, you saw and you conquered – don't throw the victory away!

C.W. ■

# NOW HEAR THESE

Times = GMT

Frequencies = kHz

## ● CLANDESTINE

Listen on **9500** around 0630 for a station announcing itself as Democratic Republic of Somalia.

## ● VENEZUELA

YVSD Radio Turismo, Valera, listed on **1160** has been reported testing on **6180**.

Radio Barquisimeto on **9510** now announces an 85kW output with a 24 hours schedule.

## ● TIBET

Lhasa has been reported on **5935** at 1220 with programme in Chinese vernacular.

## ● INDIA

All India Radio, VUD, Delhi, can be heard with the English programme at 2015 on **7215** (10/100kW).

## ● CHINA

Peking can be heard with the English programme at 2045 on **9440** and has also been heard by our Listening Post with news in English at 2030 on **9490**.

## ● UGANDA

Kampala is regularly heard by our Listening Post on **4976** (3/8kW) with news in English at 2100.

## ● SOUTH AFRICA

News in English can also be heard at 2100 from Johannesburg on **4965** (20kW).

## ● ROUMANIA

Bucharest can be heard with the English programme from 2000 to 2025 on **11940** (15/120kW).

## ● BRAZIL

Our Listening Post reports logging PRB21 Radio Panamericana, Sao Paulo, with Latin American music and identification at 2130 on **6055** (7.5kW).

Also heard was PRA8 Radio Clube de Pernambuco, Recife, with commentary in Portuguese at 2135 on **6015** (5kW).

## ● ECUADOR

Quito can be heard over HCRQ1 on **4823** around 0315 with Latin American music and station identification with echo effect.

## ● COLOMBIA

This country can be logged on **4906** around 0300 over HJAG Emisora Atlantico (1kW), Barranquilla. This one was previously listed as inactive. The address is Aéreo 174, Barranquilla.

The easiest way to listen to Colombia is to tune to either **5075** (HJGC 25kW) or **5095** (HJGG 50kW); both of these are on the Radio Sutatenza network and are located in Bogota. The address is Aéreo 7170, Bogota.

## ● BOLIVIA

CP38 Radio Altiplano, La Paz (5kW) **5045** has been heard on several occasions recently. The station has a 24 hours schedule and can best be logged around 0300.

*Acknowledgements to our own Listening Post and SCDX.* ■

## SINGLE-ENDED MINIATURE ALUMINIUM ELECTROLYTIC CAPACITORS FROM ITT

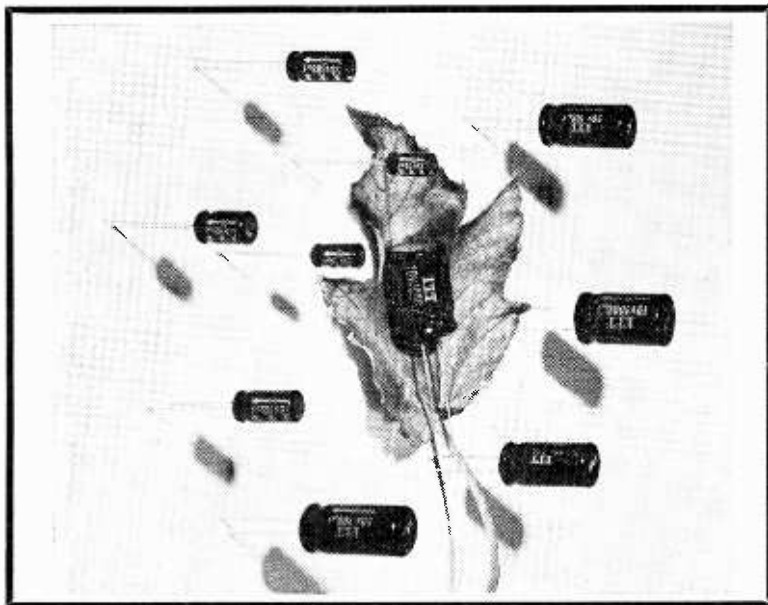

ITT is now marketing a new design aluminium electrolytic capacitor range suitable for all entertainment and semi-professional applications

A new design of miniature electrolytic capacitor is announced by ITT Components Group Europe. The capacitors have been developed to provide mechanical and electrical reliability together with cost features that will appeal to circuit designers.

The new capacitors, coded Type EN 12.35, cover voltage ranges from 6.3V to 50V d.c. and capacitances from  $0.47\mu\text{F}$  to  $1,000\mu\text{F}$ .

Housed in casings of modern design and appearance, Type EN 12.35 capacitors are fitted with insulating sleeves which, together with the single ended design, allow close spacing on printed circuit boards. The leads are welded and polarity identification is by lead length – as well as by marking on the case.

Continuous automatic manufacture of ITT Type EN 12.35 electrolytic capacitors ensures consistent quality and performance. Temperature rating is from  $-25^{\circ}\text{C}$  to  $+85^{\circ}\text{C}$ .

## PROJECTING FILMS ON THE TV SCREEN

Scientists in the United States have developed an electronic video recording system capable of playing colour or black and white pre-recorded programmes through any standard television set.

Known as a Teleplayer, the film is packaged in a seven-inch cartridge and together with a playback unit provides 25 minutes of programme material with sound. The cartridge is simply placed in the player and the images of the film are picked up and converted to video and audio signals by an electronic scanner.

Developed by Columbia Broadcasting Systems Laboratories and manufactured by Motorola of Chicago, the player will be useful for education and training. There is an audio input from an external microphone, which allows an instructor to override the sound track of a programme with his own comments. The instructor can also use the microphone when discussing a still frame. Another feature includes the use of dual sound tracks on colour programmes, permitting different narratives for different age groups or narratives in two languages.

In the United Kingdom the player will be manufactured under licence by Rank Bush Murphy at Basildon in Essex.

## SUCCESS STORIES OF IEA EXHIBITION

"All the reports reaching me so far have been success stories," said Mr. William Logan, Chairman of the International Instruments, Electronics and Automation Exhibition when it closed at Olympia, London.

The show was yet again a record-breaker. It brought in 9,658 overseas buyers from 69 countries – more than ever before. Total attendance was 110,266.

"The overall feeling is that this IEA has been the most valuable of the whole series," Mr. Logan said.

Mr. Kenneth N. Davis, Assistant Secretary of the USA Department of Commerce, said of the IEA: "I have visited many similar shows all over the world but this is certainly the most impressive I have seen."

"The comments of the smaller US companies exhibiting and those new to the U.K. market have been extremely enthusiastic. This event has proved itself to be an excellent market place for American manufacturers."

The American exhibitors reported at the close of the exhibition that they had taken orders worth seven million dollars.

Exhibitors were enthusiastic at the success of the show.

Mr. G. H. Doust, Managing Director of the Plessey Components Division, called it a first-class exhibition.

Mr. John Woods, Marketing Manager of Computer Technology, said: "We have had two years' value from this show."

Mr. R. O. Mills, Managing Director of Comark Electronics, said that his firm would have to increase production to meet the orders initiated at the show.

Computing Techniques (Mr. A. G. M. Nash, Managing Director) reported "never had a better exhibition." Comment from P.C.D. was: "One of the best ever – excellent business."

Mr. A. F. Bulgin, closely associated with the IEA since its inception, was delighted with the weight of business generated – "better than any other exhibition".

## HENRY'S RADIO INCREASE SALES AREAS

The above Company is now in the process of increasing its sales areas. During the months of June to September reorganisation is

THE RADIO CONSTRUCTOR

# COMMENT

taking place to enable a larger selection of Electronics to be offered for retail and industrial sale.

The electronics components and equipment section is moving to 354 Edgware Road. High fidelity with four demonstration rooms to 356 Edgware Road - the store at 309 Edgware Road is to become the Electronic Organ Department, coupled with public address and discotheque equipment.

The existing premises at 303 Edgware Road will handle all mail orders and identical sales for the time being. All these stores are within 100 yards of each other and will enable a customer to purchase all his requirements throughout the field of Electronics at one centre.

With the above expansion will come new ranges of Electronic and Audio equipment; the latest 350-page catalogue is revised at three-monthly periods and is definitely a must for anybody interested in Electronics.

## AMATEUR ELECTRONICS EXHIBITION

The British Amateur Electronics Club is holding its fifth annual exhibition of electronic games from July 25th to August 1st. In addition to the games previously exhibited, there are two new ones. These are the B.A.E.C. Electronic Rifle Range, which shoots flashes of light and uses LASCRs as targets, and the B.A.E.C. Electronic Reaction Timer, which is a transistorised version that times to 0.001 seconds with four Dekatrons.

This exhibition will be held at the Shelter on the Esplanade at Penarth, Glamorgan. As before, all the proceeds from these games will be given to charity.

## SOUND RECORDING CONTEST

Now available from 3M - entry forms for the Scotch magnetic tape Wildlife Sound Recording Contest, which is being run with the active co-operation of the Wildlife Sound Recording Society.

This year's contest offers a top prize of an £180 Akai X-V professional portable stereo tape recorder for the "wildlife sound recordist of the year". The junior (under-18) section carries prizes of three Bush TP.60 portable cassette recorders.

Copies of the rules and entry forms are available from W. R. Bowles, 3M Company, Wigmore Street, London.

JULY 1970

## G.S.P.K. EXTEND ELECTRONICS DEPARTMENT

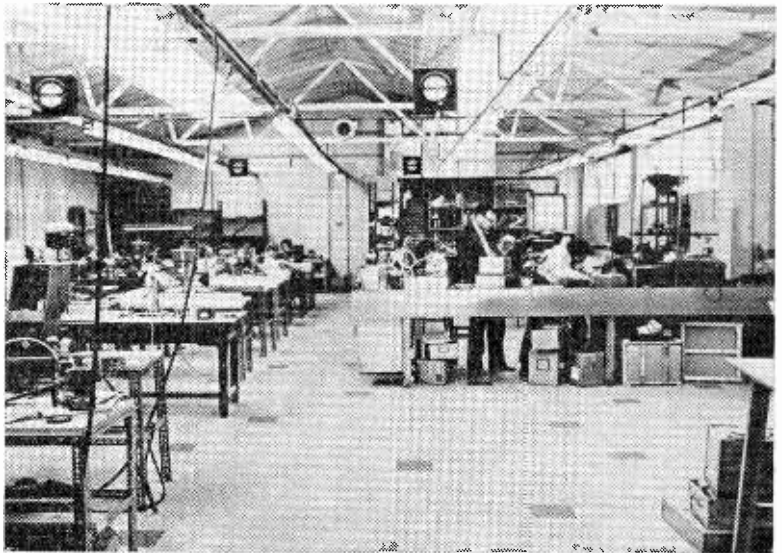

Electronic Assembly Shop

G.S.P.K. (Electronics) Limited, of Harrogate, Yorkshire one of Britain's leading electronic firms, has recently extended and modernised its electronics department in order to meet the increasing industrial needs for custom-built electronic equipment in any quantity.

The Company has increased its technical staff and is able to provide a versatile service for design, development, and manufacture in batch quantities, of custom-built equipment.

The supply of the firm's own high quality circuit boards and stocks of components, coupled with the facilities of a plastic moulding department, ensures fast delivery and close control of manufacture. In addition the Company has its own tool room and drawing office, and is experienced in the 'anglicisation' of foreign equipment using British design and components.

G.S.P.K. supplies a technical advice service for all types of customers requiring information on electronics and the Company's Electronics Department is already engaged on numerous applications including oil refinery control systems, burglary alarms, audio amplifiers and lamp flasher units. All production is subject to strict quality control, including pre-inspection and test of components.

A speedy delivery is offered and quotations are free of charge. Further details of this department are available in the firm's recently issued 22-page catalogue - also free of charge.

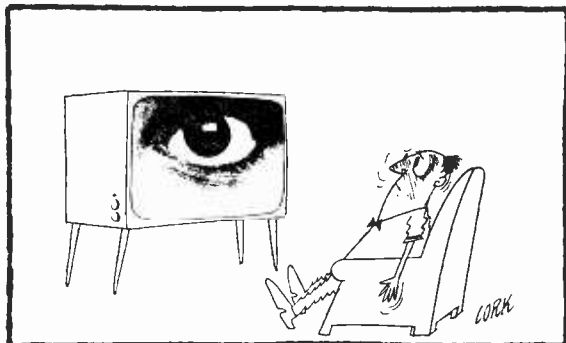



**Q  
S  
X**  
by

**FRANK A. BALDWIN**  
(All Times GMT)

● **AMATEUR BANDS**

Once again plenty of Dx fare has been provided on the various bands for those who cared to partake in the banquet. Both the c.w. and s.s.b. modes have produced a well balanced diet of tasty morsels and from Top Band to 28MHz the table has groaned with the wealth of 'goodies'.

As is usual, we start with -

**1.8MHz**

The c.w. end of good old Top Band continued to carry interesting signals with inter-G Dx and Eu Dx there for the asking from time to time although with the advent of summer, conditions have now fallen off.

**CW:** DJ3IY, GD3HQR, GI3OLJ, GM3FXM, GM3KLA, GM3LQI/P, GM3PFQ, GW3RVG, GW3VPL, GW3XJC, GW3YVQ, OE1WO/3, OLKAKU, OK1ANZ, OK1ARL, OK1ARZ, OK1AAY, OK1DOH, OK1DVM, OK1IAR, OK1KRS, OK2BIT, OK3CHL, OL5ALY, OL5ANG, OL6AMQ, OL8ANL.

**3.5MHz**

Conditions on this band, like those of Top Band, have tended to be somewhat 'down' with the usual seasonal decline. However, a few s.s.b. Dx signals have been heard early on Sunday mornings.

**SSB:** HC2GG/1, OA4LNA, OA8V, PZ1AH, VO1FX, W3GQF, W4OKZ, W4RDD/VP9.

Lack of available time precluded any operations on 7MHz - the garden took precedence!

**14MHz**

Good old 'twenty' can always be relied upon to produce something of interest and here we noted -

**CW:** CM2HB, CR6AI, CR6AL, CR6GQ, EL2CB, JA0CUV, KC6CT, LU6DEX, PY5ARK, PY7APD, TA2OZ, VK5WK, YV5BNR, ZE3JJ, ZM2IL, 6W8DQ.

**SSB:** AX3BCM, AX3RZ, EP2FB, EP2TW, HC1RTS, HR2WTA, HT1FR, HZ1AB, JA2PJC, KP4MC, LU1DLW, OA4KY, PJ1CL, TF2WKF, TF2WKI, TF2WKP, TR8MC, VP2AA, VP2KF, VP9FE, XE1WM, YT2NEG, ZM1BBH, ZM3HD, ZS2H, ZS4RN, ZS5JY, 5Z4ERR, 6Y5LA, 9L1RP, 9Q5CO, 9Q5GJ, 9Y4BFC.

**21MHz**

As things turned out, this band proved to be the best of the lot

with both c.w. and s.s.b. Dx abounding. More time was spent on this part of the dial than for many years past. Just look what turned up!

**CW:** CR6AL, CR7EY, FB8YY, FL8BE, FL8RR, FM7WF, FY7YQ, HK0BKX, HS5ABD, HT1BW, JA0YAN, JA1XUC, JA3IKG, JA3KIE, JA4ELC, JA6CUX, JA6KV, JA7OB, JA9CAF, JH1DZA, JH1TFE, JH1VOE, JH1WKS, KH6DQ, KH6IF, PJ2VD, VP9GM, XW8CZ, YC3DD, ZC4CB, ZC4DA, ZS6ED, ZS6OS, 6W8GE, 7Q7AA, 9J2KW, 9J2MC, 9M2FK.

**SSB:** CR6GA, CR7AZ, CR7IZ, EA8GA, ET3DS, JA1LSP, MT4BHH, PY6VZ, VP2ME, ZP5BR, ZS4RN, 9E3USA, 9X5AA.

**28MHz**

This band is apt to be either 'wide open' or conversely 'dead'. However, with a little luck and the right conditions, the following turned up.

**CW:** AX4FJ, CE3FI, CR6GO, HC1TH, PJ2HT, TA2E, ZE1DC, 9J2RQ.

**SSB:** CR6GA, CR7CG, EL2CF, MP4BBA, XE1AE, ZS6ACK, 5N2ABG, 6Y5DW, 9G1GD, 9J2RQ.

All-in-all, the past few weeks proved of interest on the amateur bands - with 21MHz taking the cake!

● **BROADCAST BANDS**

On these bands the most interesting stations, Dx-wise, are to be found on the lower frequencies, but to hear them requires the burning of some midnight and early morning oil, particularly the latter!

During the early evenings the African stations are audible at fair signal strengths if conditions are right, whilst from midnight onwards, and particularly towards the 0230 mark and on to 0500, the various South American stations may be logged.

When excellent conditions prevail for reception of Latin American signals, try operating over the 90 metre band (3200 to 3400kHz) when some rare catches may be the reward.

● **S. AMERICAN STATIONS**

**3378kHz 0447** HCDY4 Radio Iris, Esmeraldas, Ecuador, taped with identification and National Anthem when closing down. This one has a power of only 250 watts.

**3390kHz 0533** HCOT1 Radio Zaracay, Ecuador, taped with identification and 3 chimes. This one identifies every quarter hour and has a power of 2kW.

**4678kHz 0428** HCWE1 Radio Nacional Espejo, Quito, Ecuador, with a programme of Latin American music and identification.

**4690kHz 0425** Radio Reloj, San

José, Costa Rica, with typical Latin American music. San José is the capital city of Costa Rica.

**4865kHz 0300** PRC5 Belem, Brazil, with a musical box interval signal, identification and 1 chime. Closes abruptly at 0302; no National Anthem.

**4865kHz 0305** HCXX4 Radio Dif Cenit, Bahia de Caraquez, Ecuador. This rare catch can only be heard after PRC5 (above) closes. HCXX4 has a power of 1kW.

**4917kHz 0257** HCAH3 Radio El Trebol, Zaruma, Ecuador, with music and songs followed by identification. This one has a power of 3kW, and the schedule is from 2300 to 0300.

**5182kHz 0355** OAX8F Radio Atlantida, Iquitos, Peru, with echo effect identification followed by guitar music. Iquitos is the main town of the Loreto department of Peru. The power is 1kW.

**5970kHz 0403** HJVN Radio Horizonte, Bogota, Colombia, with a musical programme followed by station identification.

**6015kHz 2135** PRAB Radio Club de Pernambuco, Recife, Brazil, heard with a newscast in Portuguese. With a power of 5kW, this station has a schedule from 0900 to 0300.

**6055kHz 2130** PRB21 Radio Panamericana, Sao Paulo, Brazil, with Latin American music and station identification. This station has a power of 7.5kW and a schedule from 2100 to 0300. Sao Paulo is the capital city of the state of that name.

● **AFRICAN STATIONS**

For those readers who would like to 'have a go' at some of these stations, here are a few recently logged.

**4777kHz 2030** Libreville, Gabon, with dance music and announcements in French.

**4880kHz 2025** Kinshasha, Congo Dem. Republic, with talk in French.

**4890kHz 2020** Dakar, Senegal, with drama in French.

**4915kHz 2015** Accra, Ghana, with orchestral music and identification in English.

● **BEGINNERS CORNER**

Have a try at the following three African stations at the times stated - they all identify in English.

**4932kHz 0447** Benin City, Nigeria, with English announcements. If that time is rather early for you, try -

**4965kHz 2110** Johannesburg, South Africa, with news in English.

**4976kHz 2105** Kampala, Uganda, with news in English. ■

# Unusual null indicator

by

R. D. JOHN

Centre-zero meters for bridge circuits are not always to hand when required. This short article describes a simple means of overcoming the problem by taking advantage of a standard rectifier circuit

BRIDGE CIRCUITS INCLUDING, IN PARTICULAR, THOSE intended for the measurement of resistance, normally employ a centre-zero current reading meter as a null indicator. The home-constructor, whilst usually possessing at least a multimeter together with, possibly, several standard panel-mounting meters, does not always include centre-zero meters amongst his stock of measuring equipment. This fact can be a nuisance, particularly if a centre-zero meter is required in a hurry for checking out an experimental bridge circuit.

It is possible to employ a standard current reading meter as a bridge null indicator in place of a centre-zero meter by the simple addition of several small components. The indication of bridge null setting is not as sharp as when the correct centre-zero meter is employed, but it will in almost all instances be more than good enough for experimental requirements. The circuit will, in addition, enable the performance of a newly constructed home-designed bridge to be evaluated without the expense of purchasing a centre-zero meter. If, with the temporary meter circuit, the bridge offers the required performance the necessary centre-zero meter can then be obtained later. The circuit to be described may also be employed for functions such as ratio detector balance indication, which otherwise require a centre-zero current reading meter.

## NULL INDICATOR

In a standard bridge circuit a centre-zero meter is employed as null indicator in the manner shown in Fig. 1(a), in which its terminals connect to the arms of the bridge, as illustrated. If, in Fig. 1(a), the right-hand connection to the bridge arms has a potential which is positive with respect to the left-hand connection, the meter needle is deflected in one direction; if the right-hand connection has a negative potential with respect to the other connection, the needle is deflected in the opposite direction. When both ter-

JULY 1970

## NEW *HANDIPAK* **PANEL SIGNS**

IDEAL FOR WORKSHOP USE

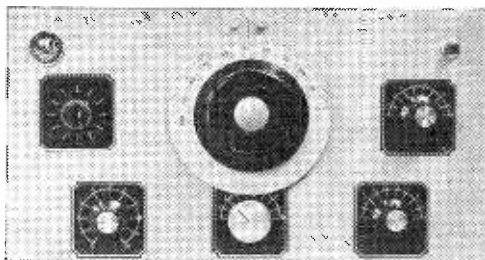

- Easy to fix
- Permanent and durable
- Staped in booklet form
- Designed to hang above workbench
- Pocket for loose cuttings
- Professional finish

- ★ Set 3 Wording—WHITE
- ★ Set 4 Wording—BLACK
- ★ Set 5 DIALS—clear background
- ★ Set 6 DIALS—black background

The Perfect Transfer for  
the Home Constructor

Each Set contains Six Sheets

**5/- per set**

(postage 4d.)

To Data Publications Ltd.  
57 Maida Vale, London, W.9

Please supply:

.....Set 3 .....Set 4 .....Set 5 .....Set 6

I enclose cheque/crossed postal order for.....

Name.....

Address.....

RC

BLOCK LETTERS PLEASE



# RADIO CONSTRUCTOR

## AUGUST ISSUE



### 'TREBLE-TWO' H.F. BANDS PRESELECTOR

Employing two pentodes (6AK5) whose performance can extend above v.h.f., this tunable preselector offers a very useful increase in signal strength over the range 13.5 to 30MHz. Optional built-in power supply (BY100).

### SECONDARY WAVE CIRCUITS

It is not generally known that one can modulate the secondary radiation of an aerial and this can be done by connecting to it one of the circuits described in this article. Using secondary waves, one can build a transmitter which has no oscillator. Instead of home-made r.f., one uses the ready-made r.f. supplied by existing transmitters. Depending on wavelength and shape of the aerial, signals can be sent up to a maximum range of 60ft. - sufficient for experiments, short range communication and baby alarms, etc.

### MAINS-BATTERY POWER SUPPLIES

An attractive proposition is a mains supply unit which automatically changes over to battery operation on cessation of the mains input. If a small drop in output voltage during battery operation can be tolerated, the circuit resolves to a standard mains power supply plus the stand-by battery and one silicon rectifier.

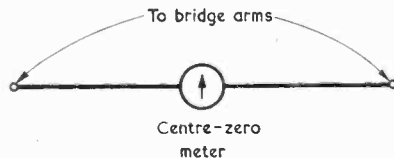

(a)

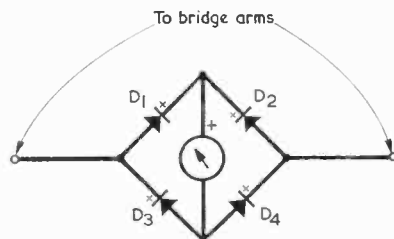

D<sub>1</sub>-D<sub>4</sub> - germanium diodes

(b)

Fig. 1 (a). The normal method of connecting a centre-zero meter into a bridge circuit (b). An alternative circuit which enables a standard current reading meter to be employed. This latter should have the same sensitivity as the centre-zero meter the circuit replaces. For example, a 0-1mA meter should be used if the centre-zero meter were 1-0-1mA

minals have the same potential the meter needle maintains its central zero position, thereby indicating that the bridge is balanced. Under this condition the meter draws no current from the bridge, as is required of a null indicator.

A standard current reading meter having zero at the left hand end of its scale may be employed instead of the centre-zero meter by connecting it in the diode circuit of Fig. 1(b). When, in this circuit, the right hand connection to the bridge arms is positive of the left hand connection, conventional current (from positive to negative) flows from the right hand connection through diode D<sub>2</sub>, the meter, and diode D<sub>3</sub> to the left hand connection to the bridge arms. The current flows through the meter in the correct direction for forward deflection of its needle (i.e. along the scale), and the latter indicates the magnitude of the current. Diodes D<sub>1</sub> and D<sub>4</sub> oppose the flow of current and do not conduct.

If, alternatively, the right hand connection to the bridge arms is negative of the left hand connection, conventional current flows from the left hand connection (which is now positive) through diode D<sub>1</sub>, the meter and diode D<sub>4</sub> to the right hand connection. Again, current flows through the meter in the correct direction for forward deflection of the meter. In this case it is diodes D<sub>2</sub> and D<sub>3</sub> which do not conduct.

When considering diode circuits of this nature, incidentally, it is of advantage to remember that the diode symbol comprises an arrowhead and a subsequent line at right angles. Conventional current flows in the diode in the direction indicated by the arrowhead.

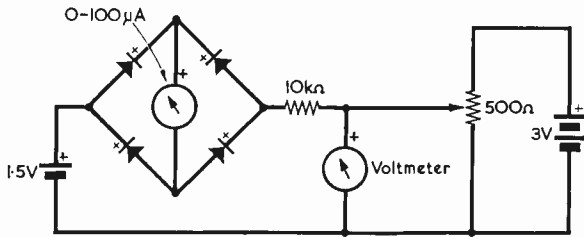

Fig. 2. A test circuit for evaluating sharpness of null indication

The third set of circumstances which may occur with the null indicator of Fig. 1(b) is given when both connections to the bridge arms have the same potential, as occurs when the bridge is balanced. Obviously, no current flows in the diode and meter circuit and the meter needle remains at zero.

It may be seen that balancing a bridge with the aid of the circuit of Fig. 1(b) involves a different interpretation of meter indication than exists with the centre-zero meter of Fig. 1(a). With the centre-zero meter the bridge is adjusted until the needle gives a central zero indication. In Fig. 1(b) the bridge is adjusted for a 'dip' to zero in the meter. Adjustments on either side of that which gives the zero reading cause the meter needle to exhibit a forward deflection.

The reason why the circuit of Fig. 1(b) functions in the manner just described is because diodes D1 to D4 form a full-wave bridge rectifier. The meter would, in consequence, give a forward indication if an alternating current were fed through the two connections to the bridge arms. Since, as a bridge rectifier working with an alternating current, the diodes would route the current on both halves of a cycle through the meter in the correct direction, they will similarly correctly route the currents which result from the application of direct voltages of alternative polarity.

## RECTIFIER CHOICE

The writer has used the circuit of Fig. 1(b) on a number of occasions in recent years. As has already been stated there is a reduction in the sharpness of null resolution as compared with a centre-zero meter, but this has not proved to be a serious disadvantage for the author's requirements. In fact there may well be a hidden advantage in the mode of null presentation when using the diode circuit insofar that adjustment for a meter needle 'dip' tends to be somewhat more impressive, subjectively, than is adjustment for a reading at the centre of a scale.

The diodes employed in the circuit must exhibit low forward resistance at a low forward voltage, and the best types here, so far as readily available components are concerned, are point contact germanium diodes. Within the writer's experience there does not appear to be any significant difference in performance between point contact diodes of different type numbers. Silicon diodes, which require a relatively high forward voltage before forward current flows, must not be employed.

To gain an idea of the effect of the diodes on the sharpness of null indication, the test circuit shown in

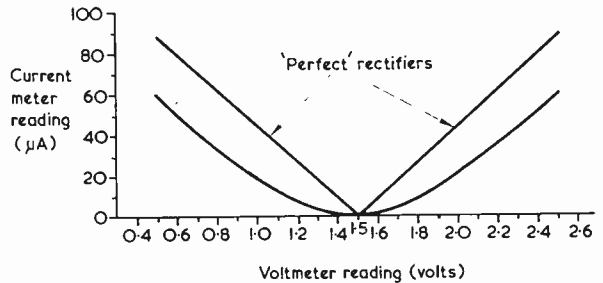

Fig. 3. The curve indicates current readings for different voltages in the circuit of Fig. 2, whilst the straight line graphs show the results which would be given with 'perfect' rectifiers

Fig. 2 was set up. In this the slider of the 500Ω potentiometer can be adjusted to obtain voltages that are positive of, negative of, or equal to that at the positive terminal of the 1.5 volt cell. Thus, current can be made to flow in either direction in the diode circuit. Current was limited by the 10kΩ fixed resistor, and the voltage on the slider of the potentiometer was monitored by the voltmeter. The diodes were all OA79's, which happened to be on hand, whilst the meter fed by the rectifier circuit had a 0-100μA movement and a nominal resistance of 1,000Ω.

The curve in Fig. 3 shows the current indicated by the meter for different voltage indications in the voltmeter. As is to be expected, the meter indicated zero for a voltage reading of 1.5, the current increasing symmetrically on either side of zero as the voltage went positive, or negative, of 1.5 volts. The straight line graphs in Fig. 3 indicate the current indications which would be given if the rectifiers were 'perfect' components, possessing zero forward resistance for all forward voltages above zero. These straight lines demonstrate the conditions where the current flowing at 1 volt is 90.9μA, due to 1 volt being applied to 11kΩ (10kΩ fixed resistance plus 1kΩ meter internal resistance), and is proportionately lower at smaller voltages.

The curved graph of Fig. 3 shows that null indication is not as sharp as would be given with 'perfect' rectifiers. Nevertheless, the approach towards zero current is still discernable, and is certainly good enough for the meter circuit to be used as a temporary null indicator before embarking on the expense of a special 100-0-100μA centre-zero meter. If the bridge would normally use a less sensitive null indicator meter, say 1-0-1mA, then the null with the rectifier circuit (using, this time, a 0-1mA meter) should be considerably sharper, since the diodes would be operating at a higher forward current. ■

## 'WAH-WAH' PEDAL UNIT

In the circuit diagram of this unit, published on pages 680 and 681 of the June 1970 issue, the inset at the lower left showing the 2N4061 lead-outs should read, from left to right, e, c and b.

# SOLID STATE A.C. MILLIVOLTMETER

by

P. CAIRNS, A.M.I.P.R.E., G3ISP

**An inexpensive design which features wide frequency range, sensitivities from 10mV f.s.d. to 100V f.s.d. and a high level of linearity at all meter readings**

THE FOLLOWING ARTICLE DESCRIBES A SIMPLE though versatile a.c. millivoltmeter. As may be seen from the specification in Table 1, its coverage, both in terms of voltage and frequency, is quite extensive, especially considering the simplicity of the circuit and the relatively small number of components used. The instrument should meet most of the requirements of the spare time service engineer, amateur constructor and experimenter. In addition, it will not only prove invaluable in all types of audio and hi-fi work but will also be extremely useful in receiver i.f. and r.f. alignment. This type of unit has, furthermore, many applications in power and ultra-sonic engineering.

When considering the design of an instrument of this nature a number of factors have first to be resolved. Ideally not only are high sensitivity and wide bandwidth desirable, but accuracy, scale linearity and high input impedance are also essential. To achieve all of these features, however, not only makes a more

complex circuit necessary, but also causes the cost, size and power requirements to increase in proportion. As is usual with such instruments therefore, some compromise must be made.

It was decided at the outset that the instrument should be small in size and therefore portable, this making it equally useful for both bench and field work. This in turn necessitated the use of transistors and an internal battery supply. To keep the current drain as low as possible a minimum number of transistors was required which, in turn, meant a relatively simple circuit with its accompanying limitations. Another point to be kept in mind was cost. If this was to be kept to a minimum, standard components and inexpensive transistors were indicated. Printed circuit or Veroboard construction was also another desirable item, this not only keeping size to a minimum but also helping to maintain standard and repeatable results. The circuit finally arrived at is shown in Fig. 1, this embodying most of the features mentioned while still maintaining a reasonably good specification.

TABLE 1

## SPECIFICATION

Range: 10mV to 100V in 5 switched ranges:  
(1) 10mV f.s.d., (2) 100mV f.s.d., (3) 1V f.s.d.,  
(4) 10V f.s.d., (5) 100V f.s.d.

Input Impedance: 100k $\Omega$  at 1kHz

Accuracy: Better than 5% of f.s.d. (see text)

Scale Linearity: Better than  $\pm 3\%$  (see Fig. 4)

Frequency Response:

Range 1 -3dB 20Hz to 3MHz

-6dB 15Hz to 5MHz

Ranges 2 to 5 -3dB 20Hz to 600kHz

-6dB 15Hz to 1MHz

Supply Errors:  $\pm 10\%$  change in d.c. supply voltage results in less than 5% change of f.s.d. (see Fig. 2)

Supply: 9V internal battery or external power supply, drain 6mA

Dimensions: Height 6in., width 8in., depth 6in.

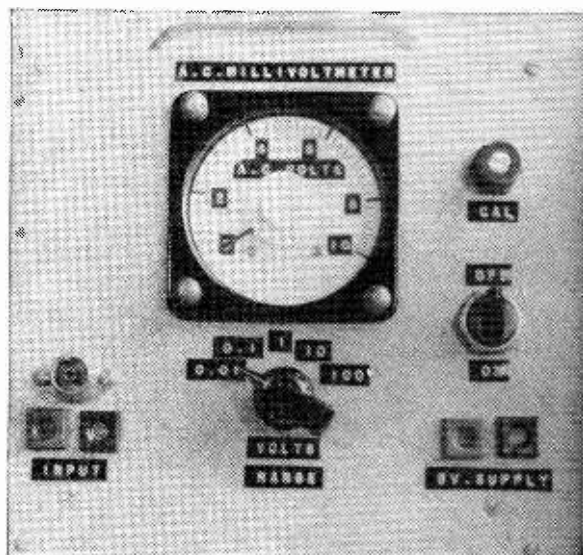

## DESIGN DETAILS

The design itself is quite straightforward, consisting of a 3-stage a.c. coupled amplifier fed by an a.c. coupled emitter follower. Negative feedback is applied individually to each stage and not, as is normally done, via a feedback loop across the complete amplifier. As the transistors are of silicon planar epitaxial construction and have both a high gain and high  $f_T$  figure, it was found that greater circuit stability was obtained with this method of feedback. Since a very high transistor gain is available a reasonable degree of feedback per stage could be applied, thus maintaining a high overall gain with a reasonably wide frequency response.

The amplifier output is fed into a diode bridge, this driving the meter. It will be noticed that a 0-1mA meter is specified although normally instruments of this nature use meters with an f.s.d. of 50 to 200 $\mu$ A. While the less sensitive meter obviously requires more drive and thus higher amplifier gain for the same overall sensitivity, a 0-1mA instrument

THE RADIO CONSTRUCTOR

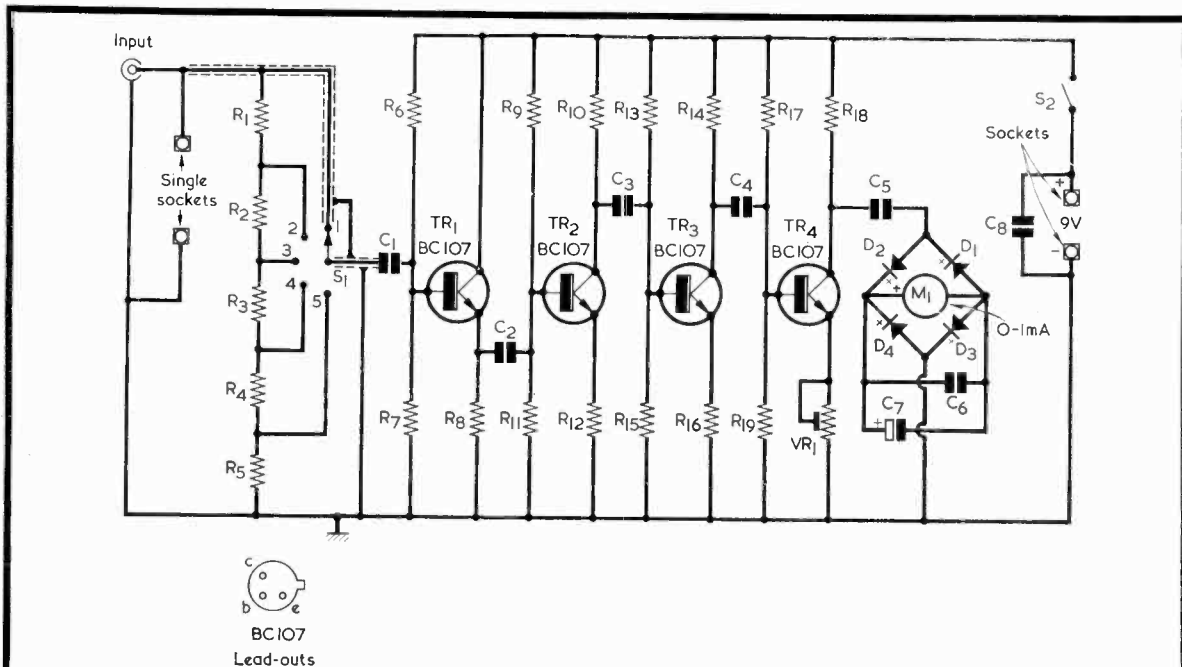

Fig. 1. The circuit of the a.c. millivoltmeter

## COMPONENTS

(All fixed values  $\frac{1}{2}$  watt 5% unless otherwise stated.)

### Resistors

*R1	100k $\Omega$
*R2	10k $\Omega$
*R3	1k $\Omega$
*R4	100 $\Omega$
*R5	11 $\Omega$
R6	1M $\Omega$
R7	330k $\Omega$
R8	3.3k $\Omega$
R9	330k $\Omega$
R10	1k $\Omega$
R11	100k $\Omega$
R12	180 $\Omega$
R13	330k $\Omega$
R14	1k $\Omega$
R15	100k $\Omega$
R16	180 $\Omega$
R17	330k $\Omega$
R18	3.3k $\Omega$
R19	100k $\Omega$
VR1	250 $\Omega$ potentiometer, linear wire-wound, preset panel-mounting

\* 1 or 2% high stability (see text)

### Capacitors

C1	2.2 $\mu$ F (see text)
C2-C5	4.7 $\mu$ F (see text)
C6	1 $\mu$ F 50V wkg., metallised polyester, polyester film, etc.
C7	50 $\mu$ F 25V wkg., electrolytic
C8	0.25 $\mu$ F 150V wkg., paper

### Semiconductors

TR1-TR4	BC107 (Mullard)
D1-D4	OA85 (Mullard)

### Meter

M1	0-1mA moving-coil
----	-------------------

### Switches

S1	1-pole 5-way Yaxley
S2	s.p.s.t. toggle

### Miscellaneous

1	coaxial socket
4	'O-Z' sockets
	Printed board or Veroboard
	Metal cabinet type W, 8 x 6 x 6in., H. L. Smith & Co. Ltd.
	Aluminium for sub-chassis and bracket
1	pointer knob

was nevertheless chosen because not only are meters of this type much more robust than the more sensitive movements, but they also tend to be rather cheaper. The actual physical size or shape of the meter is a matter of personal choice, that used by the writer being of the cirscale type having a 270 degree deflection, thus getting a much longer scale

length for a given diameter of meter. Its internal resistance is 400 $\Omega$ .

The instrument can be fed from an external d.c. supply or an internal battery of the type used for transistor radios. As the current drain is only in the region of 6mA such a battery will last a considerable time, particularly as this type of instrument is only

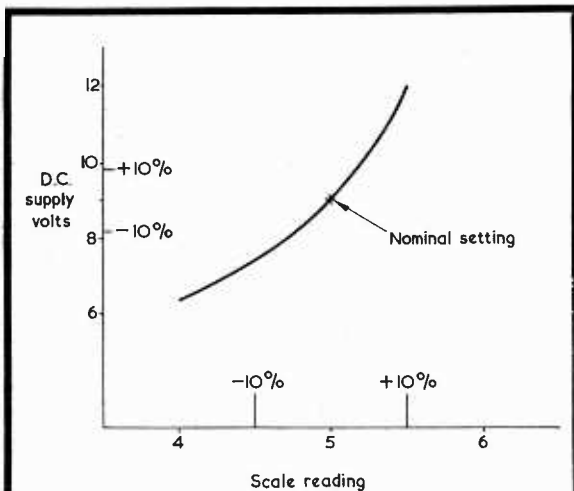

Fig. 2. Curve illustrating deflection error for d.c. supply voltage variation

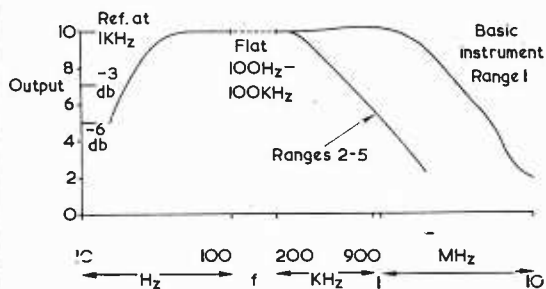

Fig. 3. The frequency response of the instrument on all ranges

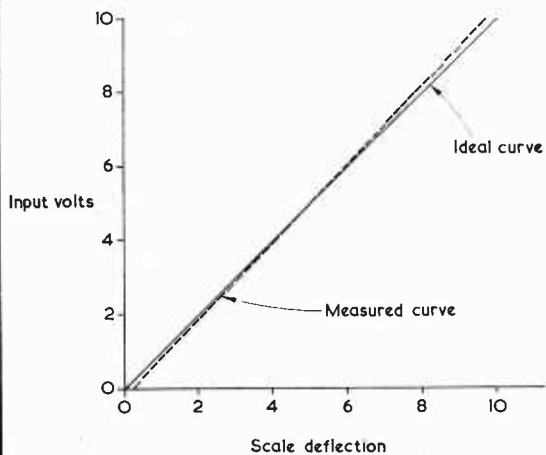

Fig. 4. Curve illustrating the low non-linearity offered by the instrument

normally used intermittently. A curve showing the errors due to changes in d.c. supply voltage is given in Fig. 2.

## RESPONSE AND ACCURACY

Curves showing the overall frequency response are given in Fig. 3. It will be seen that the curve for the basic instrument (10mV range) extends well into the MHz region, while for the other ranges it does not extend quite so far at the h.f. end. This could be compensated for by connecting a suitable capacitor across the resistor at the top of the attenuator divider (R1), a silver mica type in the 1 to 5pF range being necessary. For several reasons, however, such a capacitor is not included in the circuit. First, the actual value is rather critical and an r.f. signal generator and oscilloscope are required if the compensating capacitance is to be set correctly. Second, it was found that the inclusion of the capacitor tended to increase the non-linearity of the instrument at the higher MHz frequencies. It was therefore considered best that the capacitor be omitted and the divider left uncompensated. The bandwidth is still wide enough for most everyday practical applications.

Non-linearity is shown in the curve in Fig. 4. It can be seen that not only is the non-linearity quite small, but is nearly equally distributed about the overall scale, being positive at one extreme and negative at the other. The average non-linearity is therefore of extremely low value.

The accuracy of the basic instrument is within the limits quoted. It should be noted however that the overall accuracy on all ranges will be dependent upon the accuracy of the resistors in the input attenuator. It was found that an overall accuracy of between 3% and 5% could be achieved using high stability 1% resistors. Should resistors of lower tolerance be used (2% - 5%), the overall accuracy will of course become correspondingly lower. If accuracy is of first importance therefore, the use of 1% high stability resistors is advised.

The input impedance of the instrument is relatively constant over all ranges, being between 96kΩ and 115Ω when measured at 1 kHz. on the basic circuit therefore (10mV range) a figure of about 10kΩ per millivolt is achieved.

## CIRCUIT OPERATION

The functioning of the circuit is quite straightforward. The input signal is applied to the attenuator divider chain, R1 to R5, the appropriate level being tapped off through S1 and applied via the coupling and d.c. blocking capacitor C1 to the base of TR1. This stage is an emitter follower, R8 being the emitter load across which the output signal is developed. R6 and R7 provide the base working point and biasing. The gain of the TR1 stage is slightly less than unity, its purpose being simply impedance matching and signal isolation. The stage input presents a very high impedance to the attenuator and signal source while the output presents a very low impedance to the following amplifier.

The high gain amplifier is made up from TR2, TR3 and TR4, these stages being a.c. coupled via capacitors C2, C3 and C4. The dividers R9 and R11, R13 and R15, and R17 and R19, individually provide base biasing and have sufficient current bleed to hold



the bases at a constant level. The outputs of the stages are developed across each load resistor in turn, these being R10, R14 and R18. The load resistors are sufficiently low in value to maintain a good frequency response. An unbypassed emitter resistor in each stage (R12, R16 and VR1) provides sufficient negative feedback to keep the circuit stable and free from self-oscillation, while at the same time maintaining the gain/bandwidth ratio at a reasonable level. These resistors also effectively improve the temperature stability of the circuit although with this type of silicon transistor, temperature would not normally present any problems. By making the final emitter resistor variable, through the use of present potentiometer VR1, the gain of the last stage can be adjusted and the potentiometer can thus act as a calibration control.

The output from TR4 is coupled via the isolating capacitor C5 to the bridge rectifier provided by D1 to D4, this providing full-wave rectification of the signal to the meter, M1. It will be noticed that throughout the circuit quite large values of coupling capacitor are used, this being done to maintain a good l.f. response. Ripple and sharp signal 'spikes' across the meter are reduced by the large value electrolytic capacitor, C7. A smaller non-polarised capacitor, C6, is connected in parallel to serve the same purpose at the higher frequencies. Provision is made by means of sockets for the connection of an external d.c. supply, this being decoupled by C8. If desired, C8 may be connected into circuit after switch S2 instead of across the supply sockets.

## COMPONENTS

The components should offer no difficulty so far as availability is concerned with the possible exception of C1 (2.2 $\mu$ F) and C2 to C5 (4.7 $\mu$ F). These capacitors are non-electrolytic, and are made by a number of manufacturers. Suitable types are Radiospares polycarbonate capacitors with a rating of 63 volts working, which are available in both values. Radiospares components cannot be purchased direct, but may be ordered through a retailer. Alternatively, there is a 2.2 $\mu$ F Mullard miniature foil capacitor available Home Radio under Cat. No. 2EJ10, whilst Henry's Radio list a 4.7 $\mu$ F paper tubular capacitor in their catalogue.

If necessary, a 2 $\mu$ F capacitor could be used for C1 and 4 $\mu$ F capacitors for C2 and C5. The only effect given by the reduced capacitance will be a slight reduction in the low frequency response, approximately -2dB at 20Hz.

Another possible source of query concerns the 'O-Z' sockets listed in the Components List. These are sockets capable of taking Belling-Lee 'O-Z' plugs. An alternative would be to employ sockets suitable for 'banana' plugs.

## CONSTRUCTION

The construction of the unit should offer no problems. The type of cabinet used by the writer is specified in the Components List, but other cabinets and layouts may be used to suit individual requirements or preferences.

With the exception of a few components mounted on the front panel, the circuit may be constructed on printed board or Veroboard. Suitable layouts for

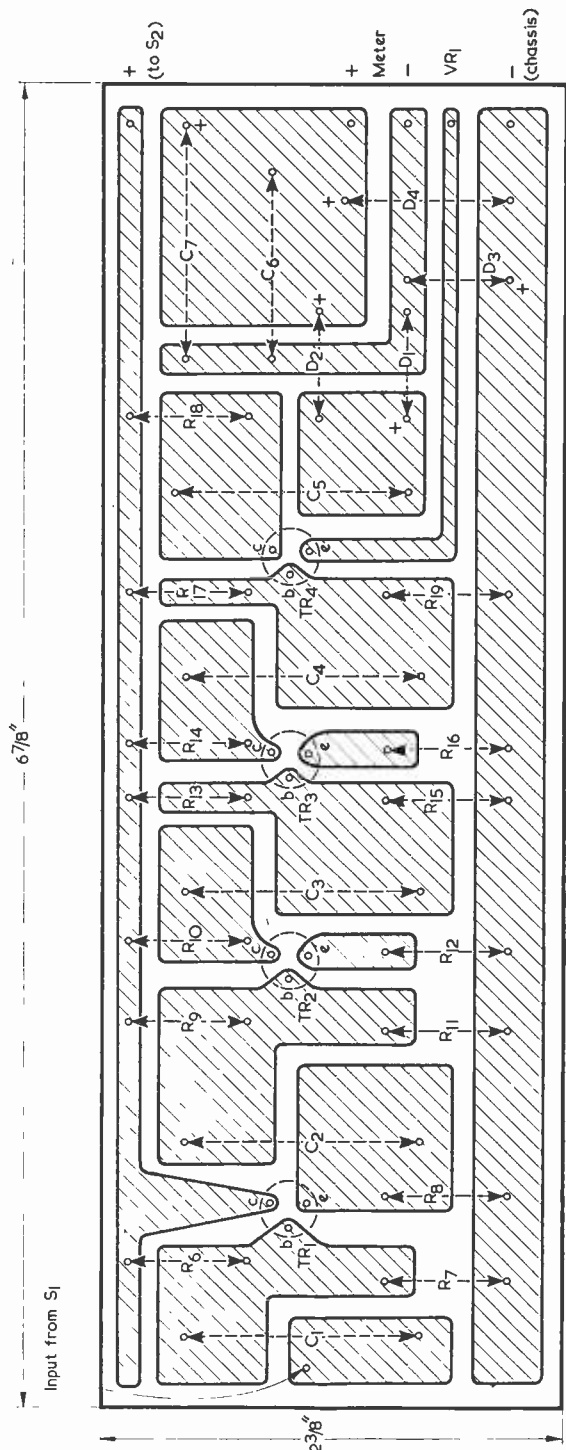
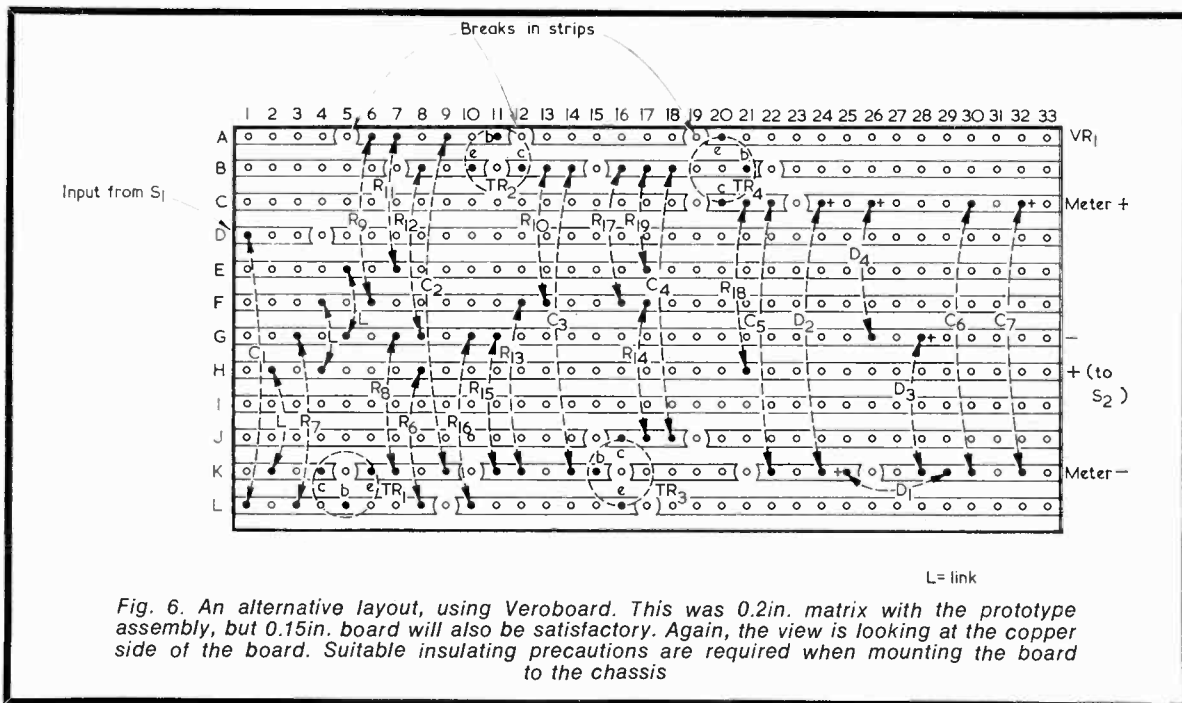

Fig. 5. The printed circuit board, looking at the copper side. Mounting holes may be drilled through the copper section connecting to chassis, as required. The board is reproduced full size, and the copper pattern may be traced



both types of construction together with component configuration are given in Figs. 5 and 6. The completed board is mounted parallel to the front panel on a simple sub-chassis which is fixed to the front panel by 6BA screws, a small angle bracket being used to mount the board to the sub-chassis. A small right angle lip is bent along one edge of the sub-chassis plate for fixing to the front panel, the fixing holes being drilled before the bend is made. This form of construction makes for simplicity and economy and is illustrated in Fig. 7.

The front panel layout, with relevant dimensions, is shown in Fig. 8. To simplify construction the components on the front panel should be mounted and wired up before the sub-chassis and component board are fitted. The attenuator resistors R<sub>1</sub> to R<sub>5</sub> are wired directly across the switch contacts. Screened

lead is used to connect the input socket to the switch and to connect the switch to the component board. It will be noticed that both 'O-Z' and coaxial socket inputs are provided. Not only is this facility useful when no coaxial lead is to hand but it also allows the input voltage being measured to be simultaneously monitored on an oscilloscope or other instrument. In the prototype, the decoupling cap-

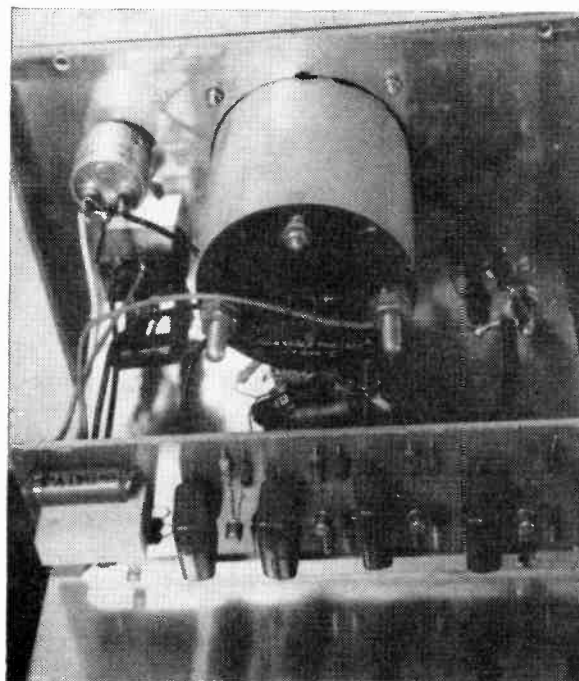
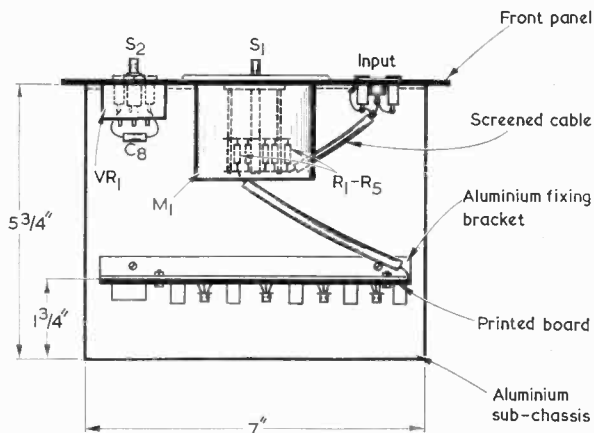

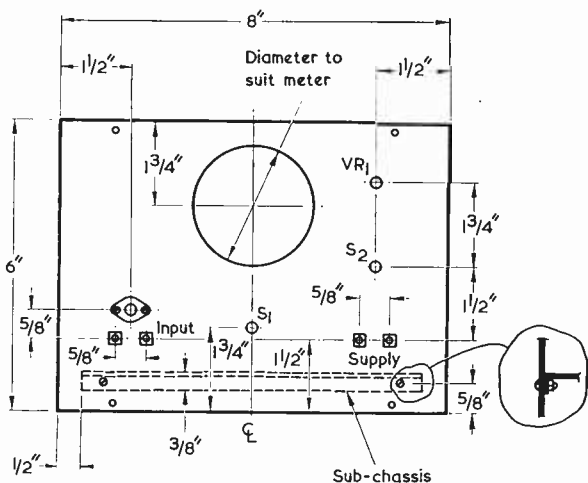

Fig. 8. The front panel, viewed from the front of the instrument

acitor C8 is connected directly across the external supply input sockets. Final extras such as rubber feet and carrying handle may be added to the cabinet if required.

### CALIBRATION

Testing and calibration are simply and quickly carried out. Before connecting and switching on the d.c. supply, carefully check the circuit for correct wiring, etc. Set the calibration control, VR1, to about half traverse and S1 to the 100 volt range (position 5). Connect the battery or external power supply and switch on. The meter pointer may give a momentary 'kick' when the supply is switched on but should afterwards remain at zero. Connect a short-circuiting clip across the input and swing S1 through all its positions; the meter should remain at zero on all ranges. Return S1 to the 10 volt range remove the input short-circuit.

To set the calibration a variable a.c. supply having a good sine waveform and of at least 0-10 volts is required, together with an a.c. voltmeter of known accuracy. Normally the simplest and often the only such source is the 50Hz mains and a standard multirange testmeter. It will be realised that the accuracy of calibration can only be as accurate as the meter being calibrated against. As most multirange testmeters of reasonable quality have specified accuracies

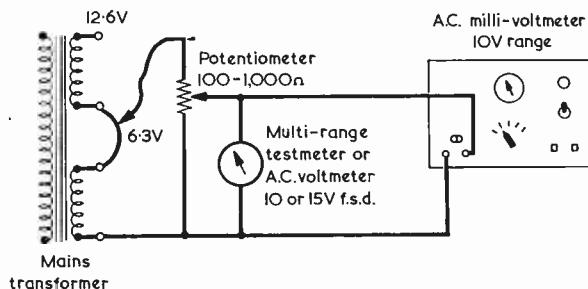

Fig. 9. A suitable circuit for test and calibration  
Front panel layout of the completed millivoltmeter

in the 2 to 3% region, this type of instrument will be adequate for normal purposes.

The calibration circuit is connected up as shown in Fig. 9. A suitable low voltage supply can be

TABLE 2

### CIRCUIT MEASUREMENTS

All voltages measured on 20kΩ per volt instrument with respect to negative line. (TR4 measurements are with VR1 set up after calibration).

Supply 9V

TR1 Emitter 2.1V

TR1 Collector 9V

TR2 Emitter 0.31V

TR2 Collector 7.2V

TR3 Emitter 0.38V

TR3 Collector 6.8V

TR4 Emitter 0.24V

TR4 Collector 3.1V

Current drain 6.1mA

Lowest measured input impedance over all 5 ranges at 1kHz: 96kΩ

Highest measured input impedance over all 5 ranges at 1kHz: 115kΩ

obtained from the heater winding or windings of a normal mains transformer. If two heater windings are available they can be connected in series. With the circuit connected as shown the potentiometer is adjusted until the multirange meter reads exactly 6 or 7 volts. The calibrate control on the millivoltmeter is then adjusted until an identical reading is obtained. This should be rechecked several times to ensure that a small change in mains voltage has not altered the initial reading. The reason for calibrating around two-thirds f.s.d. is to achieve the symmetrical non-linearity characteristic previously mentioned. A point to note, however, is that some meter movements have themselves a tendency to non-linearity, particularly the smaller less expensive type of meter. If excessive non-linearity is obtained therefore, particularly at the upper or lower extremes of the scale, the basic meter M1 should itself be checked against a known milliammeter.

Having set the calibration control as described, the potentiometer should be adjusted to give a series of readings from 0 to 10 volts, the reading on the millivoltmeter being checked in each case by the testmeter. The lower ranges can be checked in a similar manner if a low voltage variable supply is available. As however most testmeters fall off in accuracy when voltages of less than 1 volt are approached due to meter diode characteristics, accurate checks on the lower ranges are not always a practical proposition without more elaborate test apparatus. This is not particularly important however as when the instrument has been calibrated on the 10 volt range as described, the accuracy of the remaining ranges is almost solely dependant on the tolerance of the attenuator resistors. This point has already been discussed.

Once the instrument is calibrated it is ready for use and should maintain its original accuracy for a considerable time.

# AUTOMATIC MAINS BATTERY SUPPLY

by

J. C. EADE, B.A.

**A simple but effective circuit which provides continuous operation of low voltage equipment**

THE SUPPLY UNIT TO BE DESCRIBED, WHOSE CIRCUIT is given in Fig. 1, was designed to give automatic switching from mains to battery for any low voltage equipment. For example, if built into a transistor portable radio it would operate so that, in the absence of a mains supply, the battery is connected into circuit via the on/off switch as usual. When a mains connection is made a low alternating voltage appears across the transformer secondary, is rectified by the diode, smoothed by C1 and operates the relay via R. The battery is then disconnected from the circuit and the rectified supply substituted. Should the mains supply then be disconnected or fall substantially the relay will de-energise and the circuit will revert to battery operation.

This circuit does away with the complications of transistors and heat sinks—not to mention the small but continuous drain on the battery which is frequently involved in a circuit using transistor switching. As against this it could be argued that the relay takes a substantial current during the mains operation. A little calculation will show that from the point of view of the cost of mains electricity the extra is negligible. The only consideration will be whether the extra demand is too much either for the transformer or rectifier.

The relay must have at least a single pole change-over contact set and be sensitive enough to operate on a lower voltage than the lowest to which the smoothed supply might drop during normal operation. The resistance R should then be adjusted for reliable operation. Its value may be calculated, but it will probably be easier to use the empirical approach by temporarily substituting a variable resistor and adjusting this to the maximum required for reliable operation. If current consumption is no problem R can be omitted so long as the relay coil does not overheat during prolonged use.

C2, which may have, typically, a value of the order of 100 to 200 $\mu$ F, was not required in the author's version, but has been included in the

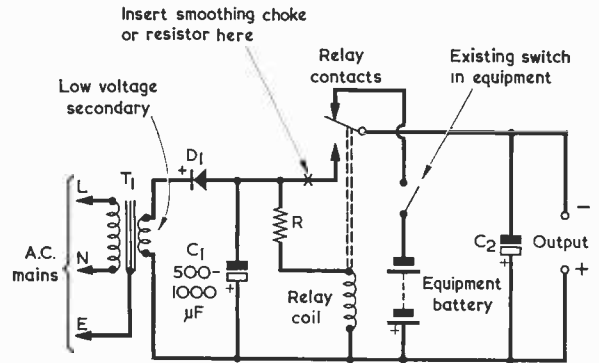

Fig. 1. The circuit of the supply unit. C1 should have a working voltage to suit the rectified voltage from D1. All other components are discussed in the text

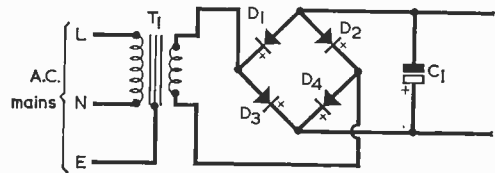

Fig. 2. A smoother supply is given if a bridge rectifier is employed instead of the half-wave rectifier of Fig. 1. The remainder of the circuit is unaltered

diagram for the sake of completeness. In many instances it will be already fitted in the equipment supplied by the power unit. It prevents a momentary interruption of the supply when the relay switches. If a smoothing resistor or choke is required, this may be inserted at the point marked with a cross in the circuit. A rectified supply with less ripple will be given if a bridge rectifier is employed, as in Fig. 2, instead of the half-wave rectifier of Fig. 1. Alternatively, a full-wave rectifier run from a centre-tapped transformer secondary may be employed. Also, a neon bulb with a suitable series resistor can be connected across the transformer primary to give warning when the mains is applied.

The circuit is suitable for a wide range of supply voltages and currents, whereupon the transformer secondary ratings depend upon the supply required. The presence of the relay coil across the rectified supply will assist in output voltage regulation due to the steady current that it draws. D1 in Fig. 1 may be a silicon diode having a p.i.v. greater than 2.8 times the transformer secondary voltage. In Fig. 2, D1 to D4 each require a p.i.v. rating greater than 1.4 times the transformer secondary voltage. Care must, of course, be taken to ensure that there is no risk of accidental shock from the mains connections to the transformer primary.



# CYBERNETIC CYNTHIA



## (PART 2)

by

L. C. GALITZ

**This concluding article describes the construction, wiring and testing of Cynthia, whose name, incidentally, is a shortened version of CYberNeTic Highly Intelligent Animal**

**I**N LAST MONTH'S ISSUE THE CIRCUIT AND FUNCTIONING of Cynthia were described. We now carry on to the construction and testing of this cybernetic device.

### MECHANICAL CONSTRUCTION

Quite a number of tags are required for securing the electronic components. The author conveniently had a turret-tag board measuring about  $6\frac{1}{2}$  by  $7\frac{1}{2}$  in. with four rows of 19 tags each to hand on which the electronics were assembled, and the whole robot was built around this. Other forms of construction such as individual tagboards or tagstrips could also be used. It should be remembered that this is an experimental project and, as such, any type of 'breadboard' apart from Veroboard or printed circuit board will do. The only troubles with these last two types of board is that they are hard to modify when experimenting, and that the copper tends to depart from the laminate after components have been repeatedly soldered and removed. (Veroboard and printed circuit board are, of course, excellent mediums for the construction of tried and proven circuits.)

Whatever is used, the basic mechanical details of Cynthia remain the same. The electronics are horizontal. Screwed to the base on which they are assembled, by means of two brackets, is a piece of plywood cut to the approximate shape of a snail without a head. (The author is no artist, yet managed, with a little experimentation, to achieve something recognisable as a snail.) The front is then painted with a spiral to represent the shell. Reference to Fig. 6 and the photographs given in Part 1 may make things a little more explicit.

Next, the head assembly is made. An 'L' shaped piece of wood is cut out, and on this is stuck a pulley. A hole is then drilled through the wood to allow an axle to pass through the assembly. The position on the back of the front panel where the head is to be pivoted is determined by experiment. At one extreme all of the straight part of the head should be visible, and at the other extreme, when the head is fully retracted, it should be completely concealed from view. The correct position for the

JULY 1970

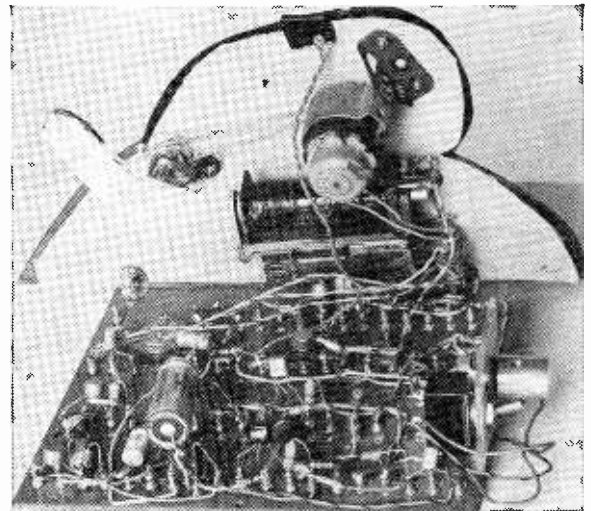

*Rear view of the prototype model, illustrating the positions of the larger components. (The electronics board wiring shown here differs somewhat from the layout given in Fig. 8; an AND gate and inverter preceding the relay driver were included when the photograph was taken, these being later removed as unnecessary)*

axle should be marked, on the main piece of plywood, and a hole should be drilled at this spot going about half way through the front panel. A double angled bracket is then used to support the other end of the axle, and is screwed in place. Reference to Fig. 6(d) and Fig. 7 should make this clear.

The next thing to be affixed to the front panel is the motor. The shaft must be perpendicular to the front panel, and a suitable bracket must be made up to hold the motor. The author used an electrolytic capacitor clip to grip the round motor employed in the prototype. A simple L-shaped bracket screwed onto the panel held the clip, and thus the motor, in

*(Continued on page 751)*

# THE "GLOBE RANGER" 4-1

F. G. RAYER, /

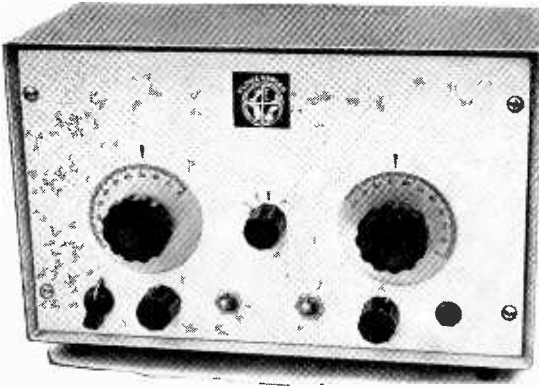

Offering reception on two short wave waves, this sensitive superhet design control. The complications of oscill completely eradicated by the us

UNLESS PLUG-IN COILS ARE USED IN A MULTI-BAND superhet receiver, there must be switching for each circuit, with the associated trimmers, padders and coils. This part of the construction and wiring can become quite complicated. To avoid such difficulties, the 'Globe Ranger' receiver described here employs a ready-made coilpack. The necessary aerial and oscillator coils, trimmers, oscillator padders and wavechange switch are already wired up as a complete unit for fitting into the receiver.

Coverage is approximately 2,000 to 16 metres in four bands as shown in the accompanying Table. This coverage provides the usual long and medium wave bands, and also takes in frequencies which are often omitted from 'all wave' receivers, these including the 80 metre and 160 metre amateur bands. For general short wave reception, the 50 to 16 metre band covers the most useful frequencies.

## THE CIRCUIT

Fig. 1 shows the circuit of the 'Globe Ranger' receiver. The colours in the circuitry around the frequency changer  $V_1$ , indicate the connections to the coilpack. Black is the aerial connection. Green is wired to the aerial tuning capacitor  $VC_1$ , and to  $C_1$ . Blue is the oscillator grid circuit, and Red the oscillator anode feedback circuit. 'MC' is the small chassis of the pack, which is connected to the receiver chassis, and in this case the Yellow tag is also taken to the chassis.

The pack has four aerial coils and four oscillator coils, with an 8-bank trimmer strip and, as mentioned, the switch, trimmers, coils and padders are ready wired.

$VC_1$  and  $VC_2$  are sections of the usual ganged tuning capacitor. Bandsread tuning is provided by  $VC_3$  and  $VC_4$ , and was found to be of great help on the short wave broadcast and amateur bands.

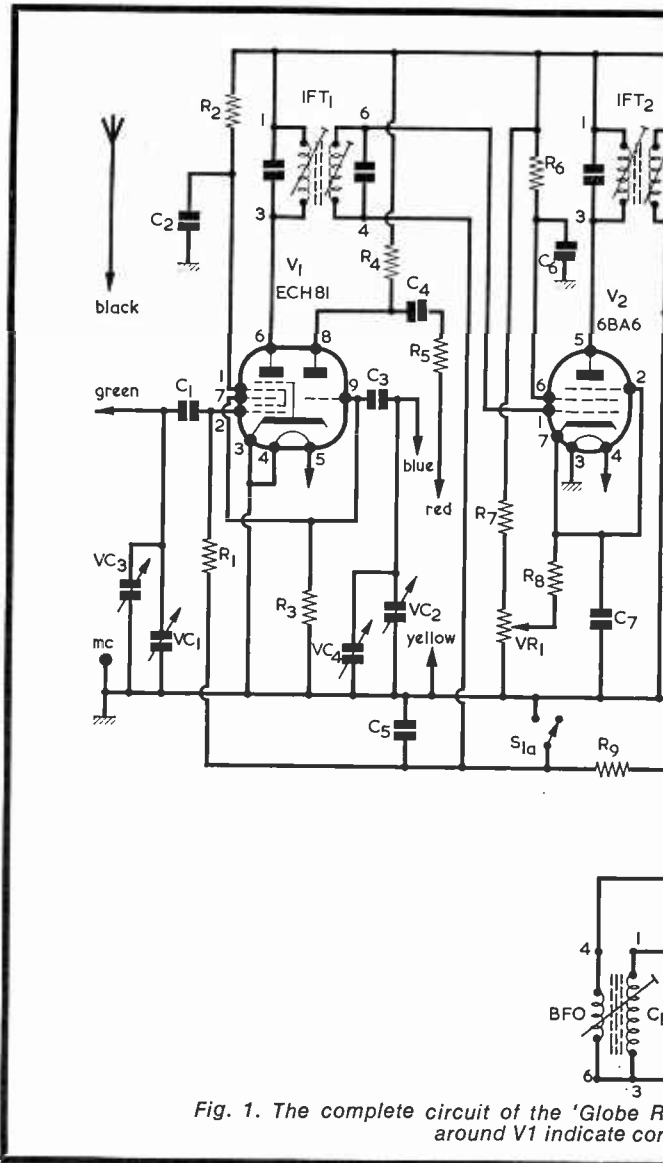

Fig. 1. The complete circuit of the 'Globe Ranger' receiver. The colours around  $V_1$  indicate connections to the coilpack.





# NGER" AND SUPERHET

E.R.E., G30GR

ands as well as on medium and long  
so incorporates a b.f.o. and an i.f. gain  
r and aerial tuned circuit wiring are  
of a ready-wired 4-band coilpack

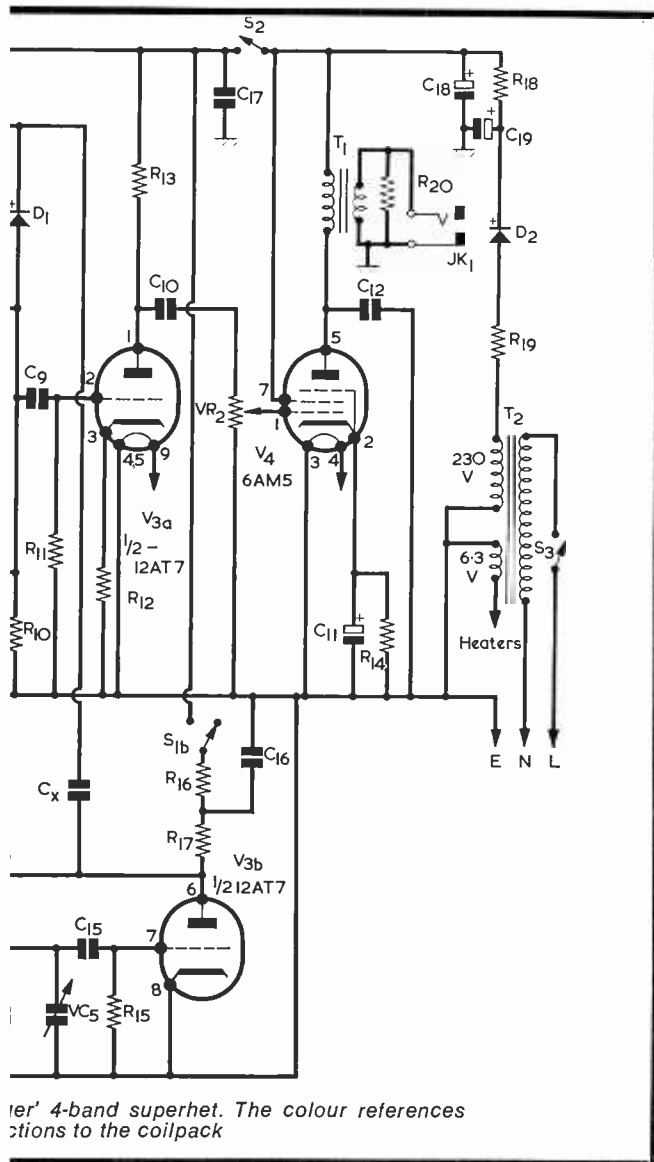

er' 4-band superhet. The colour references  
ctions to the coilpack

JULY 1970



Both 2-gang capacitors are operated by way of ball reduction drives.

Diode D1 provides detection, together with a negative potential which is used as automatic gain control bias for V1 and i.f. amplifier V2. V3(a) is one section of a twin triode, and gives audio amplification. The second section, V3(b), is a beat frequency oscillator, with the b.f.o. coil tuned by VC5. The b.f.o. allows the reception of c.w. morse, and s.s.b. (single sideband) signals. S1(a) and S1(b) are contacts of a 2-pole switch. When the b.f.o. is operating, S1(a) puts the a.g.c. to V1 and V2 out of action. Gain before the detector is then controlled by VR1.

H.T. is obtained from a half-wave rectifier circuit employing D2, and V4 is the audio output stage. S2 opens the h.t. circuit to the early stages, giving immediate switching on (or off) of the receiver. This enables the heaters to be left running when S2 is in the open or 'Standby' position, and only V4 then draws h.t. current. A 'Standby' switch was required because the receiver was to be used in conjunction with transmitting equipment. The receiver is turned completely off in the usual way by S3.

The audio output is applied to jack JK1, to which will normally be connected a 3Ω loudspeaker. R20 is wired permanently across the output to provide a load when no speaker is plugged in, thereby preventing the appearance of excessive a.f. voltages across the primary of T1 which could otherwise occur.

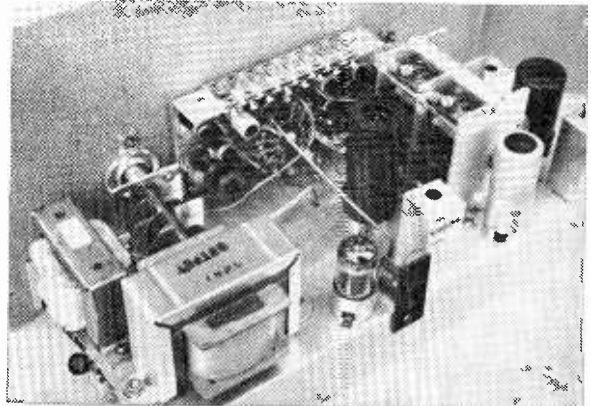

A rear top view. The coilpack is mounted above the chassis with the trimmer bank uppermost

745

## CHASSIS AND PANEL

Positions for the valveholders, intermediate frequency transformers and b.f.o. coil, speaker transformer T1, mains transformer T2, and other items can be seen from Fig. 2. Drill as many holes as

possible before mounting any components. A chassis cutter is most suitable for the valveholders. Do not forget the central holes under the i.f. transformers (to reach the lower cores) and also those in the front runner of the chassis. (See Fig. 3).

The ganged capacitor VC1/VC2 is mounted with

## COMPONENTS

### Resistors

(All fixed values 10%)

R1	1M $\Omega$ , $\frac{1}{4}$ watt
R2	22k $\Omega$ , $\frac{1}{2}$ watt
R3	47k $\Omega$ , $\frac{1}{4}$ watt
R4	33k $\Omega$ , 1 watt
R5	150 $\Omega$ , $\frac{1}{4}$ watt
R6	33k $\Omega$ , $\frac{1}{2}$ watt
R7	100k $\Omega$ , 1 watt
R8	68 $\Omega$ , $\frac{1}{4}$ watt
R9	2.2M $\Omega$ , $\frac{1}{4}$ watt
R10	270k $\Omega$ , $\frac{1}{4}$ watt
R11	470k $\Omega$ , $\frac{1}{4}$ watt
R12	2.2k $\Omega$ , $\frac{1}{4}$ watt
R13	220k $\Omega$ , $\frac{1}{2}$ watt
R14	680 $\Omega$ , 1 watt
R15	47k $\Omega$ , $\frac{1}{4}$ watt
R16	47k $\Omega$ , $\frac{1}{2}$ watt
R17	47k $\Omega$ , $\frac{1}{2}$ watt
R18	2.7k $\Omega$ , 3 watt
R19	470 $\Omega$ , 1 watt
R20	10 $\Omega$ , $\frac{1}{2}$ watt
VR1	50k $\Omega$ potentiometer, linear
VR2	500k $\Omega$ potentiometer, log, with switch S3

### Capacitors

C1	100pF silver-mica
C2	0.02 $\mu$ F disc ceramic or tubular, 350V wkg.
C3	56pF silver-mica
C4	200pF silver-mica
C5	0.1 $\mu$ F tubular, 150V wkg.
C6	0.02 $\mu$ F disc ceramic or tubular, 350V wkg.
C7	0.02 $\mu$ F disc ceramic or tubular, 250V wkg.
C8	250pF silver-mica
C9	0.01 $\mu$ F tubular, 150V wkg.
C10	0.01 $\mu$ F tubular, 350V wkg.
C11	25 $\mu$ F electrolytic, 25V wkg.
C12	0.02 $\mu$ F tubular, 350V wkg.
C13	100pF silver-mica
C14	140pF silver-mica
C15	100pF silver-mica
C16	0.25 $\mu$ F tubular, 350V wkg.
C17	0.25 $\mu$ F tubular, 350V wkg.
C18	32 $\mu$ F electrolytic, wire-ended, 350V wkg.
C19	8 $\mu$ F electrolytic, wire-ended, 350V wkg.
VC1, VC2	500 + 500pF 2-gang variable (Denco)
VC3, VC4	25 + 25pF 2-gang variable, type 02 (Jackson Bros.)
VC5	15pF variable, type C804 (Jackson Bros.)

### Inductors

IFT1	I.F. transformer type IFT11/465 (Denco)
IFT2	I.F. transformer type IFT11/465 (Denco)
BFO	B.F.O. transformer type BFO2/465 (Denco)
T1	Output transformer Cat. No. TO47 (Home Radio)
T2	Mains transformer, secondaries 230V 45mA, 6.3V 1.5A. Cat. No. TM26A (Home Radio)

### Coilpack

Coilpack type CP3F (Denco)

### Valves

V1	ECH81
V2	6BA6
V3	12AT7
V4	6AM5

### Diodes

D1	OA81
D2	BY100, or other rectifier suitable for 800 p.i.v., 60mA

### Switches

S1	d.p.s.t., toggle
S2	s.p.s.t., toggle
S3	s.p.s.t., part of VR2

### Sockets

JK1	Phone jack
Aerial-Earth socket strip	
2	B9A valveholders with skirts and screening cans
1	B7G valveholder with skirt and screening can
1	B7G valveholder with skirt

### Drives, Knobs

2	ball drives type 4511/F (Jackson Bros.)
2	2 $\frac{3}{4}$ in. dials, Cat. No. KN79 (Home Radio)
2	knobs, Cat. No. KN77 (Home Radio)
3	knobs, Cat. No. E895 (Home Radio)
1	knob, Cat. No. KN38 (Home Radio)

### Tagstrips

1	5-way, end tag earthed (see Fig. 3)
1	5-way, centre tag earthed
1	4-way, end tag earthed (see Fig. 3)
1	3-way, end tag earthed (see Fig. 3)

### Case, Chassis

1	Case, Cat. No. BX5, complete with 10 $\frac{1}{2}$ x 5 x 1 $\frac{1}{2}$ in. chassis (Home Radio)
---	---

### Miscellaneous

Grommets, mains lead, connecting wire, etc.

bolts through its feet and the chassis. VC3/VC4 is secured with two 4BA bolts, and washers or spacers raise this item  $\frac{3}{8}$  in. so that its spindle is at the same height as that of VC1/VC2.

Holes each side of T2 allow leads from this transformer and T1 to pass down through the chassis. When fitting the i.f. transformers and b.f.o. coil, check that the numbered tags take up the positions shown in Fig. 3.

The coilpack is mounted centrally just clear of the chassis. Solder a flying lead from the insulated yellow tag to the adjacent chassis tag of the pack, and take this to chassis at VC2, as shown in Fig. 2. A short wire also connects from the right hand pack 'MC' tag to the frame of VC4 (also shown in Fig. 2). Solder leads to the lower tags of VC1/VC2 before mounting it, and connect these as in Fig. 2, keeping wires clear of the chassis.

The fixing lugs of the ball drives should be flush with the front edge of the chassis, and the drives appear in 1 in. diameter clearance holes in the panel. The panel and chassis are held together by the switches and other controls shown in Fig. 3. Note that the lower edge of the front runner of the chassis is a little higher than the lower edge of the panel.

Bolt the drive lugs to the panel, and check that they turn freely. The drives have a flange, taking two 8BA bolts, and these secure the 0-100 metal dials specified in the Components List. The distance between the 8BA tapped holes in the flanges is the same as the diameter of the holes in the dials, and these mount on the flanges in the manner shown in Fig. 4. This provides a rigid method of fixing. If preferred, dials or scales may be fixed to the panel, and pointers or cursors made from Perspex can be fitted to the drive flanges.

The aerial-earth socket strip is mounted vertically above the chassis by a bolt and nut securing one of



its mounting holes to the rear chassis runner. The earth socket is that nearer the chassis surface.

## UNDERCHASSIS WIRING

Commence by taking the 6.3 volt secondary leads from T2 down through the chassis, insulating them with sleeving. Connect one lead to chassis at the tag to which is also connected the negative lead of C18. Connect the other 6.3 volt lead to the valveholder tag of V4 which is marked 'H' in Fig. 3. Continue this circuit to the tags marked 'H' of the other three valveholders, running the leads close to the chassis underside.

Deal with the 230 volt h.t. secondary leads in a similar way, connecting one to the same chassis tag and the other to the tag anchoring R19. Connect one lead of the primary of T2 to S3, and the other to the centre tag of the tagstrip used to secure the mains lead.

The primary leads of the speaker transformer, T1, connect to tag 5 of V4 valveholder and to h.t. at the positive end of C18. The secondary leads are connected to jack JK1 on the front panel. These may pass over the edge of the chassis. With most types of phone jack the mounting bush will automatically ensure that one side of the speaker secondary con-

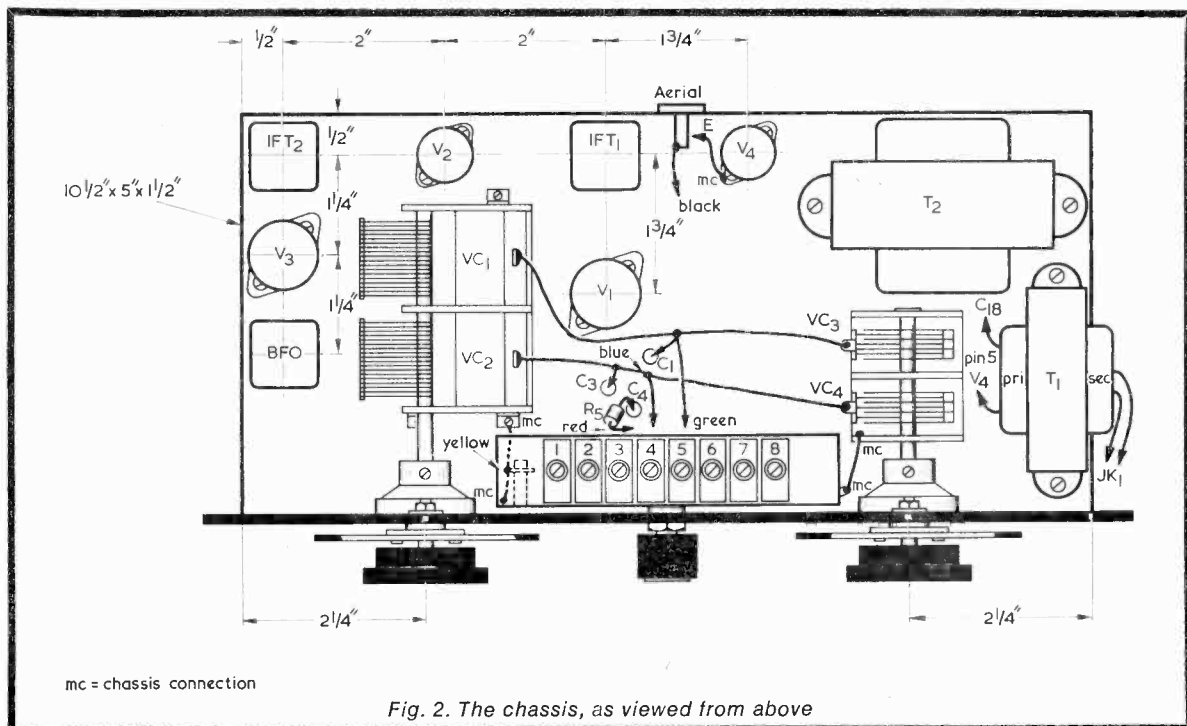

Fig. 2. The chassis, as viewed from above

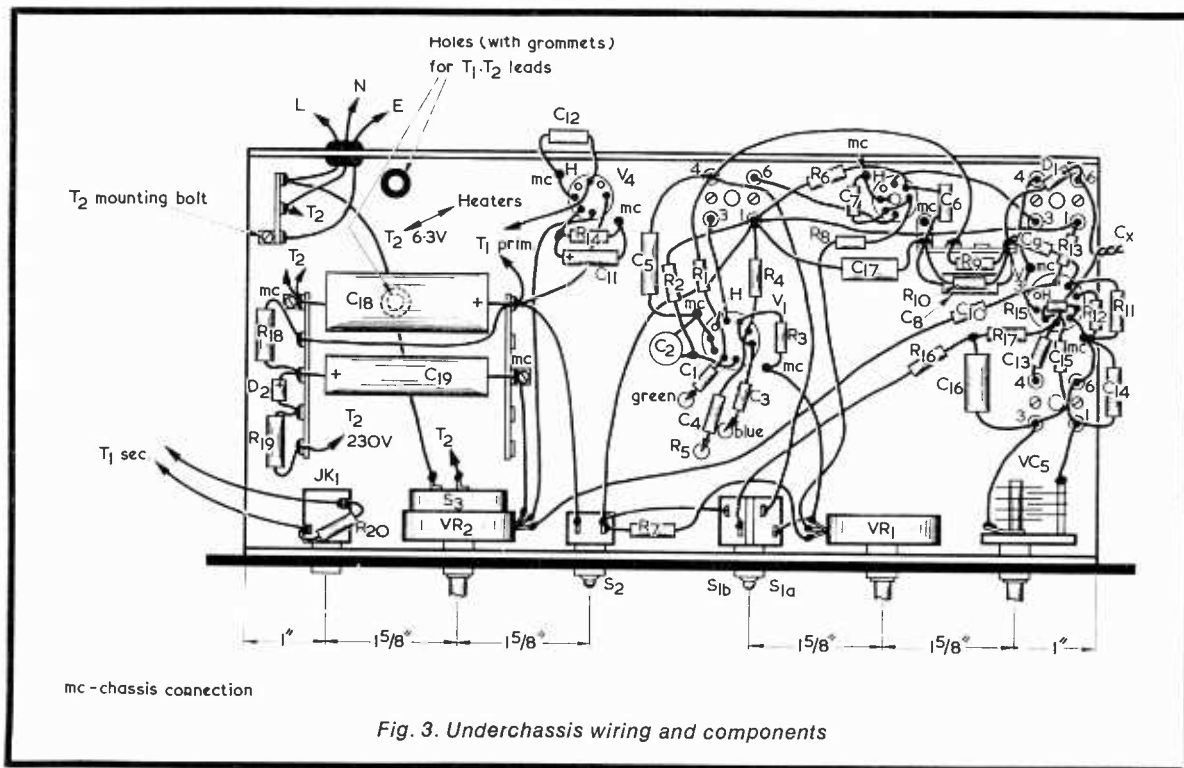

Fig. 3. Underchassis wiring and components

nects to chassis. If, however, the jack has an insulated bush, connect the jack contact nearer the front panel to any convenient chassis point.

Tagstrips anchor various leads and components. Insulated sleeving is required on all leads where there is any risk of short-circuit to adjacent conductors or chassis. All connections should be reasonably short and direct. Run the wires from VR2 close to the chassis underside. They should be clear of the 6.3 volt heater wiring leads. H.T. and a.g.c. circuit wiring is, in general, also kept against the chassis underside. On the other hand, leads and components in the r.f. circuits, such as those from the b.f.o. coil, and the anode and grid connections of V2, are kept a little clear of the chassis.

The capacitor Cx has to be of very small value, and is made by twisting together two insulated leads for about 1/2 in. of their length. Later, the capacitance can be altered by twisting or untwisting these wires, if necessary.

The mains lead should be a 3-core flexible cord, properly terminated in a 13 amp 3-way plug fitted with a 2 amp fuse. Solder the wires to the tagstrip, using the green and yellow striped core for E (Earth), the blue core for N (Neutral) and the brown core for L (Live). E connects to the chassis, N to the

primary of T2 and L to S3, as shown in Fig. 3. Make quite certain that there are no errors in these connections.

Valves are fitted as a last step in construction. V1, V2 and V3 are provided with screening cans.

### I.F. ALIGNMENT

The i.f. transformers will have approximately correct core positions as received. The alignment should then normally be sufficiently accurate to allow at least a strong medium wave or long wave transmission to be tuned in. The four i.f. transformer cores should be adjusted with a fully insulated tool for best results. S1 is left open.

A multi-range meter on a 10mA or similar range may be used as an aid when aligning. Set VR1 for minimum gain (whole resistance in circuit) and clip the meter leads to VR1 slider and chassis, the latter being negative. Adjustments are then directed towards securing *minimum* cathode current for V2, as shown by the meter, this corresponding to maximum a.g.c. voltage.

For alignment by ear, set VR1 and VR2 at maximum gain, and find a weak but stable transmission. It is best to choose a BBC station, reducing signal strength by using an extremely short aerial. The cores are then adjusted for maximum volume. Peak settings are much less easily found with this method than with the aid of a meter. When estimating output by ear, strong signals are not suitable because they operate the a.g.c. circuit.

If a modulated signal generator is available the i.f. transformers can be aligned with this to 465kHz instead of employing received signals. The signal generator output may be coupled to pin 2 of V1.



## B.F.O. ADJUSTMENT

Turn VR1 a little from the maximum gain setting, and close S1. Tune in a transmission and put VC5 to half capacitance. Rotate the b.f.o. coil core until a strong heterodyne is produced, and bring this to the central zero-beat condition. Adjustment of VC5 in either direction should now produce a tone which rises in pitch as the setting of the capacitor is taken further above or below the central zero position. If a c.w. signal is tuned in, morse will be audible at an audio frequency whose pitch is adjusted by VC5.

## COILPACK ADJUSTMENT

If the 2-gang capacitor VC1/VC2 is fitted with trimmers, they should be set fully open. Alignment of the coilpack may then proceed. It will be assumed primarily that a signal generator is not available, and that adjustments will be carried out with received signals.

Each band in the coilpack is dealt with separately. Adjustment of the oscillator coil core mainly influences coverage at the low frequency end of the band (tuning capacitor vanes nearly closed). The oscillator trimmer governs band coverage at the high frequency end of the band (tuning capacitor vanes open).

Assuming that the cores have not been moved, the oscillator cores can at present be left alone. Therefore only aerial adjustments need be made. Choose the medium waveband first. Tune in a signal near the low frequency end of the band, and rotate the medium wave aerial coil core for best results, as shown, if possible, by the cathode meter used for i.f. alignment. (Coils can easily be identified from the maker's leaflet.) Then tune to a transmission near the high frequency end of the band, and adjust trimmer 7 (Fig. 2) for best results. Repeat these adjustments until no further improvement is possible.

The long waveband can next be dealt with, adjusting the core of the aerial coil at a low frequency, and trimmer 8 at a high frequency in the band.

Deal with the short wave bands one at a time, and in the same way. Trimmer 6 is for the SW1 range, and trimmer 5 for the SW2 band.

With the short wave ranges, and especially towards 18MHz, it may be found that either of two settings of the aerial trimmer will peak up signals. This arises from the aerial circuit being tuned either above or below the oscillator frequency. The correct setting is that which places the aerial circuit on the lower of the two possible frequencies, i.e. the trimmer setting which offers the larger capacitance.

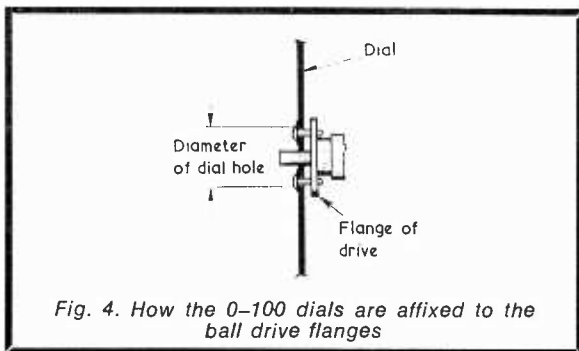

Fig. 4. How the 0-100 dials are affixed to the ball drive flanges



When a signal generator is available, band coverage can be adjusted as necessary by means of the oscillator cores and trimmers. Deal with each band individually. With the vanes of VC1/VC2 fully closed, adjust the oscillator coil core for the wanted band-end frequency. Then open the vanes of VC1/VC2 fully, and adjust the oscillator trimmer for the wanted frequency. Trimmer 1 (Fig. 2) is for SW2 oscillator, trimmer 2 for SW1 oscillator, trimmer 3 for medium wave oscillator and trimmer 4 for long wave oscillator. After any changes to the oscillator circuits, the corresponding aerial coil core and trimmer must be re-adjusted, in the way previously described, to restore alignment and obtain best results.

## OPERATING NOTES

For a.m. reception (speech and music) VR1 is normally left at full gain, and the b.f.o. is switched off. The gain of V1 and V2 then depends on the a.g.c. circuit, and VR2 is used to provide the volume wanted.

The b.f.o. is switched on for c.w. reception. With all but very weak signals VR1 is turned back to reduce gain, VR2 being at maximum. VC5 is rotated for the best tone. Occasionally interference can be removed by turning VC5 through the central zero position to put the b.f.o. on the other side of the intermediate frequency.

For s.s.b. (single sideband) reception, adjustments are as for c.w. However, tuning, and adjustment of VC5, are quite critical, because the carrier produced by V3(b) has to replace that eliminated from the s.s.b. transmission. It is also essential to use VR1 to keep down the level of the s.s.b. signal, because if it is too strong V3(b) will not produce a carrier of sufficient magnitude to give good resolution. If this effect seems troublesome, increase the capacitance of Cx by twist-

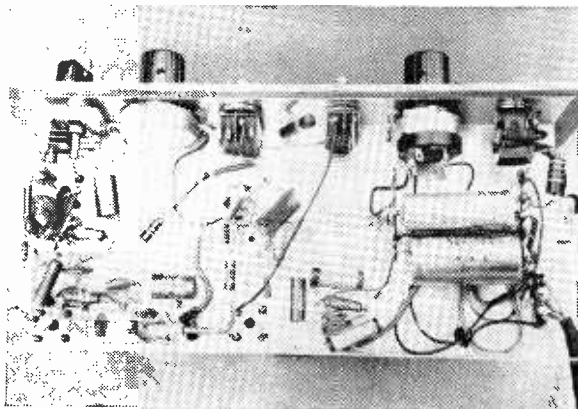

The components and wiring underneath the chassis





# CYBERNETIC CYNTHIA

(Continued from page 743)

the correct position. An elastic band is then fitted round the motor shaft and the head pulley to couple these together, and a suitable voltage is applied across the motor terminals to check if the head is free to move. Two nut and bolt assemblies were screwed to the front panel to limit the motion of the head to the limits required.

The only other pieces of equipment to be screwed to the front panel are the relay and microswitch. The microswitch used had two holes through which bolts were passed, and the microswitch was affixed to the back of the front panel just beneath the top edge, so that only the operating lever showed from the front. A bracket was made to fit on the coil retaining nut of the relay, and this was screwed onto the front panel beneath the motor.

A small sub-panel was made to hold S1 and R5, the latter being a variable component with a knob in the prototype. This panel measured 2 by 2 in. and was screwed to the electronics board at the approximate position shown in Fig. 6(c). A smaller panel could be used to take S1 on its own if R5 is a preset component.

A suitable wiring diagram is given in Fig. 8. It should be pointed out, however, that any reasonable alternative layout may be employed, provided that the wiring agrees with the circuit diagram of Fig. 4 (published last month).

## WIRING AND TESTING

It is suggested that the wiring be carried out in stages, these being completed in the following order.

1. **SUMMER.** This comprises components S2, R1, R2, R5, C1, D1 and TR1. R4 is not included until the whole circuit is complete and working, as its value is not known yet. To check that this part of the circuit works correctly, pulses are applied by means of S2. The voltage across C1 and R5 should rise slowly during a pulse, and fall very slowly between pulses. There is a slight possibility that the value of R2 may have to be changed a little. Its value is correct when a 1-second pulse on the microswitch gives a rise in value of the voltage on C1 of about 1 volt.

2. **SCHMITT TRIGGER.** This comprises components R6 to R10 inclusive, TR2 and TR3. After the circuit including these components is complete, R5 should be set to about mid-range, whereupon the high negative voltage on TR2 collector ( $-7V$  in the

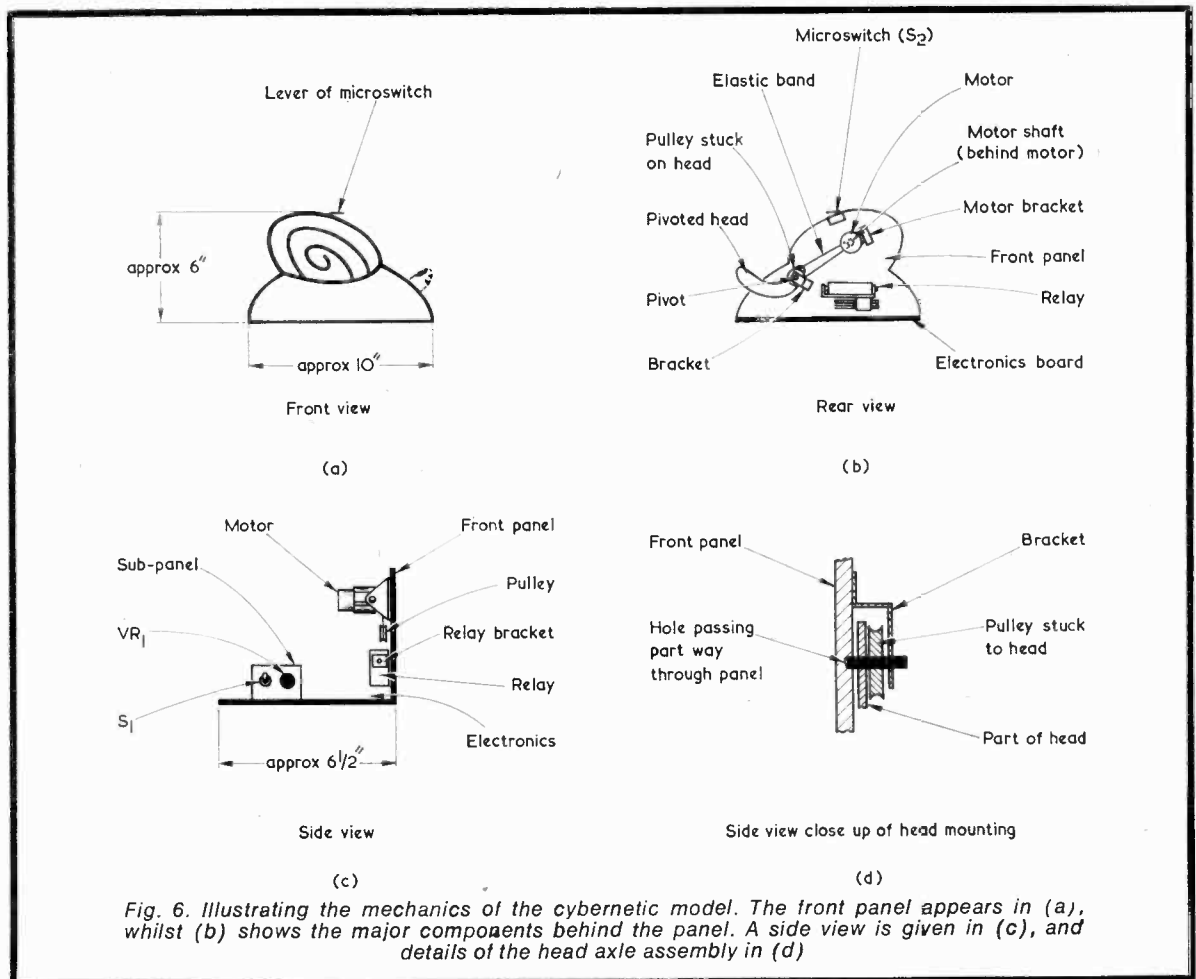

Fig. 6. Illustrating the mechanics of the cybernetic model. The front panel appears in (a), whilst (b) shows the major components behind the panel. A side view is given in (c), and details of the head axle assembly in (d)

prototype) will drop after several pulses on S2 (to about  $-1.5V$  in the prototype).

3. AND GATE. This comprises R3, R11, D2 and D3. The output of the And gate, measured between the positive line and the junction of R11 and the diodes, was of the order of  $-7.5V$  in the author's unit, with  $0.5V$  pulses when S2 was pressed. When the Schmitt Trigger fired, the voltage dropped to about  $1.7V$ . This voltage should not change, even if S2 is pressed, until the Schmitt Trigger reverts to its normal mode.

4. MONOSTABLE 1. This comprises R12 to R15 inclusive, C2, C4, TR4 and TR5. The output measured at TR5 collector is normally very low – about  $0.05V$ . When S2 is pressed the monostable will fire and the voltage will rise (to about  $-3V$  in the prototype) and then revert back to about  $-0.05V$ . The value of R13 is not determined till the next stage but, whilst testing this monostable, a  $3.3k\Omega$  resistor can be temporarily soldered into place, giving a quasistable time of about 0.3 seconds.

5. MOTOR CONTROL SECTION. This comprises R16, TR6, TR7, S1(a) and relay contacts RLA1 to RLA3 inclusive. When S2 is pressed, the motor will run in one direction for a short time. The wires to the motor must be arranged so that this is the direction which puts the snail's head in. The value of R13 can now be determined. Several values around  $3.3k\Omega$  should be tried, and the correct value is that which causes the motor to run for a fraction of a second longer than is required for Cynthia to put her head in. Naturally, the larger the value, the longer the motor will run. The resistor chosen can now be soldered into place permanently.

6. MONOSTABLE 2. This comprises R17 to R20 inclusive, C3, C5, TR8 and TR9. R18 is not known yet, and a  $6.8k\Omega$  resistor should be temporarily soldered in its position. On pressing S2, the monostable should fire at the same time as Monostable 1, and it should have quasistable time of about 4 seconds.

7. MONOSTABLE 3. This comprises R21 to R24 inclusive, C6, C7, TR10 and TR11. This monostable should trigger when Monostable 2 has reverted to its original state. A  $10k\Omega$  resistor should be temporarily soldered in for R22.

8. RELAY DRIVER. This comprises TR12, D4 and RLA/3. When Monostable 3 goes quasistable, the output from TR11 collector should switch TR12 on, energising RLA/3. If this is so, then the whole circuit can be checked for correct functioning.

It is better to carry out the construction stage by stage in the manner just described, for if anything goes wrong it is easier to pinpoint the mistake if one knows that it is confined to one stage only. A final point to mention here is that it may be found that when the Schmitt Trigger reverts to its normal state, it sends a pulse along the supply line. A  $2\mu F$  capacitor wired across R9 will remedy this.

## UNKNOWN RESISTORS

Now that the circuit is complete and operational, the final values for the unknown resistors, R4, R13, R18 and R22, can be determined.

The value of R13 should already be known, the value having been determined by the method described in section 5 under 'Wiring and Testing'.

The value of R18 is determined in a similar manner. Its resistance determines the time constant of Monostable 2, and hence, the length of time between Cynthia putting her head in, and the time when she starts putting it out again. The pause should be about three seconds, hence the quasistable time for the monostable should be about four seconds – although the time is a matter of preference. The correct value is around  $6.8k\Omega$ , and after a suitable resistor has been found, it should be permanently soldered into place.

Resistor R22 should have a value which makes the quasistable time of Monostable 3 sufficient to allow the relay to energise, and Cynthia to put her head out. When the correct value has been found, it should be soldered permanently in place.

Before the value of R4 can be determined, variable resistor R5 must be set up. Unfortunately, the values of these two resistors are interdependent, and a certain amount of going back and forth between them may be necessary before they can be permanently set up. The number of times a tactile stimulus needs to be applied before the 'threshold of insight' is reached should be initially decided upon. Let us say it is five times. The output of the Schmitt Trigger should be monitored, and R5 should be set so that the slider is at the earthy end. The robot should then be given the touch stimulus the number of times decided upon waiting, of course, for the cycle of events operating the head to be completed each time. After the last cycle of operations has come to an end the resistor R5 should be adjusted so that the Schmitt Trigger just fires. This last step must be done quite quickly because C1 is discharging all the time. C1 should then be short-circuited, and the robot tried out again with R5 in this position, to check that the correct setting has in fact been found. Once this has been found correctly, the determination of R4 can take place. The capacitor should be charged up to the value where it just fires the Schmitt Trigger, and then various value resistors should be connected across the capacitor to discharge it more quickly. The correct value of resistor is given when C1 discharges to the point where the Schmitt Trigger reverts back to its normal state after the period of time required for Cynthia to 'forget' and react normally to tactile stimuli has elapsed. This,

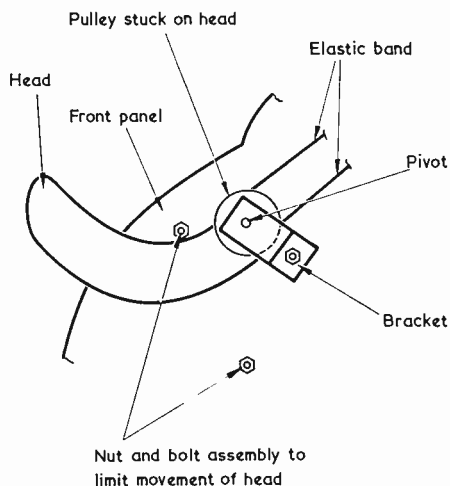

Fig. 7. Close-up rear view of the head mounting

again, can be a matter of preference. After the correct value has been found it may be necessary to re-adjust R5.

## VARIATIONS

There are several variations to the mode of operation. If the wires to the motor are transposed Cynthia's subsequent actions can be summarised in the following manner. Normally, Cynthia is asleep. When she receives a tactile stimulus she pokes her head out to investigate the cause of her rude awakening. After a few seconds of futile searching, she puts her head back in order to go back to sleep again. If she receives another touch stimulus she will repeat her previous action. After a while, however, she realises that there is nothing to be gained by investigating the originator of the touch stimulus, and when her shell is touched, she will ignore it. After a while, she will forget, and will again react to tactile stimuli.

Another variation which can be used in conjunction with the one just mentioned above is accomplished by taking the output of the Schmitt Trigger from the second collector instead of the first, this being in addition to transposing the leads to the motor. The operation of Cynthia is then as follows. Normally Cynthia is asleep, and if given tactile stimuli, she will ignore them. After several repeated stimuli she will wake up and poke her head out to investigate but, seeing nothing, she will put her head back in again to try and get some more sleep. If she is disturbed immediately after this, she will poke her head out again, still being awake, and after a few seconds, as before, she will put it back in again. If she is left alone for half a minute, this will have given her time to fall back asleep again, and she will ignore tactile stimuli until enough have been given to wake her up once more.

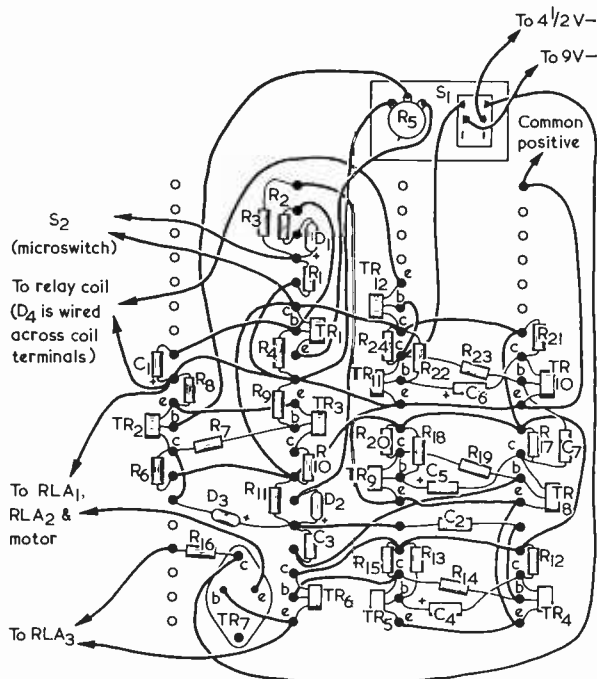

Fig. 8. A suitable layout for the components and wiring on the electronics board

As has been stated at the beginning, this article provides only the bare bones from which to work. The more experienced and more venturesome experimenter will probably wish to add his own modifications and sophistications. It is hoped that these two articles have provided food for thought. ■

## CAN ANYONE HELP?

Requests for information are inserted in this feature free of charge, subject to space being available. Users of this service undertake to acknowledge all letters, etc., received and to reimburse all reasonable expenses incurred by correspondents. Circuits, manuals, service sheets, etc., lent by readers must be returned in good condition within a reasonable period of time.

*Hitachi WH-817 Portable.* — M. J. Shepherd, 72 Westerland Avenue, Canvey Island, Essex — circuit or any details of this three waveband receiver, loan or purchase.

*Wanted.* — S. V. Fisher, 146 Hilton Street, Wolverhampton, WV10 0LF — copies of "Practical Television" for June and August 1969 or for all 1969 issues (Jan to Dec inclusive) by purchase.

*Universal Meter Type 214.* — A. W. Dyson, 139 Hamlin Lane, Exeter — manual, circuit or any information on this Metropolitan Vickers equipment.

*Murphy TV V290. CA.* — J. Henty, 24 Edward Way, Ashford, Middx. — circuit of service sheets, loan or purchase.

*Power Supply.* — S. Hardman, 24 Mill Drive, Henfield, Sussex — circuit of power supply to run

240V a.c. tape recorder from 12V car battery.

*Conversion of TV to Oscilloscope.* — M. J. Wayman, 1 Britwell Road, Sutton Coldfield, Warks. — purchase of information formerly available from Messrs Redmond of Portslade (now defunct). Also, details required of an e.h.t. supply for infra-red binoculars — battery powered circuit (transistor) producing 6.5kV at 1 $\mu$ A.

*Marconi Receiver Type AD882B.* — J. Pring, 89a High Street, Chard, Somerset — circuit, manual, modification details or any other information: loan or purchase.

*Hallicrafters Sky Champion.* — G.F. Whitwell, 90 Milverton Road, Erdington, Birmingham 23 — loan or purchase of manual or circuit of this receiver. Also for Canadian 58 Set Mk. 1. ■



# UNDERSTANDING TAPE RECORDING

by W. G. Morley

**This third article in our series on tape recording introduces the recording transfer characteristic and shows why bias must be applied, during recording, if gross distortion is to be avoided**

IN THE SECOND ARTICLE IN THIS series, published last month, we examined the record and playback amplifier response curves that are required to ensure that the overall frequency response, from record input to playback output, is maintained 'flat' over the frequency range to be recorded. Treble boost is needed in the record amplifier to overcome, mainly, the tendency of the magnetic coating on the tape to demagnetise as recording frequency increases. At the same time, bass boost is required in the playback amplifier to counterbalance the fact that the voltage induced in the playback head coil is proportional to the rate of change of magnetic field strength in its core, whereupon this voltage increases with increasing recorded frequency on the tape.

We now turn our attention to another aspect of the recording process, and shall deal in greater detail with the manner in which the

magnetic coating on the tape becomes magnetised by the record signal.

### B.H. CURVE

Up to now we have discussed the procedure of recording in very simple terms, referring only to the flow of signal current in the record head coil and the consequent creation of 'bar magnets' in the magnetic coating of the tape as it is drawn past that head. In practice, this process cannot, on its own, produce distortion-free recording on the tape, and a modification to the recording process is required if the distortion is to be eradicated. Before we can discuss this last point, however, it is first of all necessary to understand how the distortion is introduced, and this involves the examination, in sequence, of several items of simple magnetic theory. We shall now deal with the first of these.

Fig. 1 illustrates graphically what occurs when a typical magnetic material undergoes one or more cycles of changing magnetising force. The horizontal axis in Fig. 1 corresponds to the magnetising force (designated H) which is applied to the magnetic material whilst the vertical axis denotes the resultant magnetic flux density (B) which then appears in the material. The term 'flux density' defines, rather more precisely, what we have previously referred to as 'magnetic field strength,' and it applies to the number of 'lines of magnetic flux' per unit of cross-sectional area appearing in the magnetic material.

The magnetising force, H, may be conveniently provided by passing a current through a coil of wire which is wound around the magnetic material.

Let us commence initially by assuming that the magnetic material is not magnetised in any way, whereupon B is equal to zero, and that no magnetising force is applied. In consequence, the starting point for the graph is at the zero point, O, where the B and H axes cross each other. We now commence to apply a magnetising force, this increasing in the +H direction towards the right. The line from point O to point P then indicates the corresponding increase in flux density. It will be observed that increase in flux density is by no means directly proportional to increase in magnetising force. The flux density increases at a lower rate near point O and near point P than it does along the centre of the line OP, as is demonstrated by the changes of slope in the line. As may be seen, the central part of the line OP is reasonably linear. (i.e. is reasonably close to being a straight line) whereas the two ends are markedly curved.

After having taken our magnetising force, and the consequent flux density, up to the condition indicated by point P in the graph, we next reduce the magnetising force until it reaches zero again. The flux density does not now, however, similarly reduce to zero. Instead, it drops to the value, along the B axis, which is indicated by point Q. The reason why the flux density does not drop to zero is that some residual magnetism is left in the ma-

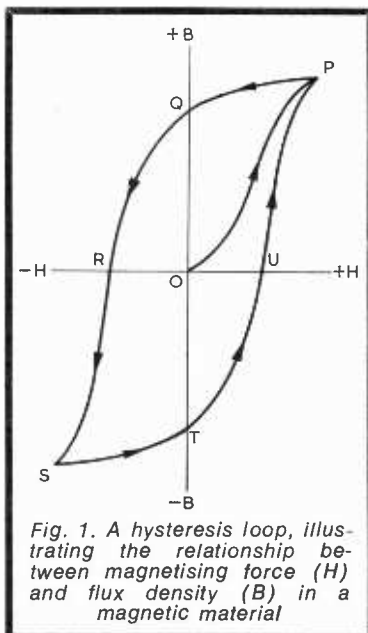

Fig. 1. A hysteresis loop, illustrating the relationship between magnetising force (H) and flux density (B) in a magnetic material

terial after the magnetising force has been removed. This retention of residual magnetism is, of course, a well-known phenomenon, and is encountered in such everyday occurrences as the magnetisation of screwdrivers and similar ferrous objects. The value of the residual magnetism, known also as the *remanence* of the magnetic material, is indicated by the height of Q above O. The process of magnetising a magnetic material by placing it in a magnetic field is described as *magnetic induction*, whereupon the residual magnetism retained by a magnetic material may, to introduce yet a third term, be referred to as the *remanent induction*.

To bring the flux density back to zero it is necessary to reverse H (i.e. to apply a magnetising force in the opposite direction) and to then increase it from zero until point R is reached. The length of the line OR then denotes the *coercive force*, or *coercivity*, of the magnetic material. If the magnetising force is further increased the curve eventually reaches point S. Here, the magnetising force is equal (but of opposite polarity) to that existing at point P as, similarly, is the flux density.

If we next reduce the magnetising force, taking it through zero and back to the right hand side again, the curve will trace out a line through T and U back to point P. The magnetic material has once again exhibited residual magnetism, as indicated at point T, and has also required a coercive force to bring the flux density back to zero at point U. After point U it proceeds to point P in the same way as it previously proceeded from point R to point S. OF is equal in length to OQ, and OU is equal in length to OR.

If we take the magnetic field through another cycle of magnetisation the resultant BH graph will once more trace out the curve through Q and R to S, and then back again through T and U to P. The initial curve from O to P only appears when the magnetic material is completely demagnetised at the onset.

The curve of Fig. 1 is known as the *hysteresis loop* for the magnetic material, the word 'hysteresis' applying to any condition where there is a lag, or delay, in an end-result subsequent to a change of force. The values of remanence and coercivity depend upon the properties of the magnetic material itself. Both will be lower in a 'soft' magnetic material than in a 'hard' magnetic material.

The curve of Fig. 1 applies to a static piece of magnetic material which is taken through the cycle of magnetisation. The situation which exists when the magnetising force is applied to the magnetic coating of

a length of tape drawn past the gap of a record head is somewhat different, particularly at low recording frequencies where the length of each half-cycle 'bar magnet' created in the tape is considerably greater than the width of the head gap. Assuming that the magnetic coating is initially demagnetised, each particle in the coating will then have applied to it the magnetising force corresponding to the level of signal current per-

netising force in the +H direction in Figs. 2(a), (b) and (c), and these should be examined with respect to the curve illustrated in Fig. 1. In Fig. 2(a) there is a strong magnetising force at the moment when the tape is at the record head gap, this causing the resultant flux density in the tape oxide to reach a level corresponding to point P. Point P here is the same as the similarly identified point in Fig. 1. After leaving the head no further magnetising force is applied to the tape, whereupon the flux density in its coating drops to the level Q, which is the same as point Q in Fig. 1. In Fig. 2(b) a lower magnetising force is applied at the moment when the tape passes the head and the flux density in the tape coating rises to the lower value, W. After leaving the tape we have a similar drop in flux density to the remanence value, this occurring at point X. Fig. 2(c) shows the effect for an even lower magnetising force, the flux density rising to Y, then dropping to the remanence value at Z.

Since, in Figs. 2(a), (b) and (c) we have only considered values of H which lie to the right of the zero point of the graph, these diagrams illustrate the situation which exists when the magnetising force is in one direction only. The BH curve for the tape will trace out a similarly shaped initial line for values of H to the left of the zero point as well, whereupon we can next draw a complete BH curve for the tape, during magnetisation, in the manner shown in Fig. 3(a). The curve to the left of the zero point is merely line OP of Fig. 1 redrawn for opposite polarities of B and H. Fig. 3(b) completes the picture, by adding drops to remanence value subsequent to the application of different values of H.

## TRANSFER CHARACTERISTIC

In Fig. 3(b) we saw the levels of remanence value, or remanent induction, existing in the tape coating for different levels of magnetising force at the record head when the tape was drawn past its gap. When the tape is later drawn over the gap of the playback head, the voltage induced in the coil of that head will be proportional to the levels of remanent induction appearing on the vertical B axis of Fig. 3(b).

We know that the magnetising force at the gap of the record head is proportional to the amplitude of the signal current flowing in the record head coil, so we may next examine the result of causing a sine wave current to flow in that coil. In Fig. 4(a) this sine wave is changed to a magnetising force having a similar waveform, and the latter is applied to the BH curve of Fig. 3(b). Vertical lines from several points on the magnetising force

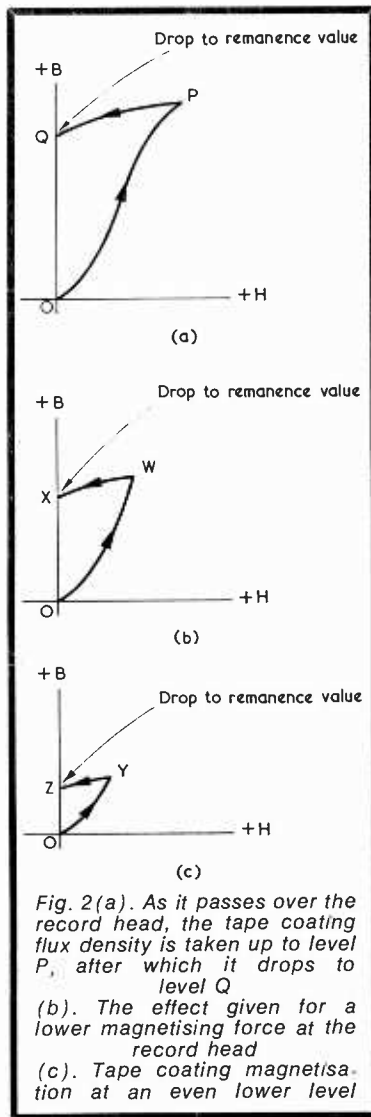
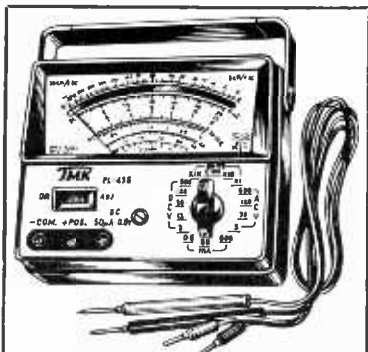

Fig. 2(a). As it passes over the record head, the tape coating flux density is taken up to level P, after which it drops to level Q  
(b). The effect given for a lower magnetising force at the record head  
(c). Tape coating magnetisation at an even lower level

taining as it passes the head. After this, since it is then physically removed from the head, no further external magnetising force is applied to it. The resultant BH curve for the coating will then follow the initial line OP of Fig. 1 during magnetisation, this being followed by a drop to the remanence value after removal from the head.

This set of circumstances is shown for several values of mag-



**SUPERB LARGE SCALE  
MULTIMETER  
AT A PRICE YOU CAN AFFORD**

★ 20,000Ω/volt ★ Mirror Scale  
★ Overload Protection ★ Free Batteries  
D.C. VOLTS: 0.6, 3, 12, 30, 120, 300  
A.C. VOLTS: 3, 30, 120, 600  
D.C. AMPS: 50μA, 600μA, 60mA, 600mA.  
RESISTANCE - 10k, 100k, 1meg, 10megs  
(half scale reading:  
60Ω, 600Ω, 6000Ω, 600kA)  
DECIBELS: -20 to +46 db.  
SIZE: 6" x 4½" x 2½"

**MONEY BACK IF NOT SATISFIED**

**ONLY £6.5.0** Plus 3/- p.p.

**IVORYET LTD. 31 Albert Road  
Hendon, London, N.W.4**

**NEW BOOKS**

(Editors & Engineers)

**RADIO HANDBOOK  
18th Edition**

by William I. Orr (April) 105/-

How To Use Integrated Circuit  
Logic Elements by J. W. Streater  
(March) 28/-

101 Questions & Answers About  
Hi-Fi & Stereo by Leo G. Sands  
& Fred Shunaman (March) 24/-

SWL & Antenna Construction Pro-  
ject by Edward M. Noll (June) 25/-

ABC's Voltage-Dependents &  
Resistors by Rufus P. Turner  
(June) 22/-

Workshop in Solid State  
by Harold E. Ennes (July) 65/-

Tape Recorder Servicing Guide  
by Robert G. Middleton (July) 35/-

ABC's of Thermistors  
by Rufus P. Turner (July) 22/-

**FOULSHAM-SAMS  
TECHNICAL BOOKS**  
(W. FOULSHAM & CO. LTD.)  
VEDEVIL RD., SLOUGH, BUCKS, ENGLAND

waveform are produced up to meet the BH curve after which drops to remanence are continued to the B axis. Finally, horizontal lines are drawn to the right to enable a waveform representing remanent induction in the tape to be constructed. This is a graphical method of determining, by drawing, the remanent induction resulting from the sine wave when it has been initially applied to the BH curve (which dictates the conditions of magnetisation at the gap of the record head) and after the subsequent drops to remanence value have been taken into consideration.

As will be noted, the waveform illustrating remanent induction in the tape is a considerably distorted

version of the original sine wave. There is a marked loss of amplitude near the zero line, this resulting from the low slope of the BH curve near the zero point. Over the sections corresponding to the more linear parts of the BH curve there is much less distortion but, at the extreme ends, there is further 'flattening' of the waveform peaks, this being due once more to reduction in slope of the BH curve.

Fig. 4(a) shows that the process of applying a sine wave signal current to the record head causes a highly distorted version of that sine wave to be created in the relative values of flux density retained in the tape after it has left the head. Our next main subject of discussion will be the examination of techniques intended to remove this distortion but it will be helpful if, before commencing on these, we spend a short time in developing the manner of illustrating the formation of the distortion, since this will simplify the presentation required in the appropriate diagrams.

It is obvious from Fig. 4(a) that the main cause of the distortion in the remanent induction waveform is non-linearity in the BH curve. At the same time, the individual drops to remanence value shown in the diagram appear, in all cases, to be proportional to the initial B values achieved during magnetisation, whereupon we may assume that these drops to remanence value do not themselves materially contribute to the distortion. In consequence, it would be reasonable, as a first step towards simplification, to omit the drops to remanence altogether and to just work in terms of the BH curve itself, as is done in Fig. 4(b). In Fig. 4(b) we draw our vertical lines up from the sine wave to the BH curve in the same manner as we did in Fig. 4(a). This time, however, we ignore drops to remanence value and simply continue the lines horizontally to construct the remanent induction waveform of Fig. 4(b) is a little larger (because of the omission of the drops to remanence) than is that of Fig. 4(a), but it exhibits exactly the same distortion. So far as investigation of distortion is concerned, the approach illustrated in Fig. 4(b) achieves the same end-result as does that of Fig. 4(a), and it is less complicated and easier to follow.

The process started in Fig. 4(b) is taken to its final conclusion in Fig. 4(c) where we have a curve which, whilst still being drawn on the B and H axes, is now referred to as the *transfer characteristic*. This curve takes into account both the non-linearity of our previous BH curve and the drops to remanence value and is, in fact, virtually the BH curve slightly reduced in height.

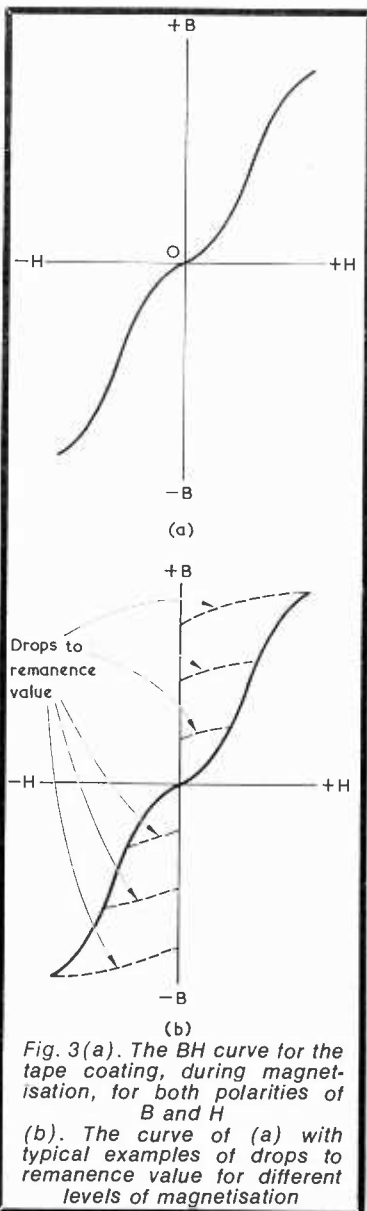
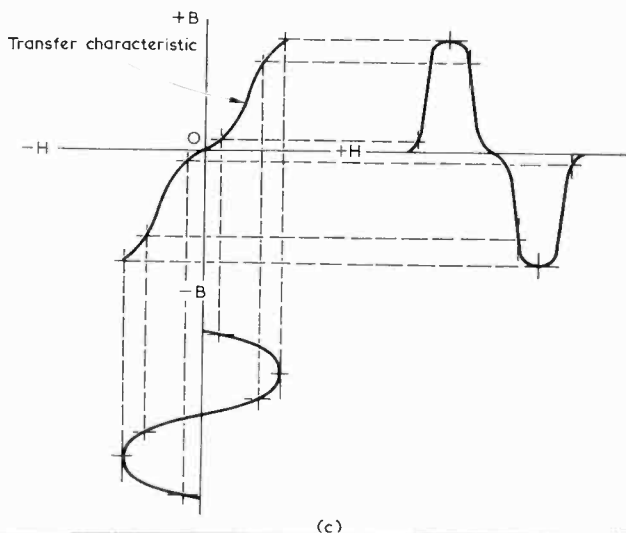
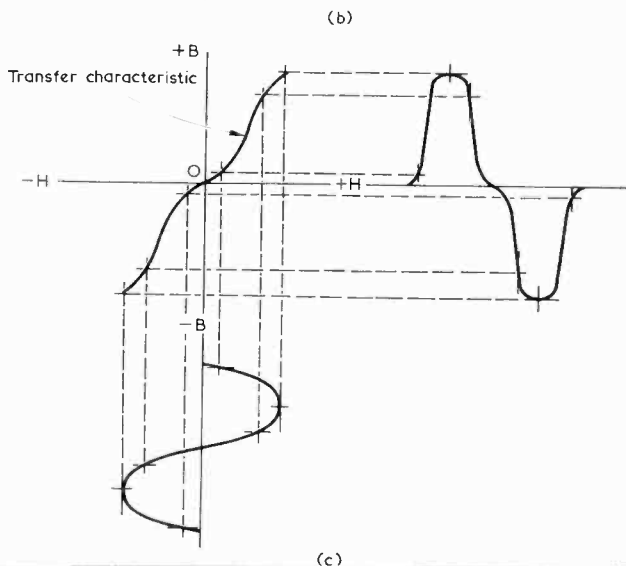
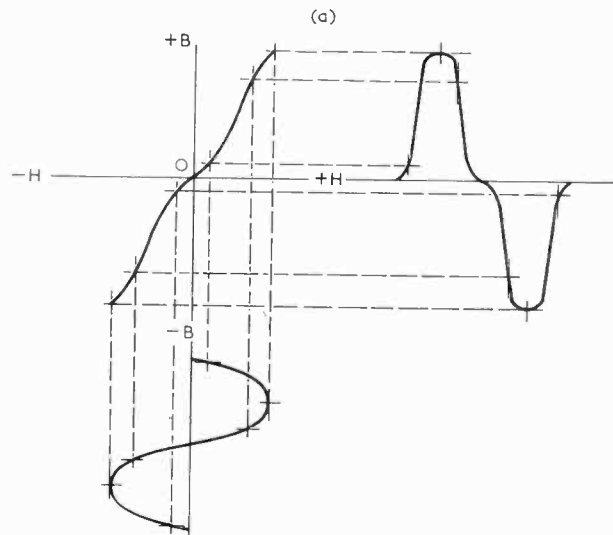
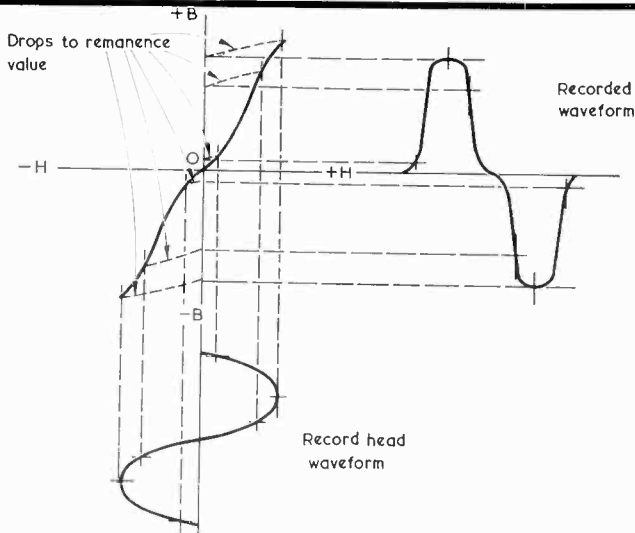

Fig. 3(a). The BH curve for the tape coating, during magnetisation, for both polarities of B and H

(b). The curve of (a) with typical examples of drops to remanence value for different levels of magnetisation





A sine wave applied along the H axis causes the production of exactly the same remanent induction waveform as was given in Fig. 4(a), and the transfer characteristic provides the true curve which links magnetising force to remanent induction on the tape.

### D.C. BIAS

An early solution to the problem of eradicating the distortion inherent in recording directly on to tape consisted of the application of *d.c. bias*. D.C. bias has been superseded for many years by a much more efficient means of overcoming recording distortion, but we shall consider it very briefly before concluding this month's article since it provides a good introduction to the method of bias employed in current-day recorders.

There are two basic methods of applying d.c. bias. The simplest, so far as explanation of the process is concerned, consists of allowing a direct current to flow in the record head in addition to the alternating signal current. The direct current has a value which causes the resultant magnetising force to be centred at the middle of the most linear section in either the upper or lower half of the transfer characteristic. Fig. 5 shows it applied to the most linear section of the upper half. The record signal current then causes the magnetising force to be varied on either side of this central position. As is to be expected, the waveform depicting remanent induction in the tape is a much less distorted version of the input sine wave than were the examples shown in Fig. 4. The main disadvantage with the scheme is that only a short section of the transfer characteristic has to be limited to a relatively low level if serious distortion is to be avoided. Also, there is liable to be a high noise level on a tape which is assumed to be in a demagnetised condition, with the result that the useful signal-to-noise ratio offered by the process is low.\*

The second method of d.c. bias consists of initially magnetising the

Fig. 4. Graphical methods of constructing the recorded waveform, produced by way of the BH curve, which result from a sine wave at the record head. In (a) drops to remanence value are taken into account. Since these drops do not materially contribute to the distortion in the recorded waveform, they are ignored in (b). The true transfer characteristic is illustrated in (c), this having the same shape as the BH curve but also taking into account drops to remanence value

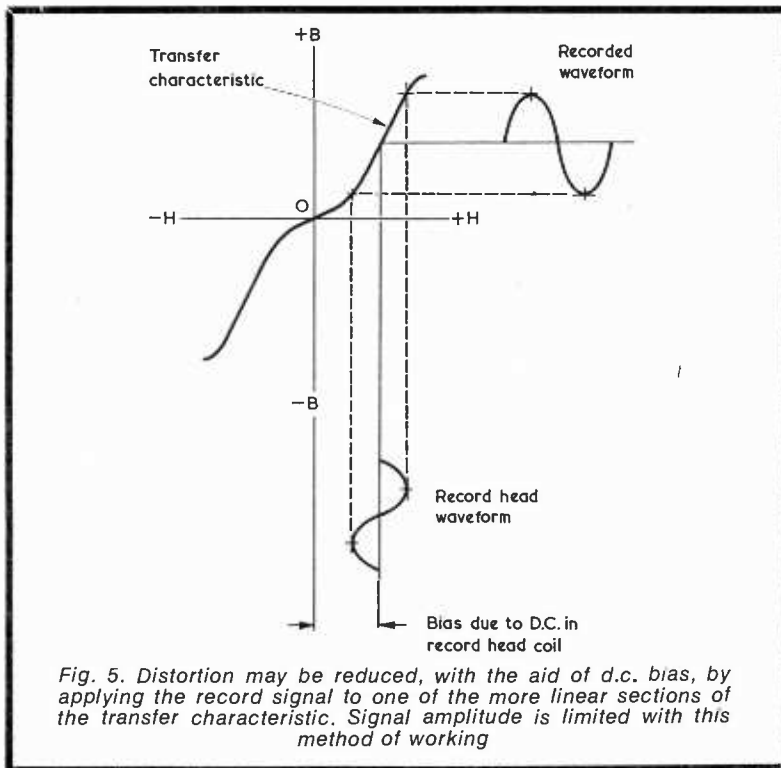

tape to a high level before it is drawn past the record head. This magnetisation can be carried out by passing the tape over one pole of a permanent magnet. The record head then has a d.c. bias which causes partial demagnetisation of the tape, the superimposed signal voltage controlling the level of demagnetisation which takes place. This method of working does not involve the transfer characteristic shown in Figs. 4(c) and 5. Instead it may be assumed that the tape, when it reaches the record head, is initially at point Q of the BH curve of Fig. 1, whereupon the demagnetisation process draws the value of B down along the curve Q, R and S in that diagram. After leaving the record head the flux then takes up a value

of remanence, this last process not seriously adding to the degree of distortion. If Fig. 1 is examined it will be noted that the line Q, R and S includes a near-linear section which is significantly longer than the near-linear section of the initial line OP (which is, of course, effectively repeated in the transfer characteristic of Figs. 4(c) and 5) with the result that it becomes possible to record at higher amplitude than occurs when using d.c. bias with demagnetised tape. However, practical performance still tends to be poor by modern standards, and signal-to-noise ratio is at a relatively low value.

Neither of these two methods of operation are employed in present-day tape recorders intended for speech and music since it is possible to obtain a much better performance with the aid of an entirely different method of biasing. We shall discuss this alternative method of applying bias in next month's issue. ■

\*It would be possible to demagnetise the tape efficiently with the aid of an erase head and erase oscillator, as are provided in conventional present-day recorders, but (as we shall be able to understand from later articles) there would then be no point in retaining the relatively inefficient d.c. method of bias at the record head.

## MULLARD POCKET DATA BOOK 1970

Mullard Ltd. recently announced the publication of the 1970 edition of their Pocket Data Book. For easy reference different coloured paper is used for each of the main product sections. All sections cover data and the type nomenclature system. Equivalents and earlier types are listed in the valve section, replacement details are given in the tube section and information on comparables is shown in the semiconductor section. The book is again being made available, through radio and TV dealers and bookshops, to electronics enthusiasts outside the trade. The recommended retail price is 4s. 0d. a copy.



"ISN'T THERE," COMPLAINED Dick, "anything we can do?" "No," replied Smithy cheerfully, "so far as I can see, there isn't."

The Serviceman settled himself more comfortably on his stool and gazed benignly about him. It was one of those quiet July afternoons where the external environment exactly matches the physiological requirements of mankind. His head nodded.

"Can't you," persisted Dick, "think of something we can do?"

The Serviceman yawned, and made no reply.

"I know," said Dick suddenly. "I'll get the cards out. We'll have a few hands at pontoon."

### A-TO-Z GAME

Smithy came abruptly to a state of full wakefulness.

"Not," he responded quickly, "with those cards of yours we won't. Half of them come from other packs and you've memorised all the backs."

The Serviceman frowned as bitter memories of past games of pontoon welled up in his mind. Suddenly, his forehead cleared.

"I know what we'll do," he said brightly. "Since it looks as though I'll never get any peace unless I join you in passing away the last half-hour of lunch-break, let's play the A-to-Z game."

"The A-to-Z game?"

"That's right," confirmed Smithy. "We ask each other questions about things in electronics working through the alphabet from A to Z. It's been more than a year since we played it last, and I enjoyed it then."

"Oh yes, I remember now," said Dick. "I enjoyed the game, too. All right, Smithy, you start it off then and ask me about something in electronics beginning with A."

"Righty-ho," replied Smithy obligingly. "Let's think now! Ah yes, here's an easy one for starters. What's 'aspect ratio' in television?"

"It's the ratio," replied Dick promptly, "between the width of the TV picture and its height. In British TV the aspect ratio is 4 to 3. Now it's my turn, so let's think about something beginning with B. What's 'barrel distortion'?"

"That's a simple one, too," said Smithy. "It's distortion of the shape of a TV picture due to shortcomings in the design of the deflector coils or to an actual fault in them. With barrel distortion the centres of the picture edges bulge outwards. (Fig. 1(a)). Barrel distortion is virtually the opposite to pincushion distortion, where the picture edges take up a shape like a pincushion." (Fig. 1(b)).

"I seem to recall," said Dick thoughtfully, "that there are other types of TV picture-shape distortion as well."

"There are," confirmed Smithy. "The two major remaining ones are parallelogram and trapezium distortion. (Figs. 1(c) and (d)). Well, that seems to have cleared up letter B, so let's get on to C. What's cathode poisoning?"

"Come again?"

"Cathode poisoning," repeated Smithy.

"Gosh, I don't know," said Dick. "That's a new one on me."

"It's an effect you get in valves," explained Smithy. "What happens is that any odd traces of gas which are left in the glass envelope tend to combine with the surface of the cathode and reduce its ability to emit electrons."

"Does it cause much trouble in practice?"

"It *can* do," replied Smithy. "The poisoning is most likely to occur if the valve cathode is kept at emitting temperature for very long periods without any cathode current being drawn inside the valve. A typical instance occurs in circuits where a valve's h.t. supply is only applied occasionally, as could occur say with the b.f.o. in a short-wave superhet. As you know, the normal practice here is to switch a b.f.o. valve off by breaking the h.t. supply. (Fig. 2(a)). This is a perfectly good practice provided that there's no possibility of the set being operated with the b.f.o. switched off for exceptionally long periods of time, because there's then a slight risk of cathode poisoning taking place inside the valve. If there's any possibility of such poisoning occurring, the anode of the valve should be coupled to the h.t. positive supply via a resistor of about  $1M\Omega$  or so

## In this month's episode we find Dick and Smithy with half-an-hour to fill before the end of lunch-break. They use the time to advantage, however, by returning to the popular game in which they go through the whole field of electronics from A to Z

when it's switched off, to ensure that its cathode continues to emit a small quantity of electrons towards the anode. This will remove the risk of cathode poisoning. The resistor can simply be wired across the on-off switch in the h.t. feed circuit, and its high value should still ensure that the b.f.o. stops oscillating when the switch is open." (Fig. 2(b)).

"I can't say," remarked Dick critically, "that I've ever experienced any trouble with cathode poisoning myself."

"Don't you be too sure," chuckled Smithy. "It appears, sometimes, in a mild form in TV sync separator pentodes. These valves are normally cut off and just pass a little pulse of current during transmitted sync pulses. You'll sometimes find that a sync separator pentode stops working or becomes intermittent, where-upon a frequent occurrence is that people swap it over with another valve of the same type in the same set. The faulty pentode works perfectly well in its new circuit position

as also, as a sync separator, does the one it replaces!"

"Well, I've certainly bumped into mysterious faults like that," admitted Dick. "If, though, the cathode poisoning has made the pentode no good as a sync separator, why does it work all right in a different application?"

"That's because," explained Smithy, "it's called upon to pass a very much larger anode and screen-grid current than occurred when it functioned as a sync separator. Cases of mild cathode poisoning seem to clear up on their own quite quickly if the valve is made to pass a reasonably high cathode current to the anode. Or, of course, to the anode and screen-grid if it's a pentode. Returning to the example of the sync separator pentode, it frequently happens that, after an hour or two of operation in a new circuit position, the valve will be perfectly ready to resume duties as a sync separator once more."

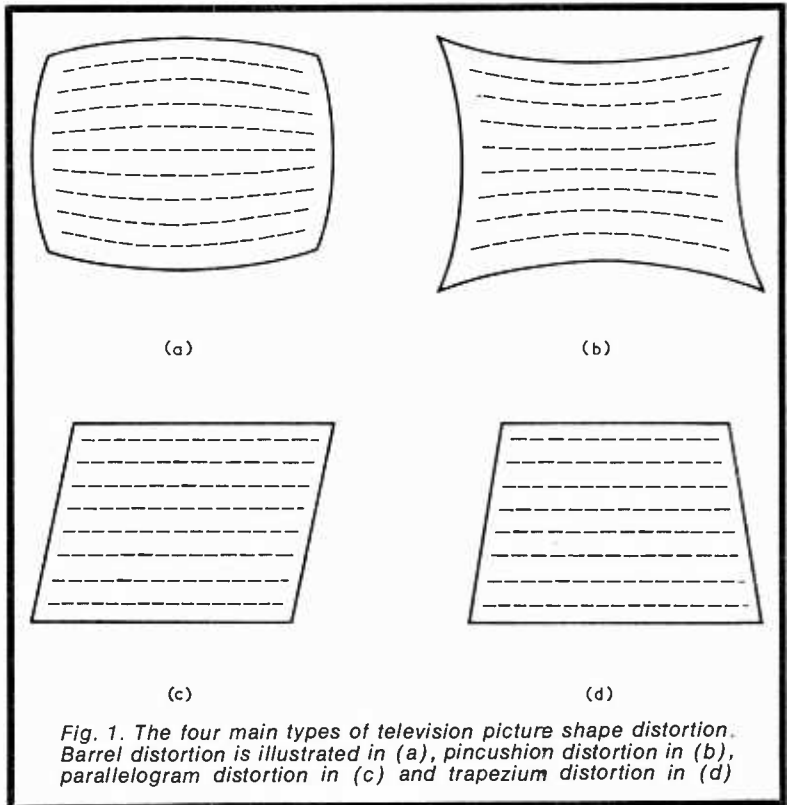

Fig. 1. The four main types of television picture shape distortion. Barrel distortion is illustrated in (a), pincushion distortion in (b), parallelogram distortion in (c) and trapezium distortion in (d)

## Your Local Supplier

LONDON

Established 1910

### H. L. SMITH & CO. LTD.

Comprehensive stocks of  
components by  
all leading makers.

287-9 EDGWARE ROAD  
LONDON W.2  
Tel: 01-723 5891

### THE MODERN BOOK CO.

Largest selection of English &  
American radio and technical  
books in the country.

19-21 PRAED STREET,  
LONDON, W.2  
Tel: PADDington 4185/2926

### TAKE THE SLOG OUT OF SOLDERING

With this lightweight miniature solder  
iron fitted with high efficiency nickel  
plated bit, & powerful 15 watt element  
ANTEX model CN240 volts **29/11**  
Special low price. ACT NOW

#### TRANSISTORS

ACY22 1/9 OC45 1/9 ZTX300 1/9  
BC108 1/9 OC71 1/9 2N706 1/9  
BFY51 1/9 OC200 1/9 2N2926 1/9  
BFY52 1/9 OC202 1/9 2N3708 1/9

All the above types are available at 16  
for £1. Brand New. Individually tested.

**MONEY BACK GUARANTEE** p&p 1/-  
J. M. KING (W), 17 Buckridge,  
Portpool Lane, London, E.C.1

HAMPSHIRE

## BOURNEMOUTH

LARGEST HI-FI AND  
RADIO COMPONENT  
STORE IN THE SOUTH

### FORRESTERS NATIONAL RADIO SUPPLIES LTD.

70-72 Holdenhurst Road  
Bournemouth  
Telephone 25232

## DYNAMIC MICROPHONE

"That's something I must bear in mind for the future," remarked Dick pensively. "Anyhow let's get on to D. So far as this letter is concerned, the particular question I'm going to ask you is one that's been puzzling me quite a bit in any case. What's a 'dynamic microphone'?"

"It's another term," replied Smithy, "for a 'moving-coil microphone'. You encounter it mainly in American books and magazines. The Americans also refer to moving-coil loudspeakers as 'dynamic loudspeakers'. Funnily enough, there's another word beginning with D which is also frequently used in America instead of the term 'moving-coil'."

"What's that?"

"You find it in references to moving-coil meters," said Smithy. "The Americans often refer to these as 'D Arsonval meters'. That's got D finished, so let's get on to E. What's the new mains wiring colour code for Earth?"

"Green-and-yellow striped," replied Dick without hesitation. "Also, blue is Neutral and brown is Live."

"Very good," commended Smithy.

"Now, ask me about something beginning with F."

## FLUTTER AND WOW

"F, eh?" said Dick thoughtfully. "Just a minute. Ah yes, what's 'flutter'?"

"In hi-fi tape and gramophone reproducing equipment?"

"Yes."

"Flutter," said Smithy, "is the term used to describe fluctuations in frequency at the output of the equipment resulting from fluctuations in the speed of the recording medium. You can have flutter from

a gramophone record if, due to an imperfection in the mechanical drive to the turntable, it isn't turning at a constant speed. And you can get flutter from a tape if it isn't pulled past the replay head at a constant speed. There's another word for frequency fluctuation due to fluctuation in speed of the recording medium, this being 'wow'. 'Wow' covers fluctuations at low frequencies whilst 'flutter' covers fluctuation at higher frequencies."

"What's the frequency at which 'wow' changes over to 'flutter'?"

"That's rather a difficult question to answer," replied Smithy. "'Wow' refers to speed fluctuations which, in the reproduced signal, can be perceived as changes of pitch. On the other hand 'flutter' applies to speed fluctuations which occur too quickly to be recognisable, in the reproduced signal, as changes in pitch, although they are still recognisable as obvious imperfections in sound quality. It is usual to say that wow ceases to be recognisable as such above about 10Hz, whereupon fluctuations above this frequency can be referred to as 'flutter'. However, *measurements* for wow and flutter usually check for wow below 20Hz and for flutter above this figure."

"Blimey," said Dick, "that's a bit complicated, isn't it?"

"In practice the situation isn't too bad," replied Smithy. "Both wow and flutter are the results of imperfections in mechanical performance and a wow and flutter measuring instrument is capable of measuring both these qualities together and thereby indicating whether the mechanical performance of the reproducing system is acceptable or not. You'll find that wow and flutter are grouped together in the specifications for

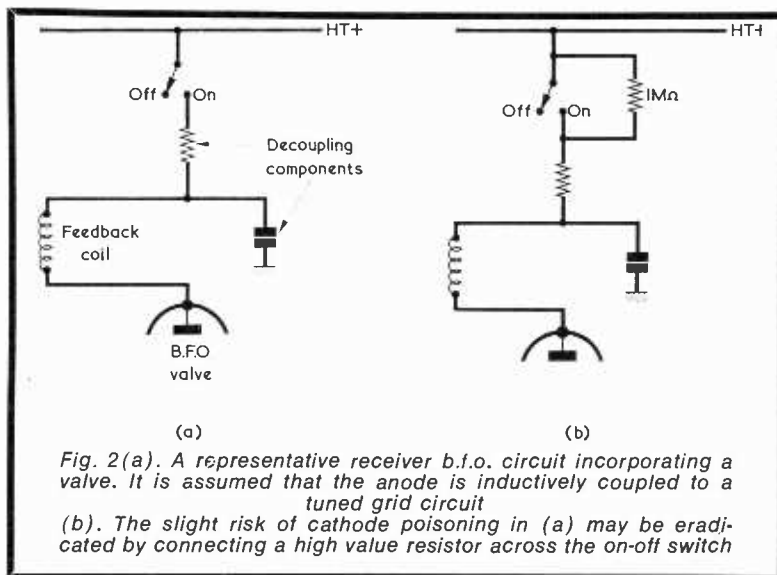

Fig. 2(a). A representative receiver b.f.o. circuit incorporating a valve. It is assumed that the anode is inductively coupled to a tuned grid circuit

(b). The slight risk of cathode poisoning in (a) may be eradicated by connecting a high value resistor across the on-off switch

most tape recorders and gramophone decks. The specification gives a total wow and flutter figure of so many per cent."

"Per cent?" queried Dick. "How can you get a percentage figure from something like wow and flutter?"

"The percentage figure for wow and flutter," replied Smithy, "is the r.m.s. value of the percentage deviation of the reproducing mechanism speed from its mean value."

"Let's," said Dick hastily, "carry on to G. I wish I'd never started this 'flutter' business now!"

"Since we've got going on the subject," pronounced Smithy sternly, "we'll see it through to its proper conclusion. To measure wow and flutter on a reproducing system you play a disc or tape on it which has been specially pre-recorded for the purpose with a constant tone, this tone being of the order of several kHz. The wow and flutter in the reproducing system will frequency-modulate this tone and you measure the level of the frequency modulation with a wow and flutter meter. This piece of equipment is, effec-

tively, a low frequency f.m. receiver. The audio output of the reproducing equipment is applied to a narrow band amplifier whose pass-band is centred on the frequency of the recorded tone, and this filters out any noise and harmonics that may be present. (Fig. 3(a)). The signal then goes to an amplitude limiter, just as you have in an f.m. receiver, and is finally passed to a discriminator circuit coupled to a meter."

Despite his previously expressed desire to proceed to the next letter, Dick's interest was aroused.

"What sort of discriminator circuit would you use?" he asked. "Would it be something like a phase or ratio detector?"

"The use of a phase or ratio detector is feasible, I suppose," said Smithy, "but the normal practice is to use a very sharply selective filter and apply the tone to one of the skirts of its response curve. A favourite for this class of work is the parallel-T resistance-capacitance filter. I'll draw out its circuit for you."

Smithy pulled his note-pad across

## Your Local Supplier

KENT

### EMSAC BASIC ANTENNA SYSTEMS

- CN1 2 metre converter, 190/- P&P 4/6.
- CN3 4 metre converter, 190/- P&P 4/6.
- PS1 Mains power supply for above. 70/- P&P 4/6.
- CN2 2 metre converter + PSU in case. 277/- P&P 6/6.
- CN4 4 metre converter + PSU in case. 277/- P&P 6/6.
- TU2 Tuning unit for matching any antenna to receiver. 1.8-30MHz. 90/- P&P 4/6.
- KM1 Morse practice oscillator/keying monitor, 160/- P&P 4/6.
- PR1 2 metre mosfet pre-amp. over 20db. gain. 95/- P&P 4/6.

**ELECTRONIC & MECHANICAL SUB-ASSEMBLY CO. LTD.**  
Highfield House, West Kingsdown, Kent  
Tel: West Kingsdown 2344

SURREY

### Portable Transistor Amplifier

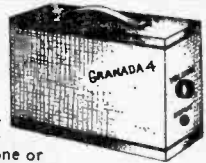

Many uses -  
Intercoms, Baby Alarms, Guitar Practice, Telephone or Record Player Amplifier. ONE WATT OUTPUT. Wooden cabinet 12x9x4". Rexine covered two-tone grey. Four transistors, 7x4" speaker. Volume control. Jack socket. Uses PP9 battery. Brand new - full makers' guarantee.

Worth double our price

**79/6**

Post Free

Full List 1/-

**Radio Component Specialists**  
337 Whitehorse Road, West Croydon, Surrey.  
Phone 01-684-1665

SUSSEX

## E. JEFFRIES

For your new television set,  
tape recorder, transistor radio,  
and hi-fi equipment.

PHILIPS, ULTRA, INVICTA,  
DANSETTE, MASTERADIO, PERDIO,  
MARCONI, PHILCO, FIDELITY

6A Albert Parade,  
Victoria Drive,  
EASTBOURNE SUSSEX

EIRE

## PEATS for PARTS

### ELECTRONIC COMPONENTS RADIO & TELEVISION

For the convenience of IRISH enthusiasts we supply:

The Radio Constructor,  
Data Books and  
Panel-Signs Transfers  
Also a postal service

**Wm. B. PEAT & Co. Ltd.**  
28 PARNELL STREET  
DUBLIN 1

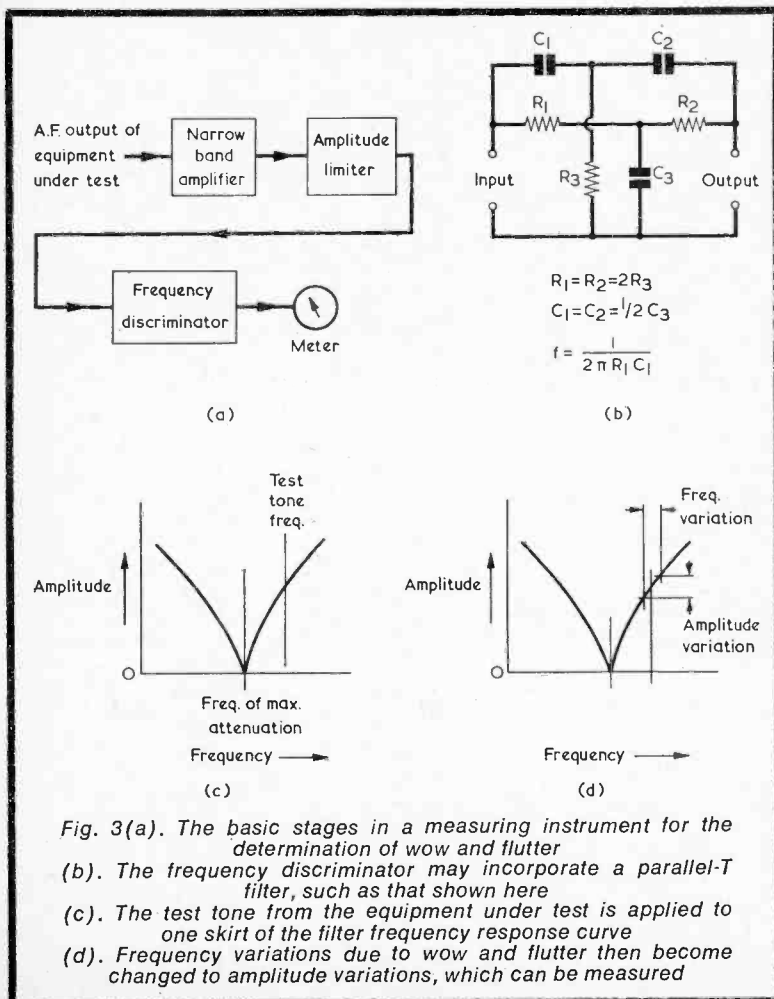

Fig. 3(a). The basic stages in a measuring instrument for the determination of wow and flutter  
 (b). The frequency discriminator may incorporate a parallel-T filter, such as that shown here  
 (c). The test tone from the equipment under test is applied to one skirt of the filter frequency response curve  
 (d). Frequency variations due to wow and flutter then become changed to amplitude variations, which can be measured

his bench and scribbled out the circuit of the parallel-T filter. (Fig. 3(b)).

"With a parallel-T filter like this," he went on, "the general idea is to have R1 equal to R2, and to have R3 equal to half of R1 or R2. At the same time, C1 should be equal to C2, and C3 should be twice the value of C1 or C2. If the output terminals are connected to a high impedance, which should theoretically be infinitely high, the filter has the remarkable property of giving infinite attenuation to the frequency which is equal to

$$\frac{1}{2\pi RC}$$

where R and C are equal to R1 and C1 respectively. Frequency here is in Hz, and resistance and capacitance in ohms and farads, or megohms and microfarads."

"Infinite attenuation? Blimey, that's something, isn't it?"

"It is rather impressive," agreed Smithy. "The parallel-T filter has a response curve with sharply sloping skirts, just like you get with a high-Q tuned circuit (Fig. 3(c)). What happens in the measurement of wow and flutter is that the filter is set up to offer infinite attenuation at a frequency slightly removed from that of the tone from the reproducing equipment. Since the tone is then applied to one of the skirts of the response curve, any frequency modulation on the tone is changed to amplitude variation. (Fig. 3(d)). If you measure the r.m.s. value of that amplitude variation, you've then got a direct indication of wow and flutter."

"Phew," said Dick. "It sounds as tough a wow and flutter measuring instrument is rather a complicated bit of gear. Not the sort of thing we'd have in the Workshop."

"It isn't," chuckled Smithy. "We don't aspire to measurements of that sort here. However, from the servicing point of view, it isn't too difficult to detect wow, at any event, with the aid of a simple listening test. The best thing to do here is to listen out for the wow whilst playing a special test tape or disc with a steady tone recorded on it. Unless you've got cloth ears, you can soon detect any variations in reproduced pitch that are caused by wow. If you haven't got a suitable test tape or disc, the next best thing to use is a piano recording. The sustained note given by a piano string after it has been struck is free from vibrato, and soon shows up any wow in the reproducing system."

Dick frowned.

"Hang on a minute," he said. "I'm getting a wee bit out of my depth here. Doesn't 'vibrato' refer to changes in amplitude rather than to changes in frequency?"

"That's a common error," replied Smithy, "and one which, I'm afraid,

has been partly created by electronic types who make up amplitude-varying devices for electric guitars and things like that, and then call them 'vibrato units'. It's 'tremolo' which is the correct musical term for variation in amplitude. 'Vibrato' is the correct musical term for variation in pitch, or frequency."

## GREAT CIRCLE

Smithy stopped for a moment.

"What," he resumed, "do I mean by 'great circle'?"

"Great circle?" repeated Dick confusedly. "Is that another musical term?"

"I've finished with all that wow and flutter business now," said Smithy. "I'm proceeding to the next letter, which happens to be G."

"Okey-doke," said Dick, collecting his thoughts. "So far as I remember, 'great circle' has something to do with radio communication."

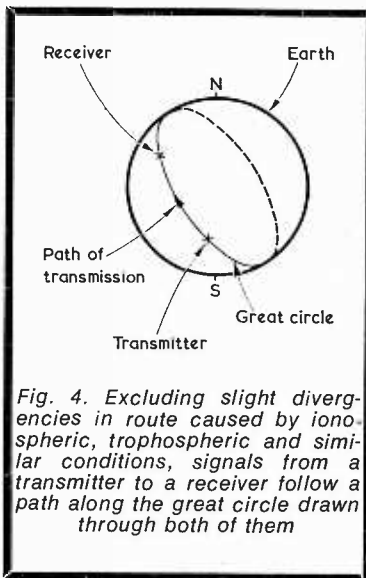

Fig. 4. Excluding slight divergencies in route caused by ionospheric, tropospheric and similar conditions, signals from a transmitter to a receiver follow a path along the great circle drawn through both of them

"That's pretty well correct," said Smithy. "A great circle is any circle drawn around the surface of the earth whose centre is at the centre of the earth. Radio waves from a transmitter to a receiver tend to travel along a great circle route." (Fig. 4).

"Do they?" quired Dick. "I'd have thought they'd have followed the shortest distance between them."

"The shortest distance is on the great circle, you nit," snorted Smithy. "In fact, the shortest distance between any two points on a sphere must lie on a great circle. If you take a sphere and pull a piece of string tightly between any two points on its surface, that string will form an arc of a circle whose centre will be the centre of the sphere."

"Oh yes. I see it now," replied Dick brightly. "It's obvious when

you think about it! Oh well, let's get on to H. What's 'high voltage'?"

"That's a darned silly question. I must say," commented Smithy irritably. "A high voltage is obviously a voltage that's high. What in heck else could it be?"

"It's got a special meaning so far as American TV is concerned," replied Dick. "I saw it referred to once in an American magazine."

"Oh, I see what you're driving at now," said Smithy, mollified. "In that case 'high voltage' is the American term for what we call e.h.t. voltage. It's funny, incidentally, that we should encounter two differences between English and American terminology in just one of these sessions. Anyhow, it's my turn next, with I. What's 'ion burn'?"

"It's a sort of a brown mark."

"True," said Smithy, pleased, "and where does it appear?"

"You'll find it on things like trousers if the smoothing iron is left on them too long!"

Smithy glowered furiously at his assistant.

"So help me," he fumed, "I'll swing for you one of these days."

"You can't," replied Dick cheekily. "They've stopped hanging."

"All the more reason," returned Smithy darkly. "for you to take care, mate."

"Sorry, Smithy," said Dick hastily. "What I should have said was that 'ion burn' was the mark that used to appear at the centres of the screens in early TV cathode ray tubes. The cathode of a c.r.t. emits a few ions as well as electrons. The ions are much heavier than electrons and, in those old tubes, used to go straight out from the cathode and bash away at the centre of the screen with the result that, after a time, the fluorescent material suffered damage and became discoloured. This discolouration was referred to as 'ion burn'."

"That's a bit more like it," grunted Smithy. "Just to complete the story, I might add that the trouble was overcome initially by employing ion trap gun assemblies and, later by using metal-backed fluorescent screens."

"J is next," put in Dick, "and it's my push. "What's a 'jack'?"

"It's a socket which accepts a jack plug," replied Smithy. "Incidentally, it's surprising how many people still refer to the plug, instead of the socket, as the 'jack'. K follows J, so I'll choose 'Kelvin'. What's the Kelvin scale of temperature?"

"Is that the same as 'absolute temperature'?"

"It is."

"Then it's the scale of temperature where absolute zero is minus 273 degrees Centigrade. And you can't get any colder than that!"

"That's correct," commended



Smithy. "And, of course, the units in the Kelvin Scale are the same as those used in the Centigrade scale."

"What puzzles me sometimes," stated Dick, "is that I occasionally see references to what seem to be Centigrade readings, but the degrees are called degrees Celsius."

"Degrees Centigrade and degrees Celsius are, for all normal practical purposes, both the same thing," explained Smithy. "Celsius was the geysier who invented the Centigrade scale. He did it in the early eighteenth century, if I remember correctly."

"That," remarked Dick, "would be a bit before my time. What's the next letter?"

"L, and it's your turn."

"L, eh?"

There was silence for several moments as Dick concentrated.

"Hurry it up a bit," remarked Smithy irritably. "Can't you think of *anything* beginning with L?"

"The only thing that comes to my mind," replied Dick, frowning, "is much too simple. You're bound to know the answer."

"Try it, anyhow."

"All right then," said Dick. "Tell me, Smithy, what is the function of 'lovers'?"

"Is this a gag or something?"

"I'm dead serious," protested Dick. "What's the function of 'lovers'?"

"I daren't trust myself to answer you," replied the bewildered Serviceman. "You tell me."

"They're meant," explained Dick, "to keep things cool."

"To keep things cool?"

"That's right," said Dick triumphantly. "Blimey, Smithy, I never thought I'd be able to beat you with a simple question like this

one. 'Lovers' are those slit things which are put in the sides of equipment cabinets to allow the hot air inside to get out."

"You steaming great hairy twit," exploded Smithy. "The word is *louvres*! You don't pronounce it 'lovers', you pronounce it so that it rhymes with 'manoeuvres'. Ye gods. I must have heard everything, now!"

"All right then," returned Dick sulkily. "You ask me something beginning with M."

"Metrosil."

"A *Metrosil*," announced Dick, "is a trade name for a semiconductor device whose resistance falls as the voltage across it increases."

"Very good," approved Smithy.

"At any event you seem to have learned *something* useful during your four years here. Dear, oh dear, 'lovers'!"

"Don't keep on about it," said Dick irately. "What's the word 'Noval' mean?"

"It's applied to a 9-pin valve base," responded Smithy. "And it's the same as 'B9A'. Now, O follows N, so I'll give you an easy one, too. What do I mean by 'overshoot'?"

"You get overshoot in a waveform," replied Dick promptly. "when a quick change initially carries on a little farther than it ought to do. Here, let me show you."

Dick pulled Smithy's pad towards him and sketched out a waveform. (Fig 5(a)).

"That's what I mean," he remarked. "There's overshoot on each of those square waves when the signal changes from negative to positive."

"Excellent," replied Smithy. "It's your turn next, with P."

"Fair enough," said Dick. "Then what's a primary battery?"

"It's a battery," responded Smithy, "which produces electricity by virtue of chemical action, and which is normally considered to be incapable of being recharged in the sense that an accumulator can be recharged. An accumulator, incidentally, is an example of a *secondary* battery."

### QUENCH FREQUENCY

Smithy glanced up at the Workshop clock.

"We'd better get a move on," he said hurriedly. "Lunch-break is almost over, so we'll have to finish the rest of the alphabet pretty smartish. It's me to go next with Q, so what's 'quench frequency'?"

"It's something," replied Dick, "to do with super-regenerative receivers, isn't it?"

"It is," confirmed Smithy, "although it has a more general application as well. 'Quench frequency' is the frequency at which an oscillator is made to go in and out of oscillation. With a super-regenera-

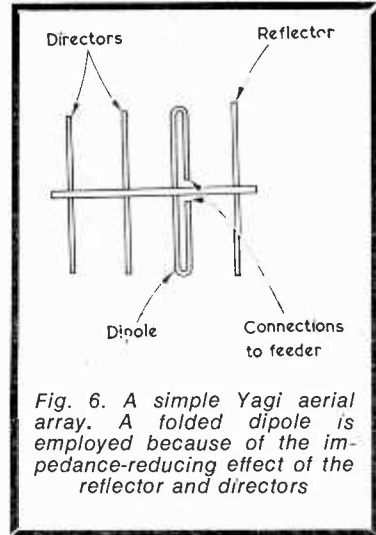

Fig. 6. A simple Yagi aerial array. A folded dipole is employed because of the impedance-reducing effect of the reflector and directors

tive receiver the quench frequency will be applied to the detector, causing that to go in and out of oscillation."

"I *thought* it was something like that," said Dick. "Well, I've got a dead easy one for R. Tell me about 'reactance'."

"Reactance," replied Smithy, "is the impedance offered by pure capacitance or pure inductance. The important thing about reactance is that it only exists when voltage and current in an a.c. circuit are exactly 90 degrees out of phase. This is different from 'impedance', where the phase difference can be any angle. What's 'singing point'?"

"Don't ask me," grinned Dick. "I've never even heard of it!"

"It is a rather unfamiliar term, I suppose," conceded Smithy. "It applies to a circuit incorporating amplification and having positive feedback from output to input, and refers to the condition where there is just sufficient gain for the circuit to start oscillating."

"I'll take your word for it," chuckled Dick. "Now, I've got a word here beginning with T that's puzzled me a bit in the past: 'tandem'. What do you mean when two circuits are in tandem?"

"They're in tandem," said Smithy, "when the output of one couples into the input of the second. Okay, U follows T, so what's 'undershoot'?"

"It's the opposite to 'overshoot'," replied Dick, taking up his pen and sketching out the appropriate waveform. "You get a little 'pip' in the reverse direction before the main changeover."

"Fine," replied Smithy. "You're next, now, with V."

"Right," said Dick briskly. "Here's another one that I'd like a bit of advice on. What's a 'VU meter'?"

"It's a volume indicator," said Smithy. "The letters V and U stand

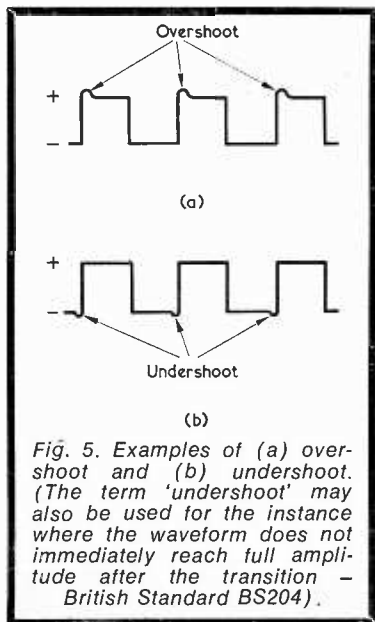

Fig. 5. Examples of (a) overshoot and (b) undershoot. (The term 'undershoot' may also be used for the instance where the waveform does not immediately reach full amplitude after the transition - British Standard BS204).

for volume units and the VU meter is used in broadcasting studios and places like that. It consists essentially of a moving-coil meter following a rectifier and it has a special kind of movement which enables its needle to respond to a sudden strong signal very quickly. In consequence, it gives an indication of the average sound power level being handled over a short period. Well now, let's press on. What's the letter X stand for?"

"It stands for reactance. Back to me again! What's a Yagi aerial?"

"Yagi aerials can best be explained by referring to the aerials that are used for TV reception in Band III and u.h.f.," said Smithy. "As you know, the usual type of aerial employed here has a dipole, to which the feeder is connected, together with a reflector behind it and one or more directors in front of it. (Fig. 6). If the aerial has a reflector and two or more directors then it can be considered as entering the Yagi category. And that's it!"

## Z LEFT

"No it isn't," protested Dick. "There's still Z to come."

Smithy rose and indicated the Workshop clock, the hands of which showed that lunch-break had ended at least ten minutes earlier.

"So far as I'm concerned," remarked Smithy, "Z stands for 'zero-hour', and we've passed that already! But if you want to complete the alphabet in terms of electronics then you can tell me what the letter Z stands for."

"It stands," replied Dick, reluctantly returning to his bench, "for impudence, of course. Oh well, back to the grind!"

Dick reached out to switch on his soldering iron, then suddenly froze into immobility. Smithy recognised the symptoms and watched with interest. His assistant had the ability on occasion to compose instant doggerel and the Serviceman wondered what would be the result of this latest visitation by Dick's Muse.

"Just a minute, Smithy, listen to this!" he called out. "I reckon it just about finishes off this session of ours today."

Dick struck a dramatic pose then gave voice.

*"Electronics from A through to Z Shows what knowledge you've got in your head.*

*If it's all too complex*

*By the time you reach X*

*Then give up and try wood-work instead!"*

And even the shuddering Smithy had to admit, privately, that this latest offering on the part of his assistant did at least possess the virtue of having obvious rhymes. ■

## LIQUID CRYSTAL DISPLAYS

The first reported multi-coloured displays using a material called 'liquid crystal' have been produced by The Marconi Company Ltd., and the development work involved promises new types of electronically controlled information displays and optical devices at low cost. 'Liquid crystal' refers to a class of liquids having a regular crystal-like structure, and which are capable of changing their appearance when a voltage is applied. They might one

The liquids employed in 'liquid crystal' displays have a type of crystal structure, in which all molecules 'point' the same way, known as a 'nematic' structure. When a voltage is applied across the liquid, ions move through it and disrupt the nematic structure, causing a change from transparent to white. When the voltage is removed, the liquid becomes transparent again as the nematic structure restores.



day be used in television screens thin enough to hang on a wall, but immediate practical uses are in data readouts for control panels, animated labelling for keyboard buttons, and see-through displays which pilots can read without losing sight of the view ahead. The panels cost little to make, and are clearly visible both in poor light and brilliant sunlight. Voltage and power requirements are low, and are compatible with standard logic circuits.

A see-through display panel is made by sandwiching a layer of 'liquid crystal', only a thousandth of an inch thick, between two sheets of conductive glass across which the voltage is applied. The information is held in the form of invisible conductive patterns in the glass.

The accompanying illustration clearly demonstrates, by means of a double exposure photograph, the two states of a 'liquid crystal' display.

## MOTOROLA SEMICONDUCTOR DATA BOOK

Motorola have just announced the availability in the U.K. of the fourth edition of *The Semiconductor Data Book*. The price is £3 (plus 6s. postage) and it is available through the Modern Book Co., 19 Praed Street, London, W.2.

This latest edition has been enlarged (it now includes 2,160 pages) and the format has been redesigned to make it easier to retrieve data. Instead of a number of product categories, discrete device specifications are presented in alphanumeric sequence in three major sections, namely: '1N' devices, '2N' and '3N' numbered devices, and devices with Motorola house numbers. Also included is a 50-page section of selection guides which enable application needs to be directly related to semiconductor device numbers. Furthermore, the Data Book lists all EIA registered 1N, 2N and 3N devices, along with their short form specifications.

In all, more than 12,700 types are listed together with details of their characteristics. Since this book gives data on a significant proportion of the world's semiconductors, it is an essential reference for all electronic design and development laboratories.

## LATE NEWS

### ★ AMATEUR BANDS

#### ● FRENCH ANTARCTIC

FB8YY has been logged on several occasions recently using c.w. in the 21MHz band. QTH given as Terre Adelie and the QSL address as via F9MS.

#### ● REPUBLIC OF CONGO

Using the s.s.b. mode on 14MHz, 9Q5CO has been heard giving his QTH as POB 99, Isiro.

#### ● VATICAN CITY

Quite active of late on 14MHz s.s.b. has been HV3SJ using 14151 and also 14280.

#### ● SAUDI ARABIA

HZ3TYQ has been active of late using s.s.b. on 14220 around 2100.

#### ● AUSTRIA

A surprise visitor to Top Band recently was OE1WO/3 down at the c.w. end working strings of G's. Other Top Band visitants have been DJ3IY and GD3HQR, both using the c.w. mode.

#### ● BALEARIC ISLANDS

Slinging out a good signal recently has been EA6BC, heard around 1930 using s.s.b. on 14145 and 14220.

#### ● EAST PAKISTAN

Heard on 14030 c.w. close to midnight, AP5CP putting in a good signal - with the wolf pack in full cry after him!

### WORLD DX CLUB CONVENTION

The World DX Club is holding its second annual conference over the weekend July 3rd to 5th at the Adelphi Hotel, Micklegate, Yorks.

The Conference commences at 1830BST on July 3rd with a dinner and other features of the gathering will include a guided tour of University Radio York, talks and demonstrations on such topics of interest to members as TV Dx'ing, medium wave and short wave Dx'ing and taped messages from members unable to be present.

A popular feature of the last Convention, held at Neath, was a quiz, with prizes to the winners. This year, the quiz will consist of identifying various stations operating on the 60 metre short wave band and the medium waves from taped excerpts. A bound volume of this magazine will be one of the prizes.

The Conference is being organised this year by Gerry Wood - a well known Dx'er.

An amateur radio station with the specially allocated call sign GB2WDX will operate from the Conference hotel during the period of the event. Special QSL cards have been printed and all SWL reports will be answered. ■

JULY 1970

### ★ BROADCAST BANDS

#### ● BELGIUM

The schedule of ORU Brussels is now from 1000 to 1200 on 15265, 17780, 17860 and 21590, with an English language programme during the last 10 minutes of each transmission. From 2215 to 2315 and from 2330 to 0100 Brussels can be heard on 15335 and 17715. Also on 6010 and 6125 for European listeners.

#### ● ECUADOR

The morning broadcasts to Europe from HCJB "Voice of the Andes" are now on 6130 in parallel with 9570. The evening transmission to Europe begins at 1800 on 21460.

HCDE4 Radio Vision de Manta, Manta (5kW) on 6140 is now beaming programmes to Europe and occasionally there are announcements in English. Schedule is from 1000 to 0500.

#### ● SEYCHELLES

The FEBA transmitter at Victoria (30/40kW) now has a regular programme schedule from 0100 to 0245 (0330 on Sundays) on 15185. The English programme on Sundays is at 0300 till 0330. FEBA is also on 15265 from 1300 to 1530 with English transmission from 1400 to 1430. Reports are required and should be sent to FEBA, Box 234, Victoria.

#### ● GREECE

The new schedule of Athens, current till 5th September, is as follows: 0700 to 0815, 1030 to 1300, 1330 to 1515, 1630 to 1700 and 1830 to 1900 on 7295 and 9605. At 0900 to 1000 (except Mondays) on 9605 and 11720. Also from 1730 to 2330 on 11720 and 15345.

*Acknowledgements to our own Listening Post and SCDX.* ■

## LAST LOOK ROUND

### MOBILE RALLIES

#### 19th July - Scarborough ARC

At Burnston Road Barracks. Talk-in stations 10am to 2pm, G4BP/A (160 metres); G3HFW (80 metres) and G3NRS (2 metres). Official opening 2pm.

#### 26th July - Pudsey & District RC

White Rose Mobile Rally, Allerton High School, King Lane, Leeds 17.

#### 26th July - Saltash & District RC

At Saltash School, Wearde Hill, Saltash. Talk-in stations GB3SAL (160 and 2 metres).

#### 2nd August - Bristol RSGB Group

Mobile Picnic at Ashton Park, Bristol.

#### 16th August - Derby & District ARC

At Rykneld School, Bedford Street, Derby. Talk-in stations from 10am to 3 pm, G3ERD/A (160 metres), G2DJ/A (4 metres) and G8DBY/A (2 metres).

#### 16th August - Torbay ARS

At Newton Abot Rugby Ground on main Newton Abbot-Exeter road.

#### 30th August - Preston ARS

At Kimberley Barracks, Deepdale Road, (alongside Preston North End football ground), Preston.

#### 20th September - Peterborough Mobile Rally

At Walton School, Mountstevens Avenue, Peterborough. ■

**AMAZING VALUE  
NEW BRANDED FULL SPECIFICATION  
SEMICONDUCTOR DEVICES**

**Best for Performance and Reliability**

**Integrated Circuits**

U.S. General Electric			
PA234	1 Watt Audio Amplifier		17/6
PA237	2 Watt Audio Amplifier		31/6
D40C1	4 Watt Darlington Amplifier. Very High Gain.		
	10,000 minimum		13/6
Plessey Microelectronics			
SL402A	Preamplifier and 2 Watt Amplifier		
	(equivalent to IC10)		40/-
Micro Electronics			
MEL 11	Photo Darlington Amplifier		9/6
Manufacturers' Data Sheets or Application Notes supplied FREE with each order for these integrated circuits.			
Connectors for D.I.L. i.c.'s			
			6/-

**High Quality Low-Cost Transistors**

GE 2N5172	1/9	MUL BFX86	6/-
ME 0412	3/9	MUL BD124	12/-
TI 2N4059	3/6	S 2N3055	14/-

**Triacs for Full Wave Power Control:**

RCA 40669	8A 400V (including insulating kit)	24/-
RCA 40583	Trigger Diode	5/3

**Plastic Rectifiers for Power Supplies:**

ITT 1 Amp 4000 series			
1N4001,	50V	1N4004, 400V	2/5
1N4002,	100V	1N4005, 600V	2/9
1N4003,	200V	1N4006, 800V	3/5
	1N4007, 1000V		4/-
Westinghouse 1N4820 1.5A 400V.			
General Instruments W005 35V. R.M.S. Bridge			
Electronic Devices PD40 250V. R.M.S. Bridge			
			12/6

**JEF ELECTRONICS (R.C.7)**

York House, 12 York Drive,  
GRAPPENHALL, WARRINGTON, LANCs.  
Mail Order Only. C.W.O. P. & P. 1/- per order  
(Overseas 7/6). Money back if not satisfied.

**BOOKS FOR YOU**

**A GUIDE TO AMATEUR RADIO**

*By Pat Hawker, G3VA*

Fourteenth edition. 100 pages.

The new edition of this indispensable aid to all who want to know more about amateur radio. Designed to assist the newcomer to this unique hobby.

Revised and expanded. **8s 10d post paid**

**THE VHF-UHF MANUAL**

*By George Jessop, G6JP*

A complete manual for frequencies above 30 MHz. Covers aeriels, receivers, transmitters and test equipment. The first book of its kind outside the USA

**23s post paid**

**RADIO COMMUNICATION HANDBOOK**

832 pages of everything in the science of radio communication. The Handbook's U.K. origin ensures easy availability of components. Complete coverage of the technical and constructional fields. A superb hard bound volume. **69s post paid**

*These are three of a complete range of technical publications, log books and maps, all obtainable from:*

**RADIO SOCIETY of GREAT BRITAIN**

35 DOUGHTY STREET, LONDON, WC1N 2AE

**TV  
FAULT FINDING  
MANUAL for  
405/625 LINES**



**8/6**

POSTAGE 8d.

**REVISED & ENLARGED**

EDITED BY J. R. DAVIES

**124 pages**

Over 100 illustrations, including 60 photographs of a television screen after the appropriate faults have been deliberately introduced.

Comprehensive. Fault Finding Guide cross-referenced to methods of fault rectification described at greater length in the text.

**To: Data Publications Ltd.,  
57 Maida Vale, London, W.9**

Please supply the 4th revised edition of TV  
FAULT FINDING, Data Book No. 5.....

I enclose cheque/crossed postal order for.....

Name.....

Address.....

.....RC  
(BLOCK LETTERS PLEASE)

# SMALL ADVERTISEMENTS

Rate: 9d. per word Minimum charge 12/-  
Box No. 2/- extra.

Advertisements must be prepaid and all copy must be received by the 4th of the month for insertion in the following month's issue. The Publishers cannot be held liable in any way for printing errors or omissions, nor can they accept responsibility for the *bona fides* of advertisers. (Replies to Box Numbers should be addressed to: Box No. —, *The Radio Constructor*, 57 Maida Vale, London, W.9.)

**NEW CATALOGUE NO. 18**, containing credit vouchers value 10/-, now available. Manufacturers new and surplus electronic and mechanical components, price 4/6d. post free. Arthur Sallis Radio Control Ltd., 28 Gardner Street, Brighton, Sussex.

**BUILD IT** in a **DEWBOX** robust quality plastic cabinet 2in. x 2½ins. x any length. S.A.E. for details. D.E.W. Ltd., 254 Ringwood Road, Ferndown, Dorset. Write now - right now.

**SERVICE SHEETS.** Radio, Television, Transistors, Tape Recorders, Record Players. Catalogue 2/6d. S.A.E. please. Hamilton Radio, 54 London Road, Bexhill, Sussex.

**FOR SALE:** Reception set R107. Good working order. £15. Radiomobile car radio. Good working order. £5. A. E. Drew, School House, Stambourne, Halstead, Essex.

**TO CLEAR.** Back numbers of "The National Geographical Magazine", from January 1959. 3/6d. each post paid. Box No. G110.

**BOOKS TO CLEAR:** "The Upper Atmosphere", Massey & Boyd, 50/-; "KEOEIT", story of the Aurora Borealis 20/-; "Teach Yourself Russian", 5/-; "Principles of Modern Book-keeping", 5/-; "Outlook", elementary weather forecasting, 7/6d; "Health Physics", principles of radiation protection, Rees 50/-. All plus postage. Box No. G111.

**MUSICAL MIRACLES.** Send s.a.e. for details of Drum Sound Modules, versatile bass-pedal accompaniment unit, self-contained with unique effects. Kits for Waa-waa pedals, 49/-. Also bargain components, reed switches, etc. D.E.W. Ltd., 254 Ringwood Road, Ferndown, Dorset.

**NEW SONY CRF-230 GLOBAL RADIO.** Amateur, Commercial & Professional reception. Brings you everything that's on the air, anywhere in the world! 23-band reception. Covers AM, SW, MW, LW & FM. Operates from batteries or AC mains. Built-in voltage selector permits use in any country. Numerous control features that put it in a class by itself. Retail at £290. yours for £250 or near offer. Telephone: Herongate 59 (2 Billericay Road, Essex).

**MAGAZINES TO CLEAR:** *CQ* 1947-November, 1955-April, 1957-February to June, 1959-July to December, complete, 1964-March missing, 1965-complete, 1/6d. per copy. *QST*, 1948 October, 1961 October to December, 1962 September, 2/- per copy. *RSGB Bulletin*, 1956-May, September, October, 1957-August, September, 1958-February, July to December, 1959-60-complete, 1961-August, September missing, 1962-February to May, 1/- per copy. 73, 1963-July, August, September to November, 1967-January, October, 1968 January, February, April & November, 1/6d. per copy. *Wireless World*, 1947-December, 1958-September, 1960-January, April, June, September to December, 1964-January, December, 1965-January to June, 2/- per copy. Box No. G114.

(Continued on page 769)

# BENTLEY ACOUSTIC CORPORATION LTD.

38 Chalcot Road, Chalk Farm,  
LONDON, N.W.11.  
01 - 722 9090

The Old Police Station  
Gloucester Road  
LITTLEHAMPTON, Sussex  
PHONE 6743

Please forward all mail orders to Littlehampton

5Z4G	7/-	ECC82	4/6	KTW62	12/6	PY801	6/9	AC156	4/-	BY126	3/6
6A05	5/6	ECC83	4/6	KT88	34/-	R19	7/6	AC157	5/-	BY127	3/6
6AT6	4/-	ECC84	6/3	PC86	10/3	U19	34/6	AD140	7/6	BYZ10	5/-
6C4	5/-	ECC85	5/6	PC88	10/3	U25	13/-	AD149	8/-	BYZ11	5/-
6/30L2	12/-	ECC86	8/-	PC95	8/3	U26	11/9	AD162	9/-	BYZ12	5/-
6B87	15/9	ECC88	7/-	PC97	8/6	U191	12/6	AF114	4/-	BYZ13	5/-
6C1W7	13/-	ECC189	9/6	PC900	7/6	U301	11/-	AF115	4/3	OA70	3/6
6F23	14/3	ECF80	6/6	PCC84	6/3	U404	7/6	AF117	4/6	OA79	1/9
6F28	14/-	ECF82	6/6	PCC85	6/6	U801	19/6	AF119	1/4	OA81	1/9
6L6GT	7/9	ECF86	9/-	PCC88	9/9	UABC80	6/6	AF121	6/-	OA90	2/6
9D7	15/6	ECH42	12/9	PCC89	9/6	UBC81	7/-	AF126	5/-	OA91	1/9
10F18	7/-	ECH81	5/9	PCC189	10/6	UBF80	5/9	AF139	13/-	OA95	1/9
30C15	13/-	ECH83	8/-	PCF80	6/6	UBF89	6/9	AF180	9/6	OA200	1/-
30C17	16/-	ECH84	7/6	PCF82	6/3	UC92	5/6	AF186	11/-	OA202	2/-
30C18	14/-	ECL80	7/6	PCF84	8/-	UCC84	8/-	AF239	7/6	OC22	7/6
30F5	16/-	ECL82	6/6	PCF86	12/9	UCC85	7/3	BA102	9/-	OC23	7/6
30FL1	13/9	ECL83	9/-	PCF200	13/3	UCF80	8/3	BA115	2/8	OC24	7/6
30FL2	15/-	ECL86	8/-	PCF801	7/-	UCH21	9/-	BA116	5/-	OC25	7/6
30FL14	14/6	EF22	12/6	PCF807	9/-	UCH42	12/-	BA129	2/6	OC28	9/6
30L17	13/9	EF41	10/-	PCF200	12/3	UCH81	6/6	BA130	2/-	OC35	7/6
30P4	10/6	EF80	4/6	PCL82	7/3	UCL82	7/3	AC107	3/6	OC37	2/6
30P4	12/-	EF85	5/3	PCL83	10/-	UCL83	10/-	BC108	3/6	OC38	8/6
30P4MR	17/6	EF86	6/3	PCL84	7/6	UF41	10/-	BC113	5/-	OC44	2/-
30P12	13/9	EF89	5/-	PCL805/85	9/-	UF80	6/9	BC118	4/6	OC45	2/6
30P19	12/-	EF91	3/3	PCL86	8/6	UF85	6/9	BCY10	5/-	OC46	2/6
30PL1	13/9	EF183	6/-	PEN45DD	15/-	UF86	9/-	BCY12	5/-	OC70	2/3
30PL13	15/6	EF184	6/-	PFL200	11/6	UF89	6/9	BCY33	5/6	OC71	2/6
30PL14	15/-	EF190	7/6	PL36	9/6	UL41	10/6	BCY34	4/6	OC72	2/6
30PL15	15/-	EL33	12/-	PL81	9/6	UL84	6/6	BCY38	5/-	OC74	2/6
DY86/87	5/9	EL34	10/6	PL82	6/6	UM80	6/6	BCY39	4/6	OC75	2/6
DY802	9/6	EL41	11/-	PL83	6/6	UY41	7/6	BCZ11	3/6	OC78	3/6
EB8CC	12/-	EL84	4/9	PL84	6/6	UY85	5/9	BD119	9/-	OC78B	3/6
EABC80	6/6	EL90	5/3	PL500	13/-	ZN404	6/-	BFY50	4/-	OC81	2/6
EP42	10/6	EM80	7/6	PL504	13/6	ZN2297	4/6	BFY51	4/-	OC81D	2/6
EB34	3/-	EM81	7/6	PL509	28/9	ZN2369	4/6	BFY52	4/6	OC83	2/3
EB91	2/3	EM84	6/6	PX4	23/6	ZN2613	7/9	BF159	5/-	OC83	4/6
EB4C1	9/6	EM87	7/6	PY33	10/-	ZN3053	6/6	BF163	4/-	OC84	3/6
EB8C1	6/6	EY51	7/6	PY81	5/3	ZN3703	3/9	BF173	7/6	OC123	4/6
EBF80	6/9	EY86/87	6/6	PY82	5/3	ZN3709	4/6	BF180	6/-	OC169	3/6
EBF83	8/-	EZ40	7/6	PY83	5/9	AA119	3/-	BY100	3/6	OC172	4/6
EBF89	6/3	EZ80	7/6	PY84	6/9	AA113	4/6	BY191	3/-	OC200	4/4
EC92	6/6	EZ81	4/9	PY800	7/6	AC127	4/3	BY105	3/6	OC202	4/6
ECC81	3/9	HVR2	10/6	QQV0	3/1024/-	AC154	5/-	BY114	3/6	OC203	4/6

Terms of business: Cash with order only. No C.O.D. Post/Packing 6d. per item. Orders over £5 post free. All orders despatched same day as received by first class mail. Complete catalogue including transistor section and components with terms of business 1/-. Any parcel insured against damage in transit for 6d. extra. Business hours 9 a.m.-5.30 p.m. Saturdays 9 a.m.-1 p.m. Littlehampton closed Sat.



\* EST. 1891

# TECHNICAL TRAINING IN RADIO, TELEVISION AND ELECTRONIC ENGINEERING

First class opportunities in Radio and Electronics await the ICS trained man. Let ICS train YOU for a well-paid post in this expanding field.

ICS courses offer the keen, ambitious man the opportunity to acquire, quickly and easily, the specialized training so essential to success.

Diploma courses in Radio TV Engineering and Servicing, Electronics, Computers, etc. Expert coaching for:

- \* C. & G. TELECOMMUNICATION TECHNICIANS CERTS.
- \* C. & G. ELECTRONIC SERVICING
- \* R.T.E.B. RADIO AND TV SERVICING CERTIFICATE
- \* RADIO AMATEURS EXAMINATION
- \* P.M.G. CERTIFICATES IN RADIO TELEGRAPHY

Examination Students Coached until Successful.

## NEW SELF-BUILD RADIO COURSES

Build your own 5-valve receiver, transistor portable, signal generator, multi-test meter and professional-type valve voltmeter—all under expert guidance.

POST THIS COUPON TODAY and find out how ICS can help YOU in your career. Full details of ICS courses in Radio, Television and Electronics will be sent to you by return mail.

MEMBER OF ASSOC. OF BRITISH CORRESPONDENCE COLLEGES.

## INTERNATIONAL CORRESPONDENCE SCHOOLS

Dept. 248, Intertext House, Stewarts Road, London, S.W.8.

NAME.....

Block Capitals Please

ADDRESS.....

7.70

# Beginner's Guide to Radio

7th Edition 1970

G. J. King AssocIERE, MIPRE, MRTS,  
Grad ITAI, DipTelevision.

For this edition the book has been completely rewritten and brought up-to-date to take account of the latest techniques and methods, and covers every aspect of the modern radio scene, while including the important basic information necessary for the newcomer. The reader is taken step by step from first principles of electricity and magnetism through radio waves, modulation and components, transmitters and stereo broadcasting, and ending with hi-fi reproduction.

408 00016 3    208 pages illustrated    20s

Available from leading booksellers or:



**The Butterworth Group**  
88 Kingsway London WC2B 6AB

# INTERNATIONAL SHORT WAVE LEAGUE



Membership 35s. 0d. per annum (U.S.A. \$5.00) including 12 monthly issues of *Monitor* — the League journal. Including free use of all Services, QSL Bureau, etc.

**THE LARGEST S.W.L. ORGANISATION  
IN THE WORLD**

For full details write to:

**The Secretary,  
I.S.W.L.,  
1, GROVE ROAD, LYDNEY,  
GLOS. GL15 5JE.**

# AUDIO AMPLIFIERS

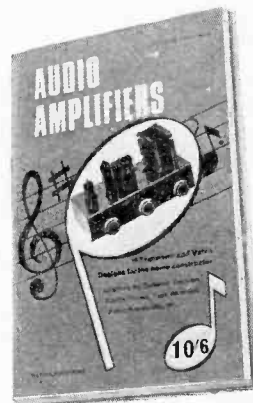

**16 Transistor and Valve Designs for the  
Home Constructor**

*Amplifiers for Tuner Units, Record  
Players, Tape Recorders, Public Address,  
etc., etc.*

Includes contributions by such  
well-known authors as

A. S. Carpenter, A. Kinloch, E. Govier,  
G. A. French, F. G. Rayer,  
P. F. Bretherick, K. Jones, D. Aldous,  
R. Murray-Shelley, C. Swires,  
G. A. Stevens and V. E. Holley.

Edited by J. R. Davies

**PRICE 10s. 6d.**

124 pages

Postage 8d.

To: **DATA PUBLICATIONS LTD.,**  
57 Maida Vale London W9

Please supply ..... copy(ies) of "Audio  
Amplifiers", Data Book No. 18

I enclose cheque/crossed postal order for.....

NAME.....

ADDRESS.....

.....  
.....  
.....  
.....

**BLOCK LETTERS PLEASE**



## SMALL ADVERTISEMENTS

(Continued from page 767)

**FOR SALE:** 25 issues *The Radio Constructor*, October 1964 to December 1969. The lot, £2/10/-, including postage and packing. Norman Pierce, 80 Railway Road, Rock Ferry, Birkenhead, Cheshire.

**FOR SALE:** Control knobs, 365pF, Wearite P coils, two PA, two PHF, mains transformers, type 3104A, Douglas, MT1, L.F. choke, M101. Jackson drive 2154, p.m. speaker 7 x 4 in. 3Ω. Two ADT140, two 500pF 2-gang. Mullard EF41, EL42. S-meter MP2P. Output transformers, 117/A, 117/E. 5 in. 15Ω speaker, HF510. Hughes, 11 Henley Road, Ludlow, Salop.

**WANTED:** Glass paper weights. Details to Box No. G117.

**JOIN THE INTERNATIONAL S.W. LEAGUE.** Free services to members including Q.S.L. Bureau, Amateur and Broadcast Translation, Technical and Identification Dept.—both Broadcast and Fixed Stations, DX Certificates, contests and activities for the SWL and transmitting members. Monthly magazine, *Monitor*, containing articles of general interest to Broadcast and Amateur SWLs, Transmitter Section and League affairs, etc. League supplies such as badges, headed notepaper and envelopes, QSL cards, etc., are available at reasonable cost. Send for League particulars. Membership including monthly magazine, etc., 35s. per annum. Secretary ISWL, 1 Grove Road, Lydney, Glos., GL15 5JE.

**WANTED:** Ilford Elmo 8TL-6 or 4 standard 8 cine camera, with 100ft. magazine. Box No. G121.

**FREE GIFT** when you request our quality stamps, supplied on approval. Generous discounts. Details from: Watson's Philatelic Service, 6 Beech Avenue, Brentwood, Essex.

**ARE YOU A MOTORING ENTHUSIAST?** The Seven Fifty Motor Club caters for all types of motor sport—racing, rallies, hill climbs, etc. Monthly Bulletin free to members. For full details write to: The General Secretary, Colin Peck, "Dancer's End", St. Winifred's Road, Biggin Hill, Kent.

**CONSTRUCTOR SELLING UP!** Most parts for high performance amateur double superhet (Brand new). Other components, magazines, multimeter, etc. S.A.E. for list. Hurley, "Invararey", Queens Road, Tipton, Staffs.

**BOOKS TO CLEAR:** At 1/6d each post paid:—Pelican books - *Man, Microbe & Malady*, *Cine-Biology*, *Science News* Nos. 11, 30, 33, 35 and 51 "Aquarium Management". All at 2/6d. each post paid:—*"Mid-century Journey"*, *"Man & The Universe"* Lodge, *"Men of Science & their Discoveries"*. All at 5/- each post paid:—*"On Scottish Hills"*, Humble, *"Model Engineering Practice"*, Camm, *"Disease & Its Conquest"*, Hollis, *"Ski-ing for Beginners"*, *"Footsteps in Civilisation"*, *"Hotels - Admin & Accounts"*, *"Principles of Executorship Accounts"*. All at 7/6d. post paid:—*"Engines for Small Craft"*, Barnard, *"Thyratrons"*, Philips, *"Sound & Cine for Beginners"*, *"Maritime Meteorology"*, Earl, *"Cloud Types for Observers"*, Met. Office, *"Science Today & Tomorrow"*, 2nd Series, *"Science Survey No. 3"*, Life & Sunday Times World Library: S.E. Asia, Scandinavia, Brazil, Japan, Israel, Britain, Italy, Russia, Mexico, France, India, Germany, Greece, Tropical Africa. Life Science Library: Man & Space, Planets, Energy. *"The Story of Atomic Energy"* Soddy, *"The Colour of Canada"*, *"Frontier to Space"* Burgess, *"Earth Satellite"* Moore, *"Man The Adventurer"*, *"Man on the Moon"*, *"Practical Yacht Racing"*. Box No. G125.

(Continued on page 771)

## FREE TO AMBITIOUS ENGINEERS

—THE LATEST EDITION OF ENGINEERING OPPORTUNITIES

Have you sent for your copy?

**ENGINEERING OPPORTUNITIES** is a highly informative 164 page guide to the best paid engineering posts. It tells you how you can quickly prepare at home for a recognised engineering qualification and outlines a wonderful range of modern Home Study Courses in all branches of Engineering. This unique book also gives full details of the Practical Radio & Electronic Courses administered by our Specialist Electronics Training Division - explains the benefits of our Appointments Dept. and shows you how to qualify for five years promotion in one year.

"Satisfaction or refund of fee" terms

Whatever your age or experience you cannot afford to miss reading this famous book. Send for your copy of "ENGINEERING OPPORTUNITIES" today - FREE.

**Practical Equipment including Tools**

The specialist Electronics Division of B.I.E.T. NOW offers you a real laboratory training at home with practical equipment. Basic Practice and Theoretical Courses for beginners in Radio, T.V., Electronics, etc. Ask for details.

Which is your pet subject?

A.M.I.E.R.E. City & Guilds  Radio Amateur's Exam.  R.T.E.B. Certificate P.M.G. Certificate  Practical Radio  Radio & Television Servicing  Practical Electronics  Electronics Engineering  Automation

The B.I.E.T. is the leading institute of its kind in the world.

Please send  
Free Books and  
Full Information

**British Institute of  
Engineering Technology**

NAME .....

ADDRESS .....

Subject  
of interest..... Age.....

ALDERMASTON COURT, Dept 480D, Aldermaston, Berks.



**FERGUSON RADIO CORPORATION LTD.**

# TROUBLE- SHOOTERS

Urgently required within a colour television receiver Production Department. Applicants should hold a City and Guilds Intermediate or Final Certificate in Radio and Television Servicing or alternatively have had considerable practical experience. Excellent working conditions and rates of pay.

Please apply, completing details below:  
to:

Personnel Manager Ts/Rc Ferguson Radio Corporation Ltd.,  
Great Cambridge Road, Enfield, Middx. 01-363 5353 Ext. 2320

NAME .....

ADDRESS .....

TEL. NO. ....

QUALIFICATIONS .....



# RADIO OPERATORS

There will be a number of vacancies in the Composite Signals Organisation for experienced Radio Operators in 1971 and in subsequent years.

Specialist training courses lasting approximately nine months, according to the trainee's progress, are held at intervals. Applications are now invited for the course starting in January 1971.

During training a salary will be paid on the following scale:-

Age 21	£848 per annum
22	906 " "
23	943 " "
24	981 " "
25 and over	1,023 " "

Free accommodation will be provided at the Training School.

After successful completion of the course, operators will be paid on the Grade 1 scale:-

Age 21	£1,023 per annum
22	1,087 " "
23	1,150 " "
24	1,214 " "
25 (highest age point)	1,288 " "

then by six annual increases to a maximum of £1,749 per annum.

Excellent conditions and good prospects of promotion. Opportunities for service abroad.

Applicants must normally be under 35 years of age at start of training course and must have at least two years' operating experience. Preference given to those who also have GCE or PMG qualifications.

Interviews will be arranged throughout 1970.

Application forms and further particulars from:-

**Recruitment Officer (R.O.63)**  
**Government Communications**  
**Headquarters,**

**Oakley,**  
**Priors Road,**  
**CHELTENHAM,**  
**Glos., GL52 5AJ.**  
**Tel: Cheltenham 21491. Ext. 2270.**

# Electronic Test Engineers

Pye Telecommunications of Cambridge has immediate vacancies for Production Test Engineers. The work entails checking to an exacting specification VHF/UHF and SSB radio telephone equipment before customer delivery; applicants must therefore have experience of fault finding and testing electronic equipment, preferably communications equipment.

Formal qualifications, while desirable, are not as important as practical proficiency. Armed Service experience of such work would be perfectly acceptable.

Pye Telecom is the world's largest exporter of radio telephone equipment and is engaged in a major expansion programme designed to double present turnover during the next 5 years. There are therefore excellent opportunities for promotion within the Company. Pye also encourages its staff to take higher technical and professional qualifications. These are genuine career opportunities in an expansionist company so write, or telephone, for an application form without delay. Interviews can be arranged anywhere in the country at locations to suit the majority of applicants.

Mrs A. E. Darkin, Pye Telecommunications Ltd., Cambridge Works, Haig Road, Cambridge. Telephone: Cambridge 51351

 **Pye Telecommunications Ltd** 

## SMALL ADVERTISEMENTS

(Continued from page 769)

**"MEDIUM WAVE NEWS"** Monthly during Dx season. —Details from: K. Brownless, 7 The Avenue, Clifton, York.

**FOR SALE: PROJECTION** Television receiver Decca, large screen (4ft. x 3 ft.) for sale in perfect working order. Fine polished walnut cabinet. £50. Box No. G126.

**POSTAL ADVERTISING?** This is the Holborn Service, Mailing lists, addressing, enclosing, wrapping, facsimile letters, automatic typing, copy service, campaign planning, design and artwork, printing and stationery. Please ask for price list.—The Holborn Direct Mail Company, Capacity House, 2-6 Rothsay Street, Tower Bridge Road, London, S.E.1. Telephone: 01-407-1495.

**HEATHKIT INSTRUMENTS.** AV3U audio millivoltmeter £12. MM1U Multimeter £7. AG9U audio generator £16. Basic Electronics Pts. 1 - 6. 30/-. All in mint condition. S.A.E. for details. Box No. G127.

**WANTED:** Back issues of *The Radio Constructor* dealing with electronic organ series, August to November 1962 inc., plus February 1963. Also *Wireless World* 1966. Fox. 71A Stanford Avenue, Brighton, Sussex.

**WORLD DX CLUB** covers all aspects of SWLing on Amateur and Broadcast Bands through its monthly bulletin "Contact". Membership costs 25s. a year. Enquiries to Secretary, WDXC, 17 Taunton Road, Bridgewater, Somerset.

**STAMP COLLECTION.** Containing ITU issues, railway centenary, and many other space, scientific and medical commemoratives. S.A.E. for details. Total catalogue price around £175. Box No. G128.

**2 WATT TRANSISTOR RECORD PLAYER AMPLIFIERS.** Not a kit, but built and tested. Complete amplifier measures 2½ x 3½ ins. Standard 3 ohms output, frequency response ± 2dB from 12 to 12,000 c.p.s. Can be used for baby alarms, intercoms, etc. Supplied with full connection details, only 22/6d, p.p. 1/6d. 500mW amplifier kit, 3 transistor, with circuit, 10/6d, p.p. 1/-. Tested transistors 8/- dozen, 1/- each, similar to 2N697, 2N706, OC44, OC71, OC81, BFY50. Assorted NPN PNP silicon germanium, untested but guaranteed 60% good, 25 for 4/-. p.p. 6d. A. Manley, 111 Mayow Road, Sydenham, London S.E.26.

**MINIATURISED TOP BAND** mains powered Tx. Top Band command Rx. £15 o.n.o. Box No. G129.

**FOR SALE:** Transistorised grid dip oscillators (also act as wavometers), 2 to 30 Mc/s. £10. — GW3YQM, 4 Green Park, Pentlepoir, Saundersfoot, Pems. S. Wales. Telephone: Saundersfoot 3351.

**HOLIDAY ACCOMMODATION.** Burwood Lodge Hotel, Dawlish Road, Teignmouth, S. Devon. Especially for parents with young children. Facing south, on the cliffs, direct access by private path to sea. Mothers' kitchen, automatic washing machines, baby listening service. Licensed lounge. Ample free parking.

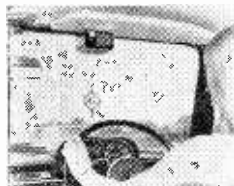

### RADAR SPOTTER

Prevention is best — YOU know it makes sense!

Use our unique non-radiating legal radar receiver. Gives early warning of Radar Speed Traps up to 1½ miles on motorways. Completely self contained (no wiring). Compact, clips on to sun visor. Weighs only 10½ ozs.

BE SAFE, NOT SORRY — ORDER NOW. £13.5.0. C.O.D. 5/- extra. **BELDING & BENNETT LTD.** (Box 38) 45 Green Lane, Purley, Surrey. For full details Tel: 01-660 2896 or send 8d. in stamps. Callers welcome by appointment.

If you're a telecommunications man and match up to the qualifications below cut yourself into a slice of Britain's future

Become a

# Radio Technician

in the fast-growing world of Air Traffic Control

Please send me an application form and details of how I can join the fascinating world of Air Traffic Control Telecommunications

Name .....

Address .....

RCT/EI

Not applicable to residents outside the United Kingdom

To: A J Edwards, C Eng, MIEE,  
The Adelphi, Room 705, John Adam Street,  
London WC2

marking your envelope 'Recruitment'

Sending this coupon could be your first step to a job that's growing in importance every year.

The National Air Traffic Control Service needs Radio Technicians to install and maintain the vital electronic aids that help control Britain's ever-increasing air traffic.

This is the kind of work that requires not only highly specialised technical skills but also a well developed sense of responsibility, and candidates must be prepared to undergo a rigorous selection process. Those who succeed are assured a steadily developing career of unusual interest and challenge. Starting salary varies from £1044 (at 19) to £1373 (at 25 or over) scale maximum £1590 (higher rates at Heathrow). There is a good annual leave allowance and a non-contributory pension for established staff.

You must be 19 or over, with at least one year's practical experience in telecommunications. ('ONC' or 'C and G' qualifications preferred)

# NATCS

National Air Traffic Control Service

# CHASSIS and CASES by



**H. L. SMITH & CO. LTD.**  
287/9 Edgware Road  
London W2  
TEL: 01-723 5891

## BLANK CHASSIS

FOUR-SIDED 16 SWG ALUMINIUM

Size	Price	Base	Size	Price	Base
6x4x2"	6/3	2/11	10x8x2 1/2"	12/-	5/6
7x4x1 1/2"	6/-	3/2	12x7x2 1/2"	12/-	5/11
7x5x2"	7/6	3/5	12x9x2 1/2"	13/9	7/-
8x4x2"	7/-	3/4	13x8x2 1/2"	13/9	6/11
8 1/2 x 5 1/2 x 2"	8/-	3/9	14x7x3 1/2"	14/6	6/6
9x7x2"	9/3	4/10	14x10x2 1/2"	16/-	8/7
10x4x2 1/2"	9/-	3/9	15x10x2 1/2"	16/6	9/11
12x4x2 1/2"	10/-	4/3	17x10x3"	19/6	10/11
12x5x3"	12/-	4/9			

## CASES ALUMINIUM, SILVER HAMMERED FINISH

Type	Size	Price	Type	Size	Price
N	8x6x2"	18/-	W	12x7x7"	37/6
N	6x6x3"	17/6	W	15x9x8"	48/6
N	4x4x2"	11/-	Y	8x6x6"	29/-
U	4x4x4"	11/-	Y	12x7x7"	45/-
U	5 1/2 x 4 1/2 x 4 1/2"	17/-	Y	13x7x9"	50/6
U	8x6x6"	23/-	Y	15x9x7"	53/6
U	9 1/2 x 7 1/2 x 3 1/2"	24/-	Z	17x10x9"	72/6
U	15x9x9"	49/-	Z	19x10x8 1/2"	78/-
W	8x6x6"	23/-			

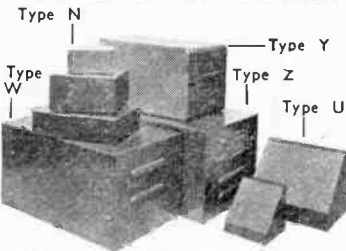

\*Height  
Type N has removable bottom. Type U removable bottom or back. Type W removable front. Type Y all screwed construction. Type Z removable back and front. Plus p. & p.

### TO FIT OUR CASES

7x5 1/2 x 1 1/2"	7/-	3/9	12x6 1/2 x 2"	10/9	5/11
7x5 1/2 x 2"	7/9	3/9	14x8 1/2 x 2"	13/6	7/11
11x6 1/2 x 1 1/2"	10/-	5/6	15 1/2 x 9 1/2 x 2 1/2"	17/-	9/6
11x6 1/2 x 2"	10/-	5/6	17 1/2 x 9 1/2 x 2 1/2"	18/6	10/6

Plus post & packing

PANELS: Any size up to 3ft. at 6/- sq. ft. 16 s.w.g. (18 s.w.g. 5/3). Plus postage and packing.

Electronics technician required for the construction and maintenance of an interesting range of electronic equipment used in the teaching and research laboratories of the Department of Zoology and Comparative Physiology. Salary according to age and ability on scale £743 - £1,047 p.a. plus London Weighting and possible £30 or £50 p.a. qualification award. Five day week. Four/five weeks annual leave. Pension Scheme. Letters only to Registrar (Z/T) Queen Mary College (University of London) Mile End Road, E.1. stating full details of age, experience and present work.

**YUKAN** SO PROFESSIONAL THE  
**SELF-SPRAY** YUKAN AEROSOL WAY-

Get these air drying **GREY HAMMER**  
**NOW!** OR **BLACK WRINKLE**  
**(CRACKLE)** finishes

Yukan Aerosol spraykit contains 16 oz. fine quality, durable easy instant spray. No stove baking required. Hammers available in grey, blue, gold, bronze. Modern Eggshell Black Wrinkle (Crackle) all at 15/11 at our counter or 16/11, carriage paid, per push-button self-spray can. Also Durable, heat and water resistant Black Matt finish (12 oz. self-spray cans only) 13/11 carriage paid.

SPECIAL OFFER: 1 can plus optional transferable snap-on trigger handle (value 5/-) for 18/11, carriage paid. Choice of 13 self-spray plain colours and primer (Motor car quality) also available.

Please enclose cheque or crossed P.O. for total amount direct to:

DEPT: N/4 YUKAN, 307a, EDGWARE ROAD, LONDON, W.2.

We supply many Government Departments, Municipal Authorities, Institutes and Leading Industrial Organisations - We can supply you too.

Open all day Saturday. Closed Thursday afternoons.

## DATA BOOK SERIES

- DB5 TV FAULT FINDING**  
124 pages. Price 8/6, postage 8d.
- DB6 THE RADIO AMATEUR OPERATOR'S HANDBOOK**  
64 pages. Price 6/-, postage 6d.
- DB16 RADIO CONTROL FOR MODELS**  
192 pages. Price 15/-, postage 1/-.
- DB17 UNDERSTANDING TELEVISION**  
512 pages. Price 37/6, postage 3/-.
- DB18 AUDIO AMPLIFIERS**  
128 pages. Price 10/6, postage 8d.

I enclose Postal Order/Cheque for ..... in payment for .....

NAME .....

ADDRESS .....

(Please use Block Capitals for both name and address)  
Postal Orders should be crossed and made payable to Data Publications Ltd.  
Overseas customers please pay by International Money Order  
All publications are obtainable from your local bookseller  
Data Publications Ltd., 57 Maida Vale, London W.9

Please mention **THE RADIO CONSTRUCTOR** when writing to advertisers

The  
**Radio Constructor**

*Incorporating The Radio Amateur*

**Index**  
to  
**Volume Twenty-three**

**August 1969 — July 1970**



## AMPLIFIERS

Design for a Class A. Battery Amplifier, by Sir Douglas Hall, K.C.M.G., M.A.(Oxon) ...	349	Jan.	'70
Dual-EL84 Hi-Fi Amplifier, by J. Hossack ...	526	Apr.	'70
Experimental Record Player Amplifier, by G. A. French ...	333	Jan.	'70
"Neophyte" Audio Amplifier, by R. J. Caborn ...	160	Oct.	'69
The "Kangaroo" Radiogram, by Sir Douglas Hall, K.C.M.G., M.A.(Oxon) ...	10	Aug.	'69
Transistor Amplifier for Battery or Mains, by G. W. Short ...	24	Aug.	'69

## AMPLIFIER ANCILLARIES

'Wah-Wah' Pedal Unit, by R. J. Caborn ...	680	June	'70
---	-----	------	-----

## ELECTRONICS

Battery Saver for Bedside Radios, by G. A. French ...	74	Sept.	'69
Comprehensive Timing Unit, by R. W. Coles ...	406	Feb.	'70
Current Protection and Trip Circuit, by G. A. French ...	726	July	'70
Cybernetic Cynthia, Part 1, by L. C. Galitz ...	672	June	'70
Cybernetic Cynthia, Part 2, by L. C. Galitz ...	743	July	'70
Decimal Coinage Calculator, by G. A. French ...	401	Feb.	'70
Economical Voltage Regulator, by R. W. Coles ...	474	Mar.	'70
Electric Drill Speed Controller, by R. M. Marston ...	416	Feb.	'70
Electronic Siren Module, by P. L. Matthews ...	590	May	'70
High Sensitivity Proximity Detector, by G. A. French ...	142	Oct.	'69
Inertia Switching Circuit, by G. A. French ...	18	Aug.	'69
Light Controlled Tone Generator, by R. J. Caborn ...	288	Dec.	'69
Self-Regulating Battery Charger, by R. M. Marston ...	479	Mar.	'70
Simple Colour Printer, by A. Kypriotis ...	155	Oct.	'69
Simple Electronic Doorbell, by H. Williams ...	668	June	'70
Simple H.T. Delay Switch, by G. A. French ...	461	Mar.	'70
Sprite Lights, by H. T. Kitchen ...	658	June	'70
Transistorised Lie Detector, by G. C. Dobbs, G3RJV ...	554	Apr.	'70

## GENERAL

Alarm for Mains Radios, by J. C. Eade, B.A. ...	92	Sept.	'69
Automatic Dimmed/Dipped Headlights, by D. G. Fripp ...	214	Nov.	'69
Automatic Mains/Battery Supply, by J. C. Eade, B.A. ...	742	July	'70
BBC World Radio Club ...	604	May	'70
Catalogues ...	490	Mar.	'70
Catalogues Received ...	491	Mar.	'70
Coil Winder for the Home Constructor, by R. P. Neave ...	687	June	'70
"Do-It-Yourself" Ceramic I.F. Filters, by G. W. Short ...	481	Mar.	'70
Electra-Scan Navigational Aid ...	572	Apr.	'70
Electronic Chronometers ...	629	May	'70
Experimenter's Power Supply, by C. Crosbie ...	394	Feb.	'70
First Attempt ...	477	Mar.	'70
First World Dx Club Convention ...	94	Sept.	'69
For the Beginner - Chassis Metalwork ...	29	Aug.	'69
For the SWL - Selectivity ...	557	Apr.	'70
For the SWL - Starting on the Broadcast Bands ...	670	June	'70
From Dead Reckoning to Pinpoint Navigation ...	411	Feb.	'70
High Quality Loudspeaker, by A. J. Whittaker ...	483	Mar.	'70
How Many Eggs? ...	545	Apr.	'70
Hubble Bubble - Toil and Trouble ...	609	May	'70
Increasing Transistor Radio Coverage ...	606	May	'70
Instant Prototype Printed Circuits ...	678	June	'70
Kaleidoscope ...	410	Feb.	'70
Midsummer Night's Dream ...	661	June	'70
Mobiling and Mobileers, by A. S. Carpenter, G3TYJ ...	38	Aug.	'69
Munich Olympic Diploma ...	573	Apr.	'70
Nomogram for Parallel Resistance or Series Capacitance, by R. H. Doughty ...	90	Sept.	'69
Poles ...	592	May	'69
Radio Canada ...	641	May	'70
Season's End ...	460	Mar.	'70
Simple Relay Counting Circuit, by G. A. French ...	534	Apr.	'70
Space Dx ...	338	Jan.	'70
Spring and All That ...	533	Apr.	'70
The Eddystone EC958 Receiver ...	106	Sept.	'69
The Good, The Bad and The Ugly ...	400	Feb.	'70
The Hi-Fi Boom ...	560	Apr.	'70
The "Kakness Ternet", by M. Walters ...	40	Aug.	'69
Top Band Dx ...	368	Jan.	'70
Top Band Trans-Atlantic Tests, 1969-70 ...	552	Apr.	'70
Torch Battery Power Pack, by R. L. Graper ...	330	Jan.	'70
Veni, Vidi, Vici ...	729	July	'70

## IN YOUR WORKSHOP

A-to-Z Game ...	758	July	'70
Amplifier Construction ...	248	Nov.	'69

Chassis Tags	434	Feb. '70
Circuit Diagram	505	Mar. '70
Choice of Transistor	246	Nov. '69
Chopper Power Supply	566	Apr. '70
Common Impedance	435	Feb. '70
Constant Current Device	696	June '70
Constant Current Devices	177	Oct. '69
Dynamic Microphone	760	July '70
Energising Current	49	Aug. '69
Feedback Control	571	Apr. '70
Flexible Torch	116	Sept. '69
Flutter and Wow	760	July '70
Great Circle	762	July '70
Half-Wave Heater Chain	307	Dec. '69
Home Construction	433	Feb. '70
Inductive Time Constant	50	Aug. '69
Long-Tailed Pair	180	Oct. '69
Low Power Dissipation	567	Apr. '70
Polymerisation	312	Dec. '69
Probe Unit Circuit	507	Mar. '70
Protection Circuit	246	Nov. '69
Quench Frequency	763	July '70
Readers' Hints	112	Sept. '69
Readers' Hints	369	Jan. '70
Refractive Index	636	May '70
Reservoir Inductor	568	Apr. '70
Resistance Box	638	May '70
RMS Current Checker	310	Dec. '69
Shading Ring	47	Aug. '69
Signal Traces	503	Mar. '70
Soldering	437	Feb. '70
Spares Box System	634	May '70
Terminal Strips	114	Sept. '69
Voltage Tests	309	Dec. '69
Wire-Wrap Tags	635	May '70

#### RECEIVERS

"Cir-Kit" Personal Portable Superhet, by <i>J. Hossack</i>	148	Oct. '69
Developing the "Spontaflex" Short Wave Receiver, by <i>Sir Douglas Hall, K.C.M.G., M.A.(Oxon)</i>	420	Feb. '70
Experimental Reflex Radio, by <i>A. Sapciyan</i>	486	Mar. '70
The "Globe-Ranger" 4-Band Superhet, by <i>F. G. Rayer, G3OGR</i>	744	July '70
High-Stability TRF Receiver, by <i>F. G. Rayer, G3OGR</i>	352	Jan. '70
Hybrid Transportable Receiver, by <i>Sir Douglas Hall, K.C.M.G., M.A.(Oxon)</i>	221	Nov. '69
Low-Cost Regenerative Receiver, by <i>A. Sapciyan</i>	339	Jan. '70
"Milliwatt" Silicon Reflex TRF, by <i>G. W. Short</i>	82	Sept. '69
Miniature Radio 2 Receiver, by <i>R. D. Owen</i>	202	Nov. '69
New Life for "Midget Receivers", by <i>P. Dewhurst</i>	168	Oct. '69
The "Airlane" 7-Transistor Aircraft Band Receiver, by <i>C. H. G. Mills</i>	224	Nov. '69
The "Discovery" Short Wave Receiver, by <i>Frank A. Baldwin</i>	464	Mar. '70
The "Discovery" - Further Notes, by <i>Frank A. Baldwin</i>	722	July '70
The "Fetaflex 4" Transistor Portable, by <i>Sir Douglas Hall, K.C.M.G., M.A.(Oxon)</i>	548	Apr. '70
The "Spontaflex" Silicon S.A.3 Portable, by <i>Sir Douglas Hall, K.C.M.G., M.A.(Oxon)</i>	266	Dec. '69

#### RECEIVER ANCILLARIES

Double Speaker Unit for the SWL, by <i>Frank A. Baldwin</i>	87	Sept. '69
High Frequency Crystal Controlled Oscillators, by <i>J. B. Dance, M.Sc.</i>	53	Aug. '69
Mains-Battery Supply with Automatic Switching, by <i>G. A. French</i>	210	Nov. '69
Transistorised Crystal Marker, by <i>S. G. Wood, G5UJ</i>	338	Jan. '70
1MHz Frequency Sub-Standard Unit, by <i>Frank A. Baldwin</i>	282	Dec. '69
2-Transistor Converter for "Ten", by <i>A. S. Carpenter, G3TYJ</i>	216	Nov. '69

#### TAPE RECORDING

Cassette Recorder Mains Unit, by <i>P. L. Matthews</i>	544	Apr. '70
For the SWL - Getting Started with a Tape Recorder	458	Mar. '70
Tape Recording Birdsong	413	Feb. '70
Understanding Tape Recording, Part 1, by <i>W. G. Morley</i>	621	May '70
Understanding Tape Recording, Part 2, by <i>W. G. Morley</i>	691	June '70
Understanding Tape Recording, Part 3, by <i>W. G. Morley</i>	754	July '70

#### TELEVISION

European Systems TV Conversion, by <i>M. N. Corbett, A.M.R.T.S.</i>	561	Apr. '70
---	-----	----------

#### TEST EQUIPMENT

Constant Current Generator for Ohmmeter Conversion, by <i>J. C. Maycock</i>	360	Jan. '70
C.R.O. Beam Switching Unit, by <i>P. Cairns, G3ISP</i>	614	May '70
Miniature Oscilloscope, by <i>R. Starksfield</i>	32	Aug. '69

Neon-L.D.R. A.F. Oscillator, by G. A. French	593	May '70
Radio Frequency Probe, by G. A. Stanton, G3SCV	470	Mar. '70
Simple Frequency Meter, by J. B. Dance, M.Sc.	424	Feb. '70
Simple Low-Cost R-C Bridge, by P. L. Matthews	271	Dec. '69
Simple Voltage Monitor, by G. A. French	662	June '70
Simplified Solid-State Distortion Meter, by G. A. Stanton, G3SCV	596	May '70
Solid-State A.C. Millivoltmeter, by P. Cairns, G3ISP	736	July '70
Solid-State D.C. Voltmeter and A.C. Millivoltmeter, by G. A. Stanton, G3SCV	96	Sept. '69
Suppressed-Zero Voltmeter, by R. M. Marston	212	Nov. '69
Transistorised G.D.O. for the H.F. Bands, Part 1, by R. J. Hulbert, G3SRY	138	Oct. '69
Transistorised G.D.O. for the H.F. Bands, Part 2, by R. J. Hulbert, G3SRY	297	Dec. '69
Unusual Null Indicator, by R. D. John	733	July '70
Versatile A. C. Millivoltmeter, by G. W. Short	342	Jan. '70
3-Volt Neon Test Unit, by G. A. French	275	Dec. '69

**TRANSMITTING**

'Getting Out' with an End-Fed Wire, by A. S. Carpenter, G3TYJ	540	Apr. '70
---	-----	----------

**RADIO CONSTRUCTORS DATA SHEET**

No. 29 Squares of Numbers	iii	Aug. '69
30 Square Roots of Numbers	iii	Sept. '69
31 Cubes of Numbers	iii	Oct. '69
32 Cube Roots of Numbers	iii	Nov. '69
33 Half-Wave Rectifier Outputs	iii	Dec. '69
34 R.M.S., Peak and Average Values	iii	Jan. '70
35 Bias Resistor Voltages	iii	Feb. '70
36 Phase Shift Oscillator C-R Values	iii	Mar. '70
37 Capacitance Units	iii	Apr. '70
38 Abbreviations - A to L	iii	May '70
39 Abbreviations - M to Z	iii	June '70
40 Hartley Oscillator	iii	July '70

**UNDERSTANDING RADIO**

43 Aug. '69	107	Sept. '69	173	Oct. '69
237 Nov. '69	302	Dec. '69	363	Jan. '70
427 Feb. '70	493	Mar. '70		

**RADIO TOPICS**

55 Aug. '69	118	Sept. '69	184	Oct. '69
249 Nov. '69	376	Jan. '70	439	Feb. '70
704 June '70				

**CAN ANYONE HELP?**

37 Aug. '69	104	Sept. '69	167	Oct. '69
234 Nov. '69	295	Dec. '69	359	Jan. '70
414 Feb. '70	480	Mar. '70	669	June '70
753 July '70				

**NEWS AND COMMENT**

22 Aug. '69	78	Sept. '69	146	Oct. '69
208 Nov. '69	280	Dec. '69	336	Jan. '70
404 Feb. '70	472	Mar. '70	538	Apr. '70
602 May '70	666	June '70	730	July '70

**QSX**

77 Sept. '69	207	Nov. '69	335	Jan. '70
478 Mar. '70	610	May '70	732	July '70

**CURRENT TRENDS**

301 Dec. '69	362	Jan. '70	432	Feb. '70
492 Mar. '70	537	Apr. '70	640	May '70
690 June '70				

**CURRENT SCHEDULES**

426 Feb. '70	488	Mar. '70	546	Apr. '70
601 May '70	677	June '70	750	July '70

**LATE NEWS**

441 Feb. '70	509	Mar. '70	573	Apr. '70
641 May '70	705	June '70	765	July '70

**LAST LOOK ROUND**

441 Feb. '70	509	Mar. '70	573	Apr. '70
641 May '70	705	June '70	765	July '70

**NOW HEAR THESE**

415 Feb. '70	471	Mar. '70	553	Apr. '70
605 May '70	671	June '70	729	June '70



## THE HARTLEY OSCILLATOR

The Hartley oscillator is identifiable by reason of the tap in its tuned coil. The basic Hartley oscillator appears in (a), and the shunt-fed version in (b). In (c) the earthy connection is shifted from the tap to one end of the coil. Transistor Hartley oscillators may have the same basic configuration as (a), (b) and (c) with the collector replacing the anode, the base the grid and the emitter the cathode, but different bias conditions are needed and the lower impedances associated with transistors can be troublesome. A practicable transistor Hartley oscillator is shown in (d). In all diagrams it is assumed that there is negligible impedance between the supply rails.

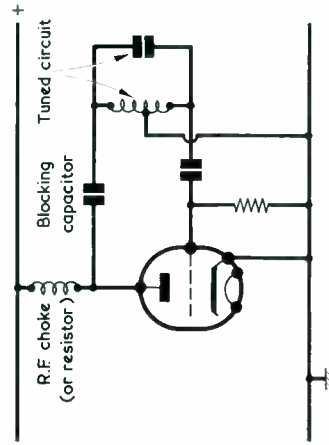

(a)

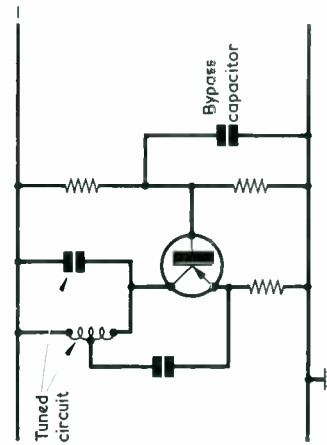

(b)

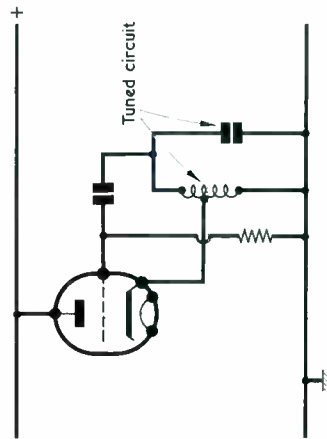

(c)

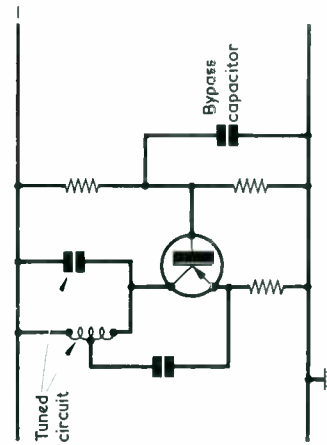

(d)

# HENRY'S RADIO LTD.

# ENGLAND'S LEADING COMPONENT AND EQUIPMENT CENTRES

## COMPLETE STEREO SYSTEM FOR £39-10-0

Hencele 5.5 Stereo Amplifier Inputs for ceramic Cartridge, Tuner/AMF etc. Output for 8 to 15 ohm Speakers. Silver with black and wood finish. British made. Size 12" x 3 1/2" x 6 1/2". Fitted headphone socket. Complete system comprises 5.5 Amplifier, Garrard 3000 or Model 50 with 9TAHC diam. Cartridge, pair EMI 10 watt Speakers, twin Tweeters and Crossover, with polished wood Cabinets 18" x 11" x 7", also Plinth and Cover.

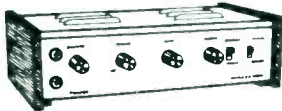

- Complete Stereo System (Recommended price £50) £39.10.0 p.p. 20/-
- Amplifier only £13.19.6 p.p. 7/6
- DHO25 Recommended Stereophones 45/-

## BUILD THIS VHF FM TUNER

5 MULLARD TRANSISTORS 300 kc/s BANDWIDTH PRINTED CIRCUIT HIGH FIDELITY HI-PRODUCTION MONO & STEREO A popular VHF/FM tuner for quality and reception of mono and stereo. There is no doubt about it—VHF/FM gives the REAL sound. All parts sold separately. Ask for LEAFLET No. 3

**PARTS TOTAL COST £6.19.6 p.p. 3/6**  
**DECODER (FOR STEREO) £5.19.6**



New printed circuit design with full power output. Fully tuneable on both mw/lw bands. 7 Mullard transistors. Fitted 5" speaker. Room filling power. Easy to build, with terrific results. Two colour leathercloth cabinet with silvered front. All local and continental stations. Complete detailed instructions.

**TOTAL COST £6.19.6 p.p. 6/6**  
 Ask for Leaflet No. 1

## BUILD YOURSELF A QUALITY RADIO



## SINCLAIR EQUIPMENT

Z30 75/- each STEREO 60 £8.10.0. PZ5 7/6. PZ6 £6.19.6.

Z50 £5.9.6. PE8 £5.19.6.

Two of Z30 STEREO 60 PZ5 (usually £23.10.0) £19 or with PZ6 in place of PZ5 £21

SPECIAL OFFER

COMPLETE RANGE OF AMPLIFIERS AND PREAMPLIFIERS IN STOCK ALL DETAILED IN CATALOGUE ABOVE

## TEST EQUIPMENT FOR YOUR HOME



- AF/105 50k/v Multimeter (Illustrated). Price £8.10.0 p.p. 3/6. Leather case 28/6
- 200H 20k/v Multimeter Price £3.17.6 p.p. 3/-. Case 12/6
- TE20D RF Generator Price £15. p.p. 7/6
- TE22D Matching Audio Generator Price £17. p.p. 7/6
- TE65 Valve Voltmeter Price £17.10.0 p.p. 3/6. (Illustrated)

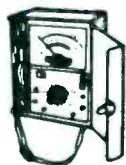

FULL DETAILS AND COMPLETE RANGE IN CATALOGUE

## HI-FI equipment to suit EVERY POCKET

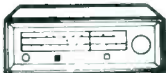

FREE STOCK LIST NO. 16/17 ON REQUEST

CHOOSE FROM 100 COMPLETE STEREO SYSTEMS — COMPLETE RANGE OF INDIVIDUAL UNITS ALSO IN STOCK DEMONSTRATIONS ALL DAY

**LOW CASH AND CREDIT/HP PRICES**  
 (CREDIT TERMS FROM £30 PURCHASE —CALLERS ONLY)



## HENRY'S LATEST CATALOGUE

NEW PRINT NOW 350 PAGES

COMPONENTS ★ EQUIPMENT ★ SPECIAL OFFERS  
 ★ TEST GEAR ★ MODULES  
 EVERYTHING FOR THE CONSTRUCTOR

Complete with 10% value discount vouchers for use with purchases

WHY NOT SEND AWAY TODAY!

PRICE 7/6 p.p. 2/-



## 25 WATT & 50 WATT RMS SILICON AMPLIFIERS

LOOK AT THE SPECIFICATIONS!

- 0.3% DISTORTION AT FULL POWER
- 1dB 11 c/s to 40 kc/s AT FULL POWER
- RESPONSE 1dB 11 c/s to 100 kc/s

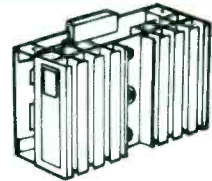

PA25 10 Silicon Transistors. Differential Input. 25 watts RMS to 8 ohms. 700mV Input. Size only 5" x 3" x 2". 4-hole fixing. Supplied with Edge Connector and Harness

PA50 12 Transistor Version 50 watt RMS into 3 to 4 ohms. Size 5" x 3" x 4"

MU442 Power Supply for one or two PA25 or one PA50

- PA25 £7.10.0
- PA50 £9.10.0
- MU442 £6

NO SOLDERING — JUST PLUG CONNECTORS!

## YOU CAN SAVE 25% WITH BRAND NEW GARRARD UNITS

(Post etc 7/6)

SP25 Mk II £11.9.6. AP75 £16.19.6

SL65B £14.19.6. SL72B £25. A70 Mk II £11.19.6

Above with Sonotone 9TAHC diam. add £2. With magnetic add 70/-. With Goldring G800 add £8.10.0.

Also fitted with 9TAHC Diamond Model 50 £8.10.0. 3000 LM £9.15.0.

Plastic Covers: Standard 99/6 p.p. 4/6

Deluxe £8.10.0 or SL72B type £8.10.0 p.p. 6/- (None for A70)

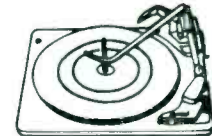

HENRY'S STOCK EVERY TYPE OF COMPONENT YOU NEED A CATALOGUE IS A MUST

## SCOOP! NEW 4 TRACK TAPE DECKS

BRITISH MADE 3-SPEED MAINS OPERATED TAPE MACHINE FITTED MARRIOTT XRPS17 and XES11 TRACK HEADS PIANO KEY OPERATION DESIGNED FOR THE HOME CONSTRUCTOR OPERATES WITH UP TO 7" SPOOLS VERTICALLY OR HORIZONTALLY SIZE 13" x 10" x 5 1/2"



PRICE £13.19.6 p.p. 7/6

## ELECTRONIC ORGANS

- ★ MODERN ALL BRITISH TRANSISTORISED DESIGNS AVAILABLE AS KITS OR READY BUILT
- ★ TEAK VENEERED CABINETS FOR ALL MODELS
- ★ 49 NOTE OR 61 NOTE SINGLE MANUAL DESIGNS ALSO TWO-MANUAL 49 NOTE
- ★ KITS AVAILABLE IN SECTIONS AS REQUIRED
- ★ HP and CREDIT SALE FACILITIES

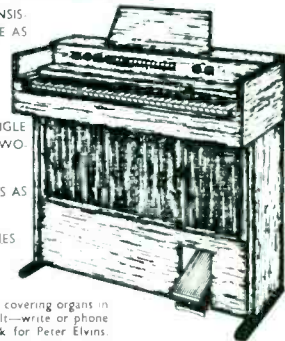

FREE 16 page organ brochure covering organs in kit form and ready built—write or phone to ORGAN DEPT. Ask for Peter Elvins

# HENRY'S RADIO LTD.

Mail Order Dept., Components, Organ Dept.  
 303 EDGWARE ROAD, LONDON W.2.  
 Telephone: 01-723 1008-9

High Fidelity and Equipment Centre  
 309 EDGWARE ROAD, LONDON W.2.  
 Telephone: 01-723 6963

OPEN MON-SAT 9am-6pm THURS 9am-1pm