

THE

# RADIO CONSTRUCTOR

Vol. 23 No. 5

DECEMBER 1969

THREE SHILLINGS

## Light Controlled Tone Generator

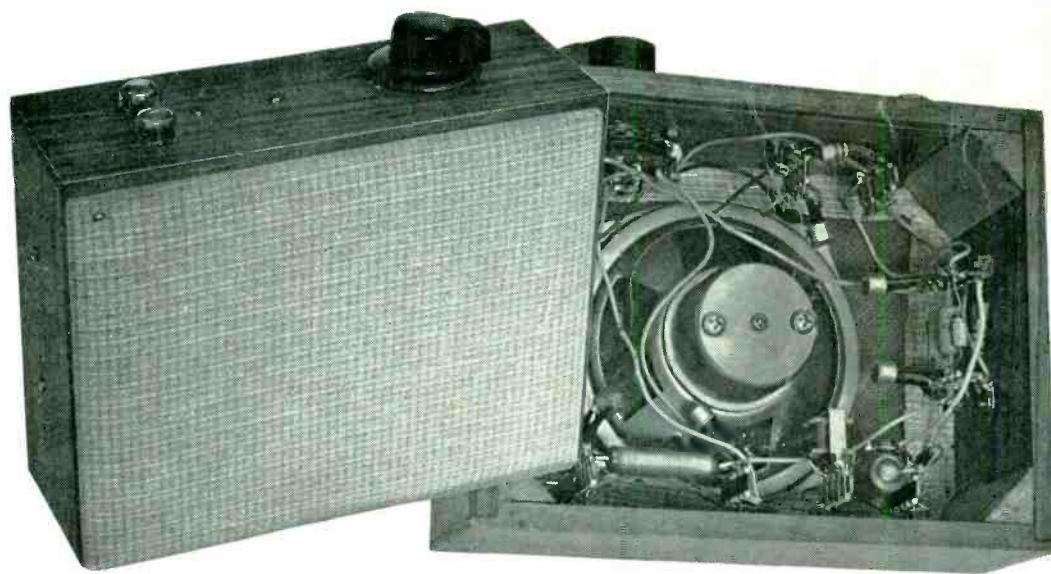

**Producing a continual or interrupted a.f. tone  
whose frequency varies with light intensity**

*Special*  
**IN THIS ISSUE**

**“Spontaflex” Silicon Portable Receiver  
1MHz Frequency Sub-Standard Unit**





## GUARANTEED TRANSISTORS

AD161-2	12/-	GET693	1/3	2N3055	16/6
AF239	10/-	HK041	2/6	2N3707	4/-
B5000G	11/3	HK101	2/-	2N3794	3/-
BD121	18/-	HK601	2/6	2N3983	5/8
BC107B	3/-	I544	1/4	2N4058	4/6
BC168B	2/3	MEM564C	16/-	2N4285	3/-
BC169C	2/6	5F115	3/-	2N4289	3/-
BF167	5/3	T1S18	7/-	2N4291	3/-
BF178	9/-	T1S60M	4/8	2N4292	3/-
BF224	4/-	T1S61M	4/11	2SB187	2/-
BF225	4/-	2N706	2/7	2SB405	5/-
BFY51	4/-	2N2926G	2/6	2SD72	5/-
		40468A	7/6		

## RECTIFIERS:

800piv, 500mA Si. IS557, 3/-; 50piv, 100mA. 1/-; Submin. Selenium Bridge, 30Vrms, 150mA dc, 3/6; Contact-cooled Sel. Bridge, 30Vrms, 700mA dc, 6/-; Silicon Bridge, 80Vrms, 1A dc, 10/-.

**£1 = 25/- ?**

It does, if you cash in on our  
**XMAS BARGAIN OFFER**

For every whole £ you send, select  
25/- worth of goods from this  
advert or our current list

**FOR ONE MONTH ONLY**  
**ENDS JANUARY 1**

## COMPONENT KITS

**NEW!** In response to many requests, we have designed an amplifier circuit for use with low-impedance speakers. The new AX5 delivers 3W to 3Ω and uses the well-tried arrangement of the AX4, plus one extra stage for higher sensitivity and input impedance.

- \* 3W rms to 3Ω. Higher loads usable
- \* -3dB at 50Hz and 20kHz
- \* 30mV in 300k for full output

The AX5 needs a 12V, 500mA supply and will work from up to 15V. Component Kit with Data Sheet 35/-.

**AND ALSO OUR REGULAR PACKS—  
RELIABLE AND EFFICIENT:**

- AX2** Mini 9V Amplifier for any load. Still only 12/6.
- AX3** 9V Amplifier, 800mW to 8Ω. Still only 22/6.
- AX4** 18-24V Amplifier, up to 5W in 8Ω. 4W in 15Ω. Still only 30/-.
- AX9** TRF Receiver Kit (printed circuit). Still only 45/-.

## CAPACITORS

Polystyrene, 160V, small, close tolerance. 6d. each: 10, 12, 15, 18, 22, 39pF, ± 1pF 9d. each: 56, 82, 100, 120, 150, 180, 220, 270, 330, 390, 560, 680, 820pF, ± 2½% 1/- each: 3300pF (.0033uF), 10,000pF (.01uF), 15,000pF (.015uF), ± 2½% 1/3 each: 22,000pF (.022uF, 22nF), ± 2½% Min. Metallised Polyester, 250V: .01uF, 8d.; 0.1uF, 10d.; 0.22uF, 1/-; J. B. Tuning Capacitors: 300pF Dilemin. 10/-; 4-gang 3-17pF FM type, built-in slow motion drive, 17/-.

## RESISTORS

Carbon Film, ¼W, miniature, low noise. 10, 12, 15, 18, 22, 27, 33, 39, 47, 56, 68, 82Ω and so on to 10M. Tol. ± 5% to 1M, 10% above 1M. All 3d. each. Carbon Skeleton Presets. Submin., vertical, linear, 100mW, 50, 150, 500Ω and so on to 1.5M. Egen Type 467, 1/6 each. Volume Control, 10K log. with d.p. switch and long aluminium spindle with flat. Standard size, Egen, 5/6 each. R. F. CHOKES. Repanco: CH1, 2.5mH, 2/6; CH2, 5mH, 3/-; CH3, 7.5mH, 3/-; CH4, 10mH, 3/-; CH5, 1.5mH, 2/6. All small, ferrite-cored. **FERRITE RODS:** 4in. or 4½in. x ½in. wound for MW (300pF), 5/-; unwound, 2/-; oval, unwound, 2 x ½ x ½in., with data, 2/6. **TRANSFORMERS, MINI. A.F.:** Eagle LT700, 1200Ω c.t. to 3Ω, 200mW, 5/-; Repanco TT47 driver for single ended push-pull, 4.5 to (1) + (1), 6/-; **TELESCOPIC AERIAL:** 7½in. opening to 47in., 9/-; **BATTERY HOLDER BH2** for two 1.5V pen cells, with snap connector, 2/6. **EARPIECES,** all 3.5mm plugged, crystal, 4/9; magnetic, 8Ω, 2/6; 50Ω, 3/-.

# THE MODERN BOOK CO

## TRANSISTOR, AUDIO AND RADIO CIRCUIT

For Radio Receivers, Radiograms, Record Players,  
Tape Record Players and Hi-Fi Equipment

**30s.**

A Mullard Publication

Postage 1s.

### Servicing with the Oscilloscope

by Gordon J. King. 28s. Postage 1s.

### Colour Television PAL System

by G. N. Patchett. 40s. Postage 1s.

### Audio Amplifiers

by DATA. 10s. 6d. Postage 6d.

### Television Engineers' Pocket Book

by J. P. Hawker. 21s. Postage 1s.

### Beginner's Guide to Radio Control

by Warring. 18s. 6d. Postage 1s.

### Electronics Pocket Book

by J. P. Hawker. 21s. Postage 1s.

### Mathematics for Radio and Electronics

Technicians by Fritz Bergtold. 50s.

• Postage 1s.

### Radio Servicing Problems

by W. A. L. Smith. 9s. Postage 6d.

### Amateur Radio Call Book 1970

by RSGB. 6s. 6d. Postage 6d.

### Basic Theory and Application of

Transistors. 17s. Postage 1s.

### The Hi-Fi and Tape Recorder Handbook

by Gordon J. King. 40s. Postage 1s.

### Transistor Manual

by General Electric Company. 21s. Postage 2s.

### Solution of Problems in Electronics and

Telecommunications by Henson. 38s.

Postage 2s.

### Beginner's Guide to Colour Television

by Squires. 15s. Postage 1s.

We have the Finest Selection of English and American Radio Books in the Country

**19-21 PRAED STREET (Dept RC) LONDON W2**

Telephone PADdington 4185

# There's Something for Everyone in the NEW HEATHKIT CATALOGUE!



- GUITAR PRACTICE AMPLIFIER
- ELECTRONIC METRONOME
- AMBASSADOR SPEAKERS
- HI-FI SYSTEMS
- AUTO TUNE-UP METER
- AIRCRAFT MONITOR RECEIVER
- CAR RADIO
- TECHNICIANS' LOW-COST VVM
- SEVERN AM/FM RADIO
- SW RECEIVERS
- FABULOUS STEREO HI-FI COMPACTS
- STEREO RECORD PLAYER
- D.I.Y. SPEAKER SETS
- GENERATORS, RF, AUDIO, TV
- POWER SUPPLIES
- D.I.Y. RADIOGRAM PACKS
- MANY OTHER MODELS TOO NUMEROUS TO MENTION

Send for this  
**FREE Catalogue**  
and see for yourself, Today!



**DAYSTROM LIMITED,**  
HEATHKIT DIVISION,  
GLOUCESTER, GL2-6EE  
Tel: Glos 29451. Telex 43216

To DAYSTROM LTD., GLOUCESTER, GL2-6EE  
Please send me my free copy of the  
1970 HEATHKIT CATALOGUE

NAME.....  
ADDRESS.....

RG-12

# BOUND VOLUME No. 22 of "The Radio Constructor" FOR YOUR LIBRARY

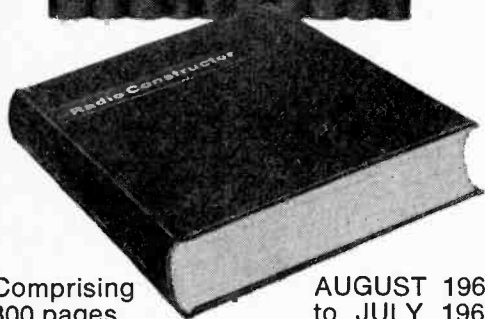

Comprising  
800 pages  
plus index

AUGUST 1968  
to JULY 1969

**PRICE 35/- Postage 4/6**

### Special discount of 10/- for regular readers

Just cut the heading from each month's contents page, including title and month of issue, and this will be sufficient evidence of readership to qualify for the discount.

Thus regular readers will still retain their copies for workbench use, while having a splendid bound volume containing issues in mint condition.

**PRICE 25/- Postage 4/6**

### Limited Number of Volume 21

(August 1967 to July 1968) still available

**Price 35/- Postage 4/6**

Available only from:-

**Data Publications Ltd.**  
57 Maida Vale London W9

## Now! A FAST EASY WAY TO LEARN BASIC RADIO AND ELECTRONICS



Build as you learn with the exciting new  
TECHNATRON Outfit! No mathematics.

No soldering—but you learn the *practical* way.

Now you can learn basic Radio and Electronics at home—the *fast*, modern way. You can give yourself the essential technical 'know-how' sooner than you would have thought possible—read circuits, assemble standard components, experiment, build . . . and enjoy every moment of it. B.I.E.T.'s Simplified Study Method and the remarkable new TECHNATRON Self-Build Outfit take the mystery out of the subject—make learning *easy and interesting*.

Even if you don't know the first thing about Radio now, you'll build your own Radio set within a month or so!

and what's more, YOU'LL UNDERSTAND EXACTLY WHAT YOU ARE DOING. The Technatron Outfit contains everything you need, from tools to transistors . . . even a versatile Multimeter which we teach you how to use. You need only a little of your spare time, the cost is surprisingly low and the fee may be paid by convenient monthly instalments. You can use the equipment again and again—and it remains your own property.

You LEARN—but it's as fascinating as a hobby.

Among many other interesting experiments, the Radio set you build—and it's a good one—is really a bonus; this is first and last a *teaching* Course. But the training is as rewarding and interesting as any hobby. It could be the springboard for a career in Radio and Electronics or provide a great new, spare-time interest.

A 14-year-old could understand and benefit from this Course—but it teaches the real thing. Bite-size lessons—wonderfully clear and easy to understand, practical projects from a burglar-alarm to a sophisticated Radio set . . . here's your chance to master basic Radio and Electronics, even if you think you're a 'non-technical' type. And, if you want to carry on to more advanced work, B.I.E.T. has a fine range of Courses up to A.M.I.E.R.E. and City and Guilds standards.

Send now for free 164-page book.

Like to know more about this intriguing new way to learn Radio and Electronics? Fill in the coupon and post it today. We'll send you full details and a 164-page book —'ENGINEERING OPPORTUNITIES'—Free and without any obligation.



### BRITISH INSTITUTE OF ENGINEERING TECHNOLOGY

Dept. 370B, Aldermaston Court,  
Aldermaston, Berkshire.

To: B.I.E.T., Dept. 370B, ALDERMASTON COURT,  
ALDERMASTON, BERKS.

I would like to know more about your  
Practical Radio & Electronics Course. Please  
send me full details and FREE 164-page book.

name.....

address.....

age.....



# This book will send you mad with desire!



Don't read on unless you're feeling really strong. This book will start you on a mad, crazy spending spree. It's got everything, but everything for the do-it-yourself radio and hi-fi man.

Everything from a vast range of electronic components available to the home electronics constructor, to a complete range of equipment for the radio "ham". What's the book?

The *Electronics Constructor's Catalogue*. Only the most exciting, mouth-watering items are there. Carefully placed in 6 sections for easy reference. And backed by truly efficient sales service.

So if you order any of the vast selection of goods, you're sure to get it pretty soon.

All you have to pay for this great big hunk of temptation is 13s.- (including packaging and postage).

**So fill in the coupon now. If you dare.**

Enclose PO/cheque made out to:  
Electroniques (proprietors Standard Telephones  
and Cables Limited), Edinburgh Way, Harlow,  
Essex. Telephone: Harlow 26811.

Name .....

Address .....

RC1

**EF**  
electroniques

# DENCO (CLACTON) LIMITED

## 355-7-9 OLD ROAD, CLACTON-ON-SEA, ESSEX

---

Our components are chosen by Technical Authors and Constructors throughout the World for their performance and reliability, every coil being inspected twice plus a final test and near spot-on alignment as a final check.

Our General Catalogue showing full product range	...	...	...	2s. 6d.
DTB4 Transistor & Valve circuitry for D.P. Coils	...	...	...	2s. 6d.
DTB9 Valve Type Coil Pack Application circuitry	...	...	...	2s. 6d.
MD.1 Decoder Circuitry for Stereo Reception	...	...	...	4s. 0d.

All post paid, but please enclose S.A.E. with all other requests in the interests of retaining lowest possible prices to actual consumers.

*Read all about building a —*

# DIGITAL PROPORTIONAL

## 6-CHANNEL RADIO CONTROL OUTFIT

*in "RADIO MODELLER" magazine*

● **SPECIAL OFFER —**

**TWO ISSUES**—Containing the 2-part article on building up the Remcon "QUANTUM SIX" six function digital proportional superhet receiver and transmitter

*for only 5/- (normally 7/-)*

**Send now, enclosing 5/- P.O. or cheque to:—**

● **RADIO MODELLER, (Dept. S.O.),**  
**64 WELLINGTON ROAD, HAMPTON HILL, MIDDLESEX**



# BI-PRE-PAK LIMITED

## FULLY TESTED AND MARKED

ACI07	3/-	OC170	3/-
ACI26	2/6	OC171	4/-
ACI27	2/6	OC200	3/6
ACI28	2/6	OC201	7/-
ACI76	5/-	2G301	2/6
ACY17	3/-	2G303	2/6
AF114	4/-	2N711	10/-
AF115	3/6	2N1302-3	4/-
AF116	3/6	2N1304-5	5/-
AF117	3/6	2N1306-7	6/-
AF186	10/-	2N1308-9	8/-
AF139	10/-	2N3819	9/-
AF239	12/6	Power Transistors	
BFY50	4/-	OC20	10/-
BSY25	7/6	OC23	10/-
BSY26	3/-	OC25	8/-
BSY27	3/-	OC26	5/-
BSY28	3/-	OC28	7/6
BSY29	3/-	OC35	5/-
BSY95A	3/-	OC36	7/6
OC41	2/6	AD149	10/-
OC44	2/6	AUY10	30/-
OC45	2/6	2N3055	15/-
OC71	2/6	Diodes	
OC72	2/6	AAY42	2/-
OC73	3/6	OA95	2/-
OC81	2/6	OA70	1/9
OC81D	2/6	OA79	1/9
OC83	4/-	OA81	1/9
OC139	2/6	IN914	1/6
OC140	3/6		

## TRY OUR X PACKS FOR UNEQUALLED VALUE

### XA PAK

Germanium PNP type transistors, equivalents to a large part of the OC range, i.e. 44, 45, 71, 72, 81, etc.

PRICE £5 PER 1,000  
POST & PACKING 4/6 U.K.

### XB PAK

Silicon TO-18 CAN type transistors NPN/PNP mixed lots, with equivalents to OC200-1, 2N706a, BSY27/29, BSY95A.

PRICE £4.50 PER 500 £8 PER 1,000  
POST & PACKING 2/6 U.K.

### XC PAK

Silicon diodes miniature glass types, finished black with polarity marked, equivalents to OA200, OA202, BAY31-39 and DK10, etc.

PRICE £4.10.0 PER 1,000  
POST & PACKING 2/6 U.K.

ALL THE ABOVE UNTESTED PACKS HAVE AN AVERAGE OF 75% OR MORE GOOD SEMI-CONDUCTORS. FREE PACKS SUSPENDED WITH THESE ORDERS. ORDERS MUST NOT BE LESS THAN THE MINIMUM AMOUNTS QUOTED PER PAK.

## NEW TESTED & GUARANTEED PAKS

B2	4	Photo Cells, Sun Batteries. .3 to .5V. .5 to 2mA.	10/-
B77	2	AD161-AD162 NPN/PNP Trans. Comp. output. Pair	10/-
B79	4	1N4007 Sil. Rec. Diodes. 1000 Piv. 1 amp Miniature.	10/-
B81	10	Reed Switches. Mixed types large and small.	10/-
B89	2	5SP5 Light Sensitive Cells. Light res. 400Ω. Dark 1MΩ.	10/-
B91	8	NKT163/164 PNP Germ. to -5. Equiv. to OC44, OC45.	10/-
B92	4	NPN Sil. Trans. A06=BSX 20, 2N2369, 500 MHz, 360 mW.	10/-
B93	5	GET113 Trans. equivalent to ACY17-21 PNP Germ.	10/-
B94	6	NPN Sil. Planar Epitaxial Trans. CS4 similar to BSY38 or BC108.	10/-
B96	5	2N3136 PNP Sil. Trans. TO-18. HFE100-300. 1C.600mA. 200 MHz.	10/-
B98	10	XB112 & XB102 equiv. to AC126, AC156, OC81/2, OC71/2, NKT271, etc.	10/-
B99	200	Capacitors, Electrolytics, Paper, Silver Mica, etc. Postage on this pak 2/6.	10/-
H4	250	Mixed Resistors. Post & packing 2/-.	10/-

**FREE!** Packs of your own choice up to the value of 10/- with orders over £4.

## LOOK! TRANSISTORS ONLY 1/- EACH

**TYPE A**  
PNP SILICON ALLOY TO-5 CAN  
Spec.- hFE 15-100. ICER at VCE=20V 1mA Max. These are of the 25300 range which is a direct equivalent to the OC200-205 range.

**TYPE B**  
PNP SILICON PLASTIC ENCAPSULATION  
Spec.- hFE 10-200. ICER at VCE=10V 1mA Max. These are of the 2N3702-3 and 2N4059-62 range.

**TYPE C**  
NPN SILICON TO-18 CAN  
Spec.- hFE 50-900. ICER at VCE=20V 1mA Max. These are similar to BC108-9 Types.

## Return of the unbeatable P.1 Pak.

### Now greater value than ever

Full of short lead semiconductors and electronic components, approx. 170. We guarantee at least 30 really high quality factory marked Transistors PNP and NPN, and a host of diodes and rectifiers. Mounted on printed circuit panels. Identification chart supplied to give some information on the transistors.

**P.1 PLEASE ASK FOR PAK P.1 ONLY 10/-**  
2/- P & P on this Pak.

## NEW UNMARKED UNTESTED PAKS

B78	12	Integrated Circuits, Data & Circuits of types, supplied with orders.	10/-
B80	8	Dual Trans. Matched O/P pairs NPN. Sil. in TO-5 can.	10/-
B82	10	OC45, OC810 & OC81 Trans. Mullard glass type.	10/-
B83	200	Trans. Makers rejects. NPN/PNP. Sil. & Germ	10/-
B84	100	Silicon Diodes DO-7 glass equiv. to OA200, OA202.	10/-
B66	150	High quality Germ. Diodes. Min. glass type.	10/-
B86	50	Sil. Diodes sub. min. IN914 & IN916 types.	10/-
B87	100	Germ. PNP Trans. equiv. to OC44, OC45, OC81, etc.	10/-
B88	50	Sil. Trans. NPN. PNP. equivalent to OC200/1, 2N706A, BSY95A, etc.	10/-
B60	10	7 Watt Zener Diodes. Mixed voltages.	10/-
H5	16	1 Amp. Plastic Diodes. 50-1000 Volts.	10/-
H6	40	250mW. Zener Diodes DO-7 min. Glass Type.	10/-

**MAKE A REV. COUNTER for your Car.** The 'TACHO BLOCK'. This encapsulated block will turn any 0-1mA meter into a perfectly linear and accurate rev. counter for 20/- each any car. State 4 or 6 cylinder.

**FREE CATALOGUE AND LISTS for:-**  
**ZENER DIODES**  
**TRANSISTORS, RECTIFIERS**  
**FULL PRE-PAK LISTS**  
**& SUBSTITUTION CHART**

MINIMUM ORDER 10/-. CASH WITH ORDER PLEASE. Add 1/- post and packing per order. OVERSEAS ADD EXTRA FOR AIRMAIL.

## MULLARD DATA BOOK

Semiconductor & Valve 3/6  
Data & equivalents. EACH  
Postage 6d.

**SPECIAL OFFER**  
12 volt Stabilised Power Units  
Input 110-250V. AC  
Output 11-13V. Stabilised  
At 1 Amp.  
Brand new  
Makers surplus  
at the unrepeatable  
price of £5 each  
plus P & P 7/6

**FREE! A WRITTEN GUARANTEE WITH ALL OUR TESTED SEMICONDUCTORS**

**BI-PRE-PAK LTD** DEPT. C, 222-224 WEST ROAD, WESTCLIFF-ON-SEA, ESSEX  
TELEPHONE: SOUTHEND (0702) 46344

# Give us a ring on Christmas day!



... or any day you please (Sundays included) – any time of day or night. Your message will be received loud and clear. Even if we are not there “live” at the other end of the line, our telephone recording machine will take your message for us to deal with as soon as we are back on the job. If your message is a fat order we’ll be delighted. If it’s just a teeny weeny order we’ll still be delighted.

*This “order-by-phone” facility is just one of the many advantages offered by our new CREDIT ACCOUNT SERVICE. Here are a few more advantages:—* Order forms and prepaid envelopes are provided, so if you want to order by post, you don’t even have to find a stamp. To settle your account you need only *one* cheque, postal order or money order per month. Normally on credit accounts there is a minimum invoice charge of 30/-, but we stipulate *no* minimum.

Of course, this Credit Account Service is available only if you are already using our catalogue for ordering components, but after you have been in the service for 12 months we regularly send you an up-to-date catalogue *FREE* of charge.

Like to know more about this trouble-saving, money-saving service? Then drop us a line or give us a ring, 01-648 8422.

You should certainly have an up-to-date copy of the Home Radio Catalogue even if you do not intend to use our Credit Account Service. It’s a *must* for every Radio and Electronics enthusiast. It has 350 pages and lists 8,000 components, over 1,500 of them illustrated. Moreover it contains 6 vouchers, each worth 1/- when used as indicated. Give *yourself* a Christmas present this year. Post the coupon with 12/- (8/6 plus 3/6 post and packing) and we’ll send your catalogue by return of post.

*Please write your Name and Address in block capitals*

NAME .....

ADDRESS .....

Home Radio (Components) Ltd.,  
Dept. R.C., 234-240 London Road, Mitcham CR4 3HD.



A Happy  
Christmas  
to all our  
readers!

# THE Radio Constructor



Incorporating THE RADIO AMATEUR

DECEMBER 1969

Vol. 23 No. 5

## CONTENTS

Published Monthly (1st of Month)  
First Published 1947

Editorial and Advertising Offices  
57 MAIDA VALE LONDON W9

Telephone 01-286 6141      Telegrams Databux, London

© Data Publications Ltd., 1969. Contents may only be reproduced after obtaining prior permission from the Editor. Short abstracts or references are allowable provided acknowledgement of source is given.

Annual Subscription 42s. (U.S.A. and Canada \$5) including postage. Remittances should be made payable to "Data Publications Ltd.". Overseas readers please pay by cheque or International Money Order.

Queries. We regret that we are unable to answer queries other than those arising from articles appearing in this magazine nor can we advise on modifications to equipment described. Queries should be submitted in writing and accompanied by a stamped addressed envelope for reply.

Correspondence should be addressed to the Editor, Advertising Manager, Subscription Manager or the Publishers as appropriate.

Opinions expressed by contributors are not necessarily those of the Editor or proprietors.

Production.—Letterpress.

THE "SPONTAFLEX" SILICON S.A.3 PORTABLE RECEIVER	266
SIMPLE LOW-COST R-C BRIDGE	271
3-VOLT NEON TEST UNIT (Suggested Circuit No. 229)	275
NEWS AND COMMENT	280
1MHz FREQUENCY SUB-STANDARD UNIT	282
LIGHT CONTROLLED TONE GENERATOR	288
INDEX - RADIO CONSTRUCTOR'S DATA SHEETS	294
CAN ANYONE HELP?	295
TRANSISTORISED G.D.O. FOR THE H.F. BANDS (PART 2)	297
RECENT PUBLICATIONS	300
CURRENT TRENDS	301
UNDERSTANDING RADIO - THE MOVING COIL METER	302
IN YOUR WORKSHOP	307

Published in Great Britain by the Proprietors and Publishers, Data Publications Ltd, 57 Maida Vale, London, W.9.

The Radio Constructor is printed by Kent Paper Company Ltd, London and Ashford, Kent.

DECEMBER 1969

JANUARY ISSUE WILL BE PUBLISHED  
ON JANUARY 1st

# THE "SPONTAFLEX" SILICON S.A.3. PORTABLE

by

SIR DOUGLAS HALL, K.C.M.G., M.A. (Oxon)

**This medium and long wave receiver updates the author's earlier S.A.4 design by employing modern silicon transistors. Only three transistors are required and the extremely low capacitive loading across the single tuned circuit is amply demonstrated by the fact that the whole of the medium wave band is covered with a 100pF tuning capacitor**

**T**HE CIRCUIT OF THIS PORTABLE receiver is based on that used in the Spontaflex S.A.4., published in *The Radio Constructor* for May, 1968. That is to say it makes use of the Spontaflex principle, but employs two transistors connected as a super-alpha pair at radio frequencies. The second transistor amplifies at audio frequencies in the common base

configuration, and the first gives a further stage of audio frequency amplification as a common collector device. The advantage of using a super-alpha pair at radio frequencies is that the input to the first transistor is maintained at a very high impedance with the result that very little damping is imposed on the tuned circuit, even though the whole

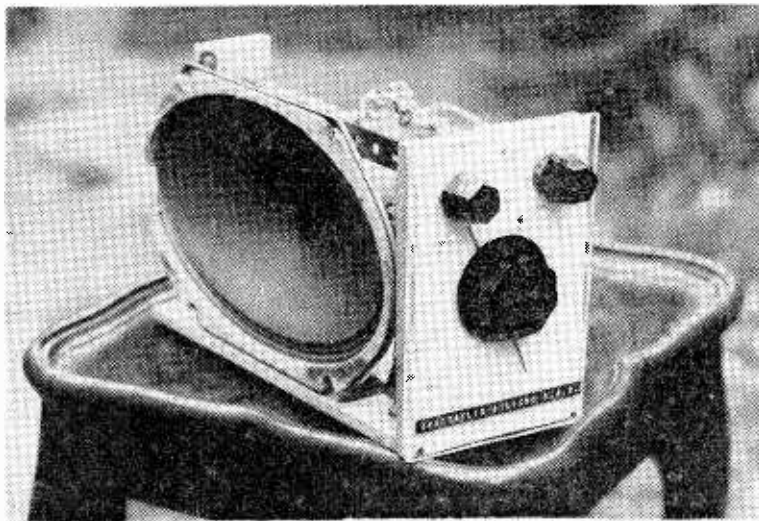

*The receiver removed from its cabinet*

of this is applied across the input. At the same time, the output of the pair is at low impedance and offers a good match to the low impedance diode used for detection. This results in an unusually high degree of both sensitivity and selectivity.

The earlier circuit used micro-alloy transistors, and two effects manifested themselves. First, there was instability if an attempt was made to use all the current amplification available at radio frequencies, and the intermediate coupling stage had to be damped to overcome this. Secondly, the receiver proved unstable at the high frequency end of the medium wave band unless about 50pF capacitance was present in the tuned circuit. As a result, a normal tuned circuit consisting of a fixed inductance and variable capacitor would require that capacitor to have a maximum of 500pF to cover the wave band. This could cause severe loss at the low frequency end of the band as a fairly high inductance to capacitance ratio is essential for efficient working of this circuit. Use was made, therefore, of a variable inductance shunted by a trimmer adjusted to about 50pF.

## NEW TRANSISTORS

Since the previous circuit was designed the author has carried out many experiments with various newer types of silicon transistor for the super-alpha pair, and has found that with the Texas BF225 (which is a very high frequency type), as TR1 and a 2N3707 as TR2 stability is maintained without the need to damp the intermediate coupling, and without the need for any extra capacitance, over and above inevitable strays, in the tuned circuit at the high frequency end. The result is even greater amplification at the high frequency end of the medium wave band, and the possibility of covering the whole band with a 100pF tuning capacitor. The internal capacitances of the BF225 are exceptionally low, and the inductance of the long and medium wave-band coils is about 800 $\mu$ H and 10mH respectively. These inductances are over three times the normal for transistor tuners and this in itself gives a starting gain of about 10 times the normal. The present receiver is easier to build than the S.A.4 since the special tuner required for the latter does not have to be made, and there are, of course, fewer components. The present version also covers the whole of the long wave band instead of the Radio 2 programme on 1500 metres only.

The need for a high 'Q' in the tuned circuit was demonstrated by the fact that the prototype of this receiver was first fitted with a solid dielectric tuning capacitor. This was later replaced by the air spaced type specified, with a marked increase in

THE RADIO CONSTRUCTOR

efficiency over the low frequency half of the medium wave band.

### CIRCUIT OPERATION

To study the functioning of the

## COMPONENTS

### Resistors

(All fixed values 1/4 watt 10%)

R1	680Ω
R2	2.2kΩ
R3	5.6kΩ
R4	47kΩ
R5	5.6kΩ
R6	75Ω
VR1	5kΩ potentiometer, log, moulded track (e.g. Cat. No. VR18B, Home Radio)

### Capacitors

C1	560pF silver-mica
C2	0.01μF paper or plastic foil
C3	0.05μF paper or plastic foil
C4	2,000pF paper or plastic foil
C5	2,000pF paper or plastic foil
C6	0.01μF paper or plastic foil
C7	100μF electrolytic, 2.5V wkg.
C8	50μF electrolytic, 2.5V wkg.
VC1	100pF variable, type C.804 (Jackson Bros.)

### Inductors

L1, L2, L3, L4	See text
L5	2.5mH choke type CH1 (Repanco)
L6	2.5mH choke type CH1 (Repanco)
T1	Output transformer type TT5 (Repanco—Home Radio Cat. No. TRC33)

### Semiconductors

TR1	BF225
TR2	2N3707
TR3	BC168B
D1	OA73

### Switch

S1	3-pole 3-way miniature rotary
----	-------------------------------

### Speaker

3Ω elliptical 8in. x 5in.

### Miscellaneous

8in. x 1/2in. dia. ferrite rod  
10-way Bulgun tagboard, Cat. No. C125 (Home Radio)  
Epcyclic slow motion drive, Cat. No. 4511/F (Jackson Bros.)  
3 knobs  
PP9 battery  
Plywood, Paxolin, Perspex, etc.

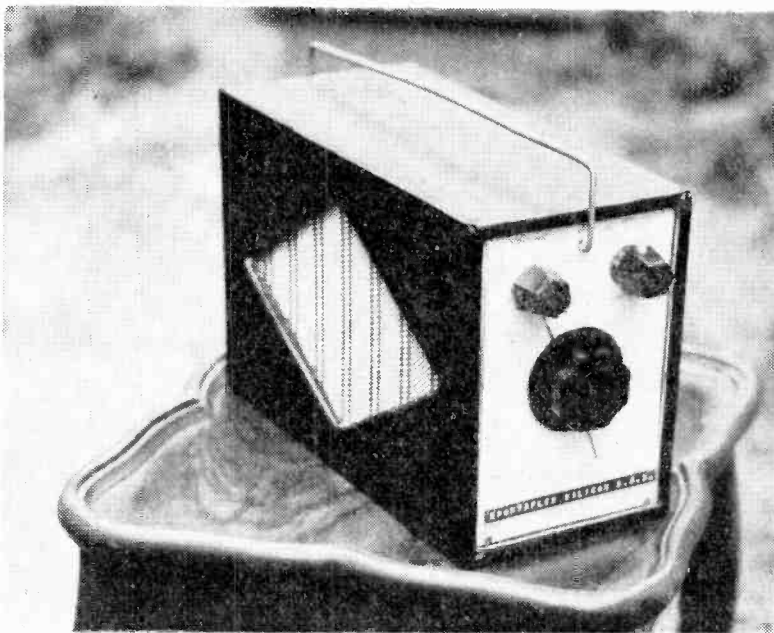

A simple case for the receiver can be readily made up. In this view the speaker aperture is visible at the left

circuit in detail, Fig. 1 should be examined. The signal is picked up by the ferrite rod assembly and passed to the base of TR1 which is at very high impedance. The output appears at the emitter of TR1 and across R1 and L5, in series with each other, L6 being effectively in parallel with these two. R1, which does not appear in the S.A.4 circuit,

is included to prevent L5 and L6 resonating and causing the possibility of instability at the natural frequency of these chokes, tuned by strays. Such effects can cause spurious oscillation.

TR2 acts as a second common collector r.f. amplifier and the output, at low impedance, appears across the diode, D1. Reaction is taken over

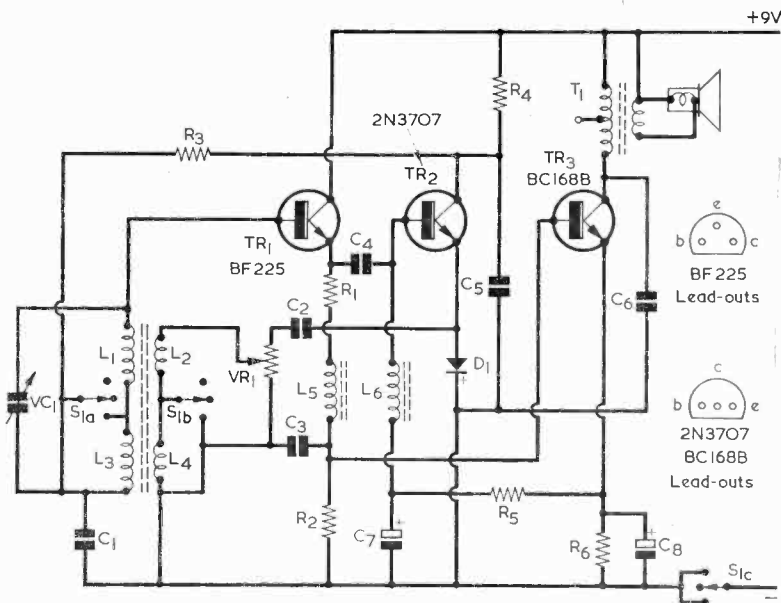

Fig. 1. The circuit of the "Spontaflex" Silicon S.A.3 Portable

both stages and is controlled by VR1. This component acts as a true volume control since it also damps the tuned circuit at low settings. The diode, being in the emitter circuit, allows TR2 to amplify as a common base audio frequency device, without the need for any coupling components, the a.f. output appearing across R4 at high impedance. The signal is then directly coupled back to TR1 which acts as a common collector audio frequency amplifier with the output across R1, L5 and R2, most of the signal voltage being across R2. Direct coupling takes place from R2 to the base of TR3 which is a silicon transistor with an exceptionally high amplification factor not so very far short of that given by both the transistors used as TR3 and TR4 in the S.A.4 design. There is overall negative feedback of d.c. through R5 which, in conjunction with R6, provides suitable bias for all three transistors.

Overall amplification will be found to be a little less than with the S.A.4., which used an extra audio frequency stage, but the dif-

ference is not great, particularly at the high frequency end of the medium wave band. Tested alongside a commercially made superhet with a 5in. ferrite slab for pickup, together with two i.f. stages and two audio stages in addition to the frequency changes, the S.A.3 gave good programme value from several stations which were only just audible on the superhet. The latter had slightly less spread on the very powerful local Radio 4 station, but on all other stations any superiority in selectivity on the part of the superhet was of no practical value.

Note that there is no electrolytic capacitor across the battery lines. Phase relationships are such that any internal resistance in the battery provides a small amount of negative feedback which helps to maintain stability and improve quality.

### CONSTRUCTION

The layout shown in Fig. 2 is recommended. Most of the components are mounted on the 10-way tagboard, which should be wired up

first. The exact positioning of components need not be as shown in Fig. 2, which has been drawn with clarity in view. There is no reason why components should not in practice, cross each other in the interests of short wiring.

The controls are mounted on a piece of 1/4in. plywood, 5 1/4in. by 3 1/4in. The mounting of VR1 and S1 is obvious. VC1 should be mounted on a small sub-panel of Paxolin or Perspex as the use of a slow motion drive is essential. An epicyclic ball drive is used and is mounted on the back of the plywood panel. Two 4BA bolts are then used with a total of three nuts each, to space the sub-panel so that the spindle of VC1 fits the ball drive.

### AERIAL COILS

An 8in. length of 1/4in. ferrite rod is used, and two separate sleeves are required for the coils. L1 and L2 are on one sleeve, and L3 and L4 on the other. The sleeves can be made of adhesive backed plastic, such as Contact or Fablon, the protective paper being left on except for a small strip cut away so as to allow the sleeve to be stuck to itself after passing round the rod. A few inches are wound round the rod, not too tightly, starting with the paper backed edge. The coils are wound on these sleeves with a home-constructed "tag panel" between them, as in Fig. 3(a).

For the "tag panel", cut out a piece of Paxolin 1in. by 1/2in., and drill a 1/8in. hole in it for the rod, as shown in Fig. 3(b). Fit six short 6BA bolts and nuts to this, these taking up the positions shown lettered A to F in Fig. 2, each bolt securing a solder tag. This "tag panel" is then passed over the rod to the position shown in Fig. 3(a) and cemented firm. The "tag panel" takes the coil connections A to F shown in Figs. 3(a) and Fig. 2. In Fig. 2 the L4 end of the rod is towards the reader. The other end of the rod is, later, cemented to a 1/8in. hole in the panel of Fig. 2, after the coils have been fitted to the rod and wired to the "tag panel".

Fit plastic sleeves to the rod, that for L1 and L2 being free to move along the rod slightly for final adjustment when setting up the receiver. (The sleeve length can be trimmed after winding with a razor blade.) The coils are then wound.

L1 has 125 turns of 32 s.w.g. enamelled wire, close-wound, and L2, separated by about 1/8in. has 10 turns of the same wire, also close-wound. L3 uses 38 s.w.g. enamelled wire and has 500 turns. These need not be close-wound, but a 2 1/2in. section of the sleeve should be divided by pencil marks into five sections each 1/2in. wide, and 100 turns of wire pile-wound into each section, giving more or less continuous pile

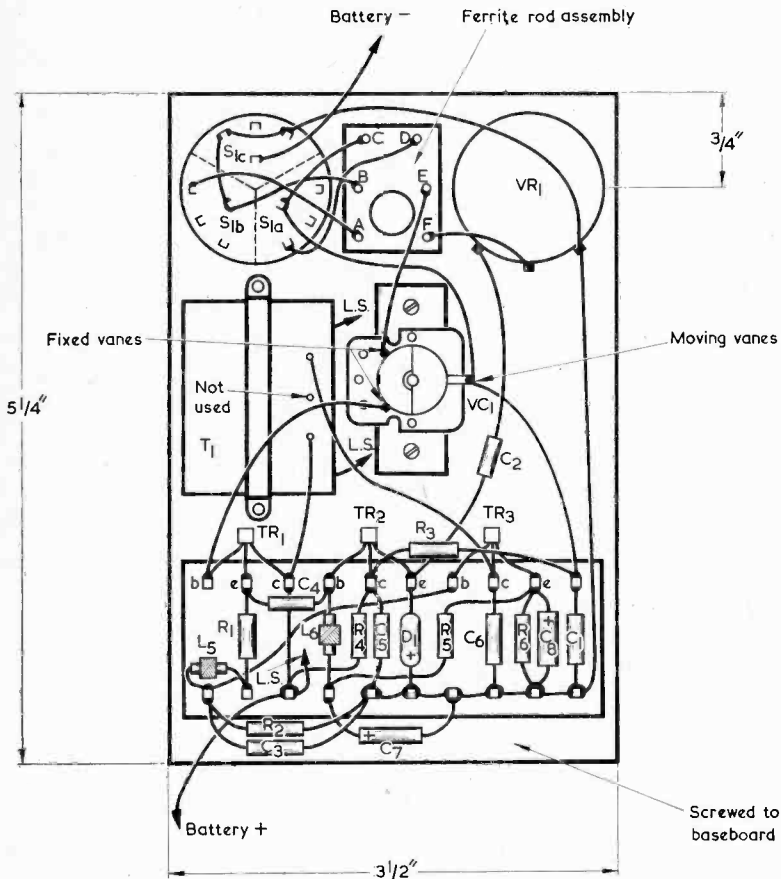

Fig. 2. Wiring and layout diagram. The lead marked "L.S." from the positive supply line may connect initially to either of the speaker tags

2½ in. long. L4 has 20 turns of 38 s.w.g. enamelled wire separated from L3 by ¼ in. All windings are in the same direction. After winding, the coil ends are connected to the central "tag panel", leaving sufficient slack in L1 and L2 leads for the sleeve on which these coils are wound to be moved slightly along the rod.

A piece of ¼ in. plywood, 2 in. x 1½ in. with a ¼ in. hole drilled through it is required as in Fig. 3(c). A further piece of similar plywood should be cut to measure 8 in. x 3¼ in., this forming a baseboard. The control panel is screwed to this as in Fig. 4. The 8 in. x 5 in. speaker is also fixed to this baseboard, by means of two stout metal brackets.

An important point to observe at this stage has to do with the shape of the speaker employed. If possible, the edge of the speaker should be close up to the panel. However, the shape of some speakers may result in the moving vanes of VC1 being fouled when they are open, whereupon the speaker must be moved along the baseboard by an appropriate amount. Moving the speaker position causes no difficulties so far as construction up to the present stage is concerned, but it does mean that the length of the case will need to be increased by a corresponding amount when this comes to be made.

The small piece of plywood in Fig. 3(c) is fitted over the end of the ferrite rod, having first been equipped with a bracket to couple it to the appropriate top mounting hole of the speaker. A further bracket connects the other top mounting hole of the speaker to the plywood panel. If sufficiently strong brackets have been used, the whole assembly will now be rigid. The small piece of plywood in Fig. 3(c) also serves to hold the top of the PP9 battery steady.

## TESTING

The receiver, when assembled and wired up, may next be tested. No adjustments are necessary except, perhaps, to move L1 and L2 a little along the rod to obtain correct coverage of the medium waveband. If motor-boating, low frequency howling or distortion should be present, reverse the primary lead connections of T1. Try, also, taking the lead from the positive line to the other speaker tag or removing it altogether. Keep the battery leads reasonably short and ensure that they are not too close to the aerial assembly. Make sure that the lead from T1 to the collector of TR3 does not pass too close to VC1, including the moving vanes when these are in the open position. As a last, and very unlikely, resort increase the value of R4 to, say, 56kΩ or so.

DECEMBER 1969

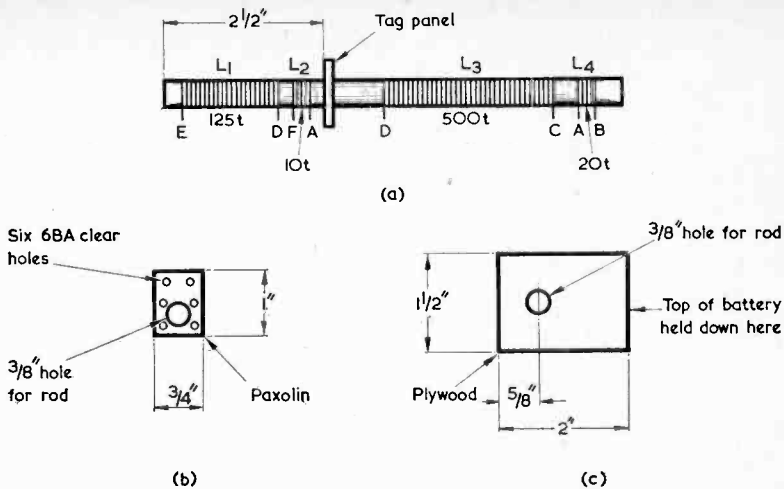

Fig. 3(a). Details of the aerial and reaction coils on the ferrite rod  
 (b). Dimensions of the aerial rod tag panel prior to fitting the solder tags  
 (c). The end support for the ferrite rod

## MAKING THE CASE

It is a simple matter to make a suitable case for the receiver, and the directions which follow apply to the prototype. As was mentioned earlier, it may be necessary to extend the length of the case to accommodate some loudspeakers. If this course should be necessary, the appropriate dimensions next to be referred to should be modified accordingly.

To commence with, two pieces of ¼ in. plywood, 8½ in. x 3½ in. should be cut for the top and bottom, one piece 5 in. x 3½ in. for the side (the other side is occupied by the control panel) and a piece 8½ in. x 5½ in., with a suitable aperture for the speaker, for the front. See Fig. 5, which also shows a stiff wire handle. One end of this passes through a hole in the 5 in. x 3½ in. side and the other through a second hole drilled through the top of the control panel,

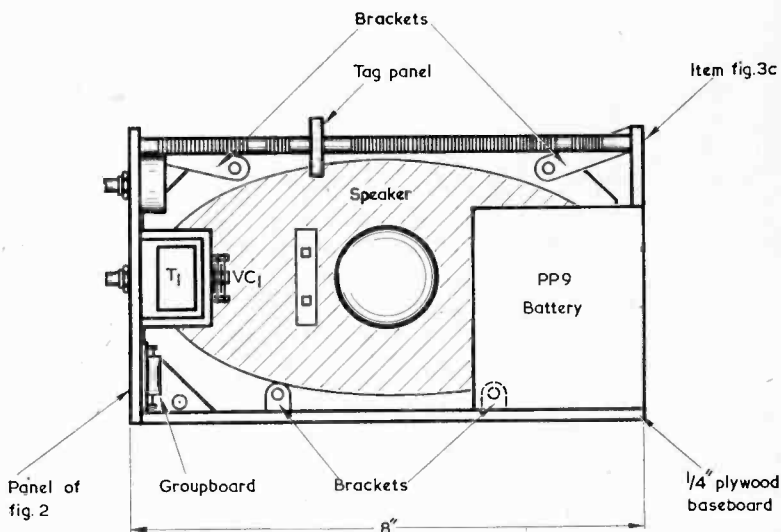

Fig. 4. The control panel is secured to the base board as shown here. Also illustrated are the mounting arrangements for the speaker and ferrite rod

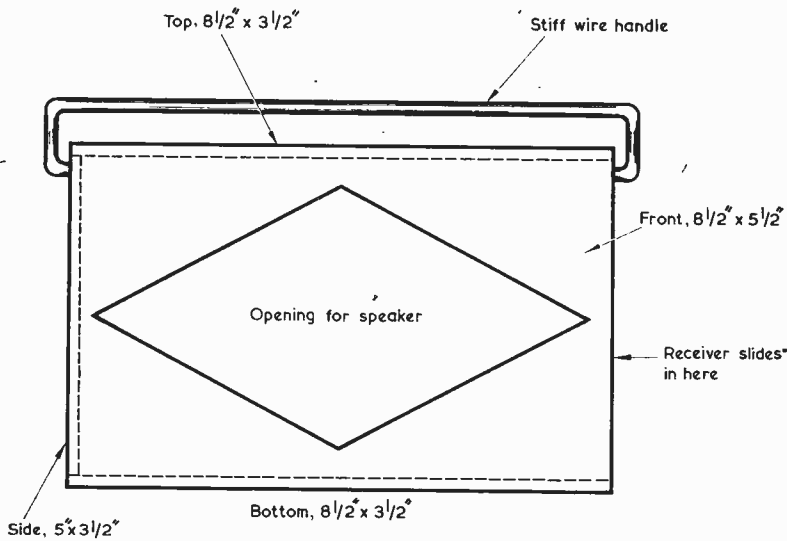

Fig. 5. Front view of the receiver case

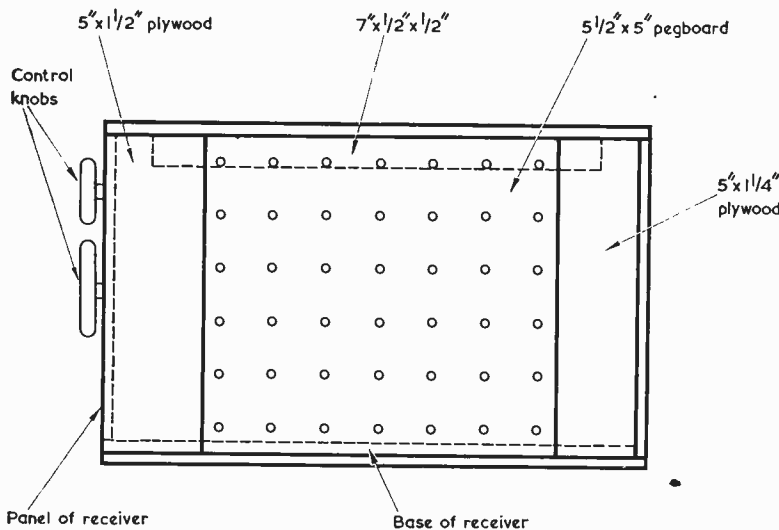

Fig. 6. The back of the case

care being taken not to damage the ferrite rod.

The back consists of two pieces of plywood measuring 5 in. x 1 1/2 in. and 5 in. x 1 1/4 in. respectively, screwed into position as shown in Fig. 6. A piece of 1/2 in. square wood, 7 in. long is screwed inside the top of the case by screws passing through the two 5 in. strips just mentioned. The square section wood serves as a support for the top of a piece of peg board which is cut to fit the open space left at the back. The bottom of the peg board is screwed to the baseboard of the receiver when this has been pushed into place. In order to replace the battery it is necessary to remove the handle and the peg board and then slide the receiver partly out of the case.

Do not attempt to save trouble

by substituting a solid plywood back for the case. This was done in the first instance with the prototype, but it was found that selectivity was such that it was necessary for most of the back to be of non-resonating material with air holes. Microphonic howling, which had been present with loud signals, disappeared completely when the change to the peg board was made, and quality was improved.

The front of the control panel should be covered with white card and calibrated for wavelength (an easy task with the very large number of stations receivable after dark) and marked as to the functions of the controls. A piece of Perspex, suitable drilled, and with the pointer moving behind it, gives a very neat finish if used as a final outer cover-

ing for the control panel. Adhesive plastic may be used to cover the case (but not the peg board back!) and a piece of speaker gauze may be slipped in front of the speaker.

## COMPONENTS

Finally, a word about components. TR1 and TR2 *must* be as specified. There may be others which would work as well, but their use might need many changes in component values. TR3 may be a different type, but this would probably result in a loss of amplification. (The author obtained all three transistors from Amatronix, Ltd.) If a more commonly used type of diode such as an OA81 is employed instead of the OA73, there will be a marked drop in sensitivity. T1 may be any output transformer with a ratio from about 15:1 to 20:1 and capable of passing 10mA without saturation. An LT700 could be used, but the TT5 gives a little more bass.

The author cannot recommend modifications to this particular circuit to enable frequencies higher than about 1.6Mc/s to be received satisfactorily, but he would be most interested to hear from any reader who is able to report success along these lines.

## SPLICER FOR CASSETTE 1/8 inch TAPE

Bib Division of Multicore Solders Ltd. announce the introduction of the Bib Model 24, Cassette Tape (1/8 in.) Splicing and Editing Kit.

Contained in a plastic wallet, attractively packed for peg board display, is a Bib Splicer with 1/8 in. width recessed block and fitted with chromium plated clamps for holding the tape while making diagonal or butt splices. Other accessories include: Plastic handle razor cutter, tape marker which may also be used for manually rotating the cassette hubs, reel of splicing tape on dispenser, device for withdrawing tape from the cassette and a comprehensive instruction leaflet.

This kit is believed to be the first to be marketed for 1/8 in. Tape, and has a recommended retail price of 29s. 0d.

The kit has been specifically designed for use in joining tape from C.60, C.90 or C.120 cassettes when it is required to cut out damaged tape and editing recordings, particularly when they have been made to synchronise with cine films or slides. It also enables music from pre-recorded cassettes to be joined so that the playing time of a single cassette is extended.

THE RADIO CONSTRUCTOR



# SIMPLE LOW-COST R-C BRIDGE

by

P. L. MATTHEWS

Simple circuitry and economy in components are combined in this design, which measures resistance from  $1\Omega$  to  $1M\Omega$  and capacitance from  $330pF$  to  $10\mu F$

ONE OF THE MOST IMPORTANT INSTRUMENTS IN THE home constructor's workshop is a reasonably accurate resistance and capacitance measuring bridge, and the design to be described aims at fulfilling this requirement at a considerably lower cost than is incurred with commercial units. The circuit employs only one transistor and about a dozen other components to provide a useful coverage of capacitance and resistance. As may be seen from the Table, capacitance readings are from approximately  $330pF$  to  $10\mu F$  in two ranges, and resistance readings are from  $1\Omega$  to  $1M\Omega$  in five ranges.

## CIRCUIT OPERATION

In order to obviate the expense of a null-reading meter or indicator tube it was decided to energise the bridge on both resistance and capacitance ranges by an audio oscillator, as is shown in Fig. 1. A crystal earpiece is then employed for null detection.

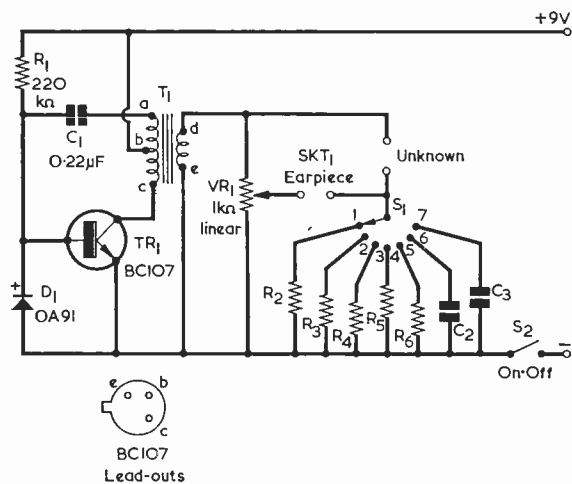

Fig. 1. The circuit of the resistance and capacitance bridge

## Resistors

(R2 to R6 and VR1—see text)

R1 220kΩ  $\frac{1}{4}$  watt 10%

R2 20Ω

R3 200Ω

R4 2kΩ

R5 20kΩ

R6 200kΩ

VR1 1kΩ wirewound, linear

## Capacitors

C2, C3 (see text)

C1 0.22μF, paper or plastic foil

C2 0.005μF

C3 0.5μF

## Transformer

T1 Radiospares transformer type T/T2  
(Home Radio Cat. No. TR60)

## Semiconductors

TR1 BC107

D1 OA91

## Switches

S1 1-pole 12-way, miniature rotary

S2 s.p.s.t., toggle or slide

## Socket

SKT1 3.5mm plastic jack socket (Home  
Radio Cat. No. JH24 or JH25)

## Battery

9-volt battery type PP7

## Miscellaneous

Crystal earpiece with 3.5mm jack plug  
6-way groupboard (Home Radio Cat. No.  
BTS13)

Battery connectors

Aluminium chassis, 6 x 4 x 2in.

Pointer knob

Self-adhesive plastic sheet (see text)

2 insulated terminals

Paxolin backing sheet for groupboard

COMPONENTS

**TABLE**

**Resistance and Capacitance Ranges**

Resistance ranges are given to extreme ends, but accuracy increases for resistance readings near the centre of a range. On Range 6 the product of dial reading and capacitance equals  $0.1\mu\text{F}$ , and on Range 7 the product of dial reading and capacitance equals  $10\mu\text{F}$ .

S. Position	Range
1	$1\Omega - 330\Omega$
2	$10\Omega - 3.3\text{k}\Omega$
3	$100\Omega - 33\text{k}\Omega$
4	$1\text{k}\Omega - 330\text{k}\Omega$
5	$10\text{k}\Omega - 1\text{M}\Omega$
6	$330\text{pF} - 0.1\mu\text{F}$
7	$0.03\mu\text{F} - 10\mu\text{F}$

The oscillator is a series-fed Hartley type, with TR1 as the oscillator transistor. T1 is a Radiospares transistor output transformer type T/T2, originally intended for feeding a  $3\Omega$  speaker from two OC72 output transistors. In the present arrangement the centre-tapped primary appears in the oscillator circuit (terminals "a", "b" and "c") whilst the secondary (terminals "d" and "e") couples to the bridge. The oscillator circuit is economical of components although there is a slight frequency shift when the transformer secondary is loaded. The frequency of oscillation is about 1 kHz, but this can be reduced, if desired, by connecting a capacitor whose value is found experimentally across the primary between points "a" and "c". The function of diode D1, which must *not* be omitted, is to reduce the magnitude of negative pulses appearing on the base of TR1. D1 would not be necessary but for the excessive feedback

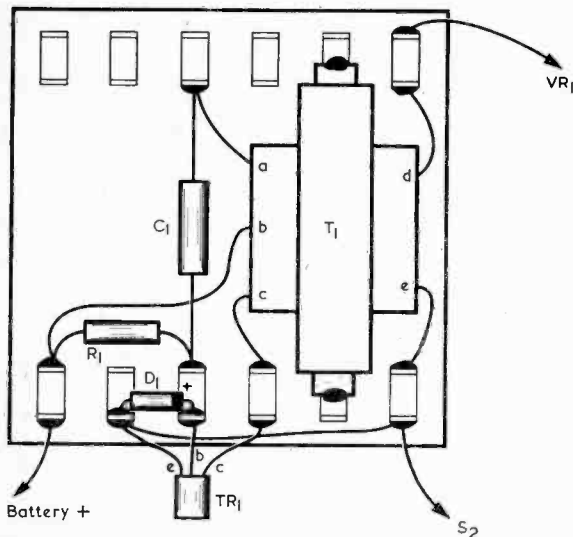

Fig. 2. The oscillator section is wired on a 6-way groupboard

in the circuit due to the centre-tapping of the tuning inductance.

From the secondary of T1, the audio signal is applied to the arms of the bridge, this consisting of VR1 and the standard and "unknown" components. The standard components are C2 and C3, and R2 to R6 inclusive. The potentiometer is directly calibrated on the front panel and it has been found possible to measure three decades without altering the standard. However, in order to provide a more accurate determination, the resistance standards are changed every decade and the capacitance standards every two decades, making seven ranges in all. The values of the standard resistors were dictated by the author's requirement of accurate measurement down to  $1\Omega$  and an indication to  $0.5\Omega$ , and this was found convenient when a value of  $20\Omega$  was employed for R2. Remaining resistance standards then go up in decades to  $200\text{k}\Omega$ , the upper limit of measurement being set at  $1\text{M}\Omega$  by the difficulty of obtaining a proper balance due to stray capacitances. The capacitance ranges were not required to be as accurate or as comprehensive as those for resistance, and it is possible to extend the coverage in both directions provided due care is taken to minimise "strays" on the lower ranges. Unfortunately, the capacitance readings increase in the opposite direction to resistance readings, but the use of suitable standards enables the values to be calculated from a simple formula.

For the  $0.005\mu\text{F}$  standard,

$$(\text{dial reading}) \times (\text{value of capacitance}) = 0.1\mu\text{F}$$

and for the  $0.5\mu\text{F}$  standard,

$$(\text{dial reading}) \times (\text{value of capacitance}) = 10\mu\text{F}$$

Readers not wishing to carry out the requisite calculations when taking readings can, of course, add a capacitance scale to the potentiometer dial, this being graduated from the resistance values on the resistance scale.

It should be noted that the values of electrolytic capacitors cannot be measured with this bridge.

**COMPONENTS**

The standard resistors R2 to R6 should have a tolerance of 2% or better. Suitable resistors, in  $\frac{1}{2}$  watt or  $\frac{1}{4}$  watt, are available with 1% tolerance from Home Radio (Components) Ltd. The same supplier also stocks  $0.005\mu\text{F}$  and  $0.5\mu\text{F}$  capacitors in 1% tolerance for C2 and C3 respectively. If a high degree of accuracy for either resistance or capacitance is not required, the associated standard components could have a tolerance of 5%.

The potentiometer used for VR1 should be a good quality wirewound component. The writer employed a Radiospares "Semi-Precision" wirewound control, but this unfortunately is not listed in the catalogues of the large mail order houses, although any radio dealer should be able to order it for the reader. (Radiospares components may only be obtained through retailers). Fig. 4 gives a dial calibration which applies to the Radiospares component, and which will be equally applicable to any other linear wirewound component provided that the overall angle of useful rotation is the same. In practice, this requirement should be met by most conventional potentiometers. VR1 is specified in the Components List as  $1\text{k}\Omega$ , but this value is not at all critical, and values between  $25\Omega$  and  $25\text{k}\Omega$  have been used with equal success. This last point could be of particular assistance to constructors who already have an assort-

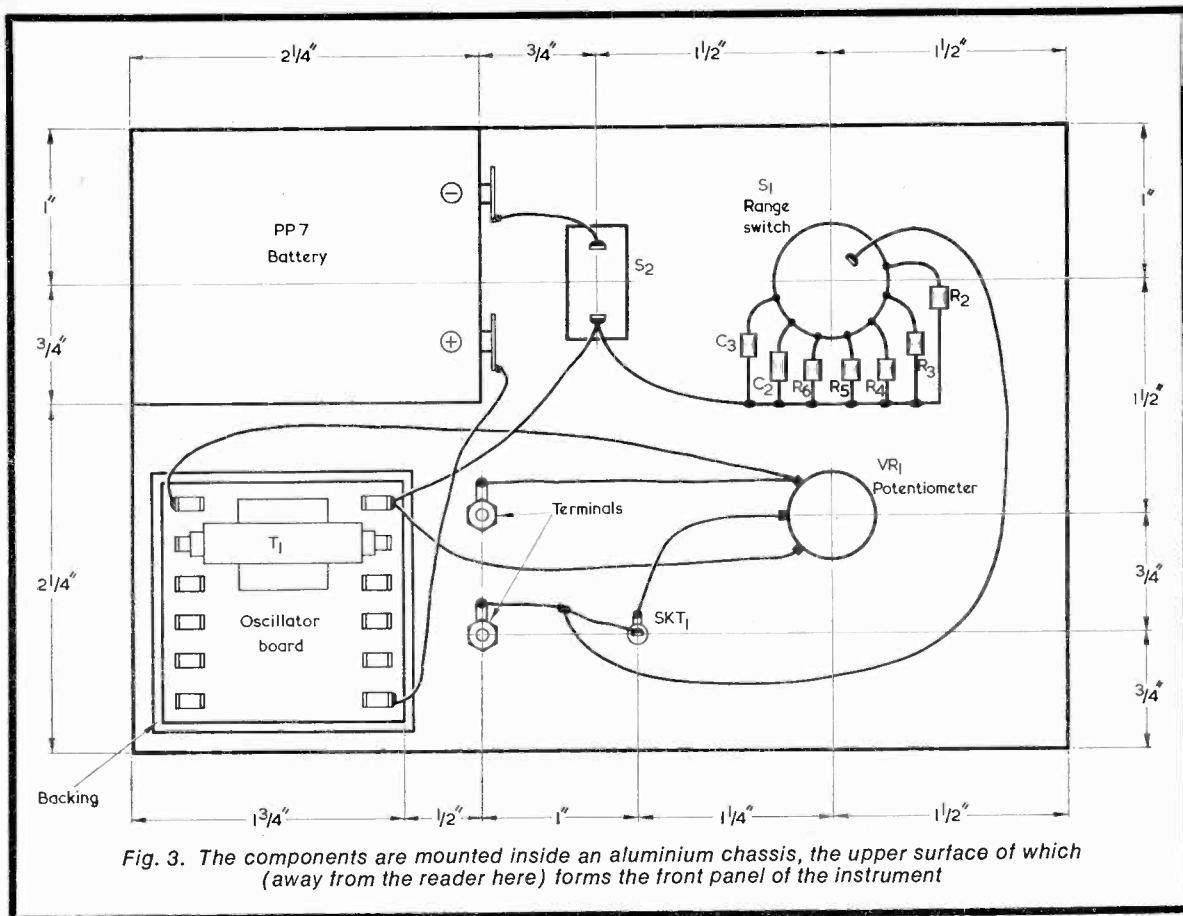

Fig. 3. The components are mounted inside an aluminium chassis, the upper surface of which (away from the reader here) forms the front panel of the instrument

ment of wirewound potentiometers on hand.

The bridge is assembled on an aluminium chassis measuring 6in. by 4in. by 2in. deep. Chassis of this size are available from Home Radio (Components) Ltd.

A miniature plastic jack socket is employed for SKT1, whilst two insulated terminals are used for the "unknown" component connections.

S1 is a single pole 12-way miniature rotary switch. Five of its positions are unused.

As a final point it should be noted that the case of the transistor specified is common to its collector. The transistor case should not, in consequence, touch any other connections.

## CONSTRUCTION

The construction of the bridge is simplified by mounting the oscillator section on a small 6-way groupboard. It was found convenient to solder the mounting lugs of transformer T1, which are intended for insertion into a printed circuit board, to two flattened tags of the groupboard, as shown in Fig. 2. After the transformer leads have been connected, the remaining four components can be soldered in position, the transistor being fitted last. The oscillator may now be checked by wiring a 9 volt battery to the correct tags and connecting the crystal earpiece across the secondary of the transformer, whereupon a loud whistle should be heard.

DECEMBER 1969

If all is well, the main chassis can next be prepared. As already mentioned, this is a 6 by 4 by 2in. deep aluminium chassis, and it should first be drilled as shown in Fig. 3. Six holes are required for the controls, socket and terminals, and probably two or more for mounting the battery. In the prototype, battery mounting was accomplished by bolting a simple L-shaped piece of aluminium through slots in the chassis, this being arranged to hold the PP7 battery against the chassis wall.

Once the chassis has been drilled it should be covered, inside and out, with self-adhesive sheeting, such as "Contact" or "Fablon", to provide electrical insulation and improve the appearance. A soldering iron will be found helpful in trimming the edges of holes through the plastic, but it must be cleaned carefully afterwards.

The next stage is to fit the battery, controls, socket and terminals. It is important to ensure that the sockets and terminals are insulated from the chassis. The component board should be glued to a piece of Paxolin or similar to act as "backing" before being glued to the chassis as, otherwise, the plastic underneath the metal tags would melt when soldering to the tags.

After all the assembly has been completed, the bridge should be wired up. Note that no direct connection is made to the chassis. At this stage only the 2kΩ resistance standard (R4) should be fitted. The remaining resistance standards are wired in later.

273

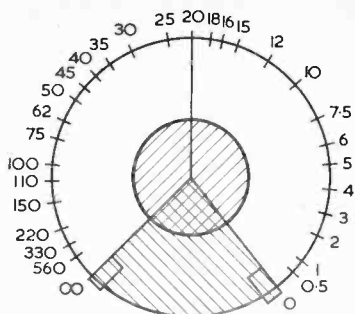

Fig. 4. The scale calibration obtained with the prototype

## CALIBRATION

The bridge can now be switched on and tested, two of the remaining standards being employed for determining the position of the dial scale.

The scale obtained with the prototype is shown in Fig. 4, and this may be cut out and affixed to the instrument panel, if desired. For the reasons already discussed, the scale will be accurate if the same type of potentiometer as was used in the prototype is employed. The scale should be reasonably accurate with most other potentiometers. First, select Range 3, connect the 200Ω standard resistor to the "unknown" terminals and balance the bridge. This resistor corresponds to "2" on the scale. Repeat with the 20kΩ resistor, which corresponds to "200" on the scale. These two settings enable the correct orientation of the scale to be found, whereupon it may be permanently affixed in position. If, due to the use of a different potentiometer, the angle of rotation between the "2" and "20" positions is considerably different from that given on the scale it will be necessary to calibrate a new scale from known values of resistance. However, the scale illustrated in Fig. 4 should be satisfactory for most potentiometers.

The remaining standards, R2, R3, R5 and R6 may now be wired in, whereupon the bridge is ready for use. A sharp null will be obtained on Ranges 1 and 2, this becoming progressively less distinct on the higher resistance ranges. As a final test, the accuracy of the bridge can be checked against any resistors and capacitors which are available. ■

## BETTER ELECTRON MICROSCOPES

Electron microscopes which will work at no less than one million volts, ten times a common voltage in use today: this is a development pioneered by Britain's National Physical Laboratory, and is being put into practical form by GEC-AEI. Reporting in a BBC broadcast, Richard Oliver said the electron microscope is the most powerful tool we have for looking at the microstructure of crystalline materials — metals, for instance. With modern machines scientists can get an idea of the way the individual atoms are linked together. These minute bonds govern the fundamental properties of everything, and knowledge of them is a step towards production of new materials which are stronger and lighter than those we have now.

The voltage of an electron microscope governs the thickness of specimens one can look at. By moving to one million volts, the scientists expect to see through specimens six times the thickness they can handle at present.

# RADIO CONSTRUCTOR

## JANUARY ISSUE

### HIGH SELECTIVITY T.R.F. RECEIVER

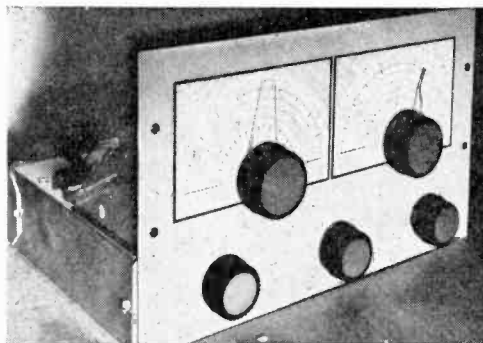

An efficient 2-valve design — 6BR7, ECL82 — in which particular care has been taken to ensure efficient regeneration over the entire frequency coverage (150kHz to 36MHz). Full details of tests carried out giving direct comparison between its performance and that of a superhet receiver.

## VERSATILE A.C. MILLIVOLTMETER

Intended for the more experienced constructor, this article describes a versatile and inexpensive design which incorporates many attractive features. These include low battery consumption and the ability to operate with any moving-coil meter having an f.s.d. within the limits 500μA to 5mA. Measuring ranges depend on the existing scale marking on the meter and may be typically, 5mV to 500V. The frequency response within 5% error extends from 20Hz to 30kHz.

## CLASS-A BATTERY AMPLIFIER

Incorporating a field effect transistor, this design may be either constructed in the form of an a.f. amplifier, or as an amplifier combined with a single transistor medium wave tuning head. In the latter instance, some of the components perform dual functions at a.f. and r.f.

## PLUS

- OTHER CONSTRUCTIONAL PROJECTS
  - DATA SHEET 34
  - SUPPORTING FEATURES
- ON SALE 1st JANUARY**

# 3-VOLT NEON TEST UNIT

by G. A. FRENCH

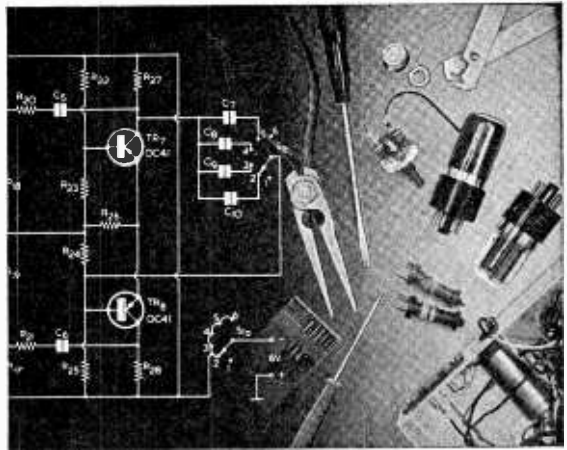

ONE OF THE SIMPLEST ITEMS OF test gear which may be employed in the amateur workshop is a device that is often referred to as a "neon leakage tester". The circuit for such a tester appears in Fig. 1, all that it requires consisting of a source of direct voltage, a small neon bulb and a series resistor. As is to be expected, the neon bulb glows when the test terminals are short-circuited. It also glows when very high values of resistance are applied to the test terminals, whereupon it becomes capable of checking for leakage. The tester is particularly useful for checking non-electrolytic capacitors having a working voltage equal to or greater than that of the neon bulb supply. If a capacitor in good condition is connected across the test terminals the neon bulb flashes once and then remains extinguished. The initial flash is due to charging current in the capacitor, and the neon bulb then remains extinguished because the capacitor retains the charge imparted to it. A slightly leaky capacitor causes the neon bulb to give a continual series of flashes. The reason for this effect is that the capacitor slowly loses its charge after each flash, the falling voltage across its plates causing the neon bulb voltage to increase until striking potential is again reached and the neon bulb once more flashes. A continual glow in the neon bulb indicates that the capacitor under test has so low a leakage resistance that it is unable to acquire sufficient charge to extinguish the neon bulb. Capacitors having very low capacitance values do not allow sufficient charging current to flow in the neon bulb to produce an initial flash. Nevertheless, the neon bulb will still give a continual glow if the capacitor leakage

resistance is less than the normal resistive value needed to produce such a glow.

## HIGH DIRECT VOLTAGE

The only disadvantage with the simple circuit of Fig. 1 is that a high supply voltage is required, this being preferably of the order of 150 to 200 volts. The necessity of providing a voltage of this nature raises difficulties when it is desired to make the tester portable. The use of batteries to provide the voltage directly would not, of course, be a particularly attractive proposition in a portable unit.

This month's 'Suggested Circuit' offers an alternative solution, and it consists basically of an oscillator which causes a series of pulses to be applied to a step-up transformer and following rectifier. As a result it is possible to obtain an off-load output voltage well in excess of 200 volts from a supply battery of 3 volts only. The output power is more than adequate for the operation of a neon tester or, indeed, for any other high voltage circuit having

low current requirements. An interesting feature of the circuit is that the step-up transformer is an ordinary valve speaker transformer having its normal secondary employed as a primary. Since this transformer is used in an application for which it was not intended, the efficiency of the circuit is not as high as if a specially designed component were employed. Nevertheless, an efficiency of nearly 50% can be achieved, which seems reasonable in the circumstances.

The circuit is given in Fig. 2. In this diagram, TR1 and TR2 form a multivibrator whose function is to cause TR3 to pass a high collector current during the multivibrator periods when TR2 is on. In consequence a series of relatively heavy current pulses are applied to the winding of T1 which appears in the collector circuit of TR3. T1 provides the step-up function, and causes high pulse voltages to be passed to D1, with the result that reservoir capacitor C3 charges up to their peak potential with its upper plate positive. The voltage across C3 then provides the d.c. voltage

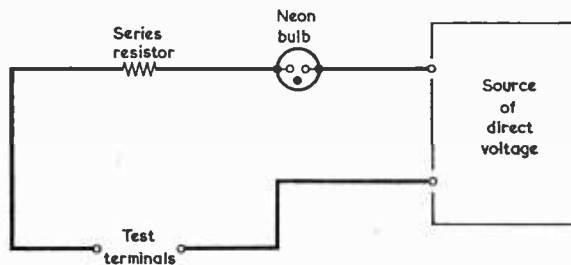

Fig. 1. The circuit of a neon leakage tester. The polarity of the direct voltage is unimportant

# BUY THIS BEST SELLER

## T.V. FAULT FINDING 405/625 LINES



### REVISED & ENLARGED

Edited by J. R. Davies

124 pages only 8/6

Over 100 illustrations, including 60 photographs of a television screen after the appropriate faults have been deliberately introduced.

Comprehensive Fault Finding Guide cross-referenced to methods of fault rectification described at greater length in the text.

Price 8/6 from your  
Bookseller

or post this Coupon together  
with remittance for 9/2  
(to include postage) to

**DATA PUBLICATIONS LTD.**  
57 Maida Vale, London, W.9

Please send me the 4th revised edition of TV Fault Finding, Data Book No. 5.

I enclose cheque/crossed postal order for .....

NAME .....

ADDRESS .....

R.C. Block Letters Please

required for R5 and NE1, the neon tester components.

Particular attention has been paid, in the design, to ensuring that a low current is drawn from the battery. Maximum current, during the multivibrator cycle, is taken when TR3 is conductive. Since the winding of T1 in TR3 collector circuit has negligible resistance, TR3 collector current can rise to the product of its base current (given, when TR2 is on, by current in R3 and R4 plus initial charge current in C2 after the multivibrator changeover) and its gain. The time constants in the multivibrator circuit are calculated such that TR1 is on for about 0.0035 second in each cycle whilst TR2 is on for about 0.0002 second only. Thus, both TR2 and TR3 are conductive for approximately one-seventeenth part of each multivibrator cycle, and the average overall current is reduced accordingly. With the prototype, the current drawn from the 3 volt battery was 30mA and, working from the reasoning just given, this figure would indicate a collector current of about 510mA in TR3. Such a figure seems reasonable when the  $h_{FE}$  spread (80 to 250) for an ACY19 is considered, and the calculations take no account of component tolerances. In any event, the current drawn from the battery can, in the practical circuit, be varied over quite wide limits by adjusting the value of R3, and thereby altering the ratio between the two periods in the multivibrator cycle. The electrolytic capacitor across the supply lines, C4, pro-

vides a low impedance for the pulse currents in the T1 winding in TR3 collector circuit, and also ensures that the overall current drawn from the battery is kept to an average value.

### THE TRANSFORMER

As already stated, transformer T1 is a valve speaker transformer with its normal secondary connected in TR3 collector circuit. The transformer employed by the author was an Elstone type MO/T (Home Radio Cat. No. TO12) this being a component of small physical size having a tapped primary which offers, in its normal application, ratios of 90:1, 55:1 and 33:1. When used in the present arrangement as a 1:90 step-up transformer, the off-load voltage across C3 was 400; whilst the 1:55 and 1:33 ratios gave off-load voltages of 240 and 130 respectively. The 400 volt output offered by the 1:90 ratio was too high for the present application and all further work was carried out with the 1:55 ratio. Judging from these results, output voltages suitable for a neon tester would be given by any valve speaker transformer having a ratio, in its normal application, between some 45:1 and 60:1. Due to the pulse drive to the transformer a slightly higher rectified output voltage is given when the winding in the TR3 collector circuit is connected one way round rather than the other.

Rectifier D1 can be any silicon rectifier having a p.i.v. of 1,000

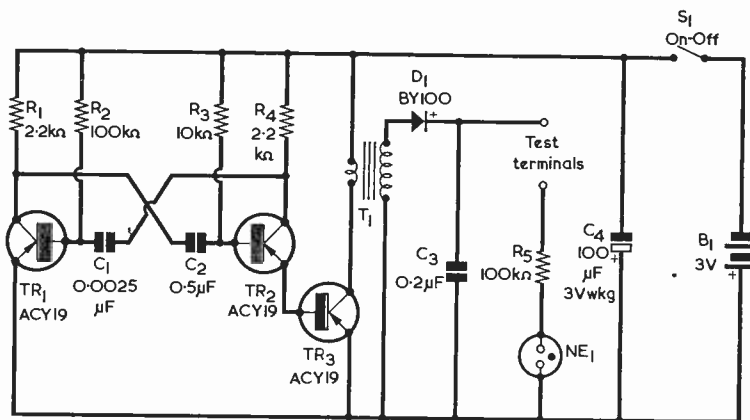

T<sub>1</sub>, NE<sub>1</sub> - see text

Fig. 2. A portable neon leakage tester. The necessary high voltage is provided by step-up transformer T<sub>1</sub>, this being a standard valve output transformer with its normal secondary in TR3 collector circuit

volts or more. The writer employed a BY100 which happened to be on hand, but any similar rectifier could be used instead. There is no advantage in employing a high value reservoir capacitor in the C3 position, and the 0.2 $\mu$ F component specified is quite adequate. A high value reservoir capacitor can, indeed, introduce a disadvantage, since it may take an appreciable time to charge up to full voltage after the unit has been switched on.

The neon bulb can be either a Hivac 16L or 34L (obtainable from Henry's Radio) or the Home Radio Cat. No. PL32A. It is a small wired-around component which strikes at around 65 volts. There is a marginal advantage in coupling the neon bulb to the positive supply line from the battery, as shown, rather than to the positive rectified voltage from D1, since there is then less demand on the insulation resistance between the bulb with its series resistor R5, and the majority of the other components and wiring in the circuit. As a result, the upper test terminal carries a positive potential of some 200 volts with respect to either of the battery supply lines. The whole unit must, therefore, be assembled in an insulated case with no external metalwork connected to either of the battery supply lines. The insulation between the test terminals themselves must be of a high order.

When, in the prototype, the test terminals were short-circuited, the voltage across C3 dropped to 105 volts, with 65 volts appearing across the illuminated neon bulb. Under these conditions, the total output is 105 volts at 0.4mA, representing a power of 42mW. Since the input is 3 volts at 30mA (representing a power of 90mW) the corresponding efficiency is a little lower than 50%.

#### COMPONENTS AND CONSTRUCTION

Some of the components have already been discussed, but a few further words are needed with respect to those not yet dealt with.

All the five resistors can be  $\frac{1}{4}$  watt 10% types. C3 should have a working voltage of 250 or more. C1 and C2 can be low working voltage capacitors, but must not be ceramic types of the high-K or low leakage resistance variety. Constructors unable to identify these last two types are advised to choose a paper or plastic foil capacitor for C2, and either a silvered mica or a paper or plastic foil capacitor for C1. C4 can, of course, have a working voltage higher than the 3 volt figure shown in Fig. 2.

The author used ACY19's for both TR1 and TR2, but it is probable that many other germanium p.n.p. types could be employed instead. TR3 needs to be a high-gain

DECEMBER 1969

## We Wish You A Happy Christmas and a Prosperous New Year



### CHRISTMAS GIFT SUBSCRIPTION

Give a subscription to your friend ensuring that he receives, by post, 12 feature packed issues as they are published.

Order now and we will send a Christmas card giving your best wishes together with a FREE copy of this issue.

My name .....

Address .....

I enclose cheque/postal order for £2.2.0 in payment for 12 issues of THE RADIO CONSTRUCTOR commencing January 1970 to be sent to:-

Name .....

Address .....

(Please use BLOCK letters and make remittances payable to Data Publications Ltd.)

transistor with a maximum collector current rating in excess of 1 amp, and this requirement is met by the ACY19 specified.

Any 3 volt battery can be employed for B1. A long life can be expected from a battery of the twin-cell cycle lamp type. Supply voltages higher than 3 volts must not, incidentally, be applied to the circuit.

The unit should be initially assembled and wired up with no connection made between TR3 collector and T1. This is because TR3 can pass a heavy standing current if, for any reason, the multivibrator is not running. Multivibrator operation can then be checked by temporarily connecting a magnetic earphone between the collector of TR3 and the negative battery supply line. If the multivibrator is running, a strong audio tone will be heard in the earphone. Because of the values chosen for C1 and R2 it may be found that some transistors, other than the ACY19, may not operate in the TR1 position.

When the multivibrator is running properly the earphone may be removed and the collector of TR3 connected to T1, as shown in the diagram. With the prototype it was found that the multivibrator tone then became faintly audible from the laminations of the transformer itself. Using a high resistance voltmeter, preferably 10,000 $\Omega$  per volt or better, next check the voltage across C3. This should be of the order of 200 volts, the actual figure given varying according to the ratio of the transformer employed for T1. Try reversing the connections to the winding of T1 which is in TR3 collector circuit. A slightly higher output voltage will be given with this winding connected one way round, and the method of connection resulting in the higher voltage should be determined and wired in permanently.

Next, insert a current reading meter between the battery and C4. If this gives a reading of some 25 to 30mA, no further adjustments are required. Higher or lower readings may be catered for by varying the value of R3 and, in consequence, the ratio between the periods when TR3 is conducting and when it is not. Increasing R3 reduces battery current and vice versa. The circuit should always be switched off when changing the value of R3 if this operation necessitates stopping the multivibrator.

### RESULTS WITH THE PROTOTYPE

As a high direct voltage generating device, the prototype unit gave the results which have already been described. Reliable operation was still given when the battery voltage dropped to 2 volts, although the output voltage naturally reduced accordingly.

The usefulness of the unit as a leakage and capacitor tester was next evaluated. The neon bulb gave a visible glow for leakage resistance across the test terminals of greater than 25M $\Omega$ . When capacitors were applied to the test terminals, those with acceptable leakage resistance caused an initial flash with no fur-

ther illumination in the neon bulb. Faulty capacitors either caused a continuing series of flashes or a continual glow. It was found that the neon bulb was sufficiently sensitive to give a visible initial flash for capacitors as low in value as 300pF.

## EXPANSION OF COLOUR TV FACILITIES

New British electronic equipment developed by the BBC, the Advanced Field-Store Television Standards Converter, should give an international boost to colour TV reception. It was announced recently that the BBC has agreed that Rank Precision Industries Ltd. in its British factories can manufacture the BBC converter under licence and market it abroad. This will mean that high quality colour transmissions from America can be available to television audiences throughout the world.

It was during the Mexico Olympics that the BBC used this equipment for the first time, for a total of 170 hours of transmission via satellite relay across the Atlantic. The high quality pictures were seen in nine other European countries in colour, and nineteen more in black-and-white. Audiences were estimated at 200 million for black-and-white and one million for colour.

At the moment there is only one of these units in existence, at the BBC Television Centre in London. Under the agreement, Rank Precision Industries will now make other units at its British factories in Welwyn Garden City and Leicester, and eventually at Ware, and these will be marketed abroad. A Rank spokesman has estimated that the costs of each converter will run into six figures, and there is a potential market for about a hundred.





# ANNOUNCING . . .

## NEW HANDIPAK

### IDEAL FOR WORKSHOP USE

WORDING (Sets 3 and 4) COMPLETELY REVISED. Over 1,000 words. Height of Letters  $\frac{3}{32}$  in. FREQUENCY LISTS (Sets 5 and 6). Now in kHz and MHz.

Supplied to Universities, Technical Colleges, Government Establishments, Research Laboratories and Industry.

- Easy to fix
- Permanent and durable
- Stapled in booklet form
- Designed to hang above workbench
- Pocket for loose cuttings
- Professional finish

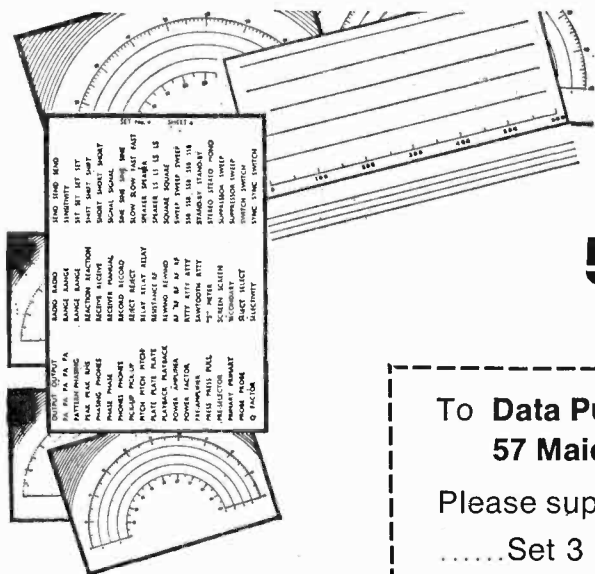

- ★ Set 3 Wording—WHITE
- ★ Set 4 Wording—BLACK
- ★ Set 5 DIALS—clear background
- ★ Set 6 DIALS—black background



The Perfect Transfer for  
the Home Constructor  
Each Set contains Six Sheets

**5/- per set**  
(postage 4d.)

To **Data Publications Ltd.**  
57 Maida Vale, London, W.9

Please supply:

.....Set 3 .....Set 4 .....Set 5 .....Set 6

I enclose cheque/crossed postal order for.....

Name.....

Address.....

.....

*BLOCK LETTERS PLEASE*

## DRY WICK METHOD OF DESOLDERING

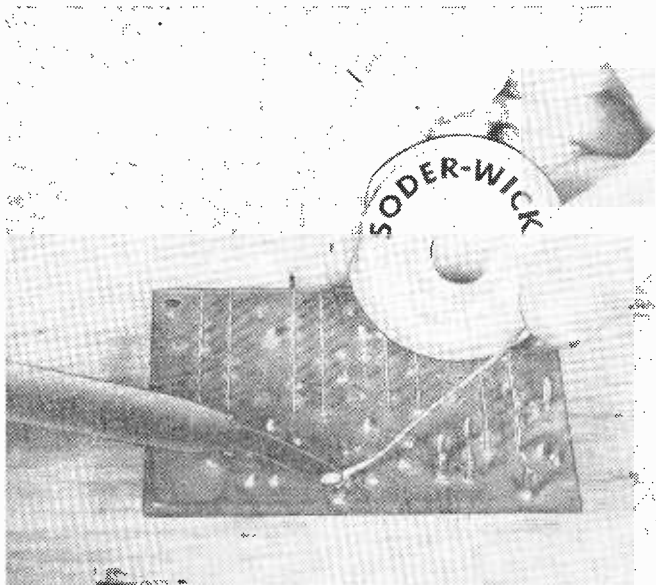

*This illustration shows "Soder Wick", a dry method of desoldering electronic joints and electrical connections, being used, with the aid of a standard soldering iron, to desolder a joint on a printed circuit board*

Southern Watch and Clock Supplies Ltd., 48/56 High Street, Orpington, Kent, have been appointed U.K. Selling Agents for "Soder Wick", a dry wick method of effectively desoldering electronic joints and electrical connections in just one second.

As can be seen in the illustration, "Soder Wick" is supplied in reel form and is used by direct contact with the joint or connection together with a perfectly standard soldering iron for heating purposes.

The two main advantages to be gained in the use of "Soder Wick" are, firstly, that no flux is required thus, flux contamination is entirely eliminated and the circuit board or connections are left entirely clean and ready for resoldering.

The second advantage is that because the operation takes only one second there is little heat build-up since "Soder Wick" draws the solder into itself quickly and without the need for excessive heat.

It can be used for all sizes of electronic joints and electrical connections from integrated circuits and printed circuit boards to telephones or any other normal electrical appliance.

The desoldered joint is left solder free, pure and non-corrosive, leaving even plated through holes clean.

"Soder Wick" is supplied complete in a transparent plastic dispenser with a colour-coded label and a table is available giving pad sizes, widths, strands, colour codes and reference number for the various reels available.

The diameter of the dispenser is 1 $\frac{1}{2}$ in. and there is approximately 60in. of dry wick in each dispenser.

Prices range from 18/- to 20/- per reel, according to pad size and width.

For those who would like to try one reel for evaluation purposes a special offer, which is open until the end of this month, is being made of 16/- for the one reel, no matter what pad size and width is required.

280

## QUOTE

*"Now is the time to bring all the colours of the spectrum into our homes. Nobody pretends that colour sets are cheap, and here the Government who wisely decided that we should go into colour could be of great help to us all. I mean by reducing the amount of deposit that the viewer has to pay on a colour set. It would be a great pity if the huge capital sums spent by the broadcasters on instruction from the Government were to be sterilised by economic restrictions imposed upon the consumer."*

From a speech by Lord Aylestone, Chairman of the I.T.A., opening the Colour Television Service Show at Leicester.

## NEW CRANK KNOB

Radiatron Limited announce the introduction of a new knob to their range of Elma collet fixing instrument knobs. The new knob is a crank type which is particularly suitable for heavy duty operation for applications where multi-turn components are used. e.g. 10 turn potentiometers.

The knob has a 36mm. base diameter and is available for spindle sizes of  $\frac{1}{4}$ in. or 6, 8 and 10mm. A small knob acts as the 'handle' and is fixed to a freely rotating shaft through the main knob allowing simple and rapid rotation of the complete assembly. The knobs are available with colour coded caps.

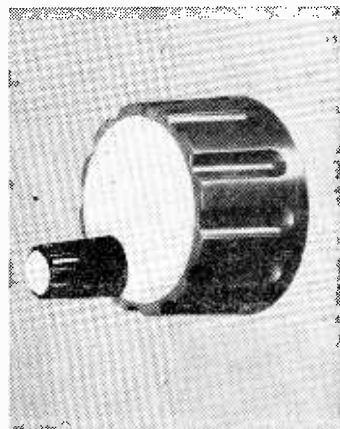

THE RADIO CONSTRUCTOR

# COMMENT

## BRITISH-MADE 100 WATT PROFESSIONAL AMPLIFIER

Adastra Electronics Ltd. have just released the "Centurion" 100 watt Amplifier which has a suggested list price of £99 and features a hand assembled 25 transistor 6 diode printed circuit construction. The four individually gain controlled inputs have a sensitivity range from 1mV to 20V.

A unique feature of the "Centurion" is that its generously rated design allows its output (100 watts at 4 $\Omega$ ; 140 watts peak) to be open or short circuited without ill effect. Presentation is in a black leather-cloth cabinet with carrying handles and matching silver/black control scale.

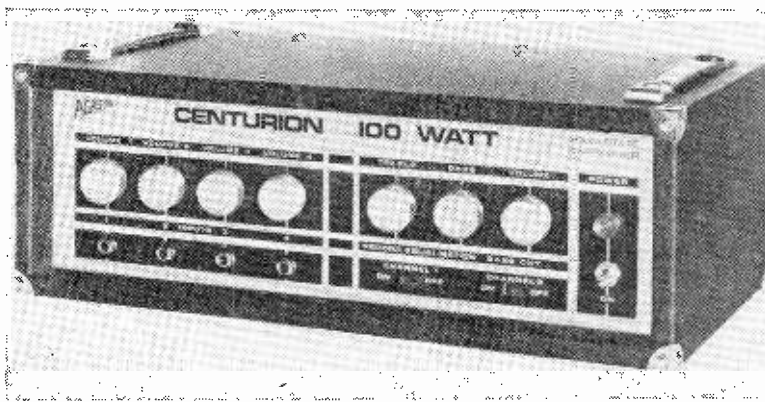

## MAGNETIC BUBBLES FOR DATA PROCESSING

Magnetic "bubbles"—tiny, movable magnetic dots, each smaller than the diameter of a human hair—may one day perform much of the work of a computer within a piece of material the size of a shilling.

The bubbles can be moved around in precise patterns so that they can represent coded information, do computations or switch signals—all on a small chip of solid material.

This technology now being developed at Bell Telephone Laboratories may have an important impact on digital data processing whether in computers or in telephone switching.

The bubbles are tiny magnetised regions in certain iron oxide materials. When a pattern of magnetic fields is generated in the material, the bubbles can be made to race around at high speeds in patterns conforming to the magnetic field.

## L.F. AMATEUR BANDS LISTENERS' CONTEST — 1970

The above event is being organised by the International Short Wave League.

The contest will be held in two parts, viz. CW only and phone only, and entrants may take part in either or both sections. The CW only section starts at 1900 hours on Saturday, 3rd January 1970, and ends at 1100 hours on Sunday, 4th January 1970. The phone only section (AM and SSB) starts at 1900 hours on Saturday, 10th January 1970, and ends at 1100 hours on Sunday, 11th January 1970. The times given refer to local time at the contestant's QTH.

The contest is only open to League members, details may be obtained from the Contests Manager, Clifford A. Tooke, 6 Chelmer Avenue, Rayleigh, Essex. Entries must arrive not later than 13th February, 1970 for both sections.

## R.T.R.A. 1970 LONDON EXHIBITION

The Radio and Television Retailers Association is to hold a trade show in conjunction with its annual conference next year. The conference is to be held at the Grosvenor House Hotel from 31st March to 2nd April. Previous conferences have been held in the provinces.

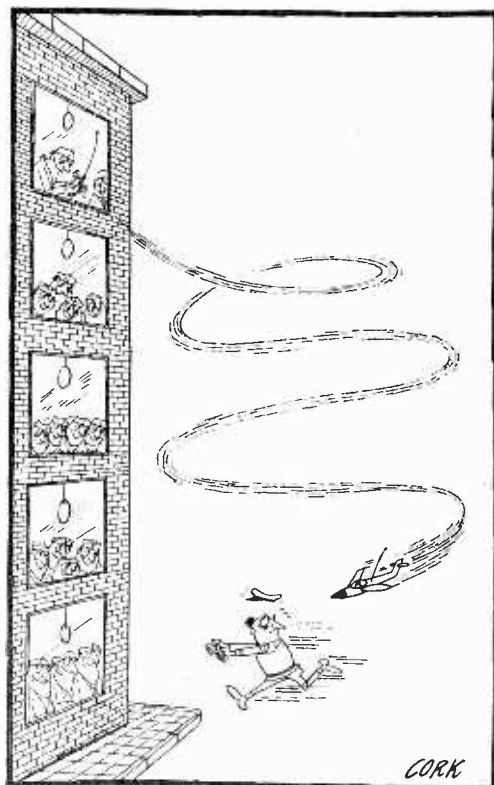



# 1MHz. FREQUENCY SUB-STANDARD UNIT

by

FRANK A. BALDWIN

This article is the sixth in a series of constructional projects in which each item is built in an Eddystone diecast aluminium alloy box. Previous articles in this series were "Aerial Tuner Unit for the SWL", published in the August 1968 issue; "Q-Multiplier and Audio Filter Unit", September 1968; "3-Band Self-Powered Preselector", December 1968"; "100/10Kc/s Frequency Sub-Standard Unit", March 1969 and "Short Wave Aerial and Changeover System", April 1969. These matching units comprise a series of ancillary equipment for use with a communications receiver. The unit presented here provides frequency marker points at every 1MHz throughout the range of 1 to 32MHz. An additional feature is the inclusion of a stabiliser tube, this providing a high level of stability of operation. The power supply is built in, and the unit is designed to have adequate ventilation

**T**HE SERIOUS SHORT WAVE LISTENER, HAVING acquired a communications receiver, will soon find that an accurate and stable frequency sub-standard unit is a most useful item of equipment for ensuring that accurate band-edge tuning settings are made. When setting up the receiver on a spot frequency, particularly on the higher frequency bands from 10 to 30 MHz, it will be found difficult to resolve the 100kHz points obtained from a frequency sub-standard operating with this fundamental frequency. It is extremely useful therefore to have at hand a crystal oscillator with a fundamental frequency of 1MHz. Resolving the 1MHz points between 10 to 30MHz then becomes a comparatively simple task.

Ideally, the short wave listener should equip himself with both a 1MHz crystal oscillator and a 100kHz unit, the latter additionally having a locked 10kHz multivibrator. In this manner, the receiver can be set to any spot frequency with the aid of a series of graphs and the use of these two ancillary units.

The 1MHz oscillator enables the receiver bandset dial to be accurately calibrated throughout the range of the receiver. When using the unit on, say, the 15MHz Broadcast band, the 1MHz oscillator is brought into use, its 14th harmonic being employed for band edge setting purposes. The bandspread dial is then calibrated against a 100kHz oscillator unit. During the calibrating process a graph may be prepared setting out the 100kHz points against bandspread dial readings.

## CIRCUIT

The circuit is given in Fig. 1 and is similar to that used in the 100/10kHz unit previously described in these pages. Of the many crystal circuits tried out by the writer in the past the Colpitts configuration shown here has always proved to be a reliable and sure-fire design, causing even the most sluggish of crystals to oscillate satisfactorily. The 1MHz oscillator stage uses an EF183 r.f. pentode, the feedback being

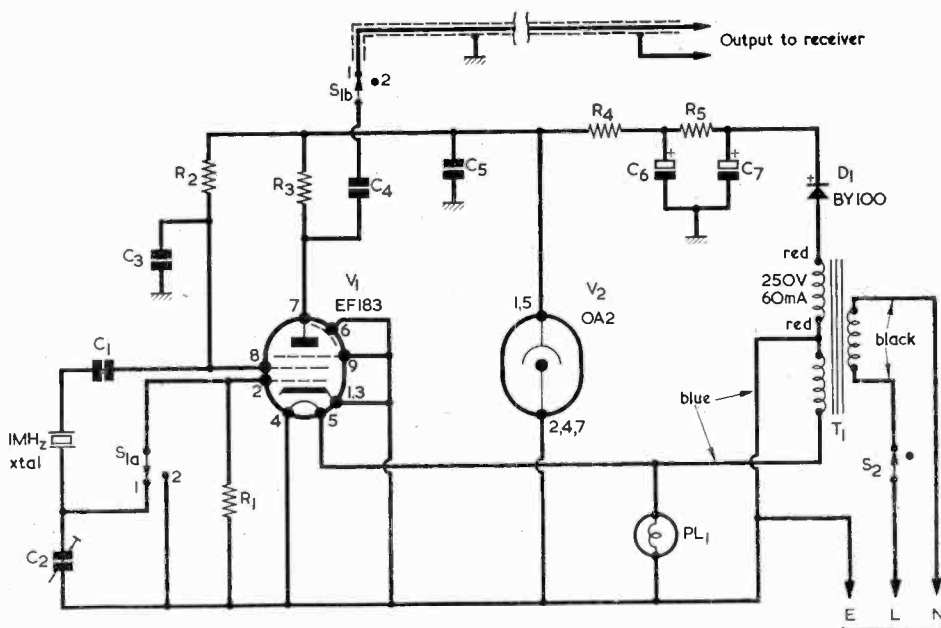

Fig. 1. The circuit of the 1MHz Frequency Sub-Standard Unit. V1 is the oscillator and V2 the voltage stabiliser

## COMPONENTS

### Resistors

( $\frac{1}{2}$  watt 5% unless otherwise stated)

- R1 220k $\Omega$
- R2 47k $\Omega$
- R3 100k $\Omega$
- R4 5.6k $\Omega$  3 watt
- R5 4.7k $\Omega$  2 watt

### Valves

- V1 EF183
- V2 OA2

### Chassis

L-shaped,  $6\frac{1}{2} \times 2\frac{3}{4} \times 1\frac{1}{2}$ in.  
(H. L. Smith & Co. Ltd.)

### Cabinet

Eddystone Die-cast Box, type 6357P  
(Home Radio Ltd., Cat. No. E903)

### Tagstrips

- 1 off 3-way end tag earthed
- 1 off 5-way centre tag earthed

### Rubber Mounting Feet

Grey (4 off) (H. L. Smith & Co. Ltd.)

### Panel Lamp Assembly

6.5V 0.15A, type LES (red)  
H. L. Smith & Co. Ltd.)

### Knob

Spun Aluminium (H. L. Smith & Co. Ltd.)

### Capacitors

- C1 200pF silver-mica
- C2 140pF trimmer
- C3 200pF silver-mica
- C4 100pF silver-mica
- C5 0.1 $\mu$ F paper or plastic foil
- C6 16 $\mu$ F, electrolytic, 350V wkg, wire-ended
- C7 8 $\mu$ F, electrolytic, 350V wkg, wire-ended

### Switches

- S1 2-pole, 2-way, miniature rotary
- S2 s.p.s.t. toggle

### Rectifier

- D1 BY100

### Mains Transformer

250V 60mA, 6.3V 1.5A, type 6BR10  
(H. L. Smith & Co. Ltd.)

### Crystal

1MHz, complete with holder  
(Henry's Radio Ltd.)

### Valveholders

- 1 B9A valveholder (with centre spigot)
- 1 B7G valveholder

### Miscellaneous

- Coaxial cable
- 3-core mains lead
- Panel-Sign Transfers, Set No. 3
- Connecting wire and sleeving
- 4BA and 6BA nuts and bolts
- 4BA and 6BA solder tags

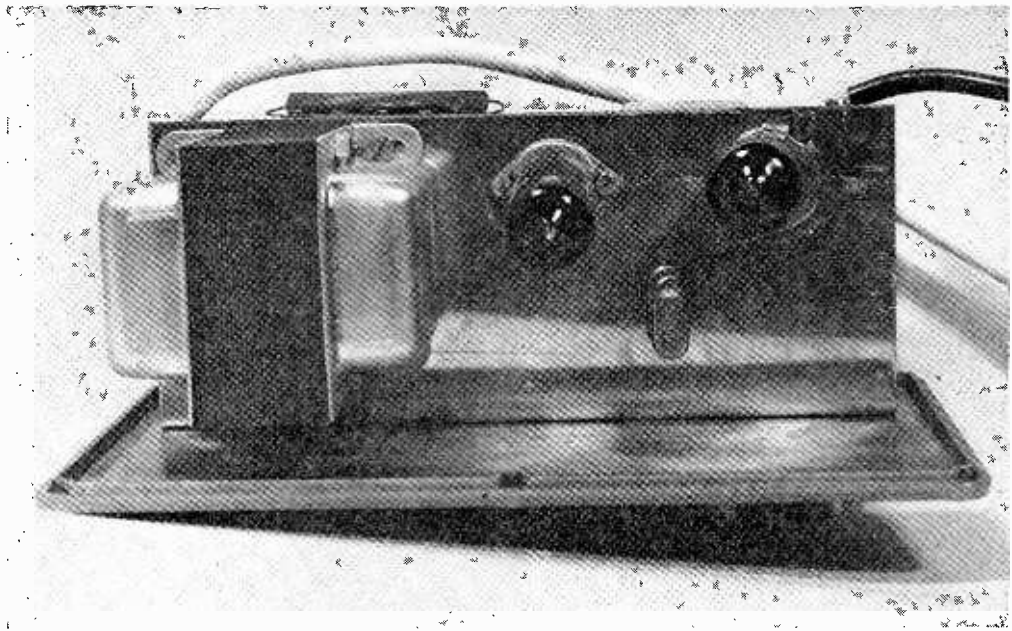

*Above-chassis view of the 1MHz crystal oscillator, V2 is at left and V1 at right. The position of the crystal is clearly shown*

obtained from the screen-grid to the control grid via the 1MHz crystal. The choice of valve ensures that very strong harmonics of the fundamental frequency are obtained up to, and including, 32MHz. The crystal frequency can be varied within small limits by means of preset capacitor C2.

With switch S1(a) in position 1, the oscillator is allowed to function. With the switch in position 2 the control grid of V1 is connected direct to chassis and the stage is rendered inoperative. The relatively high values of both R2 and R3 prevent excessive dissipation under this latter condition.

In position 1, switch S1(b) connects the anode of the oscillator valve, via C4, to the unit output lead, this consisting of a short length of coaxial cable. At the receiver end, the coaxial cable has its inner conductor bared for some 3in., this length being covered with Systoflex sleeving and wrapped around the aerial input lead or terminal to provide a capacitive coupling. The outer braiding of the cable is connected to the receiver earth terminal.

Note that pins 1, 3, 6 and 9 of the oscillator valve are connected direct to chassis. The valveholder metal centre spigot is also connected direct to chassis.

In a unit of this nature, it is imperative that stability of operation be achieved and, to this end, an OA2 stabiliser tube has been incorporated. This tube, together with the voltage dropping resistor R4, ensures that a constant and stable h.t. voltage is applied to the oscillator circuit. Also in order to gain stability of operation, and as may be noted from the illustration of the below-chassis components, all wiring associated with the oscillator stage is kept as short and direct as possible.

The smoothing components C6, R5 and C7 provide a ripple-free h.t. supply after the BY100 silicon rectifier. The small mains transformer specified for T1 *must* be used (see Components List) as alternative

transformers may not have dimensions suitable for the diecast box. The transformer specified is fully shrouded and has secondary windings rated 250V at 60mA and 6.3V at 1.5A. The colours shown around T1 in Fig. 1 are those of the lead-out wires.

A panel mounted lamp assembly (PL1) provides an indication of whether the unit is switched on or off.

The a.c. mains input wiring should be connected as shown in Fig. 4, a 3-way tagstrip being used below the chassis to take the wires from a 3-core cable. The mains plug should be a 3-way type having a 1.5A fuse fitted internally.

Switch S2 is a single-pole, single-throw panel mounted toggle type, and it functions as the on/off control.

## CONSTRUCTION

The chassis used in the construction of this unit is L-shaped with a front apron only and is shown, complete with drilling details, in Fig. 2(a).

The mains transformer itself should be used as a template, its four fixing holes being marked with a centre-punch and drilled to take 4BA bolts. Two  $\frac{1}{4}$ in. holes will also be required to allow the transformer leads to pass to the underside of the chassis. These two holes must be fitted with suitably sized rubber or p.v.c. grommets. The transformer is mounted on the chassis deck such that the two black mains input leads are nearest the adjacent edge of the chassis. Chassis solder tags are fitted under the two mounting nuts nearer the front apron. A 3-way tagstrip (see Fig. 4) is secured under the rear mounting nut near the chassis edge, the two non-earthly tags being forward of the earthed tag. A 5-way tagstrip (see Fig. 3) is secured under the other rear mounting nut.

The holes for V1 and V2 valveholders should be cut with B9A and B7G chassis cutters respectively.

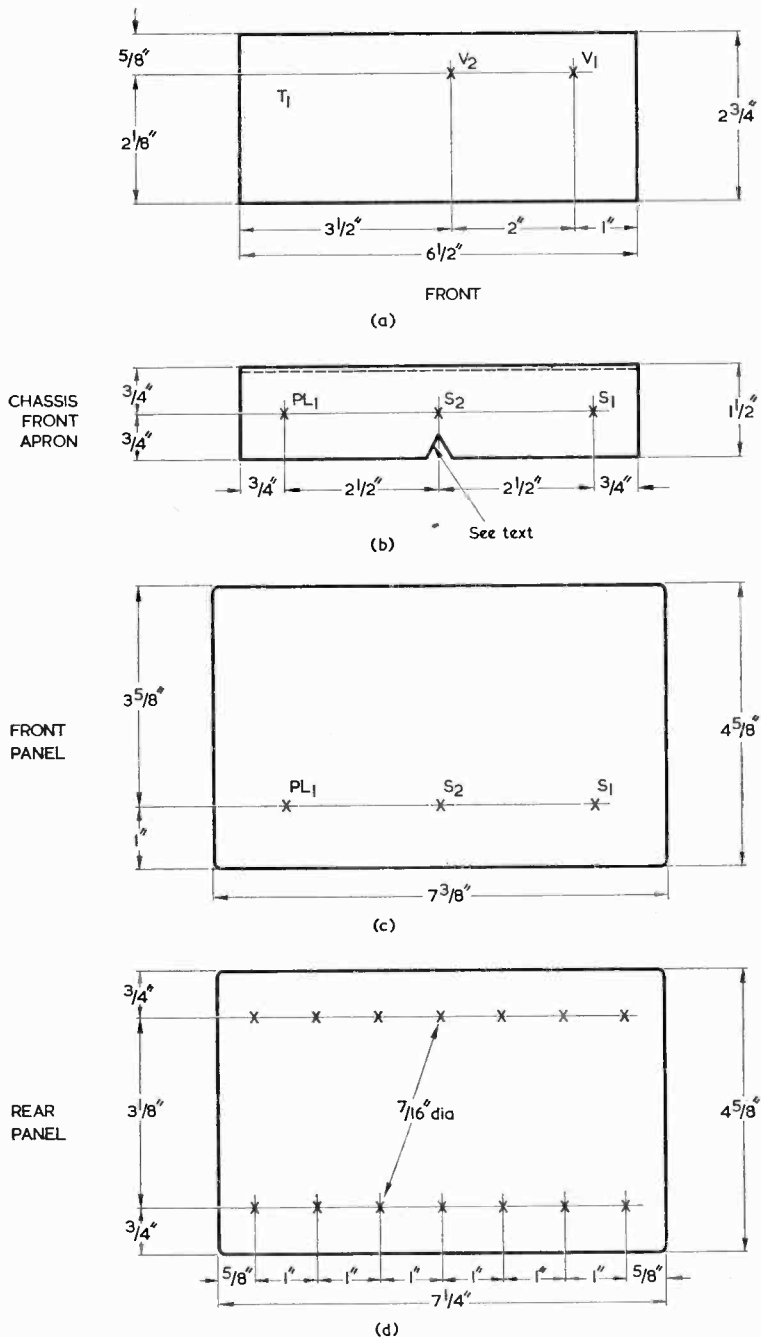

Fig. 2(a). Plan view of the chassis deck with drilling dimensions.  
The L-shaped chassis has only one apron

(b). Drilling dimensions of the chassis apron. The inverted V-shaped cut-out provides clearance when securing the front panel to the box

(c). Drilling details of the front panel

(d). The diecast box rear panel and dimensions of the ventilation holes. The outside measurements of the rear panel differ slightly from those of the front panel

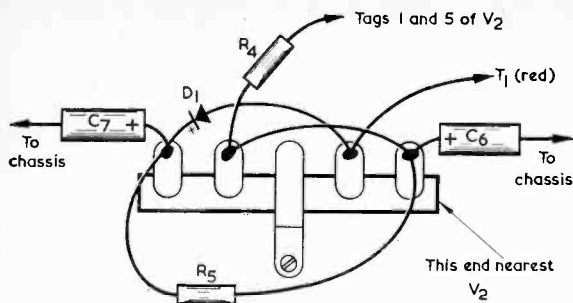

Fig. 3. Showing in "exploded" form the soldered connections at the power supply section 5-way tagstrip

V1 valveholder should be positioned such that pin 2 is nearest the front of the chassis and V2 valveholder such that pin 1 is nearest the chassis rear. A chassis solder tag is fitted under each of the securing nuts for V1 valveholder. A further chassis solder tag is fitted under the V2 valveholder securing nut which is nearer T1.

The position of the crystal is not shown in Fig. 2(a) but the location of this component may be seen from the above-chassis illustration. A special chassis mounting holder is supplied with the crystal.

Fig. 2(b) shows the drilling details for the chassis front apron, PL1 being the panel lamp assembly, S2 the mains on/off switch and S1 the oscillator on/off control. Note that a V-shaped cut-out is required in the chassis front apron in order to avoid fouling at the lower central front panel fixing bolt position. The holes in Figs. 2(a) and (b) should, of course, all be drilled and cleaned up before any components are finally mounted in position.

Fig. 2(c) shows the lid of the diecast box, which now becomes the front panel of the unit. The three holes required in the panel may be easily marked out by correctly positioning the drilled chassis apron at the rear of the panel and marking the centre of each hole with a pencil or centre-punch. When the panel is drilled, the two sets of holes will then coincide.

Fig. 2(d) shows the rear of the diecast box and the measurements for the 14 ventilation holes required, 7 at top and 7 at bottom. These ensure that a constant flow of air circulates through the unit, thus considerably assisting with respect to stability of operation. The mains lead and output coaxial cable pass through the two end holes in the lower row.

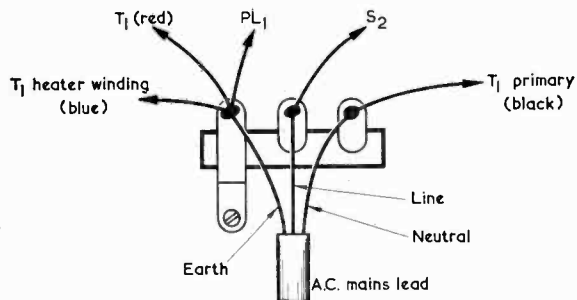

Fig. 4. The soldered connections at the 3-way tagstrip

Before construction proceeds, the panel and box may be painted or sprayed to the constructor's choice of colour. The panel should be fitted to the box during this process. If the panel and box are to be sprayed, adhesive tape fitted temporarily over the control and pilot lamp holes on the inside surface of the panel will mask the interior of the box. The rear of the box may also be sprayed if the ventilation holes are similarly masked on the inside. Otherwise, the rear may be painted carefully with a brush.

Once construction and testing of the unit has been completed, four rubber mounting feet should be fitted to the underneath of the box by means of Araldite or other suitable adhesive. Also, Panel-sign transfers may be applied to the front panel in the appropriate positions, and will considerably enhance the final appearance of the completed unit. Those shown in the photograph of the front panel are from Panel-Signs Set No. 3.

## WIRING-UP

It is best to commence operations here by wiring up the power supply section, and the appropriate

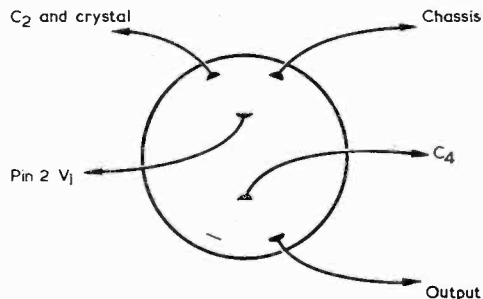

Fig. 5. The 2-pole, 2-way rotary switch S1(a), (b), shown with the tags pointing towards the reader (rear view) together with the necessary connections

connections to the 5-way tagstrip are shown in Fig. 3. The actual layout of the various components may be judged from the below-chassis illustration. Note that both R4 and R5 should be positioned, once wired to the 5-way tagstrip, so as to allow a free flow of air around them. The BY100 silicon rectifier must be positioned such that its metal casing cannot make contact with any other component or tag. Ensure that neither R4, R5, the rectifier, or any other component or connection will make contact with the metal casing of the box when the panel is finally secured into position. The negative lead-outs of C6 and C7 connect to the chassis tags under the front securing nuts of T1.

The heater winding of T1 (blue) should be cut to length, the enamel covering removed by scraping with a knife, and one wire soldered to the earthed tag of the 3-way tagstrip, as shown in Fig. 4. The remaining blue wire should be soldered to one tag of PL1 and a lead taken from this point to pin 5 of V1. The other tag of PL1 should be connected to the earthed tag of the 3-way tagstrip. Pin 4 of V1 connects to the adjacent chassis tag.

Switch S2 is wired with one tag connected to the centre tag of the 3-way tagstrip (see Fig. 4) and its



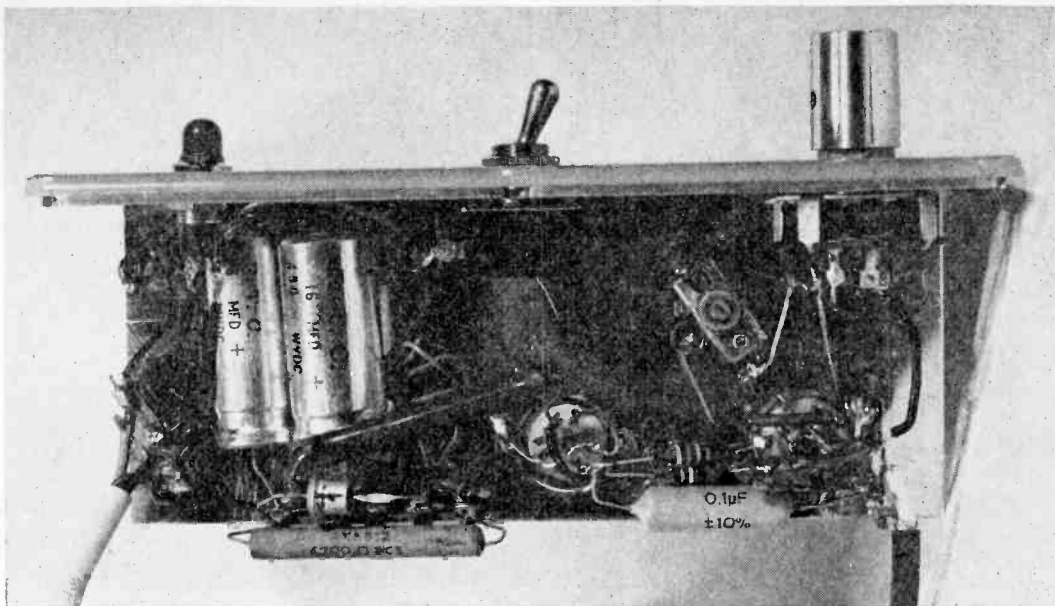

Below-chassis view of the unit showing the preset capacitor C2 and other major components

other tag to one of the black wires from T1. The remaining black wire from T1 is soldered at the 3-way tagstrip as shown in Fig. 4.

The a.c. mains input lead should now be connected also as shown in Fig. 4.

The components not shown in Fig. 3 are all wired around the V1 and V2 valveholders, ensuring that the wire ends are cut exactly to length so that no subsequent movement is possible.

One tag of preset capacitor C2 is wired to the chassis tag at V1 valveholder which is nearer the crystal holder, the other tag of C2 being soldered at the crystal holder itself. This tag of the crystal holder also connects to S1(a). The remaining tag connects to pin 8 of V1 via C1.

It will be found that no problems exist so far as the positioning of the remaining components is concerned, the main point to observe being that all leads are kept short.

The switch specified for S1 in the Components List is a 2-pole 2-way type but that actually used in the prototype was a 4-pole 2-way switch with two poles unused, this being to hand at the time of construction. Fig. 5 shows a rear view of a 2-pole 2-way switch with the tags pointing towards the reader, together with the required connections. The braiding of the output coaxial cable need not extend, inside the unit, beyond the rear chassis tag at V1 valveholder. The centre conductor of the cable then continues, on its own, to the appropriate tag of S1.

## TESTING

Once construction has been completed and the wiring checked, testing and alignment should commence. A voltage Table is given, the readings having been obtained with a voltmeter having a resistance of 10,000Ω per volt. These readings are intended only as a guide, and those obtained in units built up by

readers may vary by up to some 10% of the figures in the Table without indicating a fault condition.

**TABLE**

Voltage readings with respect to chassis, S1 in position 1.

Circuit point	Volts d.c.
Junction R5, C7	295
Junction R5, C6	230
V2 pins 1 & 5	150
V1 pin 7	46
V1 pin 8	37

To carry out the setting-up process, switch on both the communications receiver and the crystal unit, the latter being out of its box for initial alignment. S1 should be in position 2, so that the crystal oscillator is inoperative. Allow the communications receiver to attain its normal working temperature so that no frequency drift is apparent. Set the receiver to the MSF transmission on the 5MHz channel and tune to exact resonance with the receiver set to its most selective state. Switch on the b.f.o. and adjust to the centre frequency (silent point) and then disconnect the aerial from the receiver terminal, ensuring that the tuning is in no way disturbed. Switch on the 1MHz oscillator by means of S1 and adjust trimmer C2 until an exact resonant beat is obtained. Reconnect the aerial and make any further slight adjustments of C2 that may be required. Once C2 has been correctly set, no further adjustments will be required.

(Continued on page 306)

# Light Controlled Tone Generator

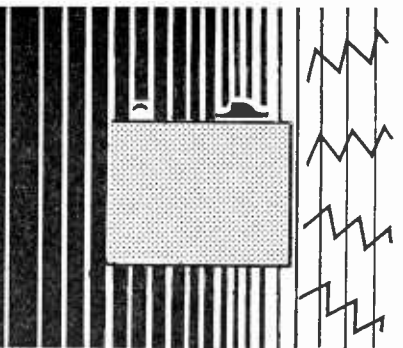

by

R. J. CABORN

SINCE THE ADVENT SOME YEARS AGO ON THE HOME-  
constructor market of sensitive and inexpensive  
photoconductive cells of the ORP12 class, a considerable  
degree of interest has centred on simple  
light-operated circuits employing these devices. The  
unit described in the present article falls into this  
category, and it was built at the bidding of the

This article gives full constructional details of a  
continual or interrupted a.f. tone whose  
further feature is that the device turns  
light. Although intended primarily for  
serious applications and can, for instance,  
It can also be introduced, to consider  
next Chris

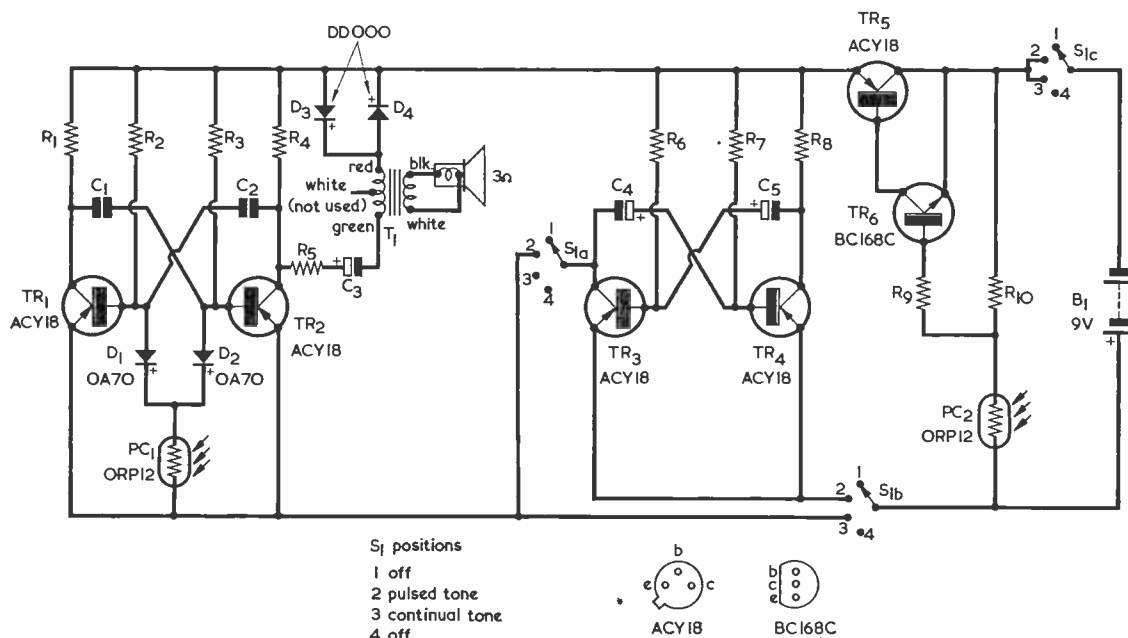
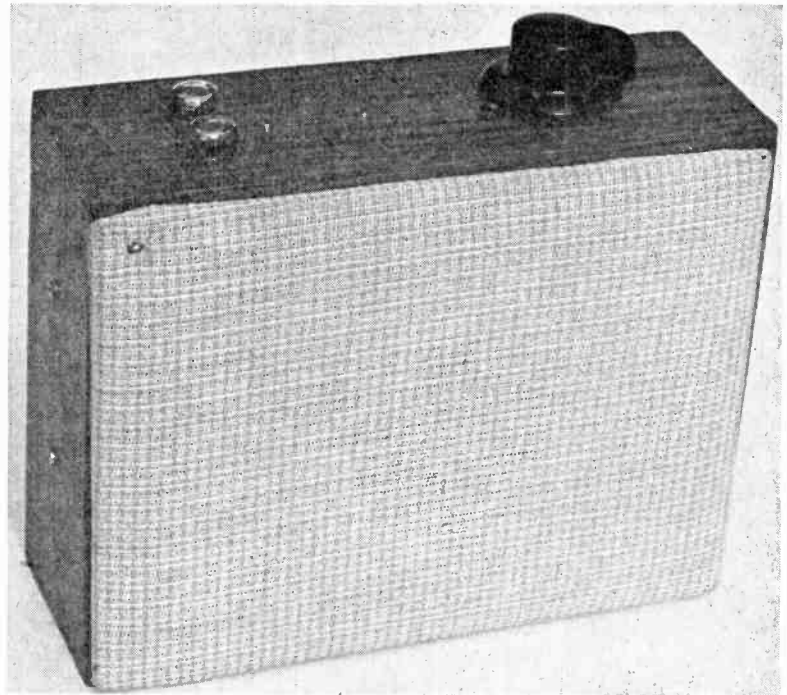

Fig. 1. The complete circuit of the light-operated tone generator



## Cover Feature



ils of a unit which produces a con-  
quency varies with light intensity. A  
off automatically in the absence of  
e early riser, the design has more  
ice, be used as an intruder alarm.  
ble advantage, at the constructor's  
as party

younger members of the writer's family, who have  
since received it with manifest satisfaction. The  
original function of the unit was to produce either  
an audible tone or a continual "bleeping" as the sun  
rose in the morning, thereby providing an early morn-  
ing alarm call. Two photoconductive cells are em-  
ployed and the effect, as ambient light increases from

### COMPONENTS

#### Resistors

(All resistor  $\frac{1}{4}$  watt 10%)

R1	2.7k $\Omega$
R2	100k $\Omega$
R3	100k $\Omega$
R4	2.7k $\Omega$
R5	1.5k $\Omega$
R6	100k $\Omega$
R7	100k $\Omega$
R8	2.7k $\Omega$
R9	2.2M $\Omega$
R10	22k $\Omega$

#### Capacitors

C1	0.1 $\mu$ F paper or plastic foil
C2	0.1 $\mu$ F paper or plastic foil
C3	2 $\mu$ F electrolytic, 10V Wkg.
C4	2 $\mu$ F electrolytic, 10V Wkg.
C5	2 $\mu$ F electrolytic, 10V Wkg.

#### Transformers

T1	Output transformer type LT700 (Eagle)
----	--

#### Semiconductors

TR1-TR5	ACY18
TR6	BC168C
D1	OA70
D2	OA70
D3	DD000
D4	DD000

#### Photocells

PC1	ORP12
PC2	ORP12

#### Switch

S1	3-pole 4-way, miniature rotary
----	--------------------------------

#### Battery

B1	9-volt battery type PP6 (Ever Ready)
----	--------------------------------------

#### Speaker

3 $\Omega$	4in. speaker
------------	--------------

#### Miscellaneous

8	Lektrokit 5-way tagstrips, centre tag earthed (see text)
	Pointer knob
	Battery connector
	Case, battery clamp, speaker fabric, nuts, screws, etc.

a very low level, is that the unit turns itself on and then produces a tone or "bleep" whose frequency rises as the illumination level increases. Conversely, as illumination decreases the frequency of the tone falls until, at a very low ambient light level, the unit turns itself off.

In practice, the circuit has been found to be extremely sensitive. It will stay in the "turned-on" condition in any part of a room illuminated by daylight or by normal electric light. The frequency variation with light level covers a wide range of audio frequencies and enhances the attractiveness offered by the basic light-operated switching circuit. The ability to change from a continual tone to a "bleeping" tone represents a further advantage, the interrupted tone being particularly useful for wakening sleepers or otherwise attracting attention.

The morning alarm facility is, of course, mainly advantageous during the spring, summer and autumn

a novelty device. Both technically and non-technically minded people seem to find the manner in which frequency varies with light level, and the fact that switchoff occurs in darkness, quite fascinating. At a party it is a good scheme to place the device in a room whose light is switched off and then stand back and watch the reactions of guests as they enter the room and switch on the light. For best results here the unit should be placed so that anyone approaching it casts a shadow over the photoconductive cells, thereby varying the frequency of the tone. Another idea consists of hiding the device in a cupboard so that it is silent until the cupboard door is opened.

The whole circuit is powered by a 9 volt battery. The current drawn from this battery is approximately 4mA when the unit is generating a tone or a "bleep" and falls to some 30 $\mu$ A or less when the unit is turned on with the photoconductive cells in the dark condi-

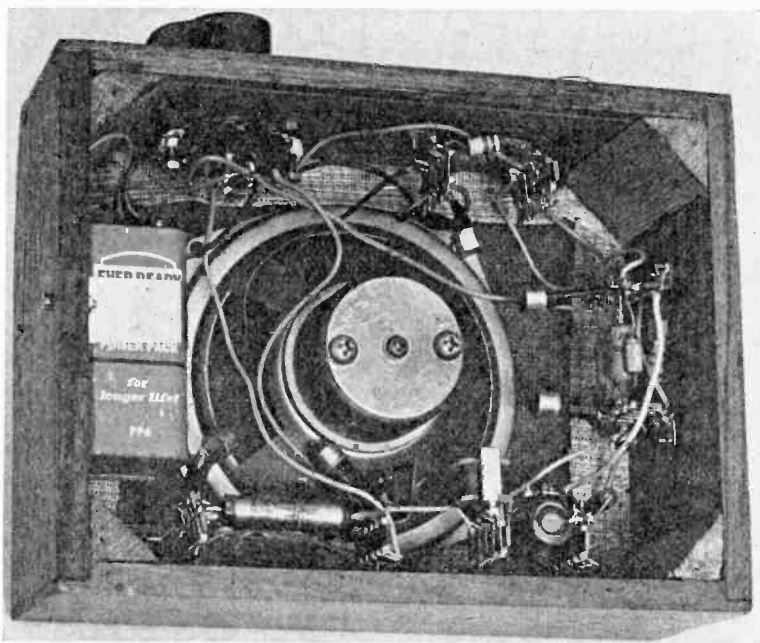

*The components inside the case. These are comfortably spread out around the inside surfaces*

months, and it will be particularly appreciated by campers and others who enjoy the open-air life. The unit cannot be employed in this manner during the winter months, when the sun rises after normal waking time. However, the design has some serious applications as well, these including its use as an intruder alarm. If the loudspeaker is positioned, on extension leads, away from the remainder of the circuit the device will give warning should intruders cause lights to appear near the photoconductive cells. Similarly, it can give advance warning of a motorist returning to his home at night-time. Provided that the photoconductive cells are so positioned that they will not be illuminated by the headlamps of cars using the main road, the returning motorist can activate them by flashing his headlamps on turning in from the road.

Now that Christmas is approaching the unit can, initially, be introduced to the family in the form of

tion. Before proceeding further, the writer must give acknowledgments to G. A. French, since the design described here is adapted from two of the "Suggested Circuit" articles, one of these appearing in the December, 1966 issue and the other, much more recently, in the May, 1969 issue.\*

## CIRCUIT DETAILS

The complete circuit of the device is given in Fig. 1, and it will be most convenient to examine this by commencing at the battery end. The battery, B1, couples initially via S1(c) to the network comprising PC2, TR5, TR6, R9 and R10. These components

\* G. A. French, "Suggested Circuit No. 193—Multivibrator With Single Resistance Control", *The Radio Constructor*, December, 1966; "Suggested Circuit No. 222—Light Operated Radio Switch", *The Radio Constructor*, May, 1969.

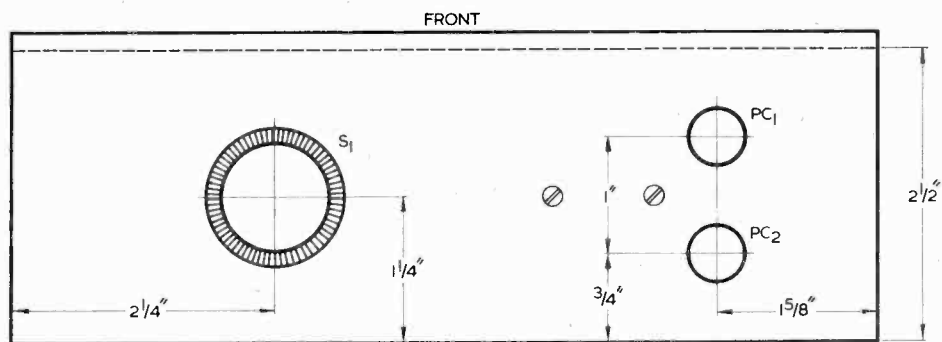

(a)

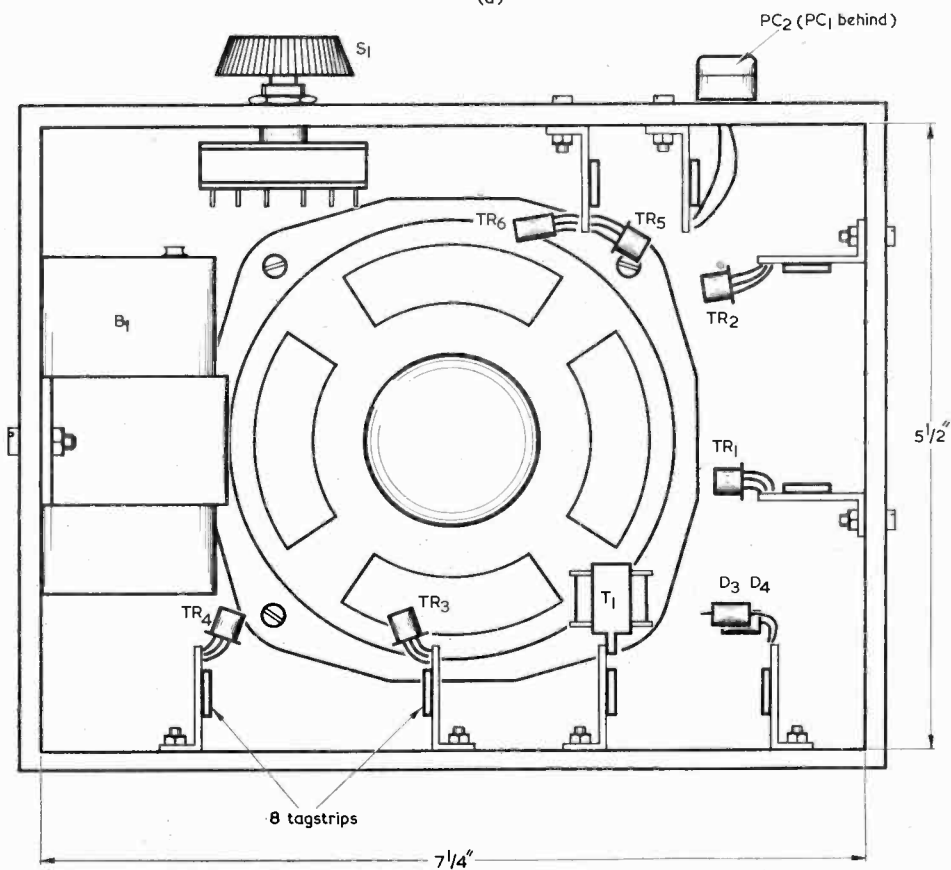

(b)

Fig. 2(a). Top view of the wooden case in which the prototype is assembled  
 (b). A view looking into the rear. Each of the tagstrips is identified by showing the principal component (or components) which couples to it. The lugs of the output transformer,  $T_1$ , are soldered to the tags of its tagstrip so that the component is vertical

appear in a simplified version of the second "Suggested Circuit" just mentioned, the simplification being possible because there are no supply rail bypass electrolytic capacitors in the remainder of the design, with the consequence that a limiting resistor is not

required, and because there is no necessity with the present unit for a preset control to vary sensitivity.  $PC_2$  and the associated components turn the remainder of the circuit on and off in the following manner. When  $PC_2$  is illuminated it exhibits a low resistance,

and causes a current from the positive supply line to flow in the base of TR6. The current gain in the combination of TR6 and TR5 is approximately equal to the product of their individual gains, and the result is that TR5 then becomes fully conductive and allows the battery supply to be coupled to the remainder of the circuit. When PC2 is not illuminated it exhibits a high resistance, whereupon both TR6 and TR5 become cut off, and the only current flowing through TR5 to the other stages is leakage current, this being typically less than  $30\mu\text{A}$ . An important feature of this light-switching circuit is that TR6 has the exceptionally high gain of 450 to 900 times, this resulting in TR5 being held hard on even when a very small current is passed by PC2.

We now have the situation where a supply of 9 volts (less the small voltage dropped in the conducting TR5) is applied to the remainder of the circuit when photoconductive cell PC2 is illuminated, this supply being cut off when PC2 is in the dark condition. We next turn to the preceding stages, and it will be of advantage to initially examine these with S1(b) set to position 3. As will be seen, this switch position causes the positive supply from the battery to be fed to the emitters of TR1 and TR2. These two

TR2 turns off, this being given via diode D2 and PC1. In consequence, the frequency of the multivibrator can be controlled by the resistance offered by PC1. When this resistance drops, due to increased illumination of the photoconductive cell, the multivibrator frequency rises. Due to its symmetry, the circuit continues to produce a 50 : 50 square wave over the range of frequencies resulting from varying resistance in PC1.

The collector of TR2 couples to a  $3\Omega$  loudspeaker by way of T1, this being an Eagle transistor output transformer type LT700 with the primary centre-tap ignored. Also included in the output circuit is the resistor R5. It was found that, without this resistor, the inductance in the transformer primary upset multivibrator operation at the lower frequencies, resulting in an abrupt change of tone quality as these frequencies were approached. It is probable that this effect was due to a shock-excited resonance in the transformer primary circuit, and it was completely cleared by the addition of R5.

Silicon diodes D3 and D4 were included for a different reason. It is a well-known fact that transistor multivibrators can operate with exceptionally low power supply voltages and currents, and TR1 and

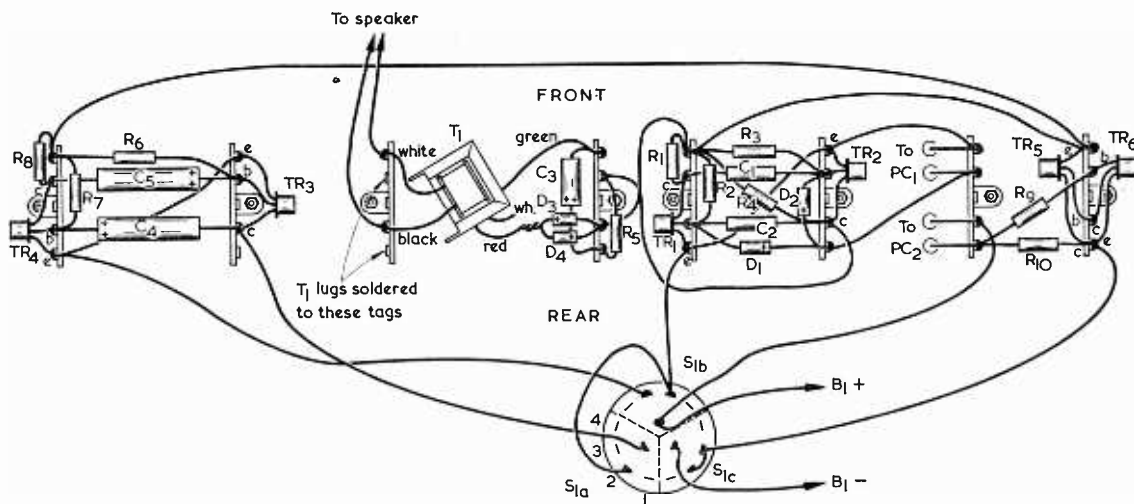

Fig. 3. Wiring diagram for the unit. Here, the top, side and bottom panels are shown "opened out" for clarity, with the switch alongside

transistors appear in a multivibrator circuit offering a 50 : 50 square wave output, the frequency of which is capable of being controlled by the resistance exhibited by photoconductive cell PC1. It will be recalled that, in a conventional transistor multivibrator, the period over which either transistor is cut off during the cycle is controlled by the time needed for its base capacitor to discharge sufficiently for the transistor to become conductive, whereupon it then initiates the next changeover. Normally, the base capacitor discharges via the resistor coupling the base to the upper supply rail but, in the present instance, there is an additional discharge path. When, for instance, TR1 turns off, its base goes positive of the lower supply rail, with the result that D1 conducts and an additional discharge path is given via PC1. A similar additional discharge path appears when

TR2 proved to be no exception. In fact, these two transistors continued to oscillate even when TR5 (with PC2 in the dark condition) was passing a leakage current of  $30\mu\text{A}$  only! In consequence, it became virtually impossible to turn the multivibrator off completely by means of the PC2 network. The audible output from the loudspeaker was extremely low under these low supply current conditions, but it was still at a level which could have been perceptible in a quiet bedroom. A number of attempts were made to ensure that the multivibrator had zero supply voltage when TR5 was passing leakage current only, but these were all unattractive because they necessitated extra loading resistors across the supply rails. It was eventually decided that the best solution would consist of accepting the fact that the multivibrator continued to oscillate and of ensuring, instead,



## Each £3 unit of Home Unit Insurance gives you protection up to the limit shown

This is the simplified insurance you have been waiting for. Not just cover on the contents of your home but a package of personal protection you and your family need. And it's how we save you so much money: just ONE policy to issue instead of nine! You can build up to the cover you need by additional units

(or  $\frac{1}{2}$  units after the first) up to a maximum of five. So simple. So easy. Apply to your Broker, Agent or local office of a General Accident company. The Home Unit Policy can replace your existing insurances. And remember - as you buy more possessions just add more Home Units at any time.

# THE YORKSHIRE INSURANCE COMPANY LIMITED

Becket House, 36-37 Old Jewry, LONDON, E.C.2.

It pays to be protected by a **General Accident** company

Please send me further particulars of the Home Unit Insurance.

Name.....

Address.....

5304 JB

that low amplitude signals did not reach the speaker. This function is carried out by D3 and D4 which, by virtue of being silicon devices, do not pass current at forward voltages below about 0.5 volt.

When TR5 is hard on, the collector of TR2 gives a square wave of nearly 9 volts peak-to-peak, about 1 volt of this being dropped across D3 and D4. When, due to PC2 being changed to the dark condition, TR5 passes leakage current only, the very low output from TR2 collector is less than 1 volt peak-to-peak, and this is insufficient to allow forward current to pass through the diodes. There is, in consequence, no perceptible output from the speaker. It is a matter of good fortune that silicon diodes have almost exactly the forward voltage/current characteristic that is required here, and they enable the multivibrator to become silenced in a most effective manner. As illumination in PC2 decreases, TR5 changes fairly abruptly from the conducting to the non-conducting state. This point, in combination with the action of D3 and D4, results in the unit changing from full output to silence over an impressively low range of light level. If, for instance, the unit is switched on just after dusk, it changes from full output to silence over a period of ten minutes only as night-time approaches.

Capacitor C3 is included in the circuit to ensure that the signal current passed by D3 and D4 swings equally on either side of zero current over the range where these two diodes conduct.

Setting S1 to position 2 causes the "bleeping" circuit to be brought into operation. In this position, S1(b) breaks the positive supply to the emitters of TR1 and TR2 and applies it to the emitters of TR3 and TR4. At the same time, S1(a) couples the emitters of TR1 and TR2 to the collector of TR3. TR3 and TR4 are in a standard multivibrator circuit, the values of C4, C5, R6 and R7 causing it to run at about four cycles per second. When TR4 is on, it draws collector current via R8 in normal fashion. However, when TR3 is on this transistor draws collector current via the entire multivibrator circuit around TR1 and TR2. Thus, TR1 and TR2 oscillate when TR3 is on, giving an attention-catching "bleeping" tone.

It is interesting to note that the unit draws approximately the same current from the battery for both the "bleeping" and the continual tone output. When switched to give a continual tone, either TR1 or TR2 draws a current of some 4mA through R1 or R4 respectively. When switched to the interrupted tone either TR4 draws about 4mA through R8, or TR3 draws 4mA through the TR1, TR2 multivibrator.

A final point concerns the switch S1(a) (b) (c). It was decided to use a 4-way switch with both end positions corresponding to "off" since it is then more easy to switch the unit off, particularly at times when one is just being awakened. Since the switch requires 3 poles, the 4-way combination is readily available in the standard range of inexpensive miniature rotary switches.

## COMPONENTS

None of the components in the unit is particularly expensive. A suitable alternative for the ORP12 listed for PC1 and PC2 is the LDR03 photoconductive cell.

TR5 and TR6 should be the types listed, the BC168C being available from Amatronics Ltd. It is probable that most p.n.p. germanium transistors would be satisfactory for TR1 to TR4 inclusive, but care should be taken to see that any alternatives that may be tried have a reverse emitter-base voltage rating of greater than 9 volts. D1 and D2 need to be germanium types, whilst D3 and D4 must be silicon types. Again, experimenters may find that adequate results are given with alternative types in these circuit positions. The writer must stress, however, that the performance described in this article was obtained with the specific semiconductors listed.

It will be noted that the Components List includes a quantity of Lektrokit 5-way tagstrips with centre tag earthed. These tagstrips were employed in the author's version, but are not necessary if alternative methods of component mounting and wiring are to be used. The Lektrokit tagstrips are available from Home Radio (Components) Ltd., and can be ordered in quantities of 10 under Cat. No. LK-2231.

## INDEX

### RADIO CONSTRUCTOR'S DATA SHEETS (January to December 1969)

DATA SHEET	19	IR Dissipation - Currents Below 50mA	365	January
	20	IR Dissipation - 50mA and Above	383	January
	21	ER Dissipation - Voltages Below 50	433	February
	22	ER Dissipation - 50 Volts and Above	541	February
	23	Sound Frequency/Wavelength Table	501	March
	24	Amateur Q Code	561	April
	25	Amateur Abbreviations	595	April
	26	625-Line Colour and Monochrome TV	iii	May
	27	Inch/Millimetre Conversion Table	iii	June
	28	Round Figure Values for $2\pi f$	iii	July
	29	Squares of Numbers	iii	August
	30	Square Roots of Numbers	iii	September
	31	Cubes of Numbers	iii	October
	32	Cube Roots of Numbers	iii	November
	33	Half-Wave Rectifier Outputs	iii	December



## CONSTRUCTION

The prototype unit is shown in the accompanying photographs. All the components are fitted into a small wooden box having internal dimensions of  $7\frac{1}{4}$  in. wide by  $5\frac{1}{2}$  in. high by  $2\frac{1}{2}$  in. deep, as shown in Fig. 2(a) and (b). This box is initially fitted with a 4 in.  $3\Omega$  speaker, for which a suitable aperture is first cut and then covered with speaker fabric. There are four wooden strengthening struts in each corner angle. These struts can be seen in the photograph of the rear of the unit, but are not shown in Fig. 2.

The components inside the case take up the positions illustrated in Fig. 2(b). Each of the tagstrips shown here is illustrated with its principal component or components attached, in order that it may be identified in the wiring diagram given in Fig. 3. The tagstrips are secured to the side and top of the case with cheese-head 6BA screws and nuts, and to the bottom with countersunk 6BA screws and nuts. The positioning of the tagstrips is not critical and the easiest approach towards construction is to first wire up the components on them, and then fit them individually into the case, drilling suitable 6BA clear mounting holes as and where required. Flying leads coupling the tagstrips together and to the switch are connected up after the strips have been mounted inside the case. The purist may prefer to secure the tagstrips with wood-screws applied from the inside so that bolt heads do not appear on the outside of the case. Since, however, the unit is intended to be an electronic device rather than an item of furniture, the few screw heads visible on the outside do not, in the writer's view, detract from its appearance.

The two photoconductive cells are secured to the top surface with Araldite, their leads passing through small holes, previously drilled, directly beneath them. These leads should be sleeved over the parts which pass through the holes. An alternative approach here would consist of recessing the cells so that their faces are flush with the top surface of the panel.

Construction should be started by first preparing the case. This includes cutting out the speaker aperture, and cutting out the hole for S1. A simple metal mounting clamp for the battery may be made up at

this stage and two suitable 6BA clear holes drilled for it in the left hand panel, as viewed in Fig. 2(b). It is merely necessary for the battery to be mounted centrally on this panel, as its exact positioning is in no way critical. Suitably finish the case by painting it, or staining and varnishing it, then fit the speaker fabric, the speaker, the two photoconductive cells, and switch S1. The battery is not mounted at this stage.

Turn next to Fig. 3, which shows the wiring laid out in one plane, as would be given if the top, side and bottom panels were "opened out" and laid end to end. First, mount the tagstrip adjacent to the photocells to the top panel underside (see Fig. 2(b)) and connect and solder the photocell leads to its tags. (Each of the tags in the Lektrokit tagstrips specified has both a top and a bottom wiring position, with the result that subsequent connections to a tagstrip need not be at the same solder joints as have been made previously.)

Take up another tagstrip and, before fitting it in the case, solder to its tags TR5, TR6 and one end each of R9 and R10, as shown in Fig. 3. Mount this tagstrip alongside the one already fitted, as in Fig. 2(b), then connect the free ends of R9 and R10 as shown in Fig. 3.

Make up an assembly comprising two tagstrips, TR1 and TR2, R1 to R4 inclusive, C1 and C2, and D1 and D2. Wire all these components up as in Fig. 3. Also solder flying leads of flexible p.v.c. covered wire to the emitter of TR2, the emitter of TR1, the collector of TR2, and the junction of D1 and D2. Connect *two* flying leads to the junction of R1, R2, R3 and R4. Despite the fact that they are not mounted to any surface during this wiring procedure, the tagstrips will be sufficiently steady after C1 and C2 have been soldered between them. Drill suitable holes in the case, then mount the two tagstrips so that they take up the positions indicated in Fig. 2(b).

Next, shortening each flying lead as necessary and following Fig. 3, connect the emitter of TR2 to one terminal of PC1, and the junction of D1 and D2 to the other terminal of PC1. Similarly, connect one of the leads from the junction of R1, R2, R3 and R4, to the emitter of TR5.

---

## CAN ANYONE HELP?

*Requests for information are inserted in this feature free of charge, subject to space being available. Users of this service undertake to acknowledge all letters, etc., received and to reimburse all reasonable expenses incurred by correspondents. Circuits, manuals, service sheets, etc., lent by readers must be returned in good condition within a reasonable period of time.*

**Type 46 Walkie-Talkie.**—R. K. Lloyd, POB 1164 Lusaka, Zambia, Central Africa—wanted, winding details of the tuning coils.

**"Simon" Ex Min. Tape Recorder.**—A. W. Bawden, 232 Exwick Road, Exeter, Devon—valve line-up, especially oscillator valve. Circuit diagram. Loan or purchase.

**Taylor Valve Tester.**—J. Hartley, 27 Worcester Road, Blackburn, Lancs.—operating instructions required for the model No. 45C.

**Eico Multimeter Model 565.**—W. Monksfield, Searchlight Cripples Workshop, Newhaven, Sussex—circuit, operating instructions or any data. Instrument made

by Electronic Instrument Co., Brooklyn, New York, U.S.A.

**Car Ignition Circuit.**—Cpl. R. Horner, 21 Signal Regt., R.A.F. Gutersloh, BFPO 47—circuit diagram for transistor ignition system required.

**Telefunken Tape Recorder Model T75.**—W. Lowens, 28 Wavertree Road, Higher Blackley, Manchester 9—loan or purchase of service sheet.

**Hartley & Erskine Type 13A D. B. Scope.**—V. C. Milford, "Grey Flints", Windsor Forest, Berks—handbook, loan or purchase.

**KW77 MkII Receiver.**—S. Smith, 19 Hyde Road, Kenilworth, Warks—loan of handbook.

Take up a single tagstrip and wire to this C3, R5, D3 and D4, as in Fig. 3. Mount this to the bottom panel in the position indicated in Fig. 2(b). Next, shortening as necessary the flying leads already fitted, and following Fig. 3, connect the collector of TR2 to one end of R5. Similarly, connect the junction of R1, R2, R3 and R4, to the tag securing one end each of D3 and D4.

Mount transformer T1 to a further tagstrip by soldering its lugs to the two tags indicated. Connect its white and black secondary leads to the two remaining tags shown and connect flying leads to these two tags. Mount the tagstrip to the bottom panel as illustrated in Fig. 2(b) then, shortening as necessary, connect the two flying leads to the speaker tags. Connect the green primary lead of T1 to the negative end of C3 and the red primary lead to the remaining free ends of D3 and D4. Note that the connection to D3 and D4 is in the form of a "mid-air joint". The white primary lead of T1 is not used and it should be tucked out of the way, taking care to ensure that it cannot short-circuit to any tag or connection.

Make up the assembly comprising two tagstrips, TR3, TR4, R6, R7, R8, C4 and C5. These are wired up in a similar manner to the previous multivibrator assembly which incorporated TR1 and TR2. Provide flying leads from TR4 emitter, TR3 collector and the junction of R6, R7 and R8. Fit this assembly so that it takes up the position shown in Fig. 2(b). Then, shortening as necessary, connect the flying lead from the junction of R6, R7, and R8 to the emitter of TR5. Similarly, connect the collector of TR3 to the arm of S1(a).

Solder the negative battery lead to the arm of S1(c). In company with a flying lead, solder the positive battery lead to the arm of S1(b). Shortening as necessary, connect this last flying lead to the unused terminal of PC2.

Either by visual inspection or with the aid of a continuity tester, determine the contacts of S1 which correspond to switch positions 1, 2, 3 and 4. Their relative positions may differ, in some switches, from those shown in Fig. 3. Connect together the two contacts of S1(c) corresponding to positions 2 and 3, then run a flying lead from these to the collector of TR5. Shortening as necessary, connect the flying lead from TR4 emitter to the position 2 contact of S1(b). Similarly, connect the flying lead from the emitter of TR1 to the position 3 contact of S1(b), and then connect this contact to the position 2 contact of S1(a).

Wiring up is now complete.

## TESTING

For initial tests it is convenient to have the battery outside the case. It is not connected up yet. First check the wiring for obvious faults, short-circuits or poor connections. If a testmeter is available, select a resistance range which causes a  $1k\Omega$  reading to be near centre deflection, then measure the resistance across the two battery clips for different positions of S1. The reading given will vary according to the energising voltage of the battery in the testmeter but, in general, it should be above  $1k\Omega$  for both positions 2 and 3. A higher reading is given with the ohmmeter leads connected one way round rather than the other,

and this point may also be checked. The meter should, of course, indicate infinite resistance when S1 is in positions 1 and 4.

Remove the testmeter and connect the battery to the unit. The speaker should now produce a continual tone with S1 in position 3 and an interrupted tone with S1 in position 2. Check that, in both cases, the tone varies in frequency when the hand is passed over PC1, thereby changing the light level falling on this photocell. Next, place the hand fully over the two photocells in order to completely exclude light from PC2, and see whether the unit turns off. If the unit is in bright daylight or a well illuminated workshop it may be found difficult to exclude sufficient light from PC2 in this manner for the unit to turn off, in which case the test should be repeated with the unit in shadow or in partial darkness. If the test is being carried out at night-time, after dusk, switch off all lights and see whether it similarly turns off. It should then be possible to turn the unit on again by striking a match some 6 to 12in. above PC2.

Finally, insert a current reading meter in series with the positive battery connection and check current consumption. This should be between 3.5 and 5mA for all tone frequencies generated on either switch positions 2 and 3. The meter needle may fluctuate slightly at pulse frequency on position 2, since the TR1, TR2 multivibrator will not draw exactly the same current as R8. Next, check current consumption with light excluded from PC2 such that the unit is turned off. The consumption should be  $100\mu A$  or less. This last test is best carried out in conditions of low ambient light level for the reasons already stated. The prototype, at night time, drew a current of some  $30\mu A$  only.

Although, in order to conserve the battery, the audio power fed to the speaker is relatively low, the nature of the tone causes the audible signal to be at more than adequate level for the purpose required of the unit.

## FINAL POINTS

After the unit has been checked out, the battery may be clamped into position, and the case fitted with a suitable back. In the prototype the back was secured with four woodscrews passing into the corner struts which are visible in the photograph of the rear.

Some constructors may prefer to assemble the unit in a metal case or on a metal chassis. The layout diagram shown in Fig. 3 may still be followed. It will be noted that, in this diagram, none of the centre earth tags of the tagstrips connect into circuit. It would be preferable to have a chassis connection into the circuit when a metal case or chassis is used, and this connection may be made to the main negative supply rail, at the emitter of TR5. If a metal-clad 9 volt battery is used to power the unit, it should not be clamped direct to the case or chassis. Its metal case should, instead, be insulated from chassis and its mounting clamp by means of p.v.c. or polythene sheet.

Due to tolerances in PC2 there is a slight possibility that some units built up to the circuit may require an inconveniently low light level before turning off. Should this occur, the value of R10 may be experimentally reduced (to a minimum of  $2k\Omega$ ) until the desired sensitivity is achieved.

# TRANSISTORISED G.D.O. FOR THE H.F. BANDS

## (Part 2)

by

R. J. HULBERT, G3SRY

In this article our contributor concludes his description of this neat and efficient g.d.o. First dealt with is the preparation of the case, after which details are given of wiring, coil winding and calibration

### CASE PREPARATION

Before proceeding further, all the metalwork described in Part 1 must be completed, and the major components tried in position to ensure that everything fits correctly.

The metal case is next prepared for painting, and it should be initially rubbed down with fine steel wool to produce a matt finish. This will provide a better key for the paint. Remove all traces of steel wool, and wipe down with a clean rag soaked in thinners, to remove any oil or grease. The case is now ready for finishing.

The prototype was sprayed with aerosol synthetic enamel, as supplied for rectification of minor car body damage. If this type of paint is used it is important to apply each coat sparingly, and allow sufficient time for the paint to become tacky, before the next is applied. Density is gradually built up, until an excellent finish is obtained. If the paint is applied too thickly, or too frequently, sags or runs will be inevitable. If applied correctly the first coat will produce a misty and somewhat spotty appearance, with little colour. If this little is laid with each coat, the final result will be good.

A popular finish with contractors is Hammerite hammer finish paint. This may be obtained in various colours, and applied by brush or spray. Applying this paint by spray requires suitable equipment, and a knowledge of spray painting techniques. There is also the point that the time involved in mixing, etc., is hardly worth the effort for such a small job. There is a definite knack in brushing Hammerite; the trick is to use a large brush, and apply a thick coat quickly. One has only ten seconds or so before the paint becomes tacky, and starts to pull. The resulting finish is inferior to professionally sprayed hammer finish, but nevertheless is more than adequate for general purposes. As soon as the paint chosen is thoroughly hard, assembly may commence.

### WIRING UP

The group board is wired as a separate unit, as shown in Fig. 5. It is then mounted in position using two 6BA chrome plated mushroom head screws, nuts and hollow  $\frac{1}{4}$ in. stand-off pillars, which may, if necessary, be cut from a piece of brass or aluminium alloy tube. The solder tag shown on the group board is secured by the nut nearer the coil socket end of

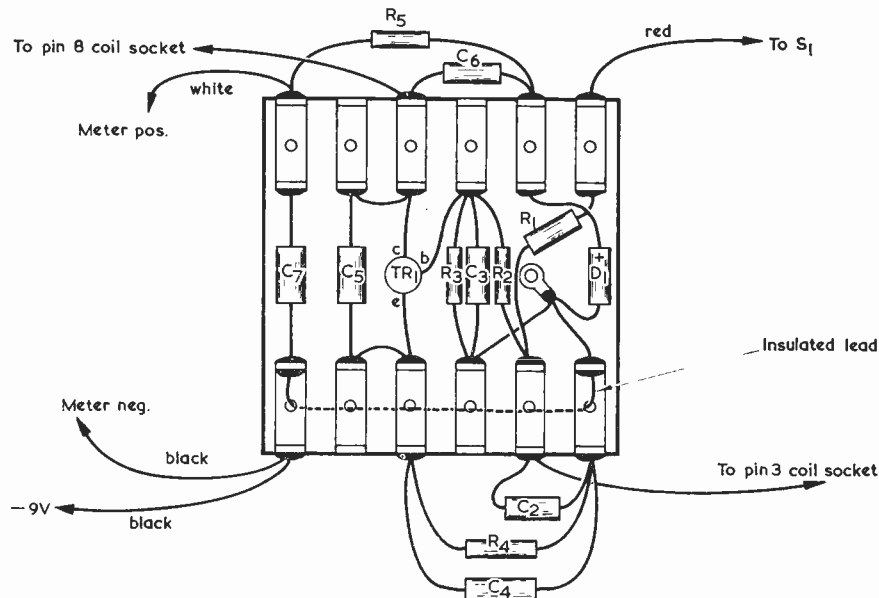

Fig. 5. Wiring up the group board

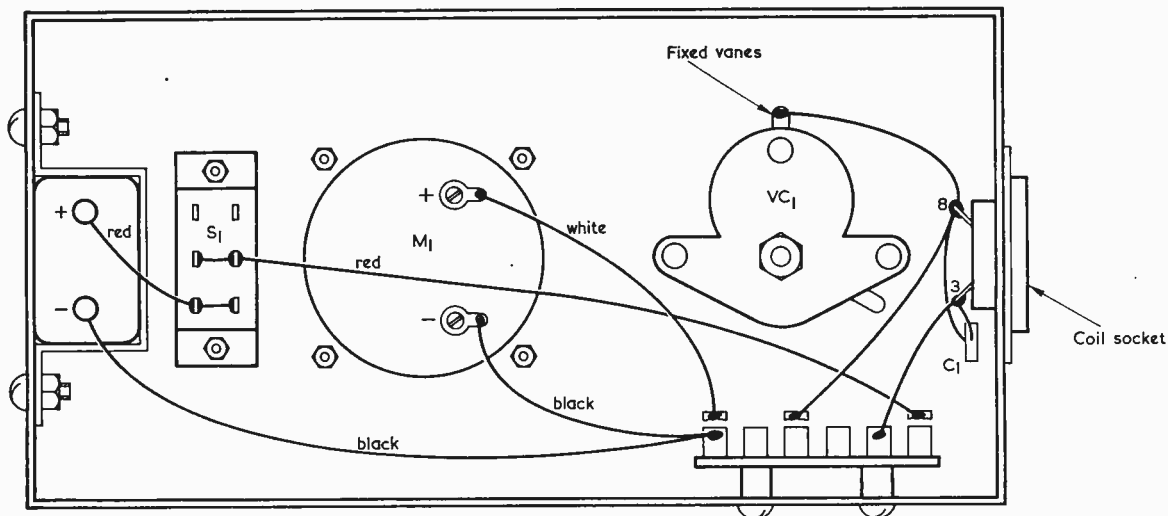

Fig. 6. The remainder of the wiring

the chassis. The coil socket, meter, switch and battery may next be mounted, using the appropriate fixing hardware. Wiring can now be undertaken, as in Fig. 6, leaving the lead to the fixed vanes of VC1 hanging for the time being. VC1 is next fitted with 6BA countersunk screws, and its fixed vanes connected. The connection to the moving vanes is automatically provided via the chassis.

The coils may now be wound. They should be wound on the specified Denco formers, using the correct gauge of wire and the number of turns given in Table II. The coil end nearer the base connects to pin 8 and the other end to pin 3. The distance between the coil and the outer end of the former is  $\frac{1}{8}$  in. The formers should be fitted to a socket whilst the coil leads are being soldered, since this will ensure that the hot pins do not move out of position in the polystyrene moulding. When winding is complete the polystyrene nuts are removed and the threaded portions sawn off.

TABLE II  
Coil Winding Details

Range	Frequency coverage	Winding details
1.	10.75 - 16 MHz	18½ turns 28 s.w.g. en. closewound
2.	15.5 - 22 MHz	14½ turns 22 s.w.g. en. closewound
3.	22 - 31 MHz	8½ turns 22 s.w.g. en. closewound
4.	31 - 46 MHz	6½ turns 22 s.w.g. en. spacewound over $\frac{3}{8}$ in.
5.	41.5 - 65 MHz	2½ turns 22 s.w.g. en. spacewound over $\frac{1}{8}$ in.

The coils are not doped with polystyrene cement at this stage, since some later adjustment may be required.

After winding, plug in each coil in turn and switch on. The meter should indicate on all ranges, the Range 1 coil giving the maximum indication and the Range 5 coil the lowest.

If all is well the scale may be prepared. This is made from matt white Formica as illustrated in Fig. 7(a). The three concentric circles are drawn in indian ink with the radii shown. Also drawn in indian ink is a line through the centre. This scale is secured to the front panel of the case over VC1 spindle with Evostik adhesive.

Next to be made is the scale cover, this being illustrated in Fig. 7(b). The material is  $\frac{1}{16}$  in. Perspex sheet. The three holes shown apply to the particular knob used by the writer and should be drilled with a No. 32 drill and countersunk. The scale cover may then be secured to the knob using short 6BA countersunk screws. As was mentioned in Part 1, if an alternative knob is employed the scale cover may be secured to it with Araldite general purpose adhesive. The scale cover has a line scribed across its diameter on the under-surface, as illustrated, this being filled with indian ink.

The scale cover and knob are now tried in position, any surplus length on VC1 spindle being removed with a junior hacksaw. VC1 is next set to full mesh, and the pointer line set to coincide with the scale end line on the scale.

## RANGE CHECKING

A receiver (or several receivers) covering the range 11 to 65 MHz is required for range checking and calibration. If no form of crystal calibrator or frequency meter is available, the calibration of the receiver dial will have to be taken as correct. This may produce some inaccuracy of calibration, but the constructor can still determine if a tuned circuit is near the required frequency, or a mile away.

Connect a short length of wire to the receiver to function as an aerial, and lay the other end close to the coil of the g.d.o. Determine the expected range of each coil, and plot its range with the receiver. Beware of the receiver's second channel, and harmonics from the g.d.o., since confusion can result from these. In general, signals produced by these means will be weaker, and can thus be identi-

fied. If the receiver is fitted with an S-meter, the task will be made simpler.

The coils most likely to require adjustment are the two highest frequency ones. If the range obtained is at a lower frequency than that required, the spacing between turns should be increased. In the unlikely event of this not affecting a complete cure, a turn, or part of a turn, may be removed. If the reverse is true, the turns should be pushed together to reduce the spacing. Once again if this does not produce the desired result, a turn or part of a turn may be added. In this case it will mean re-winding the coil. After adjustment, the coils are doped with several coats of polystyrene cement, and left to harden.

## CALIBRATION

In order to calibrate the scales, a calibration pointer is required. This is simply a scale cover, but with a slot instead of the pointer line. There is no need to go to the trouble of cutting another disc, since a strip of Perspex  $2\frac{1}{2}$  in. long by  $\frac{3}{4}$  in. wide will suffice. This is attached to a knob by any convenient means, and a slot produced with a junior hacksaw.

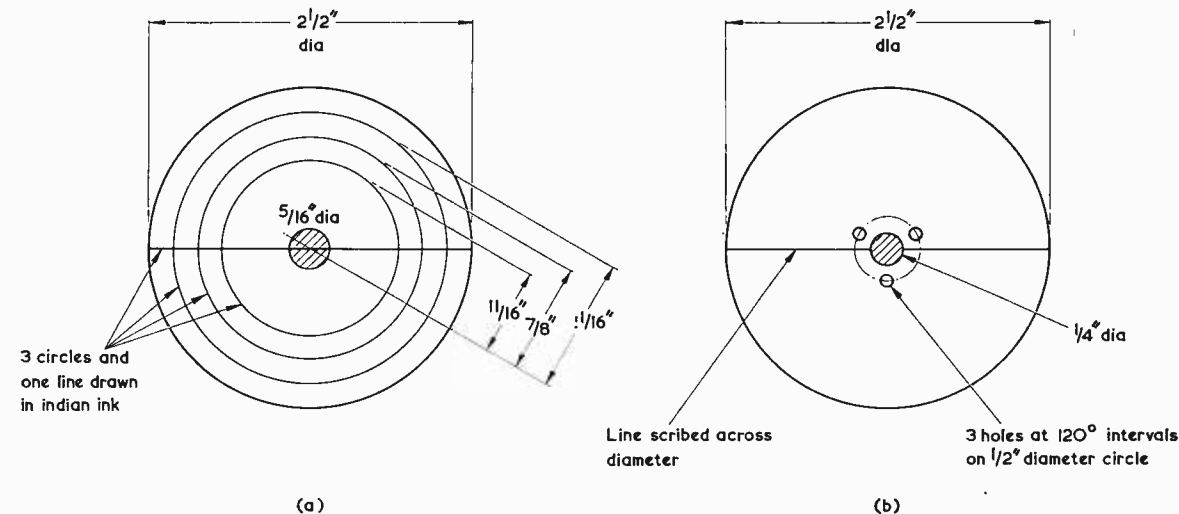

Fig. 7(a). Cutting out and marking up the scale  
(b). Details of the scale cover, which is fitted to the variable capacitor knob

It is important that the slot should be exactly in line with the centre of the spindle. The slot is now filed to a V shape, to allow a sharply pointed pencil to pass through to the dial. With VC1 exactly at full mesh, the calibration pointer is accurately fitted to the spindle so that the slot is directly over the end of the scale line on the dial. The instrument is now ready for calibration.

Using the receiver as before, the g.d.o. is switched on and each coil inserted in turn. The receiver is set to a definite frequency, and the g.d.o. adjusted to coincide. A small pencil mark is then made on the appropriate scale. If a duplicate scale is drawn on paper, the approximate position of each mark and its frequency may be noted. This will be found very useful at the inking-in stage. Continue in this way until all the coils have been calibrated. The

g.d.o. and receiver may now be switched off, and the calibration pointer removed.

Each mark can be re-drawn more permanently with indian ink and a mapping pen, and the figures added. The knob with the proper scale cover is next refitted, being carefully set up to coincide with the scale end line when VC1 is at full mesh.

The g.d.o. is now ready for use.

## USE OF A G.D.O.

A g.d.o. is normally used to determine the resonant frequency of a tuned circuit. By bringing the g.d.o. coil close to the coil under inspection and adjusting the dial, a point is found at which the g.d.o. meter reading will fall to a minimum. The sharpness of this minimum or dip is a function of the Q of the tuned circuit and the degree of coupling. The reading of the g.d.o. scale at dip coincides with the resonant frequency of the tuned circuit under investigation. The best accuracy is obtained at the minimum coupling that will produce a dip. The dip occurs because oscillator power is absorbed by the circuit under test, whereupon less voltage is available for the g.d.o. circuit.

A g.d.o. can prove invaluable if a piece of r.f. equipment has been built and one or more of the tuned circuits does not peak correctly. It becomes a simple matter to determine if the offending circuit is high or low of the required frequency, and therefore what action is required. Successful coils may be constructed armed with nothing more than the materials, an initial guess, and the g.d.o.

With its range of 11 to 65 MHz, the present instrument will deal with the earlier stages of v.h.f. transmitters, Band I TV channels, tuned circuits for the 27MHz Radio Control band, as well as the h.f. amateur bands on 10, 15 and 20 metres, and the spaces between. To appreciate how useful a g.d.o. can be, one must own one and learn to exploit its possibilities.

## RECENT PUBLICATIONS

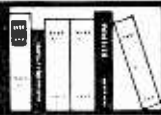

**TRANSISTOR ELECTRONIC ORGANS FOR THE AMATEUR.** By Alan Douglas, Sen.M.I.E.E., and S. Astley. 79 pages, 5½ x 8½in. Published by Sir Isaac Pitman and Sons Ltd. Price 20s.

This is the second edition of *Transistor Electronic Organs For The Amateur*, and the authors have taken advantage of its appearance to introduce devices and circuitry which are made possible by the more recent transistor techniques.

The book starts with a brief chapter describing the electronic organ and its associated terminology, after which a second chapter provides a simple introduction to transistors and transistor circuits. The third chapter devotes 25 pages to details of a practical transistorised organ having two manuals and a pedal board, the original design of which appeared, incidentally, in *The Radio Constructor*. This is a divider organ with the top 12 notes generated at 4ft. pitch by stable oscillators, all the lower pitches being provided by locked blocking oscillators. Tone forming is given by a series of filters and a considerable number of examples of successful filters are included. Vibrato and reverberation circuits are also described, as well as a swell pedal mechanism incorporating an ORP12 photoconductive cell.

The following chapter deals with circuits for other transistor organs, and describes techniques capable of more general use. The fifth chapter discusses transistor amplifiers and power supplies, whilst the sixth and last chapter deals with semiconductor keying together with circuits for percussion and sustain effects.

**110 SEMICONDUCTOR PROJECTS FOR THE HOME CONSTRUCTOR.** By R. M. Marston. 133 pages, 5½ x 8½in. Published by Iliffe Books Ltd. Price 25s.

The purpose behind this book is that of presenting information on established and new semiconductor devices by way of circuit design rather than by long-winded theory. Each chapter commences with a non-mathematical outline of the basic characteristics of the devices to be dealt with, then gives a range of practical circuits in which they can be successfully employed.

A good idea of the semiconductor devices covered is given by quoting the five chapter titles: 30 Silicon Planar Transistor Projects, 15 Field-Effect Transistor Projects, 20 Unijunction Transistor Projects, 15 Silicon Controlled-Rectifier Projects and 30 Integrated Circuit Projects. The integrated circuit employed in the last chapter is the  $\mu$ L914, having 4 transistors with associated resistors. The range of circuits dealt with is exceptionally wide and includes, to name only a few, amplifiers, timers, a chopper, variable power control units and a water level sensor.

All circuits have full component values and are accompanied by brief but very explicit descriptions of their operation.

The technique of explaining semiconductor operation with the aid of practical circuits is to be commended, and the considerable amount of information provided by the 110 working circuits in this book make it excellent value at its price.

**VHF-UHF MANUAL.** By G. R. Jessop, C.Eng.M.I.E.R.E., G6JP. 6½ x 9¼in. Published by the Radio Society of Great Britain. Price 20s.

There is much to recommend today's Radio Amateur to devote his interests more and more to the VHF-UHF bands. Limitations in real estate and planning permission difficulties often result in an unsatisfactory aerial array and this, together with the high occupancy of the lower frequency bands, discourage many from engaging in amateur radio as practiced these days on the more conventional bands. The prospects for the future of the VHF-UHF bands is however very bright – particularly with the possibility of satellites specifically designed for amateur radio communications being put into orbit in the not too distant future.

VHF-UHF techniques are a specialist field and, in the past, one has had to search throughout amateur radio literature to find the information one requires. It is good therefore to see the publication of a volume containing all one wants to know to become actively engaged in VHF-UHF communications.

The VHF-UHF Manual contains all information the newcomer to this field will want and will provide the amateur having previous experience of these techniques with new ideas and a ready reference to often required data. It is an excellent Manual which we can thoroughly recommend to the beginner and to the experienced VHF-UHF enthusiast alike.

# CURRENT TRENDS

## SEMICONDUCTOR DEVICES

New Booklet Published by  
Mullard Educational Service

The third booklet in the series of 'minibooks' published by the Mullard Educational Service is entitled 'Semiconductor Devices'. It is intended as an introduction to the subject which, being treated non-mathematically, should be easily understood by anyone with a basic knowledge of electronics.

The booklet starts with a description of germanium and silicon and shows how they can be made into n- or p-type material by the addition of minute amounts of other elements. Explanations are given of the action of the p-n junction in a diode and the p-n-p or n-p-n arrangement in a transistor. The current-amplifying property of a transistor is explained and several basic transistor circuits are included.

The booklet then describes briefly how various transistors are constructed and has a section on transistor characteristics. In the final section other solid-state devices, such as phototransistors, thyristors, thermistors, f.e.t.s., and Gunn 'diodes', are outlined. The booklet ends with a short description of integrated circuits.

'Semiconductor Devices' should be of interest to all students, and apprentices as well as lecturers and teachers of electronics in schools technical colleges and other training establishments. Priced at 5s. 0d. (including packing and postage), it can be obtained from the Mullard Educational Service, Mullard House, Torrington Place, London, W.C.1. Cash should accompany orders.

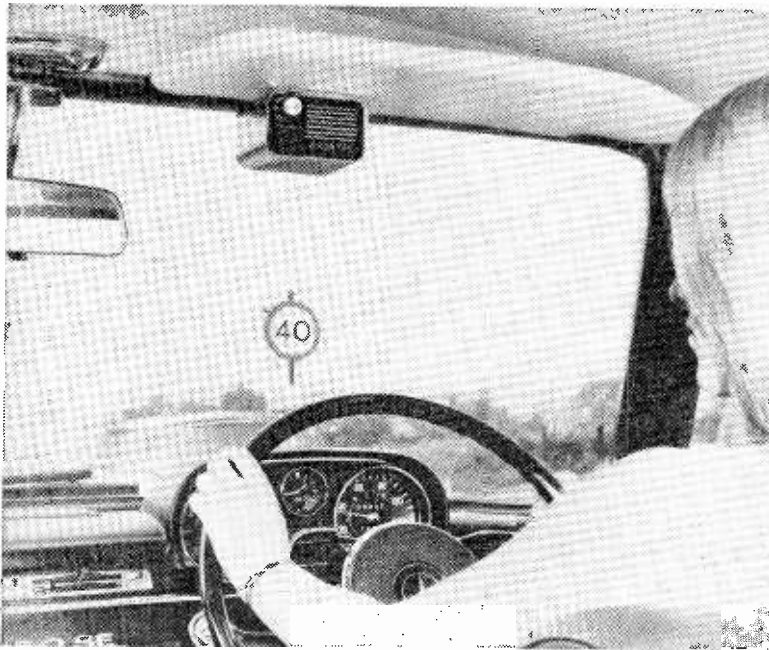

## "RADATEC" X-BAND RECEIVER

The unique solid-state microwave receiver shown in the accompanying illustration is marketed under the trade name "Radartec". The "Radartec" covers the entire X band of the radio spectrum (9,000 to 11,500MHz) and will therefore receive most of the shipping and aircraft radar beacons as well as the police radar and the 3cm Amateur band.

As will be seen from the illustration, the compact and attractively styled receiver is securely clipped to the car sun visor and picks up signals by means of a special 2½ in. long aerial fitted to the rear of the "Radartec".

The receiver is powered by a self-contained mercury deaf aid battery which has an average life of 500 hours. When in operation, the receiver, which has an integral speaker, is set such that a ticking sound is heard (similar to that of a geiger counter) by means of the volume control. Upon receiving a microwave signal, the ticking sound increases both in speed and intensity until a loud screech – with an intensity of 100dB/M at the speaker – is heard.

There are no legal complications to the installation of this receiver, it being classed as a transistor radio. By virtue of its 3cm Amateur band coverage, an ordinary domestic radio licence only is required.

The retail price of the receiver (4½ x 3½ x 3 in. outside measurements and weighing only 11 ounces) is £13 5s. 0d. ready to work and carriage paid in the U.K. All enquiries should be directed to Belding & Bennett Ltd. (Radar Division), Box 38, 45 Green Lane, Purley, Surrey. Tel. 01-660 2896.

## Dx-CIRCLE

A special programme for Medium and Short Wave broadcast band Dx'ers is now included in the English Service of the West German station Deutschlandfunk at 1800 GMT on alternate Wednesdays (December 3rd, 17th, 31st, etc.)

The programme is presented by the well-known broadcast Dx'er Alan Thompson of Neath. Tips are always welcomed for the Dx News part of the programme and may be sent direct to Alan Thompson at 16 Ena Avenue, Neath, Glam., or to "Dx-Circle", DLF English Service, 5 Cologne 51, West Germany.

The English Service is radiated on 236.5 metres (1268kHz) from 1745 to 1830 GMT.

DECEMBER 1969

# UNDERSTANDING RADIO

## MOVING-COIL METERS

$$f = \frac{1}{2\pi\sqrt{LC}}$$

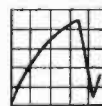

by W. G. Morley

IN LAST MONTH'S ARTICLE WE INTRODUCED THE subject of measuring instruments which incorporate a pointer, or "needle", to indicate the magnitude of the electrical quantity being measured. We examined several meters operating under different principles, these including the electrostatic meter, the thermocouple meter, and both the attraction and repulsion types of moving-iron meter. We also discussed mechanical aspects of meter design, dealing amongst other things with damping and pivot suspension.

We now carry on to the pointer instrument which is used far more frequently than any other in radio and electronic work. This is the moving-coil meter.

### MOVING-COIL METER

The basic construction of the *moving-coil meter* may be understood by referring to Fig. 1. Fig. 1(a) shows a typical magnet assembly on its own, Fig. 1(b) the coil assembly, whilst Fig. 1(c) illustrates the two parts fitted together to form the complete working instrument.

In Fig. 1(a) we have a permanent magnet of basic horse-shoe shape whose poles, or ends, are given the concave circular shape illustrated. Positioned centrally between the poles is a cylindrical soft iron core. A magnetic field is thus set up between the two poles, lines of magnetic force passing through the air gap between the poles and the central core. An important feature of the design is that, since the spacing between the magnet poles and the core surface is the same at all points, the direction of the lines of force in the air gap is always radial (i.e. they radiate from the core along lines which can be drawn through the core centre), and the field strength is constant at all points in the gap. In practice, the lines of force will not be truly radial, nor will the field strength be constant, at and very near the pole edges, but this part of the field is not employed for meter operation.

The coil assembly appears in Fig. 1(b). The coil is wound on a flat rectangular frame made of thin aluminium, on two opposite surfaces of which are affixed two pivots. The mounting of these is such that either one or both of the pivots is insulated from the aluminium frame. The two ends of the coil connect to these pivots, whereupon it becomes possible to pass a current through the coil by way of the two

spiral phosphor-bronze springs. As we saw last month, it is standard practice to use two springs of this nature in a pointer instrument; with the moving-coil meter the springs offer the added bonus of allowing current to be passed through the coil. Also shown in Fig. 1(b) are a pointer and counterweight assembly, this being mounted on the front pivot.

The assembled mechanism appears in Fig. 1(c). The ends of the coil pivots are held between bearings (omitted, together with the spiral springs, from the diagram for clarity) allowing the coil to rotate with two sides of the rectangular frame in the air gap between the core and the magnet poles. If no current is passed through the coil the two spiral springs cause it to take up a position in which the pointer gives a zero indication on the scale. When a direct current is passed through the coil the resulting motor action causes the coil to rotate on its pivots and the pointer to move across the scale. Since the magnetic field through which the coil turns pass is both radial and constant, the torque exerted on the coil due to the current passing through it is proportional to the value of the current itself, whereupon the scale over which the pointer travels can have equal spacing between graduations and becomes truly linear.

As a corollary of the inherent linearity of the moving-coil meter, it is of interest to compare this instrument with the moving-iron meter for currents which cause only a small deflection of the pointer. The presence of a strong magnetic field in the moving-coil meter (due to the permanent magnet) ensures that such a small current need only produce a single interacting field from the coil to cause the pointer to be deflected. With the moving-iron meter, the low current has to provide *all* the magnetising force (giving either attraction or repulsion according to meter type) with the result that pointer deflection becomes proportionately small. It is this last effect which causes the "cramping" of the lower end of a moving-iron meter scale.

### METER SENSITIVITY

The sensitivity of a moving-coil meter is dependent upon three main factors, these being the width of the air gap in which the coil rotates, the number of turns on the coil, and the strength of the field in the air gap due to the permanent magnet. The sensitivity increases as the first of these three factors is



reduced and as the second and third are increased. Mechanical limitations impose a limit on the narrowness of the air gap and the number of turns which can be wound on the coil. It is found that there is no useful increase in sensitivity for field strengths in the air gap above a certain high level.

In Fig. 1 the permanent magnet has a shape which allows its poles to be brought right round to the soft iron centre core. An alternative method of construction is shown in Fig. 2. Here, the field from the magnet is brought up to the core by means of specially shaped soft iron pole-pieces. This approach has the advantage that the curved surfaces adjacent to the centre core, which have to be accurately shaped and dimensioned, can be machined in a material which is easier to process than that employed for permanent magnets. Modern permanent magnet materials can be produced in a variety of shapes and it is nowadays possible to have the permanent magnet for a moving-coil meter in bar magnet form, the field being once more brought up to the centre core by way of pole-pieces.

With the assembly of Fig. 1 no adjustment is available to control the strength of the magnetic field in the air gap. On the other hand, it is possible to add a variable *magnetic shunt* to an assembly incorporating pole-pieces. This appears in the position shown in Fig. 2 and consists of a small piece of magnetic material in the shape of an elongated letter U. See the end view in Fig. 3. The shunt bypasses part of the magnetic field from the permanent magnet, with the result that the remaining field available for the air gap can be varied by changing the physical area in contact with both pole-pieces the field in the air gap is at a minimum. The magnetic shunt is set up at the factory and is then secured firmly in position by the screw shown in Fig. 3.

Most moving-coil meters have the zero position for the pointer at the left hand end of the scale. If the current to be measured is passed through the coil in the correct direction, the pointer is then deflected to the right. Should the current be passed through the coil in the incorrect direction the pointer is deflected off-scale to the left until it is prevented from further movement by an *end-stop* at the low end of the scale. A similar end-stop is fitted at the upper end of the scale, incidentally, this preventing the pointer from travelling too far off-scale to the right should excessive current in the correct direction be applied to the coil.

The moving-coil meter can only indicate direct current. It cannot, as it stands, measure alternating current (although it can be made to do so with the aid of an external rectifier circuit). Some moving-coil meters, known as *centre-zero meters*, are designed so that the zero point at which the pointer rests in the absence of coil current is in the centre of the scale. The pointer is then deflected to right or left according to the direction of the current which is passed through its coil.

A moving-coil meter has one of its terminals marked with a plus sign to indicate "positive" and, thereby, the correct way the meter should be connected into circuit. This applies to the centre-zero meter as well, in which current in the correct direction normally causes the pointer to be deflected to the right.

Damping of the pointer movement is achieved by

reason of the aluminium frame on which the coil is wound. When this frame moves in the magnetic field in the air gap, current is induced in the alumin-

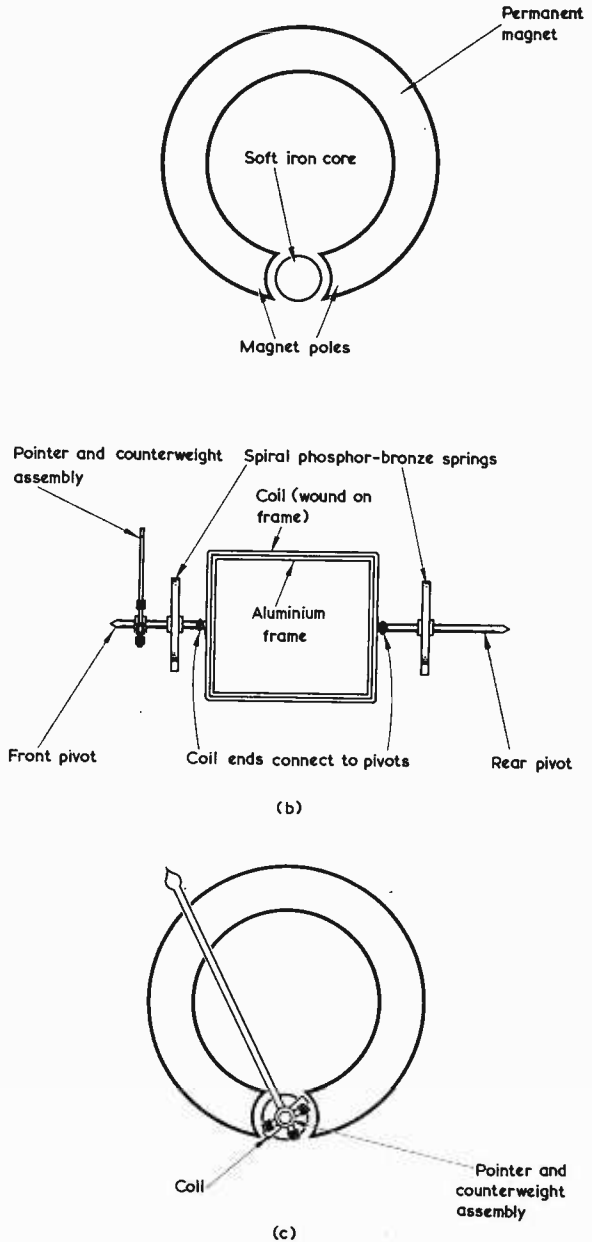

Fig. 1 (a). Basic magnet assembly for a typical moving-coil meter

(b). The coil, pivot and pointer assembly. The pointer appears in foreshortened form due to the angle of view

(c). The complete meter mechanism. For clarity, the front bearing and spiral spring are omitted

ium which causes it to produce an opposing magnetic field. The effect increases with increase in speed of movement of the aluminium frame, and the overall

result is that the requisite damping takes place. The same effect can also be produced by the coil itself. If the current passing through the coil is provided by a source of low internal resistance the meter takes longer to indicate a change in current than occurs when the source has a high internal resistance. Should it be desired to transport a sensitive

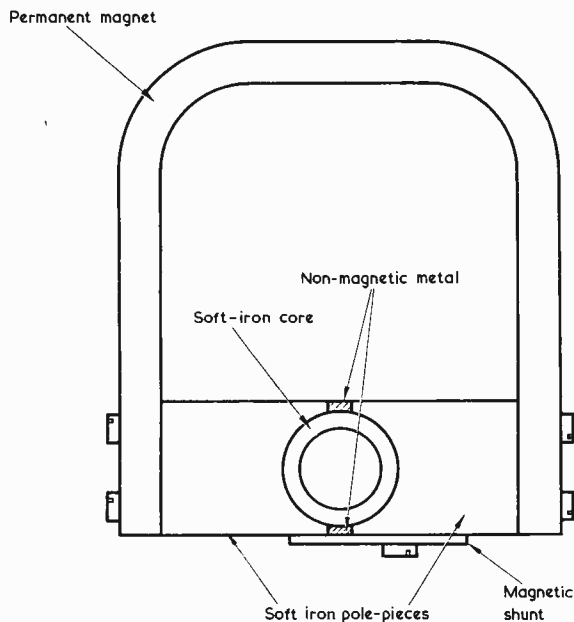

Fig. 2. An alternative magnet assembly, in which the magnetic field is brought up to the air gap by means of soft iron pole-pieces. Additional physical strength is imparted by the two pieces of non-magnetic metal, which are positioned as illustrated

and expensive moving-coil meter from one place to another, it is always a good plan to take advantage of the damping effect due to the coil and connect a piece of wire across the meter terminals to act as a short-circuit. The high level of damping imparted to the coil assembly by the coil itself then ensures that the pointer will not move violently if the instrument is bumped during transit. It will be recalled that, with the thermocouple meter discussed last month, the two terminals of a moving-coil meter are connected directly to the thermocouple. Since the thermocouple has a very low resistance the coil of the associated moving-coil meter can, if desired, be wound on a frame made of insulating material instead of aluminium, since adequate damping is imparted by the coil alone.\*

A moving-coil meter is capable of offering a high degree of accuracy, whereupon it is desirable to ensure that it is not read incorrectly due to *parallax* errors. The word "parallax" applies to the apparent change in position of an object resulting from a change in position of the observer. As is shown in Fig. 4, a

slightly incorrect meter reading can occur if the pointer and scale are inspected from an angle, as in Fig. 4(a), instead of from directly above, as in Fig. 4(b). To overcome errors due to this cause, the scales

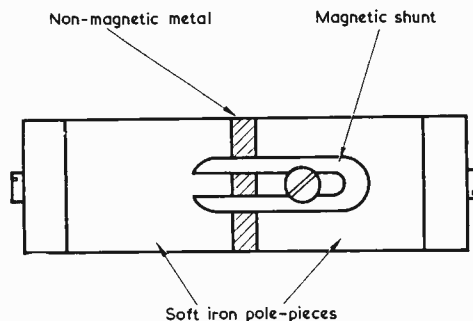

Fig. 3. End view of the magnet assembly of Fig. 2, showing the magnetic shunt in greater detail.

of high-grade moving-coil meters are sometimes fitted with anti-parallax mirrors, as in Fig. 4(c). If the person reading the meter moves his eye so that the image of the pointer in the mirror is beneath the pointer itself, then his eye is directly above the meter scale and he can read scale indications without fear of parallax error. A cheaper and somewhat less positive method of overcoming parallax error is to use a strip of thin metal as the pointer, with its plane at right angles to the meter scale surface. The eye of the person reading the meter is then moved until the apparent width of the pointer is at a minimum.

The accuracy of some moving-coil meters of the type which are intended to be mounted on a metal panel can be reduced if the panel is made of magnetic material, such as steel, instead of a non-magnetic material, such as aluminium. The result given with a panel made of magnetic material is that the meter gives low readings, the possible error being as much as 5% or more. Normally, panel-mounting meters are calibrated for a panel of non-magnetic material, and the appropriate sales literature should state whether the design is suitable for mounting on a panel of magnetic material. For instance, the panel-mounting meters available from Radiospares Ltd. have a magnetic assembly with negligible external field, and their calibration is stated to be virtually unaffected when mounted on steel panels.

Apart from the question of damping, mechanical details for the moving-coil meter are similar to those for the meters we discussed last month, in that the pointed pivot ends of the moving section are mounted between steel or jewel bearings (almost always the latter with a moving-coil instrument) and that a zero-adjust control is available on the front face of the instrument.

Finally, whilst dealing with the moving-coil meter in general, two minor incidental points need to be mentioned. The first of these is that the moving-coil meter may also be referred to as the *D'Arsonval meter*. This alternative term is frequently encountered in American literature. The second point is concerned with the term *galvanometer*. This term is sometimes encountered in references to measuring instruments and the impression is often given that the galvanometer is basically a moving-coil meter. Actually, a

\* Damping, with the thermocouple meter, is needed mainly to prevent pointer jitter under conditions of vibration, or violent pointer movement when the instrument is in transit. Electrically, the thermocouple meter is sluggish in its response to changes of current.

galvanometer is *any* instrument capable of measuring or indicating the presence of small electric currents, and it does not necessarily operate by moving-coil principles.

### ELECTRICAL DETAILS

The circuit symbol most commonly employed for a standard moving-coil meter consists of a circle

should be connected into circuit for correct deflection of the pointer. The same symbol can also be employed for moving-iron and other types of meter but, since the moving-coil instrument is almost invariably employed in radio and electronic work, the presence of a different type of instrument would normally be indicated accordingly in the circuit diagram or accompanying text. The other types of meter would not, in any case, require a plus sign to indicate desired direction of current. A centre-zero meter, which can only

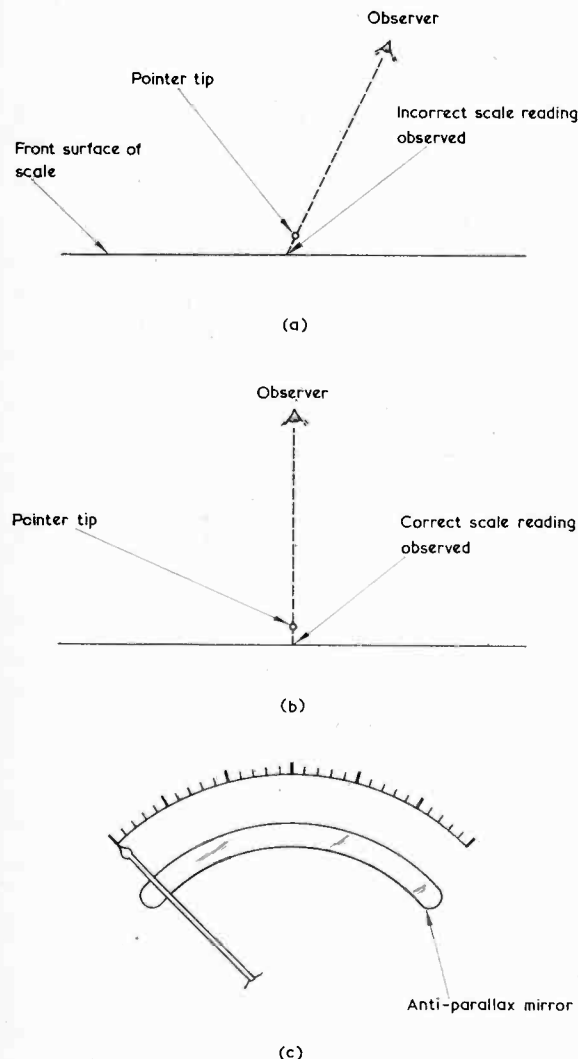

Fig. 4(a). If the pointer tip and meter scale are observed from an angle, the resulting parallax error causes an incorrect scale reading to be taken

(b). Parallax error is absent when the observer is directly above the meter scale

(c). A high-grade meter may incorporate an anti-parallax mirror to prevent parallax error. The observer moves his eye until the image of the pointer in the mirror is directly below the pointer itself

with an arrow inside sloping to the left, as in the two examples of Fig. 5(a). A plus sign alongside one terminal indicates the manner in which the meter

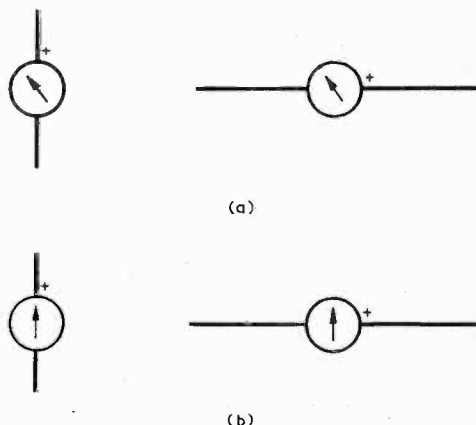

Fig. 5. Circuit symbols for (a) a standard moving-coil meter and (b) a centre-zero moving-coil meter. The circuit lines may approach the symbol vertically or horizontally according to the layout of the circuit diagram in which the symbol appears

be the moving-coil type, has the symbol shown in Fig. 5(b), with the arrow vertical. Sometimes the plus sign is omitted if the direction, on either side of zero, in which the pointer is deflected is unimportant. The current passed by the meter which causes the pointer to be moved to the highest graduation on the scale is referred to as its *full-scale deflection* (or *f.s.d.*) current, and it is usual to quote meter sensitivity in terms of zero and the f.s.d. figure. Thus, a normal instrument with an f.s.d. of 100mA is referred to as a

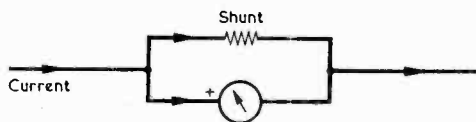

Fig. 6. A meter may be made to indicate higher currents by connecting a shunt across it. ("Conventional" current flow, from positive to negative, is assumed here).

"0-100mA meter". A centre-zero meter with an f.s.d. of 100mA on either side of zero is described as a "100-0-100mA meter". Sometimes a meter is referred to, loosely, as a "movement", although such a term really applies to its internal mechanism.

Like all other pointer instruments a moving-coil meter absorbs power from the circuit in which it is

connected. The instrument is basically a current indicating device, whereupon the power that is absorbed consists of the current flowing through the coil multiplied by the voltage dropped across the resistance offered by the coil. A typical coil resistance for a 0-1mA panel mounting meter is 75Ω. From the equation representing Ohm's Law,  $R = \frac{E}{I}$ , the voltage dropped across the coil for a current of 1mA then becomes 75mV, whereupon the power absorbed for full-scale deflection is 75μW. A meter of the same basic construction, but with an f.s.d. figure of 100μA, may have, typically, a coil resistance of 1,250Ω. The voltage dropped at f.s.d. is, in this case, 125mV, and the power absorbed is 12.5μW. These figures indicate the relatively low power requirements of the moving-coil meter, and they apply to quite robust instruments capable of being installed in equipment which may be roughly handled. The second meter chosen just now as an example will, of course, have more turns on its coil, and it is interesting to note that this fact not only results in an obvious increase in current sensitivity but, also, a decrease in the power required for full-scale deflection.

On its own, a moving-coil meter is intended for the measurement of direct current. By suitably choosing the requisite number of turns on the coil and designing the remainder of the mechanism accordingly, moving-coil meters can be manufactured to offer any f.s.d. figure between two roughly defined limits which are imposed by physical requirements. The lower of these limits corresponds to the minimum f.s.d. current figure which can be obtained without the coil wire becoming too thin or the meter mechanism too fragile for the proposed application. The upper limit is the maximum f.s.d. current which can be carried by the conductors in a practicable meter system, the conductors including the wire of the coil and the two spiral springs through which the coil current passes.

It is always possible to make a moving-coil meter (or a moving-iron or thermocouple meter, for that matter) indicate a higher current than that for which it has been calibrated. This is achieved by connecting a *shunt* across its terminals, as in Fig. 6. A shunt is a resistor of appropriate value in shunt (i.e. in parallel) with the meter. To take an example, let us assume that we have a 0-1mA meter and we want it to give a full-scale deflection of 100mA. We achieve this result by connecting across the meter a shunt having a resistive value which causes 99mA to flow through it when 100mA passes through the combination of shunt and meter in parallel. The remaining 1mA then flows through the meter. Thus, the 0-1mA meter will now indicate f.s.d. for a current of 100mA, whilst lower currents will be indicated by the meter scale figures after these have been similarly multiplied by 100. A meter manufacturer offering a range of panel mounting meters with a wide variety of f.s.d. figures can take advantage of shunts by manufacturing a small quantity of basic movements and by then fitting internal shunts as required to those having the higher f.s.d. figures.

In next month's issue we shall examine the subject of meter shunts in greater detail and shall then turn to the use of the moving-coil meter for the measurement of voltage.

## 1MHz FREQUENCY SUB-STANDARD UNIT

(Continued from page 287)

Disconnect the a.c. mains supply, fit the unit into the diecast box and secure the front panel to the box by means of the six bolts supplied. With the unit finally mounted in the box, reconnect the a.c. mains supply and switch on. Allow the unit to regain its working temperature and finally re-check against the 5MHz MSF transmission.

### OPERATION

It is often of advantage when using this unit to disconnect the aerial so that extraneous beat notes from received transmissions are not confused with the 1MHz beats – although the latter are much stronger than will be most signals likely to be received on the aerial. It is also of assistance to use the receiver b.f.o. – set to the centre frequency – whereupon an audio indication of the exact tuning point is obtained.

The most useful application of the unit is as a band-edge marker at the various MHz points, especially on the higher frequencies where the operator is likely to become confused with multitudinous beats from a 100kHz crystal standard. ■

## OSRAM CATALOGUE

A lamps and tubes catalogue giving up-to-date net trade prices on all products has been published by Osram (G.E.C.) Limited of Wembley, Middlesex.

The catalogue provides a comprehensive reference to the complete range of Osram lamps and tubes. This includes over 90 categories of Osram products, from the sub-miniature indicator lamp with a bulb of only a quarter of an inch diameter to the large 10 kilowatt lamp used for film and television studio lighting.

Maximum trade information is provided in such categories as GLS, discharge, photographic and projector lamps, and vehicle and miniature bulbs. This includes details, where appropriate, of voltage, wattage, dimensions, light centre length and standard packing quantities for each lamp, as well as net trade prices.

Also available from Osram-GEC is a new pocket booklet giving up-to-date net trade prices of the main ranges of Osram GLS lamps, fluorescent tubes and discharge lamps.

Both these publications are available on request to the Publicity Department, Osram (G.E.C.) Limited, P.O. Box 17, East Lane, Wembley, Middlesex.

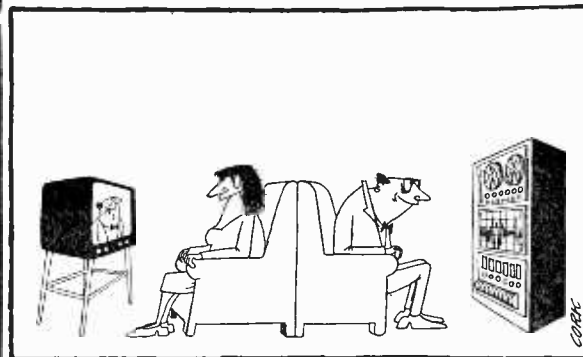

THE RADIO CONSTRUCTOR

Once again we find Smithy the Serviceman, aided as always by his able assistant, Dick, hard at work on Christmas Eve. Happily, there are much fewer sets than usual to service this year, but this fact does not prevent Dick from getting into one of his worst predicaments yet!

**I**T WAS CHRISTMAS EVE. Smithy unlocked the Workshop door and, amidst a flurry of snow, entered and switched on the lights. He rubbed his hands together in a gesture that betokened deep contentment with himself and with the world around him.

The Serviceman's sense of well-being grew in intensity as he glanced at the racks holding the receivers which were in for repair. There were only four sets requiring servicing and Smithy reflected cheerfully on the fact that this Christmas Eve would be the first for many years when the Workshop was not overburdened by a prodigious mass of domestic equipment which had mysteriously failed just before Christmas and which must be put right for the Day. There *had*, admittedly, been a servicing rush but he and Dick, by dint of Herculean labours, had managed to clear out nearly all the pre-Christmas work during the preceding few days. Yesterday had been the worst and Smithy grimaced momentarily at the memory of his assistant's behaviour. Not only had that worthy tried Smithy's patience to the limit by a never-ending series of technical questions, but he had also displayed, as the day went on, an increasingly infuriating preoccupation with the local Fancy Dress Ball which was scheduled for yesterday night, and in which Dick had some obscure function to perform. The working day had ended with Dick borrowing from the Workshop a supply of tools, insulating tape, adhesive, and odd lengths of wire, all of these being apparently necessary for the maintenance of the electronic equipment at that Ball.

### HALF-WAVE HEATER CHAIN

Smithy looked at the Workshop clock, then dismissed all thoughts of the previous day from his mind. With the slightest suspicion of a sign, he walked over to the "For Repair" racks, selected a small tape recorder, carried it over to his bench and settled down to work on it. The fault was trifling and consisted merely of a broken mains input connection at the on-off switch. Smithy had already spent quarter of an hour on the following job, a small table radio, when the door opened once more to admit a further flurry of snow and the figure of his assistant.

DECEMBER 1969

Dick was clad in a raincoat and had a very large scarf wrapped several times around his throat and the lower part of his face.

Dick walked over to Smithy's bench, deposited a collection of small tools, together with a roll of insulating tape and a cardboard carton, on its surface.

"Here," he remarked, "is that stuff I borrowed last night."

"Ta," said Smithy, as he peered into the receiver chassis in front of him. "How did the Fancy Dress Ball go last night?"

"The Ball?" replied Dick off-handedly. "Not too bad, really."

"Don't say you didn't go, after all the nattering about it you did yesterday."

"Of course I went," said Dick indignantly. "I was one of the people organising things."

"Fair enough," commented Smithy. "Well, see if you can now apply your organising ability to those remaining sets on the shelves. With a bit of luck we should be able to get finished nice and early this year."

Ignoring Smithy's mild sarcasm, Dick divested himself of his raincoat. However, he left the scarf in place, carefully adjusting it so that it

stayed firmly in position and completely covered both his neck and chin. If Smithy had not been so engrossed with the receiver he was repairing, he would have noticed that Dick's mind was very obviously burdened with thoughts which were quite unconnected with servicing. The preoccupied Dick walked reluctantly over to the "For Repair" racks. He picked up a monochrome television receiver and carried it listlessly back to his bench. Fitting its plug into one of the mains

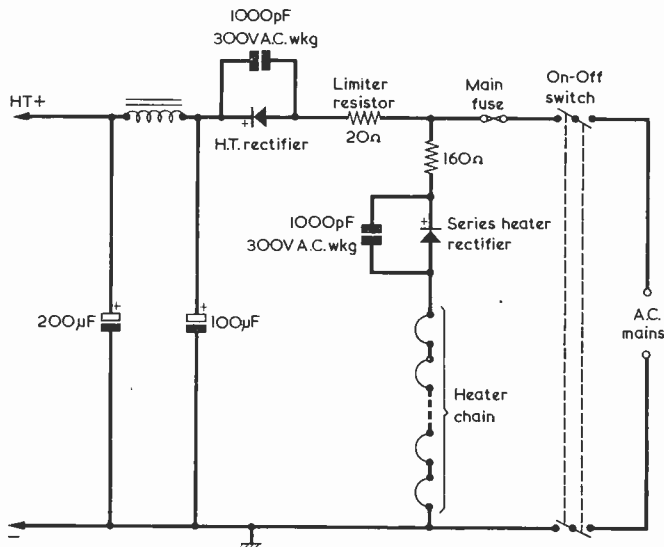

Fig. 1. Simplified version of the heater and h.t. supply section of the television receiver serviced by Dick. Both rectifiers are silicon components, and the component values given are representative of normal practice

## Your Local Supplier

LONDON

Established 1910

### H. L. SMITH & CO. LTD.

Comprehensive stocks of  
components by  
all leading makers.

287-9 EDGWARE ROAD  
LONDON W.2  
Tel: 01-723 5891

### THE MODERN BOOK CO.

Largest selection of English &  
American radio and technical  
books in the country.

19-21 PRAED STREET,  
LONDON, W.2  
Tel: PADDington 4185/2926

### ST. HELEN'S RADIO

Hi-Fi Equipment  
Tape Recorders  
Radio Receivers  
Television

SPECIALISTS IN RADIO  
& ELECTRONIC TEXTBOOKS

ST. HELEN'S GARDENS  
LONDON W.10  
Tel: 01-969 3657

HAMPSHIRE

### BOURNEMOUTH

LARGEST HI-FI AND  
RADIO COMPONENT  
STORE IN THE SOUTH

FORRESTERS NATIONAL  
RADIO SUPPLIES LTD.  
70-72 Holdenhurst Road  
Bournemouth  
Telephone 25232

sockets at the bench rear, he switched on and looked inside the back of the cabinet. Even after allowing decent time for a series heater thermistor, if fitted, to warm up and achieve its low resistance, the valves inside the cabinet refused to exhibit any heater glow at all.

Irritably, Dick pulled out the mains plug, took off the cabinet back and checked the mains input fuse. It was perfectly satisfactory.

(Fig. 2). There was no reading. He disconnected the prods, changed them over, and reapplied them to the diode. The meter needle shot over to a half scale reading, then slowly fell back to indicate a value of around  $15k\Omega$ .

"I haven't half got a queer fault here, Smithy," called out Dick. "I've got a silicon rectifier which shows a low forward resistance when you first apply the testmeter prods to it,

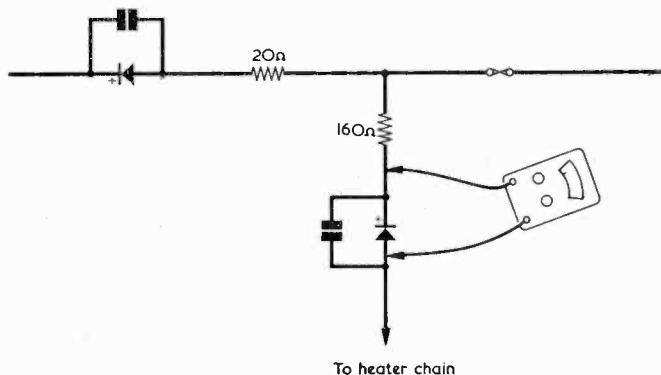

Fig. 2. The manner in which Dick checked the rectifier in series with the heater chain

Dick grunted and walked moodily towards the filing cabinet in which the service manuals were kept. Returning to his bench he opened the manual he had selected at its circuit diagram and examined the h.t. and heater supply section. The heater circuit consisted of a conventional series chain using valves with 0.3 amp heaters, and Dick's morose expression changed marginally to one of slightly aroused interest when he noticed that the circuit was of the type which incorporated a series silicon rectifier. (Fig. 1). After examining the printed board layout diagram in the manual he located the point at which the uppermost heater connected to this diode. He switched his testmeter to an ohms range and checked between this point and chassis. The meter indicated definite continuity along the heater chain.

With his testmeter still switched to the ohms range he next applied his test prods across the rectifier.

after which it changes gradually to a high resistance."

Smithy forcefully deposited his soldering iron on its stand, stood up and walked over to Dick's bench.

"Show me," he commanded.

Dick reapplied his test prods to the rectifier, whereupon the meter needle obligingly repeated its previous performance. Smithy glanced at the service manual.

"You," he remarked conversationally, "are a twit. What's happened here is that the series heater rectifier has obviously gone open-circuit."

"Then why," asked Dick, "am I getting this peculiar forward resistance reading?"

"Because," snorted Smithy, "the meter is passing a forward current, not through the heater rectifier, but through the h.t. rectifier. If you look at the circuit you'll see that the meter couples into the h.t. rectifier circuit by way of the heater chain, the  $160\Omega$  dropper resistor and the

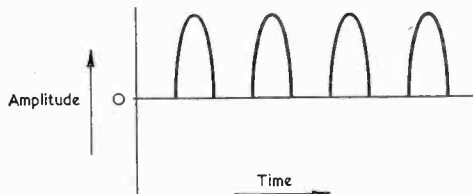

Fig. 3. The current flowing in the heaters in Fig. 1 consists of alternate rectified half-cycles, as shown here. The voltage across the heaters has the same waveform

20Ω limiter resistor. And the initial kick in the meter needle is due to the h.t. electrolytics charging up."

"Then," said Dick, reluctantly accepting Smithy's diagnosis, "all I need to do here is to fit a new rectifier in series with the heater chain."

"That's right."

## VOLTAGE TESTS

Smithy turned to make his departure, then his pace slackened. For the first time that morning he regarded his assistant closely.

"Have you," he asked, "got toothache or something?"

Dick looked uncomfortable.

"Why do you ask?"

"I've just noticed," continued Smithy, "that you've got a dirty great scarf wrapped all around your neck and chin."

"Oh, that," replied Dick, with an exaggerated attempt at carelessness. "I suppose you *could* say that I'm having a bit of trouble."

"Is this trouble," queried Smithy with interest, "a consequence of last night's festivities?"

"In a way it is," said Dick, seizing eagerly on a different subject of conversation. "Do you know, Smithy, that Fancy Dress Ball was a really smashing affair."

"What did you go as?"

"I went as Father Christmas."

with the p.a. system," replied Dick. "As it happened though, everything worked perfectly, and I was able to concentrate on enjoying myself."

"And did you?"

For the first time that morning a smile, just visible over the edge of the all-enveloping scarf, broke the gloom of Dick's face.

"I'll say I did," he said enthusiastically. "It was one of the best does I've been to for ages. It was a real gas, man!"

"Well, I'm glad you enjoyed yourself," replied Smithy, as he again prepared to leave. "However, do please hurry up now and get that TV on your bench fixed up. I'm still looking forward to getting finished early today."

The smile on Dick's face slowly disappeared as his thoughts were brought back to the world of the Workshop. He removed the chassis of the television receiver from its cabinet, after which he walked over to the spares cupboard in search of a replacement rectifier. Returning, he soldered this into position in place of the faulty component, connected the receiver to the mains, and switched on. After some moments, the heaters produced a benign glow.

Dick decided to check the voltage across one of the heaters. He switched his testmeter to an a.c. volts range and applied its prods

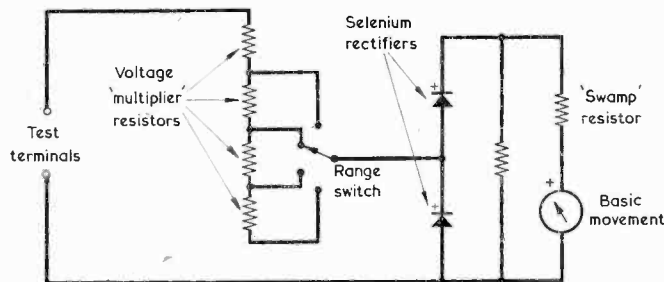

Fig. 4. Basic circuit illustrating the simple half-wave rectifier arrangement encountered in some low-cost testmeters when these are switched to read a.c. volts. The lower rectifier prevents high inverse voltages being applied to the upper rectifier, and vice versa. The series "swamp" resistor takes up variations in meter coil resistance, and the parallel resistor has a value which suits the individual meter rectifier employed

"That doesn't" remarked Smithy critically, "sound a particularly original choice of fancy dress."

"It wasn't meant to be," returned Dick, nettled. "The idea was that I should be dressed as Father Christmas so as to give out prizes for spot dances and things like that."

"In that instance," approved Smithy, "the idea of dressing up as Father Christmas was quite good. Incidentally, if you were giving out prizes, what did you want all those tools and things for?"

"Just in case anything went wrong

across the heater pins of a conveniently positioned 6.3 volt valve.

The meter indicated zero volts.

"Smithy," called out Dick, "I've got current obviously going through a valve heater in this set but there's no voltage across it!"

Muttering to himself, Smithy once more walked over to Dick's bench. He glanced at the valve indicated by Dick's finger and then looked at the testmeter.

"With a heater circuit incorporating a series rectifier," he pronounced tersely, "you're bound to get mis-

## Your Local Supplier

KENT

### EMSAC BASIC ANTENNA SYSTEMS

CN1 Nuvistor 2 metre converter. IF 28MHz. Absolutely complete with separate mains power supply, £11.10.0. Converter only, £8.10.0. P&P 4/6.

GD1 A G5RV type multi-band dipole. 102 ft. top. 100 ft. feeder. Complete and ready to go! 68/-.

GV1 General purpose vertical, useful range 1.8MHz to 28MHz. Adjustable 7 ft. to 23 ft. 92/-.

TU2 Receiver antenna tuning unit. Amateur and SW broadcast bands 1.5 to 30 MHz. 90/-.

Send SAE for details. Open weekends. Carriage extra.

**ELECTRONIC & MECHANICAL SUB-ASSEMBLY CO. LTD.**

Highfield House, West Kingsdown, Kent. Tel: West Kingsdown 2344.

SURREY

### Portable Transistor Amplifier plus Dynamic Microphone

A self-contained fully portable mini p.a. system. Many uses — ideal for Parties, or as a Baby Alarm, Intercom, Telephone or Record Player, Amplifier, etc. Attractive rexine covered cabinet, size 12 x 9 x 4in., with powerful 7 x 4in. speaker and four transistor one watt power amplifier plus dynamic microphone. Uses PP9 battery. Brand new in Makers' carton with full makers' guarantee. World famous make **90/-** Post Full List 1/- Only



**RADIO COMPONENT SPECIALISTS**  
337 Whitehorse Road, West Croydon, Surrey. Phone 01-684-1665

SUSSEX

## E. JEFFRIES

For your new television set, tape recorder, transistor radio, and hi-fi equipment.

PHILIPS, ULTRA, INVICTA, DANSETTE, MASTERADIO, PERDIO, MARCONI, PHILCO, FIDELITY.

**6A Albert Parade, Victoria Drive, EASTBOURNE SUSSEX**

EIRE

## PEATS for PARTS

**ELECTRONIC COMPONENTS RADIO & TELEVISION**

For the convenience of IRISH enthusiasts we supply:

The Radio Constructor, Data Books and Panel-Signs Transfers

Also a postal service

**Wm. B. PEAT & Co. Ltd.**  
28 PARNELL STREET  
DUBLIN 1

leading testmeter readings. To start off with, you won't get a correct indication if your testmeter is switched to read a.c. volts."

"Well, isn't it a.c. that's going through the valve heaters?"

"It's certainly not *sinusoidal* a.c.," replied Smithy. "What you're actually getting is a series of rectified alternate half-cycles. Like this."

Smithy took a pencil from his pocket and scribbled out the half-cycles on the margin of the service manual. (Fig. 3).

"When a testmeter is switched to a.c.," he continued, "it only reads accurately for sinusoidal a.c., and the current that's going through these heaters is anything but sinusoidal. Come to think of it, it isn't even a.c. at all, because when the current *does* flow it always flows in one direction only. The voltage has

the meter will then tell you the average direct voltage across that heater."

"And will that be 6.3 volts?"

"Oh no," said Smithy. "It will be 4 volts!"

Dick gave a gesture of despair.

"I'm now," he announced, "completely baffled!"

"Don't let these disparities worry you too much," chuckled Smithy. "What you have to remember is that those heaters are warming up to the temperature corresponding to the r.m.s. value of the rectified current. Now, the r.m.s. value of any cyclically varying current is that which gives the same heating power as an equivalent steady direct current. I don't want to go into too much detail here but it is a fact that the r.m.s. value of the rectified current in heaters run via a series half-

"These r.m.s. and average voltages do tend to be confusing," Smithy consoled him. "In the meantime, are you convinced that the present set-up causes an average direct voltage of 4 volts to appear across that 6.3 volt heater?"

## R.M.S. CURRENT CHECKER

"Not entirely," replied Dick stubbornly. "How can I be certain that the r.m.s. voltage across that heater really is 6.3 volts? Or that the r.m.s. current in the chain really is 0.3 amp?"

Smithy pondered for a moment. "That's an awkward one," he said finally. "The trouble is that I haven't got an instrument available which is capable of reading r.m.s. voltage or current. Wait a minute, though, I've got an idea! Could you pop over to the spares cupboard, Dick, and see if you can find an ORP12 photoconductive cell? There should be one or two knocking around, as they were used quite a lot in TV sets a few years ago."

Pleased at the thought of potential activity, Dick went to the spares cupboard. As he moved, his scarf became partly dislodged and he hastily re-adjusted it around his chin.

Returning with the photoconductive cell, Dick was surprised to find Smithy rummaging in the waste-bin.

"Ah, here we are," said the Serviceman triumphantly, as he produced a small cardboard box. "This should just about fill the bill. Now, I'm next going to remove the bulb from the torch I use occasionally for looking in dark cabinet corners. Hmm! I see that it's rated at 2.5 volts, which means that it should run near full brilliance at 0.3 amp. I'll now mount this bulb at one end of the cardboard box and the ORP12 at the other. This shouldn't take more than a brace of shakes."

Smithy quickly made up the assembly he had mentioned. He then fitted on the lid of the box. (Fig. 5).

"This little cardboard box," he remarked with satisfaction, "should be light-proof enough for present requirements. Now, the gadget I've just put together is going to act as an r.m.s. current meter. The brilliance of the light from the bulb will depend on the r.m.s. current flowing through it, and we'll check that brilliance level by measuring the resistance of the ORP12. What we next need is a 6 volt battery and a wirewound pot of about 50Ω which is capable of passing half an amp."

"I think I've got a pretty large-sized pot somewhere amongst my junk," said Dick keenly, as he searched through his spares box. "Ah, here it is!"

"Fine," said Smithy. "Well, we'll first calibrate this gubbins of mine with the aid of direct current. I'll

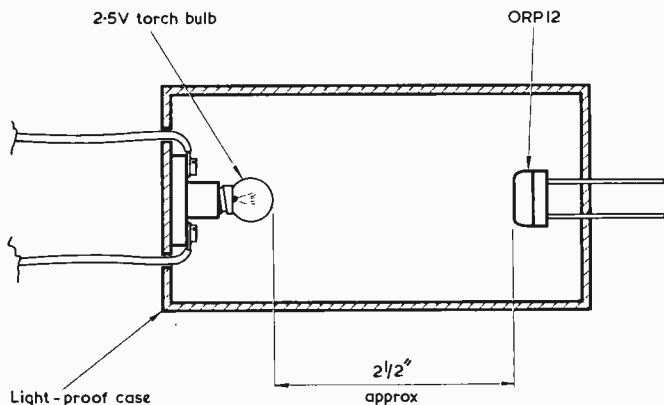

Fig. 5. The simple assembly employed by Smithy for measuring r.m.s. current, with the lid of the light-proof case removed. The torch bulb may be one of the inexpensive types available at chain stores

the same waveform as the current, and if you tried to measure it with a testmeter fitted with the usual bridge rectifier and switched to a.c. you'd get very misleading results. The testmeter you've got there is rather a low-cost model, and it's only got a half-wave rectifier in series with the meter movement instead of a bridge rectifier. (Fig. 4). That's why you got no reading at all when you connected it to the heater pins of that valve. If you change the test leads over you'd get a reading but I'd be very surprised if it was anywhere near 6.3 volts."

"Then how," asked Dick, "do you check that the correct heater voltage is appearing across these valves?"

"One way," said Smithy in reply, "consists of using the testmeter switched to a d.c. voltage range and applying it across the heater of, say, a 6.3 volt valve in the chain. Since a moving-coil voltmeter, as is used in a testmeter, reads average voltage,

wave rectifier is 0.5 times the peak value of the half-cycles, whilst the average value, as would be indicated by a moving-coil meter, is 0.32 times the peak value. It follows from this that the average value is 0.64 times the r.m.s. value. Another way of putting it is that the meter gives an indication which is equal to 64% of the r.m.s. value. The same relationships hold true for voltage. The voltage across that 6.3 volt heater of yours, as indicated by a moving-coil voltmeter, will be 64% of the r.m.s. voltage. 64% of 6.3 volts is, as near as dammit, 4 volts and if you don't believe me, go and check it for yourself!"

The perplexed Dick distrustfully switched his testmeter to a direct voltage range and applied its prods to the heater pins.

"You're dead right, Smithy," he announced bemusedly. "The reading I'm getting is exactly 4 volts. But don't ask me why!"



bring over my own testmeter to monitor the current flowing through the bulb, and we'll use yours to measure the resistance of the ORP12."

Smithy soon assembled his calibrating circuit. (Fig. 6(a)).

"If", he remarked, "you check the resistance given by the ORP12 I'll vary the current in the bulb. Okay?"

"I've got 0.3 amp going through the bulb now. What's the corresponding resistance?"

"1.2k $\Omega$ "

"And I've now got 0.4 amp in the bulb."

"The resistance," stated Dick, "is 300 $\Omega$ ."

"Excellent," said Smithy, disconnecting the battery, variable resistor and meter from the bulb. "Switch

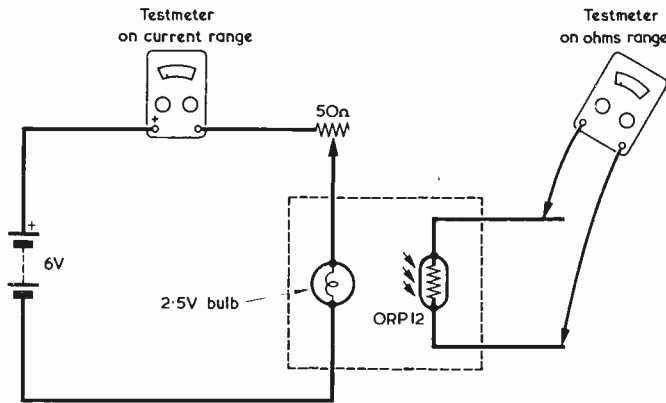

(a)

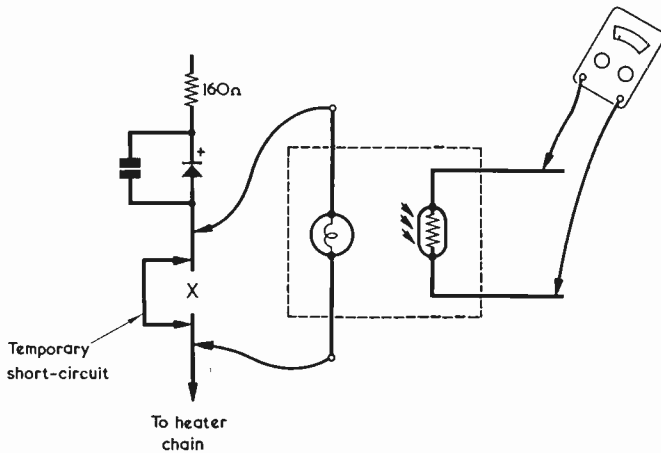

(b)

Fig. 6(a). Calibrating the bulb and photoconductive cell assembly of Fig. 5. These two components are shown here in circuit symbol form

(b). Using the assembly to check the r.m.s. heater current in the circuit of Fig. 1. The temporary short-circuit protects the bulb from switch-on current surges

"Sure," replied Dick. "I'm all ready."

"Right," said Smithy as, looking at the current-indicating meter, he adjusted the variable resistor. "I'm now putting 0.2 amps through the bulb. What's the resistance of the ORP12?"

"11k $\Omega$ ."

off that TV and I'll wire the bulb in series with the heater chain. A convenient point will be at the series rectifier itself. The heater chain in this set doesn't have a series thermistor to keep the initial heater current low, and so I'll short-circuit the bulb connections with a screw-driver until the valves are warmed

### Stella Nine Range Cases

Manufactured in Black, Grey, Lagoon or Blue Stelvetite and finished in Plastic-coated Steel, Morocco Finish with Aluminium and plates. Rubber feet are attached and there is a removable back plate. There is also a removable front panel in 18 s.w.g. Alloy.

Now all Aluminium surfaces are coated with a stripable plastic for protection during manufacture and transit. All edges are polished.

LIST OF PRICES AND SIZES  
which are made to fit Standard Alloy Chassis

Width	Depth	4" Height		6" Height		7 1/2" Height	
		£	s. d.	£	s. d.	£	s. d.
6 1/2"	3 3/8"	12	6	15	0	18	0
6 1/2"	4 3/8"	13	6	18	0	1	0
8 1/2"	3 3/8"	15	0	1	0	1	0
8 1/2"	6 3/8"	1	1	0	1	6	6
10 1/2"	7 3/8"	1	8	6	1	15	6
12 1/2"	3 3/8"	1	1	0	1	6	6
12 1/2"	5 3/8"	1	8	0	1	14	0
12 1/2"	8 3/8"	1	16	0	2	3	0
14 1/2"	3 3/8"	1	5	0	1	11	6
14 1/2"	9 3/8"	2	3	0	2	15	9
16 1/2"	6 3/8"	1	18	6	2	6	3
16 1/2"	10 3/8"	2	10	0	3	5	0

Cases—Post 4s. 6d. per Order.  
Discounts available on quantities.

### CHASSIS in Aluminium, Standard Sizes, with Gussset Plates

Sizes to fit Cases All 2 1/2" Walls

s. d.	10" x 7"		14" x 3"		s. d.	
	s. d.	s. d.	s. d.	s. d.		
6" x 3"	5	6	8	6	7	3
6" x 4"	5	9	12	3	6	9
8" x 3"	6	6	12	5	7	6
8" x 6"	7	9	12	8	10	9

Chassis—Post 3s. 0d. per Order.  
Discounts available on quantities.

### E. R. NICHOLLS

MANUFACTURER OF ELECTRONIC INSTRUMENT CASES  
(DEPT. R.C.) 46 LOWFIELD ROAD  
STOCKPORT - CHESHIRE  
Tel: 061-480 2179

### NEW VHF KIT

Receives Television Sound, Ambulances, Aircraft, Radio 2, 3 and 4 on VHF etc.

This novel little set will give you endless hours of pleasure and can be built in one evening. The Kit comes with easy to follow instructions and circuit. Powered by 9v Battery. Complete with built-in Jack Plug Socket for use with Earphones or Amplifier.

ONLY 57/- P & P FREE UK ONLY

Postal Orders, Cheques to Dept. R.C.3.,

Galleon Trading Co.,  
298A Lodge Lane,  
Romford, Essex

### FANTASTIC SALE

1,000 of the following Amplifier Kits to clear —

	List Price	Sale Price	P.S.
5 watt amplifier	£3.15.0	£1.15.0	9v
7 watt amplifier	£6.15.0	£2.5.0	9v
10 watt amplifier	£8.19.0	£2.15.0	9v

If two are required deduct the following: 2 x 5 watt 5/-, 2 x 7 watt 7/6, 2 x 10 watt 10/-. Please add 2/6 P&P.

### M. GLEAVES AND BROTHER

28 WENNY ESTATE  
CHATTERIS  
CAMBS

up again, in case the initial surge on switching on again burns it out."

Smithy busied himself with the soldering iron and completed his connections. (Fig. 6 (b)).

"Switch on again," he called out, holding a screwdriver with an insulated handle against the temporary connections he had made on the board.

Smithy waited a few moments until the heaters were glowing at full temperature then, with a grandiose gesture, withdrew the screwdriver.

"Gosh," said Dick, awed. "The

a 9 volt battery in this case because of the 12Ω resistor in series with the bulb. I calibrated our own unit at 0.2, 0.3 and 0.4 amps only, because I merely wanted to be sure that there was a wide variation in ORP12 resistance for bulb currents on either side of 0.3 amp. If you're making up a permanent bulb and photoconductive cell assembly, it would be better to calibrate at 0.25 and 0.35 amps as well. You could then make out a little graph showing ORP12 resistance against bulb current and stick it on top of the box."

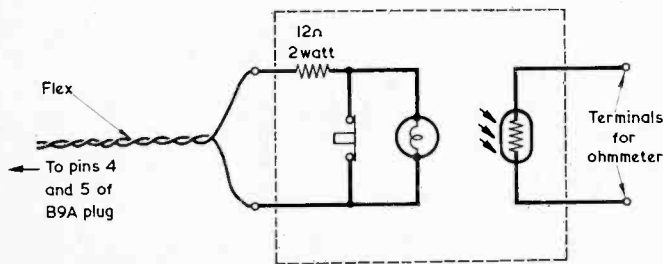

Fig. 7. A more comprehensive version of the bulb and photoconductive cell assembly. The push-button short-circuits the bulb until depressed, and protects it from switch-on surges

resistance of that ORP12 is almost exactly 1.2kΩ. Just as we had with 0.3 amp d.c. going through the bulb."

"Are you now convinced," asked Smithy, "that the r.m.s. current in those heaters is 0.3 amp.?"

"I am," replied Dick with conviction. "Incidentally, that bulb and ORP12 combination seems to represent a jolly good idea for checking r.m.s. heater current in these heater chains with series rectifiers."

"The approach," said Smithy modestly, "isn't exactly new, but I should imagine that there are quite a few people who haven't heard of it before. If you felt like doing so, you could easily assemble the gadget more permanently in a wooden box so that it becomes a fully-fledged servicing aid in its own right. A good idea would be to put a 12Ω 2 watt resistor in series with the bulb and connect the two to a length of flex terminating in pins 4 and 5 of a B9A plug. (Fig. 7). The bulb and 12Ω resistor will then drop about 6.3 volts at 0.3 amps. When you want to check the r.m.s. current in a TV heater chain with a series rectifier, you simply remove any 6.3 volt valve and put the B9A plug in its place."

"What about calibration?"

"Obviously," replied Smithy, "the calibration will vary for different bulbs and photoconductive cells, and so you need to calibrate the device after it's been made up. Just pass a current through the bulb and series resistor in the same way that we did, although it will be necessary to use

"That sounds an excellent idea," said Dick. "I think I'll make one up for myself after the Christmas holiday."

### POLYMERISATION

Absent-mindedly, Smithy's assistant tugged his scarf even higher over his chin.

"I wish," said Smithy a little irritably, "you'd remove that scarf of yours. It's unhealthy, to my mind, to wear a hot thing like that indoors."

The Serviceman reached over decisively and grabbed a protruding end of the scarf.

"Hey," called out Dick in alarm. "Leave that scarf alone."

"I'm jolly well going to take it off you," returned Smithy firmly. "I'm getting fed up with looking at the darned thing. Ah, here it comes."

"No, Smithy!"

"That's got it," stated Smithy with satisfaction, as he finally managed to unwind the scarf from his fiercely protecting assistant. "Ye gods, what in heaven's name is this?"

Completely dumbfounded, the stricken Serviceman staggered back to a stool and sat down. His jaw sagged to its lowest possible level, and he stared with utter incredulity at his assistant.

Stretching all the way from Dick's chin to his waist was a thick luxuriant beard of the most immaculate whiteness. Immediately beneath his chin it was some nine inches wide, and it gradually tapered to a width of about six inches at its lower and exceptionally fluffy extremity. The

effect of this magnificent appendage was only marred by what appeared to be a dangling moustache hovering over Dick's chin itself.

Smithy eventually managed to repeat his question.

"What," he stuttered, "is it?"

"It's my Father Christmas beard from last night," wailed Dick. "I can't get the flaming thing off!"

"Can't get it off?"

"It's stuck to my chin," lamented Dick. "I spent half an hour trying to get it off this morning and that's why I was late."

Smithy had, by now, recovered part of his usual composure, and he decided to analyse the situation.

"The last time," he remarked thoughtfully, "I heard of someone dressing up as Father Christmas, the beard he used was made of cotton-wool."

"This one," replied Dick bitterly, "isn't cotton-wool, mate, it's the real thing. It was borrowed from some theatrical outfitters and it's got real hair together with a moustache, and hook things to go over the ears."

Dick sighed despairingly as he considered the events which had led up to his present predicament.

"When," he went on, "I put the beard on last night it fitted almost perfectly, the only snag being that it kept flapping about round my chin. So I decided to stick it down at the chin with a spot of adhesive. After that I forgot all about it and just concentrated on having a good time at the Ball."

"Didn't you," asked Smithy, "take it off when you went to bed?"

"When I finally got to bed last night," replied Dick, carefully, "I was very tired."

"Tired?"

"Tired," repeated Dick firmly. "I was certainly far too tired to think about such minor matters as the removal of a false beard. Then, when I woke up this morning, I found that the damned thing was stuck completely and irremovably to my chin."

"So far as I know," said Smithy knowledgeably, "the adhesive you need for sticking on false beards and things like that is spirit gum."

"Is it?" remarked Dick disinterestedly. "I didn't have any of that with me last night and so I used some of the adhesive you lent me."

For the second time that morning, Smithy's jaw dropped open to its fullest extent.

"I used it just as you told me to," continued Dick artlessly. "I mixed together equal parts of resin and hardener from the two separate tubes in the carton, then applied them to my chin. The mixture wasn't very sticky at first, but it seemed to get better as the evening went on."

"I should jolly well think it would have done," spluttered Smithy as, after some moments, he regained his voice. "Why, you steaming great nit,

that adhesive I lent you was epoxy resin! Apart from the fact that you shouldn't get epoxy resin on the skin in any case, it was the very last thing you should have used in this particular instance since it's pretty well the most powerful adhesive going. Seeing that you've kept the mixture of resin and hardener nice and warm all evening *and* night, it should be just about fully polymerised by now."

"Polymerised?"

"Cured," explained Smithy shortly. "Set hard. Epoxy resin isn't an ordinary adhesive with a solvent which evaporates, it's a thermosetting plastic. You've now got your chin firmly embedded in a layer of hard plastic, to which is also secured that great ludicrous beard!"

"This," moaned Dick, "is as bad as the Man in the Iron Mask. Have I got to go through the rest of my life with this beard stuck on me?" Smithy examined the beard critically.

"Do you know," he remarked judicially, "I'm beginning to think that it rather suits you. At least, it isn't one of those horrible scraggy little things so many of the youngsters seem to be sporting these days."

Dick received this remark in suffering silence. Suddenly, a thought occurred to him.

"It was *you*," he said accusingly, "who lent me the adhesive in the first place."

"I know I did," snorted Smithy, outraged at the implied charge in Dick's statement. "But I thought you wanted an adhesive for this p.a. maintenance work you kept rabbiting on about. I didn't think for one moment that even you could be so moronic as to start putting it on your face."

## THE ODD DROP

"I suppose," remarked Dick morosely, "it was a bit stupid of me."

"I'll say it was," agreed Smithy, heartlessly. "Fortunately, we've nearly done all the sets that need fixing for today so, when we're completely finished, I'll see what I can do to get you and that beard separated from each other."

"Good old Smithy," said Dick warmly. "I knew you'd help me out."

"I'll do my best," replied Smithy cautiously. "But let's start thinking about work again now. Did you fit the replacement series heater rectifier in that TV set with correct polarity? This is an important point because, with some sets, the rectified half-cycles in the heater chain are used for such things as providing a bias voltage, after smoothing, for the vertical output valve, and for things like that. (Fig. 8). If the series rectifier is fitted wrong way

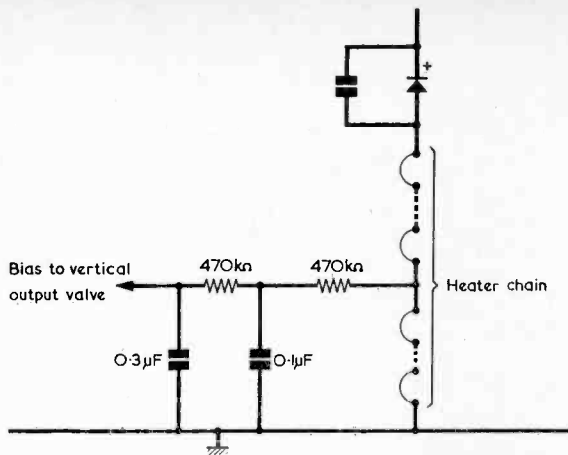

Fig. 8. In this diagram, a negative bias voltage for the vertical output valve is taken, after smoothing by the resistors and capacitors shown, from a point near the centre of the rectifier-fed series heater chain. This arrangement is employed in the Thorn 981 series of TV receivers

round it causes the biased stage to work incorrectly."

After a quick inspection, Dick announced that the replacement rectifier had, indeed, been connected into circuit with correct polarity. He and Smithy then quickly set to on the remaining work. After a period of little more than 20 minutes, the last set for the day was triumphantly carried over, by Dick, to the "Repaired" racks.

On returning, Dick discovered the Serviceman in the process of extracting some objects from the cupboard under his bench. There was the pleasant tinkle of bottle and glass.

"I haven't forgotten that it's Christmas," pronounced Smithy cheerfully, as he handed a charged glass to his assistant. "So here's a little something to celebrate the festive season."

"Thanks, Smithy," said Dick gratefully.

"And," continued Smithy, "let me wish you a very Merry Christmas."

"The same to you, too." The pair sipped the golden liquid in their glasses appreciatively.

"Put the ear-hooks up," said Smithy suddenly. "Let's see what you look like with the full set."

"Okey-doke," replied Dick agreeably.

Dick suitably adjusted the hooks in question, whereupon the white moustache which had previously dangled in front of his chin obligingly took up its proper station under his nose.

"Most effective," commented Smithy, obviously impressed. "Well, let us next be upstanding."

The pair stood and held up their glasses.

"Let us now," pronounced the Serviceman, "wish a very Merry

Christmas to all the readers who've put up with us over these last 12 months. A truly Happy Christmas to all of you!"

They both drank deeply. "And," added the unwontedly hirsute Dick, "let's end up as we have done on so many previous years, by saying 'God Bless Us, Every One!'"

**EDITOR'S NOTE** — Readers must not, of course, follow the example of the hapless Dick and purposely apply epoxy resin, or for that matter any other engineering adhesive, direct to the skin. If epoxy resin comes in contact with the skin it should be removed by rubbing with a domestic detergent and then rinsing with warm water. The product can give rise to irritation with sensitive skins.

## LAST LOOK ROUND

### ● BUILD

A simple little medium wave receiver as a 2-transistor circuit operating an earphone or as a 3-transistor set driving a speaker. Few components needed and opportunity exists for experiment with these to obtain good results with the AF126 and OC75 employed in the design. See January issue.

### ● CHECK

In the article entitled New Lift for "Midget Receivers" published in the October 1969 issue, the value of the output valve cathode bias resistor, R10, was given as 250kΩ 1 watt. This should, of course, have been 250Ω 1 watt.

# CHRISTMAS GIFT OFFER

## SUPER SWISS WATCHES



### GENTS WRISTWATCH

Ultra-modern styled watch complete with expanding bracelet in luxurious golden finish. 21-jewelled Swiss movement with automatic DAY and DATE indication in black and white clearcut figures. Centre second hand. All hands and 5-minute batons in attractive gold colour. One of the cleanest and clearest dials we've seen. Water protected and anti-magnetic. Electronically timed and tested. Screwback stainless steel back. SIX MONTHS WRITTEN GUARANTEE. List Price £6.14.0

Special Offer Price **89/6** plus 3/- P&P



### LADIES WRISTWATCH

Very attractive ladies watch in a luxurious golden finish, with matching expanding bracelet. 21-jewelled Swiss movement with automatic date change. Handsome white dial with golden colour batons and numerals. Centre second sweep hand, minute and hour hands also in gold. This watch was specially selected for its attractive and easy-to-read dial design. Water protected and anti-magnetic. Electronically timed and tested. Screwback stainless steel back. SIX MONTHS WRITTEN GUARANTEE. List Price £4.19.6

Special Offer Price **67/6** plus 3/- P&P

## RUSSIAN OPTICAL PRECISION

**SUPERB 35mm CAMERA**

TAKES NEEDLE-SHARP PICTURES BLACK & WHITE OR COLOUR

FREE CASE



ENABLES ANYONE TO TAKE PROFESSIONAL QUALITY PHOTOGRAPHS

5-speed shutter 1/15th to 1/250th sec. 5 stops f.4 to f.16. Delayed action mech. allows self portraits. Depth of field indicator. Accessory shoe. Flash socket. Supplied complete with instruction booklet & superb P.V.C. Ever Ready Case. LIST PRICE £6.14.6.

Special Offer Price **£5.0.0** plus 3/6 P&P

## COSMIC 35 CAMERA

This camera is without doubt the best value camera on the market today. Reviewed by 'Amateur Photographer' in 1964 who judged it excellent value for money and 'capable of making first class exhibition prints of 20 x 16 inches'.

SPECIFICATION:  
3 element F.4 lens.  
5 stops f.4 to f.16. Delayed

## CAR COMPASS



Extremely accurate compass manufactured by Sherrill Corporation of America, suppliers to the U.S. Government and Armed Forces. Fully compensatable with aviation type regulator magnets controlled by nylon gears. Leakproof under a wide range of temperatures. A scientifically designed instrument for all motorists and especially 'mobile' transmitter operators. Easily fitted. List Price 39/6.

Special Offer Price **29/6** plus 2/6 P&P

## FLOAT ON AIR!



## INFLATABLE ARMCHAIRS

Float on Air in a Bubble Chair. Trendsetting inflatable furniture that stores in a drawer. Tough vinyl material ensures long life. (Accidental punctures easily repaired). Available in gorgeous colours: Orange, Blue, Yellow, Black and Transparent. List Price 90/-.

Special Offer Price **69/6** plus 4/6 P&P

## EMBOSSING PRESS

Grange Park, A41

ANSTAY HILL A42

Sunningdale A44



CONWAY VALE A46

1. ALBERT ROAD A43

Emboss your own notepaper, etc. and eliminate printing costs. Most useful home and office accessory that brings prestige to correspondence and avoids errors in replies. Choice of five print styles, as illustrated. (Print styles shown approx. half size). Choice of 'in line' or 'staggered' setting. New dies readily available when required. (Please note that there is a limit of 20 letters or figures per line).

SPECIAL PRICE: **39/6** for 4 lines **49/6** for 5 lines POST FREE

Please send the following:  
(TICK WHERE APPLICABLE)

- Gents Wristwatch.....
- Ladies Wristwatch.....
- Cosmic 35 Camera.....
- Car Compass.....
- Inflatable Armchair.....  
(Colour required.....)
- Embossing Press.....  
(Style of type required.....)  
(Address 'in line' or staggered)

I enclose cheque/crossed postal order (made payable to Flairline

Supplies) for £.....

NAME.....

ADDRESS.....

BLOCK CAPITALS PLEASE

ALL GOODS SUPPLIED UNDER SEVEN-DAY MONEY-BACK GUARANTEE

**FLAIRLINE SUPPLIES** SUITE 11/12, SECOND FLOOR, 52 SHAFTESBURY AVENUE, LONDON, W.1



# Listen to the world with Eddystone

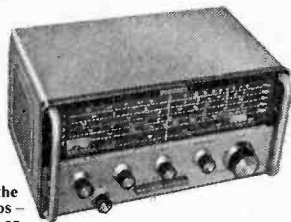

When you own an Eddystone communications receiver, you have the broadcasting world at your finger tips — wherever you happen to be — on land or at sea. The reputation these sets have attained is proof of their excellence and reliability and at Imhofs, there is a special Eddystone department where you can see, hear and compare all models listed here. Same day despatch to any part of the world; free delivery in the U.K.; plus after sales service for which Imhofs and Eddystone are world famous. **EDDYSTONE EB35** Mark II broadcast receiver AM/FM transistorised. A high performance all-band receiver, can also be used as a "Hi-Fi" tuner. Powered by 6 SP2 torch cells, or, with Type 924 power supply unit, from AC mains. £82.4.9d.  
**EDDYSTONE 940** (13 valve) communications receiver. A connoisseur's instrument combining 'Professional' appearance with performance; has a world-wide reputation, two RF stages ensure high-sensitivity. £153.0.0d.  
**EDDYSTONE EC10** transistorised communications receiver. An enthusiast's receiver at a modest price. Embodies features usually only found in much more expensive designs. Powered by 6 SP2 torch cells or Type 924 power unit (AC). £59.10.0d.  
**EDDYSTONE EC10** Mark II transistorised communications receiver. A de-luxe version of this famous design now incorporating 'S' meter and limited fine tuner. £69.10.0d.  
**EDDYSTONE EA12** 'Ham Band' receiver. Built to professional standards but specifically for the amateur enthusiast. High sensitivity for all reception modes CW, MCW, AM and SSB. FSK adaptor available as ancillary £195.0.0d.  
**EDDYSTONE EY11** a variant of the EC10 tailored to the requirements of the small off-shore boat owner. Available shortly.  
*There is an Eddystone Communications receiver for any frequency between 10kHz and 1000 MHz full details from Imhofs or your local Eddystone agent.*

**IMHOFS** MAIN EDDYSTONE DISTRIBUTORS



Dept: RC 12  
 112-116 New Oxford Street, London, WC1 Tel: 01-636 7878

R36B

# INTERNATIONAL SHORT WAVE LEAGUE



Membership 35s. 0d. per annum (U.S.A. \$5.00) including 12 monthly issues of *Monitor* — the League journal. Including free use of all Services, QSL Bureau, etc.

**THE LARGEST S.W.L. ORGANISATION IN THE WORLD**

For full details write to:

**The Secretary,  
 I.S.W.L.,  
 60 WHITE STREET, DERBY**

## RADIO CONTROL FOR MODELS



# RADIO CONTROL FOR MODELS

SHIPS, BOATS and AIRCRAFT

By **F. C. JUDD**

With sections on servo-mechanisms by

**RAYMOND F. STOCK**

*More than 200 illustrations — circuits, working diagrams, photographs & tables. Each page is packed with information.*

# 192 Pages

# 15s.

Postage 9d.

This book is basically an amalgamation of "Radio Control for Model Ships, Boats and Aircraft" and "Radio Control Mechanisms". Additional material has been added on Multi-Channel Operation; Transistorised Radio Control Receivers—Simple and Three-Channel; A Compact Efficiency Aerial; Dead Battery Information; Licence Conditions, etc.

To **Data Publication Ltd., 57 Maida Vale, London, W.9**

Please supply.....copy(ies) of your publication "RADIO CONTROL FOR MODELS" DATA BOOK No. 16.

I enclose cheque/crossed postal order for.....

NAME .....

ADDRESS .....

BLOCK LETTERS PLEASE

THE RADIO CONSTRUCTOR

## SMALL ADVERTISEMENTS

Continued from page 315

**FOR SALE:** Four Mullard RG1-240A rectifier valves, with high voltage insulation filament transformer, suitable use in pairs. £5. Box No. G100.

**FOR SALE:** UNTESTED Germ. p.n.p. equivalent OC44, 45, 71. 50-12/6. 10-2/9d. D. G. Perry, Graymare, Lostwithiel, Cornwall.

**ASSORTED LOTS OF USED COMPONENTS.** Resistors 15/- for 50. Capacitors 10/- for 20. Box No. G102.

**WORLD DX CLUB** covers all aspects of SWLing on Amateur and Broadcast Bands through its monthly bulletin "Contact". Membership costs 25s. a year. Enquiries to Secretary, WDXC, 17 Taunton Road, Bridgewater, Somerset.

**TOROIDS FOR SALE:** 550, 475, 500, 395, 480, 270, 210mH. 5/- each. Box No. G104.

**WANTED:** Line output transformer, Murphy television V310A. Reasonable. Weaver, 53 Kennylands Road, Sonning Common, Reading, Berkshire.

**POSTAL ADVERTISING?** This is the Holborn Service, Mailing lists, addressing, enclosing, wrapping, facsimile letters, automatic typing, copy service, campaign planning, design and artwork, printing and stationery. Please ask for price list.—The Holborn Direct Mail Company, Capacity House, 2-6 Rothsay Street, Tower Bridge Road, London, S.E.1. Telephone: 01-407-1495.

**FOR SALE:** Taylor 88A Multimeter, 20k $\Omega$ /V, wood case, 74 ranges to 5,000 volts and 10 amp., a.c./d.c. Resistance to 50M $\Omega$ . £15. EICO 249 VTVM, 7 $\frac{1}{2}$ in. Meter, to 1,500V, a.c./d.c. Measures p-p Complex waves to 3MHz, measures resistance to 1,000M $\Omega$ . £18. Heathkit Millivoltmeter AV3U. £10. All with manuals and leads. Box No. G106.

**FOR SALE:** Cossor 1049 MK. III Oscilloscope in good condition. £25. K. Beswick, 11 Chestnut Walk, Stratford, Warwickshire.

**FOR SALE:** TW "Communicator", Shure push-to-talk mic., speaker, ground plane antenna and 30ft. coax., all leads, battery clips, 20 volt battery meter and switch. Complete 2 metre station ready to go on the air. Immaculate. £80 o.n.o. Box No. G107.

**INNOVATION IN DX CLUBS ANNOUNCED!** Formed in October, 1965, the Radio New York Worldwide Listeners Club now has 3,600 members in 86 countries! A unique club offering shortwave listeners monthly magazines containing listening tips and technical features, numbered wallet-sized membership cards and gold 8 $\frac{1}{2}$ in. by 11in. membership certificates. Multilingual report forms available for cost of postage. "We must be doing something right!" Find out . . . join now!" Send 7s. 2d. (crossed domestic money order) for one year's membership to: The Radio New York Worldwide Listeners Club, 485 Madison Avenue, New York 10022, U.S.A.

**FOR SALE:** G2DAF Linear Amplifier and power supply. £50 o.n.o. S.A.E. for details. Box No. G108.

**IF YOU HAVE ENJOYED A HOLIDAY** on the Norfolk Broads, why not help to preserve these beautiful waterways. Join the Broads Society and play your part in determining Broadlands future. Further details from:—The Hon. Membership Secretary, The Broads Society, "Icknield", Hilly Plantation, Thorpe St. Andrew, Norwich, NOR 85S.

**FOR SALE:** Collection of stamps. £125. S.A.E. for details. Box No. G109.

**TO CLEAR.** Back numbers of "The National Geographical Magazine", to January 1959. 3/6d. each post paid. Box No. G110.

(Continued on page 319)

## RADIO CONTROL

THE NEWEST ELECTRONIC HOBBY

START WITH A SINGLE CHANNEL UNIT AT

TRANSMITTER

£8

(Kit)



RECEIVER

£4

(Kit)

leading up to sophisticated  
DIGITAL CONTROL from £80

DETAILS FROM UK'S LARGEST R/C  
KIT SUPPLIERS

FULL CATALOGUE 3/6, post included

**TELERADIO ELECTRONICS**  
325 FORE STREET, EDMONTON  
LONDON N.9

## NEW BOOKS

OCTOBER 1969

Transistor Substitution Handbook  
— 9th Edition 18/- net  
49 Easy Entertainment and Science Projects  
Vol. 1  
Robert M. Brown and Tom Kneitel 24/- net

NOVEMBER 1969

Transistor Colour TV Servicing Guide  
Robert G. Middleton 35/- net  
Closed Circuit TV for Engineers and  
Technicians  
Leonard E. Showalter 50/- net

JANUARY 1970

Understanding and Using Unijunction  
Transistors  
S. Hoberman 24/- net  
Electronic Circuit Design  
Farl J. Waters 30/- net

FEBRUARY 1970

Learn Electronics Through Troubleshooting  
Wayne Lemons 75/- net  
FM From Antenna To Audio  
Leonard Feldman 30/- net

The above are obtainable from most good bookshops  
or direct from the Publishers (see below) on re-  
mittance of the price plus 2/6 p & p.

**FOULSHAM-SAMS TECHNICAL BOOKS**

(W. FOULSHAM & CO. LTD.)

YEOVIL RD., SLOUGH, BUCKS, ENGLAND



Become a

# RADIO TECHNICIAN

and work at the nerve centres  
of civil aviation

The National Air Traffic Control Service of the Board of Trade needs Radio Technicians to install and maintain the very latest electronic aids at Civil Airports, Air Traffic Control Centres, Radar Stations and specialist establishments. Vacancies exist in various parts of the United Kingdom.

This is responsible demanding work (for which you will get familiarisation training) involving communications, computers, radar and data extraction, automatic landing systems and closed-circuit television. It offers excellent prospects with ample opportunities to study for higher qualifications in this fast-expanding field.

If you are 19 or over, with practical experience in at least one of the main branches of telecommunications, fill in the coupon now.

Salary from January 1st 1970 is £985 (at 19) to £1,295 (at 25 or over): scale maximum £1,500 (higher rates at Heathrow), and some posts attract shift-duty payments. The annual leave allowance is good and there is a non-contributory pension scheme for established staff.

Complete this coupon for full details and application form:  
To: A. J. Edwards, C.Eng., M.I.E.E., M.I.E.R.E., Room 705,  
The Adelphi, John Adam Street, London WC2  
marking your envelope 'Recruitment'

Name.....

Address.....

Not applicable to residents outside the United Kingdom.

RC/BI

**NATCS** National Air Traffic Control Service

## APPRENTICE TECHNICIAN

An opportunity to gain experience in constructing and maintaining electronic equipment and setting up systems for automated experiments and data-logging is available to someone aged 16 to 21 with four 'O' passes in English Language, Mathematics and two Science subjects or who is a registered ONC student doing a relevant course. Experience with semi-conductors, including integrated circuits, is desirable. Day release permitted for appropriate course. Salary according to age, qualifications and experience, rising from £467 p.a. at 16.

Applications and enquiries by December 15 to:

The Director,  
M.R.C. Speech and Communication Unit,  
31 Buccleuch Place,  
Edinburgh, EH8 9JT.

## FREE TO AMBITIOUS ENGINEERS

—THE LATEST EDITION OF ENGINEERING OPPORTUNITIES

Have you sent for your copy?

ENGINEERING OPPORTUNITIES is a highly informative 164 page guide to the best paid engineering posts. It tells you how you can quickly prepare at home for a recognised engineering qualification and outlines a wonderful range of modern Home Study Courses in all branches of Engineering. This unique book also gives full details of the Practical Radio & Electronic Courses administered by our Specialist Electronics Training Division — explains the benefits of our Appointments Dept. and shows you how to qualify for five years promotion in one year.

"Satisfaction or refund of fee" terms

Whatever your age or experience you cannot afford to miss reading this famous book. Send for your copy of "ENGINEERING OPPORTUNITIES" today — FREE.

Practical Equipment including Tools

The specialist Electronics Division of B.I.E.T. NOW offers you a real laboratory training at home with practical equipment. Basic Practice and Theoretical Courses for beginners in Radio, T.V., Electronics, etc. Ask for details.

Which is your pet subject

A.M.I.E.R.E. City & Guilds  Radio Amateur's Exam.  R.T.E.B. Certificate P.M.G. Certificate  Practical Radio  Radio & Television Servicing  Practical Electronics  Electronics Engineering  Automation

The B.I.E.T. is the leading institute of its kind in the world.

Please send  
Free Books and  
Full Information

British Institute of  
Engineering Technology

NAME .....

ADDRESS .....



Subject  
of interest..... Age.....

ALDERMASTON COURT, Dept. 480D. Aldermaston, Berks.



## SMALL ADVERTISEMENTS

Continued from page 317

**ARE YOU A MOTORING ENTHUSIAST?** The Seven Fifty Motor Club caters for all types of motor sport—racing, rallies, hill climbs, etc. Monthly Bulletin free to members. For full details write to: The General Secretary, Colin Peck, "Dancer's End," St. Winifred's Road, Biggin Hill, Kent.

**FOR SALE:** 500 I.T.A. converter tuners. Send 3/- to cover postage and packing for sample to: E. Graley, 15 Roskell Road, Liverpool 25.

**ESSEX GARDENERS.** Buy your bedding and rock plants, shrubs, etc., also cacti from May's Nurseries, 608 Rayleigh Road, Hutton, Brentwood, Essex. Callers only. Monday to Saturday.

**RECITALS OF RECORDED MUSIC.** The second Saturday evening of each winter month. Next recital: December 13th, 1969, 8 p.m. Woodford Green United Free Church, Woodford Green, Essex. Bus routes 20, 20A, 38A and 179—alight at "The Castle" stop. Programme includes works by Corelli, Bach, Handel and Gabrieli.

**BOOKS TO CLEAR:** "The Upper Atmosphere", Massey & Boyd, 50/-; "KEOEET", story of the Aurora Borealis 20/-; "The Living Brain", Grey Walter, 10/-; "Teach Yourself Russian", 5/-; "Principles of Modern Book-keeping", 5/-; "Outlook", elementary weather forecasting, 7/6d; "Marine Signalling Methods", Pomphrey, 10/-; "Practical Nucleonics", experiments in Nuclear Physics, Pearson & Osborne, 25/-; "Health Physics", principles of radiation protection, Rees, 50/-; "Violent Universe", Calder, 15/-. All plus postage. Box No. G111.

**PROPERTIES** for sale and to let in London and suburbs. Apply to Maggs & Stephens, Estate Agents, 229 Maida Vale. London. W.9. MAIda Vale 8123.

### HENRY'S RADIO LTD. 303 EDGWARE ROAD, LONDON, W.2

**HAVE THE FOLLOWING VACANCIES IN THEIR ORGANISATION**  
**SALES ASSISTANT:** Young man with good general knowledge of electronic components required for our retail sales dept. Please telephone 723-1008/9 ext. 1.

**SALES ASSISTANT, HI-FI DEPT.** Young man with a good general knowledge of HIGH FIDELITY EQUIPMENT required for our retail HI-FI SALES DEPT. Please contact MR. STEVENS, Telephone 723.6963.

### 3 TRANSISTOR RADIO KIT

The small transistor radio, supplied complete with earphone and powered by a small mercury battery, is mounted in a stout plastic box measuring 3" x 2" x 1". The radio is capable of receiving Radios 1, 3, 4 and Luxembourg, together with a number of Continental stations after dark. Supplied with instructions for easy assembly.

**29/6**

**ISHERWOODS ELECTRONICS 98/100 NORTHGATE BLACKBURN, LANCs.**

SEND NOW for your

**FREE**

**CALENDAR  
DIARY SECTION  
DECIMAL COIN TABLE  
DATA SHEETS**

These are all included in our

**1970 ENLARGED CATALOGUE**

RESERVE your copy now for despatch early in January

Write to: **W. E. C. Ltd. (C)  
74 The Street, Ashtead, Surrey**

A new catalogue will be sent to Readers in possession of our 1969 catalogue.

# NEW STYLE SELF-BINDER

for "The Radio Constructor"

The "CORDEX" Patent Self-Binding Case will keep your issues in mint condition. Copies can be inserted or removed with the greatest of ease. Rich maroon finish, gold lettering on spine.

Specially constructed Binding Cords are made from Super Linen of great strength, very hard twisted and twice doubled. They are attached

to strong RUSTLESS Springs under tension, and the method adopted ensures PERMANENT RESILIENCE of the Cords. Any slack that may develop is immediately compensated for, and the Cords will always remain taut and strong. It is impossible to overstretch the springs, as a safety check-device is fitted to each

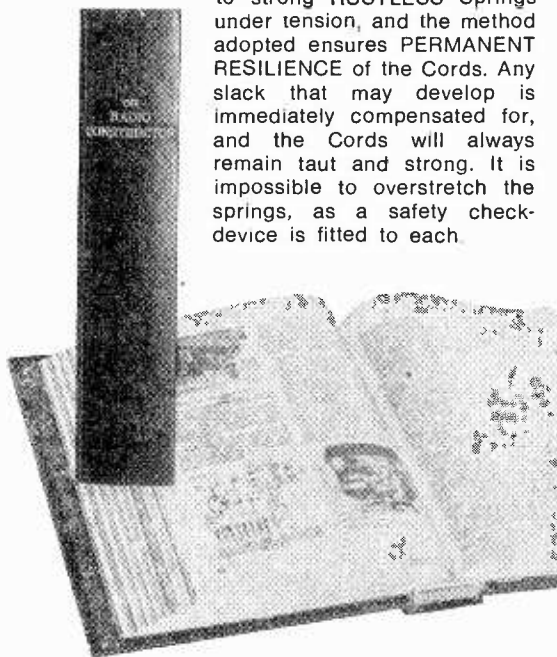

PRICE **14/-** Postage 1/6

PLAIN BACKED

For your other magazines

**13/6** Postage 1/6

Available in maroon or green

Available only from:—

**Data Publications Ltd.  
57 Maida Vale London W9**

# CHASSIS and CASES by



**H. L. SMITH & CO. LTD.**  
287/9 Edgware Road  
London W2  
TEL: 01-723 5891

## BLANK CHASSIS

FOUR-SIDED 16 SWG ALUMINIUM

Size	Price	Base	Size	Price	Base
6x4x2"	6/3	2/11	10x8x2 1/2"	12/-	5/6
7x4x1 1/2"	6/-	3/2	12x7x2 1/2"	12/-	5/11
7x5x2"	7/6	3/5	12x9x2 1/2"	13/9	7/-
8x4x2"	7/-	3/4	13x8x2 1/2"	13/9	6/11
8 1/2 x 5 1/2 x 2"	8/-	3/9	14x7x3"	14/6	6/6
9x7x2"	9/3	4/10	14x10x2 1/2"	16/-	8/7
10x4x2 1/2"	9/-	3/9	15x10x2 1/2"	16/6	9/1
12x4x2 1/2"	10/-	4/3	17x10x3"	19/6	10/1
12x5x3"	12/-	4/9			

## CASES

ALUMINIUM, SILVER  
HAMMERED FINISH

Type	Size	Price	Type	Size	Price
N	8x6x2"*	18/-	W	12x7x7"	37/6
N	6x6x3"	17/6	Y	15x9x8"	48/6
N	4x4x2"	11/-	Y	8x6x6"	29/-
U	4x4x4"	11/-	Y	12x7x7"	45/-
U	5 1/2 x 4 1/2 x 4 1/2"	17/-	Y	13x7x9"	50/6
U	8x6x6"	23/-	Y	15x9x7"	53/6
U	9 1/2 x 7 1/2 x 3 1/2"	24/-	Z	17x10x9"	72/6
U	15x9x9"	49/-	Z	19x10x8 1/2"	78/-
W	8x6x6"	23/-			*Height

Type N has removable bottom. Type U has removable bottom or back. Type W removable front. Type Y all screwed construction. Type Z removable back and front. Plus p. & p.

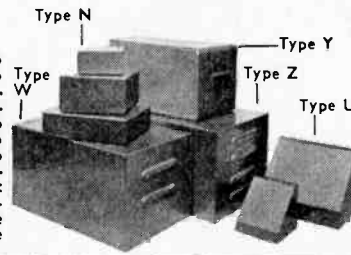

### TO FIT OUR CASES

7x5 1/2 x 1 1/2"	7/-	3/9	12x6 1/2 x 2"	10/9	5/11
7x5 1/2 x 2"	7/9	3/9	14x8 1/2 x 2"	13/6	7/11
11x6 1/2 x 1 1/2"	10/-	5/6	15 1/2 x 9 1/2 x 2 1/2"	17/-	9/6
11x6 1/2 x 2"	10/-	5/6	17 1/2 x 9 1/2 x 2 1/2"	18/6	10/6

Plus post & packing

PANELS: Any size up to 3ft. at 6/- sq.ft. 16 s.w.g. (18 s.w.g. 5/3). Plus postage and packing.

## SENSATIONAL BRITISH-MADE RADIO CONSTRUCTION OUTFIT — MAKES 5 DIFFERENT TRANSISTOR RADIOS

No soldering — No experience needed — simple lavishly illustrated step-by-step plans enables anyone 9 to 90 to build radios easily with terrific results. Educational — almost a complete Home Radio Course. — You start with a simple semi-conductor radio which takes under 1 hour to build, you then progress to multi-transistor internal loudspeaker radio complete in attractive case. All operate off tiny self-contained battery costing pennies and lasting months. True to life sound reproduction. Fully tuneable. Receives standard medium wave broadcasts. All parts down to last screw — including 3 Transistors, 1 Semi-conductor, 1 Moving Coil Loudspeaker (this alone must be worth 19/6), Personal-phone for smaller radios, all resistors, condensers, coil, wire, knobs, Radio Case, A.B.C. Plans, etc., etc. **ONLY 47/6** plus 4/6 P&P. (Parts available separately). New and boxed direct from Manufacturers to you, saving ££s in middlemen's profit. **MAKES FANTASTIC XMAS PRESENT.** (Check prices of less comprehensive educational toys in the shops!) Sold every year for the last 9 years — many testimonials. Money back guarantee.

Total building costs — everything

**47/6**

PHOENIX ELECTRONICS (RCII)  
18 Little Preston St., Brighton 1, Sussex

## CHRISTMAS REDUCTIONS—One Month Only

Pocket 1000 O.P.V. testmeter, 10-50-250-1000 volts A.C. & D.C., 1 mA, 100 mA, ohms; ranges. 45/-. Transistors, Texas 2N4061 3/-. GET 114 (A.F.) 1/-, GET 873 (R.F.) 1/2. Two way intercom set 65/-. S.C.R. 5A 400PIV. 14/6. All values 1W 5% resistors 4/- doz., Jack sockets 2/-. Jack plugs 2/1. 0.01 mF 100V cap. 3/- doz. Veroboard 17in. x 3 1/2 in. 12/-. Silicon diodes (similar OA91) 3/- doz. Grey screened mic cable 6d. per yd. 6BA screws (mixed lengths) with nut and 2 washers 1/- per doz.

Please add 1/6 in the £ postage, £5 or over post free.

### BUILD A WAH-WAH PEDAL

**SELECTIVE AMPLIFIER MODULE.** Basis of Wah-Wah Pedal. All components to build two transistor circuit including sockets, control, battery and clip. resistors, capacitors and veroboard. Full instructions provided. 30/- post free. Assembled and tested £2.

Send 1/- for our catalogue of components, testmeters, musical electronics & more details of the above items. Callers welcome.

### WILSIC ELECTRONICS LIMITED

6 Copley Road, Doncaster, Yorkshire

# DATA BOOK SERIES

## DB5 TV FAULT FINDING

124 pages. Price 8/6, postage 8d.

## DB6 THE RADIO AMATEUR OPERATOR'S HANDBOOK

64 pages. Price 6/-, postage 6d.

## DB15 TWENTY SUGGESTED CIRCUITS

48 pages. Price 3/6, postage 5d.

## DB16 RADIO CONTROL FOR MODELS

192 pages. Price 15/-, postage 1/-.

## DB17 UNDERSTANDING TELEVISION

512 pages. Price 37/6, postage 3/-

## DB18 AUDIO AMPLIFIERS

128 pages. Price 10/6, postage 8d.

I enclose Postal Order/Cheque for..... in payment for.....

NAME .....

ADDRESS .....

(Please use Block Capitals for both name and address)

Postal Orders should be crossed and made payable to Data Publications Ltd.

Overseas customers please pay by International Money Order

All publications are obtainable from your local bookseller

Data Publications Ltd., 57 Maida Vale, London W.9

# RADIO CONSTRUCTORS DATA SHEET

# 33

## HALF-WAVE RECTIFIER OUTPUTS

The Table is intended as a guide to capacitor input half-wave rectifier design for a.c. inputs of 150 to 350 volts r.m.s., and it lists mean direct voltages across the reservoir capacitor as a percentage of r.m.s. input volts. A silicon rectifier is assumed, and selenium or valve rectifiers will give somewhat lower outputs. The source resistance of  $20\Omega$  corresponds to the rectifier coupled directly to the mains supply via a  $20\Omega$  limiter resistor. The source resistance of  $300\Omega$  is representative of that offered by an isolating mains transformer secondary rated at around 100mA. To take an example, a half-wave silicon rectifier fed by a 200 volt transformer secondary for a load of 70mA, and having a  $64\mu\text{F}$  reservoir capacitor, will give a mean rectified voltage across the reservoir capacitor of about 103% of 200 volts, or 206 volts.

Reservoir Capacitance ( $\mu\text{F}$ )	Int. Resistance of a.c. source ( $\Omega$ )	Rectified Voltage (as % of applied r.m.s. input) at load currents of:						
		0mA	10mA	20mA	40mA	70mA	100mA	150mA
4	300	140	124	115	98	81	59	—
4	20	140	133	122	115	98	89	72
8	300	140	126	122	107	89	72	—
8	20	140	135	131	122	115	107	89
16	300	140	126	122	107	93	76	—
16	20	140	135	133	126	122	117	107
32	300	140	126	122	107	98	81	—
32	20	140	137	133	131	129	125	122
64	300	140	129	124	111	103	85	76
64	20	140	140	135	133	130	126	122
100	300	140	129	124	111	106	89	81
100	20	140	140	135	133	130	128	124

