

158P

# THE Radio Constructor

RADIO  
TELEVISION  
AUDIO  
ELECTRONICS

VOLUME 18      NUMBER 12  
A DATA PUBLICATION  
TWO SHILLINGS & THREEPENCE

July 1965

*An  
Electronic  
Tachometer*

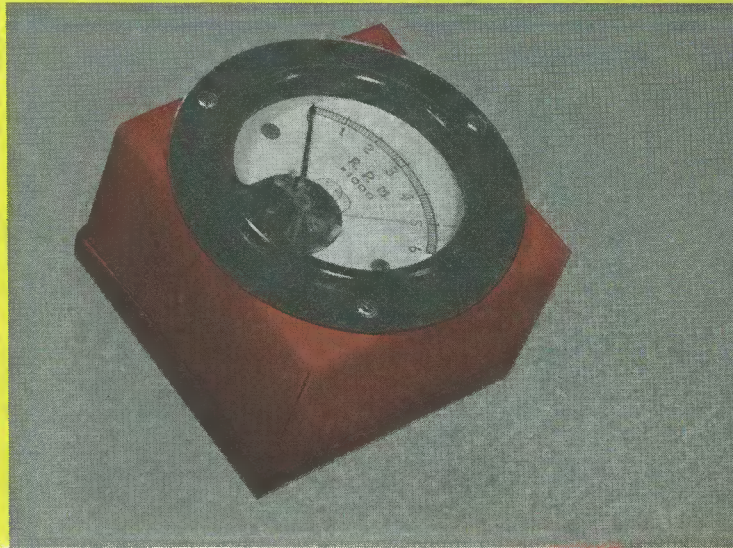

- Transistorised Multi-Range D.C. Voltmeter ★
- Beginner's 2-Valve 4-Stage Receiver ★
- Simple Valve Heater Tester ★
- Transistorised Short Wave Converters

# Scottish Insurance Corporation Ltd

38 EASTCHEAP · LONDON · EC3



## TELEVISION SETS, RECEIVERS AND TRANSMITTERS

Television Sets, Receivers and Short Wave Transmitters are expensive to acquire and you no doubt highly prize your installation. Apart from the value of your Set, you might be held responsible should injury be caused by a fault in the Set, or injury or damage by your Aerial collapsing.

A "Scottish" special policy for Television Sets, Receivers and Short Wave Transmitters provides the following cover:

- (a) Loss or damage to installation (including in the case of Television Sets the Cathode Ray Tube) by Fire, Explosion, Lightning, Theft or Accidental External Means at any private dwelling-house.
- (b) (i) Legal Liability for bodily injury to Third Parties or damage to their property arising out of the breakage or collapse of the Aerial Fittings or Mast, or through any defect in the Set. Indemnity £10,000 any one accident.
- (ii) Damage to your property or that of your landlord arising out of the breakage or collapse of the Aerial Fittings or Mast, but not exceeding £500.

The cost of Cover (a) is 5/- a year for Sets worth £50 or less, and for Sets valued at more than £50 the cost is in proportion. Cover (b) (i) and (ii) costs only 2/6 a year if taken with Cover (a), or 5/- if taken alone.

Why not BE PRUDENT AND INSURE your installation—it is well worth while AT THE VERY LOW COST INVOLVED. If you write to the Corporation's Office, quoting reference J/B, a proposal will be submitted for completion.

---

WRITE FOR FULL DETAILS TO:—

THE MANAGER  
SCOTTISH INSURANCE CORPORATION LTD.,  
38 EASTCHEAP, LONDON E.C.3

J/B



# 7 VALVE AM/FM RADIOGRAM CHASSIS

New 1965 Model Now Available.

Three Waveband & Switched Gram positions. Med. 200-550m. Long 1,000-2,000m. VHF/FM 88-95 Mc/s. Phillips Continental Tuning insert with permability tuning on FM & combined AM/FM IF transformers. 460 kc/s and 10.7 Mc/s. Dust core tuning all coils. Latest circuitry including AVC & Neg. Feedback. 3 watt output. Sensitivity and reproduction of a very high standard. Chassis size 13 1/2" x 7 1/2" x 3 1/2". Vert. pointer Horiz. station names. Gold on brown background. A.C. 200/250V operation. Magic-eye tuning. Circuit diag. now available.

Comp. with Tape, O/P socket, ext. spkr & P/U sockets and indoor F.M. aerial, and 4 knobs—walnut or ivory to choice. 3Ω P.M. Speaker only required. Recommended Quality Speakers 10" Rola, 27/6. 13 1/2" x 8" E.M.I. Fidelity, 37/6. 12" R.A. with conc. Tweeter, 42/6. Carr. 2/6.



Aligned and tested ready for £13.19.6 Carr. & Ins. 7/6.

Valves ECC85, ECH81 EF89, EA8C80, EL84 EM81, EZ80

## ANOTHER TAPE RECORDER BARGAIN

Manufacturers' end of production Surplus Offer

A 24 gns. Tape Recorder offered at the bargain price of only 15 gns. plus 10/- carr. Supplied in 3 Units already wired and tested. A modern Circuit for quality recording from Mike Gram or Radio, using latest B.S.R. Twin Track Monardeck Type TD2. Valve line-up—EF86, ECL82, EM84, EZ80 and Silicon Diode. Send for detailed list—3d. stamp.

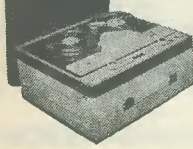

2-tone Cabinet and 7" x 4" Speaker. Size 14" x 3" x 7 1/2" ..... £3 5 0 + 5/- Carr.  
Wired Amplifier complete with 4 Valves, front Panel, Knobs, etc. .... £5 19 6 + 3/6 Carr.  
B.S.R. Monardeck Type TD2 ..... £7 7 0 + 4/6 Carr.  
Accessories: Mike, Tape, empty Reel, screened Lead and Plugs, Instructions, etc. .... £1 0 0 + 2/- Carr.

Complete Kit comprising items below BARGAIN PRICE 15 Gns. + 10/- Carr.

Jack Plugs. Standard 2 1/2" Igranite Type, 2/6. Screened Ditto, 3/3. Miniature scr. 1 1/2". Sub-min. 1/3. Jack Sockets. Open Igranite Moulded Type, 3/6. Closed Ditto, 4/-. Miniature Closed Type, 1/6. Sub-min. (deaf aid) ditto, 1/6. Stereo Jack Sockets, 3/6. Stereo Jack Plugs, 3/6.  
Phono Plugs, 9d. Phono Sockets (open), 9d. Ditto (closed), 1/-. Twin Phono Sockets (open), 1/3.  
Grundig Continental, 3 p. or 5 p. plug, 3/6. Sockets, 1/6.

Soldering Irons. Mains 200/220V or 230/250V. Solon 25 watt Inst., 22/6. Spare Elements, 5/6. Bits, 1/3 65 watt, 27/6 etc.

Alumin. Chassis. 18g. Plain Un-drilled, folded 4 sides, 2" deep, 6" x 4", 4/6, 8" x 6", 5/9, 10" x 7", 6/9, 12" x 6", 7/6, 12" x 8", 8/- etc., Alumin. Sheet. 18g. 6" x 6", 1/-. 6" x 9", 1/6, 6" x 12", 2/-, 12" x 12", 4/6 etc.

**RECORDING TAPE** Famous American Columbia (CBS) Premier quality tape at NEW REDUCED PRICES. A genuine recommended Quality Tape—TRY IT Brand new, boxed and fully guaranteed. Fitted with leader and stop foils.

Standard	Double Play	Long Play	SPECIAL OFFER. 3" Meg. 500F
5" 600'	13/-	1,200'	17/6
5" 900'	16/-	1,800'	19/6
7" 1,200'	21/-	2,400'	22/6
			25/6

Post & Package per reel, 1/- plus 6d. each for additional reels.  
Tape REELS. Mfrs. surplus 7", 2/3; 5 1/2", 2/-; 5", 2/-; 3", 1/3; Plastic spool containers, 5", 1/9; 5 1/2", 2/-; 7", 2/3.

New Boxed	VALVES	Reduced Bargain Prices	Electrolytics All Types New Stock
174	3/6	EF80 7/6	25/25V 1/9
185	6/-	EF86 8/6	50/12V 1/9
195	6/-	EL33 12/6	50/50V 2/-
354	7/-	EL34 12/6	100/25V 2/-
3V4	7/-	EL84 7/-	60+250/275V 6/6
ECC81	7/-	EY51 9/-	8/450V 2/3
ECC82	7/-	EY83 9/-	100+300/275V 12/6
ECC83	7/-	EY80 7/-	2000+4000/6V
ECL80	9/-	EZ81 7/-	1000/25V 3/9
ECL82	10/-	GZ32 9/6	Ersin Multicore Solder 60/40, 3/6
ECL86	10/6	PCC84 8/-	per yard. Cartons 2/6, etc.

## DE LUXE R/PLAYER KIT

Incorporating 4 Speed Garrard Auto-Slim unit and Mullard latest 3 watt printed circuit amplifier (ECL 86 and EZ 80) volume, bass and treble controls, with 8" x 5" 10,000 line speaker. Superb quality reproduction.

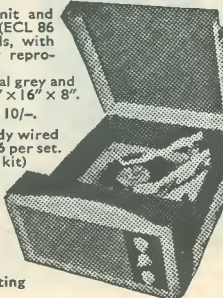

Contemporary styled two-tone cabinet, charcoal grey and off-white with matching blue relief. Size: 17 1/2" x 16" x 8".  
**COMPLETE KIT £13.19.6** Carr. & ins. 10/-.

Illuminated Perspex escutcheon, 7/6 extra. Ready wired 30/- extra. 4 Contemporary legs (6" or 13") 12/6 per set. Catalogue & construction details 2/6 (free with kit)

## STANDARD RECORD PLAYER KIT

Using BSR UA14 Unit, complete kit £11.10.0, carr. 7/6. Ready wired Amplifier, 7" x 4" quality Speaker and O/P trans., £319.6, carr. 2/6. BSR UA14 Unit, £6.10.0, carr. & ins. 5/-. Rexine covered cabinet in two-tone maroon and cream, size 15 1/2" x 14 1/2" x 8 1/2" with all accessories plus uncut record, player mounting board 14" x 13", 59/6, carr. & ins. 5/-.

## 6 VALVE AM-FM TUNER UNIT

Med. and VHF 190m-550m, 86 Mc/s-103 Mc/s, 6 valves and metal rectifier. Self-contained power unit, A.C. 200/250V operation. Magic-eye indicator, 3 push-button controls, on/off, Metal, VHF. Diodes and high output Sockets with gain control. Illuminated 2-colour perspex dial 1 1/2" x 4", chassis size 1 1/2" x 4" x 5 1/2". A recommended Fidelity Unit for use with Mullard "3-3" or "5-10" Amplifiers. Available only at present as built-up units, aligned and tested ready for use.  
Bargain Price £12.10.0. Carr. 5/-.  
This popular unit will be available in kit form within the next few weeks. Circuit and const's details, 2/6.

## ENAMELLED COPPER WIRE—

1lb reels, 14g-20g, 3/-; 22g-28g, 3/6; 36g-38g, 4/9; 39-40g, 5/-, etc.

## TINNED COPPER WIRE—14-22g.

3/- lb. PVC CONNECTING WIRE—10 colours (for chassis wiring, etc.)—Single or stranded conductor, per yd., 2d. Sleeving, 1mm. and 2mm., 2d. yd., etc.

## KNOBBS—Modern Continental types:

Brown or Ivory with Gold Ring, 1" dia., 9d. each; 1 1/2", 1/- each; Brown or Ivory with Gold Centre, 1" dia., 10d. each; 1 1/2" 1/3 each. LARGE SELECTION AVAILABLE.

## TRANSISTOR COMPONENTS

Midget I.F.'s—465 kc/s 2 1/2" diam. 5/6  
Osc. Coil—1/2" diam. M/W. 5/3  
Osc. coil P. & L.W. 5/9  
Midget Driver Trans. 1" dia. 35:1 6/9  
Ditto O/Put Push-pull 3 ohms 6/9

Elect. Condensers—Midget Type 15V 1mf-50mf, ea. 1/9. 100mf. 2/-. Ferrite Aerial—M. & L. W. with car aerial coupling coil, 9/3.

Condensers—150V. wkg. .01 mfd. to .04 mfd., 9d. .05 mfd., .1 mfd., 1/-, .25 mfd., 1/3. .5 mfd., 1/6, etc.

Tuning Condensers. J.B. "00" 208 + 176pF, 8/6. Ditto with trimmers, 9/6. 365pF single, 7/6. Sub-min. 2" DILEMIN 100pF, 300pF, 500pF, 7/-.

Midget Vol. Control with edge control knob, 5kΩ with switch, 4/9, ditto less switch, 3/9.

Speakers P.M.—2" Plessey 75 ohms, 15/6. 2 1/2" Continental 8 ohms, 13/6. 7" x 4" Plessey 35 ohm, 23/6.

Ear Plug Phones—Min. Continental type, 3ft. lead, jack plug and socket. High Imp. 8Ω. Low Imp. 7/6. High sensitivity M/coil 8-10 ohms, 12/6.

## JASON FM TUNER UNITS

Designer-approved kit of parts:  
FMT1, 5 gns. 4 valves, 20/-  
FMT2, £10.0. 5 valves, 35/-  
JTV MERCURY 10 gns.  
5 valves, 22/6.  
JTV2 £13.19.6. 4 valves, 28/6.  
NEW JASON FM ALIGNMENT BOOK, 2/6. 48 hr. Hand-book Service 7/6. P. & P. 2/6.

## MULLARD "3-3" & "5-10" HI-FI AMPLIFIERS

### 3 OHM AND 15 OHM OUTPUT

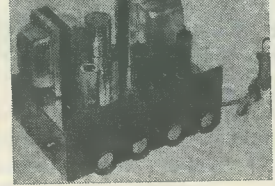

"3-3" Amp. 3-valve, 3 watt, Hi-Fi quality at reasonable cost. Bass Boost and Treble controls, quality sectional output transformer, 40 c/s-25 kc/s ± 1dB. 100mV for 3W, less than 1% distortion. Bronze escutcheon panel.

Complete Kit only £619.6. Carr. 5/-. Wired and tested 8 gns.

MULLARD "5-10" AMPLIFIER—5 valves 10W, 3 and 15 ohms output.

Mullard's famous circuit with heavy duty ultra-linear quality output tfr. Basic amplifier kit price £9.19.6. Carr. 7/6. Ready built 1 1/2 gns.

**CONTROL PANEL KIT** Bass, Treble and Volume controls with 4-position selector switch for radio, tape and pick-up and 1 1/2" x 4" escutcheon panel.

Amplifier Kit and Control Panel Kit £11.19.6. Ditto ready wired £14.19.6.

**2-VALVE PRE-AMP. UNIT** Based on Mullard's famous 2-valve (2 x EF86) circuit with full equalisation with volume, bass, treble, and 5-position selector switch. Size 3" x 6" x 2 1/2". Complete Kit £5.19.6. Carr. 3/6. Ready built £7.19.6.



Send for detailed bargain lists, 3d. stamp. We manufacture all types Radio Mains Trans. Chokes, Quality O/P Trans., etc. Enquiries invited for Specials, Prototypes for small production runs. Quotation by return.  
**RADIO COMPONENT SPECIALISTS**  
70 Brigstock Road, Thornton Heath, Surrey THO 2185. Hours: 9 a.m.-6 p.m., 1 p.m. Wed. Terms C.W.O. or C.O.D. Post and Packing up to 1/2 lb. 9d., 1 lb. 1/3, 3 lb. 2/3, 5 lb. 2/9, 8 lb. 3/6.





# Choose Heathkit models for value and performance

Easy-to-follow instruction manuals tell you how to build any model

## HI-FI AMPLIFIERS ~~~~~ TUNERS ~~~~~ RECORD PLAYERS

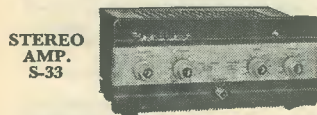

STEREO AMP. S-33



PLAYER AT-6

**HI-FI 6W STEREO AMPLIFIER. Model S-33.** 3 watts per channel 0.3% distortion at 2.5W/chnl., 20dB N.F.B. Inputs for Radio (or Tape) and Gram. Kit **£13.76** Assembled **£18.18.0**

**GOLDRING Lenco TRANSCRIPTION PLAYER. Model GL-58.** With G-60 pick-up arm and Ronette 105 cartridge. **£20.13** incl. P.T.

**GARRARD AUTO/RECORD PLAYER. Model AT-6.** With R 105 cartridge **£13.12.1** Decca Deram pick-up **£14.6.1** incl. P.T.

**HI-FI MONO AMPLIFIER. Model MA-5.** A general purpose 5W Amplifier, with inputs for Gram., Radio. Presentation similar to S-33 Kit **£10.19.6** Assembled **£15.10.0**

**PA AMPLIFIER, Model PA-1.** 50W amplifier. The ideal, compact unit. Two heavy duty speakers. Variable tremolo. Legs optional extra 17/6 Kit **£54.15.0** Assembled **£74.0.0**

### NEW! De-luxe ALL TRANSISTOR 20+20W STEREO AMPLIFIER

AA-22U.

At last a British amplifier, with high power at reasonable cost, capable of delivering full power at all frequencies in the audio range. Handsome, fully finished walnut veneered cabinet. New, compact, professional slim-line styling. Kit **£43.18.0** Assembled **£68.16.0**

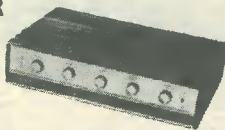

## TRANSISTOR RECEIVERS

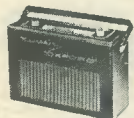

UXR-2



UXR-1



UJR-1

**"OXFORD" LUXURY PORTABLE. Model UXR-2.** Specially designed for use as a domestic, car or personal portable receiver. Many features, including solid leather case. Kit **£14.18.0** incl. P.T.

**TRANSISTOR PORTABLE. Model UXR-1.** Pre-aligned I.F. transformers, printed circuit. Covers L.W. and M.W. Has 7" x 4" loudspeaker. Real hide case. Kit **£12.11.0** incl. P.T.

**JUNIOR EXPERIMENTAL WORKSHOP. Model EW-1.** More than a toy! Will make over 20 exciting electronic devices, incl: Radios, Burglar Alarms, etc. 72 page Manual. The ideal present! Kit **£7.13.6** incl. P.T.

**JUNIOR TRANSISTOR RADIO. Model UJR-1.** Single transistor set. Excellent introduction to radio. Kit **£2.7.6** incl. P.T.

### MANY OTHER BRITISH MODELS

Covering a wide range of models for the home, workshop or service bench or laboratory. Why not send for Free Catalogue?



POWER AMP. MA-12



STEREO AMP. S-99

**HI-FI MONO AMPLIFIER. Model MA-12.** 10W output, wide freq. range low distortion. Kit **£11.18.0** Assembled **£15.18.0**

**DE LUXE STEREO AMPLIFIER. Model S-33H.** De luxe version of the S-33 with two-tone grey perspex panel, and higher sensitivity necessary to accept the Decca Deram pick-up. Kit **£15.17.6** Assembled **£21.7.0**

**HI-FI STEREO AMPLIFIER. Model S-99.** 9 + 9W output. Range controls. Stereo/Mono gram., radio and tape inputs. Push-button selection. Printed circuit construction. Kit **£27.19.6** Assembled **£37.19.0**

**POWER SUPPLY UNIT. Model MGP-1.** Input 100/120V, 200/250V 40-60 c/s. Output 6.3V, 2.5A A.C. 200, 250, 270V, 120mA max. D.C. Kit **£5.2.6** Assembled **£6.12.0**

**HI-FI CABINETS.** A wide range available, prices from **£7.15.0** to **£44.2.0** incl. P.T. Assembled or in kit form.

## INSTRUMENTS

**DE LUXE LARGE-SCALE VALVE VOLT-METER. Model IM-13U.** Circuit and specification based on the well-known model V-7A but with many worth-while refinements. 6" Ernest Turner meter. Unique gimbal bracket allows operation of instrument in many positions. Modern styling. Kit **£18.18.0** Assembled **£26.18.0**

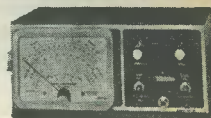

IM-13U

**AUDIO SIGNAL GENERATOR. Model AG-9U.** 10 c/s to 100 kc/s, switch selected. Distortion less than 0.1%, 10V sine wave output metered in volts and dB's. Kit **£22.10.0** Assembled **£30.10.0**



V-7A

**VALVE VOLTMETER. Model V-7A.** 7 voltage ranges d.c. volts to 1,500. A.c. to 1,500 r.m.s. and 4,000 peak to peak. Resistance 0.1Ω to 1,000MΩ with internal battery. D.c. input resistance 11MΩ. dB measurement, has centre-zero scale. Complete with test prods, leads and standardising battery. Kit **£13.18.6** Assembled **£19.18.6**

**MULTIMETER. Model MM-1U.** Ranges 0-1.5V to 1,500V a.c. and d.c.; 150μA to 15A d.c.; 0.2Ω to 20MΩ. 4 1/2" 50μA meter. Kit **£12.18.0** Assembled **£18.11.6**



RF-1U

**R.F. SIGNAL GENERATOR. Model RF-1U.** Up to 100 Mc/s fundamental and 200 Mc/s on harmonics. Up to 100mV output. Kit **£13.8.0** Assembled **£19.18.0**

**T.V. ALIGNMENT GENERATOR. Model HFW-1.** Offers max performance at lowest cost. Covers 3.6 to 220 Mc/s fundamentals. Electronic sweep oscillators. Built in marker generators (5 Mc/s crystal). Kit **£34.18.0** Kit **£44.10.0** Assembled

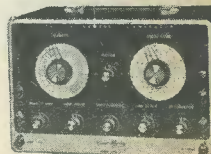

HFW-1

**5" GENERAL-PURPOSE LABORATORY OSCILLOSCOPE. Model IO-12U.** This outstanding oscilloscope, with its professional specification and styling fulfils most laboratory and service requirements. Vertical frequency response 3 c/s to over 4.5 Mc/s, sensitivity 10mV r.m.s. per cm. at 1 kc/s. T/B covers 10 c/s to 500 kc/s. Kit **£32.12.6** Assembled **£41.10.0**

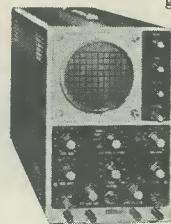

IO-12U

**ELECTRONIC SWITCH. Model S-3U.** Converts a single beam scope to double beam operation at low cost. Kit **£12.18.0** Assembled **£18.10.0**

**TRANSISTOR POWER SUPPLY. Model IP-20U.** Up to 50V, 1.5A output. Kit **£35.8.0** Assembled **£47.8.0**



# Enjoy Yourself and Save Money with these Kits

No previous experience required to build any Heathkit model



## TAPE AMPLIFIERS ~~~~~ TAPE DECKS ~~~~~ CONTROL UNITS



FM  
TUNER  
FM-4U

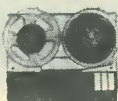

MAGNAVOX  
NEW  
TAPE  
DECK



TRUVOX  
DECK



AM/FM  
TUNER

**HI-FI FM TUNER. Model FM-4U.** Also available in two units. R.F. tuning unit (£2.15.0 incl. P.T.) with I.F. output of 10.7 Mc/s, and I.F. amplifier unit, with power supply and valves (£13.3.0).

Total Kit **£15.18.0**

**MAGNAVOX NEW TAPE DECK.** The finest buy in its price range. Operating speeds: 1½", 3¼" and 7½" p.s. Two tracks, "wow" and "flutter" not greater than 0.15% at 7½" p.s. **£14.19.6**

**HI-FI AM/FM TUNER: Model AFM-1.** Available in two units which, for your convenience, are sold separately. Tuning heart (AFM-T1—£4.13.6 incl. P.T.) and I.F. amplifier (AFM-A1—£21.16.6). Printed circuit board, 8 valves. Covers L.W., M.W., S.W., and F.M. Built-in power supply. Total Kit **£26.10.0**

**TRUVOX D-93 TAPE DECKS.** High quality stereo/mono tape decks. D93/2, ½ track, £36.15.0 D93/4, ¼ track, £36.15.0

**TAPE RECORDING/PLAYBACK AMPLIFIER.** Thermometer type recording indicators, press-button speed compensation and input selection. Mono Model TA-1M. Kit **£19.18.0** Assembled **£28.18.0**  
Stereo Model TA-1S. Kit **£25.10.0** Assembled **£35.18.0**

**MONO CONTROL UNIT. Model UMC-1.** Designed to work with the MA-12 or similar amplifier requiring 0.25V or less for full output. 5 inputs. Baxandall type controls. Kit **£8.12.6** Assembled **£13.12.6**

**STEREO CONTROL UNIT. Model USC-1.** Push-button selection, accurately matched ganged controls to ±1dB. Rumble and variable low-pass filters. Printed circuit boards. Kit **£19.10.0** Assembled **£26.10.0**

## SPEAKER SYSTEMS



SSU-1

**HI-FI SPEAKER SYSTEM. Model SSU-1.** Ducted-port bass reflex cabinet "in the white". Two speakers. Vertical or horizontal models with legs, Kit **£11.12.0**, without legs, Kit **£10.17.6** incl. P.T.

**COTSWOLD "MFS" SYSTEM.** Designed to give best possible results where floor space is at a premium. This minimum floor space model is based on standard Cotswold. Size: 36" high x 16½" wide x 14½" deep. Kit **£23.4.0** Assembled **£30.15.0**

**THE "COTSWOLD".** This is an acoustically designed enclosure 26" x 23" x 15½" housing a 12" bass speaker with 2" speech coil, elliptical middle speaker together with a pressure unit to cover the full frequency range of 30-20,000 c/s. Capable of doing justice to the finest programme source, its polar distribution makes it ideal for really Hi-Fi Stereo.

Kit **£23.4.0** Assembled **£30.15.0**

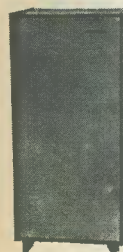

MFS

## NEW MODELS

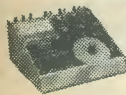

IM-30

### TRANSISTOR TESTER IM-30U

Provides complete d.c. analysis of PNP and NPN transistors and diodes. Kit **£24.18.0** Assembled **£35.10.0**

**HARMONIC DIST. METER IM-12U**  
Freq. coverage 20-20,000 c/s. Dist. ranges 1, 3, 10, 30, 100% f.s.d. VM ranges 0, 1, 3, 10, 30 volts f.s.d. Input Resistance 300kΩ. Kit **£24.15.0** Assembled **£34.0.0**



IM-12

## SEND FOR FREE BRITISH HEATHKIT CATALOGUE

American catalogue also available 1/- post paid

Deferred terms available in U.K. over £10.  
Extended terms over £75. Send for details.

**DAYSTROM LTD** DEPT. RC.7  
GLOUCESTER

## "AMATEUR" EQUIPMENT

**AMATEUR BANDS RECEIVER. Model RA-1.** To cover all the Amateur Bands from 160-10 metres. Many special features, including: half-lattice crystal filter; 8 valves; signal strength "S" meter; tuned R.F. Amp. stage. Kit **£39.6.6** Assembled **£52.10.0**

**THE "MOHICAN" GENERAL COVERAGE RECEIVER. Model GC-1U.** With 4 piezo-electric transmitters, variable tuned B.F.O. and Zener diode stabiliser, this is an excellent fully transistorised general purpose receiver for Amateur and Short wave listeners. Printed circuits, telescopic aerial, tuning meter and large slide-rule dial. Kit **£37.17.6** Assembled **£45.17.6**

**160-10M TRANSMITTER. Model DX-100U.** Careful design has achieved high performance and stability. Completely self-contained. Kit **£79.10.0** Assembled **£104.15.0**

**COMMUNICATIONS TYPE RECEIVER. Model RG-1.** A high performance, low cost receiver for the discriminating listener. Frequency coverage: 600 kc/s-1.5 Mc/s and 1.7 Mc/s-32 Mc/s. Kit **£39.16.0** Assembled **£53.0.0**

**REFLECTED POWER METER and SWR BRIDGE. Model HM-11U.** Indicates reliably, but inexpensively, whether the RF power output of your TX is being transferred efficiently to radiating antenna. Kit **£8.5.0** Assembled **£10.10.0**



RA-1

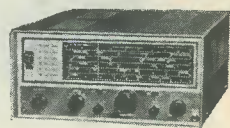

RG-1



HM-11U

## AMERICAN HEATHKIT "AMATEUR" EQUIPMENT

A wide range of American Amateur SSB equipment is now available in the U.K. Why not send for full details of range, for example:

### 80-10M RECEIVER. Model SB-300E.

Of advanced design employing up-to-date construction techniques, its specification ensures unparalleled performance.

Kit **£133.14.0** (less speaker) + import levy



SB-300E

Without obligation please send me  
**FREE BRITISH HEATHKIT CATALOGUE**

**FULL DETAILS OF MODEL(S)**

(Please write in BLOCK CAPITALS)

**NAME**

**ADDRESS**

(Tick here)

DEPT. RC.7





*in step with the*

**20 WATTS R.M.S.**

**SIZE: 8 $\frac{1}{4}$ " x 3 $\frac{1}{4}$ " x 1"**

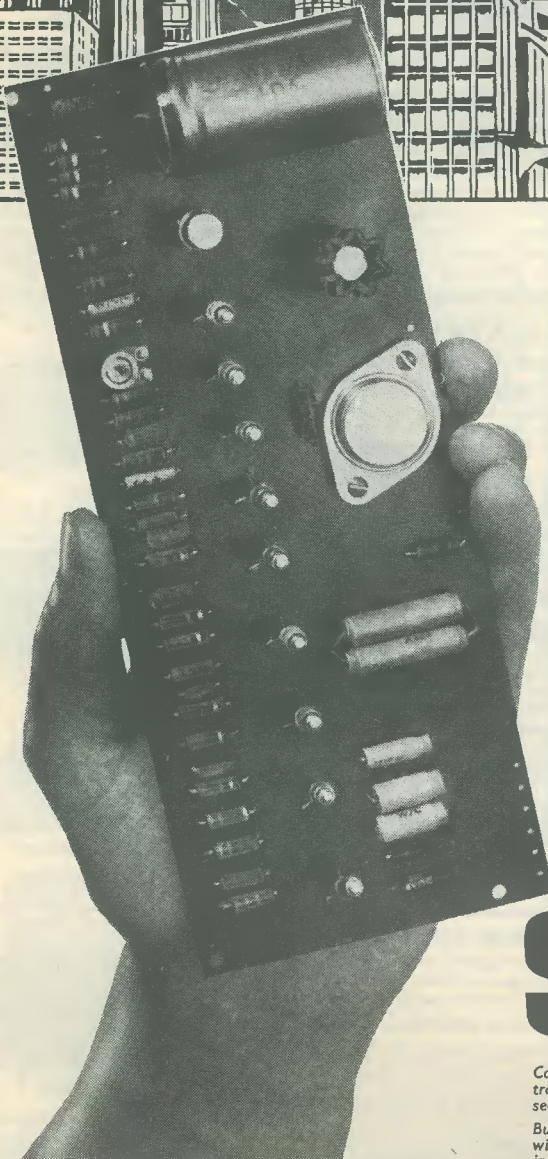

**THE WORLD'S MOST ADVANCED  
AUDIO AMPLIFIER SYSTEM**

THE SINCLAIR X-20 enables you to enjoy, for the first time ever, the advantages of using a high power, high fidelity audio amplifier truly in step with today's space age electronics. No longer does power mean problems of heat and size, for the X-20 requires neither heatsink nor special ventilation. It measures only 8 $\frac{1}{4}$ " x 3 $\frac{1}{4}$ " x 1", weighs 4 $\frac{1}{2}$  oz. and will deliver up to 20 watts R.M.S. into a 7 $\frac{1}{2}$ -8 ohms loudspeaker—40 watts output by U.S.A. standards! A 3-stage pre-amplifier of exceptional efficiency is included within the above dimensions to ensure an overall frequency response from 20 to 20,000 c/s well within  $\pm 1$ dB from input to output. With greatly improved transient response, there is corresponding improvement in the results obtained from other equipment used with the X-20 which itself has an energy conversion factor of better than 95% at the output stage. At no point in the circuitry of the X-20 are components over-run, so that the instrument is both stable and assured of indefinite working life—and it is easier to build and install than any amplifier you have ever owned. Best of all it costs far less.

**SINCLAIR**

Complete kit of parts inc. transistors and X-20 manual in sealed carton

**£7.19.6**

Built and tested with X-20 manual in sealed carton

**£9.19.6**

X-20 Power Pack sufficient to drive two X-20's

**£4.19.6**

**sinclair**

**SINCLAIR RADIONICS LTD.,**  
COMBERTON, CAMBRIDGE Telephone: COMBERTON 682



# SPACE AGE!

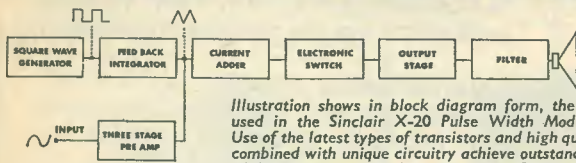

Illustration shows in block diagram form, the principal stages used in the Sinclair X-20 Pulse Width Modulated Amplifier. Use of the latest types of transistors and high quality components combined with unique circuitry achieve outstanding performance whilst retaining all the operational features of conventional quality amplifier design.

## ONLY THE X-20 HAS ALL THESE FEATURES

- ★ Easily built in an evening
- ★ No. of transistors—12
- ★ Output stage—silicon epitaxial planars
- ★ Constant square wave amplitude maintained at all times
- ★ 95% conversion efficiency factor at output stage
- ★ Superb quality and reliability
- ★ Frequency response—From 20 to 20,000 c/s  $\pm 1$ dB
- ★ Total harmonic distortion—0.1% at 10 watts R.M.S.
- ★ Input sensitivity—1mV into 5k $\Omega$
- ★ Signal to noise ratio—better than 70dB
- ★ Output into 7.5 ohms—20 watts R.M.S. music power  
15 watts R.M.S. continuous
- ★ Output into 15 ohms—15 watts R.M.S. music value  
10 watts R.M.S. continuous
- ★ Makes an ideal guitar or P.A. amplifier
- ★ Built-in low-pass filter in output stage ensures wide tolerance to load connected to the output
- ★ Power requirements—36V d.c. at 700mA
- ★ Size—8½" x 3½" x 1"
- ★ Weight—4½ ounces
- ★ Add tone and volume control systems to choice
- ★ Ideal for stereo

## SINCLAIR X-10

COMBINED P.W.M. AMPLIFIER & PRE-AMP

This superb P.W.M. assembly is ideal for more restricted listening conditions. The X-10 offers the same advantages and facilities as the X-20, but with 10 watts peak output, operating from 12 to 15V d.c. supply. It measures only 6" x 3" complete. Tone and volume controls (mono or stereo) are added to choice. Thousands of X-10's have been built and are in regular use. Construction and installation could not be simpler.

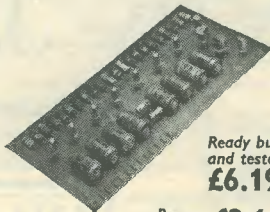

Ready built and tested  
**£6.19.6**

Power Pack **£2.14.0**

All parts with manual come to **£5.19.6**

## THE SMALLEST, MOST POPULAR CONSTRUCTOR'S SET IN THE WORLD

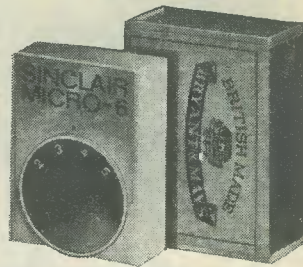

## SINCLAIR MICRO-6

Smaller than a matchbox, this world famous receiver brings in stations from all over Europe with fantastically good quality and volume. It performs with amazing efficiency in cars, buses, trains and steel-framed buildings, yet measures only 1½" x 1½" x ½" complete with self-contained aerial and batteries. The highly stable six-stage circuit provides A.G.C. and band-spread for easy Luxembourg reception. Tunes over medium waveband. Building this smart minute set is enjoyable for expert and beginner alike. Its performance is wonderful.

All parts inc. 3 M.A.T. transistors, case, light-weight earpiece and instructions come to **59/6**  
MALLORY MERCURY CELL ZM.312 (2 required), each 1/11. Pack of six, 10/6.

## TR750 POWER AMP

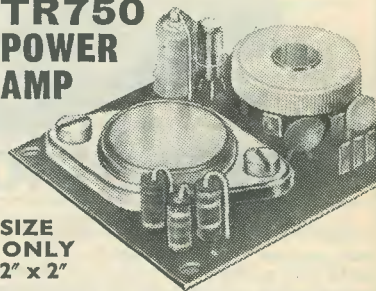

SIZE ONLY  
2" x 2"

With built-in switch and volume control. Output 750mW for feeding into standard 25 to 35 ohm speaker. Input 10mV into 2k $\Omega$ . Operates from 9V d.c. Designed principally for use with the Micro-6 to make a highly efficient car, portable or domestic loudspeaker set, this amplifier will also make a mono or stereo record player, intercom., baby alarm, etc.

All parts and instructions **39/6** Ready built and tested **45/-**

# X-20 INTEGRATED 20 WATT PULSE WIDTH MODULATED AMPLIFIER AND PRE-AMP

FULL SERVICE FACILITIES AVAILABLE TO ALL SINCLAIR CUSTOMERS

Please send me

NAME.....

ADDRESS.....

for which I enclose Cash/Cheque/Money Order value £.....s.....d.

## Guarantee

Should you not be completely satisfied with your purchase when you receive it from us, your money will be refunded in full and at once without question. Please quote R.C.7 should you prefer to write your order instead of cutting out this coupon.

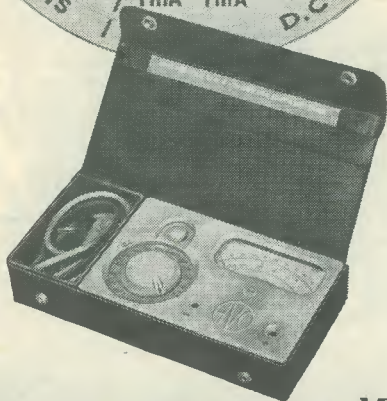

## MULTIMINOR *Mk 4*

The newly improved model of this famous AVO pocket size multi-range instrument has been enthusiastically acclaimed in all parts of the world for its high standards of accuracy and dependability as well as for its modern styling, its highly efficient internal assemblies, and its resistance to extremes of climatic conditions.

It is simple to use, one rotary switch for instant range selection, only one pair of sockets for all measurements, and a 2½ inch clearly-marked scale-plate. It is supplied in an attractive black carrying case complete with interchangeable test prods and clips, and a multi-lingual instruction booklet.



**RESISTANCE:** 0-2MΩ in 2 ranges, using 1.5V cell  
**SENSITIVITY:** 10,000Ω/V on d.c. voltage ranges  
 1,000Ω/V on a.c. voltage ranges

to send you a full specification of this great little instrument. It measures only 7½" x 4" x 1½" and weighs only 24 oz.

**AVO LTD**

AVOCET HOUSE, 92-96 VAUXHALL BRIDGE ROAD,  
 LONDON, S.W.1 Telephone: VICTORIA 3404 (12 lines)



MM 19

798

TO DESIGNERS & CHIEF ENGINEERS

# OSMOR

SPECIALISE IN WINDING MINIATURE COILS, TRANSFORMERS, ETC. OF INTEREST TO BULK MANUFACTURERS IN THE INDUSTRIAL FIELD.

MANUFACTURERS USING UP TO 50 S.W.G. WOULD FIND OUR SERVICE ECONOMICAL AND RELIABLE. ENQUIRIES APPRECIATED.

## LARGE CAPACITY AVAILABLE

PLEASE TELEPHONE CRO 5148  
 FOR SWIFT ACTION

**OSMOR RADIO PRODUCTS LTD.**  
 540 PURLEY WAY (PARKING FACILITIES)  
 (Nr. AIRPORT) CROYDON  
 CRO 5148/9

# JACKSON



the big name in PRECISION components

Precision built radio components are an important contribution to the radio and communications industry.

## BALL DRIVES

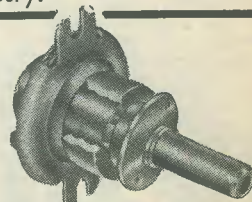

Thousands of Jackson dual-ratio ball drives are in daily use in u.h.f. television tuners. Type 4511DR provides 6:1 fast ratio and 36:1 "reverse vernier" on one spindle. Type 4511DRF, with a flange for carrying a pointer, is ideal for use in receivers and measuring instruments as well. Other Jackson ball drives provide simple 6:1 reduction or combined 1:1 forward and 6:1 reverse vernier movements. Ask for details.

Dual ratio ball drive No. 4511/DR 13/6  
 With flange No. 4511DRF 15/0  
 ★ High torque. ★ Low backlash. ★ Simple fixing.  
 ★ Take standard 0.25in spindles. ★ Utterly reliable of course!

Made in England

## JACKSON BROS. (LONDON) LIMITED

DEPT. RC., KINGSWAY, WADDON, CROYDON, SURREY  
 Phone: Croydon 2754-5 Grams: Walfico, Souphone, London



## THE GOLDENAIR "THIRTY" HI-FI AMPLIFIER

A high quality 30-watt amplifier developed for use in large halls and clubs etc. Ideal for bass, lead or rhythm guitars, schools, dance halls, theatres and public address. Suitable for any type of mike or pick-up. Valve line-up: two EF86; one ECC83; one GZ34; two EL34. Four separate inputs are provided with two volume controls. Bass and Treble controls are incorporated. Amplifier operates on standard 30 c/s mains. 3 ohm and 15 ohm speakers may be used. Perforated cover with carrying handles can be provided if required, price now 25/-.

Customers are invited to see and hear this amplifier at our shop premises at Lambert's Arcade or our new York shop. Send S.A.E. for illustrated leaflet. Available in kit form, price £11.19.6, or ready built and tested 16 gns. Constructional notes 5/- extra. Carriage 15/- to be sent with order.

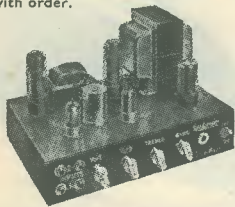

## CARAVAN RADIOS

These well made radios were designed for the Government for forces entertainment. Contains 6K8, 6K7, 6Q7, and 6V6 output. Has choke smoothing, and slow motion tuning. Printed scale. 200-550 metres. In good condition. Complete with built-in 6V power pack and 8" high quality speaker, all contained in a sturdy wooden cabinet. Ideal for use with your caravan or car. Will work from standard 6V car battery or easily converted for mains operation. Price £3.19.6, p/p 10/-.

## RE-HOUSE YOUR AMPLIFIER

Heavy Duty Amplifier Cabinet size 28" x 20" x 10". Attractive 2-tone finish. Will take most amplifiers and two 12" loudspeakers. Robust construction. Manufacturer's surplus to clear at £7.19.6, p/p 10/-.

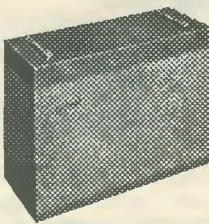

## 2-WAY RADIOS



Compact trans/receiver that can be held in the hand. Size approx. 15" x 4" x 4". Range up to three miles under favourable conditions. Uses miniature valves and self-contained standard batteries. Easy to operate, economical to run. Ideal for authorised fixed or mobile operation. A G.P.O. licence should be obtained. Available in kit form, at 10 gns., p/p 10/-.

Already built 12 gns., p/p 10/-.

Few only left in stock.

## WANTED

WE WISH TO PURCHASE FOR SPOT CASH, RADIO COMMUNICATION EQUIPMENT: TRANSMITTERS, COMMUNICATION RECEIVERS, TRANSCEIVERS (Government surplus, Commercial and Foreign). WE ARE SURE THAT MANY ENTHUSIASTS HAVE UNWANTED EQUIPMENT TAKING UP SPACE AND COLLECTING DUST. SO LOOK AROUND AND TURN YOUR REDUNDANT EQUIPMENT INTO CASH. OFFERS MADE FOR ANY SUITABLE EQUIPMENT. SEND FULL DETAILS STATING TYPE, MAKE AND CONDITION, WITH S.A.E. FOR QUOTATION TO BUYING DEPT.

## DYNAMOTOR

Run all your mains A.C./D.C. equipment from your car battery. 6V input gives 250V output, or 12V input gives 500V output at 30 watts. Very low battery drain. Size only 5 1/2" x 3 1/2". A must for the caravanner. ONLY 25/-, p/p 3/6.

M.A.T. Transistors. M.A.T. 100, 7/9; M.A.T. 120, 7/9; M.A.T. 121, 8/6; Ferrite slab aerials suitable for Transistor sets, 3/-, p/p 6d.

## OPERATORS UNIT

High purchase enables us to offer at give away price operators unit containing standard jack socket 250 mfd. electrolytic condenser, 4-way telephone socket, midget selenium rectifier, etc. Price 3/6 post free, or 2 for 6/6 post free.

## RESISTOR COLOUR CODE INDICATORS

Enables you to determine value of a resistor at a glance. A must for the constructor. Saves time. Price 1/6 each, p/p 4d.

High quality Paxolin Sheets. Strong high quality Paxolin sheets. Size 10 1/2 x 8 1/2 x 1/10". Three for five shillings, p/p 1/6. Six for 10/- post free. Twelve for 19/6 post free.

Trawler Band Receiver. A compact 4 semi-conductor receiver. Complete with personal listening earpiece. Receives amateur and maritime stations. You will be amazed at the stations that can be received on this set. Works from standard batteries. Available in kit form with full completion instructions. Price 49/6, p/p 1/6. Limited number left.

## MORSE KEYS

Morse key assembly. Key with base, cover and terminals. Complete with lead. 6/11, p/p 2/-.

2 Morse Keys for 12/6 post free.

## YORK SHOP

Extensive new shop premises now open at 97 Walmgate, York

Large selection of radio and electronic components and equipment. Full range of communication equipment in stock. Callers welcome.

Open 9 a.m.-5.30 p.m. weekdays, 9 a.m.-6 p.m. Saturdays.

## COMMUNICATION RECEIVER R155

This famous Bomber Command receiver covers 75 kc/s to 18 Mc/s in 5 ranges. The sets are easily and simply adapted for mains operation. In very good condition and in perfect working order. Fitted with latest type super slow motion tuning assembly. Price only £7.19.6, p/p 10/-.

Limited stock only.

OC71  
2/11,  
p/p 6d.

OC44  
3/11,  
p/p 6d.

OC45  
3/11,  
p/p 6d.

XD202,  
diode  
1/6,  
p/p 6d.

## MONSTER PARCEL No. 3

Six crocodile clips. One portable mains soldering iron, 6 phono plugs, 6 coils of multi-cored solder, 6 valves, 3 TV aerial plugs, 12 British octal valve holders, 12 wafers, 3 car aerial plugs, 3 sheets of 10" x 6" paxolin, 6ft. copper rod aerial, 3 sturdily made panel mounting fuse holders, 24 new resistors, 6 assorted pots, 1 operators unit, a very useful piece of equipment. All this for only 25/-, p/p 4/6.

## SURPLUS HANDBOOKS

19 set Instruction Handbook 3/6 each, p/p 6d.  
1155 Instruction Handbook 3/6 each, p/p 6d.

H.R.O. Instruction Handbook 3/6 each, p/p 6d.

Frequency Meter, BC 221 Instruction Handbook 3/6 each, p/p 6d.

46 Walkie Talkie Set Circuit and Notes 3/6 each, p/p 6d.

38 set A.F.V. Instruction Handbook Price 3/6 each, p/p 6d.

R.F. Unit 24 Circuit Diagram and Details Price 1/6, p/p 3d.

R.F. Unit 25 Circuit Diagram and Details Price 1/6, p/p 3d.

R.F. Unit 26 Circuit Diagram and Details Price 1/6, p/p 3d.

Receiver R1355 Circuit Diagram and Details Price 1/6, p/p 3d.

Receiver R124A Circuit Diagram and Details Price 1/6, p/p 3d.

R.1116/A Circuit Diagram and Details Price 1/9 p/p 3d.

Wave Meter Class D Handbook, Mk. 1, 11 111 Price 3/6, p/p 6d.

18 set Mark III circuit details and notes. Price 3/6, p/p 6d.

Tank Aerials. Fully interlocking copper sections one foot in length. Will make ideal dipoles, car or scooter aerials. Price 6 sections complete with canvas carrying case 3/6, p/p 2/6. Additional sections 6d. each. Please include sufficient postage.

19 set Trans/Rec. Mains Power Pack. Operate your 19 set receiver straight off the mains. Ready built power unit, complete with modification and fitting instructions. Price 59/6 p/p 3/6. Please state Model, MK. 2 or MK. 3.

## WIRELESS SET No. 38 AFV

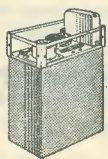

A lightweight walkie-talkie with transmitting range 5 to 10 miles and frequency coverage 7.4 to 9 mc/s. Operates from 12V and 120V external dry batteries. Large, clearly numbered tuning control, with tuning lock. In good condition. ONLY £4 per pair, p/p 5/-.

Postage rates apply U.K. only. S.A.E. with all enquiries  
New walk round store open in Lambert's Arcade, Lower Briggate, Leeds 1, next to Halfords Cycle Shop. Open all day Saturday.  
All mail orders to our Briggate House address.

Terms  
Cash with order  
5/- extra on C.O.D. orders  
No C.O.D. under 30/-



Send 1/- for lists  
Trade supplied  
Orders from  
abroad welcomed

SONA ELECTRONIC CO (DEPT RC5) BRIGGATE HOUSE, 13 ALBION PL. LEEDS 1.

# HOME RADIO OF MITCHAM

We are not averse to blowing our own trumpet, but we are delighted when our customers kindly blow it for us! Below are just a few of the many appreciative letters we have recently received.



Dear Sir, H.A. Somerset.

I recently wrote to you regarding your catalogue. It arrived the following day having crossed in the post with my letter. I wish to say it was well worth waiting for - in fact it is the best general list I have seen.

J.T.P. Notts.

Sir,

I must thank you for a real catalogue which I received on the 26th. inst. it is a pleasure to look through.

A.V.M. Bristol.

Dear Sir,

I thank you for your excellent catalogue and hope to do business with you.

V.S. Derbyshire.

Dear Sir,

Congratulations on compiling such a varied interesting and helpful catalogue. Please send me two more.

D.S. Essex.

Dear Sir

Many thanks for your catalogue.

C.L. Cornwall.

Dear Sir,

Thank you for your very fine catalogue received to-day.

D.C. Kent.

Dear Sir.

Your catalogue, just received is a wonderful document and I shall be making much use of it.

B.B.E. London W.12.

Dear Sir,

Please find enclosed 6/- for your catalogue. A friend of mine here has got one and we've agreed it is the best we've ever seen in this country!!!

W.H.T. Warwickshire.

Dear Sir,

Thanks for your wonderful catalogue just received. I shall be ordering I hope many items.

R.G. Cheshire.

Dear Sir,

Your catalogue is now to hand. Many thanks for it. Many congratulations on a well laid out and interesting book.

Please write your Name and Address in block capitals

Name .....

Address .....

Home Radio Ltd., Dept. RC, 187 London Road, Mitcham, Surrey

Send today for our Catalogue (5/- plus 1/- postage & packing) and we are sure you will agree with the sentiments expressed above. The Catalogue contains five Coupons, each worth 1/- when used as directed. Send the attached coupon today, enclosing a cheque or P.O. for 6/-.



# THE Radio Constructor



Incorporating THE RADIO AMATEUR

**JULY 1965**

Vol. 18, No. 12  
Published Monthly  
(1st of month)

*Editorial and  
Advertising Offices*  
57 MAIDA VALE LONDON W9

*Telephone*  
CUNningham 6141

*Telegrams*  
Databux, London

First Published  
1947

Transistorised Multi-Range D.C. Voltmeter, <i>by A. Foord, Grad.I.E.R.E.</i>	802
Radio Waves Power Helicopters, <i>by M. J. Darby</i>	804
Combined Torch and Leakage/Continuity Tester (Suggested Circuit No. 176), <i>by G. A. French</i>	805
Can Anyone Help?	806
2-Valve, 4-Stage Receiver for the Beginner, <i>by E. Govier</i>	807
Radio Topics, <i>by Recorder</i>	814
High Gain Composite Transistors—Facts and Figures on the “Super Alpha Pair”, <i>by J. B. Dance, M.Sc.</i>	816
In Your Workshop	818
An Electronic Tachometer, <i>by John G. Dew, B.Sc.</i>	826
Club Events	828
Understanding Radio, <i>by W. G. Morley</i>	829
20 Semi-Conductor Questions	835
R.E.C.M.F. 1965 Exhibition	836
Simple Valve Heater Tester, <i>by P. Butler, A.M.I.P.R.E.</i>	838
Simple Transistorised Short Wave Converters, <i>by A. S. Carpenter, A.M.I.P.R.E.</i>	839
Recent Publications	844
Lasers, Part 2, The Types of Laser, <i>by J. B. Dance, M.Sc.</i>	845
Index Volume 18, August 1964–July 1965	861

© Data Publications Ltd., 1965. Contents may only be reproduced after obtaining prior permission from the Editor. Short abstracts or references are allowable provided acknowledgement of source is given.

Annual Subscription 33s. (U.S.A. and Canada \$5) including postage. Remittances should be made payable to “Data Publications Ltd”. Overseas readers please pay by cheque or International Money Order.

Published in Great Britain by the Proprietors and Publishers Data Publications Ltd. 57 Maida Vale London W9  
Printed by A. Quick & Co. (Printers) Ltd. Oxford Road Clacton-on-Sea England

# TRANSISTORISED MULTI-RANGE D.C. VOLTMETER

By A. FOORD, Grad. I.E.R.E.



A portable d.c. voltmeter with an input resistance of  $1M\Omega$  per volt and f.s.d.'s of 1 volt, 5 volts, 10 volts and 50 volts

NOW THAT INEXPENSIVE SILICON TRANSISTORS ARE readily available, collector currents in the order of tens of microamps are often encountered in transistorised equipment. Conventional multi-range voltmeters may consume  $100\mu A$  or more, whereupon voltage measurements in these low current circuits become impossible. The multi-range meter to be described here employs a tran-

istorised amplifier to obtain an input resistance of  $1M\Omega$  per volt. Since this voltmeter only requires  $1\mu A$  for full-scale deflection it can be used with low current circuits without adversely affecting their functioning.

## Circuit Operation

The circuit of the instrument is shown in Fig. 1.

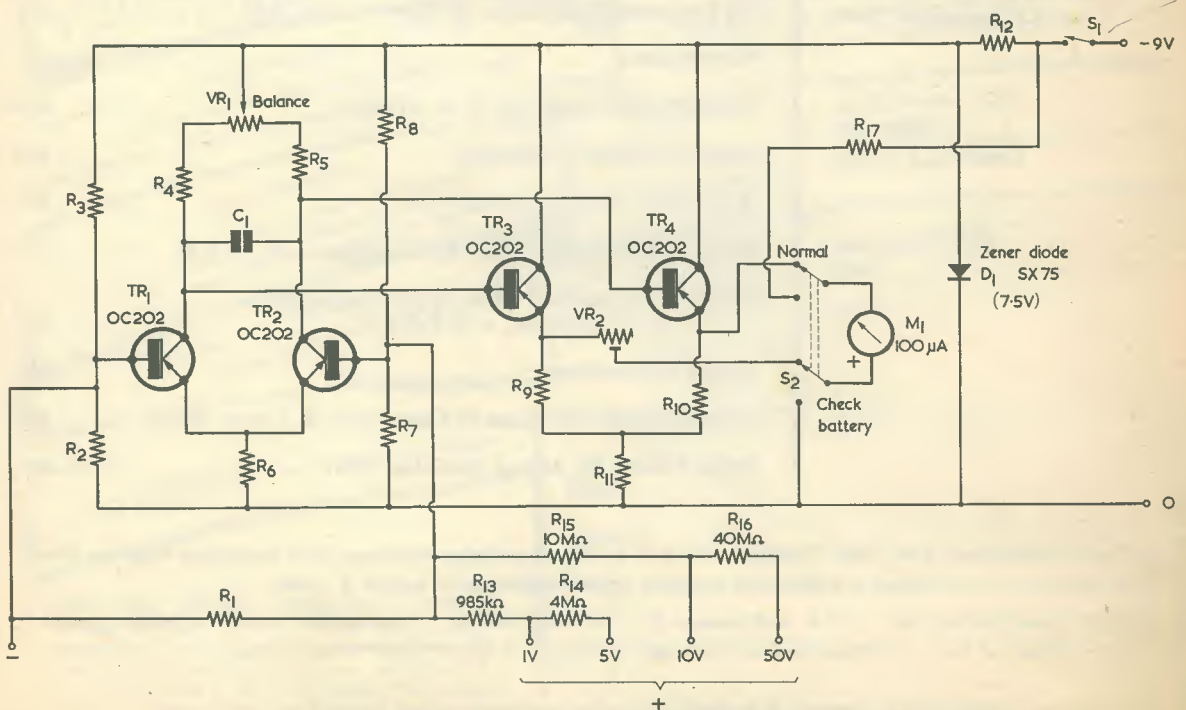

Fig. 1. The circuit of the transistorised multi-range voltmeter



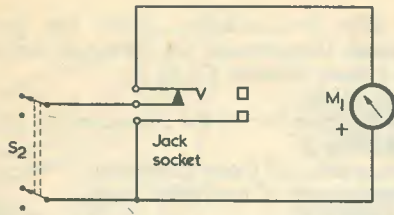

Fig. 2. If so desired, a jack can be added to the circuit of Fig. 1 between  $S_2$  and the meter. This allows direct connection to be made to the meter movement for current readings

### Components List (Fig. 1)

#### Resistors

(All fixed values  $\frac{1}{4}$  watt high-stability unless otherwise stated)

- R<sub>1</sub> 27k $\Omega$  5%
- R<sub>2</sub> 100k $\Omega$  2%
- R<sub>3</sub> 270k $\Omega$  2%
- R<sub>4,5</sub> 33k $\Omega$  5%
- R<sub>6</sub> 10k $\Omega$  5%
- R<sub>7</sub> 100k $\Omega$  2%
- R<sub>8</sub> 270k $\Omega$  2%
- R<sub>9,10</sub> 3.3k $\Omega$  5%
- R<sub>11</sub> 4.7k $\Omega$  5%
- R<sub>12</sub> 560 $\Omega$  10% carbon
- R<sub>13</sub> 75k $\Omega$ +910k $\Omega$  1%
- R<sub>14</sub> 3.9M $\Omega$ +100k $\Omega$  1%
- R<sub>15</sub> 10M $\Omega$  1%
- R<sub>16</sub> 39M $\Omega$ +1M $\Omega$  1% (see text)
- R<sub>17</sub> 100k $\Omega$  2% (see text)
- VR<sub>1</sub> 10k $\Omega$  wirewound
- VR<sub>2</sub> 5k $\Omega$  carbon

#### Capacitor

- C<sub>1</sub> 0.1 $\mu$ F paper

#### Transistors

- TR<sub>1</sub> OC202 { matched at 50 $\mu$ A collector current
- TR<sub>2</sub> OC202 { (see text)
- TR<sub>3,4</sub> OC202

#### Diode

- D<sub>1</sub> 7.5V zener diode, type SX75

#### Meter

- M<sub>1</sub> 100 $\mu$ A

#### Switches

- S<sub>1</sub> Single pole on/off
- S<sub>2</sub> 2-pole, 2-way

#### Battery

- 9V

#### Socket

- Jack, with break contacts (Fig. 2)—optional

#### Miscellaneous

- Tagboard, knob, input sockets, leads, case

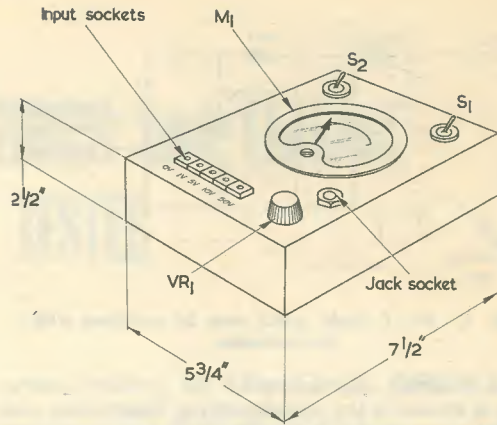

Fig. 3. External layout and dimensions of the author's prototype

It has a 100 $\mu$ A output meter, and consumes 2.7mA from a 9 volt battery. The first two transistors form a long-tailed pair amplifier. These transistors should preferably be matched, although the Balance Control, VR<sub>1</sub>, gives a wide balance range. In theory there should be two balance controls, one for an open-circuit balance and one for a short-circuit balance. Since, however, the value of R<sub>1</sub> is much less than the lowest multiplier resistor (R<sub>13</sub>) the amplifier is effectively short-circuited (from the balance point of view) whether the meter leads are open-circuited or short-circuited. This enables one balance control to be used. The input transistors feed emitter-followers TR<sub>3</sub> and TR<sub>4</sub>, which then drive the 100 $\mu$ A meter.

#### Construction and Component Details

The construction of the instrument is straightforward and Fig. 3 shows the panel layout of the author's prototype. The jack socket on the front panel gives direct access to the 100 $\mu$ A meter, so that the meter is available for other purposes. For simplicity this socket is not shown in Fig. 1, the appropriate detail being given in Fig. 2.

S<sub>1</sub> connects the internal battery supply, whilst S<sub>2</sub> connects the meter to the battery (via R<sub>17</sub>) to check the battery voltage. Since R<sub>17</sub> has a value of 100k $\Omega$  the meter will read 0-10V in the "Check Battery" position. It is assumed that the meter resistance may be neglected in comparison with R<sub>17</sub> but, if such is not the case, the value of R<sub>17</sub> should be reduced to cater for the meter resistance. To avoid zero drift due to differential temperature changes, TR<sub>1</sub> and TR<sub>2</sub> should be secured to a single small heat sink. R<sub>13</sub> to R<sub>16</sub> are the multiplier resistors, at 1M $\Omega$  per volt, R<sub>13</sub> being reduced from 1M $\Omega$  to 985k $\Omega$  to allow for the amplifier input resistance. R<sub>13</sub>, R<sub>14</sub> and R<sub>16</sub> are each made up from two resistors in series, and R<sub>16</sub> could be 20+20M $\Omega$  instead of the values shown in the Components List. The amplifier input resistance is neglected on the 10 and 50 volt ranges.

The meter employed in the author's version was a 3 $\frac{1}{2}$ in type.

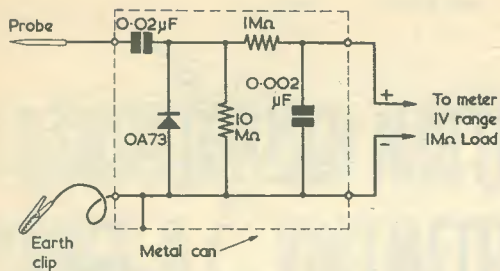

Fig. 4. An r.f. probe which may be employed with the voltmeter

The external appearance of the author's instrument is shown in the accompanying illustration, and it will be seen that it is possible to give the voltmeter a very neat finish.

#### Calibration

The instrument is calibrated by setting the zero with the Balance Control, VR<sub>1</sub>, then connecting to a known voltage and adjusting VR<sub>2</sub> until the meter reads this value. To minimise errors due to the meter movement itself, calibration should preferably be carried out with a voltage corresponding to approximately half-scale deflection in the meter. If a dry battery is used as a reference (say 6 volts on the 0-10V range) the battery should be loaded by a resistor drawing a few milliamps in order to give its correct p.d.

#### Accuracy and Drift

The instrument was switched on and the zero

adjusted after five minutes. After one hour at normal room temperature the zero had drifted by less than 1 scale division (2μA).

The maximum error of the instrument is ±2.5%.

This is given by:

Maximum error of meter movement	= ±1.0%
Maximum error of multiplier resistors	.. .. . = ±1.0%
Maximum error due to non-linearity of amplifier	.. .. . = ±0.5%

The author checked his instrument over the four ranges and found that readings fell within the maximum error figure expected.

#### Adding an R.F. Probe

If desired, an r.f. probe may be employed with the instrument, and a suggested circuit with component values is shown in Fig. 4.

This utilises a shunt diode rectifier and associated components, and gives an indication of r.f. voltage. The components can be built in the form of a shielded probe on the end of a flexible cable. This arrangement should theoretically indicate the peak value of the applied r.f., but since it is usual to measure low r.f. voltages (less than 5 volts peak-to-peak) the characteristics of the diode can result in low readings. Nevertheless, the adaptor will still give an *indication* of the presence of r.f., which can be a valuable guide. An input of 3 volts peak-to-peak gives a d.c. output of 0.5 volts at frequencies between 1Mc/s and over 50Mc/s. A usable indication is given up to 100Mc/s.

## RADIO WAVES POWER HELICOPTERS

By M. J. DARBY

One normally assumes that radio waves carry a very small amount of power when they reach a receiving aerial—perhaps less than a nanowatt. At first sight it would therefore appear ridiculous to suggest that they could provide the power necessary to fly a helicopter.

However in a public demonstration the Raytheon Company of America have recently shown that a six foot model helicopter can be made to climb to a height of fifty feet using only the microwave power picked up by its aerials. About five kilowatts of microwave power were focused by a mirror on to the model helicopter which contained thousands of small diodes to rectify the current in its aerials. The direct current thus provided was used to power a motor which turned the rotor blades.

#### Future Work

It is intended that this experiment will only be the first step in developing helicopters which are powered by microwaves beamed at them from the ground. It is hoped that in the fairly near future it will prove possible to employ powers of some hundreds of kilowatts to keep a helicopter stationary at a height of some miles for very long periods of time. Such vehicles of the future are likely to be much more complicated than the simple model used in the demonstration. Beam riding techniques can be used to keep the helicopter in the microwave beam.

#### Uses

It is suggested that such helicopter devices could be used as television relay stations, navigational aids, weather stations, aviation beacons, etc. However they may also have applications in the military field, for example in missile detection systems. Helicopters are, of course, especially suitable for this type of work, since they can remain stationary relative to the earth. If the same technique were used to power an aeroplane, the direction of the beam would have to be changed as the aeroplane moved along.



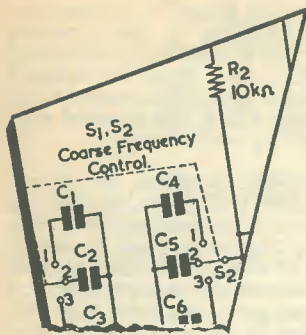

# COMBINED TORCH and LEAKAGE CONTINUITY TESTER

SUGGESTED CIRCUIT No. 176

By G. A. FRENCH

AS MOST READERS WHO HAVE HAD the experience of probing around inside ill-lit television receiver cabinets will agree, one of the more useful items of test equipment for TV servicing away from the bench is a small electric torch! This being so, it occurred to the writer that, at little extra expense, a torch could be constructed which also allowed simple continuity and insulation tests to be carried out.

This month's "Suggested Circuit" is the result of the writer's investigations and the complete device consists of a battery, an on-off switch and a bulb—as would be required for the torch proper—together with two small transistors and four test sockets. As may be gathered, the whole unit may be assembled in a small case taking up negligibly more space than would be required by the battery, switch and bulb on their own. In consequence, the unit can be slipped into the pocket for any service job that may be required, and is much more robust than an instrument incorporating a meter.

Despite its simplicity, the tester described here is capable of quite comprehensive continuity and insulation checks, positive indications being given, with the prototype circuit, for leakage resistances up to half a megohm. The prototype employed transistors which happened to be at hand and which were chosen at random, and it is probable that a higher sensitivity could be achieved with transistors selected for gain.

## The Circuit

The circuit of the unit accompanies this article. As may be seen, it is extremely simple and requires a bare minimum of components. TR<sub>1</sub> is connected as an emitter-follower directly coupled to the base of TR<sub>2</sub>. TR<sub>2</sub> is also an emitter-follower, its

load being the bulb. The latter is a Radiospares 6V 0.06A pilot light.

To make continuity or leakage checks, the instrument is first switched on, and a pair of test leads inserted into the Common socket and one of the three Range sockets. For low resistance continuity checks the Range 1 socket is used, whereupon the test prods merely complete the circuit between the negative terminal of the battery and the lamp. When the test prods connect across a low resistance the lamp lights. On Range 2 the lamp lights when the resistance between the test prods ranges from zero to an intermediate value, whilst on Range 3 the lamp lights when the resistance between the test prods ranges from zero to a high value. With the prototype circuit, Range 2 caused useful indications to be given for resistances up to 15kΩ whilst Range 3 allowed useful indications to be given for resistances up to 500kΩ.

The reason for the increased sensitivity on Ranges 2 and 3 is that

the resistance presented to the test sockets causes current to flow in the base circuit of the appropriate transistor. On Range 2 this current is amplified by transistor TR<sub>2</sub>, whilst on Range 3 it is amplified by transistor TR<sub>1</sub> as well as by TR<sub>2</sub>.

If it is desired to use the unit as a torch the switch is closed and a short-circuit placed across the common socket and any of the Range sockets. In practice even this step is not necessary, since the lamp will light at nearly full brilliance when a finger or thumb of one hand (moistened if necessary) is placed across the Common and Range 3 sockets. Such a facility can be readily achieved by fitting test sockets without insulating bushes and by mounting the Common and Range 3 sockets close together.

## Components

As was mentioned earlier, the sensitivity of the unit on Ranges 2 and 3 depends upon the gain of the transistors used. The writer

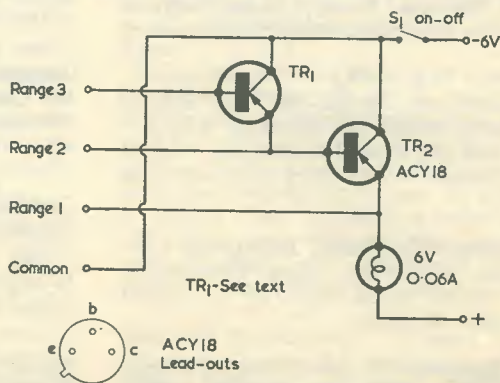

The circuit of the combined torch and leakage/continuity tester. With the transistors employed in the prototype circuit, the sensitivity was sufficient to enable leakage resistances up to 500kΩ to be indicated. Selected transistors could provide an even higher sensitivity

employed an ACY18 in the TR<sub>2</sub> position, this being a small transistor which is capable of dissipating sufficient power to operate the bulb. Maximum dissipation in TR<sub>2</sub> occurs at half-voltage, when 3 volts appears across it and across the bulb. The measured resistance of the particular bulb employed by the writer at 3 volts was 85Ω, so that the power it dissipates at this voltage is, from

$$\frac{E^2}{R}, \text{ slightly in excess of } 100\text{mW.}$$

The same power is dissipated in the transistor and is comfortably below its maximum rating, at 25°C of 240mW. Any other transistor having a suitable dissipation figure and a reasonable gain could be employed in the TR<sub>2</sub> position.

The requirements for TR<sub>1</sub> are even less critical and any small transistor having adequate gain can be fitted. In the prototype, the writer used an

OC44 chosen at random.

The 6 volt battery needed for the unit depends upon the requirements of the constructor. Since the current consumption of the bulb is low, quite a long life can be anticipated from cells of the "Penlight" type and four of these could be incorporated into a case of attractively small dimensions.

#### Results With the Prototype

After the prototype circuit had been completed, sensitivity measurements were taken. Maximum sensitivity figures were taken for 2 volts across the lamp, this corresponding to an obviously visible indication. With the particular transistors employed, these were 170Ω for Range 1, 15kΩ for Range 2, and 500kΩ for Range 3. Nearly full brilliance (4.5 volts across the lamp) was given by 33Ω on Range 1, 3kΩ on Range 2 and 100kΩ on Range 3.

When the Range 2 socket was connected directly to the Common socket, the potential drop across TR<sub>2</sub> was 0.3 volts. When the Range 3 socket was similarly connected to the Common socket, the potential drop across TR<sub>2</sub> was 0.45 volts.

The light provided by the 6V 0.06A bulb is of course less than that offered by a conventional torch bulb, as may be expected from its wattage rating of 0.36, as compared with the 0.75 watts of, for example, a 2.5 volt 0.3 amp bulb. However, the illumination it provides is quite adequate, particularly if a small reflector is provided. Slightly increased brilliance could be given by adding a further cell, making the battery voltage 7.5, and by inserting a 10Ω ¼ watt resistor in one of the supply leads. This will, of course, cause the bulb to be slightly overrun when a new battery is fitted.

## CAN ANYONE HELP?

*Requests for information are inserted in this feature free of charge, subject to space being available. Users of this service undertake to acknowledge all letters, etc., received and to reimburse all reasonable expenses incurred by correspondents. Circuits, manuals, service sheets, etc., lent by readers must be returned in good condition within a reasonable period of time*

**R1155A Receiver.**—R. E. Fields, 49 Torkington Road, Gatley, Cheadle, Cheshire—circuit and details of a mains power pack.

\* \* \*

**62A Indicator Unit.**—A. G. Millar, 45 Tankerland Road, Glasgow, S.4—details of conversion to an oscilloscope.

\* \* \*

**Decca 300 Stereo Radiogram.**—R. F. Hills, Arnside, 29 Elms Road, Harrow Weald, Middx.—circuit diagram and service data, particularly f.m. alignment data.

\* \* \*

**"Transivox" Electronic Organ.**—A. G. Roche, 1c Artillery Place, Woolwich, London, S.E.18—circuit diagram and any other information. Copies of *The Radio Constructor* featuring this unit now out of print.

\* \* \*

**Pye 39J/H Receiver.**—D. Walsh, Ballylynch, Carrick-on-Suir, Co. Tipperary, Eire—information on modifying for 10 metre amateur band and B.B.C. TV sound frequency.

\* \* \*

**18 Set Mk. III Receiver.**—T. Lever, Hope Cottage, Fovant, Nr. Salisbury, Wilts.—conversion details to extend present coverage (6 to 9 Mc/s) to other frequency bands, also details of suitable power unit.

**BC357M Receiver.**—D. Trigg, 43 The Normans, Slough, Bucks.—any information, circuit diagram, etc.

\* \* \*

**Tannoy 50/75 Watt P.A. No. T6.**—F. Miles, Cross Road, Shrewley, Warwick—information regarding voltage at input terminals, transistor pre-amp for moving coil or crystal microphone into existing mic-transformer, impedance and line voltage at output terminals.

\* \* \*

**Azimuth Indicator Unit Type 1D-260/GRO.**—H. Cowburn, 37 Westbourne Grove, Harpurhey, Manchester, 9—any information on this ex-U.S.A.F. equipment.

\* \* \*

**Oscilloscope No. 11.**—F. D. Trevarthen, 116 Pleasant View, Bridgehill, Consett, Co. Durham—circuit diagram and any details for increasing timebase range of this equipment (A.A. Predictor Mk. I O.S.1879GA).

\* \* \*

**Circuit Diagrams.**—C. W. Riley, 9 Ashley Walk, R.A.F., Boscombe Down, Amesbury, Wilts.—"Truchord" radiogram, Philips B2X98A/70R v.h.f. receiver and Ferguson 208UL receiver, loan or purchase.



# 2-Valve, 4-Stage Receiver for the Beginner

By E. GOVIER

*The design offered here, which is intended specifically for the beginner, provides a simple and inexpensive receiver in which maximum performance has been achieved over the long, medium and short wave ranges from only two valves. It could equally well serve as a standby receiver for the "shack" or as a workshop set. Construction and wiring-up are fully described. A separate power supply is required for the receiver*

THE RECEIVER DESIGN DESCRIBED HERE COULD WELL prove of interest to the beginner who has already constructed a one- or two-valve mains operated set. The type of two-valve set generally constructed is of the double-triode and output pentode variety with the first half of the double-triode acting as detector, the second half as the first audio frequency amplifier, and the pentode as the output valve. Such a design is, of course, admirable. However, like another favourite two-valve design—employing a single triode and output pentode—it suffers from two major defects which soon become apparent to the operator.

Probably the greater of these defects is the appearance of "dead spots", these referring to certain portions of the receiver coverage at which effective reaction cannot be achieved. Such "dead spots" are, more often than not, caused by the damping effect of the aerial itself, particularly when it is tightly coupled to the tuned circuit. One method of combating this trouble is to insert a variable capacitor in series with the aerial input, but this is an additional control which should not be necessary in the first place. It can also result in poor sensitivity at the points where the variable capacitor has to be reduced in value to obtain adequate reaction. A second defect is that when the reaction control is advanced into oscillation (as when receiving c.w.) radiation occurs causing interference with other nearby receivers. This effect can be particularly annoying if it takes place over the long and medium wavebands. In passing, it may interest beginners to know that, in the early years of broadcasting, the B.B.C. very often made appeals to listeners to avoid their receivers oscillating.

Both of these defects can easily be avoided by including an r.f. stage between the detector and aerial input, this acting as a buffer between them. The simplest buffer is an untuned r.f. stage and it is this type which is employed in the present design. Such a stage is simple to construct, but it provides relatively little gain. On the other hand it obviates "dead spots", prevents the radiation of oscillations and, in addition, frees the detector from the effects of changing aerial constants which may make frequency calibration unreliable.

## Circuit

The circuit is shown in Fig. 1 and it will be seen that it consists of two valves—an ECF82 triode-pentode and an ECL83 triode-output pentode—both of these being B9A based types.

The circuit of Fig. 1 is reproduced here in white against a black background, the reason for this being that the beginner may "black-out" the various connections as they are made and described in the text with the aid of a ball-point pen. In this manner, it will considerably assist the beginner to become familiar with the process of translating a circuit diagram into actual connections and components.

The first stage of the receiver utilises the pentode section of the ECF82 ( $V_{1(a)}$ ) as the untuned r.f. buffer, whilst the second stage brings the triode portion of the valve into circuit as the detector. The third stage employs the triode section of the ECL83, this being the first audio (voltage) amplifying stage. Finally, the pentode section of the the ECL83 serves as the power output stage. We have, therefore, a four stage receiver employing only two actual valves.

The aerial signal is fed via  $C_{14}$  to the grid of  $V_{1(a)}$ ,  $R_2$  being the grid leak. Cathode bias is given by  $R_3$  and  $C_3$  whilst  $R_1$  and  $C_1$  provide the screen-grid supply.  $R_4$  and the r.f.c. form the anode load, an r.f. coupling being given by  $C_2$  to the following stage.

$V_{1(b)}$  operates as a leaky-grid detector, h.t. being fed to the anode (pin 1) via the resistors  $R_5$ ,  $R_6$  and the coil primary winding (pins 8 and 9). The variable capacitor  $C_4$  controls the amount of positive feedback necessary for reaction, whilst the component values for  $C_7$  and  $R_7$  have been chosen to ensure that reaction is obtained free from "backlash" (i.e. different settings in  $C_4$  for the commencement and cessation of oscillation). The applied anode voltage also assists in this respect.

The coil secondary winding (pins 1 and 6) are tuned to the required frequency by the variable capacitor  $C_5$  and the fixed value capacitor  $C_T$  in series, together with the parallel bandspread capacitor  $C_6$ . The fixed value capacitor  $C_T$  has been included in the circuit by virtue of the fact that with the coils used (see below and in the Components

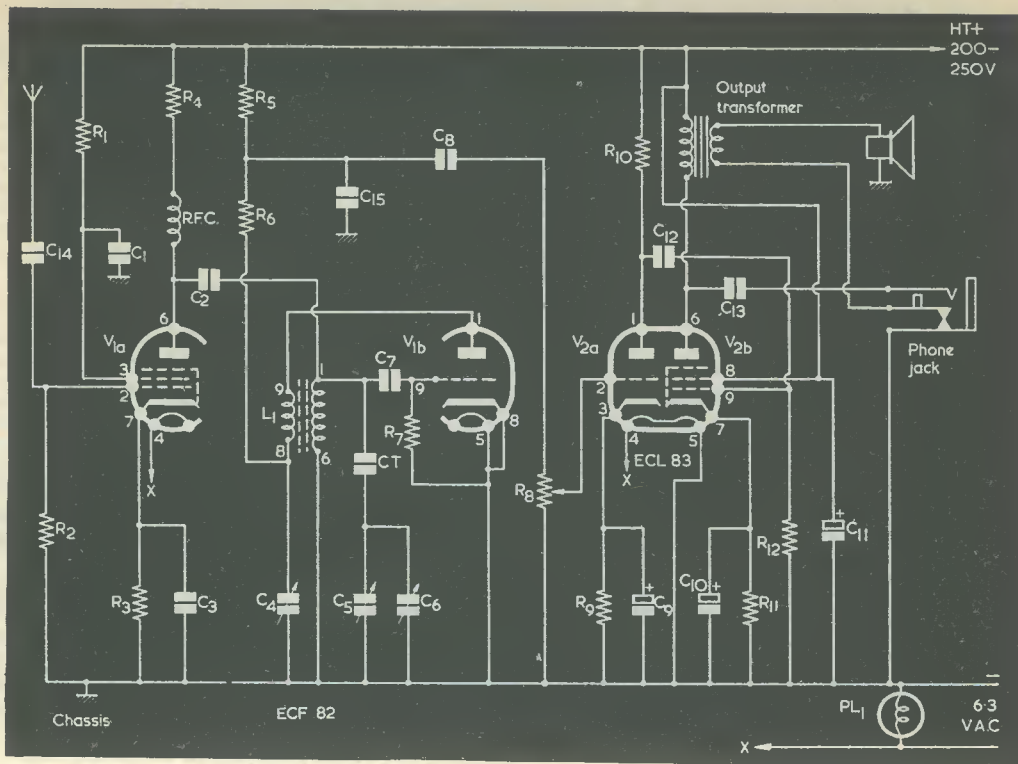

Fig. 1. The circuit of the 2-valve, 4-stage receiver

List) a total tuning capacitance "swing" of 310pF is required in order to obtain the stated frequency coverage as indicated in Table I. As this capacitance value in a single-gang variable capacitor may be rather difficult to obtain, and especially as a panel mounted component, a 500pF component was utilised (C<sub>5</sub>). This is brought close to the required capacitance value by inserting the series capacitor C<sub>T</sub> with its value of 1,000pF. The total capacitance swing is thus, with C<sub>6</sub>, brought to approximately the desired figure of 310pF. For those who already possess a 310pF component, this should be used in the C<sub>5</sub> position and C<sub>T</sub> dispensed with. C<sub>5</sub> and C<sub>6</sub> then connect directly across pins 1 and 6 of the coil.

The coils used are Denco Miniature Dual-Purpose types in the Yellow range. If coils 1 to 5 are obtained, a wavelength coverage of about 9 to 2,000 metres will result. The coils are of the plug-in type and the need for bandswitching, together with its attendant complication of switch wiring, has been

eliminated, thus ensuring considerable simplicity of design.

The detected and amplified a.f. voltage at the anode of V<sub>1(b)</sub> is fed, via coupling capacitor C<sub>8</sub>, to the grid of the following valve (pin 2 of V<sub>2(a)</sub>) after the required audio input has been tapped off by the slider of the volume control, R<sub>8</sub>.

V<sub>2(a)</sub> is the first audio amplifying stage, and R<sub>9</sub> and C<sub>9</sub> provide cathode bias for this portion of the valve. Resistor R<sub>10</sub> is the anode load and the amplified audio signal is passed through coupling capacitor C<sub>12</sub> to the grid of the following stage, V<sub>2(b)</sub>.

V<sub>2(b)</sub> is a power output pentode, C<sub>10</sub> and R<sub>11</sub> providing the required cathode bias. The anode connects to the primary of the output transformer, the secondary of which is connected, on one side, to the speaker direct and, on the other, to the headphone jack.

When the phone plug is withdrawn from the jack, the output transformer couples direct to the speaker. Once the headphone plug is inserted, however, the circuit to the speaker is automatically broken, and an output is provided to the headphones via capacitor C<sub>13</sub>. It will be noted from the circuit that one side of the speaker is permanently connected direct to chassis.

No power supply components are shown in Fig. 1 as the writer favours a separate power pack constructed on its own chassis rather than one incorporated integrally with the receiver. In this manner,

TABLE I

Coil Range	* Frequency/Wavelength Coverage	
	Metres	Mc/s
1	750-2,000	0.150- 0.400
2	194- 580	0.515- 1.550
3	57- 180	1.670- 5.300
4	20- 60	5.000-15.000
5	9- 28	10.500-31.500

\* With 310pF "Swing"



## Components List

### Resistors

(All fixed values  $\frac{1}{2}$  watt 10%)

R <sub>1</sub>	68k $\Omega$
R <sub>2</sub>	1M $\Omega$
R <sub>3</sub>	470 $\Omega$
R <sub>4</sub>	5k $\Omega$
R <sub>5</sub>	68k $\Omega$
R <sub>6</sub>	22k $\Omega$
R <sub>7</sub>	3.3M $\Omega$
R <sub>8</sub>	500k $\Omega$ pot, log track
R <sub>9</sub>	1.8k $\Omega$
R <sub>10</sub>	100k $\Omega$
R <sub>11</sub>	470 $\Omega$
R <sub>12</sub>	220k $\Omega$

### RFC

2.6mH (Denco type RFC5)

### Capacitors

C <sub>1</sub>	0.01 $\mu$ F tubular
C <sub>2</sub>	47pF silver mica
C <sub>3</sub>	0.01 $\mu$ F tubular
C <sub>4</sub>	500pF variable, mica dielectric (Denco)
C <sub>5</sub>	310 or 500pF variable, air-spaced (see text)
C <sub>6</sub>	25pF variable (Jackson Bros. type C804)
C <sub>7</sub>	47pF silver mica
C <sub>8</sub>	0.01 $\mu$ F tubular
C <sub>9</sub>	10 $\mu$ F electrolytic, 12V wkg.
C <sub>10</sub>	25 $\mu$ F electrolytic, 25V wkg.
C <sub>11</sub>	16 $\mu$ F electrolytic, 350V wkg.
C <sub>12</sub>	0.01 $\mu$ F tubular
C <sub>13</sub>	0.1 $\mu$ F tubular
C <sub>14</sub>	200pF silver mica or ceramic
C <sub>15</sub>	500pF silver mica or ceramic
C <sub>T</sub>	1,000pF silver mica (see text)

### Chassis and Panel

H. L. Smith & Co. Ltd.

### Speaker

3 $\Omega$  7 x 5in elliptical

### Phone Jack

Igranic

### Pilot Lamp Assembly

6.3V, 0.3A, red, complete with bulb (H. L. Smith & Co. Ltd.)

### Miscellaneous

Nuts, bolts, 4-way tagstrips, 3 off (see text), etc.

### Valves

V <sub>1</sub>	ECF82 (Mullard)
V <sub>2</sub>	ECL83 (Mullard)

### Coils

Denco Miniature Dual-purpose, Yellow Range, 1 to 5 (see text)

### Output Transformer

Type 117E (H. L. Smith & Co. Ltd.)

### Bandset and Bandsread Dials (2)

Scale Ball Drives (Jackson Bros. type 4489)

### Valveholders

B9A 3 required, with centre spigots

### Sockets

Aerial/Earth socket, speaker output socket—see Fig. 2 (b)

induced 50 c/s a.c. mains hum is reduced and undesirable couplings eliminated. A number of suitable circuits have appeared in this magazine, either as separate entities or as integral parts of other designs, and a circuit which will give adequate

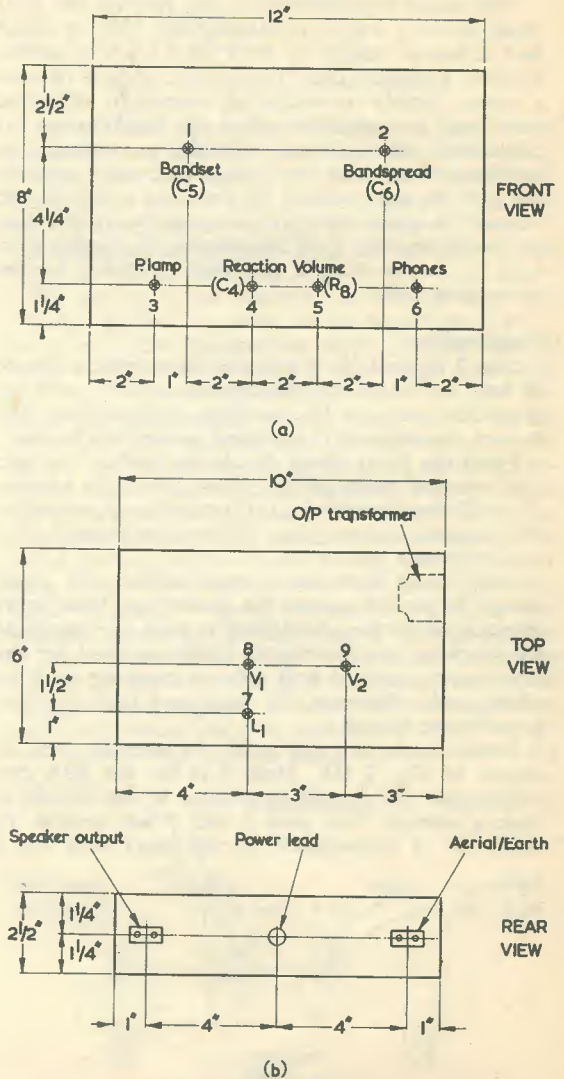

Fig. 2 (a). Panel details showing the position of the various controls and the indicator lamp  
(b). Chassis details. Note that the output transformer is mounted below the chassis

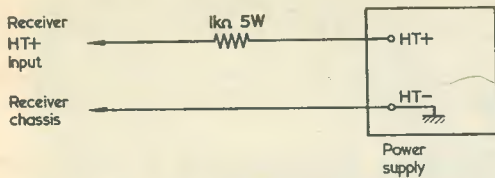

Fig. 3. A simple method of providing additional smoothing, if required

results is shown in Fig. 12. It is most important to note that the power supply used *must* have a double-wound mains transformer providing *complete* isolation from the mains.

The power requirements of this receiver are quite small and any supply producing 200–250V at 55mA and a heater supply of 6.3V at 1.5A will suffice. Ensure, however, that the rectified output of such a power supply is adequately smoothed otherwise hum may be apparent when the headphones are connected into circuit. Should a.c. ripple be apparent when using the headphones, extra smoothing may be incorporated by inserting a  $1k\Omega$  5 watt resistor in series with the h.t. positive connection, as shown in Fig. 3. This resistor, in combination with  $C_{11}$  in the receiver, will then provide a further smoothing filter.

### Construction

Fig. 2 (a) and (b) shows the measurement details of both the panel and the chassis, together with the positions occupied by the main components. The output transformer is mounted *under* the chassis.

First, the front panel should be marked out and the required holes drilled, these being (1) bandset ( $C_5$ ); (2) bandspread ( $C_6$ ); (3) pilot lamp assembly; (4) reaction control ( $C_4$ ); (5) volume control ( $R_8$ ) and (6) phone jack.

Once these holes have been drilled, the panel should be placed against the chassis and held firmly in place whilst the panel itself is used as a template for marking out the chassis holes required for the pilot lamp, reaction and volume controls, and the phone jack.

Remove the panel and drill the four holes in the chassis. Next, mark out and drill the chassis deck as shown in Fig. 2 (b). Hole 7 is for the B9A coil holder and this should be secured to the chassis in such a manner that pins 1 and 9 are nearest  $V_1$  (hole No. 8 immediately to the rear) with pin 8

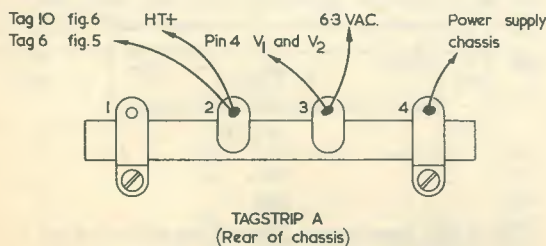

Fig. 4. Wiring-up details of tagstrip A. The h.t. + and 6.3V a.c. leads come from the power supply

nearest to the  $C_4$  position. When mounting  $V_1$  and  $V_2$  valveholders and the coilholder to the chassis, ensure that a chassis tag is fitted under one of the holding nuts of each so that chassis connections may be made to these respective points. (See Figs. 7, 8 and 9.) Orient  $V_1$  valveholder such that pins 1 and 9 are nearest to the coilholder and  $V_2$  valveholder (hole No. 9) such that pin 2 is nearest the volume control  $R_8$ . Both  $V_1$  and  $V_2$  valveholders are B9A.

Follow this by drilling one  $\frac{1}{4}$ in hole just below, and to one side, of  $C_5$ , this hole being fitted with a suitably sized grommet. This hole will later take the connection from  $C_5$  and  $C_6$ , above the chassis, to the appropriate coilholder tag below the chassis.

Place the output transformer against the chassis wall, where shown in Fig. 2 but on the *outside* of the chassis, mark the four holes for the fixing feet, and drill the chassis. Note here that the transformer will, of course be mounted inside the chassis, but that for marking purposes it is much easier to use the component itself as a template on the outside.

At the rear of the chassis, mark out (using the Paxolin socket strips as templates) the aerial/earth input and the speaker output tags respectively, as shown in Fig. 2 (b). Also, holes for the mounting bolts. This diagram also shows a central rubber grommetted hole for the power input lead from the separate power supply, which hole should now also be drilled.

Returning to the chassis itself, provision should now be made for drilling and fitting into position three 4-way tagstrips, to which will be soldered the various components, etc. These tagstrips should be mounted near to, and at the rear of (1)  $V_1$  valveholder, (2) at the rear of  $V_2$  valveholder and (3) slightly forward of the power input hole at the rear of the chassis. All tagstrips are parallel with the 10in sides of the chassis, and all should have end tags earthed (i.e. suitable for mounting purposes).

Secure the various panel mounted components in the positions as shown in Fig. 2 (a), these effectively securing the chassis to the panel. Secure also all the other components for which holes have been drilled.

### Wiring-up the Receiver

All the wiring in this receiver should be as short and direct as possible and no effort should be made to "pretty-up" the wiring. Many of the components will be soldered direct from the tagstrips. The respective tagstrips have been labelled A, B and C, and these are shown in Figs. 4, 5 and 6. That of Fig. 4 (A) is the power input strip; that of Fig. 5 (B) is the  $V_1$  tagstrip, and that of Fig. 6 (C) is that associated with  $V_2$ .

Note that the wiring drawings are shown in "exploded" form for purposes of clarity and that, in fact, the wiring should be much more compact than is illustrated.

Commence by wiring-up tagstrip A as shown in Fig. 4, feeding the power input wires (ensuring that these are of adequate length to reach from the power supply) through the rubber grommet mounted on



the rear of the chassis. It is helpful here, before proceeding further, to employ a colour scheme with coloured p.v.c. covered wire, adopting (say) red for h.t. positive; blue for heater and black for chassis (this latter connection also providing h.t. negative and the chassis side of the heater connections). Adopting a colour scheme is of assistance both with respect to wiring-up and to any later fault-finding which may be required; and the following instructions assume that the colours just mentioned are employed.

Insert the respective bare wire ends through the tagstrip holes as shown in Fig. 4 and ensure that a sound mechanical joint is made by bending over the wire ends and crimping them to the tags with a pair of pliers, but do not solder as yet. Place the red h.t. positive wire through tag 2, the blue 6.3V a.c. wire through tag 3 and the black chassis wire through tag 4. Take a further length of red and blue wire, bare one end of each, insert the red wire through tag 2 and the blue wire through tag 3, bend over the wires ensuring that neither wire is in contact with an adjacent tag or the chassis, and then solder tags 2, 3 and 4. No further connections are needed from tag 4 of this tagstrip, the required electrical path for the chassis connection being via the metal of the chassis itself.

**TABLE II**  
Resistor Colour Code

R <sub>1</sub>	68kΩ	Blue, grey, orange
R <sub>2</sub>	1MΩ	Brown, black, green
R <sub>3</sub>	470Ω	Yellow, violet, brown
R <sub>4</sub>	5kΩ	Green, black, red
R <sub>5</sub>	68kΩ	Blue, grey, orange
R <sub>6</sub>	22kΩ	Red, red, orange
R <sub>7</sub>	3.3MΩ	Orange, orange, green
R <sub>9</sub>	1kΩ	Brown, black, red
R <sub>10</sub>	100kΩ	Brown, black, yellow
R <sub>11</sub>	470Ω	Yellow, violet, brown
R <sub>12</sub>	220kΩ	Red, red, yellow

The red wire (h.t. positive) should now be taken to tag 6 of tagstrip B and thence to tag 10 of tagstrip C; do not solder as yet. The blue wire (6.3V a.c.) should be taken to pin 4 of V<sub>1</sub>, a further length of blue wire should extend from pin 4 of V<sub>1</sub> to pin 4 of V<sub>2</sub>, this wire being routed well clear of the coilholder and kept close to the chassis. Pin 4 of V<sub>2</sub> should now be soldered.

Refer now to Fig. 5 where the wiring details of tagstrip B are shown. Tags 5 and 8 are, of course, bolted to the chassis and are therefore at chassis potential. To tag 6 secure one end of R<sub>1</sub>, R<sub>4</sub> and R<sub>5</sub> (see Table II) ensuring that the wire ends are clean and that the free wires at the other ends of these components can reach their various destinations. Solder tag 6. Resistor R<sub>5</sub> connects, without soldering, to pin 5 of the coilholder. (This is used as an anchoring tag only, there being no actual connection to the coil itself at this point.) One end

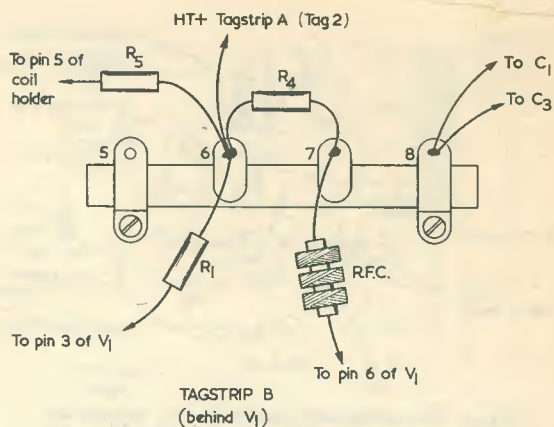

Fig. 5. Wiring-up details of tagstrip B

of R<sub>4</sub> and the r.f.c. are now soldered to tag 7. The connections to tag 8 are described later.

Refer now to tagstrip C, as shown in Fig. 6. Join tags 10 and 11 with bare wire, insert R<sub>10</sub> into tag 10 (already fitted with the red h.t. positive wire) and solder at tag 10 only. The connections to tags 9 and 12 will be dealt with later.

We next turn our attention to the wiring of the valveholder for V<sub>1</sub>, and this is shown in Fig. 7. Here, it is first necessary to obtain a short length of bare wire and connect (by soldering) pin 5 and pin 8 to the central metal spigot as shown, and the spigot tag to the adjacent chassis tag mounted under the valveholder securing nut. Do not solder at the chassis tag. Connect and solder pin 1 of the valveholder to pin 9 of the coilholder (see Fig. 8). Pin 2 of the valveholder should now be connected to C<sub>14</sub> (the other end of which connects and solders to the aerial input socket) and also to one end of R<sub>2</sub>—the other end of which is connected to the chassis tag. Solder at pin 2. One end of both R<sub>1</sub> and C<sub>1</sub> is now soldered to pin 3, the other end of C<sub>1</sub> being taken to tag 8 of tagstrip B (Fig. 5) but do not solder as yet, whilst the other end of R<sub>1</sub> is already connected to tag 6 of tagstrip B. To pin 6 of the valveholder secure and solder the r.f.c. and C<sub>2</sub>. To pin 7 solder one end of both C<sub>3</sub> and R<sub>3</sub>, the other end of the

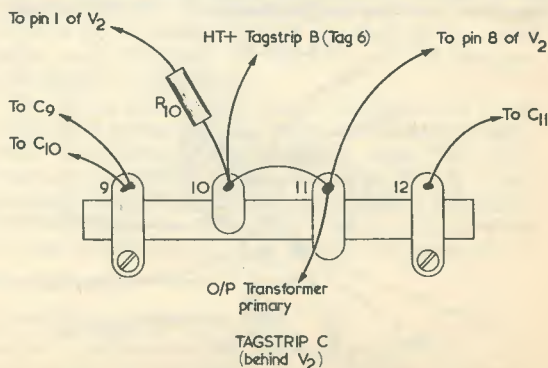

Fig. 6. Wiring-up details of tagstrip C

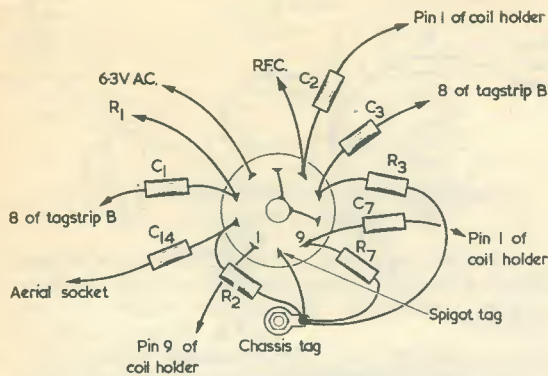

Fig. 7. The connections required to  $V_1$  valveholder. If the valveholder used here (and in Figs. 8 and 9) has no spigot tag, connect the chassis tag to the spigot itself

latter being connected to the chassis tag as shown. The free end of  $C_3$  is soldered to tag 8 of tagstrip B. Pin 9 of the valveholder is now soldered to one end of both  $R_7$  and  $C_7$ , the other end of  $R_7$  being soldered to the chassis tag. The free end of  $C_7$  is, together with the free end of  $C_2$ , connected to pin 1 of the coilholder (see Fig. 8).

The next part of the circuit to be wired is that around the coilholder and this is shown in Fig. 8. Pin 6 should be soldered via a short length of wire to the centre spigot. Pin 8 should be connected to both one end of  $R_6$  and a wire connecting to the fixed vane tag of the reaction control  $C_4$ . The earthed connection of  $C_4$  is automatically made by securing this to the chassis and panel. Solder at  $C_4$  and pin 8. The other end of  $R_6$  should now be connected to pin 5 of the coilholder together with one end of  $C_8$  ( $R_5$  is already connected to this anchoring point). To pin 1 of the coilholder should now be soldered one end of  $C_T$  (see previous remarks) and the other end of this taken, via a short length of wire, through the rubber grommetted hole in the chassis deck, to the fixed vane tag of  $C_5$ . A second wire should be soldered to this latter point, its other end being soldered to the fixed vane tag of  $C_6$ . If  $C_T$  is not required, the connection from pin 1 of the coilholder to  $C_5$ .  $C_6$  should be

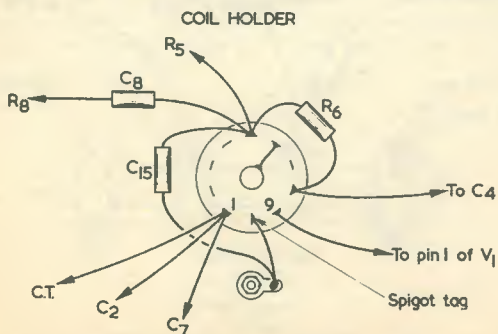

Fig. 8. Coilholder connections

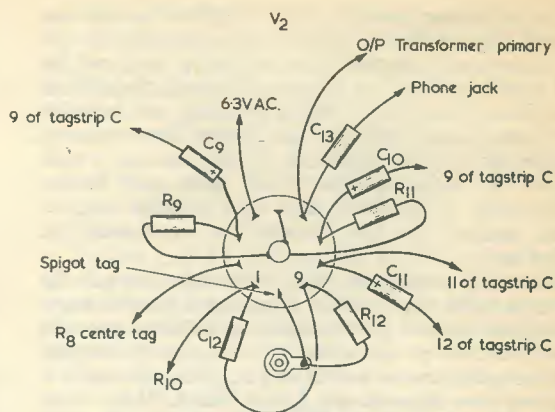

Fig. 9. Valveholder connections

made direct by means of a short length of p.v.c. covered wire. Solder one end of  $C_{15}$  to pin 5 of the coilholder and connect its other end to the chassis tag. Connect the centre spigot tag to this chassis tag and solder both connections.

Having dealt with the coilholder and  $V_1$ , proceed with the wiring for  $V_2$  valveholder. Fig. 9 shows the connections required. Solder a short bare length of wire from pin 5 to the central metal spigot and similarly join the spigot tag to the chassis tag mounted under the adjacent securing nut. Solder all connections except those at the spigot and chassis tag. Secure one end of  $C_{12}$  and the free end of  $R_{10}$  (from tag 10, tagstrip C) to pin 1 of the valveholder and solder. Solder one end of a short length of wire to pin 2, and solder the other end to the centre tag of the volume control  $R_8$  (see Fig. 10). To pin 3 of  $V_2$  solder one end of both  $R_9$  and  $C_9$  (observe polarity). The other end of  $R_9$  is now connected to the metal spigot (chassis) and that of  $C_9$  to tag 9 of tagstrip C. Pins 4 and 5 have already been dealt with. To pin 6 should now be soldered one wire of the output transformer primary (it does not matter which of the two primary wires is used) and one end of  $C_{13}$ . The other end of  $C_{13}$  should then be soldered to the appropriate phone jack tag (see Fig. 11). To pin 7 of  $V_2$  are next soldered one end of both  $C_{10}$  (observe polarity) and  $R_{11}$ , the other end of  $R_{11}$  being connected to the central metal spigot and the other end of  $C_{10}$  soldered to tag 9 of tagstrip C (see Fig. 6). To pin 8 should now be soldered one end of  $C_{11}$  (observe

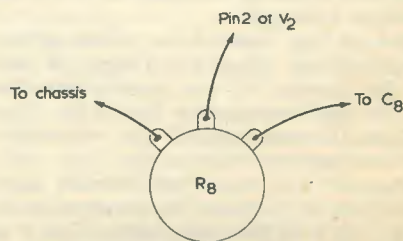

Fig. 10. Connections to the volume control  $R_8$  (rear view of the component)



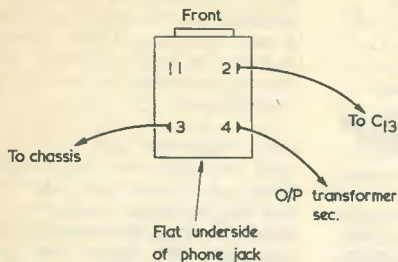

Fig. 11. Phone jack connections

polarity) together with a connecting wire to tag 11 of tagstrip C. The other end of  $C_{11}$  is now soldered to tag 12 of tagstrip C. Pin 9 may now be dealt with by soldering to it one end of  $R_{12}$  and the free end of  $C_{12}$ . Solder the other end of  $R_{12}$  at the chassis tag, and solder all connections to the spigot.

Refer to Fig. 10, which shows the rear view of the volume control. Solder the left hand tag to chassis via a short length of wire, and solder the free end of  $C_8$  to the right hand tag.

Complete the wiring to the phone jack. See Fig. 11, which shows the flat underside of the component with the tags pointing directly uppermost. Tag 1 is left blank; tag 2 has already been dealt with; tag 3 should be soldered via a short length of wire to chassis, and one output transformer secondary wire should be soldered to tag 4. The connections of the output transformer are clearly marked on a card supplied with this component, and it does not matter which way round the primary, or the secondary, windings are connected. Solder the remaining primary wire to tag 11 of tagstrip C.

One tag of the speaker output socket should now be connected to chassis and the other tag of this socket to the remaining output transformer secondary wire.

The pilot lamp assembly should have one tag connected, via a length of blue wire, to the chassis tag associated with  $V_1$ , and the other tag to pin 4 of  $V_1$ . Solder all connections.

The aerial/earth socket strip should now have the earth connection made to chassis (by soldering to the tag mounted under the securing nut of this strip). The wiring of the receiver is now complete.

### Testing the Receiver

If a meter is available ascertain, before connecting the power supply and by means of a continuity reading, that no h.t. short-circuits are present.

The receiver should now be connected to the power supply, the aerial, earth and the speaker. Insert coil number 3 and the two valves into their respective

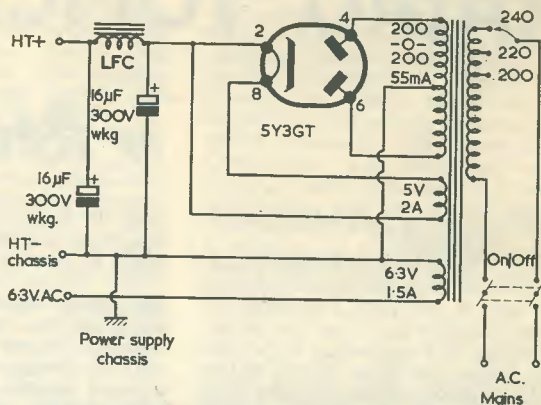

Fig. 12. Circuit of a suitable power supply. The current figures shown against the transformer secondaries are the minimum values required for the receiver. The smoothing choke should have an inductance of the order of 10H

holders and switch on. Set  $C_4$ ,  $C_5$  and  $C_6$  at mid-position and  $R_8$  at near maximum, whereupon signals should be heard. Slowly rotate the reaction control,  $C_4$ , clockwise until a "rushing" or breathing noise is heard, indicating that the set has gone into oscillation. Back-off  $C_4$  and tune the bandspread capacitor  $C_6$  for the desired signal.

### Operating the Receiver

Operating a receiver of this nature, for those who have not previously handled such a set, is largely a matter of continued practice until one becomes familiar with the controls.

The main requirement is to retain the circuit at a point just below the threshold of oscillation, in which condition the set is at its most sensitive. If the reception of c.w. (Morse) is required, then the reaction control must be advanced slightly into oscillation. The reaction control  $C_4$  must be operated "in step" with both the bandset and the bandspread capacitors  $C_5$  and  $C_6$ .

As time proceeds, the beginner will soon learn the bands on which listening should take place at various times of the day. An immediate practical aid will be the calibrating of the dial of  $C_5$ , using graph paper to mark off the various dial readings with respect to frequency.

For those who require further information about short wave operating, the writer recommends *Short Wave Receivers for the Beginner* and *The Radio Amateur Operator's Handbook*, both of which are available direct from the publisher of this magazine. Also available, for those who wish to designate the various panel controls, are Panel Signs transfers.

### International Radio Communications Exhibition

This year the exhibition will be held from 27th to 30th October at the Seymour Hall, Seymour Place, Marble Arch, London, W.1, and will feature design and construction. Ten awards will be presented for the most outstanding home-constructed equipment and the Silver Plaque for 1965 will be won outright.

# RADIO TOPICS . . .

by Recorder

"IT HAS TO BE DRAWN BEFORE IT can be made."

This maxim represents one of the basic differences between building an item of electronic equipment at home and mass-producing it in tens to hundreds of thousands at a factory. The home-constructor obtains all the bits and pieces which will constitute the final item of equipment and works out from these the size of the chassis, sheet of Paxolin or sheet of Veroboard on which they will be fitted. If the equipment is on the large side with, say, a mains transformer, a smoothing choke and large coils, then a metal chassis is called for and can be marked out for holes, after bending, by suitably positioning the components and using these as "templates".

## Mass-Production

An approach of this nature is, of course, perfectly satisfactory for equipment built at home, which falls into the "one-off" category. At the same time it is, obviously, completely out of the question so far as mass-production is concerned. It is with mass-production that the draughtsman comes into the picture and where production is controlled, not by "guesstimates", but by hard, concrete figures recorded on drawings.

There are probably quite a few readers who have not had experience of high pressure production methods. Since this is a very fascinating subject it could well merit some space here, and particularly with respect to the control offered by these mysterious "drawings". Let's, therefore, see how the manufacturer of, for example, a television receiver is carried out, following it through from its introduction to the production line right up to the end of its manufacturing run. The details which follow, I should add, apply mainly to the larger manufacturing companies.

The television receiver whose life we are to follow has, first of all, to be designed, and this is a process which is handled by the Engineering Department of the company concerned. With large companies, it is a common practice to maintain a separate design staff which is isolated

from the hurly-burly of production, and whose engineers carry out their work in relative peace and quiet. Whilst production proceeds with last year's design, these engineers work on next year's receiver. A considerable amount of work goes into the design of the receiver and this will include, when the layout is being worked out, the process of juggling around with the constituent bits and pieces until the best method of getting them to fit together is finally established. Which isn't all that different from the amateur constructor working out his layout at home!

It is when the design is approaching completion that the drawings begin to appear. Every part and sub-assembly which is to be fabricated at the factory has to be drawn up so that the appropriate departments can proceed accordingly. One piece-part for the receiver could, for instance, consist of a small mild steel bracket having a 90° bend and two holes. A very simple component, but it is important that it be made accurately and at low cost. The bracket is drawn up, the drawing is issued, and it is then immediately absorbed into the maw of the tool-making department, who set to work to design the press which will turn it out. Since the piece-part has a bend in it, it is likely that the drawing will show the holes dimensioned from this bend, since this affords a convenient reference point for handling in the press. And, of course, all dimensions on the drawing will be given tolerances, these being of the order, for metalwork, of  $\pm 0.005$ ,  $\pm 0.010$  or  $\pm 0.015$ in, according to the degree of accuracy needed. Incidentally, a tolerance of  $\pm 0.015$ in in work of this nature is considered "wide", a point which makes one think a little when one considers how light-heartedly the chassis dimensions of home-built equipment are tackled!

Other receiver parts made at the factory will include at least some of the coil assemblies, typical examples being the i.f. coils. All these coil assemblies have to be drawn, and the drawings have to define the number of turns, the wire gauge and covering, the dust cores, the formers, and so

on. With some companies, drawings for i.f. transformers also carry test information, such as inductance and Q requirements. Other companies pass on this information in separate instructions issued to the Inspection Department.

## The Components List

At the same time as the drawings appear, a Components List for the receiver is being made up. The sheets of the Components List are issued in the same way as the drawings. Our little right-angled bracket will, of course, be in this Components List, and it will appear alongside the Part Number which has been allotted to it (and which is usually the same as its Drawing Number). A Part Number is essential as, otherwise, the departments responsible for making, storing and getting the bracket to the production line when required would not be able to identify it. The Components List will also state the quantity and type of metal needed for the bracket. This enables yet another department, the Purchasing Department, to obtain quotes on the raw material (in this case mild steel sheet) and get orders placed.

Each i.f. coil will similarly appear, against a Part Number, in the Components List. But since several parts go into the construction of an i.f. coil, this becomes a sub-assembly, whereupon the Components List will include the coil former, the screening can, the coil base (which becomes *another* sub-assembly if it has tags fitted to it at the factory!), the dust core or cores and the winding wire. The latter will be specified by gauge, covering and *weight*. This is because winding wire is always bought by weight, and not by length. The complete Components List will, normally, consist of a number of sheets, each devoted to a particular sub-assembly.

An i.f. coil assembly may also include one or more capacitors and resistors, which are fitted inside the can. These, again, are given Part Numbers and they also appear on drawings. Unless, however, dimensions are important, such drawings will not usually have a "picture", as it were, of the capacitor or resistor on them. Instead, they will merely consist of a description of the capacitor or resistor and a list of acceptable manufacturers and types.

Companies vary according to the material specification which appears on a drawing or which is left in the Components List. During my own factory experience one of the most delightful drawings I ever encountered consisted of a large sheet of



paper, processed through the drawing office duplicating machine in the normal way, which showed nothing else except the typewritten words "MOTH BALLS" in the centre. The reason for this admirably explicit drawing was that the company used moth balls to keep their products dry during despatch, whereupon these had to be given a Part Number and, according to their policy, a drawing. I cannot help but feel that they were a little remiss in omitting to specify ball diameter, but there we are then.

All the examples I've quoted up to now are the "easy" bits of the television receiver. The difficult bits are the really complicated sub-assemblies, such as the line output transformer, the deflection yoke, and the tuner or tuners. Some of these cannot be completely covered by drawings and so special "line samples" are made up for the Production Department to work from.

I should also mention that, whilst all this is going on, one very important drawing has also been issued. This is the drawing which gives the circuit of the receiver!

#### Production Commences

The pace gets faster and faster as the day for commencement of production for the new receiver approaches. This is the time when all the hidden and unexpected snags begin to show up. The tool-maker finds, for instance, that his press isn't working exactly as he predicted, and one of the holes in that little right-angled bracket we mentioned just now is tending to appear several thousandths of an inch outside the tolerance shown on the drawing. Can this be accepted, or shall he have to start all over again? This one is Engineering Department's pigeon, who have a choice of three decisions. Engineering Department can either say that the error is unacceptable, whereupon the tool-maker has to re-design the press. Or they can say that the error is acceptable for a short run of brackets so that receiver production can get started, but that it must be corrected as soon as possible afterwards. Or they can say that the incorrect hole position doesn't matter at all, whereupon a relieved tool-maker can wander off to worry about other things. If the second alternative is chosen, the responsible engineer issues a "Concession Note" which states that the error in the bracket is acceptable for a certain number of brackets only. If the error is of no importance at all the engineer can, instead, issue a "Change Note". In this case the

Change Note will be an instruction to alter the bracket drawing so that the tolerances quoted take in the incorrect dimension which has appeared in practice. The drawing for the bracket is then altered, and is re-issued as Issue No. 2.

The reverse may also happen. After the tool-maker has set up his press so that it produces immaculate brackets, the Engineering Department, having encountered a last-minute snag of their own, may approach him and ask him to move one of the holes!

Comes the day when production starts and the first few receivers begin to flow off the line. This is the acid test, as these receivers all have to be assembled without undue difficulties. Also, when they are complete, they have to work. Which is asking quite a bit, when it is remembered that the Components List for the set may have many hundred individual entries, each of which, from the humblest eyelet and nut and bolt, has to play its part in the completed job. There are bound to be snags and, once again, the Changes and Concessions tend to come thick and fast, to be followed by correspondingly altered new issues of drawings or Components List sheets (should the entries in the latter have to be altered).

If the receiver is a good design it will settle down quite quickly into production. There will still, nevertheless, be Changes and Concessions. It may be found that a small proportion of production receivers are, say, a little "edgy" on picture

height. These are investigated by Engineering Department, who find that too high a value in the vertical oscillator anode load resistor is causing the trouble. Result: a Change Note which slightly alters the value of the resistor or gives it a tighter tolerance. The appropriate Components List sheet and the circuit diagram drawing are altered accordingly, and new issues made. Alternatively, it may be found that a redesign of a certain piece-part gives a small saving in price. Again, a Change Note results.

After the receiver has been in production for some time, reports from the field begin to come in. Some of the larger manufacturers employ representatives whose sole job is to drive around the country, interviewing retailers and finding what complaints they have concerning the manufacturer's products. All these are reported back to the factory and may well result, if of sufficient importance, in further Changes and issues of drawings.

It should be added that, by now, the engineers in the design department will have forgotten all about the present receiver and will be working on the next one to be produced.

#### Post-Production

After a run of, say, a year, it is decided to cease production on the receiver and start all over again on the next design. The pre-production machinery once more gets into operation, the drawings for the new receiver are issued, and the Changes

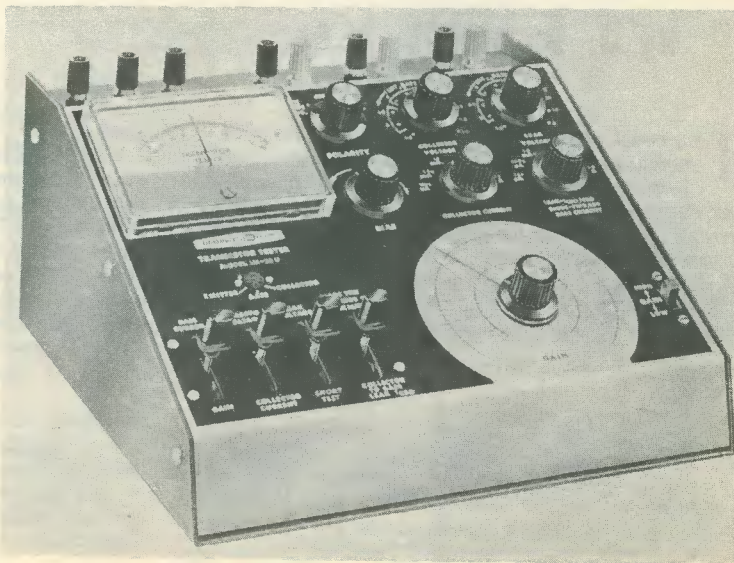

The Heathkit Model IM-30U De-Luxe Laboratory Transistor Tester

and Concessions reappear. In the meantime, the old receiver still presses through production. Finally, the day arrives when the very last solder joint on the very last receiver is made and it passes out through the factory door.

Does this mean that all its drawings and Components List sheets can now be discarded and a giant bonfire made? Not a bit of it! In many cases, some of the components and sub-assemblies will be used again in the new design and so the appropriate paper-work has still to be retained. Also, service replacements may have to be made from time to time.

It is quite possible that, five or more years in the future, service replacements in the field will need a final further manufacture of, say, a hundred of one of the sub-

assemblies peculiar to the receiver. Out will come the old faded drawings and Components List, to be studied by the Production Department. Orders will be placed for the winding wire and components, or whatever other raw materials will be required, and a further batch of the long-forgotten sub-assemblies will be manufactured, tested and despatched. After which the drawings and Components List will be finally returned to the dust of a well-earned retirement.

#### Transistor Tester

Turning from the complexities of modern mass-production to the more homely field of kit construction, the accompanying illustration shows the very impressive appearance of a new product by Daystrom Ltd.

This is the Heathkit De-Luxe Laboratory Transistor Tester Model IM-30U and it offers an exceptionally comprehensive performance at its price. Intended for servicing, design work, inspection or production testing, the Model IM-30U provides test functions which include measurement of base current, gain, collector current, collector voltage, short test, diode or collector-to-emitter leakage, and collector-to-base leakage.

Particular features are the provision of complete d.c. analyses for p.n.p. and n.p.n. transistors, d.c. gain (alpha, beta) read direct on calibrated scales, a 15 $\mu$ A basic range for leakage tests, a large easy-to-read dial, and a comprehensive construction and operation manual.

The price of the model IM-30U transistor tester is £24 18s. as a kit, or £35 10s. assembled.

## HIGH GAIN COMPOSITE TRANSISTORS

### Facts and Figures on the

### "Super Alpha Pair"

By J. B. DANCE, M.Sc.

THE GAIN PROVIDED BY A TRANSISTOR USED AS A small signal audio amplifier is, of course, largely dependent on the common emitter current gain  $\beta$  (or  $\alpha$ ) of the transistor used. A higher overall gain can be obtained by the use of several cascaded amplifier stages, but the simplest method of obtaining a higher gain involves the use of direct coupled transistors, no inter-stage transformers, resistors or capacitors being required.

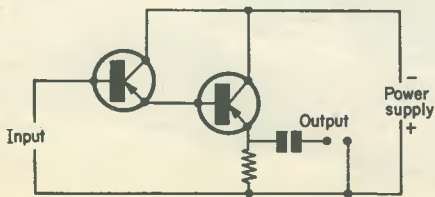

Fig. 1. The "Super Alpha Pair" circuit

#### Gain

One possible circuit, known as a "Super Alpha Pair", is shown in Fig. 1. The two transistors in this circuit may be represented as the composite transistor of Fig. 2. The pair of transistors, when connected as shown, behaves as a single transistor of very high current gain. (Typical figures are 2,000 or more at power supply voltages as low as 1.5.) The transistors are connected as emitter followers

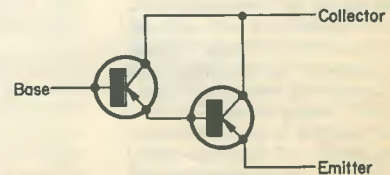

Fig. 2. A composite high gain transistor



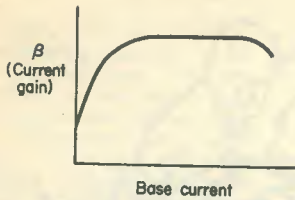

Fig. 3. Variation of current gain with base current in a typical transistor

and therefore the input impedance of the composite device can be very high (typically over  $1M\Omega$ ).

### Leakage Current

The main disadvantage of this type of composite device is that the leakage current may be high, since the second transistor amplifies the leakage current of the input transistor. If the leakage current ( $I_{CEO}$ ) of the input transistor is  $0.1mA$  and the current gain of the second transistor is 100, the current passing through the second transistor will be  $0.1 \times 100 = 10mA$ . Thus the total "leakage" current of the composite device is  $10.1mA$ . This value would almost certainly be unacceptable.

If it is desired to make a composite high gain transistor, it is thus essential that the input transistor should have a very low leakage current. A value of 1 to  $5\mu A$  is satisfactory, since the leakage current of the composite device will then be a few hundred microamps.

The current gain of a typical transistor varies with the base current as shown in Fig. 3. If the circuit of Fig. 1 is being used, there is normally a very small input current and the first transistor will not operate at its maximum gain. This disadvantage can, to

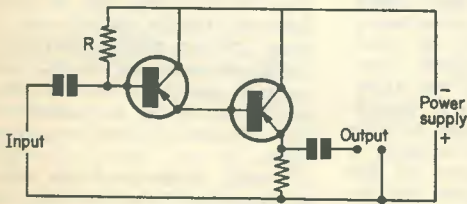

Fig. 4. Biasing the input transistor

some extent, be avoided by the use of the circuit of Fig. 4 in which a high value resistor,  $R$ , allows a small current to flow in the base circuit of the input transistor. This current must be very small (hence  $R$  must be large) or the current flowing in the collector-emitter circuit of the second transistor will be excessive.

It has been suggested\* that a 1N34A diode be used to bypass part of the leakage current of the first transistor. The circuit of the composite unit of two transistors and one diode is shown in Fig. 5. The 1N34A is approximately equivalent to the OA81 or the CV448. These germanium diodes will

\* E. A. McCready, "Build This Composite Transistor", *Radio-Electronics*, November 1962.

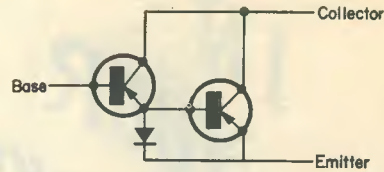

Fig. 5. A composite device comprising two transistors and a diode

only be effective if the transistors are also germanium types.

### Silicon Transistors

The use of silicon transistors in high current gain composite devices is very attractive, since these silicon devices have a much lower leakage current than germanium devices (typically about one millimicroamp). The leakage current of the composite transistor is therefore typically  $0.1\mu A$ . In addition, the use of silicon transistors reduces the possibility of thermal runaway—a risk which is very real when devices with a current gain of some thousands are being used. Special silicon transistors can be designed in which a high value of current gain is maintained at very low values of base current.

Solid State Electronics Corporation manufacture an ultra-high-gain composite transistor (Fig. 6) in which two n.p.n. silicon transistors are put into one normal transistor encapsulation. The current gain exceeds 5,000 over the working range of 1 to 500mA. The collector-emitter maximum voltage rating is 30 volts and the maximum power dissipation 1 watt. The use of silicon transistors in this device results in the wide working temperature range of  $-55^{\circ}C$  to  $+150^{\circ}C$ .

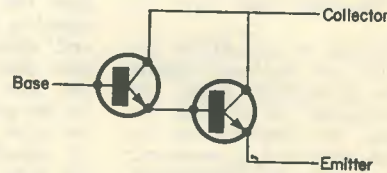

Fig. 6. A composite device using two n.p.n. transistors

### Applications

The manufacturers of this high gain transistor state that its applications include high gain, low level, linear amplifiers of high input impedance, buffer amplifiers and the operation of sensitive switches and relays.

### Acknowledgement

The writer is grateful to the manufacturers of the high gain transistor, Solid State Electronics Corporation of 15321 Rayen Street, Sepulveda, California, for sending him details of this device. It may be obtained from the British agents of this Company, Associated Instrument Marketing Ltd., 22 Charing Cross Road, London, W.C.2.

# IN YOUR WORKSHOP



This month Smithy the Serviceman continues the discussion he started last month and introduces his able assistant, Dick, to some of the further mysteries of the N.T.S.C. colour television system. He goes on to explain the functioning of SECAM and touches also on the subject of PAL.

“COLOUR TELEVISION,” SAID DICK firmly.

“We are not,” replied Smithy with equal firmness, “going to sit around nattering when there’s work to be done.”

Rebelliously, Dick picked up his soldering iron and jabbed it viciously at the loudspeaker tags of the television receiver on his bench.

“Dash it all,” he complained, “it’s been a month since we last had a gen session on colour TV, and you promised that we’d have a second one.”

“I don’t care how long it’s been,” replied Smithy stonily. “Colour television will have to wait.”

This dialogue, it should be explained, did not by any means follow the prescribed form for social intercourse. It is usual for two people in conversation to look at each other and, if necessary, accentuate points by changes of facial expression and by gesticulation. However, the Workshop was going through a period of intense hard work, and the “For Repair” racks groaned under the weight of faulty radios, record players and television receivers. In consequence the Serviceman and his assistant were shackled to their benches by invisible chains as unbreakable as the fetters of the galley slaves who brought Caesar to Miss Elizabeth Taylor. Conversation had, perforce, to be carried out with the participants back to back, phrases had to be flung over the shoulder, and emphasis had to be expressed by such artifices as the banging of one of the long-suffering Workshop soldering irons on its rest.

## Colour Again

“I still,” grumbled Dick, savagely pulling the leads from his loudspeaker, “think that it’s darned unfair. As I said just now, it was a month ago that we had a preliminary session on colour TV, and you haven’t had a dickey-bird to say on the subject ever since.”

“Is it my fault,” queried Smithy, clipping a test lead to the chassis he was repairing, “if we’ve been completely inundated with work since that time?”

“You whet my curiosity,” accused Dick, “by telling me all about hue and saturation, and about how the transmitted chrominance signal is interleaved with the black and white luminance signal. You also show me that, if we apply the R-Y, B-Y and G-Y signals to the grids of the colour cathode ray tube, we only have to apply a -Y signal to the cathodes to get the tube beams modulated by the original red, blue and green signals from the camera.”

Frowning, Smithy concentrated on his testmeter.

“Well?”

“Then,” continued Dick, manoeuvring his television chassis out of its cabinet, “after having whetted my curiosity and get me all agog and avid, you refuse to pass on any further gen whatsoever. So far as I can see, it’s a case of Tantalus all over again!”

Even Smithy’s dedicated mind slipped a groove at this statement. He abandoned his testmeter, stood up and turned round.

“It’s what?”

“A case of Tantalus,” replied Dick, “all over again.”

“What in the world is Tantalus?”

“Tantalus,” explained Dick patronisingly, unaware that the back of his head now bore the full force of Smithy’s scrutiny, “wasn’t a thing. He was a *geyser*. He stood in the water with a bunch of grapes over his head, and when he wanted a drink the water went down and when he reached for a grape the bunch went up.”

“It sounds,” commented Smithy, “rather like the service I get at my club. Anyway, you’d better forget that TV chassis you’re in process of wrecking for a bit, so that we can get this colour TV business finally sorted out. I’ll never get any peace otherwise!”

This time it was Dick’s turn to jump a groove. Startled at this sudden surrender, he turned round, to encounter Smithy’s unexpected gaze.

“Well, blow me,” he snorted indignantly. “Here I’ve been, working full blast all the time, and all you’ve been doing is leaning against the bench just chatting!”

Had Tantalus’s bunch of grapes been above Smithy’s head at that moment, his momentary glance at the ceiling would have shrivelled it to raisins. But there were no grapes, and long experience had enabled Smithy to master his emotions.

“What,” he enquired through clenched teeth, “do you want to talk about first?”

“The chrominance subcarrier,” replied Dick happily. “You told me last month that, with the N.T.S.C. colour system, the chrominance information was transmitted



on a suppressed chrominance sub-carrier."

"That's right," agreed Smithy, gradually recovering himself. "And I'd better remind you that its phase-modulated for hue, and amplitude-modulated for saturation."

"Yes, I remember that bit," replied Dick. "You also said that the suppressed subcarrier has to be reinserted at the receiver. How do you do that?"

"You have a local oscillator in the receiver," explained Smithy, "which is synchronised with the subcarrier at the transmitter by means of the colour burst."

"The colour burst?"

"The colour burst," confirmed Smithy.

He took his stool over to Dick's bench, sat down, and pulled Dick's notepad towards him.

"This colour burst," he went on, sketching out a waveform on Dick's pad (Fig. 1), "consists of about 9 cycles at the subcarrier frequency which is superimposed on the back porch of the line sync pulse from the transmitter. A phase detector at the receiver compares its phase with that from the local oscillator, and develops a correcting voltage which ensures that the oscillator has a fixed phase relationship with the burst."

"But how can it do this," queried Dick, "if the colour burst is only sent out for a short period after each line?"

"You use rather the same sort of technique," said Smithy, once more drawing out a sketch on Dick's pad (Fig. 2), "as you have in flywheel sync systems. But before explaining this, I'd better fill in a bit of background about the receiver itself. In the colour television receiver the luminance signal and the chrominance signal go all the way through the tuner, the i.f. stages and the vision detector. After the vision detector we can start to pick off the various colour signals, and this is usually done after passing through a video amplifier stage. The complete signal is applied to a colour burst amplifier. This may be just a common-or-garden pentode, and a gating signal is passed to it from the line output stage which causes it to be switched on only during the duration of the back porch. Since, at that time, only the colour burst is being transmitted, this is the only signal which it applies to the following stage. The following stage is the phase detector itself. The phase detector compares the phase of the colour burst signal with the phase of the frequency generated by the local

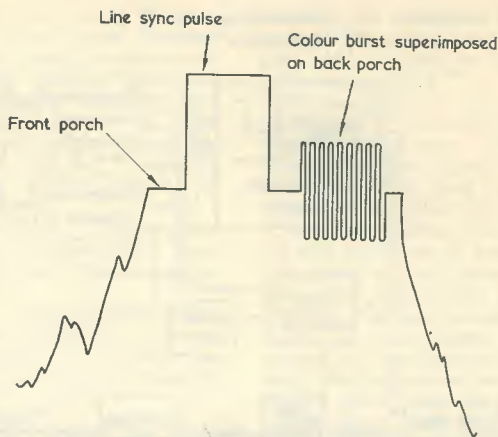

Fig. 1. With the N.T.S.C. colour television system, a colour burst for synchronising the reference oscillator in the receiver is superimposed on the back porch of the line sync pulse

oscillator and, if these do not have the desired phase relationship, it develops a correcting voltage. This voltage is passed, by way of an R.C. filter which gives a slight time delay, to a reactance valve controlling the local oscillator."

#### Flywheel Effect

"What do you want a time delay for?"

"To give you the flywheel effect," replied Smithy. "The correcting voltage is generated only during the line back porch but it couldn't be applied *direct* to the reactance valve, which requires a much steadier voltage. So you feed it through an R.C. filter which has a

time constant equivalent to about fifty lines or so. Thus, there is a smooth control voltage for the reactance valve. As I mentioned just now, the idea is the same as you have with flywheel line sync. With flywheel sync you compare the transmitted line sync pulse with the locally generated line sawtooth, obtaining a correction voltage when these have the wrong phase relationship. This correction voltage is fed, via a time delay filter which gives the flywheel effect, to a circuit which controls the local line oscillator, this being done either by way of a reactance valve or by such methods as varying the voltage applied to the oscillator grid leak.

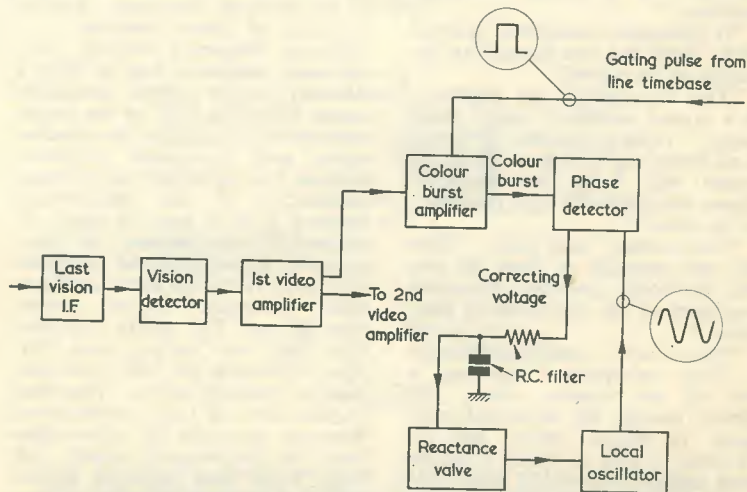

Fig. 2. Block diagram showing how the local oscillator is locked to the transmitted colour burst. It is assumed that the colour receiver has two video amplifiers, as shown in Fig. 3)

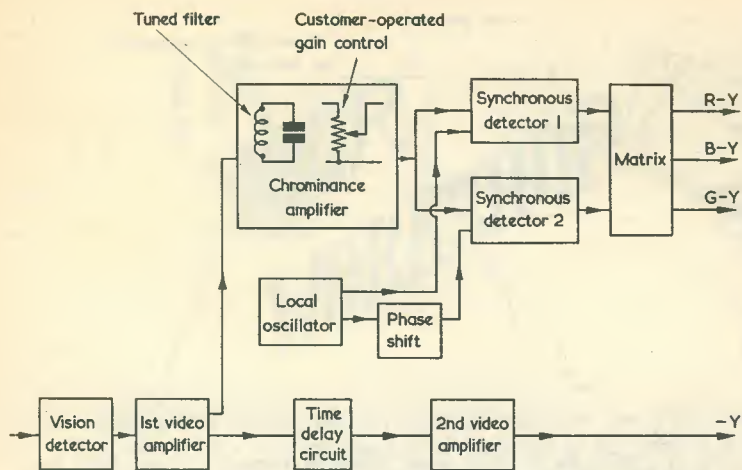

Fig. 3. Reclaiming the R-Y, B-Y and G-Y signals from the chrominance signal in an N.T.S.C. receiver. The tuned circuit shown in the chrominance amplifier block indicates that this employs tuned filters which select the band occupied by the chrominance sidebands from the full video bandwidth. The potentiometer in this block indicates that the chrominance amplifier has a customer-operated gain control. The R-Y, B-Y, G-Y and -Y signals are applied to the colour cathode ray tube

When correctly set up, the flywheel line sync circuit locks in solid, as you know. The same happens with the local oscillator which provides the chrominance subcarrier. When this is correctly set up, it locks in solid with the transmitted colour burst signals and gives the desired phase relationship.

"What form does the local oscillator take?"

"It will almost inevitably," said Smyth, "be a crystal controlled oscillator."

"It it's crystal controlled," queried Dick, "how can you change its frequency or its phase?"

"You can change the frequency of a crystal oscillator over a small range," replied Smyth. "Which is all that's required here, since the crystal will bring the oscillator almost exactly to the right frequency on its own."

"Fair enough," said Dick. "Now the next question is, how do you add the locally generated subcarrier frequency to the chrominance sidebands?"

"We are now," commented Smyth a little unhappily, "entering a part of the receiver which, I'm afraid, cannot be explained very easily in simple terms, and so I'll have to stick to block diagrams once more. I'm afraid, also, that we might have to skate over the surface a little as well, since the circuits involved are ones you won't be familiar with from normal TV work, and a full explanation

of their functioning would take far too long. Anyway, let's have a bash at it!"

Smyth scribbled once more on Dick's notepad, and a second block diagram began to take shape.

"The first thing to point out," continued Smyth, "is that the missing subcarrier isn't just added to the chrominance sidebands to make a complete signal. You have, instead, a different scheme which employs what are known as synchronous detectors. Applied to each of these detectors is a reference frequency derived from the local oscillator, and it offers a detected output whose amplitude varies according both to the amplitude modulation on the chrominance signal and the phase difference between that signal and the reference frequency. If the synchronous detector is of a type in which 0° phase difference between the chrominance signal and the reference frequency from the local oscillator offers maximum detected output, then 90° and 270° phase difference will offer zero output, and 180° phase difference will offer maximum *negative* detected output. You need at least two of these synchronous detectors to extract the information from the chrominance signal, and these work from reference signals having a phase difference between them."

Smyth paused, whilst he put the finishing touches to his diagram. (Fig. 3).

"Now all this sounds pretty complicated," he carried on, "but I should add that the circuits actually employed in N.T.S.C. colour receivers are fairly simple so far as the number of components is concerned. You start off by taking out the chrominance subcarrier sidebands from the detected video signal by picking them off at a convenient point after the vision detector. This point could, in practice, be after the first video amplifier. The chrominance signal then goes through an amplifier having tuned circuits which pass this signal only and reject the rest of the video signal. As I told you last month, the chrominance signal only takes up part of the full video bandwidth sent out by the transmitter. The amplified chrominance sidebands next pass into two synchronous detectors, these receiving a reference frequency from the local oscillator. The reference frequencies have different phases, due to a phase shift circuit following the local oscillator, so that the detector outputs correspond to what I could call a 'sampling' of the chrominance signal at two different phase angles. It is possible, by taking suitable proportions of these two signals, to finally obtain the R-Y, B-Y and G-Y signals, and this combining process is carried out in a matrix."

"Blimey," commented Dick. "All this is a bit *deep*, isn't it?"

"Yes, it is," admitted Smyth. "But don't forget that what you're trying to extract from the chrominance signal is two items of information, these being firstly its amplitude and secondly its phase. One synchronous detector on its own would merely give an output which told you what was happening relative to its particular reference frequency phase. A second synchronous detector with a reference frequency of different phase will similarly tell you what is happening relative to the *second* reference frequency phase. But if you now *combine* the two detector outputs together you can find out what is happening at any phase you desire. To take a simple example, let's say that one synchronous detector offers maximum positive output at a particular signal phase which we will call 0°, and that another offers maximum positive output for 90° phase shift from this point (Fig. 4 (a)). Let's assume that we want to find the amplitude of the phase-modulated input signal at 45°, which is half-way between the two. One very simple method of doing this will be to join the two detector outputs by two equal-value



resistors and take our  $45^\circ$  output from their junction (Fig. 4 (b)). The output will then be equivalent to the vector sum of the two detector outputs. In this simple example we have obtained an output corresponding to a particular phase angle by means of a simple resistive network following two synchronous detectors. I told you last month that, without indulging in over-simplification, the basic modulation signals for the chrominance subcarrier are the B-Y and R-Y signals. There are, in fact, two particular chrominance subcarrier phases which correspond to the R-Y and B-Y signals themselves and these can be reclaimed, after the synchronous detectors, by a resistive combining circuit in the same manner as I obtained the  $45^\circ$  signal just now. Indeed, if the reference frequencies from the local oscillator have the requisite phase, the outputs from the synchronous detectors can be the R-Y and B-Y signals themselves!

Smithy paused for a moment. "Now I don't," he went on, "want to go into further detail now, as all this is intended to give you an overall idea of how the colour demodulation part of the receiver functions, and it isn't meant to be a full description of how the individual circuits work. If you want to find out about the latter you couldn't do better than consult J. R. Davies's book *Understanding Television*, which devotes 78 full pages to colour TV including, in particular, the chrominance subcarrier and the manner in which it is modulated and demodulated.\* Returning to our block diagram, the outputs from the synchronous detectors are applied to a matrix which combines them in the required proportions needed to give the R-Y, B-Y and G-Y signals. The matrix here is just another name for a combining network, and it can add the signals by means of simple resistive networks. Also, valves can be incorporated as well if a bit of amplification or a phase reversal is required. The R-Y, B-Y and G-Y signals are then fed to the grids of the colour tube, as we saw last month."

#### Hue Control

"I see," remarked Dick, "that the luminance signal is fed through a time delay. What's that for?"

"It's to ensure," said Smithy, "that the Y signal arrives at the

cathode ray tube at exactly the same instant as the colour signals. Because the latter pass through tuned circuits having a fairly narrow bandwidth in the chrominance amplifier they become slightly delayed in time. The delay is only slight—somewhat less than  $1\mu\text{S}$ —and the Y signal is delayed by a similar amount to make up for it."

"You've shown," commented Dick, "a customer-operated gain control in the chrominance amplifier."

"That's right," said Smithy. "This is the colour saturation control. Increase gain and you increase the saturation of the colours reproduced by the tube."

"Just like that?"

"Just like that," confirmed Smithy. "Increasing the gain of the chrominance amplifier increases the amplitude of the signals passed to the synchronous detectors."

"Well," remarked Dick, "I think

I've got the basic idea of how this part of the colour receiver works. This phase demodulation is a bit of a business, isn't it?"

"It is difficult," agreed Smithy. "However, if you start off at block diagram level you will get less confused when, later, you start examining what goes on inside the blocks. The layout I've shown you is quite representative of the colour TV sets produced in America at the time being, and any major variations will occur around the synchronous detector and matrix sections. You might, in some cases, have three instead of two synchronous detectors. But there's one very important point I haven't mentioned yet."

"Oh yes," said Dick, "what's that?"

"It's the hue control," replied Smithy. "Since the hue information in the N.T.S.C. system is carried by phase modulation of the chrominance subcarrier, it follows that any

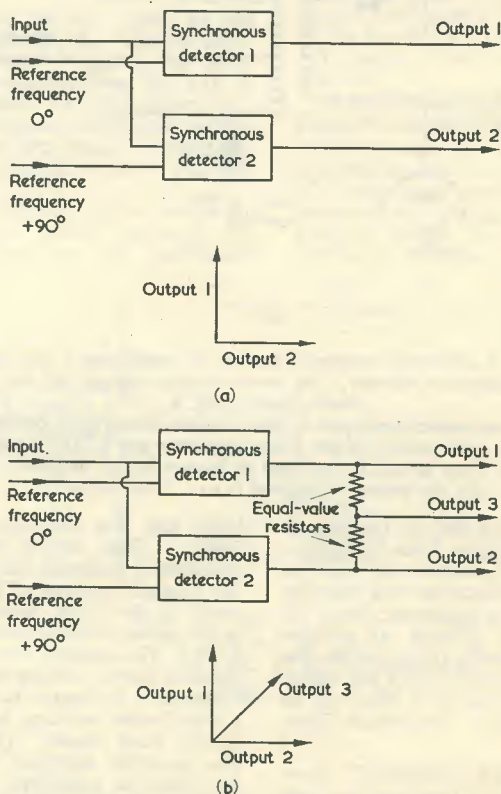
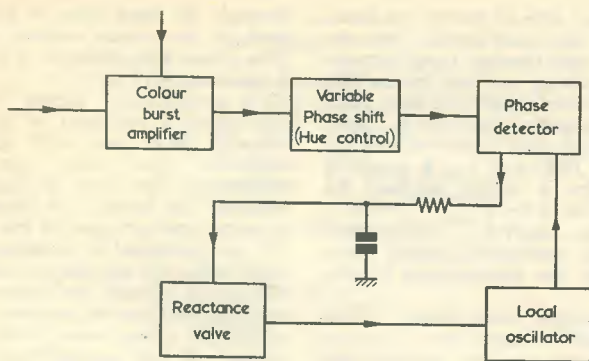
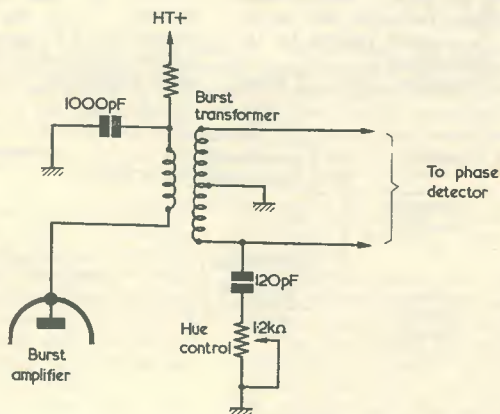

Fig. 4. A simple illustration of the fact that an output corresponding to any phase of a phase-modulated signal may be obtained from two synchronous detectors by combining together suitable proportions of their outputs. In (a) the synchronous detectors detect on phases  $90^\circ$  apart. In (b) an output corresponding to  $45^\circ$  is obtained by combining equal quantities of the outputs from the two detectors

\* *Understanding Television* is available from any bookseller, or may be ordered direct from Data Publications Ltd., 57 Maida Vale, London, W.9, at 37s. 6d., plus 2s. postage.—EDITOR.



(a)



(b)

Fig. 5 (a). A commonly employed method of introducing a hue control to the colour television receiver. The blocks in this diagram are the same as those shown in Fig. 2

(b). The components employed in the variable phase shift control of (a) may consist, quite simply, of the 120pF capacitor and 1.2kΩ potentiometer shown here. (This circuit is employed in current R.C.A. receivers, in which the hue control is referred to as a "tint control")

accidental phase shift in the overall transmitting system from the studio camera to the receiver will result in the receiver cathode ray tube showing pictures having incorrect hue. In practice it is difficult to prevent small phase shifts occurring in the system, particularly when the signal has to travel over long distances as occurs with a networked programme."

"That sounds awkward," commented Dick. "How do you get around it?"

"You get over the snag," replied Smithy, "by fitting a customer-operated hue control to the receiver. This provides a control of the phase relationship between the local oscilator and the transmitted colour burst. One simple method of obtaining a variable hue control at the receiver consists of altering the phase of the colour burst signal fed to the phase detector circuits. (Fig. 5 (a).) The control circuit may, in practice, simply consist of a pot and a capacitor connected to one end of a transformer winding handling the colour burst signal. (Fig. 5 (b).) The customer operates this control for what he considers to be best colour, but he may have to readjust it if he switches to another transmitter, or there is a change in networking. As I understand it, receiver hue controls don't need much adjustment these days, because most of the phase shift bugs on the

transmission side have been cleared out."

"Hasn't there been," asked Dick, "quite a bit of fuss recently over that hue control?"

"There has," agreed Smithy. "The alternative systems, SECAM and PAL, don't need a receiver hue control, and this has been put up as a considerable advantage for these systems."

### SECAM

"I wonder," said Dick, "how they managed to get rid of the hue control with SECAM, for instance."

"With the SECAM system," replied Smithy, "it's done by putting out the colour information in a way which is different from that employed in the N.T.S.C. system, and which completely eradicates the dependence on phase. In point of fact, SECAM is really a development from the N.T.S.C. system. I should add, by the way, that the basic operation of a SECAM receiver is quite simple to understand."

"Good show," pronounced Dick. "I'm prepared to start understanding it from this very moment!"

"Fair enough," chuckled Smithy. "Well, I'd better start off with the way SECAM is transmitted. The SECAM colour signal employs, first of all, a luminance signal which is made up, at the transmitting end, from the requisite proportions of red, blue and green, in just the same manner as occurs with N.T.S.C. Also similar to N.T.S.C. is the fact that this signal is sent out over the full video bandwidth of the transmitter in exactly the same way as a black and white signal."

"There are," commented Dick, "no changes so far."

"None at all," agreed Smithy. "SECAM also has a chrominance subcarrier which is situated some way from the main vision carrier in exactly the same way as is the chrominance subcarrier in N.T.S.C."

"Fine," said Dick. "Everything still carries on as before!"

"We come now," commented Smithy, "to the first difference."

"I thought," grunted Dick, "that things were going a bit too easy!"

"This difference," continued Smithy, ignoring Dick's comment, "is that the colour subcarrier is neither amplitude-modulated nor phase-modulated. It's frequency-modulated."

"Is it?" queried Dick. "Then how do you get both the hue and saturation signals on to it?"

"You don't," replied Smithy. "Or at least you don't at any one particular time. Please allow me to elucidate."



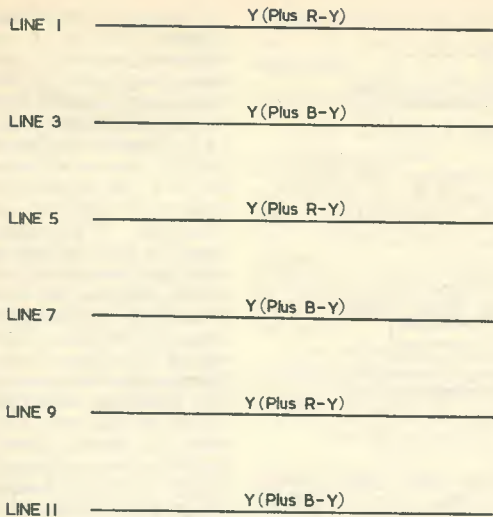

Fig. 6. In the transmitted SECAM signal, alternate lines carry R-Y and B-Y information

"Pray do."  
 "The colour information," continued Smyth, "is transmitted by frequency-modulating the subcarrier with the R-Y signal on one line and by frequency-modulating the subcarrier with the B-Y signal on the next line. To give you an example, let's start at the first line in one of the fields transmitted in the SECAM system. This line is transmitted with the luminance, Y, information on it. It also has the chrominance subcarrier which is frequency-modulated by the R-Y signal. (Fig. 6.) The next line is No. 3, and . . ."

"Hey," interrupted Dick, "hang on a minute! What's happened to line No. 2?"

"We're dealing," said Smyth, "with a normal television system in which two interlaced fields make up a picture. Because of this, line No. 2 is in the succeeding field, and the next line in our present field is line No. 3. Got it?"

"Oh, I see," said Dick. "Yes, I get what you mean, now."

"Good," commented Smyth. "Now, line No. 1 has gone out with Y and R-Y information on it. During line No. 3, the subcarrier is frequency-modulated by the B-Y signal, and this line goes out with Y and B-Y information on it. The following line in the field under consideration is No. 5, and the subcarrier modulation reverts to the R-Y signal. So line No. 5 is transmitted in the same way as line No. 1, and it carries Y and R-Y information. The next line, No. 7, goes back to B-Y, and it has Y and B-Y

information on it. And so the sequence carries on. All lines carry the luminance Y signal, and they change alternately from the R-Y to the B-Y signal and back again."

"What happens when you come to the end of the field," asked Dick, "and go into the vertical blanking period?"

"The switching process carries on regardless," replied Smyth, "although there are, of course, no

actual colour signals being sent out during vertical blanking. Every time you come to the end of a line period, you switch from an R-Y modulating input to a B-Y modulating input, or vice versa."

"Fair enough," said Dick. "Now what happens at the receiving end?"

"To explain this," said Smyth, "I have to fall back on the old block diagrams again. Although you'll find these quite a bit easier to digest than those showing the phase circuits in the N.T.S.C. receiver."

Smyth once more applied himself to Dick's notepad. (Fig. 7.)

"We begin," he announced after a moment, "with the signal which appears after the vision detector. This has the Y signal on it, together with the chrominance subcarrier frequency-modulated by either the R-Y or the B-Y signal. These signals could now go through a video amplifier, if desired, or they can be dealt with at vision detector level. At any event we take off the Y signal, pass it through a Y amplifier, if needed, and apply it to the cathodes of the colour cathode ray tube as a -Y signal. Just the same as in N.T.S.C."

"Right," said Dick. "Now, what about the chrominance signal?"

"This passes into a tuned filter," said Smyth, "which passes the band of frequencies occupied by the chrominance signal only. This, again, is similar to N.T.S.C. The output of the filter consists of the

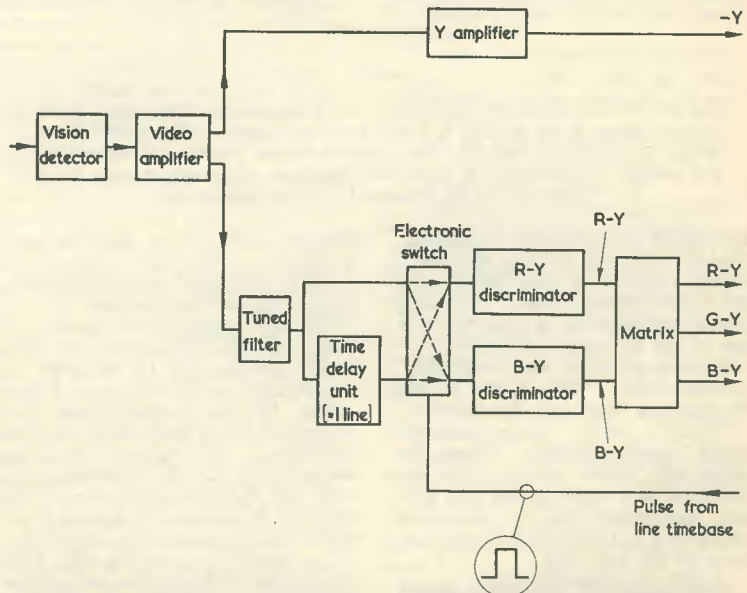

Fig. 7. Block layout showing the basic operation of a SECAM receiver. The -Y, R-Y, G-Y and B-Y signals are fed to the colour cathode ray tube

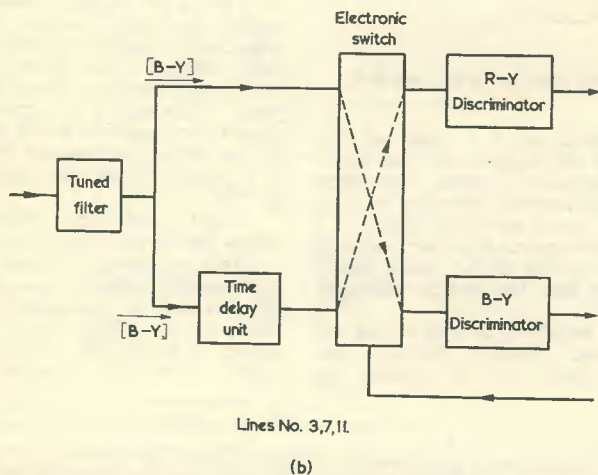
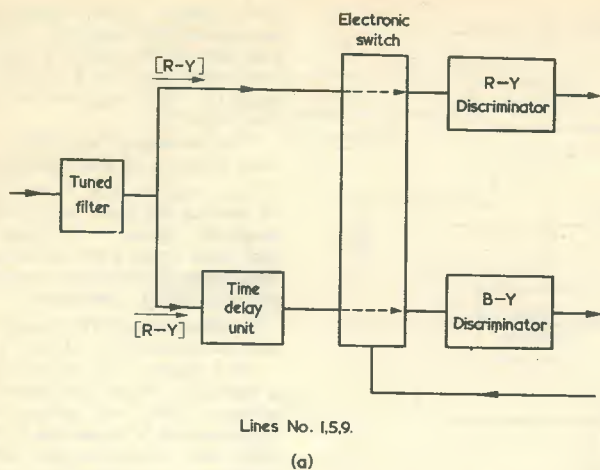

Fig. 8. The electronic switch of Fig. 7 routes the chrominance signal in the manner shown in (a) on lines 1, 5 and 9 of Fig. 6, and in the manner shown in (b) for lines 3, 7 and 11. The square brackets around the expressions R-Y and B-Y are intended to show that these are modulating signals which have later to be detected by the discriminators

modulated chrominance subcarrier. This is fed both into an electronic switch and into a time delay unit, the latter offering exactly the same amount of delay as is given by one line of the television picture.

"That's a funny idea, isn't it?" queried Dick. "What's the reason for having a delay unit like that?"

"There's every reason in the world," replied Smyth. "Since the delay unit offers exactly one line delay, an R-Y signal going into it at the commencement of one line comes out at exactly the commencement of the next line."

"I still don't see the point."

"If," said Smyth irritably, "you'd let me get on with it instead of interrupting all the time, you'd

discover *exactly* what the delay unit is for."

"O.K. Smyth," said Dick obligingly. "I'll belt up pro tem!"

"Good," commented Smyth.

"I've already mentioned the electronic switch, and I'll describe its functioning very shortly. Please notice, for the moment, that it is controlled by a pulse from the line timebase. The outputs from the switch go to the R-Y discriminator and the B-Y discriminator. The detected R-Y and B-Y signals from these discriminators are finally fed to a matrix to reclaim the G-Y signal, and thence to the grids of the cathode ray tube."

Smyth paused as he settled himself more comfortably on his stool.

"Let's now see," he said, "what happens with the transmission we discussed just now, in which alternate lines carry either R-Y or B-Y information. We'll start off at line No. 1, which has R-Y information on it. During this line the electronic switch is in a condition which allows the R-Y modulated signal to pass straight through to the R-Y discriminator. (Fig. 8 (a).) At the same time, the R-Y modulated signal goes into the time delay unit. Nothing comes out of the delay unit yet because the vertical blanking period preceded line No. 1. We come to the end of line No. 1 and go into line flyback, whereupon a pulse from the line timebase causes the electronic switch to flip over to its alternate state in which input and output couplings are transposed. (Fig. 8 (b).) Line No. 3 starts up, and it has a B-Y modulated signal on it. The electronic switch routes this through to the B-Y discriminator. Also, the B-Y signal goes into the delay unit. At the same time, the R-Y modulated signal from the previous line is now coming *out* of the delay unit, and the electronic switch routes it over to the R-Y discriminator."

"Gosh," said Dick impressed. "I'm beginning to get a glimmering of what all this is about!"

"I find it completely fascinating, myself," confessed Smyth cheerfully. "Anyway, to continue! Line No. 3 comes to an end, and the flyback pulse from the line timebase flips the electronic switch back to its original position. (Fig. 8 (a).) Line No. 5 starts up, and its R-Y modulated signal goes through the switch into the R-Y discriminator, as well as going into the delay unit. At the same time as the R-Y signal goes into the delay unit, the B-Y signal comes *out*, and the electronic switch routes this into the B-Y discriminator. The electronic switch flips over to its other state at the end of Line No. 5, and line No. 7 is treated in the same as line No. 3. And so the process goes on, from field to field and picture to picture."

"Well, I'm dashed," said Dick. "That's really *ingenious*."

"Isn't it?" agreed Smyth. "Now, as a result of these goings-on, we have, on every line, an R-Y output from the R-Y discriminator and a B-Y output from the B-Y discriminator. All this is done without any necessity for phase-modulation, as the signals are carried by an easy-to-handle frequency-modulated subcarrier. One basic disadvantage is that every alternate R-Y and B-Y signal is delayed by a line and so it



doesn't define truthfully what is going on in the line which is actually being transmitted. This results in an effect similar to a decrease in vertical colour resolution. However, such a decrease is considered acceptable because current colour TV standards already allow reduced colour resolution in the horizontal sense."

"What," asked Dick, "does the delay unit consist of?"

"The earlier delay units," said Smithy, "employed glass cylinders, but these have now been superseded by mild steel delay lines which are much cheaper and easier to produce. The signal passes through the delay line in the form of mechanical vibrations, it being injected in at one end and taken out at the other end by suitable transducers."

"Mightn't it get distorted?"

"It could do," said Smithy. "And it's possible that some frequencies going through the delay unit become more attenuated than do others. But this doesn't matter. The signal is frequency-modulated and differences in amplitude can be limited out in the same way as occurs in an ordinary f.m. receiver."

"How do you keep the electronic switch in step?" asked Dick. "If it fell out of step, you'd get R-Y signals going into the B-Y discriminator, and B-Y signals going into the R-Y discriminator, with what would be *very weird* results!"

"I don't know about the weirdness of the results," said Smithy, "but there's no problem about keeping the switch in step. Once it's set up properly it should keep in step all the time the receiver is switched on and receiving a colour programme. In practice, a simple colour recognition pulse may be sent during the vertical blanking period. If the switch was out of step, a circuit in the receiver would feed an extra pulse to it to bring it back into step again."

#### PAL

"I see," said Dick thoughtfully. "Incidentally, there's a minor little point that's been niggling at me for a bit, although I have an idea we've cleared it up already."

"Oh yes," said Smithy. "What's that?"

"How," asked Dick, frowning, "do you get the G-Y signal from the B-Y and R-Y signals? You've done this just now with the SECAM system. I know you've mentioned a similar point already, but I'm still not entirely clear."

"Well," said Smithy, "this is once again a question of obtaining one signal by combining two others in suitable proportions. A practical

approach would consist of obtaining G-Y by way of the following equation:

$$-(G-Y) = \frac{0.30}{0.59} (R-Y) + \frac{0.11}{0.59} (B-Y)."$$

Smithy wrote the equation down in Dick's notepad.

"What that means," he said, "is that if you add R-Y and B-Y in the proportions shown, you get minus G-Y. That is, G-Y with reversed phase."

"That's quite neat," said Dick. "But I don't quite see how it's derived."

"The derivation," replied Smithy, "I shall now proceed to demonstrate. If you multiply both sides of the equation by 0.59, you get

$$-0.59 (G-Y) = 0.30 (R-Y) + 0.11(B-Y).$$

Taking away the brackets, and putting Y on the left and G on the right then gives you

$$(0.59 + 0.30 + 0.11)Y = 0.59G + 0.30R + 0.11B.$$

And that ends up as

$$Y = 0.59G + 0.30R + 0.11B."$$

"Well, I'm dashed," said Dick. "Adding those two proportions of R-Y and B-Y to give minus G-Y was really just another way of writing out the original formula for Y in terms of G, R and B!"

"That's the idea," said Smithy. "Before finishing, there's a further point I want to make about SECAM, and that is that the chrominance signal is reduced in amplitude at the centre frequency, and that the amplitude increases as deviation increases. This is done to reduce interference with the luminance signal. The frequency can, incidentally, go either side of the centre frequency, according to whether the R-Y or B-Y signal is positive or negative."

"That," commented Dick, "seems to have got SECAM all buttoned up. What about my old mate, PAL?"

"PAL," said Smithy, "is very much closer to the N.T.S.C. system than is SECAM, and it uses the same type of chrominance subcarrier which is phase-modulated for hue and amplitude-modulated for saturation. With PAL, however, part of the phase-modulating signal is reversed by 180° on successive lines, with the result that a positive phase shift in the transmission system on one line is followed by a negative phase shift of about equal amount in the next. The two errors can then be averaged out in the receiver. A simple method of doing this consists of feeding the signals, as received, direct to the cathode ray tube. The alternate phase shifts causes slightly incorrect hues to be presented to the

eye on successive lines, and the eye does the averaging itself. A better and more expensive method consists of putting the signals through a delay unit, as in SECAM. With this set-up, the signal on any line can be averaged electronically with that on the preceding line, and so correct hue signals are passed to the tube. Like SECAM, a PAL receiver does not require a hue control."

#### Work Calls

"And that," said Smithy, "is *that*. This gen-session is now officially closed!"

The Serviceman glanced at the crowded "For Repair" racks and sighed.

"How on earth," he remarked, "I'm going to square my conscience over the time we've just spent in nattering I really don't know!"

"Not to worry, Smithy," said Dick sympathetically. "No doubt I'll be able to see my way towards doing a little overtime tonight."

Smithy's jaw dropped.

"I must," he remarked incredulously, "have been dreaming. I distinctly heard you volunteer to do overtime."

"So I did," replied Dick indignantly. "You've done me a favour and so I'm going to do you a favour in return."

"This," said Smithy, still somewhat shattered, "is very commendable of you."

"Not at all," stated Dick. "Like they say in the Army: if you play the game with me, I'll play the game with you."

"I seem," remarked Smithy reflectively, "to recall hearing that sentence quite a few times during my service days."

"You scratch my back," continued Dick, "and I'll scratch yours."

"An excellent sentiment."

"Cast your bread on the waters, and it will be returned fourfold."

"I don't think," said Smithy, a little doubtfully, "that that *quite* applies to the present situation."

"An eye for an eye, and a tooth for a tooth!"

"And that most definitely does *not* apply!"

Dick cast an aggressive eye at the Serviceman.

"Do you *want* me to do this overtime?"

"Of course I do."

"Then," said Dick firmly, "it's an eye for an eye, and a tooth for a tooth."

Which statement, considering the normal relationship in the Workshop, could not be considered as being too far off the mark.



Cover Feature

# An Electronic Tachometer

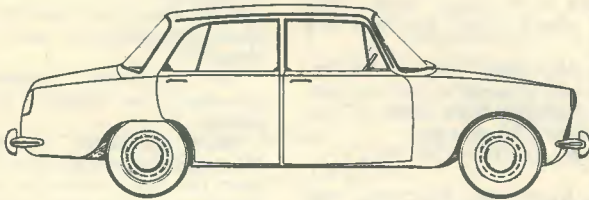

## for Your Car

By JOHN G. DEW, B.Sc.

An easily constructed tachometer for fittings to cars having positive earths. Since the tachometer is basically a frequency measuring device, this article describes also how it may be adapted to read any frequency from 0 to 10 kc/s

THE TACHOMETER, OR "REV. counter", has long been deemed a necessary piece of car equipment by racing enthusiasts, but only recently has it achieved more general

### Components List (Fig. 1)

#### Resistors

(All resistors  $\pm 10\%$ ,  $\frac{1}{2}$  watt)

- R<sub>1</sub> 47k $\Omega$
- R<sub>2</sub> 2.2k $\Omega$
- R<sub>3</sub> 470 $\Omega$
- R<sub>4</sub> 12k $\Omega$  (see text)
- R<sub>5</sub> 4.7k $\Omega$
- R<sub>6</sub> 6.8k $\Omega$
- R<sub>7</sub> 330 $\Omega$
- R<sub>8</sub> 150 $\Omega$
- R<sub>9</sub> 220 $\Omega$  (27 $\Omega$  on 6V)

#### Capacitors

- C<sub>1</sub> 4,700pF, 150V wkg., paper
- C<sub>2</sub> 0.5 $\mu$ F, 150V wkg., paper

#### Semiconductors

- TR<sub>1,2</sub> OC71, MAT100, XA104, "Red Spot"
- D<sub>1</sub> OA70, OA81
- Z<sub>1</sub> VR7-B (A.E.I.), OAZ204 (Mullard). (On 6V, VR475-B, OAZ200)

#### Meter

- M<sub>1</sub> 0-5 or 0-10mA f.s.d.

popularity. A few years ago the tachometer was a mechanical instrument requiring a cable drive which had to be attached to a modified dynamo back-plate, and the whole exercise was rather costly. Now, however, commercially made electronic rev. counters are available at a reasonable price, and it is possible to build one for an even more

modest price—about thirty shillings, in the author's case!

### The Circuit

The circuit of the instrument is shown in Fig. 1. It consists of a monostable circuit, or univibrator, in which TR<sub>1</sub> normally conducts heavily, as its base is returned to the negative supply via a fairly low resistance R<sub>4</sub>. TR<sub>2</sub> derives its base supply, through R<sub>5</sub>, from the collector of TR<sub>1</sub>, and since this is only a fraction of a volt negative, negligible current flows in TR<sub>2</sub>. The meter M<sub>1</sub> therefore indicates no reading.

However, if a negative pulse is applied to the base of TR<sub>2</sub> it can conduct, and since both transistors are then conducting the circuit becomes unstable (the resemblance to a multivibrator is obvious upon examination). The circuit becomes stable—or quasi-stable—when the other condition is reached: TR<sub>1</sub> not conducting and TR<sub>2</sub> "hard on". This state of affairs continues until the charge on the cross-coupling capacitor C<sub>2</sub> has leaked away through R<sub>4</sub>, when TR<sub>2</sub> can again conduct. Regenerative switching re-occurs and the circuit reverts to its original stable condition.

A single input pulse has thus produced a "flick" of the meter M<sub>1</sub>. However, if a series of pulses is applied the meter will show a steady deflection; as the duration of each current pulse through the meter is fixed (governed by the time constant of C<sub>2</sub> and R<sub>4</sub>), there will be a linear relationship between the frequency of the input pulses and the deflection of the meter.

This property is put to good use in the present tachometer circuit.

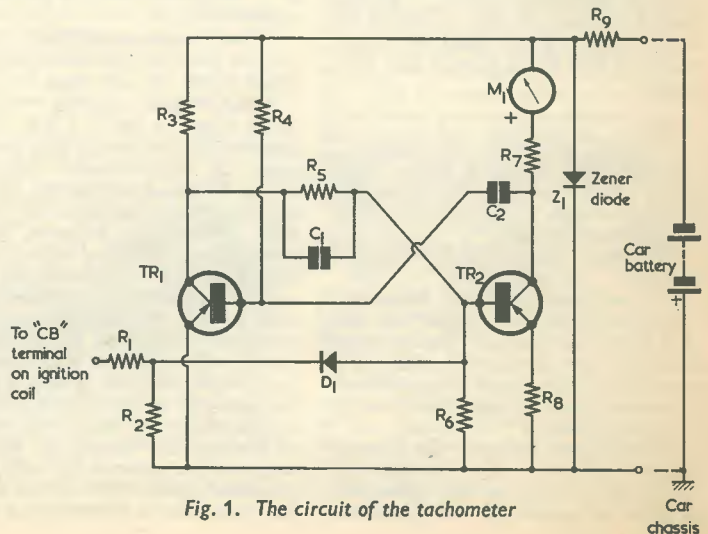

Fig. 1. The circuit of the tachometer



## Components List (Fig. 2)

### Resistors

(All resistors  $\pm 10\%$ ,  $\frac{1}{2}$  watt)

R <sub>10</sub>	10k $\Omega$
R <sub>11</sub>	4.7k $\Omega$
R <sub>12</sub>	120k $\Omega$
R <sub>13</sub>	2.2k $\Omega$

### Capacitors

C <sub>3</sub>	2 $\mu$ F, 12V wkg., electrolytic
C <sub>4</sub>	0.01 $\mu$ F, 150V wkg., paper

### Transistors

TR<sub>3,4</sub> OC71, MAT100, XA104,  
"Red Spot"

### Transformer

6.3 volt heater transformer

A negative-going pulse is obtained from the "CB" terminal of the ignition coil, suitably attenuated by R<sub>1</sub> and R<sub>2</sub>, and applied via diode D<sub>1</sub> to the base of TR<sub>2</sub>. An optional refinement in Fig. 1 is that C<sub>1</sub> shunts R<sub>5</sub> at high frequencies, so ensuring efficient switching even with low gain transistors.

The only other components calling for comment are Z<sub>1</sub> and R<sub>9</sub>. The battery voltage on a 12V system may vary between 14V on charge and 11V on tick-over, and, since the meter deflection depends a great deal on supply voltage, some method of voltage stabilisation is necessary. The stabilisation is effected by the zener diode Z<sub>1</sub>; this exhibits a reverse breakdown voltage which is relatively independent of current. In effect, Z<sub>1</sub> and R<sub>9</sub> form an a.c. potential divider, since the slope resistance of the diode may be only a few ohms, whilst R<sub>9</sub> is 220 $\Omega$ . The zener voltage and the resistance of R<sub>9</sub> are different for 6 and 12 volt supplies. (See Components List.)

### The Meter

The choice of meter is a matter of personal preference. The speed range to be accommodated is from zero to about 6,000 r.p.m., so a meter scaled 0-6 would be ideal. These, however, are rare and, unless the reader is adept at scale marking, a 0-10 calibration may have to be used. The movement itself is unimportant, a sensitivity of 5 or 10mA being suitable. Alternatively, a more sensitive meter may be appropriately shunted.\* (The author obtained a cheap 30-0-30mA meter which, with internal shunts removed,

\* A 10mA meter will not give full deflection, but if scaled 0-10 may indicate thousands of r.p.m. directly. Should full scale deflection be desired in a 10mA meter scaled 0-6 or 0-8, the value of R<sub>4</sub> could be reduced to, say, 100 $\Omega$ , which would also "turn on" TR<sub>2</sub> to a greater extent.

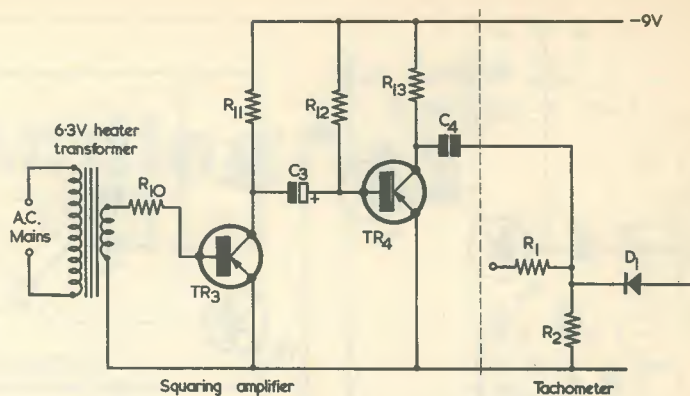

Fig. 2. Using the 50 c/s a.c. mains to calibrate the tachometer

proved to be a 3-0-3mA movement. With the zero sets wound round anti-clockwise, and new figures substituted on the dial, it became an excellent 0-6,000 r.p.m. meter!)

### Construction

The circuit may be constructed on a Paxolin board, either using a printed circuit or employing component wires for interconnection. The neatest method of mounting is to bolt the board on to the terminals of the meter itself. The meter can then be boxed in and placed in the glove-box, or may be mounted on a panel and attached below the dashboard.

The simplest way to make the electrical connections is to run all three leads in a three-core cable to the ignition coil, where the negative supply lead can be connected to the "SW" terminal on the coil—the usual take-off point for electrical extras. The pulse input lead may

then be connected to the "CB" terminal, and the positive supply lead can go to the nearest point on the chassis or body.

### Calibration

The value of R<sub>4</sub> given in the Components List is only a rough guide, as the actual meter deflection depends on the supply voltage, the values of R<sub>7</sub> and R<sub>8</sub>, and on the meter. The most obvious method of calibration is to first consult the car's handbook, where a value of "m.p.h./1,000 r.p.m." should be found; this is usually between 13 and 16 m.p.h./1,000 r.p.m. R<sub>4</sub> may be replaced by a potentiometer, the car driven at a suitable speed and the potentiometer adjusted to give the correct meter reading. The variable resistance may then be replaced by the appropriate fixed resistor(s).

The more elegant method is to use the mains electricity supply as a frequency standard. Obviously a

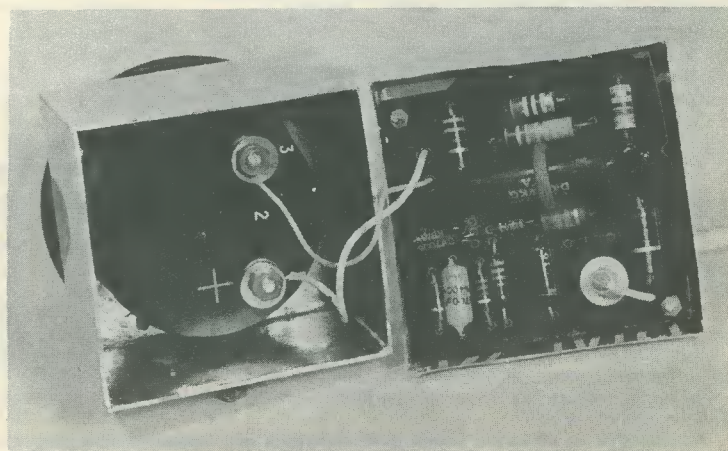

The internal construction. (This illustration shows two diodes instead of the single diode in Fig. 1. The extra diode was used to clamp the input pulse, but was later found to be unnecessary)

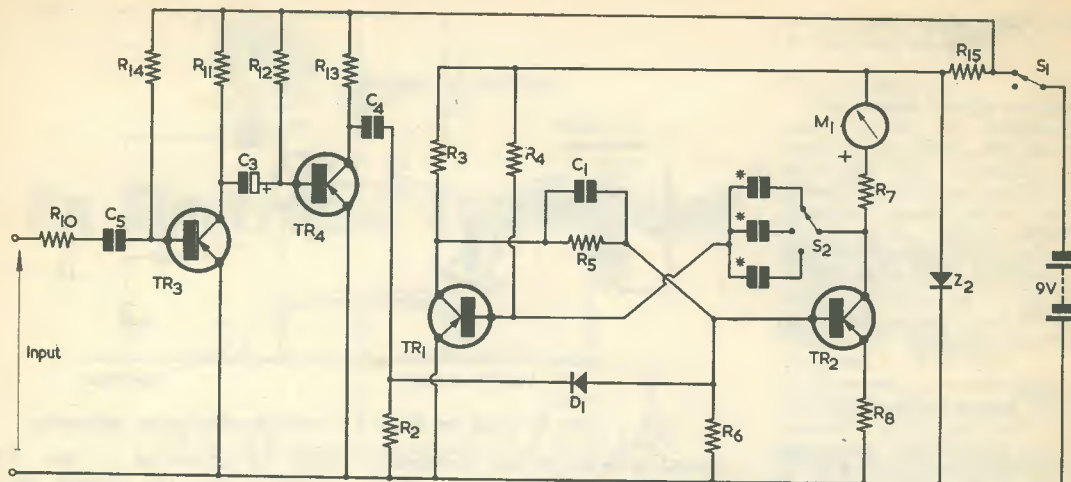

\* See text

Fig. 3. The circuit of the frequency meter

sine wave cannot be used as an input signal so a "squaring" amplifier is used as in Fig. 2. This is simply a two-stage amplifier which overloads so heavily that it produces a square-wave output. This is differentiated and applied to the junction of R<sub>2</sub> and D<sub>1</sub>.

With this method, the reading to which the meter should be adjusted is not as obvious as might at first appear. The mains produces 50 p.p.s. or 3,000 p.p.m.: however, a four cylinder engine fires twice every revolution, and so produces 3,000 p.p.m. at only 1,500 r.p.m. Similarly, a six cylinder engine produces 3,000 p.p.m. at only 1,000 r.p.m. Hence R<sub>4</sub> should be set to indicate 1,500 r.p.m. for a four cylinder engine, and 1,000 r.p.m. for a six cylinder. (For Saab fans, the value should be 1,000 r.p.m., and for the rare eight cylinder, 750 r.p.m.).

Of course, the whole business is made much simpler if a calibrated square-wave generator is available; this can then replace the 50 c/s mains supply.

#### Components List (Fig. 3)

Values not listed here are as in Figs. 1 and 2

#### Resistors

(All resistors  $\pm 10\%$ ,  $\frac{1}{2}$  watt)

R<sub>14</sub> 270k $\Omega$

R<sub>15</sub> 82 $\Omega$

#### Capacitors

C<sub>5</sub> 0.1 $\mu$ F, 150V wkg, paper

#### Semiconductors

Z<sub>2</sub> VR7-B, OAZ204

#### Switch

S<sub>1</sub> s.p.s.t.

S<sub>2</sub> Single pole 3-way range switch

#### Battery

9-volt battery

#### Frequency Meter

There is no reason why inputs other than the mains cannot be applied to the amplifier, and the

whole circuit then becomes an excellent direct-reading audio frequency meter. The only changes required are calibration in cycles per second instead of revolutions per minute, and a selection of capacitors for the C<sub>2</sub> position (marked with an asterisk in Fig. 3). Suitable capacitances and ranges would be:

0-100 c/s: C<sub>2</sub>=0.25 $\mu$ F

0-1 kc/s: C<sub>2</sub>=0.025 $\mu$ F

0-10 kc/s: C<sub>2</sub>=2,500pF

Calibration on each range would then have to be carried out by means of small alterations to the values of C<sub>2</sub>.

Obvious uses which come to mind for the frequency meter are:

- A permanent addition to an audio frequency signal generator, to replace the calibrated dial.
- As an aid to the calibration of an oscilloscope timebase.
- As a radiation counter, in conjunction with a Geiger-Muller tube.

## CLUB EVENTS Nottinghamshire Week-End Course

Along with a week-end course for youth leaders and teachers in Nottinghamshire on "The Hobby of Amateur Radio", at the Residential Youth Centre, Ollerton, Notts. on September 11th and 12th, there will run a course of lectures for invited established amateur radio enthusiasts from the East Midlands area.

The symposium, organised by the Newark and District Amateur Radio Society, is being sponsored by the Radio Society of Great Britain, who are sending speakers of international repute to cover all aspects of amateur radio.

This is the first time a venture of this nature has been organised in the area. The parallel course will be integrated so that the enthusiasm of amateurs is communicated to beginners.

In the introductory course there will be lectures and demonstrations designed to introduce the hobby into schools and the youth service.

Among the lectures for established amateurs are "International Aspects of Amateur Radio" and "The Role of Measurement in Amateur Radio".

The new residential centre at Ollerton, lying in the heart of the Robin Hood country, is equipped with many modern facilities which will be available for the use of guests at the symposium.



# understanding

## THE $I_a V_a$ CHARACTERISTIC CURVE

By W. G. Morley

# radio

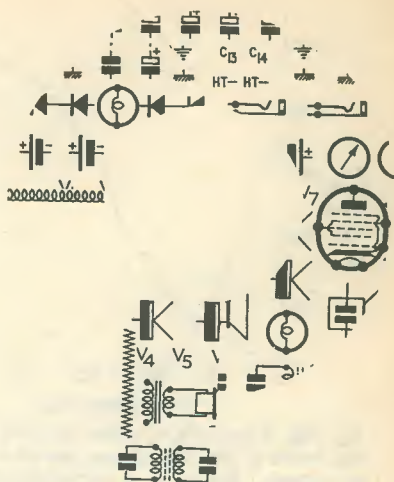

IN LAST MONTH'S ARTICLE IN THIS SERIES, WE continued our examination of the diode when employed as a detector of amplitude modulated signals, and we discussed important aspects of the diode detector circuit, these including component values, the introduction of a volume control, and a.c. shunting. We shall now carry on to other aspects of the diode.

### Characteristic Curves

It is possible to obtain an accurate measure of the potential performance of any valve by examining the *characteristic curves* for it which are published by the valve manufacturer. A characteristic curve for a valve is a graph which shows the relationship between two electrical quantities interrelated by way of the valve itself. In many instances, characteristic curves for a valve may be drawn by the student or experimenter, since the only equipment required consists of several simple meters and sources of supply.

In Fig. 289 we set up a circuit for obtaining the anode current-anode voltage characteristic curve of a diode. The equipment employed comprises the diode itself, whose heater is supplied by a battery or other source of e.m.f., a current-reading meter in series with the anode, and a variable source of positive voltage (relative to cathode). This last voltage is very conveniently provided by a potentiometer connected across a second battery, and a voltmeter tells us the potential between the slider of the potentiometer and the cathode. We plot the anode current-anode voltage graph by adjusting the potentiometer and noting the anode currents which flow at the voltages indicated by the voltmeter. It is assumed that the current meter is a low-resistance instrument which drops negligible voltage, where-

upon the voltage indicated by the voltmeter is the anode voltage itself.

A typical result of such an exercise is the anode current-anode voltage characteristic curve shown in Fig. 290. As we would expect, this shows zero current at zero anode voltage, the current increasing as the anode voltage increases.<sup>1</sup> However, the curve is not a straight line, as would be given if the diode were replaced by a resistor, but shows marked curvature, particularly at the ends. The curvature in the first part, from the zero point up to about point X, is due to a limitation in anode current imposed by the space charge in the diode.<sup>2</sup>

<sup>1</sup> As we shall see later in this article a small current does in fact flow at zero anode voltage; but this does not affect the topic under immediate discussion.

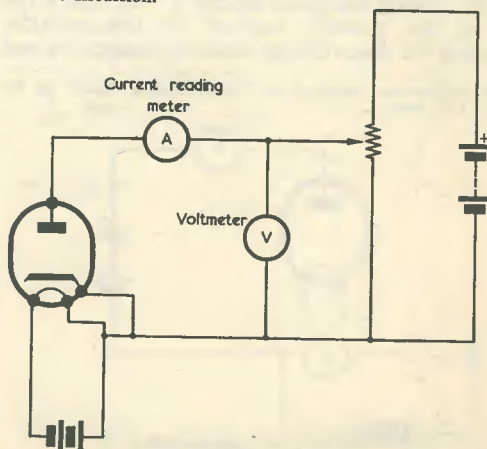

Fig. 289. A circuit suitable for plotting the  $I_a V_a$  curve of a diode

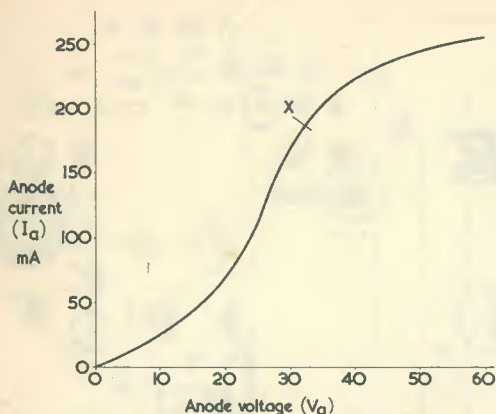

Fig. 290. A typical  $I_a V_a$  curve, as would be given with the circuit of Fig. 289. Anode voltage is with respect to cathode. The curve is representative of a small diode as used for h.t. rectification

The reason for current limitation due to the space charge may be understood if we consider two opposing effects. The first of these is that the space charge, consisting of a cloud of electrons around the cathode, repels the further electrons which are emitted from that cathode. The second effect is that the positive anode causes some of the electrons in the space charge to leave it and travel to the anode, and these lost electrons have to be made good by the acquisition of further electrons from the cathode. Up to about point X on the curve the second effect is of a lower magnitude than the first with the overall result that the space charge achieves a *partial* limitation of anode current. Put another way, it can be said that the positive anode partially, but not wholly, neutralises the repulsive effect of the space charge.

As anode voltage increases so does the second effect just referred to, and the current limitation imposed by the space charge reduces. This process continues until, at about point X, the quantity of electrons leaving the space charge is very nearly the same as the quantity emitted by the cathode, whereupon the space charge virtually disappears and

<sup>2</sup> Space charge was described in "Understanding Radio" in the December 1964 issue.

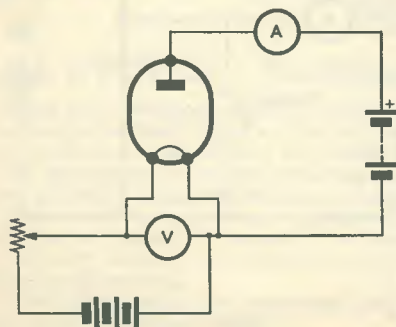

Fig. 291. A circuit for obtaining the  $I_a V_f$  characteristic curve of a diode

very nearly all electrons leaving the cathode travel straight to the anode.

Point X is usually referred to as the *saturation point* and it marks the start of the condition where almost all the electrons emitted by the cathode travel towards the anode. As anode voltage increases after the saturation point the curve flattens off, because the anode is now drawing from the cathode very nearly all the electrons that it can emit. This condition is known as *saturation* and the diode may be referred to as being *saturated*.

To sum up, the curve of Fig. 290 demonstrates that anode current is limited either by the *space charge* or by *saturation*. Up to about point X the limiting factor is the space charge whilst, after point X, the limiting factor is saturation.

It might at first be thought that the curve should become almost completely flat after the saturation point has been reached because, since all (or very nearly all) the total emission of the cathode is travelling to the anode, there should then be no further significant increase in anode current. In practice, however, the flattening of the curve is not as marked as such a consideration would lead one to believe, the reason for this being that the surface of the cathode cannot be made perfectly smooth. There must always be small microscopic pockets in the cathode surface, the insides of which become hotter than the outer cathode surface and which, therefore, emit a greater proportion of electrons. Very small space charges appear immediately outside these pockets and they can only be neutralised by higher anode voltages. Thus, there is still a small increase in anode current with increase in anode voltage after the saturation point, despite the fact that the diode is, in general, considered to be saturated.

Another factor is that the change from current limitation by space charge to current limitation by saturation is not abrupt but occurs gradually. This results from the fact that there are variations in spacing, over their length, between the cathode and the anode. Current limitation due to space charge reduces as the distance between the cathode and anode reduces, with the consequence that, at about point X in Fig. 290, it is possible for the current in the more closely-spaced sections of the cathode-anode assembly to be limited by saturation, and the current in the less closely-spaced sections to be limited by space charge. Thus, the transition from space charge limitation to saturation limitation does not occur at one clearly defined point of the curve.

The curve of Fig. 290 represents the first valve characteristic curve that we have seen in this series of articles. This particular curve is of value because it enables us to tell the anode current which will flow at any anode voltage within the range covered. Alternatively, it tells us what voltage appears between anode and cathode at any anode current in the range. This last point could, for instance, enable us to determine the voltage which will be dropped across a rectifier diode in a power supply circuit at one particular current. It is customary to use abbreviations for the quantities depicted in the



characteristic curve, and we use the abbreviation  $I_a$  for anode current and  $V_a$  for anode voltage, the subscript letter "a" indicating that the electrode to which the current or voltage refers is the anode. Thus, the curve of Fig. 290 may be described as an  $I_a V_a$  curve. It should be added that when voltages applicable to valve characteristics are quoted these are always with respect to the cathode unless otherwise stated, it being assumed that the cathode always remains at zero potential.

In the curve of Fig. 290, the diode was taken beyond saturation point. It must be pointed out, however, that allowing the anode current of a diode to pass into saturation level can, in practice, cause damage to the cathode, especially if the latter is an indirectly heated type. Saturation should also be avoided if the diode has a thoriated tungsten filament. In consequence, experimenters wishing to draw an  $I_a V_a$  curve for a diode should ensure that readings are taken only over the lower part of the curve of Fig. 290, up to the limiting maximum anode current quoted in the valve manufacturers' literature for the particular diode being investigated. It will be found, incidentally, that the maximum currents specified for small diodes intended for use as a.m. detectors are much lower than those specified for the larger diodes used as h.t. rectifiers.

#### $I_a V_f$ Curve

In radio circuits it is bad practice to apply incorrect voltages across the filament or heater of a valve unless a special effect is particularly desired. To obtain the correct cathode temperature the filament or heater should always be operated at the voltage for which the valve is designed. Despite this, it will be of value now to briefly examine the results given by plotting a curve showing the anode current of a diode at varying cathode temperatures, even if we are producing conditions which will not later be encountered in practical radio work. It will be found that the results given offer an interesting contrast with those shown in Fig. 290.

In Fig. 291 we have a diode whose filament voltage is controlled by a series variable resistor. A voltmeter connected across the filament tells us the voltage which appears across it. In this instance, we would find it more convenient to employ a diode with a filament rather than one with an indirectly heated cathode because the temperature of the filament will respond quickly to variations in filament voltage. We could obtain exactly the same results if we used a diode with an indirectly heated cathode but we would have to wait for the cathode to settle down to its new temperature after each adjustment of the heater voltage. A current-reading meter in the anode circuit indicates the anode current, and the anode voltage remains constant whilst the curve is being plotted. We will assume that the correct filament rating for the diode is 5 volts.<sup>3</sup>

The resultant anode current-filament voltage, or

<sup>3</sup> Such a filament voltage is, in fact, commonly encountered amongst directly heated h.t. rectifiers (e.g. the 5Y3, which has two diodes and a common filament).

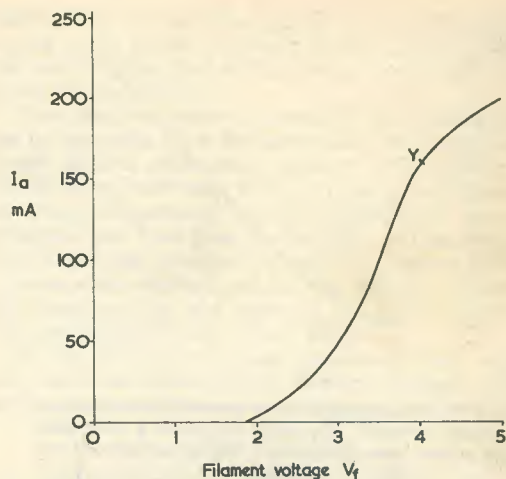

Fig. 292. A typical  $I_a V_f$  curve. A fairly low anode voltage, capable of allowing space charge limitation of current to occur after point Y is assumed. The similarity in shape to the curve of Fig. 290 may be noted

$I_a V_f$  (with "f" standing for filament) curve appears in Fig. 292. For values of  $V_f$  below about 2 volts the filament does not reach emitting temperature, and there is no anode current. At about 2 volts there is a small amount of emission. All the electrons emitted are attracted towards the positive anode and an anode current commences to flow. As  $V_f$  is raised the filament becomes hotter and there is an increased anode current, this still being given by the total emission from the cathode. This process

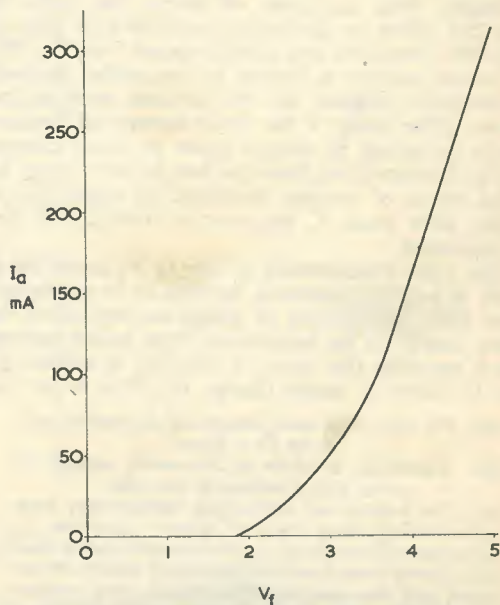

Fig. 293. Increasing anode voltage, so as to cause saturation at full filament voltage, changes the  $I_a V_f$  curve of Fig. 292 to that shown here

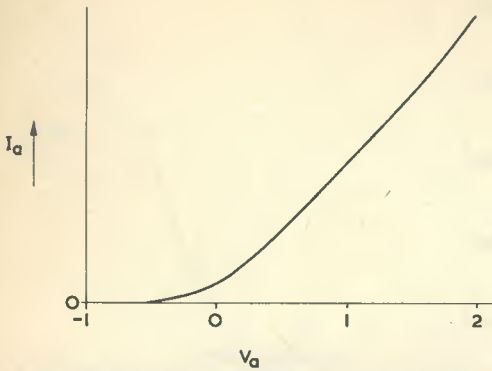

Fig. 294. Because of what is generally described as "contact potential", the anode current of a diode only falls to zero when the anode is slightly negative of the cathode

continues until, at about point Y, the filament voltage is such that the filament is approaching its correct running temperature. A relatively high quantity of electrons is now being emitted and a space charge commences to appear, this offering repulsion to further electrons emitted from the cathode. Raising filament voltage still further results in an increasing electron emission, together with a stronger space charge giving greater repulsion to the further electrons emitted by the cathode. Thus, after about point Y, the anode current is limited by the space charge and, since increasing filament voltage does not cause the corresponding increase in anode current which occurred previously, the curve begins to flatten off.

Despite their similarity of shape, the curve of Fig. 292 offers an intriguing contrast with that of Fig. 290. From the zero point to point Y of Fig. 292 the anode current is limited by *saturation*, because all electrons emitted by the cathode pass to the anode. After point Y the curve flattens off because of the limitation in current given by *space charge*. In Fig. 290 the curve, from the zero point to point X, is the result of current limitation by *space charge* whilst, after point X, the current limitation is due to *saturation*.

This brief examination of the  $I_a V_f$  curve for a diode is helpful because it enables us to appreciate more fully the limiting of anode current either by space charge or by saturation. The anode voltage which provides the curve of Fig. 292 is sufficiently low to allow a space charge to form when the

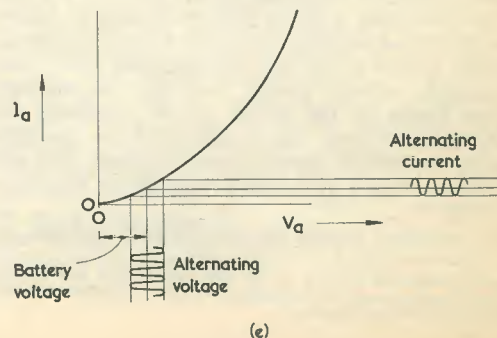
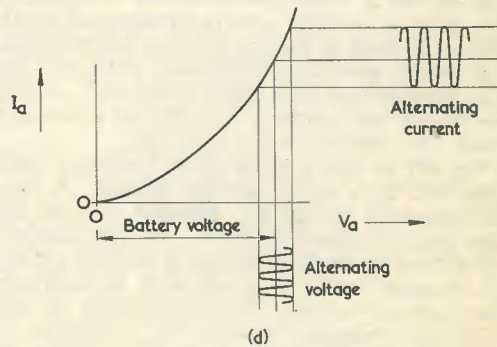
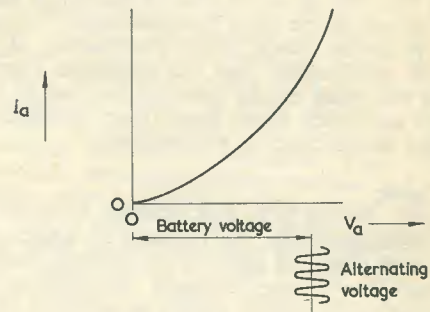
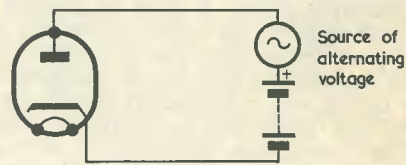
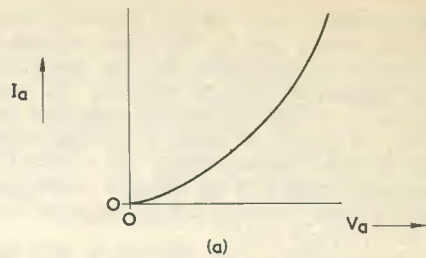

Fig. 295 (a). The lower section of a typical  $I_a V_a$  curve for a diode

(b). Connecting a source of alternating voltage, in series with a battery, to the diode

(c). The battery and alternating voltages may have values which cause them to appear along the  $V_a$  dimension of the graph in the manner shown here

(d). Taking lines from the alternating voltage to the curve, and then carrying these to the right, enables the amplitude of the alternating current to be found

(e). Applying the alternating voltage to a lower part of the curve results in a considerably smaller alternating current



filament approaches its correct running temperature. To complete the picture we should now draw another graph in which the anode voltage is sufficiently high to give saturation even when the filament reaches its proper operating temperature at a  $V_f$  of 5 volts. The resultant curve is shown in Fig. 293. This indicates a continually increasing anode current with no flattening off, because the current is at all times limited only by saturation.

### “Contact Potential”

When we discussed the  $I_a V_a$  curve of Fig. 290 we said that zero anode current flowed at zero anode voltage. This statement is not entirely true, however, and if we examine the  $I_a V_a$  characteristic of a typical diode at low values of anode voltage we will find that the anode current drops to zero only when the anode is made slightly *negative* of the cathode. At zero anode voltage a small anode current flows, as is illustrated by the curve of Fig. 294.

This effect can be generally ascribed to “contact potential”. Contact potential is, basically, the term applied to the small e.m.f. which may be produced when two dissimilar conductors are brought in contact. In a diode the surfaces of the anode and cathode will almost inevitably consist of dissimilar materials, and it can be shown that, when no external e.m.f. is applied to these two electrodes, potentials similar to those which give the contact potential effect appear immediately over their adjacent surfaces. These potentials, in combination, can be looked upon as providing a small internal e.m.f. in series with the anode voltage, the internal e.m.f. having a polarity such that anode current still flows when the anode voltage is zero. Anode current only falls to zero when the anode voltage is made slightly negative to counteract the contact potential.

In the curve shown in Fig. 294, the contact potential is such that as to permit zero anode current at an anode voltage of about  $-0.5$ . However, the actual voltage at which zero current occurs will vary for different diodes and, also, for other factors including the initial electron velocity from the cathode and the amount of gas left in the envelope.

The writer introduced the term “contact potential” in inverted commas because, although widely accepted as the general term for the effect shown in Fig. 294, it defines a phenomenon in which there are other contributory factors. Some textbooks similarly qualify the term when applying it to the overall effect.

### Anode A.C. Resistance

We may now, with the aid of the diode, very conveniently introduce a concept which will be of considerable assistance to us when, later, we come to examine more complex valves.

Fig. 295 (a) shows the lower part of the  $I_a V_a$  curve of a diode. We apply to the diode anode a source of alternating voltage in series with a battery, as is shown in Fig. 295 (b). Our next step consists of giving values to the battery voltage and the

alternating voltage which cause them to be applied to the  $I_a V_a$  graph as shown in Fig. 295 (c). What we now want to find is the *alternating current* which flows in the circuit.

This may be done very readily by drawing lines up to the curve from the centre and peak amplitude levels of the alternating voltage. The points at which these lines meet the  $I_a V_a$  curve will then tell us the corresponding currents, whereupon we may produce lines from these to the right and reconstruct the alternating waveform in terms of current. These processes are carried out in Fig. 295 (d), in which the waveform on the right of the graph indicates the alternating current which flows.

In Fig. 295 (e) we repeat the process once more, but this time with a lower battery voltage. Once again the waveform representing the alternating

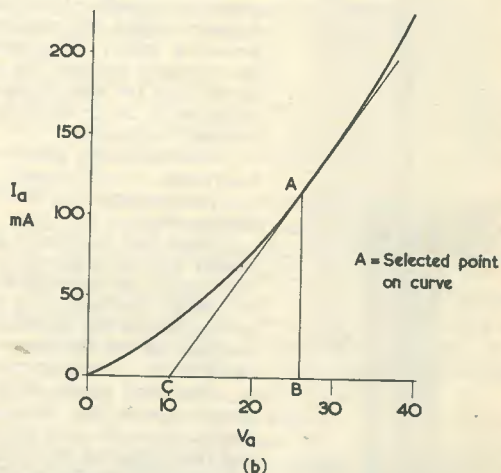
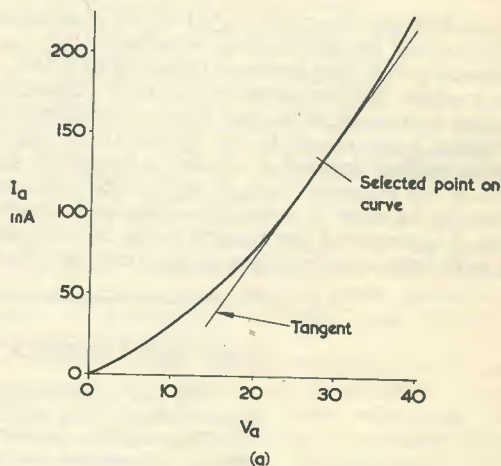

Fig. 296 (a). Drawing a tangent to the  $I_a V_a$  curve at the point where it is desired to measure the a.c. resistance

(b). All that is then required is to measure the slope of the tangent, and one way of doing this consists of producing the tangent to the zero current line. The a.c. resistance is voltage CB divided by current AB

current appears on the right but, as is obvious from the diagram, it now has a much lower amplitude. So far as the source of alternating voltage is concerned, the conditions obtaining in Fig. 295 (e) are such that, for the same alternating voltage, less alternating current flows than occurred in Fig. 295 (d). We may say, therefore, that the situation of Fig. 295 (e) corresponds to a greater *a.c. resistance* than does that of Fig. 295 (d). It is obvious that this *a.c. resistance* has increased because the alternating voltage has been applied to a part of the  $I_a V_a$  curve having a different degree of slope.

If, in Fig. 295 (d), the r.m.s. value of the alternating voltage were 1 volt, and the corresponding r.m.s. value of the resultant alternating current were 5mA,

then, from  $R = \frac{E}{I}$ , the *a.c. resistance* offered is 200Ω.

In Fig. 295 (e), the r.m.s. value of the alternating current could be about 2mA, whereupon the *a.c. resistance* in this case becomes increased to 500Ω.

In practice, it is not necessary to draw alternating voltages and currents to find the *a.c. resistance* at particular parts of an  $I_a V_a$  curve, and a much simpler method consists of drawing a tangent to the curve at the point selected, as in Fig. 296 (a), and measuring its slope in terms of voltage and current. Thus, if we continue the tangent to the zero current line and draw a vertical line to the point at which

the tangent meets the curve, as shown in Fig. 296 (b), dimension AB will show the current which corresponds to the voltage between C and B. In the example shown, the voltage between C and B is 16 and the current (AB) is 115mA, with the result that the *a.c. resistance* at point A is  $\frac{16}{115} \times 1,000 = 139\Omega$ .

As was mentioned earlier, we assume, when referring to valve characteristics, that the cathode remains fixed at zero voltage. Our alternating voltage is assumed to be applied, therefore, to the diode's anode, whereupon the *a.c. resistance* offered is described as the *anode a.c. resistance*, or *anode impedance*, of the diode. It is most important to note that the *anode a.c. resistance* has no connection whatsoever with the *d.c. resistance* offered by the diode. At point A in Fig. 296 (b) a direct voltage of 26 causes a direct current of 115mA to flow, whereupon the *d.c. resistance* becomes 226Ω. The *a.c. resistance* is, as we have seen, quite a different figure, and it depends upon the *alternating current* which flows when an *alternating voltage* is applied. The abbreviation employed for *anode a.c. resistance* is "ra".

#### Next Month

In next month's article we shall introduce the triode valve.

### THE G3RIX MOBILE AERIAL

This new mobile aerial, illustrated herewith, has been specially developed to provide a most efficient base loaded installation for use over the amateur bands.

The space-wound coil of the heaviest gauge copper wire (E), practicable for the band in use, is varnished and wound on a low-loss black polystyrene-compound former (F), which is plugged at both ends by machine turned aluminium castings (G). These items are drilled to take the two-section copper plated steel whip antenna (A) and the special mounting pillar. The latter are held in place by 2BA grub screws in holes drilled diametrically through the castings (C). These castings are a tight waterproof fit in the former and are held in place by screws (D), and the end faces (B) are mirror finished and machined at 50° to the axis of the coil both in order to streamline the unit and to improve weather resistance.

The mounting pillar is made of high tensile steel and fits a single  $\frac{1}{8}$ in hole in the bodywork.

For operation on the 10 metre band an adaptor is available to connect the whip aerial to the pillar.

Note that each coil is designed to have a nominal base impedance of 50Ω and excellent results will be obtained by using a transmitter having an output circuit designed for this impedance. As resonant frequencies and impedances will vary slightly, however, depending on the car and mounting position, best results will be obtained by using a simple tuning unit to match the impedances and adjust the resonant frequency. A capacity hat is also available to aid the latter operation. Details of a suitable tuning unit will be sent on request.

Technical details of the mobile aerial are as follows—base impedance 50Ω nominal; length of coils  $7\frac{1}{2}$ in; diameter of coils  $1\frac{1}{2}$ in; length of two-section whip aerial 8ft 1in; total height above car body 8ft 8in; weight of one coil 8oz (approx.); total weight 20oz (approx) and the suggested mounting position is front or near offside wing.

Coils for the 15, 20, 40, 80 or 160 metre amateur bands are available at £3 each; adaptor for 10 metres 9s. 6d. each; two-section 8in whip aerial 17s. 6d.; mounting pillar complete with washers and nut 15s.; capacity hat 9s. 6d. Carriage 2s. 6d. extra per item. Also available complete with coil of your choice, aerial and base, £4 15s., carriage paid, or complete with set of five coils and all accessories at £17 carriage paid. Coils may also be wound to customer's own requirements, estimates are free upon request. The terms are cash with order. Available direct from the manufacturer—Martin R. Tetley, 18 Alexandra Park, Scarborough, Yorkshire.

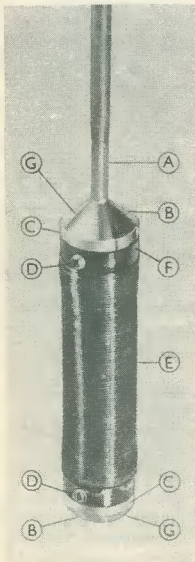



## 20 SEMICONDUCTOR QUESTIONS

Happy with transistors? Then try your hand at these questions—but be warned, as some of them aren't too easy!

**I**N EACH OF THE FOLLOWING STATEMENTS, ONLY ONE of the alternatives given is correct. In each case try to select this correct answer and write it down. The answers are given on page 852.

(Current is considered to flow in the conventional direction from positive to negative, that is, in the opposite direction from the electron flow.)

1. The electrode of a semiconductor diode marked with a red band is (a) the electrode corresponding to the anode of a thermionic diode; (b) the electrode from which the current flows; (c) the electrode to which the current flows; (d) the electrode from which the electrons flow.

2. A p:n junction can be used (a) as an audio amplifier; (b) as an inductance; (c) to provide a large power output; (d) as a variable capacitor.

3. In a normal p.n.p. earthed emitter transistor amplifier stage (a) the base and the collector are both positive; (b) the base and the collector are both negative; (c) the base is positive and the collector negative; (d) the base is negative and the collector positive.

4. The first type of transistor to be invented was (a) the drift transistor; (b) the alloy-diffused transistor; (c) the thyristor; (d) the planar transistor; (e) the point contact transistor.

5. In a conventional transistor audio amplifier circuit the load is placed (a) in the collector circuit; (b) in the base circuit; (c) in the emitter circuit; (d) elsewhere.

6. Class B audio amplifiers are used in transistor output stages because (a) they provide less distortion than Class A stages; (b) they can be matched more easily into the circuit; (c) they require less power than Class A amplifiers; (d) they provide less gain than Class A amplifiers.

7. The emitter current of an r.f. transistor amplifier stage is typically (a)  $1\mu\text{A}$ ; (b)  $50\mu\text{A}$ ; (c)  $1\text{mA}$ ; (d)  $20\text{mA}$ ; (e)  $50\text{mA}$ ; (f)  $200\text{mA}$ .

8. In transistor receivers larger values of coupling and decoupling capacitors are required than in valve circuits owing to (a) a greater tendency to instability; (b) greater impedances; (c) smaller impedances; (d) the need to keep power consumption small in a transistor battery receiver.

9. At the cut-off frequency, the current gain of a transistor is less than the gain at low frequencies by (a) a factor of ten; (b) fifty per cent; (c) 6dB; (d) 3dB; (e) 1dB.

10. When a strong signal is present at the aerial of a transistor receiver employing p.n.p. transistors, the a.g.c. line (a) takes current from the base circuits of the controlled stages; (b) makes the bases of the controlled transistors more negative in potential; (c) feeds current into the base circuits of the controlled stages.

11. The base of a silicon n.p.n. transistor used as a Class A radio frequency amplifier requires (a) a positive bias; (b) a negative bias; (c) needs no bias; (d) silicon n.p.n. devices are not suitable for use as radio frequency amplifiers.

12. Tunnel diodes are not very widely used as amplifiers because (a) they do not provide much output power; (b) they require high potentials for their operation; (c) their impedance is too low to match into many circuits; (d) they are difficult to manufacture; (e) their output is not isolated from their input; (f) they cannot operate at a very high frequency and have no particular advantages at audio frequencies.

13. The Dynaquad, the trigistor, the thyristor and the trinistor are all (a) types of transistor; (b) types of four layer device; (c) types of diode; (d) are not semiconductor devices.

14. One can usually employ much longer un-screened leads in the input circuit of a transistor a.f. amplifier than in the input circuit of a valve a.f. amplifier of similar voltage gain without hum pick-up becoming excessive because (a) transistor amplifiers normally provide less power output than valve amplifiers; (b) transistor amplifiers often derive their power from a battery; (c) the input impedance of a transistor amplifier is often smaller than that of a valve amplifier; (d) the input impedance of a transistor amplifier is often larger than that of a valve amplifier; (e) more transistors are used in a transistor amplifier than valves in a similar valve amplifier.

15. The point contact transistor is no longer commonly used because (a) it is difficult to manufacture it to reasonably close tolerances; (b) it requires greater potentials for its operation than can be conveniently obtained from a small battery; (c) it cannot provide enough gain; (d) it is very sensitive to heat; (e) it is very sensitive to mechanical shock.

16. The cathode follower valve circuit has somewhat similar properties to (a) a transistor grounded base amplifier; (b) a common collector stage; (c) a grounded emitter stage; (d) a transistor "super-alpha" pair.

17. The output impedance of a conventional transistor audio amplifier stage is (a) zero; (b) larger than the input impedance; (c) approximately the same as the input impedance; (d) unity.

18. If a transistor is to be operated at relatively high temperatures, the semiconductor material most commonly used for making the transistor is (a) germanium; (b) silicon; (c) indium phosphide; (d) carbon; (e) indium antimonide.

19. Brimistors and Silistors are (a) a form of transistor; (b) a form of rectifier; (c) a form of semiconductor resistor; (d) a form of semiconductor capacitor.

20. The following single semiconductor device cannot be used in a bistable circuit without the use of another active device (a) the point contact transistor; (b) the junction transistor; (c) the tunnel diode; (d) a p.n.p.n. four layer diode; (e) a silicon controlled rectifier.



# THE 1965 RADIO AND ELECTRONIC COMPONENT SHOW

**T**HE 19TH RADIO AND ELECTRONIC COMPONENT Show held at Olympia from 18th to 21st May was inaugurated by Mr. A. F. Bulgin, president of the Radio and Electronic Component Manufacturers' Federation. Mr. Bulgin referred to the tremendous growth of the components industry, stating that output in 1964 reached a record total of £177 million, this being more than 12% up on the 1963 figure. Exports increased even more dramatically—by 20% to a total of £70 million—and represented more than two-thirds of the export total of the entire electronics industry. A satisfactory proportion goes to hard currency areas and the biggest overseas customer is the U.S.A., which took £7.5 million worth of components, most of these being in the hi-fi audio category.

## Miniaturisation

Miniaturisation was the order of the day at the Show, and the Belclere Company Ltd. exhibited their new E.S. range of miniature mains transformers which occupy less than 1 cu. in. Four versions of these transformers are available, these being: for printed circuit mounting, for mounting with a 2-hole fixing clamp, with complete resin encapsulation, and completely screened with mu-metal.

Prominent in the microelectronics field was Hughes International (U.K.) Ltd., who showed a comprehensive range of components including diffused planar transistors, zener diodes, silicon planar epitaxial diodes and ultra-fast computer diodes. These were all available in various mechanical forms for conventional or micro-miniature methods of assembly. Also exhibited by Hughes International was miniature welding equipment.

Plessey showed a new micro-miniature tantalum electrolytic capacitor, type M, which is only 1.8mm in diameter and particularly offers itself for use in hearing aids, rescue beacons and electronic wrist-watches. Outstanding in the wide Plessey range is their new type CJ relay, which fits into a TO-5 transistor can having a diameter of 0.33in and a depth of  $\frac{1}{4}$ in!

The products of Standard Telephones and Cables Ltd. included micro-miniature circuit modules, semiconductor integrated circuits and thin film circuits. Typical of the circuit modules is the type 10B incorporating silicon transistors. It is intended for pulse logic and control systems and measures 2.6 x 1.1 x 0.6in only.

Thorn Electrical Industries Ltd. showed a Miniature Digital Indicator which offers the figures 0 to 9, a decimal point and a minus sign in a window space which is only  $\frac{1}{2}$ in square. Engraved characters on thin acrylic sheets are edge-lit by "Wheatear"

lamps on printed circuit boards. Overall depth, including the printed edge connectors, is  $1\frac{1}{4}$ in.

The Marconi Company exhibited many micro-miniature components including a complete 100 Mc/s amplifier in a TO-5 can. The Microelectronic Division of Marconi, which was formed at the end of 1964, is now concentrating on micro-circuits and components for the new MYRIAD computer, some of these being available to outside customers.

What are described as the world's smallest ferrite cores for computer storage were shown, in an experimental matrix plane, by Mullard Ltd. These cores at 0.014in in diameter, 0.006in less than the smallest hitherto made, and they can switch in less than 0.15 $\mu$ s.

The manufacture of these tiny components requires bench magnifying equipment to enable the operator to handle them, and a range of magnifiers for production line use was exhibited by Vision Engineering Ltd. This company showed their new Stereoscope instrument which, by making the magnified image appear at infinity, enables both eyes to be directed forwards instead of inwards as occurs with standard stereo microscopes. Operator fatigue is reduced in consequence. It is not even necessary to employ eyepieces and the operator's head may be a comfortable distance away from the viewing aperture.

## Measuring Equipment

New in the range of measuring equipment offered by Avo Ltd. is the general purpose transistorised Multimeter type HI.108, which has been especially designed for the electronic engineer. This has an input resistance of 1M $\Omega$  per volt up to 30 volts, after which it remains constant at 30M $\Omega$ . The ranges offered are 100mV to 1,000V a.c. or d.c. in nine ranges, 30 $\mu$ A to 3A a.c. or d.c. in eight ranges, and zero to 20M $\Omega$  in three ranges. Also new were the Avo In-Circuit Transistor Tester for small to medium power p.n.p. or n.p.n. transistors, and a happily named Holiday Detector, for the detection of "holidays", or flaws, in the protective coating of pipe lines. The famous Avo Model 8, which is now in Mk. III, was also exhibited.

Dynamco Systems Ltd. had their Heat Transfer Meter model 5900 on display. This device may be used to quickly measure the thermal resistance and thermal mass of transistor heat sinks, and it obviates the complex equipment and long periods of time which have previously been required for such evaluations. A probe unit on the end of a flexible cable is bolted to the heat sink it is intended to check, whereupon heat is applied by a servo-controlled heating element and temperature is measured by a thermistor. The results are displayed



on a large meter on the main instrument box.

Eddystone Radio Ltd. (previously Stratton and Company Ltd.) showed their new Edometer Test Instrument, Cat. No. 902. This is a small and very neat transistorised version (with extra features) of a valve grid-dip oscillator, and it offers the following facilities: standard dip oscillator, absorption wavemeter, heterodyne wavemeter, simple signal generator (modulated or unmodulated), modulation monitor, and audio tone signal source. Incorporated in the circuit are an AFZ12 r.f. oscillator, an OC71 combined a.f. amplifier and tone generator, and two OA70's in a voltage doubler rectifier circuit whose input is derived from the r.f. tuned circuit and whose output feeds the meter. An OAZ204 zener diode stabilises battery supply voltage. Seven plug-in coils are provided, five of which give continuous coverage from 1.6 to 115 Mc/s. Coils 6 and 7 are mainly for alignment purposes with the instrument functioning as a signal generator, and they cover 1,700 to 390 kc/s.

Described as "the first ready-for-use British oscilloscope under £25" was the new Serviscope Minor by Telequipment Ltd. It is intended for educational and general purposes. This new oscilloscope is available at £23 10s., weighs only 5lb and measures 5½in wide by 6in high and 9in deep. The direct-coupled Y amplifier has a bandwidth of 30 kc/s and time base sync is automatic, thereby easing control and making operation simpler for students when the oscilloscope is used for educational purposes. Screen diameter is 2½in.

#### Receiver Equipment

Introduced as new by Jackson Bros. (London) Ltd. are two 3-gang variable capacitors. One of these is the type P.30, with a minimum capacitance per section of 8.5pF and a swing of 320pF. The rotor is driven by a stainless steel shaft through an integral gear for which two reduction ratios, 3:1 or 7:1 are available. The capacitor can also be produced for f.m. use, the minimum capacitance swing per section then being 14.5pF. Trimmers can be fitted, if required. The second new variable capacitor, the type C.21, is a very small component which has been designed expressly for use in transistorised v.h.f. f.m. tuners. Dimensions are 0.64in wide, 0.809in high and 1.45in long. Also available is a 2-gang version which is, of course, smaller again. The capacitance swing per section is 14.5pF with a minimum of 3pF, and there is an integral 3:1 reduction gear. An important feature is that mechanical resonance in the structure has been obviated, thus minimising the effects of vibration.

Transistorised equipment requires batteries to drive it, and Ever Ready demonstrated their 12-volt battery type TV1 running a 6in portable TV receiver reproducing the I.T.V. programme. Also featured on the Ever Ready stand were their "High Power" cells, these employing a construction which replaces the normal electrolytic paste with a paper laminate. It is stated that for the majority of purposes the new cell gives between four and five times the working

life of a standard unit. In the case of some battery-operated toys, the new cells would last as much as twenty times as long as normal types. The cells are available in type HP2 to replace the normal U2, type HP11 to replace the U11, and HP16 to replace the U16. The HP2 and HP11 are leakproof under normal conditions of use.

Another new exhibit on the Eddystone Radio stand was the new Eddystone receiver model 990S. The provisional specification includes: coverage of 230 to 870 Mc/s in two ranges; an i.f. of 36.5 Mc/s; a.f. outputs at 3Ω, 600Ω and Low-Z for telephones; a.m. or f.m. reception; i.f. bandwidths of 1 Mc/s and 6 Mc/s; a video output matching into a 1kΩ load; the ability to be incorporated (with other standard Eddystone equipment) into a panoramic display assembly; and calibration accuracy within 1%, with crystal markers available at 50 Mc/s intervals.

#### Other Components

The semiconductor with the mostest is, probably, the new Mullard M-O-S transistor which has an input resistance of  $10^{12}\Omega$ . (M-O-S stands for Metal-Oxide-Semiconductor—see "New Semiconductor Device With a Million Megohm Input Impedance", by J. B. Dance, in the January 1965 issue.) A striking demonstration of this transistor's performance was given by an exhibit in which visitors were invited to light a candle. Above the wick of the candle were mounted two bare wire electrodes spaced about ¼in apart. Bringing a lighted match to the candle ionised the air above its wick, whereupon the tiny current that could consequently flow through the air between the electrodes was sensed by the M-O-S transistor which, by way of an amplifier, opened a shutter and released a current of air. The latter blew out the match and prevented the candle being lit. The M-O-S transistor employed was the development type 95BFY.

High powers at v.h.f. are falling more and more within the domain of the transistor and, amongst many other Mullard types shown, were the new planar power types 94BLY (development) and the BLY14. The former gives 6 watts output at 180 Mc/s and the latter 3 watts output at the same frequency.

"Rubber magnets" used to be a joke but they are now a reality. This new departure was shown by James Neill & Company, who produce the well-known Eclipse range of magnets. The flexible magnets are available in the form of "tiles" measuring 6in square and 0.04in thick. They are very nearly as flexible as normal rubber and, if held against any flat ferrous surface, remain held there by their own magnetism. The tiles may be cut with scissors, whereupon each section still shows the same magnetic properties. The magnetic material in the tiles is synthetic barium ferrite (Feroba), a dense brown powder which, after milling to a very fine particle size, may be compounded into a p.v.c. or rubber mixture. The p.v.c. or rubber accepts 80 to 90% of ferrite by weight. The magnetic sheet is

*(continued on page 853)*

# SIMPLE VALVE HEATER TESTER

By P. BUTLER, A.M.I.P.R.E.

*A simple device which considerably reduces the time involved in chasing the suspect valve in an open-circuit heater chain. It caters for nearly all valves likely to be encountered during servicing*

HAVING HAD A SUCCESSION OF OPEN-CIRCUIT heater chains in one day, I felt it was time I started thinking out a device to shorten the time taken to locate the faulty valve. From experience, most service engineers still remove each valve and then struggle to hold it steady whilst applying the meter leads to the appropriate pins. Meter terminations can vary from delicate pin-like prods to something the size of battery charger

crocodile clips! This proceeding can, and often does, lead to misleading readings; since with the B9A and B7G range of valves it is very easy to short-circuit the meter leads and miss the open-circuit heater.

## Continuity Check

Having assessed the situation, the next thing was to find out a method which not only cut down the time, but also ensured an almost foolproof method of obtaining a continuity check. It had the following specifications in mind:

- The tester must not take up too much space. (There is little spare room in our portable valve-cum-spares box.)
- It must not weigh much. (The above-mentioned box is as much as I can manage now.)
- It must be self-contained.

In a moment of inspiration the idea came. (Service engineers do have them you know!)

As will be seen from the diagram the unit is simplicity itself.

Since one will be carrying a meter anyway there is no point in burdening oneself with further meters or batteries. The tester simply extends the usefulness of the existing meter.

It will be seen that, with the two-way switch in position "A", all the valve heater sockets are in parallel so that nearly all valves in current use can be plugged in. An immediate indication will be given, not forgetting, of course, to clip the wander leads to the meter with a suitable ohms range selected. By putting the switch to position "B", all the other electrodes are tested for short-circuits or leakage to one side of the valve heaters.

The valves which can be checked by the tester are, of course, those whose heaters are brought out to pins 2 and 7 for International Octal, 1 and 8 for Mazda Octal, 3 and 4 for B7G, and 4 and 5 for B9A. This covers almost all valves likely to be met during servicing.

The whole unit was mounted in an electrical conduit box measuring 6 x 3 x 2in, with the valve-holders and switch mounted on the lid and with the wander leads brought out of a hole at the side.

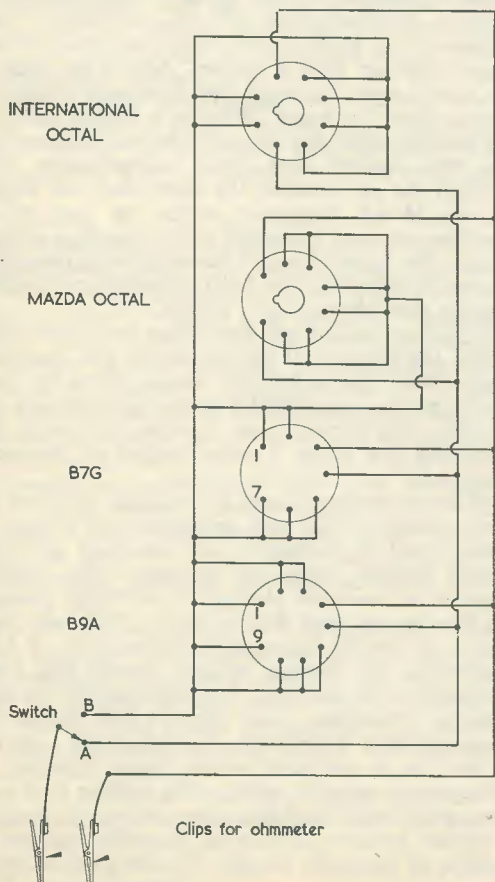



# SIMPLE TRANSISTORISED SHORT WAVE CONVERTERS

By A. S. CARPENTER, A.M.I.P.R.E.

*Two simplified units that can be used with conventional medium and long wave superhet receivers*

**A**DDING SHORT WAVE FACILITIES TO A CONVENTIONAL medium and long wave superhet receiver, whether transistorised or otherwise, is an attractive proposition. It is, now, also a practical one due to the availability of short wave coils and transformers suitable for use in transistorised converters. Transistors suitable for short wave work are also easily obtainable and are not unduly expensive.

Generally speaking there are two ways in which a broadcast band radio receiver can be utilised for short wave reception, and these are:

- (1) The audio stages it contains may be fed from a separately built short wave tuner, or
- (2) The complete receiver may be fed from a separately constructed short wave converter.

Method (2) is here considered the most satisfactory, since it requires no alterations whatsoever to the existing receiver, provided this has a suitable injection point for the converter output such as aerial and earth terminals or a car aerial input socket. The second method is to be preferred also on the grounds of overall sensitivity. The existing receiver should be a superhet; if simpler t.r.f. or reflexed types are employed erratic results may be given.

## Converter Function

For the benefit of the uninitiated it may be said that all conventional superhet receivers contain converters, and that signals received via the aerial system are frequency converted to the receiver intermediate frequency. If the tuning dial pointer is rotated to select a station on say 1.5 Mc/s (1,500 kc/s), and assuming an i.f. of 470 kc/s, the local oscillator in the receiver will inject another signal of 1,970 kc/s to form a frequency combination in which 470 kc/s will be present ( $1,970 - 1,500 = 470$ ). Such a signal will be acceptable to an i.f. amplifier fixed-tuned to this frequency and it will then be passed, after amplification, to the detector and audio stages.

A short wave converter may perform a similar function. It is tuned over the various short wave bands and provides at its output a signal frequency capable of being tuned in on a broadcast band

receiver. Most medium and long wave receivers can be tuned to 1.6 Mc/s (1,600 kc/s) and it is only necessary, therefore, to convert all the short wave transmissions to this frequency, whereupon the receiver will automatically re-convert them to its own intermediate frequency and pass them through its amplifying and detector stages to the loudspeaker.

Because the only interconnection is a lead to convey the short wave converter output to the broadcast band receiver, the two pieces of apparatus may be kept entirely separate from each other. The receiver can be used for normal purposes as required without the converter connected, but the converter is, of course, useless on its own.

## Some of the Requirements

The requirements of the converter depend largely on individual needs. Some users will want full band coverage whilst others will be content with amateur band facilities. Fortunately, ready-made transformer coils are available for both cases and the only difference in the converter design is centred on the value of the capacitor used for tuning. When partial band coverage is adequate, tuning is simplified and a rather higher efficiency is obtained, but when full coverage is required extra care is necessitated regarding the drive mechanism. Band changing also requires consideration but is simplified if a "plug-in" system for the coils is adopted.

## A Practical Circuit

The converter circuit depicted in Fig. 1 represents a very simple design since only one transistor is needed. Partial band coverage results in this version due to the rather low value tuning capacitance, a miniature 75+75pF 2-gang capacitor being employed. The triple-wound transformer coil  $T_1$  carries, in addition to its tuned winding, aerial and transistor base feed windings of the correct ratios. Transformer  $T_2$  is also triple-wound, its windings being correctly sensed to allow oscillation to occur. Both  $T_1$  and  $T_2$  are fitted with pins that will fit a Noval (B9A) valveholder so that they may be used for the plug-in application referred to earlier. The tuned circuits are so arranged that selected signals received via the aerial are changed to 1.6 Mc/s.

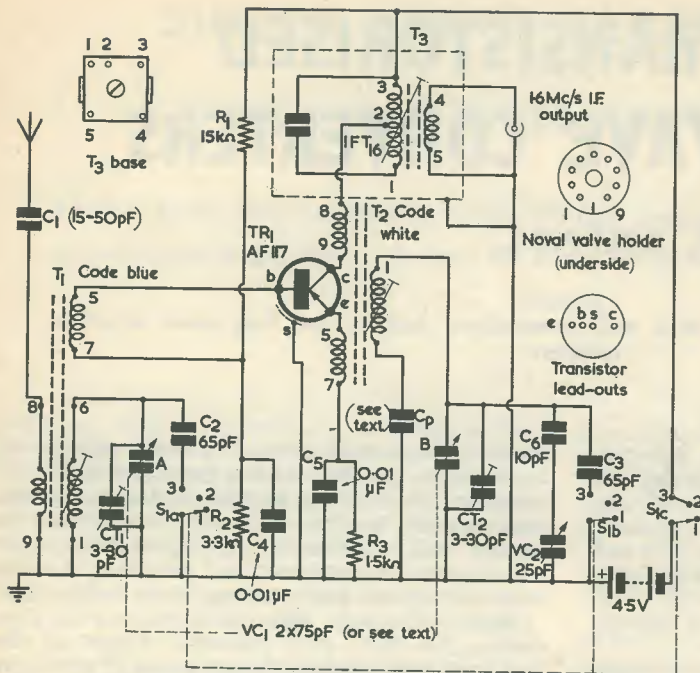

Fig. 1. A simple single transistor short wave converter

$T_3$  is tuned to this frequency, and its low impedance secondary passes the converted signals to the following receiver.

#### Bandspread and Band Coverage

Because  $VC_1$  is relatively low in value adequate bandspreading can be achieved mechanically by using an epicyclic slow-motion drive with a ratio of about 6:1, together with a variable oscillator frequency control. The latter, provided in Fig. 1 by  $VC_2$  in series with  $C_6$ , gives only a small amount of frequency variation.

#### Components List (Fig. 1)

##### Resistors

(All resistors  $\frac{1}{8}$  watt 10%)

$R_1$  15k $\Omega$

$R_2$  3.3k $\Omega$

$R_3$  1.5k $\Omega$

##### Capacitors

$C_1$  15-50pF ceramic or silver-mica<sup>1</sup>

$C_2$  65pF 5% silver-mica<sup>2</sup>

$C_3$  65pF 5% silver-mica<sup>2</sup>

$C_4$  0.01 $\mu$ F ceramic or paper

$C_5$  0.01 $\mu$ F ceramic or paper

$C_6$  10pF silver-mica

$C_p$  See Table I

$CT_1$  3-30pF trimmer

$CT_2$  3-30pF trimmer

$VC_1$  75+75pF 2-gang variable<sup>2</sup>

$VC_2$  25pF variable. Jackson Bros. "Air Tune" type C804

##### Inductors

( $T_1$  and  $T_2$  are Denco Miniature Transistor Dual-Purpose type)

$T_1$  Code blue, ranges 3, 4 and 5

$T_2$  Code white, ranges 3, 4 and 5

$T_3$  Denco miniature 1.6 Mc/s i.f. transformer type IFT.16

##### Transistor

$TR_1$  AF117

##### Switch

$S_1$  3-pole 3-way rotary<sup>2</sup>

##### Ball Drive

Jackson Bros. Cat. No. 4511

##### Battery

4.5 volt Ever-Ready type 1289 or similar

##### Miscellaneous

2 low-loss B9A valveholders

Aerial and earth sockets

Control knobs

Baseboard, panel, etc.

In the prototype the 75+75pF tuning capacitor was taken from a surplus RF27 unit,<sup>1</sup> and the total tuning capacitance (including strays) offered to the aerial and oscillator circuits is of the order of 30 to 105pF. To increase the range, the additional capacitance offered by  $C_2$  and  $C_3$  may be switched into circuit. If full coverage is required, a 300+300pF (nominal) capacitor may be used, and the manufacturers of the coils recommend that this have a minimum capacitance of approximately 11pF and a maximum capacitance of approximately 315pF. With stray and trimming capacitances, the total tuning range may then be made 39 to 352pF. A 500+500pF 2-gang capacitor may also be employed, a 0.01 $\mu$ F silver-mica capacitor being inserted in series with each section. It should be noted that higher value tuning capacitors will necessitate the use of a slow-motion drive with a much higher ratio than that used in the writer's model. They may also require more chassis space.

In Fig. 1  $VC_2$  functions as a fine tuner and enables good results to be obtained on the different ranges. Its shaft should be brought out to the panel and fitted with a pointer knob traversing a small scale graduated from 0 to 10.<sup>2</sup>

The approximate coverages obtainable with the coils specified are shown in Table I figures both for full (300pF tuning capacitor) and reduced (75pF

<sup>1</sup> RF27 units are available, at the time of writing, from Crystals and Components Ltd., 2-4 Earham Street, London, W.C.2.

<sup>2</sup> Suitable scales for this and for the main tuning scale may be obtained from "Panel-Signs" Transfers No. 6, obtainable from Data Publications Ltd., 57 Maida Vale, London, W.9.

<sup>1</sup> Fit value which gives optimum selectivity with aerial employed.

<sup>2</sup> These components not needed when a large-value capacitor is fitted in place of  $VC_1$ .  $S_1$  is replaced by a 1-pole 1-way on-off switch.



tuning capacitor) ranges being given. Actual coverages might differ slightly due to circuit capacitances and strays, etc., and it should be remembered that the variable dust cores provided allow a  $\pm 15\%$  inductance variation in most cases. The necessity for short and direct wiring is of importance and in the test model no signal-carrying lead, except that for the output signal, was longer than 1 in. Column 6 of the table shows that different oscillator coils employ different pins for the padding capacitor. It will be noted that there are gaps in column 4 and that reception of the 7 Mc/s band is not possible with the capacitance value shown. This band is catered for, however, when  $C_2$  and  $C_3$  are switched into circuit by  $S_{1(a)}$  and  $S_{1(b)}$ . The 1.8 to 2 Mc/s band cannot be received with the tuning capacitance values shown in Fig. 1.

### Mechanical Notes

The components required for the converter are small and light, and the unit can be constructed quite simply using an oddment of Paxolin as a baseboard to which is affixed a small panel. Suitable sizes are  $6 \times 3\frac{1}{2}$  in and  $6\frac{1}{2} \times 4$  in respectively, and were those employed with the test model. It should be noted that a larger overall size may be required if a larger value tuning capacitor is used.

The panel controls are Tuning, Fine Tuning and On/Off/Range. The aerial socket may also be fitted to the panel.

The baseboard is drilled to accept two B9A valveholders. The tuning capacitor is also fixed to the baseboard, leaving sufficient space for the 4.5 volt battery to stand alongside. Transformer  $T_3$  is located at one corner whilst the transistor body stands neatly above the board between the two valveholders. The layout of the unit is given in Fig. 2.

### An Improved Converter

The circuit shown in Fig. 1, although simple and effective, has limitations. Also, because no radio frequency amplifying stage is fitted, danger of oscillator radiation is present. Considerable benefit results from using a tuned r.f. stage and sensitivity is greatly increased. The overall cost is increased as well, of course, this being due to the extra transistor plus 3-gang tuning capacitor and additional coils which are required. In all, nine coils are needed to enable the converter to tune continuously from 1.67 to 31.5 Mc/s, three being required on each of the three bands.

Because of the continuous tuning facility it will be necessary to use a good quality reduction mechanism and the Jackson Bros. "Caliband" drive can be recommended since the two separately driven pointers with which it is fitted have ratios of 6:1 and 48:1.

### The 2-Transistor Circuit

A 2-transistor circuit is given in Fig. 3, in which  $TR_1$  is the r.f. amplifying transistor, this stage being tuned by one section of  $VC_1$ . A variable r.f. gain control,  $VR_1$ , is fitted in the transistor base circuit.

The 1.6 Mc/s trap situated in the aerial input lead might not always be required and may be omitted—at the start anyway.

The amplified r.f. present at the collector of  $TR_1$  is fed to the base of the mixer/oscillator ( $TR_2$ ), whereupon oscillations produced in the collector/emitter feedback circuit via  $T_3$  allow a 1.6 Mc/s output to appear which is passed, as in the simpler circuit of Fig. 1, to the output transformer,  $T_1$ .

The problem of trimming arises due to the use of plug-in coils but is largely resolved by including a panel-fitted oscillator control. This is designated  $VC_2$  and allows the oscillator circuit to be brought into line manually with the interstage circuit. Due to the aerial the first stage is damped and does not tune very sharply. Nevertheless, this stage can be brought up to optimum resonance—if an extra control is not objected to—by fitting a 30pF variable trimmer on the panel in place of  $CT_1$ .

The aerial and interstage coils are colour-coded blue and yellow respectively on all ranges, whilst the oscillator coils are coded white. The valveholders used to accept the oscillator coils may be permanently wired up with appropriate padder capacitors as specified in Table 1, the same oscillator coils being employed as in Fig. 1.

### Mechanical Notes

The largest components in this assembly are the tuning capacitor and dial mechanism but once again the use of a baseboard and Paxolin panel can be

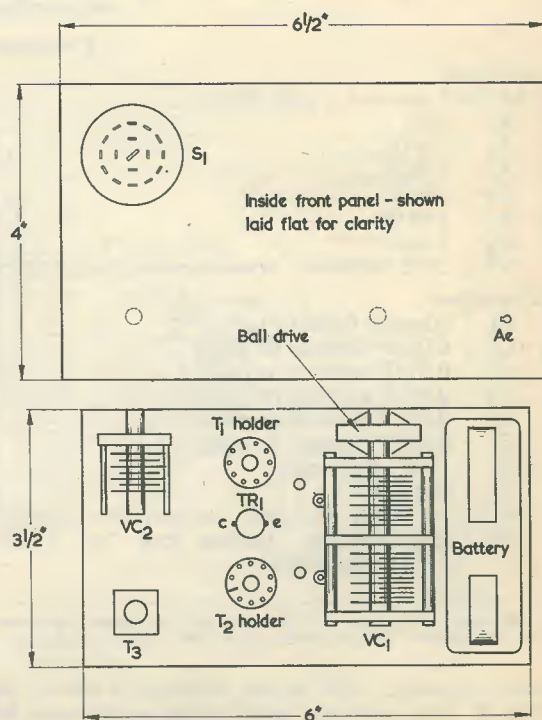

Fig. 2. A suitable layout for the converter of Fig. 1

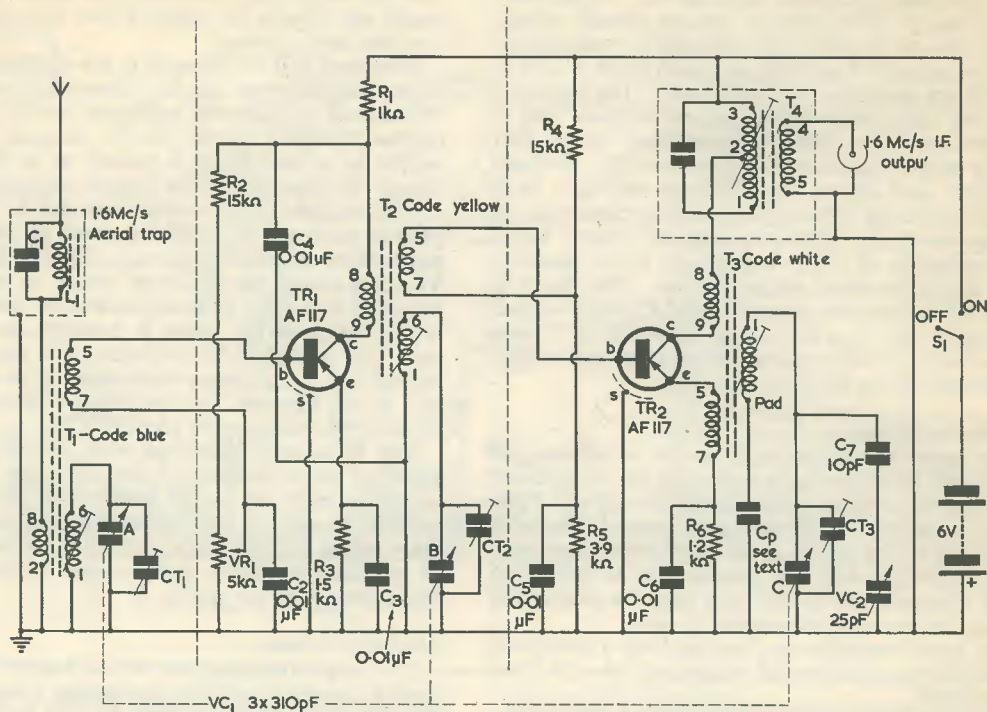

Fig. 3. A 2-transistor converter. The pin numbers for  $T_4$  are the same as those for  $T_3$  in Fig. 1. The 1.6 Mc/s aerial trap given by  $L_1$  and  $C_1$  is optional

#### Components List (Fig. 3)

##### Resistors

(All fixed resistors  $\frac{1}{8}$  watt 10%)

- $R_1$  1k $\Omega$
- $R_2$  15k $\Omega$
- $R_3$  1.5k $\Omega$
- $R_4$  15k $\Omega$
- $R_5$  3.9k $\Omega$
- $R_6$  1.2k $\Omega$
- VR<sub>1</sub> 5k $\Omega$  miniature potentiometer, linear track

##### Capacitors

- $C_1$  Already fitted to  $L_1$ \*
- $C_2$  0.01 $\mu$ F ceramic or paper
- $C_3$  0.01 $\mu$ F ceramic or paper
- $C_4$  0.01 $\mu$ F ceramic or paper
- $C_5$  0.01 $\mu$ F ceramic or paper
- $C_6$  0.01 $\mu$ F ceramic or paper
- $C_7$  10pF silver-mica
- $C_p$  See Table I
- VC<sub>1</sub> 3 x 310pF variable. Jackson Bros. type F3
- VC<sub>2</sub> 25pF variable. Jackson Bros. "Air Tune" Cat. No. C804

\* $L_1$  (and  $C_1$ ) are optional. If employed,  $L_1$  is screened by one of the cans supplied with the dual-purpose coils.

##### Transistors

- TR<sub>1</sub> AF117
- TR<sub>2</sub> AF117

##### Switch

- $S_1$  1-pole 1-way on-off switch

##### Dial and Drive

- Jackson Bros. "Caliband" drive (Cat. No. 4838) complete with glass, knobs and escutcheon

##### Battery

- 6 volt Ever-Ready type PP1 or similar

##### Miscellaneous

- 3 low-loss B9A valveholders
- Aerial and earth sockets
- Control knobs
- Baseboard, panel, etc.

##### Inductors

( $T_1$ ,  $T_2$  and  $T_3$  are Denco Miniature Transistor Dual-Purpose type)

- $T_1$  Code blue, ranges 3, 4 and 5
- $T_2$  Code yellow, ranges 3, 4 and 5
- $T_3$  Code white, ranges 3, 4 and 5
- $T_4$  Denco miniature 1.6 Mc/s i.f. transformer type IFT.16
- $L_1$  Denco 1.6 Mc/s filter coil type IFF1/1.6\*

recommended. The layout adopted is shown in Fig. 4, this permitting short wiring which may be supported on tagstrips and on unused tags of the holders associated with  $T_1$  and  $T_2$ . Small screens

of aluminium 2in high should be fitted as shown and brought close up to VC<sub>1</sub>. The baseboard should have a  $1\frac{1}{2}$ in deep runner fitted to its rear but the front can be panel-supported. Controls VC<sub>2</sub>, VR<sub>1</sub>



and  $S_1$  should be mounted below the chassis. The transistor bodies should remain above the board and coil sockets should be oriented as shown.

If—as may well happen—a 3 x 500pF (nominal) tuning capacitor is already to hand, this may be used in place of the specified type with 1,000pF silver-mica capacitors inserted in series with the leads to the fixed vane sections. The 3-gang capacitor may be fitted with trimmers, but the use of separate concentric 30pF trimmers is to be preferred.

### Setting-up Procedure

If no wiring faults can be found the converter may be connected to the receiver with which it is to be used by means of a short piece of screened cable.<sup>3</sup> If the receiver has a ferrite aerial turn it for zero signal pick-up when the dial pointer is at 1.6 Mc/s. The converter may then be switched on, whereupon a background hiss should be heard due to the oscillator. Fully engage  $VC_1$  and adjust the output transformer core for maximum noise and leave.<sup>4</sup> If no signal generator is available an approximate method of alignment must be tried, and this can yield quite good results. Sweeping  $VC_1$  through its full range of travel should cause lively noises to

<sup>3</sup> If the converter is used with an a.c./d.c. receiver, check that the aerial and earth terminals of the latter are fully and reliably isolated from chassis and the mains supply. The converter positive supply line should be connected to a reliable earth.—EDITOR.

<sup>4</sup> This assumes that no signal generator is available. Otherwise, use a 1.6 Mc/s modulated signal, or an unmodulated one if a visual tuning aid is fitted.

TABLE I  
Tuning Range and Padding Details

Denco Range No.	$L_s$	Mc/s covered 39–352pF	Mc/s covered 30–105pF	Value of padding capacitor	Padding capacitor pin No.
3	27.2	1.67–5.3	3–5.5	340pF	3
4	2.9	5.0–15.0	9.0–16.5	960pF	4
5	0.65	10.5–31.5	19.0–32.5	2,000pF	6

$L_s$  = nominal inductance value of tuned winding in  $\mu H$   $\pm 15\%$  variation due to core setting.

be heard from the receiver speaker, and trimmer and core adjustments may be made with these signals. The trimmers should be adjusted at the high frequency end of the scale and the coil cores at the low frequency end.

For best results, however, a signal generator is needed. Its output should be kept as low as is possible at all times during alignment.

Alignment of the r.f. stages is carried out using the inductor cores at the low frequency ends of the bands and in this case—if trimmers are fitted—start with the highest range to be used (Range 5) and with  $VC_2$  set to half capacitance.

The generator is then connected to the aerial via a standard dummy aerial or a 400 $\Omega$  resistor and set to the low frequency limit of the range being aligned.

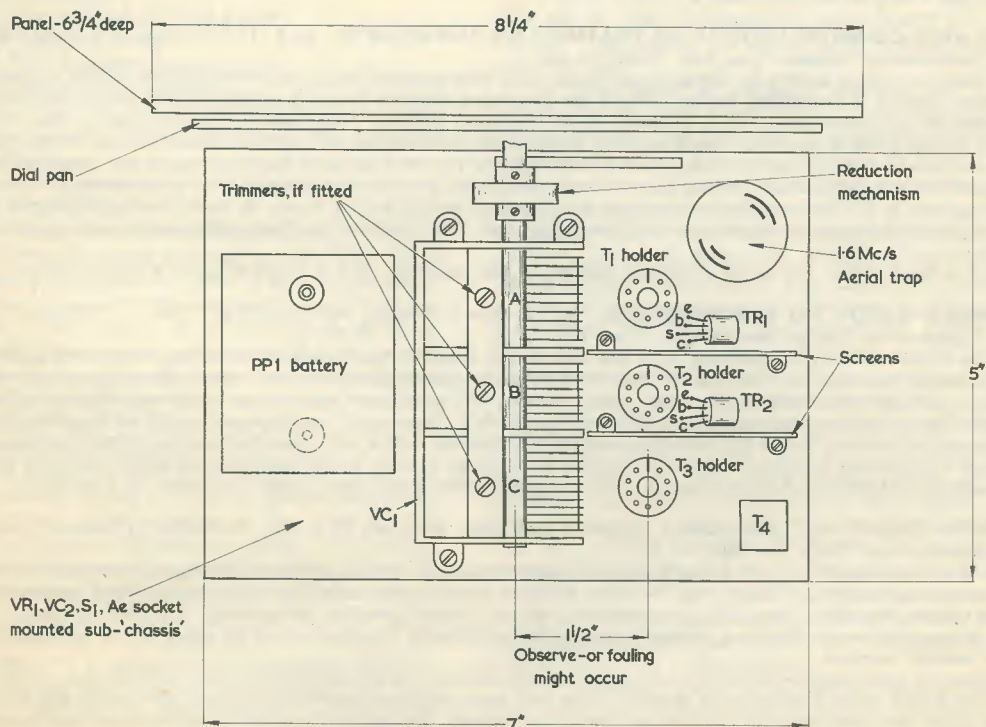

Fig. 4. The layout of the 2-transistor converter

TABLE II  
Alignment and Tracking Points  
(All frequencies in Mc/s)

Denco Range No.	Low Frequency		High Frequency	
	Band end	Tracking point	Band end	Tracking point
3	1.67	1.83	5.3	4.5
4	5.0	5.5	15.0	13.5
5	10.5	11.5	31.5	28.5

The vanes of VC<sub>1</sub> should be fully enmeshed.

The core of T<sub>3</sub> is then adjusted to receive the signal, whereupon it might be found that two responses are given. The correct one is that requiring the least core insertion.

The vanes of VC<sub>1</sub> are next fully disengaged and the generator set to the highest frequency limit of the band in use. Adjust the trimmers for maximum output. Repeat the core and trimmer adjustments.

The signal generator is now set to the low frequency tracking point as indicated in Table II and the signal tuned in on the converter. The cores of the aerial and interstage coils are then adjusted for maximum output.

The generator is next set to the high frequency tracking point and aerial and interstage trimmers adjusted for maximum response.

"Pulling" may occur when adjusting the cores to the low frequency tracking points but its effect may be overcome if the tuning capacitor vanes are rocked slightly during the alignment operation.

It is important that the oscillator operates on the high side of the signal frequency.

### Conclusion

Whilst a simple converter can never take the place of a good quality communications receiver it can definitely make possible reception of signals that would never be heard in other circumstances. Many constructors find short wave listening extremely fascinating and after a period of experimenting they find themselves drawn completely to the world of Amateur Radio.

EDITOR'S NOTE.—When plug-in coils are employed with a single set of trimmers, as occurs in the present instance, it is advisable to align the trimmers for the highest frequency range, whereupon alignment should be reasonably accurate for the lower ranges. Coils for the latter should, of course, have their cores adjusted. In Fig. 3 the panel trimmer VC<sub>2</sub> can act both as a bandspread control and as a trimmer to bring the oscillator into line with T<sub>2</sub> on the lower frequency ranges. Since the tuning drive gives a high degree of reduction, some constructors may prefer to dispense with VC<sub>2</sub> (and its series capacitor C<sub>7</sub>) and make CT<sub>2</sub> a variable panel component. CT<sub>2</sub> may then be set to an appropriate mark for each range.

## Recent Publications . . .

**DESIGN AND CONSTRUCTION OF TRANSISTOR SUPERHETS.** By R. H. Warring. 104 pages, 5½ x 8½ in. Published by Museum Press Ltd. Price 17s. 6d.

This book is written mainly for the amateur constructor who wants to build his own superhet, and its subject matter is, therefore, largely of a practical nature. There are two short chapters at the beginning which deal, firstly, with basic radio principles and the superhet and, secondly, with transistor theory. These occupy some 23 pages, after which the remainder of the book is devoted almost entirely to practical information on superhet construction. After two useful chapters on printed circuits and printed circuit assemblies, the various transistor superhet stages are described working from the ferrite rod aerial to the loudspeaker. Next dealt with are eleven professional or commercial circuit designs, of which four are by Mullard whilst the remainder are receivers available in kit form. In each case the full circuit diagram is given together with notes on circuit operation and alignment. The final chapter deals with general testing, servicing and alignment.

This is a book which will be of particular benefit to the beginner, and it is full of good practical advice.

**BEGINNER'S GUIDE TO ELECTRONICS.** By Terence L. Squires, A.M.Brit.I.R.E. 194 + viii pages, 5 x 7½ in. Published by George Newnes Ltd. Price 15s.

Due to a rather heavy programme over the last twelve months, the reviewer has to deal with this book a little later than would normally be the case. However, a delay in reviewing should not detract from the value which this book offers to those who want to learn the basic concepts and practice of electronics. *Beginner's Guide To Electronics* is not intended to replace text books but, rather, to provide a "short-cut" for those who wish to become acquainted with modern electronics. A non-mathematical approach, combined with a very clear text and excellent diagrams, jointly offer a most readable and informative book that covers a very large number of subjects, these ranging from basic electricity to such items as Dekatrons. Also included is a short chapter which gives useful advice on careers in electronics.

**FUN WITH RADIO.** By Gilbert Davey, edited by Jack Cox. 64 pages, 7½ x 10 in. Published by Edmund Ward (Publishers) Ltd. Price 13s. 6d.

One of the secrets of Gilbert Davey's high popularity amongst readers of *Boys' Own Paper*, for which he has been Radio Correspondent since 1946, is that he is an amateur home constructor having no professional connection with radio. He writes, therefore, from the same viewpoint as may be anticipated in his readers. The "Fun With. . ." series of books is intended mainly for boys, although the books may also, of course, be read by anyone with an interest in the particular subject covered.

The present book starts with a short, non-technical, introduction to set-building, and then carries on to the construction of crystal sets using a germanium diode. There are, next, battery-operated one-valve, two-valve and three-valve receivers, after which the building of mains equipment is covered, this section including constructional details for a two-valve and a three-valve receiver. Amplifiers follow, and the book concludes with building instructions for a five-valve mains superhet and a short chapter on transistors and transistor receivers.



# LASERS

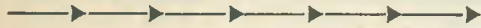

## Part 2

### The Types of Laser

By J. B. Dance, M.Sc.

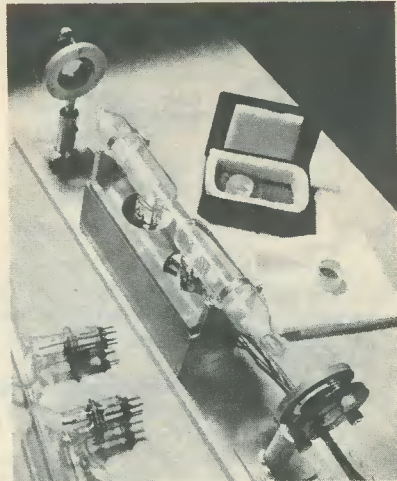

*In this series of three articles, our contributor has already discussed the phenomenon of stimulated emission of light in terms which may be readily appreciated by any reader who is familiar with basic electricity and the structure of the atom. This month the different types of laser currently in use are described*

**T**HERE ARE AT LEAST FOUR DISTINCT TYPES OF laser; these are:

- (1) The Doped Crystal Laser
- (2) The Gas Laser
- (3) The Semiconductor Laser
- (4) The Liquid Laser

These will now be considered in detail. In addition the Ring Laser will be discussed; this contains four gas lasers.

#### The Doped Crystal Laser

Doped crystal lasers are often referred to as solid state lasers, but the latter term is best avoided, since semiconductor lasers are a form of solid state laser. The first type of laser to be invented, the ruby laser, is a doped crystal laser. It is still the most commonly used type of laser, especially if high power outputs are required, partly because the crystal has good thermal properties. The ruby laser needs a fairly high input power, since it is a three level type and the efficiency is therefore fairly low.

In a ruby laser the active material is a crystal of ruby containing about 0.05% of chromium oxide which imparts a pink colour to the crystal, the remainder of which is aluminium oxide. The crystal is usually in the form of a rod about 2 to 20cm in length and about 0.2 to 3cm in diameter. Such crystals are specially grown and may have a value of some hundreds of pounds each when they are ready for use. The ends of the ruby rod must be carefully ground and polished to ensure that they are flat and parallel to each other. A coating is applied to one end of the rod which will reflect as much as possible of the incident light back along

the rod, whilst the coating at the other end is designed to transmit a few per cent of the incident light which falls on it. This transmitted light forms the laser output. The remainder of the light is reflected back into the ruby.

The ruby laser is normally pumped by a high power xenon flash tube similar to those used in photography. The flash has a duration of about a millisecond. The light output from the ruby laser is in the form of pulses, each pulse also having a duration of about a millisecond. It is not possible to operate such a laser continuously (that is, so that a steady output is obtained), since the heat evolved would damage the crystal. The maximum flash rate is often about two to three per minute, this being determined by thermal considerations. The flash frequency can be increased if the laser is cooled, for example by liquid air. At low power continuous operation has been achieved with suitable cooling.

The chromium atoms in the ruby crystal absorb light of wavelength about 5,500 Å (1 Å=1 Angstrom unit= $10^{-8}$ cm) in the blue-green region of the spectrum, this light being provided by the flash tube. This raises the energy level of the atoms to  $E_3$  in Fig. 10. Almost immediately the excited atoms lose part of their energy to the crystal, the temperature of which rises. The atoms now have an energy  $E_2$  which is a metastable state. Therefore the atoms can remain in this energy level for a comparatively long time (a few milliseconds).

If no radiation which is capable of causing stimulated emission arrives at the crystal, the atoms in the energy level  $E_2$  will emit radiation of a frequency  $(E_2-E_1)/h=431$  million megacycles, which corre-

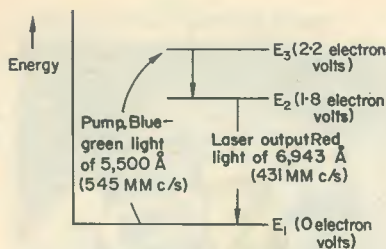

Fig. 10. The energy levels of a ruby laser

sponds to a wavelength of 6,943 Å. Thus the crystal glows with a red light of this wavelength. This red colour is the same as the normal red fluorescence of a ruby when examined in ordinary daylight, which acts as a weak pump.

If the pumping rate (or power input) is less than a certain value, the atoms in the ruby will return from E<sub>2</sub> to E<sub>1</sub> at random times. As soon as the pumping rate is great enough to cause population inversion between the states E<sub>2</sub> and E<sub>1</sub>, a photon of wavelength 6,943 Å is more likely to cause stimulated emission than to be absorbed by an atom in the ground state. Thus when a photon is produced by spontaneous radiation as an atom returns from the E<sub>2</sub> energy level to the ground state, this photon will probably cause stimulated emission. There is a high probability that the resulting photons will undergo further amplification by stimulated emission and thus a cascade process or chain reaction occurs which is very similar to the chain reaction in a chemical or atomic explosion. Many of the atoms in the energy level E<sub>2</sub> quickly lose their energy and an intense narrow beam of coherent radiation is produced.

The output of a ruby laser appears to consist of pulses which have a duration of about one millisecond. If, however, these pulses are examined more closely, it is found that they actually consist of a multitude of intensity peaks each of which has a duration of a few microseconds. As the intensity of light in the laser rises, the number of atoms in the E<sub>2</sub> level falls by stimulated emission until laser

action cannot continue. The output intensity then falls until the energy input to the ruby crystal from the flash tube has raised enough atoms into the E<sub>2</sub> level for further laser action to take place. This cycle occurs every few microseconds until the energy input from the flash tube falls.

### Optical Coupling

If a reasonable efficiency is to be obtained from a ruby laser, it is essential that a large fraction of the power output of the xenon flash tube should enter the laser crystal. The most efficient arrangement comprises an elliptical mirror with the flash tube at one focus of the mirror and the ruby crystal at the other focus (Figs. 11 (a) and (b)). As indicated in Fig. 11, any ray of light emitted by the flash tube will be reflected into the ruby crystal, since it is a property of elliptical mirrors that light radiating from one focus is reflected to the other focus. A rather simpler system consists of a flash tube and the ruby crystal at the centre of a circular mirror (see Fig. 12). The circular mirror is usually rather cheaper to produce than the elliptical mirror. In some lasers the flash tube is wound around the laser crystal in the form of a helix, but in this arrangement a considerable fraction of the flash tube output radiation is lost to the surroundings, since no external mirror is used.

### Output Power

In a typical ruby laser the flash tube provides about 200 to 2,000 joules of energy per flash, but the laser output is typically 2 to 50 joules per flash. A number of high energy lasers are available commercially, for example the laser with a 1,500 joule output per flash manufactured by Messrs. Maser Optics Inc. of Massachusetts, U.S.A. This laser requires an input of 120,000 joules per pulse which is obtained by discharging a 16,000μF capacitor initially charged to 4,000 volts through the flash tube.

The beam divergence of a typical ruby laser is a fraction of a degree at normal power levels, but this can be considerably reduced by operating the laser at low power.

Other types of doped crystal lasers employ elements such as neodymium, dysprosium, uranium or chromium in "host" materials such as calcium fluoride, calcium tungstate or glass. Some types of doped crystal laser can provide a continuous output beam instead of a pulsed output if they are operated at very low temperatures. Each type of laser material produces its own characteristic output frequency (i.e. colour) which varies slightly with temperature and with the geometrical arrangement of the laser oscillator.

The most commonly used material in a doped crystal laser after ruby is probably neodymium in glass. This gives an output at 10,630 Å in the near infra-red, but other materials such as uranium doped calcium fluoride give an output of still longer wavelength (25,600 Å).

The efficiency of doped crystal lasers is usually quite low, typical values for the ruby type laser being 1 to 5%.

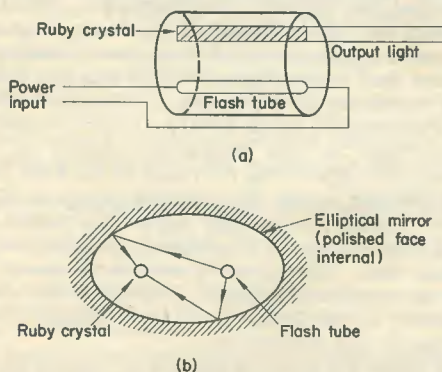

Fig. 11 (a). A ruby laser employing an elliptical mirror (b). Cross-section of the ruby laser and its elliptical mirror



## Q Switching

Doped crystal lasers are most useful for high power work where the pulsed output is no disadvantage. A technique known as "Q switching" or "Q spoiling" has been developed which allows almost all the energy stored in a ruby crystal to be given out in a very short time. Using this technique it is possible to obtain about one joule of energy in  $10^{-8}$  seconds<sup>11</sup>. This is a power level of 100 megawatts (which is of the same order as the power output of a typical power station), but it must be remembered that the laser output has a duration of only about  $10^{-8}$  second. The divergence of the beam may be only a few minutes of arc.

In the Q switching technique only one of the ends of the ruby crystal is given a mirror finish. Most of the light striking the other end from within the crystal is lost to the surroundings and thus the Q of the system is very low. When the flash tube operates, the ruby crystal of a laser in this state will store energy from the flash tube in the chromium atoms which are raised to the metastable state. Owing to the low Q, the amount of light oscillating in the system will be relatively small and therefore relatively few metastable atoms will lose their energy by stimulated emission. A rotating prism is placed at the end of the ruby which has no mirror surface, as shown in Fig. 13. At the instant this prism is rotated into the position shown, almost all of the light coming from the end of the ruby is reflected back into the crystal by the path shown. Thus the Q of the system is raised by a very large factor and laser action immediately takes place. Almost all of the energy stored in the atoms of the ruby crystal is released within a few nanoseconds and the power developed is therefore very high.\* When the light from such a laser falls on to an absorbing surface, the resulting shock wave may resemble a small detonation.

In a normal type of laser some stimulated emission takes place as soon as there are enough atoms in the metastable level. In a Q switched laser the energy is released in one large pulse.

In the Q switching system of Fig. 13, a pair of contacts on the spindle which carries the rotating prism is used to ignite the flash tube a fraction of a second before the prism reaches the position of high Q.

In another type of Q switching apparatus, no rotating prism is employed, but a high speed shutter is placed between one of the mirrors and the crystal. The shutter remains closed during most of the pumping flash so that very little light is reflected from the shutter end of the rod. When a large number of atoms have been raised to the metastable level, the shutter is quickly opened and the stored energy is released in a very intense pulse.

Mechanical shutters are comparatively slow and it is usual to employ the well-known Kerr Cell as part of the shutter. The Kerr Cell employs no moving parts and can operate very rapidly indeed; it is actuated by an applied potential.

\*1 nanosecond equals  $10^{-9}$  second, or one thousandth of a microsecond.—EDITOR.

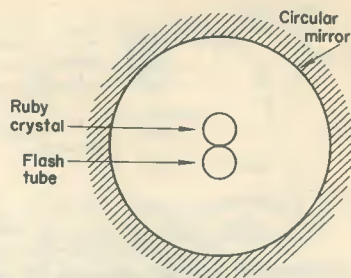

Fig. 12. A ruby laser with a circular mirror

A special passive Q switching device has recently been developed by Maser Optics Inc. A cell containing a certain liquid is placed between the laser material and one of the end mirrors. When the amount of light in the system is small (that is, whilst the ruby is building up its store of energy), the liquid absorbs much of the  $6,943 \text{ \AA}$  light from the ruby. Quite suddenly, however, when the rate of absorption of energy by the liquid exceeds a certain critical value, the liquid becomes completely transparent to the ruby radiation and the stored energy is suddenly released as a large pulse. The liquid then returns to its normal absorbing state.

Laser beams of still greater intensity may be generated by the use of a second crystal to amplify the beam from a Q switched laser<sup>10</sup>. The output from the Q switched laser is fed into the second ruby crystal which has no mirrors associated with it, and its ends are designed to prevent any appreciable reflection. The amplifier crystal is pumped by a separate flash tube. Thus a large number of chromium atoms in the second crystal are raised to a metastable state ready to give up their energy by stimulated emission when the flash from the Q switched laser arrives. Only the leading edge of the pulse from the first laser is amplified to any great extent, since the light reaching the second laser is so intense that most of the metastable atoms lose their energy before the end of the input pulse and are then in the right level to absorb the later parts of the pulse. Thus the second laser not only increases the intensity of the pulse, but it makes the pulse duration even shorter still.

Peak powers of about 500 megawatts in a beam of cross-section less than 1 sq. cm have been obtained by this technique<sup>10</sup>. Nevertheless it must be emphasised that this power output can be obtained only for an extremely short time, since the output energy per flash obviously cannot exceed the input energy per flash. It is sometimes stated that the output intensity from a doped crystal laser (power/



Fig. 13. Q switching with a rotating prism. The prism is shown in the high-Q position

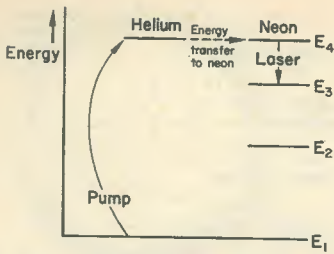

Fig. 14. A simplified diagram showing the energy levels in a helium-neon gas laser

unit area) is millions of times the output intensity from the surface of the sun. This statement is correct only if the output from the sun is considered to be that in the small band of frequencies comprising the laser output beam, the output at all other frequencies being disregarded.

### The Gas Laser

Although the construction and method of pumping of the gas laser is quite different from that of the doped crystal laser, the same general principle of amplification by stimulated emission is employed. Two gases are usually used in a tube between the mirrors, the most commonly used gas being a mixture of helium and neon. The pressure of the helium is typically 1mm of mercury and that of the neon about 0.1mm of mercury. The principle of operation of the helium-neon gas laser will be discussed in detail; other gas lasers employ somewhat similar mechanisms.

The pumping of a gas laser is normally effected by means of a pulsed or a continuous discharge through the gas. The collision of a gas molecule with a fast electron in the discharge raises the energy level of the gaseous atoms. In the case of the helium-neon gas laser, the electrical discharge raises the energy levels of the helium atoms as shown in the simplified energy level diagram of Fig. 14. The probability that the excited helium atoms, which are in a metastable level, will lose their energy by the emission of radiation is relatively small. Almost all of their energy is lost in collision with neon atoms which are thereby raised to the metastable state  $E_4$  of Fig. 14. It is very fortunate that the helium atoms in the excited state contain almost exactly the right amount of energy to raise the neon atoms to the level  $E_4$  and that the helium atoms are metastable.

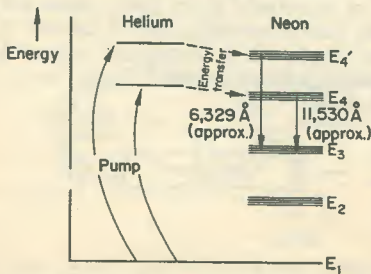

Fig. 15. The helium-neon energy level diagram

The energy level diagram of Fig. 14 is simplified, the actual energy level diagram for the helium-neon system being more like that of Fig. 15 (although this is still somewhat simplified). It can be seen that each helium atom is raised to one of two excited states and that the neon atoms are raised to the level  $E_4$  or  $E_4'$  according to the energy initially possessed by the helium atom in question. Laser action can take place between  $E_4$  and  $E_3$  or between  $E_4'$  and  $E_3$ , the respective wavelengths being about 11,523 Å (infra-red) and 6,329 Å (red). Oscillation will take place either in the infra-red or in the red region, whichever type of radiation the end mirrors will reflect. An output of 33,913 Å can also be obtained if the atoms in the  $E_4'$  level fall to a slightly lower level. The neon levels are not single levels, but each consists of a number of closely spaced sub-levels. Thus the actual output of the laser may consist of red, near infra-red or far infra-red light.

The power is usually supplied to a gas laser as about 100 watts of r.f. at a frequency of about 30 Mc/s. The r.f. voltage is supplied to electrodes clamped to the outside of the gas discharge tube. The output is continuous, but is only of the order of 50 milliwatts.

In a gas laser the density of the atoms is relatively low and the amplification of the light is therefore only a few per cent each time it passes through the gas discharge tube. This may be compared with the ruby laser where a gain of about two can be obtained each time the light passes through the laser material.<sup>12</sup> For this reason losses in a gas laser must be kept as small as possible and, in particular, the mirrors must return almost the whole of the light incident upon them to the gas-filled tube.

Special mirrors coated with dielectric films are employed, since they can reflect as much as 99% of the light striking them. The mirrors are coated with ten to thirty films of materials of high and low refractive indices deposited alternately on the surface of the reflector. The excellent reflecting properties of these mirrors for a selected wavelength of light depend upon the interference of light waves reflected from the interfaces of the film dielectrics. These dielectrics are usually transparent fluorides and sulphides. They can also be used to obtain a small amount of reflection, as in "bloomed" lenses. Their properties depend on the thickness and refractive indices of the films used. Spherical mirrors are usually employed in gas lasers, the radius of curvature of each of the mirror surfaces being made approximately equal to the distance between the two mirrors.

The spread of the output frequency of a gas laser is often limited by mechanical vibration of the reflectors used. (It was shown last month that an alteration of the reflector spacing would result in an alteration of the tuning of the laser.) Nevertheless the output of a gas laser is more nearly monochromatic than that of any other source of light, bandwidths of less than 1 c/s being obtainable. Changes of temperature cause expansion and are therefore likely to cause an alteration of the output frequency. A change of about  $10^{-5}$  cm in the dis-



tance between the two mirrors can produce a frequency change of the order of one hundred megacycles.

The two mirrors are sometimes used as the ends of the gas-filled tube, but in many gas lasers the mirrors are placed outside the ends of the tube so that the distance between them can be more accurately controlled. In this case the windows at each end of the gas-filled tube must be optically flat. They cannot be placed perpendicular to the axis of the tube since the light loss by reflection would then be considerable. The windows must be inclined to the axis of the tube at an angle known as the Brewster angle; the tangent of this angle is equal to the refractive index of the window material. A typical system of this type is shown in Fig. 16. The two windows allow light which is polarised in one particular plane to pass through them without reflection. In the case of other planes of polarisation, the losses are so great (due to reflection at the windows) and the Q so low that negligible laser action occurs. Quartz windows and a quartz tube are usually used, since glass windows convert an appreciable fraction of the light energy into heat.

The length of the gas-filled tube is normally about one metre. The tube diameter should not be too large. This is because, when atoms which are in the  $E_3$  energy level (Figs. 14 and 15) collide with the walls of the tube, they return to the ground state and give their energy to the wall. The use of a fairly narrow tube ensures that the atoms make frequent collisions with the walls of the tube and consequently there are relatively few atoms in the  $E_3$  energy state to absorb the output light. The optimum gas pressure is inversely proportional to the radius of the tube.

The gas laser is capable of continuous operation. The frequency spread of the output light can be made less than 1 c/s, but a greater output power can normally be obtained if oscillation occurs at several frequencies simultaneously. The helium-neon laser is by far the most commonly used type of gas laser, but laser action has been obtained using oxygen mixed with either neon or argon. In addition, the gases helium, neon, argon, krypton, xenon and caesium vapour have been used alone as laser materials. Caesium vapour may be pumped optically, but the other gases are pumped by means of an electrical discharge. Many commercial gas lasers are designed so that they can operate at one of a number of frequencies which can be selected by an appropriate choice of mirror coatings.

### Semiconductor Lasers

The semiconductor laser, invented in 1962, consists of a p-n junction in a semiconductor material such as gallium arsenide. A cubical shaped piece of the semiconductor material may be used, the sides of which are each a fraction of a millimetre in length (see Fig. 17). Two opposite edges of the crystal are highly polished and form the resonant system of the laser. The two other edges are left rough. No coating is required on the polished edges since the semiconductor material is itself an excellent

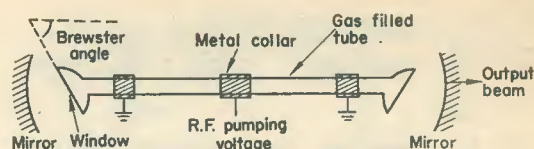

Fig. 16. A gas laser

reflector. The junction region itself is only about  $1/10,000$ in in depth, but must form a smooth resonator with parallel faces.

The semiconductor laser is operated by passing a fairly large current through the junction in the forward direction. Infra-red radiation (of about  $8,400 \text{ \AA}$  in the case of gallium arsenide) is emitted from the junction and, at current densities exceeding about 10,000 amps per sq. cm of the junction area, the whole of the radiation emitted is fairly coherent. The actual current required is not excessive, since the junction area is very small. Smaller current densities can be used at low temperatures.

Free electrons in the conduction band of a semiconductor material have more energy than those in the valency band. If these free electrons are injected from the n region into the semiconductor junction and combine with (one might say "fall into") holes, a portion of their energy is converted into photons. The injection of the electrons into the junction is comparable with the pumping process in the lasers discussed previously. The large number of photons produced at high current densities can stimulate further electrons to combine with holes. Photons are thus produced and in turn they can stimulate the production of further photons. Laser action will take place at the junction only if the number of electrons in the conduction band exceeds the number in the valency band; this condition will be satisfied at high current densities when large numbers of electrons in the conduction band are injected into the junction.

In most lasers the electrons are bound in atoms, but in the semiconductor laser it is the energy of the free electrons in the conduction band over those bound in the crystal lattice which is used to achieve laser action. The semiconductor laser has the advantages that the injection or pumping can be accomplished directly by means of an applied potential and the efficiency is high, since nearly every electron injected into the junction results in the emission of a photon.

Semiconductor lasers can only be operated under pulsed conditions at room temperatures or they will become overheated. They are more commonly

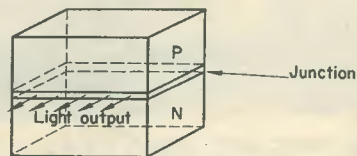

Fig. 17. A semiconductor laser. The front and rear faces are polished. The output is emitted in a direction perpendicular to the front face

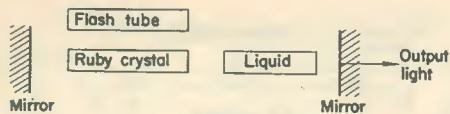

Fig. 18. A liquid laser. The mirror system around the flash tube and ruby crystal has been omitted

operated continuously at liquid air or liquid helium temperature in order to obtain much higher efficiencies. The semiconductor laser can be encapsulated in a normal transistor case; it has a much greater efficiency (up to 70%) than the doped crystal or gas laser and requires a small amount of input power. Nevertheless the gallium arsenide laser cannot provide as much output power as the ruby or the gas laser and the beam width is greater than that of other types of laser owing to diffraction effects at the junction face. The frequency is relatively unstable owing to heating effects, etc., and the spectral width is of the order of 100,000 Mc/s. The most important advantage of the semiconductor laser is probably the ease with which the output light can be modulated up to at least some hundreds of megacycles. Modulation is accomplished merely by altering the current passing through the device.

Gallium arsenide is the most commonly used semiconductor laser material, since its properties are well known and it is fairly easy to fabricate. Other materials which have been used are indium phosphide, indium antimonide, and indium arsenide. Some variation of the output frequency can be obtained by the addition of phosphides to the semiconductor material. For example, it has been found that radiation of any wavelength between 6,200 and 8,400 Å can be produced by variation of the ratio of gallium arsenide to gallium phosphide in the semiconductor material. Gallium arsenide/indium arsenide can be used in the same way in the range 8,400 to 31,000 Å. Some variation of frequency can also be achieved by alteration of the operating temperature.

If an attempt is made to employ common semiconductor materials, such as germanium and silicon, in a semiconductor laser, no laser action will be obtained. In these semiconductor materials electrons and holes can recombine only if they interact with the atoms in the crystal lattice. Instead of the energy being converted into light, it is changed into vibrations of the crystal lattice and eventually be-

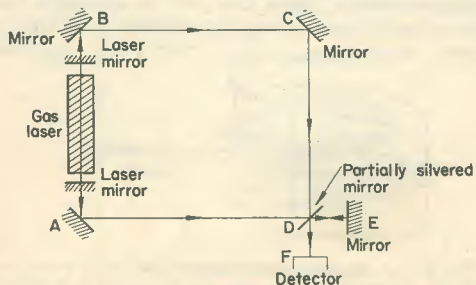

Fig. 19. A laser rotational sensor

comes heat. Only a very small amount of light is obtained.

In a typical case, an input of about 1 volt at 40mA will produce a light output power of about 10 to 20 milliwatts. The divergence of the output beam is of the order of a few degrees. At liquid air temperatures the peak brightness of a gallium arsenide junction can be well over one megawatt per sq. cm and the mean brightness over 10,000 watts per square cm.<sup>13</sup>

### Liquid Lasers

Liquid lasers are usually pumped by means of a powerful ruby laser, the basic arrangement of the apparatus being as shown in Fig. 18. The light output of the ruby laser is concentrated into the active liquid which absorbs a portion of the incident light. The absorbed energy is given out in a narrow beam of coherent radiation at frequencies which are determined by the properties of the liquid used. Thus the wavelength of the light from a liquid laser can be altered by merely changing the liquid used. The laser liquid is normally cooled in liquid nitrogen.

Liquid lasers depend on the Raman effect. This effect occurs when a beam of light strikes a substance and the light scattered from this substance is found to contain not only the incident frequency, but also other frequencies, the photons of which differ in energy from those of the incident frequency by an amount equal to the energy of vibration of the molecules of the material. Thus incident photons may give up energy to the molecules and so make their vibrational energy greater or alternatively may absorb energy from vibrating molecules. The ordinary Raman effect produces incoherent light of very low intensity, but the liquid laser can produce light by the Raman effect with an intensity up to about one-half of that of the incident beam.

Various types of liquid have been employed, one of the most commonly used being europium or terbium ions combined with benzolacetate dissolved in alcohol. Trivalent europium ions show a strong fluorescence and would appear to be a suitable material for use in a four level laser. Unfortunately the europium ions show little tendency to absorb radiation of the type usually used for the pumping process. This difficulty can be to some extent overcome by using the europium ions in an organic chelate (such as benzolacetate).† The chelating agent takes the europium ions into its molecule. It serves the purpose of absorbing light energy and then donating this energy to the europium ions trapped within its molecule. Such chelates may also be dispersed in a plastic material instead of a liquid and used in a laser.

Liquid lasers are a recent discovery and it will take some time before their potentialities can be fully investigated. It appears, however, that they will be a useful research tool for finding information about the vibrational properties of certain molecules.

†A rough, approximate, definition of a chelate is that it is a compound which takes ions into its molecules, where they are held by co-ordinate valency bonds.—EDITOR.



## Ring Systems

Some types of lasers have been developed in which light rotates around the apparatus. One type is shown in Fig. 19.<sup>8</sup> Some light is emitted from each end of the laser tube. Light from the one end is reflected at the mirrors B and C and some of it passes through D to the photosensitive detector F. Light from the other end of the laser tube is reflected at A so that some of it passes through D to the mirror E which in turn reflects it back to D and it finally passes to the detector F.

Let us consider the effect of rotating the whole laser equipment in a clockwise direction. During the time a beam of light is travelling from B to C, the mirror C will be moving away from the beam (for clockwise rotation) and thus the distance to be travelled is increased. Similarly, as a beam travels from A to D, D will be moving towards A and the distance to be travelled is less than it would have been if the system had been stationary. This effect can be detected and used to determine the rate of rotation of the equipment or the angular displacement of the system. Laser equipment of this type may find applications where gyroscopes are being used at the moment.

In the ring laser shown in Fig. 20, four separate gas laser tubes are employed. One beam of light passes around the system in a clockwise direction whilst another beam travels in an anticlockwise direction. Oscillation occurs over the whole of the circuit. Any photon which travels around the system in a clockwise direction will continue to do so, being amplified somewhat each time it passes through a laser tube. The whole square of the apparatus is therefore a single laser.

A small amount of light travelling in the clockwise direction passes through the partially silvered mirror to the photosensitive detector. Similarly a small fraction of the beam travelling in the anticlockwise direction passes through the same partially silvered mirror and hence to the detector by the path shown.

If the apparatus is at rest, the time taken by the light to travel once around the system in a clockwise direction is the same as that taken for the light to circulate in the anticlockwise direction. If the whole ring laser is rotated, however, a ray travelling in the direction of the rotation will be speeding towards a mirror which is receding from it, whereas a ray travelling in the opposite direction will be speeding towards an approaching mirror. Thus the ray travelling in the direction of rotation will have to travel farther than the ray travelling in the opposite direction. This effect may be compared with the alteration of the distance between the two mirrors of an ordinary gas laser. Thus it can be seen that the two beams of a rotating ring laser which are circulating in opposite directions are tuned to slightly different frequencies. A beat note will be formed at the output of the photosensitive detector, the frequency of this beat note being equal to the difference in frequency of the clockwise and anticlockwise laser beams.

This type of apparatus can be used to measure

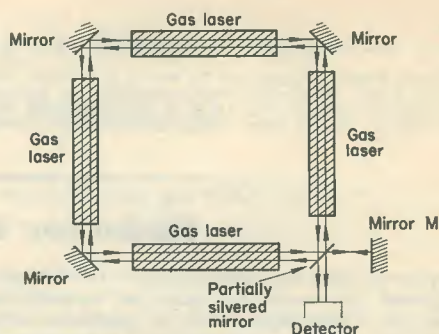
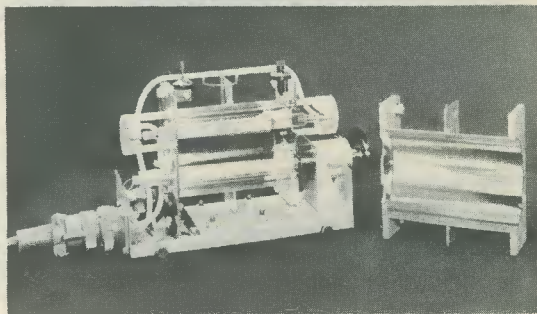

Fig. 20. A ring laser. (The two rays are shown slightly displaced for clarity)

very low rates of rotation. For example, a rate of rotation of about one minute of arc per minute should give a beat note of about 4 c/s in a laser of dimensions one metre square. It should be possible to measure the rate of rotation of the earth by a carefully designed ring laser.

## Other Types

Various interesting suggestions have been made as to how new types of laser might be designed. One suggestion of particular interest is that the laser material might be mixed in with certain chemicals which provide the pumping radiation when they react. (Lasers have already been constructed in which the pumping radiation is provided by a chemical reaction in a material surrounding the active laser atoms.) It has been suggested that a flame could be operated as a laser and that oxygen and acetylene might be a suitable chemical system.<sup>14</sup> Another especially interesting suggestion is the use of nuclear fuel inside a gas laser to provide the pumping energy.<sup>15</sup> It is thought that the use of such a system might improve the efficiency of gas lasers by a factor of about 10 and yield higher output powers. It is planned to use nuclear energy to heat a cathode so that the emitted electrons excite the surrounding gas. It seems certain that many new types of laser will be invented, but only time will tell what form they will take.



The neodymium doped glass laser type L650 (manufactured by M.E.L. Equipment) with one side of the mirror system removed. The flash tube is shown at the top of the enclosure. (M.E.L. Equipment Company Ltd.)

**References**

- (Details of references numbers 1 to 10 inclusive were given last month.)
11. *Wireless World* Editorial. Vol. 70, No. 11, p. 543 (Nov. 1964).
  12. E. W. Ayers. "Lasers and Communications". *The Post Office Electrical Engineers' Journal*, Vol. 57, pt. 3, p. 182 (October 1964).
  13. C. Hilsum. "Light from Semiconductors", *New Scientist*,

- Vol. 20, No. 369, p. 666 (12th December, 1963).
  14. R. Bleekrode and W. C. Nieuwpoort. *Physics Letters*, Vol. 12, p. 204. (Reported in *New Scientist*, Vol. 24, No. 415, p. 312 (29th October, 1964).
  15. F. M. Johnson. "Laser Excited by Nuclear Heat", *Nucleonics*, Vol. 22, No. 4, p. 57 (April 1954).
- (to be concluded)

## Radio for the Sea Traveller

Britain's first radio designed especially for the use of seafaring men all over the world, has recently been announced by Ekco Export Ltd. of Southend-on-Sea, Essex, England.

Developed after consultation with representatives of the National Union of Seamen (British), the receiver incorporates a number of special features regarded as essential for the use of seamen on or off duty. It is also ideal for use wherever a powerful and robust receiver with full waveband coverage from 13 to 1930 metres is required, including the trawler band.

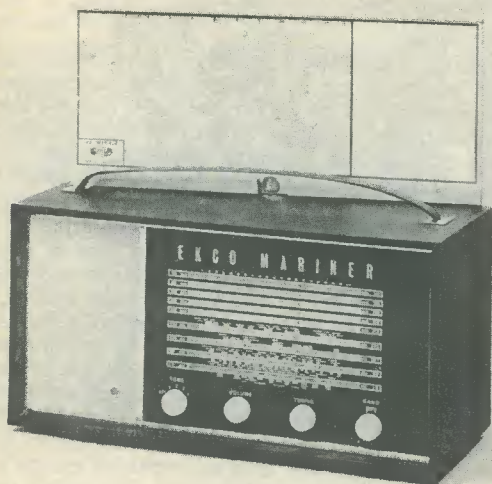

The Ekco "Mariner" was developed after consultation with the National Union of Seamen (British). It covers all wavebands from 13 to 1930 metres and operates from almost any mains supply a.c. or d.c.

Known as the Ekco "Mariner", the receiver is housed in a strong wooden case, attractively finished in black leather cloth with silver-colour trim and the fully-enclosing front cover is in contrasting grey leather cloth. A built-in carrying handle makes it easy to carry while on the inside of the removable front cover is printed a World map pinpointing over 200 short-wave stations. The latter feature combined with a very large clearly-calibrated tuning dial covering nine wavebands, including five bandspreads, makes programme finding easy in every part of the world.

The receiver can be set to suit almost any mains supply, a.c. 25-100 c/s or d.c., of voltages from 110-125 or 200-250. Technical features include high sensitivity and high-efficiency automatic gain control to combat fading and a special "Tonemaster" 4-position tone control for best possible sound reproduction under varied reception conditions. The receiver is fully tropicalised for use in all climates and a special rubberised non-slip base keeps the receiver in place on board ship. Although the receiver has a distinctly "professional" appearance with a performance to match, its price is competitive with better-class domestic receivers.

### Answers to "20 Semiconductor Questions" (see page 835)

Score 5 for each correct answer.

- |       |        |        |        |
|-------|--------|--------|--------|
| 1. b. | 6. c.  | 11. a  | 16. b. |
| 2. d. | 7. c.  | 12. e. | 17. b. |
| 3. b. | 8. c.  | 13. b  | 18. b. |
| 4. e. | 9. d   | 14. c. | 19. c. |
| 5. a. | 10. c. | 15. a. | 20. b. |

### Our Ratings

- 0-25. Only fair. (Keep up to date by reading *The Radio Constructor* regularly.)
- 30-50. Still not so good.      55-75. Good.
- 80-85. That's more like it!      90-95. Excellent.
100. Top of the shop!

## New Brimar Valve Manual

A new Brimar Valve and Cathode Ray Tube Manual, Number 10 has just been published by Thorn-AEI Radio Valves and Tubes Ltd., of 155 Charing Cross Road, London, W.C.2.

The Brimar Manual is a bound book of 416 pages giving data on 629 types of Brimar valves and teletubes, while industrial cathode ray tubes and industrial switching transistors have been added for the first time. Adequate design data with curves is given for "Current Equipment" types, full data without curves for "Maintenance" types, and abridged data for all the "Obsolescent" and "Obsolete" types back to the beginnings of Brimar. New types introduced as recently as the 1965 London R.E.C.M.F. Components Exhibition are included.

In addition to valve and tube data, the Brimar Manual contains other useful reference material, such as designers selection tables both by valve construction and by application, operational recommendations for designers, new Brimar circuits, an up to date list of British sound and T.V. broadcasting stations, channels and frequencies, radio formulae in a new easy-to-read presentation, component colour codes and Brimar's largest ever equivalents list containing over 1,200 commercial and C.V. types.

The book is arranged in a new self-indexing manner so that all valves may be looked up directly by type number without knowing the valves classification. A Continuing index at the foot of the main data pages gives the cross reference to data given under alternative nomenclatures and to abridged data for "Obsolete" types. Equivalent and C.V. type numbers are given on each main data page, in addition to the separate equivalents list. The introduction, explaining the self-indexing system, is given in English, French, German and Spanish.

The book is intended primarily for the designer of industrial electronic equipment, but it will also prove a valuable reference for the retail maintenance trade (it has been edited by a former retail service manager). Copies are available from Brimar wholesalers or direct from the Brimar Publicity Department and the retail price is seven shillings and sixpence, post free.



# New Marconi High-Stability Frequency Standard

Only 30 millionth of a cycle variation at 100 kc/s

An extremely high-stability oscillator, having an accuracy comparable with that of a modern atomic frequency standard, has been developed by The Marconi Company. This device, which has a frequency variation of only 30 millionths of a cycle at 100 kc/s, is one of the most stable and accurate frequency standards available in production in the world.

The oscillator, which has a short term frequency stability of better than 3 parts in  $10^{10}$  and an aging stability of 1 part in  $10^9$  per month, produces three simultaneous standard frequencies of 100 kc/s, 1 Mc/s and 2.5 Mc/s.

The oscillator uses a highly polished, 2.5 Mc/s, 5th overtone A-T cut crystal, developed and manufactured by the Company's quartz crystal factory at Hackbridge in South London. This polishing process is carried several stages further than in the production of a normal crystal. There are eight perfect interfaces within the Crystal, which has a Q value of over 6 million. Gold contacts are thermally evaporated on to two of the outside faces of the crystal, to provide the output connections.

The utmost temperature stability of the crystal and oscillator is ensured by enclosing them in the inner of two ovens, both of which are proportionally controlled and sensitive to temperature changes of as little as one thousandth of a degree. In addition, the crystal is operated at the extremely low power level of  $\frac{1}{2}$  microwatt.

The crystal output of 2.5 Mc/s is fed into the frequency division stage where 'staircase divider' circuits are used to obtain the 1 Mc/s and 100 kc/s outputs with high phase stability. These circuits, together with the buffer output stages, use fully-transistorised printed circuit boards.

The complete unit is mounted on a standard 19in panel and contains its own power supplies enabling it to operate from any normal mains supplies. In case of a mains failure the oscillator will continue to operate from its own built-in emergency batteries with the same frequency stability.

The accuracy and stability of this device makes it ideally suited for navigational guidance systems, computers, satellite aerial guidance, military and defence uses and many other applications in high precision systems.

## DATA SUMMARY

Frequency:	2.5 Mc/s, 1.0 Mc/s and 100 kc/s.
Ambient Temperature Range:	-20° to +55°C.
Stability:	Better than $\pm 3$ parts in $10^{10}$ short term in all causes.
Aging:	Less than +1.0 in $10^9$ per month.
Frequency Adjustment:	Coarse: 4 parts in 107. Fine: 2 parts in 108.
Output:	1V r.m.s. sinewave into 50Ω.
Power Supplies:	230V, 50 c/s mains. Built-in emergency batteries.
Dimensions:	19 wide x 7 high x 11½in deep. Rack mounting.

## THE 1965 RADIO AND ELECTRONIC COMPONENT SHOW

(continued from page 837)

produced by calendering and, since the mixture cannot be made other than in self-colour, colours and finishes are obtained by painting or bonding on a second sheet of normal p.v.c. or rubber. Some of the applications envisaged are for easily moved and positioned display data, as occur on progress boards in factories, etc., and announcement cards on cars, boilers and cookers in showrooms. A tile of the material bearing a sales message can, for instance, be placed against the metal side of a car, whereupon it will stay in position without marking the surface. The material is magnetised with alternate close-spaced North and South poles along its length, the pattern being the same as if the upper level of each line of print in this column presented a continuous horizontal North pole and the lower

level of each line of print a continuous horizontal South pole.

A. F. Bulgin and Company Ltd. had many new components in addition to their extremely extensive existing range, these including (with list numbers following): a contemporary self-fixing Push-For-On switch with red, white or black button and rated at 1 amp up to 28 volts (M.P.22); a complete range of double-pole moulded insulation toggle switches for 2 amps up to 250 volts a.c. (S.M.270); new strip edge connectors for 1 to 12 poles (T.106-T.111); a 4-cell magazine for U7 cells which can be inbuilt in any equipment and which can give series connection for 6 volts or series-parallel connection for 3 volts (B.4-B.5); and new mains neon message indicators (D.920 and D.930).

# LEARN ELECTRONICS AS YOU BUILD 25 CIRCUITS ... EXPERIMENTS ... TEST GEAR ...

including

## ● CATHODE RAY OSCILLOSCOPE

- VALVE EXPERIMENTS
- SQUARE WAVE GENERATOR
- SIGNAL TRACER
- BASIC AMPLIFIER
- SIMPLE TRANSMITTER
- BASIC COMPUTER CIRCUIT
- BASIC RECTIFIER
- TRANSISTOR EXPERIMENTS
- BASIC RADIO RECEIVER
- PHOTO ELECTRIC CIRCUIT
- BASIC OSCILLATOR
- MORSE CODE OSCILLATOR
- TIME DELAY CIRCUIT
- ELECTRONIC SWITCH
- ETC. ETC.

This complete practical course will teach you all the basic facts of electronics by making experiments and building apparatus. You learn how to recognise and handle all types of components—their symbols and how to read a circuit diagram. You see how circuits are built and how they work **BY USING THE OSCILLOSCOPE PROVIDED**. Applications of all the main electronic circuits are

demonstrated—radio reception and transmission; photo-electrics; computer basics; timers; control circuits; etc.; including servicing techniques. **NO MATHS USED OR NEEDED. NO THEORY NEEDED. NO PREVIOUS KNOWLEDGE OR EXPERIENCE NEEDED.** Tutor service available. No extras needed—tools provided. Send now, for *Free Details* without obligation, to address below

To **RADIOSTRUCTOR, Dept. K3, READING, BERKS.** Please send free details of your electronics kit set to:

**POST NOW**



NAME \_\_\_\_\_  
ADDRESS \_\_\_\_\_

## SMALL ADVERTISEMENTS

Use this form for your small advertisement

To: **The Advertisement Manager, Data Publications Ltd., 57 Maida Vale, London, W.9**  
Please insert the following advertisement in the ..... issue of **THE RADIO CONSTRUCTOR**

16 words at 9d.  
= 12/-

**ALL WORDING  
IN  
BLOCK LETTERS  
PLEASE**

I enclose remittance of ..... being payment at 9d. a word. **MINIMUM 12/-.**  
Box Number, if required, 2/- extra.

NAME \_\_\_\_\_  
ADDRESS \_\_\_\_\_

Copy to be received four weeks prior to publication. Published on the 1st of every month



## SMALL ADVERTISEMENTS

Rate: 9d. per word. Minimum charge 12/-.  
Box No. 2/- extra.

Advertisements must be prepaid and all copy must be received by the 4th of the month for insertion in the following month's issue. The Publishers cannot be held liable in any way for printing errors or omissions, nor can they accept responsibility for the *bona fides* of advertisers. (Replies to Box numbers should be addressed to: Box No. —, The Radio Constructor, 57 Maida Vale, London, W.9.)

**THE INCORPORATED PRACTITIONERS IN RADIO AND ELECTRONICS (I.P.R.E.) LTD.** Membership conditions booklet 1s. Sample copy of I.P.R.E. Official Journal 2s. post free.—Secretary, Dept. D, 32 Kidmore Road, Caversham, Reading, Berkshire.

**SERVICE SHEETS, 1925-1965.** From 1s. Catalogue 6,000 models, 1s. 6d. S.A.E. enquiries.—Hamilton Radio, 13 Western Road, St. Leonards, Sussex.

**HAMMER FINISH PAINT.** The modern finish for electronics. Can be BRUSHED or sprayed. Blue or Silver. 2½ oz tins 3s. 6d., post 8d., ½ pint 7s. 6d., post 1s. 9d., 1 pint 15s., post 2s. 9d. Orders over 30s. post free. Retailers supplied. Write for details. Amazing results! Return of post service.—Finnigan Speciality Paints (RC), Mickley Square, Stocksfield, Northumberland.

**GOVERNMENT SURPLUS** electrical and radio equipment. Our new catalogue No. 16 ready now, 2s. 6d. post free, cost refunded on purchase of goods over £2.—Arthur Sallis Radio Control Ltd., 93 North Road, Brighton, Sussex.

**FOR SALE.** Over 300 electronic components in one great parcel including printed circuit panel with condensers, resistors, coils, diodes, transistors, silicon rectifiers, potentiometers, IF's, valve bases, tuning condensers, transformers, etc. You can't afford to miss this great bargain offer. Send 10s. plus P. & P. 2s. 6d. to—D. & W. Ltd., 224 West Road, Westcliff-on-Sea, Essex.

**LAFAYETTE "INTERNATIONAL" TAPE.** Example: 7" 2,400ft Polyester, 22s. 6d. P. & P. 2s. Wide range. S.A.E. list.—Leda Tapes, 27 Baker Street, London, W.1.

**FOR SALE.** Teleprinters 7B complete from £5. Also auto-transmitters, reperforators, signalling rectifiers, etc. from—William Batey & Co. (Exports) Ltd., 77 Akeman Street, Tring, Herts. Please ring Tring 3476.

**CONVERT ANY TV SET INTO AN OSCILLOSCOPE.** Instructions and diagrams, 12s. 6d.—Redmond, 42 Dean Close, Portslade, Sussex.

continued on page 857

## BENTLEY ACOUSTIC CORPORATION LTD

38 CHALCOT ROAD CHALK FARM LONDON NW1  
THE VALVE SPECIALISTS Telephone PRIMROSE 9090

1L4	2/3	6X5	5/3	DK92	8/-	EF40	8/9	EZ81	4/3	U25	8/6
1R5	4/-	630L2	9/-	DK96	6/6	EF41	6/6	HABC80	9/3	U26	7/6
1S4	5/-	9BW6	9/6	DL96	6/-	EF80	4/-	KT66	12/3	U31	6/6
1S5	3/3	10C1	9/9	DM70	5/-	EF83	9/9	N339	25/-	U191	9/6
1T4	2/3	10C2	12/-	DY86	6/6	EF85	4/6	PABC80	6/9	U282	12/3
2D21	5/-	10F1	10/-	DY87	7/6	EF86	6/6	PC86	9/9	U301	11/-
3D6	3/9	10F18	9/9	E88CC	10/-	EF89	4/-	PC88	9/-	U329	9/-
3Q4	5/3	10LD11	9/6	EABC80	5/9	EF91	3/-	PC95	6/9	U404	6/-
3Q5	6/9	10P13	8/3	EAF42	7/9	EF92	2/6	PC97	6/9	U801	15/-
3S4	4/9	10P14	11/6	EB91	2/3	EF97	10/-	PCC84	5/6	UABC80	5/-
3V4	5/-	12AH8	10/9	EBC33	6/-	EF98	9/9	PCC85	6/9	UAF42	6/9
5Y3GT	4/9	12AT6	4/6	EBC41	7/-	EF183	7/3	PCC88	10/6	UBC41	6/3
Z24	7/6	12AU6	5/9	EBC81	5/9	EF184	6/6	PCC89	8/6	UBC81	6/3
6A05	5/9	12AV6	5/9	EBF80	5/9	EL33	6/6	PC8189	10/-	UBF80	5/6
6AT6	3/9	12BA6	5/3	EBF83	7/3	EL34	9/9	PCF80	6/6	UBF89	6/6
6AU6	5/9	12BE6	4/9	EBF89	6/-	EL36	8/9	PCF82	6/-	UBL21	10/9
6AV6	5/6	12BH7	6/-	EBL21	10/3	EL41	7/-	PCF84	8/6	UC92	6/3
6BA6	4/6	19AQ5	7/3	EC92	6/6	EL42	7/9	PCF86	8/6	UCC84	8/-
6B6	4/3	20D1	10/-	ECC40	7/-	EL83	6/9	PCF801	10/-	UCC85	6/6
6BH6	5/3	20F2	11/6	ECC81	3/6	EL84	4/6	PCF802	10/-	UCC80	8/3
6B16	5/6	20L1	12/6	ECC82	4/6	EL85	7/6	PCL82	6/6	UCH21	8/-
6BQ7A	7/6	20P1	12/6	ECC83	4/6	EL86	7/3	PCL83	9/6	UCH42	8/-
6BR7	8/3	20P3	12/-	ECC84	5/6	EL95	5/6	PCL84	7/6	UCH81	6/6
6BR8	8/-	20P4	13/3	ECC85	5/9	EL80	13/6	PCL85	8/6	UCL82	7/3
6BW6	7/6	20P5	12/3	ECC88	8/9	EN34	11/6	PCL86	8/9	UCL83	9/3
6CD6G	18/-	30C18	8/9	ECC189	11/6	EM71	15/6	PL36	9/-	UF41	6/9
6CH6	5/-	30F5	7/3	ECF80	7/3	EM80	6/3	PL38	16/-	UF42	4/9
6F1	9/6	30FL1	9/3	ECF82	6/3	EM81	7/-	PL81	6/9	UF80	6/3
6J7G	4/6	30L15	9/6	ECF86	11/6	EM84	6/9	PL82	5/-	UF85	6/9
6K7G	1/3	30P4	12/-	ECH21	9/-	EM85	8/9	PL83	6/-	UF86	9/9
6K8G	3/3	30P12	7/6	ECH35	6/-	EM87	7/6	PL84	6/3	UF89	5/6
6L1	10/-	30P19	12/-	ECH42	8/-	EY51	5/6	PM84	9/3	UL41	7/-
6L6GT	7/3	30PL1	9/3	ECH81	5/9	EY81	7/3	PY33	8/9	UL84	5/6
6L18	10/-	30PL13	10/6	ECH83	6/6	EY83	9/3	PY80	4/9	UM80	8/3
6LD20	5/6	35W4	4/6	ECH84	9/6	EY84	9/6	PY81	5/-	UY21	7/9
6Q7G	4/-	85A2	4/6	ECL80	3/9	EY86	5/6	PY82	4/9	UY41	5/-
6S17	5/3	5763	7/6	ECL82	6/6	EY88	8/9	PY83	5/6	UY85	4/9
6SN7	4/-	AZ31	6/6	ECL83	8/9	EZ40	5/3	PY88	7/3	VP4B	12/-
6V6G	3/6	DAF96	6/-	ECL86	8/-	EZ41	6/3	PY800	5/9	X41	10/-
6X4	3/9	DF96	6/-	EF37A	7/-	EZ80	3/9	PY801	7/6	X78	20/6

Terms of business: Cash with order or C.O.D. only. Post/packing 6d. per item. Orders over £5 post free. C.O.D. 3/6 extra. All orders despatched same day. Complete catalogue including transistor section and components with terms of business 6d. Any parcel insured against damage in transit for 6d. extra. We are open for personal shoppers 9 a.m.—5.30 p.m. Saturdays 9 a.m.—1 p.m.

## EXCLUSIVE OFFER — V.H.F. RECEIVERS

Pye PTC114, 65-100Mc/s, 12 volts D.C. supply

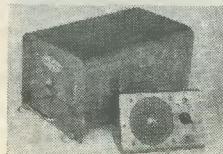

This is an 11 Valve Double Superhet Receiver, operating on one fixed frequency between 65-100 Mc/s, crystal controlled, speaker output (housed in control box) using midjet valves throughout. Supplied in first-class condition with tuning data, circuit diagram, and complete crystal formula. Ideal for the 4 meter band (70.2 Mc/s) offered at only 70/-, post 5/-, or tuned to any requested frequency in the above band. Complete with crystal, air tested, 45/- extra. Control boxes (not necessary), 9/6.

**Guaranteed Brand New**  
in original wood packing crate  
**CANADIAN MARCONI 52 RECEIVERS**  
Few only at £10. 10. 0  
MAINS POWER UNIT £2. 0. 0

Supplied with Outer Case, Handbook and Circuit.  
Set has Crystal Calibrator, Speaker, etc.  
Range 1.75-16 Mc/s.

J. T. SUPPLY (Dept. F), 38 MEADOW LANE, LEEDS 11

# THE MODERN BOOK CO

**Transistor Electronic Organs for the Amateur.** By A. Douglas. 18s. Postage 1s.

**Transistor Transmitters for the Amateur.** By D. Stoner. 21s. Postage 1s.

**Introduction to Electronics.** By U.S. Navy. 8s. Postage 1s.

**Basic Theory and Application of Transistors.** By U.S. Army. 10s. Postage 1s.

**World Radio TV Handbook—1965.** 26s. Postage 1s. 2d.

**Magnetic Recording for the Hobbyist.** By A. Zuckerman. 20s. Postage 1s.

**Troubleshooting with the Oscilloscope.** By R. Middleton. 20s. Postage 1s.

**Worked Examples in Electronics and Telecommunications.** By B. Holdsworth. Vol. 1. 25s. Postage 1s.

**Short Wave Listener's Guide.** By C. Woodruff. 12s. 6d. Postage 9d.

**Design and Construction of Transistor Superhets.** By R. Warring. 17s. 6d. Postage 1s.

**Electronic Organ Handbook.** By H. Anderson. 35s. Postage 1s.

**Radio and Audio Servicing Handbook.** By G. King. 25s. Postage 1s. 3d.

**Wireless for Beginners.** By C. Boltz. 18s. Postage 1s.

**TV Fault Finding.** By Radio Constructor. 6s. Postage 8d.

**Understanding Television.** By J. Davies. 37s. 6d. Postage 1s. 6d.

**The All-in-One Tape Recorder Book.** By J. Lloyd. 13s. 6d. Postage 1s.

**Transistor Substitution Handbook.** By H. Sams. 12s. 6d. Postage 9d.

**Radio Valve Data.** By Wireless World. 7s. 6d. Postage 1s.

Complete Catalogue 1s.

We have the Finest Selection of English and American Radio Books in the Country

**19-21 PRAED STREET (Dept RC) LONDON W2**

Telephone PADDington 4185

**AMATEUR RADIO**  
**CHAS. H. YOUNG LTD.**

**MIDLAND AGENTS**  
**FOR**

- \* **EDDYSTONE RECEIVERS & COMPONENTS**
- \* **NATIONAL RECEIVERS & TRANSCEIVERS**
- \* **GREEN & DAVIS EQUIPMENT**
- \* **KW EQUIPMENT**
- \* **MOSLEY AERIALS**
- \* **WITHERS**

- **H.P. FACILITIES AVAILABLE**
- **PART EXCHANGES**

## AERIAL EQUIPMENT

**TWIN FEEDER.** 300 ohm twin ribbon feeder similar K25, 6d. per yard. 75 ohm twin feeder, 6d. per yard. Post on above feeders and cable, 2/- any length.

**COPPER WIRE, 14G, H/D, 140ft, 22/6; 70ft, 11/6.** Post and packing 3/-. Other lengths pro rata.

**FEEDER SPREADERS.** 6" Ceramic type F.S., 10d. each. Postage 2/- up to 12.

**CERAMIC CENTRE PIECE** for dipoles, Type AT, 1/6 each. P. & P. 1/6.

**2 METRE BEAM, 5 ELEMENT W.S. YAGI.** Complete in box with 1" to 2 1/2" masthead bracket. Price 49/-. P. & P. 4/-.

**SUPER AERAXIAL, 70/80 ohm coax, 300 watt very low loss, 1/8 per yard. 50 ohm 300 watt, 1/9 per yard. P. & P. 2/6.**

**TOUGH POLYTHENE LINE,** type MLI (100lb), 2d. per yd. or 12/6 per 100 yds. Type ML2 (220lb), 4d. per yd. or 25/- per 100 yds., ML4 (400lb), 6d. per yd. Ideal for Guys, L.W. Supports, Halyards, etc. Postage 1/-.

**ABSORPTION WAVEMETERS.** 3.00 to 35.00 Mc/s in 3 Switched Bands. 3.5, 7, 14, 21 and 28 Mc/s. Ham Bands marked on scale. Complete with indicator bulb. A MUST for any Ham Shack. ONLY 25/- EACH. Post free.

**BANDCHECKER MONITOR,** 3.00-35.00 Mc/s in 3 switched Bands. 0-1mA Indicator. Monitor Socket. Very sensitive, £3.13.6. P. & P. 3/-.

**VARIABLE CONDENSERS.** All brass with ceramic end plates and ball race bearings. 50pF, 5/9; 100, 6/6; 160, 7/6; 240, 8/6; and 300pF, 9/6. Extension for ganging. P. & P. 1/6.

**RACK MOUNTING PANELS:** 19" x 5 1/2", 7", 8 1/2", or 10 1/2", black crackle finish, 5/9, 6/6, 7/6, 9/- respectively. P. & P. 3/-.

**GELOSO VFO UNITS.** 4/102 with new dial and escutcheon. Outputs on 80, 40, 20, 15 and 10. For 2-807 or 6146 Tubes. Only £8.15.3, valves to suit, 24/-. ALL POST FREE.

**30 WATT MOD. TRANS.** 2 x 807 mod. to 807 R.F. Few only, 18/6 each. P. & P. 3/6.

**2 METRE BEAM, 5 ELEMENT W.S. YAGI.** Complete in box with 1" to 2 1/2" masthead bracket. Price 49/-. P. & P. 4/-.

**CHAS. H. YOUNG LTD**

**170-172 Corporation St., Birmingham 4**

Please print your address. No C.O.D. under £1. 'phone CEN 1635



## SMALL ADVERTISEMENTS

continued from page 855

**TRANSISTOR BARGAINS.** NPN red spots 1s. OC71 equivalents 9d. Silicon power transistors 2S012 10s. 400 p.i.v. silicon rectifiers 3s. Much more. Send 6d. stamp for our new list. Still available our famous 25 TRANSISTORS 10s. 100 diodes 12s. State AF or RF types.—L.S.T. COMPONENTS, 182B HIGH ROAD, BENFLEET, ESSEX.

**TELEVISION SETS FROM 30/-**, not working, 20 for £1 each. Callers only.—20 Palmerstone Road, Earley, Reading, Berks.

**FOR SALE.** Labgear transmitting low pass filter E.5034, £3. Heathkit Balun coil unit Model B-1U, £3. Postage on each extra.—Box No. F236.

**OFFERS invited** *Practical Wireless*, January 1954–April 1965. First five volumes bound.—Guthrie, 3 Deansgate Terrace, Grimsby, Lincs.

**BOOKS TO CLEAR:** *Frequency Modulated Radio*, 1956 (Sturlev), 5s.; *Practical Television Circuits*, 1954 (Camm), 5s.; *Testing Radio Sets*, 5th edition (Reyner), 7s. 6d.; *First Course in Television*, 1958 (Decibel), 6s.; *Transmitting Valves*, 1951 (Heyboer & Zijlstra), 10s.; *High Fidelity Sound Reproduction*, (Molloy), 7s. 6d.; *How to Install & Service Auto Radios*, 1959 (Darr), 7s. 6d.; *Television Today*, 1947 (Norris), 5s.; *Introduction to TV Servicing*, (Swalum & Van der Woerd), 10s.; *Television Receiver Design*, 1953 (Neeteson), 7s. 6d.; *Low Frequency Amplification*, 1953 (Voorhoeve), 10s. All at less than half price.—Box No. F238.

**FOR SALE.** Labgear LG 300 transmitter unit, VFO section converted for RTTY FSK. This makes an excellent RTTY Tx. Owner only selling as converting SSB rig for RTTY. £25 o.n.o. Plus carriage.—Box No. F239

**FOR SALE.** Heathkit valve millivoltmeter, model AV-3U. Unused. £15.—Box No. F240.

**FOR SALE—VALVES.** DL92, EB91, EF92, IT4 at 1s. 6d. ECC82, EL91 at 3s. CV1075, U14, VR91, VT136, 955, 6AT6 at 5s. EF40, 801, 830B, T20 at 7s. 6d.—Box No. F241.

**FREE POWER TRANSISTORS**, new super semiconductor packs to save you pounds, plus hundreds of other bargains. S.A.E. for free lists to—D. & W. Ltd., 224 West Road, Westcliff-on-Sea, Essex.

**INTERESTED IN AMATEUR RADIO TELEPRINTING?** Then join the British Amateur Radio Teleprinter Group. Details from Hon. Sec., G3LLV, 15 Havelock Square, Broomhill, Sheffield 10.

continued on page 859

## TESTED TRANSISTORS

1/- each Red or White Spots. 10/- per doz.

2/- each XA101, XA102, XA111, XA112, XB103, NKT122, 2E1, OA70, OA90, OC430.

3/- each OC44, OC45, OC70, OC71, OC81, OC81D, OC82, OC82D, OC169, OC200.

4/- each AF114, AF115, AF116, AF117, XA103, XB102, XC121, XU611, OC170, OC171.

5/- each OC72, OC139, OC204, ORP60, XC141, BY100, ACY22, GET8, AFZ11, AFZ12.

10/- each OC22, OC26, OC28, OC35, ORP12, AFY19, GET571, BFY17, BSY26, BSY29.

**ZENER DIODES** 4.7 volt to 30 volt  $\frac{1}{2}$  watt, 3/6 each, 1.5 watt, 5/- each, 7 watt, 6/- each.

Plus lots not listed—i.e. S.C.R.'s, V.H.F. and N.P.N.'s. Send 6d. stamp for Full Lists and Equivalent Chart.

## B. W. CURSONS

78 BROAD STREET, CANTERBURY, KENT

## 20 SUGGESTED CIRCUITS

by G. A. FRENCH

No. 15 in our Data Book Series. This book contains the first 20 circuits to be published in the very popular series of the same name appearing in *The Radio Constructor*.

The Contents include: simple and inexpensive two-valve capacity bridge, short wave regeneration preselector, one-valve speech operated switching circuit, transformer ratio analyser, series noise limiter, receiver remote mains on-off control, and many others; covering subjects ranging from electronic laboratory equipment to a simple 2-Stage Gram Amplifier.

PRICE 3s. 6d. Postage 4d. 48 pages

Available from your usual supplier, or direct from

**DATA PUBLICATIONS LTD**  
57 Maida Vale London W9

# What every tape recordist should know

TAPE Recording Magazine is YOUR MAGAZINE! FIRST to be established in Europe dealing exclusively with tape recording. STILL THE MOST constructive, informative and creative. TOP NAMES write for it. VARIETY keeps it TOP of the tree! Regular features include: TEST-BENCH reports on tape recorders; do-it-yourself construction and drama recording; tape record reviews, NEW PRODUCTS, news of the CLUBS and a WORLDWIDE TAPE EXCHANGE column.

**PUBLISHED 3rd WEDNESDAY EACH MONTH**

★ TAPE Recording Magazine is easily recognised by its covers—the "zebra" stripes and brilliant monthly consecutive change of colours . . . Red, Orange, Yellow, Purple.

**Price 2/-**

or yearly subscription of 25/- (USA \$3.75) incl. postage

WRITE TO THE PUBLISHERS FOR A FREE SPECIMEN COPY but be sure to mention "The Radio Constructor".



**PRINT & PRESS SERVICES LTD., 7 TUDOR ST., LONDON, E.C.4**

## THE DUCHESS OF KENT PERMANENT BUILDING SOCIETY

*Member of the Building Societies Association*

ESTABLISHED



1865

Savings in this old established Building Society combine sound investment with an attractive return

Shares are in units of £25 each (maximum investment £5,000) . . . BUT, for the smaller saver, Subscription Share accounts may be opened with any sum from 1/- upwards. Interest is payable half-yearly on Fully Paid Shares—credited annually on Subscription Shares—all interest accrues monthly

WITHDRAWALS AT SHORT NOTICE

**INTEREST IS AT 4% PER ANNUM**

(There is NO DEDUCTION FOR INCOME TAX, as this is paid by the Society)

FOR FURTHER INFORMATION APPLY TO

**DUCHESS OF KENT  
PERMANENT BUILDING SOCIETY**

**103 Cannon Street London EC4**

Telephone MANsion House 8011

Please send to me, without obligation, free brochure and a copy of the audited statement of accounts. (I understand that I shall not be troubled with calls by representatives)

Name .....

(If lady, please state Mrs. or Miss)

Address .....

R.C.

(Please use Block Capitals for both name and address)



## SMALL ADVERTISEMENTS

continued from page 857

**JOIN THE INTERNATIONAL S.W. LEAGUE.** Free Services to members including Q.S.L. Bureau. Amateur and Broadcast Translation. Technical and Identification Dept.—both Broadcast and Fixed Stations, DX Certificates, contests and activities for the SWL and transmitting members. Monthly magazine, *Monitor*, containing articles of general interest to Broadcast and Amateur SWLs, Transmitter Section and League affairs, etc. League supplies such as badges, headed notepaper and envelopes. QSL cards, etc., are available at reasonable cost. Send for League particulars. Membership including monthly magazine, etc., 35s. per annum.—Secretary, ISWL, 12 Gladwell Road, London, N.8.

**THE INTERNATIONAL HAM HOP CLUB** is a non-profit-making organisation open to RADIO AMATEURS AND SHORT WAVE LISTENERS. OBJECT: to improve international relationships through an organised system of hospitality. MEMBERS offer overnight hospitality to visiting members, subscription 10s. per annum. ASSOCIATE MEMBERS invite radio amateurs to visit their stations. Associate membership 5s. per annum. FAMILY EXCHANGE holidays arranged, also FRIENDSHIP LINKS between radio clubs. The Club's official journal is free to both Full and Associate Members.—Hon. Gen. Secretary: G. A. Partridge, G3CED, 17 Ethel Road, Broadstairs, Kent.

**NO** Aerial  
Car radio  
Licence  
Connections to  
ANYTHING!

WITH THE

**Dewtron**

WAVE TRAP for medium waves.

Pat. app. for  
Gives **BOOST** to ANY transistor portable radio **39/6**  
★ IN CAR replaces car aerial; reduces fading.  
★ IN HOME boosts distant and PIRATE stations. P. & P. 2/- extra  
★ ON HOLIDAY improves reception in remote areas. A MUST for caravanners. Attaches to any window.  
Supplied complete with PP3 battery and instructions.  
Money-back guarantee.

**D.E.W. Ltd., (R.C.),** Ringwood Road, Ferndown, Dorset



## YOUR CAREER IN RADIO ?

Big opportunities and big money await the qualified man in every field of Electronics today—both in the U.K. and throughout the world. We offer the finest home study training for all subjects in radio, television, etc., especially for the **CITY & GUILDS EXAMS.** (Technicians' Certificates); the Grad. Brit. I.R.E. Exam.; the **RADIO AMATEUR'S LICENCE**; P.M.G. Certificates; the R.T.E.B. Servicing Certificates; etc. Also courses in Television; Transistors; Radar; Computers; Servo-mechanisms; Mathematics and Practical Transistor Radio course with equipment. We have **OVER 20 YEARS'** experience in teaching radio subjects and an unbroken record of exam. successes. We are the only privately run British home study Institute specialising in electronic subjects only. Full details will be gladly sent without any obligation.

SEND FOR FREE BROCHURE TO:

**BRITISH NATIONAL RADIO SCHOOL**  
DEPT 4, RADIO HOUSE · READING · BERKSHIRE

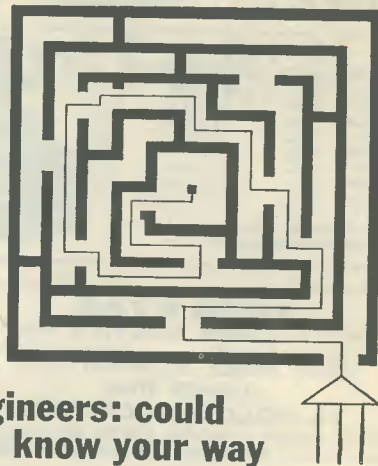

## Engineers: could you know your way round a computer?

An IBM Data Processing Customer Engineer does. It's his job to keep data processing installations working smoothly. He works with his own customers in their offices, yet within daily reach of his home. His job is stimulating and rewarding; it is never dull. As well as maintaining a wide range of electronic and associated electro-mechanical machines, he applies his engineering knowledge and skill and develops a real understanding of his customer's needs. As customer management moves towards a more effective use of highly complex equipment, new problems may arise. The IBM Customer Engineer has the ability to produce new ideas and has confidence in his own judgement. He is a responsible man on whom all customer staff rely.

We provide a thorough training for a worthwhile career. You should be between 21 and 29 and have a basic knowledge of Electronics. An acceptable standard would be a Radar/Radio/Control Equipment Fitters Course, Telecommunications experience or ONC/HNC Electrical or Electronic.

Starting salaries are in the region of £1,000 a year, with more for men with special aptitude or specific experience. Increases are on individual merit. As a Customer Engineer you could be earning between £1,250 and £1,700 in three years. Promotion is also on merit and from within the company.

If you're not quite old enough to have reached the standards we've indicated we'd still like to hear from you. If you've just left school with 'A' level Maths and English or are studying for ONC Electrical Engineering, there could be a place for you.

Please write briefly, summarising details of age, experience, training and background to Mr. I. F. Bush, IBM United Kingdom Limited, 101 Wigmore St., London, W.1, quote ref. CE/RC/224.

You can grow with **IBM**

# CHASSIS and CASES by



287/9 Edgware Road  
London W2  
TELEPHONE  
PADDINGTON 5891/7595

## BLANK CHASSIS—Same Day Service

Of over 20 different forms made up to YOUR SIZE.  
(Maximum length 35", depth 4")

### SEND FOR ILLUSTRATED LEAFLETS

or order straight away, working out total area of material required and referring to table below which is for four-sided chassis in 16 s.w.g. aluminium.

48 sq. in.	4/3	176 sq. in.	9/-	304 sq. in.	13/6
80 sq. in.	5/6	208 sq. in.	10/-	336 sq. in.	14/9
112 sq. in.	6/6	240 sq. in.	11/3	368 sq. in.	15/9
144 sq. in.	7/9	272 sq. in.	12/6		and pro rata
	P. & P. 3/-		P. & P. 3/6		P. & P. 4/-

Discounts for quantities. More than 20 different sizes kept in stock for callers.

**FLANGES** (1" or 1 1/2"), 6d. per bend.  
**STRENGTHENED CORNERS**, 1/- each corner.  
**PANELS**

Any size up to 3ft at 5/3 sq. ft. 16 s.w.g. (18 s.w.g. 4/6).  
Plus postage and packing

## CASES

### ALUMINIUM, SILVER HAMMERED FINISH

Type	Size	Price	Type	Size	Price
U	4 x 4 x 4"	10/-	Y	8 x 6 x 6"	26/6
U	5 1/2 x 4 1/2 x 4 1/2"	15/-	Y	12 x 7 x 7"	41/-
U	8 x 6 x 6"	21/-	Y	13 x 7 x 9"	46/-
U	15 x 9 x 9"	44/6	Y	15 x 9 x 7"	48/6
W	8 x 6 x 6"	21/-	Z	17 x 10 x 9"	66/-
W	12 x 7 x 7"	34/-	Z	19 x 10 x 8 1/2"	71/-
W	15 x 9 x 8"	44/-		* Height	

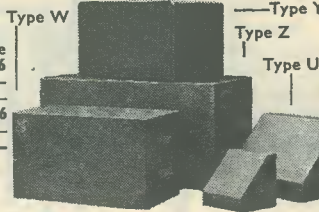

Type Z has removable back and front panels.  
Type Y all-screwed construction.

## NYLON P.T.F.E.

ROD BAR SHEET TUBE STRIP WIRE  
*No quantity too small List on application*  
BRASS COPPER BRONZE ALUMINIUM LIGHT ALLOYS  
STAINLESS STEEL

### H. ROLLET & CO LTD

HOWIE STREET, LONDON, S.W.11 BATTERSEA 7872  
Also at Liverpool, Birmingham, Manchester, Leeds, Glasgow

## J. B. LOWE

115 CAVENDISH ROAD  
MATLOCK, DERBYSHIRE

### ALL ITEMS BRAND NEW

Morse keys, good, fully adjustable, 3/6. Rotary switches, all types from 2/-.

Miniature pots, 1k, 50k, 1Meg., carbon, 2/-. Chokes of every type. Relays. Hundreds in stock, 6V, 12V and 24V, from 2/-.

Vibrators 12V, 4 pin, 6d. Practice buzzers, 4/-.

Terminal boards all shapes and sizes, 6d. each, 10 for 4/-.

A must for any construction work. Dubilier 1,000mF 12V miniature electrolytics, 1/6; 15 for £1.

Miniature colour-coded 1/2W resistors, 2d.; 100 for 15/-, your choice. Lots of miniature ceramics, etc., ideal for transistor work, from 2d.

Power Supplies: 250 V.a.c. or 12 V.d.c. in; 12.6 V.a.c. and 175 V.d.c. out. Brand new Marconi, a beautiful rugged bench supply at an incredible £2.10.0.

Transistor supply, 250 V.a.c. in, 10 volts zener diode regulated out. Brand new, modern, miniature for 30/-.

Lots of other good buys in components, receivers, transmitters, test gear, etc. A s.a.e. will get you my latest price list.

Orders over £1, POST FREE; 5/- and under, add 2/-; 10/- and under, add 3/-; £1 and under add 4/-.

the unique **PANL** black crackle paint

4/-d. per 1/8 pt. Can

(We regret we can only supply on cash with order basis)

### BRUCE MILLER LTD.,

249 Coastal Chambers,  
Buckingham Palace Road, S.W.1.

## TRANSISTOR REFERENCE CATALOGUE

Our Catalogue contains Gen on British, American and Continental Semiconductors, grouped as selections for various specific purposes, e.g.:

Transmitters, UHF and VHF Amplifiers, Tunnel Diodes, etc.

There are also selections of useful miniature components specially chosen for Transistor circuitry applications.

Please send one shilling (stamps) for Reference Catalogue—sixpence for March Supplement.

Please remember our new address:

(Callers welcome all day Saturday)

176 HAGLEY ROAD, HALESOWEN, BIRMINGHAM

John Williams Electronics Ltd. (J. Williams & Co.)

## YUKAN SELF-SPRAY

Get this Air-drying Grey  
HAMMER FINISH  
NOW —

IT'S SUPERB . . . . . THE PUSHBUTTON WAY !

YUKAN Aerosol spraykit contains 16 ozs. fine quality durable easy instant spray. No stove baking required. Available in Grey Hammer at 14/11 at our counter or 15/11, carr. paid, per pushbutton self-spray can. SPECIAL OFFER: I can plus optional transferable snap-on trigger handle (value 5/-) for 18/11. Please enclose cheque or P.O. for total amount to:



### YUKAN

Dept. RC/7 307a EDGWARE ROAD LONDON W.2  
(Closed Thursday afternoons, open all day Saturdays)

Choice of 13 self-spray plain colours and primer (motor car quality) also available

## THE RADIO CONSTRUCTOR — BOUND VOLUMES

LIMITED NUMBER ONLY:

Volume 17, August 1963 to July 1964 Price £1 10s 0d Postage 3s 6d

Where all issues are returned: Price £1 Postage 3s 6d

We regret Volumes 13, 14, 15 and 16 are now sold out

Send for our latest brochure containing details of our other publications

**DATA PUBLICATIONS LTD 57 MAIDA VALE LONDON W9**



# THE **Radio Constructor**

*Incorporating THE RADIO AMATEUR*

## **Index**

### **To Volume Eighteen**

*August 1964–July 1965*



**Data Publications Ltd**

**57 Maida Vale**

**London**

**W9**

## AMPLIFIERS

Economical Amplifier and Portable Receiver Circuits, by Sir Douglas Hall, K.C.M.G., B.A.(Oxon)	322	Dec.	'64
Experimental 12AX7-12AU7 Gram Amplifier, by J. C. Noakes	182	Oct.	'64
Portable P.A. Amplifier, by V. E. Holley	300	Dec.	'64
Simple Echo Unit, by P. F. Exeter	689	May	'65
Simple Mixer Unit, by S. G. Wood, G5UJ	679	May	'65
Transistor Public Address Amplifier, by A. Kinloch	686	May	'65
Workshop Amplifier/Power Supply for the Beginner, by E. Govier	732	June	'65
2-Transistor Miniature A.F. Amplifier, by K. Jones	688	May	'65

## ELECTRONICS

A "Flashing Man", by M. Farnsworth	409	Jan.	'65
An Electronic Tachometer, by John G. Dew, B.Sc.	826	July	'65
"A-Pealing" Door Chimes, by R. Bebbington	478	Feb.	'65
A Repeater Timer, by A. P. Ainge	345	Dec.	'64
"Blowing out" an Electric Light Bulb, by G. A. French	159	Oct.	'64
Electronic Locks and Anti-Thief Devices, Part 1, by R. M. Marston	309	Dec.	'64
Part 2	381	Jan.	'65
Gas Filled Counting Tubes, by J. B. Dance, M.Sc.	188	Oct.	'64
High Output Electronic Metronome, by K. Berry	633	Apr.	'65
Magnetically Operated Dry Reed Switch Circuits, by G. A. French	520	Mar.	'65
Modulated Light Transmitter and Receiver, by M. J. Banthorpe	101	Sept.	'64
Percussion and Sustain Circuits for Electronic Organs, by A. Douglas, Senior Member, I.E.E.E.	42	Aug.	'64
Relay Binary Circuit, by B. W. Osborn	315	Dec.	'64
Sensitive Sound-Operated Switch, by J. Spencer	469	Feb.	'65
Single Transistor Door Chime Repeater, by I. M. Rees	236	Nov.	'64
The "Transivox" Monophonic Organ, by A. T. Hawkins	402	Jan.	'65
Transistor-Operated Anemometer, by H. S. King, G3ASE	38	Aug.	'64
Transistor Thermostat, by J. Spencer, M.A.	242	Nov.	'64
Using Transistors in Pulse Circuits, by M. F. Audus	116	Sept.	'64

## GENERAL

Cathode Ray Tube Power Supply Unit, by H. N. Rutt	401	Jan.	'65
Combating Modulation Hum and Mains Borne Interference in F.M. Receivers, by J. Burgess	12	Aug.	'64
Combined Choke and Capacitor Input Power Supply, by G. A. French	738	June	'65
Constructing a Solid Bass Guitar, by Angus Geddes	334	Dec.	'64
Current Limiting in Low Voltage Power Packs, by John G. Dew, B.Sc.	636	Apr.	'65
Errors in Measurement, by J. R. Squires	337	Dec.	'64
Experimental Metal Locator, by C. Morgan	379	Jan.	'65
Experiences of an Early Amateur, Part 1, by C. H. Gardner	45	Aug.	'64
Part 2	123	Sept.	'64
Part 3	179	Oct.	'64
Part 4	256	Nov.	'64
Part 5	340	Dec.	'64
Ferroxcube Decoupling Beads, by M. J. Darby	169	Oct.	'64
Fundamentals of Single-Sideband, by R. Youngs	92	Sept.	'64
High Gain Composite Transistors—Facts and Figures on the "Super Alpha Pair", by J. B. Dance, M.Sc.	816	July	'65
Hybrid A.F. Mixer Circuit for Valve Amplifiers, by G. A. French	306	Dec.	'64
Lasers, Part 1, The Principles of Laser Operation, by J. B. Dance, M.Sc.	764	June	'65
Part 2	845	July	'65
Mains Failure Alarm, by C. P. Finn	758	June	'65
Mains Transformer Memory Unit, by G. A. French	15	Aug.	'64
Making Service Pay, by John T. Benson, F.T.S.	457	Feb.	'65
Mounting a Kit-Constructed Unit in an Old Receiver, by K. Harker	20	Aug.	'64
New Semiconductor Device with Million Megohm Input Impedance, by J. B. Dance, M.Sc.	421	Jan.	'65
Operation and Use of Thermal Delay Switches, by E. Lawrence	131	Sept.	'64
Peal Level Indicator, by A. R. Hoare	539	Mar.	'65
Quicker and Cheaper Method of Etching Printed Circuits, by C. D. Auger	112	Sept.	'64
Radio Caroline, by F. C. Judd, A.Inst.E.	567	Mar.	'65
Radio Waves Power Helicopters, by M. J. Darby	804	July	'65
R.E.C.M.F. 1965 Exhibition	836	July	'65
Simple Capacitor Tests, by G. A. W. Partridge	463	Feb.	'65
Some Notes on the Electric Bass Guitar, by R. A. Jeffrey	461	Feb.	'65
Stereo Balance Meter, by T. W. Hannen	762	June	'65
The Arcotron, by J. B. Dance, M.Sc.	252	Nov.	'64
The GT21 Glow Thyatron, by J. B. Dance, M.Sc.	62	Aug.	'64
The Phototran, by M. J. Darby	759	June	'65
The 1965 International Audio Fair	773	June	'65
Three Low Voltage Series Regulated Power Supplies, by A. Foord, Grad.I.E.R.E.	459	Feb.	'65
Transistor Mains Intercom, by I. M. Rees	204	Oct.	'64
Transistor Microphone Pre-Amplifier, by A. Kinloch	537	Mar.	'65
Transistorised Turning Indicator and Warning Device, by J. G. Ransome	594	Apr.	'65
High Frequency Converter for 15 to 7.5 Metres, by G. Wade	40	Aug.	'64
Midget Transistor Economiser, by A. J. Ley	377	Jan.	'65
Two-Way Home Telephone System, by J. N. Price	325	Dec.	'64
Transmitter Power Supply Using Semiconductors, by E. Lawrence	280	Nov.	'64



	Page No.	Issue
Unusual Loudspeaker Enclosure, by <i>F. Walker</i> .. .. .	453	Feb. '65
Using the OCP71, by <i>G. C. Dobbs, G3RJV</i> .. .. .	165	Oct. '64
Use of Heat Sinks with Power Transistors, by <i>A. Foord, Grad.I.E.R.E.</i> .. .. .	708	May '65
Variable H.T. Supply, by <i>J. Thornton Lawrence</i> .. .. .	774	June '65
20 Semi-Conductor Questions .. .. .	835	July '65
220 Amp Tunnel Diodes, by <i>J. B. Dance, M.Sc.</i> .. .. .	617	Apr. '65
1964 International Radio Communications Exhibition .. .. .	352	Dec. '64
1964 Television and Radio Show .. .. .	187	Oct. '64

## IN YOUR WORKSHOP

	Page No.	Issue		Page No.	Issue
Alternative Heater Chain Circuits .. .. .	558	Mar. '65	Reclaiming the Colours .. .. .	757	June '65
Applying A.F. .. .. .	247	Nov. '64	Resistor Replacements .. .. .	108	Sept. '64
Audible and Inaudible Hum .. .. .	32	Aug. '64	Secam .. .. .	822	July '65
Back to Black and White .. .. .	757	June '65	Simple Power Unit .. .. .	702	May '65
Bandpass Circuits .. .. .	329	Dec. '64	Simple Record Player .. .. .	395	Jan. '65
Battery Filaments .. .. .	559	Mar. '65	Substitution Resistor Assembly .. .. .	177	Oct. '64
Cathode Circuits .. .. .	556	Mar. '65	Stylus Trouble .. .. .	399	Jan. '65
Colour Again .. .. .	818	July '65	Tracing a Fault .. .. .	250	Nov. '64
Colour Signals .. .. .	753	June '65			
Colour Terms .. .. .	752	June '65	Transistor Multivibrators .. .. .	613	Apr. '65
Derating Curves .. .. .	109	Sept. '64	Transistors at U.H.F. .. .. .	327	Dec. '64
Different Power Levels .. .. .	34	Aug. '64	U.H.F. Oscillator .. .. .	327	Dec. '64
Discharge Curve Law .. .. .	615	Apr. '65	V.D.R. Curve .. .. .	482	Feb. '65
Dust Cores .. .. .	611	Apr. '65	Vertical Oscillator Stabilising .. .. .	485	Feb. '65
Flywheel Effect .. .. .	819	July '65	Voltage Tests .. .. .	397	Jan. '65
Hue Control .. .. .	821	July '65			
Mixer Oscillator Stage .. .. .	330	Dec. '64	Well-known V.D.R. .. .. .	483	Feb. '65
New Rectifier .. .. .	396	Jan. '65	Wirewound Resistors .. .. .	110	Sept. '64
Pal .. .. .	825	July '65			
Quarter-Wave Lines .. .. .	331	Dec. '64			

## RADIO CONTROL

Crystal Tone Transmitter for Model Control, by <i>F. G. Rayer</i> .. .. .	392	Jan. '65
Simple Wavemeter for Model Control, by <i>M. Whitford-Walders</i> .. .. .	114	Sept. '64

## RECEIVERS

Experimental Battery Receiver, by <i>C. Morgan</i> .. .. .	21	Aug. '64
Improving the Performance of the AR88, by <i>J. Hollingworth</i> .. .. .	668	May '65
Inexpensive Transistor Superhet, by <i>G. F. Parker</i> .. .. .	670	May '65
Simple M.W. Receiver for the Beginner, by <i>E. Govier</i> .. .. .	166	Oct. '64
Super-Regenerative Transistor Circuit for Medium and Long Waves, by <i>Sir Douglas Hall, K.C.M.G., B.A.(Oxon)</i> .. .. .	676	May '65
The "Athenian" 4-Band Superhet Receiver, Part 1, by <i>James S. Kent</i> .. .. .	619	Apr. '65
Part 2 .. .. .	693	May '65
Part 3 .. .. .	748	June '65
The "Constructors" Portable Six, by <i>F. G. Rayer</i> .. .. .	260	Nov. '64
The "Single Span" Mains Driven Receiver, by <i>Sir Douglas Hall, K.C.M.G., B.A.(Oxon)</i> .. .. .	197	Oct. '64
Top Pocket Transistor Radio, by <i>G. Jeffries</i> .. .. .	156	Oct. '64
Understanding Radio, Part 35, by <i>W. G. Morley</i> .. .. .	28	Aug. '64
Part 36 .. .. .	97	Sept. '64
Part 37 .. .. .	170	Oct. '64
Part 38 .. .. .	237	Nov. '64
Part 39 .. .. .	317	Dec. '64
Part 40 .. .. .	387	Jan. '65
Part 41 .. .. .	465	Feb. '65
Part 42 .. .. .	547	Mar. '65
Part 43 .. .. .	602	Apr. '65
Part 44 .. .. .	680	May '65
Part 45 .. .. .	743	June '65
Part 46 .. .. .	829	July '65
"Zephyr" Three Short Wave Receiver, by <i>B. W. Hollinshead</i> .. .. .	444	Feb. '65
2-Valve, 4-Stage Receiver for the Beginner, by <i>E. Govier</i> .. .. .	807	July '65
6-Stage, 3-Transistor Short Wave Reflex Receiver, by <i>Sir Douglas Hall, K.C.M.G., B.A.(Oxon)</i> .. .. .	54	Aug. '64

## RECEIVER ANCILLARIES

Aerial Preselector Unit for Short Wave Receivers, by <i>James S. Kent</i> .. .. .	48	Aug. '64
Adding Tuning Meters to Transistor A.M. Receivers, by <i>G. A. French</i> .. .. .	591	Apr. '65
Cascade T.R.F. Feeder Unit, by <i>G. E. Lewis, G3NFS</i> .. .. .	18	Aug. '64
F.M. Tuner Unit using Pulse Counting Detector, by <i>K. H. Parkes, G3EHM</i> .. .. .	253	Nov. '64
Pilot Lamp Tuning Indicator for Transistor Radios, by <i>G. A. French</i> .. .. .	664	May '65
Simple Transistorised Short Wave Converters, by <i>A. S. Carpenter, A.M.I.P.R.E.</i> .. .. .	839	July '65
Switch-off Indicator for Transistor Radios, by <i>G. A. French</i> .. .. .	232	Nov. '64
The "Crystarlet" Crystal Controlled F.M. Tuner, Part 1, by <i>Sir John Holder</i> .. .. .	473	Feb. '65
Part 2 .. .. .	541	Mar. '65
3-Stage Preselector for the Beginner, Part 1, by <i>E. Govier</i> .. .. .	532	Mar. '65
Part 2 .. .. .	596	Apr. '65

**TAPE RECORDING**

Extra Features for Your Tape Recorder, by <i>G. D. Howat</i> .. .. .	184	Oct. '64
Guide to Better Tape Recording, by <i>Alan Ford</i> .. .. .	493	Feb. '65
Variable Spooling for the Collaro Tape Deck, by <i>J. Howell</i> .. .. .	411	Jan. '65

**TELEVISION**

B.B.C.2 Pre-Amplifier, by <i>J. D. Benson, F.T.S.</i> .. .. .	606	Apr. '65
B.B.C.2 U.H.F. Amplifier, by <i>J. D. Benson, F.T.S.</i> .. .. .	121	Sept. '64
The New Dual-Standard TV Sets, Part 4, by <i>Gordon J. King, Assoc. Brit. I.R.E., M.T.S., M.I.P.R.E.</i> .. .. .	51	Aug. '64
Part 5 .. .. .	127	Sept. '64
Part 6 .. .. .	194	Oct. '64
Part 7 .. .. .	274	Nov. '64
Part 8 .. .. .	342	Dec. '64
Part 9 .. .. .	418	Jan. '65
Part 10 .. .. .	490	Feb. '65
Part 11 .. .. .	561	Mar. '65
Part 12 .. .. .	624	Apr. '65
Part 13 .. .. .	778	June '65
Wave-Trap for Television, by <i>J. D. Benson, F.T.S.</i> .. .. .	525	Mar. '65

**TEST EQUIPMENT**

Bridge Building, Part 1, by <i>C. Mackay</i> .. .. .	415	Jan. '65
Part 2 .. .. .	488	Feb. '65
Part 3 .. .. .	552	Mar. '65
Part 4 .. .. .	629	Apr. '65
Combined A.F. Signal Generator and Tracer, by <i>P. F. Bretherwick</i> .. .. .	83	Sept. '64
Combined Torch and Leakage/Continuity Tester, by <i>G. A. French</i> .. .. .	805	July '65
Dynamic Gain Transistor Tester, by <i>D. Bollen</i> .. .. .	691	May '65
"Economy" Capacitance Bridge, by <i>G. A. French</i> .. .. .	450	Feb. '65
Frequency Sub-Standard, by <i>C. Mackay</i> .. .. .	660	May '65
Geometric Progression Resistance Box, by <i>G. A. French</i> .. .. .	88	Sept. '64
Inexpensive Output Meter, by <i>E. S. Barker</i> .. .. .	164	Oct. '64
Inexpensive Rectifier Checker, by <i>Q. Bassim El-Dhuwaib</i> .. .. .	740	June '65
L.F. Sine Wave Generator, by <i>I. M. Rees</i> .. .. .	378	Jan. '65
Low Cost Leakage and Insulation Tester, by <i>G. A. French</i> .. .. .	375	Jan. '65
Low Gain, Wide Band Oscilloscope Amplifier, by <i>P. Cairns, G3ISP</i> .. .. .	627	Apr. '65
Novel Signal Tracer, by <i>I. M. Wilson</i> .. .. .	618	Apr. '65
"Oscar" Sub-Miniature R.F. Signal Generator, by <i>W. Studley</i> .. .. .	526	Mar. '65
Repair Your Meter, by <i>A. L. Jackson, A.M.S.E.</i> .. .. .	516	Mar. '65
Simple Quality Oscilloscope, Part 1, by <i>D. M. Williams, B.Sc.</i> .. .. .	201	Oct. '64
Part 2 .. .. .	268	Nov. '64
Simple Valve Heater Tester, by <i>P. Butler, A.M.I.P.R.E.</i> .. .. .	838	July '65
The "Tracos" Signal Tracer and Oscillator, by <i>S. Akkal</i> .. .. .	383	Jan. '65
Timebase Expansion Generator, by <i>J. R. Knight</i> .. .. .	103	Sept. '64
Transistorised Calibrating Oscillator, by <i>D. H. Leslie</i> .. .. .	162	Oct. '64
Transistorised Capacity Tester, by <i>J. G. Dew, B.Sc.</i> .. .. .	227	Nov. '64
Transistorised Multi-Range D.C. Voltmeter, by <i>A. Foord, Grad.I.E.R.E.</i> .. .. .	802	July '65
Versatile Portable Oscilloscope, Part 2, by <i>P. Cairns, G3ISP</i> .. .. .	23	Aug. '64
Wavemeter W1191A, by <i>S. Chisholm</i> .. .. .	58	Aug. '64
2 kc/s Transistor Sawtooth Generator, by <i>A. Foord, Grad.I.E.R.E.</i> .. .. .	588	Apr. '65
500 kc/s Crystal Frequency Marker, by <i>W. Studley</i> .. .. .	347	Dec. '64

**TRANSMITTING**

Automatic Code Sender, by <i>S. G. Wood, G5UJ</i> .. .. .	638	Apr. '65
Modulated-Light Broadcast Transmitter, by <i>D. Letts</i> .. .. .	523	Feb. '65
The "Mint with the Hole" Transmitter, by <i>F. C. Judd, A.Inst.E.</i> .. .. .	372	Jan. '65

**RADIO TOPICS**

Page No.	Issue	Page No.	Issue
57	Aug. '64	208	Oct. '64
277	Nov. '64	422	Jan. '65
496	Feb. '65	639	Apr. '65
710	May '65	814	July '65

**CAN ANYONE HELP?**

Page No.	Issue	Page No.	Issue
19	Aug. '64	231	Nov. '64
305	Dec. '64	449	Feb. '65
522	Mar. '65	666	May '65
739	June '65		

**NEWS AND COMMENT**

Page No.	Issue	Page No.	Issue
37	Aug. '64	161	Oct. '64
235	Nov. '64	380	Jan. '65
456	Feb. '65	601	Apr. '65
667	May '65		





## FULLY DETAILED AND ILLUSTRATED CATALOGUE

Over 90 big pages. The largest range available in the country. All types of components and equipment at competitive prices.

PRICE  
2/6  
(post paid)

## PROVED & TESTED DESIGNS FULL AFTER SALES SERVICE AND GUARANTEE

★ CALL IN FOR DEMONSTRATIONS ★  
DETAILED LEAFLETS FREE ON REQUEST



### MW/LW POCKET SUPERHET RADIO

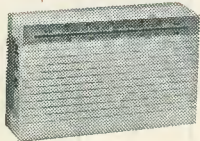

**RADIO**  
TOTAL COST TO BUILD  
**85/-** P.P. 2/-  
(Battery 2/6 Phone 5/-)

★ All parts sold separately.

- ★ 6-Transistor design. Push-pull output.
- ★ 2½" Cleartone speaker. Printed circuit.
- ★ Attractive moulded cabinet.
- ★ Slow motion tuning.
- ★ Full medium and long waves.
- ★ Size: 5" x 3" x 1½".

● AMAZING SENSITIVITY AND SELECTIVITY ●

- ★ 6-Transistor push-pull design.
- ★ Uses factory built panels.
- ★ Permeability geared tuning.
- ★ Full med./long wave tuning with push-button wave change.
- ★ Double tuned IFT's.
- ★ Chromed front panel plate.
- ★ Size: 7" x 4" x 2". Fits any car.
- ★ Pre-built units sold separately.

TOTAL COST TO BUILD  
**£8.19.6**  
P.P. 3/6



(7" x 4" speaker with car fixing kit and baffle board 20/- extra.)

**TWO WAVEBAND ALL-TRANSISTOR CAR RADIO TO ASSEMBLE**  
● HIGH PERFORMANCE SUPERHET ●

### 2- AND 4-TRACK TAPE RECORDERS TO ASSEMBLE

Pre-built Equipment—6 Valves—Collaro Studio Decks—Portable Cabinets with Speakers. Complete record and playback.

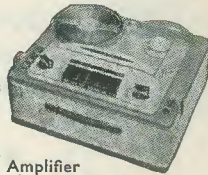

★ 2-track deck 10 gns. P.P. 5/-. Amplifier 11 gns. Cabinet with speaker 5 gns.

OR SPECIAL PRICE **£26** P.P. 8/6 **TWO TRACK**

★ 4-track deck **£13.19.6** P.P. 5/-. Amplifier 12 gns. Cabinet with speaker 5 gns. OR SPECIAL PRICE **£30** P.P. 8/6 **FOUR TRACK**

Prebuilt and tested units. Low distortion, low noise.

### 10W & 20W HI-FI AMPLIFIERS

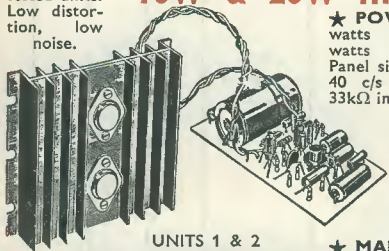

UNITS 1 & 2

★ **POWER AMPLIFIERS.** 10 watts R.M.S. music power, 20 watts peak. 6-Transistor design. Panel size 4" x 2½" x ¾". Response 40 c/s to 20 kc/s. 100mV into 33kΩ input.

**UNIT 1.** For 12/15 ohm speakers. 40 volt supply. PRICE BUILT **£5.19.6** P.P. 2/6

**UNIT 2.** For 3 to 5 ohm speakers. 24/28 volt supply. PRICE BUILT **£5.10.0** P.P. 2/6

★ **MAINS UNITS.** 59/6. To power one amplifier or 69/6 to power two amplifiers. (State 24 or 40 volt version.)

**PREAMPLIFIERS.** Mono and stereo versions, 8 inputs, 1½ to 300mV at 1k to 500k. Response 30 c/s to 20 kc/s. Complete range of controls. Mains unit or battery operated. For pick-ups, tuners, tape, microphones, etc.

**UNIT 3.** Mono full-function pre-amplifier. Size 9½" x 2½" x 2". PRICE BUILT **£5.10.0** P.P. 2/-

(Brown/Gold front panel plate 8/6)

**UNIT 4.** Simplified version of Unit 3. Price 65/- P.P. 1/6. Panel plate 6/6.

**UNIT 5.** Stereo preamplifier for use with two units 1 or 2. Size 9" x 3½" x 1½". PRICE BUILT **£10.19.6** P.P. 3/6

(Front panel plate 12/6)



UNIT 5

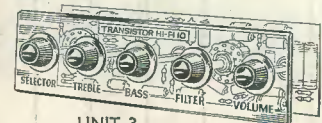

UNIT 3

THE FINEST QUALITY HI-FI AT UNBEATABLE PRICES

We stock:

- TRANSISTORS
- RECTIFIERS
- VALVES
- CRYSTALS
- MICROPHONES
- TEST GEAR
- TAPE DECKS
- SPEAKERS
- MULTI-METERS
- RADIO CONTROL AMPLIFIERS
- RECORDERS
- TUNERS
- RECORD DECKS
- TWEETERS
- RECEIVERS
- GENERATORS
- COMPONENTS AND ACCESSORIES

### SINCLAIR DESIGNS

- ★ Micro-6 MW/ radio 59/6
- ★ TR750 "Add-on" power amp. 39/6
- ★ Micro injector 27/6
- ★ Micro amp. 28/6
- ★ X10 Amp. kit £5.19.6

### NEW X 20 AMPLIFIER

Kit **£7.19.6**  
Built **£9.19.6**  
Mains unit **99/6**

### 4 WATT AND 1½ WATT PACKAGED AMPLIFIERS

- ★ 6-Transistor push-pull printed circuit designs
- ★ Size only 2½" x 2" x 1½"
- ★ 4 watt 12/18 volt, 1½ watt 9/12 volt
- ★ For 3 to 5 ohm speakers
- ★ 7mV into 1kΩ
- ★ 4 kc/s to 15 kc/s

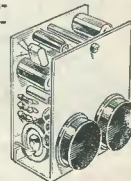

PRICES BUILT **1½w 65/-** P.P. 1/6 **4w 79/6** P.P. 1/6

### 4-CHANNEL MICROPHONE MIXER

Transistorised, 4 inputs up to 100 kΩ. Full mixing. PRICE **49/6** P.P. 1/6

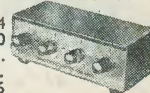

## VALUE FOR MONEY DESIGNS

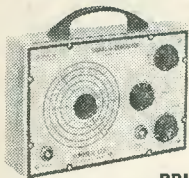

### TRANSISTOR PORTABLE TEST EQUIPMENT

All units size 6½" x 4½" x 2½".

★ RF generator, 150 kc/s to 350 mc/s in 8 ranges. RF, Mod., RF, AF outputs.

PRICE **£9.10.0** P.P. 2/6

- ★ Resistance/capacitance bridge. **£8.5.0** P.P. 2/6.
- ★ Audio generator 10 c/s-100 kc/s. 4 ranges. **£16.15.0** P.P. 2/6.



### VHF/FM TUNER TO ASSEMBLE

★ Two pre-built plus metal work and front panel. Total Cost **£12.17.6** P.P. 2/6

- ★ Size: 9½" x 3½" x 4"
- ★ 88 to 108 mc/s tuning.
- ★ 100mV to 100kΩ output
- ★ 6-Transistor printed cct. superhet design

### TWO WAVE BAND PUSH-BUTTON TRANSISTOR PORTABLE TO BUILD

TOTAL COST  
**£7.19.6**

P.P. 3/6  
(Batteries 6/-)

★ 5" speaker.

★ 6-Transistor push-pull design

- ★ Easy to follow printed circuit.
- ★ 8" ferrite aerial. D/T IFT's.
- ★ Push button wave change.
- ★ Geared tuning. Full Med./L.W.
- ★ Attractive sturdy cabinet with handle. Size: 10" x 7" x 3½".

### SENSITIVE SUPERHET RADIO

Let us quote for parts for your circuit. Send a list for quick reply. Quality components at realistic prices.



### VHF/FM TRANSISTOR TUNER TO BUILD

TOTAL COST  
**£6.19.6**

P.P. 2/6  
(complete with

frontplate) (Gold sprayed cabinet 20/- extra).

- ★ 5-Transistor 4 diodes.
- ★ Printed circuit superhet.
- ★ Geared tuning 87 to 105 Mc/s FM
- ★ RF stage and double tuned IFT's.
- ★ Output up to 1 volt peak up to 100kΩ.
- ★ 9 volt 9mA supply.
- ★ Size in cabinet 4" x 3½" x 2½".
- ★ All parts sold separately.

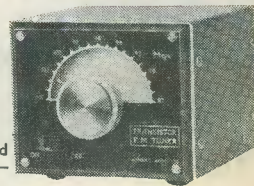

### HENRY'S RADIO LTD.

303 EDGWARE ROAD, LONDON, W2

FADDINGTON 1008/9

Open Mon. to Sat. 9-6. Thurs. 1 p.m.  
Open all day Saturday