

# THE Radio Constructor

RADIO  
TELEVISION  
AUDIO  
ELECTRONICS

VOLUME 16 NUMBER 5  
A DATA PUBLICATION  
PRICE TWO SHILLINGS

**December 1962**

**The  
"Capri" Personal  
6-Transistor  
Receiver**

*Also featured*

A Radio Astronomy Receiver

•  
More Gadgets for Your  
Christmas Party

•  
Voltage Stabilisation for  
Transistor Car Radios

etc., etc., etc.



## THE MODERN BOOK CO

**High Fidelity Pocket Book.** By W. E. Pannett. 40s. Postage 1s.

**TV Fault Finding.** A Data Pub. 5s. Postage 6d.

**Hints and Kinks for TV, Radio and Audio.** By M. Clifford. 18s. 6d. Postage 9d.

**An Electronic Organ for the Home Constructor.** By A. Douglas. 15s. Postage 1s.

**Fun With Electronics.** By G. Davey. 12s. 6d. Postage 1s.

**The Practical Hi-Fi Handbook.** By G. J. King. 25s. Postage 1s.

**Fun With Short Waves.** By G. Davey. 12s. 6d. Postage 1s.

**Guide to Broadcasting Stations.** By "WW". 3s. 6d. Postage 6d.

**The Radio Amateur's Handbook 1962 Ed.** Compiled by A.R.R.L. 36s. Postage 2s.

**Tape Recording Year Book 1962/3.** 7s. 6d. Postage 9d.

**Rapid Radio Repair.** By G. W. Heath. 23s. Postage 1s.

**Radio and Television Test Instruments.** By G. J. King. 25s. Postage 1s.

**Cabinet Handbook.** By G. A. Briggs. 7s. 6d. Postage 1s.

**Radio Data Charts.** By R. T. Beatty. Revised by J. M. G. Sowerby. 10s. 6d. Postage 1s.

**Collecting Gramophone Records.** By E. T. Bryant. 12s. 6d. Postage 6d.

**Radio Valve Data 7th Ed.** Compiled by "WW". 6s. Postage 10d.

We have the Finest Selection of British and American Radio Books in the Country  
Complete catalogue 1s.

**19-21 PRAED STREET (Dept RC) LONDON W2**

Telephone PADDington 4185



## SCOTTISH INSURANCE CORPORATION LIMITED

38 EASTCHEAP · LONDON · EC3

### TELEVISION SETS, RECEIVERS AND TRANSMITTERS

Television Sets, Receivers and Short Wave Transmitters are expensive to acquire and you no doubt highly prize your installation. Apart from the value of your Set, you might be held responsible should injury be caused by a fault in the Set, or injury or damage by your Aerial collapsing.

A "Scottish" special policy for Television Sets, Receivers and Short Wave Transmitters provides the following cover:

- (a) Loss or damage to installation (including in the case of Television Sets the Cathode Ray Tube) by Fire, Explosion, Lightning, Theft or Accidental External Means at any private dwelling-house.
- (b) (i) Legal Liability for bodily injury to Third Parties or damage to their property arising out of the breakage or collapse of the Aerial Fittings or Mast, or through any defect in the Set. Indemnity £10,000 any one accident.
- (ii) Damage to your property or that of your landlord arising out of the breakage or collapse of the Aerial Fittings or Mast, but not exceeding £500.

The cost of Cover (a) is 5/- a year for Sets worth £50 or less, and for Sets valued at more than £50 the cost is in proportion. Cover (b) and (ii) costs only 2/6 a year if taken with Cover (a) or 5/- if taken alone.

Why not BE PRUDENT AND INSURE your installation—it is well worth while AT THE VERY LOW COST INVOLVED. If you will complete and return this form to the Corporation's Office at the above address, a proposal will be submitted for completion.

NAME (Block Letters).....  
If Lady, state Mrs. or Miss  
ADDRESS (Block Letters).....

J/B

## PCR COMMUNICATION RECEIVERS

Manufactured by Pye and Philips. One of the Army's most versatile and sensitive sets. RF stage and 2 of IF, using 6 British I.O. type valves Large 180 degrees. Illuminated and Calibrated Dial. Flywheel tuning with locking device. Aerial trimmer. Tone and volume controls. Band switch from panel jacks for speaker or phones. In black metal case, size 17" L x 8" H x 10" D. Model PCR covers 6-18 Mc/s, 200-550 metres and 850-2,000 metres and has internal 5" speaker. £6.19.6. Model PCR2 has similar L & M waveband coverage. Short wave 6-22 Mc/s, but no speaker. Used but excellent condition, £5.19.6. Every receiver aerial tested before despatch. Add 10/6 carr. all models. Designed to operate from bulky EXTERNAL power supply, but any set can be fitted with BRAND NEW COMPONENTS INTERNAL PACK for 200/250V a.c. at extra cost of £2.

S.A.E. FOR ILLUSTRATED LEAFLET

## TEST METERS FOR EVERY PURPOSE & POCKET



**2,000 O.P.V. MODEL TP-10.** Reads A.C. and D.C. volts up to 1,000; D.C. Current to 500mA; resistance to 1 Meg; Capacitance to 1µF; Decibels from -20 to +36; Output jack for Audio Measurements. Size 3½" x 5" x 1½".  
£3.19.6



**20,000 O.P.V. MODEL TP-55.** Reads Voltage up to 1,000; D.C. at 20,000 ohms per volt and A.C. at 10,000 o.p.v.; D.C. Current to 500mA; Resistance to 10 Meg.; Capacitance to 0.1µF; Decibels from -20 to +36. Size 3½" x 5½" x 1½".  
£5.19.6



**30,000 O.P.V. MODEL 500.** Volts to 1,000; D.C. at 30,000 o.p.v., A.C. at 20,000; 12 Amps D.C. Current; 60 Meg. Resistance; -20 to +56 Decibels; Internal buzzer short circuit warning. Size 3½" x 6½" x 2½".  
£8.19.6

All new stock, with leads, prods & internal batteries. 6 mths. guar. backed by full service facilities. Details S.A.E.

### FOR CALLERS ONLY

**10 Valve Canadian Receiver No. 52.** Covers 1.75-16 Mc/s (19-170 metres) in 3 bands. Built-in 3-valve crystal calibrator and internal speaker. Circuit and instructions supplied. Store soiled and untested, and accordingly will only be sold to callers. ONLY 50/-.

**HRO Senior Table Model Receivers.** Complete with 9 coil sets covering 50 kc/s to 30 Mc/s. Used, very good condition, aerial tested. ONLY £17.10.0 (carriage, etc., 30/-). A few late Model 5T with I.O. valves, £22.10.0 plus carr.

**AMPLIFIER TYPE A1413.** Ex-R.A.F. For normal A.C. mains use. 5Z4 rectification with 6V6 output. Input and output jack sockets, gain control, fully fused. 600 ohms output transformer, easily changed for 3 ohms type. Standard rack mounting size 19" x 7" x 6". Used, good condition. ONLY 59/6 (carriage, etc., 10/6).

**POWER UNITS TYPE 234.** Primary 200/250V 50 cycles. Outputs of 250V 100mA and 6.3V 4A. Fitted double smoothing. For normal rack mounting (or bench use) having grey front panel size 19" x 7". Fitted input and output voltmeter, 79/6, or model less meter, 59/6 (carriage either type 10/6).

**12 VOLT AMERICAN DYNAMOTORS.** Deliver 220 volts at 100mA. Size 5½" x 3½" diameter. Ideal for running Electric Shaver, etc., from car battery. ONLY 32/6 (post 2/6).

**AVOMETER MODEL 7 LEATHER CASES,** fitted with carrying handle and long strap. BRAND NEW. ONLY 32/6 (post 2/6).

### "P.W. TROUBADOUR" 7 Transistor Personal Receiver



Designed by the technical staff of Practical Wireless: easy to build, using printed circuit and 1st grade Matched Transistors and Diode. Full Medium and Long Wave coverage to internal speakers. All parts sold separately (new components only) enabling you to buy as required, and full detailed price list will be sent on request. Constructional details 1/6. TOTAL COST INCLUDING BATTERY AND CABINET £8.10.0. "P.W. 6" £7.19.6. Parts List S.A.E.

### COMBINED VIBRATOR/MAINS UNIT.

The Power Pack section of the Army R.107 Receiver. Has Vibrator for 12 volts DC operation, and Mains Transformer for 100/250 volts AC. Output 12.6 volts 3 Amps LT, and 250 volts 100mA HT. Complete with Vibrator, 6X5G Rectifier, and connecting data. Ideal for driving TCS or Type 52 Receivers, etc., or Mobile Equipment. BRAND NEW IN MAKER'S CARTONS. ONLY 45/- (carr. 5/6).

### THE "GOOD COMPANION" Mk. II

Using transfilters, the latest manufacturing technique to save alignment difficulty.

As described in "THE RADIO CONSTRUCTOR", August issue  
**THE FINEST COMBINED PORTABLE AND CAR RADIO YET DESIGNED FOR THE HOME CONSTRUCTOR**

★ 750mW output.

★ 6 transistors and 2 diodes.

★ Full Medium and Long Wave coverage.

★ Quality speaker.

★ Brilliantly styled 2-tone cabinet, size 11" x 8" x 3".

★ Very fine tuning with calibrated dial.

★ Latest printed circuit. ★ Internal high gain aerial with car aerial socket. Easy to follow construction data (available separately 3/6).

All parts sold separately and full illustrated details will be sent on request.

Total Cost **£9.19.6**

With alternative luxury cabinet using 7" x 4" speaker, £10.19.6. Either type, plus 5/- post and ins. (Battery 3/6 extra.)

### "POCKET 4" TRANSISTOR RECEIVER

Uses miniature speaker, proper tuning condenser, and volume control. Built-in aerial makes unit efficient and portable. Ideal for the beginner. Full medium wave coverage. All components and case for only 42/6 (p. & p. 2/6). Ten-page constructional book free with parts or separately 1/6. S.A.E. for parts price list.

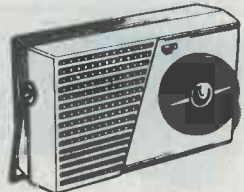

## HARRIS ELECTRONICS (LONDON) LTD

(DEPT. M)  
138 GRAY'S INN ROAD LONDON WC1

Telephone TERminus 7937

Please include carriage costs on ALL items.  
(Open until 1 p.m. Saturdays.) We are 2 mins. from High Holborn (Chancery Lane Station) and 5 mins. by bus from King's Cross.

# Heathkit

DAYSTROM



SB-10U

**SINGLE SIDEBAND ADAPTOR.** Model SB-10U. May be used with most A.M. transmitters. Less than 3w R.F. input power required for 10w output. Operation on 80, 40, 20, 15 and 10m bands on U.S.B., L.S.B. or D.S.B. **£39.50**



DX-40U

**AMATEUR TRANSMITTER.** Model DX-40U. Covers all amateur bands from 80 to 10 metres; crystal controlled. Power input 75W C.W., 60W peak controlled carrier phone. Output 40W to aerial. Provision for V.F.O. Filters minimise TV interference. **£33.19.0**



GD-1U

**GRID-DIP METER.** Model GD-1U. Functions as oscillator or absorption wave meter. With plug-in coils for continuous frequency coverage from 1.8 Mc/s to 250 Mc/s. **£10.19.6**



O-12U

Three Additional Plug-in Coils Model 341-U extend coverage down to 350 kc/s. With dial correlation curves. **17/6**



S-3U

**TRANSISTORISED VERSION.** Model XGD-1. Similar to GD-1U. Fully transistorised with a frequency range of 1.8 to 45 Mc/s. **£10.18.6**



AG-9U

**5" OSCILLOSCOPE.** Model O-12U. Has wide-band amplifiers, essential for TV servicing, FM alignment, etc. Vertical frequency response 3 c/s to over 5 Mc/s, without extra switching T/B covers 10 c/s to 500 kc/s in 5 ranges. **£38.10.0**



C-3U

**2½in. SERVICE 'SCOPE.** Model OS-1. Light, compact portable for service engineers. Dim. 5" x 8" x 14½" long. Wt. 10½lb. **£19.19.0**

**ELECTRONIC SWITCH.** Model S-3U (Oscilloscope Trace Doubler.) Enables a single beam oscilloscope to give simultaneous traces of two separate and independent signals. Switching rates approx. 150, 500, 1,500, 5,000 and 15,000 c/s. Sig. freq. response 0-100 kc/s. ±1dB. Separate gain controls and sync. output. Sig. input range 0.1-1.8V r.m.s. **£11.15.6**

**RESISTANCE CAPACITANCE BRIDGE.** Model C-3U. Measures capacity 10pF to 1,000µF, resistance 100Ω to 5MΩ and power factor. 5-450V test voltages. With safety switch. **£9.5.0**

**AUDIO SIGNAL GENERATOR.** Model AG-9U. 10 c/s to 100 kc/s, switch selected. Distortion less than 0.1%, 10V sine wave output metered in volts and dB's. **£21.9.6**

**TRANSISTOR INTERCOM.** Models XI-1U & XIR-1U. The master unit uses a 4-transistor amplifier, constructed on a printed circuit board, and an internal 9V battery. Remote stations use a similar battery for call only. Up to five remote units can be ordered for each master. **£4.7.6**

XI-1U (master) **£10.19.6**

**SUGDEN MOTOR UNIT "CONNOISSEUR CRAFTSMAN."** Heavy duty motor operating at 33½ and 45 r.p.m. Very heavy 12" turntable. Virtually no rumble. **£18.3.6**

**AMATEUR TRANSMITTER.** Model DX-100U. The world's most popular, compact and completely self-contained Amateur Transmitter. Covers all amateur bands: 160-10 m. 150W d.c. input. Careful design has achieved the stability and high performance for which the DX-100U is noted and no less than 35 disc ceramic capacitors reduce TVI to a minimum. **£74.19.0**



DX-100U

**VARIABLE FREQUENCY OSCILLATOR.** Model VF-1U. Calibrated 160-10 m. Fundamentals on 160 and 40 m. Ideal for our DX-40U and similar transmitters. **£11.17.6**



VF-1U

**BALUN COIL UNIT.** Model B-1U. Will match unbalanced co-axial lines to balanced lines of either 75 or 300Ω impedance. **£4.15.6**

**THE "MOHICAN" GENERAL COVERAGE RECEIVER.** Model GC-1U. With 4 piezo-electric transmitters, variable tuned B.F.O. and Zener diode stabiliser, this is an excellent fully transistorised general purpose receiver for Amateur and Short wave listeners. Printed circuit boards, telescopic whip antenna, tuning meter and large slide-rule dial, 10 transistors. **£39.17.6**



GC-1U

## THE BEST QUALITY

**4-WAVEBAND TRANSISTORISED PORTABLE RECEIVER.** Model RSW-1. This model possesses Medium, Trawler and two Short-wave bands and is midway between the domestic broadcasting and professional general communications receiver. Ideal and inexpensive for those who wish to listen to world broadcasts, shipping and aviation communications. In a handsome leather case, it has retractable whip aerial and socket for car radio use. **£22.8.0**



RSW-1

**TRANSISTOR PORTABLE RADIO.** Model UXR-1. Pre-aligned I.F. transformers, printed circuit and a 7" x 4" high-flux speaker. Real hide case. **£14.3.0**



UXR-1

**HI-FI AM/FM TUNER.** Model AFM-1. Available in two units which, for your convenience, are sold separately: Tuning heart (AFM-T1—£5.5.6 incl. P.T.) and I.F. amplifier (AFM-A1—£20.13.0). Printed circuit board, 8 valves. Built-in power supply. Total **£25.18.6**

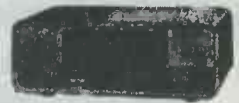

AM/FM TUNER

**HI-FI FM TUNER.** Model FM-4U. Also available in two units as above: R.F. tuning unit (£3.2.0 incl. P.T.) with I.F. output of 10.7 Mc/s, and amplifier unit, with power supply and valves (£12.6.0). Total **£15.8.0**



FM TUNER

**POWER SUPPLY UNIT.** Model MGP-1. Input 100/120V 200/250V, 40-60 c/s. Output 6.3V, 2.5A A.C.: 200, 250, 270V, 120mA max. D.C. **£5.2.6**

### MONEY-SAVING "PACKAGED DEALS"

For the benefit of customers wishing to purchase several units of their Hi-Fi equipment at the same time, useful price reductions are offered. Such "Packaged Deals" may include RECORD PLAYERS and TAPE DECKS of your preference, not necessarily featured in our catalogue. Two money-saving examples are given here and quotations for your own special requirements will gladly be sent on request.

GL-58 Transcription Unit	£19.12.6	TA-1M	£19. 2.6
S-33 Stereo Amp.	£13. 7.6	Collaro "STUDIO"	£17.10.0
Twin SSU-1 Speakers (Bookcase Type)	£22.10.0	USC-1	£19.10.0
	£55.10.0	MA-12	£11. 9.6
			£67.12.0
	<b>Packaged £53.4.0</b>		<b>Packaged £63.15.0</b>

All models directly available from the makers:

**DAYSTROM Ltd GLOUCESTER**

# FINEST ELECTRONIC KITS IN THE WORLD



"GLOUCESTER"

**HI-FI EQUIPMENT CABINETS.** Our four equipment cabinets meet a wide variety of tastes and requirements: the "CHEPSTOW" was designed for those who have little floor space, the contemporary "MALVERN" for the Tape and Gram. enthusiast, and the "GLOUCESTER" Mk. I and II for those with traditional tastes. All parts are pre-cut and drilled for easy assembly, and left "in the white".

Prices from £11.12.6 to £18.10.0

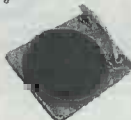

GL-58

**TRANSCRIPTION RECORD PLAYER (STEREO).** Manufactured by Goldring-Lenco. This 4-speed unit is fitted with a G60 pick-up arm. Infinitely variable speed adjustment from 33½ to 80 r.p.m. Fixed speed of 16 r.p.m. Its balanced turntable (3½ lb) reduces rumble, wow and flutter to very low level. The unique lowering device fitted provides absolutely safe means of placing pick-up on record **£19.12.6**



S-33

**6W STEREO AMPLIFIER, Model S-33.** 3 watts per channel, 0.3% distortion at 2.5 w/chnl., 20dB N.F.B. Inputs for Radio (or Tape) and Gram., Stereo or Monaural, ganged controls. Sensitivity 100mV. **£13.7.6**

## AT LOWEST PRICES



Truvox D83

**TRUVOX D83 & D84 TAPE DECKS.** High quality mono/stereo tape decks. D83, 2 track, for highest fidelity. **£31.10.0**

D84 (identical presentation), 4-track, for most economical use of tape. **£29.8.0**



"STUDIO"

**COLLARO "STUDIO" TAPE DECK.** The finest buy in its price range. Operating speeds: 1½, 3½ and 7½ i.p.s. Two tracks. "Wow" and "flutter" not greater than 0.15% at 7½ i.p.s. Long Term Speed Stability better than 0.5%. **£17.10.0**

**HI-FI STEREO/MONO PRE-AMPLIFIER, Model USP-1.** Extremely versatile unit. Gain may be preset over a wide range. Input 2mV-20mV. Output 20mV-2V **£7.7.6**

**HI-FI SINGLE CHANNEL AMPLIFIER, Model MA-12.** 12W output, wide freq. range, low distortion. **£11.9.6**

### TAPE RECORDING AND REPLAY HI-FI AMPLIFIER

Mono model TA-1M, Stereo model TA-1S. For use with most tape decks. Thermometer type recording indicators, press-button speed compensation and input selection, 3-position bias level and printed circuit construction.



TA-1S

TA-1M ..... **£19. 2.6**  
TA-1M & Collaro STUDIO **£30.10.0**  
TA-1M & TRUVOX D83 ... **£47. 2.6**  
TA-1M & TRUVOX D84 ... **£45. 5.0**  
TA-1S ..... **£24.10.0**  
TA-1S & STUDIO ... **£35.14.0**  
TA-1S & TRUVOX D83 ... **£52. 6.0**  
TA-1S & TRUVOX D84 ... **£50. 9.6**



USC-1

**STEREO CONTROL UNIT, Model USC-1.** Push-button selection, accurately matched ganged controls to ±1dB. Negative feedback, rumble and variable low-pass filters. Printed circuit boards. **£19.10.0**

**VALVE VOLTMETER, Model V-7A.** 7 voltage ranges d.c. volts to 1,500, a.c. to 1,500 r.m.s. and 4,000 peak to peak. Resistance 0.1Ω to 1,000MΩ with internal battery. D.C. input impedance 11MΩ. dB measurement has centre-zero scale. Complete with test prods, lead and standardising battery. **£13.18.6**



V-7A

**MULTIMETER, Model MM-1U.** Ranges 0-1.5V to 1,500V A.C. and D.C.; 150μA to 15A D.C.; 0.2Ω to 20MΩ. 4½" 50μA meter. **£12.10.0**



MM-1U

**R.F. SIGNAL GENERATOR, Model RF-1U.** Up to 100 Mc/s fundamental and 200 Mc/s on harmonics and up to 100mV output on all bands. **£12.15.6**

**AUDIO WATTMETER, Model AW-1U.** Up to 25W continuous, 50W intermittent. **£15.15.0**

**AUDIO VALVE MILLIVOLTMETER, Model AV-3U.** 1mV-300v A.C. 10 c/s to 400 kc/s. **£14.17.6**

**AUDIO SINE-SQUARE WAVE GENERATOR, Model AO-1U.** Covers 20 c/s to 150 kc/s and square waves to 50 kc/s in four ranges. Maximum output 10V, distortion less than 1%. **£13.15.0**

**CAPACITANCE METER, Model CM-1U.** Direct-reading 4½" scale. Full-scale ranges 0-100μF, 0-1,000μF, 0-0.01μF and 0-0.1μF. **£15.15.0**

**HI-FI SPEAKER SYSTEM, Model SSU-1.** Ducted-port bass reflex cabinet "in the white". Twin speakers. With legs **£11.9.6** **£11.5.0**

**HEATHKIT ELECTRONIC WORKSHOP, Model EW-1.** This educational kit will teach and amuse your children. It can make 21 exciting experiments including transistor radios, burglar alarm, radio or TV silencer, intercom., etc. **£7.18.0**

**JUNIOR TRANSISTOR RADIO, Model UJR-1.** Single transistor set. Excellent introduction to radio. An instructive present. **£2.13.6**

**HI-FI STEREO AMPLIFIER, Model S-99.** 18W output. Ganged controls. Stereo/mono gram., radio and tape recorder inputs. Push-button selection. Printed circuit construction. **£27.19.6**

**THE "COTSWOLD".** This is an acoustically designed enclosure 26" x 23" x 15½" housing a 12" bass speaker with 2" speech coil, elliptical middle speaker together with a pressure unit to cover the full frequency range of 32-20,000 c/s. Capable of doing justice to the finest programme source, its polar distribution makes it ideal for really Hi-Fi Stereo.

**COTSWOLD "MFS" SYSTEM.** Specially developed to give best possible results in small rooms. This minimum floor space model is based on standard Cotswold. Size: 36" high x 16½" wide x 14½" deep. Either Model, **£23.4.0**



S-99



THE "COTSWOLD"

Prices include free delivery U.K. Deferred terms available over £10  
Assembled models also available—prices on request

★ SEND THIS COUPON NOW FOR FURTHER INFORMATION  
(Please write in BLOCK CAPITALS)

NAME .....

ADDRESS .....

Without obligation please send me (Tick here)

FREE BRITISH HEATHKIT CATALOGUE.....

FULL DETAILS OF MODEL(S).....

**DAYSTROM LTD DEPT RC12**  
**GLOUCESTER . ENGLAND**

A member of the Daystrom Group, manufacturers of the  
**WORLD'S LARGEST-SELLING ELECTRONIC KITS**



### VOLUME CONTROLS

Long spindles. Midget 5K ohms to 2 Meg.  
L/S 3/- D.P. 4/6  
Stereo L/S 10/6 D.P. 14/6  
Linear or Log Tracks.

### 80 ohm Coax CABLE

Semi-air spaced 3in. Stranded core. 6d. yd. 40 yds. 17/6; 60 yds. 25/-  
Fringe Quality, Air Spaced 1/- yd.

### EXTENSION SPKR. CONTROL 10 Ohm 3/- TELESCOPIC CHROME AERIALS 13in. extending to 43in. 8/6 each. Coax. Adaptor 1/6.

RESISTORS. Preferred values. 10 ohms to 10 meg. 1/4 w., 4d.; 1/2 w., 6d.; 1 w., 8d.; 2 w., 1/-.

HIGH STABILITY. 1/2 w., 2/- Preferred values. 10 ohms to 10 meg. Ditto 5%, 10 ohms to 22 meg. 9d. 5 watt WIRE-WOUND RESISTORS 1/3 10 ohms-10,000 ohms 2/- 15 watt 2.5K to 50K 10 w 3/-

### I.F. TRANSFORMERS 7/6 pair

465 kc/s Slug Tuning Miniature Can. 2in. x 3in. x 3in. High Q and good band width. Data sheet supplied.

### WIRE-WOUND Pots. 3 WATT. Pre-set Min.

TV Type. All values 10 ohms to 25K, 3/- ea.; 30K, 50K, 4/-, Carbon 30K to 2 meg. 3/-

### WIRE-WOUND 4 WATT POTS. Long

Spindle, Values, 50 ohms to 50K, 6/6; 100K, 7/6.

TRIPLEXERS, Bands I, II, III, 12/6  
COAXIAL PLUGS, 1/- PANEL SOCKETS, 1/-  
LEAD SOCKET, 2/- OUTLET BOXES, 4/6  
BALANCED TWIN FEEDER, 6d. yd., 80 or 300 ohms  
TWIN SCREENED FEEDER, 1/6 yd., 80 ohms  
TRIMMERS, Ceramic 30, 50, 70 pF, 9d.; 100 pF, 150 pF, 1/3; 250 pF, 1/6; 500 pF, 750 pF, 1/9; Philips, 10 pF, 30 pF, 1/- each.

### 1962 RADIOGRAM CHASSIS



Three Wavebands S.W. 16 m.-50 m. Latest Mullard M.W. 200 m.-500 m. ECH81, EF89, EBC81, L.W. 800 m.-2,000 m. EL84, EZ80  
12-month Guarantee. A.C. 200-250V, 4-way switch. Short-Medium-Long-Gram. A.C.C. and Negative Feedback, 4.2 watts. Chassis 13 1/2" x 5 1/2" x 2 1/2". Glass diode size 10" x 4 1/2", horizontal or vertical. Two Pilot Lamps. Four Knobs, Walnut or Ivory. Aligned and calibrated. Chassis isolated from mains.

**BRAND NEW £9.10.0 Carr. 4/6**

Matched Speakers 8" 17/6; 10" 25/-; 12" 30/-  
BLACK CRACKLE PAINT. Air drying, 3/- tin.  
NEON MAINS TESTER SCREWDRIVER, 5/-  
SOLDER RADIOGRADE, 4d. yd., 1 lb. 5/-

### HIGH GAIN TV PRE-AMPLIFIERS BAND I B.B.C.

Tuneable channels 1 to 5. Gain 18 dB. ECC84 valve. Kit price 29/6 or 49/6 with power pack. Details 6d. (PCC84 valves if preferred.)  
BAND III I.T.A.—Same prices  
Tuneable channels 8 to 13. Gain 17 dB.

PAXOLIN PANELS, 3in. x 10in. x 8in. 2/-  
MINIATURE CONTACT COOLED RECTIFIERS. 250 v. 50 mA, 7/6; 250 v. 60 mA, 8/6; 250 v. 85 mA, 9/6; 200 mA, 21/-; 300 mA, 27/6. Full Wave Bridge 250V. 75mA, 10/-; 120mA, 15/-.

SELENIUM RECT., 300 v. 85 mA, 5/-  
COILS. Wearite "P" type, 3/- each. Osmor Midget "Q" type, adj. dust core from 4/- each. All ranges.  
TELETRON D.W.R. L. & Med. T.R.F. with reaction, 4/-; Med. only DR, 3/6.  
FERRITE ROD AERIALS. M.W., 8/9; M. & L., 12/6.  
FERRITE ROD AERIALS. L & M. for transistor circuits, 10/- each. FERRITE RODS 8in. x 1in., 3/- 8in x 1/2in. 3/- 6in. x 1in., 3/-.

ALUMINIUM CHASSIS. 18 s.w.g. Plain, undrilled 4 sides, riveted corners, lattice fixing holes, 2 1/2in. sides. 7in. x 4in., 4/6; 9in. x 7in., 5/9; 11in. x 7in., 6/9; 13in. x 9in., 8/6; 14in. x 11in., 10/6; 15in. x 14in., 12/6;  
ALUMINIUM PANELS. 18 s.w.g., 12in. 12in. 4/6; 14in. x 9in., 4/-; 12in. x 8in., 3/- 10in. x 7in., 2/3 8in. x 6in. 2/-.

H.F. CHOKES, 2/6. Osmor OC1 6/9.  
T.R.F. COILS A/HF, 7/- pair; HAX, 3/-; DRR2, 4/-  
ALADDIN FORMERS and cores. 2in. 8d., 3in. 10d. 0.3in. FORMERS 5937 or 8 and cans TV1 or 2, 3in. sq. x 2 1/2in. or 2in. sq. x 1 1/2in., 2/- with cores.  
SLOW MOTION DRIVES. Epicyclic ratio 6-1, 2/3.  
SOLOIN IRON, 25 w., 200 v. or 230 v. 24/-  
PRECISION Sub-miniature Iron. 200 or 240 v. 29/6.

**4 TRANSISTOR PUSH-PULL AUDIO AMPLIFIER** Size 3 x 1 1/2 x 7 1/2  
A ready built miniature push-pull amplifier with input- and output transformers, 4 transistors. Ideal for use with record players, intercoms or BABY ALARM.  
Complete with full instructions and circuit.  
**PRICE 52/6** 9v Batt. 2/3, 2 1/2" SPEAKER 15/-

MAINS DROPPERS. Midget. With adj. sliders. 0.3A, 1,000 ohms 5/-; 0.2A 1,200 ohms, 5/-; 0.15A 1,500 ohms, 5/-; 0.1A, 2,000 ohms, 5/-.

TELEVISION REPLACEMENTS Line Output Transformers  
Tom 45/- each, NEW Stock and other timebase components  
Most makes available. S.A.E. with all enquiries

MIKE TRANSFORMER 50:1, 3/9.  
P.V.C. CONN. WIRE, single or stranded, 2d. yd.  
SLEEVING, 1 or 2 mm, 2d.; 4 mm, 3d.; 6 mm, 5d. yd.

### FERRODYNAMICS AMERICAN "BRAND FIVE" PLASTIC RECORDING TAPE

Double Play 7" reel, 2,400 ft.	60/-	Spare Plastic Reels
5" reel, 1,200 ft.	37/6	
Long Play 7" reel, 1,800 ft.	35/-	3" 1/6
5 1/2" reel, 1,200 ft.	23/6	4" 2/-
5" reel, 900 ft.	18/6	5" 2/-
Standard 7" reel, 1,200 ft.	25/-	5 1/2" 2/-
5" reel, 600 ft.	16/-	7" 2/6

"Instant" Bulk Tape Eraser and Head Defluxer, 200/250V A.C. 27/6. Leaflet S.A.E.

ARDENTE TRANSISTOR TRANSFORMERS  
D3035, 7.3 CT:1 Push Pull to 3 ohms for OC72, 9/6.  
D3034, 1.75:1 CT. Push Pull Driver for OC72, 9/6.  
D3058, 11.5:1 Output to 3 ohms for OC72, etc., 9/6.  
D167, 18:2:1 Output to 3 ohms for OC72 etc., 12/-.  
D239, 4.5:1 Driver, 3in. x 3in. x 3in., 10/-  
D240, 8.5:1 Driver, 3in. x 3in. x 3in., 10/-  
ARDENTE TRANSISTOR VOLUME CONTROLS. Type VCI545, 5K with switch, dia. 9in., 5/3. Type VCI760, 5K with switch, dia. 7in., 10/6.  
DEAF AID EARPIECE Xtal or magnetic 7/6.  
SPEAKER FRET. Gold cloth, 17in. x 25in., 5/-; 25in. x 35in., 10/-  
TYGAN, various colours, 52in. wide, from 10/- ft.; 26in. wide from 5/- ft. Samples S.A.E. Expanding Metal, Gold, 12in. x 12 in., 6/-

### BARGAIN SINGLE PLAYER KIT

**£8.15.0 post free**  
WITH 2-STAGE 3-WATT AMPLIFIER.  
HIGH-FLUX 5" SPEAKER.  
HANDSOME PORTABLE CASE 13" 10 1/2" x 7 1/2".  
COLLARO JUNIOR 4-SPEED MOTOR.  
CRYSTAL PICK-UP FOR L.P./STANDARD RECORDS, 7"-10"-12".

Few only 3-speed models with B.S.R. motor. Complete Kit £7.15.0 only.

### MONARCH RECORD PLAYER



**BUILD IT YOURSELF** using 4-SPEED BSR MONARCH AUTOCHANGER READY BUILT 3W AMPLIFIER, HANDSOME PORTABLE CASE, HIGH FLUX LOUDSPEAKER. FULL INSTRUCTIONS  
Total Price Carr. and ins. 5/- **£12.10.0**

### De-Luxe Kit with GARRARD Quality Auto-changer £12.19.6 Carr. & Ins. 5/-

**RECORD PLAYER BARGAINS**  
Complete with LP/STD Xtal Heads.  
4 Speed Autochangers: POST 2/- each  
BSR, U.A.14.....£7.10.0  
BSR, U.A.12 Stereo/Monaural.....£8.5.0  
Garrard Autostim Changer.....£7.19.6  
4 Speed Single Players:  
EMI Junior with separate pick-up.....£3.9.6  
EMI with auto. stop.....£6.5.0  
All Sapphire Stylis available from 6/-  
All Crystal Cartridges available from 21/-  
**AUTOCHANGER ACCESSORIES**  
Amplifier player cabinets with cut boards, 70/-  
2-valve amplifier and 6 1/2" speaker for above, ready mounted on baffle, 12in. x 7in., 3in. deep, Wired and tested ready for use, £4.15.0.

### QMAX CHASSIS CUTTER

The cutter consists of four parts: a die, a punch, an Allen screw and key.  
1 1/2" 14/6, 1 1/4" 14/9, 3/4" 15/6, 1/2" 15/9, 1" 17/6, 1 1/8" 17/6, 1 1/4" 20/-, 1 1/2" 20/6, 1 3/4" 22/6, 2" 34/3, 2 1/4" 37/9, 2 1/2" 44/3, 1" square 3/16, 1 1/4" square 28/-.

### WEYRAD COILS AND TRANSFORMERS FOR A 2-WAVE TRANSISTOR SUPERHET WITH PRINTED CIRCUIT AND FERRITE ROD AERIAL

Long and Medium Wave Aerial—RA2W with car aerial coil. On 6in. rod, 7in. diameter, 208 pF. tuning, 12/6. Oscillator Coil P501AC. Medium wave. For 176 pF. tuning, 5/4. 1st and 2nd I.F. Transformer—P50/2CC. 470 kc/s. 1in. diameter by 3in. high, 5/7. 3rd I.F. Transformer—P50/3CC, to feed diode detector, 6/-; 24-Fixed resistors 10/6.  
Driver Transformer—LFD74, 1 1/2in. x 3in. x 1 1/2in., 9/6. 16-Fixed condensers 21/-.  
Printed Circuit—PCAL. Size 2 1/2in. x 8 1/2in. Ready drilled and printed with component positions, 9/6. Jackson 00 gang 10/6. 35 ohm Speakers, 7in. x 4in., 25/-; 3 1/2in., 19/6. Wavechange Switch 3/6. Volume Control 4/6. Set of 6 Mullard Transistors and diode, 42/6.  
These components are approved by transistor makers and performance is guaranteed.  
Constructor's Booklet with full details, 2/-.

### NEW MULLARD TRANSISTORS

OC71...6/- OC81...7/6 OC44...8/9 OC171...10/6  
OC72...7/6 OC81...7/6 OC45...8/6 AF171... 9/6  
Sub-miniature Electrolytics (15 V) 1 mid. 2 mid., 4 mid., 5 mid., 8 mid., 16 mid., 30 mid., 50 mid., 100 mid., 2/6.  
Diodes OA81, 3/-; GEX 34, 4/-.

B.B.C. 2 Transistor, M.W. and L.W. Radio Kit, 22/6. Earpiece, 7/6. Battery 2/3.

### 6 TRANSISTOR RADIO MED. & LONG WAVE KIT £4.5.0

First-class components to make a 6-transistor 2-waveband superhet chassis. Ideal for portable or table radio. All parts including BVA transistors ferrite aerial, printed circuit, 8 1/2in. x 2 1/2in., but EXCLUDING speaker and cabinet. Simple instructions, 1/6 (Free with kit). 35 ohm Speakers, 3 1/2 in. 19/6, 5 in. 22/6, 7 x 4 in. 25/-.

**"CHRISTMAS GREETINGS" TO ALL SPECIALISTS** 337 WHITEHORSE ROAD WEST CROYDON Telephone THO 1665  
P. & P. charge 1/-, New List, 1/-, C.O.D. 2/-, (Export welcome. Send remittance and extra postage)

# FREE TO AMBITIOUS ENGINEERS

— THE LATEST EDITION OF ENGINEERING OPPORTUNITIES

## Have you sent for your copy?

ENGINEERING OPPORTUNITIES is a highly informative 156-page guide to the best paid engineering posts. It tells you how you can quickly prepare at home for a recognised engineering qualification and outlines a wonderful range of modern Home Study Courses in all branches of Engineering. This unique book also gives full details of the Practical Radio & Electronics Courses, administered by our Specialist Electronics Training Division—the B.I.E.T. School of Electronics, explains the benefits of our Employment Dept. and shows you how to qualify for five years promotion in one year.

## We definitely Guarantee "NO PASS—NO FEE"

Whatever your age and experience you cannot afford to miss reading this famous book. If you are earning less than £25 a week send for your copy of "ENGINEERING OPPORTUNITIES" today—FREE.

**BRITISH INSTITUTE OF ENGINEERING TECHNOLOGY** (Incorporating E.M.I. Institutes)  
(Dept. SE/23), 29 Wright's Lane, London, W.8

### WHICH IS YOUR PET SUBJECT?

Mechanical Eng.,  
Electrical Eng.,  
Civil Engineering,  
Radio Engineering,  
Automobile Eng.,  
Aeronautical Eng.,  
Production Eng.,  
Building, Plastics,  
Draughtsmanship,  
Television, etc.

### GET SOME LETTERS AFTER YOUR NAME!

A.M.I.Mech.E.  
A.M.I.C.E.  
A.M.I.Prod.E.  
A.M.I.M.I.  
L.I.O.B.  
A.F.R.Ae.S.  
B.Sc.  
A.M.Brit.I.R.E.  
City & Guilds  
Gen. Cert. of Education  
Etc., etc.

### PRACTICAL EQUIPMENT

Basic-Practical and Theoretical Courses for beginners in Radio, T.V., Electronics, Etc., A.M.Brit.I.R.E. City & Guilds Radio Amateurs' Exam.  
R.T.E.B. Certificate  
P.M.G. Certificate  
Practical Radio  
Radio & Television Servicing  
Practical Electronics  
Electronics Engineering  
Automation

### INCLUDING TOOLS!

The specialist Electronics Division of B.I.E.T. (Incorporating E.M.I. Institutes) NOW offers you a real laboratory training at home with practical equipment. Ask for details.

### B.I.E.T. SCHOOL OF ELECTRONICS

### POST COUPON NOW!

Please send me your FREE 156-page "ENGINEERING OPPORTUNITIES"  
(Write if you prefer not to cut page)

NAME .....

ADDRESS .....

SUBJECT OR EXAM THAT INTERESTS ME .....



# Premier RADIO

23 Tottenham Court Road London W1 Telephone MUSEum 3451/2 and 309 Edgware Road London W2 Telephone PADdington 6963



THE "MID-FI" A NEW DESIGN 4½W AMPLIFIER KIT MAY BE BUILT FOR 95/- plus 3/- P. & P.  
A new circuit for the home constructor requiring a good quality med. powered amplifier for reproduction of records or f.m. broadcasts. Technical spec.: sep. bass and treble controls. Valves: EF86, EL84, EZ80. Voltage adjustment for a.c. mains from 200/250V, 3 or 15Ω imp. Neg. feedback. Size 7" x 5" x 2", overall ht. 5". Silver hammered finished chassis.

for reproduction of records or f.m. broadcasts. Technical spec.: sep. bass and treble controls. Valves: EF86, EL84, EZ80. Voltage adjustment for a.c. mains from 200/250V, 3 or 15Ω imp. Neg. feedback. Size 7" x 5" x 2", overall ht. 5". Silver hammered finished chassis.



### WHY NOT DO IT YOURSELF!

Long & Medium Waveband  
T.R.F. Receiver

May be built for **£5. 10. 0** Plus 5/- P. & P.

This receiver uses the very latest circuitry and when constructed is housed in a Bakelite cabinet size 12" x 6½" x 5½", available in either walnut or ivory. Individual instruction books 1/- each, post free.

### WE HAVE BEEN APPOINTED STOCKISTS FOR FULL RANGE OF STERN'S RADIO (Fleet Street)

Famous Mullard Designs such as Type 'C' Tape Pre-amplifier and Erase Unit, including separate Power Supply. Complete Kit of Parts ..... £14. 0. 0 or Completely assembled and tested .....

..... £17. 0. 0 and £14. 10. 0 respectively.

Stern's Model HF/TR3 Mk.2. Tape Amplifier Complete Kit of Parts ..... £13. 14. 0 or Completely assembled and tested .....

..... £17. 0. 0 Complete Mullard 5-10 Amplifier with Pre-amplifier on same Chassis

Complete Kit with Parmeko O/P and Mains Transformers ..... £11. 10. 0 Completely assembled and tested .....

..... £13. 10. 0 Complete Mullard 3-3 Amplifier Kit ..... £7. 10. 0

Completely assembled and tested .....

..... £8. 19. 6 P. & P. 6/6 Mullard 10-10 Stereo Power Amplifier based on the famous Mullard 5-10

Complete Kit of Parts ..... £18. 10. 0 Completely assembled and tested .....

..... £21. 0. 0 (Control Unit on Main Chassis) Also available with separate dual-channel Pre-amp. Complete Kit for Power Amp. & Pre-amp .....

..... £26. 0. 0 Complete assembled and tested. .... £30. 0. 0

All components used in these kits are of the highest possible standard and strictly to circuit specifications. Full descriptive literature available on these products and Circuit Diagrams may be purchased separately.

### The "Handyphone" Intercom

Fully Transistorised Battery Operated 89/6 P. & P. 4/-

Including PP3-Battery and 25 yds. lead with plugs. At last a completely Portable Intercom with 101 uses being ideally suitable for the office or even as a Baby Alarm, since being battery operated, it is completely safe. Two-way calling system and volume on/off switch, the units are housed in attractive plastic cabinets (black/white) with chrome stands. It is extremely economical operating on one 9-volt battery, replacement price being 2/6.

### The "Petite" PORTABLE

MAY BE BUILT FOR £7.0.0 plus 5/- P. & P. Batteries extra HT 10/- (Type B126) or equiv. LT 1/6 (Type AD35) or equiv.

★ Size only 8" x 8" x 4½"

★ Instruction book 1/6

Battery Eliminator, available in component form price 3/6 plus 2/- P. & P.



## Speaker Bargain

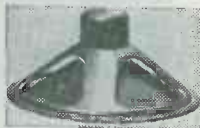

12" High-Fidelity loudspeaker. High flux permanent magnet type with standard 3 ohm speech coil. Will handle up to 12 watts. Brand new by famous maker. Price 27/6, plus 3/6 Post and Insurance.

## Hi-Fi Snip—Infinite Wall Baffle

Nicely veneered and polished. Corner fitting (attaches to picture rail). Takes up no floor space. Gives really fantastic results with only low-priced 8" speaker. Fitting for tweeter.

Only 45/- each. Carr. and Insurance 3/6.

## Hi-Fi Speakers

E.M.I. Ceramic magnet 12,000 lines, size 13" x 8" (roughly equivalent to 12" round speaker). Bass frequency 40-50 c/s. Handles up to 10 watts. Price 33/6, plus 5/- carriage and ins. State whether 15 ohm or 3 ohm. Similar model but specially designed and hand-made, for very low frequencies (25-35 c/s). Price £7.10.0.

## Ice-Stat

This is a small thermostat which cuts on and off at around freezing point. Has many uses, one of which could be an ice warning device to be fitted under your motor car. Price 7/6. Post 1/-.

## 15 amp. Thermostat (Sunvic)

Adjustable over a fairly wide range of temperatures but set for 70°F. suitable for wall mounting to control room heaters. Exceptional bargain at 9/6, plus 1/- post and ins. Crackle finished and calibrated case, suitable for mounting this (only minor adjustment), 5/- extra.

## LAST FEW OF THESE!



## CABINET AND PICK-UP

An extremely fine looking cabinet, must have cost at least £2 to make. Complete with handle and fasteners as illustrated. Also included is a Cosmocord pick-up with crystal cartridge and sapphire stylus. Both items new and perfect.

**ONLY 19/6** Plus 4/6 post and insurance.

## THIS MONTH'S SNIP

Silent running mains motor by very famous maker. Ideal for gramophone, tape recorder, fan, etc., etc., 200-250 volts, A.C., shaded pull start. Size approximately 2 3/4" x 2 1/4" x 1 3/8". 2,750 r.p.m. spindle diameter 3/8". Spindle length 3/8". Brand new guarantee. Price 12/6, plus 1/- post.

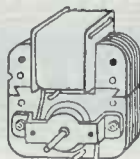

## FLUORESCENT LIGHTING

Complete Kit, Comprises: Hi-Craft choke unit, starter lamps, 2 lamp holders, white enamel metal work and 40 watt tube. Price 30/- complete, plus carr. and ins. 6/-.

Ditto but for 5ft. 80 watt, 39/-, complete, plus carr. and ins. 6/-.

(Lots of 12 or more carriage 3/- each.)



## MULTI-METER BARGAINS

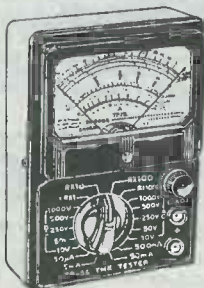

**MODEL TPSS.** (Illus. on left). 20,000 ohms per volt. D.C. volts, 5 ranges up to 1,000. A.C. volts, 5 ranges up to 1,000, resistance, 2 ranges up to 10 meg., capacity, 2 ranges up to 1 decibels—20 to 26. One switch control, really beautifully made precision instrument, size only 3 1/4" x 5 1/2" x 1 1/2". Price only £5.19.6. Post free.

**MODEL 500.** Similar to above but 30,000 o.p.v. Reads voltages up to 1,000 D.C. at 30,000 o.p.v., and A.C. at 15,000 o.p.v.; D.C. current to 12 amps; Resistance to 60 meg.; Decibels from -20 to -56. Size 3 3/4" x 6 1/2" x 2 1/2". £8.19.6. Post free.

## The "Good Companion" Mk. II Using Transfilters

In the "de-luxe" cabinet as illustrated it cost £10.19.6 to build—but what a set!

Scan these pages and you will find nothing to compare with its specification. It uses transfilters instead of I.F. transformers, has variable feedback as well as all the usual features. A.V.C., Push-pull output. Ferrite Aerial, Slow Motion Tuning, etc., etc., and is a very powerful Medium and Long Wave set, conservatively rated at 750 mW. Every component used is by a famous maker, such as American Philco, MADT R.F. transistors—Mullard A.F. transistors—Jackson Brother's tuning condensers—Rola-Celestion loudspeaker—Dubilier—T.C.C. Morganite resistors and controls. Also full after-sale service available. You will definitely be doing the right thing if you buy a GOOD Companion.



## The "POCKET COMPANION"

"A jolly fine set, but deserving a better case"



This is a comment which many constructors have voiced and therefore we now offer a De-luxe version of the Pocket Companion. This uses a solid hide case of very pleasant red with gold lettering and our Pocket Companion now has the 15-guinea look.

The most up-to-date Superhet portable of its type, it uses a transfilter in conjunction with Philco R.F. transistors and Mullard output transistors. Complete building costs with plastic case £6.15.0 or with solid hide case, £7.15.0.

If you have already built and want to change your case, then return the plastic case with a postal order for £1, or if you wish to retain the plastic case then send 26/-, plus 1/6 Post and insurance for the hide case only.

## Yaxley Switches

All new and in first class condition

1 pole, 2 way	1/6	1 pole, 3 way	1/6
1 pole, 4 way	1/9	1 pole, 5 way	2/6
1 pole, 7 way	3/-	1 pole, 9 way	3/-
1 pole, 11 way	3/-	1 pole, 12 way	3/3
2 pole, 2 way	2/-	2 pole, 4 way	2/6
2 pole, 5 way	3/6	2 pole, 6 way	3/6
2 pole, 12 way	5/6	3 pole, 3 way	2/-
3 pole, 6 way	3/6	3 pole, 12 way	8/6
4 pole, 2 way	2/-	4 pole, 3 way	3/-
4 pole, 4 way	3/6	4 pole, 5 way	4/6
4 pole, 6 way	5/6	4 pole, 11 way	10/6
4 pole, 12 way	11/6	5 pole, 3 way	3/6
5 pole, 6 way	7/6	5 pole, 12 way	14/6
6 pole, 2 way	2/6	6 pole, 3 way	3/6
6 pole, 6 way	8/6	6 pole, 11 way	16/6
6 pole, 12 way	17/6	8 pole, 2 way	3/6
6 pole, 4 way	4/6	8 pole, 6 way	11/6
6 pole, 12 way	23/6	12 pole, 2 way	3/6
12 pole, 5 way	16/6	12 way fader	3/6
1 pole, 6 way. Incremental Shorting	3/6		

Big stocks of most types. Special prices for quantities

## Gramophone Motor

E.M.I. 4 speed with turntable and pick-up on control board £4.5.0, plus 5/- post and ins. Plinth for mounting same in cupboard or drawer, 12/6. Post free if ordered with motor.

## INFRA-RED HEATER

Make

up one

of these

latest

type heaters,

ideal for bath-

room, kitchen, bedroom,

etc. They are simple to

make from our easy to follow in-

structions—uses silica enclosed elements

designed for the correct

infra-red wavelength (3 microns).

Price for .750-watt element and

instructions, 15/6 plus 2/6 post and

insurance



## Tape Recorders



One of the easiest ways to learn anything is to 'tape' it and then keep playing it back. Try this new learning technique—you will be amazed.

Prices range as follows:

Child's Model £4.19.6

Assemble yourself Model £6.19.6

Model No. Hil-3 £7.15.0

The "Pocket Secretary" £14.14.0

The first two are not really good enough for music but they are quite good for speech. The last two are reasonable also for music. All have a value out of all proportion to their cost. It is the writer's opinion that there is bound to be a big demand for them as Christmas presents so there is a good reason why you should buy your tape recorder immediately.

## Limited Quantity Only!

Waterproof heater wire. 16 yd. length. 70 watts. Self regulating temperature control. 10/-, post free.

## ELECTRONIC PRECISION EQUIPMENT LTD

★ Orders received by post are despatched from our warehouse, Dept. 34, 66 Grove Road, Eastbourne, and to save time, please post your order to this address. Please include enough for postage. Callers, however, should use one of the following addresses: **John Bull**

520 High Street North  
Manor Park, E.12

42-46 Windmill Hill  
Ruislip, Middx.

266 London Road  
Croydon

29 Stroud Green Road  
Finsbury Park, N.4

246 High Street  
Harlesden, N.W.10

# STERN'S MULLARD DESIGNS

Designed by MULLARD—presented by STERN'S strictly to specification

## MULLARD "5-10" MAIN AMPLIFIER

For use with the MULLARD 2-valve pre-amplifier with which undistorted power output of up to 10 watts is obtained. We supply SPECIFIED COMPONENTS AND NEW MULLARD VALVES, including PARMEKO MAINS TRANSFORMER and choice of the latest Ultra-Linear PARMEKO or the PARTRIDGE Output Transformer.

COMPLETE KIT OF PARTS (PARMEKO Output Trans) **£10.10.0**

Alternatively we supply ASSEMBLED and TESTED. **£11.10.0**

INCORPORATING PARTRIDGE OUTPUT TRANSFORMER, £1.6.0 EXTRA.



## MULLARD'S PRE-AMPLIFIER TONE CONTROL UNIT

Employing two EF86 valves, and designed to operate with the MULLARD MAIN AMPLIFIERS, but also perfectly suitable for other makes.

PRICE COMPLETE KIT OF PARTS **£6.6.0**

ASSEMBLED AND TESTED **£8.0.0**

Supplied strictly to MULLARD'S SPECIFICATION and incorporating:

- Equalisation for the latest R.I.A.A. characteristics.
- Input for Crystal Pick-ups, and variable reluctance magnetic types.
- Input (a) Direct from High Imp. Tape Head. (b) From a Tape Amplifier or Pre-Amplifier.
- Sensitive Microphone Channel. ● Wide range BASS and TREBLE Controls.



## THE MULLARD "510/RC" AMPLIFIER

The popular complete "5-10" incorporating Control Unit providing up to 10 watts. Only Specified Components and new MULLARD VALVES are supplied including PARMEKO MAINS TRANSFORMERS and choice of the latest PARMEKO or PARTRIDGE ULTRA-Linear Output Transformers.

KIT OF PARTS **£11.10.0** OR ASSEMBLED and TESTED **£13.10.0**

H.P. Dep. £2.6.0 12 months at 17/- Dep. £2.14.0 12 months at 19/10 ABOVE incorporating PARTRIDGE OUTPUT TRANS. £1.6.0 extra



## THE MULLARD "33/RC"

THE IDEAL AMPLIFIER FOR A SMALL HIGH QUALITY INSTALLATION PROVIDING EXCELLENT REPRODUCTION OF UP TO 3 WATTS OUTPUT COMPLETE KIT **£7.10.0** OR ASSEMBLED and TESTED **£8.19.6** (plus 6/6 carriage and insurance) H.P. Terms: Deposit **£2.0.0** and 8 months at **£1.0.0**. Complete to MULLARD'S SPECIFICATION including Mullard valves and a PARMEKO OUTPUT TRANSFORMER.



## Mk. II "Fidelity" FM TUNING UNIT

An attractively presented Unit incorporating KIT OF MULLARD PERMEABILITY TUNING HEART PARTS **£10.0.0** and corresponding Mullard valve line-up. ASSEMBLED and TESTED **£14.5.0** Very suitable to operate with our Mullard. AND TESTED **£14.5.0** Deposit: **£2.17.0**. 12 months of **£1.0.11**.

## A BULK PURCHASE ENABLES US TO OFFER

### THE "TUDOR" AM/FM TUNING UNIT

A SELF POWERED HIGH FIDELITY TUNER PROVIDES FULL COVERAGE OF THE VHF/FM TRANSMISSIONS and also the LONG and MEDIUM WAVE BANDS.

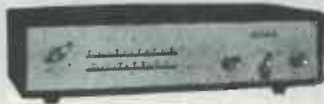

PRICE ONLY **£19.19.0** Deposit **£4.0.0** and 12 months **£1.9.4**

Incorporates Multiplex outlet socket for stereophonic purposes (when adapted) and separate controls for tuning FM and AM bands. Operates perfectly with the STERN-MULLARD AMPLIFIERS and contains matching FRONT PANEL in Black/Gold or White/Black. Also operates equally well with any Amplifier requiring input of 100 to 350 mV/olts.

## THE "TUDOR" STEREO AMPLIFIER



For Only **£18.18.0**

Deposit **£3.16.0** 12 months **£1.7.8**

A self contained Amplifier designed to provide high quality stereophonic and monophonic reproduction. Each channel provides a rated output of 6 watts and for monophonic operation approx. 12 watts is produced. Separate BASS and TREBLE CONTROLS, DESCRIPTIVE LEAFLET IS AVAILABLE.

## PRICE REDUCTIONS

(a) The KIT OF PARTS to build both the "5-10" Main Amplifier and the 2-valve PRE-AMP CONTROL UNIT H.P. Dep. **£3.7.0** and 12 months at **£15.15.0** £1.2.9

(b) The "5-10" and the 2-stage PRE AMP both ASSEMBLED and TESTED H.P. Dep. **£3.16.0** and 12 months at **£18.18.0** With Partridge O/put Transformer **£1.6.0** extra.

## RECORD PLAYERS

The Standard GARRARD "AUTO-SLIM" 4-speed Autochanger with Crystal Pick-up..... **£8.10.0**

COLLARO "JUNIOR" 4-SPEED SINGLE RECORD PLAYER with separate Crystal Pick-up..... **£3.15.0** Carriage and Insurance 5/-. Above Pick-up separately for **£1.6.6**.

GARRARD "AUTOSLIM DE-LUXE" 4-speed Autochanger incorporates transcription Pick-up Arm..... **£12.14.6**

The COLLARO C60 4-speed. Autochanger unit with Studio "O" Pick-up..... **£7.19.6**

B.S.R. MODEL UA14. A 4-speed mixer Autochanger with Crystal Pick-up..... **£7.19.6**

GARRARD MODEL TAJMK.11 4-speed Player fitted high output Crystal Pick-up..... **£8.10.0**

PHILIPS MODEL AG1016 A 4-speed Player which can be operated both manually and automatically. Suitable for Mono or Stereo operation..... **£13.13.0**

Carriage and Insurance on each above 5/- extra.

## MULLARD FOUR CHANNEL MIXING UNIT

Self powered. Cathode follower output. Incorporates Two inputs for MICROPHONES. One input for CRYSTAL PICK-UP and a fourth for RADIO or TAPE



Kit of Parts **£8.8.0** Assembled and Tested **£10.0.0**

TERMS: Deposit **£2** and 12 months at 15/-. Alternatively MODEL I.L. provides for one microphone input matched for moving coil or Ribbon Mike. **£1.17.0** extra.

## THE "MONO-GRAM" AMPLIFIER

A small Amplifier capable of genuine high quality performance. It incorporates the new MULLARD ECL86 Valve, separate BASS and TREBLE CONTROLS and when driven by the standard Crystal Pick-up a



power output of 3 watts is achieved without distortion. The "MONO-GRAM" is ideally suited to incorporate in Portable Record Players. A specially designed case finished in two tone Rexine is available and this will accommodate both the Amplifier and matching 8" x 5" P.M. Loudspeaker.

PRICE AMPLIFIER ONLY **£4.14.6** (Carr. and Ins. 5/- extra.)

PORTABLE CASE **£4.0.0** 8" x 5" LOUDSPEAKER **£1.0.0**

COMBINED PRICE (3 Units) **£9.10.0** also available as a kit of parts, price on application.

## !! SENSATIONAL BARGAIN !!

A BULK PURCHASE ENABLES US TO OFFER THE GRUNDIG "MINI BOY" TRANSISTOR RADIO for only **£10.10.0**

USUAL PRICE **£26.5.0**

Small enough to fit in your pocket—or a big set performance at home by sliding the transistor set into the speaker enclosure. Ferrite Rod Directional Aerial. Med. wave coverage 185-590M. Size 4" x 2 1/2" x 1". Speaker enclosure size 9 3/4" x 3 3/4" x 1 1/2", fully guaranteed.

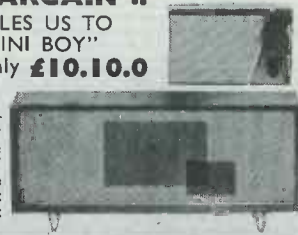

## STERN RADIO PREMIER RADIO

MAIL ORDERS and all POSTAL ENQUIRIES to

# Stereophonic Sound by Stern's

## THE "STP-1" STEREO TAPE PREAMPLIFIER

● BRENELL Mk. V TAPE DECK incorporating 1/2-TRACK MINI-FLUX TAPE HEADS.

- PUSH-PULL OSCILLATOR
- 4-SPEED EQUALISATION
- FERROXCUBE OSCILLATOR TRANSFORMER
- METER FOR SIGNAL LEVEL
- SEPARATE GAIN CONTROLS
- MULLARD VALVES

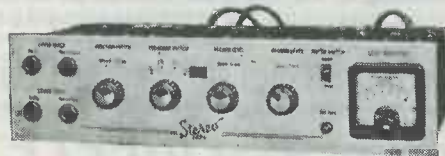

### COMBINED PRICE SCHEDULE

- (a) The BRENELL Mk V 1/2 TRACK DECK with complete KIT to build the STP-1 Deposit £12.4.0. 12 months of £4.9.6. **£61.0.0**
- (b) The COLLARO "STUDIO" 1/2 TRACK DECK with complete KIT to build the STP-1 Deposit £7.16.0. 12 months of £2.17.3. **£39.0.0**

## DESIGNED TO OPERATE WITH

COLLARO "STUDIO" TAPE DECK incorporating 1/2-TRACK TAPE HEADS.

OVERALL SIZE CASE 13 1/2 x 3in. FRONT PANEL (Choice of Black or White) 14 x 3 1/2in.

### PRICES INCLUDE SEPARATE POWER UNITS

- KIT OF PARTS **£22.0.0** ASSEMBLED AND TESTED **£28.0.0**  
 Deposit £4.8.0. 12 months of £1.12.3. Deposit £5.12.0. 12 months of £2.1.1
- (a) The BRENELL Mk V 1/2 TRACK DECK with the STP-1 assembled and matched to the Deck ... **£67.0.0**  
 Deposit £13.8.0. 12 months of £4.18.3.
- (b) The COLLARO "STUDIO" 1/2 TRACK DECK with the STP-1 assembled and matched to the Deck ... **£45.0.0**  
 Deposit £9.0.0. 12 months of £3.6.0.

THE MULLARD "10 plus 10" AMPLIFIER (described below) with the STP-1 PREAMPLIFIER and one of the TAPE DECKS provide a complete STEREOPHONIC INSTALLATION. Details are readily available.

## MULLARDS "10 PLUS 10"

### STEREO AMPLIFIER

A high fidelity design providing up to 10 watts (per channel) Superb reproduction. Frequency response flat to within 3 db from c/s. to 60 Kc/s at 50Mw. Total Harmonic Distortion at 10 watts 0.1%.



- (a) ASSEMBLED AMPLIFIER, including CONTROL UNIT (as illustrated) **£21.0.0**  
 Deposit £4.4.0. 12 months at £1.10.10
- (b) A complete KIT OF PARTS. **£18.10.0**  
 Deposit £3.14.0. 12 months at £1.7.2

We supply the assembled MAIN AMPLIFIER only for operation with our DUAL CHANNEL PREAMPLIFIER, this provides for more versatile installation and would be essential if a low output Pick-Up, such as the Decca, is to be used.

- (a) THE ASSEMBLED MAIN AMPLIFIER with the ASSEMBLED DUAL CHANNEL PREAMPLIFIER. **£30.0.0**  
 Deposit £6.0.0. 12 months at £2.4.0.
- (b) A complete KIT OF PARTS for both Units. **£26.0.0**  
 Deposit £3.4.0. 12 months at £1.18.2

Illustrated and Descriptive Brochure available. Please enclose S.A.E.

## DUAL CHANNEL AMPLIFIER

A four valve design both STEREO-PHONIC or MONAURAL operation. It is designed primarily to operate with our range of MULLARD MAIN AMPLIFIERS but will also operate equally well with any make of Amplifiers requiring an input of 250 mv/olts.



- KIT OF PARTS **£12.10.0** ASSEMBLED AND TESTED **£15.0.0**  
 H.P. £2.10.0 & 12 mths. at 18/4. H.P. £3.0.0 & 12 mths. at £1.2.0

## THE "TWIN THREE" STEREO AMPLIFIER

ASSEMBLED AND TESTED for **£7.15.0** (Carr. & Ins. 7/6 extra)



Based on a design by MULLARD LTD. Ideally suited for use in PORTABLE RECORD PLAYERS for which purpose we offer a specially designed Portable Case. Incorporates MULLARD ECL 86 Valves, separate BASS and TREBLE CONTROLS and produces excellent reproduction of up to 3 watts per channel. Frequency response is 40 c/s to 30 Kc/s, size 1 1/2in. x 3in. x 5in.

To construct a STEREO PORTABLE RECORD PLAYER we offer:—  
 The assembled AMPLIFIER with two ROLA 8in. x 5in. LOUDSPEAKERS and the PORTABLE CASE for £14 (Carr. and Ins. 10/- extra.) Deposit £2/16/-, 12 months £1.0.6. SUITABLE RECORD PLAYERS FROM £8.14.0

## HF/TR3 TAPE AMPLIFIER

(Mullard Type "A" design)

A very high quality Amplifier incorporating 3-speed treble equalisation, by the latest FERROXCUBE POT CORE INDUCTOR FOR COLLARO-TRUYOX-BRENELL WEARITE Tape Decks, has GILSEN Output Transformer. Includes separate Power Supply Unit.



- KIT OF PARTS **£13.13.0** ASSEMBLED AND TESTED **£17.0.0**  
 Deposit £2.15.0 12 months at £1.0.0 Deposit £3.8.0 12 months at £1.4.11

## ADD "HI-FI" TAPE RECORDING TO YOUR EXISTING AUDIO INSTALLATION WITH STERNS-MULLARD TYPE "C" TAPE PREAMPLIFIER—ERASE UNIT

INCORPORATING THE NEW FERROXCUBE POT. CORE PUSH-PULL OSCILLATOR and 3-SPEED TREBLE EQUALISATION by means of the latest FERROXCUBE POT CORE INDUCTOR.



- PRICES ... INCLUDING SEPARATE SMALL POWER UNIT  
 KIT OF PARTS **£14.0.0** ASSEMBLED AND TESTED **£17.0.0**  
 Deposit £2.16.0. 12 months £1.0.6. Deposit £3.8.0. 12 months of £1.4.11.  
 ALSO AVAILABLE EXCLUDING POWER SUPPLY UNIT FOR **£11.15.0** and **£14.10.0** respectively. (Carr. and Ins. 5/- extra)

## SPECIAL "COMBINED ORDER" PRICES

- For Constructors with their own cabinet—WE OFFER—
- (a) KIT to build the HF/TR3 Amplifier together with the COLLARO "STUDIO" DECK **£26.0.0**  
 Deposit £5.4.0. 12 monthly payments of £1.18.2
- (b) As above but with the HF/TR3 supplied ASSEMBLED AND TESTED **£29.10.0**  
 Deposit £5.18.0. 12 monthly payments of £2.3.4
- (c) KIT to build the HF/TR3 AMPLIFIER with the BRENELL Mk. V TAPE DECK **£42.0.0**  
 Deposit £8.8.0. 12 monthly payments of £3.1.7
- (d) As above but with HF/TR3 supplied ASSEMBLED AND TESTED **£45.10.0**  
 Deposit £9.2.0. 12 monthly payments of £3.6.9
- (e) THE ASSEMBLED AND TESTED HF/TR3 AMPLIFIER with the WEARITE MODEL 4A DECK, incorporates Wearite Head Lift Transformer etc. **£60.10.0**  
 Deposit £12.12.0. 12 monthly payments of £4.8.9.
- (a) The COLLARO "Studio" Deck with Model "C" Preamplifier and POWER UNIT ASSEMBLED AND TESTED **£29.10.0**  
 Deposit £5.18.0. 12 monthly payments of £2.3.3
- (b) As above but the TYPE "C" UNIT and POWER UNIT supplied as KIT OF PARTS **£26.10.0**  
 Deposit £5.6.0. 12 monthly payments of £1.18.10
- (c) The BRENELL Mk. V Deck with the Model "C" PREAMPLIFIER and POWER UNIT. ASSEMBLED AND TESTED **£46.0.0**  
 Deposit £9.4.0. 12 months at £3.7.6
- (d) As above but Model "C" PREAMPLIFIER and POWER UNIT supplied as a KIT OF PARTS **£43.0.0**  
 Deposit £8.12.0. 12 monthly payments of £3.3.1
- (e) THE WEARITE MODEL "4" DECK with ASSEMBLED and TESTED Model "C" PREAMPLIFIER and POWER UNIT incorporating WEARITE HEAD LIFT TRANSFORMER, Etc. **£60.10.0**  
 Deposit £12.2.0 and 12 months at £4.8.9 (Carriage and Insurance on each above is 10/- extra.)

**109, FLEET ST., LONDON, E.C.4.**  
 TELEPHONE FLEET ST., 5812-3  
**23, TOTTENHAM COURT RD., LONDON W.1.**  
 TELEPHONE MUSEUM 3451  
**7-9 TUDOR PLACE, TOTTENHAM COURT RD.,**  
 LONDON, W.1. TELEPHONE MUSEUM 6128/9

WE WELCOME ENQUIRIES and our TECHNICAL STAFF will with pleasure assist with choice of suitable equipment.

# LASKY'S RADIO

**LONDON'S LARGEST STOCKS OF  
EQUIPMENT AND COMPONENTS**  
SPEEDY MAIL ORDER SERVICE

Lasky's for All Types of Pocket and Personal Transistor Radios

## BUILD IT YOURSELF . . . REALISTIC SEVEN

The finest receiver at present available for home construction. Fully tunable long and medium wavebands. Uses 7 Mullard Transistors: OC44, 2 OC45s, OC71, OC81D and 2 OC81s, plus Crystal Diode OA70.



### STAR FEATURES ★★★★★

★ 7 Transistor Superhet. ★ 350 milliwatt output into 4" high flux speaker. ★ All components mounted on a single printed circuit board, size 5½" x 5½", in one complete assembly. ★ Plastic cabinet with carrying handle, size 7" x 10" x 3½", in choice of colours: red/grey, blue/grey, all grey. ★ Easy to read dial. ★ External socket for car aerial. ★ IF frequency 470 kc/s. ★ Ferrite Rod internal aerial ★ Operates from PP9 or similar battery. ★ Full comprehensive data supplied with each Receiver. ★ All coils and IFs, etc., fully wound ready for immediate assembly.

An Outstanding Receiver. Lasky's price for the complete parcel including Transistors, Cabinet, Speaker, etc., and Full Construction Data. All components available separately. Battery 3/9 (included free with complete parcel). Data and instructions separately, 2/6, refunded if you purchase the parcel.

Postage and Packing 4/6.

# £6.19.6

### The Corover "6"

The latest in our range of Constructors' Parcels. The Corover '6' is a 6 transistor plus two diode receiver using the latest circuitry. Three Mullard AF117 alloy diffused transistors are used in the first stages with OA79 and OA91 diodes, followed by OC81D and two OC81s in push-pull to complete the output stages.

Fitted in a very attractive contemporary styled plastic cabinet, the receiver covers the full medium and long wavebands, with separate easy-to-read scales for each.

Sockets are fitted for a personal earpiece or tape recorder, and car radio aerial. The 3" high flux speaker gives excellent tonal quality, maximum output is 330mW. Large internal ferrite rod aerial ensures good reception of local and distant stations. Operates from four 1.5 volt pen torch batteries.

All components mounted on a single printed circuit. Easy to build from simple stage-by-stage instructions.

Cabinet size 6½" x 4" x 1½". With carrying handle. All coils and i.f.s ready wound. ALL COMPONENTS AVAILABLE SEPARATELY.

**CAN BE BUILT FOR £5.19.6.** P. & P. 4/- extra. Data and instructions separately 2/6. Refunded if you purchase the parcel.

### The Beta Two

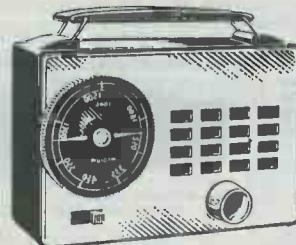

A 2-transistor plus 2 diode personal receiver for home construction. Uses printed circuit and ferrite rod aerial. Personal earphone gives clear reception for private listening. Tunes over full medium waveband. Size 5½" x 3½" x 1½" overall. All components available separately.

**CAN BE BUILT FOR 21/-.** Postage 2/6 extra.

Including personal earphone, cabinet, etc. Circuit diagram and step-by-step instructions 1/6. (Free with parcel.)

**133 TOTTENHAM COURT ROAD W1**

2 mins. Oxford Street. Nearest Station Goadge Street. MUSEUM 2605

**207 EDGWARE ROAD W2**

Few yards from Praed Street PADDINGTON 3271/2

Both addresses open all day Saturday. Close 1 p.m. Thursday

PLEASE ADDRESS ALL MAIL ORDERS TO DEPT. W AT ABOVE EDGWARE ROAD ADDRESS  
ALSO NOW AT: 152/3 FLEET STREET, E.C.4 FLEET 2833. Open all day Thurs., closed 1 p.m. Sat.

# RETURN-OF-POST SERVICE

We offer a really efficient Mail Order Service on all items stocked. All cash orders are dealt with on the day of receipt.  
 ★ Hire purchase orders are subject to slight delay but this is kept to the absolute minimum.

## ● P.W. STRAND, MAYFAIR & SAVOY UNITS

We stock parts for the P.W. Strand Amplifier, Mayfair Pre-amplifier and Savoy F.M. Tuner. Detailed price lists are available.

## ● P.W. MERCURY

P.W. Mercury (Osmor printed circuit version) including Mullard first grade transistors and instruction manual. Complete set of parts, £9.19.6. Instruction manual available separately at 2/6 post free. Separate components supplied. Send for list.

## ● NEW ILLUSTRATED LISTS

Illustrated lists are available on LOUDSPEAKERS, TAPE DECKS, TEST GEAR, GRAMOPHONE EQUIPMENT, AMPLIFIERS. Any will be sent free upon request.

## ● STEREO COMPONENTS

Morganite ganged potentiometers as specified for the Mullard circuits. ★ Log/Anti-Log, 500k, 1 meg., 2 meg. ★ Log/Log, 50k, 250k, 1 meg., 2 meg. ★ Lin/Lin 250k, 500k, 1 meg. All 10/6 each.

## ● TRANSISTORS

MULLARD. Reduced prices. Current production types, not rejects. All in makers' boxes. Postage 3d. on each. OC44, 9/3; OC45, 9/-; OC70 and OC71, 6/6; OC72, 8/-; OC72 Matched Pairs, 16/-; OC78, 8/-; OC81, 8/-; OC170, 9/6; OC171, 10/6.

## ● OUTPUT TRANSFORMERS

GILSON: W0696A, W0696B, 50/6, post 2/6. W0710, 55/6, post 2/6. W0892, 62/3, post free; W0767, 27/-, post 1/6. W01796A, 57/6, post 2/6. W01932, 84/- post free.  
 PARTRIDGE: P3667, 75/-; P4131, 65/-; P5202, P5203, £5.18.6. All post free.  
 PARMEKO: P2629, 45/6; P2642, 43/3; P2643, 45/6. All plus post 2/9. P2641, 28/3, post 2/-; P2928, 15/3, post 2/-; P2932, 39/3, post 2/6.  
 ELSTONE: OT/ML, 45/-, post 2/9; OT/3, 25/-, post 2/6.

## ● MAINS TRANSFORMERS

GILSON: W0741AB, 63/-, post free; W0839, 40/9, post 2/9; W01328 58/6, post 3/6; W01288, 58/-, post 3/6; W01566, 80/- post free; W01341 (Choke), 36/-, post and packing 2/-.  
 PARMEKO: P2631, 33/9, post 2/9; P2630, 52/6, post 3/3; P2644, 73/6, post free; P2930, 39/3, post 3/-; P2931, 54/6, post 3/3.  
 ELSTONE: MT/MU, 45/-, post 3/3; MT/3/M, 35/-, post 3/-; MT/510, 42/-, post 3/3.

## ● LOUDSPEAKERS

GOODMANS: Axiette 8", £5.17.7; Axiom 10", £7.0.0; 12", Axiom 201, £10.7.0; 12", Axiom 301, £14.10.0; 12", Audiom 51 Bass, £8.14.0; 12" Audiom 61 Bass, £13.14.0; Trebax Tweeter, £6.4.0; X05000 Crossover unit, £1.19.0.  
 WHITELEY: HF1016 10", £7.16.0; HF1012 10", £4.17.6; HF816 8", £6.13.9; T816 8", £6.6.9; T10 Tweeter, £4.8.3; T359 Tweeter, £1.14.0; CX3000 Crossover unit, £1.11.6; CX1500 Crossover unit, £2. H.P. Terms available on all speakers.

## ● AMPLIFIER KITS

We have full stocks of all components for the Mullard 510, Mullard 3-3, Mullard 2 and 3 Valve Pre-amp, Mullard Stereo, Mullard Mixer, GEC 912 Plus. Fully detailed list on any of these sent upon request. Instructional Manuals: All Mullard Audio Circuits in "Circuits for Audio Amplifiers", 9/5. GEC912, 4/6. All post free.

## ● LATEST TEST METERS

	Cash Price		Hire Purchase	
	Deposit	Mthly/Pmts.	Deposit	Mthly/Pmts.
AVO Model 8 Mark II	£24. 0.0	£4.16.0	12 of	£1.15. 2
AVO Model 8 with leather carrying case	£27.18.0	£5.12.0	12 of	£2. 0.11
AVO Model 7 Mark II	£21. 0.0	£4. 4.0	12 of	£1.10.10
AVO Multiminor	£9.10.0	£1.19.0	12 of	14/4
AVO Multiminor with leather carrying case	£11. 9.0	£2. 5.0	12 of	17/-
TAYLOR MODEL 127A	£10.10.0	£2. 0.0	12 of	15/8
CABY A-10	£4.17.6	£1. 7.6	3 of	£1. 6.8
CABY B-20	£6.10.0	£2. 0.0	3 of	£1.13.4
CABY M-1	£2.14.0	—	—	—

Full details of any of the above supplied free on request  
 The AVO Models 7 and 8 are both latest models from current production—not to be confused with Government Surplus.

## ● TERMS OF BUSINESS

Cash with order or C.O.D. We charge C.O.D. orders as follows: Up to £3, minimum of 3/2. Over £3 and under £5, 1/6. Over £5 and under £10, 1/8. Over £10, no charge. Postage extra on CASH orders under £3 except where stated. Postage extra on overseas orders irrespective of price.

## ● TRANSISTORISE YOUR CRYSTAL SET

We have two new designs for Transistor amplifiers which can be used to greatly improve the signal from any crystal set. RLD4 Kit, one stage, 12/-; RLD5 Kit, two stage, 21/-; both post free. The kits are easy to build and very detailed instructions are supplied. Leaflet available.

## ● NEW MULLARD CONDENSERS

We now stock the following range of the new Mullard Miniature Foil and Polyester condensers as used in the latest TV and Transistor sets. Fully detailed list available giving full technical information and dimensions  
**Miniature Foil.** 30 volt working for Transistor sets. .01mfd, 74d; .022mfd, 9d.; .047mfd, 9d.; 1mfd, 11d.  
**Polyester Tubular Capacitors.** Moulded outer case designed to withstand accidental contact with the soldering iron. Tolerance 10%. 125V range: .01mfd, .022mfd, .047mfd, all 9d. each. .1mfd, 1/2; .22mfd, 1/3; 47mfd, 1/6; 1mfd, 3/-.  
 400V range: .001mfd, .0022mfd, .0047mfd, .01mfd, .022mfd, all 9d. each. .047mfd, 1/2; .1mfd, 1/3; .22mfd, 1/6; .47mfd, 2/5. Postage extra.

## ● PICK-UP CARTRIDGES—SPECIAL OFFER!

B.S.R. TC8M, TC8H, 19/6 each.  
 ACOS GP67/2, 14/6 each. (All post free.)

## ● GRAMOPHONE EQUIPMENT

ALL LATEST MODELS ALL POST FREE	Cash Price		Hire Purchase	
	Deposit	Mthly/Pmts.	Deposit	Mthly/Pmts.
<b>RECORD CHANGERS</b>				
GARRARD AUTOSLIM	£7.19.6	£1.12.6	12 of	12/3
GARRARD AUTOSLIM De-luxe (GC8 PU)	£12.14.8	£2.11.8	12 of	18/8
GARRARD AUTOSLIM De-luxe (EV26A PU)	£13.12.9	£2.14.9	12 of	20/-
B.S.R. UA14 (TC8 PU)	£7.17.6	£1.12.6	12 of	12/1
B.S.R. UA14 Monarch (TC8S Stereo/LP/78)	£8.17.6	£1.16.6	12 of	13/5
<b>SINGLE RECORD PLAYERS</b>				
B.S.R. TU12 (TC8 PU)	£4.5.0	£1. 5.0	3 of	£1.3.4
B.S.R. GU7 (TC8 PU)	£5.11.6	£1.13.6	3 of	£1.9.4
<b>TRANSCRIPTION UNITS</b>				
GARRARD 4HF (GC8 PU)	£17.19.6	£3.11.6	12 of	£1.6.5
PHILIPS AG1016	£13.13.0	£2.15.0	12 of	£1.0.0

Many of the above can be supplied for stereo working. See our Gramophone Equipment List for details.

## ● TAPE RECORDING EQUIPMENT

ALL CARRIAGE FREE	Cash Price		Hire Purchase	
	Deposit	Mthly/Pmts.	Deposit	Mthly/Pmts.
B.S.R. TD2	£8.19.6	£1.16.6	12 of	13/7
Latest COLLARO Studio	£10.19.6	£2.3.6	12 of	16/4

## ● TAPE AMPLIFIERS

We now stock the Martin Recorder Kits. These are partly assembled kits for complete tape recorders. The Amplifier Printed Circuit panels are completely wired, but the assembly of this and external components is left to the constructor. Very complete instructions are supplied. Send for leaflet.

MODEL C for Collaro Studio Deck, £11.11.0.

MODEL B for BRS TD2 Deck, £8.8.0.

**CARRYING CASES.** Smart carrying cases are available to take the above amplifiers and decks. Fitted with speaker.  
 For Model C Amplifier and Collaro Deck, £5.5.0.  
 For Model B Amplifier and BSR Deck, £4.4.0.  
 H.P. Terms available for amplifiers, cases and decks.

## ● TAPE PRE-AMPLIFIERS

MULLARD TAPE C PRE-AMPLIFIER. We stock complete kits and all components. Send for list.  
 MARTIN. Pre-amp kit for Collaro Studio Deck, £8.8.0.

## ● "BRAND FIVE" RECORDING TAPE

Long Play: 900' (5"), 18/6; 1,200' (5 1/2"), 23/6; 1,800' (7"), 35/-, post free

## ● JASON F.M. TUNER KITS

Kits supplied complete with every item needed including instruction manuals. Fully detailed list available. Separate items supplied, ask for price list. H.P. Terms available on any kit.  
 FMT1, £6.12.6; FMT2 (less power), £7.15.0.  
 FMT2 (with power), £9.12.6; FMT3 (less power), £9.9.6.  
 FMT3 (with power), £11.7.6. Mercury 2, £10.14.6. JTV/2, £14.12.6.

# WATTS RADIO

(MAIL ORDER) LTD.

54 CHURCH STREET WEYBRIDGE SURREY

Telephone Weybridge 4556

Please note: Postal business only from this address

# HOME RADIO OF MITCHAM

Dept. AC, 187 London Road,  
Mitcham, Surrey. MIT 3282  
Shop Hours: 9.0 to 6.0 p.m.  
(Weds. 1.0 p.m.)



## GLOBE KING "SKY RANGER" 500 A

Brand new world beater available in kit or ready-built form. Uses two dual valves giving the equivalent of a four-valve four-stage circuit. World wide range, and the precision bandsread tuner makes it a delight to use. In neat metal case with built-in speaker and provision for headphones. A.C. Mains 200 to 250V, double wound transformer for complete safety. Never mind the weather this winter; pull up your armchair to the fire and tour the world on shortwaves. The finest hobby of all. COMPLETE SET OF PARTS, £13.12.6, or READY BUILT AND TESTED, £15.12.6, carriage & packing 5/- extra.

## GLOBE KING 100/A

Designed for the newcomer, the 100/A gives really long distance at minimum cost. Highest grade components, and built up to a standard, not down to a price. One-valve high efficiency battery circuit (extra audio stage can be added price 21/6 if desired). Three plug-in coils cover 10 to 100 metres, and extra coil available for 10 to 180. KIT OF PARTS WITH THREE MATCHED COILS, £3.19.6, post 1/6.

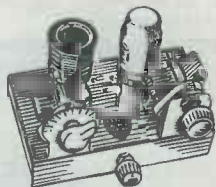

## FANTASTIC BARGAIN OFFER

JUST IN TIME FOR CHRISTMAS!  
Brand new, boxed and fully Guaranteed precision electric shavers by Morphy-Richards. Dual voltage, 110 and 200/250 A.C. Usually £3.17.6. OUR SPECIAL PRICE, ONLY £2.12.6, plus 1/6 post. Act NOW and start shaving the easy way.

## HAVE YOU GOT OUR SUPER CATALOGUE?

★ 166 pages ★ 600 illustrations  
★ Over 5,000 items  
Price 2/6 Post 9d.

## WE ARE MAIN STOCKISTS FOR THE FAMOUS HEATHKITS

## TREAT YOURSELF TO A HI-FI CHRISTMAS WITH GOODMANS

We are main stockists for GOODMANS Hi-Fi Speakers.

Axiette 8. 6 watts, 15 ohms, 8" die-cast chassis with new Feroba 11 high-flux magnet, PRICE £5.17.6, post 1/6.

Axiom 10. 10 watts, 15 ohms, 10" die-cast chassis with new Feroba 11 high-flux magnet, PRICE £7.0.0, post 1/6.

Axiom 201. 15 watts, 15 ohms, twin diaphragm giving powerful smooth response from 30 to 16,000 cycles. High flux magnet and aluminium voice coil with special suspension. Suitable Mono and Stereo. PRICE £10.7.0, post 2/6.

Axiom 301. The most advanced 12" twin diaphragm speaker ever produced. Similar appearance to the 201 but will handle up to 20 watts. PRICE £14.10.0, post 2/6.



## TRIPLETONE FM TUNER



A really first class, immaculately engineered FM/VHF tuner designed to bring crystal-clear interference-free reception of all B.B.C. programmes. Coverage 86-104 Mc/s. Complete in case for shelf or cabinet mounting. Very sensitive and with interstation muting to give quiet tuning. Size 11" x 6 1/2" x 3". Leaflet with full specification on request with s.a.e. PRICE £13.19.6 without power pack, plus 1/6 post. £15.14.6 self powered, plus 1/6 post.

## TWO IDEAL GIFTS FOR A YOUNGSTER

### ELECTRONIC WORKSHOP

20 different exciting experiments can be made including radios, intercom, burglar alarm, electric eye, T.V. silencer, etc. Supplied with 72-page illustrated manual giving simple instructions. This kit will keep a youngster happy for hours and lead to an enjoyable understanding of electronics. PRICE £7.18.0, post paid.

### OPTIKIT

Over 20 different and absorbing optical instruments can be made with this first-ever Optical Kit including microscopes, projectors, telescopes, kaleidoscopes, range-finder, sextant, etc. Complete with 116-page illustrated manual. Will delight any boy or girl. PRICE £7.10.0, post paid.

## NEW MULLARD ECL86 10 WATT AMPLIFIER

Printed-circuit boards for this remarkable new ECL86 Amplifier now available from stock, PRICE 12/6 each, post 6d. Two required for full 10 watts push-pull each channel, 7 valve stereo. Trade enquiries invited.

## HI-FI ENTHUSIASTS

Have you tried CEIBALINE? This is a new super sound-absorbent material with self-adhesive backing for lining the inside of speaker cabinets and enclosures. Clean and easy to use, no wastage and really wonderful results. Gives good clean deep bass without resonance. PRICE 2/6 per square foot, plus 1/6 post on order.

## METERS

A further delivery of high grade 50 micro-amp moving coil meter movements by Sangamo Weston. 900 ohms DC resistance. Size approximately 3" x 2 1/4" x 1 1/4". VERY GOOD VALUE AT 19/6, post 1/6.

## Eddystone Receivers



Compact size, light weight, attractive styling, make this the ideal dual-purpose Domestic and Short Wave receiver. Full Long and Medium wave plus three Short wavebands covering 12 to 2,000 metres. Gear driven full width dial with special vernier logging scale. Built-in speaker. Operates any voltage, AC or DC, 110 to 250 volts. PRICE £34.15.6, post paid U.K. Special Export Price, £26.0.0, carriage 30/-.

# THE Radio Constructor

Incorporating THE RADIO AMATEUR

Vol. 16, No. 5  
Published Monthly

Annual Subscription 29/-  
(including postage)

Editorial and  
Advertising Offices  
57 MAIDA VALE LONDON W9

Telephone  
CUNningham 6141  
(2 lines)

Telegrams  
Databux, London

## DECEMBER 1962

Suggested Circuits No. 145: An Electronic Timer using an L.D.R., by G. A. French	326
Electronics in Third Stage Music, by F. C. Judd, A.Inst.E.	329
Trade Review: Steadfast Electrician Kit No. 4	331
Modernise that Valve Portable, by V. T. Rolfe	332
News and Comment	338
Voltage Stabilisation for Transistor Car Radios, by Sir Douglas Hall, K.C.M.G., B.A.(Oxon)	339
Understanding Radio, Part 16, by W. G. Morley	342
Radio Controlled Model Yachts	348
Can Anyone Help?	350
In Your Workshop	351
More Gadgets for Your Christmas Party, by W. Holmes	358
Book Reviews	364
The "Capri" Personal 6-Transistor Receiver, described by E. Govier	365
Radio Astronomy, Part 1: A Radio Astronomy Receiver, by Frank W. Hyde, F.R.S.A., F.R.A.S.	372
Radio Topics, by Recorder	379
1962 International Radio Communication Exhibition	381

© Data Publications Ltd, 1962

CONTENTS may only be reproduced after obtaining prior permission from the Editor. Short abstracts or references are allowable provided acknowledgment of source is given.

CONTRIBUTIONS on constructional matters are invited, especially when they describe the construction of particular items of equipment. Articles should be written on one side of the sheet only and should preferably be typewritten, diagrams being on separate sheets. Whether hand-written or typewritten, lines should be double spaced. Diagrams need not be large or perfectly drawn, as our draughtsmen will redraw in most cases, but all relevant information should be included. Photographs should be clear and accompanied by negatives. Details of topical ideas and techniques are also welcomed and, if the contributor so wishes, will be re-written by our staff into article form. All contributions must be accompanied by a stamped addressed envelope for reply or return, and should bear the sender's name and address. Payment is made for all material published.

OPINIONS expressed by contributors are not necessarily those of the Editor or the proprietors.

TRADE NEWS. Manufacturers, publishers, etc., are invited to submit samples or information of new products for review in this section.

TECHNICAL QUERIES must be submitted in writing. We regret that we are unable to answer queries, other than those arising from articles appearing in this magazine; nor can we advise on modifications to the equipment described in these articles.

CORRESPONDENCE should be addressed to the Editor, Advertising Manager, Subscription Manager or the Publishers, as appropriate.

REMITTANCES should be made payable to "DATA PUBLICATIONS LTD."

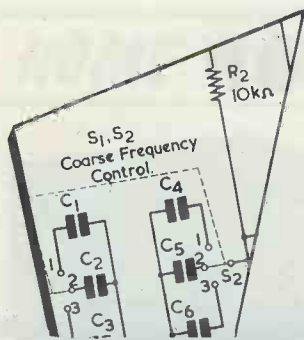

## suggested circuits

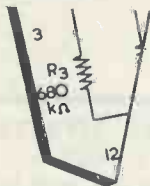

The circuits presented in this series have been designed by G. A. FRENCH, specially for the enthusiast who needs only the circuit and essential data

### No. 145 An Electronic Timer Using An L.D.R.

ONE OF THE MORE FASCINATING devices which has become available to the experimenter over the last few years has been the light dependent resistor, or l.d.r. This consists of a cadmium sulphide cell whose resistance drops when it is illuminated. The light dependent resistor is particularly useful in television receivers, wherein it can automatically adjust contrast or brilliance according to ambient room lighting, and this application has resulted in a large market for the device. However, the l.d.r. has a number of other uses, these including its employment (in company with an illuminating lamp) as a one-way coupling link between two circuits. The first of these circuits may provide a variable current which is used to control the brilliance of the lamp, whilst the second is controlled by the resultant varying resistance in the l.d.r. itself. Typical applications include the stabilisation of d.c. coupled transistor amplifiers, and the stabilisation of power packs.<sup>1</sup>

The writer discussed l.d.r. relay circuits in "Suggested Circuit" No. 139 (June 1962 issue), and described a method of obtaining remote volume control with an l.d.r. in "Suggested Circuit" No. 142 (September 1962 issue). In the present article, an l.d.r. is employed to control a relay directly, the relay used for the writer's prototype circuit being a small component

having a coil resistance of 5kΩ and an energising current around 2mA. However, a heavier relay could be employed, and readers wishing to obtain further information on this point, as well as on energising voltage and l.d.r. dissipation, are advised to refer back to "Suggested Circuit" No. 139, in which all these factors were dealt with in detail. The particular l.d.r. discussed in the previous article was the ORP12, and this component is employed in the device to be described.

#### The Circuit

Practically all electronic timer circuits rely on the delay which occurs when a capacitor either charges or discharges via a resistor. When the voltage across the capacitor reaches a certain predetermined level the timing period is over, and an external circuit is opened or closed by way of a relay or similar switching device. Normally, an amplifier is interposed between the capacitor and the relay, one of its functions being to present a high impedance circuit to the timing capacitor and a low impedance circuit to the relay.

Changes in timing period may be obtained by varying the value of the timing capacitor, and/or the value of the resistor through which it charges or discharges.

For reliable operation, when a mechanical relay is employed, it is always desirable to have a high rate of change of relay coil current near the end of the timing period.

Otherwise, variations in energising or de-energising current in the relay due to mechanical causes may result in excessive variations in the timing period, and the timer becomes less reliable in consequence.

The present circuit employs a mechanical relay and offers almost instantaneous shutting-off of coil energising current at the end of the timing cycle. In consequence, varying de-energising currents in the relay have no effect whatsoever on the timing period. Another feature of the present circuit is that it employs no transistors or valves, the conversion from the high impedance CR timing circuit to the low impedance relay circuit being effected by a combination of l.d.r. and neon bulb.

The experimental circuit checked by the writer is given in Fig. 1, this being employed to check the feasibility, in practice, of the present scheme. A 300 volt source of supply is applied via S<sub>1(a)</sub> to the timing capacitor C<sub>T</sub>, this being an electrolytic having a value of the order of 50μF. When S<sub>1(a)</sub> is closed capacitor C<sub>T</sub> becomes charged to the full supply potential. A low-value limiting resistor, R<sub>L</sub>, is inserted in series with S<sub>1(a)</sub> to prevent heavy current surges when this switch is closed.

Connected across C<sub>T</sub> is the variable resistor R<sub>T</sub>, together with the neon bulb and its series resistor R<sub>S</sub>. The neon bulb illuminates an ORP12, the latter being connected in series with a 5kΩ relay and a 24 volt supply. When the neon bulb

<sup>1</sup> Gosling, W.: "Unusual Circuits Using Photoelectric Effects". *British Communications and Electronics*, October 1962.



is ignited, the consequent low resistance in the illuminated ORP12 causes the relay to energise and its make contacts to close.

To consider the operation of the timing circuit, let us commence at a time when  $S_1$  is in the "Re-set" position.  $S_{1(a)}$  then causes  $C_T$  to be charged to the full supply potential, whilst  $S_{1(b)}$  ensures that the external circuit is broken. Since  $C_T$  is fully charged the neon bulb is ignited and the l.d.r. is in the illuminated condition. In consequence the relay is energised and its make contacts are closed.

To start the timing period,  $S_1$  is set to "Trigger".  $S_{1(b)}$  then completes the external circuit, which becomes switched on. Capacitor  $C_T$  is now disconnected from the supply, and it commences to discharge into  $R_T$  and into the neon bulb via its series resistor.

After a period, depending upon the value of the timing capacitor and its discharge current, the voltage across the plates of  $C_T$  falls below the maintaining voltage for the neon. The latter suddenly extinguishes, whereupon the ORP12, now non-illuminated, exhibits a high resistance and causes the relay to de-energise. In consequence, the make contacts of the relay open and break the external circuit. The timing period is now complete.

At any time subsequent to the end of the timing period,  $S_1$  may be put to the "Re-set" position. This causes  $C_T$  to charge once more and allows the circuit to revert to its original condition. A further timing period may then be initiated by throwing  $S_1$  to "Trigger" once more.

As may be gathered, the circuit can offer a very dependable action despite the small number of components required. The almost instantaneous shutting-off of relay energising current at the end of the timing period is given by the fact that the neon extinguishes immediately when the voltage across  $C_T$  falls below its maintaining level. The ORP12 then changes from the illuminated to the non-illuminated condition, and the relay energising current drops sharply in consequence. Another factor is that the discharge current drawn by the neon circuit is low, partly because of the relatively high value of its series resistor. Due to this, much of the discharge current from  $C_T$  may flow in  $R_T$  and in its own internal resistance. The result is that  $C_T$  does not require an excessively large capacitance when long timing periods are required.

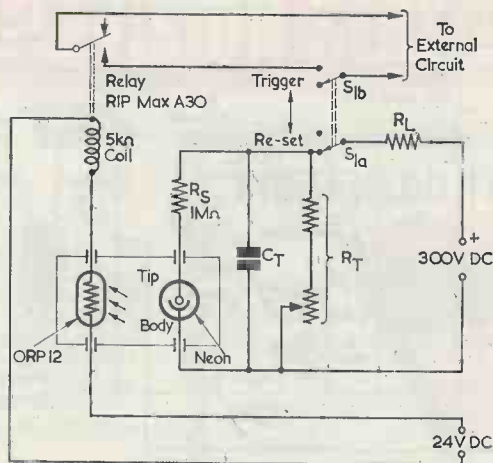

Neon-Button Tuneon (G.E.C.)

M588

Fig. 1. The basic circuit of the timer

### Practical Points

The circuit given in Fig. 1 shows the experimental prototype checked by the writer, the more critical components being specified by manufacturer and type number.

The  $5k\Omega$  relay used was a Rip Max type A30.<sup>2</sup> This has light contacts and can be set up to energise at approximately 2mA.

The l.d.r. is an ORP12,<sup>3</sup> this being a type which is ideally suited to the present application because of its shape and sensitivity.

The neon is a "Button Tuneon" manufactured by G.E.C., and that employed in the prototype extinguished when the potential across  $C_T$  fell below some 150 volts. It is necessary to obtain a very tight coupling between the neon and the

l.d.r. Since both have flat faces this coupling may be very conveniently arranged as shown in Fig. 2. In this diagram the front surfaces of both neon and l.d.r. are in contact with each other, and the two components are enclosed in a light-tight cylinder. (In the prototype they were taped together.) The light output from the neon is not high, but it falls into the red region of the spectrum, where the ORP12 has maximum sensitivity. The writer found that more light was apparently given when the positive connection was made to the tip of the neon rather than to its body.

With the prototype it was found that, when the potential across  $C_T$  was 300 volts, the resultant relay current via the ORP12 was 4mA. This current fell gradually to 2.5mA at maintaining voltage, after which it dropped to a negligibly low value as the neon extinguished. These currents correspond to resistances in the l.d.r. of  $1k\Omega$  and  $4.6k\Omega$  respectively. Both are sufficient to

<sup>2</sup> This relay is available from Home Radio (Mitcham) Ltd., 187 London Road, Mitcham, Surrey, under Cat. No. Z70.

<sup>3</sup> The Mullard ORP12 may be obtained from Henry's Radio Ltd., 5 Harrow Road, London, W.2.

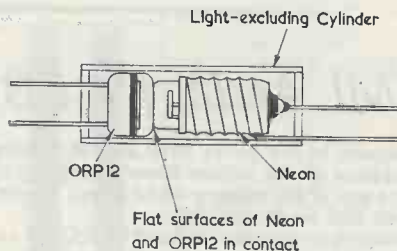

M589

Fig. 2. The neon bulb and l.d.r. assembly

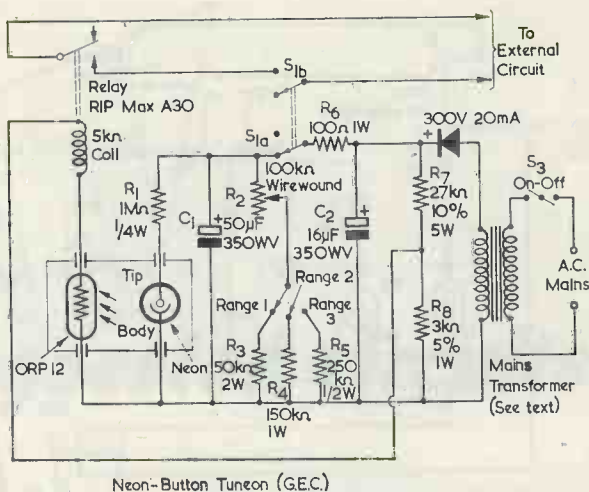

Fig. 3 A suggested mains-powered version of the timer. The values given for R<sub>3</sub>, R<sub>4</sub> and R<sub>5</sub> are intended for guidance only

keep the relay in the energised condition; and it should be pointed out that the *de-energising* current of the relay will be significantly less than the 2mA energising current mentioned earlier. De-energising current should, then, always be well below the final 2.5mA current passed by the l.d.r. just before the end of the timing period.

Experimenters who wish to try neons other than the type specified should remember that a tight coupling between the neon and the l.d.r. is required if the latter is to achieve an adequately low resistance.

The values of C<sub>T</sub> and R<sub>T</sub> depend upon the timing periods required. Assuming negligible neon current and leakage current in C<sub>T</sub>, the timing period should be approximately four-fifths of the time constant of these two components.

#### A Full Circuit

Fig. 3 gives a suggested circuit for

a mains-powered version of Fig. 1. The same relay is employed in this circuit, and it should be pointed out that its contacts are only adequate for low voltage circuits, and could not be employed for mains switching. As was mentioned earlier, the question of using heavier relays was discussed in "Suggested Circuit" No. 139, and this previous article should be consulted with respect to this point. An alternative approach, for mains switching, is to use a second heavier relay whose coil is energised via the "External Circuit" terminals of the timing circuit.

It is desirable to obtain some 300 volts d.c. across the reservoir capacitor C<sub>2</sub>, and this should be given by a half-wave mains transformer secondary winding rated around, or slightly less than, this figure. Many of the inexpensive "converter" transformers generally available have secondary voltages around 250 and, when 240 volt mains

are available, a higher secondary voltage may be obtained by tapping down the primary (i.e. applying the 240 volt supply to a 200-210 volt primary tapping).

A potential divider across the rectified supply, R<sub>7</sub>R<sub>8</sub>, provides a potential of 20 to 30 volts for the relay and l.d.r. circuit, and it draws a standing current of approximately 10mA. If relay chatter is troublesome, due to the absence of smoothing components, an electrolytic capacitor of the requisite value and working voltage may be connected across R<sub>8</sub>. An 8μF component rated at 50 w.v. should be adequate here.

R<sub>6</sub> is a limiting resistor whose function is to prevent heavy current surges when S<sub>1(a)</sub> is closed.

Suggested values for C<sub>T</sub> and R<sub>T</sub> are given in Fig. 3, the appropriate components being C<sub>1</sub>, R<sub>2</sub> to R<sub>5</sub>, and S<sub>2</sub>. As a rough guide, and assuming very low neon and capacitor leakage currents, Range 1 should give timing periods from 2 to 6 seconds, Range 2 should give periods from 6 to 10 seconds, and Range 3 periods from 10 to 14 seconds. However, the periods given in practice may vary from those just detailed, and the requisite values for R<sub>3</sub> to R<sub>5</sub> will need to be determined empirically. For this reason, the values shown in Fig. 3 for these components are intended for guidance only. The timing ranges may, of course, be extended by employing different values for C<sub>1</sub>.

The timing capacitor C<sub>1</sub> should be a new component of reliable manufacture in order to ensure that leakage current is low. If the capacitor employed in the C<sub>1</sub> position has been in stock for an appreciable time, it is advisable to have several preliminary runs to ensure that it is fully formed before calibrating R<sub>2</sub>.

## EMI Aerial for BBC at Moray Firth

Many more residents in the Moray Firth area of Scotland will be able to receive stronger television signals when extensions are completed at the British Broadcasting Corporation's television station at Rosemarkie. An additional aerial will double the size of the existing aerial array. A contract for the supply and installation of the new aerial array has been placed with EMI Electronics Ltd.

Signals being radiated in this area are Band 1 B.B.C. TV programmes. Reception will be greatly improved by the new EMI aerial, particularly for people living in outlying areas.

The additional aerial, which is being built to B.B.C. specifications, will be erected in sections and fully tested at the EMI Hayes factory, before it is delivered to its site in Rosemarkie where it will come into use during the autumn of 1963.

# ELECTRONICS IN THIRD STAGE MUSIC

By F. C. JUDD, A.Inst.E. (PART 1)

TO BEGIN WITH, WHY "THIRD STAGE MUSIC"? THIS merely implies that we are dealing with "Electronic Music and Musique Concrète", which many modern composers regard as the third stage in the development of music. The second stage is that which we normally classify as traditional music with an accepted set of rules for notation, harmony, tempo, rhythm, timbre and so on. In the more abstract and surrealistic Musique Concrète, harmony and tempered scales, etc., are usually dispensed with completely.

## The Parameters

Some composers look upon all sound as a continuum in which traditional music occupies only a very small part, and they regard the use of electronics as a valuable means of allowing very much more of the continuum to be used. On this assumption, many who have taken up this new form of music have simply adopted the use of three parameters, namely pitch, intensity and duration. Pitch is no longer confined to twelve semitones per octave; an audio signal generator provides the composer with continuously variable pitch over the entire audible frequency range. Intensity is controlled only by the dynamic range of the best known recording medium, namely magnetic tape. Duration (of a sound) is controlled only by our ability to hear a sound of extremely short duration, i.e. pulsed sounds. (The loudspeaker as an electronic reproducing device may also place some limitation on the shortness of duration.) Between the sine wave and the square wave are an infinite variety of sound shapes (if viewed by an oscilloscope) that provide an almost infinite range of timbre. Electronics have much to offer the modern composer<sup>1</sup>.

## Audience Reaction

During its short history, however, Electronic Music has suffered a considerable setback because of failure on the part of its innovators to produce compositions acceptable to the general public. This has occurred, not only in electronic music but also in Musique Concrète, which is created out of natural sound.

Other problems have been lack of awareness as to its real potential, acoustical unfamiliarity on the part of the listener, and the presentation of material aimed to provide a "novelty value". The science fiction and horror film has done a great deal of harm with sound tracks of "atonal bleeps" and "electronic shrieks" which amount to nothing more

than unflattering imitations of the real thing produced with the aid of an audio tone generator and a tape recorder.

The resulting public reaction has therefore not been exactly encouraging. To the man in the street "electronic music" à la movie films, TV and radio play has become little more than a series of hideous echoed noises, most of which have been produced by composers (?) with about as much knowledge of music as an infant school percussion group. Concerts, recitals and instruction have, of course, been given to stir up interest but public reaction still remains polite yet indifferent.

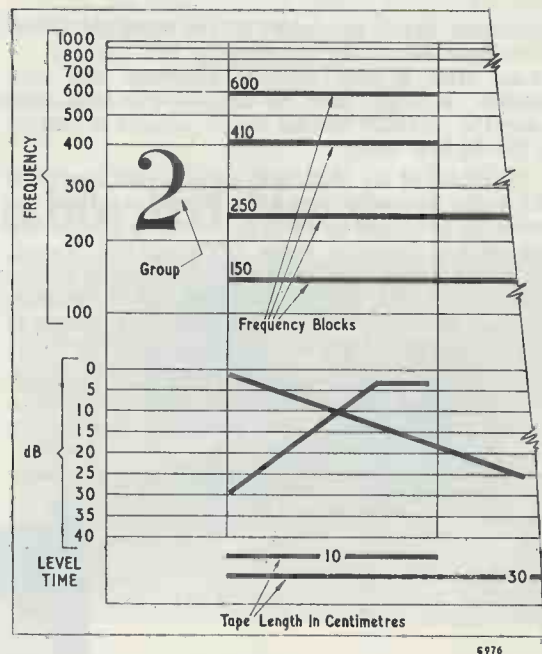

Fig. 1. Form of notation used in Electronic Music studios

## What is Electronic Music

Many attempts have been made to create new musical sounds, mostly by means of instruments employing some form of electronic tone generator, as for instance, the "Electrophone" by Jorg Mager and the "Theremin" named after its inventor; but these were really the forerunners of the so-called electric organ and should not be regarded as

<sup>1</sup>Die Reihe. 1. *Electronic Music* —Universal Editions, London.



Luciano Berio (right) explains an Electronic Music technique to students at the Dartington School of Music. (L. Berio is the Founder of the Milan Studio of Electronic Music)

electronic music producers in the accepted sense<sup>2</sup> Electronic Music is an entirely new concept of music with a new musical language and new sounds. Wrongly used, its unfamiliarity may drive away the potential listener within minutes of hearing it for the first time.

Foremost of the electronic music sound sources is the audio frequency sine-wave generator. Here the tones are produced by electrical elements and, unlike the electric organ or other keyboard instruments, frequency selection is continuously variable over a wide range and allows the composer to produce "scales" other than the conventional equal tempered series with their repeated octaves (Figs. 1 and 2).

The square wave, be it from a sine wave oscillator with a squared output or a multi-vibrator, serves to complement the pure tone, chiefly because of the

wide range of harmonics that can be included or filtered out as desired.

The so called "white noise generator" is yet another electronic sound source and various hybrid generators have been produced to provide certain tone colours.

#### Transformation

The second stage in electronic music creation is the electronic treatment and transformation of sound with electrical filters, which allows the composer to alter his fundamental tones and provide certain textural effects. Modulation forms can be generated with such devices as a ring modulator, and unusual reverberation provided with both mechanical and magnetic tape feedback systems.

Tape recording techniques are one of the greatest assets to the composer and permit glissandi and arpeggios which no human performer could produce with a conventional musical instrument. Magnetic

<sup>2</sup>Electronic Music and Musique Concrète—F. C. Judd. A.INST.E., Neville Spearman Limited, London.

Greek composer X. Xenakis at work in the R.T.F. Studio of Musique Concrète, Paris



tape is also used to piece together the musical elements of a composition and provide the composer with a means of controlling the attack and decay of generated sounds.

### Reproduction

Electronic music and Musique Concrète are both reproduced by the loudspeaker, and considerable freedom as to the position of the reproduced sound is permitted by "stereophonic" techniques. In Henk Bading's "Genesis", four sound tracks, timed to create an unusual sense of reverberation, were fed to loudspeakers placed around the concert hall. This technique alone allows the composer to expand his composition with spatial effect and to provide actual movement to a sound or a sequence of sounds.

### The Future of Electronic Music

In its true form, electronic music offers a wider scope in dynamics, tempo and brilliance than an orchestra comprised of traditional instruments and performers could ever achieve. On the other hand traditional and electronic music can combine to create contemporary works that are not bound by the twelve-tone serial system.

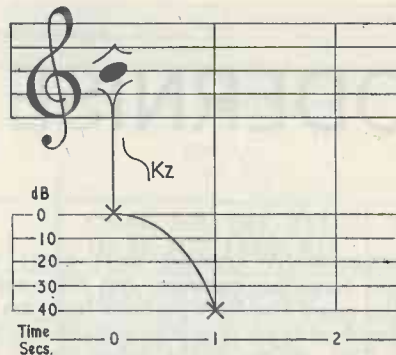

Fig. 2 Experimental notation used by the Music Concrète groups

The future of electronic music depends on time and quality. Time is necessary for the public ear to become accustomed to the new sounds. Quality must depend entirely on the composers who decide to employ this electronic medium which, up to the moment, has been scarcely used in any real attempt to develop popular interest.

(to be continued)

## TRADE REVIEW . . .

# Steadfast Electrician Kit No. 4

For those readers (and their wives) who are perhaps still somewhat perplexed over the Christmas gift problem, we feel we cannot do better than to suggest the above kit as a useful and practical present—especially should the recipient be a home handyman, a radio constructor or a serviceman. The gift suggested, suitably boxed for the occasion, is a really worthwhile set of electricians tools which are always in demand and constant use.

The complete set is contained within an attractive and handy blue plastic wallet having a clear plastic inside cover enclosing the tools. From the illustration shown alongside, it will be seen that the kit is packaged in an attractively and colourfully designed box suitable for the festive occasion.

The kit comprises a set of quality tools specially selected for the electricians use, the wallet being designed to fit within an overall pocket. The contents are: a mains neon tester screwdriver, diagonal nippers, insulated combination pliers with side cutters, insulated screwdriver and a small plastic handled screwdriver.

The price of the kit is 25s. 3d. retail and it may be obtained from any tool stockist. A leaflet of other tool



gifts, similarly packed, may be obtained direct from the manufacturer—J. Stead and Co., Ltd., Manor Works, Cricket Inn Road, Sheffield, 2.

## Quinn's Electrical Engineering, Radio and Television Diary

Of the various diaries which appear at this time of the year, this one has much to recommend it. It is of very convenient breast pocket size, reasonably thin and of an ideal format size, viz.,  $3\frac{1}{2} \times 5\frac{1}{4}$  in.

The 1963 edition has been rearranged and revised throughout, much new data having been included for the electronics engineer. This new material includes valve data and pin connections, paralleled resistor network data, passive networks and recording characteristics. Of the original material, there is such a wealth that it is quite impossible to mention it all in a short review. Suffice it to say that data on most aspects of electronics appears to be included in the reference section of this diary. There is also a very useful road map section covering the British Isles included. The actual diary section is well laid out with adequate space for entries.

The diary is available leather bound at 7/- each, cloth bound at 6/- each, post paid, from H. O. Quinn Ltd, 151 Fleet Street, London, E.C.4.

# MODERNISE *That Valve Portable*

By V. T. Rolfe

NO DOUBT MANY READERS HAVE BUILT THEMSELVES transistor receivers, but there must be many more who have portable receivers using valves. Some of these receivers will use the 50mA series of B7G valves, whilst some of the older models may use the Octal based 1.4V series. It is the purpose of the present article to give some hints on how these receivers may be modernised to use the 25mA series of B7G valves, and in many cases this will result in a substantial reduction in the battery consumption. Apart from the reduction in heater current, there is also some saving in the current drawn from the h.t. battery.

The modification of receivers using battery valves in *series chains* is not recommended, as the redesign of a 50mA chain to use 25mA valves is quite involved and the heaters of these valves must operate within close limits. In any case, such receivers are normally intended for mains/battery operation and therefore battery economy is not of such importance.

Table 1 gives a list of valves likely to be incorporated in battery portables. To simplify the text, only the Mullard type numbers are used wherever possible. For example, when the DK91 is mentioned the remarks will apply equally to equivalent types given in the above table (1C1, 1R5, X17). The Mazda 141 range is in general very similar to the D30 range except for the base and pin connections, so remarks on the D30 range apply to the 141 range also.

## General Notes—Mechanical

Each stage will be considered in turn, as it is practical to either convert the whole set to the low consumption D96 range or to convert individual stages. Some readers may wish to modify the complete receiver, whereas others may find that one valve in their portable has ceased to function, and may wish to fit an up-to-date replacement either because the old valve is no longer available or may become obsolete in the near future.

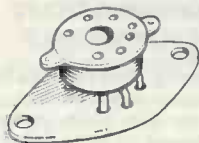

M404

Fig. 1. Method of mounting a B7G over a paxolin octal valveholder

Direct equivalents to the D96 series have not been included as the Mullard valves can be used as plug-in replacements in these cases. In replacing other B7G valves (column C in Table 1) there are no mechanical problems. The circuit changes necessary will be dealt with later.

In replacing valves in column A or B, the question of a new valveholder arises. There are several methods of overcoming this:

- The old valveholder can be removed from the chassis and replaced by an aluminium plate holding the new B7G valveholder. This is the best solution.
- The new valveholder can be mounted on top of the old octal valveholder (taken from the old valve) and appropriate connections made (g1 pin to g1 pin, etc.).
- As in (b) but pin 1 connected to pin 1, pin 2 to pin 2, etc., the under-chassis connections being changed as required.
- In some cases it may be possible, where a paxolin valveholder is fitted, to connect short wires to the B7G type and "plug-in" to the octal valveholder, soldering the short wires to the octal connectors (see Fig. 1).

Of these four methods, (a) is preferable, but if this is not possible, either (c) or (d) should be used. If (b) is used, wires must be crossed in the adaptor and this is liable to lead to instability. There is also the possibility of mistakes being made in wiring the adaptor. These are far less likely with (c) or (d). Some thought should be given to the best orientation.

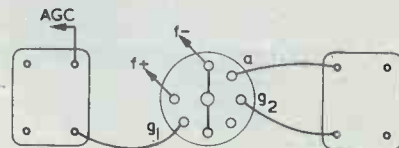
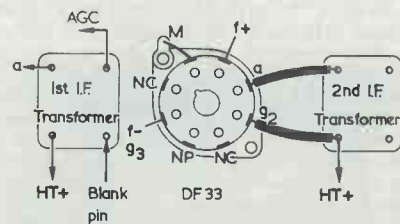

DF96

M405

Fig. 2. A DF96 used in place of a DF33 type valve

**TABLE I**  
**Valves Used in Portable Receivers**

	Mazda Octal Range A	Octal Range B	B7G Types	
			50mA C	25mA D
Frequency Changer	FC141	DK32, 1A7GT	DK91, 1C1, 1R5, X17 DK92, 1C2, 1AC6, X18	DK96
I.F. Amplifier	SP141	DF33, 1N5GT	DF91, 1F3, 1T4, W17	DF96
Det. A.F. Amplifier	H141D	DAC32, 1H5GT HD14	DAF91, 1FD9, 1S5, ZD17 1U5	DAF96
Output Valve	Pen 141	DL33, 3Q5GT, N16 DL35, 1C5G, N14	DL92, 1P10, 3S4, N17 DL94, 1P11, 3V4, N19 DL91, 1S4	DL96

**TABLE II**  
**Comparison of Output Valves**

Valve Type	Pen 141	DL33	DL35	DL91 DL92	DL94	DL96			
Va	82	85	83	67.5	82	85	64	85	V
Vg2	82	85	83	67.5	82	85	64	85	V
Vg1	8.1	-5	-7	+7	-8.2	-5	-3.3	-5.2	V
Vin (r.m.s.)	4.9	3.5	5	5.5	6.3	3.5	2.5	3.4	V
Ia	5.0	7	7	7.2	10	6.9	3.5	5	mA
Ig2	1.0	0.8	1.6	1.5	2.2	1.5	0.65	0.9	mA
Ik	6.0	7.8	8.6	8.7	12.2	8.4	4.15	5.9	mA
Ra	10	9	9	5	5.5	10	15	13	kΩ
Pout	210	250	200	180	320	250	100	200	mW
Transformer Ratio*	57:1	55:1	55:1	40:1	42:1	57:1	70:1	65:1	

\* For 3Ω Speaker.

Valve manufacturers usually arrange pin connections so that the input pin (g1) and the output pin (a) are on opposite sides of the valve. The valveholder should be orientated to give the shortest possible lead lengths to these two pins. A typical example is given in Fig. 2, which shows a DF96 used in place of a DF33. In this case, the grid lead was previously brought out to the top cap. It will sometimes be found that this connection is also brought out to a connection on the base of the i.f. transformer, or alternatively there is a blank pin on the base. The can should be removed and the connection re-routed to the underside of the chassis.

**General Notes—Electrical**

The D96 range of valves is designed for operation from a h.t. line not greater than 90V. Some of the earlier types will operate from higher voltages, up to a maximum of 120V. No portable receivers exist with 120V batteries, but if a table model receiver using a 120V battery is modified, dropping resistors

must be fitted or the battery changed to ensure that any D96 valves that are used are not subjected to this voltage.

One portable receiver, the Burgoyne "Playboy", employs 45V h.t. batteries. The manufacturers' data for the D96 series does not contain characteristics or operating conditions at 45V, and performance under these conditions cannot therefore be guaranteed.

**The Output Stage**

The operating conditions of the output valves listed in Table I are given in Table II. From this table the principal differences between the types can readily be seen. In all cases the operating conditions should be changed to correspond as closely as possible to those given for the DL96. It will be noticed that the sensitivity of the DL96 is slightly higher than the other valves, but the output power is slightly lower. These differences are not, however, serious. A more serious difference is the higher value of optimum load required for the DL96.

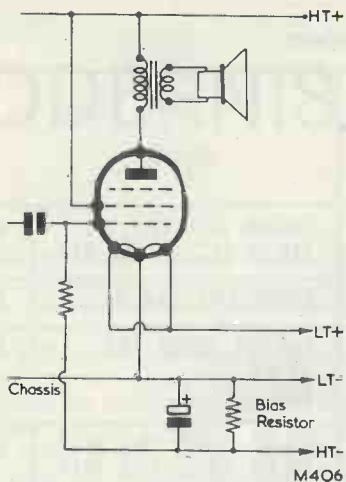

Fig. 3. Total h.t. current flows through the bias resistor, the voltage derived being used as bias for the output valve. Changing the valve will result in change of the total h.t. current. (See text)

If possible it would be advisable to change the load, but in the majority of cases this cannot be done economically, and some mismatch will take place. With a battery voltage of 90V and with a load of 9kΩ, the DL96 can be expected to give an output of about 150mW at 10% distortion, instead of the 200mW shown in the table. With a 67.5V battery the optimum load for the DL96 is 15kΩ, whereas the DL91 or DL92 (and equivalents) have a 5kΩ load under these conditions. In these circumstances, the mismatch would cause a considerable drop on the already low output of 100mW, and on the face of it such a substitution could not be recommended, unless of course the load can be altered by using a different ratio transformer, or changing the speaker to one having a higher impedance. In a receiver modified by the writer, however, the Marconiphone P17B, it was found that the DL92 was biased back to reduce the h.t. drain. Under these conditions the optimum load is higher and the output lower. In this receiver the load was estimated to be 13.5kΩ and the output about 70mW. The load was close to the 15kΩ required for the DL96 in this case, so the modification was carried out and proved successful.

Valve	Base Type	1	2	3	4	5	6	7	8	TC
DAC32	International Octal	M	f+	a	NC	ad	NP	f-	NC	g
DAF91	B7G	f-, g3	NP	ad	g2	a	g1	f+	—	—
DAF96	B7G	f-, g3	IC	ad	g2	a	g1	f+	—	—
DF33	International Octal	M	f+	a	g2	NC	NP	f-, g3	NC	g1
DF91	B7G	f-, g3	a	g2	NP	f-, g3	g1	f+	—	—
DF96	B7G	f-, g3	a	g2	IC	f-, g3	g1	f+	—	—
DK32	International Octal	M	f+	a	g3, g5	g1	g2	f-	NC	g4
DK91	B7G	f-, g5	a	g2, g4	g1	f-, g5	g3	f+	—	—
DK92	B7G	f-	a	g2	g1	g4	g3	f+, g5	—	—
DK96	B7G	f-	a	g2	g1	g4	g3	f+, g5	—	—
DL33	International Octal	NC	f+	a	g2	g1	NP	f-	fct, g3	—
DL35	International Octal	NC	f+	a	g2	g1	NP	f-, g3	NC	—
DL91	B7G	f-, g3	a	g1	g2	f-, g3	a	f+	—	—
DL92	B7G	f-	a	g1	g2	fct, g3	a	f+	—	—
DL94	B7G	f-	a	g2	NC	fct, g3	g1	f+	—	—
DL96	B7G	f-	a	g2	NC	fct, g3	g1	f+	—	—
FC141	Mazda Octal	f	NC	a	g2	g1	M	g3, g5	f	g4
H141D	Mazda Octal	f-	NP	a	NC	ad	M	NP	f+	g
Pen141	Mazda Octal	f-	NP	a	g2	g1	NC	NP	f+	—
SP141	Mazda Octal	f-	NP	a	g2	NC	M	NP	f+	g1
1U5	B7G	f-, g3	a	g2	ad	NC	g1	f+	—	—

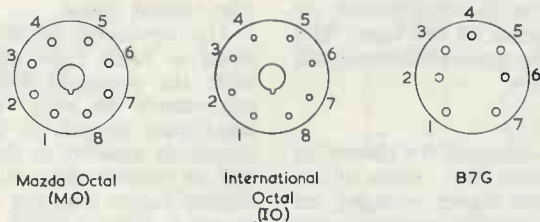

Fig. 4. Valve base connections

M407



**TABLE III**  
Comparison of A.F. Valves

	H141D	DAF91				DAF96		
Vb	82	67.5	67.5	90	90	64	85	V
Ra	0.47	0.47	1	0.47	1	1	1	MΩ
Rg2	—	1.8	3.9	1.8	3.9	2.7	2.7	MΩ
Rg1	4.7	10	10	10	10	10	10	MΩ
Rg1 of output valve	2.2	1.0	2.2	1.0	2.2	2.2	2.2	MΩ
Gain	35	55	71	66.5	90	57	65	
Ik	65	112	58	166	83.7	60	85	μA

**TABLE IV**  
Comparison of I.F. Amplifiers

	SP141	DF33	DF91		DF96		
Va	83	90	67.5	90	64	85	V
Vg2	83	90	67.5	67.5	64	64	V
*Rg2	0	0	0	16	0	39	kΩ
Vg1	0	0	0	0	0	0	V
Ia	1.55	1.2	3.4	3.5	1.65	1.65	mA
Ig2	0.5	0.3	1.5	1.4	0.55	0.55	mA
gm	750	750	875	900	750	750	μA/V
Ik	1.65	1.5	4.9	4.9	2.2	2.2	mA

\* Rg2 is sometimes common to the i.f. valve and frequency changer (see text).

**TABLE V**  
Comparison of Frequency Changers

	FC141	DK32	DK91		DK92	DK96		
<i>Voltages</i>								
Anode (Va)	90	90	67.5	90	85	64	85	V
Screen-grid	45	45	67.5	67.5	60	64	68	V
Osc. anode	90	90			30	35	35	V
Osc. grid (r.m.s.)	—	—	—	—	4	4	4	V
<i>Currents</i>								
Anode (Ia)	0.55	0.6	1.4	1.6	0.7	0.55	0.6	mA
Screen-grid	0.6	0.7	3.2	3.2	0.15	0.12	0.14	mA
Osc. anode	1.2	1.2			1.6	1.6	1.5	mA
Osc. grid (Ig1)	35	35	250	250	100	85	85	μA
Total (Ik)	2.4	2.5	5	5	2.55	2.45	2.4	mA
gc	250	250	280	300	325	275	300	μA/V

When replacing the DL91 or DL92, any screen-grid dropping resistor and decoupling capacitor which is fitted can be removed. The only other change necessary is the bias. The bias is normally obtained in these receivers by a resistor connected between the h.t. negative and l.t. negative leads. The total h.t. current flows through this resistor, and the voltage derived is used as bias for the output valve (Fig. 3). Changing the output valve will cause

a change in the total h.t. current and will therefore necessitate a change in bias resistor. The value of this resistor is given by

$$R = \frac{V_{g1}}{I_{tot}}$$

The value of Vg1 for the DL96 is 5.2V (with a 90V battery) and 3.3V (with a 67.5V battery). The value of I tot will depend upon the valve complement,

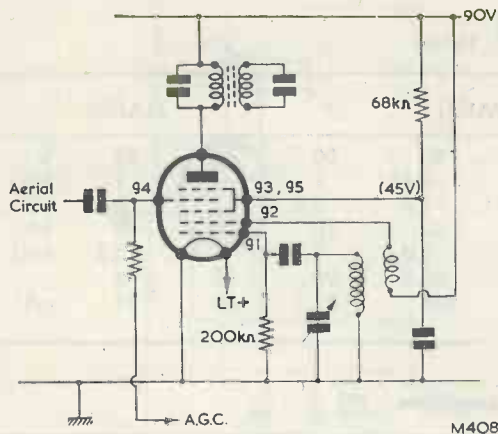

Fig. 5. Circuit using a DK32 valve

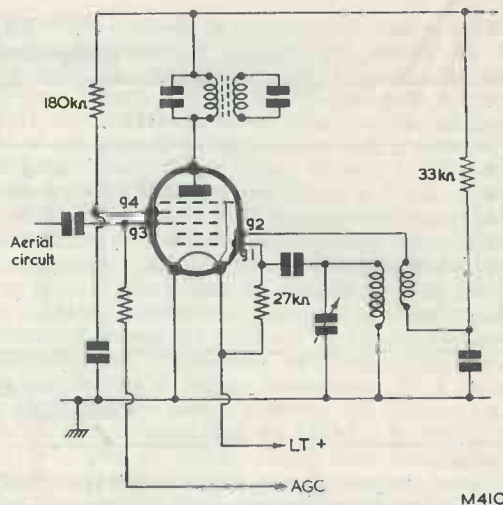

Fig. 7. Circuit using a DK92 valve

and can be obtained by adding the cathode currents given in Tables II to V.

The DL96 has the same pin connections as the DL94. The pin connections of the DL92 and DL91 differ. The connections for all these valves are given in Fig. 4.

#### Voltage Amplifying Stage

Table III compares the operating conditions of the DAF96 with the earlier DAF91 and equivalents. With similar anode loads, the DAF96 gives a gain reduction of about 25%. Where the DAF91 is used with a 470kΩ load however, the gain of the DAF96 with a 1MΩ load will be comparable. The base connections of both valves are the same. The 1U5 has identical characteristics to the DAF91, but different pin connections. (See Fig. 4.) The only

circuit change necessary is to change the screen-grid dropping resistor to 2.7MΩ.

No operating conditions are given for the DAC32 or its equivalents. With a  $\mu$  of 65, a voltage gain of about 35 can be expected. The  $\mu$  of the DAF96 triode connected is only 16, so it is not possible to use it triode strapped as a replacement. It is therefore necessary to provide a screen-grid resistor and capacitor and use the valve as a pentode. This gives a 50% increase in the stage gain and greatly improves the sensitivity of the receiver. The grid lead should be re-routed under the chassis as mentioned previously.

#### The I.F. Amplifier

Table IV gives a comparison of the i.f. amplifier

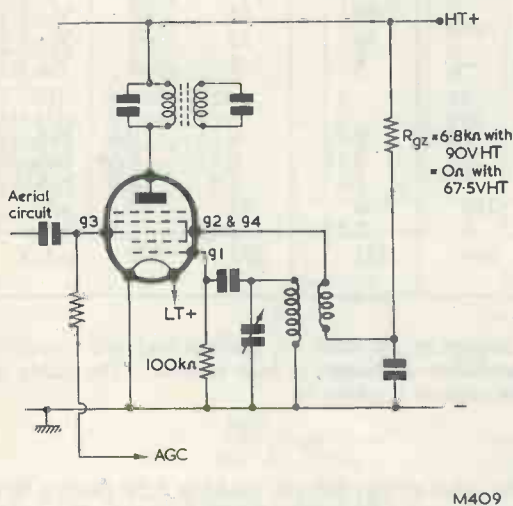

Fig. 6. Circuit using a DK91 valve

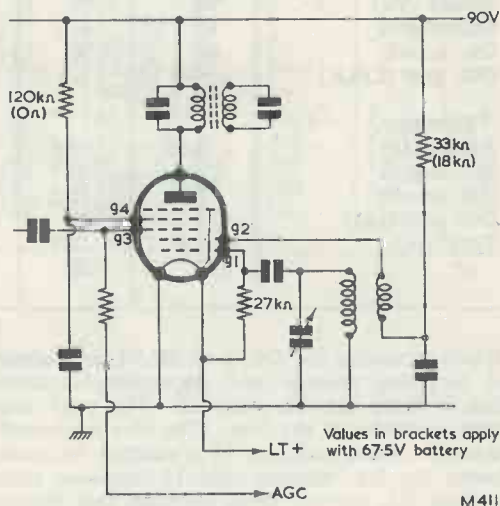

Fig. 8. Circuit using a DK96 valve

valves which may be encountered in portable receivers. When replacing the DF91 with the DF96 the screen-grid dropping resistor should be changed. In some receivers, particularly those using a DK91 frequency changer (or equivalent) a common resistor is used to feed the screen-grids of the frequency changer and i.f. valve. In such cases the most straightforward method is to use separate resistors for each screen grid, but some economy may be effected by using a common one. The value is given by:

$$R_{g2} = \frac{B_b - V_{g2}}{I_{g2(a)} + I_{g2(b)}}$$

Where  $V_b$  is the battery voltage,  $V_{g2}$  the required screen-grid voltage, and  $I_{g2(a)}$ ,  $I_{g2(b)}$  the screen-grid currents of the i.f. valve and frequency changer. These will depend on the valves used, and can be obtained from Tables IV and V. After the valve has been changed, the i.f. transformer may need re-alignment.

#### The Frequency Changer

Table V lists the operating conditions of the various frequency changer valves. Modification of this part of the circuit is far more critical than any other stage. The situation is complicated by the fact that these valves have different electrode arrangements, and the circuit used with each type differs. Typical circuits for the DK32, DK91, DK92 and DK96 are shown in Figs. 5 to 7.

The simplest method of describing the substitutions is to deal with each type in turn, commencing with the DK92. The electrode structure of the DK96 is similar to the DK92, and the pin connections are identical. Only one circuit change is

necessary: The value of the screen dropping resistor should be changed from  $180k\Omega$  to  $120k\Omega$ . The DK96 should not, however, be used in receivers with a short-wave band, as its short-wave performance is inferior to the DK92.

In the DK91, the screen-grid ( $g_4$ ) and the oscillator anode ( $g_2$ ) are strapped internally. This also implies a change in the pin connections (see Fig. 4). The conversion slope ( $gc$ ) is very similar to the DK96.

The changes necessary are as follows:

- (a) Disconnect pin 5 from the circuit, and if necessary complete the filament circuit via pin 1.
- (b) Change the oscillator anode resistor to the correct value for the DK96. ( $18k\Omega$  at 67.5V,  $33k\Omega$  at 90V.)
- (c) Connect a  $120k\Omega$  resistor from h.t. + to pin 5, and a  $0.1\mu F$  capacitor from pin 5 to earth.  
(If the receiver uses a 67.5V battery, these two components will not be required. It is then sufficient to connect pin 5 directly to the h.t. line.)
- (d) Replace the  $100k\Omega$  resistor between pin 4 and chassis with a  $27k\Omega$  resistor between pin 4 and pin 7. (f+.)

In the DK32,  $g_4$  is the signal grid and  $g_3 + g_5$  form the screen grid. The screen-grid dropper is usually  $68k\Omega$  and must be changed to  $120k\Omega$ . The oscillator anode is normally fed direct from the h.t. line (via the anode winding), and it will be necessary to fit a  $33k\Omega$  resistor and a  $0.1\mu F$  decoupling capacitor. The oscillator grid leak should also be removed and a  $27k\Omega$  resistor connected between  $g_1$  and f+.

## LARGE RELAY STATION ORDER FROM THE B.B.C.

The British Broadcasting Corporation has awarded a third contract to Marconi's for the supply of a considerable quantity of television and f.m. sound radio transmitter and translator equipments. These will be used by the B.B.C. as relay stations in areas of poor reception, in continuance of the Corporation's plan for as nearly as possible 100 per cent satisfactory coverage throughout the British Isles.

The contract covers the supply of 10 watt translator drivers and transmitter equipments, as well as 100 watt and 500 watt amplifiers. This new order brings the total number of units purchased by the B.B.C. up to 118.

Relay stations receive a main station transmission at a position of good signal strength, amplify it and retransmit it on a different channel into the area of poor reception. Since the equipments normally have to operate with the receiving and transmitting aerials in close proximity, a sophisticated form of design is necessary to prevent interaction between the retransmitted signal and the receiver.

At such stations all equipments are in duplicate, with one 10 watt driver in operation and one on standby, with automatic changeover in the event of failure of the operational equipment. The driver feeds a pair of amplifiers usually operating in parallel, but at some stations operating on an either/or basis; thus if one of these should fail, the service continues until the fault is rectified.

The equipment ordered by the B.B.C. is a specially designed version of standard equipment which has been supplied by Marconi's to overseas customers, including Sweden, Norway, Canada, Venezuela, Lebanon, Kenya, and Gibraltar. Because the British 405-line television system uses amplitude-modulated sound, cross-talk is a greater problem than is the case with frequency-modulated sound systems and special circuit precautions have to be taken on this account.

# News and Comment . .

## Admiralty's Valve Weighs 4½ Tons!

What is thought to be the largest thermionic valve in the world is being constructed at the Admiralty's Microwave Electronics Division of the Services Electronic Research Laboratory at Harlow, Essex. It is 18 feet long, over 7 feet high, 6 feet wide and weighs 4½ tons, and will be used for research into the upper atmosphere—sponsored by the Ministry of Aviation—at Great Baddow, near Chelmsford.

The valve is a travelling wave tube and will provide 100 megawatt pulses of energy at a frequency of 420 megacycles per second. Power is obtained by interaction between a radio wave travelling along inside the valve and a beam of electrons travelling at about the same speed. By suitable design it can be arranged that the electrons give up about half of their energy to the radio wave, and thus a very high power can be obtained if a high energy electron beam is used. To obtain 100 megawatts of radio power, a 250 megawatt beam will be used, in which the electrons are travelling at four-fifths the speed of light. The electrons are accelerated to this velocity by means of a modulator which gives pulses of up to 500,000 volts at 500 amps.

In use, the valve will give out copious X-rays, and to protect operators from these it will be housed underground in a pit having lead walls and a seven-inch thick lead roof.

## Model Control by Ultrasonics

Very high frequency sound waves, or ultrasonics as they are technically called, have been used for many professional purposes, such as navigational depth finding, but their application to model control is somewhat novel.

Gulton Industries (Britain) Ltd., have introduced a new ultrasonic transducer which makes this application possible. Only one inch in diameter and just over an inch in length, the basic model 1404, has a centre frequency of 40 kc/s. A typical ultrasonic control system, consists of two such units; the transmitter being a 1404 transducer driven by two transistors and the receiver a similar transducer picking

up the signal and feeding a simple transistor amplifier converted to supplying a control device within the model. Both these circuits can be easily constructed by an amateur. The small size of these transducers makes them very suitable for model control work, but they can also, of course, be used for other purposes such as opening garage doors, domestic alarm systems, etc. Multi-channel control systems can be made by using one set of transducers only, but Gulton ultrasonic transducers of different centre frequencies are available if required.

As the makers point out, two advantages of this type of control system over the usual radio one is that no radio control transmitting licence is required and interference by other control systems operating nearby is completely eliminated.

Model control by ultrasonics is in its infancy, but to cater for radio control enthusiasts we have just published *Radio Control for Models* by F. C. Judd with sections on servomechanisms by Raymond F. Stock. Basically this addition to the Data Book series is an amalgamation of *Radio Control for Model Ships, Boats and Aircraft* and *Radio Control Mechanisms*, brought up to date with detailed information on transistorised receivers, batteries, etc.

*Radio Control for Models*, Data Book No. 16, has 192 pages packed with information and is profusely illustrated with diagrams, circuits, and photographs, and costs only 15s. per copy.

## Symposia

There is to be a three day "Symposia and Exhibition" held at Bristol Technical College on the 11th, 12th and 13th of this month.

The Symposia will cover Silicon Control Rectifiers and Cold Cathode Devices by Mullard Limited; Static Switching and Control Engineering with Sub-Assemblies by Mullard Equipment Limited; Transducers and Oscilloscopes by Cossor Instruments; Transistor Analysis and recent Instrument Development by Avo Limited.

In addition to the Static displays in the Exhibition section, there will be working demonstrations of Solid

State Switching Systems recently engineered in the West Country.

There is to be an International Meeting and Symposium of Radio Amateurs on the 7th April, 1963 during the International Aeronautics and Space Fair, Congresses and Competitions at Sao Paulo. Interested Radio Amateurs should contact B.O.A.C. for travel arrangements.

## Capacitor Suggestion Wins £425

The highest ever award by Standard Telephones and Cables Limited under its employee Suggestion Scheme was recently made.

Mr. Netherton, of the Company's Paignton factory, suggested an improvement in the process of sealing tantalum capacitors. This has proved highly successful and resulted in his receiving a cheque for £425 from S.T.C.'s Managing Director, Mr. Rex B. Grey.

S.T.C.'s factory at Paignton was the first in Europe to start full-scale production of tantalum capacitors, both in the foil and the sintered anode types. These capacitors have many applications in electronics equipment where small size and the ability to work at extremes of temperature are required. They are widely used in transistor circuits.

The awards made are directly related to the value of the suggestion when applied.

## A.G.M.

The Radio Teleprinter Group had a most enjoyable and successful Annual General Meeting and Get-together at the "Olive Branch", near Marylebone Road, on Saturday evening, 3rd November.

The gathering was honoured by the attendance of the President of the Norwegian Amateur Radio Society, and the international aspect of this growing branch of radio amateur activity was further stressed by the presence of two Dutch members of the group.

Following the business meeting, at which the previous year's officers were re-elected, coloured slides were shown of teleprinter operation at various amateur stations including, of special interest, pictures of the Dutch VERON H.Q. station, PAØAA.

## Car Number Plates

We understand that radio amateurs in New York State can now have their call signs registered as their car numbers.

Apparently the right has been given in recognition of the services given by amateurs in emergencies. U.K. please copy.

# Voltage Stabilisation for Transistor Car Radios

By SIR DOUGLAS HALL,  
K.C.M.G., B.A. (Oxon)

*This article offers some ingenious suggestions for overcoming changes in car radio performance due to differing battery voltages. A 12 volt supply is assumed and it is necessary for the receiver chassis to be isolated from the metalwork of the car*

THE TRANSISTOR CAR RADIO is becoming increasingly popular. It is very economical, so that it can be used for long periods with the car stationary; and it can have a very quiet background as there is no vibrator unit or rotary converter. But it suffers from one disadvantage. It is designed to work at optimum efficiency from the 14 volts which are produced by a car battery under running conditions, and this means that its efficiency is low when the car is stationary. If, on the other hand, it were designed for maximum results from 12 volts it would become unstable while the battery was being charged by the dynamo. To a lesser degree there is a fall in efficiency also when the headlights are in use, as these cause a drop of at least half a volt; and things are at their worst when the car is being driven at night in heavy traffic with the ammeter showing a discharge. The battery voltage may soon drop to 11.5 or lower in these circumstances.

In the circuits to be described arrangements are made to ensure that, with the engine switched off and the headlights switched on, all the earlier stages of the radio receive the voltage they were designed to receive with a supply of 14 volts. The wiring circuits of the car are used so that when the dynamo starts to charge, or the headlights are switched off, potentiometer networks are introduced which reduce the voltage supplied to the earlier stages. The action is entirely automatic and only two extra connections between radio and car circuits are required. The car's wiring remains unchanged.

## Automatic Control

Fig. 1 shows the last two stages of a typical transistor car radio. 560Ω is an average value for  $R_1$  and it may be assumed that the consumption of the radio, excluding the

output stage, is about 10mA. With 14 volts applied to the set the low potential end of  $R_1$  would therefore be 8.4 volts negative of earth.

In order to apply automatic control to cover both dynamo and headlights it is necessary for the voltage drop originally caused by  $R_1$  to be shared between the negative and positive lines and  $R_1$  becomes  $R_1$  plus  $R_2$  in Fig. 2. For the automatic control circuit to function, it is also necessary to reduce the value of  $R_1$  and  $R_2$  so that 8.4 volts is applied to the earlier stages when the battery is delivering 11.5 instead of 14 volts.  $R_1$  plus  $R_2$  should therefore drop 3.1 volts only which, for 10mA current flow means a total value of 310Ω. 150Ω for each resistor is quite near enough.

$R_3$  and  $R_4$  are preset variable resistors—ordinary small potentiometers of the volume control type are suitable—of 25kΩ and 10kΩ respectively. HFC<sub>1</sub> and HFC<sub>2</sub> are ordinary high frequency chokes

which are not critical in either inductance or resistance, and which are included to prevent interference being injected from the wiring of the car. They should be mounted outside the radio. The variable resistors may be fitted inside or outside but should be reasonably handy for a "once only" adjustment.

Fig. 2 shows the relevant part of the wiring of a car with the positive of the battery connected to earth. It will be seen that when point A of the radio circuit is joined to point X of the car wiring and the headlights are switched on, the series combination of  $R_3$  and HFC<sub>1</sub> is in parallel with  $R_1$ . As  $R_3$  will have a very much higher resistance than  $R_1$  the resultant effect on voltage is negligible. When, however, the headlights are switched off, point A becomes connected to the positive terminal of the battery and  $R_1$ ,  $R_3$  and HFC<sub>1</sub> form a potentiometer.  $R_3$  and HFC<sub>1</sub> in series with each other are in parallel with the internal resistance of the earlier stages of the radio and a voltage drop takes place in the supply to these stages, this drop being dependent on the value of  $R_3$ . It has been assumed that these earlier stages require 8.4 volts at which they consume 10mA, but these figures can be no more than estimates. Rather than calculate the theoretical value for  $R_3$  it is better to adjust it so that in practice the voltage between the junction of  $R_3$  and  $R_1$  and the junction of  $R_2$  and  $R_4$  remains constant whether the headlights are switched on or off.

The more important part of the circuit is that which controls voltage changes brought about by the action of the dynamo. It will be seen from Fig. 2 that point B is connected to the "D" terminal of the dynamo.

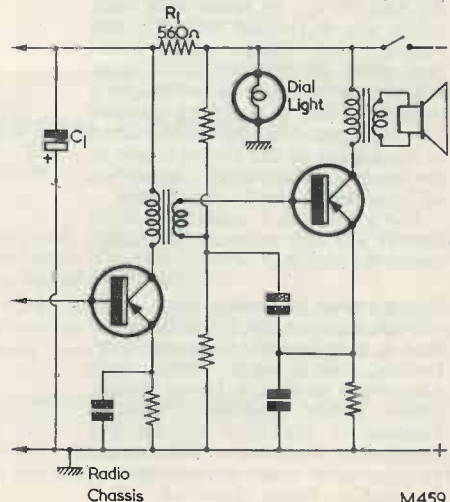

Fig. 1. The last two stages of a typical transistor car radio

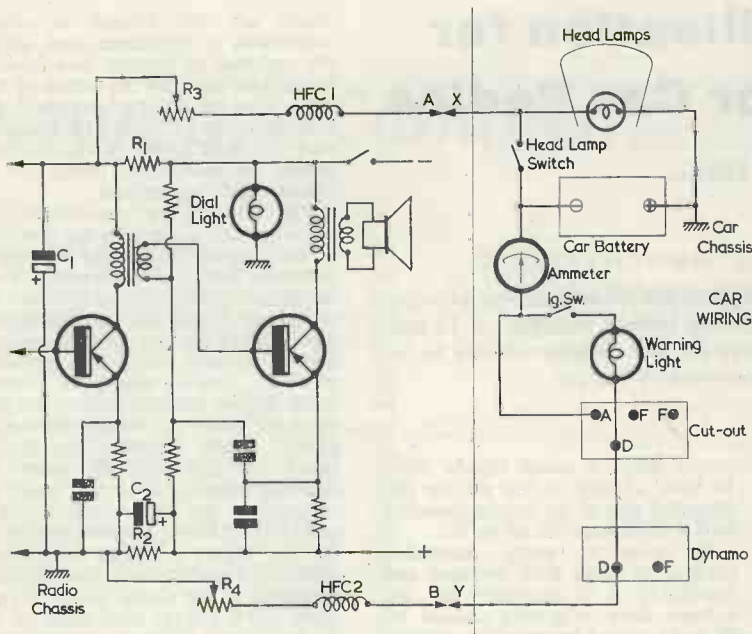

Fig. 2. A circuit which reduces supply voltage changes for the earlier stages of the receiver

This terminal is at positive potential when no charge is being delivered, and is at negative potential when charging takes place and the cut-out has done its job. It is this change of potential, of course, which enables the tell-tale light on the dashboard to function. The effect on the radio is similar to that described in connection with the headlights. When no charge is being delivered  $R_2$  and  $HFC_2$ , in series with each other, are in parallel with  $R_3$ , and virtually no change takes place. But, when the dynamo starts charging, a potentiometer is formed as a result of point B assuming negative potential, and a voltage drop occurs in the supply to the earlier stages of the receiver. Once again, the setting of  $R_4$  is best found by experiment.

For a car with a negative earthed battery it is only necessary to change round  $R_3$  and  $R_4$ .

#### Incorporating A Choke

With many radios it will be found that it is impossible to avoid interference, particularly from such accessories as electric petrol pumps, unless a low resistance choke is inserted in the lead to the live terminal of the battery. This trouble is, of course, quite independent of the circuits being described. If a

choke has to be used in order to avoid interference it can also be employed to form part of a potentiometer to correct voltage variations

caused by use of the headlights, and Fig. 3 shows how this can be done. An incidental advantage, if a low resistance choke is necessary in any event to prevent interference, is that with dial bulbs wired as shown in Fig. 3 the voltage drop at the output stage, with the headlights switched on, is less than it is with the bulb wired in the more normal way directly between the negative and positive lines of the radio, as shown in Fig. 2.

$HFC_1$  in Fig. 3 is the suppressor choke and should have a resistance of about  $1\Omega$ . It can be made by using about 1 oz. of 26 s.w.g. enamelled wire to put 120 turns on a lin former.  $HFC_3$  is a similar choke included to prevent interference via the car wiring when point A is connected up. A potentiometer is formed by  $HFC_1$  dial light 1 and  $HFC_3$  in conjunction with the internal resistance of the whole receiver. This functions in a similar manner to the potentiometer previously described except that the output transistor is included in the network, which accounts for the far lower resistance values involved. If the circuit is studied it will be seen that dial light 1 becomes extinguished when the headlights are turned on. This accounts for the addition of dial light 2 which plays no part in the voltage control but lights up when the headlights are switched on, whether the radio is switched on or not. It becomes extinguished when the headlights are switched off so

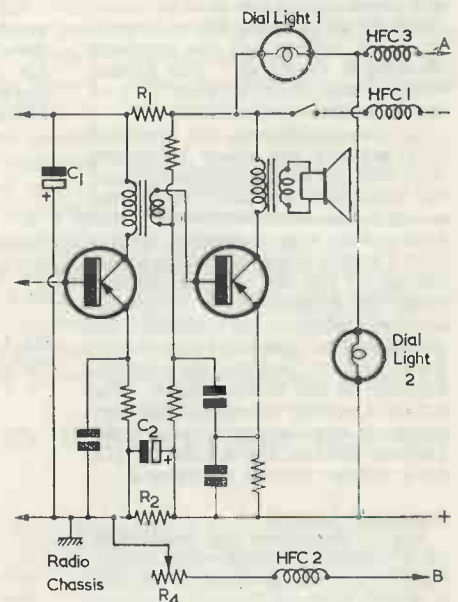

Fig. 3. An alternative circuit which includes the output stage of the receiver

that only one of the dial lights is in use at any one time.\*

HFC<sub>1</sub> in Fig. 3 will cause a voltage drop, for which reason R<sub>1</sub> and R<sub>2</sub> should be decreased to some 100Ω each. The extent of the voltage control will depend on the wattage, and hence the resistance, of dial light 1. If sensitivity rises with the headlights on, the wattage is too great; if it drops the wattage is too small, 3.6 watts probably proving about right. The wattage of dial light 2 is not critical.

It will be seen that the circuit in Fig. 3 retains the arrangement already described to compensate for changes due to the dynamo.

#### Negative Earth

Fig. 4 shows a circuit for cars which have the negative terminal connected to earth and used by the writer in his 1936 Bentley equipped with a radio made up from a Repanco kit. It will be seen that no resistance is required in the positive line of the receiver and the whole 200Ω (220Ω was used as the nearest easily obtainable value) appears as R<sub>1</sub>. Because of the reversed battery polarity points A and B change over.

It is possible, though this has not happened during the writer's experiments, that the reduction in value of

\* It may be noted that, when the receiver is switched off, a supply is still fed to it via dial light 1 when the head lights are switched on. The voltage across the receiver will probably be too low for it to operate under these conditions. It is possible, of course, to employ a double pole on-off switch in the receiver, the additional pole breaking the connection between dial light 1 and the receiver negative supply line.—EDITOR.

Fig. 4. Connections required with negative earth wiring

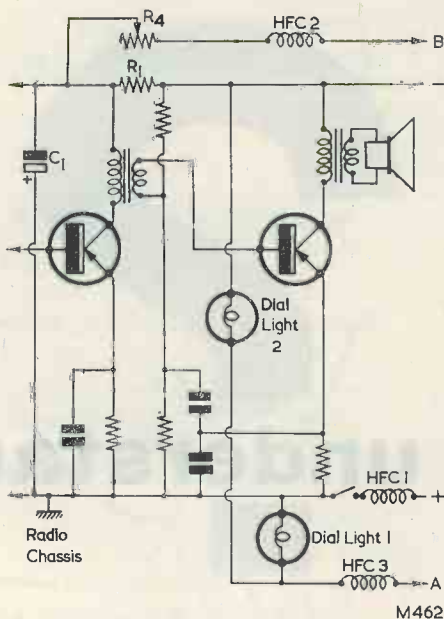

R<sub>1</sub> in Figs. 2, 3 and 4 will cause instability, necessitating an increase in capacitance of C<sub>1</sub>. C<sub>2</sub> in Figs. 2 and 3 should be not less than 100μF.

The arrangements described are definitely worth trying out. Little expense is involved and no risk is incurred to the electrical system of the car provided points A and B are carefully connected up. The very real improvement in reception when the car is stationary is most marked. The device to compensate for losses due to the use of the headlights is

less important, as already stated, this being especially true if no suppressor choke is needed to prevent interference and Fig. 2 is followed. The headlight part of the circuit can, of course, be omitted.

The full circuits in Fig. 3 and 4 are well worthwhile if a suppressor choke is needed in any case, and particularly in the case of Fig. 4, where hardly any extra components are required to cover voltage drop caused by headlights.

## Transport Minister

### Opens Medway Scheme

The Right Hon. Ernest Marples, M.P., officially opened a new radar and radio control centre for the Medway Conservancy Board on 2nd November, 1962. The ceremony was carried out in the new Control Room and was seen by visitors in the Reception Centre on a Closed Circuit Television chain supplied by Pye Limited.

A very well planned operation room, built on top of Garrison Point Fort at Sheerness, houses the Control Consoles for the three viewing units of the Decca Harbour Surveillance Radar and the Pye v.h.f. radiotelephone equipment. The Pye radio transmitters, which are sited on the Southdown Hills two miles from the Operations Room, give the best possible coverage to shipping in the Medway.

The Medway Port and Information Service has now been extended to include Harbour Surveillance Radar and the Pye Radiotelephone system has been improved and enlarged.

International radiotelephone channels recommended by the Hague Convention are used and two-way v.h.f. radio communication between the Port Authorities and Ships' Masters help in the safe and fast movement of shipping in the Medway.



*The sixteenth in a series of articles which, starting from first principles, describes the basic theory and practice of radio*

*part 16*

# understanding radio

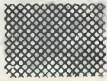

**By W. G. MORLEY**

**I**N LAST MONTH'S ISSUE WE DISCUSSED ALTERNATING current waveforms, pointing out that the sine wave represents the a.c. waveform which is constantly employed in radio calculations, and which is assumed to be the simplest waveform that can be given by an alternating quantity. We concluded by considering the effect given by connecting an a.c. generator to a capacitor, and saw that the current which flowed led the voltage by  $90^\circ$ . We shall now carry on to the effect given by applying a.c. to an inductor.

## **A.C. And Inductance**

In Fig. 94 (a) we connect an a.c. generator to an inductor, thereby causing an alternating current to flow through it. The waveform of this current is shown in Fig. 94 (b).

When we examined the effect of applying an alternating voltage to a capacitor we saw that the latter had to maintain, throughout the cycle, the same potential across its plates as was delivered by the generator. In consequence, the current which flowed in the circuit consisted of the charge or discharge current needed to maintain the capacitor in this condition. With an inductor the effect is different, and it is helpful to commence our examination with the current which flows through it rather than with the voltage across its terminals. We must remember also that an inductor always attempts to oppose changes in current by generating its own back e.m.f., the latter being opposite in polarity to that of the applied e.m.f.

In Fig. 94 (b), then, we start by examining our current waveform at point A. At this point the current is changing at its fastest rate and, as is to be expected, back e.m.f. is at a maximum in its attempt to oppose this change of current. As the cycle proceeds, the rate of change of current

reduces, with the result that back e.m.f. reduces also. At point B the rate of change of current is, for an instant, zero, and back e.m.f. is, similarly, at zero level. After point B, the rate of change of current commences to increase again, only this time in a reverse direction. To counteract the change, the back e.m.f. once more commences to increase, its polarity being similarly reversed. At point C we once more have the instance where rate of change of current is at its maximum, causing the back e.m.f. to be at peak value also. After C we continue along the rest of the cycle through points D and E, whereupon the set of circumstances which took place between points A and C is repeated, except that the direction of the current and the polarity of the back e.m.f. are now reversed.

As may be seen from Fig. 94 (b), the back e.m.f. lags on the current by  $90^\circ$ . This must be so, because the back e.m.f. passes through zero level when the current is at its maximum, and reaches its own peak when the current has returned to zero level. This phase relationship is clearly shown in the diagram.

However, our examination of the phase relationship between current and back e.m.f. takes us to an intermediate stage only. We must now take the further step of considering the applied voltage. This is obviously  $180^\circ$  out of phase with the back e.m.f. generated by the inductor and if we now add it to the diagram, as we do in Fig. 94 (c), we obtain a full picture of the relationship between this voltage and the current which flows through the inductor. As may be seen, the applied voltage leads the current by  $90^\circ$ . Alternatively, it may be stated that the current in the inductor lags by  $90^\circ$  on the applied voltage. This state of affairs is directly opposite to that given by a capacitor, with which current leads on the applied voltage by  $90^\circ$ .

Before proceeding further it might be helpful to



devote a few words to the discription just given concerning the relationship between alternating voltage and current in an inductor. Quite a few beginners find the reasons for current lag with an inductor more difficult to follow than the reasons for current lead with a capacitor. This is understandable, because the effect with the inductor is somewhat less obvious. Also, what is probably the easiest way to explain the inductor case is to commence with current and work back to voltage (as was done just now) whereas, with the capacitor, the obvious approach is to commence with voltage and work back to current. The beginner may find the concept of an initial voltage causing a current to flow more acceptable than the concept of an initial current causing a voltage to appear!

Nevertheless it is, of course, quite in order to look upon the current-voltage relationship in the manner just described. It may prove of assistance to finally sum up the process by stating that the a.c. generator in Fig. 94 (a) is a *current* generator, and that the voltage which appears across its terminals is that required to oppose the back e.m.f. produced by the inductor.

The opposition offered by the inductor is described as its *reactance*, and it is measured in ohms in just the same manner as is the reactance of a capacitor. It is important to remember that the reactance of an inductor is not the same as the reactance of a capacitor, because in the former the current lags by  $90^\circ$  on the voltage and in the latter it leads by  $90^\circ$  on the voltage.

As is to be expected, the opposition to alternating current flow, or reactance, of an inductor increases as the inductance increases. The reactance of an inductor increases also when frequency increases. This is another relationship which is simple to comprehend because an inductor opposes changes in current, and the rate of change of current must manifestly increase as frequency increases. The formula linking the three factors together is:

$$X_L = 2\pi fL,$$

where  $X_L$  is the reactance of the inductor in ohms,  $f$  is the frequency in cycles per second,  $L$  is inductance in henrys, and  $\pi$  is 3.1416.

The term  $2\pi f$ , frequently encountered in radio calculations, is often represented by  $\omega^1$ , whereupon the formula becomes  $X_L = \omega L$ .

The letter "X" signifies reactance, the small "L" which follows indicating that the reactance is inductive.

Two examples will help in familiarising ourselves with the equation for inductive reactance. We may commence, therefore, by finding the reactance of a 10 henry inductor at 100 c/s.

$$\begin{aligned} X_L &= 2\pi fL \\ &= 2\pi \times 100 \times 10 \\ &= 6,280. \end{aligned}$$

Thus, the reactance of the inductor is 6,280 ohms.

What is the reactance of a 2.5mH inductor at 1 Mc/s?



(a)

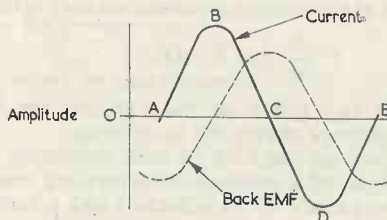

(b)

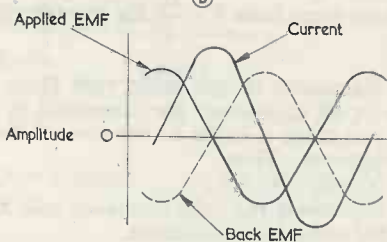

(c)

M583

Fig. 94 (a). An a.c. generator connected to an inductor (b). The back e.m.f. produced by the inductor lags on the current by  $90^\circ$ .

(c). The applied e.m.f., being  $180^\circ$  out of phase with the back e.m.f., leads the current by  $90^\circ$ .

$$\begin{aligned} X_L &= 2\pi fL \\ &= 2\pi \times 2.5 \times 10^{-3} \times 1 \times 10^6 \\ &= 2\pi \times 2.5 \times 10^3 \\ &= 15,700. \end{aligned}$$

Therefore, the reactance is 15,700 ohms.

Readers who are not familiar with the indices used in this last example will obtain the same result if the calculation is made without them. Thus:

$$\begin{aligned} X_L &= 2\pi fL \\ &= 2\pi \times \frac{2.5}{1,000} \times 1 \times 1,000,000 \\ &= 2\pi \times 2.5 \times 1,000 \\ &= 15,700 \end{aligned}$$

In this instance we divided the 2.5mH by 1,000 to bring it to henrys, and we multiplied the 1 Mc/s by 1,000,000 to bring it to cycles per second.

### Voltage, Current and Reactance

We have seen that the reactance of a capacitor or inductor is measured in ohms, but we have not yet examined the behaviour of reactance in relation with voltage and current.

The equation for these quantities is:

$$X = \frac{E}{I}$$

<sup>1</sup> The small Greek letter "omega".

Where  $X$  is reactance (either capacitive or inductive) in ohms,  $E$  is the e.m.f. in volts and  $I$  is current in amps. This is a similar equation to that for resist-

ance, where  $R = \frac{E}{I}$ , but it must be emphasised that

the current which flows in the reactance is  $90^\circ$  out of phase with the voltage.

As with the resistance equation we may also state:

$$I = \frac{E}{X}, \text{ and } E = IX.$$

These last two forms of the equation are merely different ways of saying the same thing.

If we have an e.m.f. of 10 volts appearing across the terminals of a component possessing reactance (either a capacitor or an inductor) and a current of

5 amps flows then, from  $X = \frac{E}{I}$ , the reactance will be

2 ohms.

When reactances of the same type (that is, all inductive or all capacitive) are connected in series, the total reactance is equal to the sum of the individual reactances. Thus:

$$X = X_1 + X_2 + X_3 + \dots$$

where  $X$  represents the total reactance and  $X_1, X_2, X_3$ , etc., the individual reactances.

It is worth pointing out that this is, in practice, just another method of stating what we already know so far as reactive components connected in series are concerned. Thus, taking the case of inductors we have:

$$X_L = X_{L1} + X_{L2} + X_{L3} + \dots$$

therefore

$$2\pi fL = 2\pi fL_1 + 2\pi fL_2 + 2\pi fL_3 + \dots$$

Since  $2\pi f$  is the same for the total reactance and the individual reactances, it may be cancelled out, giving us:

$$L = L_1 + L_2 + L_3 + \dots$$

Which, as we have learnt already, is the expression for inductors in series.

With capacitors, we may say:

$$X_C = X_{C1} + X_{C2} + X_{C3} + \dots$$

therefore 
$$\frac{1}{2\pi fC} = \frac{1}{2\pi fC_1} + \frac{1}{2\pi fC_2} + \frac{1}{2\pi fC_3} + \dots$$

Once more, the expression  $2\pi f$  may be cancelled out, whereupon we have:

$$\frac{1}{C} = \frac{1}{C_1} + \frac{1}{C_2} + \frac{1}{C_3} + \dots$$

This, as we know, is the equation for capacitors in series.

When reactances of the same type are connected in parallel we have:

$$\frac{1}{X} = \frac{1}{X_1} + \frac{1}{X_2} + \frac{1}{X_3} + \dots$$

where  $X$  is the total reactance and  $X_1, X_2, X_3$ , etc., the individual reactances. Where there are only two individual reactances, we may say:

$$X = \frac{X_1 X_2}{X_1 + X_2}$$

Here again, the formulae for total reactance are based upon what we already know about reactive components connected in parallel, and may be similarly reduced to the corresponding equations.

### Vectors

Reactance is different from resistance because the current flowing in a reactive component is  $90^\circ$  out of phase with the voltage. This phase difference has to be taken into account if we are to proceed further, and it is necessary for us to introduce a tool which enables us to express on paper both the magnitude and the phase relationship of electrical quantities.

The simple tool we employ for carrying out this function is the *vector*. A vector quantity has mag-

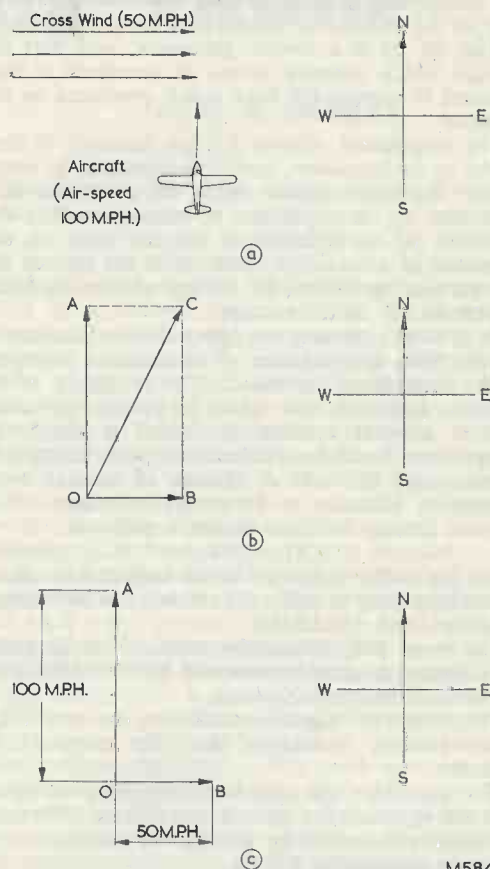

Fig. 95 (a). A problem which can be solved by vectors. What is the actual speed and course, relative to the ground, which is flown by the aircraft?

(b). In this diagram vector  $OB$  represents the direction and speed of the wind, and vector  $OA$  the direction and air-speed of the aircraft

(c). The actual course and speed of the aircraft relative to the ground is shown by the resultant vector  $OC$

nitude and direction and can be represented by a vector line whose length is equal to the magnitude of the quantity, and which points in the same direction.

To illustrate how vector presentation works, let us take an example involving magnitudes and directions which are readily understandable. In Fig. 95 (a) we have an aircraft flying towards North at an air-speed of 100 m.p.h. At the same time, this aircraft is acted upon by a cross-wind which blows from West to East at a speed of 50 m.p.h. What course, relative to the ground, does the aircraft actually follow, and what is its actual speed?

The simplest way of solving this problem consists of presenting it by means of vectors. In Fig. 95 (b) we have a vector line OA, and this shows the direction in which the aircraft is pointing, i.e. from South to North. A second vector, OB, shows the direction in which the wind is blowing; that is, from West to East. Since the air-speed of the aircraft (100 m.p.h.) is twice the speed of the wind (50 m.p.h.) we draw vector OA twice as long as vector OB. Therefore, each vector now represents both a magnitude and a direction.

The actual direction in which the aircraft flies may be found by drawing the parallelogram OACB, as in Fig. 95 (c), whereupon the direction is shown by the line OC.<sup>2</sup> The length of OC also gives us the actual speed of the aircraft and, if we measure it, will tell us that this is 112 m.p.h. Also, if we measure the angle AOC we will find that this is 27°. So our aircraft flies, relative to the ground, at 112 m.p.h., and its course is 27° East of North.

Let us next assume that our aircraft, with its air-speed of 100 m.p.h., flies towards the East, and that the 50 m.p.h. wind blows in a direction which is several degrees North of West, as in Fig. 96 (a). We can, once more, draw our vectors, giving us the diagram shown in Fig. 96 (b), in which OC shows the actual direction and speed of the aircraft. Let us next assume that the 50 m.p.h. wind blows directly to the East, as in Fig. 96 (c), with the result that the two vectors point in opposite directions and, in fact, form a straight line. See Fig. 96 (d). We cannot now construct a parallelogram, but common sense tells us that the direction of the aircraft will remain due East, and that its actual speed will be equal to its air-speed minus the wind speed. This is shown by the vector OC, which is equal to OA minus OB.<sup>3</sup> If wind speed (OB) had been greater than the air-speed (OA), vector OC would have become equal to OB minus OA and would have pointed in the same direction as OB. In other words, the aircraft would have travelled backwards relative to the ground.

We may see from this that, when two vector quantities are opposed to each other in direction, the smaller subtracts from the larger and the resultant is equal to the difference between them. Also it points in the same direction as the larger vector.

<sup>2</sup> In this instance the parallelogram is a rectangle, because angle AOB happens to be a right angle.

<sup>3</sup> If Fig. 96 (d) is compared with Fig. 96 (b) it may be noted that it gives the impression of the parallelogram OACB having been "flattened out" into a straight line.

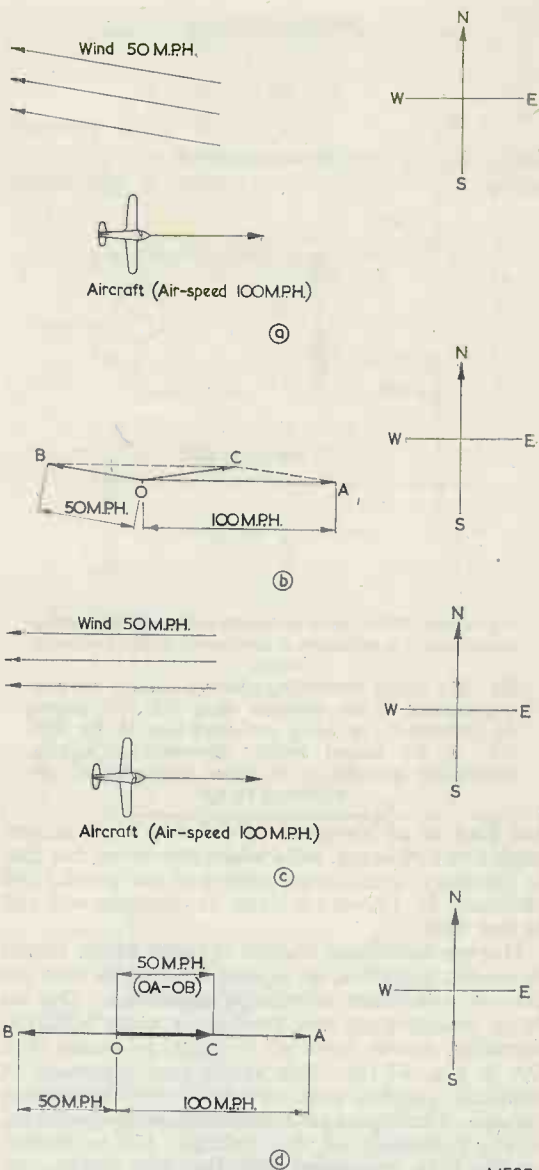

M585

Fig. 96 (a). Another combination of wind speed and air-speed  
 (b). Vector OC again indicates actual course and speed relative to the ground  
 (c). In this instance, aircraft and wind directions are directly opposed  
 (d). The resultant vector, OC, now lies on OA and points in the same direction. (If this diagram is compared with Fig. 96 (b), it may be noted that it gives the impression of the parallelogram having been "flattened out" into a straight line)

It can be similarly shown that, when two vectors point in the same direction, the resultant vector is equal to the sum of the individual vectors and also points in the same direction. If our aircraft, flying

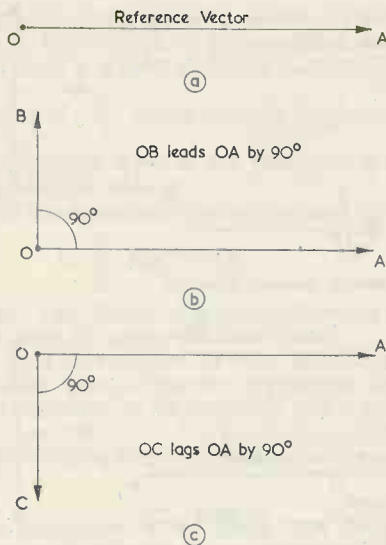

M586

Fig. 97 (a). When using vectors to represent alternating quantities, it is necessary to commence with a reference vector

(b). If a second alternating quantity leads on the first (represented by the reference vector OA) it is shown, by convention, as being anti-clockwise of the first (c). If the second vector represents a lagging alternating quantity it is shown clockwise of the reference vector

due East at an air-speed of 100 m.p.h., is accompanied by a 50 m.p.h. wind which also blows due East its resultant actual speed relative to the ground will obviously be 150 m.p.h., and its direction will still be due East.

Having introduced vectors in terms which should be readily digestible, let us next see how we may use them to investigate alternating quantities. This we do by commencing with a *reference vector* which, is, normally, drawn from left to right, as occurs with OA in Fig. 97 (a). This vector may represent an electrical quantity such as a sine wave alternating voltage, whereupon its length will be proportional to the magnitude of that voltage. Let us further assume that, associated with this first voltage, we have a second sine wave alternating voltage which leads it by  $90^\circ$ . We may represent this second voltage by OB, which is removed from OA by  $90^\circ$  in the anti-clockwise direction as in Fig. 97 (b). If our second voltage had lagged on the first voltage by  $90^\circ$ , we would have represented it by OC in Fig. 97 (c), in which diagram it is removed from OA by  $90^\circ$  in the clockwise direction. The process of representing a leading angle by anti-clockwise displacement from the reference vector, and a lagging angle by clockwise displacement, is a convention.

Whilst it is easy to visualise air-speeds and wind speeds as vector quantities having angular displacements between them, it may be a little dis-

concerting at first to find that we are similarly imparting angular displacements to alternating voltages. However, we have already seen in Fig. 85<sup>4</sup> that a sine wave is traced out by the tip of a radius as it revolves in a circle. If we were to have two sine waves displaced by a phase angle of  $90^\circ$ , the corresponding radii in the circle would be similarly displaced by  $90^\circ$ . Vectors representing the two sine waves are then merely pointing in the same directions as the radii at one particular instant, and have the same angular displacement.<sup>5</sup>

### Resistance and Inductance

In Fig. 98 (a) we have an a.c. generator connected to an inductor, having a value of L henrys, which is in series with a resistor having a value of R ohms. What we want to find is the relationship between the voltages which appear across each component and that which is provided by the generator.

Obviously, the same current must flow through both the resistor and the inductor, and this gives us a common factor. Let us assume that this current is I amps, and let us draw its vector OP, as in Fig. 98 (b). As with our earlier discussion on the reactance of the inductor, we shall now commence our investigation with this current, and work back to voltage.

We next investigate the voltage appearing across the resistor. This is shown in Fig. 98 (a) as  $E_R$  and its value must be equal to IR. Also, it is in phase with the current, and we may now add it to our vector diagram as OQ in Fig. 98 (b). Since it is in phase with the current our new vector points in the same direction. Further, we give it the dimension  $E_R (=IR)$ .

We know that the voltage across an inductor leads by  $90^\circ$  on the current flowing through it, and so we can now add another vector, OR, as in Fig. 98 (c). This vector leads on the current vector by  $90^\circ$ . (See Fig. 97 (b)). The length of the vector will correspond to the voltage across the inductor, which is shown in Fig. 98 (a) as  $E_L$ . Since the voltage across an inductor is equal to  $IX_L$ , we dimension the length of its vector accordingly, as shown in Fig. 98 (c).

The total voltage across the resistor and inductor will now be represented by the resultant vector OS shown in Fig. 98 (d), this being drawn across the parallelogram produced from OQ and OR in the same manner as the resultant vectors were drawn in Figs. 95 (c) and 96 (b). The length of this vector is proportional to the voltage appearing across the a.c. generator in Fig. 98 (a), and we refer to it here as  $E_{TOTAL}$ .

If we examine Fig. 98 (d) we may see that the vector  $E_{TOTAL}$  forms the hypotenuse of a right-angled triangle, the two other sides being the vector OQ (having a length of  $E_R$ ) and the side of the parallelogram opposite vector OR (which has a length of  $E_L$ ).

<sup>4</sup> Published in last month's issue.

<sup>5</sup> This analogy may be taken further by pointing out that the lengths of the two radii would be proportional to the amplitudes of the corresponding sine waves. The radii then become vectors themselves

The length of SQ is equal to that of vector OR whereupon, from Pythagoras, we get:

$$(E_{TOTAL})^2 = E_R^2 + E_L^2$$

therefore  $E_{TOTAL} = \sqrt{E_R^2 + E_L^2}$ .

The second thing we can learn from Fig. 98 (d) is that, whilst the total voltage leads on the current, it does so by an angle less than 90°. The angle may be found, for a particular set of voltages, by drawing the vector diagram and measuring the angle between the resultant voltage and the current with a protractor, or by expressing it as a trigonometrical ratio.<sup>6</sup>

The series combination of inductance and resistance causes opposition to the flow of electric current and we shall now refer to this as the "impedance" of the combination, defining this new term in greater detail later. For the moment let us concern ourselves only with the fact that impedance, like reactance and resistance, may be measured in ohms.

We have noted that both resistance (in which voltage and current are in phase) and reactance (in which voltage and current are 90° out of phase) are

equal to  $\frac{E}{I}$ , and it does not seem unreasonable to

expect that impedance (in which voltage and current are less than 90° out of phase) should similarly be equal to this expression. In fact this is true and, in the case of the impedance of the series resistor and inductor combination we are now considering, we may consequently state that:

$$Z = \frac{\sqrt{E_R^2 + E_L^2}}{I}$$

because  $\sqrt{E_R^2 + E_L^2}$  is the voltage appearing across the components which offer the impedance. Now,

and therefore we may say that

$$Z = \frac{\sqrt{(IR)^2 + (IX_L)^2}}{I}$$

therefore  $Z^2 = \frac{(IR)^2 + (IX_L)^2}{I^2}$

<sup>6</sup> In which case, the tangent of the angle of lead will be  $\frac{E_L}{E_R}$

Fig. 98 (a). An a.c. generator coupled to a resistor and inductor in series

(b). The current vector, OP, is employed as a reference vector. Since the voltage across the resistor is in phase with the current, its vector, OQ, points in the same direction as OP

(c). The voltage across the inductor leads on the current by 90°, and is represented here by vector OR

(d). The total voltage across the combination of resistor and inductor is represented by the resultant vector OS. Angle SOQ is the angle by which this voltage leads on the current

(e). If  $E_R$ ,  $E_L$  and  $E_{TOTAL}$  are divided by  $I$  (which is the same for all three), the vector diagram can be re-drawn as shown here, the dimensions now being  $R$ ,  $X_L$  and  $Z$

$$= \frac{I^2 R^2 + I^2 X_L^2}{I^2}$$

$$= R^2 + X_L^2$$

therefore  $Z = \sqrt{R^2 + X_L^2}$ .

That is, the impedance offered by the series combination of resistor and inductor is the square

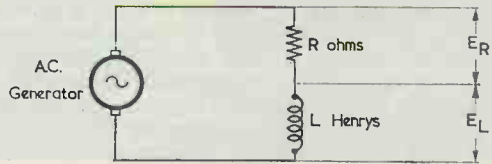

(a)

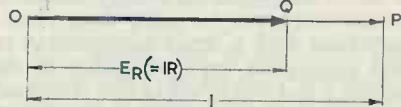

(b)

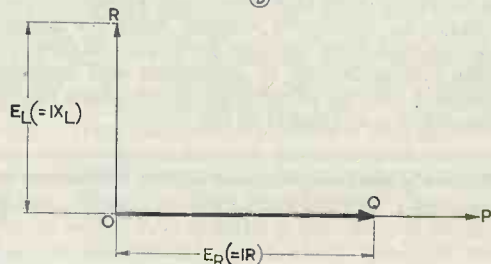

(c)

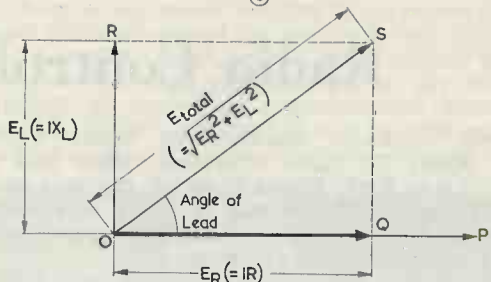

(d)

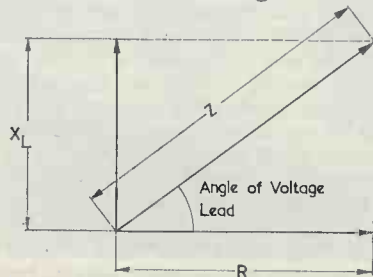

(e)

root of the sum of the resistance squared and the reactance squared.

We have seen that the two initial voltage vectors of Fig. 98 (d) have lengths of  $E_R$  and  $E_L$  respectively and that the resultant vector is equal to  $\sqrt{E_R^2 + E_L^2}$ . If either of these three voltages is divided by  $I$  the results are  $R$ ,  $X_L$  and  $Z$  respectively. The same current,  $I$ , flows through the resistor, the inductor and, obviously, their series combination; with the consequence that  $E_R$ ,  $E_L$  and  $E_{TOTAL}$  are in proportion to  $R$ ,  $X_L$  and  $Z$  respectively. We may now re-draw our vector diagram of Fig. 98 (d) in the manner shown in Fig. 98 (e). The relative lengths of all three vectors are the same as before, but we now give them dimensions corresponding to  $R$ ,  $X_L$  and  $Z$ , instead of the voltage dimensions previously ascribed to them.

The vector diagram of Fig. 98 (e) is much more helpful than that of Fig. 98 (d), because it has dimensions which can be easily determined. If we are confronted with a series combination of resistance and inductance, we have merely to determine the resistance and reactance of our components and we can at once produce our vector diagram. This will then tell us our total impedance and will also show us the angle by which the voltage leads the current. Also, the fact that we can draw our vectors with lengths corresponding to resistance and reactance simplifies a number of other problems which we may encounter in a.c. circuits in the future.<sup>7</sup>

<sup>7</sup> It should be noted that the relationship  $Z = \sqrt{R^2 + X_L^2}$  is obvious from Fig. 98 (e). Also, that the tangent of the angle of lead is  $\frac{X_L}{R}$ .

We must next return to the term *impedance*, which we introduced just now with respect to the opposition to current flow given by the series combination of resistance and inductance. Impedance defines the opposition to current flow of any circuit containing reactance and resistance. Up to now we have seen that impedance appears with a combination of resistance and inductive reactance, and we shall see, next month, that it appears also with resistance and capacitive reactance. It is given, again, in circuits containing all three quantities, i.e. resistance, inductance and capacitance. Impedance differs from reactance and resistance because, with the former, voltage and current are always exactly 90° out of phase and, with the latter, voltage and current are always exactly in phase. With impedance, the angle of phase difference is not fixed.

As has been noted, impedance is measured in ohms and is represented by the letter  $Z$ . Also,

$$Z = \frac{E}{I} \text{ where } Z \text{ is impedance in ohms, } E \text{ is e.m.f. in}$$

volts and  $I$  is current in amps. Similarly applicable are the complementary equations:

$$I = \frac{E}{Z} \quad \text{and } E = IZ.$$

#### Next Month

In next month's article, we shall carry on to the impedance of circuits containing resistance and capacitance, and to resonance.

## Radio Controlled Model Yachts

**T**HE NATIONAL CHAMPIONSHIP MODEL YACHT Races for radio controlled yachts held at Eaton Park, Norwich, earlier this year gave the author his first chance of seeing some radio controlled model yachts in action, and it proved to be a most fascinating experience.

The radio control of model power craft is now quite commonplace, but radio controlled model yacht racing is still a comparatively rare speciality of R/C model activities. This was very apparent from observation of the yachts taking part in the event, each owner having a different approach to the problems involved in ensuring adequate control. There was none of the standardisation often found these days in power craft models.

For the uninitiated, it should be explained that the two essential controls needed on a model yacht are those of the rudder and the ability to pull in or let out the sails. This latter may require quite a large degree of movement, the sails ideally being capable of being trimmed from hard in, to right out, at right angles to the centre line of the boat. For

successful racing, the degree of movement may need accomplishing in as short a space of time as possible.



A 10-Rater with vane steering and additional radio control

It is possible to interconnect the sails and the rudder mechanically so that an increase in wind, which might "head" the yacht up into the wind and so stop her forward movement, is counteracted by a corresponding movement of the rudder to steer her off the wind, so that an ultimate compromise is reached and the boat sails a straight course. By altering adjustments on sails and rudder, various courses can be sailed, viz., reaching, running, beating, etc. Of course, once these adjustments have been made and the yacht has left the side of the pond, no further changes in sail trim or rudder position can be made. The interconnection between sails and rudder will look after changes in wind direction and force and enable the yacht to sail a



A group of radio controlled model yachts at Eaton Park, Norwich, showing the portable transmitters used by some of the contestants



This radio controlled transmitter has provision for 27 Mc/s and 465 Mc/s channels and provides a console at a convenient height for operating.

The two controls on top provide smooth proportional control of rudder and sails

straight course. But it will not enable the yacht to change direction. Radio Control provides a means of doing this and, in a well equipped model, proportional control of the rudder is provided and means are devised for letting out or pulling in both the mainsail and the foresail. These two sails, one in front of the mast, the other behind, are usually interconnected mechanically by means of cords running through pulleys. These cords—or "sheets" as they are called nautically—are brought to a drum which is rotated by an electric motor and suitable gearing, the direction of rotation of the motor being controlled via the radio link. Similarly, the rudder is driven by another electric motor which can be reversed and started and stopped by radio in any

position, thus giving any intermediate positions between hard-to-port or hard-to-starboard.

Some dozen or so boats were to be seen at Eaton Park. There is not, as yet, a special class design for radio controlled yachts and the yachts used therefore conform to designs of the recognised classes of model yacht. The largest of these is the International "A" Class yacht, which has a waterline length of 52 inches and a sail area of 1,628 square inches. There were several yachts of this class to be seen. Next in size are the 10-Raters, 48 inches on the waterline, with an overall length of about 5ft 6in. These too were represented. The smallest class in which R/C is fitted is that known as the M Class or Marblehead Class, these being 50 inches overall in hull length.

The radio equipment installed in the largest class boats provided control for both sails and rudder. In the smaller classes, control of the rudder only was provided, some additional control also being provided by mechanical interconnection between sails and rudder. A feature of most modern model yachts, is the provision of "vane steering", a



A beautiful model with full control on rudder and sails. The small drum winch controlling the fore and mainsail sheets can be seen in the centre of the deck

modified type of wind vane being provided on the stern, which is controlled by the relative direction of the wind and in turn is connected to the steering. Radio control can be superimposed on this basic system.

Boats fitted for both 465 Mc/s and 27 Mc/s equipment were to be seen, in one case, provision for using either being included in the same boat. This allows team and relay racing, in which two

boats can be sailed at the same time, one using the former and the other the latter frequency.

Of the various methods of radio controlling models, the mark/space system seemed to be the most popular and when applied to the 465 Mc/s frequency, the degree of control available was quite amazing and most intriguing to watch. Our photos show a representative selection of yachts and equipment to be seen at the gathering.

## CAN ANYONE HELP?

*Requests for information are inserted in this feature free of charge, subject to space being available. Users of this service undertake to acknowledge all letters, etc., received and to reimburse all reasonable expenses incurred by correspondents. Circuits, manuals, service sheets, etc., lent by readers must be returned in good condition within a reasonable period of time*

**R155F, etc.**—J. Sartorius, 88 Urmson Road, Wallasey, Cheshire, would like to obtain modification data and any information, including the availability of crystals for this receiver and the following—BC624A, R27/ARC5, R2A/ARR3.

\* \* \*

**10QB/6037.**—D. R. Pienay, 11 Dade Avenue, Inkersall, Stoveley, Chesterfield, Derbys, would like to obtain information on how to convert the above unit into an oscilloscope.

\* \* \*

**Oscilloscope No. 11.**—R. W. Howe, G3PLB, 162 Victoria Road, London, N.22, would like to obtain the circuit and handbook for this equipment.

\* \* \*

**Halicrafter S38.**—A. Strom, Arvika, Heathwell Gardens, Swalwell, Newcastle upon Tyne, would like to purchase or borrow circuit diagram or service manual for this receiver.

**Triplett Combination Valve Tester, Model 1183SC.**—H. Jebbett, 51 Uplands Road, Oadby, Leicester, would like the manual, or any details, of the above American test equipment—loan or purchase.

\* \* \*

**G.E.C. SR/838 VHF Receiver.**—P. L. Grieveson, 46 Clarence Crescent, Sidcup, Kent, requires any data whatsoever on this receiver, also any of the 5-pin crystals for use with this unit.

\* \* \*

**Cossor S.W. Receiver Model 527/X.**—H. Hueby, 16 Parkside, New Haw, Weybridge, Surrey, wishes to obtain coil details for this receiver.

\* \* \*

**Electronic Echo Chamber.**—W. F. Dickson, 18 Primrose Road, Salisbury, Wilts, requires circuit details of such a unit. He is interested in the type which does not employ an endless tape with multiple heads but one which will produce both sustained echo (reverberation) and repetitive echo with variable time factor.

## New DX Programme

The International Service of the Canadian Broadcasting Corporation announces the start of a new DX programme on 1st December. The programme is being designed to give DXers a lively picture of the technical facilities of the C.B.C. International Service and to answer the many questions about the broadcasts from Canada that DXers characteristically ask.

The English-language version of the programme will be given by S. B. Duke, the Supervisor of the Engineering Services of Canada's shortwave operation. It will be broadcast every other Saturday during the regular period of the English-language transmissions from Canada to Europe, Africa, the Caribbean area and Australasia. English-language times and frequencies are as follows:

	GMT	
Africa	1832-1915;	15.32, 11.72, 9.63 Mc/s
Europe	2045-2130;	15.32, 11.72, 9.63 Mc/s
Caribbean	2300-2330;	15.19, 11.72, 9.625 Mc/s
Australasia	0830-0900;	9.63, 5.97 Mc/s

The new DX programme will also be transmitted in the C.B.C. International Service's German service every other Sunday starting on 2nd December. The German transmission is heard between 1815 and 1830 G.M.T. over the following frequencies—15.32, 11.72 and 9.63 Mc/s.

Other language sections of the C.B.C. International are also considering versions of the new DX programme.





This month Smithy the Serviceman, aided by his able assistant, Dick, is once more embroiled in the seasonal Christmas rush. As always, however, the pair manage to win through at the end!

**C**HRISTMAS EVE IS, TRADITIONALLY, a time for Getting Things Done. It is the day when the ladies frenziedly stuff turkeys, stir puddings and hide away all manner of gifts for good little boys and girls, whilst the men of the house stumble around in everybody's way stringing up fairy lamps and worrying anxiously about the bills which are due on January 1st. It is the time when our sons from the Services are with us, having craftily negotiated their Christmas Grants (plus 48 hour leave, plus 36 hour pass, plus Early Chit). And it is the time when service engineers go mildly doolally, as they work their way through great masses of receivers which habitually cease to function after December 20th.

So it was in the Workshop. Had we entered the Workshop any time in the morning of December 24th we would have seen Smithy the Serviceman, together with his assistant Dick, battling grimly against a vast accumulation of sets. We would have heard the sizzle of resin-cored solder applied to the iron, and the clatter of unserviceable valves as they were flung into the waste box. We would have heard also the piercing squeal of 1,000 c/s signal generator tones combined with the eldritch shrieks given by their heterodynes with unstable i.f. amplifiers. And we would have noticed the many visual symptoms which were offered to our worthy pair: screens with pictures which rolled upwards, screens with pictures which rolled downwards, screens with pictures which zig-zagged sideways, and screens which simply showed no picture at all.

Had we returned in the early afternoon we would still have been confronted with the same scene of frenzied activity. But we would have noticed a significant reduction in the ranks of receivers requiring repair. A re-visit, around three o'clock, would have shown Smithy and Dick still in the full flush of their labours but, now, with a mere handful of sets before them. At a quarter to four we would have found Smithy and Dick both returning from the "Repaired" rack, and looking bemusedly around them.

#### Heater Trouble

"Blimey," said Dick, flopping down on his stool. "There's only one set left to repair."

"So there is," agreed Smithy, mopping his brow.

The pair gazed at the single receiver in the centre of the Workshop.

"Phew!" said Dick at length. "This must have been the busiest day I've ever known."

"It's certainly been a stinker," agreed Smithy. "Thank goodness things ease off after Christmas."

Dick looked at the clock.

"Oh well," he remarked, "I'd better get started on this final set if we're ever going to get away tonight. Let's hope it's got a nice simple fault on it."

"It should be dead easy," remarked Smithy. "In fact I've been keeping it until the last, just because of that. It belongs to a Mrs. Jones, according to the label, and all that's wrong with it is that the heaters don't light up."

Dick's face took on an expression of relief.

"That should be a nice change," he remarked, walking over and picking up the set. "Just an open-circuit heater, then."

"Probably," agreed Smithy, carelessly. "Anyway, I know the model well enough. It's a straightforward 405 line t.v., and it has direct line sync and mean amplitude a.g.c. So there are no flywheel sync or gated a.g.c. circuits to worry about."

By this time Dick had removed the back cover of the receiver, connected it up to the mains and switched it on. After a few moments he peered inside.

"Well, the complaint is true enough," he announced. "The heaters quite definitely do not light up. I suppose I'll have to go through all the valves in the chain now, and find which one has the open-circuit heater."

"I should test the fuse first," commented Smithy, "and then see if the mains is getting past the switch to the heater dropper. (Fig. 1.) You can do this by just popping your testmeter between chassis and any of the dropper tags. It's a simple check, but it can save you a lot of trouble. After that, I'd check the tube heater before trying the valves because it's easy to get at."

Obediently, Dick carried out Smithy's instructions.

"The mains is getting through the switch," he remarked after a moment, "and the tube heater's O.K. So I'd better start on the bottles now."

"As you like," said Smithy. "The logical thing to do would be, I suppose, to check for continuity across

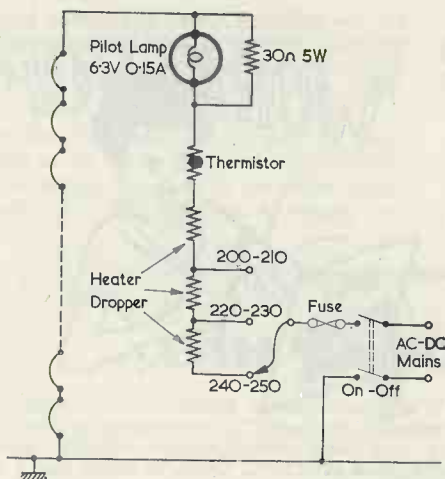

M599

Fig. 1. A typical television heater chain. The heater dropper sections are incorporated in a single multiple unit

different sections of the heater chain and isolate the faulty valve that way. However, it shouldn't take too long to pull out each valve and check it individually."

"Righty-ho," said Dick cheerfully, "I'm starting off right now."

Commencing with those which were most convenient to approach, Dick removed each valve, checked for continuity across its heater pins and replaced it. After the ninth valve his face assumed a rueful expression. He next proceeded to take off the valve screens on the tuner unit. His face lengthened as he found no fault with the tuner valves and he started to unfasten the bolts holding the line output cage screen.

"It would be the last ones, wouldn't it?" he grumbled.

"It always is," grinned Smithy. "That's the Principle of Natural Cussedness taking effect. Whenever you check a heater chain, the faulty valve is always the last one!"

"Well, here's the line output valve," said Dick, extracting a valve from the chassis. "And blow me if this isn't O.K. too! Which leaves the booster diode."

Dick pulled out the booster diode and applied his testmeter to its pins.

"Darn it," he snorted. "This one's all right as well."

"Not to worry," remarked Smithy. "Check the thermistor. Thermistors sometimes crack across and go open-circuit."

"It looks O.K.," said Dick, after he had given the thermistor an experimental prod with his finger. "Also, it reads about 350Ω."

"That seems fair enough," commented Smithy. "This would drop down to some 30Ω or so when it warmed up, of course."

"If it warms up," grunted Dick. "Don't forget it's Christmas Eve and I want to get finished!"

"Don't let's panic," said Smithy, getting up from his stool and walking over to the receiver. "Let's see if there's anything else in the heater chain which could cause trouble."

"There's a pilot lamp," Dick volunteered, "which lights up the channel indicator."

"Right," said Smithy, "then check that."

"However, it's got a dirty great resistor across it," Dick pointed out. "So that, even if the bulb does burn out, the resistor will still maintain the heater chain."

"Dirty great resistors," remarked Smithy patiently, "have been going open-circuit ever since Marconi first sent signals across the Atlantic. And probably for many years before that as well. So, slap your testmeter across the bulb and the resistor and see what happens."

Dick did as he was bid, and his face lit up.

"That's it, Smithy!" he exclaimed. "Both the bulb and the resistor have gone."

"Fine," said Smithy. "Then let's pop in some replacements as soon as we can and get shot of this set."

#### Video Output Stage

It did not take Dick long to fit a new bulb and resistor, and a grin spread across his face as the valves

lit up when he reapplied the mains supply. Hopefully he connected up an aerial.

"We're on the last lap now, Smithy," he remarked happily. "I'll give this set a final check over, and then we're finished for the day."

"It seems to be taking a long time to warm up," commented Smithy.

The Serviceman leaned over and adjusted the brightness control. A raster appeared on the screen as he turned the control fully clockwise, but there was no picture. He swung the tuner to the alternative local channel, but no picture appeared here either.

"Dash it all," groaned Dick. "Don't say we've got another snag!"

"It looks like it," said Smithy. "You'd better get the service manual out."

"As you like," replied Dick. "I know it's an Epsilon receiver. What's the model number?"

"It's an Epsilon model 336B."

There was silence for a moment as Dick rummaged through the manuals.

"We haven't got it," he announced at length.

"Try looking for a Gamma model 220 or a Zeta model X350," suggested Smithy. "They're both the same set. Different cabinets, of course."

"Ah, here we are," called out Dick. "I've found the Zeta X350 manual. You know, Smithy, it beats me how you can remember which of these brand names is which."

"It's easy enough," replied Smithy.

"All you have to do is to keep up to date with happenings in the industry. For instance, you may recall that, some years ago, Epsilon receivers were manufactured by Sigma Electronics Ltd., who also made radios and record-players under the Kappa Music label. They were then taken over by Omicron Television, who proceeded to amalgamate with Delta Entertainment Products after having primarily formed Upsilon Vision as a holding company to assist in the marketing of transistors manufactured by Mu Amplifiers and valves made by Iota Tubes Ltd., in the shares of both of which companies Omicron Television has a majority holding."

Smithy paused for a moment.

"A merger," he continued, "was then proposed by the Lambda Electric group, which was already producing Eta and Gamma receivers, and which had previously acquired the valve interests of Mu Amplifiers together with the semiconductor production of Iota Tubes Ltd.; this new consortium then enabled Omicron-Delta and Lambda to produce entertainment products under the

Epsilon, Kappa, Delta, Eta and Gamma labels, the appropriate marketing body being Omega Sales Ltd."

Smithy scratched his head thoughtfully.

"Come to think of it," he added, "it was about this time that the old Theta Radio Company was absorbed. This was done either by Omicron or by Lambda, but I'm never quite certain which. In any case it doesn't matter, as they're now making computers."

"I can see why the Epsilon and Gamma receivers are the same," commented Dick. "But where do the Zeta sets come in?"

"Zeta sets were the same as Epsilon and Gamma sets for a short time following the Omicron-Lambda merger," explained Smithy. "But Zeta is now part of the rival Rho Records and Radio group. In any case, Zeta never actually manufactured Zeta sets."

"Who did, then?"

"The sets were made under contract by Alpha Electronic Production Ltd.," said Smithy, "who also made sets for Omicron-Lambda for six months following the merger. After this, they were taken over by the American Phi-Beta-Kappa Corporation, Inc."

"Who were taken over?"

"Alpha were."

"What trade name are they making sets under now, then?"

"They aren't," said Smithy. "They're making computers, too."

"Blimey," commented Dick, "it gets a bit complicated, doesn't it?"

"Things do get a little confusing in the industry at times," said Smithy. "Anyway, let's get back to this set of ours. First of all, let's try a new video output valve."

Smithy watched as Dick fitted a new video output valve. The performance of the receiver remained unaltered.

"It looks," commented Smithy, "as though you'll have to get the works out."

"Okey-doke," said Dick. "You have a look at the circuit diagram whilst I get weaving on it."

"Fair enough," replied the Serviceman, studying the manual as Dick started to remove the knobs. "Now, the symptoms are that we get a blank raster when the brightness control is turned to full. I see also that this set uses a partial d.c. coupling between the video output anode and the cathode of the tube (Fig. 2). Since I have to turn the brightness control almost to the extreme limit to get a raster, I would guess that the tube cathode is quite a little more positive than it should be. Because of the partial d.c. coupling, this

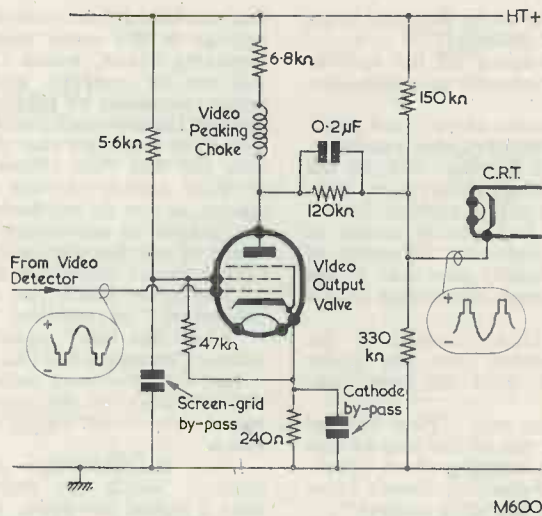

Fig. 2. A basic video output stage which gives partial d.c. coupling to the cathode of the cathode ray tube. Where applicable, representative component values are given

could be caused by the video output anode going too positive. The fact that we're getting no signals through also points to the video output stage. Incidentally, this is why I suggested that you should try swapping the video output valve before we went to the trouble of pulling out the chassis. Which, I see, you've now done."

"It's all ready for you," said Dick. Smithy settled himself at Dick's bench in front of the chassis and picked up his assistant's test prods.

"Right," he said. "Now let's first check the video output anode voltage. This is reading nearly 200 volts, which is pretty close to that on the h.t. line. So my hunch about this anode going positive is correct. Screen-grid voltage is next. Ah, here we are! On the screen-grid we have a magnificent sum total of zero volts, with the result that the valve does not pass any current and its anode goes right up to the h.t. line. Quite a nice easy fault, after all."

"Which is the faulty component?" asked Dick. "The screen-grid by-

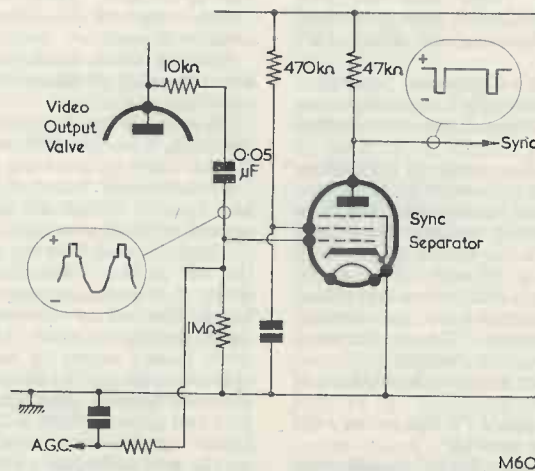

Fig. 3. The sync separator circuit examined by Dick and Smithy. The 10kΩ resistor couples to the video output valve of Fig. 2

pass capacitor or the dropping resistor from h.t. positive?"

Smithy switched off the receiver and set the testmeter to a resistance range.

"The capacitor doesn't read short-circuit," he remarked after a moment. "So it won't be that. No, it's the series resistor which has gone high. You'd better pop in another, Dick."

But Dick had already rushed to the spares cupboard. Glancing at the clock, Smithy saw that it was 4.30. He could understand Dick's haste.

Quickly, Dick returned to the receiver, snipped out the faulty resistor and fitted the new component.

"Right," he said. "Now let's get this receiver out of the way so that we can start thinking about Christmas. Mrs. Jones just doesn't know the hardship her set is causing!"

Confidently, Dick switched on the receiver and waited expectantly. After a while the screen lit up brilliantly. Dick turned back the brightness control, to reveal a heavily over-contrasted picture with not the faintest vestige of line or vertical synchronisation whatsoever. Irritably, Dick wrenched at the line hold control. The line output transformer whistle changed audibly as he turned the knob and the picture changed in characteristic fashion. But synchronisation was completely and utterly absent.

#### Sync and A.G.C.

"What the devil's up with this set?" grunted Dick. "We've already fixed two snags on it and it still doesn't work."

"Take it easy," said Smithy soothingly. "This isn't the first receiver we've had in with more than one fault. Besides," he added, "it's Christmas."

"I know it's Christmas," exploded Dick. "That's why I'm getting more and more annoyed over this dratted set."

Smithy's face took on an expression of angelic beatitude.

"You must remember, Dick," he said in a gently chiding tone, "that Christmas is the season of goodwill and peace to all men. This is the time when all differences are settled and when everyone lives in harmony with his brother. This is the time, Dick, to bury the hatchet."

Dick threw a malevolent glance at the receiver.

"I know where I'd like to bury the hatchet," he growled.

"Come, come, Dick," said Smithy, reprovingly. "We must at all times approach our work from a calm and detached viewpoint. Who knows but

that the Mrs. Jones to whom this set belongs is not some poor, aged, trembling widow, whose Christmas will not be complete without the felicity dispensed by people such as Richard Dimpleby or Charlie Chester. You must remember that the happiness she will then obtain will be provided entirely through our own agency, in that we will have repaired her receiver in accordance with the tenets of our humble trade."

Dick looked interestedly at Smithy. "I've never heard you talk like this before," he remarked.

"I talk like this," replied Smithy simply, "because I feel that I must."

Had the Serviceman walked across the Workshop at that moment he would have trailed visible clouds of glory.

"Let us therefore," continued Smithy, "tackle the present snag from a logical viewpoint. So would you kindly start by changing the sync separator valve?"

"Why the sync separator valve?" Smithy's face momentarily lost its expression of extreme serenity, but he quickly recovered himself.

"Because," he said sweetly, "if you don't get sync, the first thing to do is to try changing the sync separator."

Dick studied the circuit around the sync separator in the service manual (Fig. 3).

"What about that 10kΩ series resistor connecting to the video output anode?" he asked tentatively. "Perhaps it's gone o/c."

"It could be that resistor," said Smithy judiciously. "But what makes you plump for that particular component?"

"We've had two open-circuit resistors up to now," Dick pointed out. "And things of this nature always come in threes."

With an effort Smithy maintained his expression of benevolent reasonableness.

"You could hardly call that logical servicing," he pointed out mildly. "So let's just try the valve first."

Dick quickly found a new valve and inserted it into the receiver. It caused no improvement.

"Right," said Smithy, picking up the test prods. "We must next get down to a logical approach. As we know, the set is overloading and we're getting no sync. At the same time, there's stacks of video at the video output anode, because we can see it on the tube. The sync separator grid and cathode form a diode which causes the positive tips of the signal on the grid to be just a little positive of cathode. Because of this, the valve only passes sync pulses, which is what it is meant to do, and a

negative voltage corresponding to average signal level appears on the grid for use as a.g.c. But since the set's overloading, it's almost certain that there's no a.g.c. voltage. Everything, in fact, points to a fault in the sync separator grid circuit.

"The first thing I'll do," continued Smithy, "is to quickly check the sync separator anode and screen-grid potentials. These give us about 120 and 30 volts respectively. Which means that the valve is conducting, and that the cathode circuit should be O.K. Let's next check the voltage on the grid. If you use a high resistance meter on a serviceable receiver the sync separator grid reading should be at least 10 to 20 volts negative of chassis, because of rectified video. In this case, however, I'm only getting about three-quarters of a volt negative, which will be due to contact potential in the valve. Also, this voltage is unaltered if I change to a dead channel and back again."

"What does that grid reading tell us?"

"It tells us firstly," said Smithy, "that there's no video getting to the grid. The low voltage reading also tells us that we haven't any low resistance shorts between the grid and chassis. If there were such shorts, the contact potential wouldn't appear. It also tells us that the 0.05μF coupling capacitor isn't leaky. If it had been, the grid would either be at chassis potential or slightly positive."

"Hmm," commented Dick impressed. "That's a good point. One voltage test can show up quite a few snags sometimes, can't it?"

"Indeed it can," replied Smithy. "Let's next find why the video on the video output anode isn't getting to the sync separator grid. One reason could be that the 0.05μF capacitor has gone open-circuit. It will only take a jiffy to bridge it temporarily with another of the same value."

Dick quickly found a 0.05μF capacitor and handed it over to Smithy. The Serviceman opened out the lead-out wires and applied the capacitor temporarily across that in the receiver. There was no improvement in performance.

"That's a pity," frowned Smithy. "The next component is the 10kΩ resistor. A quick voltage check will soon tell us what condition this is in. We've got about 120 volts on its upper end, which is, of course, the same as that on the video output anode. This voltage is a bit lowish, but that's because the video output valve is carrying a very heavy signal at the moment. We should get pretty well the same voltage on the

lower end of the resistor. But we don't! I'm only getting about 10 volts here."

Smithy leaned back and dropped the test prods on Dick's bench.

"There you are," he said triumphantly, "that 10kΩ resistor has gone high."

"I said it was the resistor," commented Dick.

"Ah yes," admitted Smithy condescendingly. "But you were only guessing. I found it by logical servicing."

"Well, I don't care," said Dick, aggrievedly, "if you'd listened to me first of all we'd have saved at least ten minutes. Don't you know it's nearly ten to five?"

"Is it? Then you'd better get a new resistor popped in straight away."

Dick needed no second bidding and a new 10kΩ resistor was fitted in record time. Smithy watched approvingly and, when Dick had finished, switched on the receiver.

"Just think, Dick," he said, a benevolent smile creasing his face, "by our combined efforts we have now ensured that poor old Mrs. Jones will have a happy Christmas after all. We should consider ourselves lucky to be able to spread such pleasure around."

As Smithy spoke the screen of the receiver came to life. This time the overload condition had completely disappeared and Smithy adjusted the brightness control for a reasonable brilliance level. His benign expression became visibly more radiant as he turned the line hold control and obtained a satisfactory lock. The picture was rolling quickly downwards, and Smithy next adjusted the vertical hold control. His benign expression slipped very noticeably, however, when he found that this control had no effect whatsoever. Whatever the setting of the control, the picture continued its rapid rolling at exactly the same speed.

#### Vertical Hold

"Corluvaduk," said Dick in disgust. "We'll be here till New Year's Eve if we carry on with this set much longer! We've already cleared three faults on it and it's five o'clock already."

"We mustn't let this beat us, Dick," said Smithy soothingly. "As I said just now, we've had quite a few sets in with multiple faults before now."

"I know we have," snorted Dick, "but not on Christmas Eve."

"I admit that it's trying," agreed Smithy, "but we must still learn to be tolerant. This is, after all, the festive Season. Let's have a look

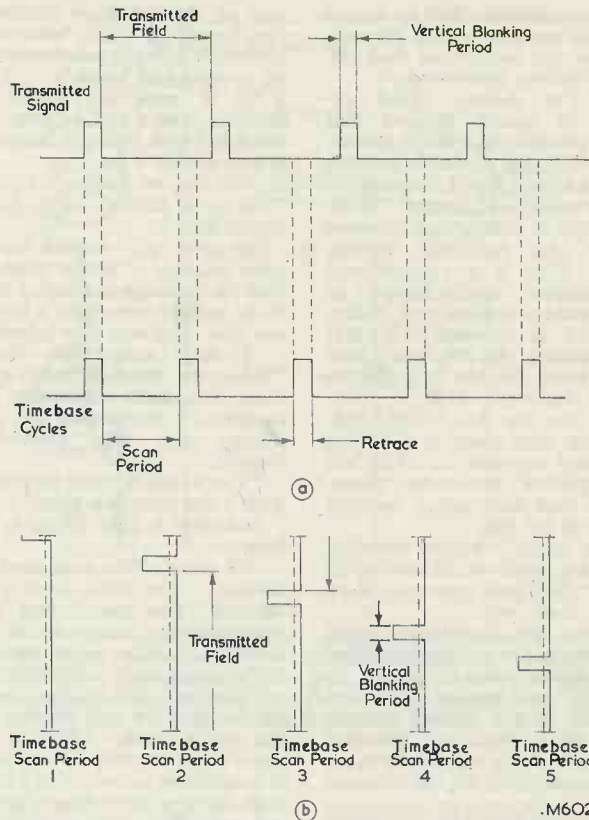

Fig. 4 (a). The time relationship between the transmitted signal and the vertical timebase when the latter has too high a frequency  
(b). The effect given in successive vertical timebase scan periods. In each successive scan period, the transmitted blanking period appears lower down, giving the impression that the picture is rolling downwards

at that service manual again." Dick handed the manual over to Smithy, who inspected it closely.

"I don't think we'll have much trouble here," he remarked. "There are two main clues to the fault. First of all, there is the fact that adjusting the vertical hold control has no effect on field frequency whatsoever. Secondly, there is the fact that the picture is rolling downwards. Now the vertical timebase circuit for this set . . ."

"Just a minute, Smithy," interrupted Dick. "What's so important about the picture rolling downwards?"

"It's obvious," replied Smithy. "It means that the vertical timebase is running too fast."

"I'm sorry," said Dick, "but I don't see the relationship."

"It's easy enough," commented Smithy, "if you try to visualise things. First of all, you have the transmitted

signal, together with a vertical timebase which is running at too high a frequency."

Smithy sketched out the waveforms on a piece of paper (Fig. 4 (a)).

"Now," he continued, "all you have to do is to see what happens over a number of successive timebase scan periods (Fig. 4 (b)). In the first scan period the transmitted vertical blanking period happens to coincide with flyback in the vertical timebase. The picture then starts in its correct position on the screen. Before it reaches the next blanking period, however, the vertical timebase goes into retrace, and you see a bit of the end of the video information at the start of the next scan period before the transmitted blanking period comes along. At the end of this second scan period the vertical timebase goes into retrace too early once more and, in the next scan period, the transmitted blanking period

appears lower down. And so it goes on through successive scan periods, giving you the impression that the picture is rolling downwards."

"Well, I'm dashed," Dick remarked. "I hadn't realised that before. I presume that, if the picture rolls upwards, the vertical timebase is running at too low a frequency."

"That's right," said Smithy. "Now let's get back to the vertical timebase circuit in this particular receiver (Fig. 5). This is a conventional cathode-coupled multivibrator in which frequency control and, hence, vertical lock, is provided by a  $1M\Omega$  variable resistor. All this does is vary the time taken for the  $0.05\mu F$  capacitor to discharge. O.K.?"

"Yes, I can see that," said Dick. "I see also that there is a  $470k\Omega$  fixed resistor between the  $1M\Omega$  pot and the grid of the second triode. I suppose that this resistor restricts the range of the pot."

"That's right," agreed Smithy. "There's not much use in having the pot short the grid down to deck when it's hard over!"

"Another point," continued Dick, "is that the pot is coupled into the set via screened cable."

"Correct," said Smithy. "The pot is mounted in the cabinet quite a distance away from the timebase components, and it's perfectly satisfactory to couple it up via screened cable."

"Fair enough," said Dick. "What do we do now?"

"You tell me!"

"Well," said Dick, "could it be

one of the timebase triodes? As you know, we often have to select valves for vertical timebases because of varying grid bases."

"If it were the valves," said Smithy, "you'd still be able to vary the speed with the hold control, even if you couldn't get sync."

"Oh yes, of course," said Dick. "The hold control must be open-circuit then."

"It can't be," replied Smithy, a little irritably. "We've already said that the timebase is running too fast. If the control were open it would run too slow. And very slow indeed, too."

"I see," said Dick frowning. "When the timebase runs too fast, then, it means that the  $0.05\mu F$  capacitor is discharging too quickly. There's too little resistance in circuit!"

"You've got it," said Smithy. "So, what's the probable fault?"

Suddenly a light shone in Dick's face.

"Of course," he exclaimed. "It's obvious! The hold control pot is shorted. This means that it can't control the frequency and that there's always too little resistance for the  $0.05\mu F$  capacitor to discharge into."

"Exactly," said Smithy, switching off the receiver and picking up the test prods again. "Well, we won't waste any more time. Your diagnosis is completely correct, and I find that I do have a dead short across the pot, regardless of its setting."

"Do you want a new control, Smithy?" called out Dick from the spares cupboard.

"Not yet," replied the Serviceman. "I'm a bit too wily a bird to be caught at this stage. Pots don't usually go short-circuit. But screened cable often does!"

Smithy inspected the ends of the screened cable.

"Ah, here we are," he said, after a moment. "The girl who soldered the braiding on this cable at the factory must have been feeling especially keen that morning on getting plenty of heat into the joint. The p.v.c. at one end is just nicely melted under part of the braiding, with the result that we have a good old intermittent short."

Dick picked up a soldering iron. "I'll soon get this fixed, Smithy," he said. "Then, perhaps, we will be able to get this darned set out of the way!"

It took Dick only a minute to strip the screened cable back sufficiently far to clear the faulty p.v.c. and to re-solder the centre lead and braiding back into position. He then switched the set on and watched it as it came to life. It displayed an excellent picture and vertical hold was now as steady as a rock. The sound came up at full strength and was free of distortion. Dick switched to the second local channel with equally good results. The receiver was now working perfectly.

"We've done a really good job there, Dick my lad," said Smithy with supreme satisfaction. "We can now start on our Christmas festivities, conscious of the fact that we have fully met our commitments."

"I feel rather happy about it myself, too," said Dick. "After all, it is up to us to help others as much as we can at this time of the year, isn't it?"

"Well said, Dick," said Smithy heartily, slapping him on the back. "It's still only quarter past five, so we aren't too late after all."

Absent-mindedly, Dick turned the tuner of the receiver to an unused channel. The screen went blank, then suddenly became illuminated with violent flashes. At the same time, the loudspeaker gave voice to a series of sharp crackles. Hastily Dick returned to the previous channel, only to find that the set was now completely dead.

The agonised eyes of Dick and Smithy suddenly turned to the receiver tuner unit, from which a little puff of black vapour ascended in the manner of an Indian smoke signal.

#### Tuner Trouble

"Oh no," gasped Dick. "Not a tuner snag! Haven't we suffered enough already?"

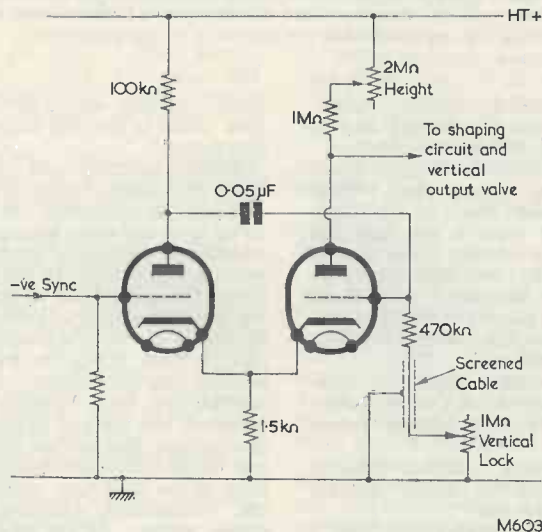

Fig. 5. A cathode coupled multivibrator. In the receiver serviced by Dick and Smithy the vertical lock control was coupled to the timebase circuit by screened cable

Manfully, Smithy struggled to preserve his previous geniality. "We mustn't give up yet, Dick," he said. "After all, remember poor old Mrs. Jones!"

Dick muttered under his breath. "What did you say?" asked Smithy suspiciously.

"I said jolly good luck to Mrs. Jones," snarled Dick. "I only hope she realises the trouble she's causing us."

"We must," continued Smithy, "persevere nevertheless. I'm quite certain that it will be just a simple fault."

He removed the cover of the tuner unit and looked inside. He then turned once more to the service manual.

"There's a resistor burnt out in the tuner," he remarked. "It's the  $1k\Omega$  which decouples the PCC84" (Fig. 6).

"That's delightful," snorted Dick sarcastically. "I suppose the PCC84's got an internal short-circuit which only comes up on one channel!"

"The fact that the snag only came up on one channel," said Smithy, "should lead us to the trouble. Ah, here we are! The channel you selected was on Band I and the primary and secondary coils in the bandpass circuit for this channel are so close together that they're touching each other. They've got the usual T.N.A. insulation. And I shouldn't be a bit surprised to find that this has broken down between them."

"What would happen then?"

"The breakdown would cause a circuit to be made," said Smithy, "from h.t. positive via the  $1k\Omega$  resistor and the shorted primary and secondary windings to the grid of the PCF80 pentode. The latter will then pass a very hefty grid current. Which is hard luck on the PCF80, and even harder luck on the  $1k\Omega$  resistor!"

Dick looked somewhat relieved.

"Well, it doesn't sound too bad after all," he remarked. "Have you located an actual short between those two windings yet?"

"Yes, there's quite an obvious one," said Smithy, busy with the testmeter, "also, there's a neat little bit of charred wire insulation between the adjacent ends of the windings."

He removed the biscuit holding the offending windings.

"I'm afraid that Mrs. Jones has had that channel in the future," he remarked, explaining his action. "I couldn't possibly repair it without taking off turns or something like that."

"Good old Mrs. Jones," said Dick. "She won't miss it!"

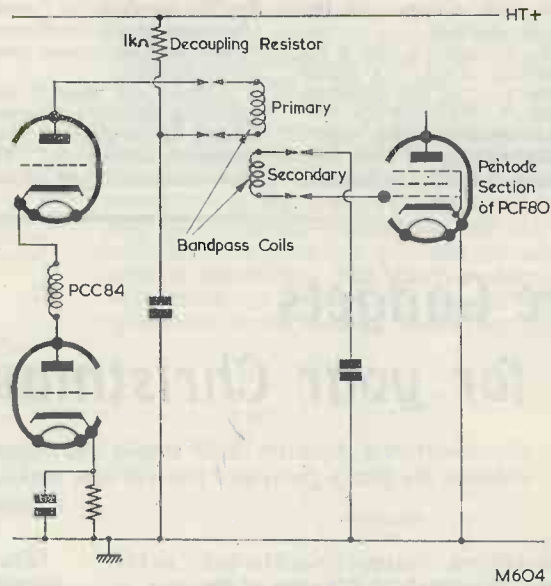

Fig. 6. A short-circuit between the primary and secondary bandpass windings on one channel caused the  $1k\Omega$  PCC84 decoupling resistor to burn out. This fault may especially occur with miniaturised or disc tuners, in which some Band I primary and secondary windings are very close together on the former

"No, she won't," agreed Smithy. "But she will have to be told about it, in case she ever moves somewhere else where it happens to be one of the local channels. We'd have to give her a new coil segment in that case."

"It's funny that the snag only turned up just now, isn't it?"

"Not entirely," remarked Smithy. "Apart from the fact that the short would, in any case, only appear after a period, it's doubtful if the tuner has ever remained on that channel for any length of time at all. Even if the coils have been shorting together for quite some time, they still wouldn't cause a lot of trouble if the turret was quickly flicked past them when changing channels."

"Trust me to put the tuner on that channel," said Dick. "Anyway, I'll get a new  $1k\Omega$  into that tuner right away."

"And a new PCF80 as well," grinned Smithy. "The one that's in there now has had a pretty heavy bashing."

#### The Last Few Words

The Workshop was empty of all receivers. The van driver had just made his final call, picking up the remainder of the sets on the racks together with Mrs. Jones's now fully

serviceable receiver (albeit minus one channel). As the sounds of the engine faded into the distance, Dick and Smithy settled back on their stools. Despite their earlier desire to get everything cleared up as soon as possible, they now felt a strange reluctance to leave.

"That's the end," commented Dick eventually, "of yet another Christmas rush, Smithy."

"It is indeed," replied the Serviceman.

He rose and walked purposefully over to the filing cabinet.

"It's filed under 'W'," called out Dick.

Smithy chuckled.

"You aren't supposed to know about this," he grinned, producing a bottle and two glasses. "However, I think we deserve a little relaxation after the strain we've undergone today."

Dick sipped appreciatively at the glass Smithy handed him, and looked around.

"I suppose," he remarked reflectively, "that this isn't a bad old dump to work in, really."

Smithy glanced around at the benches, the now empty racks, the battered and motley array of Workshop utensils by the sink, and the debris and solder-splashes on the

floor which gave evidence of the day's frenzied activities.

"It could", he agreed, "be a lot worse. Anyway, Dick, it's about time I wished you the Compliments of the Season."

"And the same to you, too," returned Dick warmly.

"We must, also," continued

Smithy, standing up, "wish a Merry Christmas to the readers who've put up with our adventures over the past twelve months."

"Indeed we must," said Dick, following Smithy's movements and holding up his glass. "A very Merry Christmas to you all!" He paused for a moment. "And let us end," he

continued, "as we have done over the last two years, by adding 'God Bless Us, Every One!'"

EDITOR'S NOTE: The "companies" named in Smithy's light-hearted and exaggerated parody of relationships in the industry are, of course, purely imaginary. No reference is intended to any existing company or group.

## More Gadgets for your Christmas Party by W. HOLMES

*Our contributor discusses some simple and inexpensive electronic devices which will not only enhance the future festivities but will also make the Christmas Party a unique and distinctive occasion*

THE INVENTIVE HOME-CONSTRUCTOR OFTEN receives an appeal, at this time of the year, to provide novelties which will help the Christmas party go with a swing. The writer described some simple electronic devices twelve months ago<sup>1</sup> which were intended to meet this particular requirement. The article proved to be popular with readers, and he has now been asked to pass on further ideas in this present issue.

What are especially required for the Christmas party are gadgets which can be quickly made up, which are inexpensive, and which do not require elaborate introduction and presentation. The devices to be described here fall readily into this category.

### Microphone and Amplifier

One of the most popular novelties for a party, especially where children are present, is a simple microphone and amplifier set-up. The microphone is placed in one room and the loudspeaker in another, whereupon messages, sketches and charades, etc., are "broadcast" over the system. The idea is very old-fashioned and very simple but, like so many old-fashioned and simple things, it can often prove to be a winner.

With an arrangement of this nature it is essential to provide high quality of reproduction, since much of the fun experienced by both speakers and listeners will be due to the ability to hear individual voices with as little distortion as possible. What would meet the situation best is a professional equipment incorporating microphone, amplifier and loudspeaker; but these things may be precisely what the home-constructor does not have! However, it is a fairly simple matter to set up a really effective amplifying system with material which may already be on hand.

For purposes of this nature, it is desirable for the output stage feeding the loudspeaker to be capable of providing at least two to three watts with low distortion. However, it is hardly worthwhile building a complete amplifier for the occasion, and it is much easier to modify equipment which may already be available. A suitable speaker, output stage and voltage amplifier will be given by almost any superhet valve radio (or radiogram) having a power transformer giving full isolation from the mains. A temporary pre-amplifier is all that is then required, and this can be constructed very easily in a matter of hours. Also, it can draw its power from the radio supply circuits without excessive current drain. The major requirement is that the radio must have an isolating power transformer. *A receiver having a "live" chassis must not be employed because the microphone leads would then be at mains potential, and there would be an excessive shock hazard.* Transistor receivers are not recommended for the present application, because of their relatively low power outputs. People using the microphone are almost certain to speak too closely or too loudly every now and again, and the amplifier should have enough reserve power to handle such overloads without introducing distortion.

Practically all mains superhet receivers employ a triode a.f. voltage amplifier followed by an output pentode or tetrode. All that is then needed for adequate microphone amplification is an add-on triode pre-amplifier. Fig. 1 shows the circuit for such an amplifier and, as may be seen, few components are required. The valve employed is not at all critical and may consist of any type in the 6J5 class, or one half of a 6SN7, 6SL7, or 12AU7. Again, the triode section of any double-diode-triode which is to hand may be employed. So, also, could a straight (i.e. non vari-mu) r.f. pentode, it being triode-connected with screen-grid and anode strapped. The triode should give more than enough gain

<sup>1</sup>"Gadgets For Your Christmas Party" by W. Holmes. *The Radio Constructor*, December 1961.



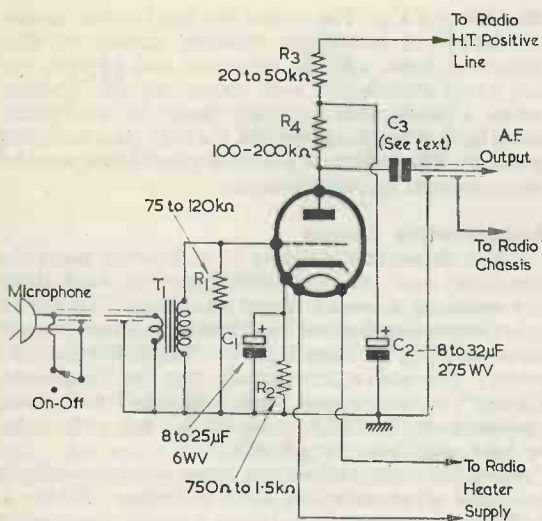

M591

Fig. 1. A simple pre-amplifier which may be employed for temporary microphone-loudspeaker installations. Component values are not critical, and the capacitor working voltages specified are minimum figures

for the present requirement, and it handles a low input signal. In consequence, the values of the cathode bias and anode load resistors are quite uncritical. Additional h.t. decoupling is given by  $R_3$  and  $C_2$ . Such decoupling is essential, as the existing triode and output valve in the receiver will almost certainly be returned direct to the smoothed h.t. positive line. If the additional valve were not

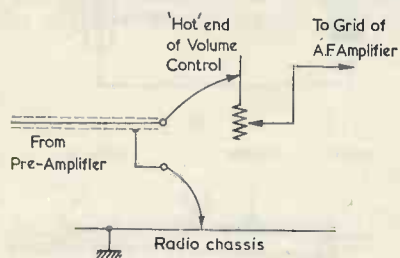

(a)

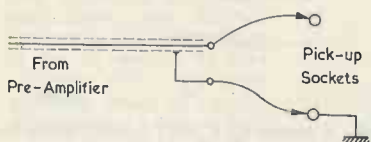

(b)

M592

Fig. 2 (a). Coupling the pre-amplifier to the receiver volume control  
(b). The pre-amplifier may also be coupled to the pick-up sockets. The "earthy" socket should connect direct to the receiver chassis

decoupled, motor-boating or a similar form of instability may result. Obviously, the pre-amplifier valve should require the same heater voltage as that used by the valves in the receiver.

The output of the pre-amplifier is fed to the receiver via the screened cable following  $C_3$ . This cable may be coupled into the receiver circuits at the volume control, as in Fig. 2 (a), or at the pick-up sockets, as in Fig. 2 (b). The pre-amplifier should pick up its chassis connection via the screened cable braiding, and this will also provide the h.t. negative connection. The heater connection should be obtained, via a twisted pair, from any convenient valveholder on the receiver chassis; and this method

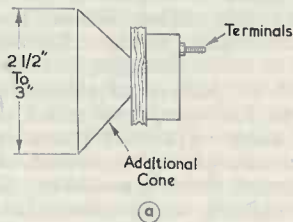

(a)

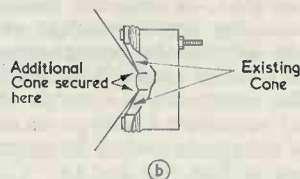

(b)

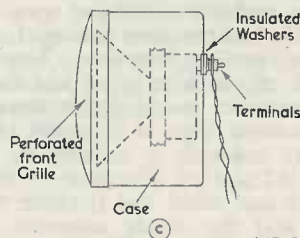

(c)

M593

Fig. 3 (a). Fitting an additional cone to an ex-W.D. moving-coil phone  
(b). Detail of the manner in which the additional cone is secured to the existing cone  
(c). A suitable housing for the assembly. The phone is secured to the case by its terminal screws

of wiring should be employed even when one side of the heater supply in the receiver is at chassis potential. No heater current should flow through the outside braiding of the screened cable, or hum may result.

The pre-amplifier can be fitted on any small chassis or metal strip and should be mounted in the receiver cabinet well away from the mains transformer. This is to prevent hum pick-up in the microphone transformer. The h.t. and heater current drawn by the pre-amplifier should be well

within the capabilities of the receiver power supply circuits but, if there is any doubt on this point, the frequency-changer and/or i.f. amplifier valve may be removed. Indeed, it may be found possible to use the triode section of the frequency-changer as the pre-amplifier valve!

Transformer  $T_1$  can consist of a speaker transformer with its high impedance primary connected to the grid circuit, but much better results will be given by the use of a proper microphone transformer. A suitable component with a 100:1 ratio is marketed by Radiospares.<sup>2</sup> If the speaker transformer is used, it will probably be possible to omit  $R_1$  without any noticeable change in performance.

The microphone is coupled to the pre-amplifier via screened cable which should be kept clear of unscreened mains wiring. Television coaxial cable would be quite adequate here. Volume level is adjusted at the receiver, a simple on-off switch being fitted at the microphone which short-circuits the screened cable. The microphone is a moving-coil type and can, of course, consist of a "professional" instrument if this is available. Alternatively, a small moving-coil loudspeaker (the smaller the better) may be employed instead. There are a number of ex-W.D. moving-coil headphones and microphones on the surplus market which, whilst they are of no use for the present requirement as they stand, can make excellent microphones when modified. The modification consists of removing the cover and varnished fabric protection in front of the cone of the phone, and of fitting an additional cone as shown in Figs 3(a) and (b). Care must be taken during disassembly to avoid damaging the existing cone, and the additional cone is fitted to it around the centre semi-spherical form with Bostik or a similar adhesive. The additional cone is made of cartridge paper and has an angle sufficiently acute to ensure that it clears all parts of the phone other than at the point of adhesion. The complete assembly is secured by the phone terminals, as in Fig. 3(c). The weight of the additional cone does not affect the position of the coil excessively, and the whole assembly makes an extremely cheap and sensitive moving-coil microphone.

It will be noted that the microphone suggested (i.e. "professional" types, loudspeakers, or modified ex-W.D. units) will all have varying impedances. This is not of great importance here. Provided that impedances are below  $20\Omega$  or so, results will be quite adequate.

The final process consists of setting up the pre-amplifier and of finding the best value for  $C_3$  in Fig. 1. The equipment should be connected up, including the microphone and its lead, and switched on. The microphone transformer (or the complete pre-amplifier chassis) may then be experimentally oriented for minimum hum from the field around the mains transformer. It is probably that a small amount of hum will still be evident after this operation, and it may be obviated by reducing

the value of  $C_3$ . The writer has used values as low as 500pF in temporary systems similar to that described here, and the resultant loss of bass has not been detrimental with speech inputs. Indeed, when a loudspeaker (which tends to accentuate bass) is used as a microphone, the high-pass coupling given by a low value in  $C_3$  often results in a marked improvement in reproduction.

### Light-Sensitive Devices

Light dependent resistors have become generally available over the past twelve months, and these are excellent devices for party gadgets. The use of l.d.r.'s for relay control has already been adequately covered by G. A. French in the "Suggested Circuit" series. The writer understands that the "Suggested Circuit" in the present issue also deals with relay operation by an l.d.r., and so he will only refer to l.d.r. switching very briefly.

An l.d.r. relay circuit can cause electrical effects to occur when a ray of light is broken. Thus, a bell may be made to sound when a visitor approaches the front door. The simple circuit needed is shown

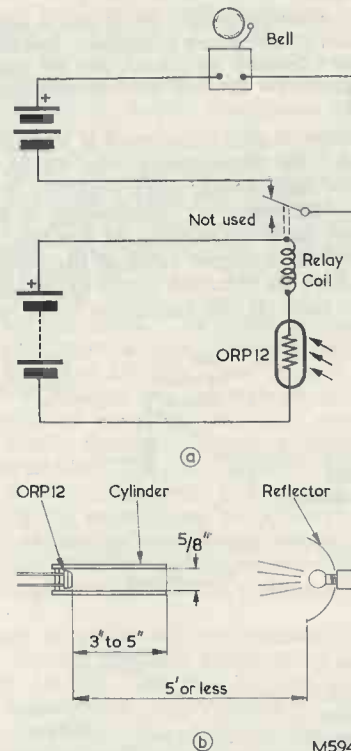
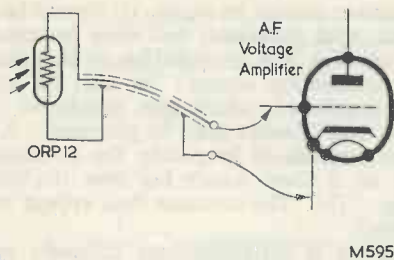

Fig. 4 (a). A simple l.d.r. relay circuit, which causes the bell to ring when the light beam illuminating the l.d.r. is broken. The relay should be capable of energising at currents of the order of 2 to 5mA (b). Illumination of the l.d.r. by a flash lamp bulb with, perhaps, a simple reflector should be adequate up to spacings of 5ft or so. For greater spacings it may be necessary to employ a more powerful lamp, or a more efficient reflector

<sup>2</sup> This transformer is available from Home Radio (Mitcham) Ltd., under Cat. No. M22.



M595

Fig. 5. Coupling an ORP12 to an a.f. voltage amplifier valve causes volume level to be considerably increased when room lighting is switched off

in Fig. 4, wherein the l.d.r., an ORP12, is mounted inside a cylinder to shield it from ambient light. Sufficient illumination will be given by a flash lamp bulb mounted up to 5 ft. away from the l.d.r. with, perhaps, a simple reflector behind it. If the light ray is broken the l.d.r. offers a high resistance and the relay de-energises. When using the circuit of Fig. 4 it should be remembered that maximum dissipation in the l.d.r. is given by

$$P = \frac{E^2}{R}$$

where P is the dissipation in watts, E is half

the applied d.c. potential (applied to the relay and l.d.r.) in volts, and R is the resistance of the relay coil in ohms. The limiting dissipation for the ORP12 up to 50°C is 100mW. Also the maximum potential which may appear across it is 1.10 volts.

Apart from its use as a switching device, an l.d.r. can give other effects which, to the uninitiated, can be extremely mystifying. A typical instance is shown in Fig. 5, in which an ORP12 is connected between grid and cathode of the voltage amplifier in a valve radio or record-player. The ORP12

should be positioned such that it is illuminated by the normal room lighting. Under these conditions it presents a low resistance, and the radio plays at reduced volume. As soon as the room lighting is switched off the ORP12 assumes a high resistance, and volume level increases by a very large amount. The ORP12 should be coupled to the first a.f. grid in the associated amplifier (i.e. the grid immediately following the detector or pick-up). Where there is a live chassis, the screened lead to the ORP12, and the device itself, must be fully insulated to prevent risk of shock.

### The Spoken Command

Devices which operate when "spoken to" can provide quite a lot of amusement, and they do not necessitate the expenditure of a great deal of time in their assembly. A typical example is shown in Fig. 6. In this diagram a 12AX7 offers a high degree of a.f. amplification, the signal on the anode of the second triode being fed via C<sub>3</sub> to diode V<sub>2</sub>. When a sound is applied to the microphone, an amplified version of the a.f. signal is passed to the diode. This rectifies, causing a negative voltage to be fed to the relay triode, V<sub>3</sub>, which then cuts off and de-energises the relay. The time during which the relay remains de-energised depends upon the amplitude of the original sound and the time taken for C<sub>3</sub> to discharge into R<sub>3</sub> and R<sub>6</sub>. C<sub>3</sub> has an experimental value, but it would be helpful to start off with 0.25μF and reduce this if the de-energising periods are too long.

The microphone may consist of a "professional" instrument or a small loudspeaker or modified ex-W.D. moving coil phone, as was discussed for the amplifier set-up of Fig. 1. A correct microphone transformer is needed in the T<sub>1</sub> position, since a speaker transformer connected "wrong

Fig. 6. A device which causes a relay to de-energise when the microphone is "spoken to". As may be seen, component values are, once more, not critical. However, a 12AX7 is essential in the V<sub>1</sub> position to give sufficient gain. The relay employed should be capable of energising when V<sub>3</sub> grid is at chassis potential

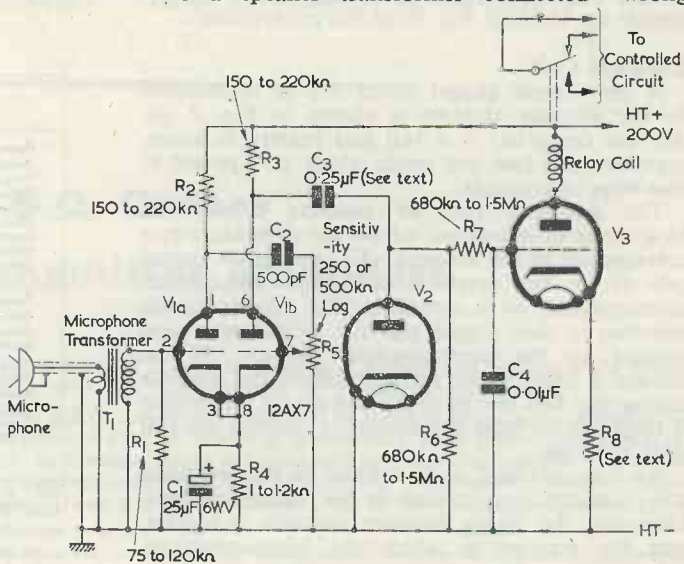

M596

way round" will introduce too many losses. Coupling capacitor  $C_2$  has a low value to reduce difficulties due to hum pick-up, and a common cathode bias circuit is employed for both sections of the 12AX7. The sensitivity control,  $R_5$ , is inserted in the grid circuit of  $V_{1(b)}$  rather than  $V_{1(a)}$  in order to simplify wiring requirements. This is because hum picked up in the grid circuit of  $V_{1(b)}$  will cause considerably less trouble than would a similar level of hum in the grid circuit of  $V_{1(a)}$ ; the position of  $R_5$  in the layout then becomes less critical, and there is no need to screen the leads connecting to it.

A thermionic diode is needed for  $V_2$  because it is possible for very high a.f. voltages to be applied via  $C_3$ . Such voltages could cause the maximum reverse voltage of a germanium diode to be exceeded and such a component might then break down. The diode employed may be of any type, or it could even consist of a triode with grid and anode strapped. If desired, the relay switching triode,  $V_3$ , may be a non vari-mu r.f. pentode with screen-grid and anode strapped. To obtain maximum sensitivity it is preferable to employ, in the  $V_3$  position, a valve having a short grid base (i.e. one which cuts off at a low negative grid voltage). The resistor  $R_8$  provides a small cathode bias potential to protect the triode when, in the absence of a.f., its grid is at chassis potential. The value of  $R_8$  should be kept reasonably low, in order to ensure that  $V_3$  provides a useful relay energising current, but it should not of course be so low as to cause excessive dissipation in the valve.

When built, the device of Fig. 6 should be switched on and allowed to warm up.  $R_5$  may then be set up to the required sensitivity and, if necessary, the speed of relay operation varied by adjusting the value of  $C_3$ . It is probable that the circuit should allow the relay to function with normal speech up to three feet from the microphone.

### Electrical Quiz

A very simple gadget which will be appreciated by the younger children is shown in Fig. 7 (a). All this comprises is a bell and battery in series, together with two test prods which are applied to two rows of contacts.

The left-hand row of contacts corresponds to a series of questions, whilst the right-hand row corresponds to the answers. To operate the device one of the test prods is applied to the contact corresponding to a question. The answer to the question is then found and the second test prod applied to the corresponding contact. If the answer is correct, the wiring between the contacts causes the bell circuit to be completed, whereupon it rings. If an incorrect answer is selected the bell does not ring.

As may be seen, each contact in the left-hand row connects to a contact in the right-hand row. However, the wiring between contacts is hidden, and the manner in which the interconnections are made is random. As a result, without experience of the device, guesses at the correct contact point

for an answer cannot be made. (It should be noted, of course, that questions, and their corresponding correct answers, are arranged so as to agree with the interconnecting wiring.) In use, the contacts may be numbered, whereupon numbered sets of questions and answers may be prepared. A better approach consists of preparing the questions and answers on a sheet which fits over the contacts, as in Fig. 7 (b). The contacts then appear at holes in the sheet.

The device is extremely easy to make up, and the contacts can consist of domed brass paper fasteners fitted to a wooden panel. The interconnecting wires may then be soldered to the paper fastener legs behind the panel. The number of contacts employed and the order in which those in the left-hand row are connected to those in the right-hand row depends entirely upon the constructor. There is no need to follow the interconnections given in Fig. 7 (a), which are intended purely for purposes of illustration.

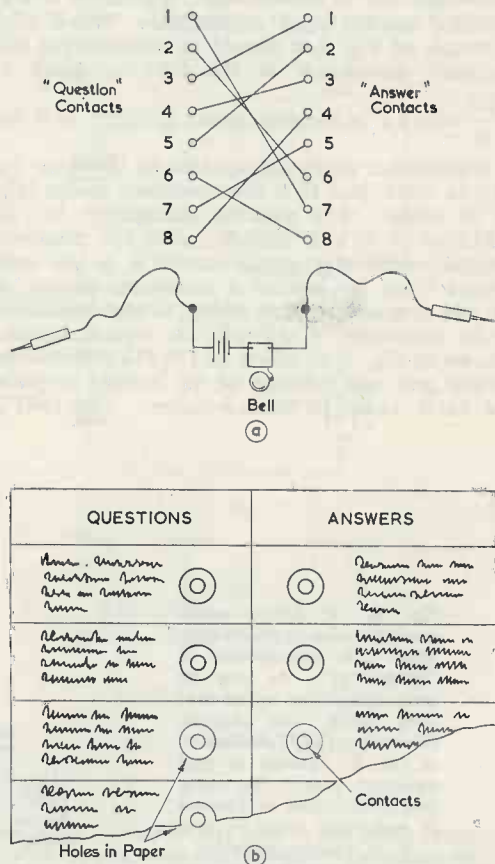

Fig. 7 (a). A simple Question and Answer game. One prod is placed on the appropriate Question contact and the other on the Answer contact adjudged to be correct. If the choice is right the bell rings (b). A series of sheets may be prepared as shown here, questions and answers being provided against holes

M597

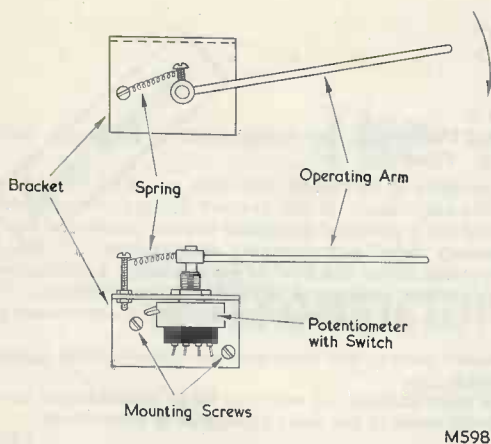

Fig. 8. A simple door-operated switch which is capable of controlling mains voltages

### Door-Operated Switches

A number of party gadgets rely on devices being switched on or off when doors are opened. In cases where battery power supplies are used, the associated door-operated contacts may be easily made up from strips of brass, etc., but such contacts are unsafe if it is intended to control mains circuits. The best solution then consists of employing suitably rated micro-switches. Unfortunately, it is not always possible for the home-constructor to obtain micro-switches at short notice or at low cost.

An effective solution is provided by the use of potentiometers fitted with on-off switches. Such potentiometers are frequently discarded because of noisy or worn-out tracks, whereupon the cost of a door-operated switch employing such a compo-

nent becomes negligible. The switches associated with potentiometers are normally rated at mains voltages (the rating is frequently shown on the component itself) and are, in consequence, quite safe for mains switching provided that an insulated housing ensures that the tags cannot be touched.

The potentiometer, with its switch, is mounted as shown in Fig. 8. In this diagram the potentiometer is fitted to a suitable bracket, and an arm is coupled to its spindle. When the arm is moved in the direction of the arrow (i.e. by opening a door) the spindle turns clockwise and the switch is turned on. Further movement of the arm is quite permissible, as it merely causes the potentiometer spindle to rotate in the same manner as it did in its original application. If pressure is removed from the arm (by closing the door) the spring causes it to return to its original position, and the associated switch is then turned off again.

Obviously there are other applications for this very simple gadget, which makes use of a component which would otherwise be discarded as useless.

### In Conclusion

The devices described in this article are examples of the many gadgets which the inventive home-constructor can make up for Christmas, and they can go a long way towards creating that really individual party which is the wish of every keen host and hostess. Practically all that is required for the construction of these novelties are the odds and ends which fill the average spares-box, and yet they can add a touch to the festivities which is completely unique.

In conclusion, the writer would now like to take this opportunity of hoping that readers' Christmas parties this year will be the best they have ever had; and that everyone shall have the Merriest of Christmases followed by the most Happy and Prosperous of New Years!

## B.B.C. Orders

### E.M.I. Transmitter Amplifiers

Following the start of a delivery of thirty EMI 1 Kw v.h.f. frequency modulated transmitter amplifiers, the British Broadcasting Corporation has placed another order with EMI Electronics Ltd for an additional thirty-six.

All these transmitter amplifiers will be built to B.B.C. specifications and will be installed at secondary transmitting stations in remote areas where present sound reception is weak or subject to interference, or to extend sound coverage to areas outside the range of existing transmitters. Each station will be equipped with six transmitter amplifiers, with two working in parallel on each frequency for the Home, Light and Third sound programmes. This means that these stations can be left unattended for long periods as the failure of one amplifier would not cause a breakdown in programme transmission.

Concurrent with this work, EMI transmitter engineers are completing modification work on the EMI u.h.f. transmitter equipment installed at Crystal Palace, making it suitable for use in a programme of experimental transmissions on the new 625-line standard proposed by the Pilkington Committee and accepted in the Government White Paper.

## BOOK REVIEWS . . . .

**ELECTRONIC CIRCUIT ANALYSIS, VOL. 1, PASSIVE NETWORKS.** By Phillip Cutler. 454 pages, 6in by 9in. Published by McGraw-Hill Publishing Company, Ltd. Price 62s.

The book under review is the first of two volumes whose purpose is to explain the basic concepts of advanced electronic engineering in a manner which can be appreciated by the technician. In the present volume this purpose is achieved in commendable fashion, partly because the book is based on a practical collegiate course conducted by the author and partly because of the considerable amount of explanatory detail accompanying each section. Of especial value to students is the practice of developing equations in step-by-step form: the flow of mathematical explanation is not broken by disconcerting hops from one equation to another which has undergone half a dozen manipulations. The text is crisply written, and new concepts are based on preceding matter. An understanding of practical electronics and mathematics around G.C.E. level is assumed.

The book starts off with Ohm's law and proceeds through network analysis and theorems, a.c. circuit analysis, transient analysis, transformers, and graphic analysis of valve circuits.

The reviewer would confidently recommend this book to the keen student. It may also be of considerable use to the engineer who, through specialisation, has fallen out of touch with some of the basic principles of electronics.

J.R.D.

**A DICTIONARY OF ELECTRONICS.** By S. Handel. 384 pages, 4½in by 7½in. Published by Penguin Books Ltd. Price 7s. 6d.

Those of us who attempt to work our way through the enormous amount of literature published during the year on electronics and allied subjects occasionally find ourselves confronted with completely unfamiliar words. Electronics is a widening science: new devices are continually being introduced and they are given names which are quite devoid of association or any etymological significance. Why, for instance, is a maser so named? Because it derives from Microwave Amplification by Stimulated Emission of Radiation. The word which defines the principle now also embraces the device.

A dictionary which fully covers the terms employed in electronics can obviously be of help here. It may also be of considerable interest, as a condensed text book, to the general reader. However, such a dictionary has to cover a very wide field if it is to meet all the demands placed upon it. Also, it has to be up-to-date and to comply with the recommendations of the various Standards Institutions throughout the English-speaking world. Again, definitions have to be concise; but they must not be so concise that the reader is not made fully aware of the meaning of a word consulted, or the functioning of the device it defines. All these requirements are satisfied by the book under review, which has the further advantage of relatively low cost due to its paper-back format. It should be added that, where applicable, the text is reinforced by diagrams, and that a number of useful tables are included.

**RADIO-ELECTRONIC TRANSMISSION FUNDAMENTALS.** By B. Whitfield Griffith. 624 pages, 6in by 9in. Published by McGraw-Hill Publishing Company Limited. Price 60s.

It is refreshing to find, in a book which carries on to deal at advanced level with transmitters, transmitting aerials and transmission lines, that the entire subject is introduced from first principles. For instance, Chapter 13—out of the 68 chapters in the publication under review—deals fully with  $j$  notation, Chapter 14 carries on to the arithmetic rules for complex numbers, and Chapter 20 covers the basic concept of calculus. These mathematical tools are required in later parts of the book but this fact need not deter readers unfamiliar with their manipulation, since they have been adequately introduced and described earlier.

In any event, the author does not introduce an excessive amount of mathematics, but just enough to ensure that each aspect dealt with is fully understood without the use of short-cuts.

*Radio-Electronic Transmission Fundamentals* deals with electrical networks, transmission lines, aerials and transmitters. The approach is extremely clear and lucid, and theoretical points are dealt with on a practical level. The book is intended for the radio operator, both amateur and professional, the technician; the student technician, and the engineer who has tended to specialise in other fields.

**TRANSISTOR RADIOS—CIRCUITRY AND SERVICING.** 72 pages, 5½in by 8½in. Published by Mullard Limited. Price 5s.

This excellent booklet, presented with the care and attention to detail which is evident in all Mullard publications, offers a non-mathematical approach to the subject of transistor radios and the transistors employed in them. Especially to be commended are the first three chapters, which deal with transistor functioning and manufacture. These difficult subjects are dealt with at a depth which permits the basic operation to be understood without causing the newcomer to flounder in excessive detail.

Further chapters deal with printed wiring; a.f., i.f. and r.f. transistor circuits as used in broadcast-band and f.m./a.m. receivers (and incorporating alloy-diffused as well as junction transistors); servicing techniques; and test equipment. All information on servicing is aimed at the working service engineer at the bench.

Much of the material in the booklet has appeared previously in a series of articles in *Mullard Outlook*. This material has now been enlarged for presentation in booklet form. The original series was intended as an introduction to transistor radios for the apprentice service engineer, but the reviewer feels that this range could well include the home-constructor as well and, in particular, the beginner.

Cover Feature

# The "CAPRI" Personal 6-Transistor Receiver

Described by E. GOVIER



The "Capri" Personal 6-Transistor Receiver has been described, correctly we feel, as the most compact design, complete with speaker, yet offered to the home constructor in this country. It is not a design for the beginner to attempt (see author's remarks) and the sequence of construction is vitally important—hence the full description given here.—Editor

NOW THAT CHRISTMAS LOOMS RATHER LARGE on the horizon, many home constructors will be seriously thinking of the annual gift problem. For those, like the writer, who have a teenage daughter (or son) madly keen on music—especially the "pops" with the accompanying almost eternal jangling beat—the receiver about to be described is an ideal answer to the dilemma. It has been described as the most compact transistor radio, with speaker, available to the home constructor and the size— $4\frac{1}{2}$  x  $2\frac{3}{4}$  x  $1\frac{1}{2}$  in—bears out this contention.

The design utilises the very latest in miniature components and conforms to modern circuitry standards. Using Mullard transistors throughout, a printed circuit board is employed and all components are supplied in packets with the individual contents clearly identified both in respect of values (with accompanying colour codes) and the C and R designations, etc.

Two choices of cabinet design are offered, one being red/white and the other blue/white, both types having a gold mesh speaker grill and tuning knob centre fitting. The two-tone moulded plastic cabinet presents a most attractive appearance and this may easily be judged from a glance at the front cover illustration.

The "Capri" is a fully transistorised medium wave receiver having a partially tuned long waveband. It employs a self-oscillating mixer, two i.f. stages and a single-ended output stage. Both i.f. stages have single tuned i.f. transformers. A germanium diode is included as the detector. Provision has been made, via a cabinet-fitted socket, for a deaf-aid insert (which automatically mutes the speaker) or for tape recording purposes.

The frequency coverage is from 540 kc/s to 1620 kc/s medium wave and on the long waves the receiver is tunable over 200 kc/s (1,500 metres).

The sensitivity on medium waves at 1,000 kc/s is  $330\mu\text{V}/\text{metres}$  and on long waves at 210 kc/s it is  $1.5\mu\text{V}/\text{metres}$ , both for 5mW output.

The adjacent channel selectivity at 1,000 kc/s is 31dB and, at 210 kc/s, 39dB.

A.G.C. efficiency is such that, for a signal input change of 60dB, the output changes by less than 6dB. The output power is 100mW for 10% distortion into an  $80\Omega$  speaker, this being a  $2\frac{1}{2}$  in round component, with a field strength of 7,700 lines.

The image rejection is 30dB on the long waveband and 38–47dB on the medium waveband, whilst i.f. rejection is some 36 to 45dB.

The transistors employed are Mullard OC44M as the self-oscillating mixer; two OC45M types as the i.f. stages; OC81DM audio amplifier and a matched pair of OC81M's as the single-ended push-pull amplifier. The germanium diode detector is a Mullard OA90.

Power is supplied by means of a 9V Vidormax T6003 battery or similar type. The consumption is 8mA under quiescent conditions, and at average listening level 15 to 20mA.

The intermediate frequency is 470 kc/s.

## Circuit

The circuit is shown in Fig. 1, from which it will be seen that, on medium waves,  $L_1$  is tuned by the variable capacitor  $C_2$  with  $C_{2(a)}$  in parallel.  $C_2$  and  $C_3$ , together with the trimmers  $C_{2(a)}$  and  $C_{3(a)}$ , are contained within a ceramic casing, the former two capacitors being, of course, a two-ganged component. (See Component List for circuit values.)  $L_1$  and  $L_2$ , the latter feeding direct into the base of  $TR_1$  (OC44M), are both wound on a ferrite slab. On long waves,  $C_1$  is effectively brought into parallel with both  $C_2$  and  $C_{2(a)}$ .

The oscillator winding  $L_4$  is tuned by  $C_3$  with the trimmer  $C_{3(a)}$  and  $C_{19}$  in parallel, and  $C_6$  in

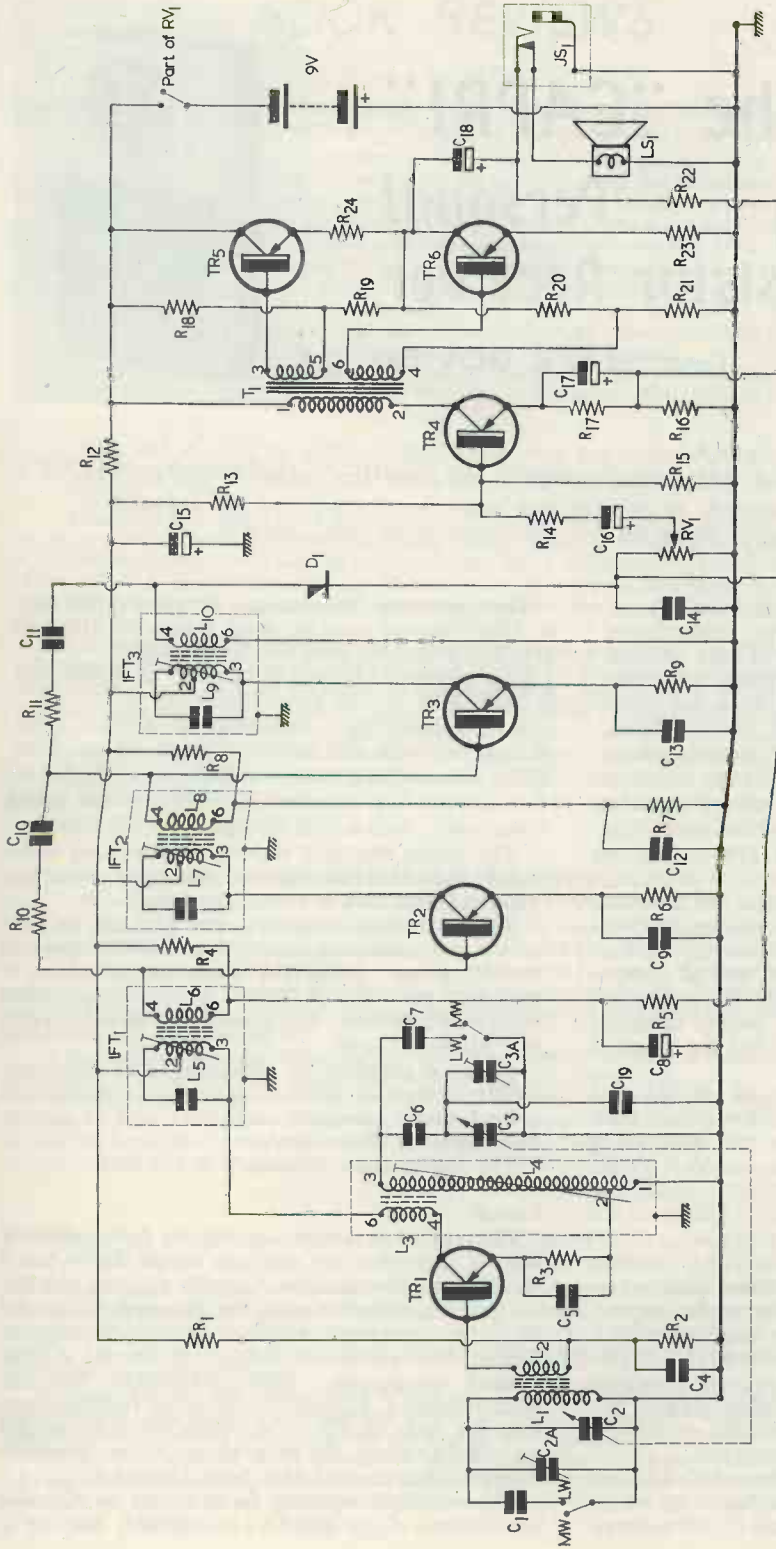

Fig. 1. Circuit of the "Capri" Personal Transistor Receiver

M575

Components List

- R10 1.2kΩ
- R11 3.9kΩ
- R12 680Ω
- R13 47kΩ
- R14 1.2kΩ
- R15 10kΩ
- R16 15Ω
- R17 1kΩ
- R18 2.2kΩ 5%
- R19 75Ω 5%

- R20 2.2kΩ 5%
- R21 75Ω 5%
- R22 2.7kΩ
- \*R23 5.6Ω
- \*R24 5.6Ω
- RV1 5kΩ log with single pole switch, complete with supports and outer tyre.

\* (Become shorting wire links if LFH3M packaged transistors are supplied)



### Capacitors

C <sub>1</sub>	1,350pF, 2%, styrene, 125 w.v.
†C <sub>2</sub>	190pF
†C <sub>3</sub>	190pF } ganged, variable
C <sub>4</sub>	0.04μF, 20%, 150 w.v.
C <sub>5</sub>	0.01μF, 20%, 150 w.v.
C <sub>6</sub>	210pF, 2%, styrene, 125 w.v.
C <sub>7</sub>	160pF, 2%, styrene, 125 w.v.
C <sub>8</sub>	8μF, electrolytic, 6 w.v.
C <sub>9</sub>	0.04μF, 20%, 150 w.v.
C <sub>10</sub>	56pF, 5%
C <sub>11</sub>	18pF, ±1pF
C <sub>12</sub>	0.04μF, 20%, 150 w.v.
C <sub>13</sub>	0.04μF, 20%, 150 w.v.
C <sub>14</sub>	0.01μF, 20%, 150 w.v.
C <sub>15</sub>	45μF, electrolytic, 10 w.v.
C <sub>16</sub>	8μF, electrolytic, 6 w.v.
C <sub>17</sub>	32μF, electrolytic, 6 w.v.
C <sub>18</sub>	45μF, electrolytic, 10 w.v.
C <sub>19</sub>	5pF ± 1pF, styrene, 125 w.v.

† (Complete with C<sub>2</sub>(a), C<sub>3</sub>(a), 10pF respectively and wavechange switch)

### Inductors

L <sub>1</sub> L <sub>2</sub>	Ferrite aerial
L <sub>3</sub> L <sub>4</sub>	Oscillator (Red)
L <sub>5</sub> L <sub>6</sub>	IFT <sub>1</sub> 470 kc/s (Yellow)
L <sub>7</sub> L <sub>8</sub>	IFT <sub>2</sub> 470 kc/s (Blue/Yellow)
L <sub>9</sub> L <sub>10</sub>	IFT <sub>3</sub> 470 kc/s (Black)
T <sub>1</sub>	Driver Transformer

### Battery

9V, Vidormax type T6003 or similar

### Semi-Conductors

TR <sub>1</sub>	OC44M Mullard	} Miniature RFG3M Package
TR <sub>2</sub>	OC45M Mullard	
TR <sub>3</sub>	OC45M Mullard	
TR <sub>4</sub>	OC81DM Mullard	} Miniature LFH3M Package
†TR <sub>5</sub>	OC81M Mullard	
†TR <sub>6</sub>	OC81M Mullard	
D <sub>1</sub>	OA90 Mullard	

† (Matched pair)

### Miscellaneous

LS <sub>1</sub>	2½in M5/80Ω speaker
JS <sub>1</sub>	Jack socket
	Cabinet
	Speaker grill
	Tuning dial with circlip
	Printed circuit board
	Aerial retaining strip
	Battery connector
	Clips retaining printed board
	Speaker pad
	Speaker insulator
	Wire, sleeving, etc.

series for the medium wave position. On the long waves, C<sub>7</sub> is brought into circuit. The wavechange mechanism is entirely automatic and is contained within the variable capacitor C<sub>2</sub>, C<sub>3</sub>.

The output from the self-oscillating mixer stage is taken from the collector of TR<sub>1</sub> via L<sub>3</sub> to the first i.f. transformer, only one winding of which, L<sub>5</sub>, is tuned. From the secondary winding of this transformer, L<sub>6</sub>, the i.f. is applied direct to the base of TR<sub>2</sub> (OC45M), a.g.c. being applied to this stage by way of R<sub>5</sub>, C<sub>8</sub> and L<sub>6</sub>.

The output from TR<sub>2</sub> is fed into the base of TR<sub>3</sub> (OC45M) via the second i.f. transformer windings, L<sub>7</sub> and L<sub>8</sub>. The collector of TR<sub>3</sub> couples via the third i.f. transformer windings L<sub>9</sub> and L<sub>10</sub>, to the germanium diode detector D<sub>1</sub>. Neutralisation for the i.f. stages is supplied via R<sub>10</sub>, C<sub>10</sub>, R<sub>11</sub> and C<sub>11</sub>.

The rectified audio from the diode is now applied to one side of the variable potentiometer RV<sub>1</sub>, the unwanted i.f. being filtered to chassis via C<sub>14</sub>. From the slider of RV<sub>1</sub>, via C<sub>16</sub> and R<sub>14</sub>, the signal is applied to the base of TR<sub>4</sub> (OC81DM).

The amplified audio is next taken from the collector of TR<sub>4</sub>, via the driver transformer T<sub>1</sub>, to the respective bases of TR<sub>5</sub> and TR<sub>6</sub> (matched pair OC81M), the final audio output being fed to the speaker by way of C<sub>18</sub> and the contacts on jack socket JS<sub>1</sub>. Negative feedback is fed via R<sub>22</sub> and C<sub>17</sub> to the emitter of TR<sub>4</sub>. Insertion of the jack into the socket JS<sub>1</sub> automatically mutes the speaker. The on/off switch is an integral part of the volume control RV<sub>1</sub>.

### Construction—Preliminary Details

Owing to the extremely small size of the receiver, a few words before proceeding with the constructional details may not come amiss—especially to those who have not attempted such an undertaking previously.

The writer found that a small soldering iron is essential, any type having a  $\frac{3}{16}$ in. diameter bit or smaller such as Antex or Litesold would be ideal for the purpose. The assembling and soldering work is "close", and the constructor must be exact and precise if a successful result is to be achieved.

Some time should be spent, before proceeding with the actual construction, in checking over the components and their locations on the printed circuit board. The layout is given in Fig. 2, this showing the "plain" side of the board on which ALL the components are mounted. The various wire lead-outs are then fed through small holes and soldered to the copper of the actual printed circuit. Mistakes in placing components, once soldered, will be extremely difficult to rectify.

The components marked R and C in Fig. 2 (with their suffix number), and shown in circles, MUST be mounted in a vertical position above the hole in the centre of the circle. Failing this, it will be impossible to proceed with the construction owing to the small amount of space available, the compactness of the components when they are

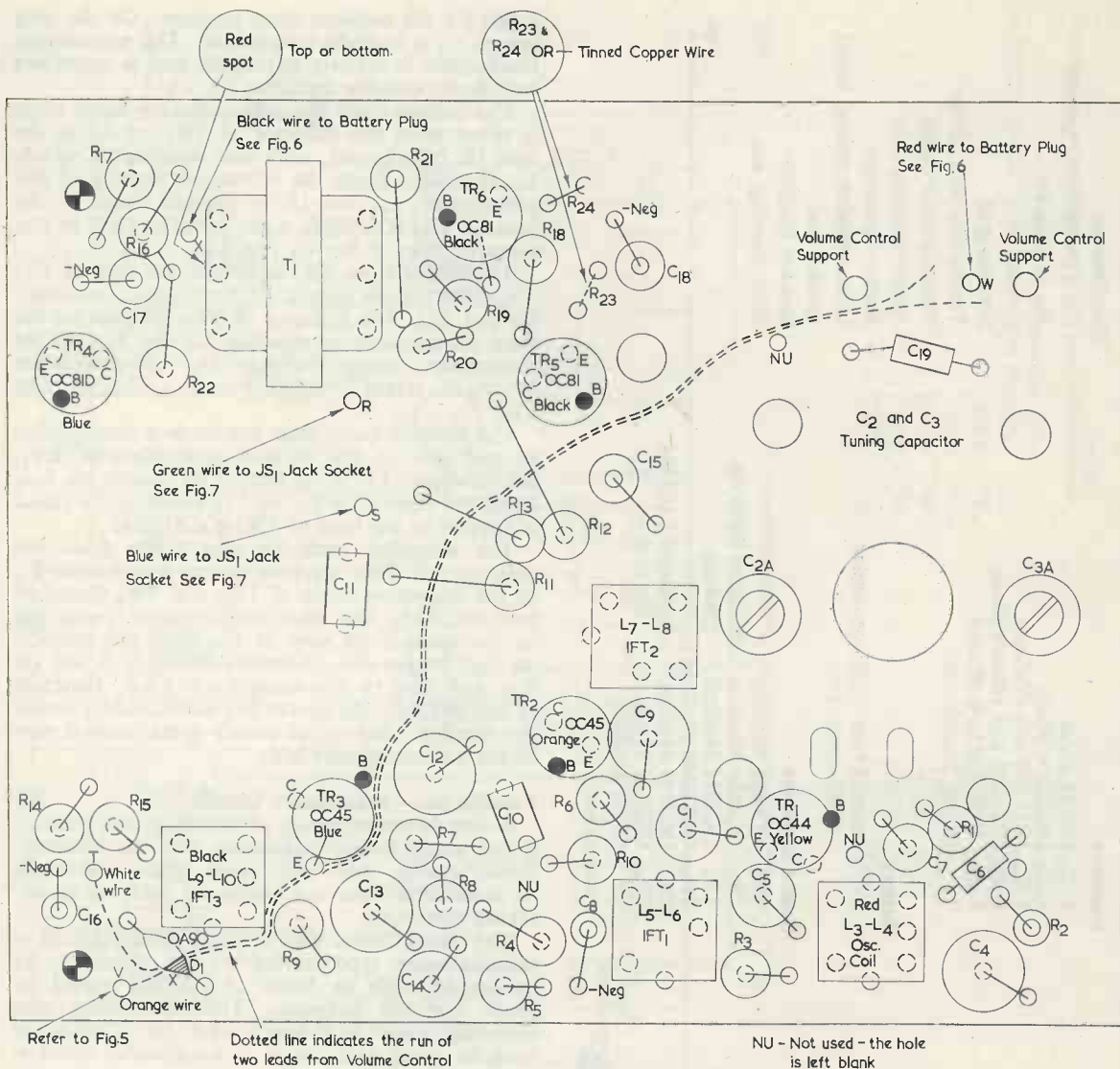

Fig. 2. Printed board (plain side) showing the layout of components

once mounted into position, and the eventual fitting of the board into the moulded case.

One wire of the vertically mounted components **MUST** be bent down in order to pass through the associated fixing holes in the printed board, leaving just sufficient wire for soldering before cutting. The bent wire will pass close to, and alongside, each individual component in most cases.

The writer found that it was an advantage, with the particular board obtained, to clean the printed circuit carefully with a small pad of Duraglit, or similar, and then to highly polish the copper

foil with a soft rag—this greatly assisting later with the soldering process. The polishing process should be done **GENTLY** in order that damage to the thin copper is not caused. The connecting wires of all components should be lightly scraped clean, oxidation introducing bad soldered connections if this is not carried out.

It will be noticed that each electrolytic capacitor has the *negative* wire brought out of the metal case and held to the metal side by the sleeving of the component. The *positive* wire is that which appears directly at the bottom of the capacitor, and protrudes centrally through the insulation.

Showing the components mounted on the printed circuit board. Note the compact assembly, vertical mounting of components and compare with Fig. 2.



Great care should be taken, when mounting these capacitors, to ensure that the polarity is correct as shown in Fig. 2.

The writer also found that, when mounting these sub-miniature components, care had to be exercised to see that none of the wire lead-outs were making contact with each other.

Owing to the small size of the printed board, it is vitally important that the operations are carried out in the **STRICT SEQUENCE** described here. This is, in fact, the sequence adopted by the writer. Any attempt at deviation in order to make a so-called "short cut" will cause both the receiver under construction, and the writer's time in determining the pitfalls, to be virtually wasted.

Great care must be exercised in the soldering of the transistors and the germanium diode, their performance being adversely affected by the application of excessive heat. When each lead-out is to be soldered, a heat shunt must be applied to conduct the applied heat away from the component body.

#### Assembly and Wiring Instructions

Constructors should now follow the sequence, in paragraph order, as described here.

Fold the ferrite slab aerial card retaining strip around the aerial as shown in Fig. 3, holding it in place with a thin strip of adhesive tape. The loose wires of the windings should then be tucked

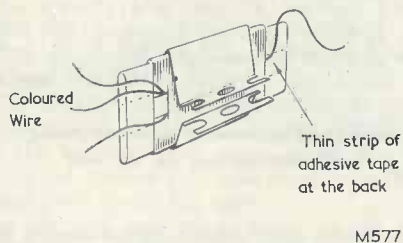

Fig. 3. The ferrite aerial with retaining strip

away until their connections are made, as described later.

Carefully bend over the soldering lugs on the ganged tuning capacitor (do not forget the centre earthing tag at the rear of the assembly) with a small pair of thin-nosed pliers in order to enable these lugs to be plugged into the board (see end of next paragraph). Great care must be taken when bending these lugs, especially those connecting to the switch contacts, as they are extremely fragile.

Place the overlapping portion of the ferrite aerial retaining strip flat on the printed board, and line up the tuning capacitor over it so that the lugs pass through the holes—see Figs. 2 and 3. Be ready to solder the capacitor into this position, the ferrite aerial now lying flat on top of the capacitor. It is *vital* to provide a heat sink when dealing with these lugs, the switch contacts are internally insulated with polystyrene which easily melts unless great care is taken. Solder the lugs to the printed circuit.

Mount resistor  $R_1$  (56k $\Omega$ , green, blue, orange, silver) and solder.

Solder into position  $C_7$  (160pF) styrene. Use a heat shunt.

Cut a  $\frac{1}{4}$ in length of white sleeving and thread it over the base connection of transistor  $TR_1$  (OC44M). Mount the transistor as shown in Fig. 2 ensuring that the base lead-out passes through

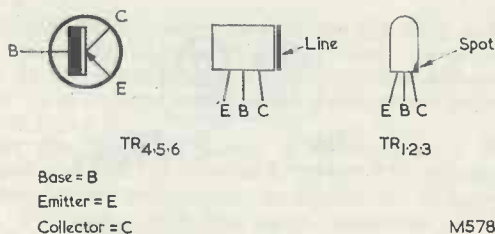
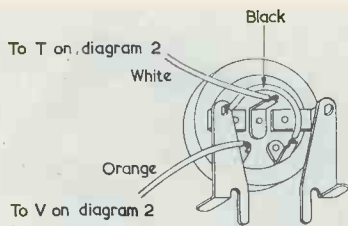
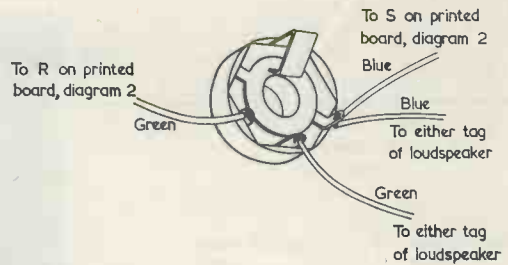

Fig. 4. Transistor connections



M579

Fig. 5. Volume control assembly and wiring colour code



M58i

Fig. 7. JS<sub>1</sub> jack socket connections and wiring colour code

the hole coded in this diagram with a black spot. Refer to Fig. 4 for all transistor connections. Use a heat shunt.

Mount and solder C<sub>6</sub> (210pF) styrene into circuit. Use a heat shunt.

Obtain the oscillator coil L<sub>3</sub>L<sub>4</sub> (coded red), mount into position and solder all the connections. As with all soldered connections to this printed board, do not "dwell" the iron too long on the joint when dealing with these inductances otherwise short-circuits to the can may result.

Solder into position C<sub>4</sub> (0.04μF).

Mount the resistor R<sub>2</sub> (10kΩ, brown, black, orange, silver) into position and solder.

Similarly deal with capacitor C<sub>5</sub> (0.01μF).

The resistor R<sub>3</sub> (3.9kΩ, orange, white, red, silver) is next mounted and soldered.

Deal next with C<sub>19</sub> (5pF) styrene—use a heat shunt.

Bare one end of the red battery wire and solder to the printed circuit as shown in Fig. 2.

Obtain the volume control and the two associated metal supports. Push the volume control firmly into the holes of the two supports, as shown in Fig. 5, making sure that the two perpendicular edges of the support brackets are facing outside, and solder the supports to the metal of the control itself. Again, refer to Fig. 5. Having done this, connect the various coloured wires as shown, observing the colour code given. Now solder the whole assembly on to the printed board, the control knob being adjacent to the edge of the board. Finally, turn the volume control fully to the "off" position and push on the volume

control "tyre" so that the black indicator line is central. (See the cover illustration, in which the receiver is shown switched off.)

Mount into position and solder IFT<sub>2</sub> (L<sub>7</sub>L<sub>8</sub>) coded white (or, in some cases, blue).

Connect the electrolytic capacitor C<sub>15</sub> (45μF 10 w.v.) into circuit.

Mount and solder into position the following, and in correct order as described: C<sub>9</sub> (0.04μF); C<sub>1</sub> (1,350pF) styrene (use heat shunt); R<sub>6</sub> (680Ω, blue, grey, brown, silver); IFT<sub>1</sub> (L<sub>6</sub>L<sub>5</sub>) coded orange; R<sub>10</sub> (1.2kΩ, brown, red, red, silver) and C<sub>8</sub> (8μF electrolytic 6 w.v.).

Deal next with transistor TR<sub>2</sub> (OC45M) ensuring that the base connection is sleeved with about ¼ in of systoflex and is inserted into the correct hole (see Fig. 2). Use a heat shunt.

Deal next<sup>1</sup> with the following, R<sub>23</sub> (5.6Ω, green, blue, gold, silver); C<sub>18</sub> (45μF electrolytic 10 w.v.); R<sub>24</sub> (5.6Ω, green, blue, gold, silver) and R<sub>12</sub> (680Ω, blue, grey, brown, silver).

Mount and solder into circuit transistor TR<sub>5</sub> (OC81M) making sure that the sleeved base con-

<sup>1</sup>If LFH3M packaged transistors are supplied, both R<sub>23</sub> and R<sub>24</sub> must be omitted from the circuit and replaced with wire shorting links.

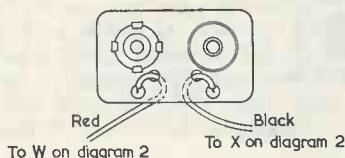

M580

Fig. 6. Battery plug connections showing colour codes

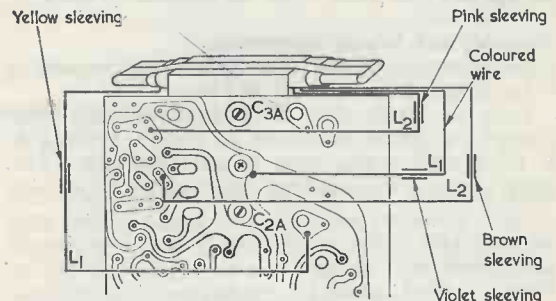

NOTE: L<sub>2</sub> winding must be connected for correct phasing—i.e. it will only work effectively one way round

M582

Fig. 8. Ferrite aerial connections and sleeving colour codes. The location of the trimmers C<sub>2(a)</sub> and C<sub>3(a)</sub> are also shown

nection is inserted into the correct hole as shown in Fig. 2. A heat shunt must be used.

Having proceeded thus far, deal next with the following: R<sub>18</sub> (2.2kΩ, red, red, red, gold); R<sub>11</sub> (3.9kΩ, orange, white, red, silver); R<sub>13</sub> (47kΩ, yellow, mauve, orange, silver); C<sub>10</sub> (56pF) and R<sub>4</sub> (68kΩ, blue, grey, orange, silver).

Deal now with the following components: R<sub>5</sub> (8.2kΩ, grey, red, red, silver); R<sub>20</sub> (2.2kΩ, red, red, red, gold); and R<sub>19</sub> (75Ω, mauve, green, black, gold).

Take Transistor TR<sub>6</sub> (OC81M), sleeve the base connection as previously described, and insert into the correct holes as shown in Fig. 2. Use a heat shunt.

Mount and solder into circuit the following, R<sub>21</sub> (75Ω, mauve, green, black, gold); disc ceramic capacitor C<sub>11</sub> (18pF); C<sub>12</sub> (0.04μF); R<sub>7</sub> (4.7kΩ, yellow, mauve, red, silver); R<sub>8</sub> (22kΩ, red, red, orange, silver); C<sub>14</sub> (0.01μF).

Take transistor TR<sub>3</sub> (OC45M), sleeve the base lead-out wire, and insert the transistor into the correct holes as shown in Fig. 2. Use a heat shunt.

Solder into circuit the following: C<sub>13</sub> (0.04μF); R<sub>9</sub> (1kΩ, brown, black, red, silver) and IFT<sub>3</sub> (L<sub>9</sub>L<sub>10</sub>) coded black.

Dealing next with the germanium diode D<sub>1</sub>, ensure that the positive lead-out is inserted into the hole marked "+" in Fig. 2. Note here that the positive end of the diode may either be coded red or with a white line.

Take the following components, and mount and solder them to the board in the following sequence.

R<sub>15</sub> (10kΩ, brown, black, orange, silver); R<sub>14</sub> (1.2kΩ, brown, red, red, silver); C<sub>16</sub> (8μF electrolytic 6 w.v.); black battery wire to the printed board—see Figs. 2 and 6; transformer T<sub>1</sub>, ensuring that the red spot on this component matches with the position shown in Fig. 2.

Continue with R<sub>22</sub> (2.7kΩ, red, mauve, red, silver); R<sub>16</sub> (15Ω, brown, green, black, silver); R<sub>17</sub> (1kΩ, brown, black, red, silver); C<sub>17</sub> (32μF electrolytic 6 w.v.).

Mount and solder into position transistor TR<sub>4</sub> (OC81DM), noting from Fig. 2 the correct connections. Fit the base connection with sleeving and use a heat shunt.

The ferrite aerial connections should now be made and these may be determined from Fig. 8. Note particularly that the L<sub>2</sub> winding must be connected for correct phasing, and that it will only work effectively when in the correct "sense".

Next, on the open space of the board (plain side) the speaker foam pad should be secured into position with Bostik or a similar adhesive.

Take the speaker grill, place it on the square cut-out of the cabinet face and bend over the four fixing lugs from inside the case.

Solder the red and black wires to the battery connecting strip as shown in Fig. 6.

Take the jack socket (JS<sub>1</sub>) and connect the

green and blue wires as shown in Fig. 7. Solder them to the loudspeaker, making sure that the length is sufficient to reach the speaker solder tags once the speaker is sited within the case.

Place the speaker into the recess in the case and fit the plastic speaker insulation over the speaker magnet. Insert the jack socket into the hole provided in the side of the case and secure from the outside of the case with the nut provided.

Take the two printed board retaining clips and push them into position in the slots within the case, ensuring that the hook sections at the top face *inwards* so that, when the printed board is later fitted, the clips will fit tightly to the edge of the board.

Fit the battery connector to the 9V battery and switch on, proceeding with the alignment details described hereunder.

### Alignment Details

During the alignment procedure, great care should be taken to ensure that the slugs of the various inductances are not over-turned, only a slight adjustment should be required to bring the various tuned circuits into line. All i.f. transformers are pre-aligned as supplied.

If a low voltage a.c. meter is to hand, connect it across the jack socket JS<sub>1</sub>. If no meter is available, carry out the following procedure aurally, using an insulated screwdriver for adjustments or, better still, a small plastic knitting needle with the end suitably filed flat and to correct size.

Set the tuning capacitor to a point, on the pre-set long waveband, midway between the point at which the switch operates and the full clockwise travel, i.e., at 1,500 metres.

Adjust the core of L<sub>4</sub> to tune in the Light programme on 1,500 metres.

Tune in a weak signal just anti-clockwise of the switch operating position (on the medium waveband) and make the adjustments to be described on this signal. (The corresponding signal generator setting is 600 kc/s=500 metres.)

Slightly turn the core of L<sub>9</sub> for maximum output from the signal. (Or from a signal generator set to 470 kc/s.)

Slightly turn core of L<sub>7</sub> for maximum output from the signal. (Or from a signal generator set to 470 kc/s.)

Slightly turn core of L<sub>5</sub> for the maximum output from the signal. (Or from a signal generator set to 470 kc/s.)

Slide L<sub>1</sub>L<sub>2</sub> coil on ferrite slab (see Fig. 3) in order to obtain the maximum output from the signal and fix into position with a small length of adhesive tape. (The corresponding signal generator frequency is 600 kc/s.)

Set the tuning capacitor to approximately 300 metres and turn the trimmer C<sub>3(a)</sub> until the Midland Home Service programme, or Hilversum, is heard. (Or trim C<sub>3(a)</sub> with the signal generator set to 1,450 kc/s=207 metres.)

Adjust the trimmer C<sub>2(a)</sub> for maximum output.

(Or trim  $C_{2(a)}$  with the signal generator at 1,450 kc/s.)

If necessary, repeat the above procedure for maximum performance.

#### Final Details

Carefully fit the completed and aligned printed circuit chassis into the case, using the clips to retain the actual board. Fix the 6BA bolt through from the front of the case (under the tuning knob).

Push on the circlip to the tuning knob spindle, locate the flat on the capacitor spindle and gently push on the dial ensuring that it is clear of the case.

Place the 9V battery into position inside the case in such a manner that the battery connector is at the *opposite end* of the case to jack socket JS<sub>1</sub>.

Finally, locate the grooves in the case and gently push on the rear half.

The "Capri" receiver is now complete.

# A Radio Astronomy Receiver

## for the Advanced Constructor

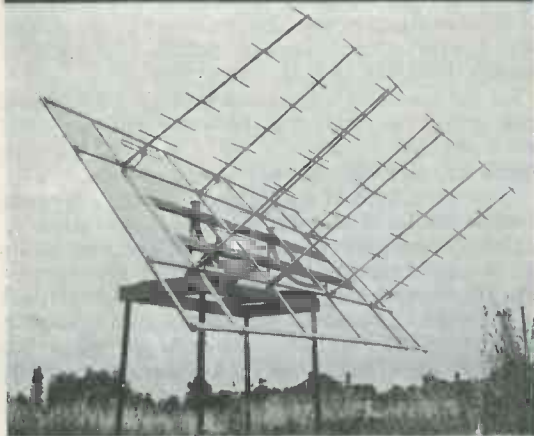

**I**N THIS SERIES OF FOUR ARTICLES A COMPLETE RADIO telescope is described; it will consist of a steerable aerial array, a receiver and a power pack. Full constructional details will be given for both the aerial and the receiver, and it is intended that the first two parts of this series shall be devoted to the receiver, the third to the construction of the aerial, and the fourth to the application of the instrument.

This radio telescope has been designed to cover certain specific work which can be undertaken by an amateur and is of such a size that it is easily accommodated in the ordinary back garden.

The frequency of operation lies between 200 and 220 Mc/s. This frequency has been chosen for the special reason that almost certainly there will be an Independent Television Authority transmitter nearby

By Frank W. Hyde F.R.S.A., F.R.A.S.

*This is the first of a series of four articles written by the foremost amateur authority on radio astronomy in this country. These articles cover the construction and assembly of a complete radio telescope installation*

which can be used for checks on the operation of the assembly. The signals from such stations, of course, will have to be very severely attenuated before being applied to the receiver or instability and overloading will result.

It will perhaps be proper to outline the requirements of a receiver for radio astronomy before proceeding with a description of the receiver itself. The part played by the receiver in the radio telescope is to amplify the very small amount of power which is collected by the aerial. This must be taken to a level where it can operate a recorder or some form of meter. There is, of course, no difficulty in obtaining high amplification with modern circuitry but there are, however, certain difficulties which are inherent with the normal receiver; these being associated with the internal noise of the receiver itself. It is necessary, therefore, to determine first the level which is expected from those parts of the sky to be examined and to assess the requirements of the receiver accordingly. A normal radio receiver, if carefully designed, can have a sensitivity such that it would be able to detect noise powers of the order of  $10^{-12}$  watts. This, however, is not nearly sensitive enough for the radio astronomer; he needs a receiver whose internal noise level will be of the order of  $10^{-14}$  watts. With this receiver he will endeavour to detect radiations less than a thousandth of this level. It is necessary, therefore, to have some system whereby we can measure this radiation through the high background level. The noise available at the detector will be made up of many parts: (a) the noise of the receiver and its various stages, (b) the self-generated noise in the aerial, (c) the radiation to be received.

### Receiver Noise

Receiver noise is made up of random voltages due to the movement of electrons in the conductors. These random voltages are built up across various sections of the circuit including resistors and capacitors. The variation of current in the anode circuits is known as "shot" noise; the name derives from its resemblance to the sound produced by shot falling on to a hard surface. The value of this is assessed as an equivalent noise generated and applied to the grid and, when it is compared with thermal agitation, it is known as "Johnson noise". It becomes more convenient to express the shot noise value in terms of a resistor, i.e. it is regarded as an imaginary resistor connected in the grid circuit.

Thermal agitation arises from two sources, the change in ambient temperature due to local heating, and the internal thermal change due to current flowing.

There is a third type of noise which is usually referred to as induced grid noise, and this is due to the random variations in the electron stream as it passes through the grid to the anode. The electrostatic charges carried by the electrons induce noise voltages in the grid circuit. The value of this variation depends upon the impedance of the grid circuit and also the frequency of operation. At high frequencies induced grid noise is most noticeable because of the transit time of the electrons. Once again it has a finite value and can be represented as a resistance across the grid circuit.

Multi-electrode valves have higher inherent noise levels than triode valves, for example. There is a formula for determining the equivalent noise resistance and this is given by:

$$\text{Triode valve } R_{eq} = \frac{2.5}{g_m} \text{ kilohms.}$$

For a Pentode it is modified as follows:

$$R_{eq} = \frac{I_a}{I_a + I_g} 2 \left( \frac{2.5}{g_m} + \frac{20 I_g}{g_m^2} \right) \text{ kilohms}$$

Fig. 1. The effect of differing time constants in the receiver. The upper pen recording was taken with a short time constant, and the lower recording with a long time constant

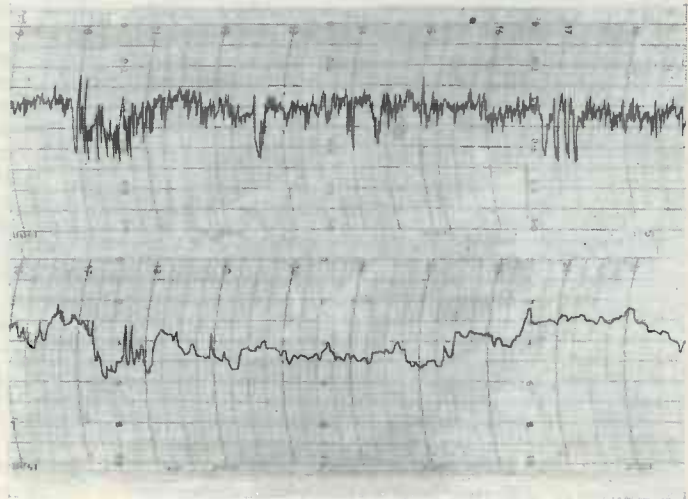

The main source of noise in a receiver will be that which is generated in the first circuits and this is successively amplified.

So far as radio astronomy is concerned, since wide bandwidths are in normal use, and since the noise currents and voltages occupy the whole band of frequencies in the electro-magnetic spectrum, we speak of the average noise power. The formula which indicates the noise factor is:

$$i_n^2 = \frac{4KT\Delta F}{R}$$

where  $i_n^2$  = mean squared noise current (amperes<sup>2</sup>)

$K$  = Boltzman's constant (Joules per degree Kelvin) =  $1.37 \times 10^{-23}$

$T$  = temperature (degrees Kelvin)

$\Delta F$  = bandwidth in cycles per second (c/s)

$R$  = resistance in ohms

The term  $\Delta F$  is important in reference to the bandwidth of the receiver.

If we were to express this as a voltage in series with a resistor then  $e_n^2 = 4KT\Delta FR$ . Every endeavour therefore, must be made to keep the first circuit noise to as low a level as possible.

### Aerial Noise

If the impedance of an aerial is measured with an impedance bridge, it will be found to be made up partly of resistance and partly of reactance. The reactive component is usually tuned out so we can exclude this at the moment. The resistance of the aerial is made up of two parts: loss resistance and the radiation resistance. The losses are made up from the actual resistance of the aerial wire, leakage across insulators and the effect of the immediate surroundings of the aerial, i.e. the proximity of trees or buildings. The radiation resistance is the property which determines the amount of power that the aerial would dissipate. A good aerial system should achieve an equivalent noise temperature of not more than 100° Kelvin.

### Components List (Fig. 2)

- R<sub>1</sub> 47kΩ
- R<sub>2</sub> 1kΩ
- R<sub>3</sub> 78Ω
- R<sub>4</sub> 1kΩ
- R<sub>5</sub> 100kΩ
- R<sub>6</sub> 47kΩ
- R<sub>7</sub> 47kΩ
- R<sub>8</sub> 1kΩ
- R<sub>9</sub> 78Ω
- R<sub>10</sub> 100kΩ
- R<sub>11</sub> 100kΩ
- R<sub>12</sub> 2.7kΩ
- R<sub>13</sub> 3.3kΩ
- R<sub>14</sub> 3.3kΩ
- R<sub>15</sub> 10kΩ
- R<sub>16</sub> 15kΩ
- R<sub>17</sub> 1kΩ wirewound

RFC 15 turns 22 s.w.g.  
p.v.c. insulated wire

- C<sub>1</sub> 0.001μF
- C<sub>2</sub> 0.001μF
- C<sub>3</sub> 0.002μF
- C<sub>4</sub> 0.002μF
- C<sub>5</sub> 0.002μF
- C<sub>6</sub> 0.001μF
- C<sub>7</sub> 0.001μF
- C<sub>8</sub> stray capacitance (see text)
- C<sub>9</sub> 0.002μF
- C<sub>10</sub> 0.002μF
- C<sub>11</sub> 0.001μF
- C<sub>12</sub> 47pF
- C<sub>13</sub> 0.002μF

- C<sub>14</sub> stray capacitance (see text)
- C<sub>15</sub> 0.002μF
- C<sub>16</sub> 25pF
- C<sub>17</sub> 0.002μF
- C<sub>18</sub> 5pF
- C<sub>19</sub> 10pF
- C<sub>20</sub> 10pF

- C<sub>21</sub> stray capacitance (see text)
- C<sub>22</sub> 16μF electrolytic
- C<sub>23</sub> 0.002μF
- V<sub>1</sub> PCC89
- V<sub>2</sub> PCC89
- V<sub>3</sub> ECC81

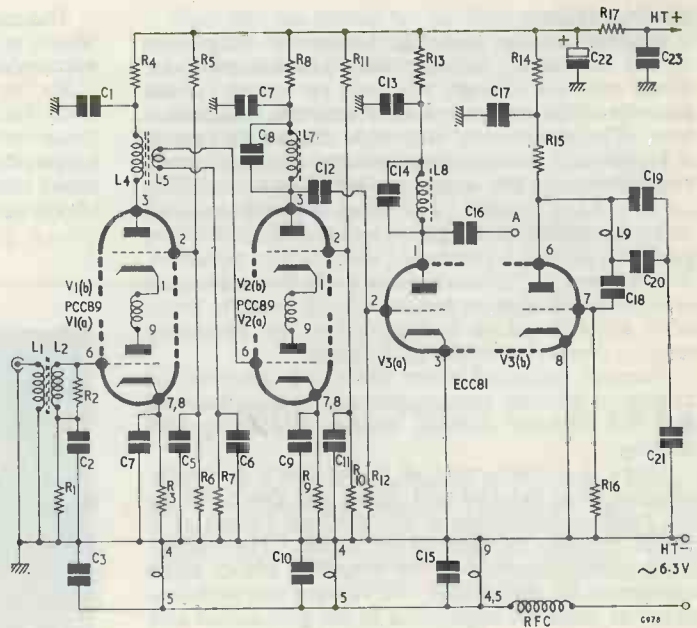

Fig. 2. The r.f. and mixer stages of the receiver

The noise from the aerial and the receiver system itself being of a random nature will consist of pulses which largely cancel each other out over a period of time. This will leave us with a small output which is the radiation we are endeavouring to detect. It is necessary to use an integrating system to show the residual power. In order to make this apparent we lengthen the time constant at the detector output of the receiver, thereby effectively discarding the random noise and leaving a small difference which represents the radiation collected by the aerial. Using a time constant of one second it is possible to detect radiations which are nearly two thousand times below the combined noise level. The actual length of the time constant will depend upon the work which is to be done with the telescope. This in turn will be governed by the size of the source that is being measured. If a source will take, say, ten seconds, to pass through the beam of the aerial, then the time constant could be increased to ten seconds. This will in itself effect a further improvement in the receiver's ability to detect these small powers. The effect of differing time constants is shown in

Fig. 1. The difference can be readily appreciated on examination of these actual tracings.

There is however, a limit to the application of these principles; if the radiations are such that they occur in sharp bursts as would be the case if we were looking for flares and activity on the sun, these might last much less than a second. A time constant, then, of even one second might be too long. However, in this case we do have the advantage that such outbursts of radiation are usually of a very high intensity and, therefore, the shorter time constant does not prove to be detrimental to the experiment.

It will be appreciated that as the time constants get longer so the random variations due to slow drift in the receiver might be a limiting factor. This is another reason why it is necessary for the power supply to be well regulated in order that residual drifts shall be reduced to the lowest possible level. This will be covered in greater detail when dealing with that part of the receiver.

#### The Receiver

The receiver to be described has the general



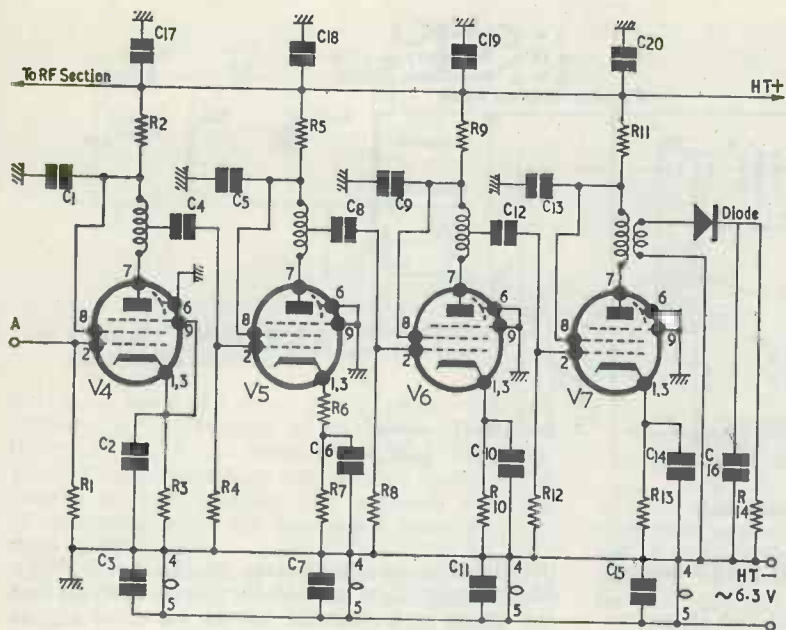

Fig. 3. The circuit of the i.f. section

Components List  
(Fig. 3)

R<sub>1</sub> 47kΩ  
R<sub>2</sub> 2.2kΩ  
R<sub>3</sub> 180Ω  
R<sub>4</sub> 47kΩ  
R<sub>5</sub> 2.2kΩ

R<sub>6</sub> 33Ω  
R<sub>7</sub> 68Ω  
R<sub>8</sub> 47kΩ  
R<sub>9</sub> 2.2kΩ  
R<sub>10</sub> 100Ω

R<sub>11</sub> 2.2kΩ  
R<sub>12</sub> 47kΩ  
R<sub>13</sub> 150Ω  
R<sub>14</sub> 1MΩ

V<sub>4</sub> EF80  
V<sub>5</sub> EF80  
V<sub>6</sub> EF80  
V<sub>7</sub> EF80  
Diode OA81 or equivalent

C<sub>1</sub> 0.002μF  
C<sub>2</sub> 0.001μF  
C<sub>3</sub> 0.002μF  
C<sub>4</sub> 0.001μF  
C<sub>5</sub> 0.002μF  
C<sub>6</sub> 0.001μF  
C<sub>7</sub> 0.002μF  
C<sub>8</sub> 0.001μF  
C<sub>9</sub> 0.002μF  
C<sub>10</sub> 0.002μF  
C<sub>11</sub> 0.002μF  
C<sub>12</sub> 0.001μF  
C<sub>13</sub> 0.002μF  
C<sub>14</sub> 0.001μF  
C<sub>15</sub> 0.002μF  
C<sub>16</sub> 100pF

appearance shown in the two illustrations reproduced herewith. The power supply is a separate and independent unit. One illustration shows the top view of the chassis and the various controls; these have been arranged for convenience: reading from left to right we have—pen output jack socket; switch for changing from valve voltmeter to trans-

lator unit; pen sensitivity; pen centring; time constants (a choice of two); audio frequency gain and audio frequency output jack socket. The general layout of the wiring is shown in the other illustration.

The circuit can be regarded as being in three sections. The first section is the r.f. unit, this

Top view of the chassis

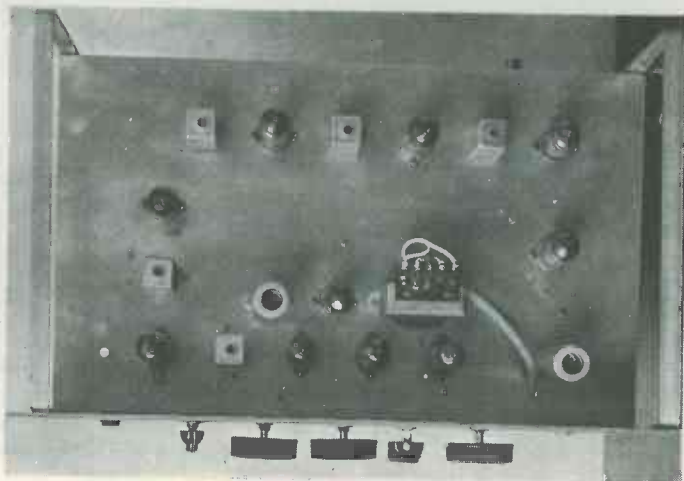

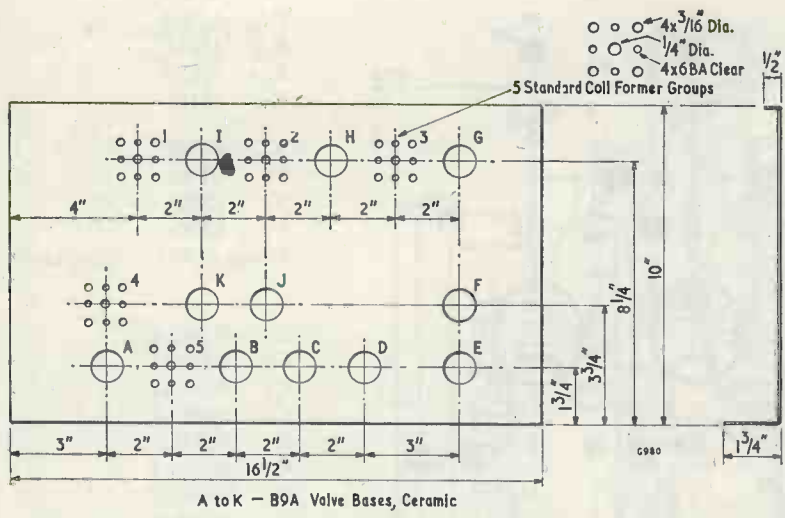

Fig. 4. Drilling dimensions for the main components

consisting of two r.f. stages each in itself a cascode coupled stage.

The valves chosen for these first two stages are type PCC89.<sup>1</sup> The decision to have two r.f. stages was based on the fact that the mixer is inherently noisy; raising the amplification at the r.f. end therefore enables us to relate the noise to the grid of the frequency changer, thereby rendering it less effective.

The gain of each of these stages is quite modest and is between 7 and 10 times. Considerable care is necessary to achieve this gain whilst retaining reasonable stability. Careful positioning of wiring is very important as is also the careful soldering of the joints, which should first be made mechanically sound.

Fig. 2 shows the r.f. section and the mixer. The input signal is fed via  $L_1 L_2$  to  $V_{1(a)}$  and thence to  $V_{1(b)}$ . Transformer coupling is used to transfer

the signal to the next stage via  $L_4 L_5$  to  $V_{2(a)}$ . Choke coupling is used in the anode of  $V_2$  (b) and the energy is transferred via the capacitor  $C_{12}$  to the grid of the frequency changer.

The frequency changer is an ECC81. One section forms the oscillator in the normal Colpitts form with  $L_9, C_{18}, C_{19}$  and  $C_{20}$ .  $C_{21}$  is given by the capacitance between the coils and other components and the chassis.

The intermediate frequency is led off via the choke coupling,  $L_8$  and  $C_{16}$ . The intermediate frequency is 38 to 40 Mc/s. The tuning of  $L_8$  is by dust core and the self-capacitance of the coil, which is represented by  $C_{14}$ .

The h.t. supply comes from the main busbar, which is connected to the stabilised power pack. Additional smoothing and r.f. filtering is accomplished by  $C_{22}$  and  $C_{23}$  and  $R_{17}$ .

The complete r.f. stage has no gain control, the circuits working at maximum gain at all times.

Fig. 3 shows the intermediate frequency amplifier,

<sup>1</sup>The PCC89 has a 7.5V heater. It is run from the 6.3V heater line in order to reduce noise.—Editor.

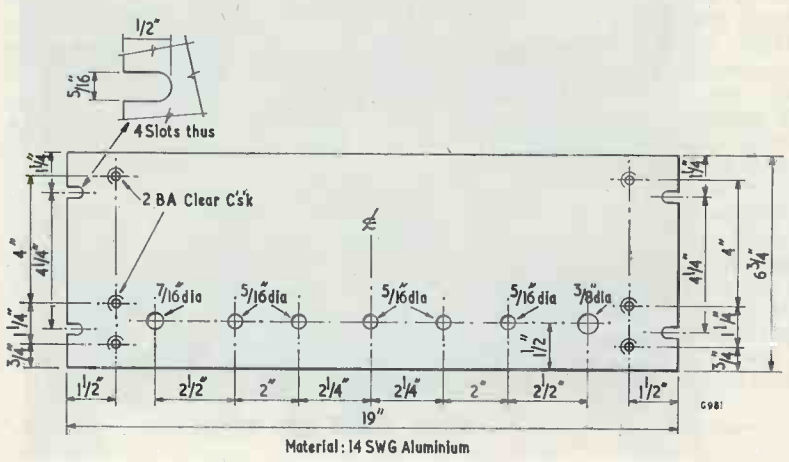

Fig. 5. Front panel dimensions

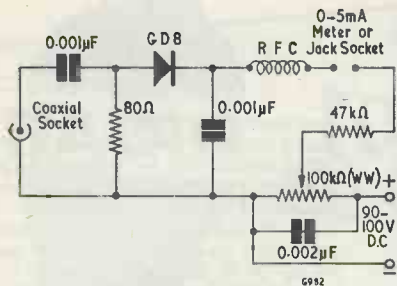

Fig. 6. The circuit of a noise generator which may be employed for final alignment

the input being fed from the frequency changer, at point A, to the grid of an EF80. There are three i.f. stages, all identical in their couplings. Tapped choke coupling was decided upon in the interest of both stability and accurate matching of each stage, since the bandwidth needs to be as wide as practicable.

It will be seen from the diagram that it is a conventional type of circuit, but here again care is necessary in the layout for very high gains are achieved with these stages. Many of the problems

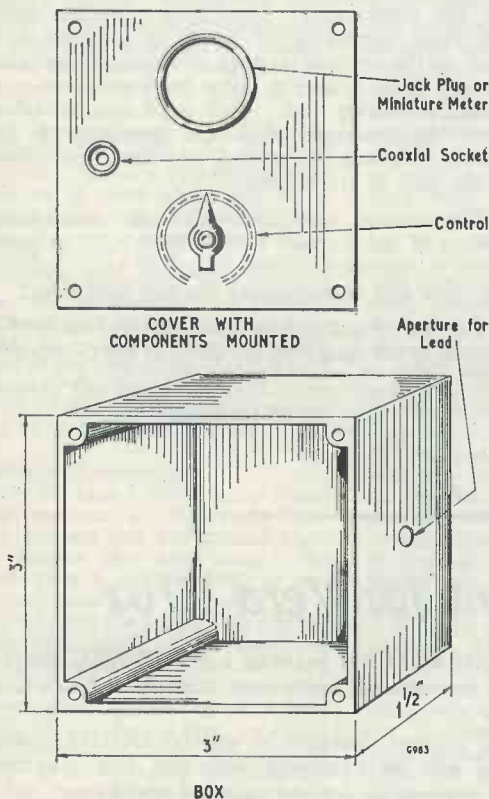

Fig. 7. A suggested layout for the noise generator. A standard switch box is employed

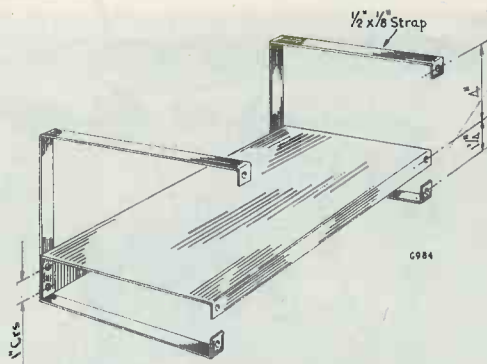

Fig. 8. Supports for the chassis and front panel

will have to be sorted out during construction, since the material of which the chassis is made has a considerable bearing on the gain and the stability. It is recommended that the chassis should be of aluminium. As far as possible components closely related to one another should be grouped around each valveholder. The valves  $V_4$ ,  $V_5$  and  $V_6$  have similar couplings. The output from  $V_7$  is by transformer coupling to the diode rectifier, from which the audio output is taken off across  $R_{14}$ , whose value is  $1M\Omega$ .

Figs. 4 and 5 show the mechanical layout of the chassis with dimensions for the position of valveholders and transformers. The front panel in the prototype model was in fact an  $\frac{1}{8}$ in steel panel that was available. However, since aluminium is far easier to work with it is suggested that this is adopted. The original was designed for fitting into a 19in relay rack and the dimensions for the panel are given accordingly.

It is important that the whole receiver should be well shielded since, with such high gains, there is always the possibility of breakthrough at i.f. (See Figs. 8 and 9.)

#### A Simple Noise Generator

As has already been stated the frequency chosen for this receiver is close to the television bands

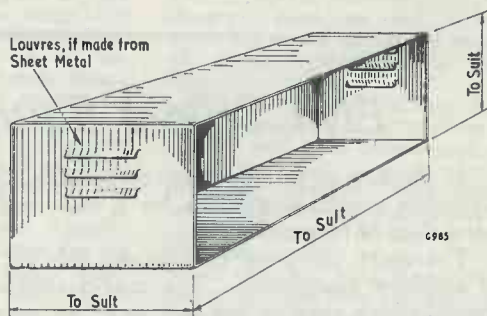
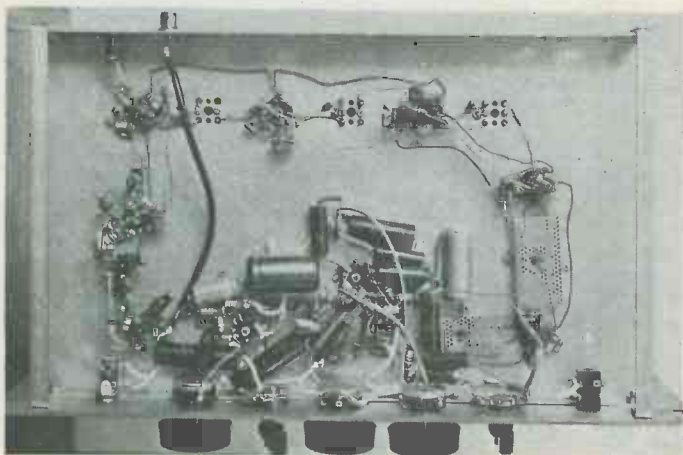

Fig. 9. A suitable chassis cover. The material may be sheet steel, aluminium or perforated zinc



Underside of the chassis. The aerial input passes via the coaxial cable to  $V_1$  at front left of the chassis.  $V_2$  is behind  $V_1$ , and  $V_3$  is behind  $V_4$ . The i.f. stages proceed along the rear of the chassis then carry on to the front,  $V_7$  being at front right. Note the perforated covers over the anode inductor wiring for  $V_6$  and  $V_7$ .  $V_5$ ,  $V_6$  and  $V_7$  have earthed metal plates soldered to the centre spigot to provide screening between grid and anode tags

and preliminary tests of the receiver, and later of the polar diagram of the aerial, can be made using these signals, whichever is appropriate to the reader's area. However, for the final alignment of the receiver (after normal methods of alignment have been used, such as setting up the i.f. with the signal generator and so on), the sensitivity of the receiver will be such that the normal leakage radiation from the average signal generator will be enough to overload it. A simple noise generator is therefore necessary for the final alignment.

A certain amount of the alignment can be done using the receiver noise itself, but this is likely to be deceptive for, should the i.f. stages prove to be too noisy, they might well swamp the incoming signal.

A simple noise generator can be constructed using a germanium diode. The construction of such a piece of apparatus is so simple and its uses are so wide that it is recommended that it should become one of the standard instruments in the workshop. It should be emphasised that this generator is for the purpose of tuning the receiver and getting the best performance from it, and *not* as a means of measuring the absolute noise factor.

The circuit of the noise generator is shown in Fig. 6. A suggested layout is given in Fig. 7. The circuit diagram is straightforward and needs no explanation since all components are identified. A jack plug is provided so that any handy meter can be plugged in. If there is a spare meter which reads 0-5mA, it could be incorporated in the design of the complete equipment. This is a matter for the constructor's own choice. When setting the noise generator to work, it may be found that, as the current through the diode is increased, there will be a rise in noise level and then a fall before a further rise. This need not be of any great disadvantage when the generator is used merely to assess the tuning, and the improvement, of the gain of the receiver.

The audio amplifier and the measurement section of the receiver will be dealt with in greater detail in the next article, together with details of the coils and transformers already mentioned.

The list of components required for each of the circuits so far described are given in the Components List.

*(to be continued)*

## EMI Studio Equipment for Vera Cruz

In the face of strong U.S. competition EMI Electronics Ltd has secured a U.S. \$70,000 contract to provide studio equipment for a new small private commercial television station in Vera Cruz, on the Gulf of Mexico.

The units comprise two studio vidicon television camera channels, a vidicon telecine channel and ancillary equipment. The studio vidicon cameras will be equipped with the EMI "joystick" control, which enables one operator to control studio cameras as well as telecine equipment.

EMI already has television equipment in the shape of three EMI 4½in image orthicon television cameras working in Mexico City.



# RADIO topics

By RECORDER

**A** HOME-CONSTRUCTOR FRIEND OF mine recently obtained two old single-channel television receivers from his acquaintances for virtually no cost at all. Indeed, the people to whom the sets belonged were only too happy to get rid of them, as they were merely taking up house-room and had long since become defunct. Having got them to his shack, my friend proceeded to strip them down for the components, and had just completed this job when I dropped in on him a week or so ago.

It does not seem to be generally realised that these old television receivers contain a surprisingly large number of parts which can be of considerable use for other jobs. The line output transformers, frame output transformers and scanning yokes are, admittedly, not of much use for present-day applications; although one could, I suppose, keep them as a source of coil-winding wire if one was really economically minded. On the other hand, quite a lot of the remaining components can be employed as they stand.

## Salvaged Components

By the time I arrived, my friend had removed all the parts from the receivers and had stacked them in various tins and boxes. We then spent a pleasant hour or two sorting these out.

First came the valves. We decided that these should all be considered as being suspect until they had been tested. In consequence, they were stored away to await test at a later time. If, at a future date, my friend encountered a chassis with, say, an EF91 in it, he would then use this to test the EF91's he had "won" from the old television receivers. Some valves just seem to carry on

indefinitely, and there was no reason to believe that at least a few of those which had been taken from the old sets were not in this category.

Potentiometers came next. Several of those which had previously been brought out to the front panel had rather fanciful spindle diameters and lengths. After a quick check for resistance and slider contact, these were retained for experimental jobs. The remaining potentiometers were either pre-set, or had perfectly respectable  $\frac{1}{2}$ in spindles. When they had been checked, these formed a very useful addition to my friend's stock of spares. Their usefulness was enhanced by the fact that, in most cases, they had probably only been adjusted several times whilst they were in the television receivers, whereupon wear would be negligible.

Old television receivers abound in electrolytic capacitors. (In the days when such sets were made, h.t. smoothing was not effected by the 100+200 $\mu$ F components which we now take for granted.) The ones we found had that somewhat doubtful look which all electrolytics acquire after a period of years. We decided to give them a quick check with the testmeter switched to a resistance range. If the needle gave a reasonable kick on being connected and then fell back nearly to infinity, we felt that they would be good enough for possible use at some future date provided they were employed in circuits where there was no risk of damage if they broke down. Incidentally, all the electrolytics passed our test.

We next carried on to the fixed resistors. My friend had made no attempt to unsolder them, but had merely cut the lead-out wires as close to the tags as possible. Usually, this involved cutting across the tag itself, whereupon a quick touch with the iron was sufficient to enable the broken piece of tag on the lead-out wire to be shaken free. This is a much more sensible

idea than trying to reclaim an extra half-inch of lead-out wire by unwrapping the wire from the tag with the iron applied. In these early sets component lead-out wires were tightly "clenched" to their tags before soldering, and the heat involved in unwrapping them frequently does more harm than good. (I should add however that, when there is only a small amount of solder on the tag, it is frequently possible to tear off the wire by twisting it round with a pair of taper-nosed pliers, and with no heat applied at all. With this process some of the wire tinning stays on the joint.)

We had a good pile of resistors of assorted values and wattages, and we started sorting these out initially by appearance. Any carbon composition resistor which looked discoloured due to possible overheating was thrown out. We then checked the resistances of those with values above 470k $\Omega$ , as these are the ones which most frequently go high. This process revealed an open-circuit 1M $\Omega$ , an open-circuit 1.5M $\Omega$  resistor, together with a 680k $\Omega$  resistor which was reading 1.2M $\Omega$ . Slightly disconcerted at this, we checked *all* the resistors, and found that a 2.2k $\Omega$  resistor had gone up to 5k $\Omega$  and a 100k $\Omega$  up to 160k $\Omega$ . The moral of this little episode seems to be: never trust any carbon composition resistor obtained from an old receiver which has seen a reasonable amount of service. Measure its value first.

We next attacked the capacitors. These consisted of a number of ceramic and mica components, together with quite a good selection of paper capacitors from 0.01 $\mu$ F up. My friend was mainly worried about the paper capacitors since, after the number of years during which they had been stored away, they might well have become leaky. We had no leakage tester with us and so we fell back on a dodge I have often used in the past with

components of this nature. The scheme consists simply of connecting the paper capacitor between chassis and the h.t. positive line of a valve receiver, and of then discharging the capacitor by touching its leads against a metal plate. The capacitor should give a tiny spark when it is first connected to the h.t. supply and another spark when it is discharged. If the second spark does not occur, the capacitor is leaky. The charge and discharge sparks can be seen, and *heard*, quite distinctly in fairly dark and quiet surroundings. Obviously, the h.t. voltage employed must be equal to or lower than the working voltage of the capacitor. Equally obviously, capacitors with dead short-circuits should be sorted out beforehand, or there will be a few fireworks given when they are connected across the h.t. supply!

If would seem fairly safe to assume that, if the discharge spark is roughly equal in intensity to the spark given when charging, the time between charge and discharge should be less than the time constant of the capacitor value and its leakage resistance. A leakage resistance of 500M $\Omega$  would be a reasonable minimum in a paper capacitor and this, in combination with 0.01 $\mu$ F, gives a time constant of 5 seconds. If, therefore, a 0.01 $\mu$ F capacitor gives a good discharge spark after 5 seconds, its leakage resistance should be better than 500M $\Omega$ . Larger capacitors should hold their charge for a proportionately longer time for the same leakage resistance.

The test is very easy to carry out and, considering its simplicity, is surprisingly effective. It can be used for paper capacitors down to 0.005 $\mu$ F but, below this value, the charge and discharge sparks tend to be rather small and difficult to perceive.

We checked the stock of paper capacitors from the old television receivers by this method and found about 10% rejects. We found that the good capacitors were very good indeed, and could hold their charges for a period significantly longer than that corresponding to 500M $\Omega$  leakage resistance. The bad capacitors were, on the other hand, obviously bad and, whilst not exhibiting complete short-circuits, were so leaky that they gave a charge spark if they were touched across the h.t. line almost immediately after the first charge spark. The good capacitors gave one charge spark only, after which they remained fully charged up.

The remaining components in

the television sets fell into the miscellaneous category. Two quite useful speakers and speaker transformers were reclaimed, together with a good amount of assorted ironmongery. Both cathode ray tubes were on their last legs, and were unceremoniously ditched.

The bare chassis had the valve-holders still eyeleted to them, and we decided to leave these *in situ*. It was felt that they weren't worth the trouble of drilling out the eyelets and that their contacts and insulation would, in any case, be pretty unreliable after all these years.

Taken all in all, the whole exercise was quite interesting and instructive. For my friend it was also rewarding, since he had become the richer by a sizeable number of quite good components. There is the further fact that it is very nice, every now and again, to take a rest from constructing things and to apply oneself to the process of stripping them down instead!

#### U.H.F. Television

In last month's issue I gave a detailed account of present and future events with regard to 625 line broadcasts in this country on u.h.f. Since this went to press a little further information has come my way, which I shall now pass on.

The experimental test transmissions currently in progress are planned to be broadcast from 10.30 a.m. to 5 p.m., and 8 p.m. to 9.30 p.m. on Mondays to Fridays. Occasional transmissions may also be made at other times.

I said last month that the two test transmissions will be changed, probably in 1963, to two of the permanent channels allocated to the London area. Now, however, I learn that the plan is to have both the test transmitters paralleled to operate on *one* of the frequencies allocated to London. Also, the transmitting aerial will be increased in size to give an enhanced e.r.p. The installation and adjustment of the aerial and associated equipment should be completed in time for the start of regular programme transmissions early in 1964, the e.r.p. on the single channel being about 500kW. This should give a range of about 30 miles. There will, however, be pockets within the service area where local screening may cause reductions in signal strength; and one of the objects of the present trials is to establish the size and importance of such pockets.

#### "The New Atlantis"

We owe a minor debt of gratitude to science fiction, in that this type of writing can quite often open our eyes to imaginative projects which our more rational selves might otherwise refuse to entertain. Also, science fiction has presented us with the invaluable Finagle's Law!\*

We tend to forget, however, that for many hundreds of years imaginative authors have been describing events which, to their contemporaries, were quite as fantastic as are those predicted by the science fiction writers of today. One such was Francis Bacon (1561-1626), and I am indebted to Dartford Tape Recording Society for bringing to my attention the extract from Bacon's book *The New Atlantis* which appears below. This is taken from an old copy belonging to Miss Daphne Oram, who is well known for her work in the field of Electronic Music and who has accepted the office of President in the Dartford Tape Recording Society.

I feel that, apart from the almost incredible accuracy of the predictions it contains, the following extract provides a unique commentary on the aims and aspirations of the composers of Electronic Music, as well as on the mechanics of musical production as described for instance by Mr. F. C. Judd in his article on Third Stage Music in the present issue, or by Mr. S. Astley in his series on electronic organ construction which concluded last month.

"Wee have also Sound-houses, wher wee practise and demonstrate all Sounds, and their Generation. Wee have Harmonies which you have not, of Quarter-Sounds, and lesser Slides of Sounds. Diverse Instruments of Musick likewise to you unknowne, some sweeter than any you have; Together with Bells and Rings that are dainty and sweet. Wee represent Small Sounds as Great and Deepe; Likewise Great Sounds, Extenuate and Sharpe; Wee make diverse Tremblings and Warblings of Sounds, which in their Originall are Entire. Wee represent and imitate all Articulate Sounds and Letters, and the Voices and Notes of Beasts and Birds. Wee have certaine Helps, which sett to the Eare doe further the Hearing greatly. Wee have also diverse Strange and Artificiall

\*Finagle's Law states: If in any system something can go wrong, it will.

Echo's, Reflecting the Voice many times, and as it were Tossing it: And some that give back the Voice Lower than it came, some Shriller, and some Deeper; Yea some rendring the Voice, Differing in the

Letters or Articulate Sound, from that they receive. Wee have also meane to convey Sounds in Trunks and Pipes, in strange Lines, and Distances."

Whilst that voice from nearly

three and a half centuries ago is still in our minds, let us now look forward to the end of 1962.

With, I must add, all my sincere wishes for a Christmas which is truly Happy and Merry.

## 1962 International Radio Communication Exhibition

THIS EXHIBITION, AN ANNUAL event of great interest to radio amateurs and constructors alike, was held this year at the Seymour Hall, Seymour Place, W.1. In the writer's opinion, the new venue was a great improvement over that of former years. Once the main doors had been entered, a much more cosy atmosphere was at once apparent and, in addition, the hall was well lit, warm and comfortable. It is a personal contention that these exhibitions should be held bi-annually, there not being sufficient new developments apparent within the space of one calendar year to warrant the present frequency. Some evidence of this is the fact that many well-known concerns engaged in the marketing of components, etc., for the home constructor or amateur markets were again missing from the hall this year.

The most notable new introduction to the amateur scene was that of the K.W. Electronics Ltd, KW77 communications receiver. Introduced in prototype form last year, this receiver has now been in production for some months. Having the following advantageous features, it will become one of the best known receivers within a very short period of time—triple conversion, geared precision drive, slot filter, crystal controlled first mixer, built-in crystal calibrator, sideband selection, audio filter, absolute frequency stability, four passbands (3.8, 2.1, 1.0 and 0.5 kc/s), two-speed a.g.c., and a coverage of all amateur bands from 10 to 160 metres. From a close visual inspection the layout and mechanics were superb. In addition to the KW77, other receivers on show at this stand were from the Hammarlund, Hallicrafters and Drake ranges. The well-known KW "Viceroy" and "Vanguard" transmitters were also displayed.

Another new item of some note to the writer was the "Falcon", a rather unique 2-metre transmitter available for both a.c. mains operation or for 12V d.c. mobile use.

It is extremely robustly constructed, 100% plate and screen modulation, 3-channel switching, c.w. function and has a silver-plated chassis. Messrs Green and Davis also displayed their 2-metre nuvistor converter, this having a very low noise factor, a 6CW4 nuvistor r.f. stage, silver-plated chassis, an EF95 mixer and a crystal-controlled oscillator chain (6J6-EF95). A further 2-metre converter exhibited had a similar specification but with a 6BQ7A cascode r.f. stage. A 6CW4 nuvistor r.f. pre-amplifier for 2-metres, self-powered, was also featured.

Electroniques (Felixstowe) Ltd., introduced their first complete dial assembly, this consisting of a crystal clear dial escutcheon with hair-line cursor and slow-motion drive. The assembly provided several alternative blank scales for self-calibration and a well-designed tuning knob. The writer found this to be an extremely well made and attractive dial ideal for shortwave operation. Additionally, a wide range of their efficient "Stabcoils" were on display. This range of coils have a built-in adjustable capacity trimmer, core, and temperature compensation and a similar range, less trimmers, is available under the trade mark "Coilmax". A considerably extended range of high "Q" i.f. transformers were also to be seen on this stand, these transformers covering the frequency range 50 kc/s. to 2.2 Mc/s. Another new range of great interest here were the complete detector units, consisting of an i.f. transformer, an audio diode and a.g.c. diode complete with all the associated decoupling resistors and capacitors assembled, wired, tested and all enclosed within the i.f. metal can!

A feature of the exhibition this year was the G.P.O. stand, where the writer was intrigued by the communication satellite system working display. One had only to press a button in order to receive a verbal explanation of the project.

The M-O Valve Co. Ltd, displayed

a wide range of valves for communication purposes, these including v.h.f. and h.f. types for both transmitting and receiving. Audio amplifier, modulator and instrument types were also included. A low noise converter for the 70 cms and 23 cms bands, both with A2521 grounded grid r.f. amplifier stages, were featured, as was a demonstration 70 cms low power transmitter having a grounded grid A2521 output stage delivering some 2.5 watts to a dummy load. Also to be seen was a transmitter, for the same range, having a grounded grid DET24 power amplifier capable of some 12 watts output.

E. J. Phillpott's Metalworks Ltd, again had on show their well-known range of metal cabinets for all amateur purposes. Finished in various colours, and most attractive ones at that, they represented a modern trend in the departure from the once eternal black-crackle finish so evident some years ago. Several versions of differing style cabinets, based on the present popular "S" line, complete with two-colour finishes, were a special feature this year.

Salford Electrical Instruments Ltd, had on display their very latest presentation of multi-range test instruments, these including the high sensitivity "Selectest Super 50" and the pocket-sized "Minitest", both of these being particularly suitable for the checking of both radio and TV circuits. The latest types of miniature contact-cooled selenium rectifiers were of interest as were the quartz crystal units in a variety of different holders. These units are now available over a frequency range of 200 c/s to 136 Mc/s.

Daystrom Ltd, exhibited most items in their very large range of equipment specially designed for the home constructor. Of note here was the new QPM-1 "Q" Multiplier—actually on show for the very first time. Also noted were the world famous DX-100U and DX-40U transmitters, the SB-10U single

sideband adaptor, the VF-1U v.f.o. unit, the GC-1U fully transistorised general coverage receiver together with the B-1U balun coil unit and the GD-1U grid dip meter. All of these units made a most attractive display and one over which the writer could have spent a great deal of time—if only it were available!

The Minimitter Co. Ltd, presented for the first time their new transistorised mobile receiver for the 1.8 Mc/s band, this being complete with a built-in speaker and battery. This receiver has a "Q" multiplier circuit included and the whole assembly is enclosed in a total area of some 0.07 cubic feet. Also to be inspected here was the "Mercury 200" transmitter in its latest phase and the MR44/11 receiver. Some aerials to be seen here were the "Minibeam plus X20"—a 3-band combination array and the all-band "FB5", in addition to telescopic masts and v.h.f. aerials, etc.

Webb's Radio featured a wide range of Eddystone communication receivers, among these being the recently introduced "940" which includes a cascode r.f. stage and separate detectors for a.m. and c.w./s.s.b. This receiver has an excellent signal to noise ratio and is a great improvement over its predecessor, the well-known "680X"

which it now supersedes. The 8-valve "840C", the third and latest development in the "840" series, was also to be seen. A further receiver which the writer found of some interest was the fully transistorised "960" with a coverage from 500 kc/s to 30 Mc/s in six ranges and operating from a 12 volt battery. Intended primarily for professional usage, the superb "880/2" was a real beauty with thirty wavebands each being 1Mc in width, this being undoubtedly the ultimate in communication receivers!

In such a short report as this it is obviously impossible to cover all the stands fully, still less to mention all the interesting products which they so well displayed. All the Services were well represented with attractive stands and displays, not to mention the varied and interesting equipment which was to be seen on them.

The various society stands were also of interest, representing as they do the great enthusiasm necessary in such ventures and the volunteer staffs who so helpfully gave of their time and energies in order to make their individual stands both attractive to look at and, at the same time, helpful to all and sundry as well as to their

own existing members. The Radar and Electronics Association stand featured models showing the basic principles of the Telstar satellite; The Amateur Radio Mobile Society displayed "The Courier", a compact transceiver designed and built by a team of members; The British Amateur Television Club had a very interesting exhibit in the 9.5 mm telecine machine constructed by R. W. Tebbutt, the resulting cartoon being of great interest to onlookers; the Radio Society of Great Britain had a varied selection of their excellent publications on sale and also featured several items of amateur radio equipment including some entries for the Home Constructors' Competition. This was won by A. L. Mynett, G3HBW, for his transistorised communication receiver covering from 432 to 436 Mc/s and from 1296 to 1300 Mc/s.

The £120 KW77 communication receiver was won by a Mr. R. V. Sturtart of Yelvertoft, near Rugby.

Altogether the exhibition this year was an enjoyable event for the writer and next year my hope is that it will be both the biggest and most successful yet, it being the 50th anniversary (silver jubilee) of the Radio Society of Great Britain.

## A NEW-PRACTICAL WAY of UNDERSTANDING

### RADIO · TELEVISION · ELECTRONICS

Including: Transistors; VHF/FM; Hi-Fi Equipment; Computers; Servo-Mechs. Test Instruments; Photo-electrics; Nucleonics; etc.

Radiostructor—an organisation specialising in electronic training systems—offers a new self-instructional method using specially designed equipment on a "do-it-yourself" basis. You learn by building actual equipment with the big kits of components which we send you. You advance by simple steps, performing a whole series of interesting and instructive experiments—with no complicated mathematics! Instructional manuals employ the latest techniques for showing the full story of electronics in a practical and interesting way—in fact, you really have fun whilst learning!

**FREE** THIS BOOK WILL INTEREST YOU!

LEARNING the PRACTICAL WAY

FOR ... Your Career  
... Your Own Business  
... An Absorbing Hobby

**Radiostructor**  
EQUIPMENT-COURSES

# RADIOSTRUCTOR

LEADS THE WORLD  
IN ELECTRONICS TRAINING

## POST NOW

To RADIOSTRUCTOR (Dept. G149), READING, BERKS.  
Please send brochure, without obligation, to:

\*Name

\*Address

(We do not employ representatives) 12/62  
\*Block Caps Please



# Build the Sinclair MICRO-AMPLIFIER

ACTUAL SIZE

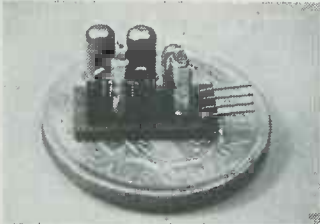

This amplifier is made possible by the remarkable micro-alloy transistors it uses. These are available separately at the following prices:—

MAT 100	7/9
MAT 101	8/6
MAT 120	7/9
MAT 121	8/6

This microscopic amplifier, the smallest of its type in the world, out-performs amplifiers 20 times as large. The main features of the design are listed below:

- 1) Power Gain—60dB (1,000,000 times)
- 2) Power Consumption—from 0.4mA at 1.3V to 1mA at 9V. Any battery may be used.
- 3) Output Power—sufficient to drive ANY type of ear piece or even a loudspeaker.
- 4) Frequency Response—30 c/s to 20 kc/s  $\pm 1$ dB. True High Fidelity performance.
- 5) Clear and detailed instructions enable the micro-amplifier to be built in under two hours with ordinary tools.
- 6) Uses brand new microminiature components and micro printed circuit.
- 7) Free applications data supplied with every kit showing how to use the amplifier with high and low impedance pick-ups—and micro-phones and hi-fi stereo headphones. Circuitry is given for using the amplifier in micro-radios and transmitters, and with a micro telephone pick-up coil (also available).
- 8) Satisfaction guaranteed. Overall Size  $\frac{3}{4}$ "  $\times$   $\frac{3}{8}$ "  $\times$   $\frac{1}{2}$ "

**28/6** plus 1/6 postage and packing from:

**SINCLAIR RADIONICS LTD**  
Telephone Cambridge 53965

**69 Histon Road, Cambridge**  
(Trade enquiries invited.)

## with a MARTIN RECORDAKIT

YOU CAN BUILD YOUR OWN



**TAPE RECORDER QUICKLY, EASILY, CHEAPLY**  
WITH NO PREVIOUS EXPERIENCE

With a Martin Recordakit everything you need is supplied, ready to assemble—even down to wire cut to length. The easiest and cheapest way to own a Hi-Fi quality Tape Recorder. Fill in the coupon for full details.

Post to: MARTIN ELECTRONICS LTD.  
155 HIGH STREET, BRENTFORD, MIDDX.  
Please send me free leaflet on Martin Recordakits

NAME .....

ADDRESS .....

(In block letters).....RC12/62.....

# AT LAST

an inexpensive, quick, simple and reliable Transistor Tester for Service Engineers and amateur radio enthusiasts.

- ★ The K.L.B. Transistor Check requires no setting up
- ★ Checks A.C. gain at the press of a button
- ★ Positive indication of good transistors by cold-cathode glow tube
- ★ Checks NPN and PNP transistors. No damage to the transistor if the wrong button is pressed; the two types can thus be differentiated.
- ★ Supplied with special plugs for flexible leads for "in circuit" checking of transistors.

PRICE including Packing and Postage (less battery) **£4.12.6**



**K. L. B. ELECTRIC LTD.** Holloway Engineering Works Parkhurst Road London N7

## YOU CAN HOLD EUROPE IN THE PALM OF YOUR HAND WITH

# The "CAPRI"!

The miniature pocket transistor Radio that **REALLY** works! Six first-grade Mullard transistors plus diode are employed in a highly sensitive superhet MW and pre-set LW circuit embodying the most modern design practices. A special 2½in high-gauss loudspeaker provides surprising volume and a personal earpiece socket is also available. An attractive two-tone plastic case is supplied in two colours—ivory/red or ivory/blue, the full constructional details being furnished with each set of parts. The total measurements of the Capri are 4½ x 2¾ x 1¼in.

**SEE AND HEAR A WORKING MODEL TODAY**

**TURN TO PAGE 365 FOR FULL CONSTRUCTIONAL DETAILS OF THIS WONDERFUL RECEIVER. WE HAVE LARGE STOCKS OF ANY OR ALL OF THE PARTS SPECIFIED FOR THE "CAPRI". SEND A STAMPED AND ADDRESSED ENVELOPE FOR A FREE PRICED PARTS LIST.**

Inclusive price for all associated components, case and constructional data, complete in every detail, or our BUY AS YOU BUILD Scheme. **ANY PARTS SOLD SEPARATELY.** (9 volt battery 2/6 extra.)

**£5.19.6**  
ONLY plus 2/- P. Pkg.

## RADIO CLEARANCE LTD

ESTABLISHED 35 YEARS

27 TOTTENHAM COURT RD., LONDON, W.1  
The oldest Component Specialists in the Trade

Telephone: MUSEUM 9188

# COLLARO STUDIO TAPE RECORDER KIT

SPECIAL BARGAIN OFFER. Comp. Kit only £25 Carr. 12/6

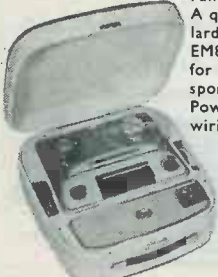

Famous mfr's. surplus offer—listed 42 gns. A quality Tape Recorder Kit based on Mullard's famous design—EF86, ECC83, EL84, EM81 and Rectifier. Specially designed Kit for Collaro latest Studio Deck, freq. response  $\pm 3$ db, 60 c/s—10 kc/s. Amp. and Power Pack already wired, inter. unit wiring only required. Cabinet size: 18" x 16 1/2" x 6" finished in contemp. 2-tone blue Rexine with gilt Speaker Escutcheon. Magic Eye indicator. Circuit and Tech. H/book, supplied free with kit. Send 3d. stamp now for full details of today's outstanding Tape Recorder Bargain.

**COLLARO TAPE DECK**  
£12.10.0 Carr. 7/6

CABINET £3.15.0. P. & P. 6/6  
AMPLIFIER KIT £8.19.6. P. & P. 5/-  
SPEAKER 7" x 4" 16/6. P. & P. 2/-  
If above items are £12.19.6 P. & P. purchased together 10/-

New Boxed	VALVES	Guaranteed	All Electrolytics	All Types New Stk.	
1T4	6/-	ECC83 8/-	PCC84 9/6	25/25V 1/9	8+8/450V 4/6
1R5	7/6	ECL82 10/6	PCF80 9/6	50/12V 1/9	16+16/450V 5/6
1S5	7/6	ECL80 10/6	PCL83 12/6	50/50V 2/-	32+32/275V 4/6
354	7/6	EF80 8/-	PCL84 12/6	100/25V 2/-	50+50/350V 6/6
3V4	7/6	EF86 12/6	PL81 12/6	8/450V 2/3	60+250/ 2/3
DAF96	9/-	EL84 8/6	PL82 9/6	4/350V 2/3	275V 12/6
DF96	9/-	EY51 9/6	PL83 10/6	16+16/450V 5/6	100+200/ 12/6
DK96	9/-	EY86 10/-	PY32 12/6	32+32/450V 6/6	275V 12/6
DL96	9/-	EZ81 7/6	PY81 9/6		
ECC81	8/-	GZ32 12/6	PY82 7/6		
ECC82	8/-	EM84 9/6	U25 12/6		

**RECORDING TAPE—REDUCED BARGAIN PRICES**  
Famous American Columbia (CBS) Premier Quality Tape at NEW REDUCED PRICES. A genuine recommended Quality Tape—TRY IT! Brand new, boxed and fully guaranteed. Fitted with leader and stop foils.

Standard	Long Play	Double Play
5" 600ft, 13/-	900ft, 17/6	1,200ft, 31/6
5 1/2" 900ft, 16/-	1,200ft, 19/6	1,800ft, 37/6
7" 1,200ft, 21/-	1,800ft, 28/6	2,400ft, 47/6

Post and Packing, per reel, 1/-, plus 6d. each for additional reels.  
**SPECIAL OFFER**—3" mfrs. surplus tape, Std. 150 ft. 3/9, L.P. 225 ft. 4/9, D.P. 300 ft. 6/6. P. & P. per reel 6d. Plastic Tape Reels 3" 1/3, 5" 2/-, 5 1/2" 2/-, 7" 2/3. Plastic Spool Containers 5" 1/6, 5 1/2" 2/-, 7" 2/3

**Jack Plugs.** Standard 2 1/2" Igranite Type, 2/6. Screened Ditto, 3/3. Miniature 1 1/2", 2/3. Screened Ditto, 2/6.  
**Jack Sockets.** Open Igranite Moulded Type, 3/3. Closed Ditto, 3/9. Miniature Closed Type, 1/9. Sub-min (deaf aid) ditto, 1/3.  
**Phono Plugs 1/-.** Phono Sockets (open), 1/-, Ditto Closed, 1/6. Twin Phono Sockets (open), 1/6.  
**Soldering Irons.** Mains 200/220V or 230/250V. Solon 25 watt Inst., 22/6. Spare Elements, 4/6. Bits, 1/- 65 watt, 27/6 etc.  
**Alumin. Chassis.** 18g. Plain Undrilled, folded 4 sides, 2" deep. 6" x 4", 4/6, 8" x 6", 5/9, 10" x 7", 6/9, 12" x 6", 7/6; 12" x 8", 8/- etc.  
**Alumin. Sheet.** 18g. 6" x 6", 1/-, 6" x 9", 1/6, 6" x 12", 2/-, 12" x 12", 4/6 etc.

**Volume Controls**—5K-2 Meg-ohms, 3" Spindles Morganite Midget Type. 1 1/2" diam. Guar. 1 year. LOG or LIN ratios less Sw. 3/- DP. Sw. 4/6. Twin Stereo less Sw. 6/6. D.P. Sw. 8/-.

**COAX 80 OHM CABLE**  
High grade low loss Cellular air spaced Polythene—1/4" diameter. Stranded cond. Famous mfrs. Now only 6d. per yard.  
**Bargain Prices—Special lengths** 20 yds. 9/- P. & P. 1/6. 40 yds. 17/6 P. & P. 2/- 60 yds. 25/- P. & P. 3/-  
Coax Plugs 1/- Sockets 1/- Couplers 1/3. Outlet Boxes 4/6.

**Close Tol. S/Micas**—10% 5pF 500pF 8d. 600-5,000pF 1/- 19% 2pF-100pF 9d. 100pF-500pF 11d. 575pF-5,000pF 1/6. Resistors—Full Range 10 ohms-10 megohms 20%  $\pm$  and 1/2W 3d., 1/2W 5d. (Midget type modern ratings) 1W 6d, 2W 9d. Hi-Stab 10% 1/2W 5d., 1W 7d. 5% 1/2W 9d., 1% 1/2W 1/6. W/W Resistors 25 ohms to 10K 5W 1/3, 10W 1/6, 15W 2/- Pre-set T/V Pots. W/W 25 ohms—50 K 3/-, 50 K-2 Meg. (Carbon) 3/-.

**JASON FM TUNER UNITS**  
Designer-approved kits of parts: FMT1, 5 gns. 4 valves, 20/- FMT2, £7. 5 valves, 37/6. JTV MERCURY 10 gns. JTV2 £13.19.6. 4 valves, 32/6.  
**NEW JASON FM HANDBOOK**, 2/6. 48 hr. Alignment Service 7/6. P. & P. 2/6.

**Speakers P.M.**—3 ohms 2 1/2" E.M.I. 17/6. Goodmans 3 1/2" 18/6. 5" Rola 17/6. 6" Elac 18/6. 7" x 4" Goodmans 18/6. 8" Rola 20/- 10" R. x A. 25/-, 9" x 6" Goodmans 25/- E.M.I. Tweeter 29/6.  
**Speaker Fret**—Expanded bronze anodised metal 1/4" x 1/4" diamond mesh, 4/6 sq. ft., multiples of 6" cut. Max. width 4 ft.  
**TYGAN FRET** (contemp. pat.) 12" x 12" 2/-, 12" x 18" 3/-, 12" x 24" 4/-, 18" x 18" 4/6

**BARGAINS 4-SPEED SINGLE PLAYER UNITS**  
Single Players carr. 3/6  
Garrard TA Mk. 2 £7.19.6  
B.S.R. Latest Model TU12 79/6  
E.M.I. Junior "985" 89/6  
**Auto-Changers** carr. 5/-  
Garrard RC209 9 1/2 gns.  
Garrard "Auto-Slim" £8.12.6  
Collaro C60 £7.15.0  
B.S.R. (UA14) £7.10.0

**ENAMELLED COPPER WIRE**—1lb reels, 14g-20g, 2/6; 22g-28g, 3/-; 30g-40g, 3/9. Other gauges quoted for.  
**PVC CONNECTING WIRE**—10 colours (for chassis wiring, etc.)—Single or stranded conductor, per yd., 2d. Sleeving 2d. yd.

**TRANSISTOR COMPONENTS**  
Midget I.F.'s—465 Kc/s 1/2" diam. 5/6  
Osc. Coil—1/4" diam. M/W. 5/3  
Osc. coil M. & L.W. 5/9  
Midget Driver Trans. 3.5:1 6/9  
Ditto O/Put Push-pull 3 ohms 6/9  
Elect. Condensers—Midget Type 12V 1mfd-50mfd, ea. 1/9. 100mfd, 2/-  
Ferrite Aerial—M. & L.W. with car aerial coupling coil, 9/3.

**Condensers**—150V. wkg. .01 mfd., to .04 mfd., 9d. .05 mfd., 1 mfd., 1/- .25 mfd., 1/3. .5 mfd., 1/6, etc.  
**Tuning Condensers.** J.B. "00" 208+176pF, 8/6. Ditto with trimmers, 9/6. 365pF single, 7/6. Sub-min. 1/2" DILEMIN 100pF, 300pF, 500pF, 7/-  
**Midget Vol. Control** with edge control knob, 5K $\Omega$  with switch, 4/9, ditto less switch, 3/9.  
**Speakers P.M.**—2" Plessey 75 ohms, 15/6. 2 1/2" Continental 8 ohms, 13/6. 7" x 4" Plessey 35 ohm, 23/6.  
**Ear Plug Phones**—Min. Continental type, 3ft. lead, jack plug and socket, High. Imp. 8/- Low Imp., 7/6.

**TRANSISTOR BARGAINS**  
Brand New—BVA 1st Grade

OC44	8/6	OC70	5/6
OC45	8/-	OC71	6/-
OC81	7/6	GEX34	2/9
2/OC81	15/6	OA70	2/9
GET114	6/6	OA81	2/9
OC72	7/6		

**SPECIAL OFFER**  
OC44 } 21/6 OC81D } 19/6  
2/OC45 } 2/OC81 }

**TRIMMERS, Ceramic.** (Compression Type)—30pF, 70pF, 9d., 100pF, 150pF, 1/3; 250pF, 1/6; 600pF, 1/9.  
**PHILIPS, Bee Hive Type** (conc. air spaced)—2-8pF, 1/-; 3-30pF, 1/-  
**KNOB**—Modern Continental types: Brown or Ivory with Gold Ring, 1" dia., 9d. each; 1 1/2", 1/- each; Brown or Ivory with Gold Centre, 1" dia., 10d. each; 1 1/2", 1/3 each.  
**LARGE SELECTION AVAILABLE.**  
**METAL RECTIFIERS, STC Types**—RM1, 4/9; RM2, 5/6; RM3, 7/6; RM4, 16/-; RM5, 21/-; RM4B, 17/6.

## MULLARD "3—3" HI-FI AMPLIFIER 3 VALVES 3 WATT

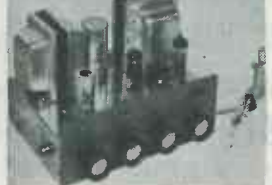

**3 ohm and 15 ohm Output**  
A really first-class Amplifier giving Hi-Fi quality at a reasonable cost. Mullard's latest circuit. Valve line-up: EF86, EL84, EZB1. Extra H.T. and L.T. available for Tuner Unit addition. This is the ideal companion Amplifier for FM tuner units.

**TECHNICAL SPECIFICATION**—Freq. Response:  $\pm 1$ db. 10 Kc/s. Max. Bass Boost 14 db. at 80 c/s. sensitivity: 100 MV. for 3V output. Output Power (at 400 c/s): 3W. at 1% total harmonic distortion. Hum and Noise Level: At least 70 db. below 3W.

**COMPLETE KIT** (incl. valves, all components, wiring diagram and special quality sectional Output Trans.)  
**Bronze Escutcheon Panel, Printed Vol., Treble, Bass, On-Off,** supplied with each Kit.

**ONLY £6/19/6 carr. 4/6d.**  
Complete wired and tested 8 gns. Wired power O/P socket and additional smoothing for Tuner Unit, 10/6 extra.  
**Recommended Speakers**—WBHF 10 £2.65, Goodmans Axiom 10 £5/15/8, Axiote £6/10, or Axiom 112 £8/10.

## RECORD PLAYER CABINETS

Contemporary style, rexine covered cabinet in mottled red and white polka dot. Size 18 1/2" x 13 1/2" x ht. 8 1/2", fitted with all accessories including baffle board and anodised metal fret. Space available for all modern amplifiers and auto-changers, etc. Uncut record player mounting board 14" x 13" supplied.  
**Cabinet Price £3.3.0 Carr. and Ins. 5/-**



**2-VALVE 2 WATT AMPLIFIER**  
Twin stage ECL82 with vol. and neg. feedback tone control. A.C. 200/250V with knobs etc., ready wired to fit above cabinet. £2.17.6. P. & P. 1/6. 6" Speaker and trans, 22/- P.P. 2/-

**COMPLETE R/PLAYER KIT.** Ditto RECORD PLAYER KIT As ill. carr. BSR UA14 Unit £12.19.6. Carr. 7/6.

Send for detailed bargain lists, 3d. stamp. We manufacture all types Radio Mains Transf. Chokes, Quality O/P Trans., etc. Enquiries invited for Specials, Prototypes for small production runs. Quotation by return  
**RADIO COMPONENT SPECIALISTS**  
70 Brigstock Rd., Thornton Heath, Surrey  
THO 2188 Hours: 9 a.m.—6 p.m., 1 p.m. Wed. Terms C.W.O. or C.O.D. Post and Packing up to 1 lb 9d., 1 lb., 1/3 3 lb., 2/3 5 lb., 2/9 8 lb. 3/6  
Est. 1946

# MINISETS LTD Hatherley Mews London E17

## THE IMPERIA

An easy-to-build 6-Transistor Portable Superhet which can be built by the constructor. Pre-assembled circuit board for easy construction. All components are new. 5" speaker giving good tone and output. Attractive case of exclusive design 8½" x 5½" x 2½" with gold-plated grille. Specially designed matching coil for use in car. Only first grade fully guaranteed matched transistors and diodes are used. Anyone can build this set for **£7.17.0**

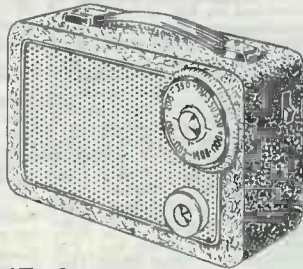

Everything supplied except soldering iron. P. & P. 3/-. Full instructions 1/6 (free with order).

## 6-Stage Transistor Pocket Portable

Can be built for **£4.19.6** P.P. 2/6  
 ★ Completely self contained, no aerial or earth required.  
 ★ Push-pull output, 250 milliwatts.  
 ★ 3" high flux speaker  
 ★ Pre-assembled circuit board with simple instructions ensuring easy construction  
 ★ High Q Ferrite Rod Aerial  
 ★ After-sales service  
 Can be supplied with long-wave 6/- extra



Full instructions, price list 1/6 (Free with order)

## 3-Transistor Radio (plus 2 diodes)

Total building **70/-** P.P. 2/6

- ★ Pre-assembled circuit board, ensuring easy construction
- ★ Full medium-wave coverage
- ★ Attractive case 5½" x 3" x 1½"
- ★ All components including transistors are brand new and direct from manufacturers
- ★ Ferrite Rod aerial coil, no external aerial or earth required
- ★ 2½" high flux speaker direct from manufacturer
- ★ After-sales service

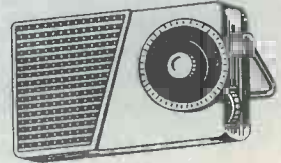

Send 1/6 for instructions, circuit and price list

## THE RIETI

6-Stage super sensitive Transistor Portable. Easy to build. All components first grade. A real portable transistor radio, covering Medium wave reception. 5" speaker, high Q ferrite aerial especially designed. Pre-assembled circuit board enables the complete set to be assembled and tested before placing in case.

Attractive case 8½" x 5½" x 2½" with gold-plated grille. Total build costs **£5.2.6** P. & P. 3/-

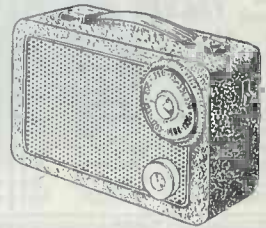

Medium and Long wave 8/- extra. Full instructions 1/6 (free with order).

# PANDORA

THE NEW

TRANSISTOR 6

Designed By

Mel Electronic  
**ONLY £6.19.6.**

USING NEW HIGH GRADE PARTS

FULL AFTER SALES SERVICE



TOTAL BUILDING COST

SEND S.A.E. ONLY FOR FREE DETAILS and Information on other Transistor designs

- MEDIUM WAVE, LONG WAVE/LIGHT PROGRAMME
  - 6 TRANSISTORS + DIODE
  - SUPERHET CIRCUIT
  - AUTOMATIC WAVECHANGE
  - 500mW PUSH PULL OUTPUT
  - PRE-TINNED PRINTED BOARD
  - EXCELLENT RESULTS
- Obtainable from your local stockist or in case of difficulty DIRECT FROM

## ½ WATT 3-TRANSISTOR AMPLIFIER

- ½ Watt Peak Output
- Output to 3Ω Speaker
- 9 Volts Operated
- Push-pull Output Stage



A PRINTED CIRCUIT HIGH GAIN AMPLIFIER

Size 3½ x 2 x ¾ in.

Price **45/-** P. & P. 1/6

Using two Newmarket transistors (NKT251 and NKT252). Ideal for intercomm. or as record player amplifier.

## 2 WATT 4-TRANSISTOR AMPLIFIER

with Two Drivers and Push-Pull Stage

Size 4 x 2¾ x ¾ in.

Ready Built **62/6** P. & P. 1/6

MEL ELECTRONIC CO.

R/O 240 HIGH STREET BECKENHAM KENT

# SMALL ADVERTISEMENTS

Private: 3d. per word, including address.  
Minimum charge 2/6.  
Use of Box Number, 2/- extra.

Trade: 9d. per word. Minimum charge 12/-.  
Terms: Cash with order.

All copy must be received by the 6th of the month for insertion in the following month's issue. The Publishers cannot be held liable in any way for printing errors or omissions, nor can they accept responsibility for the *bona fides* of advertisers.

## PRIVATE

**FOR SALE.** Short wave receivers: R107, 1.2-18 Mc/s, built in speaker, mains power supply, £12 10s. 0d.; R208, 10-60 Mc/s, built in speaker, mains power supply, £10 10s. 0d.; R1475, 1.8-20 Mc/s, mains battery power unit, £12 10s. 0d.; CR100/8, 60 kc/s-30 Mc/s, built in mains power unit, £18 10s. 0d. All guaranteed good condition. Carriage paid.—Clappison, 291 Beverley Road, Hull.

**WANTED.** R1155N or L, unmodified. Good clean condition.—Harwood, 32 Moorhey Road, Maghull, Nr. Liverpool.

**WANTED TO BUY.** RX BC348, working condition, modified or unmodified.—Replies to: Henderson, 26 Coatham High Street, Redcar, Yorkshire.

**WANTED.** Wearite FR7 record head. State price.—7 Estate Road, Hadleigh, Essex.

**FOR SALE.** Motek K10 tape deck, £2 o.n.o. Martin Type C tape amp, less valves, £2 o.n.o.—Darke, Wejbank Hall, Bootle, Cumberland.

**FOR SALE.** Newnes *Radio and Television Servicing*. Seven volumes, complete to 1959. As new, £7 10s. 0d.—127 Kirriemuir Avenue, Glasgow, S.W.2.

**FOR SALE.** Avo sig. gen. 50 kc/s-80 Mc/s, as new. Cossor oscilloscope, amplifiers, tape decks, TV and radio sets, components.—Leszczynski, 8 Cedar Court, Upper Park Road, New Southgate, London, N.11. Tel.: ENT 3796 (evenings and weekends); PAL 1003 (day-time).

**FOR SALE.** Baker corner speaker, double cone, oak, sandfilled baffle, superb quality, £10.—Marsh, 108 Eden Park Avenue, Beckenham, Kent. Tel.: BEC 1825.

**FOR SALE.** 5 volumes *Radio Constructor* (one unbound); 9 volumes *Practical Wireless*, both to 1961. Zeiss Nettar Camera f4.5. Case. Exchange Avo meter 7 or cash.—12 Seafeld Gardens, Aberdeen.

**XMAS OPPORTUNITY.** At half cost price. 8 volumes *Newnes Radio and Television Servicing*. As new, £8. Prefer buyer collects. Otherwise half carriage extra.—C.L.R., 56 Avondale Avenue, Off Hornby Street, Bury, Lancs.

**FOR SALE.** Goldring 700 Mk. II Stereo Cartridge £4, and Hemlock 580 Cartridge £2. Both used for one hour only.—22 Goding Avenue, Long Eaton, Nottingham.

**WANTED.** 6½in wafer type loudspeakers.—Box No. F164.

*continued on page 389*

# BENTLEY ACOUSTIC CORPORATION LTD

38 CHALCOT ROAD CHALK FARM LONDON NW1  
THE VALVE SPECIALISTS Telephone PRIMROSE 9090  
ALL GOODS LISTED BELOW IN STOCK

\*indicates valves with new type chemical cathode for extra life & reliability

OA2	17/6	757	9/6	DD41	13/7	EL83	19/5	R19	19/5	MIDGET
OB2	17/6	774	7/6	DF66	15/6	EL84	7/6	SP41	3/6	SILICONE
OZGT	5/6	8D2	3/6	DF96	7/6	EL85	13/7	SP61	3/6	RECTI-
IA5	6/6	9BW6	14/11	DF97	9/6	EL86	16/10	SU25	27/2	FIERS
IA7	12/6	9D2	4/6	DH63	6/6	EL91	5/6	T41	9/6	
IC5	12/6	10C1	12/6	DH76	5/6	EL95	10/6	TDD4	12/6	Mullard
IG6	17/6	10C2	25/11	DH77	6/6	EL360	27/6	TP22	15/6	BY100
IHSGT	10/6	10D2	11/8	DK40	21/10	EL820	18/2	TY86F	13/6	Output 250
IL4	3/6	10F1	25/11	DK91	6/6	EL821	25/11	UI2/14	8/6	v. at 1 amp.
ILD5	5/6	10P13	15/6	DK92	10/6	EL822	19/6	UI6	10/6	No larger
ILN5	5/6	10P14	18/9	DK96	8/6	EM4	17/9	UI8/20	8/6	than a shirt
INSGT	10/6	12A6	5/6	DL66	17/6	EM34	9/6	UI9	48/6	button!
IR5	6/6	12AC614/11		DL68	15/6	EM71	23/10	U22	8/6	8/- each.
IS4	9/6	12AD616/10		DL92	6/6	EM80	9/6	U24	29/6	
IS5	5/6	12AE6	13/7	DL94	7/6	EM81	9/6	U25*	17/6	TRANS-
IT4	3/6	12AH8	12/6	DL96	7/6	EM84	10/6	U26*	9/6	ISORS
IU4	12/6	12AT6	7/6	DL510	10/6	EM85	16/10	U31	11/6	DIODES
IUS	5/6	12BA6	8/6	DM70	7/6	EN31	53/6	U33	29/11	GD3
2D21	15/6	12BE6	9/6	E80F	30/6	EY51	8/6	U35	29/11	GD4
2X2	4/6	12BH7	20/9	E83F	30/6	EY83	16/2	U37	32/4	GD5
3A4	6/6	12J7GT	8/6	E180F	34/6	EY86*	7/6	U45	13/6	GD6
3A5	10/6	12K5	17/6	EAB80	9/6	EZ40	6/6	U50	5/6	GD7
3B7	12/6	12K7GT	5/6	EAC91	4/6	EZ76*	7/6	U52	4/6	GD9
3D6	5/6	12K8	14/6	EAF42	9/6	EZ80	6/6	U76	6/6	GD10
3Q4	7/6	12Q7GT	5/6	EB41	8/6	EZ81	6/6	UI07	19/6	GD12
3Q5	9/6	12SA7	8/6	EB91	4/6	GU50	41/6	UI91	16/2	GD15
354	6/6	12SC7	8/6	EBC33	5/6	GZ30	9/6	U201	16/2	GD16
3V4	7/6	12SK7	6/6	EBC41	8/6	GZ32	10/6	U281	19/6	GET106
5R4GY	17/6	12SC7	11/6	ECC31	19/6	KT63	19/6	U282	22/8	GET114
5U4G	4/6	19AQ5	10/6	EBF80	8/6	GZ34	14/6	U301	22/8	GET873
5V4G	10/6	19H1	10/6	EBF83	13/7	HL2	7/6	U329	14/6	GET874
5Y3	5/6	20D1	14/11	EBF89	9/6	HN309	29/11	U339	16/2	GEX13
5Z3	19/5	20F2*	25/11	EBL31	22/8	HVR2	10/6	U404	6/6	GEX35
5Z4G	9/6	20L1*	25/11	EC52	5/6	HVZ2A	6/6	U801	29/11	GEX36
6A6	9/6	20P1*	25/11	EC54	6/6	KT33	5/6	U4020	9/6	GEX45
6AG5	5/6	20P3*	22/8	EC70	17/6	KT33C	8/6	UACB80	9/6	GEX55
6AG7	7/6	20P4*	25/11	EC81	27/6	KT36	32/4	UAF42	9/6	15/6
6AK5	8/6	20P5*	22/8	EC92	13/6	KT41	29/11	UB41	12/6	GEX64
6AQ5	7/6	25A6G	10/6	ECC32	5/6	KT44	12/6	UBC41	8/6	GEX66
6AT6	6/6	25L6GT	11/6	ECC33	8/6	KT61	12/6	UBC81	11/6	AF102
6AU6	10/6	25Z4G	11/6	ECC34	23/11	KT63	7/6	UBF80	9/6	AF114
6B8	3/6	25Z5	10/6	ECC35	8/6	KT66	15/6	UBF89	9/6	AF115
6BA6	6/6	27SU	25/11	ECC40	17/6	KT88	43/6	UCC85	7/6	AF116
6BE6	6/6	28D7	7/6	ECC81	5/6	KT101	32/4	UCF80	6/6	AF117
6BH6	8/6	30C1*	7/6	ECC82	5/6	KTW61	6/6	UCH42	9/6	OA5
6BJ6	6/6	30C15	16/2	ECC83	7/6	KTW62	7/6	UCH81	9/6	OA10
6BQ7A	15/6	30F5*	6/6	ECC84	9/6	KTW63	6/6	UCL82	9/6	OA70
6BR7*	9/6	30FL1*	9/6	ECC85	7/6	MH14	7/6	UCL83	18/9	OA73
6B8	18/2	30L1*	7/6	ECC86	18/2	MU14	8/6	UF41	9/6	OA75
6B57	25/6	30L15*	9/6	ECC87	10/6	N37	25/11	UF42	12/6	OA81
6BV6*	10/6	30P4*	15/6	ECC88	10/6	N78	29/11	UF80	2/6	OA85
6BV7*	5/6	30P12	7/6	ECC89	15/6	N108	29/11	UF85*	9/6	OA86
6C5	6/6	30PL1	9/6	ECC85	6/6	N308	20/11	UF86*	13/6	OA91
6C9	13/6	30PL13	10/6	ECC42	9/6	N339	15/6	UF89	8/6	OA92
6C06G	3/6	35C5	21/6	ECC45	13/6	P595	13/6	UL18	18/2	OA93
6CH6	7/6	35L6GT	9/6	ECC83	13/7	PCC84*	7/6	UL44	25/11	OA21
6D6	6/6	35W4	7/6	ECL80	9/6	PCC85	9/6	UL46	14/6	OC16W35
6E5	12/6	35Z3	18/2	ECL82	9/6	PCC88	18/2	UL84*	8/6	OC19
6F2	25/11	35Z4GT	6/6	ECL83	18/9	PCC89*	8/6	UM34	17/9	OC22
6F6G	7/6	35Z5GT	9/6	ECL86	16/2	PCF80*	7/6	UM34	16/10	OC26
6F7	10/6	50L6GT	10/6	EF2	22/8	PCF82	10/6	UM60	14/11	OC30
6F23	10/6	50L6GT	10/6	EF22	14/6	PCF84	16/10	UR1C	18/2	OC36
6F24	9/6	52K10	14/4	EF36	4/6	PCF86	9/6	U6	19/5	OC41
6F33	7/6	53KU	19/5	EF37A	8/6	PCL82*	9/6	U08	25/11	OC44
6J5	5/6	72	4/6	EF39	4/6	PCL83*	9/6	U09	6/6	OC44PM
6J6	3/6	78	6/6	EF40	15/6	PCL84*	7/6	UY1N	18/2	OC45
6J7G	4/6	80	9/6	EF41	8/6	PCL85*	10/6	UY21	16/2	OC45PM
6K7G	2/6	83	15/6	EF42	10/6	PCL86	16/2	UY41	6/6	OC65
6K8G	5/6	85A2	16/6	EF50(A)	7/6	PEN25	4/6	UY85	6/6	OC66
6K25	19/5	90AG	67/6	EF50(E)	5/6	PEN45	19/6	VM54B	15/6	OC70
6L1	22/8	90AV	67/6	EF54	5/6	PEN46	4/6	VP4	15/6	OC71
6L6G	7/6	90CC	37/6	EF73	10/6	PL33	8/9	VP4B	22/8	OC72
6L7GT	7/6	90CV	37/6	EF80*	5/6	PL36*	15/6	VP13C	7/6	OC73
6L18	13/6	90C1	16/6	EF85*	6/6	PL38	25/11	VP23	6/6	OC75
6N7	8/6	150B2	18/6	EF86*	9/6	PL8	10/6	VR105	7/6	OC76
6P28	25/11	150C2	17/6	EF89	9/6	PL82	7/6	VR150	7/6	OC77
6Q7G	6/6	185BT	32/4	EF91	3/6	PL83	9/6	W76	5/6	OC78
6R7G	10/6	807	6/6	EF92	4/6	PL84*	12/4	W81M	6/6	OC81
6S17	6/6	5763	7/6	EF97	9/6	PL820	18/2	X61	12/6	OC81M
6SN7	5/6	AC6PEN	7/6	EF98	13/6	PM84	16/10	X65	12/6	OC82
6J4GT	12/6	AZ1	10/6	EF183	18/2	PM84	10/6	X66	12/6	OC83
6U5G	7/6	AZ4	13/7	EF184	9/6	PY31	16/2	X76M	14/6	OC84
6V6G	4/6	B36	9/6	EK32	8/6	PY32*	13/6	X78	29/11	OC140
6V6GT	8/6	BL63	7/6	EL32	5/6	PY80	7/6	X79	45/6	OC170
6X4	4/6	CL33	18/9	EL33	12/6	PY81	7/6	XD(1.5)	6/6	OC171
6X5	5/6	CY1	18/2	EL34	15/6	PY82	7/6	XFG1	18/2	OCP71
6/30L2	10/6	CY3	11/6	EL37	23/11	YB3	7/6	XFY34	17/6	PCX101
7B7	8/6	D5	13/6	EL38	25/11	YB3	7/6	XF54	18/2	PCX101A
7C5	8/6	D43	17/9	EL41	9/6	PZ30	19/5	XH(1.5)	6/6	6/6
7C6	8/6	DAF91	5/6	EL42	10/6	R16	25/11	Y63	7/6	XA103
7H7	8/6	DAF96	7/6	EL81	16/2	R18	14/6	Z66	9/6	XA104

All goods new and first grade only. Please note that we do not sell secondhand goods. Complete list of valves, resistors and other components 6d.  
Terms of business:—Cash with order or C.O.D. only. Post 6d. per item. Orders over £3 post free. C.O.D. 2/6 extra. All orders despatched same day. C.O.D. orders by telephone accepted for immediate despatch until 3.30 p.m. Any parcel insured against damage in transit for 6d. extra. We are open for personal shoppers 8.30-5.30. Sats. 8-1 p.m. Please enquire for any item not listed with stamped addressed envelope.

## SMITH'S of Edgware Road BLANK CHASSIS

Precision made in our own works from commercial quality half-hard Aluminium. Two, three or four sided.

### SAME DAY SERVICE

of over 20 different forms made up to YOUR SIZE. Order EXACT size you require to nearest  $\frac{1}{16}$ " (maximum length 35", depth 4").

SPECIALS DEALT WITH PROMPTLY

### SEND FOR ILLUSTRATED LEAFLET

Or order straight away, working out total area of material required and referring to table below, which is for four-sided chassis in 18 s.w.g. (for 16 s.w.g. add  $\frac{1}{4}$  th)

48 sq. in.	4/-	176 sq. in.	8/-	304 sq. in.	12/-
80 sq. in.	5/-	208 sq. in.	9/-	336 sq. in.	13/-
112 sq. in.	6/-	240 sq. in.	10/-	368 sq. in.	14/-
144 sq. in.	7/-	272 sq. in.	11/-	and pro rata	
	P. & P. 2/6		P. & P. 2/9		P. & P. 3/-

Discount for quantities. Trade enquiries invited. Spray finish arranged for quantities of 25 or over.

FLANGES ( $\frac{1}{4}$ ",  $\frac{3}{8}$ " or  $\frac{1}{2}$ ") 6d. per bend.

STRENGTHENED CORNERS, 1/- each corner. PANELS. The same material can be supplied for panels, screens, etc. Any size up to 3ft (18 s.w.g.) at 4/6 sq. ft. (16 s.w.g. 5/3). P. & P., up to 72 sq. in. 1/3, 108 sq. in. 2/-, 144 sq. in. 2/6, 432 sq. in. 2/9, 576 sq. in. 3/3.

## H. L. SMITH & CO. LTD

287/289 EDGWARE ROAD LONDON W2  
Telephone PAD 5891/7595

## ☆ FOR THE TRANSISTOR SPECIALIST ☆

First grade, fully guaranteed, commercial components only

T.S.L. SUB MINIATURE TRANS. I.F.'s—Q 100. Built in capacitor. High Q Ferrite cores. Just over  $\frac{1}{2}$ " square x  $\frac{1}{8}$ " high. Set 3 plus osc. coil. Circuit diagrams included. 25/- set.

TRANSISTOR HOLDERS—Takes 3, 4, or 5 lead transistors. 1/6 each.

T.S.L. "BABYVAR" sub-miniature 2 gang tuning capacitor. 120+120 pfd. including trimmers. Only  $\frac{3}{8}$ " square x  $\frac{3}{8}$ " deep. 17/6 each.

SUB-MINIATURE SLIDE SWITCHES. 1/6 each.

"LO-OHM" Resistors. 4.7 $\Omega$ , 5.6 $\Omega$ , 6.8 $\Omega$ , 8.2 $\Omega$ ,  $\frac{1}{2}$ W, 6d. 1W, 7d. 1 $\Omega$ , 1.8 $\Omega$ , 2.7 $\Omega$ , 3V, 1/3.

SUB-MINIATURE  $\frac{1}{2}$ W RESISTORS. 10 $\Omega$  to 220k $\Omega$ , 7d. each. MINIATURE EDGE V/C. Less switch, 3k, 5k, 10k. 3/- each.

THE NEW MULLARD MINIATURE FOIL CAPACITORS. 30V wkg. .01, .022, .047, .1. from 7 $\frac{1}{2}$ d. each.

SUB MINIATURE ELECTROLYTICS. 1, 2, 4, 5, 8, 10, 16, 25, 32, 50, 100, 250, 500, 1,000 mfd. all 15V wkg. 2/3 each.

JACKSON "OO", "O", "Dilemin" tuning condensers. Full range.

SUB MINIATURE JACK SOCKETS, PLUGS. 1/6 either.

SMALL DISC CERAMICS. 470pF, 800pF, .001, .002, .0025, .005, .01. All at 7d. each.

STANDARD  $\frac{1}{2}$  & 1 WATT RESISTORS 4d. & 5d. each

Full range first grade MULLARD Transistors always in stock.

Terms of business: Cash with order; C.O.D. 3/- extra; postage extra under £3 total value. General list stamp please.

## Glasgow Electronic Services

21 OLD DUMBARTON ROAD GLASGOW C3

Telephone WEST 2642

# TV FAULT FINDING

Data Book Series No. 5

Contains information and fault finding details of both the B.B.C. and I.T.A. transmissions. Lavishly illustrated by photographs taken from the screen of a television set exhibiting the faults under discussion. A comprehensive fault finding guide is included, and this is cross referenced to the book itself.



Over 100 Illustrations and Diagrams

104 pages, high quality paper with laminated plastic board cover

Price 5/- Postage 5d.

"... A book that should be in every television dealer's service workshop, and in every home-constructor's, for that matter."—*Journal of the Television Society*

"... The book will undoubtedly be of value to TV service engineers, particularly those who are not fully experienced in translating the appearance of faulty pictures into the necessary adjustments or receiver fault location."—*Wireless and Electrical Trader*.

Available from your usual supplier, or direct from

**DATA PUBLICATIONS LTD 57 Maida Vale London W9**

## SMALL ADVERTISEMENTS

continued from page 387

### PRIVATE—continued

**FOR S.A.E.** Genuine unused components left over after completion of manufacturer's contract for sound film equipment. Metal rectifiers, capacitors, motors, mains transformers, 6-way plugs, sockets, connectors, rubber feet, leather carrying handles, amplifiers, photo-cells, valves, projector lenses, and other items suitable conversion tape recorder.—Send S.A.E. for list to Rudd, 32 Hall Park Gate, Berkhamsted, Herts.

### TRADE

**PANL**, recognised for many years as the unique one-coat black crackle finish. Brush applied, no baking. Available by post in eighth-pint cans at 3s. 9d. from G. A. Miller, 255 Nether Street, London, N.3.

**THE INCORPORATED PRACTITIONERS IN RADIO AND ELECTRONICS (I.P.R.E.) LTD.** Membership conditions booklet 1s. Sample copy of I.P.R.E. Official Journal 2s. post free.—Secretary, 20 Fairfield Road, London, N.8.

**SERVICE SHEETS (1930-1962)** from 1s. Catalogue 6,000 models. 1s. 6d. S.A.E. enquiries.—Hamilton Radio, 13 Western Road, St. Leonards, Sussex.

**"MEDIUM WAVE NEWS."** Monthly during DX season.—Details from B. J. C. Brown, 196 Abbey Street, Derby.

**METALWORK.** All types cabinets, chassis, racks, etc., to your specifications.—Philpott's Metalworks Ltd., Chapman Street, Loughborough.

**RADIO AMATEUR COURSE.** A postal course for those wishing to take the Amateur Examination. A sound basic training in radio communication. Very reasonable terms. Send for brochure.—Premier School of Radio, BCM/Wireless, London, W.C.1.

**AMPLIFIERS AND FEEDERS.** Covers the construction of direct-coupled amplifiers and an assortment of radio feeders. Price 3s. 6d.—High Fidelity Co., 18 Melville Road, Birmingham 16.

**FIND TV SET TROUBLES IN MINUTES** from that great book *The Principles of TV Receiver Servicing*, 10s. 6d., all book houses and radio wholesalers. If not in stock, from Secretary, I.P.R.E., 20 Fairfield Road, London, N.8.

**JOIN THE INTERNATIONAL S.W. LEAGUE.** Free Services to members including Q.S.L. Bureau, Amateur and Broadcast Translation, Technical and Identification Dept.—both Broadcast and Fixed Stations, DX Certificates, contests and activities for the SWL and transmitting members. Monthly magazine, *MONITOR*, containing articles of general interest to Broadcast and Amateur SWLs, Transmitter Section and League affairs, etc. League supplies such as badges, headed notepaper and envelopes, QSL cards, etc., are available at reasonable cost. Send for League particulars. Membership including monthly magazine, etc., 2/1s. per annum.—Secretary ISWL, 12 Gladwell Road, London, N.8.

**BEST MAKES RECORDING TAPE.** Trade supplied. Special BULK discounts.—Kendall & Mousley Ltd., 18 Melville Road, Birmingham 16.

**THE INTERNATIONAL HAM HOP CLUB** is a non-profit-making organisation open to RADIO AMATEURS AND SHORT WAVE LISTENERS. OBJECT: To improve international relationships through an organised system of hospitality. MEMBERS offer overnight hospitality to visiting members, subscription 10s. per annum. ASSOCIATE MEMBERS invite radio amateurs to visit their stations. Associate membership 5s. per annum. FAMILY EXCHANGE holidays arranged, also FRIENDSHIP LINKS between radio clubs. The Club's official journal is free to both Full and Associate members.—Hon. Gen. Secretary: G. A. Partridge, G3CED, 17 Ethel Road, Broadstairs, Kent.

continued on page 391

### AMAZING RESULTS from OUR LATEST 5-STAGE TRANSISTOR RECEIVER.

A highly sensitive receiver using top grade transistors and components. Fully tunable over medium waves.

- ★ Can be built in 1 hour.
- ★ High flux moving coil speaker.
- ★ Built-in ferrite rod aerial.
- ★ Specially designed coils for maximum signal strength.
- ★ Volume on/off control.
- ★ Eyeletted circuit board.
- ★ Easy to follow building plans.

Total Building Costs **59/6** P. & P. 2/6

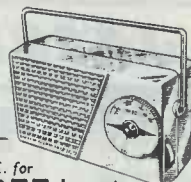

Send S.A.E. for **FREE** Layout plans and parts lists

### LISTEN TO THE WORLD on "TELSTAR" our easy to construct 1-VALVE SHORT WAVE RADIO



Total Building Costs only **35/-** P. & P. 2/-

- ★ Receives speech and music from all over the world.
  - ★ Construction price includes valve and one coil covering 40-100 metres.
  - ★ Can be extended to cover 10-100 metres.
  - ★ Can be converted to 2 or 3 valve.
- Send 2/- for wiring diagram and components price list.

### 5-STAGE SUPER-SENSITIVE TRANSISTOR PORTABLE EASY TO BUILD ★ FIRST GRADE PARTS

A truly portable transistor radio giving full medium wave reception. Incorporates 5" High Flux Speaker, push pull output, first grade transistors, High-Q ferrite aerial, socket for car aerial, pre-tagged circuit board for easy construction. Attractive two-tone case. All parts sold separately.

Total Building Costs **95/-** P. & P 2/6



Send 1/6 for itemised price list & full assembly instr. (free with order)

**R.C.S. PRODUCTS (Radio) LTD**  
11 Oliver Road · London · E17 (Mail Order Only)

# OSMOR

## P.W. BEST SETS

### P.W. POCKET SHET

Case 5½ x 3½ x 2 12/6

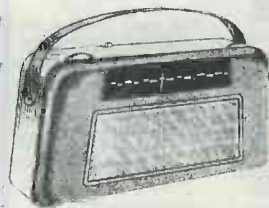

Case 11½ x 6 x 3¼ 25/-

### P.W. MERCURY SIX

3 IFS and Osc. 22/-  
Driver and Output 16/3



For above and all similar transistor circuits

**CONSTRUCTIONAL BOOKLETS 2/6 each**

COMPONENT LISTS ON REQUEST

**OSMOR LTD** 418 BRIGHTON ROAD  
S. CROYDON SURREY

# JASON TAKE TAPE INTO HI-FI WITH THE JTL

The completing link in the modern hi-fi chain. The JTL Unit is advanced to true professional levels and affords an unequalled degree of flexibility and high standards of operation.

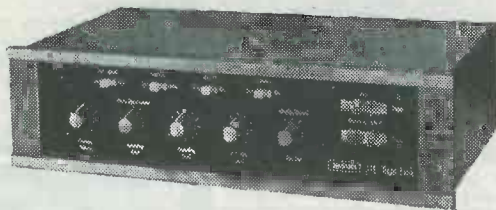

A brilliantly successful unit equal to the demands of most advanced recording techniques. Provides for 2- or 4-track operation, stereo or mono, with true monitoring facilities and variable bias control whilst the unit is readily adaptable to the requirements of any amplifier and deck with 3 heads. The JTL is at its best with the J.2-10/Mk. III stereo amplifier. It can be left permanently connected without disturbing the normal function, making instant recording possible at all times. With signal level and bias indicators. Self powered.

**29 gns.**

In  
Kit form  
**21 gns.**

## JASON J2-10/Mk. III STEREO AMP

The very heart of your high fidelity system, the J.2-10/Mk. III accepts inputs directly from all sound sources and reproduces them with great power and faithfulness. This amplifier can be connected with the Jason Tuner of your choice, with any pick-up (including the Decca fss), with a JTL Tape Unit, a microphone and tape heads, etc. Connections are standardised for easy linking. High and low pass filters, phase matching, and output selector control are but few of the many refinements of this outstanding amplifier. 12W output per section.

**39 gns.**

## JASON TUNERS

**FMT/4:** Sensitive FM Tuner for fringe reception. Variable A.F.C. noise limiters. Self powered. In newly styled case. **£17.5.0**  
+£4.14.6 P/Tax.

**JTV/2:** For 3 main B.B.C. programmes and TV sound channels at the turn of a switch. Self powered, in case. **£19.4.0**  
+£5.10.10 P/Tax

**MONITOR:** Similar to JTV/2 but for cabinet mounting; unpowered. **£14.5.0**  
+£4.2.4 P/Tax

FROM ALL GOOD STOCKISTS

# JASON

S.A.E. please for literature

**JASON ELECTRONIC DESIGNS LTD**  
2 (WD) KIMBERLEY GARDENS LONDON N4 STA 5477

## FRADAN FOR QUALITY KITS—We guarantee results

The fabulous **CAROUSEL** unequalled for performance.

- ★ First grade BVA Transistors
- ★ Car aerial socket
- ★ High gain circuit, using Mullard AF117
- ★ Push-pull output
- ★ 5" high flux loudspeaker
- ★ De-luxe two-tone Cabinet

**£4.19.6** plus 3/6 post and packing.  
Size 9" x 6" x 3"



- ★ One-valve receiver
  - ★ Covers 20-60 Metres.
  - ★ Electrical Bandsread
  - ★ Low loss airspaced variables
  - ★ Attractive blue hammer finish.
  - ★ Chassis press punched for accuracy
  - ★ Easily converted to two-valves
  - ★ Other plug-in coils available
- 37/6** plus 2/6 post and packing.

The 208 our new printed circuit pocket portable, announced last month and already proving a winner.

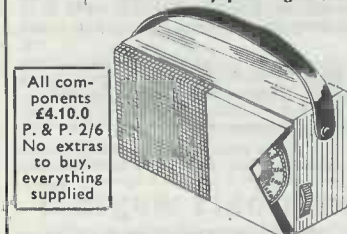

All components  
**£4.10.0**  
P. & P. 2/6  
No extras to buy,  
everything supplied

- ★ Printed Circuit
- ★ Push-Pull Output
- ★ High flux Loudspeaker
- ★ 1st. grade transistors
- ★ Vol. Cont.-On/off Sw.
- ★ Variable sensitivity
- ★ High gain ferrite aerial
- ★ 4 transistors—2 diodes

Tunes—LUX., LIGHT, HOME, A.F.N., R, EIRE and Many Others.  
**FRADAN RADIO 36 LEIGH ROAD LEIGH LANCASHIRE**

## The "NEW ERA" 5+1 Transistor Pocket Portable



FEATURING

- ★ Pre-drilled board
- ★ 250mW Push-Pull Output
- ★ 5 top grade Trans. and 1 Diode
- ★ High Q Ferrite Aerial
- ★ 2½" P.M. Speaker
- ★ Book of Instructions 1/6 (Free in Kit)

P. & P. 2/-  
**£4.15.0**

EX T.V. AND RADIO VALVES GUARANTEED PERFECT

EF91	} 1/6	SU25	} 2/6	6K7	} 2/6	635PT	} 3/6
EF80		UU8		6P25		DD41	
EF50		U22		6P28		EBC3	
EB91		U24		6SN7		EBC33	
		U31		185BT		EF36	
		U35				EF39	
		Y63				EL33	
D15	} 2/6	Z66	} 2/6	7C5	} 3/6	KT63	} 3/6
DF1		2D4A		7Y4		PEN45	
SP41		6B8G		12SK		PEN46	
SP42						PL38	
SP61						T41	

A FEW U801 AT 25/-

**THE NEW ERA RENTAL CO.**

70A Baring Road, S.E.12 (KIP 7978) 148 Battersea Bridge Road, S.W.11



## SMALL ADVERTISEMENTS

continued from page 389

### TRADE—continued

**CATALOGUE No. 15.** Government surplus electrical and radio equipment. Hundreds of items at bargain prices for the experimenter and research engineer, 2s. 6d. post free. Catalogue cost refunded on purchase of 50s.—Arthur Sallis Radio Control Ltd., 93 North Road, Brighton.

**ANY KIT BUILT AND TESTED.** Radios, test gear, Tx, amplifiers, etc. Kits and components supplied. S.A.E. for quotations or lists.—Buildakit Service (Dept. RCD), 16 Haycroft Road, Stevenage, Herts.

**MIXING UNITS.** Two, three or four stages, transistorised. Unique features. S.A.E. for full details to: Morgan Laboratories, 9 Parker Road, Croydon, Surrey.

### SITUATION VACANT UNIVERSITY OF GLASGOW

Biological Electronics Technician wanted to construct research equipment. Experience with valve and transistor amplifiers and/or pulse equipment desirable. Salary within the range of £540 to £745 per annum with qualification supplement. Applications should be sent to the Assistant Secretary of University Court, The University, Glasgow, W.2. marked "Technician (Electronics)".

## REPANCO

### MINIATURE TRANSISTOR TRANSFORMERS

- ★ Overall Size  $\frac{3}{8}'' \times \frac{3}{8}'' \times \frac{3}{8}''$
- ★ High Permeability Laminations
- ★ Fully Impregnated
- ★ Printed Circuit Pins
- ★ Clearly Colour Coded
- ★ Bifilar Windings

★ Trade Supplied

- Type TT45** Driver Transformer for Double-ended Push-Pull. Ratio 4.5 : 1+1
- Type TT46** Push-Pull Output Transformer for 3 ohm Speaker. Ratio 4+4 : 1
- Type TT47** Driver Transformer for Single-ended Push-Pull output using 35 ohm Speaker. Ratio 4.5 : 1+1
- Type TT49** L.F. Interstage Coupling Transformer. Ratio 4.5 : 1

ALL TYPES 5/- EACH (post 3d.)

Send 3d. stamp for complete list of Repanco Coils and transformers for the Home Constructor

**RADIO EXPERIMENTAL PRODUCTS LTD**  
33 MUCH PARK STREET - COVENTRY

### SUPERHET RADIO CHASSIS



These well-made chassis were made for the Government for Forces entertainment using 6K8, 6K7, 6Q7, 6V6. Choke smoothing slow-motion tuning, printed scale, 200-550 metres. BRAND NEW, only 57/6, post 5/-. Case with 8" speaker to fit, 27/6.

### 12 VOLT VIBRATOR UNIT

(P.C.R. series) 100mA output, double choke smoothed, bridge rectified, spare vibrator, fusewire, battery clips, indicator bulbs. Brand New in maker's cartons. Only 22/6, carr. 5/6.



J. T. SUPPLY (Dept. Q) 309 Meanwood Rd. Leeds 7

## R. COOPER G8BX RADIO OF CROYDON

32 South End Croydon Surrey CRO 9186

### ★ VALVES New Tested and Guaranteed

1R5	6/6	6K8GT	8/6	DAF96	8/-	ECC85	8/6	PL82	10/6
1S5	6/6	6Q7G	7/6	DCC90	11/6	ECF82	7/6	PY81	8/-
1T4	4/6	6SL7GT	8/-	DF91	4/6	ECH81	10/6	PY82	7/-
354	6/9	6V6G	7/6	DF96	8/-	ECH42	8/6	PCC84	9/6
3V4	7/6	6X4	7/6	DH76	8/6	ECL80	9/6	PCF80	9/-
5U4G	6/-	12A7	6/-	DH77	7/6	EF41	8/6	PCF82	11/-
5Y3GT	7/6	12AU7	6/-	DK91	6/6	EF80	8/-	PCL82	7/6
5Z4G	9/-	12AX7	7/6	DK92	7/6	EF86	9/6	PCL83	12/6
6AK6	6/6	12BH7	10/6	DK96	8/-	EF91	4/-	PCL84	8/6
6AL5	4/6	12K7GT	8/6	DL92	6/9	EL41	9/-	U76	8/6
6AM6	4/-	12KBGT	13/6	DL94	7/6	EL84	8/-	UBC41	10/6
6AT6	7/6	12Q7GT	6/6	DL96	8/-	EY51	7/6	UCH42	10/6
6BA6	8/6	25A6G	10/6	EB91	4/6	EZ40	6/6	UF41	10/-
6BE6	7/6	25L6GT	9/-	EBC41	9/6	EZ80	6/6	UL41	8/-
6BR7	10/6	35Z4GT	8/6	ECC81	6/-	EZ81	7/-	UY41	8/-
6BW6	8/6	35L6GT	9/6	ECC82	6/-	GZ32	10/6	W76	8/6
6J7GT	8/6	5763	10/6	ECC83	7/6	KT66	15/-	Z77	4/-
6K7G	7/6	DAF91	6/6	ECC84	7/6	PL81	12/6	ZD17	7/6

**MATCHED PAIRS.** EL84, 17/-; EL85, 25/-; 6V6G, 17/-; 6BW6, 18/-; KT33C, 19/6; 807, 14/6, pair; KT66, 32/6.

### SETS OF VALVES

DK96, DF96, DAF96, DL96 "REAGENT"	29/6	per set
DK91, DF91, DAF91, DL92, or DL94	21/-	per set
1R5, 1T4, 1S5, 354, or 3V4	21/-	per set
12K8, 12K7, 12Q7, 35L6, 35Z4, "G" Types	35/-	per set
ECH42, EF41, EBC41, EL41, EZ40	37/6	per set
UCH42, UF41, UBC41, UL41, UY41	35/-	per set

**Rotary Switches.** 1P. 3W., 1P. 4W., 1P. 8W., 2P. 2W., 2P. 3W., 2P. 4W., 3P. 2W., 3P. 3W., 4P. 2W., 4P. 3W. 3/-, 2P. 5W., 2 Bank, 2P. 6W., 2 Bank 5/6.

**Instrument Switches Push to Test.** 3/6. **Toggle Switches, S.P.S.T.** 2/-; S.P.D.T., 2/6; D.P.S.T., 3/6; D.P.D.T., 4/-

**Volume Controls.** Midge Long Spindle 1/5K to 2M, Non-Switch 3/-; D.P. Switch 4/6; Min. Edge Type 3/6; D.P.S. 5/6.

**Pre-Set Controls.** 3W w.w. to 30K  $\pm$ W Carbon 50K to 2M 3/-; Wire Wound Long Spindle  $\pm$  4V. 50 $\Omega$  to 100K 6/-.

**Block Capacitors.** .004 2kV 2/9; .05 4kV 2/6; .5 2.5 kV Nitrogl 4/3; 1 MFD 350V. T.C.C. 1/6; 2 MFD 350V. Nitrogl 3/-; 4 MFD. 350V. Nitrogl 4/3; 4 MFD. 1,000V. T.C.C. 4/6; 4 MFD. 100V. T.C.C. 2/-; 4 MFD. 500V. Dubilier 4/9; 4 MFD. 600V. Nitrogl 5/6; 4 MFD. 750V. Nitrogl 6/6; 8 M.F.D. 600V. Dubilier 6/-.

P. & P. 6d. C.O.D. 3/- S.A.E. FOR ALL ENQUIRIES.

## FREE! EARN



There's plenty of room at the top for technically trained men—room for YOU if you want quick promotion or a better-paid, more interesting career. N.I.E. can quickly give you a guaranteed spare-time Postal Training, in the comfort of your own home, and open up a whole new world of opportunity for you.

## MORE

Radio & Elec-  
tronic Eng. I.R.E.  
Radio/TV A.M.I. Mech. E.  
Servicing A.M.I. Prod. E.  
R.T.E.B. Cert. A.I.O.B.  
Rad. Amateurs' A.R.I.C.S.  
Exam A.M.I.M.I.  
Telecomms. A.M.I. Struct. E.  
(C & G) M.R.S.H.  
A.I.Q.S.

Find out, as thousands of others have done, how easy it is to learn at home with N.I.E.—Send for *Success in Engineering*—120 pages of information—and details of pay-winning courses in Radio/TV., Electrical and other branches of engineering, building, etc. Get your copy today—FREE!

## SOON

### POST COUPON NOW!

Please send me a FREE copy of "Success in Engineering".

NAME .....

ADDRESS .....



Subject or exam of interest .....

**NATIONAL INSTITUTE OF ENGINEERING**  
(Dept. 445) 148-150 Holborn London EC1

THE GATEWAY TO BETTER LIVING

The thrills of VHF can now be yours for only 39/6d, complete kit! Tunable 150-100 Mc/s, simplified construction, write today for leaflet. Also, if a newcomer to Amateur Radio, ask for free copy of the world famous "Globe-King" kits and receivers, stamp please to cover postage:

**Johnsons (Radio) St. Martin's Gate Worcester**

### H.A.C. THE ORIGINAL SUPPLIERS OF SHORT-WAVE KITS

One valve Super Sensitive All-dry Short-wave Receiver, Model "K". Complete kit including valve and chassis, 77/- (Other S.W. kits from 25/-) Before ordering call and inspect a demonstration receiver, or send stamped envelope for full specification, catalogue and order form.

**H.A.C. SHORT-WAVE PRODUCTS (DEPT. R) 44 OLD BOND STREET LONDON W1**

Portable Transistor Kit £5.19.6 (post 3/6), covers M. & L. Waves, no aerial required, no difficulty aligning, simple to follow instructions. Pocket Kit 65/- (post 2/-). Pocket Superhet Kit, £6.19.6 (post 3/-). Genuine Red Spot Transistors, 2/3; White Spots, 2/3; Yell/Green, 3/-; Mullard OC71, 6/-; OC72, 7/6; OC44, 7/6; OC45, 7/6. Sets of 6 for Superhets: Mullard, 40/-; our selection, 30/- Newmarket V15/10P, 15/- Silicon Rectifiers 70 piv. 1/2 amp., 3/3; 400 piv. 1/2 amp., 4/9. R109A set, brand new, £4 (carriage paid). Sub-min. Electrolytics 2, 4, 8, 10, 16, 32, 50µF, 1/9; 100µF, 2/9; 250, 500, 1,000µF, 3/3. Terms C.W.O. Post extra, excess refunded. Send 10d. stamps for Transistor Notes.

MOORE'S EXPERIMENTAL SUPPLIES Dept. C 8/10 Granville St. Sheffield 2

### G2ACC offers you . . .

- A 56 page illustrated catalogue No. 12 Your buying guide for short wave, broadcast and transmitting components. 9d. post free (refundable on first order). U.K. and H.M. Forces anywhere.

**SOUTHERN RADIO AND ELECTRICAL SUPPLIES**

SORAD WORKS REDLYNCH SALISBURY WILTS Telephone Downton 207

What about that 12 w.p.m.

### Morse Code Test ?

You can only reach the goal by keen listening and constant practice with a Morse Key. The amount of "hard labour" involved depends on the method of training.

### The CANDLER System

will help you as it has helped thousands of others over many years, and give you a sound basis. It turns a difficult task into a pleasurable pursuit.

Send 3d. stamp for details of our Special Course for Amateur Transmitting Licence

### The CANDLER System Co.

Dept. RC, 52b ABINGDON ROAD, LONDON, W8

Candler System Co., Denver, Colorado, U.S.A.

### SURPLUS RADIO SUPPLIES

2 LAING'S CORNER MITCHAM SURREY

SEND 2/6 FOR OUR CATALOGUE OF 400 BARGAINS

(2/- REFUNDED ON FIRST ORDER OVER 10/-)

S.A.E. for list of meters

### New Boxed Meters by Sangamo Weston

50 microamps full scale deflection. Limited quantity

19/6. P. & P. 2/6

### BRASS · COPPER · DURAL · ALUMINIUM · BRONZE

ROD, BAR, SHEET, TUBE, STRIP, WIRE.

3,000 STANDARD STOCK SIZES.

No Quantity too small

List on application

**H. ROLLET & CO LTD**

6 CHESHAM PLACE SW1

BELGravia 4300

Also at Liverpool, Birmingham, Manchester, Leeds

### Quality Components FOR CONSTRUCTORS

capacitors, resistors, coils, valves, transistors, controls, chassis, transformers, speakers, pick-ups, cartridges, stylii, and all types of components in stock.

PRICE LISTS AVAILABLE ON REQUEST

**J. T. FILMER**

82 DARTFORD ROAD  
DARTFORD KENT  
Telephone Dartford 24057

### FAULT FINDING IS EASY!

Controlled Electronics Model 644 is a pencil-sized, signal injecting fault locator, which will pin-point in seconds trouble in R.F., I.F. and A.F. stages of radio and some stages of TV receivers. It can save you headaches, time and money. Available from your local dealer, or by mail direct from us at 55/6 plus 2/6 P.P. Battery 1/10 extra. S.A.E. for details.

**CONTROLLED ELECTRONICS 62 High St. Croydon Surrey**

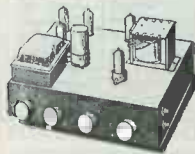

### ULTRA LINEAR AMPLIFIER

High Fidelity 15. watts. Valves two ECC83s, two EL84s, E281. Two inputs. Sensitivity 10 millivolts. Bass and Treble controls. 3 and 15 ohms outputs. Kit £6.10.0 plus 5/- carr. Factory built £9 plus 5/- carr. Similar 30 watt £12 plus 7/6 carr. Leaflet free. Same day despatch.

**STROUD AUDIO, Bath Rd, Stroud, Glos**

### "LITON" Photoelectric Construction Manual

2nd edition coming out shortly

10 interesting PHOTOELECTRIC PROJECTS fully described with building plans and circuit diagrams which can be easily made by amateurs from standard components. Hints on the use of photo-cells and phototransistors. A mine of practical information for the experimenter. All units available built and tested, or in kit form.

1. Battery burglar alarm kit, 65/-
2. Mains burglar alarm
3. Light saver
4. Customer announcer
5. Simple garage door opener
6. Photoelectric counter. Price (2 to 6) Kit £4.12.6. Built £5.10.0.
7. Long range infra-red mains alarm
8. "MIRA" miniature infra-red battery alarm. Total consumption 0.2 watt.
9. Motorised garage door opener
10. Door opener with electronic lock

If you are interested in electronics or electro-mechanical gadgets send 1/- stamp for this 24-page profusely illustrated publication to: "ST. JOHN'S RADIO" 3 Jews Row London SW18

### SAVOY TRANSISTOR RADIOS

with Miniature Loudspeaker

No drilling. No soldering. Simple to construct. Can be done by anyone. Complete kit of parts. Full medium wave band coverage.



### SAVOY MINI-5

5 transistors. Size: 4 1/2" x 2 3/8" x 1 1/4"  
Battery 1/-  
P. & P. 2/- extra

57/-

### SAVOY 3

with 3 transistors and 2 diodes. Size: 4 1/2" x 2 3/8" x 1 1/4"  
Battery 1/-, P.&P. 47/-  
2/- extra



### SAVOY SUPER-4

Moving coil loudspeaker with 4 transistors and 2 diodes. Size: 5 1/2" x 3" x 1 3/8"

Battery 2/3, P.&P. 75/-  
2/9 extra

**SAVOY ELECTRONICS (SALES) LTD.** Callers Welcome

15 Maiden Lane, Strand, London, W.C.2

(TEM 5484)

# BRAND NEW TEST METERS - BEST VALUE - FOR ALL PURPOSES



**£8.19.6**

30,000 ohms per Volt  
Model 500

8 Ranges D.C. volts to 1 kV.  
7 Ranges A.C. volts to 1 kV.  
5 Ranges D.C. current to 12 amps.  
3 Range resistance to 60 meg.  
Short circuit buzz test. Output meter dB, etc., etc. Size 6½" x 4½" x 2½". With Leads, Batteries and Instructions.

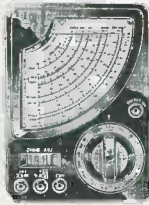

**5 GNS.**

20,000 ohms per Volt  
Model ITI-2

6 Ranges D.C. voltage to 2½ kV.  
5 Ranges A.C. voltage to 1 kV.  
3 Ranges D.C. current to 250mA.  
Resistance to 6 meg.  
Capacity and dB ranges.  
Size 4½" x 3½" x 1½" with leads, batteries and instructions.



**75/-**

2,000 ohms per Volt  
Model THL33

0/10/50/250/500/1,000 volts D.C.  
0/10/50/250/500/1,000 volts A.C.  
0/500µA/10/250mA., D.C.  
Resistance 0/10K/100K/1 meg.  
Capacity and dB ranges, etc.  
Size 5" x 3½" x 1½" with batteries, test leads and instructions.

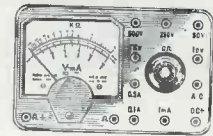

**49/6**

1,000 ohms per volt  
Model PT34

0/10/50/250/500/1,000 volts A.C./D.C. 0/1/100/500mA D.C. Resistance 0/100k ohm.  
Ideal pocket sized multi-tester for all radio and domestic work. Size 36" x 28" x 1½" with battery, leads and instructions.

**All Meters Fully Guaranteed for 6 months. Full Service Facilities.**

## MINIATURE CLEAR FACED Brand New PANEL METERS

0-50 microamp D.C.	39/6
0-500 " D.C.	32/6
0-1 milliamp D.C.	27/6
0-5 " D.C.	27/6
0-300 volts D.C.	27/6
"S" meter 1mA	35/-
"VU" meter	42/6

## CRYSTAL MICROPHONES

**ACOS 39-1.** Stick Microphone with screened cable and stand (list 5 gns.), 32/6. P.P. 1/6.  
**ACOS 40.** Desk Microphone with screened cable and built-in stand (list 50/-), 15/- P.P. 1/6  
**ACOS 45.** Hand Microphone with screened lead, very sensitive, 25/- P.P. 1/6.  
**100 C.** Stick Microphone with muting switch and screened cable, detachable desk stand and neck cord, 39/6. P.P. 1/6.  
**MC 24.** Stick Microphone with muting switch and cable, 25/- P.P. 1/6.  
**LAPL.** Miniature Microphone with clip. Ideal for recording, 15/- P.P. 1/-.  
**BM 3.** De Luxe Stick Microphone with muting switch cable, neckcord and detachable stand. Complete 52/6. P.P. 2/-.

(Illustrations of all types in our New Catalogue. 1/- post free.) FULLY GUARANTEED.

## 4-TRANSISTOR PUSH-PULL AUDIO MODEL PK-5 3 AMPLIFIER

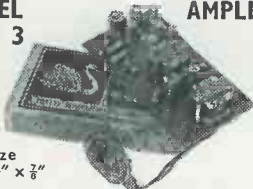

Size 3" x 1½" x ¾"

A ready-built miniature 250mW push-pull amplifier incorporating input and output transformers, 4 transistors, 9 volt battery snap cord, speaker and column connection leads. Ideal for use with record players, intercoms, hearing aids, tape recorders, etc. Complete with full instructions and circuit diagram.

**PRICE 52/6** P.P. 1/6.  
SUITABLE 2½ in. SPEAKER 16/6

**NEW 44-PAGE CATALOGUE, 1/-**



## LIGHTWEIGHT HEADPHONES

- 2,000 OHMS 12/6
  - 4,000 OHMS 14/6
- HIGH EFFICIENCY

## RUN YOUR RADIO OR AMPLIFIER FROM MAINS. BATTERY ELIMINATORS AND CHARGERS.

1. For PP3 or equivalent 9 volt Pocket Radio Battery. 18/6. P.P. 1/-.
2. For PP4, PP7, PP9, PP10, 9 volt Portable Radio Batteries up to 300mA. 45/- P.P. 2/-.
3. De Luxe version of No. 1, also charges PP3 type batteries. 29/6. P.P. 1/-.
4. Rechargeable PP3 battery. Runs as long as 100 batteries. Complete with charger unit. 29/6. P.P. 1/-.

## 3-TRANSISTOR SUB-MINIATURE AMPLIFIER

New 3-transistor amplifier. 125mW push-pull output to 35 ohm speaker. PP3 9-volt operated  
● Size only 1.9" x 1" x 1"  
Complete with circuit. **45/-** P.P. 1/-  
Suitable 2½" Speaker, 15/-

## STEREO AMPLIFIER

4-Valve Amplifier with 2 watts output per channel to 3 ohms. Ready built, complete with Dials, Sockets and Knobs. Full tone, volume and balance controls. Crystal input. 220/250 volt mains input. **79/6** P.P. 2/-  
Fully Guaranteed 8" x 5" Speakers 49/6 Pair.

## TYPE 38, TRANSMITTER RECEIVER

Complete with 5 valves. In new condition. These sets are sold without guarantee but are serviceable. **22/6** P.P. 2/6  
7.4 to 9 Mc/s. Headphones 7/6 pair. Junction Box 2/6. Throat Mike 4/6. Aerial Rod 2/6.

## TRANSISTORS

COMPLETE NEW RANGE OF 1ST GRADE A.E.I. TRANSISTORS, DIODES, MATCHED SETS, NPNS, POWER H.F., ETC. NOW IN STOCK. NEW VERY LOW PRICES.

SPECIAL REDUCTIONS FOR MATCHED SETS  
NEW FREE CATALOGUE WITH CONNECTION DIAGRAMS, EQUIVALENTS AND DETAILS

## OFFICE, WORKS OR HOME USE

### COMPLETE INTERCOMM. SYSTEMS

- 2-transistor transformer coupled, two speakers in moulded cabinets. Features 2-way Buzzer system and talking. Supplied complete with cable **89/6** P.P. 1/6
- 4-transistor de luxe version, with 2-way calling and talking. Moulded cabinets, long battery life—very sensitive. With cable and batteries. **£7.10.0** P.P. 2/-

## POCKET RADIO BOOSTER

Tubular unit, size 9½" x 3½" dia., which plugs into earphone socket of any transistor radio. Performance increase is fantastic. Ideal for home or car. 52/6. P.P. 1/6.

## STEREO PHONES

New stethoscope type stereo earphones with adjustable tubes. Fitted miniature jack plugs and leads. 2 x 8 ohms impedance, 27/6.

## TRANSISTOR SIGNAL INJECTOR

A new design pocket size tester for fault finding on valve or transistor radios, TV amplifiers, etc. Built-in indicator and batteries with detachable probe. 42/6.

## NEW MINIATURE TELESCOPIC AERIALS

- 3½" closed, 14" extended. Complete with screw-in socket. 3/6. P.P. 6d.
  - 8½" closed, 38" extended, with threaded end. 6/6. P.P. 6d.
  - 9" closed, 64" extended. 17/6. P.P. 1/-.
- All types heavily plated.

## BATTERY RECORD PLAYERS

- 6-7½ volt Garrard turntable with crystal pick-up. Plays 45 r.p.m. Ideal for above amplifier. **55/-** P.P. 1/6.
- Suitable cabinet for amplifier and player, 17/6 P.P. 2/-.
- EMI 4-speed 9 volt player 79/6 P.P. 2/-.

## HENRY'S RADIO LTD

PADddington 1008/9  
5 HARROW ROAD, LONDON W2  
Open Monday to Sat. 9-6, Thurs. 1 o'clock

**PLEASE TURN TO BACK PAGE**

Published in Great Britain by the Proprietors and Publishers Data Publications Ltd. 57 Maida Vale London W9

Printed by A. Quick & Co. (Printers) Ltd. Oxford Road Clacton-on-Sea England

Obtainable abroad through the following: Collets Subscription Service Continental Publishers & Distributors Ltd. William Dawson & Sons Ltd. Australia and New Zealand Gordon & Gotch Ltd. Electronics Publications (Australia) South Africa Central News Agency Holland "Radio Electronica" Registered for transmission by Magazine Post to Canada (including Newfoundland)

# COMPARE THE PRICES—COMPARE THE QUALITY AND PERFORMANCE!

★ DETAILS OF ANY MODEL ON REQUEST

★ IDEAL GIFTS ON ALL OCCASIONS

● FULL DETAILS OF ANY MODEL ON REQUEST—WRITE NOW ●

## The fabulous 'Contessa' Mk. III

★ combined portable and car radio ★

- NOW WITH 600mW MELLOWTONE OUTPUT ON MEDIUM AND LONG WAVES
- NOW FITTED HORIZONTAL TUNING SCALE WITH ALL STATIONS CLEARLY MARKED
- NOW SUPPLIED WITH SIX MULLARD TRANSISTORS AND TWO DIODES
- NOW FITTED RECORDING SOCKET AND CAR AERIAL SOCKET
- NOW SUPPLIED WITH TWO-TONE BEIGE OR TWO-TONE BLUE CABINET WITH GOLD FITTINGS

GUARANTEED THE VERY BEST OBTAINABLE

● All parts sold separately ●

TOTAL COST  
**£10.19.6** P.P. 3/6



OVERALL SIZE  
10½" x 7½" x 3½"

● Detailed Leaflet on Request ●

The New "CONTESSA" 6-Transistor Portable Superhet Radio. Features simple printed circuit construction and fully illustrated building instructions, with all parts clearly marked and identified. Fitted with 8" Ferrite aerial. Double IFTs and the latest in components and design. Full tuning of both Medium and Long Wave bands with unbeatable selectivity and sensitivity. Clearly marked station dial and room-filling "MELLOWTONE" push-pull output are standard features. FULL AFTER-SALES SERVICE AND GUARANTEE

★ ALL THESE EXTRA FEATURES AT NO EXTRA COST ★

★ NEW HUGE PURCHASE REDUCES TOTAL COST SEE PAGE 365 THIS ISSUE ★

### "CAPRI" POCKET-6 6-TRANSISTOR SUPERHET



Size only  
4½" x 2½" x 1½"  
**REALLY POCKET SIZE!**

The most compact 6-transistor and diode radio with speaker available to the home constructor. Features the latest in miniature components and circuitry. Supplied with Mullard transistors and two-tone moulded cabinets in red/white or blue/white with gold fittings. All components are supplied in packets and clearly identified. A printed circuit is used with fully illustrated building instructions. Push-pull output coupled with a sensitive and selective circuit make the "CAPRI" hard to beat. Fitted Earphone/Record socket. Full tuning on medium waves with long wave Light.

TOTAL COST **£5.19.6** P.P. 2/-

★ Detailed Leaflet on Request ★  
After Sales Service and Guarantee

### POCKET TRANSISTOR RADIO

Special offer of brand new 6-transistor pocket radio. With leather case and phone. Tested and ready to use. **£5.19.6**  
Ideal Christmas Gift. P. & P. 2/6

NEW 44 PAGE 10½" x 7½" ILLUSTRATED CATALOGUE FULL OF COMPONENTS AND UNITS. 1/- POST FREE

### "QUINTET" MEDIUM AND LONG WAVE POCKET RADIO

PUSH-PULL SPEAKER OUTPUT

Size  
5½" x 3" x 1½"

Red or Blue with Gold trim

Total Cost  
**99/6** P.P. 2/-

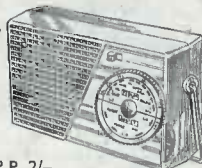

New Improved 5-Transistor and Diode Medium and Long Wave Printed Circuit Loudspeaker Radio. Features Ediswan transistors and plainly marked printed circuit with carded components. Now with better quality and greater sensitivity. Excellent results with full station separation guaranteed. Including Radio Luxembourg. Push-pull output up to 200mW. Fitted phone/record socket and car aerial socket.

Leaflet on request.

Full after-sales service and guarantee.



### ¾ WATT-TRANSISTOR AMPLIFIER

★ 1½ watt peak output.

± 3dB 70 c/s to 12 kc/s.

Output to 3 ohm speaker.

9 volt operated.

Details on request.

Built and Kit of Tested Parts

**59/6 OR 52/6**  
P.P. 1/6 P.P. 1/6

A printed circuit high gain amplifier size 4" x 2½" x ¾" using Ediswan XB112, XB113 and XC171 Transistors. Ideal for Intercomm., Record Player, Tuner Amplifier or any application requiring a quality and reliable amplifier. New Improved Design.

We can supply most of the components specified on circuits published in this and other magazines and books. Let us quote for your circuit. Competitive prices.

### IT'S TINY BUT POWERFUL "MINIRANGER"

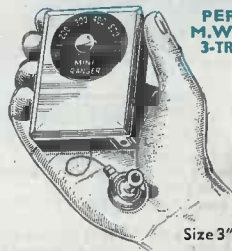

PERSONAL M.W. RADIO 3-TRANSISTOR, 2-DIODE

Size 3" x 2" x ¾"

The smallest printed circuit transistor radio available for home construction. Full coverage of Medium waves and top band without any aerial or earth. Fitted calibrated dial, volume control and 9 volt battery. All stations including Radio Luxembourg are received with amazing clarity. Pre-tinned printed circuit clearly marked with component details.

● Simple to Build ●  
Guaranteed Amazing Results

TOTAL COST OF ALL PARTS **59/6** P.P. 1/6

● Designed for your top jacket pocket Circuit Diagram Free on Request ●

Medium and Long Wave Superhet Radio

Size  
5½" x 3½" x 2"

**£7.19.6** P.P. 2/-

Modified version of previously advertised "PW" Superhet. Now with new style Two Tone Cabinet. First grade components and transistors. Printed circuit. Features matched set of 6 Transistors. New 2½" quality speaker and new illustrated building instructions.



PLEASE TURN PAGE

**Henry's Radio Ltd**  
PADdington 1008/9

5 HARROW ROAD LONDON W2  
Open Monday to Sat. 9-6. Thurs. 1 o'clock