

52 A Quick Look

# RADIO



# BOOKS

**Tape and Wire Recording.** A selection of articles reprinted from the pages of *The Radio Constructor*, covering both the theory and practical applications. A really useful book on this latest development of the hobby. 4th Edition, 3/-. Postage 3d

**Receivers, Preselectors and Converters.** Practical articles, again reprinted from past issues of *The Radio Constructor*, which will prove of interest to many radio enthusiasts. 2/6. Postage 3d

**TV Fault Finding.** Profusely illustrated with photographs taken from a television screen depicting the faults under discussion, and containing a wealth of technical information, with circuits, enabling those faults to be eradicated. 5/-. Postage 4d

**F.M. Tuner Units for Fringe and Local Area Reception.** Including optional Tuning Indicator and circuit of Osram 912 Amplifier. 2/-. Postage 2d

**The Argonaut AM/FM MW/VHF Tuner Receiver.** Describing the construction, alignment, and other details of a high quality tuner (or complete receiver), together with map of present and projected coverage areas. 2/-. Postage 3d

**Radio Amateur Operator's Handbook.** An indispensable aid to the amateur transmitter and listener, containing all details of information which are constantly required. Prefix Lists, Zone Boundaries, Call Areas, Codes, and Mileage Tables, together with Maps and much other useful operating data. 1957/8 edition, 3/-. Postage 3d

**Inexpensive Car Radio.** In which two versions, one constructed from surplus and one from new components, are described. 1/6. Postage 2d

**Radio Control for Model Ships, Boats and Aircraft,** by F. C. JUDD, G2BCX. A comprehensive work on this fascinating subject. Standard edition 8/6. Postage 5d  
Cloth bound edition 11/6. Postage 7d

**The "Eavesdropper."** A miniature transistor local station receiver. Complete constructional details of this pocket portable. 1/6. Postage 2d

**Radio Control Mechanisms,** by RAYMOND F. STOCK. The only book dealing solely with this important part of radio control. 4/6. Postage 4d

All available from your local bookseller, or from

## DATA PUBLICATIONS LTD

57 MAIDA VALE LONDON W9

Telegrams Databux London

Telephone CUNningham 6141 (2 lines)

Published in Great Britain by the Proprietors and Publishers

Data Publication Ltd 57 Maida Vale London W9

Printed by A Quick & Co Ltd Oxford House Clacton on Sea England

Obtainable abroad through the following Collects Subscription Service Continental Publishers & Distributors Ltd William Dawson & Sons Ltd Australia and New Zealand Gordon & Gotch Ltd South Africa Central News Agency Holland "Radio Electronica"

Registered for transmission by Magazine Post to Canada (including Newfoundland)



## Collaro Tape Deck Connections

VOLUME 10  
NUMBER 11  
JUNE  
1957

# The RADIO Constructor



RADIO · TELEVISION · AUDIO · ELECTRONICS

## TRANSISTOR TWINS

The  
"RADIOSETTE"  
and  
"NURSERYETTE"  
Miniature Receivers



Included in this issue  
ALTERNATIVE SUPERHET  
"DIRECT-COUPLED" TRANSISTOR RECEIVER  
UNUSUAL AUDIO OSCILLATOR  
THE "RAMBLER" PORTABLE RECEIVER, Part 2  
AUTO-SELECTION COIL UNIT

# DATA Publications 1/9

## THE MODERN BOOK CO

**The Radio Amateur's Handbook, 1957.** By A.R.R.L. 32s. 6d. Postage 1s. 6d.

**Television Synchronizing Separators.** By G. N. Patchett. 5s. 0d. Postage 4d.

**The Radio Amateur Operator's Handbook.** A Data Publication. 3s. 0d. Postage 4d.

**MK Electronic Tube Handbook.** 10s. 6d. Postage 9d.

**Practical T.V. Aerial Manual for Bands I and III.** By R. Laidlaw. 5s. 0d. Postage 4d.

**Tape and Wire Recording.** A Data Publication. 3s. 0d. Postage 4d.

**Radio Valve Data.** Compiled by "W.W." 5s. 0d. Postage 6d.

**Introduction to Printed Circuits.** By R. L. Swiggett. 21s. 0d. Postage 9d.

**Maintaining Hi-Fi Equipment.** By J. Marshall. 23s. 0d. Postage 1s.

**Television Receiving Equipment.** By W. T. Cocking. 30s. 0d. Postage 1s.

**The Gramophone Handbook.** By P. Wilson. 15s. 0d. Postage 1s.

**A Beginner's Guide to Radio.** By F. J. Camm. 7s. 6d. Postage 6d.

**An Introduction to the Cathode Ray Oscilloscope.** By H. Carter. 12s. 6d. Postage 6d.

**T.V. Fault Finding.** A Data Publication. 5s. 0d. Postage 4d.

We have the Finest Selection of British and American Radio Books in the country  
Complete list on application

19-23 PRAED STREET (Dept RC) LONDON W2

Telephone PADdington 4185

## TRANSISTOR IF TRANSFORMERS

Designed for 315 kc/s operation. High-Q "potted" construction, in screening cans 1" x 3/8" diam., 6/6 each. Oscillator coils, transistor type ferrite rod aeriels for MW band, and circuit data, also available.

### SUPER INDUCTOR COILS · MINIATURE DUST CORE TYPES

Selective crystal diode coil type HAX, 3/- (MW); HAX L, 3/6 (LW). Dual wave TRF coils, with adjustable iron dust cores, type A/HF, 7/- matched pair. Type S.S.O. supersonic oscillator coil for tape recorders (*Radio Constructor*, April, 1956). Provides 6.3V 0.3A for pre-amp. heater plus record/erase bias, price 15/- each.

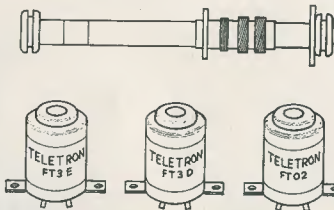

### TELETRON FERRITE ROD AERIALS

Wound on high permeability Ferroxcube rod. No external aerial required. Full sensitivity. Reduces static and whistles. Extremely selective. Simply fitted as replacement for Ae coil or frame aerial. Ideal for battery portable receivers.

Medium wave type FRM, 4" x 5/16" 8/9  
Dual wave type FRD, 8" x 5/16" 12/9

**THE TELETRON COMPANY LIMITED**  
266 Nightingale Road · London N9

HOW 2527

Trade enquiries to sole distributor **S. Mozer** 95 Kendal Ave N18 Telephone EDMonton 7707

## data for AUDIOPHILES\*

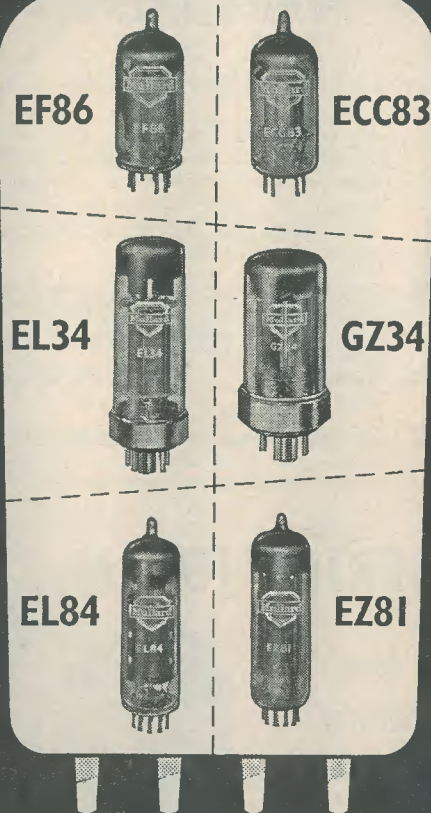

Audiophiles all over the world are demanding Mullard audio valves for their high quality sound equipment. And who can blame them when they know that the Mullard World Series of Audio Valves is the finest in the world.

Fill in the coupon below for free data on Mullard World Series Audio Valves.

\* Audiophile — Enthusiast for high quality sound reproduction who is satisfied with nothing but the best.



This popular book is available now from most dealers, price 3/6d. It contains designs and full constructional details of the new Mullard EL34 High Quality 20 Watt Amplifier, a Mullard Band II F.M. Tuner, pre-amplifiers for the Mullard EL34 Amplifier and for the popular Mullard 5 Valve 10 Watt Amplifier, together with other useful technical information.

### COUPON

TO: MULLARD LTD., PUBLICITY DIVN.

Please send me, free of charge, leaflets on the Mullard World Series of Audio Valves, and details of "High Quality Sound Reproduction".

NAME .....

ADDRESS .....

# Mullard

WORLD SERIES  
AUDIO VALVES



Mullard Ltd · Publicity Division  
Mullard House Torrington Place  
London WCI

MVM 349A



## Radio Control Mechanisms

by  
RAYMOND F. STOCK

A new publication—and the first devoted entirely to the subject of radio control linkage mechanisms. Complementary to *Radio Control for Model Ships, Boats and Aircraft* and to other books on radio control.

64 PAGES ART BOARD COVER  
70 ILLUSTRATIONS

First Edition . . . 4/6 plus 4d. postage

DATA PUBLICATIONS LTD 57 MAIDA VALE LONDON W9



## PULLIN SERIES 100 MULTI-RANGE TEST SETS

— yours by return on the  
easiest of easy terms

£2. 10. 0. deposit and nine monthly payments of £1. 4. 6.

From HOME RADIO of MITCHAM

To: Home Radio (Mitcham) Ltd., 187 London Rd.,  
Mitcham, Surrey

PLEASE FORWARD DESCRIPTIVE LITERATURE OF THE PULLIN SERIES 100 MULTI-RANGE TEST SET AND DETAILS OF YOUR EASY PAYMENT TERMS.

NAME .....

ADDRESS .....

If over 21 ..... Occupation .....

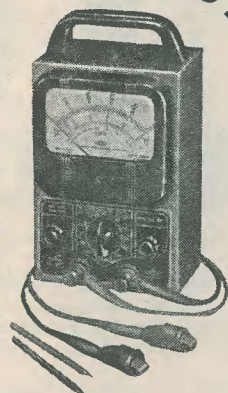

CASH PRICE £12. 7. 6

A compact portable instrument with a total of 21 ranges a.c./d.c. from 100 microamps to 1,000 volts. Sensitivity 10,000 ohms per volt.

MULTI-RANGE TEST SETS

## The R.C. "RAMBLER"— SPEAKS FOR ITSELF!!!

—"The splendid results I am receiving from the set and attractive finish make it really outstanding." —H. Co. Durham

—"I am delighted with my Rambler Portable. It receives all the B.B.C. Stations and also Radio Luxembourg at excellent strength here in Edinburgh." —G. Edinburgh I

—"the quality and selectivity of reception is far above many commercial receivers." —W. Wilts

—"Very satisfied with the performance of this little set and am indeed very grateful for your after-sales service." —W. Northern Ireland

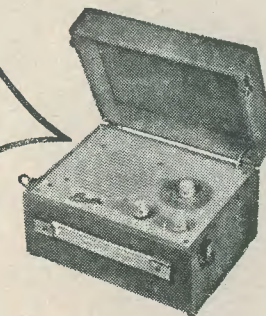

(Extracts from a few of the many letters in praise of the RAMBLER)

The RAMBLER all-dry portable has been the popular choice of a vast number of discerning people since its introduction by us some two years ago. To-day, an ever-increasing demand is being made for the improved version, which is available at the original price, in kit form, of £7. 7. 0 plus 2/6 post and packing! As we are sure you will want to lose no time in placing your order, we are proud to present the complete price list for your convenience.

### PRICE LIST

|                                | s.   | d. |                                    | s.   | d. |
|--------------------------------|------|----|------------------------------------|------|----|
| Cabinet                        | 32   | 6  | 5 0.01mF capacitors                | each | 9  |
| Punched chassis                | 5    | 0  | 2 100pF mica or ceramic capacitors | each | 6  |
| Panel with engraved dial       | 10   | 0  | 1 150pF SM 2 1/2                   | each | 9  |
| 5" p.m. loudspeaker            | 19   | 6  | 1 460pF SM 1 1/2                   | each | 9  |
| Cursor indicator with knob     | 2    | 9  | 1 0.005mF paper                    | each | 9  |
| 2 knobs                        | each | 8  | 1 8mF 150V electrolytic            | 1    | 6  |
| Twin gang tuning capacitor     | with |    | 1 packet solder                    | each | 6  |
| trimmers                       | each | 8  | 4 B7G valveholders                 | each | 6  |
| 2 I.F. transformers            | pair | 9  | 1 6-way tag strip                  | each | 3  |
| Output transformer             | each | 4  | 1 yd. systoflex                    | yd   | 2  |
| Coil Q08                       | each | 4  | 4 yds wiring wire                  | yd   | 2  |
| Coil Q09                       | each | 4  | 1 2-pin batt. plug                 | each | 5  |
| Coil QLI                       | each | 4  | 1 3-pin batt. plug                 | each | 5  |
| Frame aerial QFA2              | each | 3  | 12 1/2 watt resistors              | each | 3  |
| IR5                            | each | 8  | Hardware kit                       | 3    | 0  |
| 3V4                            | each | 9  | 1 instruction book                 | 1    | 6  |
| 1T4, 1S5                       | each | 7  |                                    |      |    |
| 4-pole 2-way switch (w/change) | each | 2  | <b>EXTRAS</b>                      |      |    |
| 1 megohm pot. with d.p. switch | each | 5  | 1 B126 90V h.c. battery            | 10   | 0  |
| 2 50pF trimmers                | each | 6  | 1 AD35 1.5V l.t. battery           | 1    | 6  |

The total purchase price of all the components required to build the RAMBLER is approximately £8. 16. 0. If, however, all the items are purchased at one time, the whole will be supplied at the inclusive price of £7. 7. 0 (less batteries), p and p 2/6. A MAINS UNIT for using the above Receiver on a.c. mains 200/250V is available in kit form at £2. 7. 6 plus 1/6 post and packing.

**CLYNE RADIO LTD.**

18 TOTTENHAM COURT ROAD  
LONDON W1 MUSEum 5929/0095



LONDON'S LARGEST SELECTION RADIO COMPONENTS & EQUIPMENT  
50 yds from Tottenham Court Rd. Tube!

# SALE

PRICES OF COMPONENTS

All post paid

Dozen lots deduct 25% (except waxed tub. and cer. tub.). Block, hermetically sealed: 4 $\mu$ F 250V 1/6; 8/250V 3/-; 8/600V 6/-; 2/800V 2/6; 2/1,200V 3/-; 4/1,200V 4/-; 4/1,500V 7/6; 2/2,500V 8/6; 0.5/6kV 10/- Tubular: 0.1/350V Hunt Mould-seal 8d.; 0.001-2.5 $\mu$ F, 0.01, 0.02 waxed min. 350V 3/- doz; 0.1/4kV bakelite 3/- Mica: 0.1/1,500V 2/-; 0.001/5kV transmitting 6/6. Variables: 1-gang 9-60pF 4/-; 2-gang 500pF 4/-; 3-gang 160pF 2/9; 4-gang 500pF 5/- Ceramic tub. miniature 1,000, 2,000 and 3,000pF 500V 4/6 doz.

Power Pack and 2-valve Amplifier for your Jason F.M. Tuner Unit and many other applications. Full wave metal rectifier; separate treble and bass controls; volume/on-off. Only £5.5.0 (p. and p. 2/6). Delivery from stock. Chassis size 6 $\frac{1}{2}$ " x 4 $\frac{1}{2}$ " x 5 $\frac{1}{2}$ " over transformer. 6 $\frac{1}{2}$ " p.m. speaker, 3 ohm Goodman, Plessey or Elac, 16/6; Goodman 7" x 4", 18/-.

## GLADSTONE RADIO

82B HIGH ST CAMBERLEY SURREY

## ARTHURS HAVE IT!

Large Stocks of Valves and C.R.T.s  
Full Range of Meters available  
Avo, Taylor, Cossor, Advance, etc.  
Particulars on Request

FM Kit of Parts £5, less valves  
(Ref. Radio Constructor July 1954)

Amplifier Tape Recorders and  
Loudspeakers

Jason FM Tuner Unit £15 17  
Jason Power Pack £3 10 0  
Radios and Television always in stock

### VALVE MANUALS

Mullard, 10/6; Brimar No. 6, Osram, Part I,  
5/-; Osram, Part II, 10/-  
Postage 9d. each extra

Publications "Lodestar" Tape Recorder 3/6

Goods offered subject to price alteration and  
being unsold

# Arthurs first

Est.  
1919

Proprietors ARTHUR GRAY LTD

OUR ONLY ADDRESS Gray House  
150-52 Charing Cross Road  
London WC2

TEmpLe Bar 5833/34 and 4765

# MAXI-Q

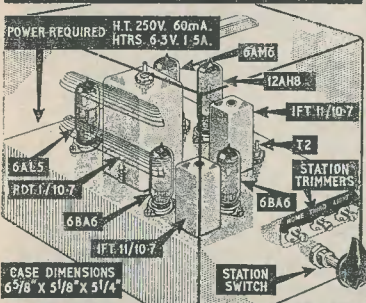

## PRE-SET F.M. TUNER

### VHF/FM HOME, LIGHT AND THIRD PROGRAMMES—Instantly selected at the turn of a switch . . . .

Full constructional details, point-to-point wiring diagrams and alignment instructions for building the "MAXI-Q" PRE-SET FM TUNER and also the VARIABLE TUNED version are given in Technical Bulletin DTB.8, 1/6

Completely punched Chassis, Screens and Bronze finished Cover, 19/-. Station Indicator Plate, 1/1. 3-position Switch 4/3. Station Condenser Trimmers, 3-9pF, 2/- each. Complete set of RESISTORS and CONDENSERS for either version, 48/- RATIO DISCRIMINATOR TRANSFORMER, RDT. 1/10.7 Mc/s. Secondary winding of bifilar construction, iron dust core tuning, polystyrene former, silver mica condensers Can size: 1 $\frac{3}{8}$ " square x 2 $\frac{1}{2}$ " high, 12/6

I.F. TRANSFORMER, 1FT.11/10.7 Mc/s. Miniature I.F. Transformer of nominal frequency 10.7 Mc/s. The 'Q' of each winding is 90 and the coupling critical. Can size 4 $\frac{1}{8}$ " square x 1 $\frac{7}{8}$ " high, 6/6

COILS TYPE L1, T1 and T2. Specially designed for use in this unit, are wound on polystyrene formers complete with iron dust core tuning, 3/11 each

THE "MAXI-Q" PRE-SET F.M. TUNER is available completely wired, assembled, valved and housed in a sturdily made bronze finished cover at £8.11.5, plus £3.8.7 P.T.=£12 VARIABLE F.M. TUNER completely assembled, £11.0.0 including P.T. (carriage 3/-, terms c.w.o.)

GENERAL CATALOGUE covering technical information on full range of components, 1/- post free

DENCO (CLACTON) LTD (DEPT. R.C.) 357/9 OLD ROAD CLACTON-ON-SEA ESSEX

STOP PRESS: "MAXI-Q 60 kc/s TAPE DECK OSCILLATOR COILS, TDO.1—for high impedance Erase Heads (Truvox, etc.), 5/- TDO.2—for low impedance Erase Heads (Brenell and Collaro), 5/- Trading Terms for direct Postal Orders, C.W.O. plus appropriate postal charge

# NEW! - THE PRACTICAL WAY of learning RADIO TELEVISION ELECTRONICS AMATEUR S.W. RADIO MECHANICS PHOTOGRAPHY CARPENTRY etc. etc.

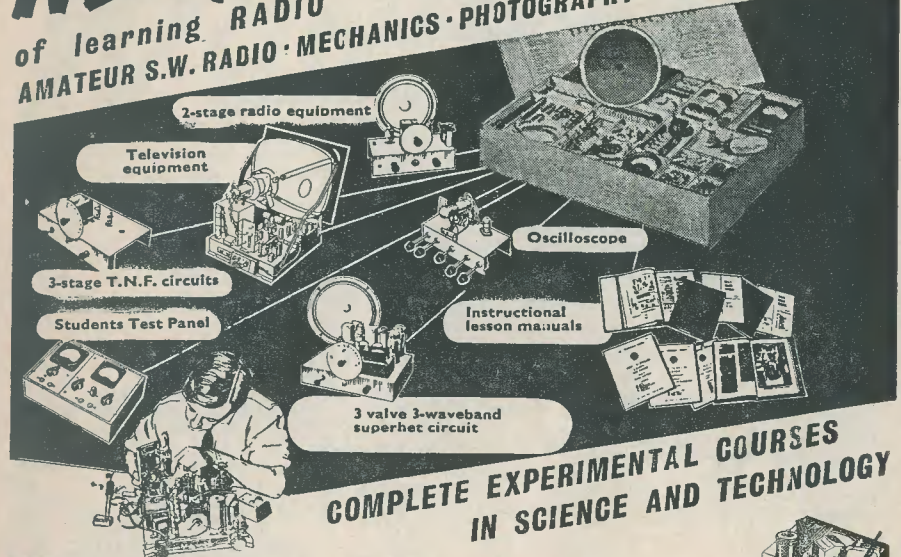

**NEW**—completely up-to-date methods of giving instruction in a wide range of technical subjects specially designed and arranged for self-study at home under the skilled guidance of our teaching staff.

**NEW**—experimental outfits and lesson manuals are despatched on enrolment and remain the student's property. A tutor is allotted to each student for personal and individual tuition throughout the course. In the case of radio and television, specially prepared components are supplied which teach the basic electronic circuits (amplifiers, oscillators, detectors, etc.) and lead, by easy stages, to the complete design and servicing of modern commercial radio and television receivers. If you are studying for an examination, wanting a new hobby or interest, commencing a career in industry or running your own full-time or part-time business, these practical courses are ideal and may be yours for moderate cost. Send off the coupon to-day for a free Brochure giving full details. There is no obligation whatsoever.

### SUBJECTS

INCLUDE:-

- RADIO
- SHORT WAVE RADIO
- TELEVISION · MECHANICS
- CHEMISTRY · PHOTOGRAPHY
- ELECTRICITY · WOODWORK
- ELECTRICAL WIRING · DRAUGHTSMANSHIP · ART, ETC.

COURSES FROM 15/- PER MONTH



Send without obligation your FREE book. E.M.I. INSTITUTES, Dept. 179X, London, W.4

NAME \_\_\_\_\_ Age \_\_\_\_\_ (If under 21)  
ADDRESS \_\_\_\_\_

I am interested in the following subject(s) with/without equipment

(We shall not worry you with personal visits) June/57 IC.85

The only Home Study College run by a world-wide Industrial organisation.

# EMI INSTITUTES

- Part of "His Master's Voice", Marconiphone, etc. etc.

# ◆◆◆◆ REPANCO ◆◆◆◆

## HIGH GAIN COILS and QUALITY COMPONENTS for the constructor

### TRANSISTOR COMPONENTS

- FERRITE SLAB AERIAL TYPE FS2.** A new super-sensitive aerial, Long and Medium Wave, specially designed for transistor portable receivers. Complete with fixing brackets. Length  $5\frac{1}{2}''$  13/6
- COMBINED OSCILLATOR AND 1st I.F. TRANSFORMER TYPE OT1** (315 k/c), fully screened,  $\frac{1}{2}'' \times \frac{1}{2}'' \times 1\frac{1}{2}''$  ... .. 11/6
- 2nd I.F. TRANSFORMER TYPE TT2** (315 k/c),  $1'' \times \frac{3}{8}''$  dia. ... .. 5/-
- 3rd I.F. TRANSFORMER TYPE TT3** (315 k/c),  $1'' \times \frac{3}{8}''$  dia. ... .. 5/-
- PUSH-PULL INTER-STAGE TRANSFORMER TYPE TT4.** Ratio 1:1 ct. Stack  $1\frac{3}{8}'' \times 1\frac{1}{16}'' \times \frac{7}{16}''$  8/6
- PUSH-PULL OUTPUT TRANSFORMER TYPE TT5.** Ratio 15:1 ct. Stack  $1\frac{3}{8}'' \times 1\frac{1}{16}'' \times \frac{7}{16}''$  8/-

All components complete with theoretical circuit and layout diagram of Transistor Portable

### HIGH GAIN COILS

- |  |   |  |
|--|---|--|
| Dual-range Miniature Crystal Set Coil with circuit, type DRX1 ... .. 2/6                           | } | Matched pair TRF Dual-range Coils with Reaction. With mains, battery and feeder unit circuits, type DRM3 pr. 8/-                 |
| Dual-range Coil with Reaction. With 2 mains, 2 battery and Transistor Circuit type DRR2 ... .. 4/- |   | Pair Dual-range Superhet Coils. With mains and battery circuits, type SH4 pr. 8/-  |
| Ferrite Rod Aerial, Long and Medium Wave. With fixing brackets, type FRI 12/6                      | } | Miniature I.F. Transformers, pre-aligned, 465 k/c $\frac{1}{2}'' \times \frac{1}{2}'' \times 1\frac{1}{2}''$ , type MSE ... 12/6 |

### 'R' COILS

|   | Range            | Aerial | H.F. | Osc. |
|---|------------------|--------|------|------|
| Miniature Iron Dust Cored Superhet Coils<br>465 i.f., 0.0005 $\mu$ F Tuning | 800-2,000 metres | RA1    | RHF1 | RO1  |
|   | 190-550 metres   | RA2    | RHF2 | RO2  |
|   | 70-230 metres    | RA3    | RHF3 | RO3  |
|   | 15-50 metres     | RA4    | RHF4 | RO4  |

**REPANCO F.M. COIL SET** 29/6 Complete

### REPANCO EASY-TO-BUILD RECEIVERS

Constructors' Envelopes of easy wiring plans, instructions and detailed price lists of components

- THE HIWAYMAN** ... .. Envelope 1/6 (post 3d.)  
Four-valve superhet Dual-range Portable using Ferrite Rod Aerial
- REPANCO ONE-VALVE** ... .. Envelope 9d. (post 3d.)  
Beginner's Dual-range Radio Set for use with headphones
- REPANCO F.M. TUNER UNIT** ... .. Envelope 1/6 (post 3d.)  
Using 4 EF91, 1 EB91, 1 EM80 Valves, Ratio Detector
- REPANCO "THREE DEE"** ... .. Envelope 9d. (post 3d.)  
Dual-range Transistor Radio using 3 Transistors and Crystal Diode. Amazing loud-speaker reception from  $7\frac{1}{2}$  volt battery supply
- REPANCO "TRANSETTE"** ... .. Envelope 1/6 (post 3d.)  
A new 7 Transistor superhet Portable with preset station tuning using Repanco transistor components

MAIL ORDER and TRADE—

**RADIO EXPERIMENTAL PRODUCTS LIMITED**

33 MUCH PARK STREET COVENTRY.  
Telephone 62572

WHOLESALE and EXPORT—

**REPANCO LTD**

O'BRIENS BUILDINGS  
203-269 FOLESHILL ROAD COVENTRY  
Telephone 40594

# Wanted!

## QUALIFIED MEN AND WOMEN

Industry and Commerce offer their best posts to those with the qualifications — appointments that will bring personal satisfaction, good money, status and security. As part of a modern industrial organisation, we have skilled knowledge of what is required and the best means of training personnel for its present day and future requirements. We specialise also in teaching for hobbies, new interests or part-time occupations in any of the subjects listed below. Write to us to-day for further information. There is no obligation of any kind.

### PERSONAL & INDIVIDUAL TRAINING IN—

- |                   |                     |                     |
|-------------------|---------------------|---------------------|
| Accountancy       | Electronics         | Production          |
| Advertising       | Electronic          | Planning            |
| Aeronautical Eng. | Draughtsmanship     | Radar               |
| A.R.B. Licences   | Eng. Drawing        | Radio               |
| Art (Fashion,     | Export              | Radio Amateurs      |
| Illustrating,     | General Certificate | (C&G) Licence       |
| Humorous)         | of Education        | Radio & Tele-       |
| Automobile Eng.   | Heating &           | vision Servicing    |
| Banking           | Ventilation Eng.    | Refrigeration       |
| Book-keeping      | High Speed          | Sales Management    |
| Building          | Oil Engines         | Sanitary Eng.       |
| Business          | Industrial Admin.   | Salesmanship        |
| Management        | Jig & Tool Design   | Secretaryship       |
| Carpentry         | Journalism          | Shorthand & Typing  |
| Chemistry         | Languages           | Short Story Writing |
| City & Guilds     | Management          | Sound Wave Radio    |
| Exams             | Maintenance Eng.    | Sound Recording     |
| Civil Service     | Mathematics         | & Reproduction      |
| Commercial        | M.C.A. Licences     | Telecommuni-        |
| Subjects          | Mechanical Eng.     | cations             |
| Commercial        | Metallurgy          | Television          |
| Art & Drawing     | Motor Eng.          | Time & Motion       |
| Customs Officer   | Decorating          | Tracing             |
| Draughtsmanship   | Photography         | Welding             |
| Economics         | P.M.G. Cert.        | Workshop Practice   |
| Electrical Eng.   | Police              | Works M'gement      |
| Electrical        | Production Eng.     | and many others     |
| Installations     |                     |                     |

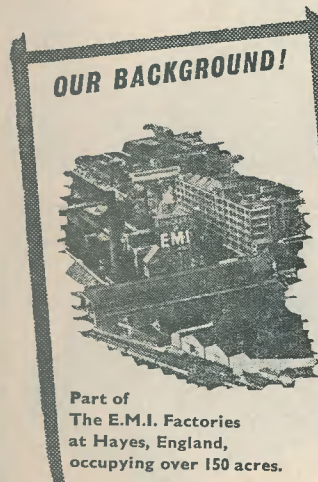

The only Home Study College  
operated by a world-wide  
manufacturing organisation

**NEW!** Courses with PRACTICAL EQUIPMENT  
IN RADIO · TELEVISION · MECHANICS · CHEMISTRY  
ELECTRICITY · DRAUGHTSMANSHIP  
PHOTOGRAPHY, ETC., ETC.  
COURSES FROM 15/- PER MONTH



# EMI INSTITUTES

POST THIS TODAY

E.M.I. INSTITUTES, Dept. 179K, London, W.4

NAME \_\_\_\_\_ AGE \_\_\_\_\_  
(if under 21)

ADDRESS \_\_\_\_\_  
I am interested in the following subject(s) with/without equipment

FREE BLOCK CAPS PLEASE

(We shall not worry you with personal visits). JUNE/57 1C92

—Part of "His Master's Voice", Marconiphone, etc, etc.

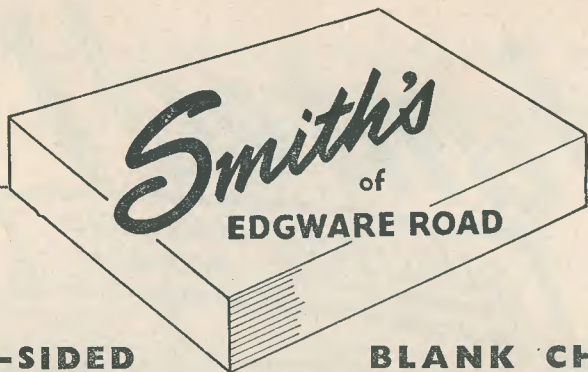

### FOUR-SIDED

### BLANK CHASSIS

Made in our own works from commercial quality half-hard aluminium of 16 s.w.g. thickness, these chassis will carry components of considerable weight and normally require no corner strengthening.

Standard stock sizes (in inches) are as follows:—

|             |      |             |      |              |      |              |      |
|-------------|------|-------------|------|--------------|------|--------------|------|
| 6 x 4 x 2   | 5/-  | 9 x 8 x 2½  | 7/6  | 10 x 8 x 3   | 8/6  | 14 x 10 x 2½ | 10/- |
| 7 x 5 x 2   | 5/6  | 10 x 8 x 2½ | 7/10 | 13 x 8 x 2½  | 8/10 | 12 x 10 x 3  | 10/3 |
| 10 x 4 x 2½ | 6/4  | 12 x 5 x 3  | 7/11 | 12 x 9 x 2½  | 8/11 | 15 x 10 x 2½ | 10/6 |
| 9 x 7 x 2   | 6/6  | 12 x 7 x 2½ | 8/-  | 14 x 7 x 3   | 9/6  | 17 x 10 x 2½ | 11/3 |
| 12 x 4 x 2½ | 6/10 | 11 x 8 x 2½ | 8/3  | 13 x 10 x 2½ | 9/9  | 17 x 9 x 3   | 11/6 |
|             |      |             |      |              |      | 17 x 10 x 3  | 12/3 |

The above are sizes for which we have most demand, but we can also make other sizes to order (at a small extra charge) within the following limits: Depths 1", 1½", 2", 2½" and 3" only. Maximum length 17". Minimum width for 3" depth is 5". Minimum width for 2½" depth is 4". Minimum width for 2" depth is 3½". Minimum width for 1½" depth is 3". Minimum width for 1" depth is 2". We cannot undertake to make odd shapes, extra bends, lips, etc. To arrive at the approximate cost of a special size of chassis take the nearest standard size above and add 2/6. **PANELS**—We can also supply the aluminium for use as panels, screens, etc., cut to any size up to 3' x 3' at 4/- per square foot. **NOTE**—A panel cannot be sent through the post if the length plus twice the width exceeds 6'. Keep this list for reference.

H. L. SMITH & CO. LTD. 287/9 Edgware Road London W2 Telephone Paddington 5891

## Build for Quality

### WITH THE FAMOUS JASON ARGONAUT KIT (AM-FM TUNER OR RECEIVER)

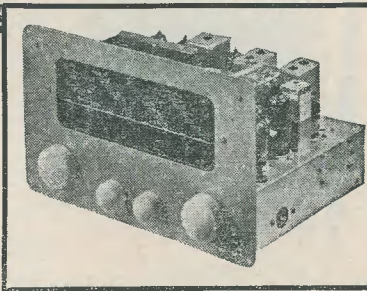

The "Argonaut" is a super-sensitive unit to receive medium-wave AM and FM transmission. It can be built either as a tuner for feeding to amplifier, or a complete receiver. Switching and wiring are reduced to complete simplicity without sacrificing performance and efficiency, and since its introduction the "Argonaut" is creating more and more enthusiasts for its all-round excellence.

Full building instructions are available as a Data Publications reprint, price 2/-

- **DIAL ASSEMBLY**  
With chassis, flywheel tuning, Jackson Bros. 4-gang condenser, 500pF+500pF, and 15pF+15pF, glass scale. Station-name calibrated on both bands. Hammer finish front panel **£4.4.0**
- **SET OF COILS**  
All coils, including ratio detector, M.W. coils and 2 twin-i.f.t.'s (472 kc/s and 10.7 Mc/s) **£2.17.9**

Approximate cost to build, as a self-powered receiver **£16.0.0**

Send S.A.E. for complete list of components and prices

## JASON MOTOR AND ELECTRONIC CO

328 CRICKLEWOOD LANE LONDON NW2  
Telephone SPEedwell 7050



# BRIMAR 6BQ7A

The Brimar 6BQ7A is a double triode consisting of two independent high slope sections with similar characteristics. The valve is particularly useful as a cascode R.F. amplifier for television receivers and also as a combined oscillator and mixer for frequency modulation receivers. It can, of course, be used wherever high slope triodes are required, and features low interaction between the sections as an internal screen is provided which is brought out to a separate base pin.

### TYPICAL CHARACTERISTICS

|   |     |     |     |                  |
|---|-----|-----|-----|------------------|
| Anode voltage                               | ... | ... | ... | 150 volts        |
| Cathode bias resistor                       | ... | ... | ... | 220 ohms         |
| Anode current                               | ... | ... | ... | 9mA              |
| Mutual conductance                          | ... | ... | ... | 6.4mA/V          |
| Amplification factor                        | ... | ... | ... | 39               |
| Anode resistance                            | ... | ... | ... | 6,100 ohms       |
| Grid cut-off voltage (I <sub>a</sub> =10μA) | ... | ... | ... | -10 volts approx |

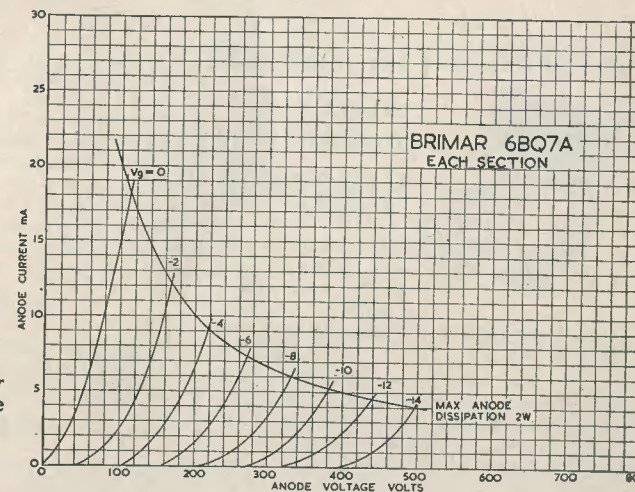

Cut this out for further reference or write to the Publicity Department at Footscray for a data sheet



## Standard Telephones and Cables Limited

(Reg. Office: 63 Aldwych, London, WC2)

FOOTSCRAY SIDCUP KENT Telephone 3333

## JIFFY PUNCH CHASSIS CUTTER

For cutting smaller holes neatly blow of a light hammer

| HOLE    | RETAIL |
|---------|--------|
| 1/8 in. | 6/6    |
| 1/4 in. | 7/6    |
| 3/8 in. | 8/9    |

| HOLE SIZES            | RETAIL |
|-----------------------|--------|
| 1 in. x 1 1/2 in.     | 19/6   |
| 1 1/4 in. x 1 3/4 in. | 18/9   |
| 1 1/2 in. x 1 7/8 in. | 22/6   |
| 1 3/4 in. x 2 in.     | 27/3   |

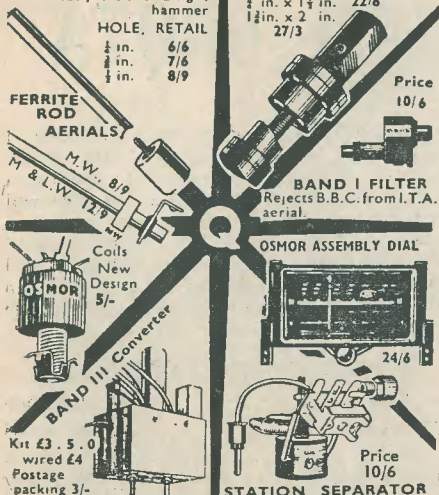

**OSMOR RADIO PRODUCTS LTD**  
418 BRIGHTON ROAD SOUTH CROYDON  
SURREY (Dept. RC11) Telephone CROydon 514B-9

## PRECISION-BUILT COMPONENTS



# JACKSON

### 'O' GANG CONDENSER

Miniature model in 1 or 2 gang, capacities up to 365pF swing, front area 1 3/8" x 1 1/2" including sweep of vanes, length 1 gang 1", 2 gang 1 1/4", spindle 1/4" dia. x 3/8" long. Aluminium vanes, cadmium plated steel chassis

1 gang 7/6  
2 gang 11/6

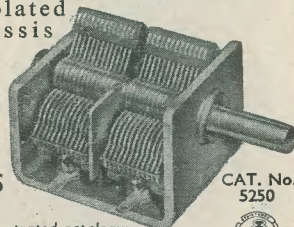

CAT. No. 5250

It's Reliable  
If It's Made  
By JACKSONS

Please write for illustrated catalogue  
**JACKSON BROS. (London) Ltd.**  
Kingsway . Waddon . Surrey Phone CROydon 2754/5

# The Radio Constructor

incorporating THE RADIO AMATEUR



## CONTENTS FOR JUNE

VOL. 10. NO. 11

JUNE 1957

ANNUAL SUBSCRIPTION 21/-

Editorial and  
Advertising Offices

57 MAIDA VALE LONDON W9

Telephone  
CUNningham 6141  
(2 lines)

Telegrams  
DATABUX, LONDON

Editor  
C. W. C. OVERLAND, G2ATV

Advertising Manager  
F. A. BALDWIN, AMIPRE

- 732 Suggested Circuits: An Experimental Hygrometer, by G. A. French
- 735 In Your Workshop
- 743 Television for the Home Constructor, Part 12, by S. Welburn
- 749 Book Reviews
- 750 The "Rambler" Portable Superhet, A Receiver for Home and Countryside, Part 2, described by James S. Kent
- 753 Technical Forum—Collaro Tape Deck Connections
- 756 Transistor Twins—The "Radiosette" and "Nurseryette" Miniature Receivers, described by E. Govier
- 761 Radio Miscellany, by Centre Tap
- 763 Strong Chassis Making—Quickly, Easily and Cheaply, by J. D. Loader, G3HVO
- 764 Alternative Superhet, by A. S. Carpenter
- 769 Right—from the Start: Part 15, Transmitters, by A. P. Blackburn
- 772 Can Anyone Help?
- 773 Valve Nomenclature, Part 2, by V. T. Rolfe
- 776 An Unusual Audio Oscillator, by W. E. Thompson, A.M.I.P.R.E.
- 778 A Constructor Visits the 1957 Audio Fair
- 780 Auto-Selection Coil Unit, by F. G. Rayer
- 783 A "Direct-Coupled" Transistor Receiver
- 785 Field Report on the "Isotron," by Peter Penlenham, A.M.S.D.B.

THE CONTENTS of this magazine are strictly copyright and may not be reproduced without obtaining prior permission from the Editor.

Opinions expressed by contributors are not necessarily those of the Editor or proprietors.

## NOTICES

THE EDITOR invites original contributions on construction of radio subjects. All material used will be paid for. Articles should preferably be typewritten, and photographs should be clear and sharp. Diagrams need not be large or perfectly drawn, as our draughtsmen will redraw in most cases, but all relevant information should be included.

All MSS must be accompanied by a stamped addressed envelope for reply or return. Each item must bear the sender's name and address.

TRADE NEWS. Manufacturers, publishers, etc., are invited to submit samples or information of new products for review in this section.

QUERIES. We regret that we are unable to answer queries, other than those arising from articles appearing in this magazine; nor can we advise on modifications to the equipment described in these articles.

ALL CORRESPONDENCE should be addressed to THE RADIO-CONSTRUCTOR 57 Maida Vale, London W9

## ★ HOLIDAYS AHEAD



HAVE A GAY  
TIME WITH THE  
**HIWAYMAN**

4 valve all-dry portable with latest high gain Ferrite rod aerial. Medium and Long wave.

Cost of building £7.10.0. Full constructional data and price list 1/6.

All parts in stock for the Repanco "Three Dee" Dual Range Loudspeaker Transistor set. Constructional data and price list Price 9d.

**IMMEDIATE DELIVERY.** Limited number of the fabulous QUAD F.M. Tuner £30.9.0. Details on request.

ALSO ALL PARTS IN STOCK FOR THE G.E.C. JUNIOR AMPLIFIER, G.E.C. 912 AMPLIFIER, MULLARD 3-3 and 510 AMPLIFIERS, EAVESDROPPER PORTABLE, MULLARD TAPE AMPLIFIERS

## HOME RADIO (MITCHAM) LTD

187 LONDON ROAD MITCHAM SURREY Telephone MIT 3282

## TSL High Stability FM/VHF Tuner

With visual tuning indicator pre-set audio level and self-contained power supplies. 6 valves and 10 tuned circuits combining high sensitivity and best signal to noise ratio.

Send s.a.e. for full technical specification.

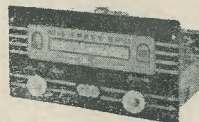

PRICE £17.10.0

Also TSL High stability amplifier to suit above in neat cabinet £13.13.0

## MORSE KEYS

Brand new No. 2 Mk. III with fully adjustable heavy duty brass contacts. Limited number. Price 1/6 each plus 6d. post.

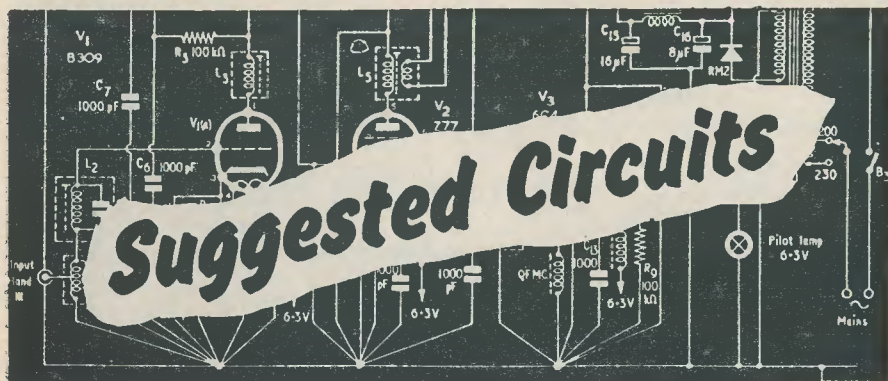

The circuits presented in this series have been designed by G. A FRENCH, specially for the enthusiast who needs only the circuit and essential relevant data

## No. 79. AN EXPERIMENTAL HYGROMETER

EVERY NOW AND AGAIN, THE WRITER feels that it is desirable to introduce a subject into these articles which does not fall readily within the limits of conventional electronics. Several devices which enter this category have appeared in the past, a typical example being an experimental photo-flash circuit which was published some years ago. Even now, letters concerning this circuit continue to arrive at *The Radio Constructor* offices! An advantage given by occasionally including out-of-the-way devices of this type is that they offer a welcome break from the more prosaic items of equipment with which we are familiar. The writer has also been given to understand that they help to provide readers with ideas for solving problems allied to, but not identical with, the particular circuit published.

This month's Suggested Circuit describes an electronic hygrometer (that is, an instrument designed to measure the relative humidity of the atmosphere). The writer must stress that the circuit is definitely in the experimental class, and that the results obtained are liable to depend, amongst other things, upon the care with which the

"hygrometric detector" employed in the circuit is constructed. The device has a certain novelty value, although it could nevertheless be capable of fairly serious application if this were intended. The novelty value is given by the fact that, by merely breathing on to the detector, electric circuits may be set into operation. The factor causing the switching operation is, of course, the moisture present in the breath. Although the long-term stability of the device is liable to be low, it should be capable of giving reliable results over periods of several weeks or so. However, this point is not very serious because the chemical employed in the detector is easily obtainable and incurs negligible cost.

### The Detector

The somewhat impressive term, "hygrometric detector," describes what is, in practice, an extremely elementary and inexpensive piece of equipment. This consists, quite simply, of two electrodes insulated from each other and covered by a thin layer of common table salt. The salt (sodium chloride) provides the humidity-sensitive material, and functions in the following

manner. When dry, it acts as an insulator and does not allow the passage of current between the two electrodes. On becoming damp it exhibits a certain amount of conductivity, the current which flows in consequence travelling through the salt solution provided. Within limits the resistance between the electrodes then varies according to variations in humidity, and a measure of the latter may, therefore, be made by purely electrical means.

For initial experimental work there is little point in going to excessive or expensive lengths in making the detector. A possible detector assembly is illustrated in Fig. 1. In this diagram a round electrode is mounted on to a tin lid such that a small space exists between its lower surface and the upper surface of the lid. The electrode is mounted by a bolt and insulating washers, as shown, these fixing it at a hole in the centre of the lid. The electrode, which may at this stage be made from any available metal, then forms one element of the detector, the lid providing the other. Relative dimensions are not very important, and the lid may have approximately the same size as that used on round tins of 50 cigarettes. Salt is next poured into the lid such that it just covers the electrode and fills the space underneath it. The detector is then ready for use.

### Valve Circuit

In a device of this type, in which many parameters are experimental, the writer always feels a little hesitant at showing a circuit diagram with exact component values. It should be pointed out, therefore, that the circuit given in Fig. 2 is meant to be illustrative only, and that the home-constructor may find that alterations, notably to the values of  $R_1$  and  $R_2$ , may need to be made to enable satisfactory results to be finally obtained. So far as the other resistors are concerned, components which are already on hand and are reasonably close in value to those shown could be pressed into service. The valve circuit functions, in practice, merely as a sensitive ohmmeter, the hygrometric detector being connected, via a limiting resistor  $R_1$ , between the h.t. positive line and the grid of the triode. When the detector is non-conductive the grid of the valve is held at cut-off potential by means of its grid-leak  $R_2$  and the cathode voltage tapped off on the potentiometer  $R_6$ . A 0-10 milliammeter (or thereabouts) is connected in series with the h.t. supply to the triode anode, this measuring the anode current given when the grid potential rises. The series resistor  $R_3$  is included to prevent excessive current passing through the meter in the event of zero bias at the valve grid.  $R_3$  should always be set initially so that it inserts maximum resistance into circuit.

The operation of the hygrometer is very simple. When the salt in the detector is dry it passes no current, and the valve is held at cut-off. On becoming moist, the salt exhibits a proportional amount of conductivity. This causes the voltage at the grid of the triode to rise, with the result that anode current flows through the meter. When the circuit is correctly set up, the meter then provides indications proportional (within limits) to the degree of relative humidity in the air around the detector.

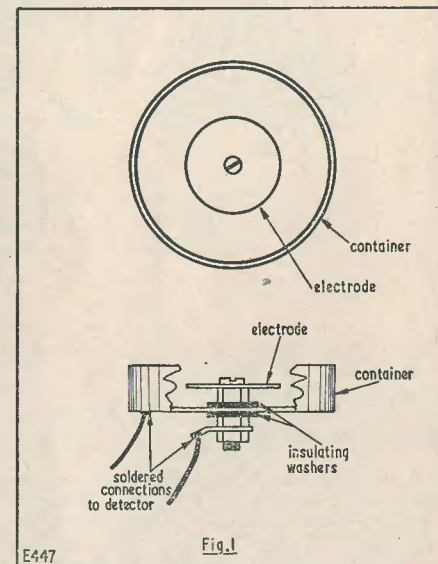

### Practical Points

In order to obtain a range of sensitivity which is reasonably wide it is advisable to use a triode having a long grid base. A good choice would be given by employing one section of an ECC82 (12AU7). A number of other valves, including pentodes strapped as triodes, would be equally suitable. The values of  $R_1$  and  $R_2$  need to be found experimentally, although those shown in the diagram should be sufficiently near what is required for initial checks. The changes required in these two resistors may be quite large and, if it is found that  $R_1$  needs to have a relatively low value, it would be advisable to connect a diode across the cathode and grid of the triode to prevent excessive grid current when the detector is conductive. Such a diode is shown in dotted line in Fig. 2 and could be provided, if desired, by a second triode with grid and anode strapped. (This would then enable both sections of a double triode to be



effectively used.) The potentiometer  $R_6$  is a sensitivity control and should be adjusted so that the triode is just cut off when the salt in the detector is dry.

should be noted that the recovery time of the detector will depend upon the warmth and humidity existing at the time of making the tests.

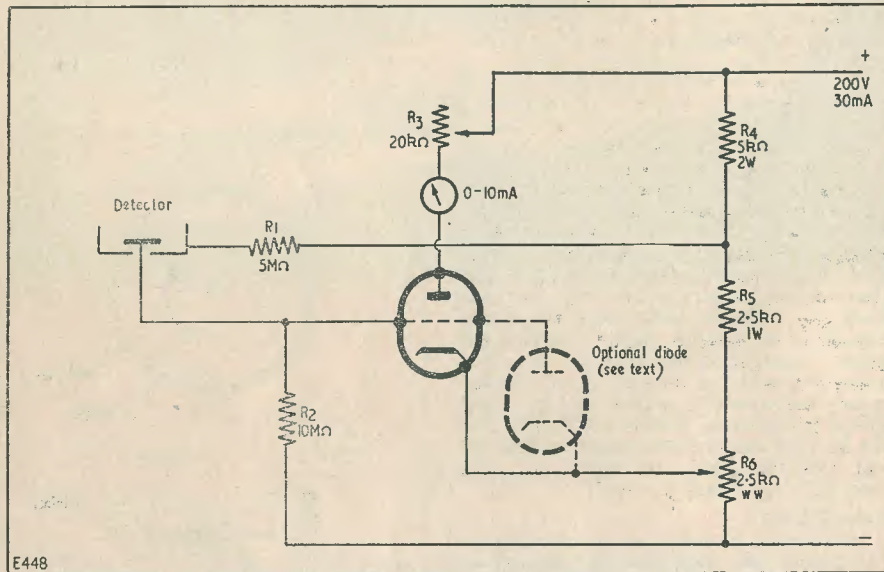

Fig. 2

After the valve circuit has been wired up, the device may be checked by initially connecting up the detector without its salt filling, switching on the power supply, and allowing the triode to warm up.  $R_3$  should be in the position wherein it inserts maximum resistance into the circuit. The optimum setting of  $R_6$  for grid cut-off is next determined. The resistance inserted by  $R_3$  may then be reduced until a reading of approximately four-fifths of f.s.d. is given when the grid and cathode of the triode are connected together. (The alteration of the value of  $R_3$  may necessitate a slight re-adjustment of  $R_6$ .) Dry salt should next be poured into the detector, whereupon the meter reading may increase slightly. The detector should then be breathed upon, whereupon a noticeable increase in meter reading should result. After the device has been found to function reasonably well, the final range of operation required may be found by varying the values of  $R_1$  and  $R_2$  with, possibly, some re-adjustments to the potentiometers  $R_3$  and  $R_6$ . It

#### Final Points

The above description is intended to give details of a rather rough-and-ready hygrometer, and experimenters may wish to improve upon this after they have obtained some experience with its operation. The major field of experiment lies in the construction of the detector, wherein improvements could be effected by employing electrode metals whose surfaces would not corrode with time and by using a mechanical design which enabled the detector to be readily stripped down for cleaning.

It needs to be emphasised that, due to the manner in which it is connected into the circuit, the detector may assume a potential above earth which is high enough to cause shock. In this event care should be taken to ensure that it cannot be touched by people unfamiliar with its operation.

If it is desired to use the hygrometer to switch external circuits at certain levels of humidity, this may be achieved by connecting the coil of a suitable relay in place of the meter and  $R_3$ .

# In your Workshop

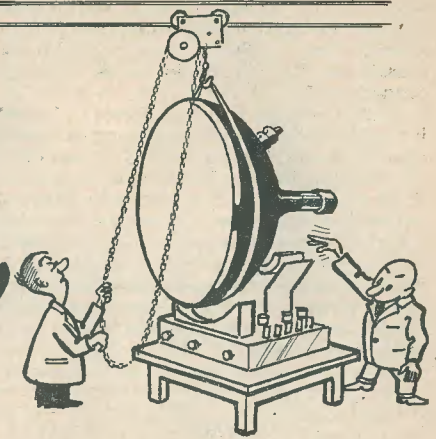

Smithy the Serviceman, aided by his able assistant, Dick, continues to run the Workshop

"SMITHY, I'M IN TROUBLE!"

With which wail of sorrow Dick announced to the world that he had become "stuck" in the repair of a particular receiver he had on his bench.

"What's the snag?" asked Smithy, looking up from his work.

"It's this t.v. set I've got here," replied Dick. "There's something wrong with the line timebase, but everything I've examined checks O.K. I've also swapped every valve in the circuit, but the trouble just refuses to clear up."

Smithy wandered over and examined the set. Straightaway he pointed to one of the valves on the chassis.

"You'll probably find that this is the culprit," he remarked. "Unfortunately, however, you may need to try quite a number of valves before you find one that'll work correctly. This particular set is a model which only works with selected valves in the position I've indicated."

Dick looked surprised.

"Well, that's a turn-up for the book, I must say," he commented. Smithy chuckled as Dick walked over to the valve cupboard.

#### Changing Valves

"It's all part of the business of being a service engineer," he remarked, as Dick checked a number of valves in the faulty chassis. "You don't often encounter sets which need specially selected valves to

function properly, but they aren't entirely unknown. I must admit that the process of sorting out valves certainly puts up the time on the job so far as the serviceman is concerned, and it's liable to put a little extra on the customer's bill as well."

After a while Dick found a valve that seemed to clear up the trouble in the faulty receiver. Smithy, who had been watching him out of the corner of his eye, nodded with approval.

"I'm pleased to see that you switched the set off each time you changed the valve," he remarked. "It's a good habit to get into."

"As a matter of fact I only do it because you told me to," Dick confessed. "Actually, I'm a wee bit hazy as to the reason. Is it something to do with the surge currents which would flow when you put the new valve in and completed the heater chain again?"

"You're miles off the mark," said Smithy. "The real reason is that, when you have all the heaters of a television receiver connected in series, breaking the chain is liable to subject the heater-cathode insulation of some of the valves to a greater strain than they were designed to stand. If you look at this sketch I've made (Fig. 1a) you'll see what I mean."

"Let's start by supposing that  $V_8$  in the heater chain becomes suspect and you decide to swap it for another valve you know to be good. If you leave the set switched on and pull  $V_8$  out of its socket, all the heaters above it will rise to the same potential as that of the

live side of the mains (Fig. 1b). In consequence the mains potential will appear between the heaters and cathodes of these valves; their cathodes being coupled to chassis via the circuits in which they are connected.”\*

“But surely,” Dick protested, “valves intended for series heater operation can stand heater cathode potentials as high as this without breaking down! In any case, aren't you liable to have the same sort of breakdown if one of the valves burns out, as it can do in the ordinary course of events? If you followed your argument to its logical conclusion it would mean that, when one valve burned out all the valves which were higher up the chain would break down between heater and cathode as a result.”

“The situation is by no means as bad as that” smiled Smithy, “and I would certainly admit that damage rarely results if valves are subjected to higher heater-cathode potentials than their manufacturers specify over a short period of time. Nevertheless, if you look at the maximum recommended heater-cathode potentials of some typical valves used in television receivers you may see that the situation is not quite as rosy as you think. Now, a valve which would probably be fairly safe in the event of the chain being broken below it is the PCF80. The limiting heater-cathode potential for this valve, in both its triode and pentode sections, is 200 volts d.c. or a.c. (r.m.s.). The latter assumes a sinusoidal supply. An EF80, on the other hand, has a limiting value of 150 volts only—d.c. or

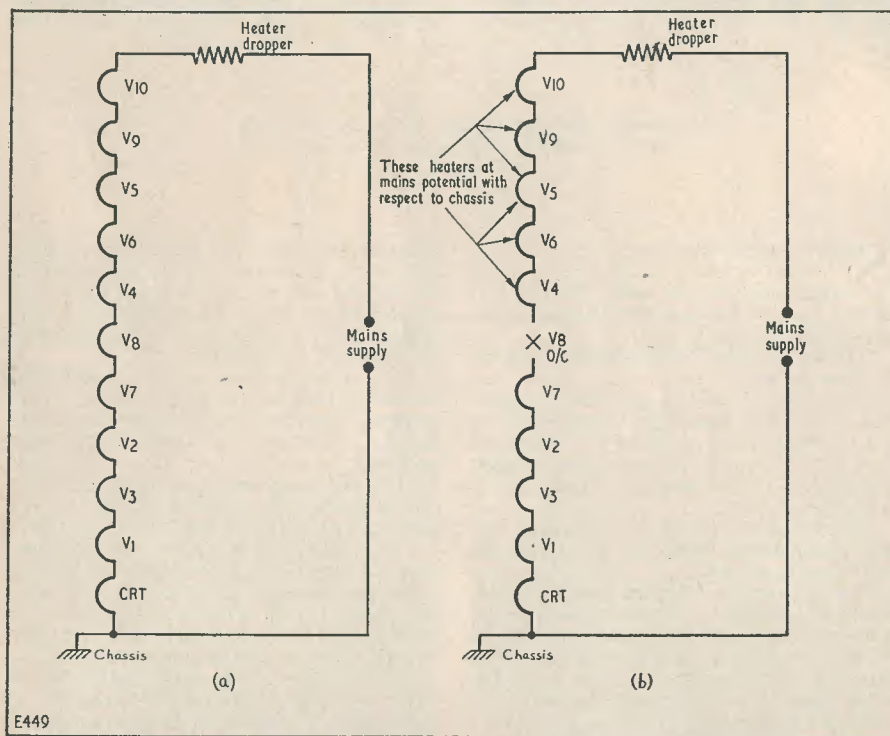

Fig. 1 (a). The heater circuit of a television receiver. (A full complement of heaters is not shown)

(b) If one valve in the heater chain is removed, or becomes open-circuit, all the heaters in the chain above it rise to mains potential

\* In some cases cathode-heater potentials may consist of the mains voltage plus a d.c. voltage derived from the h.t. supply. However, most valves will connect to chassis via low-resistance cathode bias circuits and these are what Smithy is concerned with here.

a.c. r.m.s.—between its heater and cathode; and it would be unwise to exceed this potential for long periods of time. As I said just now, we don't get the case in practice where

valves go pop one after the other, like a Chinese cracker, if the heater of one happens to go open-circuit. At the same time a risk still exists, and I just don't believe in taking chances. That is why I always like to switch the set off before I remove a valve. There is, mind you, a minor snag in switching a set on and off continually if it is fitted with a valve h.t. rectifier. The reason for this is that the rectifier cathode may not be at the full emitting temperature when the set is switched on again, and the heavy surge currents which flow at that instant may damage this electrode. I don't think the risk of damage to the rectifier is very high, however, because its surge limiting resistor should keep such currents within safe limits. Metal h.t. rectifiers should be able to stand up to surge currents of this nature without any worry about damage.”

“Thanks for the gen,” Dick remarked. “I shall now continue to switch television sets off before I swap any valves I may suspect in them. Only from now on I'll know *why* I'm doing it! By the way, is there any special reason for the order in which valve heaters are connected up in a series heater string? One often sees heater wiring travelling all over a chassis to couple in the various valves, when much shorter wiring could be used if the heaters were wired up according to their position in the layout.”

“The position which each valve takes up in the chain is quite important,” answered Smithy, “and I should imagine that the business of working out the chain is quite a headache for the t.v. designer. The reason for this is that a good 50% of the valves in the set have excellent reasons for wanting to get down to the chassis end of the chain. In practice, the heater which is nearly always right at the chassis end of the chain is that of the c.r.t. There are two reasons for having the c.r.t. heater in this position. The first is that, whenever any point in a heater chain short-circuits to chassis, a heavier current than normal passes through that part of the chain above it. By having the tube heater at the chassis end, short-circuits to chassis cannot possibly cause it any harm. The second reason is that, if the tube heater is at chassis potential, the voltage between its heater and cathode is kept as low as the receiver circuitry will allow. Its heater-cathode insulation is, thereby, subjected to as little strain as possible. There is no purely technical reason for taking such especial care with the tube heater, of course: precautions are taken merely because the tube is a very costly item in the receiver.

“So far as the valves themselves are concerned, the major difficulty encountered, apart from keeping heater-cathode potentials within limits, is hum injection into cathode circuits from heaters. It is for this reason

that the heaters of the first valves in the receiver—those of the tuner and the early i.f. stages—are nearly always very near the chassis end of the chain. Timebase valves occasionally require a low position in the chain. This fact applies especially to such valves as flywheel sync discriminators and the like whose cathodes may work into high impedance circuits and which cannot, in consequence, be decoupled to chassis via large value condensers. If valve diodes are used as sound or vision interference limiters their cathodes may be connected to high impedance circuits also, whereupon they, too, need to be positioned well down the chain. In some receivers the video amplifier cathode cannot be decoupled to chassis by a large value of capacity, and this valve similarly needs to take up a low position in the heater string. In the case of the video amplifier, however, this is not necessarily because hum may appear on the video applied to the c.r.t., but rather because it may be passed to the sync separator which follows it. The hum might affect the frame sync pulses.”

“It all sounds pretty complicated to me,” remarked Dick. “I don't quite see how hum would affect the frame sync pulses, though. Surely, if hum *did* alter the shape of the frame sync pulse the effect would be the same for each pulse?”

“Not entirely,” replied Smithy. “Although I must admit that I've raised rather an academic point. Don't forget that, although the frequency of a mains supply running from the National Grid is the same as the transmitted frame frequency, the long-term phase relationship between the two may vary. If heavy hum were present on the frame sync pulse I could visualise the case where interlace would be good for one phase relationship and bad for another. More important, perhaps, is the fact that you need to keep hum out of the frame sync pulses in order to cover the instance where the receiver is run from unsynchronised mains. There are still quite a number of unsynchronised mains supplies in the country, and the set designer has, of course, to keep these in mind.”

“I see,” said Dick. “By the way, before finishing on heater chain questions, here's one little thing I'd like to ask you. As you know, it now and again becomes necessary during servicing to cut out a particular stage in a receiver in order to help in isolating a fault. If the set uses a mains transformer with parallel heaters you can put a stage out of action simply by pulling out the associated valve. How can you 'kill' a stage in a set which has its heaters connected in series?”

“Well, of course, you obviously can't pull out the valve in that case,” replied Smithy. “I would say that, if the valve doesn't require too high a heater voltage, a fair solu-

tion would consist of shorting out its heater pins. The valve would soon lose emission and the chain would remain unbroken. I'm not really too keen on this process because the resultant current in the heater chain could be excessively high if the short-circuited heater dropped a high voltage. Also, if

a friend of mine who does a little servicing recently ran into rather a queer fault, and I'd like your comments on it. He was checking a television receiver in a customer's house and he found that the h.t. voltage was rather low; it being about 185 volts instead of the 195 it was supposed to be. He was rather worried

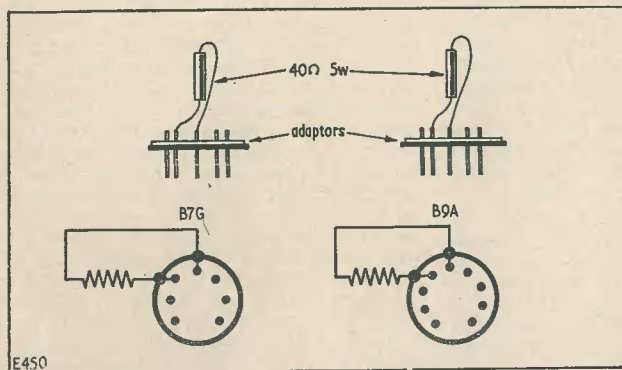

Fig. 2. Valve "cheaters." If it is necessary to put a stage out of action during servicing, the appropriate valve may be replaced by one of the adaptors shown here

crocodile clips were used to do the job, there is a risk of shorts to chassis and adjacent valveholder pins. What is probably a much better idea is to replace the heater with a fixed resistor. A good scheme for inserting the resistor into circuit would consist of making up a couple of adaptors to fit into the appropriate valve-sockets instead of the valve, each adaptor having its own resistor. One adaptor could be a B7G type having the resistor connected between pins 3 and 4, whilst the other could be a B9A type with the resistor connected between pins 4 and 5 (Fig. 2). All other pins would be blank. A 40 ohm 5 watt component should prove satisfactory for the resistor. This would drop 12 volts at 0.3 amps and would not disturb the heater chain current too much if it was inserted in place of the heater of most valves likely to be encountered. The adaptors would be much safer and quicker to fit than temporary measures using crocodile clips. Admittedly, they wouldn't be required very often, but they'd be useful to have around.

"That's quite a good idea," commented Dick. "Are B7G and B9A adaptors easy to get hold of?"

"Oh yes," Smithy replied. "I understand that they are available from one or two stockists."†

#### Varying H.T. Voltages

"By the way," said Dick, "I hope you'll excuse a rather drastic change of subject, but

† For instance, H. L. Smith of Edgware Road, B7G 2s., B9A 2s. 3d.

about this because the set was only just coping at this voltage and, on a hunch, he disconnected it from the 5 amp socket it was running from and connected it to a 15 amp power socket nearby. At once the h.t. voltage came up to approximately 194, which cleared up his main worry. However, the surprising thing about the whole story is that, when he checked the a.c. voltages on the 5 and 15 amp sockets, they both read the same. Have you any idea what caused the different h.t. voltages?"

"There's a fairly well-known reason for the discrepancy," replied Smithy, "although the case you've just quoted appears to be rather extreme. Would I be correct in assuming that the nominal mains voltage of the particular district concerned was low—say, about 210 or so?"

"Yes, that would be true," said Dick.

"Well, that partly explains the large change in h.t. voltage," Smith said. "The story you have just told me is, to a certain extent, symptomatic of one of the difficulties which are always present in television power supply circuits. I don't need to remind you that practically all television receivers in this country employ a half-wave rectifier, this feeding into a high capacity reservoir condenser via a low value limiting resistor. The arrangement you get is something like this (Fig. 3). I've shown a valve rectifier, but a metal rectifier would be equally at home in the diagram. As you can see, the circuit employs three input taps, these allowing for mains

voltages of 200–210, 220–230 and 240–250. The voltage taps function by connecting different values of resistance in series with the half-wave rectifier.

"Now the h.t. drawn by a television receiver is usually relatively high, being of the

tionately large drop in h.t. voltage. For instance, if you increased a 25 ohm limiter to, say, 35 ohms, you might find that the h.t. voltage would drop by as much as 10 volts. The reason for the large drop is that, by increasing the limiter resistor, you are

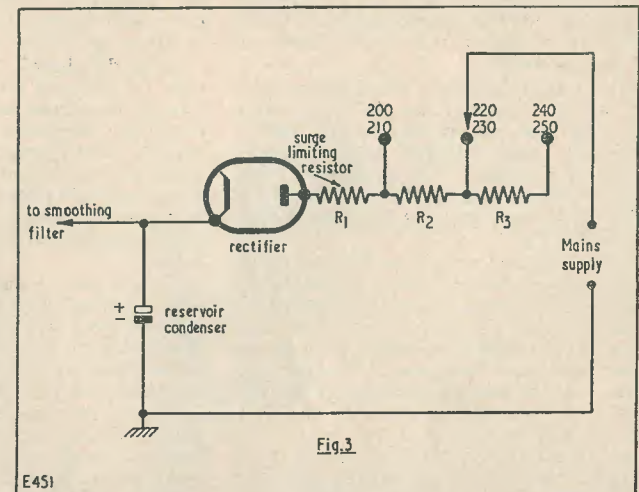

Fig. 3. The h.t. rectifier circuit of a conventional television. R1 is usually a limiting resistor having a relatively low value

order of 200 to 250mA. This current is provided, after the smoothing filter, by the reservoir condenser. The only time that this condenser receives current to make up for that discharged into the receiver is during the peaks of positive half-cycles from the mains. The voltage appearing across the condenser is rather like this (Fig. 4), wherein we have a long discharge period followed by a short charge period.

"During the short charge period quite a heavy current is passed by the diode, and it is the purpose of the limiting resistor to keep this to a value which is safe both for the rectifier and the electrolytic reservoir condenser. You will note that in the circuit (Fig. 3), the only resistance which is in circuit between the lowest mains tap and the rectifier is the limiting resistor itself. For the two higher taps extra resistance is put into circuit.

"When at work on his set, the television receiver designer is usually searching for all the h.t. volts he can safely obtain, so you often find that the resistor brought into circuit on the lowest voltage tap approaches the smallest value which the circuit will take. Values as low as 25 ohms for this resistor are not uncommon in practice. If you experiment with a circuit of this type you will find that increasing the value of the limiting resistor by quite a small amount can cause a dispropor-

reducing the heavy reservoir condenser charging currents which flow during positive peaks.

"On the lowest voltage tapping, therefore, the resistor in series with the rectifier usually has, of necessity, a relatively low value. More resistance must obviously be inserted for the higher mains tappings but, even here, resistor values are still low. Average values for R2 and R3 (Fig. 3) could easily be around the 20 to 25 ohm figure. Once again, slight increases of resistance in series with R2 or R3 can cause disproportionately large drops in rectified h.t. voltage but, for the same number of ohms increase, the drop is not so large.

"So far, so good. But now we come to the snag! As you are aware, we can represent pretty well everything in radio by an equivalent circuit, and the mains supply is no exception. Here is an equivalent circuit for the mains supply as given at the two contacts of a mains socket in a house (Fig. 5). This supply consists, quite simply, of a generator in series with a resistance. The resistance represents the internal resistance in the generator plus the resistance in the wires between its terminals and those of the socket. To be really accurate we should call the resistance an *impedance* as, with a.c. mains circuits, there is usually a certain amount of capacitive or inductive reactance knocking

around. However, for our purposes here, we can assume that the reactances are low and that the impedance is well-nigh entirely resistive.

"Now the internal resistance of the mains generator should normally be as near to zero as the electricity suppliers can make it. The generator will usually be a sub-transformer somewhere in the neighbourhood whose secondary windings will have very low resistance indeed."

"To be really accurate, shouldn't we take into account the resistance in the primary circuit of the sub-transformer as well?" interjected Dick, who had been following Smithy very closely. "Theoretically, I can see us chasing the internal resistance of the mains all the way back to Battersea Power Station!"

"I can see that you have far too much imagination to be a successful student, even if it might make you a successful engineer!" chuckled Smithy. "Anyway, I think we had better take the internal resistance of Battersea Power Station as being read. So also may we consider the internal resistance of the sub-transformer, plus the resistance of the street wiring which brings the current up to the house. It is usually in the house wiring, after the meter, that ohms begin to raise their ugly heads; especially in the 5 amp circuits, where they are liable to go unnoticed."

"I can see that I shall have to take the high-resistance six inch nails out of our fuse box at home!" commented Dick, "and invest in some genuine high-conductivity copper fuse wire."

"Well, even six inch nails aren't too troublesome," laughed Smithy. "On the other hand, long runs of relatively thin wiring can introduce quite high resistances. I daresay you've seen a number of installations in people's homes wherein 5 amp sockets are run from ordinary lighting flex stapled to the wainscoting. These installations are usually highly dangerous; as well, incidentally, as being illegal when the flex connects to a 'regular' mains point outside the room in which the socket is installed. I've been told by a friend who handles this sort of thing that up to ten ohms or so quite often appears in series with the 5 amp sockets in some houses. So far as a 50 watt reading lamp is concerned, a series resistance of 10 ohms only means a drop of approximately 2.5 volts on a 200 volt mains supply. If, however, you connect a t.v. set to that socket you could lose as much as 10 to 15 volts h.t. quite easily, simply because the 10 ohms in the mains supply becomes effectively connected in series with the limiter resistor in the set. At higher mains voltages the effect is not so bad for reasons I have just described, but it can still be severe enough to cause trouble

at times. It can be especially embarrassing if the district in which the set is installed has a mains voltage which drops badly during peak periods and where you're after every h.t. volt you can get."

"Well, that seems to explain my friend's particular snag," Dick remarked. "So far as the 15 amp sockets are concerned I suppose one could assume practically zero internal resistance in almost every instance."

"Oh, definitely," Smithy concurred, "if only for the very good reason that 15 amp circuits are almost certain to be installed by competent engineers with heavy, adequate wiring. In any case, when you have fires and stoves taking currents of five and ten amps you simply *can't* have any sizeable resistance in series with the supply. Unless, of course, you're thinking of having central heating in the house!"

"I have just thought of something," said Dick. "What happens if you run a television receiver from a 1:1 isolation transformer during servicing? Isn't the isolation transformer likely to introduce an effective series resistance and give false h.t. readings?"

"That's quite possible," said Smithy, "and you've raised a very good point there, because small isolation transformers can introduce quite noticeable series resistances. That's a thing to watch for when using such transformers."

"Well, you've given me a few more items to add to my stock of knowledge," said Dick. "But I think I would be safe in saying that internal mains resistances are by no means the only things which cause low television h.t. voltages."

"You would be perfectly safe," confirmed Smithy, "because there are quite a number of other contributing factors. The h.t. rectifier is often a cause of trouble in this respect. Although things aren't so bad these days, metal rectifiers used to give a certain amount of difficulty some years ago. What used to happen was that when the t.v. receiver left the factory its h.t. rectifier would have a nice low forward resistance<sup>‡</sup>, and the set would have a comfortably high h.t. voltage as a result. As time went by this h.t. voltage used to drop, quite steadily and regularly, until the occasion finally arose in which it was too low to operate the set. Not *all* metal rectifiers behaved in this fashion, of course; it was just a certain percentage.

"Nowadays, this sort of thing doesn't happen so often, although one still finds that the forward resistance of some rectifiers increases slightly during the first few months of use. It would be inadvisable to generalise on this sort of thing; but one quite often

<sup>‡</sup> Forward resistance is the resistance exhibited by the rectifier when conducting.

finds, during these first few months, that the h.t. of the receiver drops by 10 volts or so, after which it seems to 'settle down' for the rest of the life of the set."

"I seem to remember seeing somewhere that metal rectifier ratings depend to a large extent on the temperature at which they work," Dick interjected.

with the result that higher watts-losses appear in the elements. These cause the generation of more heat, further increased forward resistance, higher watts-losses again, and so on; with the consequence that, over a period of time, you get a 'snowballing' effect which is only terminated by the final demise of the rectifier."

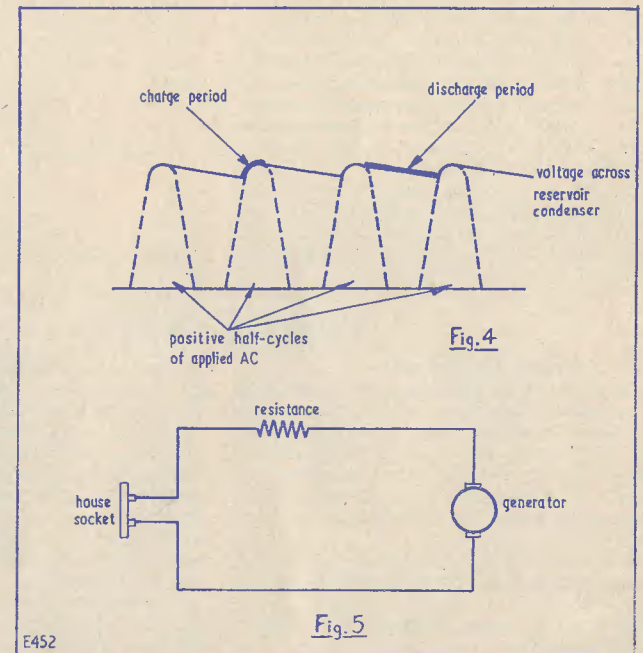

Fig. 4. The voltage waveform appearing across the reservoir condenser of Fig. 3 takes up the appearance illustrated here.

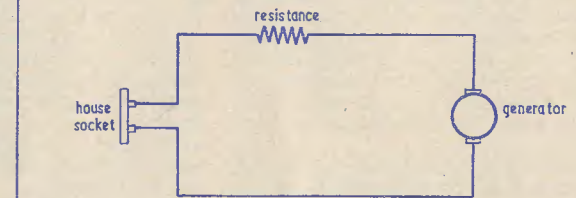

Fig. 5. An equivalent circuit illustrating the presence of resistance in a mains circuit

"That's quite true," said Smithy. "If you look up the maximum ratings of selenium rectifiers you will find that they have to be derated when their operating temperature rises above a certain figure. By 'derated' I mean that the maximum ratings have to be reduced. Metal rectifiers are often operated fairly close to maximum temperatures in television receivers, with the result that you have to be careful to ensure that cooling arrangements are not prevented from operating efficiently. If t.v. sets are put on small tables with their feet overhanging the edge you often get bad ventilation and cooling, because the flow of air through the bottom of the cabinet is impeded.

"One of the reasons why it is important to avoid overheating metal rectifiers is that these components have a tendency towards self-destruction once they exceed the temperatures corresponding to the currents they are passing. Increases in temperature in a selenium rectifier cause increases in forward resistance,

"The moral of the story," Dick commented, "is, therefore, to ensure that metal rectifiers run as cool as possible. I suppose that most rectifiers are kept cool by convection currents."

"This is usually the case," agreed Smithy, "hot air rises from the rectifier and cool air comes in to take its place. Quite a lot of heat is lost by radiation as well. Of course, the metal rectifier isn't the only component on a t.v. chassis which needs to be kept cool, and convection currents have to serve other parts as well. That's where good cabinet design and chassis layout assist each other; and you may find in some sets that all the heat-generating components combine in the formation of a steady convection current. Indeed, some t.v. sets exhibit almost a 'chimney' effect, and have ventilation holes at the bottom of the cabinet, and at the top of the rear cover, with none in the middle. The resultant air current is almost in the nature of a forced air draught, and you might actually decrease cooling efficiency if you added extra

holes in the middle of the rear cover! Quite a good method of seeing what convection currents exist in a television cabinet consists of blowing in a little cigarette smoke at the bottom. With some sets, and particularly with compact designs, you'll be surprised to see how soon this re-appears at the top!

"To return to the metal rectifier. Much of its heat is taken away from this component, as I remarked, by convection currents. Incidentally, this fact emphasises the importance of mounting heavily-loaded metal rectifiers horizontally, so that the cooling air has greatest contact to the fins as it passes by them. There is a particular type of rectifier, however, which is not cooled in quite the same way. This is the contact-cooled rectifier. Contact-cooled rectifiers have no fins and are bolted flat to a chassis, with the result that the heat they generate is conducted away by the metal of the chassis itself. You could then consider the chassis as acting as one very large cooling fin for the rectifier."

#### That Problem

"Well, you've certainly told me a lot about rectifiers that I hadn't known before," remarked Dick. "Incidentally, I hope you haven't forgotten that 'hocus-pocus' problem you raised the other day. I might point out that I spent half of Saturday afternoon trying to get the darned thing out!"

"Well, it took me nearly an hour myself," confessed Smithy. "But, as I say, the time limit for the 11-plus examinees who did it was five minutes only—or so I understand. You may remember that the original went:

H O C U S  
P O C U S  
P R E S T O

"When translated into figures the result is:

9 2 8 3 6  
1 2 8 3 6  
1 0 5 6 7 2

Simple, when you know the answer, isn't it?"

## TRADE NEWS

### Vidor Television Replacements

A number of set manufacturers are making arrangements for Direct TV Replacements, of 134-136 Lewisham Way, S.E.14, to maintain the supply of their older type replacements. Vidor are the latest company to operate in this manner, and so assure that replacement parts are available for all their t.v. models.

The Vidor models for which Direct TV Replacements have been appointed official suppliers are:—

Model 377 Line Output Transformer Uniscan, 39/-.

\*Models 390 Line Output Transformer Type 15623, \*391, \*405, \*406, \*4201, \*4202, 50/-.

\*NOTE.—Two types of line output are used on this model. The above type is used where a single winding width coil is employed. In models using double wound width coil the line output transformer has to be sent to D.T.V. for special rewind, taking 48 hours.

Models 4206, Type of Line Output 15747, 4207, 4208, 4209, 4212, 45/-.

Deflector Coils CP.77916 for the above models, 45/-.

### Low-Microphony Pentode for A.C./D.C. Audio Equipment

A new addition to the Mullard range of 100mA a.c./d.c. valves opens up important possibilities for the design of high quality audio amplifiers for a.c./d.c. operation.

Until now, lack of a suitable low-noise pentode for the pre-amplifier or mixer stages of high-gain amplifiers has made really low hum and microphony levels difficult of achievement in a.c./d.c. apparatus.

The UF86, which has just been announced by Mullard, is a low-hum, low-microphony pentode with a heater rating of 12.6 volts at 100mA. Its characteristics are virtually identical with those of the well-established World Series pentode type EF86. Used in circuit with other Mullard 100mA valves it makes possible the design of compact, economical a.c./d.c. apparatus having signal-to-noise ratios approaching those of the best a.c. apparatus.

For example, a UF86 feeding two UCL82 triode-pentodes, and with a UY85 half-wave rectifier, would form the basis of an inexpensive push-pull amplifier giving a sensitivity of 10mV for 7 watts output at a low distortion level, and a signal-to-noise ratio of 55db.

The UF86 is available for immediate delivery.

### Sellotape's New Polythene Electrical Tape

A recent addition to the range of Sellotape self-adhesive tape products is polythene electrical tape.

The tape, with a tensile strength of 16lb per inch width, has been developed with a number of new special characteristics to provide a reliable, waterproof insulating tape, with enough elasticity to enable it to conform closely to surfaces and ensure a tight seal. Its elongation at breaking point is 175 per cent.

Good ageing properties are provided by an adhesive which is immune from corrosive effects. Plasticiser migration from the tape is eliminated by the absence of plasticisers in the polythene film.

(continued on page 760)

# TELEVISION for the HOME CONSTRUCTOR

PART 12

by S. WELBURN

*In this, his last article for some time, S. Welburn deals briefly with the past and the present, then discusses a number of important questions embracing existing controversies and the future progress of television.*

WRITING A REGULAR MONTHLY ARTICLE is an occupation which can provide both pleasure and pain! It must be admitted that, so far as the present articles are concerned, pleasure has constituted by far the greatest proportion of the writer's sensations. Pain only becomes evident when he finds that the monthly date of submission to the Editor appears, uncomfortably, far nearer than he had anticipated. Normally, it is possible to have articles prepared well in advance but, due to unforeseen circumstances, last month's contribution was somewhat delayed. When the writer *did* start work on it he also started the first few days of a bout of 'flu! Apart from a mysterious "kink" in one of the waveform diagrams—which was fortunately straightened out just before the block was made—the article concerned doesn't seem to have suffered too much by the conditions under which it was written.

Speaking seriously, however, the author would like to point out at this stage that this is going to be the last of the present series of articles, and that he will be taking a holiday from writing for a number of months. During this time the continuity of articles on television in *The Radio Constructor* will be maintained by other contributors. If all goes to plan the writer will be returning, refreshed, ready for the fray and full of new ideas, in the autumn.

### In Retrospect

There is, usually, little to be gained in persistently looking back into the past, but a very brief excursion every now and again does not normally do any harm. Indeed, it can often help to bring both the present and the possible future into truer perspective. Readers may recall that the first of the regular television articles appeared in the July 1955 issue of this magazine; appearing, therefore, at a time when very considerable interest on the part of the technical and the non-technical public was focused on the reception of Band

III transmissions. The first article confined itself to a description of the Valradio Tuner Unit type TP20P, this being employed for the conversion of the Magna-View for Band III operation. Later articles were devoted also to Band III topics, the September and October issues describing the Teletron Mark I and Mark II converters respectively. It was, in fact, the October article which introduced the Mark II version to the home-constructor for the very first time, and the writer obtains a certain pleasure from the association he has had with this now extremely well-known and successful unit. It would be difficult to say how many Teletron converters have been built, but the number must be considerable. What is more, these converters are still being constructed at the present time in various districts in order to receive Band III transmitters as they come on the air.

After the first twelve articles it was decided to widen their scope, and so a second series was started. This commenced, in the July 1956 issue, with a description of the line fly-wheel sync circuit developed by R. G. Young and intended especially for the amateur. Later articles, coming up to the present date, dealt with many of the problems encountered in modern television engineering, including the design of duplexing and splitting circuits, remote control arrangements, and discussions of the various parts of television circuitry which are most applicable to the home-constructor.

### The Present

So much for the past, which has provided many interesting topics, and which has also demonstrated how quickly new techniques in television become taken for granted. The present scene exemplifies the continually changing developments which occur in television design, even though some of these, due to their complexity, may not be immediately applicable to the home-constructor sphere. To attempt to sum up the amateur position it

could be said that, at the immediate moment, the construction of *complete* televisors seems to be following well-established techniques which have become familiar over the past three or four years. "Wide-angle" (70 degree) tubes are practically standard equipment in present-day receivers, both home-constructed and commercial, and the timebase and scanning circuits for these have not undergone any major alteration. So far as commercial receivers are concerned there is a trend towards 90 degree tubes, but at the time of writing it is difficult to calculate how this will be reflected in home-constructor fields of interest. One of the major advantages of 90 degree tubes is that they require less cabinet volume, thereby enabling a cheaper receiver to be manufactured as a result. A disadvantage given by the 90 degree tube is that greater power is required for horizontal scanning and that scanning components have to meet higher specifications than heretofore. From the amateur point of view it seems feasible that the saving in a cabinet cost (rather problematic in this context) may be considerably outweighed by the circuit complications involved. At any event, much depends upon the components which will become generally available for use with 90 degree tubes.

Apart from the new tubes, and, of course, Band III, general receiver design has for some time remained fairly stable. This remark applies both to commercial and to home-constructor design. There is a current commercial leaning towards the manufacture of "portable" television receivers, but these mostly consist of more-or-less conventional chassis served up with new dressing. Once again, home-constructor reactions are problematic.

Band III has completely altered the front-end of the television receiver, but this aspect is one which amateurs have taken very confidently in their stride. The availability of commercial tuners, such as the Valradio unit mentioned above, has helped considerably to ease difficulties in this sphere. The writer has, in the past, given design details for reasonably simple Band I-Band III tuners capable of being made by the more experienced amateur, and he understands that his notes have been of assistance in this field.

As was mentioned above, some of the previous articles in the series have dealt with television remote control circuits, and it would seem that this is a subject in which a surprisingly large amount of interest is shown.

All in all, therefore, it seems safe to say that present home-constructor interests lie not so much in the construction of television receivers as a whole, but rather in the improvement of existing techniques, with

especial reference to equipment ancillary to the televisor proper.

### The Future

It is when we commence to consider what television holds for the future that we enter into the most interesting field of discussion. The essential function of television is that of representing visually, as a complete picture, information which is transmitted sequentially. At the time being we have only one device which is capable of carrying out such representation cheaply and successfully—the cathode ray tube. Some years ago the writer held the opinion that the cathode ray tube was a relatively clumsy and cumbersome device which must eventually be replaced. Nowadays, he is not so sure. The reasons for his earlier opinion were given mainly by the purely mechanical limitations of the cathode ray tube. Unless projection was employed, it was impossible to obtain a picture larger than the maximum flat area given by the glassware of the tube; and the total amount of glass employed had to be made proportionately very large in order to obtain a bulb shape that would withstand the heavy atmospheric pressures to which it was subjected and which would enable the basic requirements of scanning to be achieved. One could only have a large picture at the expense of a structure which was very much more bulky than the part on which the picture appeared.

Whilst trying to avoid a "science-fiction" approach, it cannot be gainsaid that, if deflection and modulation could be applied not to an electron beam but to a beam of light, a picture of almost any size whatsoever could be obtained simply by projection on to a screen. A beam of light is, of course, weightless, and even small deflection angles could give a sizeable picture, if the "throw" to the screen were sufficiently long. The only major limiting factor to screen size would be the brightness available after modulation. The question of modulating and deflecting the light beam is by no means insurmountable, and it is possible that a device of this type may, one day, rival the cathode ray tube. The writer would like to add that the idea of obtaining a television picture in this manner is by no means a new thing at all: a receiver employing this principle and functioning on 405 lines was manufactured before the war!

### Definition

The writer does not want to give the impression that he considers that large pictures are the prerequisites of all television design, although he must point out that it is desirable to be able to obtain reasonably large pictures without incurring excessively high costs. At present, very large pictures—in the home at any rate—are not attractive owing to the definition given by our present 405-line sys-

tem. On the other hand it needs to be emphasised that, when correctly set up and accurately interlaced, a 405-line picture can provide a surprising amount of sharpness on really large screens. Due to the fact that Great Britain was the first country in the world to have a regular high definition television service we are now tied to the standard

the large bandwidth signals required into the u.h.f. bands, and the necessary transmitters could, initially, be centralised in areas of dense population. Experience has always shown that television service areas are, in practice, larger than those originally anticipated, and it may be that the u.h.f. transmitters would give a coverage extending outside

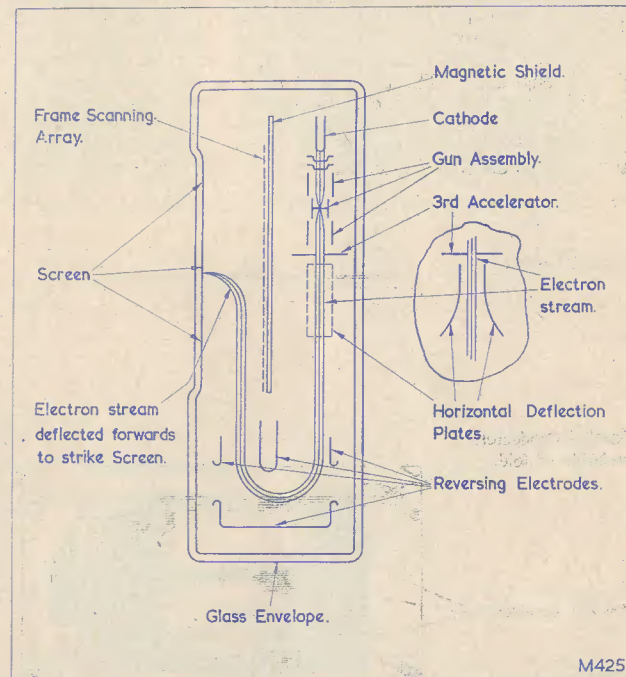

Fig. 1. Simplified diagram, showing a cross-section across the Gabor tube. The shadow-mask and cathode ray tube employed for colour reproduction are not shown

of 405 lines which we chose in 1938. (Nearly twenty years ago!) From the point of view of definition, incidentally, it should be pointed out that 405 lines is not so bad as some commentators would have us believe, and the writer can assure readers that not a great deal is gained visually (indeed, some horizontal resolution may be lost) by changing over to the American 525 or C.C.I.R. 625-line standards. Apart from the argument that it may assist in the design and manufacture of export receivers, for Great Britain to convert to 525 or 625 lines would, quite simply, just not be worth the heavy expenses involved. If an increase in the number of lines of the television picture is to take place, then it needs to be one that is really worth while; say to 1,000 lines or more. There is no reason why such an increase should not take place at some time in the future, even if transmissions could only be received in the first instance by those residing in the more heavily populated areas of the country. It would be necessary to move

their initial service areas by a significant amount. The rather disappointing results given by u.h.f. transmissions in the United States need not necessarily be repeated in this country, as the prevailing conditions would be different. The problem of making higher definition signals "compatible" with existing 405-line standards would be the least of the difficulties. One way out of the problem could consist of originating programmes in the higher definition system, and "converting" these to 405 lines with techniques similar to, or improved upon, those currently used for Eurovision. Alternative schemes employing entirely electronic methods of conversion may be feasible.

### The Gabor Tube—A New Approach

Earlier on the writer referred to the c.r.t., and remarked that he is nowadays not so sure that this is quite so clumsy a device as he had hitherto considered it to be. It is worth while returning to the subject of the c.r.t. because

this opens up yet another interesting aspect of television of the future. So far as the writer's change of view is concerned, this is partly due to the fact that he has recently been able to inspect a modern 110-degree tube, and he feels that this marks a definite step in achieving a ratio of supporting glass area to screen area which is not cumbrously large. Indeed, if it were not for the inevitable neck protruding from its rear, the 110-degree tube would begin to approach the "picture on the wall" concept that has been predicted by a number of engineers. The process of scanning a 110-degree tube is not easy but it can, of course, be done; and the advantages given by the tube may well outweigh the complication of the deflection circuits.

quently reported in the *Wireless World*.\* Descriptions of the tube have also appeared in the American press,† on the Continent‡ and in Australia.†† Other references to the Gabor tube have, doubtless, appeared elsewhere. It is difficult to describe the functioning of the new tube in a short space, but the simplified outline which follows may give a reasonably good idea of how it works.

Briefly, the Gabor tube employs a "flat" construction; there being no necessity to have a tube neck or any of the scanning components associated with the conventional c.r.t. The flat construction is achieved by bending the electron beam from a conventional cathode through 180 degrees before it enters the vertical scanning section of the tube and,

before the beam is bent; the deflecting force being provided by two deflecting plates, these being somewhat similar to those employed in electrostatic deflection tubes. Vertical deflection is achieved by a technique which is unfamiliar and completely new.

Just in front of the magnetic shield which divides the two halves of the tube (Fig. 1) is what is described as the "frame scanning array." This consists of a relatively large number of parallel conductors (approximately 120) which are printed on to a sheet of insulating material. The exact number of conductors is unimportant and does not need to have an exact relationship with the number of lines in the picture. The sheet on which the conductors are printed is bent round at either end so that the electron beam, on leaving the screen area, falls on the inside of either

from full charge to minimum charge being distributed gradually over this zone.

When the electron beam, after bending through 180 degrees, travels up from the bottom of the tube (Fig. 1), it is not deflected by the full positive potential of the conductors below line XX because the phosphor screen is held at an equivalent positive potential by an external source. In consequence the beam travels through an equi-potential field, and proceeds upwards in a straight line. However, once the beam approaches the transition zone, it becomes deflected by the gradually reducing positive charge, the deflecting force being greatest around line YY and the conductors above. These conductors are negative with respect to the potential of the screen and the beam is consequently deflected towards the latter, finally striking it at a height which

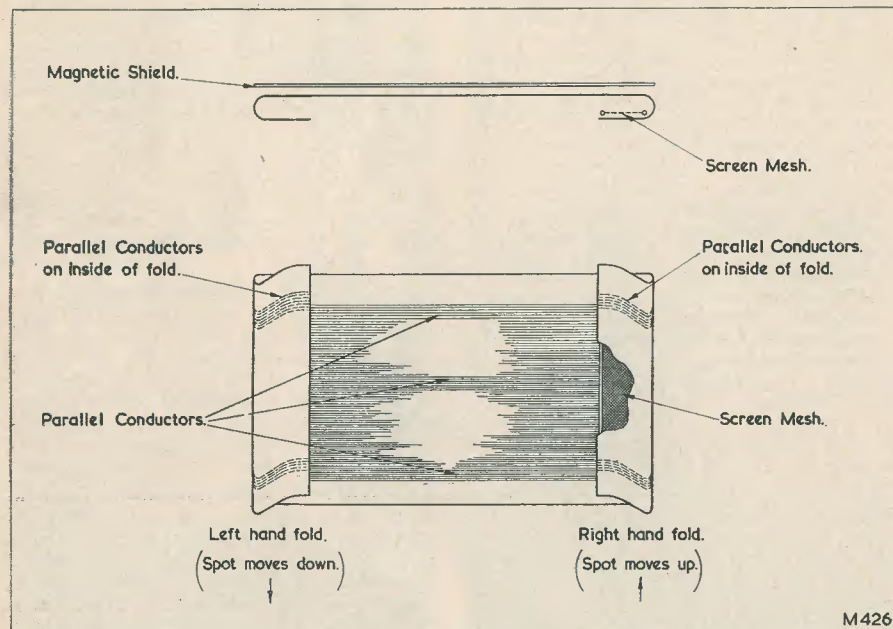

Fig. 2. The frame scanning array of the Gabor tube. The cross-section of Fig. 1 cuts across the centre of this array which, in that diagram, is at right angles to the paper

Another reason which may tell considerably in favour of the cathode ray tube type of presentation is the possible manufacture of a new type altogether. This new tube, at present in the experimental stage, falls very closely into the "picture on the wall" concept; and it has been the subject of much comment in the technical press. The new device is the Gabor tube (named after its inventor, Dr. D. Gabor of London). The Gabor tube was described in a lecture to the Television Society in 1956, this being subse-

thence, the screen. Fig. 1 gives an idea of the construction of the tube, as well as showing the route covered by the electron beam in travelling from the gun to the screen. Horizontal deflection of the beam is achieved

\* "Flat Tube for Colour T.V.," *Wireless World*, Dec. 1956.  
 † "Flat T.V. Tube," Eric Leslie, *Radio-Electronics*, March 1957.  
 ‡ "Platte Beeldbuis Voor Kleuren-Televisie," *Radio Electronica*, March 1957.  
 †† "A Projected Flat Display Tube for Colour T.V.," *Radio Television and Hobbies*, Feb. 1957.

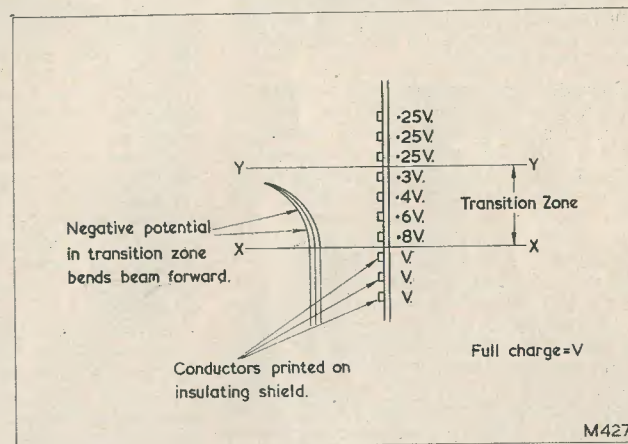

Fig. 3. A possible distribution of potentials on successive conductors in the transition zone. This diagram is intended for illustrative purposes only, and is not intended to exactly represent the potentials existing in an actual tube

the left-hand or right-hand fold (Fig. 2). The purpose of the frame scanning array is to provide an electrostatic potential which bends the electron beam forward to make it strike the screen. The conductors of the scanning array are not connected physically to any source of voltage, and they obtain their potentials entirely by holding electrostatic charges.

Fig. 3 illustrates a typical potential relationship which may exist at some position down the scanning array. The conductors below line XX in this diagram hold a full positive charge. Above the line XX, the charge held by successive conductors becomes less positive until we reach line YY, above which all conductors hold minimum charge. Minimum charge is approximately equal to one quarter of the full positive charge. The zone between lines XX and YY may be described as the "transition zone," the change

corresponds to the height of the transition zone. Since the beam undergoes deflection by the changing potentials of the transition zone it becomes focused at the point of impact on the screen. (Electron beams tend to focus when subjected to deflection.)

The potentials held by the conductors of the scanning array are, as was just mentioned, held electrostatically. These charges are controlled by the beam itself. In order to consider the overall scanning operation, it is advisable to commence half-way through a frame, at a time when the spot is tracing a line half-way down the picture, with the transition zone in a similar position behind it.

At the end of its line scan the spot flies back to, and rests on, the inside of the left-hand fold of the insulating sheet holding the parallel conductors (Fig. 2). Whilst resting on the conductors on the inside of the fold the beam partially discharges them, causing

them, therefore, to become less positive. Due to this discharge the transition zone moves down slightly with the result that, when the beam scans the next line, it travels across the screen at a position slightly lower than that of the previous line. At the end of this second line the beam returns to the left-hand fold once more and again partially discharges the conductors on which it rests. Once more the transition zone moves down, and once more the following line is a little further down the screen. As may be readily imagined, the speed at which the transition zone moves downwards depends on the rate at which discharge takes place during each flyback period. (It will be appreciated that at the end of each line the beam rests on the conductors only long enough to cause partial discharge; discharge to the minimum potential occurring after a number of these partial discharges have taken place. It is possible that the beam is somewhat defocused when it rests on the inside fold.)

Whilst the beam automatically controls its own downward deflection, it becomes obvious that some alternative process is needed to deflect the spot upwards again at the end of the frame scan. Here, again, the beam controls its own deflecting process. At the end of the frame scan the beam moves to the right-hand fold of the scanning array instead of to the left. In this case the beam does not strike the conductors directly but has first to pass through a mesh which has a high positive potential applied to it from an external source. The behaviour of the mesh and the conductors is rather similar to that of the screen-grid and anode of a tetrode valve when the anode potential is lower than that of the screen-grid. What happens in the Gabor tube is that the beam, on striking the conductors at the bottom of the right-hand fold, releases secondary electrons which are attracted to the positive mesh. Since the conductors struck by the beam lose electrons, they become, once more, positively charged. Being positively charged they cause the transition zone to move upward, to be followed by the beam. In travelling up, the beam falls on conductors higher up in the array, makes these positive by secondary emission, and causes the transition zone to rise yet again. The process carries on until all, or almost all, of the conductors are positively charged and the beam is at the top of the tube once more. The device is then ready to scan another frame by the downward-going method we have already discussed.

It may have been noted, in Fig. 2, that the parallel conductors appear to be "staggered upwards" at the right and left-hand folds. This staggering is necessary in order to obtain the correct register between the position at

which the beam is deflected and the height of the transition zone.

#### Colour T.V.

The above provides a simplified description of the scanning action of the Gabor tube. Although its principles are complicated—or seem complicated when first encountered—its mechanical construction does not necessarily fall into the same category. It should be noted, incidentally, that receiver circuitry may be simplified by the absence of magnetic scanning, and the fact that line deflection is electrostatic. All in all, there is little reason to suppose that the Gabor tube may not eventually prove to be a formidable rival to the conventional cathode ray tube when it has been finally developed into a form suitable for production. This is definitely a tube of the future.

A considerable advantage of the Gabor tube is that, by fitting a shadow-mask close to the phosphor screen, and the appropriate three guns, it may be used for colour reproduction without excessive departure from the principles employed for black-and-white operation. Without going into details of the additions needed for colour presentation, it may be said briefly that they should not cause the same increase in cost as is occasioned by the conversion of a conventional black-and-white tube to existing tricolour shadow-mask design. A Gabor colour tube may also be considerably less sensitive to external magnetic fields.

It is on the question of colour T.V. that the writer would like, finally, to devote his space. Fostered perhaps by the daily press, public interest is being continuously whetted by reports predicting the early arrival of colour television. Apart from Oxo advertisements (!), what the future does actually hold in the way of colour television is anyone's guess. The writer's own private opinion is that we will be lucky if we see anything approaching regular public schedules before, say, 1962. The writer bases this opinion partly on the economic conditions prevailing at present. In just the same way that colour photography is inevitably more expensive than black-and-white photography, so also must colour television be more expensive than black-and-white television.

Another point delaying the start of colour television is the fact that no real agreement has yet been apparent amongst responsible engineers as to the standards which will be employed. Many important questions have yet to be settled. For instance, is it worth going over to colour television whilst still employing a 405-line system? Should the American N.T.S.C. system, or a modified version of this system, be used, bearing in mind the known disadvantages of its com-

plex and expensive receiver design? (Although things have probably speeded up since then, about a year or so ago it used to take a service engineer a full day to instal and set up a colour television receiver.) Again, is it really worth while embarking on a colour system which *must* be compatible, or would it be better to forget about compatibility altogether and concentrate only on optimum colour reproduction? These, and many more, questions need to be satisfactorily answered before colour television becomes an economic

proposition in the U.K.

The writer has seen B.B.C. colour transmissions reproduced on a colour receiver, and was considerably impressed by the life which colour brings to the screen. But, after the first impact had worn off, he found himself looking more critically at the picture and noticing imperfections which had escaped his notice at the onset. Perhaps the same reactions would be given by the general public if we embarked on colour television in its present state.

## BOOK REVIEWS

**UHF TUBES FOR COMMUNICATION AND MEASURING EQUIPMENT.** Book XI in the Philips Technical Library. 60 pages, 76 illustrations and diagrams. Distributed in England by The Cleaver-Hume Press Ltd., 31 Wrights Lane, Kensington, London, W.8. Price 9s. 6d.

Devoted to specialised types of valves for use in u.h.f. techniques. This book contains descriptions of a few valves, their characteristics, and discusses some of their applications.

Some examples of apparatus are shown, such as an h.f. section for a receiver to use in the 300–400 Mc/s range, a u.h.f. oscillator for 470 Mc/s, a push-pull oscillator for 440 Mc/s, and an oscillator using the disc-seal EC55 for frequencies in the 730–1,350 Mc/s range.

Some klystrons and several noise diodes are also included.

**A GUIDE TO AMATEUR RADIO—6th Edition.** Edited by John Clarricoats, O.B.E. 40 pages, 24 illustrations and diagrams. Published by the Radio Society of Great Britain, New Ruskin House, Little Russell Street, London, W.C.1. Price 2s. 6d., postage 4d.

This popular handbook has been brought right up to date and contains practical information for those seeking to find out about the interests of amateur radio.

The nine chapters, though short, are free from frills. The first chapter answers many of the questions that are in the minds of those about to venture into amateur radio. There follow chapters on simple receiving apparatus and station equipment, short instructions on learning the Morse code, correct operating procedure, QSL cards, and the Tests and Contests into which operators can enter. Information is given on how to obtain a transmitting licence, and some advice is proffered on taking the Radio Amateur Examination.

The last chapter indicates the advantages of belonging to the R.S.G.B., and sets out many of the facilities the society offers to members. Appendices contain details of the International Q-code, call-sign prefixes, and abbreviations commonly used by amateurs.

**TV CONVERSIONS FOR I.T.A.** By C. E. Lotcho. 240 pages, 145 illustrations and diagrams. Published by George Newnes Ltd., Tower House, Southampton Street, Strand, London, W.C.2. Price 25s.

A considerable amount of information has been gathered within the pages of this book, mainly from manufacturers' service manuals.

The first section of the book contains brief discussions on conversion methods for Band III, aerial installations, and r.f. interference problems. Some more might have been said about cross-over filters to make the part on aerials more complete.

The major part of the book, running into 188 pages, is given over to comprehensive descriptions of the con-

versions necessary for several current receivers. No less than 31 makers' products are dealt with here, and there is considerable useful information to be found therein.

Reference data in Section 3 is also comprehensive. Details of the BBC and ITA transmitting stations are given, and it is thought that here the effective radiated power of the stations might well have been included. A most useful set of tables gives details of i.f. frequencies of 41 makers' sets. A noteworthy point is the table containing details of models suitable only for upper sideband reception. Two indexes complete the book, one being a general index for the receivers mentioned in the various sections, the other being an index to converters.

**TUBE SELECTION GUIDE: 1956–1957.** Compiled by Th. J. Kroes. 118 pages. Distributed in England by The Cleaver-Hume Press Ltd., 31 Wrights Lane, Kensington, London, W.8. Price 9s. 6d.

A handbook in the Philips Technical Library devoted to listings of receiving valves, cathode ray tubes, and valves for industrial and transmitting applications.

The introductory remarks and the list of technical terms are given in several languages. Section 1 is an index of tube types listed in the book which indicates in which one of the following six sections that further information is to be found. Sections 2 to 7 then list tubes for receivers and amplifiers, cathode ray tubes, transmitting valves, tubes for micro-wave equipment, industrial tubes, and miscellaneous types. Each section has its own index which also gives near or direct equivalents, and the tables in each section indicate essential characteristics of current equipment types, together with lists of replacement types and obsolete ones.

There is no data quoted such as is more likely to be given in lists which show static and dynamic characteristics; the information given in the listings of current equipment types is more concerned with the applications of the tubes.

**TUBES FOR COMPUTERS.** Book XII in the Philips Technical Library. 52 pages, 59 illustrations and diagrams. Distributed in England by The Cleaver-Hume Press Ltd., 31 Wrights Lane, Kensington, London, W.8. Price 9s. 6d.

Technical data and descriptions of valves specially developed for counters and computers. The introductory chapter discusses briefly the binary system of notation upon which the circuits for such apparatus are based, various forms of multi-vibrator, and gating circuits.

Some details of the construction and basic circuits of plug-in units are given, for applications such as low and high-speed counters, multivibrators, decade counters, etc.

W. E. THOMPSON



# The "RAMBLER" PORTABLE SUPERHET

A Receiver for Home and Countryside

PART 2. by JAMES S. KENT

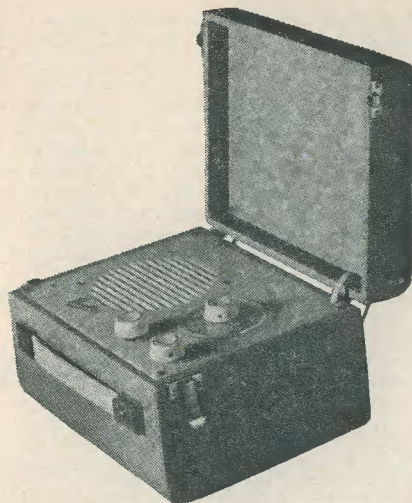

### Alignment

With the assembly and the wiring of the receiver completed, and with batteries and frame aerial attached, the alignment is the next step. The use of a signal generator is by far the best and surest method of aligning this, or any other, receiver; however, it is possible to obtain satisfactory results by using broadcast stations as a signal source. The i.f. transformers having been pre-aligned to 470 kc/s, it should not be necessary to touch the cores of these; only the cores of L<sub>1</sub>, L<sub>2</sub> and L<sub>3</sub> should be adjusted as shown in Fig. 4.

has been already fitted), in order to provide signals of reasonable strength.

Set the wavechange switch to the Medium Wave position and adjust C<sub>3</sub> and C<sub>4</sub> to mid-capacitance. Set the volume control to maximum and rotate the tuning control until a signal is received. At this stage it may be necessary, in some cases, to carefully trim the i.f. transformer cores in order to peak the signals. Care should be taken, however, not to move these excessively as they have already been set to the required frequency. Ensure that the cursor is fitted correctly to the tuning condenser spindle. With the gang

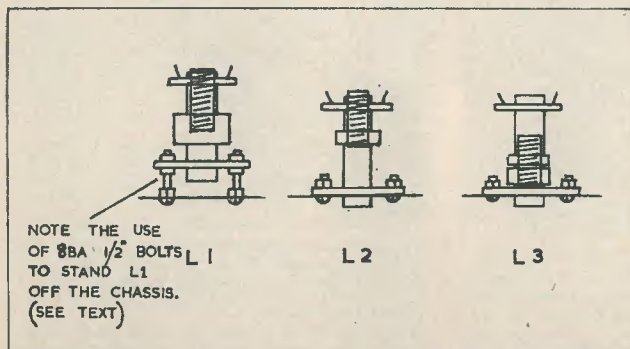

Fig. 4. Showing approximate positions of cores

It may be necessary to utilise an external aerial in order to receive broadcast signals for alignment purposes. Wind a few turns of an external aerial around the frame aerial (the lid of the cabinet will suffice if the frame aerial

fully closed, the cursor should be in that position shown in Fig. 5. Adjust the tuning control to the loudest signal (this will probably be the Home Service on 330 metres), and note whether the cursor line is high or

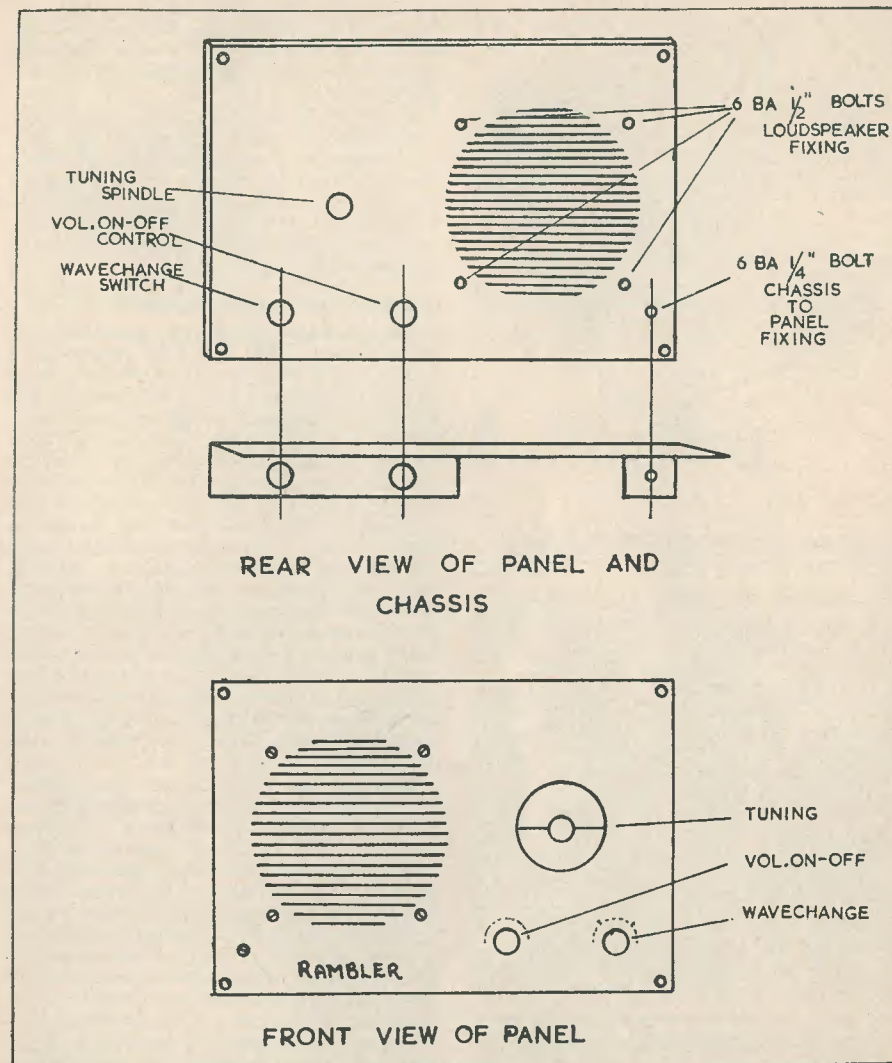

Fig. 5

low on the dial reading. Should the station be tuning in too high (towards the high wavelength end of the dial) screw in L<sub>2</sub> core until the correct setting is obtained.

If, however, the station is tuning in too low, then the core of L<sub>2</sub> must be slightly unscrewed from the holder. It will only require a couple of turns, perhaps, to bring the station to the correct setting.

Next, adjust the tuning control to the low wavelength end of the dial; i.e. the Light

programme on 247 metres. Should this station be tuning in too low, unscrew C<sub>4</sub> slightly and, if tuning too high, reverse the procedure. At the same time adjust C<sub>3</sub> for the maximum signal strength. It will now be necessary to repeat the above adjustments a few times by continuing to adjust both C<sub>4</sub> and the core of L<sub>2</sub> until the selected marker stations are received in agreement with the dial readings. Finally, adjust C<sub>3</sub> for maximum signal strength at the low wavelength

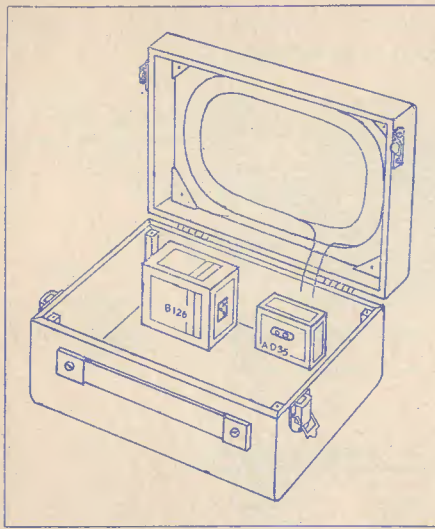

Fig. 6. Showing position of batteries

position with the external aerial removed.

It is quite probable that broadcast signals will be received without recourse to all to any external aerial for alignment purposes.

To align the Long Wave band, switch to the appropriate position and couple the external aerial as before, should this be necessary. Ensure that the cores of  $L_1$  and  $L_3$  are in the approximate positions as shown in Fig. 4. Next adjust the trimmers  $C_1$  and  $C_8$  to mid-position. Do not alter the i.f. transformer core settings. Tune in the 1,500 metre (200 kc/s) Light programme by rotating the tuning control and adjust the core of  $L_3$  for the correct setting of the dial cursor. Having completed this, tune to the low wavelength end of the dial (800–1,000 metres), locate a known signal and adjust  $C_8$  for the correct dial setting. Repeat the foregoing instruc-

#### Station List for Calibration Purposes

| Station            | kc/s  | Metres |
|--------------------|-------|--------|
| Allouis (Paris) .. | 164   | 1,829  |
| Moscow ..          | 173   | 1,734  |
| BBC Light ..       | 200   | 1,500  |
| Warsaw ..          | 227   | 1,322  |
| Luxembourg ..      | 233   | 1,286  |
| Prague ..          | 272   | 1,103  |
| Athlone ..         | 566   | 530    |
| BBC Third ..       | 647   | 464    |
| BBC Scottish ..    | 809   | 371    |
| BBC London ..      | 908   | 330    |
| BBC Midland ..     | 1,108 | 276    |
| BBC N. Ireland ..  | 1,151 | 261    |
| BBC Light ..       | 1,214 | 247    |
| Luxembourg ..      | 1,439 | 208    |

tions several times until the marker stations tune in at the correct dial settings. Finally, adjust the trimmer  $C_1$  for the maximum signal at the low wavelength marker station position.

A short list of broadcast stations for calibration purposes is reproduced herewith. It is important to remember that it is preferable to use marker stations on each band as far apart as possible with respect to frequency. Cores should be adjusted at the high wavelength end of the bands and the trimmers at the low wavelength limits.

#### Alignment by Signal Generator

The Medium wavelength alignment frequencies are 1,500 kc/s (200 metres) and 550 kc/s (550 metres). The Long waveband frequencies are 160 kc/s (1,900 metres) and 300 kc/s (1,000 metres). The i.f. is 470 kc/s. Feed in a modulated signal of 470 kc/s between the grid (pin 6) of  $V_1$  (1R5) and the chassis. Short the a.v.c. line to chassis (short across  $C_6$  or  $C_{11}$ ). Set the waveband switch to Medium Wave and the tuning control to approximately mid-position. The volume control should be set at maximum. The i.f. cores should require very little adjustment; but should this be necessary, tune the cores in the following sequence for maximum output—top core i.f.t.<sub>2</sub>; bottom core i.f.t.<sub>2</sub>; top core i.f.t.<sub>1</sub>; and bottom core i.f.t.<sub>1</sub>. Reduce the signal generator output at each step in order to avoid overloading. Repeat once again for the final trim. This completes the i.f. alignment.

To align the Medium and Long Wave bands, it will be necessary to couple the signal generator to the frame aerial. The best method of doing this is to connect a short length of insulated wire to the generator output and wind this around the frame aerial. The other earthy lead is connected to chassis. It may be necessary to vary the degree of coupling in order to obtain optimum results. This method effectively prevents undue damping of the aerial circuit that would otherwise result from a direct connection.

Having aligned the i.f.'s, continue with the Medium Wave alignment. Adjust the signal generator to 550 kc/s (550 metres) and the tuning dial cursor to the same frequency. Adjust the core of  $L_2$  for maximum signal. Tune the dial to 1,500 kc/s (200 metres), set the signal generator to 1,500 kc/s and peak the trimmer  $C_4$  for maximum signal. Next return to the 550 kc/s alignment point and repeat the process. Finally, peak the trimmer  $C_3$  at the 1,500 kc/s alignment setting.

Set the wavechange switch to Long Wave, tune the dial to 1,900 metres (160 kc/s), and set the signal generator to 160 kc/s. Adjust the core of  $L_3$  for maximum output, at the same time peaking the core of  $L_1$ . Next set

the dial at 1,000 metres (300 kc/s) and set the generator to the same frequency. Trim  $C_8$  and  $C_1$  for maximum response. Repeat the above until the alignment is correct at both ends of the band. Remove the short circuit from the a.v.c. line. This completes the alignment instructions.

#### Conclusion

The "Rambler" is, without a doubt, not only pleasing to the eye, but also a wonderful performer over its entire frequency range. It has been thoroughly tested and tried in all sorts of localities by the writer, both within

and outside a car, and has been found to more than fulfil all expectations. Reasonably inexpensive to purchase, easy to construct, with all the component parts readily available from several advertisers, it is unquestionably one of the finest portable radios available at present on the home constructor market. For that portable radio, most needed at this time of the year, one cannot do better than to construct the "Rambler."

Note: All trade enquiries should be addressed to the distributors, V. L. Dewitt Ltd., 24–26 Hampstead Road, London, N.W.1.

## Technical Forum

#### Tape Deck Switching

IN THE NOVEMBER, DECEMBER AND FEBRUARY issues last we ran a short series on the simple use of standard tape decks in conjunction with existing amplifiers. It was shown that with quite elementary additions to the amplifiers very good results could be obtained from a wide choice of tape units, and this has been confirmed by readers who have already completed their equipment. Generally it was possible to employ two separate wafer type switches as suggested in the original circuit diagrams; but some readers encountered difficulty when attempting to use a tape deck which incorporated built-in switches, as it was found that the deck switching did not altogether meet the circuit requirements. This particularly applied with that very excellent tape deck which is designed and produced by Collaro, and for the benefit of readers who are using this deck, we are considering this month its application to the original circuit.

The Collaro tape deck, or Tape Transcriber as it is sometimes known, is a fairly ambitious unit having provision for three tape speeds and double track recording. This latter is achieved by running the tape first from the left-hand spool to the right-hand one and thence back from right to left. In so doing, the need for rewinding the tape between using the top and bottom tracks is avoided. This does, however, necessitate the use of two sets of heads, one for playing from left to right and the other for right to left. Thus it is that the Collaro deck is fitted with four heads, a record/replay and an erase head for each direction of the tape. There is no doubt that this is one of the best ways of achieving twin-track working; but the extra

set of heads does involve additional switching, which is perhaps one of the main reasons that complications arise in the application of this tape unit.

The Collaro deck is equipped with four slide switches each of which has an eight-pole two-way section making a total of 32-pole 2-ways. In addition there is the mechanical speed change switch assembly which is capable of being altered so that it can also operate the equalising switch in the amplifier unit. A clear understanding of the way in which the slide switch functions will greatly facilitate the task of connecting it up. Each section consists of three separate contacts located side by side on the static portion of the assembly, whilst on the central sliding part there is a shorting bar. As the switch is moved from one position to the other, this bar joins either the bottom pair of contacts or the top pair. In other words, the centre contact of each trio is connected to its neighbour either directly above or below it. In each case the centre of three contacts is the pole of the switch, with the two adjacent contacts the alternative ways.

When the tape deck is purchased, the switch assembly is ready mounted on the motor board, but none of the wiring is connected up. Each of the record/replay heads has a short length of screen cable coming from it, whilst the leads from the erase heads are unscreened. Of the 32 poles on the switch, 10 are employed to switch the heads and the remainder are free to switch the input circuit, the tuning indicator used for level indication, and tone control networks should these be employed. This switch cannot, of course, be employed to operate the tone equalising circuits for various tape speeds. This function is best

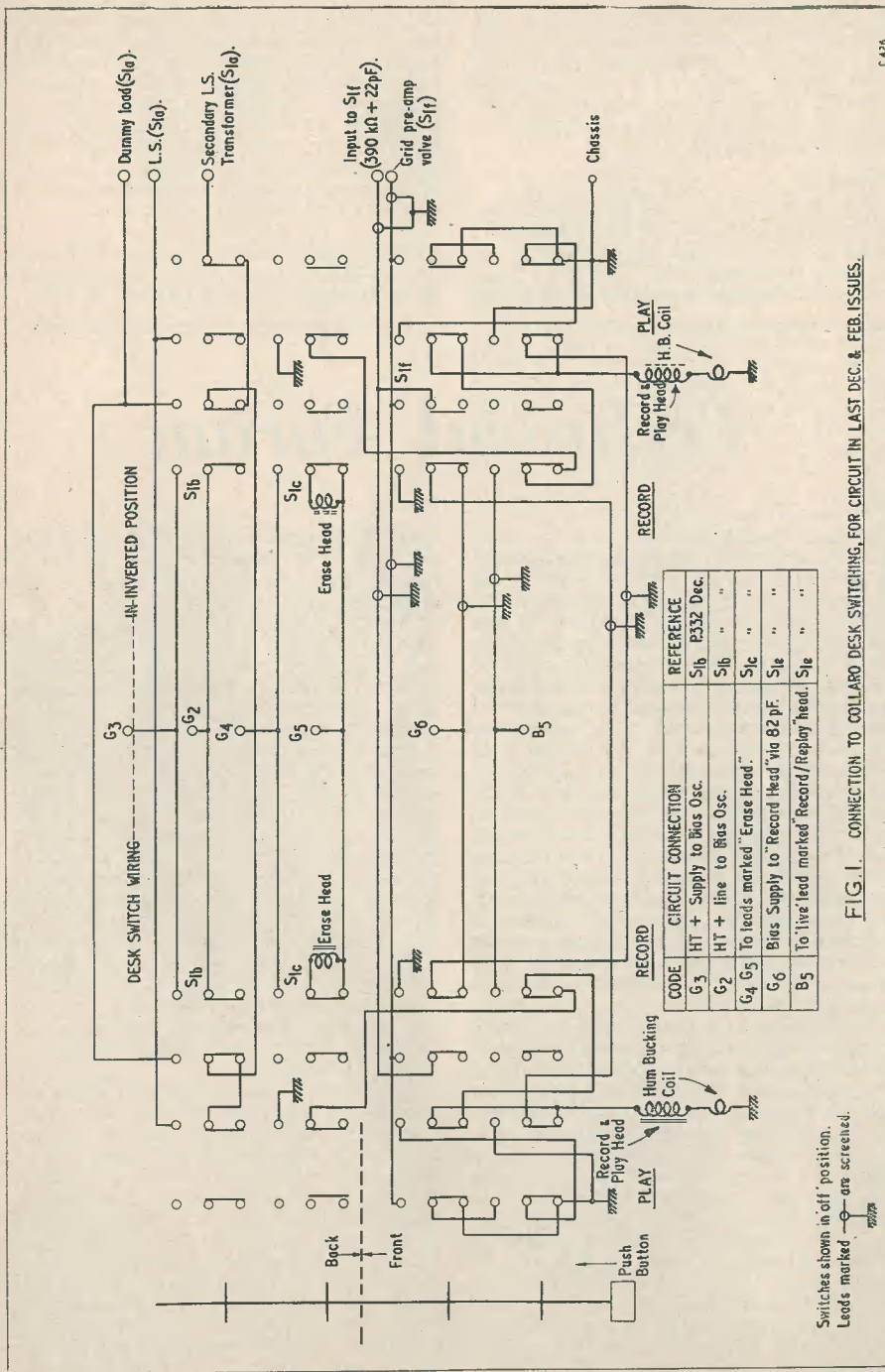

FIG. 1. CONNECTION TO COLLARO DESK SWITCHING, FOR CIRCUIT IN LAST DEC. & FEB. ISSUES.

performed by a separate switch or one which is mechanically linked with the speed change mechanism on the deck itself. But more about this later.

The diagram of Fig. 1 shows the complete switch assembly and its connection in the circuit of the simplified tape recorder already described (Nov., Dec. and Feb. issues). The original switch designations have been employed to avoid confusion. The switch recommended for the circuit was a 6-pole 3-way unit arranged to give "Record," "Erase" and "Replay" in the three positions. The centre or erase position is by no means essential, as the tape can be cleaned by running it through the machine with the switch on the "Record" position and the amplifier gain turned down to minimum. To accommodate the Collaro switching, this position has been eliminated and the circuit wired up for 6-pole 2-way working. This change is a very minor one and simply involves omitting the centre contact in the three-position switch shown in the original circuit (Fig. 1, p. 332 Nov. issue). The diagram shows the switch assembly wired as a complete unit with the heads in position; several flying leads are then used to join the assembly into the amplifier circuit, and these have been clearly labelled. It must be remembered when examining this diagram in conjunction with the original circuit that these flying leads are those which were shown going to the switch S<sub>1</sub>. The resistor or capacitor value shown by the leads in Fig. 1 indicate the components to which they are connected on the original circuit.

To avoid hum pick-up a number of these are interswitch contact connections a little patience is required to make a neat job, and avoid the outer screening accidentally shorting some of the contacts. One of the miniature soldering irons is ideal for doing a job of this nature, as it permits better access to certain of the rear switch connections.

The slides of the switches in Fig. 1 are shown in the "off" position—as each of the four buttons is depressed the slides move up towards the viewer, as the assembly is pictured in the inverted position as it would be for wiring up. Each of the four sections

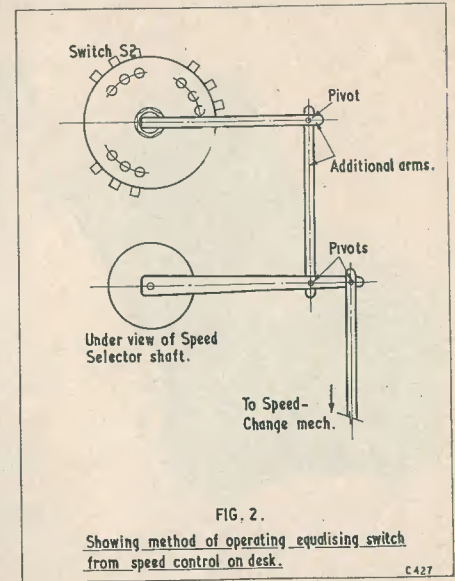

has eight poles arranged in two banks designated front and rear to indicate which is nearer the observer.

The Collaro tape deck is of the three-speed type with the speed selector knob mounted in the top centre of the motor board. This knob actuates the mechanism through a pivoted arm, and the more ambitious constructor may wish to employ this knob to also select the correct equalising components in the main amplifier. This is achieved by means of switch S<sub>2</sub> in our original circuit. This switch may be coupled to the cross arm on the main knob shaft as shown in Fig. 2. The additional operating arm is attached to the switch shaft by means of a 1/4 in collar taken from an old flexible shaft coupling, the collar being soldered to the arm. A little experimental work will be necessary to determine the length of this arm, but the work involved will be well repaid by a most reliable and simple operating mechanism.

## COMPONENT REVIEW

We have received from Messrs. R. Fagelston, 46 Hardwicke Road, London, N.13, samples of Transistor Holders now being supplied by them. These holders are truly miniature and of very light weight. Intended to be suspended in the wiring, they have three small tags to which other components associated with the circuit may be soldered, the transistor wires being inserted into the holder. By this method, the heat damage hazard to transistors is obviated, and replacement during experimental work becomes a matter of moments. On these accounts alone, they are well worth the cost of 1/- each, 5 for 4/7, 6 for 5/6, postage 2 1/2 d.

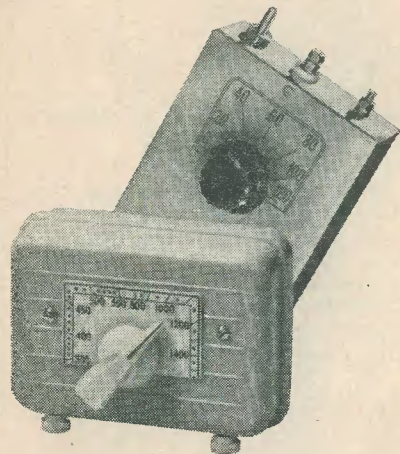

# TRANSISTOR TWINS

## The RADIOSETTE and NURSERYETTE

Miniature Receivers

Described by **E. GOVIER**

WITH THE INTRODUCTION OF THE transistor and the crystal diode, the demand for, and the popularity of, simple local station receivers has risen and continues unabated among home-constructor circles. Of these, two that have proved to be

popular are the R.C.S. "Radiosette" and "Nurseryette," both being simple, easy to construct, inexpensive and efficient head-phone-receivers. These are ideal sets for the beginner in that the total construction time involved, and the cash outlay, is very small indeed. Moreover, a complete kit of parts for either receiver is available from several advertisers in this magazine.

### Circuit

From the circuit of Fig. 1 it will be seen that both are two-stage receivers utilising a crystal diode as a detector followed by a p-n-p junction type transistor in cascade working as an i.f. amplifier in the earthed emitter mode.

In order to achieve the maximum signal output which is required in all receivers of this type, the design includes the new R.C.S. Vari-Loopstick transistor inductance—the "Q" of this being of an extremely high order. The design of this inductance enables a micrometer adjustment of the iron dust core to be made by the operator, as an additional external control.

The miniature variable tuning condenser C<sub>2</sub>, with which is incorporated two earthed and two holding tags, effectively permits the whole receiver ("Radiosette") to be contained within a case measuring only some 4in × 2½in × ½in. Thus, the completed receiver may be held in the hand or contained within a pocket.

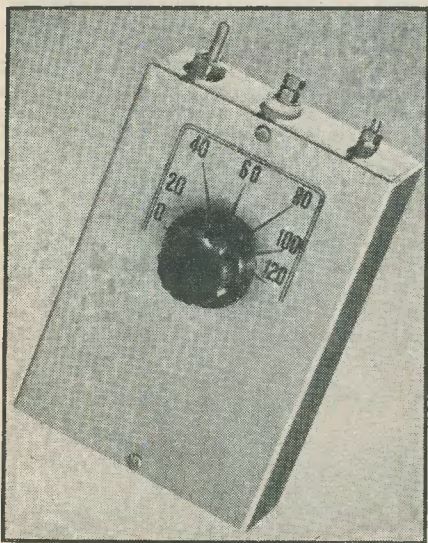

The "Radiosette"

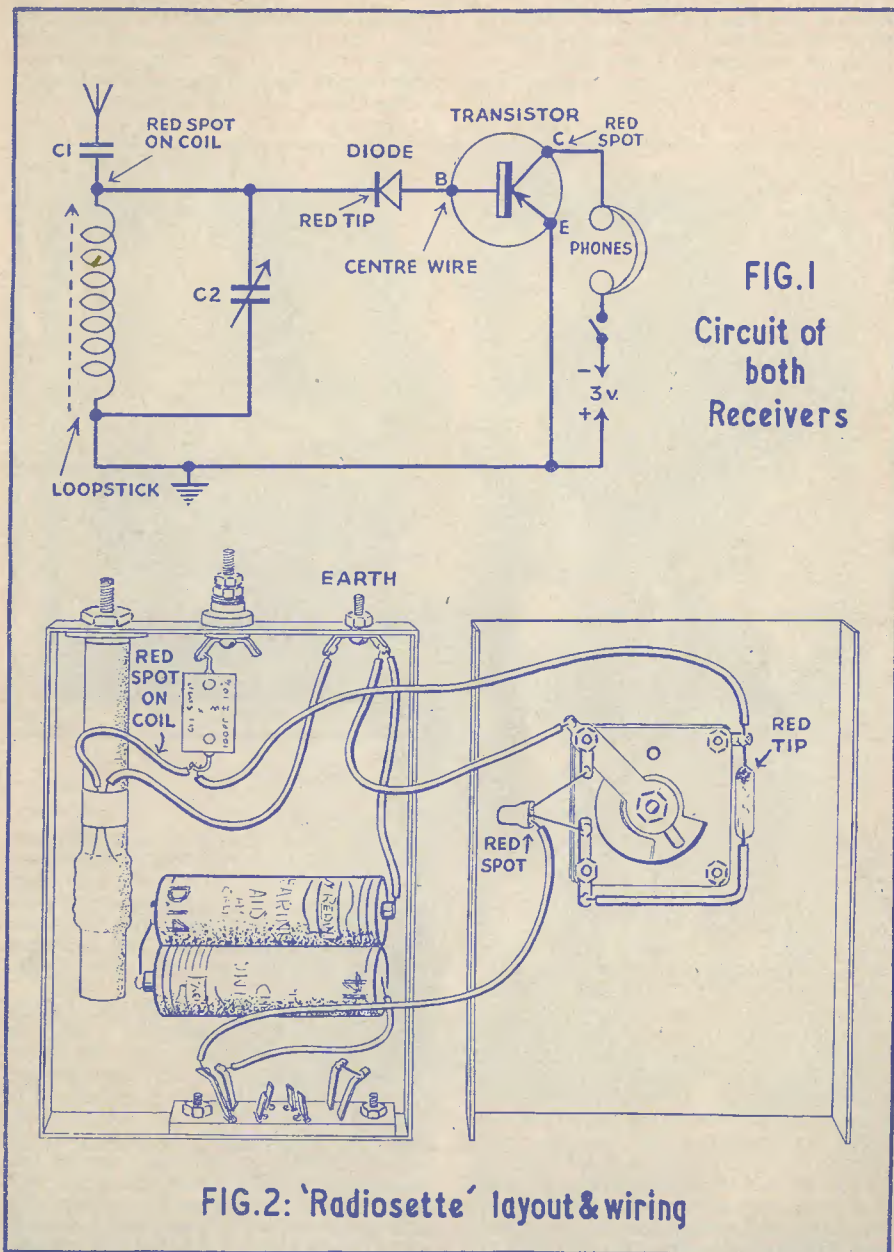

FIG. 1  
Circuit of  
both  
Receivers

FIG. 2: 'Radiosette' layout & wiring

### Assembly Instructions "Radiosette"

The assembly of this small receiver is simple in the extreme and no difficulty should be encountered. Provided the following

instructions are carefully followed, it may be completed in a very short time indeed. The utmost care should be taken to ensure that the transistor is connected into circuit correctly, and also that the batteries are

placed in the right manner with respect to polarity as shown in the diagrams. Failure to comply with either of these precautions will probably result in the destruction of the transistor.

other ceramic washer (from the outside of the case), and follow this by screwing into position one of the nuts, taking care that the small paxolin washer is located in the actual aperture through the top of the case. Pro-

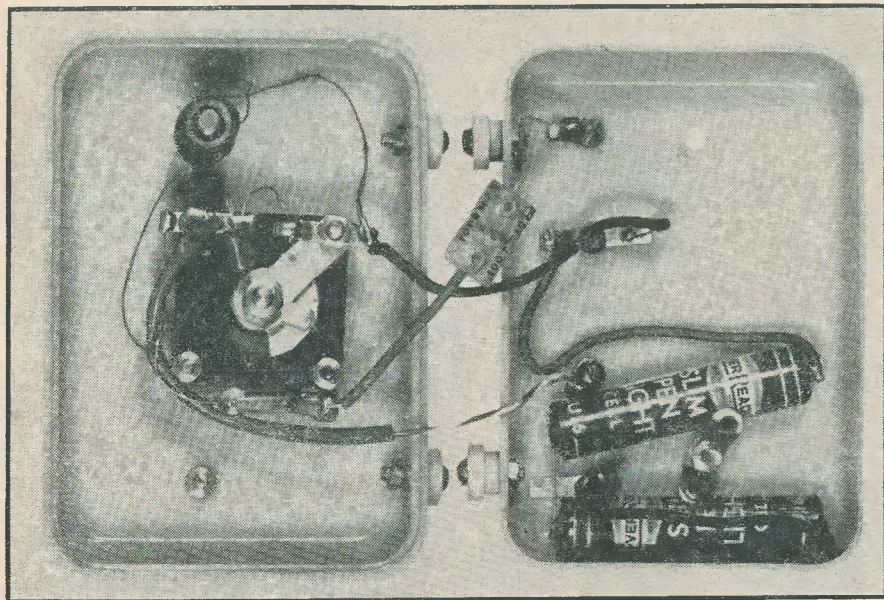

Internal view of "Nurseryette" showing layout

The first component part to assemble is the phone socket strip at the bottom of the case; but before doing so a short length of wire should be soldered across the two tags coloured *yellow* and *blue*, this being much easier to accomplish while the strip is outside the case. The strip should now be fixed into position, as shown in the drawing, using two 6BA screws—at the same time ensuring that the *white* and *blue* tags are located against the corresponding *white* and *blue* spots on the inside of the case. The object of this correct location procedure is to ensure that the strip is finally mounted in the right position.

The next component to assemble is the aerial terminal, this being composed of a bolt, solder tag, two ceramic insulators, a small paxolin washer and two nuts. Holding the bolt firmly, place one solder tag on this and then follow by placing on the bolt one ceramic and one paxolin washer in that order. This small sub-assembly is then placed into the pre-punched hole (see diagram) in the top of the case from the *inside* (i.e., threaded portion protruding through the top of the case). Next place on the bolt threadway the

provided the above instructions have been carefully followed, the aerial terminal should now be effectively insulated from the case itself, this, of course, being of the utmost importance. Finally, the remaining 6BA nut is then located on the aerial terminal bolt, this being used for securing the aerial wire to the terminal.

Next affix the earth terminal in the case by placing a 6BA screw with solder tag through the terminal and through the correct pre-punched hole in the top of the case (see diagram). This screw, of course, should be mounted from the inside of the case—a nut now being secured over the screw from the outside in order to hold the assembly into position. Finally, a further nut should now be threaded on to the same screw—this being used to secure the earth wire to the receiver.

The Vari-Loopstick aerial coil should now be placed in position from the inside of the case, ensuring at the same time that the packing washer is placed on the coil before the one-hole fixing bush of the coil is placed through the hole in the case (see diagram). Then, having done this, the one-hole fixing

nut is placed into position from the outside of the case and secured.

The last item of assembly is the 400pF variable tuning condenser, this being placed in position on the front panel of the case, as shown in the diagram, with one nut left on the spindle bush and the other secured into position from the outside of the panel.

#### Wiring Instructions "Radiosette"

*Wire No. 1.*—One side of the 100pF fixed condenser is soldered to the aerial terminal tag, as shown in the diagram, the other end of the condenser being soldered to *red* coloured tag on the 400pF variable condenser. The coil lead marked with the *red* spot is also connected to this latter side of the 100pF fixed condenser.

*Wire No. 2.*—The remaining coil lead, marked with a *green* spot is connected to the earth terminal solder tag.

*Wire No. 3.*—This wire is connected from the earth terminal solder tag to the tag coloured *green* on the 400pF variable tuning condenser.

*Wire No. 6.*—A short length of wire is next soldered to the *red* spot lead of the transistor and covered with a length of insulating sleeving which is supplied. The other end of this wire is then soldered to the tag on the phone socket strip coloured *red*.

*Wire No. 7.*—The remaining wire of the transistor is now connected to the tag coloured *green* on the variable tuning condenser.

*Wire No. 8.*—Next two Ever-Ready batteries No. D14 are connected in series, as shown in the diagram, i.e., with the brass cap of one cell connected to the metal bottom of the other cell. The two cells are then secured together, around the centres of each, with a small strip of Sellotape or any other adhesive tape.

*Wire No. 9.*—A short length of *red* wire is now soldered to the remaining brass cap on one cell, the other end of this wire being connected to the end of the earth terminal solder tag.

*Wire No. 10.*—A length of *black* is now soldered to the bottom of the other cell, as shown in the drawing, the other end of this

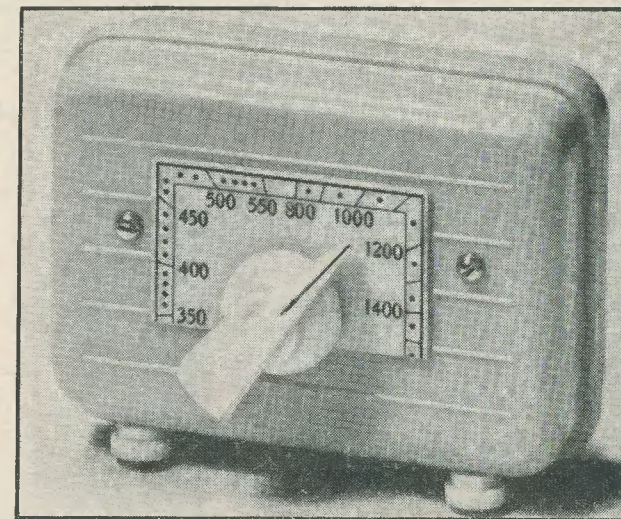

The  
"Nurseryette"

*Wire No. 4.*—The *red* end of the crystal diode detector, this being the small glass tube component, is connected to the tag coloured *red* on the variable tuning condenser. The remaining end of the diode should now be connected to one side of the tag coloured *blue* on the same tuning condenser.

*Wire No. 5.*—Connect the *centre* wire of the transistor to the tag coloured *blue* of the variable tuning condenser.

wire being soldered to the tag coloured *red* on the phone strip. It is advisable now to place adhesive tape lengthwise, from end to end, of the cells—thus completely covering both soldered ends; this will ensure that the cells will not short circuit to the metal case.

*Phones.*—The ends of the phone leads should now be soldered to the two pins with a coloured *red* spot on the phone plug. The other two pins should be connected together

### Component List (both receivers)

- C<sub>1</sub> 100pF Silver Mica  
C<sub>2</sub> 400pF miniature variable (RCS Products Ltd.)  
Crystal Diode Mullard OA71  
Transistor p-n-p junction type, Red Spot  
Phones 1,000Ω impedance (RCS Products Ltd.)  
Case and Panel (R.C.S. Products Ltd.)  
Insulators, wire, etc. (RCS Products Ltd.)  
Vari-Loopstick Inductance (RCS Products Ltd.)

externally with a short length of wire. This latter connection ensures that when the phones are inserted into circuit, the receiver is switched on. Conversely, when the phone plug is withdrawn, i.e., phones disconnected from the set, the receiver is automatically switched off, and it follows, therefore, that the phones should be withdrawn when the receiver is not in use. Failure to do this will result in an unwanted battery drain.

#### Operating the Receiver

The aerial should now be connected to the aerial terminal on the top of the receiver. In many localities the earth connection may not be necessary owing to the very high "Q" of the Vari-Loopstick aerial. In some districts probably only a very short aerial will suffice. Cut and try is, of course, the answer here. It is probably best to connect both an aerial and an earth in the first instance, and follow this by experimenting as outlined above.

Stations should be tuned in by rotating the variable tuning condenser. Variation of the micrometer adjustment of the aerial core will

provide a large degree of variation with respect to the waveband range of the receiver.

#### The "Nurseryette"

This is the front receiver featured on our front cover for this issue. In essence it is the same receiver as the "Radiosette"—except that the case is, of course, the more attractively styled. The circuit is exactly the same as that of Fig. 1. From the front cover illustration and that shown here, an excellent idea of the layout may be obtained. The assembly instructions for the "Radiosette" will, of course, largely apply here, except that the layout is somewhat different.

The rear half of the case (which is detachable from the front), contains the batteries and their holding strip, the phones output and the aerial and earth tags. Connection of the headphones automatically switches the battery into circuit.

The front half of the case contains the miniature variable condenser, the diode and the transistor—both of these latter components being soldered directly on to the condenser. Also contained in this front portion of the case is the Vari-Loopstick aerial coil. In this version of the receiver the aerial former itself has been cut down in size, so that only a portion of the threaded brass dust core adjustment protrudes through the rear of the case once this is closed together.

The "Nurseryette" is an ideal receiver for the children of the household to handle. It is absolutely safe—no high voltages being present—easy to operate, attractively styled in three colours—either in red, blue or green, and will provide endless hours of fun and enjoyment for the youngsters.

### TRADE NEWS *contd. from page 742*

The tape, which has an insulation resistance of five million meg. ohms, and a dielectric strength of 13,300 volts, is available in red, black, blue, green, yellow and white rolls of 25 yards. Widths are half, five-eighths and three-quarters inch, and increasing widths at quarter-inch intervals.

It is marketed by the Industrial Sellotape Division of Gordon & Gotch Limited, 8-10 Paul Street, London, E.C.2.

#### New Firm Marketing V.H.F. Aerials

The ever-increasing use of v.h.f. radio in business and professional fields is emphasised by the announcement of a new company specialising in v.h.f. aerial systems.

Radio Telephone Aerial Systems Ltd., directors John H. Theakston (managing) and J. H. Theakston, Snr., has been formed (in association with J-Beam Aerials Ltd. and Sky-Masts) to handle Sky-Beam v.h.f. aerials.

These Sky-Beam aerials, designed by Mr. B. Sykes and developed in the laboratory at

J-Beam Aerials, Northampton, have been used by Sky-Masts for their important installations throughout the country, during the past few years.

The volume of enquiries for these highly efficient End Fed Dipoles, Yagis and Skeleton Slots has become so heavy that a separate company is needed to handle marketing.

Radio Telephone Aerial Systems Ltd., with its close contacts with J-Beam Aerials Ltd. and Sky-Masts, will be able to offer complete and sound advice on all aspects, technical and practical, of v.h.f. aerial systems.

This is the first time radio telephone users have been offered a complete specialist service. Main clients will be exporters, manufacturers of v.h.f. equipment, installation agents and all users of radio telephone equipment such as ambulance services, police, car hire and other business firms.

The new firm will operate from offices, workshops and showrooms now being prepared at Redan Street, W.14, with telephone numbers Shepherds Bush 6426 and Riverside 7878.

# Radio Miscellany

ON TWO OCCASIONS THIS COLUMN HAS been pleased to remark on the gratitude of readers who have received friendly assistance from fellow-hobbyists in the way of information, circuits, etc., through the medium of our "Can Anyone Help" columns. This time I have the unhappy experience of being called upon to place on record the opposite side of the picture. A reader suggests I might pass on his experience to serve as a warning to others to be at least a little circumspect when asked to forward money. In response to his appeal he received an offer of a "Manufacturer's circuit. Very useful" which the writer was willing to sell for 7s. 6d. As my correspondent wanted the fullest details rather urgently he sent off the money. After a pause of several days he received a small single sheet containing only a skeleton circuit showing nothing more than the values of the major components.

Readers who are familiar with regular Servicing Sheets will know how detailed they are. They cover such points as re-threading the drive cord, etc.; and not unnaturally from the description it was a Service Sheet of this type the reader expected to get for his money. Despite his anger at being "caught," he realised that there was little or nothing he could do about it. Any attempt to do so would have simply been throwing good money after bad. The circuit was obviously prepared by the manufacturer (probably part of something else), and it was useful—within its limitations. Even had a bigger sum been involved, legal redress on a question of misrepresentation would have been far from easy. He simply had to write the money off as "Experience, dearly bought."

A further touch of irony. He later received the loan of the manufacturer's full Service Manual from another reader. Unfortunately this offer arrived a week or so after that of the profiteering gentleman.

The incident recalls an occasion when the wife of a friend, a well-known transmitting amateur, was similarly taken in. A few days before the Coronation she saw a small ad. in the Personal Column of a national daily: "Coronation seats. Two guineas. Box . . ."

Imagining them to be seats on the route,

she sent £4 4s. for herself and a friend. A couple of days before the event she received two flimsy camp-stools. Crudely stencilled on the canvas were the words "Coronation 1953."

After their disappointment and annoyance wore off they did at least get a good laugh out of it. My correspondent is not likely to get much of a laugh out of his but, as he says, his experience will be less dearly bought if it serves to save others from the same sharp practice.

#### That Little Something—

A considerable part of this column in recent months has been given over to readers' (and my own) views on f.m. tuners and receivers. As is so often the case, letters are now arriving from those holding somewhat different views. There is quite a strong feeling that too much of *our* magazine is already given over to f.m., and a.m. design and construction has had to suffer in consequence.

T.S.D. (A.M.I.C.E.) of Merriion Avenue, Blackrock, Co. Dublin, another Old Timer and former transmitting amateur, is one of these. He particularly enjoys many of the continental orchestras—a taste which, if it is to be reasonably satisfied whenever listening time is available, demands a really first-class superhet receiver or a converter with a quality amplifier. Nor is he alone in this matter. In fact, at least a couple of readers mention they want consistently good reception from European stations for language study and practice, and a great number of others want occasional reception from more distant stations either for special items or by way of a change from too much BBC.

These are very reasonable requirements, and I am sure the vast majority of readers will readily agree that a set capable of certain, and good quality, Dx reception—given an average aerial—is a decided asset. As these correspondents point out, in recent years the superhet receivers offered for home construction might well have been designed ten or fifteen years ago, and are little better than the normal run of factory-built receivers. What is wanted is an up-to-the-minute design with a truly efficient r.f. stage. The latter is the minimum requirement. True, such a

receiver would cost a bit extra to build; but just as the hi-fi fans cheerfully pay that bit more for a few kc/s at each end of the musical register, receiver constructors are equally willing to go to the extra expense and trouble for super performance. What about it, you designers?

### Stuck Up

Some weeks ago a non-hobbyist friend wanted a midget universal receiver, and I recommended him to one of really tiny dimensions based on a design in one of our back numbers. He 'phoned me to say he was pleased with the result, and when I visited him last week he seemed to be well on the way to becoming an enthusiast, plying me with scores of questions about transistors and further miniaturisation. But what impressed me most was the cabinet he had made for the midget. It was the most perfect I have ever seen. He made it entirely of resin-bonded mahogany-faced plywood. It was not only of most eye-pleasing proportions, but beautifully grained, and fitted the tiny chassis like a glove. There wasn't a single piece of reinforcement used at any point, which made the inside as sleek as the outside. For all that, it was remarkably strong, and the mirror-like finish seemed to sparkle like cut-glass.

tremendously strong joints and internal reinforcement is not necessary. Don't use fillers on the surface. Repeated applications of amateur types of French polish sanded off with "flour" variety sandpaper give more certain results for the tyro.

It all adds up to nothing more than lots of attention to every little detail, but if the superlative finish achieved by my friend is the result, my previous attempts at cabinet making must have been slap-dash affairs. By the way, what he says about impact adhesives is true. Once you have seen the effect you are so nervous about placing the surfaces to be joined slightly out of position that your hands start to tremble and you feel you are more likely than ever to misfire. Once the surfaces touch, whoosh, you've had it!

### Taped

Despite the fact that in recent issues "Radio Miscellany" has been allowed to run well over its allotted two pages, I still haven't found opportunity to touch on several subjects of current interest. These have included the cost of c.r.t.'s and the Monopolies Commission, a recently introduced computer in kit form, I.G.Y. Satellite programme, the BBC's new plan for sound radio starting in the autumn, and the

autograph some years ago. I felt so flattered about it that I was sorely tempted to give the autograph-hunter a half a crown to go with it. I well recall my hand shaking so nervously that I scarcely recognised my own writing. He took one searching look at it and let out a snort of disgust. Scrutinising me carefully,

he muttered: "Blimey, you *are* like Raymond Massey," and went off. Was I glad I kept my half-crown in my pocket?

That one doesn't really count, but this request is genuine—in writing, too!

P.S.: I have a couple of partly worn hats that seem to have shrunk a bit. Any offers?

## STRONG CHASSIS MAKING

QUICKLY, EASILY & CHEAPLY

by J. D. LOADER, G3HVO

THE WRITER, WHILST ENGAGED ON THE production of prototype radio gear, had a need for making strong chassis of different shapes and sizes without using the facilities offered by the machine shop, except for the use of two pieces of angle iron, a pair of tin snips and a 4in-metal engineer's vice. This type of vice is a useful investment for

any home constructor, even if only to hold potentiometer spindles whilst sawing to length.

At first, chassis were made in the standard way as shown in Fig. 1. This proved uneconomical in material, and did not result in a very strong chassis when using 18 s.w.g.

(continued on page 782)

## CENTRE TAP

talks about

Items of  
General Interest

Knowing he does not have a workshop worth mentioning, and precious few tools, I was naturally curious to know how he produced such a result. Apparently the only secret about it is lots of attention to detail, and I will try to briefly outline the points he stressed.

Start with a larger area of the best faced plywood you can get and don't worry about the wastage. By using carefully selected areas you can add greatly to the effect by matching the grain to suit the design. Cut all holes, speaker and dial apertures with a fretsaw. Whatever you do, don't use a drill on the surface. They split or tear the surrounding area. Wherever possible, cut with a really sharp chisel along a steel rule, or a fine-toothed saw held at the shallowest possible angle. Go slowly at the end of the cut and avoid chipped corners. If the cabinet is to be small, the joints can be "butted-in" by cutting away layers of the ply from the back. Use a cross-cut file for truing the edges; not a plane. Glue it together with one of the modern rubber-bonded impact adhesives. They make

probable further delay before colour t.v. starts in Britain (my guess, 1963), and the B.A.T.R.S. The latter has been most unfortunate because twice I have written about it and each time it had to be omitted on account of space considerations. The initials, of course, stand for the British Amateur Tape Recording Society. With links in Australia and the U.S., an International organisation has been formed to further extend their already numerous services and activities, which include a sound "magazine," technical information bureau and library, and tape-response between members. Readers, and I know there are many, interested in tape recording wishing to have further details, should write to the General Secretary, Edward Yates, G3ITY, 210 Stamford Road, Blacon, nr. Chester, Cheshire.

### Such is Fame

Having used the nom-de-plume *Centre Tap* for over twenty years, it is at last becoming famous. I have had my first letter requesting my autograph! True, I was asked for an

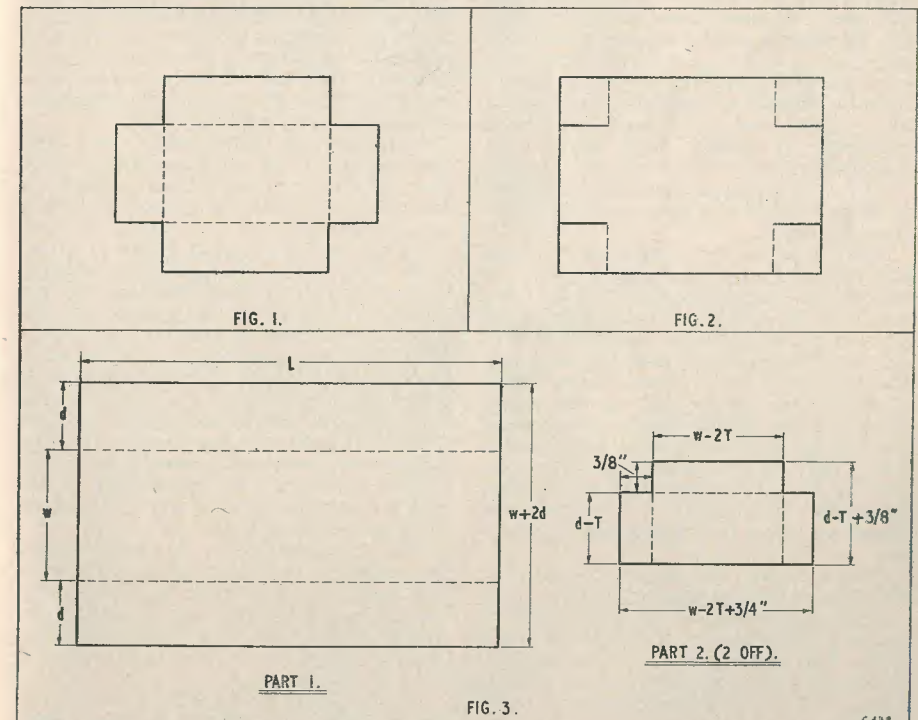

# ALTERNATIVE SUPERHET

by A. S. CARPENTER

THIS RECEIVER IS EMINENTLY SUITABLE FOR building into one of the many cabinets being offered today at attractive prices.

Many of us are capable of building receivers satisfactorily, but when it comes to fitting a cabinet we are up against it; and unless one is skilled in cabinet construction the completed receiver is viewed unsympathetically by our friends and acquaintances. Of course we say, like the car dealer, that it is what's under the bonnet that counts. True enough, but an attractive outside sets off the inside—the same applies to radio.

One can quite easily purchase a complete kit of parts including the cabinet to build either a t.r.f. or a superhet receiver, and this may appeal to some. Construction then consists of nothing more than assembling and wiring up—a dull project for the keen constructor who prefers to have something he can fiddle about with and use his own initiative on. A great deal of enjoyment and extra knowledge is gained from one's own experimenting.

Why not purchase a suitable cabinet and its fittings and have a go at building something different?

Many firms in advertising their kits state that "all parts are available separately." A cabinet, dial and mechanism, control knobs, speaker to fit, and blank aluminium chassis (16 swg) is required. The chassis should have the same dimensions as that normally supplied with the kit, and it is best obtained blank so that holes can be cut as and where required. The chassis supplied in the usual way may not be made of aluminium and may consequently be hard to cut. Also, the holes may not be in the places required, as these chassis are often pre-drilled. With the blank chassis the layout can be arranged to suit the case.

There are scores of designs to choose from, both of the t.r.f. and superhet variety.

A t.r.f. is easy to build and is cheap, but if one wishes to listen to, say, Radio Luxembourg in the West country (the author's location), then nothing less than a superhet will do if fading and selectivity problems are to be avoided.

The receiver described here meets both these requirements admirably, and output power is really more than sufficient.

It employs four valves plus a rectifier and two germanium crystal diodes for demodulation purposes. Consider Fig. 1. The first valve is the frequency changer, providing at its anode an intermediate frequency of 465 kc/s for feeding to V<sub>2</sub>, the i.f. amplifier. Only a single i.f. transformer has been used, and this is one supplied by The Teletron Co., whose advertisements appear in these pages. These are superb little transformers, and the type used is fitted with a tertiary winding to provide variable selectivity in conjunction with the control R<sub>5</sub>. Variation of this control permits a greater or lesser degree of coupling at will, and considerably improves quality on the local transmissions. Where one wishes to listen to a transmission adjacent to a local one which is inclined to "spread," the control R<sub>5</sub> will be found very useful.

Provision has been made for both Medium and Long wave reception. Note that when receiving Long waves a capacitor, C<sub>7</sub>, is switched across the Medium wave oscillator coil—so saving a coil. Tracking on the Long waveband is necessarily poor, but as the Light Programme is the only one that was considered in the original, this is of no consequence as this station can be tuned in perfectly. A value of 500pF has been specified for C<sub>7</sub>, although slight variation may be necessary due to differing tolerances; but by varying it a little and by altering the core setting of L<sub>2</sub> no great difficulty should be experienced. If Long waves are not required, L<sub>2</sub> may be omitted or a Short wave coil used instead; but in this case a corresponding oscillator coil must be switched for use with it.

The i.f. is amplified by V<sub>2</sub> and passed for demodulation to a pair of crystal diodes. The anode of V<sub>2</sub> contains L<sub>4</sub> tuned to the intermediate frequency and decoupled by means of R<sub>7</sub>, C<sub>11</sub>. This is, of course, the familiar tuned anode coupling, which is capable of large gain.

Demodulation is carried out by the two crystal diodes operating in a voltage mul-

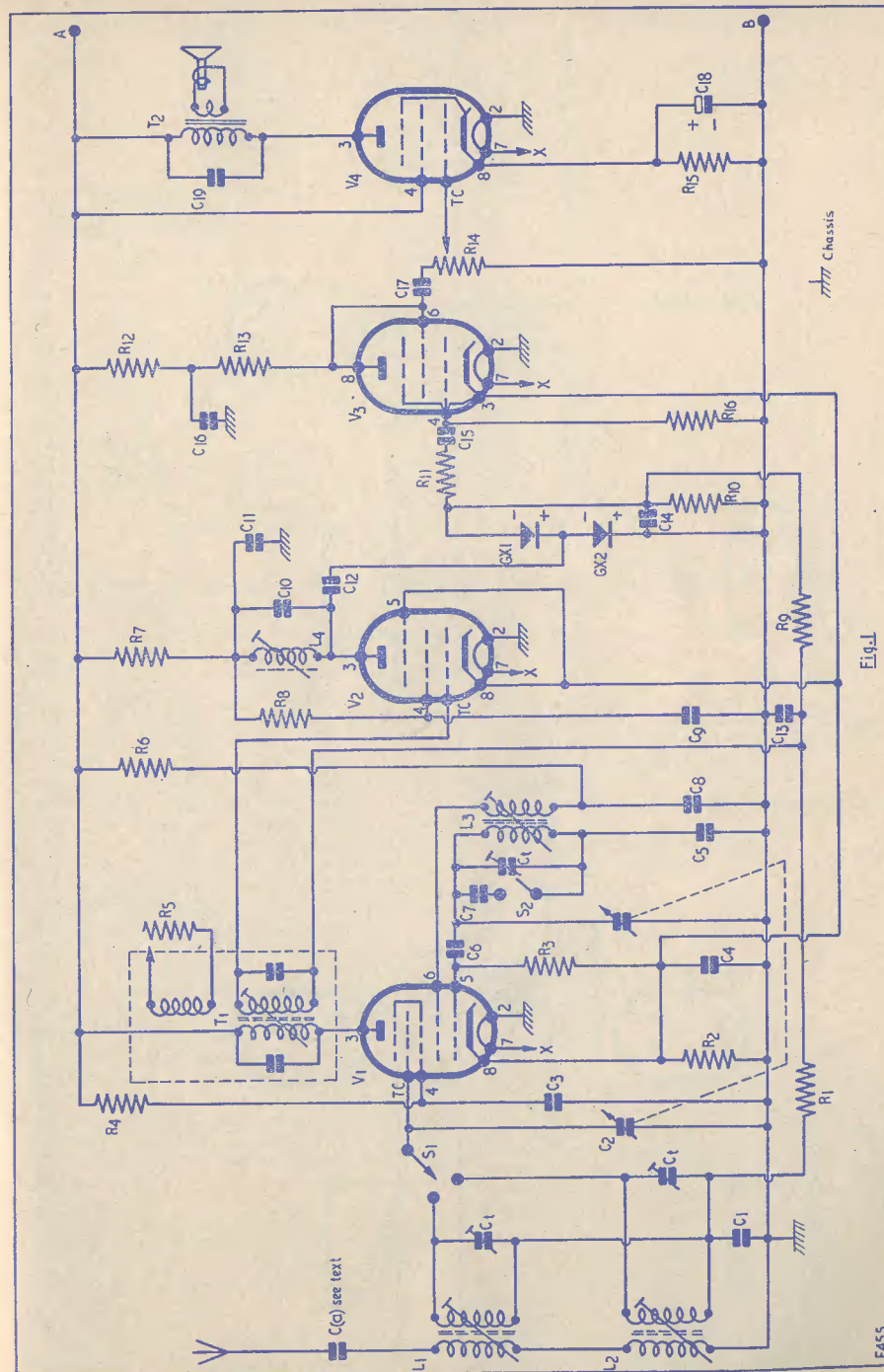

Fig. 1

E455



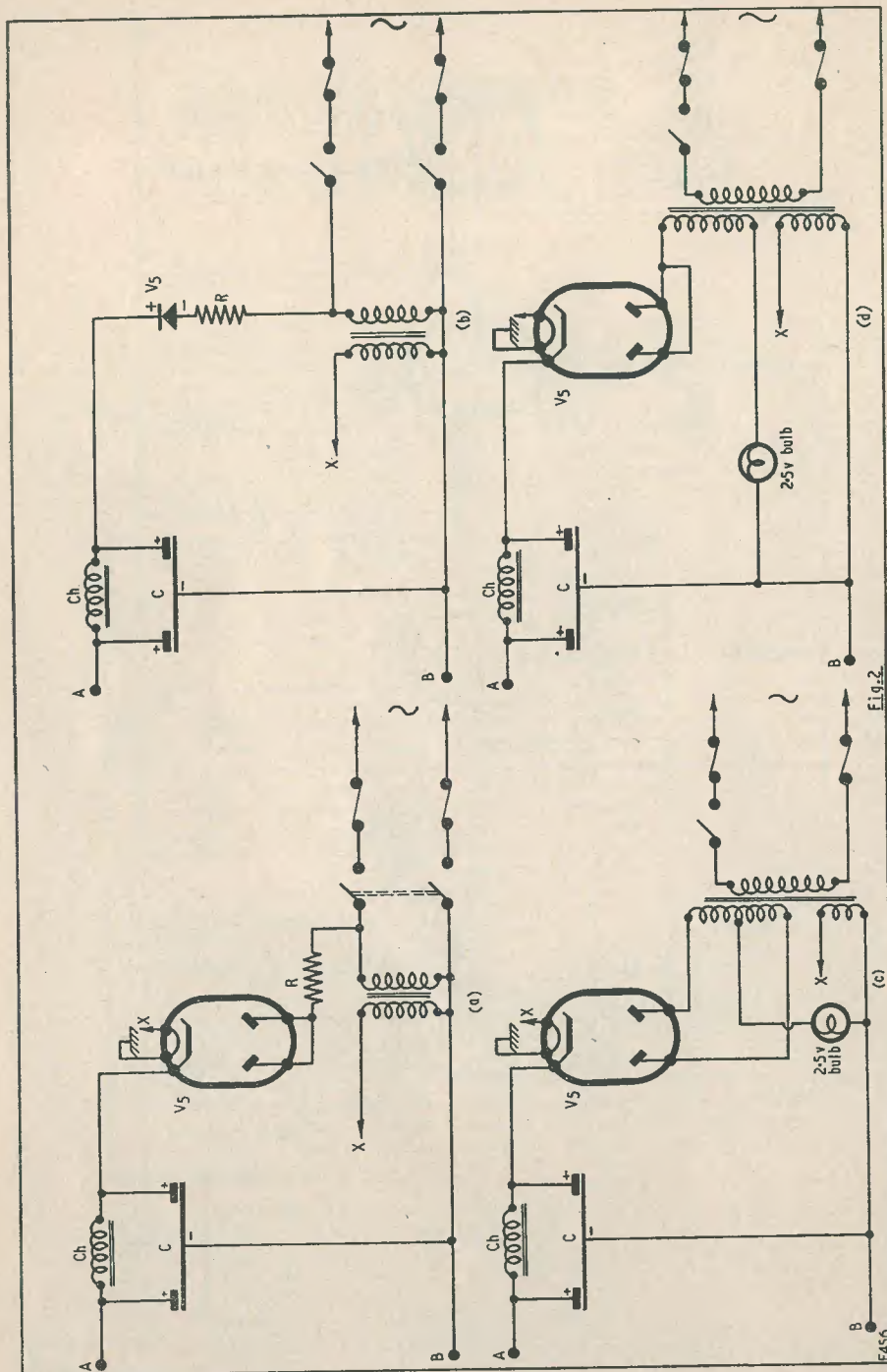

Fig. 2

tipling circuit, the output being taken from the anode of GX1 which is negative with respect to the chassis. Capacitor C<sub>12</sub> should be as large as possible providing selectivity is not impaired, and an even lesser value than that specified may be necessary in some cases.

The d.c. load of the demodulating circuit is R<sub>10</sub> and from this point the a.v.c. is taken and fed back to valves 1 and 2 via the decoupling network, R<sub>9</sub>, C<sub>13</sub>, R<sub>1</sub>, C<sub>1</sub>.

The a.c. is passed on to V<sub>3</sub> for l.f. amplification and thence to V<sub>4</sub> for output to the speaker transformer T<sub>2</sub>.

The resistor R<sub>16</sub> has been made four times that of R<sub>10</sub> as the a.c. load comprises these two resistors plus R<sub>11</sub> in parallel, ignoring the reactance of C<sub>15</sub>. The a.c. load is, therefore, less than the d.c., which is unavoidable. If R<sub>16</sub> is reduced, distortion will increase. If R<sub>10</sub> is reduced, distortion will be decreased—as will be output.

Standing bias for the first three valves is secured by means of the voltage drop across R<sub>2</sub>, and C<sub>4</sub> is its decoupling capacitor. This saves the use of two capacitors and two resistors.

A fixed capacitor C<sub>19</sub> across the primary of the output transformer provides a certain amount of tone correction in the form of top-cut; should more cut be required, this capacitor may be increased in value. Alternatively, it may be connected from the anode of V<sub>4</sub> to chassis; or a mica type of approx. 100pF can be connected between anode and grid to provide feedback.

On/off requirements are best met by including them in the volume control potentiometer R<sub>14</sub> (see later under Power Supply regarding the type of switch to use), but care should be taken to ensure that "off" corresponds with minimum volume. If, when switching on, the reverse is found to be the case, then switch off and reverse the connections to the potentiometer.

The front of the chassis will carry four control knobs, viz. tuning, wavechange, volume, selectivity; if there are only three holes provided on the cabinet, the selectivity control can be mounted at the rear or alternatively another hole can be cut in the cabinet. If it is a bakelite or plastic type, this can be done by burning a small hole with a large needle or something similar and then enlarging it carefully by means of a circular file. It will more than likely make an unholy stink, so be warned against family repercussions.

Is it necessary to stress holding the wires of the germanium crystal diodes with a pair of pliers to form a heat shunt when soldering? It is a point that can save two crystals.

**The Power Supply**

As will have been noticed, Fig. 1 does not include any power supplies. This does not

**COMPONENT LIST**

- Capacitors*  
 C<sub>1, 3, 4, 8, 9, 11, 13, 15, 16, 17</sub> 0.01μF  
 C<sub>2</sub> 500pF twin-gang variable (see text)  
 C<sub>5</sub> 500pF  
 C<sub>6, 12</sub> 100pF  
 C<sub>7</sub> 500pF (see text)  
 C<sub>10</sub> 150pF  
 C<sub>14</sub> 200pF  
 C<sub>18</sub> 50μF 25V electrolytic  
 C<sub>19</sub> 0.006μF  
 C<sub>a</sub> 100pF mica (see text)  
 C<sub>t</sub> 50pF trimmers (3)

- Resistors*  
 R<sub>1, 9</sub> 1MΩ  
 R<sub>2</sub> 100Ω  
 R<sub>3, 4, 6, 11</sub> 50kΩ  
 R<sub>5</sub> 5kΩ pot  
 R<sub>7</sub> 1kΩ  
 R<sub>8</sub> 20kΩ  
 R<sub>10, 11</sub> 500kΩ  
 R<sub>12</sub> 5kΩ  
 R<sub>13</sub> 250kΩ  
 R<sub>14</sub> 1MΩ pot with switch (see text)  
 R<sub>15</sub> 500Ω 1W  
 R<sub>16</sub> 2MΩ

Cabinet and chassis complete with p.m. speaker (see text)

- Coils*  
 L<sub>1</sub> QA8  
 L<sub>2</sub> QA12  
 L<sub>3</sub> QO8  
 L<sub>4</sub> IF1 (all Osamor)  
 I.F. transformer 465 kc/s, type N/S Teletron  
 2-pole, 2-way Yaxley type switch (S<sub>1</sub>, S<sub>2</sub>)  
 Germanium Crystal Diodes (2)  
 I.O. holders (4)  
 Output transformer 66 : 1 or to suit speaker

- Valves*  
 V<sub>1</sub> EK32, 6K8, ECH35  
 V<sub>2</sub> 6K7  
 V<sub>3</sub> 6SH7  
 V<sub>4</sub> EL32

- Power Supply (see text)*  
 V<sub>5</sub> 6X5  
 L.F. choke 20H, 80–100mA  
 16 + 16 μF electrolytic  
 Transformer to suit

mean that a separate power chassis is used—it is shown like this so that the constructor can choose either one of those shown in Fig. 2 or one of his own design. Decide this before you start building; and if you choose one from the four shown, connect A to A and B to B, incorporating the components on the same chassis.

A 6X5 valve rectifier is suitable for use in either Figs. 2 (a), (c) or (d) as it does not require a separate heater winding on the main transformer. In (a), (b) and (d) half-wave rectification is used for h.t., the l.t. being supplied by a small heater transformer in (a)

and (b). This is an inexpensive method, but if either of these is used the on/off switch should be of the double-pole variety and R should have a value of 100 ohms,  $\frac{1}{2}$  watt. It is essential that this resistor be included, and also  $C_a$  in Fig. 1. The resistor is a protection against an h.t. current overload should a cathode/heater short develop—in  $V_5$ , for instance—and the capacitor is necessary to isolate the aerial as the chassis will be live to the mains and must not be earthed directly. These are the disadvantages. In (c) and (d) an isolating transformer is used. The on/off switch can now be of the single-pole variety and  $C_a$  may be omitted. The chassis will not be live to the mains and can be handled or earthed if required—it is quite safe. It is, of course, more expensive to construct this type of power supply, but suitable cheap transformers are often obtainable for a few shillings. Considering that a heater transformer will cost in the region of six or seven shillings, the isolating transformer is well worth the added expense. Of the four shown, (c) is the most satisfactory as it provides full-wave rectification and it is also possible to use a 1,000 ohm resistor (3 watts) instead of the

choke. In all the others the choke (Ch) should be rated at 20 henrys.

The electrolytic capacitors (C) can be  $16 + 16\mu\text{F}$  or similar.

Note that in (c) and (d) a 2.5v torch bulb is included as a safety fuse in the mains transformer secondary.

#### Alignment

This is best carried out with a signal generator; details of procedure have been included in these pages many times. If one is not available, the best that can be done is to get  $T_1$  and  $L_4$  "in line" with each other. The precise value of i.f. may not be exactly 465 kc/s, but there is a certain amount of tolerance given by the variable dust cores of  $L_1, 2, 3$ . Once any kind of signal has been obtained by means of rotating the twin-gang, the i.f.t. cores can be adjusted for maximum strength, and also the core of  $L_4$ . Trimming and padding may then be carried out on the signal frequency cores and trimmers and the oscillator coil and trimmer. Trim at the high frequency end of the scale and pad at the low.

Note:  $R_5$  should be at minimum when finally aligning  $T_1$ .

## Radio on the "Mayflower"

When the *Mayflower II* left England she was, in almost all respects, a facsimile of the original ship which left her mark on the pages of history. There was one detail, however, in which the new ship differed from its predecessor: Board of Trade regulations required that she carried radio.

The fitting of the radio equipment makes interesting reading in a recent Press release (redolent with 17th century nautical terms) from the Marconi International Marine Communication Co. Ltd. The equipment installed was the Marconi "Transarctic II" transmitter/receiver, this being run from a bank of 24 volt batteries supplied in duplicate and charged by a small diesel generator. Due to lack of space for fuel storage this generator can only be run for limited periods. The batteries themselves are fitted in a box in the Great Cabin, ventilation being provided by running a 3in pipe from this box through the bulkhead to a mushroom ventilator on the top deck.

The earth connection presented a problem due to the wooden hull. A solution was found by fitting a copper plate, 30in square, to the outside of the hull below the waterline, and running a 35ft earthing strip from this to the transmitter/receiver in the Great Cabin.

The transmitting aerial also offered difficulties. This aerial was, eventually, run from the top of the foremast to the mainmast and, thence, to the top of the mizzen mast at the stern of the ship. The 70ft mainmast of the *Mayflower II* has a considerable amount of whip, this being sufficient to snap a taut aerial. In consequence the aerial was secured at the foremast only, being free to run through the block insulators at the main and mizzen masts. The receiving aerial was seized (or lashed) to the after starboard shroud of the mainmast.

A Marconi Marine radio officer, Mr. J. D. Horrocks, sailed with the ship on her epic voyage to America. The equipment was installed by Mr. E. A. Kitt.

## RIGHT—From the Start

### PART 15

## TRANSMITTERS

by A. P. BLACKBURN

SO FAR IN THIS SERIES, THE MAJORITY OF THE articles have been devoted to receivers or general matters connected with them, but no mention has been made of transmitters. As usual, there are innumerable types, but generally speaking the amateur is only concerned with amplitude modulation, so the field is narrowed somewhat. The coming of frequency modulation has turned considerable attention to f.m. receivers, but not a great deal to transmitters, as yet.

We will briefly recall what a transmitter has to do. The mechanism of radio communication is to generate a high frequency signal and radiate it electromagnetically from an aerial. This radiation must now have some form of intelligence impressed upon it. One way is to control it in bursts in the form of the morse code. Another is to modulate it, with speech or music, etc.

#### C.W.

Transmitters which radiate an unmodulated signal are called "continuous wave" or c.w. transmitters. The intelligence may easily be superimposed by switching the transmitter on and off in a coded manner; for example, the Morse Code.

In the simplest case, the transmitter need only consist of a simple oscillator with the morse key interrupting the h.t. as shown in Fig. 1. The output coupled in the aerial would look something like Fig. 2; an "envelope" filled with the oscillation or "carrier" when the key is closed. The key in the anode circuit will, of course, be "live," i.e. at h.t.+. A safer way would be to place the key in the negative lead, as shown dotted. Another way is to bias the valve beyond cut-off, and remove the bias when the key is depressed, as shown in Fig. 3. When the bias is removed the circuit will oscillate.

Morse transmission, then, can be fairly simple—merely stopping and starting oscillation. What of speech and music transmission? First we will have a look at the modulated waveform required, as shown in Fig. 4. This shows the carrier being changed in amplitude in sympathy, so to speak, with the modulation. This is what we have to do, then—to produce a modulation envelope not

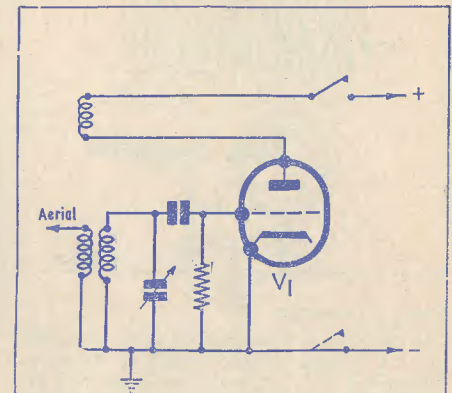

FIG. 1.

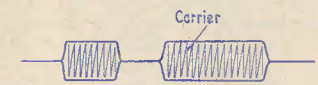

FIG. 2.

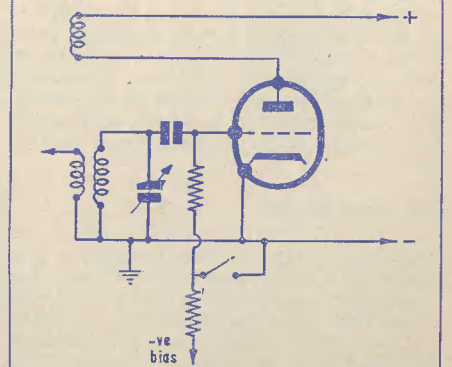
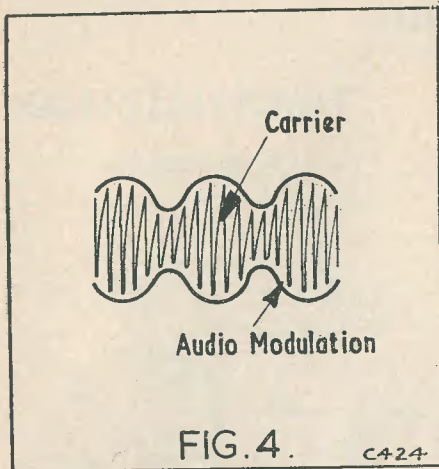

FIG. 3.

6423

starting and stopping like the Morse one, but varying in amplitude as the modulation varies in amplitude.



#### Anode Modulation

A commonly used method is to modulate the h.t. voltage of the oscillator valve, as shown in Fig. 5.  $V_1$  is the oscillator, and the amplitude of the carrier it produces may be varied by varying the h.t. voltage to the valve. If we interpose a resistance  $R_1$  in its h.t. + lead, and connect  $V_2$  as shown, variations of current in  $V_2$  will produce similar variations in voltage across  $R_1$ . Say, for example, the grid of  $V_2$  were made suddenly a little more positive, then the current in  $V_2$  would increase. The voltage dropped across  $R_1$  would also increase, leaving  $V_1$  with a smaller anode voltage. It is pretty clear now, then, that if we fed an audio signal into the grid of  $V_2$ , the anode voltage of  $V_1$  would be "modulated" by it, thereby producing the envelope of Fig. 4.

Naturally, this simple system has its drawbacks. The greatest is that variation of the anode voltage of the oscillator will almost certainly cause the oscillation or carrier frequency to change as well as the amplitude. This is undesirable for a number of reasons, and so some method of overcoming it must be found.

#### The Power Stage

Probably the most universally used method is to separate the functions of oscillator and modulated stage into two or more valves. An oscillator working under as nearly ideal conditions as possible (for stability reasons) feeds a power amplifying stage. The modulation is now applied to the anode of the latter, as shown in Fig. 6.

$V_3$  is the power amplifier, and its anode is common with that of the modulation stage more or less as in Fig. 5. This time a choke has been substituted for the resistor  $R_1$ . This is more efficient, because even in the absence of modulation a considerable amount of power would be dissipated in  $R_1$  due to the valve currents flowing through it. To return to the power amplifier, however,  $V_3$  thus serves two purposes; it increases the oscillator power and enables the oscillator to work with a constant h.t. voltage and therefore to remain more stable in operation. In very high power transmitters there may be many stages of amplification between the oscillator and the final power amplifier.

A feature of anode modulation is that the modulation valve must be able to produce as much modulation power as the power amplifier produces r.f. power. If the power amplifier produced 1kW of r.f., the modulator valve must produce 1kW of audio power, or greater. This consideration leads to the choice of other modulation methods for many purposes.

The grid of a valve really represents a point at which a large power may be controlled by a relatively small power. For example, a power of microwatts at the grid of the first stage in a receiver controls an anode power of milliwatts in that valve, and so on through the receiver until the speaker is driven by watts of power.

So, in the case of our transmitter, the large carrier power at the anode could be controlled by a smaller power at one of the grids in the P.A. stage. This may be done by applying the modulation to the control grid as shown in Fig. 7. In effect, the audio is changing the radio frequency choke in the grid circuit instead of the more conventional grid leak resistor, because modulation power must arrive at the grid and a resistance would dissipate some of this and the system would be inefficient.  $C_1$  and  $C_2$  are important.

The reactance of  $C_1$  should be large at the highest audio frequency in use but small at the carrier frequency, so that audio is not passed through it, but the carrier arrives at the grid unimpeded.  $C_2$  should have a small reactance to the carrier and large to audio, like  $C_1$ . The purpose of  $C_2$  is to bypass any r.f. to earth and prevent it reaching the modulation circuits.

If a pentode is used in the power amplifier stage, suppressor grid modulation may be used. Here the control grid is used exclusively to deal with the carrier, and the audio modulation is fed to the suppressor grid. The action is very similar to that of control grid modulation.

A half-way method of modulation is cathode modulation. The basic circuit is

shown in Fig. 8, where it can be seen that the modulating valve is placed in the cathode circuit of the power amplifier. A higher power modulator is required for this than in the case of grid modulation, but not so high as for anode modulation. The circuit is really a combination of grid and anode systems.

choke  $L_1$  becomes the secondary of the transformer and the anode of  $V_2$  is connected to the primary. This transformer has to be designed, of course, to cope with the modulation power required, and in a large transmitter may be a very bulky item indeed.

#### Frequency Multiplication

At higher frequencies, crystals to control

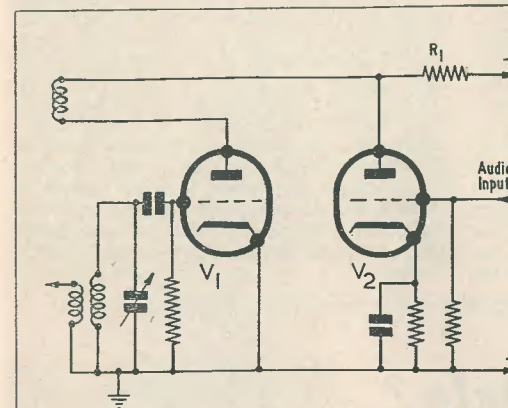

FIG. 5.

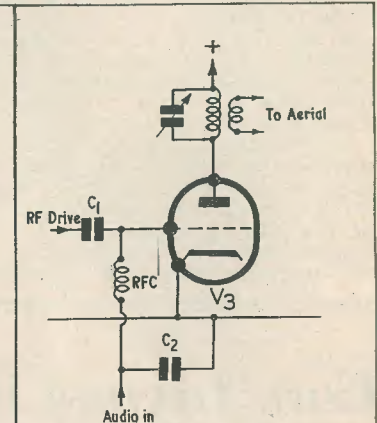

FIG. 7.

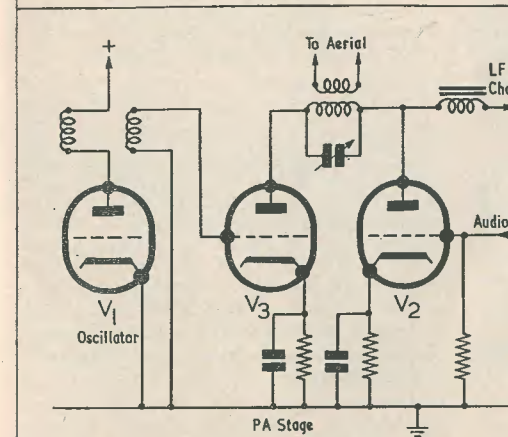

FIG. 6.

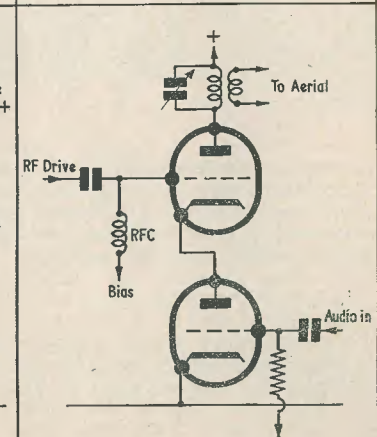

FIG. 8.

#### Coupling

In all these systems of modulation the greatest efficiency is obtained when the modulator is correctly matched to the power amplifier. In order to achieve this simply, a transformer is often used. The connection is perfectly simple; for example, in Fig. 6 the

the master oscillator driving the power amplifier stage are not available. To enable the transmitter to operate at these frequencies the power-amplifier can be made to multiply its driving frequency.

The method is an extension of one used to obtain high efficiency. This is class "C"

operation. The bias of the power amplifier is such that the valve is cut-off. When the carrier drive is applied, the positive waves cause the valve to conduct suddenly. The anode current is, therefore, in pulses of current which kick the tuned circuit into oscillation. In normal operation this tuned circuit has a resonant frequency equal to the drive frequency, i.e. it is tuned to the drive frequency, and produces an output in the aerial at that frequency.

If, now, the anode circuit is tuned to three times the drive frequency, it will receive a "kick" from the drive waveform for every three cycles it produces. The efficiency is obviously lower in this mode of operation.

It can be shown that in the normal mode of operation (not frequency multiplying), class C operation is the most efficient. By efficiency in this sense is meant the relation between the r.f. power in the aerial and the d.c. power supplied to the anode of the valve. Class "C" operation of the P.A. valve has the

advantages that high efficiency may be obtained and frequency multiplication may be used if required.

#### Aerial Coupling

As a conclusion to this very thin scratch on the surface of transmitter topics, a word should be said about the coupling of the transmitter to the aerial.

This depends in detail to a great extent upon the type of aerial used. However, the aim always is to get as much of the power generated into the aerial as possible, just as one wishes to transfer as much power as possible from an amplifier to a loudspeaker. The transmitter condition is very similar—the transmitter must be matched to the aerial.

Very often this process takes the form of a transformer just as in the amplifier-loudspeaker case, but the primary or secondary of the transmitter "output" transformer is usually tuned to the frequency of the carrier.

## Can Anyone Help?

G. WATSON, 8 Linn Drive, Muirend, Glasgow S.4, would be very pleased to hear from any fellow-reader who has successfully converted the BC.453.A Command Receiver to a car radio.

\* \* \*

G. GIBBINS, 106 Windermere Road, Reading, Berks, would like to purchase or borrow the circuit and information for converting the Command Receivers BC.454 3-6 Mc/s or BC.455 6-9 Mc/s to a car receiver.

\* \* \*

C. B. RAITHEY, School House, Martin, Lincoln, wishes to obtain the circuit for the 9.72 Mc/s I.F. Strip reference 10U/254.

\* \* \*

G. H. PRICE, 128 Kingsbury Road, Coundon, Coventry, Warwicks, would greatly appreciate any information on the ex-A.M. Receiver type 1466.

\* \* \*

A. L. STEVENSON, 195 Borrion Street, Glasgow, C.4, urgently requires the circuit diagram of the Regentone W66 (a.c./d.c.) and will pay for same.

*Requests for information are inserted in this section free of charge, subject to space being available*

D. WILLCOX, "Tudor Gate," Henfield, Sussex, wishes to obtain a service sheet for a Pilot (U.S.A.) T.47 a.c./d.c. radio set.

\* \* \*

R. Low, 100 Millar Road, Saltcoats, Ayrshire, Scotland, wonders if anyone can supply him with the circuit or any information on the Etronic T.V. model ETV.1536 in exchange for other radio or t.v. circuits.

\* \* \*

A. R. LARKIN, 3 Stag Close, Stag Lane, Edgware, Middx., wishes to buy or borrow a handbook or manual on the Hallicrafters S.20.R receiver.

\* \* \*

E. JONES, Highlands, Station Road, Epping, Essex, wishes to obtain a circuit or servicing data for the Philips 785.AX receiver, serial No. 5778.

\* \* \*

J. TEASDALE, 10 Barker Road, Linthorpe, Middlesbrough, Yorks, asks if anyone can help with data and circuit of the ex-A.M. Test Set type 5A, ref. No. 10S/20. All letters acknowledged.

# Valve Nomenclature

## PART 2

by V. T. ROLFE

### Ferranti

As with most manufacturers, a large number of American types now appear on the Ferranti list, and in addition a number of Continental types. In fact, all the current types shown in the latest "Radio Valve Data," published by *Wireless World*, have either American or Continental type numbers.

The Ferranti code only applies, therefore, to replacement and obsolete types: it consists of a letter group to indicate the type of valve, followed by a number indicating the heater voltage, with a further letter if necessary to differentiate between similar types. The following letters are used:

\*D—Diode  
 DD—Double-diode  
 H—Triodes  
 HL—Triodes  
 L—Triodes  
 LP—Power triode  
 PT—Pentode  
 QPT—Q.P.P. valve  
 SPT—"Straight" pentode  
 VHT—Vari- $\mu$  hexode  
 VPT—Vari- $\mu$  pentode  
 VFT—Tuning indicator.

\* In the case of a double-diode triode or double-diode pentode, a single D is used as a suffix, e.g. H2D, H4D, PT4D. The letters used are rather similar to those used by Cossor, but precede the number.

The heater designation is comparatively simple. Two volt valves are distinguished by a figure 2, four volt valves by a figure 4, and 6.3V types by a 6. A.C./D.C. types having odd values of heater voltage are distinguished by the letter Z (e.g. PTZ).

### Marconi

Many Marconi valves have the same type numbers as Osram valves, and the same letter code holds good. With more recent valves, a serial number is used to indicate the "range" a valve belongs to. Thus the "145" range consists of the X145, W145, Z145, N145, DL145 and U145; these being the frequency changer, variable- $\mu$  r.f. pentode, "straight" r.f. pentode, output pentode, double-diode triode and rectifier respectively. This letter code is dealt with under the Osram section which follows.

Apart from all valves in the same range having the same number, there is no significance in the numbers themselves.

### Osram

The present code consists of a letter (or letter group) which indicates the valve type (triode, pentode, etc.) followed by a number with either two or three digits. The letter code has been in existence for a number of years, and the principal letters used are shown below:

B—Double-triode  
 D—Diode or double-diode  
 H—Triode (high- $\mu$ )  
 KT—"Kinkless" tetrode  
 L—Triode (low- $\mu$ )  
 N—Output pentode or tetrode  
 U—Rectifier  
 W—R.F. pentode (variable- $\mu$ )  
 X—Frequency changer  
 Y—Tuning indicator  
 Z—R.F. pentode ("straight").

Combinations of these letters are often used. DH indicates a double-diode triode, KTW indicates a variable- $\mu$  r.f. beam tetrode and LN a triode/output pentode.

The numerical group may consist of two or three digits. No rigid rules can be applied to the numerical groups, but the following notes may prove useful. 1.4V battery valves on octal bases use the numbers 14, 15 and 16. The miniature B7G range use the numbers 17 and 18. The older 2V valves used numbers in the "20" series.

Numbers in the "60" range were used to indicate octal-based valves having 6.3V heaters, and in the "30" range for valves with 300mA heaters.

With the introduction of the miniature range an attempt has been made to rationalise the system, the first figure being used to indicate the heater rating and the last figure the base. In the case of three-figure numbers, the centre figure can be regarded as a serial number. The first figure code is as follows:

7—6.3V heater (for parallel operation)  
 1—100mA heater (for series operation)  
 3—300mA heater (for series operation)

The last figure code is as follows:

7—B7G base  
 9—B9A base

In some cases an "8" may be used to indicate a B7G base. All the 100mA and 300mA range have three-figure numbers. In the case of the former this avoids confusion with the 1.4V battery valves, e.g. X17 and X18 are 1.4V battery-operated frequency changers, whereas X109 is a 100mA frequency-changer on a B9A base.

## Mullard

The present Mullard system is well established and gives more information than most valve codes. It is also in use on the Continent, which is a great advantage.

Basically it consists of two (or more) letters followed by a two-figure number.

The first letter gives the heater rating, according to the following code:

- A—4V heater
- C—200mA heater
- D—1.4V filament (or heater)
- E—6.3V heater
- G—5.0V heater
- H—150mA heater
- K—2.0V filament
- P—300mA heater
- U—100mA heater.

In addition to the above, V is used on the Continent—but not in this country—to indicate a 50mA heater.

The second, and any subsequent letters, indicate the electrode structure, in accordance with the following lists:

- A—Diode
- B—Double-diode
- C—Triode
- D—Output triode
- E—Tetrode
- F—R.F. pentode
- H—Hexode or Heptode\*
- K—Octode or Heptode\*
- L—Output pentode
- M—Tuning indicator
- N—Thyratron
- †P—Secondary emission valve
- Q—Nonode
- X—Gas-filled rectifier
- Y—Half-wave rectifier
- Z—Full-wave rectifier.

\* Heptodes used as "single stream" frequency changers are denoted by K (e.g. DK96). In the case of triode heptodes, CH is used (e.g. ECH81).

† Used only as a third letter.

These letters may be used together to indicate multiple valves: e.g. EABC80 is a triple-diode triode with a 6.3V heater.

The first figure indicates the type of valve base:

- No figure—Side contact
- 2—Loctal (B8G)
- 3—Octal
- 4—Rimlock
- 5—Special
- 6—Subminiature 5-pin (B5G/F)
- 7—Subminiature 8-pin (B8D/F)
- 8—Noval (B9A)
- 9—Miniature 7-pin (B7G)

A "1" is used on the Continent to indicate a special German base, the Y8A. The "5" can mean anything from wire-ends (as in the case of EY51) to B9G (as in the case of the

EF50). The "7" is used on the Continent for a type of B8G base (e.g. EM71).

The final figure is a serial number. Because a valve bears this nomenclature it is not necessarily a Mullard type. The EM71 mentioned above is made only by Brimar in this country, as is also the PY83. There are also one or two valves of Continental origin which contravene the code, notably the UM4 and the D20 range (DAC21, DF21, DF22, DK21 and DL21), all of which have octal bases, but "Continental" connections (heater or filaments on pins 1 and 8, instead of the normal 2 and 7). Of these, only the UM4 is a Mullard type.

## Previous Code

Prior to adopting the European type numbering system, a single code consisting of a letter group to indicate the type of valve and a numerical group to indicate the heater voltage was employed.

The letters used were as follows:

- ACO—A.C. mains output valve
- DO—Directly-heated output valve
- DW—Directly-heated full-wave rectifier
- FC—Frequency changer
- HVR—High-voltage rectifier (e.h.t.)
- IW—Indirectly-heated full-wave rectifier
- PEN—Output pentode
- QP—Quiescent push-pull valve
- SP—"Straight" r.f. pentode
- TDD—Double-diode triode
- TH—Triode heptode or Triode hexode
- TSP—Television screened pentode
- TT—Triode
- TV—Tuning indicator
- UR—Half-wave rectifier
- VP—Variable-mu pentode
- 2D—Double-diode

With the exception of the ACO's, DO's and all the rectifiers, these letters may be followed by a figure (or figures) indicating the heater voltage. For example, the FC2, FC4 and FC13 have 2V, 4V and 13V heaters respectively. In the case of full-wave rectifiers (IW and DW) the number group consists of two parts, the first giving the heater voltage, and the second the maximum anode voltage. The DW4-350, for example, is a directly-heated full-wave rectifier with a 4V filament and a maximum anode voltage of 350V r.m.s.

There are also a large number of Mullard valves of early vintage, which have the suffix "PM." Judging by old Mullard catalogues, this appears to be an abbreviation for "Pure Music."

## Tungfram

The majority of modern Tungfram valves bear either the American or European

nomenclature. As these are explained elsewhere in this article, it is only necessary to deal with the older types of valves here.

A letter prefix is used with Tungfram types indicating the class of valve, followed by a number giving some information on the heater ratings.

The following letters have been used:

- A—Prefix used for some 4V a.c. mains valves
- CB—Class-B output valve
- DDT—Double-diode triode
- HL—Triode
- HR—Triode (for use as resistance-capacity-coupled amplifier)
- HP—H.F. pentode
- LD—L.F. triode
- LL—Driver triode
- LP—Low power triode
- MH—Heptode frequency changer
- P—Power triode
- PP—Power pentode
- PX—Super power triode
- PV—Power valve (i.e. rectifier)
- SE—Screen-grid valve
- SP—"Straight" r.f. pentode
- SS—"Straight" screen-grid valve
- TX—Triode hexode
- VO—Variable-mu octode
- VX—Variable-mu hexode

Several codes seem to have been used as far as the numbers are concerned. A number of older valves have just a single figure, a 2 or a 4, which indicates 2 and 4V heaters respectively. There is also a series of 13 volt valves (HL13, DDT13). Similarly, the TX21 which is a triode hexode with a 21-volt heater.

But the vast majority of valves have four-figure numbers which indicate the heater voltage and current. The HP4100, for instance, is an r.f. pentode with a 4V 1A heater; the HP2018 is also an r.f. pentode, with a heater rated at 20V, 180mA. (There is a whole range of these valves with 180mA heaters.) The PV4201 is a full-wave rectifier with a 4V, 2A heater.

There is also another system which was used at one time to specify rectifiers. The

RV200/600 is an example of this. This can be "translated" as meaning "Rectifier 1/2 valve" giving an output of 200mA at 600V.

## Miscellaneous

### BVA Code

During the war years a very limited range of valves was manufactured, and no makers, names were marked on the valves. They were marked with a three-figure code which distinguished battery and a.c. mains valves, valve function and manufacturer. The details of this code are shown below.

#### 1st figure—Heater group

- 1—Battery type
- 2—A.C. mains type

#### 2nd figure—Valve type

- 1—Rectifier
- 3—Double-diode triode
- 4—R.F. pentode
- 6—Output pentode
- 7—Frequency changer

#### 3rd figure—Manufacturer

- 1—Cossor
- 2—Mazda
- 3—Ferranti
- 4—G.E.C.
- 5—Marconiphone
- 6—Mullard
- 7—Brimar

## Service Codes

As most readers will be aware, the Armed Forces now use a common valve or "CV" code. Each valve used is allocated a type number. The numbers in themselves do not indicate anything, but are merely serial numbers. The Americans have a somewhat similar system of "VT" numbers.

Prior to the adoption of the CV code, each Service used its own number. The prefixes VR, VT, VI and VU were used by the R.A.F. to indicate valve, receiving; valve, transmitting; valve, indicating; and valve, rectifier. VCR was used for cathode ray tubes. The Navy used such prefixes and NR and NT, and the Army AR, AT, etc.

## Literature Received . .

**Catalogue No. 13.**—We have received from Arthur Sallis (Radio Control) Ltd. a copy of their latest Catalogue containing over 500 itemised components and units, etc. Attractively produced and comprising 80 pages plus heavy cover, it costs but 2/- post free in this country, which is refunded against any order over 20/- in value.

Of especial interest to radio control enthusiasts are the many types of escapements and relays displayed therein; indeed, this catalogue is claimed to be the only one

of its kind in this country in this respect. Of appeal to the radio enthusiast are the many items of surplus units, equipment and components available. Lavishly illustrated throughout, this latest edition of a well-known catalogue should find a place in most workshops.

## Technical Bookguide

Published by Hansom Books Ltd., 21 Lower Belgrave Street, London, S.W.1, this handy monthly reference to the latest books published is available from bookstalls at 6d. per copy.

# AN UNUSUAL AUDIO OSCILLATOR

by W. E. THOMPSON, A.M.I.P.R.E.

SOME EXPERIMENTS WITH A MODIFIED multivibrator circuit were described by Louis E. Garner, Jr., in the September 1956 issue of *Radio and Television News*, in which it was shown that the basic circuit, Fig. 1, could be regarded as having the two triodes connected in parallel across the h.t. supply. Altering the circuit to that shown in Fig. 2 produces what Garner calls a series multivibrator, because the two triodes can now be seen as in series or cascade. The circuit is not unlike the configuration that has become known as the cascode. Garner also showed that variations on the basic circuit of Fig. 2 could be produced, from which different waveforms could be obtained at the low and high impedance points.

One example is the simple circuit of Fig. 3, a series multivibrator whose output has a sine waveform at both the low and the high impedance points indicated by the dotted connections.

Experiments by the present writer have shown that some further development can provide a useful audio source which has a sine waveform, at a resonant frequency of 1,000 c/s. With the circuit of Fig. 4 there is good sine waveform free from harmonics, producing about 2.5V r.m.s. at low impedance.

There are several uses to which such a source can be put, two examples being (a) modulation for an r.f. signal generator, and (b) a frequency source for certain bridge measurements. The writer has used it successfully as a source of alternating voltage in a Maxwell bridge for inductance measurements.

The resonant frequency can be altered by changing the values of  $C_1$  and  $C_2$ . It has been found, for instance, that when  $C_1 = 0.004\mu\text{F}$  and  $C_2 = 0.02\mu\text{F}$  the resonant frequency is 400 c/s, which is the usual modulation frequency for signal generators. Altering the value of either  $C_1$  or  $C_2$  will, of course, change the operating frequency, though it seems that  $C_2$  has the greater effect. For example, if  $C_2$  in Fig. 4 is increased in value from  $0.01\mu\text{F}$  to  $0.02\mu\text{F}$ , the resonant frequency falls to 500 c/s, and retaining this new value for  $C_2$  and increasing  $C_1$  from  $0.001\mu\text{F}$  to  $0.004\mu\text{F}$  reduces the resonant frequency from 500 c/s to 400 c/s. The values of all other components remain unchanged in these examples.

Perhaps the most noticeable feature of the circuit is the absence of inductive components

and, if more modern audio oscillators are considered, the apparent absence of conventional phase-shift networks. Even though the circuit is so simple, its frequency stability is good. There is no noticeable drift with long periods of operation, and stable operation is reached as soon as the valve has warmed up. Oscillation commences readily even when the h.t. rises gradually from zero. These conditions applied with any sample of 6SN7 which was tried in the experiments. One valve, tried purposely because it has a heater-cathode leakage of  $4M\Omega$ , did not seem to do any more than produce a mere trace of 50 c/s intermodulation.

A fairly stable h.t. supply is an advantage, though not essential. Measurement shows that the resonant frequency drifts slightly with changes of h.t. voltage, but fortunately it is not serious. Small changes of h.t. voltage are almost insignificant, but a drop from 200V to 150V causes a rise in resonant frequency of about 30 c/s.

The current drawn from the h.t. supply is extremely small. The maximum value registered with the several 6SN7's tried in Fig. 4 was 0.8mA. The same circuit, at 400 c/s, drew about 1.2mA.

A rather unusual feature noticed during the experiments is that disconnecting the decoupling capacitor  $C_3$  causes oscillation to cease. This curiosity can be put to advantage for at least one purpose, for if the earth return for  $C_3$  is taken via a morse key, one has quite a useful code practice oscillator! It was also found that the value of  $C_1$  cannot be made too large, otherwise oscillation will stop. In fact, one of the difficulties first encountered was found to be due to a value of  $0.05\mu\text{F}$ , specified by Garner, being too large; this had to be reduced to  $0.01\mu\text{F}$  before oscillation started.

This circuit does not seem to lend itself readily to operation as a variable audio oscillator. On the other hand, it is easy to make it work on a number of chosen spot frequencies controlled by a switch to change the values of  $C_1$  or  $C_2$ , or both. It is not inconceivable that with other circuit configurations producing different waveforms, one could make a simple musical instrument. This thought, for what it is worth, is offered to those who like to try out new ideas for making weird and wonderful noises.

As far as components are concerned, they can all be found in practically any junk box, and the circuit takes but a few minutes to wire up.

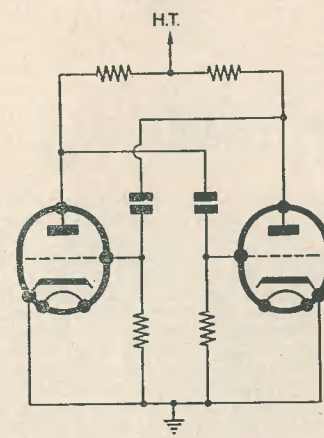

FIG. 1.  
Basic Parallel Multivibrator  
Circuit.

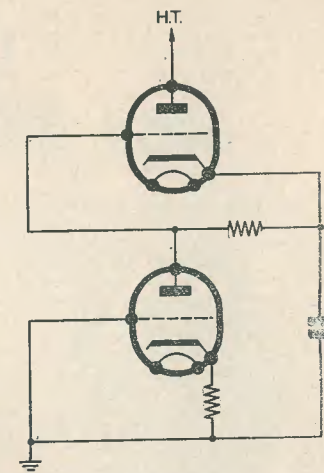

FIG. 2.  
Basic Series Multivibrator  
Circuit.

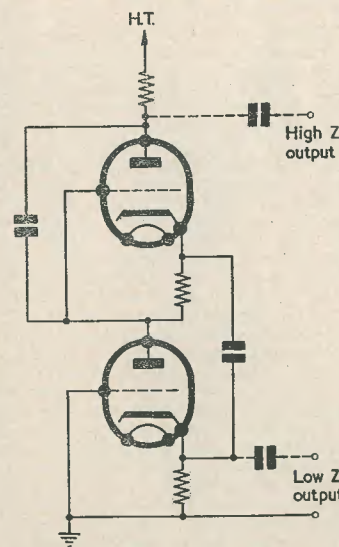
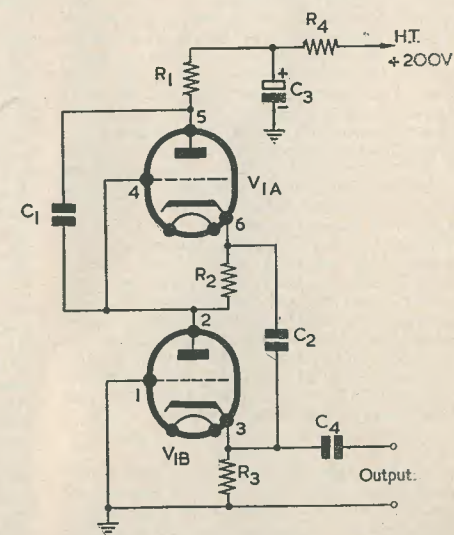

FIG. 3.  
Basic Sine Wave Multivibrator  
Circuit.



$R_1 = 15\text{ k}\Omega$      $C_1 = 0.001\mu\text{F}$      $V_1 = 6\text{SN7}$   
 $R_2 = 3.3\text{ k}\Omega$      $C_2 = 0.1\mu\text{F}$   
 $R_3 = 3.3\text{ k}\Omega$      $C_3 = 8\mu\text{F}$   
 $R_4 = 120\text{ k}\Omega$      $C_4 = 0.1\mu\text{F}$

FIG. 4.  
1000 c/s Audio Oscillator.

M428

## THE 1957 AUDIO FAIR

AT AN EXHIBITION DEVOTED TO AN ART SUCH as the design of high fidelity reproducing equipment, wherein perfection overall remains only a tantalisingly small fraction out of reach, it is hardly to be wondered at that practically all products shown achieve exceptionally high standards of workmanship and of performance, and that an attitude of keen enthusiasm exists amongst the exhibitors. The Audio Fair is, to the writer's mind, unlike any other large "electronic" exhibition staged in London. At most exhibitions one finds that the scene is dominated by the salesman rather than by the development engineer, and that technical queries often cannot be handled because the stand personnel simply do not know the answers. Occasionally one is able to unwinkle from some remote fastness an engineer who is fully conversant with the technical details of his firm's products; but, even here, one occasionally finds oneself tempering inquisitiveness with sympathy for his obviously boring tour of stand duty.

At the Audio Fair the whole outlook is different. Here the engineer is almost completely in control, and talk is not so much of sales but of performance specifications. In many cases, exhibitors' representatives are themselves high fidelity enthusiasts, and they welcome the questions of neophytes just as warmly as they do those of seasoned devotees. Discussion of individual products is largely objective—it is probably only at the Audio Fair that an exhibitor is prepared to detail both the advantages and the shortcomings of his particular equipment. To the engineer the essential charm of high fidelity work is that, by judicious use of the resistors, condensers, and other components with which most of us have been playing all our lives, a device can be created which truly adds to the very best things of this world. There have been many craftsmen in the past who have built exquisite musical instruments; *electronic* craftsmen are now beginning to join their ranks.

### The Fair

The Audio Fair this year was held at the Waldorf Hotel, Aldwych. This is the second London Fair; the first, an overwhelming success, having been held in the more confined accommodation of the Washington Hotel. In a report of this nature it is almost impossible to detail everything that was shown. Such a report would read, in any case, rather like a catalogue of the various firms' products. Comment on the performance of particular equipments is also difficult, but the reader can rest assured that the performance of all those mentioned below is very good indeed. In general, the writer attempted to discover products which were new or whose specifications were of major interest.

Philips Electrical presented an interesting development in what they describe as their Hi-Z output circuit. This circuit employs no output transformer, thereby deleting a rather troublesome link in the reproducing chain. The Hi-Z arrangement is used in the Philips 12-watt amplifier type NG5200, the output stage of which contains four pentodes in a series-parallel arrangement, this number of valves being necessary to produce the required output power and to bring the output impedance to a usable value. The four valves of the output stage are driven by a triode splitter, and the speaker is fed from the output cathodes via a blocking condenser. The impedance of the speaker employed (a Philips model) is 400 ohms and the damping factor given by the circuit is 60. It is claimed that the new output circuit enables full rated power to be delivered throughout the a.f. range, with negligible phase shift and superlative transient response.

The General Electric Company demonstrated their stereophonic sound equipment and announced modifications to some of their equipment. For instance, minor modifications have been made to the BCS 2417/8 amplifier, which is now available in unit-form under the type number BCS 2417/8A. (Incidentally, the writer understands that the letters BCS—so common on G.E.C. equipment—stand for Broad-Cast Sound.) G.E.C.'s v.h.f./f.m. tuner unit has been re-designed to give improved sensitivity and generally improved performance, with a considerable reduction in h.t. power requirements. This latter enables the unit to be fed, via suitable decoupling circuits, from existing amplifier power packs. However, the main item of G.E.C. news at the Fair was the introduction of their "Periphonic" speaker system. Briefly, the "Periphonic" system works in the following manner. When a moving coil loudspeaker is fed by an amplifier, its cone does not follow perfectly the movement transmitted to it by the voice coil. Some flexure is inevitable, particularly at the periphery. This flexure causes distortion. In the "Periphonic" system two loudspeakers are mounted very close together with their cones moving in opposite directions. Because of this, distortions introduced by flexure in one speaker are cancelled out by an equal and opposite flexure in the other. Radiation of the sound is then obtained from the exposed surfaces of the cones. The air compression between the two speakers working in anti-phase is considerable, and a very robust assembly, such as is provided in G.E.C. metal cone speakers, is essential. The "Periphonic" system requires a specially designed cabinet, details of which may be obtained from G.E.C.

A very interesting new microphone, the "Cadenza," was the feature of an impressive demonstration by Simon Sound Service Ltd. The demonstration consisted of the reproduction of a recording by the full choir and organ of St. Matthias, Richmond Hill. The reproduction showed excellent balance between the choir and organ, and was equivalent to any similar performance the writer has heard. The recording had been made with one "Cadenza" microphone positioned 40 feet away from the source of sound.

### "Watt's Folly"

An excellent reproducer, type "CQ", available from R.G.A. Sound Services (Plymouth) Ltd., was exhibited at the Fair. This consists of a relatively small rectangular enclosure mounted on four legs, and it should prove ideal for the living-room of the enthusiast who does not wish to invest in a heavy outlay. The price of this unit is twelve guineas only and, in the writer's opinion, its performance was as good as that of many others in the Fair at much higher cost. Power handling is of the order of six watts. Considering the compactness of the unit, bass response was exceptionally good. The reproducer employs a 10-in elliptical speaker and a 4-in m.c. tweeter.

Also shown in the same demonstration room was a much larger reproducer. This has been designed by Mr. Cecil Watts and was described by the demonstrator as "Watt's Folly." Apparently there is only "one off" of this reproducer available at the time being, and "nobody knows what's inside it"! The cabinet stands some four or five feet high, and looks rather like a truncated mummy-case. There are two round apertures at the flat top, with lateral apertures around the uppermost foot or so of the body. Whilst the writer was in the demonstration room, the reproducer was switched in for a record of "Hernando's Hideaway." "Just wait for that knock on wood," said the demonstrator. "It's out of this world." It certainly was. This reproducer may be going into production soon.

H. J. Leak and Co. have always been a very active firm, both in the home and in the export markets. New production techniques made possible by this company's large sales have now enabled it to tackle this year's equipment both from the point of view of increased performance standards and of reduced prices. H. J. Leak have also paid considerable attention to the styling of their products, a very important point in the U.S. where hubby has less say in the purchase of high fidelity equipment than has his spouse. The new Leak Varislope III pre-amplifier now supersedes the Varislope II, and is one guinea cheaper. The new pre-amplifier is styled by Lonsdale-Hands and presents an exceptionally pleasing appearance. New facilities in the Varislope III include a rumble filter, independent treble control, and two pick-up input circuits. A tape recorder input is also available. Harmonic distortion is less than 0.02% at full output, and hum and noise are 66 db down. A new, improved, Leak amplifier is the TL/12-plus which succeeds, at a much lower price, the original well-known TL/12. Despite its reduced cost, the new amplifier

provides lower distortion and greater power output. Yet another new amplifier is the TL/25-plus, which, whilst being less expensive than its predecessor, again gives better performance. This amplifier uses an ultra-linear output stage, and, with the other two units just described, was exhibited at the Fair for the very first time.

It is worth mentioning that, to avoid visitors asking the same obvious questions over and over again, the Leak demonstration room sported a very large sign on one wall stating exactly what equipment was being demonstrated. This was a sensible move which did much to prevent the formation of crowds of enquirers around the demonstrator, an irritating feature in other rooms.

Another firm which pays attention to styling is Electric Audio Reproducers Ltd. Two of the record reproducers made by this firm have been selected by the Council of Industrial Design for exhibition at the 1957 United States World Trade Fair as examples of British design and craftsmanship. E.A.R. do not believe in holding back information in their literature. Leaflets include a full circuit diagram of the amplifier used, complete with component values.

There are, of course, a number of very large firms who make high fidelity equipment in addition to a wide range of other goods. As readers will know, Decca have been a high fidelity pioneer in this class for many years now. Provisional specifications for a new amplifier to be made by this company (the model "fir 25") show a power output of 25 watts with 0.05% total harmonic distortion. The circuit uses an ultra-linear output stage, and hum and noise are quoted as 90 db down at 25 watts. The Control Unit for this amplifier houses the pre-amplifier and employs an input circuit which enables pick-ups of any impedance to be quickly and accurately matched, irrespective of output.

### Next Year—

Thus we see the end of the second Audio Fair held in London. Despite the larger space available it was still fairly crowded—though not, during the writer's visit, anywhere near as badly as occurred last year at the Washington Hotel. In order to keep numbers down, the organisers limited entry to those with complimentary tickets, and this course has apparently been successful in preventing overcrowding. Nevertheless, complaints were apparent from some enthusiasts who could not obtain tickets in time, and the ticket situation may perhaps be a little easier next year. In these busy days not everybody can afford to plan their movements a fortnight or so in advance.

Since this article was written, it has been reported, in *Hi-Fi News*, that the official attendance figures were: for Friday, 12,000; Saturday, 13,000; Sunday, 14,000; and Monday, 10,000—a total of 49,000.

**Errata.**—Owing to a typographical error in the "Rambler" Component List on page 685 of the May issue, the l.t. battery was given as 5V instead of 1.5V. The type number, AD35, was correct.

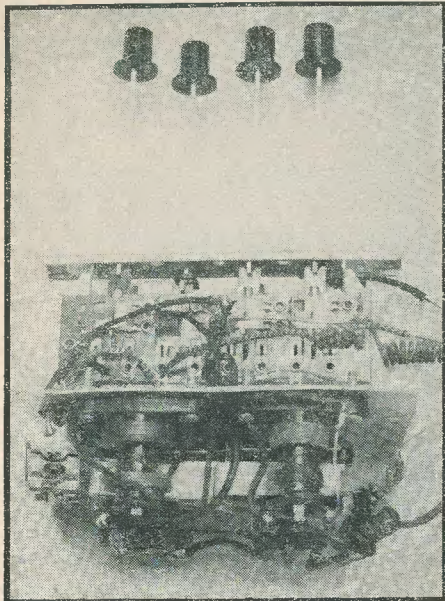

# AUTO- SELECTION COIL UNIT

by F. G. RAYER

IT IS A GREAT CONVENIENCE TO BE ABLE TO select two or three local stations accurately and instantly by some automatic tuning method, and the unit described here provides for this. It is a self-contained coil assembly, with pre-sets, and can be used in any standard mains or battery superhet having a 465 kc/s intermediate frequency. Manual tuning by means of the usual gang condenser is also possible. If this is not required, as in the case of local-station quality sets, an additional pre-selected station can be arranged for with this switch position.

The whole assembly is mounted directly on the push-button switch, as shown in Figs. 1 and 2. A 4-button switch is used, but a larger switch may readily be employed if more pre-selected stations are wanted. As illustrated, an aluminium plate 3in by 4in is bolted to the switch, being spaced from the back of the latter so that the button plungers can operate. The coils are bolted to this plate. A further metal strip, about 3½in by ¾in, is bolted in the position shown in Fig. 1, so that the pre-sets can be mounted. These are shown in Fig. 2. The actual values chosen will depend to some extent on the stations required, as 500pF pre-sets have too high a minimum capacity to tune to the low wavelength end of the band. In Fig. 2, one double

500pF pre-set is used for the Light Programme on 1,500 metres; the other is for the Third Programme near the upper end of the Medium waveband. The 50pF pre-sets were for the required low-wavelength M.W. station. It is suggested 500pF be used for L.W. and for 300 to 550 metres on the M.W. band, with 200pF for about 230 to 300 metres, and 50pF for wavelengths below 230 metres. If the minimum capacity is too high for a desired station, it is usually possible to remove a plate or so from the condensers. Another twin pre-set will be required for any further pre-selected station.

The coils actually employed were obtained from "Supacoils," but there is no reason why other coils of suitable type should not be used with equal success. These coils require a L.W. padder of 200pF, and M.W. padder of 500pF. If manual tuning is to be used, the correct padder values must be employed. For pre-set tuning only, the actual padder values are not of much importance. The push-button switch was obtained from Astral Radio Products.

### Switching Circuit

Such circuits may, of course, be wired up in many ways. That adopted is shown in Fig. 3. When the L.W. button is depressed,

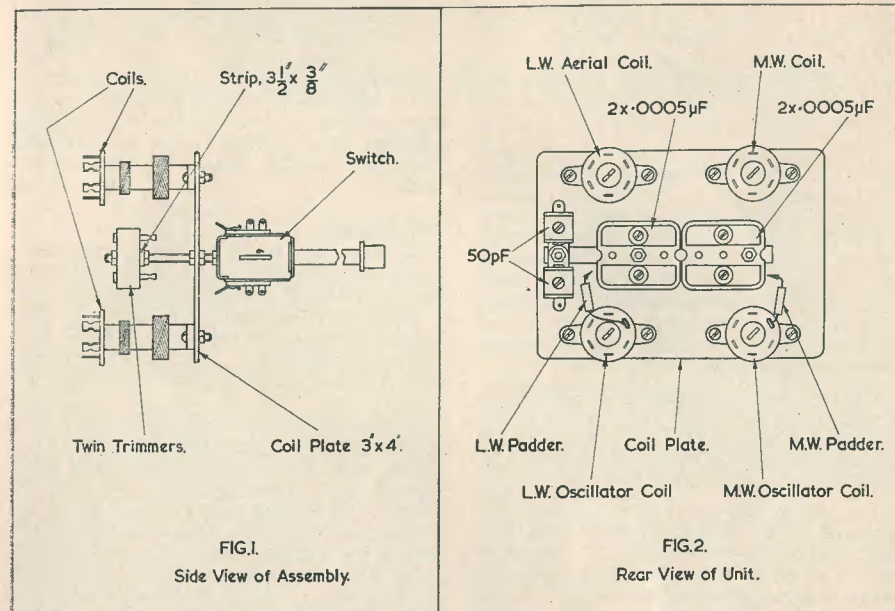

FIG. 1.  
Side View of Assembly.

FIG. 2.  
Rear View of Unit.

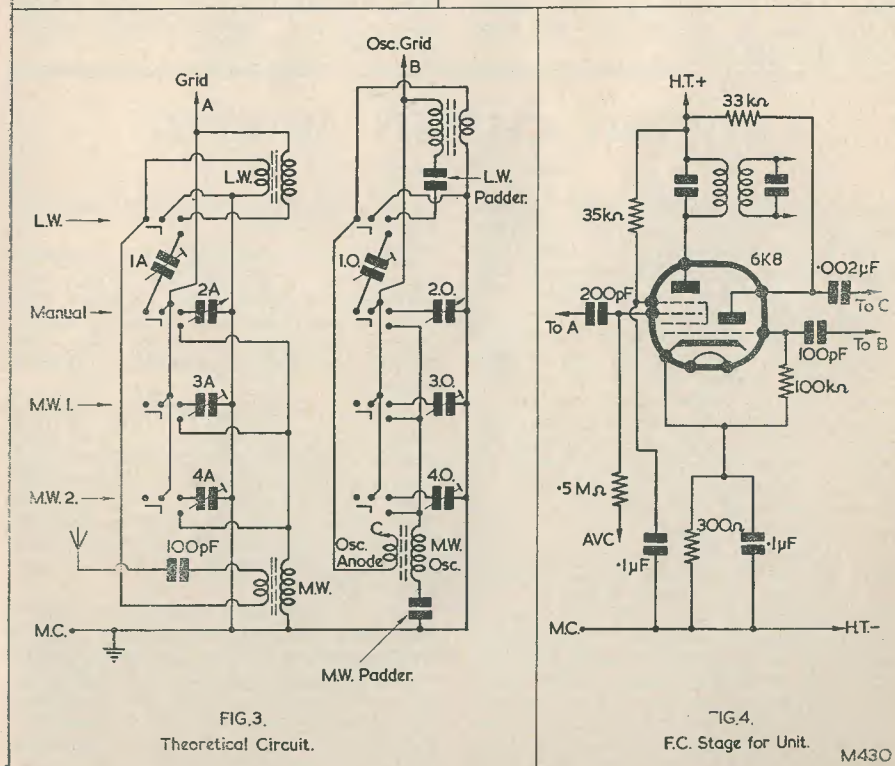

FIG. 3.  
Theoretical Circuit.

FIG. 4.  
F.C. Stage for Unit.

M430



pre-sets 1<sub>A</sub> and 1<sub>O</sub> are brought in, for L.W. Aerial and Oscillator tuning. Both L.W. tuned windings are switched in, and both L.W. primaries (for aerial coupling and oscillator) are in circuit. These two pre-sets are thus tuned for the desired L.W. station.

When the "Manual" button is depressed, the L.W. button springs out, shorting the L.W. primaries out of circuit, and disconnecting both L.W. pre-sets and the L.W. coils. The M.W. coils are now in circuit, with the 2-gang condenser (500pF each section) 2<sub>A</sub> and 2<sub>O</sub>, for Aerial and Oscillator. With either the M.W.1 or M.W.2 button depressed, the coil circuit is the same, pre-sets 3<sub>A</sub> and 3<sub>O</sub>, and 4<sub>A</sub> and 4<sub>O</sub> being in circuit, for Aerial and Oscillator tuning.

The coils mentioned operated satisfactorily in both circuit positions with M.W. and L.W. primaries in series, on the L.W. band. If manual tuning is not wanted, further pre-sets are wired in instead of the gang condenser.

The unit is best wired up separately, with coloured leads to identify Aerial, Grid, Osc. Grid and Osc. Anode connections. These four leads are then taken to the appropriate points in the receiver. The coil unit chassis is also wired to the receiver chassis. Two further fly-leads can be attached for the gang condenser connections.

A frequency changer stage suitable for 6.3V or 0.3 amp operation is shown in Fig. 4. It will be noted that a.v.c. is applied through a leak, so that the coils may be taken directly to the chassis. The oscillator primaries are also condenser fed so that no h.t. circuit is required here. Other types of standard frequency changer stage can be equally suitable.

#### Adjustments

If manual tuning is provided this button should be depressed. The M.W. coil cores are then adjusted for maximum sensitivity, at a high-wavelength point on the dial. The gang condenser trimmers are adjusted at a low-wavelength point. The pairs of pre-sets are then adjusted, each button being depressed in turn.

If a slight reduction in efficiency is not objected to, the coil primaries may be left in series, unswitched, on both M.W. and L.W. bands. The unused contacts can then be taken to the bottom ends of the M.W. tuned windings (the padder being in circuit in the case of the oscillator coil). This will provide L.W. manual tuning in addition to the three automatically selected stations and M.W. manual tuning. For L.W. manual tuning, both L.W. and "Manual" buttons will be depressed simultaneously.

## STRONG CHASSIS MAKING

*continued from page 763*

duralumin, unless unsightly corner brackets were added. The second method tried by the writer was as shown in Fig. 2, bending along the dotted lines and so utilising the previously wasted corner pieces for strengthening by bolting or riveting these to the shorter sides.

This method, although providing quite a strong chassis, was not at all easy to manoeuvre whilst bending, and did not look very pretty. The last method tried, and used for many hundreds of jobs since, is far easier and quicker to make, and has the advantage that should the piece of gear built be scrapped, the sides can be removed and used again. It makes an extremely strong chassis and wastes very little material indeed.

Three pieces of material are required, one piece forming the rear, top and front, whilst the other two pieces form the sides. The writer has made chassis from 2in x 4in to 17in x 10in by this method. There are four factors to be taken into account, requiring only a few minutes calculation before marking, cutting and bending. These are the length l, width w, depth d and thickness of material T. The diagrams (Fig. 3) are self-explanatory. 4-BA screws and nuts every

$\frac{3}{8}$ in or so along the edges  $\frac{3}{16}$ in are used for securing the sides.

Cut out part one with tin snips to the correct dimensions. Drill the side fixing holes 4BA clearance  $\frac{3}{16}$ in and  $\frac{3}{8}$ in apart along the side of length w + 2d working outwards from a marked centre point, then bend between the pieces of angle iron along the dotted lines.

Next cut out the two ends, and  $\frac{3}{16}$ in along the side of length w - 2T drill 4-BA clearance holes  $\frac{3}{8}$ in apart working outwards from a marked centre point. Drill no holes along the other edges yet. Then bend the three edges dotted in the same direction between the two pieces of angle iron as above or, if a small chassis, in the vice jaws themselves.

Bolt the sides on to the underside of the chassis top and then, and then only, drill the smaller edges of the sides by drilling through the marker holes in the material forming the top, front and rear. Then insert screws in these holes and use serrated washers below the nuts. This will produce a fine, strong chassis in a minimum of time.

# A "DIRECT-COUPLED" TRANSISTOR RECEIVER

*This article describes an interesting transistor receiver which has been designed by a reader*

ONE OF THE MOST FASCINATING BRANCHES of transistor receiver construction is provided by the possibility of designing extremely small headphone receivers which are capable of giving high levels of volume with negligible battery drain. Receivers of this type offer many practical advantages, and amply repay the low costs incurred in their manufacture. Simple transistor receivers falling into this category have many uses and have been described in this journal from time to time, with quite a number being successfully built by home-constructors.

An extremely interesting new circuit for a set of this type has been designed by Mr. S. S. Smith of Surbiton, Surrey, and this circuit is the subject of the present article. Mr. Smith's receiver employs ingenious circuitry and has the advantage of requiring an exceptionally small number of components.

two trimmers C<sub>1</sub> and C<sub>2</sub> being adjusted for reception of the Home and Third programmes, as applicable. (The maximum values shown for these trimmers in Fig. 1 are applicable to the frequencies available in the district in which the prototype was built; and it may be necessary to employ alternative values in other localities or for the reception of different transmitters.) If desired, the two-station pre-tuned arrangement can, of course, be replaced by a continuously variable tuning circuit, this employing a conventional 500pF variable condenser connected directly across the aerial coil.

In Fig. 1 the aerial is connected to a low-impedance tap into the coil, this ensuring that the tuned circuit is not too heavily damped when large aerials are employed. An earth connection is desirable due to the fact that, in

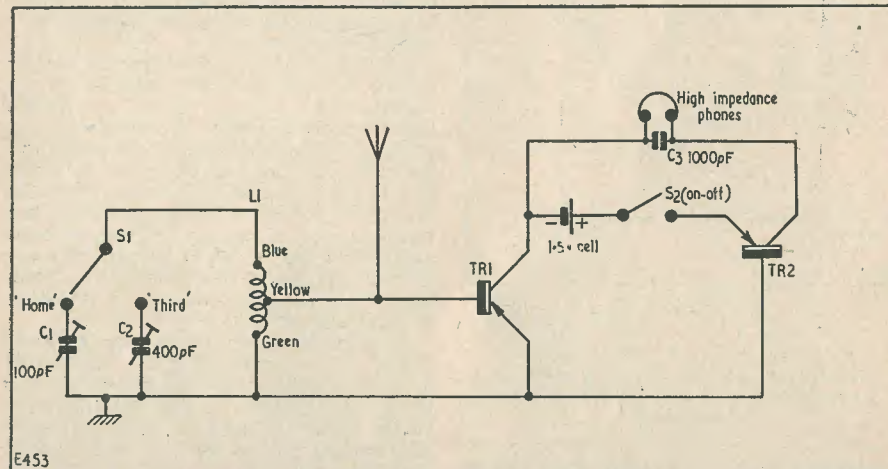

Fig. 1. The circuit of the prototype receiver. The coil is a Repanco component type DRR2, and the transistors are "Red Spot" units

The circuit of the receiver is illustrated in Fig. 1. As will be seen from this diagram, the set consists of a conventional tapped-down medium-wave tuning coil feeding into two transistors. The aerial tuning arrangement employs pre-selected station switching, the

common with other battery-operated receivers of this size, the chassis has such small dimensions that it cannot offer itself as a useful counterpoise to the aerial. The coil tap employed by the aerial is also used for applying the selected signal to TR<sub>1</sub>.

### The Transistor Section

It is the transistor section which is of greatest interest in this receiver, and it is necessary to examine the circuitry involved in several steps, if its operation is to be fully appreciated.

Transistor TR<sub>1</sub> functions both as detector and a.f. amplifier, and it is powered by the 1.5 volt cell. The negative terminal of this cell connects directly to the collector of TR<sub>1</sub>, whilst the positive terminal connects to the emitter via the emitter-base path of TR<sub>2</sub>. Apart from the impressed signal voltage, the base of TR<sub>1</sub> is held at the same potential as its emitter by reason of the d.c. circuit existing between these two points. Due to the zero bias consequently obtained, only a low current passes through the emitter-collector circuit of TR<sub>1</sub>. The opposition offered to this small current by the emitter-base path of TR<sub>2</sub> is low, because the current flow is in the forward direction for the P-N section involved. As a result, almost all the 1.5 volt potential available from the cell appears across the emitter and collector of TR<sub>1</sub>.

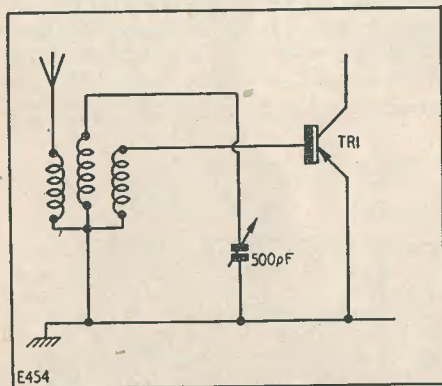

Fig. 2. An alternative aerial input circuit using a triple-wound coil such as the Teletron type HAX. The continuously-variable tuning shown here may, of course, be replaced by pre-tuned switching, if this is desired

The base and emitter of TR<sub>1</sub> form a diode which detects the applied r.f. signal in the following manner. The diode does not conduct (to any great extent) when the half-cycles applied to the base are positive with respect to the emitter, but does do so when the half-cycles are negative. The flow of current in the base-emitter circuit during negative half-cycles results in a corresponding change of current in the collector-emitter circuit, this change of current being proportional to the

average level of the detected signal. Summed up, it may be said that TR<sub>1</sub> detects and causes an a.f. current, superimposed on the standing d.c. current, to appear in the collector-emitter circuit.

The transistor TR<sub>2</sub> is also powered from the 1.5 volt cell. In this case the emitter connects directly to the positive terminal, and the collector connects to the negative terminal via the headphones. TR<sub>2</sub> represents, therefore, an earthed emitter amplifier, with its base receiving bias current via the collector-emitter path of TR<sub>1</sub>. In consequence, the base of TR<sub>2</sub> receives a standing bias current, plus the a.f. current flowing in TR<sub>1</sub>. TR<sub>2</sub> amplifies this a.f. and applies it to the headphones.

### Circuit Details

There is little which needs to be stated about the receiver from the practical point of view, as the extreme simplicity of the circuit ensures that few troubles are likely to be encountered in a built-up version. The current drawn from the 1.5 volt cell is very small, having a value of approximately 100 $\mu$ A. Since it will need to be replaced at infrequent intervals only, this cell may, therefore, be soldered into circuit. It should be remembered that neither terminal of the cell is at earth potential. There is little to be gained, incidentally, by employing a voltage higher than 1.5 to power the set; checks having shown that increased voltages have negligible effect on gain.

It will probably be found that C<sub>3</sub> may be deleted in many practical versions of the receiver. This is due to the fact that quite a high capacity normally exists between the leads of a conventional pair of headphones, and this residual capacity may be quite sufficient to bypass any r.f. voltages present in this part of the circuit. There is also the fact that, because of the low r.f. amplification provided by the transistors themselves, whatever r.f. is present at the headphone terminals may, in any case, have too low an amplitude to cause any difficulties.

An alternative and more selective aerial circuit is illustrated in Fig. 2. This circuit employs a Teletron medium-wave coil type HAX, and provides a very selective input circuit whilst still retaining the low-impedance tapping required for TR<sub>1</sub>. If long-wave reception is required, a coil type HAXL may be used instead of the HAX. The use of the alternative aerial coil causes no increase in the number of components required for the receiver. It is worth mentioning that the HAX coil is now available in minaturised form, whereupon it becomes possible to make the receiver very compact and small indeed.

The transistors employed in the prototype were "Red Spot" units, available through the normal suppliers.

## FIELD REPORT ON THE ISOTRON

by PETER PENLENHAM, A.M.S.D.B.

WHEN THE WRITER RELEASED ADVANCE details of the Isotron amplifying device in the April issue of this magazine, he anticipated that a considerable amount of interest would become apparent from readers. Events confirmed this prediction, and quite a number of letters have since been passed on to him by the Editor.

For some reason which the writer cannot wholly ascertain, nearly all the letters he has received refer to the Isotron and to his article in terms—almost—of levity. Typical of these is the following, received from a lady in Bridlington, Yorkshire.

"I must write," she says, "and congratulate you on a very good April Fool. I had been trying to make my husband listen to me talking to him, all the time he kept saying 'be quiet, dear, I am reading something really marvellous.' At the end you should have seen his face, your names were dirt."

In the same vein, B. H. Whitehead, Yardley, Birmingham, asked that the following be inserted in the "Can Anyone Help?" column:

"V. Hardup of Upper Jumper Street, Birmingham 2, would like to acquire a gas-tight reservoir (capacity 4 galls.) for use with an Isotron. The present one has to be relieved of helium gas every four days or it commits suicide."

A letter in more serious vein was received from C. H. Bigmead of Southway, London, N.W.11:

"I was more than somewhat cut up about the article in your April issue giving details of the 'Isotron' self-powered amplifying device. I have recently perfected a system of self-powered valves for use in a pocket binary encoder/decoder of my own design, which proved extremely useful in the Oxford and Cambridge General Certificate of Education Examination at Ordinary Level. Naturally enough, the publication of what I feel sure to be an inferior system (I rigged up the circuit published using an 'Isotron' constructed from a carefully annealed gin bottle, and obtained very poor results, an overall distortion of approximately 12 cycles/ft. for every decibel of amplification) rather took me aback, and it is clear that these rather unfortunate circumstances force me to publish my system earlier than I had intended (I meant to wait

until the world was ready for it), and consequently I am preparing an article for publication in April next year.

"Mr. Penlenham may be interested to know that I wrote to the Mongolian Electronic Manufacturing Co. Ltd., enclosing a stamped-addressed envelope, a sixpenny P.O. and an old sock. I received no reply. On making enquiries I found it had gone into voluntary liquidation as the result of a disagreement with its landlady."

The writer would like to point out that the statement, in Mr. Bidmead's letter, that the Mongolian Electronic Manufacturing Co. has gone into voluntary liquidation is quite untrue. But more of this later.

Several letters purporting to come from the manufacturers of the Isotron were also received, these claiming that the article contained what they described as incorrect production figures, technical details, and the like. It is felt that these letters were intended as a form of practical joke aimed at the writer because, after he had checked up (and he is nobody's fool), he found that they did not originate from the Mongolian Electronic Manufacturing Co. at all.

Only one reader wrote directly to the company at its address at Lower Puderley, and he found that his letter was returned by the Post Office as "not known." This reader sent the returned envelope, marked clearly in the top left-hand corner with the words "April Fool," to the offices of *The Radio Constructor*, and asked indignantly for an explanation.

To satisfy this last point and that raised earlier, the writer would like to take this opportunity of mentioning that the Mongolian Electronic Manufacturing Co. has now removed from Lower Puderley. This is due to the fact that an Isotron was inadvertently left running with its leakage resistors disconnected, with the result that the company's premises disintegrated. As, also, did Lower Puderley. A new development laboratory has since been set up in temporary hutted accommodation on South Uist, and it is anticipated that any further delays will soon be overcome. Due to Mongolian's active policy, it may be safely stated that the Isotron will be in full production by the fourth month of next year.

For a really  
professional finish  
use . . .

## PANEL-SIGNS TRANSFERS

Set No. 1: Receivers and Amplifiers  
Five Sheets  $8\frac{1}{2}'' \times 5\frac{1}{2}''$  containing one  
Large scale, twelve control panels and  
wording. 3s. 6d. Postage 2d.

Set No. 2: Test Instruments  
Five sheets  $8\frac{1}{2}'' \times 5\frac{1}{2}''$  containing two  
Medium scales, twelve control panels  
and wording. 3s. 6d. Postage 2d.

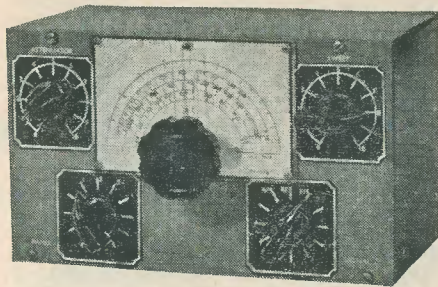

Set No. 3: Wording  
Wording for Receivers, Amplifiers,  
Transmitters, Test Equipment and other  
Radio Apparatus.  
4 Sheets, Approx. 400 words, 2s. 6d.  
Postage 2d.

Panel-Signs Transfers Fixing Varnish  
1s. per bottle Postage 4d.

Note—all wording is in white

Published by

# DATA PUBLICATIONS LTD

57 MAIDA VALE · LONDON W9

Telephone CUNningham 6141 (2 lines)

Telegrams Databux London

### LOOK! SUMMER BARGAINS T.V.s

17" £19.19.6

17" Rectangular  
tube on adapted  
chassis. Any or all  
channels. The

TURRET TUNER  
can be added later  
as an extra at our  
special price, to  
chassis purchasers  
50/- . Valve line-up  
(5 valves:- 2-6D2's,  
6SN7G, 6P25, EY51)  
Others, 6L18, EL38,  
and 7-6F1's—these  
may be on YOUR shelf. Chassis size  $11\frac{1}{2}'' \times 14\frac{1}{2}'' \times 11''$ .  
12 months' guarantee on the rectangular tube. 3  
months guarantee on valves and chassis. Ins., carr  
(incl. tube), 25/- . All complete and working on any  
channel 1-5, but less valves. With 5 valves £21.19.6  
All valves £25.19.6

14" T.V. CHASSIS, TUBE & SPEAKER £13.19.6  
As above, with a 14" round tube, which you can  
convert later if you wish to a 17" rectangular tube.  
I.F.s 10.5-14 Mc/s. LESS valves. Chassis, valves and  
tube guaranteed 3 months. Price with 5 valves  
£15.19.6. With all valves £19.19.6. Ins., carr.  
(incl. tube) 25/-

A Turret Tuner of famous manufacture is fitted  
free to any of the above chassis, giving choice of  
channels at an extra charge of 50/- toward cost of  
tuner. Only available to chassis clients.  
8" P.M. Speakers, 8/9. Buy while stocks last. Let  
the lady of the house listen to that TV or radio pro-  
gramme. P. and p. 1/9

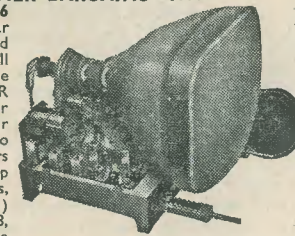

### ARGOSY PUSH-PULL R/GRAM CHASSIS 139/6

8 valve latest  
models. 3 w/  
band and gram  
switched.  
Over 10 watts  
output. Full  
one range, 4  
knob control.  
Ins., carr. 5/6

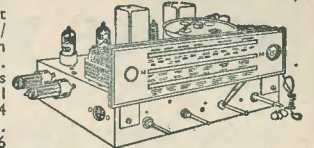

(Less valves). Drawing FREE with order or 3/6.

T.V. CONSTRUCTOR CHASSIS  
Sound and Vision Strips 35/6. Tested working.  
Complete vision strip LESS valves. I.F.s 16.5-16.5  
19.5 Mc/s. FREE drawings. p. and p. 2/6

Power Pack, 39/6. R.F. E.H.T. unit 7/9kV incl. Tested  
working. LESS valves. FREE drawings. Ins., carr. 5/-  
Time Base, 25/6. Complete with focus units, etc.  
Tested working. LESS valves. FREE drawings.  
P. and p. 3/6

Co-ax Cable, 6d. yd. Cut to any length. Good  
quality. P. and p. on 20 yds, 1/6. 45/- per 100 yds.  
P. and p. 3/6

### POPULAR RADIO OR R/GRAM CHASSIS 39/9

3 w/band and gram., s/het  
5-valve international octal.  
Ideal table gram, but still  
giving high quality output.  
4-knob control. 8" p.m.  
speaker 7/9 with order.  
Set of knobs 2/- . Chassis  
15" x 6" x 7 1/2" LESS valves. Ins., carr. 4/6



Mains Transformers, 17/6. 425-0-425V sec; 5V at 6A,  
6.3V at 12A, 6.3V at 0.6A; 200-250V screened primary.  
P. and p. 3/6

**DUKE & CO.** (R.C.) 621-3 ROMFORD ROAD MANOR PARK LONDON E12 Open SATURDAY  
all day.  
FREE Catalogue Liverpool St. to Manor Park Stn. 10 mins. Telephone GRA 6677-8 2791

## Osmor Switch-Tuned FM

(Frequency controlled)

A Highly Sensitive, Completely Stable  
and Drift-free Tuner with Cathode  
Follower Output.

Size  $4\frac{1}{2}'' \times 4\frac{1}{2}'' \times 5\frac{1}{2}''$  deep

Circuit, wiring diagram, price list, etc.,  
sent on receipt of s.a.e.

Suitable for feeding Hi-Fi Amplifier or  
for adding to existing Radio or Radio-  
gram. Power supply available.

### OSMOR RADIO PRODUCTS LTD

418 BRIGHTON ROAD SOUTH CROYDON  
SURREY

(Dept. RC11) Telephone CROydon 5148-9

## 62ACC offers you . .

### Ceramic Capacitors

Hi-K Disc: 500V d.c. wkg., 470pF, 0.001µF,  
0.002µF, 0.003µF, 0.005µF, 9d. each; 2,000V  
d.c. wkg., 0.01µF, 2/6. Standard tubular: 500V  
d.c. wkg., 1, 1.5, 2, 3pF, 1/- each; 5, 7.5, 10, 15,  
20, 25, 30, 40, 47, 50, 60, 75, 100pF, 10½d. each;  
150, 200, 250, 300, 350, 400, 500pF, 1/2 each.  
Hi-K midget tubular: 500V d.c. wkg., 500,  
1,000, 1,500, 2,000, 3,000pF, 10½d. each;  
0.005µF, 0.01µF, 1/- each. Negative tempera-  
ture coefficient type: 3, 4.7, 6.8, 10, 15, 30, 50,  
75, 100pF, 1/- each.

### Close Tolerance Silver Mica Capacitors

Plus or minus 1pF: 1.5, 2, 2.2, 3.9, 4.7, 5, 5.6,  
8.2, 10, 15, 20, 25, 30, 40pF, 11d. each. 1%: 47,  
50, 56, 60, 68, 75, 80, 100pF, 1/- each. Other  
sizes above see catalogue.

Postage extra on orders under £3

### Illustrated Catalogue No. 10

The above are amongst the 2,000 items listed in the 54 page  
catalogue with 135 photographic illustrations. Guaranteed  
new goods by the leading makers. 6d. post free. Stock-  
taking Bargain List free of charge.

**SOUTHERN RADIO  
and ELECTRICAL SUPPLIES**  
SORAD WORKS REDLYNCH SALISBURY  
Telephone Downton 207

## RADIOSETTE & NURSERYETTE

(Featured in this Issue)

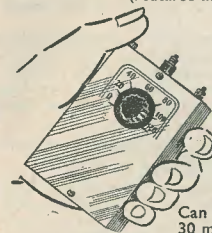

The ideal low cost  
transistor pocket radio  
for the beginner. The  
circuit utilises the new  
R.C.S. VARILoop-  
STICK transistor coil.  
A specially designed  
miniature .0004 tuning  
condenser permits the  
set to be in a case  
which fits the palm of  
your hand.

Can be built in  
30 minutes **30/-**

All components are sold separately, full construction  
data including plan of parts, 2/-

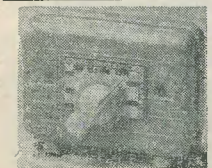

The Nurseryette has  
been specially pro-  
duced for those who  
require an attractive  
but inexpensive re-  
ceiver for the children.  
It is safe to handle and  
will give months of  
service from the small  
battery included. The  
design includes the  
miniature .0004 tuning  
condenser.

R.C.S. VARILoopSTICK transistor coil and a  
miniature .0004 tuning condenser.  
All components are sold separately, full construction  
data including plan of parts, 2/-  
Postage: Under 10/-, 9d. Under 40/-, 1/6 **30/-**  
Over 40/-, post free

**R.C.S. PRODUCTS (RADIO) LTD.**  
11 Oliver Road London E17 Mail Order only

## The Walk-around Shop

**U.S.A. ALTITUDE SWITCHES.** Totally enclosed  
incremental network of  $14 \times 2.5K$  ohms 10% 1 watt  
resistors on two-bank 11-way Yaxley type switch unit.  
Insulated mounting flange and handsome glass covered  
dial with large central switch knob covering 11 positions  
in steps of 25 "feet." Rear socket, 4 connection  
to network and earthing point for screening. 3" dia. x  
5" long. Brand new, boxed, 4/- post free.

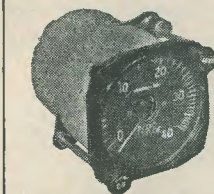

### RADIO ALTIMETER.

5mA panel mounting meter,  
3" dia., 8" circular scale.  
Large magnet. Scale easily  
removable leaving finished  
faceplate for re-calibration.  
Basis for sensitive portable  
multimeter. Brand new,  
boxed, 7/6 post free.

### GYRO UNIT AND IN- VERTER.

Inverter: 12 volt  
D.C. input, 3 phase 190 cycle output. (These inverters  
can be used successfully as 12 volt D.C. Motors for  
Models.) Gyro Unit: operates on 3 phase output from  
Inverter. Peak speed 11,400 r.p.m. Caged. Precision  
made equipment. These units are ideal for experiment-  
ing and demonstration purposes. Size: Inverter  $4'' \times 3''$   
 $\times 3''$ ; Gyro  $4''$  dia. incl. cage. Price 12/6 per pair, plus  
3/- p.p.

**CHARGER RECTIFIER.** 12 volt 4 amp Full Wave.  
Size  $4\frac{1}{2}''$  dia by  $2\frac{1}{2}''$  5/16th Whit Fixing Bolt protruding  
 $\frac{1}{2}''$  either side. Price 12/- each plus 2/- p. & p.

**PROOPS BROS. LTD** Open all day Saturday  
Dept. R, 52 Tottenham Court Rd. W1  
Hours 9-6 p.m. Thursday to 1 p.m. LAngham 0141





**GUARANTEED — Over 3,000 in Stock**  
**VALVES**

EF92, EAC91, 6J6, 6CA, 4/6; 6K7, EC91, 5/6; 6AL5, 6SK7, R10, 3A4, 807, 6/-; 6AM6, EL91, 6X4, 6/6; 6BE6, 6CH6, 6F17, 6F33, 7/6; 12AT7, 12AX7, 12AU7, 6BA6, 6BW6, 8/-; 6BR7, 12E1, 85A2, 2D21, 10/-; EF86, 6L6M, 5B/225M, 5B/251M, 11/6.

**A. A. W. SKILLMAN**  
79A FRANCHISE STREET WYEMOUTH

**BRASS, COPPER, DURAL ALUMINIUM, BRONZE**  
ROD, BAR, SHEET, TUBE, STRIP, WIRE  
3,000 STANDARD STOCK SIZES

No Quantity too Small List on application

**H. ROLLET & CO. LTD**

6 Chesham Place SW1 Telephone SLOane 3463  
Also at Liverpool Birmingham Manchester Leeds

**H.A.C. THE ORIGINAL SUPPLIERS OF SHORT-WAVE KITS**

One-valve Kit, price 25/-. Two-valve Kit, price 50/-. Improved designs with Denco coils. All kits complete with all components, accessories and full instructions. Before ordering, call and inspect a demonstration receiver, or send stamped envelope for catalogue.

**H.A.C. SHORT-WAVE PRODUCTS (DEPT. R)**  
11 OLD BOND STREET LONDON W1

Complete this Amplifier and have Hi-Fi with ample power for any future use. 30 watts, 2 to 15 ohms output. Valve line-up: EF37A, ECC33, two KT66. High impedance 50mV input with Jack, Treble Bass and Volume Controls. Large output Transformer. High grade components. Fully tested for frequency response, less valves and power pack, £7. Postage extra. Instructions for building simple power pack supplied with amplifier. Power requirements 6V 4A, 350V 180mA. Can be supplied with 12V heater for battery operation. Further information from—

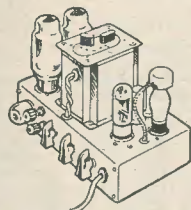

**E.M.A. ELECTRONIC ENGINEERS**  
41 COWBRIDGE HERTFORD HERTS

Telephone HATFIELD 2740

DATA BOOK No. 8 PRICE 3/- postage 3d.

**“Tape and Wire Recordings”**

(Revised Edition)

**DATA PUBLICATIONS LTD**  
57 MAIDA VALE LONDON W.9  
CUN 6141 (2 lines)

**SMALL ADVERTISEMENTS**

continued from page 791

**TRADE—continued**

PANL, the air-drying black crackle paint. 3s. 6d. per 1/8th pint can.—G. A. Miller, BCM/PANL, W.C.1.

MORSE CODE TRAINING. Special course for Beginners. Full details from (Dept. RC) Candler's System Company, 52b Abingdon Road, London, W.8.

FREE: Brochure giving details in Home Study Training in Radio, Television, and all branches of Electronics. Courses for the hobby enthusiast or for those aiming at the A.M.Brit.I.R.E., City and Guilds, R.T.E.B., and other Professional examinations. Train with the college operated by Britain's largest Electronics organisation. Moderate fees. Write to E.M.I. Institutes, Dept. RC28, London, W.4.

MAINS TRANSFORMER, 3/9. 4V-4V heaters. 200-250V prim. 350-0-350 sec. P. and p. 2/3. Duke & Co. 621-3 Romford Road, Manor Park, London, E.12 Telephone GRA 6677-8 2791

MAINS TRANSFORMERS, 2/9. 350-0-350V 12V-4V heaters. 200-250V prim. P. and p. 2/3. Duke & Co. 621-3 Romford Road, Manor Park, London, E.12 Telephone GRA 6677-8 2791

**Radio Control**

FOR MODEL SHIPS BOATS AND AIRCRAFT

by  
**F. C. JUDD**  
G2BCX



To operate a model ship or aircraft is a most interesting hobby. But how much more fascinating it would be if one could emulate the skipper or pilot and remain in control after the model has been set off on its course. This, thanks to radio control, can now be done, and enthusiasm for it is steadily mounting. Radio Control for Model Ships, Boats and Aircraft has become a recognised handbook in this field.

144 pages 135 diagrams and illustrations

Standard Edition, art board cover, 8s. 6d. postage 5d.

Cloth bound, with gold lettering, 11s. 6d. postage 7d.

**DATA PUBLICATIONS LTD**  
57 MAIDA VALE LONDON W9

**SCOTTISH INSURANCE CORPORATION LTD**



**62-63 Cheapside London EC2**

**TELEVISION SETS, RECEIVERS AND TRANSMITTERS**

Television Sets, Receivers and Short Wave Transmitters are expensive to acquire and you no doubt highly prize your installation. Apart from the value of your Set, you might be held responsible should injury be caused by a fault in the Set, or injury or damage by your Aerial collapsing. A "Scottish" special policy for Television Sets, Receivers and Short Wave Transmitters provides the following cover:

- (a) Loss or damage to installation (including in the case of Television Sets the Cathode Ray Tube) by Fire, Explosion, Lightning, Theft or Accidental External Means at any private dwelling-house.
- (b) (i) Legal Liability for bodily injury to Third Parties or damage to their property arising out of the breakage or collapse of the Aerial Fittings or Mast, or through any defect in the Set. Indemnity £10,000 any one accident.
- (ii) Damage to your property or that of your landlord arising out of the breakage or collapse of the Aerial Fittings or Mast, but not exceeding £500.

The cost of Cover (a) is 5/- a year for Sets worth £50 or less, and for Sets valued at more than £50 the cost is in proportion. Cover (b) (i) and (ii) costs only 2/6 a year if taken with Cover (a), or 5/- if taken alone.

Why not BE PRUDENT AND INSURE your installation—it is well worth while AT THE VERY LOW COST INVOLVED. If you will complete and return this form to the Corporation's Office at the above address, a proposal will be submitted for completion.

NAME (Block Letters).....  
If Lady, state Mrs. or Miss  
ADDRESS (Block Letters)..... /JB

**YOU CAN RELY ON US**

We specialise ONLY in radio and electronic components, a comprehensive stock of which are held by us, to supply Government, educational and commercial laboratories. Can we be of some help to you, the experimenter and constructor? ?

**QUALITY AMPLIFIER KITS**

IN STOCK

ALL SPECIFIED PARTS FOR

MULLARD 3 WATT QUALITY AMPLIFIER INCLUDING WYNALL TRANSFORMERS  
MULLARD 510, F.M. UNIT, PRE-AMP  
20 WATT AMPLIFIER

OSRAM 912, PASSIVE UNIT, PRE-AMP, F.M. UNIT

TRANSFORMERS FROM STOCK—

WYNALL, PARTRIDGE, GILSON, W.B., ELLISON

Detailed Price List Available on Request New Catalogue No. 14 on Request

Next to South Ealing Tube Station 65 Bus

**82 SOUTH EALING ROAD**  
LONDON W5 Telephone EAL 5737

**RADIO SERVICING CO**