

# PRACTICAL WIRELESS

SEPTEMBER 1965

2¢

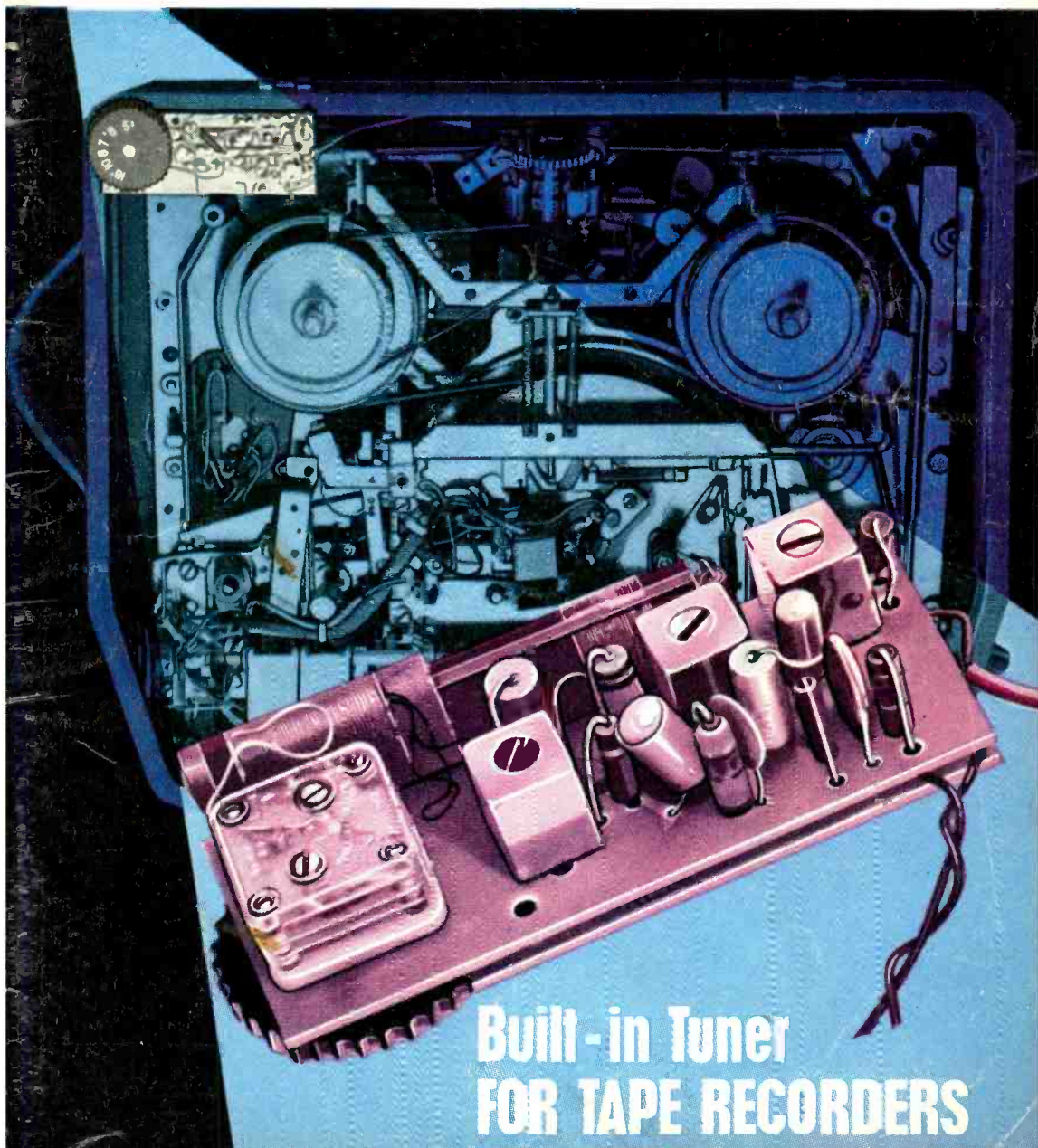

**Built-in Tuner  
FOR TAPE RECORDERS**



**SOLDERING EQUIPMENT**

FOR THE RADIO CONSTRUCTOR

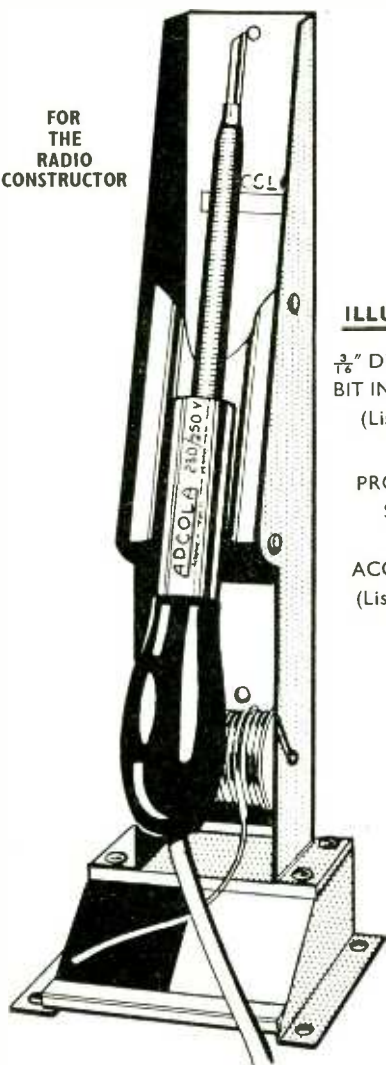

**ILLUSTRATED**

$\frac{3}{16}$ " DETACHABLE BIT INSTRUMENT

(List No. 64)

IN PROTECTIVE SHIELD WITH ACCESSORIES (List No. 700)

FOR CATALOGUES APPLY DIRECT  
**ADCOLA PRODUCTS LTD.,**  
**ADCOLA HOUSE,**  
**GAUDEN ROAD,**  
**LONDON, S.W.4**

Telephones:  
 MACaulay 3101  
 4272  
 Telegrams: "SOLJOINT" LONDON SW4

The **SUPER 6**  
 LONG & MEDIUM WAVE  
 TRANSISTOR RADIO



A quality radio available as a kit or ready built. The sparkling performance and superb finish of the completed receiver give you value equivalent to a £12. 12. 0 commercial model.  
 ★ All new parts. ★ 6 transistors and diode. ★ 350mV output.  
 ★ Superhet circuit, Ferrite rod aerial. ★ Weymouth Radio printed circuit board. ★ Component positions and references printed on back of board. ★ Nicely styled wooden cabinet, 11 x 7½ x 3½in. ★ Vinyl covered in various colours. ★ 6 x 4in. speaker giving good bass and treble response. ★ Full instruction booklet 2/- free with kit. ★ I.F. Frequency 470 kc/s. ★ Lining up service if required. ★ All parts supplied separately. Write for list. S.A.F. please. ★ 9v. battery required. VT9 or P.P.9 (3/9 with kit).

**COMPLETE SET OF PARTS FOR BUILDING THE RADIO £4.17.6**

PLUS 5/- POST

OR FULLY BUILT £6.17.6 Tax & Carr. Paid

V.H.F. Pre-amplifier with high signal-noise ratio and gain of at least 3:1 under average fringe area conditions. Metal container 3½ x 3½ x 1½in. high, with strap for eaves, loft or skirting fixing. 9 volt battery operated, using transistor AF114. Covers all British and some Continental stations. 88 to 108 Mc/s. Order with confidence of improved reception.

29/6 (2/6 p. & p.)

**ELECTRONICS (Camberley) LTD.**  
 15 VICTORIA AVENUE, Camberley, Surrey  
 Post orders only please

**NOMBREX INSTRUMENTATION**  
 TRANSISTORISED SIGNAL GENERATOR

Model 27 £9.16.9



Also available:

- ★ INDUCTANCE BRIDGE 66 ... £18.6.9
- ★ POWER SUPPLY UNIT 61 ... £6.14.6
- ★ C.R. BRIDGE 62 ... £8.11.9
- ★ AUDIO GENERATOR 63 ... £17.1.9

(Postage increases)

All Prices include Battery, Post and Packing.  
 Prompt delivery

S.A.E. for Technical Leaflets

Trade and Export enquiries invited

**NOMBREX LTD.** Phone: 3S15  
 Estuary House, Camperdown Ter., Exmouth, Devon

# Why

## NOT BUILD ONE OF OUR PORTABLE TRANSISTOR RADIOS...

BACKED BY OUR SUPER AFTER SALES SERVICE

### ROAMER SEVEN Mk III 5 WAVEBAND PORTABLE OR CAR RADIO

Amazing performance and specification ★ Now with PHILCO MICRO-ALLOY R.F. TRANSISTORS

● 9 stages—7 transistors and 2 diodes

Covers Medium and Long Waves, Trawler Band and two Short Waves to approx. 15 metres Push-pull output for room filling volume from rich toned heavy "Celestion" speaker. Air spaced ganged tuning condenser. Ferrite rod aerial for M & L waves and telescopic aerial for S Waves Real leather-look case with gilt trim and shoulder and hand straps. Size 9 x 7 x 4 in. approx. The perfect portable and the ideal car radio. (Uses PP7 battery available anywhere.)

Total cost of parts now only **£5.19.6** P. & P. 5/6  
Parts Price List and easy build plans 3/-

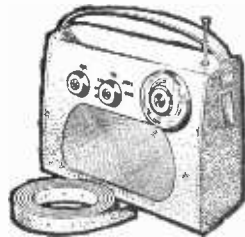

"... amazed at volume and performance... has really come up to my expectations."

S. G. Stockton-on-Tees.

● 8 stages—6 transistors and 2 diodes

### TRANSONA 5 or POCKET 5

● 7 stages—5 transistors and 2 diodes

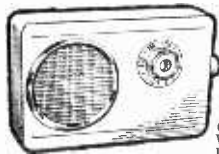

"Transona Five" size 6 1/2 x 4 1/2 x 1 1/2 in. approx.

Covers M. and L. Waves and Trawler Bands, a feature usually found in only the most expensive radios. On test Home, Light, 200, and many Continental stations were received loud and clear. Designed round supersensitive Ferrite Rod Aerial and new type fine tone super dynamic 2 1/2 in. speaker, attractive plastic cases with red grille.

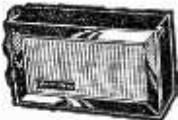

"Pocket Five" size 5 1/2 x 1 1/2 x 3 1/2 in.

### MELODY SIX



Wonderful reception of B.B.C. Home and Light, 200 and size case, only 6 1/2 x 3 1/2 x 1 1/2 in. approx. with gilt speaker grill and supplied with hand and shoulder straps.  
Parts Price List and Total cost of all easy build plans 2/- parts now only **£3.9.6** P. & P. 3/6

Our latest completely portable transistor radio covering medium and long waves. Incorporates pre-tagged circuit board, 3in. heavy duty speaker, top grade transistor, volume control, tuning condenser, wave change slide switch, sensitive 6in. ferrite rod aerial. Push-pull output.

Total cost of all parts for **42/6** P. & P. 3/6  
either type now only (State type required.)  
Parts Price List and easy build plans 2/-.

### TRANSONA SIX

● 8 stages—6 transistors and 2 diodes

This is a top performance receiver covering full Medium and Long Waves and Trawler Band. High-grade approx. 3in. speaker makes listening a pleasure. Ferrite rod aerial. Many stations listed in one evening including Luxembourg loud and clear. Attractive case in grey with red grille. Size 8 1/2 x 4 1/2 x 1 1/2 in. (Uses PP4 battery available anywhere.) Carrying strap 1/- extra.



Total cost of all **59/6** P. & P. 3/6  
parts now only  
Parts Price List and easy build plans 1/6

### ROAMER SIX New !!

NOW WITH PHILCO MICRO-ALLOY R.F. TRANSISTORS

● 6 WAVEBAND !!

● 8 stages—6 transistors and 2 diodes



Listen to stations half a world away with this 8 waveband portable. Tunable on Medium and Long waves. Trawler band and two Short Waves. Sensitive ferrite rod aerial and telescopic aerial for short waves. Top grade transistors, 3-inch speaker, handsome case with gilt fittings. Size 7 1/2 x 5 1/2 x 1 1/2 in. Carrying strap 1/6 extra.

★ EXTRA BAND FOR EASIER TUNING OF LUX., ETC.  
Parts Price List and Total cost of all easy build plans 2/- parts now only **£3.19.6** P. & P. 3/6



### SUPER SEVEN

● 9 stages—7 transistors and 2 diodes

Covers Medium and Long Waves and Trawler Band. The ideal radio for home, car, or can be fitted with carrying strap for outdoor use. Completely portable—has built-in Ferrite rod aerial for wonderful reception. R.F. Stages, push-pull output. Size 7 1/2 x 5 1/2 x 1 1/2 in. (Uses 9V battery, available anywhere.)

Total cost of all **£3.19.6** P. & P. 3/6  
parts now only (State type required.)  
Parts Price List and easy build plans 2/-.

All components used in our receivers may be purchased separately if desired. Parts price lists and easy build plans available separately at fixed prices stated. Overseas post 10/-

### SPECIAL COMPONENT BARGAINS

- TRANSISTORS, PHILCO MADT (Micro Alloy Diffused), Type 2N503, Maximum frequency of oscillation over 500 Mc/s ..... 15/-
- HEADPHONES, High Fidelity miniature magnetic earpieces (2) on slim band with lead and plug, Easily converted to stereo, American manufacture, 100 ohms impedance. Transformers supplied free for higher impedances..... 13/6. P. & P. 1/6.
- TUNING CONDENSERS, Air spaced fine quality German manufacture with slow motion drive, 0.0005 with oscillator section ..... 6/-, Post 1/-.
- CHILDREN PERMEABILITY TUNERS, Full M.W. coverage. Fitted coupling coil, oscillator coil, ferrite slugs and slow motion tuning with cursor, etc. GIVE AWAY PRICE..... 10/- P. & P. 1/-.

## RADIO EXCHANGE CO.

61, HIGH STREET, BEDFORD. Phone: 2367

Callers side entrance  
Barratts Shoe Shop  
Open 9—5 p.m.  
Sats. 10—12.30 p.m.

# LASKY'S RADIO

# Offer the Finest Value to HOME CONSTRUCTORS

We consider our construction parcels to be the finest value on the home constructor market. If on receipt you feel not competent to build the set, you may return it as received within 7 days when the sum paid will be refunded less postage.

## THE "SKYROVER" RANGE

### GENERAL SPECIFICATION

7 transistor plus 2 diode superhet, 6 waveband portable receiver. Operating from four 1.5 V. torch batteries. The SKYROVER and SKYROVER DE LUXE cover the full Medium Waveband and Short Waveband 31-94 M and also 4 separate switched band-spread ranges, 13M 16M, 19M and 25M, with Band Spread Tuning for accurate Station Selection. The coil pack and tuning heart is completely factory assembled, wired and tested. The remaining assembly can be completed in under three hours from our easy to follow stage by stage instructions.



### NEW—The SKYROVER Mk III

Now supplied with redesigned cabinet, edgewise controls, black and chrome plastic cabinet. Size 10 x 6½ x 3½ in. with carrying handle.

Can now be built for **£8.19.6** Post 5/-.

H.P. Terms: 27/- dep. and 11 months at 15/8. Total H.P. Price £210/03.

### The SKYROVER DE LUXE

Tone Control Circuit is incorporated with separate Control. In a wood cabinet, size 11½ x 6½ x 3½ in., covered with a washable material with plastic trim and carrying handle. Car aerial socket fitted.

Can now be built for **£10.19.6** H.P. Terms: 33/- dep. and 11 mths at 19/2. Total H.P.P. £12.3.10

A simple additional circuit provides coverage of the 1100/1950M. band (including 1500 M. Light programme). All components and detailed construction data. Post **Only 10/- extra** Free This conversion is suitable for both models that have already been constructed.

Data for Receiver 2/6 extra. Refunded if you purchase the parcel. Four U2 batteries 3/4 extra. All components Available Separately.

## SPECIAL OFFER

### GOLLARO STUDIO TAPE DECKS

3 speed model—11, 3½ and 7½ i.p.s., available with either 1 track or 2 track heads. Fitted with 3 motors; pause control and tape position indicator. Fast forward and rewind. Deck size: 12½ x 10½ x 4". For use on 110-125V. 50 or 60 c.p.s. mains but by the simple addition of a step-down auto transformer these decks can be operated direct from normal 200-250V. A.C. mains. State whether 50 or 60 c.p.s. model required when ordering (note: U.K. mains is normally 50 c.p.s.). Brand new and unused.

**LASKY'S PRICE** 1 track Model **£6.19.6**

**LASKY'S PRICE** 2 track Model **£10.10.0**

Carriage and Packing 7/6 extra.

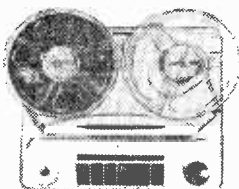

Suitable Mains auto transformer 15/8 if ordered with the deck. (List price 19/6).

## TEST METER ADAPTOR

Type P.E. E20. Transistorised device which enables any 50 microamp D.C. Multimeter to be used in place of a valve volt meter. On the 1v. range an impedance of 1 megohm is offered which increases on the 1000v. range to 100 megohms, 7 ranges immediate connection to Avo 8 but suitable for use with any other 50 microamp meter. Size 6 x 6 x 5 in. New and boxed. List Price 7 Gns.

**LASKY'S PRICE** 39/6, post 2/6. Set of batteries 7/5 extra.

## U.H.F. TUNERS

Only a few available. Complete with PC86 and PC88 valves. We regret no circuit or data is available. Knobs included but not shown.

**LASKY'S PRICE** 79/6. Post 2/6.

## COMMUNICATION RECEIVER KIT—MODEL KT320

Supplied in sub-assemblies for easy building. Covers range from 640 Kc/s to 30 Mc/s. Ham Band is provided with a scale for direct reading and can also be band spread. Facilities: A.N.L., A.V.C. and M.V.C. Q Multiplier also serves as B.F.O. H.F. stage and two I.F. stages ensure high sensitivity and selectivity. Valve line-up 2x6BE6, 2x6BE6, 2x6AV6, 1x6X5 and 5Y3. 2 aerial sockets. Standby position for use with a transmitter

All parts new and fully guaranteed. Complete with full construction data and operating manual. **LASKY'S PRICE** 25 Gns. Carriage and Packing FREE. Construction and ins. book will be loaned against a deposit of 5/- (Returnable)

## INTERNATIONAL TAPE

3in. Message tape, 150ft.	3	6
3in. Message tape, 225ft.	4	11
3in. Message tape, 300ft.	5	17
3½in. Triple play, 600ft., Mylar base	15	0
4in. Triple play, 900ft., Mylar base	17	6
5in. Double play, 1,200ft., Mylar base	15	0
6in. Long play, 900ft., Acetate base	10	0
6in. Standard play, 600ft., PVC base	8	6
6in. Triple play, 1,800ft., Mylar base	35	0
6½in. Double play, 1,800ft., Mylar base	22	6

### Famous American Brand—Fully Guaranteed

5½in. Long play, 1,200ft., Acetate base	12	6
5½in. Standard play, 850ft., PVC base	11	6
6in. Triple play, 2,400ft., Mylar base	45	0
7in. Standard play, 1,200ft., Mylar base	12	6
7in. Standard play, 1,200ft., Acetate base	10	0
7in. Long play, 1,800ft., Mylar base	19	6
7in. Double play, 2,400ft., Mylar base	25	0
7in. Long play, 1,800ft., Acetate base	15	0
7in. Triple play, 3,600ft., Mylar base	58	6

P. & P. 1/- extra per reel, 4 reels and over Post Free

## The "REALISTIC" Seven

★ 7-transistor Superhet. ★ 350 milliwatt output into 4in. high flux speaker. ★ All components mounted on a single printed circuit board ★ Full medium and longwave cover. ★ Plastic cabinet with carrying handle, size 7 x 10 x 3½ in. Blue/Grey or all Grey. ★ Socket for car aerial. ★ I.F. frequency 470 Kc/s. ★ Ferrite rod internal aerial. Operates from PP9 or similar battery. ★ Full data supplied. All coils and I.F.'s etc. fully wound ready for immediate assembly. An Outstanding Receiver.



Can be built for **£5.19.6**

Post 4/6

PP9 Batt. 3/9. Data and Instructions separately 2/6. Refunded if you purchase the parcel. All parts sold separately.

## REALISTIC Seven DE LUXE

With the same specification as standard Model—PLUS a superior wood cabinet to contemporary styling with full vision circular dial. **ONLY £1 EXTRA**

## SINCLAIR MINIATURES.

**THE MICRO-6**  
Self-contained pocket radio. Size only 1¼ x 1½ x ¼ in. Amazing performance. Complete with earphone and detailed construction data. Can be built for only **59/6** Mercury cell 1/11 extra. All parts sold separately.

**THE SLIMLINE**  
2-transistor pocket radio. Size only 2½ x 1½ x ¼ in. Micro alloy transistors on printed circuit. **AN BE BUILT FOR 49/6**

**THE NEW X-30 AMPLIFIER**  
20 watts P.W.M. amplifier and pre-amplifier built on single printed circuit size 8½ x 3½ in.—weight only 4½ ozs. built! Imp. sens. 1mV for 20 watts out. Output Imp. 15 and 15 ohms. **£7.19.6** Post Free  
**AVAILABLE READY BUILT AND TESTED 29.19.6.**  
3 pots. for vol., bass and treble, 7/6 the 3 extra. mains power pack. If required £4.19.6.

**THE X-10 AMPLIFIER**  
10 watt power amplifier fitted with integrated pre-amplifier. Requires only 1mV. for an output of 10 watts. Only 6 x 3 x ½ in.  
**KIT PRICE £5.19.6** Post Free  
**AVAILABLE READY BUILT, TESTED AND GUARANTEED, £6.19.6.** Post Free  
3 pots for Volume, Bass and Treble, 7/6 the 3 extra. Mains power pack. If required £4.19.6.

## RECORD PLAYERS

45 r.p.m. 6 volt Batt. operated. Complete with pick-up fitted crystal cartridge. Size only 7½ in. x 6 in. Fitted auto stop and start. New and perfect. **45 r.p.m. Model 49/6** Post 2/6

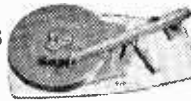

2-speed model for 33 and 45 r.p.m. (as illustrated) **Post 2/6**

207 EDGWARE ROAD, LONDON, W.2

Tel: PAD 3271/2

33 TOTTENHAM CT. RD., LONDON, W.1

Tel: MUS 2605

Both open all day Saturday. Early closing Thursday.

42 TOTTENHAM CT. RD., LONDON, W.1

Tel: LAN 2573

152/3 FLEET STREET, LONDON, E.C.4

Tel: FLE 2833

Both open all day Thursday. Early closing Saturday.

Please address all Mail Orders to Dept. X.W. 207 Edgware Road, London, W.2.

# LASKY'S FOR D.V.Y. CONSTRUCTION BARGAINS

# SURBITON PARK RADIO

## MARTIN AUDIOKITS & RECORDAKITS

- F.M. TUNER UNITS** Nos. 15, 16 and 17..... Cash £12-17.6  
 Or Dep. 51/6 and 12 m. pymts. of 18/10..... (H.P. Price £12-17.6)  
**TRANSISTORISED AMPLIFIER** with 5 position input selector, pre-amp and controls, 10 watt amplifier and Power Pack.  
 For 3 Ohm Speaker, Cash £14.5.0  
 Or Dep. 57/- and 12 m. pymts. 20/10..... (H.P. Price £15/7.0)  
 For 15 Ohm Speaker, Cash £15.8.0  
 Or Dep. 62/- and 12 m. pymts. 22/6..... (H.P. Price £16-12.0)  
**All above include Front Panels, Knobs and Instructions.**  
**TWO TRACK RECORDAKIT AMP.** (Valve) **FOR STUDIO DECK**, 6 valves, controls, self powered..... Cash £11-11.0  
 Or Dep. 47/- and 8 m. pymts. 25/8..... (H.P. Price £12-11.0)  
**COLLARO STUDIO DECK** 3 speed latest Two Track Cash £10-19.6  
 Or Dep. 44/- and 8 m. pymts. 24/6..... (H.P. Price £12.0.0)  
**COMPLETE KIT** with case, spkr., tape and mic..... Cash £29-19.6  
 Or Dep. 120/- and 12 m. pymts. 44/-..... (H.P. Price £32.8.0)  
**FOUR TRACK AMP.** as above..... Cash £12-12.0  
**FOUR TRACK AMP.** as above..... (H.P. Price £13-12.0)  
 Or Dep. 52/- and 8 m. pymts. 27/6..... (H.P. Price £13-12.0)  
**FOUR TRACK COLLARO DECK** Marriott "X" Series heads  
 Cash £13-19.6  
 Or Dep. 56/- and 12 m. pymts. 20/6..... (H.P. Price £15.2.0)  
**COMPLETE KIT** with case, spkr., tape and mic..... Four Track Cash £33-19.6  
 Or Dep. 136/- and 12 m. pymts. 49..... (H.P. Price £36.14.0)  
**TAPE PRE-AMP** for Studio Deck, self powered..... Two Track Cash £9-8.0  
 Or Dep. 34/- and 6 m. pymts. 25/8..... (H.P. Price £9/10.0)  
**TAPE PRE-AMP** as above..... Four Track Cash £9-9.0  
 Or Dep. 39/- and 6 m. pymts. of 28/4..... (H.P. Price £10-9.0)  
**We are leading stockists for all Martin Constructional Kits**

## AMPLIFIERS-TUNERS Selection

- ARMSTRONG 222** 10-10 watts Stereo Amplifier..... Cash £27-10.0  
 Or Dep. 110/- and 12 m. pymts. 40/4..... (H.P. Price £29-14.0)  
**ARMSTRONG 224 F.M. TUNER** Powered..... Cash £22-10.0  
 Or Dep. 90/- and 12 m. pymts. 33/-..... (H.P. Price £24-6.0)  
**ARMSTRONG 223 AM/FM TUNER** Powered..... Cash £28-15.0  
 Or Dep. 115/- and 12 m. pymts. 42/2..... (H.P. Price £31-1.0)  
**ARMSTRONG 127 MONO 5W** with AM/FM..... Cash £26-10.0  
 Or Dep. 106/- and 12 m. pymts. 38/10..... (H.P. Price £28-12.0)

# SURBITON PARK RADIO LTD.

- ARMSTRONG 127 STEREO** as above Stereo amp..... Cash £37-10.0  
 Or Dep. 150/- and 12 m. pymts. 55/-..... (H.P. Price £40-10.0)  
**ARMSTRONG 227 MONO** 10W amp. with AM/FM..... Cash £36-15.0  
 Or Dep. 147/- and 12 m. pymts. 53/10..... (H.P. Price £39-13.0)  
**ARMSTRONG 227 STEREO** as above with Stereo Amp..... Cash £52-15.0  
 Or Dep. 211/- and 12 m. pymts. 77/4..... (H.P. Price £56-19.0)  
**ARMSTRONG 226 STEREO** as above, but Mag. P.U. Filter..... Cash £61-0.0  
 Or Dep. 260/- and 12 m. pymts. of 88/-..... (H.P. Price £66-16.0)  
**Teak Cases** for all Armstrong Units..... £3-10.0  
**ROGERS CADET MK. 3** 10-10 watt Stereo Amp. Mag. P.U..... Cash £29-10.0  
 Or Dep. 118/- and 12 m. pymts. of 43/3..... (H.P. Price £31-17.0)  
**CASE MODEL ROGERS CADET MK. 3**..... £3-0.0 extra  
**LEAK STEREO 30 TRANSISTOR**..... Cash £49-10.0  
 Or Dep. 198/- and 12 m. pymts. of 72/7..... (H.P. Price £53-9.1)

## LOUDSPEAKERS Selection

- FANE 122/10** heavy Duty 12in. 20 watt..... Cash £5-5.0  
**WHARFEDALE SUPER 8/RS/DD**..... Cash £6-14.3  
**WHARFEDALE SUPER 10/RS/DD**..... Cash £10-18.0  
 Or Dep. 44/- and 8 m. pymts. of 24/3..... (H.P. Price £11-18.0)  
**GOODMANS MAXIM**..... Cash £17-10.6  
 Or Dep. 70/6 and 12 m. pymts. 25/8..... (H.P. Price £18-18.6)

## MOTORS-PICK-UPS Selection

- GARRARD SRP10 Mono**..... Cash £5-10.0  
**GARRARD Model 1900 Mono**..... Cash £7-10.0  
**GARRARD Model 2000 Mono Large Table**..... Cash £9-10.0  
 Or Dep. 34/- and 6 m. pymts. 26/-..... (H.P. Price £9-10.0)  
**GARRARD Model 3000 Stereo Lightweight arm**..... Cash £11-11.0  
 Or Dep. 47/- and 8 m. pymts. 25/8..... (H.P. Price £12-11.0)  
**GARRARD S.P. 25** Less cart. Single player..... Cash £12-10.0  
 Or Dep. 50/- and 8 m. pymts. of 27/6..... (H.P. Price £13-10.0)  
**GARRARD at 60** Less cart. Heavy table..... Cash £13-0.0  
 Or Dep. 52/- and 12 m. pymts. 19/-..... (H.P. Price £14-0.0)  
**GARRARD A 70** De Luxe changer, Less cart..... Cash £22-10.0  
 Or Dep. 90/- and 12 m. pymts. 33/-..... (H.P. Price £24-6.0)  
**GARRARD L.A. 80** Push button oper. less cart..... Cash £27-10.0  
 Or Dep. 110/- and 12 m. pymts. of 40/4..... (H.P. Price £28-14.0)  
**GARRARD 401** Transcription Table, No arm..... Cash £32-10.0  
 Or Dep. 130/- and 12 m. pymts. 47/8..... (H.P. Price £35-2.0)  
**GOLDRING G66 Mono Single Player**..... Cash £11-11.0  
 Or Dep. 47/- and 8 m. pymts. 25/8..... (H.P. Price £12-11.0)  
**GOLDRING GL58** less cart. Heavy table, single play Cash £17-1.0  
 Or Dep. 69/- and 12 m. pymts. 24/11..... (H.P. Price £18-8.0)  
**GOLDRING GL70** trans. Unit with arm, less cart., Cash £29-19.6  
 Or Dep. 120/6 and 12 m. pymts. 43/9..... (H.P. Price £32-5.8)  
**Leakets** available on all items advertised upon receipt of 6d. stamp.

48-50, Surbiton Road, Kingston-on-Thames, Surrey  
 Phone KIN. 5549 :: Hours 9 a.m. to 6 p.m. daily (1 p.m. Weds.)

# BIRTH of a Catalogue...

Most people today acknowledge that the Electronics industry is developing more rapidly than any other field of human progress. This fact demands the continual preparation of new editions of our components catalogue. Immediately we have produced one edition we begin to prepare the next. At least six months before a new edition is due we have a staff conference to decide on deletions, additions, new layout, and in particular to consider ways of making the catalogue even easier to use. Then the real work begins! We contact all our suppliers to obtain not only the latest information and prices, but if possible details of new products about to be introduced. Then the necessary amendments to the catalogue are made, printing blocks are obtained, the cover is designed and the paper ordered. Eventually the proofs begin to arrive and are carefully checked—line by line, word by word, price by price. Finally the last corrected proof is returned to the printers and we give them the Full Steam Ahead! And so another edition of the **Home Radio Components Catalogue** is born. It may be hard labour, but judging by the many letters of appreciation we receive, it is well worth the effort. When you buy your catalogue, don't look upon it as a mere collection of cold facts and figures. Please spare a thought for the months of toil and tears that have gone into its production!

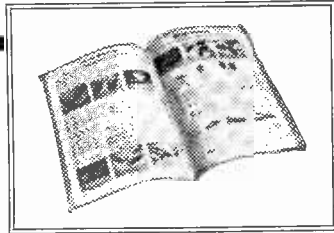

Now for the vital statistics of our latest lusty infant—it has 210 pages, plus a separate supplement of prices, valves and transistors, over 5,800 items accurately indexed and priced—over 900 of them illustrated. With each catalogue we give a free brochure, value 6d, of items available from the new Semi-Conductor Centres, of which Home Radio is one. In the brochure you will find some exciting new components from America, such as Solar Drive Motors and Silicon Light Cells which operate the motors direct off the sun's rays!

The Home Radio Components Catalogue costs 7/6, plus 1/- postage and packing, and every copy contains 5 coupons, each worth 1/- when used as directed. Note too that because of the separate price supplement we can keep your catalogue up to date, from the point of view of prices, for as long as you wish to continue using it. Send off the attached coupon with your cheque or P.O. for 8/6. Why delay? Post today!

Please write your name and address in block capitals

NAME .....

ADDRESS .....

.....

HOME RADIO LTD, Dept. PW, 187 LONDON ROAD, MITCHAM

# BENTLEY ACOUSTIC CORPORATION LTD.

Suppliers to H.M. Government. 38 CHALCOT ROAD, LONDON, N.W.1 Telephone: PRIMROSE 1990

**NEAREST UNDERGROUND: CHALK FARM.** ALL GOODS LISTED BELOW ACTUALLY IN STOCK  
ALL GOODS ARE NEW, BEST QUALITY BRANDS ONLY, AND SUBJECT TO MAKERS' FULL GUARANTEE, PLEASE  
NOTE THAT WE DO NOT SELL ITEMS FROM USED EQUIPMENT NOR MANUFACTURERS' SECONDS & REJECTS,  
WHICH ARE OFTEN DESCRIBED AS "NEW AND TESTED" BUT HAVE A SHORT AND UNRELIABLE LIFE

O.A2	4/6	6BW7	5/1	7/5	8/-	25Z5	7/3	AC/PEN	EAF42	7/8	ELW4	4/6	LZ319	6/6	R32	7/6	U281	8/9	G38	5/6	
OB2	6/1	6BX4	4/1	7/6	6/9	23Z6GT	8/-	(5) 17/6	EB34	1/-	EL85	7/8	LZ329	6/6	RG12/40A		U282	12/3	G36	3/6	
024GT	4/3	6C3	2/3	7/7	5/-	27SU	23/3		EB41	4/9	EL86	7/8	MHJ24	7/6		64/-	U301	11/1	GD14	10/6	
IA4	12/6	6C6	3/-	7D3	15/6	28D7	6/9	(7) 17/-	EB91	2/3	EL91	9/6	MHL0612/6	KK34		7/3	U329	9/1	GET103	7/3	
IA5	5/-	6C8	3/-	7D6	14/6	30C1	6/6	AC/CPEN	EB3	20/6	EL96	5/6	M84B	20/6	SP4B	19/6	U403	9/6	GET104	10/-	
IA7GT	6/7	6C9	10/9	7H7	5/9	30C17	11/9	12/-	ERCA1	7/-	EL820	10/4	M8P4	12/-	SP13C	12/6	U404	15/6	GET107	9/6	
IC1	4/-	6C10	8/-	7R7	12/6	30C18	8/9	AC/TH110	EB081	5/9	EL822	9/3	M2112/4	4/6	SP41	2/-	U401	15/6	GET113	6/9	
IC2	5/-	6C12	5/9	7D7	5/-	30F5	7/3	AC/CP7	EB090	3/9	ELL80	13/6	MX40	3/9	SP42	12/6	U402	15/6	GET114	6/9	
IC3	6/6	6C16DG	18/-	7Y4	5/-	30FL1	9/3	AC/VP1 12/-	EB031	5/6	EM4	17/6	N37	10/6	SP61	2/6	VMP40	11/6	GET116	17/6	
IC5	5/-	6C16H	6/6	8V2	2/6	30L1	5/6	AC/VP1 12/-	EBF96	9/9	EM34	11/6	N78	36/-	SP25	27/2	VMS44	12/6	GET120	9/6	
IC6	10/6	6C24W	24/-	9BW6	6/6	30L13	5/6	ATP4	2/3	EBF83	7/3	EM35	12/6	N108	36/2	T41		VP2B	9/6	GET13	9/6
ID6	6/6	6D1	1/6	9D2	3/-	30L17	12/9	AZ1	8/6	EBF89	6/-	EM71	15/6	N339	25/6	TD02	12/6	VP2B	9/6	GET13	9/6
ID6	6/6	6D1	1/6	9D2	3/-	30L17	12/9	AZ1	8/6	EBF89	6/-	EM71	15/6	N339	25/6	TD02	12/6	VP2B	9/6	GET13	9/6
ID6	6/6	6D1	1/6	9D2	3/-	30L17	12/9	AZ1	8/6	EBF89	6/-	EM71	15/6	N339	25/6	TD02	12/6	VP2B	9/6	GET13	9/6
ID6	6/6	6D1	1/6	9D2	3/-	30L17	12/9	AZ1	8/6	EBF89	6/-	EM71	15/6	N339	25/6	TD02	12/6	VP2B	9/6	GET13	9/6
ID6	6/6	6D1	1/6	9D2	3/-	30L17	12/9	AZ1	8/6	EBF89	6/-	EM71	15/6	N339	25/6	TD02	12/6	VP2B	9/6	GET13	9/6
ID6	6/6	6D1	1/6	9D2	3/-	30L17	12/9	AZ1	8/6	EBF89	6/-	EM71	15/6	N339	25/6	TD02	12/6	VP2B	9/6	GET13	9/6
ID6	6/6	6D1	1/6	9D2	3/-	30L17	12/9	AZ1	8/6	EBF89	6/-	EM71	15/6	N339	25/6	TD02	12/6	VP2B	9/6	GET13	9/6
ID6	6/6	6D1	1/6	9D2	3/-	30L17	12/9	AZ1	8/6	EBF89	6/-	EM71	15/6	N339	25/6	TD02	12/6	VP2B	9/6	GET13	9/6
ID6	6/6	6D1	1/6	9D2	3/-	30L17	12/9	AZ1	8/6	EBF89	6/-	EM71	15/6	N339	25/6	TD02	12/6	VP2B	9/6	GET13	9/6
ID6	6/6	6D1	1/6	9D2	3/-	30L17	12/9	AZ1	8/6	EBF89	6/-	EM71	15/6	N339	25/6	TD02	12/6	VP2B	9/6	GET13	9/6
ID6	6/6	6D1	1/6	9D2	3/-	30L17	12/9	AZ1	8/6	EBF89	6/-	EM71	15/6	N339	25/6	TD02	12/6	VP2B	9/6	GET13	9/6
ID6	6/6	6D1	1/6	9D2	3/-	30L17	12/9	AZ1	8/6	EBF89	6/-	EM71	15/6	N339	25/6	TD02	12/6	VP2B	9/6	GET13	9/6
ID6	6/6	6D1	1/6	9D2	3/-	30L17	12/9	AZ1	8/6	EBF89	6/-	EM71	15/6	N339	25/6	TD02	12/6	VP2B	9/6	GET13	9/6
ID6	6/6	6D1	1/6	9D2	3/-	30L17	12/9	AZ1	8/6	EBF89	6/-	EM71	15/6	N339	25/6	TD02	12/6	VP2B	9/6	GET13	9/6
ID6	6/6	6D1	1/6	9D2	3/-	30L17	12/9	AZ1	8/6	EBF89	6/-	EM71	15/6	N339	25/6	TD02	12/6	VP2B	9/6	GET13	9/6
ID6	6/6	6D1	1/6	9D2	3/-	30L17	12/9	AZ1	8/6	EBF89	6/-	EM71	15/6	N339	25/6	TD02	12/6	VP2B	9/6	GET13	9/6
ID6	6/6	6D1	1/6	9D2	3/-	30L17	12/9	AZ1	8/6	EBF89	6/-	EM71	15/6	N339	25/6	TD02	12/6	VP2B	9/6	GET13	9/6
ID6	6/6	6D1	1/6	9D2	3/-	30L17	12/9	AZ1	8/6	EBF89	6/-	EM71	15/6	N339	25/6	TD02	12/6	VP2B	9/6	GET13	9/6
ID6	6/6	6D1	1/6	9D2	3/-	30L17	12/9	AZ1	8/6	EBF89	6/-	EM71	15/6	N339	25/6	TD02	12/6	VP2B	9/6	GET13	9/6
ID6	6/6	6D1	1/6	9D2	3/-	30L17	12/9	AZ1	8/6	EBF89	6/-	EM71	15/6	N339	25/6	TD02	12/6	VP2B	9/6	GET13	9/6
ID6	6/6	6D1	1/6	9D2	3/-	30L17	12/9	AZ1	8/6	EBF89	6/-	EM71	15/6	N339	25/6	TD02	12/6	VP2B	9/6	GET13	9/6
ID6	6/6	6D1	1/6	9D2	3/-	30L17	12/9	AZ1	8/6	EBF89	6/-	EM71	15/6	N339	25/6	TD02	12/6	VP2B	9/6	GET13	9/6
ID6	6/6	6D1	1/6	9D2	3/-	30L17	12/9	AZ1	8/6	EBF89	6/-	EM71	15/6	N339	25/6	TD02	12/6	VP2B	9/6	GET13	9/6
ID6	6/6	6D1	1/6	9D2	3/-	30L17	12/9	AZ1	8/6	EBF89	6/-	EM71	15/6	N339	25/6	TD02	12/6	VP2B	9/6	GET13	9/6
ID6	6/6	6D1	1/6	9D2	3/-	30L17	12/9	AZ1	8/6	EBF89	6/-	EM71	15/6	N339	25/6	TD02	12/6	VP2B	9/6	GET13	9/6
ID6	6/6	6D1	1/6	9D2	3/-	30L17	12/9	AZ1	8/6	EBF89	6/-	EM71	15/6	N339	25/6	TD02	12/6	VP2B	9/6	GET13	9/6
ID6	6/6	6D1	1/6	9D2	3/-	30L17	12/9	AZ1	8/6	EBF89	6/-	EM71	15/6	N339	25/6	TD02	12/6	VP2B	9/6	GET13	9/6
ID6	6/6	6D1	1/6	9D2	3/-	30L17	12/9	AZ1	8/6	EBF89	6/-	EM71	15/6	N339	25/6	TD02	12/6	VP2B	9/6	GET13	9/6
ID6	6/6	6D1	1/6	9D2	3/-	30L17	12/9	AZ1	8/6	EBF89	6/-	EM71	15/6	N339	25/6	TD02	12/6	VP2B	9/6	GET13	9/6
ID6	6/6	6D1	1/6	9D2	3/-	30L17	12/9	AZ1	8/6	EBF89	6/-	EM71	15/6	N339	25/6	TD02	12/6	VP2B	9/6	GET13	9/6
ID6	6/6	6D1	1/6	9D2	3/-	30L17	12/9	AZ1	8/6	EBF89	6/-	EM71	15/6	N339	25/6	TD02	12/6	VP2B	9/6	GET13	9/6
ID6	6/6	6D1	1/6	9D2	3/-	30L17	12/9	AZ1	8/6	EBF89	6/-	EM71	15/6	N339	25/6	TD02	12/6	VP2B	9/6	GET13	9/6
ID6	6/6	6D1	1/6	9D2	3/-	30L17	12/9	AZ1	8/6	EBF89	6/-	EM71	15/6	N339	25/6	TD02	12/6	VP2B	9/6	GET13	9/6
ID6	6/6	6D1	1/6	9D2	3/-	30L17	12/9	AZ1	8/6	EBF89	6/-	EM71	15/6	N339	25/6	TD02	12/6	VP2B	9/6	GET13	9/6
ID6	6/6	6D1	1/6	9D2	3/-	30L17	12/9	AZ1	8/6	EBF89	6/-	EM71	15/6	N339	25/6	TD02	12/6	VP2B	9/6	GET13	9/6
ID6	6/6	6D1	1/6	9D2	3/-	30L17	12/9	AZ1	8/6	EBF89	6/-	EM71	15/6	N339	25/6	TD02	12/6	VP2B	9/6	GET13	9/6
ID6	6/6	6D1	1/6	9D2	3/-	30L17	12/9	AZ1	8/6	EBF89	6/-	EM71	15/6	N339	25/6	TD02	12/6	VP2B	9/6	GET13	9/6
ID6	6/6	6D1	1/6	9D2	3/-	30L17	12/9	AZ1	8/6	EBF89	6/-	EM71	15/6	N339	25/6	TD02	12/6	VP2B	9/6	GET13	9/6
ID6	6/6	6D1	1/6	9D2	3/-	30L17	12/9	AZ1	8/6	EBF89	6/-	EM71	15/6	N339	25/6	TD02	12/6	VP2B	9/6	GET13	9/6
ID6	6/6	6D1	1/6	9D2	3/-	30L17	12/9	AZ1	8/6	EBF89	6/-	EM71	15/6	N339	25/6	TD02	12/6	VP2B	9/6	GET13	9/6
ID6	6/6	6D1	1/6	9D2	3/-	30L17	12/9	AZ1	8/6	EBF89	6/-	EM71	15/6	N339	25/6	TD02	12/6	VP2B	9/6	GET13	9/6
ID6	6/6	6D1	1/6	9D2	3/-	30L17	12/9	AZ1	8/6	EBF89	6/-	EM71	15/6	N339	25/6	TD02	12/6	VP2B	9/6	GET13	9/6
ID6	6/6	6D1	1/6	9D2	3/-	30L17	12/9	AZ1	8/6	EBF89	6/-	EM71	15/6	N339	25/6	TD02	12/6	VP2B	9/6	GET13	9/6
ID6	6/6	6D1	1/6	9D2	3/-	30L17	12/9	AZ1	8/6	EBF89	6/-	EM71	15/6	N339	25/6	TD02	12/6	VP2B	9/6	GET13	9/6
ID6	6/6	6D1	1/6	9D2	3/-	30L17	12/9	AZ1	8/6	EBF89	6/-	EM71	15/6	N339	25/6	TD02	12/6	VP2B	9/6	GET13	9/6
ID6	6/6	6D1	1/6	9D2	3/-	30L17	12/9	AZ1	8/6	EBF89	6/-	EM71	15/6	N339	25/6	TD02	12/6	VP2B	9/6	GET13	9/6
ID6	6/6	6D1	1/6	9D2	3/-	30L17	12/9	AZ1	8/6	EBF89	6/-	EM71	15/6	N339	25/6	TD02	12/6	VP2B	9/6	GET13	9/6
ID6	6/6	6D1	1/6	9D2	3/-	30L17	12/9	AZ1	8/6	EBF89	6/-	EM71	15/6	N339	25/6	TD02	12/6	VP2B	9/6	GET13	9/6
ID6	6/6	6D1	1/6	9D2	3/-	30L17	12/9	AZ1	8/6	EBF89	6/-	EM71	15/6	N339	25/6	TD02	12/6	VP2B	9/6	GET13	9/6
ID6	6/6	6D1	1/6	9D2	3/-	30L17	12/9	AZ1	8/6	EBF89	6/-	EM71	15/6	N339	25/6	TD02	12/6	VP2B	9/6	GET13	9/6
ID6	6/6	6D1	1/6	9D2	3/-	30L17	12/9	AZ1	8/6	EBF89	6/-	EM71	15/6	N339	25/6	TD02	12/6	VP2B	9/6	GET13	9/6
ID6	6/6	6D1	1/6	9D2	3/-	30L17	12/9	AZ1	8/6	EBF89	6/-	EM71	15/6	N339	25/6	TD02	12/6	VP2B	9/6	GET13	9/6
ID6	6/6	6D1	1/6	9D2	3/-	30L17	12/9	AZ1	8/6	EBF89	6/-	EM71	15/6	N339	25/6	TD02	12/6	VP2B	9/6	GET13	9/6
ID6	6/6	6D1	1/6	9D2	3/-	30L17	12/9	AZ1	8/6	EBF89	6/-	EM71	15/6	N339							



**MAIL ORDERS TO:**

54 WELLINGTON STREET, LEEDS 1  
 Terms: C.W.O. or C.O.D. No C.O.D. under £1. Postage 2,9 extra under £2. 4/6 extra under £5. Trade Supplied. S.A.E. with all enquiries please. Personal shoppers welcomed at any of the branches below. Open all day Saturday.

**BRADFORD** 10 North Parade (Half-day, Wed.)

**BRISTOL** 14 Lower Castle Street (Half-day Wednesday)

**BIRMINGHAM** 30/31 Gr. Western Arcade, opp. Snow Hill Station, Central 1279. No half-day

**DERBY** 26 Osmoston Rd., The Spot (Half-day Wed.) Tel: 41361

**DARLINGTON** 13 Post House Wynd (Half-day Wednesday) Tel: 68043

**EDINBURGH** 133 Leith Street, (Half-day Wed.)

**GLASGOW** 326 Argyle Street, Tel: CITY 4158 (No half-day).

**HULL** 51 Savile Street (Half-day Thursday) Tel: 20505

**LEICESTER** 32 High Street (Half-day Thurs.) Tel: 56420

**LEEDS** 5-7 County (Mecca) Arcade (No half-day) Tel: 28252

**LIVERPOOL** 73 Dale St. (No half-day) Tel: CENTRAL 3573

**LONDON** 238 Edgware Road W2 (Half-day Thursday) Tel: PADINGTON 1629

**MANCHESTER** 60A-60B Oldham St. Tel: CENTRAL 2778 (No half-day) New large store.

**MIDDLESBROUGH** (Half-day) Wednesday 106 Newport Road Tel: 47096

**SHEFFIELD** 13 Exchange Street Castle Market Bldgs. (Half-day Thursday) Tel: 20716

**JASON FMTI** V.H.F./F.M. Radio Tuner design. Total cost of parts including valves, tuning dial, escutcheon, etc. **£6.19.6**

**SUPERBITE FEEDER UNIT.** Design of a high quality Radio Tuner (specially suitable for use with our Amplifiers). Delayed A.V.C. Controls are Tuning, Wch. and Vol. Only 2V. 15mA H.T. and L.T. of 8.3v. 1amp. required from amplifier. Size approx. 9 x 6 x 7in. High. Simple alignment procedure. Point-to-Point wiring diagrams. Instructions and priced parts list with illustrations, 2/6. Total building costs £5.5.0. S.A.E. for leaflet.

**TRANSISTOR SALE** Mullard OCT1 2/11/ OC45 3/11, OC44 3/11, OCT2 2/11, OC81 2/11/ OC171 8/9, AF117 6/9, Ediswan XA101 3/9, XA112 3/9, XC101A 3/9. Postage 6d. for up to 3 transistors.

**EX GOVT. SELENIUM RECTIFIERS** 12v 15 AMP (BRIDGE) F.W. ONLY **19/9**

**EX. GOVT. SMOOTHING CHOKES.** 200mA. 3-5 H. 50 ohms, Parmeko 8/9; 150mA, 10H, 50 ohms 8/9; 120mA, 12H, 10 ohms 8/9; 100mA, 10H, 100 ohms 6/9; 60mA, 9-10H, 250 ohms, 2/11.

**TANNOY RE-ENTRANT LOUD-SPEAKERS.** For outdoor or Factory use, 8 ohms, 8 watts. Only **25/9**

**EX. GOVT. 2V ACCUMULATORS.** 16 A.H. Size 7 x 4 2in. Brand new, 4/9 each. Three for 12/6, Carr. 5/-.

**HI-FI 10 WATT AMPLIFIERS** BRAND NEW Carr. 6/6  
**EX-GUITAR AMPLIFIERS** 8 Gns. 6/6  
 Manufacturers' discontinued Model. Push-pull output. Latest high efficiency valves. Dual separately controlled inputs for 'Mike' and gram. Separate Bass and Treble Controls. High Sensitivity. Output for 3 or 15 ohms speaker. Guaranteed tested and in perfect working order.

**R.S.C. MAINS TRANSFORMERS (FULLY GUARANTEED)**

Interleaved and Impregnated. Primaries 200-250V 50 c/s. Screened TOP SHROUDED DROP THROUGH

250-0-250V. 70mA. 6.3v. 2a.	0-5-6.3v. 2a.	17/9
350-0-350V. 100mA. 6.3v. 2a.	0-5-6.3v. 2a.	21/9
250-0-250V. 100mA. 6.3v. 2a.	6.3v. 1a.	21/9
250-0-250V. 100mA. 6.3v. 3.5a.	C.T.	28/9
250-0-250V. 150mA. 6.3v. 4a.	0-5-6.3v. 3a.	37/9
300-0-300V. 130mA. 6.3v. 4a.	6.3v. 1a. for Mullard 510 Amplifier	35/9
300-0-300V. 100mA. 6.3v. 4a.	0-5-6.3v. 3a.	28/9
350-0-350V. 100mA. 6.3v. 4a.	0-5-6.3v. 3a.	28/9
350-0-350V. 150mA. 6.3v. 4a.	0-5-6.3v. 3a.	37/9

FULLY SHROUDED UPRIGHT

250-0-250V. 60mA. 6.3v. 2a.	0-5-6.3v. 2a.	18/9
Midget type 2 1/2 x 3 3/8in.		28/9
250-0-250V. 100mA. 6.3v. 4a.	0-5-6.3v. 3a.	28/9
300-0-300V. 100mA. 6.3v. 4a.	5v. 2a.	29/9
300-0-300V. 130mA. 6.3v. 4a.	C.T. 6.3v. 1a. for Mullard Amplifier	36/9
350-0-350V. 100mA. 6.3v. 4a.	0-5-6.3v. 3a.	29/9
350-0-350V. 150mA. 6.3v. 4a.	0-5-6.3v. 3a.	37/9
425-0-425V. 200mA. 6.3v. 4a.	C.T. 5v. 3a.	57/9
425-0-425V. 200mA. 6.3v. 4a.	4x 1w/2w. 5v. 3a.	59/9
450-0-450V. 250mA. 6.3v. 4a.	C.T. 5v. 3a.	69/9

FILAMENT TRANSFORMERS

200-250V. 50 c/s primaries	6.3v. 1.5a, 5/8; 6.3v. 2a, 7/6; 12v. 1a, 7/11; 6.3v. 3a, 8/11; 6.3v. 6a, 17/6; 12v. 1.5a, twice, 17/6.
----------------------------	--

**MIDGET MAINS TRANS.** 2 1/2" x 2 1/2" x 2 1/2"  
 250-0-250V. 6.3v. 2a. 15/9  
 250-0-250V. 60mA. 6.3v. 2a. 14/9

**OUTPUT TRANSFORMERS**

Standard Pentode 5,000 $\Omega$ to 3 $\Omega$	5/9
Standard Pentode 7,000 $\Omega$ to 3 $\Omega$	5/9
Push-Pull 8 watts, EL84, or 6V6 to 3 $\Omega$ or matched to 15 $\Omega$	9/9
Push-Pull 10-12 watts to match 6V6 or EL84 to 3-5-8 to 15 $\Omega$	18/9
Following types for 3 and 15 $\Omega$ speakers	19/9
Push-Pull 10-12 watts, 6V6 or EL84	19/9
Push-Pull 15-18 watts, 6L6, KT66	22/9
Push-Pull Mullard 510 Ultra Linear	29/9
Push-Pull 20 watts, sectionally wound 6L, KT66, EL34, etc.	49/9

**SMOOTHING CHOKES**

60mA. 10H 400 $\Omega$ 4/11. 100mA. 10H 200 $\Omega$ 8/9
90mA. 10H 350 $\Omega$ 5/9. 150mA. 10H 250 $\Omega$ 11/9

**CHARGER TRANSFORMERS**

All with 200-230-250V. 50 c/s Primaries:

0-9-15V. 1a. 12/9; 0-9-15V. 2a. 14/9; 0-9-15V. 3a. 16/9; 0-9-15V. 5a. 19/9; 0-9-15V. 6a. 23/9; 0-9-15V. 8a. 28/9
--

**ADDED up/Step down TRANS.**

6/12v. 1a. 3/11. 100mA. 10H 200 $\Omega$ 8/9
6/12v. 2a. 6/11. 6/12v. 10a. 26/9
6/12v. 3a. 9/9. 6/12v. 15a. 35/9
6/12v. 4a. 12/3

Consist of 50-80 watts, 13/9; 150 watts, 27/9; 250 watts, 49/9; 500 watts 99/9.

**MIKE TRANSFORMERS** 12:1 8/9

**R.S.C. BATTERY CHARGER AND KITS**

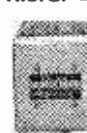

for A.C. Mains 200/250v., 50c/s. ASSEMBLED HEAVY DUTY Fitted Amps 6/12v. 4 amps. meter and variable charge rate selector F.W. (Bridge) Selenium Rectifier. Plug for 6V. Adjustable Charge Rate Selector panels. Plugs, Fuses, Fuse-holder and Carriage 59/9. Carriage 4/6.

or 12v. charging. Louvered steel case with stoved grey hammer finish. Fused and ready for use with mains and out-put leads and battery clips. 59/9. Carr. 4/6. Terms: Deposit 12/- and 5 monthly payments of 12/- (Total £12.10.0).

**SELENIUM RECTIFIERS F.W. (BRIDGE) TYPES**

6/12v. 1a. 3/11. 100mA. 10H 200 $\Omega$ 8/9
6/12v. 2a. 6/11. 6/12v. 10a. 26/9
6/12v. 3a. 9/9. 6/12v. 15a. 35/9
6/12v. 4a. 12/3

**COMPLETE POWER PACK KIT**

Consist of Mains Trans., Metal Rectifier, Double electrolytic smoothing choke chassis and circuit. For 200/250 V. A.C. mains. Output 250v., 60mA. 6.3v. 2a. **19/11**

**ARMSTRONG, TRUVOX, LEAK, QUAD, ROGERS, LINEAR, W.B., FANE, WHARFEDALE, GOODMAN, GARRARD, GOLDRING, GRAMPIAN, LUSTRAPHONE, SHURE, RESLO, TANDBERG, FERROGRAPH Products stocked. Usual credit terms available.**

**SCOOP PURCHASE OF HIGH QUALITY RECORD CHANGERS**

Brand new Garrard 3000 L.M. Very latest model. Normal Retail price approx. £12.15.0. Heavy Turntable and light weight pick-up arm. High fidelity Stereo/mono cartridge. Fully guaranteed. Carr. 5/6

**10 GNS.**

**R.S.C. 4/5 WATT AS HIGH-GAIN AMPLIFIER**



A highly-sensitive 4-valve quality amplifier for the home, small club, etc. Only 50 millivolts input is required for full output so that it is suitable for use with the latest Hi-Fi pick-up heads in addition to other types of pick-ups and practically all "mikes". Separate Bass and Treble Controls are provided. These give full long-playing record equalisation. Hum level is negligible being 71 dB down 15 dB of Negative feedback is used. H.T. of 300V. 25mA and L.T. of 6.3v. 1.5a. is available for the supply of a Radio Feeder Unit or Tape-Deck pre-amplifier. For A.C. mains 200-230-250V. 50 c/s. Output for 2-3 ohms speaker. Chassis is not alive. Kit is complete in every detail with fully punched Gold Hammer finished chassis, point-to-point wiring diagrams and instructions. Exceptional value £21.5.0. or assembled ready for use 35/- extra, plus 3/6 carr., deposit 22/6 and 5 monthly payments of 22/6 (Total £6.15.0) for assembled unit.

**R.S.C. GRAM AMPLIFIER KIT.** 3 watts Negative feedback. Controls Vol., Tone and Switch. Mains operation 200-250V. A.C. Fully isolated chassis. Circuit, etc., supplied. Only 39/9. Carr. 3/9.

**GL3A MINIATURE 23 WATT GRAM AMPLIFIER.** For use with an auto-change unit. Output for 2/3 ohm speaker. For 200-250V. A.C. mains. Size 1 1/2 x 2 1/2 x 2 1/2in. Controls: Vol. and Tone with Switch. Only **59/6**

**COMMUNICATION RECEIVERS RX 60 DE LUXE 4 BAND** 220/240v. 50/60 c/s. A.C. mains operation. Frequencies covered 1600 Kc/s to 39 Mc/s continuous. Incorporates 5in. speaker. Slide rule tuning dial 'S' meter. Internal ferrite aerial for medium wave. Telescope whip sockets for short waves. Fitted with optional outdoor aerial. Headphones, external speaker socket. Other features are electrical bandspread tuning, Noise limiter, A.V.C., B.F.O., stand by switch. Size approx. 12 1/2 x 5 1/2 x 8 1/2in. Handsome crackle finished metal cabinet. Brand new with full instructions manual. Usual guarantee **19 Gns.** Carr. & pkg. 10/-.

**VACANCIES FOR PERMANENT STAFF AT VARIOUS BRANCHES**

**R.S.C. 4 WATT GRAM. AMPLIFIER KIT.** Complete set of parts to build a good quality compact unit suitable for use with any record playing unit. Mains isolated chassis, Separate Bass and Treble controls. Output for 2-3 ohm speaker. For 200-250V. A.C. **59/9**

**R.S.C. BABY ALARM or INTER-COMM KIT.** Complete set of parts with diagrams, etc. Housed in two polished walnut finished cabinets of pleasing design. High sensitivity. For 200-250V. A.C. mains. Fully isolated. Controllable at both units. An Intercomm. of this class would normally cost £20-£30. Only 89/6, carr. 3/-. Ready for use. **6 Gns.**

**R.S.C. BATTERY TO MAINS CONVERSION UNITS.** Type B.M.I. All-dry battery eliminator. Size 5 1/4 x 2 1/2 in. Approx. Completely replaces batteries, supply 1.4v and 90v where A.C. mains 200-250V. 50 c/s is available. Suitable for all battery portable receivers requiring 1.4v. and 90v. Complete kit with diagram 39/9 or ready for use 46/9



## R.S.C. STEREO 20/HIGH FIDELITY AMPLIFIER

PROVIDING 10/14 WATTS ULTRA LINEAR PUSH-PULL OUTPUT ON EACH CHANNEL

SUITABLE FOR "MIKE", GRAM., RADIO OR TAPE. INTENDED FOR THE HOME OR STUDIO BUT SUITABLE FOR LARGE HALLS OR CLUBS

- \* Four-position tone compensation and Input Selector switch.
  - \* Will amplify direct from Tape Heads.
  - \* Stereo/Mono switch so that peak monaural output of 25 watts can be obtained.
  - \* Separate Bass "Lift" and "Cut" and treble "Lift" and "Cut" controls.
  - \* Neon panel indicator.
  - \* Handsome Perspex Frontplate.
- Send S.A.E. for illustrated leaflet.

Based on a current Mullard design and 4 employing valves ECC83, ECC85, ECL86, ECL86, ECL86, ECL86. Output transformers are high quality sectionally wound to required specification. Output matchings for 3 and 15 ohm speakers on each channel (complete set of parts with point-to-point wiring diagrams and instructions). **13 Gns.** Carr. 10/-

or Factory assembled, tested and supplied with our usual 12 months' guarantee for 18 gns. or DEPOSIT 5/- and 9 monthly payments of 39/10 (total £20.15.6).

FREQUENCY RESPONSE  $\pm 2$  dB. 30-20,000 c.p.s.  
HUM LEVEL 54dB down.  
SENSITIVITY: 3 millivolts maximum.  
HARMONIC DISTORTION (each channel) 0.2%.

## AUDIOTRINE HI-FI TAPE RECORDER KIT 25 1/2 Gns.

REALISM AT INCREDIBLY LOW COST. CAN BE ASSEMBLED IN AN HOUR. Incorporating the latest Collaro Studio Tape Transcriber. The Audiotrine High Quality Tape Amplifier with negative feedback equalisation for each of 3 speeds. High Flux P.M. Speaker, empty Tape Spindle, Reel of Best Quality Tape and a Handsome Portable Carrying Cabinet tastefully covered in two contrasting shades of Rexine and Vynair, Size 14 1/2 x 15 x 8 1/2 in. high and circuit. Total cost if purchased individually approximately £40. Performance equal to units in the £60-£80 class. S.A.E. for leaflets. TERMS: Deposit 4 gns. and 12 monthly payments of 42/- (Total 25 Gns.).



## R.S.C. A10 30 WATT ULTRA LINEAR HIGH FIDELITY AMPLIFIER

A highly sensitive Push-Pull high output unit with self-contained Pre-amp. Tone Control Stages. Certified performance figures compare equally with most expensive amplifiers available. Hum level 70 dB down. Frequency response  $\pm 3$  dB. 30-20,000 c/s. A specially designed sectionally wound ultra linear output transformer is lead with 807 output valves. All components are chosen for reliability. Six valves are used EPR6, EPR6, ECC83, 807, 807, GZ34. Separate Bass and Treble Controls are provided. Minimum input required for full output is only 12 millivolts so that ANY KIND OF MICROPHONE OR PICK-UP IS SUITABLE. The unit is designed for CLUBS, SCHOOLS, THEATRES, DANCE HALLS or OUTDOOR FUNCTIONS, etc. For use with Electronic ORGAN; BASS, LEAD OR RHYTHM GUITAR, STRING BASS, etc. For standard or long-playing records. OUTPUT SOCKET PROVIDES L.T. and H.T. for 11 Gns.

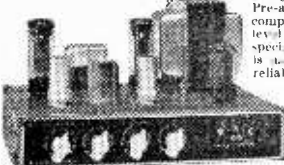

RADIO FEEDER UNIT. An extra input with associated vol. control is provided so that 200-250 v. 50 c/s. A.C. Mains output for 3 and 15 ohm speakers such as Gram and "Mike" can be mixed. Complete Kit of parts with fully punched chassis and point-to-point wiring diagrams and instructions. Supplied factory built with EL24 output valves and 12 months' guarantee. **11 Gns.** Carr. 10/-

If required perforated cover with carrying handles can be supplied for 15/9. Send S.A.E. for leaflet, also speaker. TERMS: DEPOSIT 45/- and 9 mthly. payments of 32/4 (Total 16 gns.)

ONLY 3 PAIRS OF SOLDERED JOINTS PLUS MAINS

## 12in. 10 WATT HIGH QUALITY LOUDSPEAKER

In walnut veneered cabinet. Gauss 12,000 lines. Speech coil 3 ohms or 15 ohms. Only **£4.19.6** Carr. 5/6

Terms: Deposit 11/3 and 9 monthly payments of 1/3 (Total 25.12.6). 12in. 20 WATT HI-FI LOUD-SPEAKERS IN CABINETS. Size 18 x 18 x 10in. Finish as above. Only 27.19.6. Terms: Deposit 17/9 and 9 monthly payments of 17/9 (Total 28.17.6). Carr. 8/6.



## INTEREST CHARGES REFUNDED

on H.P. and CREDIT SALE accounts settled in 6 months.

LINEAR TAPE PRE-AMPLIFIER. Type LP/1. Switched Equalisation, Positions for Recording at 15in., 3 1/2in., 7 1/2in. per sec. and Playback, FM84 Recording Level Indicator. Designed primarily as the link between a Collaro Tape Deck and Hi-Fi amplifier, suitable almost any Tape Deck. Only 9/9 gns. S.A.E. for leaflet.

## HIGH FIDELITY 12-14 WATT AMPLIFIER TYPE A11

PUSH-PULL ULTRA LINEAR OUTPUT "BUILT-IN" TONE CONTROL PRE-AMP STAGES

Two input sockets with associated controls allow mixing of "mike" and gram, as in A10. High sensitivity. Includes 5 valves, ECC83, ECC83, EL84, EL84, EZ81. High Quality sectionally wound output transformer specially designed for Ultra Linear operation and reliable small condensers of current manufacture. INDIVIDUAL CONTROLS FOR BASS AND TREBLE "Lift" and "Cut". Frequency response  $\pm 3$  dB 30-20,000 c/s. Six negative feedback loops. Hum level 60 dB down. ONLY 23 millivolts input required for FULL OUTPUT. Suitable for use with all makes and types of pick-ups and microphones. Comparable with the very best designs for STANDARD or LONG PLAYING RECORDS. FOR MUSICAL INSTRUMENTS such as STRING BASS, LEAD OR RHYTHM GUITAR, etc. OUTPUT SOCKET with plus provides 300v., 30mA. and 6.3v. 1.5A. for supply of a RADIO FEEDER UNIT. Size approx. 12 x 9 x 7 1/2 in. For A.C. mains 200-250v. 50 c.p.s. Output for 3 and 15 ohm speakers. Kit is complete to last nut. Chassis is fully punched. Full instructions and point-to-point wiring diagrams supplied. (Or factory built 51/6 extra). Only **8 Gns.** Carr. 10/-

If requires louvered metal cover with 2 carrying handles can be supplied for 18/9. TERMS ON ASSEMBLED UNITS. DEPOSIT 33/3 and 9 monthly payments of 24/1 (Total 212.10.0). Send S.A.E. for illustrated leaflet detailing Cabinets, Speakers, Mikes, etc.

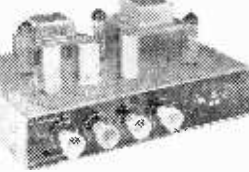

R.S.C. JUNIOR BASS REFLEX CABINET. Designed for above speaker, but suitable for any good quality 8in. or 10in. speaker. Acoustically lined and ported. Polished walnut veneer finish. Size 18x12x10in. Strongly made. Handsome appearance. Ensures superb reproduction for only 24.7.6.

R.S.C. STANDARD BASS REFLEX CABINET. For 12in. loud-speaker acoustically lined and ported. Size 20 x 14 x 13in. Beautiful walnut veneer finish. Recommended for use with Audiotrine Speaker system. 25.19.6.

AUDIOTRINE CORNER CONSOLE CABINETS. Strongly made. Beautiful polished walnut veneer finish. Pleasing design.

JUNIOR MODEL. For up to 10 in. speaker. Approx. 20x11x8 1/2 in. 49/9

STANDARD MODEL. To take up to 10in. speaker. Size 27 x 14 x 14in. 5 Gns. Carr. 7/6

SENIOR MODEL. To take up to 12in. speaker and with Tweeter cut-out. Size approx. 30 x 30 x 15in. (Recommended for use with Audiotrine speaker system). 8 gns. Carr. 8/6. Terms available.

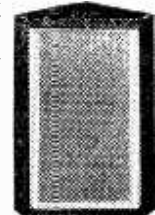

AUDIOTRINE HI-FI SPEAKER SYSTEMS. Consisting of matched 12in. 12,000 line, 15 ohm high quality speaker; cross-over unit (consisting of choke, condenser, etc.) and Tweeter. The smooth response and extended frequency range ensure surprisingly realistic reproduction. Standard 10 watt rating. 24.19.6. Carr. 5/-

Or Senior 20 watt, 26.19.6. Carr. 7/6.



## R.S.C. STEREO/TEN HIGH QUALITY AMPLIFIER

A complete set of parts for the construction of a stereophonic amplifier giving 5 watts high quality output on each channel (total 10 watts). Sensitivity is 50 millivolts. Suitable for all crystal stereo heads. Ganged Bass and Treble Control give equal variation for "Lift" and "Cut". Provision is made for use as straight (monaural) 10-watt amplifier. Valve line-up ECC83, ECC83, EL84, EL84, EZ81. Outputs for 2-3 ohm speakers. Point-to-Point wiring diagrams and instructions supplied. Send S.A.E. for leaflet. Full constructional details and price list 2/6.



Or supplied factory assembled with 12 months' guarantee for £11.7.6. Terms: Deposit 2 gns. and 9 monthly payments of 24/2 (Total 212.19.6).

## 5/4 STEREO AMPLIFIER

A complete set of parts to construct a good quality Stereo amplifier with an undistorted output total 8 watts. For A.C. mains input of 200-250 v. Sensitivity 180 m.v. Ganged Volume and Tone Controls. Preset balance control. Full instructions and wiring diagrams supplied. **5 Gns.**

Always in Stock at keen prices SINGLE and AUTO RECORD PLAYING UNITS, PICK-UPS, CARTRIDGES, MICROPHONES, VALVES, CABINETS and COMPONENTS TOO NUMEROUS TO LIST.



## R.S.C. BASS-REGENT 50 WATT AMPLIFIER

AN EXCEPTIONALLY POWERFUL HIGH QUALITY ALL-PURPOSE UNIT  
For lead, rhythm, bass guitar and all other musical instruments  
For vocalists, gram, radio, tape and general public address

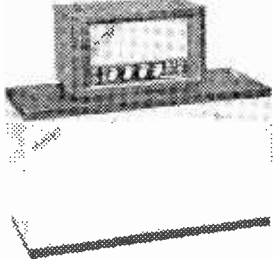

- ★ UNUSUALLY POWERFUL LOUDSPEAKER COMBINATION consisting of a FANE HIGH FLUX 15in. 30 watt unit PLUS A FANE 12in. 20 watt unit with extended frequency response.
  - ★ 4 Jack Socket Inputs and two independent Vol. Controls for simultaneous use of up to 4 pick-ups or 'mikes'.
  - ★ Separate cabinets fully covered in contrasting tones of Rexine/Vynair with gold trimming, for speakers and amplifiers.
  - ★ Separate Bass and Treble Controls giving 'Boost' and 'Cut'.
- Send S.A.E. for leaflet. Or call at one of our many branches and compare the Bass-Regent with units at more than three times the cost. Or deposit £7.16.0 and 12 monthly Carr. 25/- payments of 81/6. (Total 54 Gns.)

49

### TRANSISTORISED SOUND MIXER

Enables mixing of up to 4 standard jack inputs, i.e. mic., tape, gram., tuner, etc., into single output. Compact and completely self-contained, uses standard 9 volt battery. **49/6** Post 3/6.

Full Range of FANE and GOODMANS Speakers in Stock and all type 'Mikes'. Credit terms if required.

**R.S.C. B20 MULTI-PURPOSE AMPLIFIER** especially suitable for Bass Guitar. A highly efficient unit incorporating massive 15in. high flux loudspeaker specially constructed to withstand heaviest load conditions. Rating 25 watts. Individual bass and treble controls give ample 'Boost' and 'Cut'. Two jack socket inputs separately controlled. Cabinet is of substantial construction and attractively finished in two contrasting tones of Rexine and Vynair. Size approx. 24 x 21 x 13ins. Send S.A.E. **29/1 Gns.** Carr. 17/6. Or deposit £4.14.6 and 12 monthly payments of 49/- (Total 32/1 gns.).



**R.S.C. G15 15 WATT AMPLIFIER for Lead or Rhythm Guitar, 'Mike', Gram or Radio** High-fidelity push-pull output. Separate bass and treble 'Cut' and 'Boost' controls. Twin separately controlled inputs so that two instruments or 'mike' and pick-ups can be used at the same time. Loudspeaker is a heavy duty flux 12in. 20 watt model with cast chassis. Cabinet is covered in contrasting shades of Rexine/Vynair. Size approx. 18 x 18 x 8in. **19 Gns.** OR DEPOSIT 3 Gns. and 12 monthly payments of 31/6 (Total 21 gns.) Send S.A.E. for leaflet. Carr. 10/-

**R.S.C. G5 AMPLIFIER** 4 watt high quality output. Incorporating high flux 12in. 10 watt loudspeaker. Sensitivity 40 m.v. High impedance jack input. Handsome cabinet (size 14 x 14 x 7in. approx.) finished in Rexine/Vynair. 200-250v. A.C. mains. Suitable for Lead or Rhythm Guitar in home or small club etc. **£9.19.6** Or Deposit 30/9 and 9 monthly payments of 22/3 (Total 11 Gns.) Carr. 7/6.

INTEREST CHARGES REFUNDED ON H.P. ACCOUNTS SETTLED IN 6 MONTHS



Addresses Page 373

## R.S.C. COLUMN SPEAKERS

Covered in two-tone Rexine/Vynair. Ideal for vocalists and Public Address. Normally supplied for 15 ohm matching but can be supplied for 100v line for 35/- extra.  
Type C38, 15-20 watts. Fitted five 8in. high flux speakers. Overall size approx. 42 x 10 x 5in. **12/7 Gns.** Carr. 10/-  
Or deposit of £2 and 9 monthly payments of 27/9 (Total £14.9.9).  
Type C412, 40 watts. Fitted four 12in. 12,000 line 10 watt speakers. Overall size 56 x 14 x 9in. approx. **19/1 Gns.** Carr. 15/-  
Or deposit of 3 gns. and 9 mthly pymts. of 43/2 (Total 21/1 gns.).

## 30 WATT HIGH QUALITY AMPLIFIER for Lead, Rhythm and Bass Guitar and for Vocal or Instrumental Groups



A Four Input, two volume control Hi-Fi unit with separate Bass and Treble 'Cut' and 'Boost' controls. Designed for vocal or Instrumental groups. For Bass, Lead or Rhythm Guitar, Mullard or Brimar latest type valves. Housed in strong Rexine covered cabinet with twin carrying handles. Attractive black and gold perspex fascia plate. For 200-250v. A.C. mains. Output for 3 or 15 ohm speakers. Send S.A.E. for leaflet. or Deposit £3 and 9 monthly payments of 37/- (Total **17 Gns.** Carr. 12/6 £19.13).

# WEYRAD

## TRANSISTOR COILS

The P50 series remain the most popular and widely used components for Medium and Long-wave Transistors Superhets:—

P50 1AC Oscillator Coil for 176 pF tuning ... ..	5/4 ea.
P 50 2CC 1st & 2nd I.F. Transformers ... ..	5/7 ea.
P50 3CC 3rd I.F. Transformers ... ..	6/- ea.
All mounted in individual cans 1 1/8 in. diam. x 3/4 in. high.	
RA2W Ferrite Rod Aerial 208 pF Tuning ... ..	12/6 ea.
LFDT4 Driver Transformers ... ..	9/6 ea.
OPT1A Output Transformers ... ..	10/6 ea.
PCA1 Printed Circuit Panel ... ..	9/6 ea.
Constructor's Booklet ... ..	2/- ea.

## VALVE RECEIVER COILS

Our individual "H" type iron-cored coils are without equal for the construction of a wide range of receivers. For the simplest T.R.F. sets covering one or more wave-bands the Aerial and H.F. Transformer coils are ideal. The standard superhet circuit using the ever-popular triode-hexode frequency change layout would employ the Aerial and Oscillator coils and the coverage can be selected from 7 different bands ranging from 12.5 to 2,000 metres. For a really high-performance receiver an R.F. stage can be added by using the Aerial, H.F. Transformer and Oscillator Coils and a circuit is provided illustrating such a layout.

H Coils 3/9 each.

PLEASE NOTE OUR CHANGE OF NAME  
**WEYRAD (ELECTRONICS) LIMITED**

REGENT FACTORY, SCHOOL STREET,  
WEYMOUTH, DORSET

# STERN-CLYNE

Electronics Centres throughout Great Britain

## HIGH-FIDELITY EQUIPMENT

### Ready Built or in Kits of Parts



(1)



(2)



(3)



(5)



(6)



(8)



(9)

#### (1) Mullard "10 Plus 10" Stereo Amplifier

A High Fidelity design providing up to 10 watts (per channel).

**KIT OF PARTS £20.0.0**  
Built and tested £24.0.0 (C. & L. 7/6)

We can also supply the Main Amplifier for operation with our Dual Channel Pre-amplifier.

**KIT OF PARTS £27.0.0**  
Built and tested £34.0.0 (C. & L. 10/6)

#### (2) Mullard Dual Channel Pre Amplifier

A four-valve design for both Stereophonic and Monophonic operation.

**KIT OF PARTS £12.10.0**  
Built and tested £15.0.0 (C. & L. 5/-)

#### (3) The "Twin Three" Stereo Amplifier

Based on a recent design by Mullard Ltd. it is ideally suited for use in Portable Record Players.

**Built and tested £9.0.0 (C. & L. 7/6)**

To construct a Stereo Portable Record Player, we offer:  
Assembled Amplifier with two 4 x 5in. Loudspeakers and Portable Case for £16.10.0 (C. & L. 10/-).

#### (5) Tudor AM/FM Tuner

Self powered VHF/FM long and medium waves. FM 87.5-108.5 Mc/s. AM.MW 522-1650 Kc/s. LW 145-270 Kc/s. Multiplex output.

**Built and tested 24 Gns. (P. & P. 7/6)**

#### (6) Mullard 3-Valve Pre-Amplifier Tone Control

Designed mainly for the Stern/Mullard range of Monophonic Power Amplifiers.

**KIT OF PARTS £10.0.0**  
Built and tested £13.13.0 (C. & L. 5/-)

#### (8) Mullard "5-10" Main Amplifier

For use with Mullard 2- or 3-valve pre-amplifiers with which an undistorted power output of up to 10 watts is obtained.

**KIT OF PARTS £10.0.0**  
Built and tested £13.10.0 (C. & L. 6/6)

Above incorporating Partridge Output Transformer £1.6.0 extra.

#### (9) Mullard "5-10RC" Amplifier

The popular "5-10" complete incorporating Passive Control Unit providing up to 10 watts high quality reproduction with an input of 600 mV.

**KIT OF PARTS £12.0.0**  
Built and tested £16.0.0 (C. & L. 7/6)

With Partridge Output Transformer £1.6.0 extra.

#### (10) Mullard "3-3RC"

A high quality Amplifier developed from the very popular 8-watt Mullard "4-3" design.

**KIT OF PARTS £8.8.0**

Built and tested £11.10.0 (C. & L. 6/6)

#### (11) The "Mono-Gram"

A small Amplifier of genuine high quality performance producing up to 3 watts undistorted output.

**KIT OF PARTS £4.10.0**

Built and tested £6.0.0 (C. & L. 8/6)

#### (12) Stereo Tape Pre-Amplifier Model STP-1

For use with current Truvox Beasell or Gears "Studio" 1- and 1-track Stereo Decks.

**KIT OF PARTS £22.0.0**

Built and tested £28.0.0 (C. & L. 8/6)

#### (13) Mullard Type "C" Tape Pre-Amplifier

Suitable for most 1-track Mono Tape Decks.

**KIT OF PARTS £14.0.0**

Built and tested £19.10.0 (C. & L. 7/6)

#### (14) Mullard Tape Amplifier Model HF/TR3

Based on Mullard's type "A" design and suitable for most 1-track Mono Tape Decks.

**KIT OF PARTS £13.13.0**

Built and tested £19.0.0 (C. & L. 7/6)

#### (16) J110 Power Amplifier

Incorporates the latest diode/pentode ECL86 valves in push-pull Partridge ultra linear output transformer.

Partridge mains transformer and smoothing choke. 10 watts power output, surplus power output, surplus power available for tuner.

**Built and tested £12.12.0 (C. & L. 7/6)**

#### (17) Double Feature Pre-Amplifier

Inputs for microphone, crystal or magnetic pick-ups, tuner unit, and in addition offers full facilities for tape recording and high fidelity replay.

This unique feature means that should you wish to include tape in your hi-fi system at a later date all that is required is a suitable tape deck.

Push-button switching for 3 tape speeds equalised.

**Built and tested £18.18.0 (C. & L. 5/-)**

Prices if both units purchased together.

**Built and tested £30.9.0 (C. & L. 10/-)**



(10)



(11)



(12)



(13)



(14)



(16)



(17)

Fully descriptive leaflets available on any of the above items.

Instruction Books and Detailed Price Lists are supplied Free with Kits of Parts but may be purchased separately if required.

Items 1, 2 and 14, 3/- each; 6 and 13, 3/6 each; 7, 8, 9, 10, 2/- each; 11, 2/6 each; 12, 5/-, All Post Free.

## MULLARD 2-VALVE PRE-AMPLIFIER

Employing two EF86 valves and designed to operate with the Mullard AMPLIFIER but also perfectly suitable for other makes with input up to 250 mV.

★ Equalisation for the latest R.I.A.A. characteristics. ★ Inputs for Crystal Pickups and variable reluctance magnetic types.

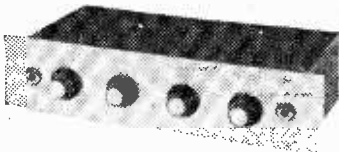

★ Input (a) Direct from High Imp. Tape Head, (b) From a Tape Amplifier or Pre-Amplifier. ★ Sensitive Microphone Channel. ★ Wide range BASS and TREBLE Controls. Now with brushed aluminium front panel with contrasting lettering and control knobs.

**KIT OF PARTS £6.6.0 BUILT AND TESTED £9.10.0** (Carr. & Ins. 5/-)

**MAKE AN IDEAL COMBINATION WITH THE 2-VALVE PRE-AMP. PLUS OUR "5-10" MAIN AMP.**

### COMBINED PRICE REDUCTIONS

Mullard 5-10 Main Amplifier and 2-valve Pre-amplifier. **BUILT AND TESTED £21.10.0 (C. & L. 8/6)**  
 Mullard 5-10 Main Amplifier and 3-valve Pre-amplifier. **BUILT AND TESTED £25.10.0 (C. & L. 8/6)**  
 Above items with PARTRIDGE Transformer (£1.6.0 extra.)

# STERN-GLYNE

Electronics Centres throughout Great Britain

## LOUDSPEAKERS

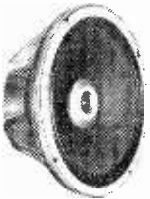

We supply a complete range of Goodmans, Wharfedale, Stenorian, TSL Speaker Units and complete systems. A comprehensive leaflet is available on request this covers technical specifications and prices of

- nearly 50 types including:-
- Celestion CX1512 (Hus.) .. £11.10.0
  - Celestion Model CX2012 .. £18.10.0
  - Stenorian HF 312 5 watts .. £3.10.0
  - Stenorian HF1012 10 watts .. £4.12.0
  - Goodmans Axiote 8 6 watts .. £5.10.11
  - Goodmans Axiom 10 10 watts .. £6.5.11
  - Goodmans Axiom 201 15 watts .. £10.17.4
  - Wharfedale Super 8/RS/12/DD 8 watts .. £6.14.2
  - Wharfedale Golden ES/DD 8 watts .. £7.17.5
  - Wharfedale RS/12/DD 15 watts .. £11.10.0
- Guitar Speakers include:-
- Wharfedale W12EG 15 watts .. £10.10.0
  - Wharfedale W15EG 20 watts .. £17.10.0
  - Goodmans Audiom 51B 15 watts .. £9.2.8
  - Goodmans Axiom 61B 20 watts .. £14.7.8
- Carr. and Ins. extra

## AMERICAN RECORDING TAPE

- 5in. 600ft. Std. Acetate .. 8/8
  - 5in. 900ft. LP Acetate .. 10/-
  - 5 1/2in. 1,200ft. LP Acetate .. 12/8
  - 7in. 480ft. DP Polyester .. 11/8
  - 7in. 1,200ft. Std. Polyester .. 12/8
  - 5in. 1,200ft. DP Polyester .. 15/-
  - 7in. 1,800ft. LP Polyester .. 20/-
  - 5 1/2in. 1,800ft. DP Polyester .. 22/8
  - 7in. 2,400ft. LP Polyester .. 25/-
- P. and P. 1/- per reel. 4 or more Reels POST FREE.

**FULLY AUTOMATIC TAPE SPLICER**  
14/6. P. & P. 1/6.

**PLASTIC TAPE SPOOLS** 2 1/2in., 1/-  
3in., 1/3; 4in., 2/-; 5in., 2/3;  
7in., 2/6.

**PLASTIC SPOOL CONTAINERS.** For  
spool sizes 5in., 1/6; 5 1/2in., 2/-; 7in., 2/3;  
Any single item plus 6d. P. & P. Orders  
over £1 post free.

We carry fully comprehensive stocks of  
Tape Recorders, Decks and Accessories  
at all Branches or order with confidence  
by mail.

## LEADING AGENTS FOR EQUIPMENT

All B. & O. and SABA  
EQUIPMENT  
also  
SONY  
TAPE RECORDERS

## THE TRAVLER Mk. II CAR RADIO

- ★ MEDIUM AND LONG WAVES
- ★ 12 VOLT POSITIVE EARTH
- ★ Push Button Wave Change
- ★ SIZE 7 x 2 x 7 inch
- ★ TRANSISTORISED



**9 1/2 gns.** P. & P. 5/-

Ready built complete with 7 x 4in. speaker fitted to battle fixing brackets, filter unit all units and bolts and fitting instructions.

Optional Extras: Chromium plated weatherproof telescopic aerials. Type 1, 22in./50in. 19/6. Type 2, 12in./43in. 29/6. Type 3, fully retractable and locking 1in./50in. Depth below wing, 14in. 39/6. All plus P. & P. 2/6 if purchased separately.

The "HIGHWAYMAN" Car Radio to build yourself. Similar in appearance to above but with on/off push button switch. Complete set of parts only £7.19.8. P. & P. 5/-.

## RECORD PLAYER BARGAINS

**B.S.R. UA.25**  
4-speed Autochanger with mono cartridge .. £5.19.8



**B.S.R. UA.15**  
"SUPER SLIM" 4-speed auto-changer with mono cartridge .. £9.19.8

## SPECIAL GARRARD OFFERS!

3000 4-speed Autochanger with Sonotone 9TA Stereo Cartridge £9.19.8.  
LAB "A" GCS Mono £15.15.0. LAB "A" on plinth £17.17.0.

## OTHER GARRARD MODELS

SRP.10 Single Player £5.9.11. A.1000 with cartridge £8.10.0.  
SR.25 Single Player £13.10.8. AT.60 with cartridge £14.1.1.  
4HF with GCS cartridge £16.17.6. A70 less cartridge £22.11.1.  
LAB 80 less cartridge £27.10.0. 301 Transcription Unit £25.6.4.  
401 Transcription Unit £32.10.0.  
Carriage and insurance 5/- extra all models.

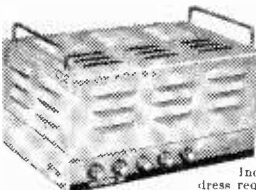

## PRESENTING THE NEW VERITONE 30 AMPLIFIER

A general purpose Amplifier of outstanding quality ideally suitable for Dance Bands, Clubs, Hotels, Factories.

Indoor and Outdoor Public Address requiring a powerful robust portable Amplifier which will provide high quality reproduction, distortion free. The Amplifier has two standard Jack Socket inputs, high gain and low gain with individual volume controls and with the master volume control the inputs may be mixed and balanced as required. The Amplifier is housed in a really robust steel case finished in smooth grey hammer finish with chrome handles and brushed aluminium front panel with contrasting letters and knobs.

- Bass and Treble Controls
- Master Volume Control
- Mixing Facilities
- Built-in Pre-Amplifier and Control Unit
- 30 Watt Undistorted Output
- Switched Output for 8 or 15 ohms Loudspeakers
- Two Inputs, high gain and low gain with individual volume controls.

**Price 18 Gns.**

fully assembled and tested, carriage and insurance 10/-.

Ventilated Cover with chrome handles as illustrated 35/- extra

## TUNER UNITS



**ARMSTRONG**  
Mono/Tuner Amp. Model 127M £26.10.0  
Stereo/Tuner Amp. 127 .. £37.10.0  
AM/FM Tuner £23 .. £28.15.0  
FM Tuner £24 .. £22.10.0  
Carr. and Ins. 7/6

**JASON**  
FMT1 FM Tuner. Kit of Parts .. £6.15.0  
FMT2 FM Tuner. Kit of Parts .. £10.12.6  
FMT3 FM Tuner for Fringe areas. Kit of Parts .. £12.5.0  
FMT4 FM Tuner .. £20.0.4  
JTV2/FM/TV Sound. Kit of Parts .. £15.15.0  
Carr. and Ins. on above 5/- each.

**TRIPLESTONE**  
FM Tuner unpowered .. £13.19.8  
FM Tuner self-powered .. £15.14.6  
Carr. and Ins. 5/- each  
Descriptive leaflets free on request  
Please state model required

## COMMUNICATION RECEIVERS

HE 40. 550 Kcs/s-30 Mc/s in 4 bands. £19.19.0. Carriage 10/-.  
HE 30. 550 Kcs/s-30 Mc/s in 4 bands. £24.13.0. Carriage Paid.  
Surgit 90 Watt Transmitter. Band coverage 80-40-20-15 and 10 Meters. £30.9.0. Carr. 15/-. (H.P. Terms available).  
Send SAE for fully descriptive brochure.

## VERITONE 300

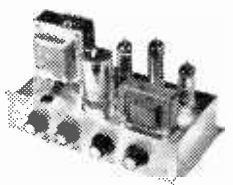

A small versatile Gram Amplifier with an output of 3-4 watts suitable for Crystal Pick-up or Radio Tuner, ideally suited for a small domestic installation requiring good quality low output output impedance 3 ohms, volume control, treble control, bass control and middle control. Valve line-up: E284 EF86, EX80.

Smooth grey hammer finished chassis, size 8 1/2 x 4 x 1 1/2in. with brushed aluminium front panel, contrasting letters and knobs, front panel size 8 1/2 x 2 1/2in.  
Fully assembled and tested 6 gns. carr. and ins. 5/-.

## VISIT YOUR NEAREST STERN-GLYNE ELECTRONICS CENTRE

### LONDON

18 Tottenham Court Road, W.1. Museum 5929/0995. Half Day Saturday.  
23 Tottenham Court Road, W.1. Museum 3451/2. Half Day Thursday.  
309 Edgware Road, W.2. Paddington 6963. Half Day Thursday.  
109 Fleet Street, E.C.4. Fleet street 5812/3. Half Day Saturday.  
162 Holloway Road, N.7. North 7941. Half Day Thursday.  
9 Camberwell Church Street, S.E.5. Rodney 2875. Half Day Thursday.

### CROYDON

12 Suffolk House, George Street, MUnicipal 3250. Half Day Wednes..y.

### BRISTOL

26 Merchant Street, Bristol 1. Bristol 20281. Open 6 days a week.

### LIVERPOOL

52 Lord Street, Royal 7450. Open 6 days a week.

### MANCHESTER

20/22 Withy Grove, Manchester 4. BLackfriars 5379/5246. Open 6 days a week.

### SHEFFIELD

125 The Moor, Sheffield, Sheffield 29993. Half Day Thursday.

## MAIL ORDERS AND ENQUIRIES TO:

Dept. P.W. 3/5 Eden Grove, Holloway, London N.7. North 8161/5.



# Here's vital time-saving data

## to earn money for you!

PROVE IT BY EXAMINING NEWNES RADIO & TV SERVICING — FREE

See for yourself the wealth of time-saving and money-making information contained in Newnes RADIO & TV SERVICING. Produced by a team of expert technicians this 12th Edition provides all the **CIRCUITS—DIAGRAMS—AND REPAIR DATA** you need for servicing nearly 2,300 models and including car radios, tape recorders, radiograms . . . 1964 back to 1958. Complete in six sturdily-bound volumes it is essential equipment that will repay you over and over again. Nearly 60,000 sets of previous editions have been sold . . . solid proof of its importance to you—the engineer in Radio and TV. Use this new edition for a week free—post coupon today!

3,500 PAGES OF REPAIR INFORMATION FOR NEARLY

# 2,300 Popular Models!

DATA FOR OVER 90 MAKES 1964 BACK TO 1958

Acc, Aerodyne, Ajax, Alba, Argosy, Baird, Beethoven, Berec, B.R.C., B.S.R., Bush, Capitol, Champion, Channel, Collaro, Cossor, Cyldon, Dansette, Decca, Defiant, Doric, Dynatron, E.A.R., Eddystone, Ekco, Elizabethan, Elpico, E.M.I., Emerson, Emisonic, Eumig, Ever Ready, Ferguson, Ferranti, Fidelity, Ford Motor Co., Garrard, G.B.C., G.E.C., Gramdeck, Grundig, H.M.V., Invicta, K-B, Magnavox, Marconiphone, Masteradio, McMichael, Motorola, Murphy, National, Nematic, Pageant, Pam, Perdio, Peto Scott, Philco, Philips, Pilot, Playmate, Portadyne, Portogram, Pye, Pye Telecommunications, Radiomobile, Raymond, Recording Devices, Rediffusion, Regentone, Retra, Revelation, R.G.D., Roberts' Radio, Sobell, Sonolor, Sony, Sound, Spencer-West, Standard, Stella, Stereosound, Stuzzi, Thorn, Trans Arena, U.K.W., Ultra, Vidor, Volmar, Walter, Waltham-Standard, Zenith.

- TELEVISION
- RADIO
- RADIOGRAMS
- TAPE RECORDERS
- RECORD REPRODUCERS
- CAR RADIOS

POST COUPON NOW FOR

## 7 days FREE TRIAL

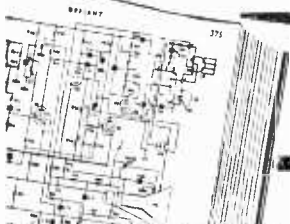

NEARLY 1,200  
CIRCUITS



HUNDREDS OF  
DIAGRAMS

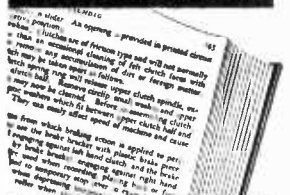

PACKED WITH  
REPAIR HINTS



GIVEN WITH EVERY SET  
NEWNES TV ENGINEERS  
POCKET BOOK  
(VALUE 12/6)

An invaluable companion to your set for on-the-spot repairs. 272 pages of reference data on installing, fault-tracing and repairing, servicing equipment, etc.



NO CHARGE FOR CREDIT IF KEPT AFTER FREE TRIAL

To: George Newnes Ltd.,  
15-17 Long Acre,  
London, W.C.2

If under 21 your father must fill up coupon.

Please send Newnes  
RADIO & TELEVISION  
SERVICING and TV  
ENGINEERS POCKET BOOK  
without obligation to  
buy. If you accept this  
application I will post  
16/- deposit 8 days after  
receipt of books, then  
20/- monthly for 16  
months, paying £16 16s.  
in all—or return the  
books. Cash in 8 days  
£16 16s.

Full Name \_\_\_\_\_ (Mr., Mrs., Miss)

Address \_\_\_\_\_

Occupation \_\_\_\_\_

Signature \_\_\_\_\_ (Mr., Mrs., Miss)

(RV)41/1379

Tick  where applicable

The address on left is —

My Property

Rented unfurnished

Parents' Home

Furnished Accom.

Temporary Address

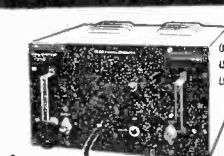
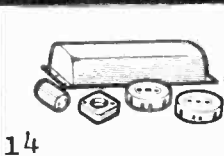
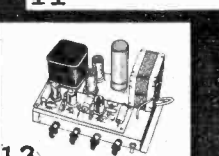
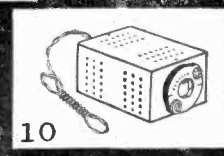
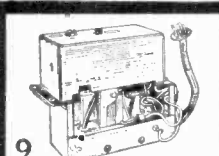
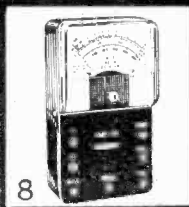
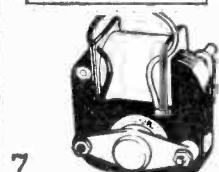
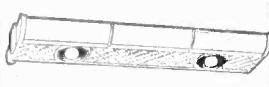
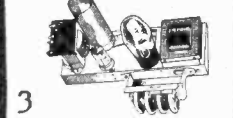
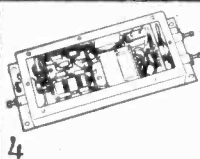
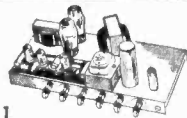
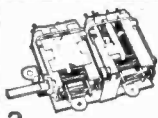

1. **6 VALVE 15 WATT PUSH-PULL AMPLIFIER.** 15 x 7 x 1 1/2 in. A.C. Mains 200-250 volts. 4 inputs with controls for same and bass and treble lift controls. Tapped for 3 and 15 ohm speakers. Extra H.T. and L.T. for F.M. Tuner supplies etc. Built and tested. 7 gns. P. & P. 13/6.

2. **CYLDON A.M. F.M. PERMEABILITY TUNERS FOR ALL TRANSISTOR OPERATION.** Size 2 1/2 x 2 1/2 in. approx. By famous manufacturer. A.M. I.F. 470 Kc/s. F.M.-I.F. 10.7 Mc/s. A.M. coverage from 1620 Kc/s-525 Kc/s. F.M. coverage 108 Mc/s-88Mc/s. Circuit diagrams 2/6. FREE with Tuner. 1st, 2nd and 3rd A.M. I.F.'s, 1st, 2nd, 3rd and 4th F.M. I.F.'s V.H.F. Osc. choke. A.M. I.F. trap. All the above are the R.F. end of an A.M./F.M. receiver car radio etc. The above items, £2.10.0.

3. **AMPLIFIER KIT, 3 to 4 watt Amplifier Kit.** Comprising chassis 8 1/2 x 2 1/2 x 1 1/2 in. Double wound mains transformer, output transformer, volume and tone controls, resistors, condensers etc. Valves 6V6, ECC81 and metal rectifier. Circuit 1/6, free with kit. 2/6 plus 4/6 P. & P.

4. **TRANSISTOR INVERTOR.** 50 v. D.C. Input. Output 240 v. A.C. 40 watts incorporating transformers, choke, condensers and 2 GET573. In solid 16 gauge aluminium case, size 1 1/2 x 6 x 2 1/2 in. by famous manufacturer. 19/6, plus 7/- P. & P.

5. **FLOUORESCENT LIGHT FITTING.** Twin 40 watt 200/250 v. less tubes. 39/6. P. & P. 7/-.

6. **OSCILLOSCOPE for D.C. and A.C. APPLICATIONS.** Push-pull X amplifier, Fly-back suppression; Internal Time-base Scan Wave form available for external use; pulse output available for checking TV line O.P. Transformers, etc. Provision for external I.P. and C.R.T. Brightness Modulation A.C. mains 200/250 v., £18.18.0. P. & P. 10/- FULL 12 MONTHS' GUARANTEE INCLUDING VALVES and TUBE.

7. **A.C. MAINS MOTOR.** Can be used for a variety of purposes, silent running, satisfactory in every way. 230/250v. A.C. 9/6. P. & P. 3/-.

8. **POCKET MULTI-METER.** Size 3 1/2 x 2 1/2 x 1 1/2 in. Meter size 2 1/2 x 1 1/2 in. Sensitivity 1,000 O.P.V. on both A.C. and D.C. A.C. and D.C. volts. 0-15, 0-150, 0-1,000. D.C. current 0-150 mA. Resistance 0-100kΩ Complete with test leads, battery and full instructions. 42/6. P. & P. 3/6. FREE GIFT for limited period only. 30 watt Electric Soldering Iron value 15/- to every purchaser of the Pocket Multi-Meter.

9. **CHANNEL TUNER I.F.** 16-19 Mc/s. Continuously tunable from 174-216 Mc/s. Valves required—PCP80 and PC084 (in series). Cover BBC and ITA ranges. Also Police, Fire and Taxis, etc. Brand new by famous maker, 10/- P. & P. 3/-.

10. **POWER SUPPLY KIT** in metal case, size 3 1/2 x 2 1/2 x 2 in. incorporating mains transformer, rectifier and condensers. 230/250 A.C. mains Output: 9v., 100mA. 10/6 plus 3/- P. & P.

11. **B.S.R. MONARCH UA14 WITH FULL FI HEAD.** 4-speed, plays 10 records, 12in., 10in., or 7in. at 16, 33, 45 or 78 r.p.m. Internixes 7in., 10in. and 12in. records of the same speed. Has manual play position: colour brown. Dimensions: 12 1/2 x 10 1/2 in. Space required above baseboard 4 1/2 in., below baseboard 2 1/2 in. Fitted with Full FI turnover crystal head. £5.19.6. P. & P. 7/6.

12. **50 MICRO-AMP METER** movement by world famous manufacturer. Size 3 x 2 1/2 in., 25/-, plus 2/- P. & P.

13. **8-WATT 5-VALVE PUSH-PULL AMPLIFIER & METAL RECTIFIER.** Size: 9 x 6 x 1 1/2 in. A.C. Mains: 200-250 v. 5 valves. Fit size with 8in. or L.P. records, musical instruments, all makes of pick-ups and mikes. Output 8 watts at 5 per cent total distortion. Separate bass and treble lift controls. Two inputs, with controls for gram. and mike. Output transformer tapped for 3 and 15 ohm speech coils. Built and tested. £3.19.6. P. & P. 8/-.

14. **40W. FLOUORESCENT LIGHT KIT** incorporating GEC Choke size 8 1/2 x 1 1/2 x 1 1/2 in. 2 bi-pin holders, starter and starter holder 11/6. P. & P. 4/6. Similar to above: 80W Fluorescent Light Kit incorporating GEC choke size 11 1/2 x 1 1/2 x 1 1/2 in. 2 bi-pin holders, starter and starter holder 17/6. P. & P. 5/6.

15. **FIRST QUALITY PVC TAPE**

8 1/2 in. Std. 850ft.	.. 9/-	5 in. L.P. 850ft. ..	.. 10/6
7 in. Std. 1200ft.	.. 11/6	3 in. T.P. 600ft. ..	.. 8/-
3 in. L.P. 240ft.	.. 4/-	5 in. T.P. 1800ft. ..	.. 20/6
5 1/2 in. L.P. 1200ft.	.. 11/6	5 1/2 in. T.P. 2400ft. ..	.. 27/6
7 in. L.P. 1800ft.	.. 18/6	7 in. T.P. 2600ft. ..	.. 37/6

P. & P. on each 1/6. 4 or more Post Free.

16. **FIXED FREQUENCY SIGNAL GENERATOR.** Crystal controls in metal case, size 10 x 6 x 6 in. Incorporating two FC13 valves, mains transformer, metal rectifier, choke, indicator, lamp, crystal and numerous components. Modulated and unmodulated output socket. Originally used for I.T.V. frequencies. Brand new. 39/6, plus 7/- P. & P. A.C. mains 200-250 volts.

SILICON RECTIFIERS. 250v. P.I.V. 750 mA. Six for 7/6 post paid.

## RADIO & T.V. COMPONENTS (ACTON) LTD.

21b High Street, Acton, London, W.3.

All enquiries S.A.E. Goods not despatched outside U.K.  
Shop hours 9 a.m.—6 p.m. Early closing Wednesday

# SPECIAL OFFER! FROM R. & T.V. LTD.



## COMBINED PORTABLE & CAR RADIO

- 4in. **SPEAKER** The Radio with the STAR features
- ★ 7-transistor superhet. Output 350mW.
  - ★ Grey wooden cabinet, fitted handle with silver coloured fittings. Size 12½ x 8½ x 3½in.
  - ★ Horizontal tuning scale, size 11¼ x 2⅝in. in silver with black lettering.
  - ★ All stations clearly marked.
  - ★ Ferrite-rod internal aerial.
  - ★ I.F. neutralisation on each stage 460 kc/s.
  - ★ D.C. coupled output stage with separate A.C. negative feed back.
  - ★ All components, ferrite rod and tuning assembly mounted on printed board.
  - ★ Operated from PP9 battery.
  - ★ Full comprehensive instructions and point-to-point wiring diagrams.
  - ★ Printed circuit board, back printed

**ONLY £4.4.0**

Plus 6/6 P. & P. Parts list & circuit diagram 2/6. FREE with parts.

**SPECIAL OFFER—POWER SUPPLY KIT** to purchasers of "Elegant Seven" parts, incorporating mains transformer, etc. A.C. mains 200-250V. Output 9v. 50mA. 7/6.

- ★ Fully tunable over medium and long waveband.
- ★ Car aerial socket.
- ★ Full after-sale service.

**RADIO & TV COMPONENTS (ACTON) LTD** 21C High St., Acton, London W3

Open 9 a.m.—6 p.m. including Sats. Early closing Wed. Goods not despatched outside U.K. All enquiries S.A.E. Terms C.W.O.

**THE  
PEMBRIDGE  
COLLEGE  
OF ELECTRONICS  
PROVIDES TRAINING  
IN RADIO  
AND TELEVISION**

## FULL-TIME COLLEGE COURSE IN RADIO AND TELEVISION

Our Course has now been extended to sixteen months' duration to include theoretical and practical instruction on transistor television receivers, U.H.F. television receivers and colour television.

Next course commences 7th Sept., 1965.

This Course is recognised by the Radio Trades Examination Board (R.T.E.B.) for the Radio and Television Servicing Certificate examinations.

Provides excellent practical experience on valve and transistor radio receivers and all well-known makes of television receivers.

**To:**  
The Pembridge College of Electronics (Dept. P11)  
34a Hereford Road, London, W.2.

Please send, without obligation, details of the Full-time Course in Radio and Television.

Name \_\_\_\_\_

Address \_\_\_\_\_

\_\_\_\_\_

Brand new individually checked and guaranteed VALVES

Table listing various vacuum tube types and their specifications, including AC/HL, AC/PA, AC/PEX, etc., with columns for tube type, quantity, and price.

MANY OTHERS IN STOCK include Cathode Ray Tubes and Special Valves. All U.K. orders below £1, P. & P. 1/-; over £1, 2/-; over £3, P. & P. free. C.O.D. 2/6 extra. Overseas Postage extra at cost.

MARCONI COMMUNICATION RECEIVERS CR. 150. Frequency coverage 2-60 Mc/s in S bands. Two fts 1st 1,600 kc/s, 2nd 463 kc/s. Image signal protecting over 40 dB up to 30 Mc/s and 20-40 dB from 30-60 Mc/s. Self-checking calibration (built-in calibrator). Stabilisation of supply and temperature compensation. Electrical and mechanical indicator Bandpass from 100 c/s to 10 kc/s bandspread. Metering and visual tuning in 5 stages. Acoustic filter associated with 100 c/s. Bandpass position for CW reception. Facilities for diversity reception. Excellent checked condition, £39. Mains P.S.U. by P.C. Radio £4.10.0. Carriage 30/- CR.150/2. Frequency coverage 1.5-22 Mc/s in 4 bands, all other features as in CR.150. Price £31. Carriage 30/-.

P.C. RADIO'S mains P.S.U. for above, 90/-.

H.R.O. SENIOR TABLE MODEL in excellent, fully checked and tested condition together with set of 9 general coverage coils and mains P.S.U. £28. Carriage and Packing 30/-.

ORIGINAL MAINS POWER SUPPLY UNIT FOR H.R.O. RECEIVER, 250/115v. Brand New 65/-, P. & P. 5/-.

VERY HIGH CLASS COMMUNICATION RECEIVER TYPE BRT 402E. 150 kc/s-385 kc/s, 510 kc/s-30 Mc/s. Fully tested £60. Carriage 30/-.

EVERSHED MEGGER CIRCUIT TESTER. 2 ranges 0 to 1,000Ω, 100Ω to 200,000Ω. With test leads, leather carrying case. Tested £4.19.6. P. & P. 3/6.

PANEL METERS (round) table listing meter types (e.g., 0-50 microamps, 0-100 microamps) and their prices.

\*\* "Weston", as usually used in H.R.O. as "S" meter. \*Projection type. 2 KW ULTRASONIC GENERATOR together with power supply unit for 200-250v. A.C. Complete two chassis with interconnecting cables. Frequency 37 to 43 kc/s adjusted by fine control. Peak output 2kw, average output 500w. Completely new with valves and manual £65. Carriage paid U.K.

P.C. RADIO LTD 170 GOLDHAWK ROAD, W.12, Shepherd's Bush 4946. Open 9-5.30 p.m. Thursday 9-1 p.m.

R.F. CHOKES. Ideal for vibrators and anti-interference filters. Very low resistance (0.02). 30μh inductance. 4/3 incl. post.

STABILISED POWER SUPPLY UNIT TYPE R.2001 (EDISWAN) with 2 independent outputs. 1. 0-100v. 50mA metered and regulated by coarse and fine adjustments. 2. 250v. Bias as 5mA. Stability 0.02%. Price £18.

VARIOMETER for No. 19 set, 17/6, P. & P. 3/-.

AR8B RECEIVERS. Fully reconditioned, £55, rebuilt models £85. Carriage paid U.K.

NEW DHR. HIGH-RESISTANCE HEADPHONES. 14/-, P. & P. 1/6.

TELEPHONE HANDSET. Standard G.P.O. type, new 12/5, P. & P. 2/-.

WIRELESS SET No. 52 (CANADIAN) Complete station consisting of Transmitter, Receiver, supply unit for 12 v All contained in special carrier. 1.75-16 mc/s in 3 bands. 813 as output valve. 45-75 w. phone and MCW, 70-100 watt CW. M.O. or crystal. Receiver includes crystal calibrator. Tx can be exactly tuned to Rx frequency. Noise limiter. Sidetone. Loudspeaker on receiver with on/off switch. All brand new with accessories. Export. Price on application.

OUTPUT TRANSFORMERS for push-pull small battery valves (1T4) with output winding for 15 and 600 ohm impedance. 15/- carriage paid.



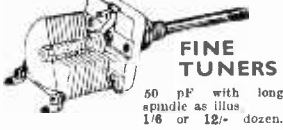

**FINE TUNERS**

50 pF with long spindle as illus 1/6 or 12/- dozen.

**Infra Red Heater**



Make up one of these latest type heaters, ideal for bathroom, kitchen, bedroom, etc. They are simple to make from our easy to follow instructions—uses silica enclosed elements designed for the correct infra-red wavelength (3 microns). Price for 750 watt element and metal casing as illustrated, 19/6 plus 2/6 post and insurance. Full switch 8/- extra.



**SELF ENERGISED TELEPHONES**

These require no batteries; in fact they have only to be connected by a pair of wires. They can thus be fitted into existing bell circuits. Results are extremely good and maintenance costs are nothing.

Handsets only 15/- each, post etc. 2/6. Two, post free.

**MAKING AN FM TUNER**

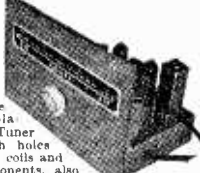

Available at present is a very nice cadmium-plated F.M. Tuner chassis with holes punched for coils and other components, also a nicely printed perspex front, calibrated usual F.M. frequencies. Real bargain 6/6 + 2/- or with two-gang tuning condenser 10/- + 2/- postage

**Sheet Paxolin**



Ideal for transistor projects. Special offer 12 panels 5 x 5in. 5/-

**TRANSISTOR SET CASE**



Very modern cream cabinet, size 5 1/2 x 3 x 1 1/2in. with chrome handle, tuning knob and scale. Price 4/6 plus 1/6 postage.

**Speaker Bargain**



12in. High-fidelity loudspeaker. High flux magnet type with either 3 ohm or 15 ohm speech coil. Will handle up to 10 watts. Brand new by famous maker. Price 20/6 + 3/6 post and insurance.

**Brayhead Turret Tuner**

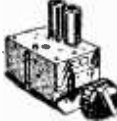

Complete with Band 1 and Band 3 coils. Less valves 10/- each, with valves 17/6 each. Post 2/6. Knobs 3/6 extra.

**EX-ROYAL NAVY SOUND-POWERED TELEPHONE**

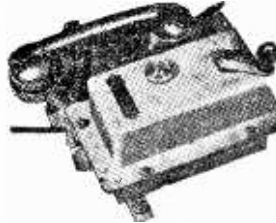

These require no batteries and will go for long periods without attention. Complete with generator and sounder which gives a high-pitched note easily heard above any other noise. Also fitted with an indicator lamp which in quiet situations can be used instead of the sounder or, where several telephones are used together, will indicate which one is being called. Size 7 1/2 x 9 x 7 1/2in. wall mounting, designed for ship's use but equally suitable for home, office, warehouse, factory, garage, etc. In good order but soiled. Price 29/6 each, plus 6/6 carriage.

**INFRA-RED BINOCULARS**

These if fed from a high voltage source will enable objects to be seen in the dark, providing the objects are in the rays of an infra-red beam. Each eye tube contains a complete optical lens system as well as the infra-red cell. These optical systems can be used as lens for TV camera—light cell etc. (details supplied). The binoculars form part of the army night driving (Tabby) equipment. They are unused and believed to be in good working order, but sold without a guarantee. Price 22.17.6 plus 10/- carriage and insurance. Handbook 2/6.

**THIS MONTH'S SNIP**

**Ex W.D. SCOPE UNIT**

Here is an opportunity for you to build an oscilloscope with the minimum of trouble—we offer this month a "snip" price an Ex. W.D. indicator unit—which is half the work done for you. The unit contains adjustable mounting, base, mask and light shield for the "90" tube 45Pe VFR 317 etc. (obtainable and low price) in addition on the front of the unit are the Brilliance, Focus and Time base controls also input sockets—within the unit are hundreds of components including—10 pots—9 valve holders—4 diode holders—50 resistors some hi-stal some wire wound 30 conductors some 4 K.V. working—plus flexible drives—switches knobs, transformers—control coaks etc. etc.—also most important is the very good metal chassis and easily removable cover.

These units which measure approx. 9' x 9' x 18" must have cost at least 450 each but we offer them to you at only 12/6 plus 7/6 postage. Don't miss this!!!

**AUTOCHANGER BARGAIN**

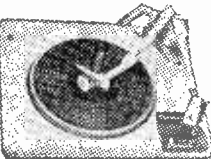

**Garrard Auto-Slim Record Changer**

One of the latest record changers that this famous company make—Automatic selection of records which may be mixed—may also be played manually. Finger tip adjustment of stylus pressure. Fitted with monohead—but pick-up wired for stereo—suitable 200/250 A.C. mains. Cabinet space required 14 x 12 1/2in. with 4 1/2in. above and 2 1/2in. below. DONT MISS THIS SPECIAL SNIP only 25.15.0 (post and insurance, 6/6).

**750 mW TRANSISTOR AMPLIFIER**



3 transistors including two in push-pull input for crystal or magnetic microphone or pick-up—feed back loops—sensitivity 5 mV

**Price 19/6**

Post and insurance 2/6. 35 ohm Speaker 12/6 extra.

**Making a Fan Heater**

Miniature motor laminated poles. Operates off 220-230V. D.C. Original cost at least 25/- each, 8/6 plus 1/6 postage and insurance. Mains model 9/6 plus 2/6 postage and insurance



**Cabinet Snip**



This fine cabinet as illustrated but less control knobs is available this month at a special snip price of 12/6 plus 3/6 post and insurance. Size is 13 1/2in. x 9in. x 4in. and it is nicely covered in two tone L.C.I. fabric.

**Five Core Cable**

Ideal for switching circuits, intercoms. P.A. ritts etc. each core flex copper with rubber insulation, cores covered overall in tough rubber or P.V.C. 8d. per yd. or 30 yds. length 15/- plus 5/- post.

**Waterproof Heater Wire**

16 yds. length 70 watts, self regulating temperature control. 10/-, post free.

**THERMOSTATS**

Type 'A' 15 amp. for controlling room heaters' greenhouse, airing cupboard, over kiln, immersion heater or to make fanostat or fire alarm. 8/6 plus 2/6 post and insurance.

Type 'B' 15 amp. This is a 17 in. long rod type made by the famous Suvvic Co. Spindle adjusts this from 50-550°F. Internal screw alters the setting so this could be adjustable

over 30° to 1,000°F. Suitable for controlling furnace, over kiln, immersion heater or to make fanostat or fire alarm. 8/6 plus 2/6 post and insurance.

**COMPONENT BARGAINS**

- 465 Kcs IF Transformers. Standard type in aluminium can with trimmers, size 1 1/2in. square 1/6 each, 12/- doz.
- 46 Receiver/Transmitter. Complete except for crystals packed with valves and components, easily buildable into other gear. 19/6, plus 1/6 carriage and insurance.
- Output Transformer. Stand and pentode type 2/6, 24/- doz.
- Mullard 510. Amplifier chassis complete with inner screening section, stove enamelled 7/6, plus 2/6 postage.
- Precision Wheatstone Bridge. Opportunity to build 100K wire wound pot, 15 watt rating, 5/- only. Also 100K 100 watt. American made, 15/-, post 3/9.
- Toggle Panel Switch, 25/50 amp, single pole, 2/6, 64/- dozen.
- Toggle Switch, 10 amp, double pole, 2/-, 18/- dozen.
- Electric Lock. 24v. coil but rewindable to other voltage. 4/6; 48/- dozen.
- Head Phones ideal for short wave listening etc. Low resistance, best makers. 6/-, post 2/6.
- Sound Powered Insert (D.I.R.S.) as P.E. Intercom, as speakers or microphones, 5/6; 54/- dozen.
- 1 Meg. Potentiometers. Sealed type by Morganite, among the best ever made. Standard 1/2in. long, 6/- dozen. 2 meg. ditto, 6/- doz. 1 meg. ditto, 6/- doz. 100K, ditto 5/6 dozen. 50K, 5/- dozen. MU Metal Screen for American 5 CPl etc. 8/6 pair or VCR97 and other 6in. tubes. 7/- complete. Ditto for 2-2kn, tubes, 6/- complete.
- Trimmer Bank. 5 x 50 pF compression trimmers mounted on metal strip 3 1/2in. long, ideal if making pre-set station receiver—ceramic/mica insulation. 2/- each; 18/- doz.

**MAINS POWER PACK**

Designed to operate transistor sets and amplifiers. Adjustable output set 6v—9 to 12 volts for up to 500mA (class B working). Takes the place of any of the following batteries: PP1-PP3-PP4-PP6-PP7-PP8 and others. Kit comprises: mains transformer—rectifier smoothing and load resistor 5000 and 500 mfd condensers, zener diode and instructions. Retail snip at only 14/6 plus 2/6 post.

Where postage is not definitely stated add 2/- all orders under £3.

**ELECTRONICS (CROYDON) LTD**

Dept. P.W. 266 LONDON ROAD, WEST CROYDON, SURREY  
Post orders to: 43 Silverdale Road, Eastbourne, Sussex

# ELECTRONICS

## LEARN - THE PRACTICAL WAY . . .

your career . . .  
hobby . . .  
own business . . . ?

The demand for good Electronic Engineers is increasing almost daily throughout the world. Electronics is now the most rapidly expanding of all industries with its applications reaching into almost every sphere of human activity. If you are looking for a new career with new opportunities, then now is the time to choose—Electronics. If you are already employed in this field—then now is the moment to seek high qualifications to secure the top jobs which are waiting to be filled. Most of all, the great potential of electronic development means unlimited scope for the future and will ensure a secure occupation for you—unlikely to be affected by possible future recessions in other industries.

The British National Radio School has had 25 years' experience of HOME STUDY coaching for students wishing to master the fascinating subjects of Electronics—whether the object be career or as a hobby or new interest. The School is entirely independent and specialises ONLY in the teaching of electronic subjects. It employs only fully qualified staff to conduct and supervise each individual course taken by a student and it is this close and personal contact between Tutor and Student which we believe makes possible the successful completion of a course of study.

A special feature of our system is that all courses start right from the beginning and no previous knowledge or experience is necessary or expected. Training is carried out in easy step-by-step stages using the most modern methods of tuition. The great advantage of the home study method is that it provides a complete self-contained course giving everything needed for the subject concerned and enabling work to be done in the comfort of one's own home and over any period of time desired.

### EXAMINATION COURSES

- CITY & GUILDS TELECOM. TECHNICIANS CERT.
- CITY & GUILDS FULL TECHNOLOGICAL CERT.
- A.M.Brit.I.R.E. EXAMINATION
- RADIO AMATEURS LICENCE EXAMINATION
- P.M.G. CERTIFICATES FOR RADIO OPERATORS
- R.T.E.B. SERVING CERTIFICATES.

### OTHER COURSES

- MATHEMATICS
- TELEVISION
- TRANSISTORS
- SERVO-MECHANISMS
- COMPUTERS
- RADAR & NAVIGATIONAL AIDS

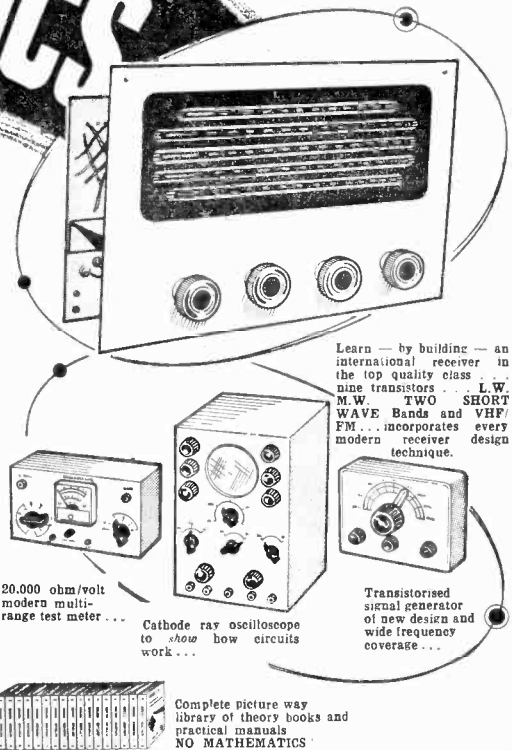

## BUILD AND EXPERIMENT WITH ALL THE ABOVE—AS—YOU—LEARN . . .

This is a new complete experimental course comprising a mixture of theory and practical work using a very full range of electronic components and apparatus. Starting right from the beginning—or at a later stage if needed—the course enables the student to build up all the basic electronic circuits—amplifier; oscillator; rectifier; detector; etc.—and finally to the design, construction, testing and servicing of a latest design fully transistorised receiver using nine transistors and covering long and medium wave and TWO SHORT WAVEBANDS plus VHF/FM reception. It is of real luxury quality throughout—operates from a 9v. battery and can be used anywhere in the world. Every present-day technique in circuitry is covered and the course also includes multi-range test meter; signal generator and oscilloscope. By the end of the course the student will be able to deal with any type of servicing work with confidence and will also have a very useful workshop of equipment. Nearly 100 interesting and absorbing EXPERIMENTS are carried out during this comprehensive course enabling anyone to gain full mastery of electronics.

# FREE



## POST NOW

TO: BRITISH NATIONAL RADIO SCHOOL, RADIO HOUSE, READING, BERKS.  
Please send me your free Brochure, giving details of your Courses, without any obligation, to:—

NAME .....

ADDRESS .....

} Block Caps Please

I am interested in..... courses above  
(We do not employ representatives) PW 9/65

# British National Radio School

# PRACTICAL WIRELESS

SEPTEMBER 1965  
VOL 41 NO 703

## DX IS WHERE YOU FIND IT

IN the June *RSGB Bulletin*, G3HDA relates some provocative facts on the recent exotic "DXpedition" to Desventorados Island, where CEØXA did a 3-day stint on all bands from 3.5-28Mc/s. Apart from giving amateurs and SWL's the opportunity to tuck another new "country" under their belts, the activity from CEØXA exposed the latent lack of enterprise in many enthusiasts.

As our own G3JDG has found, most DX'ers mechanically switch to 14Mc/s where the DX is thick and heavy, virtually ignoring the l.f. bands and paying scant attention to 21 and 28Mc/s. "But with the sunspot cycle as it is", we hear, "Twenty is the only decent DX band". But is it?

Certainly that hectic 350kc/s is prolific in signals from all over the world, but, as G3HDA points out, CEØXA was coming through well on all bands and was, in fact, easier to work on 3.5Mc/s than much vaunted 14Mc/s. This was mainly due to less QRM but it clearly proves a point.

We would like to see much more activity, transmitting and listening, on the less fashionable bands. This would not only ease the fearful congestion on 14Mc/s but would instil a new zest to DX'ing. After all, DX is only a relative term. The hordes of W's audible on even the simplest lash-up on 14Mc/s can only be termed "locals", yet these same stations on 1.8 or even 3.5Mc/s are real DX.

So why not consider trying something more useful than 14Mc/s DX? And, if you are a broadcast band listener, have a go at medium wave DX this season; this is a real challenge and test of listening skill. If you doubt what can be heard, we suggest you order a copy of next month's issue!

## CONTENTS

	<i>page</i>
News and Comment	386, 416
Built-in Tuner for Tape Recorder	388
Variable Voltage Transformer	391
Practically Wireless	396
On the Short Waves	399
Principles of Audio	401
2-transistor Reflex Receiver	405
Tape Terminology—Part 2	407
Transistor Band Edge Marker	411
The Versatile EF50	412
Practical Substitutes—Part 2	418
"Tailor-made" Tagboards	429
Preparing for the R.A.E.	433
Books Reviewed	438
Club News	442

All correspondence intended for the Editor should be addressed to: The Editor, "Practical Wireless", George Newnes Ltd., Tower House, Southampton Street, London, W.C.2. Phone: TEMple Bar 4363. Telegrams: Newnes Rand London. Subscription rates, including postage: 29s. per year to any part of the world. © George Newnes Ltd., 1965. Copyright in all drawings, photographs and articles published in "Practical Wireless" is specifically reserved throughout the countries signatory to the Berne Convention and the U.S.A. Reproduction or imitations of any of these are therefore expressly forbidden. The OCTOBER ISSUE WILL BE PUBLISHED ON

SEPTEMBER 9TH.

## Sell or Loan Column

SOME of us who are fortunate enough to have access to reference material try to help by passing information on to those who may be in difficulty. This is done with great pleasure, and although no acknowledgement is sought, many letters of thanks are received.

It is, however, essential that original material, loaned to someone in difficulties, should be returned. Just over a year ago, I sent on loan to one of your readers some details of a RA 1B receiver, and in spite of repeated requests for its return, have heard nothing.

I am hoping that you will publish this letter for general information and to enhance the success of your correspondence column. It is perhaps too much to hope that my missing document will return to its home.

**J. W. Murland.**

County Down,  
Northern Ireland.

*Unfortunately, many newcomers to radio do not seem to adhere to the legendary Ham spirit, and you probably will not be surprised to know that other readers wishing to be helpful have had similar experiences. There certainly seems to be some degeneration in recent years in responsibility among certain radio enthusiasts.—Editor*

## Competence Again

WITH reference to R. A. Packer's comments in the May issue of PRACTICAL WIRELESS, it is not the components a constructor uses which indicate his competence (or incompetence) it is the way that they are used, i.e. due attention being paid to rating, tolerance, temperature coefficient, etc.

I enjoyed Mr. Ball's letter (July issue). I too come from Ross-shire and gained considerable knowledge and enjoyment using 2 volt and 4 volt pre-war valves.

I wish Mr. Ball and his son many years of happy experimentation.

**Robert B. Kerr.**

New Southgate,  
London, N.11.

# NEWS AND.

## ELECTRONIC DIAGNOSIS OF CANCER

An electronic computer, operating according to a special programme at the Herzen Institute of Oncology in Moscow, diagnoses with great accuracy certain forms of malignant tumours.

The computer gives a correct answer in 97% of the cases of cancer of the lactiferous gland and the larynx.

The diagnosing machine is used by physicians not so much to establish the disease as determine the mathematical regularities. When these regularities have been specified with its help, the mathematicians will be able to draw up several tables which will help the doctors to diagnose cancer without the machine.

## RADIOPHONE SERVICE FOR CARS IN LONDON

London's new Radiophone Service was opened on 5th July when the Postmaster General, the Rt. Hon. Anthony Wedgwood Benn, from Post Office Headquarters in the City made a telephone call to Mr. Richard Dimbleby in his car 'somewhere in London'.

The new service covers an area of up to 30 miles in a rough circle round the centre of London, and caters for 350 subscribers at present. Provided they are in the service area, subscribers can make and receive calls to any part of the country and to other cars connected to the service.

The subscriber will need to buy (£350) or rent (£30-35 per quarter) the mobile equipment from an approved supplier.

The service area is divided into three sections each of which is served by a radio station (see map) and calls are centrally controlled by operators at the Gallery Exchange, Victoria.

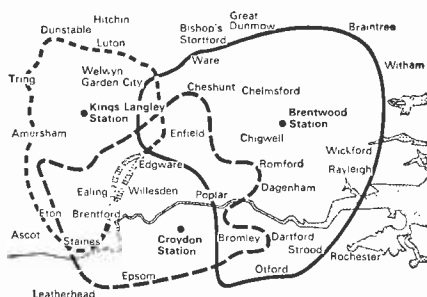

— Area of indifferent reception  
 — North East area covered by the Brentwood Station  
 - - - South area covered by the Croynod Station  
 ····· North West area covered by the Kings Langley Station

## HAMS AT GERMAN RADIO SHOW

The German Amateur Radio Club (DARC) will be organising a special feature at the German Radio Show to be held in the Killesberg grounds from 27th August to 5th September. For the first time visitors will be able to see hams making contact with other amateurs in Europe and overseas by radio and television.

A television station built to conform with European transmitting standards, will be transmitting on the 70cm band and the transmitting centre at the Radio Show will be equipped with aerials for the 70cm, 2m, 10m, 15m, 40m and 80m wavebands.

The many ways in which Hams have transmitted calls for aid and have helped during catastrophes, as well as successfully tracking satellites will be shown by models and photographs.

# .. COMMENT

## BICC TELEPHONE CABLES FOR NEW ITALIAN LINERS

British Insulated Callender's Cables Limited have supplied all the cables required for the extensive telephone systems in the two new "Italia" Line passenger liners *Michelangelo* and *Raffaello*.

There are some 800 telephone sets in each liner and 269,000 yards of telephone cables have been installed.

The cables were supplied through BICC's Italian agents, Tecnimex of Milan.

## MARCONI RADAR FOR MINISTRY AIRFIELD

Boscombe Down research airfield run by the Ministry of Aviation is to have a Marconi 50cm surveillance radar type 2S64 A/H to provide comprehensive all-weather radar cover on a standby basis for a new radar system which is being built at the airfield.

Boscombe Down is situated near a number of other airfields and major airways, and with the increasing speed of aircraft reliable all-weather cover is becoming increasingly important to the airfield controllers. The wavelength of 50 cm provides an ideal compromise between the need to see aircraft through heavy rain and the need for good definition in order to identify targets clearly.

The S264 A/H has a range of about 200 nautical miles which is due to the fact that it has been designed to produce a very low ratio of noise to the received signal.

## 70th "COSMOS" SATELLITE LAUNCHED

*Cosmos-70* was launched in the Soviet Union on 2nd July. It is carrying a radio transmitter operating on the frequencies of 20-005 and 90-002 Mc/s. A radio system for the exact measurement of elements in orbit and a radio telemetric system for transmitting to earth data on the operating of the instruments and scientific apparatus are also incorporated.

## HEATHKIT AUDIO MIXER

From Daystrom Ltd., Gloucester, comes the Heathkit Audio Mixer model TM-1, designed for the tape enthusiast or the public address man. It is fully transistorised and has four channels. The frequency response (ref. 1kc/s at full output) is 15c/s—30kc/s ± 3dB. Power requirements:

9V at approx. 6mA. The Cabinet is finished in oiled walnut with a gold anodised extruded aluminium front panel. Dimensions are 11 $\frac{1}{8}$  in. wide × 7 $\frac{1}{2}$  in. deep × 3 $\frac{3}{4}$  in. high. Net weight is 4 $\frac{1}{2}$  lb and, in kit form the unit costs £11 16s. 6d. The unit is also available ready built and tested for £16 17s. 6d.



more News and Comment

## Notes on the R.A.E.

IN the February issue of P.W. in the R.A.E. article, Fig. 37, the value of the capacitance should in fact have been 100pF.

Also the second part of the question in the February issue needs explaining. To resonate at 2,517kc/s the total capacity required would be 400pF. To obtain the value of the parallel connected capacitor the value of the original capacitor would have to be subtracted from the 400pF.

In paragraph 4.7, "Resonance", the statement should have read:

$$f = \frac{10^6}{2\pi\sqrt{LC}}$$

where C is in micromicrofarads ( $C \times 10^{-12}$ ).

Brian Robinson.

Scunthorpe, Lincs.

## CR100 (B28) Handbook

I AM a regular reader of PRACTICAL WIRELESS and I have often noticed in the "Sell or Loan" column that people ask for details of circuitry on the CR100 (B28) receiver.

This handbook is easily obtainable from:—Ministry of Defence, Naval Books Distribution Centre, Block C, Station Approach Buildings, Kidbrooke, London, S.E.3, and is the BR1430 handbook, costing 10s. 6d.

Hugh M. Roberts.

Cross Hills, Keighley, Yorkshire.

## Tutor Wanted

I HAVE just completed the Hawaiian guitar featured in the June issue of *Practical Wireless* and have had very good results, but unfortunately I am unable to obtain a tutor for same. Could you please tell me where I may purchase one?

A. Bolton.

Fulham.

London, S.W.6.

You can obtain a tutor on the Hawaiian guitar from Rudall Carte Ltd., 8-10 Denman Street, London, W.C.1.—Editor.

on page 416

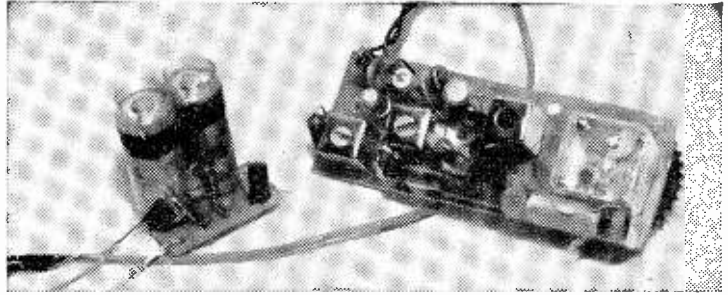

## Built-in Tuner for TAPE RECORDERS

**T**HE modern domestic tape recorder incorporates a high-gain, low-noise audio amplifier in order to deliver sufficient volume with satisfactory quality when driven by the small signal produced by the replay head. With the addition of a suitable tuning unit it would thus make a very satisfactory radio set, with the added advantage of making possible recordings from radio programmes direct, providing a much quieter and more faithful recording than obtained by using a microphone and a standard radio.

by A. J. McEvoy, B.Sc.

Circuits for such tuners have been published from time to time but these normally require a battery power supply and take the form of an add-on unit. The writer of this article, on the contrary, developed a unit to fit inside the tape recorder, forming a permanent part of it, and operating from the recorder power supplies.

Some of the more recent tape recorders already incorporate a transistorised preamplifier in order to benefit from the superior quality of modern transistor amplifier stages at low signal levels (e.g. the current Philips and Cossor models); there will already be a low-voltage d.c. supply in such machines and, with the addition of a dropper resistor, if necessary, this would be suitable for the tuner. All other recorders, however, will have a 6.3V a.c. supply for the heaters of the valves, from which 6V d.c. can be obtained using a silicon diode as a half-wave rectifier, followed by a smoothing network.

Fig. 1 shows the layout, circuit and method of construction of this unit. Holes are drilled in the pattern shown in a small piece of paxolin. The components are mounted through these holes, and the connections made on the other side of the board, using the leads of the components to connect them. As these component leads are fairly stiff, and the rectifier unit is very light, it was considered satisfactory to mount the unit by the leads from the appropriate pins (usually 4 and 5 of a B9A valvebase) of any convenient valveholder. (The reader will understand that more explicit instructions cannot be given, since details depend on the particular model of recorder being modified.)

Note the polarity of the diode and capacitors—the reverse of that used for h.t. supplies to valve equipment. (Incidentally, constructors may find this power supply unit useful in other cases where transistorised auxiliary units are to be used with mains apparatus, e.g. mixers for p.a. amplifiers, v.h.f. boosters, etc.)

The tuner itself is constructed on a printed cir-

cuit board which the constructor must make from a panel of copper-clad paxolin laminate, size  $3 \times 1\frac{1}{2}$  in. The overall depth of the completed unit is slightly over  $\frac{1}{2}$  in., so that space can be found for it even in the most compact recorder. The circuit is a simple superhet, this being chosen for its superior selectivity, because, whereas a 2-transistor t.r.f. tuner would be comparable on grounds of sensitivity and cost, lack of adequate selectivity and the high gain of the amplifier of the recorder would make satisfactory station separation impossible in many areas. A.V.C. was considered unnecessary, since only one stage of i.f. amplification is employed, and the recorder gain control can be used to prevent overdriving. The components supplied with the Eagle Products type H402 coil set were used for economy and convenience—even a small dial is included in this kit. (The extra i.f. transformer supplied is a useful spare to have—the constructor can use it to make a 470kc/s oscillator, for example.)

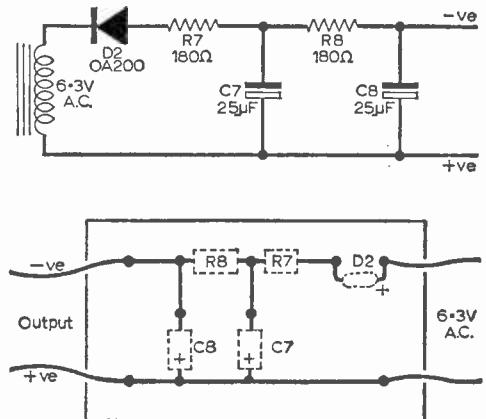

Fig. 1: The simple circuit of the power pack and its layout.

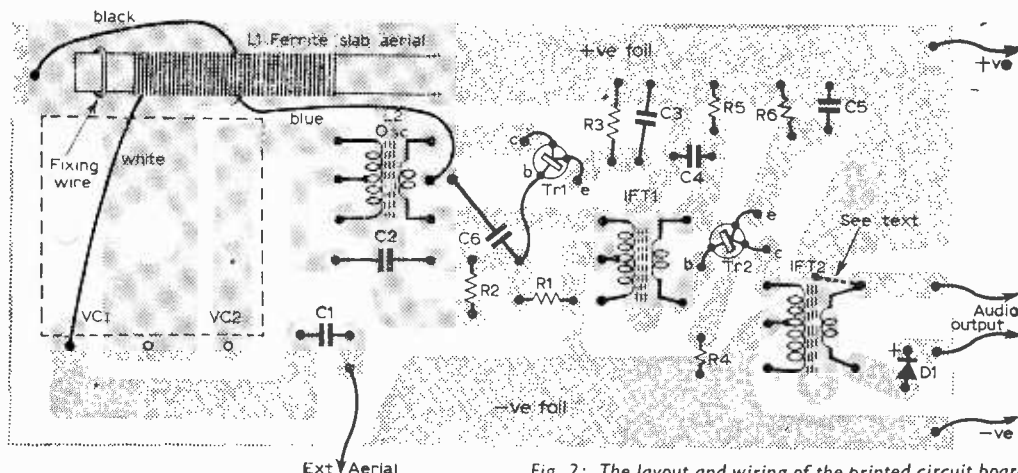

Fig. 2: The layout and wiring of the printed circuit board. Shaded parts are copper.

Construction begins by drilling the laminate to take the components, in accordance with Fig. 2, which shows the copper side of the board. The holes must be drilled from this side, otherwise there would be danger of damaging the bond between the copper and the paxolin. The slots for the ferrite aerial are now to be cut with a fretsaw. Any scale or oxide must next be removed from the copper using "flour" grade sandpaper. The printed wiring pattern is then painted on the copper using a cellulose paint and a very fine brush; when the paint is dry it will protect the copper it covers during the etching process, and permit the unprotected metal to be removed. This is done by soaking the board in a saturated solution of ferric chloride (FeCl<sub>3</sub>) until all the unwanted copper has vanished. The board is then washed, dried, and the paint removed. Assembly may now begin.

**Constructional Details**

The tuning capacitor, oscillator coil and i.f.t.'s are mounted first, then resistors and capacitors, and finally the transistors. All these are inserted into the board from the plain side through the appropriate holes and soldered carefully to the copper side. A single quick application of a clean hot iron to each joint should be aimed at. The aerial coil is wired in, observing the colour coding of the leads. The ferrite slab is mounted and secured in place with plastic adhesive tape passed round the slab and through the slots already cut in the circuit board. Screened cable is used to carry the output audio signal to the recorder amplifier.

One question remains to be settled at this point—whether or not the unit should be earthed to the chassis of the tape recorder—and here the design of the recorder must be taken into account. If so, following usual transistor practice, it is the positive line that must be earthed. Hence if one side of the heater supply to the valves of the recorder is earthed, then this must be used as the positive of the power supply to the tuner and the rectifier taken to the other side of the a.c. low-tension supply.

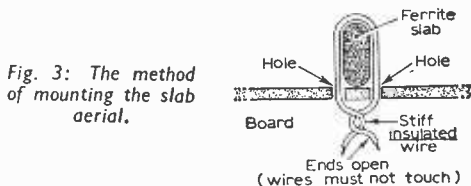

Fig. 3: The method of mounting the slab aerial.

**COMPONENTS LIST  
Tuner**

- Resistors:**
  - R1 22kΩ
  - R2 6.8kΩ
  - R3 2.2kΩ
  - R4 82kΩ
  - R5 10kΩ
  - R6 470Ω
- Capacitors:**
  - C1 33pF silver mica (optional)
  - C2 0.01μF
  - C3 0.05μF
  - C4 0.05μF
  - C5 0.05μF
  - C6 0.01μF
- Transistors:**
  - Tr1 OC44
  - Tr2 OC45
- Miscellaneous:**
  - L1 Ferrite slab aerial
  - L2 Oscillator coil, type E360 (red core)
  - IFT1 1st i.f. transformer, type S301 (yellow core)
  - IFT2 2nd i.f. transformer, type S203 (grey core)
  - VC1/2 Twin gang tuning capacitor (including dial)
  - D1 OA70

Eagle Products IFT and Coil Kit type H402

**Power Supply**

- R7 180Ω
- R8 180Ω
- C7 25μF 15V electrolytic
- C8 25μF 15V electrolytic
- D2 OA 200
- Paxolin board (chassis)
- All resistors 10% 1/4W miniature, all capacitors miniature paper unless otherwise stated.

In this case, the output from the tuner is taken from the diode and the other pin of the secondary of i.f.t.2 earthed to the positive line by a small wire jumper on the copper side of the circuit board: the braiding of the screened cable is also taken to the positive line. On other recorders, however, the heater supply is centre-tapped, the centre tap being earthed; if either side of the d.c. supply were to be earthed now, half the heater supply would be short-circuited, with the risk of serious damage to recorder and tuner. Therefore the second pin of the secondary of i.f.t.2 is not

regardless of the position. Holes are cut in the deck to permit the tuning control to be operated and the calibrations to be seen. The double pole slide switch is mounted as close as possible to the microphone socket and the "grid" lead (core of the screened cable from the amplifier to the microphone socket) transferred to the centre tag of one pole. This pole then switches either the tuner or the socket to the amplifier when wired as in the Fig. 5. The other pole is used to switch on the d.c. supply to the tuner. Provision may be made for an external aerial as shown in the circuit

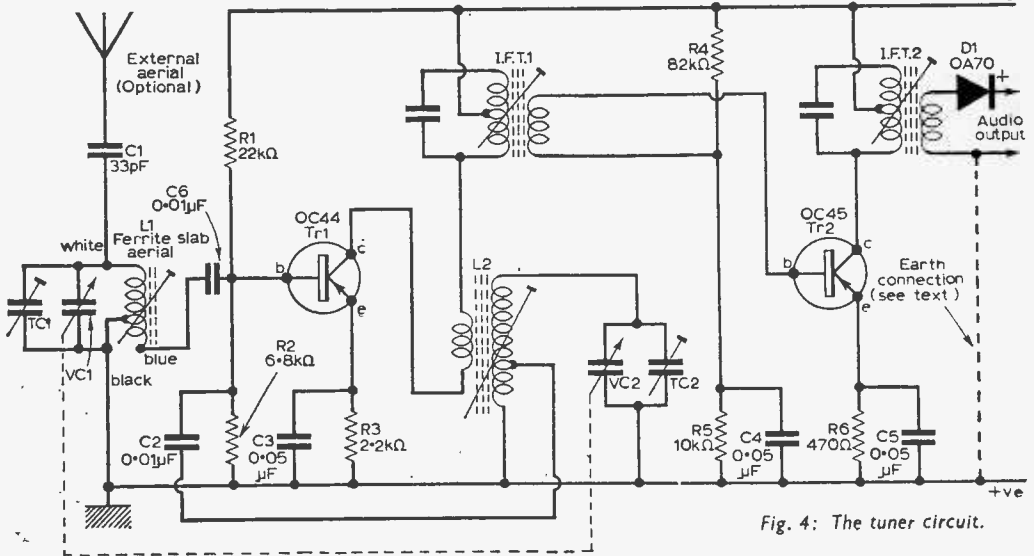

Fig. 4: The tuner circuit.

connected to the positive line in this case; it is taken directly to the chassis of the recorder via the braiding.

**Testing and Alignment**

The tuner is now ready for testing and alignment. Due to the high gain of the following amplifier, alignment is very simple, even without instruments; and there are only two i.f.t.'s to be adjusted. On switching on, the local station should be audible at some point on the dial, even without an external aerial. Adjust the i.f.t. cores for maximum volume. A station at the low frequency (high wavelength) end of the medium waveband is next sought and peaked using the core of the oscillator coil and by moving the aerial winding along the ferrite slab. Finally, a station at the high frequency (low wavelength, "Lux." end) is tuned; it is peaked by the trimmers on the tuning capacitor. The whole process may be repeated until the constructor is satisfied no further improvement is possible.

**Fitting to the Tape Recorder**

The unit should now be mounted in the chosen position in the recorder, preferably as far as possible from the erase oscillator, though the writer had no trouble from this source in the prototype

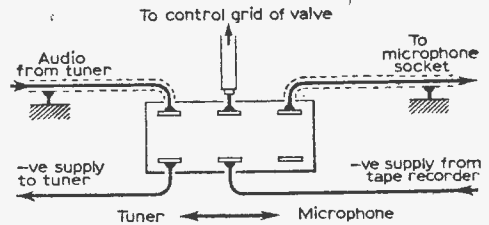

Fig. 5: The double-pole switching for tuner or socket.

diagram (Fig. 4) which certainly improves reception, especially on weak or distant stations; but the writer found the built-in aerial adequate for most purposes.

As already stated, details of the mounting, depending as they do on the individual recorder, are not given; however the cover photograph shows how the writer approached this problem in a Cossor model CR1602 tape recorder. The tuning dial appears at one side of the deck and is edge operated. The calibration engraving is visible through a small hole. The unit is therefore easily operated whether or not there is a tape reel on the deck.



# THE DESIGN AND CONSTRUCTION OF A Variable Voltage Transformer

BY F. L. THURSTON

THE amateur radio enthusiast and the experimenter often have need of a variable voltage a.c. power supply for testing such things as unmarked transformers, energising a.c. motors, improvising power supply units, etc.

Such a variable unit must be very versatile. It may be in use one day for giving a 6 or 12V supply at 6A to a battery charger unit and the following day for feeding a power amplifier rectifier and smoothing unit at 350V at 200mA or perhaps as an energising source for an improvised impedance bridge.

The most well known type of variable voltage transformer is the Variac but these are very expensive and not without their disadvantages. To meet the aforementioned needs, for example, the unit must be able to supply a current of at least 6A and this puts it in the £14 bracket right away. Most Variacs will only give up to 260V maximum, so a second transformer will be needed in series to give the required 350V.

In addition to this the instrument will not give a smoothly variable supply but one that varies in a number of steps, the magnitude of these steps being dictated by the number of turns on the transformer. While these steps may be of no importance at reasonably high voltages it may be found that at the lower voltages, when only a few volts are being used, they become quite significant. The outstanding advantages of such a transformer are the relatively small size and the convenience of use. The price alone will put it beyond the reach of most amateurs, however.

There are, fortunately, other means of obtaining the desired variable voltage which the enthusiast can afford and these will be described in this article, together with constructional information for a continuously variable transformer capable of fulfilling all of the tasks set above.

Of the many possible methods, i.e. having an enormous number of taps on a single winding, using resistors as potential dividers, etc., two systems are of outstanding interest. The first of

this is based on the binary system of numbers.

It is a fact that if a series of numbers are formed starting with number one and each succeeding number being double the value of the preceding one, i.e. 1, 2, 4, 8, 16, 32, etc., then any number within the range of the sum of the series can be formed by adding a group of the basic numbers so formed. For example, 27, can be obtained by adding 1, 2, 8 and 16. Again, 47=32+8+4+2+1 or 13=8+4+1. In the series above only six numbers have been used, the maximum attainable number from the series being 63, that is double the last number in the series minus one.

If the series is extended to give nine numbers then the maximum attainable number will be 511. Clearly if a transformer were made up using nine separate windings, each giving a voltage corresponding to one of the numbers in the series, it would be possible by connecting the windings in the desired order to obtain any voltage from 0 to 511 in steps of 1V.

To make the transformer reasonably convenient to use switching can be introduced to enable each winding to be either in or out of circuit. Fig. 1 shows such an arrangement. It can be seen that nine switches are used, one for each winding. Each switch is a two-pole, two-way toggle type. In one position of each switch its winding is in use, in the other the winding is out of circuit and a shorting link connected in its place. It is important that the windings are connected to their switches in the correct phase as if they are not their voltage will be subtracted from instead of added to the overall output. It is also essential that the switches be of the break-before-make type and it is recommended that the supply to the transformer be turned off before the voltage range is altered, otherwise arcing may occur.

The second method of obtaining a variable voltage supply is also based on series of numbers. It is a fact that if a series of numbers is formed, starting at 1, and each succeeding number is made

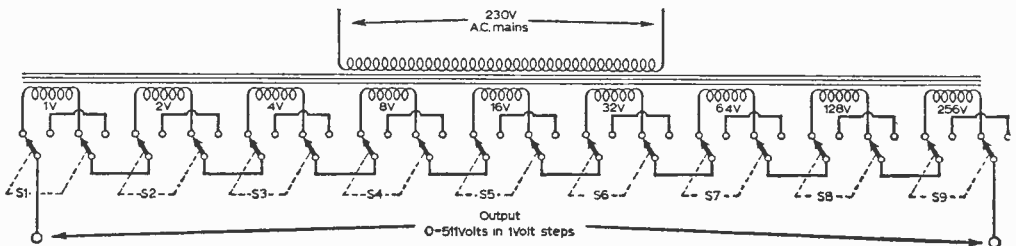

Fig. 1: The switching arrangement for the variable transformer based on the binary system of numbers. This provides 0-511V in one-volt steps.

equal to double the sum of all the preceding numbers\* plus 1, i.e. 1, 3, 9, 27, 81, 243, etc., then any number within the range of the sum of all the numbers in the series, i.e. 364, may be formed by adding or subtracting a group of the numbers in the series. For example,  $70 = 81 + 1 - 9 - 3$ . Again,  $296 = 243 + 81 - 27 - 1$ .

Once again the system can be put to practical use in a transformer by using the same number of windings as there are numbers in the series, each winding being wound to give an output equal to one of the numbers in the series. When it is desired to add voltages the windings are connected in phase and when they are to be subtracted the windings are connected out of phase. This does no harm to the transformer and the system is in fact used in a number of commercially made power supply units. If desired an extra winding

**Design Procedure**

The design and construction is quite straightforward, but it is possible that individual readers may decide that they require a transformer with a different rating, than the one forming the basis of this article, perhaps with a higher or lower voltage range or current rating.

For this reason details of the general design procedure are included.

The first step in the design of any mains transformer is to calculate the total power in Watts that it will be expected to supply. In the case under consideration it was decided to use a transformer of the "add or subtract" type, using 7 windings with voltage and current ratings as follows:

1:V 6A, 3V 6A, 9V 6A, 27V 2A, 81V 200mA, 243V 200mA and 147V 200mA

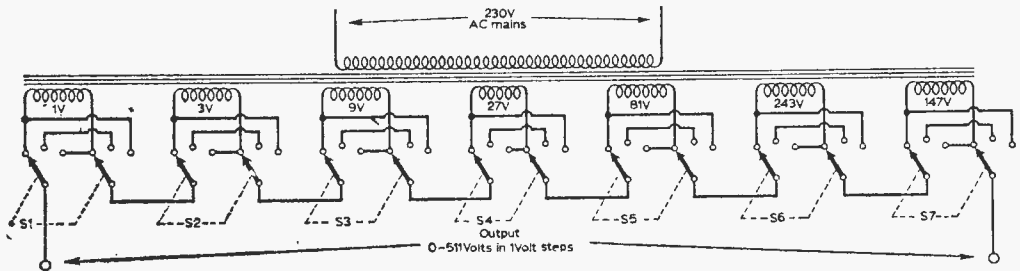

Fig. 2: This arrangement provides the same voltage range in the same increments as that of Fig. 1. It has the advantage of using less switches, however each switch is three-way instead of two-way as in the first circuit.

may be added in order to give the transformer the same range as the one using the binomial system. In this case the winding will give an output of 147V.

This second system is not as convenient to use as the binomial one but it has the advantage that only seven windings and switches are used as compared with nine in the alternative system, with the result that the transformer is easier to construct. The reduction in cost of components is offset by the fact that three-way switches must be used instead of two-way for selecting voltages.

Fig. 2 shows the switching layout used with this circuit. With the switches turned to the left position the windings are connected in phase. In the centre position the windings are out of circuit and a shorting link connected across the switch. In the right hand position the connections of the windings are transposed so that the voltages are in anti-phase. Once again the switches should be of the break before make type, and the supply to the transformer should be broken before ranges are changed.

The 2 pole, 3 way switches should preferably be of the lever type and for convenience of use of the finished instrument the front panel should be marked by each switch with a plus minus, or off sign with the voltage and current rating of the corresponding winding.

\* This is, of course, the same as saying that each number is made three times as great in value as the number which preceded it, but in the view of the author the expression used in the text makes the fact of the effect of the series more comprehensible.

The total Watts, therefore, are:—

$$(1 \times 6) + (3 \times 6) + (9 \times 6) + (27 \times 2) + (81 \times 0.2) + (243 \times 0.2) + (147 \times 0.2) = 6 + 18 + 54 + 54 + 16.2 + 48.6 + 29.4 = 226.2W.$$

The cross sectional area of the core may now be evaluated, using the formula:—  $A = \frac{\sqrt{W}}{5.58}$ , where

W = Watts and A = the cross sectional area in square inches. The area is the product of the width of the centre limb of the core and the thickness of the total stack. For reasonable efficiency the thickness of the stack should be between 1 and 1.5 times the centre limb width.

Using the above formula it is found that \*A = 2.7 in. approximately.

The formula giving the number of turns required to give a particular voltage is:—

$$E = \frac{4.44 \times f \times H \times N \times A}{100,000,000}$$

where E is the voltage required, f is the frequency of the supply, H is the working number of lines of magnetic flux per square inch of the core, N is the number of turns on the winding and A is the area as above.

\* In some text books, when calculating the cross sectional area of the centre limb, the formula is based on the power drawn by the primary, which is, of course greater than that given by the secondary windings. It is found, however that in these cases the calculation is usually based on the assumption that the maximum flux density will be 60,000 lines, and not the figure of 50,000 lines used in this article. Either case will give about the same result

The frequency will be 50c/s and a safe flux density figure for working purposes is 50,000. Assuming these figures, the formula can be simplified to give the required number of turns per volt

for any winding, as follows:— 
$$N = \frac{I}{0.1332 \times A}$$

Using this formula it is found that the turns per volt required is approximately 3, errors of several per cent being allowable in these calculations.

The primary winding should be tapped for 210, 230 and 250V working and the number of windings will therefore be  $250 \times 3 = 750$ , tapped at 690 and 630. The secondary windings will have 3, 9, 27, 81, 243, 729 and 441 turns respectively.

The wire gauges may now be determined. The transformer will have an efficiency of between 80 and 90%, so the transformer primary will be drawing more power from the mains than is being given out by the secondaries. If an efficiency of 80% is assumed and remembering that the secondary is to supply up to 226W, the primary

will be required to supply up to  $226 \times \frac{100}{80} = 285W$ .

The normal mains voltage will be 230V, so the primary will take up to  $\frac{285}{230} = 1.24A$ . When choosing

the gauge of wire it should be selected on the basis of a maximum current flow of 2,000A per square in. The cross sectional area of a suitable wire will therefore be:  $\frac{\text{Amps}}{2,000}$ , and bearing in mind that the

area of a circle is given by the formula  $\pi r^2$ , the following formula may be evolved to give the diameter of wire required, where D is the diameter and A is

the working Amps:  $D = 2 \times \sqrt{\frac{A}{6280}}$ , which in the above example works out at 0.0284in. Reference to a table of wire gauges will show that 22s.w.g. will therefore be satisfactory for the primary winding.

The 6A secondaries will require 14s.w.g., the 2A winding 19s.w.g., and the 200mA windings 28s.w.g.

In home constructed transformers it is best to use enamel covered wire in the lighter gauges up to about 28sw.g. and silk or double cotton covered for the heavier gauges.

The space taken up by the windings should now be checked. Reference to wire tables will show how many turns per square inch will be taken for different types of wire, and from this the window area required for a given transformer can be worked out.

The primary is 22s.w.g., d.c.c. and can be wound at 640 turns per square in., so the 750 turns of the primary will occupy just under 1.2 square in.

14s.w.g., d.c.c. occupies one square in. with about 140 turns, so the 39 turns of the three 6A windings will fill about 0.3 square in.

The 19s.w.g. is wound at about 350 turns per square in., but as this gauge may be difficult to

obtain 18s.w.g. may be considered as an alternative at about 290 turns per square in., in which case the 81 turns of the 2A winding will occupy about 0.28 square in.

28s.w.g. enamel covered winds at 3,700 per square inch, so the remaining total of 1,413 turns will occupy a further area of about 0.38 square inch.

The total area occupied by the windings will therefore be  $1.2 + 0.3 + 0.28 + 0.38 = 2.16$  square in. Added to this must be a certain amount for insulation and the bobbin on which the windings will be wound. With these dimensions in mind and remembering that the cross sectional area of the core must be about 2.7 in., a list of core stampings may be consulted to find the most suitable type.

For the transformer constructed it was decided that No. 33 Stalloy core stampings would meet the stipulated requirements, the width of the centre limb being 1.25 in., and the window width and height being 1 in. and 2.75 in. respectively.

The 2.7 square in. Cross sectional area of the core worked out at the beginning of the calculations is the minimum permissible area. It must also be remembered that the core is made up from a number of laminations, each one of which is coated on one side with an insulating material so that the completed core will have a high overall electrical resistance and will absorb little power from the mains, which would otherwise result in overheating of the core. The insulation material will take up a certain amount of space and for this reason the physical thickness of the core should be some 10% greater than the calculated electrical thickness. The total physical thickness of the core in this example must therefore be at least 2.42 in., so to keep the figures nice and round a thickness of 2.5 in. (or 2.25 electrical in.) While

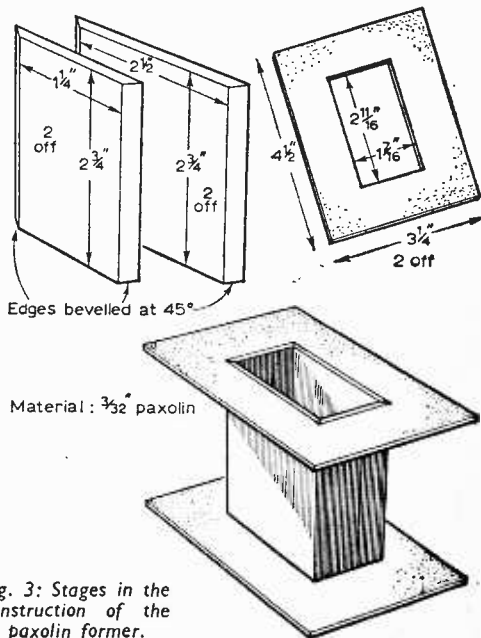

Fig. 3: Stages in the construction of the paxolin former.

this figure is higher than the optimum 1:1 to 1:1½ centre limb width to thickness ratio stipulated earlier for maximum economy, it may still be considered as satisfactory.

The former on which the windings are to be laid will take up a certain amount of window space, and the one used in the construction of this transformer was made from 3/32 in. paxolin to the dimensions shown in Fig. 3, although stout cardboard coated with shellac varnish may be used if preferred. The former will reduce the available window area in three directions and the area now available now becomes:

$$.29/32 \times 2\frac{7}{8} = 2.32 \text{ square inches.}$$

This leaves 0.16 square in. of window space for insulation between the windings. With all the necessary calculations for the design of the transformer now completed, the construction may start. This is a quite straightforward task.

### Construction

The former is made first, with inside dimensions as shown in Fig. 3. Each end of the four individual "walls" must be bevelled at 5°, so the outside dimensions of the wall should be made longer than the inside by twice the thickness of the wall material. A pair of end cheeks must then be made, as shown, which must be a TIGHT fit over the resulting tube. The bobbin may now be given a test fit on the centre limb of the transformer, which may be temporarily assembled. When it has been checked that the bobbin is perfectly square all the joints should be locked together with a strong adhesive such as Araldite, ensuring that none comes into contact with the core. When the assembly has dried a few turns of insulating tape may be wound on to it to prevent any sharp edges from damaging the insulation of the windings.

As the windings are laid their ends may be taken out through holes drilled in the end cheeks. These holes may be drilled before the bobbin is assembled or as they become necessary, whichever is preferred. In the latter case, however, care must be taken to ensure that windings are not damaged in the drilling process.

The primary winding should be laid on first. One end should be taken out through a suitable hole in the end cheek and the remainder of the winding wound on to the former.

22s.w.g. d.c.c. winds at about 25 turns per in., so the 750 turns will occupy about 12 layers. Starting at one end, the turns must be laid on evenly side by side and when a layer has been completed wound back in itself, the tension being kept even all the time. When the 630th and 690th turns are reached, a loop should be taken out through a hole in the end cheek for mains tapping points.

When a considerable voltage exists across a winding there is a danger that there may be sufficient potential difference between individual layers of the winding to cause the insulation to break down with resulting damage to the transformer. This danger is particularly acute if enamel insulated wire is used, and it is good practice in this case to place a layer of some insulating material, such as empire cloth, wax paper, etc., between about every fourth layer or so. In the case of

double cotton covered wire this may not be considered so necessary but nevertheless it will do no harm and in the case of this particular transformer a layer of thin wax paper was laid every fourth turn.

The number of turns must be carefully counted and care taken to ensure that the direction of winding is not inadvertently reversed after taking out a tapping point.

When the winding is completed its end should be taken out through the end cheek and the complete winding covered with empire cloth or glassite.

An electrostatic screen, to prevent mains interference being transmitted to the secondaries, may be wound over the finished primary winding. A single layer of 34s.w.g. enamel will do, one end being anchored internally and the other brought out via insulated sleeving for attachment to earth of the chassis of the instrument in use. The winding will draw no current but none the less, no turns may be short circuited, otherwise damage will occur to the transformer. This winding must also be covered with empire cloth, as must all the remaining windings.

The secondary windings are wound in a manner similar to that outlined above, insulation being provided where required.

When all the windings have been completed the assembly may be given a few extra layers of insulation tape to occupy the full window area and then fitted over the transformer centre limb, the lamination being interleaved in the normal manner. The last few stampings must be a tight fit in the bobbin in order to prevent transformer vibration.

Clamps are now made up to the dimensions shown in Fig. 3 and fitted to the core, holding the laminations tightly together and providing a means of mounting the finished transformer.

Finally, the windings should be given a check for insulation between each other and (except in the case of the electrostatic screen winding) the transformer core. If possible this check should be carried out at a minimum of 1,500V. If the test is passed, as it no doubt will be, the transformer can be connected to the mains supply, via a fuse, and the voltages checked. If these are as designed, a working load, preferably at the maximum rated output, may be placed across the secondary windings and the instrument left in operation for an hour or two, after which time the transformer should still be running reasonably cool. If all these tests are passed, and they should be if the procedure laid down in the preceding pages has been correctly followed, the variable voltage transformer may be considered "ready for use".

To make the transformer more versatile the circuit shown in Fig. 4 may be used. This allows either a.c. or d.c. outputs to be selected, as required, and provides overload protection to all the windings. A warning lamp is connected across the 3V winding so that an indication is given when the unit is turned on. It can be seen that seven fuses are fitted for the secondary windings, one to each winding, and one 3A slow blow fuse is fitted to the primary winding. In the d.c. output position the a.c. output from the transformer is fed to a bridge rectifier, the output of which is fed to the two output terminals. It would be possible, by

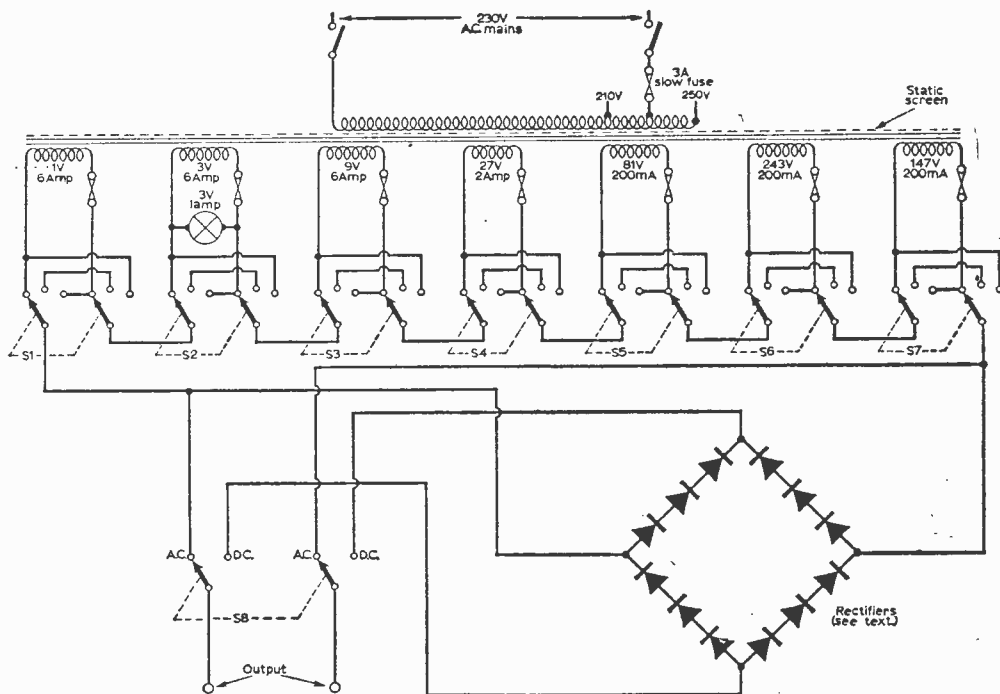

Fig. 4: An improved design which provides for either a.c. or d.c. outputs and which includes an overload protection to all the windings.

more complex switching arrangements, to make available a choice of two rectifier circuits, one rated to pass 6A at 40V and the other to pass 200mA at 511V depending on which windings are in circuit. This would have the advantage that the cost of the rectifiers would not be so great and that a smoothing circuit could be built into the unit for use with the higher voltage supply. It was considered, however, that a smoothing circuit

would detract from, and not add to, the versatility of the unit, and that the reduction in cost of rectifiers would be more than offset by the increased cost of switching. The unit shown in Fig. 4 therefore gives an unsmoothed d.c. output and uses a total of 12 rectifiers, 3 in series in each arm of the bridge. Each rectifier is rated at 200 p.i.v. 6A, available from G. W. Smith (Radio) Ltd., 34 Lisle Street, London, W.C.2.

# Meanwhile, in Practical Television (Sept. issue, out Aug. 19) there are articles on:

- GETTING THE BEST FROM TV AERIALS: FAULT-FINDING TESTS: THERMOPLASTIC VIDEO RECORDING: PRACTICAL OSCILLOSCOPY: REGULAR SERVICING FEATURES: NEWS: COMMENT AND MUCH MORE.

**Only 2/-**

## CAN YOU COMPLETE THESE TITLES?

- Commentary . . . . . Auto . . . . .
- Noughts . . . . . Machine
- Audible . . . . . Car
- Echo . . . . .

If not see September  
**PRACTICAL ELECTRONICS**  
on August 12

P.S. See you at GOONHILLY on page 764

## A COMMENTARY BY HENRY PRACTICALLY WIRELESS

# No. 13 Hey-Nano- Nano

IT is a couple of months since Britain decided to scrap the rod, pole and perch for decimal measure. To read the frantic announcements in the Daily Press, this was a sudden, panic decision, construed, according to one's political leanings, as a sop to some Gallic Cerberus or a late qualification for the Common Market. The fact that the rest of Europe is still at Sixes and Sevens after a thousand years of living in each other's backyards is overlooked.

We are not really so remiss. The change has been coming about for years. Indeed, the Association of British Chambers of Commerce acidly commented that they were pressing for conversion in 1867. And in 1960, the Pharmacopoeia Commission had asked the President of the Board of Trade to include provisions for conversion to the metric system in weights and measures legislation.

We radio bods are in the forefront of the metric (though hardly meteoric) advance. Even the most conservative among us accepts little Pico. In characteristic British fashion, we dub him with the accolade of a nickname, "puff". Nano is beginning to creep into service data and decimal points are commonplace.



An n on a diagram is a  $\mu$  printed upside down.

There are, it is true, some service engineers who tend to think that an n on a diagram is a  $\mu$  printed upside-down by mistake. Who are happier with "two-O's-one" or "thousand-puff" than the simple 1nF.

Henry is interested in the semantics of the matter. These prefixes have such euphonious names. Pico strikes me as a bambino; cheeky, quicksilver, all curls and flashing eyes. Nano is his buxom mother, all "ten-to-the-ninth" of her. The rapsallion Tera is the father-figure, doyen of the betting shop and Labour Exchange queue, while Giga can only be the skittish teenage daughter.

Think how different it might have been had some British Commission been entrusted with the titling. Some Snow-type professor, with one eye on the devalued M.B.E., would have christened the terms, Bander, Grubbit and Splodge.

Straightforward conversation is fair enough. We can manage to think of a 23in. cathode ray tube as 59 centimetres, and we may even be happier with 19 and 9.5cm/sec speeds for our tape recorders than the familiar  $7\frac{1}{2}$  and  $3\frac{1}{2}$ in/sec, while 4.75 is a boon to the chap whose typewriter does not sport an "eighth".

But there is more to it than this. Screw sizes, cable specifications, appliance weights and capacities will have to be altered. No doubt there will be some retooling in the "white goods" sector of the trade as kettles, for example, have modified capacities from pints to decilitres. Round figures look better in advertising.

You can bet that the consumer will gain little by such conversions that entail a quantity change. Like the grabber who stuck an extra ha'penny a packet on detergents because the petrol tax went up by sixpence a gallon,



Round figures look better in advertising.

and made a fat profit, the dealer who has to extend his counter-top measure by 3.37in. to make a yard into a metre is hardly likely to split the difference on the retail price of cable. The increase always goes, as we note at Budget time, to the next highest whole figure.

We radio enthusiasts get a bit of a boost in remembering that we are in the forefront of the modernising trend. We have been dealing in kilocycles and megohms and happily shifting the decimal point along the decibel scale since we graduated from thinking about crystal sets.

Of course, this streamlining of terms is all part of the trend to internationalise life. In a world of quick communications, it is necessary that we all understand each other.

Which brings us, eventually, to the crux of the matter. The utter failure of manufacturers, at domestic level, to back their products with adequate information.

What use is it to internationalise the terms and specifications of radio and electronics when the hardware that lands on our workshop-bench has not so much as an accepted component coding, let alone the common courtesy of a circuit diagram to enable us to sort out the puffs from the Nanos?

# Wharfedale MAGNIFICENT BASS UNITS

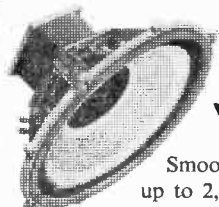

### W15/RS

15 ohms.

Smooth response up to 2,000 c/s and down to 25 c/s in suitable enclosures as small as 4 cu. ft. Flux density 13,500 oersteds.

**£17.10.0**



### W12/RS/PST

15 ohms. For clean bass down to 25 c/s in large enclosures or 30 c/s in small ones. Flux density 14,000 oersteds.

**£10.15.0**



### SUPER 3

3 or 15 ohms. One of the most efficient treble units in the world, covers the range 1,000 to 20,000 c/s with remarkable smoothness. Flux density 14,500 oersteds.

**£5.16.8 inc. PT**



### SUPER 5

3 or 15 ohms. Similar to Super 3, particularly useful in compact systems. Covering 300 - 17,000 c/s. Flux density 14,500 oersteds.

**£5.19.7 inc. PT**



### PST 4

15 ohms only. Low cost tweeter with cloth surround and polystyrene diaphragm covering 300 to 15,000 c/s. Flux density 11,500 oersteds.

**£3.4.2 inc. PT**

# Wharfedale TWEETERS

# Wharfedale CROSSOVER UNITS

for fully descriptive folders on Bass Units, Tweeters and Crossover Units write Dept. P

**WHARFEDALE WIRELESS WORKS LTD**

IDLE, BRADFORD, YORKSHIRE

Tel. Bradford 612552/3

Grams: "Wharfedale" Bradford



### QS/800

Quarter section two-way network with crossover frequency of 800 c/s. 7 - 16 ohms. only. Maximum attenuation of about 6dB per octave.

**£2.17.6**

### HS/400/3

Half section three-way separator with crossover frequencies at 400 and 3,000 c/s. 7 - 16 ohms. only. Attenuation of about 12dB per octave.

**£6.5.0**

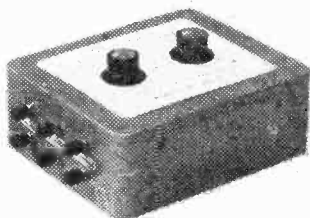

THE WORD **MAXI-Q** IS THE REGISTERED TRADE MARK  
REGD.  
 OF Denco (CLACTON) LIMITED  
 IT IS ALSO A GUARANTEE OF  
 WORKMANSHIP AND  
 TECHNICAL PERFORMANCE

OUR RANGE OF PRODUCTS IS SO GREAT THAT WE NOW HAVE TO REQUEST THE AMOUNT OF 2s. 0d. FOR OUR GENERAL CATALOGUE AND TO SAVE YOU POSTAL ORDER POUNDAGE CHARGE WE REQUEST SEND 2s. 0d. IN STAMPS.

**ADVANCE INFORMATION.** Shortly available Self Contained Multiplex Decoder Plug In Unit, aligned ready for immediate use, that will convert your two receivers—tuner and two amplifiers—tuner and stereo amplifier or stereo receiver without Multiplex provision to a complete B.B.C. Stereo Broadcast Reception Unit. Provisional Price **£8.0.0.** Technical publication MD.I. price 4s. 0d. post paid.

**IFT11/465** kc/s centre tapped transformer for use in crystal filter circuits are now being produced in response to increasing demands. Price **10s. 6d.** each plus 8d. postage.

In order to maintain our lowest possible selling prices will all readers please send S.A.E. with all enquires to ensure reply.

**DENCO (CLACTON) LTD.**

(DEPT. P.W.)

357/9 OLD ROAD, CLACTON-ON-SEA, ESSEX

**NOW ADD F.M. RADIO to your MARTIN AUDIOKIT SET-UP**

with only 3 easy-to-assemble prefabricated units

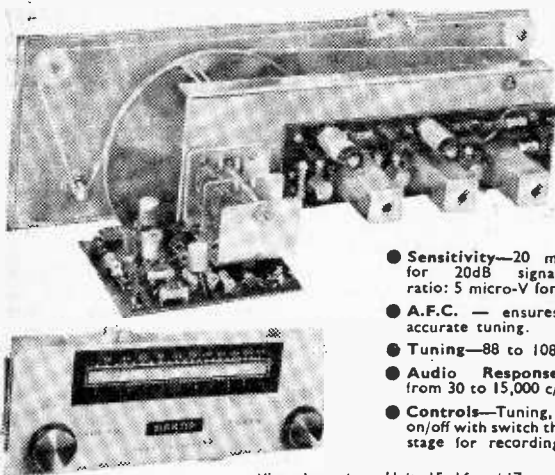

The unique and outstandingly successful system developed by Martin Electronics whereby prefabricated transistorised units can be assembled to make your own choice of hi-fi now brings 3 further Units, No. 15, 16 and 17 to enable you to build a modern F.M. Tuner of exceptionally good design and performance. Intended primarily for those who have chosen an Audiokit hi-fi set-up, the Tuner may also be used with other good amplifiers if desired. With a few simple connections, you will have a tuner of excellent appearance to please the most critical ear, yet it is surprisingly inexpensive.

A whole range of Audiokit Units is available which you can assemble to your own choice with ease and complete success. Ask for the Audiokit leaflet.

- Sensitivity—20 micro-V for 20dB signal/noise ratio; 5 micro-V for 40dB.
- A.F.C. — ensures easy accurate tuning.
- Tuning—88 to 108 Mc/s.
- Audio Response—Flat from 30 to 15,000 c/s.
- Controls—Tuning, and on/off with switch through stage for recording, etc.

View above shows Units 15, 16 and 17 assembled. Below, the attractive escutcheon.

**UNIT 15**  
F.M. Head & tuning condenser

**£5.12.6**

**UNIT 16**  
I.F. Amp.

**£5.7.6**

**UNIT 17**  
Mounting drive escutcheon & controls.

**£1.17.6**

**SUPERB QUALITY FOR VERY MODEST OUTLAY**  
From Radio and Hi-Fi Stockists

Trade enquiries invited

**MARTIN ELECTRONICS LTD.** 154/5 High Street, Brentford, Middlesex ISLeworth 1161/2

**MARTIN ELECTRONICS**  
 154 High Street, Brentford, Middlesex  
 F.M. Tuner Leaflet ● Audiokit Leaflet ●  
 Tick as required

Name .....

Address.....

.....

P.W.9



# on the Short Waves

## MONTHLY NEWS FOR DX LISTENERS

All times are in G.M.T.

All frequencies are in k/cs.

### The Broadcast Bands—by John Guttridge

SO much has happened this month that we are giving the information in short note form. We hope this will make it easier for you to pick out items you are interested in.

**China:** *Radio Peking* has English to Australia, 0830—1030 on 9,457/9,340/11,600/11,650/15,060/17,835; to Europe, 2030—2230 on 6,210/7,080/9,457/11,630. (W. Smith, D. Hill, E. Conduit and E. Ashburner.)

**Japan:** *Radio Japan*. Tokyo is running a competition for true stories concerned with the promotion of international goodwill. The stories should be 600 words in length and must arrive at Radio Japan by August 31. The European service is now on 11,780/15,135 from 0615—0845. Full QSL verification is now reported. (E. Conduit and M. Barraclough.)

**North Korea:** *Radio Pyonyang* now uses 6,540/7,580/9,875/11,750 for the 1900—2000 English transmission and 14,520/15,520 for the 0400—0500 transmission. Full QSL verification. (E. Conduit.)

**Australia:** *Radio Australia* (P.O. Box 428G, Melbourne) made the following changes in its summer schedule: English: 2059—2300 17,715/15,240; 0645—0915 11,710/9,570; 1800—2215 9,600; 0645—0745 (U.K.) 11,710/9,570; French, 2315—0015 17,715. (E. Conduit.)

**U.S.A.:** *Radio New York Worldwide* (New York 19), summer English schedule is 1200—2400 on 15,440; 1245—1600 17,845; 1600—2145 17,840; 1445—2200 17,730. On August 27th at 2330 and August 28th at 1900 it is to hold its Dxing Worldwide contest with souvenirs for all who enter. (Roy Patrick and A. J. Price.)

**A.F.R.S.** (250 West 57th Street, New York, New York 10019), has extended transmission hours to 1330—2245 15,430/15,330; 1330—2300 15,350, 2300—0400 9,715 and 0045—0400 on 6135. The 9,715/6,135 transmissions are beamed to the Caribbean but can be heard in the U.K.

Medium wave stations WINS, New York, on 1,010, WNEW, New York on 1,130 and WMEX Boston, on 1,510 may be heard at 0400. (Roy Patrick.)

**United Nations Radio**, United Nations, New York. Evening debates are relayed to Europe by 15,315 (Bethany) /15,150 (Bound Brook) /11,940 (Greenville). (E. Conduit.)

**Canada:** CHU (3 Observatory Crescent, Ottawa 4, Ontario), is a time signal station and transmits continuously. It may be heard around 2230 on 14,670. Gives full QSL verification. (E. Conduit.)

**Cuba:** *Radio Habana* (Apt. Postal 7026, Habana), English to Europe from 2010—2040 now

on 15,155. Interference with ELWA, Monrovia, makes the channel useless. Some QSLs give full details. (W. Smith, E. Conduit and B. Young.)

**Windward Islands:** Windward Islands Broadcasting Service, St. George's, Grenada, has moved from 15,085 to 15,100. Transmits from 1900—2235 with request programme at 2100 (P. Harris.)

**Swan Island:** *Radio Americas* (P.O. Box 352, Miami, Flo., U.S.A.), may be heard on 1,160 medium wave in Spanish during the very early morning. (Roy Patrick.)

**Brazil:** *Radio Journal do Comercio* (Rua Marquêsdo Recife, Pernambuco), may be heard at excellent strength after 2200 on 15,145. (P. Harris.) *Radio Nacional Brasilia* (Setor Radio eTV, C.P.95, Brasilia), is good strength on 11,720 after 2200. May be heard on 15,445 at 2245 when VOA-Monrovia closes. (P. Harris.) *Radio Guaibe* (Rua Caldas Jr 219, Porto Alegre), gives full QSL verification. (M. Barraclough.)

**Venezuela:** *Radio Rumbos* (Apt 2618; Caracas), gives full QSL verification.

**Ecuador:** *La Voz de los Andes* (HCJB). (Cas 691, Quito). Transmits now to Europe from 0430—0700 and 0930—1000 Sundays on 11,915/9,745/6,050 and 1800—2200 on 17,890/15,115. (French 1830, English 1845—2030.) This station is now changing its QSL every month and will insert full details if requested. (E. Conduit and P. Reilly.)

**Argentina:** *Radio El Mundo* (Maipu 55), has been heard on 1,070 medium wave (call LR1) at 0430. (Roy Patrick.) *Radiodifusion Argentina al Exterior* (Sarmiento 151, Buenos Aires), now broadcasts to Europe in English from 2010—2020 on 6,090/11,710/11,780. The best outlet is 11,780.

**Romania:** *Radio Bucharest*, (P.O.B. 111 Bucharest) has dropped its 2100—2130 English transmission. At 1500 there is English to Asia on 15,250 and Africa on 15,315/11,940/11,810. Transmissions to North America are at 0130—0230, 0300—0330, 0430—0500 on 11,940/11,810/9,590/9,510/6,190/6,150 and 9,535 (not 0130).

**Bulgaria:** *Radio Sofia*, now uses 9,700 instead of 6,070 for English to North America at 0000—0030 and 0400—0430. For the 2130—2200 English broadcast 7,255 is now being used in parallel with 6,070. (W. Smith.)

**Hungary:** *Radio Budapest*. 0300—0330 English transmission is now on 9,833/7,305/7,215. To be a member of this station's Dx Club listeners must report on at least one programme a week, reports being sent in in the last week of the month. Special report forms are provided. (W. Smith.)

**Vatican:** *Vatican Radio* now uses 15,120/11,740 for its 1600—1615 English transmissions to India. (W. Smith.)

**Satellites:** Both American and Russian satellites have used the 19,990 to 20,010 band but none of these has sent signals of the sort mentioned in the

July PW. Both countries will verify correct reports on their satellites. (J. Layton and M. Barraclough.)

**V.H.F. DX:** On May 28 from 1700—1900 many European and even Near East stations were coming through on v.h.f.—f.m. The best was the 10kW AFN Stuttgart on 102.4Mc/s. (P. Harris.)

## The Amateur Bands—by David Gibson G3JGD

**T**HE pitiful pleas of your scribe for 28Mc/s logs has been answered by a few angels of mercy.

**K. Chattenton** (Middlesbrough, S740, 21Mc/s dipole 12ft high) reports DL, F2, 11, EA4 and ON on a.m. or s.s.b. between 1700 and 1830. **Wilfred Smith** (West Bromwich, EC10 plus pre-selector, 200ft. folded dipole) logged these on a.m.:—9J2DT, UA6OEQ, CR6BR, LU7HAR, CTIOF.

**Alex Thurlow** (Croydon) answers the call for "anyone with a beam". He uses a 3-ele. homebrew and reports I, EA, UA and other Europeans. From further afield: CR6HF, 6GL (1826); CX2CN (2134), EL2O (1729), LU1DAB, 3BAC, 4DM (2130), OD5CS (0954), PY1KZ (1912), VS9ADD (1543), ZE2JA (1057), ZC4PC (1452), 4U1ITU (1155), 5N2KOB, AAF, AAC (1813); 5Z4AQ, 7X2BB, 9G1FS, 9H1R, 9J2DT. Times in GMT as a guide to openings.

On July 4th, short skip opened up and the band was jammed (literally) with Europeans. I worked HB9ADH 599, DL3HS 58, and DJ3JX 56, on a 12ft. piece of lighting flex draped across the workbench.

### FIFTEEN

Only two brave souls ventured forth and sent in a log. **Keith Ranger** (Strood) with a t.r.f. and 27ft. of wire round the room raised the following on c.w.: CR4AE, 6DA, EL8X, KV4CX, VP5BH/MM, ZD8BC.

**P. Collins**, Leeds (Marconi RX, 90ft. long wire); CE2DN, CN8BB, CR3DA, 5SP, 6JM, 7BS; CT3AL, EP2BU, ET3LS, FL8OR, HK1ASP, HP1BH, JA6BGS, KP4AXC, LU8DB, LX1DC, MP4DAA, ZS8C, 4X4LM, 5X5AU, 7X2BB, 9H1R (Malta new prefix), 9J2DT, 9K3FR (Kuwait—Saudi, Neutral Zone), 9N1KB (Nepal), 9X5DV, 9U51V, all on a.m.

### L.F. BANDS

No one bothered with topband this month. One of the interesting points about this band is the number of mobile rallies. Nearly always there is a talk-in station on 160 and one can hear the /M (mobile) getting instructions from the talk-in on how to get there.

On Eighty, **Alex McKeown**, Co. Fermanagh (19 set, 135ft. long wire): numerous G's and GW3R1B, 5B1, 3SVY, GM2CUV, EI6AL, HAN, 3Z, and G13MZZ. **J. Barton**, Walmer (Domestic RX, 12ft. whip) reports his G activity on eighty including GW3SOA, TOX. He also reports harmonics from Radio Caroline!

On 40 S. **Wilson** using a CR45 and another of those darned coathangers got these in 15 minutes on c.w.: UR2AC, PAØCD, G3PTO, DJ7SI, DL8NE, PX1UE (Andorra).

**Alan Dailey** (Leeds) found VP2SM 56 at 2335 and ZP5KT 56 at 2355 both s.s.b. on 7Mc/s. Alan suggests that SWL Jolley's "5K4ALE" is HK4ALE since the difference between 5 and H is only one dot.

### TWENTY

Wide open and with world-wide traffic on it most of the time. **D. Rollett**, Navenby (AR77E, 150ft. long wire) VK2NN, VK5AL, VP6WR, VS9HB, VU2CQ, ZD8HL, 5X5IU, KR6KS, W2Z1A/ZK1, all s.s.b.

**Alan Dailey** (R107 plus pre-selector, 90ft. long wire) CE1CU, CP5AD, CEØXA (San Felix), DU1AA, HR3HH, IP1ZGY (Pantellaria Is.), JT1KAA (Mongolia). Well done, Alan! KH6FBJ/KJ6, OA8P/3, PZ1BW, VK5MS (at 2330 too!), VP4VP, VR2EK, ZP5CG, 9M2CR. All s.s.b.

Messrs. **McNeill and Johnson**, Glasgow (CR300/2, 50ft. long wire) found these on a.m.:—AP2DS, BY2BEE, EL4AC, EP2RW, H14PU, HZ1AB, KP4RU, MP4TBT, OHØAB, PY1NAX, SVØWGG, TU2AA, VK2OLM, JY1AU (Jordan), LU2BG, VE8RA, W6VPH, YV5AEV, 6Y5LK, ZC4GT, XP5EE, 3A2CP, 5A1TJ, 7Q7TBD, 9X5CF (Rwanda).

**N. Ponsford**, Devon (CR45, 60ft. long wire): 11, OH, OZ, SM, UW, and 5A2TR, 5N2JEB, VU2CQ, HM1AX (Korea).

**C. Edwards**, Warwick (R107, PR30, RF26, 20m dipole) did well on s.s.b. with HZ1AB (1535), JY1AU, KH6OR, KL7FDA, OA4AJ, OHØAB (1715), PY2TXC (1916), VE8RX, VK2NN, VP3HAG, VS9AE (1723), W2Z1A/ZK1, YV1OT, YV5ANF (1910), ZL3HA, 5N2FMT (0800), 5X5IU (1846), 7Q7PBD. All between 0530-0630 except where otherwise given.

**S. Shaw**, Cheshire (HE30, 150ft. E/W longwire) found KP4AXC, MP4BCC, OX3JV, PY4AS, VE7CE, VEØNE/MM, ZL3MG, 3A2BF, 4X4DK.

### THIS AND THAT

VR6TC (Pitcairn Is.) is on 14040kc/s c.w. usually Mondays around 2130. 5J4RC is a special station in Bogota (Colombia). VK9CR is on Cocos-Keeling and VK9DR still brass pounding from Christmas Is. JT1KAA is active from Mongolia (Anyone heard this one?). Tnx Alan Dailey.

Twenty metres reported wide open to W6 and 7 early mornings with Pacific and Australian DX coming in as late as 17-1800. GB3LER, the 28Mc/s beacon, has been heard several times in Stockport at 1030, 1100 and 1700. Reports on this beacon would be appreciated. It is thought that W8CV is an American church which has skeds

—continued on page 406

# PRINCIPLES OF AUDIO

by G. D. Howat

## PART ONE

**I**N the world today, everyone is constantly surrounded by sounds of many kinds—to escape noise is almost an impossibility. Yet how many people know exactly what sound is—how it travels—what sounds would look like if they were visible?

It is the aim of this article to attempt to answer some of these basic questions and also to probe the mysteries of sound recording and reproducing methods. A knowledge of the nature of sound is essential for anyone wishing to design apparatus for recording it.

### Molecule Movement

Supposing a ruler is fixed with one end clamped against a table and the other end is "plucked". The ruler oscillates producing a buzzing sound—a trick known to every schoolboy. This simple experiment gives an interesting clue to the nature of sound waves: consider the motion of the air molecules about and beneath the ruler.

As it moves up and down the molecules are pushed rapidly backwards and forwards as shown in Fig. 1. This is what constitutes a sound wave, a back-and-forth motion of the air molecules through which the sound is passing. Each oscillating molecule pushes the adjacent molecules to and fro and thus the wave is propagated in all directions.

In point of fact the molecules constituting a gas are

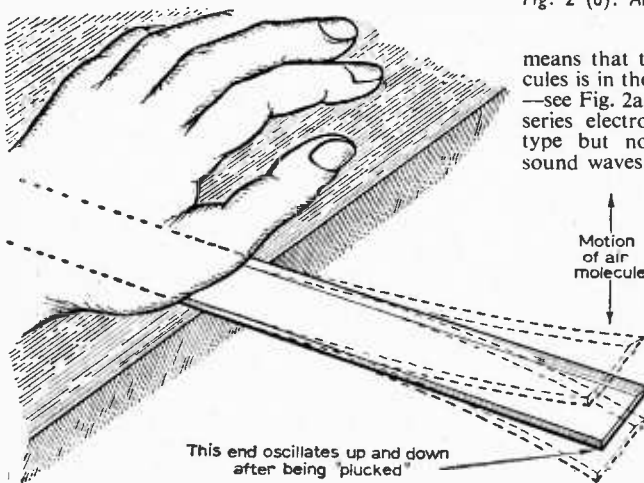

Fig. 1: This simple ruler experiment gives a clue to the nature of sound waves.

not stationary (except at absolute zero); at room temperatures they are rushing around at speeds of several hundred feet per second. However, this does not invalidate the arguments, since there is always a certain number of molecules in a given volume of gas. The molecules are not quite 100% elastic so the amplitude of the oscillations falls off at increasing distances from the source.

One important feature about this type of wave should be noted—it is a longitudinal wave which

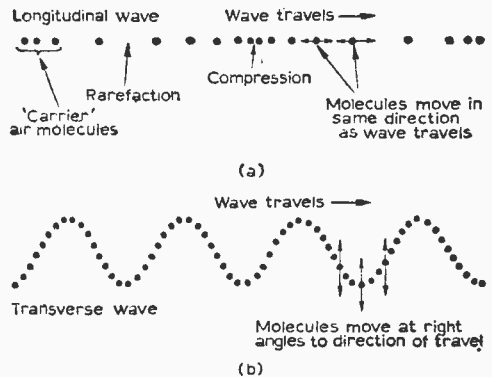

Fig. 2 (a): Air molecule longitudinal wave motion, (b): transverse wave motion.

means that the back-and-forth motion of the molecules is in the same direction as the wave is travelling—see Fig. 2a. The representation of sound waves as a series electromagnetic waves are of the transverse type but not sound waves. Unfortunately, when sound waves are displayed on an oscilloscope screen they appear as the transverse type, this fact can lead to confusion.

### Velocity and Wavelength

The velocity of sound varies a great deal with external factors. The medium through which it travels has the greatest effect—the velocity in air at 0°C is 1087ft. sec.<sup>-1</sup> but in aluminium it is nearly 17000ft. sec.<sup>-1</sup> The temperature of the medium has an effect on velocity and in the case of gaseous media such factors as the percentage saturation by water or other vapours causes quite a change.

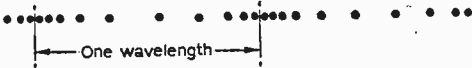

Fig. 3: One wavelength of a longitudinal wave, showing the successive compressions (rarefactions).

The wavelength of a longitudinal wave is the distance between successive compressions (or rarefactions)—see Fig. 3. The frequency of the wave is the number of compressions passing a given point during a fixed time interval, usually 1 second. Velocity  $V$ , wavelength  $\lambda$  and frequency  $n$  are connected by the simple equation  $V=n\lambda$ , this being true for any wave of any type.

It is seen from this that  $n$  and  $\lambda$  are inversely proportional to each other, i.e. if one increases the other must decrease. There is a definite relation between pitch, frequency and musical scales—this will be discussed later.

### Loudness and Amplitude

It has already been shown that sound waves consist of a back-and-forth oscillation of air molecules. It is to be expected that the loudness of a sound is some function of the amplitude of the oscillations and this is in fact found to be the case.

Unfortunately, it is not a linear function as the human ear has a logarithmic response. This means the appreciated loudness of a sound is proportional to the logarithm of the wave amplitude. Due to this a logarithmic scale of loudness is used when dealing with sound, the units used being decibels (dB).

The quietest audible sound is assigned a value of 0dB which is equal to an intensity of 0.0002 dyne  $\text{cm}^2$ . If the intensity is made ten times greater the sound is 10dB louder. However a further increase of ten times the power intensity makes the sound only 20dB above the threshold level. A table of decibels against power input can be drawn up:

Intensity in terms of threshold=0.0002 dyne $\text{cm}^2$	dB
1	0
10	10
10 <sup>2</sup>	20
10 <sup>3</sup>	30
10 <sup>4</sup>	40
10 <sup>5</sup>	50
10 <sup>6</sup>	60
10 <sup>7</sup>	70
10 <sup>8</sup>	80
10 <sup>9</sup>	90
10 <sup>10</sup>	100

The general equation is  $\text{No. dB} = 10 \log_{10} \frac{P_2}{P_1}$

$P_2$  = power intensity concerned  
 $P_1$  = reference intensity (=0.0002 dyne  $\text{cm}^2$  in this case)

Examples of the loudness of certain sounds in terms of dB are:

- Threshold of hearing 0dB
- Rustle of leaves in gentle breeze 10dB
- House in large city 40dB

- Ordinary conversations 65dB
- Busy street 70dB
- Hammer blow on steel plate 115dB
- Threshold of pain 130dB

The maximum difference between the quietest musical instrument and a full orchestra going flat out is of the order of 80dB, from the previous equations this is seen to correspond to a power ratio of 1:10<sup>8</sup> (i.e. 1 to a hundred million).

### Pitch

As previously discussed, the frequency of a sound wave is the number of compressions passing a given point per unit time. The pitch of a note is a direct function of the frequency of the sound waves carrying it; the lower the frequency of the wave, the lower the pitch. There is considerable controversy as to the limits of frequency which the human ear can perceive. Various authors quote the upper limit as being anywhere from 10-40kc/s.

The truth is, of course, that no two people have identical hearing responses, and that of a given individual often varies widely throughout life. Average valves are somewhere in the region of 30c/s to 15kc/s. The note "middle C" on a piano or organ corresponds (in physics) to a frequency of 256c/s, and the International Concert pitch gives the A above middle C a frequency of 440c/s.

If the frequency of a wave is doubled, then the pitch rises one octave. The octave is thus the most fundamental interval in musical notation. Values of frequency for the various "c" notes on a piano are: (take  $c^1$  = middle C = 256c/s).

Note: CCCC CCC CC C  $c^1$   $c^2$   $c^3$   $c^4$   $c^5$   
 Freq. (c/s): 16 32 64 128 256 512 1024 2048 4096

It is clearly seen that each note is double the frequency of the previous one, and from experience, the difference between two "c"s is one octave. Each octave can be subdivided into a number of smaller intervals, normally into eight, hence the name octave. The frequency spacing between adjacent notes (better called tones) can be further subdivided into semitones, each one having one semitone above it (a "sharp") and one below it (a "flat").

From a purely theoretical point of view, the sharp# of one tone is not quite the same as the flat# of the next tone up the scale, so in the "natural scale" one octave consists of the notes C C# D# D# Eb E E . . . . C1. A piano covering the same range as normal, CCCC— $c^5$ , if provided with all these notes would have a keyboard nearly ten feet long and would be quite unplayable.

Fortunately, the difference between a sharp and the adjacent flat is so slight as to be discounted and it is possible to construct a scale using only twelve notes per octave. This is the equally tempered scale and the twelve subdivisions are formed of notes separated by frequency ratios of 1.0595. The scale begins thus:

Note: C C# D Eb E  
 D# D#

Freq. Ratio: 1.0000 1.0595 1.1225 1.1890 1.260

F# come before E# on the natural scale, but F# comes so close to E, and E# so close to F that in the equally tempered scale there is no note corresponding to E# and F#. Similarly B# and C# are transposed and there is no B# and C#. The above table can therefore

be drawn in full for a whole octave on the equally tempered scale:

Note(s):	C	D $\flat$	D	E $\flat$	F $\flat$	E $\sharp$	G $\flat$	G	A $\flat$	A	B $\flat$	C $\sharp$	B $\sharp$
Freq. Ratio:	1-0006	1-0595	1-1225	1-189	1-260	1-335	1-414	1-498	1-587	1-682	1-782	1-888	2-000

All normal musical instruments use the equally tempered scale.

**Waveforms**

A good sine-wave generator will produce a waveform of the type shown in Fig. 4a. A pure sine-wave, heard by itself, is a most uninteresting sound, lacking any real musical interest and sounding somewhat "ethereal" or ghostly.

Hardly any musical instruments produce pure sine-waves or anything approaching them. Most instruments form highly complex waveforms, even tending towards square waves (Fig. 4b) in some extreme cases. These variations in waveform result from the addition, to the fundamental frequency, of varying amounts of higher frequencies, related to the fundamental by a simple mathematical expression, and called harmonics or overtones.

The harmonics of a fundamental frequency  $f$  are

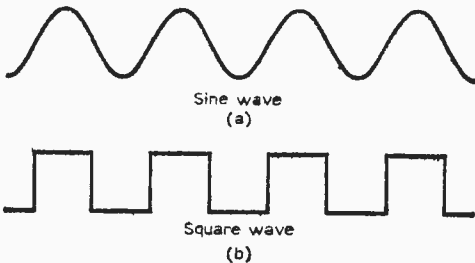

Fig. 4: Waveforms from (a) a sine wave generator and (b) a square wave generator.

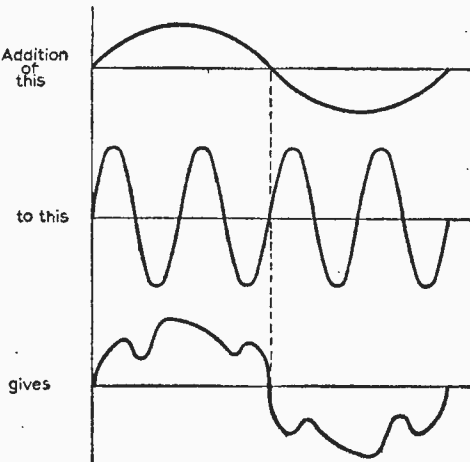

Fig. 5: Addition of fundamental and third harmonic sine wave frequencies.

2f, 3f, 4f, 5f... etc. The result of mixing a fundamental frequency with its own third harmonic is shown in Fig. 5; it is clearly seen that the resultant waveform bears little resemblance to a pure sine curve. The output of many instruments contains very many harmonics, many of which will be above the upper frequency limit of hearing but which nevertheless have an effect on the final waveform.

In the case of certain woodwinds, some harmonics are radiated more strongly than the fundamental note. The harmonics of a given frequency are not necessarily consonant with the fundamental, indeed, many will be dissonant (i.e. from a displeasing chord (dischord) when sounded with the fundamental) as shown below:

FUNDAMENTAL = 250c/s		
Harmonic	Harmonic frequencies	
2nd	500c/s	consonant
3rd	750c/s	consonant
4th	1000c/s	consonant
5th	1250c/s	consonant
6th	1500c/s	consonant
7th	1750c/s	dissonant
8th	2000c/s	consonant
9th	2250c/s	dissonant
10th	2500c/s	consonant
11th	2750c/s	dissonant
12th	3000c/s	consonant
13th	3250c/s	dissonant
14th	3500c/s	dissonant
15th	3750c/s	dissonant

**Attack and Decay**

It was formerly thought that the difference between different musical instruments playing the same note was due entirely to the difference in harmonic content between them. Obviously, a piano, a violin and an oboe sounding the same note, sound very different and it is not difficult to show that the harmonic content of these instruments varies a great deal. However, more recent work has shown that it is the attack and decay times which give sounds their characteristic quality rather than the harmonic content.

This concept of attack and decay can be examined in more detail. The names refer to the precise manner in which the amplitude of the sound varies, at the instant it starts or stops. A plucked string, as in a guitar, has a violent and rapid attack as can be seen from Fig. 6, sounding the well-known "twangy" note.

Conversely, when a key is depressed on an organ, especially at the bass end of the scale, there is a finite time before the air molecules become organised into the oscillating standing-wave pattern which produced the sound. Such an attack has a form shown by Fig. 7.

As is to be expected, the decay of a note is the rate at which it dies away. The amplitude of the vibrations in a plucked string dies away exponentially with respect to time. The note of an organ continues to

sound as long as the key is held down and, because most organs are situated in large buildings, may take several seconds to die away when it is released. Fig. 8 illustrates two contrasting waveforms of decay. Although harmonics are important in determining tonal quality, the contributions due to attack and decay features should never be under-estimated.

If several instruments begin playing simultaneously, as at the opening passage of a musical work, the sum total of the various waveforms may well be a sharp pulse as shown in Fig. 9. Sudden pulses of this sort occur from time to time in music and cause some

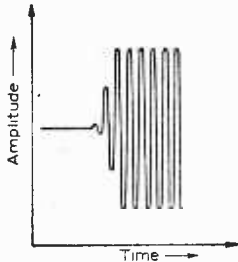

Fig. 6: Waveform of a 'plucked' guitar string—sharp attack, giving a 'twangy' note.

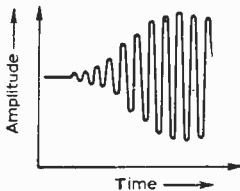

Fig. 7: Waveform for an organ bass attack note—slow attack.

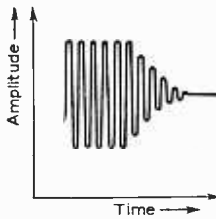
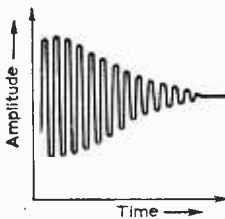
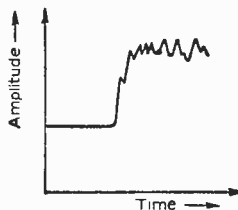

Fig. 8a (left): Slow decay time of an organ bass note; b (right): fast decay time.

Fig. 9: Sum total of waveforms when several instruments commence together — note sudden sharp wave fronts.



difficulty to designers of recording equipment. This problem will be studied later.

Another source of trouble is the existence of transients—short, non-repetitive complex waveforms where harmonics may be very far above the normal upper limit of hearing. They are often of very high amplitude and originate frequently from percussion instruments.

### Properties of the Ear

Having now given an extremely brief account of the nature of sound, attention can be turned to the practical application of this information as it is related to sound recording. Before doing so, however, a very short discussion of the properties of the human ear would not be out of place. Of course, the effects which the ear has will exist whether the sound being heard

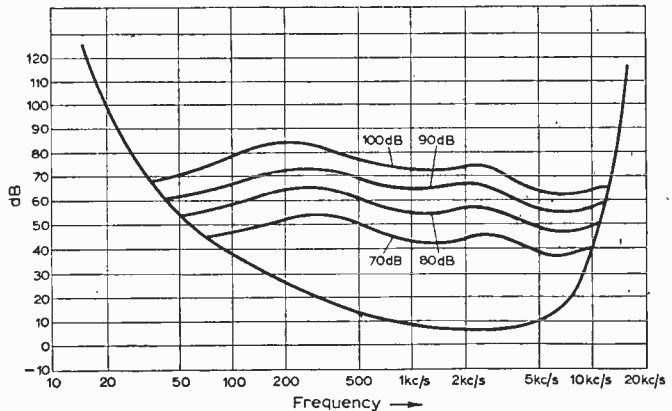

Fig. 10: Graph depicting response for average human hearing.

is live or recorded and do not invalidate any of the previous arguments.

It has already been stated that the average limits of frequency audible to the human ear are 30c/s and 15kc/s. The main curve of Fig. 10 shows that in fact the frequency limits are dependent on loudness—if sounds of no louder than +60dB were used to test the audible range, the result would be 50c/s–13kc/s. The frequency at which the ear is most sensitive is seen to be 2–3kc/s, and the sensitivity falls off on either side of this area. It is possible, using Fig. 10 to examine the range of audible frequencies which can be detected in an orchestra playing at various levels of loudness.

It is questionable whether "absolute fidelity" can ever be attained, although modern equipment comes fairly close to it. The basic necessities of any hi-fi system are that it should reproduce every sound exactly as it was formed, and not add anything to that sound while reproducing it. Without confining attention to any particular method of recording, next month the essential requirements will be discussed in some detail.

NEXT MONTH PART TWO

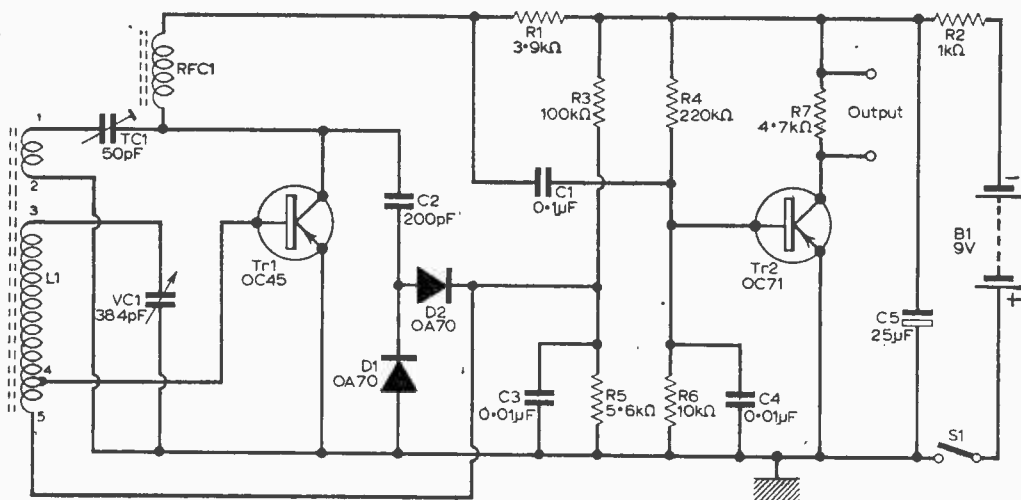

Fig. 1: The simple reflex circuit of the receiver.



## 2-transistor reflex receiver

by G. W. Suckling

**T**HE circuit is a reflex design covering the medium waveband. The incoming signal is fed into Tr1 and is amplified at radio frequency. The r.f. signal is passed to D1 and D2 via C2 the 200pF coupling capacitor. The detected signal (audio) is fed back to Tr1 base for a.f. amplification. The amplified a.f. signal is taken from the collector and now fed to Tr2 for further amplification. To summarise—r.f. amplification, detection, a.f. amplification, a.f. amplification.

### Constructional Details

The receiver is constructed on a  $3 \times 1\frac{1}{2} \times \frac{1}{8}$  in. piece of paxolin, with a bus bar running down each edge. The components are simply wired between the bus bars, with the ferrite rod aerial (fitted last). Note the method of mounting the ferrite rod. Stiff insulated wire is used with the ends passing through small holes in the board and bent over on the underside to hold the aerial securely in position. The wire ends of these twisted loops must *not* be allowed to touch, otherwise it

### COMPONENTS LIST

#### Resistors:

R1	3.9kΩ	R5	5.6kΩ
R2	1kΩ	R6	10kΩ
R3	100kΩ	R7	4.7kΩ
R4	220kΩ		

All resistors 10% miniature  $\frac{1}{2}$ W

#### Capacitors:

TC1	50pF trimmer
VC1	38.4pF—Jackson Bros. twin gang, 00 (see text)
C1	0.1μF paper
C2	200pF silver mica
C3	0.01μF paper
C4	0.01μF paper
C5	25μF electrolytic, 9-25V

#### Miscellaneous:

D1, 2	OA70 diodes
Tr1	OC45
Tr2	OC71
S1	Toggle switch s.p.s.t.
B1	9V PP3 or PP6 power pack battery
RFC1	1.5-2.5 mH radio frequency choke
L1	Ferrite rod aerial (see text).
	Crystal earpiece with jack plug and socket, wire, solder, knobs, bus bar wire, 1mm. dia. plastic sleeving, paxolin $3 \times 1\frac{1}{2} \times \frac{1}{8}$ in., etc.
	$2\frac{3}{4} \times \frac{5}{16}$ in. ferrite rod.

will constitute a shorted turn and therefore dampen the aerial circuit and impair performance.

When the receiver has been assembled and tested it may be fitted into a small plastic box, the type that may be obtained from most radio component stockists.

### Ferrite Rod Aerial

Take a strip of thin paper, about 3in. wide, just enough to wrap around the rod, with a small overlap for fixing. Hold it in position along its "seam"

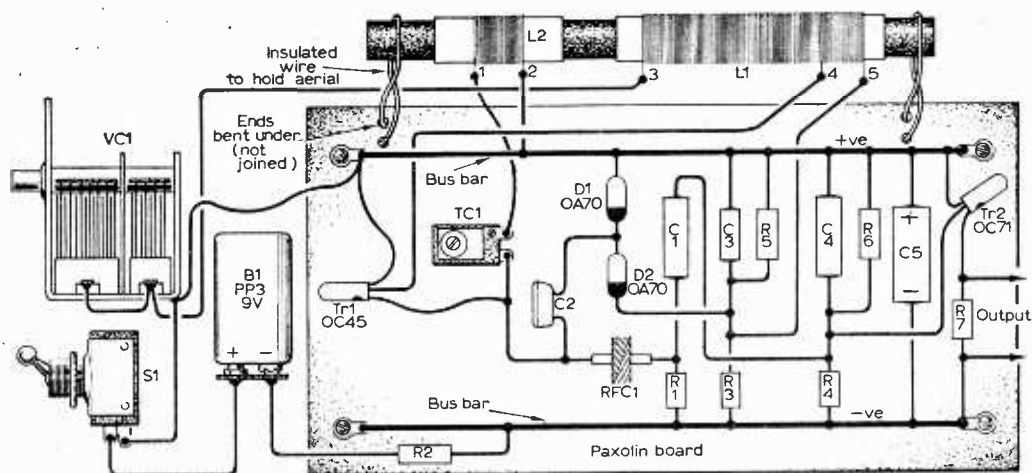

Fig. 2: The complete layout and wiring. The output is taken to the earpiece socket, and thence to the crystal earpiece.

with "Sellotape". Now wind on ten turns, of 28s.w.g. enam. copper wire, close wound. At the tenth turn make a loop and twist it so as to have a tap. Now close wind another forty turns, making fifty in all. Leave about 3½ in. spare and then cut it. This winding may be held in place by using "Sellotape".

Now wrap some more paper around the far end. This paper should be about ¼ in. wide, and just long enough for an overlap. Fix it with "Sellotape". Wind in this eight turns of the 28s.w.g. enam. wire, on the thin strip of paper. This forms the reaction winding (L2).

*N.B.* The reaction winding must be wound in the same direction as the first winding.

The wire ends must have the enamel scraped off, and tinned.

#### General Hints

- 1 The battery clips may be taken off an old PP3 battery.

- 2 The two sections of the Jackson Bros. 00 gang capacitor (208pF and 176pF) should be connected in parallel to give the required 384pF.

- 3 The bus bar wire can be 16s.w.g. tinned copper wire, and should be held at each end by 6BA nuts and bolts.

#### Adjustment

The trimmer TC1 controls the feedback and has to be adjusted for optimum results. When testing, first tighten the centre screw of the trimmer. When the set is switched on, it should be oscillating violently. If not, reverse connections to the reaction winding. If it still does not oscillate check the wiring thoroughly. When it is oscillating slacken off the trimmer so the receiver is oscillating weakly. One should be able to tune in many stations as whistles. Further careful adjustment will stop oscillation and stations should be perfectly stable. The set now needs little further adjustment. ■

#### ON THE SHORT WAVES

—continued from page 400

with its mission in the Congo. Should be an interesting one to listen for.

S. W. L. Cox (Westham) says I gave his QTH as Pevensey last month. Result was that two SWL's spent hours frantically searching Pevensey back yards for a garden with a vertical in it. They finally ran him to earth at 2150 (Sri O.M.!).

A number of amateurs are working at the radio station HCJB (Ecuador). After work they usually congregate on 15 or 20 a.m. or s.s.b. Calls to listen for are HC1OW, JJ, MX, HG, CM, GE, WR.

I. Black (Kent) bemoans the A3A stations who use the c.w. sector of 14Mc/s. Keith Evans (Shepperton) queries if Cyprus call signs are back, as he's heard 5B4TI on 20. This is a strange thing because on N.F.D. the Verulam group worked a

5B4/P and promptly claimed 12 points. Please, somebody write in and confirm.

VU2 is a call from Andaman Is. and Willis Is. is still on the r.f. map with VK4. Cape Verde Is. has been logged by some people already (CR4) and Crozet Is. FB8 is believed "at it" on c.w. only. OHØ—Aaland Is. is still quite an easy one to hear now and was worked some time ago at G3JDG on 7Mc/s using the P.W. 7Mc/s transceiver. YA—Afghanistan is quite rare and PY2's SO and CQ are a husband and wife station in Sao Paulo.

Contests and Rallies include: Aug. 1st, SLADE D/F Qualifying Event. 14/15th, WAE Contest (c.w. section) Mobile Rallies. 15th, Derby ARC. 30th, Peterborough M.R. listen for the talk-ins about 1,900kc/s. Sept. 4/5th, Region 1 IARU VHF Contest, also 4/5th VHF NFD. Deadline for next month is 26th.



# TAPE TAPE TAPE TERMINOLOGY TAPE

## PART TWO

by H. W. Hellyer

**FADE ERASE**

A method of continuously varying the erasure of recorded signals in such a way as to make it appear the signals themselves had been faded in and out.

The method is useful during editing and superimposition but alternative methods of "sound-on-sound" or multiply dubbing present more popular methods. The difficulty is to retain a constant bias level during the process.

**FOUR-TRACK**

More correctly termed "quarter-track" this specifies that the recording head gaps are so arranged as to give four recorded tracks. Usual style of numbering is 1, 2, 3, 4, from top to bottom, the upper gap recording the outer tracks (track 1 with tape normal, track 4 with tape inverted), and the lower gap recording the inside tracks, 2 and 3. For dimensions and spacing see "Tracks".

**FREQUENCY RANGE**

An often-quoted, but not always very significant set of figures denoting the upper and lower sounds that can be reproduced by the equipment. Unless the volume level is stated, and the limits of variation given, frequency range is not so important as . . .

**FREQUENCY RESPONSE**

This is the more precise statement of the variation of output with frequency for a fixed input level. Tolerance limits are stated and the

frequency response is more easily shown as a graph, as in Fig. 6.

Specifications might state a frequency response such as 50-12,000c/s  $\pm$  3dB at 3 1/2 in/sec. for a typical tape recorder.

**GAIN**

Relationship, stated as a ratio, between output level and input level of a piece of equipment, or, more usually, a stage of amplification.

**GAP**

Recording, playback and erase heads are made by winding a number of turns of fine wire on a laminated or ferrite former, the core of an electromagnet thus formed when current passes. The polepieces are brought close together to concentrate the field in the gap (the space between them).

To preserve mechanical rigidity and assist in this concentration of flux, a non-magnetic metallic shim is used to fill the gap. A metal such as beryllium copper may be used. Gap disposition varies according to track sense.

**GAP WIDTH**

The width of the gap in a recording head is very important, and even more exacting in playback head construction to maintain good frequency response.

The width of the gap must be smaller than the wavelength of the highest frequency to be reproduced. For a given speed of tape travel, the

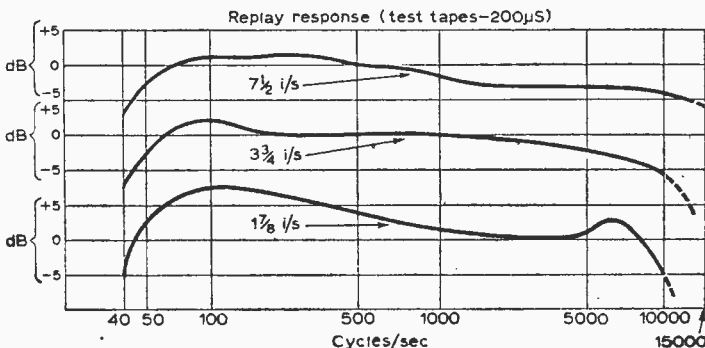

Fig. 6: Replay response curves of a typical, three-speed tape recorder. Note the "roll-off" at low frequencies and the extension of high frequency response with increased speed of tape travel.

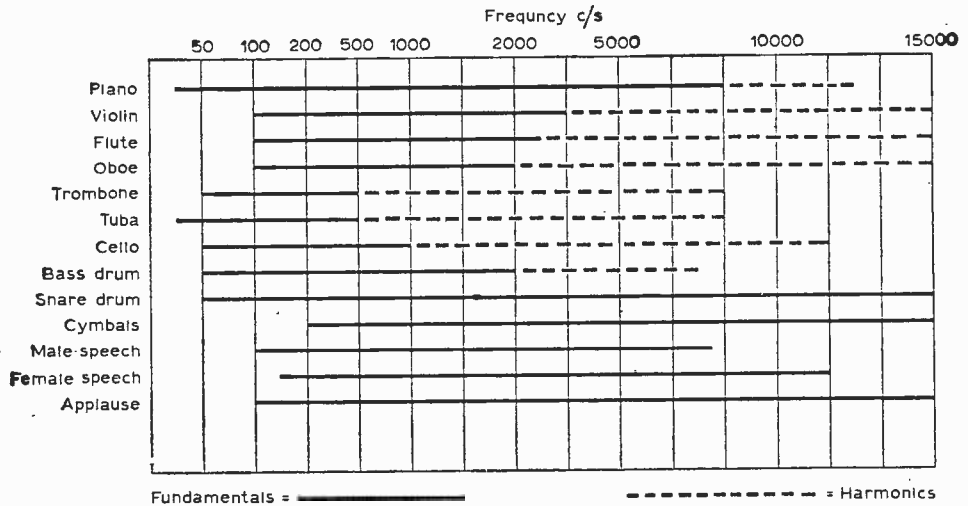

Fig. 7: Frequency range of sounds commonly recorded. Fundamental tones are shown drawn solid and overtones or harmonics, which give coloration to the tones, shown dotted. As can be seen, a very wide audio frequency range is needed to do justice to the whole gamut of normal sound.

narrower the gap the higher the frequency response for any tape recorder.

Gap width is generally measured in *mils*, one mil being 0.001 in. (thousandth inch). Domestic machines nowadays employ heads with gaps as fine as  $\frac{1}{4}$  mil.

#### HALF-TRACK

System of recording where two tracks are recorded on the tape. Normal method is to record the upper half of the tape (moving past the head left to right), then, after inversion of the tape, to record the other half.

Stereo half-track recordings employ both tracks in the same sense by recording with a "stacked" head, i.e., one with the gaps immediately above each other.

Note that the two halves of the recorded tape do not overlap. There is a safety lane of unrecorded tape between the tracks to prevent interaction of signals. For details of track dimensions, see "Tracks".

#### HEAD

An electromagnet, basically ring-shaped, with fine turns of wire comprising the windings. The pole pieces, of ferrite or laminated ferrous material, are brought together and faced, to form a fine gap, across which the recording current develops a flux, energising the oxide of the tape surface.

Similarly, when the energised tape is passed across the gap in the head facing, the varying flux sets up small currents in the head windings.

Dimensions, gap widths and impedances of heads vary according to their application. Ideally, a separate head should be used for Recording, for Playback and Erase, but a compromise is normal

with medium-priced domestic machines, which have a combination Record/Playback head (which will often be designated R/P Head).

Erase heads are usually separate, but at least one combination R/P/E Head has been developed commercially. A further example of design ingenuity is the "self-oscillating" erase head devised for some transistor applications.

#### HUB

The centre spindle of the spool carrier, shaped to retain the spool, usually by three tapered flanges.

#### HUB-LOCK

A method of clamping the spool to the hub. Several proprietary devices have been marketed, including a clamping screw, a rubber insert or expanding sleeve, a collet system, or an engaged catch in the hub, with a spring-loaded "bolt" in the spool.

#### IMPEDANCE

A.C. resistance. In tape recording, the term has special application to input and output matching (see "Matching") and to the heads themselves.

As the impedance of a recording head is largely inductive, many turns of fine wire produce a high impedance head while a few turns of larger diameter wire produce a low impedance head. Transistorised tape recorders generally employ a lower impedance head than valve-operated machines.

For correct energy transfer, and therefore most efficient amplification, the impedance of the head should correctly match the amplifier.

**INCHING**

Method of moving a tape in small steps, to find a place. This may be done mechanically or electrically.

**INPUT**

The signal applied to the amplifier. On most machines there is provision for several inputs, e.g., Microphone, Radio, Pickup, and Line. Mixing facilities may also be found at the input of a tape recorder, enabling two or more signals to be combined, ideally without loss or deterioration of either.

The input stage of a machine is very important, as signals are small, and every effort must be made to reduce the amplification of noise. Microphone signals, for example, may be 2 millivolts or less. The input from some pickups or radio tuners may be a hundred times as great, and from a Line source, a thousand times as great, in terms of signal voltage.

**IPS, IN SEC, or 1/S**

Inch per second, referring to tape speed. Tape speeds are standardised as follows: 30, 15,  $7\frac{1}{2}$ ,  $3\frac{1}{2}$ ,  $1\frac{1}{2}$  and  $\frac{1}{2}$  inches per second. The highest speed is only used professionally, and the two lowest speeds, because of restricted frequency response, are not suitable for high fidelity work, although adequate for speech and some kinds of music.

All other things being equal, the higher the speed, the better the frequency response of a tape recording system.

**LEADER TAPE**

Section of non-magnetic tape which may be supplied to the end of a reel, or inserted between sections of recording as a timing device.

**LEVEL**

A term used to indicate the amount of modulation, expressed as a proportion of the volume range. Peak level is thus the level at which a recording can be made before distortion sets in. For further details, see "Modulation" and "Modulation Level Indicator".

**MAGAZINE**

(See also "Cassette".) This is a case which contains the spools of tape, positioned so that the entire assembly may be clipped into position easily, the spool centres taking their place immediately on the hubs.

Some magazines also incorporate brakes, and in one or two cases, a recording or erase head also is built into the assembly.

**MATCHING**

For maximum energy transfer, the impedance of coupled stages or sections of the recording and amplifying chain should match.

This is often done by insertion of a transformer, an example being the output transformer which matches the relatively high impedance of a valve output stage to the low impedance of the loud-speaker voice coil. In other cases, combinations of resistance, capacity and inductance may be used.

Some "Insertion Loss" must be expected where matching devices are used, and this can be important in early (input) stages. A "Mismatch" is said to take place when an energy loss results from the coupling of dissimilar impedances.

**MAGIC EYE**

An electronic valve with a fluorescent target "screen" which is illuminated in proportion to

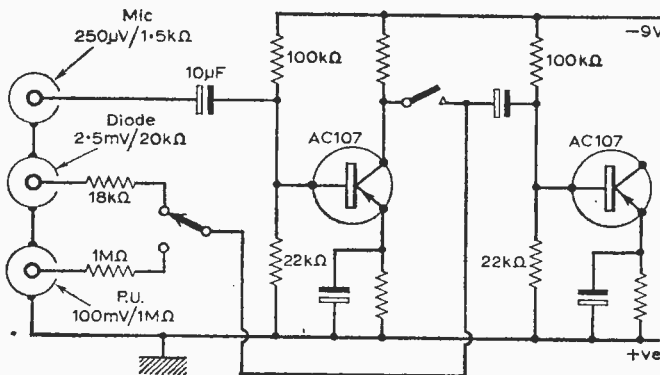
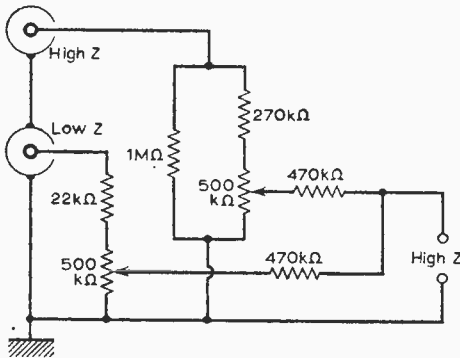

Fig. 8a (below): Input circuit for a transistorised machine, less switching and unnecessary details. Mixing is effected by closing the microphone switch, coupling the output of the microphone pre-amplifier to the second stage.

Fig. 8b (above): Potentiometer input used in a passive mixer. Such a device has an "insertion loss" of as much as 6dB, limiting its usefulness, except where strong signals are available.

the applied signal level. See also "Modulation Level Indicators".

**MIXING**

The process of combining applied signals. Simple methods of "passive" mixing are shown in Fig. 8b. A method of combining widely disparate signals into a single, composite signal for application to an input stage may be done by use of a Mixer which incorporates one or more amplifying stages.

Separate gain controls for the various inputs may be provided and an overall gain used to regulate the composite signal. (See also "Input".)

The increase in transistorisation has resulted in many ingenious circuits for self-powered mixers, and examples have appeared in these pages.

**MONITOR**

A method of checking the signal either prior to recording or after modulation of the tape is known as monitoring. The first method is simply effected by tapping off part of the signal and applying to a suitable transducer.

In practice there are two methods: either the high level signal is taken to an output socket to feed an earphone or another amplifier, or the signal is internally amplified and reproduced through the internal loudspeaker.

The second method requires the fitting of a third (playback) head, mounted just subsequent to the R/P head with its own amplifier and output, thus giving an immediate check on recorded material.

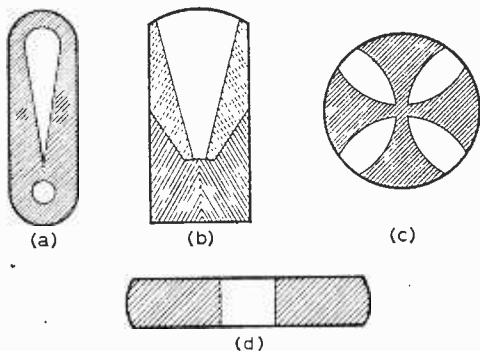

Fig. 9: Types of magic eye display. (a) dot-and-dash or exclamation mark of DM70 indicator. (b) closing-leaf display of EM81, where illuminated sections close toward centre to indicate full modulation. (c) "Maltese Cross" display of EM34, which serves the same purpose, and (d) fluorescent display of EM87, whose illuminated end sections close toward the marked centre strip to indicate depth of modulation.

**MICROPHONES**

The four principal types are (a) crystal, or piezo-electric, (b) moving coil, (c) condenser and (d) ribbon.

The most popular type for medium or low-price tape recorders is the crystal microphone, with its high output and relative cheapness. It is a high impedance device with a circular polar response (i.e. sounds from all directions are picked up equally): this response can be modified by methods of housing.

Certain types, such as the flat desk-mounted microphones and the lapel types respond mainly to frontal sounds. The high frequency range tends to be limited due to some peakiness. Bass response depends very critically on correct input matching.

The moving coil microphone comes in many forms and prices and is the most popular general-purpose type mainly because of its robustness. Output is low as is the impedance, generally requiring the mounting of a "step-up" transformer in the housing.

Standard type has a cardioid (heart-shaped, with mainly frontal pick-up) response, again modified by housing. Well-known "ball and biscuit" type has omni-directional response.

Condenser microphones are of very high impedance, with medium output and a wide frequency range. This type needs a polarising d.c. voltage, and is very suitable for tape recorder work where such a supply is available.

The ribbon microphone has a very low impedance and output, thus requiring an input transformer. The frequency response is very good and the figure-of-eight polar diagram makes it particularly suitable for studio work.

**METALLISING**

A layer of conductive paint applied to the tape to provide a shorting path to activate an Auto-stop system.

**TO BE CONTINUED**

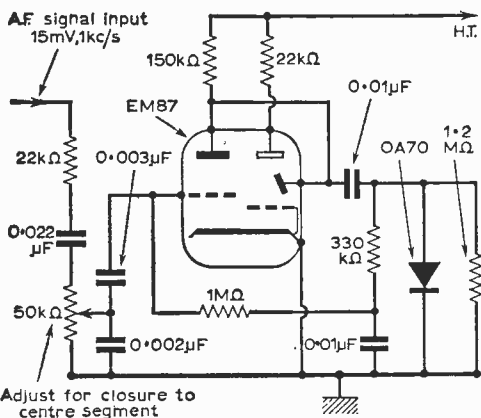
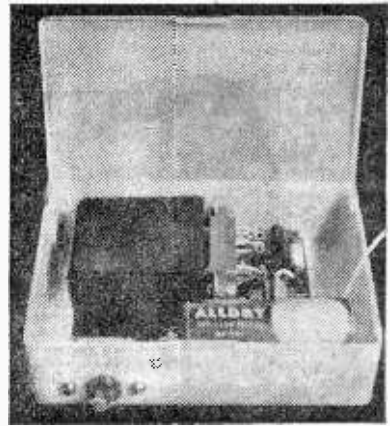

Fig. 10: Magic eye circuit suitable to handle signal of 15mV, with preset adjustment to allow closure of illuminated strips to be arranged to indicate full modulation or overload. Signal is amplified by the triode section, rectified by the OA70 and re-applied to the triode. This now acts as a d.c. amplifier and the output is fed to the target electrode to give a visual indication of changes in modulation. This is a "peak-responding" device.



# TRANSISTOR BAND EDGE MARKER

by F. G. Rayer, G30GR



WITH home constructed receivers (and also many ready made sets of popular type) there is often some difficulty in locating the amateur bands, or defining the edge of each band. To overcome this, and avoid searching for stations to use for calibration purposes, a crystal controlled amateur band edge marker can be used. The marker described here employs a single transistor, and can be built in a very short time. It runs from a single 4.5V or similar battery.

The circuit is shown in Fig. 1. An OC44 was fitted, but other r.f.-type transistors with a cut-off frequency of about 7Mc/s or higher should be satisfactory. Any good quality transistor as used for a self-oscillating mixer in a medium wave receiver should be suitable.

There is no tuned circuit, but the r.f. choke must be effective at the crystal frequency. Both 1Mc/s—30Mc/s short wave and miniature transistor type medium wave chokes were found satisfactory.

### Assembly

All the components are readily assembled on a small paxolin panel, as in Fig. 2. The method of construction is not likely to be important. A small plastic box, or any other case to hand, will serve to house the unit and battery.

The small capacitor C is merely a turn or two of insulated wire round the collector circuit lead. Current drawn depends on the transistor and crystal, and was about 2mA with the OC44. The unit should not be switched on until the crystal is inserted.

### Crystal and Harmonics

The crystal may be surplus or new, with  $\frac{1}{4}$  in. or  $\frac{1}{2}$  in. pin spacing, etc., the holder being chosen to suit. A 3500kc/s crystal is ideal. This gives 3.5Mc/s on its fundamental, and multiples of 3.5Mc/s on harmonics. If the receiver is first adjusted to a

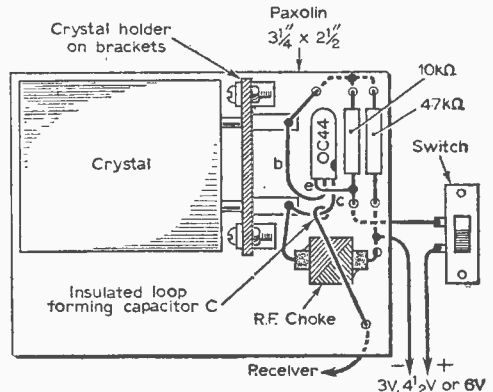

Fig. 2: Component layout showing method of forming capacitor, C.

lower frequency than 3.5Mc/s, and tuned progressively towards higher frequencies, the marker signal will be heard as follows:—

- Fundamental, 3.5Mc/s: Low Frequency end of 3.5—3.8Mc/s band.
- 2nd Harmonic, 7Mc/s: L.F. end of 7—7.1Mc/s band.
- 3rd Harmonic, 10.5Mc/s: Ignore.
- 4th Harmonic, 14Mc/s: L.F. end of 14—14.35Mc/s band.
- 5th Harmonic, 17.5Mc/s: Ignore.
- 6th Harmonic, 21Mc/s: L.F. end of 21—21.45Mc/s band.
- 7th Harmonic, 24.5Mc/s: Ignore.
- 8th Harmonic, 28Mc/s: L.F. end of 28—29.5Mc/s band.

—continued on page 415

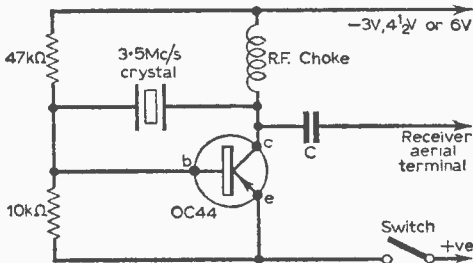
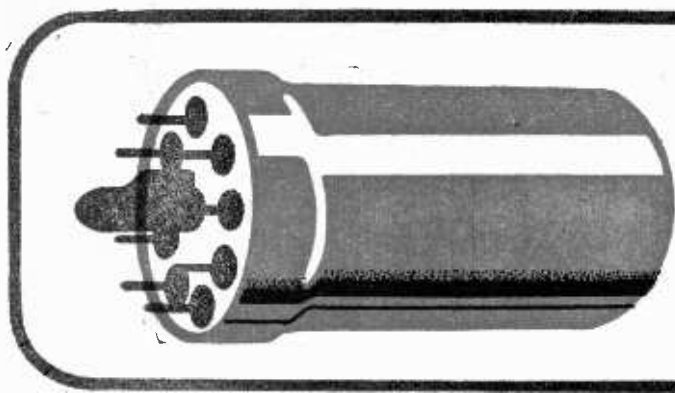

Fig. 1: Circuit of the unit using an OC44.



the VERS  
EF50

**E**F50 valves are obtainable at almost give-away prices, frequently as little as 1s. 6d. each. Constructors active in the immediate post-war years need no introduction; at a time when home construction of TV receivers reached its zenith this valve formed the basis of many commercially sponsored home constructor designs and was also featured in numerous ingenious "conversions" of war surplus units to domestic TV use.

### Decline

The EF50 valve then cost about five times the present prices, but when interest in home construction of TV receivers began to wane in the face of ever-increasing circuit complexity, the popularity of this valve faded rapidly, and it may well be that constructors who are comparative newcomers to the hobby will have little knowledge of the many uses to which this versatile valve can be put.

Firstly, a few general remarks concerning the EF50 valve. It is basically an r.f. pentode with an all-glass nine-pin base, listed in valve manuals as "B9G". The unusual feature is that the outer envelope of the bulb is made of aluminium and this forms an extremely efficient r.f. screen. This outer screen connects to a central metal locating spigot which in turn makes contact with a central lug on the valveholder.

There is also internal screening within the valve brought out to pins 5 and 8. All these points are normally connected to earth (chassis) of the receiver. Fig. 1 shows the valve base connections.

This valve was one of the very first types to be designed specifically for the much higher frequen-

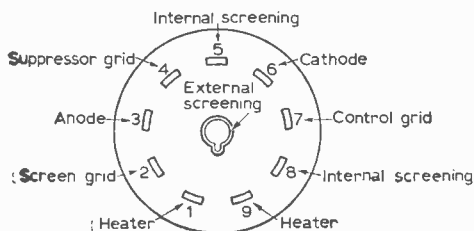

Fig. 1: EF50 base connections.

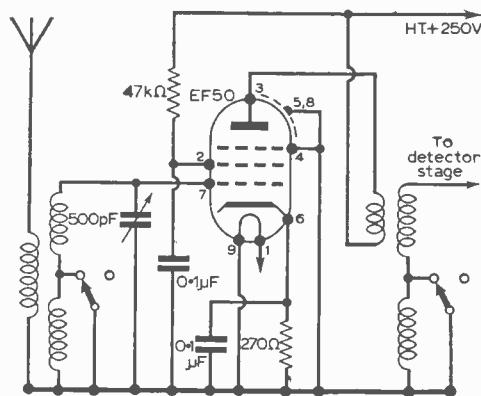

Fig. 2: EF50 as r.f. amplifier.

cies experienced in TV receivers, hence the elaborate r.f. screening. There are two versions of the valve obtainable on the surplus market: the British-made valve in a plain aluminium envelope and the American type with the envelope painted bright red.

The latter is usually slightly higher in price and is said to be of slightly greater efficiency and dependability, but in the author's experience there is no discernible difference between their performance.

There are also two types of valveholder obtainable, one made of low-loss ceramic material, the other of conventional paxolin; this latter type is more robust and perfectly suitable for all the applications described in this article.

### Cleaning

As both the valves and valveholders now on offer will have had a long period of storage the contact pins and valveholder sockets will in many cases have become tarnished and the valve pins should be gently rubbed with emery paper until bright metal is exposed. At the same time the glass seals through which the valve pins protrude

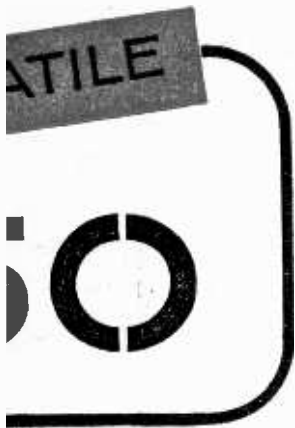

**J. B. WILLMOTT**

should be examined and if any show signs of being cracked the valve should be discarded. The valveholder sockets can be cleaned by pressing a stout needle through the holes several times to remove dirt and dust.

The valveholders require a 1½ in. diameter hole cut in the chassis to accommodate them, and if any quantity of constructional work is contemplated it will be well worth while to purchase one of the proprietary chassis cutters of the appropriate size.

## Clamping

A desirable refinement is that EF50 valves should be held firmly in place with one of the two types of clamp readily obtainable. One type comprises a springy metal ring which is fastened on top of the chassis by the same bolts used to secure the valveholder. When the valve is inserted the retaining spring is pressed downwards to allow free insertion of the valve, then on releasing the spring it will be found to grip the outside rim of the valve very firmly.

The second type comprises a threaded ring of slightly larger diameter than the valve envelope which can be screwed down on to a similarly

threaded base which is bolted to the chassis surface. When placing valves into, or removing them from, the valveholder a firm, straight pull (or push) must be used; any attempt to "wriggle" the valve from side to side will almost certainly result in cracking one or more of the glass seals around the valve pins.

## Power Supplies

The EF50 has a 6.3V 0.3A heater and is recommended for use with an h.t. supply line of 200 to 250V; it has an extremely high "slope" (mutual conductance) and thus gives very high gain when used as an r.f. or a.f. amplifier. Primarily designed for use as an r.f. amplifier it can nonetheless be used in practically any stage in domestic radio receivers.

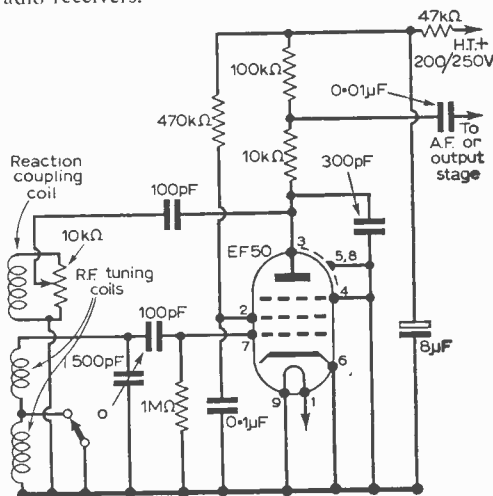

Fig. 4: Grid detector with reaction.

## R.F. Amplifier

The recommended component values for use as a conventional r.f. amplifier are shown in Fig. 2. The EF50 is not a variable- $\mu$  valve and any attempt to vary gain by alteration of cathode bias would tend to detune the control grid circuit. But at broadcast band frequencies this does not appear to be serious and a moderate variation of stage gain can be obtained by replacing the 270 $\Omega$  cathode bias resistor with a 2k $\Omega$  potentiometer. A 50 $\Omega$  resistor should be inserted between the valve cathode and the "top" of the potentiometer to ensure that at maximum volume setting the valve is not entirely deprived of bias which would not only lead to distortion but also seriously shorten the working life of the valve.

## I.F. Amplifier

The valve can also be used as an i.f. amplifier in superhet circuits, using the same component values, but as it is easily overloaded if too strong a signal is presented to the control grid care must

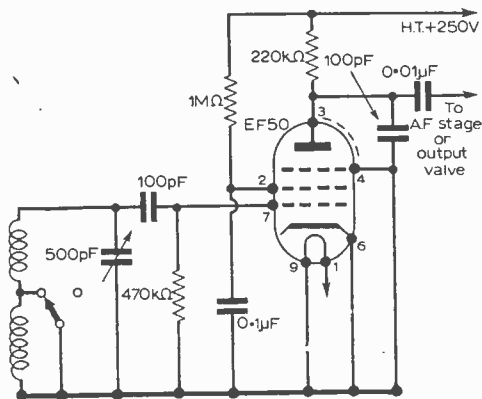

Fig. 3: Grid detector (no reaction).

be taken to see that not too much amplification takes place in preceding stages.

Figs. 3 and 4 show typical circuit arrangements and component values for using the valve as a grid-leak detector with or without reaction. The EF50 works particularly well in this application, giving both efficient detection with a worth-while audio gain.

The efficient internal and external screening helps to prevent the entry of mains-borne 50c/s hum from heater wiring, etc., often the bugbear of mains-operated grid-leak detector circuits.

### Anode Bend Detector

Fig. 5 shows the valve in use as an anode bend detector, which is probably the most popular type of detector for use in simple t.r.f. circuits, its merits being simplicity and ability to handle a larger input signal without distortion. It also imposes a smaller load on the tuned circuit connected to the control grid, making selectivity better (unless, of course, a grid detector with reaction is used, in which case the latter gives an even greater degree of sharpness to the tuning).

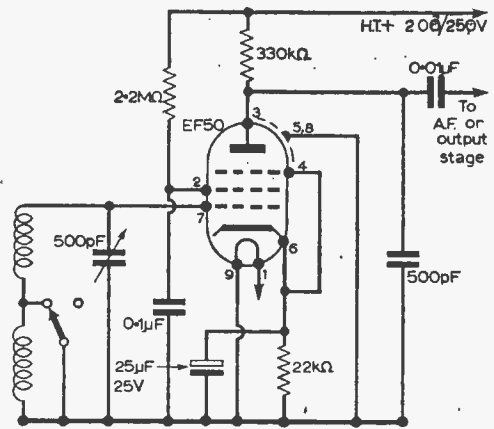

Fig. 5 (above): Anode bend detector.

Fig. 6 (below): Infinite impedance detector.

### Infinite Impedance Detector

Fig. 6 shows the circuit requirements for the so-called infinite impedance detector, which is the most distortion-free of all detector circuits, capable of handling the strongest of signals, and is thus greatly favoured in high-fidelity tuner units. As this circuit gives no audio gain an additional stage is required, but with EF50s at 1s. 6d. each who cares?

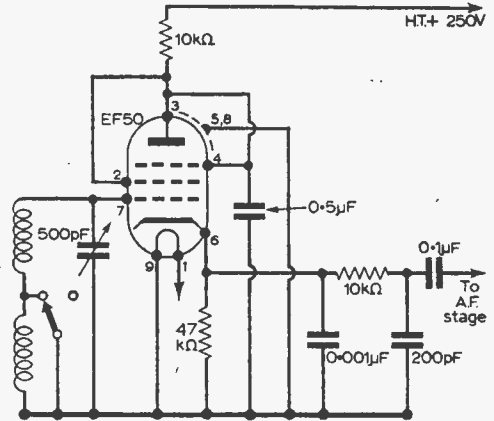

Fig. 7 (below): Phase inverter stage.

### Audio Amplifier

Fig. 8 shows the EF50 as an audio amplifier, either as a triode or as a pentode. In the latter case a very high degree of audio amplification is obtainable and, as a result, microphony is sometimes a problem. Microphony means that anything, including audio waves from the loudspeaker, setting up vibration of the chassis on which the valve is mounted produces unwanted signals in the control grid circuit which are amplified and result in an unpleasant "ringing" sound emanating from the loudspeaker every time the receiver is disturbed. In very bad cases this may build up into an uncontrollable howling sound.

Careful layout and screening of the valve from direct impingement of sound waves from the loudspeaker can do much to mitigate these symptoms and the triode circuit will usually give ample signal gain comparatively free from microphony.

### Phase Inverter

Fig. 7 shows recommended circuit values for the use of an EF50 as the phase inverter valve to precede the output stages in a push-pull amplifier. Fig. 9 shows the EF50 as an audio output valve, a function which it will discharge very satisfactorily where an output in the region of 1W is ample.

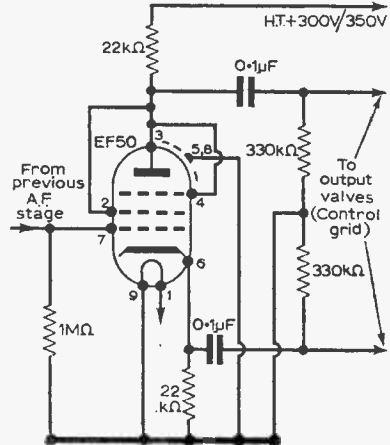



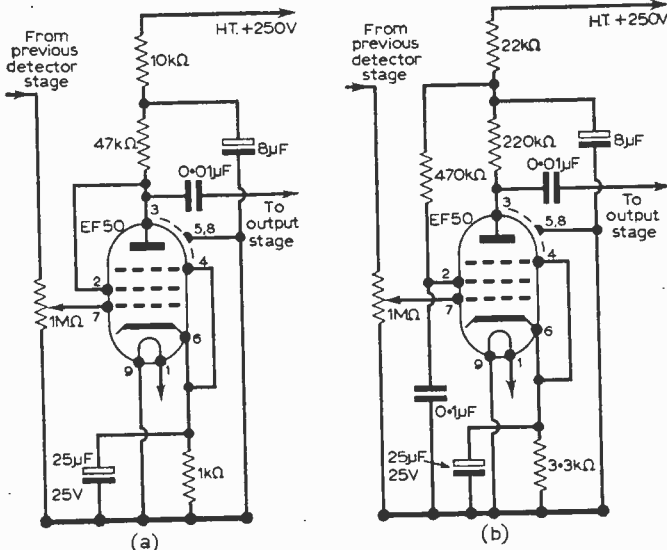

Fig. 8: Triode connected (a) and pentode connected (b) a.f. amplifiers.

It is important that the h.t. line voltage should not exceed 250V, indeed a value of 200V is possibly preferable in the interests of valve life. An output transformer of high impedance (say 7,000Ω) should be used to match the valve to a nominal 3Ω loudspeaker, but as the anode current is quite small a miniature component will easily be able to cope with these requirements.

Note the inclusion of a grid stopper resistor, which is particularly desirable when using a high-slope r.f. pentode as an audio output valve. This resistor must be mounted as close to the grid pin of the valve as possible, leaving no more than ¼ in.

### TRANSISTOR BAND EDGE MARKER

—continued from page 411

By counting the marker signals from 3.5Mc/s, this gives the low frequency band edge for 80, 40, 20, 15 and 10 metre bands, so tuning the receiver slightly in a high frequency direction (gang capacitor opening) from these points will allow the bands to be heard and covered.

If a crystal of different frequency is to hand, it will still allow the amateur bands to be located, if its harmonics fall in them. For example, a 3550 kc/s crystal, such as can be used with a transmitter for working in the 3.5—3.8Mc/s band, would give harmonics on 7.1Mc/s, 14.2Mc/s, 21.3Mc/s and 28.4Mc/s (ignoring unwanted 3rd, 5th and 7th harmonics).

To find the bands, and for receiving purposes, one marker point or band edge calibration is normally sufficient. For full calibration, a 100kc/s marker is really required.

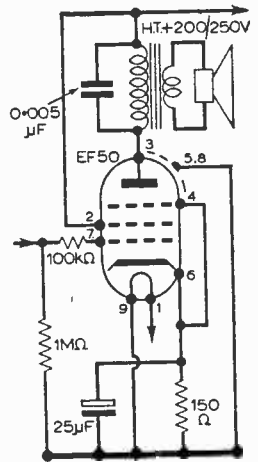

Fig. 9: Audio output stage.

of wire between the end of the resistor and the valveholder tag.

It has been shown that the EF50 at its present-day price is a real bargain for the enthusiastic constructor. It is interesting to note that some 12 years ago the writer, then a comparative novice, constructed a "local station" radio receiver to give good quality reception of the three main BBC programmes (this was before the days of v.h.f.-f.m.), utilising EF50 valves as r.f. amplifier, infinite impedance detector, triode connected first audio amplifier. A conventional 6V6 output stage and full-wave power unit were incorporated.

It is still in daily use and after 12 years the only repairs carried out have been replacement of the output transformer and the main smoothing electrolytics. It is hoped to describe this receiver shortly in PRACTICAL WIRELESS.

### Marker Signal

With the oscillator shown, all harmonics up to 28Mc/s were over S9, and thus easily found. The signal is an unmodulated carrier. (That is, the same as an ordinary broadcast station transmission during a silent interval, when no programme material is present.)

With a t.r.f. receiver, the fundamental and harmonics can be tuned in if reaction is advanced so that the detector is just on the oscillating point.

If the receiver is a superhet with beat frequency oscillator, the b.f.o. needs to be switched on. If there is no b.f.o. an insulated lead may be twisted round the intermediate frequency anode and grid connections, to provide enough capacity to cause oscillation in the i.f. stage. The carrier will then be audible when tuning through fundamental or harmonics.

Should the receiver have a tuning indicator or tuning meter, this will respond to the marker signal, so that tuning points can be seen with reasonable accuracy. It is then not essential to have a b.f.o. in the receiver, or to introduce oscillation in the i.f. stage.

## Frequency Conversion

ON the surplus market from time to time there appear receivers that can be bought quite cheaply. The snag is, however, that they are crystal-controlled usually at frequencies outside the amateur bands and are therefore of little use to the hobbyist.

I feel sure that there must be other amateurs besides myself who would be interested in a detailed article on how to convert a crystal - controlled receiver into a tunable one. A sort of general article that would cover all receivers and not one receiver in particular is what is needed.

L. W. Turtill.

Ipswich,  
Suffolk.

## Correspondents

I SHOULD like to correspond with anyone who has made any modifications to the P.W. Monophonic Organ.

R. Walker.

20 Hatfield Crescent,  
Blurton,  
Stoke-on-Trent,  
Staffordshire.

I WOULD like to correspond with anyone who is interested in electronics and foreign languages (English, French, Greek and Italian) I am 14 years of age.

Lawrence Thompson.

3 Nevill Road,  
London, N.16.

I WOULD like to tapespond with a boy of my own age (14). My tape-recorder is a Philips 4-track. It has a speed of 3½ i.p.s. I am also a keen SWL. All tapes will be answered.

Colin Coker.

6 Lower Collins Road,  
Totnes, Devon.

I WOULD like to correspond with anybody of my own age (12) in any country who is a beginner in the field of radio and electronics. All letters will be promptly answered.

J. Thackeray.

Norwich House,  
Worstead,  
Nth. Walsham,  
Norfolk.

# NEWS AND.

## NORTH WEST V.H.F. GROUP

The 1965 North West v.h.f./u.h.f. Convention and Dinner will be held at the Grosvenor Hotel, Deansgate, Manchester, on Saturday, September 18th, 1965, from 13.30 onwards. The Dinner will be at 19.30.

The Convention Station, under G3UHF/A will be on 144Mc/s from the hotel early morning onwards, and a /P station on high ground to the south will look for distant mobiles.

Tickets for the Convention and Dinner are 25s., and requests for tickets and accommodation should be sent to Mr. Tom Davison, G3AGS, 18 Boardman Road, Higher Crumpsall, Manchester 8 (Cheetham Hill 2762).

All other information concerning the Convention can be obtained from Geoff Barnes, G3AOS, 5 Prospect Drive, Hale Barns, Cheshire (Ringway 2415).

## 3-WAVEBAND TRANSISTOR PORTABLE

Standard Radios of Japan offer a new and powerful portable radio (H504L) with eight transistors and two loudspeakers covering long, medium and short wavebands at a price of 14 gns.

This radio has been designed to combine good tone, power and range, and still remain reasonably priced, by incorporating the latest technical advances in design, e.g. transformerless output and drive stages.

Only three U2 batteries are required to power the H504L, which weighs 3lb. and measures 9½ x 5 x 2in.

The U.K. distributors to the trade are Denham and Morley Limited, Denmore House, 173/175 Cleveland Street, London, W.1.

## AMERICANS CHOOSE BRITISH ELECTRONIC EQUIPMENT

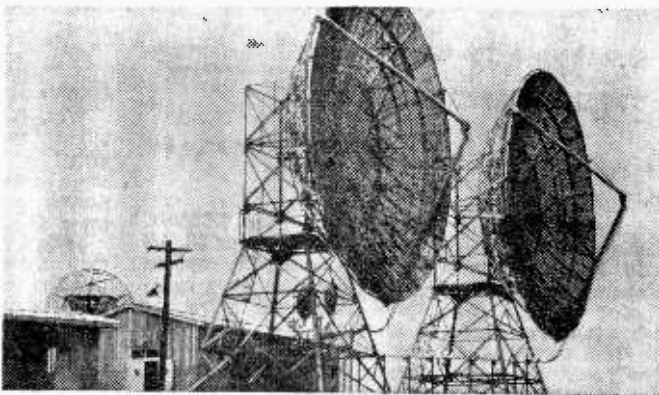

"Autospec" error correcting equipment manufactured by the Marconi Company, has been incorporated in an American-built radio communications network now operating in South Korea. The photograph above shows some of the aerials used for the link.

"Autospec" has been used to improve the quality of the teleprinter channels of the circuit, by reducing the teletype error rate. The equipment is fully transistorized, completely automatic in operation and does not require the attention of an operator.

# .. COMMENT

## NEW PORTABLE FROM BANG AND OLUFSEN

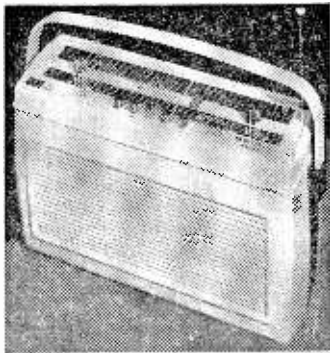

*Bang and Olufsen (Denmark) announce the Beolit 600 portable radio. It has four wavebands including f.m., an "extra long" long waveband with a special radio-beacon range which is of particular interest to boat owners. There is also a marine band covering all coastal radio stations. Separate bass and treble are incorporated and there is provision for connecting a car aerial, tape recorder and extension speaker.*

*The Beolit 600 retails at £27 6s. and is available from all B. & O. appointed dealers.*

## MICROWAVE LINKS FOR CIVIL AIRWAYS RADAR

The Ministry of Aviation has recently ordered the final link in a chain of microwave radio paths that will connect all Ministry radar sites in the UK civil airways system to the country's two main air traffic control centres at London and Manchester.

This latest link (between Clee Hill and Manchester) will bring the total length of the chain to 384 miles. The ten terminal stations and ten unattended repeater stations of the chain have been designed, built and installed by the Marconi Company.

When completed, the system will allow the air traffic controllers at London and Manchester to see radar pictures of the air traffic situation in parts of the country which are out of their direct radar range. Ultimately these controllers—who are responsible for the whole of the civil air traffic flying over the British Isles—will have information from each radar available at the turn of a switch.

## EDDYSTONE TO OPERATE AS MARCONI SUBSIDIARY

Stratton and Company Ltd., manufacturers of the well-known Eddystone range of professional radio communication receivers and accessories since 1923, has now been officially renamed Eddystone Radio Limited. This follows the announcement last March that the Stratton radio interests had been acquired from Laughton and Sons Ltd., by English Electric, and that the company would be operated as a subsidiary of the Marconi Company.

Eddystone Radio produce a range of radio receivers which covers the frequency scale from 10kc/s to 1000M/cs, which have been sold in practically every country in the world.

## "PROJECTED STEREO" FROM H.M.V.

A new stereo record producer—the H.M.V. "Stereomaster" priced 59 gns—is announced by British Radio Corporation Ltd.

The "Stereomaster" gives "projected stereo" without the use of separate speakers by "firing" two speakers sideways and two forwards, all four incorporated in the cabinet. With the player angled across the corner of a room sound waves are projected towards the walls and deflected back to the listener.

The audio output is 14W and the circuit incorporates 20 transistors and the deck uses a Garrard 3000 low-mass pick-up with ceramic cartridge and diamond stylus.

**BECAUSE OF THE LARGE NUMBER OF OUTSTANDING "SELL OR LOAN" REQUESTS NOW HELD BY US, WE REGRET THAT FOR THE NEXT FEW MONTHS WE WILL NOT BE ABLE TO ACCEPT ANY LETTERS FOR THIS COLUMN.**

*Sir, I would be grateful if any reader could sell or loan me . . .*

. . . the circuit or any other information on the Monitor type 61 oscilloscope unit.—A. Anglicas, 49 Latrigg Crescent, Langley, Middleton, N., Manchester.

. . . any information on building a tape echo chamber.—J. Roden, 30 Rosemary Lane, Norton Estate, Stourbridge, Worcestershire.

. . . any information on receiver No. R1139 and transmitter/receiver, No. TR9H.—P. Barker, 26 Woodlands, Todmorden, Lancashire.

. . . the original official Government handbook for the 19 set ;lk. 3 and/or the circuit diagram of the SCR522 Transmitter/Receiver.—P. F. Schofield, 42 Rollason Road, Radford, Coventry, Warwickshire.

. . . any information (circuit or manual) on wireless set 88 type 3A.—J. Hirst, Ashville College, Harrogate, Yorkshire.

. . . information on the suitable batteries for a Zenith Trans-Oceanic portable model 8G005.—D. Strange, 52 Grosvenor Street, Cheltenham, Gloucestershire.

. . . the service manual or any other information on the B2B receiver.—James Whitaker, Baker House, Allhallows-School, Rousdon, Lyme Regis, Dorset.

. . . the circuit diagram of a 30—60W transistor amplifier suitable for guitar, incorporating independent bass and treble controls.—M. Callaghan, 19 Burgess Street, Cooper's Wharf, Port Elizabeth, Cape Province, South Africa.

. . . information on wire recorder Agafon type 399155—3 and/or information on direct disc cutting instrument Emdicita model 2400E and/or Antenna tuner BC-939-A.—Mohamed J. Daya, P.O. Box 1187 Dar-es-Salaam, Tanzania.

. . . circuit diagrams of Standard radio Tx A.P.59517 Trans SAH. Also mod unit and a.t.u. of above transmitter. Also details of the 1392 v.h.f. Rx.—J. J. Phillips, 3 Queens Road, Westbury, Wiltshire.

. . . circuit diagrams for R1466 receiver and A1413 amplifier.—D. M. McLeod, Wallsend, Northumberland.

. . . the circuit diagram or any information on ex-Admiralty transmitter A.P. T8980.—J. A. Finch, 57 Lower Drayton Road, Drayton, Portsmouth, Hants.

. . . the circuit and any information on the type 62 indicator unit ref. 10Q/13000.—Anthony Smyth, "Cherry Vale", Ballykeel, Lurgan, Co. Armagh.

. . . any information on the SCR522.—M. F. Overbury, 9 Jerome Drive, St. Albans, Herts.

. . . service manual or information concerning Westminster radiogram 373 F.M. (made in 1959).—F. Horne, 204 Market Street, Eastleigh, Hants.

. . . circuit or plug connections for the Canadian 58 Mk. 1 Rx/Tx.—D. R. Griffiths, 31 Moon Street, Widnes, Lancashire.

. . . the handbook and valve placement diagram with power connections for the 19 set.—D. Woodhall, 67 Belver Avenue, Blackpool, Lancashire.

. . . details of the value of the two types of variable capacitors used in the Bendix TA12B transmitter.—F. G. Sadler, 63 Newbury Avenue, Enfield Middlesex.

. . . circuit diagram and calibration details of a Mullard R/C bridge GM4140/1 (ex-WD).—A. G. Thorburn, 27 Banklands Workington.

# Practical Substitutes

by M. L. Michaelis, M.A.

## PART TWO

### SMOOTHING ELECTROLYTICS

Readers often ask the meaning of "high ripple rating" or "high surge rating" when specified for an electrolytic capacitor.

Electrolytic capacitors are nowadays available either as tubular components of surprisingly small physical size or as large chassis mounting "cans" with the same voltage rating and capacitance values as the much smaller items. Many large can-type electrolytics are obsolescent but this is not the full story.

All electrolytics manifest a leakage current which may be depicted as a virtual high-value resistor in parallel with the ideal capacitor of infinite insulation. This leakage resistor does not obey Ohm's Law but decreases approximately logarithmically with increasing applied voltage up to the normal rated working voltage of the electrolytic capacitor. Above the working voltage the leakage resistance decreases much more rapidly, so that the leakage current commences to rise disproportionately.

Thus an electrolytic capacitor does not behave like a paper capacitor, which maintains excellent insulation up to a certain breakdown voltage above which it flashes over and breaks down. An electrolytic capacitor leaks to an increasing extent the higher the applied voltage until a point is reached at which this leakage is considered to be intolerable.

There are two aspects in which this leakage may become intolerable. It may represent an excessive loss of available h.t. current, but this is hardly ever the decisive factor. In most cases the leakage is considered intolerable when it has reached a magnitude sufficient to cause excessive heating and electrolytic dissociation of the capacitor. Such limitations are obviously more critical in the case of small tubular electrolytics than in the case of large can types.

A second group of

THE lists of parts for constructional articles are those found satisfactory in the prototypes. Queries which the Editor receives show that many beginners regard these lists as strictly binding down to the last detail.

It is the aim of these articles to help beginners make on-the-spot substitute decisions when their dealers do not have specific components on stock. The information should also help when replacing obsolete components and making use of junkbox parts.

interrelated effects within electrolytic capacitors concerns their series resistance. This is made up of two components, the electrolyte resistance and the contact resistance of the positive lead to the edges of the rolled-up foil anode. These resistances are in series with the virtual parallel combination of the ideal capacitance and the leakage resistance.

They consequently carry the leakage current as well as the charging current, both of which contribute to the heat dissipation within the component. Fig. 5 shows the equivalent circuit of an electrolytic capacitor.

### SURGE LIMITATIONS

It is easy to see that the electrolytic and anode contact series resistances of small tubular electrolytics will both be much greater than in the case of a large can component of the same capacitance. Fig. 6 shows a rectifier and smoothing circuit with decoupling branches for h.t. feeds to different stages.

Since the reservoir capacitor C1 maintains a large fraction of the output voltage throughout all a.c. input cycles the rectifier D1 conducts only around the positive peaks of the a.c. waveform. The steady d.c. current drawn off from the smoothing capacitor C2 is thus delivered as a sequence of brief pulses of high amplitude from the rectifier D1 into the reservoir capacitor C1, which has to withstand large repetitive current surges indefinitely.

These current surges flow through the series resistance and develop a disproportionately large amount of heat because the heat dissipation in any component is proportional to the square (mean square) of the current flowing through it. Conditions are much more steady at the smoothing capacitor C2, which does not have to take up heavy surges of current.

In general a small tubular electrolytic is likely to be quite satisfactory for C2 and even more so for C3 to C5. A small tubular electrolytic at C1 may give trouble when the a.c. input voltage is high, the rectifier is of low impedance and the d.c. output current drain is high, even if the capacitance and voltage ratings seem adequate.

If D1 is a modern silicon diode which has negligible internal resistance the surge impulses into C1 will be very brief and will take on very large amplitudes. This will sooner or later damage a small tubular electrolytic if the h.t. output current drain is large (100mA or more).

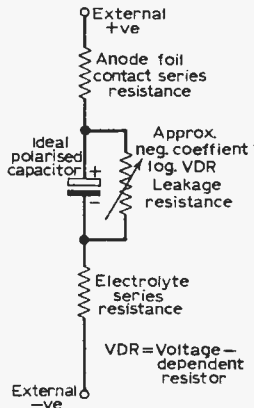
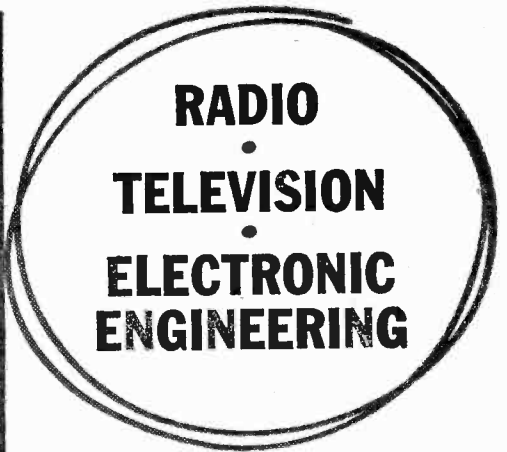
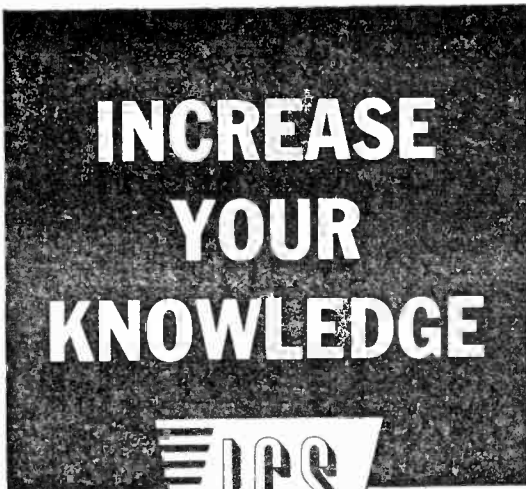

Fig. 5: Practical equivalent circuit for an electrolytic capacitor.



MEMBER OF THE ASSOCIATION  
OF BRITISH CORRESPONDENCE COLLEGES

**CHOOSE THE RIGHT COURSE FROM:**

RADIO AND TELEVISION ENGINEERING  
INDUSTRIAL TELEVISION, RADIO AND  
TELEVISION SERVICING, ELECTRONICS,  
COMPUTERS AND PROGRAMMING  
ELECTRONIC TECHNICIANS, SERVO MECH-  
ANISMS, TELEMETRY, COLOUR TV,  
INSTRUMENTATION, AND PRINCIPLES OF  
AUTOMATION.

**ALSO EXAMINATION COURSES FOR:**

Inst. of Electronic and Radio Engineers  
C. & G. Telecommunication Techns' Cert.  
C. & G. Supplementary Studies  
R.T.E.B. Radio/TV Servicing Cert.  
P.M.G. Certificates. Radio Amateurs' Exam.

**LEARN AS YOU BUILD**

Practical Radio Courses: Gain a sound knowledge of Radio as you build YOUR OWN 5-valve superhet Receiver and Transistor. Portable Signal Generator and High Quality Multitester. At the end of the course you have invaluable practical equipment and a fund of personal knowledge and skill. ICS Practical Radio Courses open a new world to the keen amateur.

**THERE IS AN ICS COURSE FOR YOU**

Whether you need a basic grounding, tuition to complete your technical qualifications, or further specialised knowledge, ICS can help you with a course individually adapted to your requirements.

There is a place for you among the fully-trained men. They are the highly paid men—the men of the future. If you want to get to the top, or to succeed in your own business, put your technical training in our experienced hands.

ICS Courses are written in clear, simple and direct language, fully illustrated and specially edited to facilitate individual home study. You will learn in the comfort of your own home—at your own speed. The unique ICS teaching method embodies the teacher in the text; it combines expert practical experience with clearly explained theoretical training. Let ICS help you to develop your ambitions and ensure a successful future. Invest in your own capabilities.

**FILL IN AND POST THIS COUPON TODAY**

You will receive the FREE ICS Prospectus listing the examinations and ICS technical courses in radio, television and electronics. PLUS details of over 150 specialised subjects.

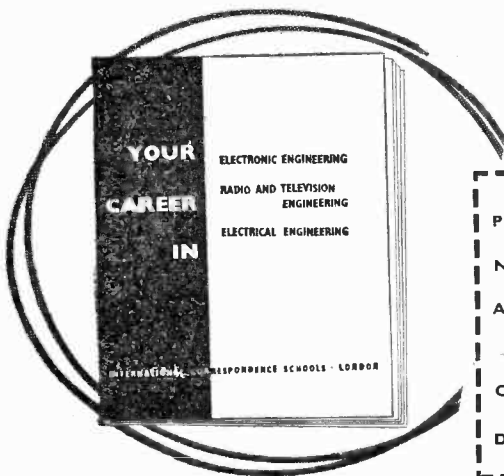

PLEASE SEND FREE BOOK ON.....

NAME .....

ADDRESS .....

OCCUPATION..... AGE.....

INTERNATIONAL CORRESPONDENCE SCHOOLS  
Dept. 170, INTERTEX HOUSE, PARKGATE RD, London SW11  
9.65

DE-LUXE RECORD PLAYER

Incorporating 4 Sp. Garrard Auto-Shim unit and Mullard latest 3 watt printed circuit amplifier (ECL 86 and EZ2 80), vol., base and treble controls, with 8 x 8in. 10,000 lbe speaker. Complete with 2-tone cabinet, charcoal-grey and off-white with matching blue relief. Size 17 1/2 x 16 x 8in. A stylish unit capable of quality reproduction. Circuit and construction details 2/6 (free with kit).



COMPLETE KIT £13.19.6

Illuminated perspex control panel, eschschon, 7/8 extra. Ready wired 30/- extra. Four contemporary mounting legs (6 or 18in.) 1/6 per set.

BSR TWIN TRACK RECORD-PLAYBACK TAPE AMPLIFIER

Wired and Tested with valves EF86, ECL82, EZ80 and magic eye recording indicator EM84. Complete with front panel and knobs, chassis size 12in. x 3 1/2in. 45.19.8. Carriage 3/6.

CLOSE TOL. S/MICAS-10%, 5pF-500pF. 8d. 500-5,000pF. 1/4, 1/2, 2pF-100pF. 9d. 100pF-500pF. 11d. 575pF-5,000pF. 1/6.

RESISTORS-Full Range 10 ohms to 10 megohms 20% 1/2 and 1/4W. 3d.-ditto 10%, 4d., 1/4W. 5d. (Midrange type modern rating) 1W. 6d., 27, 9d. Hi-Stab 5% 1/4W 100 ohms 9d. megohms. 6d. Other values 9d. 1 1/2, 1/4W. W/W Resistors 28 ohms to 10K 5W. 1/3; 10W. 1/6; 15W. 3/-. Resistor W/W Pots. W/W 25 ohms 50K. 3/-. 50K-2 Meg. (Carbon) 3/-. SFEAKER FRET-Expanded grid 3/4 1/6.

anodised metal 1/2 x 1/2in. diamond mesh. 4/8 sq. ft. multiples of 8in. cut. Max. size. 4ft. x 3ft., 4/76. Carr. extra. Ditto. Aner mesh. 4/8 sq. ft. Multiples 12in. only. max. size 3ft. x 2ft., 2/76. Plus Carr.

TYGON FRET (contemp. pat.) 12 x 12in. 2/-; 12 x 18in. 3/1/-; 12 x 24in. 4/-; 18 x 18in. 4/6; etc.

BONDACOUT Speaker Cabinet Acoustic Wadding, superior grade, lin. thick, 18in. wide. Any length cut. 2/3 per ft. 8/- per yd.

KNOBS-Modern Continental types: Brown or Ivory with Gold Ring, lin. dia., 9d. each; 1 1/2in. 1/- each; Brown or Ivory with Gold Centre, lin. dia., 10d. each; 1 1/2in. 1/3 each. LARGE SELECTION AVAILABLE.

TINNED COPPER WIRE-14-23g. 3/4 1/6.

L.P. RECORDING TAPE - BARGAIN OFFER!

By leading British Manufacturers Professional Grade DOUBLE SIDED (each side coated) 5 1/2 in. reels only.

Special Price Offer

1,450 feet (2 reels) 20/- post free.

Ideal for the experimenter who wants to record both sides, and a good L.P. Tape for the enthusiast who wishes to record single side only.

LATEST BSR TWIN TRACK TAPE DECK TYPE TD2

Brand new and guaranteed. £7.10.0 Carriage 5/-.

CONDENSERS-Silver Mica. All values. 2 pF. to 1,000 pF. 6d. each. Ditto ceramic 9d. 7th. 450V. T.C.C. etc. .001 mFd. .01 and 1/350V. 9d. .02-1/500V. 1/--. 25 Hume. 1/6. .5 T.C.C. 1/6. etc. RESISTORS-Modern ratings Full range 10 ohms to 10 megohms. 20% 1/4-1/2W. 3d. ea. ditto 1w. 6d. ea. 2w. 9d. ea. 10% 1/4-1/2W. 4d. ea. 5/16. 1 1/2W. 6d. ea. 1.5. Hi-stab. 1w. 1/8 ea. below 100 ohms 2/- ea. ea. VOLUME CONTROLS-5K-2 Meg. ohms. 3in. SPINDLES MORGANITE MIDGET TYPE. 1 1/2in. dia. Guar. 1 year. LOG or LIN. ratios, less Sw. 3/4. D.P. Sw. 4/8. Twin Stereo less Sw. 6/6. Some valves with DP Sw. 9/6. ENAMELLED COPPER WIRE-1 1/2b. reels. 14g-20g. 3/-; 22g-23g. 2/6; 20g-34g. 4/8; 36g-39g. 4/9; 39g-40g. 5/- etc.

Table with columns: New Boxed VALVES, Reduced Bargain Prices. Lists various valve types and prices.

Send for detailed bargain lists. 3d. stamp. We manufacture all types Radio Valves. Transf. Chokes, Quality O/P Trans., etc. Enquiries invited for Specials, Prototypes for small production runs. Quotation by return.

RADIO COMPONENT SPECIALISTS

70 Brigstock Road, Thornton Heath, Surrey. THO 2188. Hours: 9 a.m.-6 p.m., 1 p.m. Wed. Terms: C.W.O. or C.O.D. Post and Packing up to 1 lb. 9d., 1 lb. 1/3, 3 lb. 2/3, 5 lb. 2/9, 8 lb. 3/6.

JASON P.M. TUNER UNITS

Designer-approved kits available. PW11. 5 val. 4 valves. 20/- PW12. £7.10.0 5 valves. 25/-.

JTV Mercury. 10 gns. 3 valves. 28/6 JTV8 £12.19.8. 4 gns. 28/6.

NEW JASON P.M. HANDBOOK 2/6 Prompt Alignment Services 7/6 plus 2/6.

R.S.T. VALVE MAIL ORDER CO.

211a STREATHAM ROAD, MITCHAM, SURREY Tel. MITCHAM 6202 and 6771

Mon.-Sat. 9 a.m. -5.45 p.m. Wednesday 1 p.m. Open Daily to Callers

Large table listing various valve types and their prices in columns.

SPECIAL 24 HOUR SERVICE OBSOLETE TYPES A SPECIALITY QUOTATIONS FOR ANY VALVE NOT LISTED Postage 6d. per Valve. C.W.O. No C.O.D.

Special 24 Hour Express Mail Order Service SETS OF VALVES DAF91, DF91, DK91, DL92, DL94 DAF96, DF96, DK96, DL96 BRAND NEW TRANSISTORS OC35 10/- OC72 6/- OC44 5/- OC81 6/- OC45 5/- OC81m/pr 12/6 OC71 5/-

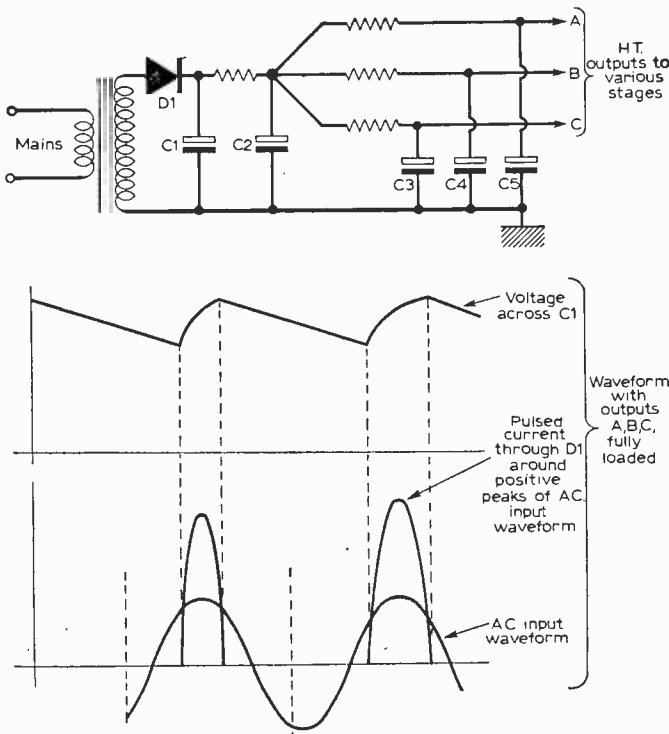

Fig. 6: Surge currents in rectifiers and electrolytics (see text).

In this case C1 gradually goes open-circuit, hum increases and the h.t. voltage drops. This is because the excessive heating on the surge pulses gradually disrupts the positive anode foil connection and dries out the electrolyte.

If a selenium or a valve rectifier is used the peak current on each pulse is less, since these rectifier types offer a somewhat higher impedance. In the case of a valve rectifier it is also necessary to observe the maximum capacitance permitted for C1 as stated by the valve manufacturer.

Smaller values of capacitance may certainly be substituted for C1 if reduced smoothing is tolerable, but larger values can damage the valve rectifier due to excessive surge currents through it. This factor is of lesser importance for selenium rectifiers and normally quite unimportant for silicon rectifiers, which can withstand repetitive surge pulses of many amperes indefinitely.

**PRACTICAL SOLUTIONS**

With all semiconductor rectifiers (especially silicon) the principal consideration is the reliability of the reservoir capacitor C1 (Fig. 6) in the face of the surge current demands, calling for an electrolytic of high surge or ripple rating. If a substantial can-type electrolytic is used, with adequate voltage rating, preferably equal to the peak a.c. input voltage to the rectifier (e.g. 350-380V for r.m.s. transformer voltages up to 250V), the surge rating condition is always satisfied.

If a physically smaller component is essential

for C1 it is advisable to use the resistor-input smoothing circuit of Fig. 7 if the h.t. current drain exceeds about 50mA. Generally R1 can be  $100V/I$  ohms where V is the d.c. h.t. output voltage and I is the h.t. current drain in mA. A small tubular electrolytic may then be used at C1 for h.t. current drains between 50-100mA.

This applies to silicon rectifiers. With small selenium or other metal rectifiers R1 may generally be halved or even omitted at the lower current drains. The capacitance of C2 should be doubled if necessary to restore adequate smoothing.

In miniature equipment with r.m.s. a.c. input voltages not exceeding 250V (regardless of rectifier type) and total h.t. output current drains not exceeding about 50mA it is generally satisfactory to use small tubular electrolytics in all positions.

**SMOOTHING CHOKES AND RESISTORS**

The smoothing action of a resistor (R1 in Fig. 8a) and a choke of the same net impedance (L1 in Fig. 8b) is, contrary to common belief, quite identical. The only difference is the greater a.c. voltage drop across the resistor and the consequent

greater dissipation of heat and loss of available h.t. voltage, which can become intolerable at high current drains.

The d.c. resistance of a smoothing choke is only a small fraction of its ripple impedance, so that the voltage drop and heat dissipation are less. If it is desired to use a choke in place of a specified smoothing resistor its d.c. resistance must be determined and the smoothing resistor reduced by that amount instead of being discarded entirely unless an increase of h.t. output voltage is tolerable (Fig. 8c).

If it is desired to substitute a resistor for a

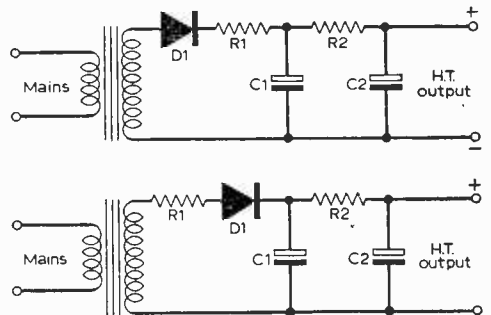

Fig. 7: Resistor-input (R1) smoothing circuits.

specified smoothing choke it must have the same value as the d.c. resistance of the choke and C2 (Fig. 8b) will need to have  $n$  times the specified capacitance where  $n$  is the ratio of impedance to d.c. resistance of the choke. The impedance of a choke may be taken as being 300L for 50c/s half-wave rectifier circuits and 600L for full-wave and bridge rectifier circuits, these figures being in ohms when L is the choke inductance in henries.

Where this involves unmanageably large values for C2 the smoothing resistor may be increased in value if the resulting loss of h.t. output voltage at normal loading is tolerable.

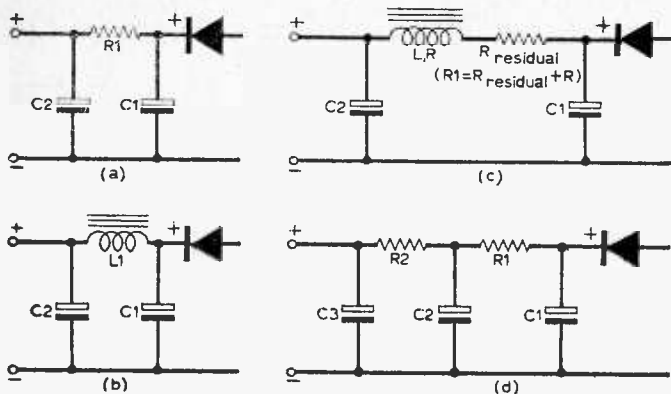

Fig. 8: Smoothing choke and resistor arrangements.

feed an entire amplifier. In Fig. 9b the choke has been discarded and the output stage V1 draws its anode current directly from the reservoir capacitor C1. This is permissible since there is no gain subsequent to the output valve anode and therefore hum remains negligible. The total current drain of the output stage screen grid and all other stages is much less, so that a smoothing resistor R1 of much greater value than the resistance of the smoothing choke L1 has been substituted without loss of h.t. voltage.

This type of substitution is generally permissible either way—unless extreme high-fidelity conditions are involved where it may be assumed that the design leads to minimum background hum.

### SMOOTHING CHOKES RATINGS

It is always permissible to substitute a smoothing choke of higher inductance than specified but having the same or very nearly the same resistance. It is always permissible to connect two identical smoothing chokes in parallel, doubling total current rating and halving the inductance and d.c. resistance.

Two identical or dissimilar smoothing chokes connected in series will give a current rating equal to that of the individual choke of lowest current rating. The d.c. resistance and total

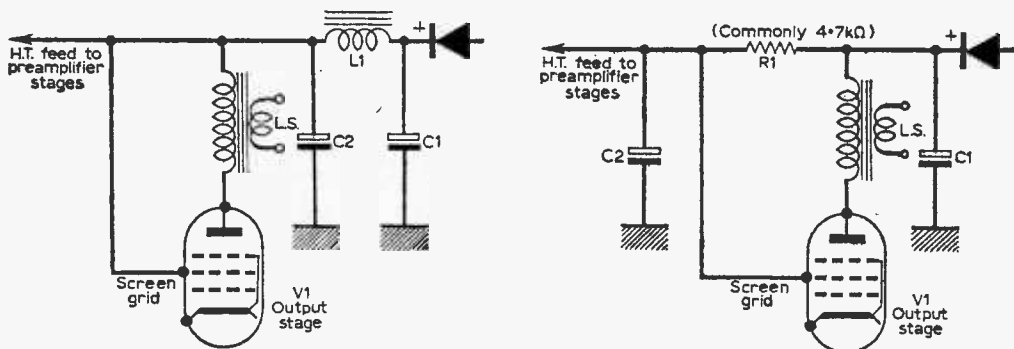

Fig. 9 (a and b): Replacing a smoothing choke L1 with a larger smoothing resistor R1 in a conventional audio amplifier circuit.

Alternatively a two-stage smoothing circuit (Fig. 8d) may be used. The value of C1 should not be above that specified but the values of C2 and C3 increased experimentally until the desired degree of smoothing is obtained. R1 and R2 are each one half of the resistance of the rejected choke if the same output voltage is to be maintained.

If sufficient smoothing is unobtainable with manageable values for C2 and C3, R1 and R2 will need a lesser degree of increase than formerly so that the loss of h.t. voltage resulting is not so great.

In Fig. 9a a choke smoothing circuit is used to

inductance are the sum of the individual values.

It is always permissible to use a smoothing choke having the specified resistance and inductance values but a higher or much higher current rating than specified. Indeed the d.c. resistance is often of so little importance that it may be disregarded. Any other choke is then a satisfactory substitute as long as it has approximately the specified inductance, will carry at least the working current involved and does not have an excessive d.c. resistance. Tolerance limits are certainly  $\pm 20\%$  of specified ratings and may even



# FOR PEAK PERFORMANCE AT LOW COST —

# PICK CODAR

## AMATEUR RADIO EQUIPMENT

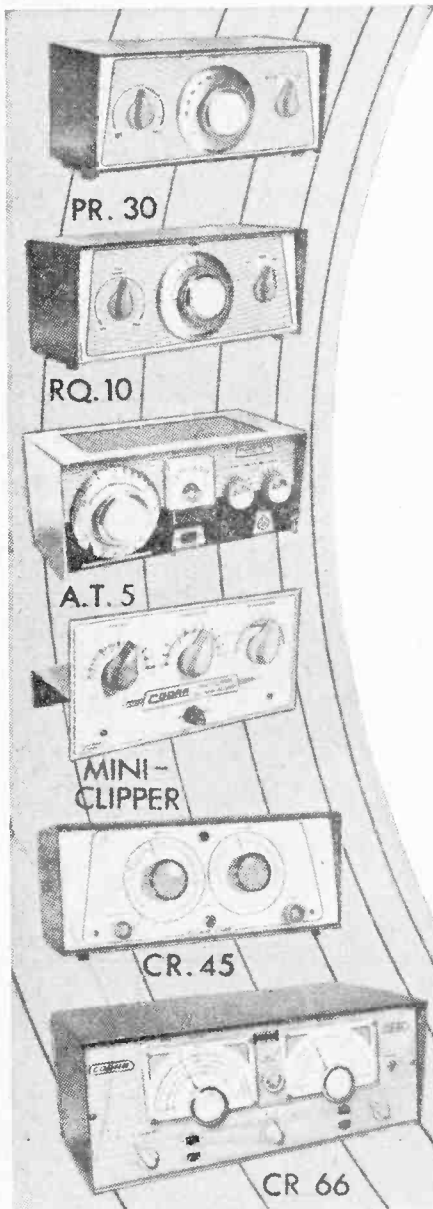

Advanced design and craftsmanship plus an unequalled reputation proved by the many hundreds of testimonials received from CODAR users is your guarantee of complete satisfaction. Only the best is good enough for CODAR—Mullard, Brimar, Jackson, Denco, Electronics, Thorn, A.E.I., are just some of the famous names built into CODAR equipment. CODAR-KITS are supplied with clear pictorial diagrams and easy to follow instructions—no technical knowledge or special tools are required for complete success. Build your Short Wave Station with CODAR-KITS and enjoy peak performance and world wide reception previously possible only from much more expensive equipment.

For illustrated leaflets giving fullest details send 6d. in stamps.

**CODAR R.F. PRE-SELECTOR.** Will considerably improve the performance of any superhet receiver. "Results are amazing." "Well worth the money". **MODEL P.R.30.** Uses EP183 Frame Grid tuned R.F. Amplifier and provides up to 20dB gain plus substantial image rejection. Improved signal/noise ratio and selectivity. Selector switch for either dipole or single wire antenna. Power requirements 180-250 volts 12 M/A H.T. 6.3 volts, 3 amp L.T. Size 8½ x 5 x 4in. Ready built, complete with cables, plugs and instructions. £4.19.6. Carr. 3/6. **MODEL P.R.30X.** Self powered version for 200-250V. A.C. and also provides 25 M/A at 200V. H.T. and 6.3v. 1 amp L.T. for other accessories. £7.4.0. Carr. 3/6.

**CODAR "Q" MULTIPLIER MODEL R.Q.10.** For use with any superhet receiver with an I.F. between 450 and 470 Kc/s. Provides considerable increase in selectivity for either peaking or rejecting a signal on AM, CW, or SSB. Both PEAK and NULL functions tunable over receiver I.F. passband. BFO. facility included. Size 8½ x 5 x 4in. Power requirements 180-250V. H.T. at 5 M/A 6.3v. 3 amp L.T. Ready built complete with cables, plugs and instructions. £6.15.0. Carr. 3/6. **MODEL R.Q.10X.** Self powered version for 200-250V. A.C. and also provides 25 M/A at 200V. H.T. and 6.3v. 1 amp L.T. for other accessories £8.8.0. Carriage 3/6.

**CODAR A.T.5. 12 WATT 2 BAND TRANSMITTER.** The newest most compact transmitter for fixed or mobile use on 160-60 metres. "The tiny TX with the BIG voice". Size only 8½ x 5 x 4in. (Base area is less than two-thirds of this page!) High stability new type calibrated VFO. 1.8-2.0 Mc/s and 3.5-3.8 Mc/s (up to 1 Mc/s export). Air-spaced CODAR COIL Pi-net output. P.A. Plate current meter 'ack. Plug changeover for 6 or 12 volts heater supply. Ready built £16.10.0. Carr. 4/-. **A.T.5 POWER SUPPLY UNITS.** Type 250/S. For 200/250V. A.C. with Stand-by/Net/Transmit and aerial changeover switching. stabilised VFO supply. neon standby/transmit indicator £8.0.0. Carr. 6/6. Type 12/MS 12 volt solid state power supply unit. £11.5.0. Carr. 6/-. Type 12/RC Remote Control and Aerial Switching unit. £2.7.6. Carr. 3/-. (H.P. Terms available).

**CODAR-KIT MINI-CLIPPER—OUR FAMOUS SHORT-WAVE RECEIVER.** ★Can be built in one evening ready to switch on and bring the World to your fingertips at very low cost. ★Supplied complete with valve, one coil 25-75 metres and 4 page instruction manual. PRICE 39/6. Carr. 3/-. Extra coils 4/9 each. Instruction Manual only 2/- (credited on order). Electrical bandwidth available. Provision to add 2 transistor amplifier.

**CODAR-KIT CR45 MAINS T.R.F. SHORT-WAVE RECEIVER.** World wide reception—North and South America, Russia, India, Australia, Far East, Amateurs, Shipping, etc. ★Separate electrical bandwidth. ★3 slow motion vernier drives. ★Low loss polystyrene plug-in coils, factory aligned. ★Dials calibrated in frequencies and degrees. ★Power output 3 watts for 2/3 ohm speaker. ★Valve line-up: ECC81, EL84, EZ80. **CODAR-KIT CR45** complete with valves, 3 coils (10-26, 25-75, 60-176 metres) and 11 page instruction manual LESS Cabinet). £7-5.0. Carr. 5/6. **CR45 CABINET.** 12in. x 5½in. x 7in. with sliding door for easy coil changing 35/-. Extra coils: 4/9 each. Instruction manual only 4/- (credited on order). (Can now be supplied ready built—price on request). (H.P. terms available).

**CODAR-KIT CR 66 COMMUNICATION RECEIVER.** The finest superhet kit ever offered. ★Covers 540 Kc/s—30 Mc/s in 4 bands. ★Separate electrical bandwidth. ★Factory aligned. Coil unit and I.F. Transformers. ★Regenerative I.P. stage for maximum gain and BFO. for C.W. reception. ★Power output 3 watts for 2/3 ohm speaker. ★Panel controls: Aerial Trimmer, A.V.C., Standby Bandswitch, AF Gain, IF Gain, BFO, etc. ★Valve line up: ECH81, EBF89, ECC81, EL84, EZ84. ★Size 8½ x 6½ in. x 6½ in. x 6½ in. **CODAR-KIT CR 66.** Complete with 17 page instruction manual. £19.15.0 (Ready-built £23.0.0). CR 66 "S" Meter Model Kit £22.0.0 (Ready-built £25.0.0). Carr. 7/6 extra on all models (H.P. terms available). Instruction Manual only, 7/6 (credited on order).

**CODAR COILS AIR-Spaced INDUCTORS.** A complete range of low loss air-spaced inductors developed by CODAR. Over 40 different sizes from 1in. to 3 in. diameter suitable for all types of circuit application including VFO, P.A. tank, Pi-network, ATU, aerial loading, etc. Full data and prices on request.

### CODAR RADIO COMPANY

G31RE G3HGQ

BANK HOUSE, SOUTHWICK SQUARE,  
Southwick, Sussex.

Tel. 3149

Canada: Codar Radio of Canada, Inwood, Ontario

# WIRECOMP ELECTRONICS

## WIRECOMP'S BARGAIN STORE

48 Tottenham Court Road, London, W.1

Thousands of Bargains: Transistor Radios—Record Players—Tape Recorders—Radiograms—Rock Bottom Prices

### FAMOUS MAKE TRANSISTOR RADIO THE "STELLA"

7 transistor portable radio. Long Med. and Short wavebands. Fitted tone switch and sockets for personal earphone and external aerial; chrome telescopic aerial. Uses four 1.5 v. torch batteries. Plastic cabinet in beige and red, size 4 x 7 x 1 1/2 in. Excellent tone. 3in. p.m. speaker. Comp. with shoulder strap and external aerial. Full guarantee. List price 17 £ns. **£9.19.6** P. & P. 5/- WIRECOMP'S PRICE

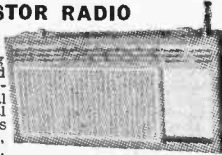

### NEW SUPER MINIATURE POCKET RADIOS

**THE SINCLAIR MICRO-6.** Self-contained pocket radio. Size only 1 1/2 x 1 1/2 x 1 1/2 in. Complete with earphone and detailed construction data. Can be built for only **59/6** Mercury cell 1 1/2 extra (2 required).

**THE SINCLAIR SLIMLINE.** The new 2-transistor pocket radio size only 2 1/2 x 1 1/2 in. Micro alloy transistorised and printed circuit. All components available separately. Easy to assemble. Can be built for **49/6**

### INTERNATIONAL BRAND TAPE—Fully Guaranteed

MYLAR BASE	ACETATE BASE
3 1/2 in. Triple play, 600ft. 15/-	3in.—150ft. 3/6
4in. Triple play, 900ft. 17/8	3in.—225ft. 4/11
5in. Double play, 1,200ft. 15/-	3in.—300ft. 7/6
5in. Triple play, 1,800ft. 35/-	5in. Long play, 900ft. 10/-
5 1/2 in. Double play, 1,800ft. 22/6	5 1/2 in. Long play, 1,200ft. 12/6
5 1/2 in. Triple play, 2,400ft. 45/-	7in. Stand play, 1,200ft. 10/-
7in. Stand play, 1,200ft. 12/6	7in. Long play, 1,800ft. 15/-
7in. Long play, 1,800ft. 39/8	P.V.C. BASE
7in. Double play, 2,400ft. 55/-	5in. Stand play, 600ft. 8/6
7in. Triple play, 3,600ft. 58/6	5 1/2 in. Stand play, 840ft. 11/6

P. & P. 1/- extra per reel, 4 reels and over Post Free.

### THE "SKYROVER" RANGE

7 transistor plus 2 diode superhet. 8 waveband portable receiver. Operating from four 1.5 v. torch batteries. Cover the full Medium Waveband and Short Waveband 31-94 M and also 4 separate switched band-spread transmitters. 13M, 16M, 19M and 25M, with Band Spread Tuning for accurate Station selection.



**NEW—THE "SKYROVER" Mk III** Now supplied with redesigned cabinet, edgewise controls, black and chrome plastic cabinet. Size 10 x 6 1/2 x 3 1/2 in. Can now be built for **£8.19.6** Post 5/- built for **£11.19.6** H.P. Terms: 27/- dep. and 11 months at 15/9. Total H.P. Price £10.0.3

**THE "SKYROVER" de LUXE** (Tone Control Circuit is incorporated with separate Control. In a wood cabinet, size 11 1/2 x 6 1/2 x 3 1/2 in., covered in a washable material, fitted carrying handle. Can now be built for **£10.19.6** Post 5/- H.P. Terms: 33/- dep and 11 built for mths. at 18/2, Total H.P.P. £12.3.10.

A simple additional circuit provides coverage of the ONLY Post 1100/1950M. band. This conversion is suitable for 10/- Free both models that have already been constructed. **EXTRA**

Data for Receiver 2/6 extra. Refunded if you purchase the parcel. Four U2 batteries 3/4 extra. All components available separately

### PAMPHONIC HI-FI EQUIPMENT

TYPE 3001 Integrated Stereo Amp. List price £38.10.0. WIRECOMP'S PRICE 23 £ns. Post 10/6.  
TYPE 1002A Control Unit. WIRECOMP'S PRICE £4.19.6. Post 2/6.  
TYPE 1002B Control Unit/Pre-amp. List Price £25.4.0.  
WIRECOMP'S PRICE £6.19.6. Post 2/6.  
TYPE 2001A Pre-Amplifier. WIRECOMP'S PRICE £5.19.6. Post 3/6.  
TYPE 732A Switched Radio Tuner. WIRECOMP'S PRICE £5.19.6. Post 7/6  
All fully described in our advertisement in "P.W." April 1965.

323 EDGWARE RD., LONDON, W.2. **AMBassador** 7115  
All Branches open all day Saturday Early closing Thursday

378 HARROW RD., LONDON, W.9. **CUNningham** 9530  
Mail Orders to the above address for prompt service

## STOCKTAKING CLEARANCE!

We have many items which we are clearing at special prices. A list is now available and will be sent upon request. Please enclose 4d. stamp for postage.

### WATTS RADIO (Mail Order) LTD

54 CHURCH STREET, WEYBRIDGE, Surrey

PLEASE NOTE: Postal business only.

Your complete basic guide devoid of mathematics and circuitry . . .

## BEGINNER'S GUIDE TO COLOUR TELEVISION

by Terence L. Squires, A.M.Brit.I.R.E.

Explains fully how the signals are created in the television studios, how they are transmitted and the techniques used to receive and display them. Covers: Historical Outline - The Colour Signal - The Chrominance Signal - Colour Transmission - Receiving the Colour Signal - Domestic Aerial Systems - The Receiver Block Diagram - The SECAM Receiver etc. 128 pages. 58 diagrams.

15s. from ALL BOOKSELLERS

... or, in case of difficulty, 16s. by post from George Newnes Ltd., Tower House, Southampton Street, London, W.C.2.

NEWNES

## NO THE Dewtron

Aerial Car radio Licence Connections to ANYTHING!

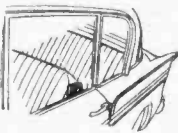

WAVE TRAP gives BOOST to ANY transistor portable radio, **39/6** Pat. app. for

★ IN CAR replaces car aerial; reduces fading.

★ IN HOME boosts distant and PIRATE stations. P. & P. 2/- extra.

★ ON HOLIDAY improves reception in remote areas. A MUST for caravanners. Attached to any window. Supplied complete with PP3 battery and instructions. Money-back guarantee.

**D.E.W. Ltd., DEPT. P.W.** RINGWOOD ROAD, FERNDOWN, Dorset

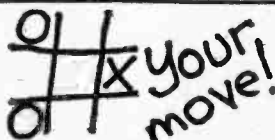

Unless you put your X between the two O's the machine will win at the next move. Even if you do the machine puts the next O in the centre square, which not only stops you winning but also guarantees the machine's win at the next move. Try it and see.

As Brian Trueman of Granada TV said after demonstrating the machine on television on April 12th. "I'm glad I wasn't playing it for money". One machine that did play for money, at 3d. a go, refunded if a drawn game, raised £3 in three hours for charity. Full circuit wiring diagram, instructions for this fabulous unbeatable machine, 3/6d post free. Built for about 26s.

**PLANET INSTRUMENT CO.** 25 (W) DOMINION AVE., LEEDS 7

## 2 METRES 4

The thrills of VHF Amateur Radio! Complete kit, 70-150 Mc/s, costs only 42/6 (by post, UK, 3/3 extra) also now available. Short-Wave kit, model TR2, 10-180 metres. Ideal for beginners to Ham radio via simplified "Easy-Built" step-by-step instruction, from 79/6. Write today enclosing a stamped addressed envelope for literature and full details. Overseas enthusiasts note we despatch to all parts of the world—local stamp OK for literature. "GLOBE-KING" (Regd.) precision standard products tried and trusted by Amateurs everywhere.

**JOHNSONS (Radio)** St. Martins Gate, Worcester

be  $\pm 40\%$  or more in many cases. *The choice of a smoothing choke is hardly ever critical.*

Loudspeakers with electromagnetically energised field coils are now obsolete, modern loudspeakers using permanent magnets, but they may turn up in older equipment and may need replacing.

The field coil is generally also the h.t. smoothing choke. If a modern loudspeaker is substituted and the original field coil is still intact it should be detached from the speaker frame and mounted elsewhere for retention as an h.t. smoothing choke.

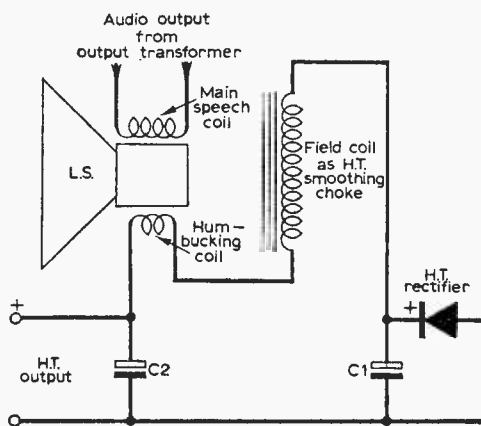

Fig. 10: Circuit of energised loudspeaker.

Fig. 10 shows the usual arrangements of an energised speaker, including the hum-bucking coil. The latter is an additional speech coil winding in series with the field coil to cancel hum due to the simultaneous use of the field coil as h.t. smoothing choke. This hum-bucking coil should be discarded, making direct connections to the detached field coil.

The magnetic circuit of the field coil must be retained and it is advisable to fill the speech coil gap with Durafix after the cone and speech coil assembly has been discarded. Thereafter any modern p.m. moving-coil speaker of the correct impedance may be substituted across the output transformer secondary.

If trouble is due to a burnt-out field coil for which a replacement is unobtainable a rewind is hardly advisable because modern p.m. speakers are so much more efficient. In such cases substitute a p.m. speaker and replace the field coil with a standard smoothing choke or resistor arrangement in the h.t. circuit according to the general lines discussed previously.

## VALVE SUBSTITUTIONS

A comprehensive book of valve data is absolutely essential for the serious constructor. When purchasing such a book from a dealer or bookshop make sure that it is as generalised as possible and that it gives full details of typical operating ratings as well as limiting ratings for all electrode voltages and currents, including current,

obsolescent and the more important obsolete valves.

Most foreign countries now use valves which are identical with current British types and which bear the same type numbers, so that unfamiliar foreign valve types encountered in imported equipment are likely to be obsolete or obsolescent even in their country of origin. It is nevertheless useful if a purchased valve data book makes some attempt at establishing an international character, listing the more important foreign valves.

It is also useful, but not essential, if the data books contain all major characteristic curves depicted graphically for each valve. It is not possible to make reliable decisions regarding substitution of valves, transistors and diodes without adequate data tables. Get the best you can!

If it is desired to use a different valve than the one specified in a design, or to substitute a current international range type for an obsolete type in older equipment, first look up the characteristics of the particular valve which is to be replaced and compare these with the actual operating conditions employed in the equipment to be modified.

The valve data tables should then be searched for a readily available current valve type whose ratings correspond as closely as possible to those of the original and whose limiting ratings (maximum permissible electrode voltages, currents and power dissipations) will at least permit the existing operating conditions.

There is at this juncture no imperative need to consider base connections or base type but heater voltages (for parallel heaters) or heater currents (for series connections of heaters in a.c./d.c. equipment) should be the same. The normal anode and screen currents of the substitute valve should not differ greatly from those of the original at the prevailing h.t. voltages. If the slope (mutual conductance) of the intended substitute valve is much greater than that of the original, parasitic instability may result of a stopper resistor is not connected *directly* to the grid (and possibly to the screen grid) pin. Common values are 1-10k $\Omega$  for grid and 100 $\Omega$  for screen. Where possible ensure that the substitute valve has about the same slope as the original.

The cathode bias resistor should be replaced by one having the value specified in the data tables for the new substitute valve. In output stages aim to use a substitute with roughly the same power output, otherwise the existing loudspeaker and possibly output transformer may not be able to handle the greater output power of modern valves.

## VOLTAGE AMPLIFIER STAGES

When making a valve substitution in a voltage amplifier stage working into a high anode load the chief consideration is to maintain the same mutual conductance if performance is not to suffer. This applies to RC-coupled audio stages as well as r.f. or i.f. amplifiers whose anode load is the high resonant impedance of a tuned circuit. In such stages, especially with pentodes, gain is largely proportional to the slope of the valve. If decreased gain, or instability due to increased gain, is to be avoided, substitute valves should have roughly the same slope.

A variable-mu valve (whose slope varies according to the negative grid bias voltage) may be substituted for a straight characteristic valve, or vice versa, provided that the maximum slope of the variable-mu valve is roughly equal to that of the straight valve. The variable-mu valve permits manual or automatic gain control via the applied variable grid bias voltage.

A fact less commonly realised is that no valve, not even straight types, manifest a quite constant slope independent of the grid bias, i.e. independent of the operating point. Even those listed as "straight" often respond well if operated at low anode current with increased cathode bias resistors.

Avoid using variable-mu valves in *audio* stages unless the stage concerned handles only very minute signal amplitudes, otherwise severe distortion will result. A variable-mu characteristic is nothing more than a very curved characteristic instead of the linear one required for low-distortion high-amplitude amplification. This point is largely unimportant in r.f. and i.f. stages since any distortion there simply leads to the production of harmonics which are rejected again by the subsequent tuned circuits.

The range of possible substitutions among the r.f. pentode class of valves is thus virtually unlimited and once a valve appears to be reasonably suitable, experiment is often the quickest method of deciding the issue.

If an intended substitute valve is rated for about the same anode and screen current, or if the external anode and screen resistors are so high that excessive current could not flow even if the valve should represent a virtual short-circuit, simply try the valve in the circuit, using the listed cathode bias resistor or a larger one.

More critical conditions arise in *video amplifiers* and in *v.h.f.* designs. Here the ratio of the slope to the grid input capacitance of the valve is frequently the decisive factor, since this ratio determines the achievable bandwidth for a given gain.

Also make sure that a substitute valve for such circuitry is rated for a maximum working frequency at least as great as that involved in the particular equipment, even if this rating may not be as high as that for the specified original valve.

## GAIN ADJUSTMENTS

If an audio output valve of higher slope is substituted for a valve of the same anode current rating the drive signal at the grid must be reduced by altering the gain of the previous audio amplifier stage. Fig. 11 shows the simplest way of effecting this reduction of gain.

Assuming, for example, that the new output valve V2 in Fig. 11b substituted for V2 in Fig. 11a

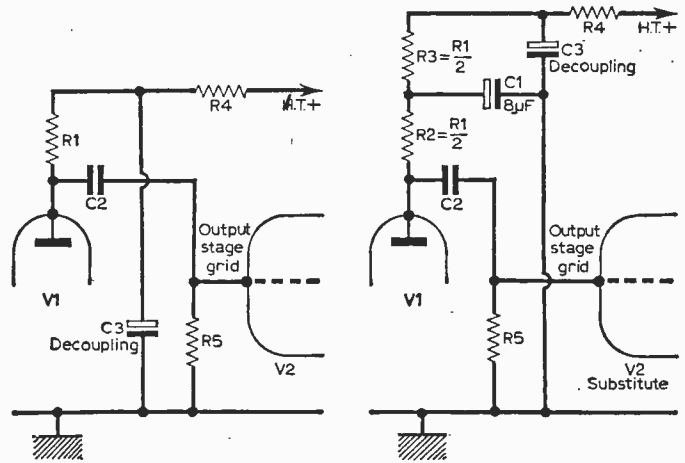

Fig. 11: Gain adjustment when substituting an output valve requiring less grid drive.

requires only half as much grid drive voltage, then the anode load resistor R1 of Fig. 11a must be split into two resistors each half as large, R2 and R3 (Fig. 11b), with the one at the h.t. end shunted to chassis with a small tubular electrolytic of about  $8\mu\text{F}$  (C1 in Fig. 11b). Alternatively R3 may be included in R4 by making R4 suitably larger when R2 and C1 are not required as separate components.

Do not alter the coupling capacitor C2 or the grid-leak R5 unless the new high-slope output valve is listed as not able to tolerate the original value of R3, when C2 must be increased in value in the same ratio as R5 has to be decreased. Otherwise bass loss results.

Modern valves, particularly high-slope ones, can be damaged if the grid-leak exceeds a certain maximum resistance (often  $500\text{k}\Omega$  or  $1\text{M}\Omega$ ). Positive grid current due to ions derived from residual gas in the valve envelope could otherwise produce cumulative destructive rise of anode current. This trouble hardly ever arises with older low-slope valve types unless the valve concerned has gone soft (deteriorated vacuum). Any value of grid-leak less than the specified maximum may be used if required.

Many batches of "manufacturers' rejects" released for cheap sale without guarantee can be particularly prone to positive grid current on high grid-leaks, particularly if output valves or other high-slope types are involved. When using any such bargain valves it is advisable to make the grid-leak resistance not more than one half of the maximum rated value for a new and guaranteed valve of the same type.

## VALVEHOLDERS

A valve substitution may require a change of the valveholder type or rewiring of connections to the same valveholder. If it is inconvenient to replace the valveholder or to rewire the existing one an adaptor may be built up from the base of

—continued on page 437



# Why anyone can build a Heathkit model—and save money

## The success of a HEATHKIT MODEL

is assured by the world-famous HEATHKIT MANUAL

- 1—Clear, step-by-step instructions enable assembly of models without difficulty.
- 2—Components are pictured with full size drawings enabling easy identification.
- 3—Extra large Pictorials illustrate clearly, each step given in text.
- 4—All manuals give operation and adjustment instructions.

## A KIT FOR EVERY INTEREST . . . HOME, SERVICE WORKSHOP, LABORATORY

### 'AMATEUR' EQUIPMENT

A wide range of models including:

- AMATEUR BANDS RECEIVER, RA-1** (160-10 m).  
Kit £39.6.6 Assembled £52.10.0
- COMMUNICATION TYPE RECEIVER, RG-1** (600kc/s-1.5Mc/s, 32Mc/s-1.7Mc/s)  
Kit £39.16.0 Assembled £53.0.0
- AMATEUR TRANSMITTER, DX-100U** (160-10 m)  
Kit £79.10.0 Assembled £104.15.0
- AMATEUR TRANSMITTER, DX-40U** (80-10 m).  
Kit £33.19.0 Assembled £45.8.0

Other kits in range include: **SSB Adaptor, SB-10U** £39.5.0  
**Variable Freq. Oscillator, VF-1U**, £10.17.6. **Balun Coil Unit, B-1U**, £4.15.6. **Grid-Dip Meter, GD-1U** £10.19.6. **Multiplier, QPM-1** £8.10.0 **Reflected Power Meter, HM-11U**, £8.5.0.  
Also wide range of American models. Please send for details



**NEW!**  
**TRANSISTOR MIXER, TM-1.**  
A must for the tape enthusiast. Internal 9v battery operation.  
Kit £11.16.6 Assembled £16.17.6

### HI-FI

- F.M. TUNER** (in two parts)  
Total price Kit £16.8.0, incl. P.T.
- AM/FM TUNER** (in two parts).  
Total price Kit £27.5.0, incl. P.T.



FM Tuner

- 6W STEREO AMPLIFIER, S-33H.**  
Kit £15.17.6 Assembled £21.7.6
- 18W STEREO AMPLIFIER, S-99.**  
Kit £28.9.6 Assembled £38.9.6
- 6W STEREO AMPLIFIER, S-33**  
Kit £13.7.6 Assembled £18.18.0
- 40W ALL TRANSISTOR STEREO AMPLIFIER, AA-22U**  
Kit £43.18.0 Assembled £68.16.0
- 5W MONO AMPLIFIER, MA-5**  
Kit £10.19.6 Assembled £15.10.0
- 10W POWER AMPLIFIER, MA-12**  
Kit £11.18.0 Assembled £15.18.0
- 50W POWER AMPLIFIER, MA-50**  
Kit £19.18.0 Assembled £27.18.0
- MONO TAPE PRE-AMPLIFIER, TA-1M**  
Kit £19.18.0 Assembled £28.18.0
- NEW "STUDIOMATIC" TAPE DECK (MONO)**  
£14.19.6.
- LOW PRICED SPEAKER SYSTEM, SSU-1**  
Legs 14/6 extra. Kit £11.17.6, incl. P.T.
- A range of Record Players, Cabinets, Mics, etc.

### TEST & SERVICE INSTRUMENTS



- 5" OSCILLOSCOPE, IO-12U** (TB 10c/s-500kc/s)  
Kit £35.17.6 Assembled £45.15.0
- 2 3/4" PORTABLE 'SCOPE OS-1**  
Kit £22.18.0 Assembled £30.8.0
- 4 1/2" VALVE VOLTMETER, V-7A**  
Kit £13.18.6 Assembled £19.18.6
- 6" VALVE VOLTMETER, IM-13U**  
Kit £18.18.0 Assembled £26.18.0

10-12U RF and HV probes available as extras.  
**REGULATED POWER SUPPLY, IP-20U** (Transistorised)  
0.5-50v d.c. to 1.5A Kit £35.8.0 Assembled £47.8.0

**TV ALIGNMENT GENERATOR, HFW-1** (3-6-220Mc/s)  
Kit £37.18.0 Assembled £47.10.0

**RF SIGNAL GENERATOR, RF-1U** (Up to 100 Mc/s fund)  
Kit £13.8.0 Assembled £19.18.0

**MULTIMETER, MM-1U** (wide V, A, res, dB ranges)  
Kit £12.18.0 Assembled £18.11.6



**NEW!**  
**HARMONIC DISTORTION METER, IM-12U**  
Enables fast, accurate noise and distortion measurements to be made in amplifiers, etc.  
Send for Full Details.  
Kit £24.15.0 Assembled £34.0.0

Other instrument kits include: **R/C Bridge, C-3U**, £10.10.0.  
**Wattmeter, AW-1U**, £17.5.0. **Cap. Meter, CM-1U**, £15.15.0.  
**Transistor Tester, IM-30U**, £24.18.0.

**Power Supplies, Decade R and C Boxes, etc.**  
Many other instruments in the American range. Full details and catalogue, 1/-, post paid.

### TRANSISTOR RADIOS

- "OXFORD" LW/MW RECEIVER, UXR-2**  
Kit £14.18.0, incl. P.T.
- 6 TRANSISTOR PORTABLE, UXR-1, LW/MW.** Kit £12.11.0, incl. P.T.
- "MOHICAN" GENERAL COVERAGE RECEIVER, GC-1U**  
Kit £37.17.6 Assembled £45.17.6
- ELECTRONIC WORKSHOP, EW-1** (Experimental Kit)  
Kit £7.13.6, incl. P.T.
- JUNIOR RADIO, UJR-1**  
Kit £2.7.6, incl. P.T.  
Headphones 30/- extra. Additional amplifier stage (will work speaker), 16/6 extra.



**A WIDE RANGE OF BOOKS ON ELECTRONICS AND RADIO. PLEASE SEND FOR LISTS OR PRICES.**

**FREE CATALOGUE** of the  
**BRITISH HEATHKIT RANGE**  
Gladly sent on request . . .

**TO DAYSTROM LTD. Dept. P.W.-9, GLOUCESTER, ENG.**  
Please send me **FREE BRITISH CATALOGUE (Yes/No)**  
Full details of model(s).....  
American Catalogue, 1/- Post Paid (Yes/No)  
NAME.....  
ADDRESS.....



# “Tailor-made” Tagboards

By  
A. Cassera, B.Sc.

## CIRCUIT BOARD CONSTRUCTION THE CHEAP WAY

THE circuits made up by the amateur using alloy chassis construction so often look untidy in layout because he does not have the “tailor made” tagboards that the professional uses. Odd insulated tags have to be placed here, there and everywhere to prop up the ends of components. As the circuit becomes more complicated the “components suspended in the wiring” system of construction comes to look like a rat’s nest. One solution to this problem is to mount all the components on to an insulating board rather than a metal one.

### Circuit Boards

Printed circuit boards are difficult for the amateur to make. They require planning of the layout, followed by careful drawing, etching and cleaning of the special copper laminated board. However, one of the most important advantages of the printed circuit, that of fitting the components direct to an insulating board and thus getting rid of the metal chassis as the main element for the mechanical support of the components, can easily be copied by the amateur.

### Method of Construction

The ordinary resin-impregnated boards used by the handyman such as Formica are ideal for the construction of circuit boards. Offcuts of a size suitable for electronic work are very cheap, since they are too small for many other jobs. The material is easy to work with, sawing, planing and drilling cleanly and having a hard surface available

in many attractive colours. It appears to have good electrical insulating properties, at least at low and medium frequencies. The circuits are assembled direct on to pieces of the board. All the resistors, capacitors, transistors and any other small wire-ended components are fixed to the finished (coloured) side of the boards by soldering to 6BA double-ended tags held to the boards by resin, 6BA nuts and bolts. Both ends of the tags are bent up at right-angles to the board. The tags

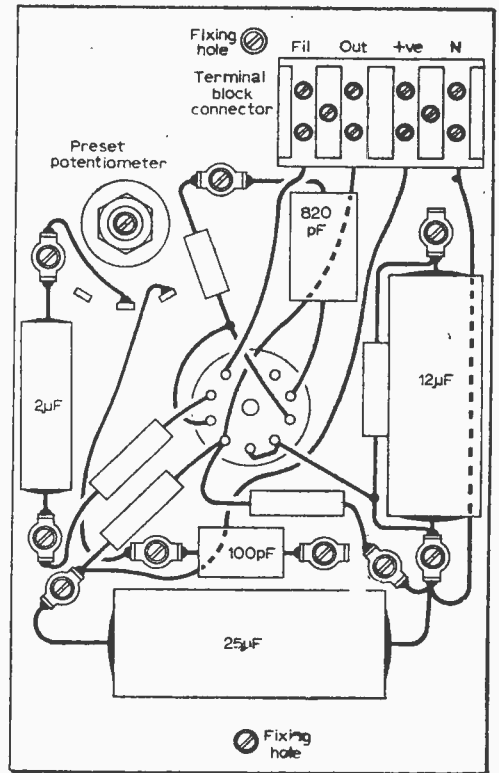
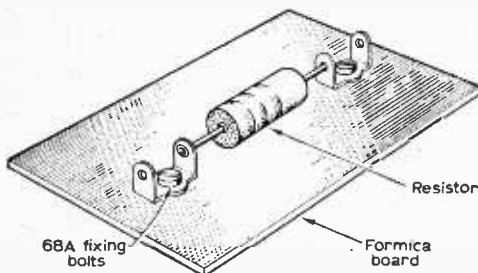

Fig. 1: Method of fixing components to Formica with 6BA tags.

Fig. 2: Assembly round a B9A valveholder using Formica and 6BA tags.

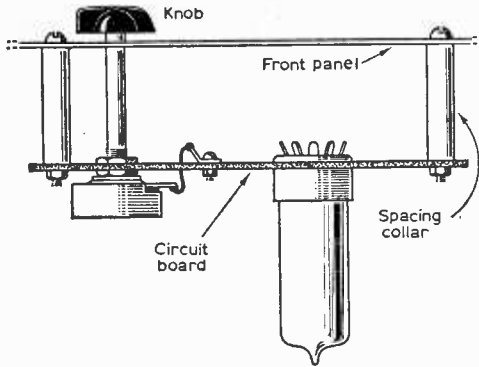

Fig. 3: Method of mounting circuit board in cabinet by means of long bolts with spacers.

can be placed close up to the component so that only a little free wire end is needed. This is useful when salvaged components are used. All the components are fitted to the board as neatly as possible, often around a valve or transistor. It is best to do the construction actually on the board. A bent tag is screwed to the board and one end of the component soldered to it. Another bent tag is slipped on to the wire end, which is trimmed to length. The position of the component is then decided and the bolt hole drilled and the nut and bolt fitted. Finally the joint is soldered. Thus all the tags are "tailor made" and yet cost less per tag than the standard commercial tagboards. Valve holders are fitted to the board just as they are to a metal chassis, the chassis punches cutting Formica very cleanly. Transformers and chokes can be bolted direct to the board and the bosses of switches and "pots" are passed through holes as normal. The components are wired up, using PVC single core wire soldered to the free ends of the tags. Obviously a little planning of the layout before-hand leads to the shortest runs of wire between components. If fairly long runs are needed they can be held in place by cementing the wire to the board with a few spots of adhesive. Wires can pass from one side of the board to the other through small holes; no grommets are needed.

### Mounting the Boards

Using this system of construction it is often convenient to split a circuit into several stages and make each up on a separate board. Many of the circuits made by the author using this system are experimental only and are mounted merely by screwing the edges of the boards to blocks of wood. If it is desired to fit the equipment into a cabinet, then the boards are fixed parallel to the front panel of the cabinet by long bolts, using spacing collars to keep the components clear of the panel. If switches and "pots" with long spindles are used these can then come through holes in the front panel to be fitted with knobs. If valves are used they stick out behind the board. Further boards can be mounted behind these if long bolts with spacers are used. The boards are connected one to another by chocolate block connectors fitted to the edges of the board. If screening is needed, then screen wires must be used.

Using this method of construction the author has found that the neatness of his layouts has increased a lot and yet the actual cost of construction has gone down, since he is spared the cost of alloy chassis and tagboards and is now able to use up those boxes of components with short wire ends that he has salvaged from surplus equipment. ■

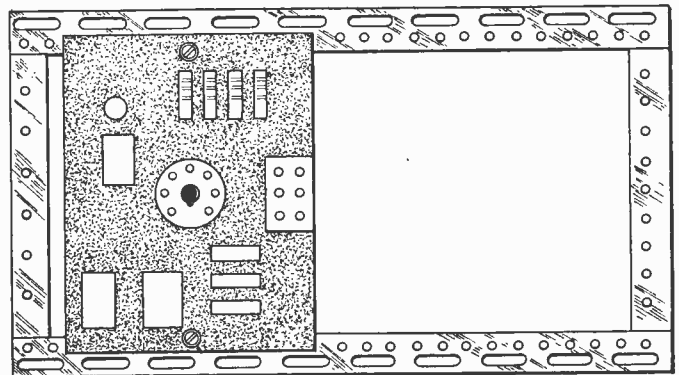
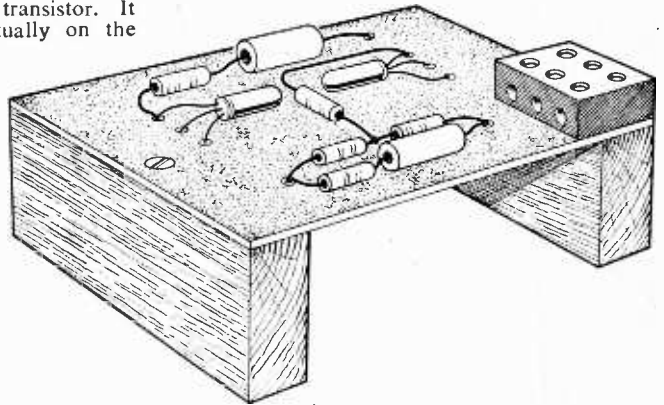
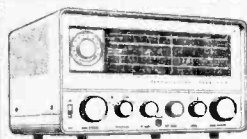

Fig. 4: Two methods of mounting circuit boards: top, on wooden blocks; bottom, on Dexion strip.





**LAFAYETTE HA 63 COMMUNICATION RECEIVER**

valves + Rectifier. 4 Bands 550 Kc/s-31 Mc/s. 'S' Meter-BFO-ANI-Bandspread Tuning. 200/250v. A.C. Brand New. 24 Gns. Carr. paid.

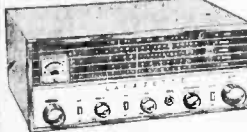

**STAR SR 40 COMMUNICATION RECEIVER**

4 Bands 550 Kc/s-30 Mc/s. 'S' Meter-BFO-ANI - Bandspread Tuning-Built in speaker, 200/250v. A.C. Brand New. 18½ Gns. Carriage 10/-.

**OS/8B/U OSCILLOSCOPES**

High quality Portable American Oscilloscope. 3in. c.r.t. T/B 3c/s-50 kc/s X Amp: 0-500 kc/s Y Amp: 0-2 Mc/s. Power requirements 105-125v. A.C. Supplied in "as new" condition, fully tested. £25. Carr. 10/- Suitable 230/115v. Transformer. 15/6.



**CLEAR PLASTIC PANEL METERS**

First grade quality. Moving Coil panel meters available ex-stock. S.A.E. for illustrated leaflet. Discounts for quantity. Available as follows.



50µA	22/6	3V DC	22/6
100µA	22/6	10V DC	22/6
200µA	22/6	20V DC	22/6
300µA	22/6	50V DC	22/6
500µA	22/6	100V DC	22/6
100mA	22/6	150V DC	22/6
150mA	22/6	300V DC	22/6
200mA	22/6	500V DC	22/6
300µA	22/6	750V DC	22/6
500µA	22/6	15V AC	22/6
50-0-50µA	22/6	50V AC	22/6
100-0-100µA	22/6	150V AC	22/6
500-0-500µA	22/6	300V AC	22/6
1mA	22/6	500V AC	22/6
	22/6	'S' Meter 1inA	22/6

POST EXTRA. Larger sizes available - send for lists.

ILLUMINATED 'S' METER 1½" sq. in. square front. Cal. in 8 units. 6V. lamp. 20/6. P.P. 1/- Ditto 2½" sq. in. square 39/6. P.P. 1/-.

**AVOMETERS**



Supplied with additional guaranteed perfect. Model D. £8.19.6. Model 7. £12.10.0. Post & Ins 5/-

**ARMY FIELD TELEPHONE TYPE F**



Generator Bell Ringing 2 Line Connection. With Wood Carry Case. Fitted Batteries Supplied Fully Tested. £4.19.6. Pair Carr. 7/6.

**SILICON RECTIFIER**

200 P.I.V.	200mA	2/6
300 P.I.V.	amp	5/6
1,000 P.I.V.	500mA	7/6
800 P.I.V.	500mA	5/6
400 P.I.V.	3 amp	7/6
400 P.I.V.	500mA	3/6
150 P.I.V.	165mA	1/-
95 P.I.V.	1 amp	3/6
	3 amp	5/6

Post extra.

**AMERICAN TAP**

First grade quality American tapes. Brand new and guaranteed. Discounts for quantities.

3in. 225ft. L.P. acetate	4/-
3½in. 600ft. T.P. mylar	10/-
5in. 600ft. std. plastic	8/6
5in. 400ft. L.P. acetate	10/-
5in. 1200 ft. D.P. mylar	15/-
5in. 1800ft. T.P. mylar	35/-
5½in. 1200ft. L.P. acetate	12/6
5½in. 1800ft. D.P. mylar	22/6
5½in. 2400ft. T.P. mylar	25/-
7in. 1200ft. std. mylar	12/6
7in. 1800ft. L.P. acetate	15/-
7in. 1800ft. L.P. mylar	20/-
7in. 2400ft. D.P. mylar	25/-
7in. 3600ft. T.P. mylar	58/6

Postage 2/- Over £3 post paid.

**ERSKINE TYPE 13 DOUBLE BEAM OSCILLOSCOPES**



Timebase 2 c/s-750 kc/s Separate Y1 and Y2 amplifiers. Up to 5.5 Mc/s. calib. at 100 kc/s and 1 Mc/s. 110/230 v. A.C. Guaranteed perfect. £27.10.0. Carr. 20/-.

**MINE DETECTOR No. 4A**

Will detect all types of metals. Fully portable. Complete with instructions. 39/6 each. Carr. 10/- Battery 8/6 extra.

**BEST BUY!**

Send 1/- P.O. for full catalogue and lists. Trade supplied. Open 9 a.m. to 6 p.m. Every day. Monday to Saturday.



**NEW MODEL! LAFAYETTE HA-230 AMATEUR COMMUNICATIONS RECEIVER**

supercedes model HE-30. 2 valves + rectifier. Continuous coverage on 4 bands. 550 kc/s-30 Mc/s. Incorporates 1 RF and 2 IF stages. Q Multiplier. BFO. ANL 'S' meter. electrical bandspread. Aerial trimmer. etc. Supplied brand new and guaranteed. 33 Gns. SAE for full details.



**NEW MODEL! LAFAYETTE HA-55 Aircraft Receiver**

108-136 Mc/s. High selectivity and sensitivity. Incorporates 2 RF stages including 6CW4 Nuvistor. 8 tubes for 11 tube performance. solid state power supply. adjustable squelch control. slide rule dial. built in 4in. speaker and front panel phone jack. 220/240v. A.C. Supplied brand new and guaranteed. 19 Gns. Carr. 10/-.

**TE-22 SINE SQUARE WAVE AUDIO GENERATORS**

Size: 20 c.p.s. to 200 Kc/s on 4 bands. Square: 20 c.p.s. to 25 Kc/s.



**LAFAYETTE-46 RESISTANCE CAPACITY ANALYZER**  
2pF 2,000 mFd. 2 ohms. 200 megohms. Also, checks impedance. Turns ratio. Insulation 200/250v. A.C. Brand New. £15. carr. 7/6.



**LAFAYETTE TE-20A R.F. SIGNAL GENERATOR**

120 Kc/s-390 Mc/s on 6 ranges. Variable R.F. and A.F. outputs. Large clear scale. Size 7½ x 10½ x 4½ in. 250/250v. A.C. operation. Brand New. £12.19.5. Carr. 7/6.

**TWO WAY RADIOS**

3 Transistor Receiver. Range up to 1 mile. £9.19.6 per pair complete.  
9 Transistor Receiver. Range up to 5 miles. £25 per pair complete. Post extra. S.A.E. for full details.

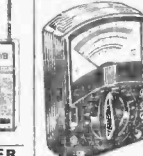

**MODEL TE-12**

20,000 O.P.V. 0/106/6,130/120/600/1,200/3,000/6,000 v. D.C. 0/6/30/120/630/1,200 v. A.C. 0/60µA/6/60/600 mA. 0/6K/600K/6. Meg. 160 Meg. 0 P.F. 2 MFD. £5.19.6. P. & P. 3/6.

**VOLTAGE STABILIZER TRANSFORMERS**

Will stabilize your mains voltage. Ideal for TV Receivers and Industrial equipment. Input 80-120 v. and 160-240 v. Constant output 110 v. or 240 v. 250 watts. Brand new guaranteed. £10.10.0 Carr. 7/6.



**MODEL 500**

30,000 O.P.V. 0/51/12.5/10/25/100/250/500/1,000v. DC 0/2.5/10/25/100/250/500/1,000 v. A.C. 0/50µA/5/50/500mA/12 amp DC. 0/60K/6 Meg/60 Meg 0 £5.17.6. Post Paid S.A.E. for full details.

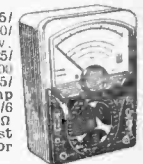

**VARIABLE VOLTAGE TRANSFORMERS**

Brand New Guaranteed. Fully Shrouded. Input 230v. 50/60 c/s. output 0-23v.  
1 Amp £4.10.0.  
2.5 Amp £5.17.6.  
5 Amp £9.0.0.  
8 Amp £13.10.0.  
10 Amp £17.10.0.  
12 Amp £19.15.0.  
20 Amp £32.10.0.  
2.5 Amp Portable Metal Case with Meter Fuses etc. £9.17.6.

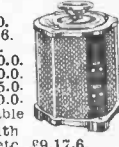

**TE-51 NEW**

30,000 Ω / VOLT MULTI METER  
0/6/60/120/1,200/300/600/3,000 v. D.C. 0/60µA/12/300 mA. DC. 0/60K/6 Meg. ohm. £4.5. post & pack. 2/6.



Stockists of Nombrex, Codan, Sinclair, and all Electronic Equipment and Components.

**G.W. SMITH & CO (RADIO) LIMITED**  
Phone: GERRARD 8204/9155  
Cables: SMITHEX, LESQUARE  
3-34 LISLE STREET, LONDON, W.C2

# TECHNICAL TRAINING

*in radio television and electronics*

Whether you are a newcomer to radio and electronics, or are engaged in the industry and wish to prepare for a recognised examination, ICS can further your technical knowledge and provide the specialized training so essential to success. ICS have helped thousands of ambitious men to move up into higher paid jobs—they can help you too! Why not fill in the coupon below and find out how?

Many diploma and examination courses available, including expert coaching for:

- Institution of Electronics & Radio Engineers (Brit.I.R.E.)
- C. & G. Telecommunication Techns' Certs.
- C. & G. Supplementary Studies
- R.T.E.B. Radio/T.V. Servicing Certificate
- Radio Amateurs' Examination
- P.M.G. Certs in Radiotelegraphy
- General Certificate of Education, etc.

Examination Students Coached until Successful

## NEW SELF-BUILD RADIO COURSES

Learn as you build. You can learn both the theory and practice of valve and transistor circuits, and servicing work while building your own 5-valve receiver, transistor portable, signal generator and multi-test meter—all under expert tuition. Transistor portable available as separate course.

### POST THIS COUPON TODAY

for full details of ICS courses in Radio, T.V. and Electronics.

**INTERNATIONAL CORRESPONDENCE SCHOOLS**

Dept. 171, Intertext House, Parkgate Road, London, S.W.11

Please send me the ICS prospectus—free and without obligation.

(State Subject or Exam.) .....

NAME.....

ADDRESS .....

..... 9.65

**INTERNATIONAL CORRESPONDENCE SCHOOLS**

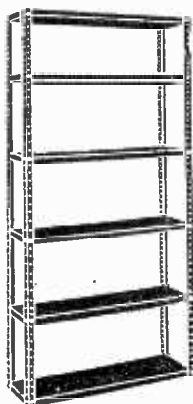

## STEEL SHELVING

**BRAND NEW**

C.W.O. or C.O.D. FREE DELIVERY within 14 days. N. Scotland, Ireland, I.O.M. 10% extra.

**65/-**

71in. high x 34in. wide 12in. deep with 6 shelves as illustrated.

Each shelf will hold over 3 cwt. Shelves adjustable every 2 in. Stove enamelled dark green. White enamel units 50% extra.

Height	Width	Depth	No. of shelves	Price	Price each 3 or more	Extra shelves
71 in.	34 in.	9 in.	6	63/-	61/-	7/-
71 in.	34 in.	12 in.	6	65/-	63/-	8/-
71 in.	34 in.	15 in.	6	74/-	72/-	9/6
71 in.	33 1/2 in.	18 in.	6	86/-	84/-	11/8
85 in.	34 in.	12 in.	6	73/-	71/-	8/-
85 in.	42 in.	12 in.	6	81/-	89/-	11/-

Contractors to H.M. Govt. and United Kingdom Atomic Energy Authority. Exporters of Steel Shelving.

Buy direct from the manufacturers

**ROCHDALE METAL PRODUCTS**  
 Dept. P.W. WATERFOOT - LANC'S  
 Phone Rossendale 322113

## Any holes in your knowledge of TRANSISTORS?

Whatever your interest in transistor circuitry, you will find the Mullard "Reference Manual of Transistor Circuits" and "Transistor Radios—Circuitry and Servicing", valuable sources of reference.

The former describes more than sixty circuits for both domestic and industrial applications.

The latter is an introduction to the subject and describes the basic properties of semiconductors, their function, elementary circuitry and servicing.

REFERENCE MANUAL OF TRANSISTOR CIRCUITS  
 U.K. PRICE 12/6  
 Post extra 1/-

TRANSISTOR RADIOS  
 Circuitry and Servicing  
 U.K. PRICE 5/-  
 Post extra 6d.



Get your copies from your radio dealer, or send remittance with order to:

MULLARD LTD · MULLARD HOUSE · TORRINGTON PLACE · LONDON WC1

# PREPARING FOR THE R.A.E

BRIAN ROBINSON:

of increasing frequency a representative picture of the electromagnetic spectrum can be obtained. Shown in Fig. 99 is a diagram to represent the electromagnetic spectrum. It must be remembered that the divisions between the various types of radiation are not rigid and that some overlap may occur.

Radio waves are often also called Long Waves (l.w.), Medium Waves (m.w.), Short Waves (s.w.)—and high frequency radio waves may be called Very High Frequency (v.h.f.) or Ultra High Frequency (u.h.f.) waves.

### 11.3 The Propagation of Radio Waves

Radio waves travel in straight lines. It would seem impossible therefore for radio signals to travel distances further than the visible horizon. (In fact radio signals can be transmitted directly to about 1½ times the distance to the visible horizon). In 1901, Marconi was able to send a radio signal almost half way round the world. The English scientist *Heaviside* put forward the explanation that a layer of particles existed far above the earth and that Marconi's radio signals had in fact been bounced off these and reflected back to the earth. In about 1925 it was established that a layer of ions and electrons existed at a height of about 65 miles above the earth's surface. This layer became known as the Heaviside Layer or the Heaviside-Kennelly Layer.

The density of the electrons and ions in the Heaviside Layer is sufficient to reflect radio waves back to the earth.

Radio waves are not in fact simply reflected by the layer of ions and electrons but are actually "bent" before being returned to earth. This bending is called REFRACTION. The greater the concentration of ions and electrons in the Heaviside Layer, the greater the degree of refraction.

In Fig. 100 the transmitter is represented by the letter T. Waves 1, 2, and 3 are waves radiated by the transmitter at different angles to the tangent to the earth at that point.

## 11. PROPAGATION OF RADIO WAVES AERIALS

### 11.1 Wavelength, Frequency and Velocity of Radio Waves

RADIO waves, in common with light, travel at a speed of 186,000 miles per second (approximately). If this speed is converted into metric units it is equal to 300,000,000 metres per second.

Imagine an aerial transmitting radio waves on a frequency of 200,000c/s. Each cycle will take 1/200,000 of 1 second to be radiated by the aerial, and at the end of this time a new cycle will start to be radiated. As radio waves travel at 300,000,000 metres per second, in 1/200,000 of a second the first wave will have travelled a distance of  $300,000,000 \times 1/200,000$  or 300,000,000/200,000 or 1500 metres. This distance travelled by one wave before the second sets out is called the WAVELENGTH of the radio wave. Obviously the lower the frequency the greater the wavelength and vice versa.

The wavelength of a radio wave could easily be determined from the following expression:

$\lambda = 300,000,000/f$ , where  $\lambda$  is the wavelength in metres, and  $f$  is the frequency in cycles per second. If the frequency were in kilocycles per second the expression would be:

$\lambda = 300,000/f$ , or if the frequency were in megacycles per second it would be:  
 $\lambda = 300/f$ .

For example, to find the wavelength of a radio wave of frequency 30 megacycles per second:

$\lambda = 300/30 = 10$  metres.

### 11.2 The Nature of Radio Waves

Radio waves are but part of a much larger system called the ELECTROMAGNETIC SPECTRUM. Other forms of radiation such as light, infra red and ultra violet waves, X-rays, gamma rays etc., are all thought to be forms of radiation by means of waves. These various types of radiation differ greatly in their frequencies (and wavelengths) and if they are arranged in say order

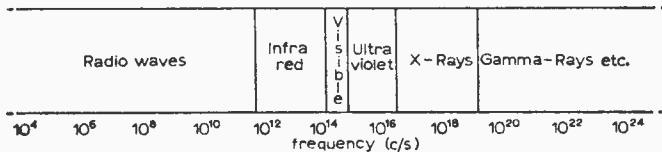

Fig. 99: The electromagnetic spectrum.

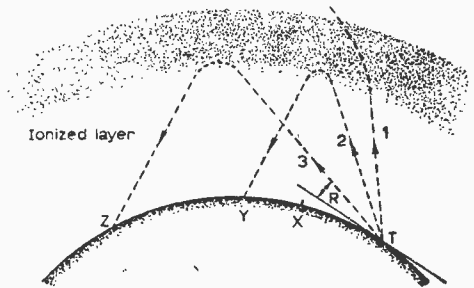

Fig. 100: Reflection of radio signals from the ionosphere.

The angle of radiation of signal 1 is such that insufficient bending occurs to bring the signal back to earth. A certain **CRITICAL ANGLE OF RADIATION** must be reached before radio waves can be refracted sufficiently to bring them back to earth.

Signal 2 is a signal which is radiated at an angle just **LESS** than the critical angle and is consequently bounced back to the earth. The distance from the transmitter to a receiver at a point Y is the minimum distance in this case which can be covered by ionospheric propagation. This distance is often called the **SKIP DISTANCE** for the signal.

Signal 3 is a signal which is transmitted with a lower angle of radiation and the distance covered by the signal is consequently much larger.

The maximum distance travelled by a signal which is not reflected from the ionised layer is from T to X. The radiation which reaches a point such as X is called **GROUND WAVE** radiation.

#### 11.4 The Maximum Usable Frequency

If a very low frequency signal is transmitted with a radiation angle of  $90^\circ$ , i.e. vertically, the signal will be reflected back to the earth. If the frequency of transmission is then gradually increased at a certain frequency the reflection will fail to occur. This is called the **CRITICAL FREQUENCY** for the particular ionised layer.

The critical frequency enables a transmitting station to use the highest frequency possible when transmitting signals over a certain specified distance. This highest frequency possible is called the **MAXIMUM USABLE FREQUENCY** or the m.u.f. If for example in Fig. 100 a signal of frequency 10Mc/s is radiated at an angle R, and is to be received at Z. If increasing the frequency of transmission makes the signal "skip" over Z then the m.u.f. would be 10 Mc/s.

#### 11.5 Angle of Radiation for Covering the Maximum Distance

To cover the maximum distance the signal must be radiated along the tangent of the earth at the point where the transmitter is situated. The angle of radiation for maximum distance coverage would therefore be  $0^\circ$ .

#### 11.6 Multi-hop Transmission

In order to transmit signals over considerable distances the radio wave may, after being bounced back to earth, be reflected back to the ionosphere by the earth and then returned to the earth once more. Where reflection occurs from the ionosphere more than once the type of transmission is often called **MULTI-HOP TRANSMISSION**.

Each reflection will naturally result in a loss of power by the radio signal.

Fig. 101 shows in diagram form the principle of multi-hop transmission.

#### 11.7 Sunspot Effect on the Ionosphere

The ionisation in the Heaviside and other layers is promoted by the action of ultra violet light from the sun and therefore if variations occur in the amount of radiation from the sun the condition of the ionosphere will vary.

Disturbances on the sun's surface occur in an 11 year cycle and this is called the **11 YEAR SUN-SPOT CYCLE**. When sunspot activity is at a maximum, m.u.f.'s are also at a maximum and vice versa. At periods of minimum sunspot activity only low frequencies, say between 2 and 10Mc/s, are useful for transmission at night-time.

Seasonal changes also occur which result in variations of the m.u.f.

#### 11.8 The Appleton Layer

A second ionised layer about 170 miles above the earth was discovered by *Sir Edward Appleton* and radio waves can be reflected by this in much the same way as from the Heaviside Layer. (The Heaviside layer is often called the "E" layer and the Appleton layer the "F" layer.)

#### 11.9 Magnetic Storms

At times of exceptional activity on the sun's surface charged particles may leave the surface of the sun and travel to the ionosphere and cause intense magnetic storms to occur. The degree of ionisation in the ionosphere is thereby considerably increased and radio signals are completely absorbed by it. The period of fade out due to magnetic storms may be fairly long—several days.

#### 11.10 Aerials—the Polarisation of Radio Signals

The obvious function of the aerial is to make sure that the power from the transmitter is radiated efficiently into the atmosphere. Generally the term "aerial" includes any feed lines to the aerial.

If the aerial is vertical the radio waves transmitted will be polarised vertically (and therefore also received best by a vertical aerial) and if the aerial is horizontal the radio waves will be polarised horizontally. If the aerial is slanting or in any other position than vertical or horizontal, the radiated wave will contain both horizontal and vertical components.

#### 11.11 The Impedance of an Aerial

If at any point on an aerial the current and voltage can be measured then the impedance of the aerial at that point is given by  $Z = E/I$  and will be expressed in Ohms.

#### 11.12 The Half Wave Aerial

This is one of the simplest forms of aerial, and as its name suggests it is a wire whose length is equal to half the wavelength of the transmitted signal. The correct name for this type of aerial is the **DIPOLE**.

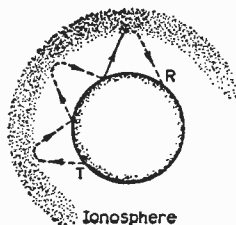



Fig. 101: Multi-hop transmission.

# SUPAMOLD



## AN OUTSTANDING NEW PAPER DIELECTRIC CAPACITOR



Temperature rating:  $-40^{\circ}\text{C}$  to  $+85^{\circ}\text{C}$



Clean, rigid, plastic moulding



Withstands excessive vibration

Impervious to moisture

Capacitance available up to  $0.33\mu\text{F}$   
 Voltage range up to 1000 at  $85^{\circ}\text{C}$ , 1500 at  $70^{\circ}\text{C}$   
 Cap. Tolerance at  $.01\mu\text{F} \pm 25\%$   
 Power Factor less than .01 at 1000c at  $20^{\circ}\text{C}$

DESIGNED FOR THE  
 HIGHER TEMPERATURE RANGES

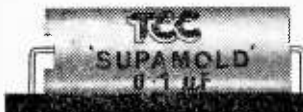
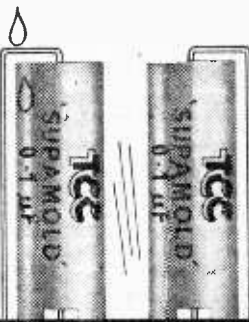

For full technical details  
 send for T.C.C.  
 Bulletin No. 89R.

**THE TELEGRAPH CONDENSER CO. LTD.** (Head Office & Works) North Acton, W.3. Tel: ACOrn 0061  
 also at Chessington, Surrey and Bathgate, Scotland Telex: 261383

## LEARN ELECTRONICS AS YOU BUILD 25 CIRCUITS EXPERIMENTS TEST GEAR

including:

- MINIATURE CATHODE RAY OSCILLOSCOPE
- VALVE EXPERIMENTS
- BASIC AMPLIFIER
- BASIC RECTIFIER
- PHOTO ELECTRIC CIRCUIT
- TIME DELAY CIRCUIT
- SQUARE WAVE GENERATOR
- SIMPLE TRANSMITTER
- TRANSISTOR EXPERIMENTS
- BASIC OSCILLATOR
- ELECTRONIC SWITCH
- SIGNAL TRACER
- BASIC COMPUTER CIRCUIT
- BASIC RADIO RECEIVER
- MORSE CODE OSCILLATOR ETC. ETC.

This complete practical course will teach you all the basic facts of electronics by making experiments and building apparatus. You learn how to recognise and handle all types of components—their symbols and how to read a circuit diagram. You see how circuits are built and how they work BY USING THE OSCILLOSCOPE PROVIDED. Applications of all the main electronic circuits are demonstrated—radio reception and transmission; photo-electrics; computer basics; timers; control circuits, etc; including servicing techniques. **NO MATHS USED OR NEEDED. NO THEORY NEEDED. NO PREVIOUS KNOWLEDGE OR EXPERIENCE NEEDED.** Tutor service available. No extras needed—tools provided. Send now for **FREE DETAILS** without obligation, to address below

**TO: LERNAKIT, Dept. K 10, RADIO HOUSE, 40 RUSSELL STREET, READING**

**POST NOW**

Please send free details—

NAME .....

ADDRESS .....

.....

## AMATEUR RADIO CHAS. H. YOUNG LTD.

The Sensational  
**ALL-TRANSISTOR!**  
 Communications Receiver



**EDDYSTONE EC10**

for use in the home, caravan, car or boat, H.P. facilities. **Only £48** Part exchanges.

Write for brochure

**170-172 CORPORATION STREET BIRMINGHAM 4**

Telephone **CEN 1635**

# PRICE SPECIAL RADIO CHASSIS OFFERS

HI-FI CONTINENTAL STEREOGRAPHIC RADIOGRAM CHASSIS

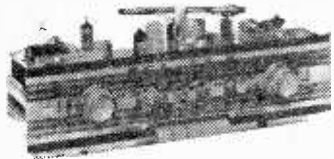

Magnificent 'Continental' Stereographic Radiogram Chassis with piano key switches, built-in ferrite rod aerial. Comes complete with two 10" elliptical loudspeakers, plus a mono/stereo 4-speed automatic record changer.

Special terms available of £4.10.0 deposit followed by 18 monthly payments of £1.13.0 (total H.P. of £34.4.0) + 15/- P. & P. Send £5.5.0 now.

## IMPERIAL HI-FI STEREOGRAPHIC RADIOGRAM CHASSIS



The Imperial stereographic 4 wayband chassis has the most advanced specifications yet offered in this country. There is a built-in ferrite rod aerial, seven piano key buttons, controlling mono/stereo selection-Gram Long-Medium-Short-FM-ON/OFF. The unit comes complete with two 10" elliptical loudspeakers plus a mono/stereo 4 speed automatic record changer.

Special terms available of £6.4.6 deposit followed by 24 monthly payments of £1.15.10 (total H.P. £44.9.6) + 17/6 P. & P. Send £7.2.0 now.

## HI-FI EMPRESS RADIOGRAM CHASSIS

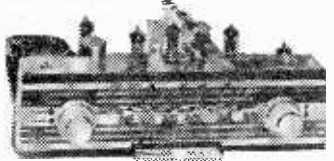

This fabulous 'Empress' Hi-Fi radiogram chassis is offered complete with 10" loud-speaker plus 4 speed autochanger. At only 23 gns this is the bargain of the year. Special terms available of £3.12.6 deposit followed by 18 monthly payments of £1.6.7 (total H.P. £27.11.0) + 15/- P. & P. Send £4.7.6 now. All Lewis Radio equipment including valves are fully guaranteed for one year. Send your cheque or P.O. today while stocks last to Dept. P.95:—

### LEWIS radio

LEWIS RADIO, 100, CHASE SIDE, SOUTHGATE  
LONDON, N.14. Telephone: PAL 3733/9666

## LISTEN

AND ENJOY THE  
WORLD'S RADIO AMATEUR  
AND BROADCAST STATIONS WITH  
THE GREATEST OF EASE !!!

ONLY 7' 6" LONG!

WE HAVE SOLVED your aerial problem for WORLD-WIDE RECEPTION—NO MATTER WHERE YOU LIVE !!!

World Expert Radio Amateur W1BB (U.S.A.) claims the "JOYSTICK" aerial—easier to read stations than with his massive 520' VEE aerial 70' high !!! ZL4GA, who is probably NEW ZEALAND'S best known Radio Amateur, has scrapped his outstanding 300' 45' high aerial and has WORKED ALL CONTINENTS on the "JOYSTICK" in under 12 hours !!!

"CQ" the Radio Amateur's journal claims "JOYSTICK" better for reception than the world popular DIPOLE (four different receivers used to confirm this decision)

YOU CAN BE THE PROUD OWNER OF THE WORLD'S MOST VERSATILE & COMPACT "JOYSTICK" COMPLETE RECEIVING SYSTEM FOR AS LITTLE AS

£5.5.0. ("DX-MAGNET" system), £6.6.0 (Standard system), £7.7.6 (De-luxe system) including carriage and packing.

Money Back if not Delighted

Not convinced? Then send for brochure and showers of testimonials to:—

### PARTRIDGE ELECTRONICS LTD

(Dept. P.W.)  
"CAISTER HOUSE", PROSPECT ROAD  
BROADSTAIRS, KENT

FAMOUS FOR THIRTY YEARS for  
SHORT-WAVE EQUIPMENT of QUALITY

## H.A.C. SHORT-WAVE KITS

H.A.C. were the original suppliers of Short-Wave Receiver Kits for the amateur constructor. Over 10,000 satisfied customers—including Technical Colleges, Hospitals, Public Schools, R.A.F., Army, Hams, etc.

IMPROVED 1965 RANGE

1-Valve model "CX", complete kit, Price 34/6 Customers say: 'Definitely the best one-valve S.W. kit available at any price'. This kit contains all genuine short-wave components, a drilled chassis, accessories and full instructions. Ready to assemble and of course, as all our products, fully guaranteed. FULL RANGE of other kits still available including the famous model 'K'. Price 77/-. Before ordering call and inspect a demonstration receiver or send for a descriptive catalogue and order form to—

"H.A.C." SHORT-WAVE PRODUCTS  
(Dept. T.H.), 44 Old Bond St., London W.1

## TEST METERS

20,000 O.P.V. MODEL TP 55. Reads voltage up to 1,000 D.C. at 20,000 ohms per volt and A.C. at 10,000 O.P.V.; D.C. Current to 500mA; Resistance to 10 Megs.; Capacitance to 0.1µF; Decibels from -20 to +36. Size 3 1/2 in. x 5 1/2 in. x 1 1/2 in. £5.16.0.

2,000 O.P.V. MODEL TP 10. Reads A.C. and D.C. Volts up to 1,000; D.C. Current to 500mA; Resistance to 1 Meg.; Capacitance to 1µF; Decibels from -20 to +36; Output jack for Audio Measurements. Size 3 1/2 x 5 x 1 1/2 in. £3.19.6

30,000 OHMS PER VOLT MODEL 500. Reads voltages up to 1,000 D.C. at 30,000 ohms per volt and A.C. at 15,000 O.P.V.; D.C. Current to 12 amps. Resistance to 60 Megs.; Decibels from -20 to +56; Incorporates internal buzzer for audible warning of direct shorts and blocking condenser for A.F. output measurements. Size 3 1/2 in. x 5 1/2 in. x 1 1/2 in. £8.19.6.

TRANSISTORISED TEST EQUIPMENT. Fully guaranteed, brand new. By NOMBREX: 150 Kc/s.—350 Mc/s. Signal Generator, £9.10.0. Resistance-Capacitance Bridge, £8.5.0. 1-15 volts D.C. Power Supply, £6.10.0. Audio Generator 10/100,000 c/s. £16.16.0. Inductance Bridge, £13.0.0.

SPECIAL OFFER OF AMERICAN VALVE VOLT-METERS. 11 Megs. Input. 6 D.C. Voltage ranges to 1,000. 6 A.C. voltage ranges to 1,000 6 Resistance range to 1,000 Megohms. 4in. 200 microamp. meter. For 110/250 volts A.C. operation. With test prods and operating instructions. Manufactured by UCA and Electronic Designs. ONLY £7.19.6 (Post etc. 3/6).

LINEAR AMPLIFIERS. L1334, 4 watts, size 8 1/2 x 4 1/2 x 2 1/2 in. high, £5.5.0. L45A 5 watts, size 7 x 7 x 5 in. high, £5.19.6. Protective cover L12/1,5/35 5 watts stereophonic, size 10 1/2 x 8 x 6 in., £12.12.0. Cover with carrying handles, 25/-, "Diatonic" 10 watts Hi-Fi Ultra Linear Push-pull size 9 x 7 x 6 1/2 in. high, £12.22.0. Cover with carrying handles, 19/6. L1/10 10 watts Hi-Fi Ultra Linear size 9 x 7 x 3 in. high, £13.13.0. Cover with carrying handles, 19/6. "Conchord" 30 watts Hi-Fi Ultra Linear size 12 1/2 x 9 x 7 1/2 in. high, £16.16.0. Cover with carrying handles, 25/-, 150 watts Hi-Fi Ultra Linear, size 14 x 10 x 8 in. high, £23.2.0. Cover with carrying handles, 32/6. All amplifiers for normal A.C. mains, and ex stock. Details on request.

"Tripletone" Convertible Amplifier. Size 10 x 8 x 4 1/2 in. high. 4 watts output matched for 2-3 ohms, OR 2 amplifiers can be coupled together for STEREO, £6.19.6 each.

"Tripletone" F.M. Tuner, size 11 x 6 x 3 in. high. Coverage 86-104 Mc/s. £13.19.6 (unpowered), or £15.14.6 (self-powered). Details on request.

MICROPHONES. Crystal Types. Guitar, 12/6. Desk, with built-in stand, 15/-. Acos 39/1. Stick and Table Stand 32/6. Super Stick, with heavy Desk Stand 49/6. Moving Coil Types. Stick with heavy Desk Stand, 59/6. "Slimline" Stick, 60K impedance, with switch, 75/-. Omni-directional chrome plated die-cast frame, 50K with switch, 99/6.

## HARRIS ELECTRONICS (London) LTD.

138 GRAY'S INN ROAD,  
LONDON, W.C.1

Telephone: T E R M I N U S 7937

Please include carriage cost on ALL items.

Trading hours 9 a.m.—6 p.m. Monday—Friday.  
Closed Saturday. We are 2 mins. from High Holborn (Chancery Lane Station) and 5 mins. by bus from King's Cross.

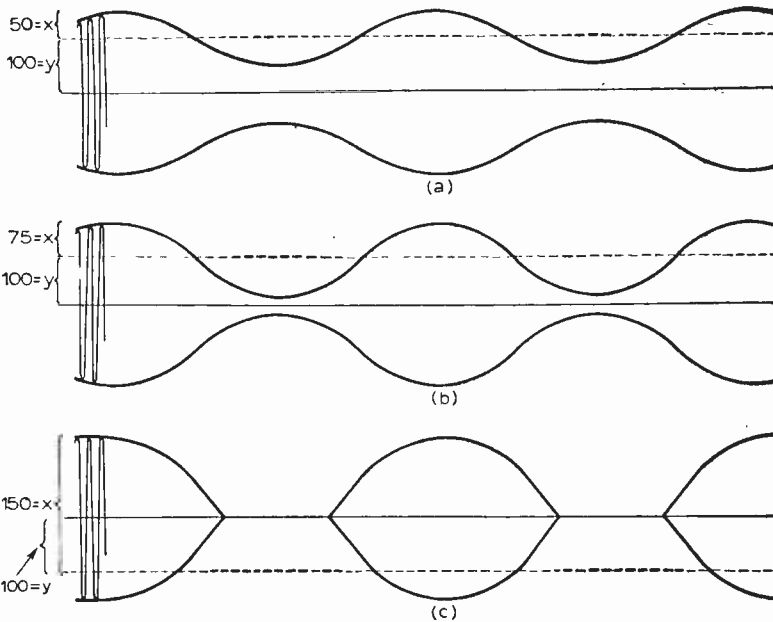

Fig. 103: Solution to last month's question.



Fig. 102: Radiation from a dipole.

The length of the dipole would be approximately half a wavelength in space—but at ground level where the aerial has to be supported (thereby adding capacity to it), the length is correspondingly decreased.

In the dipole the current distribution is such that it is at a maximum at the centre and (theoretically) zero at the ends. The voltage is maximum at the ends and minimum at the centre. In practice the r.f. voltage in the aerial will not be zero at the centre due to the resistance of the aerial. This resistance is composite of the resistance of the aerial due to the material from which it is constructed, and to the RADIATION RESISTANCE of the aerial. (The radiation is a representation of the radiation properties of the aerial.)

Shown in Fig. 102 is the radiation pattern for a dipole aerial. It must be remembered that the diagram is a vertical cross section and that in fact the three dimensional shape is rather like an apple cut in half.

**Question**

Draw a diagram to show how a radio signal is transmitted by a station T and is received by a receiver R. The signal is reflected twice by the ionosphere. Draw in a dotted line the path you would expect the signal to take if the frequency of transmission were increased, and mark the new position of the receiver as R1.

**Last Month's Question**

Diagrams of the type required for last month's question are shown in Fig. 103.

**PART 12 NEXT MONTH**

**PRACTICAL SUBSTITUTIONS**

—continued from page 426

any old valve fitting the existing valveholder. The base should be extracted from the old valve envelope and its pins appropriately wired to the required new valveholder, which is then fixed on top of the old base.

Series or parallel cathode bias correcting resistors, small bias electrolytics, grid or screen stoppers can be inserted between the base and the pins of the new valveholder within the adaptor. The substitute valve is then inserted into the adaptor and the assembly plugged into the old valveholder on the chassis without any modification of the main equipment. This is often the quickest and cheapest way to modernise vintage equipment.

If all valves are changed in this manner the heater winding on the mains transformer can also be changed (e.g. converting from 4V a.c. heaters to modern 6.3V heaters). Ignore the original 4V winding and use a separate 6.3V heater transformer or wire one half of a second centre-tapped 4V winding in series with the original 4V winding. Observe current ratings of the windings in relation to the requirements of the new valves.

**PART THREE NEXT MONTH**

# BOOKS REVIEWED

**RADIO AND AUDIO SERVICING HANDBOOK**  
by Gordon J. King, Assoc.I.E.R.E., M.I.P.R.E., M.T.S.  
Published by Odhams Books Ltd., Long Acre, London,  
W.C.2.  
256 pages, 140 illustrations, 9in. x 6in., hard covers.  
Price 25s.

**SUPERFLUOUS** to stress that Mr King's trump card is an almost deceptive readability. Deceptive, for there is nothing facile about this book, which attempts to cover a very wide ground, and largely succeeds.

The reviewer's only criticism can be that loudspeakers and enclosures, tape recorders and f.m. radio theory and servicing receive too little attention, but we can refer to the author's other well-known works, where these subjects receive special treatment.

To compensate, this book has two meaty chapters devoted to transistor radio servicing, with an introductory few pages on the transistors themselves. The reader is not frightened off—as too often occurs—by mathematics and strange diagrams, but led firmly into the practical matter of tackling receiver faults.

This is, in fact, a practical guide, and should be of equal use to the practising technician as to the amateur enthusiast. We go through workshop techniques, service procedure, methods of fault-finding, equipment one is likely to meet, mains radios, tuners and receivers for v.h.f. A number of commercial circuits are given. Valve portables and transistor sets have three chapters.

"Record Reproducers" serves as the vehicle for information on amplifiers generally, though hi-fi amplifiers, as such, are not dealt with, and negative feedback receives only a perfunctory mention. A chapter on Turntable units includes some direct advice on converting an older unit to modern style, and another deals fairly fully with tape recorders, their principles and practice.

It must be understood, however, that with electro-mechanical devices such as autochanger units and tape recorders, the methods of doing the same operation seem almost limitless, and Mr King has not attempted to explain in detail the very many designs on the market. His work gives sufficient guidance for the intelligent handyman to follow the jog through from basic principles.

Of particular interest is the author's method, also developed in earlier books, of laying out a procedure chart, giving at-a-glance check points for particular faults. These have been very carefully and cleverly worked out, and the six of them might well stand publication as a combined wall-chart in the workshop or den.

Quite certainly, this is a book that should be added to the enthusiast's shelf.—H.W.H.

**TAPE RECORDERS—HOW THEY WORK**  
By Charles G. Westcott and Richard F. Dubbe  
Published by Foulsham-Sams Technical Books Ltd.,  
Slough, Bu ks.  
224 pages, 8½ x 5½in., hard covers. Price 26s.

**A**LTHOUGH there are a number of books on tape recording at present on the market, very few offer the amateur enthusiast precisely what he wants—a description of the equipment, some details of the theory behind it, typical layout diagrams and circuits, with practical notes on maintenance.

Some, but not all, of this information, can be found in various publications. In this book, an admirably balanced mixture has been achieved, and although American in origin nevertheless contrives to deal with the general subject of tape recording in a way that the British reader can readily assimilate and understand.

An introductory preface purports to give guidance to the British reader, but it is surely unnecessary after all this time to tell us that VTVM means "Valve-Voltmeter" and "Vacuum-tubes" are valves. The principal differences that matter relate to mains supplies and certain trade terms such as "puck wheels" for "idler wheels", gimmicks, shut-off, etc., easily understood from the text, plus the need to re-orientate when reading circuit diagrams that have h.t. lines anywhere but at the top!

In only one respect can this "universal" approach be faulted: this is the failure to mention that there are other systems of equalisation besides the American NAB and alternative spool dimensions. However, readers of a book such as this will be conversant with the facts of tape recorder life and will know where to look up the CCIR data if needed!

The book begins with the inevitable chapter on Magnetic Recording History followed by a very simple chapter on the theory and two chapters on the mechanics of tape recording, transport mechanism and motors. These are well worth careful study.

A short chapter on Recording Level Indicators gives due weight to the VU meter, as might be expected, and fails to mention the PPM, which is one of the reviewer's pet hobby-horses, and leads the way to the basic electronics—the Bias Oscillator, Equalisation, Record and Playback amplifier (Transistor amplifiers and pre-amplifiers are given full measure here, we are glad to note). Chapters on Heads and Tape complete the treatment of the machine proper, while the final two chapters deal with Test Procedures and Special Applications.

The book can be safely recommended as an interesting and informative read for amateur and professional alike.—L.E.H.



Another step forward . . .

# AN IMPROVED AVOMETER Model 8 Mk. III

- Fused ohms circuit provides increased protection against inadvertent overload.
- Improved temperature coefficient over whole range. With the aid of a range of d.c. shunts, measurements can be made up to 400 amps d.c.

This new model incorporates increased sensitivity, the lower AC ranges and wide frequency characteristics, with the traditional Avometer features including the AVO automatic cut-out mechanism and interlocking rotary switches for quick range selection.

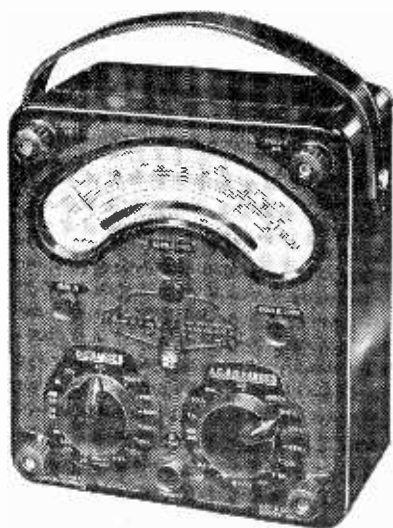

Write for fully descriptive Folder or for complete Catalogue of AVO Instruments.

**AVO LTD** AVOCET HOUSE - 92-96 VAUXHALL BRIDGE ROAD - LONDON, S.W.1 - VICTORIA 3404



## Electrical

### Newnes Practical Electrical Engineering

The more experienced you are the better your prospects and the bigger your income . . . it's as simple as that! In **NEWNES PRACTICAL ELECTRICAL ENGINEERING** 87 qualified specialists help you. Containing over 2,000 explanatory drawings and photos, 2,350 pages, it is your complete and authoritative library. Installation Works—Wiring regulations, methods, equipment, testing. Lighting, Heating, Refrigeration, Time switches, Alarm Systems, Public Address equipment, etc. Instruments, Machines, Equipment—Motors and Control Gear, Transformers, Rectifiers, Instruments, Meters, Electronic Control, etc. Operation, Maintenance Repair—Welding Plant, Furnaces, Electric Traction Cranes, Lifts, Testing, etc. Generation, Transmission, Distribution—Power Stations, Supply Cables, Faults, etc.

**4 Volumes**  
Case of  
36 Charts  
*Nuclear Power  
Stations Booklet  
Electrical Pocket  
Book*  
**THE  
COMPLETE  
SET IS YOURS  
BY POST ON  
A WEEK'S  
FREE  
TRIAL**

To: George Newnes Ltd., 15-17 Long Acre, London, W.C.2  
Please send **NEWNES PRACTICAL ELECTRICAL ENGINEERING** without obligation to buy. If you accept this application I will post 16/- deposit 8 days after receipt of books, then 20/- monthly for 16 months, paying £16.16s. in all—or return the books. Cash in 8 days £16.16s.

*If under 21 your father must fill up coupon.*

Full Name \_\_\_\_\_ (BLOCK LETTERS) (Mr., Mrs., Miss)

Address \_\_\_\_\_

Occupation \_\_\_\_\_

Signature \_\_\_\_\_

(PEE)72/1536

*Tick V where applicable*  
The address on left is—

My Property	<input type="checkbox"/>
Rented unfurnished	<input type="checkbox"/>
Parents' Home	<input type="checkbox"/>
Furnished Accom.	<input type="checkbox"/>
Temporary Address	<input type="checkbox"/>

## EXPRESS-ELECTRONICS

32 SOUTH END, CROYDON, SURREY  
Telephone: CROYDON 9186  
FOR THE FOLLOWING BRAND NEW UNITS

AMPLIFIERS			
TRIPLETONE HI-FI MAJOR	12 watt	...	£15.18.6
TRIPLETONE CONVERTIBLE	5 watt	...	£6.19.6
TRIPLETONE GEMINI STEREO	5 watt	...	£15.15.0
LINEAR	3 watt	...	£6.6.0
LINEAR DIATONIC	12 watt	...	£12.12.0
LINEAR CONCHORD	30 watt	...	£16.16.0
ADASTRA 3-3	4 watt	...	£4.19.6
LEAK TL12	14 watt	...	£18.18.0
LEAK VARISLOPE PRE-AMP	...	...	£15.15.0
LEAK TL50	50 watt	...	£33.12.0
QUAD	15 watt	...	£22. 1.0
QUAD STEREO/MONO PRE-AMP	...	...	£25. 0.0

LOUDSPEAKERS			
GOODMANS AXIFITTE 8in.	6 watt	...	£5. 5.0
GOODMANS AXIOM 10in.	10 watt	...	£6. 6.0
GOODMANS AXIOM 20i	15 watt	...	£10.15.0

BAKERS 'SELHURST' 3 or 15 ohm			
JUNIOR 8in.	8 watt foam	...	£5. 5.0
STALWART 12in.	15 watt	...	£5. 5.0
BASS GUITAR 12in.	25 watt	...	£5. 5.0
STANDARD Heavy Duty 12in.	20 watt	...	£7. 7.0
BASS Heavy Duty 12in.	25 watt	...	£12.12.0
AUDITORIUM 15in.	35 watt	...	£18.18.0

RECORD PLAYERS			
GARRARD SRP10 4-speed	...	...	£4.19.6
GARRARD AUTOSLIM 4-speed	...	...	£6. 7.6
GARRARD AT6 TRANSCRIPTION	...	...	£9.17.6
GARRARD 4HF TRANSCRIPTION	...	...	£14.17.6
GARRARD A LAB SERIES	...	...	£17.10.0
GARRARD 301 LAB SERIES	...	...	£19. 5.0
DECCADEC WITH DERAM HEAD	...	...	£14.15.0
BSR TAPE-DECKS PD2 Twin Track	...	...	£7. 9.6

De-Luxe record players with excellent sound reproduction incorporating the latest BSR 4-speed autochanger, independent tone and volume controls, high quality speaker. Not in kit form but factory made and tested. Finished in most attractive two-tone cabinets in blue-grey, red/grey or charcoal/grey with gilt trim. 200-250v. AC. £12.12.0.

Delivered free U.K. S.A.E. enquiries.

**MAKE 5 DIFFERENT TRANSISTOR RADIOS FOR**



**35/-**

**NO EXPERIENCE NECESSARY.**

No Soldering. Only 8 connections for first radio to work. Just look, you get A.B.C. Plans, Cabinet, Loudspeaker (alone 17/6), Earphone, 4 Semi-conductors, Coils, Condensers, Resistors, Tuner, Switch, Screws, etc. **YES - EVERYTHING!** Loud clear English and Foreign reception. As supplied to Educational Authorities, H.M. Forces, etc. **TESTIMONIALS GALORE!** Mr. R. O'D. of Londonderry, writes: "... I received your components and I must say that I am very satisfied with them. I have it already set up! ... **COMPLETE HOME RADIO COURSE! ORIGINALLY 28 SEND ONLY 35/- plus 3/6 post, etc.**

**NEW RADIO**

**ANYONE CAN BUILD IN 2-3 HOURS**

**19/6**



**EVEN THE OLDER CHILDREN BUILD THEM!** ... no soldering—only 16 connections! then hear it reach out bringing in station after station, loud and clear. Palm-of-hand size 4 1/2 x 2 1/2 x 1 1/2 in. Many Testimonials: M.H. of Bradford, writes: "... I have just completed one of your sets successfully, it is the first time I have ever tackled anything like a radio, and I must state here and now, I am amazed how easy it is to a layman like me. Your instructions and plan have obviously been very carefully thought out so that even the most dim can follow them ... **Direct from Manufacturers to You. Send 19/6 plus 2/6 post, etc.**

**PARTS AVAILABLE SEPARATELY**

**AMAZING CIGARETTE RADIO**

**ONLY 18/6**



Yes, a perfectly ordinary packet of cigarettes! — but watch your friends astonish! on hearing it fetch in station after station, loud and clear! Still holds 10 Cigarettes—yet cleverly conceals highly sensitive, fully transistorised circuit (including tiny battery). Even a young boy can assemble it in under 2 hours. No soldering. No experience necessary. Only 16 connections to make. Ideal for taking to work with you. From our bulging testimonial file. Mr. D.B. of Huddersfield, writes: "... I have fitted the parts in and it is working wonderfully ... **ALL PARTS INCLUDING Semi-Conductors, A.B.C. Plans, etc. ONLY 18/6 plus 2/6 post, etc.**

**PARTS AVAILABLE SEPARATELY**

**IT HAD TO COME EVENTUALLY! THE "SKYSCRAPER" PERSONAL COMMUNICATIONS RECEIVER.** Highly sensitive. World-wide short-waves reception including news in English and countless other broadcasts from RUSSIA, AMERICA, etc., etc.

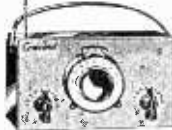

Take it anywhere—it's featherweight! 6in. x 3 1/2 in. x 1 1/2 in. Broad-spread Tuning. Vernier Dial. Miniature Valve Circuits, Plug-in Coils, Own Rod Aerial, etc. 50% of production to be exported. Anyone can assemble it within 2 hours—only a few connections to make—experience unnecessary. Parts incl. Case, Personal phone, Easy-to-follow plan—49/8 plus 2/6 Post, etc. Ref. Q'tec.

**READ WHAT JUST A FEW OF OUR SATISFIED CUSTOMERS SAY**

R.C. of Harringay writes Received with thanks Skyrama ... Very pleased. Working well.

B.M. of Harrogate write ... I would like to thank you ... It is a real bargain.

L.S. of London W.8 writes ... given it a good try out and I am very pleased with the results.

S.B. of Somerset writes ... delighted with this radio ... glad if you could send one more.

T.F. of Stevenage writes ... I would just like to say how pleased my son is with this radio.

**TRANSISTOR RADIO KITS**

**SOLD IN DEPARTMENT STORES AT 48.5.0.**

OUR PRICE **37/6**  
P. & P. 3/6  
Extra



Well-known brand Transistor Radio Kits—YOU SAVE 23.15.8. Covering all medium/long wave with parts including Mullard Semi-Conductors, 48 page instruction manual. Entertaining and educational. No soldering, just plug in, making many different Radios in a few mins. Money back if not delighted.

**CONCORD ELECTRONICS**

LTD. (Dept. P.W.24) 9 Western Road, Hove, Sussex

**THE FITTALL 5 PLUGS in ONE!**

**IDEAL FOR POWER TOOLS**

**JUST ONE PLUG** adjusted in seconds to fit any of **5 SOCKETS!**

Fits 13 Amp fused, 15 Amp or 5 Amp, 2 and 3-pin sockets.  
Costs ... **ONLY 12/6**

Get one now from any good electrical or radio dealers, hardware store, etc., or if in difficulty write to:  
**FITTALL PLUGS**  
Coastguard Rd., Larne, N. Ire.

**RADIOS & PROJECTORS**

**1 RECORD PLAYERS**

**BARGAINS FROM BROADWAY ELECTRONICS**

**TRANSISTORS:** AF115, AF116, AF117, OC170 all at 4/8 ea. OC26 7/8. Mullard RF Packs OC44 two OC45 12/8; AF Packs OC81D two OC81 8/6; OC43 3/6; OC45 3/-; OC71 2/8; OC72 3/-; OA81 Diode 2/8; ORP12 Light Cell 7/6.

**TRANSISTOR ELECTROLYTICS:** 1, 2, 4, 5, 8, 10, 16, 32, 50, 100 mfd. all at 15 volts. 1/8 each.

**EARPIECES** with cord and 3.5 mm plug. 8 ohm magnetic 3/-; 250 ohm 4/-; 180 ohm magnetic with clip 6/6; Xtal 4/-.

**GUITAR PICK-UP** complete with clip and screened lead. 12/6. **B.M.3. XTAL MIKE** 30/-; table stand for same 9/6.

**GARRARD A.T.6.** Mono 28.19.6. Stereo 29.5.0. **A.T.5.** Stereo 28.10.0. Autoslim 25.10.0; Autoslim pick-up arm fitted with Ronette Stereo only 25/-; A.T.6 shells 6/6; G.C.8. G.C2 cart. with brackets 15/- ea. Motor Board A.T.6 x 1 1/2 in. 12 mm ply cut out for Garrard or B.S.R. changer, 7/6 ea.

Cabinets suitable for tape deck, A.T.6 etc., 18 x 14 1/2 x 8 1/2 in. covered in red and black Rexine with carrying handle, 6/7.6. Speaker cabinets to match with sloping front to take 12in. speaker, 42/6; to take 10in. speaker, 37/6.

The "BLAKE" 12in. Heavy Duty Cabinet. Size 24 1/2 x 18 x 3in. The Baffle is 1in. thick. Plain white wood 23/- covered in Rexine and Vynair 85/-; De Luxe model veneered with wood grain Formica and standing on smart fin. legs 25. Please add 10/- for carriage.

"HAYDON" Cabinet. 16 1/2 x 15 x 7 1/2 in. Fabric covered, suitable 12in. speaker 45/-. Postage 7/6.

Vynair speaker cloth 50in. wide 14/- yard. Rexine leather cloth 50in. wide 10/6 yard (S.A.E. for samples).

**NEON PANEL LIGHTS.** 240v A.C. Acrolelectric, 2/8 ea.

**TERMS: C.W.O. or C.O.D.**

**BROADWAY ELECTRONICS**  
92 MITCHAM ROAD, TOOTING, S.W.17

Phone: BALham 3984  
(four minutes from Tooting Broadway Underground Station)

**PRACTICAL TRANSISTOR SERVICING**

By William C. Caldwell

Published by Foulsham-Sams Technical Books Ltd., Slough, Bucks.

191 pages, 8½in. x 5½in., hard covers Price 24s.

**P**RACTISING radio engineers may be forgiven for imagining that 90% of the transistor radios in use (or, more accurately, out of use!) have been imported. Certainly, this underlines the fact that transistor radio servicing must be carried out by reverting to first principles and fathoming out unfamiliar layouts with patience. Diagnosis is the crux.

✓ This book is a purely practical work directed entirely to that end. The emphasis is on diagnosis of a fault in a transistorised receiver using only tests and symptoms as a guide. As the author begins by saying: "... anybody can change parts ..."

The secret in dealing with an unfamiliar set is to relate its circuit to known fundamentals. And as these factors are international, there is little need for the mental gymnastics of interpreting American writing to our own use, once we grasp what is meant by "A" line, etc.

One criticism is that the author does not provide enough actual circuits, even though the pages abound in typical transistor configurations. He has not given enough weight to modern output stages, nor to mixer (converter) and oscillator circuits, where the most perplexing faults will be encountered.

Despite this, there is plenty of useful matter. Chapters on voltage tests and the interpretation of incorrect voltages make the book worthy of attention, as does a chapter giving easy tests for typical transistors, in and out of circuit.

It is good to see, also, a whole chapter devoted to car radio servicing, including dealing with "hybrid" receivers. The numbers of car radios in use are rapidly growing: undoubtedly some bargains will be available on the surplus market, needing perhaps only simple tests and remedies.

A seven-page index makes up for the rather untidy progression of the subject, which is the one complaint that irked this reader. There are many better, more comprehensive books on the subject, and a few more directly instructional, but for the average reader this book represents the best marriage between theory and practice we have seen.—B.R.G.

**ELECTRONIC HAWAIIAN GUITAR**

We have been advised that Mullard rod magnets type No. FD196, as specified for this instrument in our June issue, may be obtained from Radio Crosland, 24/25 Foley Street, London, W.1. They are priced at 36s. for a set of six (6s. each), plus 2s. 6d. extra for all post orders.

**DESIGNING A MULTIMETER**

The circuit on page 135 of the June issue contains two errors. There should not be a connection between position 8 on S1B (1mA range) and the +ve input terminal. Also, it will be necessary to join S1A switch positions, 8-9-10 and 11 together, and a lead taken to the -ve input terminal to complete the circuit.

# NEXT MONTH IN PRACTICAL WIRELESS

**TWO-STAGE VFO**

Comprises a Clapp oscillator, followed by buffer/multiplier. Output on 3, 5, 7, 14, 21 and 28 Mc's amateur bands. Provision for 1.8 Mc/s operation.

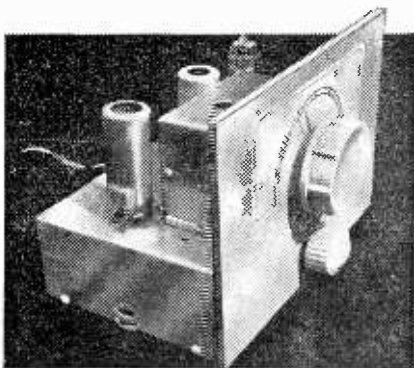
**SOLID-STATE PHOTOFLASH**

Simple and reliable electronic photoflash unit using semiconductors and a Xenon flash tube.

**ECONOMY FM RADIO**

5-valve FM radio unit, using a prebuilt front end and Foster-Seeley discriminator. Cost £3 or less.

**ADD-ON BFO**

Diode-plus-transistor add-on unit to provide facilities for c.w. reception on short-wave sets. Designed to fit into many transistor portables.

**OCTOBER ISSUE**

ON SALE SEPTEMBER 9th

**ORDER YOUR COPY NOW!**

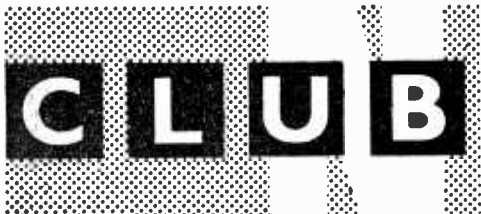

#### **ACTON, BRENTFORD AND CHISWICK RADIO CLUB** Hon. Sec.: W. G. Dyer, G3GEH, 188 Gunnersbury Avenue, Acton, London, W.3.

The next meeting of the Club will be on Tuesday, 17th August, at 7.30 p.m. at which G3IGM will be talking about his "Transistorised Double Superhet".

Meetings are held at 66 High Road, Chiswick. Visitors are always welcome.

#### **BASILDON AND DISTRICT AMATEUR RADIO SOCIETY** Hon. Sec.: C. Roberson, Secretary's Office, Milestone Cottage, London Road, Wickford, Essex.

The Society has approached the Local Education Authority with a view to arranging classes, to commence in the autumn of this year, for the R.A.E. The success of this venture depends on the number of people wishing to take the course so that the Secretary will be pleased to hear from anyone wishing to take the course.

#### **BROMSGROVE AND DISTRICT AMATEUR RADIO SOCIETY** Hon. Sec.: J. K. Harvey, 22 Elm Grove, Bromsgrove, Worcestershire.

Monthly meetings continue to be held in Co-operative Rooms, High Street, Bromsgrove at 2000 BST on the second Friday of each month. Morse code classes precede the meetings at 1915 BST.

#### **CLIFTON AMATEUR RADIO SOCIETY** Hon. Sec.: J. Rose, G3OGE, 63 Broomfield Road, Beckenham, Kent.

SWL Frank Bettis was the winner of the nocturnal d.f. contest, while G3JKY was successful in the first daytime event.

During the summer, informal meetings are held on Fridays and Wednesdays at 8 p.m. at 225 New Cross Road, London, S.E.14.

#### **COPULL AND DISTRICT RADIO CLUB** Hon. Sec.: R. Calderbank, 165 Preston Road, Coppull, Near Chorley, Lancashire.

This is a Club which has only recently been formed. Meetings are held at Scout HQ, Cherter Lane, Charnock Richard, Near Chorley, Lancashire.

#### **DERBY AND DISTRICT AMATEUR RADIO SOCIETY** Hon. Sec.: F. C. Ward, G2CVV, 5 Uplands Avenue, Littleover, Derby.

The 1296Mc/s Tests were held on 17th/18th July. The Eighth Annual Mobile Rally will be held on 15th August.

#### **EAST WORCESTERSHIRE AMATEUR RADIO GROUP** Hon. Sec.: M. Nicholas, G3TOI, 12 Crabtree Close, Redditch, Worcestershire.

On 12th August there will be a discussion and construction night on the Club project 'Two Metre Converter'.

Meetings are held on the second Thursday of each month at the Redditch Old Peoples' Centre, Park Road, Redditch.

#### **HALIFAX AND DISTRICT AMATEUR RADIO SOCIETY** Hon. Sec.: J. Ingham, G3RMQ, Lambert House, Greetland, Halifax, Yorkshire.

There will be a Junk Sale on 28th September and the Annual General Meeting will be held on 26th October.

Meetings are held at the Beehive & Cross Keys Hotel, King Cross Street, Halifax, at 7.30 p.m.

#### **HARLOW AND DISTRICT RADIO SOCIETY** Hon. Sec.: G. O'Donald, G3TLJ, "Great East", Roydon Road, Roydon, Harlow, Essex.

"Harlow Day", sponsored by the local Council will be held on Saturday, 28th August and Sunday 29th, and the Society will be exhibiting various aspects of Amateur Radio and members' equipment.

/A Stations will be operating on most bands. On the Sunday we are including, in addition, a Mobile Rally.

#### **MID-WARWICKSHIRE AMATEUR RADIO SOCIETY** Hon. Sec.: H. C. Loxley, 5 Guy Street, Warwick.

On 28th June there was an exhibition of members' equipment. There will be an Open Meeting on 12th July.

Unless otherwise stated, all meetings will be held in the Civil Defence Training School, Harrington House, Newbold Terrace, Leamington Spa, and commence at 7.45 p.m.

#### **NORTHERN HEIGHTS AMATEUR RADIO SOCIETY, G2SU** Hon. Sec.: A. Robinson, G3MDW, Candy Cabin, Ogden, Halifax, Yorkshire.

On 7th July there was a display of members' gear, and on the 21st a Ragchew. There was a lecture on D.F. Equipment on the 4th August, given by M. Niman, G3LGN.

#### **PETERBOROUGH AND DISTRICT AMATEUR RADIO SOCIETY**

Hon. Sec.: D. Byrne, G3KPO, Jersey House, Eye, Peterborough, Northamptonshire.

Meetings are held every Friday evening at the Clubroom in the Old Windmill on the London Road, Peterborough.

Shortwave listeners will receive a warm welcome at the Mobile Rally and Radio Treasure Hunt to be held on the river bank near the swimming pool at Peterborough on August Bank Holiday. No charge for admission and plenty of parking space.

#### **PURLEY AND DISTRICT RADIO CLUB** Hon. Sec.: A. Frost, G3FTQ, 62 Gonville Road, Thornton Heath, Surrey.

The A.G.M. was held on 18th June and the following officers were elected: Chairman, E. R. Honeywood, G3GKF; Secretary, A. Frost, G3FTQ and J. M. Nisbet, G3OGO, Treasurer. The Club holds meetings regularly on the first and third Fridays of each month.

The meeting on 6th August will be "CW Practice and Ragchew" and on 20th August there will be an evening portable expedition to Headley Heath.

#### **RODING BOYS' SOCIETY** Hon. Sec.: G. Cooke, 20 Eastwood Road, South Woodford, London, E.18.

The Society has recently been preparing for its 1965 Summer Camp. Generator power packs and transmitters have been rebuilt, and the Society has acquired a small printing press.

#### **SALOP AMATEUR RADIO SOCIETY** Hon. Sec.: Dr. Kan Jones, G3RRN, Greystones, Shrewsbury Road, Church Street, Salop.

The Club still has no fixed abode but formal meetings on the second Thursday in the month continue to be held at the Morris Hall, Bellstone, Shrewsbury.

Recent events have included a talk on "Construction Techniques" by G3RRN and G3KYU, and a most enjoyable visit to the Observer Corps H.Q. in Shrewsbury.

On 30th August, the Club station (G3SRT/A) will be operating at the Church Streeton Traction Engine Rally.

#### **SALTASH AND DISTRICT AMATEUR RADIO CLUB** Hon. Sec.: D. Bowers, B.R.S. 26760, 95 Grenfell Avenue, Saltash, Cornwall.

On 30th July, there was an Evening River Trip which was enjoyed immensely by all who attended.

Meetings are held alternate Fridays at 7.30 p.m. in the Toc-H Hall, Burraton, Saltash, Cornwall.

#### **SOUTH BIRMINGHAM RADIO SOCIETY, G3OHH** Hon. Sec.: J. Rowley, G3TQO, 195 Castle Lane, Solihull.

On 15th July, Bob Jennings, G3NXV, gave a demonstration and talk on his KW2000 Transceiver.

On 19th August, George Brown, G5BJ, will give one of his very special lectures.

#### **SOUTH SHIELDS AND DISTRICT AMATEUR RADIO CLUB** Hon. Sec.: D. Forster, G3KZZ, 41 Marlborough Street, South Shields.

Over the weekend 6th, 7th and 8th August the Club joins other exhibitors at the South Shields Annual Flower Show. This is held in Bents Park, South Shields. The Club will be setting up a station to operate on bands 160m up to 2m, and will also put up a static display.

#### **VERULAM AMATEUR RADIO CLUB, G3STA** Hon. Sec.: G. Slaughter, G3PAO, 6 Leggats Wood Avenue, Watford, Hertfordshire.

At the meeting on 16th June at the QTH in the Service Department, Hedley Road, St. Albans, the Club held an inquest on N.F.D. After this there was a junk sale. Mr. Turner of the G.P.O. gave a lecture on BCI and TVI, on 21st July.

On Wednesday, 18th August, the meeting will be devoted to our SWL members, our 'G8 plus three' licensed members and 70cms.

#### **WEST KENT AMATEUR RADIO SOCIETY** Hon. Sec.: H. F. Richards, 17 Reynolds Lane, Tunbridge Wells, Kent.

At the meeting on 23rd July N.F.D. arrangements were completed.

Meetings are held on the second and fourth Fridays of each month at Culverden Park Road, Tunbridge Wells, commencing about 7.30 p.m.

# FIDELITY PERFORMANCE from the LUSTRAND

The Lustrand microphone is a moving coil, omnidirectional microphone with fidelity performance characteristics. Compact, elegant and weighing only 8 ozs, it is fitted with a stirrup for table standing which is recessed for easy hand use. Can also be supplied for direct use with tape recorders. Full details on request.



## LUSTRAPHONE

the foremost name in microphones  
Lustraphone Ltd., St. George's Works,  
Regents Park Road, London, N.W.1.  
PRImrose 8844

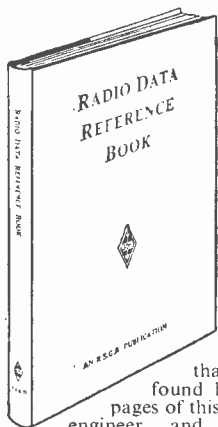

## RADIO DATA REFERENCE BOOK

Compiled by  
G. R. JESSOP, A.M.I.E.R.E.

Formulae, charts and tables that cannot usually be readily found have been collated into 116 pages of this book for the radio designer, engineer, and especially for the radio amateur. The subjects encompassed range from Ohm's Law to transmission lines, filters, wideband couplers, aerials, transmitter p.a.'s, rectifiers and noise generators. Listed at the rear of the book are numerous tables, amongst which information on FT241 crystal frequencies, insulating materials, units, wire and even the self-resonant frequencies of capacitors may be found.

Price 12s. 6d. from leading booksellers,  
or 14s. including postage direct from:

**R.S.G.B. PUBLICATIONS**  
Dept. PW, 28 Little Russell Street,  
London, W.C.1. HOLborn 7373, 2444.

### BRAND NEW AM/FM (V.H.F.) RADIO GRAM CHASSIS AT £13.13.0 (Carriage Paid)

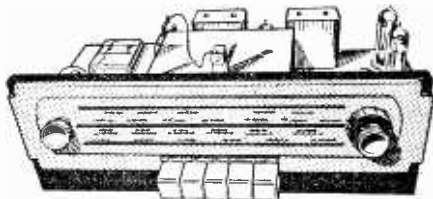

Chassis size 15 x 6 1/2 x 5 1/2 in. high. New manufacture. Dial 14 1/2 x 4 in. in 2 colours, predominantly cream. 200-250v. A.C. only.  
Pick-up, Ext. speaker, Ac. E. and Dipole Sockets. Five pushbuttons—OFF, L.W., M.W., F.M., and Gram. Aligned and tested O.P. Transformer. Tone control 1000-1900 Mc.; 200-350 Mc.; 88-108 Mc/s. Valves EZ80 rect.; E1881, EP89, EAB750, EL84, ECC85. 3-ohm speaker required.  
10 x 6 in. ELLIPTICAL SPEAKER 25/- to purchasers of this chassis. TERMS: (chassis) £3.10.0 down and 5 monthly payments of £2.4.0. (Cheap Room Dipole for V.H.F., 12/6. Feeder 6d. per yard.  
ALTERNATIVE DESIGN. L.W. 1000-1900 Mc.; S.W. (9-15 Mc/s); M.W. 190-475 Mc.; V.H.F. 87-100 Mc/s; Gram position. Otherwise similar to above chassis. Price £13.15.0 (car. paid). TERMS: £3.10.0 down and 6 monthly payments of £2.4.0. Total H.P. price £16.14.0. Circuit diagram 2/6.

### 2-VALVE GRAMOPHONE AMPLIFIER Price 37/6d. (P. & P. 2/6d.)

Overall size 4" wide x 5" high x 2 1/2". Vol. and tone controls. Mains lead. Screened lead input. With output transformer for 3-ohm. For series connection to Garrard and B.S.R. Autochangers and Players, having 90 v. tapping.  
Can also be supplied on fabric covered board with mains transformer and 8" x 4" speaker at 55/- (P. & P. 5/-).

### BATTERY ELIMINATOR

For 4 low consumption valves (96 range) 90 v. 15 mA and 1.4 v. 125 mA. 42/6d. (4/- post), 200-250 v. A.C. Also for 250 mA. 1.4 v. and 90 v. 16 mA. at same price. Two units to replace existing batteries.

### SELF-POWERED V.H.F. TUNER CHASSIS.

Covering 88-95 Mc/s. Mulard permeability tuner. Dims. 8 x 6 x 6 in. high. Valves EUC85 and 2-EP89's plus 2 diodes with EZ80 rectifier. Mains transformer. Fully wired and tested ONLY £3.17.6 (car. paid). Boom dipole 12/6. Feeder 6d. per yard.

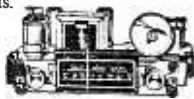

### HIGH GAIN PUSH-PULL OUTPUT AMPLIFIER £5.4.6 (6/- post)

Valves EZ80, EUC85 and 2-ECL 82 giving 8 watts. Chassis 12 x 3 1/2 x 3 1/2 in. With O.P. Trans. for 3 and 15-ohm speaker. Isolated chassis. Bass and treble cut. Mike, guitar, radio and crystal pick-up input. Facilities for mixing mike and radio etc. Front panel fixed.  
Also available as straight 10-watt amplifier with bass, treble and volume controls at £5.5.0. (6/- post). Front panel may be removed on this amp.

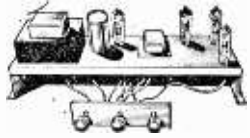

### 4 TRANSISTOR MINI- ATURE PUSH-PULL AUDIO AMPLIFIER HIGH IMPEDANCE

PRINTED CIRCUIT. 4 in. x 2 1/2 in. x 1 1/2 in. over transformers. Output for 3-ohm speaker. Suitable for microphone, record player and intercom. 9 volt battery required. Frequency range 100 cps. to 25 Kcps. Push-pull output class B. Instruction sheet provided. Fully wired ready for use. Three types. 200mW 35/-; 500mW 41/-; 1.2W 57/6. (P. & P. 3/6 each).

### CM21 CRYSTAL MICROPHONE

With 3.5 mm. Jack plug. 12/6 (Post 1/6).  
4 TRANSISTOR BABY ALARM. Attractive walnut veneer speaker cabinet 13 x 8 in. front. Ear piece as mike sensitive at 20ft. x 60ft. Ext. Lead. (P.P.6 battery required)—will last for hundreds of hours. Volume Control and On/Off. Price £3.19.6. (P. & P. 5/-).

## GLADSTONE RADIO

66 ELMS ROAD, ALDERSHOT, Hants.

(2 mins. from Station and Buses.) Aldershot 22240

(CLOSED WEDNESDAY AFTERNOON  
CATALOGUE 6d.

Regret overseas orders cannot be executed.

*in step with the*

**20 WATTS R.M.S.**

Size— $8\frac{1}{4}'' \times 3\frac{1}{4}'' \times 1''$

**A SINCLAIR BRITISH DESIGN**

## THE NEW APPROACH TO BETTER SOUND

By the use of Pulse Width Modulation in circuitry developed exclusively by Sinclair Radionics, the unique X-20 achieves standards never before reached by any audio amplifier in the world. From the input of the integrated pre-amp through to the power output stage, this amazing amplifier gives quality and power far ahead of anything in its class to make it the most original and interesting design in years. You use your X-20 like any conventional quality amplifier, but it occupies far less space, costs less, behaves perfectly and brings a refreshingly new approach to audio that is setting the standard for the whole industry.

### An X-20 user writes

"Please send me another X-20 amplifier, I received ~~one~~ last week and it works very well."—(Signed) J. B., Ellesmere.

- ★ 12 transistors
- ★ Output stage — silicon epitaxial planars
- ★ Constant square wave amplitude
- ★ 95% conversion efficiency at output
- ★ Superb quality and reliability
- ★ 20 to 20,000 c/s  $\pm 1$ dB
- ★ Total harmonic distortion — 0.1% at 10 watts R.M.S.
- ★ Input sensitivity — 1mV into 5k $\Omega$
- ★ Signal to noise ratio— better than 70dB
- ★ Power requirements — 36V d.c. at 700mA
- ★ Output into 7.5 ohms— 20 watts R.M.S. music power  
15 watts R.M.S. continuous
- ★ Output into 15 ohms— 15 watts R.M.S. music value  
10 watts R.M.S. continuous
- ★ Makes ideal guitar or P.A. amplifier
- ★ Built-in low-pass filter ensures wide tolerance load at output
- ★ Add tone and volume control, mono or stereo, system to choice
- ★ Easily built in an evening

weighs  
only  
 $4\frac{1}{2}$  ozs.

### X-20 MANUAL

Details various tone and volume control systems, stereo operation, input switching stage, etc. Supplied FREE with every X-20. Available separately, 2/- post free.

# SINCLAIR X-20

**INTEGRATED 20 WATT PULSE WIDTH  
MODULATED AMPLIFIER AND PRE-AMP**

Complete kit of parts  
inc. 12 transistors,  
instructions and X-20  
manual

**£7.19.6**

Built and  
tested  
X-20 Mains  
Power Unit

**£9.19.6**  
**£4.19.6**

Full service facilities available to all Sinclair Customers

**sinclair**

**SINCLAIR RADIONICS LTD.**  
**COMBERTON, CAMBRIDGE**

Telephone  
COMBERTON  
682

# SPACE AGE!

- THE WORLD'S SMALLEST RADIO
- FANTASTIC RANGE AND POWER
- IDEAL FOR PERSONAL LISTENING

## SINCLAIR MICRO-6

■ 1 4/5" x 1 3/10" x 1/2" ■ weighs under 1 oz.

No transistor set has ever yet compared with the Micro-6 for size, power, performance and design. No set has ever given such pleasure and satisfaction both in building and using it. Thousands upon thousands are now in use throughout the world. Everything except the lightweight earpiece is contained within the smart minute white, gold and black case. Unique features include bandsread over the higher frequency end of the medium waveband for easy reception of Luxembourg, powerful A.G.C. to counteract fading of distant stations, and vernier type tuning. Quality of reproduction is outstandingly good. Order your Micro-6 now and prove for yourself why it cannot be too highly recommended as an intriguing design to build and a most practical radio to use. When you have built it, you will want to have it with you always—and it plays everywhere! Build it in an evening.

*It's easy to build your Micro-6 and have it working in an evening. All parts including the special Metal Alloy Transistors, case, dial, lightweight earpiece and easy to follow instructions come to*

# 59/6

MALLORY MERCURY CELL ZM312 (2 required) each 1/11 (Pack of 6—10/6)  
 "Transrista" black nylon wrist strap for Micro-6—7/6.

FULL SERVICE FACILITIES AVAILABLE TO ALL SINCLAIR CUSTOMERS

## SINCLAIR X-10

### Integrated P.W.M. Amplifier

Recommended for use where a less powerful amplifier than the X-20 is required. The X-10 also offers wonderful advantages of quality, compactness and price, and it can be battery operated if desired. Tone control system added to choice. For 12-15 volt operation.

Complete kit and instructions

£5-19-6

Ready built and tested

£6-19-6

X-10 power supply unit

£2-14-0

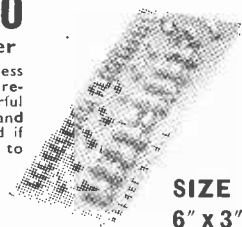

SIZE  
6" x 3"

Manual free with all X-10's

# SINCLAIR

P.W.M. AMPLIFIERS  
 MICRO-RECEIVERS  
 MICRO-DESIGNS



## ALL IN A SET SMALLER THAN A MATCH BOX

The technical specification of the Micro-6 is fantastic for its size: The 6-stage circuit using 3 M.A.T.'s provides 2 stages of R.F. amplification, double diode detector and high gain 3-stage A.F. amplifier plus A.G.C. Tunes over medium waveband.

- A POWERFUL AMPLIFIER
- FOR YOUR MICRO-6

TR  
750

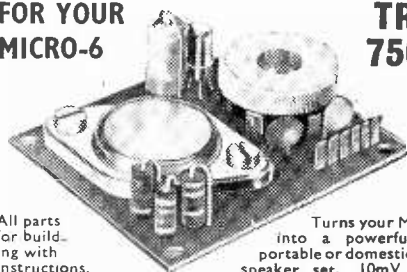

All parts for building with instructions.

39/6

Ready Built 45/-

Turns your Micro-6 into a powerful car, portable or domestic loud-speaker set. 10mV input gives 750 milliwatt output into a standard 25-30Ω speaker. Frequency response 30-20,000 c/s ± 1dB. Also makes a good record player, intercom, baby alarm, etc. Complete with built-in volume control and switch. 9v. operation.

### OTHER SINCLAIR CONSTRUCTOR DESIGNS

MICRO AMPLIFIER—smaller than a 3d. piece. Suitable for A.F., R.F., F.M., etc., etc.

28/6

MICRO-INJECTOR—easy to build and use fault tracer. Ready-built 32/-

27/6

## GUARANTEE ORDER FORM

### Guarantee

*Should you not be completely satisfied with your purchase when you receive it from us, your money will be refunded in full and at once without question. Please quote PW.9 should you prefer to write your order instead of cutting out this coupon.*

Please send me

.....  
 .....  
 .....

NAME .....

ADDRESS .....

for which I enclose Cash Cheque/Money Order

value £.....s.....d.

.....





**RECEIVERS & COMPONENTS**

(continued)

**GARRARD 'AUTOSLIM** Autochange Units, £5. **BUTLIN**, 25 North Road, Brighton.

**MARCONI CANADIAN RECEIVER NO.52**



Shipping Amateur & Broadcast. Magnificent 10-valve receiver in three switched wavebands covering 1.75-16 Mc/s. (19 - 170 m.crea), plus 3 valve crystal call-

ibrator employing dual crystal to provide marker check at 10-1000000 c/s. One RF and two IF stages. Other refinements: valve HT, and signal check meter. Internal 3in. speaker and two H/Phone outputs with switched control. RF-AP (Gain, Noise Limiter, Filter, BFO Heterodyne pitch control. Wide and Narrow Bandwidth, Man or AVC on CW & RT. Fast and Slow tuning with lock. Additional OSC Tuning (plus & minus). Power requirements HT 160v. 60mA; LT 12v. 1 1/2 ampere. ONLY £9.19.8. Carr. 15/8 or complete with Power supply unit suitable for 116/230v. AC mains £12.19.8. Carr. 20/-.

No. 52 **GROUND-STATION** comprising Receiver, Transmitter and 12v. D.C. Power Unit. £27.10.0. Carr. £2.10.0. (Mainland only).

**4 VALVE 4 WATT AMPLIFIER**

"C" Core transformers A.C. Mains 110/230 volts 600 ohms of high impedance input. Output 3 or 600 ohms (static choice) Control: On/Off switch. Gain control. Indicator light. Valve inspection panel. 19 x 7 x 7 1/2in. Brand New in maker's carton. 79/6. Carr. 10/-.  
**TELESCOPIC AERIAL MASTS.** Tubular steel coped, spray finish, ring cam locking on each section provides for full or any height required. Suitable all fixings and base locations. Bottom section 1 1/2in. diameter, 20ft. (4 section) Closed 5ft. 9in. Weight 10lb. 55/-. Carr. 5/-. 8ft. (6 section) Closed 6ft. 6in. Weight 20lb. 75/-. Carr. 5/-. Further height by adding 3-4ft. Whip sections 19/8. Carr. 4/-. Special price for quantities.



**WAVEMETER CLASS D**

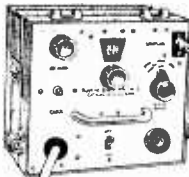

Freq. band 1,900 Kc/s. to 8,000 Kc/s. (158-37.5 metres) in two ranges, 1,900 Kc/s. 4,000 Kc/s. also 4,000 Kc/s. 8,000 Kc/s. supply 6 v. D.C. input. Complete with twin crystal. As new. PRICE 52/6. P. & P. 5/-.

**CREED TELEPRINTERS.** 7 1/2 Used condition. Price from £15. Carr. 30/-.

**MOVING COIL HEADPHONES.** (BRAND NEW). Chamois pad-led, complete with jack plug, 15/6. Post 2/-, also available with matching moving coil Microphone, 10/6, post 2/-.

All No. 19 Set parts available.

Many other bargains! S.A.E. All enquiries.

**A. J. THOMPSON (Dept P.W.)**  
"EILING LODGE"  
CODICOTE, HITCHIN, HERTS.  
Phone: CODICOTE 242

**BUSINESS OPPORTUNITIES**

**BUILD** a fully automatic low cost telephone system. Ideal for renting or selling to factories, offices, etc. Up to ten lines simple construction, full technical details, diagrams and instructions 15/6 inc. postage **PART-RIDGE TECHNICAL PUBLICATIONS**, Dept. P.W.J. 21-25 Hart Road, Thundersley, Benfleet, Essex.

**FOR SALE**

**HAMMER FINISH PAINT.** The modern finish for electronics. Can be brushed or sprayed. Blue or Silver. 2 1/2oz. tins 3/6, post 8d.; 1-pint, 7/6, post 1/9; 1 pint 15/-; post 2/9. Orders over 30/- post free. Retailers supplied. Write for details. Amazing results! Return of post service **FINNIGAN SPECIALITY PAINTS (PW)**, Mickley Square, Stocksfield, Northumberland.

**MORSE MADE !**

The famous **RHYTHM RECORDED COURSE** cuts the practice time down to an absolute minimum.

One student, aged 20, took only 13 DAYS, and another, aged 71, took only 6 WEEKS to obtain a G.P.O. pass certificate. If you wish to read Morse easily and naturally, please enclose 8d. in stamps or two international reply coupons for full explanatory booklet.

To G3CHS,

45 GREEN LANE, PURLEY, SURREY

**TELEVISION SETS** from 30/-, 20 for £1 each, not working, callers only. 20 Palmerstone Road, Early, Reading. Phone: 62905.

**NOW READY!**

A modern way case assembly using our "Die Strip". The strip has been specially made for us at Birmingham on qty production, for low price to the public. It is made of high strength alloy and will enable anyone to assemble an instrument case or cabinet in minutes. Full details of these products will be sent free. Please send large envelope self addressed.

88 set transmitter/receiver. Chassis less valves, 20/- each. Post paid.

Copper Laminate Board, single or double sided, 5/- per square foot panels either type 3ft. by 4ft., 33/-.

High Stab Resistors, 5%, 6d.; 2%, 9d.; 1%, 1/-. Every six packed in 7-compartment linen finish component box.

Speakers 3 ohm P.M. 5in., 5 1/2in., 6in., 7 x 4in., 7 1/2in., 8in., 8 1/2in., 10in., 12 1/2in.

Please send S.A.E. for full Lists of other goods on offer.

U.K. ONLY

**E. R. NICHOLLS**

Mail Order and Retail Shop  
46 LOWFIELD ROAD  
off SHAW HEATH, STOCKPORT  
CHESHIRE

**FOR SALE**

(continued)

**RUSH R1** Wire Stripper, excellent order. **GEC 5kW Magnetiser**, Quad 22 FM Tuner, Control Unit and Amplifier, must be sold for best offers as we are closing down. **SOUND SERVICE RADIO**, 2 Gibbon Road, Kingston-on-Thames. 8008.

**TRANSISTORS**

11/- each. Red or White Spots.

2/- each. XA101, XA102, XB103, OA90, XA111, XA112, OC430, V10/IS.

3/- each. OC44, OC45, OC70, OC71, OC81, OC81D, XA151, XB104, XC101, XC101A, OC169, OC200.

4/- each. AF114, AF115, AF116, AF117, OC170, OC171, XA103, XA116, XB102, XB105, XC121, XU611.

5/- each. OC139, OC140, OC204, ORP60, XA701, XA703, GET7, GET8, GET9, XC141, BY100, OA211.

10/- each. OC19, OC22, OC25, OC26, OC28, OC35, 2S013.

**ZENNER DIODES**

4.7v. to 30v., 1/4w. 3/6, 1.5w. 5/-, 7w. 6/- each.

Plus many more. Send 6d. in stamps for full list and eq. chart

**B.W. CURSONS**

78 BROAD STREET  
CANTERBURY, KENT

**CONDENSER BARGAIN!** Miniature Paper Condensers 1/2in. x 1/2in. Ideal for transistor sets. .001, .001, .002, .005, .02, 4uF. also small 500uF and 2.2uF Condensers. All 7/6 per 100. £3 per 1,000. G. F. MILWARD, 17 Peel Close, Drayton Bassett, Staffs.

**240 WATT ELECTRIC POWER ANYWHERE**

**ANYTIME** from 12<sup>th</sup> CAR BATTERY  
WITH THE **AMERICAN DYNAMOTOR UNIT**

Input 12v. output 200, 250w. at 150 to 220v. 220w. Perfect for TELEVISION, POWER TOOLS and all universal AC/DC ELECTRICAL EQUIPMENT, gives wonderful results. Price ONLY £8.95 + 10/- carriage. Send stamped envelope for full illustrated details. "S" SCIENTIFIC PRODUCTS, CLEVELAND, OHIO

**YUKAN SELF-SPRAY**

**YUKAN** Aerosol spray kit contains 16 ozs. fine quality durable easy instant spray. No stove baking required. Available in Grey Hammer at 14/11 at our counter or 15/11. Carr. paid per push-button self-spray can.

**SPECIAL OFFER:** 1 can plus optional transferable snap-on trigger handle (value 6/-) for 18/11.

Get this Air Drying Grey **HAMMER FINISH** now - IT'S SUPERB... THE PUSH-BUTTON WAY

Please enclose cheque or P.O. for total amount to:

**YUKAN**  
Dept. P.W.9  
307a EDGWARE RD.  
LONDON W.2

(Closed Thurs. afternoons, open all day Sat.)

Choice of 13 self-spray plain colours and primer (Motor car quality) also available.



## P.C.R. COMMUNICATIONS RX

Covers long and medium wave and S.W. 6 to 18 Mc/s. Made by PYE and PHILIPS. 6 valves RF and 2 IF stages, built in 5in. speaker. There is ample room to build an internal Power Pack. Supplies required 250v. 50mA and 12v. 1.5a or 6v. 3a. R.E.M.E. reconditioned and tested.

Price £6.10.0 plus 12/6 carriage. See June "Practical Wireless" for mods. to these RX's.

## MARCONI CANADIAN RECEIVER No. 52

Shipping, Amateur and Broadcast. 10 valves receiver, three switched wave-bands covering 1.75 to 16 Mc/s (19-170 metres) plus 3 valve crystal calibrator to provide marker checks at 10-100-1000 kc/s. One RF and two IF stages. Other refinements: valve, H.T. and Signal check meter. Internal 3in. speaker and two H/Phone outputs with switched control. RF-AF Gain, Noise Limiter, Filter, BFO Heterodyne pitch control. Wide and Narrow band width, Main or AVC on CW and RT. Fast and Slow tuning with lock. Additional OSC Tuning (plus and minus). Power requirements HT 160v, 60mA; LT 12v. 1½ amps. Brand new with circuit and outer case £9.17.6. Plus 12/6 carriage.

## TOGGLE SWITCHES

Small instrument type 250v, 3 amps. Price 4 for 6/6, post paid.

## Class D WAVE METER

Frequency 1.9 to 8 Mc/s in two bands, 1.9 to 4 and 4 to 8 also 1 Mc/s Harmonics up to 25 Mc/s. These are supplied complete in transit case with headphones, spare valve vibrator, instruction book and circuit diagram. These units are intended to work off 6v DC, but are easily converted to mains operation. Simple conversion details supplied. They are supplied in new condition and are ideal for use with types 19,38 and similar Trans. receivers.

Price £3.7.6, plus 7/6 carriage.

230 to 6v transformers for mains conversion, 9/6.

## METERS 5Q/171

500UA scaled 10 to 5. Marconi type single hole fixing 2½in. OSD 90 ohms. New ex-equipment. Price 15/6, plus 2/- post.

## R.F. 26 UNITS

This unit covers the band 50 to 65 Mc/s. Manual tuned (no XTALS required) giving a IFO/P of 7 Mc/s. Valves EF54 RF Amp, EF 54 Mix, EC52 L.O. A Muirhead slow motion drive is fitted, also Aerial Trimmer. These units are easily converted to the band 80 to 100 Mc/s. Power requirements 250v, 25mA and 6.3v 1a. The IFO/P from these can be fed into a RX or IF amp tuned to 7 Mc/s. Circuit diagram and connections supplied. These units are supplied new and boxed.

Price 37/6, plus 5/6 carriage.

## B. SLATER

34 Lifford Street,  
Sheffield 9.

## FOR SALE

(continued)

## ELECTRIC SOLDERING-IRON



### FANTASTIC BARGAIN OFFER

Lightweight Pistol Grip handle 40 watt. 240/250v. A.C. Solid copper bit. Detachable handle forms cover for iron when not in use. With 4ft. Safety 3-core flex. Indispensable for every home handyman. A boon to model makers and a necessity for every wireless enthusiast. Offered to you at this new amazing price.

ONLY  
9/6

P & P

1/1

**C. H. SERVICE, (Dept. P.W.)**  
Lusted Hall Lane, Tatsfield, Kent.

## SITUATIONS VACANT

**RADIO AND TV Exam. and Courses** by Britain's finest Home-study School. Coaching for Brit.I.R.E., City and Guilds Amateur's Licence, R.T.E.B., F.M.G. Cert., etc. FREE brochure from **BRITISH NATIONAL RADIO SCHOOL**, Russell Street, Reading.

## SITUATIONS VACANT

(continued)

**TV & RADIO — A.M.I.E.R.E., City & Guilds, R.T.E.B. Cert. etc., on "Satisfaction or refund of fee" terms. Thousands of passes. For details of Exams and Home-training Courses (including practical apparatus) in all branches of radio, TV and electronics, write for 156-page handbook — FREE. B.I.E.T. (Dept. 242G), 29 Wright's Lane, London, W.8.**

**LABORATORY TECHNICIANS** — required in the Department of Physics, Chelsea College of Science and Technology, Manresa Road, London, S.W.3.

Is electronics your hobby? Why not let your hobby earn your living? We can use your ability and initiative in the interesting and varied practical work in our laboratories. 5-day week. Day release for approved studies encouraged. Salary £270—840 plus London Weighting of up to £45 depending upon age and qualification supplements of up to £50. Good prospect of promotion to higher grades. Write or telephone for an application form to Superintendent of Laboratories, Department of Physics, PLA 6421, Ext. 28.



## AVIATION SERVICE AND REPAIR DIVISION

Aviation Service and Repair Division at Airport Works, Rochester, provides unique servicing facilities for the airlines of the world. It services aircraft instruments, autopilots and complete control systems involving electronic assembly to the very highest standards. Because of the need for reliability the work is carried out in first class working conditions. Owing to our expansion programme we now have immediate vacancies for:—

## ELECTRONIC INSTRUMENT MECHANICS

Capable of complex fault diagnosis on electronic airborne equipment (radio and television servicing or H.M. Forces experience would be an advantage).

## INSTRUMENT MECHANICS (GYROSCOPIC)

Previous experience in the overhaul of gyroscopic equipment is considered necessary.

Applications should be made in writing, quoting reference number ASR/2, and giving brief details of previous experience to:—

M. J. MORAN, Personnel Officer, Elliott Brothers (London) Limited, Airport Works, Maidstone Road, Rochester, Kent.

All applications will be answered within seven days.



A member of the Elliott-Automation Group

SITUATIONS VACANT (continued)

# School Leavers

**Have you started work yet?**

*If Not there is a place available in the two-year full-time course in*

## INDUSTRIAL ELECTRONIC SERVICING AT WOLVERHAMPTON

Candidates should have followed full-time education up to the age of 16 years. Further information from the Head of the Department of Electrical Engineering.

Course commences Mid-September 1965

**WOLVERHAMPTON AND STAFFORDSHIRE COLLEGE OF TECHNOLOGY**

Wulfruna Street, Wolverhampton.

A.M.I Mech. E., A.M.I.E.R.E., City & Guilds, G.C.E., etc Become a Technician or Technologist for high pay and security Thousands of passes. For details of Exams and Courses in all branches of Engineering, Building, Electronics, etc write for 156-page handbook—FREE. B.I.E.T. (Dept. 242B), London, W.8.

### EDUCATIONAL

**CITY & GUILDS** (electrical etc.), on "Satisfaction or refund of fee" terms. Thousands of passes. For details of modern courses in all branches of electrical engineering, electronics, radio, T.V., automation, etc., send for 156-page Handbook—FREE. B.I.E.T. (Dept. 242A), 29 Wright's Lane London, W.8.

**RADIO OFFICERS** training courses. Write: Principal, Newport and Monmouthshire College of Technology

### TRAIN FOR SUCCESS WITH ICS

Study at home for a progressive post in Radio, TV and Electronics. Expert tuition for I.E.R.E., City & Guilds (Telecoms and Radio Amateurs') R.T.E.B., etc. Many unique diploma courses incl. Colour TV, Electronics, Telemetry & Computers. Also self-build kit courses—valve and transistor. Write for FREE prospectus and find out how ICS can help you in your career  
ICS DEPT 541, PARKGATE ROAD LONDON, S.W. 11

### EDUCATIONAL

(continued)

**RADIO OFFICERS** see the world. Seagoing and shore appointments. Our many recent successes provide additional trainee vacancies during 1965/66. Grants available. Day and boarding students. Stamp for prospectus. WIRELESS COLLEGE, Colwyn Bay.

**THE INCORPORATED PRACTITIONERS IN RADIO AND ELECTRONICS (I.P.R.E.) LTD.** Membership Conditions booklet 1/-. Sample copy of I.P.R.E. Official Journal 2/- plus free Secretary Dept. B, 32 Kilmore Road, Caversham, Reading, Berks.

### METAL WORK

**METAL WORK.** All types cabinets, chassis racks, etc to your specifications. PHILPOTTS METAL WORKS LTD., Chapman St. Loughborough

### CABINETS • CASES CHASSIS

Anything in metal. "One-offs" a pleasure. Send your drawing for quote. Stove enamelled in any professional finish

### MOSS, WATSON

40 Mount Pleasant Street, Oldham Lancs. MAIN 9400 P.W.

### BOOKS & PUBLICATIONS

**AUDIO.** America's foremost journal. Year's subscription 43/-. specimen copy 4/- All American radio journals supplied — list free. WILLEN (Dept. 46), 61a Roadway, London, E.15.

### SERVICE SHEETS

**SERVICE SHEETS,** Radio and Television, 3/6 post paid. VEST AND EMERY, 17 Holgarth St., Durham.

**SERVICE SHEETS,** Radio, TV, 5,000 models. List 1/- S.A.E. inquiries. TELRAY, 11 Maudland Bank, Preston.

**SERVICE SHEETS** for all makes of Radio and TV, 1925-1965. Prices from 1/- with free fault-finding guide. S.A.E. inquiries. Catalogue of 6,000 models 1/8. Valves, modern and obsolete. Radio/TV Books, S.A.E. lists. HAMILTON RADIO, Western Road, St. Leonards, Sussex.

**SERVICE SHEETS** (75,000) 4/- each. Callers welcome. Always open. 5 South Street. Oakenshaw, Bradford.

**RADIO AND TV SERVICE SHEETS.** All makes and models from 1924. 4/- each. plus s.a.e. If we haven't got it you won't get it GRIMSDYKE RADIO, 77 Merrion Ave, Stanmore, Middlesex.

### SERVICE SHEETS

4/- ea., plus postage

We have the largest display of Service Sheets for all makes and types of Radios, Televisions, Tape Recorders, etc., in the country. Speedy service.

To obtain the Service Sheet you require please complete the attached coupon.

From:

Name: .....

Address: .....

To: **S.P. DISTRIBUTORS**  
44 Old Bond St., London, W.1

Please supply Service Sheets for the following:

Make: .....  
Model No..... Radio/TV  
Make: .....  
Model No..... Radio/TV  
Make: .....  
Model No..... Radio/TV  
I also require list of Service Sheets at 1/6.

(please delete items not applicable)

I enclose remittance of.....

MAIL ORDERS ONLY SE. PW

(Continued on next page)

WANTED

WE BUY New Valves for cash, large or small quantities, old types or the latest. Send details. Quotations by return. WALTONS WIRELESS STORES, 15 Church Street, Wolverhampton.

WE BUY New Valves and Transistors. Amplifiers, Short-wave Receivers and Components, etc. A.D.A. MANUFACTURING CO., 116 Alfreton Road, Nottingham.

WANTED VALVES ONLY

Must be new and boxed Payment by return

WILLIAM CARVIS LTD.

103 North Street, Leeds 7

URGENTLY WANTED. new modern Valves, Transistors, Radios, Cameras, Tape Recorders and Tapes, Watches, Tools, any quantity, S. N. Willetts, 16 New Street, West Bromwich, Staffs. Tel: 2392.

A PROMPT CASH OFFER for your surplus brand new Valves and Transistors. R.H.S., Beverley House, Mannville Terrace, Bradford 7.

DAMAGED AVO METERS wanted. Models 7 and 8. Any condition. Any quantity. HUGGETT'S LTD., 24 Pawsons Road, W. Croydon.

MISCELLANEOUS

CONVERT ANY TV SET into an Oscilloscope. Instructions and diagrams 12/6. REDMOND, 42 Dean Close, Portslade, Sussex.

ELECTRONIC MUSIC?

Then how about making yourself an electric organ? Constructional data available—full circuits, drawings and notes! It has 5 octaves, 2 manuals and pedals with 24 stops—uses 41 valves. With its variable attack you can play Classics and Swing.

Write NOW for free leaflet and further details to C. & S., 20 Maude Street, Darlington, Durham. Send 3d. stamp.

A.R.R.L. RADIO AMATEURS HANDBOOK 1965

New Edition 40/-. Postage 3/3

101 Ways to Use your Signal Generator by Middleton. 21/-. P. & P. 1/- Handbook of Transistor Circuits by Lytel. 35/-. P. & P. 1/3. Troubleshooting with the Oscilloscope by Middleton. 20/-. P. & P. 1/-. Computer Circuit Projects You Can Build by Boschen. 21/-. P. & P. 1/-. Electronic Organ for the Constructor by Douglas. 20/-. P. & P. 1/-. Single Sideband for the Radio Amateur new ed. by A.R.R.L. 24/-. P. & P. 1/3. Solar Cell and Photocell Experimenters' Guide by Hoberman. 24/-. P. & P. 1/-. Electronic Motor Control by Lytel. 30/-. P. & P. 1/3.

UNIVERSAL BOOK CO.

12 Little Newport Street, London, W.C.2 (adjoining Lisle Street)

PADGETTS RADIO STORES

OLD TOWN HALL, LIVERSEDGE, YORKS. Telephone: Cleckheaton 2866

Bush 12in. TV34C 13 channel. Tested with good tube, only wants cleaning. 75/-. carriage 10/-.

14in. 13 Channel. Untested TV sets, 30/-, carriage 10/- Well packed but sent out at owner's risk.

Special Offer. Brand new Tubes (not seconds) MW43/69, 85/-, AW43/88, 75/-, MW36/24, 37/6, MW36/44, 37/6. Carriage 10/- Fully guaranteed.

Single Phase 240 volt 1400 r.p.m. i-h.p. motor with pulley, 26/-, less pulley, 24/-, fully guaranteed, ex. washing machine. Carriage 8/6.

One Sixth H.P. Motor. 240 volts, 15/-, post 6/9.

VALVE LIST

Table with 4 columns: Valve designation, Price, and other details. Includes items like EL91, EL80, ECC82, etc.

Brand new Boxed Battery amp, packed in a wooden box, makes a fine tool box 7/6, post 6/8; amp less box 2/6.

PM Speakers, ex TV sets. All perfect. Roma, 6 x 4, 3/-, post 2/-; six for 20/-, post free.

Goodmans, 7 x 4, 5/-, post 2/-; six for 32/-, post paid.

Phillips, G.E.C., Plessey, 6in. and 5in. round, 3/-, post 2/-.

Reclaimed TV Tubes, Six Months' Guarantee. Mullard MW 43/80, 30/-; Mullard MW 43/69, 30/-; Mazda CRM 17/-. 30/-; Mazda CRM 142, 17/- Carriage 10/- New 12in. Speakers with built-in tweeter, 28/6, post paid.

when replying to advertisements

please mention

Practical Wireless

96 pages of factual tabulated data

"PRACTICAL WIRELESS" RADIO AND TELEVISION REFERENCE DATA

Compiled by J. P. Hawker Contains full details of colour codes; everyday formulae, for calculating the

values of biasing components, potential dividers, resonance, gain, etc.; aerial dimensions; a quick frequency-wavelength conversion table; stations and frequencies; common symbols and abbreviations; notes on amateur radio and a list of call-sign prefixes; communication receiver I.F.s; mathematical data including logarithm tables; wire and cable data: battery equivalents: valve, transistor and picture tube pin connections, bases, ratings and equivalents, including selected CV types. 96 pages, illustrated, over 62 pages of tables.

10s. 6d.

FROM ALL BOOKSELLERS

... or, in case of difficulty 11s. 6d. by post from GEORGE NEWNES LTD., Tower House, Southampton Street, London, W.C.2.

NEWNES

NEW VALVES! Guaranteed Set Tested 24-HOUR SERVICE

Table listing various valve types and their prices, such as 1RS, 1S5, 1T4, 3S4, 3V4, DAF91, etc.

Postage on 1 valve 9d. extra. On 2 valves or more, postage 6d. per valve extra. Any parcel insured against damage in transit 6d. extra, no callers.

GERALD BERNARD

83 OSALDESTON ROAD STOKE NEWINGTON, LONDON, N.16.

# RADIO CLEARANCE LTD.

27 TOTTENHAM COURT ROAD, LONDON W.1. Telephone: MUSEum 9188  
Trade enquiries invited. The oldest component specialist in the trade. Est. 35 yrs.

## LOUDSPEAKER BARGAINS STILL AVAILABLE

Enormous purchases of Brand New and Guaranteed Plessey loudspeakers enable us to offer these units at THE LOWEST PRICES EVER! Don't miss this golden opportunity to obtain a first-grade permanent-magnet LOUDSPEAKER off the production line at LESS THAN THE MANUFACTURER'S COST! Read carefully the prepared list below and choose just the right speaker for the job—COMPARE THE PRICES ANYWHERE! SELLING FAST—STOCKS CHANGING RAPIDLY.

Size in. inches	Gauss in. lines	Imped. in. ohms	Price	Size in. inches	Gauss in. lines	Imped. in. ohms	Prior	Size in. inches	Gauss in. lines	Imped. in. ohms	Prior
2	7000	80	8/-	3 1/2	9500	3	10/6	4	9500	4	11/6
2 1/2	7000	35	8/6	3 1/2	9500	4	10/6	5	6000	3	8/6
2 1/2	7000	50	8/6	3 1/2	7000	35	8/6	5	7600	3	8/6
3	8500	3	10/-	4	9500	50	11/6	5	8300	3	8/6
3	6000	5	8/6	4	6000	35	10/6	5	8500	3	10/6
3	7000	5	9/-	4	7000	35	11/-	5	9000	15	12/6
3	7000	35	8/6	4	7500	5	9/6	5	8500	25	10/6
3	6500	80	9/6	4	9000	50	11/6	5	9500	35	11/6
3 1/2	6000	15	10/-	4	9500	35	11/6	5 1/2	6000	3	11/-
3 1/2	7000	3	9/6	4	9500	15	12/-	8	6000	15	15/6
5 x 3	6000	3	7/6	7 x 3 1/2	7000	3	9/6	8 x 2 1/2	9500	3	10/-
5 x 3	9000	35	12/-	7 x 3 1/2	9500	3	10/6	8 x 6	8500	3	11/-
5 x 3	7000	3	8/-	7 x 3 1/2	9500	3	11/-	8 x 5	11000	3	13/6
5 x 3	9000	3	8/6	7 x 4	9500	30	12/6	10 x 6	11000	3	22/6
5 x 3	9500	3	9/-	7 x 4	9500	30	12/6	10 x 6	11000	3	22/6
6 x 4	8500	3	8/6	7 x 4	10000	3	8/6	10 x 6	11000	3	22/6
6 x 4	9500	3	10/-	8 x 2 1/2	6000	3	8/6	10 x 6	11000	3	22/6
6 x 4	9500	35	12/-	8 x 2 1/2	7000	5	8/6	10 x 6	11000	3	22/6

ALLOW 2/6 each Speaker for postage and packing and handling charge and please specify the exact requirements—the nearest available will be sent.

### SELECTED BARGAINS

Beautifully geared AM/FM 2 gang Condensers, 4/6; AM/FM IFT'S 465 kc/s and 10.7 Mc/s 4/6 pair; Magnavox Crystal Tape Recorder Mikes, 12/6; 3 watt Stereo Amplifiers, DIODES—0A8, 0A90, 0C48H, GD10, 2/- each. Sentercell rectifiers R3/2D-D3-2-1-Y, 2/8 each. TRANSISTORS: OC45 4/6, PXA101 3/6, AP15 4/6. Sub. min. Germanium diode 1/3, M1 diode 6d. each. Silicon diodes, 200 p.i.v. 200 mA, 1/- each. 400 p.i.v., 330mA, 2/6 each. catalogue—our stocks move too quickly! Kindly make provision for additional postage and package charge to avoid delay. Terms: Cash With Order or C.O.D. on Orders over 10/-.



**INTERCOM/BABY ALARM**  
Usualy 5/6  
Our Price ONLY  
**59/6**

Modernize your Office, Shop, Warehouse, Workshop, Surgery, Nursery and Home with this latest two-way TRANSISTOR INTERCOM. Consists of two units MASTER and SUB. in strong plastic cabinets with chrom. stands. Specially designed for instant communications (Call/Talk), between two persons anywhere indoors or outdoors. Operates on one 9V battery. Complete with accessories. Ready to operate. P. & P. 2/6. Outstanding value.



**TRANSISTORISED MICROPHONE MIXER**  
Usualy 95/-  
Our Price ONLY  
**49/6**

This 4-CHANNEL MIC. MIXER permits to mix 4 signals: Tape, Mic., Tuner and Records into a single output. Delightful for amateur and professional recorders alike. Post free.



**Transistor BATTERY CHARGER**  
Usualy 2/6  
Our Price ONLY  
**27/6**

Use your TRANSISTOR RADIO or INTERCOM. from domestic A.C. mains, and charge 9v. dry battery PP3, VD3, VT3 or 216 the most battery's life many times. Unbeatable value. Immense saving on batteries. Complete with Plug, Lead and Snap cord. P. & P. 1/6. Full price refunded if not satisfied in seven days. WEST LONDON DIRECT SUPPLIES (PW/1) 6 CHIGNELL LANE, WEST EALING, LONDON, W.13.

# FREE TO AMBITIOUS ENGINEERS

—THE LATEST EDITION OF ENGINEERING OPPORTUNITIES

**Have you sent for your copy?**  
ENGINEERING OPPORTUNITIES is a highly informative 156-page guide to the best paid engineering posts. It tells you how you can quickly prepare at home for a recognised engineering qualification and outlines a wonderful range of modern Home Study Courses in all branches of Engineering. This unique book also gives full details of the Practical Radio & Electronics Courses, administered by our Specialist Electronics Training Division—the B.I.E.T. School of Electronics, explains the benefits of our Employment Dept. and shows you how to qualify for five years promotion in one year.

### WHICH IS YOUR PET SUBJECT?

- Mechanical Eng.
- Electrical Eng.
- Civil Engineering.
- Radio Engineering.
- Automobile Eng.
- Aeronautical Eng.
- Production Eng.
- Building, Plastics, Draughtsmanship, Television, etc.

GET SOME LETTERS AFTER YOUR NAME!

- A.M.I.Nech.E.
- A.M.I.C.E.
- A.M.I.Prod.E.
- A.M.I.M.I.
- A.I.O.B.
- B.Sc.
- A.M.I.E.R.R.
- City & Guilds
- Gen. Cert. of Education
- Etc., etc.

### PRACTICAL EQUIPMENT

Basic Practical and Theoretical Courses for beginners in Radio, T.V., Electronics, Etc. A.M.I.E.R.E., City & Guilds  
Radio Amateurs' Exam, R.T.E.B. Certificate  
P.M.G. Certificate  
Practical Radio  
Radio & Television Servicing  
Practical Electronics  
Electronic Engineering  
Automation

### INCLUDING TOOLS!

The specialist Electronics Division of B.I.E.T.  
NOW offers you a real laboratory training at home with practical equipment. Ask for details.

### B.I.E.T. SCHOOL OF ELECTRONICS

### POST COUPON NOW!

Please send me your FREE 156-page "ENGINEERING OPPORTUNITIES"  
(Write if you prefer not to cut page)

NAME \_\_\_\_\_  
ADDRESS \_\_\_\_\_

SUBJECT OR EXAM THAT INTERESTS ME \_\_\_\_\_



### SATISFACTION OR REFUND OF FEE

Whatever your age or experience, you cannot afford to miss reading this famous book. If you are earning less than £20 a week, send for your copy of "ENGINEERING OPPORTUNITIES" today—FREE.

BRITISH INSTITUTE OF ENGINEERING TECHNOLOGY  
(Dept. SE/21), 29 Wright's Lane, London, W.8

THE B.I.E.T. IS THE LEADING ORGANISATION OF ITS KIND IN THE WORLD





## GUITAR AMPLIFIERS WITH TREMOLO

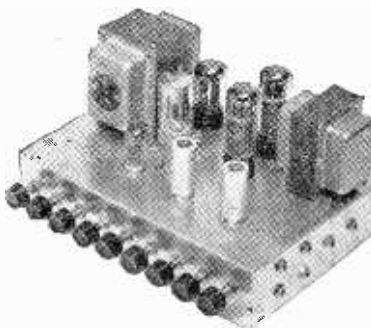

Five Jack socket inputs, four with separate mixing volume controls, and one input 'straight through'. All inputs are of very high sensitivity only 10 millivolts input is required for full output, making them suitable for all types of guitars and microphones. Separate Bass and Treble controls, giving a wide range of lift and cut. Separate master gain control. Tremolo speed and depth controls. Jack socket for remote tremolo switching. Outputs for 3 and 15 ohms speakers. Valves used in the 30 watt amplifier ECC83, ECC83, EL34, EL34, GZ34. In the 15 watt amplifier ECC83, ECC83, EL34, EL34, E231. An extra valve ECC83 is used in the tremolo circuit. The chassis is complete with base plate and is solidly made of 18 gauge steel, finished silver grey hammer. Size 12 x 8 x 6 1/2 inches high.

and cut. Separate master gain control. Tremolo speed and depth controls. Jack socket for remote tremolo switching. Outputs for 3 and 15 ohms speakers. Valves used in the 30 watt amplifier ECC83, ECC83, EL34, EL34, GZ34. In the 15 watt amplifier ECC83, ECC83, EL34, EL34, E231. An extra valve ECC83 is used in the tremolo circuit. The chassis is complete with base plate and is solidly made of 18 gauge steel, finished silver grey hammer. Size 12 x 8 x 6 1/2 inches high.

PRICES

50 watt with tremolo .....	£20.10.0
50 watt less tremolo .....	£19.10.0
30 watt with tremolo .....	£15.10.0
30 watt less tremolo .....	£14.10.0
15 watt with tremolo .....	£12.10.0
15 watt less tremolo .....	£11.10.0

Add carriage 10/- any amplifier. Send S.A.E. for Descriptive Leaflet.  
**CREDIT TERMS ARRANGED** Export Inquiries invited.

## STROUD AUDIO

CASHES GREEN ROAD, STROUD, GLOS.



**SAVBIT. ALLOY**  
*saves wear on soldering iron bits*

The world-famous copper loaded alloy containing 5 cores of non-corrosive flux, that saves the soldering iron bit. ERSIN Multicore Solder is also available in high tin quality alloys. 60/40 in 22 s.w.g. for printed circuits, transistors, etc.

### SAVBIT SIZE 1 CARTON

Contains approximately 30 feet of 18 s.w.g. SAVBIT. It is also supplied in 14 s.w.g. and 16 s.w.g. Obtainable from radio and electrical stores.



5/- each

### THE HANDY DISPENSER



Easy to find in the tool box—simple to use. Virtually a third hand for tricky soldering jobs. 12 feet 5-core 18 s.w.g. ERSIN MULTICORE SAVBIT alloy in a continuous coil used direct from free-standing dispenser. **2/6 each**

### BIB WIRE STRIPPER AND CUTTER



Strips insulation without nicking wire, cuts wire cleanly, adjustable to most thicknesses. Splits extruded plastic twin flex. **3/6 each**

### MULTICORE SOLDERS LTD.

MULTICORE WORKS · HEMEL HEMPSTEAD · HERTS.  
 Hemel Hempstead 3636

CMMS 24a

## TRANSISTOR ELECTRONIC ORGANS FOR THE AMATEUR

This book presents not only a detailed design for a full scale organ, but a complete explanation of everything to do with transistorised organs. Profusely illustrated with clear diagrams.

By A. Douglas & S. Astley

18/- Postage 1/-

**AMATEUR RADIO MOBILE HANDBOOK**, by C. Caringella.

24/- Postage 1/-

**SOLAR CELL & PHOTOCCELL**

Experimenters Guide, by S. Hoberman. 24/- Postage 1/-

**THE AMATEUR RADIO HANDBOOK**, an R.S.G.B. Pub. 34/-

Postage 2/6

**BASIC THEORY & APPLICATION OF TRANSISTORS**. U.S. Dept.

Army 10/- Postage 1/-

**TRANSISTOR IGNITION SYSTEMS HANDBOOK**, by B. Ward.

20/- Postage 1/-

**HANDBOOK OF LINE COMMUNICATION**, Vol. 1. R. Signals.

HMSO. 30/- Postage 2/6

**COMPLETE CATALOGUE 1/-**

BRITAIN'S LARGEST STOCKISTS of British and American Technical Books

## THE MODERN BOOK CO.

19-21 PRAED STREET LONDON, W.2

Phone: PADdington 4185  
 Open 6 days 9-6 p.m.

### RECORDING TAPE: All Brand New and Boxed. Excellent quality.

Double Play	2400 ft. 34/6d.
7" Long Play	1800 ft. 21/6d.
5 1/2" Double Play	1800 ft. 24/-
5 1/2" Long Play	1200 ft. 16/6
5" Standard Play	600 ft. 11/8d.

plus many others.

**LOUDSPEAKERS:** New—Top quality  
 2" x 8 ohms 9/6d. 2 1/2" x 8 ohms 9/6d.  
 2 1/2" x 3 ohms 15/6d. 3" x 3 ohms 15/9d.  
 3 1/2" x 35 ohms 19/3d. 5" x 35 ohms 22/6d.  
 8" x 3 ohms 28/3d. 10" x 3 ohms 32/6d.  
 FANE 12" x 15 ohms (20 Watt) 5 GNS.

**CHASSIS**—made to your specification. Standard stock sizes available.

**EAR PIECES:** Vast range from 4/11d. to 10/6d. to suit all transistors.

**TEST METERS** Panel to multimeters at very keen prices. An excellent "all-rounder" is the Multimeter—20 Kohm/volt £4.19.6d.

**AND HERE'S A SNIP!** 300 x 100 x 100 x 16 MFD. 350 VOLT WKG. CAPACITORS AT ONLY 5/8d.

Give yourself the treat you deserve—call at our shop, see our qualified staff and discuss your electronic problems, no matter how simple or complex—we'll do our best to help.

Also you can use our postal service or telephone 80U 2904



**BOTHWELL ELECTRIC SUPPLIES (Glasgow) LTD.**  
 54 EGLINTON STREET GLASGOW C.5.  
 Member of the Lander Group

## BBC2 (625 LINE) TV AERIALS



**Mast Mounting Arrays**, 9 element 45/-; wide spaced high gain, 11 element 55/-; 14 element 62/6. **Wall Mounting** with Cranked Arm 9 element 60/-; wide spaced, high gain, 11 element 67/6; 14 element 75/-; Chimney Arrays Complete, 9 element 72/-; wide spaced high gain, 11 element 80/-; 14 element 87/6. **Loft Arrays**, 7 element 32/6; wide spaced high gain, 11 element with Tilting Arm, 62/6; 14 element 70/-; All high gain units have special Multi-rod Reflector. Low loss Co-axial cable 1/6 per yard. VHF transistor pre-amps from 75/-.

## BBC · ITV · F.M. AERIALS



**B.B.C. (Band 1)**. Telescopic loft 21/-. External S/D 30/-  
**I.T.V. (Band 3)**. 3 Element loft array 25/-, 5 element 35/-, Wallmounting, 3 element 35/-, 5 element 45/-  
**Combined B.B.C./I.T.V.** Loft 1+3, 41/3; 1+5 48/9; Wall mounting 1+3 56/3; 1+5, 63/9; Chimney 1+3, 63/9; 1+5, 71/3.  
**VHF transistor pre-amps** from 75/-

**F.M. (Band 2)**. Loft S/D 12/6. "H" 30/-, 3 element, 52/6. External units available Co-ax cable 5d. yrd. Co-ax plugs. 1/3. Quiet boxes 4/6. Diplexer Crossover Boxes. 12/6. C.W.O. or C.O.D. P. & P. 3/6. Send 6d. stamps for illustrated lists.

**K.V.A. ELECTRONICS (Dept P.W.)**  
 3b Godstone Road, Kenley, Surrey  
 CRO 2527



**Inexpensive books for all enthusiasts...**

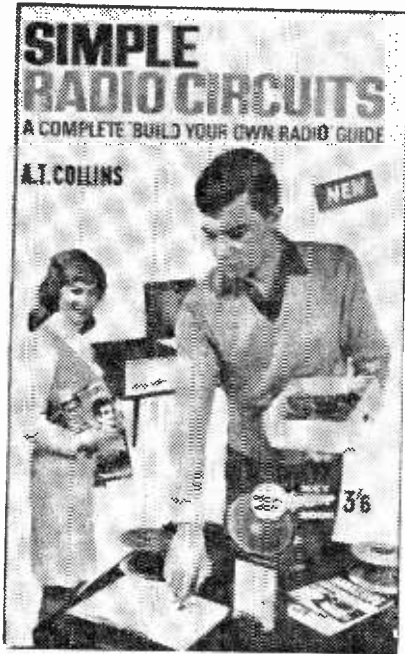

*Each 96 pages. Extensively illustrated with easy-to-follow diagrams.*

**—KEY BOOK—  
—paperbacks—  
SIMPLE  
RADIO CIRCUITS**

by A. T. Collins

A Complete 'Build Your Own Radio' Guide. Simple Mains Short Wave Receiver, Medium Wave Transistor Receiver, Dual Wave One-valver, Broadcast Bands Receiver, Two-valve Short Wave, Amateur Bands Hybrid, Transistor Superhet Tuner, Battery-operated Short Wave Converter, Five-transistor T.R.F. Receiver. Four-valve Superhet Portable. **With 55 diagrams 3s 6d**

**HI-FI  
AND AUDIO**

by A. T. Collins

Modern Designs for the Amateur Constructor. High Sensitivity Amplifier, Two-valve Pre-amp and Equaliser, Mains Gramophone Amplifier, Output Transformers and Loudspeakers, Crossover Networks for Loudspeakers, Seven-watt Quality Amplifier, Five valve Stereo Amplifier, Design for a Bass Reflex Cabinet, Radiogram Cabinet Design, etc.

**With 51 diagrams 3s 6d**

**Only 3s 6d each**

FROM ALL BOOKSELLERS, including all branches of W. H. Smith, Wymans, Menzies, and Boots or in case of difficulty use this handy order form below . . .



order here

Please send me the following KEY BOOKS:—

.....SIMPLE RADIO CIRCUITS  
.....HI FI AND AUDIO

3s 6d each (4s by post)

**ORDER  
NOW**

Name .....

Address .....

Simply send this form with your remittance of 4s each title to George Newnes Ltd., Tower House, Southampton Street, London, WC2. P.W. 9.65

NEWNES

Head Office and Warehouse:
44A WESTBOURNE GROVE
LONDON W2
Tel.: PARK 6641/2/3

Z & I AERO SERVICES LTD.

Please send all correspondence and Mail Orders to the Head Office
When sending cash with order, please include 2/6 in £ for postage and handling
MINIMUM CHARGE 2/- No C.O.D. orders accepted

Retail Shop:
85 TOTENHAM COURT ROAD
LONDON W1
Tel.: LANgham 8403
Please write for Catalogue of
valves and semiconductor

Table listing various electronic components such as vacuum tubes (6A2, 6X4, etc.), semiconductor diodes, and rectifiers, including their types, quantities, and prices.



FIVE ACES!

This is a hand that can't be beaten. Five models from our tremendous range of soldering instruments. Superb performance. Amazingly compact. Developed to simplify YOUR soldering. Copper bits for greatest speed. Permatip bits for long life. May we deal you in?

Brochure P.W.10 post free on request
LIGHT SOLDERING DEVELOPMENTS LTD., 28, Sydenham Road, Croydon, Surrey
Telephone: CROydon 8589

# PRACTICAL WIRELESS

## blueprints

Send (preferably) a postal order to cover the cost of the Blueprint (stamps over 6d. unacceptable) to PRACTICAL WIRELESS, Blueprint Dept., George Newnes, Ltd., Tower House, Southampton Street, London W.C.2.

### DOUBLE-FEATURE BLUEPRINTS

The Strand Amplifier ... ..	}	5/-
The PW Signal Generator ... ..		
The Savoy VHF Tuner ... ..	}	5/-
The Mayfair Pre-amplifier ... ..		
The Berkeley Loudspeaker Enclosure	}	5/-
The Luxembourg Tuner ... ..		
The PW Troubadour ... ..	}	7/6
The PW Everest Tuner ... ..		
The PW Britannic Two ... ..	}	6/-
The PW Mercury Six ... ..		
Beginner's Short Wave Two ... ..	}	5/-
S.W. Listener's Guide ... ..		
Beginner's 10-watt Transmitter	}	5/-
Transmitting and Aerial Data... ..		
P.W. "Sixteen" Multirange Meter ...	}	5/-
Test Meter Applications Chart ...		
The Celeste 7-transistor Portable Radio	}	5/-
The Spinette Record Player ... ..		
Transistor Radio Mains Unit ... ..	}	5/-
7 Mc/s Transceiver ... ..		

### SINGLE-FEATURE BLUEPRINTS

The Tutor ... ..	3/-
The Citizen ... ..	5/-
The PW Pocket Superhet ... ..	5/-
The P.W. 35-watt Guitar Amplifier ...	5/-
The Mini-amp ... ..	5/-
The PT Multimeter ... ..	5/-
The Autocrat Car Radio ... ..	5/-
The Beginner's Short Wave Superhet ...	5/-
The Empire 7 Three-band Receiver ... ..	5/-
Electronic Hawaiian Guitar ... ..	5/-

**PLEASE NOTE** that we can supply no blueprints other than those shown in the above list. Nor are we able to supply service sheets for commercial radio, TV or audio equipment.

## QUERY SERVICE

The P.W. Query Service is designed primarily to answer queries on articles published in the magazine and to deal with problems which cannot easily be solved by reference to standard text books. In order to prevent unnecessary disappointment, prospective users of the service should note that:

(a) We cannot undertake to design equipment or to supply wiring diagrams or circuits, to individual requirements.

(b) We cannot undertake to supply detailed information for converting war surplus equipment, or to supply circuitry.

(c) It is usually impossible to supply information on imported domestic equipment owing to the lack of details available.

(d) We regret we are unable to answer technical queries over the telephone.

(e) It helps us if queries are clear and concise.

**(f) We cannot guarantee to answer any query not accompanied by the current query coupon and a stamped addressed envelope.**

### QUERY COUPON

This coupon is available until 9th September, 1965 and must accompany all queries in accordance with the rules of our Query Service.

PRACTICAL WIRELESS, SEPTEMBER, 1965

### ● MW LW POCKET SUPERHET RADIO TO BUILD



- ★ 6-transistor plus diode.
- ★ Push-pull speaker output.
- ★ Easy printed circuit.
- ★ Slow geared tuning.
- ★ Full MED and long waves.
- ★ Moulded cabinet 5 x 3 x 1 1/2 in.

TOTAL COST TO BUILD **85/-**

P.P. 2/- (Battery 2/6, Phone 5/-)  
Amazing sensitivity and selectivity.

### ● TWO WAVEBAND ALL TRANSISTOR CAR RADIO TO ASSEMBLE



TOTAL COST TO BUILD **£8.19.6**

P.P. 3/6.

- ★ Supplied as factory built assemblies—just interconnect.
- ★ 6-transistor push-pull design—double tuned IFT'S.
- ★ Push-button wavechange—full tuning range.
- ★ Size 7 x 4 x 2 in.—fits any car—chromed front dial.
- ★ Units available separately.
- ★ Guaranteed high performance and quality.

### ● TWO AND FOUR TRACK PORTABLE TAPE RECORDERS TO ASSEMBLE

Prebuilt equipment—6 valves—Collaro studio decks—portable cabinets—8 x 5 in. speakers. Complete recording and playback.



- ★ Two track deck 10 gns. P.P. 5/-.
- ★ Amplifier 11 gns. P.P. 3/6.
- ★ Cabinet with speaker, 5 gns. P.P. 3/6.

or **SPECIAL PRICE £26**

P.P. 8/6 **TWO TRACK**

- ★ Four Track dec £13.19.6. P.P. 5/-.
- ★ Amplifier 12 gns. P.P. 3/6.
- ★ Cabinet and speaker 5 gns. P.P. 3/6.

or **SPECIAL PRICE £30** P.P. 8/6 **FOUR TRACK**

### ● VHF FM TUNER TO BUILD



- ★ 5-transistors, 4-diodes.
- ★ Printed circuit superhet.
- ★ Tuning range 87 to 105 Mc's.
- ★ RF stage and double tuned IFT'S—9 volt 9 mA operated.

★ All parts sold separately.

★ Output up to 1 volt.

★ Size 4 x 3 1/2 x 2 1/2 in.

P.P. 2/6 (complete with front panel)

★ Cabinet Assembly 20/- extra.

TOTAL COST TO BUILD **£6.19.6**

### ● 4 WATT AND 1 1/2 WATT PACKAGE AMPLIFIERS



- ★ 6-transistor push-pull printed circuit designs.

★ Peak output 8 watt and 3 watt.

★ Size only 2 1/2 x 2 x 1 1/2 in.

★ 4 watt, 12 18 volt; 1 1/2 watt, 9 12 volt.

★ Output for 3 to 5 ohm speakers.

★ 7 mV into 1 Kohm, 40 cs to 15 kc/s.

PRICES 1 1/2 WATT BUILT **65/-** P.P. 1/6      4 WATT **79/6** P.P. 1/6

### ● VHF FM TUNER TO ASSEMBLE

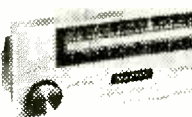

- ★ Supplied as prebuilt and aligned units plus metal work just interconnect.

★ 88 to 108 Mc/s. FM tuning.

★ 100 mV to 100 Kohm output.

★ 6-transistor, printed circuit, Superhet design.

★ Size 9 1/2 x 3 1/2 x 4 in.

(All units available separately).

P.P. 2/6

TOTAL COST TO BUILD **£12.17.6**

## PROVED and TESTED DESIGNS

FULL AFTER SALES SERVICE AND GUARANTEE  
UNBEATABLE FOR PERFORMANCE AND VALUE  
★ DETAILED LEAFLETS FREE ON REQUEST ★

### CATALOGUE

Fully detailed and illustrated catalogue. Now 96 pages. All types of components and equipment at competitive prices. Price 2/6 post paid.

FREE! New 8 page book with details of over 80 projects, available from stock. Uses transistors, light cells, scr's, etc., etc. Ask for your FREE copy.

### NEW! "GLOBEMASTER"

- ★ SHORT WAVES
- ★ MEDIUM AND LONG WAVES

The only FULLY tunable 3-Waveband Radio available to the Home Constructor. Printed circuit. 1 watt output. Geared tuner. Car aerial socket with special circuits. Push-button unit. 6-transistor high gain superhet design. Size 11 x 7 1/2 x 3 1/2 in. Case fabric covered with chromed front and fittings. All parts sold separately and fully guaranteed



TOTAL COST TO BUILD **£8.19.6** P.P. 3/6.  
★ "CONVAIR" as previously advertised. Two Waveband Portable to Build, still available. Total Cost **£7.19.6** P.P. 2/6.

### 10 WATT AND 20 WATT AMPLIFIERS

- ALL TRANSISTOR PRE-BUILT AND TESTED UNITS

Units 1 and 2

- ★ POWER AMPLIFIERS

10 watts RMS music power output. 20 watts peak. 6-transistor designs. Response 40 cs to 20 kc/s. 100 mV sensitivity.

Unit 1. For 12 15 ohm speakers, 40 volt supply.

PRICE BUILT **£5.19.6** P.P. 2/6

Unit 2. For 3 to 5 ohms. 24 volt.

PRICE BUILT **£5.10.0** P.P. 2/6

(Mains units Mono 59/6 Stereo 69/6)

- ★ PREAMPLIFIERS—MONO AND STEREO VERSIONS.

8 inputs. 1 1/2 mV to 300 mV at 1K to 500 Kohm. Response 30 cs to 20 kc/s. Complete range of controls.

Unit 3. Mono full function preamplifier.

Size 9 1/2 x 2 1/2 x 2 in.

(Brown/Gold front panel, 8/6).

Unit 4. Simplified version of Unit 3. Price built 65/-, P.P. 1/6.

Unit 5. Stereo preamplifier for use with two power amplifiers.

Size 9 x 3 1/2 x 3 1/2 in. PRICE BUILT **£10.19.6** P.P. 3/6. (Brown/Gold panel 12/6)



- LOW NOISE—LOW DISTORTION QUALITY DESIGNS—Enables complete Mono or Stereo equipment to be assembled at a fraction of the cost of a commercial comparable design. Simple to interconnect, outstanding quality.

SINCLAIR. Micro-6, 59/6; X10 Kit, £5.19.6; X10 built, £6.19.6; X20 Kit, £7.19.6; X20 built, £9.19.6.

**HENRY'S RADIO LTD.**  
303 EDGWARE RD., LONDON W2

Open Mon. to Sat. 9-6  
Thurs. 1 p.m.

PADDINGTON 1008 9

Open all day Saturday

Let us quote for Parts for your circuit. Send a list for quick reply.