

# AN ANTI-INTERFERENCE AERIAL

# PRACTICAL 13

# WIRELESS

FEBRUARY  
1959

EDITOR: E.J. GAMM



## CONTENTS

PUSH-BUTTON MULT METER  
MATCHING TAPE RECORDERS  
SERVICING RADIO RECEIVERS  
CONTROL OF STEREO BALANCE  
REFLEXING SUPERHETS  
BASIC THEORY FOR CONSTRUCTORS  
Etc. Etc. Etc.

# For maximum reliability

## 'LECTROPACK'

### ETCHED FOIL ELECTROLYTICS

The Constructor depends upon the reliability of the components he uses. The fact that so many designers specify T.C.C. Condensers is evidence of their supremacy.

T.C.C. "Lectropack" Dry Electrolytic Condensers are robust yet compact and employ ALL-ALUMINIUM non-corrosive internal construction. The range below is a useful guide to the types available.

Capacity $\mu$ F.	D.C. Volts		Ripple Current Max. M/A	Dimensions in inches		T.C.C. Type No.	List Price
	Wkg.	Surge		L	D		
60 - 100	275	325	450	4 1/2	1 1/2	CE 37 HE	16/-
60 - 250	"	"	530	4 1/2	1 1/2	CE 60 HE	28/-
100 - 200	"	"	650	4 1/2	1 1/2	CE 60 HEA	28/-
100	350	400	450	2 1/2	1 1/2	CE 10 LE	13/6
200	"	"	770	4 1/2	1 1/2	CE 36 LE	24/-
60 - 100	"	"	500	4 1/2	1 1/2	CE 36 LEB	23/-
60 - 250	"	"	500	4 1/2	1 1/2	CE 60 LEB	34/-
100 - 100	"	"	550	4 1/2	1 1/2	CE 36 LEA	26/-
100 - 200	"	"	700	4 1/2	1 1/2	CE 60 LEA	33/-
60	450	550	450	3 1/2	1 1/2	CE 38 PE	14/-
60 - 100	"	"	500	4 1/2	1 1/2	CE 60 PE	29/-



List 140c contains the extended range.



## THE TELEGRAPH CONDENSER CO. LTD

RADIO DIVISION : NORTH ACTON · LONDON · W3 · Telephone : ACOrn 0061

## THE NEW



# STENTEREO

## STEREOPHONIC SPEAKER SYSTEM

(Pat. App. 33293/58)

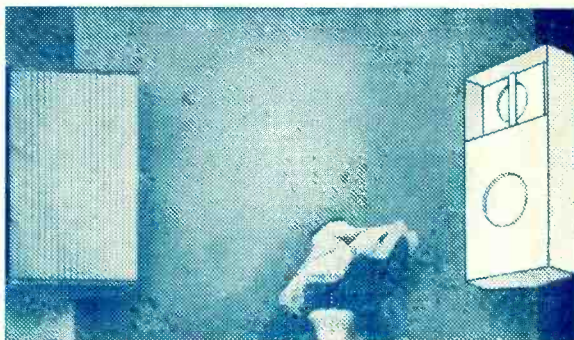

### Corner Cabinet £7.10.0

Plinth for floor mounting 17/- extra.

### H.F.810 and H.F.812

These are both 8" Units, with a handling capacity of 5 watts. Frequency response, 50 c.p.s. to 13,000 c.p.s. Bass resonance, 45 c.p.s.

H.F.810 incorporates a 10,000 gauss magnet and has a steel chassis. £3.2.0 (inc. P.T.).

H.F.812 incorporates a 12,000 gauss magnet, is fitted with cambric cone and universal impedance speech coil, and has a die-cast chassis. £4.3.6 (inc. P.T.).

S.510 is a 5" unit, with a 10,000 gauss magnet. £2.2.0 (inc. P.T.).

CX.1500 Crossover Unit. £1.18.3.

This consists of two corner loudspeaker enclosures, each divided into two sections, the lower taking the form of an infinite baffle. Into this may be fitted a W.B. Stenterion speaker, H.F.810 or H.F.812, to provide the lower and part of the middle register of sound.

For the upper and remainder of the middle register a W.B. S.510 is used and the two units are coupled by a crossover unit.

The high frequency spectrum tends to be directional, and provision is made in the upper section for rotating the baffle to give the best stereo effect.

WHITELEY ELECTRICAL RADIO CO. LTD.  
MANSFIELD · NOTTS.



# QUICK, EFFICIENT UP-TO-DATE COMPONENT SERVICE!

### TWO-TRANSISTOR POCKET SET

Can Be Built For **47/6**



**BUILD THE "SKY PIXIE" VEST-POCKET TWO-TRANSISTOR PLUS DIODE RADIO** which gives a superb performance and is highly sensitive. Size only 4 1/4 in. x 3 1/4 in. x 1 in., weight under 7oz.—yet it is a **THREE-STAGE** receiver covering all medium waves, working entirely off a tiny "pen-light" battery. Every part tested before despatch! **SPECIAL STEP-BY-STEP PLANS FOR ABSOLUTE BEGINNERS.** Total building cost including case, transistors, etc.—only 47/6 with plans. Postage, etc. 2/- C.O.D. 2/- extra. (Parts sold separately. Priced parts list and plans 1/6.) **RUSH YOUR ORDER TODAY!**

### POCKET VALVE RADIO

Can Be Built For **37/6**

Anyone Can Build This Beautiful Precision Pocket Radio In One Hour. No knowledge whatever needed, our Simple, Pictorial Plans take you step by step! You can't go wrong. Remarkably sensitive—covers all medium waves, incl. Luxembourg, Home, Light, size only 2 1/2 in. x 3 in. x 5 1/2 in. **Not a Toy! But a Real Valve Radio!** Uses self-contained battery and is a really personal-phone, pocket radio with Detachable Rod Aerial. **IDEAL FOR BEDROOM, GARDEN, etc.** We can supply all the parts necessary, including Case, Screws, Gas, Step-by-Step Plans—in fact everything for the Special Price of 37/6. (Plus 2/6 post, etc.) **BUILD YOURS NOW!** (All parts sold separately.) Priced parts list, etc., 1/6. **Big demand certain—Send Today!** C.O.D. 2/- extra.



## RECORD CHANGER AND PLAYER BARGAINS!

**B.S.R. MONARCH**, 4-speed, mixer auto-changer unit, model H.A.S. Fully complete with crystal pickup, etc. Brand new—Limited Stocks Only. **GIFT 25/10 6.** (Plus post and packing, 5/-) **LATEST "COLLARO"** 4-speed auto-changer, with Hi-Fi, pickup. Complete in maker's sealed cartons. **BARGAIN 27/10 6.** (Plus post and packing 4/6) **"COLLARO" JUNIOR**, 4-speed, single player, with crystal pickup, using Hi-Fi 150 cartridge. **OUR PRICE 92 6.** (Plus 4/- post and packing.)

Choice of beautiful walnut veneered cabinet or Ivory or brown bakelite. This is the lowest possible price consistent with high quality. No radio knowledge whatever needed... can be built by anyone in 2-3 hours, using our very simple easy-to-follow diagrams. The terrific new circuit of the **"OCEAN-HOPPER"** covers all medium and long waves, has razor-edge selectivity and exceptionally good tone. Price also includes ready drilled and punched chassis, set of simple easy-to-follow plans—in fact, everything! **Parts tested before despatch!** (Use standard octal-base valves. For A.C. mains 200-250 volts size 12 in. x 6 in. x 5 in. Build this long-range powerful midset NOW. **TOTAL BUILDING COST INCLUDING PLANS, ETC., 25/7 6.** (Post and packing 3/6.) Parts sold separately. Priced parts list and plans 1/6. C.O.D. 2/- extra.

Can Be Built For **107/6**



## COMPONENT BARGAINS!

Red-Spot Transistors, tested, 8/6. White-Spot Transistors, tested, 15/- . Also all Mullard and standard types stocked.

Moving Coil P.M. Speakers, 2 in., 17/6; 3 1/2 in., 19/6; 5 in., 17 6; 8 in., 19 6.

**ALL TYPES OF COMPONENTS STOCKED AT COMPETITIVE PRICES**

### PRINTED CIRCUIT POCKET SET

**BUILD THIS 3 TRANSISTOR POCKET RADIO... PRINTED CIRCUIT VERSION:** The "Companion" is comparable in sensitivity to a three-valve battery set. It is exceptionally small in size (4 1/4 in. x 2 in. x 1 1/2 in.) and is a self-contained pocket radio that does not need aerial or earth. It has built-in speaker and covers medium and long waves. This unique little set **CAN BE BUILT FOR ONLY 97 6.** **EVERYTHING INCLUDED!** (Plus post and packing 2/6.) All parts sold separately. Price list, etc., 1/6. C.O.D. 2/- extra.

### PRINTED CIRCUIT POCKET SUPERHET

**BUILD THIS PROFESSIONAL-LOOKING, FIRST-CLASS 8 TRANSISTOR POCKET SUPERHET THE "TRANSIDYNE."** Size only 6 1/2 in. x 3 1/2 in. x 1 1/2 in. Beautiful red and cream plastic case with engraved dial. Set weighs only 26oz. with batteries! Covers medium and long waves. Works off two No. 8 batteries. The second I.F. Stage is reflexed to give additional audio gain. In-built ferrite rod aerial and 2 1/2 in. P.M. speaker. This **TRANSIDYNE** is probably the best yet of its kind, it is simple to build and really sensitive. **ALL COMPONENTS INCLUDING CABINET, PRINTED CIRCUIT, TRANSISTORS—IN FACT EVERYTHING CAN BE SUPPLIED FOR 211,15/-.** (Plus post and packing 2/6.) (All parts sold separately. Price list, circuit, etc., 1/6.) C.O.D. 2/- extra.

**CAN BE BUILT FOR 47/6**

Build this exceptionally sensitive high efficiency Pentode radio. Use unique assembly system and can be built by anyone without any radio knowledge whatever in 45 minutes. Handsome black-crackle steel case with specially made black and gold dial with stations printed. Size of radio only 6 1/4 in. x 6 in. x 3 in. Covers all Medium and Long waves—uses only one all-dry battery. H.T. consumption only 1 to 1.5 m.A. Uses personal phone. Ideal for Bedroom, Garden, Holidays, etc. **BUILD THE "SKYROMA" NOW!** Total building cost everything down to last nut and bolt—47 6 (Postage etc., 2/-)—with full set of clear, easy-to-follow plans. (Parts sold separately. Priced Parts Lists & Plans 1/6.) C.O.D. 2/- extra.

### READ WHAT OTHERS SAY!

"I WAS SURPRISED AT THE NUMBER OF STATIONS"  
L. D. C., of Worcester, writes, "—Just a few lines to let you know how pleased I am with the midset portable radio. I was surprised at the number of stations I could get, with a clear performance. The price was a real bargain. Have you lists of other bargains? If so, please send them."

"I MUST SAY I AM VERY PLEASSED..."  
J. W. S., of Scarborough, Yorks, writes, "—I feel I must say I am very pleased in the way you do business and it at any time I require anything, or can recommend you to anyone, I will not hesitate to help you."

"I'VE HEARD MUCH PRAISE OF THEM..."  
J. E., of Hilton, Nr. Derby, writes, "—I should like one of your portable radio kits as I've heard much praise of them."

"THIRTY-TWO STATIONS RECEIVED..."  
J. N., of Oxford, writes, "—Yesterday evening on the Medium Waveband, between 10 p.m. and 10.20 p.m., I counted 32 distinguishable stations! I am very pleased with the set, which is well worth the money."

"MY DEEPEST ADMIRATION..."  
J. B., of North Shields, Northumberland, writes, "—The honest and direct dealing of your firm has earned from me my deepest admiration."

"ITS PERFORMANCE IS ALMOST UNBELIEVABLE..."  
E. P., of Ipswich, writes, "—For so small a set I think it is a wonderful station getter with ample volume on all. Its performance is almost unbelievable, and it is very convenient little set giving me stations I've never been able to get on a larger set."

### THIS TRANSISTOR SET

**CAN BE BUILT FOR ONLY 29/6**

**VERY SPECIAL OFFER WHILE STOCK OF PARTS LASTS!**—The "Sky-Scout" Pocket two-stage transistor set, size only 1 1/2 in. x 3 1/4 in. x 4 1/4 in. Covers all medium waves and works entirely off tiny "penlight" battery which costs 6d. and fits inside case. All parts tested before despatch. Can be built for 29 6, plus 2/- post and packing, including case, Transistor. **STEP-BY-STEP PLANS FOR ABSOLUTE BEGINNERS.** nuts, bolts, etc. C.O.D. 2/- extra. Parts sold separately, priced parts list & Plans 1/6. **VERY SIMPLE TO BUILD**

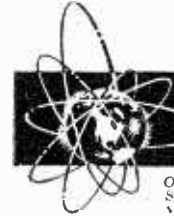

# CONCORD ELECTRONICS

69, PRESTON STREET, BRIGHTON

Dept. PW4

Orders receive prompt attention. Cheques accepted. Cash on delivery 2/- extra. Please print name and address in block letters. Suppliers to Schools, Universities, Government and Research Establishments. Complete range of components and valves stocked. Regret no C.O.D. abroad.

# BENTLEY ACOUSTIC CORPORATION LTD.

THE VALVE SPECIALISTS. 38 CHALCOT ROAD, LONDON, N.W.1. Telephone: PRIMROSE 9090.

EXPRESS SERVICE! C.O.D. ORDERS RECEIVED BY 3.30 P.M., EITHER BY LETTER, PHONE OR WIRE, DESPATCHED THE SAME AFTERNOON, ALL ORDERS RECEIVED BY FIRST POST DESPATCHED SAME DAY.

ANY ORDER UP TO £10 INSURED AGAINST DAMAGE IN TRANSIT FOR ONLY 6d. EXTRA. ORDERS OVER £10 INSURED FREE.

IA3	3/-	6C6	6/6	6X5GT	6/6	20P1	27/10	9006	6/-	DK9E	10/-	EL38	27/10	KTZ63	10/6	PZ30	20/11	UCF80	23/-
IA5	6/-	6C8	12/6	6Z4/84	12/6	20P3	24/4	AC/PEN	DL2	15/-	EL41	11/-	L63	6/-	QF21	7/-	UCH21	24/4	
IC5	12/6	6C9	12/6	6Z5	12/6	20P4	27/10	5 & 7	DL33	9/6	EL42	11/6	LN152	14/-	QF25	15/6	UCH42	11/4	
ID5	17/5	6C10	12/6	6J30L2	10/-	20P5	24/4	AC2PEN	DL66	15/-	EL81	15/-	LZ319	9/-	QS150	15/6	UCH81	11/6	
ID6	10/6	6CD6G	31/4	7A7	12/6	25A6G	20/2	24/4	DL92	7/6	EL84	10/6	MH4	7/-	10/6	UCL82	15/6	UCL83	25/9
IH5GT	11/-	6CH6	12/6	7B7	8/6	25L6GT	10/-	AC2PEN	DL94	9/-	EL91	5/-	MHD4	25/9	QV047	15/-	UF41	9/-	
IL4	6/6	6D3	20/11	7C5	8/-	25Y5	10/6	DD	DL96	10/-	EL95	10/6	MHL4	7/6	R2	10/6	UF42	19/6	
ILD5	5/-	6D6	6/6	7C6	8/-	25Y5G	10/-	AC4PEN	DLS10	10/6	EM34	10/6	MHLD6	12/6	R12	12/6	UF80	10/6	
ILN5	5/-	6E5	12/6	7D5	24/4	25Z5	10/6	27/10	DM70	8/6	EM71	10/6	ML6	6/6	R19	25/11	UF85	10/6	
INS5GT	11/-	6F1	27/10	7H7	8/-	25Z4G	10/-	AC5PEN	EA50	2/-	EM80	10/6	MPT4	5 (5 or	SD6	12/7	UF86	24/4	
IR5	8/-	6F6G	7/-	7S7	10/6	25Z6G	10/-	AC5PEN	EA76	9/6	EM81	10/6	MPT4	5 (5 or	SP4(7)	15/-	UF89	10/6	
ISS	8/-	6F6GTM	8/-	7V7	8/6	25Z6GT	10/-	AC5PEN	EABCB80	9/6	EN31	34/9	7 pin	24/4	SP4	3/6	UL41	10/6	
IT4	6/6	6F8	12/6	7Y4	8/-	25Z6GT	10/-	17/5	DD	27/10	EAC91	7/6	EY51 (Small)	MU14	10/-	SP41	3/6	UL44	27/10
IU5	10/-	6F11	18/1	8D2	3/6	27S10	20/11	AC6PEN	EAF42	10/6	EAF2	10/6	MX40	27/10	SP42	12/6	UL44	27/10	
2A7	10/6	6F12	7/6	8D3	7/6	28D7	7/-	AC/H/L	EBA3	2/6	EY51 (Large)	N37	20/11	SP61	3/6	UL46	15/6		
2C26	4/-	6F13	12/6	9D2	4/-	30C1	9/-	DDD	EB41	8/6	12/6	N108	19/6	SU25	27/10	UL84	11/6		
2D13C	7/6	6F14	27/10	10C1	15/-	30C5	8/-	AC/P4	EB91	6/6	EY83	17/5	N308	21/7	SU61	10/6	UM4	18/1	
2P	27/10	6F15	16/6	10C2	27/10	30FL1	10/-	AC/TP	EB43	10/6	EY86	14/6	OA70	5/-	T41	24/4	URIC	17/5	
2X2	4/6	6F16	9/6	10F1	19/6	30L1	9/-	AC/VPI	EBCC31	10/6	EZ35	6/6	OA71	6/-	TDD4	25/9	UJ6	20/11	
3A4	7/-	6F17	12/6	10F9	11/6	30P12	12/6	15/-	EYF80	10/-	EZ40	8/-	OB2	17/6	TDD13C	UJ8	27/10	UYIN	17/5
3A5	12/6	6F32	10/6	10F18	12/6	30P16	10/-	AC/VP2	EBL21	24/4	EZ80	9/6	OC72	30/-	TH47	27/10	UY21	17/1	
3B7	12/6	6F33	7/6	10LD3	6/6	30PL1	12/6	27/10	EBL31	24/4	EZ81	9/-	OZ4	6/-	TH41	27/10	UY41	8/6	
3D6	5/-	6G6	6/6	10LD11	16/9	31	7/6	AL60	AP4	7/6	EC52	5/6	FC2A	25/9	P61	3/6	TH233	34/9	
3Q4	7/6	6H6GTG	3/-	10P13	17/6	33A/158M	30/-	ATP4	AP4	7/6	EC54	6/6	FC4	27/10	P215	10/6	TH232	20/-	
3Q5GT	9/6	6H6GTG3	10P14	20/2	30/-	ATP4	5/-	EC55	AP4	7/6	EC55	6/6	FC4	27/10	P215	10/6	TH232	20/-	
3S4	7/6	6J5G	5/-	11D3	25/9	35S51	12/6	AZI	AP4	7/6	EC70	12/6	FC13	27/10	PABC80	15/-	TP22	15/-	
3V4	9/6	6J5GTG	5/6	11E3	15/-	35A5	11/6	AZ31	10/6	EC331	15/-	FC13C	27/10	15/-	TP25	27/10	VMP4G	15/-	
5R4GY	17/6	6J5GTM	6/-	12A6	6/6	35L6GT	9/6	AZ41	14/8	EC332	10/6	FW4/500	PCC84	9/-	TP2620	34/9	VP2(7)	12/6	
5U4G	8/6	6I6	5/6	12AH7	8/-	35V4	8/6	B36	25/9	EC333	8/6	10/-	PCC85	12/6	TY86F	20/11	VP4(7)	15/-	
5V4G	11/6	6J7G	6/-	12AH8	10/6	35Z3	10/6	BL63	7/6	EC334	25/9	FW4/800	PCF80	9/-	U16	12/-	VP48	24/4	
5X4G	12/6	6J7GT	10/6	12AT6	10/6	35Z4	7/6	CI	12/6	EC335	8/6	10/-	PCF82	12/6	U18/20	10/-	VP13C	7/6	
5Y3G	8/-	6K6GT	8/-	12AT7	8/-	35Z5GT	9/-	CIC	12/6	EC336	8/-	GZ30	10/6	PCL82	12/6	U22	8/-	VP41	6/6
5Y3GT	8/6	6K7G	5/-	12AU6	24/4	41MTL	8/-	CBL1	27/10	EC337	8/6	GZ32	12/6	PCL83	11/6	U24	31/4	VR105/30	9/-
5Y4	12/6	6K7GT	6/-	12AU7	7/6	42	24/4	CBL31	24/4	EC338	10/-	GZ34	14/-	PEN4DD	U25	24/4	VR150/30	9/-	
5Z3	12/6	6K8G	8/-	12AX7	10/-	43	24/4	CH35	24/4	EC339	10/-	H30	5/-	27/10	U26	14/4	VR150/30	9/-	
5Z4G	10/6	6K8GT/G	12BA6	9/-	50C5	12/6	CK506	6/6	EC339	9/6	H63	12/6	PEN25	20/11	U31	10/-	U33	27/10	
5Z4GT	12/6	11/-	12BE6	10/-	50CD6G	6/6	EC339	5/6	EC339	5/6	HABC80	PEN36C	U33	27/10	U33	27/10	VT61A	5/-	
6A7	27/10	6K25	20/11	12BH7	22/3	31/4	CL33	20/2	ECF80	13/6	13/6	24/4	U35	27/10	U35	27/10	VT501	5/-	
6B8	10/-	6L1	24/4	12C8	15/-	50L6GT	9/6	CV63	10/6	ECF82	13/6	HK90	10/-	PEN40DD	U37	27/10	W61M	27/10	
6AB7	8/-	6L6G	9/6	12E1	30/-	53KU	20/11	CV85	12/6	EC33	27/10	HL133DD	PEN45	25/6	U43	10/6	W76	7/6	
6AB8	14/-	6L7GT	12/6	12J5GT	4/6	72	4/6	CV271	10/6	EC335	9/6	HL23	12/6	PEN45	19/6	U45	10/6	W77	5/6
6AC7	6/6	6L18	13/-	12J7GT	10/6	75	25/9	CV428	30/-	EC335	9/6	HL23	10/6	PEN45DD	27/10	U52	8/6	W107	12/6
6AG5	6/6	6L19	24/4	12K7GT	7/6	77	8/6	CY1	17/5	EC342	9/6	HL23DD	27/10	U52	8/6	W107	12/6		
6AJ8	9/-	6LD20	16/9	12K8GT	14/-	78	8/6	CY31	17/5	EC341	9/6	HL18	18/1	PEN46	7/6	U76	7/6	W279	19/6
6AK5	8/-	6N7	8/-	12Q7GT	7/6	80	9/-	D1	3/-	EC340	12/6	HL41DD	PEN43DD	U107	17/5	X41	27/10		
6AK8	9/-	6P25	24/4	12S47	8/6	83V	12/6	D15	10/6	EC342	12/6	HL41DD	20/2	34/9	U191	20/11	X42	27/10	
6AL5	6/6	6P28	27/10	12S7	8/6	85A2	15/-	D42	10/6	EC343	5/6	EC343	5/6	HL42DD	PEN/DD	U251	15/-	X61	12/6
6AM6	7/6	6Q7G	10/-	12S7G	8/6	150B2	15/-	D63	5/6	EC344	5/6	EC344	5/6	HL42DD	PEN/DD	U202	20/11	X61M	27/10
6AQ5	8/6	6Q7GT	11/-	12S7H	8/6	185B7	34/9	D77	5/6	EF37A	8/-	HN309	25/9	PL33	20/2	U282	23/8	X63	10/6
6AT6	8/6	6R7G	10/-	12S7J	8/6	185B7A	34/9	DAF91	8/-	EF40	15/-	HVR2	20/-	PL36	24/4	U301	24/4	X65	12/6
6AU6	10/6	6SA7GT	8/6	12SK7	8/6	203THA	27/10	DAF96	10/-	EF41	9/6	HVR2A	6/-	PL38	27/10	U329	15/-	X66	12/6
6BH6	9/-	6S7	10/6	12SN7	25/9	27/10	DD41	14/8	EF42	12/6	KF35	8/6	PL81	16/-	U339	20/11	X78	22/3	
6B4G	6/6	6S7GT	8/-	12SQ7	12/6	220P	10/6	DD41	14/8	EF42	12/6	KF35	8/6	PL81	16/-	U404	10/6	X109	18/1
6B7	10/6	6SH7	8/-	12SR7	8/6	220TH	25/9	DDT4	25/9	EF50(A)	7/-	KK32	23/-	PL82	10/6	U801	31/4	XD(1.5)	6/6
6B8G	4/6	6S17	5/-	12T4	10/6	402PENA	DF33	11/-	EF50(E)	5/-	KL35	8/6	PL83	11/6	U801	31/4	XF81	18/-	
6B8GTG	5/-	6SK7GT	8/-	14S7	17/-	24/4	DF41	6/6	EF54	5/-	KT2	5/-	PM2B	12/6	U4020	17/5	UAB80	6/6	
6BA6	7/6	6SL7GT	8/-	15D1	27/10	807	7/6	DF96	10/-	EF73	10/6	KT33C	10/-	PM12	6/6	UAB80	6/6	XF12	6/6
6BE6	7/6	6SN7GT	7/6	18	24/4	956	3/-	DH63	10/-	EF80	8/-	KT36	27/10	PM12M	6/6	10/6	XH(1.5)	6/6	
6BG6G	24/4	6S7GT	8/-	19AQ5	11/-	1203	7/-	DH63(M)	EF85	7/6	KT41	27/10	PX4	34/9	UAF42	10/6	XSG(1.5)	6/6	
6B16	7/6	6S7	8/-	19BG6G	1821	17/5	17/6	EF86	14/6	KT44	15/-	PX25	62/7	UB41	12/6	6/6	6/6	6/6	6/6
6B17	11/6	6U4GT	12/6	24/4	4033L	12/6	DH76	7/6	EF89	10/-	KT61	20/2	PY31	17/5	UBC41	10/-	Y63	7/6	
6B18	9/6	6U5G	7/6	19H1	10/-	5763	12/6	DH77	8/6	EF91	7/6	KT63	7/6	PY32	20/11	UBC81	14/8	Z63	10/6
6B19	8/-	6U7G	8/6	20D1	16/-	7193	5/-	DH107	14/8	EF92	5/6	KTW61	8/-	PY80	8/-	UBF80	9/6	Z66	20/-
6B20	8/-	6V6G	7/6	20D2	27/10	7475	7/6	DK32	23/-	EL32	5/6	KTW62	8/-	PY81	9/-	UBF89	10/6	Z77	7/6
6B21	7/6	6V6GTG	8/-	20F2	27/10	9002	5/6	DK91	8/-	EL33	20/2	KTW63	8/-	PY82	9/-	UBL21	24/4	Z79	8/-
6C4	6/6	6X4	7/-	20L1	27/10	9003	5/6	DK92	10/6	EL34	17/6	KTZ41	8/-	PY83	9/6	UBC85	10/6	Z79	14/-

## NEW METAL RECTIFIERS—FULLY GUARANTEED

DRM-1B	15/4	RM-3	9/6	WX3	3/6	14A100	27/-	14R1-2-8-2	19/-	16R2-2-1-8-1	8/6
DRM-2B	16/2	RM-4	18/-	WX4	3/6	14A124	28/-	14R1-2-8-3	23/6	18R1-1-8-1	4/6
DRM-3B	23/3	RM-5	24/-	WX6	3/6	14A163	38/-	14R1-2-1-16-1	21/-	18R1-1-1-16-1	6/6
RM-0	7/11	W4	3/6	14A86	18/-	14B130	18/-	16R1-1-1-16-1	8/6	18R1-2-8-1	11/-
RM-1	7/-	W6	3/6	14A97	25/-	14B261	11/6	16R2-2-8-1	12/-	18R2-2-8-1	15/-

Technical leaflet on Metal Rectifiers or Hivac Miniature Valves free on receipt of S.A.E.

## ELECTROLYTIC CONDENSERS

**Don't Be Caught Like This**

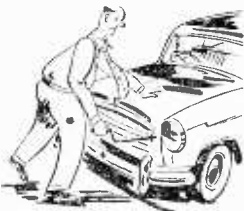

**Car Starter Charger Kit**

All parts to build 6 and 12 volt charger which can be connected to a "flat" battery and will enable the car to be started instantly. Kit comprising the following:

Mains Transformer .....	22 6
6-amp. Rectifier .....	17 6
Regulator Stud Switch .....	3 6
Resistance Wire .....	2/-
Resistance Former .....	2 6
Mains on/off Switch .....	2 6
0.5 amp. Moving Coil Meter .....	12 6
Construction Data .....	1 6

Or if bought all together price is 52 6, plus 3/6 post and packing.

**Hi-Fi Snip  
Infinite Wall Baffles**

Nicely veneered and polished. Corner fitting (attaches to picture rail). Takes up no floor space. Gives really fantastic results with only low-priced 8in. speaker. Fits in for tweeter. Only 45/- each, carriage and insurance 3/6.

**Transistor Timer**

All the parts for making transistorised Enlarging or Process Timer with constructional details. £2 10/-, plus 2/6 post and pkg.

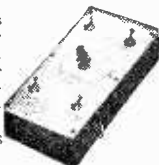

**Instantus Heater**

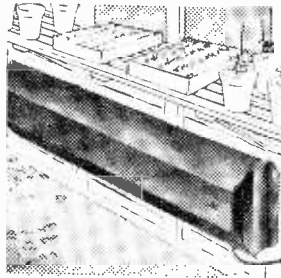

Convector heater. Made from heavy gauge sheet steel (galvanised). For greenhouse, workshop, aviary, etc. 500 watt. £1 12 6; 1,000 watt. £2 10/-; 1,000 watt with wired but separate thermostat. £3 17 6. 2K watt free standing or wall mounting. £3 19 6; 2K watt with built-in thermostat. £4 19 6. Carriage and insurance 5/- per heater. ALL ARE GUARANTEED FOR 5 YEARS.

**Pullin Series 100 Test Set**

Undoubtedly a most useful instrument by a firm long famous for fine instruments, entirely redesigned. It has a square movement with diacon plastic cover this makes for a brighter more readable scale, extra scale length and wide range of vision. With the test set is included a pair of combined test prods and crocodile clips also a stand for inclining the meter at the best reading positions. Range:

A.C. Volts: 0-10, 0-25, 0-101, 0-250, 0-500, 0-1,000, ditto D.C.  
A.C. Current 0-100 mA. D.C. Current 0-2.5, 0-10, 0-100, 0-500 mA.  
Resistance: 0-1M and 0-10K. All at 10,000 ohms per volt. Price £12 7 6, or £1 deposit and 24 fortnightly payments of 10/-, non caller's add 5/- carr. and ins.

**FREE GIFT.**—All purchasers of the above item this month will receive Range Extender scale and data which add: capacity 2pF.—1mFd., in two ranges, inductance 0-100 henrys, etc. etc.



**Medresco  
Hearing Aid**

As supplied by National Health, completely overhauled and in good working order with six months' guarantee. Only £3 15 0, plus 2/6 post and ins. Complete with earphone and new ear plug but not batteries, these can be supplied as an extra for 5/- per set. Superior model—new—higher gain—and self-contained batteries £7 10 0, or 10/- deposit and 15 fortnightly payments of 10/-.



**Stereo Outfit**

Stereo Amplifier outfit comprising 7 watt twin channel amplifier for A.C. mains working and two 8in. P.M. Speakers on veneered and polished corner baffles. Whole outfit giving really terrific reproduction and amazing 3D effects. £14 complete, plus carriage and insurance. Or £1 down and 25 weekly payments of 10/-.

**Famous Transmitter Virtually Given Away**

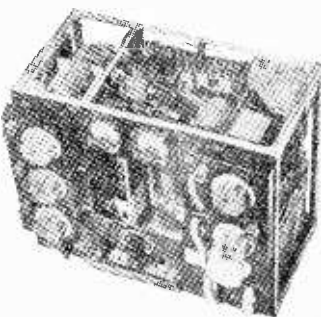

The famous R1151—unused but slightly soiled and not tested. Covers 200-500 kc s.; 2-3.5 Mc s and 5.5-10 Mc s. Has unique "click stop" mechanism (7 stones) and permits selected frequency to be held, returned to, etc. Hartley oscillator, power amplifier, keying and speech. Wonderful breakdown value meters, relays, switches. Complete with valves—real bargain at 29 6, plus 10/- carriage.

**Electronic Precision Eqp't. Ltd.  
FOR ADDRESSES SEE  
PAGES 944 AND 945**

**Fluorescent Lighting**

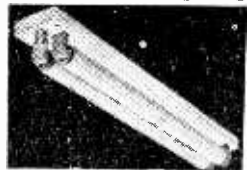

Complete lighting fittings. Built-in ballast and starters—stove enamelled white and ready to work. Ideal kitchen, workshop—anywhere.  
Twin 20 approximately 27in. long complete with two 20W tubes. 39 6.  
Single 40 approximately 4ft. long complete with one 40W tube. 39 6.  
Inductor 85 approximately 5ft. long complete with one 80W tube. 59 6. Carriage and insurance up to 150 miles 5 3, up to 250 miles 7 3

**Novelty Radio**

Completely wired tunable medium and long wave, originally intended for B.G. valves and external batteries but could easily be converted for transistors with internal batteries. Less valves and speaker otherwise complete. 15/-, plus 1/6 postage.



**For Your Lab.**

Resistance substitution boxes are great time savers and you really cannot have too many of them, here then, is an opportunity to acquire these at a very low rate. Our R.S. Kit available for only 8 6, plus 1/3 postage, comprises a 50 W. precision variable resistor 0-100 K., six 2-3 watt fixed resistors, one 6-position switch, one pointer, knob and one ordinary knob and instructions. This unit when made up will give an infinite variability over the range 100 ohm to 2 meg.

**All for less than the price of the cabinet**



Fine walnut veneered, table receiver cabinet complete with metal chassis, three colour glass scale, back plate and scale mounts, as illustrated but less knobs. Offered at less than the price of the cabinet, namely, 39 6, plus 5/- carriage and insurance.

**Speaker Bargain**



12in. Hi-fidelity loudspeaker. High flux. Permanent magnet with standard 3 ohm speech coil. Will handle up to 12 watts. Brand new by famous maker. Price 33 3, plus 3/6 post and insurance.

**A.C./D.C. Multimeter Kit**

Ranges: D.C. volts 0.5, 0.50, 0-100, 0-500, 0-1,000. A.C. volts 0.5, 0.50, 0-100, 0-500, 0-1,000. D.C. milliamps 0.5, 0-100, 0-500. Ohms 0-50,000 with internal batteries. 0-500,000 with external batteries. Measures A.C./D.C. volts, D.C. current and ohms. All the essential parts including metal case, 2in. moving coil meter, selected resistors, wire for shunts, range selector, switches, calibrated scale and full instructions. Price 19/6, plus 2/6 post and insurance.



**Cabinet Snip**



This fine cabinet as illustrated but less control knobs is available this month at special snip price of 12/6, plus 3/6 post and insurance. Size is 13 1/2in. x 9in. x 4in. and it is nicely covered in two-tone I.C.I. fabric.

**Tube Tester and Re-Activator**

We can supply all the main components for making this unit which will not only test Cathode Ray Tubes but will also re-activate them. Supplied complete with full instructions. Price £3, plus 2/6 post and ins.

**Motor Snip**

Miniature motor 2 1/2in. long x 1 1/2in. diameter. Laminated poles and armature. separate winding for reversing. Operates off 20-30 v. D.C. or off A.C. mains through stepdown transformer. Original cost at least £3 each. Snip price for one month only 8/6, plus 1/6 postage and insurance.

**Band III Converter**

Suitable Wales, London, Midlands, North, Scotland, etc. All the parts including 2 EF80 valves, coils, fine tuner, contrast control, condensers and resistors. (Metal case available as an extra.) Price only 19/6, plus 2/6 post and insurance. Data free with parts or available separately 1/6. Please send two more kits. The one you sent last week is performing magnificently.

We receive this sort of letter every day of the week, so if you have hesitated because you thought our kits too cheap you need hesitate no longer.

**Latest AVO Testmeter**



Can be yours for only 10/- deposit and 19 fortnightly payments of 10/-. Like all AVO meters it is a very fine instrument. It has a sensitivity of 10,000 ohms per volt and 19 most useful ranges as follows— D.C. volts 0-1,000 (7 ranges). A.C. volts 0-1,000 (5 ranges). D.C. current 0-1 amp (5 ranges). resistance 0-2 megs. (2 ranges) (complete with test leads). Immediate delivery. Cash Price £2/10/0. **FREE GIFT.**—All purchasers will receive Range Extender scale and data which add: capacity 0-1 mfd., in two ranges. Inductance 0-100 henrys, etc., etc.

**LAST FEW**

**HIGH FIDELITY AMPLIFIER**

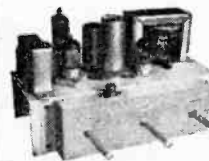

3 valve 4 watt with frequency response better than 40-15,000 C.P.S. Control Panel size 8 x 2 1/2in. comes fixed to chassis but is intended for independent mounting. Separate bass and treble controls giving fullest variation of cut and lift. Separate switch, absolutely no mains hum. Remarkable value at £1/19/6.

**Complete Walkie-Talkie 25/-**



This is the 46 Walkie-Talkie. It has a range of approx. 5 miles—just right for search parties, fire brigades, etc. Operates from dry batteries. Complete with six valves and in metal case. Size approx. 12in. x 6in. x 3 1/2in. Complete but less crystal, not tested nor guaranteed. 25/-, plus 2/6 carriage.

**Last Chance for this Fine Bargain**

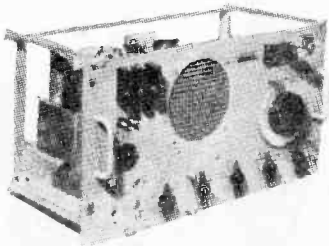

This is a super short wave receiver covering 5-30 metres (10-60 Mc/s). Uses 6 valves. Has R.F. stage, 2 I.F. stages B.F.O., etc. Muirhead instrument drive, two internal power packs, mains and battery vibrator pack. Complete with own P.M. speaker. Provision for phones and speaker muting. Complete in metal transit case; size approx. 21 x 18 x 12in.; weight 70lb. Suitable A.C. mains. 100-250 and 6 volt battery. In perfect condition, practically unused. Tested before despatch and guaranteed. Handbook free with each. Price £6/19/6, carriage and insurance 15/-. Or 10/- deposit, plus 15/- carriage, and 15 fortnightly payments of 10/-.

**Beginner's Superhet**

All the components including metal chassis, valves, metal rectifier, coils, tuning condenser, etc., etc., required to build the "Beginner's Superhet" as described in the January, 1958, issue, are available as a parcel. Price £3, plus 3/- post and insurance.



**Simplex Transistor Kit**

Makes ideal bedroom radio, uses one transistor and one crystal diode. Complete less case 19/6, case 5/- extra, post and ins. 1/6.



**Sapphire Needles**

Unrepeatable bargain—new and perfect—two types available: miniature E.M.I. and Standard (trailer). Sale price 1/- each or 10/- doz.



**Morganite Potentiometers**

Single and 2-gang types available, standard size with good length spindle, all new and boxed. Single types 1/- each. Valves available: 5K, 10K, 25K, 50K, 100K, 250K. 1 meg., 2 meg. Gang type, 3/- each—valves available: 5K, 5K, 100K, 100K, 1 meg., 2 meg. + 2 meg.

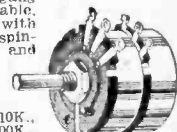

**Connecting Wire**



P.V.C. covered in 100ft. coils—2/9 a coil or four coils different colours. 10/- post free.

**Yaxley Switches**

4-pole, 2-way	1/6
12-pole, 2-way	1/6
6-pole, 3-way	2/-
3-pole, 3-way	1/6
9-pole, 3-way	2/-
2-pole, 4-way	2/-
4-pole, 4-way	2/9
5-pole, 4-way	2/9
4-pole, 5-way	2/6
2-pole, 5-way	2/6
1-pole, 7-way	2/6
1-pole, 12-way	2/6
2-pole, 12-way	4/6
6-position shunting switch	4/6
Double-pole mains switch for attaching to Yaxley switches	1/6.

**RI155 for Spares**



These are less valves but otherwise reasonably complete—ideal for spares—prices £2 to £4 depending on condition—carriage 7/6.

For convenience of callers all items advertised may be obtained from the following companies.

- |   |   |   |
|---|---|---|
| <b>Electronics (Ruislip) Ltd.</b><br>42-46, Windmill Hill,<br>Ruislip, Middx.<br>Phone: RU1SLIP 5780.<br>Half day, Wednesday. | <b>Electronics (Croydon) Ltd.</b><br>266, London Road,<br>Croydon<br>Phone: CRO 853<br>Half day, Wednesday. | <b>Electronics (Finsbury Park) Ltd.</b><br>29, Stroud Green Rd.,<br>Finsbury Park, N.4.<br>Phone: ARCHWAY 1040<br>Half day, Thursday. |
|---|---|---|

Charging Switchboard

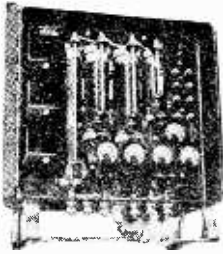

Offered at about one-twentieth of original cost. This is an ex-Government switchboard. It contains three reverse current relays, one voltmeter, one main ammeter, two secondary ammeters and three variable resistors for controlling circuits. These are original cases. Price £2 15/-, carr. 10/-.

Thermostats



Useful for the control of appliances such as convector, bluepots, vulcanisers, hot plates, etc. Adjustable to operate over temperature range 50-550 deg. F., fitted with heavy silver contacts. 8/6. Other types: 11 amp., 3/6; 5 amp., 8/6; 2 amp., QMB, 5/6; 15 amp., QMB, 15/-; 15 amp., enclosed wall mounting type, 29/6.

Making a Solder Gun



A 7-second solder gun of the type costing £2-41 was described in a previous issue. Only two essential parts are required—(a) the transformer and (b) the push switch. These we can supply at 11/6, plus 2/- post. The rest of the parts you will have in your own "junk" box. Copy of the article concerned given free with the kit.

Coil Pack Snip



Covers the Medium Waveband 200-550 metres and two short wavebands 35-120 metres and 13-42 metres, for 465 Kc. I.F. Extremely well made, supplied complete with diagram of connections. Only 9/6, plus 1/6 post and insurance.

Saturn Spin Drier



A Spin Drier will not only make Washing Day much less of a burden but will also prevent that damp atmosphere created by wet clothes drying indoors. The Spin Drier illustrated is the famous Saturn which although quite small actually holds as much washing as the larger floor standing type. The big advantage of the Saturn is that it can be stood on the draining board, rinsed washing from the sink and the water spun out back into the sink, no mess, no special emptying and, being light, it can easily be put into a cupboard or stood on a shelf. Your Wife or Mother will be really pleased with one of these. Price £21.17/6, or £1 deposit and 22 fortnightly payments of £1 each.

Dulci AM/FM Radiogram Chassis

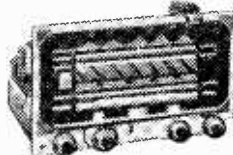

Chassis Model H.3. This has three wavebands, F.M., 87-101 Mc s., Medium Wave 187-540 metres and Long Wave 1,000-2,000 metres, uses 7 of the latest miniature valves and built-in ferrite aerial. Why not modernise your Radiogram, get the best from modern recordings with this hi-fi 4 watt output chassis. The price of the H.3 is £20.17/-, or £1 deposit and 22 fortnightly payments of £1. Four waveband model, £24.6/6 (H.4), or push-pull output, £29/3/10—all available on terms.

THIS MONTH'S SNIP

High output car battery charger, gives quick (car start charge) or trickle charge. Input standard A.C. mains, output 6 or 12 volt at 1-2; or 4 amps. With meter and variable charge selector. Complete in hammer finish louvered case. Only 75/-, plus 4/6 carriage, or 10/- deposit and 8 fortnightly payments of 9/-. New and unused, guaranteed for 2 years.

T.V. Service Sheets

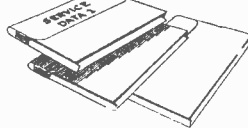

150 sheets covering the most popular post-war Televisors by leading makers—Cossor, Ekco, Ferguson, Pyc, etc., £1.10.0, post free.

FOUR ITEMS FOR PRICE OF ONE

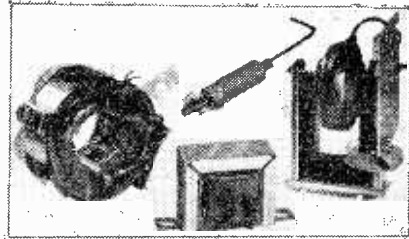

Set of modern T.V. parts suitable for modernising old television or for a new one. For wide angle 14in. or 17in. tubes comprises: (1) Line output E.H.T. transformer. (2) 700 scanning coils on ferrite yokes. (3) Width control with ferrite core. (4) Frame output transformer. (5) Circuit diagram of a modern television. Offered at the price of the Line output transformer only, namely, 57/6, plus 2/6 post and insurance.

Unrepeatable Bargains

Metal Rectifier. Equivalent of RM5-250 mA., 250 v., 12 6.  
Welding Transformer, 12 v.-50 amp., continuous rating—intermittent rating for spot welding—exceeds 2,000 amps., 45-, carriage and packing 5-/-.  
6ft. Unbreakable Mains Lead. Type of lead fitted to electric razors, makes fine lead for test meters and any other devices where subject to continuous bending. Twin figure eight construction, soft cream P.V.C. covered. Normally costs 2/- per yard—we offer three leads for 2/-.  
.1 Mfd. 350. Small tubular metal cased condensers made by Dubilier, 2 8 doz.

Connecting Wire P.V.C. Covering. All colours. Sale price 2/6 per 100 ft. coil or 5 coils different colours, 10/- the lot.

50 Assorted Resistors. Well mixed and useful values 1 and 1/2 watt, 5- for 50.

Maint. Transformer. Standard 230 v., input 250-0-250 at 80 mA., 6.3 v. at 5 A, 12/6.

Toggle Switch. Standard metal body, type with round dolly, fixing ring and on/off indicating plate, 1/3 or 12/- doz.

Metal Rectifier. 250 v. 60-80 milliamps, ideal for mains set or instrument or to replace that expensive valve, 4/6.

Screened Cable. Rubber covered flexible with metal braiding, ideal for microphone or gramophone extensions, 4d. per yd., 30/- per 100 yds.

Install 2-way Switches. Our outfit comprises: 30 yd. multicore cable, two 2-way switches, two wood blocks. Full instructions, 9/6 each, post and insurance 2/6.

Loos, Medium and Short Wave Coil Pack. An exceptionally well made coil pack which covers the standard long, medium and short wavebands for 465 K c. I.F., complete with diagram of connections, 14/6, plus 1/6 postage and insurance—limited quantity only.

Neon Lamp, midge wire ended. Ideal for making mains tester or for any of the dozen-and-one applications to which a neon can be put, 2/-.

Instrument Transformer. Input 200-230 v., output 6.3 v. at 3/4 amps., and two separate 85 v., 10 milliamp windings which can be joined in series or parallel, 8/6, plus 1/6 post & packing.

3 1/2in. Meter Moving Coil. Flush mounting, really beautifully made by G.E.C. Two types available 500-0-500 microamp and 1 milliamp f.s.d., 37/6, plus 2/- p. & i.

Winking Eye, telephone or circuit indicator, 5/-.

Cathode Ray Tube VCR517, 7/6, carriage, etc., 3/6.

Install Those Extra Power Points: 3 core cable 7.029 (15 amps.) 500 v. grade—a big purchase enables us to sell this at 37/6 per coil (50 yds.), carriage 7/6.

Auto Transformer. Totally enclosed, primary 200-250 v., secondary 110-120 rated 200-250, 27/6, carriage and insurance 2/6.

Dimmer or Regulator. Total resistance 1,000 ohms. Maximum current of .50 amps. This is a beautiful unit which uses a 32 position stud switch, resistance is divided into 31 sections each approx. 30 ohms. In ventilated metal case, size approx. 7in. x 7in. x 5 1/2in. with wall mounting brackets and large control knob, 15/-, plus 2/6 post & insurance.

ELECTRONIC PRECISION EQUIPMENT LTD.

66, GROVE ROAD, EASTBOURNE, SUSSEX

This is the correct address for post orders, and for prompt attention please mark your envelope Dept. 7. Also add enough for postage.

## Mains Transformers

**DROP THROUGH TYPE, 12/9.** 350.0-350 volts at 250 mA., 6.3 volt at 4 amp., 6.3 volt at 4 amp., 4 volt at 3 amp., 22 volt at 3 amp., 4 volt centre tapped at 1.5 amp. Primary 200-250 volt 50 cycles. P. & P. 3/9.

**DROP THROUGH TYPE, 12/9.** 350.0-350 volts at 250 mA., 6.3 volt at 5 amp., 4 volt at 4 amp., 4 volt at 7 amp., 4 volt centre tapped at 1 amp. Primary 200-250 volt 50 cycles. P. & P. 3/9.

**UPRIGHT TYPE, 3/9.** 350.0-350 volt at 80 mA., 12 volt at 1.5 amp., 4 volt at 2 amp. Primary 100-120-200-250 volt. Fully shrouded. Ideal for mains auto transformers. P. & P. 2/9.

**MAINS AUTO, 12/6.** 0-205-225-245 volts at 300 mA. Isolated windings of 6.3 volt at 2-6 amp., 6.3 volt at 3-6 amp., 2 volt at 1-4 amp. P. & P. 3/9.

**O.P. TRANS., 1/3.** Standard size 2-5 ohms. Post 1/-, 20 for £1. Post 5/6.

## Heater Transformers

**HEATER TRANSFORMER, 12/9.** 12 volt at  $\frac{1}{2}$  amp., 0-200-250 volts primary. P. & P. 1/9.

**HEATER TRANSFORMER, 3/9.** 2-1 Ratio or 1-2 Ratio auto transformer; 2 volt at 1.4 amp. primary., 4 volt secondary. P. & P. 1/9.

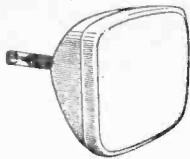

## REGRETTERED IMPROVED VACUUM T.V. TUBES

17in. Rect. £7.10.0.  
14in. Rect. £5.10.0.

### 12 MONTHS' GUARANTEE

Our 12 months' guarantee (6 months' full replacement, 6 months' progressive) illustrates our wholehearted confidence in the Tubes we offer. We sell many hundreds a week throughout the country and have done so for the past 7 years. Many of them go to the Trade, i.e., to Insurance Companies, Renters and Retailers who are thoroughly satisfied with our supplies. Remember they also hold a 10 days' money back guarantee.

9in., 10in., 14in., 15in. and 16in. ROUND TUBES. Our special offer of these sizes, £5; 12in. T.V. Tubes, £6. Three months' guarantee on Round Tubes. Ins. Carr. 15/6.

### EXPRESS DESPATCH SERVICE

Please phone to confirm Tube in stock. Send Telegraph Money Order. Tube despatched Passenger Train same day.

## Sound and Vision Strip, 25/6

Plessey. Tested. I.F.s 10.5 Mc/s sound, 14 Mc/s vision. Eight valveholders. Less valves. Size 8 $\frac{1}{2}$  x 5 x 4 $\frac{1}{2}$ in. Circuit included. The Tuner unit plugs directly into this chassis. P. & P. 2/6.

**SOUND AND VISION STRIP, 10/6.** Salvaged. Complete sound and vision strip. Eight valveholders. Less valves. I.F.s 16-19.5 Mc/s. Size 8 $\frac{1}{2}$  x 4 $\frac{1}{2}$  x 4 $\frac{1}{2}$ in. Drawings free with order. P. & P. 2/6.

**SOUND AND VISION STRIP, 10/6.** Salvaged. Superhet. Eight valveholders. Less valves. I.F.s 7.25 Mc/s sound, 10.75 Mc/s vision. Vision complete from input up to video output. Sound complete from input to A.F. amplifier. P. & P. 2/6.

**TIME BASE, 4/9.** Containing scanning coils, focus unit, line transformer, etc., less valves. Drawings free with order. P. & P. 2/6.

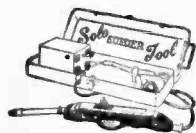

## Solo Soldering Tool, 12/6

110 v., 6 v. or 12 v. (special adaptor for 200/240 v., 10/- extra). Automatic solder feed including a 20ft. reel of Ersa 60/40 solder and spare parts. It is a tool for electronic soldering or car wiring. Revolutionary in design. Instantly ready for use and cannot burn. In light metal case with full instructions for use. Post 2/9.

## 17in. T.V. CHASSIS, TUBE & SPEAKER, £19.19.6

17in. Rectangular Tube on modified chassis. Supplied as single channel chassis covering B.B.C. channels 1-5, or incorporating Turret Tuner which can be added as an extra, at our special price to chassis purchasers of 50/-, giving choice of any two channels (B.B.C. or I.T.A.). Extra channels can be supplied at 7/6 each. Chassis size 12 x 14 $\frac{1}{2}$  x 11in., less valves. Similar chassis are used by well-known companies because of their stability and reliability. With Tube and Speaker £19.19.6. With all valves, £25.19.6. Complete and working with Turret Tuner. £28.9.6. 12 months' guarantee on the tubes. 3 months' guarantee on the valves and chassis. Ins. Carr. (incl. Tube), 25/-.

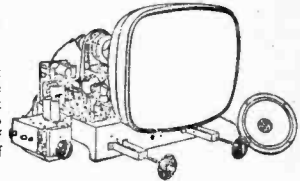

## 14in. T.V. Chassis, Tube & Speaker, £15.19.6

As above, with 14in. Rectangular Tube. 12 months' guarantee on the Tube, 3 months' guarantee on chassis and valves. Chassis with Tube and Speaker (less valves), £15.19.6. With all valves, £21.19.6. Complete and working with Turret Tuner, £24.9.6. Ins. Carr. (incl. Tube), 25/-.

## Popular 12in. Plessey T.V. Chassis, 39/6

This is a real bargain for anyone wanting to make up their own T.V. at a very low cost. I.F.s 10.5-14 Mc/s. Simply adapted for a 12-Channel Turret Tuner and can be modified to take a larger Tube. A chassis in one unit. Untested. Less valves, tube, speaker and scanning coils. (All can be supplied as extras.) Circuit diagram available at 3/6, or free with order. Carr. & Ins. 10/6.

## Super Chassis, 99/6

5-valve superhet chassis including 8in. P.M. speaker and valves. Four control knobs (tone, volume, tuning, w/change switch). Four w/bands with position for gram. p.u. and extension speaker. A.C. Ins. Carr. 5/6.

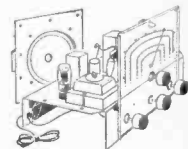

## Electric Convector Heater, 99/6

**SMOG!** Not from your house if you install our Electric Convector heaters. Economy and cleanliness, too. A.C./D.C. Switched for 1 or 2 kW. Illuminated grille. Size 26 x 18 x 7 $\frac{1}{2}$ in. deep. Ins. Carr. 10/6.

## Power Pack & Amplifier, 29/6

R.F. E.H.T. Not tested. Amplifier stage 6V6 with O.P. trans. 3 ohms matching. Smoothed H.T. 350 volt at 250 mA., 6.3 volt at 5 amp., 22 v. at 3 amp., 6.3 v. at 4 amp. and 4 v. centre tapped. Less valves. Drawings free. Size 14 $\frac{1}{2}$  x 8 x 7in. Ins. Carr. 5/6.

**POWER PACK AND AMPLIFIER, 19/6.** Output stage PEN45. O.P. trans. choke. Smoothed H.T. 325 volt at 250 mA., 4 v. at 5 amp., 6.3 v. at 5 amp., 4 v. at 5 amp. centre tapped. Valve base for rectifier. Octal or 4 pin. Output is taken from standard plugs. Less valves. Ins. Carr. 5/6.

**POWER PACK AND AMPLIFIER, 19/6.** Output stage 6V6 with O.P. trans. 3 ohms choke. Smoothed H.T. 350 v. at 250 mA., 6.3 v. at 5 amp., 22 v. at 3 amp., 6.3 v. at 4 amp. and 4 v. centre tapped. Less valves. Not tested. Ins. Carr. 5/6.

# DUKE & CO.



## RECORD PLAYER CABINETS

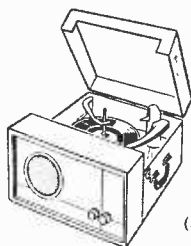

**79/6** (R.P.3)

A delightful-looking cabinet 14½ x 17½ x 8½ in. in two-tone leatherette. Will take a B.S.R. Monarch 4-Speed Autochanger and 6½ in. round speaker. Carr. & Ins. 4/6.

(R.P.4) **79/6**

Stylish cabinet by famous manufacturer. Cloth covered in contrasting colours (red and grey). Grilled front controls panel. Size 15 x 19 x 8½ in. deep. Beautifully made—a cabinet of which you can really be proud. Takes 4-Speed B.S.R. Autochanger, 6½ in. round or elliptical speaker. Room for any amplifier of your own choice. Carr. & Ins. 4/6.



**69/6**

(R.P.2)

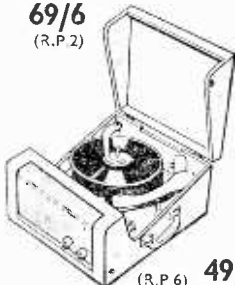

A beautifully styled cabinet. Made by a famous manufacturer. In polka dot grey cloth with clipped lid and carrying handle. Size 16 x 14½ x 8½ in. deep. Will take B.S.R. Monarch 4-Speed Autochanger and 4 x 7 in. elliptical speaker and most of the modern portable amplifiers. Carr. & Ins. 4/6.

(R.P.6) **49/6**

Elegant cabinet, cloth covered in grey or red with sunken control panel and speaker fret. Size 13 x 17 x 8 in. Takes a B.S.R. 4-Speed Autochanger, 7 x 4 in. elliptical speaker and most of the modern portable amplifiers. Carr. & Ins. 4/6.

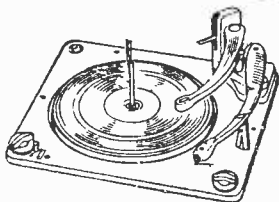

**Collaro  
1-Speed  
Autochanger  
£7. 19. 6**

Incorporating auto and manual control complete with studio crystal p.u. and sapphire stylus.

A few only: Stereophonic 4-Speed Autochangers.

### **B.S.R. 1-Speed Autochanger £6. 19. 6**

Incorporating auto and manual control complete with turnover crystal p.u. and sapphire stylus. P. P. & Ins. 5/6.

A well designed cabinet in brown leatherette. Strong clip fasteners, easy carrying handle. Takes B.S.R. Monarch Autochanger and space for a 4 x 7 elliptical speaker. Can be made up into an ideal Record Player. Size 16 x 14½ x 8½ in. deep. Carr. & Ins. 4/6.

**59/6**  
(R.P.5)



**49/6** (R.P.1)



A practical cabinet, nicely designed, cloth covered two-tone (brown and coffee). Size 15 x 17 x 8 in. deep. Takes B.S.R. 4-Speed Autochanger and 6½ in. round or elliptical speaker. Carr. & Ins. 4/6.

**39/6**

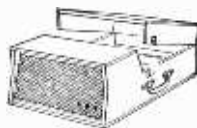

Latest contemporary style rexine-covered cabinet in two-tone colour scheme. Hinged clipped lid, carrying handle. Space available for all modern amplifiers and autochangers, etc. Size 19½ x 15½ x 9 in. Carr. & Ins. 4/6. Many other types of beautifully designed cabinets in stock at similar prices to the above.

## AMPLIFIERS

### 12 MONTHS GUARANTEE PORTABLE AMPLIFIER MARK D.1, 59/6

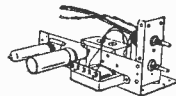

Brand new. Latest design with printed circuit. Dimensions 7 x 2½ x 5 in. A.C. only. Mains isolated. 2-3 watts output. Incorporating EL84 as high gain output valve. Volume and tone controls. Knobs 2/6 extra. P. & P. 3/6.

### PORTABLE AMPLIFIER MARK D.2, 79/6

Printed circuit. Latest design. Dimensions 7 x 2½ x 5 in. A.C. only. Mains isolated 3-4 watts output. Incorporating the latest ECL82 triode pentode output valve giving higher undistorted output. Volume and tone controls. Knobs 2/6 extra. P. & P. 3/6.

### PORTABLE AMPLIFIER MARK D.3, 89/6

De luxe model. Printed circuit. Latest design. Dimensions 7 x 2½ x 5 in. A.C. only. Mains isolated 3-4 watts output. Incorporating the latest ECL82 triode pentode output valve, giving higher undistorted output. Volume, treble and bass control. Knobs 3/6 extra. P. & P. 3/6.

### PORTABLE AMPLIFIER MARK D.4, 69/6

Brand new. By famous manufacturer. Especially built for portable record players. Dimensions 4½ x 3½ x 4 in. A.C. only. 2 valves: EL84 as high gain output valve; EZ80 as rectifier. Volume and tone controls. Knobs 2/6 extra. P. & P. 3/6.



### Extension Speakers 19/9

Polished wood cabinet of attractive appearance. Fitted with 8 in. P.M. Speaker W.B. or Goodmans of the highest quality. Standard matching to any receiver (2-5 ohms). Switch and flex included. Ins. Carr. 3/6.



8 in. P.M. Speakers 8/9. 4 x 7 in. elliptical speakers 19/6. 6½ in. P.M. Speakers 12/6. Postage 2/9.

# DUKE & CO.

(Dept. D.2.), 621/3, Romford Road, Manor Park, E.12.

Send for FREE Catalogue  
THURSDAY CLOSED 1 p.m.

TERMS AVAILABLE  
OPEN SATURDAY ALL DAY

Tel.: 1LF. 6001/3.

# Fully Guaranteed Components

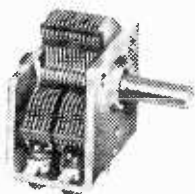

**"00" TWIN CONDENSER**

Designed for use in miniature transistor receivers. The front (aerial) section is 208 pf. to provide coverage for medium waves, and the rear section is 176 pf., which may be padded to match the oscillator—very robust yet light weight. Front area 1 1/2 in. x 1 17/32 in. x 1 1/32 in. deep, price 9s. 6d.



**S.L. 16 DRIVE**

A general purpose slide rule Drive for F.M./V.H.F. Units, short-wave converters, etc. Printed in two colours on aluminium, with a 0-100 scale and provision is made for individual calibrations. Complete with bronze escutcheon and glass. Price 13s. 9d.

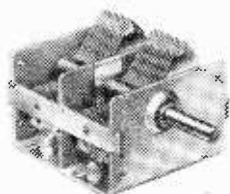

**F. GANG CONDENSER**

A good general purpose gang Robust but small in size. "E" law to match our S.L.8 Full Vision, Square Plane and Air Plane Drives. Size 2 1/2 in. x 1 21/32 in. x 2 9/16 in. long (3 gang 3 11/16 in.). Price for 2 Gang, 13s. 3d. 3 Gang, 17s. 6d. Complete with trimmers.

**JACKSON BROS.** (London) Ltd. **PRECISION BUILT COMPONENTS**  
KINGSWAY · WADDON · SURREY

Telephone: Croydon 2754/5



**ADCOLA**

(Regd. Trade Mark)

## SOLDERING EQUIPMENT

THE INSTRUMENTS CREATED FOR THE DISCRIMINATING USER.

British & Foreign Pats., Regd. Designs, etc.

### ILLUSTRATED

Protective Shield  
(Cat. No. 68)

Instrument 1/8" Bit  
(Cat. No. 70)

The ideal combination for transistor and other intricate work.

Apply direct for catalogues:—

**ADCOLA PRODUCTS LTD.,**  
GAUDEN RD.,  
CLAPHAM HIGH ST.,  
LONDON, S.W.4.

Telephones  
MACaulay 4272 and 3101

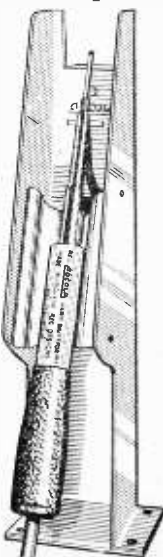

## G2AK: This Month's Bargains

### SPECIAL OFFER

12 v. Miniature Rotary Convertors. Only 4 1/2 in. x 2 1/2 in. Output 360 v. 30 mA. or 310 v. 70 mA. NEW LOW PRICE 12/6 ea. or 22/6 pr., p. & p. 1/6.

**VOLTMETERS.** Dual range 0-5 v. and 0-100 v. voltmeters, M.C. 1,000  $\Omega/v$ . Ranges easily extended. With test prods and leads. Complete in solid leather carrying case, 6 1/2 in. x 5 in. x 2 1/2 in. A gift at 25/- post free.

**B.S.R. MONARCH UAB RECORD CHANGERS.** New mir.'s stock. Manual and Auto. Full Hi-Fi cartridge. List £9 15.0. OUR PRICE £7.15.0, carriage paid

**AMERICAN 807s.** New, boxed, 4 for 25/- or 7/6 each, post free.

**HEADPHONES.** H.R. Type 4,000 ohms, very sensitive. Only 12/6 pr. Post 1/6. C.L.R. type (low res.), 8/6. Post 1/6.

**SHADED POLE MOTORS** for Tape decks or gram. units. 3-hole fixing, Twin Coil closed field type; 200/240 v. 50 c/s. 15/- ea. or 27/6 for 2, p. & p. 2/-.

**R.F. CHOKES.** 2.5 mH, 120 mA. pie-wound, 2/- each. 3 or more post free. National Type R30CU pillar-mounting choke, 1 mH, 300 mA, 3/- each.

**ACOS MIC 33/2.** New in maker's cartons. List 55/- OUR PRICE 35/- P. & P. 1/6.

**AERIAL WIRE.** Copper, 7.25 stranded; 140ft., 10/-; 70ft., 5/-; Hard Drawn 14g.: 140ft., 17/-; 70ft., 8/6. P. & P. 2/-.

**RIBBED GLASS 3in. AERIAL INSULATORS.** 1/6 ea., or 6 for 7/6. P. & P. 1/6.

**CONDENSERS.** 8  $\mu F$  600 v. Trop. 750 v. normal condensers. NEW, ex W.D. stocks, 5/6. P. & P. 1/6.

**ABSORPTION WAVEMETERS,** 3 to 35 Mc/s in 3 switched bands. Complete with indicator bulb. 17/6 post free.

## CHAS. H. YOUNG LTD.

Dept. 'P,' 110, Dale End, Birmingham, 4. (CEN 1635)  
No C.O.D. on orders under £1.

Please Print Your Name and Address



# The Popular Stern's "fidelity" TAPE RECORDER

for truly "Hi-Fi" Recordings

**PRICE INCORPORATING**

COLLARO DECK MK. IV  
TERMS. Dep. **£9.18.0** and 12 monthly payments of **£3.12.7** or Dep. **£16.10.0** and 12 monthly payments of **£3.0.6**.

PRICE WITH TRUVOX DECK INCORPORATING REV. COUNTER. **£52.10.0**

H.P. TERMS. Dep. **£10.10.0** and 12 monthly payments of **£3.17.0** or Dep. **£17.10.0** and 12 monthly payments of **£3.4.2**.

**THEY INCORPORATE**

- Choice of the latest COLLARO TRANSCRIPTION DECK or
- The NEW TRUVOX MK. IV DECK
- The model HF/TR3 "fidelity" AMPLIFIER. (Described below.)
- ROLA CELESTION 10in. x 5 P.M. Speaker.
- 1.200 reel EMI tape.
- ACOS Crystal Microphone.

BEFORE CHOOSING YOUR TAPE RECORDER YOU SHOULD HEAR THIS MODEL—TRULY "HI-FI" RECORDINGS ARE OBTAINABLE and it is comparable to much higher-priced Recorders. Alternatively send S.A.E. for ILLUSTRATED LEAFLET.

(Plus £1.0.0 Carriage and Insurance, of which £1 is refunded on return of Packing Case.)

**THE MODEL HF/TR3 TAPE AMPLIFIER**

INCORPORATING 3-SPEED TREBLE EQUALISATION by means of the latest FERROXCUBE POT CORE INDUCTOR.

PRICE FOR COMPLETE KIT OF PARTS **£12.15.0**  
PRICE FULLY ASSEMBLED & TESTED **£16.10.0**

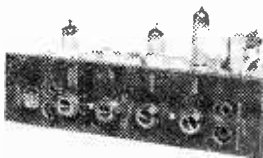

HIRE PURCHASE. Deposit **£3.6.6** and 12 monthly payments of **£1.4.2**. A very high-quality Amplifier based on the very successful TYPE "A" design completed in the MULLARD LABORATORIES. ONLY NEW HIGH-GRADE COMPONENTS are incorporated including MULLARD VALVES and a GILSON OUTPUT TRANSFORMER. Other features are—Magic Eye Recording hand indicator—Effective Tone Control—Monitoring and Extension Speaker Sockets—Has own Power Supply and can be used as independent Amplifier for direct reproduction of Gram Records or from Radio Tuner. Overall size 11in. x 6in. x 6in. Can be supplied for use with Truvox—Collaro—Lane—Brenell or Motek Decks. Please specify which

Send S.A.E. for leaflet or 2/6 for the complete Assembly Manual.

**STERN'S TAPE PRE-AMPLIFIER and ERASE UNIT**  
STERN'S MODEL HF/TR1P

A completely assembled Pre-amplifier with own Power Supply. Can be supplied correctly matched for use with Truvox or Collaro Decks and incorporates Recording Level Indicator and Monitoring facilities. Please send S.A.E. with any enquiry. PRICE **£11.10.0** (Plus 5/- Carr. and Ins.)

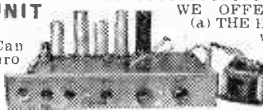

**WE OFFER YOU**

- (a) THE HF/TR1P PRE-AMPLIFIER together with the COLLARO MK. IV TAPE DECK (see note). PRICE **£32.10.0**
- (b) THE HF/TR1P together with the TRUVOX MK. IV DECK (Incorp. Precision Rev. Counter). PRICE **£38.0.0**

TO BUILD A COMPLETE PORTABLE TAPE RECORDER ... ALL EQUIPMENT IS AVAILABLE FOR SEPARATE SALE AT PRICES SHOWN IN BRACKETS ... WE OFFER—

(a) THE PORTABLE CASE illustrated above (€5.0.0). 1.200ft. E.M.I. TAPE (€1.15.0). ACOS CRYSTAL MIKE (€1.15.0). ROLA 10in. x 6in. LOUDSPEAKER (€1.10.0). ALL FOR ... **£9.0.0**

AVAILABLE ON HIRE PURCHASE WITH (b) or (d) below.  
(b) The COLLARO MK. IV TAPE DECK (€24.0.0) and the HF/TR3 AMPLIFIER Assembled and Tested. FOR ... **£36.0.0**

H.P. Deposit **£7.4.0** and 12 months of **£3.12.6**.  
(c) As in (b) above, but HF/TR3 supplied as COMPLETE KIT OF PARTS ... **£32.0.0**

(d) The TRUVOX MK. IV TAPE DECK incorporating Precision Rev. Counter (€30.9.0) and the HF/TR3 AMPLIFIER Assembled and Tested ... **£41.10.0**

H.P. Deposit **£3.6.0** and 12 months of **£3.0.10**.  
(e) As in (d) above, but the HF/TR3 supplied as COMPLETE KIT OF PARTS ... **£38.0.0**

(Carriage and Insurance on above quotes 10/- extra.)

NOTE: Messrs. Collaro when supplying the MK. IV Deck do not wire up the Deck Switches. We will do this at charge of **£1.0.0**, or supply a Wiring Diagram to the Home Constructor.

Please send S.A.E. with all correspondence.

**HOME CONSTRUCTORS**  
SPECIAL PRICES FOR COMBINED ORDERS

TO ADD FULL TAPE RECORDING FACILITIES To any modern "HI-FI" AUDIO AMPLIFIER (such as our Mullard "5-10" and 2 valve Pre-amplifier) ... ALL YOU NEED IS ... THE

- TYPE "C" PRE-AMPLIFIER and a TAPE DECK ... WE OFFER—
- (a) The COLLARO MK. IV TAPE DECK and the MULLARD TYPE "C" PRE-AMPLIFIER and Power Unit **£37.0.0**
- Assembled and Tested ...
- H.P. Deposit **£7.8.0** and 12 months of **£2.14.3**.
- (b) As in (a) above but the Type "C" supplied as COMPLETE KIT OF PARTS ... **£34.0.0**
- (c) The TRUVOX MK. IV TAPE DECK incorporating Precision Rev. Counter and the MULLARD TYPE "C" PRE-AMPLIFIER and Power Unit Assembled and Tested ... **£42.10.0**
- H.P. Deposit **£8.10.0** and 12 months of **£3.2.4**.
- (d) As in (c) above but the TYPE "C" supplied as COMPLETE KIT OF PARTS ... **£39.10.0**

(Carriage and Insurance on above quotes 10/- extra.)

**STERN RADIO LTD.**  
109 & 115 FLEET ST., LONDON, E.C.4  
Telephone: FLEET STREET 5812/3/4

**AMPLIFIERS  
PRE-AMPLIFIERS  
FOR THE "HI-FI" ENTHUSIAST**

**MULLARD DESIGNS FOR  
THE  
HOME CONSTRUCTOR**

**THE VERY  
POPULAR  
MULLARD  
"5-10" MAIN  
AMPLIFIER**

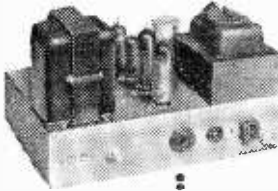

**MULLARD'S  
NEW 2-STAGE  
PRE-AMPLIFIER  
TONE CONTROL**



**THE NEW  
MULLARD 3-3  
MAIN  
AMPLIFIER**



Undoubtedly the most successful amplifier yet designed, and used in conjunction with the new Mullard Pre-amplifier, an undistorted power output of up to 10 watts is obtained. Thoroughly recommended to the "Hi-Fi" enthusiast who contemplates a very high quality home installation. In addition the versatility of the equipment makes it quite suitable for use in small halls, etc. We supply complete to MULLARD'S Specification with specified valves and components and including the latest PARMEKO Ultra-linear Output Transformer and the PARMEKO Mains Transformer which has power available to drive Radio Tuning Unit.

COMPLETE KIT **£10.0.0** Alternatively we supply **£11.10.0**  
OF PARTS ASSEMBLED & TESTED  
(Carriage & Insurance 5/- extra.)

THIS "5-10" with the latest PARTRIDGE **£1.6.0** EX-  
ULTRA-LINEAR OUTPUT TRANSFORMER for

A completely new design employing two EP35 valves, and in particular designed to operate with the Mullard range of Power Amplifiers, but also perfectly suitable for other makes, etc. Briefly it incorporates:

- Equalisation for the latest R.I.A.A. characteristics.
- Input for variable reluctance.
- Magnetic Pick-Ups.
- Input for Crystal Pick-Ups.
- Input for Tape replay.
- (a) Direct from High Impedance Tape Head.
- (b) From a Tape Amplifier or Pre-amplifier.
- Sensitive Microphone Channel.
- Wide range Bass and TREBLE Controls.
- Attractive Perspex front control panel.
- Our Kit is strictly to MULLARD'S SPECIFICATION.

COMPLETE KIT OF **£6.6.0** Alternatively we supply **£8.0.0**  
PARTS ASSEMBLED & TESTED  
(Carriage & Insurance 5/- extra.)

Based entirely on the present very popular "3-3" model and designed to operate in conjunction with the new 2-stage PRE-AMPLIFIER (shown left) thus providing all the facilities associated with the more expensive "Hi-Fi" Equipment. We recommend it as the IDEAL HOME INSTALLATION where very high quality is desired at the lower volume level (up to 3 watts). We supply completely to MULLARD'S SPECIFICATION including the latest PARMEKO Output Transformer, specified Valves and Components. Has power available to drive a Radio Tuning Unit.

COMPLETE KIT OF **£7.0.0** Alternatively we supply **£8.0.0**  
PARTS ASSEMBLED & TESTED  
(Carriage & Insurance 5/- extra.)

Please enclose S.A.E. if ILLUSTRATED and DESCRIPTIVE LEAFLETS are required; the ASSEMBLY MANUAL, etc., are available at 1/6 each.

Only NEW HIGH GRADE Components and MULLARD VALVES are supplied with these Kits—

**SPECIAL PRICE REDUCTIONS . . .**

- (a) The COMPLETE KIT OF PARTS to build both the "3-3" MAIN AMPLIFIER and the 2-STAGE PRE-AMPLIFIER-CONTROL UNIT **£12.10.0**
  - (b) The COMPLETE KIT OF PARTS to build the "5-10" MAIN AMPLIFIER and the 2-STAGE PRE-AMPLIFIER-CONTROL UNIT **£15.15.0**
- PRICES FOR THE "5-10" ARE SUBJECT TO £1.6.0 EXTRA IF THE PARTRIDGE TRANSFORMER IS REQUIRED.

(a) The "3-3" and the 2-STAGE PRE-AMPLIFIER **£15.0.0**  
both ASSEMBLED and TESTED . . . . .  
H.P. : DEPOSIT £3.0.0 and 12 Monthly Payments of £1.2.0 or DEPOSIT £5.0.0 and 12 Monthly Payments of 18/4.

(b) The "5-10" and the 2-STAGE PRE-AMPLIFIER both ASSEMBLED and TESTED . . . . . **£18.18.0**  
H.P. : DEPOSIT £3.16.0 and 12 Monthly Payments of £1.7.8 or DEPOSIT £6.8.0 and 12 Monthly Payments of £1.3.1.

When ordering include an extra 7/6 to cover Carriage and Insurance.

**THE NEW  
COMPLETE  
MULLARD 5-10  
AMPLIFIER**

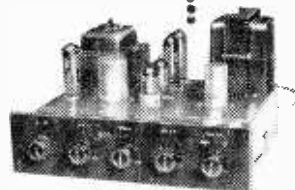

**THE NEW  
COMPLETE  
MULLARD 3-3**

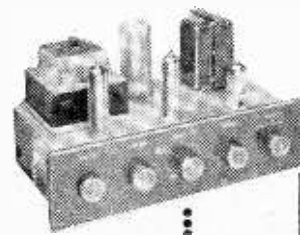

Designed for a simple domestic installation with Genuine High Quality reproduction up to a maximum of 10 watts. Separate BASS and TREBLE Controls are incorporated with switched inputs for 78 and L.P. Records plus Radio Tuning Unit. We incorporate SPECIFIED COMPONENTS and NEW MULLARD VALVES. We also give the purchaser the choice of two of the best ULTRA-LINEAR OUTPUT TRANSFORMERS made—first the latest by PARMEKO LTD. and also the latest by PARTRIDGE (£1.6.0 extra). We also supply the PARMEKO MAINS TRANSFORMER and this has extra power available to supply a Radio Tuning Unit. The Control Unit can easily be detached from the Amplifier Chassis for use in a remote position.

COMPLETE KIT OF PARTS **£11.10.0** Alternatively we supply **£13.10.0**  
(PARMEKO Transformer) ASSEMBLED AND TESTED

H.P. Terms : Dep. £2.14.0 and 12 Monthly Payments of 19 10 or Dep. £4.10.0 and 12 Monthly Payments of 16/8. Send S.A.E. for ILLUSTRATED LEAFLET or 1/6 for the COMPLETE ASSEMBLY MANUAL.

**THE IDEAL AMPLIFIER FOR A SMALL HIGH QUALITY INSTALLATION**

COMPLETE KIT **£7.10.0** Alternatively supplied ASSEMBLED OF PARTS and FULLY TESTED **£8.19.6**  
(plus 6 6 coverage and insurance)

Developed from the very popular 3-valve 3-watt Amplifier designed in the Mullard Laboratories. Our kit is complete to MULLARD'S SPECIFICATION including supply of specified components, Mullard valves and a PARMEKO OUTPUT TRANSFORMER. Send S.A.E. for leaflet or 1/6 for ASSEMBLY MANUAL.

**STERN RADIO LTD.**



# STERN'S FOR STEREO

OUR POPULAR MULLARD MAIN AMPLIFIERS ARE RECOMMENDED FOR USE WITH THE DULCI STEREO PRE-AMPLIFIERS

THE "STEREO EIGHT" PRE-AMPLIFIER

£23.2.0

(Carr. & Ins. 5/- extra.)



THE "STEREO TWO" PRE-AMPLIFIER

£9.9.0

(Carr. & Ins. 5/- extra.)

Both Pre-amplifiers can be supplied to correctly operate with our very popular MULLARD "3-3" and "5-10" MAIN AMPLIFIERS (described opposite). For Stereo reproduction TWO Main Amplifiers are necessary, but for normal "Hi-Fi" reproduction the "Stereo Eight" and the "Stereo Two" are perfectly suitable to operate with ONE Main Amplifier and the second Main Amplifier can then be added at any time, thus transforming a standard "Hi-Fi" installation over to Stereo. FULLY DESCRIPTIVE LEAFLETS ARE AVAILABLE. ENCLOSE S.A.E. WE OFFER

- (a) The "Stereo Two" with one "3-3" MULLARD MAIN AMPLIFIER ..... £17.0.0
- (b) The "Stereo Two" with two "3-3" MULLARD MAIN AMPLIFIERS (This provides Stereo reproduction of max. 6 watts output and is an ideal Home installation) ..... £24.10.0
- (c) The "Stereo Two" with one "5-10" MULLARD MAIN AMPLIFIER ..... £20.10.0
- (d) The "Stereo Two" with two "5-10" MULLARD MAIN AMPLIFIERS ..... £31.10.0
- (e) The "Stereo Eight" with two "5-10" MULLARD MAIN AMPLIFIERS (This provides for up to 20 watts output) ..... £44.10.0
- (f) The above (e) with one MULLARD "5-10" ..... £34.0.0

OTHER STEREO EQUIPMENT AVAILABLE: GRAM UNITS fitted with Stereo Cartridge by . . . GARRARD-COLLARO LENCÓ-B.S.R. These include Autochangers, Single Record Playing and Transcription Units. STEREO CARTRIDGES and PICK-UPS by . . . B.J.-GARRARD-COLLARO-LENCÓ-B.S.R. (Please enclose S.A.E. with any inquiry.) HIRE PURCHASE AND CREDIT SALE TERMS ARE AVAILABLE.

## TO MODERNISE YOUR OLD RADIOGRAM THE NEW ARMSTRONG "JUBILEE"

A.M.F.M. RADIOGRAM CHASSIS

PRICE £30.9.0

(Plus 7/6 Carr. and Ins.)

HIRE PURCHASE: Deposit £6.2.0. Months at £2.4.8.

Messrs. Armstrong have always been associated with very high-class equipment, and this chassis is undoubtedly one of the best they have ever produced.

### MAIN FEATURES

- 6 watts push-out output with negative feedback. ● 9 valves and 12 diodes.
- Full F.M. band (87-103 Mc/s) plus medium and long waves. ● Automatic frequency control on F.M. ● Adjustable Ferrite rod aerial on A.M. bands.
- Tap-to-playback and record facilities. ● Two compensated pick-up inputs.
- Frequency response 30-22,000 cps. ± 2 dB. ● Separate wide-range bass and treble controls. ● Output impedance for 3-7Ω and 15-ohm SPEAKERS.
- Tuning indicator. ● Size of chassis 12in. x 8in. x 7in. high.

### A SPECIAL CASH ONLY OFFER !!

This very attractive PORTABLE AMPLIFIER CASE together with a good quality GRAM AMPLIFIER and a matched P.M. SPEAKER.

ALL FOR ONLY **£8.7.6** (Plus 7/6 Carr. & Ins.)

The Amplifier consists of a 2-stage design incorporating 3 modern B.V.A. valves and has separate BASS and TREBLE CONTROLS. The Portable Case will also accommodate almost any make of Autochanger and is attractively finished in Maroon and Grey Rexine. WE ALSO SUPPLY SEPARATELY—

- (a) The 2-stage plus Rectifier AMPLIFIER **£4.2.6**
  - (b) THE PORTABLE CARRYING CASE **£3.17.6**
  - (c) P.M. SPEAKER **18/9**
- Carriage and Insurance 4/- extra.



CAR BATTERY CHARGER **£2.15.0**

WE offer a COMPLETE KIT OF PARTS FOR ONLY. EASY-TO-FOLLOW ASSEMBLY INSTRUCTIONS ARE INCLUDED. Will charge 6 or 12 volt Batteries at max. 21 amps. The design incorporates Ballast Resistor and Fuse, and we supply complete with Metal Box container.

**109 & 115 FLEET ST., LONDON, E.C.4**  
Telephone: FLEET STREET 5812/3/4

# !!! RECORD PLAYERS !!!

THE LATEST MODELS ARE IN STOCK MANY AT REDUCED PRICES!!! SEND S.A.E. FOR ILLUSTRATED LEAFLET A FEW CASH BARGAINS

- B.S.R. MONARCH
- UA8 4-speed mixer
- Autochanger with
- Crystal Pick-up

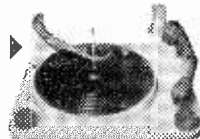

£6.19.6

The COLLARO "CONQUEST" 4-speed Autochanger. Studio Pick-up ..... **£7.19.6**

The latest COLLARO "CONTINENTAL" 4-speed MIXER Autochanger. Studio "O" Pick-up ..... **£8.15.0**

The COLLARO 4-speed Single Record Player. Studio Pick-up ..... **£6.19.6**

THE NEW B.S.R. Model UA12 is in Stock. A 4" SPEED MIXER AUTOCHANGER. .... **£8.19.6**

UA12 also available incorporating the B.S.R. STEREO Pick-up, plays L.P. and 78 Records ..... **£11.17.6**

B.S.R. MODEL TU9 4-speed Single Record Player, complete with separate Crystal Pick-up ..... **£4.10.0**

(This high output Pick-up is available separately for £12.6.) Carriage and Insurance on each above 5/- extra.

## HIGH FIDELITY UNITS IN STOCK

The latest GARRARD TRANSCRIPTION MOTOR "301" with Stroboscopically marked turntable ..... **£28.0.11**

The new GARRARD Model 4HF High-quality Single Record Player fitted with the latest T.P.A.12 Pick-up Arm and G.C.8. Crystal Cartridge ..... **£19.7.10**

As above but fitted with the G.M.C.5 Moving Coil Pick-up and T.P.1 Transformer ..... **£27.14.7**

GARRARD Model TA/MK. II Single Record Player fitted with high output Crystal Pick-up ..... **£9.15.8**

The GARRARD T.P.A.12 TRANSCRIPTION PICK-UP ARM is available separately or with Crystal or Moving Coil Pick-up Heads. GARRARD AUTOCHANGERS AVAILABLE FROM STOCK. Send S.A.E. For Leaflet.

NEW HIRE PURCHASE TERMS ARE AVAILABLE ON ALL EQUIPMENT VALUE £10 AND OVER.

STERN'S MK. II fidelity F.M. TUNING UNIT PRICE (Plus 5/- Carr. and Ins.) **£15.0.0**



HIRE PURCHASE: Deposit £3.0.0 and 12 Monthly Payments of £1.3.0 or Deposit £5.0.0 and 12 Monthly Payments of 18/4. Incorporates the latest MULLARD PERMEABILITY TUNING HEART and the corresponding MULLARD VALVE LINE-UP comprising EC88s, 2 type EF85s (or EF89s) BM4 Tuning Indicator, plus 2 type O.A.79s Germanium Diodes. A really first-class Tuner, very attractively presented and comparable to many offered at much higher prices. Power consumption is only 1.5 amps at 6.3 volts and 25 ma at 250 volts.

HOME CONSTRUCTORS - YOU CAN BUILD THIS TUNING UNIT FOR ONLY £11.0.0 (Plus 5/- Carr. & Ins.) Please send S.A.E. for fully descriptive leaflet, or the Assembly Manual is available for 1/6. This unit easily followed PRACTICAL DIAGRAMS together with relative instructions.

## HOME CONSTRUCTORS

A RANGE OF "EASY TO ASSEMBLE" PREFABRICATED CABINETS

Designed by the W.B. "STENTORIAN" COMPANY for "Hi-Fi" Loudspeaker systems or to accommodate high-quality equipment. The acoustically designed Bass Reflex Cabinets containing the very successful "Stentorian" Speakers give totally first-class reproduction and are well recommended. Models are also available to accommodate high-quality

Amplifiers, Preamplifiers, Tuning Units, Record Players, etc. All models are very easily assembled, in fact, only a screwdriver is required. Fully illustrated leaflets are available, including complete specifications of the various STENTORIAN LOUSPEAKERS. PLEASE ENCLOSE S.A.E. WITH ALL CORRESPONDENCE.

 <p><b>"Q Coils"</b> All ranges Adjustable iron dust cores With full circuit Amazing efficiency</p>	 <p><b>Potted 5/- Coils</b> Ensure selectivity Superhet, T.R.F. For Sets or Tuners</p>	<p><b>Collaro TAPE COILS</b> Officially recommended Bias Osc., QT9, 7/6 Push-pull circuit, 7/5 Bias Filter, QT6, 7/6 Treble Boost, OT7, 27/6</p>	<p><b>Speaker Cross-over Coils</b> 4.5 MH., 17/6. 675 <math>\mu</math>F. 10/6. Mullard New Type C Tape Amplifier Coils. Push-Pull Osc. Coil, 36/- Treble Boost Coil, 20/- T.V. Sound Tuner Coils. Coils for Modernising T.V.</p>	<p><b>STOP!</b> T.V. Patterning easy to fit <b>SIMPLE REMEDY 10/-</b></p>
<p><b>STEEP CUT Whistle Filter 7/6</b> (Circuit supplied) <b>Scratch Filter Coil</b> Cut-off 5-13 Kc/s. Essential for all older records, 10/6</p>	<p><b>DUAL RANGE COILS</b> T.R.F., 5/6, 10/6 pr. T.R.F. with reaction, 7/6 Super-het., 12/6 pr. All high performance coils</p>	<p>deal for normal reception areas <b>Mini-Magic F.M. Tuner Kit</b> Coils only £2.12.6 Complete £4-10-0</p>	<p><b>"W. WORLD" 7 TRANSISTOR PORTABLE.</b> Booklet, 2/9, including price list. Coils as specified, inclgd. F. rod, 42/6 set.</p>	<p><b>SUB-MINIATURE</b> M.W. L.W. Trawler W High Q with ferrite core <b>5/-</b> High performance guaranteed</p>
<p><b>FERRITE ROD AERIALS</b> M.W. 8/9. Trawler, 8/9 M. &amp; L.W., 12/9 M., L. &amp; Tr., 15/6</p>	<p><b>I.T.A. Converter</b> To fit inside T.V. FOR ALL SETS KIT Complete <b>65/-</b> Very efficient <b>£4</b></p>	<p><b>DIAL ASSEMBLY</b> 6 W/bands <b>24/6</b> complete Calibrated for Osmor coils</p> 	<p><b>THE WONDER 1v. SHORT WAVE</b> World Wide Reception <b>KIT 57/6</b> Phones, 20/- extra</p>	<p><b>ITA/BBC EQUALIZER &amp; TUNABLE REJECTOR</b> Automatically Gets rid of Fuzz with instructions <b>10/6</b></p>
<p><b>SUB-MINIATURE COILS</b> For Transistor Circuits. Potted Ferrite Core—Canned Size 5/8in. x 11/16in. .. Guaranteed High "Q" 1st., 2nd., 3rd., I.F. (465 Kc/s) Oscillator Coil ... .. 7/6</p>	<p><b>Coils for Car Radio Circuits</b> including "Hybrid" (Valve-transistor)</p>	<p><b>COILS for A.M. &amp; F.M. &amp; Crystal Tuners</b> for hi-fi amplifier circuits</p>	<p>Very "Hi Q" Standard <b>Midget I.F. Trans.</b> With ferrite cores 14/6 per pair. Pre-aligned</p>	<p><b>F.M. COILS FOR OSMOR</b> "Wireless World" &amp; many other circuits From Radio Press</p>

**FREE!** OSMOR COILS are regularly used and recommended by designers writing in "Practical Wireless," "Wireless World" and "Radio Constructor." Why not follow the experts?

Please State your current interests for special attention. ★

Send 1/- (stamps) for fully descriptive literature AND OSMOR DESIGNS—5-Valve 5'Het. Miniature ditto, Battery and Battery/Mains Receiver, Mains T.R.F. 5'Het and T.R.F. Feeders, Band 3 Converters, F.M. Tuners, Wiring Diagrams, Chassis Templates, Coil and Coilpack information and price lists and information on circuits in "Wireless World," "Practical Wireless," "Radio Constructor." Full Circuits included.

**P30, 418 BRIGHTON ROAD, SOUTH CROYDON, SURREY**

# Absolutely No Pre-Cleaning with the VICTOR

## Soldering Tool



Covered by British & World Patents

The VICTOR is *revolutionary*—it heats the work direct by gripping it with the twin arms of the tool. Simply press the button, the work instantly heats up and the solder runs. *No pre-cleaning—even of oil—is required except where the metal has been oxidised previously.* Operation is from a 6 VOLT supply.

For heavier materials and work the 6-12 volt VENUM Soldering Tool is available. Price £4 4s.

**TRADE ENQUIRIES INVITED.**

- \* Speed in operation
- \* Versatility
- \* Low-voltage safety and economy

Price **£2. 2s.**

Please supply VICTOR/VENUM (quantity.....) soldering tool/s or send me free illustrated literature.

I enclose P.O./cheque value £.....

NAME .....

ADDRESS .....

..... P.W.202.

**ALLIED DISTRIBUTING CORPORATION LTD. 13/17 Rathbone St., London, W.1. MUS 5411**



**VALVES**

**Guaranteed  
All Tested  
Before  
Dispatch.**

AC6PEN 6/6	ECL80 13/6	HL23DD 8/6
*AC/P 8/6	ECL82 13/-	K40N 9/-
AC/THI 34/9	EF36 6/-	KF35 8/6
ATP4 3/6	EF37A 12/-	KLL32 8/6
AZ31 15/-	EF39 6/6	KT24 8/6
CBL1 11/-	EF40 14/6	KT33C 10/-
CBL31 24/4	EF41 9/9	KT55 12/6
CCH35 24/4	EF42 11/9	KT66 15/-
CL4 12/6	EF50 4/-	KTW61 6/6
CL33 20/2	EF54 6/6	KTW63 7/6
CY31 12/-	EF80 8/6	KTZ41 5/-
DFAF56 10/6	EF85 9/6	ME91 7/6
DF96 10/6	EF86 9/6	MH41 7/9
DH63 9/6	EF89 10/6	MSP4 10/-
DK96 10/6	EK32 8/6	MSP4/5 11/6
DL96 10/6	EL32 5/6	MSP4/7 11/6
DM70 8/6	EL33 15/-	N37 18/1
EA50 1/6	EL38 27/10	EF55 10/6
EABC80 10/6	EL41 11/-	N78 12/6
EAF42 10/6	EL42 12/-	DZ4 5/6
EB34 2/-	EL84 10/6	P61 3/6
EB41 9/6	EL91 7/6	PC84 10/-
EBC33 7/6	EM34 9/-	PCF80 13/6
EBC41 10/6	EM80 10/6	PCF82 12/6
EBF80 10/6	EM81 11/6	PCL82 12/6
EBF89 18/6	EY51 13/6	PCL83 14/6
EBL21 24/4	EY86 13/6	PL38 20/-
ELB1 24/4	EZ40 9/-	PL81 16/-
ECC84 10/3	EZ80 8/9	PL82 8/6
ECC85 9/6	EZ81 11/10	PL83 11/6
ECF80 13/6	EZ90 8/-	PX25 12/6
ECF82 13/6	ELI48 2/-	PY80 9/-
ECH21 24/4	FW4/50010	PY81 10/-
ECH35 10/6	GZ32 12/-	PY82 9/-
ECH42 10/6	H30 5/-	PY83 10/-
ECH45 10/6		PZ30 20/11

**LARGEST RANGE OF RECEIVING VALVES IN THE NORTH OF ENGLAND. ALL AVAILABLE EX-STOCK. RETURN POST SERVICE.**

PEN4DD 27/10	UL44 10/6	IT4 7/-	6CD6G 31/4	6V6GT 7/-	12SQ7 8/6
PEN4VA 27/10	UL44 24/10	IU5 7/6	6CH6 9/-	6V6M 9/6	1457 14/6
	UL46 27/10	2C26 1/6	6D6 5/-	6X4 7/6	15D2 7/9
	UL84 11/6	2X2 4/6	6F1 14/-	6X5G 7/-	20D1 16/-
PEN25 5/-	UU6 20/11	3A4 7/6	6FG 7/6	6X5GT 7/-	20F2 27/10
PEN44 27/10	UU8 27/10	3ABGT 6/6	6FGM 7/6	6/30L2 11/6	20P1 27/10
PEN46 7/-	UU9 8/6	3D6 5/-	6F13 12/6	7B7 8/6	20P3 24/4
PEN220A	UY41 8/6	3Q4 9/6	6F15 14/-	7B8 7/-	20P5 20/11
	UY85 10/-	3Q5GT 9/6	6G6G 4/6	7C5 8/-	25A6G 11/6
PENA4 15/-	VP28 8/-	354 8/6	6H6 2/6	7C6 8/-	25L6GT 10/-
OP21 7/6	VP13C 3/6	3V4 5/-	6H6GT 2/6	7D6 13/6	25Y5 9/9
SP41 3/-	VP23 6/6	4D1 3/6	6J5M 6/6	7H7 9/-	25Y5G 9/6
SP61 3/-	VP41 8/6	5R4GY 9/6	6J6 6/-	7Q7 9/-	25Z4 9/9
T41 24/4	VR105/30/8	5U-G 8/6	6J7G 6/6	757 9/6	25Z5 10/-
TP22 8/6	VR116 4/-	5Y3G 8/6	6J7M 9/-	7Y4 8/6	25Z6 10/6
TP23 8/6	VR150/30/9	5Y3GT 8/6	6KA6GT 7/6	8D2 2/9	30F5 9/6
TP25 27/10	VU120A 3/6	5Z-G 10/6	6KG7 5/6	9D2 3/6	30FL1 11/6
U10 10/6	VU39 (MU 6A7	6K7M 6/9	6K7G 6/9	10F1 (Sec- 30P4 21/6	
U12 8/6	12/114) 8/9	6K8G 10/6	6K8G 8/6	onds) 15/-	30P12 12/6
U25 15/-	VU111 2/6	6AC7 6/6	6K8GT 10/-	12A6 6/6	30PL1 9/6
U26 12/6	W77 8/6	6AG5 5/6	6K25 20/11	12AH8 11/6	35L6GT 12/6
U37 27/10	W729 11/-	6AK5 6/6	6L6G 9/-	12AT6 10/6	35W4 8/6
U45 15/-	X65 11/6	6AL5 6/6	6L7 7/6	12AT7 9/6	35Z4GT 8/6
U50 8/6	X78 15/-	6AM6 7/6	6L8 15/-	12AU6 10/6	35Z5GT 9/6
U403 8/6	X79 11/6	6AQ5 7/6	6N7 7/6	12AU7 9/6	42 8/-
U404 11/10	Y63 9/-	6AT6 8/6	6P28 27/10	12AX7 9/6	50C5 11/6
U801 31/4	Z309 9/6	6AU6 10/6	6Q7G 9/6	12BA6 9/6	50L6GT 8/6
UABC80	Z359 9/6	6B4 5/-	6Q7GT 9/6	12BE6 9/6	75 11/6
	Z759 9/6	6B8G 4/6	6SA7GT 8/6	12CB 8/6	77 7/6
UAF42 9/6	IA3 3/6	6BA6 7/6	6S7G 7/6	12HG6T 3/6	80 8/6
UP41 9/6	IA5GT 6/6	6BE6 8/6	6SH7 6/6	12JGT 4/6	142BT 3/6
UBC41 10/6	IA7 12/6	6BG6G 24/4	6S7 8/6	12JGT 10/6	210DDT 4/6
UBF80 9/6	IC2 11/6	6BH6 16/6	6SK7 5/6	12KGT 7/6	210VPT 3/6
UCC84	ICSGT 12/6	6B8 9/6	6SL7GT 8/6	12K8GT 13/6	807 6/6
	ID5 12/6	6BR7 11/6	6SN7GT 7/6	12QGT 7/6	954 2/6
UCF80 23/-	ID6 12/6	6B8W 8/6	6SQT 9/3	12SG7 7/6	955 4/9
UCH42 10/6	IHSGT 10/6	6BW6 8/6	6U4GT 12/6	12SH7 5/6	956 3/6
UCH81 11/6	IL4 6/6	6BW7 10/-	6US/6G5 18/1	12SJ7 8/6	9001 5/6
UCL83 17/6	IN5 10/6	6C4 7/-	6U5G 8/6	12SL7 8/6	9002 5/6
UF41 10/6	IRS 8/-	6CSGT 6/6	6U7G 8/6	12SN7GT 8/6	9004 5/6
UF85 10/6	IS4 7/6	6C6 5/-	6V6G 7/-	15/-	9006 5/6
UF89 10/6	IS5 7/6	6C8G 5/-			

**MAINS TRANSFORMERS**

MT1—3-way mounting. Primary 200/250 v. Secondary 250 v.-0-250 v. at 80 m.a., 6.3 v. at 4 a. tapped 4 v. and 5 v. at 2 a. tapped 4 v. ...	each	7in. x 5in. Units by Goodmans ... 19/6
250 v. Secondary 350 v.-0-350 v. at 80 m.a., 6.3 v. at 4 a. tapped 4 v. and 5 v. at 2 a. tapped 4 v. ...	21/9	8in. x 5in. Units by Goodmans ... 25/6
MT2—3-way mounting. Primary 200/250 v. Secondary 350 v.-0-350 v. at 80 m.a., 6.3 v. at 4 a. tapped 4 v. and 5 v. at 2 a. tapped 4 v. ...	21/9	10in. x 6in. Units by Plessey ... 25/6
MT3—3-way mounting. Primary 200/250 v. Secondary 0-12-15-20-24-30 v. 2 amps. Can be tapped for practically any voltage in steps of 3 up to a maximum of 30 v. ...	21/9	
MT4—0-10 v.-120 v.-200 v.-250 v. 150 w. Auto transformer ...	21/9	
MT4A—As above. 60 w. ...	15/6	
MT5—3-way mounting. Primary 200/250 v. Secondary 0-5 v.-11 v.-17 v. at 4 a. Charger Transformer to charge 2 v.-6 v.-12 v. batteries ...	21/-	
MT5A—As above. 2 a. ...	15/-	

**ALPHA RANGE OF LOUDSPEAKER UNITS**

\* All brand new. \* Note Special Prices.  
\* All Permanent Magnet 3 ohms Impedance.

5in. Units by Plessey, Goodmans, Lectrona ...	17/6
6in. Units by Plessey ...	18/6
8in. Units by Goodmans ...	19/6
10in. Units by Elac, Plessey ...	25/6
6in. x 4in. Units by Plessey ...	19/6
7in. x 4in. Units by Goodmans ...	19/6

8in. Loudspeaker Unit, 3 ohms Impedance with a Matching Output Transformer suitable for 6V6. Brand New but soiled, offered at a Special Price of 11/6 each, postage 2/-.	each	17/6
6in. Mains Energised Loudspeaker with Matching Output Transformer, Field Coil, 6,000 ohms ...	each	17/6
8in. Mains Energised Loudspeaker with Matching Output Transformer, Field Coil, 600 ohms ...	21/-	

**LINE OUTPUT TRANSFORMERS**

Type No. Used in Model No. Price	
LO1 Pye V14C, PAM 750-751, Invicta 126, 122 ...	47/10
LO2 Pye VT17, PAM 752-753 ...	46/11
LO3 Pye 754-755, Invicta 123-124, 125 - 133 - 134, CS17C, CTM17T, CW17, CS17, CW17T ...	46/11
LO4 Pye V4-V7-VT4-VT7 ... PAM 908-909-952-953-958, Invicta 118-119-120 ...	55/2
LO5 Pye V2-VT2, PAM 954 ...	39/5
LO8 Pye V54C ...	47/2
LO9 Pye MV30, Invicta 108-110 ...	37/6
LO10 PAM 906, Invicta 114-115, Pye FV2C, FV4C, PAM 901 ...	50/9

LO11 Invicta 112-117-904, PAM 904 ...	37/6
LO12 Invicta 105-107-111 ...	55/11
LO13 Regentone BIG 12/5 ...	81/11
LO14 Regentone 14T, BIG 15/5 and 17T ...	109/3
LO15 Regentone BIG 15-17T-17C and 17 COMB ...	88/-
LO16 Regentone R143T, R143C, R173T, R173C, R173 COMB ...	95/-
LO17 Alba T372, T472, T372V, T392, T492-9872B, TR9872, UI253 ...	43/2
LO18 Alba T483B, T493, 0971B, T483-0971 ...	46/-
LO19 Alba T394, T484, 5874, T304, T494, T504, 1974, T301 ...	43/2
LO20 T321, R324, T524, T424 ...	34/5
LO21 T536, T436 ...	43/2
LO22 Regentone BIG 12 ...	90/-
LO23 Cossor 935-933-940-939-934-937-938-931, R17A-942-944-946-930-943 ...	61/11
LO24 Cossor 927-932-929 ...	58/6
LO25 Cossor 919-920-921-924-926-925-928 ...	69/5
LO26 Cossor 916-917-918-923 ...	76/-

**L.T. METAL RECTIFIERS FULL WAVE**  
12 volt 1 amp., 4/3 ; 12 volt 2 amp., 7/- ; 12 volt 3 amp., 10/- ; 12 volt 4 amp., 12/6 ; 12 volt 6 amp., 15/9. Order now. We do not expect these rectifiers to last long at these give-away prices.



**103 LEEDS TERRACE  
WINTON STREET  
LEEDS 7**

**TERMS : Cash with order or C.O.D. Postage and Packing charges extra, as follows : Orders value 10/- add 1/- ; 20/- add 1/6 ; 40/- add 2/- ; £5 add 3/- unless otherwise stated. Minimum C.O.D. fee and postage 3/-. All single valves postage 6d. Personal Shoppers Monday-Friday 9 a.m. to 5 p.m. Saturday 10 a.m. to 1 p.m.**

**R.S.C. BATTERY CHARGING EQUIPMENT**

All for A.C. Mains 200-250 v., 50 ccs. Guaranteed 12 months.

**ASSEMBLED CHARGERS**

6 v. 1 amp	19/9
6 v. or 12 v. 1 amp	27/9
6 v. 2 amps	29/9
6 v. or 12 v. 2 amps	38/9
6 v. or 12 v. 4 amps	56/9

Above ready for use. With mains and output leads. Carr. 3/5.

**SELENIUM RECTIFIERS**

<b>F.W. BRIDGE TYPES</b>	
6/12 v. 1 a.	3/11 LT. Types H.W.
6/12 v. 2 a.	7/3 2-5 v. 1 a. 1/11
6/12 v. 3 a.	9/9 3/12 v. 1 a. H.W. 2/9
6/12 v. 4 a.	13/11 LT. Types H.W.
6/12 v. 6 a.	14/11 150 v. 40 mA. 3/9
6/12 v. 10 a.	25/9 250 v. 50 mA. 5/9
6/12 v. 15 a.	35/9 250 v. 80 mA. 7/9
24 v. 2 a.	14/9 250 v. 250 mA. 11/9
24 v. 6 a.	26/9 250 v. 250 mA. 11/9

**BATTERY CHARGER KITS**

Consisting of Mains Transformer, F.W. Bridge, Metal case, Fuses, Fuse-holders, Grommets, panels and circuit. Carr. 2/9 extra.

6 v. or 12 v. 1 amp	22/9
As above, with Ammeter	32/9
6 v. 2 amps	25/9
6 v. or 12 v. 2 amps	31/6
6 v. or 12 v. 2 amps. Inclusive of Ammeter	41/6
6 v. or 12 v. 4 amps	53/9

**BATTERY CHARGER KIT**  
6/12 v. 6 amp, consisting of F.W. Bridge Rectifier, Mains Trans. and Ammeter. 49/9.  
Post and packing 4/6.

**ASSEMBLED CHARGER**

6 v. or 12 v. 2 amps.  
Fitted Ammeter and selector plug for 6 v. or 12 v. Metal case finished attractive hammer blue. Ready for use. With mains and output leads. Double Fused.  
Only 49/9  
Carr. 3/9



**Assembled 6 v. or 12 v. 4 amps.**

Fitted Ammeter and variable charge rate selector. Also selector plug for 6 v. or 12 v. charging. Louvered steel case with stoved blue hammer finished. Fused 7/5- and ready for use with Carr. 4/6 mains and output leads. Credit Terms: Deposit 14/11 and 5 monthly payments 14/11.

**R.S.C. MAINS TRANSFORMERS (GUARANTEED)**

Interleaved and Impregnated. Primary: 200-230-250 v. 50 ccs. Screened.  
**TOP SHROUDED DROP THROUGH**  
250-250 v. 70 mA. 6.3 v. 4 a. 5 v. 2 a. 16/9  
350-350 v. 80 mA. 6.3 v. 2 a. 5 v. 2 a. 18/9  
250-250 v. 100 mA. 6.3 v. 4 a. 5 v. 3 a. 23/9  
300-300 v. 100 mA. 6.3 v. 4 a. 5 v. 3 a. 23/9  
350-350 v. 100 mA. 6.3 v. 4 a. 5 v. 3 a. 23/9  
350-350 v. 100 mA. 6.3 v. 4 a. 4 a. C.T. 0-4-5 v. 3 a. 23/9  
350-350 v. 150 mA. 6.3 v. 4 a. 5 v. 3 a. 29/9  
**FULLY SHROUDED UPRIGHT**  
250-250 v. 60 mA. 6.3 v. 2 a. 5 v. 2 a. 17/6  
Midjet types 21-3-in. 17/6  
250-250 v. 100 mA. 6.3 v. 4 a. 5 v. 3 a. 26/9  
250-250 v. 100 mA. 6.3 v. 6 a. 5 v. 3 a. 26/9  
for R1355 conversion ... 31/2  
300-300 v. 100 mA. 6.3 v. 4 a. 5 v. 3 a. 26/9  
350-350 v. 100 mA. 6.3 v. 4 a. 5 v. 3 a. 26/9  
300-300 v. 130 mA. 6.3 v. 4 a. 6.3 v. 1 a. 26/9  
for Mullard 510 Amplifier ... 35/9  
350-350 v. 150 mA. 6.3 v. 4 a. 5 v. 3 a. 33/9  
350-350 v. 150 mA. 6.3 v. 2 a. 6.3 v. 2 a. 5 v. 3 a. 35/9  
425-0-425 v. 200 mA. 6.3 v. 4 a. C.T. 6.3 v. 4 a. C.T. 5 v. 3 a. Suitable Williamson Amplifier, etc. ... 49/9

**CHARGER TRANSFORMERS**  
All with 200-230-250 v. 50 c/s Primaries:  
0-9-15 v. 11 a., 11/9; 0-9-15 v. 3 a. 16/9;  
0-9-15 v. 5 a. 19/9; 0-9-15 v. 6 a. 23/9.

**SMOOTHING CHOKES**  
150 mA. 7-10 H 250 ohms... 11/9  
100 mA. 100 H 200 ohms... 8/9  
80 mA. 10 H 350 ohms ... 5/9  
60 mA. 10 H 400 ohms ... 4/11

**OUTPUT TRANSFORMERS**  
Midjet Battery Pentode 66:1 low 3S4, etc. ... 3/9  
Small Pentode, 5,000 Ω to 3 Ω ... 3/9  
Small Pentode 78,000 Ω to 3 Ω ... 3/9  
Standard Pentode 5,000 Ω to 3 Ω ... 4/9  
Standard Pentode, 7,800 Ω to 3 Ω ... 4/9  
10,000 Ω to 3 Ω ... 4/9  
Push-Pull 10-12 watts 6V6 to 3 or 6V8 ... 15/9  
to 3-5-8 or 15 Ω ... 16/9  
Push-Pull EL84 to 3 or 15 Ω ... 16/9  
Push-Pull 15-18 watts, 6L6, KT68 ... 22/9  
Push-Pull for Mullard 510 Ultra Linear ... 29/9  
Push-Pull 20 watts sectionally wound 6L6, KT68, etc., to 3 to 15 Ω ... 47/9

**ELIMINATOR TRANSFORMERS**  
Primaries 200-250 v. 50 c/s.  
12 v. 40 mA, 5-0-5 v. 1 a. ... 15/9  
90 v. 15 mA, 4-0-4 v. 500 mA. ... 9/9

**STAR GALAXY 4-SPEED MIXER AUTO-CHANGER.** A precision manufactured unit with a motor which virtually eliminates "wow" and rumble. Fitted pick-up with dual sapphire tipped stylus. For 200-250 v. A.C. mains. Limited stock. S/t cracks. Only £4-19-6  
Brand New, cartoned. Carr. 4/6.

**PORTABLE CABINETS.** High Quality Finish. Rexine covered. Attractive design. Inside measurements: 17in. x 12in. x 8in. high. Clearance above base-board 5in. Below 2in., 69/9 each.

**SPECIAL OFFER.** Above cabinet. LG3 Amplifier, Stear Charger and 6in. P.M. Speaker. 11 GNS. Carr. 7/6.

**THE SKYFOUR T.R.F. RECEIVER.** A design of a 3-valve Long and Medium wave 200-250 v. A.C. Mains receiver with selenium rectifier. High gain H.P. stage and low distortion anode bend detector. Power pentode output. Valve line-up 6X7, 6SP6, 6V6G. Selectivity and quality arc well up to standard, and simplicity of construction is a special feature. Point-to-Point wiring diagrams, instructions and parts lists, 1/9. Maximum building costs £4.19.6, inc. attractive Brown or Cream Bakelite or Walnut veneered wood cabinet 12 x 6 1/2 x 5 1/2 in.

**FILAMENT TRANSFORMERS**  
All with 200-250 v. 50 c/s. primaries 6.3 v. 1.5 a. 5/9; 6.3 v. 2 a. 7/6; 0-4-6.3 v. 2 a. 7/9; 12 v. 1 a. 7/11; 6.3 v. 3 a. 8/11; 6.3 v. 6 a. 17/6; 12 v. 3 a. or 24 v. 1.5 a. 17/6.

**R.S.C. BATTERY TO MAINS CONVERSION UNITS**

Type BML. An all-dry battery eliminator. Size 5 1/2 x 4 1/2 x 2 1/2 in. approx. Completely replaces battery supplying 1.4 v. and 90 where A.C. mains 200-250 v. 50 c/s is available. Suitable for all battery portable receivers requiring 1.4 v. and 90 v. This includes latest low consumption types.  
Complete kit with diagrams, 39/9. or ready to use, 46/9.



Type BM2. Size 8 x 5 1/2 x 2 1/2 in. Supplies 120 v. 90 v. and 60 v. 40 mA. and 2 v. 0.4 a. to 1 amp. fully smoothed. Thereby completely replacing both H.T. batteries and L.T. 2 v. accumulators. When connected to A.C. mains supply 200-250 v. 50 ccs. **SUITABLE FOR ALL BATTERY RECEIVERS** normally using 2 v. accumulator. Complete kit of parts with diagrams and instructions, 49/9. or ready for use, 59/6.

**STEREOPHONIC EQUIPMENT AT SPECIAL PRICES**

(a) Linear L33 Stereo Amplifier, 7 GNS.; (b) Star Galaxy Auto-Changer fitted Turn-over head for Stereo, Long Playing and Standard Records, £3.19.6, carr. 4/6; (c) Matched 12in. P.M. Speakers in polished Walnut finished wood cabinets, £8.15.0 per pair; (d) Cabinet Speakers, illustrated below, £9.19.0 pair; (e) Matched High Flux 6in. P.M. Speakers in polished Walnut veneered Cabinet, £3.19.9 pair; (f) Matched 6in. R.A. 19 GNS., carr. 15/-; (a), (b) and (d) 22 GNS., carr. 15/-; (a), (b) and (e) 18 GNS., carr. 15/-; (a), (b) and (f) 17 GNS., carr. 15/-.

**12in. 10 WATT HIGH QUALITY LOUD-SPEAKERS IN POLISHED WALNUT FINISHED CABINET**  
Gauss 12,000 lines. Speech coil 3 ohms or 15 ohms. Only £4.19.6 Carr. 5/-.  
Terms: Deposit 11/- and 9 monthly payments

**D.C. SUPPLY KIT,** 12 v. 1 a. consisting of partially drilled metal case, mains trans., F.W. Bridge Rectifier. 2 fuse-holders and fuses. Change Direction switch, variable Speed regulator and circuit. For 200-250 v. A.C. mains. Suitable Electric Trains, etc. Limited number available at 29/9.

**ACOS CRYSTAL 'MIKE' INSERTS.** Approx. 1in. square. Fly lead connections. Only 5.11 each. Brand New. Round type approx. 1in. diam. Ex-equipment, tested. 4/11 each.

**AM/FM RADIOGRAM**

By leading manufacturer, Brand New. Cartoned with guarantee. 4 wavebands including V.H.F. Auto-changes at 3 speeds. Hi-fi duo-point sapphire stylus pick-up. 29 1/2 GNS.  
For 200-250 v. A.C. mains. Limited stocks at a fraction of normal price. Credit Terms. Deposit £6.19.6 and 9 monthly payments of 3 GNS. Carr. 10/-

**COMPLETE AUTO-CHANGER RECORD PLAYERS, 4-SPEED.** By well-known manufacturer. Hi-fi crystal pick-up. Matched amplifier and speaker. Attractive, well-finished rexine covered cabinet. For 200-250 v. A.C. mains. Brand New. Cartoned. Limited number. List price well over 15 GNS. Carr. 10/- £20.

**AM/FM RADIOGRAM CHASSIS HIGH QUALITY 6-8 WATT PUSH-PULL OUTPUT**  
For 200-250 v. Mains. Long wave. Medium. F.M. and Gram. Complete with 8 B.V.A. valves. Guaranteed 12 months. Only 22 GNS. Or Deposit £2.12.0 and 9 monthly payments of £2.12.0.

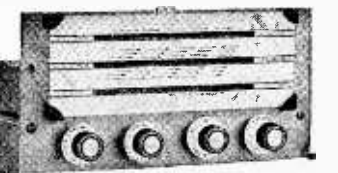



**R.S.C. A8 ULTRA LINEAR 12 WATT AMPLIFIER**

High-Fidelity Push-Pull Amplifier with "Built-in" Tone Control. Pre-amp stages, high sensitivity, includes 5 valves (407 outputs). High Quality sectionally wound output transformer, specially designed for Ultra Linear operation, and reliable small condensers of current manufacture. INDIVIDUAL CONTROLS FOR BASS AND TREBLE - "Lift" and "Cut". Frequency response +3 db, 30-30,000 c/c.s. Six negative feedback loops. Hum level 71 db. down. ONLY 70 millivolts INPUT required for FULL OUTPUT. Suitable for use with all makes and types of pick-ups and practically all microphones. Comparable with the very best designs.

For STANDARD or LONG - PLAYING RECORDS. For MUSICAL INSTRUMENTS such as STRING BASS, GUITARS, etc. OUTPUT SOCKET with plug provides 300 v., 20 mA. and 6.3 v. 1.5a. For supply of a RADIO FEEDER UNIT. Size approx. 12.9-7in. For A.C. mains 200-230-250 v. 50 c.c.s. Outputs for 3 and 15 ohm speakers. Kit is complete to last nut. Chassis is fully punched. Full instructions and point-to-point wiring diagrams supplied. Unapproachable value. at £7/15-0 or factory built 45/- extra. Carriage 10/-.  
If required louvred metal cover with

**£7-15-0**

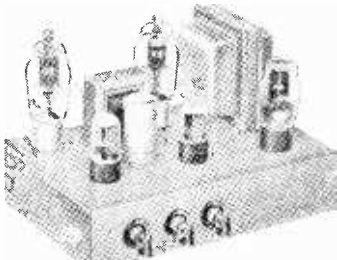

carrying handles can be supplied for 18/9. Additional input sockets, with associate Vol. control so that two different inputs such as Gram and Mike or Tape and Radio can be mixed, can be provided for 13/- extra. Guaranteed 12 months. TERMS on assembled two input model: DEPOSIT 18 10 and 12 monthly payments. 18 10. HIGH FIDELITY MICROPHONES and SPEAKERS in stock. Keen cash prices or credit terms if supplied with amplifier.

**R.S.C. 30 WATT ULTRA LINEAR HIGH FIDELITY AMPLIFIER A10**

A highly sensitive Push-Pull high output unit with self-contained Pre-amp, Tone Control Stages. Certified performance figures compare equally with most expensive amplifiers available. Hum level 70 db. down. Frequency response 3 db., 30-30,000 c.c.s. A specially designed sectionally wound ultra linear output transformer is used with 407 output valves. All components are chosen for reliability. Six valves are used, EF86, EF86, ECC83, 807, 807, GZ33. Separate Bass and Treble Controls are provided. Minimum input required for full output is only 12 millivolts so that ANY KIND OF MICROPHONE OR PICK-UP IS SUITABLE. The unit is designed for CLUBS, SCHOOLS, THEATRES, DANCE HALLS or OUTDOOR FUNCTIONS, etc. For use with Electronic ORGAN, GUITAR, STRING BASS, etc. For standard or long-playing records. OUTPUT SOCKET PROVIDES L.T. and H.T. for a RADIO FEEDER UNIT. An extra input with associated vol. control is provided so that two separate inputs such as Gram and Mike can be mixed. Amplifier operates on 200-250 v. 50 c.c.s. A.C. Mains and has output for 3 and 15 ohm speakers. Complete kit of parts with fully punched chassis and point-to-point wiring diagrams and instructions. If required cover as for A8 can be supplied for 18/9. The amplifier can be supplied, factory built with 12 months' guarantee, for £13.18.6. TERMS: DEPOSIT 24 9 and 12 monthly payments of 24 9.

**11 GNS.**

Carr. 10/-

**COLLARO RC54 3-SPEED AUTO-CHANGERS** with Studio Pick-up. Brand new. For 110 v. 50 c.p.s. A.C. mains. Price with 110 v. to 220-250 v. Auto Trans. only £5/19.6. Carr. 5/6.

**COLLARO CONQUEST 4-SPEED AUTO-CHANGER** with high fidelity Studio Pick-up. Latest model. Brand new. Cartoned. For 200-250 v. 50 c.p.s. A.C. mains. Price £7/19.6. Carr. 5/6.

**COLLARO 4-SPEED-SINGLE PLAYER** with separate pick-up, as fitted RC457. For 200-250 v. A.C. mains. £4/10.0. Post 3/1.

**PICK-UP ARMS** complete with Hi-Fi turnover crystal head. Acos GP54. Limited number brand new, perfect, at approx. half price. Only 29/9.

**LG3 MINIATURE 2-3 WATT GRAM AMPLIFIER.** For use with above or any other single or auto-change units. Output for 2-3 ohm speaker. For 200-250 v. 50 c.p.s. A.C. mains. Overall size 6 1/2 x 4 1/2 x 2 1/2 in. Controls: Vol. and Tone with switch. Guaranteed 12 months. Only 55/9.

**SUPERHET FEEDER UNIT.** Design of a high quality Radio Tuner Unit (specially suitable for use with any of our Amplifiers). Delayed A.V.C. employed. The W.Ch. Sw. incorporates Gram position. Controls are Tuning, W.Ch. and Vol. Only 250 v. 15 mA. H.T. and L.T. of 6.3 v. 1 amp. required from amplifier. Size of unit approx. 9.5-7in. high. Simple alignment procedure. Point-to-Point wiring diagrams. Instructions and priced parts list with illustration, 2/6. Total building cost 24 15/- . For descriptive leaflet send S.A.E.

**LINEAR L45 MINIATURE 4.5 WATT QUALITY AMPLIFIER.** Suitable for use with Collaro, B.S.R. or any other record playing unit, and most microphones. Negative feedback 12 db. Separate Bass and Treble Controls. For A.C. mains input of 200-250 v. 50 c.c.s. Output for 2-3 ohm speaker. Three miniature Mullard valves used. Size of unit only 6.5-5 1/2 in. high. Output for 2-3 ohm speaker. Guaranteed for 12 months. Only 25/19.6. Send S.A.E. for illustrated leaflet. Credit Terms. Deposit 22 6 and 5 monthly payments of 22 6.

**LINEAR "DIATONIC" 10-14 WATT HIGH FIDELITY PUSH-PULL ULTRA LINEAR AMPLIFIER.** For 200-250 v. A.C. mains. Valves ECC83, ECC83, EL84, EL84, EZ81 miniature Mullard. Self-contained Pre-amp. Tone Control stage, and separate Bass and Treble Controls. Independent Mike and Gram input sockets are provided. Output Matches for 3 and 15 ohm speakers. Only 12 GNS. or Deposit 22 3 plus 10/- carr. and 12 monthly payments of 22 3. Send S.A.E. for leaflet.

**R.S.C. 4.5 WATT AS HIGH-GAIN AMPLIFIER**

A highly-sensitive 4-valve quality amplifier for the home. small club, etc. Only 50 millivolts input is required for a full output so that it is suitable for use with the latest high-fidelity pick-up heads, in addition to all other types of pick-ups and practically all "mikes". Separate Bass and Treble Controls are provided. These give full long-playing record equalisation. Hum level is negligible being 71 db. down. 15 db. of negative feedback is used. H.T. of 300 v., 25 mA. and L.T. of 6.3 v., 1.5 a. available for the supply of a Radio Feeder Unit, or Tape-Deck pre-amplifier. For A.C. mains input of 200-230-250 v. 50 c.c.s. Output for 2-3 ohm speaker. Chassis is not alive. Kit is complete in every detail and includes fully punched chassis (with baseplate) with Blue hammer finish and point-to-point wiring diagrams and instructions. Exceptional value at only 24 15/-, or assembled ready for use 25/- extra, plus 3/6 carr. or Deposit 22 6 and 5 monthly payments of 22 6 for assembled unit.

**LINEAR STEREPHONIC L3 3-4-3 WATT QUALITY AMPLIFIER**

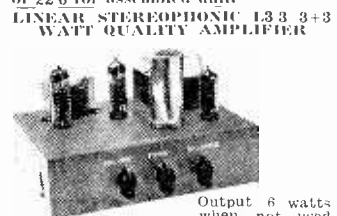

Output 6 watts when not used with stereo head. For 200-250 v. 50 c.p.s. A.C. mains. Ganged controls, Volume and Tone. Outputs matched by preset balance control. For use with 2 matched 3 ohm speakers. Only requires connecting to Pick-up speakers and mains point. Sensitivity 150 m.v. Supplied with guarantee and instructions. Send S.A.E. for leaflet. Terms available.

**7 GNS.**

Terms: C.W.O. or C.O.D. No C.O.D. under £1. Post 1/9 extra under £2; 2/9 extra under £5. All goods supplied subject to terms and guarantee as detailed in current catalogue. Open 9 to 5.30; Weds. until 1 p.m. Catalogue 6d. Trade supplied. S.A.E. with all enquiries.

**LINEAR 50 WATT HIGH FIDELITY AMPLIFIER.**

Sensitivity 25 millivolts for full output. Suitable for any kind of microphone or pick-up. Output matches for 3 and 15 ohm speakers. Brand New. Guaranteed 12 months. For 200-250 v. A.C. mains. Only 19 gns. Carr. 7/6. Terms available. Twin handled cover available at 25/- . Send S.A.E. for leaflet.

**LINEAR LT45 HIGH QUALITY TAPE DECK AMPLIFIER.**

With "built in" power pack and output Ready for stage. For Tape Decks Use ONLY with High or Low Impedance. Playback and Erase Heads, such as Lane, Truvox, Collaro, Brenco. Carr. 7/6 c.c.s. For A.C. Mains 200-250 v. 50 c.c.s. Linear Frequency response of + 3 db. 50-11,000 c/c.s. Negative feedback equalisation. Illustrated leaflet 6d.

**12 GNS.**

**SPEAKERS.** All 2-3 ohms, suitable for use with LG3, L45, A5 or A7 amplifiers, 5in. Goodmans, 17/9. 7 x 4in. Elliptical Elac., 19/9. 6in. Goodmans, 17/9. 8in. Rola, 19/9. 10in. R.A., 27/9. 10 x 6in. Elliptical Goodmans, 29/9. 12in. Plessey, 29/11. 10in. W.B. Stentorian 3 or 15 ohms type HF1012 10 watts, hi-fidelity type. Recommended for use with our A8 Amplifier. £4 10/9. 12in. Plessey 2 ohms 10 watts (12,000 lines), 59/6.

**PLESSEY DUAL CONCENTRIC 12in. 15 ohms HIGH FIDELITY SPEAKER** (12,000 lines) with built-in tweeter (completely separate elliptical speaker with choke, condensers, etc. proving extraordinarily realistic reproduction when used with our A8 or similar amplifier. Rated 10 watts. Price only 25/17/6.

**ACOS HGP55 Hi-Fi Crystal Cartridges.** (Turnover type with sapphire stylus) Standard replacement for Garrard and B.S.R. Only 19/9.

**R.S.C. 3-4 WATT A7 HIGH-GAIN AMPLIFIER**

For 230 250 v. 50 c.c.s. Mains input. Appearance and Specification, with exception of output wattage, as A5. Complete Kit with diagrams, 23/15/- . Assembled 22/6 extra. Carr. 3/6.

**RADIO SUPPLY CO. (LEEDS) LTD.** Mail Orders to 29/31 Moorfield Rd., Leeds 12. Callers to 5 and 7 County Arcade, Briggate, Leeds 1.

# A television course for you to study at home

Entirely new! Practical!  
Bang up to date!

## THE FAMOUS BENNETT COLLEGE OFFERS YOU THIS

An entirely new course of study based upon up-to-date techniques has now been prepared by The Bennett College.

The course is non-mathematical, and contains clear diagrams, starting from the very beginning (even including the basic principles of sound radio receivers, if desired) and covering all that you need to know!

This is what you've been looking for! A home-study course includes: production

of the signal, scanning and reproduction of picture from signal. Aerials, types and purpose. The cathode-ray tube. Time-base oscillators, and output circuits. Synchronisation. Video frequency amplifiers. The TV tuner, turret, incremental, etc. Television test gear. Television faults.

For more details, fill in the coupon below. Your studies cost little, the book you need is included in the cost.

THE BENNETT COLLEGE (Dept. B104TV, Sheffield)

Please send me details of the new  
TELEVISION SERVICING COURSE

NAME .....

ADDRESS .....

AGE .....

# Best Buy at Britain's

R.F. UNITS. R.F.24, 12/6; R.F.26, 17/6; R.F.27, 22/6; Condition as new. Post each, 3/6.

CR100 COMMUNICATIONS RECEIVERS. Covers 60 kc/s—30 Mc/s in 6 bands. 11 valves, 2 R.F. and 3 I.F. stages. Crystal rate, B.P.O. etc. Ready for 200-250 v. A.C. mains. 2T watts output, for 3 ohms speaker. SUPERB CONDITION AND OUTSTANDING PERFORMANCE for ONLY £21. S.A.E. for illustrated details.

CR100 SPARES KITS. 15 valves, 2 of U50, DH63, KT63, X66 and 7 KTW61. Output transformer, resistors, condensers, electrolytics, lamps. ALL BRAND NEW, 59/6, post 4/6.

HRO COMMUNICATIONS RECEIVERS, complete with 9 coils. From 18 gns. S.A.E. for full particulars.

R1155B, with latest drive, first-class condition, £7.19.6. R1155L, £12.19.6. S.A.E. for full particulars.

MOVING COIL 'PHONES.—Finest quality Canadian, with Chamois ear-muffs and leather covered headband. With lead and jack plug. Noise excluding, supremely comfortable, 19/6, post 2/6.

MOUSE TRAINERS.—Uses two valve oscillators (one with ritch control). For one or two operators. In polished oak case 12 1/2 x 10 x 8 in. With leads, 2 keys, circuit and instructions. Less batteries and 'phones. Special CHRISTMAS AND NEW YEAR OFFER. 12/6, carr. 7/6. Headphones, 7/6 pair.

INVICTA LOUDSPEAKERS.—Good quality 10 in. unit (impedance 3 ohms) in wooden cabinet 17 x 17 x 6 in. Complete with 50 ft. lead and jack plug, BRAND NEW, 39/6, carr. 5/6.

WESTON E772 ANALYSERS.—Multimeter. Current, 0 to 100 microamps 1, 10, 50, 100, 500 mA., D.C. 0 to 1, 1.5 Amps. A.C. volts. 0 to 2.5, 10, 50, 250, 1,000, D.C. and A.C. Resistance 0 to 100, 1,000, 100 K., 10 Megohms. Complete in "Rexine" covered carrying case, with leads and battery. Guaranteed, £8.19.6, carr. 4/6.

AMRIBOX MULTIMETERS, by Precision U.S.A. 400 microamps basic, A.C. and D.C. volts to 6,000 D.C., milliamps to £0. Ohms to 5 Megs., 20 ranges in all. In polished wooden case, 7 1/2 x 7 1/2 x 5 1/2. Complete with leads, batteries and instructions. Tested and guaranteed, £5.19.6, post 3/6.

INSULATION TESTERS.—"Recorded" hand generator type, C-50 Megohms at 500 v. pressure. In leather case, £7.19.6, post 4/6.

TRANSFORMER BARGAIN.—Input 0-200/250 tapped. Outputs 250-0-250 v., 80 mAmps.; 5 v. 2 Amps.; 6.3 v. 4.5 Amps. Upright mtg. BRAND NEW, Boxed, Ex-Admiralty, made 1952. A fine 50 c s. mains tranny for ONLY 18/6. Post FREE.

PLEASE ADD POSTAGE OR CARRIAGE ON ALL ITEMS

CHARLES BRITAIN (RADIO) LTD.  
11 Upper Saint Martin's Lane, London, W.C.2

Temple Bar 0545

Shop Hours 9-6 p.m. (9-1 p.m. Thursday). Open All Day Saturday.

## EDDYSTONE COMMUNICATION RECEIVERS



Model 840A illustrated

Model	Cash Price	12 Monthly Payments of
820 VHF Unit	£16 16 0	£1 10 0
870	£34 16 0	£3 2 6
840A	£55 0 0	£5 0 0
858A	£110 0 0	£10 0 0
680X	£120 0 0	£10 18 0

Carriage paid per passenger train.

Models 840A and 870 are A.C./D.C. 110/250 v. Others are 110/240 v. A.C. These sets are the choice of the discerning professional and amateur users. Descriptive literature gladly forwarded.

The  
**Eddystone**  
Specialists  
**RADIO SERVICES LTD.,**  
51, COUNTY ROAD, LIVERPOOL, 4  
Telephone: AINTREE 1445 ESTAB. 1935

## COVENTRY RADIO

Audio & Component Specialists Est. 1925  
189-191, Dunstable Rd., Luton, Beds.  
HI-FI EQUIPMENT CABINETS IN

Record Housing: "Stork" Range in Oak, Walnut, Mahogany.

Speaker Enclosure...	£5.17.6
Equipment Cabinet...	£5.19.6
Record Cabinet (159 records)...	£4.17.6
Continental Bench...	£4.17.6
Polenaise Hi-Fi Cabinet...	£11.5.0
W.K. Prelude Speaker Cabinet...	£11.11.0
W.B. Prelude Equipment Cabinet...	£13.13.0
W.B. Prelude Corner Speaker Cabinet...	£10.10.0
W.B. Table Equipment Cabinet...	£9.19.6
W.B. Senior Hi-Fi Console...	£18.18.0
W.B. Junior Hi-Fi Console...	£12.12.3
W.B. Junior Base Reflex...	£9. 9.0
W.B. Standard Base Reflex...	£10.10.0
W.B. Senior Base Reflex Corner Cabinet...	£11.11.0
B.K. AUDIO PLAN	
B.K. Speaker Cabinet...	£16.19.6
B.K. Equipment Cabinet...	£17.19.6
B.K. Record Cabinet...	£16.18.0
B.K. Continental Bench 48in...	£7. 7.0
B.K. Continental Bench 72in...	£13.19.0
B.K. Set 4 Legs tilt & glide feet...	£3. 3.0
B.K. Set 4 Legs Plain Ebonised	19.6
SOUTHDOWN HI-FI Cabinet...	£29.10.0
R.C.A. Lowboy Cabinet...	£18.10.0
HIFALS Chairside for Quad...	£29. 5.0
HIFALS Chairside...	£37. 0.0
BEPARCLIFFE Equipment Cabinet...	£30. 9.0
ARMSTRONG Equipment Cabinet...	£34.19.0

Leaflets available on request.

## FM and HI-FI Components

DENCO F.M. TUNER circuits	1s. 6d.
RADIO CONST'R. F.M.	2s. 0d.
MULLARD AMPLIFIERS	3s. 6d.
G.E.C. 912 PLUS AMPLIFIER	4s. 0d.
JUPITER STEREO UNIT	2s. 6d.

Separate price lists available on request to  
**J. T. FILMER 82, DARTFORD RD., DARTFORD, KENT.**  
Tel. Dartford 4057.

## B.B.C.-I.T.V.-F.M. AERIALS

B.B.C. (Band 1).—Telescopic loft, 19/6. External S/D, 23/6. "X" Chimney unit, 75/-.

I.T.V. (Band 3).—3-element, loft array, 24/-; 5-element, 32/6. Wall mounting, 3-element, 33/9; 5-element, 41/3.

Combined B.B.C. & I.T.V. Loft 1+3 element, 41/3; 1+5 element, 49/6. Wall mounting, 1+3 element, 56/3; 1+5 element, 63/9. Belling "Golden V" room aerial, 42/-.

Antiference "V", 25/-.

F.M. (Band 2).—Loft "H" 28/-; 3-element, 52/6. S/D loft, 12/6. External S.D., 26/3. State channel when ordering. C.W.O. or C.O.D. PIP 2/6. Coaxial cable, 8d. yd. Coaxial plugs, 1/3. Send fd. stamps for Illustrated Lists.

K.V.A. ELECTRONICS (Dept. P.W.).  
3B, Godstone Road, Kenley, Surrey.

## Genuine British Transistors

EDISWAN XB101 10/-  
Full details supplied  
**WHITE SPOT 1/36**  
**RED SPOT 7/6**  
**GREEN/YELLOW 7/6**  
**RED/YELLOW 15/6**  
**CRYSTAL DIODES 1/-**  
Teletron TRANSYDYNE 6 transistor s/het. FULL KIT, £11.19.6. Circuit 11d.  
Resistors: All Values 10c. 1 watt, 8d. ea.  
ELECTROLYTICS—GUARANTEED  
16—16 mid. 450 v. 150 mA. 2 1/2" x 1". 4/3.  
16 mid. 450 v. 150 mA. 1 1/2" x 1". 2/4 each.  
8-8 mid. 450 v. 100 mA. 1 1/2" x 1". 2/8.  
8-16 mid. 450 v. 100 mA. 1 1/2" x 1". 2/8.  
50 mid. 50 v. 100 mA. 25 v. 1.8  
ALL PRICES ARE POST PAID.  
TERMS: C.W.O. or C.O.D. (over 12).

**OAKFIELD RADIO**  
"The Transistor People."  
44 OAKFIELD ROAD, STOCKPORT

# PREMIER RADIO COMPANY

Tel.: AMBassador 4033

B. H. MORRIS & CO. (RADIO) LTD.

Tel.: MUS. 3451

207 EDGWARE RD., LONDON, W.2 & 23 TOTTENHAM COURT RD., LONDON, W.1



## The "Petite" PORTABLE

MAY BE BUILT FOR

**£7.7.0**

Plus p. & p. 3/-

Batteries Extra. H.T. 10 - (type B125) or equivalent. L.T. 1/6 (type AD35) or equivalent.

★Size only 8in. x 8in. x 4 1/2in.

★Instruction book 1 6.

PREMIER BATTERY ELIMINATOR. housed in two containers which are approx. the same size as AD35 and B125 Batteries. Kit 37 6 plus 2 - p. & p.

These two receivers use the latest type circuitry and are fitted into attractive cabinets 12in. x 6 1/2in. x 5 1/2in. in either walnut or ivory bakelite or wood (1/- extra). Individual instructions books 1/- each, post free.

2 BAND T.R.F. MAY BE BUILT FOR **£5.10.0**

3 BAND SUPERHET MAY BE BUILT FOR **£7.7.0**

Postage & Packing 3/- (either kit)

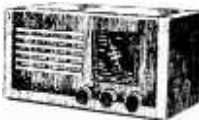

## THE PREMIER 7 WATT STEREOGRAPHIC AMPLIFIER KIT

This amplifier uses 2—ECL82 valves. 1—12AX7 valve. 1—EZ80 valve rectifier. Provision is made for both 3 ohms and 15 ohms speakers. The base and treble tone controls are ranged and balance is achieved with a separate control. Parts may be assembled on a gold hammered finished chassis, with a black perspex dial with gold lettering. Complete set of parts. Price **£6 19'6** plus 5 - p.p. Instruction booklet. 1 -.

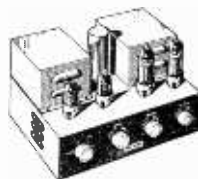

## THE PREMIER 3 + 3 STEREOGRAPHIC AMPLIFIER KIT

This amplifier uses 2—ECL82 valves and EZ80 rectifier. Provision is made for 3 ohms and 15 ohms speakers, one ranged tone control and balance control. Complete set of parts. Price **£4 19'6**. Instruction booklet. 1 -.

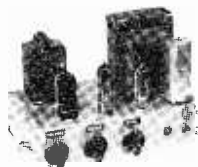

**GENEROUS H.P. TERMS AVAILABLE, MINIMUM DEPOSIT NOW ONLY 10% REPAYMENTS TO SUIT YOUR POCKET.**

## PREMIER Portable STEREO AMPLIFIERS

### THE PREMIER STANDARD STEREO PORTABLE

2 Premier 1 valve 21 watt Amplifiers **£5 19'6**, plus pkg. and post 4/6.

Amplifier Cabinet **£12 19'6**, plus pkg. and post 5 -.

Elliptical 7 x 4in. Speaker **£1 1'6**, plus pkg. and post 1/6.

5in. Speaker **19'6**, plus pkg. and post 1/6.

Extension Speaker Cabinet matching the Premier Amplifier cabinet **19'6**. Suitable for either 7 x 4in. or 5in. loudspeaker.

PUT IT TOGETHER YOURSELF AND SAVE POUNDS!

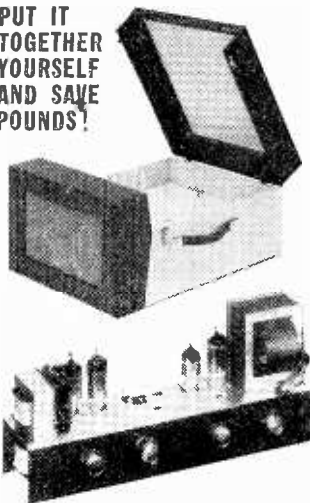

### THE PREMIER DE LUXE STEREO RECORD PLAYER AMPLIFIER

This is a 4 valve Stereo Amplifier with tone balance, speaker switch and volume control, size 12in. long, 5 1/2in. high, 3in. wide, output of each section is 3; watts. **£8**, plus pkg. and post 4/6.

Collaro 4-speed Changer **£3 19'6**, plus 5 - pkg. and post.

BSR 4-speed Changer **£7 19'6**, plus 5 - pkg. and post.

### A COMPLETE RANGE OF PREMIER STEREO EQUIPMENT!

And a Permanent Demonstration at two of London's Leading Stereo Showrooms

You can convert your radiogram for stereo discs for only

**£18. 14. 11**

Stereo Amplifier **£12 12s. 0d.**  
Stereo Cartridges from **£5 15s. 5d.**  
Wharfedale Spkr. **£3 7s. 6d.**

**£18 14s. 11**

## Special Offer—Limited quantity only THE NORA AM/FM RADIOGRAM CHASSIS

Designed for the American market by a famous continental manufacturer.

CASH **£16. 19. 6** Plus 7/6 packing and carriage.

OR Deferred Terms:—

This Chassis is of the very latest design and has a much wider coverage on F.M. than Standard Receivers. It has 5 valves plus a full-wave Metal Rectifier, piano type push buttons for long, medium, F.M. and Gram, separate tuning on F.M. and A.M. and incorporating a Ferrite Rod Aerial for medium and long wave-bands, also Gram Pickup switching. Output 5 watts. Dial size: 12" x 2 1/2". Overall size: 12" x 5 1/2" x 7 1/2" in.

## THE "TRANSIDYNE"

Printed Circuit Transistor Pocket Superhet. A printed circuit Pocket size Transistor Receiver, professional in appearance and of outstanding performance. Incorporates T.C.C.



Printed circuit, six transistors (push-pull) to cover medium and long waves, utilizes 2 Ever Ready or equivalent, No. 8 batteries. Attractive cream and red plastic cabinet with engraved dial. Overall dimensions 7 1/2in. x 3 1/2in. x 1 1/2in. Total weight when assembled, including batteries, only 20 ozs. Our price for all required components, including batteries, **£11/19/6**, plus 2/6 p.p. Complete cabinet and dial assembly, printed circuit, battery holder, nuts and bolts and full assembly instructions. 25/- plus 1/6 p.p.

ADDRESS ALL MAIL ORDER ENQUIRIES TO: (Capt. P.W.) 207 EDGWARE RD., LONDON, W.2

# BJ STEREO AVAILABLE NOW

New Stereo Cartridge, complete in shell with diamond,  
8 Gns., inc. tax.

Stereo Cartridge only, with diamond, 7 Gns., inc. tax.

BJ Stereo TAN/II arm, £4.8.3, inc. tax.

BJ Stereo Super '90' Mk. II, £16.3.5,  
inc. tax.



Stand the new top 'C' treble unit on your Loudspeaker System, TV, Radio and Tape Recorder. New omni-directional sound spread adds Hi-Fidelity. Complete with BJ high efficiency unit, crossover and volume control, the Top 'C' is finished in beautiful selected walnut or oak veneers. Available in 15 and 3 ohms impedances. Only 5 Gns., inc. tax.

Send for details NOW



**BURNE-JONES & CO. LTD.**  
**18, BRUNSWICK ROAD, SUTTON, SURREY**



Just Right  
for your pocket!

## THE MULTIMINOR

### 19 Ranges

- D.C. Voltage: 0-1,000V in 7 ranges
- A.C. Voltage: 0-1,000V in 5 ranges
- D.C. Current: 0-1A in 5 ranges
- Resistance: 0-20,000 Ω, 0-2M Ω

Pocket Size: 5½ x 3½ x 1½ inches.  
Weight: 1 lb. approx.

List Price **£9 : 10s.**

Complete with Test Leads and Clips.  
Leather Case if required 32/6.

Sensitivity :  
10,000 ohms per volt  
on D.C. voltage ranges.  
1,000 ohms per volt  
on A.C. voltage ranges.

Accuracy :  
On D.C. 3% of full  
scale value.  
On A.C. 4% of full  
scale value.

To meet special  
requirements, instru-  
ments can be supplied  
to a higher degree of  
accuracy for a small  
additional charge.

This splendid AVO Instrument has been developed to meet a definite demand for a sturdy pocket-size multi-range test meter at a modest price, suitable for use on modern electronic apparatus as well as for radio and television receivers, motor vehicles, and all kinds of domestic appliances and workshop equipment. Readings are obtainable quickly and easily on a very open scale, and range selection is by means of a robust, clearly marked rotary switch of the characteristic AvoMeter type. Measurements of A.C. and D.C. Voltage, D.C. Current and Resistance are made by means of only two connection sockets.

Designed and Manufactured by

**AVO LTD** AVOCET HOUSE • 92-96 VAUXHALL BRIDGE RD. • LONDON • S.W.1

Telephone: VICTORIA 3404 (12 lines)

M.M.2



# PRACTICAL WIRELESS

EVERY MONTH  
VOL. XXXIV, No. 626, FEBRUARY 1959  
COMMENTS OF THE MONTH

EDITOR : F. J. GAMM

26th YEAR  
OF ISSUE

BY THE EDITOR

## INTERESTING BBC STATISTICS

THE BBC issues annually a handbook in which it gives facts and figures relating to its service on sound and television. They are anything but dull and the keen radio enthusiast should obtain a copy. For example, over 140,000 contracts in a year are issued to those who contribute to the programmes. The contracts cover individuals, as well as orchestras. The BBC receives 200,000 letters a year. Last year, they trained 620 students; 8,000,000 schools pamphlets are produced a year; the BBC staff numbered 15,472 at March 31st, 1958. There are 157 studios for domestic sound programmes in the U.K. First performances of musical compositions numbered 170 last year. Three hundred and sixty-eight SOS messages are broadcast every year. Three thousand five hundred light entertainment programmes are produced each year for sound radio, including performances in the General Overseas Service; 30 religious programmes are broadcast every week. External services are broadcast in English, and 41 other languages, for 81 hours every day. These are but a few of the facts in this interesting book which are worth remembering. It includes quick reference tables of all BBC transmitting stations—long, medium wave, V.H.F. and television. There is a map showing the locations. There is a list of the opening dates of TV and V.H.F. stations, as well as several technical articles, including advice on how to get the best reception, wavelength allocation, and an outline of the work of the various engineering departments of the BBC.

### THE "P.H." EXHIBITION FREE TICKETS!

THE Practical Householder Exhibition takes place at Earls Court from February 18th to 28th. It will occupy twice the floor space of last year, and there will be many more exhibits and demonstrations. This is the most important exhibition for those interested in do-it-yourself. A free entrance ticket appears in every copy of the March issue of *Practical Householder*, on sale February 6th.

### RADIO SHOW 1959

THE 26th National Radio and Television Exhibition will be held at Earls Court, London, from Wednesday, August 26 to Saturday, September 5, with a pre-view on Tuesday, August 25.

### PREFERRED VALUES

VERY few components such as condensers and resistors are of critical value. Contributors of articles on the construction of receivers naturally specify the values of the components they have actually used. Our readers, intent on complying in every detail with our published specification, may turn down the alternative of a near value component offered by the dealer, who may be out of stock of the value specified. Readers may quite safely accept a preferred value near to the one specified. Indeed, some of the values specified, if taken from ex-Government apparatus, may no longer be available.—F. J. C.

Our next issue, dated March will be published on February 6th

Editorial and Advertisement Offices :  
PRACTICAL WIRELESS  
George Newnes, Ltd., Tower House,  
Southampton Street, Strand, W.C.2.  
© George Newnes Ltd., 1959.

Phone : Temple Bar 4363.  
Telegrams : Newnes, Rand, London.  
Registered at the G.P.O. for trans-  
mission by Canadian Magazine Post.

### SUBSCRIPTION RATES

including postage for one year

Inland - - - 19s. per annum  
Abroad - - 17s. 6d. per annum  
Canada - - - 16s. per annum

### CONTENTS :

	Page
Editorial	959
Round the World of Wireless	960
Push-Button Multimeter ...	962
Control of Stereo Balance ...	965
Radiogram Control Unit ...	967
Reflexing Superhets	969
Anti-interference Aerial ...	970
Servicing Radio Receivers ...	975
On Your Wavelength ...	977
Basic Radio Theory	978
A Mains Transportable	982
Tape-Recorder Matching ...	985
Printed Circuits ...	986
Making Ohm-meters	989
Transmitting Topics	991
Servicing Without Instru- ments ...	996
Ex-Government Reference Numbers ...	1003
Car Radio in Kit Form ...	1007
News from the Trade ...	1008
News from the Clubs ...	1012
Programme Pointers ...	1015
Open to Discussion ...	1016

The Editor will be pleased to consider articles of a practical nature. Such articles should be written on one side of the paper only, and should contain the name and address of the sender. Whilst the Editor does not hold himself responsible for manuscripts, every effort will be made to return them if a stamped and addressed envelope is enclosed. All correspondence intended for the Editor should be addressed: The Editor PRACTICAL WIRELESS, George Newnes, Ltd., Tower House, Southampton Street, Strand, W.C.2. Owing to the rapid progress in the design of wireless apparatus and to our efforts to keep our readers in touch with the latest developments, we give no warranty that apparatus described in our columns is not the subject of letters patent.

Copyright in all drawings, photographs and articles published in PRACTICAL WIRELESS is specifically reserved throughout the countries signatory to the Berne Convention and the U.S.A. Reproductions or imitations of any of these are therefore expressly forbidden. PRACTICAL WIRELESS incorporates "Amateur Wireless."

# ROUND THE WORLD OF WIRELESS

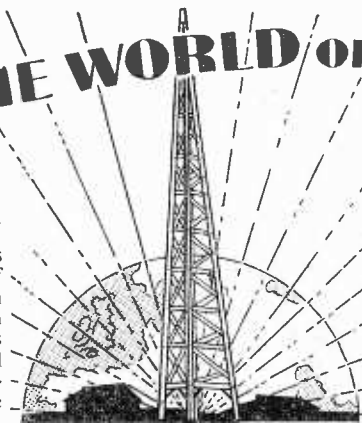

By "QUESTOR"

## Broadcast Receiving Licences

THE following statement shows the approximate number of Broadcast Receiving Licences in force at the end of October, 1958, in respect of wireless receiving stations situated within the various Postal Regions of England, Wales, Scotland and Northern Ireland. The numbers include licences issued to blind persons without payment.

Region	Total
London Postal	1,001,118
Home Counties	1,000,774
Midland	738,355
North Eastern	907,917
North Western	703,059
South Western	611,213
Wales and Border Counties	379,205
<b>Total England and Wales</b>	<b>5,341,641</b>
Scotland	643,492
Northern Ireland	174,059
<b>Grand Total</b>	<b>6,159,192</b>

## Morse Instruction

A R.A.E. course for instruction in morse is held at 7 p.m. on Tuesdays at Yew Tree Schools under West Bromwich Education Committee. Intending applicants are invited to join at once.

## International Convention on Transistors

THE Radio and Telecommunication Section of The Institution of Electrical Engineers have found it necessary to hold their International Convention on transistors and associated semi-conductor devices a few days earlier than previously announced. The new dates are 21st-27th May, 1959. The alteration has become necessary through changes in the availability of some of the accommodation at Earls Court, where the convention is to be held.

Associated with the convention will be an International Technical Exhibition covering the manufacturing, application, research, development and other aspects of transistors and associated semi-conductor devices. This exhibition, which will remain open during the period

of the convention, will also be held at Earls Court.

## Radio Hobbies Exhibition

THIS show, which was held in November last, had nearly 10,000 visitors—3,000 more than last year.

The £400 Racial receiver offered as a free-entry prize was won by Mr. Kenneth R. Rogers, of Hitchin, a Hertfordshire C.I.D. officer, who is an enthusiastic short-wave listener.

Exhibitors were enthusiastic about the success of the show. They did excellent business. One company reported that over 4,000 leaflets describing a particular kit had been distributed and 2,500 enquiry forms had been completed by visitors to the exhibition. The Territorial Army reported that over 30 potential recruits had completed forms and more are expected.

The colour TV arranged by Mr. Bernard Rogers attracted huge crowds and reception was excellent. The Radio Society of Great Britain

made over 200 new members at the show.

## "Eyes" for Pluto Reactor

A HIGH-DEFINITION closed circuit television system specially developed by E.M.I. Electronics Ltd., for use in nuclear reactors, is in operation at the Atomic Energy Authority's establishment at Harwell.

The cylindrical camera unit, which measures only 3in. in diameter and is approximately 48in. long, is constructed so that it can be lowered through an inspection cover directly into the Reactor Pluto's heavy water. A transparent tube encases it to afford protection.

A remotely controlled mirror mounted in front of the lens enables the operator to view all parts of the interior of the

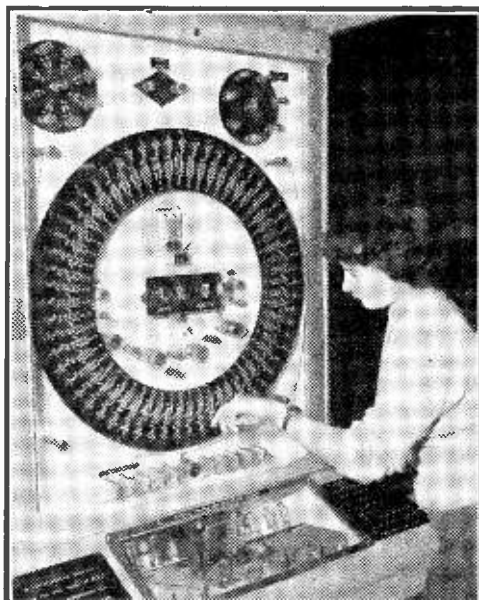

Miss Carol Creagh checks her watch with an electronic clock. This clock was a working display to show comprehensive collection of valves and components, at the Radio Hobbies Exhibition, held last year, on the Standard Telephone and Cable Company's stand.

reactor, which has been specially illuminated. Switched scan reversal circuits have been incorporated in the camera control unit to compensate for reversal of the mirror's reflection. Remote inspection of many of the reactor components without removal from the reactor now means that radiation hazards to personnel and the time required for preventive maintenance may be greatly reduced. The E.M.I. camera channel works on the 625 line system, and employs the latest construction techniques.

#### Higher-rated Transistors

**T**HERE is an increasing demand for transistors with higher ratings for specialised applications. To meet this demand Newmarket Transistors have considerably raised the dissipation rating of their audio and R.F. transistors.

This is the result of improved manufacturing processes and application technique. The transistors are now supplied with an increased dissipation rating which can be raised to the maximum rating by mounting the transistors with a special clip supplied by the manufacturers. There is no change in price—the clips are supplied free.

#### New British Standard

**I**N this new publication (B.S. 3045: 1958) the sone scale is specified by its relation to the phon scale, the relation used being an approximation based on assessments of the available experimental evidence. It does not necessarily represent the degree of accuracy required for research purposes, nor should it be deemed to serve any function other than the conversion of loudness levels to loudness in sones, and vice versa.

Copies of this Standard may be obtained from the British Standards Institution, Sales Branch, 2, Park Street, London, W.1. Price 3s.

#### Automatic Broadcasting is Here

**A** SOUTH AMERICAN radio station now stays on the air 24 hours a day, seven days a week and is able to broadcast for one and a half days without staff. All station



*Marconi V.H.F. receiver being used to report progress during Donald Campbell's record-breaking speed event in Bluebird at Coniston Water.*

employees have their Saturday afternoons and Sundays free.

Scotch magnetic tape has made this possible. Music and commercials are now recorded on this tape so that the station can transmit automatically, without staff, said a spokesman of the Minnesota Mining and Manufacturing Co. Ltd.

Owner and director of CX28 Radio Imparcial, Montevideo, Mr. Higueira Moran, claims that his station can now make transmissions which are free from unwanted noise and embarrassing "dead air." He now exercises complete control over all his programmes, which are recorded and re-recorded on the tape until perfect. They are then broadcast in the deserted studio.

BBC sound engineers use similar tape, which is made at the 3M Company's factory in Birmingham.

#### Marconi V.H.F. Radio in Bluebird

**D**ONALD CAMPBELL'S record breaking Bluebird was equipped with Marconi mobile V.H.F. radio. During the record-breaking runs, continuous two-way communication was maintained between Mr. Campbell and his chief mechanic, Mr. Leo Villa, in the control boat. Mr. Campbell reported continually during the runs on the speed and performance of Bluebird, while Mr.

Villa kept him informed on the meteorological and water surface conditions.

#### Mullard Amateur Award

**T**HE Directors of Mullard Limited are presenting, until further notice, a yearly award for distribution by the Radio Society of Great Britain. This award will be made to the member of the Society resident in the United Kingdom who, in the opinion of a Committee set up for the purpose, has through the medium of amateur radio during the preceding calendar year, rendered outstanding personal service to the community by his own endeavours or by his own example of fortitude and courage. The members of the Committee will be three representatives of Mullard Limited and three representatives of the Council of the R.S.G.B. The award will consist of electronic or electrical apparatus and/or books to the value of £25 and a commemorative plaque. It will be presented in April of each year.

Nominations for the award will be invited in January of each year by the R.S.G.B. through its official journal. Every nomination will need to be supported by at least three corporate members of the Society and will be expected to provide a factual account of the personal service rendered by the nominee.

# A Push-button Multi-range Testmeter

EASY RANGE SELECTION IS A FEATURE OF THIS WELL-DESIGNED INSTRUMENT

By Hugh Guy

**I**N a multi-meter using push-button switches any range can be selected instantly by pressing the appropriate button, the previously chosen range being automatically cancelled. Furthermore, such push-buttons are readily available on the surplus market.

By using two such switches, each with six buttons, a versatile universal multi-range instrument can be constructed covering two resistance ranges, two A.C. and four D.C. voltage ranges, and four direct current ranges.

### Instrument Ranges

Using a 0-1 mA full-scale deflection moving-coil meter the instrument will have the following ranges:

- Resistance 1 k., 100 k.
- Current 1 mA, 10 mA, 100 mA, 1 A.
- Volts (D.C.) 3 v., 10 v., 100 v., 300 v.
- Volts (A.C.) 10 v., 300 v.

These cover most constructional and service requirements, and such a design yields an instrument with a sensitivity of 1,000  $\Omega$ /volt.

If greater sensitivity is required then a 0-100  $\mu$ A

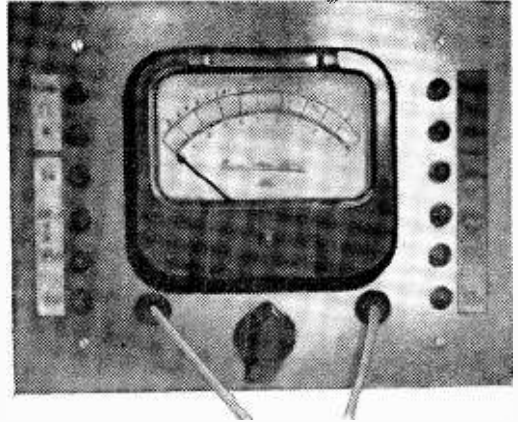

meter should be used. With such a movement the resistance range on the meter can be extended, the two ranges then being 0-10 k. and 0-1 megohm. In addition there may be some advantage in redistributing the current ranges to provide readings on the four ranges of 0-100  $\mu$ A, 0-3 mA, 0-100 mA, 0-1 A. The top limit of 1 amp. may be too low for some uses, particularly for the reader whose principal current measuring requirement is associated with his car electrical system, when 10 amps. would be nearer the mark. These points are at the discretion of the reader and though basically an instrument is described centred on the use of 0-1 mA meter with the above ranges, sufficient information is given in the text to enable each reader to make his own version by using the simple formulæ described.

Accuracy of readings is the main criterion in any instrument, and in a multi-range instrument the accuracy is determined by the circuit conditions in which it is used.

### Accuracy

For voltage measurements in a circuit the greater the sensitivity of the instrument the greater the accuracy of the reading. This is not generally appreciated and an example best illustrates the problem.

Consider a typical instance as shown in Fig. 1 where the screen voltage of a pentode is being monitored. This pentode is the I.F. stage of a superhet set and is coupled to the 200 v. H.T. supply via a resistance of 50 k. The screen should be at a potential of 100 v. and the screen current drawn is 2 mA.

If an instrument using a 0-1 mA meter is connected between screen and earth to measure the screen voltage on the 100 v. range, even though the circuit is functioning satisfactorily, the voltage reading will *not* be 100 v. In fact, assuming the screen current remains constant, the meter will indicate approximately 67 volts.

Switching the meter to the 300 volt range would improve matters slightly, giving a reading of 86 v. approximately.

These errors arise because the meter itself must draw a fraction of the circuit current to give a deflection. Therefore, the lower the current drawn, the greater the accuracy of the reading.

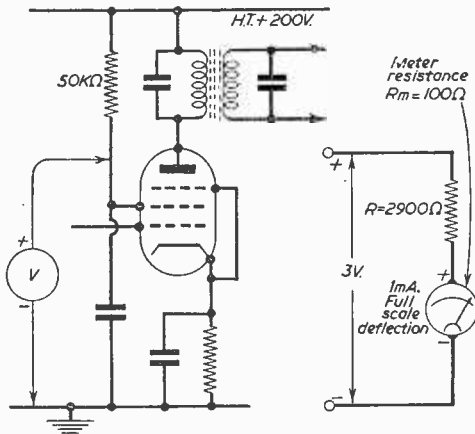

Fig. 1 (Left).—Shows the measurement of the screen voltage of a valve.

Fig. 2 (Right).—Using a meter with a multiplier  $\approx$  read 0.3 v. D.C.

This is particularly important when making readings in high impedance circuits such as the one just considered and the only cure is to use a more sensitive instrument.

If, for example, the meter used had been a 0-100  $\mu$ A movement, then on the 100 v. range in the above example it would have read 95 volts and on the 300 v. range, more than 98 volts.

This is an important point to bear in mind when deciding what sort of meter movement to use if the instrument is to be used for general circuit work.

One final cheering word to dispel any gloom that this thought may have created: the service

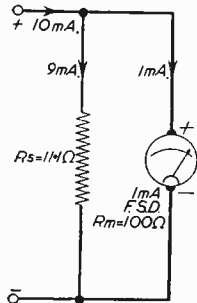

Fig. 3 (Left).—Using a meter with a shunt to read 0-10 mA, D.C.

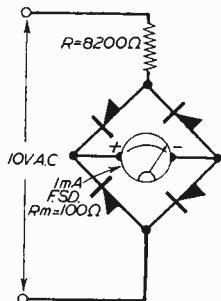

Fig. 4 (Right).—Circuit with a bridge rectifier to read 0-10 v. A.C. R.M.S.

sheets issued by most reputable radio and TV manufacturers take this limitation into consideration by quoting typical voltage levels in their circuits at values read on a 1,000  $\Omega$ /volt instrument.

**Basic Meter Circuits: Voltmeter**

A moving coil milliammeter can be converted into an instrument reading voltage simply by connecting a resistance of appropriate value in series with it. This resistance is known as a multiplier, and a typical example of the arrangement is shown in Fig. 2. Here a 100  $\Omega$  resistance meter with a 0-1 mA movement is converted into a voltmeter with a full-scale reading of 3 volts by the addition of a multiplier R of value of 2,900 ohms. This value of R may be calculated for different meters from the formula

$R = \left( \frac{V}{I_m} - R_m \right)$  ohms where V is the required full-scale voltage;  $I_m$  is the full-scale meter current in amps; and  $R_m$  is the meter resistance, in ohms.

Different full-scale voltage readings and hence range changing is achieved by switching in the appropriate value of R for the range in question.

**Current**

The same basic movement may be converted into an ammeter (or milliammeter with a different full-scale reading) by connecting a resistance known as a shunt in parallel with the meter. This shunt, value  $R_s$ , literally shunts away the difference between the current required to give full-scale deflection of the basic meter and the current that the meter is required to read.

In the circuit of Fig. 3 for example the 1 mA movement is shown connected to read a full scale of 10 mA and to do this the value of the shunt is designed to pass the difference of 9 mA.

Here again the value of the shunt  $R_s$  may be varied to obtain different ranges and is calculated from the formula  $R_s = \left( \frac{I_m}{I - I_m} \right) \times R_m$  ohms

where I is the required full-scale current in amps the other symbols being as indicated earlier.

**Alternating Voltage**

The moving coil meter responds only to direct current. Hence to give an indication of alternating quantities the latter must first be rectified. Small bridge rectifiers are available designed specifically for this purpose; in the case of 100  $\mu$ A instruments it is even possible to use four crystal diodes, such as "Westectors," connected in a bridge circuit (see Fig. 4).

A slight complication is introduced here by the manner in which a meter responds to a rectified alternating current. Meters always indicate the mean or average current flowing whereas the quantity which is always used in A.C. terminology is the R.M.S. (root mean square) value.

This method of specifying alternating quantities arises from a consideration of the power available from an A.C. source compared with that from a D.C. source. If power is measured in the same value of load connected to each supply then the power will be the same when the A.C. source, expressed as an R.M.S. value, equals the value of the D.C. source.

To be of any use, therefore, the average current that the meter reads must be expressed in R.M.S. current. Now for a sine wave the R.M.S. value is always 1.11 times as great as the average value. If it is always assumed that the waveform of the alternating supply being measured by the instrument is sinusoidal then the meter will read R.M.S. values directly if the current through it is increased by a factor of 1.11. This in turn can

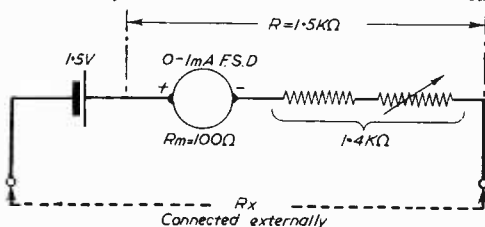

Fig. 5.—A circuit for measuring resistance up to 100 k $\Omega$ .

be achieved by reducing the total circuit resistance by this factor, known as the form factor (short for waveform factor). The assumption that waveform is sinusoidal is fair enough for most cases, particularly in mains supply measurement where the distortion present is not sufficient to detract from the accuracy of the reading.

In calculating the multiplier necessary to produce any given full-scale voltage reading on an alternating voltmeter some allowance must be made for the voltage drop across the rectifier and meter combination, and a commonly allowed figure of 1 volt provides a good design value.



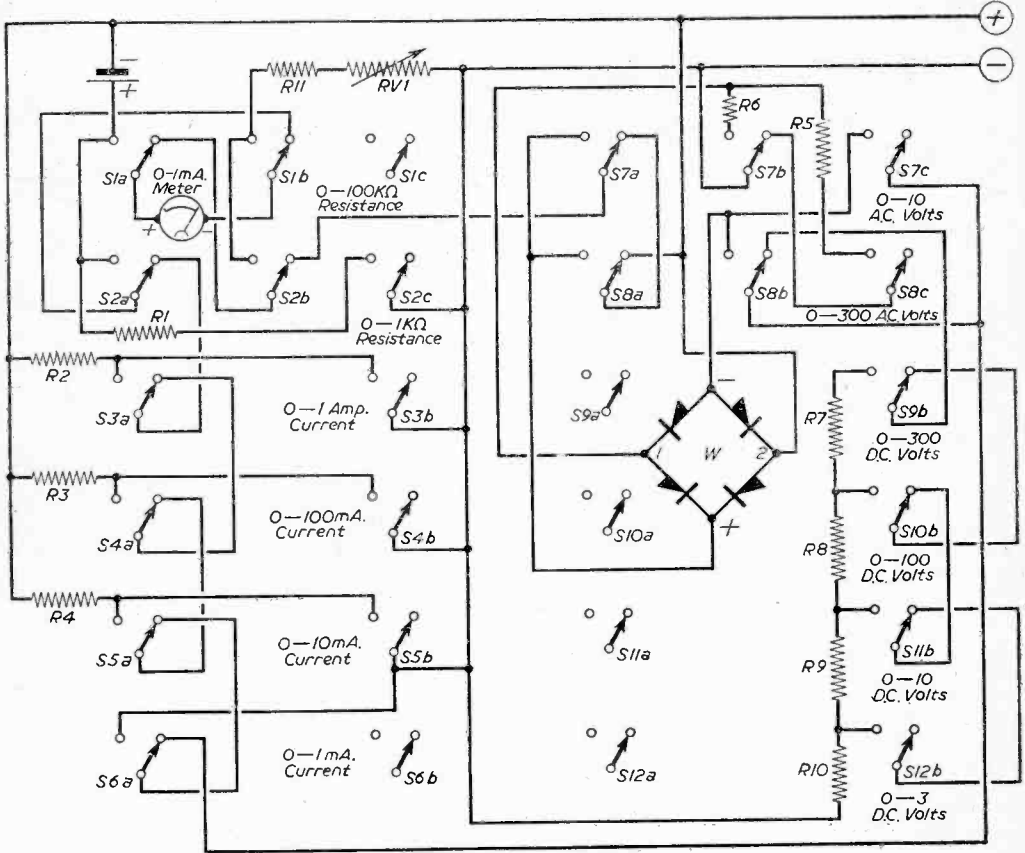

Fig. 6.—Complete circuit diagram of the multi-range meter.

The formula for the multiplier resistance R for A.C. voltmeters is therefore  $R = \frac{V_{ac}-I}{1.11 \times I_m}$  ohms where  $V_{ac}$  is the required full-scale alternating R.M.S. voltage reading.

In Fig. 5 is shown how resistance is obtained by measuring the current flowing through the unknown resistance connected between the two terminals of the meter. The current is provided by a battery which is built into the instrument.

**Resistance**

Before measuring the unknown resistance the meter terminals must be shorted together and the variable resistance adjusted so that the meter needle just indicates full scale. For the 1 mA meter shown, with the 1.5 v. battery, full-scale deflection is produced when the sum of the fixed built-in resistance, the variable resistance and the meter resistance is 1.5 k, as shown.

The unknown resistance is then connected between the two terminals and the meter deflection falls accordingly. The higher the value of the unknown resistance the smaller the current that flows in the circuit, and hence the smaller the meter deflection. Consequently a separate scale is required for resistance, being interpreted

from the current through the series circuit comprised of the unknown resistance, and the meter and internally wired resistances. This scale will not be uniformly distributed and furthermore, unlike the normal meter scale, will have increasing values moving from right to left on the scale. The method of calibration is to be described.

For a meter circuit resistance of R ohms—1.5 k. in Fig. 5—the unknown resistance  $R_x$  may be calculated from the formula  $R_x = R \left( \frac{1-D}{D} \right)$  ohms where D is the fraction of the full-scale current.

For example, in the meter circuit of Fig. 5, if the meter shows a deflection of 0.4 mA when an unknown resistance is being measured then the value of the latter would be 2,250 ohms. Similarly at a deflection of 0.2 mA the formula shows that the resistance would be 6,000 Ω. The formula, therefore, enables a complete calibration table to be drawn up so that a resistance scale can be drawn on the meter. For the meter circuit of Fig. 5 a value "6,000" ohms would be written against 0.2 mA on the scale of the instrument.

A table showing such a calibration will be given in the next article for a 1 mA movement with a resistance of 100 Ω.

(To be continued)

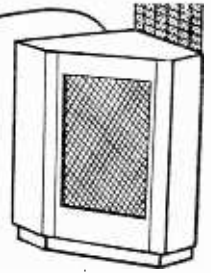
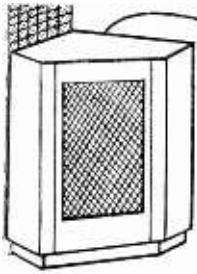

# CONTROL OF STEREO BALANCE

## ADDING A SECOND CHANNEL TO EXISTING SINGLE-CHANNEL EQUIPMENT

By G. Earl

**N**OW that stereo discs and pick-ups are readily available, an increasing number of hi-fi enthusiasts and experimenters are exploring the possibilities of this new sound effect by adding a second channel to their existing single-channel equipment. This is by no means difficult and the expense of the project is considerably governed by the type of equipment already in use. If an expensive hi-fi hook-up is being used on the single channel, then a similar set of equipment will have to be obtained in order to secure hi-fi stereo. On the other hand, if a simple record player type of amplifier at present serves the single channel it will only cost a few pounds to multiply to stereo.

### A Stereo Disc

A stereo disc and pick-up provides two signal outputs of the same programme material. However, owing to the positioning of the microphones during the recording process the signals differ in phase and level to match the sound as heard by each ear at the studio. These signals have to be individually amplified so that their particular identity is not destroyed and then applied to separate loudspeakers which are positioned in the listening room to give the optimum stereo effect. The idea is illustrated in Fig. 1.

The pick-up usually has three lead-out wires or three tags, one being common to both signals, (the "earthy" connection) and the other two carrying the individual signals.

Although hi-fi stereo, obtained by way of expensive hi-fi amplifiers and loudspeaker systems, obviously sounds better than stereo derived from simple two-stage amplifiers and inexpensive loudspeakers, a remarkable improvement in quality from a simple inexpensive set-up

is possible by running it stereo-wise. This is a rather controversial subject, but in the author's opinion, inexpensive stereo is far better than inexpensive single-channel reproduction and cheap stereo often approaches single-channel hi-fi standards. This, in one instance, was vividly demonstrated during one of the stereo transmis-

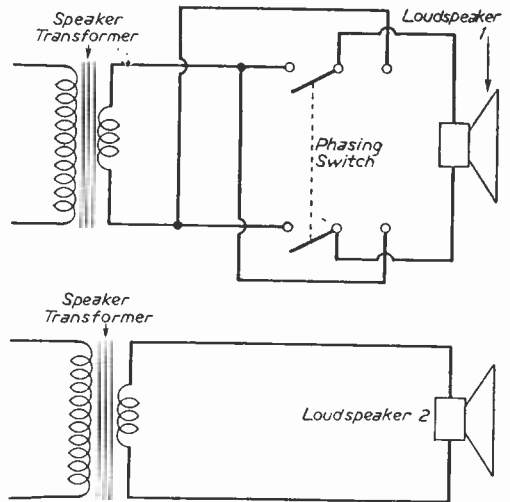

Fig. 2.—Correct phasing can be achieved by reversing the connections to one of the loudspeakers. A convenient phasing switch can be wired as shown.

sions given by the BBC when hi-fi-flavoured sound was created by an inexpensive table TV set sound channel and an all-dry battery portable!

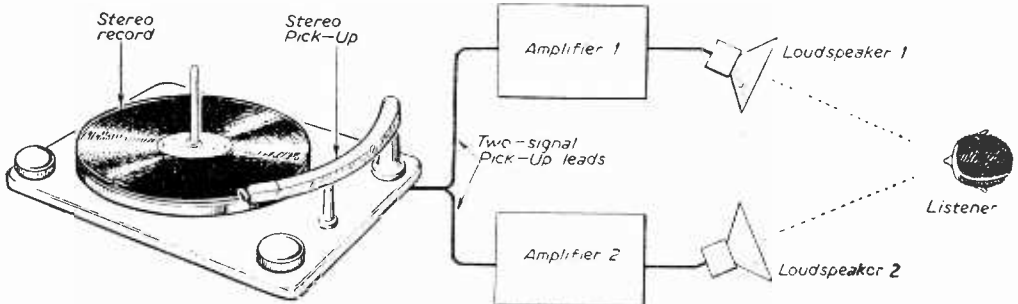

Fig. 1.—The stereo set-up from record to loudspeakers.

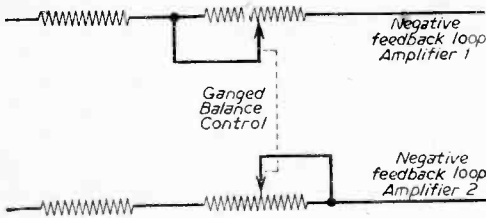

Fig. 3.—Securing a control of balance by ganged variable resistors in the negative feedback loops of the two amplifiers. This arrangement is adopted by Pamphonic.

**Balance and Phasing**

No matter what equipment is used, the true stereo effect can be obtained only when the two channels are in correct balance and phase. Two-channel stereo amplifiers feature a balance control, which serves over a small limit to increase the gain of one channel while reducing the gain of the other, and a phasing switch, which simply reverses the connections to one of the loudspeakers.

The "Pamphonic" stereo amplifier also has a channel reversing switch so that the signal channels can quickly be reversed. This may be necessary if the signal leads of the pick-up are connected round the wrong way which would give a laterally reversed impression of sound movement and position. However, since the record manufacturers have now an agreed channel recording standard such a switch is not essential (though it may have a convenience value), for once the correct pick-up connections have been established they hold for all records.

**Method of Connecting**

Fig. 2 shows the method of connecting a phasing switch to one of the loudspeaker circuits. A simple type of double-pole double-throw toggle switch is perfectly suitable for 5- to 10-watt amplifiers, but a more substantial switch should be used on larger amplifiers, bearing in mind that failure of the switch would remove the loud-

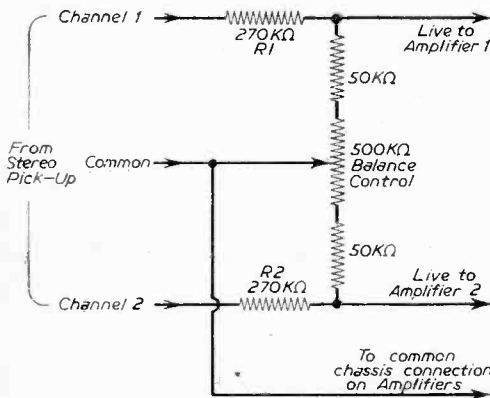

Fig. 5.—A method of stereo balance which is suitable for the less exacting type of amplifier. The circuit can be built into a metal box and connected to the pick-up sockets and pick-up itself through screened cable.

speaker load and possibly ruin the output transformer and output valves.

When two identical amplifiers are used in the stereo chain it may be a fairly simple matter to balance the outputs by setting the volume controls to similar positions, but if the loudspeakers used differ in sensitivity such settings would not represent equal sound levels from the loudspeakers and one control would have to be retarded or advanced with respect to the other. This fine adjustment is made even more difficult by the speaker positioning and room acoustics, especially if one speaker is slightly shielded by a piece of furniture or curtain.

By far the best idea is to employ a balance control which provides a fine adjustment by increasing the gain of one amplifier while decreasing the gain of the other. The control

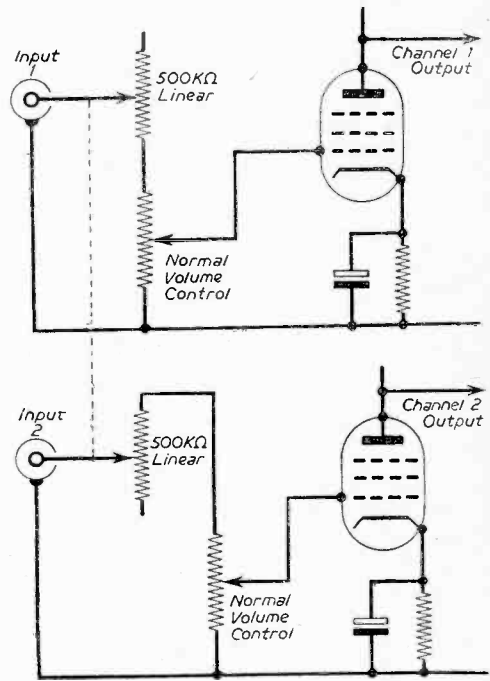

Fig. 4.—This method of balancing makes use of ganged potentiometers in the signal input circuit. The control should be installed preferably in a stage where the signal is at a high level.

should be arranged so that the amplifier gains are equal when the control is adjusted to the centre of its travel. At this point a rough level should be established by the normal volume controls and optimum stereo effect obtained by careful adjustment of the balance control. The true stereo illusion also depends somewhat upon the correct balance of the tone controls, but in some cases enhanced overall performance is possible by applying a little treble boost to the channel dealing with the treble side of the orchestra.

(Continued on page 968)

# A Radiogram Control Unit

CONSTRUCTIONAL DETAILS OF THE TONE CONTROL FOR THE RECORD PLAYER

(Concluded from page 903 of the January issue)

**R**ADIO signals can be adjusted to equal those from the gramophone in the feeders themselves, but equalising 78 to L.P. record output must be included in the control unit as the same pickup and input leads are used. In this particular case, given in the circuit in Fig. 1, shown last month, allowance is made for the fact that the average output on 78 records is about four times that on L.P. records, so at the 78 position R9 is inserted in series and R10 introduced in parallel with the volume control so that the load is 1 M $\Omega$ . For L.P. records R9 is shorted out

being only .3 amp. at 6.3 volts A.C. for the heater and a maximum of 10 mA at 250 volts for H.T.

### Construction

It is recommended that the circuit be made up in the simple fashion given in Fig. 1 without input correction in the first instance. When this is working, and if the pickup to be used needs an alternative type of input circuit, the appropriate components can then be built on, knowing that the main circuit is quite satisfactory. The chassis is made from a piece of sheet aluminium cut to the shape and dimensions given in Fig. 3. Before proceeding to make this up, however, it is as well to give some thought to the way in which the chassis is to be fixed into the cabinet. Much will depend on the cabinet design, but it will be seen that the chassis extends  $\frac{1}{2}$  in. beyond the sides and is drilled so that it will take four screws which will pass through the chassis into the underneath of the motor-board. The position of holes is given but there is no point in giving actual dimensions where these are likely to vary. This applies to tagboards and the socket strip. These should be measured and the appropriate holes suitably placed.

When this work is completed the flaps on the long sides are bent at right angles so that the work, as drawn, is inside the chassis. The  $\frac{1}{2}$  in. flaps on the short dimension are not folded—they are for mounting the unit as above. The chassis when folded should appear as in Fig. 4(a). A bracket is needed for the valveholder as in Fig. 4(b). This takes the B9A valveholder which should be orientated so that the space in the pins is towards the mounting flap. Before screwing this bracket, with the valveholder already fixed to it, on to the main chassis a length of wire should be soldered to each pin and identified by means of a label, except for pin 1 to which R2 and C2 should be fixed; pin 5 which should be connected to pin 4; pin 7 to C5 and R6; pin 8 to R4 and C3.

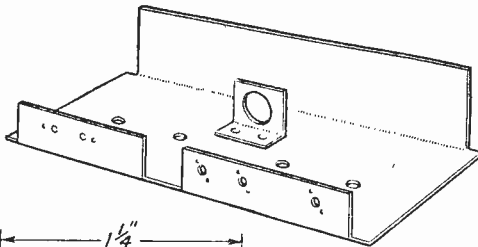
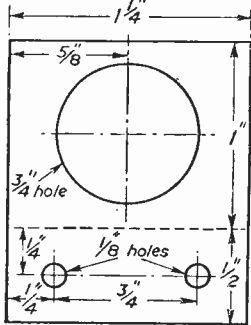

Fig. 4(a) Above.—The chassis folded.  
Fig. 4(b) Left.—Bracket for the valveholder.



and R10 is taken out of circuit completely so that the volume control, which is 1 M $\Omega$ , provides the only load. To work out the values of R9 and R10 is a simple exercise with resistors in series and

in parallel. The total resistive load is to be 1 M $\Omega$  and R9 has to be three times the resultant of R10 and VR1 in parallel, i.e., three-quarters of the load of 1 M $\Omega$ : the nearest preferred value is 680 K $\Omega$ . R10 is the resistance which, in parallel with 1 M $\Omega$ , makes 250 K $\Omega$  and so is made 470 K $\Omega$ . The actual sizes used by the constructor can be adjusted according to the requirements of his pickup. The remaining bank on the switch, bank (c), serves to feed H.T. to the two feeders when they are needed, so that when they are not needed they are rendered inoperative.

### Manual Tone Controls

Manual tone controls are provided in the inter-stage circuit. VR2 provides treble control, giving boost at the upper end of its travel and cut at the lower end. The bass control, VR3, similarly gives boost at the upper end and cut at the lower end. The signal is taken off from the cathode resistor R5 via a screened lead. The power needed from the main amplifier is quite modest,

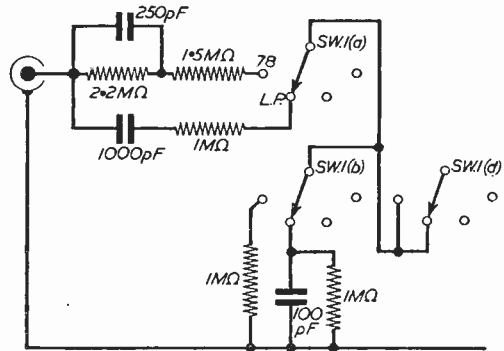

Fig. 5.—Correction for GP20 Hi-g pic'up.

### Wiring Diagram

Fig. 2 gives the wiring diagram on which the valveholder is shown flat merely for convenience of drawing. The tagstrip is also drawn out of place, and the segments of the switch have also been displaced for the sake of clarity. It will be noticed that the least accessible sector of the switch, i.e., that inside and nearer the chassis is used for switching H.T. This assumes, of course, that those chassis providing the F.M. and A.M. signals derive their power from either the main supply or from a supply separate from the tuners. As shown in Fig. 2, a separate lead is provided to a power supply made up specially for the tuners but actually stored alongside the main amplifier. If the main amplifier is, in fact, to provide power for all units this separate lead will not be required, but it will be necessary to avoid passing the current for the tuners through the resistance smoothing provided on the present chassis. The lead from the tagstrip that goes to the selector switch will therefore need to be connected to the H.T. input point alongside the out-

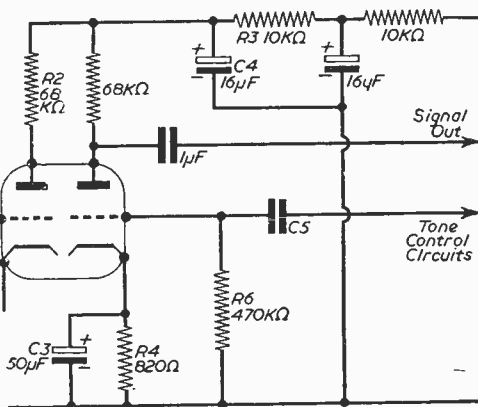

Fig. 6.—Conversion to two-stage amplifier.

put sockets and not to the decoupled H.T. point on the tagstrip itself. The third possibility is that the tuning units are self-powered and that it is not convenient to bring the H.T. into the control chassis. It is simplest to arrange for muting on the tuner chassis themselves, if this is found necessary. A switch on the control panel with five segments could be used, of course, using segment (c) to mute, say the A.M. signal, by earthing the lead from the input socket at positions where this input is not needed and using the additional segment to mute the F.M. signal.

Fig. 5 gives the method of adapting the input for correction for specific pickups. This incorporates the circuits recommended for the GP20 Hi-g pickup. Finally, Fig. 6 gives a modification to the circuit to convert the second half of the double triode into an amplifying stage which will cope with either a lower level of input or a lower amplification in the main amplifier itself.

In Fig. 2 of last month's issue, a wire was omitted. This runs from L.P. on the lower left-hand segment of the switch to the moving arm of the upper left-hand segment.

## CONTROL OF STEREO BALANCE

(Concluded from page 966)

### Ganged Controls

Pure stereo amplifiers use ganged volume and tone controls so that the degree of balance adjustment is limited, usually over a range of approximately plus and minus 6db, by the design of the control circuit.

A very effective system, used in the "Pamphonic," is shown in Fig. 3. Here the negative feedback is decreased on one channel and increased on the other as the balance control is rotated. It will be seen that the variable resistors in the feedback loops are wired in opposition, and that at the centre position, corresponding to the theoretical balance point, the resistance is the same in both circuits.

Another idea is given in Fig. 4, which could easily be adapted for use on simple amplifiers which are used for stereophony. The only addition is a two-gang 500 k  $\Omega$  linear potentiometer. This is connected to the pick-up input circuits in such a way that as the control is rotated the value of the normal volume control is effectively decreased in one amplifier and increased in the other. This, of course, varies the input signals over small limits and balances them when the control is set to the centre of its travel. The normal volume controls continue working in the ordinary way, and these are adjusted first to establish a rough balance and then the balance control is adjusted for optimum results.

Another experimental circuit is given in Fig. 5. This would be suitable for the less exacting types of amplifier, and can be connected between the stereo pick-up and the pick-up sockets of the amplifiers. Resistors R1 and R2 may have to be altered in value to suit the pick-up used and the available gain of the amplifiers. They do, of course, attenuate the signal from the pick-up, but this does not matter a great deal if sufficient compensating gain is at hand. It would be a good idea to build the circuit into a metal box, to serve as a screen, and then wire it to the amplifiers and pick-up through screened cable.

## PRACTICAL TELEVISION

Chief Contents of January Issue

NOW ON SALE, 1/3

TRANSISTORS IN TV RECEIVERS  
 HOME CONSTRUCTED TV RECEIVER  
 AN AUTOMATIC AERIAL SWITCH  
 SERVICING TELEVISION RECEIVERS  
 TELEVISION TABLE  
 RELAXATION OSCILLATORS  
 VISION-ON-SOUND AND SOUND-ON-  
 VISION PROBLEMS  
 REPLACING CATHODE RAY TUBES  
 AN INEXPENSIVE EHT VOLTMETER  
 A QUAD AERIAL FOR THE LOFT  
 IMPROVING OLD TV SETS  
 AND ALL THE USUAL FEATURES



# REFLEXING SUPERHETS

IN THIS CIRCUIT THE I.F., DETECTOR AND A.F. STAGES ARE COMBINED

By Richard Page

**T**HE aim of this circuit is three-fold; to save money, space and current. An inspection of the circuit diagram (see Fig. 1) shows that this circuit can be inserted between any conventional frequency changer and output stage and can be used in battery or mains equipment. In the diagram shown a DF96, vari-mu R.F. pentode is used and its control grid is fed from the appropriate pin of a 465 kc/s I.F. transformer in the usual way. This valve amplifies the I.F. signal which appears across the secondary of the second I.F. transformer. It is at this point that the circuit departs from normal practice. The grid, diode pin of I.F.T. 2 is connected directly to the black end of a "Westector" WX6 and the red end of the "Westector" to chassis. The other end of the secondary winding of I.F.T. 2 (A.V.C./diode load pin) is connected to three points: (a) 470 k resistor, returned to chassis; (b) 500 pF condenser, returned to chassis; (c) 22 k resistor, returned to the A.V.C. pin of the first I.F. transformer. This A.V.C. pin is by-passed through a condenser *not exceeding* 500 pF, and is also the starting point of the A.V.C. line to previous stages.

### L.F. Amplification

Thus we have the detected signal, now at audio-frequency, fed back through the 22 k resistor (R2) and the secondary of I.F.T. 1 to the control grid of the DF96. The valve now acts as a triode audio-frequency amplifier, using the screen as the triode's anode and it is from this electrode that the amplified A.F. signal is passed, via a .01 mfd. condenser, to the grid of the output valve. The 2 megohm grid-leak of DL96 is a potentiometer and is used as the volume control.

The 500 pF condenser (C4) merely by-passes residual I.F. and R.F. currents to chassis and is well worth inclusion.

### Output

The output from this circuit is not quite so great as if the normal DF96, DAF96, DL96 set-up is used. This is because DF96 is running at a lower screen voltage than usual and its A.F. amplifying action is that of a triode rather than that of a high gain audio pentode. The requirements of the

circuit are: (a) 25 mA on the L.T. line (50 if the DAF91 is used instead of DAF96); (b) a milliamp or two of H.T. current; (c) the cost of a valve, valveholder and associated components; (d) a good deal of room on the chassis.

For real space-saving the type of Westector the size of a ¼ watt resistor should be used. R6, the auto-bias resistor, should be of a value to give 5.2 (negative) volts bias.

If a DK96 is the frequency changer, and is used according to the maker's recommendations, then the value of this resistor will be about 400 ohms.

### A Mains Version

In a mains version of this circuit, in which any suitable vari-mu I.F. valve may be used, the suppressor grid will be connected to cathode and cathode taken direct to chassis. The valve then relies on the biasing voltage fed through R2. The series screen resistor should be higher than normal, since it is also the anode load resistor in the valve's audio-frequency function. A resistor of 100 k is about right. The stage is best followed by a sensitive output valve such as 6F6, EL41 or 50L6.

[Note: The Westector type WX6 may be obtained direct from the Westinghouse Brake and Signal Co. Ltd., 82, York Way, London, N.1.]

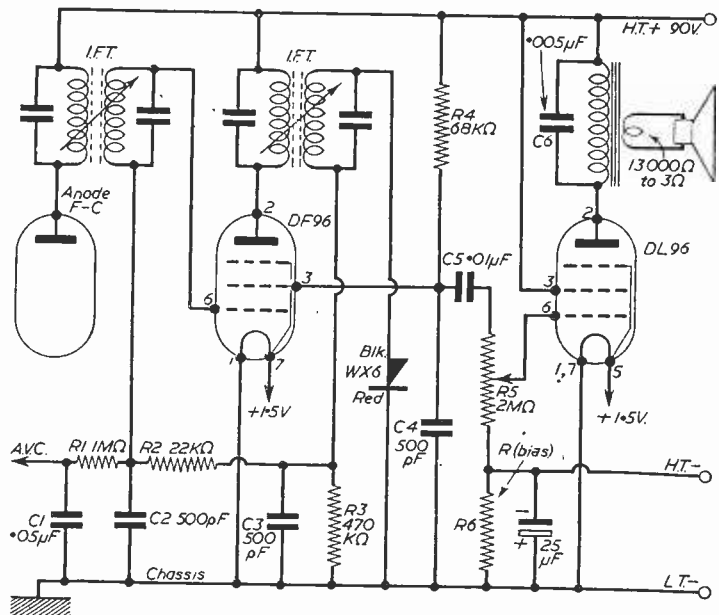

Fig. 1.—Reflex circuit using battery valves.

# An Anti-interference Aerial

THIS SYSTEM IMPROVES RECEPTION, PARTICULARLY ON SHORT WAVES

By A. W. Mann

**T**HERE are some locations which from the point of view of the short-wave listener are bad ones owing to electrical interference created by industrial machinery, domestic appliances and motor car ignition.

Suppression at the source often calls for co-operation. This is not always forthcoming and the listener must, therefore, adopt such methods at the receiving position as he can afford to apply in an attempt to improve matters.

Apart from mid-morning periods of domestic activity, and car ignition interference at all times, the author considers his location as fairly good. One of the receivers in use is a very sensitive R1155A. This particular type of receiver has a reputation for having an unfavourable signal to noise ratio when used with a power output stage.

This criticism is not fully justified. In the first instance too many listeners use too high a volume level when listening to far-away places. It is surprising how effective an L.F. volume control can be if fitted and used correctly.

While I have always suspected that some of the background noise attributed to this type of receiver is due to external pick-up by the aerial

system, my chief concern was to reduce the effects of electrical interference to a minimum. Mains filters were already in use and the only remedy which showed promise was the erection of an anti-interference aerial. Sufficient space, however, was not available for the erection of either a split doublet or a single ended one.

## Final Choice

A vertical-rod type was the final choice. It was decided to try out an experimental model using an 8ft. whip and mount the system (built as a complete unit) at the top of the 27ft.  $\times$  3in. square pole already supporting other vertical aeriars.

As cut and try methods applied at the top of a 30ft. ladder set at an acute angle did not appeal to the writer, home-constructed matching transformers were ruled out. A complete anti-interference aerial kit as advertised by Premier Radio in this journal was therefore obtained. The kit, which includes amongst other items two screened matching transformers and 60ft. lengths of aerial wire and screened coaxial-transmission line, was examined and the specification and drawings put in hand.

It was essential that the aerial system should be made and completed in the workshop as a complete weatherproof unit which once erected would remain until such times as repainting was considered necessary. In addition erection and dismantling single handed from the top of the ladder with the minimum of risk was an important factor.

## The Aerial Unit

Sufficient 2in.  $\times$  1in. white wood was obtained to make the bracket required and in the dimensions of which are given in Fig. 1. Fig. 1 also shows the 5 $\frac{3}{4}$ in. square platform on which the rubber base of the whip aerial is mounted (see A).

Woodscrews should be used throughout when making this bracket as rigidity is most desirable. It will be noticed that the inside of the bracket is divided into three separate compartments, B, C and D. Compartment B houses the aerial step-down transformer and when the unit is completed it is entirely enclosed and weatherproof. Compartments C and D remain open in order to reduce wind resistance. The bracket when completed should be well painted.

The matching transformer is totally enclosed because all the connecting stubs are at the top of the transformer, and in any case would require some form of protection against the weather. By totally enclosing the stubs and soldered connections the general efficiency of the system will remain constant. When this transformer is used as originally intended (i.e., with doublet aeriars) lowering for inspection at intervals is not

(Continued on page 973)

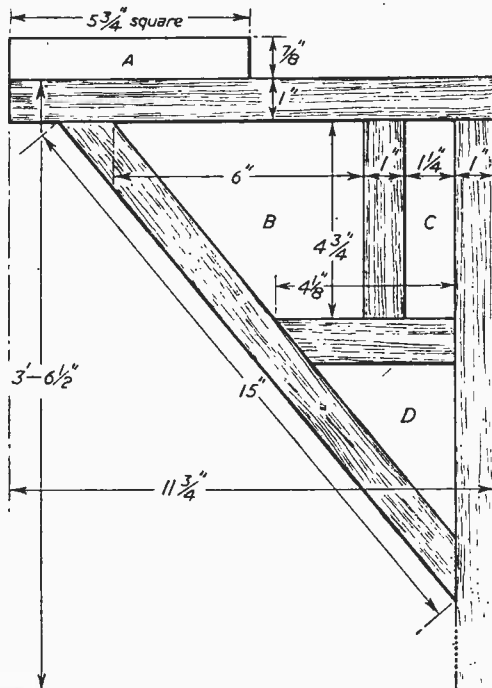

Fig. 1.—Dimensions and structure of the mounting platform of the whip aerial.

# BUILD YOUR OWN TAPE RECORDER

## The TRUVOX way

Take 1 Truvox Mk. III or Mk. IV Tape Deck (available from 23 gns.), and 1 Truvox Type "K" Amplifier (available from 19 gns.), add 1 loudspeaker and cabinet and you not only have the thrill of owning a tape recorder that is well up to semi-professional standards, but the added satisfaction of having built it to suit, exactly, your own requirements.

You can build your own amplifier from the circuitry supplied FREE with each Tape Deck.

### GO STEREO WITH TRUVOX

Truvox Tape Decks can be supplied fitted with a stereophonic head at an extra charge. Add a second loudspeaker and amplifier and you'll have all the thrill of stereophony in your own home.

TRUVOX TAPE RECORDER COMPONENTS ARE AVAILABLE AT YOUR LOCAL STOCKISTS—SEND FOR FULL TECHNICAL DETAILS.

**TRUVOX LIMITED**  
NEASDEN LANE, LONDON, N.W.10. Telephone: Gladstone 6455.

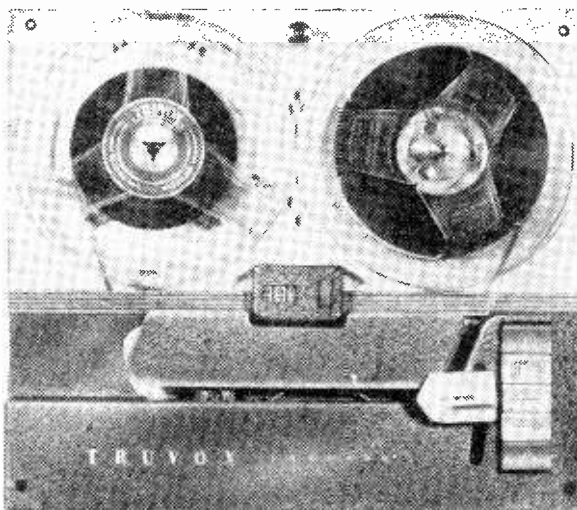

TRUVOX Tape Deck Mk. IV.

TRUVOX TYPE "K" Amplifier accurately matched to Truvox Tape Decks.

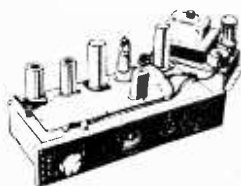

TRUVOX Radio Jack for direct radio reception and programme recording.

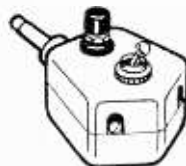

TRUVOX Stereophonic Head for replay of pre-recorded stereophonic tapes.



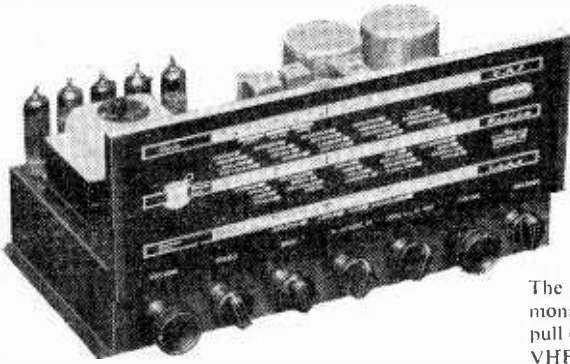

# Armstrong

## STEREO-TWELVE

### RADIOGRAM CHASSIS

price 37 guineas

The most complete unit yet produced for stereo and monaural reproduction, giving 6 watts high fidelity push-pull output on each channel, 12 watts for monaural. Full VHF band (87:108 mc/s), medium and long wave-bands with adjustable ferrite aerial on AM and automatic frequency control on FM. Stereo and monaural inputs are provided for records, tape and radio and a tape output for stereo and monaural tape recording. A 12 valve chassis measuring 14½ in. by 8 in. by 7 in. high which can easily be fitted with the help of the brass escutcheon and veneered fascia board which are available. There is comprehensive matching for all types of crystal pick-ups both monaural and stereo and speaker matching on both outputs of 3, 7½ and 15 ohms.

Post this coupon or write for descriptive literature and details of Home Trial facilities. Hire Purchase Terms and Guarantee or call at our Holloway Showroom for full, unhurried demonstration and professional advice on your installation. Open 9-6 Weekdays and Sats.

NAME .....  
ADDRESS .....  
PFS

The name ARMSTRONG is the registered trade mark of  
**ARMSTRONG WIRELESS & TELEVISION CO. LTD.**  
WARLTERS ROAD, LONDON, N.7. Tel. NOR. 3213.

Great Britain's Valve



Mail Order House

- MULLARD AZ1 17- AZ21 17- AZ21 14- CBL1 27- CBL31 24- CCH35 24- CL4 24- CL3 30- CY1 17- CY31 17- DAC32 (M CL) 18- DAF91 18- DAF96 18- DCS93 24- DF30 (M CL) 18- DF91 16- DF92 16- DF96 16- DF97 16- DK32 23- DK40 22- DK91 18- DK92 18- DK98 18- DKB3 18- DL33 18- DL35 18- DL71 15- DL72 15- DL92 16- DL94 16- DL96 18- DM70 16- DQ93 34- DQ93 27- DW4 503 17- DW4 503 17- EASO 10- EAB90 18- EAC91 20- EAF42 17- EB34 16- EB41 12- EB91 12- EEC33 20- EEC34 20- EEC34 23- EEC34 25- EEC35 25- EEC40 24- EEC81 19- EEC82 19- EEC83 19- EEC84 19- EEC85 19- EEC86 19- EEC87 19- EEC88 19- EEC89 19- EEC90 19- EEC91 19- EEC92 19- EEC93 19- EEC94 19- EEC95 19- EEC96 19- EEC97 19- EEC98 19- EEC99 19- EEC100 19- EEC101 19- EEC102 19- EEC103 19- EEC104 19- EEC105 19- EEC106 19- EEC107 19- EEC108 19- EEC109 19- EEC110 19- EEC111 19- EEC112 19- EEC113 19- EEC114 19- EEC115 19- EEC116 19- EEC117 19- EEC118 19- EEC119 19- EEC120 19- EEC121 19- EEC122 19- EEC123 19- EEC124 19- EEC125 19- EEC126 19- EEC127 19- EEC128 19- EEC129 19- EEC130 19- EEC131 19- EEC132 19- EEC133 19- EEC134 19- EEC135 19- EEC136 19- EEC137 19- EEC138 19- EEC139 19- EEC140 19- EEC141 19- EEC142 19- EEC143 19- EEC144 19- EEC145 19- EEC146 19- EEC147 19- EEC148 19- EEC149 19- EEC150 19- EEC151 19- EEC152 19- EEC153 19- EEC154 19- EEC155 19- EEC156 19- EEC157 19- EEC158 19- EEC159 19- EEC160 19- EEC161 19- EEC162 19- EEC163 19- EEC164 19- EEC165 19- EEC166 19- EEC167 19- EEC168 19- EEC169 19- EEC170 19- EEC171 19- EEC172 19- EEC173 19- EEC174 19- EEC175 19- EEC176 19- EEC177 19- EEC178 19- EEC179 19- EEC180 19- EEC181 19- EEC182 19- EEC183 19- EEC184 19- EEC185 19- EEC186 19- EEC187 19- EEC188 19- EEC189 19- EEC190 19- EEC191 19- EEC192 19- EEC193 19- EEC194 19- EEC195 19- EEC196 19- EEC197 19- EEC198 19- EEC199 19- EEC200 19- EEC201 19- EEC202 19- EEC203 19- EEC204 19- EEC205 19- EEC206 19- EEC207 19- EEC208 19- EEC209 19- EEC210 19- EEC211 19- EEC212 19- EEC213 19- EEC214 19- EEC215 19- EEC216 19- EEC217 19- EEC218 19- EEC219 19- EEC220 19- EEC221 19- EEC222 19- EEC223 19- EEC224 19- EEC225 19- EEC226 19- EEC227 19- EEC228 19- EEC229 19- EEC230 19- EEC231 19- EEC232 19- EEC233 19- EEC234 19- EEC235 19- EEC236 19- EEC237 19- EEC238 19- EEC239 19- EEC240 19- EEC241 19- EEC242 19- EEC243 19- EEC244 19- EEC245 19- EEC246 19- EEC247 19- EEC248 19- EEC249 19- EEC250 19- EEC251 19- EEC252 19- EEC253 19- EEC254 19- EEC255 19- EEC256 19- EEC257 19- EEC258 19- EEC259 19- EEC260 19- EEC261 19- EEC262 19- EEC263 19- EEC264 19- EEC265 19- EEC266 19- EEC267 19- EEC268 19- EEC269 19- EEC270 19- EEC271 19- EEC272 19- EEC273 19- EEC274 19- EEC275 19- EEC276 19- EEC277 19- EEC278 19- EEC279 19- EEC280 19- EEC281 19- EEC282 19- EEC283 19- EEC284 19- EEC285 19- EEC286 19- EEC287 19- EEC288 19- EEC289 19- EEC290 19- EEC291 19- EEC292 19- EEC293 19- EEC294 19- EEC295 19- EEC296 19- EEC297 19- EEC298 19- EEC299 19- EEC300 19- EEC301 19- EEC302 19- EEC303 19- EEC304 19- EEC305 19- EEC306 19- EEC307 19- EEC308 19- EEC309 19- EEC310 19- EEC311 19- EEC312 19- EEC313 19- EEC314 19- EEC315 19- EEC316 19- EEC317 19- EEC318 19- EEC319 19- EEC320 19- EEC321 19- EEC322 19- EEC323 19- EEC324 19- EEC325 19- EEC326 19- EEC327 19- EEC328 19- EEC329 19- EEC330 19- EEC331 19- EEC332 19- EEC333 19- EEC334 19- EEC335 19- EEC336 19- EEC337 19- EEC338 19- EEC339 19- EEC340 19- EEC341 19- EEC342 19- EEC343 19- EEC344 19- EEC345 19- EEC346 19- EEC347 19- EEC348 19- EEC349 19- EEC350 19- EEC351 19- EEC352 19- EEC353 19- EEC354 19- EEC355 19- EEC356 19- EEC357 19- EEC358 19- EEC359 19- EEC360 19- EEC361 19- EEC362 19- EEC363 19- EEC364 19- EEC365 19- EEC366 19- EEC367 19- EEC368 19- EEC369 19- EEC370 19- EEC371 19- EEC372 19- EEC373 19- EEC374 19- EEC375 19- EEC376 19- EEC377 19- EEC378 19- EEC379 19- EEC380 19- EEC381 19- EEC382 19- EEC383 19- EEC384 19- EEC385 19- EEC386 19- EEC387 19- EEC388 19- EEC389 19- EEC390 19- EEC391 19- EEC392 19- EEC393 19- EEC394 19- EEC395 19- EEC396 19- EEC397 19- EEC398 19- EEC399 19- EEC400 19- EEC401 19- EEC402 19- EEC403 19- EEC404 19- EEC405 19- EEC406 19- EEC407 19- EEC408 19- EEC409 19- EEC410 19- EEC411 19- EEC412 19- EEC413 19- EEC414 19- EEC415 19- EEC416 19- EEC417 19- EEC418 19- EEC419 19- EEC420 19- EEC421 19- EEC422 19- EEC423 19- EEC424 19- EEC425 19- EEC426 19- EEC427 19- EEC428 19- EEC429 19- EEC430 19- EEC431 19- EEC432 19- EEC433 19- EEC434 19- EEC435 19- EEC436 19- EEC437 19- EEC438 19- EEC439 19- EEC440 19- EEC441 19- EEC442 19- EEC443 19- EEC444 19- EEC445 19- EEC446 19- EEC447 19- EEC448 19- EEC449 19- EEC450 19- EEC451 19- EEC452 19- EEC453 19- EEC454 19- EEC455 19- EEC456 19- EEC457 19- EEC458 19- EEC459 19- EEC460 19- EEC461 19- EEC462 19- EEC463 19- EEC464 19- EEC465 19- EEC466 19- EEC467 19- EEC468 19- EEC469 19- EEC470 19- EEC471 19- EEC472 19- EEC473 19- EEC474 19- EEC475 19- EEC476 19- EEC477 19- EEC478 19- EEC479 19- EEC480 19- EEC481 19- EEC482 19- EEC483 19- EEC484 19- EEC485 19- EEC486 19- EEC487 19- EEC488 19- EEC489 19- EEC490 19- EEC491 19- EEC492 19- EEC493 19- EEC494 19- EEC495 19- EEC496 19- EEC497 19- EEC498 19- EEC499 19- EEC500 19- EEC501 19- EEC502 19- EEC503 19- EEC504 19- EEC505 19- EEC506 19- EEC507 19- EEC508 19- EEC509 19- EEC510 19- EEC511 19- EEC512 19- EEC513 19- EEC514 19- EEC515 19- EEC516 19- EEC517 19- EEC518 19- EEC519 19- EEC520 19- EEC521 19- EEC522 19- EEC523 19- EEC524 19- EEC525 19- EEC526 19- EEC527 19- EEC528 19- EEC529 19- EEC530 19- EEC531 19- EEC532 19- EEC533 19- EEC534 19- EEC535 19- EEC536 19- EEC537 19- EEC538 19- EEC539 19- EEC540 19- EEC541 19- EEC542 19- EEC543 19- EEC544 19- EEC545 19- EEC546 19- EEC547 19- EEC548 19- EEC549 19- EEC550 19- EEC551 19- EEC552 19- EEC553 19- EEC554 19- EEC555 19- EEC556 19- EEC557 19- EEC558 19- EEC559 19- EEC560 19- EEC561 19- EEC562 19- EEC563 19- EEC564 19- EEC565 19- EEC566 19- EEC567 19- EEC568 19- EEC569 19- EEC570 19- EEC571 19- EEC572 19- EEC573 19- EEC574 19- EEC575 19- EEC576 19- EEC577 19- EEC578 19- EEC579 19- EEC580 19- EEC581 19- EEC582 19- EEC583 19- EEC584 19- EEC585 19- EEC586 19- EEC587 19- EEC588 19- EEC589 19- EEC590 19- EEC591 19- EEC592 19- EEC593 19- EEC594 19- EEC595 19- EEC596 19- EEC597 19- EEC598 19- EEC599 19- EEC600 19- EEC601 19- EEC602 19- EEC603 19- EEC604 19- EEC605 19- EEC606 19- EEC607 19- EEC608 19- EEC609 19- EEC610 19- EEC611 19- EEC612 19- EEC613 19- EEC614 19- EEC615 19- EEC616 19- EEC617 19- EEC618 19- EEC619 19- EEC620 19- EEC621 19- EEC622 19- EEC623 19- EEC624 19- EEC625 19- EEC626 19- EEC627 19- EEC628 19- EEC629 19- EEC630 19- EEC631 19- EEC632 19- EEC633 19- EEC634 19- EEC635 19- EEC636 19- EEC637 19- EEC638 19- EEC639 19- EEC640 19- EEC641 19- EEC642 19- EEC643 19- EEC644 19- EEC645 19- EEC646 19- EEC647 19- EEC648 19- EEC649 19- EEC650 19- EEC651 19- EEC652 19- EEC653 19- EEC654 19- EEC655 19- EEC656 19- EEC657 19- EEC658 19- EEC659 19- EEC660 19- EEC661 19- EEC662 19- EEC663 19- EEC664 19- EEC665 19- EEC666 19- EEC667 19- EEC668 19- EEC669 19- EEC670 19- EEC671 19- EEC672 19- EEC673 19- EEC674 19- EEC675 19- EEC676 19- EEC677 19- EEC678 19- EEC679 19- EEC680 19- EEC681 19- EEC682 19- EEC683 19- EEC684 19- EEC685 19- EEC686 19- EEC687 19- EEC688 19- EEC689 19- EEC690 19- EEC691 19- EEC692 19- EEC693 19- EEC694 19- EEC695 19- EEC696 19- EEC697 19- EEC698 19- EEC699 19- EEC700 19- EEC701 19- EEC702 19- EEC703 19- EEC704 19- EEC705 19- EEC706 19- EEC707 19- EEC708 19- EEC709 19- EEC710 19- EEC711 19- EEC712 19- EEC713 19- EEC714 19- EEC715 19- EEC716 19- EEC717 19- EEC718 19- EEC719 19- EEC720 19- EEC721 19- EEC722 19- EEC723 19- EEC724 19- EEC725 19- EEC726 19- EEC727 19- EEC728 19- EEC729 19- EEC730 19- EEC731 19- EEC732 19- EEC733 19- EEC734 19- EEC735 19- EEC736 19- EEC737 19- EEC738 19- EEC739 19- EEC740 19- EEC741 19- EEC742 19- EEC743 19- EEC744 19- EEC745 19- EEC746 19- EEC747 19- EEC748 19- EEC749 19- EEC750 19- EEC751 19- EEC752 19- EEC753 19- EEC754 19- EEC755 19- EEC756 19- EEC757 19- EEC758 19- EEC759 19- EEC760 19- EEC761 19- EEC762 19- EEC763 19- EEC764 19- EEC765 19- EEC766 19- EEC767 19- EEC768 19- EEC769 19- EEC770 19- EEC771 19- EEC772 19- EEC773 19- EEC774 19- EEC775 19- EEC776 19- EEC777 19- EEC778 19- EEC779 19- EEC780 19- EEC781 19- EEC782 19- EEC783 19- EEC784 19- EEC785 19- EEC786 19- EEC787 19- EEC788 19- EEC789 19- EEC790 19- EEC791 19- EEC792 19- EEC793 19- EEC794 19- EEC795 19- EEC796 19- EEC797 19- EEC798 19- EEC799 19- EEC800 19- EEC801 19- EEC802 19- EEC803 19- EEC804 19- EEC805 19- EEC806 19- EEC807 19- EEC808 19- EEC809 19- EEC810 19- EEC811 19- EEC812 19- EEC813 19- EEC814 19- EEC815 19- EEC816 19- EEC817 19- EEC818 19- EEC819 19- EEC820 19- EEC821 19- EEC822 19- EEC823 19- EEC824 19- EEC825 19- EEC826 19- EEC827 19- EEC828 19- EEC829 19- EEC830 19- EEC831 19- EEC832 19- EEC833 19- EEC834 19- EEC835 19- EEC836 19- EEC837 19- EEC838 19- EEC839 19- EEC840 19- EEC841 19- EEC842 19- EEC843 19- EEC844 19- EEC845 19- EEC846 19- EEC847 19- EEC848 19- EEC849 19- EEC850 19- EEC851 19- EEC852 19- EEC853 19- EEC854 19- EEC855 19- EEC856 19- EEC857 19- EEC858 19- EEC859 19- EEC860 19- EEC861 19- EEC862 19- EEC863 19- EEC864 19- EEC865 19- EEC866 19- EEC867 19- EEC868 19- EEC869 19- EEC870 19- EEC871 19- EEC872 19- EEC873 19- EEC874 19- EEC875 19- EEC876 19- EEC877 19- EEC878 19- EEC879 19- EEC880 19- EEC881 19- EEC882 19- EEC883 19- EEC884 19- EEC885 19- EEC886 19- EEC887 19- EEC888 19- EEC889 19- EEC890 19- EEC891 19- EEC892 19- EEC893 19- EEC894 19- EEC895 19- EEC896 19- EEC897 19- EEC898 19- EEC899 19- EEC900 19- EEC901 19- EEC902 19- EEC903 19- EEC904 19- EEC905 19- EEC906 19- EEC907 19- EEC908 19- EEC909 19- EEC910 19- EEC911 19- EEC912 19- EEC913 19- EEC914 19- EEC915 19- EEC916 19- EEC917 19- EEC918 19- EEC919 19- EEC920 19- EEC921 19- EEC922 19- EEC923 19- EEC924 19- EEC925 19- EEC926 19- EEC927 19- EEC928 19- EEC929 19- EEC930 19- EEC931 19- EEC932 19- EEC933 19- EEC934 19- EEC935 19- EEC936 19- EEC937 19- EEC938 19- EEC939 19- EEC940 19- EEC941 19- EEC942 19- EEC943 19- EEC944 19- EEC945 19- EEC946 19- EEC947 19- EEC948 19- EEC949 19- EEC950 19- EEC951 19- EEC952 19- EEC953 19- EEC954 19- EEC955 19- EEC956 19- EEC957 19- EEC958 19- EEC959 19- EEC960 19- EEC961 19- EEC962 19- EEC963 19- EEC964 19- EEC965 19- EEC966 19- EEC967 19- EEC968 19- EEC969 19- EEC970 19- EEC971 19- EEC972 19- EEC973 19- EEC974 19- EEC975 19- EEC976 19- EEC977 19- EEC978 19- EEC979 19- EEC980 19- EEC981 19- EEC982 19- EEC983 19- EEC984 19- EEC985 19- EEC986 19- EEC987 19- EEC988 19- EEC989 19- EEC990 19- EEC991 19- EEC992 19- EEC993 19- EEC994 19- EEC995 19- EEC996 19- EEC997 19- EEC998 19- EEC999 19- EEC1000 19- EEC1001 19- EEC1002 19- EEC1003 19- EEC1004 19- EEC1005 19- EEC1006 19- EEC1007 19- EEC1008 19- EEC1009 19- EEC1010 19- EEC1011 19- EEC1012 19- EEC1013 19- EEC1014 19- EEC1015 19- EEC1016 19- EEC1017 19- EEC1018 19- EEC1019 19- EEC1020 19- EEC1021 19- EEC1022 19- EEC1023 19- EEC1024 19- EEC1025 19- EEC1026 19- EEC1027 19- EEC1028 19- EEC1029 19- EEC1030 19- EEC1031 19- EEC1032 19- EEC1033 19- EEC1034 19- EEC1035 19- EEC1036 19- EEC1037 19- EEC1038 19- EEC1039 19- EEC1040 19- EEC1041 19- EEC1042 19- EEC1043 19- EEC1044 19- EEC1045 19- EEC1046 19- EEC1047 19- EEC1048 19- EEC1049 19- EEC1050 19- EEC1051 19- EEC1052 19- EEC1053 19- EEC1054 19- EEC1055 19- EEC1056 19- EEC1057 19- EEC1058 19- EEC1059 19- EEC1060 19- EEC1061 19- EEC1062 19- EEC1063 19- EEC1064 19- EEC1065 19- EEC1066 19- EEC1067 19- EEC1068 19- EEC1069 19- EEC1070 19- EEC1071 19- EEC1072 19- EEC1073 19- EEC1074 19- EEC1075 19- EEC1076 19- EEC1077 19- EEC1078 19- EEC1079 19- EEC1080 19- EEC1081 19- EEC1082 19- EEC1083 19- EEC1084 19- EEC1085 19- EEC1086 19- EEC1087 19- EEC1088 19- EEC1089 19- EEC1090 19- EEC1091 19- EEC1092 19- EEC1093 19- EEC1094 19- EEC1095 19- EEC1096 19- EEC1097 19- EEC1098 19- EEC1099 19- EEC1100 19- EEC1101 19- EEC1102 19- EEC1103 19- EEC1104 19- EEC1105 19- EEC1106 19- EEC1107 19- EEC1108 19- EEC1109 19- EEC1110 19- EEC1111 19- EEC1112 19- EEC1113 19- EEC1114 19- EEC1115 19- EEC1116 19- EEC1117 19- EEC1118 19- EEC1119 19- EEC1120 19- EEC1121 19- EEC1122 19- EEC1123 19- EEC1124 19- EEC1125 19- EEC1126 19- EEC1127 19- EEC1128 19- EEC1129 19- EEC1130 19- EEC1131 19- EEC1132 19- EEC1133 19- EEC1134 19- EEC1135 19- EEC1136 19- EEC1137 19- EEC1138 19- EEC1139 19- EEC1140 19- EEC1141 19- EEC1142 19- EEC1143 19- EEC1144 19- EEC1145 19- EEC1146 19- EEC1147 19- EEC1148 19- EEC1149 19- EEC1150 19- EEC1151 19- EEC1152 19- EEC1153 19- EEC1154 19- EEC1155 19- EEC1156 19- EEC1157 19- EEC1158 19- EEC1159 19- EEC1160 19- EEC1161 19- EEC1162 19- EEC1163 19- EEC1164 19- EEC1165 19- EEC1166 19- EEC1167 19- EEC1168 19- EEC1169 19- EEC1170 19- EEC1171 19- EEC1172 19- EEC1173 19- EEC1174 19- EEC1175 19- EEC1176 19- EEC1177 19- EEC1178 19- EEC1179 19- EEC1180 19- EEC1181 19- EEC1182 19- EEC1183 19- EEC1184 19- EEC1185 19- EEC1186 19- EEC1187 19- EEC1188 19- EEC1189 19- EEC1190 19- EEC1191 19- EEC1192 19- EEC1193 19- EEC1194 19- EEC1195 19- EEC1196 19- EEC1197 19- EEC1198 19- EEC1199 19- EEC1200 19- EEC1201 19- EEC1202 19- EEC1203 19- EEC1204 19- EEC1205 19- EEC1206 19- EEC1207 19- EEC1208 19- EEC1209 19- EEC1210 19- EEC1211 19- EEC1212 19- EEC1213 19- EEC1214 19- EEC1215 19- EEC1216 19- EEC1217 19- EEC1218 19- EEC1219 19- EEC1220 19- EEC1221 19- EEC1222 19- EEC1223 19- EEC1224 19- EEC1225 19- EEC1226 19- EEC1227 19- EEC1228 19- EEC1229 19- EEC1230 19- EEC1231 19- EEC1232 19- EEC1233 19- EEC1234 19- EEC1235 19- EEC1236 19- EEC1237 19- EEC1238 19- EEC1239 19- EEC1240 19- EEC1241 19- EEC1242 19- EEC1243 19- EEC1244 19- EEC1245 19- EEC1246 19- EEC1247 19- EEC1248 19- EEC1249 19- EEC1250 19- EEC1251 19- EEC1252 19- EEC1253 19- EEC1254 19- EEC1255 19- EEC1256 19- EEC1257 19- EEC1258 19- EEC1259 19- EEC1260 19- EEC1261 19- EEC1262 19- EEC1263 19- EEC1264 19- EEC1265 19- EEC1266 19- EEC1267 19- EEC1268 19- EEC1269 19- EEC1270 19- EEC1271 19- EEC1272 19- EEC1273 19- EEC1274 19- EEC1275 19- EEC1276 19- EEC1277 19- EEC1278 19- EEC1279 19- EEC1280 19- EEC1281 19- EEC1282 19- EEC

inconvenience. In this instance the condition of the whip aerial will decide the time for a general overhaul, which in a heavy industrial area will be about two years.

### Fitting Up

Before fitting any components in place an  $\frac{1}{4}$ in. diameter hole should be drilled through the centre of the aerial base platform and bracket top piece into compartment B. A  $\frac{1}{4}$ in. hole should also be drilled through the base of compartment B and another directly below it, i.e., through the 1.5in. supporting members (see Fig. 2).

The next item required is the mounting bracket shown also in Fig. 2 together with a small bridge which is needed to mount the earthing terminals. This may be made in the form of an insulated terminal block mounted on a suitable wooden block.

The tin-plate bracket requires a screw hole in each flange and a larger hole in the centre of the  $1\frac{1}{2}$ in. platform so that the coax. socket at the base of the aerial transformer will pass through and the nut and tighten up as shown in Fig. 2. This coax. connector, by the way, is not used for any purpose in the original instructions so far as connecting up is concerned. When the transformer has been fitted to the bracket the combined unit can be fitted into place in compartment B as shown.

### Transformer Connections

The connecting stubs of the aerial transformer are numbered 1, 2, 3, 4 and 5. The aerial lead should be connected to No. 1. This lead should be of sufficient length to pass through the hole in the bracket and base platform and couple to the screw fitted in the inside of the aerial base. The base should then be screwed to the platform.

The coax. screened cable connections are: screening to stub 2; centre conductor to stub 5. A 50 pF capacitor should be connected between stubs 4 and 2. Before soldering the screened cable connections fasten the coax. by means of two small insulated staples to the vertical side of compartment B after passing it through the holes in the bracket and base respectively. Otherwise, the coiled up cable will be suspended from the connecting stubs which could result in fractured joints or stub breakage. Good sound soldered joints are essential and when all the connections are made a double check against the above instructions is recommended.

The coax. cable stapled down one side of the bracket is shown in Fig. 2. It also shows the totally enclosed static discharge unit with a short lead connecting the top end terminal to the outside aerial terminal of the aerial base. The remaining terminal shown as earthed is connected by a length of insulated aerial wire to the earthing terminal at the base of the bracket. When the aerial is erected and in place, another length of wire is taken from the earth terminal to an earth spike driven well into the ground.

The next job is to enclose the compartment completely with tinplate covers cut to size in the manner shown in Fig. 3. The covers after cutting to size should be drilled so that each side has holes for half a dozen small, round-headed,

screws. Paint these covers well on both sides, and paint the inside edges about  $\frac{1}{16}$ in. wide all round before screwing in place. Paint the joint edges when this is done. This will result in a weatherproof unit.

### Static Discharger

This is built into a two ounce tobacco tin. All necessary dimensions are given in Fig. 4.

Now a word of warning concerning the construction of this unit. The saw-toothed elements

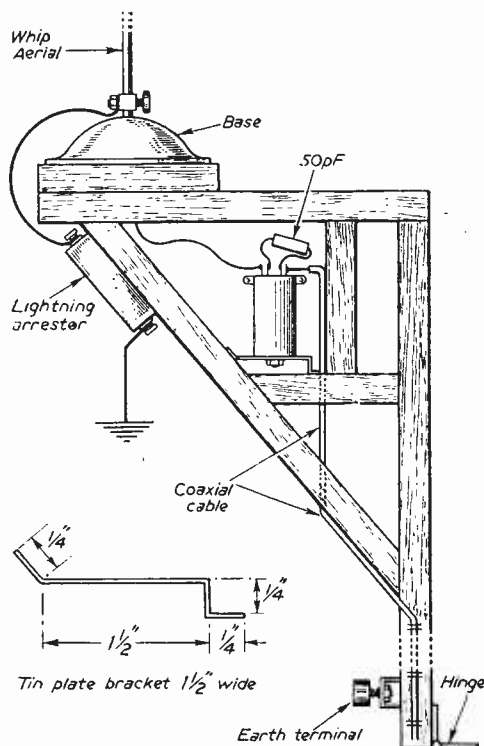

Fig. 2.—The various parts of the aerial system in position. Inset is shown the mounting bracket for the transformer.

must be completely insulated from the tin case, otherwise the aerial system will be earthed. This insulation can be carried out with a very short piece of sleeving, little more than the thickness of the box end fitted on the terminal shanks.

Very thin Paxolin sheet can be used to insulate the terminal base from the box ends and between the box ends. These washers will fit over the terminal shank insulation and butt up against the tin ends and insulate the spark gap elements from the ends.

Cut the spark gap elements so that they overlap one another. Drill a small hole in each end of the elements so that they will pass over the insulated terminal shanks. The ends of the elements when fitted should be clear of the box bottom.

Cut one element to half the inside length of the box. Fit in position and mark off the over-



lap after fitting it in place. Withdraw it and cut it to give a gap of one sixteenth of an inch and having done so file out the saw teeth. Now fit up the complete unit not forgetting the insulation. Having done so check for continuity.

If correctly assembled each terminal and its associated saw-toothed element should give a deflection on the meter or a light if a battery and bulb are used for the test. From the tin case to either terminal or element "no continuity" should result.

### Erection

The aerial unit completed has the screened coax. coiled up. Readers will notice that a stout hinge is screwed to the bottom of the bracket. This makes single-handed erection much

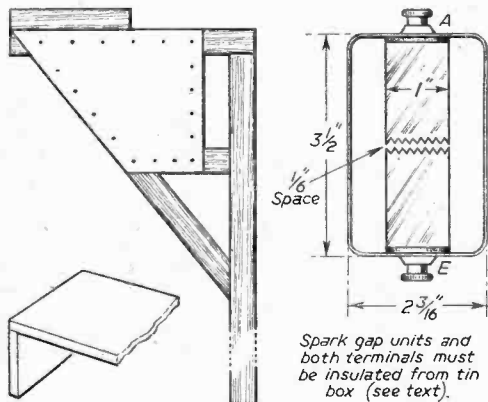

Fig. 3 (Left).—The transformer compartment weatherproofed with tin-plate covers.

Fig. 4 (Right).—Dimensions of the static discharger. Inset shows L-shape of brackets.

easier. The unit less the whip aerial is placed in position squared up and screwed to the pole with two screws. The hinge is then screwed to the pole. The two screws holding the bracket in position are withdrawn and the bracket carefully lowered. The whip aerial is then inserted in the base socket and the aerial bracket lifted into position and again screwed to the pole.

The coax. cable should now be unrolled ready to run to the receiving position, and an earth lead of sufficient length should be taken from the earth terminal to an earth rod driven well into the ground.

### The Receiver Matching Transformer

This transformer can be fitted inside the receiver. This applies especially to a receiver which is totally screened, as is the R1155. In the case of this receiver it can be mounted inside an unused D.F. valveholder but must be entirely insulated from it and the chassis. Do a continuity test and make sure of this. No reading should be obtained between the metal case of the transformer and the receiver chassis.

The author has fitted a small Paxolin panel in front of the unused D.F. loop socket. On this is mounted a coax. socket. The centre is

connected to No. 5 stub of the transformer, while the outside tag goes to No. 2. The set aerial and earth input should be taken by short leads to stub No. 4 and stub No. 3 respectively. The author has transposed each pair of leads.

### Testing

Do not cut the coax. cable until a test has been carried out. Bare the insulation at the end of the cable and fit the coax. plug. Plug into the coax. socket and try out the aerial system on all bands.

### Results

Tests carried out with the new system showed that on the two short-wave ranges there was a marked increase in signal strength and a much better signal-to-noise ratio.

In addition motor car ignition interference is entirely eliminated and vacuum cleaner interference considerably suppressed and once tuned to a transmission was well below the signal level except for very weak signals. Had additional height been possible there is no doubt that further improvement would have resulted.

On medium waves clearer reception resulted. The long-wave bands showed a less favourable signal-to-noise ratio but a 14ft. whip or the centre loading of the existing one would provide considerable improvement. The principal interest is, however, on the short-wave bands.

## Books Received

**ELEMENTARY TELECOMMUNICATIONS EXAMINATION GUIDE.** By W. T. Perkins, M.Inst.B.E., A.M.Brit.I.R.E. 318 pp. 187 illustrations. Published by Geo. Newnes Ltd. Price 17s. 6d.

This is the first book of its kind to cover the two main subjects comprising the City and Guilds of London Institute first year Telecommunications Course. It contains a wide selection of questions typical of those which are set by the Institute, and provides model answers. Examination papers set in years 1955 to 1957 are reproduced.

**TELEVISION ENGINEERS' POCKET BOOK.** By J. P. Hawker. 264 pp., profusely illustrated. Published by Geo. Newnes Ltd. Price 12s. 6d.

This is a new and enlarged edition of the pocket manual and data book which has already found favour amongst engineers and servicemen.

**BBC HANDBOOK, 1959, 286 pp. Price 5/-.** Published by the BBC.

This gives many interesting facts concerning the BBC programmes and other data. For instance, 200,000 letters a year are received by the BBC; 620 students were trained by the Engineering Training Department; 8,000,000 schools pamphlets are produced in a year; the BBC staff numbered 5,472 at March 31st, 1958. These are only a few of the interesting facts to be found in the latest edition of this Handbook.

# Servicing Radio Receivers

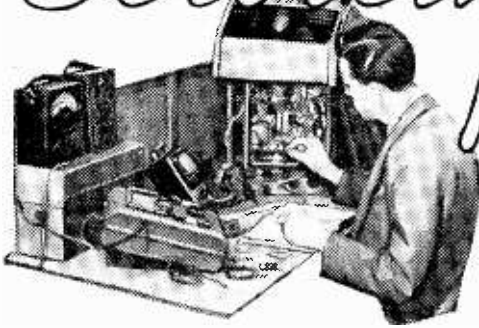

## THE REGENTONE MODEL "DOUBLE TWO"

By Gordon J. King, A.M.I.P.R.E.

**T**HIS is a fairly recent model and takes the form of a semi-personal portable suitable for operation on both mains and batteries. It is a two waveband set: L.W. 160-260 kc/s (1.875-1.150 metres) and M.W. 525-1.630 kc/s (570-187 metres), and uses four low-consumption all-dry battery type valves.

On mains it can be powered over the range of 110-120 V. and 190-250 V. D.C. or A.C. 25-100 c.s. while on battery it requires a 90 v. H.T. and 1.4 v. L.T., which is usually supplied by an Ever Ready type B147 unit. This has a life expectation in the region of 100 hours under normal conditions, but can be prolonged by the use of the "battery economy" switch, which is a feature of the receiver.

Reproduction is by way of a 5in. 9,000-line 3-ohm loudspeaker, and the internal aerial is of the ferrite-rod variety. Provision is made, however, for the connection of an external aerial in heavily screened areas and where it is required to receive distant stations.

### Circuit Description

The full circuit is given in Fig. 1, and the valve line-up is as follows: V1 (DK96) frequency changer; V2 (DF96) I.F. amplifier; V3 (DAF96) detector, A.G.C. and audio amplifier; V4 (DL96) power output.

The circuit is reasonably conventional and little difficulty should be experienced in following it: L1 and L2 form the windings on the ferrite-rod aerial, and in conjunction with the aerial section of the gang (C6) L1 and L2 in series tune over the L.W. band. When the M.W. push-button is depressed section L2 is short-circuited and L1 serves as the M.W. aerial coil. On L.W. C3 acts as a fixed trimmer, while on M.W. C4 is also brought into circuit and thus constitutes the M.W. variable trimmer.

The oscillator coils (L5 and L6) are common to both bands, but the oscillator section (S3) of the push-button wavechange switch selects the required L.W. or M.W. capacitive loading, and in both cases the tuning is accomplished by the oscillator section of the gang (C12). The oscillator works at 470 kc/s above the tuned signal frequency of the received signal, and the resulting

I.F. signal is developed across the first I.F. transformer T1.

This signal, as developed across L4, is applied to the I.F. amplifier valve, V2, and is re-developed in amplified form across the second I.F. transformer T2. The signal, as across L8, is fed to the signal diode in V3. R11 can be considered as the diode load resistor, and I.F. filtering is accomplished by R10 in association with C22.

The A.F. signal across the load is coupled to the volume control through C24, from which it is applied to the control grid of V3 pentode section through C26. The pentode amplifies the A.F. and the signal appears across the anode load resistor R26. From here it is coupled to the control grid of the output pentode V4 through C28, and in turn is transformed in terms of power of correct impedance to match the loudspeaker by the output transformer T3.

### A.G.C. Bias

The D.C. content of the I.F. signal, which increases negatively with signal increase, and is also developed across the load resistor R11, is reflected into the signal grid circuits of V1 and V2 by R7 and R4 respectively. This serves to bias the valves mentioned and provides automatic control of gain (A.G.C.), since the gain of the frequency changer and I.F. amplifier valves is reduced as the signal rises and as the grids are made more negative. The converse happens, of course, when the signal strength drops; for example, when tuning from a strong to a weak signal, or in the event of a signal fade.

### Mains Operation

When the receiver is operated from the mains supply both H.T. and L.T. are supplied by the metal H.T. rectifier (Westinghouse type 18RA-1-1-16-1). The necessary circuit changes are brought about by operation of the "battery/mains" switches which, changing from battery to mains operation, are actuated by the insertion of the mains supply socket at the rear of the receiver.

The H.T./L.T. supply is filtered and smoothed by electrolytics EC1, EC2, EC3 and EC4 and R25; R28 is also an aid to filtering as is the H.T. resistor chain. On mains, H.T. is applied to the H.T. rail from the junction of R17 and R21 by way of R25, while the L.T. is applied to the

heater of V4 from the end of R20. The filaments are connected in series in the following order: V4 to V1 to V2 to V3 to chassis. The tap of V4 filament, however, is at +5.2 v. in relation to the chassis, and it is this potential which is used to bias the valves, it being applied to the A.G.C. line. It should be observed that under zero signal condition the signal grids of V1 and V2 are of a potential equal to their filaments, thereby giving the condition of maximum gain. The grids rise negative with respect to the filaments as the result of the normal A.G.C. action, as described.

The pre-set resistor R8 allows adjustment of the filament current. It is accurately set at the factory to suit the output valve, but if this valve is replaced, readjustment of the resistor should be made until an Avo model 8 or similar high-resistance meter indicates 3.9 v. at pin 1 (heater) of V4, after first having established that the mains adjustment tap coincides with the applied mains voltage.

**Battery Operation**

The receiver is automatically switched for battery operation by the removal of the mains socket at the rear of the receiver. This operates the battery/mains changeover switches which disconnect the mains unit, introduce the batteries and arrange for the valve filaments to be connected in parallel across the L.T. battery.

The H.T. current in R31 produces a potential across the resistor which serves to bias the output valve.

When the economy switch is in the "economy" position, only one half of V4 filament is energised. This reduces the available A.F. output power,

of course, but it also results in a 20 per cent. saving of L.T. and H.T. power over the other setting, which switches in both halves of the filament.

**Alignment Information**

Alignment is best carried out with the receiver operating on batteries.

With a 470 kc/s modulated signal applied to the signal grid of V2 through a 0.1  $\mu$ F capacitor, the dust-iron cores of T2 should be adjusted in turn for maximum audio output, either as indicated on an output meter connected across the speaker speech coil or direct from the modulation tone from the loudspeaker. The receiver's volume control should be set at maximum, and to avoid errors owing to the action of the A.G.C., the smallest possible input signal, consistent with useable output indication, should be maintained—the input signal being reduced as the circuits approach resonance. This applies throughout the alignment process, and the audio output should not rise above 50 mW.

With the receiver tuned to the high-frequency end of the M.W. band, the generator signal should next be applied to the signal grid of V1, and then the cores in T1 should be adjusted for maximum output. This concludes the I.F. alignment.

Next the M.W. R.F. alignment. After having first ensured that the tuning pointer coincides with the zero mark on the scale when the tuning gang is fully closed, the generator "live" output lead should be connected through a dummy aerial to the receiver's aerial socket and the "earthed"

(Continued on page 988)

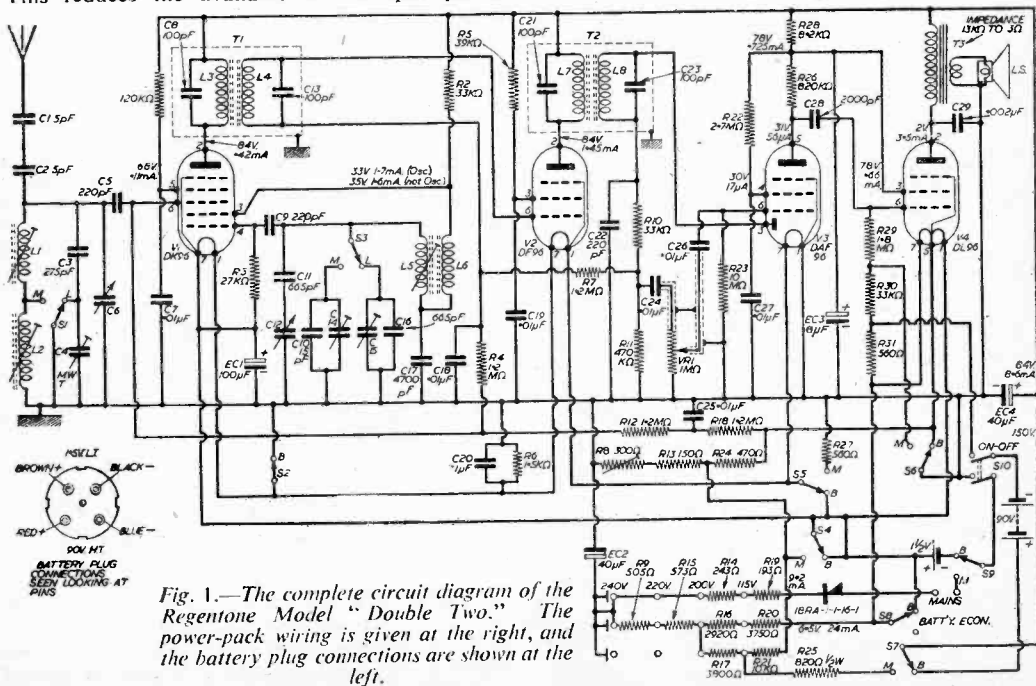
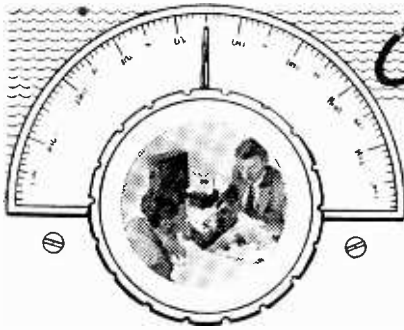

Fig. 1.—The complete circuit diagram of the Regentone Model "Double Two." The power-pack wiring is given at the right, and the battery plug connections are shown at the left.



# On Your Wavelength

BY THERMION

if you can tell a bright child from a dull one, the eleven-plus tests will confirm it. If you cannot, the test is useless.

## Where is Brisbon?

IN giving the Test Match results, the BBC announcers are referring to "Brisbon." Can someone tell me where it is? Do you think they can be referring to Brisbane? I also want to know what are "skattered shaws," "belley," and "kennet," "ars and ars," "yers and yers," "Serviette Union." Also where is Margit? I am glad to see that the *Sunday Times* continues to augment my attack on announcers' English. I gather that the meanings to the foregoing are: "scattered showers"; "ballet"; "cannot"; "hours and hours"; and "years and years"; and "Soviet Union." Incidentally, there is one announcer who bisyllableises "hours" and makes it "owers."

Some of the artists are not beyond criticism. Gladys Morgan, for example, infuriates me by the way she smacks "old" round her chops and makes it "ohuld." To her, "house" becomes "hohse." Let me have your lists of any further monstrosities you hear over the radio or on TV.

## The Teenage Cryners

THERE is something really pathetic in watching a theatre audience, at the command of some work-shy teenage singer with a voice like a coalman with the croup, hypnotising an audience into clapping while he sings. What satisfaction they can get out of it, I do not know. The unfortunate result of the publicity accorded to these born-tired buskers, who should confine their activities to singing outside public houses, is that it is encouraging similar born-tired youths to want to do the same.

## All Lies?

A MORNING newspaper the other day published a review of a book on the life story of a well-known pop-singing youth. The newspaper published as a result a letter in the following terms:

*"So a smart publicity agent—on his own admission—built up a pop singer by a pack of lies.*

*"Having stated so, will newspapers continue to use his doubtful hand-outs? I rather think so. The motto of some, it seems, is 'anything for a story.'*

*"In this particular instance it is all very harmless, but nevertheless Mr. Kennedy has lied and cheated to 'achieve' what he has, and thinks he is doing himself well by telling the world.*

*"Is it not time that newspapers made an investigation into the facts these smart deacs dish out ad lib. instead of blindly publishing them?"*

*"Perhaps Mr. Kennedy will now be censored by the Press Council."*

## Verbal Diarrhoea

IN a book concerned with teachers and progress in education, there is an article dealing with the controversial eleven-plus examination system. In that article, the following sentence appears:

*"The main criticism that can justifiably be brought against it is that it has at times been required to accomplish the virtually impossible task of segregating into courses which are sharply differentiated children between whose abilities, attainments and ascertainable needs there is a scarcely perceptible difference."*

My criticism of this pompous piece of writing, written in the same strain, is that it is prolix, verbose, tautological and tergiversatory. You would need to be 51 plus to get the meaning of it in one go. I gather that what it means is that

## Combined TV and V.H.F. Radio

A MANUFACTURER of combined TV and V.H.F. radio receivers says that at first sight, the combined set is technically attractive. When it appears that the TV set already contains almost all the parts necessary for V.H.F. reception it seems a pity not to add the extra coils in the turret and the F.M. detector in order to provide the useful extra band 2 facility.

In practice, it does not work out so happily. If proper attention is to be paid to valve life, extensive switching is required, the heater chain becomes complicated and a thermistor has to be incorporated which lengthens the time it takes before the picture appears when switching to TV either from cold or from V.H.F. The standard sound television I.F. of 38.15 Mc/s is not really suitable for F.M. work, and the audio end of a television set is often of a lower standard than is expected from a radio set. On the whole, then, the V.H.F. performance of the combined sets hitherto on the market has been inferior in most respects, and few engineers have had a good word to say for them.

## PRACTICAL WIRELESS ENCYCLOPÆDIA

(13th Edition)

By F. J. CAMM

21/-, by post 22/6

From GEORGE NEWNES, LTD.,  
Tower House, Southampton Street, Strand, W.C.1

# Basic Theory For Constructors

No. 1.—RADIO CALCULATIONS FOR THE BEGINNER

By G. Palmer

**A** FLOW of electricity constitutes a movement of electrons in a given direction. Electrons move more freely in some materials than in others, and where they move freely the material is known as a conductor. All conductors possess a certain resistance to the flow of electricity, but with good conductors, such as copper connecting leads, the resistance is usually so small that it can be neglected. Materials in which the electrons do not move freely are known as insulators, glass and mica being examples.

In Fig. 1 is shown a resistor connected across a battery. The leads themselves connecting the resistor to the battery have a resistance which is

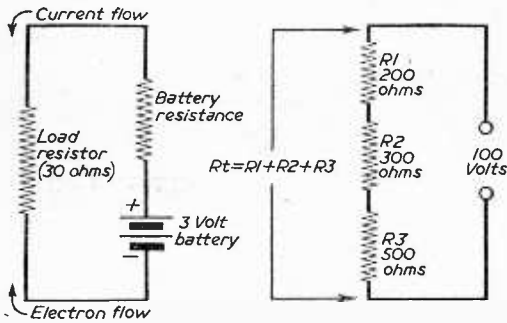

Fig. 1 (Left).—A simple series circuit, illustrating the application of Ohm's law.

Fig. 2 (Right).—Resistors connected in series.

very low in relation to that of the resistor and so are not taken into account in simple circuits. The battery itself also has a certain value of resistance, and is also represented in the circuit in Fig. 1.

Electrons flow in the circuit from the negative pole of the battery through the load resistor and back to the positive pole of the battery by way of its internal resistance. Current, on the other hand, is said to flow in the opposite direction, that is, from positive to negative. The current flow aspect is purely convention which remains with us from the days before the electron theory was evolved. However, to keep in with convention we will from now on consider current flow, as distinct from electron flow, unless otherwise stated.

The quantity of current in the circuit is governed by the value of the resistance in ohms and the condition and voltage of the battery.

Current is measured in amperes or fractions of this unit. A thousandth of an ampere being a milliampere (mA) and a millionth a microampere ( $\mu$ A).

## Ohm's Law

It was discovered by Ohm that the circuit current in amperes is equal to the applied voltage (electro-motive-force) divided by the resistance.

Current is denoted in formulæ by the capital letter I, while voltage and resistance are expressed by capital letters E and R respectively. Ohm's law formulæ may, therefore, be written as:  $I = E/R$ ,  $R = E/I$  and  $E = I \times R$ , the various arrangements being obtained by simple algebraic manipulation.

Thus, if the battery in Fig. 1 is rated at, say, 3 volts and the resistance is 30 ohms, then the circuit current ( $I = E/R$ ) is equal to  $3/30$ , which is 0.1 ampere, or 100 mA.

## Internal Resistance of Battery

It will be realised, of course, that the current in the circuit is also flowing through the internal resistance of the battery. When the battery is in good condition, this resistance is very low and does not itself have a large limiting effect on the circuit current. However, as the battery ages the internal resistance rises, and the battery is not capable of supplying the same high current as when new.

Let us suppose that a worn 3-volt battery is used in the circuit in Fig. 1, and that a voltmeter connected across the load resistor indicates only two volts. This means that 1 volt is being lost across the battery resistance. The current in the circuit in this case is in the region of 0.06 ampere (2 volts divided by 30 ohms).

The internal resistance of the battery can be discovered by dividing the voltage lost across the battery resistance by the circuit current ( $R = E/I$ ), that is, by dividing 1 volt by 0.06 ampere, which gives about 16 ohms.

If the load resistance is disconnected and the battery terminal voltage measured with a voltmeter, almost the full voltage of the battery will be indicated. This is because the voltmeter takes only a very small current and the voltage dropped across the battery resistance is correspondingly less.

Here is shown the folly of battery checking with an unloaded high resistance voltmeter, as is practiced in many radio shops. The only real test is to load the battery with a resistance which will pass a current comparable with that which the battery will be expected to supply in service, and then measure the voltage across the resistor. This test will soon reveal a battery which is faulty or which has been in stock for any length of time.

Some radio shops which understand this theory test all-dry L.T. batteries on the "10-amp" range of a multi-meter. This puts almost a dead short across the battery, but provided this is not prolonged, the possibility of the battery being ruined is remote. The current reading to be expected from batteries of various types is gleaned from experience, but if the reading is below an expected average, the internal resistance is high and it is unlikely that the unit would give the expected life span.

(Continued on page 981)





**HOOVER ROTARY TRANSFORMERS**



12 v. input, 500 v. output at 65 mA. or 6 v. input, 250 v. output at 75 mA. Not offered at only **10/6** EACH P. & P. 2/-

Order now while stocks last!

**HEADPHONES**

**D.I.R.1.** Low resistance with cord and plug. 3/6. P. & P. 2/-.  
**CHAMOS PADDED.** Most comfortable type ever manufactured. Low resistance, moving coil. 25/- P. & P. 2/6.  
**D.I.R.** Balanced armature, high resist. Only 12/6. P. & P. 2/-.  
**D.L.R. No. 5.** Balanced armature, low resist. Only 7/6. P. & P. 2/-.  
**H.S.30.** American lightweight with miniature earpieces. Only 15/- P. & P. 2/-.

**MALLORY 12V. VIBRATORS**

Type G634C. 4-pin. Only 2/6. P. & P. 9d.

**WIRELESS SET No. 19 Mk. III**

Two transmitter-receivers and an intercom amplifier in one case. "A" Set covers 2 to 8 Mc/s. in two switch bands R.T. and C.W. "B" Set 2.35 Mc/s. R.T. only. Complete with all valves. 500 micro-amp. check and tuning meter.

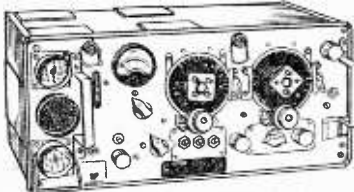

Advantages of the Mk. III over previous models is a much lower battery consumption and control, slow motion tuning, netting switch in place of push button, wider range of note in het tone control and the incorporation of R.F. gain control.

These sets are supplied in used condition with circuit diagram and instruction booklet. Price 90/- plus P. & P. 10/- or complete with power unit 26/10/- P. & P. 12/6.

**ATTACHMENTS FOR ABOVE :**

Brand New Variometer. 12/6 each ; Morse Key, 3/6 each ; 12ft. Aerial, 7/6 each ; Aerial Base, 3/- each ; 12-volt Power Unit, 25/- each ; Mk. III, 50/- each. Please add post.

**COMPLETE No. 1 HEADGEAR.** Brand new. Consists of low impedance padded headphones and No. 7 hand microphone with moving coil insert. Price. 10/- P. & P. 3/6.

**SCR 522—2 METRE INSTALLATION**

Complete V.H.F. Transmitter Receiver consisting of an automatically tuned, 4-channel, crystal controlled transmitter receiver, covering 100-156 Mc/s. amplitude modulated voice giving output of 12 watts. Consisting of 18 valves : 2-832, 3-12A6, 1-6C6, 2-6SS7, 1-12J5, 1-12C8, 1-9002, 3-9003, 1-12A4H7, 3-12SG7. Power requirements 300 volts H.T. and 12 volts L.T. Housed in black metal case. Size 12 1/2 in. x 16 in. x 9 1/2 in. Complete Transmitter Receiver only. Supplied complete with full operating details and circuit diagram. **70/-** Carr. 10/-.

**WIRELESS SET No. 46**

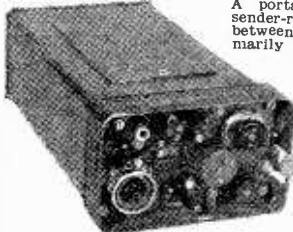

A portable R.T. and M.C.W. sender-receiver for frequencies between 3.6 and 9.1 Mc/s. Primarily a man-pack set, it is especially adaptable for use under difficult conditions, such as those prevailing during landing operations. Fixed crystal controlled tuning is employed on both sender and receiver, with a switch for three alternative channels. Thus, the usual "tuning in" and netting operations are eliminated. These sets are supplied complete with all valves but less crystal, which can be obtained to suit your own requirements. Price, including circuit diagram, 45/- P. & P. 4/-.

and netting operations are eliminated. These sets are supplied complete with all valves but less crystal, which can be obtained to suit your own requirements. Price, including circuit diagram, 45/- P. & P. 4/-.

**B. ADLER & SONS (RADIO) LTD.**

KING'S HEAD YARD, COPTIC ST., LONDON, W.C.1  
 TEL : MUS 9606

**A NEW BOOK**

by **G. A. BRIGGS**  
 with R. E. COOKE, B.Sc.(Eng.)  
 as TECHNICAL EDITOR

**LOUDSPEAKERS**

5TH EDITION

COMPLETELY REVISED AND ENLARGED • NOW 336 PAGES  
 230 ILLUSTRATIONS • FINE ART PAPER • CLOTH BOUND

PRICE 19/6 (20/9 Post Free)

31 Chapters including

- Reminiscences - Frequency Responses - Directional and Phase Effects - Baffles, Cabinets and Horns - Electrostatic Speakers - Stereo - Audio Fairs and Concert Halls

Most aspects of the design, construction and use of loudspeakers are also covered by test and experience in preference to theory and, as usual with this writer, the pages are salted with touches of humour.

Other books by G. A. Briggs still available :

**SOUND REPRODUCTION** 17s. 6d. (18s. 6d. Post Free)  
**PIANOS, PIANISTS & SONICS** 10s. 6d. (11s. 6d. Post Free)



**Wharfedale**

**WIRELESS WORKS LTD  
 IDLE BRADFORD YORKS**

Telephone : Idle 1235/6 Grams: 'Wharfedel,' Idle, Bradford

**REPANCO HIGH GAIN COILS**

- Dual Range Crystal Set Coil, Type DRX1 ... .. 2/6
- Dual Range Coil with Reaction, Type DRR2 ... .. 4/-
- Matched Pair Dual Range T.R.F. Coils, Type DRM3, Pair ... .. 8/-
- Pair Dual Range Superhet Coils, Type SH4, pair ... .. 8/-
- Miniature Iron Dust Cored Coils, Type "R" :-
- Range Aerial H.F. Osc.
- 800-2,000m. RA1 RHF1 RO1
- 150-550m. RA2 RHP2 RO2 each 3/3
- 70-230m. RA3 RHF3 RO3
- 15-50m. RA4 RHF4 RO4
- Ferrite Rod Aerial, Dual Range Type FRI ... .. 12/6
- Miniature I.F. Transformers, Type MSE (465 Kc/s), pair 12/6
- Standard I.F. Transformers, Type TCG (465 Kc/s), pair 13/6
- REPANCO EASY-TO-BUILD RECEIVERS**
- Constructors' Envelopes of easy wiring plans, instructions and detailed price lists of components.
- REPANCO ONE-VALVE** ... .. Envelope 9d. (post 3d.)
- Beginner's Dual-range Radio Set for use with headphones...
- REPANCO FM TUNER UNIT** ... .. Envelope 1/6 (post 3d.)
- Using 4 EF91, 1 EB91, 1 EM80 Valves, Ratio Detector ... ..
- REPANCO "THREE DEE"** ... .. Envelope 9d. (post 3d.)
- Dual-range Transistor Radio using 3 Transistors and Crystal Diode, Amazing loudspeaker reception from 7 1/2 volt battery supply.
- REPANCO "TRANSEVEN"** ... .. Envelope 1/6 (post 3d.)
- A new 7 Transistor superhet Portable with preset station tuning.
- REPANCO "MINI-7"** ... .. Envelope 1/6 (post 3d.)
- The amazing new transistor pocket portable radio with all the technical features of a standard receiver. Seven transistors, superhet circuit, fully tunable over medium wave. Size 5 1/2" x 3 1/2" x 1 1/2".
- JUST PUBLISHED!** A new comprehensive component catalogue for the radio enthusiast. With 56 pages and over 200 illustrations this offer should not be missed. Send 2/- postal order now. (Post free.)

**RADIO EXPERIMENTAL PRODUCTS LIMITED**

33, MUCH PARK STREET, COVENTRY  
 Telephone 62572

**Resistors in Series**

When resistors are connected one to the other, as shown in Fig. 2, they are said to be series-connected, and the total resistance ( $R_t$ ) in circuit is equal to the sum of the resistor values. For example,  $R_t = R_1 + R_2 + R_3$ . In Fig. 2, this gives a total resistance of 1,000 ohms. Thus, by Ohm's law ( $I = E/R$ ), the current in the series-connected chain is equal to  $100/1,000$  which is 0.1 ampere, or 100 mA.

Knowing the current and the values of the individual resistors, the voltage developed across each resistor can easily be found. The voltage across  $R_1$  is equal to  $200 \times 0.1$  ( $E = I \times R$ ), which, of course, is 20. Similarly, 30 volts are developed across  $R_2$  and 50 volts across  $R_3$ , giving a total of 100 volts, which is as would be expected since it is the value of the applied voltage.

**Resistors in Parallel**

When resistors are connected in parallel, as shown in Fig. 3, the total resistance ( $R_t$ ) is expressed as follows:

$1/R_t = 1/R_1 + 1/R_2 + 1/R_3$ . Thus, in Fig. 3 we have

$$\begin{aligned} 1/R_t &= 1/6,000 + 1/3,000 + 1/2,000 \\ &= (1 + 2 + 3)/6,000 \\ &= 6/6,000 \end{aligned}$$

Thus,  $R_t = 6,000/6$  ohms  
 $= 1,000$  ohms.

The current in the circuit when 100 volts are applied is, therefore, exactly the same as in the circuit in Fig. 2, which is 0.1 ampere ( $100/1,000$ ), but in the parallel case the voltage is the same across each resistor.

The current through each resistor differs, but can be computed by using  $I = E/R$ . If one cares to do a little arithmetic, it will be found that the sum of the resistor currents amounts to 0.1 ampere (which is fairly obvious).

**Resistors in Series-parallel**

In Fig. 4 is shown a circuit in which there is a combination of parallel-connected and series-connected resistors. As such networks are

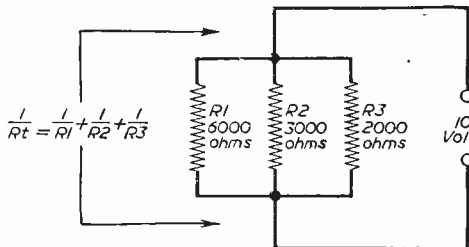

Fig. 3.—Resistors connected in parallel.

frequently encountered in circuit practice, it is well worth while to analyse the one shown in Fig. 4 in some detail.

To find the total resistance ( $R_t$ ) as present across the supply terminals, it is best to resolve the parallel-connected elements first. The parallel resistance of  $R_1$ ,  $R_2$  and  $R_3$ , it will be recalled, is expressed  $1/R_p = 1/R_1 + 1/R_2 + 1/R_3$ . Thus, with resistors valued at 6,000 ohms, 3,000 ohms and 2,000 ohms,  $R_p$  is equal to 1,000

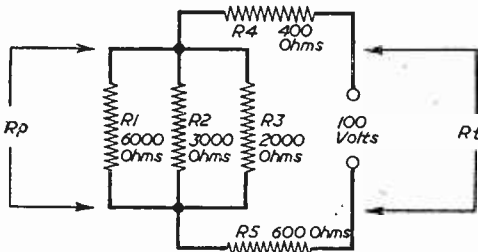

Fig. 4.—Resistors in series-parallel.

ohms. Fig. 4 may now be written in the simplified form of Fig. 5, including  $R_p$  as a single element.

This gives three resistive elements connected in series, the total value of which is equal to  $R_p + R_4 + R_5$ , that is  $1,000 + 400 + 600$  ohms, or 2,000 ohms, which is that value present across the supply terminals.

**“Kilo” and “Mega”**

At this stage it is convenient to note that, instead of bothering with three noughts when thousands of ohms are dealt with, the small letter k (meaning kilo) may be substituted. 2,000 ohms may thus be expressed as 2k-ohms, as 2k $\Omega$  or simply as 2k. Similarly, the capital letter M (meaning mega) may be used in place of the six noughts when the value is in millions

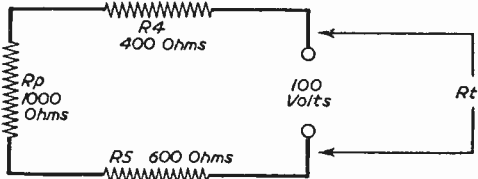

Fig. 5.—The circuit of Fig. 4 can be simplified as above.

of ohms. It is far neater and easier to write 2M, instead of 1,000,000 ohms or 1,000k. It is simply necessary to remember that k means thousand and M means million.

Now to return to the circuit. The current  $I$  is equal to the applied voltage  $E$  divided by the total resistance  $R_t$  ( $I = E/R_t$ ), which, in this case, is  $100/2k$ , or 0.05 ampere, which is the same as 50 mA.

From this, of course, we can easily discover the voltage across each resistor in Fig. 5. We use the formula  $E = I \times R$ . This gives 20 volts across  $R_4$ , 30 volts across  $R_5$  and 50 volts across  $R_p$ .

Because  $R_p$  comprises  $R_1$ ,  $R_2$  and  $R_3$  in parallel, 50 volts are present across each of these resistors, and since their values are known, we can find the current in each element by using  $I = E/R$ . We find that in  $R_1$  there is 8.33 mA, in  $R_2$  16.66 mA and in  $R_3$ , 25 mA. Bearing in mind the recurring decimal places in the values of current in  $R_1$  and  $R_2$ , the total current works out to 50 mA, which is as it should be to match the current in the main circuit.

(Continued on page 1004)

# An Economy Mains Transportable

No. 2.—THIS ARTICLE DEALS WITH THE DRILLING OF THE CHASSIS

By R. Hindle

LAST month the tuning requirements were discussed, and a calculation follows to determine the values of tuning capacitors required.

The calculation is based on the standard formula  $f = \frac{1}{2\pi \sqrt{L.C}}$

where  $f$  is the frequency in cycles per second,  $L$  is the inductance in Henries and  $C$  is the capacitance in Farads. It can be converted, expressing  $f$  in kc/s,  $L$  in  $\mu H$  and  $C$  in pF into,

$$f = \frac{10^6}{2\pi \sqrt{L.C}}$$

By inversion an expression for  $C$  is derived:

$$C = \left( \frac{10^6}{2\pi f \sqrt{L}} \right)^2 = \frac{10^{12}}{4\pi^2 f^2 L}$$

By substitution of the constants for the present problem ( $f = 200 + 465 = 665$  kc/s,  $L = 100 \mu H$ ), it will be found that  $C$  is approximately

625 pF. The trimmer and strays can be expected to contribute around 25 pF, so that  $C_4$  is expected to be about 600 pF. In the case of the prototype it was found that 660 pF was needed.

$C_1$ , the aerial capacitor, can be calculated in a similar fashion to tune to 200 kc/s using the inductance of the long-wave aerial winding, but actually this is not necessary because it is easy to find the value experimentally as the oscillator tuning always takes charge, and after bringing the station in on the oscillator circuit it is simply a matter of trial and error, a first approximation having been arrived at by realising that in this case the coil is a normal long wave one such as normally tunes the long-wave Light programme around midway on the dial, and between 200 pF and 300 pF would therefore be expected.

## Economy in Design

It was intended to make the receiver as simple

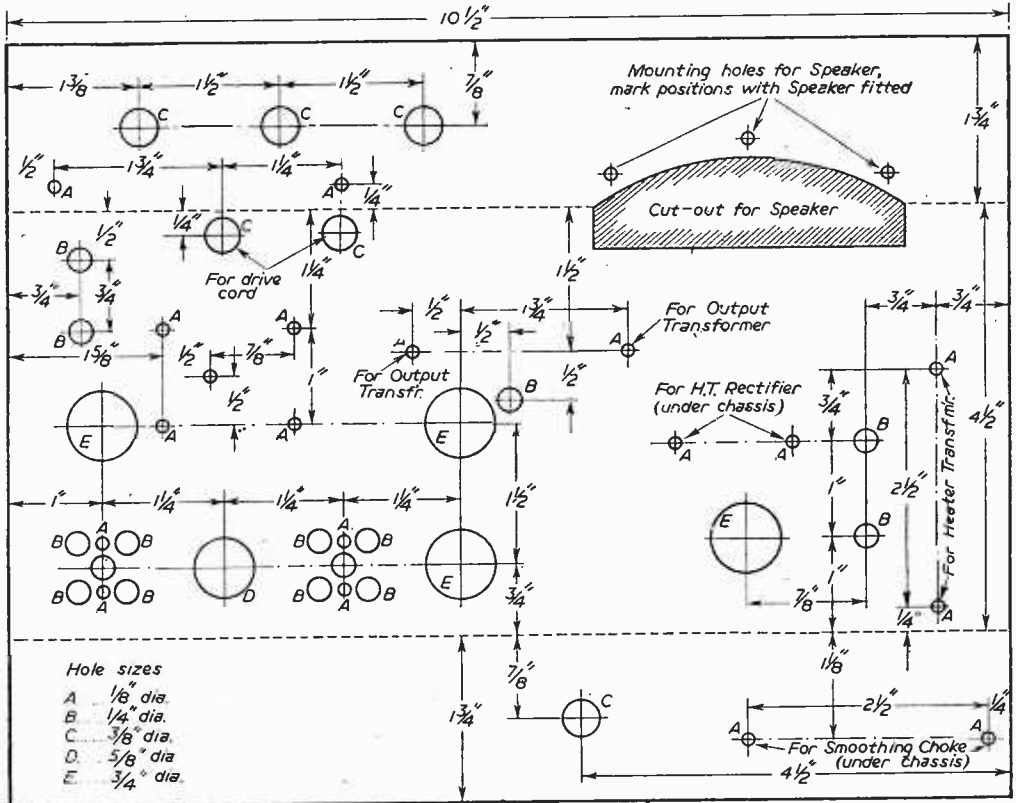

Fig. 2.—Drilling diagram of the top of chassis.

as possible and as a result every component normally used in this type of circuit was critically examined to see if it was really necessary. A.V.C. requires quite a few components and even on the very rare occasions when a more distant station is listened to, many people find the distortion, that is accentuated at intervals by

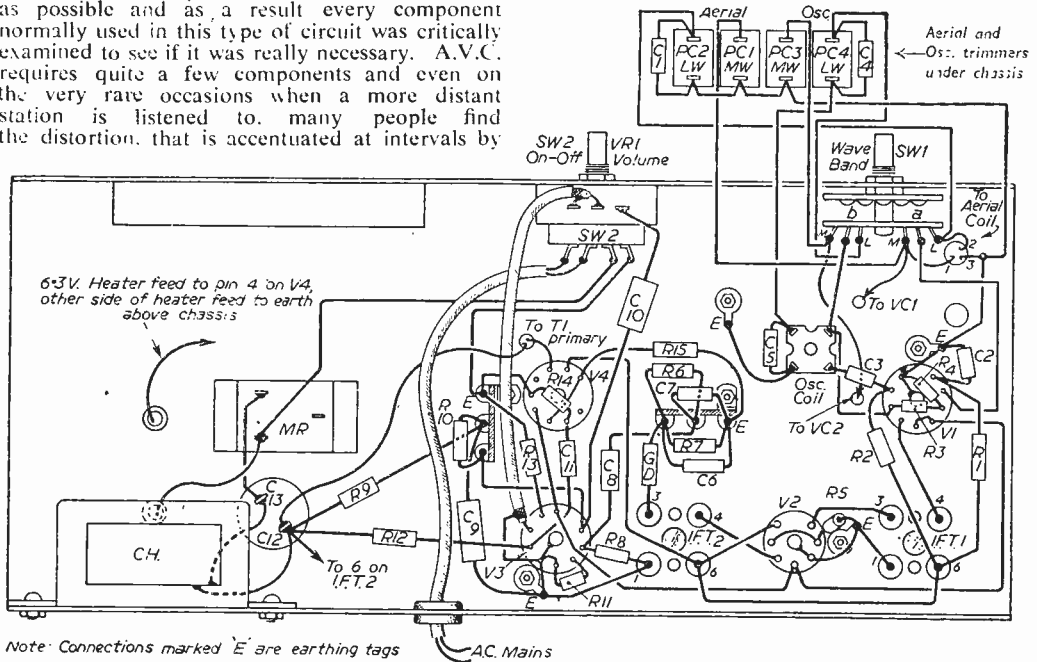

Fig. 3.—Wiring diagram of receiver.

A.V.C., far more distressing than the fading of the signal. The argument in favour of A.V.C. is generally the avoidance of overloading of the pre-volume control stages on a strong signal, but the use of a ferrite rod aerial inside the cabinet makes this very unlikely, except in a few exceptional districts. Application of A.V.C. introduces quite considerable complications apart from the cost of components. This design in its basic form therefore avoids the use of A.V.C.

A major fault of many of these small transportable receivers is that they have insufficient sensitivity and often one has to add a small external aerial for satisfactory results. This results in losing the full benefit of transportability. The avoidance of A.V.C. allows the use of an I.F. amplifier valve of higher gain and a 6AM6 is used in this stage.

The absence of many other components usually found in such a circuit as this has probably been noted. The frequency-changer stage uses a 12AH8 in a fairly conventional circuit except for the apparently missing components. This valve has a simple series screen resistance in place of the usual potentiometer of two resistors to feed it. This is quite as satisfactory in view of the absence of A.V.C.; C2 keeps the screen potential constant from a short term point of view. The cathode resistors of both V1 and V2 are without bypass capacitors. This is not a mistake. In practice these components contribute little to overall efficiency in this type of receiver. The same line of thought leads to the elimination of the usual grid capacitance between oscillator coil and triode grid of the frequency changer. The function generally claimed for this component,

i.e., that of providing self-bias for the oscillator, is equally well carried out by the padder C5 which has to be in circuit in any case.

**Detection**

The third valve of a domestic receiver is commonly a double-diode-triode, one of the diodes being used as a detector. A germanium diode is a very effective detector however and it is cheap and requires no heater current. There is a much greater freedom in connection and so a Brimar GD5 is used. This permits the use of a double triode in the third valve position, each section being used as an audio amplifier so that without any extra valves a higher gain than usual for this type of circuit is achieved. The first stage is decoupled by means of R9, C9 and the arrangement proves to be quite stable. Once more the cathode resistors are without bypass capacitors. The resultant slight negative feedback is not very great and can be afforded in view of the large amount of gain available; if in any given case extra gain could be used the effect of bypass capacitors could be tried, but the prototype gave adequate results. The output valve cathode circuit is similarly treated and no doubt the resultant negative feedback contributes to the clean reproduction of the receiver.

It will be seen that the volume control is placed between the two stages of audio amplification. This is the best place for it since the first stage is not likely to be overloaded when using an aerial inside the cabinet. The problem is to increase the amplification rather than to decrease it. In fact, overloading of this stage is unlikely because it will handle an input signal of 2 volts. In

this position between stages a volume control of normal size can be used, whereas if the control is used as diode load before the first audio stage it will need to be of a lower value than usual, because the germanium diode uses a smaller load than the equivalent valve circuit.

For the H.T. this receiver uses one of the new contact cooled metal rectifiers. This rectifier has two half-wave rectifiers brought out to three tags. The units are in series, the centre tag being connected to the centre-tap, and so can be used as voltage doublers, but in the present case ordinary half-wave rectification is used, connections going only to the outside terminals. The virtue of this type is that it is very small and convenient because it is simply bolted direct to the chassis instead of being fitted to allow for air space around it for ventilation purposes. The chassis itself serves to conduct away the heat and so the need is to ensure that there is a firm contact between the whole under-surface of the rectifier and chassis. A small resistor, R16, can be used to prevent excessive current when the rectifier is connected direct to the mains as in the present design, though it is not absolutely essential. It was not fitted to the prototype of this receiver and all goes well after many weeks of operation. Consequently it does not appear on the wiring diagram, but it is mentioned here because the constructor may wish to take this precaution.

### Construction

A chassis, dial, drive and knobs were provided with the cabinet used for the prototype and this is the usual practice with cabinets of the type needed for this receiver. The dial is a push fit into the cabinet aperture and does not mount on the chassis itself as may be the case with some alternative cabinets. The advantage of the type that fits into the cabinet is that there is a better dirt seal; it presents a problem of alignment, but this is easily overcome as will be explained later. The chassis is punched for a standard layout using octal valves and this will not suit the present design so it is necessary to make a new chassis. The dimensions of this are the same as the one provided with the cabinet; the holes in the front for the three controls must be in the same places to conform to the cabinet drilling and the single hole in the back for the mains lead must similarly match the one in the loose back of the cabinet. It was found unnecessary to provide for the screwing of the chassis into the cabinet because the fit was tight and the back of the cabinet when screwed into place held the chassis firmly.

### The Chassis

The top of the chassis has to be drilled to suit the present design and Fig. 2 gives the layout. The drilling of front and back for the cabinet used in the prototype is also given. The constructor should not drill his chassis until he is sure that the components that he is to use will fit. The position of the holes for the valve holders are indicated, but not the holes for bolting these to the chassis. The best way is to drop the valve holders into the holes as indicated; to turn them

until the sockets are in the positions indicated in the wiring diagram (Fig. 3) and then to mark the position for the bolts through the valve holders. Keeping to the layout of the chassis given, it is not difficult to allow for controls in a different place if the cabinet to be used requires it. The only control whose position is critical in relation to the chassis layout is the wavechange switch. The tuning control can be almost anywhere because the run of the driving cord can be changed to suit, and the volume control can also be placed elsewhere provided that the signal leads going to and from it are in the form of screened leads.

The positions of the I.F. transformers are shown in Fig. 2 by means of the centre hole only. Actually it is easier to make a template from the component itself and to use this to determine the position of the holes by putting it on the chassis with the centre hole coinciding with the one marked on the chassis layout than to attempt to mark out the positions by measurement. Take care that these transformers are placed on the chassis with the holes for the mounting screws in the correct positions as given in the layout, and also when screwing them to the chassis see that the connections are in the relative positions indicated on the wiring diagram, Fig. 3.

After folding the chassis, the layout as shown at Fig. 2 being then to the outside, the speaker can be tried in the cut-out provided. Holding the speaker in position so that the three mounting holes are in the position indicated (in the case of the speaker specified there is only one position where this will be so), mark the front of the chassis to coincide and drill holes for the mounting bolts. The actual positions are not

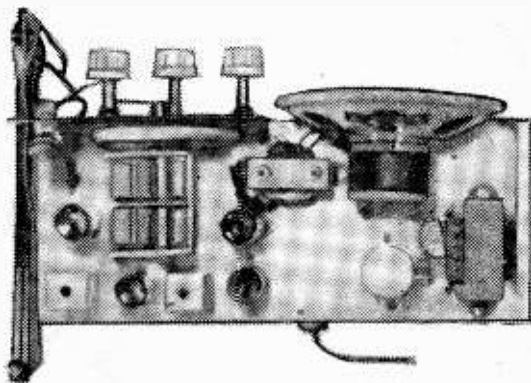

*View of chassis from above.*

given for these holes because once again it is easier to use the actual component as its own template, though care must be used in handling the speaker. It might be necessary to touch up the aperture with a file if the speaker does not fit snugly.

### Mounting the Tuning Capacitor

The dial backplate is screwed flush against the front wall of the chassis and the variable capacitor is set in such a position that the spindle projects through the centre hole by about  $\frac{1}{4}$  in.

*(To be continued)*



# TAPE-RECORDER MATCHING

IMPROVED RESULTS MAY BE OBTAINED WITH FEW EXTRA PARTS

By J. Brown

**M**ANY owners of tape recorders connect two wires from the extension speaker sockets of a radio set to the input of a tape recorder, usually to the high-impedance input. This is a mismatch, as an impedance of, say, 2 ohms is connected into an impedance of up to 1 megohm at the grid of first amplifier valve in the recorder.

In Fig. 1. is shown perhaps the simplest modification needed, in this a high-impedance output from the radio for the recorder is taken from

input. This is again a high-impedance output.

The volume control will not be in operation as far as the recorder is concerned, and the input to the recorder can be monitored by using the internal speaker of the set.

If you do not want to interfere with your receiver, you may still obtain better results, by using the method shown in Fig. 3. In this there is an input/output which is reversible by operating the switch. There are four

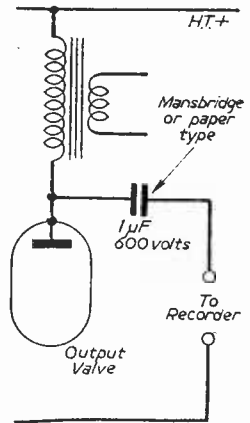

Fig. 1.—Circuit for obtaining a high-impedance output from a radio.

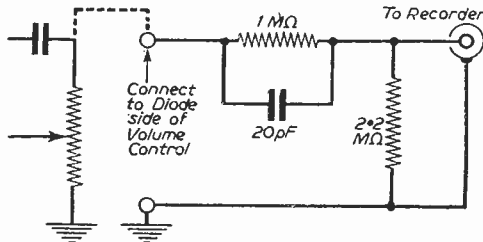

Fig. 2.—Connections to a radio for best results.

the anode of the output valve via a blocking condenser. This keeps out the D.C. anode voltage but allows the passage of the audio frequencies. These connections can be permanently wired to a pair of terminals on the radio set for use at any time. The correct connections for obtaining the best results when recording radio are shown in Fig. 2. A connection is taken from the diode side of the volume control of the radio via a resistor/capacitor arrangement to the recorder

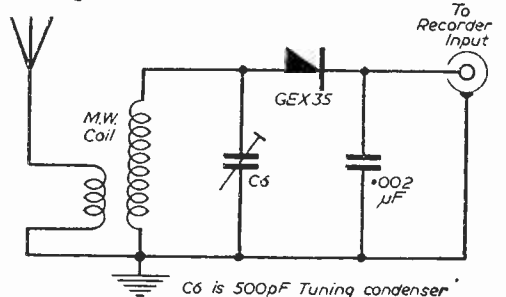
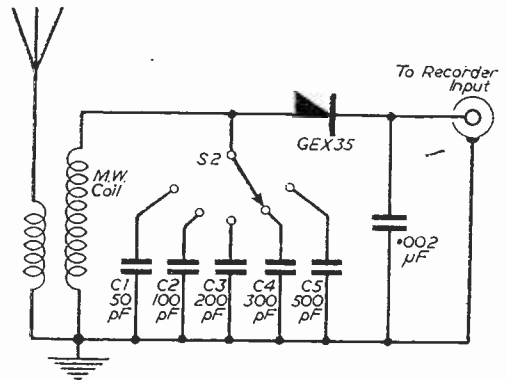

Fig. 4.—Crystal detector circuits which give a high-impedance output.

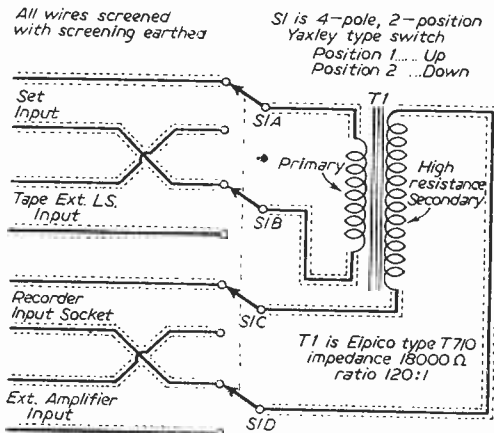

Fig. 3.—Using a transformer for matching.

connections, which may be four sockets or four permanently connected leads. A low-impedance input and high-impedance output or vice versa may be obtained. The ext. speaker wires go to the

(Continued on page 990)

**P**RI-N-T-E-D circuits are by no means a new idea. The first were made in the early years of this century, to manufacture resistance grids, and made their appearance in radio about 1928, when Hescho of Germany produced a variable capacitor complete with wave-change switch having printed silver connections. In World War II they were used extensively by the Americans in proximity fuses, and, after the war, development proceeded on both sides of the Atlantic. By 1950 they were in use here on guided missiles and, soon after, on electronic computers (Fig. 1). The Americans quickly adapted the technique for radio and television, but here radio manufacturers had a more conservative approach, and it was only at the last Radio Show that printed circuits were found to be extensively used on radio and television.

#### Features of Printed Circuits

Printed circuits have the features of economy, ease of duplication, and reliability. It is necessary to provide some form of mounting for the components, such as a chassis, tag boards, and so forth. The printed circuit takes the place of all these, and, at the same time, provides the wiring between the various components. It may even form certain components, such as a small inductor or capacitor, or a multi-way plug. Cutting and stripping of wires, and attaching them to components, is avoided. In fact, by using automatic assembly and soldering, a labour saving of more than 90 per cent. can be achieved. These methods will be described later in this series. Naturally,

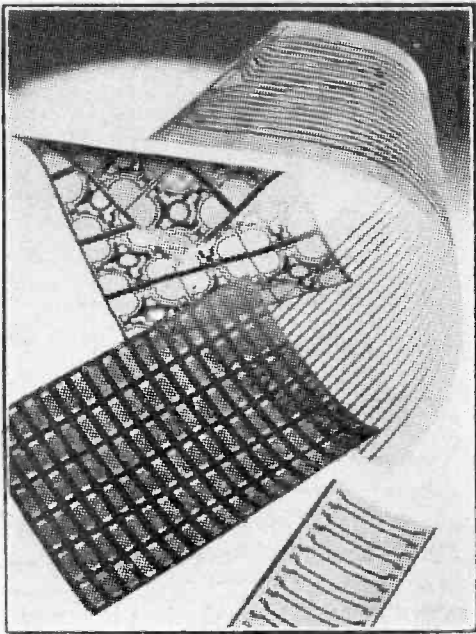

Fig. 3.—Flexible printed circuits produced as described on page 987.

# PRINTED

A SHORT SERIES DESCRIBING HOW THE MOST ADVANCED METHODS OF PRODUCTION

these economies can only be realised on quantity production, except in such cases as, for example, a complicated commutator disc, where even one off may pay.

#### Accurate Mass Production

Every circuit of a given pattern is an exact reproduction of the original. Thus, instability or loss of sensitivity by wires either incorrectly placed or of the wrong length is avoided. Furthermore, no wires can be omitted or wrongly connected.

#### Reliability

Reliability provided the impetus for early use of printed circuits in guided missiles. It is well known that these devices have high acceleration,

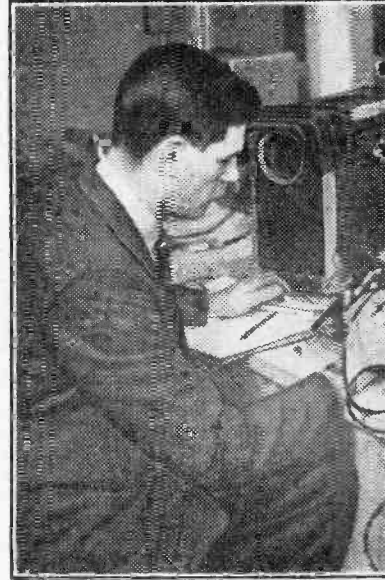

Fig. 5.—An engineer checking the production of a printed circuit.

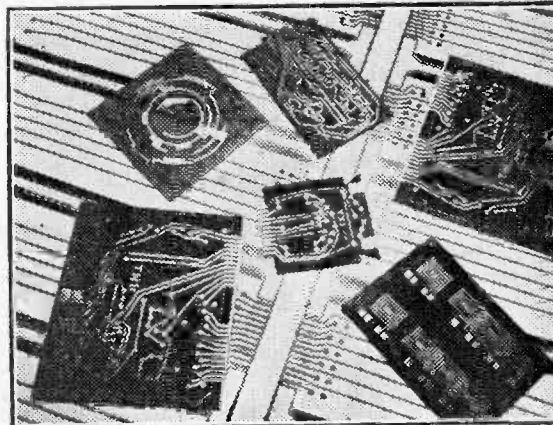
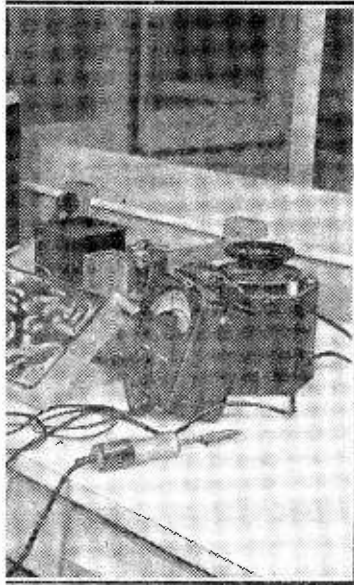

Fig. 1.—Typical printed circuits for computers, etc.

# CIRCUITS

ERN CIRCUIT IS DESIGNED AND VARIOUS

By W. G. F. Roberts



type of a printed circuit receiver.

which is specified in such instances as the number of times the force of gravity. Thus, an object accelerated at, say, 10G, weighs ten times as much as it does when stationary, as weight is mass X gravity. Thus, all components and wiring must be firmly fixed, and the printed circuit offers an excellent way of doing it. Of course, the domestic radio receiver is not subject to violent acceleration, but receives instantaneous accelerations through bumps and vibration in transit, and from vibration from the loudspeaker in use. This can lead to broken wires, which use of the printed circuit eliminates. Small wonder, then, why printed circuits are coming into extensive use, and the keen amateur will want to know all about them, especially if he intends to enter the electronic industry.

We will first consider the material of which a printed circuit is made. The method most widely used employs an insulating base material completely covered with copper foil on one or both sides. The copper foil is subsequently etched away to leave the required circuit pattern. The method by which this foil is produced is shown diagrammatically in Fig. 2. It is usually .00135in. thick, and it is difficult to roll copper as thin as this, especially as it must be up to 4ft. wide or more to manufacture standard size sheets. The drum slowly rotates in the electrolyte, containing a shaped copper anode. A point on the drum starts to be copper plated as soon as it enters the electrolyte. The drum is made of stainless steel, so that the

plating does not adhere. Thus, the copper plating is stripped off as a foil. One side, the one that was in contact with the drum, is smooth and polished, the other has a matt finish which assists subsequent adhesion. This process is known as electroforming. Sometimes foils of aluminium or resistance metals are used.

## Base Material

The base is usually made of bakelite sheet. In manufacture, a number of paper sheets, covered

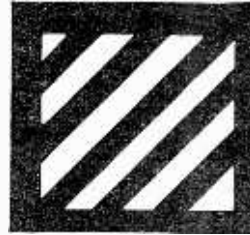
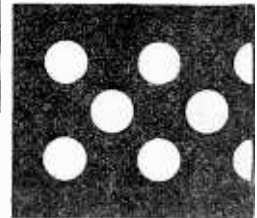

Fig. 4.—Avoiding warping by breaking up large areas.



with a resin, are laid on top of each other, and a piece of foil, matt side down, laid on top. A stainless steel sheet is then laid on, and the process repeated until a convenient stack is formed. It is then placed between heated platens on a hydraulic press, and each sheet bonded together by heat and pressure. The foil is thus firmly attached to resist all subsequent processes.

For radio work, this material is adequate. For other work, a sheet of melamine may be laid underneath the copper to resist tracking. For greater mechanical strength, with slightly worse electrical characteristics, linen is used instead of paper. To withstand military and similar conditions, glass fabric is substituted, and silicone, melamine, or polytetrafluorethylene (P.T.F.E.) resins used instead of the usual phenolic type.

Flexible circuits may also be made by using only a thin sheet of base material (Fig. 3). In some cases, the foil is simply coated with a resin. The latter type has the advantage that it may be of

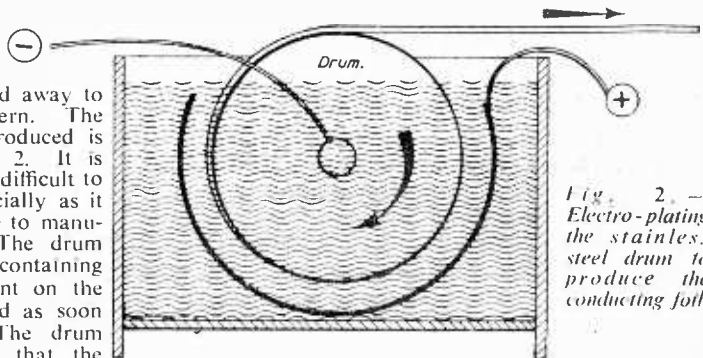

Fig. 2.—Electro-plating the stainless steel drum to produce the conducting foil.

any length. For radio and TV work, the usual material is cold-punching quality, synthetic resin bonded paper sheet, 1/16in. thick, covered with 0.00135in. copper one side.

Having chosen the material, it is now necessary to design the circuit pattern.

### Width of Lines

The width of a line on the circuit is determined by the current it has to carry, the permissible resistance, and by considerations of manufacture. For standard 0.00135in. copper foil, the characteristics are:

Resistance: 0.008 ohms per inch at 20°C. for 1/16in. width.

Current: 6 amp. per 1/16in. for 40°C. temperature rise. 1/16in. width is the preferred figure, but if necessary it can be reduced to 1/32in. In rare cases, 0.015in. can be used, but this is expensive because rejects are caused by small pinholes in the foil. There is no upper limit to the width.

### Spacing of Lines

The spacing between two conductors is determined by the capacity that can be allowed, and by the flashover voltage. For standard base material we have:

Capacity: Between two conductors  $\frac{1}{4}$ in. apart the capacity is 0.7 pF per inch, for 1/16in. apart it is 0.85 pF per inch, and for 1/32in. apart, 1.0 pF.

Flashover: Two conductors, 1/32in. apart, flash over at 1.8 kV under normal atmospheric conditions.

One-sixteenth inch spacing is preferred, but may

be reduced to 1/32in. Exceptionally, 0.015in. can be used, but the circuit must then be treated with insulating varnish when finished.

### Terminations

The conductors terminate in a hole through which the component wire or tag protrudes. The end of the printed wire should have a diameter at least 1/16in. greater than that of the hole, to leave adequate copper area for soldering.

There are one or two other conditions imposed on the designer of a printed circuit. Lines should preferably have flowing curves, and sharp points and corners should be avoided. It is often the practice to break up large areas as shown in Fig. 4, to avoid warping of the board during soldering. New techniques have tended to overcome this necessity.

It is advisable to leave  $\frac{1}{4}$ in. clear of wiring round the edge of the board, and no hole should be closer to the edge of the board than twice the thickness of the board. In addition, no two holes should be closer than the thickness of the board.

It must be admitted that this seems to be a rather formidable list of restrictions to the designer of printed circuits. However, they are essentially practical, and, if the designer uses lines 1/16in. wide, spaced not less than 1/16in. apart, with  $\frac{1}{4}$ in. diameter circles for his terminations, and keeps clear of the extreme edge of the board, he will not go far wrong. In the next article, we shall see exactly how this works out in a practical design. A transistorised audio amplifier has been selected for the exercise.

(To be continued)

## SERVICING RADIO RECEIVERS

(Continued from page 976)

generator lead should be connected to receiver chassis.

The generator (modulated) and the receiver should next be tuned to 575 kc/s and the core in L5 and the position of L1 on the ferrite-rod aerial should be adjusted for maximum output.

The generator and receiver should be retuned to 1,500 kc/s (200 metres) and then C14 and C4, in that order, adjusted for maximum output. The foregoing adjustments should be repeated to secure optimum tracking.

For L.W. alignment, the receiver and generator should be tuned to 225 kc/s (1,335 metres) and C15 adjusted for oscillator resonance (maximum output). At the same frequency, the position of L2 on the ferrite-rod aerial should also be adjusted for maximum output. The process should be repeated for the best results.

### Servicing Notes

Should the receiver operate normally on batteries, but give no signals at all on mains, the trouble may well be caused by failure of the local oscillator. This often happens when the metal H.T. rectifier nears the end of its useful life, especially during the winter months when the mains voltage may be low. The H.T. voltage should be in the region of 85 V., and if this is

low, attention should first be directed towards the mains voltage selector to ensure that this setting coincides with the applied mains voltage.

If all is well, the voltage at pin 1 of V14 should be checked and, if necessary, R8 adjusted so that it reads 3.9 V. The average voltage across each heater should be close to 1.3 V.

Low emission V1 may result in failure on mains operation, though may not affect battery operation if the L.T. is in good condition. If this is the cause, however, it would be as well to replace V1, even though the set may be used only on batteries, since the batteries will operate the set for a longer period with a new valve.

No results on batteries, but normal on mains, nearly always indicates that the batteries are exhausted, but there is also the possibility that the battery/mains changeover switch is defective or not going properly into position when the mains socket is removed from the set.

Failure on both services should lead first to a check of the filaments of the valves. An open-circuit heater will cause the H.T. line voltage to rise abnormally on mains operation.

Excessive distortion may be caused by V4 having low emission, by C28 having poor insulation or by R26 or R22 having gone high in value. A nearly exhausted battery will give the same trouble, of course, and it should be appreciated that distortion at high volume levels will be greater when the set is used in the "economy" condition.

# MAKING OHM-METERS

THE THEORETICAL AND PRACTICAL ASPECTS OF DESIGN

By J. S. Kendall

(Concluded from page 878 of the January issue)

THE 1,000-ohm meter with a 9-volt battery can be used up to 50,000 ohms if it has 50 divisions on its scale. On the other hand, it could not be relied upon to measure less than 20 ohms. The idea of increasing both the internal resistance of the meter and the battery voltage ten times will probably occur to the reader. This will increase the maximum resistance that can be measured to 50,000 ohms with the above-mentioned meter. For low resistance

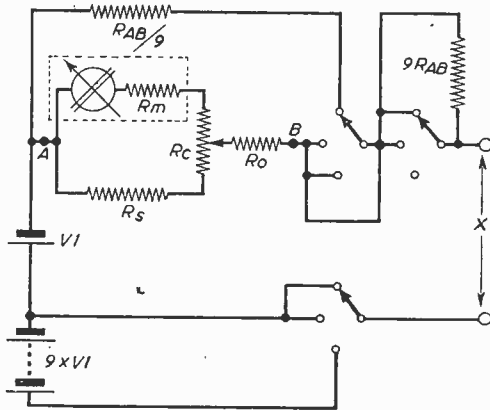

Fig. 7.—Circuit for multi-range compensated ohm-meter.

measurements, say 1/10th of the range of the one just mentioned, it is necessary to keep the battery voltage the same and shunt the meter. One part of the total current must go through the meter and nine parts through a shunt. The circuit is shown in Fig. 4. A further range is shown where 99 times as much current should pass through the shunt as through the meter; since this ratio is nearly 100:1 this figure is used as it is easy to obtain resistors in the ratio of 100:1, but not in the ratio of 99:1. There are, of course, low resistance measuring limits which occur when the current drain is about one ampere. The internal resistances of meters are usually such that the output voltage is halved at this current. The ideal meter movement for this work would be one with, say, a ten micro-ampere movement, as it would allow the use of lower voltage cells and give a higher top reading. Also the Varley silver-zinc cells could be used. These are expensive but exceptionally small and robust. Their voltage is slightly less than that of a dry battery, but they have a very low internal resistance and will give a large current for short periods.

## A Compensated Meter

Most of the home-designed ohm-meters do not have any compensation for an ageing battery. With the last meter, it was suggested that several

sets of charts be prepared to allow for this. In this case, it is suggested that some sensitivity and accuracy be sacrificed in order that a compensated meter can be made. The latter has the advantage of being quicker to use—the reading can be taken direct from the meter scale instead of from charts. Circuits for such a meter have been published many times and the author has noticed that most contain the same error. A circuit is shown in Fig. 5 and this has appeared in a very large number of articles. It will be seen that the "zero-set" control is in series with the meter and the battery so that the total resistance of the unit is varied in order to make the meter read exactly full-scale with terminals "X" shorted. Since the total resistance of the meter is used as the standard for measuring, the standard is being varied in such a manner that an error of 50 per cent. may occur. The true compensated high-range ohm-meter is shown in Fig. 6. It consists of the meter movement,  $R_c$ , and  $R_s$ , all in series and forming a complete circuit. The resistance values of all three of these should be as far as possible identical. The meter resistance should be as low as possible. A typical meter for this type of circuit would be a 0.1 mA meter of 100 ohms internal resistance:  $R_c$  and  $R_s$  would also be of 100 ohms. With the slider of the resistance  $R_c$  at either end of the track the total resistance will be  $66\frac{2}{3}$  ohms, with it at the centre, 75 ohms. Thus, there will be a variation of nearly 10 ohms. This may be regarded as plus or minus 5 ohms and then it does not sound so much. It is, however, a variable error in the meter. With a 1 mA meter and a 1.5 v. cell, it must be arranged that the total resistance between points A and B is such that 1 mA can go through the meter and up to 2 mA through the shunt. Say 1 mA either way—that with 1.5 volts means that a series resistor,  $R_o$ , of (750-70) ohms is required (i.e., the value of  $R_o$ , the series resistor, is the total resistance required minus the average resistance of the shunt and meter network). Now the basic error mentioned was a matter of 5 ohms either way, and 5 ohms in 750 is under 1 per cent. The meter could be direct reading to an accuracy of some 5 per cent. and this would allow for all errors.

A higher reading meter could be made by increasing both the battery voltage and the series resistor some ten times. Rotary switches should be used and then two or three ranges can be covered on the same switch. A 1/10 range can

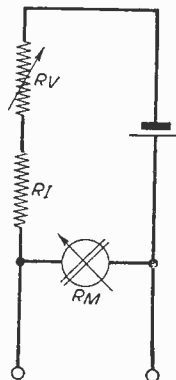

Fig. 8.—Circuit for a compensated ohm-meter for low resistances.

be incorporated by the shunting of the low range by a suitable resistor of 1/9th of the total resistance of the ohm-meter on that range. The complete circuit is shown in Fig. 7.

**Making a Compensated "Low Ohm-meter"**

The compensated "low ohm-meter" is a very useful meter of which the circuit very rarely appears in print. It can be one of the simplest and cheapest meters to make and most of the items can be bought on the "surplus" market.

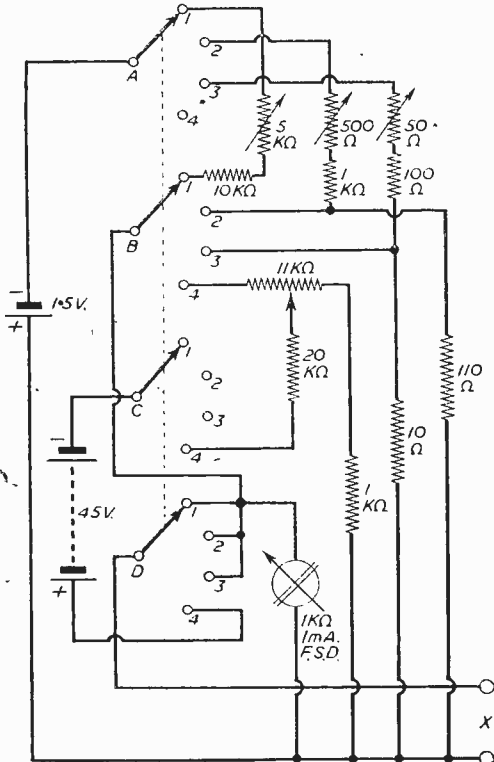

Fig. 9.—Circuit for a comprehensive multi-range ohm-meter.

even the meter if its exact resistance is known. It is most convenient if it is 100 or 1,000 ohms, but one of 10 ohms would be better. The basic meter is shown in Fig. 8. The current through the meter is regulated by the two series resistors R1 and Rv. R1 is of such value that with a new battery the meter can be overloaded to the extent of 100 per cent. Rv has a maximum value of about double that of R1. The greater the battery voltage, the higher will be the accuracy of the meter when complete. The value of R1 should be about 10 times the resistance of the meter. In use the current is set so that the meter reads full-scale deflection. When a resistance is joined across the terminals current passes through the resistance and the reading of the meter falls by that amount. Thus, for example, if half of the total current is taken through the resistance

under test, then the resistor will be equal to the resistance of the meter. Again, if the reading only falls by 1/50th of the scale, then the resistance will be 50 times that of the meter. As in all ohm-meters, it is best to use a standard resistance box for the calibration, rather than to attempt to calculate and then to transfer the calculations to the scale of the meter.

**A Comprehensive Ohm-meter**

For those requiring a comprehensive ohm-meter, a typical circuit with component values is shown in Fig. 9. It was designed for use with a meter of 1,000 ohms internal resistance and of 1 mA full-scale deflection. On the other hand, the meter can be a surplus type made up to 1,000 ohms. Most of the components for the meter need only be of 20 per cent. tolerance. The potentiometers shown were, in the original, "Lab" presets. There are, however, three precision resistors in the meter, 20K 1 per cent. at 1W, 10 ohms and 110 ohms 1/2W 1 per cent. all to British Grade One Standard. The switch used is a four pole, four way. The meter can be made to cover from 0.1 ohms to 2 megohms in four ranges.

**TAPE-RECORDER MATCHING**

(Continued from page 985)

connections shown: the output to the recorder is also indicated. If the switch is moved to position 2, the process is reversed.

If you live in an area of high signal strength, you can record radio using simple equipment, and Fig. 4 gives effective crystal detector circuits. These are easy to assemble and tune, and no power supply is needed.

Note that some modern recorders have live chassis. A loud hum may be caused or sparks may occur when the connections are made. The remedy here is to isolate the recorder from the set by using the arrangement in Fig. 3, or that in Fig. 5, in which the isolation is carried out with condensers. The high-value resistors are to remove any static.

To explain Fig. 3 in more detail, T1 is a standard output transformer and by switching the windings each side of it can be made to work as input or output. For example, in the positions shown, the input from the extension loudspeaker sockets is fed to the low-impedance winding by S1a and S1b; the output to the recorder is taken from the high resistance winding.

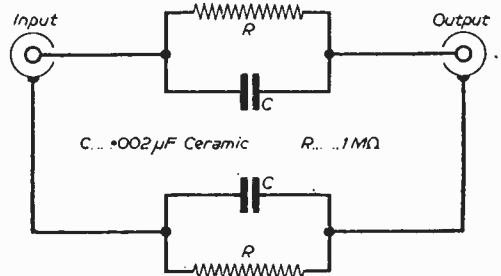

Fig. 5.—Isolating the recorder from the radio set.



# TRANSMITTING TOPICS

## PROPAGATION

By O. J. Russell, B.Sc.(Hons.), G3BHJ

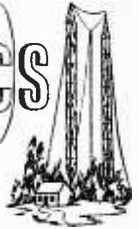

WHILE we cannot control ionospheric conditions, we can, by using different wavebands, take advantage of conditions to work DX in given directions. Moreover, some experience of conditions and their seasonal and long-term variation is essential if the DX worker is to make best use of the wavebands available. In fact, of course, so many factors are involved that one is always learning about conditions, and slowly adapting to variations throughout the sunspot cycle. Thus, the experienced amateur generally is able to assess conditions at any given time from past experience, make a reasonable forecast of what conditions *should* be like at any time of the day, and also to "sense" when the

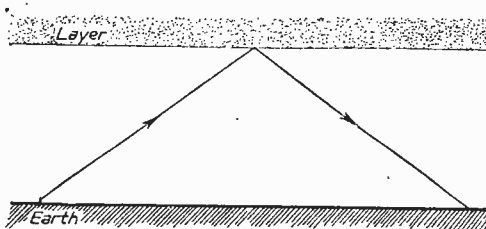

Fig. 1.—Conventional representation of reflection by an ionised layer.

sunspot cycle has advanced to such an extent that his previous experience needs recasting in the light of generally altered overall conditions owing to the change.

The ionised layers depend upon the ionising radiations emitted from the sun for their existence, and the intensity of the solar ionising radiations vary greatly over the years. The sunspot activity of the sun is, in fact, a very good guide to the ionising activity of the sun.

### Sunspot Activity

The sunspot activity of the sun follows an approximately eleven year cycle. At present we are just past the peak of the greatest sunspot activity ever recorded. This has meant very good DX conditions extending to long distance propagation on very high frequencies. DX workers are now taking a gloomy view of the possibilities for the future. Because we are now leaving a high maximum, and approaching a coming minimum, that is not necessarily as bad as it seems. In any case, while high solar activity may result in long distance propagation on high frequencies, it may also result in "solar noise outbursts" in which a high level of "hiss" may suddenly swamp signals on the higher frequency bands. Also, solar flares may cause the "Dellinger fade-

outs," when charged particles from the sun may cause "radio black-outs," when DX signals vanish. In fact, high solar activity is often accompanied by disturbed conditions, when fade-outs and similar matters may interfere with DX working.

As examples, during a complete "fadeout" when there were no signals audible in the 20 Mc/s region at all, the writer suddenly heard the first Sputnik's signals break in on a dead band. As there was no ionospheric reflection of signals, the Sputnik signals were audible only when it was "above the horizon," and they appeared suddenly, held steady and disappeared abruptly. Also high auroral activity may give a fluttery effect to signals generally. This "polar flutter" is, in fact, noticeable on Alaskan and Californian signals that traverse near the Poles, as well as on signals from Antarctica and Greenland, that originate in polar regions. With high auroral activity such "polar flutter" may be noticed on signals that do not travel near the Poles. In fact, observations of such flutter on signals gives a quick indication of the general extent to which abnormal auroral conditions exist outside the usual Polar regions. In the last two years such conditions have occurred frequently. Further abnormal propagation conditions noticed with high ionisation levels is the reception of "back scatter" signals. Thus British stations working DX may often be heard with a typical fluttery rough QSB on them, when they

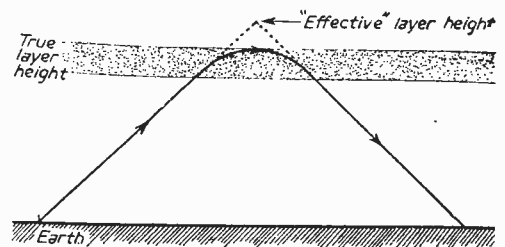

Fig. 2.—A more accurate representation of how a radio wave is bent round and returned to earth in an ionised layer. The actual height of the ionised medium is thus slightly lower than the "geometrical" height of a sharply reflecting "mirror-like" surface.

are well outside the usual reception distances on the H.F. bands. Thus with a good receiver and a beam aerial, "back scatter" QSO's have been enjoyed by the writer with "G" stations throughout England. When working a "DX Threeway," back scatter often enables two British stations to hear each other when both are working the same DX station.

### "Round the World Echo"

A further phenomenon is the "round the world echo." Thus when the writer and a local station were working the same DX station, the local station was conveniently right on a "null" of the writer's TA-33 beam aerial. To my surprise, a distinct echo was audible on the local station's signals. This may have been back scatter, but most likely was an actual round the world echo. "Round the world echoes" are, in fact, commonly noticed. Further propagation conditions are commonly noticed, particularly the "lightning" fadeout. Very often the 10 metre band is alive with American signals well after dark. Suddenly,

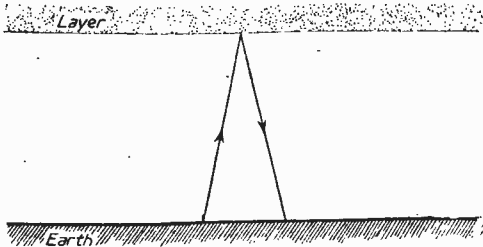

Fig. 3.—At the lower frequencies a wave is reflected even at high angles of incidence.

within a minute, the signals have all disappeared often in "mid QSO." This can be so sudden that the receiver may become suspect. In fact, certain recent spells of "dead bands" have caused amateurs to frantically overhaul receivers, as with a really "dead" band, the usual incoming noise level is virtually absent, and the receiver may really sound "dead." On the other hand the "lively" feel of an open band is usually quite characteristic.

As Fig. 1 shows, rays from a transmitter are reflected to a distant point via the ionosphere. Generally for DX transmissions the F layers are involved. Moreover, although Fig. 1 shows a conventional reflection as at a sharp mirror surface, in fact the "reflection" is a gradual "refraction" process as shown in Fig. 2. Thus the "effective height" of an ionising layer as determined by a simple geometrical process as in Fig. 1, is actually rather higher than the somewhat indeterminate height of the refracting layer shown in Fig. 2. Moreover, the reflection of a radio wave in an ionised layer depends upon the angle at which the wave strikes the ionosphere, the frequency of the waves and the ionisation density in the layer and so on.

For a given intensity of ionisation in the layer, waves of a frequency less than a certain critical frequency will be reflected even if they strike the layer squarely on, that is, approach at right-angles. This is the mode by which even quite local contacts on the L.F. bands are carried on, that is, the waves travel upwards and are reflected down again even at right-angles or nearly so as shown in Fig. 3.

Waves of a frequency higher than the critical frequency will *not* be reflected at high angles of incidence but will pass through. However, such waves if not too high in frequency will be reflected if they strike the reflecting layer at low angles of incidence (Fig. 4). In fact, the *higher* the frequency of the wave, the more glancing the angle necessary before the wave can be reflected. Thus for propagation on a high frequency, only "low angle" radiation is effective as the high angle radiation escapes through the layer, and is not reflected. Moreover, the higher the ionisation in the layer, the higher the angle at which high frequency waves will be reflected. This, of course, accords with normal experience that the higher frequencies become usable only when ionisation is high.

When communication becomes impossible on a given frequency, dropping to a lower frequency will restore communication. In fact, on 10 metres, the top half of the band may be "dead," while the lower half is still wide open for DX working. Thus the C.W. operators at the L.F. ends of the band are in the most favourable position for maintaining communication on a given band.

### Multiple "Hops"

The above "background" now gives us enough information to consider how we manage to hear and work DX. Firstly, medium ranges up to, say, 2,000 miles or so may be by a "single hop" as shown in Fig. 1. However, longer ranges are by double or multiple "hops," in which the radiation after reaching the ground is reflected back to the

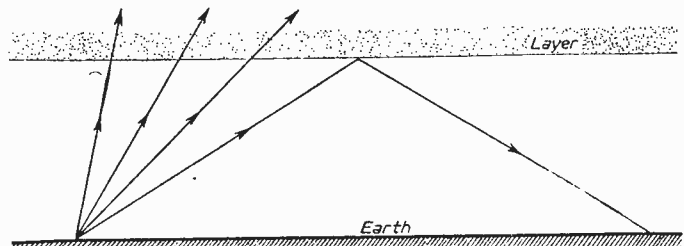

Fig. 4.—At the higher frequencies a wave will not be reflected until it strikes the reflecting layer at a sufficiently low angle. Otherwise the wave travels through the layer and is lost into space.

layer for a second reflection and so on. Of course, although the diagrams show the earth as flat, owing to the curvature of the earth, communication at any given distance can only be by

(Continued on page 995)

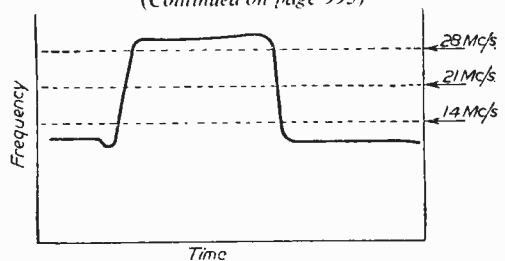

Fig. 5.—A typical propagation chart.

**NEW**  
**UP-TO-DATE**  
**EDITION**

**FOR**  
**READERS OF**  
**"PRACTICAL**  
**WIRELESS"**  
**AT REMARKABLY**  
**LOW COST!**

# RADIO, TELEVISION & ELECTRICAL REPAIRS

**SAVES YOU POUNDS!**

Here is just the practical, at-a-glance guidance YOU need, whether you wish to know how to service radio and TV sets, install an extra lighting point, or repair any domestic electrical appliance—from a bell or an iron to a vacuum cleaner or washing machine. Explains, in simple language, basic principles and working of modern radio and TV sets and electrical appliances. Shows how to test for faults and carry out maintenance and repair work by the most modern methods. Special section on the operation and servicing of frequency modulated receivers. 480 pages. Over 400 illustrations. Amazing value—Standard Edition, 18/- inc. postage, packing, etc.

**ESSENTIAL TO EVERY SERVICE ENGINEER,  
ENTHUSIAST AND HANDYMAN!**

## GETTING THE BEST FROM RADIO AND TV SETS

Here is expert advice that will enable you to make the necessary adjustments or repairs in order to get the best possible performance from any radio or TV set. **All you need to know about DOMESTIC WIRING**

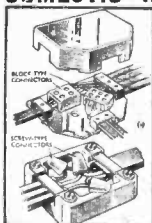

Learn from these helpful pages how to carry out all kinds of installations and extensions — with efficiency and safety! Complete guidance on conductors, insulation, safety regulations, cables, earthing, practical work, fuses, flexible cords, etc.

## BASIC RADIO CIRCUITS

All you want to know about circuits, so that you can find your way around modern sets without hesitation. How components form various types of set; gives circuits for one-valve receiver, 3-valve receiver, battery TRF receiver, 4-valve superhet, Universal sets, etc.

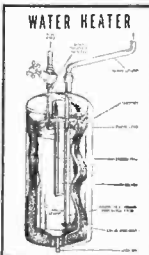

## FIRES & SPACE HEATERS

Full, easy-to-follow instructions for servicing small domestic fires—whether of the radiant, reflector or convector type.

## WATER HEATING

All you should know about the various types of electric water-heaters and how to install them and keep them in perfect working order. Advice that will save you POUNDS!

## TRACKING DOWN TROUBLE

This grand book is invaluable for tracing faults in radio and TV sets. Tells you all you want to know—from how to carry out Preliminary Tests to how to align R.F. and I.F. circuits. Shows how to carry out Dynamic Testing. Also shows how to trace the cause of Noises, Distortion and Instability and deal with the trouble. Gives detailed information on Components and Loudspeakers and how to deal with any faults that may develop.

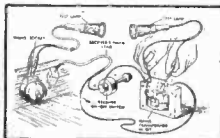

## DO THIS NOW!

Simply fill in form and post in 2d. stamped, unsealed envelope to Dept. E.B.35, People's Home Library, Basted, Sevenoaks, Kent. Offer applies in U.K. and Eire only, closes Feb. 28. **FULL SATISFACTION or No Charge GUARANTEE**

See how to maintain  
**Vacuum Cleaners and  
Floor Polishers,  
Refrigerators, Cookers  
and Boiling Plates,  
Washing Machines, etc.**



Disconnecting Boiling Plate on Cooker

**Do your own BATTERY CHARGING**  
Here are clear, complete instructions.

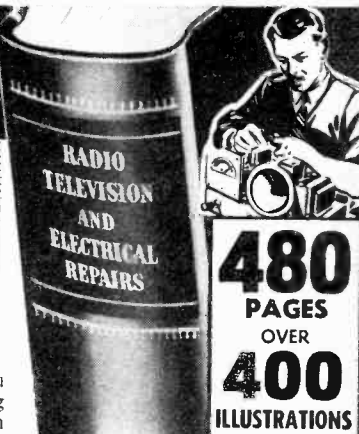

**ALL THIS—AND  
MORE—IN ONE  
GREAT VOLUME**

*Comprehensive Contents Include:*

Current, Voltage, and Resistance. Coils, Capacitors and Valves. Basic Radio-receiver Circuits. Preliminary Tests. Instruments for Set Testing. Locating Faults. Dynamic Testing. Tuned Circuit Alignment. Noises, Interference, Distortion and Instability. Components. Loudspeakers. Pick-ups. Gramophone Motors. Frequency Modulation. Television Circuits and Test Gear. Television Faults, Symptoms and Cures. Aerials and Pre-amplifiers. Maintenance of Domestic Electric Wiring. Small Appliances, Fires and Space Heaters. Vacuum Cleaners and Polishers. Rewinding Small Motors. Cookers and Boiling Plates. Washing Machines. Refrigerators. Electric Water Heaters. Battery Charging, Testing and Repair, etc.

The book that cuts out guess-work! **TV FAULTS—** their SYMPTOMS AND CURES

**POST FORM NOW!**

Dept. E.B.35, People's Home Library, Basted, Sevenoaks, Kent.

WITHOUT OBLIGATION reserve me "Radio, Television and Electrical Repairs" and send Invoice with "100% Satisfaction or No Charge" Guarantee.

BLOCK LETTERS

NAME .....

Full Postal ADDRESS .....

Firmly affix 2d. stamp in margin

E.B.35/Feb. '59.....

# THE LINEAR 'DIATONIC'

A 10-WATT HIGH FIDELITY ULTRA LINEAR AMPLIFIER WITH INTEGRAL PRE-AMP

A special feature is the compactness of the unit. Full advantage has been taken of latest component miniaturisation developments to produce a 10-watt Hi-Fi push-pull amplifier incorporating tone control pre-amplifier stages within the measurements of 9 x 7 x 6½ ins. In addition two high impedance input sockets are provided for microphone and gram, etc. Each input has its associated vol. control, five B.V.A. valves are employed ECC83, ECC83, EL84, EL84, EZ81. H.T. and L.T. power supply point is included for a radio tuner.

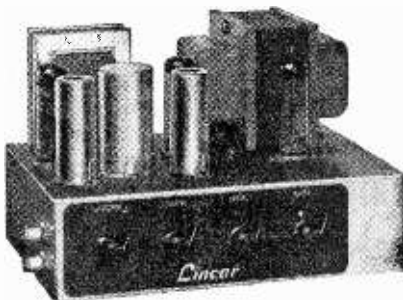

Weight 12½ lbs. Power consumption 90 watts. For 200-230-250 v. 50 c.p.s. A.C. mains. Outputs for 3- and 15-ohm speakers. Chassis finish stoved Blue-Grey hammer.

**HIGHEST QUALITY!** Retail price  
**MAXIMUM RELIABILITY!**  
**AT A PRICE YOU CAN AFFORD.** Available through your local dealer, leading mail order firms, or direct from us. Send S.A.E. for descriptive literature.

**FREQUENCY RESPONSE**  
± 2 d.b., 30-20,000 c.p.s.  
**MAXIMUM POWER OUTPUT**

In excess of 14 watts.  
**RATED OUTPUT 10 WATTS.**

**SENSITIVITY**  
Volume (1) 22 millivolts for rated output.  
Volume (2) 220 millivolts for rated output.

**TREBLE LIFT CONTROL**  
Continuously variable + 6 d.b. to -13 d.b. at 12,000 c.p.s.

**BASS CONTROL.**  
Continuously variable + 13 d.b. to -18 d.b. at 15 c.p.s.

**HUM LEVEL**  
Referred to maximum output and including integral pre-amp -60 d.b.

**HARMONIC DISTORTION**  
0.19% measured at 6 watts.

**NEGATIVE FEEDBACK**  
Total 32 d.b. including 24 d.b. in main loop.

## L45 MINIATURE 4.5-WATT QUALITY AMPLIFIER

Size only 6 x 5 x 5½ in. high. 12 d.b. Negative Feedback. Sensitivity 30 m.v. for full output. 3 Mullard valves. ECC83 Twin Triode, EL84 Power Output, EZ90 Rectifier. Separate Bass and Treble Controls. Mains switch incorporated in control. For 200-250 v. 50 c.p.s. A.C. Mains. An ideal unit for use with Gram, or 'Mike.' Output matching for 2-3 ohm speakers. Retail Price **£5-19-6**

Also available: LG3 3-watt Gram Amplifier, 55/9. LT 45 Complete, Tape Amplifier, 12 gns. "Conchord" 30-watt Amplifier, 15 gns. L10 10-watt Amplifier with separate pre-amp, 15 gns. L3/3 Stereo Amplifier 3+3 watt, 7 gns. L5/5 Stereo Amplifier 5+5 watt, 11 gns.

**TRADE ENQUIRIES to**

**LINEAR PRODUCTS LTD.**

**ELECTRON WORKS, ARMLEY, LEEDS.**

# A SMALL DEPOSIT will bring you enough parts to make a complete TRANSISTOR POCKET RADIO

(Size 5¾ x 3¼ x 1¼) using a printed circuit

★ Send for **FREE PRICE LIST** (all parts sold separately) and/or 3/- for new simplified instruction booklet with suggested circuits and assembly details.

**OUR CIRCUITS OFFER  
HIGH SENSITIVITY  
HIGH SELECTIVITY**

using

R.F. Transistors **1 GN.** each  
L.F. Transistors, **10/-** each  
all specially selected to give **HIGH OVERALL GAIN** with A.V.C.

**FULL MEDIUM & LONG WAVE COVERAGE**

for as little as **£9 . 19 . 6**

- Miniature loudspeakers, only 27/6  
3/16 in. deep x 2½ in. diam.
- Miniature oscillator and i.f. coils, 8/-  
1/16 in. high, 5/16 in. diam.
- Jackson 00 twin gang tuning condenser with intersection screen 10/6
- Attractive high impact polystyrene cabinet with fittings for tuner, trimmers, speaker and circuit board 12/6

MANY OTHER SUB-MINIATURE COMPONENTS AVAILABLE

**SPECIALISED ELECTRONIC COMPONENTS LTD**

8 Eccleston Square · London · SW1

MAIL ORDERS ONLY

reflected waves, and not by direct "groundwave," so that certain areas may be out of communication because the layer will not reflect waves into them. These "skip zones" are well known, and it will be seen that a given distance may come within or without a skip zone depending upon the ionisation density in the reflecting layer.

A further mode of long distance propagation is the so called "M" Mode. In this, waves may be reflected from a high reflecting layer, and instead of reaching the ground be reflected back up again from a lower reflecting layer before finally being reflected back to earth.

The name "M" mode comes from the "M"-shaped path of the rays.

**Propagation Charts**

These considerations show that the time of day is a very important factor in propagation considerations. Thus, if we consider early morn-

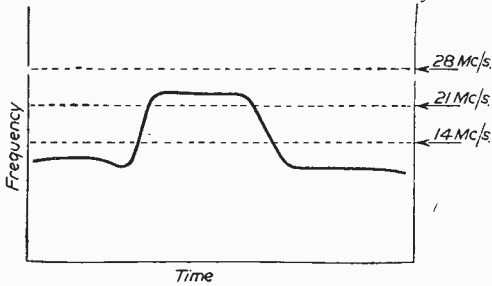

Fig. 6.—With a lower value of ionisation, 10 metres may not "open."

ing before the sun has risen, ionisation in the layers will be low, and the higher frequency band will be closed for long distance communication. As the sun rises and ionisation builds up in the layers, progressively higher and higher frequencies will become "open" for communication. Moreover the *direction* in which the band will become open will depend upon geographical factors. Thus, even before sunrise the band may be open towards the *east*, as the sun has *already risen* on countries lying eastwards. Thus, as a matter of experience,

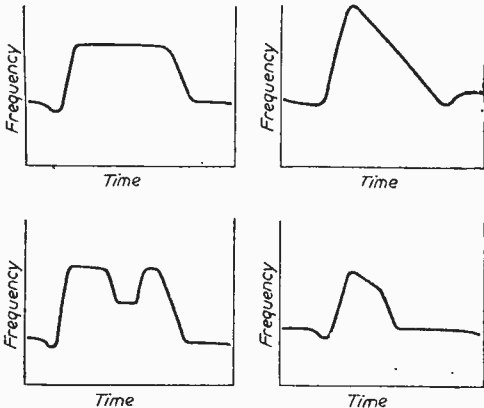

Fig. 7.—Some typical propagation charts for various DX operating circuits.

we may be working the Middle East on say 15 metres well before the band opens for America. The situation may become quite complicated, when multiple hops and geographical locations in various directions have to be considered. Thus during the summer when we have a "long twilight," bands may remain open for long periods. In winter they may close down very shortly after sunset. For long multiple hop paths to the Antipodes, there may in fact be *two* paths open simultaneously. Thus the "long" and "short" path circuits to Australia are well known, and even VK contacts may often best be made with the beam directed directly *away* from Australia to utilise the "long" path. It is general therefore to construct "propagation charts" for various DX directions on a monthly basis showing which frequency bands will be open at various times. For amateur use these may be constructed on a "maximum useable frequency" basis, showing the highest frequency likely to be useable at any given time.

A typical example of such a chart is shown in Fig. 5. It will be observed that directly after sunrise at some critical point along the route, the "MUF" rises sharply and the various DX bands may thus open one after the other. Twenty metres opening first, then 15 metres and finally 10 metres. However, as shown by Fig. 6, at times of lower ionisation or nearer sunspot minima, 10 metres may not open at all. Accordingly the best DX periodicals supply their readers with monthly propagation charts showing the conditions to be expected for various DX areas. Unfortunately no British periodical prints such charts for amateur use, although DX predictions

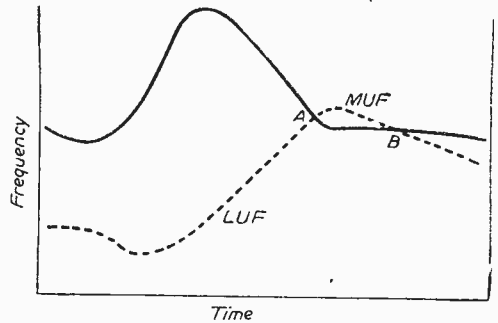

Fig. 8.—If the "Lowest Usable Frequency" is higher than the "Maximum Usable Frequency," as between times A and B, then the path cannot be used.

for various operating bands are printed by the R.S.G.B. Fig. 7 illustrates the several differing types of chart that may exist for varying DX locations during the same month.

Furthermore, the MUF (maximum usable frequency) may not be too exact an indication. Thus quite often a band may be just open when the chart says it should be closed and the reverse may also occur. Moreover, the charts refer to average "undisturbed" conditions, and during sunspot cycle peak periods conditions are likely to be disturbed fairly frequently. Under

(Continued on page 1000)

# Servicing Without Instruments

FAULT FINDING AND REPAIRS FOR THE BEGINNER

By Gordon Cole

LAST month's article concluded by pointing out the danger of electrical shock which may exist when receivers of the A.C./D.C. type are serviced and for safety it is best to ensure that the neutral wire of the mains supply is connected to the chassis. This is easily established by connecting a household lamp between the chassis and a good earth point, keeping the hands clear of the connections (see Fig. 1). The bulb will light if the chassis is "live," in which case the mains connections to the receiver

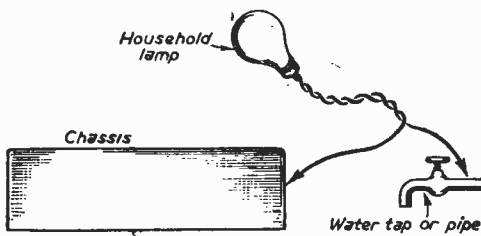

Fig. 1.—It is desirable to ensure that the chassis of the receiver under repair is connected to mains neutral. If the bulb lights, the mains connection to the receiver should be reversed. This applies mainly to sets of the A.C./D.C. type.

should be reversed. A neon lamp or screwdriver-type neon tester is also useful in this respect, since the neon will glow when in contact with a "live" chassis.

## The A.F. and Detector Stages

If the tests detailed in the previous article indicate that the output stage is working, then, if the receiver is still dead, simple tests must be made to the stages which supply signal to the output valve. In some receivers the demodulated detector signal is applied to a voltage amplifier triode or pentode to lift the A.F. content to a level suitable fully to drive the output valve, while in other receivers the signal across the detector load itself is applied direct to the output valve.

In Fig. 2 is shown the usual arrangement where a double-diode-triode serves as the detector, A.G.C. rectifier and A.F. amplifier. To check whether the signal is coupled from the anode of the triode to the control grid of the output valve a 0.1  $\mu$ F capacitor can be connected between the chassis

and the anode of the triode as shown. If all is well, a fairly loud click will occur each time the capacitor is connected to the anode point. In order to avoid having to discharge the capacitor, it is a good idea to connect across it a 100K resistor.

The next point to make a test is at the grid of the triode. If this point is touched with a finger or with a screwdriver blade on which a finger is resting a loud hum should occur from the loudspeaker if the A.F. section is in order. This test injects a mains signal (50 c/s) into the grid circuit, the signal being picked up by the body from spurious mains fields which are usually present in the proximity of the receiver. Unless there is a powerful mains field radiated by the house wiring, a battery receiver will not exhibit the effect, but on scraping the blade of a screwdriver on the grid connection crackling should be heard from the loudspeaker. When this test is performed, the receiver's volume control should always be set at maximum.

If a signal can be produced at the anode but not at the grid, the trouble lies somewhere in the triode section. There is very little to go wrong here, and it is usually found that either the valve itself or the anode resistor R1 is defective.

Having established that the A.F. and output stages are passing a signal, it is best to check the I.F. amplifier and detector stages in one go, and this is where the buzzer tester can be used to

(Continued on page 999)

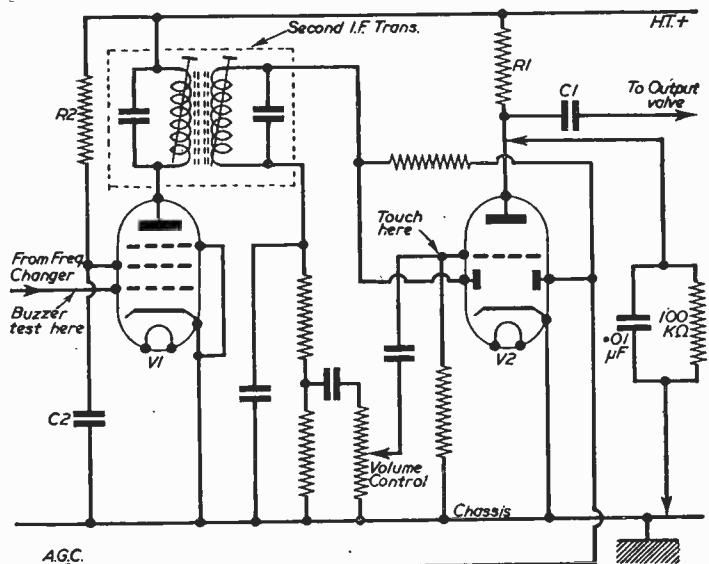

Fig. 2.—A circuit diagram showing the I.F., detector and A.F. stages and various test points.



# HOME RADIO OF MITCHAM

(Dept. P), 187 LONDON ROAD, MITCHAM, SURREY. MIT 3282

Shop Hours: 9 a.m.—6.30 p.m. Wednesday 9 a.m.—1 p.m.

We are stockists for: EDDYSTONE, PANDA, ARMSTRONG, DULCI, DENCÖ, JACKSON BROS., WB STENTORIAN, REPANCO, TELETRON, GOODMAN'S OSMOR WHARFEDALE, GRAYSHAW, BULGIN, etc.

## HEADPHONES



Amazing offer of BRAND NEW light-weight high resistance headphones in maker's original boxes. 4,000 ohms resistance. Weight 7 ozs. Made to sell at 45/- pair. Not Ex-Govt. OUR PRICE 15/- PAIR. Add 1/- post.

## I.T.V. PRE-AMPLIFIER

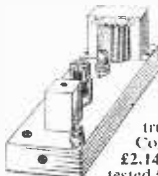

Gives amazing improvement to your Commercial TV picture especially in difficult areas. No need to touch television. Full constructional data I.3. Complete kit of parts £2.14.0. Ready built and tested £3.14.0. All post paid.

## SPECIAL OFFER RESISTORS

High grade 5 watt wire-wound resistors in following values:—

- 5.6 ohms, 33, 47, 62, 100, 150, 220, 1,000, 2,500, 2,700, 3,300, 3,900, 6,800, 8,200, 12,000.

All at 9d. each or 6/- doz. your assortment.

## EMPRESS STEREOPHONIC RADIOGRAM CHASSIS



Model SS8 full stereophonic radiogram chassis. Long, Medium, and FM/VHF. Bass, Treble, Volume, and balance controls. Switch for monaural or stereo. For A.C. Mains 200/250 v. Size 15" x 6 1/2" x 7 1/2". Illustrated leaflet on request. PRICE 27/- p.c.s. plus 2/6 packing and carriage.

## EMPRESS STEREOPHONIC AMPLIFIER



Amazing value for a full twin channel stereophonic amplifier 3 1/2 watts output each channel. Tone, Volume, and balance controls. Switch for monaural or stereo. Size 12" x 3" x 5 1/2". A.C. Mains 200/250 v. Leaflet on request. PRICE ONLY £8.0.0. plus 2/6 packing and carriage.

## VOLUME CONTROLS

Brand new MORGANITE volume controls with S.P. switch. Following values 10K, 25K, 50K, 100K, 250K, 500K, 1 meg., all at 4/- each, post 6d. 250K and 2 meg. less switch at 2/6 each, post 6d.

Latest valve and CRT data book. 5/-, plus 9d. post. TCC 0.1 mfd. 500 v tubulars, 9d. ea., or 7/6 dozen.

## TOOLS SPECIALLY DESIGNED FOR THE RADIO CONSTRUCTOR

Side cutters. Special really small and slim. 8/9. De luxe version in silver steel, 11/6. Long-nosed Pliers. Precise slender points, 8/9. De luxe version in silver steel, 11/6. Soldering Irons. Litesold sub-miniature. Ideal for transistor work. State voltage, 24/- Solon 625 instrument iron. The best iron for all radio wiring. State voltage, 24/- Primax Soldering Gun. The perfect soldering tool for Service engineers. Ready for use in 6 seconds, balanced grip, gets into awkward corners. Price 74/6. Send for leaflet.

## MULLARD 3-3 AMPLIFIER

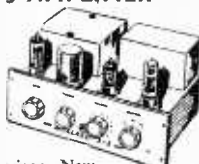

Separate Bass & Treble controls. Suitable gram, radio, mic, or guitar. Really amazing quality and performance. State whether 3 or 15 ohm output required. Bronze finish front panel. Complete ready to use.

PRICE £8.8.0 plus 2/6 carriage. New STEREO Version now available from stock. PRICE £12.0.0 plus 2/6 carriage. Leaflets on request.

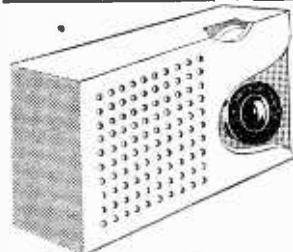

## THE MINI-7

Radio in your pocket everywhere. The amazing MINI-7 pocket portable gives loudspeaker results on internal aerial. Build one today and be the envy of your friends. Can be purchased and assembled in 4 easy stages. Seven transistor superhet circuit. Full constructional data and price list. 1/9, post paid. Kit £9.19.6.

## THE MAJOR 7

A seven transistor portable with push-pull output and 7" x 4" speaker. Medium and Long wave, attractive cabinet, and very economical running from single 7 1/2 volt battery. Full constructional data and price list. 1/9, post paid. Complete kit, £13.18.6 with goldtop transistors.



## NEW SERIES 100 PULLIN MULTI-RANGE TEST SET

Completely restyled with new diakon meter cover giving wide angle of vision and very clear scales. Carrying handle and ingenious three position stand incorporated. Printed circuit gives rugged accurate instrument with 21 ranges. Sensitivity 10,000 ohms per volt. CASH PRICE £12.7.6 or terms available. Send 3d. stamp for illustrated leaflet.

## SPECIAL OFFERS

Recording Tape. 1,200 ft. PVC on plastic spool, 20/-, 4 gang 350 pf. tuning condensers, 5/-, Coaxial cable 75 ohms low loss, per yd., 8d. Acos crystal microphone inserts, 5/-, 46 mfd. 350 v. tubular electrolytics, 1/6, TCC 1 mfd. 500 v. tubulars, 9d. Microphone cable single screened, per yd., 6d. B9G ceramic holders (EF50), per dozen, 2/6.

## HOME CONSTRUCTOR KITS

ONE VALVE beginner's dual range radio. Full data, 1/3. Kit of parts, £2.6. MERCURY F.M. TUNER, with switched tuning. Full data, 1/9. Kit of parts, £10. HIWAYMAN 4 valve all-dry portable. Full data, 1/9. Kit of parts, £7.10.0. THREE DFE 3 transistor dual range radio. Full data, 1/- Kit of parts, £4.10.0. MULLARD 5/10 pre-amp. and amplifier. Full constructional data, 4/-, COMPANION 3 transistor printed ckt radio. Full data, 9d. Kit of parts, £4.15.0. JASON F.M. TUNER. Thousands in use daily. Full data, 2/3. Kit of parts, £7.7.6. TELETRON TRANSIDYNE 6 transistor pocket portable. Full data, 1/-, Kit of parts, £13. COSSOR F.M. RECEIVER 701K. Complete kit including printed circuit, speaker, valves, etc., £15.15.0. Mullard "A" and "C" TAPE AMPLIFIERS. All parts in stock and list on request. COSSOR 3 watt amplifier with printed circuit, twin speakers, valves, etc. PRICE £9.15.0. ALL ABOVE PRICES ARE POST PAID.

## LOUDSPEAKERS

Full range of W.B. STENTORIAN Hi-Fi Speakers and cabinets in stock and illustrated leaflets on request. H F 1 0 1 2, £4.19.9. New Super HT1016 £8.0.0. 4in. tweeter, 35-. Cross-over, 30-.



## STEREO PICK-UP CARTRIDGES

Ronette L.P. and stereo, £3.9.6. Ronette L.P. 78, and stereo, £4.3.5. Acos GP71 L.P. and stereo, £2.15.5.

FULL RANGE OF EDDYSTONE SHORT WAVE COMPONENTS. Send 6d. stamp for Eddystone list.

## TRAWLER BAND R1155s.

The latest version of this famous Communications Receiver to be released by the Air Ministry. Covers 5 wave ranges - 18.5-7.5 Mc s., 7.5-3.0 Mc s., 3.0-1.5 Mc s., 1.5 Mc/s.-600 kc/s., 500-200 kc/s. As used by Coastal Command, Air-Sea Rescue Launches, etc. All sets thoroughly tested and in perfect working order before despatch, and on demonstration to callers. Have had slight use, but are in excellent condition. ONLY £12/19/6. "B" Models also available. As above but instead of 3.0-1.5 Mc s. band has 200-75 kc/s. coverage. ONLY £7 19/6.

**A.C. MAINS POWER PACK OUTPUT STAGE.** In black crackle case to match, enabling it to be operated immediately, by just plugging in, without any modification. Supplied with built-in 8in. P.M. speaker. £8 10.

**DEDUCT 10/- IF PURCHASING RECEIVER AND POWER PACK TOGETHER.**

Send S.A.E. for illustrated leaflet, or 1/3 for 11-page booklet which gives technical information, circuits, etc., and is supplied free with each receiver. Add carriage 10/6 for Receiver, 5/- for Power Unit.

## OSCILLOSCOPE No. II

Made for Anti-Aircraft Command, and just released by Ministry of Supply. Manufactured by A. C. Cossor in 1952, this is a First Grade L.F. Oscilloscope incorporating a Hard Valve Time Base. An existing model of this Oscilloscope, but is easily converted at a cost of a few shillings to produce speeds of 3 cycles per second to 30 kc/s. Has High Class Amplifier with Fine and Coarse gain controls, plus Brightness and Focus controls, and X and Y shifts. Conservatively rated Mains Power Pack is for nominal 115 v. and 230 v. input, and is adequately fuse protected in all circuits. Tube employ is 21in. AC110. Will make up into an ideal workshop of servicing oscilloscope. Has grey and black engraved front panel size 19in. x 7in., depth of unit being 12in. In heavy steel transit case, in which it can be used, or removed for standard 19in. rack mounting. Complete with leads and suggested modification data. BRAND NEW. ONLY £12 10/- (carriage 15/-).

## AMPLIFIER N24

Manufactured for the Admiralty in 1952 by Burndy, this utilises 4 valves, 1 each 5Z47 - 6V6C - 6J7G - 6X5G, and high quality component such as "C" Core Transformers and Block Paper Smoothing Condensers. Has A.C. Mains Pack for nominal 110-230 volts. Provision for 600 ohms or High Impedance Input, and has Output to 600 ohm line. For normal use only requires changing Output Transformer. Can be used for Speech or Music, giving High Quality Reproduction. Output approximately 4 watts. Enclosed in metal case, and designed for Standard 19in. Rack Mounting, having grey front panel size 19in. x 7in. with Chromium Handles. All connections to rear panel, front having "On Off" Switch, Gain Control, Indicator Light, Fuses and Valve Inspection Panel. BRAND NEW IN MAKER'S PACKING. ONLY £23 8 (carriage 10/6).

**HIRO MAINS POWER UNITS.** Input 115-230 volts A.C. D.C. output (fully smoothed) 230 volts 75 mA., and 6.2 volts 3.5 amps. Complete in black crackle case. ONLY 69 8 (carriage 3/6).

**MT (HEAD) SLOW-MOTION PRINTS.** A really precision product of this famous maker. 3in. in diameter and fitted to removable white back plate marked 0-180. Overall diameter 4in. BRAND NEW IN MAKER'S CARTONS. ONLY 10 6 (Post 1 6).

**12 VOLTS AMERICAN DYNAMOTOR.** Delivers 220 volts at 100 milli. Ideal for running Car Radio or Electric Shaver, etc., from Car Battery. ONLY 32 8.

**8 v. VIBRATOR PACKS.** Output approx. 130 v. at 30 mA., fully filtered and smoothed. Complete. BRAND NEW. ONLY 12 6.

**R1155 SUPER SLOW-MOTION TUNING ASSEMBLY.** As used on all late model 1155s. Easily fitted to "A" sets, etc. BRAND NEW. ONLY 12 6.

**HIT TRANSFORMERS.** 5.5 kv. (Rect.) with 2 v. 1 a., 79 6. 7 kv. (Rect.) with 2 v. 1 a., 89 6. 2.5 kv. (Rect.) with 2-0-2 v. 1.1 a., 2-0-2 v. 2 a. (for VCR97 tube, etc.). 42 8 (postage 2/- per trans.).

**POCKET VOLTMETERS.** Read 0-15 volts and 0-300 volts A.C. or D.C. BRAND NEW AND UNUSED. ONLY 18 6.

**CROWSAIR.** British Standards 2-pin 300 kc s., 15-. Miniature 200 kc s., 10-.

**ROLA 6in. P.M. SPEAKER.** Mounted in grey crackled metal cabinet 9in. x 9in. x 4 1/2in., with volume-control. Ideal for use with receiver, or as extension. BRAND NEW. ONLY 27 6 (Post 2 6).

**MAINS ISOLATING TRANSFORMER.** Manufactured by Vortexion. Fully shrouded. Will provide true 1:1 ratio from nominal 230 v. Primary. Rated at 100 watts. BRAND NEW. ONLY 22 6 (Post 2 6).

**SPRAGUE CONDENSERS.** Metal cased, wire ends. New 01 mfd. 1,000 volt, and .1 mfd. 500 volt. 7 6 per-dozen. Special quotes for quantities.

# HARRIS ELECTRONICS

(LONDON) LTD.

138 Gray's Inn Road, London, W.C.1.

(Phone TERMINUS 7937)

Please include carriage costs on all items.

(Open until 1 p.m. Saturdays. We are 2 mins. from High Holborn (Chancery Lane Station) and 5 mins. by bus from King's Cross.)

**Let I.C.S. train YOU!**

**COURSES ON:—**

- **RADIO and TELEVISION**
- **SERVICING ELECTRONICS**

### EXAMINATION COURSES FOR:—

- **P.M.G.'s Certificate** (Marine Radio Operators)
  - **C. & G. Radio Amateurs' Exam.** (Amateurs' Transmitting Licence)
  - **C. & G. Radio Servicing Certificate (RTEB)**
  - **British Institution of Radio Engrs., etc.**
- Whether you plan to have your own business, to become an electronics engineer or to take up a career in industry, an I.C.S. Course will help you to succeed. You learn at home in your own time, under expert tuition. Moderate fees include all books.

## LEARN-AS-YOU-BUILD

### Practical Radio Course

A basic course in radio, electronic and electrical theory backed by thorough practical training. You build a 4-valve T.R.F. and a 5-valve superhet radio receiver, signal generator and multi-tester.

Other Learn-as-you-Build radio courses are available

**MULTI-TESTER**  
(Sensitivity 1,000 ohms per volt)

**5-VALVE SUPERHET RECEIVER**

**RF/AF SIGNAL GENERATOR**

**Post this Coupon TODAY!** for FREE book on careers in Radio, etc., and full details of I.C.S. Courses.

**INTERNATIONAL CORRESPONDENCE SCHOOLS**

Dept. 170, International Buildings, Kingsway, London, W.C.2

Name..... Age.....  
(Block Letters please)

Address .....

Occupation..... 2-59

**INTERNATIONAL CORRESPONDENCE SCHOOLS**

advantage. This was described in the previous article, but is again shown here in Fig. 3. The rapid make-and-break action of the buzzer produces square waves which are rich in harmonics rising to frequencies well in excess of the broadcast bands, and these signals can be injected, for example, into the control grid circuit of the I.F. amplifier valve (V1 in Fig. 2) to check stage continuity.

If a loud buzz is produced in the loudspeaker when this connection is made, it can be assumed that the I.F. amplifier and detector stages are in order, but if there is no response or if the buzz from the loudspeaker is very weak, attention should be directed towards the I.F. amplifier valve and the components associated with this and the detector circuit.

Under normal conditions, the I.F. valve is fairly warm, though not at such a high temperature as the output valve or rectifier, so if a finger test of temperature reveals that this valve is cool, it may either be low in emission or a component defect may be starving it of voltage. The presence of screen and anode potential can be established by means of a  $0.1 \mu\text{F}$  capacitor. If this is connected between the chassis and either screen or anode it will charge, and a small spark will occur when it is discharged across the chassis or other metal object—the use of a larger value capacitor will produce a larger spark on discharging.

Lack of voltage at the anode is caused by the primary (anode) winding of the second I.F. transformer being broken, while lack of voltage at the screen is caused either by the screen-feed resistor R2 being open-circuit or the decoupling capacitor C2 being short-circuit. In the latter case, however, the excessive current in R2 may cause this resistor to overheat if its value is not too high. If the voltages are present on the valve and it is cool in operation, it should be checked for emission and replaced if necessary.

In some circuits a resistor is connected in series with the cathode of the valve to produce a standing bias, and open-circuit of this com-

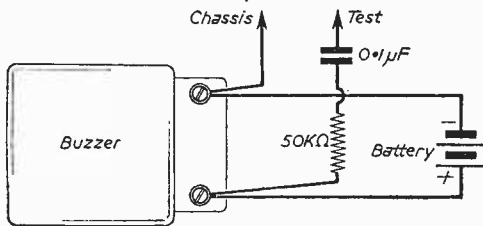

Fig. 3.—A buzzer set-up for test purposes.

ponent will produce the symptom under consideration, but a quick check is possible by shorting the resistor with a short length of wire while the buzzer signal is applied. If this results in stage continuity, the cathode resistor should be replaced.

If the valve and its voltages are normal, the trouble may be caused either by misalignment of the second I.F. transformer or by a fault in the detector circuit. There is a probability that the detector diode in V2 is faulty, though this is not very likely if the triode is working correctly,

though, nevertheless, it may save time to have V2 checked in obstinate cases. A quick test of the components in the detector circuit is possible by injecting a signal from the buzzer into the signal diode circuit of V2. A buzz will be heard from the loudspeaker, the volume of which will be controllable by the receiver's volume control if the circuit is in order. As will be seen, there is little in this section to go wrong, and final testing generally resolves to the substitution of suspect components.

Severe misalignment of the second I.F. transformer may require the use of a signal generator to establish the correct I.F., but the two tuned circuits may be balanced with respect to each other by injecting a signal from the buzzer into the control grid of the I.F. valve and adjusting the I.F. trimmers for maximum output.

### The Frequency Changer and Aerial Circuits

If a good signal can be pushed through the receiver from the grid of the I.F. amplifier valve, then the trouble lies somewhere in the frequency changer stage or aerial circuits. The circuit of Fig. 4 shows this section of the circuit relating to a receiver of the A.C./D.C. mode, in which, it will be noticed, the aerial and earth connections are isolated from the chassis by means of capacitors C1 and C2.

If operation of the wavechange switch gives rise to distinct clicks from the loudspeaker the local oscillator and aerial circuits should be investigated. The first move is to disconnect the aerial from the aerial terminal on the set and connect it direct to the signal grid of the frequency changer valve V1. This will bypass the aerial coupling circuits. If signals can now be tuned in there is conclusive evidence that the local oscillator is in order, and that the trouble lies in the aerial coupling circuits. In this case attention should be paid to the aerial section of the wavechange switch, the connections on the tags of the switch and the components between the aerial socket and the coils. If all bands are dead with the aerial inserted correctly in its socket, the lead should again be removed from the socket and applied in turn to the various components between the socket and coils in an endeavour to find the point where the signal fails to pass. For example, the aerial lead could be applied to the coil end of C3 in Fig. 4 or between C1 and C3; if the set works with the aerial connected to the coil end of C3 but not at the junction of C1 and C3, it would follow that C3 is open-circuit.

If it is found possible to receive signals only when the aerial is connected to the signal grid of V1, the alignment of the aerial coils may be adrift or a fault may have developed in the padding capacitor C4. There is also the possibility of an open-circuit aerial winding L1.

If signals cannot be received even with the aerial connected to the signal grid of V1, but if loud crackles result when the aerial wire is drawn across the tag at this point, failure of the local oscillator should be suspected. If all bands are out of action, the most likely cause of the trouble is a low emission valve (triode or oscillator section), but a defect in R1 or C5 would have the same effect. Open-circuit in the resistor

Fig. 4.—The frequency changer and aerial circuits of a typical receiver.

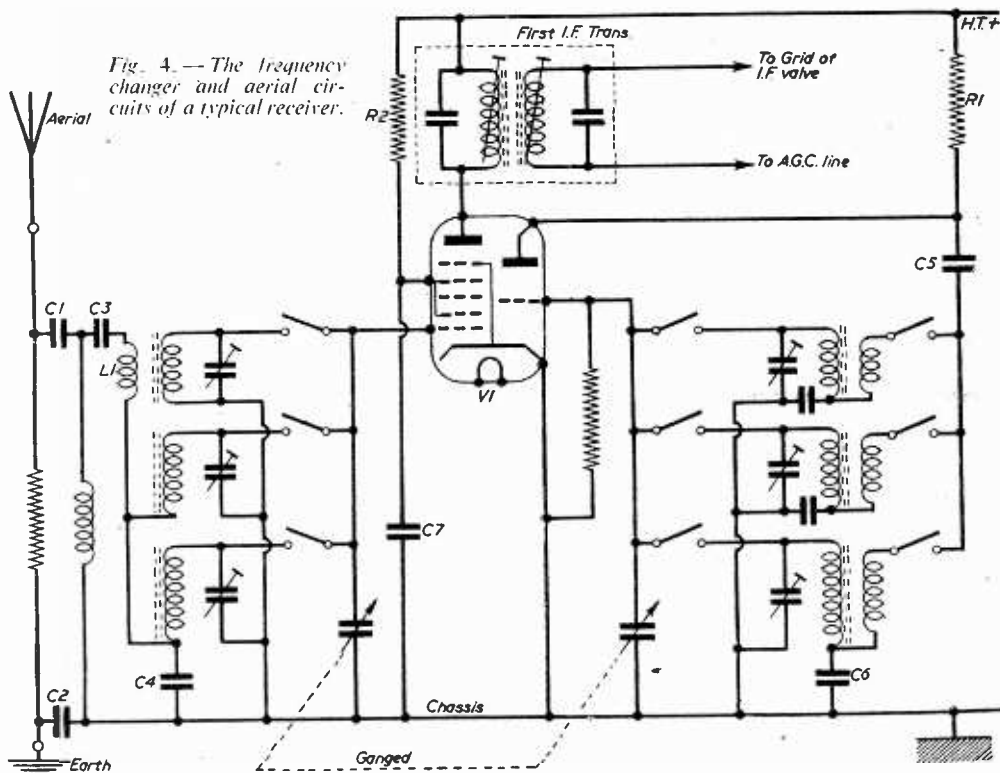

would remove the voltage from the anode of the oscillator valve, and voltage at this point can be proved along the lines already described, while open-circuit in C5 would open the oscillator coupling and mute the oscillator altogether; a quick substitution check is desirable if this component is suspected. If only one band is faulty, a check should be made on the associated padding capacitor, such as C6.

Complete misalignment of the oscillator circuits should not prevent the receiver from working, but would be revealed by the local stations coming in well off their expected points on the dial, and it may be necessary to connect the aerial direct to the signal grid of the frequency changer to get any signal at all.

If V1 stage seems to be totally dead, and it is found impossible to pass the buzzer signal through the receiver from the signal grid point, lack of emission of the valve is a possibility worth investigating. If the valve is only just warm it would also be a good idea to check for the presence of voltage on the anode and screen tags, as in the case of the I.F. amplifier valve. R2 or C7 may be faulty. It sometimes happens that a short occurs in the capacitor, and the resulting heavy current causes the resistor to fail a little while later. There is also the possibility of the primary winding of the first I.F. transformer being open-circuit.

If only a weak buzz is produced in the loudspeaker one of the fixed tuning capacitors in the

I.F. can may have altered in value or gone open-circuit. This can usually be proved by applying the buzzer signal at the signal grid of the valve and adjusting the trimmers on the suspect transformer for maximum output. If this necessitates the trimmers being fully compressed or at maximum value, the fixed capacitors should be replaced, or, at least, the capacitor associated with the winding which is not tuning correctly. If the windings are trimmed by dust-iron cores, the effect would be revealed by the output beginning to increase when the core is fully in the winding.

## TRANSMITTING TOPICS

(Continued from page 995)

disturbed conditions, anomalous propagation, fadeouts, "polar flutter," strong signals from unexpected areas or blackouts may often occur. A point often *not* shown on these propagation charts we have been considering, is that there is also a complementary curve of the "lowest usable frequency." This is shown on the chart in Fig. 8. When the "lowest usable" frequency exceeds the "highest usable" frequency, obviously communication is impossible. Generally in commercial practice a working frequency below the MUF is selected to ensure that communication will be possible despite fluctuations in the "expected" maximum working frequencies that will be open.

# RETURN-OF-POST SERVICE

## GRAMOPHONE EQUIPMENT

	Cash Price	Deposit	Hire Purchase Mthly. Pmnts.
<b>RECORD CHANGERS</b>			
COLLARO, Conquest	£9.19. 6	£1.10. 6	12 of £1.10. 8
GARRARD, RC121/4	£9.15. 0	£1.12. 0	6 of £1.13. 0
GARRARD, RC88/4	£14.19. 6	£2. 5. 6	6 of £2. 5. 7
BSR U48 Monarch	£8.12. 6	£1. 4. 6	6 of £1. 7. 2
BSR U412 Monarch	£9.19. 6	£1.10. 6	6 of £1.10. 8
<b>SINGLE RECORDED PLAYERS</b>			
COLLARO 4564	£7.19. 6	£1. 5. 6	6 of £1. 4.10
GARRARD TA MK. 2	£9.15. 8	£1.10. 2	6 of £1.10.11
GARRARD 4SP	£7.19. 6	£1. 5. 6	6 of £1. 4.10
BSR TU9	£4.15. 0	£1. 5. 0	3 of £1. 6. 8
<b>TRANSCRIPTION UNITS</b>			
COLLARO, 4T/200	£19.10. 0	£2. 0. 0	12 of £1.13. 9
with PU			
COLLARO, 4TR/200.			
Motor	£14.11. 0	£2. 2. 0	6 of £2. 5. 5
GARRARD, 4HF			
with GCB PU	£19.17.10	£1.18.10	12 of £1.13.10
GARRARD, 301			
Motor	£26. 8. 3	£2.12. 3	12 of £2. 3. 8

All the above are fitted with Monaural cartridges. Some can be supplied with Stereo Inserts and details are given in our illustrated list of Gramophone Equipment.

**STEREO PICK-UP CARTRIDGES**

These cartridges will enable you to convert your BSR or Collaro Changers and Players to Stereo. Full details and length of suitable cable included.

BSI. Ful-F1 TC8S. £3.10.0.

RONETTE (Studio). For all Collaro models. £4.4.0.

## JASON FM TUNER KITS

We can fully recommend these kits as being the best of all the F.M. Kits available. Construction is easy and results are first class.

Our kits are really complete, the instruction book, all components, valves and small items such as nuts, bolts, wire and solder being included. There is definitely nothing else to buy. All items are available separately if required and detailed lists are available free. Instruction books for either tuner are available at 2/3 each, post free.

**VARIABLE TUNING.** Kit includes well-made chassis assembly with glass scale and hammer finish front panel. PRICE £8.19.6 post free. H.P. Terms—Deposit 19/6 and six monthly payments of £1.2.6.

**MERCURY SWITCHED TUNER.** All three BBC programmes at the turn of a switch. Kit includes the front-end unit already built and tested. Not suitable for Wenvoe area. PRICE £9.19.0 post free. H.P. Terms—Deposit £1.10.0 and six monthly payments of £1.10.4.

**NEW F.M.TV SOUND TUNER AND NEW FRINGE FM TUNER.** Full details of these are not available at the time of going to press, but are expected by the time of publication. Send for our fully detailed lists.

## JASON STEREO KITS

We now stock these Kits and detailed price lists are available on request.

## MULLARD TAPE C AMPLIFIER

Kits for the new version now available. Send for list. Kit available for converting old model to new version. Send for details.

## ILLUSTRATED LISTS.

We now have available separate illustrated lists on all of the following:—

**GRAMOPHONE EQUIPMENT.**—This list details no less than 14 different items including Record Changers, Single Record Players and Transcription Units. Some at special prices.

**READY BUILT AMPLIFIERS.**—Hi-Fi and less expensive popular types.

**TEST GEAR.**—Test Meters, Signal Generators, etc., by AVO, Pullin and Taylor.

**LOUDSPEAKERS.**—Full details of Goodmans, Whiteley, Wharfedale, G.E.C. and Elac types which we stock.

**TAPE DECKS.**—All the popular makes including a special offer.

**RECORDING TAPES.**—We have a very wide range of tape and accessories by all the well-known makers.

Any of these lists will be sent free upon request.

## READY-BUILT AMPLIFIERS

	Cash Price	Deposit	Hire Purchase Mthly. Pymts.
QUAD. Main Amplifier and Control Unit	£42. 0.0	£4. 4.0	12 of £3. 9. 4
LEAK, TL12 Plus Main Amp.	£19.18.9	£1.18.3	12 of £1.11. 2
LEAK, Varislope III Pre-Amp.	£15.15.0	£1.12.0	12 of £1. 5.11
LEAK, Point One Plus Pre-Amp.	£12.12.0	£2. 0.0	6 of £1.18. 1
LEAK, TL12 and Vari-slope III	£34.13.0	£3.11.0	12 of £2.17. 0
LEAK, TL12 and Point One	£31.10.0	£3. 2.0	12 of £2.12. 0
TRIPLE TONE, Hi-Fi Major	£15.18.9	£1.10.9	12 of £1. 6. 4
TRIPLE TONE Popular	£6.19.6	£1. 1.6	6 of £1. 2. 2
ASV Hi-Gain	£3.19.6	£1. 3.6	3 of £1. 2. 0

## AMPLIFIER KITS

**MULLARD 510 AND GEC 912 PLUS**

We carry full stocks for all versions of these popular Amplifiers and our price lists are available free.

**MULLARD 2 VALVE PRE-AMPLIFIER**

Latest Mullard circuit for use with the 510 Amplifier. Booklet giving full details now available 1/3 post free.

Complete Kit, including drilled chassis and control panel. £6.12.0. H.P. Terms. Deposit 19/- and six monthly payments of £1.1.4.

**CONSOR 2 VALVE AMPLIFIER**

Ready built, supplied with valves, speaker and separate Tweeter for home assembly on baffle or in cabinet. Complete instructions included. £9.15.0. H.P. Terms. Deposit £1.9.6 and six monthly payments of £1.10.1.

**HIRE PURCHASE.** H.P. Terms are available on any item. Repayments may be spread over 3, 6 or 12 months. Details as follows:—Three months: Deposit 6/- in the £. Service charge 2%, but minimum charge 10/-. Six months: Deposit 3/- in the £. Service charge 7 1/2%, but minimum charge 15/-. Twelve months: Deposit 2/- in the £. Service charge 10%, but minimum charge 20/-.

## LATEST TEST METERS

	Cash Price	Deposit	Hire Purchase Mthly. Pymts.
AVO Model 8	£23.10.0	£2. 7.0	12 of £1.18. 9
AVO Model 8 with leather case	£26.10.0	£2.13.0	12 of £2. 3. 9
AVO Model 7	£19.10.0	£1.19.0	12 of £1.12. 2
AVO Model 7 with leather case	£22.10.0	£2. 5.0	12 of £1.17. 1
AVO Multiminor	£9.10.0	£1. 8.0	6 of £1. 9. 6
AVO Multiminor with case	£11. 2.6	£1.13.6	6 of £1.14. 0
TAYLOR Model 71A	£12.10.0	£1.17.6	6 of £1.18. 2
PULLIN Series 100	£12. 7.6	£1.16.6	6 of £1.16.10
TAYLOR MONITROSE	£3.10.0	£1. 0.0	3 of £1. 0. 0
PIFCO All-in-One	£1.12.6	—	—

## R.L.D. CONSTRUCTION KITS

Introducing a new range of construction kits for the home constructor. All Kits are absolutely complete and are supplied with the fullest possible instructions.

**R.L.D. KIT NO. 1. CRYSTAL SET.** A modern crystal circuit built into a small plastic cabinet. KIT 18/- post free. Less headphones.

**R.L.D. KIT NO. 2. TRANSISTOR AMPLIFIER FOR CRYSTAL SETS.** A simple transistor amplifier which can be added to any crystal set. The addition of this amplifier will increase the volume in the headphones several times. No soldering required in this kit. KIT 27/6 post free.

**R.L.D. KIT NO. 3. TRANSISTORISED CRYSTAL SET.** An up-to-date crystal circuit followed by a transistor amplifier built into a small plastic case. KIT 43/6. post free. Less headphones.

**HEADPHONES.** Brand new (not ex-Govt.) light-weight high resistance headphones at 16/6 per pair, plus 1/- post. *Instruction kits for any kit 6d., plus 3d., post.*

Terms of Business—Cash with order or C.O.D. Postage extra under £3. We charge C.O.D. orders as follows. Up to £3. postage and C.O.D. fee minimum 2/6. Over £3 and under £5. C.O.D. fee only 1/6. Over £5 no charge.

# WATTS RADIO (MAIL ORDER) LTD.

54 CHURCH STREET, WEYBRIDGE, SURREY. Telephone: Weybridge 4556

PLEASE NOTE. POSTAL BUSINESS ONLY FROM THIS ADDRESS.

# WEYRAD

## COILS AND TRANSFORMERS FOR A 2-WAVE TRANSISTOR SUPERHET WITH PRINTED CIRCUIT AND FERRITE ROD AERIAL

- LONG AND MEDIUM WAVE AERIAL—RA2W  
On 6in. rod, 7/16in. diameter, flying lead connections, 208 pF tuning ... .. 12/6
- OSCILLATOR COIL—P50/1AC  
Medium wave in screening can. For 176 pF tuning condenser ... .. 5/4
- 1st AND 2nd I.F. TRANSFORMERS—P50/2CC  
470 Kc/s operation with 250 pF tuning in cans. 11/16in. diameter by 3/4in. high ... .. 5/7
- 3rd I.F. TRANSFORMER—P50/3CC  
Last stage transformer to feed diode detector. Size as P50/2 ... .. 6/-
- DRIVER TRANSFORMER—LFDT1  
Fully enclosed with six connecting tags—case 11/16in. square by 1 1/8in. high ... .. 17/6

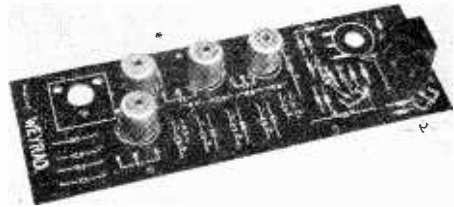

PRINTED CIRCUIT—PCA1  
Size 2 3/4in. x 8 1/4in. Ready drilled and printed with component positions ... .. 9/6

THESE COMPONENTS ARE APPROVED BY TRANSISTOR MAKERS AND PERFORMANCE IS GUARANTEED.

Constructor's Booklet with full details, 2/-.

**WEYMOUTH RADIO MANUFACTURING CO., LTD.**  
CRESCENT STREET, WEYMOUTH, DORSET

### MOTEK TAPE DECK

*makes a better Recorder*

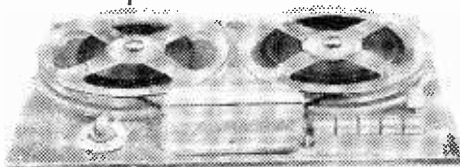

Motek is the core of many recording machines. Manufacturers build-in Motek—and then out of sight and mind—which is as it should be, for built-in Motek has built-up immense confidence from manufacturers and customers alike. And no wonder, with these five star features: Push Button Operation, Counter, Safety Erase Button, Pause Control, Three Speeds.

List 21 Gns.

Details on request. Patents Pending

**MODERN TECHNIQUES**  
Wcdmore Street, London, N.19. Tel: ARCHway 31.4.

DHB 6353

### EXPRESS ELECTRONICS

ROSEDENE LABORATORIES  
KINGSWOOD WAY, SELSDON, SURREY

#### VALVES NEW, TESTED AND GUARANTEED

1AC6 9-	6BA6 7-	12J7GT 10-	DL86 8/6	N17 7/6
1C1 7/6	6BE6 7-	12K7GT 6/9	EABC80 8/6	N18 8-
1C2 9-	6BR7 10/6	12K8GT 12/6	EB91 5/6	N19 8-
1C3 8/6	6BW6 7/6	12Q7GT 7/6	EB41 10-	PC84 9-
1F1 8/6	6BW7 7-	15A3 9-	EBF80 9/6	PC80 9-
1F2 7/6	6C40 9-	25A8 10/6	ECC81 7/6	PC82 10/6
1FD1 8/6	6CH6 7-	25L6GT 7/6	ECC82 7/6	PL38 22/6
1FD9 7/6	6D2 5/6	25Z4 9-	ECC83 7/6	PL82 9-
1L1 8/6	6F12 6/6	35L6GT 9-	ECC84 8/6	PY81 8/6
1P1 8/6	6F36 5/6	35W4 8/6	ECP80 10/6	PZ80 17/6
1P10 7/9	6J7GT 8/6	35Z4GT 8-	ECP82 10/6	U52 8/6
1P11 8-	6K7C 2/6	578 10/6	ECH32 9/-	U76 7/6
1R5 7/6	6K8G 7/6	D77 6/6	ECH81 8-	U78 7-
1S5 7/6	6L6G 10/6	DAF91 7/9	EP180 13/6	UBC41 8/6
1T4 7/6	6Q7GT 8/6	DAF96 8/6	EF41 9-	UCH42 9/-
1U5 6/-	6S1GT 7/6	DF81 7/8	EP80 8/6	UF41 8/6
2A5 10/6	6AN7GT 8-	DF96 8/6	EP91 8/6	UL41 10-
3Q4 8-	6V6G 7/6	DH76 7/6	EF92 5/6	UY41 7/6
3A4 7/6	6X4 7-	DH77 5/6	EL38 22/6	W76 6/9
3V4 8-	6X5GT 6-	DH142 8/6	EL41 10-	W142 8/6
3U6 8/6	8D3 8/6	DH150 10-	EL84 8/6	X17 7/6
3Z4G 9/6	12AH 10/6	DK91 7/8	EP51 10/6	X18 9-
6AK6 8/6	12AT6 8/6	DK92 9-	EZ40 7/6	X142 9-
6AL5 5/8	12AT7 7/6	DK96 8/6	EX86 8-	X159 9/-
6AM6 8/6	12AU7 7/6	DL92 7/6	EZ81 8-	Z77 8/6
6AT6 7-	12AX7 7/6	DL94 8-	KT38C 9/6	ZD17 7/6

VOLUME CONTROLS MIDGET SIZE LONG SPINDLES D.P. switch, 3/9; S.P. 3/3; No S.W., 2/6.

#### MATCHED PAIRS

EL81 21 -, 6V6G 17 -, KT66 27 6, 6BW6 18 - per pair. Push Pull O.P. Transformers for above 3-15 ohm 14/6

#### SETS OF VALVES

DK91, DF91, DAF91, DL92 or DL154.....	27/6
DK96, DF96, DAF96, DL96.....	35/6
1R5, 1T4, 1S5, 3A4 or 3V4.....	27/6
6K8, 6K7, 6Q7, 6V6, 5Z4G or 6X50.....	27/6

Postage and packing 6d. Over £1 post free. C.O.D. 2/6.



# Ex-Government Reference Numbers

## A FURTHER LIST OF RESISTOR AND CAPACITOR NUMBERS

SOME years ago we published a list of Service reference numbers for certain components, but as all back numbers concerned are now out of print, we are continually receiving requests to re-print this information, or to add to it. Letters on this subject have been published in our correspondence pages, and as a result of these, the following details have been received from Mr. J. P. Marchant. If any reader is able to furnish any more complete data we should be glad to consider it for publication.

### RESISTORS

10W/6—500 ohms.	10W/11382—150 k.	HES.GC.3610—250 k. pot.
10W/7—15 k.	10W/11384—1 meg.	(ordinary).
10W/8—50 ohms.	10W/11499—100 k.	(Both the above sub-miniature).
10W/342—75 ohms.	10W/11670—5 k.	NDZA.5077—1 meg. pot.
10W/998—20 k. pot. (small).	10W/11674— $\frac{1}{2}$ meg.	10C/8924—1 k. pot.
10W/999—20 k. pot. (larger).	10W/6289—5 k.	10C/8925—5 k. pot.
10W/1018—2 k.	10W/8740—100 k.	10C/8926—10 k. pot.
10W/1025—10 k. pot. w.w.	10W/16741—200 k.	10C/8927—25 k. pot.
10W/6341—150 k. pot. pre-set.	10W/8750—250 k.	10C/1063—750 k. pot.
10W/1725— $\frac{1}{2}$ Meg. pot. min.		10W/16190—20 k. pre-set pot.
pre-set.		10W/10719—5 k. pre-set pot.
10W/6662—100 k.	JXS.GC.3610—250 k. pot. (1	10C/8740—100 k. E.H.T. pot.
10W/7313—5 k. pot. (carbon).	side earthed).	10C/81376—200 $\Omega$ pot.

### CONDENSERS

1 pF=.000001  $\mu$ F. 100 pF=.0001  $\mu$ F. 1,000 pF=.001  $\mu$ F.

10C/14—.001 $\mu$ F.	10C/2015—1,670 pF.	10C/3192—.0025 $\mu$ F.
10C/15—5 pF.	10C/2016—6,170 pF.	10C/3195—.01 $\mu$ F.
10C/16—10 pF.	10C/2017—300 pF.	10C/3196—300 pF.
10C/18—80 pF.	10C/2027—5 pF.	10C/3303—10 pF.
10C/96—100 pF.	10C/2066—3-18 pF trimmer.	10C/3317—
10C/97—.002 $\mu$ F.	10C/2070—3-20 pF trimmer.	10C/3396—.001 $\mu$ F.
10C/347—.01 $\mu$ F.	10C/2071—3-18 pF ganged.	10C/3399—.1+.1+.1 $\mu$ F.
10C/432—150 pF.	10C/2072—2-8 pF trimmer.	10C/3401—.5 $\mu$ F.
10C/626—500 pF.	10C/2073—10 pF.	10C/3402—8-105 pF variable.
10C/627—.001 $\mu$ F.	10C/2075—30 pF.	10C/3436—.0001 $\mu$ F.
10C/733—25 $\mu$ F 25 v.	10C/2076—.003 $\mu$ F.	10C/3503—8 pF.
10C/792—500 pF.	10C/2078—50 pF.	10C/3580—.001 $\mu$ F.
10C/793—.001 $\mu$ F.	10C/2079—50 pF.	10C/3787—16 $\mu$ F.
10C/796—.05 $\mu$ F.	10C/2082—2-6.8 pF variable.	10C/3788—.005 $\mu$ F.
10C/798—0.1 $\mu$ F 1 kV.	10C/2083—.05+.05 $\mu$ F.	10C/3789—60 pF.
10C/799—.15 $\mu$ F.	10C/2084—.1+.1 $\mu$ F.	10C/3790—160 pF variable.
10C/960—2.5+2.5+.1 $\mu$ F.	10C/2189—.1 $\mu$ F.	10C/3791—160 pF 2-gang vari-
10C/962—As 960.	10C/2192—.1 $\mu$ F.	able.
10C/963—100 pF.	10C/2235—.5 $\mu$ F.	10C/4099—300 pF.
10C/964—.005 $\mu$ F.	10C/2237—.004 $\mu$ F.	10C/4100—100 pF.
10C/967—.1 $\mu$ F.	10C/2238—.25 $\mu$ F.	10C/4232—25 $\mu$ F.
10C/968—75 pF.	10C/2239—2 $\mu$ F.	10C/4250—.001 $\mu$ F.
10C/969—800 pF.	10C/2240—4 $\mu$ F.	10C/4256—
10C/970—.5 $\mu$ F.	10C/2347—100 pF.	10C/4260—93 pF.
10C/971—600 pF.	10C/2428—100 pF.	10C/4268—200 pF.
10C/972—200 pF.	10C/2599—25 $\mu$ F.	10C/4271—100 pF.
10C/974—10-115 pF trimmer.	10C/2624—.1 $\mu$ F.	10C/4321—75 pF.
10C/976—5-60 pF trimmer.	10C/2625—.01 $\mu$ F.	10C/4325—500 pF.
10C/978—15 pF.	10C/2626—.005 $\mu$ F.	10C/4326—200 pF.
10C/979—4 $\mu$ F.	10C/2627—.005 $\mu$ F.	10C/4327—200 pF.
10C/1271—.02 $\mu$ F.	10C/2629—.02 $\mu$ F.	10C/4328—150 pF.
10C/2001—2 pF.	10C/2630—.05 $\mu$ F.	10C/4329—100 pF.
10C/2002—4 pF.	10C/2649—65 pF.	10C/4501—50 $\mu$ F.
10C/2005—.00455 $\mu$ F.	10C/2920—30 pF.	10C/4502—500 pF.
10C/2006—100 pF.	10C/3027—25 pF.	10C/4568—2 $\mu$ F.
10C/2007—25 pF.	10C/3043—50 pF.	10C/4569—1 $\mu$ F.
10C/2008—240 pF.	10C/3055—.01 $\mu$ F.	10C/4570—.5 $\mu$ F.
10C/2009—80 pF.	10C/3064—300 pF.	10C/4572—1 $\mu$ F.
10C/2011—.002 $\mu$ F.	10C/3100—.001 $\mu$ F.	10C/4632—3 pF.
10C/2013—1,320 pF.	10C/3124—30 pF.	10C/4633—2 pF.
10C/2014—537 pF.	10C/3129—5-60 pF variable.	10C/4922—30 pF.

CONDENSERS—(Continued)

- 10C/4923—160 pF.
- 10C/4995—100 pF.
- 10C/5352—.005  $\mu$ F.
- 10C/5484—250 pF.
- 10C/5598—16+8  $\mu$ F.
- 10C/5645—.01  $\mu$ F.
- 10C/5683—10 pF.
- 10C/5874—9-175 pF variable.
- 10C/5875—3-8 pF.
- 10C/7901—.001  $\mu$ F.
- 10C/7906—.01  $\mu$ F.
- 10C/8009—500 pF.
- 10C/8010—.002  $\mu$ F.
- 10C/8275—2  $\mu$ F.
- 10C/8286—8  $\mu$ F.
- 10C/8382—.25  $\mu$ F.
- 10C/9097—1  $\mu$ F.
- 10C/9629—.05  $\mu$ F.
- 10C/9755—.01  $\mu$ F.
- 10C/10164—.005  $\mu$ F.
- 10C/10165—.1  $\mu$ F 375 v.
- 10C/10221—.05  $\mu$ F.
- 10C/10226—.0005  $\mu$ F variable.
- 10C/10227—3-35 pF variable.
- 10C/10228—160 pF.
- 10C/10229—1,050 pF.
- 10C/10230—3-17 pF variable.
- 10C/10301—3 pF.
- 10C/10552—50 pF.

- 10C/10553—100 pF.
- 10C/10554—.1  $\mu$ F.
- 10C/10568—50 pF.
- 10C/10607—15 pF.
- 10C/10629—.01  $\mu$ F.
- 10C/10948—20 pF.
- 10C/11120—.001  $\mu$ F 1 kV.
- 10C/11121—.002  $\mu$ F 1 kV.
- 10C/11122—.005  $\mu$ F 1 kV.
- 10C/11123—.01  $\mu$ F.
- 10C/11124—.02  $\mu$ F.
- 10C/11125—.05  $\mu$ F.
- 10C/11126—.1  $\mu$ F 350 v.
- 10C/11127—.1  $\mu$ F 1 kV.
- 10C/11128—.25  $\mu$ F.
- 10C/11130—.5  $\mu$ F 350 v.
- 10C/11131—.5  $\mu$ F.
- 10C/11134—.5  $\mu$ F 500 v.
- 10C/11140—.004  $\mu$ F.
- 10C/11156—.05  $\mu$ F.
- 10C/11157—.1  $\mu$ F.
- 10C/11394—.25  $\mu$ F.
- 10C/11407—200 pF.
- 10C/11476—.1  $\mu$ F.
- 10C/11482—4  $\mu$ F.
- 10C/11485—50 pF.
- 10C/11658—200 pF.
- 10C/11694—.003  $\mu$ F.
- 10C/11748—1.25  $\mu$ F.

- 10C/11753—.01  $\mu$ F.
- 10C/11754—.05  $\mu$ F.
- 10C/11755—4  $\mu$ F.
- 10C/11756—.25  $\mu$ F.
- 10C/12114—40 pF.
- 10C/12384—25  $\mu$ F.
- 10C/12503—.1  $\mu$ F F.H.T.
- 10C/12574—1  $\mu$ F.
- 10C/12776—4  $\mu$ F 400 v.
- 10C/13194—8  $\mu$ F.
- 10C/13212—16  $\mu$ F 500 v.
- 10C/13258—4  $\mu$ F.
- 10C/13260—4  $\mu$ F.
- 10C/13364—.001  $\mu$ F.
- 10C/13408—4  $\mu$ F.
- 10C/13409—25  $\mu$ F.
- 10C/13624—2  $\mu$ F.
- 10C/14211—40 pF.
- 10C/14583—70 pF.
- 10C/14616—.5  $\mu$ F.
- 10C/14719—2 pF.
- 10C/14757—4 pF.
- 10C/14758—4  $\mu$ F 600 v. (paper).
- 10C/16071—560 pF.
- 10C/16072—.001  $\mu$ F.
- 10A/8496—.01  $\mu$ F.
- AP5073—4  $\mu$ F 350 v.

Basic Theory For Constructors

(Continued from page 981)

Resistance offered to the flow of current produces heat, just the same as heat is produced when a moving body is subjected to resistance or friction. Power is thus dissipated across a resistance in proportion to the current in it and the voltage across it. This power is measured in watts (W), and is the power rating unit of resistors.

Power Rating

Basically, the power in watts dissipated by a resistive circuit is equal to the voltage across the circuit multiplied by the current flowing through it, that is,  $W = I \times E$ . Let us take the simple circuit in Fig. 6. Here we have 100 volts across 100-ohm resistor, which gives a current of 1 ampere. According to the power formula, this means that the resistor is going to get pretty hot since it will dissipate 100 watts. It would be of the size, or larger, of a mains dropping resistor used in A.C./D.C. receivers, and would be wire-wound.

If a small wire-wound or carbon resistor were used in this circuit, it would very quickly overheat and burn out.

The power formula can be modified to suit various applications. Instead of writing  $W = I \times E$ , we can substitute  $E/R$  for  $I$ , as taken from the Ohm's law formula, which gives  $W = (E/R) \times E$ , which is the same as  $W = E^2/R$ .

Similarly, from the Ohm's law formula, we can substitute  $I \times R$  for  $E$ , which gives  $W = I \times I \times R$ , which is the same as  $W = I^2 \times R$ .

We thus have three power formulae,  $W = I \times E$ ,  $W = E^2/R$  and  $W = I^2 \times R$ . All of

these will be found to give the same power (100 watts) when applied to the circuit in Fig. 3.

Other simple transformations of the formulae which are useful for the constructor are:  $I = W/E$ ,  $I = \sqrt{W/R}$ ,  $E = W/I$ ,  $E = \sqrt{W \times R}$ ,  $R = W/I^2$  and  $R = E^2/W$ .

Another exercise will help. In Fig. 7 is drawn

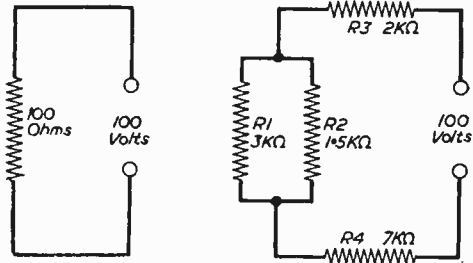

Fig. 6 (Left) and Fig. 7 (Right).—Circuits illustrating the calculations given in the text.

a simple parallel-series resistive circuit.  $R_1$  and  $R_2$  in parallel equal 1k, while  $R_3$  and  $R_4$  in series bring the total resistance to 10k. With 100 volts applied to the circuit,  $I = E/R$  reveals that the current in  $R_3$  and  $R_4$  is 0.01 ampere (10 mA), and by using  $W = I^2 \times R$ , it will be discovered that the power dissipated by  $R_3$  is 0.2 watt and by  $R_4$ , 0.7 watt.

From  $E = I \times R$  it will be found that 10 volts\* are present across the parallel combination  $R_1$  and  $R_2$ , so by using  $W = E^2/R$  it will be found that 0.033 watt is dissipated by  $R_1$  and 0.066 watt by  $R_2$ . In practice, 1/2-watt resistors would be used by all but  $R_4$ , which would possibly be rated at 1-watt.

# ILLUSTRATED CATALOGUE 1/- <sup>post</sup> 3d.

**BUILD A POCKET RADIO** with this latest deaf aid complete with crystal mike, on/off and volume controls, subminiature valves, etc., internal batteries, only 5 x 2 1/2 x 3/16 in., beautifully styled, offered complete with all required conversion items at the ridiculous price of 80/-.



**COMMUNICATION RECEIVER RI155.** This magnificent receiver covers 5 ranges: 75-200 kc/s, 200-500 kc/s, 600-1,500 kc/s, 3:7.5 Mc/s, 7.5-18.5 Mc/s. Fully tested before despatch. Complete with circuit and instruction booklet, £8.10.0. Carriage 10/-.

**BUILD AN F.M. TUNER** with this **MINIATURE 373 I.F. STRIP 9.72 MC/S.** Complete with 6 valves, 3 EF91, 2 EP92, 1 EB91, F.T.s, etc., supplied with circuit and complete conversion to F.M. Tuner details. The best buy of the year at 40/- with valves. 12/6 less valves. P. & P. 2/6.

**MICROPHONES. BRAND NEW.** Throat, magnetic, 4/6; No. 8 carbon with switch, 6/6; No. 7 moving coil, 8/6.

**SWITCHES. D.P.D.T. 2/6. P. & P. 6d.**  
**INFRA-RED MONOCULAR.** Ideal for night viewing, etc. Complete with push-button zamboni pile power unit and focus lens. Brand new in beautiful leather carrying case. Originally cost Govt. £40. OUR PRICE 17/6. P. & P. 2/6.

**VIBRATOR PACKS.** 12 v. input, 300 v. output at 150 mA., consist of 12 v. vibrator, 4 metal rectifiers, chokes and smoothing condensers, 25/- Carr. 7/6. 6 v. input, 230 v. output at 100 mA., complete with 4-pin vibrator, OZ4 rectifier. Fully smoothed, 25/- Carr. 3/6.

**PORTABLE AMPLIFIER, PRINTED CIRCUIT.** Size 6 1/2 in. wide, 2 1/2 in. deep, 3 in. high. Will suit all crystal pick-ups. Output 3 watts. Uses UCL82 output, UY85 rectifier. Volume and tone controls. With circuit diagram. **ONLY 45/-.** 7 in. x 4 in. elliptical speaker for above, 14/6.

**HEADPHONES. BRAND NEW.** American, chamois padded (as illus.), moving-coil 100 ohms, 25/- U.S.A. lightweight, Type H.S.30, 15/- Low resistance 120 ohms, 6/6. High resistance, 12/6. P. & P. 1/6 on each.



## PYE 10" EXN. SPEAKER

3 1/2 in magnificent cabinet. Complete with lead and plug. Brand new, 45/- Carr. 5/-.

## T.C.S. TRANSMITTER



Covering 1.5-12 Mc/s (160-80-40 metres) consists of V.F.O., Buffer, Doubler, P.A. with internal push/pull modulator, and provision for V.F.O. or crystal control on 4 channels. Output 40 watts phone, 100 watts C.W. Complete with aerial current and plate current meters.

In excellent condition. **£9.10.0** Carr. T.C.S. RECEIVER, 15/- £8.10.0. Carr. 15/-.

## RELDA TRANSFORMERS

Interleaved and impregnated. Primaries 200-230-250 v. 50 c/s.

250-0-250 v. 80 mA., 6.3 v. 3.5 a; 4 v. 4 a; 0-4.5 v. 2 a.	22/6
350-0-350 v. 80 mA., 6.3 v. 3.5 a; 4 v. 4 a; 0-4.5 v. 2 a.	22/6
250-0-250 v. 100 mA., 6.3 v. 3.5 a; 5 v. 2 a; 6.3 v. 1 a.	25/6
300-0-300 v. 100 mA., 6.3 v. 3.5 a; 5 v. 2 a; 6.3 v. 1 a.	25/6
6.3 v. 2.75 a. Filament transformers ... ..	7/6
0-12-15-20-24-30 v. 2 a. Filament transformers ...	20/6
0-5-11-17 v. 4 amps. Battery charger type ... ..	22/6

## SUPPLY UNIT No. 5

Contains Hand Generator giving 6 v. output with overload cut-out, ideal to boost a flat car battery; 6 volt Vibrator Pack giving 3 volts and 150 volts with output leads, plugs, etc., for Army 38 and 18 sets; Battery box for three 2 v. accumulators. This is a fully portable and multi-purpose power supply unit. BRAND NEW.



ONLY **30/-** Carr. Paid.

## POLICE-AIRCRAFT-HAM

**RECEIVER BC624.** 100-156 Mc/s, 12 valve Superhet, with R.F., 3 I.F.s, second det., and O.P. stages. Full operating details and circuits, etc. Only 30/- each. P. & P. 5/-. Mains Power Pack Kit, 42/6.  
**TRANSMITTER BC625.** 15W. Only 45/- each. P. & P. 5/-. Complete Trans/Receiver Assembly, 70/- Carr. 10/-.

## WALKIE/TALKIE SET

ONLY **60/-** EACH P. & P. 4/-



Consisting of transceiver covering 7.4-9 Mc/s, range up to 10 miles, complete with 5 valves, headphones, microphone, junction box & 6ft. telescopic aerial. Only requires 120 v. & 3 v., dry battery. These magnificent Walkie/Talkie sets (as used by H.M. Forces) are ideal for any application and can be operated with ease by young and old alike.

TWO FOR **£6** POST FREE.

## AERIAL VARIOMETERS.

These magnificent instruments will enable you to receive maximum signal strength on all Short Wave receivers. Precision calibrated control. Complete with connection details. 12/6. P. & P. 2/6.



**AMERICAN ROTARY CONVERTOR.** With cooling Fan. Input 12 v. D.C. Output 250 v. at 90 mA. Completely suppressed. Ideal for running car radio, electric shaver, etc., from battery. Only 17/6. P. & P. 3/6.  
**MALLORY 12 v. 4-pin VI-BRATORS.** Brand new, 2/6. P. & P. 1/-.

**WESTINGHOUSE 1.50 PEN-CIL RECTIFIERS.** 500 v. 5 mA.. 5/- P. & P. 1/-.

**WIRELESS SET No. 19 Mk. II.** This famous Transmitter-Receiver incorporates "A" Set -TX/RX covering 2-8 Mc/s (37.5-150 metres), "B" Set -VHF TX/RX covering 230-240 Mc/s (1.2-1.3 metres) and intercom. amplifier. Complete with 15 valve 500 micro-amp check and tuning meter, circuits and instruction book (American manufacture), £5/- Carr. 10/- or complete with all attachments, 12 v. supply unit, variometer, control box, aerial, phones, mike, £6.10.0. Carr. 20/-.

**METERS.** 0-1 mA. 2in. square. 22/6. 500 micro-amp. 2in. circular, calibrated 0-15 and 0-600 volts, 17/6. 1 amp. H.F. 2in. circular, 5/6. P. & P. 1/6 on each.  
**TELEPHONE HANDSET.** Brand new, 12/6. P. & P. 1/-.  
**12 v. SUPPLY UNIT.** Output 150 v. at 65 mA. and 40 v. at 35 mA. Brand new. Only 12/6. P. & P. 3/6.

**ARMOUR RECORDING WIRE.** U.S.A. top quality on original reels. Length 3,700 yds., 8/6. P. & P. 1/6.

**U.S.A. WHIP AERIALS.** 12ft., 12/6. Post Paid.

**AMERICAN MIDGET ACCUMULATORS.** 36 volts, lead acid type, 2/6 ea. P. & P. 1/-.

**PLESSEY SPEAKERS.** 7in. x 4in. elliptical 3 ohms. 5in. circular 3 ohms, 14/6 ea. P. & P. 1/6.

**ACCUMULATORS.** 2 volts 16 A.H. (unspillable). Ideal for 6 and 12 volts supply, etc. Brand new. Original cartons. Size 4in. x 7in. x 2in., 5/6 each. P. & P. 1/6. 3/6 for 15/- P. & P. 3/6. 6 for 27/6. P. & P. 5/-.



32a, COPTIC STREET, LONDON, W.C.1.  
and  
87, TOTTENHAM CT. RD., LONDON, W.1.  
Telephone: MUSEUM 9607.

All post orders and correspondence to:  
(Dept. 'P') 32A, Coptic Street, London, W.C.1.

Visit the City's new acoustically designed

# HI-FI Centre

COME AND HEAR THE LEADING MAKES IN AMPLIFIERS AND TUNERS

#### AMPLIFIERS BY

VERDIK  
ARMSTRONG  
ROGERS  
DULCI

GOODSELL  
QUAD  
LEAK  
W.B., etc.

#### V.H.F. TUNERS BY

ARMSTRONG  
LEAK  
QUAD

ROGERS, etc.

#### T.S.L.

DULCI  
GOODSELL

#### HI-FI SPEAKERS BY

GOODMAN  
PLESSEY  
WHARFEDALE  
LORENZ, etc.

W.B.  
T.S.L.  
G.E.C.

## A GIFT FOR THE SERVICE MAN BRAND NEW IN WOODEN CASE

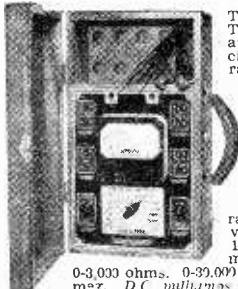

The Weston Model 772 Type 6 super sensitive analyser. This precision designed multi range test instrument has a large visible finely divided scale giving some of the range shown. Range: D.C. volts 20,000 ohms per volt or 1,000 per volt. 2.5 volt range 50,000 ohms. 10 volt range 200,000 ohms. 50 volt range 1 megohm. 250 volt range 5 megohms. 1,000 volt range 20 megohms. Ohms: 0-3,000 ohms. 0-30,000 ohms. 0-3 meg. 0-30 meg. D.C. milliamps. 10, 50, 250 I.M.A. or 50 microamps. A.C. volts: 1,000 ohms per volt. ONLY £12.10.0. plus post and pkg. 7/6.

Collaro Mk. 111 tape transcriber deck, with Digital Counter, Twin Track 3 speed, Pause Control, Brand new and Guaranteed. Limited number at 15 gns. Carriage & Packaging 12/6. Suitable tape amp. with magic eye. 12 gns.

Collaro 41,200 transcriber motor. Turntable and Studio Turnover Crystal PUP using the new TX88 Styli. Brand new in manufacturers' carton. Our Price, £16.19.6. Carriage & Packaging, 7/6.

## LESS THAN HALF PRICE

A REPEAT OFFER AT A STILL GREATER REDUCTION Limited quantity of this famous maker's 9" tube, round face white fluorescent 4V heater. 1A heater current. Max. Anode voltage 7 KV. Now Only 24/17.6. Coating and Carriage 11/6.

# Electronics (FLEET ST.) Ltd

Dept. E, 152/3, FLEET STREET, LONDON, E.C.4  
Business Hours: Weekdays 9-6. Saturdays 9-1. Tel.: FLEet 2833

## SOLDERING EQUIPMENT

BY



### PRECISION SOLDERING INSTRUMENTS for the ELECTRONICS INDUSTRY

- Comprehensive range
- Robust & Reliable
- Light weight
- Rapid heating
- Bit sizes 3/32in. to 3/8in.
- 'Permatit' or Copper bits
- All voltage ranges 6/7v. to 230/250 v.
- Prices from 19/6

Illustrated is the 25w. 3/16in. replaceable bit model with safety shield.

British and Foreign Patents. Registered designs. Suppliers to H.M. and Foreign Governments. Agents throughout the world.

Brochure No. S.10 sent free on request.

Sole proprietors and manufacturers:  
**LIGHT SOLDERING DEVELOPMENTS  
LIMITED**

106 George Street, Croydon, Surrey.  
Phone: CROydon 8597 Grams: Litesold Croydon



## REPANCO

### HIGH GAIN TRANSISTOR COMPONENTS

#### STANDARD RANGE

Ferrite Slab Aerials Type FS2. Designed for Long and Medium Wave reception with transistor portable superhet receivers. Slab size 5 1/2 in. x 3 in. x 5/32 in. Complete with fixing brackets, 13/6. Combined Oscillator and 1st I.F. transformer Type OT1. 13/16 in. sq. x 1 1/2 in. I.F. Frequency 315 Kc/s., 11/6. 2nd I.F. Transformer (315 Kc/s.) Type TT2, 5/-. 3rd I.F. Transformer (315 Kc/s.) Type TT3, 5/-. I.F. Transformers enclosed in iron dust pots with slug tuning. Push Pull Interstage Transformer Type TT4. Ratio 1 : 1 C.T. Stack size 1 3/4 in. x 1 1/16 in. x 7/16 in., 8/6. Push Pull Output Transformer Type TT5. Ratio 15 : 1 C.T. Size as TT4. Matched to 3 ohm speaker, 8/-.

#### MINIATURE RANGE.—For pocket receivers.

Ferrite Slab Aerial Type FS3. Medium Wave only. With fixing grommets. Size 3 in. x 3 in. x 5/32 in., 7/6. Oscillator Coil Type XO8. Medium Wave only. Overall size 3/4 in. dia. x 1 in. Enclosed in Ferrite pots, 5/-. I.F. Transformer Type XT6. Suitable for 1st and 2nd I.F. 455 Kc/s. Size 3/4 in. sq. x 1 1/16 in., 10/-. I.F. Transformer Type XT7. Designed for 3rd I.F.T. or detector I.F.T. 455 Kc/s. Size as XT6, 10/-. Push Pull Interstage Transformer Type TT9. Ratio 1 : 1 C.T. Radiometal Core. Size 3/4 in. x 3/4 in. x 13/32 in., 12/6. Push Pull Output Transformer Type TT10. Ratio 8 : 1 C.T. Matched to 3 ohm speaker. Size as TT9, 12/6. Practical and Theoretical circuits enclosed with each Repanco Transistor Component.

**JUST RELEASED. "THE MAJOR-7"** a new portable transistor receiver. Size 9 in. x 7 in. x 4 in. Send 1/9 P.O. for instructions.

Mail Order and Trade:  
**RADIO EXPERIMENTAL  
PRODUCTS, LTD.**  
33 Much Park St.  
COVENTRY  
Tel.: 62572

Wholesale Enquiries and Export:  
**REPANCO, LTD.**  
O'Brien's Buildings  
203-267 Foleshill Rd.  
COVENTRY  
Tel.: 40594

# Car Radio in Kit Form

A REASONABLY PRICED RADIO THAT IS SIMPLE TO CONSTRUCT

**A** NEWCOMER to the D.I.Y. movement is a car radio kit that is supplied by Mayra Electronics Ltd., 551, Holloway Road, London, N.19. We recently had a complete kit for assembly and the easy-to-follow instructions which are supplied with the parts makes it possible to build the radio and loudspeaker chassis in three to four hours.

## New Hybrid Design

Of new hybrid design

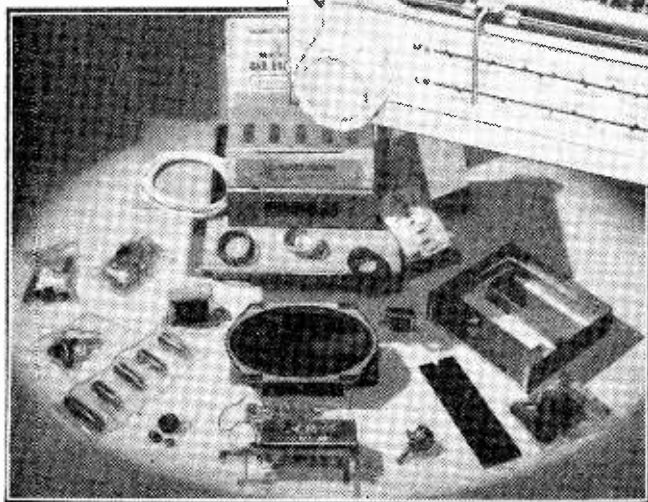

the receiver uses a transistor with five special Brimar 12 v. valves which gives exceptional power output with negligible fade (even under bridges). The R.F. stage ensures level volume under all conditions.

The radio is for 12 v. operation only with a low current consumption of 1.5 amps. The elliptical speaker measures 7in.  $\times$  4in. and gives exceptionally good tonal quality. It has two-knob control, the knob shown on the right of the illustration being for tuning and for changing the waveband (pull out for long waves) and the knob on the left is the on-off switch and volume control.

## Various Stages

The receiver measures 8in.  $\times$  7in.  $\times$  2½in. and will fit all modern cars. The price of the kit for the complete receiver is £13 10s., and an aerial, if required, costs £1 13s. The kit comprises four stages each of which can be purchased separately if desired. Stage 1 which includes a printed circuit panel including resistors, valve, condensers and transformer costs £5 19s. 6d. (postage and packing 1s. 6d. each). Stage 2 contains general chassis

assembly, including tuner units complete, volume control, dial sockets, screws, etc., costs £5 17s. (postage and packing 2s. extra). Stage 3 contain-

*The illustration shows the kit of parts. The receiver has two-knob control, the one on the right being for tuning and for changing the waveband (pull out for long waves), and the one on the left being the on-off switch and volume control.*

ing filter box assembly, including chokes and metal box costs 7s. (postage and packing 1s. extra). Stage 4 includes 7in.  $\times$  4in. elliptical speaker output stage with transistor, transformer, sub-chassis and plug costs £2 6s. 6d. (postage and packing 1s. 6d. extra). The above items should be purchased in the order indicated so that the set can be built up in the simplest manner.

## Tools Required

The set can be constructed using only the following tools: electric soldering iron, small screwdriver, pair of cutters, medium-sized screwdriver, pliers and razor blade.

An electric soldering iron with a fine bit is essential when wiring the printed circuit board and these are also available for 12 v. or mains operation from the above firm together with the other tools mentioned if required.

When installed it is essential to fit suppressors to the engine and a complete suppressor kit together with fitting instructions can also be supplied by Mayra Electronics Ltd.

## NEWNES RADIO ENGINEER'S VEST POCKET BOOK

By F. J. CAMM

6/-, or by post 6/4

Obtainable from booksellers, or by post from George Newnes, Ltd. (Book Dept.), Tower House, Southampton Street, Strand, W.C.2.

# NEWS FROM THE TRADE

LATEST DEVELOPMENTS  
IN RECEIVERS AND  
COMPONENTS

## TERMINAL BLOCK AND CROCODILE CLIP

CREATORS LTD., Sheerwater, Woking, Surrey, announce their new Faston A-MP type terminal block, which is available in various lengths up to 20-ways, and has been specially designed for use with A-MP type crimped terminals. These

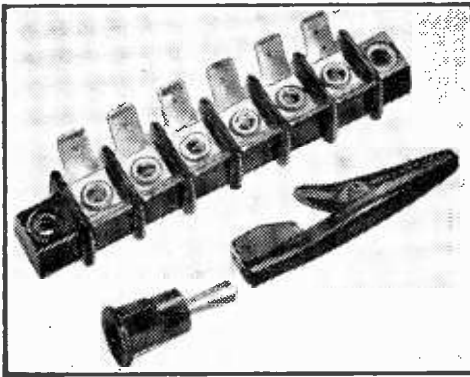
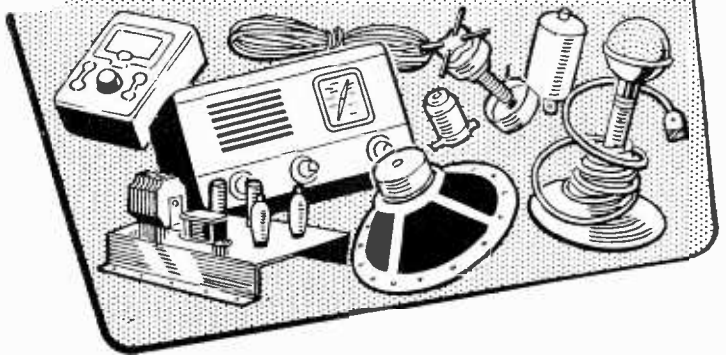

Terminal block and new type crocodile clip.

blocks accommodate in each way an insert having from two to six tags. Various types of tag are available. Prices vary from 1s. to 5s. each, according to quantity and the type of tag.

The crocodile clip, also shown on the illustration, is made of polystyrene with a brass insert. Connections can be made to the body of the clip by any standard single stem plug, thus obviating the necessity for an insulated shroud. The overall length of the clips is 2in. These clips, being of plastic, are rust-proof, which makes them particularly suitable for outside applications. Prices are 1s. each and the clips are available in black or red.

## NEWMARKET PRICES

THE Intermediate Power Transistor, which was introduced by Newmarket Transistors Ltd., Exning Road, Newmarket, Suffolk, in April this year, has now been reduced in price by more than one-third. Increases in efficiency and production in the Newmarket factory have reached the stage where it is

possible to pass on this price reduction to the customer. It is now hoped that the intermediate power types V60/201P, V30/201P and V15/201P will obtain wider usage in many applications including R.F. transmitters, domestic receivers and D.C. converters.

## "STENTEREO" LOUDSPEAKER SYSTEM

AT the Autumn Audio Fair, held in Harrogate in October last year, Whiteley Electrical Radio Co. Ltd., of Mansfield, Notts, introduced a stereophonic loudspeaker system called the W.B. "Stentero" System. It consists of two corner loudspeaker enclosures which embody many novel features. The enclosures are divided into two sections, the lower section taking the form of an infinite baffle into which may be fitted a W.B. Stenterian loudspeaker type H.F.810 or H.F.812. In the upper section of the cabinet

(Continued on page 1011)

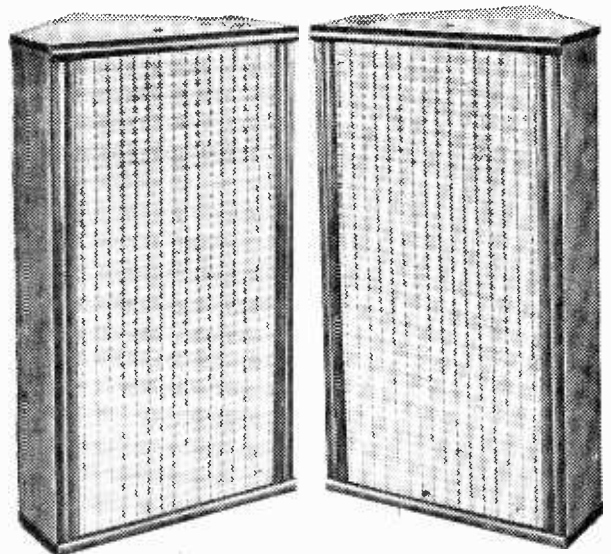

W.B. "Stentero" System consisting of two loudspeaker enclosures.

**WONDERFUL OFFER OF A.M.-F.M. CHASSIS AT £14 (P. & P. 10/-)**

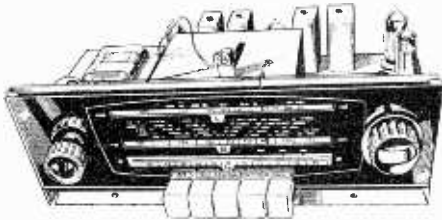

Why buy a F.M. Tuner at the same price? Tapped input 220-225 v. and 226-250 v. A.C. ONLY. Chassis size 15" x 6 3/4" x 5 1/2" high. New manufacture. Dial 14 1/2" x 4" in gold, red and deep brown. Pick-up, Extension Speaker, Ac., E. and Dipole sockets. Five "piano" push buttons—OFF, L.W., M.W., F.M. and Gram. Aligned and tested. With all valves & O.P. Transformer. Covers 1,000-1,900 M.: 200-500 M.: 88-99 Mc/s. Valves E280 rect., ECH81, EF89, EABC80, EL84, ECC85. Speaker & Cabinet to fit, polished, with back, 70/-.  
**10" x 6" ELLIPTICAL SPEAKER, 20/-.**  
**TERMS:—(Chassis) £5 down + carr. and 5 Monthly**  
**down + carr. and 6 Monthly Payments of £2.**

Payments of 38/-, or with Cabinet and Speaker £6 down + carr. and 6 Monthly Payments of £2.

**HIGH GAIN I.T.A. CONVERTER ONLY £4.7.6.**  
(3/- p. & p.).

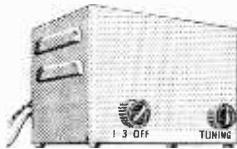

All areas, all sets except Philips with only twin feeder input. Internal power pack; direct switching I.T.A. to B.B.C. NO ALTERATION TO YOUR SET. Fitted in 10 mins. Valves ECC81; fine tuner. (A.C. only.)

**GENERAL-PURPOSE AMPLIFIER** using 6K6 and two 6K7 valves. Rexine carrying cabinet 13" high x 12" x 5". Two inputs, 4 controls. Vol. (1st input); vol. (2nd input); treble tone; base tone. 200-250 v. A.C. double-wound transformer; 3 w. from 8" speaker; metal rectifier. Bargain price of **£4.15.0 (5/- carr.)**. Brand New, as are all goods offered by us.

**BATTERY CHARGER, 1 amp. 6 v. and 12 v., £2.**

**EXPANDED METAL ALUM. GRILLES.** 24" x 18" at 5/- (p. & p. 2/6 any quantity). 24" x 12 1/2", 3/9. (post 2/- any quantity).

**ADMIRALTY TIMEBASE UNIT** (unused) in cast box. 10 valves: 6 EF50 and 1 each VR54, VR92, VU120 and 5Z4G. Resistors (36), potentiometers (8), block condensers (4), etc. etc. New condition in original waterproof transit case. Only **52/6**. Plus **7/6 carr.**

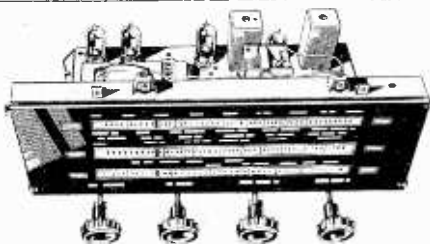

**OFFER OF RADIOGRAM CHASSIS.** Chassis 13" x 7 1/2" x 8" high. Covers 800-2,000 M.: 190-550 M.; 18-55 M. Mains trans. 200/210; 220/230 v.; 240/250 v. A.C.; Gram. socket and Aer. and Ea.; with o.p. trans.; 4 knobs: On-off/Tone; Vol.; W.ch.; Tune. With new Mullard valves: ECH81; EBF80; EF41; EL41; EZ40. Dial 13" x 5". ONLY **£7.15.0 (7/6 p. and p.)**. Fully guaranteed. Cabinet and 6 1/2" Speaker, **62/-**.

**LOUDSPEAKERS—VERY SPECIAL OFFER!**—Rola 10,000 line (2-3 ohm), 3 1/2" square, 15/- (1/-); 8" x 5" Celestion elliptical 20/- (1/6); 6 1/2" circ. 14/6 (1/6); 5" circ. 13/- (1/6); 5 1/2" with trans. 15/- (1/6); all 2-3 ohm. (p. & p. in brackets). **BRAND NEW.**

**GLADSTONE RADIO—25,**  
**82B, High Street, Camberley, Surrey, Tel.: 2633;**

**AUTOMATIC RECORD CHANGERS COLLARO CONQUEST** with manual play also. Turnover crystal pick-up, 4-speed, A.C. mains 200-250 v., see illus. ALSO Collaro single player AC1/554, 4-speed, turnover crystal pick-up with "T" head, **£6.16.6 (3/6 p. & p.)**.



**£8.15.0 (5/- p. & p.)**

**AERIALS.** I.T.A. for clipping to existing mast 1" to 2" dia. or for wall mounting (state which), 3-element, 27/-; 5-el., 35/-; 9-el., 55/-; combined single B.B.C. and 4-el. I.T.A. with chimney lashings, 75/-; FM Aerials single dipole room mtg., 17/6; ditto loft mtg., 20/-; "H" with chimney lashings, 65/- Co-axial low loss cable 8d. yard or 20 yds. 12/6, all these items carriage paid.

**GRAMOPHONE AMPLIFIER** with 5in. SPEAKER. On Fabric-covered Baffle 12 1/2" x 5". Mains and Output Transformers. Metal Rectifier. ECL82 Valve. Tone and Volume Controls. On-off switch. Plenty of Volume. Fully Guaranteed. Two Knobs supplied. Ready to play. ONLY **60/- (Post 3/-)**.

**BUILD YOUR OWN RECORD PLAYER AT COST OF £8.2.0.** Rexine cabinet to take above amplifier, 42/- (post 3/6); B.S.R. Regent 3-speed single player to fit cabinet, 60/- (post 3/6); all items supplied separately. Carr. on all 3 items ordered together, 4/6. Completed player as above, **£9.15.6 (carr. 4/6)**.

**UNIC SHAVERS** (Swiss) again available at **£7.17.6**. Year's guarantee. Order with confidence. 200-240 v. a.c. **WRITE FOR LEAFLET.**

**BATTERY ELIMINATOR.** Converts your Battery Set to Mains. For 4 Low Consumption Valves (DK96 range). 90 v. 15 ma. and 1.4 v. 250 ma., **42/6 (2/6 post)**. 200-250 v. A.C. Size 5 1/2" x 3 1/2" x 2".

Send 6d. (stamps will do) for our illustrated catalogue of the above items and others.

Posted Orders to Worthing, please. Delivery by return.

Terms:—One-third down and balance plus 7/6 in four equal monthly payments. Postage with down payment. (C.O.D. 2/- extra.)

**SEE SPECIAL TERMS FOR A.M./F.M. CHASSIS.**

Wordsworth Road, Worthing, Sussex, Tel.: 235;  
 3, Church Road, Redfield, Bristol, 5, Tel.: 51207.



# Printed Circuit reliability for the Mullard **3** AMPLIFIER STRAIGHT OR STEREO

FIRST-TIME EVER  
TO BE APPROVED  
TO MULLARD  
SPECIFICATION



### Performance Details

Frequency response virtually linear  
from 20 to 30,000c.p.s.  $\pm$  1db.  
Tone Control —  
Max. Bass boost—15db at 70c.p.s.  
Max. Treble cut—20db at 10,000c.p.s.  
Overloading occurs at about 3.5w.  
Hum and noise at least 70db below 3w.  
Sensitivity—Radio—100m/v for 3w.  
Gram—100-150m/v for 3w.  
Dimensions of amplifier chassis—  
4 1/8" x 7 1/2" x 3 1/2"



- NO WIRING
- ★ SPEEDS ASSEMBLY
- ★ REDUCES SIZE
- ★ ENSURES ACCURACY
- ★ COMPLETE DATA SHEET for only

Bribond Printed Circuits revolutionise chassis assembly, providing error-free connecting without wiring and component deck ready drilled. Size is under half that of conventional assembly as smaller components are used. Complete absence of wiring ensures maximum efficiency on first test! You can build this famous amplifier with Bribond help. You need only a screwdriver and soldering iron. Bribond supply the printed circuit for only 15/- post paid and full component list with assembly instructions for amplifier and power pack for only 1/6. Send now for this data and see how easy printed circuits make it. Use the coupon below today!

**Two in tandem provide stereo**  
Two Mullard 3/3 Amplifiers provide twin-channel reproduction for stereophonic sound (with a larger transformer in the Power Pack) giving 6 watts total output. So if you build one 3/3 Amplifier now, you can extend to stereo whenever you wish! Bribond also make a Printed Circuit base for the Mullard 5/10 Amplifier, too! Complete Data Sheets are available for these for 1/6 each. It pays to contact Bribond and be really up-to-date in construction methods!

## 1/6 BRIBOND PRINTED CIRCUITS

To BRIBOND LTD., BURGESS HILL, SUSSEX  
Please send Printed Circuit Component/Assembly Data for—  
 Mullard 3/3 Amplifier & Power Pack  
 Mullard 3/3 Twin Channel Stereo  
 Mullard 5/10 Amplifier

for which I enclose P.O. for ..... (1/6 each)  
Name .....  
Address .....

## Build your own TAPE RECORDER "ASPDEN"

Tape Deck and Amplifier Kits

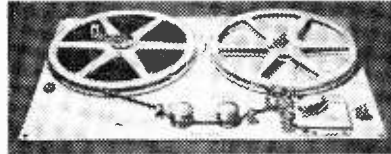

TAPE DECKS. 2-speed, twin track, easy to assemble kits with finest motor. Ferroxcube heads and full instructions.  
Model 582 for 5in. spools, kit £8.5.0.  
Model 782 for 7in. spools, kit £9.5.0.  
Either model assembled and tested, 30/- extra.

AMPLIFIER kit, 2! watt, record/replay, 2 recording positions, neon indicator, etc., £5.18.0. Power Pack kit for above, £2.18.6 (both without valves). Carr. and packing extra.

You can obtain high quality as Mr. E. T. of Sussex, who writes:—  
*'The performance is very good, in fact some of my friends say that it is equal to any of the more expensive recorders.'*  
At a very low price, as Mr. R. C. K. of Durham, who writes:—  
*'Many people who have heard it have been staggered that such quality can be obtained for such a low price.'*

Build your recorder now.  
Send STAMP for full particulars to:—  
**W. S. ASPDEN** Stanley Works, Clevedon Road, Blackpool, Lancs.

## RST

MAIL ORDER DEPARTMENT  
211 Streatham Road, Mitcham, Surrey.  
ALL VALVES LISTED ARE NEW STOCK  
• Terms C.W.O. or C.O.D. Postage 3d. per valve.  
MITCHAM 6201.

AZ31 10/6	EF85 7/6	N153 11/3	UF41 9/-	6K7 4/6
B65 8/6	EF86 12/-	N154 11/3	UF80 10/-	6K7GT 10/-
DAF91 9/-	EF89 10/-	N727 8/6	UL41 9/6	6K1GT
DAF93 9/6	EF91 8/6	PCC81 11/6	UL44 8/6	12/6
DD260 10/6	EF95 14/-	PCF80	UY41 7/6	6L1 17/6
DF91 8/6	EL42 10/-		UY85 8/-	6L6G 7/6
DH719 9/6	EL84 9/-	PCF82	VP4B 17/6	6L18 12/6
DK91 9/-	EL90 8/6	PCL92	WB1M 8/6	6L19 21/6
EABC39	EM80 10/-	PCL92	W142 8/-	6N7G/GT
EAF42 10/6	EM81 11/6	PCL83	W719 8/6	8/-
EB91 5/9	EY81 10/-		W727 8/6	6SL7GT
EBC41 9/3	EY94 13/-		X78 19/-	7/6
EBP30 8/6	FY86 14/6	PENA4	X79 11/9	6SN7GT
EBP83 8/6	ET91 9/-	PEN4VA	Z21 10/6	8/6
EC91 8/9	EZ35 18/6		Z27 10/6	6X5GT 8/6
ECC33 8/6	EZ40 8/-	PL36 15/-	Z32 8/6	7S7 12/6
ECC31 8/6	EZ41 10/6	PL42 10/-	Z152 8/6	7Y4 7/6
ECC81 8/6	EZ90 8/-	PL82 8/-	Z219 8/6	8D3 8/6
ECC83 8/6	EZ91 8/-	PL83 14/-	1R5 9/-	10LD11 9/-
ECC84 10/6	FC2 18/6	PL83 14/-	5Y3GT 8/6	14/6
ECC85 10/6	FC4 23/6	PY80 13/3	SZ4G 10/-	12AH10 10/6
ECF30	FC13 14/6	PY81 9/6	6A8GT	12AT6 8/9
	FC130 19/6	PY82 8/6		12AT7 8/9
ECF32 12/6	GZ32 13/6	RY3 8/6	6AL5 5/9	12AU7 8/9
	H30 4/9	R10 22/-	6AM6 9/-	12AX7 8/6
ECH35 12/6	H63 10/-	R19 19/6	6AN5 8/6	12BA6 8/6
	HLBC90 8/-	TDD4 15/-	6AQ5 7/6	12BE6 9/3
ECH42 9/6	HL92 11/6	TP22 12/6	6BA6 8/6	12BH7 10/-
ECH81 9/6	HL13DD	U142 8/6	6BE6 8/3	12J7G/GT
ECL80 9/6	KT30C 11/6	U147 9/9	6BJ6 7/6	10/6
		U83 9/6	6BT7 12/-	
ECL32 12/6	KT33C	UACB80	6BW6 8/6	12K7GT
			6BW7 8/6	10/6
EF37A 13/6	KT66 18/6	UAF42.0-	6BX6 9/6	12K8GT
	LZ319 12/6	UBC41 8/6	6D2 5/9	12Q7 12/3
EF40 10/3	MKT(5)	UBC40 9/6	6E9 8/6	12Q7GT 8/6
EF41 9/6	(or 7) 21/-	UCH2	6F1 19/6	8/6
EF42 12/-	ML4 12/6	UCH1	6F12 8/6	35Z4GT 8/6
EF30 (A)	MSP4 15/-	UCH8	6F13 18/6	8/6
	MU14 10/-	UCL83	6J5G 6/6	8/6
EF80 4/6	MX40 15/-		6J7GT 10/-	50L6GT 10/6
	N142 9/6			10/6

Quotations given for any types not listed. Obsolete and old types a speciality. Send for lists.

a type S.510 loudspeaker can be used and the two loudspeakers are coupled by means of a cross-over unit type CX.1500. Provision is made in the upper section of the cabinet for rotating the H.F. loudspeaker on its baffle, so as to obtain the best stereo effect. (A single cabinet may be used for single channel listening.) The unit is 22in. high, 12½in. wide and 10in. deep. The total cost is £14 12s. 3d. for each cabinet, using the H.F.810, and using the H.F.812, each cabinet would cost £15 13s. 9d.

### COAXIAL CABLES

**AERIALITE LTD.**, Castle Works, Stalybridge, Cheshire, inform us that the price of their Aeraxial cable, Cats. 597 and 598 is now 9d. per yard, retail.

### A MIXER UNIT

**PENCO PRODUCTS**, King's Langley, Herts. announce the "Epigram" transistorised pre-amplifier and mixer unit, which has been designed to provide mixing facilities for three channels and is intended for the more serious user of tape recorders and amplifiers. There are three inputs: two for low impedance (15 to 30 ohms) and one for high impedance. There are four controls on the panel: three gain controls, one for each channel, and an on/off switch.

The input sockets at the rear accept standard jack plugs and the output is taken from a standard coaxial socket, and normally is of high impedance. The output lead is supplied with a coaxial plug at one end and screened jack plug at the other and is approximately 1 yard long.

Input matching transformers are not used in the unit and microphony is avoided by the use of transistors. A 4-volt mercury cell is the power supply and as the current consumption is low, the battery has long life. The use of a battery eliminates mains hum which is often a problem in pre-amplifiers. No tone controls are provided on the standard models since these will normally

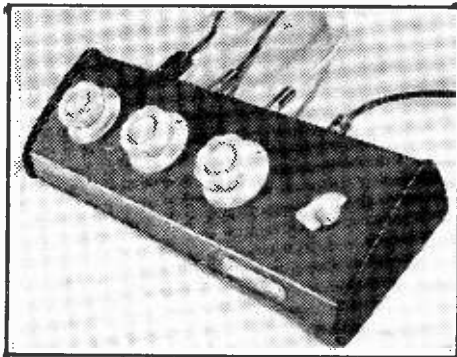

"Epigram" transistor mixer unit.

be present on the existing equipment. This modern-style unit, some 14in. long, is finished in light-coloured stove enamel, with large cream control knobs.

There are two standard models: the MIX/3, at 19 guineas, uses three transistors and feeds into

the high impedance, microphone input of a tape recorder or amplifier. The MIX/35, at 25 guineas, uses five transistors to give a greater output signal.

### "DOMINO" MINIATURE UNITORS

**MORE** details are now available regarding the range of "Domino" miniature Unitors originally introduced by Belling & Lee earlier in the year.

These miniature Unitors have been designed for use on small equipment where space and weight considerations prevent the use of the standard Unitor.

There are three basic plug and socket versions comprising two 8-way types (one with four small and four large pins, the other with eight small pins) and one 12-way type. Surface and flush

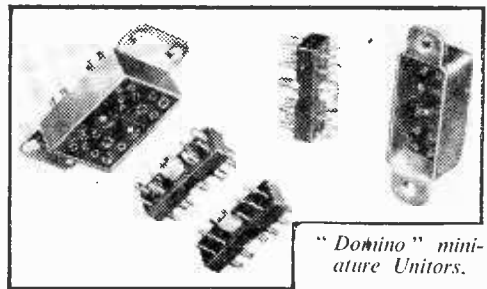

"Domino" miniature Unitors.

mounting metal shrouds are available to accommodate one, two or three Unitors, thus giving a wide choice of pin combinations and arrangements.

Body mouldings—which are of black, moisture and tracking resistant phenolic material—are coded on each side of both plugs and sockets to facilitate wiring and fault finding.

Plug pins are formed from brass and supplied either gold- or silver-plated. Socket pins are of beryllium copper, slotted to ensure good contact with the plug member. Each assembly has a locating centre pin which polarises the plug on engagement, and an 8 B.A. stud is provided for mounting the Unitor on chassis or panel. (Belling & Lee, Ltd., Enfield, Middlesex.)

### ANTI-STATIC RECORD CLEANING KIT

**THE** Chemicals Division of Thorn Electrical Industries, announce that they have commenced production of a record cleaning kit, to be marketed under the brand name "EXstatic."

The kit comprises a special polythene atomiser bottle containing "EXstatic" cleaning fluid and a foam-plastic pad for distributing the fluid evenly over the record. The pad is non-hardening and can be easily washed. The fluid gives powerful anti-static treatment and safely removes the fine abrasive particles which may be found in the micro-grooves.

The bottle and pad are contained in a small attractive compact. The complete outfit retails at 3s. 6d. and supplies sufficient fluid to treat up to 200 sides of 12in. L.P. records. Thompson, Diamond and Butcher have the sole agency for this product in England and Wales, and their address is 5-9, University Street, London, W.C.1.



#### NORTHAMPTON SHORT WAVE RADIO CLUB

Hon. Sec.: J. Tate (G3LGT), 57, Edinburgh Road, Northampton.

At the Annual General Meeting, the following officers were elected: President, B. Sykes (G2HCO); Chairman, I. C. Millar; Vice Chairman, M. Perry (G2ANS); Treasurer, B. Cadd; Hon. Sec., J. Tate (G3LGT); and Committee Member, S. Befridge (G3ITW). The meeting also voted that the annual subscription remains at 7s. 6d., and meetings continue to be held at 8, Duke Street, each Thursday. Prospective members and visitors are always welcome.

#### SPEN VALLEY AMATEUR RADIO SOCIETY Affiliated R.S.G.B.

Hon. Sec.: Norman Pride, 100, Raikes Lane, Birstall, W. Leeds.

The above club are holding their Annual Dinner, at Hagenboch's Café, Dewsbury on Saturday, January 24th, at 6.30 p.m. There will be the usual attractions. The Guest Speaker will be Mr. I. C. I. Lamb, Station Engineer of the Emley Moor Transmitter of the Independent Television Authority. Entertainment will be provided by members of the Society. Tickets, price 11s. 6d. each, are obtainable from the Social Secretary, Mr. J. J. Rose, 14, South View Terrace, Hill Head, Dewsbury.

#### Correction

The fixtures under the heading of The Bradford Amateur Radio Society given in the January issue should have been under the heading of the above society.

#### THE BRITISH INSTITUTION OF RADIO ENGINEERS

The following Institution meetings will be held during January:—

*London*.—At London School of Hygiene and Tropical Medicine, Keppel Street, Gower Street, W.C.1.

Friday, January 23rd, 6.30 p.m. Inaugural meeting of the Institution's Medical Electronics Group. An Address will be given by Professor A. V. Hill, C.H., M.A., Sc.D., F.R.S.

Wednesday, January 28th, 6.30 p.m. Papers on Mechanical Speech Recognition: "Theoretical Aspects of Mechanical Speech Recognition," by Professor D. B. Fry, Ph.D.; "The Design and Operation of the Mechanical Speech Recogniser at University College, London," by P. Denes.

*Bristol*—South Western Section.  
Thursday, January 29th, 7 p.m. "Recent Developments in Printed and Potted Circuits," by H. G. Manfield. At the School of Management Studies, Unity Street, Bristol. 1.

*Cardiff*—South Wales Section.  
Wednesday, January 14th, 6.30 p.m. "Computer Control of Machine Tools," by H. Ogden, B.Sc.(Eng.). At Cardiff College of Advanced Technology.

*Edinburgh*—Scottish Section.  
Friday, January 16th, 7 p.m. "Satellite Development and the Moon Rocket," by P. H. Tanner, B.Sc. At the Department of Natural Philosophy, The University, Drummond Street, Edinburgh.

*Glasgow*—Scottish Section.  
Thursday, January 15th, 7 p.m. "Satellite Development and the Moon Rocket," by P. H. Tanner, B.Sc. At the Institution of Engineers and Shipbuilders, 39, Elmbank Crescent, Glasgow.

*Malvern*—South Midlands Section.  
Thursday, January 29th, 7 p.m. "Industrial and Underwater Television," by B. V. Somes-Charlton. At the Winter Gardens, Malvern.

*Newcastle-on-Tyne*—North Eastern Section.  
Wednesday, January 14th, 6 p.m. "The Design and Construction of an Electronic Digital Computer," by R. W. Walker. At the Institution of Mining and Mechanical Engineers, Neville Hall, Westgate Road, Newcastle-on-Tyne.

*Wolverhampton*—West Midlands Section.  
Wednesday, January 21st, 7.15 p.m. "Learning Machines," by P. Huggins. At the Wolverhampton and Staffordshire College of Technology, Wulfruna Street, Wolverhampton.

#### THE LONDON SHORT WAVE CLUB

Hon. Sec.: K. R. Piper (G3LOO), 2, Catherina Terrace, Stockwell, S.W.8.

REGULAR weekly meetings are now being held, and quite good attendances are being obtained. We would, however, welcome more members, and visitors.

The Club station should be operational by the time these notes appear, under the club call G2CLR. Activity is at present on Friday only, between 7.30 and 9.30 p.m. all bands from 80 to 10 metres. During the teething period we would appreciate reports from any source, direct to the Secretary or via QSOs.

January 16th. G3MEO.T will be giving a demonstration of amateur TV equipment. This will be an informal "do," questions welcomed.

January 30th (provisional). Cossor lecture on test equipment including oscilloscopes.

Alternate weeks will be devoted to items of internal interest, and instructional features. C.W. class, etc.

#### HALIFAX & DISTRICT AMATEUR RADIO SOCIETY

Hon. Sec.: A. Robinson, G3MDW.

At the monthly meeting of the above Society held at the Sportsman Inn on December 2nd, 1958, there was a very good attendance of members to hear a lecture on crystal microphones by Mr. Newman, of Keighley, who illustrated his lecture by the use of slides. The meeting was presided over by Mr. Makin, G3FDC.

The next meeting was held on January 6th, 1959, and Mr. Duncan Enock, G3KLZ, gave a lecture on fault finding made easy.

#### BRADFORD AMATEUR RADIO SOCIETY

Hon. Sec.: D. M. Pratt, G3KEP, "Glenlucy," Lyndale Road, Eldwick, Bingley.

JANUARY 13th. Mobile operation. J. J. Platt (G2VO).

Jan. 27th. Display of members' gear.  
February 10th. Colour television. G. N. Patchett, Ph.D., B.Sc., M.I.R.E., M.Brit.I.R.E., M.I.E.E., at the Bradford Institute of Technology.

February 24th. Transmitter design and construction. D. M. Pratt (G3KEP).

March 10th. Junk sale.  
March 24th. Annual general meeting.  
April 7th. Stereophonic sound reproduction. F. Thistlethwaite.  
April 21st. Visit to Esholt Sewage Works. Meet at Esholt Hall at 7 p.m.

May 5th. Field day arrangements.  
May 26th. Visit to Emley Moor I.T.A. station (date provisional).

June 9th. Oscilloscope design and construction. G. F. Craven.  
June 23rd. Subject to be announced later. L. A. F. Stockley (G3EKE).

July 7th. Colour photography. A. R. Bailey, M.Sc. (G3IBN).  
July 21st. Informal meeting.

August 18th. Informal meeting.  
September 8th. First meeting of new session.  
Except where otherwise stated meetings commence at 7.30 p.m. Morse classes are held by arrangement before meetings. We welcome to our meetings all interested in radio or television.

## PUBLICATIONS AND CATALOGUES RECEIVED

**SEMI-CONDUCTOR BIBLIOGRAPHY** from the Newmarket Transistor Co. Ltd. A reference to all that has been published on semi-conductors for the past 15 years.

**A GUIDE TO AMATEUR RADIO** issued by the Radio Society of Gt. Britain. Price 4s. post free.

**R.S.G.B. CALL BOOK.** The 1959 Edition of Amateur Radio Stations in this country. By the Radio Society of Gt. Britain, price 4s. post free.

**SECOND REPORT OF THE MOBILE RADIO COMMITTEE** from H.M. Stationery Office. Price 1s. 6d. net.

**VALVES AND SEMI-CONDUCTORS FOR THE RADIO AMATEUR** from the Mullard Company. This lists, with abridged data, those valves and semi-conductors which are of especial interest to the radio amateur.

... another TRS Winner

**TRS**

Latest 4-sp. BSR Player Unit and P.U. ... £4.12.6 carr. 3/6  
2 v. Amplifier wired complete with speaker, etc., on Mounting Board. ... £3. 5.0 carr. 2/6  
Contemporary styled light-weight case in Maroon and Grey. 14 1/2 in. x 11 1/2 in. x 6 in. ... £1. 7.6 carr. 2/6

**SPECIAL OFFER**

all 3 units  
only £9 carr. 4/6

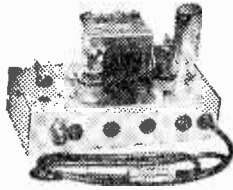

**BAND 3 T/V CONVERTER—180 Mc/s - 205 Mc/s**

Suitable for London, Midland, North, Scottish, Welsh and I.o.W. ITA Transmissions.

Mk. 2 Model, as illustrated. Latest Cascade circuit using ECU84 and EF80 valves giving improved sensitivity (+10db) over standard circuits. Built-in Power supply AC 200-250 v. Dimensions only 6 1/2 in. x 3 in. Ht. 4 in. Simple and easy to fit—only external plug-in connections, wired, aligned and tested ready for use. State channel required. **Gar. Bargain Offer—good results or full refund, only £3.13.6.** Carr. & Pck. 2/6. **Band 3** c/w Switch and BFC aerial socket, fitted and wired to converter, 8-c extra.

**CONVERTER ACCESSORIES**

Hand 1-Band 3 Cross-over Unit, 7/6. Var. Attenuators 6db-36db, 7/6. 11db Pattern Filter, 5/6. Band 3 Aerials—outside Single Dipole with 4 yds. coax., etc., 12/6. 3 Element Beam, 27/6. 5 Element, 35/6.

**VOLUME CONTROLS**

10,000 ohms—2 Megohms. All long spindles. Morganite Midget type. 1 1/2" diameter. (Gar. 1 year. Log. or Linear Ratios. Less Sw. 3/-, 10 P. 2 w. 4/8.

RESISTORS.—Full range, 10 ohms—10 Megohms. 20% 1 w. 3d., 1 w. 5d., 1 w. 6d., 2 w. 9d. 10% Hi-Stab. 1 w. 5d., 1 w. 7d., 5% 1 w. 9d. 1% Hi-Stab., 1 w. 1 6 (10 ohms—100 ohms, 2/-).

**RECORD PLAYER CABINETS**

Contemporary style, revolve covered cabinet Price **£33.3.0.** In fawn and brown with cream interior. Size Carr. and Ins 13 1/2 x 13 1/2 x 14 1/2. Ins 3 1/2. 8 1/2 in., fitted with all accessories, including speaker baffle board and anodised metal fret. Space available for all modern amplifiers and auto changers, etc. Latest record player mounting board 14 x 13 in. supplied.



**2-valve AMPLIFIER Mk 2**

Latest developed circuit giving a higher fidelity response and greater output (2 1/2 watts) using twin stage valve ECU82 and neg. feedback Tone Control. Complete with knobs wired and tested with film. Speaker, etc., ready to fit in above cabinet. Only **£3.19.6.** Carr. 2/6.

**RECORD PLAYER BARGAINS**

**New Reduced Prices!**  
**SINGLE PLAYERS** 4-speed BSR (T19), 92/8; 4-speed COLLARO JUNIOR, 90/-; 4-speed GARRARD (1 w. P.), 27.15.0. GARRARD (TA Mk. 11), 29.5.0. Carr. and Ins. 3/6.  
**AUTO-CHANGERS** 4-speed BSR (T1AS), 28.19.8; 4-speed COLLARO, 27.19.6; 4-speed GARRARD (R120 411 2), 29.15.0.  
**GARRARD (R121 D Mk. 11)** Plug-in head, 30 kbs. Carr. and Ins. 5/-. All above units are latest 4-speed models, fitted lightweight crystal pick-up and twin sapphire styl. Complete and ready to use.  
**FINEST SELECTION AVAILABLE—ALL BRAND NEW AND GUAR.**

**C.R.T. Heater Isolation Transformers**

New Improved types—mains prim. 200/250 v. tapped.

All Isolation Transformers now supplied with alternative *no load*, 100%, and *plus 50%* boost taps, at *no extra charge*.

2V.	2A type	12 6 (P. & P. 1 6)
6.3V.	.6A	12 6 "
10.5V.	.3A	12 6 "
13V.	.3A	12 6 "

Other voltages in course of production. **Small size and tag terminated for easy fitting.**

**JASON F.M. TUNER UNIT 87-105 Mc.s.**

Designer Approved Kit of parts to build this modern highly successful unit, drilled chassis and superior type dial, coils, cans, and all quality components, etc., for only 5 gns., post free. Set of 4 spec. EP81s or equiv. valves, 30/- post free. Illustrated hand-book with full details, 2/- post free. FREE WITH KIT. 48 hr. alignment service, 7/6 plus 2/- P. & P.

**NEW BOXED VALVES ALL GUARANTEED**

1R5, 1T47 6/DF96	9 - EF41	10 8/PF82	10 8
1R5, 1R4 7 6/DK96	9 - EF80	10 6/PCL83	12 9
3Z4, 3V4 8 - DL96	9 - EF86	13 6/PL1	14 6
5Z4	9 6/EL91	8 6/PL2	10 6
6AT6	8 6/EARC90	10 6/PL5	11 6
6K7	6 6/EB91	6 6/EL84	11 6/PY90
6K8	8 6/EB41	10 6/EM85	11 6/PY81
9Q7	8 6/EC98	12 6/EY51	12 6/PY82
6V6	8 6/EC84	12 6/EY86	14 6/PY83
6X4	7 6/EF90	12 6/EZ40	8 6/ET2
6X5	7 6/EF92	12 6/EZ80	8 6/UT25
6X5	7 6/EC42	10 6/EZ81	8 6/UC42
7C5	9/-/EFH81	10 6/MU14	9 6/UT11
7Y4	8 6/EC80	12 6/PY84	10 6/PL14
DAF96	9/-/PCL52	12 6/PCE90	10 6/UCY41

**SPECIAL PRICE PER SET**

1R5, 1T4, 1R5, 1R4 or 3Z4, or 5V4	... 27 6
DK96, DF96, DA996, DL96	... 35 -
6K8, 6K7, 9Q7, 6V6, 5Z4 or 6X5	... 35 -

**RE-GUNNED TV TUBES GENUINE OFFER**

New Heater, Cathode and Gun Assembly can now be fitted to your old Tube—Reconditioned virtually as new. Fully guaranteed to highest standards—as used by our own Service Dept.  
12in. £8. 14in. £8.10.0. 17in. £10.  
Regret only Mullard and Mazda types at present. Delivery approx. 7 days. Carr. & ins. 12/6.

**ELECTROLYTICS ALL TYPES NEW STOCK**

Tubular Wire Ends	32 x 32/350 v. B.E.C.	5 6
25 25 v. 50 12 v.	1 9 Can Types, Clips 3d. ea.	3 -
25 50 v. T.C.C.	2 - 8 500 v. Dub.	4 6
50 50 v., 4 300 v.	2 - 8 x 8 450 v. T.C.C.	5 6
100 25 v., 2 450 v.	2 - 8 x 16 450 v. Hunts	5 6
8 450 v. T.C.C.	2 316 x 16 450 v. T.C.C.	5 6
8 x 8 450 v. B.E.C.	4 32 350 v. B.E.C.	4 -
8 x 16 450 v. T.C.C.	5 32 x 32 275 v. Hunts	4 6
16 450 v. B.E.C.	3 32 x 32 450 v. T.C.C.	6 6
16 16 450 v. T.C.C.	5 60/350 v. B.E.C.	8 6
32 350 v. B.E.C.	4 - 250 350 v. T.C.C.	6 6
32 500 v. Dub.	5 - 60 x 250 275 v. B.E.C.	12 6
50 x 20, 350 v. B.E.C.	6 100 x 200 275 v. B.E.C.	12 6

**ALL-WAVE RADIOGRAM CHASSIS 3 WAVEBANDS 5 VALVES**

8.W.V. 10 m.—30 m. LATEST MIDGET M.W.V. 200 m.—500 m. BVA SERIES  
Brand new and guaranteed. 200, 250 v., 4 post. AC/DC core core coils. Latest circuit technique, delayed AVC and neg. feedback O P 4 watts. Chassis size 13 x 5 1/2 x 2 1/2 in. Dial 10m x 3 1/2 in. Hor. or Vert. station numbers. Walnut or ivory knobs to choice. Aligned and calibrated ready for use. **Quantity and Quality at Low Cost.** Carr. and ins., 4/6.  
7 Valve De Luxe, push-pull EL41 equivalent, 7 watt output, with H Duty Output Transformer, £12.10.0. Carr. & ins., 7/6.

**SPEAKER FRET—Expanded Bronze finished metal 8 x 8 in., 2 3/4; 12 x 8 in., 2 3/4; 12 x 12 in., 4 6; 12 x 15 in., 6 -; 24 x 12 in., 9/-, etc.**

**TYGON FRET** (Impermy pattern) 12 x 12 in., 2 -; 12 x 18 in., 3 -; 12 x 24 in., 4/-, etc.

**SPEAKERS P.M.** 3 ohm 2 1/2 in. Elec. 16 6. 2 1/2 in. Goodman's, 18 6. 5 in. R. & A., 17 6. 6 in. Celestion, 18 6. 7 x 4 in. Goodman's, 19 6. 8 in. Rola, 20 -; 8 in. Special Cone Gimmings, 21 6. 10 in. R. & A., 25 -.

**EMTAPPE Re-ording Tape ALL NEW & BOXED.**

3 in. ... 175ft. 7 -	Type 88 (Stand.)	250ft., 8 -
5 1/2 in. ... 850ft., 19 -	Type 99 (Long Play)	850ft., 24 -
5 1/2 in. ... 850ft., 20 -		1,200ft., 31 6
7 in. ... 1,200ft., 30 -		1,800ft., 45 -

Spare Reels (Unboxed) fin. metal, 1/6; Tin, plastic (EMT), 3/6.

**RECORDING TAPE.—1,200 ft. on 7 in. Plastic reel 88 Type, Hi Quality Product. Each boxed, 22 6**

**NEW REDUCED PRICES! 80 OHM CO-AX CABLE**

Semi-rigid, low-loss, high quality 50 ohm co-axial, stranded conductor, standard 1/4 in. dia. Famous make. **ONLY 8d. per yard.**  
See what you save by ordering:  
20 yds. ... 12 6 | 40 yds. ... 20 -  
Carr. 1/6 | Carr. 2/-

**TRANSFORMER & COIL WINDING CAPACITY AVAILABLE FOR PROTOTYPES & SMALL RUNS**

Listed above are only a few items from our very large stock. Send 3d. stamp today for Complete Bargain List.

Terms: C.W.O. or C.O.D. Kindly make cheques, P.O.s, etc., payable to T.R.S. Post/Packing up to 1lb 7d., 1lb. 1/1, 3lb. 1/6, 6lb. 2/-, 10lb. 2/6. Hours: 9 a.m.-6 p.m. 1 p.m. Wed. Open all day Saturday.

**TRS**

**RADIO COMPONENT SPECIALISTS (Est. 1946)**

70 BRIGSTOCK ROAD, THORNTON HEATH, SURREY (THO 2188)

50 yards Thornton Heath Station. Buses: 130A, 133, 159, 166 and 193

## THE E.M.I. COLLEGE OF ELECTRONICS

10 PEMBRIDGE SQUARE W.2

Propose to commence a further One Year Course in Radio and Television on 14th April 1959. After 29th July 1959 the E.M.I. College of Electronics will cease to exist and students will be accepted by the Pembridge College of Electronics, 34a, Hereford Road, London W.2. Same staff, equipment and syllabus, will be used by both Colleges.

*Details and enrolment forms may be obtained from*

The Registrar, Dept. No. 32  
10 PEMBRIDGE SQUARE  
LONDON W.2

1A/66

## THE PEMBRIDGE COLLEGE OF ELECTRONICS

This new College has been founded by Mr. J. B. McMillan, M.A., B.Sc., and other members of the present staff of the E.M.I. College of Electronics, and from September 1959 will conduct full-time One Year courses in Radio and Television, similar to those at present run by the E.M.I. College.

The first course begins on 8th September 1959 and succeeding courses in January, April and September of each year. Students wishing to start this type of course earlier than September 1959 should enrol with the E.M.I. College of Electronics, 10, Pembridge Square, London, W.2. for the One Year course beginning on 14th April, and transfer after 29th July to the Pembridge College for the completion of their course.

*Details of courses and admission forms may be obtained from—*

The Principal, Dept. No. P10  
34a HEREFORD ROAD  
LONDON W.2

PCI

## P. P. COMPONENTS LTD. (Dept. P.W.2)

219, ILFORD LANE, ILFORD, ESSEX.

Telephone ILF. 0295.



**LATEST CONTEMPORARY PLAYER CABINET.** 49/6. Famous manufacturer. In very smart red leatherette. Plated clip fasteners, carrying handle. Takes B.S.R. Monarch player and a 4in. x 6in. elliptical speaker. P. & P. 4/6.

**RECORD PLAYER CABINETS.** 79/6. A delightful looking cabinet in two tone leatherette. Size 14 1/2 in. x 17 1/2 in. x 3 1/2 in. Will take B.S.R. Monarch 4-speed auto-changer and 6 1/2 in. round speaker. P. & P. 4/6.

**RECORD CASES.** Beautifully made. Leatherette covered. Hinged top for easy access to records. Plated clip fasteners. This strong modern case is hardwearing and washable. Carrying all your records including very expensive

long players safely to parties and record sessions. P. & P. 2/6.

Size—12in. holding 40 records—48/-. .

Size—12in. holding 25 records—32/6.

Size—10in. (come 7in.) holding 50 records—37/3.

Size—7in. holding 40 records—32/6.

Size—7in. holding 25 records—28/6.

**8in. P. M. SPEAKERS.** 8/9. For extension to kitchen, workshop, garage, etc. Work while you listen to your favourite programme. With O.P. Trans., 10/-, P. & P. 2/9. Also we have now a 8in. P.M. Speaker at 5/9. A bargain offer, but limited quantity of these modern speakers. All tested, but have a slight cone fault, which is repaired, not affecting the quality. P. & P. on 1, 2, 3, on 2, 3/6.

**EXTENSION SPEAKER.** 19/9. Fitted attractive cabinet with flex and switch. Make an ideal present, or to keep the lady of the house happy. Ins. carr. 3/6.

**MAINS POWER TRANSFORMERS.** 12/6. 350-0-350 v. 250 mA. 6 v. at 5 a., 4 v. at 5 a., 4 v. at 2 a. Centre tapped. Drop-through type. Post and packing 3/9.

**MAINS POWER TRANSFORMERS.** 12/6. 350-0-350 v. 250 mA. 6.3 v. at 5 a., 6.3 v. at 4 a., 22 v. at 3 a., 4 v. centre tapped. Post and packing 3/9.

**MAINS TRANSFORMER.** 5/3. 250-0-250 v. 80 mA. 6 v.-4 v. heaters. 200-250 v. Prim. Post and packing 2/3.

**MAINS TRANSFORMER.** 3/3. 350-0-350. 80 mA. 12 v.-4 v. heaters. 200-250 v. Prim. Post and packing 2/3.

Stamp for FREE Catalogue. U.K. only. Money Back Guarantee!

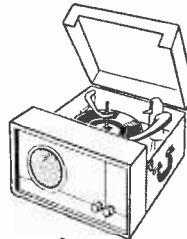

## TELETRON MINIATURE TRANSISTOR SUPERHET COIL KIT,

42/- 470 k/c.



I.F. Transformers & Osc. coil, in screening cans 1/2 in. x 1/2 in. dia. Dual wave Ferrite rod aerial 5 1/2 in. x 5/16 in., dia. For the TRANSIDYNE printed circuit Superhet. ★ 6 Transistors. ★ P.P. output. ★ A.G.C. ★ Reflex. Full constructional folder, 9d. All component parts available from advertisers.

Push-pull and single ended

Tape oscillator coils available for most decks at 8/5 each.

Bias rejector coils and top lift inductors.

Dual range and Xtal diode coils, etc.

Lists, 6d.

THE  
TELETRON CO. LTD.,  
112B, Station Rd., London, E.4.

Phone: SIL. 0936.

# Programme Pointers

OUR CRITIC, MAURICE REEVE, REVIEWS SOME RECENT PROGRAMMES

## "Lizzie Borden"

THE sixth in the *Verdict of the Court* series was an American trial, that of Lizzie Borden in 1893, who was found not guilty of the murder of her father and mother. It made noticeable a point that I have meant to draw attention to before; the increasing and fading out of volume at the commencement and termination of speeches and quotations in this type of programme and the documentary generally. As the narrator introduces a character he is brought on to the stage, as it were, from a great distance away, and, similarly, disappears when he has said his bit and done his stint. Many of his opening and closing words are lost together with, very often, the gist and point of what he is saying.

In this item Bessie Love, Mary Wimbush, Michael Balfour, George Coulouris and James McKechnie simulated the American accent with more realism than is usually imparted to it.

## "The Kidders"

In this Monday Night Theatre presentation we had the unusual and unexpected event of the son and daughter of a distinguished English actor and former favourite in American films, brought in specially "as obvious choices for a play demanding authentic American accent and idiom" (*Radio Times*), to wit, Faith and Lyndon Brook, offsprings of none other than Clive Brook. Faith and Lyndon relapsed into the American accent with easy skill and confidence though they have long been living in England.

## The "Fifty-one" Society

No more interesting subject than "What Future for Sound Radio" could have been found by the "Fifty-One" Society, so far as radio and television addicts are concerned. With Tom Driberg to initiate the debate and Neil Pearson in the chair, some lively and stimulating discussion resulted. The general consensus was that sound radio definitely had a future and that the drop in licences from the eleven million odd peak in 1951 had probably reached bottom.

## "In Town Tonight"

After twenty-five years, *In Town Tonight* has been given an entirely "new look." Instead of the galaxy of visitors from all over the world, engaged, of course, as artists, and really forming an excellent half hour's variety programme: we are given a series of drab and dreary interviews with Londoners. Gone or *Knightsbridge*, the traffic noises, the flower sellers, etc., as well as

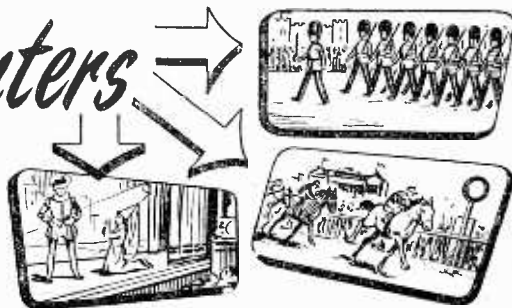

the visiting artists and "interesting people who are in Town tonight." Instead we have just another interview programme, a variant of *Radio Newsreel*. Very boring and most unoriginal. Franklin Englemann takes John Ellison's place as introducer and Charles Chilton is the new producer.

## "Scrapbook for 1918"

I always listen to the *Scrapbooks* with one hand on the volume knob of my set which I turn down for all the marching songs and music hall ditties which are so lavishly sprinkled throughout their pages. They seem so meaningless and incongruous in 1958. "Scrapbook for 1918" was no exception. Dedicated to the men in the services, in honour of the fortieth anniversary of the armistice, it was nothing but a "history" of the last year of the war with England playing the rôle of Atlas. Everyone else had either descended into mutiny or were too late coming in to be of much use. Not a mention of what had gone before. There were many poignant moments but it could have been greatly improved at several points.

## "Town Forum"

I hadn't heard a *Town Forum* before, until I listened to it from Lyons. The team consisted of Rebecca West, C.B.E., Maurice Edelman, M.P., Major-General Lyne, C.B., D.S.O. and Sir Norman Kipping, J.P.; with Denis Morris in the chair. On much the same lines as *Any Questions* and other similar programmes it did not go with the same panache or verve as Freddy Grisewood's show, probably because of the language difficulty. But everyone in Lyons seemed to enjoy it very much.

## "With Courage"

Whilst British regimental bands practise "Deutschland Über Alles" and servicemen the "present" to German V.I.P.s, the BBC in the form of unveilings, war plays and *With Courage* programmes, offer us constant reminders of the two great wars of this century. Together with the spate of war films which pour out from the studios on both sides of the Atlantic, we are not likely to embrace our German cousins with the warmth and fraternity that might otherwise pertain. Two of the *With Courage* programmes I heard seemed to lack reality or conviction. Can anybody really be interested in them?

# Open to Discussion

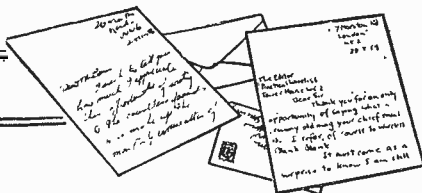

The Editor does not necessarily agree with opinions expressed by his correspondents.

## A Novice Licence

SIR.—I always look forward to my copy of PRACTICAL WIRELESS, and the first page to be opened at is "Transmitting Topics" and then "Open to Discussion," where I saw (page 832, December, 1958) that Novice Tickets got another "airing" by L. J. B., Birmingham.

If only the P.M.G. could see his way to issuing one, I think it would be the answer to clearing the air of pirates and gain him an increase in licence fees. I for one would pay twice the normal £2 fee.

Say, after a fixed time lapse of a novice ticket being issued, he was found to operate satisfactory a normal licence could be issued, after all experience on the air is what matters. I should know, I was prosecuted for it, but there are lots still getting away with it and always will when a little enjoyment is forbade them.—P. BLOOR (Burton-on-Trent).

Whilst we are always pleased to assist readers with their technical difficulties, we regret that we are unable to supply diagrams or provide instructions for modifying commercial or surplus equipment. We cannot supply alternative details for receivers described in these pages. WE CANNOT UNDERTAKE TO ANSWER QUERIES OVER THE TELEPHONE. If a postal reply is required a stamped and addressed envelope must be enclosed with the coupon from page iii of cover.

## TV on Radio

SIR.—I was extremely interested in both Mr. B. K. Middleton's and Mr. D. Wickham's letters concerning TV sound on radio receivers.

I receive TV on my R.208 (10-60 Mc/s) very easily. The best frequency is 44 Mc/s. however, I can also hear it, still audible from at least 30ft., on 37.8 Mc/s. I receive all programmes (although Light, Home and Third are harmonics) on a 6ft. steel ruler.

I would be glad to answer any letters from readers concerning what one can pick up on a R.208, if they would enclose a stamped, self-addressed postcard.

I also would recommend a R.208 to any readers who want a radio receiving BBC/TV, Light, Home, Third programmes, Moscow, Hams, America and Sweden.—SIMON DIPLOCK (Hill Side, Tonbridge).

## Stereophonic Sound

SIR.—We were interested to read your comments on stereophonic sound at the Radio Show. However, we would take issue with you on your remark that demonstrations were held "in almost laboratory conditions." In fact, conditions were very much the reverse, and it is normally to be expected that domestic conditions

will give superior results than were to be heard at the Radio Show.

For one thing, in the home the walls are usually made of something more substantial than hardboard and therefore should not flex at low frequency. Nor is it to be expected that there will be a demonstration in the adjoining room operated at such power that at times it almost drowns one's own demonstration. Many of the demonstration rooms were much more "live" than the average living-room owing to the lack of furnishings, and many of the rooms were larger

than under normal conditions, which also did not necessarily make matters casier.

The majority of the equipment on the market at present is designed for use in the home, and home conditions, while not necessarily ideal, should give superior

results than are to be expected when demonstrations are given under other conditions.—F. H. KNIGHT (Technical Service Department, Cosmocord Ltd.).

## Correspondents Wanted

SIR.—I am 17 years of age and I am very interested in radio as a hobby and I would like to correspond with any amateurs of the same age.—J. E. MAYS (20, Bell Lane, Hendon, London, N.W.4).

SIR.—I wish to correspond with short-wave listeners and any radio amateurs who are 14 years of age.—R. A. MCEWEN ("Kiltane," 5, Melville Terrace, Stirling, Scotland).

## Using Transistors

SIR.—I have read many criticisms of transistors and should like to add my experiences to those which have already been given on this subject. Firstly, they are definitely worth while, provided that they are used correctly. This is the most important point as I have found that many constructors just use them in more or less standard valve circuits and express dissatisfaction at the results. They do not replace the valve. They are a different component, but if used properly they are able to give a very good account of themselves. It is not necessary to use miniature resistors, etc. Some constructors appear to think that they must use miniatures, but naturally, if advantage is to be taken of the small transistors then miniatures enable a small unit to be made up.



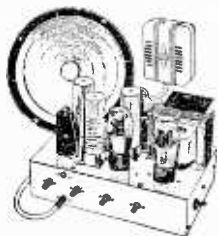

**8-WATT PUSH-PULL AMPLIFIER**  
COMPLETE WITH CRYSTAL MIKE AND 8in. LOUDSPEAKER

A.C. mains 100/250 v. Size 10 1/2 in. x 6 1/2 in. x 2 1/2 in. Incorporating 6 valves, H.F. pent., 2 triodes, 2 output pens., and rectifier. For use with all makes and types of pick-up and mike. Negative feedback. Two inputs, mike and gram., and controls for same. Separate controls for Bass and Treble lift. For use with Std. or L.P. records, musical instruments such as Guitars, etc.

Plus P. & P. 7/6. **£4.19.6** Plus P. & P. 7/6. Or 35/- deposit Plus P. & P. 7/6, and 3 monthly payments of 25/-.

**PORTABLE AMPLIFIER**

Size 6 1/2 in. long, 5 1/2 in. high, 2 1/2 in. deep. Will suit any type of crystal pick-up. Output approx. 2 watts. Incorporating ECC83 double triode, Cossor 142BT output pentode and contact-cooled rectifier. Fully isolated mains transformer for 200/250 A.C. mains. Base, treble and volume controls.

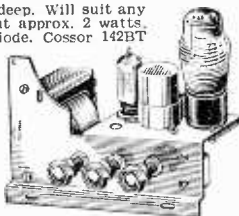

**49/6** Plus P. & P. 3/6. 5in. SPEAKER with O.P. TRANSFORMER, purchased with the above, 18/6, plus P. & P. 1/6.

**AC/DC POCKET MULTI-METER KIT**

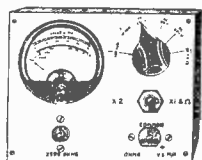

Comprising 2in. moving coil meter, scale calibrated in AC/DC volts, ohms and milliamps. Voltage range AC/DC 0-50, 0-100, 0-250, 0-500. Milliamps 0-10, 0-100. Ohms range 0-10,000. Front panel, range switch, wire-wound pot (for ohms zero setting), toggle switch, resistor and rectifier. In grey hammer finish case.

**19/6** Plus P. & P. 1/6 Built and tested 7/6 extra.

Point to point wiring diagram 1/-, free with kit.

**COLLARO MIXER 4-SPEED AUTOMATIC CHANGER**



Model 457. Type "O" Pick-up, size 12in. x 13 1/2 in. Minimum clearance above baseboard 5in., below 2 1/2 in. 10 records. A.C. mains 200-250 v. Turnover crystal head. BRAND NEW. Fully guaranteed. 25/- deposit plus P. & P. 5/- and 7 monthly payments of 25/-.

Cash **£8.19.6** Plus P. & P. 5/-

**MAINS TRANSFORMERS**

All with tapped primaries. 200-250 volts. 0-160, 180, 200 v., 60 ma., 6.3 v. 2 amps. 10/6. 320-0-320 v. 75 ma., 6.3 v., 2.5 amp., 5 v., 2 amp., 10/6. 350-0-350 v. 250 ma., 6.3 v. 7 amp., 5 v. 2 amp., 19/6. Postage and packing on the above 3/-.

**SIGNAL GENERATORS**

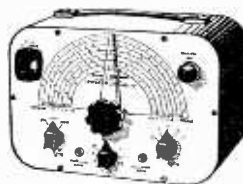

Cash **£6.18.6**, or 25/- deposit and 6 monthly payments of 21/6. Post and Packing 5/- extra.

Coverage 100 Kc/s-100 Mc/s on fundamentals and 100 Mc/s to 200 Mc/s on harmonics. Metal case 10in. x 6 1/2 in. x 5 1/2 in., grey hammer finish. Incorporating three miniature valves and Metal Rectifier. A.C. Mains 200/250 v. Internal Modulation of 400 c.p.s. to a depth of 30%. Modulated or unmodulated R.F. output continuously variable 100 millivolts. C.W. and mod. switch, variable A.F. output. Incorporating magic eye as output indicator. Accuracy plus or minus 2%.

Cash **£4.19.6**, or 25/- deposit plus P. & P. 5/- and 4 monthly payments of 21/6, plus P. & P. 5/-.

Coverage 120 Kc/s-84 Mc/s. Metal case 10in. x 6 1/2 in. x 4 1/2 in. Size of scale, 6 1/2 in. x 3 1/2 in. 2 valves and rectifier. A.C. mains 200-250 v. Internal modulation of 400 c.p.s. to a depth of 30%. Modulated or unmodulated R.F. output continuously variable 100 millivolts. C.W. and mod. switch, variable A.F. output and moving coil output meter. Grey hammer finished case and white panel. Accuracy plus or minus 2%.

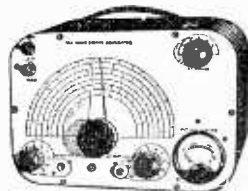

**2 Valve and rectifier AMPLIFIER KIT**

Approx. output 2 watts, negative feedback, tone and volume controls. All the parts to make above less chassis speaker and O.P. transformer. (2 of these would be suitable for stereo-phonics.) **19/6**. P. & P. 3/-.

**B.S.R. MONARCH**



**UA8**

4-speed, plays 10 records 12in., 10in. or 7in. at 33, 45 or 78 r.p.m. Intermixes 7in., 10in. and 12in. records of the same speed. Has manual play position; colour brown. Dimensions: 12 1/2 x 10 1/2 in. Space required above baseboard 4 1/2 in., below baseboard 2 1/2 in. Fitted with Full-F1 turnover crystal head.

**£6.19.6** Plus 5/- postage & packing. or 25/- deposit and P. & P. 5/- and 5 monthly payments of 27/-.

**PLAYER CABINET**

Finished in 2 tone leatherette, will take B.S.R. UA8, with room for amplifier and 7 x 4 speaker. Overall size 15 1/2 in. x 13 1/2 in. x 9 1/2 in.

**£2.19.6** Plus 5/- P. & P.



**13 CHANNEL TUNER**

I.F. 11-16 Mc/s. or 34-38 Mc/s. (state frequency required) complete with PCF30 and ICC84. These have been removed from chassis.

**19/6** Plus P. & P. 2/6. Knobs 3/6 extra.

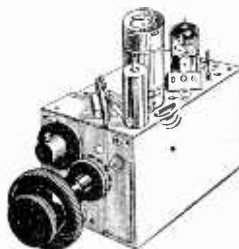

**CONSTRUCTORS' PORTABLE PARCEL**



Comprising case, chassis, top plate, scale, 5in. P.M. speaker with O.P. trans., twin gang, 2 470 Kc/s. I.F.s., trimmers, four valve holders, wave-change switch and volume control with switch.

**39/6** Plus 3/6 postage & packing.

**RADIO & T.V. COMPONENTS (Acton) LTD.**

23 HIGH STREET, ACTON, LONDON, W.3.

All enquiries S.A.E. Goods not dispatched outside U.K.

# YOU can build any of these at Low Cost!

## A MINI TRANSISTOR RADIO

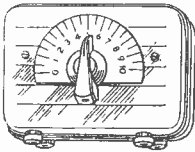

### AN IDEAL PRESENT

A two-stage highly sensitive circuit uses a new super high gain transistor coil and mini tuning condenser. Gives remarkable performance. With step-by-step instructions. Beginners can't go wrong. Includes Plastic case mini ear-piece, Batteries etc. All parts sold separately.

**37/6**

Get your order in while prices are low. Send 2/- for wiring diagram and component price list.

Ideal for:

- Late night listening.
- Children's nursery, etc.

## 1v. WORLDWIDE SHORT-WAVE RADIO

### EXPLORE THE WORLD ON SHORT WAVES!

Can be built for from our list of components which can all be purchased separately, covers 10-100 metres and is capable of receiving speech and music from all over the world. Price includes the famous 954 acorn valve and one coil covering 40-100 metres. Provision is made to increase to two or three valves and all components are colour coded. Send 2/- for point to point wiring diagram, layout and price list.

**35/-**

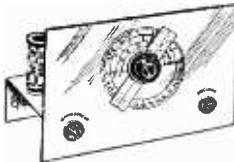

Post and packing: Under 10/- add 5d.; under 40/- add 1/6; over POST FREE.

## TRANSISTOR POCKET RADIO



The ideal low cost transistor pocket radio for the beginner. The Two-Stage circuit utilizes the new R.C.S. VARILOOPSTICK transistor coil. A specially designed miniature .0005 tuning condenser permits the receiver to be in a case which fits in the palm of your hand. Works for months off small battery costing 7d. Can be built in 30 minutes. PRICE

**30/-**

All components are sold separately, full construction data, including plan to parts for 2/-.

## PERSONAL PORTABLE RADIO

### THE SET FOR PERSONAL LISTENING

This little set was designed to give you a real personal portable radio that you can listen to anywhere without disturbing others. Use it on camping trips, in bed, in your office. Supplied with detachable rod aerial, it covers all the medium waves 200-500 metres. Average building time one hour. PRICE

**35/-**

Send 2/- for specification, point to point circuit and parts price list.



R.C.S. PRODUCTS (RADIO) LTD., 11, OLIVER ROAD, LONDON, E.17. (Mail Order only)

# YOURS FOR 10% DEPOSIT

Detailed below is a selection of equipment available on easy repayment terms. Whatever your requirement—we stock it.

	Cash	Deposit	12 M'thly payments of	18 M'thly payments of
<b>AMPLIFIERS &amp; CONTROL UNITS</b>				
Acoustical	Quad			
Mk. II...	£42 0 0	£1 4 0	£3 12 6	£2 10 6
Leak TL12 and				
Point One CU...	£31 10 0	£1 3 0	£2 14 4	£1 17 10
Rogers Junior Mk. II	£23 0 0	£2 18 0	£2 3 4	£1 13 7
<b>LOUDSPEAKER ENCLOSURES COMPLETE &amp; SPEAKER UNITS</b>				
Wharfedale S.F.B.3	£33 10 0	£4 0 0	£3 8 1	£2 7 4
Goodmans Axton 400	£16 1 0	£1 13 3	£1 7 7	19 3
Goodmans Axton 300	£11 5 9	£1 4 0	19 4	13 6
Wharfedale Super 12 FS AL	£17 10 0	£1 15 3	£1 10 2	£1 1 0
Tape Recorders				
*Grundig TK20	£54 12 0	£5 10 4	£4 14 1	£3 5 5
*Grundig TK35	£36 2 0	£8 13 6	£7 8 5	£5 3 3
Sound 555	£59 5 0	£6 17 3	£5 17 8	£1 1 10
Stuzel Transistor				
Battery	£72 9 0	£7 15 2	£6 4 0	£4 6 3
*Hitachi 'Essex'	£69 5 0	£6 17 3	£5 17 8	£4 1 10
Stellophone	£36 3 0	£6 12 6	£5 11 1	£3 19 9
Sound 444	£47 5 0	£4 14 6	£4 1 6	£2 16 9
*Plus Microphone				
<b>TRANSCRIPTION RECORD PLAYERS</b>				
Garrard 301 Stroboscope	£23 0 11	£2 17 6	£2 8 3	£1 13 7
Connoisseur Type B	£29 5 3	£3 0 0	£2 10 4	£1 15 0
Leno G.L.58/RD (with Stereo Pickup)	£29 3 10	£2 19 6	£2 10 1	£1 14 11

**The Radio Centre** E & G THE RADIO CENTRE LTD.  
 33 Tottenham Court Road, London, W.1.  
 Tel.: MUS 55m 6657  
 YOUR TAPE RECORDER CENTRE

# VALVES • SAME DAY SERVICE

All Guaranteed New and Boxed

1.4 v. midget. IR5, 1S5, 1T4, 3S4, 3V4, DAF31, DF31, DK01, DK12, DL22, DL31; ANY 4 for 27/8.

1A7GT	18/6	6K4	7/-	DF31	6/9	PF81	8/6
1D3	9/6	6X3GT	6/6	DF96	8/6	PF92	5/6
1H3GT	10/6	7B7	8/-	DH76	7/6	EL33	16/9
1N5GT	10/6	7C5	8/-	DH77	7/3	EL39	22/6
1R1	8/-	7C1	8/-	DK32	16/6	EL41	9/6
1S1	10/-	7H7	8/-	DK91	8/-	EL42	11/6
1S1	7/6	7S7	9/-	DK92	8/6	EL94	8/9
1T1	7/-	7Y4	8/-	DK93	8/6	EM80	9/6
1U5	6/6	12AH3	9/-	DL33	9/-	EM81	9/6
3A5	10/6	12AT7	8/-	DL33	14/6	FM84	13/6
3Z4	8/6	12AU7	7/6	DL32	7/6	FR51	11/6
3S1	7/6	12AX7	8/-	DL94	8/6	FR83	12/6
3V4	8/6	12BA6	8/-	DL98	8/6	EZ40	7/9
5U4G	7/-	12K7GT	7/6	EABC33	7/9	EZ41	10/-
5V4G	11/-	12K8GT	12/6	EAC91	5/6	EZ99	8/6
5Y3GT	7/6	12X7GT	7/6	EAP42	9/6	EZ91	9/6
5Z4G	9/6	14S7	14/6	EB31	5/6	FW4/500	10/6
6AL5	5/6	19AQ5	7/6	EBC33	7/-	GZ32	11/-
6AM5	5/-	25A6G	11/-	EBC41	9/6	KT3C	8/6
6AM6	6/9	25Z4G	9/-	EBF30	8/8	KT4	14/6
6AQ5	7/-	25Z6G	9/-	ECC91	8/-	KT81	6/6
6AT5	7/6	35L6GT	10/-	ECC92	7/6	MH4	6/-
6BA6	7/6	35Z4GT	7/6	ECC33	8/-	MU11	9/-
6BE6	7/6	35Z5GT	8/6	ECC81	9/6	N18	8/6
6BH6	9/-	43	12/6	ECC85	9/6	PCC31	9/-
6BJ6	7/6	50CD6G	26/9	ECP80	11/6	PCF82	11/6
6BR7	10/6	50L6GT	8/6	ECP82	11/6	PCF82	12/-
6BW7	7/6	AZ1	12/6	ECH31	10/-	PCL82	12/-
6CD6G	26/9	B36	15/6	ECH42	9/6	PL33	14/6
6F6G	6/6	CL33	16/9	ECH81	8/6	PNA41	11/-
6K7G	4/6	CY31	12/6	ECL80	11/9	PEN3C	9/6
6K7GT	6/-	D77	5/6	ECL82	11/9	PEM45	6/-
6K9G	7/9	DAC2	10/6	EP33	5/8	PL31	22/6
6Q7G	8/6	DAF91	7/6	EF41	9/6	PL41	9/6
6SL7GT	7/-	DAF33	8/6	EF42	11/6	PL32	8/6
6SN7GT	7/6	DCC30	10/6	EP80	7/6	PL33	10/6
6U4GT	11/-	DF33	10/6	EP83	14/-	PY80	8/-
6V6GT	7/6						

Postage 6d. pr valve extra.  
 Any Parcel Insured Against Damage in Transit 6d. extra.

**READERS RADIO**  
 24, COLBERG PLACE, STAMFORD HILL,  
 LONDON, N.16. STA 4587

Finally, do use a heat sink. I have found more transistors which have been ruined by soldering than sets using printed circuits which have been ruined from the same cause.—SERVICE ENGINEER (Wolverhampton).

Ex-Service Reference Numbers

SIR,—In reply to Ian Hetherington's letter on ex-Service reference numbers, I would like to say that, although the actual number in question is not included I do, in point of fact, have a fairly comprehensive list. On this are included potentiometers and Yaxley switches.

I reproduce this list for the benefit of other readers even if not for Mr. Hetherington.

Potentiometer Code.

10C/8924—1 k	52034—25 k
10C/8927—25 k	52035—50 k
10C/8929—5 k	52036—100 k
(=CLR 4003/13 = DB1307/9)	52037—250 k
10C/9328—500 k	52038—370 k
10W/16190—200 k	52039— $\frac{1}{2}$ Meg
10W/3731—5 Meg.	52040—1 Meg.
AP/52040—	52041—2 Meg
10C/8740—	52044—5 k + 5 k
10C/10719—	52045—100 k + 100 k
52033—10 k	52046— $\frac{1}{2}$ Meg + $\frac{1}{2}$ Meg

Ex-Service Yaxley Switch Code

10 FB 848—S.P.D.T.	10 F 1257—6 connector
10 FB 847—D.P.D.T.	wave change
10 FB 849—D.P.	10 F 3189—D.P.D.T.?
Triple Throw	
—M. PRITCHETT (Woking).	

SIR,—I have access to the stores numbers you require, but I find that 10C/8676 does not exist, but 10W/8676 does. This is a variable, non-sealed resistor type 2154, 1M $\Omega$   $\pm$  20 per cent., 1 $\frac{1}{2}$  watts. Body sizes: 1.9/16in. diameter, 1-1/32in. depth, 3-pin  $\frac{1}{4}$ in. long spindle.  $\frac{1}{4}$ in. diameter. plain. 7/8in. length.—J. FRANCIS (Winchester).

"An Obscure Fault"

SIR,—I was interested to read about "An Obscure Fault" (J. Nelson. November issue). I have experienced similar trouble on a seven transistor portable I constructed recently. The main difference with mine is that reception deteriorates after the set has been switched on for some considerable time. This condition can be cured by shorting to chassis a resistor limiting the amplitude of the oscillator transistor (this I found out by accident) or by shorting the case of the oscillator transistor to H.T.

My receiver when working normally receives most of the medium-wave stations from 200 metres to 500 metres, making it appear rather more sensitive than Mr. Nelson's.

One thing I am sure of, and that is that the fault does not lie in the output stage, as when I have injected an audio signal into the output stage with the set in its non-working condition the output stage has resolved the signal normally. A meter connected in the push-pull stage gave me a reading of 25 mA consumption (Class B).

Another fault is that the set, for no apparent reason, fades out and the place of the programme is taken up by a violent crackling noise. This again can be cured by shorting out the above mentioned items. Any clues Mr. Nelson?—D. NEWMAN (S.W.16).

Electronic Flash Unit—Power Section

SIR,—I have had several letters from readers who have successfully constructed the Electronic Flash described in one of my articles recently published, asking for constructional information on the making of a transistor power supply to replace the batteries recommended in the article.

The circuit shown below is designed around the OC72 transistor and gives a power supply delivering approximately 5 mA at 250 volts. A small output transformer can be rewound to give the correct turns ratios as shown in the diagram, particular care being observed in connecting up the windings to give the correct polarity of outputs.

Some adjustment on test may be necessary to get the transistor multivibrator to oscillate; the diode resistance combination is included in the conventional manner to provide a "self-starting" facility. In use,

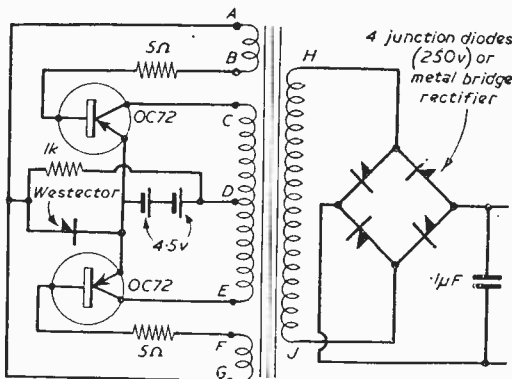

Circuit of transistorised power section for the Electronic Flash Unit described in the September issue.

the circuit, driven from two "flat" 9-volt batteries, should be switched on prior to closing the circuit connecting the flash electrolytic condensers, via the charging resistance.—HUGH GUY (Sunbury).

TRANSFORMER DETAILS

Turns	Start	Finish	Gauge
100	A	B	28 s.w.g.
300	D	C	28 s.w.g.
300	E	D	28 s.w.g.
100	F	G	28 s.w.g.
3,500	H	J	40 s.w.g.

Information Required

SIR,—Some time ago, I purchased an instrument called a "Portable Dose-Rate Meter Type 11178." It has a 50  $\mu$ A meter to register the dose. The unit contains three thyratrons in parallel and the current is integrated to work the meter.

My trouble is the H.T. supply. There are a number of contacts inside the case, but information about the batteries is lacking. If any reader can supply information about the unit, I should be very grateful.—R. A. Y. (Cheam).

**SIR**.—I have a 1132 RX which covers 100-124 Mc/s which I wish to convert for the 144 Mc/s band and should be grateful for anyone's help.—JOHN R. TYE ("Inter-Nos," Swanton Morley, Dereham, Norfolk).

#### Automatic Time Switch

**SIR**.—May I suggest a modification to the automatic time switch described by E. N. Romley in the September, 1958, issue of "Practical Wireless"?

If, instead of studs around the clock face, a series of overlapping metal strips are bolted on, together with slightly shorter insulating strips underneath each, then the hands would always be in contact with a section and would drop from one to the next with a quick make-and-break action, as I have attempted to illustrate in the sketch below.

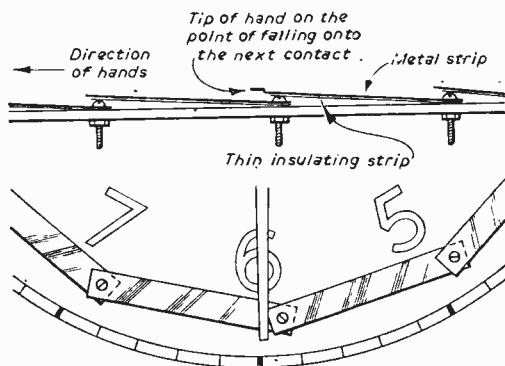

Proposed modification to the automatic time switch.

I should be interested to hear Mr. Romley's opinion.—A. W. BUCKINGHAM (Southall).

#### Electronic Organ

**SIR**.—I am surprised at the amount of interest my letter in the Open to Discussion column of the December issue of PRACTICAL WIRELESS has aroused among readers, and while I do not wish to be discourteous to, or damp the ardour of fellow readers, it must be appreciated that I cannot possibly write out constructional details and draw circuit diagrams, almost daily, for individual enquirers.

What seems to puzzle readers most is the use of a vibrating reed as half a condenser microphone in the organ I mentioned, which is used as the tone generator. It is very simple. Each tongue has adjacent to it a stud, which can be a brass screw, the studs are mounted on an insulated strip and are adjustable. The strip must be firmly mounted for these studs must not vibrate, as there will be a potential of at least 200 volts across tongue and stud, so beware they never touch.

It is better that this voltage should be in steps of 200, 300 and 400, controlled by a switch,

and in no circumstances must this be supplied by the amplifier's H.T.: it must be entirely separate. All studs and all reeds are respectively connected very carefully and negative goes to the connected studs and positive to the connected reeds, and the latter with all their frames are earthed. The studs go to the grid of the amplifier, or pre-amplifier through a 100 kilohm resistor and a .1  $\mu$ F condenser to earth.

I doubt that many readers could undertake the building of a complete reed organ, so the interested should buy one. There are thousands tucked away in the country which could be bought cheaply. Buy as simple a one as possible, and a harmonium if possible, that has bellows and an air chamber, an American organ is drawn, not blown, and has only the bellows. If there are more than one set of reeds block out the others with cardboard or plastic material, also for a start use the existing bellows and air chamber, you may fit a powered blower later. Also do not to be in a hurry to discard stops: couplers could be useful. Your ingenuity is called for in any such conversion, and since it is conversion I suggest no hard and fast rules can be laid down.—R. H. COWTAN (Thetford).

#### Beginner's Constructional Course II

**SIR**.—I recently suggested that I would like to see one of the "Beginner's Course" radios constructed by an absolute beginner. You were good enough to arrange, through your query department, that one was sent to me by a reader from London, E.5.

The radio concerned worked when the reader put pressure on various parts, and he often left a pair of pliers resting on one of the valves. The volume control did not work and the valves lit up like old fashioned bright emitters.

On inspection I found that the following points accounted for all the troubles:

1. Components not done up tight. Earth tags not tight.
2. Nearly every joint was of the "dry" type with the tag not tinned with solder.
3. The filament transformer fitted was not of the type recommended.
4. Some joints had "whiskers" of stranded wire not soldered in a safe position.

I put these matters right and on test the receiver worked very well.—E. V. KING (Author of Beginner's Constructional Course II).

#### "Making Ohm-meters"

**SIR**.—There is an error in Mr. Kendall's article on ohm-meters in the January, 1959, issue. On page 878, column two, it is stated that:

$$R_x = \frac{R_m(V_1 - V_2)}{V_2} \quad \text{or} \quad R_x = \frac{R_m(V_1)}{V_2} - 1 \text{ ohms.}$$

This second expression is wrong; it should read:

$$R_x = R_m \left( \frac{V_1}{V_2} - 1 \right) \text{ ohms.}$$

Using the values given in Mr. Kendall's typical calculation, the first expression would give about 1,357 ohms.

Using the formula I give, the correct result is about 358 ohms.—W. E. THOMPSON (St. Leonards).

ADVERTISER'S ANNOUNCEMENT

# “Unaccustomed as I am—

“I . . . er, er . . . a don't know just what to say on the subject.”

“I wasn't expecting to be called on to speak.”

“Mr. Bell can tell you more about the idea than I can.”

“Er . . . that is not very clear, but that's the best I can do.”



## . . . Yet 4 Weeks Later He Swept Them Off Their Feet!

In a daze he slumped to his seat. Failure . . . when a good impression before these men meant so much. Over breakfast next morning, his wife noticed his gloomy, preoccupied air.

“What's the trouble, dear?”

“Oh . . . nothing, I just fumbled my big chance last night, that's all!”

“John! You don't mean that your big idea didn't catch on!”

“I don't think so. But Great Scott, I didn't know they were going to let me do the explaining. I outlined it to Bell—he's the public speaker of our Company! I thought he was going to do the talking!”

“But, dear, that was so foolish. It was your idea—why let Bell take all the credit?” They'll never recognise your ability if you sit back all the time. You really ought to learn how to speak in public!”

“Well, I'm too old to go to a class now. And, besides, I haven't got the time!”

“I've got the answer to that. Where's that magazine? . . . Here—read this. Here's an internationally known institute that offers a home study course in effective speaking. They offer a free book entitled *How To Work Wonders With Words*, which tells how any man can develop his natural speaking ability. Why not send for it?”

He did. And a few minutes' reading of this amazing book changed the entire course of John's business career. It showed him how a simple and easy method, in twenty minutes a day, would train him to dominate one man or thousands—convince one man or many—how to talk at business meetings, lodges, banquets and social affairs. It banished all the mystery and magic of effective speaking and revealed the natural Laws of Conversation that distinguish the powerful speaker from the man who never knows what to say.

Four weeks sped by quickly. His associates were mystified by the change in his attitude. He began for the first time to voice his opinions at business conferences. Fortunately, the opportunity to resubmit his plan occurred a few weeks later; But John, this time, was ready. “Go ahead with the plan,” said the Managing Director, when John had finished his talk.

“I get your idea much more clearly now. And I'm creating a new place for you—there's room at the top in our organisation for men who know how to talk!”

And his newly developed talent has created other advantages for him. He is a sought-after speaker for civic, banquets and lodge affairs. Social leaders compete for his attendance at dinners because he is such an interesting talker. And he lays all the credit for his success to his wife's suggestion—and to the facts contained in this free book—*How To Work Wonders With Words*. For twenty-five years the Speakers' Service has been proving to men that ability to express oneself is the result of training, rather than a natural gift of a chosen few. Any man can absorb and apply quickly the natural Laws of Conversation. With these laws in mind, the faults of timidity, self-consciousness, stage-fright and lack of poise disappear; repressed ideas and thoughts come forth in words that sparkle with brilliance, charm and power.

Have you an open mind? Then send for this free book *How To Work Wonders With Words*. Over 100,000 men and women in all walks of life have found in this book a key that has opened a veritable floodgate of natural speaking ability. See for yourself how you can become a popular and dominating speaker! Your copy is waiting for you—free. Enclose 3d. stamp for postage.

Send for this Amazing Book

Now Sent  
**FREE**

THE SPEAKERS' SERVICE,  
(Dept. PWL/ES1),  
Marple, Cheshire.



**RECEIVERS & COMPONENTS**

**TELEVISIONS.** 9in. models. £7/10/-; 12in. models. £13/10/-; 12in. 5-channel models. £19/10/- each, all working, carriage paid. Send for list. TOMLINS, 127, Brockley Rise, Forest Hill, S.E.23. (FOR 5497.)

**SPEAKER REPAIRS.** Cones/Fields fitted. Clock Coils Wound. L.S. REPAIRS, Pluckley, Ashford, Kent.

**FM-AM STEREO****Radiogram chassis-CB8**

Paired output, 4 W. used on radio.  
A hand-built quality receiver.  
Only £29, with 2 speakers.

**BEL SOUND PRODUCTS CO.**  
Marlborough Yard, London, N.17.

**MAINS FROM 12v. CAR BATTERY.** American Dynamotor Unit, runs 200/250 AC/DC radios, televisions, tape recorders, etc., from 12v. car battery, continuous duty, perfect, cost £25.80/-; s.a.e. full details. **SCIENTIFIC PRODUCTS**, Cleveleys, Lancs.

**LARGE STOCKS**

Manufacturers' and Government Surplus Equipment: Valves, Meters, Condensers, Resistors, Transformers, Chokes, Switches, etc. etc. Callers only. Usual shop hours.

**N. R. BARDWELL & CO.**

81/83/83a, Sellers Street, Sheffield, 8.  
Phone: 52885.

**OPENING OFFERS at Bargain Prices.** Bendix Receiver R.A.10, 4 waveband superhet, 150 kc/s-10 Mc/s. 8 valves. Superb receiver for communications, boat, etc. (Conversion, P.W. Sept., 1957.) £4/15/-, plus 7/6 carriage. APN-4-LORAN, 15-valve Receiver (6SK7, 5U4G, etc.), valves only cost more. Only £3/17/6, plus 10/- carriage. Post only to: JASPER, 42, West Bar, Sheffield, 3.

**KINGSLAND****ELECTRONIC COMPONENTS**

We open our first trading year with this stupendous offer.

One pair throat microphones, 50 assorted resistors, approx. 150 assorted screws, one dial pointer 2ft. 2in. screened lead with sockets, one 5 Henry 200 m.A. choke, 2 electrolytic condensers, radio knobs, toggle switches, Octal valve bases, vibrators, one pair M.C. earphones, one waveband switch, 4 Co-Ax. plugs, one box of assorted coils, cartridge fuses, 3 potentiometers, one WW multiplier, 24 assorted condensers, one Festoon lamp and holder, one coil PVC wiring-up wire, plus one file, one drill bit, one screwdriver and one B.A. spanner. 35/-, p. & 4/6.

**A RADIO CHASSIS WITH OVER 200 USEFUL PARTS,** consisting of condensers, resistances, valve holders, chokes, switches, relays, coils, nuts and bolts, etc., 10/6, p. p. 4/5.  
**50 ASSORTED RESISTANCES,** 10/-, p. p. 1/3.  
**35 ASSORTED CONDENSERS,** 10/-, p. p. 1/3.  
**ONE 5 HENRY CHOKE 2 AMPS.,** 7/6, p. p. 1/3. Open all day Saturday, personal callers welcome.  
183, Kingsland Road, Shoreditch.  
Tel.: SH0 6572.

**RATES:** 5/6 per line or part thereof, average five words to line, minimum 2 lines. Box No. 1/- extra. Advertisements must be prepaid and addressed to Advertisement Manager, "Practical Wireless," Tower House, Southampton St., Strand, London, W.C.2.

**PETHERICK'S RADIO SUPPLIES**

9a, WESTCOMBE, BIDEFORD, N. DEVON

**FERRITE SLAB AERIALS,** Medium Wave, 7/6; Medium and Long, 13/6 with circuits.  
**CRYSTAL SET COILS,** M & L with circuit, 2/6.  
**DUAL RANGE COILS** with reaction winding with circuits, 4/- each.

**CRYSTAL DIODES,** 1/- each, 10/8 doz.  
**TRANSISTORS,** Red Spot or Green/Yellow, 7/6; White Spot or Red/Yellow, 15/-; Special R.F. GOLD SPOT, 18/6.  
**REACTION CONDENSERS,** .001, .0033, .005, All at 4/- each.  
**VALVES,** EL32, EF36, SP31, GJ5G, all 3/9 each.  
**HEARING AID** with Plug and Lead, 12/3 each.

**TRANSISTOR SET CASE** in Aluminium, 4" x 2 1/2" x 1" with suggested layout, 4/8.  
**ALL-LEAD-ROCK COIL** with Transistor Circuit, 4/6.

ALL ABOVE SENT POST FREE.  
PLEASE PRINT NAME AND ADDRESS.

**MIDDLESBROUGH.** Largest stocks on N-East coast. Radio, TV components, FM Kits, Gram. Cabinets, Tape Decks, Leak Amplifiers, Valves, etc. Callers only. PALMERS, 106, Newport Road. (Phone: 3096.)

**METERS (NEW BOXED M.O.S.)**

Ammeters, 6" round, switchboard mounting, moving iron, 50 cycles, A.C. scaled 0-50. Price £4, postage 3/6. Ammeters 2" round, moving coil, complete with shunt, 5 m/a basic movement, scaled 0-20. Price 10/6, postage 1/6. Voltmeters, moving coil, 2" round, 10,000 ohms resistance, scaled 0-50. Price 10/6, postage 1/6. Voltmeters, 2 1/2" round, moving iron, 50 cycles, scaled 0-300. Price 17/6, postage 1/6. Cheap Radio & Electrical Components. S.A.E. list.  
**SHED ELECTRICALS,** Robinsons Yard, Church St., Basford, Nottingham.

**P. HARRIS ORGANFORD DORSET**

**AMERICAN 5 in. HI-FLUX P.M. SPEAKERS,** in 6 in. dia. metal cabinets, ideal for cars, 25/- (3/6). **AMERICAN POLICE CAR TRANSMITTERS** for 6 v. input, 30-40 Mc/s F.M. crystal controlled. Output 30 watts. £12/10/- (20/\*). **AMERICAN PORTABLE TRANSMITTER RECEIVERS** for 6 v. 12 v. or 24 v. input, 27/39 Mc/s F.M. crystal controlled. Output 2 watts. £17/10/- (20/\*). **DST-100 RECEIVERS,** £19/10/- (30/\*). **5 ft. DE LUXE AMERICAN 2 1/2 in. TUBULAR MAST SECTIONS,** telescopic, 12/6 (5/- reduction on quantity). **AMERICAN 75 ft. PLYWOOD MASTS,** with all fittings, £35 (special). **TBS TRANSMITTERS,** new, less valves, 60/80 Mc/s, £4/10/- (30/\*). **TBS RECEIVERS,** 60/80 Mc/s, new, less valves, £4/10/- (30/\*). **WODEN CHOKES,** 2 H., 40 m/a, 20/(5/-). **RECTIFIERS** in cabinets, 100/250 v. A.C. to 110 v. 700 m/a, 50/(10/-). **MODULATION TRANSFORMERS,** Woden 85 watt audio, pri. 1,700 and 2,500 ohms T.T. sec. 5,000 and 6,000 ohms C.T. 20 lb., 45/(7/6). **G.E.C. 200 watt audio 2=TZ-40 inc. 2=33T, 65/(10/-). 6 ft. BENDIX TRANSMITTER CABINETS,** totally enclosed, full length rear door, takes standard rack panels, £6 (20/-). **F.L.T. POWER LINES,** 23 v. A.C. to 3,071 v. 500 m/a, smoothed, 3 cwt., £25 (special).  
Amounts in brackets are carriage England and Wales\*. Include 10/- returnable case, 49-p. s.e. list over 1,000 different items available.  
We have vast stocks of "bits and pieces." Please send your requirements—we can probably help.

**RECEIVERS & COMPONENTS**

(Continued)

**NO. 19 WIRELESS SET MANUALS,** not photostats, 12/- ea., p.p. G. EATON, 54, Yoxall Rd., Shirley, Warwickshire.

**COMPONENTS.** Valves, Tubes, etc. Write or phone for free list. **ARION TELEVISION,** 4, Maxted Rd., Peckham, S.E.15. (New X 7152.)

**ANNAKIN**

**Test Set Portable No. 2.** Ranges 1.5 v. 3 v., 150 v., 6 m.A., 60 m.A., 5,000 ohms, 25,000 ohms. Has 2 1/2 in. M.C. meter (calibrated), Range switch, in Bakelite case 5 1/2 in. x 4 1/2 in. x 4 1/2 in. A handy little tester at the very low price of only 45/- ea., post 2/3 (less battery).

**Disc Magnets,** 4 in. D x 1 in. Very powerful. With labels numbered 0-9. Useful for schools, etc. New 3d. ea., 2/6 doz., post extra.

**Thermistats,** Operate at Freezing point. O.K. for Frost Warning Devices. Adjustable. Usual, 2/- ea., post 7d.

**Vibrators,** 12 v. non-sync. 4 pin. New, 4/6, post 8d.

**Carbon Mike's,** With breast-plate and harness. Mouthpiece. Plug. Only 3/- ea., post 1/6.

**Rectifiers,** Selenium, 6-12 v. 1 A. Bridge, 4/11, post 9d. 6-12 v. 3 A. Bridge, 10/-, post 1/6. 200 v. 250 m.A. 1 w./6, post 1/6.

**Tranx. Unit 81.** With 6 valves, 1-3A4, 2-351, 3-1L1. An F.M. Tranx. on approx. 100 mc. A really great bargain, 36/6 ea., post 3/6.

**Mains Transformers,** Quality bottled jobs, 250 v. in. 423-0-423 v. 134 m.A., 12 v., 100 m.A., Out. Only 15/- ea., post 3/6.

**Mike Transformers,** 120-1 ratio, 1/6 ea., post 9d. Most of previous bargains are still in stock except 1143 equip. and 1 80 ohm resistors. Above prices Mainland only. S.A.E. for Lists.

25, ASHFIELD PLACE, OTLEY, YORKS

**SOUND RECORDING**

**TAPE/DISC/TAPE Transfer,** 1,800ft. LP new tape, 37/6. Mixer Units for quality work. **SOUND NEWS,** 10, Cliford St. London, W.1.

**SALE OF TAPES**

Surplus quantity of brand new 850' tapes available on reels in boxes, 11/6 per reel, postage free, for a minimum order of four reels. Single reels may be called for at 12/6 each. Three days money back guarantee if dissatisfied.

**STANLEY SCHOFIELD PRODUCTIONS LTD.,** 6, 7 & 8, OLD BOND STREET, LONDON, W.1. MAYfair 4642/3

**SERVICE SHEETS**

**SERVICE SHEETS** for sale and hire. Radio/TV. S.A.E. enquiries, J. PALMER, 32, Neasden Lane, N.W.10.

**SERVICE SHEETS AND VALVES**

S.A.E. enquiries. **NEW VALVES,** Guaranteed 3 months, return of post (ECH21, N30, U37, 6BG6, EL33, GZ31, EF33, EL34, EL37, 6LD2), 6L1, 12C3, 15/- each) (EC031, EL34, E230, EC033, KC037, KF35, PL32, 10/- each), GZ32, ECF40, 18/- each.

**JOHN GILBERT RADIO**

20, Extension Shepherds Bush Market, London, W.12. Phone: SH0 3352.

**SERVICE SHEETS,** Radio/T.V. Sale and hire: s.a.e. with inquiry. **SULTAN RADIO (PW),** 23b, Albert St., Tumbidge Wells; Kent.

# TV SETS

## 12in. UNTESTED TABLE MODELS

Note some of these sets are working (some may have dud tubes or other components), mostly on Channels I or III. Most makes available, but please state an alternative. These sets (except for a few Type 1) all contain miniature valves and are nearly all later A.C. D.C. types. **£3/15/-**

(Carr. & packing 10/-)

**T.V. SETS**, best only valves, speakers and tubes, 9 and 10in., 10/-; 12in., 15/- (Carr. etc., 9/-)

**5-CHANNEL T.V.** Table models, tested pictures before dispatch, all good tubes, tuneable all B.B.C. stations, all top makes. **£3**. Carr. etc., 10/-

**13-CHANNEL T.V.s.** Consisting of a 5-channel B.B.C. T.V. with separate mains-driven Band III converter (new, listed £7). **£11** (Carr. etc., 10/-). Satisfaction or Money Back Guarantee. If returned unused within 7 days.

**STARR GALAXY SPARES**. 1,000's available, low prices. S.A.E. list.

# TV TUBES

**FACTORY REVACUUMED. ALL GUARANTEED 6 MONTHS.** Carriage and insurance 12 6.

Due to the increasing demand for our superior television tubes and the small number of returns we are now able to effect a substantial reduction in their prices. Nearly all types of Mullard, Mazda, Brimar, Cossor, Emiscope, Emitron, Ferranti, Catholon, G.E.C., available ex-stock.

All 9in. and 10in. Types. **£2 15/-**.

All 12in., 14in., 15in., 16in., **£2 19/-**.

Except those listed under:

CRM/123, MW3146, MW3174, 3 31, 332, CRM143, MW41 1, CRM152. All Mullard 14in., **£4 10/-**.

All 17in. Types. **£7 10/-**.

2 1/2in. Types. **£7 10/-**.

**TRANSISTORS**. Red Spot, L.F., 7/-; White Spot, R.F., 12 6. Latest "Top Hat" Ediswan X101, 12 6. S.A.E. details.

**GUARANTEED P.M. SPEAKERS.**

Standard 3 ohms, ex-shipment, tested, top makes, performance guaranteed. 5in., 9/-; 6 1/2in., 9/-; 7 x 4, 12/-; 8in., 9/-; 10 x 6, 14/-; 10in., 14/-.

**RECTIFIERS**. Selenium. 12V. 1A., 5/-; 12V. 2A., 7 6; 12V. 3A., 9 6; 250V. 50mA., 5/-; 250V. 250 mA., 12 6; contact coated, 250V. 50mA., 7 6; 250V. 250mA., 18/-; 250V. 500mA., 22/-.

## GUARANTEED TV VALVES 24-HOUR SERVICE

174	6 3	12AX7	8 6	6F8	7 9	6Y84	8 6
5140	6 8	12K7GT	7 6	6F83	7 9	6Y82	8 6
5240	9	1277GT	7	6F85	9 6	6Y86	9
6AM6	6 6	20D1	9 6	6F91	6 6	6Y61	2 6
6BA6	6 6	24F2	9 6	6L22	4 6	741	8 6
6B35	6 6	20F1	11	6L23	11	622	7 6
6C5	4 6	23A4	8	6L27	9 6	624	12 6
6C5	9 3	25J6GT	8 6	6L41	9 6	631	9
6D2	5 6	37JGT	7 6	6L81	9 6	633	9 6
6F1	8 6		7 6	6V51	11	635	9 6
6F12	6 6	807(BR)	3 9	6V59	11	632	6 6
6F13	9 6		11	6Z30	8	6322	9
6F15	11	10H77	7 6	6Z41	10	6291	7 6
6F15	11	6AF42	9	6Z50	8 6	6281	7 6
6F33	6 6	6B41	7 6	6Z52	10	6404	11 6
6H6	2	6B61	5 6	6K230	9 6	6801	13 6
6J3M	5	6B741	8	6K237	11	6AF12	9
6J33	3	6B633	7	6K61	9 6	6B41	8 6
6K74	4 6	6B131	12 6	6K61	9 6	6B41	8 6
6K84	7 6	6F231	9 6	6K703	6	6CH42	9
6K25	9 6	6F281	7 6	6L152	9 6	6F41	9
6L4	9	6F282	8 6	6L237	9 6	6F42	9
6L18	9 6	6C83	8 6	6M114	9	6L41	8 6
6L66	8	6C84	9 6	6N78	8	6L44	9 6
6L129	9 6	6F283	9 6	6PC84	8 6	6L46	9 6
6P28	11	6F280	12	6P878	11 6	6T7	9 6
6K74T	6	6P435	9	6P870	9 6	6T8	11 6
6K74T	5 9	6P442	9	6P882	11	6Y41	8 6
6U4GT	12	6E180	12 6	6P83	11	6W7	6 6
6V6GT	6 6	6P236	4	6L28	11	6W77	5
6X4	6	6E239	5	6P41	15	266	9 6
10P1	9 6	6F281	12	6P42	9	277	6 6
10P13	11	6F41	9	6P43	11	277	6 6
10P14	12	6F42	11	6P50	12	2132	8
12A7	7 6	6F30A	8	6P51	10	2719	7
12A17	6 6	6F30B	3 6	6P50	8	21152	8 6

For full list Valves, Loudspeakers, T.V. Tubes, etc., send 6d. in stamps or p.p.

### 12-PAGE LIST OF 750 KNIPS

All brassless 5%, and post free for a dozen.

Post 1 3 in E.L. Min. 5d. No C.O.D. 10,000 KNIPS FOR CALLERS.

**TECHNICAL TRADING CO.**  
350/352, FRATTON ROAD,  
PORTSMOUTH

## FOR SALE

**100 BAYS** of brand new adjustable steel She'ving. 72in. high x 34in. wide x 12in. deep; stove enamelled, dark green; sent unassembled; 6-shelf Bay. **£3/15/-**; sample delivered free; quantity discounts. N. C. BROWN, LTD., Eagle Steelworks, Heywood, Lancs. (Tel.: 69018.)

**SEND 4d. STAMPS** for Hi-fi guide. Finest chassis, cabinets and grams. Unique easy terms. M. Richards, Dunke'd, Carvoza Rd., Truro, Cornwall.

**MAINS RADIO IN YOUR CAR**, complete unit, runs 200/250 AC/DC radio, television, tape recorders, etc., from 12v. battery, perfect, cost **£25 80/-**, stamp full details. **SCIENTIFIC PRODUCTS**, Cleveleys, Lancs.

**ORGAN BY MILLER**, authentic 2 keyboard and pedalboard console, complete, 2 Philips amprs., 2 spkrs., requires overhaul. Details: **NEW 2330**.

**T.V. AERIALS 25/6**. For all I.T.A. channels. Outdoor or loft. 3 elements. P. & P. 2/6.

**AERIALS 15/9**. B.B.C. indoor type. Folded dipole with 12ft. Co-ax cable fitted. Postage 1/3.

**T.V. AERIALS 7/9**. For all channels complete with Co-ax cable. For use indoors or in the loft. Postage 1/3.

**DUKE & CO. (Dept. D.2.)**, 621/3, Ronford Road, Manor Park, E.12. Tel. ILF 6001/3

**AMERICAN MAGAZINES**. Year's subscription. "High Fidelity," 50/-; "Radio and T.V. News," 35/6; "Audio," 35/-. Specimens: "High Fidelity," 5/-, others 4/- each. Full catalogue free. **WILLEN LTD.** (Dept. 40), 9, Drapers Gardens, London, E.C.2.

**POWER IN PACKETS**.—H.T.s at the right price. 64 x 87 x 4 1/2. 10/9; 162 x 12 x 3 1/2. 10/9 (15 sets); 6 1/2 x 4 1/2. Send 1/- for new 20-page catalogue (refunded on first purchase). Stamp for new list only showing new items including Meter Rectifiers, 1 and FW 240v. Rectifiers. Aldis lamps, small Neons, etc. R. J. DIGGINS, 129/133, Radnor St., Hulme, Manchester, 15.

## OUR NEW Q.P. RANGE

(Quantity Production)



Veneered in **TOLA** with choice of shades.  
**QP E5**  
Price **£9.19.6** or 30-dep. and 9 monthly payments of 20 4.  
Motor board 23in. x 14in.  
**QP E6**  
Price **£12.12.0** or 38-dep. and 9 monthly payments of 25 7.  
**SEND FOR NEW ILLUSTRATED CATALOGUE** showing full details of many other new designs. to:  
**A. L. STAMFORD (Dept. C29)**, 84, Weymouth Terrace (off Hackney Road, E.2). Phone: SHO 5093

## FOR SALE (Continued)

**AMAZING OFFER**.—Originally **£40-£100** each. Ekco, Pye, H.M.V., Marconi, Philips, Murphy, etc., 9-10in. Televisions, complete, not working. 50/- each; carriage paid; immediate dispatch; 12in., **£5/5/-**; 15in., **£9**; Philips 17in. Projection Televisions. **£9/15/-**. **TOMLINS**, 127, Brockley Rise, London, S.E.23.

## WANTED

**URGENTLY REQUIRED**, new Radio. Television or Industrial Valves. Also old and obsolete types. Cash prices offered for any quantity. Write, call or phone: **MIT 6202**, 201, Streatham Road, Mitcham, Surrey.

**ALL TYPES** of Valves wanted. **PL81**, **ECL80**, **EY51**, **U25**, **PCF80**, **PZ30**, **U801**, etc., etc., best cash price by return. **STAN WILLETTS**, 43, Spon Lane, West Bromwich, Staffs. (Tel.: WES 2592.)

**A PROMPT CASH OFFER** for your surplus Brand New Valves, Speakers, Components, Test Instruments, etc. **R.H.S.**, 155, Swan Arcade, Bradford, 1.

**URGENTLY REQUIRED**, Radio or Electrical Goods of all types, large or small lots. We collect and pay cash. 22, Lathom Ave., Morecambe, Lancs.

## WANTED VALVES

All types for prompt cash. Must be new State quantity.

## WILLIAM CARVIS LTD.

103, North Street, Leeds, 7.

## SITUATIONS VACANT

**A.M.I. Mech. E.**, **A.M. Brit. I.R.E.**, City and Guilds, G.C.E., etc., bring high pay and security. "No pass—no fee" terms. Over 55% successes. For details of exams and courses in all branches of Engineering, Building, Electronics, etc., write for 148-page handbook, free. **B.I.E.T.** (Dept. 242B), London, W.8.

**CITY AND GUILDS** (Electrical, etc.), on "No pass—no fee" terms. Over 95% successes. For details of modern courses in all branches of Electrical Engineering, Applied Electronics, Automation, etc., send for our 148-page handbook, free and post free. **B.I.E.T.** (Dept. 242a), 29, Wright's Lane, London, W.8.

**T.V. AND RADIO**, **A.M. Brit. I.R.E.**, City and Guilds, **R.T.E.B.**, Cert., etc., on "No pass—no fee" terms. Over 95% successes. For details of Exams and Courses (including practical apparatus) in all branches of Radio, T.V. and Electronics, write for 148-page handbook, free. **B.I.E.T.** (Dept. 242C), 29, Wright's Lane, London, W.8.

**THERE** is a national shortage of Mercantile Radio Officers. Why not make Communications your career? You can be assured of a sea-going appointment after qualifying at The School of Marine Radio and Radar (A.S.T.), Hamble, Southampton. For details, apply Commandant, quoting A.12.

(Continued overleaf)



## EDUCATIONAL

**INCORPORATED** Practical Radio Engineers home study courses of radio and TV engineering are recognised by the Trade as outstanding and authoritative. Moderate fees to a limited number of students only. Syllabus of Instructional Text is free. The "Practical Radio Engineer" journal, sample copy 2/-, 6,000 Alignment Peaks for Superhets. 5/9. Membership and Entry Conditions booklet, 2/-, all post free from the SECRETARY, I.P.R.E., 20, Fairfield Road, London, N.8.

**WIRELESS.** See the world as a Radio Officer in the Merchant Navy: short training period; low fees; scholarships, etc., available. Boarding and Day students. Stamp for prospectus. **WIRELESS COLLEGE,** Colwyn Bay.

**THERE** is a national shortage of Mercantile Radio Officers. Why not make Communications your career? You can be assured of a sea-going appointment after qualifying at The School of Marine Radio and Radar (A.S.T.), Hambro, Southampton. For details, apply Commandant, quoting A.12.

## II+ EXAMINATION

Time is vital to your child. Write NOW for FREE 24-page GUIDE and Test stating age of child to (Dept. M.8), **MERCER'S CORRESPONDENCE COLLEGE,** 69 Wimpole Street, London, W.1.

## LYONS RADIO LTD.

Dept. M.P., 3, GOLDHAWK ROAD, SHEPHERDS BUSH, LONDON, W.12  
Telephone: *SHepherd's Bush 1723*

**LOUD-SPEAKER SPEAKERS.**—Handle up to 8 watts, with output transformer, speech coil 7 ohms. Mounted in wood case approx. 9 x 8 x 7 in. Ex-Covt. by Tannoy. PRICE ONLY 17/6, post 3/6.

**VIBRATORS.**—Standard 4-pin U.K. base non-synchronous type: 6 volt, 8.6; 12 volt, 5-. Post 9d.

**POWER UNITS TYPE 234.**—Input 200/250 v. 50 cps. A.C. mains. Output: 250 v. approx., smoothed D.C. at 100 mA and 6.3 v. A.C. at 5A. Two-section choke condenser filter unit gives exceptionally good smoothing. For bench or rack mounting, size 19 x 7 x 10 in. deep. Front panel fitted with switched meter to indicate input or output volts. Supplied in good condition and working order. PRICE ONLY 63/-. or less meter. 57/6. Carriage 9/6.

**ELECTRIC SOLDERING IRONS.**—By famous maker. 25 watt lightweight (weigh approx. 5 ozs.) with Pencil Bit and warning light in handle. 230/250 v. SPECIAL PRICE 18/6, post 1/6.

**FRACTIONAL H.P. MOTORS.**—200/250 v. 50 cps mains. 1,200 r.p.m. Approx. 3 in. dia. x 3 in. with 1/2 in. dia. spindle x 1 in. long. Suitable for Tape Decks, Grams, model operation, etc. In new condition. PRICE ONLY 18/6 each, or 35/- pair. Post 2/-.

**RECEIVERS TYPE 83.**—Ex-R.A.F. 13-valve superhet communication receivers. Frequency range 2-20 Mc/s (15-150 metres) in 4 switched bands. Valves employed are 3-CV1053, 2-CV1922, 2-CV1917, 3-CV387 and 1 each, CV1051, CV253, V1103. With crystal controlled scale check, B.F.O. noise limiter, magic-eye tuning indicator, etc. Power requirements: H.T. 250 v. smoothed D.C. at 60 mA, and L.T. 12 v. A.C. or D.C. at 1.5A. In good condition and working order complete with valves and plugs. PRICE ONLY 83/15.0, carriage 9/6.

## ● AERIALS ● TURRET-TUNERS ● CONVERTERS

Our I.T.V. service offers a complete before and after sales advice. Your problems settled by return mail. Whether novice or expert, let our extensive I.T.V. experience ensure your success.

### AERIALS

● 5 ELEMENT add-on I.T.V. aerial at 39/6 complete with universal clamp bracket and cranked stand-off arm.

8 ELEMENT, as above, 51/6.

● EASIFIX. All aerials pre-assembled and collapsed for transit.

● EASIMOD. All aerials can be modified to double arrays if found necessary.

### ACCESSORIES

● CO-AX. High grade low-loss cable, 8d. per yard. (Any length supplied.)

● DIPLEXERS (filter boxes). Skirting board type, 10/3. Outdoor type, 13/-.

● NOTE: Outdoor type is essential if using existing downlead for BBC/ITV. Indoor type is optional with separate downleads—often used to avoid changing over aerial leads.

IF IN DOUBT:—We advise using a separate downlead for best results on I.T.V.

STATE YOUR NEEDS or ASK OUR ADVICE. We can supply any accessories from wall nails to chimney lashings.

### TURRET-TUNERS

The famous BRAYHEAD Turret tuner. £6.19.6. Plug-in adaptor to suit your particular T.V.. 7/6.

● EASIFIX. Over 600 models can be altered to up-to-date turret tuning and I.T.V. by simple plug-in technique.

● GUARANTEE. If you are unable for any reason to obtain successful I.T.V. with a turret tuner we will allow full credit against an external converter (see below) on return of this tuner undamaged.

### External CONVERTERS

● No external converter can equal the performance of a turret tuner, BUT OUR EXTERNAL CONVERTER comes very near to it.

● Handsome appearance.

● Easifix—in fact, dead easifix! Place on top of T.V. and connect up. No Alterations to T.V. necessary.

● Efficient. 2 valve circuit—the best external converter on the market for the money. Not junk, giving re-radiation, etc., but a first-class job. £6.19.6. Accessories, 7/6.

### VALVES AND COMPONENTS

● We have useful stocks of these, suitable for Radio or T.V. constructors, AT VERY FAVOURABLE prices. Write us for advice or quotations. We can save you POUNDS. PLEASE STATE SET MAKE AND MODEL NO. AND CHANNELS REQUIRED WHEN ORDERING EQUIPMENT.

## WILSON

48, CATHAY, BRISTOL, 1.

(Tel.: 57819 or 26242.)

Mail Order Only. Terms C.W.O.  
Postage 1/6. Above £2 Free Except Aerials 2/6.

## be TRANSISTORWISE! be POCKET-WISE!



"RECO" MIDDY TRANSISTOR ONE KIT (Medium and Long Waves) or Medium and Short Waves. 4 1/2" x 3 1/2" x 1 1/2"

Sensitivity control for weak stations, vari-Q ferrite rod aerial for maximum gain, with "Sonotone" miniature earphone and battery. 37/6, p.p. 2/-.

"RECO" MIDDYGEN TWO TRANSISTOR KIT (Medium and Long Waves) High-Q Regeneration control with variable ferrite rod aerial. Complete with "Sonotone" miniature earphone and battery. 59/6, p.p. 2/3.

"RECO" MIDDYGEN THREE TRANSISTOR KIT (Medium and Long Waves)

Regeneration control for maximum gain in poor reception areas. Quality "Sonotone" miniature earphone with lead. Attractive case, On Test Home and Continental Stations. No Aerial. Complete kit with battery, 72/6, p.p. 2/3.

"RECO" TRANSGEN THREE KIT

(Medium and Long Waves)



Size 6 1/2" x 4 1/2" x 1 1/2". Entirely self contained (no external aerial required). Features oscillating detector stage using R.F. red yellow spot transistor and two A.F. green yellow spot. "Sonotone" super dynamic miniature earpiece with moulded ear insert. On test, this receiver tuned in the "Third," "Home," "Light," and, after dark, Radio Luxembourg, A.F.N., Radio Eireann and many others. The receiver was tested at approximately 50 miles from the nearest transmitter. Complete kit. 75/-, p.p. 2/6.



(Medium, Long and Two Short Wave Bands)

Our latest receiver kit, with "Sonotone" super dynamic miniature earphone giving improved tonal quality. Ferrite rod aerial for sensitivity. Sensitivity control for distant stations. A fine transistor kit complete with 1.5 v. battery. 75/-.

"RECO" PUSH-PULL FOUR KIT

As above but with push-pull output stage and 2 1/2 in. loud-speaker which fits under red plastic speaker grille. 99/6, p.p. 2/6. Size 6 1/2" x 4 1/2" x 1 1/2".

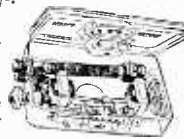

"RECO" PUSH-PULL ADD ON UNIT. Complete with 2 1/2 in. loud-speaker. Case size as above. 69/6, p.p. 2/3

PRACTICAL WIRING DIAGRAMS PARTS PRICE LIST, ETC., FREE WITH KITS OR 1/3 each. AFTER SALES SERVICE

**RADIO EXCHANGE CO.**

(Dept. P.W.)

27, Harpur Street, Bedford  
Telephone 2367

Brand new, individually checked and guaranteed

# VALVES

A864	4/6	EA50	1/6	HP4101	6/-
AC/DD	2/6	EAC91	4/6	KBC32	5/-
AC/HL	2/6	EB34	1/9	KF35	5/-
AC/P	2/6	EBC33	6/-	KR611	3/6
AC/P1	2/6	EC52	4/6	KRN2A	15/6
AC6/PEN	4/6	ECC54	3/6	KRN3	15/6
AL60	4/-	ECC32	4/-	KT2	4/-
AR6	2/6	ECC91	5/-	KT30	7/-
ARP3	3/-	EF22	7/3	KTW62	4/-
ARPI2	3/-	EF36	5/-	LP2	6/6
ARP24	3/6	EF39	5/6	L55B	12/-
ARP34	4/6	EF50	3/-	L57B	12/-
ATP4	3/6	EF55	6/-	MH4	4/-
ATP7	5/6	EF91	7/-	MH41	6/6
B30	3/6	EF92	7/-	MHLD6	4/6
BL63	6/-	EL32	4/6	ML4	4/6
D41	3/3	EL91	7/6	ML6	6/-
D77	5/-	EY91	4/6	MS/PEN	6/-
DD620	4/6	FA15	4/6	MS/PENB	6/-
DET19	1/6	GDT-4B	4/-		
DET20	2/6	H30	5/-	N34	8/-
DH76	4/9	H63	3/6	NR15A	3/-
DLS10	4/6	HL2	2/6	NR61	7/-
EL148	2/-	HL4	3/6	NT37	3/-
EL323	1/9	HL42/DD	6/-	(4033A)	14/-

NT62A	4/-	SU215CA		3E29		6K8G	7/-	12WR7	6/-	813	70/-
OD3	6/-			(829B)	75/-	6K8GT	8/-	15D2	6/-	815	80/-
OZ4	5/-	TT11	3/-	4A1	4/6	6L5G	6/-	15E	8/-	843	7/6
OZ4A	5/-	U8	12/6	4D1	2/6	6L6	10/-	15R	7/6	872A	35/-
P61	2/6	VE85	5/-	5T4	10/-	6L6G	8/6	19E2	5/-	954	2/-
PEN46	5/9	V19C6	4/6	5U4G	7/-	6L6GA	8/6	28D7	8/-	956	3/6
PEN141	4/-	V2023	8/-	5Z3	8/6	6L34	4/6	35T	30/-	1625	4/6
PEN220A	3/-	V2D33B	8/-	6A6	5/-	6N7GT	7/-	39/4A	6/-	1626	6/6
		VR59	8/-	6A7	5/-	6S47	7/-	41FP	1/9	1629	4/6
PEN1340	6/-	VR150/30		6AC7	5/-	6S67	7/-	45	7/-	7193	1/9
PM28A	3/6			6AG5	5/6	6S7	5/-	53A	3/-	7575	5/-
PM2DL	3/6	VE110	4/-	6AG7	8/6	6S17	7/6	58	6/-	8010AR	22/6
PM2HL	3/-	VT25	8/6	6AK6	7/6	6SK7	5/6	59	6/-	8020	6/-
PM4DX	3/-	VU33	2/6	6AL5	5/6	6SL7GT	7/-	71A	4/6	9001	5/-
PM2C2	7/6	VU111	3/-	6AM5	8/6	6SN7	5/6	76	9/-	9004	4/-
PT15	8/-	VU120A	3/-	6AM6	7/-	6SN7GT	5/6	77	6/-	9006	4/-
PT25H	7/6	W42	7/-	6B4G	4/6	6SQ7	6/6	82	8/-		
QP21	6/-	Y66	8/-	6BB	6/-	6S57	8/-	83	12/-		
QP25	5/3	IA3	3/6	6BBG	3/-	6V6G	6/-	89	6/-		
RG1-240A		IA5GT	5/-	EC4	5/6	6X5G	6/-	89	6/-		
		IE23	11/-	ED2	2/6	6Y2	3/-	216FL	3/-		
RG3-250	17/6	IE24	11/-	6E6	4/6	9D2	3/-	210VPT	3/-		
		IE32	11/-	6C8	5/-	11E2	5/-	217C	17/6		
RG4-1250	17/6	IB32	10/-	6D6	5/-	11E3	5/-	220VSG	3/-		
		ID8GT	6/-	6F6	7/-	12A6	5/-	446A	14/-		
RK34	3/-	IL4	4/-	6F6G	5/-	12AH7	7/-	446B	14/-		
RKR72	5/6	ILD5	3/6	6F8G	8/-	12C8	7/6	705A	17/6		
RKR73	5/6	ILN5	5/-	6F12	7/-	12E1	22/6	715B	97/6		
SP2	4/6	2A3	8/-	EG6G	3/-	12H6	2/6	717A	8/6		
SP4B	7/6	2A6	7/-	6H6	2/3	12J5GT	3/6	801	6/-		
SP13C	4/6	2C34	2/6	6H6GT	1/9	12SG7	6/6	803	22/6		
SF41	2/9	2D4A	4/-	6J5	5/-	12SH7	4/9	805	30/-		
SP61	2/9	2X2	4/-	6J6	5/-	12S17	6/-	807AMER			
STV280/40		3A4	6/6	6K7G	4/-	12SK7	7/-				
		3B24	3/-	6K7GT	6/-	12SL7	7/-	807BR	6/6		

813	70/-
815	80/-
843	7/6
872A	35/-
954	2/-
956	3/6
1625	4/6
1626	6/6
1629	4/6
7193	1/9
7575	5/-
8010AR	22/6
8020	6/-
9001	5/-
9004	4/-
9006	4/-

**Cathode**

**Ray**

**Tubes :**

3BP1	25/-
5CP1	42/6
5FP7	45/-
5MP1	17/6
VCR97	10/-
VCR517	10/-

**Special Valves :**

417A	15/-
723AB	52/6
726A	27/6

All Orders below 10/-, P. & P. 1/-; over 10/-, 1/6; Orders over £2 P. & P. free.

Brand new original spare parts for AR88 Receivers. Please see advert. Dec. issue.

**SCR.522. Transmitters** (BC625), including all valves, 45/-, P. & P. 5/-.  
**H.R.O. Mains.** 150/230 v. **Power Supply Unit**, complete with valve, checked, £3.9.6. P. & P. 2/6.

**High Resistance Headphones.** 4,000 ohms. Brand new, cx W.D. boxed. Type DHR, 10/6 per pair. P. & P. 1/-.

**Low Resistance Headphones.** Brand new, type CLR, 5/-, DLR, 6/6 per pair. P. & P. 1/-.

**Modulation Transformers** (U.S.A. Collins), primary imp. 6,000 ohms. C.T., secondary 6,000 ohms, 20 W., 9/6 each. Post free.

**Microphone Transformers.** Balanced input 30 or 250 ohms. U.S.A. manufacture, 7/6. P. & P. 1/6.

**813, Ceramic Valveholders,** 3/- each. P. & P. 1/6.

**Marconi Signal Generator.** TF144G: 85 kc/s, 25 Mc/s. Made up to new standard, £70, delivered free.

**Telephone Handset.** Standard G.P.O. type. New, 10/-, P. & P. 1/-.

**Hallcrafters' S27 Receivers,** 27-143 Mc/s. Fully reconditioned, £30.10.0, delivered free.

**AR88D and L.F. Receivers,** completely overhauled and tuned, £60 and £57.10.0 respectively. Completely rebuilt with P.V.C. wiring, £85.

**Complete V.F.O. Unit** from TX53. Freq. range in 4 switched bands from 1.2-17.5 Mc/s. Two V.T. 501s as oscillator and buffer, 807 as driver, two 5130s as voltage stabilizers. Output sufficient to drive two 813s in parallel. Slow motion drive directly calibrated in Mc/s. Provision for crystal control, metering of buffer and driver stage. Power requirements 400 v. and 6.3 v. D.C. Can also be used as low power transmitter. In excellent condition with valves and circuit diagram £5. P. & P. 15/-.

**P. C. RADIO LTD.**  
170 GOLDHAWK RD.,  
W.12 SHEPHERDS BUSH 4946

**R.C.A. Master Oscillator** (V.F.O.) with stability of 0.0007%. Frequency range 2-20 Mc/s with built-in constant frequency tone generator. Regulated A.C. power supply 115/230 v. and fitted with plate and volt meters. Valves line-up: Electron coupled oscillation 3Q5(2). Buffer amplifier—007, tone generator—6AB7(1), 6F6(1), regulated power supply 5U4(2), 6Y6(5), 18B2(1), VR150/30(2). Brand new, complete in grey crackle steel cabinet size 67in. x 22in. x 17in. Fitted with full-length door at rear with standard 19in. panels. Can be used as complete TX with existing 807 output. The bottom half of the cabinet with 3 blank panels being empty ready for installation of complete R.F. modulator and power unit, thus making a complete totally enclosed compact TX. Circuit diagrams and working instructions supplied. Price complete with valves, £27/10/- each. Supplies strictly limited.

**PERSONAL CALLERS WELCOME**

An Electronic Organ for the Home Constructor, by A. Douglas, 16/-, Postage 1/-.

**World Radio Handbook, 1959,** by Hans Johansen, 14/6. Postage 1/-.

**R.S.G.B. Radio Amateurs' Call Book, 1959,** 3/6. Postage 6d.

**Brimar Valve and Tele Tube Manual** No. 7, 6/-, Postage 8d.

**The Radio Amateur Operators' Handbook, 1959,** 3/6. Postage 6d.

**T.V. Fault Finding,** by Data Publications, 5/-, Postage 6d.

**Electronic Novelties for the Constructor,** by Bradley, 5/-, Postage 6d.

**Oscilloscope Equipment Circuits for the Constructor,** Easterling, 5/-. Post 6d. We also have a full range of Slide Rules and Drawing Instrument Sets. Send for list.

**UNIVERSAL BOOK CO.**  
12 Little Newport Street, London, W.C.2  
(adjoining Lisle Street)

**0-500 MICROAMP Moving Coil Meter,** 2in. Brand new, 17/6. P. & P. 1/6. Suitable 25-range A.C./D.C. circuit, 9d.

**MULTIMETER KIT FOR 1 mA METER.** Ranges 10, 100, 250, 500 v. A.C. and D.C., 2.5 v. D.C., 10, 100, 1,000 mA. D.C. ohms to 200 K. Kit comprises: Ready adjusted three-range 1% shunt, Salford rectifier, 7 hi-stabs 1%, 1 w.w. res., 0.3%, 2 hi-stabs 10%, w.w. pot., 2 p. 4w. and 1 p. 8w. switches, circuit and instructions. 35/6 post free. Circuit 9d.

**NEW CIRCUITS.** MM40 40-range multimeter for 500 uA meter, 9d. Gadget for increased sensitivity voltage measurements in high-resistance circuits, 9d.

**SHUNT FOR 1 mA 100-OHM METER.** Ranges 10, 100, 1,000 mA., 1% accuracy, 8/6.

**SHUNT FOR 500 uA 500-OHM METER.** Ranges 5, 50, 500 mA., 1% accuracy, 8/6. Postage extra. S.A.E. with enquiries, please.

**PLANET INSTRUMENT CO.**  
25, Dominion Avenue, Leeds, 7.

## H.A.C. SHORT-WAVE EQUIPMENT

Noted for over 20 years for... S.W. Receivers and Kits of Quality.

Improved designs with Denco coils: As supplied to Technical Colleges, etc. **One-Valve Kit, Model "C,"** Price 25/- **Two-Valve Kit, Model "E,"** Price 50/- **New Addition: Model "K,"** Super sensitive "All Dry" Receiver. Special incl. price, Complete Kit, 77/-.

All kits complete with all components, accessories and full instructions. Before ordering call and inspect a demonstration receiver, or send stamped, addressed envelope for descriptive catalogue and order form.

**"H.A.C." SHORT-WAVE PRODUCTS**  
(Dept. TH), 11, Old Bond Street, London, W.1.

# LASKY'S RADIO

## "Easy-to-Build" Radios

Complete Parcels. All components available separately.  
CIRCUIT DIAGRAM & BUILDING INSTRUCTIONS  
FOR ANY OF THESE, 1/6 each, post free.

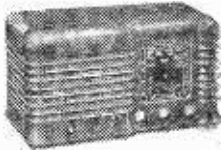

### 3-VALVE T.R.F.

For 200/250 v. A.C. mains, med. & long wave. Can be built complete for £5/10/- plus 2/6 post.

### 4-VALVE S/HET

For 200/250 v. A.C. mains, med., long & short wave. Can be built complete for £7/19/6 plus 2/6 post.

### LASKY'S F.M. TUNER

Printed Circuit version of the G.E.C. 912 "F.M.Plus." Can be built complete for £7/19/6 plus 3/6 post.

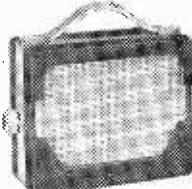

### TRANSISTOR PORTABLE

Uses 7 transistors and 1 germanium diode. Can be built complete for £9/19/6 plus 3/6 post.

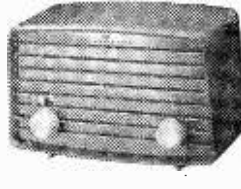

### MIDGET T.R.F.

For 200/250 v. A.C. mains, med. & long wave. Uses 2 double-purpose valves. Can be built complete for £4/19/5 plus 3/- post.



### 4-VALVE S/HET PORTABLE

Med. & long wave. BATTERY version can be built for 7 Gns. plus 3/6 post (only batteries extra).

MAINS/BATTERY version can be built complete for 9 Gns. plus 3/6 post.

**TRANSISTOR AUDIO AMPLIFIER**  
200/250 milliwatts. Can be built complete for 79/6 plus 3/6 post.

**TRANSISTOR SUPERHET TUNER**  
Battery operated. Can be built complete for £5/12/9 plus 3/6 post.

### LASKY'S (HARROW ROAD) LTD.

42, TOTTENHAM COURT ROAD, W.1.  
370, HARROW ROAD, PADDINGTON, W.9.

Telephone: MUScum 2605.  
LAD. 4075 and CUN. 1979.

Open all day SATURDAY. Half-day Thursday.

PLEASE ADDRESS ALL MAIL ORDERS TO HARROW ROAD.

**20,000 VALVES IN STOCK**  
Brand new surplus and imported valves, also full stocks of B.V.A. valves and C.R. Tubes. List post free.

## SPECIAL OFFERS

\*149 APN-4 RECEIVERS, containing: 4-6SK7GT, 3-B4G, one each 6SN7GT, 6SA7GT, VR113-30, 5U4G, 6H6GT, 6SL7GT, 6S1J7GT—now reduced (while the present stock lasts) to 80/- only. P.P. 10/-.

\*BC-1066 TEST RECEIVERS, 150-235 mc/s; two tuned detector circuits 1D9GT and two A.F. Amplifiers, 957. Power Requirements 135 v. and 1.5 v. Brand new, only 30/-, P.P. 5/-.

\*4-198 SIGNAL GENERATOR, 150-235 mc/s. One valve 957 in a self blocking oscillator circuit tuned by a parallel line. Power Requirements 135 v. and 1.5 v. Brand new, only 29/-, P.P. 5/-.

\*BC-949 RANGE CALIBRATOR: contains a resonating circuit to produce micro-second pulses of 12, 60 and 120 msec. Valves: 6SL7GT, 6H3; handsome steel case with carrying handle. Brand new, only 15/-, P.P. 4/-.

\*ROTATING BEAM AERIAL BASES, tubular, 2in. dia. x 6ft. high, with rotating handle (worm and wormwheel) and azimuth indicator, 35/-; 6ft. extension masts (max. of two per base), 15/- each, P.P. 12/6.

BRAND NEW HIGH CLASS MAINS ENERGISED SPEAKERS. Save weight and expense by saving a choke.  
6in. 68 ohms field coil, 3.5 ohm sp. coil, 8/6.  
6in. 1,000 ohms field coil, 5 ohm sp. coil, 8/6.  
6in. x 13in. 1,000 ohms field coil, 4 ohm sp. coil, 12/6.  
10in. 68 ohms field coil, 3 ohm sp. coil, 12/6.

BRAND NEW P.M. SPEAKERS, 5in., 3 ohms, 16/6; 6in., 3 ohms, 16/6; 6in. x 10in., 4 ohms, 22/6; 8in., 4 ohms, 17/-; 8in., 3 ohms with 3/7,000 ohms matching transformer, 22/6; 8in., 3 ohms, 17/-, P.P. 3/6 per speaker.

LARGE STOCK OF VALVES AND METERS. Please send s.a.e. for lists.

COMPREHENSIVE RANGE OF SMALL COMPONENTS, resistors, condensers, switches, etc., all attractively priced, available in the self service section of our retail shop, at:

85, Tottenham Court Road, London, W.1. Near Goodge Street Station.

Telephone LANGham 8403

## Z & I AERO SERVICES LTD.

Head Office: 14, South Wharf Road, London, W.2.  
Tel.: AMBassador 0151/2

Please send mail orders and all correspondence to the Head Office.

We urgently require Receivers BC-348 and AR88D.

## FREE TO AMBITIOUS ENGINEERS!

This 148-page Book

Have you sent for your copy?



'ENGINEERING OPPORTUNITIES' is a highly informative guide to the best-paid Engineering posts. It tells you how you can quickly prepare at home on "NO PASS—NO FEE" terms for a recognised engineering qualification, outlines the widest range of modern Home-Study Courses in all branches of Engineering and explains the benefits of our Employment Dept. If you're earning less than £20 a week you cannot afford to miss reading this unique book. Send for your copy to-day—FREE.

### WHICH IS YOUR PET SUBJECT?

- Mechanical Eng.
- Electrical Eng.
- Civil Engineering
- Radio Engineering
- Automobile Eng.
- Aeronautical Eng.
- Production Eng.
- Building, Plastics, Draughtsmanship, Television, etc.

### GET SOME LETTERS AFTER YOUR NAME!

- A.M.I.Mech.E.
- A.M.I.C.E.
- A.M.I.P.E.
- A.M.I.M.I.
- L.I.O.B.
- A.F.R.Ae.S.
- B.Sc.
- A.M.Brit.I.R.E.
- CITY & GUILDS
- GEN. CERT. OF EDUCATION
- etc., etc.

--- FREE COUPON ---  
Please send me your FREE 148-page "ENGINEERING OPPORTUNITIES"

NAME .....  
ADDRESS .....

Subject or Exam. that interests me.....

British Institute of Engineering Technology,  
409 B, College House, 29-31, Wright's Lane,  
London, W.8.

## BIET

# Why save up for a test set?

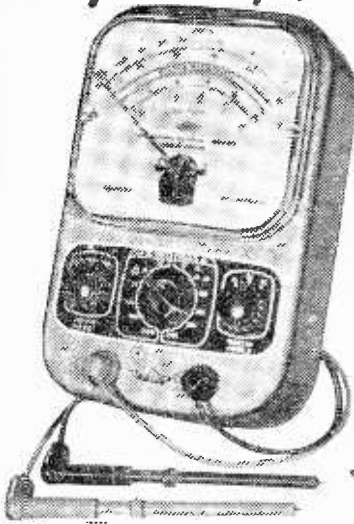

**-you can have one NOW**

Don't be at a loss waiting for a test set until you have sufficient money saved to buy one. You can have one of the well-known M.I.P. Series 100 Multi-Range test sets sent to you almost at once. A deposit of 47/6 secures. Balance payable over 6 or 12 months. Cash price £12.7.6.

**Extended Terms**

Deposit 47/6 and 6 monthly payments of £1.15.0  
 Deposit 47/6 and 12 monthly payments of 17/11

**★ 21 SELF-CONTAINED RANGES covering :**

10-1,000 d.c. volts. 10-1,000 a.c. volts. 100 Microamps to 500 Milliamps d.c. 100 Microamps a.c. 0 to 1 Megohm. 0 to 10,000 ohms.

All voltage measurements a.c. and d.c. are at 10,000 ohms per volt.



GD.23

POST COUPON FOR FULL DETAILS

**MULTI-RANGE TEST SET-SERIES 100**

MEASURING INSTRUMENTS (PULLIN) LTD.  
 Electric Works, Winchester St., Acton, London, W.3.

Please send illustrated leaflet of the Series 100 Test Set with details of new easy payments scheme

NAME .....

ADDRESS .....

E259

## IT'S SIMPLE !

Yes! YOU can build professional equipment without test gear! Over 100,000 enthusiasts have benefited from our Home Radio Constructor's Handbook, which gives full parts lists, circuits, etc., of many receivers, tape recorder, oscilloscope, tester units, communications set, hi-fi amplifiers, power pack, crystal set, etc. (including "P.W." Coronets). Packed also with data, construction, soldering and servicing hints, facts, formulae, colour code, etc. "Easy-as-A.B.C." FULL SIZED p.p. Construction sheets are available FREE with orders. Even the beginner gets professional results first time! This claim confirmed by many hundreds of genuine testimonials received. Introduced virtually at printing cost, we invite you to send 3-TODAY for your copy. Don't delay.

**NOWHERE IS THERE A BOOK SO VALUABLE TO THE NOVICE CONSTRUCTOR AND EXPERT!**

### RODING LABORATORIES

Hurn Airport, Christchurch, Hants

### TESTOSCOPE MAINS TESTER

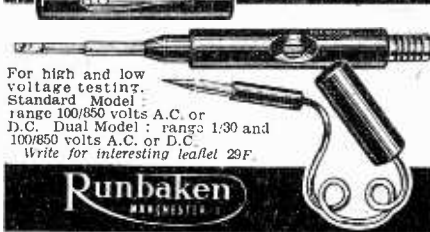

For high and low voltage testing.  
 Standard Model : range 100/850 volts A.C. or D.C.  
 Dual Model : range 1/30 and 100/850 volts A.C. or D.C.  
 Write for interesting leaflet 29F



BOOKLET—"Hints on Electrical Testing," post free 1/-.

- GARRARD TA Mk. 2 4-speed Single Record Unit with GC P.U. .... £9 15 8
- GARRARD. RC121/4D Mk. II. 4-speed Auto-changer with GC8 Pick-up..... £13 13 11
- GARRARD 4 H.F. 4-speed Single Record Unit with TPA12 Transcription Arm and G.C.8 Pick-up..... £49 7 10
- W.B. PRELUDE Bass Reflex Console Cabinet ..... £11 11 0
- W.B. PRELUDE Hi-Fi Console Cabinet (houses tape-deck, amplifier, tuner, etc.) £13 13 0
- W.B. T359 cone Tweeter..... £1 15 0
- W.B. H.F. 1016 Speaker..... £8 0 0
- W.B. H.F. 1012 Speaker..... £4 19 9
- COSSOR 3 valve 3 watt Amplifier Kit, complete with 2 speakers..... £9 15 0
- COSSOR 6 valve FM Receiver Kit, with 10in. x 6in. speaker..... £15 15 0
- COLLARO Mk. IV Tape Transcriptors £25 0 0
- AVO MULTIMINOR..... £9 10 0
- Teletron TRANSIDYNE 6 Transistor 2-wave Pocket Receiver Kit..... £11 15 0
- TRANSISTORS. Yell./Gr. Spot (A.F.), 10/-; Yell./Red Spot (R.F.), 15/-; Mullard OC70, 21/-; OC71, 24/-; OC72, 30/-; OC44, 40/-

ALL The Above Items Sent Carriage Paid.

COMPONENTS are still available for all OSRAM and MULLARD Circuits.

Send 9d. in stamps for Illustrated List.

## L. F. HANNEY

77 LOWER BRISTOL ROAD, BATH

# RADIO SUPPLY CO.

(LEEDS) LTD., Dept. C, 5 & 7 COUNTY ARCADE, BRIGGATE, LEEDS, 1

EX-GOVT. METAL BLOCK PAPER CONDENSERS. 500 v. 8-10 mfd., 3/9.

**MANUFACTURERS' SURPLUS MAINS TRANS.** Primary 200-250 v. Universal Mgr., 350-0-350 v. 100 mA., 6.3 v. 4 a. C.T., 0-4.5 v. 3 a. only. 18/9.

EX-GOVT. DOUBLE WOUND STEP UP STEP DOWN TRANSFORMERS. 10-0-100-200-220-240 v. to 9-0-110-122-136-148 v. or REVERSE. 300 watts, 50 c.p.s. 35/9, plus 7/6 cart.

EX-GOVT. CASES. Size 14-10-8 1/2 in. high. Well ventilated, black crackle finished, undrilled cover. IDEAL FOR BATTERY CHARGER OR INSTRUMENT CASE, OR COVER COULD BE USED FOR AMPLIFIER. Only 9/9, plus 2/9 postage.

Size 8 1/2 x 13 1/2 x 6 1/2 ins. with undrilled, well ventilated cover finished in stove grey enamel. Suitable for charger or instrument case. 7/9, plus 2/9 post.

2 v. 16 a.h. EX-GOVT. ACCUMULATORS. New, boxed. Only 5/6 each. 3 for 15/-, post 2/6. 6 for 27/6, carr. 3/6.

**EX-GOVT. VALVES (NEW)**  
 1R5 7/9 6J5 5/9 ECC91 4/9  
 1T1 7/9 6J6 4/9 EF80 7/9  
 1S7 7/9 6V6G 7/9 EB91 4/9  
 3S1 8/9 6X4 6/9 EF81 8/9  
 5Y3C 8/9 6X5GT 8/9 EL32 3/9  
 6U4G 8/9 6L6G 11/9 KT44 8/9  
 54ZG 9/9 807 7/9 KT61 9/9  
 6KT7 5/9 12A6 7/9 EZ90 8/9  
 6S7GT 6/9 15D2 4/9 EL54 10/6  
 6SLGT 8/9 35ZAGT 6/9 MU12 14/9  
 6SN7GT 8/9 MH4 4/9 FW4500 9/9  
 6AT5 7/9 ECC83 9/9 SP61 2/9

**VOLUME CONTROLS** with long (1in. dia.) spindles all values less switch, 2/9, with switch, 3/9.

**EX-GOVT. SMOOTHING CHOKES**  
 250 mA. 20 H 200 ohms ... 19/9  
 200 mA. 3-5 H Parmeko 50 ohms ... 9/9  
 150 mA. 10 H 100 ohms ... 11/9  
 120 mA. 12 H 100 ohms ... 9/9  
 100 mA. 5 H 100 ohms ... 3/11  
 80 mA. 20 H 900 ohms ... 6/9  
 60 mA. 5-10 H ... 2/11

Terms: C.W.O. or C.O.D. No C.O.D. under £1. Post 1/9 extra under £2. 2/9 under £5.

**SPECIAL OFFERS:** Electrolytics. 150 mfd. 450 v., 3/9. Small .0005 mfd. 2-gang, 4/9 ea. Westinghouse Rectifiers 250 v. 1.0 mA., 7/9.  
 CO-AXIAL CABLE. 75 ohm. 1in. 8d. yd. Twin-Screened Feeder 11d. yd.

**14 WATT AMPLIFIERS.** Unused and in good order but store soiled. For 200-200 v. A.C. mains input. Outputs for 3 and 15 ohm speaker. Inputs for "mike" and Gram. Limited number complete with valves. Only 6 Gns., carr. 5/-.

**JUNCTION TRANSISTORS** Brand new R.F. type. 17/6. A.F., 7/6.

## EXTENSION SPEAKERS

Ready to use in walnut veneered cabinet.

6In. 2-3 ohms. 29/11.  
 8In. 2-3 ohms. 35/9.  
 Very limited number



**ELECTROLYTICS** (current production) NOT EX-GOVT.

Tabular Types	Can Types
8uF 450 v. ... 1/9	16 mfd. 350 v. ... 1/11
8 mfd. 500 v. ... 2/6	16uF 450 v. ... 2/9
16uF 350 v. ... 2/3	32uF 350 v. ... 2/11
16uF 450 v. ... 2/9	32 mfd. 450 v. 4/9
16uF 500 v. ... 3/9	100 mfd. 450 v. 2/9
32uF 350 v. ... 3/9	8-8uF 450 v. ... 2/9
25uF 25 v. ... 1/3	8-16uF 450 v. 3/11
50uF 12 v. ... 1/3	16-16uF 450 v. 4/11
50 mfd. 25 v. ... 1/6	32-32uF 350 v. 4/9
50uF 60 v. ... 1/9	32-32uF 450 v. 5/9
100 mfd. 12 v. ... 1/9	100-100 25 v. ... 2/3
100 mfd. 25 v. ... 2/3	700-700 mfd. 6 v. 1/6
3,000 mfd. 6 v. ... 3/9	275 v. ... 6/9

**HEADPHONES.** Brand new. Low resistance. Only 6/9 pr.



**LUCAS 6 v. 2.2 A.C.H. MOTOR-CYCLE BATTERY-UPS.** Brand New. Sealed. List price £3/11/- Limited number available at only £2/6, carr. 4/6.

**HEAVY DUTY BATTERY CHARGER KIT.** 12 v. 50 amp. (Two outputs each 12 v. 15 a.). Suitable Garages or transport firms, etc. Kit consists of Mains Trans. A.C. 200-250 v., 2 Rheostats, 2 Ammeters, 6 Fuses (Panel Mounting), 4 Terminals, 2 F.W. Bridge Selenium Rectifiers and Circuit. £9.19/6, carr. 17/6.

**VIBRATORS.** Oak and Wreath synchronous 7-pin 2 v. 7/6. 6 v., 8/9. New.

**RE-ENTRANT SPEAKERS.** Tannoy. 8 watt. 7-5 ohms. Only 25/- each.

**EX-GOVT. MAINS TRANSFORMERS.** All 200-250 v. 50 c/s input.  
 250-0-250 v. 60 mA., 6.3 v. 3 a., 6.3 v. 1 a. Potted 41-31-3in. ... 11/9  
 Pr. C-110-200-220-250 v. 275-0-275 v. 100 mA. 6.3 v. 7 a., 5 v. 3 a. ... 21/9  
 230-0-230 v. 60 mA. 12.5 v. 1.5 a., 5 v. 2 a. ... 11/9  
 250-0-250 v. 150 mA. 5 v. 3 a. ... 16/9  
 350-0-350 v. 150 mA. 6.3 v. 5 a., 5 v. 3 a. 27/9  
 450-0-450 v. 250 mA. 6.3 v. 3 a., 6.3 v. 1 a., 5 v. 5 a., 5 v. 3 a. ... 49/9  
 12.5 v. 3 a., 5 v. 3 a. ... 12/9  
 0-24-26-28 v. 15 amp. A.C. conservative Govt. rating (marked with D.C. rating after rectification), 89/9, carr. 15/-  
 0-20-25 v. 24 a. (Govt. rating) 79/6, carr. 15/-

**INSULATED STAPLES.** 1in. Boxes of 100, 1/- ea., 10/6 doz., £5 10 per gross.  
**5 CORED FLEN.** Rubber Insulated. 14/36, 1/3 yd., 50/- 50 yds., £4 per 100 yds.

## ALFRED PADGETT

40 MEADOW LANE, LEEDS, 11

Tel.: CLECKHEATON 2866

12in. T.V. Chassis complete with focus coil, etc., less valves 15/-, Carr. 5/-. Ultra, Plessey, Banner, Marconi, etc.

12in. Table T.V. Cabinets 5-. Carr. 6/-. 12in. Console Cabinet 20-. Carr. 7/6. Ideal for table R.G. Hi-Fi cases, etc.

We can supply any valve removed from 10in. and 12in. T.V. chassis for 8/6 each, EF80, 4-. 6AM6 3-. Post 8/6. Mazda, Mullard or Marconi. All tested up to standard.

New 3BP1 Tube 10-. Post 2/6. Base and screen for tube 4-. Post 2/6. Or complete 13/-.  
 Heavy Duty Pots. 200 ohms 40 watts. 3in. dia., 4- each. Post 1/-. 100,000 ohms. 100 watts. 4 1/2 in. dia., 4-. Post 1/9.

New Valves. U50 6/3. 5Z1 6/6. X63 6/6. DH3 6/6. U14 6/6. KTW61 2/-. 6K7 2/-. 954 1/-. 8SN7 4/-. 6H 6/6. EF50 1/9. Red EF50 2/6. VR75 1/-. VR92 6d. 2X2 1/-. VR137 6d. HL2 1/3.

Electronic Scrap. Units, Receivers, Transmitters, spares of all kinds. Sold by weight. Half cwt. 10/- net. Carr. 12/-.

Mixed Radio Panels full of Resistors, Condensers, etc. 5- per doz. Post free.

New Magic Eye. Removed from equipment Type Y.65 complete with base, resistors and panel bracket 5/-. Post 1/3.

New Pots. Less switch 250K preset or lin. spindle 6d. each. Post 9d. 4/6 doz. Post free.

New Co-ax. Cable. 75 ohms, multi-strand B.B.C. or I.T.V. worth 13 p. per yard. Our price 6d. per yard. Any length cut. Post free.

## TRANSISTOR SUPPLIES

Red Spots, 7/6; White Spots, 15/-; Yell./Gr. 10/-; Yell./Red, 21/-; OC70, 21/-; OC71, 24/-; OC72, 30/-; OC45, 35/-; OC44, 40/-; XA102, 40/-; XA101, 35/-, Sub-min. Electrolytics: 5, 8, 10, 16, 25 and 32 uF, each 3/6 each. Teletron Companion—all parts with printed circuit, £5/11/6; Repanco Mini-7, all parts, £11/2/6. 5in. P.M. Speaker, 18/6; 2in., 29/-. Ardente Transformers, D239 and D240, 10/- each; T1079, 12/-; D131 and D132, 12/9 each; D167, 12/-. Mullard Circuit Trans. Driver P.P., 13/6 and 18/6; output to 3 ohms., 13/6 and 18/6.

**BARGAINS.**—These prices include post. Phones (H.R. Ex.-Gov.), 10/6; Power Hand Mikes, 6/6; Crystal Inserts, 4/9; Super 75 Ohm Coax., 8d. yd.; Condensers, variable air, .0003, 4/-; .0005, 6/6; 0005 T-gang, 7/6; Morse Keys, 3/3.

**TERMS.**—Cash With Order. Post Extra; excess refunded. Don't miss our notes on transistors—send 8d. stamp for same.

## MORCO EXPERIMENTAL SUPPLIES

8 & 10, Granville St., Sheffield, 2  
 Tel.: 27461

## RES/CAP. BRIDGE 35/-

Checks all types of resistors, condensers 6 RANGES

Built in 1 hour. Direct reading

### READY CALIBRATED

Stamp for details of this and other kits.

### RADIO MAIL (Dept. PK)

Raleigh Mews, Raleigh Street, Nottingham

## Forrest

Transistor Transformers for Quality Equipment

## H. W. FORREST (Transformers) Ltd.

349, Haslucks Green Road, Shirley, Solihull, Warwick. Tel.: Shirley 2483.

## ROTARY SWITCHES

Superior Wafer Switch. Spindle Type. Renowned Manufacturer. Unopened boxes. Offered at fraction of cost.

Single Pole, 8 pos., 2/- each, 18/- doz.  
 3 Pole, 3 Pos. (2 Bank), 2/6 each, 22/- doz.  
 3 Pole, 3 Pos. (3 Bank), 3/- each, 30/- doz.  
 4 of each type (12 switches), 25/-

### HEADPHONES

High Resistance, Top Quality, boxed, 16.6. Single C.L.R. Earphone with Headband and Lead (S.C.B.), 3/6. (Ideal for Crystal Sets, Telephones, etc.)  
 Postage and Packing extra 1/6 per item. High Quality Short Wave Components. Stamped envelope for List.

## H.A.C. PRODUCTS (Components) Dept.

11, Old Road St., London, W.1.

## 1-Finger Pianist

Build your own electronic keyboard and play everything! Send for free leaflet. Guitar, cele. flute and trumpet are all easy. Write now...

C & S, 10 Duke St., Darlington, Co. Durham

# INTRODUCING THE COMBINED POWER PACK AND AMPLIFIER FOR THE "MAXI-Q" PRE-SET OR VARIABLE F.M. TUNER WHICH NOW OFFERS YOU A COMPLETE RECEIVER

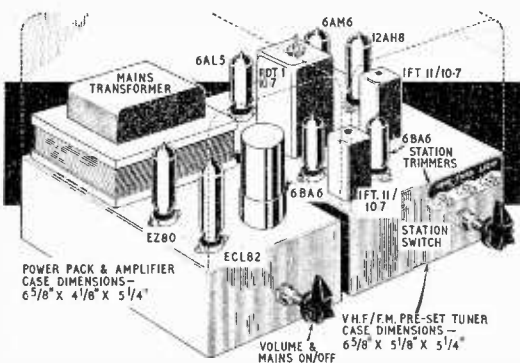

Full constructional details, point-to-point wiring diagrams and alignment instructions for building the "MAXI-Q" COMBINED POWER PACK AND AMPLIFIER, PRE-SET F.M. TUNER and also the VARIABLE TUNED version are given in Technical Bulletin DTB.8. 1/6

**POWER PACK AND AMPLIFIER.** This unit consists of Mains Transformer, E280 and ECL82 valves. Volume Control complete with mains on/off switch and is housed in a gold-finished case. Power supplies available for any tuner—Heater 1.5 amps at 6.3V. H.T. from 220 V. at 50 mA to 265 V. at 20 mA.

The unit is available completely wired and ready for use at £5/10/-, plus 2/6 carriage or available in kit form at £5.

**PRE-SET F.M. TUNER.** Completely punched chassis, screens and bronze-finished cover, 19/-.

**RATIO DISCRIMINATOR TRANSFORMER.** RDT 1107 Mc/s. Secondary winding of bifilar construction, iron dust core tuning, polystyrene former, silver mica condensers. Can size 1 1/2 in. sq. x 2 1/2 in. high, 17.6.

**I.F. TRANSFORMER.** IFT.11 10.7 Mc/s. Miniature I.F. of nominal frequency 10.7 Mc/s. The "Q" of each winding is 90 and the coupling critical. Can size 1 3/16 in. sq. x 1 1/2 in. high, 6/6.

**COILS.** TYPE L1, T1 and T2. Specially designed for use in this unit, are wound on polystyrene formers complete with iron dust core tuning, 1/1. Three-position switch, 4/3. Station Condenser Trimmers, 3-9 pF. 2/-.

**THE "MAXI-Q" PRE-SET F.M. TUNER** is available completely wired, assembled, valued and housed in a sturdy made gold-finished cover at £8/11/5, plus £3/8/7 P.T.—£12 (carriage 3/-).

**VARIABLE F.M. TUNER** completely assembled at £7/17/2, plus £3 2/10 P.T.—£11 (carriage 3/-).

**GENERAL CATALOGUE** covering technical information on full range of components, 1/3, post free.

**TRADING TERMS** for direct postal orders, c.w.o., plus appropriate postal charge. Please send S.A.E. with all enquiries.

## DENCO (CLACTON) LTD. (Dept. P.W.), 357/9 Old Road, Clacton-on-Sea Essex

### CONSTRUCTIONAL DETAILS AND PRICE LISTS

REP 1 Valve ...	9d.	Trans-7 ...	1/6
3 DEE ...	9d.	Major-7 ...	1/6
Mini-7 ...	1/6	F.M. Tuner ...	1/6
		Highwayman ...	1/6

Please add 3d. postage.

**FULL RANGE OF T.S.L. HIGH STABILITY 1/2 WATT 10% RESISTORS**  
6d. each. Any Quantity Post Free.

Gold Spot (V3/R2) Transistors ...	24/-	
Red/Yellow Transistors ...	21/-	
Green/Yellow Transistors ...	17/-	Post
White Spot Transistors ...	10/6	Free
S.T.C. T83 Transistors ...	13/8	
Red Spot Transistors ...	9/-	
W.B. 2 1/2 Inch Speaker ...	22/-	Post
Collection 2 1/2 Inch Speaker ...	29/-	Free
Sub-miniature Electrolytics 1, 5 and 8 mid., 15 v.w. 3'-each		
Teletron "Transidyno" six transistor pocket radio. Complete Kit.	£11 19/6.	p.p. 2/6.
All parts sold separately.		
Teletron HAX coils. MW. 3'-. LW. 3'6.		
Add 3d. Postage.		

### Q-MAX CUTTERS

1in. ...	12/9	Key 1/1	6d.	Postage
1 1/2 in. ...	13/9	Key 1/1		
1in. 1 1/2 in. 1 1/2 in.	16/-	Key 1/6		Cutter.

Miniature Single Ended Transistor Output Transformer. 7/6.  
All Enquiries Welcome  
Send 1/- P.O. for 59 page illustrated catalogue  
**FAIRDEAL RADIO (Dept. P.W.),**  
73 WEST DERBY RD., LIVERPOOL, 6.  
Tel.: Anfield 5235

### SPARKS' DATA SHEETS present THE AMAZING "COX'N" A.C./D.C. 3

For unlimited New Thrills and Interest on 10 TO 220 METERS  
Amateurs, Trawlers and Liners, etc. Unique Cathode Regen. circuit ensures Highest Efficiency. Full-size Data Sheet plus instructions, 3/3 Post Free.  
All Components, Chassis and Coil available.  
**L. ORMOND SPARKS (P),**  
Valley Road, Corfe Castle, Dorset

## FIRST-CLASS RADIO COURSES ... GET A CERTIFICATE!

QUALIFY AT HOME—IN SPARE TIME

After brief, intensely interesting study—undertaken at home in your spare time—YOU can secure your professional qualification. Prepare for YOUR share in the post-war boom in Radio. Let us show you how!

### FREE GUIDE

The New Free Guide contains 132 pages of information of the greatest importance to those seeking such success-repelling qualifications as A.M.Brit.I.R.E., City and Guilds Final Radio, P.M.G. Radio Amateurs, Exams., Gen. Cert. of Educ., London B.Sc. (Eng.), A.M.I.P.E., A.M.I.Mech.E., Draughtsmanship (all branches), etc., together with particulars of our remarkable Guarantee of **SUCCESS OR NO FEE**

Write now for your copy of this invaluable publication. It may well prove to be the turning point in your career.

**FOUNDED 1885—OVER 150,000 SUCCESSES—**  
**NATIONAL INSTITUTE OF ENGINEERING**  
(Dept. 461), 148, HOLBORN, LONDON, E.C.1.

## BENSON'S BETTER BARGAINS

**RELAYS.** U.S.A. Semi-rotary action, DPDT heavy silver contacts; SPDT & SPST 1089 contacts. 12 volt. 7/6. **SWITCHES.** 10c/6d. U.S.A. DPDT. 1/6. **COMMAND RECEIVERS.** Brand new, 6 valves, med. wave (0.22-1.5 mc) 97/6; used 82/6 (post 3/6). Conversion data a/circ. to CAR RADIO. 1/6. I.F. TRIFID 578, new, with 4 valves. 37/6. **VIBRATORS.** Military 6BR4K 12 v. 4 pin. 7/6. R.F. 38, R.F. 27, good cond., 12 v. (0.4-3.0). **DYNAMOTORS** (post 3/6): 12 v. to 250 v. 65 mA, and 8.5 v. to 2.5 A. 11/6. 6 v. to 250 v. 6 mA. 12/6. **METAL RECTIFIERS.** 240 v. 100 mA. 4/-; 240 v. 30 mA. 3/6; 1,000 v. 30 mA. 7/6. **CHOKES.** I.P.F. 10H, 120 mA. Screened, 7/6; 5 H. 200 mA. 4/6. **SWITCHES.** Water, 1p 6v 5t. 2/6; 1p 11v 2t. 4p 2t. 4t. 3/6. Stud type, Muirhead 1P24W2T. 7/6. **R1155B.** New condition, tested, with handbook, £7.10.0 (Ball 10/-). **VARIACS.** 113 135 v. 15 A. (for gauging), Type 100, 90/-; SCR522 Modulation or Driver Trans., either, 7/6. **CONDENSERS.** 50 mfd., 550 v.w., 12in. dia. 3/6. **VARIOMETERS** (1p set), new, 15/-; **INDICATORS** with C.R.T.s VCR530 and VCR130A, 10 valves, etc., 50/- (Gail 8/6). **CONVERTERS (ROTARY).** 24 v. D.C. to 50 v. 400 mA. 4/-; 240 v. D.C. to 250 v. 60 mA. 4/6. **BARPIECES** (1p set), med. wave carbons, 2/6. **NORSE TRAINER SET** with buzzer and key wired for 4 1/2 v. battery, 8/6. **DRIVES:** Slow-motion, Admiralty 200; 1 ratio, 50/6; 0-100, 5/6. **R1155 S.M. "N" type** new, 10/6. **VIBRAKES,** 4 v. D.C. to 250 v. 60 mA., smooth-tuned, 22/6. 12 v. to 250 v. 60 mA., 20/- (b.p. 3/6). **METERS,** contain 2 separate micro-amp. movements and 2 neon, new, 8/6. Cross-over needle (L.R.) 100mA each section; New, 12/6 or 10 mA. x 2. 8/6. **GBL518 50T.** I.S. extension leads (4 core), with plugs, 17/6. Lamp resistance change-over boxes, 25/-; **CONDENSERS,** sprague, 0.1 mid., 200 v.w., dozen 5/-; ditto, 1,500 v. doz. 7/6. **U.S.A. VALVEHOLDERS,** octal, doz. 5/-; **TRANSFORMERS,** Input 230 v., Outputs, 4.5 and 6.3 v. TW (0.2 GBVA), 8/6 (Post 2/6). **LIST AND ENQUIRIES:** S.A.E., please! Terms, C.W.O. Postage extra. Immediate despatch.

Callers and Post: **W. A. BENSON**  
136 Rathbone Road, Liverpool 15, NEP 68-53.  
Callers: **SUPERADIO (Whitechapel) LTD.**  
(P.W.) 116 Whitechapel, Liverpool 2, ROY 1130.

# KINGSMERE SUPPLIES LIMITED

MAIL ORDER HOUSE

TERMS: Remit with Order or C.O.D.

All Goods Post Free. (Export extra.)

Built to the highest specifications, these chassis offer the finest value to the enthusiast

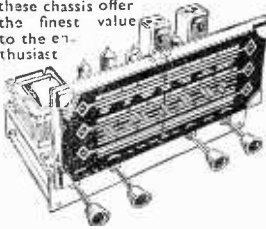

**ALL BRITISH RADIOGRAM CHASSIS. 3 WAVEBANDS 5 MULLARD VALVES**

ECH42, EF41, EBC41, EL41, EZ40. Brand new and guar. A.C. 200/250 v. Short-Medium-Long-Gram. P.U. High Q dust core coils. Latest circuit technique. AVC and neg. feedback. 4 watts. Chassis size 13 1/2 x 6 x 8in. high. Aligned and calibrated ready for use. Quality at Low Cost. Chassis isolated. H. P. Dep. £5 and five monthly of £1.

**OUR PRICE £9-9-0**

Matched Speakers, 5in., 6in. x 4in., 6 1/2in., 8in. 17/6 ea. 10in. 25/-

90-DAY GUARANTEE	VALVES	ALL BRAND NEW
6/6	7/6	1/6
5U4	3A5	95A
6K8G	6Q7G	EA53
6N7M	12AX7	E1148
6V6G	EF41	6H6GT
6X5G	EL84	2/8
6AM6	EZ40	6K7G
		6AC7M

**SPECIAL PRICE PER SET**

6K8G, 6K7G, 6Q7G, 6V6G, 6X5G...	27/6
IR5, IT4, IS5, 3V4	25/-
Matched Pairs 6V6G	12/5
Valve Boxes, All Sizes	2/- doz.
Carbon Pots, 5K to 2M, 3/-; DP, 4/-	

**BSR 4-SPEED SINGLE PLAYER Model TU9.** Our bargain price, 95/-, with cut out mounting board, 12 1/2in. x 16 1/2in.



**BRAND NEW AND BOXED**

**OUR PRICE £6-19-6**

LIST PRICE £9-15-0

U.S.A. WORLD'S FINEST 4-SPEED AUTOCHANGER IDEAL FOR USE WITH BOTH OUR CHASSIS H. P. Dep. £3-10 and four monthly of £1.

H. P. Dep. £3-10 and eight monthly of £1.

**CONTINENTAL SIEMENS "NORA" AM-FM RADIOGRAM CHASSIS (Leaflet S.A.E.)**

MADE IN WEST GERMANY CANCELLED EXPORT TO U.S.A. 5 Valves ECH85, ECH81, EF83, EA9C80, EL95. Plus full wave metal rectifier.

Free of Interference, Jamming and Whistles. Circuit of latest technique, covers entire V.H.F., F.M.—MEDIUM and LONG WAVE. Ferrite Aerial, Gram. Pick-Up switching. Tone and Volume controls. 3 watts. Music and Speech—intimate and clear. Size 12 1/2in. x 7 1/2in. x 6 1/2in. A.C. 100/250. FULL GUARANTEE.

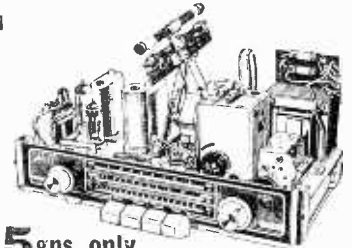

**15 gns. only**

Speakers, 5in., 6 1/2in., 8in. 17/5, 10in. 25/-

**FOAMCOURT WAY, FERRING, WORTHING, SUSSEX**



**Solve that Circuit trouble!**

**PIFCO Radiometer**

Not only circuit tests but everything electrical can be tested with this handy compact meter. Tests H.T. & L.T., Valves, components, electrical appliances and car lighting systems, etc. May be used on A.C. & D.C. mains.

See the Radiometer at your dealer or writes for illustrated leaflet to—

**PIFCO LTD. WATLING STREET · MANCHESTER · 4.**

only **32/6** complete

## SOUTHERN RADIO'S WIRELESS BARGAINS

**TRANSCEIVERS.** Type "38" (Walkie-Talkie) complete with 5 valves, etc. New condition, untested by us, but serviceable, no guarantee. 22/6 each.

**ATTACHMENTS** for Type "38" Transceivers. ALL BRAND NEW. PHONES, 15/6; THROAT MICROPHONES, 4/6; JUNCTION BOXES, 2/6; AERIALS, No. 1, 2/6; No. 2, 3/-; WEBBING, 4/-; HAVERSACKS, 5/-; VALVES, A.R.P.12, 4/5; A.T.P.4, 3/6. Set of FIVE VALVES, 19/- the set.

**TRANSCEIVERS.** Type "18" Mark III. Two Units (Receiver and Sender). Six Valves, Micrometer, etc. Metal Case. Untested. No guarantee, but COMPLETE. £2 18s. 6d.

**ATTACHMENTS** for "18" Transceivers. ALL BRAND NEW. HEADPHONES, 15/6; HAND MICROPHONE, 12/6; AERIALS, 5/- SET OF 6 VALVES, 30/-.

**RESISTANCES.** 100 Assorted useful values. New wire end, 12/5

**CONDENSERS.** 100 Assorted. Mica, Tubular, etc. NEW. 15/-

**LUFBRA HOLE CUTTERS.** Adjustable 3/8" to 3 1/2". For Metal, Plastic, etc. 7/-

**QUARTZ CRYSTALS.** Types F.T.241 and F.T.243, 2-pin, 1/2" Spacing. Frequencies between 5,675 Kc/s and 8,650 Kc/s. (F.T.243) 20 Mc/s. and 38.8 Mc/s. (F.T.241, 54th Harmonic), 4/- each. ALL BRAND NEW. TWELVE ASSORTED CRYSTALS, 45/-.

Holders for both types, 11/- each. Customers ordering 12 crystals can be supplied with lists of frequencies available for their choice.

**TRANSPARENT MAP CASES.** Plastic. 14" x 10 1/2". Ideal for Maps, Display, etc. 11/6

**STAR IDENTIFIERS.** Type I A-N Covers both Hemispheres. 5/6

**CONTACTOR TIME SWITCHES.** 2 Impulses per sec., in case. 11/6

**REMOTE CONTACTOR.** For use with above. 7/6

**MORSE TAPPERS.** Midget Type, 2/7. Standard, 3/5. Heavy Type on Base, 5/5. ALL BRAND NEW.

**MORSE PRACTICE SET.** TAPPER with BUZZER on Base. Complete with Battery. BRAND NEW. 12/5

**MAGNETS.** Strong Bar Type, 2" x 1". 1/6 each.

**PACKARD-BELL AMPLIFIERS.** Complete BRAND NEW with Valves; Relay, etc., etc. 17/6 each.

**SPECIAL OFFER. 12 ASSORTED METERS.** Slightly damaged. Mainly broken cases (perfect movements). Including 3 Brand New Aircraft Instruments. 12 for 45/-.

**POST OR CARRIAGE EXTRA. FULL LIST OF RADIO BOOKS, ETC., 3d.**

**SOUTHERN RADIO SUPPLY LTD. 11, LITTLE NEWPORT ST., LONDON, W.C.2. GER. 6653.**



● NEW 2ND EDITION  
**ELEMENTARY  
TELECOMMUNICATIONS  
EXAMINATION GUIDE**

17/6. W. T. Perkins Postage 1/-

**TELEVISION ENGINEERS' POCKET BOOK.** By J. P. Hawker. 12/6. Postage 8d.

**EVERYMAN'S WIRELESS BOOK.** By F. J. Camm. 17/6. Postage 9d.

**RADIO SERVICING—Vol. 4. Fault-Finding.** By G. N. Patchett. 5/- Postage 4d.

**AUDIO DESIGN HANDBOOK.** By H. A. Hartley. 23/- Postage 1/-.

**RADIO DATA CHARTS.** By R. T. Beatty & revised by J. McG. Sowerby. 10/6. Postage 1/-.

**PRINCIPLES OF ELECTRONICS.** By H. Buckingham and E. M. Price. 17/6. Postage 1/-.

**RSGB AMATEUR RADIO CALL BOOK.** 1959 ed. 3/6. Postage 6d.

**THE MODERN BOOK CO.**

BRITAIN'S LARGEST STOCKISTS of British and American Technical Books

19-23 PRAED STREET, LONDON, W.2.

Complete catalogue 6d.  
Phone: PADdington 4185.  
Open 6 days 9-6 p.m.

**CABINETS & HI-FI EQUIPMENT**

We can supply any Cabinet to your own specification.

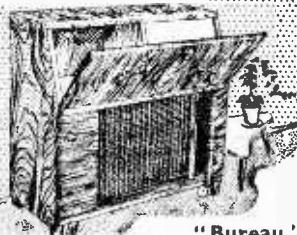

"Bureau"  
£16.10

This ever popular walnut bureau cabinet is veneered with the finest selected Walnut and beautifully polished in a medium shade. Designed to accommodate any type of Automatic Record Changer, Tape Deck, Amplifier, chassis, etc., and to give generous storage compartments.

We can also supply and fit this or any cabinet with the latest Hi-Fi amplifiers, tuners, transcription units, record changers, speakers, etc.

Write for our NEW 24 page fully illustrated catalogue of cabinets and details of our complete range of chassis, autochangers, tape decks, speakers, etc., all available on cash terms.

**LEWIS RADIO**

120 (PW29) Green Lanes, Palmers Green London, N.13. BOWES Park 1155.6 (Nr. The Cock Tavern)

**THE WAVEMASTER**  
TRANSISTOR PORTABLE



**AN OLYMPIC WINNER**

Pick of the World's Stations at your finger-tips.

Long and Medium Wavebands. Comprehensive assembly data and Components Lists, 1/6.

Complete Receivers Available.

**OLYMPIC RADIO COMPONENTS, LTD.**  
224, Hornsey Road, Holloway, N.7.

**ASTRAL RADIO PRODUCTS**

**COIL PACKS.** L/M/S. 38/- post 3/-  
**HOME RADIO.** 32-page illustrated booklet. Simple wiring instructions for Crystal Set, 1, 2, 3 Valves, 2/- post 3d.  
**TRF COILS.** 7- pr., post 6d. **DUAL WAVE HF Coil** with REACTION. Specified for "Summer All Dry Portable," A.C. Double Triode 1" etc., 4/6 post 3d.  
**IFTS Miniature.** 1" x 1 1/2" x 2 1/2" in cans. Extra high "Q." Special offer, 9/- pr., post 6d.  
**Crystal Set Coils.** L. & M.W. 2/6 post 3d.  
**82 Centurion Road, Brighton**

**RADIO AND TELEVISION COMPONENTS**

We operate a prompt and efficient MAIL-ORDER Service. 3d. stamp (only) for Catalogue.

**JAMES H. MARTIN & CO.**  
FINSTHWAITE, NEWBY BRIDGE, ULVERSTON, LANCs.

**WIRING ACCESSORIES**

Return of Post Service. Lowest possible prices consistent with high quality. Money back guarantee.

**PVC Cable Flat Twin Twin with E. 3 Core**

1.044	£2. 1. 8	£2.15. 1	£2.19. 4
3.029	£2.14. 2	£2. 8.11	£2.19. 0
3.036	£3.18. 5	£4.10. 9	£5.10.10
7.029	£4.19.11	£6. 1.11	£6.18. 3

**TRS CABLE**

1.044	£2. 3. 5	£2.13.11	£3. 0.10
3.029	£2.15. 9	£3. 6.10	£4. 5. 4
3.036	£3.15. 2	£4. 8. 5	£5. 8. 2
7.029	£4.13.10	£5.18. 2	£6.18. 7

Prices per 100 yds. All sizes stocked. Supplied in 25, 50, 75 or 100 yd. lengths. 7.029 and above cut to length—no cutting charge. Carriage paid on all orders over £2. Full range of accessories available. Send for complete lists.

**F. HUNT & CO.**  
STEPCOTE HILL, EXETER.

Phone: Exeter 36687.

**EDDY'S (Nottm.) LTD.**

(Dept. P.W.),

172, ALFRETON ROAD, NOTTINGHAM

**B.S.R. MONARCH 4-SPEED AUTOMATIC RECORD CHANGER.**

Complete with High Fidelity "Turnover Head" capacity of 10 records. Plays 12in., 10in., 7in. intermixed in any order. 78, 45, 33 and 16 rpm for A.C. mains 100-250 volts. Exclusive Magi-Disc selector gives quietest and quickest change over. Brand New, £6.19.6. Post and Packing 5/-.

**MORSE TAPPERS.** Plated Contacts. Adjustable Gaps. Heavy Duty. Good Quality. Special Price 3/6 each. Post 9d.  
**THROAT MIKES.** 1/- each. Post 6d. Can be used for electrifying musical instruments, etc.

**JACK PLUGS.** Standard type. 1/11 each. Post 4d.

**NEON MAINS TESTER/SCREW-DRIVERS.** 4/6 each. Post 6d.

**SUB-MINIATURE TRANSISTOR CONDENSERS.** 1.6 mfd, 5 mfd, 10 mfd, 16 mfd, 32 mfd. 2/6 each. Postage and Packing 4d.

**TRANSISTORS.** Yellow/Green Spot. 6/11. Post 4d.

**TRANSISTORS.** Yellow/Green R.F. 12/11 each. Post 4d.

**ACOS CRYSTAL MIKE INSERTS.** 4/11 each. High quality. Can be used for Tape Recorders, Baby Alarms, Musical Instruments, etc. Post 8d. New.

**MIDGET BATTERY ELIMINATORS.** To convert most types Dry Battery Portable to Mains Operation. 57/6 each. Post 2/6. Smaller than H.T. battery alone. Size 3.7 in. x 1.8 in. x 2.5 in. (Please state make and model No.).

**RECTIFIER/STABILISER.** Input voltage 150 v at 10 m.a. For low consumption battery valves. 6/6. Post 6d.

**LOUDSPEAKERS.** Best makes. All New. Post, etc., 2/- each.

5 in. 17/6. 8 in. 18/11. 7 x 4 Elipst. 17/6.

**TUBULAR WIRE END CONDENSERS** New (Not Ex. Govt.)  
8-8 mfd, 450 v, 2/6; 16 mfd, 450 v, 2/9;  
16-16 mfd, 450 v, 5/6; 32 mfd, 450 v, 4/6;  
32-32 mfd, 350 v, 6/6; 25 mfd x 25 vdc  
Midget Condensers, size 1in. 1/3; 50-50 mfd, 400 v, 6/11. Post, etc. 4d.

**SURPLUS, NEW AND GUARANTEED VALVES—ALL TESTED BEFORE DESPATCH**

Cash with Order or Cash on Delivery. Postage and Packing 6d. per valve extra. Over £3 free. S.A.E. with all Enquiries.

1D5	10/-	6X5GT	6/6	EB91	5/11
1R5	7/6	10F9	10/6	EBF80	9/11
1S5	7/-	12AH7	7/6	EF41	9/6
1T4	5/6	12K7	7/6	EF50	5/6
3D6	4/9	12Q7	7/6	EF50(R)	4/11
5U4G	6/6	25A6G	12/11	EF80	8/6
6B8G	2/11	35Z4	7/6	EF86	14/6
6B16	7/6	807(B)	3/9	EL84	9/-
6C4	4/9	807(USA)	5/6	EY86	13/6
6F1	12/6	954	1/6	L63	5/11
6F13	12/6	955	3/11	MU14	8/6
6F15	12/6	956	2/11	PCB84	9/-
6F6M1	2/-	AZ1	12/6	PCCF80	11/6
6J5GT	3/11	AZ31	12/6	PL81	16/-
6K7G	2/11	CY31	12/11	PL82	9/6
6K8G	7/6	DAF96	9/-	PL83	10/6
6L6G	5/11	DF96	9/-	PY81	8/6
6SN7GT	5/9	DK96	9/-	UF41	9/-
6V6G	5/11	DL96	9/-	UY41	7/11
6V6GT	6/6	DM70	7/11	VT52	2/11

All parcels insured against damage in transit for only 6d. extra per order. All uninsured parcels at customers' risk.

SEND FOR 56 PAGE ILLUSTRATED CATALOGUE, PRICE 1/-.

# SPUTNIK-SPECIAL—THE WORLD IN YOUR HOME

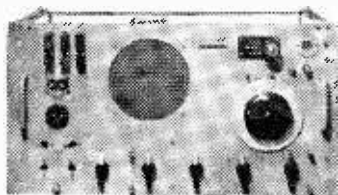

## SHORT-WAVE RECEIVER 10-60 MC/S (5-30 Metres) RECEPTION SET TYPE 208

Complete with 6 valves, 2-6K8G, 2-EF39, 6Q7G and 6V6G. Internal mains power pack and 6v vibrator pack. Built-in 6½" speaker. Muirhead slow-motion drive. B.F.O. and R.F. stage. I.F. freq. 2 Mc/s. Provision for phones and muting and 600 ohm extension speaker: input 110/250v A.C.: 6v vibrator pack included for battery operation. All sets in new condition and air tested. **£6.19.6.** Carr. 15/6.

### NO WORK REQUIRED

**JUST PLUG IN AND SWITCH ON!**

### AC/DC PORTABLE RADIO

- ★ 5 valve superhet
- ★ Built-in frame aerial
- ★ Size 10" x 10" x 4" deep
- ★ All Marconi valves
- ★ Med. long and short wave-band
- OR Med. and two short wavebands
- ★ Gram. sockets (for crystal or magnetic pick-ups)
- ★ 7" x 4" elliptical speaker
- ★ Slow motion tuning
- ★ Ideal for a radiogram

**ONLY £7.12.6.** Post 7/6

Portable polished cabinet ... .. 27/6  
 Super portable rexine cabinet ... .. 37/6  
**GUARANTEED BRAND NEW AND IN WORKING ORDER**

### AC/DC 200/250 v. PORTABLE-GRAM AMPLIFIER

Completely assembled on Baffle Board size 12½ in. x 4½ in. Depth 3 in.

Containing two Mullard valves type UL84 and UY85, Elac 7 x 4 Elliptical Speaker. Volume Control, Tone Control. Nothing else to buy, just plug in to Mains and connect your Crystal Pick-up or Mic. to Amplifier. **ONLY 67/6.** Carr. 2/6.

10 in. P.M. Speaker in portable baffle cabinet with 30ft. lead and jack. 45/-. P. & P. 5/-.

### DYNAMOTORS

12 volts D.C. input, 220 volts, 165 mA. output. 32/6. Post FREE.

**ROTARY CONVERTER.** 24 v. D.C. to 230 v. A.C. 50 cycles. 100 watts. Brand new and unused. **£5.10.0.** Carr. 7/6.

### 373 MINIATURE I.F. STRIPS 10.72 MC/S



**12.6** (less valves) **37/6** (with valves)

Postage and packing 2/6 (either type)

The ideal F.M. conversion unit as described in P.W., April/May, 1957. Complete with 6 valves, three EF91's, two EF92's and one EB91. I.F.T.'s, etc., in absolutely new condition. With circuit and conversion data.

### RADAR TX UNIT TYPE 1683

Complete with the following valves: 2-6C4; B32A; 829B; 2-5R4G; 3-6AC7; 6V6GT; 931A photo multiplier with associated network. Also 2-blower motors. Input 80-115 volt 400 to 2,600 c/s. 26v. D.C. **£6.10.0.** P. P. 5/-. BRAND NEW.

### 426 CONTROL UNIT

Includes: 4-EF50; 2-SP61; EB34; multibank switches, pots, etc. **Only 30/-** P. & P. 2/6.

### PYE 45 Mc/s STRIP TYPE 3583.

Complete with 12 valves. 10-EF50; EB34; EA50; with modification data. **ABSOLUTE BARGAIN ONLY 39/6** Carriage 5/6.

### SYNCHRONIZER UNIT

Includes: 3-6L6M; 12-6AC7; 1-6SQ7; 5-717A; 6-6SN7GT; 1-6SQ7; 1-6H6; slow motion drive; transformers; chokes, etc. **£4.19.6.** P. P. 5/-. BRAND NEW.

**LARGEST RANGE IN THE COUNTRY OF QUARTZ CRYSTALS AND VALVES. SEND FOR FREE LISTS.**

**HENRY'S (RADIO) LTD. (Dept. P.W.F)** 5, HARROW ROAD, EDGWARE ROAD, PADDINGTON, LONDON, W.2.

Opposite Edgware Road Tube Station. PADDINGTON 1008/9.

### RC A 6½ in. SPEAKER IN CABINET with Vol./Control and 600 ohm line transformer. 27/6. P. P. 2/6.

### TRIPLET AC/DC POCKET TESTMETER TYPE 666H

15 ranges 1,000 ohms per volt  
 In new condition with Prods and Internal battery.  
 A.C./D.C. 10/50/250/1,000/5,000 volts. Milliamps 0-10/100/500. Ohms, 0-300/250,000. **NOW ONLY £4.19.6.**  
**A MUST FOR THE SERVICEMAN AND EXPERIMENTER**

### NEW BOXED VALVES

AZ31	MP/PEN(7)	X41
AC/SG	MKT4	SP4(7)
AC/SGVM	MS4B	TDD4
AC/PEN	MVS/PEN(7)	URIC
AC/VP(15)	MVS/PENB	VMS4
AC/VP(17)	MVS/PEN(5)	VP4(7)
AC/VP2	MS/PEN(5)	VP4B
AC/HLDD	MS/PEN(7)	VP4(5)
CYIC	MX40	VMP4G
DDT4	PEN4VA	W42
FC4	PEN36C	ID5
GU50	PP36	7D5
H30	SP4(5)	7D6
MHD4	S4VB	41MPG
N41		

SEND FOR FREE COMPLETE VALVE LIST OF OVER 400 DIFFERENT TYPES. **10/-** each

**VIBRATOR PACKS.** Input 6v. D.C. Output approx. 100v. D.C. at 30 m/amps., fully smoothed and R.F. filtered. Size 6½ x 5 x 2 in. Fitted with Mallory 629C vibrator, BRAND NEW. Boxed. 12/6.

### RF UNITS TYPE 25 Switched

Tuning 30 to 40 Mc/s. Includes three SP61's. Carriage 2/6.  
**TYPE 26.** Variable tuning, 50 to 65 Mc/s. Including two EF54's and one EC52. Carriage 2/6.  
 (Circuits in stock for both types 9d. ea.) **25/-**

### STROBE UNIT

Complete with: 6—EF50; 5—EA50; SP61. Relays, etc. **35/-** P. & P. 2/6.

### MIXER UNIT TYPE 79

Frequency range 172 to 190 Mc/s. Comprising: VCR139A Cath. ray tube: 7-EF50; EF55; 4-EA50; 2-EB91; 5U4; VU120 and EC52. Standard main input 200-250 volts 50 c/s. Ideal Scope Basis. **£5.10.0.** Carriage 5/-.  
**CRYSTAL CALIBRATOR For No. 19 Set**

10 kc/s.; 100 kc/s.; 1 Mc/s.; spot frequencies; Crystal controlled oscillators; includes 5-12SC7 valves, neon modulator handbook, etc. **£4.19.6.** Post free.  
 BRAND NEW and BOXED.

### RF WATTMETER TS/87/AP

3 switched positions 0/10/15/30 watts. Complete with photo-cell spare lamps; calibration charts; leads and transit case. **BRAND NEW £8.19.6.** Post free.

### PACKARD BELL PRE-AMP

Complete with screened case with 6SL7GT; 28D7; leads, jack plugs; handbook, etc. Sealed in carton. **Only 12/6** P. & P. 2/-.

**SEE OUTSIDE BACK COVER FOR MORE BARGAINS.** →

# Practical Wireless BLUEPRINT SERVICE

## PRACTICAL WIRELESS

	<i>No. of Blueprint</i>
<b>CRYSTAL SETS</b>	
2/- each	
Crystal Receiver ...	PW71*
The "Junior" Crystal Set ...	PW94*
2/6 each	
Dual - Wave "Crystal Diode" ...	PW95*

## STRAIGHT SETS

<b>Battery Operated</b>	
One-valve : 2/6 each	
The "Pyramid" One-valver (HF Pen) ...	PW93*
The Modern One-valver ...	PW96*
Two-valve : 2/6 each	
The Signet Two (D & LF) ...	PW76*
3/6 each	
Modern Two-valver (two band receiver) ...	PW98*
Three-valve : 2/6 each	
Summit Three (HF, Pen, D, Pen) ...	PW37*
The "Rapide" Straight 3 (D, 2 LF (RC & Trans) ) ...	PW82*
F. J. Camm's "Sprite" Three (HF, Pen, D, Tet) ...	PW87*
3/6 each	
The All-dry Three ...	PW97*
Four-valve : 2/6 each	
Fury Four Super (SG, SG, D, Pen) ...	PW34C*

## Mains Operated

Two-valve : 2/6 each	
Selectone A.C. Radiogram Two (D, Pow)...	PW19*
Three-valve : 4/- each	
A.C. Band-Pass 3 ...	PW99*
Four-valve : 2/6 each	
A.C. Fury Four (SG, SG, D, Pen) ...	PW20*
A.C. Hall - Mark (HF, Pen, D, Push Pull) ...	PW45*

## SUPERHETS

<b>Battery Sets : 2/6 each</b>	
F. J. Camm's 2-valve Superhet ...	PW52*
<b>Mains Operated : 4/- each</b>	
"Coronet" A.C.4 ...	PW100*
AC/DC "Coronet" Four	PW101*

*No. of  
Blueprint*

## SHORT-WAVE SETS

<b>Battery Operated</b>	
One-valve : 2/6 each	
Simple S.W. One-valver	PW88*
Two-valve : 2/6 each	
Midget Short-wave Two (D, Pen) ...	PW38A*
Three-valve : 2/6 each	
Experimenter's Short-wave Three (SG, D, Pow) ...	PW30A*
The Perfect 3 (D, 2 LF (RC and Trans) ) ...	PW63*
The Band-spread S.W. Three (HF, Pen, D (Pen), Pen) ...	PW68*

## MISCELLANEOUS

2/6 each	
S.W. Converter-Adapter (1 valve) ...	PW48A*
The P.W. 3-speed Auto-gram ...	(2 sheets), 8/-*
The P.W. Monophonic Electronic Organ (2 sheets), 8/-	

## TELEVISION

The "Argus" (6in. C.R. Tube) 3/-*	
The "Simplex" ...	3/6*
The P.T. Band III Converter	1/6*

*All the following blueprints, as well as the PRACTICAL WIRELESS numbers below 94, are pre-war designs, kept in circulation for those amateurs who wish to utilise old components which they may have in their crates box. The majority of the components for these receivers are no longer stocked by retailers.*

## AMATEUR WIRELESS AND WIRELESS MAGAZINE

### STRAIGHT SETS

<b>Battery Operated</b>	
One-valve : 2/6	
B.B.C. Special One-valver ...	AW387*
<b>Mains Operated</b>	
Two-valve : 2/6 each	
Consoelectric Two (D, Pen), A.C. ...	AW403

## SPECIAL NOTE

THESE blueprints are drawn full size. The issues containing descriptions of these sets are now out of print, but an asterisk denotes that constructional details are available, free with the blueprint.

The index letters which precede the Blueprint Number indicate the periodical in which the description appears. Thus P.W. refers to PRACTICAL WIRELESS, A.W. to *Amateur Wireless*, W.M. to *Wireless Magazine*.

Send (preferably) a postal order to cover the cost of the Blueprint (stamps over 6d. unacceptable) to PRACTICAL WIRELESS, Blueprint Dept., George Newnes, Ltd., Tower House, Southampton Street, Strand, W.C.2.

*No. of  
Blueprint*

## SHORT-WAVE SETS

<b>Battery Operated</b>	
One-valve : 2/6 each	
S.W. One-valver for American ...	AW429*
Two-valve : 2/6 each	
Ultra-short Battery Two (SG, det Pen) ...	WM402*
Four-valve : 3/6 each	
A.W. Short Wave World-beater (HF, Pen, D, RC, Trans) ...	AW436*
Standard Four-valver Short-wave (SG, D, LF, P) ...	WM383*
<b>Mains Operated</b>	
Four-valve : 3/6	
Standard Four-valve A.C. Short-waver (SG, D, RC, Trans) ...	WM391*

## MISCELLANEOUS

Enthusiast's Power Amplifier (10 Watts) (3/6)	WM387*
Listener's 5-watt A.C. Amplifier (3/6) ...	WM392*
De Luxe Concert A.C. Electrogram (2/6) ...	WM403*

## QUERY COUPON

This coupon is available until Feb. 6th 1959, and must accompany all Queries sent in accord with the notice on our "Open to Discussion" page. PRACTICAL WIRELESS, FEB. 1959.

**MINOR****IMPROVED !**

- ★ Variable tuning over medium waves.
- ★ 3-stage reflex circuit.
- ★ Highly sensitive.
- ★ Internal ferrite aerial.
- ★ Drilled chassis.
- ★ Long-life battery.
- ★ Complete constructional details.
- ★ Weight less than 2 ozs.
- ★ Size only 3 x 2 x 7/8 in.

Total cost, including transistor, personal miniature 'phone, case, battery and complete circuit and layout diagrams, 52/6 post free. All components sold separately. Circuit and shopping list FREE. Call and Hear Demonstration Model.

As described in Oct. issue of "Radio Constructor."

**MAJOR****IMPROVED !**

- ★ 4-stage reflex circuit.
- ★ Variable tuning over medium waves.
- ★ Highly sensitive.
- ★ No aerial or earth.
- ★ Home, Light and Third.
- ★ Economical.
- ★ Drilled and mounted chassis.
- ★ Size 4 1/2 x 3 x 1 1/2 in.
- ★ Internal ferrite aerial.
- ★ Weight less than 4 ozs.
- ★ Complete layout diagram.
- ★ May be built in 1 hour.

All items can be supplied, including EDISWAN transistors, battery, case and personal 'phone, etc., for 72/6, post free. All components sold separately. Circuit and shopping list FREE. Call and Hear Demonstration Model.

**"THE TRANSISTOR—8"****Push-Pull Portable Superhet.**

This Portable 8 Transistor Superhet is tunable for both Medium and Long Waves and is comparable in performance to any equivalent Commercial Transistor Set. Call and Hear Demonstration Model.

**STAR FEATURES**

- ★ 8 EDISWAN Transistors.
- ★ 250 Milliwatts Output Push-Pull.
- ★ All components identified.
- ★ Medium and Long Waves.
- ★ Internal Ferrite Rod Aerial.
- ★ Elliptical Speaker.
- ★ Drilled chassis 8 1/2 x 2 1/2 in.
- ★ Point-to-Point Wiring and Practical Layout.
- ★ Economical. Powered by 7 1/2 v. battery.
- ★ Highly sensitive.
- ★ Attractive lightweight contemporary case. In various colours.

**COMBINED PORTABLE/CAR RADIO**

Two sets for the price of one.

We can supply all these items including Cabinet for £11.10.0, P.P. 2/6. All parts sold separately. Circuit diagrams and shopping list free.

Car Radio Conversion Components, 8/- extra. A.V.C., 5/9 extra. 325 mW. version, 40/- extra.

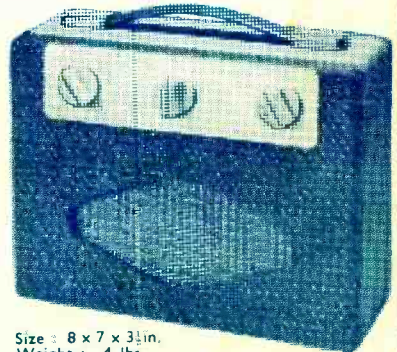

Size : 8 x 7 x 3 1/2 in.  
Weight : 4 lbs.

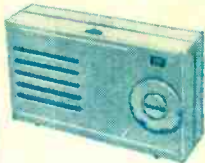
**TELETRON "TRANSIDYNE" RECEIVER****Six Transistor Pocket Superhet.**

Size : 6 1/2 x 3 3/4 x 1 1/2 in.

All components, including EDISWAN TRANSISTORS, cabinet, batteries, etc., can be supplied for £11.19.6, P.P. 2/6. All parts sold separately. Circuit and shopping list 9d.

- ★ TCC Printed Circuit.
- ★ Medium and long waves.
- ★ Powered by two No. 8 batteries.
- ★ Push-Pull Output.
- ★ Moulded Plastic case.
- ★ Rola 2 1/2 in. P.M. speaker.
- ★ Internal ferrite aerial.
- ★ Weight 20 ozs.
- ★ Complete layout instructions.
- ★ Easy to assemble.
- ★ (All components identified.)
- ★ THE BEST YET!

**CONSTRUCTOR'S PARCEL FOR TRANSISTOR POCKET RADIO**

Perdio attractive moulded cabinet, size 5 1/2 x 3 1/2 x 1 1/2 in., 12/6. I.B. screened twin gang 208 + 176 pf., to fit cabinet, 10/- Perdio 2 1/2 inch min. 3 ohm speaker, 21/- 20 : 1 Single ended output transformer to match, 10/-

ALL FOR 49/6 P.P.  
ONLY 2/6

Complete Selection of Miniature Transistors and Components in stock : Free List on request.

**CRYSTAL MIC. INSERTS**

1 in. Square ... 3/6 1 1/2 in. Round (Acos) ... 7/6  
1 in. Round (Acos) ... 5/- 2 1/2 in. Round (Acos) ... 12/6  
Moulded plastic hand mic. case suitable for any of above, only 2/6

SEE OTHER ADVT. INSIDE

**TRANSISTOR SIGNAL TRACER.**

Complete Kit with 2 Transistors, Components, Phones and Circuit and plastic case.

37/6

**TRANSISTOR SQUARE WAVE GENERATOR**

2.5 Kc/s. Complete Kit with 2 Transistors, Components. Circuit and plastic case.

20/-

**HENRY'S (RADIO) LTD. (Dept. P.W.F.)**

Opposite Edgware Road Tube Station. PADDDINGTON 1008/9.

5, HARROW ROAD, EDGWARE ROAD, PADDDINGTON, LONDON, W.2.  
OPEN MONDAY to SAT. 9-6, THURS. 1 o'clock.

**NEW TYPE TRANSISTORS—PRICE REDUCTIONS**  
**JUNCTION TYPE P.N.P.**

EDISWAN XA104 6 Mc/s. osc./mixer : R.F. amplifier	18/-
" XA103 4 Mc/s. I.F. and R.F. amplifier	15/-
" XB104 1 Mc/s. Audio output and driver	10/-
(A pair in push-pull will give up to 250 mW. audio output.)	
EDISWAN XC101 Audio for up to 325 mW. in push-pull,	60/- pr.
Newmarket V15/10P up to 10 watts dissipation	20/-
" V15/20P " " " " " " "	39/-
" V15/30P " " " " " " "	48/-
" V30/10P " " " " " " "	48/-
" V30/20P " " " " " " "	54/-
" V30/30P " " " " " " "	57/-
" V15/20IP up to 2 watts dissipation	25/-
" V30/20IP " " " " " " "	35/9
Mullard OC44 12 Mc/s. osc./mixer : R.F. amp.	40/-
Mullard OC45 6 Mc/s. I.F. and R.F. amp.	35/-
Red Spot 800 Kc/s. Audio Amplifier	7/6
White Spot 2 to 5 Mc/s. R.F. and I.F. amp.	12/6
Green/Yellow 600 Kc/s. Audio Amplifier	7/6
Red/Yellow 1.5 to 8 Mc/s. R.F. and I.F. amp.	15/-

DATA SHEET AVAILABLE ON ALL TYPES.  
FULL TRADE DISCOUNTS.

LARGE RANGE OF SUB-MINIATURE TRANSISTOR COMPONENTS IN STOCK : SEND FOR NEW FREE LIST.

**MORSE PRACTICE BUZZER UNITS**

COMPLETE WITH KEY ON BOARD

Ready wired, ONLY 4/6 each. Headphones to match, 7/6 pair.  
Only requires 4 1/2 volt battery.