

V.H.F. RECEIVERS

Practical Wireless

9^D
EVERY
MONTH

Vol. 23. No. 487. || Editor: F. J. CAMM || JANUARY, 1947

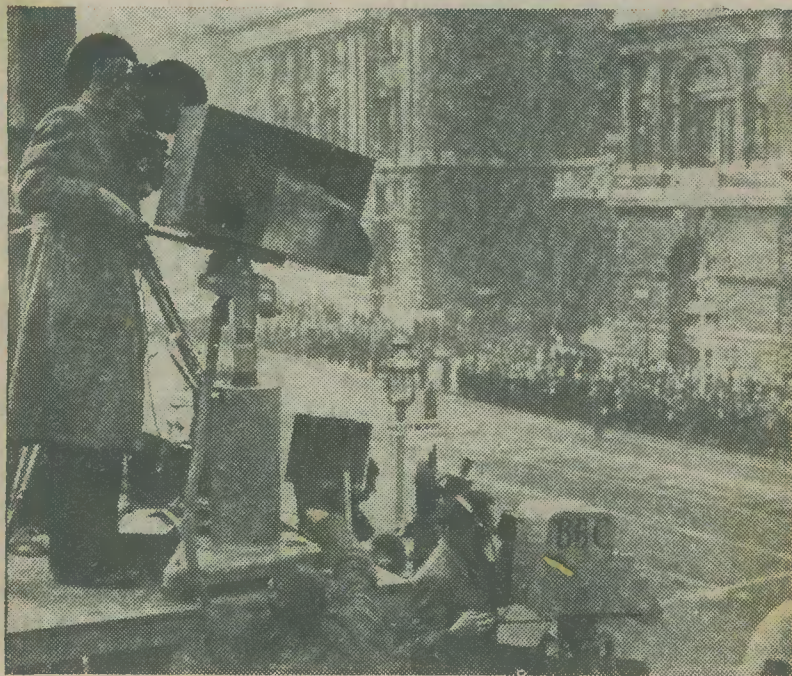

See page 84.

PRINCIPAL CONTENTS

Transmitting Circuits
Thermionic Insulation Tester
The D-X.5
On the Amateur Bands

Frequency Modulation
A 5-valve Radiogram
Analysis of the Television Receiver
Technical Notes

"LET ME BE YOUR FATHER"

This is expressed the friendly, *personal* bond existing between Bennett College and each student. It is this close individual tuition which leads to quick success. We teach nearly all the Trades and Professions by post in all parts of the world. The most progressive and most successful Correspondence College in the world. If you know what you want to study, write for prospectus. If you are undecided, write for our fatherly advice. It is free.

Distance makes no difference.



EARNING POWER IS A SOUND INVESTMENT

DO ANY OF THESE SUBJECTS INTEREST YOU ?

Accountancy Examinations	Advertising and Sales Management	Agriculture	A.M.I. Fire E. Examinations	Applied Mechanics	Army Certificates	Auctioneers and Estate Agents	Aviation Engineering	Aviation Wireless	Banking	Blue Prints	Boilers	Book-keeping, Accountancy and Modern Business Methods	B.Sc. (Eng.)	Building, Architecture and Clerk of Works	Builders' Quantities	Cambridge Senior School Certificate	Civil Engineering	Civil Service	All Commercial Subjects	Commercial Art	Common Prelim. E.J.E.B.	Concrete and Structural Engineering	Draughtsmanship. All Branches	Engineering. All branches, subjects and examinations	General Education	G.P.O. Eng. Dept.	Heating and Ventilating	Industrial Chemistry	Institute of Housing	Insurance	Journalism	Languages	Mathematics	Matriculation					
Metallurgy	Mining. All subjects	Mining, Electrical Engineering	Motor Engineering	Motor Trade	Municipal and County Engineers	Naval Architecture	Novel Writing	Pattern Making	Play Writing	Police, Special Course	Preceptors, College of	Press Tool Work	Production Engineering	Pumps and Pumping Machinery	Radio Communication	Radio Service Engineering	R.A.F. Special Courses	Road Making and Maintenance	Salesmanship, I.S.M.A.	Sanitation	School Attendance Officer	Secretarial Exams.	Sheet Metal Work	Shipbuilding	Shorthand (Pitman's)	Short-story Writing	Short-wave Radio	Speaking in Public	Structural Engineering	Surveying	Teachers of Handicrafts	Telephony and Telegraphy	Television	Transport Inst. Exams.	Viewers, Gaugers, Inspectors	Weights and Measures Inspector	Welding	Wireless Telegraphy and Telephony	Works Managers

If you do not see your own requirements above, write to us on any subject. Full particulars free.

COUPON-CUT THIS OUT

To DEPT. 104, THE BENNETT COLLEGE, LTD., SHEFFIELD.

Please send me (free of charge)

Particulars of..... (Cross out line
Your private advice..... which does
about..... not apply.)

PLEASE WRITE IN BLOCK LETTERS

Name.....
Address.....
.....

PERTRIX REDRESSED FOR PEACE



PERTRIX BATTERIES have emerged from the testing ground of war as more reliable, more efficient than ever before. You will soon see them in the smart new post-war pack shown above. It denotes the finest battery for radio use yet made.

★

HOLSUN BATTERIES LIMITED
137 Victoria Street, London, S.W.1.

P.T.B.

Practical Wireless

15th YEAR
OF ISSUE

EVERY MONTH
VOL. XXIII. No. 487. JANUARY, 1947.

and PRACTICAL TELEVISION

Editor F. J. CAMM

COMMENTS OF THE MONTH.

BY THE EDITOR

The First Year of the T.D.B.

THE Radio Industry Council came into existence in 1944 as a unified body, co-ordinating four associations representing the radio industry. It was then realised that the post-war years would bring many technical problems which could better be solved by one parent body, rather than by four associations working independently. For this reason, a technical directive board was formed representing these four bodies, and the board acted in an advisory capacity to the Radio Industry Council. A technical executive committee was also set up to carry out the normal technical activities of the radio industry.

Each constituent association elected two representatives to the board, which also had the services of two representatives of the technical executive committee for liaison purposes.

Nine meetings of the board have been held. Amongst the subjects dealt with may be mentioned a series of meetings to ensure adequate co-operation between those responsible for the preparation of Service Specification for radio components in industry, and this naturally led to general questions of technical co-operation between the Services and those in industry whose task it is to see that the country is supplied with up-to-date and reliable apparatus.

These meetings led up to the formation of the Radio Components Standardisation Committee.

The discussion between Great Britain, U.S.A. and Canada on the standardisation of screw threads affords an example of the assistance which the board was able to put forward to enhance the viewpoint of the British radio industry.

The board has also done a great deal of work on the standardisation of valves.

Standardisation of radio apparatus in matters affecting the user have also received attention by the British Standards Institution and the board, acting in concert. Also in the field of international standardisation the board has made its views known to the International Standards Co-ordinating Association, and it has maintained close and cordial relations with the Institution of Electrical Engineers on the proposed regulations for the electrical equipment of ships; also in the preparation of a

number of I.E.E. codes of practice, including those dealing with radio interference.

The board has taken a leading part in the work of the joint-committee on practical training in the electrical engineering industry and has helped in the preparation of the syllabus. In the important field of radar, the board has been able satisfactorily to clear up the question of the official view as to the best wavelength for general purpose navigation, and to eliminate doubts on the efficiency of the 3 cm. system.

Amongst its other activities, the board has dealt with industry representation at various conferences, such as the British Commonwealth Standards Conference and a number of electrical research association committees. It also co-operated radio exhibits at the "Britain Can Make It" Exhibition.

The Technical and Scientific Register

THE Technical and Scientific Register, which is a centralised branch of the Ministry of Labour Appointments Department, offers a valuable service to employers seeking professionally qualified technicians and scientists, and to technically and scientifically qualified people who are seeking employment or a change of employment.

The minimum qualification for enrolment on the register is, in general, a university degree or its equivalent in subjects appropriate to the profession or post concerned.

In the case of engineers, the Higher National Certificate or the professional examination of recognised engineering institutions or a regular training as a pupil or apprentice, followed by an executive position (normally for at least five years) above the rank of foreman are alternative qualifications necessary for enrolment.

The register is divided into sections, each in charge of technical officers with high professional qualifications and standing in the professions and subjects with which they deal.

The address of the Technical and Scientific Register is: York House, Kingsway, London, W.C.2. Telephone: Temple Bar 8020.

Editorial and Advertisement Offices:
"Practical Wireless," George Newnes, Ltd.,
Tower House, Southampton Street, Strand,
W.C.2. Phone: Temple Bar 4363.
Telegrams: Newnes, Band, London.

Registered at the G.P.O. for transmission by
Canadian Magazine Post.

The Editor will be pleased to consider articles of a practical nature suitable for publication in "Practical Wireless." Such articles should be written on one side of the paper only, and should contain the name and address of the sender. Whilst the Editor does not hold himself responsible for manuscripts, every effort will be made to return them if a stamped and addressed envelope is enclosed. All correspondence intended for the Editor should be addressed: The Editor, "Practical Wireless," George Newnes, Ltd., Tower House, Southampton Street, Strand, W.C.2.

Owing to the rapid progress in the design of wireless apparatus and to our efforts to keep our readers in touch with the latest developments, we give no warranty that apparatus described in our columns is not the subject of letters patent.

Copyright in all drawings, photographs and articles published in "Practical Wireless" is specifically reserved throughout the countries signatory to the Berne Convention and the U.S.A. Reproductions or imitations of any of these are therefore expressly forbidden. "Practical Wireless" incorporates "Amateur Wireless."

ROUND THE WORLD OF WIRELESS

Television Tests

TWO further half-hourly test periods are now available as a result of a request from the British Radio Equipment Manufacturers' Association. These periods are from 2.30 to 3 and from 4 to 4.30 p.m.

Portable Transmitters

A SPECIAL licence is now available for the use of portable transmitters. The additional fee is 10s. and allows the transmitter to be operated with a radius of 10 miles of the permanent address of the licensed amateur, or within a similar radius of another stipulated address. This licence does not include organised club field days, for which permission is granted free of charge. As in pre-war days, the transmitter will be operated under the licensee's ordinary call-sign prefixed by "P." Maximum power is 25 watts on all bands except the 1.8-2.0 mc/s band, for which 10 watts is the maximum.

1947 R.C.M.F. Exhibition

THE Annual Private Exhibition of British Radio and Communications Components and Accessories will be held at the new Royal Horticultural Hall, Greycoat and Elvinton Streets, Westminster, S.W.1, during the period 10th to 13th March, 1947.

The display is organised by the Radio Component Manufacturers Federation and, as in former years, is intended to acquaint radio manufacturers and engineers with the most recent advances in the design and development of British radio components, accessories and materials.

The Exhibition will be open to visitors, by invitation only, from 10 a.m. to 6 p.m. daily during the four days Monday to Thursday inclusive, and it is hoped to attract a record attendance of overseas visitors.

Further particulars will be announced in due course.

Ecko Engineering Appointment

E. K. COLE, LTD., announce the appointment of Mr. H. L. Oura, M.B.E., B.Sc., M.I.E.E., to take charge of their Western Development Unit located at Malmesbury, Wiltshire. Mr. Oura, who will work directly under Mr. A. W. Martin, Chief Engineer, took up his duties on Monday, October 7th. He was for many years with the Gramophone Company and was connected with the earliest developments in electrical recording both in this country and abroad. He has a distinguished war record, having been closely associated with radar development, in particular H2S and G.L. equipment, and wide and varied work for the Admiralty. Immediately prior to his ECKO appointment, Mr. Oura was a director of E.M.I. Engineering and Development, Ltd.

Schools Broadcasting

IT is announced by the Central Council for School Broadcasting that there are now more than 13,000 schools registered as listening to the B.B.C. schools broadcasts—an increase of 1,300 over last year's figure. Scotland reports 1,684 schools registered.

Broadcast Receiving Licences

THE following statement shows the approximate numbers of licences issued during the year ended 30th September, 1946.

Region	Number
London Postal	2,050,000
Home Counties	1,360,000
Midland	1,543,000
North Eastern	1,045,000
North Western	1,413,000
South Western	880,000
Welsh and Border	617,000
Total England and Wales	9,517,000
Scotland	1,036,000
Northern Ireland	153,000
GRAND TOTAL	10,706,000

The total includes 3,350 television licences, but this figure does not represent the number of television sets in use, as viewers holding unexpired 10s. licences are not required to take out television licences until their 10s. licence expires.

Unlicensed Sets: Post Office Drive

THE Post Office drive to detect unlicensed sets still continues, and many persons have been prosecuted in recent weeks for operating wireless receiving apparatus without a licence.

The requirement that each householder using wireless apparatus should have a licence applies not only to householders operating their own sets, but also to those using sets which are rented or hired.

Motorists are again reminded that it is necessary for them to take out a separate broadcast receiving licence for a wireless set fitted in a motor-car.



Peter Brough devotes as much attention to making up his ventriloquist doll, Archie Andrews, as to his own make-up. He is seen here preparing for a recent broadcast.

Philips' X-ray Expert for U.S.A.

MR. S. W. WEST, of the X-ray Division, Philips Lamps, Ltd., a well-known figure in the industry, has left London by American Overseas Airways for the United States of America. It has been announced that he will join the North American Philips Company as Technical Manager X-ray Division, in the New York Office.

In conjunction with Philips Lamps, Ltd., Mr. West holds a number of patents in the field of X-ray science. He developed and perfected a Pedestal Bucky apparatus of particular value in obstetrical and general radiography, which has been adopted by hospitals in many parts of the world. In 1940, to meet the urgent need for X-ray inspection in war industries, he originated a system of factory-planned x-ray protection, by prefabricated units which could be erected rapidly without expert supervision, making use of a home-produced substitute for metallic lead. Likely to be of far-reaching importance in the new hospital service, the system was extensively employed throughout the war and resulted in a saving of many tons of vitally needed material during a period of critical shortage.

Radio Teleprinter Link

AS a first step to bringing all the Dominions Air Forces into direct teleprinter communication with the R.A.F., a new radio teleprinter circuit was recently opened between Canada and this country. A similar link will be opened later between this country and Australia. The teleprinter link utilises standard teleprinters at each end, the impulses from the various letters afterwards being transmitted by radio.

New Zealand Transmitters

THE Australian firm of Amalgamated Wireless, Ltd., which built most of New Zealand's original national radio transmitting stations, is the successful

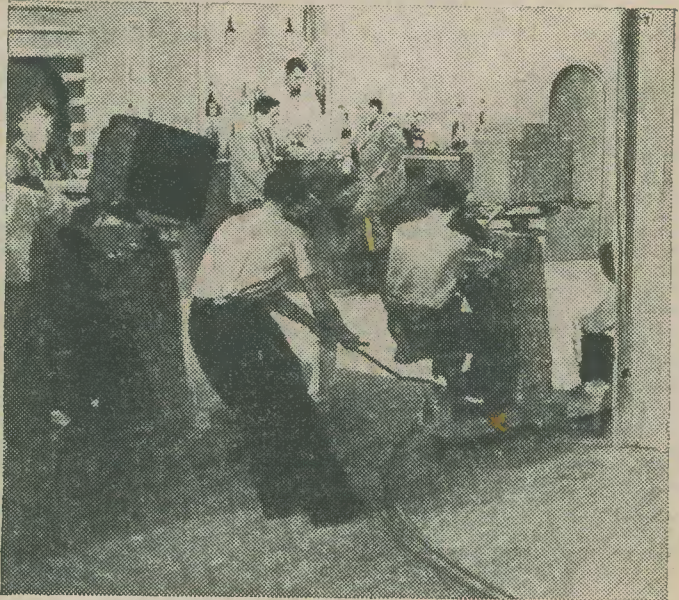

Scene in a French television studio showing the three-wheeled trolley carrying operator and assistant. The operator is provided with mike and headphones and his movements are directed by the producer.

tenderer for a £200,000 New Zealand Government contract for the work of replacing the out-dated and worn out equipment of the Dominion's radio network. Competition for the contract came from British and American concerns. Most of the work at present contemplated is deferred wartime replacement, but also includes the installation of new stations where coverage is so far inadequate. The major individual item will be replacing the 60-kilowatt transmitter at Wellington Station, 2YA, which gives Dominion-wide coverage.

Philco Presentation to Yorks Town

THE first Philco radio set produced in the new Airmec Ltd. factory at Ossett, Yorks, some time ago, was officially presented to the borough at a ball at the local town hall recently. Attended by nearly 700 people, the ball was organised jointly by Airmec Ltd. and Philco Radio to celebrate the establishment of the factory, which was opened in March last year.

The set, an "A 535 B" all-wave table model, bearing a suitably inscribed silver plaque, was presented to the Mayor of Ossett, Alderman J. Gill, by Mr. L. D. Bennett, chairman of the Radio Tel Group of companies. Accepting the gift for the borough, the Mayor said he hoped Ossett would soon become known the world over. The Mayoress, Mrs. Gill, members and officials of the Ossett Council were present at the ceremony.

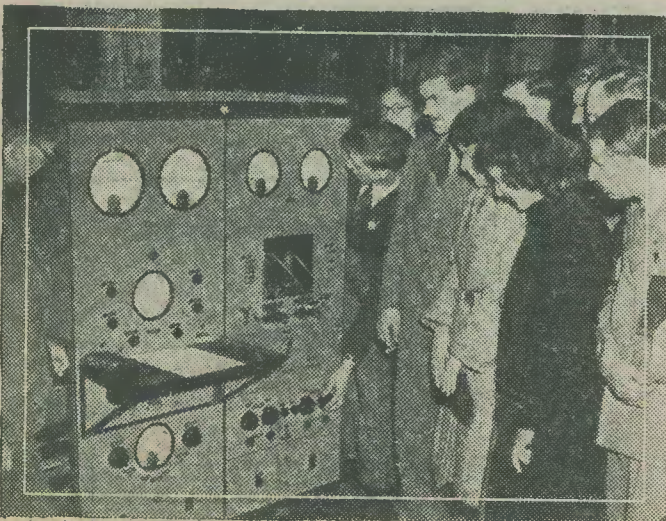

Fifty members of the Surrey Radio Contact Club recently visited the Mullard Valve Factory at Mitcham. In the above illustration some of them are seen inspecting one of the visual valve characteristic machines. The lady in the light coat is Miss Nellie Corry, G2YL, one of our outstanding amateur transmitters.

V.H.F. Receivers

Circuit and Constructional Details of Equipment for Use on 10 Metres and Below

By WM. NIMMONS

WITH the opening of the Alexandra Palace television service, the ultra-short waves (or, as they have come to be called, V.H.F. or very high frequencies) are coming once more within the province of the amateur constructor. Apart from the vision part of the transmission, which is useless except to those who have a vision receiver, there is the sound channel which gives very high quality. In addition, there is some agitation for the opening of a purely sound programme on V.H.F., which could give quality reproduction not attainable on the longer wavelengths. So we see that there is something to be said for the construction of a V.H.F. receiver.

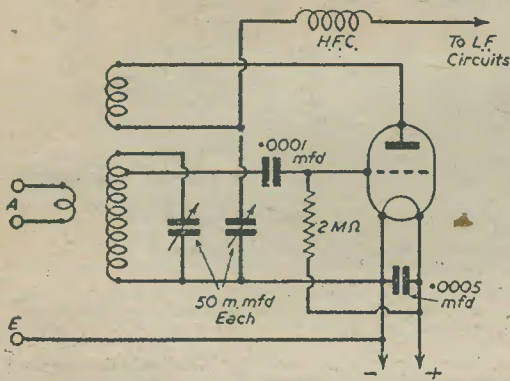

Fig. 1.—The straight circuit designed for V.H.F. work. Note the tapping down the coil to reduce damping.

Whilst it is generally reckoned that the range of such a receiver is the purely optical range from the transmitter (later knowledge has shown that this is increased by about 50 per cent.), there are occasions when "freak" reception is obtained from as far away as America. The laws governing such freak reception are not yet perfectly understood, and the amateur has here left him a profitable ground for experimental work. If V.H.F. receivers were as numerous as medium-wave receivers it is probable that many more reports of such long-distance reception would be obtained, as the results may be very local in character. In addition there are the amateur transmitters, who are to be heard on some of the V.H.F.

Receivers for V.H.F. have to be very carefully designed if they are to function properly. For wavelengths of from 5 to 10 metres ordinary valves may be used; in fact, the ordinary triode valve may be employed down to about 3 metres, providing care is taken to achieve a symmetrical layout. In this connection the length of the leads often constitutes a considerable proportion of the circuit, and it is essential to mount the coils so that they are close up to their associated variable condensers.

The Straight Circuit

For wavelengths of the order of 7 metres, the ordinary simple regenerative receiver may be used, but it should be noted that this is only suitable for large signal intensities. Fig. 1 gives the requisite circuit for a set of this character. The coils are wound with stiff wire of the order of No. 12 or 14 s.w.g., and should be about

in. in diameter. The grid and reaction coils are of three complete turns, and the aerial coil is one turn only, supported about an inch from the grid coil; the reaction coil should preferably be made movable, so that the best position may be decided by trial and error, but it may be supported about half an inch away as a first trial, being brought nearer or removed farther away according to the behaviour of the circuit, always bearing in mind that we want the circuit to oscillate gently and no more.

The Colpitts Circuit

The ordinary straight circuit often behaves erratically, however, on frequencies as high as 50 mc/s. It may not oscillate at all, even with the greatest care in designing. A much more ready oscillator, such as the Colpitts circuit, may be used with advantage. The Colpitts circuit is shown in Fig. 2.

In actual construction, the coils may be raised on pillars so as to bring them close to the terminals of the variable condensers, the valveholder also being raised from the chassis for the same reason. The ultra-short wave H.F. choke consists of about 30 turns of fine wire on a former having a diameter of about one-third of an inch.

Self-quenching

As previously mentioned, this class of circuit requires a fairly high signal strength for satisfactory operation. The super-regenerative receiver, however, can operate with a much-reduced input and still give a satisfactory output. A two-valve super-regenerative set is indicated in Fig. 3. This is known as the self-quenched type, and the quench action depends upon the condenser C_3 , which has a capacity of .0005 mfd. It is not proposed to go into the theory of the quenching action, let it suffice to say that with the assistance of R_4 (50,000 ohms, variable) the valve can be induced to work with far more regeneration than is commonly employed, with consequent increased amplification. The grid-leak, R_1 , also affects the performance, and various values should be tried, starting with 2 megohms; it is also an advantage to try a grid-leak of 10 megohms connected between grid and H.T. positive as some valves work better this way.

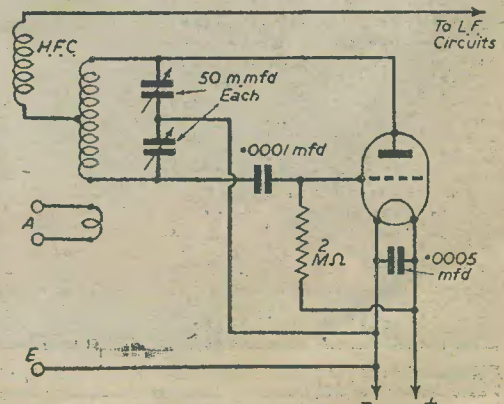

Fig. 2.—This is the Colpitts circuit, which will be found a ready oscillator.

The grid condenser C_2 is a ceramic condenser of 50 m.mfd. while the variable condenser C_1 , is a midget type of 15 m.mfd. C_4 and C_6 are both of 2 mfd., and C_5 is a by-pass condenser of about .0003 mfd.

The resistors R_2 and R_3 are for the purpose of preventing threshold howl, and should not be omitted. The value of R_2 should lie between 100,000 ohms and 500,000 ohms, depending upon the characteristics of the transformer; but 250,000 ohms is often a satisfactory value. R_3 is less critical, and 25,000 ohms is about right.

The operation of Fig. 3 is simple, but it should be noted that as both plates of C_1 are at high H.F. potential it is necessary to use an extension spindle if freedom from hand capacity effect is desired. The aerial coupling should be fairly tight, as the circuit is a ready oscillator, and movement of R_4 should be tried after the station has been tuned in. It should also be noted that this circuit is not suitable for quality reproduction.

The Superhet

The foregoing are only suitable for headphone use, and the gain is small. For high gain it is essential to employ the super-heterodyne system, and commercial practice has settled down to some form of Colpitts or Ultraudion circuit for the oscillator section of the frequency-changer. This simply means a coil connected between the anode and grid, with a grid condenser and grid-leak interposed to prevent grid tick. The circuit of such a frequency-changer is shown in Fig. 4, and there are one or two points worthy of special mention. This circuit may be made up in the form of a converter, for joining to existing apparatus.

The point of using such a circuit is that, with the customary oscillator, the conversion gain is very limited and a further difficulty is that the circuit is liable to generate parasitic oscillations; these render the whole circuit useless. This difficulty can be got over fairly successfully by employing the Colpitts oscillator.

Note also the condenser connected across the filament. This should have a value of round about .0005 mfd., and should be connected as close to the filament ter-

minals as possible, with a length of lead not exceeding $\frac{1}{2}$ in. The two 25 m.mfd. variable condensers are preferably not ganged, and the first will be found to give the broader tuning. The aerial coupling should be fairly loose, and should consist of one turn of thick wire, separated from the grid coil by about half an inch, the aerial itself being very short.

The I.F.T. follows usual practice, the transformer being designed for 465 kc. in the case of a complete superhet.; or a higher value for a converter to follow

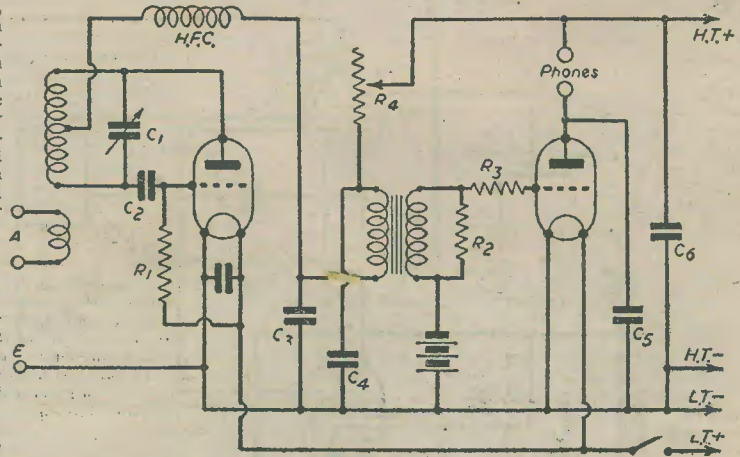

Fig. 3.—A super-regenerative circuit, in which the quench action is controlled by C_3 .

on to an existing set. The reason for this is that the tuning arrangements of the existing set will not cover 465 kc., and it will be necessary to employ a 600 kc. I.F.T.; this will bring the wavelength output of the converter within the range of the set (500 metres) so that it can be amplified and passed on. It is, of course, essential that the add-on set should have at least one H.F. stage.

Push-pull Operation

This circuit (Fig. 4) employs a triode-hexode, and this type of valve is recommended for V.H.F. operation. As far as heptodes are concerned, this type of valve works best in push-pull, and the symmetry with which the circuit can be arranged is a decided advantage. Each valve is tapped across half of the coil, and the total damping is reduced and increased gain is obtained. The method of making connection to the centre-tap of the coils may be by crocodile clip, but once the correct spot has been found it is recommended that a permanent soldered joint be made; this makes a better connection than the clip, which may give trouble owing to corrosion, etc., and as the clip may be made of ferrous metal this would absorb a great deal of power from the circuit, due to its being in the field of the coil.

As previously mentioned, it is essential in all practical receivers built from circuit diagrams that all wires be as short as possible, and careful placing of the components is necessary to ensure

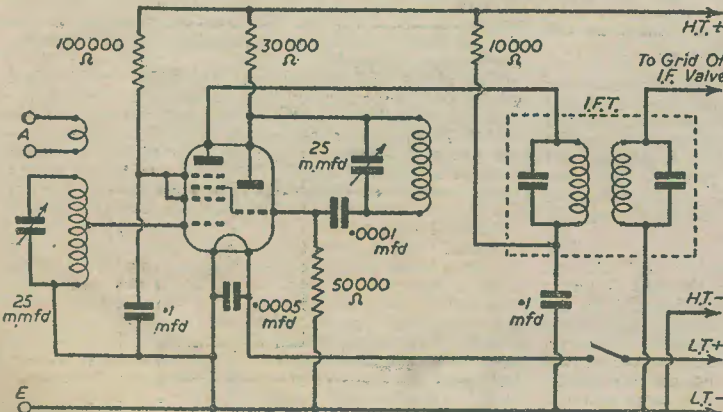

Fig. 4.—A frequency-changer for V.H.F., employing the Ultraudion circuit for the oscillator section.

Frequency Modulation-5

Instructions for Lining-up a Receiver of the F.M. Type

By C. A. QUARRINGTON

It will be recalled that the previous article described how the amplitude limiter and frequency amplitude converter functioned, and provided an audio frequency output of a few volts amplitude. It now remains to consider the introduction of de-emphasis and any special requirements of the output stage and power pack, in order to complete the general principles of the frequency-modulated receiver. To complete the picture, however, some general information is included on alignment problems peculiar to this type of receiver.

Fig. 1 shows the complete circuit of a typical limiter, converter, audio frequency amplifier and output stages, which not only embodies all the necessary details to illustrate the points made in this article, but includes that part of a frequency-modulated receiver which differs from an amplitude-modulated receiver. Reference to Fig. 1 will show that the audio output from the frequency amplitude converter is taken through a pair of triodes arranged for phase splitting, the resistance R_3 and condenser C_4 being arranged as a filter to attenuate, to negligible proportions, any radio frequency that might otherwise appear at troublesome amplitude in the audio-frequency stages. The values for this filter are not particularly critical as long as the higher audio frequencies are not attenuated, unless, of course, the filter is intended to perform the additional office of de-emphasis. Suitable values for these components are 100,000 ohms and 50 to 100 pfd., or if it is desired to introduce de-emphasis the value of the condenser would be increased as necessary to conform with a degree of pre-emphasis used in the transmitter. It will be noted that a push-pull amplifier is shown using negative feed-back; the circuit used for the audio-frequency section has, of course, no direct connection with frequency modulation except that some high-

quality amplifier will presumably be used, as it would appear somewhat illogical to go to the trouble of wide-band frequency modulation and finish up with easily avoidable distortion in the output stage.

Alternative Phase-splitter

It is possible to introduce an interesting variation by substituting the phase-splitting arrangement shown at Fig. 1 for a pair of triodes in ordinary push-pull and rearrange the discriminator circuit so that a symmetrical output is obtained. It is merely necessary to remove the earth tap from the outer end of R_2 and place it at the junction between R_1 and R_2 ; this rearrangement results in a symmetrical output that can be used to feed the push-pull triodes. If de-emphasis is used with this rearranged system, it will be desirable to place a filter in each grid lead. This alternative arrangement appears at first sight to be preferable to the arrangement at Fig. 1, and surprise may be evinced that it has been selected for illustration in preference to the alternative. Given perfectly matched components, and a perfectly-designed receiver, there is much to be said for the alternative arrangement, but under less favourable conditions the arrangement illustrated is probably more satisfactory. One advantage is a gain in stability which in practice appears when one or other of the diode cathodes is connected direct to the earth line, instead of via the condenser potentiometer C_1, C_2 . A further advantage is readily apparent by reference to Fig. 1. The use of the centre-tap diode circuit may introduce undesirable lack of balance, if the increase of potential difference across one resistance is not sensibly equal to the decrease across the companion resistance under conditions of modulation; when the centre tap is not employed, the audio-frequency amplifier

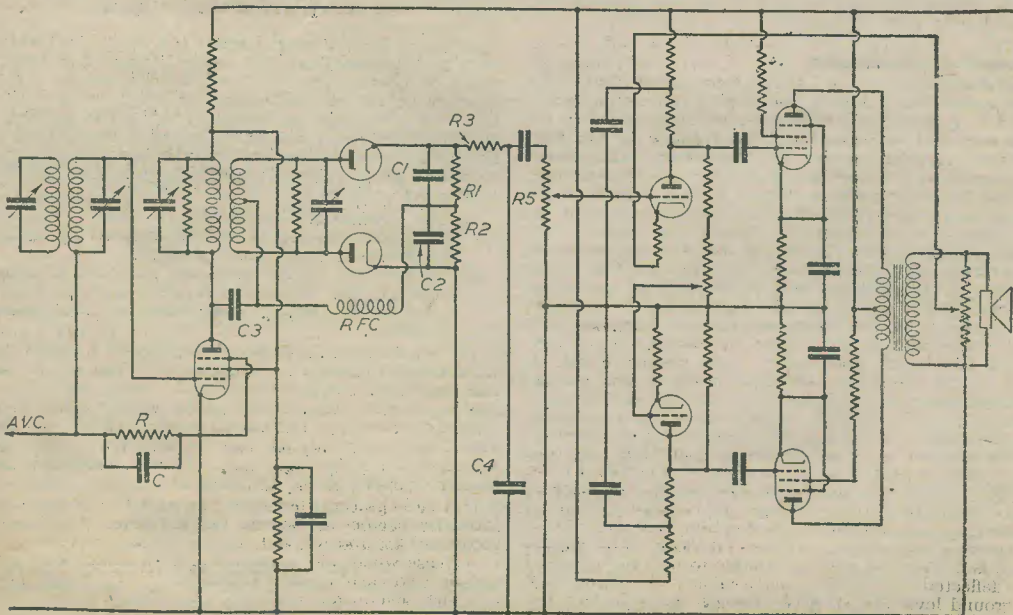

Fig. 1.—The complete circuit of a typical limiter, converter, A.F. and output stages.

is only affected by the sum of the difference of potential across R_1 and R_2 and slight lack of symmetry is not so serious.

Power Pack

The power pack of a frequency-modulated receiver will be quite conventional and a single rectifier may be used for supplying high tension to all stages if so desired, particularly if a push-pull output stage is used; if, however, a non-push-pull output circuit is employed, it is sometimes desirable to arrange for a separate rectifier to supply the audio frequency and output stage, to avoid the difficulties that might otherwise arise in the oscillator stage due to audio-frequency feedback. The danger of this has been explained in a previous article, which also explained the need for keeping mains hum out of the frequency-changer stage. It is a matter of convenience whether the hum level in the frequency changer is kept down to acceptable limits by improvement of the smoothing as a whole, or whether by the provision of additional smoothing to the appropriate stage. The latter course is preferable on economic grounds but the pros and cons cannot be usefully discussed as the question is so influenced by the design of the receiver as a whole.

Special care is needed when aligning all tuned I.F. circuits in a frequency-modulated receiver. A good signal generator is essential and, in addition to having adequate accuracy, must be capable of variation over the required bandwidth without appreciable change in output amplitude. This is particularly important, as serious shortcomings of signal generator design will bring about unsymmetrical working of the frequency-amplitude converter, which is a serious matter from the point of view of the quality of reproduction.

The foregoing alignment instructions are given primarily for use without an oscilloscope, since those who are fortunate enough to possess this piece of equipment are usually well experienced in interpreting alignment instructions given for use with other equipment. It may be pointed out, however, that the unquestionable advantages of the oscilloscope when used for ganging the normal receiver, using a wobbled signal generator, are lost when aligning a wideband frequency-modulated receiver, unless a special type is available having a variable wobbling bandwidth up to ± 75 kc/s or more.

Without An Oscilloscope

The alignment of the last I.F. transformer, that is the one immediately before the frequency amplitude converter, requires separate consideration, and for the purpose of the instructions given below it has been decided to coin the phrase "converter transformer" especially to describe this particular I.F. transformer, all others being referred to as I.F. transformers in the usual way. The term unmodulated frequency in the foregoing instructions is meant to convey the unmodulated radio frequency or the unmodulated intermediate frequency as appropriate, the latter being, of course, the mid-point of the wide-band characteristic or nominal intermediate frequency as produced by the frequency changer when fed with the unmodulated transmitter frequency.

(1) Disconnect the limiter bias resistance (R_1 at Fig. 1) at the earth end and insert a low reading milliammeter—if available, a 0-500 microammeter is usually most convenient; a large-scale type instrument is preferable. (Some frequency-modulated receivers are fitted with a jack or terminals and link, for this particular purpose.)

(2) Connect the signal generator between the grid of the frequency-changer valve and earth exactly as when lining up a normal superhet.

(3) Stop the oscillator section of the frequency changer from oscillating by any convenient means, e.g., earthing the grid.

(4) Set the signal generator to the unmodulated intermediate frequency and adjust I.F. transformers to

resonance in the usual way. Resonance will be shown by maximum reading of the meter connected in series with the limiter bias resistance. At all times the oscillator output must be kept low enough to ensure that the limiter is not saturated; check this frequently by noting that the milliammeter needle shows a marked increase if the signal generator output is experimentally increased. If a marked increase does not result, the signal generator output is too high. As resonance is obtained on various successive windings, the oscillator output will need to be reduced so that the limiter valve has a workable input. Where over-coupled I.F. transformers are employed, resonance will not be shown by maximum meter deflection, and the centre of the peaks must be "felt for" by swinging the trimmers until the mid-point between the peaks is found as accurately as possible; the presence of sharply-peaked single tuned circuits elsewhere in the circuit increases the difficulty of lining up the over-coupled tuned circuits.

(5) Assuming all I.F. transformer primaries and secondaries to be adjusted to resonance, as nearly as possible, attention can be given to the shape of the overall response curve. Starting from the unmodulated intermediate frequency, set the oscillator alternatively above and below this frequency by progressively equal small steps, noting that each deviation in one direction produces the same meter reading in the opposite direction; continue this procedure until the bandwidth is covered. Unless abnormal good luck is encountered the desired symmetry will not be obtained without further adjustment of the I.F. trimmers by trial and error methods. When such readjustment seems to be approaching finality, note that attenuation is not too rapid towards the edges of the bandwidth; that is to say, the response as shown by the meter at the edge of the bandwidth should not be less than 30 per cent. of the response at the unmodulated intermediate frequency. (This figure is based on an average receiver and is, at best, very approximate.)

(6) Should it be desired to carry out alignment as described in (4) and (5) above with more than average care, a final check for symmetry can be made by plotting the responsive curve on squared paper and by setting frequency deviation against meter deflection.

(7) Remove meter and re-connect limiter resistance to earth.

(8) Some form of output meter is now required which may be introduced into the audio frequency or output stage as convenient. If the available output meter happens to be an oscilloscope, or valve voltmeter, it can with advantage be connected across the frequency amplitude converter output. The set is now rigged to check the action of the amplitude limiter and align the converter transformer. It is necessary to bear in mind two rules:

(i) The symmetrical working of the frequency amplitude converter is mainly achieved by tuning the converter transformer primary.

(ii) Attainment of the necessary zero output when receiving the unmodulated frequency is mainly achieved by tuning the converter transformer secondary.

(9) Set the signal generator conveniently between the unmodulated frequency and the edge of the bandwidth and note that the limiter action is correct by rocking the signal generator output control, when no deflection should be noted on the output meter. Obviously, the signal generator output must be varied over a range which, when duly amplified, will not underload the limiter or overload the I.F. amplifier.

(10) Set the signal generator exactly to the unmodulated frequency and adjust the converter transformer secondary for zero output.

(11) Set the signal generator to a frequency half-way between the unmodulated frequency and the bandwidth edge successively on either side and adjust the converter transformer primary until similar readings are obtained

on the output meter. A closer approach to perfect symmetrical working can be obtained by checking at several values of deviation on each side of the unmodulated frequency.

(12) Re-check zero setting by repeating (10) above.

(13) Some converter transformers are provided with variable coupling between primary and secondary. This adjustment is best left alone unless experience and more advanced test gear are available. If for any reason readjustment is necessary—i.e., after unavoidably upsetting adjustment while effecting repair—manufacturers' alignment instructions should be obtained appropriate to the particular transformer and/or receiver.

(14) Remove output meter and signal generator and counteract steps taken to stop frequency changer oscillator from oscillating.

(15) The R.F. tuned circuits will not require such frequent alignment as the I.F. amplifier and converter

transformer, but, when necessary, it can be accomplished in the normal manner using unmodulated output from the signal generator, and employing an indicator meter in the limiter grid circuit as described for other purposes in (1) above.

Frequency modulation has been little used in this country. There is, therefore, no cut-and-dried alignment procedure that can be considered as standard for general purposes. The above procedure has been used successfully by the writer for lining up both narrow and wide-band frequency modulated receivers and was evolved in difficult circumstances after considerable trial-and-error experiment and will, it is hoped, act as a basis for individual requirements. The cathode-ray oscilloscope and special wide-band frequency modulated signal generator are ideal instruments for aligning this type of receiver, and it is presumed that the fortunate few who possess, or have access to, such equipment will have no difficulty in adapting the above notes.

Tone Compensation by Negative Feed-back

An Account of Some Practical and Simple Experiments, by G. T. EDWARDS

THE high-fidelity reproduction of gramophone records and broadcast programmes often necessitates the provision of some form of tone corrector to compensate for deficiencies in the overall frequency response of the reproducing equipment used. These deficiencies are attributed to one or more of the following reasons:

- (i) Non-linear response of the loudspeaker and pick-up.
- (ii) Attenuation of the higher modulation frequencies due to sharply-tuned H.F. and/or I.F. amplifying circuits.

(iii) The falling frequency-amplitude characteristic of a gramophone record below the region of approximately 250 c.p.s.

A very attractive and effective method of compensation is available to the radio constructor in the use of negative feed-back, and this article is the outcome of a number of experiments carried out by the writer. No highly-specialised apparatus or expensive components are needed for the incorporation of the following systems in existing amplifiers and receivers. Further, with slight

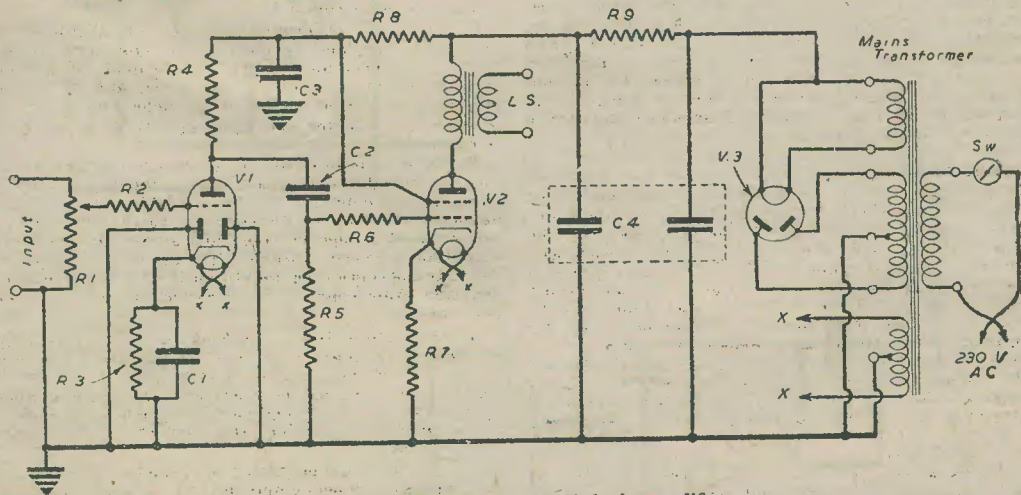

Fig. 1.—Circuit diagram of basic amplifier.

COMPONENTS

No.	Value	No.	Value	Valves
R1	.25 MegΩ V.C.	R8	1,000Ω ½ w.	V1
R2, R6	50,000Ω ½ w.	R9	2,000Ω 5 w. min.	V2
R3	2,000Ω ½ w.	C1	50 μF 12 v. wkg.	V3
R4	.25 MegΩ ½ w.	C2	.01μF, 450 v. wkg.	M.T.
R5	.5 MegΩ ½ w.	C3	8 μF, 450 v. wkg.	Prim.: 230 v.
R7	90Ω ½ w.	C4	8 and 8 μF, 500 v. wkg.	Sec.: 350-0-350 80 mA.
				6.3 v. 2. A.C.T.
				5 v. 2 A.

modifications, these circuits are easily applicable to battery-operated apparatus.

The circuit diagram of the simple amplifier used as a basis for these experiments is shown in Fig. 1. It consists of the triode section of a DH63 R-C coupled to a high sensitivity output tetrode. (KT61). Power is derived from a conventional full-wave rectifier circuit,

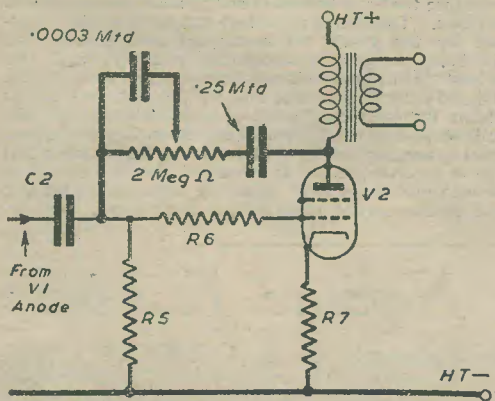

Fig. 2.—Tone control circuit No. 1.

employing resistance-capacity smoothing. The gain of this amplifier was not reduced inconveniently by the inclusion of any of the following tone-control circuits.

The additional components and wiring needed for the various tone-control circuits are shown in heavy lines in Figs. 2 to 5.

Circuit No. 1

The action of this circuit (Fig. 2) is as follows: When the .0003 mfd. condenser is completely out of circuit the percentage feed-back is fairly constant at all audio frequencies, therefore the response of the amplifier is reasonably linear. The actual percentage of the output voltage applied to the grid is roughly 20.

On the other hand, however, when the condenser is fully across the 2 MΩ resistance the proportion of the output voltage applied to the grid circuit gradually increases with frequency. Therefore, the bass notes are

amplified to a greater degree than the high notes. This is because the resultant impedance of the 2 MΩ resistance, in parallel with the .0003 mfd. condenser, becomes progressively less as the frequency increases. The shunting effect of the .0003 mfd. condenser is made variable by connecting it as shown.

Control with this circuit was found to be smooth and ideally suited for bass compensation in gramophone record reproduction.

Clearly, an alternative arrangement would be to use a fixed 2 MΩ resistor and to connect a variable .0003 mfd. condenser across it.

Circuit No. 2

This system provides variable "top-boost" by negative current feed-back, or variable "top-cut" by the more usual method (Fig. 3). A single 100,000Ω potentiometer is used to perform both functions.

Additional current feed-back is provided by the extra 200Ω resistor included in the cathode circuit of V2. The correct grid-bias is still obtained by connecting the bottom end of the grid resistor (R5) to the junction of R7 and the additional 200Ω resistor.

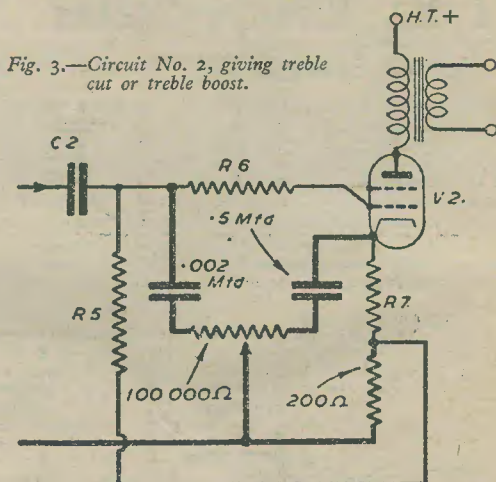

Fig. 3.—Circuit No. 2, giving treble cut or treble boost.

In the maximum "treble-boost" position, where the .5 mfd. condenser is connected fully across the cathode resistances, the percentage feed-back is reduced as the frequency increases, thus giving increased gain at the high frequency end of the audio scale.

In the maximum "top-cut" position, the .002 mfd. condenser is connected directly across the input circuit of the output stage so that the high notes are by-passed to an extent which increases with frequency.

Circuit No. 3

This circuit (Fig. 4) was developed to provide two facilities: (a) A fixed degree of both treble and bass-boost for local radio reception of orchestral programmes, and (b) fixed bass-cut for speech reproduction. Facility (b) is particularly desirable to prevent "boominess" on "speech" should the loudspeaker being used have a pronounced resonance in the region of 100 c.p.s.

With the D.P.D.T. switch in the "music" position the .01 mfd. condenser is included in the voltage feed-back circuit from V2 anode to M1

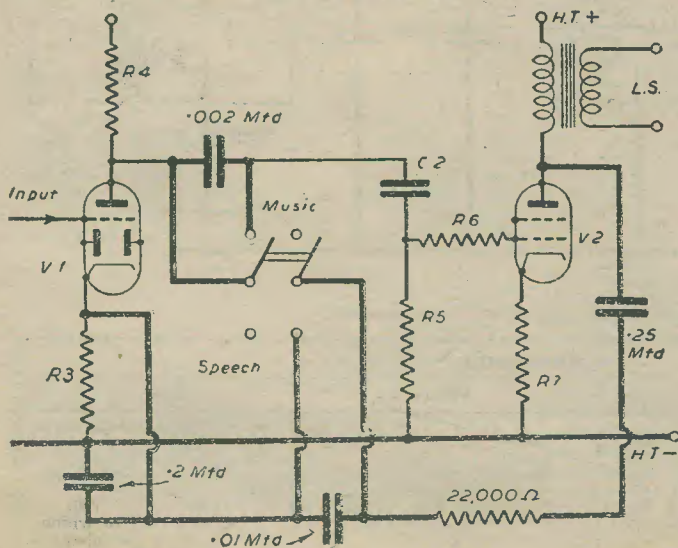

Fig. 4.—Circuit No. 3, showing "Speech-Music" Switching.

Analysis of the Television Receiver-6

This Month We Deal With Tube Sensitivity and Deflection Amplifiers

FIG. 35 makes clear the operation of Fig. 34 given last month. A free-running generator of the type described is of no value in the television receiver, however, for although it might be possible to obtain the requisite line and frame operating frequencies of 10, 125 and 50 cycles per second respectively by critical adjustment of R_3 and R_2 , these frequencies would not remain constant for long, due to small fluctuations in the H.T. supply and other unavoidable variations in operational conditions. In practice, therefore, the discharge of the generating condenser is controlled by the synchronising pulses.

The circuit then functions as follows: V_1 is cut off by the bias developed across R_2 as before and the

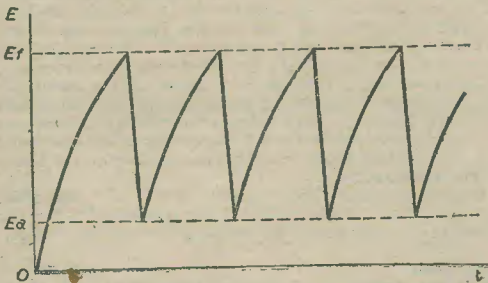

Fig. 35.—The output of the circuit of Fig. 34 when the value is free-running in the absence of synch pulses.

voltage across C rises, carrying the anode of the discharger towards positive H.T. At a given stage of this charging cycle, when the anode voltage is not quite at the critical striking value, the sharp positive-going synch pulse is presented to the grid via C_1 and R and reduces the negative grid voltage just sufficiently to allow the valve to fire. As soon as the valve conducts C discharges itself through the ionised gas and the valve goes out when the condenser voltage has fallen to a value equal to the valve drop. C then commences to re-charge, and the cycle repeats on the arrival of the following synch pulse. The circuit is, now no longer free-running but generates a controlled saw-tooth waveform at a frequency determined by the frequency of the synchronising pulses. By using two

separate discharger valves and feeding one with the line synch pulses and the other with the frame synch pulses, saw-tooth voltage waveforms of the desired 10, 125 and 50 cycles per second are automatically secured.

The manner of feeding the saw-tooth waveforms to the respective deflector plates of the cathode-ray tube presents certain difficulties. Much depends upon the sensitivity of the tube, its anode voltage and the extent of the non-linearity of the sweep that can be tolerated. Nothing can be done on the part of the constructor regarding the construction of the tube and he has to take what the designer offers him, but care can be exercised in its choice, and the method adopted for feeding the deflector plates once he has bought his tube is entirely in his own hands for success or failure. For this reason a few notes will be made on the subject of tube sensitivity.

Tube Sensitivity

The actual movement of the spot on the screen of a cathode-ray tube depends upon various factors in the tube construction. The closer the deflection plates are located to the electron stream, the greater is their influence, and it is general to arrange each pair in a diverging position as shown in Fig. 36. This system of construction gives the advantages of closeness without allowing the beam to actually strike a plate due to excessive deflection.

With a given arrangement of deflector plates, a certain maximum angular movement of the electron stream is permissible; in the figure this angle is indicated by θ . It is apparent at once that the longer the tube is made the greater will be the movement of the spot for a given value of θ . Thus a long slender tube is generally more

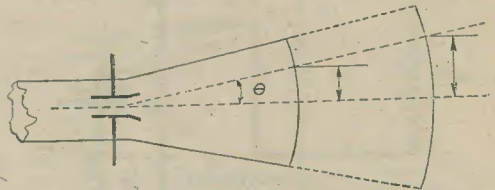

Fig. 36.—The sensitivity of a long tube is greater than that of a short one.

sensitive than a short fat one, the deflection angle θ being smaller for the same movement of the spot.

Yet another factor affecting the tube sensitivity is the final anode voltage. The velocity of the electron stream is directly proportional to the voltage on the final anode of the tube, and by doubling the anode voltage the sensitivity of the deflector plates will be approximately halved. Most readers will no doubt have noticed the lengthening effect on the time-base sweep of an oscilloscope when the tube anode supply is switched off and the tube anode voltage falls to zero. This is because the sensitivity of the plates is increased and the time-base voltage produces a longer sweep. The effect is quite common. The brilliance of the spot increases, of course, as the anode voltage is raised on any tube, as does the ability to obtain a sharp focus, and so a

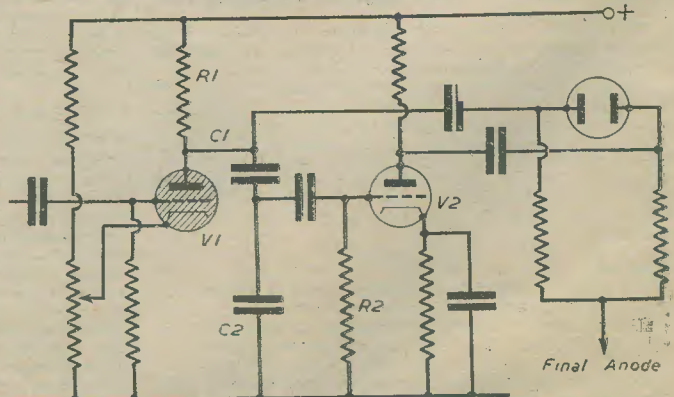

Fig. 38.—A simple push-pull deflection amplifier where the gas-discharger valve itself is one of the amplifiers.

compromise has to be drawn between these conflicting requirements of sensitivity and definition. The anode voltage is the only factor under the control of the user; the size of the screen, the shape and disposition of the deflector plates are all fixed by the manufacturers.

Most makers therefore express the sensitivity of a tube in terms of the final anode voltage, so:

$$\text{Sensitivity} = \frac{k}{V} \text{ mm. per volt.}$$

where k is a constant depending on the tube design and V is the final anode voltage. A maximum permissible anode voltage is also generally stated. Thus a tube may have a sensitivity of $1,000/V$ mm. per volt, which means that for 3,000 volts on the final anode a voltage of 1 volt applied across the deflector plates will cause the spot to move $\frac{1}{3}$ mm. across the screen. Taking the screen diameter to be 250 mm., then 750 volts must be applied across the deflector plates in order to move the spot completely across the screen.

It is general to obtain sensitivities in this way for both the horizontal and the vertical deflecting plates. Thus, a tube may be calibrated in this way:

$$\begin{aligned} \text{X-plate sensitivity} &= \frac{850}{V} \text{ mm./volt} \\ \text{Y-plate sensitivity} &= \frac{800}{V} \text{ mm./volt} \end{aligned}$$

the plates situated nearest to the final anode having the greatest sensitivity, in this case the X plates. In

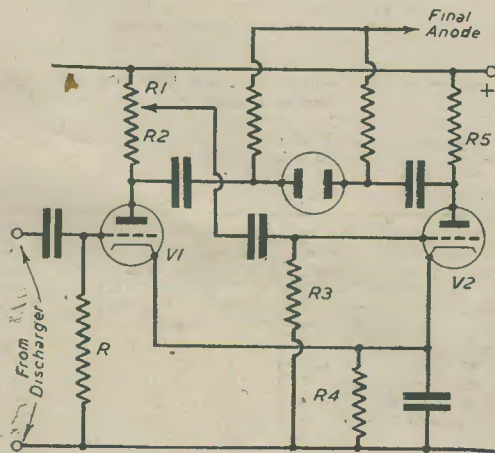

Fig. 39.—A typical push-pull deflection amplifier, the output of each valve being equal and opposite and balanced about the final anode of the cathode-ray tube.

television, since the ratio of picture width to height is 5:4, it obviously pays to use the most sensitive pair of plates for the horizontal deflection. (Fig. 37.)

A useful size of picture tube for the experimenter is one with an 8in. to 10in. diameter screen, designed to work with a final anode voltage of 2,500 to 3,000 volts. Suppose the screen shown in Fig. 37 is 10in. diameter, then for $W/H=5/4$, the size of the maximum full rectangular image will be 7.8in. \times 6.2in. In practice, it is general to ignore the corners of the picture and increase the central picture area accordingly. In the example under discussion 8.5in. \times 7in. ($=216 \times 178$ mm.) would be quite suitable for good viewing. Now the deflection voltages required to build up a raster of this size can be readily calculated as follows, assuming that the plate sensitivities are those quoted above, with a final anode voltage of 3,000 volts. Working with the X plates for the horizontal, or line deflection, we have:

$$\begin{aligned} \text{Peak-to-peak deflecting volts} &= W \cdot \frac{V}{k} \\ &= \frac{216 \times 3,000}{850} \text{ volts.} \\ &= 762 \text{ volts} \end{aligned}$$

and for the frame, or vertical deflection:

$$\begin{aligned} \text{P-to-p deflecting volts} &= \frac{178 \times 3,000}{800} \\ &= 668 \text{ volts.} \end{aligned}$$

Thus, for a tube of this nature, we must supply the horizontal plates with 762 volts peak-to-peak at a frequency of 10,125 cycles per second, and the vertical deflecting plates with 668 volts peak-to-peak at a frequency of 50 cycles per second.

Deflection Amplifiers

When using gas triodes for saw-tooth generation it is customary, in the interests of linearity, to arrange that the charging condenser only charges up to about 15 per cent. of its full voltage before being discharged through the valve. If the tube deflector plates were fed directly from the discharger stage, this process would not be very practical, however, for the charging source would have to have a voltage six or seven times as high as the scanning stroke required, and this would mean a time-base H.T. supply of some 6,000 to 8,000 volts.

It is usual, then, to include deflection amplifiers in the television receiver, so that a small linear saw-tooth generated by the gas discharger is amplified to the required magnitude, without distortion, demanded by the cathode-ray tube. It is possible to use a straight-forward valve amplifier, feeding the output to one plate of a

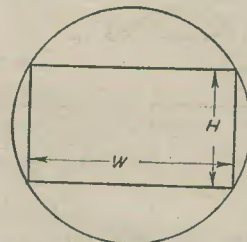

Fig. 37.—Diagram used for calculating maximum picture size and required deflection voltage.

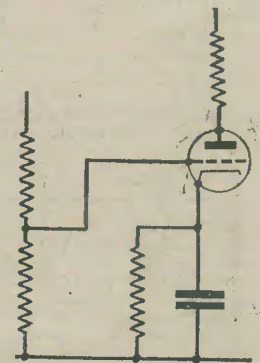

Fig. 40.—An alternative method of feeding the second stage of Fig. 39.

pair, the other plate being returned to final anode or earth, but in general this system is unsatisfactory since it leads to a form of picture distortion known as the trapezium effect. This is due to one or other of the deflector plates moving up or down in potential with respect to the final anode, thus affecting the tube sensitivity from instant to instant. This results in the edges of the picture being trapezium shaped instead of at right angles; in extreme cases the whole picture is badly "warped" right across the screen. In order to overcome this difficulty, a form of symmetrical deflection is almost invariably resorted to, one deflector plate of each pair being caused to rise in potential as the other falls by a similar amount. The mean plate potential with respect to the final anode is then maintained at a constant value and trapezium distortion is avoided. This symmetrical system of deflection is obtained by using a push-pull scanning amplifier such as is shown in Fig. 38.

In this figure the discharger valve itself provides one half of the scan, with an amplifying stage V_2 providing the other half. The circuit is quite straight-forward, the actual charging condenser being split into

a capacity potentiometer consisting of C_1 and C_2 . Only a portion of the saw-tooth generated across C_1C_2 is applied to the grid of V_2 , the gain of this stage being so chosen that the anode output voltage is exactly equal, but opposite in phase to the anode output voltage of V_1 . When the anode potential of V_1 is rising, therefore, that on V_2 is falling, so that the tube deflector plates receive scanning potentials in opposite directions. The deflection produced is proportional to the total voltage difference across them, but as they are both above and below the final anode by equal amounts, no distortion occurs. Linearity is likely to be bad with this type of circuit, however, owing to the necessity of having to charge C_1C_2 to a fairly high percentage of the total H.T. supply.

A better form of deflection amplifier is shown in Fig. 39. Both valves have the same characteristics and are self biased by the common cathode resistance R_4 . R_1 and R_2 are so chosen that they are together equal to R_5 , and the outputs of V_1 and V_2 are arranged to be equal by making their grid inputs equal. Since a large amplification of the saw-tooth waveform from the discharger is provided by V_1 , the input to V_2 is taken from the centre point (not electrically) of R_1 and R_2 so that:

$$\left\{ \frac{R_1 + R_2}{R_1} \right\} = \text{amplification of } V_2$$

assuming that R_2 is very much larger than R_1 .

There is a reversal of phase in each valve so that the potential applied at any instant to a deflector plate is equal and opposite to that applied to the other, being symmetrical about the final anode. R_1 and R_2 may conveniently be an adjustable potentiometer of the correct total value.

The input of V_2 need not be tapped along a portion of the anode resistance of V_1 to secure the correct magnitude of input voltage, but may be taken from a point along its own grid resistance. Fig. 40 shows this part of the circuit. This system is preferable from the point of view of avoiding hum pickup, but it is not generally used in line amplifiers owing to the input

capacity effect of V_2 on the frequency response which must be high to avoid distortion. For frame amplifiers, however, it is quite useful.

Practical forms of the deflection amplifiers discussed above largely follow ordinary amplifier practice, but requirement of frequency response and phase-shift effects cause the time-base amplifiers to differ from audio patterns in several important respects.

The frame amplifier must give negligible phase shift over a frequency-band of 50 to 500 cycles per second, while the line amplifier must deal adequately with the much greater range of 5,000 to 100,000 cycles per second. The frame amplifier is consequently far easier to construct than the line amplifier, the main difficulty in the latter being associated with the falling off in high-frequency response due to stray capacity. When the response is poor at high frequencies, the spot fly-back time is increased, with the result that the left-hand edge of the picture is missing altogether or appears "folded" back upon itself.

The frame deflection amplifier of Fig. 41 consists of two power triodes, V_{14} and V_{15} , with the line deflection amplifier using similar valves V_{17} and V_{18} . Both stages are push-pull, and the only difference between them is that brought about by the higher frequency requirements of the line deflector plates. These differences will now be discussed; first, the frame amplifier, V_{14} and V_{15} .

The saw-tooth voltage waveform is developed across C_{12} and C_{13} , and a fraction of this is applied to the grid of V_{14} via C_{15} and R_{27} . The output of V_{14} appears across R_{30} and R_{31} in the grid circuit of V_{15} , and a tapping from R_{31} applies a fraction of the total voltage to the grid of the valve. The reason for taking the feed of V_{15} from a point on the grid resistance rather than from the anode load of V_{14} has been given previously; a smaller proportion of the hum voltage on V_{14} is transferred to the grid of V_{15} by adopting this method. For the frame time-base amplifier, where a high-frequency response is not essential, the input capacity of V_{15} has no effect upon the performance and a low grid tapping point is permissible.

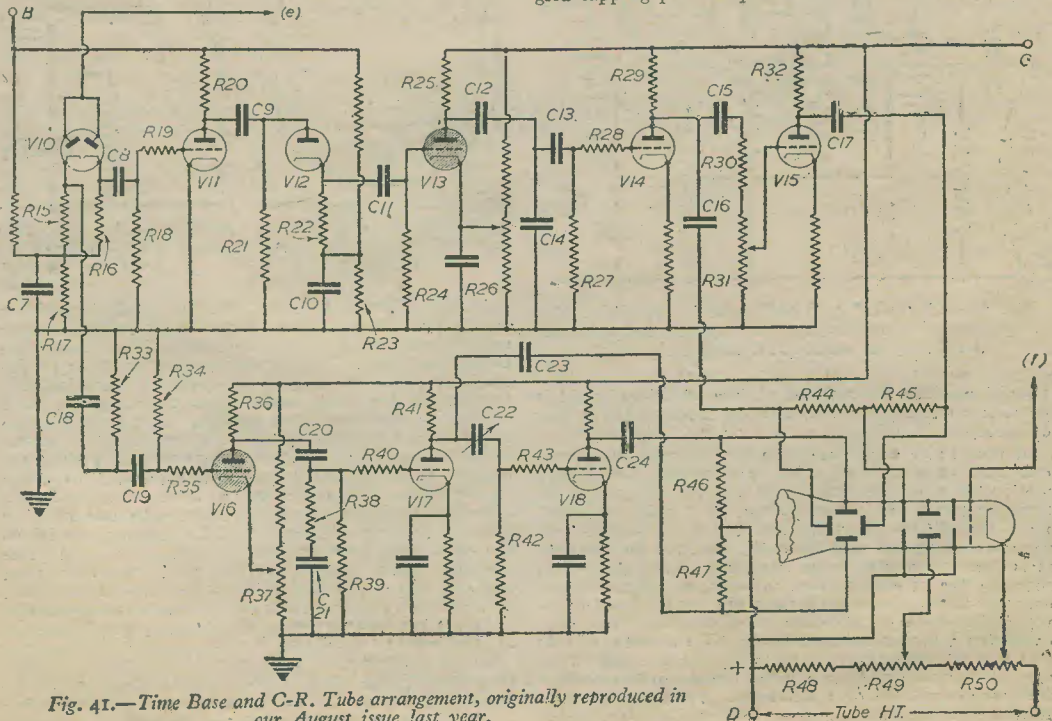

Fig. 41.—Time Base and C-R. Tube arrangement, originally reproduced in our August issue last year.



ON YOUR WAVELENGTH

By THERMION

Business in Burma

SEVERAL radio firms in Burma have written to me complaining that whilst they are anxious to push British goods, they do not find British firms so accommodating. They either do not reply to letters or send churlish replies. There are, of course, certain barriers, both artificial and conventional in connection with trade in Burma.

During four years of Burma's isolation due to war, firms established in India, Ceylon, Malay and Singapore held the sole selling rights in certain goods as far as Burma was concerned. This, it is thought, is unjust to the consumers in Burma, as well as to exporting British manufacturers who should not permit their goods to be handled by agencies which are not in a position to study the tendencies of overseas markets, nor to control the trade in Burma.

I am informed that in the interests of both the Burmese and the countries with which the Burmese have to develop trade relations, intermediary elements such as Indian firms in India who have been given the privilege of sole selling rights in Burma should be entirely eliminated.

Burmese are to-day more business conscious than pre-war, and are handling trade for their own welfare and rehabilitation. They ask British manufacturers to deal with them directly. Of course, only tropicalised receivers are saleable in that country, and they should cover a wave-range of from 13 to 500 metres with band-spread. If any English manufacturers are interested I shall be glad to put them into touch with reliable firms.

The Black Market in Servicing

I AM always amazed when someone recounts to me his experiences at the hands of the thousands of private "service engineers," who are making a ready living and a profitable one cashing in on the shortage of really qualified service engineers. In very few cases is satisfaction given. These otherwise intelligent people will pass out to a comparatively unknown man a receiver which has cost £30 or so, and then wonder when they get it back why the set either does not function or is worse than before.

These black marketeers do not work cheaply. They know that the legitimate service stations have long waiting lists, and so they knock at doors posing as experts in radio and ask whether the receiver requires an overhaul. One of the tricks they play after an examination is to say that they will have to take it back to their "workshop." That is the last the owner sees of his wireless set. One or two of these common swindlers who successfully pit their Camberwell wits against those of Cambridge have been caught by the police and are doing long terms of imprisonment. But still the game goes on for there seem to be mugs everywhere and as the Americans put it "a sucker is born every minute."

Very few of my readers will be caught by these specious people, but one the other day wrote to me a piteous letter concerning the treatment he had had at the hands of one of these fly and slimy gentry. His set had been out of action for some weeks and the local repairer could not take it on because of the shortage of a particular type of valve and some electrolytic condensers. Why my reader should presume that an unknown man knocking at doors should have supplies of goods denied to normal traders I do not know. People are so trusting these days when, in a period of pilfering, they should be more than ordinarily cautious. However, my reader was sufficiently misguided to believe that this unknown man

would be able to perform the necessary miracle and the man duly returned the receiver when only his wife was at home. That is a trick, of course, which they always play. The wife parted with £3 5s. without displaying the necessary intelligence of asking to have the receiver demonstrated before she paid the money.

Not only had the receiver not been repaired but all of the valves had been removed as well as the loudspeaker and a number of other parts. The set is, of course, now worthless, and I have no doubt that in addition to the £3 5s. the "expert" has made a further sum by the sale of the valves and other components.

Of course, the only thing to do in such circumstances is to report the matter to the police but it is seldom that one of these lowest forms of tricksters from 'oxton, Petticoat Lane, or the gutters of the East End of London, is caught.

When they are I hope the magistrates make it really warm for them. My readers will be performing a service to the radio industry by warning their wives, sweethearts and friends not to deal in any case with door-knocking "experts." It is not only in the radio trade that these gentry operate. They call to buy up old gold, old clothes, and bric-a-brac. The unsuspecting housewife is easily cheated. You cannot expect her to know that a pound of gold is 120z. Troy weight. I am aware that there are similar frauds with business addresses, who trick their customers by charging for replacements which have not been made. I know that the radio industry has been concerned for years with purging the Augean stables of these undesirables.

Deal only with recognised shops. Make quite certain if you are new to a district that the proprietor knows his business or employs someone who does.

Whenever you take a receiver to be serviced see that you get a receipt which details the work done and the replacements made. Learn to *know* your set, so that you can spot on inspection whether replacements have been made or not. Preferably deal with the recognised agents for the particular receiver. Best of all, learn how to service the receiver yourself by studying a good handbook on the subject.

Readers who have had experiences such as those recounted earlier are invited to write to me in confidence so that I may warn other readers. The name and address of the reader concerned should be given, but not for publication unless it is desired.

"Snoopers"

[Press Note—A daily paper reporter (who may be misinformed) says in regard to police broadcasts on short waves that "the unauthorised amateur listener will be prosecuted wherever sufficient evidence can be obtained."] Shall modern crime detectors,

With zeal their eyeballs glistening,
Fall like a thousand tons of bricks
On amateurs caught listening?
Won't someone kindly tell them
They can't do that there here?
We think the actual facts might well
Be made a bit more clear.
Some danger here to liberty,
Of that there is no doubt,
The "crime" is not in "listening-in,"
But, later, "speaking out."
To that, of course, we don't object,
The Law we must support,
But we must not have it misconstrued,
And, blameless, haled to Court.
So listen-in, if so inclined,
The Law permits you that,
But mind that messages picked up
Are kept inside your hat!—"Torcu."

Underneath the Dipole

Television Pick-ups and Reflections.

By "THE SCANNER"

GENERALLY speaking, television viewers are a dissatisfied set of people! The more technically minded ones are forever looking forward, striving after technical improvements rather than watching the progress of the artistic side or sitting back to enjoy the nightly entertainment. With a distant expression in their eyes, they talk easily about three-colour 1,000-line stereoscopic pictures as if these tremendous developments were just around the corner. They switch on their perfectly good pre-war television receivers as if they were make-shifts or stop-gaps, not to be taken too seriously. Others, not so technically minded, take innocent pleasure in the prestige which the possession of such instruments gives them in the eyes of their neighbours. Owing to the painfully slow deliveries of post-war television receivers, the vast public, which will in due course look upon television purely as a form of entertainment, is, as yet, untapped. I don't think I have yet come across a viewer who treats television in the same manner as most people look upon ordinary broadcast listening. Sound radio has now become an essential part of the equipment of a household, in the same category as the gas-stove or the plumbing, and, like the dripping tap, it is frequently allowed to become a mere musical background to the activities of the household.

Restricted Viewing

Television demands concentration on the part of the viewer. That is both its strength and its weakness. Considered as a form of home entertainment, it is all-absorbing, and in the natural course of events viewers are forced to restrict their periods of viewing and to select in advance those items in the programme which have the greatest personal appeal.

These are points which must affect to a great extent the shape of things to come in television. But we must realise that the next steps will be big ones, involving major changes in receivers and transmitters, and such changes will not be embarked upon without experiments and tests which may cover a period of years. Therefore, I feel we can sit back and enjoy the entertainment offered, and persuade our friends to purchase a set and do likewise, safe in the conviction that the present standards will not be changed for a very long time. I know that at the transmitting end, the boys at the Alexandra Palace are getting things well under control, and the producers and directors are no longer the entire slaves of exacting technical limitations. We are approaching a period when we can contemplate the television picture without constantly thinking of the complicated chain of electrical wizardry which makes it possible.

Stereoscopy

Nevertheless, if it is possible to give viewers a foretaste of the technical marvels yet to come, without the disadvantages of scrapping the present receivers or of rigging up elaborate "adaptors," I feel sure such a step would be generally appreciated. Take, for instance, stereoscopy. This has

had a fascination for many in its various forms. First, there was the stereopticon, a simple home viewer which enabled the user to view pairs of still stereo photographs, with the right eye seeing only the picture which was taken through the right-hand lens of the stereo camera, and the left eye restricted to the left-hand picture. It was a scientific novelty which had a long lease of life, and the third dimension continued to amaze and amuse for many years, whether presented in the form of remarkably solid views of Venice or in the more commercial penny-in-the-slot "What the Butler Saw" machines on seaside piers. Attempts to obtain the stereoscopic effect on the cinema screen were, at first, quite unsuccessful, owing to the fact that views of the right and left eye of a spectator could not be "insulated" from one another. Animated stereoscopic photographs were therefore restricted to instruments which would do this part of the job for one viewer only, and the "Kinora" took the place in the home of the old still stereopticon, while the seaside pier model, the Mutoscope, gave an animated version of the Butler's recollections for the sum of one penny.

Colour Separation

Next came the idea of isolating the left and right eye views by means of colour separation. Stereo photographs or special dual drawings were made with left and right pictures tinted red and green respectively, and the selection of the appropriate picture by the correct eye was made by observing the pictures through spectacles having glasses tinted red on one side and green on the other. With line drawings, it was possible to super-

(Continued on page 63)

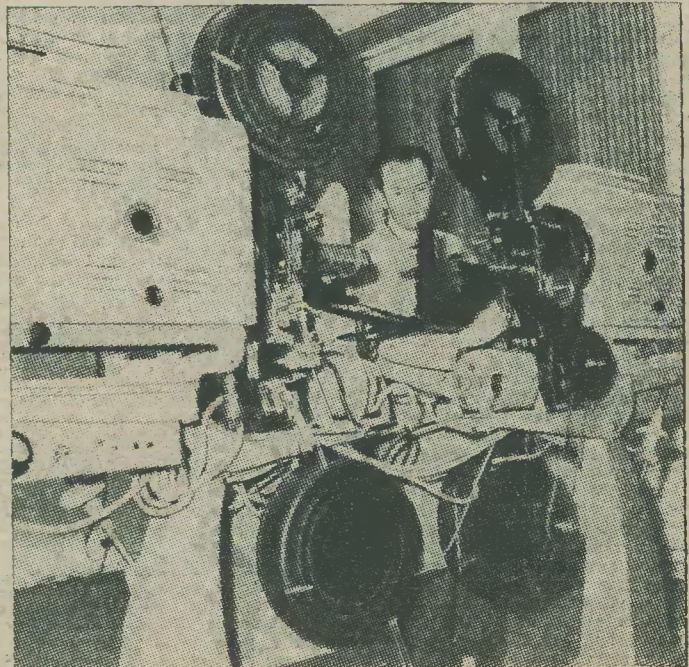

A French television-cinema camera combination—the camera on the left and the projector on the right.

GAMAGES Sensational OFFER.

Over **£100** of BRAND NEW EQUIPMENT for **15 GNS.**

Ex-Govt. Surplus ARMY PORTABLE RECEIVER-SENDER STATION No. 58

Regret radio sets cannot be sent on approval.

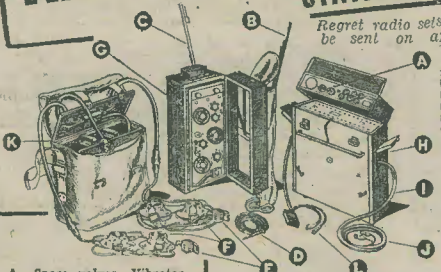

H.T. BATTERIES 15/- Extra

- A. Spare valves, Vibrator and Fuses.
- B. Rod Aerial.
- C. Telescopic Aerial.
- D. Wire Aerial.
- E. Microphones (Two).
- F. Headphones (Two pairs)
- G. 8-Valve Receiver/Transmitter.
- H. Vibrator unit.
- I. Accumulators.
- J. Charging leads.
- K. Battery box.
- L. Connecting leads.

For the Radio Enthusiast and Amateur Transmitter this equipment is undoubtedly the finest ever likely to be offered. Built regardless of cost—every piece perfect and in original waterproof packings. Will receive and transmit on 33 to 150 metres. Complete book of operating instructions supplied.

£15.15.0

Carriage & Packing, 100 miles 7.6, 200 miles 9.6, 300 miles 11/-, Scotland and Ireland, 12/-.

GAMAGES, HOLBORN, LONDON, E.C.1. Phone: Holborn 8484.



Products of
Quality & Reliability

**MAINS TRANSFORMERS
A. F. TRANSFORMERS
SMOOTHING CHOKES
THERMAL DELAY SWITCHES
POWER RESISTANCES**

Made by

OLIVER PELL CONTROL LTD

Telephone: WOOLWICH 1422
CAMBRIDGE ROW, WOOLWICH S-E 18

Manufacturers
SPECIFY IT BECAUSE IT IS
THE FINEST CORED SOLDER
IN THE WORLD



SPECIAL HANDY CARTON
6"
ENOUGH FOR 300 AVERAGE JOINTS

You
WILL PREFER TO USE
IT BECAUSE IT MAKES
PRECISION SOLDERING
SO SIMPLE

MULTICORE SOLDERS LTD, MELLIER HOUSE, ALBEMARLE STREET, LONDON, W.1

SPARKS' DATA SHEETS

Consist of a Full-size Print showing Drilling, Assembly and Detailed Wiring Plans of Guaranteed Designs.

THE TINY TWO

No. LO/T. All-dry 2-Valve. Self-contained Med.-wave Aerial, Speaker and Batteries. Size 5 1/2 x 5 1/2 x 5 1/2 ins. Specially designed for "Individual Listening" on Speaker to Local Stations. Only 18 v. H.T. Complete Data Sheet, 2/6

SEND STAMP FOR FULL LIST OF 33 DESIGNS and with Order.

L. ORMOND SPARKS (P),
9, Phoebe Road, Brockley, S.E.4.
Phone: Lee Green 0220

HENRY'S

5, Harrow Rd., Edgware Rd., W.2.

Trade Supplied
SPECIAL OFFER.

MIDGET I.F. UNIT.—Comprising 185, 1T4 Valves, 4-pole 3-way switch, Twin Volume Control, 500 mfd. 12 v. wkg. Con., O.Trans., and 20 midget Resistors and Condensers. 25/- New and Unused.

MIDGET I.F. UNIT IN ALUMINIUM CAN.—Can size, 4 1/2 in. x 2 1/2 in. x 1 in. Comprising 465 kc/s Midget I.F. Transformer, Iroa cored, 1T4 Valve and 8 midget Resistors and Condensers. 15/- New and Unused.

Send Stamp for 1947 Price List

Phone PADdington 2194

RADIO

CELESTION

LOUDSPEAKERS

Chassis Diameters range from
2½" to 18"
Power Handling Capacities range from
25 Watt to 40 Watt.

Celestion Limited
Kingston-upon-Thames
Telephone: KINGSTON 5656-7-8



FOR THE RADIO SERVICE MAN, DEALER AND OWNER

The man who enrolls for an I.C.S. Radio Course learns radio thoroughly, completely, practically. When he earns his diploma, he will KNOW radio. We are not content merely to teach the principles of radio, we want to show our students how to apply that training in practical, every-day, radio service work. We train them to be successful!

INTERNATIONAL CORRESPONDENCE SCHOOLS

Dept. 94, International Buildings,
Kingsway, London, W.C.2.

Please explain fully about your instruction in the subject marked X.

Complete Radio Engineering
Radio Service Engineers
Elementary Radio

If you wish to pass a Radio examination, indicate it below.
British Institute for Radio Engineers
P.M.G. Certificate for Wireless Operators
City and Guilds Telecommunications
Wireless Operator, R.A.F.
Wireless Mechanic, R.A.F.

Write to the I.C.S. Advisory Dept., stating your requirements. It places you under no obligation.

Name..... Age.....
(USE BLOCK LETTERS)

Address.....

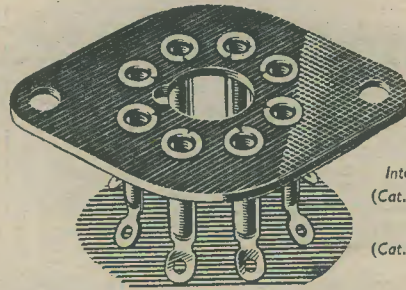

International Octal
(Cat. No: VH 232/8)
Mazda Octal
(Cat. No: VH 92/8)

CLIX SINGLE PLATE OCTAL VALVEHOLDERS

(Standard 1½" fixing centres)

These valveholders, incorporating the latest "CLIX" resilient sockets, will retain the valve under most exacting conditions. In use by leading Set Manufacturers for Home and Export Sets.

See current Price List for details of all Clix components

BRITISH MECHANICAL PRODUCTIONS LTD.

21 BRUTON STREET, BERKELEY SQUARE, W.1
Grams: TROLINX. WESDO. LONDON Phone: MAYFAIR 5543

We Have What You Need in RADIO SPARES

UTILITY 100 : 1 SLOW-MOTION DIALS.—By Wilkins & Wright, sealed 0-180 degrees. W.181, 8/9; W.170, 6/9.

COILS.—All-wave superhet for 465 kc/s I.F., 10-50 m. 200-580 m., 850-2,000 m., with diagram of connections. Per set, 12/6. Wearite "P" coils, all types 3/- each. Denco Maxi-Q coils with adjustable iron-dust core, plug-in octal valveholder; blue, yellow and red, 3/9; green, 4/6.

H.F. CHOKES.—Eldystone: U.H.F., 1/6; S.W., 2/6; All wave, 3/6. Denco: U.H.F., 1/6; S.W., 2/-; All wave (wire ends), 3/- (chassis fixing), 3/6.

DENCO I.F. TRANSFORMERS.—465 kc/s or 1.0 mc/s, 8/-, with screened top lead, 8/6.

SCREW-GRIP TOOLS.—A handy tool for holding screws and nuts in awkward places, 1/6 or 1/9, post free.

EDDYSTONE SHORT-WAVE MANUAL, No. 5.—Constructional details of U.H.F. and S.W. transmitters, receivers, preselectors, etc., 2/6 or 2/7 post free.

MICROPHONES.—Carbon inset, with desk stand containing transformer in base, 9/-. Ex-Govt. hand microphones with carbon inset, switch in handle and cord with socket, 10/-. Inset only, 6/9. All these microphones are good on speech.

Postage must be sent on all orders under £2.

At the time of going to press all the above goods are in stock and can be sent by return of post. If you are interested in Short Wave Reception or Transmission, send 6d. for our latest illustrated catalogue containing details of Denco, Eddystone, Hamrad, J.B., N.S.F., Londex, Q.C.C., Raymart, Woden, etc. We are specialists in short-wave equipment.

Southern Radio & Electrical Supplies,
85, Fisherton Street, Salisbury, Wilts.

Phone: Salisbury 2108.

(Continued from page 60.)

impose the two colour printings almost on top of one another, and still obtain excellent separation and stereoscopic effect. It will be readily appreciated that when viewed through the red spectacle, the red lines of the drawings could not be seen, but the green lines appeared solidly black. In the case of the green spectacle, the reverse was the case. This same principle was utilised later in several excellent cinematograph stereoscopic film systems, notably M.G.M.'s "Audioscopes," and with a Lumière invention, both of which required the members of the audience to view the screen through green and red spectacles. For film purposes, the image photographed through the right-hand lens was taken through a red filter, and the left-hand picture through a blue-green filter. The resultant negatives were combined on one print, with alternate frames taken from "red" and "green" negatives in succession, and each frame was tinted the appropriate colour. Viewed without coloured spectacles, the result was a jumbled-up hotch-potch of colour and fuzz; but with the coloured spectacles on, left and right aspects were correctly divided, and the stereoscopic effect was most startling. When a figure on the screen held out a packet of chewing gum towards you and said "Have some gum, chum?" he appeared almost to be putting a stick of that extraordinary compound right into your mouth! This system was by far the most effective stereoscopic arrangement for the cinema, but it could only be used as a special stunt, in view of the fact that every member of the audience had to be provided with a pair of simple cardboard-cum-gelatine spectacles.

Trade News

Mullard Valve and Service Guide

SUPPLIES of the Mullard Valve and Service Guide (published for use by the Trade only) are now available.

The Guide is divided into four sections. The first gives illustrations, in diagrammatic form, of the bases of the valves listed and their connections. The range of valves dealt with is as follows:

"E" Series.	Rectifiers.
Battery types 1.4 volt.	American Types.
Battery types 2 volt.	UX Base.
A.C. Mains, 4 volt.	Special Types.
A.C./D.C. Mains types.	

The second section gives characteristics and operating data of the same range in tabulated form, while the third section gives equivalents tables.

The fourth and last section is devoted to a table of replacement and substitution types.

The Mullard Valve and Service Guide runs to twelve pages, and is enclosed in an attractive brown and yellow cover.

Wearite Ceramic Switches

SUCH is the demand for Ceramic Switches in various combinations that Messrs. Wright & Weaire, Ltd., of 740, High Road, Tottenham, London, N.17, have placed on the market through certain specialist retailers and distributors a made-up chest of Ceramic Switch Components, so that the "Ham," the Student and the Home Constructor can readily obtain combinations to suit the case in hand. In the Receiver Manufacturer's Laboratory, too, this kit will prove its worth in allowing experiments to be carried out *ad infinitum*. To these ends the making up of the chest was given much careful thought, and the following points were given due consideration: (a) Provision must be made for a variety of contact combinations; (b) a variety of wafer spacings must be possible; and (c) non-shorting contacts are vital in a number of the combinations. Everything is included in the kit to meet these eventualities. . . . Switch Wafers in assorted 1-pole 12 position, 2-pole 6 position, and 4-pole 3 position combinations. . . .

The same method might be used in television, but would require provision at the receiving end of some kind of revolving shutter having red and green sectors, running at the correct synchronous speed, and phased for separating the superimposed pictures (transmitted alternately from two Emitron cameras, side by side, filtered respectively red and green). A simpler method would be to transmit two pictures side by side, from left- and right-hand Emitron cameras, so that they appeared on the home screens in more or less the same relation to one another as the original stereopticon photographs. No filters would be used, but the home viewer would come slightly closer to the screen than usual, and hold a piece of cardboard up in front of his face, so that the right eye could see only that picture picked up by the right-hand Emitron camera, and the left eye was confined to the left picture. After a few experiments in finding out the correct size of cardboard and the appropriate distance from the cathode-ray tube screen of your set, there should be no more "fiddling" required.

Colour Television

If the rotating motor-driven shutter, or filter sector holder, was adopted, then experiments could also be readily made with two-colour television. Three-colour television is still a long way off, and will probably be most easily applied to projection television, especially with receivers having mechanical scanning of some kind.

These suggestions, I must stress, are merely ideas for experiments which would greatly interest a large section of the enthusiastic veterans owning pre-war sets.

Switch Indices with Spindles. . . . Spacers. . . . Side Rods. . . . Moulded Plastic Bearing Straps. . . . Assembly Nuts and Washers. . . . And behind the design of each and every component lies over 25 years of Messrs. Wright & Weaire's practical experience, whilst the actual manufacture is backed by their reputation. When made up, these Ceramic Switches are robust, trouble-free, and with all contacts, including Wiping Contacts, in Silver-copper Alloy. Full details, together with the price, may be obtained from Messrs. Wright & Weaire, Ltd., at their London address: 740, High Road, Tottenham, London, N.17. (Tel: TOTtenham 3847-8-9), or their North Country factory: Simonside Works, South Shields, Co. Durham. (Tel: South Shields 2301-2-3).

Britannia Batteries

IN order to enable them to cope with increased business, Messrs. Britannia Batteries, Ltd., makers of Alkum and Britannia Batteries, have moved into new offices.

Their address is now:

Britannia Batteries, Ltd., Trafalgar House, 9, Great Newport Street, London, W.C.2. (Telephone: TEMple Bar 2354/5.)

S. G. Brown's Headphones

AN illustrated leaflet is now available from Messrs. S. G. Brown relative to their standard range of headphones. A separate leaflet also includes details of the Type K moving-coil headphone which has recently been released. As far as is known, Messrs. S. G. Brown are the sole manufacturers of the moving-coil headphone in this country, and listeners who are anxious for a really sensitive high-quality headphone will no doubt be interested in the details. Special matching transformers are made for these phones, but may be in short supply for some time yet. These headphones are £5 5s. per pair, and have the following characteristics: D.C. Resistance, 94 ohms per pair; Impedance, 104 ohms at 1,000 c.p.s.; Sensitivity, 8 Dbs. above 1 microwatt per bar at 1,000 c.p.s. The matching transformer, two patterns of which are available at high and low resistance, are designed to match loads of 5,000, 7,000, 10,000 and 2, 6 and 15 ohms.

Transmitting Circuits

Details of Some Standard and Unusual Circuits for the Beginner and the Old Hand

By W. J. DELANEY (G2FMY)

WHEN the newcomer enters the transmitting field he usually starts off with a one-valve circuit employing the Tritet arrangement. This is a more or less fool-proof circuit, provided that good components are employed and that care is taken in the initial wiring and setting up. As more experience is gained or more funds become free this is modified, at the same time rendering more power available. The usual jump from the single Tritet is to add a good P.A.,

circuit, using the method of modulation favoured by the builder.

Non-standard Circuits

So far the arrangements are standard and will be found to be those adopted by the majority of experimenters. Experiments with transmitting circuits are not so easily carried out as those with receivers, mainly on account of the fact that one hesitates to "go on the air" with an unknown performer, or because tests on an A.A. do not always show up to the best advantage just what takes place under open aerial conditions. There are, however, some very interesting circuits available to those who care to carry out serious experiments and take the usual precautions to see that they do not wander off the recognised bands or radiate harmonics which may interfere with broadcast receivers.

The crystal oscillator is the first stage in which one can find room for experiment. The Pierce oscillator is fairly well-known, but the Jones exciter is perhaps not quite so well-known as it deserves to be. It is a little fussy in regard to one fixed condenser, that labelled "C" in Fig. 2. This circuit is a two-stage, C.O. and P.A. using the Jones arrangement. The originator recommends a capacity of about .00035 to .00039, and one of the older type neutralising condensers of the tubular type, with a glass tube for the dielectric, will be found very useful in enabling adjustments to be made to obtain the optimum value for this particular arrangement. The remainder of the circuit is quite straightforward, although, if desired, the grid circuit of the P.A. may be tuned, and link coupling employed between the two stages. Keying may be carried out in either stage, and modulation applied as desired. The valve which has been found to work most satisfactorily as the C.O. by the writer in this particular scheme is a 6V6, and this valve is, of course, quite economical in its current demands.

Single-stage Push-pull

For those experimenters who are keen to see just what can be done with a minimum of equipment, the circuit of Fig. 3 offers good ground for many interesting hours of work. Here two 6L6's are employed in a push-pull scheme and it is highly probable that it will not work when first set up! The circuit has definitely got

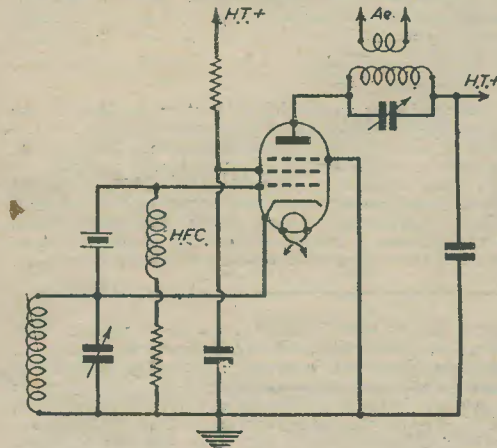

Fig. 1.—The standard Tritet circuit.

for instance an 807 or equivalent. A further modification is sometimes carried out at this stage, the tuned circuit on the cathode side being shorted out and the original Tritet valve then employed as a simple C.O. The serious experimenter will find, however, that although such a two-stage transmitter will bring him good reports from most parts of the world it has a number of drawbacks. It is preferable, after some experience has been gained with this two-stage affair, to rebuild to include a further stage, a frequency-doubler.

A Three-stage Transmitter

For this purpose it is desirable to build each stage on a separate chassis, the C.O. on one, the doubler on another, and the P.A. on yet a further chassis. If the standard rack assembly is employed this will not make an untidy assembly, but will enable experiments to be carried out in each stage in a very simple manner without upsetting the remaining parts of the equipment. Coupling between the various stages is then ideally carried out by the link method and full flexibility is thereby obtained. When licensed for increased power it is then possible to build a complete new P.A. and utilise the original as a driver or replace it.

So far we have considered C.W. only, but the building of a modulator stage does not present much difficulty and this may easily be added to any type of

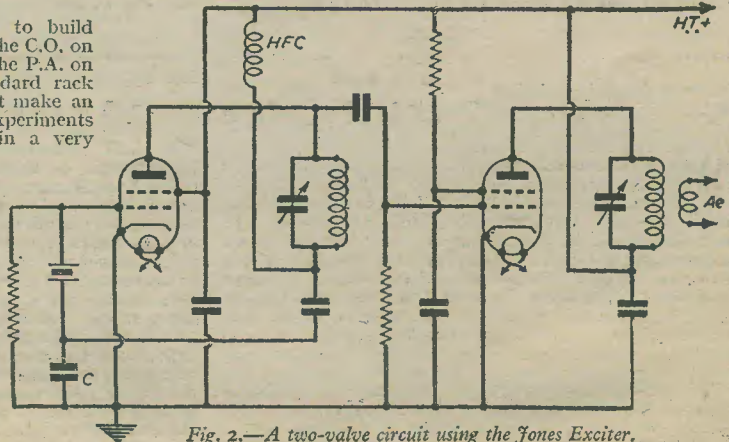

Fig. 2.—A two-valve circuit using the Jones Exciter.

to be balanced on both sides and maximum performance will not be obtained until it is. But then, very often when a perfect balance has been obtained, in both components and wiring, the circuit will probably oscillate all over the band and not just at the crystal frequency. It will be found, however, that this can probably be cured by inserting a very small choke in one anode lead. This choke can be made by just twisting the actual lead from anode to tuned circuit round the finger to provide upwards of two turns. It may be found very critical but such a choke in one anode lead will definitely kill unwanted oscillation. This circuit may be used to cover two separate bands, using either plug-in coils for the P.A. side, or a coil tapped on each side of the centre and adjusted in that manner, with two crystals on the grid side, with a simple change-over switch to select the desired frequency. Alternatively, a large capacity split-stator condenser may be employed with a coil chosen to cover both of the desired ranges, although this is always a risky procedure in view of the probability of selecting the crystal frequency when changing bands. A closed-circuit jack is shown in the cathode circuit for keying, and modulation may be applied to the anode in the usual way for Fone. By using two 6L6's for both the crystal oscillator and for a push-pull modulation amplifier a very effective two-stage transmitter can be built, and such an arrangement will prove very useful as a "portable" for field days.

Other Schemes

The arrangements so far described are in the nature of complete transmitters, but they by no means exhaust the possible schemes which may be used. With all of these schemes, however, there is one point which is considered by many as a drawback. That is, the restriction to one frequency which is governed by the crystal in use. Very often it is found that a really good D.X. transmitter is heard on a spot widely apart from your own crystal frequency, and most of the long distance boys seem to have a habit of searching only just around their own particular frequency, with the result that it would be hopeless to reply to his call. A number of crystals may be fitted into a transmitter and selected by means of a good rotary multi-point switch, but this is an expensive arrangement. A very good alternative is to build a variable-frequency oscillator, or E.C.O. Provided that care is taken to stabilise such a circuit it will give results which will always bring you a T9x,

but there is one important point. Under the terms of your licence you must have a really reliable frequency meter available to ensure that you are adjusted to the correct band. By using Break-in working and with a well-designed transmitter, you can, however, rapidly adjust the transmitter to a desired spot in a given band and thus increase the number of worth-while QSO's.

Meters

With all of the circuits so far mentioned and, in fact, with any worth-while transmitter, it is very desirable that every part of the circuit should be metered. Usually, only one meter is employed and jacks are provided so

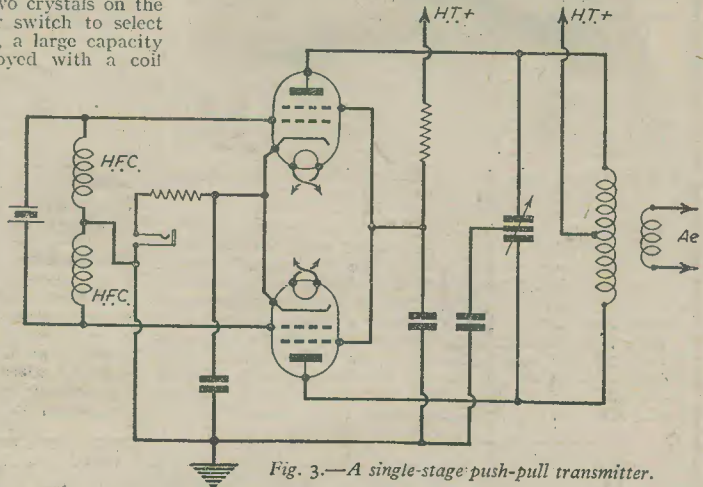

Fig. 3.—A single-stage push-pull transmitter.

that it may be moved from stage to stage. This is quite satisfactory with a simple scheme, but there are adjustments which have to be made and which necessitate a balance between two or more separate currents. It is, therefore, worth while considering the inclusion of meters in all parts of the circuit where such readings are required, for instance, in all anode circuits and in the grid circuit of the P.A. at least.

Finally, we must point out that as our Query Service has been temporarily suspended it is not possible to deal with detailed queries regarding values or layouts for any of the circuits above described, but holders of transmitting licences should have no difficulty in constructing apparatus round the circuits given.

Star Sound Studios

WE recently had the pleasure of visiting some of the studios of the above company, and were very impressed with the standard of equipment which is fitted. There are five studios in the West End area, one of which is 175ft. long by roof. wide, in which various B.B.C. features (Music from the Movies, Dancing Through, Music While You Work, etc.), are often performed. From our point of view the main interest lay in the technical equipment provided for the making of records from any of the studio broadcasts or from any radio programme.

The equipment includes a high-fidelity amplifier, with a total of seven disc recording machines, five of which will cut up to 17½ in. discs at either 78 or 33½ r.p.m. These recorders may be coupled to land lines

linking various studios, including certain B.B.C. studios, or to radio receivers in the radio transcription studio. Provision is made for "hill and dale" recording, and when desired programmes on I.M. may also be recorded. Records may be made of items from programmes originating from the majority of European stations and the main overseas short-wave broadcasting stations, and artists may thus have a record made at any time for personal criticism, for auditions, etc. The quality of records made on this equipment is of a very high order, and the frequency range is far wider than one normally associates with gramophone discs. Fuller details of the equipment will be given at a later date, but readers desiring particulars can obtain a leaflet from the company on application to their offices at 17, Cavendish Square, London, W.1.

The

Construction Details of a Short-wave Receiver

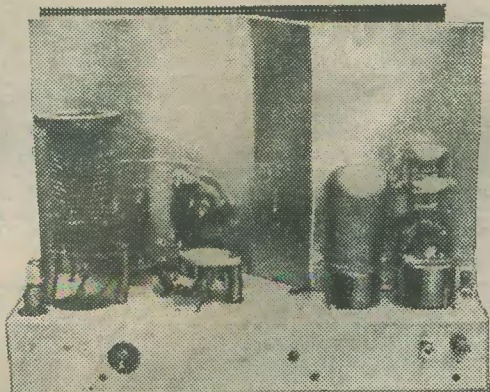

Fig. 1.—A rear view of the completed receiver chassis, with valves in position.

THIS is a five-valve T.R.F. short-wave receiver intended for the constructor who has had some experience and favours the "straight" circuit. It gives sufficient amplification for loudspeaker reception of many stations and the use of bandspreading, with separate bandsetting condensers for tuning both R.F. and detector stages, ensures maximum efficiency without any ganging troubles, or losses through misalignment on various parts of the tuning ranges. Plug-in coils are used as these give good results, simplify wiring, and allow any desired short-wave range to be tuned.

The Circuit

As Fig. 5 shows, the first R.F. stage is untuned. This greatly simplifies construction and enables the second R.F. stage to function without the damping of the aerial-earth system. Both R.F. stages are controlled by a single V.M. potentiometer. The use of transformer coupling, followed by tuned-grid coupling, enables 4-piñ coils to be used and gives good selectivity and gain.

The detector is an ordinary triode, and is followed by a triode L.F. amplifier transformer coupled to the pentode output valve. A top-cut control is added to reduce hiss and background. The result is a circuit which will put up a good performance, and as there are no auto-bias or voltage-dropping networks the circuit may also be built up in 3- or 4-valve form by omitting one R.F. stage, and the triode L.F. stage. Consequently the set may be built as a 3- or 4-valver, and the additional valves added later without interfering with the original constructional work.

Construction

Although reference to Figs. 3 and 4 will show there is very little wiring for a 5-valve receiver, it is recommended that the theoretical circuit be kept in view when wiring to avoid errors. A metal chassis 2 in. by 10 in. of suitable depth is used. Both the coil holders and the R.F. and detector valve holders are mounted above the chassis by bolts to facilitate wiring. L.F. and output holders are bolted to the chassis as shown.

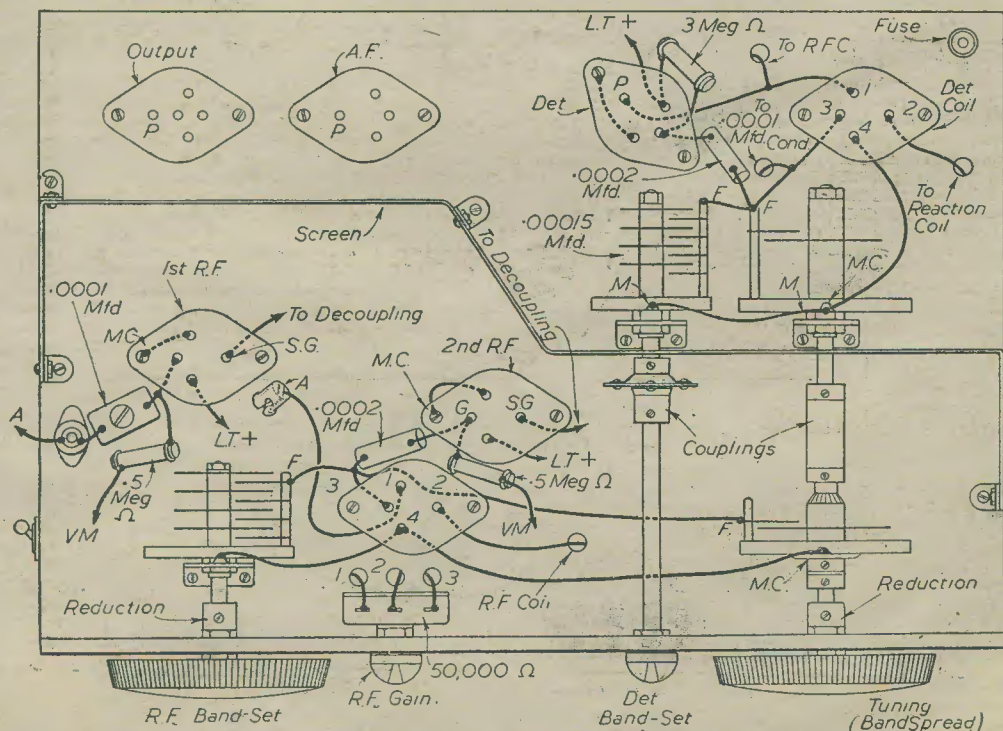

Fig. 3.—Top view of the chassis showing the wiring.

D-X.5

Receiver Described by F. G. RAYER

To begin construction, mount the two bandspreading condensers, coupled with an extension spindle, allowing sufficient space near the panel for a concentric reduction drive of about 6:1 ratio. The detector bandset condenser should now be mounted beside the detector bandspreader as shown, a further extension spindle being added. Reaction and R.F. bandset condensers are then fixed in the position shown, noting the latter also has a concentric reduction drive. The panel should now be bolted to the front runner, when the potentiometer and variable resistor may be added to complete the panel controls. If flexible couplings are used on the extension spindles, this will ensure smooth action even if the spindles are not quite correctly aligned. Fig. 6 shows the panel layout.

The valve and coil holders should now be mounted, placing the sockets in the position shown. The only other part on the top of the chassis (excluding the screen, which should be left to last) is the small stand-off insulator for the aerial connection. Resistors, etc., are suspended in the wiring. All the connections shown in Figs. 3 and 4 may now be added, keeping coil and condenser leads well away from the chassis, and using insulated wire for battery and other leads which require to pass through the chassis.

Note that the coil connections are numbered to agree with Fig. 5. Other makes of coils may be used (Premier coils being suitable) provided the coil holders are suitably

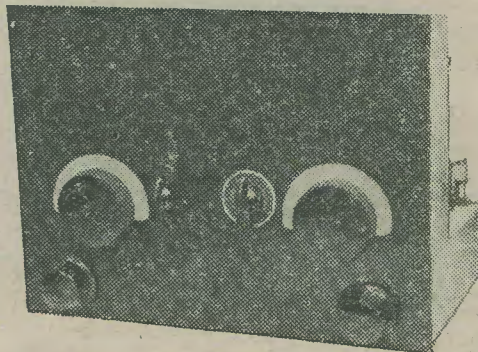

Fig. 2.—Front view of the receiver, showing the control layout.

wired. Reference to the numbers in Fig. 5 will make the connections for other coils clear.

Sub-chassis Wiring

It is now necessary to fix in position the L.F. transformer, 3-point on-off switch, large condensers, fuse-holder and speaker terminals. Note the components and wiring are grouped in sections which should be kept apart as in Figs. 3 and 4. In particular it is essential the three R.F. chokes be well apart, and they may be arranged at different angles to reduce any chance of interaction. The connections of the V.M. bias circuit (near the

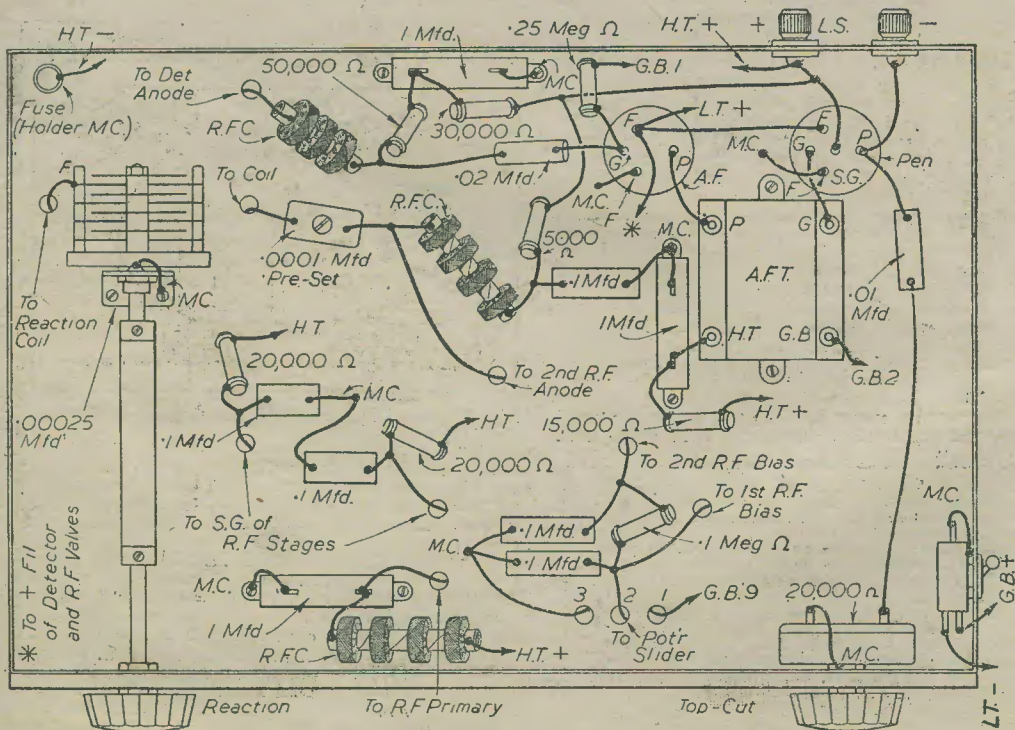

Fig. 4.—Underside of the chassis wiring.

Practical Hints

Chassis Handles

RECENTLY I constructed some radio equipment in a rack, and I quickly found that it was not very easy to remove the chassis rapidly for adjustments. To overcome this difficulty I made a pair of handles in the following manner.

An old cycle pedal was obtained from a friendly cycle dealer, and from this pedal I removed the two spindles which support the rubber blocks. Firstly, the spindles must be annealed to prevent cracking when they are bent. This is effected by heating until they are red hot, and then cooling slowly. Next,

THAT DODGE OF YOURS!

Every Reader of "PRACTICAL WIRELESS" must have originated some little dodge which would interest other readers. Why not pass it on to us? We pay half-a-guinea for every hint published on this page. Turn that idea of yours to account by sending it in to us addressed to the Editor, "PRACTICAL WIRELESS," George Newnes, Ltd., Tower House, Southampton Street, Strand, W.C.2. Put your name and address on every item. Please note that every notion sent in must be original. Mark envelopes "Practical Hints."

SPECIAL NOTICE

All hints must be accompanied by the coupon cut from page iii of cover.

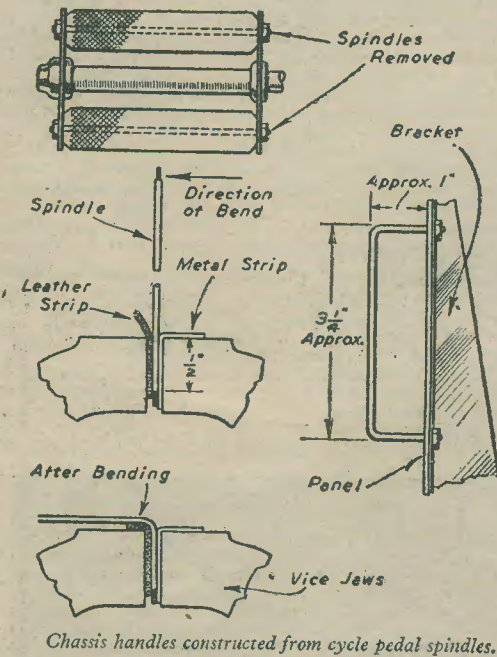

is filed in the side of the valve-holder adjacent to the anode pin, similar connection being made here to a thin brass strip, the length of which allows it to bend end to clip over the end of the cell, and so keep it secured in the valve-holder.

The assembly is then placed in the appropriate valve socket in the apparatus being used. The cell can easily be changed by pulling aside the spring clip and inserting a new cell.

In making the valve-pin connections, the old wire must be unsoldered and removed. Fresh wires being inserted and resoldered.—R. A. BERNARD (London, N.W.6).

Aerial Erection

I SUCCESSFULLY used the following method to erect an aerial at the top of a tall and rather unsteady clothes pole, no ladder being available.

An old piece of chest expander spring, about 4in. long, was used, an eye being bent around at both ends. This is laid against the back of the clothes pole and a length of stout wire (twisted in the middle to connect to insulator) is held around front of pole and the ends put through the eyes of the spring. The ends of the wire are then pulled back and secured, thus extending spring and making a tight fit around pole.

A prodder as shown in sketch is used to push the assembly upwards, odd lengths of batten or broomsticks being successively nailed on until the necessary height is obtained.—M. J. WESTLAKE (Plymouth).

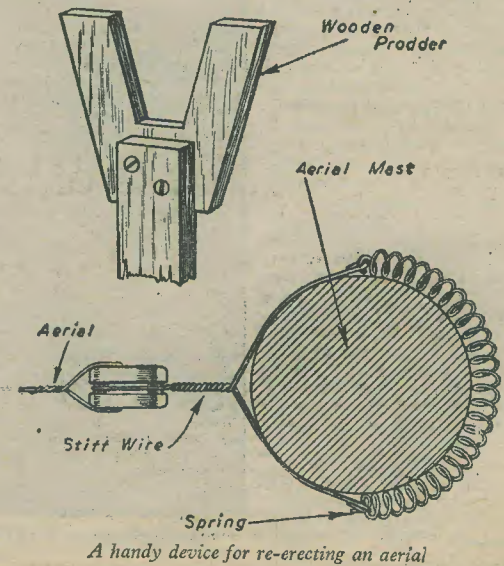
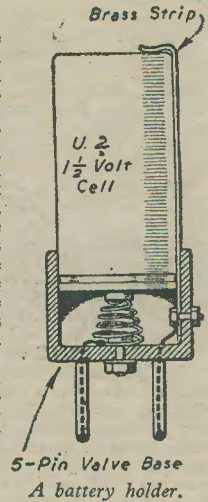

loose rust is removed with a file, and when an even surface has been formed one end of the rod is fixed about half an inch deep in the vice. A few sharp taps with a hammer will bend the rod over to form a right-angle. When the other end has been similarly treated a rough handle will be formed.

A smooth polish can be obtained by rubbing with fine emery cloth and if a thin coat of clear varnish is applied a rustless silver handle will be obtained.

The finished handles are fixed to the panel by means of the nuts obtained from the original cycle pedal. A bracket between the panel and chassis is, however, desirable to prevent bending the panel when the set is held by the handles.—J. D. T. DAVIS (Bexhill-on-Sea).

Battery Holder

FOR those who use 1.5 volt filament supply, I have devised a useful method of housing the cell.

An old 5-pin valve base is cleaned out, and the centre hole is used to hold a compression spring, connection from this being made to the grid pin. A partial recess

On the Amateur Bands

A Monthly Report of Results and Conditions Experienced
on the Short Waves.
By "KAYAK"

THE aim of this column is to bring to you up-to-the-minute happenings on the amateur short-wave bands. Never before in the history of amateur radio has there been such activity in our hobby; and never before have there been such opportunities to thrill to the reception from remote places. This is *your* column, and *your* DX jottings are wanted for inclusion!

The 14 mc/s band has continued to be the most consistent as regards DX, and most of this month's column will be devoted to this band. Ten metres has been "wide open" on a few occasions and has well paid attention. The 7 mc/s band continues out of favour with DX addicts and this band will not regain favour until the broadcast stations are removed. We have heard nothing on this band other than east coast Americans and Canadians mostly inter-working.

Best 'phone stations on 14 mc/s have been KT4CE, Puerto Rico, T12OA, Costa Rica, T12RU, EL5B, Nigeria, and OX2MJ, Greenland. The operator of this latter station is an American working with the American Overseas Airways Corporation. QSL cards should go to his home address, 293, Graham Street, Brooklyn, New York.

South Americans, both on 'phone and C.W. have been prolific. Consistent 'phones have been PY6AO, Bahia; HK3AB, P.O. Box 1728, Bogota, Columbia; while Mexico produced XE3FG, 14,320 kc/s. On "key" we came across LU1EK, CK1FY, HH5PA, all around 14,100 kc/s; VO5Z, Newfoundland, 14,050 kc/s; XE1A, and W5KGI/C7. Cards for the latter station go to Glen Simpson, A.P.O. 912, c/o Postmaster, U.S. Army, China.

A "late session" on one recent occasion rewarded us with VO8AB, Mauritius; VO3HJP, Tanganyika; KL7BP, Alaska, all on C.W. South Africa produced ZS6DW ('phone), ZS5BZ and ZS2X, the last two on key. These stations were heard at a most unusual time, between 04.00 and 05.00, with very good signal strength. Mention should also be made of ZB1AB, Malta, who came up during the same period and was the loudest signal on the band. All these stations were working to Pacific coast or east coast Americans.

The DX contest organised by the Wireless Institute of Australia over the first two week-ends in November produced a large crop of signals from the Antipodes. All Australian districts, including Tasmania, were well received. A full list of all calls heard would run into many pages!

From Wing-Commander Wallich, G6BW, comes an interesting letter full of DX topics. On 28 mc/s 'phone G6BW has worked XZ2YT, Rangoon Signal Centre, R.A.F. South-east Asia Command; VO3EDD, P.O. Box 166, Dar es Salaam, Tanganyika; VO3TOM, P.O. Box 457, Dar es Salaam; ZL2BE, 311, Queen Street, Hastings, New Zealand; and OQ5BL, P.O. Box

201, Jadotville, Belgian Congo. From the latter station, G6BW received not only a QSL card by air mail but also confirmation by way of a telegram! Best on 14 mc/s was ZB8AC, British Legation, Asuncion, Paraguay. G6BW also tells us that he is running 28 mc/s schedules with VS9AB (ex G6VK), who is station engineer at R.A.F., Khormaksar, Aden. Spot frequency for VS9AB is 28,600 kc/s. For your information G6BW has a world-wide reputation as a 'phone DX man. To date he has worked 105 countries on 'phone and has received confirmation from 99. One more confirmation will entitle G6BW to that much coveted award, the DX Century Club Certificate.

Mr. Leslye, Ilford, sends along a list of 14 mc/s C.W. DX., including HC1OE, Quito, Ecuador (14,086 kc/s); VE8NW (14,082 kc/s); W7FP (14,048 kc/s); and TA1BA, Turkey. We look upon all "TA" calls with suspicion! Recent information received from Turkey stresses the fact that the Turkish authorities will not issue amateur licences, but that the matter will be considered next time the country's radio regulations come up for revision. A few months ago there were one or two American Airlines operators working on 14 mc/s from Southern Turkey, using "X" call signs, but it is believed that they have now closed down. Mr. Leslye asks us what country is represented by the prefix "UB." The country is Ukraine. Normal Russian prefix is "UA," while that for White Russia is "UC."

John Brookes, North London, reports OQ5LL, Box 16, Stanleyville; SV1GY, Athens; CO7QX, Cuba; and EL5B. EL5B is a good 'phone signal on 14 mc/s. Can any reader supply the QRA of EL5B? We have come across this station many times giving QRA as "Nigeria, West Africa," but that is hardly enough to guarantee safe delivery of a letter! John also reports KL7BP, Alaska, and VE8NW, which he believes to be in the Yukon.

John brings up the question of "XA" prefixes and



Amateur station W2IXY, operated by Dorothy Hall—internationally known on 14 mc/s and 28 mc/s 'phone.

wonders whether they are pirates. The answer is that they are quite genuine and the prefix is that officially granted to military personnel operating from enemy occupied territories. Call signs consist of the prefix letters "XA" followed by two further letters. We understand that cards for "XA" stations may be sent to Captain Peter Keller, XADZ, British Army, A/5, G.H.Q., C.M.F., Italy, who will forward. On 7 mc/s John reports the usual spate of East Coast Americans and Canadians and one or two weak Australians. DX hunters on this band should look out for signals from Oceania from about 0600 onwards. There is plenty of good DX to be heard on this band if only one gives it a try!

We are glad to have been able to contact Dennis Tyler, a pre-war contributor to one of our short-wave columns. Dennis never uses other than a two-valve battery receiver, and his results, as you will see, are excellent. Which only goes to prove that it is careful listening what counts, and not the size of the set. Dennis reports the following: AC4YN, Lhasa, Tibet, ZD8A, Ascension Island; OQ5LL, Box 16, Stanleyville; VS7ES, Colombo; VE8AW, Yukon; VP2MY, Montserrat, Leeward Islands; YV5ABS, P.O. Box 1247, Caracas, Venezuela; and OA4M, Box 849, Lima.

Dennis also reports XU1YY, Tientsin, China, and XU1RY. Both these stations were R7 and were working a few kilocycles away from each other. The time was around mid-day and the band 14 mc/s. XU1YY was working traffic to the U.S.A., and was heard to say that his input was 3 kilowatts! Some Chinese stations are using the prefix "XU" while others would appear to be using the single letter "C."

28 mc/s Band

Apart from occasional dead periods due to sunspot activity this band is settling down and producing

consistent DX. The charm of this band lies in its unpredictable happenings. Conditions on this band should continue good apart from temporary sunspot upsets.

Phone stations from the Antipodes have been peaking at around 2000 hours, while Pacific coast Americans and Canadians come through early evenings. Unfortunately space at our disposal does not permit of a long commentary on this band this month. We shall have much more to say about "ten" next month.

Shorts

Cards in bulk for American and Canadian stations may be sent to American Radio Relay League, West Hartford, Connecticut, U.S.A. XAEJ, Italy, was heard complaining of ignition QRM due to miniature car race in progress. QRA is on top of 600ft. hill overlooking Bay of Naples. Cards should go to H.Q. Technical Unit, 15, Forces Broadcast Service, Central Mediterranean Forces. Australian amateurs now have the whole of the ten-metre band back. QTH for TF2AX is Box 284, Reykjavik, Iceland. Several British amateurs were lucky enough to work the American Super-fortress "Pacusan Dreamboat" on its recent flight. G8KP worked the "Dreamboat" while it was over Iceland while G8IG contacted it over Alexandria. Reports are wanted by VP9D, J. A. Mann, R.N. W/T Station, Bermuda, on his 14 mc/s transmissions. Spot frequencies of VP9D are 14018, 14020 and 14045 kc/s. Dutch amateurs are complaining about the large number of QSL cards reaching them from this country bearing insufficient postage. Check mail rates before posting!

Which brings us to the end of this month's news. Suggestions and contributions to this feature will be welcomed. In submitting DX reports please give as many details as possible, and send them to "Kayak," care of this magazine.

Air Traffic Control

THE Ministry of Civil Aviation makes the following announcement:

A number of misleading statements have been made recently about air traffic control in the London area.

The facts are that the system of air traffic control in force at the London and Northolt Airports is in line with the most up-to-date anywhere in the world to-day. Although no one can say of airlines, any more than railways, that accidents will not happen, the public may rest assured that no practice which is not compatible with the utmost possible safety is tolerated in the London area or, indeed, at any British commercial airport.

Co-ordination of the control at the London and Northolt Airports has been developed steadily during the past year. Further improvements in the traffic pattern are about to be made as a result of consultations during recent months with the operators and the British Airline Pilots' Association. The fact that closely situated airports can be operated with perfect safety and without interference has long been demonstrated in the United States. Further, the number of aircraft movements per day in the London area is not allowed to build up beyond that which can be handled safely in the weather prevailing.

At present an average of only 50 arrivals and departures per day is being maintained at the London and Northolt Airports, giving a total of 700 movements per week for the two airports together. This figure compares with more than 1,000 movements per week which have been handled successfully at Croydon for long past. It contrasts also with more than 2,450 scheduled movements per week at such airports as New York and Washington in the U.S.A.

Wartime Aids

Statements have been made that wartime radar aids have not been applied to civil airport control—to the

disadvantage of Civil Aviation. Although there can be no doubt that development in the field of radar and radio will materially improve air-traffic handling methods in the future and will make possible a greater number of arrivals and departures in worse weather than can be handled to-day, nevertheless, methods evolved directly for wartime needs, where the high standards of safety demanded for Civil Aviation had to take second place to operational requirements, cannot be applied to Civil Aviation without much development.

There is much public-misunderstanding about the meaning of radar and about the ways in which different radar techniques can serve Civil Aviation. Although some radar aids to instrument approach already exist at the London and Northolt Airports, and others are in process of installation, radar for air traffic control is just emerging from the experimental stage and as yet is installed at no civil airport in the world. The United Kingdom is well ahead in its preparations for such use of radar in the future.

A demonstration of projected British radar aids for civil use was held in England in September.

The London and Northolt Airports are being equipped with suitably modified military radar aids as an additional safety check on standard radio navigational aids. The problem is largely that of getting supplies of new equipment, much of which has had to be specifically designed to serve the needs of Civil Aviation. Until radar and other devices are available to make possible landings in lower visibility than at present, the British policy remains that aircraft will be diverted to other aerodromes when safety demands it. The number of diversions and cancellations that are likely has, however, been greatly over-estimated in some quarters.

The British Airways Corporation, as the record shows, make the safety of passengers their prime consideration. Air traffic controllers are instructed that diversions should be made whenever the weather is such as to create any doubts on safety.

Thermionic Insulation Tester

A Useful Aid for the Serviceman and Constructor.

By J. C. THWAITES

INSULATION test meters of the type that incorporate a small hand-driven generator are expensive. The instrument about to be described was designed to take the place of this usual type, be simple in operation and construction, and yet to have fair accuracy. It relies on a valve to convert small changes of voltage between its grid and cathode into changes of current which are indicated on a milliammeter in the valve anode circuit.

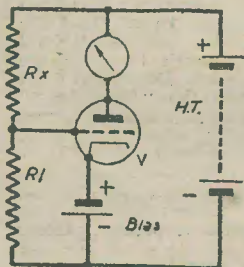

Fig. 1.—Basic circuit of the insulation tester described in this article.

How It Operates

The valve V in Fig. 1 is biased negatively on its grid by a voltage drop in its cathode circuit (represented by the diagram by a battery). The resistor R_1 is connected between grid and H.T. negative and a meter in the anode circuit of the valve reads the anode current. The electrical components or circuit of which it is required to find the leakage resistance R_x is connected between H.T. positive and the grid. The voltage which is developed across R_1 and applied to the grid is dependent upon the resistance of R_x .

Let us suppose, for example, that R_1 has a value of one megohm. If R_x is 30 megohms then the voltage developed across $R_1 = \frac{1}{31} \times$ the total voltage across the potentiometer, which is the H.T. voltage—say 60 volts, then the voltage across the grid resistance $R_1 = \frac{1}{31} \times 60$ volts. If the mutual conductance of the valve is

1.5 milli-amps per volt then this voltage will give a change in anode current of $60 \times \frac{1}{31} \times 1.5 = 2.9$ mA.

When the resistance R_x is below a certain value the voltage on the grid rises above that of the cathode. It is not able to rise much, however, because of the flow of grid current. To prevent the grid current flow being excessive should the leakage be zero ohms, a resistor R_2 (Fig. 2) is connected in series with the item under test. Its value is not critical, about one megohm will do.

To bias the valve a potentiometer circuit is used. It consists of R_3 , between the cathode of the valve and H.T. negative, resistor R_4 , and variable resistor VR_6 , which is adjusted so that voltage developed across R_3 is nearly the cut-off voltage of the valve.

The variable resistor VR_5 is to prevent more than full-scale deflection current flowing through the milliammeter.

To increase the range of the instrument R_1 is made larger, to reduce it R_1 is made of lower value. A dual range meter could be made by arranging that a resistor could be switched in parallel with R_1 .

Constructional Details

The chassis is made from 20 gauge aluminium sheet and the layout is as shown in Fig. 3. The front panel is made from 3/16in. sheet ebonite (see Fig. 4). The wiring is straightforward and the positioning of the wire is not critical, although the insulation between the grid and other parts should be particularly good.

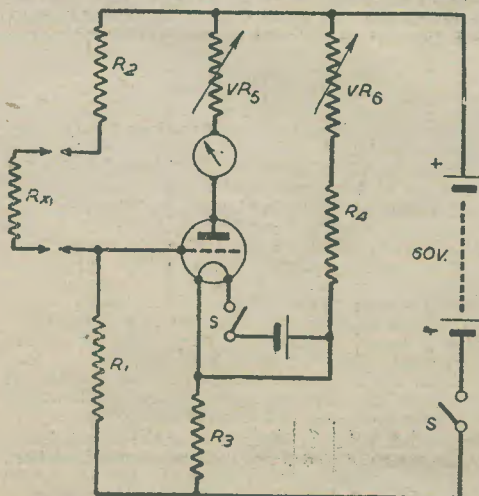

Fig. 2.—Complete circuit of the tester.

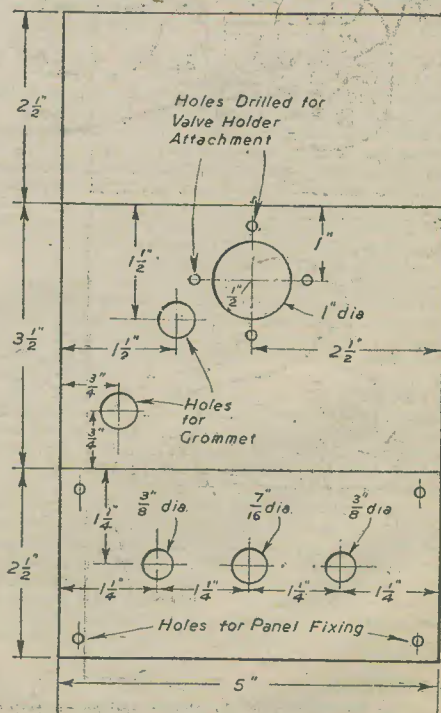

Fig. 3.—Drilling details for the chassis.

There are moving coil 0-40 volt meters on sale by PRACTICAL WIRELESS advertisers which may be used in this test meter. They are five milliamp full-scale deflection, and are suitable for use as a milliammeter if the series resistor has been removed or short-circuited.

The valve used is a low-impedance triode—a 220PA with 60 volts high tension. With other types of triode it may be necessary to increase the high tension to 90 volts.

Calibration

To set up the equipment for calibration or for use it is necessary to carry out the following steps:

1. Turn off switch.
2. Connect up L.T. and H.T. batteries.
3. Adjust VR₅ for maximum resistance and VR₆ for maximum resistance, both fully clockwise.
4. Set zero adjuster so that the needle is set correctly to zero.
5. Turn on switch (when if all is correct the meter will read between 1 and 5 milliamps).
6. Turn VR₆ anti-clockwise until the meter reads one-quarter of a milliamp.
7. Short test terminals.
8. Turn VR₅ anti-clockwise until the meter reads 5 milli-amps.
9. Remove short from test terminals.

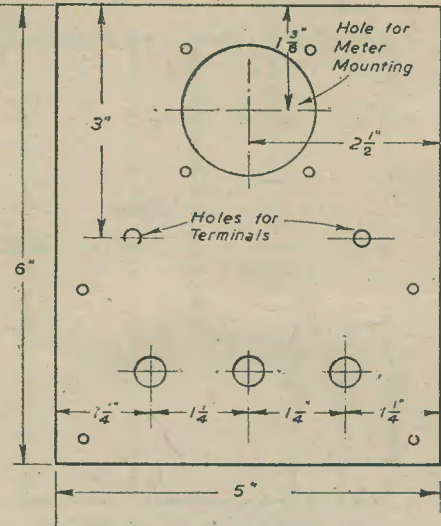

Fig. 4.—Drilling details for the panel.

The instrument is most easily calibrated against known resistors. Resistors of the carbon-rod type are placed across the test terminals and the meter readings

LIST OF COMPONENTS

- R₁—1 megohm resistor.
- R₂—1 megohm resistor.
- R₃—1,000 ohms.
- R₄—5,000 ohms.
- VR₅—10,000 ohms.
- VR₆—10,000 ohms.
- One valve, 220PA.
- One 0.5 mA meter.
- One British valve socket, 4-pin.
- One double-pole toggle switch.
- Two terminals
- One sheet ebonite, 6in. x 5in. x 3/16in.
- One sheet aluminium, 8 1/2in. x 5in. (20 gauge).
- Nuts, bolts, wire, etc.

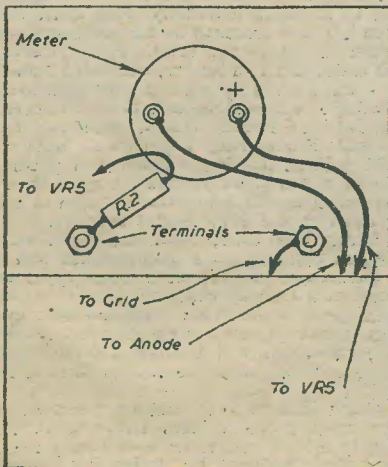
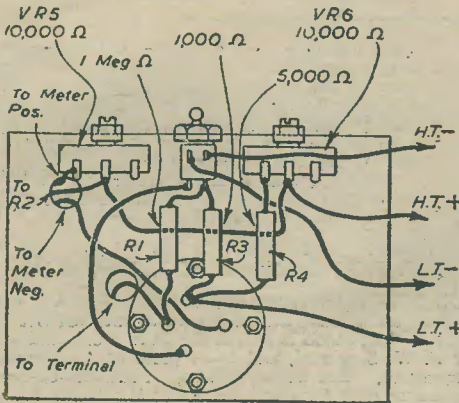
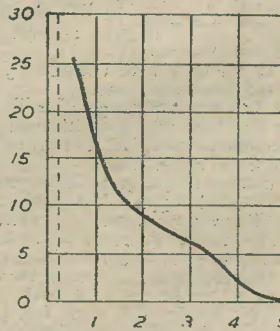

Fig. 5.—Complete wiring of the chassis and panel section of the tester.

noticed. The higher resistances are made up by connecting a number of resistors in series. The value may be checked on a Megger although 10 per cent. or 5 per cent.



Megs	1	2	3	4	5	6	8	10	12	16	20
mA	4.35	4.05	3.75	3.6	3.38	3.03	2.38	1.82	1.5	1.12	0.85

Fig. 6.—How to prepare a calibration graph for the tester.

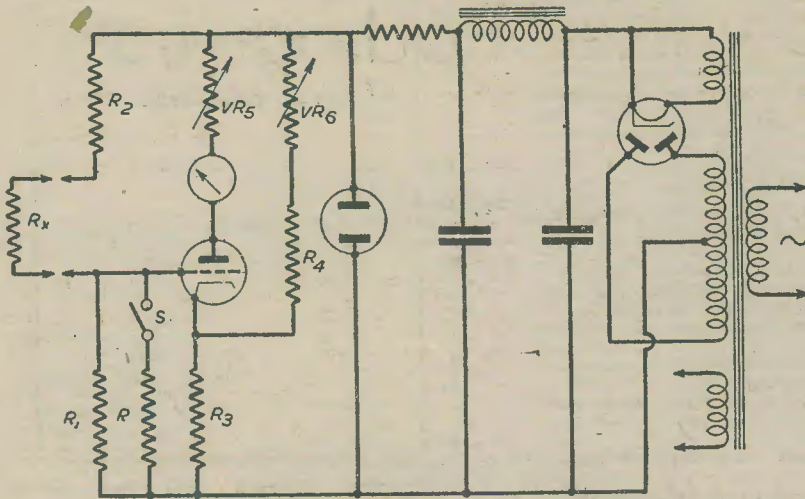

Fig. 7.—Suggested mains-operated version of the tester.

tolerances marked by silver or gold markings are quite reliable. The readings should be noted and a graph plotted as shown in Fig. 6. The graph may be pasted to the front panel or if it is preferred the meter scale be marked directly with Indian ink.

It is suggested that an improved version of this instrument could be built if A.C. mains are used as a source of power. The suggested circuit is shown in Fig. 7. The H.T. voltage is stabilised by a suitable stabiliser tube. The circuit also shows how the resistor R is switched in on a lower range as previously mentioned. Of course, a separate calibration graph would have to be drawn for each range.

Fan-mail for Philco Workers

THE avidity with which English technical publications are sought and scrutinised in all parts of the world has been brought to our notice on several occasions recently.

Two Philco workers, Miss Joyce Oughton and Mrs. Gladys Perman, of the Perivale factory, have both been in the news of late and both have received letters from students and technicians in countries as far apart as Nigeria and Malaya.

These native correspondents show their interest in the latest radio and electrical developments, or maybe an article in the latest issue of the journal to reach them, and then comes a polite request for further information and catalogues.

Miss Oughton, who is this year's "Miss Philco," has herself quite a fan-mail, which she takes considerable pleasure in answering. A short time ago a Flight-Sergeant serving in the Middle East wrote her and exchanged a pair of Nylons for a pin-up photograph.

Both of these Philco workers received their fan-mail from readers of PRACTICAL WIRELESS, and the following is a copy of one of the letters received by Mrs. Perman:

Nigeria, 1-10-46.

"Dear Mrs. Perman,

Greetings to you in our dear Lord's Name "Jesus" who died on the Cross for us to be saved.

I heartily congratulate you for the great success you achieved during the war time which entitle you to be awarded B.E.M. honours for the past activities; may the Lord God help you the more, Amen.

You may wonder how do I manage to know you, and why am I so much interested in you. Yes, I will answer both questions. (1) I saw your name and address in a newspaper called PRACTICAL WIRELESS of April issue this year. (2) I was at the same time interested in you, because I am interested in Radio Engineers, because I think you are one, so, I therefore wish to befriend you whether you are a Radio Engineer or not. Oh, I have much interest in you, so I beg you not to let me down by refusing this offer.

I am presently taking a course in England for Radio Service Engineering, and I am taking the practical side of it here. So when you reply this my letter, I will be able to give you more details about myself.

I have written you a letter before, which I posted by ordinary mail, but the messenger I gave it to, to buy

3d. stamp and post it, posted it with a 1½d. stamp and brought back to me 1½d. change. Because this will bring taxation on you, I therefore write this by air, to meet you before that, and to tell you not to take that, because it is the same content in this, you will find there. I beg of you not to be annoyed.

I'm eagerly waiting your reply.

I am, Your sincere friend,
S. A. OSHKOVA."

Television School Looks Ahead

E. K. COLE'S television courses for dealers are now well under way, with a mounting waiting list of "pupils." The school is part of the service organisation under F. W. Shepherd, and takes place at the Service Headquarters, Somerton Works, Southend-on-Sea. Each course runs for one week—Monday to Friday—and up to 12 students are invited per course. Every effort is made to maintain a friendly team spirit and accommodation has been arranged for all under one roof in a large guest house in the town. Each morning (9 to 12 noon) is devoted to a lecture, which is followed by practical work from 1 to 5.15 in the afternoon. On the final Friday afternoon, the students are conducted on a tour round the EKCO Works, including the Development and Engineering Department, drawing offices, assemblies lines, lighting division and plastics plant. There is a tea-break in the Lecture Room both morning and afternoon, and lunch is taken in the Executive Canteen at the Main Works near by.

The very latest Test Gear, including the EKCO Television Pattern Generator, has been installed and a feature is a permanent display of various types of aerials mounted on a dummy chimney stack.

Mr. A. W. Stephen is proving a popular instructor. He has 15 years in the company to his credit and has only recently returned from radio and signal work in the Royal Navy, including a period with the British Mission in Murmansk.

Dealers wishing to attend or to send a representative are invited to contact Radio Sales Division, E. K. Cole, Ltd. Already there are no vacancies till early 1947.

The course has been found by dealers to have a valuable secondary function in enabling them to put problems arising from their day-to-day business to a sales executive who is always available.

A 5-valve Radiogram

Details of a Reader's Equipment Employing a 5-valve TRF Circuit With Double Diode Triode as Detector and A.V.C.

By J. L. HALL

AS far as I know, there is nothing original about this circuit, but it certainly fulfils my need for a first-class radiogram.

It is built into an old-fashioned H.M.V. acoustic gramophone cabinet. All the old works were removed, and the doors of the record cupboard at the bottom were joined into one piece to form the baffle board for the speaker—a R.G.D. roin. energised. Behind this, on the same floor, is the power pack, a 350-0-350 at 200 mAs with four 4v. L.T. windings and rectifier winding, a massive component but serviceable and silent.

The sound doors above this old record cupboard hide the control panel, with the main radio works behind. The layout is a dead straight line, with the first R.F. in front. Each R.F. stage, and the D.D.T., is completely screened, lids as well (because of the gramo. electric motor up above). A cable (each pair of heater wires screened) with an eight-pin octal plug connects the radio to the power pack. The output transformer is mounted by the Pen 45, and the speaker leads plug into the sockets of the radio chassis. The field leads plug into sockets on the power pack. Another screened cable carries the mains to the D.P. switch on the front panel and up to the motor. The aerial is 6ft. of

covered wire laid out round the back of the cabinet.

The Controls

In London, for Home and Light programmes, the volume control has no need to go beyond three of ten divisions, the Third Programme requires about five. The radio/gram Yaxley switch is mounted by the grid of the HL41DD in the vertical screen. The pick-up is immediately above this valve, so pick-up leads to switch are only 6in. Tuning is by my own idea, three ball-bearings and springs select Home, Light and Third programmes, there is no slow-motion drive or lighted dial, just a pointer. I have extension speakers, and a two-bank Yaxley switch selects either internal, external or both. When the internal speaker is off the set is dead silent. (The third position shown on the radio/gram switch is for a 1-v short-wave unit).

The tone control, a simple top-cut affair, remains untouched, without any cut, even for the gramophone (only thorn needles used). The A.V.C. regulation is perfect (but has to be disconnected for trimming). The condensers across the mains and H.T. are 1,000v. working and were necessary to cure slight modulation hum. The Pen 45 is an excellent output valve but

(Continued on page 81).

Vertical Screens Above and Below Chassis

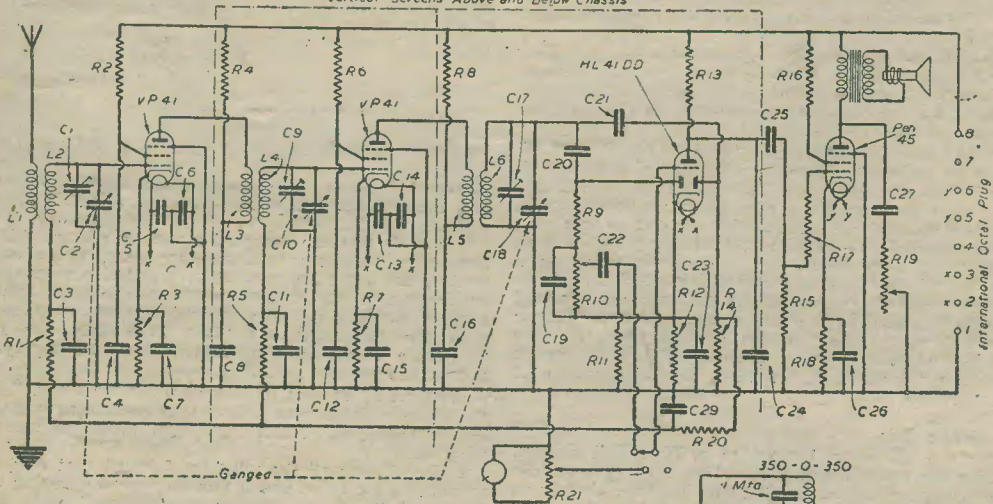

COMPONENTS.

- R1,3-25 megohm; R2-75,000 ohms; R3-450 ohms; R4,6-58,000 ohms; R7-250 ohms; R8,9-50,000 ohms; R10-.25 megohm pot.; R11-2.0 megohms; R12-1,000 ohms; R13-30,000 ohms; R14,20-1.0 megohm; R15-.5 megohm; R16-50 ohms; R17-5,000 ohms; R18-175 ohms; R19-5,000 pot.; R21-As fitted to P.U.
 C1,9,17-30 mmfd.; C2,10,18-150 mmfd.; C3,4,7,8,11,12,15,16,25,27-.1 mfd. mica; C5,6,13,14-.01 mfd. mica; C23,26-50 mfd., 50 v.; C28-.05 mfd.
 L1,2-Wearite P.A.2; L3,4,5,6-Wearite P.H.F.2.

International Octal Valve Holder

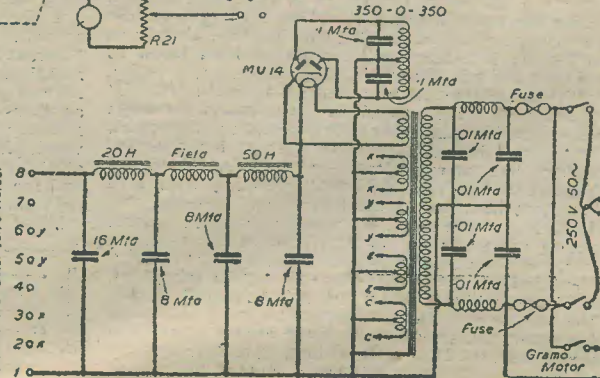

Programme Pointers

MAURICE REEVE Here Continues His Comments on the Adaptations of Music to Various Instruments and Combinations

IN arriving at the modern perversions, maltreatments and travesties of the classics which burst upon our over-patient ears these days, and which scream out at us from all points of the compass in all places and at all times, we are up against many acute problems of modern life and "new age" trends of thoughts and actions. Much of it has probably, and most regrettably, come to stay with much other degrading of art and quality in living. But in order to prove the contention I set out to solve, I will describe for you what I might call a "tour of the classics" I made recently. I pretended I had no knowledge of them in their original forms; I decided to make a list of all the numbers I heard during my tour, and find out afterwards through what mediums they were given to the world and to hear them when I returned home in their original versions or settings.

I began by turning on my wireless during breakfast, when a famous regimental band gave a programme of what the B.B.C. term light classics. Two numbers were particularly famous: a selection from "Carmen," and "O Star of Eve," from "Tannhäuser."

After that, a well-known radio orchestra included Debussy's "Girl with the Flaxen Hair"—one of the 24 Preludes for piano solo—and Mendelssohn's "Song Without Words," popularly known as "La Chasse," and also written originally for piano solo.

The third programme I heard, before proceeding on my inquiries elsewhere, was in the feature called "Keyboard Cavalcade." This particular keyboard—or boards—belonged to a cinema organ, and the classics played were "Melodies" from the "Swan Lake Ballet," by Tchaikowsky, "Tunes" from Sullivan's "Mikado," and the Overture to Mozart's "Magic Flute."

I then switched off and, softly humming to myself one of these "tunes" or "melodies," proceeded into town and took lunch at a popular restaurant which provided music through the skill of a five piece orchestra, plus a harmonium—an instrument whose presence in an orchestra always affects me like a hair would in a plate of soup—rather *de trop* and out of place.

I entered this palace of the gastronomic arts and satisfactions q.v. to the strains of an Italian operatic masterpiece, "Tosca," which was followed halfway through my meal, by a neo-classic, Rachmaninov's "Melodie," and that, in turn, by a selection of Schubertiana.

An Organ Trip

For the afternoon I went to a West End cinema. During the break between the showings of the feature film, a theatre organ, complete with soloist already at the keyboard making music, came up from below to give us a few minutes music. He announced, verbally, that he would conduct us through "a garden of love," or some such garden, to which the words of the songs he introduced into his story were flashed on to the screen. The "turn" included three or four of the songs of Schubert, Schumann's "Devotion" and Tchaikowsky's "None but the Weary Heart," finishing with love triumphant in a less classical example.

Back home once more, the wireless brought me some amazing virtuosity on an accordion in the form of, either, "William Tell," "Poet and Peasant" or "Zampa"—I'm afraid I always get these favourites mixed up, but I have an idea it was "Poet and Peasant." Whilst in the same programme two duettists rendered Schubert's "Serenade," the soprano taking the high road and the baritone the low. I had had an idea that it was originally written for a solo voice.

My tour of the classics concluded at a friend's house, where he played some gramophone records of a very famous two piano combination playing Grieg's "Peer Gynt" suite and a medley of Strauss waltzes.

Now what had I heard? When I returned home and mused over this question before retiring, it didn't take me very long to realise that I had heard it all hundreds of times before. Also that I had heard things like the Schubert "Serenade" and the "Peer Gynt" suite on many different instruments and combinations of instruments as well as those I had heard this day. Which fact naturally prompted me to ponder on for what instruments they had originally been intended.

The Original Settings

To ascertain this I thought the catalogues of the famous gramophone companies might enlighten me. But, oh dear! this put me into the greatest confusion as everything seemed to have been recorded on everything and by everybody!

But there ends fantasy; as the reader knows I only pretended I knew nothing of these works. The question is, what did I lose, and what do you lose, by their transference to these other media? The answer can only be given in one word, "everything," with, perhaps, one small qualification. The "tunes" remained—those things which the whole human race whistles and hums to itself.

The Melody Only

I'm afraid it was only the tunes, or melodies, which received any serious attention on either side. The public wanted to be entertained with them in the various places I resorted to, and the entertainers knew this full well. Harmony, nuance, tone colour, atmosphere; all these and many other components of the originals meant little.

One reply to these charges I can already hear. "It is impossible to get symphony orchestras, opera companies, first-class pianists, singers, etc., etc., to restaurants or cinemas. It is the melodies we like to hear. Many of us know the originals very well, but we are satisfied with the nostalgia that 'One Fine Day' or the 'Serenade' creates in us, no matter on what it is played, and we are grateful for it."

Well, well! to that hypothetical answer I say, "did the chicken rissole you had in that restaurant where I heard 'Tosca,' etc., create a nostalgia of roast chicken?" (Not 'arf.)

I played over all the numbers I heard that day, on records. First there was a famous soprano singing the "Serenade." Then another of "Tosca," with full symphony orchestra for background. Rachmaninov himself played his "Melodie" on another; and on yet another an equally great pianist played the haunting Debussy Prelude. And so on and so on. Orchestral, vocal, piano, tone colour and nuance, the tender passion of the soprano, the amazing palette of the orchestra and the percussive brilliance of the piano. All gone in the name of compromise, nostalgia, light entertainment.

What had I lost? Everything.

WIRE AND WIRE GAUGES

By F. J. CAMM. 3/6, or by post 3/9 from
George Newnes, Ltd., Tower House, Southampton St.,
London, W.C.2.

WEBB'S Radio

—At last!
THE NEW

EDDYSTONE Short Wave MANUAL

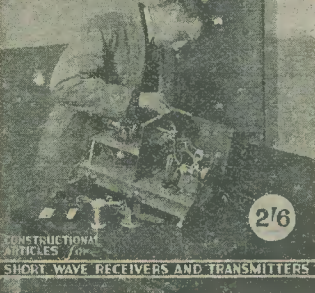

2/6

Contains articles on:—

BAND-SPREAD

ALL-DRY RECEIVER

V.H. FREQUENCY METER

★ **FIVE & TEN METRE**

CONVERTER

TWO VALVE PRE-SELECTOR

FIVE & TEN METRE

TRANSMITTERS, etc.

Until supplies improve we
are forced to say **CALLERS**

ONLY for this book

★ The really efficient 5 & 10 metre Converter described therein is available ready-built at WEBB'S. Uses new valves EF54-RL7, EC52-RL16, EF50. Price ... £13 : 10 : 11.

WEBB'S RADIO

14, SOHO ST., LONDON, W.1.

Note our SHOP HOURS : 9 a.m. to 5.30 p.m.

Sats., 9 a.m. to 1 p.m.

Telephone : GERrard 2089

RADIO SPARES

MAINS TRANSFORMERS. Primaries 200/250 volts. Secondaries 350-0-350 volts.

TYPE C. 100 ma. 4v. 5a. 4v. 3a. ... 34/6

TYPE D. 100 ma. 6.3v. 5a. 5v. 3a. ... 34/6

TYPE E. 120 ma. L.T.'s as Type C. ... 37/6

TYPE F. 120 ma. L.T.'s as Type D. ... 37/6

TYPE H. 200 ma. Three L.T.'s of 4v. 6a. +4v. 3a. Rectifier ... 47/6

TYPE I. 200 ma. Three L.T.'s of 6.3v. 6a. +5v. 3a. Rectifier ... 47/6

Secondaries 500-0-500

TYPE J. 200 ma. Three L.T.'s of 6.3v. 6a. +5v. 3a. Rectifier ... 56/-

TYPE K. 200 ma. Three L.T.'s of 4v. 6a. +4v. 3a. Rectifier ... 56/-

TYPE L. 250 ma. Three L.T.'s of 6.3v. 6a. +5v. 3a. Rectifier ... 59/-

TYPE M. 250 ma. Three L.T.'s of 4v. 6a. +4v. 3a. ... 59/-

Secondaries 400-0-400

TYPE R. 120 ma. 4v. 5a. 4v. 3a. ... 42/6

TYPE S. 120 ma. 6.3v. 5a. 5v. 3a. ... 42/6

SPECIAL UNITS MANUFACTURED TO FRIENDS' REQUIREMENTS

Please note Types H to M have 2 of the L.T.'s centre-tapped. Owing to dimensions and weights of these types, kindly add 2/6 for carriage and packing.

HEAVY DUTY MULTI-RATIO OUTPUT TRANSFORMER

120ma. 15 watts, tapping for 6L6s in push-pull, PX4s in push-pull, low impedance triode, low impedance pentode, high impedance triode. 27/6 ; complete instructions with each unit.

OUTPUT TRANSFORMERS. Special offer. Multi-ratio 30 : 1, 45 : 1, 60 : 1, 90 : 1. 7/6.

SMOOTHING CHOKES. 20 henrys, 100 or 120 ma., 14/6 ; 20 henrys, 150 ma., 16/6 ; 30, 35 or 40 henrys, 200 ma. or 250 ma., 27/6.

WOULD FRIENDS PLEASE NOTE THAT OWING TO DEMAND FOR OUR TRANSFORMERS AND CHOKES WE HAVE CEASED TO STOCK OTHER RADIO COMPONENTS.

H. W. FIELD & SON,

Colchester Road,

HAROLD PARK - ESSEX

PANEL MOUNTING METERS BY B.P.L.

(Flush mounting type)

We are carrying an extensive range of A.C. and D.C. Moving Coil Meters. We detail some popular types below:—

0-100 Microammeter D.C. 2 1/2 in. Round 63/6

0-500 " " " " " " 56/0

0-500 " " " " " " 3 1/2 in. " 66/0

0-500 " " " " " " R'angular 67/6

0-500 " " " " " " 5 in. (Specially reduced) 100/0

0-1 Milliammeter D.C. 2 1/2 in. Round 51/0

0-1 " " " " " " 3 1/2 in. " 61/0

0-1 " " " " " " R'angular 62/6

0-1 " " " " " " 5 in. (Specially reduced) 100/0

0-50 " " " " " " A.C. 3 1/2 in. Round (reduced) 75/0

0-100 " " " " " " D.C. 2 1/2 in. " 48/6

0-10 Voltmeter " " " " " " 3 1/2 in. " 63/6

• **FOUNDATION METER FOR MULTI-RANGE TEST SET.** Basic 0-1 milliammeter, 3 1/2 in. Rectangular. Scale calibrated. 0-50, 0-100 volts, and ohms, 62/6.

• **UNIVERSAL 17 range, B.P.L. TEST SETS, £8/17/6.**

• **B.P.L. SIGNAL GENERATORS, 100 kc/s—30 mc/s., £21/0/0.**

• **SIFAM Double Range Voltmeters, 0-12, 0-120 D.C. Pocket type, 45/-.**

SPECIAL OFFER

COMPLETE 10-Valve TRANSMITTER-RECEIVER to operate on 15-185 Mega-cycles, easily convertible from the Type R3002 RADAR I.F.F. (Identification Friend or Foe) RESPONDER. The biggest bargain yet. 79/6d. (carriage 4/-).

S.A.E. for Lists.

M.O.S.

MAIL ORDER SUPPLY CO.

24, NEW RD., LONDON, E.1

Stepney Green 2763.

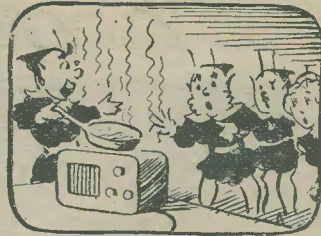

The "Fluxite Gains" at Work

"You're the craziest fool that I've met. That's no stove! It's a radio set!"
Grinned Ol. "But its heat Cooks the bacon a treat.
Get FLUXITE! Short circuit I bet."

See that FLUXITE is always by you—in the house—garage — workshop — wherever speedy soldering is needed. Used for over 30 years in government works and by the leading engineers and manufacturers. Of all ironmongers—in tins, 10d., 1/6 and 3/-.
●
●

Ask to see the FLUXITE POCKET BLOW LAMP, price 2/6.
●

To CYCLISTS : Your wheels will NOT keep round and true unless the spokes are tied with fine wire at the crossings and SOLDERED. This makes a much stronger wheel. It's simple — with FLUXITE—but IMPORTANT.

The FLUXITE G'JN puts FLUXITE where you want it by a simple pressure. Price 1/6, or filled, 2/6.



FLUXITE

IT SIMPLIFIES ALL SOLDERING

Write for Book on the ART OF "SOFT" SOLDERING and for Leaflets on CASE-HARDENING STEEL and TEMPERING TOOLS with FLUXITE, also on "WIPED JOINTS." Price 1d. EACH.

FLUXITE LTD. (DEPT. W.P.), BERMONDSEY ST., S.E.1.

Bulgin Components in

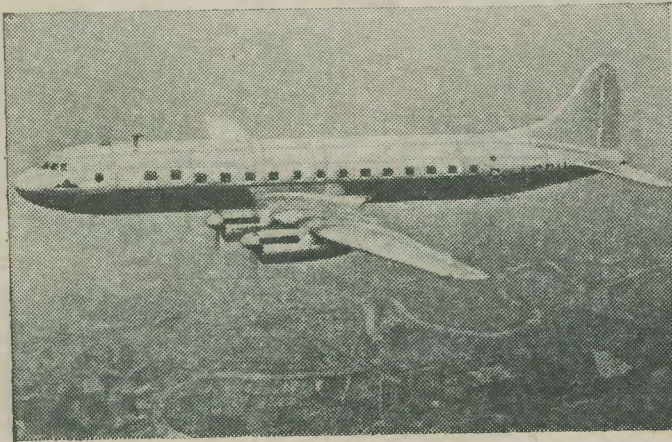

Britain's Greatest Air Liner

The Avro Tudor II is making aviation history. Huge in size, with a wingspan of 120 feet and a length of 105 feet, the Tudor II is the commercial air liner of the future, bringing the capitals of the world within easy reach of Britain. Precision-built to the last detail, this flying giant incorporates every modern accessory, including components by BULGIN. Switches and signal lamps by these famous makers play their part as they did in the mighty bombers of the R.A.F. That battle record and the skill and research of twenty-five years are behind every component that bears the BULGIN name.

☆ *Bulgin Signal Lamps in 36 types from miniature to wide vision-angle panel mountings for button-neons or M.E.S. bulbs.*

☆ *Bulgin Toggle Switches available in over 200 standard types from light to heavy duty.*

BULGIN

(REGD. TRADE MARK)

*A name Famous
in Radio for over
1,000 Components*

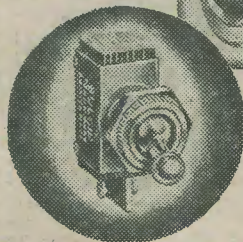

A. F. BULGIN & CO. LTD. · BYE PASS ROAD · BARKING · ESSEX
Telephone: R1Ppleway 3474 (5 lines)



Have you had your copy of the Eddystone Short Wave Manual? If not, get in touch with your Eddystone Authorized Dealer—it can be obtained ONLY from him.

WE REGRET—A NOTE OF WARNING

It is our duty to you (and in fairness to our registered Dealers) to be frank regarding the present supply position of Eddystone Components. In view of to-day's manufacturing difficulties (common to all) we are not finding it easy to meet the demand as quickly as we would wish. We must, in the Nation's interest, maintain our Export Drive thus leaving only a portion of our output for the Home Market. To avoid disappointment, order your Eddystone Components well in advance. Don't blame your dealer if he cannot fulfil your entire requirements over the counter—he is doing his best for you and we are doing our best for him. You may be sure that we, the manufacturers, are doing everything possible to increase output. Distribution of our products is being made evenly throughout the country—you may not have to wait, but if you do, please be patient.

If you do not know your local Eddystone dealer, we will, if you desire, inform you of his address (please send postage). We do NOT supply direct.

Published by

STRATTON & Co. Ltd.
WEST HEATH, B'HAM, 31

Technical Notes-3

"DYNATRON" Here Concludes His Discussion on the Vector Problem

IN another series of articles in PRACTICAL WIRELESS, I have recently dealt with the alleged difficulties of vectorising valve circuits.

Considering the "noise" that has been made on the question of conventions, etc., I did not expect my treatment to escape criticism, but it appears no objections have been recorded so far! Needless to add, such criticism is welcomed, or if there are still any difficulties I shall be glad to deal with them in these columns.

The vector rules themselves are extremely easy. They can be reduced to a simple statement.

In a valve stage with pure resistance load, the phase-shift is 180 deg. If there is inductive reactance and resistance, turn the output voltage vector, V_o , by an angle ϕ in an anticlockwise direction, where $\tan \phi = X/R$. For capacitive reactance and resistance, change this to clockwise direction.

Figure 1 shows these three cases. It will be seen that the 180 deg. angle of $I(a)$ becomes $(180^\circ + \phi)$ in (b), and $(180^\circ - \phi)$ in (c). In (b), the phase-shift may, of

fixed potential of H.T. +, the valve voltage V_o (anode-to-cathode) falls, and so is of opposite phase to V . But not one of the authorities consulted would even agree that V existed!

In justice to them, let me add that there are some pretty cogent arguments against V . As far as I know, there is but one textbook which shows a supply voltage in some vector diagrams, taking its existence for granted in the actual text.

The objection is this: *it is impossible to find any alternating potential of a phase opposite to V_o in any valve stage where the load is in the anode circuit.* For example, an oscilloscope test will always show V_o .

That certainly seems conclusive. V_o is the output voltage, and, if experiment fails to demonstrate any other, then V and V_o must be one and the same as regards magnitude and phase.

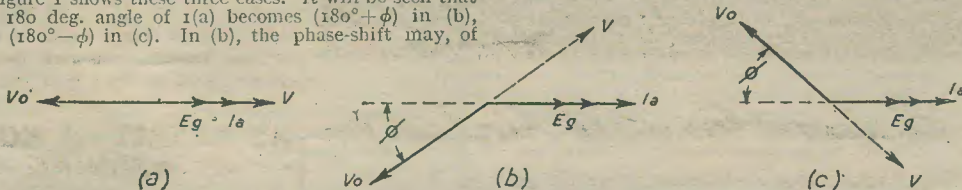

Fig. 1.—Vectors showing phase-shift with (a) pure resistance load; (b) inductive reactance and resistance load, and (c) capacitive reactance and resistance load.

course, be stated as the smaller angle between E_g and V_o . Thus if $\phi = 60^\circ$, $(180^\circ + \phi) = 240^\circ$, but this is the same as $(360^\circ - 240^\circ) = 120^\circ$.

For a purely inductive or capacitive load reactance, $\phi = 90^\circ$, and the total phase-shift is also 90 deg.

However, in these Notes I would like to tell you something of a "history" behind my deliberations on the vector conventions in valve circuits. It will explain why the whole subject has been made to look so abstruse.

A "Technical Argument"

I had been aware for some years of lack of agreement and contradictory views among authorities interested in the problems.

Looking over some correspondence, I find that I questioned certain statements made by writers on vector relationships in oscillators as far back as 1939. It became important to obtain authoritative opinion upon a particular text-book account.

With all due respect and thanks to the authorities whom I consulted, I found a complete lack of agreement on fundamental issues—or ways of looking at things which led to unnecessarily difficult conventions. The main point at issue was the phase-reversed output voltage, V_o , of an ordinary resistance amplifying stage, Fig. 2(a).

I submitted what has been put forward in my recent articles, namely: that there is an applied voltage component across R , from the H.T. source, equal to but of opposite phase to V_o —represented by V in Fig. 2(a). In course of the discussion, I pointed out that the phase of V_o represents the load reaction—a term borrowed from "The Principles of Radio-Communication," by Morecroft, though this eminent authority did not discuss specific applications to valve networks.

After all, a valve amplifier is simply a device for converting D.C. power from a battery or mains unit into A.C. power in an anode load. By a current "swing," a proportion of the H.T. E.M.F. is developed as an A.C. "supply voltage" across the load, which is the voltage V . At the same time, because one end of the load is at the

Difficulties

But that view will give rise to more difficulties than it solves. It is at the root of all the ambiguities and inversions in trying to make sense of vector principles.

First, it flatly contradicts standard A.C. theory. In a pure resistance, voltage and current are in-phase. But if the same resistance is put in series with a valve, the student is asked to believe they are 180 deg. out of phase! For, if V_o is one and the same as the supply voltage, the latter must be given a negative sign relative to the current.

That is, as long as we say the alternating current I_a is of "positive sign." The authorities got over this by giving I_a also a reversed phase. Perfect agreement with A.C. theory then results. V_o and I_a are in phase, but both are phase-reversed in relation to the grid input E.M.F. E_g .

Here all the difficulties and confusions begin. Conventions had to be devised to explain how I_a and E_g could be regarded as being at 180 deg. to one another, whereas common-sense demands they should be exactly in-phase!

Let us consider this point in a little more detail.

Eg and Ia at 180 Deg. P

When the grid potential is varying in a positive sense—an E.M.F. acting towards the grid, or away from cathode, see arrow Fig. 2 (a)—the anode current I will be increasing, above its mean value I_o .

At all ordinary frequencies the current will reach its peak at the same instant as E_g , and the obvious statement is that the two things are exactly in phase—like the flux and magnetising current of a transformer.

But to try to get consistent results by ignoring V , this oblique convention was invented by putting E_g and I_a 180 deg. out of phase. Our current increase ("positive" change) then becomes "negative," whilst to turn things topsy-turvy properly, a decrease below the mean datum line is treated as a "positive" change.

It contradicts mathematical conventions and plain commonsense. We need not go into certain A.C.-D.C. conditions which might be postulated to justify such

inversions of straightforward ideas, because simple recognition of the applied voltage V gets rid of all difficulties at one stroke.

Note, again, that all the confusions arise because V_0 was said to be the only alternating voltage component existing in the anode circuit.

The "Supply Voltage" Again

At the risk of repetition of what has been said in this and previous articles, let me state once again why we must consider a supply component itself at 180° deg. to V_0 .

Still keeping to a load resistance R , we have, by elementary A.C. theory, a "p.d.," "drop," or "voltage" across the resistance given by $I_a \times R$ —or, strictly, a voltage-change, since there is also a steady drop of $I_0 R$ volts.

In any ordinary A.C. circuit we would simply regard this as the supply voltage, *in-phase with the current*. There is nothing in valve circuits that demands violation of this basic A.C. principle. The current and "voltage" in a resistance are necessarily *in-phase*, whether the resistance is that of a wire, a lamp, a heater, or one inserted in the anode circuit of a valve.

Therefore, we say the alternating current I_a develops a "drop" across R —or, if you like, "more volts" are developed across the resistance, from the H.T. source. These volts are exactly *in-phase* with I_a ; and are what we call the *supply volts* denoted by V .

Thus, for a positive change of E_g , voltage V rises to a maximum, in step with I_a (and E_g). The three quantities, E_g , I_a , and V , are of the same phase throughout, which makes it unnecessary to postulate any bizarre phase-inversions.

But, at the same time that V rises to a maximum, the valve anode-to-cathode, or output voltage V_0 , falls by exactly the same amount as V increases. After all, "volts" are derived from the H.T., and it is simply a case of

would have none of it. All maintained that my "supply voltage V " was non-existent, and subsequent writings and correspondence on the subject in the technical press prove that they actually believed this right.

True, some did write that " V_0 is the load voltage in a negative sense," thereby tacitly admitting there must be an opposite component of "positive sense" somewhere!

At the time we were discussing the pure resistance case, Fig. 2. But very often, if a point or principle can be conclusively established for one particular case, there is more than a reasonable presumption that it must be true generally.

For example: we cannot imagine a current flowing or changing in any sort of circuit—resistive, inductive, or capacitive—without application of "supply volts"! In every valve circuit there must be an equivalent voltage, even though at 180° deg. to some other E.M.F.

If, as in Fig. 3(a), we substitute for R a *pure inductance* L , we cannot get away from the facts: (a) that there is a *back E.M.F.* of self-induction, E , in the coil turns, and (b) that there must be an applied voltage V , at 180° deg. to E .

Both these E.M.F.s must be accounted for in any and every inductive circuit, and Fig. 3 is no exception. Let us again consider the detailed action.

Let E_g change in a "positive sense," as before—from zero to maximum. The current I_a will be increasing exactly in step with E_g , and the magnetic field around L will be increasing.

By the laws of electromagnetic induction, a back E.M.F. will be induced in the coil *opposing the current increase*. What direction of E.M.F. will do that?

Only one answer is possible. E will be directed *against* +H.T. (and -H.T.), as indicated by the dotted arrow in Fig. 3. The H.T. is acting positively around the circuit anti-clockwise (from + to -), whilst the back E.M.F. is directed the opposite way.

We would be quite correct in saying: the counter E.M.F. has a *positive direction* opposite to that of the H.T. But the standard electrical convention is to treat such a direction as *negative* (mathematically, $E = -L \cdot di/dt$), the negative sign merely denoting the *fact* of phase-opposition to an applied voltage of positive direction.

Therefore we have two E.M.F.s in mutual opposition. What happens? I_a will go on increasing to its peak, whilst the back E.M.F. retards the growth. The effect will be to throw the current quarter of a cycle (90° deg.) out of phase with both E.M.F.s— I_a leading 90° deg. on E , and lagging 90° deg. on V .

We need not consider this 90° shift for the moment. Since E is in direct opposition to the H.T., a *proportion of the H.T. volts will be thrown across L* , equal but opposite to the counter E.M.F. This is our applied voltage V again. Is any further argument necessary to demonstrate its existence?

But, once more, we are up against that paradoxical quantity, the Output Voltage V_0 . Will this have the same phase as E , or V , or some other E.M.F.?

Across the valve, exactly the same happens as in Fig. 2—forgetting the 90° angle in Fig. 3. An increase in the volts dropped across the inductance is accompanied by an *equal fall* in the volts across the valve. The total increase (peak) across L is V volts. Therefore $V_0 = -V$ volts as before.

Thus V and V_0 are still at 180° deg. This is true *whatever the nature of the anode load*—resistance, inductance, or mixed impedance. The anode-to-cathode volts fall by exactly the same amount as the volts dropped across the load rise. Or, conversely, during a negative half-cycle, the valve volts rise.

Because they are at 180° deg., V_0 still has a "negative sign" relative to V . Since E also has a negative sign

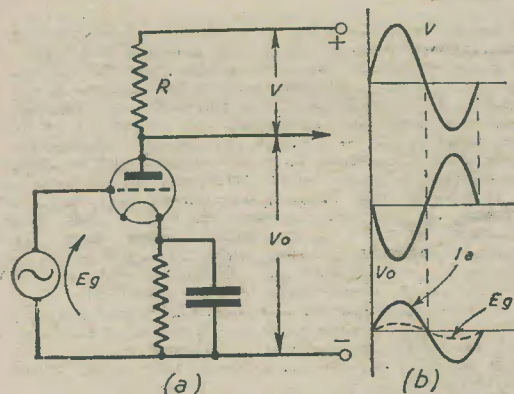

Fig. 2—Circuit and derived vector for a simple resistance amplifying stage.

robbing Peter to pay Paul—the larger drop across the load robs the valve of that much H.T. So we say: V_0 changes in "opposite sense," or is *phase-reversed* with respect to V , I_a , and E_g .

And that is all this business of "phase-reversal" really means! Mathematically, a "decrease" in something is regarded as a "negative" change, implying that V_0 is the same as V looked at "negatively," or V in reversed sense: $V_0 = V$, numerically, by $V_0 = -V$ as regards relative phase.

Graphically there is only one possible way of representing V and V_0 —by sine curves or vectors at 180° deg., as in Fig. 2(b) and (c).

A Conclusive Argument

While the facts we have emphasised seem perfectly obvious even on superficial examination, the authorities

relative to V , it follows by elementary logic that E and V_0 are in-phase. The output voltage taken off the anode has the phase of the back E.M.F. in the inductive load.

By a rather longer route, we arrive back at the same conclusion as in Fig. 2—that V and V_0 are 180 deg. out of phase. In Fig. 3, the total phase-shift between V_0 and E_g will not be 180 deg., but 90 deg., because V is turned round anti-clockwise to lead on I_a by a quarter-cycle—instead of being in-phase with I_a as in the resistance case (see Figs. 2 (b) and 2 (c), comparing with 3 (b) and 3 (c)).

“Load Reaction”

Here was a pretty conclusive argument. But, it was argued, it is all very well to take an inductive case where the conditions are entirely different. What about a load resistance? You have no “back E.M.F.” there!

The back E.M.F. in an inductance is one form of a load reaction. In electrical circuits it denotes an E.M.F. or potential - difference of opposite sign, and therefore phase-opposing the applied voltage.

Is there such a voltage in a resistance? In inductive circuits we have a tangible counter E.M.F. self-induced by the magnetic field. But surely nothing of this kind applies to a pure resistance, i.e., a non-inductive resistance?

True, there is no back E.M.F. of “induction.” Nevertheless, there is a very definite load reaction, which takes the form of a potential-difference opposing the applied E.M.F. It differs from a back E.M.F. of self-induction in being at 180 deg. instead of 90 deg. to the current.

When you say that volts are “dropped” in a resistance you really imply they are cancelled-out by some equal and opposite potential. What is “lost,” of course, is energy—electrical energy converted into heat. But the very fact that volts are lost means that they set up an internal potential-difference of opposite sign to the applied E.M.F.

“Potential-difference,” and “Applied E.M.F.” are in mutual opposition, as you will see if you consider the relative signs of each. The + and - signs attached at say ends A and B of a resistance denote an applied E.M.F. acting in the direction A—B. They also denote the potential-difference acting B—A. Because terminal A is at a higher + potential than B, this difference acts as an “opposition,” or “counter-potential” to the applied E.M.F.

It takes a little thinking to see the point. In general, of course, when we refer to “voltage drop” we simply mean loss of applied volts. With the single exception of the American work, *Principles of Radio-Communication*, by Morecroft, I know of no textbook that even mentions a load reaction in electrical circuits analogous to the better known “reactions” in mechanics.

In most circuits the direction of the internal potential-difference is relatively unimportant—except perhaps when you consider the internal loss of volts in a battery. But, remember, what we had to show was something equivalent to a “back” E.M.F. in an anode load resistance.

The negative sign of the output voltage in Fig. 2 should thus be clear. It takes the sign of the load reaction, just the same as it did in Fig. 3, where we had a

more tangible counter E.M.F. Otherwise, what has been said before should make it abundantly clear that the load voltage V exists, not across the valve, but directly across the load impedance in the anode circuit, and that in all cases it is at 180 deg. to the output voltage.

Conclusions

It appears from an article I recently read in another periodical that this subject of the load reaction has received much learned attention in some of the more academic technical journals.

As far as I am aware, the correct term, *load reaction*, was not employed. If it had, there would not be much room left for argument. I pointed it out to the authorities who took part in my

“argument” in 1939-40. I claim no particular originality in doing so, since Morecroft had published his explanation even at that time.

The writer of the article I read recently sets a problem for his readers on

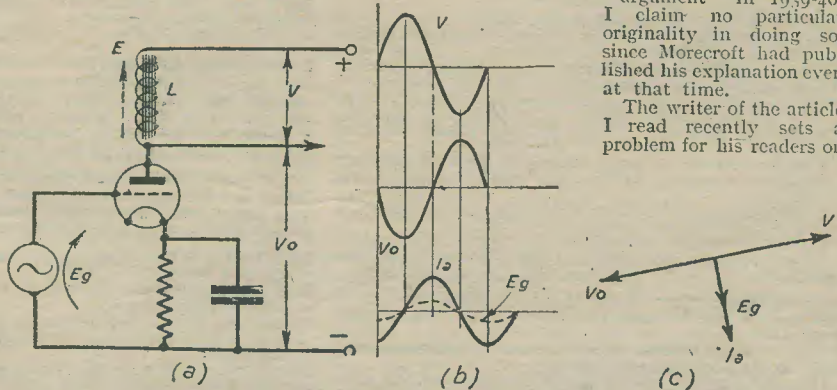

Fig. 3.—An amplifying stage in which the load resistance of Fig. 2 is replaced by a pure inductance.

the question we have just been discussing—the relative directions of applied E.M.F. and potential-difference.

It appears, too, from the article, that the subject gave rise to involved controversy in two or three of the leading technical journals. Considering that Morecroft had elucidated the point years ago, whilst I tried to get authorities to see it was the real explanation of phase-reversal in a resistance stage, one wonders whether radio technicians will ever reach agreement on anything!

It is about time radio engineers should agree on their vectors, as electrical engineers have done ages ago. Teachers of radio, in particular, should have the student's interests at heart, and I am always open to discuss in these columns any criticisms or objections to the principles outlined in PRACTICAL WIRELESS.

I think I can claim to have demonstrated conclusively the root cause of disagreements. I will go so far as to ask the Editor to invite more authoritative opinions if it can be shown my reasoning is faulty or fallacious on any point.

That is a fair enough offer. If objections are still not forthcoming, shall we take the issue as settled once and for all time?

A 5-VALVE RADIOGRAM

(Concluded from page 75).

certainly gets hot as the makers mention. I tried a PX4 and two PX4s in P.P., but reverted to the single-ended Pen. The gram, reproduction is excellent; it does justice to Yehudi Menuhin playing The Flight of the Bumble Bee as it does to Widor's Toccata from the Fifth Symphony, the heaviest record I know. The pick-up is a B.T.H. magnetic (I have never been able to get good results with a crystal).

These details will no doubt interest other readers, and may serve as a basis for those who are desirous of constructing a reliable radiogram.

News from the Clubs

HALIFAX EXPERIMENTAL RADIO SOCIETY

Hon. Sec.: L. Blagbrough, 39, Fountain Street, Sowerby Bridge, Yorks.

THE above society was recently formed, and its aims are for the advancement of amateur radio in the district, to encourage newcomers into the movement, and to increase the knowledge of principles and practice among amateurs.

Morse classes have commenced on the society's premises. It is hoped that many wishing to learn Morse, both elementary and advanced, will take advantage of these facilities.

A number of lectures and discussions are scheduled for the coming meetings, which are held at the Toc H, Clare Road, Halifax. Anyone interested is asked to communicate with the secretary at the above address.

THE WEST MIDDLESEX AMATEUR RADIO CLUB

Hon. Sec.: Norman S. C. Priest, 7, Grange Road, Hayes End, Middlesex.

THE club has now got well into its stride, and the membership continues to grow steadily. At a recent meeting over 40 members listened with great interest to a talk on "High Quality Reproduction," given by a member, Mr. A. C. Gott, who invited members to hear his own home-constructed equipment.

A brisk discussion followed, bringing to light the fact that many types of high-quality speakers were being constructed by members.

It may be possible to obtain these for a club exhibition of members' work later in the season.

The club continues to meet at the Southall Labour Hall Rooms, at 7 p.m. on the second and fourth Wednesdays in each month.

THE SOUTH SHIELDS AMATEUR RADIO CLUB

Hon. Sec.: W. Demell, 12, South Frederick Street, South Shields.

THE above club is now fully established, and at a General Meeting new officials were elected and a programme was made out for the forthcoming weeks.

These lectures will be illustrated by lantern-slides, and other gear will be employed to make things interesting. The lectures begin at 8 p.m. each Friday evening, and a cordial welcome is extended to any person interested.

Further particulars can be obtained from the secretary.

THE STOURBRIDGE AND DISTRICT RADIO SOCIETY

Hon. Sec.: I. D. Rock, Flat 1, Block 1, Worcester Road, Summerfield, nr. Kidderminster.

AT a recent meeting in King Edward's Grammar School, Stourbridge, presided over by the secretary (G8PR), the main interest was a lecture on "The Technique of Aerial Design," given by Mr. S. Button, A.M., I.R.E. (G5JY), of Romsley. Interesting details were given of various types of aerials, including square loop aerials, omni-directional and uni-directional types—mainly applicable to the centimetre. Many questions were put to G5JY, to whom the society passed a vote of thanks, and would like to record their appreciation of his visit and lecture.

Future meetings will include talks on Power Distribution, discussions on Oscillators, Transmitters, etc. It is hoped that all interested people in the area will attend. Also, will members please note the new address of the secretary (given above).

SLADE RADIO SOCIETY

Hon. Sec.: L. A. Griffiths, 47, Welwyndale Road, Sutton Coldfield, Birmingham.

HAVING obtained permission from the G.P.O. to work portable, G2AK is now working in conjunction with the Slade Radio Society to hold a D.F. test as soon as possible. A provisional date has been fixed for the first test, which, in view of shortage of petrol, will take place on foot and will cover a much smaller area than is customary.

A recent meeting was devoted to a discussion on the circuits which it was felt could be most easily made and used by the newer entrants. Hints on the plotting and transferring of bearings were also given, and nine members expressed their preparedness to compete.

READING AND DISTRICT AMATEUR RADIO SOCIETY

Hon. Sec.: L. A. Hensford, B.E.M., G2BHS, 50, Boston Avenue, Reading, Berks. Phone: Reading 40744.

AT the September meeting of the Reading and District Amateur Radio Society, the annual election of officers took place, several changes being made.

The Lewis Cup and Nash Cup competitions were judged by well known Hams of District 7, Norman Turner, G4NT, Bert Sherry, G6JK, Don May, G2BB, the winners this year being G6KB the Lewis Cup, G5XB the Nash Cup.

Meetings at Palmer Hall, West Street, Reading, at 6.30 p.m. (as from November), the second Wednesday and last Saturday of the month.

WIRRAL AMATEUR TRANSMITTING AND SHORT WAVE CLUB

Hon. Sec.: B. O'Brien (G2AMV), 26, Coombe Road, Irby, Heswall, Cheshire.

THE inaugural meeting of the Wirral Amateur Transmitting and Short Wave Club was held on September 25th at the Y.M.C.A., Whetstone Lane, Birkenhead. Thirty-three members were present to hear G3CK give a brief resumé of the work of the club up to the outbreak of war, and also G8OC, who delivered a most interesting and practical talk entitled "Receivers." Details of membership may be obtained from the secretary.

ALTRINCHAM AND DISTRICT RADIO SOCIETY

Hon. Sec.: J. G. Barnes, 4, Victoria Road, Hale, Cheshire.

MR. Barnes has been asked by a number of local amateurs and enthusiasts to reform the above society. The above address will find him for all correspondence.

BIRMINGHAM AND DISTRICT SHORT WAVE SOCIETY

Hon. Sec.: C. W. Thompson, 6, Caldwell Road, Birmingham, 9.

AT the last meeting members were taken through the recent amateur examination paper, question by question, and specimen answers were given. Another feature was the "monthly log," when a member describes reception conditions and DX heard.

The society meets at the "Hope and Anchor Hotel," Edmund Street, at 7.45 p.m. on the first Monday of every month. Any S.W. listener who is interested is invited to write the secretary for full details, or to drop in at the next meeting.

STOKE-ON-TRENT AND DISTRICT AMATEUR RADIO SOCIETY

Hon. Sec.: Dan Poole, 13, Oldfield Avenue, Norton-Le-Moors, Stoke-on-Trent, Staffs.

THE attendance at each meeting has been very good, and more have joined since the last report; they have passed the 50 mark.

The club has been divided into three sections—TX, RX and the Auxiliaries. Each one is in charge of an experienced senior man whose duty is to organise lectures, demonstrations and practical periods for his particular section. By the way, this is working out fine—other clubs please note.

We are hoping that each section will be able to design and construct its own particular unit that will fit together with the rest and become the club's station outfit, then we shall be on the air as soon as we get the licence.

Recently we've had two lectures—one by Mr. A. Hackney on L.F. amplifiers, and one by Mr. Scroey on Klystrons.

Electronic scrap was bought and sold to the members recently; there's a big demand for this scrap. G3UD has completed a 5- and 10-metre rig from scrap and it is very good.

New call signs recently issued are: GS1X, Mr. G. Tagg, 17, Nelson Road, Hanley; G3AQJ, Mr. A. H. Crossland, 35, Keeling Road, Cheddle; and G3QLW, the Secretary. One member is awaiting the exam. and eight are under instruction for a "G" ticket.

ILFORD AND DISTRICT RADIO SOCIETY

Hon. Sec.: H. T. Stott, 17, Sylvan Avenue, Mill Hill, N.W.7.

AN unusually interesting and informative evening was spent at the Ilford and District Radio Society recently when Messrs. Mould and Falconer of the G.E.C. gave a lecture on, and demonstration of, F.M. The underlying principles of this system were outlined and explained, and many unfamiliar points clarified.

Following the lecture and demonstration, many questions were asked and ably answered, and the proceedings concluded with a hearty expression of thanks to the lecturers for providing so entertaining and instructive an evening.

INTERNATIONAL ROUND TABLE RADIO CLUB

Rep.: C. W. Fowler, B.S.W.L. 1681, 21, Sydney Street, Brampton, Chesterfield, Derbyshire.

MR. C. W. FOWLER has been appointed representative in the British Isles of the International Round Table Radio Club, and if any readers who would like to join would contact him, or Mr. R. G. Baker, 137, Hartham Road, Isleworth, Middlesex, they would be very pleased to hear from them.

A monthly bulletin is sent to all members.

THE SLIDE RULE MANUAL

By F. J. CAMM

5/- or 5/6 by post from George Newnes, Ltd., Tower House, Southampton Street, Strand, W.C.2.

PRATTS RADIO

1070 Harrow Road
LONDON, N.W.10
(Nr. SCRUBS LAKE)
Phone: LADbroke 1734.

COILS. Weymouth 3 wave coil packs, 38/8 each; L, M. and S. wave coils, Aerial and Osc., 465 kc/s, 12/6 per set; L, and M. wave coils with reaction, 9/- pair; M. wave coils, 5/6 pair; dual range coils with reaction, 4/6 each; set of 3 coils 12-60 metres, 9/-; Weirite "B" coils, 4/- ea.

VARIABLE CONDENSERS. .0005 2-gang with trimmers, 12/6; less trimmers, 11/6; reaction con., .0005 and .0003, 4/3 ea.; trimmers 5/50 pf., 9d. ea.; 5/500 pf., 1/8 ea.

TRANSFORMERS. Mains 350-0-350v, 6v. and 5v. or 4v., 4V/15, 26/6; similar but 4v., 4v., 5v., 6v. 120 mA. 3/16; both types extremely reliable. Speaker Transformers: pentode, 5/9; multi-ratio, 6/6; midget Universal, 5/-; 25 watt multi-ratio, 2/6.

SPEAKERS. P.M. L.T.R., 2 1/2 in., 25/-; 3 1/2 in., 28/-; 5 in., 20/6; 8 in., 23/6; 6 in., 22/6.

CHOKES. 10 by, 300 ohms 40 mA, 4/9; 20 by, 360 ohms 60 mA, 6/9 ea.

CONDENSERS. Elect. 2 cond., 3/6; T.M.C. 16 x 8 mid., 8/3; 8 x 3 mid., 8/9; 4 mid., 3/5 (all 450,500v.); 125 mid., 25v., 1/9; 50 mid., 50v., 3/-; 50 mid., 12v., 2/3. Most types of paper and silver mica con. in stock.

MAINS DROPPERS. 3 amp., 800 ohms, 5/-; 2 amp., 1,000 ohms, 4/9 ea. (inc. fixing feet and sliders); Linecord, 3 amp. 60 ohms, per ft.; 3-way, 8d. ft.; 2-way, 7d. ft.

MISCELLANEOUS. Octal valve screens, 9d. ea.; knobs, 1in. to 2in., black or brown, 6d. to 9d. ea.; volume-controls, most values, less sw., 8/3, with sw., 5/- ea.; midget interval transformers 5-1 or 3-1, 5/6 ea.; valveholders, 7d. ea.; Amphenol Octal, 9d. ea.; fuseholders, 1 1/2 in. single, 4d., twin, 7d.; Class "B" driver transformers, 7/9 ea.

VALVES. 1C5, 1A7, 1H5, 1N5, 1A5, 6J7, 6K7, U31, 25Z8, 25Y5, 25Y5G, 25Z5, 6L6, PX4, PX25, 12K3, 12SQ7, EF39, EF9, EL32, etc. etc. S.A.E. for List or Enquiries. Postage extra. C.W.O. or C.O.D. Buses 662, 664, 16B pass door.

NEW UNUSED GOODS ONLY.

LONDON CENTRAL RADIO STORES

Ex-Govt. Reflector Type P.M. Speakers. By Tannoy and Truvox. Suitable for small P.A. work, factories, etc. A robust job in heavy wooden case, 9in. x 9in. x 7in. 25/17s. 6d.

25 p.f. Air Trimmer Condensers. New, 3/-.

Ex-Govt. High Speed Relays with platinum contacts. D.C. resistance of coil 500 ohms. Enclosed in dust-proof brass box. Size 3in. x 1 1/2 in. x 1in. New, 6/6.

"Westectors" Type W.N.6. New, 1/6 each.

Moving Coil Mike Incerts. Coil 30 ohms. 5/- each.

Ex-R.A.F. Tubular Bakelite Electrolytic Condensers. 8 mf., 650 volt working, 2/-.

Tuning Condensers. Single .0005. Best quality, air spaced, 1/2 in. spindle. New, 3/6 each.

Condensers. Split Stator 2-gang, 10/6.

Yanley Type Switches. 2-pole, 6-way, 2/6.

Vibrators. 12 volt, 4 pin. New, with holder, 9/6 each.

Wire Wound Pots. Resistance 300 ohms and 25,000 ohms, 1/9 each.

Ex-R.A.F. T.1154, advertised in December issue at 30/-, does not include valves and meters.

23, Lisle Street, London, W.C.2
GERard 2969

U. E. I. CORP.

EX R.A.F. "Identification Friend or Foe" Responder Units. Complete with valves and Rotary Transformer. Component value well over £20. A few only at 75/- (G.W.O.), carriage 4/-.

VIBRATOR UNITS. 2v. input, 180 v. output, L.T. and G.B. Complete with 2 accumulators. Brand New, 80/-.

TELESCOPIC AERIALS, 102in. long, collapsing to 15in., 15/-; 16-section rod aerials, 12/6.

MINIATURE VALVES, Types 1S5, 1T4, 1R5, 3D6/1,299, 17/6 each.

ELECTROLYTICS, 500 v. working, can-type, 8 mfd., 2/10; 3 x 8 mfd., 5/6; 16 mfd., 4/9.

MAINS TRANSFORMERS, The "Two-in-One" 350-0-350, 80 ma., 6.3 v. 3 a., 5 v. 2 1/2 a., 4v. 4a., 4v. 2 1/2 a., 32/6. 350-0-350, 150 ma., 6.3 v. 3 a., 5 v. 2 1/2 a., 37/6. 500-0-500, 200 ma., 6.3 v. 3a., 6.3 v. 2 1/2 a., 5 v. 3 a., 45/-.

YANLEY TYPE SWITCHES, 4-pole, 3-way, 3/6, 2-pole, 6-way, 2/9.

LINE CORD, first grade only, 3 amp., 2-way, 1/4 yard, 3-way, 1/7.

RESISTANCES, 4 watt, 4d.; 1 watt, 5d.; 1 watt, 7d.; 2 watt, 1/3.

VALVE HOLDERS, Amphenol, 7d.; Faxolin, 5d.; Acorn (Ceramic), 2/6.

SCREENED WIRE, Single core, 9d. per yard, twin core, 1/-.

SET OF HEADPHONES AND MICROPHONE, as used on Canadian 58 Transceiver, 22/6 complete. Brand New.

Post orders only. C.W.O. or c.o.d. over £1. Carriage paid over £1. Send S.A.E. for Current Lists, Country Dealers send for particulars of our "Country Dealers Service."

U.E.I. CORP,
32, St. Gabriel's Road,
London - - N.W.2.

SCOTLAND'S LARGEST STOCKISTS

Anything Radio we have it
EDDYSTONE-AGENTS-RAYMART
Send for Parts and Kits List.
BUCCLEUCH RADIO MANUFACTURERS
Melville Terrace, Edinburgh.
Phone Edinburgh 42803. Grams. Therm. Edin.

MIDLAND INSTRUMENT CO.

LEVCO'S COPPER WIRES,—16-24-28-29-32-34-36 g. enam. at 3/-, 4/-, 4/6, 4/7, 5/1, 5/6, 6/- lb.; 14-20-22-24-28-29-31-32-33-34-38-40 g. Lewmex at 3/3, 4/3, 4/7, 4/11, 5/7, 5/9, 6/3, 6/6, 6/9, 7/-, 8/3, 8/3 lb.; any weight supplied. Also D.C.C. enam.s.s.c. coverings, resistance wires, and hundreds of other Radio and Electronic items. Lists 2d., with s.a.e.

18, Harborne Park Road,
Birmingham, 17.

A FREE BOOK

for all interested in

MORSE CODE TRAINING.

There are Candler Morse Code Courses for Beginners and Operators.

Send for this Free "BOOK OF FACTS" It gives full details concerning all Courses.

THE CANDLER SYSTEM CO. (S.L.O.)
121, Kingsway, London, W.C.2.
Candler System Co., Denver, Colorado, U.S.A.

COULPHONE RADIO

PROP. C. COULBORN: G3AJM
"THE RETURN OF POST MAIL ORDER SERVICE."

Station Road, New Longton, Near Preston.

New Goods Only—Over 15,000 satisfied clients. Most comprehensive stock of radio service gear in the country. C.O.D. or cash with order. All orders over 5/- post free. A few of our lines are listed below, send 2d. stamp for latest 16-page catalogue.

Valves—All B.V.A. and Tungfram, including American.

Eddystone short wave gear. 21d. stamp for catalogue. S.W. Manual 2/6

Mains Transformers—Interleaved and Impregnated. For 200/250 v. mains, 300 v. 60 mA, 4 v. or 6 v. L.T.S. 17/6; 350 v. 100 mA, 4 v. or 6 v. L.T.S. 24/-; 450 v. 200 mA. with three L.T.S. 4 v. or 6 v., 42/6.

Smoothing Chokes—40 mA., 4/6; 60 mA., 6/-; 90 mA., 7/-; 100 mA., 12/6; 200 mA., 21/6

Speaker Transformers—Midget Pen., 40 mA., 4/6; Midget Power/Pen., 40 mA., 5/-; Std. size Push-Pull Universal, 60 mA., 6/-; Heavy Duty, P.-P., 2 1/2", Extra H.D. 100 mA., 37/6.

Mains Dropper Resistors, with feet and two sliders, 2 amp., 4/3; 3 amp., 4/6. Resistors 1w. 6d; 1w. 9d.

Loud Speakers P.M., 2 1/2 in. 25/-; 3 1/2 in., 28/6; 5 in., 20/6; 8 in., 23/6; 10 in., 33/6. With Trans. 5 in., 29/6; 10 in., 39/6.

Weymouth Tuning Coil Pack—Completely wired. Short, Medium and Long Wave Superhet type for 465 kc/s. I.F. 38/6. Midget I.F.T.'s 19/6.

Line Cord, 60/70 ohms per foot, 3 amp. Note price per yard, 2-way, 1/6; 3-way, 1/9.

Tuning Condensers—Midget 2-gang .0005 with 2-speed drive, 16/6. Aluminium Chassis 3in. Deep, 10in. x 8in., 6/6; 12in. x 9in., 9/6; 14in. x 9in. and 10in. x 8in. 10/6; 20in. x 8in. 12/6.

EXCLUSIVELY MAIL ORDER

THESE ARE IN STOCK

- THE RADIO TUBE VADE MECUM.** By Brans, 12/6. Postage 6d.
- RADIO LABORATORY HANDBOOK.** By M. G. Scroggie, 12/6. Postage 4d.
- PRACTICAL WIRELESS CIRCUITS.** By F. J. Camm, 6/-, Postage 4d.
- RADIO ENGINEERING.** By F. E. German, 30/-, Postage 7d.
- EVERYMAN'S WIRELESS BOOK.** By F. J. Camm, 6/-, Postage 5d.
- MATHEMATICS FOR ELECTRICIANS AND RADIO-MEN.** By Nelson M. Cooke, 22/6. Postage 7d.
- AMERICAN MIDGETS.** By J. Bull, 2/6. Postage 2d.
- CATHODE RAY OSCILLOGRAPHS.** By J. H. Reyner, 8/6. Postage 4d.
- TESTING RADIO SETS.** By J. H. Reyner, 15/-. Postage 5d.
- THE WIRELESS WORLD VALVE DATA.** 2/-, Postage 2d.
- THE TECHNIQUE OF RADIO DESIGN.** By B. E. Zepher, 21/-, Postage 6d.
- THE AMATEUR RADIO HANDBOOK.** 3/6. Postage 6d.
- THE RADIO HANDBOOK SUPPLEMENT.** 2/6. Postage 4d.
- ELECTRONIC EQUIPMENT AND ACCESSORIES.** By R. C. Walker, 25/-, Postage 7d.

We have the finest stock of English and American Radio Books. Write or call for complete List.

THE
MODERN BOOK COMPANY
(Dept. P.11.)
19-21, Praed Street, London, W.2

Impressions on the Wax

Review of the Latest Gramophone Records

GOETHE'S tragedy "Egmont" is not more famous than the brilliant overture Beethoven wrote for it.

This piece was written when the composer was at the height of his fame, and shows him in dramatic mood, master of every orchestral resource. The heavy chords for strings at the opening are dark with meaning and the downward plunge at the commencement of the allegro is as thrilling as anything in orchestral music. At the end of the overture is one of those massive climaxes Beethoven knows so well how to produce, not unlike the coda of the finale in the C minor Symphony. Beethoven, unlike some composers, had a fine literary taste; the books in his collection at his death showed a high standard of reading, and evidently Goethe's tragedy inspired him enough to draw forth one of the finest overtures in the orchestral repertory. "Egmont" is a score that provides ample opportunities for individual interpretations, and this latest recording on *Columbia DX1273* by the Philharmonia Orchestra, conducted by Alceo Galliera, is sure to find many warm admirers.

Another interesting release this month is a recording of Elgar's "Concerto in E Minor, Op. 85," on four 12 in. records—*H.M.V. DB6338-41*. It has been recorded by the B.B.C. Symphony Orchestra, under the able baton of Sir Adrian Boult with Pau Casals playing the 'cello.

Beniamino Gigli is one of the finest tenors in the ranks of Italian artists, with an extensive repertory in both opera and art-song. His recent debut at Covent Garden was a tremendous success. He has recorded this month "Amarilli" and "O del mio amato ben," both of which are sung in Italian on *H.M.V. DB6313*.

Tchaikovsky's ballet music from the "Sleeping Princess" is another highlight in the latest releases, and it has been recorded by the Royal Opera House Orchestra, Covent Garden, conducted by Constant Lambert on two 12 in. records—*Columbia DX1281-2*.

H.M.V. Album Series

BEETHOVEN'S "Symphony No. 6 in F Major" ("Pastorale") is featured in the above series and consists of a set of five 12 in. records—*Columbia LX963-7*. The recording is made by the Philharmonia Orchestra, conducted by Bruno Walter.

Other interesting recordings are "Die Meistersinger" (Act 3) by the well-known baritone, Herbert Janssen, on *Columbia LX947*, "Reverie and Caprice," played by the Philharmonia Orchestra, conducted by Constant Lambert, on *Columbia LX946*, with Joseph Szigeti (violin), "Fantasia on a Theme of Tallis," by the Hallé Orchestra, conducted by John Barbirolli, on *H.M.V. C3507-8* and "Addio del Passato" and "Si, Mi Chiamano mimi," sung by Margherita Carosio, soprano, on *H.M.V. DB6343*.

New Tauber Record

RICHARD TAUBER'S repertory of songs of various schools is indeed amazing. He seems to have the power of identifying himself completely with the nationality and characteristics of the composer whose song he sings, and his fine tone never fails him. This month Tauber has selected two Tchaikovsky pieces: "Fifinella" is a love song in the Florentine tradition, in which Tchaikovsky skilfully reproduces the Italian style. Companion to it is the very beautiful "In the Ballroom"—*Parlophone RO20549*. The singer is accompanied by an orchestra, conducted by Harry Geehl, who has arranged both the songs.

A new issue of Scottish records this month presents several items of great interest. Chalmers Wood and his Country Dance Orchestra give us a selection on *Parlophone F3363*, including the traditional reel "Tulloch"

and "Coming Through the Rye." On *Parlophone F3364*, the Mansfield Singers provide a beautiful interpretation of the "Hundred Pipers," the words written by Lady Nairne, famous as the poet who wrote "The Land of Leal."

Light Music

THE big new show staged by C. B. Cochran, with book by Sir Alan Herbert and music by Vivian Ellis, has links with Gilbert and Sullivan's "Iolanthe" in that it deals amusingly with politics—though "Big Ben" is devoted to the House of Commons, while the Sullivan opera had more to do with Lords. The new production is on a grand scale, beautifully dressed and organised in the true Cochran tradition. This month Vivian Ellis himself plays six pieces from the show as piano solos on *H.M.V. B9500*. "London Town" is one of the finest of them, a rousing piece given to the King's Bargemaster and his jolly watermen. The three waltzes are jellifflous and happy, and in them Vivian Ellis has epitomised the gaiety and elegance of this attractive revue.

Glancing through the vocal recordings I noticed records by most of the popular English singers. On *H.M.V. B9507*, for instance, we have Webster Booth singing "Nazareth" and "O Come all ye Faithful" in his own inimitable style, whilst Joan Hammond sings "The Donkey" and "Magdalen at Michael's Gate" on *H.M.V. B9503*. Also Jeanette MacDonald, the popular film star has recorded a very old favourite, "Smoke gets in your Eyes," on *H.M.V. B9510*. On the reverse side she sings "Sweetheart Waltz."

The evergreen "Rigoletto" turns up again on *Columbia DB2269*, sung by Luigi Infantino, tenor, and another old favourite "The Vagabond" has been recorded by Robert Irwin on *H.M.V. B9504*. As a coupling to this record he sings "Bright is the Ring of Words" from "Songs of Travel, No. 2."

Dance Music

FINALLY, I come to the dance music which seems to cater for all tastes. All the latest popular hits have been recorded by well-known dance bands.

The latest Irving Berlin number from his film "Blue Skies," "You keep coming back like a Song," has been recorded by the Skyrocks Dance Orchestra, conducted by Paul Fenouillet on *H.M.V. BD5945*. The coupling is "Let it be Soon."

Other releases are "Strange Love" and "One More Tomorrow," by Tex Beneke with the Glenn Millar Orchestra on *H.M.V. BD5946*. "There's No One but You" and "Ah—Yes There's good Blues To-night," played by Tommy Dorsey and his Clambake Seven on *H.M.V. BD5944*. "This Heart of Mine" and "By the Sleepy Lagoon," played by Vaughan Monroe and his Orchestra on *H.M.V. BD5939*. "Pretending" and "You're Nobody," played by Victor Silvester and his Ballroom Orchestra, in strict dance tempo, on *Columbia FB3247*. "As Long as I Live" and "It's a Beautiful Day," by Carroll Gibbons and the Savoy Hotel Orpheans on *Columbia FB3237*, and finally "Sunrise Serenade" and "Missouri Waltz," by Frankie Carle and his Orchestra, on *Columbia FB3239*. This is the first Columbia recording featuring this orchestra.

OUR COVER SUBJECT.

OUR cover illustration this week shows the B.B.C. television cameras at work during the Remembrance Day ceremony at the Cenotaph. It will be noted that the vantage point is the same as that used by the Cinema News-cameras.

Open to Discussion

The Editor does not necessarily agree with the opinions expressed by his correspondents. All letters must be accompanied by the name and address of the sender (not necessarily for publication).

An Amateur's Views

SIR.—I heartily endorse G. C. Bagley's letter re DX listening.

Perhaps it has not occurred to your readers that logging stations of commercial concerns, whose power of several kilowatts is beamed more often than not towards this country, can hardly be called or rated an achievement. After all, where is there anything outstanding in listening to stations which are listened to all day, every day, figuratively speaking, by ordinary operators, as a job of work which has to be done.

In the case of the "ham" who uses precious little power, whose antenna arrangements depend on the size of his garden more often than not, one may feel that something has been achieved and something done when signals are logged and reported on, and a QSL card obtained. Both sides have reason for satisfaction. Two men with a hobby or carrying out experiments receive a kick out of things, and thereby are spurred on to greater things.

Remember, if you send a report to a "ham" you are sending it to an individual, a man who has built and is operating his own gear. If you send a report to a "commercial" you are sending it to a "Department," and the chances are that the operator in the latter case will never see it, and probably couldn't care less. In return if you are lucky you will get a purely formal reply or card written out by some poor, underpaid junior clerk.

My advice to listeners who want to make the most of their hobby is to concentrate on the "hams" especially on the higher frequencies, because they are so uncertain, and therein lies the spirit of adventure and romance which has always been the heart and soul of the British pioneer.—G. G. KENDALL, G3APA (Earlsdon).

Ceylon Reader's Thanks

SIR.—May I crave the hospitality of your columns for expressing the deep debt of gratitude to all those readers who responded to my appeal in the PRACTICAL WIRELESS.

I take this opportunity to remind all correspondents once again that all letters will be answered, and therefore please continue writing to the same address.

With best wishes.—MAHINDA WANIGASURIYA ("Siri Wasa," Mount Lavinia, Ceylon).

Local Contact Wanted

SIR.—I am interested in S.W. work generally and would be pleased if experimenters in this district would get in touch with me to exchange logs, circuits and aerial data, etc.

I should also like to correspond with anyone outside the British Isles on these matters.

Wishing your paper continued success.—ARTHUR F. WALTON (396, Moorside Road, Fagley, Bradford, Yorks.).

Odd Tuning Effects

SIR.—I shall be glad if any of your readers can give me the answers to two questions:

(i) What has happened to the power of the transmitter handling the 261.1 metre Light Programme in the Glasgow district? For some time now I have been unable to obtain satisfactory reception of this station on my home-made set (H.F.-Det.-R.C.C. coupled PM22A), though all other stations are perfectly satisfactory.

(ii) Will someone please explain the following queer phenomenon? Having tuned in to the Light Programme on 261.1 metres, I then advanced the differential

reaction condenser to increase volume. The result was no increase in volume of the Light Programme but, on advancing the condenser to a point just below oscillation, I was surprised to hear, loudly and distinctly, a French voice saying "Ici Londres," followed by the usual string of volubility.

Curiosities to note are:

(a) I always understood a differential reaction condenser did *not* affect tuning.

(b) There was no trace of the "Ici Londres" announcer except at just below the oscillation point, and no suggestion of the Light Programme when in this position. Neither programme appeared to butt in on the other, yet all that was changed to produce separate programmes was the movement of the reaction condenser, which is supposed *not* to affect tuning.

Is the answer that "Ici Londres" is a harmonic of a B.B.C. short-wave station, or is the effect due to the queer layout of my set, which is different from any other I've ever seen?

I've been experimenting with battery sets for some years on ideas culled from PRACTICAL WIRELESS, but this is the first set I've ever made completely from my own design and from old and odd components stripped from junk sets.

With many thanks for all your help over the years to constructors in the enjoyment of the best indoor hobby in the world.—K. G. RICHMAN (Glasgow).

Short-wave Results

SIR.—I have been a reader of your excellent journal for a long time, but I have not written before. Since being demobbed from the Forces I have renewed my pre-war DX listening. Until recently I have had a DX Economy Three, and very good results were obtained.

Last month I purchased a Philips PCRx communications receiver. I would very much like to hear from any reader who has one of these jobs, so as to compare reports, etc. At present I am using a 30ft. indoor aerial, but in the near future I will be trying out a few different types of aerials so as to obtain best results.

So if any DX enthusiasts care to write I would be only too pleased to hear from them.

Here are a few stations logged recently, mainly on 7 and 14 mc.s.:

B4HH	G5GK	WBOS
CKNC	G2QH	WLWS
C2RX	G8TY	WLWO
D4ANM	IcNI	W3LYQ
FAER	LA6W	W4DSY
G8AL	OZ4PA	WCAN
G8PO	OZ2H	W3BEC
G5SK	OX1Z	W3CPA
G5AU	SM7VI	W2MDQ
G5FA	WLWK	XAER
G4BB	WCBX	ZB1L
G8PT	WRUL	

—ROBERT G. PRIME (20, Livingstone Road, Palmers Green, London, N.13.).

A.C. versus D.C. Receivers

SIR.—If you will allow me to enter the camp and smoke a peace pipe with the "Experimenter" of Chailey, I would very much like to clear up one or two points arising out of his letter in your December issue.

I am well aware that the "Experimenter" did not include the word "impossible" in his letter of September. I concluded my first paragraph with that word, maybe ill-chosen. However, the object of using it was to

convey to the reader that it is not beyond the technical resources of radio engineering to voltage double with a D.C. supply.

I would like readers to note that my description of a piece of apparatus to convert D.C. into A.C. was the inverter.

The use of the term "D.C. transformer" was employed because it conveys more readily what an inverter does. Care was taken to put this term between inverted commas. I feared that it would be confused with the rotating machine, apparently with justification.

The fact that I appear to have fallen into a trap just shows that one must not jump too readily to conclusions. What was the trap? The "Experimenter" quite rightly maintains that the voltage doubler is essentially a circuit for A.C. input.

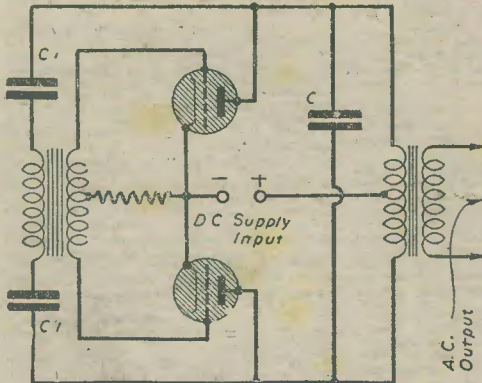

The "D.C. transformer" referred to in Mr. J. Copley-May's letter.

The careful reading of a letter before replying is an essential these days, as it is so easy to "trigger off" a mass of technically capable people who may each have a different interpretation of the subject.

I did not suggest that voltage doubling could be achieved with a D.C. "input" to the circuit. My contention is that a voltage doubler can be made to function from a D.C. "supply." That was made clear in my first letter.

I attach a circuit of an inverter—"D.C. transformer"—the functioning of which is almost self-explanatory.

The transformer on the left, which supplies a small A.C. voltage fluctuation (obtained by feedback through C1) drives the grids of the two valves alternately less negative. During alternate cycles each valve strikes and conducts, draws current and charges C. The top of C becomes alternately positive and negative with respect to the centre tap of the transformer. Therefore, A.C., voltage doubler for the use of.

I endorse the last paragraph of Mr. G. W. House's (December) letter, and most of the contents.—J. COPLEY-MAY (Richmond).

Correspondent Wanted

SIR,—Taking up DX listening again after a lapse of six years, for the past month, listening for about eight hours weekly, I have logged 168 Hams on 20 metres in 16 different countries. The set I am using is a 5-valve superhet (commercial) with a 16ft. 6in. aerial indoors, and all were heard on the loudspeaker. Included in the log are: CE1AR, LU7AZ, W4NRU, W4KAK, W4TM, W9CAC portable in Iceland, VE2DD, etc.

Through the medium of your excellent journal I would like to contact any readers who may have built or operated the 2½-watt transmitter, battery operated, described in this paper before the war.—JOHN V. LOVE (Stonewall, Bailieborough, Co. Cavan, Eire).

Hints to Manufacturers

SIR,—Why do not the manufacturers of radio parts and accessories cater more for the amateur here in England?

I have yet to see Fahnestock clips on sale. They are surely one of the greatest time-savers for an experimenter yet invented. We also require:

Small plastic boxes for meters, etc.

Plastic cabinets for radio sets, midget size upwards.

Metal speaker cabinets to match the metal set type.

Escutcheons, oblong, in various sizes for dials.

Escutcheons, round and square, from about 1½in. upwards. (These are badly needed for speakers and dial openings.)

Telescopic aerials for fixing in side of set from 6in. upwards, i.e., as in the "Handle-Talkie."

Books of service sheets such as those issued by the "Rider Manuals" in the U.S.A.; or is it that the circuits of some British sets are so skimmed that the makers do not dare to publish them? These are a few of the things we require—what about it, manufacturers?—A. W. J. MARSH (Newport, I.W.).

News from Jerusalem

SIR,—Your readers may be interested in the following:—

ZC1AR/2C6. This infamous station operated jointly by the writer and two other Servicemen was located in Palestine, near Jerusalem. As no licences were granted in Palestine at that time, we very stupidly used a ZC1 call. All cards to be sent to Box 360, Cairo, Egypt, for forwarding to the respective operators. SWL reports will be welcomed, provided they are detailed and sensible. QSLs will be sent to those of this nature.

ZC6FP was genuine at R.A.F. Station, Agir, Palestine.

JX calls are shortly to be issued to Servicemen in Palestine for 10, 5 and 2½ metres with maximum input of 50 watts. The calls shall have no figure, i.e., similar to XA calls. I expect to be JXJC.—"JACK" (Jerusalem).

Television Results in Northants

SIR,—The enclosed photograph, which is an enlargement of a 35 mm. "snap," may interest those readers who are following television trends outside the Alexandra Palace service area. The receiver is operated at Wellingborough in an extremely busy part of the town where car interference is at its worst. The receiver consists of a two-stage pre-amplifier tuned to the vision and sound frequencies, frequency changer common to vision and sound, four vision I.F.s and anode-bend rectifier feeding the tube, a 6in. electro-magnetic.

The amount of interference which can be tolerated on the picture without becoming too annoying is very much greater than that on sound. On the screen, car interference appears generally as white blobs and flashes, sometimes upsetting the frame synchronising, but the noise from the speaker is ear-splitting. Television has little opportunity of development from the viewers' point of view (no pin intended!) until some form of compulsory car suppression is brought into force. Everything depends on the activities of those readers whose reception areas lie outside the range adequately covered by Alexandra Palace and who are plagued by cars, cinemas, fans and other forms of television interference.—S. A. KNIGHT (Wellingborough).

[The photograph was not suitable for reproduction, but showed a remarkably "clear" screen.—ED.]

Radio Engineer's Vest Pocket Book

3/6, or 3/9 by post from

GEORGE NEWNES, LTD., Tower House,
Southampton Street, Strand, London, W.C.2

CLASSIFIED ADVERTISEMENTS
LITERATURE, MAPS, etc.

RADIO SOCIETY OF GREAT BRITAIN invites all keen experimenters to apply for membership. Current issue R.S.G.B. Bulletin "and details, 1/- below—

THE TRANSMITTING LICENCE. A new 32 page R.S.G.B. publication in the series "Amateur Radio," 9d., or 1/- post free; below—

AMATEUR RADIO HANDBOOK (300 pages), paper cover, 4/-; cloth, 6/6. Radio Handbook Supplement (140 pages), paper cover, 2/9; cloth, 5/-. R.S.G.B., 28-30, Little Russell Street, London, W.C.1.

WEST OF ENGLAND Amateur Radio Club, a club for short-wave listeners. Join now. S.A.E. for particulars to Hon. Sec., "Bosca Brea," Tregence, St. Issey, Cornwall.

MORSE & S.W. EQUIPMENT

"H.A.C." Short-wave Receivers. Famous for over ten years. Improved one-valve model now available. Complete kit of components, accessories, and full instructions, now 19/3, postage 9d. Easily assembled in one hour. S.A.E. for free catalogue.—A. L. Bachous, 109, Hartington Road, London, S.W.8.

KX-60V. Field-Morse and Telephone Unit with tapper and generator, new, in portable carrying cabinet, 25/- Universal, 221, City Road, London, E.C.1.

RECEIVERS & COMPONENTS

WRITE to us for your valves and test equipment, IR5, 174, 185 button valves, 14/-; 2S-A7, 6S-A7, AC-11H, 1299 valves, 14/-; PND4020, A2F/2DD valves, 15/3; MKT4, PenVA valves, 5 or 7 pin, 12/10. Many other types in stock, 6L6, 6N7, 6N8, etc. AVO model 7 test meters, 419/10.0. AVO AVO model 40 test meters, 217/10.0. AVO Universal Motor test meter, 29/10.0. AVO valve tester, 216/0.0. Other test gear available. New and guaranteed. Carriage paid, C.O.D. or cash with order.—Radio Sales & Services, 29/31, Southampton Row, W.C.1, H.Q. 4025.

THE last word in Radio Kits! Really detailed Instructional Manuscript how to build best type of A.C./D.C. 4-valve receiver, 2/6. Absolutely complete kit, inc. valves and super cabinet, 28. Advice free. All standard radio components supplied by return C.O.D. Our aim is a new, higher standard of Service.—Northern Radio Services, 66, Parkhill Road, London, N.W.3. Tel.: Gulliver 1453.

KITS, Kits, Kits. Two waveband. All mains 4 valve. Tube line up 6K7, 6V7, 2526, 25L6. Polished aluminium chassis. Really first-grade component standard dial. Delivered complete to last nut. Full wiring instructions. Price 27 8/0 C.W.O. or C.O.D.—Isherwoods, Remo House, Plungerton Road, Preston, Lancs. Tel.: 3348 Preston, Radio Repairs. Est. 1935.

OSCILLATOR KITS—all wave modulated. Includes new valves, components, chassis, coils and switches, ready wired and tested. A.C.-D.C. kit, 85/-. Battery kit, 55/-. Circuit and details of both, 1/6.—49, Booth Farm Road, Birmingham, 22.

FEKRANT, 3 a. Charger, 65/- or near. —Gode, Clifton, Potland, L.W.

RADIOLECTRON
22, Frances St., Scunthorpe, Lincs.
NEW GOODS ONLY

RESISTORS. All values, carbon, 1/2 and 1 watt, 5d. and 8d.; wire wound, 1 and 5 watt, 1/2 and 1/9; mica droppers, 2ad, taps and feet, 2 amp, 1,000 ohms, 4/-; 3 amp, 800 ohms, 4/3.

CONDENSERS. Tubular 350 and 500v. wkg., up to 0.06 mfd., 9d.; to 1.11d.; .25 and 5, 1/6; 1 mfd., 2/4; electrolytic, 500v, 4 mfd., 3/-; 8 mfd., 3/2; 8-8 mfd., 6/-; 25 mfd., 25v., 1/10; 50-50, 2 1/0; mica, up to .005 mfd., 1/- to .01, 1/3; tuned tuning, 2 gang, .005 mfd., 11/-, with trimmers 12/6.

VOLUME CONTROLS. All values, long spindles, 3/-; 4/6 with 3V wire wound, 2,000, 7,500, 10,000, 30,000 ohms, 3/6, less S.W. TRANSFORMERS. Intervalve, direct feed, ratio 3-1 or 5-1, 7/6.

VALVE HOLDERS. Brit. 4, 5, 7 pin, 6d.; Int. Oct. 7d. Grid clips, 1d. Screen caps, 8d. Eng. or Oct. Bakelite knobs, 1/4n. bore, 1/4n. 1/4n. dia., 9d.; 2 1/4n. 1/-; pointer, 9d. Wander plugs, spare terminals, red or black, 3d. Croc. clips, 2/4n. Many other bargains; please state your requirements enclosing S.A.E. Terms—Cash with order, post free over 10/-.

TELERADIO NEW COIL PACK—

Easing of export commitments enables us to offer home constructors the coil pack and accessories used in one model. A full set of practical and theoretical set of drawings have been prepared around the units, making it a simple matter to construct a really high gain all-wave superhet radiogram chassis up to commercial standards. A rust-proof fully drilled chassis made specially for the export model is offered with the coil pack. Prices are reasonable. Chassis with 5 Amphenol valve-holders and A.E. and P.U. sockets, all riveted in position, size 13 1/2 x 5 1/2 x 10 1/2 plus post; coil pack with circuit, 32/6 plus post. Coil pack with chassis, High Q I.F.'s and full blueprints, 70/- plus post. Blueprints and list of parts is supplied at 5/-. Note: All inducances are supplied ready aligned and calibrated to special dial available and no trimming is therefore necessary. Send stamp for any further details. Initial deliveries limited.—Teledradio (Dept. S.P.), 157, Fore Street, N.18, A.C./D.C. 5 v. Superhet Receiver. All-wave. Very attractive "Plastele" and encreed cabinets. Excellent reproduction and performance. Priced at 216 16s. Early delivery. Trade enquiries invited.—Morgan Osborne, Ltd., Southview Road, Warrington, Surrey.

25A7 OR 32L6 miniature valve urgently needed by service man overseas.—Box No. 132, Practical Wireless, Tower House, Southampton Street, W.C.2.

CHARLES AMPLIFIERS have pleasure in announcing the opening of their new premises. Customers old and new will be welcome to try our famous Amplifiers of exceptionally High Fidelity and Tuning Unit. The latest in High Fidelity Speakers, decorative Baffles and equipment and latest records. Blueprints of our 3- and 7-valve Cathode Follower Amplifiers, which are meeting with an extraordinarily enthusiastic response, and our newest Tuning Unit and a High Fidelity All-wave Superhet with full-size point to point wiring diagrams, 2/6 each, 5/- the set of three. Complete kits or separate components supplied. Stamp for details.—Charles Amplifiers, 1c, Palace Gate, Kensington, London, W.8. (One minute from the Albert Hall.)

THE NAME TO NOTE for all kinds of radio and electrical metalwork to specification, modern rustproofing, all shapes and sizes undertaken, and for tropical use. Components and sub-assemblies executed to meet recognised wiring and material standards. Consultation, advice without obligation: Write Dept. C3, Sea Rescue Equipment, Ltd., Chiltern Works, Colchester Road, Weymouth, Dorset.

MIDLAND RADIO COIL PRODUCTS. Manufacturers of Radio-frequency Inductances, Intermediate-frequency Transformers, Radio-frequency Chokes and Filters.

Our Specialised Knowledge is Completely at Your Service. We offer to the discriminating constructor, in addition to our "IQ" short-wave range of inductances of last month—

INTERMEDIATE - FREQUENCY TRANSFORMERS.—Matched pairs of I.F. transformers for 465 kc/s. designed for maximum gain and selectivity in the small screen dimensions of 3 1/2 in. high by 1 1/2 in. square. Dust plunger tuned, Litz winding type wire ends for easy assembly. Fixed tuning condensers are mounted inside the can, which is two-hole fixing to the chassis. Per pair, boxed, receiver tested and guaranteed, 14/-.

INTER-FREQUENCY COILS.—The "IQ" series for Short, Medium and Long Waves, 0.005 tuning swing. Supplied in 30 types, Aerial Q.A., H.F. QF and oscillator QO, for the standard ranges 15-50, 200-560, and 800-2,000 metres. Connections colour coded and circuit diagram included. Each, 2/-.

"IQ" SHORT AND ALL WAVE CHOKES.—R.F. Chokes, short-wave types covering 10 to 150 metres, 1/3. All-wave types, 2/3. Wire ends wound on polystyrene formers. First-class jobs.

MISCELLANEOUS.—Octal valve screens, 3 piece, complete, 10d.; Coil formers, 2in. by 1/4 in., undrilled, 6d. each. With tags riveted on, 8/6 tags, 9d. SPECIALISE in radio inducances and can produce any type of R.F. coil to your specification. Trade supplied. All orders post extra. C.O.D. MIDLAND RADIO COIL PRODUCTS, 13a, Silver Street, Wellingborough, Northants.

REWIND SERVICE.—

Transformers—Fields—Pickups—Speakers—New Cones and Speech Coils fitted—Armatubes—Vacuum Cleaners—Gram, and Fractional H.P. Motors. All work guaranteed and promptly executed. Special Terms to the Trade. Send S.A.E. for Price List and Radio Spares.—A.D.S. Co., 261-3-5, Lichfield Road, Aston, Birmingham.

All makes and kinds of Electrical and Radio Measuring Instruments repaired by skilled technicians, A.I.D. approved. All work quoted by return without charge. Also for sale, large variety of Voltmeters, Ammeters, Milli-ammeters, 2in. and 2 1/2 in. Dial, reconditioned, ex-Argon Military stock.—C. Gertler, Dept. E, 29-31, Cowcross St., E.C.1. Tel. Cle 6783.

REPAIRS to moving coil speakers, cones, coils fitted, field rewind or altered; speaker transformers, clock coils rewind, guaranteed satisfaction, prompt service.—L.S. Repair Service, 49, Trinity Rd., Upper Tooting, S.W.17. Phone: BALHAM 2359.

FENWICK for Aluminium Panels, 18in. x 8in., 14 gauge, 4/-; 18in. x 8in. 3/-; 18in. x 6in., 2/6. 18 gauge; post paid. Speaker gauge, 6in. square, 1/3. 12in. 2/9. 12in. 4/3. Postspeg, 18in. x 1 1/2 in. 5/16in. 21/-; or half size 10/-; 10 in. TRF coils with reaction, 1 or 2 m.a., 10/6. H.T. and L.T. units. Ex W.D. hand mikes with plug and switch, 9/-; transformers to suit, 6/-; Cake inserts, 3/-; post paid. Weymouth A-wave S.H. coils, 1/6 pair, on ready assembled coil pack, 35/6. M.L. TRF coils with reaction, 9/6 pair, circuits supplied post 6d. extra. We have the largest and most varied stocks of radio components in the Midlands. Pick-ups, Valves, Transformer, Chokes, Speakers 2in. to 12in., including W.B. Send us your enquiries. Circuits 8d. each, 2v. and 3v. Battery, 2v. A.C., 5v. A.C. S.Het, Multirange Test-ner, Radio Reference Handbook, 13/-; Amplifier Manual, 3/-; Service Manual, 2/9. Radio Constructors' Manual, 3/6; post paid, Single M.L. coils, with full drawing, 5/4. Whatever your wants write to Fenwick, Dept. E, Gt. Brickkiln Street, and Snowhill, Wolverhampton.

O. GREENLICK LTD. Bernards' Radio Reference Handbook No. 45, the final authority on radio, clothbound at 12/6; Test Gear Constructor, No. 43, at 12/6; Amplifier Manual, No. 41, at 2/-; Resistance Constructor, rotary, at 1/-; Constructor's Manual, No. 53, at 3/-; Radio Valve Manual, No. 30, at 3/6; Radio Service Manual, No. 44, at 2/6; Simplex Four diagrams, still the best 4-valve A.C./D.C. midset, at 4/6.

COILS. Weymouth All Wave Coil Pack at 465 kc/s. per matched pair, 19/6; Standard I.F.s, 465 kc/s, 15/-; M.L. wave coils, T.R.F. coils, per pair, 5/-; M.L. wave coils with reaction, boxed with circuit, 7/8; the latest iron-cored T.R.F. coils, M/L type, with adjustable iron cores, per pair, 10/6; Superhet coils, S.M.L. wave, per pair, 10/6.

CONDENSERS. Tubular 1, .05, .01 mfd. at 9d.; Mica .0001, .0002, .0005 mfd. at 9d.; .0037 mfd. at 1/-; Electrolytics, 8 mfd., 150 v., at 6/3; 200 mfd., 12 v., at 2/-.

DRIVES AND DIALS. Bicycle drive, 3/3; Slow-motion Drum Drive, 3/-; Square Plane, slow-motion drive assembly, complete with glass, escutcheon, etc., size of dial 4 1/2 in. x 3 1/2 in., each 11/6; Coloured all wave dials, Ivorine, 4in. x 3 1/2 in., 2/-; 5in. x 5 1/2 in., 2/6; Coloured M/L wave dials, transparent, 6in. x 5 1/2 in., 1/6.

CHOKES. "Ultra" midset smoothing chokes, 360 ohms, 40/50 m.a., 5/-; Midset ditto, 33/60 m.a., 5/6; standard ditto, 100 m.a., 8/6; heavy duty ditto, 150/200 m.a., 12/6.

POTENTIOMETERS. Wire Wound potentiometers, 50,000 ohms, 4/-; CHASSIS. All with speaker cut-out for 6in. speaker and all component holes, cadmium plated. The Simplex Four chassis, size 1 1/2 in. x 4 1/2 in. x 2 1/2 in., at 6/-; the "W5V" chassis, for the Weymouth Coil Pack, etc., size 1 1/2 in. x 5 1/2 in. x 2 1/2 in., at 6/6.

TRANSFORMERS. "Ultra" midset speaker transformer, at 5/-; midset ditto, at 5/-; Heavy duty P.P. output transformer, 6,000 A to A load, Tapped output, 7.5 and 15 ohms, each 21/-.

P.V.C. WIRE. P.V.C. connecting wire, 50ft. coils, at 3/-; SPEAKER GRILLES. Chrome wire mesh, 8in. x 8in., at 3/-.

NUTS/SCREWS. 4 and 6 BA. Per gross (2 cross in all), 6/6. "Ultra" Midset Comprehensive Lists monthly 21d. stamp, well worth having.—O. GREENLICK LTD., 3a, Baneroff Road, Cambridge Heath Road, London, E.1. Phone: STEELEY Green 1334.

FRED'S RADIO CABIN

EX R.A.F. 1155 Communication Receivers. Brand spanking new. Complete with all 10 valves. Straight from manufacturer. Not to be confused with the surplus shop soiled models previously advertised. Price £17/10 each. WW Modification leaflet for above, 6d. each.

1155 complete with Output Stage and Power Pack to work from A.C. mains 200-250 volts, £22/10/0 each. Demonstrated to callers. Above are sold under our usual money back or previously advertised guarantee.

ERC SMOOTHING CHOKES. 450 ohms, 20 h. 150 m.a., 25/-; 450 ohms, 20 h. 250 m.a., 27/6.

ERC MULTI RATIO output transformers. 30 watt, 22/6.

WODEN A.C. TRANSFORMERS. 200-250 v., 350-450 v., 780 m.a., 4 v. 4, 2 v. 21 a., 27/6, or with American Outputs, 6.3 v. 3 a. and 5 v. 2 a., price 27/6.

FORTHINGTON STEEL A.C. TRANSFORMERS. 200/250 v., 480-480 v., 250 m.a., 4 v. 6 a. C.T., 4 v. 4 a., 6.3 v. 5 a., 5 v. 3 a., price 65/- each.

WEYMOUTH ALL WAVE COIL PACKS. 3 wds as advertised and reviewed in P.W., with a pair of 465 kc/s. iron core ceramic I.F. coils, 45/- lot.

VALVE MANUAL. English and American valves, 3/6 copy.

ERC MULTI RATIO speaker transformers. Tapped, sec. and tapped primary, price 3/6 each. Power/Pentode L.S. Trans., 7/6. Midget L.S. trans., 4/2 to 1 ratio C.T. primary, 6/6.

SINGLE .0005 mfd. variable condensers. 4/6 each.

PANOLIN TAG STRIPS. 17 pairs tags for res. and conds., 1/6.

COLOUR CODE CHARTS. 1/- each. Save your eyes, time and temper.

ERC Dual range adjustable iron cored T.F. coils. Complete with circuit for A.C./D.C. midget set, price 3/6 per pair.

FRED'S RADIO CABIN, 75, Newington Butts, Elephant and Castle, S.E.11. (One minute from Tube.) Telephone: **RODNEY 2180.**

SOUTHERN RADIO'S WIRELESS BARGAINS.

LATEST RADIO PUBLICATIONS: *Radio Valve Manual.* Equivalent and alternative American and British types, with all data, 3/6. *Radio Circuits.* Fully illustrated receivers, power packs, etc., 2/-. *Amplifiers.* Fully descriptive circuits, 2/-. *Radio Coil and Transformer Manual.* 2/-. *Short Wave Handbook.* 2/-. *Manual of Direct Disc Recording.* 2/-. *Test Gear Construction Manual.* 1/6. *Radio Pocket Book.* Formulas, tables, colour code, etc., 1/- *Ten Hours for Radio Constructors.* 1/-. *Radio Reference Handbook.* Cloth bound, comprehensive and up-to-date, covering all branches of radio. 12/6. *American Service Manuals.* Sparton-Emerson, Crosley-Beimont (Parts 1 and 2), Stewart-Werner-Cada, Emerson. 12/6 per volume. *Radio Resistor Chart.* Colour codes at a flick, 1/- each. *Bulgin Radio Service Manual.* 2/6. *Radio Constructors' Manual.* 3/-. Postage extra.

VALXLEY Type 10-way Rotary Switches, 5/-. Tubular Condensers, 0.1+0.1+0.1 (cans), 2/6. Resistances, brand new, wire-ended, 1/ and 1 watt, assorted values, 30/- per 100; 1/2 watt only, assorted values, 20/- per 100; 1/4 watt, 22/6 per 100.

ACE "P.O." Microphones complete with transformer, usable with any receiver, 7/6. Permanent Crystal Detector, 2/6. Insulated Push Back Wire, 25 yards, 5/-. Insulated Sleeving, assorted sizes and colours, 3/6 per dozen yard length; Single Screened Wire, 7/6 per dozen yards; Twin Screened, 15/- per dozen yards. Aluminium Panels, un drilled 16 gauge, 18 inches x 7 inches, 3/6; 18 inches x 9 inches, 4/6. Ceramic and Faxoline Postage Stamp Trimmers, 30p., single, 1/3 each; double bank, 2/-. **Golden Harmer Power Rheostats** 30 ohms, 4/6. **Power Rheostats**, 10 ohms, 4/6. **LUBRA Adjustable Hole Cutter** for use on metal, wood and plastics, etc., 5/- each, including postage.

A Large Assortment of ex-Geonair Material in Stock.

R.A.F. 1155 Receivers available from Stock. These have been pre-tested and guaranteed. Complete with plug, 215 lbs., Carriage and Packing, 7/6 extra. Spare 1155 Plugs, 3/6.

SOUTHERN RADIO SUPPLY CO., 46, LISLE STREET, LONDON, W.C. Gerrard 6953.

VALLANCE'S OFFER

an inexpensive and useful CATHODE RAY OSCILLOSCOPE in kit form. Complete with power supply and all components for wire-base. Comprises special mains transformer. Input 200/230/250V. Primary screened 350-0-350V. 15 ma., 4v. 1 amp. 4v. 1 amp., 4v. 1 amp. C.T., 4v. 1 amp. Upright mounting with terminal panel. Price 41/-

17-pin Amphenol valveholder, 11d. each. 25-pin Amphenol valveholder, 1/- each. 17-pin Amphenol valveholder, 1/4 each. 1 Cathode Ray Tube Holder, 4/- 1-8-8 mid. 500v. can condenser and clip. 6/10. 4-2 mid. 1,000v. oil immersed paper condensers. 4/6 each. 1-1 mid. 1,000v. paper block condenser, 3/6.

TUBULAR CONDENSERS. 1,000v. 1 mfd. 1/6. 0.1 mfd. 1.4. .002 mfd. 10d. 500v. .0001 mfd. 10d. .05 mfd. 11. 2 50,000 ohm Potentiometers, 4/6 each. 1 25,000 ohm. 2/8. 1 20,000 ohm. 4/6. 1 1 megohm with switch, 6/6. 12 1 watt resistors 6d. each. 1 metal chassis, aluminium, 16in. x 10in. x 2in., 10/-. 4 Belling Lee Terminals, 1/2 each. 2 Belling Lee Terminal Mounts, 6d. each. 1 Pointer Knob 7d. 4 Fluted Knobs, 1/- each. 1 S.P.S.T. Toggle Switch 2/6. 1 box Resin Core Solder, 6d. 3 sheets 18in. x 18in. aluminium 18 s.w.g. for making case, 3/6 per sheet. 3 doz. 4BA x 1/4 in. nuts and bolts, 1/- doz. 2 doz. 4BA solder tags, 6d. doz. 12 yds. 18 s.w.g. VIE Wire 2d. yd. 6

VALVES FOR ABOVE, U.14, 11-, GTIC, 25-, W.42, 1210. Cathode Ray Tube, 70/- Immediate attention to all orders and assorted tags. Payment C.W.O. or C.O.D. whichever best suits you. When sending C.W.O. please include extra for packing and postage.

VALLANCE'S

144, Brigatte, Leeds, 1.

CIRCUITS "DORSET" SERIES

**NEW BATTERY SUPERHET
4-VALVE ALL DRY 3-WAVE
A.C./D.C. 5-VALVE 3-WAVE
SUPERHET**

**A.C./D.C. AMPLIFIER, 6-8 WATTS
A.C./D.C. 4-VALVE T.R.F. MEDIUM
WAVE WITH L.W. CONVERSION**

Manuscripts containing 5 or 6 pages of drawings, point to point wiring instructions, etc. 5/- each, post free. Theoretical circuit of superhets with price list, 2/6.

**WELDONA RADIO ACCESSORIES,
LTD., SWANAGE**

POST-WAR TELEVISION

The advance in Radio Technique will offer unlimited opportunities of high pay and secure posts for those Radio Engineers who have had the foresight to become technically qualified. How you can do this quickly and easily in your spare time is fully explained in our unique handbook.

Full details are given of A.M.I.E.E., A.M. Brit. I.R.E. City & Guilds Exams. and particulars of up-to-date courses in Wireless Engineering, Radio Servicing, Short Waves, Television, Mathematics, etc., etc.

We guarantee "NO PASS—NO FEE." Prepare for to-morrow's opportunities and post-war competition by sending for this very informative 112-page guide NOW—FREE and without obligation.

**BRITISH INSTITUTE OF
ENGINEERING TECHNOLOGY**
(Dept. 242),

17, Stratford Place, London, W.1.

COPPER instrument wire. Cotton-covered 1lb. reels, 18, 20, 22, 24g., 1/6; 25, 28g., 1/9; 30, 32g., 2/-; 34g., 2/3. Enamelled do. same prices including 36g., 2/3; 38, 40g., 2/6. Silk-covered 16g., 1lb. 5/-; 18g., 1lb. 7/-; 22g., 1lb. 2/6; 20z. reels, 24, 26, 28g., 1/6; 30, 32, 34, 36g., 1/9; 38, 40g., 2/-; 42g., 2/3; 44, 45g., 10z. 2/-. Laminated bakelite panels, 4in. thick, 6in. x 4in., 1/3; 6in. x 6in., 1/9; 6in. x 6in., 2/3; 10in. x 6in., 2/9; 10in. x 8in., 3/6; 12in. x 8in., 4/-. Ditto, 1/16in. thick, same sizes, 10d., 12, 1/6, 1/10, 2/4, 2/8. Polished Ebony panels, 2/3; 44, 45g., 10z. 2/-. Laminated set coils with 1/2" B.A. screws, gross useful sizes, 2/6; ditto, nuts, 2/6 gr.; assorted gross screws and nuts, 2/6; brass washers, 1/6 gr.; fibre washers, 1/6 gr.; assorted soldering tags, 2/6; assorted eyelets and rivets, 1/5 gr. New ex-G.P.O. hand telephone with microphone, switch and 6ft. cord, 12/6. Rubber-covered copper stranded wire, 11d., 21d. yd. Timed copper connecting wire, 20ft., 6d.; rubber-covered, 10ft., 2d. 24 core, 2/6. Stranded and single push-back wire, 12 yds., 2/3; resin cored solder, 1lb., 1/-. Lead-in tubes, 4in., 9d.; 6in., 1/-; 9in., 1/4. New "Lucerne" permanent crystal detector, 2/6. semi-perm. perikon detector, 2/6. "Lucerne" crystal coil with wiring instructions, 3/6; glass tube crystal detector, complete, 2/6. Single earphone, ideal for crystal sets, etc., 5/6. Reconditioned headphones, 4,000 ohms, complete, 2/6. All postage extra. Trade only. Post Radio Supplies, 33, Bourne Gardens, London, E.4.

RADIOGRAPHIC, LTD. (B.R.S. 12040), of Glasgow, are forging ahead in getting supplies of vital interest to all Radio Enthusiasts. Keep in constant touch for the latest news of their supplies, Transmitters, Transceivers, Valves (RX & TX), and all components.—Radio-graphic, Ltd., 66, Osborne Street, Glasgow, C.5.

FOR SALE.—AVO All-wave Oscillator, as new, £9/10/0. A.C. mains.—11, Edgeware Road, Birmingham, 23.

S.P.'s comm. rec., 12v., 6w.b. as new. Nearest £55. Box No. 133, "Practical Wireless," Tower House, Southampton Street, W.C.2.

PERFEX cabinets in pastel colours supplied to the trade. Own specification if desired. Enquiries invited.—Tresha Services, 33, Fleet Street, London, E.C.4. Cdn. 6163.

POWER TRANSFORMERS rewound from 15/6. E.H.T. television a speciality. All types O.P.; chokes, coils, and pick-ups repaired. New transformers to your specification.—North West Electrical, 21a Goldhurst Terrace, N.W.6.

SITUATIONS VACANT

"ENGINEERING OPPORTUNITIES"—FREE 112-page guide to training for A.M.I.Mech.E., A.M.I.E.E., and all branches of Engineering and Building. Full of advice for expert or novice. Write for free copy and make your future secure—B.I.E.T. (Dept. 242B), 17 Stratford Place, London, W.1.

TUITION

RADAR, WIRELESS, TELEVISION. Manual. Be prepared for tremendous peace-time developments. Students of both sexes trained for appointments in all branches of radio. Boarders accepted. Low fees, 2d. stamp for prospectus, Wireless College, Colwyn Bay.

PRACTICAL Training in Radio Physics. A three month Laboratory Course is now available at The British National Radio School, a long established and highly successful institution specialising in converting "Operators" and "Mechanics" into Radio Engineers. Correspondence Courses in Radar, Radio and Television. Ask for details of our unique "Four Year Plan" leading to Brit. I.R.E. and I.E.E. examinations with five City and Guilds certificates as interim rewards. Studies Director, B.N.R.S., 66, Addiscombe Road, Croydon, Surrey.

THE Tuitionary Board of the Institute of Practical Radio Engineers have available Home Study Courses covering elementary, theoretical, mathematical, practical and laboratory tuition in radio and television engineering. The text is suitable coaching matter for I.R.E. Service entry and progressive exams.; tuitionary fees at pre-war rates—moderate. The Syllabus of Instructional Text may be obtained, post free, from the Secretary, 20, Fairfield Road, Crouch End, N.8.

Practical Wireless BLUEPRINT SERVICE

SPECIAL NOTICE

THESE blueprints are drawn full size. The issues containing descriptions of these sets are now out of print, but an asterisk beside the blueprint number denotes that constructional details are available, free with the blueprint.

The index letters which precede the Blueprint Number indicate the periodical in which the description appears: Thus P.W. refers to PRACTICAL WIRELESS, A.W. to Amateur Wireless, W.M. to Wireless Magazine.

Send (preferably) a postal order to cover the cost of the Blueprint (stamps over 6d. unacceptable) to PRACTICAL WIRELESS, Blueprint Dept., George Newnes, Ltd., Tower House, Southampton Street, Strand, W.C.2.

PRACTICAL WIRELESS		No. of Blueprint	F. J. Cunn's A.C. Superhet 4	---	PW59*
CRYSTAL SETS			F. J. Cunn's Universal 41 Superhet 4	---	PW60
Blueprints, 6d. each.			"Quisitione" Universal Four	---	PW73*
1927 Crystal Receiver		PW71*			
The "Junior" Crystal Set		PW94*			
STRAIGHT SETS. Battery Operated.					
One-Valve: Blueprints, 1s. each.			One-valve: Blueprint, 1s.	---	PW88*
All-Wave Unipen (Pentode)		PW31A*	Simple S.W. One-valver	---	PW38A*
Beginners' One-valver		PW89*	Two-valve: Blueprints, 1s. each.		PW91*
The "Pyramid" One-valver (HF Pen)		PW93*	Midgel Short-wave Two (D, Pen)	---	PW30A*
Two-valve: Blueprint, 1s.		PW76*	The "Flat" Short-wave Two (D (HF Pen), Pen)	---	PW63*
The Signal Two (D & I P)		PW70	Three-valve: Blueprints, 1s. each.		PW68*
Three-valve: Blueprints, 1s. each.		PW37*	Experimenter's Short-wave Three (SG, D, Pow)	---	
Selectone Battery Three (D, 2LF (Trans))		PW45*	The Perfect 3 (D, 2 LF (RC and Trans))	---	
Summit Three (HF Pen, D, Pen)		PW49*	The Band-spread S.W. Three (HF Pen, D (Pen), Pen)	---	
Hall-Mark Cadet (D, LF, Pen (RC))		PW51*			
F. J. Cunn's Silver Souvenir (HF Pen, D (Pen), Pen) (All-Wave Three)		PW55*	PORTABLES		
Cameo Midgel Three (D, 2 LF (Trans))		PW56*	Three-valve: Blueprints, 1s. each.		
1936 Sonotone Three-Four (HF Pen, HF Pen, Westector, Pen)		PW57*	F. J. Cunn's ELF Three-valve Portable (HF Pen, B, Pen)	---	PW65*
Battery All-Wave Three (D, 2 LF (RC))		PW58*	Parvo Fly-weight Midgel Portable (SG, D, Pen)	---	PW77*
The Monitor (HF Pen, D, Pen)		PW59*	Four-valve: Blueprint, 1s.		
The Tutor Three (HF Pen, D, Pen)		PW60*	"Imp" Portable 4 (D, LF, LF (Pen))	---	PW86*
The Centaur Three (SG, D, P)		PW61*	MISCELLANEOUS		
The "Cult" All-Wave Three (D, 2 LF (RC & Trans))		PW62*	Blueprint, 1s.		
The "Rapid" Straight 3 (D, 2 LF (RC & Trans))		PW63*	S.W. Converter-Adapter (1/2 valve)	---	PW45A*
F. J. Cunn's Oracle All-Wave Three (HF, Det. Pen)		PW64*	AMATEUR WIRELESS AND WIRELESS MAGAZINE CRYSTAL SETS		
1938 "Triband" All-Wave Three (HF Pen, D, Pen)		PW65*	Blueprints, 6d. each:		
F. J. Cunn's "Sprite" Three (HF Pen, D, Det)		PW66*	Four-strand Crystal Set	---	AW427*
The "Hurricane" All-Wave Three (SGD, Pen), Pen)		PW67*	Lucerne Tuning Coil for A.W.427*, 6d.	---	AW444
F. J. Cunn's "Push-Button" Three (HF Pen, D (Pen), Det)		PW68*	1934 Crystal Set	---	AW450*
Four-valve: Blueprints, 1s. each.		PW69*	1500-mile Crystal Set	---	
Beta Universal Four (SG, D, LF, Cl. B)		PW70*			
Nelson Class B Four (SG, D (SG), LF, Cl. B)		PW71*	STRAIGHT SETS. Battery Operated.		
Fury Four Super (SG, SG, D, Pen)		PW72*	One-valve: Blueprint, 1s.		
Battery Hall-Mark 4 (HF, Pen, D, Push-Pull)		PW73*	B.E.C. Special One-valver	---	AW387*
"Acme" All-Wave 4 (HF Pen, D (Pen), LF, Cl. B)		PW74*	Two-valve: Blueprints, 1s. each.		
The "Admiral" Four (HF Pen, HF Pen, D, Pen (RC))		PW75*	Melody Ranger Two (D, Trans)	---	AW388*
		PW76*	Full-volume Two (SG det. Pen)	---	AW392*
		PW77*	A Modern Two-valver	---	WM409*
		PW78*	Three-valve: Blueprints, 1s. each.		
		PW79*	75 cc. S.G. 3 (SG, D, Trans)	---	AW412*
		PW80*	Lucerne Ranger (SG, D, Trans)	---	AW423*
		PW81*	Es. 3. Three Tube Luxe Version (S, D, Trans)	---	AW435*
		PW82*	Transportable Three (SG, D, Pen)	---	WM271
		PW83*	Simple-Two Tube (SG, D, Pen)	---	WM327*
		PW84*	Economy 4-tube Three (SG, D, Pen)	---	WM337
		PW85*	"W.M." 4-tube Standard Three (SG, D, Pen)	---	WM351*
		PW86*	23.38 Three (SG, D, Trans)	---	WM354
		PW87*	1935 25 cc. Battery Three (SG, D, Pen)	---	WM371
		PW88*	P.T.P. Three (Pen, D, Pen)	---	WM383
		PW89*	Certainty Three (SG, D, Pen)	---	WM396*
		PW90*	Miniature Three (SG, D, Trans)	---	WM400
		PW91*	All-wave Winning Three (SG, D, Pen)	---	
		PW92*	Four-valve: Blueprints, 1s. 6d. each.		
		PW93*	638 Four (SG, D, RC, Trans)	---	AW370
		PW94*	Maintained Four (SG, D, LF, Cl. B)	---	WM331
		PW95*	Lucerne Straight Four (SG, D, LF, Trans)	---	WM350
		PW96*	25.56 Battery Four (HF, D, 2LF)	---	WM361*
		PW97*	The H.K. Four (SG, SF, D, Pen)	---	WM364*
		PW98*	The Auto Straight Four (HF, Pen, HF, Pen, DDT, Pen)	---	WM464*
		PW99*	Five-valve: Blueprints, 1s. 6d. each.		
		PW100*	Super-quality Five (2HF, D, RC, Trans)	---	WM320
		PW101*	Class B Quadradyne (2 SG, D, LF, Class B)	---	WM386
		PW102*	New Class B Five (2 SG, D, LF, Class B)	---	WM344
		PW103*			WM340
		PW104*	Mains Operated		
		PW105*	Two-valve: Blueprints, 1s. each.		
		PW106*	Consoelectric Two (D, Pen) A.C.	---	AW403*
		PW107*	Economy A.C. Two (D, Trans) A.C.	---	WM386
		PW108*	Three-valve: Blueprints, 1s. each.		
		PW109*	Home Lover's New All-Electric Three (SG, D, Trans, A.C.)	---	AW383*
		PW110*	Mantovani A.C. Three (HF, Pen, D, Pen)	---	WM374*
		PW111*	213.35 1936 A.C. Radiogram (HF, D, Pen)	---	WM401*
		PW112*	Four-valve: Blueprints, 1s. 6d. each.		
		PW113*	All-Metal Four (2 SG, D, Pen)	---	WM329
		PW114*	Harris' Jubilee Radiogram (HF, Pen, D, LF, P)	---	WM395*

SUPERHETS			
Battery Sets: Blueprints, 1s. 6d. each.			
Versity Four	---	WM395*	
The Request All-Waver	---	WM407	
Main Sets: Blueprints, 1s. each.			
Heptode Super Three A.C.	---	WM359*	

PORTABLES			
Four-valve: Blueprints, 1s. 6d. each.			
Holiday Portable (SG, D, LF, Class B)	---	AW393*	
Family Portable (HF, D, RC, Trans)	---	AW447*	
Tyers Portable (SG, D, 2 Trans)	---	WM397*	

SHORT-WAVE SETS. Battery Operated			
One-valve: Blueprints, 1s. each.			
S.W. One-valver for America	---	AW429*	
Roma Short-Waver	---	AW452*	
Two-valve: Blueprints, 1s. each.			
Ultra-short Battery Two (SG, det. Pen)	---	WM402*	
Home-made Coil Two (D, Pen)	---	AW450	
Three-valve: Blueprints, 1s. each.			
Experimenter's 5-metre Set (D, Trans, Super-regen)	---	AW438	
The Carrier Short-waver (SG, D, D)	---	WM390*	
Four-valve: Blueprints, 1s. 6d. each.			
A.W. Short-wave World-beater (HF, Pen, D, RC, Trans)	---	AW436*	
Standard Four-valver Short-waver (SG, D, LF, P)	---	WM388*	
Superhet: Blueprint, 1s. 6d.			
Simplified Short-wave Super	---	WM397*	

Mains Operated			
Two-valve: Blueprints, 1s. each.			
Two-valve Mains Short-waver (D, Pen), A.C.	---	AW453*	
Three-valve: Blueprints, 1s.			
Emigrator (SG, D, Pen) A.C.	---	WM392*	
Four-valve: Blueprints, 1s. 6d.			
Standard Four-valve A.C. Short-waver (SG, D, RC, Trans)	---	WM391*	

MISCELLANEOUS			
S.W. One-valve Converter (Price 6d.)	---	AW329	
Enthusiast's Power Amplifier (1/8) Lister's 5-walt A.C. Amplifier (1/8)	---	WM387*	
Radio Unit (2v.) for WM392 (1/2)	---	WM398*	
Harris Radiogram battery amplifier (1-1/2)	---	WM399*	
De Luxe Concert A.C. Electrogram (1-1/2)	---	WM403*	
New Style Short-wave Adapter (1-1/2)	---	WM386	
Short-wave Adapter (1-1/2)	---	AW456*	
B.L.D.L.C. Short-wave Converter (1-1/2)	---	WM405*	
Wilson Tone Master (1-1/2)	---	WM406	
The W.M. A.C. Short-wave Converter (1-1/2)	---	WM408*	

HINTS COUPON

This coupon is available until January 6th, 1947, and must accompany all Practical Hints.

PRACTICAL WIRELESS, January, 1947.

All applications respecting Advertising in this Publication should be addressed to the ADVERTISEMENT DIRECTOR, GEORGE NEWNES, LTD., Tower House, Southampton Street, Strand, London, W.C.2. Telephone: Temple Bar 4363.

CONDITIONS OF SALE AND SUPPLY: This periodical is sold subject to the following conditions, namely, that it shall not, without the written consent of the publishers first given, be lent, re-sold, hired out or otherwise disposed of by way of Trade except at the full retail price of 9d.; and that it shall not be lent, re-sold, hired out or otherwise disposed of in a mutilated condition or in any unauthorised cover by way of Trade; or affixed to or as part of any publication or advertising, literary or pictorial matter, whatsoever.

'AVO'

Registered Trade Mark

Precision
ELECTRICAL
TESTING
INSTRUMENTS

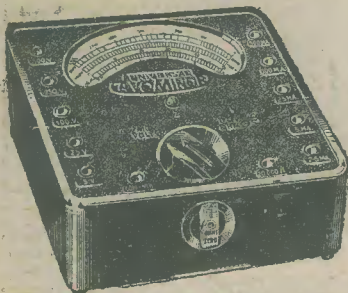

The UNIVERSAL AVOMINOR Electrical Measuring Instrument

A small but highly accurate instrument for measuring A.C. and D.C. voltage, D.C. current, and also resistance. It provides 22 ranges of readings on a 3-inch scale, the required range being selected by plugging the leads supplied into appropriately marked sockets. An accurate moving-coil movement is employed, and the total resistance of the meter is 200,000 ohms.

The instrument is self-contained for resistance measurements up to 20,000 ohms, and, by using an external source of voltage, the resistance ranges can be extended up to 10 megohms. The ohms compensator for incorrect voltage works on all ranges. The instrument is suitable for use as an output meter when the A.C. voltage ranges are being used.

Supplied complete with leads, testing prods, crocodile clips, and instruction booklet.

Size: 4 3/4" x 3 3/4" x 1 1/2"

Nett weight: 18 ozs

D.C. Voltage	A.C. Voltage
0-75 millivolts	0-5 volts
0-5 volts	0-25 "
0-25 "	0-100 "
0-100 "	0-250 "
0-250 "	0-500 "
0-500 "	
D.C. Current	Resistance
0-2.5 milliamps	0-20,000 ohms
0-5 "	0-100,000 "
0-25 "	0-500,000 "
0-100 "	0-2 megohms
0-500 "	0-5 "
	0-10 "

Sole Proprietors and Manufacturers:—

AUTOMATIC COIL WINDER & ELECTRICAL EQUIPMENT CO., LTD.
Winder House, Douglas Street, London, S.W.1

Phone: VICTORIA 3404-9

WHERE
YOU
NEED
IT!

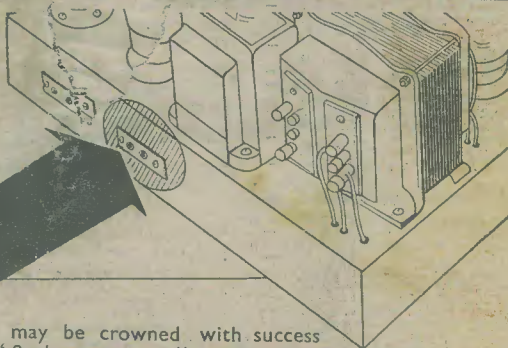

So that your endeavours may be crowned with success your selection of the "final component" needs just as much discrimination as do the other details of your circuit. Stentorian speakers are specially designed to match any desired impedance. As you listen to the faithful reproduction from your Stentorian, you will be delighted at the results you are obtaining. Ask your dealer to demonstrate.

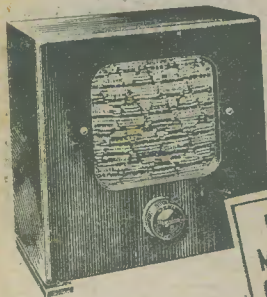

PERMANENT
MAGNET MOVING
COIL SPEAKERS

Stentorian

THE FINEST EXTRA SPEAKER FOR ANY SET

PRICES

Minor Type MX (for Low Impedance Extension) -	39/6	Baby Type BX (for Low Impedance Extension) -	53/6
Minor Type MC (with Universal Transformer) -	45/6	Baby Type BC (with Universal Transformer) -	69/6

WHITELEY ELECTRICAL RADIO CO. LTD., Mansfield, Notts.

Published on the 7th of each month by GEORGE NEWNES, LIMITED, Tower House, Southampton Street, Strand, London, W.C.2, and printed in England by W. SPEAIGHT & SONS, LTD., Exmoor Street, London, W.10. Sole Agents for Australia and New Zealand: GORDON & GOTCH (A/sia), LTD. South Africa: CENTRAL NEWS AGENCY, LTD. Subscription rates including postage: Inland 10s. 6d. per annum; Abroad 10s. per annum. Registered at the General Post Office for the Canadian Magazine Post.