

**HOW MANY L.F. STAGES?**—See page 483.

# Practical and Amateur Wireless

**3<sup>d</sup>**  
EVERY  
WEDNESDAY

Edited by F.J. CAMM

a GEORGE  
NEWNES  
Publication

Vol. 10, No. 255.  
August 7th, 1937.

AND PRACTICAL TELEVISION

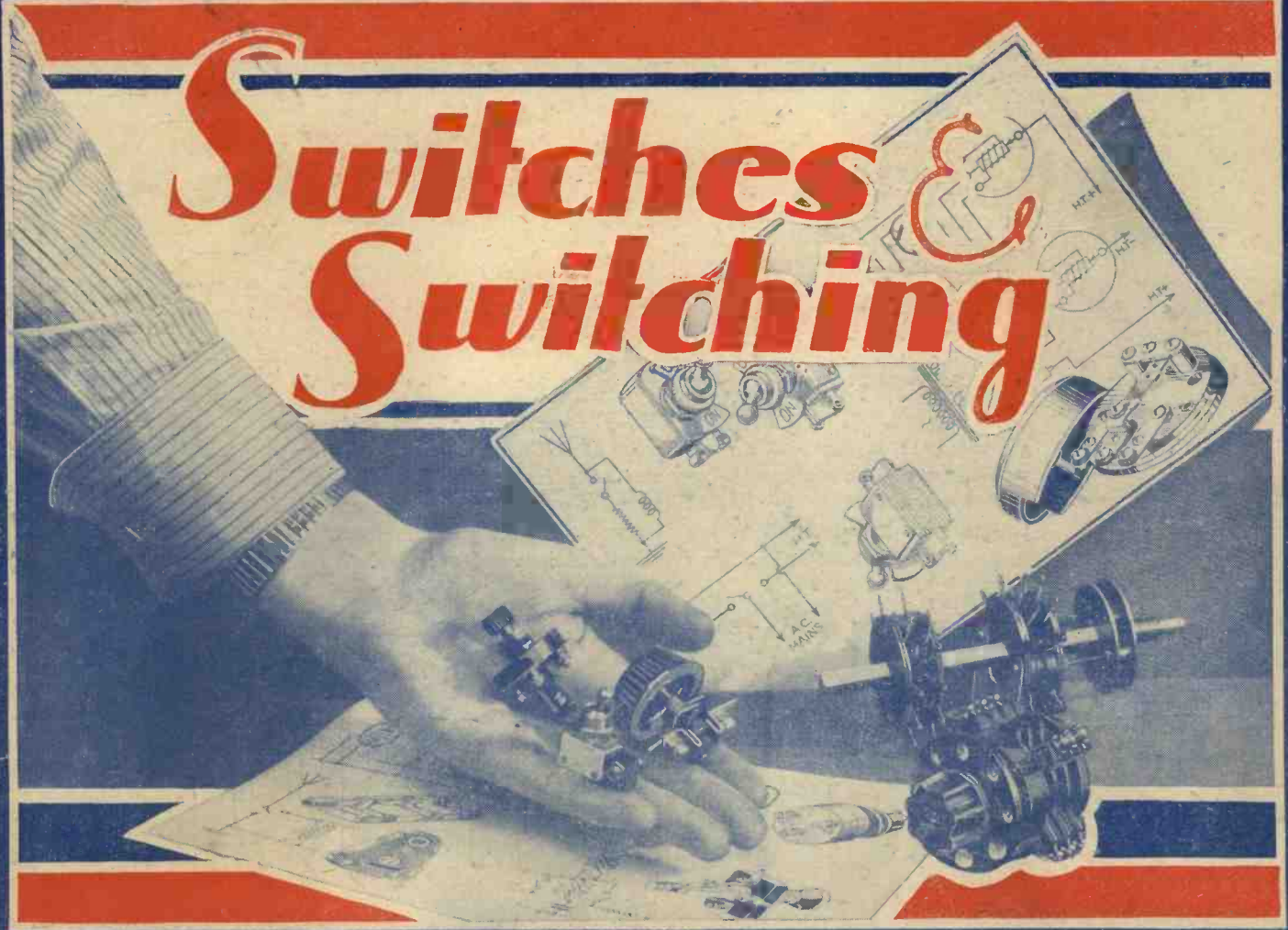

**THE WIRELESS CONSTRUCTOR'S ENCYCLOPÆDIA**  
By F. J. CAMM (Editor "Practical and Amateur Wireless.")

Wireless Terms and Definitions stated and explained in concise, clear language by one of the best known and most popular designers and writers of the day. Profusely illustrated. A veritable treasury of wireless knowledge and literally invaluable to all who are interested in the science whether as amateurs or experts.

Fully  
illustrated

**NEWNES**

FROM ALL BOOKSELLERS  
or 5/6 post free from Tower House, Southampton Street, Strand, W.C.2.

**LONDON**

Only  
**5/-**  
net



The August "POPULAR FLYING" contains a detailed review of all that is new in air warfare. It also includes never-before-published photographs of new types of aircraft used by the R.A.F. Apart from service flying there is a fully illustrated description of the Empire Flying Boat which is revolutionising air transport, and numerous articles on aviation at home and overseas.

# POPULAR FLYING

**THE NATIONAL AVIATION MAGAZINE**  
of all Newsagents and Bookstalls, or by post 7½d. from the  
Publisher, C. Arthur Pearson, Ltd., Tower House, Southampton  
Street, Strand, London, W.C.2.

**6<sup>D.</sup>**  
**AUGUST**

# A SIMPLE FREQUENCY METER See page 496



## Practical

## and Amateur

## Wireless

Edited by F. J. CAMM

Technical Staff:  
W. J. Delaney, H. J. Barton Chapple, Wh.Sch.,  
B.Sc., A.M.I.E.E., Frank Preston.



VOL. X. No. 255. August 7th, 1937.

## ROUND *the* WORLD of WIRELESS

### Switches and Switching

**S**WITCHES are amongst the most important parts of a modern receiver, and in too many cases the set-builder is content to obtain the cheapest component without consideration for the actual work which it has to carry out. Accordingly he is faced with troubles almost from the start, and in many cases a defective switch can introduce difficulties which are very hard to trace. There are so many different types of switch that the beginner might well be pardoned for failing to understand the differences, and on page 492 this week we endeavour to clear up some of the difficulties by explaining the various purposes for which the switches are used, together with illustrations showing the circuits and types of switch which are most suitable. It should be remembered, however, that where exposed contacts are employed, they should be kept clean but not oiled, as this will result in a bad contact. Furthermore, any cleaning which has to be carried out should be on the lines indicated in the article so that metal dust does not find its way into moving parts of the receiver and thereby give rise to further troubles.

### "Next Please"

**A** HIGH-SPEED variety programme will be heard in the National programme on August 4th, and will have the title "Next Please." It will include old and new artists and an important feature is that the supporting orchestra will be the new combination formed for Stage purposes by Bram Martin, who has been associated for a long time with the Holborn Restaurant. This will be the first radio appearance of the new orchestra.

### "Fats" Waller

**I**N the Northern programme on August 10th, a gramophone recital of the works of this coloured pianist will be given. He has a large following in this country, although he is known only by his records, and musical experts differ in their opinions concerning his work. Listeners will be able to form their own opinions after hearing this programme.

### Camp Fire Concert

**T**HE Public Secondary Schools' Cadets close their camp at the Hunting Butts Farm, Cheltenham, with a sing-song, and

part of this will be broadcast in the Midland programme on August 9th. George Gibbs, the Wolverhampton baritone, who has frequently broadcast, is in charge of the camp entertainments, as well as being Hon. Sec. of the Public Secondary Schools Cadets' Association, and there are over a thousand cadets attending this particular camp.

### Moscow's New Broadcasting House

**I**T is claimed that the main studio at Moscow, now nearing completion, will be the largest in the world. It will have an

to any seat of alarm and protect the animals. The microphones were the very small Brush components, ideally suited for such a purpose.

### Football Broadcasts

**T**HE B.B.C. announces that it has now been agreed that running commentaries on certain association football matches will be given during the 1937-1938 season. The Council of the Football Association have agreed to the recommendation that broadcasts of the following events take place: The Final Tie for the English Cup, on April 30th, 1938; the International match between England and Scotland, on April 9th, 1938; and the F.A. Charity Shield match in October, 1937. In addition, permission in principle is also granted for commentaries to be broadcast on mid-week International matches and replayed semi-final Cup Ties. Commentaries on other replays of Cup Ties during the season will be broadcast with the consent of the clubs concerned.

### Week-end Away

**O**N August 12th, in the series entitled "Week-end Away," a motorist, a cyclist and a walker will give some routes for those who are leaving Truro to explore the surrounding countryside. This popular series of talks in the Western programme has proved particularly useful for holiday-makers, and centres already dealt with include Bristol, Bournemouth, Swindon and Exeter.

### Music Items

**M**USIC plans for the remaining part of the summer season include the following main features. An eight-weeks' season of Promenade Concerts will be given as usual in the Queen's Hall from August 7th to October 2nd. The B.B.C. Symphony Orchestra, with 90 players, will be conducted by Sir Henry J. Wood.

In light music two series will be devoted to (a) dance music of the sixteenth, seventeenth, eighteenth and nineteenth centuries, entitled respectively "At the Court," "On the Green," "In the Theatre," "In the Ballroom"; and (b) music by violinists of the seventeenth, eighteenth, nineteenth, and twentieth centuries, from Tartini to Heifetz.

ON OTHER PAGES.	
	Page
How Many L.F. Stages ?	483
Transmitting Topics	485
On Your Wavelength	487
Installing a Powerful Receiver	489
Readers' Wrinkles	491
Switches and Switching	492
Practical Television	494
A Simple Frequency Meter	496
Short-wave Section	497
Readers' Letters	501
Queries and Enquiries	503

area of approximately 600 square yards and will be 30ft. high. It will accommodate an orchestra of 250 performers, together with an audience of 350.

### Radio and the Foxes

**F**ROM America we hear of another adaptation of the microphone and amplifier circuit. This time it is being used for the protection of foxes on farms where these animals are reared for their pelts. To prevent the destruction of the young by other animals, microphones of the crystal type were erected in the various nest houses and a central listening post provided. This eliminated the necessity of an attendant continually patrolling the farm and enabled him better to go quickly

# ROUND the WORLD of WIRELESS (Continued)

## Listeners' Panel

FOLLOWING the B.B.C.'s invitation to interested listeners to join in criticising a series of six fortnightly Cinema Talks, a large and representative panel has been formed.

The response to the invitation was immediate and enthusiastic, and more than a thousand persons in widely differing walks of life will provide what should prove a valuable cross-section of public opinion. Two talks have already been given, and the subsequent dates and speakers are as follow:—

August 15th: F. Andrew Rice.  
August 29th: Graham Greene.  
September 12th: William Farr.  
September 26th: Miss C.A. Lejeune.

## "Green Fingers"

A RADIO-REVUE on Gardens and Gardeners entitled "Green Fingers," has been adapted from the book of the same name by Reginald Arkell, and will be produced by Francis Dillon on August 9th in the Western Programme. The book and lyrics are by Reginald Arkell and Dorothy Worsley, and the music by Mai Jones.

## Two Seaside

### Orchestras

POPULAR orchestras with popular conductors and leaders are to entertain the Northern radio audience on August 8th, when both the Whitby Municipal Orchestra and the Scarborough Spa Orchestra are "on the bill." In the case of the concert by the Whitby players, conducted by Frank Gomez, the audience will, in fact, be far bigger than an ordinary Northern one, for this lunch-time concert is being taken by the National programme. The orchestra at the Spa, Scarborough, which will be heard—this time by Northern listeners only—in the evening, is conducted by Kneale Kelley, who needs no introduction to B.B.C. listeners.

## "Glamour"

A CONCERT party presented by Harry Benet from the Alexandra Gardens, Weymouth, will broadcast in the Western programme on August 10th. The Cosmopolitan Band, directed by Cyril Dawson, will play.

## Orchestral Concert from Bournemouth

JACK GREENSTONE and his Orchestra will broadcast from Bright's Restaurant, Bournemouth, on August 10th. Jack Greenstone formed this orchestra three years ago, and limits himself to playing popular classics and light music by British composers. Two members whose work attracts attention are Frank Senior, who

## INTERESTING and TOPICAL NEWS and NOTES

plays sleigh bells, and Austin Jowett, who gives accordion solos. These two artists also play piano duets, and Austin Jowett is arranger for the orchestra.

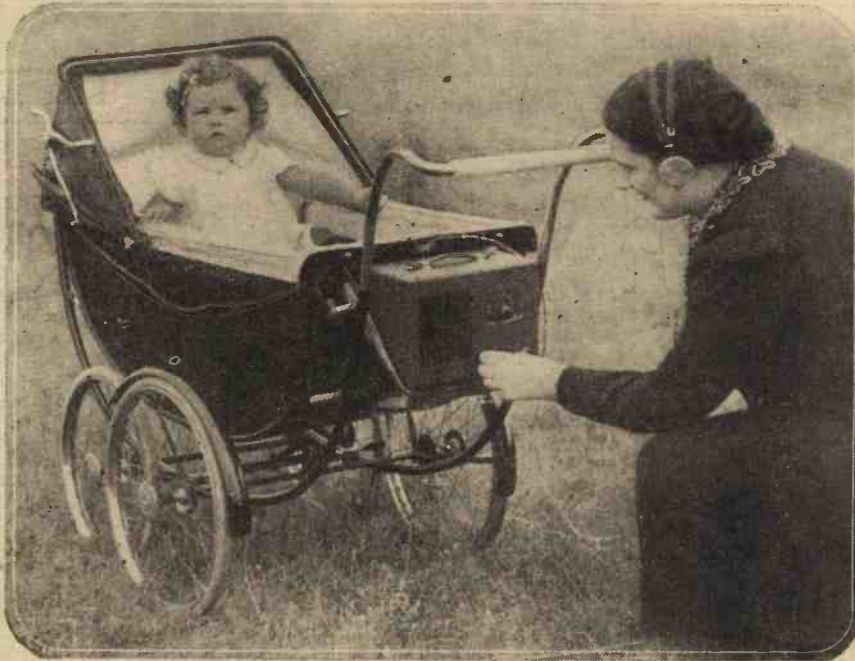

"She shall have music wherever she goes" appears to be the motto of this resident at Kingsgate, Kent, who has devised this unusual idea of attaching a portable wireless set to her baby's perambulator so that she can enjoy music while taking the baby out for walks in the park.

## Cinema Organ Recital

THE three-manual Christie organ which was specially designed for the Plaza Theatre, Rugby, was frequently heard in

## SOLVE THIS!

### PROBLEM No. 255

Jones bought a moving-coil speaker having a 6 volt 1 amp. field winding. Having an old transformer on hand with an output winding rated at 6 volts, 1 to 2 amps, he decided to use this for energising the speaker field winding. Why were results unsatisfactory? Three books will be awarded for the first three correct solutions opened. Address your solutions to the Editor, PRACTICAL AND AMATEUR WIRELESS, Tower House, Southampton Street, Strand, London, W.C.2. Envelopes must be marked Problem No. 255 in the top left-hand corner, and must be posted to reach this office not later than the first post on Monday, August 9th, 1937.

### Solution to Problem No. 254

The I.F. valve of Spicer's receiver was oscillating. Reception seemed very good on the short-wave band because C.W. morse signals were being picked up. The following readers successfully solved Problem No. 253, and books are accordingly being forwarded to them: F. Gott, Jowneley, Pine View Road, Verwood, Nr. Bournemouth; R. J. Cox, 14, Gyllyngdune Gardens, Seven Kings, Hford, Essex; W. T. Dean, 51, Park Road, East Hill, S.W. 19.

the radio programmes when Frank Newman was organist there. He has now been succeeded by John Bennett, one of whose recitals there will be broadcast for the first time on August 12th in the Midland Regional programme.

## Popular Classics for Orchestra

SCHUBERT'S "Unfinished" Symphony (No. 8 in B minor) will be one of the six popular orchestral compositions which the B.B.C. Scottish Orchestra will play under Kemlo Stephen on August 9th. The others will be the "Ruy Blas" Overture by Mendelssohn; "Moto Perpetuo" by Johann Strauss; the Ballet Music from Faust, by Gounod; and "The London-derry Air" and "Shepherd's Hey," by Grainger.

## Coltness Works

### Band

ONE of the oldest brass bands in Scotland, Coltness Works Band, will broadcast a programme of four pieces on August 14th, under the baton of George Hawkins. It will play a march, "Kimberley," by an anonymous composer; the overture to "The Magic Flute" (Mozart); "Kirkconnel Lea" (arranged by G. J. Grant); and a Rhapsody, "Lord of the Isles" (Rimmer).

John Arnott will play the trombone solo in "Kirkconnel Lea," and in the same programme C. Archer Mitchell (entertainer) will appear.

## Concert from Plymouth

A CONCERT by Foden's Works Band, with Harry Moreton at the organ, will be broadcast from the Guildhall, Plymouth, on August 12th in the Western programme.

## The "Fol-de-Rols"

FOLLOWING the great success last year of the broadcast given by three different companies of the Fol-de-Rols in one programme, Harry S. Pepper is arranging a similar broadcast this year but on a bigger scale. The programme, which will run for seventy minutes, will be broadcast from Eastbourne, Llandudno, Sandown (Isle of Wight) and Hastings by the respective "Fol-de-Rols" concert parties at these places. This broadcast will be given in the National programme on August 12th.

## Concert from Leamington

MILLICENT WARD, of East Retford, Nottinghamshire, will be the vocalist with Jan Berenska and his Orchestra in a concert on August 7th from the Pump Room, Leamington Spa. She will sing songs by Richard Strauss, German and Sullivan. The orchestral music will include Brownsmith's arrangement of "Musical Comedy Favourites."

# How Many L.F. Stages?

This Question is One Which Is Often Debated in the Mind of the Constructor, and It Is Here Analysed from the Practical Point of View. By FRANK PRESTON

It used to be a common idea that the more L.F. stages that were used, the greater the output volume must be. There is, of course, a certain amount of justification for that, but the statement calls for a good deal of qualification. Paradoxical as it may seem, it is not impossible for the volume to be reduced by the addition of an extra stage of L.F. amplification. There are various reasons for this, one of which is that if a valve is overloaded it might be partially "paralysed" or "saturated." In the case of a battery set there is another reason, which is that the batteries might have an insufficient output to feed all of the valves properly, with the result that none of them can operate at full efficiency.

### Calculation and Experience

The subject of valve loading and overloading is a complicated one. We can calculate just how great a signal voltage a valve can be given without its being overloaded; we can also calculate the optimum signal voltage input and the corresponding output. But the calculations are never easy to carry out, largely because there is a large number of factors which have to be taken into consideration. In consequence, the average amateur constructor and experimenter finds it better to use "rule-of-thumb" methods, these being assisted by the results of experience.

Perhaps it will be best to take a few simple examples, referring principally to battery receivers in the first place. Most of our conclusions can be applied to mains receivers, since the principles are the same. It is fairly safe to say that the L.F. circuit shown in Fig. 1 is the most popular to-day, as far as the simpler types of receiver are concerned. The detector valve is coupled to a power pentode by means of a parallel-fed transformer or auto-transformer. By using a transformer which gives a step-up

ratio of about 1 to 5 an appreciable voltage step-up is obtained in the coupling circuit, whilst the amplification afforded by modern high-efficiency pentodes is extremely high.

### Adequately Loaded

By using a pentode of this type (the Cosor 220 HPT is a good example), the maximum undistorted output of that valve can be obtained on the nearer transmitters,

But when using the simple diode in a circuit of this nature, there is much to be said for the use of two L.F. stages, as shown in Fig. 2. A more convenient alternative is to use a double-diode triode followed by either a pentode, as in Fig. 1, or by a push-pull stage, as in Fig. 3. In the latter circuit a triode detector is shown prior to the push-pull circuit, but this might well be replaced by the L.F.-triode portion of the D.-D.T. valve.

### Value of Push-pull

Of the two arrangements mentioned, the push-pull one is preferable, for it gives better quality and also permits the use of a much larger output. When using the pentode, the volume-control potentiometer shown in Fig. 2 would be almost essential, although it need not be used before the push-pull stage, provided that another system of volume control were incorporated in the set. It is worthy of mention at this point that push-pull does not—in theory, at any rate—provide any more amplification than could be obtained from one of the valves used in a normal transformer-coupled amplifier. In practice, it is frequently found that the greater efficiency of push-pull results in a higher gain. The main advantage of push-pull, however, is that the maximum undistorted output which it can provide is greater than twice that of one of the two valves; it is about 2½ times as great. Thus, if a single valve has a maximum output of, say, 300 milliwatts, two such valves used in push-pull can give an output of approximately 750 milliwatts. Take care that you do not confuse output and amplification.

### Single Stage Preferred

From what has been written, it might appear that a single L.F. stage is usually to be preferred. In my opinion, for the amateur constructor, it is, although ideas vary on this point.

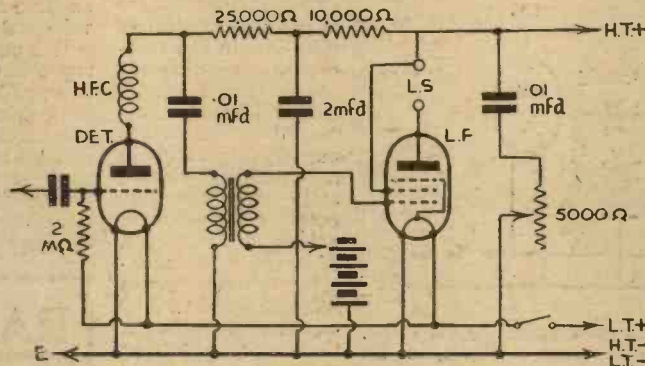

Fig. 1.—The most popular type of L.F. amplifier for a battery set. The triode detector feeds a high-efficiency pentode through a parallel-fed transformer.

even when there is no H.F. amplification prior to the detector. This, of course, assumes the use of reaction, for this considerably increases the output from the detector stage. When a single efficient high-frequency valve is used before the detector, the output valve can be fully loaded with the signals from a fair number of stations. In fact, it is often necessary to turn down the H.F. volume control to prevent overloading when listening to the local stations.

If the receiver is of the superhet type, the detector being preceded by an I.F. stage and the frequency-changer, a mild form of A.V.C. is to be preferred if overloading is to be avoided. Even when using a diode detector it is often possible fully to load the output pentode when using the simple form of L.F. amplifier under consideration.

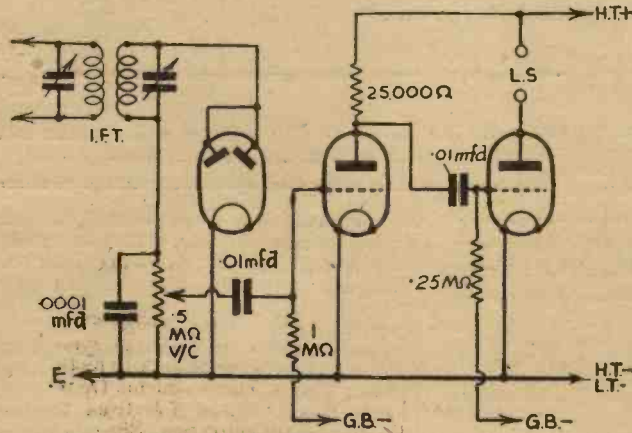

Fig. 2.—Skeleton circuit of a double L.F. amplifier suitable for use after a diode in a battery superhet. A double diode valve is shown, but is used as a single diode by joining together the two anodes. A.V.C. connections are omitted for simplicity.

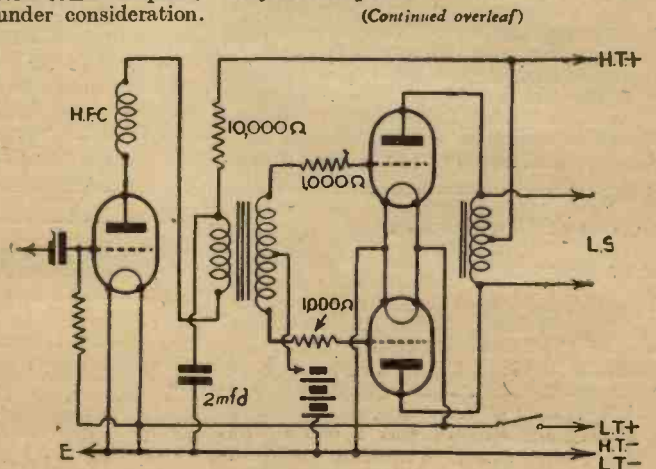

Fig. 3.—A push-pull amplifier which can be used directly after the detector, no matter what its type.

(Continued overleaf)

HOW MANY L.F. STAGES?

(Continued from previous page)

There are cases, of course, where two L.F. stages are almost essential. The most important of these is when using class B amplification, for a driver valve must then precede the double output valve. The driver can be fed by either a triode or diode detector, the former being preferable in a "straight" set, and the latter in a superhet. Perhaps the most important instance in which two L.F. stages are desirable is when good volume and quality are desired from a set providing only a small amount of H.F. amplification, or one fed from an inefficient indoor aerial.

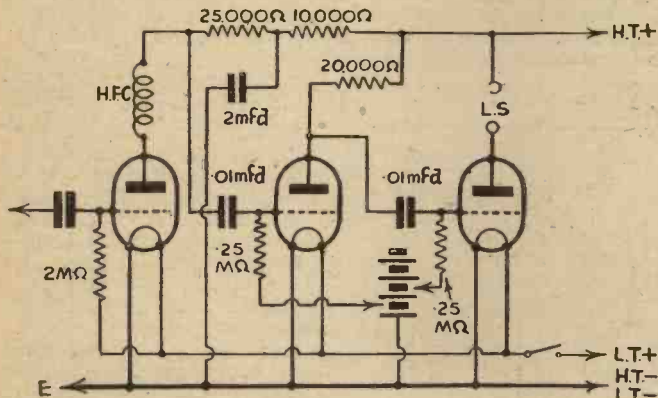

Fig. 4.—A two-valve R.C.C. amplifier such as is typified by this circuit, gives only about the same amplification as the circuit in Fig. 1, but has certain advantages, as explained.

H.T. Supply

An arrangement such as that shown in Fig. 4 is then very satisfactory. Here there are two triodes after the detector, resistance-capacity coupling being used throughout. The first L.F. valve can be of the general-purpose or L.F. type, the output valve being a medium-power valve. It should be observed that a circuit such as this does not generally give any greater degree of amplification than one such as that in Fig. 1, but it is more likely to provide rather better quality in the hands of the average user. A serious objection is that, although costing only about the same amount initially, it is less economical of high-tension and low-tension current. Another point which is often overlooked is that the maximum undistorted output of the power valve is less than that of the small pentode, especially if a full 150 volts H.T. cannot conveniently be used.

This is often an important point, for it is a fact that the output and amplification provided by most battery sets could be increased to an appreciable extent by using a higher H.T. voltage. This naturally entails a heavier H.T. current consumption, and it is thus wise to use either a high-capacity H.T. battery or an H.T. accumula-

tor—a battery eliminator is equally suitable, but that virtually converts a battery set into a mains set.

One of the best and most economical methods of combining high output and high degree of amplification in a battery set is by using two pentodes in push-pull (same fundamental circuit as in Fig. 3) or by using Q.P.P., which has rather faded into the background during recent years. It has been shown that pentodes do not necessarily give inferior quality to that provided by triodes, but even if they do most of the objections are removed by employing a push-pull circuit with a resistance-capacity tone-control filter across the output transformer or choke.

same time, however, it is often better to use a transformer having a ratio of about 1 to 3.5 instead of 1 to 5, so as to safeguard against the possibility of overloading.

Two L.F. stages are seldom required in a mains receiver for ordinary "home" use, because the average mains pentode today has a maximum undistorted output in the neighbourhood of 3 watts. If two stages are used it is sufficient to employ R.C.C. coupling, and by this means it is easier to obtain a large output with the minimum of distortion.

Diode-pentode

In a superhet circuit a diode second detector is now employed almost invariably, and it is a proven fact that a modern

pentode can be adequately loaded by means of a simple diode, especially if transformer coupling is employed. A few years ago it was held as a maxim that an intermediate L.F. stage was desirable after a diode, but both constructors and manufacturers have disproved this. It is, of course, possible nowadays to use a double-diode pentode as second detector and output valve, but this is really suitable only when a modest output will suffice.

When using a double-diode triode in the second-detector position, it is found that most pleasing results are given by following this with a resistance-coupled triode or pentode, the latter generally being preferred. The general circuit arrangement is that shown in Fig. 5. It would be difficult greatly to improve on this arrangement, which gives the requisite ample output without any valve being loaded to its full extent, and without depending upon an iron-cored transformer to provide a voltage step-up.

It is only when building a public address type of amplifier that more than one stage of amplification is required after a double-diode triode. The enthusiastic constructor often feels that better reception would be possible by using three or more L.F. stages, but he is strongly recommended to keep to a simpler and less-expensive system; he is more likely to be pleased with such an amplifier after trial.

## RADIOLYMPIA

Stand No. 10,  
Ground Floor.  
Same place, same stand number as  
last year.

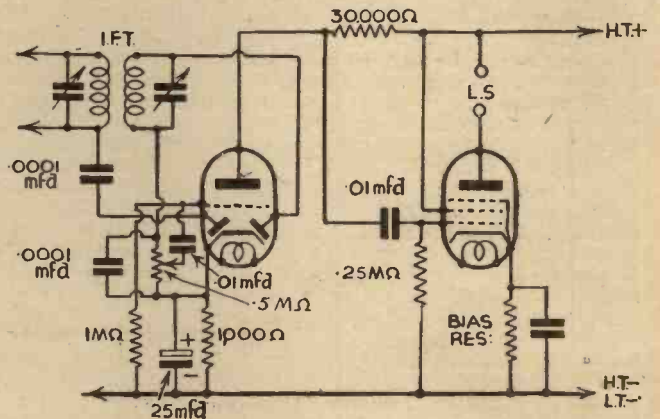

Fig. 5.—One of the best L.F. circuits for use in a mains superhet with double-diode triode in the detector-first L.F. circuit.

Return of Carroll Levis

ARRANGEMENTS have been completed by John Watt, Variety Director, for a new series of three programmes by Carroll Levis and his Discoveries. The first will be given in the second week of October and the remainder at monthly intervals. The new programmes will be on similar lines to those previously presented by Carroll Levis, who has been touring the country in search of fresh material. Although the Discoveries will be representative of the whole country, they will be brought to London to broadcast.

PROGRAMME NOTES

Promenade Concerts, 1937

ACCORDING to a recent B.B.C. announcement, 33 British composers will be represented by original works in the "Proms" this year. Of these, both Elgar and Vaughan-Williams are honoured by a whole first half being devoted to their works (Elgar on August 10th and Vaughan-Williams on September 14th), while Delius

will be played four times, Purcell, William Walton and Arnold Bax, three times each; John Ireland, Gustav Holst and Stanford, twice each; and the following will be represented by one work each: Granville Bantock, Arthur Bliss, Joseph Holbrooke, Eugene Goossens, Balfour Gardiner, Lord Berners, Constant Lambert, Edmund Rubbra, Frank Bridge, Rutland Boughton, Landon Ronald, Edward German, Herbert Howells, Frederic d'Erlanger, George Dyson, George Butterworth, Frederic Austin, Gordon Jacob, B. J. Dale, Armstrong Gibbs, Peter Warlock, Alan Bush, Maurice Johnstone, and Herbert Murrill.

# TRANSMITTING TOPICS

ONE item which is so often the bugar of would-be transmitters is the adequate supply of high-tension current.

Fortunately for the beginners of to-day, the problem is not so serious as it was in the early days when conditions necessitated the use of hand generators, racks of cells or piles of dry batteries, all of which did not lend themselves to ideal operation or economical upkeep.

Now that the efficiency and range of available valves have reached a stage far beyond the pioneers' wildest dreams, it is possible to obtain quite good worthwhile range with cells or dry batteries, thus allowing the less fortunate enthusiasts who are without mains supplies to enter the transmitting circle.

The limiting factor with cells and dry batteries is not so much a matter of voltage, but current, and if one is forced to use either of these sources of H.T. supply it is vitally important to design the outfit to operate with the minimum possible current consistent with wattage desired. Actually the problem should be considered the other way round—assuming upkeep cost to be an important factor—and limit the choice and design of the circuits by the source of H.T. available.

Large-capacity H.T. accumulator blocks are, of course, more satisfactory than dry cells, but if the station is situated in the country many miles from the nearest charging plant, then fresh complications are introduced.

The cells which are rechargeable from a six-volt accumulator offer some solution to the problem, as it is far easier to arrange transport for a single six-volt accumulator than for, say, several trays of smaller cells.

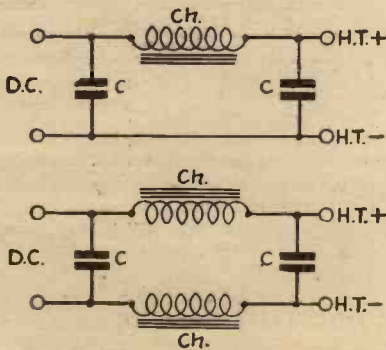

Figs. 2 and 3.—Circuit diagrams of smoothing arrangements and connections.

Rotary converters, operating from 6 or 12 volt accumulators, provide the nearest approach to A.C. mains, as they can be obtained with quite large wattage outputs; they are compact and reliable, and if reasonable care is taken with their housing and smoothing arrangements they are interference free.

An even better method of supply—at least so far as rendering the user absolutely independent of any form of charging—is the small petrol-driven A.C. generator which is now on the market for radio and P.A. work. It is capable of delivering 300 watts A.C. and 50 watts D.C., the latter being suitable for charging if so desired. One of these petrol-driven units is shown in Fig. 1.

The initial cost of the last two methods is, of course, rather on the high side for the

## Various Sources of Power Supply are Discussed in this Article.

By L. ORMOND SPARKS

average amateur, but if serious prolonged work is contemplated then they would become an economical investment.

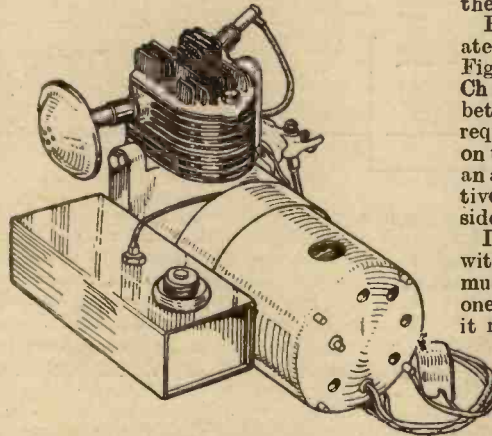
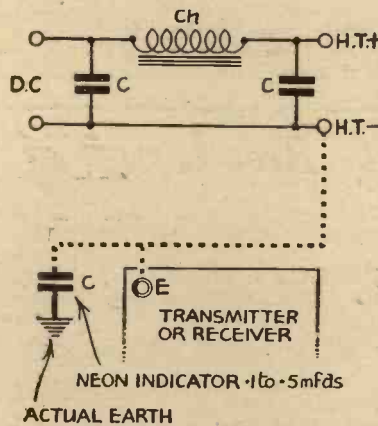

Fig. 1.—A small petrol-driven generator with an output of 200 watts.

### Mains Supplies

Where electricity supplies are available, the whole problem—to all intents and purposes—is solved, as adequate power can be obtained at a cost far below that of



A.C., it becomes necessary to use a generator involving, of course, additional heavy expense. Although the supply is of a direct current nature, on no account must it be connected to the transmitter direct. However good the supply, there is bound to be a slight ripple present and it is absolutely essential for all trace of that to be removed before applying the feed to the H.T. circuits.

Fortunately, the procedure is not elaborate or expensive, the arrangement shown in Fig. 2 usually being sufficient. The choke Ch is of the L.F. type having an inductance between 5 and 10 henries when the total required current is flowing. Depending on the nature of the mains, it is sometimes an advantage to wire the choke in the negative lead or, better still, insert one in each side of the mains, as shown in Fig. 2.

It must be remembered when dealing with D.C. mains that the negative side must never be connected direct to earth, as one side of the mains is always earthed and it might be the positive, in which case a short circuit would be produced if the negative were not isolated from the earth terminal of the transmitter. It is usual and necessary—the same as with D.C. receivers—to insert a non-inductive condenser between the actual earth and the earth terminal, as shown in Fig. 3.

As direct connection is being made to the mains for the H.T. supply, adequate switching arrangements and fuses should always be embodied. A double-pole single-throw switch should be connected between the mains and the fuses, thus allowing the transmitter circuit and fuses to be rendered "dead" when the occasion arises.

### Alternating Current

Although the use of alternating current involves greater initial costs, it has definite advantages over D.C. It can, for example, be stepped up or down according to requirements, so making its application much wider or more flexible than the fixed maximum value of direct current supplies. The only disadvantage—if it can be considered as such—of A.C. mains is that it is necessary to provide some means to rectify the alternating current into a steady, ripple-free direct current.

This can be carried out by the use of valve or metal rectifiers, typical examples of the methods being shown in Figs. 4 and 5. While it is, of course, vitally important to see that the mains transformer is really

(Continued on next page)

other means, and, in the case of A.C., the voltage can be increased or decreased by the use of a simple transformer to meet the needs of the apparatus in use.

### D.C. Supplies

The average direct current supply is ideal for a low-power outfit. It presents a source of power which, comparatively speaking, is ready for use, but—and this is the reason why the stipulation "low-power" is used—the voltage is invariably between 200 and 250 volts. If a higher voltage is required, then, unlike

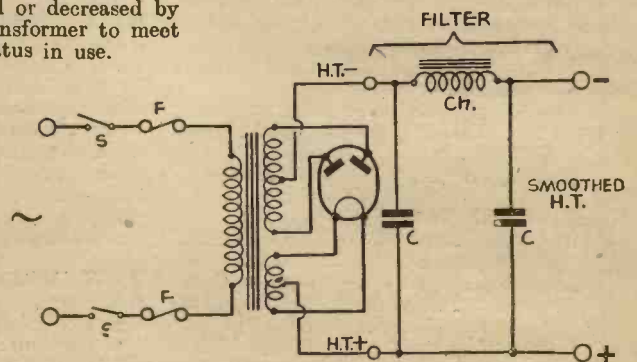

Fig. 4.—Circuit diagram of a full-wave valve rectifier.

**TRANSMITTING TOPICS**

*(Continued from previous page)*

good in an electrical and engineering sense ; that it is designed for the rectifier concerned, and that both are capable of supplying the output required, it is also of vital importance to pay particular attention to the smoothing of the rectified current.

Rectified A.C. requires more smoothing than the normal D.C. mains, and, as much higher voltages are likely to be involved,

it is essential to see that the smoothing equipment is selected with a "safety" factor of at least 50 per cent. above normal working conditions.

The smoothing or filter circuit is identical with the D.C. arrangement, excepting the inductance of the choke, which should have a higher value. For rectifiers up to the 500 volt range, it will be found that 20-25 henries with condensers of 4mfd.-6mfd. will be quite satisfactory.

It must be remembered that the capacity of the smoothing condensers can affect the output of the rectifier to a marked extent, therefore they must be chosen with consideration for the rectifier to be used.

Double-pole switches and fuses should be inserted in the primary side of the transformer, and the circuit should be so arranged that some visual indication is given when the circuit is alive.

**High Power Rectifiers**

When H.T. voltages above 1,000 volts are required, it is now usual to use hot-

cathode mercury vapour rectifiers such as the Ediswan M.U.1, and the Osram G.U.1, to quote two makes, which will supply 250 mA at 1,000 volts.

This type of rectifier has a higher efficiency than the two-electrode thermionic valve ; its internal impedance being much lower, thus increasing the efficiency and producing a practically constant voltage drop across the valve. For example, the drop across the two types mentioned above

in the bulb, a blue glow being produced during the process.

As they operate as half-way rectifiers, it is usual to use two in a bi-phase circuit to give complete rectification of the whole wave.

One point should be noticed about the filter circuit used with such arrangements, Fig. 6 : it is usual, in order to provide adequate and satisfactory regulation of the rectifier, to connect a choke filter input before the smoothing condenser, the choke having an inductance of, say, 1 to 2 henries at maximum current but a very much higher value when minimum current is flowing. The resistance R limits the minimum current and serves to discharge the condenser completely when power is switched off.

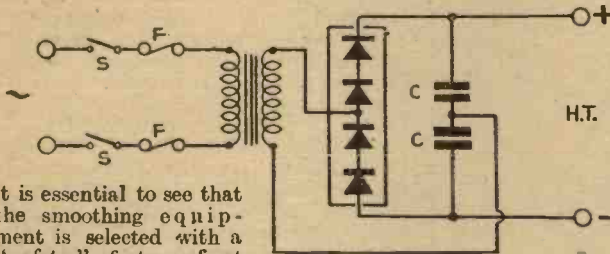

Fig. 5.—Diagram showing a metal rectifier used in a voltage-doubler circuit.

is in the neighbourhood of 15 volts.

It is essential with a mercury vapour rectifier to allow the cathode to reach its correct operating temperature before the H.T. is applied, and the makers invariably specify the use of delayed switching.

The valve depends for its operation on the ionisation of the mercury vapour contained

Fig. 6.—Using two half-wave rectifiers in a bi-phase circuit.

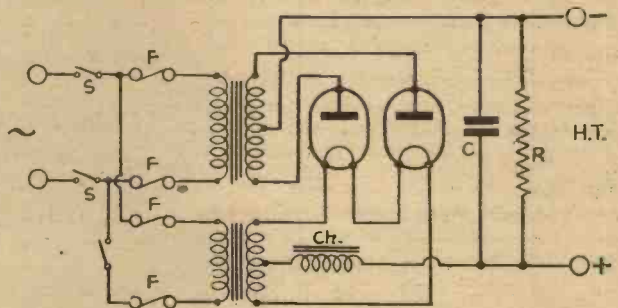

**RADIOLYMPIA**  
**AUGUST 25th to**  
**SEPTEMBER 4th**  
**OUR STAND**  
**No. 10**  
**GROUND FLOOR.**

*Important Broadcasts of the Week*

**NATIONAL (261.1m. and 1,500m.)**  
 Wednesday, August 4th.—Mid-week Variety programme.

Thursday, August 5th.—Murder in the Embassy : A musical play by Francis Durbridge and Augustus Franzel.

Friday, August 6th.—Music from the South : Instrumental Concert.

Saturday, August 7th.—Promenade Concert : Opening night of the forty-third season of Promenade concerts, from Queen's Hall, London.

**REGIONAL (342.1m.)**

Wednesday, August 4th.—Murder in the Embassy : A musical play by Francis Durbridge and Augustus Franzel.

Thursday, August 5th.—Concert party programme.

Friday, August 6th.—Northern Music Hall : Variety, from the Grand Theatre, Doncaster.

Saturday, August 7th.—Music Hall.

**MIDLAND (296.2m.)**

Wednesday, August 4th.—An Instrumental Recital, from Cheltenham College.

Thursday, August 5th.—Forgotten Rivalries—4 : Piccini-Gluck, a side-light on contemporary musical opinion.

Friday, August 6th.—Recital of Modern Part Songs.

Saturday, August 7th.—Orchestral Concert from Leamington Spa.

**NORTHERN (449.1m.)**

Wednesday, August 4th.—Orchestral programme.

Thursday, August 5th.—Pleasure on Parade, from the Floral Pavilion, New Brighton.

Friday, August 6th.—Hawthorn Tower : Some talk and singing from the Boys' Brigade Camp.

Saturday, August 7th.—Music Hall, from London.

**WELSH (373.1m.)**

Wednesday, August 4th.—The Royal National Eisteddfod of Wales, Machynlleth : Choral and Orchestral Concert.

Thursday, August 5th.—Sailing the Seven Seas : Adventures of Ships and Sailors, a Talks Feature.

Friday, August 6th.—Orchestral concert.  
 Saturday, August 7th.—The Royal National Eisteddfod of Wales, Machynlleth, 1937 : A Festival of Song.

**WEST (285.7m.)**

Wednesday, August 4th.—Speedway : Bristol v. Southampton. A running commentary on part of the Provincial Trophy Match, from Southampton.

Thursday, August 5th.—Naval Occasion, feature programme from Plymouth.

Friday, August 6th.—Christy Minstrel songs and choruses.

Saturday, August 7th.—Holiday Fare : Bubbles, a Concert party from the Pier, Boscombe.

**SCOTTISH (391.1m.)**

Wednesday, August 4.—Georgian Summer : A Miscellany of Poetry with Music, devised by James Fergusson.

Thursday, August 5th.—A Recital of Scots Songs.

Friday, August 6th.—Landings at Lossiemouth : a programme about the work behind the scenes of the fishing industry.

Saturday, August 7th.—Gaelic Concert.

**NORTHERN IRELAND (307.1m.)**

Wednesday, August 4th.—A Ballad Concert.

Thursday, August 5th.—Bird in Hand, a West Country comedy in Three Acts by John Drinkwater ; adapted for broadcasting by Cyril Wood, from West.

Friday, August 6th.—Light Orchestral Concert, from the Chalet, Crawfordsburn.

Saturday, August 7th.—Orchestral programme.





# On Your Wavelength



By Thermion

## The Passing of Marconi

THE death of Marconi leaves an irreplaceable gap in the world of wireless. Since that epoch-making day in 1901 when three dots were received from Newfoundland at Poldhu in Cornwall, which demonstrated the practicability of radio telegraphy and telephony, Marconi assiduously and continuously applied himself to the science which he made his life's work. Like all pioneers he suffered misrepresentation at the hands of free-lance journalists without technical knowledge but extravagant imagination, and the results of his experiments were quite often represented to the public in burlesque form. It is perhaps understandable that we should wish to surround with a halo the man who laid one of the foundation stones of a new science and a new industry, but we should also revere and bear in memory the work of those other pioneers who really made wireless possible. I am referring to Hertz, Faraday, to a minor degree Sir Oliver Lodge, and very largely to Sir Ambrose Fleming. It has always been popularly supposed that Marconi invented wireless, and he was always denying the credit for this. Wireless was not invented by any one man, and certainly Marconi had very little to do with the introduction of radio telephony. The discovery of electronic emission from the filament of a carbon filament lamp by Edison laid the foundations of radio telephony upon which Sir Ambrose Fleming was able to perfect the thermionic valve. The "Edison effect" marked the beginning of a new era in wireless. It was as a director and co-ordinator of the efforts of others that Marconi excelled—not as an inventor. Sir Oliver Lodge brought wireless a step further when he invented the tuning circuit. He it was who discovered that by connecting a variable condenser in parallel with a tuning coil, one end

of which was connected to an aerial and the other end to earth, that the tuning range could be varied. Thus, in two important things in connection with wireless we must not ascribe the credit to Marconi—the tuning system and the wireless valve. Edison and Fleming discovered that the electrons emitted from the filament could be collected on the plate, and de Forest added the grid. Lengthy and expensive litigation followed. Latterly Marconi had directed his attention to beam wireless, a system which is still short of perfection; and to transmission on micro-wavelengths. A short time before his death he suffered the indignity of being accredited with the invention of a ray device which could bring aeroplanes hurtling to earth from incredible altitudes, and which could bring fleets of motor-cars to a standstill. The editor of this journal debunked these wide statements nearly two years ago, and the accuracy of his judgment was confirmed by Marconi himself who wrote: "The nearest thing I got to a death ray was when I killed a rat with an intricate device at a distance of 3ft." We must not forget to accord our due measure of credit to his collaborators, Mr. G. S. Kemp and Mr. P. W. Paget, without whose assistance in the early days Marconi could not have succeeded in his experiments. Marconi conducted an interesting and successful experiment when in March, 1930, he transmitted power by beam to Australia from his yacht *Elettra* at Genoa, and lit 2,000 lamps in Sydney, New South Wales, 11,000 miles away. The survivors of the *Titanic* disaster have every reason to bless him, and signified their gratitude by presenting him with a gold medal. It is reported that he believed that wireless would eventually lead to interplanetary communication. He lost the sight of an eye in a road accident in 1912. He was born on April 25th, 1874, and died on July 20th, 1937.

Thus, a great man passes—one whose name will literally reverberate down the centuries, and till the crack of doom. But, in order to set the matter in its true perspective, we must remember, as he would have been the first to admit, that he collected a large amount of credit to which he was not entitled.

## The Wireless Exhibition

MAKE a note that the Wireless Exhibition commences on Wed., August 25th, for 10 days and ends Sat., Sept. 4th. The theme of the Exhibition this year is All-World Radio. In the short compass of 12 years the nations of the world have been linked by radio, and although the Tower of Babel still exists and wireless has not brought forth an All-World language, neither has it caused nations to speak peace unto nations! But that is a hope for the dim and distant future, for whilst nations contend and have their differences, there is always the possibility that wireless, by a process of erosion and attrition, may wear down the suspicion with which one nation regards another. But the theme of All-World Radio intrigues me. It is a development of the all-wave radio theme of the previous year. Is it not rather a reflection on our own programme that as an inducement to buy we have to stress the pleasures of listening in to foreign programmes? Does not this desire to listen far afield create trouble for the manufacturer? Foreign programmes are intended for listeners in the particular country from which they are radiated, and their transmitting gear is not necessarily specially designed so that the programmes can be received all over the world. In encouraging the desire to listen to foreign programmes the manufacturer is making a rod for his own back. He is bound to get complaints from customers whose sets will not receive programmes from particular foreign stations. I do hope this year that we shall not see so many elaborate engraved dials containing the names of dozens of stations which the set does not receive, or cannot receive free from interference.

### Large Screen Television

THE Philips Company announce a television development of great importance. They have developed a small cathode-ray tube giving a picture 2ins. wide which can be magnified by an optical system and projected on to a screen as large as 3ft. square, although for normal use it is intended to be used on a screen measuring 20ins. by 16ins. At this size it is claimed that the reception is excellent. The small high voltage cathode-ray tube is arranged vertically, and the light beam is passed through a system of magnifying lenses which throw the picture on to a mirror set at 45 degrees. The final picture is viewed on a ground glass screen of the size stated. The detail is excellent, and brilliant. The picture is yellowish in colour but a tube is being developed to give the usual sepia tone. I believe that a voltage of nearly 25,000 is used, but adequate safety precautions are included. The screen is, of course, remote from the cabinet.

### Machine that Makes Weather

BRITAIN'S worst weather conditions occur daily in Coventry—in a glass cabinet about a yard high.

Here the conditions can combine a temperature of 160 in the shade with a humidity factor of 98 per cent.—almost complete wetness. In this tropical atmosphere the General Electric Company test every new type of radio set for a month at a stretch. Ten days in the cabinet equals two to three years' open air use in the tropics, where thousands of G.E.C. sets are exported every year. Buyers in Britain also benefit, for the testing applies to every model produced.

During and after production every set is subjected to the most rigorous and comprehensive system of testing and inspection that can be devised. Thus any set which reaches the Tropics Department is already faultless for the home market, but only if it passes the hot-box test is it approved for production. Ingenious instruments on the box not only reproduce the weather, but also register the quality of performance and the operations of all the critical components. At intervals experts scrutinise the set's own cabinet, warping and cracking being barred.

### For Dance Fans

IT seems from my post-bag that a small number of readers are dance fans, and the following news will, no doubt, interest them. The B.B.C. aims at widening the appeal of "dance music" and making each programme by a dance band into a



### P.M. Speakers

WE often get enquiries concerning the use of permanent magnet speakers in place of mains energised models. In most receivers designed for use in conjunction with mains energised speakers a permanent magnet model may be substituted. The substitute speaker must however be fitted with an output transformer suitable for matching the output valve, or valves, in the set. For example, if the output stage of the set is of the push-pull type, the speaker output transformer must be of the centre-tapped type suitable for matching the particular valve types used. The transformer primary winding on the new speaker must also be capable of passing the current taken by the output valve without overheating. Another important point has to be considered when making the speaker substitution—a choke having approximately the same resistance, inductance and current-carrying capacity as the original speaker field winding must be connected in place of the latter.

### Hallmark 4

THE majority of commercial receivers have the speaker field winding connected in the common H.T.+ line, the winding having a resistance of between 2,000 and 2,500 ohms. It has been mentioned in these notes before that the speaker field winding resistance in the A.C. Hallmark 4 is 2,000 ohms, but so many queries on this point are being received in connection with this receiver that no excuse is made for repeating this point. In the Hallmark 4 two 41 MP valves are used in push-pull, and therefore the speaker transformer should provide a load of 6,000 ohms (the optimum load for each valve is 3,000 ohms). The field winding replacement choke should have a resistance of 2,000 ohms and a current carrying capacity of 60 mA. or slightly higher.

### Defective On-off Switch

A SOMEWHAT obscure fault which often occurs in battery sets is a high resistance on-off switch. This trouble is seldom experienced with the old push-pull type of switch, but is not uncommon in the Q.M.B. type normally fitted to the volume control potentiometer. The set may work reasonably well when this fault exists, but the valve filaments will not be getting the correct voltage and therefore distortion and low sensitivity will result. When making L.T. voltage tests the meter prods should be connected across the filament sockets of the valve holder and not across the accumulator.

broadcast entertainment in itself. Three kinds of programmes will be given, all specially designed to please a section of listeners.

First, there will be programmes labelled "for dancing only," for people who like to dance to the wireless, and here the bands will play in strict dance rhythm without vocal refrains of any sort. (Does anyone dance to the radio?) Then there will be programmes for the much larger section of the public which enjoys music by dance bands but does not actually want to dance to it. Here special presentation, popular songs of all kinds, and other ways of entertaining listeners will be introduced. There will be no restrictions, except of quality, on the number of vocal refrains, or on any other way of making these programmes go over successfully. The third type of programme will be for the connoisseur of dance music. It will include a certain number of records and musically interesting forms of jazz, and also some foreign relays.

Quite apart from programmes by dance bands, a new feature will be introduced in the daytime, consisting of popular songs sung as songs and not as dance music. If this experiment is successful, programmes of this type will automatically be included in evening broadcasting hours. Save me from it, and crooners. I dislike their execution but am in favour of it!

### Performing Right Society

IT is officially announced by the Performing Right Society that during the past quarter thirty-eight composers and authors were elected to membership. The Society is responsible for the collection of fees due to composers, authors and music publishers for the public performance of their works. The total membership of the Society is now 1,530.

### Halfpenny for an Earth

I WAS very interested to receive the following details from a radio dealer. The facts are quite true, strange as it may seem.

On inspecting an earth wire recently it was found to traverse the walls of two rooms and a long passage, eventually entering the soil outside. As no earth tube or similar component was visible, the wire was given a slight tug, and to amazement and amusement came up with a halfpenny dangling on the end.

The owner explained that a friend advised him to connect the earth wire to a piece of copper for the best reception, and that he noticed a marked improvement after he did it!

# INSTALLING A POWERFUL RECEIVER

Important Points to be Considered, Including Short-wave Requirements, Dipole Aerials, and Earthing Systems, are Discussed in this Article. By G. V. COLLE

It is not generally realised that the more powerful a set the better the aerial required to operate it. At least, that is how matters work out, although in actual fact the cycle of events is somewhat more involved. In order to explain the apparently paradoxical position, namely a better aerial for a more powerful set, it is necessary to establish certain details as a basis for discussion.

By the statement "more powerful set" it is intended to imply that the overall sensitivity or amplification in the H.F. stages is greater. A superhet could possess increased sensitivity by adding a further I.F. valve and coupling, or, as is more usual, by placing an H.F. stage before the first detector, to operate at the signal frequency.

Additional sensitivity in a "straight" receiver, otherwise increased amplification with respect to the aerial, can only be achieved in the latter sense, namely, by adding further H.F. stages. A more powerful set is therefore one which has enhanced sensitivity and is capable of giving an intelligible output from transmissions which are just above the prevailing static level. In receivers of lesser sensitivity (or overall H.F. magnification) such transmissions do not or cannot produce sufficient signal input in the detector to allow for rectification and hence to all intents and purposes they are non-existent.

There is no possibility of drawing a line of demarcation between sets having specified numbers of H.F. stages, because much depends on the circuit scheme. For instance, in receivers having Q.A.V.C. or delayed A.V.C., the maximum sensitivity is rarely achieved due to the limiting action of the automatic grid-biasing system. Smaller sets having a lesser number of H.F. stages might dispense with A.V.C., etc., and consequently possess an equal or even higher initial sensitivity. On the other hand, if provision is made in the "larger" receiver for omitting A.V.C., or its equivalent, it is possible to "reach out" and pick up everything that is receivable.

## All-wave Sets

Many all-wave sets possess this high sensitivity, as on the ultra-short-wave bands delayed A.V.C. cannot be tolerated, due to necessity for counteracting high speed fading. The system most favoured is A.V.C. with an instantaneous action, which allows for maximum sensitivity in the absence of a carrier wave.

With these extremely powerful receivers for all-wave reception the most minute carrier wave above static level will create a sufficient detector input. It is easy to see that a local source of interference, which in the normal way would be unnoticeable, will be more than sufficient to either blot out the weak carrier or else make listening extremely unpleasant.

Our first deduction, therefore, is that an aerial providing satisfactory results on the medium and high-powered stations is not necessarily good enough for what one might term "DX" listening. A second point which arises from the foregoing is that, depending on the particular waveband to which importance is attached, so should the aerial be erected to give the maximum efficiency over that frequency spectrum.

## Short-wave Requirements

All-wave sets invariably show up aerial limitations on the short waves, and hence it must be erected with the short-wave requirements in mind. At the same time, merely to regulate the aerial proportions (such as a dipole) to some matching point in the short-wave range is not good enough. The essential requirement is to obtain a large signal-to-noise ratio.

To receive weak carrier waves without a noisy background (due to local electrical appliances or vehicles) the aerial must be so situated that it is outside these zones of interference. Therefore, height is the important factor and with the utmost emphasis the writer would suggest that this

transmissions were desired. It is unlikely such a scheme would appeal to many readers of this journal, but the reasoning was that if a listener is prepared to pay something like £80 for a short-wave set, then he obviously is also prepared to take exceptional steps to obtain the maximum entertainment from it.

A horizontal "dipole" aerial erected at a good height will invariably provide improved short-wave results and at least as good a performance on medium and long waves. Its inherent noise-reducing properties on the latter wavebands are not usually as effective as a screened downlead system, but this is of little moment if the aerial proper (the horizontal portion) is

unaffected by electrical static, and a suitable coupler used at the receiving end of the twin downlead. Although there are theoretical grounds for claiming that the twin downlead or feeder from a dipole aerial cancels out interference induced into it, yet in practice, it is necessary to arrange the receiver coupler windings so that they have a purely inductive coupling. This can be achieved either by astatically winding the primary sections, or alternatively (or additionally) interposing an earthed electrostatic metal screen between the primary and secondary.

A further scheme which the writer has often advocated is to provide a high inverted "L" aerial with a screened downlead system for wavelengths between, say, 75 and 2,100 metres, and a separate high dipole for wavelengths below 75 metres. By this means, compromise in aerial design is avoided and readers hardly need to be reminded that "compromise" in noise-proof aerials means lower overall efficiency!



Here is a typical example of a modern powerful set. The makers supply detailed instructions concerning suitable aerials and equipment.

be the paramount consideration in erecting any aerial system.

Recently, an enthusiastic short-wave listener called upon the writer with a view to eliminating car ignition static on his expensive commercial 4½ to 100-metre multi-valve set. The problem was not simple of solution, as various dipole aerials had been tried, well away from the highway, and it was not possible to arrange for greater separation or "staggering." Whereas the suggestion was made that the aerial system be erected at a greater height, the final result was in doubt, as the receiver possessed such enormous amplification that a non-directional dipole would still tend to be affected to some extent. Being an exceptional case, and such importance was attached to reception, a further suggestion was made as being the only likely solution.

## Dipole Aerials

The owner of the set was recommended to erect a number of dipole aerials, those for the bottom end of the scale (4½ to 10-12 metres) to be of the vertical type with reflectors, and the remainder in the horizontal plane approximately directional to those points of the compass from which

reminded that "compromise" in noise-proof aerials means lower overall efficiency!

## Earthing Systems

The position with regard to an earthing system is interesting. Those receivers designed only for matched dipole inputs are not usually critical to the effectiveness or otherwise of the earth. It is only when the receiver input arrangement calls for a normal type of aerial and earth that the effect of a low resistance earthing path begins to be felt. A soundly bonded heavy cable, say, of 7/0.29 (15 amp. electric wiring) or its equivalent, connected to a long earthing tube or a perforated zinc mat buried in the soil, is always an asset and particularly so for the case quoted, for the following reasons: (a) a low D.C. resistance path to earth does not allow earth currents to circulate in the earth wire, and thereby assists to guard against electrical interferences; (b) it provides an efficient earth point or electrode for the condenser effect between aerial and earth, thereby promoting signal pick-up; (c) the absence of earth resistance does nothing to reduce the effectiveness (or Q) of the aerial coil,

(Continued on next page.)

## INSTALLING A POWERFUL RECEIVER.

(Continued from previous page.)

and hence the selectivity in that circuit is unimpaired.

The reserve of amplification in powerful sets, plus the masking effect of A.V.C. systems, tend to belie the value of a good earthing system, but it is easy to disprove that notion by merely using a crystal set with a microammeter in place of the 'phones, and noting the difference in the readings for various earthing arrangements.

### Mains Aerials

One of the purposes of these notes was to discuss mains aerials in relation to modern receivers of a highly sensitive type. Now that it comes to the actual point, it is well nigh impossible to say anything in their favour. They are admittedly very inefficient, and the only excuse for their existence is apparently that they offer means of local station reception under impossible conditions. Listeners residing in modern steel-framed hotels or flats, and who are debarred from erecting external aerials, are apparently the chief users of mains aerials, but it is hoped this list does not extend in other spheres where the possibilities of erecting other aerials exist. On the other hand, it is not suggested that a

room aerial in a steel building will prove as effective as a mains aerial—rather the reverse.

Where one is a tenant of a flat, there is always the possibility of co-operating with neighbours in persuading the owner of the property to allow the erection of a community aerial on the roof. Such an aerial can be made neat and fairly inconspicuous, or to harmonise with the surroundings, its expense can be jointly defrayed, and not only can it be made lightning- and noise-proof, but coupled up to the various receivers without mutual interaction, and with a comparatively high degree of efficiency.

A mains aerial, which is connected to the set (via a fixed condenser) or internally by means of a switch or plug fitted at the back, allows the electric supply wiring throughout a building to act as the aerial collector. It can introduce all manner of static noises into the receiver created by appliances operated from the supply. Generally speaking, its doubtful receptive properties disappear if a mains filter is introduced into the supply leads to the receiving equipment, due to H.F. bypassing properties of the condenser filter.

An aerial scheme more likely to prove of service under severe restrictions is one in which a fixed or telescopic metal rod is mounted outside a window, the base of the

rod being fixed and insulated at the window sill, with the rod itself tilting outwards at about 45 degrees. Such an aerial is available commercially and, while it cannot obviously compare to a high horizontal span, it should in most cases prove superior to a mains capacity connection. The reasons being obscure are enumerated thus: (a) a mains aerial acts as a capacity collector and therefore imposes a heavy damping on the receiver input circuit. A rod aerial, with a lead-in taken from its base, has a relatively small capacity to earth and, hence, does nothing to affect the sharpness of tuning, (b) the greater input discrimination or increased sharpness of tuning allows tunable interferences to be avoided, (c) although a rod aerial is normally within zones of interference, the signal-to-noise ratio is usually slightly better than with the mains version.

Most modern receivers are completely and effectively screened and, in the absence of aerial and earth, but connected to the mains and at full sensitivity, are completely silent, except perhaps for valve hiss or slight hum. It follows, therefore, the only vulnerable points for the entrance of electrical static are the mains and aerial-earth connections, either collectively or individually. Having disposed of the aerial and earth, there remains the question of isolating the mains from the receiver from an H.F. point of view.

### Mains Filters

A common error is to suppose that a mains filter should be incorporated in the receiver as an integral part of the apparatus. By a little thought it will be seen that under such conditions the unfiltered mains leads are brought close to the aerial and earth, thereby allowing the mains radiations to be induced into the nearby leads. The proper position for the filter is close to the local power plug from which current is derived.

No attempt is made here to describe the various types of mains filters available, nor yet the steps which can be taken to increase their efficiency. Apart from the enormous scope of the subject, there are numerous firms specialising in suppression devices, and additionally, extensive information can be obtained from British Standards Specification, No. 613, price 2s. 2d., post free, from British Standards Institution, 28, Victoria Street, London, S.W.1.

## SELF-QUENCHING DETECTORS

WE recently published details of short-wave receivers utilising self-quenching detectors, and as a matter of interest we give below a query raised by a reader in connection with these circuits and the author's reply, which may solve some difficulties met with by other readers. The article in question was published in our issue dated January 9th last. The reader says:—

"The self-quenching detector described in Fig. 1 was built first, and quenched quite O.K., but I could not even hear our local 5-metre telephone station, which I can receive on my ordinary short-wave set. The latter, however, is very unsatisfactory on such high frequencies due to erratic reaction.

"I next built the separate-quenched detector in Fig. 2, but am unable to make it quench. All I can hear is a sort of motor-boating which decreases in frequency when a higher voltage is applied to the quench valve. There is also a very faint high-pitched whistle, almost inaudible, in the background. One side of the quench coil has been reversed, but to no avail.

"I heard that the quench could be injected into a screen-grid valve, via the screen, but the results were the same as those previously described, when using a triode.

"Perhaps you may be able to give me advice concerning this trouble, which you may have encountered during your experiments."

### The Problem Solved

The author's reply is as follows:—

"Since the circuit of Fig. 1 is working all right, the reason why you cannot tune your local 56 m/c station is evidently because you are either above or below the band, and most probably the former. As you know, it does not require much extra stray inductance and capacity to increase the minimum wavelength in U.S.W. gear, and as no two constructors build alike, I think your trouble is here.

"There are two ways in which you can check the tuning range of your 5 m. receiver: by building the 5 m. wavemeter I described in PRACTICAL AND AMATEUR WIRELESS dated January 30th, or by getting a rough calibration from the receiver which does tune in the local station and transferring it to the super-regenerative one. Set the super-regenerative quenching hard at about the middle of its tuning range and then search for the radiation from it on the other receiver. You should hear a signal which sounds like high-pitched ICW, but as you may encounter harmonics, look for the fundamental—the loudest beat. By the way, are you quite sure your local station is in the band? I believe you are referring to a G.P.O. link station, and I am under the impression they operate these transmitters just above the 5 m. band. This can, of course, be verified locally. If you refer to an amateur station, it would be advisable to have some sort of frequency check with him.

### Faulty Quench Unit

"With regard to the difficulty in the separate quench circuit of Fig. 2, the trouble is evidently in the quench unit itself—the part enclosed by dotted lines. As I take it you are using the same quench coils in both, and they work properly in the Fig. 1 arrangement, the circuit values require adjustment. This can be tried in the following order: Increase leak-value R to  $\frac{1}{2}$ -megohm; increase feed condenser Cf to .01 mfd. or thereabouts; reduce C2, C3 to .0005 mfd. A combination of these alterations should put matters right.

"As regards feeding the quench frequency to the screen-grid of an S.G. valve as detector, you will find this is shown in Fig. 3 of the same article to which you refer in your letter. When you get the quench unit working correctly with a triode detector, it should function equally well in the circuit of Fig. 3. Some people are using a separate quench unit which can be switched in for reception of S.W. broadcast and 20 m. 'phone, with good results."

## Join Newnes' Practical Group!

### PRACTICAL MOTORIST

The owner-driver's journal which tells you how to repair, overhaul and obtain the best performance from your car.

3d.—Every Friday.

### PRACTICAL MECHANICS

The only English journal of its type. It deals with every branch of Science, Mechanics, Invention, Model-making, Chemistry, Astronomy, Photography, Television.

6d.—Every Month.

### THE CYCLIST

The leading weekly for every Cyclist, Clubman, Utility Cyclist or Tourist. Join "The Cyclist" Road Club and also take advantage of the FREE Insurance.

2d.—Every Wednesday.

A PAGE OF PRACTICAL HINTS

SUBMIT YOUR IDEA

READERS WRINKLES

THE HALF-GUINEA PAGE

A Small Testing Rack

THE accompanying sketch illustrates the general construction of a testing rack which I have designed to facilitate home servicing a receiver chassis, and the multitude of different tests which I have been able to effect by reason of the rack's adjustability, have certainly justified the efforts I have put into the design and construction.

Tests can easily be arranged if the small test panel circuit is carefully worked out and wired up neatly with adequate precaution by way of insulation so far as the mains voltage is concerned. All that I use is a small neon lamp for continuity and

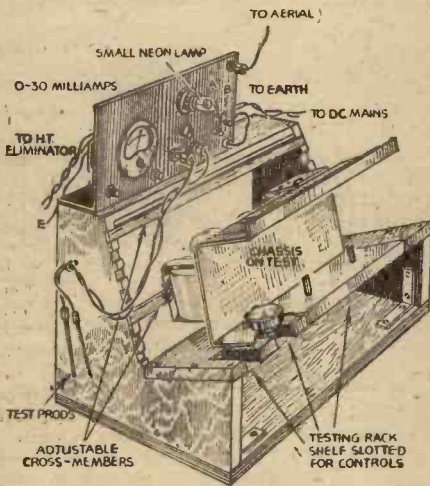

General view of a small testing rack.

leakage tests, a 0-30 milliammeter for resistance and condenser tests and flashes, provision being made for differential readings by parallel and series meter resistances and under the control of two push buttons "A" and "B". The mains control switching is effected by two S.P.D.T. telephone key switches, the two poles of the mains being individually controlled, and again the metal fittings of the panel are at earth potential.

All supply leads from the receiver (if of the battery type) go to the eliminator and accumulator, whilst for D.C. mains working the leads are accessible for immediate use. A.C. mains working is in my case effected by means of a rotary converter, the supply leads of which are interchangeable with the D.C. input leads on the test panel.—O. G. WENTWOOD (London, E.7).

A Stand-off Insulator

THE accompanying sketch shows an H.F. bushing for an S.W. transmitter. It can also be used for a stand-off insulator for a chassis built set. The parts required are an old motor-car plug with porcelain insulator, if possible, an 1/4 in. brass bolt (2BA), and a 2BA terminal nut. The centre part was unscrewed out of the steel body, which was then marked off where it

THAT DODGE OF YOURS!

Every Reader of "PRACTICAL AND AMATEUR WIRELESS" must have originated some little dodge which would interest other readers. Why not pass it on to us? We pay £1-10-0 for the best wrinkle submitted, and for every other item published on this page we will pay half-a-guinea. Turn that idea of yours to account by sending it in to us addressed to the Editor, "PRACTICAL AND AMATEUR WIRELESS," George Newnes, Ltd., Tower House, Southampton Street, Strand, W.C.2. Put your name and address on every item. Please note that every notion sent in must be original. Mark envelopes "Radio Wrinkles." DO NOT enclose Queries with your wrinkles.

needed cutting. The reason for cutting the body is that it would be very difficult to find a nut with a suitable thread to fit, for it is metric. The porcelain body was then cleaned to free the grease and dirt from the electrode for sweating. The centre of the head of the brass bolt was then drilled to a depth of a 1/4 in. and the diameter of the electrode. After the bolt is sweated on the electrode and the terminal screwed on, the component is finished.—C. REGAN (Warwick).

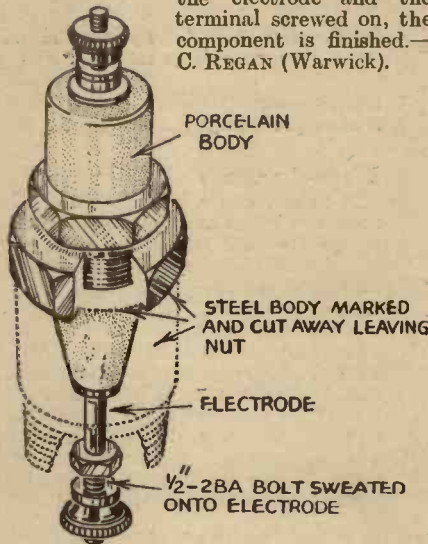

A stand-off insulator made from a disused sparking-plug.

A Set for Cyclists

THE small receiver described below may prove interesting to those constructors who are cyclists, and would like to take their radio with them on picnics, etc. The set itself is a two valver and all the components are standard ones, only the coil being home made. It is built in a plywood case made to fit into the front of the cycle frame, as illustrated. Small hooks are fitted to each side of the case, and by placing

strong elastic bands across these, and passing them once round the cross-bar, vibration is greatly minimised.

The coil consists of two windings on a 2in. former. The grid winding (about 45 turns 22 D.C.C.) is first wound on the former and then covered with a layer of Empire tape or waxed paper. The reaction winding (about 25 turns 26 D.C.C.) is then wound on over the grid winding. The coil is mounted on the case by means of two small metal brackets.

Care should be taken to see that the valves are tight in their holders by opening the valve legs where possible. It may also be found necessary to put cotton wool inside the coil to keep the detector valve in position. In the original set it was found that grid bias was not necessary, and the lead from the transformer was taken straight to L.T.—. A small cell, however, may be incorporated in the case if necessary. It was also found that an earth was not entirely necessary.

Batteries may be carried in the saddle-bag, and a 3-volt dry battery may be used for L.T. if a suitable resistance is placed in the L.T.+ lead. The value of this resistance may be determined by dividing the difference between the battery voltage and the specified filament voltage (2 volts) by the filament current, this being obtainable from the valve data.

The aerial consists of about 12ft. or so of flex hung over a hedge or suspended from the branch of a tree. Over twenty stations can be received on this little set at reasonable 'phonestrength.—P. WATSON (Wealdstone).

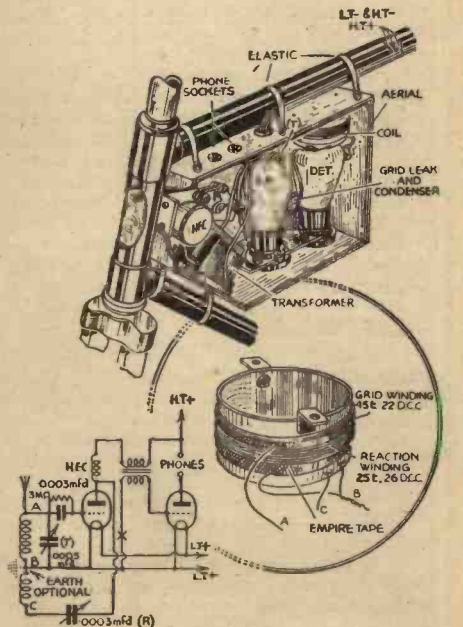

These sketches show a small receiver attached to the frame of a cycle, and theoretical circuit diagram. Coil details are given in the inset.

BUY "THE CYCLIST," 2d. Every Wednesday

# SWITCHES AND

A Detailed Account of the Various Types of Switches Used and Some of the Troubles Which Can Arise in Connection

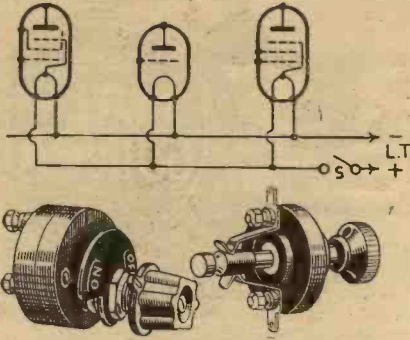

Fig. 1.—Filament switching in a battery receiver, and the usual types of switch which are used.

THE switch is regarded by many wireless engineers as the most important part of a modern wireless receiver, and it is quite true to state that this component gives more trouble than any other part of the combined apparatus. Apart from noises, a defective switch can produce an endless number of faults, some of which are apparent but others of which are exceedingly difficult to trace. In general, switches may be divided into two classes—those employed in circuits in which a large current is flowing and those used in H.F. circuits or circuits where only a very small current is present. The requirements in the two cases are quite distinct as will be shown at a later stage. The various illustrations accompanying this article illustrate not only the particular types of switch but also give in nearly every case the circuit in which such a type of switch may be employed.

The simplest type of switch is that com-

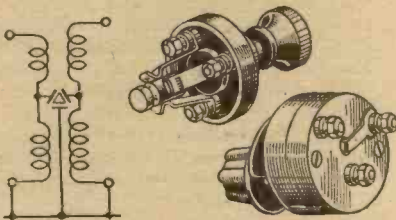

Fig. 2.—For wave-change switching a 3-point switch is often employed.

monly referred to as the push-pull component operated by means of a plunger which is insulated for most of its length, but which is provided with a metal end (supplied in various shapes) which makes contact with metal arms. In its simplest form only two arms are provided, and thus when the metal plunger is present between those arms an electrical circuit is completed and when withdrawn or pushed clear, the circuit is opened.

### L.T. Switching

This type of switch is met with most commonly in the simple battery receiver, where it performs the function of switching the L.T. supply on and off. The filament current of the receiver therefore flows through it (Fig. 1), and thus a poor contact will result either in a lowered current supply to the valves, resulting in weak signals, or an intermittent supply resulting in erratic signals or a background of noises such as crackling. Do not clean the contact faces of this type of switch with emery or other abrasive unless the switch is first removed from the receiver and afterwards thoroughly cleaned. The metal dust which

will be removed by such cleaning will, in many cases, lead to more trouble than the original fault, and, therefore, in most cases it is only necessary to clean the surfaces periodically by the simple expedient of inserting a piece of ordinary brown or other rough paper between the contact faces and operating the switch once or twice to remove the film caused by the action of the atmosphere. In Fig. 1 an alternative form of switch is indicated for this position, which has the advantage that it is totally enclosed and therefore

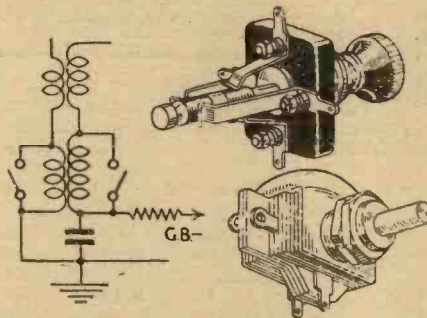

Fig. 3.—Here is a double-pole switch used for wave-change switching.

free from this trouble, and also has a snap action, providing a more certain contact.

### Wave-change

A third contact is sometimes added to these two types of switch, and as the three points are then connected or interrupted the device may be used for wave-change switching, as shown in Fig. 2. The circuit shows the usual arrangement of the contacts on the tuning coil. The third arm is in some cases shortened, and the insulated plunger is provided with a further metal contact so that when operated the connection from one arm to another may be changed. It is possible in this way to obtain a single-pole change-over arrangement, or a double-pole on and off switch, and the latter arrangement is shown in a typical

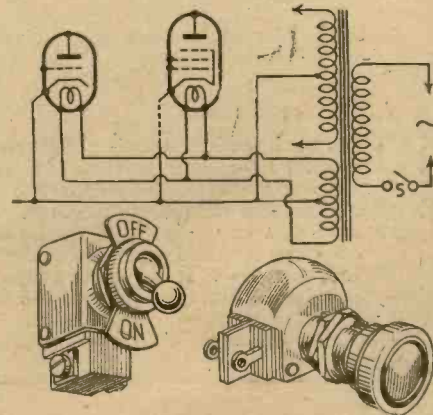

Fig. 4.—A Q.M.B. switch should be used for breaking a mains lead, as in an A.C. receiver

circuit in Fig. 3, together with an alternative switch for the same purpose, designed on slightly different lines. This switch is known as a Q.M.B. type for the following reason.

### Arcing

Where a fairly large current is being carried, if the circuit is interrupted slowly it will be found that an arc or spark will take place between the open ends of the circuit as the break is made, until the distance between the two ends is so great that the current will not jump the gap. If two points are continually opened and closed slowly to produce this arc, it will soon be found that a small hollow forms in the metal, or it becomes what is technically known as "pitted." The pitted surface will, of course, offer a very poor

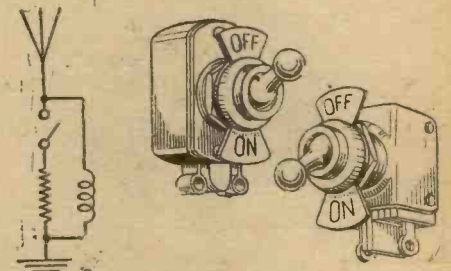

Fig. 5.—Here is a "local-distance" switch and the circuit arrangement.

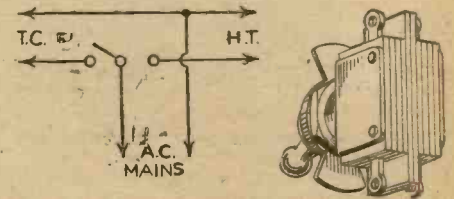

Fig. 6.—A single-pole change-over switch of the Q.M.B. type, and a typical circuit in which it is used.

contact, and will result in noises, apart from the fact that the arc will cause interference in the receiver in the form of a crackle. The main requirement in such cases is, therefore, to open and make the circuit rapidly, and a switch for this purpose is known as a quick make-and-break, abbreviated to Q.M.B., and it is generally totally enclosed, and of the general form shown in Fig. 4. The left-hand model operates by pressing the small knob up or down, whilst the right-hand model has a rotary movement. In both cases the internal contacting piece jumps over in each direction with a "snap" action and prevents arcing and ensures a really sound contact. An alternative use for a switch of this type is shown in Fig. 5, although in most cases it will be found undesirable to use this type of switch for H.F. circuits, where a much more certain contact is required. The same type of switch is obtainable in the form of double-pole, single-pole double-throw and other

# D SWITCHING

in Modern Wireless Receivers, Their Uses and Misuses,  
With These Components = = = By W. J. DELANEY

combinations, one very common model being seen in Fig. 6, where it is employed for switching the A.C. mains supply from a trickle charger to the normal mains H.T. unit. For breaking the D.C. mains supply to a receiver both leads should be interrupted and a suitable Q.M.B. switch is shown in Fig. 7.

## Radio-gram Switching

For changing from radio to gramophone a single-pole single-throw, or single-pole change-over switch is required, and this may be of the push-pull or rotary type, the latter being illustrated in Fig. 8. A Q.M.B. model may be used, of course, or the ordinary push-pull type of component. When using mains apparatus it is often desirable that the H.T. supply shall not be completed until valves of the indirectly-heated type

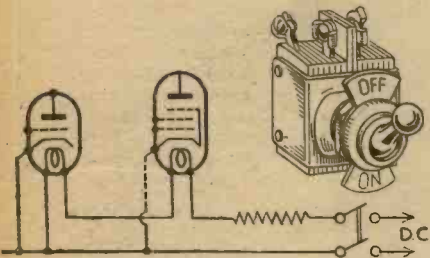

Fig. 7.—In a D.C. receiver both mains leads should be operated, and a Q.M.B. double-pole switch of the type indicated, should be used.

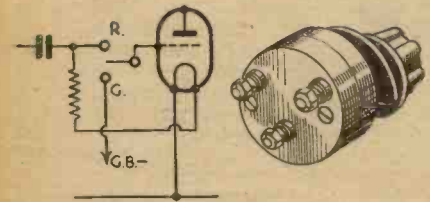

Fig. 8.—A single-pole change-over switch for radio-gram switching.

have warmed up. To ensure that this will be carried out satisfactorily a delay-action switch is recommended and a popular model is seen in Fig. 9. This component is fed from the 4-volt heater winding and takes a certain time for the contact strip to attain such a temperature that it bends and completes the H.T. circuit as seen from the theoretical diagrams. It is adjustable, but is supplied in a form which will take approximately the same time to operate as the ordinary A.C. indirectly-heated valves take to attain normal emission.

## Aerial Switching

It is a rule that the aerial should not be left connected to the receiver, so that static charges cannot accumulate in the aerial circuit, and for a safeguard in the event of a thunderstorm. Many listeners employ for this form of switching a simple single-

pole single-throw switch of the type shown in Fig. 10. Whilst this is quite a satisfactory scheme it must be covered in to prevent the loss occasioned by rain and dirt, and it must, of course, be outside the house to perform the function of a safety device. The other component shown in this illustration is a special form of aerial switch having a quick make-and-break action, and being

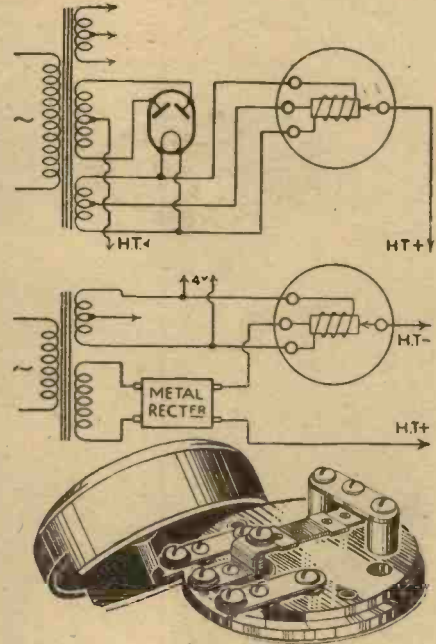

Fig. 9.—Delay switching is advisable if a directly-heated rectifier is used, and this illustration shows a typical circuit and the switch.

provided with a fuse to act as a safeguard in the event of a storm.

## Modern Coil Switching

The modern receiver utilises three or more coils, and the complicated switching necessitated by the fact that the short waves may be covered in addition to the two normal broadcast wavebands, means that very

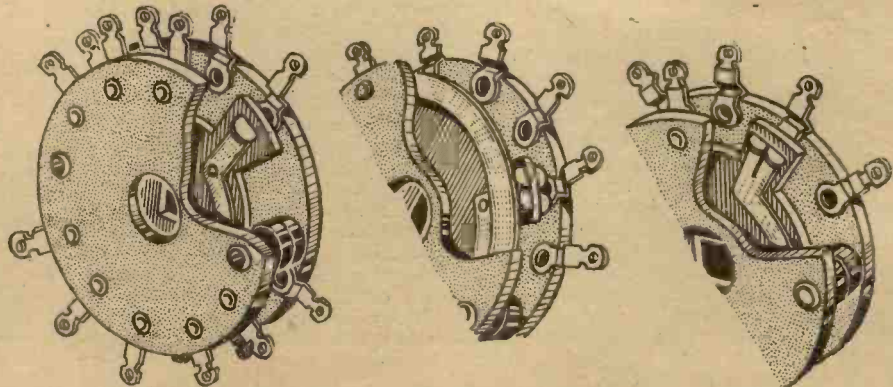

Fig. 11.—Modern coil switching is best carried out by means of a multi-contact switch of this type.

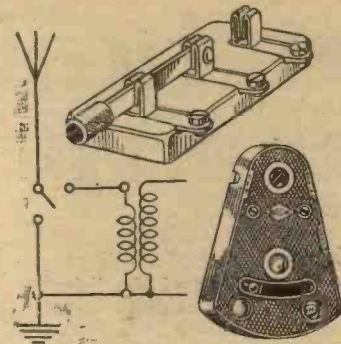

Fig. 10.—For safety an aerial-earth switch should be fitted, and this diagram shows the circuit and two types of switch.

many contacts are required. For this purpose some special types of switch have been developed, and three types are shown in Fig. 11. These have special contacts designed to reduce high-frequency losses, the surfaces being silver-plated for this purpose. They are made in such a manner that any number may be mounted on a square section rod and all operated from a single control knob. Thus any number of circuits may be switched, and complicated change-over arrangements carried out.

## New Types

A modification of the Q.M.B. type of switch has recently been placed on the market and this has only one permanent or fixed position. The alternative position is only maintained whilst the switch knob is depressed, and when released it flies back to the original position. In one model the circuit is held closed, and in the other model the circuit is held open. This type of switch is obviously of most use in experimental apparatus but may be applied to various circuits where it is necessary to make tests from time to time.

There are also available, modifications of the multi-contact switch shown below, where the contacting segments are arranged in some form other than a circle as shown. Thus in one type the spindle is built up in square section with paxolin strips, and the contacts are supported in such a position that the strips of metal on the spindle make and open various combinations. In another form, the spindle is a flat strip of paxolin and the shorting strips of metal are arranged on each side. The principles of working are exactly similar, however, and these switches are principally employed for coil-switching in receivers of the modern all-wave type.

# Practical Television

August 7th, 1937

Vol. 3

No. 62

## New Receivers

PRIOR to the opening of the Science Museum television exhibition, only five firms were manufacturing and marketing television receivers on a proper commercial scale. Two more commercial sets were added so as to be in time for inclusion in the television demonstrations, which have proved such a popular feature at South Kensington. An eighth is also shown in experimental form, but at Radiolympia next month fourteen firms have promised to display their sets in the demonstration rooms. It will be interesting to see on what lines these new models have been developed, particularly in relation to certain controversial features. Will the vision chassis favour the T.R.F. or super-heterodyne, and what scheme will be adopted for the provision of sound? Which will achieve the greater popularity, direct or indirect viewing of the picture on the screen of the cathode-ray tube, and will the long-promised mechanical set at last be revealed to an interested public? Picture size is another important item, and countless arguments will take place as to the merits or demerits of the 10in. by 8in., 12in. by 10in. and anything larger or smaller than these figures which at present represent normal practice. At the Science Museum Scophony have shown a picture 24in. by 20in., but until the picture seen conforms to the present B.B.C. standard, and is shown receiving the normal radiated picture, it cannot be included in any commercial category for comparison purposes. The next few weeks will provide replies to these questions, and according to reports the general public will be agreeably surprised at what the manufacturers will have to show.

## Over Seven Years Ago

IT was just over seven years ago that the first play was televised. Called "The Man with a Flower in his Mouth," it was produced by Lance Sieveking; the part of the Man being acted by Val Gielgud. This early effort is recalled by the presentation of the same play at the B.B.C. Alexandra Palace Station. The contrast in both the picture results and the method of production when compared with the thirty-line efforts was remarkable. In 1930 the scanner was a thirty-holed disc which could not be panned, while the photo-electric cells (the spotlight principle was being employed) were fixed in position. Special scenery was drawn by Nevinson, and only the head and shoulders of a single player was seen at any one time. The occasion was a memorable one, however, as it coincided with the introduction of the first big screen—2ft. by 5ft.—by the Baird Company; this being built up from 2,100 tiny lamps housed in separate compartments of a honeycomb mesh. The enormous progress made in the past seven years, both at the transmitting and receiving ends, was shown very clearly by this latest B.B.C. effort, and if the same rate of improvement is maintained, then television of the future will be a remarkable accomplishment.

## Offsetting Stray Effects

WHEN a cathode-ray tube is operated externally by means of magnetic coils which focus and deflect the electron stream, there is always a tendency for the fields so produced to deviate from their required paths, and in so doing bring about a measure of distortion in the scanning field seen on the tube's screen. In some cases small fixed magnets are used to counteract the passage of stray fields, but considerable care in adjustment is generally



Russell Swann, the conjurer, before the television camera at the Alexandra Palace studio.

necessary in a case of this nature. A much better scheme is now employed in one or two commercial receivers for the frame-deflecting unit which has a ferro-magnetic core. A pair of adjustable laminated pole pieces are provided, these having the appearance of short arms at the terminating sections of the magnetic core. When the receiver is installed on site any slight irregularity in the scan due to stray or misplaced magnetic fields is offset by adjusting these wing arms. Most effective in practice and simple to operate, the scheme is a very sound one.

## An Early Defect

WHEN the large diameter cathode-ray tubes were first used for television some two or three years ago, they possessed many inherent defects, the bulk of which have now been overcome by more exact methods of manufacture. Although some of the points have been mentioned before, the accepted essentials of a good television C.R. tube are worth repeating: The production of an electron beam through the medium of an electrode system which also directs it towards the front screen, to evidence itself as a small bright spot of circular cross section and uniform in brightness over its whole area. Following on this comes the movement of the spot in a series of horizontal lines, so that it traces

out a rectangularly-bounded area without optical distortion. The screen must be uniform in colour and thickness and free from obscuring patches, with the glass envelope thoroughly tested to overcome any risk of flaws causing implosion. Modulation of the electron stream so that the picture formed possesses the full black to white range through all the half tones and shown at sufficient brilliance to be observed in a room whose lighting is normal. In producing tubes of this nature manufacturers have encountered many difficulties, and not the least of these is the flaking off of the fluorescent screen during use. With a horizontally-mounted tube these flakes do not upset the electrode system, since the pieces lodge at the base of the screen. In the case of vertical tubes, however, any portions of the screen which may become dislodged find their way on to the orificed anodes and block the electron stream if they fall on the hole, while sometimes they seat themselves on the cathode itself and destroy the emission. This was a very major problem, but judging from present-day performance this form of defect has been successfully overcome without the binding agent upsetting any of the screen's other characteristics.

A Year Ago  
A SPECIAL committee of the Institution of Electrical Engineers a year ago presented a report dealing with the interference of electrical apparatus on

radio reception. Certain recommendations were made for schemes to cure this trouble, and now after a lapse of twelve months it is learned that legislation is being prepared to meet the case. Why there should have been this "lag period" is difficult to understand, and since the report was published it has been demonstrated very forcibly that not only ordinary radio equipment but also television receivers are prone to the deleterious effects of certain specialised forms of electrical apparatus. In very many cases quite simple precautions taken at the source of the offending equipment will bring about a cure, and this is far more effective than palliatives adopted at the receiving end. It was proposed that the Post Office should enforce any regulations that may be framed, and although difficulties may arise in some cases, the effect of the Parliamentary bill should be beneficial to a very large section of the community.

## RADIOLYMPIA

### NOTE THE DATES

August 25th to September 4th.



# BRIEF RADIO BIOGRAPHIES-17

By RUTH MASCHWITZ

## Scott and Whaley

SCOTT AND WHALEY, cross-talk comedians of "Kentucky Minstrels" fame, met by chance. Over thirty years ago a little, ragged, shivering boy found his way into a public bar in Syracuse, U.S.A. He was half-starved and was trying to make a few cents by playing the piano and doing acrobatic tricks. Serving behind the bar there chanced to be another young coon, and that was how Scott and Whaley, first singers of ragtime in this country, came to meet. Since then they have stayed together.

Scott's parents were determined he should become a solicitor after leaving High School, but instead he learned acrobatics, and at the first opportunity joined a travelling circus as a clown. Unfortunately when the circus reached Canada, the manager absconded with the takings, leaving Scott quite penniless. He tramped through the snow to the next village, but here the police sternly warned him that no tramps were allowed. "Follow the railroad for fifteen miles and you'll come to another village," they suggested.

By doing odd jobs he eventually made his fare to a town near Buffalo and found work at the local theatre, where he made good. Imagining himself well on the way to success, he boarded a train for the States, but here he was not so lucky and at last was forced to return home. He was, however, still determined to follow the profession he had chosen, and before long he set out all over again.

Meanwhile Whaley had been having quite as hard a time as Scott. He, being mad on dancing and something of an acrobat, also ran away from home to join a circus. Here he received half a dollar a week and was put in charge of the monkeys.

He sang as well, but this brought him no increase of salary. When the circus went into winter quarters, Whaley found himself stranded. After much privation he got the job of errand boy to a dentist. In the evenings he augmented his pay by playing and singing in a public house. From then his appearances at the dentist's became rather erratic, and the man sacked him. He then started to serve drinks at the bar.

Scott and Whaley, now united, worked up an act with Scott at the piano and the latter singing. They could both dance. They decided to try this out in New York,



Scott and Whaley in characteristic mood.

and as they hadn't a dime between them, they had to reach the City by hanging on to the backs of lorries, dropping off from time to time to earn a few cents by singing at various bars. At last they reached New York, penniless but triumphant, and their first job earned them six dollars, which seemed princely to them.

Their next job brought them in five times as much, but, because they were not starred, they walked out on it. An agent now approached them and booked them for a road show. From then onwards they never looked back.

In 1909 they first came to England and declare that they never wish to leave. English audiences can't be beaten in their estimation.

# A DISTORTION SUGGESTION

TRAPEZOIDAL distortion which destroys the rectangular shape of the scanning field on a cathode-ray tube has been the subject of serious investigation by many television engineers. When present in a receiver the effect is very annoying, being due primarily, in the case of electrostatically operated tubes, to the lines of force between the two pairs of deflector plates tending to fan or spread outwards at the edges of the plates. This non-uniformity of the field through which the beam of electrons has to pass gives an incorrect deflecting force, so that on the screen the lines do not cover a uniform distance as would be the case with a perfect

field; that is, one with perpendicular lines of force over the whole of the space between each pair of plates. Plate shaping is one method used to neutralise the effect, but another suggestion is to use a form of guard ring at the deflecting plate ends near the accelerating orificed anode. By properly adjusting the voltages applied to this ring the field spread can be prevented. In the case of electromagnetically operated tubes this trouble does not occur, for the line and frame deflector coils used external to the tube can be so shaped, either before or after installation of the receiver in the home, that no distortion of the scanning field is seen at all.

# PETO-SCOTT

## Peto-Scott NOISE SUPPRESSING LL-WAVE AERIAL



- Eliminates Man-made Static.
- Increase Signal Strength on all Bands.
- Improves Selectivity.
- Waterproof and Weatherproof.
- Two Transformers.

Obtain utmost entertainment by using this Aerial Outfit, the first really economical solution for overcoming the noise of man-made static. AERIAL OUTFIT COMPRISES Duplex enamelled aerials, insulators, waterproof "lead-in" wire. Aerial and Set Transformers, assembled and ready with instructions and drawings illustrating the method of erection. CASH OR G.O.D. CARRIAGE PAID. £17/6 Or 8 monthly payments of 2/6.

26 DOWN

## HERE'S NEWS!

A revolutionary new advance in Short Wave Home Construction! Peto-Scott's famous Short-Wave Experts have worked together and produced the—PILOT

### "SHORT-WAVE EXPERIMENTER"

a booklet of 34 pages, illustrating and describing a range of 9 wonderful new PILOT short-wave kits. Each of these designs incorporates a standard chassis and panel. Commencing with a modest, but super-efficient 1 - valve Adapter - Converter you may, whenever you please, build this up, on the same chassis, into varying forms of 1, 2, 3 and 4 - valve Short-Wave Receivers, complete in steel cabinet. No short-wave fan can afford to miss the fascinating hours this booklet will bring him.



Send 1/6 in stamps for free copy of this 6d. Booklet.

All Postal Orders must be crossed and currency registered.

**PETO-SCOTT Co. Ltd.,** Established 1919

77 (Pr. W. 46), City Road, LONDON, E.C.1

62 (Pr. W. 46), HIGH HOLBORN, LONDON, W.C.1

Holborn 3248

## ELECTRADIX BARGAINS

TRANSMITTERS, MORSE AND SIGNAL KEYS, Royal Air Force model, balanced action, solid brass bar, tungsten contacts, indicator lamp. Type KB3L, a guinea key for 7/6. Other keys from 4/6 to 30/-.

LEARNER'S outfit complete, 4/6. Ask for Muster List Key List.

TELEPHONES for House, Office, Garage and Field Sports. Wall type, as illustrated, 15/-. Other Wall and Table models cheap. Send for lists.

METERS, for fault finding, etc. Bargain line in portable moving coil by Everett Edgecombe, 40 to 120 volts for home conversion to multi-range, 21/6. Western Push band milliammeters, 0-30 or 0-100, 17/6 each. E.E. voltmeters, A.C., 240 v., 25/-.

A £15 A.C./D.C. Type "8" Radio Tester, as new, 55/17/6.

PANELS. Aluminium 16- and 18-ounce one side enamelled. Paxolin and Ebonite, any size, from 24in. x 24in. at low prices.

CONDENSERS. 2-range variable 0005, new, 2/6; single, 1/6.

COILS, Philips Superhet set of 3 in maker's carton, 3/- set. 8-W. coils plug-in, 1/6. Ribbed formers, 6d. Long-wave and B.C. 2-pin, 1/-.

Reaction tuners, 9d. H.P. twin chokes, mains, 9d. Rugby and other coils in stock. All wavelengths in 2-pin, 1/3. Brownie dual-range 200/2,000, 1/6. M.I.C. concert coils, set of 4, 2/6; aerial, react., long, short and multiple, 1/6. 8-W formers, ribbed and slotted, 4d.

RESISTANCES. H.M.V. in glass tube, wire ends, 10,000, 25,000, 50,000, 100,000, 500,000 ohms and 1 meg., 1/6 set of 6.

CRYSTAL SETS. Still the Best Radio Receiver. No battery or valves wanted. Quiet and efficient reception. 500 shop-sold sets, cheap. Enclosed type, 5/6 and 7/6 each.

HEADPHONES. Light weight, 2,000 ohms, 4/6. Single high res. earpieces, 2/6. Sullivan 120 ohm W.D. model. Aluminium body and headbands. Maker's price to-day, 15/-. Our price 2/6 per pair, 3d. postage.

DOUBLE CURRENT GENERATORS, D.C., 600 volts 100 m.a., and 6 volts, 3 amps. Cost £15 Ex. Govt. 25/-.

X-RAY TUBES. As illus. previous issues. Brand new W.O. Hospital Surplus. 7in. dia. bulb big tungsten electrodes. Full emission. Cost 45. Sale 15/-.

TACKLING, 2/6.

SPARK COILS. 4in., 1 1/2in. and 1 1/4in. gap, with condensers, 10/6.

Large 7in. coils in mahog. case, 27/10/6. Short wave spark transmitters for boat model control, 17/.

SOLENOIDS. 6-volt, for model work or distance switch, core travel 1in., pull 1oz., 3/6. A.C. Magnets, 230 volts, 30 m.a., 14 oz. lift, 2/6.

FLEX CORDS. 3-way, 6ft. long, 6d. 4-way, 12ft., 1/-.

4-way, 6ft with plug and socket, 1/6. Govt. 6ft. telephone cord, with plug, 1/6.

LIGHT AND RAY CELLS. Selenium Cells 5/- and 7/6. Kingston 10/-. Raycraft Bridge 21/-. Beck Angle Prisma, mounted in carrier, 5/6. Micrometer adjusters for lens, 1/6. Eyepieces with prisms and lenses for photoelectric inspection, 12/6. Selenium Cells, 5/- and 7/6. Ray Selenium, 1/- piece.

MIRROBS.—5 1/2in. dia. Helio or Television, 1/6. Parabolic Concave, 10in., 20/-; 20in., 25/-; 24in., 30/-.

COPY FWD. Neon Lamps, 2/6 and 3/- each, with holder. Miniature Neons, 2/6.

TOTE SELECTOR RELAY SWITCHES, 6 gangs of 25 ways, magnet operated, 8/6.

MAGNETIC TRIP SWITCHES, 1 to 1 amp. A.C. or D.C. 5v. to 500 volts, bakelite cover, ideal circuit protectors, 6/6.

Summer Interest in ELECTRIC HOME RECORDING. Our prices are unbeatable as factory cost was twice our sale price. The FEIGH RECORDER fits any Radiogram and is positive drive by worm gear and rack. Only 37/6.

**ELECTRADIX RADIOS,** 218, Upper Thames Street, London, E.C.4

Telephone: Central 4611

# A SIMPLE FREQUENCY METER

An Inexpensive Unit which can be Used Either as a Frequency Meter or Monitor is Described in this Article

IT is surprising how many amateur transmitting stations do not use, or even possess, a frequency meter or monitor. Perhaps the reason for this is that they rely too much upon the accuracy of their crystal or crystals.

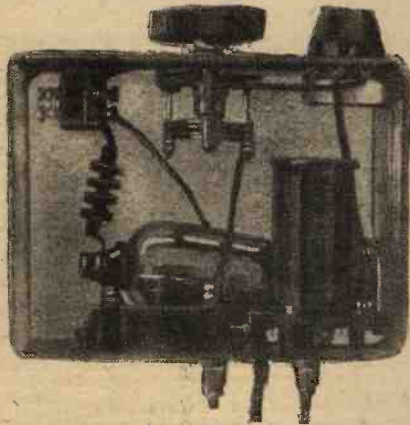

Fig. 2.—View of the interior of the meter showing the valve and coil in position. The by-pass condensers have been omitted.

The apparatus required is very simple and inexpensive, consisting of a valve oscillator and accompanying tuning arrangements. In the design of such a unit there are several points which must be noted, namely, 1. Complete stability with inclusion of good components for accurate calibration; 2. Complete rigidity and constant voltage regulation; and, 3. Inclusion of means for monitoring the transmitter.

In Fig. 1 will be seen a general view of the unit, which consists of a screening box with tuning and regeneration controls, and the monitor 'phone jack. The circuit consists of an electron-coupled oscillator, which incorporates to the best advantage all the points enumerated above. The 3.5 megacycle band is used as fundamental, as it is very stable, and also gives the best harmonics on the higher frequencies. An A.C. mains valve is used, as it affords an easy means of electron coupling, and voltage regulations are more reliable with this valve than with a battery type.

## General Arrangement

A general view of the interior of the unit is given in Fig. 2, from which it will

### LIST OF COMPONENTS

- One screening box, 7in. by 5in. by 4in.
- One 25 mmfd. variable condenser, type 1045 (Eddystone).
- One 100 mmfd. preset condenser (Formo).
- One .0003 mfd. mica condenser (Dubilier).
- Two .1 mfd. tubular condensers (T.C.C.).
- One 5-pin valveholder (W.B.).
- One 4-pin valveholder, type 1015 (Eddystone).
- One .1-megohm gridleak (Eric).
- One .1 meg. potentiometer (Dubilier).
- One H.F. choke, type 1010 (Eddystone).
- One plug and jack (Igranic).
- One coil former (Eddystone).
- Two midget stand-off insulators (Eddystone).
- One valve, type S4VB (Mullard).
- Screws, wire, systoflex, etc.

be seen that the valve is placed in a horizontal position, while the coil is also horizontal but at right angles to the valve. The coil is tuned by a .0001 mfd. pre-set condenser which acts as band-set, and an Eddystone type No. 1045 bandsread condenser with integral slow motion.

Regeneration is controlled by a .1 megohm potentiometer which varies the screen voltage. If a metallised valve is used care must be taken that it does not touch the box, for should it do so the cathode tap would be shorted and oscillations would cease. The grid condenser, the connections for which are less than 1/16 in. long, is of .0003 mfd. capacity, with a .1 megohm gridleak across it. A single closed jack has been included in the plate circuit, with an H.F. choke in series. When a pair of 'phones are inserted in the unit acts as a monitor. Two .1 mfd. by-pass condensers

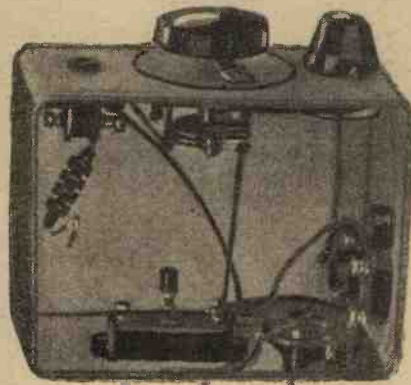

Fig. 3.—The short grid leads will be seen in this illustration, which also shows the band-set pre-set condenser.

are included, one from the screened grid to earth, and the other across the H.T. supply.

Provision has been made for a short piece of wire to act as a pick-up for higher frequencies or transmitter carrier, and this is connected to the set through a very small capacity condenser, consisting of a few turns of wire wound round a wire covered with systoflex, attached to the grid end of the coil. This is brought out to a midget insulator on the back of the box, as is also an earth connection.

The coil consists of 26 turns of 22-gauge enamelled wire on an Eddystone threaded former, with the cathode tap at the sixth turn.

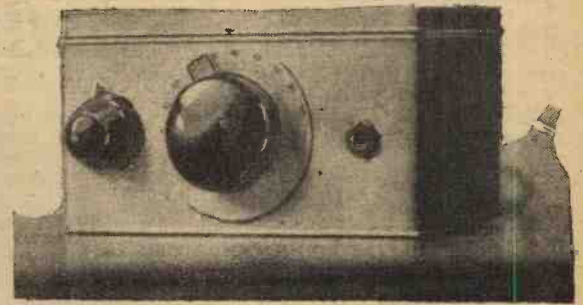

Fig. 1.—A general view of the frequency meter, showing the two controls and 'phone jack.

## Operating Details

Using a valve such as the Mullard S4VB, and about 150 to 200 volts on the plate, the potentiometer about half-way, and the unit placed a few feet from the receiver which is tuned to 40 metres, a beat note should be found when the preset is turned. This condenser is mounted, it will be noticed, some way off the box by means of insulating washers. Having found this beat, the preset should now be adjusted until, with the lid on the box and the bandsread condenser set between 0 and 15 degrees, the beat comes in at the H.F. end of the 40-metre band. The receiver is now set at a known frequency in the 40-metre band and the meter bandsread adjusted until the beat is again heard. This new reading is noted, a new known frequency on the receiver is taken, the meter brought into line, and its reading again noted. This process is repeated until enough points have been found to form a graph of frequency against dial readings on the meter. As has already been mentioned, it may be found that a short wire will have to be connected to the aerial terminal on the meter to transfer R.F. from the meter to the set when using it on the higher frequency bands.

## Calibration

The signal in the receiver which is to be calibrated, or whose frequency is to be measured, must not be too strong, or it will spread, and an inaccurate measurement will result. For 14 mc/s working the frequencies have only to be doubled for corresponding readings on the meter dial. An alternative and more accurate way of calibrating this meter is to use a 100 kc/s quartz crystal, whose harmonics can be picked out every 100 kc/s.

The meter can be operated from the receiver power supply.

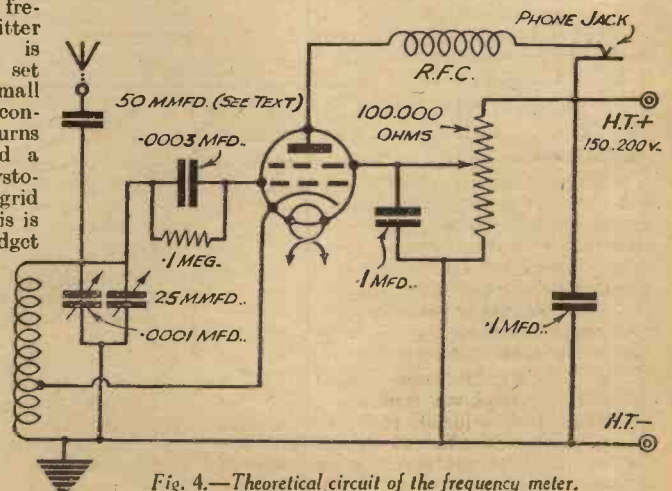
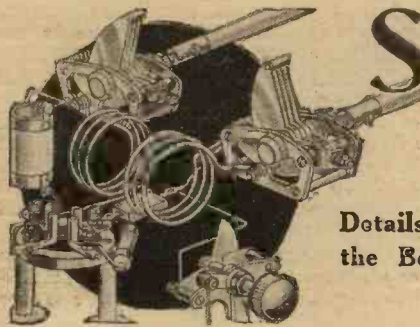

Fig. 4.—Theoretical circuit of the frequency meter.



# Short Wave Section

Details of a Simple and Efficient Set for the Beginner are Given in this Article  
By A. W. MANN.

THOSE who are about to take an active interest in short-wave listening view the subject from various angles. For example, a multi-stage loud-speaker set may have an appeal, but the cost may be prohibitive apart from the limited constructional abilities of the individual, and the fact that a number of spare components are on hand which he desires to use.

Apart from the duplication of sponsored

two aerial inputs are provided, and thus it is possible to use aperiodic coupling by connecting the aerial to socket A2, whilst in the event of dead spots being experienced the .00005 mfd. pre-set condenser can be introduced into the circuit by transferring the aerial to socket A1.

It will be noted that standard low-frequency transformer coupling is included. Whilst the advantages of R.C.C. and parallel feed are appreciated, the writer is

than justifies the expense of the bandspread condenser. I have specified one of 15mmfd. capacity, and in purchasing a suitable condenser readers should keep in mind the Raymart product, which is capable of modification within limits, and enables the overall spread to be increased if desired.

### Concerning H.F. Chokes

Now a few remarks concerning the high-frequency choke. As plug-in coils are used it is possible with the aid of suitable coils to extend the tuning range of the set. For example, Eddystone and B.T.S. make a full range of coils from 9 metres to 2,000 metres. The short-wave enthusiast will, in most instances, limit his reception to 80 metres, but later may desire to extend the range to cover the 160 to 170 metres bands, in order to receive top band amateur 'phone and trawler 'phones, etc. It is far better to look ahead in this respect, and therefore to fit one of the new screened type all-wave H.F. chokes.

The average range of choking efficiency as stated by various makers is 12 metres

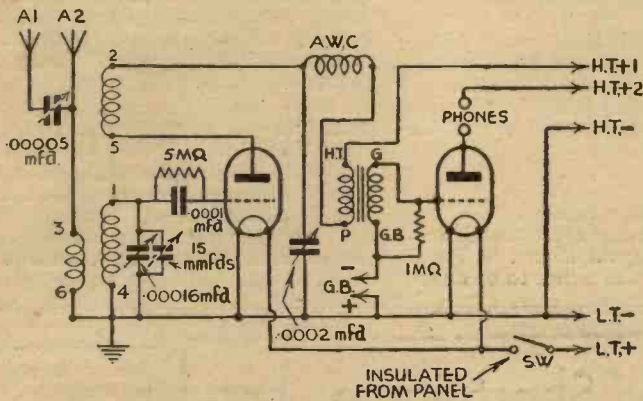

Fig. 1.—Theoretical circuit of the receiver described on this page.

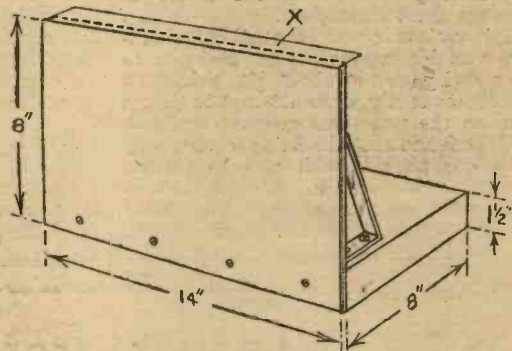

Fig. 2.—How to make up the chassis and panel.

designs and specifications, it is inadvisable to attempt the construction of an elaborate short-wave receiver at the start, and so far as experimental models are concerned the best plan is to choose a circuit which is within one's constructional ability and financial resources, and in addition, is most likely to be trouble free.

There are all kinds of transmissions to be heard on the short waves nowadays, and whilst the beginner may eventually specialise in listening to short-wave broadcasts, amateur phone and C.W., it is as well to choose a circuit which will enable him to listen to them all at the start and enjoy more or less unlimited scope.

### Essential Features

The most important features considered to be desirable in a short-wave receiver are sensitivity, selectivity, maximum volume with low noise ratio, together with ease of operation and stability.

A super selective short-wave receiver is a very expensive proposition. We must, therefore, rest content with average selectivity. Sensitivity, low noise level and ease of operation are, however, within our scope. The idea, therefore, must be to make the best use of the materials available, avoiding the introduction of complications or original ideas until more experienced.

Fig. 1 shows the theoretical circuit of a two-valve headphone receiver capable of providing world-wide short-wave reception. The popular and efficient six-pin coils are used. The numbers given being those of standard connections as recognised by coil manufacturers. It will be noticed that

of the opinion that providing a good make of L.F. transformer is used, and care exercised during the construction and wiring of the receiver, there is no reason why a set using this type of L.E. coupling should not provide satisfactory results.

Moreover, an L.F. transformer is usually to be found amongst the home-constructor's spare components.

The inclusion of band-spreading, as shown, is a very valuable feature, and more

to 2,000 metres. In some instances it is possible to obtain efficient choking down to 10 metres, but in any case should reception on the latter band be desired, an ultra-short-wave choke and the all-wave choke in series will enable satisfactory results to be obtained.

Having decided to use the circuit shown in Fig. 1 as the basis of an experimental receiver, the first consideration is the method of construction to adopt.

### Chassis Construction

The writer favours chassis construction, and in deciding on dimensions we must exercise care and look ahead a little. For example, we wish in the interests of efficiency to keep wiring short and direct, yet cramping must at all costs be avoided. On the other hand, however, the chassis dimensions must not exceed certain limits, as this will introduce longer wiring.

When the writer tried out the circuit, as outlined, during a series of experiments, results were very satisfactory indeed. (Continued overleaf)

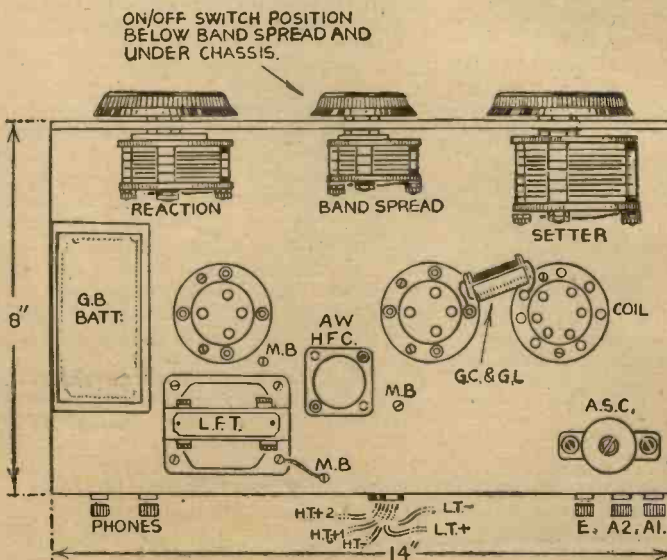

Fig. 3.—A suggested practical layout for the 2-valver.

### SHORT-WAVE SECTION

(Continued from previous page)

The fact that others will use different components, however, must be taken into account, together with circuit differences and losses in practice.

The dimensions of the chassis and panel, as shown in Fig. 2, have been chosen with those considerations in mind, and will be found to meet most requirements, and in addition, leave sufficient space for the inclusion of decoupling components, and an L.F. output choke, etc., at a later date, if desired.

Now chassis and panel assemblies are comparatively simple to make, but it is advisable, in order to avoid trouble later on, to exercise caution. It is, therefore, a good plan to carry the foil the full length of the underside, and then fasten the end runners in place.

Another important point concerns panel brackets, but before discussing this, we must first consider the panel requirements. A heavy gauge metal panel, whilst the most satisfactory, must in this instance be ruled out on the score of expense. The cheapest method is to use a plywood panel, and an aluminium sub panel, the former of 3/16in. plywood, and the latter of 20 gauge sheet aluminium.

Now various types of available short-wave variable condensers are designed to suit metal panels of about 1/4in. thickness, and, consequently, if we attempt to mount them on the panel arrangement outlined, it will be found that the fixing nut has only about one thread hold, and to tighten extremely will result in stripped threads.

The most satisfactory procedure under the circumstances, is to drill the aluminium

panel to suit the condenser bushes, and in the wooden panel drill clearance holes of sufficiently large diameter to clear the condenser fixing nuts. Before doing so, however, the sub panel and front panel together with brackets should be set up as a unit. After this remove panels leaving brackets fastened to them, and mark out the centres on the aluminium panel. Next, dismantle and drill to individual requirements.

Reverting to panel brackets, etc., whip must be avoided, and as the front panel is simply an overlay, it is advisable to fit wooden blocks butting against back metal face under chassis, and screw firmly. In addition, by allowing an extra 1/4in. width, and bending over the top edge of panel, as at X, Fig. 2, a more rigid assembly will be obtained.

The panel mounting brackets should have as much bearing on the chassis face as possible, and the wider they are in the base the more rigid the assembly. If, however, panel component bushes are of sufficient length to mount satisfactorily through the double panel thickness, the possibilities of whip will be considerably reduced.

It will be noted that panel drilling dimensions are not given in Fig. 2, as dials and condensers of different dimensions will be used, so it is better that the individual constructors arrange matters to suit circumstances.

#### Layout

One of the most important considerations relative to short-wave receiver construction, is layout. The layout shown in Fig. 3 has been found by the writer to be a most

satisfactory one, which enables the wiring between the band-setting condenser and coil-holder to be kept extremely short.

The metal panel and chassis foil are at earth potential, and the moving vanes of the three tuning condensers are also at earth potential, via the metal panel. The earthed side of the filament is made direct to the foil via the small bolts MB, and same applies to the earthy end of the grid and aperiodic coils.

The wiring up and general construction of a simple two-valve receiver is more or less straightforward. It is, however, advisable to use small washers in conjunction with mooring bolts, one to face of chassis, one to foil face with wire in place, and another washer on top of the wire loop.

Double nuts will ensure a satisfactory connection, but this should not be taken for granted, and a continuity test between bolts and earth terminal common to foil and sub panel, should be carried out. This applies to every chassis type receiver.

A receiver of this type when put on test will, providing care has been exercised during construction, prove to be satisfactory, and a general run around the various tuning ranges will bring in a variety of signals.

At first the beginner should just tune around to see what he can find, get a general idea as to the various ranges covered, and regard learning how to operate the set as the chief concern of the moment. Later, calibration of band-setter and spreader over all ranges can be carried out, and DX listening to schedule undertaken.

#### Switzerland Tests on 56 mc/s

THE Union of Swiss Short-Wave Amateurs

will carry out a series of tests in

transmission and reception on 56 mc/s on Saturday and Sunday, August 14th-15th. The station, installed on Mont Tendre (Jura) at an altitude of 1,683 metres, will use the call-sign HB1AQ, with a power of 40 watts. The schedule has been established as under: G.M.T. 18.00-18.15: in morse: CQ Five de HB1AQ; 18.15-18.30, period reserved for reception; 18.30-19.00, replies in telegraphy and telephony. These tests will be carried out hourly from Saturday, August 14th, at G.M.T. 18.00, to Sunday (August 15th), finishing at G.M.T. 16.00. A QSL card will be sent to all listeners who forward reports on the reception of the HB1AQ signals.

#### A Far-flung Call

France is developing her Colonial system of short-wave broadcasts, and recently added a further unit by the opening of a transmitter at Fort-de-France in the island of Martinique. The station works on 31.73 m. (9.454 mc/s) daily between G.M.T. 16.00-17.00, and again from 22.15-23.00. During the evening a relay is effected of the Paris-Colonial news bulletins.

#### America's Most Powerful S.W. Station

The new WEF, Rocky Point (N.J.) station has been installed to put over signals to Europe under all conditions of interference such as atmospherics, fading and so on; its power is 200 kilowatts. The channel used for commercial work is 28.25

## Leaves from a Short-wave Log

mc/s) is now heard almost daily on a lower channel, namely, 27.17 m. (11.04 mc/s). The station now comes on the air at G.M.T. 16.00. A

woman announcer presides over the studio, and a bugle call is used as an interval signal.

#### Two New South Americans

A correspondent informs me that he has logged a call: TI2H, emanating from San José (Costa Rica), on 51.75 m. (5.798 mc/s), which appeared to be a prelude to a series of tests carried out from G.M.T. 03.00. From another source, I learn that TG2, in Guatemala City (Republic of Guatemala) has been experimenting on 47.5 m. (6.31 mc/s), and was asking for reception reports. This may, however, not be a new station, but TG2X, Guatemala City, picked up last year by many listeners on 50.51 m. (5.94 mc/s), and stated to be operated by the National Police Headquarters in the Guatemalan capital.

#### "Mystery" Station

On 31.46 m. (9.535 mc/s), announced in German, a station has been frequently heard during the past few days, and although certain indications are provided, the actual location of the transmitter is carefully kept secret. The broadcasts, which consist of news bulletins and long talks on the freedom of nations, is carried out regularly every night after midnight B.S.T. in German, Spanish, and Italian. War news bulletins are included in an otherwise dull programme. From the call, "Radio Libertad," and the many references to local topical events, the station would appear to be situated in Spain, and to be operated by the Government party.

m. (10.62 mc/s), and it has been reported that the morse transmissions received in the British Isles are from 750-1,000 times stronger than those sent out from the United States on long waves at equal power.

#### Japan's Altered Schedule

In view of the present trouble in the Far East it is interesting to note that the two Tokio-Atagoyama stations now broadcast simultaneously a short news bulletin in English every evening between G.M.T. 20.00-21.00. The transmitters in use are JZK, 50 kW, on 19.79 m. (15.16 mc/s), and JZJ, of equal power, on 25.42 m. (11.80 mc/s). The broadcasts are made daily in English and German, but in French on Mondays, Wednesdays, and Fridays only; they are preceded or followed by a short concert of Japanese or Western music.

#### Is This Warsaw's New Station?

Listeners reports the reception of tests carried out by a Polish transmitter on 22.22 m. (13.5 mc/s) between G.M.T. 10.00-12.00, and which gives out the call-letters: SPAO, followed by the words "Postes et Télégraphes, Varsovie (Warsaw). So far, broadcasts from Poland on short waves have been captured through SPW on 22 m. (13.635 mc/s).

#### Lisbon on New Channel

CSW, Lisbon (Portugal), which was testing some little time ago with a programme relayed from the medium-wave National transmitter, on 27.28 m. (10.995

# Constructional Details of "Practical Wireless" Receivers—12

THE simplest receiver is capable of producing remarkable results on the short-wave bands, and provided that it is well designed and constructed it will provide many hours of entertainment. In the Prefect S.W. Three a simple detector stage with one tuning circuit is employed, and to make certain of adequate volume two L.F. stages are added, thus making the receiver into a three-valve set. As an additional point good quality is ensured by arranging that one of these L.F. stages shall employ resistance-capacity coupling, whilst the other utilises a standard L.F. transformer. To keep the H.T. consumption to a reasonable figure only triodes are employed, but it will be found that these provide quite a good combination and if the constructor desires he can, of course, replace the output triode by a pentode.

The illustration gives a good idea of the neatness of the lay-out and it will be seen that only the coil, condenser and valves appear on top of the chassis, all the remaining parts being underneath out of the way of dust.

## Construction

The full-size blueprint, No. PW63, gives the lay-out and wiring, and it will be found a very simple matter to construct this receiver. As it may be desirable to tune to some very low wavelengths, the wiring to the tuned circuit should be carried out with thick tinned copper wire to reduce losses and the special low-loss coil-holder and valveholders which are specified should be employed. It is important to note that the terminals which are specified are provided with insulating bushes, and unless these are used the aerial, earth and loudspeaker terminals will short-circuit across the metallised rear strip of the chassis. An important point to note is that on the underside of the chassis there are two anchor points, where leads and resistors are joined to the head of a screw. This screw must on no account be of such

The Prefect S.W. Three is the Subject of This Article. It is an Easy-to-build Receiver Especially Suited to the Beginner

a length that it projects far enough to make contact with the metallised surface, as it will then short-circuit the H.T. and G.B. supplies. If it is not possible when building

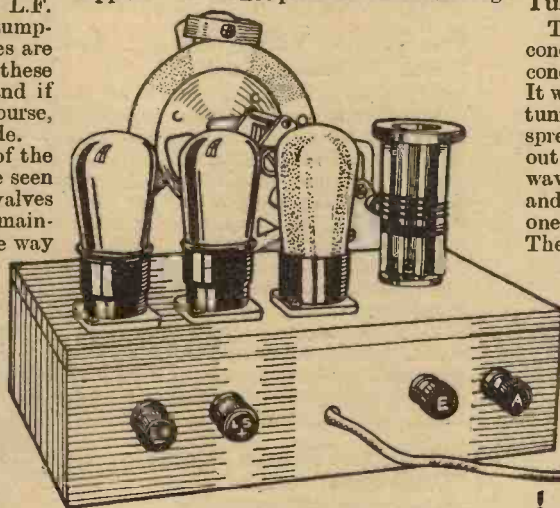

The Prefect S.W. Three removed from its cabinet.

the receiver to find a screw which is short enough, it should be screwed into the chassis, removed, and then the metallised surface round the point where it protruded should be thoroughly scraped and cleaned away so that when re-inserted no risk of a short-circuit will occur.

## Wavebands Covered

The special six-pin coils may be obtained in various sizes to cover different wave-

bands, even up to the normal broadcast wavelengths, and therefore it is possible to tune to any desired wavelength. The most useful band, especially for the beginner who is not used to the handling of a short-wave set, is the 24 to 52-metre range. There are dozens of stations available, including the 40-metre amateurs, and when the handling of the tuning control has been mastered at the lower part of this range one of the shorter range coils, going down to 10 metres or so, may be employed.

## Tuning

The main tuning is carried out on the condenser C1, and the small band-spreading condenser C2 is used as a vernier device. It will be found that by advancing the main tuning control, say one degree, the band-spreading condenser may be turned through-out its complete range to spread out the wavelengths covered by that one degree, and the main control may then be advanced one degree further and the process repeated. The receiver should be kept just off the oscillation point and the reaction condenser, C3, should be kept at a suitable setting. It will probably be found in most cases that it will have to be advanced slowly as the tuning condenser is advanced in order to keep the receiver in a suitably sensitive condition.

## LIST OF COMPONENTS

- One 6-pin S.W. coil, type S.P.C. (B.T.S.).
- One .00025 popular log tuning condenser, type 1040 (J.B.).
- One dual-ratio S.M. drive, type 2092 (J.B.).
- One 15 mfd. bandspread condenser, type 2140 (J.B.).
- One .0003 mfd. Dilexon reaction condenser (J.B.).
- One Niclet L.F. transformer (ratio 1:5), type D.P.22 (Varley).
- Three 4-pin valveholders, type U.H. 4 (B.T.S.).
- One 6-pin S.W. coil base, type S.P.B. (B.T.S.).
- Two fixed condensers (.0002 mfd. and .01 mfd.), type 300 (T.C.C.).
- Three 1-watt resistances (50,000 ohms, 1 megohm and 3 megohms) (Dubilier).
- One S.W. choke, type H.F.3 (Wearite).
- One 60 mA microfuse and holder (Microfuse).
- Four type B terminals (Aerial, Earth, L.S.+ and L.S.— (Belling Lee).
- One 5-way battery cord (30in.) (Belling-Lee).
- Three "Bow-spring" wander plugs (G.B.+ , G.B.—1, G.B.—2) (Belling-Lee).
- One pair G.B. battery clips, type No. 5 (Bulgin).
- One junior on/off switch, type S.38 (Bulgin).
- Three component-mounting brackets (Peto-Scott).
- One Metaplex chassis (10in x 6½in. with 2½in. runners) (Peto-Scott).
- Three valves D.210, L.210 and P.215 (Hivac).
- One 120-volt H.T. battery.
- One 9-volt G.B. battery.
- One 2-volt L.T. accumulator.
- One W.B. Stentorian 36/J loudspeaker and pair of headphones.
- One cabinet.

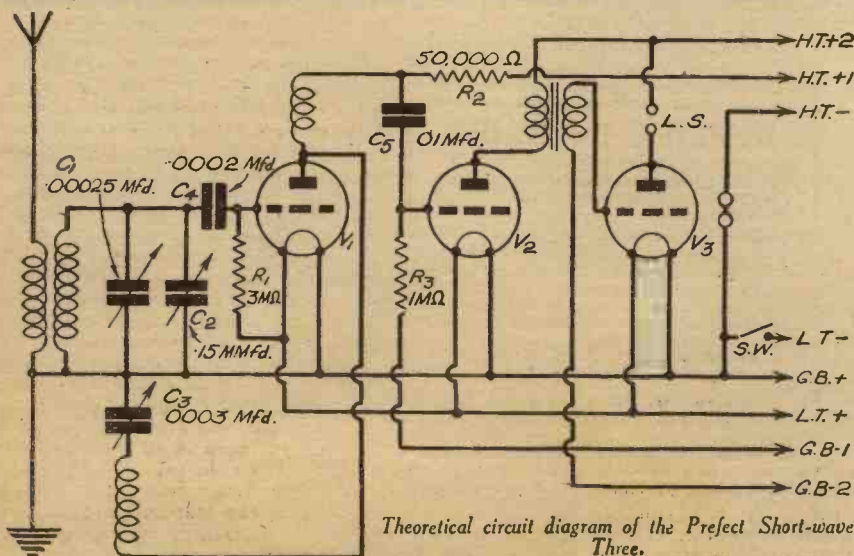

Theoretical circuit diagram of the Prefect Short-wave Three.

## EVERYMAN'S WIRELESS

BOOK

By F. J. Camm

Wireless Principles and Fault Tracking simply explained.

3/6 or 4/- by post from Geo. Newnes, Ltd., Tower House, Southampton Street, Strand, London, W.C.2.

## A New 40-Page Booklet—Free



This booklet, which is yours for the asking, gives particulars of the many opportunities open to trained men engaged in the Radio industry. It also gives full information about the specialized instruction offered by the I.C.S.

The industry is progressing with amazing rapidity. Only by knowing the basic principles can pace be kept with it. I.C.S. Instruction includes American broadcasting as well as British wireless practice, and provides ambitious men with a thoroughly sound training.

Here are the I.C.S. Courses:  
**Complete Radio Engineering**  
**Complete Radio**  
**Radio Servicemen's**  
**Elementary Radio**  
**Radio Service and Sales**  
**Television**

Preparatory Courses for:  
**I.W.T. Associateship and Associate Membership Exams.**  
**City and Guilds Exams. in Radio Communication.**  
**P.M.G. Certificates in Wireless Telegraphy.**  
**I.E.E. Graduateship Exam.**  
 The Complete Radio Course covers equipment and radio principles as well as practice.

Efficient Servicing is of first importance to every wireless dealer and his assistants.

In addition to inculcating the art of selling, the Service and Sales Course provides that knowledge which enables the salesman to hold his own with the most technical of customers.

Television will soon be a tremendous branch of the industry. Our Course deals adequately with this subject.

**SEND FOR OUR BOOKLET TO-DAY**  
 And, if you wish, ask for our free advice.

*Our standard fees are substantially reduced during the summer months.*



**INTERNATIONAL  
 CORRESPONDENCE  
 SCHOOLS LTD.**

**Dept. 94, International Buildings,  
 Kingsway, London, W.C.2.**

## RADIO CLUBS AND SOCIETIES

*Club Reports should not exceed 200 words in length and should be received First Post each Monday morning for publication in the following week's issue.*

### The Liverpool Short-wave Radio and Transmitting Club

THE above club now holds its meetings every Monday and Thursday nights at their club rooms above No. 13, Wavertree Road, Liverpool, 7, at 8.15 p.m.

It is proposed to become the Liverpool Chapter of The British Short-wave League, and one of the above nights will be set aside for this purpose. The other will be for our transmitting members. Of course, members could attend on either or both nights.

For particulars of the L.S.W.R.T.C. or the B.S.W.L., write to the Hon. Secretary, Mr. C. E. Cunliffe, 368, Stanley Road, Bootle, Liverpool, 20.

### The Thames Valley Amateur Radio and Television Society

APPRECIATING the value of close observation on the five-metre amateur band from summer to winter conditions, the 56 mc/s group of the Thames Valley Amateur Radio and Television Society have organised a listening contest to take place over a period of six months, commencing on August 1st. Reports will be sent to amateur transmitters active on these frequencies, and their co-operation in confirming reception will be appreciated. All the members of the society's experimental group interested in ultra high-frequency work are holders of transmitting licences. W. G. Pyke, Manager, 19, Grove Road, Surbiton, Surrey.

**Slough and District Short-wave Club**  
 THE second meeting of this club was held on July 21st, at 20, Chalvey Road East, Slough. The chairman, Mr. Paine (G6PR), was unfortunately unable to be present. The formal business of the meeting, which was conducted first, consisted of the formulation of rules, and the arrangement for a listening contest on the amateur bands on July 25th. Meetings will in future be held on Tuesdays.

Anyone interested in short waves is welcome to this club, and those who are doubtful about joining may, by arrangement with the assistant secretary, attend one meeting without payment or obligations of any kind. Those interested are requested to communicate with the assistant secretary, J. Gilbert, 26, King Edward Street, Slough, Bucks.

### REPLIES IN BRIEF

*The following replies to queries are given in abbreviated form either because of non-compliance with our rules, or because the point raised is not of general interest.*

**S. C. (Castleford).** You can leave the terminals disconnected, and the indication is that your stray wiring is such that the padding condenser is not required. It would be preferable to endeavour to obtain the correct results unless you are now satisfied with the performance.

**F. G. P. (N.19).** We regret that we are unable to supply a blueprint for the type of apparatus mentioned by you.

**G. A. (Cardiff).** No change has been made in the wavelength of the London station. You are probably trying to hear the station before 5 p.m. and we would remind you that the Nationals (with the exception of the Scottish) do not start up until 5 p.m.

**C. E. B. (Shefford).** Your query is replied to in the article in last week's issue. A good connection to the earth side of the mains leads (or screening) will prove ideal in your case.

**B. S. (Chelmsford).** The unit could be used with any other battery receiver, but would not deliver enough

H.T. for a mains receiver. The A.C. type valves mentioned are mains valves, requiring 200 to 250 volts H.T.

**J. B. (Beckenham).** We are sorry that we cannot publish your request. If we did so, we should be inundated with similar requests from other readers and therefore we can only suggest that you take a small advertisement in our advertisement columns for your purpose.

**J. A. B. (Coventry).** We are unable to give you the details required and think you would find it difficult to make a satisfactory unit.

**W. M. (Huddersfield).** The receiver was designed for use with a centre-tapped frame aerial, and it is difficult to obtain good results with the ordinary aerial system. The only satisfactory plan would be to rebuild the set, but the oscillator coil will not be of much use in this connection.

**L. M. (West Sunnyside).** We are unable to recommend individual commercial receivers, but suggest that you obtain one or two chassis of the type indicated on approval in order that you can make your choice under your own home listening conditions.

**G. B. (E.11).** Probably the L.S. Repair Service whose advertisement appears in our pages each week could undertake the work for you.

**E. E. (Woodseats).** Messrs. Wright & Weare will still be found at the address mentioned in your letter.

**W. F. W. (S.W.11).** The circuit is quite in order and should work satisfactorily.

**B. A. S. (N.15).** We regret that we cannot supply a diagram or blueprint of a receiver of the type mentioned.

**C. R. (Clifton).** A standard L.F. amplifier may be added, but we are not familiar with the coil from the K.B. set and in any case a coil would not be required for an L.F. stage.

**A. T. R. (Toines).** The transformer costs 10s. 6d. and the rectifier 20s., plus a slight increase due to the rise in price of raw materials. Some difficulty might be experienced if you try to use this unit with the set referred to and we advise you to wait until we publish details after we have tried the combination.

## T.R.F. OR SUPERHET?

THE radio side of the different makes of television receivers quite naturally have several points in common, but there are still considerable differences of opinion as to whether it is better to amplify the television signal at its incoming or carrier frequency, or use the superheterodyne method to reduce the frequency to a more convenient lower level. Neither scheme is a perfectly straightforward one, and in the case of ordinary radio readers will remember that it is only within the last two or three years that superhets have achieved the same degree of popularity as the T.R.F. The enormously high carrier frequencies of the television signal necessitates amplifiers of very special design. First of all there is the limiting effects produced by the stray circuit capacities, while at ultra-short carrier frequencies the valves behave in a peculiar manner. They act as if relatively low resistances were connected across the electrode capacities, due to the absorption of energy from the source of potential in the grid cathode circuit by free electrons, whose time of flight is comparable with the time period of the H.F. oscillation. In spite of these and other difficulties there are one or two television receivers available whose vision set operates directly at the 45 megacycle carrier frequency. With superhets the amplifier operates at the intermediate frequency, and while similar to the T.R.F. amplifier is certainly free from some of the troubles peculiar to the T.R.F. circuit. On the other hand there is no set policy for the intermediate frequency employed. If high, most of the advantages of the superhet principle are not present, while if low, precautions must be taken to see that there is no risk of picking up comparable frequencies which will, of course, ruin the picture. To compensate for a certain degree of frequency attenuation, correcting devices are often incorporated, but if the measure of boosting secured in this way is too pronounced the picture will show the result as hard double images looking somewhat like a stereoscopic effect.



# Letters from Readers

The Editor does not necessarily agree with the opinions expressed by his correspondents. All letters must be accompanied by the name and address of the sender (not necessarily for publication).

## An Old Rule Modernised

SIR,—With reference to the letter on the above subject which recently appeared in your journal, I would suggest several better methods of expressing the equation: "Ohms in thousands" or "Ohms divided by 1,000" or

$$\text{Milliamps} \times (\text{Ohms}/1,000)$$

I would add that I make no claim of originality for the  $E/I \times R$  formula, which I know was published many years ago in various papers, but merely for the introduction of the mnemonic or key-words, EITheR or ERic.—D. ALDOUS (Ilford).

## Our Free Service Dept

SIR,—May I express my appreciation of the help you rendered me in completing the "Gladiator All-Wave Three" set, and on several other occasions in the past, when your valuable advice concerning my difficulties has always proved of real worth. I got reception for the first time this afternoon when I was very much struck with the purity of tone. In comparing the tone with my late model, "The All-Pentode Three," I am quite satisfied that the new one is superior, and with an old portable three-valve, which I keep to fall back upon, there is no comparison.

I do not wish to bring a jarring note into this letter of thanks to you, but I must mention the carelessness of some makers of repute who claim to sell tested components and charge top prices for faulty material. This is a sure way of sending old customers to the cheaper agents.—J. MARSH (Derby).

## "The Experimenters'" Articles

SIR,—I would like to express my appreciation of the articles by "The Experimenters," which I enjoyed reading. I am a new reader of about five months' standing, and I have a very high opinion of PRACTICAL AND AMATEUR WIRELESS. Some of the articles, however, I found were too technical for me.

With the advent of the new series for beginners, however, I think you have forged the missing link, which hundreds like myself will appreciate. I sincerely hope that you will continue to print such articles by The Experimenters—and I herewith offer a suggestion that the subject for a future article will be "The Straight Three," with general comments. It might also interest you to know that I am expressing the sentiments of several of my friends regarding the above-mentioned articles.—ARTHUR P. SIMS (Dinas Powis, Glam).

## A 14 mc/s Log from Cheshire

SIR,—I herewith append a log of the stations heard here during the past three months on the 14 mc/s phone band:—  
Africa.—SU1CH, 1DB, 1KG, 1RO, 1SG, FA8GT, FT4AG, CT2AB, OQ5AA, EA8AE and CN8AM.

North America.—VE5HI, 5JG; W5DUK, 6AH, 6AL, 6AM, 6BGH; and 6GCT.

Central America.—COTVP; HI1M, 5X; K4ENY and 4SA.

South America.—LU1QA, 6KE; CE1AO; HK4AG; YV5AE, HUIJW and nine Brazilians.

Asia.—VS2AK and YI2BA.

Australia.—VK2HF and 3AL.

The outstanding point of DX conditions recently is the great increase in strength and numbers of the South American stations. The receiver is an o-v-1 employing a 66ft. outdoor antenna.—A. P. L. CASLING (Hale, Cheshire).

## A Mains-less H.T. Unit

WE wish to point out a printer's error in our list of parts for the "Mains-Less H.T. Unit" in our issue of July 17th. The H.T.V.2, which is of the non-synchronous type, is not suitable for the circuit. The H.T.V.1 model must be used.

Messrs. Bulgin state that as a reservoir condenser we have employed a capacity of  $4 \mu\text{F}$ , also on the smoothed H.T. side we have employed  $4 \mu\text{F}$  instead of  $8 \mu\text{F}$  as recommended by them.

They think our readers may also be interested in a method of improving the smoothed output of the unit, this being—connecting in series with the  $.01\text{-}\mu\text{F}$  buffer condensers, resistances having a value of  $100 \Omega$ , also connecting in parallel with the  $.1\mu\text{F}$  low-tension buffers, resistances of

CUT THIS OUT EACH WEEK.

# Do you know

- THAT glass may be used as a substitute for ebonite in panels and so on.
- THAT special anti-interference chokes are obtainable for inclusion in the aerial lead to a receiver.
- THAT H.F. interference can be carried to a receiver through the mains leads.
- THAT an aerial must be kept well clear of any earthed body especially metal gutters and pipes.
- THAT the earth lead must not be permitted to come into contact with other earthed bodies and should preferably be insulated.
- THAT a fixed condenser across a switch will sometimes prevent trouble and noise due to arcing.

The Editor will be pleased to consider articles of a practical nature suitable for publication in PRACTICAL AND AMATEUR WIRELESS. Such articles should be written on one side of the paper only, and should contain the name and address of the sender. Whilst the Editor does not hold himself responsible for manuscripts, every effort will be made to return them if a stamped and addressed envelope is enclosed. All correspondence intended for the Editor should be addressed: The Editor, PRACTICAL AND AMATEUR WIRELESS, George Newnes, Ltd., Tower House, Southampton Street, Strand, W.C.2. Owing to the rapid progress in the design of wireless apparatus and to our efforts to keep our readers in touch with the latest developments, we give no warranty that apparatus described in our columns is not the subject of letters patent.

500  $\Omega$ . This will help to preserve an interference-free output, and also ensure that the maximum life is extracted from the vibrator.

We stated that a low-resistance smoothing choke, type L.F.44, can be inserted in series with a 6-volt filament supply to drop the surplus 4 volts. They state that this choke has a resistance of  $6.1 \Omega$ , and, therefore, the correct load current should be passed to obtain the necessary voltage drop.

## A. S.W. Log From Cambridge

SIR,—As I have not seen a S.W. log from Cambridge in PRACTICAL AND AMATEUR WIRELESS I enclose mine. The receiver used is a 5-valve battery superhet. Phone stations heard during the past few weeks are: OA4AL, VK2VB, 2HF, K4ENY, CX2AK, VO6L, PY1EW, SAM, 2FF, 2AJ, 2CK, 2ET, YV5AE, 5AN, 5AV, 5ABE, NY2AE, W6CQI, 6NNR, 6AL, CO2WW, LU6KE, LU2CA, LU7AG, U3BC, CE1AO, 3DW, VU2CQ, SU1SG, 1CH, FT4AG, 4AN, 4AA, SPIHH, LY1J, ZB1H, HB9A, HA8N, HR3A, HK4AG, YI2BA and SV1KE.—V. H. THORNE, Homerton Street, Cambridge.

## A Novel Pocket Torch

THE accompanying illustration shows a novel torch which has been invented by Mr. J. Wearham and which will prove of great interest to radio receiver constructors. As will be seen from the illustration, it incorporates a portable inspection device, but unlike previous ideas modelled

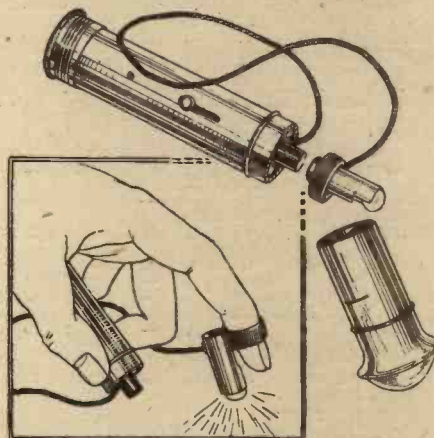

The torch in use, and enlarged view showing the removable lens holder.

round this arrangement, this is in addition to the ordinary function as a torch. The torch is built up in the following manner: A small bulb holder is provided with a reflector, to which is attached an expanding ring which is of such a size that it may comfortably be slipped over the finger. The reflector acts also as a shield and thus when clipped to the finger the bulb may be inserted into various corners of apparatus, such as a wireless receiver, in order to carry out inspection work without the light affecting the eyes. A flexible wire is attached to the bulb-holder, and this terminates in a screw adapter which is inserted into the normal bulb holder on the torch or battery container, and the flex is of sufficient length to enable the device to be used under many different conditions. To enable the torch to be used in the ordinary way the bulb shield is recessed to pass over the screwed plug and the usual lens is mounted on an extension which is of sufficient length to accommodate the bulb and shield. The flex is wrapped round the finger ring after the bulb is placed into position, and the torch, therefore, assumes a normal appearance.

# Practical and Amateur Wireless BLUEPRINT SERVICE

Practical Wireless CRYSTAL SETS	No. of Date of Issue, Blueprint.	No. of Date of Issue, Blueprint.
Blueprint, 6d.		
1937 Crystal Receiver	9.1.37	PW71
<b>STRAIGHT SETS. Battery Operated.</b>		
One-valve : Blueprint, 1s.		
All-wave Unipen (Pentode)	—	PW31A
Two-valve : Blueprints, 1s. each.		
Four-range Super Mag Two (D, Pen)	11.8.34	PW36B
The Signet Two	29.8.36	PW76
Three-valve : Blueprints, 1s. each.		
The Long-Range Express Three (SG, D, Pen)	24.4.37	PW2
Selectone Battery Three (D, 2 LF Trans)	—	PW10
Sixty Shilling Three (D, 2LF RC & Trans)	—	PW34A
Leader Three (SG, D, Pow)	22.5.37	PW55
Summit Three (HF Pen, D, Pen)	8.8.34	PW37
All Pentode Three (HF Pen, D, Pen)	29.5.37	PW39
Hall-mark Three (SG, D, Pow)	12.6.37	PW41
Hall-mark Cadet (D, LF, Pen RC)	16.3.35	PW48
F. J. Camm's Silver Souvenir (HF Pen, D, Pen, Pen) (All-Wave Three)	13.4.35	PW49
Genet Midget (D, 2 LF Trans)	June '35	PM1
Cameo Midget Three (D, 2 LF Trans)	8.6.35	PW51
1936 Sonotone Three-Four (HF Pen, HF Pen, Westector, Pen)	17.8.35	PW53
Battery All-Wave Three (D, 2 LF RC)	—	PW55
The Monitor (HF, Pen, D, Pen)	—	PW61
The Tutor Three (HF Pen, D, Pen)	21.3.36	PW62
The Centaur Three (SG, D, P)	—	PW64
The Gladiator All-Wave Three (HF Pen, D, Pen, Pen)	29.8.36	PW66
F. J. Camm's Record All-Wave Three (HF Pen, D, Pen)	31.10.36	PW69
The "Colt" All-Wave Three (D, 2 LF RC & Trans)	5.12.36	PW72
<b>Four-valve : Blueprints, 1s. each.</b>		
Sonotone Four (SG, D, LF, P)	1.5.37	PW4
Fury Four (2 SG, D, Pen)	8.5.37	PW11
Beta Universal Four (SG, D, LF, Cl. B)	—	PW17
Nucleon Class B Four (SG, D, SG), LF, Cl. B)	6.1.34	PW34B
Fury Four Super (SG, SG, D, Pen) Battery Hall-Mark 4 (HF, Pen, D, Push-Pull)	—	PW46
F. J. Camm's "Limit" All-Wave Four (HF Pen, D, LF, P) Mains Operated.	20.9.36	PW67
<b>Two-valve : Blueprints, 1s. each.</b>		
A.C. Twin (D, Pen, Pen)	—	PW18
A.C.-D.C. Two (SG, Pow)	—	PW31
Selectone A.C. Radiogram Two (D, Pow)	—	PW19
<b>Three-valve : Blueprints, 1s. each.</b>		
Double-Diode-Triode Three (HF Pen, DDT, Pen)	—	PW23
D.C. Ace (SG, D, Pen)	—	PW25
A.C. Three (SG, D, Pen)	—	PW20
A.C. Leader (HF Pen, D, Pow)	7.4.34	PW35C
D.C. Premier (HF Pen, D, Pen)	31.3.34	PW35B
Ubique (HF Pen, D, Pen, Pen)	28.7.34	PW36A
Armada Mains Three (HF Pen, D, Pen)	—	PW38
F. J. Camm's A.C. All-Wave Silver Souvenir Three (HF Pen, D, Pen)	11.5.35	PW50
"All-Wave" A.C. Three (D, 2 LF RC)	17.8.35	PW51
A.C. 1936 Sonotone (HF Pen, H.F. Pen, Westector, Pen)	—	PW56
Mains Record All-Wave 3 (HF Pen, D, Pen)	5.12.36	PW70
<b>Four-valve : Blueprints, 1s. each.</b>		
A.C. Fury Four (SG, SG, D, Pen)	—	PW20
A.C. Fury Four Super (SG, SG, D, Pen)	—	PW34D
A.C. Hall-Mark (HF Pen, D, Push-Pull)	24.7.37	PW45
Universal Hall-Mark (HF Pen, D, Push-Pull)	9.2.35	PW47
<b>SUPERHETS.</b>		
<b>Battery Sets : Blueprints, 1s. each.</b>		
£5 Superhet (Three-valve)	5.6.37	PW40
F. J. Camm's 2-valve Superhet	13.7.35	PW52
F. J. Camm's £4 Superhet	—	PW53
F. J. Camm's "Vitesse" All-Waver (5-valver)	27.2.37	PW75
<b>Mains Sets : Blueprints, 1s. each.</b>		
A.C. £5 Superhet (Three-valver)	—	PW43
D.C. £5 Superhet (Three-valve)	1.12.34	PW42
Universal £5 Superhet (Three valver)	—	PW44
F. J. Camm's A.C. £4 Superhet 4	31.7.37	PW59
F. J. Camm's Universal £4 Superhet 4	—	PW60
"Qualitone" Universal Four	16.1.37	PW73
<b>SHORT-WAVE SETS.</b>		
Two-valve : Blueprint, 1s.	—	PW38A
Midget Short-wave Two (D, Pen)	—	PW38A

<b>Three-valve : Blueprints, 1s. each.</b>		
Experimenter's Short-Wave Three (SG, D, Pow)	—	PW30A
The Prefect 3 (D, 2 LF RC and Trans)	7.8.37	PW63
The Bandsread S.W. Three (HF Pen, D, Pen, Pen)	29.8.36	PW68
"Tele-Cent" S.W.3 (SG, D, SG), Pen)	30.1.37	PW74
<b>PORTABLES.</b>		
<b>Three-valve : Blueprints, 1s. each.</b>		
E. J. Camm's ELF Three-valve Portable (HF Pen, D, Pen)	—	PW65
Parvo Flyweight Midget Portable (SG, D, Pen)	19.6.37	PW77
<b>Four-valve : Blueprint, 1s.</b>		
Featherweight Portable Four (SG, D, LF, Cl. B)	15.5.37	PW12
<b>MISCELLANEOUS.</b>		
S.W. Converter-Adapter (1 valve)	—	PW48A
<b>AMATEUR WIRELESS AND WIRELESS MAGAZINE</b>		
<b>CRYSTAL SETS.</b>		
Blueprints, 6d. each.		
Four-station Crystal Set	12.12.36	AW427
1934 Crystal Set	—	AW444
150-mile Crystal Set	—	AW450
<b>STRAIGHT SETS. Battery Operated.</b>		
<b>One-valve : Blueprints, 1s. each.</b>		
B.B.C. Special One-valver	—	AW387
Twenty-station Loudspeaker One-valver (Class B)	—	AW449
<b>Two-valve : Blueprints, 1s. each.</b>		
Melody Ranger Two (D, Trans)	—	AW388
Full-volume Two (SG det., Pen)	—	AW392
B.B.C. National Two with Lucerne Coil (D, Trans)	—	AW377A
Big-power Melody Two with Lucerne Coil (SG, Trans)	—	AW338A
Lucerne Minor (D, Pen)	—	AW426
A Modern Two-valver	—	WM409
<b>Three-valve : Blueprints, 1s. each.</b>		
Class B Three (D, Trans, Class B)	—	AW386
New Britain's Favourite Three (D, Trans, Class B)	15.7.33	AW394
Home-built Coil Three (SG, D, Trans)	—	AW404
Fan and Family Three (D, Trans, Class B)	25.11.33	AW410
£5 5s. S.G.3 (SG, D, Trans)	2.12.33	AW412
1934 Ether Searcher: Baseboard Model (SG, D, Pen)	—	AW417
1934 Ether Searcher: Chassis Model (SG, D, Pen)	—	AW419
Lucerne Ranger (SG, D, Trans)	—	AW422
Cosor Melody Maker with Lucerne Coils	—	AW423
Mullard Master Three with Lucerne Coils	—	AW424
£5 5s. Three: De Luxe Version (SG, D, Trans)	19.5.34	AW435
Lucerne Straight Three (D, RC, Trans)	—	AW437
All-Britain Three (HF, Pen, D, Pen) "Wireless League" Three (HF Pen, D, Pen)	3.11.34	AW451
Transportable Three (SG, D, Pen) £6 6s. Radiogram (D, RC, Trans)	—	WM271
Simple-tune Three (SG, D, Pen)	June '33	WM318
Economy-Pentode Three (SG, D, Pen)	Oct. '33	WM327
"W.M." 1934 Standard Three (SG, D, Pen)	—	WM337
£3 3s. Three (SG, D, Trans)	Mar. '34	WM351
Iron-core Band-pass Three (SG, D, QP21)	—	WM354
1935 £6 6s. Battery Three (SG, D, Pen)	—	WM362
PTP Three (Pen, D, Pen)	June '35	WM371
Certainly Three (SG, D, Pen)	—	WM388
Minute Three (SG, D, Trans)	Oct. '35	WM393
All-wave Winning Three (SG, D, Pen)	Dec. '35	WM396
<b>Four-valve : Blueprints, 1s. each.</b>		
65s. Four (SG, D, RC, Trans)	—	AW400
"A.W." Ideal Four (2 SG, D, Pen)	16.9.33	AW370
2HF Four (2 SG, D, Pen)	—	AW402
Crusaders' A.V.C.4 (2 HF, D, QP21) (Pentode and Class B Outputs for above : Blueprints, 6d. each)	18.8.34	AW445
Self-contained Four (SG, D, LF, Class B)	25.8.34	AW455A
Lucerne Straight Four (SG, D, LF, Trans)	Aug. '33	WM331
£5 5s. Battery Four (HF, D, 2LF)	Feb. '35	WM350
The H.K. Four (SG, SG, D, Pen)	Mar. '35	WM381
The Auto Straight Four (HF Pen, HF Pen, DDT, Pen)	April '36	WM384
<b>Five-valve : Blueprints, 1s. each.</b>		
Super-quality Five (2HF, D, RC, Trans)	May '33	WM404
Class B Quadrydne (2 SG, D, LF, Class B)	Dec. '33	WM320
New Class-B Five (2 SG, D, LF, Class B)	Nov. '33	WM344
<b>Mains Operated.</b>		
<b>Two-valve : Blueprints, 1s. each.</b>		
Consolectric Two (D, Pen) A.C.	—	AW403
Economy A.C. Two (D, Trans) A.C.	—	WM286
Unicorn A.C.-D.C. Two (D, Pen)	—	WM394

These blueprints are drawn full size.  
Copies of appropriate issues containing descriptions of these sets can in some cases be supplied at the following prices, which are additional to the cost of the blueprint. A dash before the Blueprint Number indicates that the issue is out of print.

Issues of Practical Wireless	.. 4d.	Post paid
Amateur Wireless	.. 4d.	"
Practical Mechanics	.. 7d.	"
Wireless Magazine	.. 1/3	"

The index letters which precede the Blueprint Number indicate the periodical in which the description appears; thus PW refers to PRACTICAL WIRELESS, AW to Amateur Wireless, PM to Practical Mechanics, WM to Wireless Magazine.

Send (preferably) a postal order to cover the cost of the blueprint and the issue (stamp over 6d. uncollectable), to PRACTICAL AND AMATEUR WIRELESS Blueprint Dept., Geo. Newnes, Ltd., Tower House, Southampton Street, Strand, W.C.2.

<b>Three-valve : Blueprints, 1s. each.</b>		
Home-Lover's New All-electric Three (SG, D, Trans) A.C.	—	AW383
S.G. Three (SG, D, Pen) A.C.	—	AW390
A.C. Triodyne (SG, D, Pen) A.C.	19.8.33	AW399
A.C. Pentaquester (HF Pen, D, Pen) A.C.	23.6.34	AW439
Mantovani A.C. Three (HF Pen, D, Pen) A.C.	—	WM374
£15 15s. 1936 A.C. Radiogram (HF, D, Pen)	Jan. '36	WM401
<b>Four-valve : Blueprints, 1s. each.</b>		
All-Metal Four (2 SG, D, Pen)	July '33	WM326
Harris Jubilee Radiogram (HF Pen, D, LF, P)	May '35	WM386
<b>SUPERHETS.</b>		
<b>Battery Sets : Blueprints, 1s. each.</b>		
Modern Super Senior	—	WM375
Varsity Four	Oct. '35	WM395
The Request All-Waver	June '36	WM407
1935 Super Five Battery (Super-het)	—	WM379
<b>Mains Sets : Blueprints, 1s. each.</b>		
1934 A.C. Century Super A.C.	—	AW425
Heptode Super Three A.C.	May '34	WM359
"W.M." Radiogram Super A.C.	—	WM360
1935 A.C. Stenode	Apr. '35	WM385

<b>PORTABLES.</b>		
<b>Four-valve : Blueprints, 1s. each.</b>		
Midget Class B Portable (SG, D, LF, Class B)	20.5.33	AW389
Holiday Portable (SG, D, LF, Class B)	1.7.33	AW393
Family Portable (HF, D, RC, Trans)	22.9.34	AW447
Two H.F. Portable (2 SG, D, QP21)	June '34	WM363
Tyers Portable (SG, D, 2 Trans)	—	WM367
<b>SHORT-WAVE SETS - Battery Operated.</b>		
<b>One-valve : Blueprints, 1s. each.</b>		
S.W. One-valver converter (Price Gd.)	—	AW320
S.W. One-valve for America	23.1.37	AW429
Rome Short-Waver	—	AW452
<b>Two-valve : Blueprints, 1s. each.</b>		
Ultra-short Battery Two (SG dot., Pen)	Feb. '36	WM402
Home-made Coil Two (D, Pen)	—	AW440
<b>Three-valve : Blueprints, 1s. each.</b>		
World-ranger Short-wave 3 (D, RC, Trans)	—	AW355
Experimenter's 5-metre Set (D, Trans, Super-regen)	30.6.34	AW438
Experimenter's Short-wave (SG, D, Pen)	Jan. 19. '35	AW463
The Carrier Short-waver (SG, D, P)	July '35	WM390
<b>Four-valve : Blueprints, 1s. each.</b>		
A.W. Short-Wave World-Beater (HF, Pen, D, RC, Trans)	—	AW436
Empire Short-Waver (SG, D, RC, Trans)	—	WM313
Standard Four-valver Short-waver (SG, D, LF, P)	Mar. '35	WM383
Superhet : Blueprint, 1s. 6d.	—	WM397
Simplified Short-waver Super	Nov. '35	WM397
<b>Mains Operated.</b>		
<b>Two-valve : Blueprints, 1s. each.</b>		
Two-valve Mains short-waver (D, Pen) A.C.	—	AW453
"W.M." Band-spread Short-waver (D, Pen) A.C.-D.C.	—	WM368
"W.M." Long-wave Converter	—	WM380
<b>Three-valve : Blueprint, 1s.</b>		
Emigrator (SG, D, Pen) A.C.	—	WM352
<b>Four-valve : Blueprint, 1s. 6d.</b>		
Standard Four-valve A.C. Short-waver (SG, D, RC, Trans)	Aug. '35	WM391
<b>MISCELLANEOUS.</b>		
Enthusiast's Power Amplifier (1/6 (16))	June '35	WM387
Listeners' 5-watt A.C. Amplifier	—	WM392
Radio Unit (2v) for WM392	Nov. '35	WM398
Harris Electrogram (battery amplifier) (1/-)	Dec. '35	WM399
De-Luxe Concert A.C. Electrogram	Mar. '36	WM403
New-Style Short-Wave Adapter (1/-)	—	WM388
Trickle Charger (6d.)	Jan. 5. '35	AW462
Short-Wave Adapter (1/4)	Dec. 1. '34	AW450
Superhet Converter (1/4)	Dec. 1. '34	AW457
B.L.D.L.C. Short-wave Converter (1/-)	May '36	WM405
Wilson Tone Master (1/-)	June '36	WM406
The W.M. A.C. Short-Wave Converter (1/-)	—	WM408



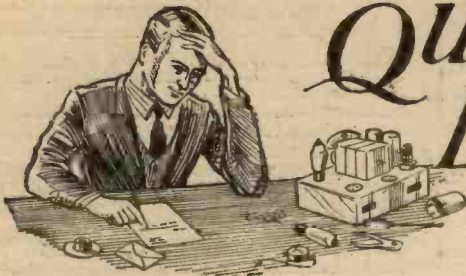

# QUERIES and ENQUIRIES

## Receiving Short Waves

"I have a battery S.G.3 and wish to attach a short-wave set externally, so I should like you to recommend a set of components or ready-made set for this purpose."—C. S. (Sandown, I.O.W.).

AS the receiver employs an H.F. stage you can add a short-wave converter. We have described several different types; and blueprints are available for some of these. Probably the most convenient unit is that shown on Blueprint PW48A, as this is an all-purpose device suitable for battery or mains operation, and also may be used either as an adapter or converter.

## Three-range S.W. Coil

"In a recent issue you published a letter from a reader who had built the Simplest Short-waver incorporating a triple-range short-wave coil. I should be glad to know the name of the makers of this particular component, as I would like to use one."—J. B. (Airdrie).

THE coil was a Lissen component which is no longer obtainable. A special switch was supplied by the makers for wave-change purposes, and the coil could be mounted on the switch to reduce external wiring. We believe the coil may still be obtained from certain stores which deal in manufacturers' surplus and similar goods.

## Experimenters' One-valver

"I should like to know whether I could use in the Experimenters' One-valver the coil known as Telsen Dual-range Aerial Coil with the incorporated variable selectivity device, cat. No. W.76."—W. J. L. (North Finchley).

IN the receiver referred to it is possible to utilise any type of dual-range coil. If you adopt the coil you refer to you will not, of course, require the pre-set or fixed condenser in the aerial lead which was referred to by the Experimenters in the article in question.

## Mains-less H.T. Unit

"I have the parts to make the mains-less H.T. unit, but the transformer is the M.T.5. The set I want to run is a 3-valve battery set at 150 volts 12 milliamps. I have been told I can get 150 volts by a resistor in the positive lead and a bleeder resistor across the positive and negative to reduce the surplus in the circuit. Is this correct?"—I. W. (Manchester, 10).

YOU can adopt the scheme mentioned, and the values of the resistors will have to be carefully calculated. Less current is supplied, actually, by the M.T.5 transformer than by the lower-voltage component, so that theoretically a series resistance alone is all that is required. You will have slightly over 150 volts to dissipate at 12 to 15 mA, and therefore require a resistance of approximately 13,000 ohms. The wattage would be approximately 2.

## B.B.C. Wavelength Changes

"I have lately found that I cannot get the Welsh station, and there seems to be a jumble after 5 o'clock which was not there before. Nobody in our street can now get the old results in the afternoon, and I should like to know whether there have been any changes in the stations."—B. L. and others.

CERTAIN changes have recently been made, and the position is as follows: firstly, the Western National transmitter has ceased to exist as such; and the programme is now radiated from Washford Heath on a wavelength of 285.7 metres. As this was originally the wavelength of the Scottish National this transmitter has now ceased to use that wavelength, and now uses the common National wavelength of 261.1 metres. A further complication, and the one which is apparently affecting

## Automatic Bias

"Will you please tell me the way to make my battery set work without grid battery? What condensers and resistances are required for G.B. 3 volts, 4½ volts and 12 volts? My set is operated from an eliminator."—L. S. (N.19).

THE resistances for biasing must be inserted in the H.T. negative lead and, therefore, in your case the H.T. negative terminal of the eliminator should be disconnected from your receiver and the resistances placed between the two pieces of apparatus. We cannot give the values as these depend upon the current flowing. If you wish to bias more than one valve you will have to use separate resistors to make up the total value required for the output valve (maximum bias) and the values of the separate resistors will have to be selected so that tapplings may be taken from the junction points to provide the necessary voltage. The value of the resistance is calculated by dividing the voltage required by the current flowing, and this is the total current of your set. If you do not know the value you will have to insert a milliammeter in the H.T. negative lead in order to find it.

## Hi-Q Coil Unit

"I have obtained one of the Lissen Hi-Q Coil units and should be glad if you could recommend one of your receivers into which I could build this. I do not wish to use more than 3 valves in the interests of economy."—V. C. (Deal).

THE only set in which we have used the coil unit in question is the Tele-Cent Three, a short-waver employing an S.G. aperiodic H.F. stage, S.G. detector and a Harries Output valve. A blueprint is available for this receiver, No. PW47, and it was described in our issue dated January 30th last.

## Speakers in Phase

"I am building a large radio-gram, and I have three old loudspeakers of different sizes. I have tried these out temporarily, and am very pleased with the balanced effect which they give. I have intended to incorporate all three in a large cabinet, and have drawn up tentative designs. A friend has somewhat upset me, however, by telling me that results will be bad, due to the fact that the speakers may not all be in phase. I wonder if you could tell me what this means and whether I could make use of them in the manner I have outlined."—G. F. E. (Finchley).

THE point your friend was referring to was the relative movement of each of the cones. It is evident that if they are just connected up as they are at present, there is a possibility that when switched on one cone may be driven forward whilst one of the others may move backward. They will both give rise to the same sound, but as they are close together the movement of the air round each speaker will cancel out, or tend to cancel out, the air movement of the other. It is necessary, therefore, to arrange that each speaker cone moves out at the same moment, and this may be done by reversing the connections to the speech coil, where it is found necessary. If you are unable to follow the movement of the cones when receiving a signal, connect a flash-lamp or other small battery across the speaker transformer.

### RULES

We wish to draw the reader's attention to the fact that the Queries Service is intended only for the solution of problems or difficulties arising from the construction of receivers described in our pages, from articles appearing in our pages, or on general wireless matters. We regret that we cannot, for obvious reasons—

- (1) Supply circuit diagrams of complete multi-valve receivers.
- (2) Suggest alterations or modifications of receivers described in our contemporaries.
- (3) Suggest alterations or modifications to commercial receivers.
- (4) Answer queries over the telephone.
- (5) Grant interviews to querists.

A stamped addressed envelope must be enclosed for the reply. All sketches and drawings which are sent to us should bear the name and address of the sender.

Requests for Blueprints must not be enclosed with queries as they are dealt with by a separate department.

Send your queries to the Editor, PRACTICAL AND AMATEUR WIRELESS, George Newnes, Ltd., Tower House, Southampton Street, Strand, London, W.C.2.

The Coupon must be enclosed with every query.

you most, is that the remaining National transmitters are closed down every day until 5 p.m., but the Scottish National transmitter is on daily until that hour, although it does not always radiate a "national" programme. On some days it takes special school and educational programmes, whilst other days it takes a local programme.

## A.C. Gramophone

"I am desirous of constructing an A.C. gramophone. I possess an M.C. speaker, motor, turntable and pick-up. Kindly inform me if you have a blueprint and/or back numbers describing a suitable apparatus."—T. S. V. R. (Tulse Hill).

YOU do not indicate the power you require and we are therefore unable to make a definite recommendation. A good 5-watt amplifier is shown on Blueprint WM392, but the issue of the "Wireless Magazine" describing the construction is out of print. A Power Amplifier (10 to 15 watts) is shown on Blueprint WM387 and is described in the "Wireless Magazine" dated June, 1935, a back number of which may still be obtained. You could also probably adapt the Harris Electrogram or the A.C. Electrogram, blueprints WM399 or WM403.

The coupon on page 504 must be attached to every query.

**Miscellaneous Advertisements**

Advertisements are accepted for these columns at the rate of 3d. per word. Words in black face and/or capitals are charged double this rate (minimum charge 3/- per paragraph). Display lines are charged at 6/- per line. All advertisements must be prepaid. All communications should be addressed to the Advertisement Manager, "Practical and Amateur Wireless," Tower House, Southampton Street, Strand, London, W.C.2.

**RECEIVERS, COMPONENTS AND ACCESSORIES**  
Surplus, Clearance or Secondhand, etc.

**RADIOMART SHORT-WAVE MANUAL**

Packed with short-wave information and circuits of mains and battery receivers, including straight, superhet and 5-metre transmitters, modulators, etc. Information on transmitting licences, aeriads, Class B amplifications, neutralizations, superhet alignment, etc. The most comprehensive manual published, written by practical engineers, price 6d., post free, 7d. including catalogue.  
1937 Short-wave Catalogue only (3 times enlarged) price 1½d., post free.

**44, HOLLOWAY HEAD, BIRMINGHAM 1**

**SPECIAL Summer Sale** now proceeding at our Holborn premises. All lines previously advertised still in stock.

**RADIO CLEARANCE, 63, HIGH HOLBORN, W.C.1.** Tel.: Hol. 4631.

All goods previously advertised are standard lines, still available. Post card for list free.

**VAUXHALL UTILITIES, 163a, Strand, W.C.2.** Over Denny's the Booksellers. Temple Bar 9338.

**CONVERSION UNITS** for operating D.C. Receivers from A.C. Mains, improved type, 120 watts output at £2/10/0. Send for our comprehensive list of speakers, resistances and other components.

**WARD, 46, Farringdon Street, London, E.C.4.** Telephone: Holborn 9703.

**REPAIRS** to Moving Coil Speakers, Cones and Coils fitted or rewound. Fields altered. Prices Quoted including Eliminators, Loudspeakers, Repaired, 4/-. L.F. and Speech Transformers, 4/- post free. Trade invited. Guaranteed. Satisfaction. Prompt Service. Estimates free. L.S. Repair Service, 5, Balham Grove, London, S.W.12. Battersea 1821.

**THE largest stock** of components in England, over 500 lines, new catalogue now ready 1½d.—J. Bearfield, 105, Upper Street, London, N.1.

**BANKRUPT BARGAINS.** List free. All new goods A.C./D.C. 5v. superhet chassis complete Mullards and M.C. speaker, £4/10/0. Halcyon S.W. converters with valve A.C., 20/-. Large stock sets and components. Butlin, 6, Stanford Avenue, Brighton, Sx.

**CONDENSERS, British Manufacture, fixed paper in metal cases; 800-volt wkg., 4 mfd. 3/0; 2 mfd. 2/-; 1 mfd. 1/6; 500-volt wkg., 4 mfd. 2/6; 2 mfd. 1/6; 1 mfd. 1/-; 400-volt wkg. 4 mfd. 1/6; 2 mfd. 1/-; 1 mfd. 8d.; guaranteed; post or c.o.d.—Mentone Radio Stores, 364, Fulham Road, London, S.W.10.**

**VALVES**

**BIGGER AND BETTER VALUE IN AMERICAN B VALVES, 3/-** any popular type. 6/- each, 210, 250 and 81. Variety of Octal Base Tubes, 3/- to 4/-. All types transmitting tubes in stock. Majestic and Spartan Types, 4/6 each.—Radiographic, Ltd., 60, Osborne Street, Glasgow, C.1. Bell 848.

**RADIO BARGAINS**

**ALCO ELIMINATORS AND CHARGERS.** Standard outputs, 18/-. With charger, 25/-. Charger 7/6. Year's guarantee. Details free.—P. and D. Radio, 1, Gooding Road, N.7.

**PREMIER SUPPLY STORES**

All goods guaranteed perfect; carr. paid over 5/-; under 5/- postage 6d. extra.  
**ALL POST ORDERS TO JUBILEE WORKS, 167, LOWER CLAPTON RD., LONDON, E.5.**  
Phone: Amhurst 4723.

**CALLERS, AS USUAL, TO 165 & 165a, FLEET ST., E.C.4** (Next door to Anderson's Hotel), Central 2833. New Branch: 60, HIGH ST., OLAPHAM, S.W.4 (Macaulay 2381).

Have you had our **GIANT ILLUSTRATED CATALOGUE AND VALVE LIST?** Send 4d. IN STAMPS FOR THIS BARGAIN LIST.

**NEW 1937 1-VALVE SHORT-WAVE RECEIVER OR ADAPTOR KIT, 13 to 86 Metres without coil changing. Complete Kit and Circuit, 12/6. VALVE GIVEN FREE 1 DE LUXE MODEL 14 to 150 Metres, complete Kit with Chassis, 4 Coils and all parts, 17/6.**

**SUPERHET CONVERTER KIT, 12/6.** De Luxe Model, 18/6. S.W. SUPERHET CONVERTER KIT, for A.C. Mains Receivers, 20/-. A.C. Valve given FREE 1

**NEW 1937 2-VALVE S.W. KIT, 13 to 86 Metres without coil changing. Complete Kit and Circuit, 19/6. VALVES GIVEN FREE. DE LUXE MODEL, 14 to 150 Metres, complete Kit and Chassis, 4 Coils and all parts, 25/- VALVES GIVEN FREE. 3-VALVE S.W. KIT, S.G. Det. and Pen., 42/- VALVES GIVEN FREE.**

**SHORT-WAVE COILS, 4- and 6-pin types, 13-26, 22-47, 41-94, 78-170 metres, 1/9 each, with circuit. Special set of 3 S.W. Coils, 14-150 metres, 4/- set, with circuit. Premier 3-band S.W. Coil, 11-25, 19-43, 38-86 metres. Simplifies S.W. receiver construction, suitable any type circuit, 2/6.**

**COIL FORMERS** in finest plastic material, 1 1/4in. low-loss ribbed, 4- or 6-pin, 1/- each.

**The New "Premier" Short Wave CONDENSERS, with Trolin insulation. Certified superior to Ceramic. All-brass Construction. 15 mmfd., 1/4; 40 mmfd., 1/7; 100 mmfd., 1/10; 160 mmfd., 250 mmfd., 2/6. S.W. H.F. Chokes, 9d.; screened, 1/6. All-Brass S.W. Condensers with integral stop-motion, .00015 Tuning, 3/9; .00015 Reaction, 3/3.**

**Famous EUROPA MAINS VALVES. 4 v. A.C. and 20 v. 18 Universal. All standard types, 4/6. 1 H. Pentodes and P.W. Rectifiers, 5/6.**

**BATTERY VALVES, 2 volts, H.F., L.F., 2/3. Power, Super-Power, 2/8. R.G. Var-Mu-S.G., 4- or 5-pin Pentodes, H.F. Pens., V-man-H.F. Pens., 5/-. Class B, 5/-.**

**AMERICAN VALVES. Genuine American HYTRON and TRIAD first-grade Valves, 3 months guarantee. All types in stock, 5/6 each. 210 and 250, 8/6 each. New Metal-Glass Valves all types, 6/8 each. Genuine American DIOTRON Valves, all types, 3/6 each. Valve holders for all above types, 6d. each. OCTOL bases, 9d. each.**

**3-WATT A.C. AMPLIFIER, 2-stage** for mike or pick-up. Complete kit of parts with 3 valves, 40/-. Wired and Tested, 22/15/0.

**7-WATT A.C./D.C. AMPLIFIER, 3-stage high-gain, push-pull output.** Complete kit of parts with 5 specially matched valves. 24 4s. Completely Wired and Tested, £5,5/0.

**COSMOCORD PICK-UPS, with tonearm and volume control, 10/6 each. PICK-UP HEADS only, 4/6 each.**

**PREMIER MAINS TRANSFORMERS, wired-end type with screened primaries, tapped 200-250 v. Centre-tapped Philips. Guaranteed one year. H.T. 250-250 v. 60 m.a., 4 v. 1 a., 4 v. 2 a., and 4 v. 4 a., all C.T. 8/6. 350-350 v. 120 m.a., 4 v. 1 a., 4 v. 2 a., and 4 v. 4 a., all C.T. 11/-. Any of these transformers with engraved panel and N.P. terminals 1/6 extra. 500-500 v. 150 m.a., 4 v. 2-3 a., 4 v. 2-3 a., 4 v. 2-3 a., 4 v. 3-4 a., all C.T. 17/6. SPECIAL OFFER PHILIPS MAINS TRANSFORMERS, 250-250 v. or 300-300 v. at 80 m.a., 4 v. 3 a., C.T.; 4 v. 1 a. Tapped Primary 100-250 volt., 6/11. 450-450 v. at 150 m.a. or 500-500 v. 100 m.a., 4 v. 4 a. C.T., 4 v. 4 a. and 4 v. 3 a. Screened Primary. Tapped input 300-250 v., 12/8. AUTO TRANSFORMERS, step up or down, 50 watts, 7/6; 100 watts, 10/-. SMOOTHING CHOKES 25 m.a., 2/9; 40 m.a., 4/1; 60 m.a., 5/8. 150 m.a., 10/6. Speaker Replacement Chokes, 2,500 ohms, 60 m.a., 5/6.**

**Electric SOLDERING IRONS, 200-250 v., A.C./D.C., 2/3.**

**SPECIAL OFFER LISSEN TWO-GANG SCREENED ALL-WAVE COILS, 12 to 2,000 metres, complete with switching and wiring diagrams, 6/11 per set.**

**Special Offer BTH Energised Moving Coils 10 1/2in. diam. 1,650 ohms field Power or Pentode transformer (state which), 14/6.**

**BOLA latest type P.M.a., 15L. R. & A. mains energised 2,500 ohms field, 10/6 each; Jensen P.M.s, 10/6.**

**W.B. 1936 STENTORIAN SPEAKERS, Standard model (list, 22/6), 22/6. Brand new in original sealed cartons.**

**OUTPUT TRANSFORMERS** for Power or Pentode, 2/6; Multi-Ratio, 4/6.

**TUBULAR CONDENSERS, non-inductive all values up to 5 mfd., 6d. each. 1 Watt Resistors, 6d. 4 Watts, 1/-.**

All Goods previously advertised, still available.

**MISCELLANEOUS**

**G.P.O. Telephones** (microphone, receiver, switch). Guaranteed, 4/- each. Bargain.—Electromicro, 75, Masbro' Road, W.14.

**"NEWNES TOURIST ATLAS** of Great Britain and Route Guide." Edited by John Bartholomew & Son, Ltd., 120 pages of fully coloured contour maps for the whole of England, Scotland, Ireland and Channel Islands, with Index to the principal Motoring and Cycling centres and distances, 2s. 6d. from all Booksellers.—George Newnes, Ltd., Tower House, Southampton Street, Strand, London, W.C.2.

**VISITORS TO LONDON** should get Newnes Handy Pocket Atlas and Street Guide to London, Edited by John Bartholomew & Son, Ltd., 18 coloured Maps, General Index to Streets and Railway Stations, 2s. from all bookstalls.—George Newnes, Ltd., Tower House, Southampton Street, Strand, London, W.C.2.

**"WIRELESS FOR THE MAN-IN-THE-MOON,"** by Columbus and Decibel, 2s. 6d. net.—Writing about the book the "Midland Daily Telegraph" says: "It is both good fun and sound theory."—at all booksellers and libraries, or from George Newnes, Ltd., Tower House, Southampton Street, Strand, London, W.C.2.

**"THE OUTLINE OF WIRELESS,"** by Ralph Stranger. Fifth edition, 8s. 6d. net.—This book, which covers the subject from A to Z, is to be recommended to all who desire to master the theory of Modern Wireless. At all Booksellers and Newsagents.—George Newnes, Ltd., Tower House, Southampton Street, Strand, London, W.C.2.

**A DICTIONARY OF WIRELESS TERMS,** by Ralph Stranger. A Wireless Work of Reference that should be on the bookshelf of every keen amateur. Compiled by a master of lucidity, it gives the meanings of all Technical terms in general use. Price 2s. 6d. from all Booksellers and Newsagents.—George Newnes, Ltd., Tower House, Southampton Street, Strand, London, W.C.2.

**FIFTY TESTED WIRELESS CIRCUITS,** by F. J. Cannon, 2s. 6d.—This handbook contains every modern circuit complete with instructions for assembling, component values, and notes on operation. Obtainable at all Booksellers and Newsagents.—George Newnes, Ltd., Tower House, Southampton Street, Strand, London, W.C.2.

**MORE THRILLING THAN FICTION.**—Newnes Wide World Library contains the finest true-life travel and adventure books, great literature and exhilarating reading. Each 2s. 6d. net from all Booksellers.—George Newnes, Ltd., Tower House, Southampton Street, Strand, London, W.C.2.

**PERPLEXITIES AND TANTALISERS.**—"The Strand Problem Book" is the finest collection of puzzles of all kinds ever assembled, mathematical, geographical, jiterary—acrostics and codes, by W. T. Williams (Tantalus) and G. H. Savage. Only 2s. 6d. net from all Booksellers.—George Newnes, Ltd., Tower House, Southampton Street, Strand, London, W.C.2.

**TELEVISION.**—Newnes Television and Short-wave Handbook, by F. J. Cannon, deals authoritatively with Scanning Systems (Drums, Mirror Screws, Discs, etc.), Neon Lamps, The Cathode-Ray Oscilloscope, How to build Short-wave and Ultra-short-wave Receivers. Fully illustrated, 3s. 6d. net. From your bookseller.—George Newnes, Ltd., Tower House, Southampton Street, Strand, London, W.C.2.

**FREE ADVICE BUREAU COUPON**

This coupon is available until August 14th, 1937, and must be attached to all letters containing queries.  
**PRACTICAL AND AMATEUR WIRELESS,**  
7/8/37.

**Add 50/- WEEKLY to your earnings**

Charge accumulators in your spare time.  
**Complete Charger, incorporating Westinghouse Metal Rectifiers.** Will charge 6-8 accumulators weekly.  
**Price £4.4.0** or 8/- monthly.  
Send for full particulars.  
**M.P.R. ELECTRICAL CO., 252, Victoria Road, Romford, Essex.**





**MCCARTHY**

**OUTSTANDING 9-VALVE  
FOUR-WAVE SUPERHET**

*For all-wave reception  
at its very best*

To the all-wave enthusiast, this exceptional receiver offers a number of interesting features, with quite unusual range, and power output. Few receivers at present on the market can claim so high a standard of design and performance.

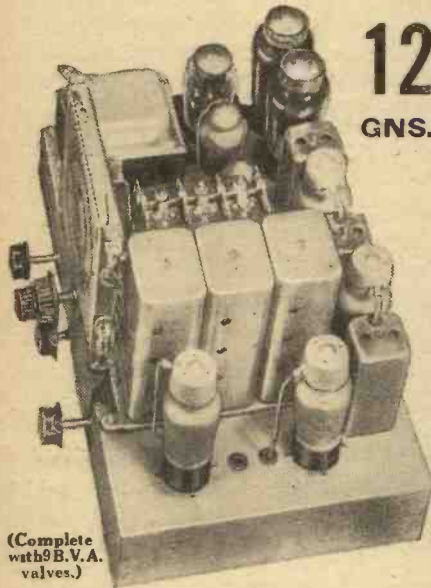

**12  
GNS.**

(Complete with 9 B.V.A. valves.)

4 wavebands: 12.8-33, 29-80, 190-550, 800-2000 metres. Illuminated dial with principal station names. Separate coloured lights for each waveband.

Circuit in Brief.—Aerial input to pre-selector circuit, radio frequency amplifier, latent type triode-hexode frequency changer, 2 band-pass I.F.T. coupled I.F. amplifiers, double diode detector, I.F. amplifier, paraflex transformer-coupled push-pull triode output giving 8 watts. Heavy cadmium-plated steel chassis. Finest components and workmanship throughout.

**DE LUXE MODEL 14 GNS.**

Many additional refinements—full particulars on application.

Controls.—A feature of the receiver is the number of independent controls fitted, making it extremely interesting to operate. These include: sensitivity control (varying bias on R/F stage), Q.A.V.C. with manual muting control, and switch for inter-station noise suppression. 5-position wave-change and gramophone switch. Progressive variable tone control operative on radio and gram.

A.C. models ready for immediate delivery.

A.C./D.C. models also in production, and will be available for delivery shortly.

**IMPORTANT**

The prices at which McCarthy Chassis are advertised include Marconi Royalties. "Practical and Amateur Wireless" readers should, for their own protection, make sure before purchasing any receiver that the quoted price includes the Royalty payment.

All McCarthy receivers supplied complete with valves, knobs, pilot lamps, leads, mains cable and plug. 12 months' guarantee.

Deferred terms on application, or through London Radio Supply Co., 11, Oat Lane, E.C.2.

Cash with order on 7 days' approval. Also write for illustrated catalogue of complete range of all McCarthy receivers.

**MCCARTHY RADIO LTD.**  
44a, Westbourne Grove, London, W.2

Telephone: Bayswater 3201/2.

**"ENGINEERING OPPORTUNITIES" FREE!**



This unique Hand-book shows the easy way to secure A.M.I.C.E., A.M.I.Mech.E., A.M.I.E.E., A.M.I.A.E., A.M.I.W.T., A.M.I.R.E., and similar qualifications. **WE GUARANTEE—NO PASS—NO FEE.** Details are given of over 150 Diploma Courses in all branches of Civil, Mech., Elec., Motor, Aero, Radio and Television Engineering, Building, Government Employment, etc.

Write for this enlightening Hand-book to-day FREE and post free. British Institute of Engineering Technology, 409, Shakespeare House, 17, 18, 19, Stratford Place, W.1.

**MISCELLANEOUS**

**EVERYMAN'S WIRELESS BOOK**, by F. J. Camm. 3s. 6d. net. An invaluable book of reference, explaining the operation, upkeep and overhaul of all types of wireless receiver. 200 illustrations. From all Booksellers and Newsagents.—George Newnes, Ltd., Tower House, Southampton Street, Strand, London, W.C.2.

**THE PRACTICAL MOTORIST'S ENCYCLOPEDIA**, by F. J. Camm, 3s. 6d. net. A lucid exposition of the principles, upkeep and repair of every part of the car. 442 illustrations. From book-sellers everywhere.—George Newnes, Ltd., Tower House, Southampton Street, Strand, London, W.C.2.

**PRIZES For Your PHOTOGRAPHS**

Special Competitions  
Every Month in

**The HOME PHOTOGRAPHER**

THE HELPFUL MONTHLY FOR AMATEURS

On sale 1st of each month at all Newsagents and Bookstalls, or by post 7d. from the Publisher, George Newnes, Ltd., Tower House, Southampton St., Strand, London, W.C.2.

**6<sup>d</sup>**  
MONTHLY

**ADVERTISEMENT INDEX**

	Page
British Institute of Engineering Technology	Inside Back Cover
Bulgin, A. F. & Co., Ltd.	Inside Back Cover
Electradix Radios	495
International Correspondence Schools	500
M.P.R. Electrical Co.	504
McCarthy Radio, Ltd.	Inside Back Cover
New Times Sales Co.	Inside Back Cover
Peto-Scott Co., Ltd.	495
Premier Supply Stores	504

**BARGAIN!**

Something Entirely NEW!  
**"3-in-1" SHORT-WAVE KIT**

Adaptor—Converter—Receiver  
LIST VALUE 37/6 BARGAIN **25/-**

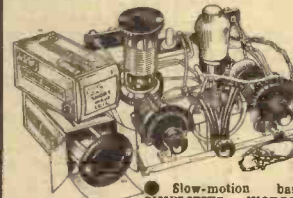

12-94 metres  
Adapts or converts your battery set for short-wave reception, or may be used as an efficient one-valve Short-Wave Receiver.  
● Reacting Detector Circuit.  
● Slow-motion bandspread tuning.  
**SIMPLIFIES WORLD RECEPTION!**  
● Low-loss reaction condenser. ● Air-spaced bandspread and tank condensers. ● SPECIAL ANTI-BLIND SPOT CONDENSER. ● 3 scales calibrated degrees and tenths.  
The N.T.S. "3-in-1" Short-Wave Kit is entirely unique in short-wave technique. This amazing combined Adaptor-Converter-Receiver is offered you for the first time... at an astonishingly low price.  
KIT "1" comprises every part for assembly, including 3 4-pin coils, wiring and assembly instructions, less valve only. Cash or C.O.D. Carr. Pd. 25/-, or 2/6 down and 10 monthly payments 2/6.  
Kit "2." With British valve, £18/9, or 2/6 down and 11 monthly payments 2/8.  
If N.T.S. headphones required, add 7/6 to Cash Price, or 8d. to deposit and each monthly payment.

**FREE!** Write for free Booklet to-day describing in full, with actual photographs, the "3-in-1" Short-Wave Kit and 4 other entirely new N.T.S. Bargain Short-Wave Kits and range of Short-Wave Components.  
**SEND FOR BIG LIST OF BARGAIN SETS BY ATLAS, BRITISH RADIO-PHONE B.T.S., K.E., LISSEN, McMICHAEL, PETO-SCOTT AND ZONO-PHONE.**

Postal Orders must be crossed and currency registered.  
**NEW TIMES SALES CO.,**  
56 (Pr. W. 27.) Ludgate Hill, London, E.C.4.  
EST. 1924

**BULGIN BULLETIN**

**SENT FREE**

The Bulgin Bulletin is more than just another House Organ. It is a miniature radio magazine of four pages, containing articles, circuits, notes on lab. work, advance information on new components and similar items of interest to technicians, traders and amateur constructors alike. It is posted free to those on our mailing list. If you are not getting your copy, fill in and send the coupon below.

To Messrs. F. BULGIN & Co., Ltd.  
BARKING, ESSEX.  
Please put my name on your list for future issues of the Monthly Bulletin.  
Name.....  
Address.....  
N. (BLACK LETTERS, PLEASE)

# The Outstanding Work For All Electrical & Wireless Engineers

## "PRACTICAL ELECTRICAL ENGINEERING"

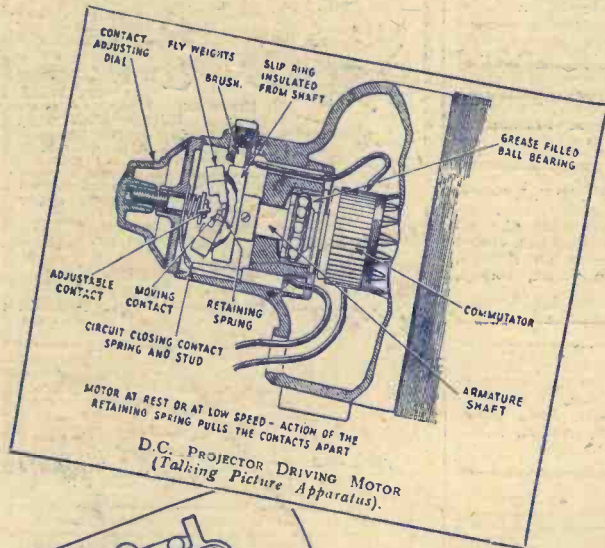

IN Electrical Engineering, advancement and success come to the man who is best equipped to tackle and understand the multifarious jobs and problems he may encounter. This new and up-to-date work will help you to acquire the necessary combination of theoretical and practical knowledge. It is invaluable alike to the Student and to the practising engineer. It shows the approved methods of dealing with every type of work, from the installation, erection, wiring, and maintenance of an electrical plant for a small house to that of a large factory replete with the most up-to-date equipment.

In addition, the most modern applications of electricity, including sound-film reproduction, wireless, etc., are fully dealt with, and the Volumes contain a great deal of most valuable data which cannot be found in any other work. Send for the illustrated prospectus—and judge for yourself.

Over 30 SPECIALIST CONTRIBUTORS.

More than

1,000 ILLUSTRATIONS. 2 FOLDING PLATES. SECTIONAL MODELS IN FULL COLOURS.

Over 1,900 Pages.

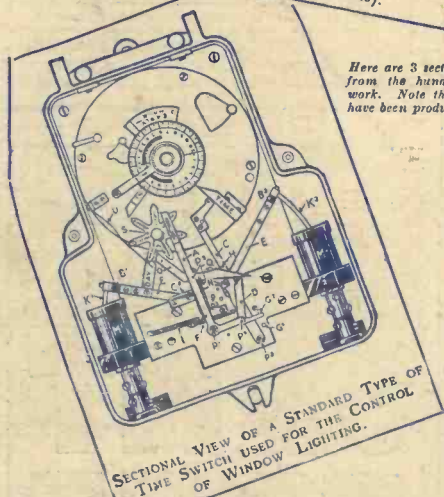

Here are 3 sectional diagrams taken at random from the hundreds included in this valuable work. Note the clarity of each—the drawings have been produced with infinite care.

A few of the important subjects:  
**ELECTRICAL MACHINERY, GENERATION & DISTRIBUTION, INSTRUMENTS AND METERS, WIRES & CABLES, LIGHTING AND ILLUMINATION, INSTALLATION WORK, OPERATION AND MAINTENANCE WORK, INDUSTRIAL USES OF ELECTRICITY, THEATRE AND CINEMA WORK, TELEGRAPHY & TELEPHONY, ELECTRIC TRACTION.**

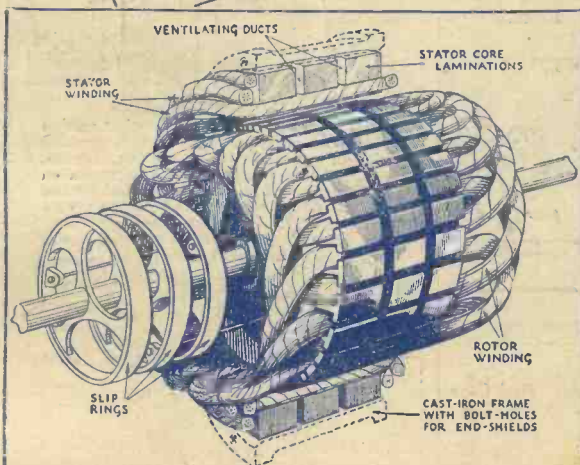

GENERAL ARRANGEMENT OF STATOR AND ROTOR OF A SLIP-RING MOTOR.

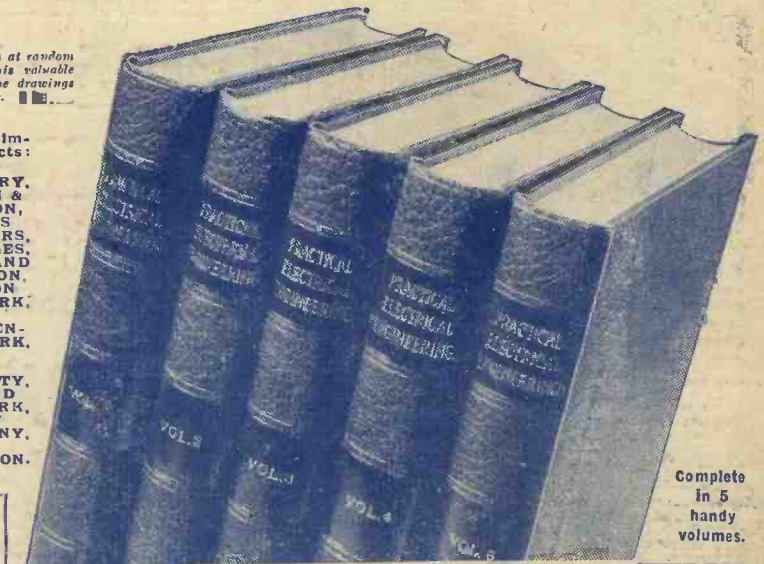

Complete in 5 handy volumes.

**HOME LIBRARY BOOK COMPANY**  
 TOWER HOUSE, SOUTHAMPTON STREET,  
 STRAND, LONDON, W.C.2

Please send me, without any obligation to purchase, full particulars of PRACTICAL ELECTRICAL ENGINEERING and details of your scheme of Easy Payments with immediate delivery.

Name .....

Address.....

..... PRAC. W. 7837

If you do not wish to cut your copy, send post card mentioning "Practical Wireless" to address above.

**POST  
 COUPON  
 FOR  
 FREE  
 BOOKLET**

OVER TO THE SHORT WAVES—See page 516.

# Practical and Amateur Wireless

**3<sup>D</sup>**  
EVERY  
WEDNESDAY

Edited by F.J. CAMM

a GEORGE  
NEWNES  
Publication

Vol. 10. No. 256.  
August 14th, 1937.

AND PRACTICAL TELEVISION

# Radiolympia



## NEWNES TELEVISION AND SHORT-WAVE HANDBOOK

By F. J. CAMM (Editor, Practical and Amateur Wireless)

EVERYTHING ABOUT—Drums, Mirror Screws, Scanning Discs and other Scanning Systems, Neon Lamps, the Cathode-Ray  
Oscillograph. How to Build Short-wave Receivers; How to Build Ultra-Short-Wave Receivers, Straight and Superhet types.

Fully  
Illustrated

NEWNES or 4/- post free from Tower House, Southampton Street, Strand, W.C.2. LONDON

only  
**3/6**  
net

"Spectatoritis"  
is the latest craze  
dealt with in  
**RUDE  
LETTERS  
TO YOUTH**

from **BILL BACK-BENCH, M.P.**

Including Notes from G. O. ALLEN,  
H. C. OWEN-SMITH and BERNARD JOY.

Illustrated by BATEMAN.

Introduction by IAN HAY.

"Frank, sensible, cogent."—*The Sunday Times*.

"A remarkable book."—*Mid-Devon Times*.

"Plain chunks of robust and realistic common-sense."—*The Daily Telegraph*.

"A natural product of the times."—*Western Morning News*.

"The author's intentions are admirable, and his occasionally unctuous manner is becomingly tempered by a prefectorial whimsicality."—*The Times*.

From all booksellers **2/6** net, or by post  
2/9 from the publishers,

**C. ARTHUR PEARSON, LTD.**  
(BOOK DEPT.),

**TOWER HOUSE, SOUTHAMPTON STREET,  
LONDON, W.C.2.**

**A VIVID ACCOUNT OF THE ZEPPELIN  
RAIDS ON ENGLAND, SEEN THROUGH  
THE EYES OF THE BOMBERS**



Read the thrilling description of bitterly cold journeys in total darkness. Often they culminated in breathless duels with fast defence 'planes whose bullets turned the airships into blazing death-traps. The stirring true narrative appears in the September "AIR STORIES."

*Other Contents include:*

**RAIDERS OF THE FRONTIER** By J. H. Stafford  
**FIGHTER PILOT** - - By "McScotch"  
**SKY CODE** - - By Captain J. E. Doyle  
**A SPOT OF SALVAGE** By Major L. S. Metford

IN  
THE  
SEPTEMBER **AIR**  
**STORIES** **7<sup>D</sup>**

Of all Newsagents and Bookstalls, or by post 9d. from the  
Publisher, George Newnes, Ltd., Tower House, Southampton  
Street, Strand, London, W.C.2.

RADIOLYMPIA—AUG. 25th.-SEPT. 4th.—OUR STAND No. 10 (GROUND FLOOR)

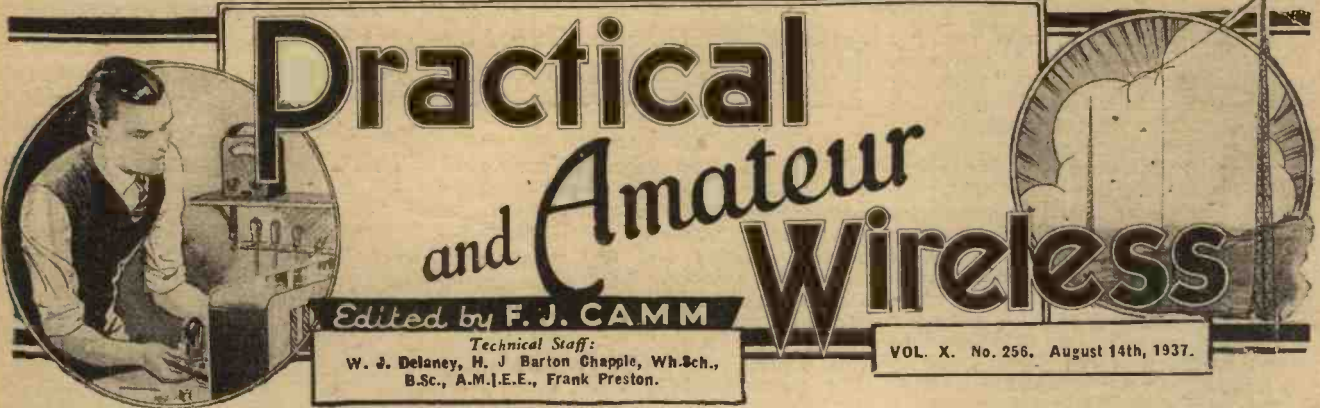

# Practical and Amateur Wireless

Edited by F. J. CAMM

Technical Staff:  
W. J. Delaney, H. J. Barton Chaplin, Wh.Sc.,  
B.Sc., A.M.I.E.E., Frank Preston.

VOL. X. No. 256. August 14th, 1937.

## ROUND *the* WORLD of WIRELESS

### Radiolympia

WITH only two weeks left before the opening of this year's Radio Exhibition, excitement is growing as to the nature of many of the exhibits. So far, it has definitely been established that many new television receivers will be on view, and the majority of the receivers to be shown will embrace all-wave tuning as the main theme. Indeed, this year the authorities have adopted all-wave listening as the key-note of the Show, and thus every visitor will be anxious to see the improvements which have been made in the design of apparatus for short-wave reception, combined with ordinary broadcast reception. Thermion gives, in this issue, his forecast of the Show, and it now only remains for the manufacturers to release the last-minute details to enable us to pass on to our readers in advance news of the exhibits and features which will be worth seeing this year. Next week we shall be in a position to give some exclusive notes concerning components and receivers which will be exhibited, and the issue following that will contain a Complete Guide to the Show. Make certain of your copies and place an order now with your newsagent to avoid disappointment.

### Film Star in Radio Serial

A WELL-KNOWN American radio company broadcasts a serial every day of the week from one of its high-powered stations, and they announce that Dorothy Gish, the famous stage and screen star, has been signed to play the feminine lead in this serial. Supporting her is Harold Vermilyea, also a well-known Broadway stage and radio star. This will mark Miss Gish's debut in radio as the star of her own programme. This programme may be heard on 428 metres on the medium-wave band and also from station W8XAL on 49.5 metres, at 2.45 p.m.

### Prize Onions

THIS is not, as might be imagined from the title, a talk on harvesting the exhibition crop, but a light comedy to be broadcast from the Welsh transmitter on August 18th. It is a repeat broadcast of a successful transmission carried out last year, the author being E. Eynon Evans and the producer Dafydd Gruffydd.

### Tower Ballroom Organ

ON August 18th a big Blackpool broadcast is to be given from the Northern Regional in which Reginald Dixon will be heard on the Tower Ballroom organ. On the following day, Horace Finch, the well-known Blackpool organist, will also be heard in a programme of music on this instrument.

### Meet the McKittricks

THE McKittricks are going to the seaside. You will know people like this family if you have ever been to a popular seaside resort—they are what you might call

**NEXT WEEK!**

**ADVANCE OLYMPIA  
SHOW DETAILS**

and

**IMPORTANT  
ANNOUNCEMENT**

concerning our

**SPECIAL SHOW  
NUMBERS**

inevitable. In this country we have the Bugginess, and the McKittricks are their Irish counterpart. There is Mrs. McKittrick, Mr. McKittrick and little Artie. Their adventure at the seaside will be broadcast to Northern Ireland on August 20th, beginning with the rush for the train—and so on through the usual channels.

### Whiteley Electrical to Make Sets

WHITELEY ELECTRICAL RADIO, LTD., makers of the popular W.B. speakers, have now decided to produce a range of complete broadcast receivers, and accordingly have joined the R.W.T.A. The sets will be shown at Olympia and will include a 3-valve A.C. straight set, a 4-valve battery superhet, and a 5-valve four-band

A.C. superhet. Two portables will also be seen.

### North-east Regional Station

THE B.B.C. N.E. Regional station at Bewley, Northumberland, should be ready for use by the end of September. The exterior of the transmitter is now completed, and the installation work has been commenced. It is stated that a beacon-light is to be provided at the head of the mast in order to warn aircraft.

### Open Air Television

THE first open-air demonstrations in London of television are being given in the West End, where television receivers have been installed at the entrances to a cinema and five-minute shows are given.

### Big-screen C.R. Television

THE first English demonstration of big-screen home television by means of a projector-type cathode-ray tube apparatus took place recently. The receiver, of Philips manufacture, utilises a 20in. by 16in. screen, which is raised when the lid is lifted. By using a separate screen it is claimed that a bright picture 3ft. square may be obtained. At the demonstration the tennis game which was being received enabled the detail to be clearly identified, and the ball was visible when served from the far court.

### Lincolnshire Entertainment

TWO popular East Coast resorts will figure in the "Lincolnshire Night's Entertainment," an outside broadcast programme for Northern listeners, on August 11th. From the Pier Pavilion, Skegness, "The English Entertainers," under the direction of Leonard Lovesey, will demonstrate how bright and bracing Skegness is; and the Theatre Royal, Cleethorpes, will be the source of a variety programme. An excerpt will also be taken from the Pier Pavilion at Cleethorpes, where Bob Walker and his Band will be playing.

### Swindon Band Concert

THE G.W.R. Staff Association Silver Band will broadcast from the Town Gardens, Swindon, on August 15th. Throughout the summer on Sundays and certain evenings band concerts are given, and recently a new enclosure has been opened. The Town Gardens are situated in Old Town, and provide many and varied walks.

# ROUND the WORLD of WIRELESS (Continued)

## Where is the "Café Colette"?

**W**ALFORD HYDEN, who conducts the "Café Colette" Orchestra, recalls that the "Café Colette" Orchestra owed its genesis to letters of abuse which poured in when he was touring the country with his famous Magyar Orchestra. The abuse was directed, not at the playing, but at the players, for it was felt that they must be foreigners; no English orchestra could infuse such a romantic and exotic flavour into their performances. Walford Hyden then decided that he would prove the ability of English musicians to equal, if not excel, their continental cousins, and in consultation with Eric Maschwitz he evolved the idea of the "Café Colette." The "Café" was a colossal piece of bluff, so successful that Walford still receives applications from people who want to book seats in the café itself. Letters have come from Paris asking "dans quelle rue" the café is situated.

Walford Hyden emphasises that every one of his performers is British.

## From the Light Operas

**T**HE artists in a concert "From the Light Operas," to be broadcast in the Western programme on August 16th, will



Miss Judy Shirley, singer of popular songs, who is well known to listeners. She regularly broadcasts with Harry Pepper's popular feature, "Monday at Seven."

be Hilda Blake (soprano), Frederick Harvey (baritone), and the Clifton Light Orchestra, conducted by J. Leslie Bridgmont.

## Concert from Bristol

**E**DITH MILLS (contralto) will be the soloist at a concert to be broadcast on August 13th by the City of Bristol Police Band, conducted by Captain F. W. Wood. Edith Mills is a native of Barnstaple, and first started singing professionally when she was nineteen. She gained experience at local concerts, and won silver and bronze medals at the Plymouth Musical Festival. She has also been a soloist in many London concerts.

## INTERESTING and TOPICAL NEWS and NOTES

### An Hour at Blackpool

**A** BIG Blackpool programme on August 18th will bring nine outside broadcast points into use. The entertainment will be presented to Northern listeners under the title of "Going up" and among the places of entertainment which will be visited by microphone will be the Tower Ballroom, the "Arcadian Follies" at the South Pier, "Punch and Beauty" at Feldman's Theatre, the Tower Circus, the Pleasure Beach, Palace Theatre, and the Central Pier Follies.

### Variety from Plymouth

**A** VARIETY programme will be broadcast from the stage of the Palace Theatre, Plymouth, on August 13th.

### Midland Band Concert

**T**HE Rugby Steam Shed Band is to broadcast for the first time on August 13th. This band was founded in 1854 by John Austin, a railwayman in the service of the L. and N.W.R. It has been in the prize list of the Leicester Festival Championship Section for the last two years and has won the Department Cup at that Festival for four successive years. E. C. Moore is its musical director. Alice Vaughan will sing a group of contralto solos in the interlude.

### "Ocean Times"

**L**ISTENERS who enjoyed the popular revue feature entitled "London Pie" may like to note that Harry Howard and

Sydney Vivian have written a special summer show called "Ocean Times," a Mediterranean carouse, which will be broadcast in the Empire and National programmes on August 27th.

### Torquay Municipal Orchestra

**T**HIS popular orchestra, led by Harold F. Petts and conducted by Ernest W. Goss, will broadcast from the Pavilion, Torquay, on August 15th. Helel Sandow



BENIAMINO GIGLI, the world-famous tenor, is here seen examining the recording wax after making some of his latest records for "His Master's Voice." The new Gigli record is "On with the Motley" and "My husband, Punchinello," from "Pagliacci," on H.M.V. DB. 3158.

(contralto) will be the vocalist in a concert by the orchestra on August 17th.

### The Clifford Quintet

**T**HE programme to be given from the Midland Regional on August 16th by this quintet will include "Green Room Minuet," by Frederick Bye, the Birmingham composer, his own arrangement of the Strauss overture to "A Night in Venice," and four examples of music for the theatre arranged by Anthony Bernard, music director to the Shakespeare Festival Company at the Memorial Theatre, Stratford-upon-Avon.

### "From the Esplanade"

**T**HE Weston-super-Mare Municipal Orchestra will give a concert, "From the Esplanade," conducted by H. C. Burgess, from the Rozel Bandstand, Weston-super-Mare, on August 17th.

### "The Show Supreme"

**A** CONCERT Party, "The Show Supreme," will be presented by Harry Benet from the Pavilion, Teignmouth, on August 19th. The cast will include—Hay Plumb (comedian), Daphne De Wit (soubrette), Billy Blackburn (jus' popped in from Yorkshire), Tessa Newman (soprano), Barry Piddock (light comedian), Phyl Sylvern (comedian), Fred Mason (comedian), Alice Maude (impersonator), and Bobby Day (and a piano).

## SOLVE THIS!

### PROBLEM No. 256

Budge's receiver gradually developed distortion and when tests were eventually made in an endeavour to trace the fault, it was found that the anode voltage on each valve was excessive. Where was the defect? Three books will be awarded for the first three correct solutions opened. Address your solutions to the Editor, PRACTICAL AND AMATEUR WIRELESS, George Newnes, Ltd., Tower House, Southampton Street, Strand, London, W.C.2. Envelopes must be marked Problem No. 256 in the top left-hand corner, and must be posted to reach this office not later than the first post on Monday, August 16th, 1937.

### Solution to Problem No. 255

A rectifier should have been used in conjunction with the 6 volt 1 amp. transformer.

The following readers successfully solved Problem No. 254, and books are accordingly being forwarded to them—R. V. Jones, 7, Clinton Terr., Budleigh Salterton, Devon; V. Harrison, 2, Westbrook Ave., Teignmouth, Devon; H. Bracegirdle, 20, Maple Ave., Haydock, Lancs.



# Pre-Detector Amplification

*A General Review of the Most Popular Forms of High-frequency Amplifier Circuits, which will be of Main Interest to the More Experienced Constructors.* By **FRANK PRESTON**

THE detector-L.F. receiver which used to be so popular has gradually been dying out during the past few years. There are many who regret the passing of what is still affectionately called the "straight three," but we must face the

fact that it is rarely quite suitable in present-day conditions. By this I do not mean to suggest that it is obsolete, or even that it is useless, but that its sphere of utility is limited.

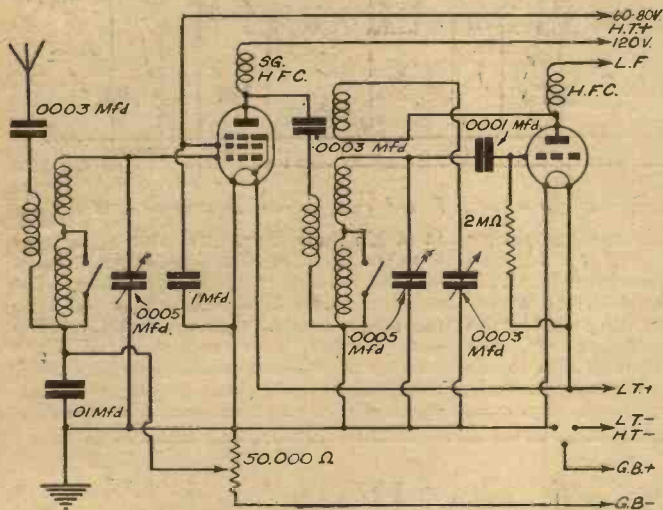

Fig. 1.—A form of tuned-grid coupling, using a coil with separate primary winding.

fact that it is rarely quite suitable in present-day conditions. By this I do not mean to suggest that it is obsolete, or even that it is useless, but that its sphere of utility is limited.

Although the prime object in using pre-detector amplification (H.F. or I.F.) has always been to increase the useful range of reception, it confers the other very important advantage of increased selectivity. When using any form of amplification between the aerial and detector, each stage generally incorporates its own tuning circuit. This acts as a "filter," and several of these "filters," used one after the other, serve to cut out all except the wanted signals.

## How Much H.F.?

It has been argued that pre-detector amplification, as such, is of little value, since if you amplify the required signals you must also amplify background noises, which are not tuned to any definite frequency. This is an interesting line of thought, but the idea applies in practice only on rare occasions. But a similar argument can be quite sound when dealing with the degree of amplification which can usefully be employed. It is evident that

less, but it is intended to show that there is a limit to the useful amount of H.F. amplification which can be used, and that it is usually better to have fewer valves operating in an efficient arrangement than a large number of valves, each of which contributes only in small degree to the overall amplification.

In some respects, this is the reverse of the position when considering a low-frequency amplifier, and there will be many who disagree with the conclusions drawn. Nevertheless, it has been proved that a modern, well-designed set consisting of one H.F. stage followed by a detector and L.F. amplifier can bring in all the worthwhile stations if connected to a good

aerial-earth system. In fact, my own experiments have led me to believe that a set of this type can be as satisfactory as the average superhet.

It certainly has the advantage of a silent background, whilst it is comparatively easy to build and adjust; the cost is relatively low. The reader is probably wondering just what circuit arrangement is suggested. Two alternatives for the H.F. and detector stages are shown in Figs. 1 and 2, and either of these can be followed by a resistance-fed transformer and high-efficiency pentode, as described last week. The circuit in Fig. 1 uses a variable- $\mu$  H.F. pentode connected to the aerial through a modern screened coil with loose-coupled aerial winding and feeding into a triode detector through a modified tuned-grid coil. Actually, the latter coil is a transformer of the same general form as that used in the aerial circuit. Reaction is applied in the usual manner by means of a variable condenser. Variable- $\mu$  control is by means of a 50,000-ohm potentiometer connected across a 9-volt G.B. battery, and a three-point on-off switch is used to prevent the potentiometer from draining the battery when the set is switched off. There are no "frills" on the circuit, and its effectiveness is governed to a large extent by the choice of coils of sound construction or well-known make.

## Tuned-anode Coupling

Due to the looseness of coupling in the two tuning circuits there is available a degree of selectivity which is adequate for most requirements, and the H.F. stage is intrinsically stable. In Fig. 2 an H.F. pentode is again used, but this need not be of the variable- $\mu$  type, since a fair measure of input volume control is provided by the variable condenser in series with the aerial. Increased amplification is obtained by using tuned-anode coupling between the two valves, and therefore more care in design and construction is required to maintain complete stability. There is no reason why the H.F. stage should not be stable if both coils are well screened, and if the leads between the anode of the H.F. pentode and the coil, and between the reaction winding and the reaction condenser are screened. It is also desirable that short leads be used between both coils.

In Fig. 2 a fixed potentiometer is used to supply the screening-grid voltage to the first valve, but a separate lead, as in Fig. 1, could be used instead if preferred. Another point to note is that a fixed resistance is used in series with the reaction winding;

(Continued overleaf)

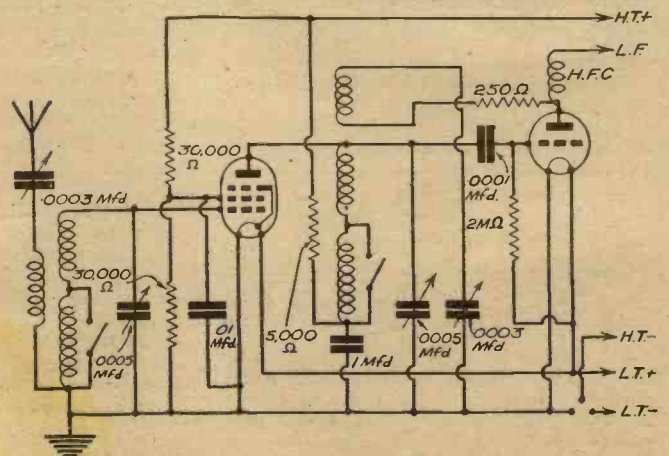

Fig. 2.—Tuned-anode coupling, which gives greater amplification, although it requires more care in design to avoid instability.

### PRE-DETECTOR AMPLIFICATION.

(Continued from previous page)

this frequently helps to "smooth out" reaction control. At the same time, it will be understood that a compromise could easily be made between the two circuits in question without difficulty. Perhaps it should be mentioned that if it were proposed to use a potentiometer for the S.G. and another for variable-mu control, a four-point on-off switch would be required.

### A.V.C. and H.F.

Automatic volume control is generally preferred in a set which is to be used for the reception of a large number of stations, and this could not very satisfactorily be incorporated in either of the two simple circuits dealt with. To ensure a reasonable measure of control it is necessary to have two H.F. stages, and this brings us to the circuit in Fig. 3. In this case a double-diode valve is used (as a single diode) for detection and A.V.C., and reaction is not employed. If the set is suitably designed, reaction is not required, since the degree of amplification is adequate without it.

Although employing two H.F. stages, it is not difficult to obtain complete stability. To assist in this, two different forms of coupling are used—between the two amplifiers, and between the second H.F. stage and the diode. Tuned-anode is employed after the first amplifier, and tuned-grid after the second. A three-gang condenser, with trimmers, is suggested for tuning, and this renders operation very simple. All three coils may be of similar pattern, and the tuned-grid circuit could be similar to the arrangement shown in Fig. 1, if preferred. Accurate ganging of the three tuning stages is essential if full amplification is to be obtained, and given this the range should be at least equal to that of the alternative circuits previously considered; the loss of reaction is compensated for by the extra H.F. stage.

### Band-pass Filter

So far there has been no suggestion of

using a band-pass filter, but that would be desirable in the two-valve circuits if good-quality reproduction is considered as being of great importance. The question arises as to the most suitable position for the band-pass filter. It is usual to place this in the aerial-input circuit, but that is not the ideal arrangement. A better method is to use the single-circuit tuner there, and to include band-pass between the H.F. valve and the detector.

The reason for this assertion is not hard to see. If a band-pass filter precedes the first valve it limits the band-width of the signals applied to the second tuning circuit, and if this is slightly off tune—as it might

wide. The band-pass filter then narrows the width to, say, 9 kc/s., with the result that the maximum permissible frequency range is passed on to the detector. There is one objection to this scheme, which is that reaction, if used, must be applied to the second circuit of the band-pass filter, and this might tend to throw the tuning slightly "out of balance," although the effect is not great if differential reaction control is employed.

In this article we have dealt only with high-frequency pre-detector amplification, so the various superhet arrangements remain to be considered. Space does not permit of that this week, but it is proposed

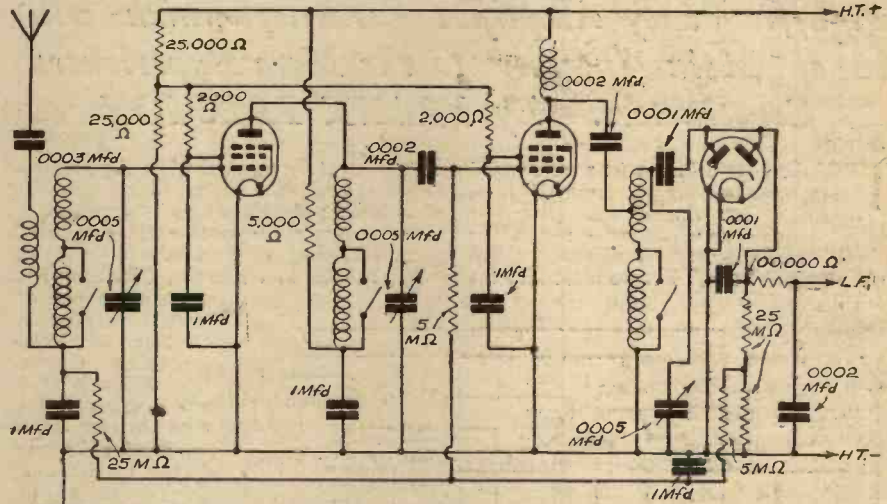

Fig. 3.—Skeleton circuit for a two-H.F. and diode detector arrangement with A.V.C.

be at certain settings of the tuning condenser—tuning might well be so sharp that distortion would result. On the other hand, if a single-circuit tuner is used in the aerial-circuit, this is damped to some extent by the aerial, so that the band-width of the signals applied to the first valve, and also to the second tuned circuit, is comparatively

to tackle the subject in a later article. It is unquestionable that there is much to be said for the superhet, and even though the simpler circuit has been advocated here the superiority of the superhet for many purposes has been amply proved by a number of receivers which have previously been described in these pages.

## Important Broadcasts of the Week

#### NATIONAL (261.1 m. and 1,500 m.)

Wednesday, August 11th.—Promenade Concert (Bach), from Queen's Hall, London.

Thursday, August 12th.—S O S, a play by Taffrail.

Friday, August 13th.—Promenade Concert (Beethoven), from Queen's Hall, London.

Saturday, August 14th.—Sonata Recital.

#### REGIONAL (342.1 m.)

Wednesday, August 11th.—Orchestral programme.

Thursday, August 12th.—Hyde Park: a dramatic narrative by Jonquil Antony.

Friday, August 13th.—S O S, a play by Taffrail.

Saturday, August 14th.—Promenade Concert from Queen's Hall, London.

#### MIDLAND (296.2 m.)

Wednesday, August 11th.—English Song Writers—"Rutland Boughton": a recital.

Thursday, August 12th.—Rock-a-bye Rhythm.

Friday, August 13th.—Band Concert.

Saturday, August 14th.—From the Musical Comedies: orchestral programme.

#### NORTHERN (449.1 m.)

Wednesday, August 11th.—Lincolnshire Night's Entertainment, from the Pier Pavilion, Cleethorpes, The Pier Pavilion, Skegness, and the Theatre Royal, Cleethorpes.

Thursday, August 12th.—The Rydal Sheep Dog Trials: Running Commentaries, from the Vale of Rydal, Westmorland.

Friday, August 13th.—A Day at Blackpool: a Lancashire sketch in dramatic form by Tom Simm.

Saturday, August 14th.—The Buxton Lawn Tennis Tournament: an eye-witness account.

#### WELSH (373.1 m.)

Wednesday, August 11th.—Choral Concert, from the Gorse Hall, Swansea.

Thursday, August 12th.—The Fruits of the Eisteddfod: Review of and readings from some of the successful compositions at the National Eisteddfod, 1937.

Friday, August 13th.—An organ recital from Christ Church, Llanfairfechan.

Saturday, August 14th.—Aberystwyth, Fifty Years Ago: a Welsh Talks Feature.

#### WEST OF ENGLAND (285.7 m.)

Wednesday, August 11th.—Instrumental programme.

Thursday, August 12th.—Band Concert from Plymouth.

Friday, August 13th.—Variety programme from Palace Theatre, Plymouth.

Saturday, August 14th.—Bridgwater Flower Show and Band Festival.

#### SCOTTISH (391.1 m.)

Wednesday, August 11th.—Concert Party from the Winter Gardens, Rothesay.

Thursday, August 12th.—Concert of Favourite Scots Songs.

Friday, August 13th.—Men and Matters: a Talk, from Edinburgh.

Saturday, August 14th.—For Men Must Work: a play by William H. D. Joss and George Fields.

#### NORTHERN IRELAND (307.1 m.)

Wednesday, August 11th.—Chamber Music Concert.

Thursday, August 12th.—Promenade Concert, from Queen's Hall, London.

Friday, August 13th.—Variety Programme from the Ritz Cinema, Belfast.

Saturday, August 14th.—Promenade Concert, from Queen's Hall, London.



# On Your Wavelength

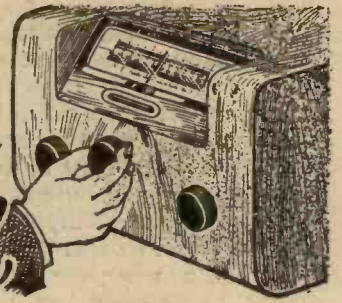

By Thermion

## Loyalty

I OFTEN receive letters from overseas readers who tell me of the difficulties they sometimes experience in purchasing this journal. These difficulties are in no way due to our Publishing Department, which unflinchingly distributes the paper over the whole world. But, occasionally, there is a keen fan who resides in the wilds remote from the usual sources of communication, and it is often the case that he has to wait a month for the current issue. So loyal are these readers that they are willing to make very lengthy journeys through the jungle in order to obtain their copies, and very frequently they have to pay as much as 1s. for a copy. It keeps them in touch with the home country, and it is a fine thing to reflect that they can still maintain enthusiasm for a hobby which they must practise under severe handicaps. They cannot purchase components round the corner, and they have to make do with home-made apparatus of a practical yet crude kind. I often receive pictures from them showing the difficulty under which they work. It is always a source of pleasure to me to read letters from my overseas readers. They do not grumble at their lot, and their letters breathe loyalty to the old paper, to the staff, and to the hobby. Delays in delivery can be expected in foreign parts, but there is no excuse if PRACTICAL AND AMATEUR WIRELESS is not available on your breakfast table every Wednesday morning. Now and again I hear instances of newsagents who do not seem to carry on the traditions of the trade. Listen to this from T. K., who resides in Ormskirk. He says that he used to get his copy at a local newsagent's, but as the latter did not deliver it until Saturday each week he cancelled his order and gave it to another newsagent. The copies then arrived regularly for a little while, and then the newsagent got careless,

and started to deliver a few days late. So this reader has been compelled to cancel his order again and find another newsagent. Our Publishing Department has taken up the matter. I should be glad if readers who experience the slightest difficulty in purchasing this journal would get into touch with me.

## At The Show

I LEARN from the Editor that we shall offer, as in previous years, a further twenty-five loudspeakers in a simple competition to be set in the first special Show issue, to be published next Wednesday week. The Show seems to come round more swiftly each year. It will see me with a few more grey hairs, and fewer hairs as well. Fifteen years of my life have been spent amongst wireless—a pretty useful portion of it, too. The blush of youth may have left me but my enthusiasm is still as boundless as the schoolboy's. I was looking through some files of my writings the other day, and am really surprised to see what a colossal total it makes. Like the compiler of the *Encyclopædia Britannica* I am entitled to say: "Did I really do all that?" Some really interesting components are going to be on show this year, and the constructor will not be neglected. For me the main interest will be in the television section, and I am hopeful that prices of television receivers will show a marked reduction and that components for constructors of television receivers will be available. The designs are in this office awaiting the production of the necessary components.

## Gramophones in U.S.A.

I SEE from a recent American magazine that the American public are beginning to go back to the gramophone, or at least to the gramophone record, for their entertainment. I do not know whether this indicates that they are now dissatisfied with the reproduction from the radio stations, or that the in-

duction is that the commercial programmes are at last palling on them. It is interesting to note, however, that there are 95 different models of radio-gram combinations on the American market, made by 18 different firms. Almost half of these instruments are fitted with automatic record-changers, and the cabinet styles vary considerably. I note that the sale of gramophone records is nearly eight times that of 1931, and one manufacturer with de-luxe radio-grams priced over \$1,000 is reputed to have sold 3,000 during the last year, and sales for this year show an increase to date.

## All-Wave Tuning Coils

I AM glad to find that so many component manufacturers are now turning their attention to the production of all-wave tuning coils for the constructor. There have been a few coils of this kind available for a year or two, but most of them were far too large for my liking. Some of the new units that I have examined are extremely compact and include their own wavechange-switch system.

By using these new coils it is going to be a comparatively simple matter to convert many existing broadcast receivers to all-wave models. I am glad of this, because it will give a still larger proportion of listeners a chance to "sample" the short waves, which always provide something of interest. During the recent weeks when hours of daylight have been so numerous, I have almost confined my DX activities to the higher frequencies, and have been rewarded by a quiet background and only slight fading.

The new coils give another instance of the advantages of home construction: those who have built their own sets can readily modify them, whilst users of commercial models would, in nearly every case, find it impossible to effect the alteration. Their only method of keeping up to date is to buy a completely new set.

## What Next?

I QUOTE the following without any comment, as I am sure that anything I said would spoil your fun:—  
With the return of popular interest

in self-created music, a new musical tool has been made available for the music-lover—again a gift of radio! This new musical aid is the radio-valve amplifier which makes it possible for the relatively weak tones of any instrument to be built up in volume to any desired loudness, yet still retaining all the quality and richness of the original sounds.

Simply a miniature "public-address" system hooked on to a particular instrument—such an amplifier has enabled stringed instruments in quartets to be reinforced in volume, until the impression given is that of many performers playing similar instruments. For several years viols and violas in dance orchestras have made use of these amplifier devices to give added volume. A microphone pick-up is placed under the strings, and the amplification is depended upon to give any desired loudness.

Viols, violins, mandolins, guitars, banjos and other stringed instruments have already been equipped with radio-valve amplifiers with great success. In some cases, the instruments themselves have been specially designed or modified for amplification pick-ups. In other instances, special compact amplifier units have been provided, with a microphone which can be slipped under the strings or into the sound-box—thus making any ordinary instrument an amplified device at will.

And now the piano has been added to the list of radio-valve devices.

The present strong trend to smaller and smaller uprights in the piano field and the recent rapid decline of larger uprights and grands since the introduction of the miniature pianos, have lowered prices and improved furniture values, due to the cute small designs. But with each decrease in piano size, the tone had become worse and worse.

#### Tone of Concert Grand

**B**UT now adapting the principles of radio-tube amplifiers and controls, these smaller pianos can be given finer tone and greater volume than even a concert grand, though still using the compact small designs. Already seven or eight piano manufacturers are bringing out such new "radio pianos"

Others are developing small keyboards and string sound boards with microphones, which can be plugged into any home radio set, thus affording the humblest home a piano of unsurpassed tone and volume, at little cost.

Meanwhile, the progress in home electric organs goes on. These com-



## Notes from the Test Bench

### Valve Tests

**I**T is surprising the number of readers who still think that if a valve shows filament continuity it must be in good order. A filament test is certainly useful and is the first test that should be made when a valve is under suspicion. A valve can be quite useless, however, even though its filament is intact. This is especially so in the mains type. In a battery type it is generally the filament that becomes defective, but in mains valves the filament or heater very seldom burns out. Insulation trouble or loss of emission is commonly experienced after about 12 months' use, however. The home constructor can easily test the emission by connecting a milliammeter in the anode lead when H.T. and L.T. voltage is being applied. The reading obtained can then be compared with the manufacturer's figures and the emission condition of the valve decided.

### Insulation Tests

**I**NSULATION tests are more difficult to make, however, and if a valve is suspected of leakage due to bad internal insulation it is advisable to have it tested by the manufacturers or by a reliable local radio engineer. Poor insulation is generally indicated by crackling noises. Intermittent signals are also commonly due to a valve defect. If a certain valve (usually the output valve) is suspected of causing intermittent reception the best procedure is to try a substitute if one can easily be procured—the majority of valve-testers cannot be relied upon to indicate a fault of this nature.

### Vitesse A.V.C.

**W**E had a letter from a reader the other day concerning the Vitesse which we had serviced for him. He was very pleased with the performance but thought the automatic volume-control was not very effective. He complained that distant stations still faded at times. Like many more listeners, he was under the impression that A.V.C. should keep signal strength from every station at the same level. This cannot be done, of course. If a station fades to inaudibility A.V.C. cannot control it—the maximum signal strength of a station can be reduced but the minimum cannot be raised.

### An Ideal Book for the Beginner! Everyman's Wireless Book

By F. J. CAMM

3/6, or 4/- by post from George Newnes, Ltd.,  
Tower House, Southampton St., Strand, London,  
W.C.2.

compact instruments have lately been provided with player-roll operation. The next step in this field may be the incorporation of the compact organ-tone generator and keyboard directly into radio sets of the better console type, so that a music-lover—failing to find "on the air" music to his liking—can pull a chair up to his radio-set "organ keyboard" and play his own arias and fugues.

### And Still It Worked!

**H**ERE is yet another example of one of the freak results which often happen at a fire.

It concerns "His Master's Voice" High Fidelity Model 800, which suffered considerable damage when the owner's house caught fire, but still gave fair results afterwards.

The instrument was sent to E.M.I. Service, Ltd., at Hayes, by a dealer in the North of England for them to estimate the possibility of repair. In common with all instruments admitted for this purpose it was given general routine electrical tests, the first of which is "the 'will it work' test." Only two valves needed replacing, as these were so affected by heat that the glass envelopes had become detached from the bases, thus disconnecting the internal wiring. The mains, earth and aerial were fixed and the instrument switched on—it worked!

One can imagine the severity of the heat from the fact that a record melted. Perished pick-up rubbers made it impossible to extend the test further, though the auto-mechanism was still in working order.

Such a performance is truly consistent with the general workmanship and quality of materials employed by "His Master's Voice" and is a matter for congratulation.

### B.B.C. Stands at Radiolympia

**W**E understand that the main B.B.C. stand this year will demonstrate the Empire broadcast service. To enable the public to see the various times at which the six transmissions from Daventry take place, and to appreciate the enormous areas that are covered by the service, there will be six maps which will be illuminated in turn, and a clock above them showing when broadcasting is actually going on from London.

Another feature of the stand will be the B.B.C. Empire Broadcasting Journal. Specimen copies of the journal, for which subscriptions may be taken out by members of the public desirous of keeping their friends abroad in touch with the broadcast programmes, will be on view.

# Practical Television

August 14th, 1937

Vol. 3

No. 63

## JUDGING TELEVISION RECEIVER PERFORMANCE.

A Large Number of New Television Receivers will Shortly Become Available, and it is Useful to Know Exactly How to Judge Their Performance.

**T**HIS year's Radiolympia will herald the appearance on the market of many new television receivers. It is essential, therefore, to know what points to look for in judging television receiver performance. No attempt will be made here to cover all the points, and furthermore, the order in which they are taken is not necessarily the order of importance.

The original opposers of cathode-ray tubes for picture reproduction on the screen at the large face end gave several reasons why in their opinion this device would be unsatisfactory, and foremost among these was the statement that there was inadequate picture brilliance. Observations on set performance soon disproved these statements, but then followed the argument that for viewing purposes the room had to be completely darkened, and this prevented any other form of activity being undertaken in the same room by those members of the family not particularly interested in the programme. Recent research, however, and marked improvements in tube manufacture are meeting this objection, and when judging modern set performance careful note should be taken of picture brilliance. At least one firm can produce tubes whose resultant picture is so brilliant that either in daylight or with the normal room lighting viewing can be undertaken without the slightest degree of difficulty.

The working characteristic of the tube has been arranged so carefully, that whereas in the old type tubes increasing the screen brightness destroyed the degree of signal modulation which could be handled without distortion, the new tubes are in no way affected. Be careful to observe then whether with maximum brightness the range of contrast between full black and full white is reduced, giving a picture which appears to be either half built or sadly lacking the half tones so necessary for real picture quality. If the signal volts which have to be applied to the modulator electrode of the tube for full picture range are too high, the degree of brightness which can be secured is generally of lower intrinsic value than those tubes which need a smaller value, and operating the brightness control will soon settle this point to the satisfaction of the would-be purchaser.

### Picture Detail

The degree of picture detail is a function of the frequency characteristic of the amplifiers used in the receiver's vision chassis, if it is assumed that the signal as radiated from the Alexandra Palace embraces the full 2.5 megacycles modulation frequency possible in a 405 line 50 frame, interlaced picture. For adequate picture detail, therefore, the set must be capable of amplifying this ultra-high signal frequency without any stage introducing amplitude distortion. This calls for the most careful design and skilful chassis layout, otherwise the finer qualities of the picture will be lost on the observer. In achieving this object, however, correcting

devices are often incorporated in the set. This is quite satisfactory for boosting certain frequencies which would otherwise be attenuated. If this correction scheme is carried too far, however, the picture will bear evidence by exhibiting what has been popularly termed the "ringing" effect. Sharp black edges such as a man's evening dress coat or a woman's dress will exhibit on the right a white outline giving the appearance of a double image. This is objectionable, and must not be regarded as a satisfactory alternative to partial lack of detail. If too wide a frequency band is

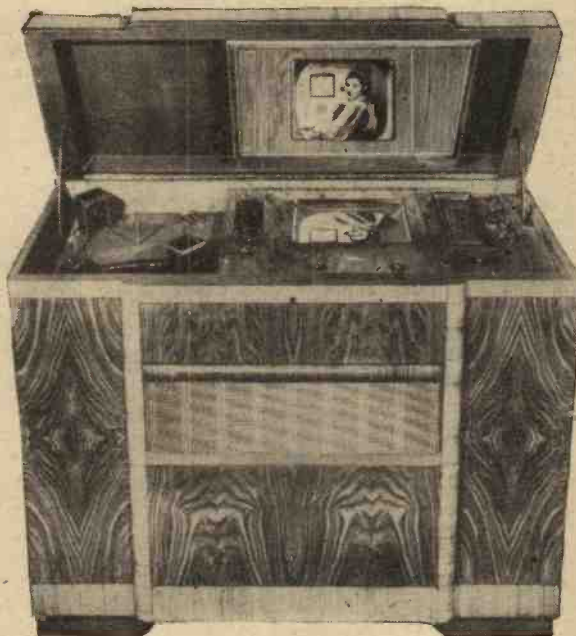

The Marconiphone Television Receiver, for which the makers supply a special aerial to ensure that the best results are obtained.

encompassed by the receiver there is a possibility that high frequency mush will become apparent on the picture screen. If not too marked, however, this is lost on the observer when he watches the picture at the minimum viewing distance of approximately six feet, but, where possible, steps should be taken to eradicate this eventuality.

### Controls

Many people are under the impression that to operate a television receiver satisfactorily demands a degree of skill not possessed by the user until he has had weeks of practice. This feeling may have been engendered by the imposing array of control knobs which characterised the earlier models of cathode-ray tube receivers. It was soon found, however, that although available for operation these control knobs were touched only occasionally. Since there is only one transmitting station, tuning on both vision and sound can be pre-set on installation. At the same time,

once the magnitude of the received signal has been ascertained the degree of amplification required in the receiver can be settled and left. Similarly, the focus of the picture, once the whole receiver has warmed up thoroughly, should not drift, and another control is thereby eliminated. The two controls which may need occasional adjustment are contrast and brightness. Some viewers prefer a very bright picture, while others are content with a lower overall brilliance. Again, just as some listeners show a preference for listening to a speaker which is almost overloading, so some viewers like to watch a picture in which the blacks and whites are over-accentuated (soot and whitewash is the colloquial term). As long as these two controls are within easy reach for adjustment when desired the modern set can have the other knobs hidden from sight, for use in emergency or alternatively adjusted by the service engineer on installation, then locked away to prevent tampering. The use of one picture standard has removed the necessity for time base generator switching at stated intervals. Furthermore, the problems of synchronising have been so thoroughly overcome that once set up on site the picture will remain locked in both the line and frame scan directions, so that these controls need not be operated. In judging modern receiver performance, therefore, examine carefully to see whether the set is left unattended during a programme period or whether the operator is compelled to make frequent adjustments. The best set from this standpoint will then be obvious.

### Interference

One of the principal difficulties associated with receiver installation has been the question of interference. Motor-car ignition systems, and certain types of electrical equipment, have played havoc with picture and sound in unfavourable situations, such as those in close proximity to main roads, or near hospitals using diathermy apparatus. The suppression of these extraneous noises on the sound side and the elimination of the white splashes or wide bright bands on the picture has engaged the attention of all the television firms, and there is no doubt that in many cases, if not eradicated, the degree of interference observed and heard has been reduced to a very low level. Special aerials and feeder systems, and a careful choice of the aerial site, has done much to help in this matter, but in addition, the sets themselves can now incorporate devices which play their part also in helping to remove one of television's biggest problems. In judging a receiver's performance, therefore, the assessment should include a careful observation of the type of environment, that is, whether in a veritable hotbed of electrical interference or whether the locality is a "quiet" one. The amount of interference, if any, can then be judged in its proper relation to performance and a decision arrived at concerning the steps which have been taken to cope with this problem in a satisfactory manner. In some sets a device called a "black spotter" is included. This functions in

## PRACTICAL TELEVISION

(Continued from previous page)

such a way that it converts the strong white interfering signal to a black one. This is regarded as less annoying to viewers, but at the best can only be regarded as a palliative and not a cure for the trouble.

### Distortion

The effects of non-linearity in the movement of the scanning spot produced by the time-base generator circuits are not always immediately apparent to the observer. A slowing down of the trace speed towards the end of the line or frame trace periods makes the scan close up somewhat. If present, it will show most marked on worded captions, and is a sure sign of bad design in this section of the complete receiver. Modern time base generators using either

hard or soft valves are quite capable of producing true linear scans when the design has been carried out correctly, and any failure to conform to this standard is a point on the debit side of the set.

Another form of distortion is brought about if the scanning spot does not remain in correct focus over the whole of the available picture field. Those areas not in focus will reveal themselves as somewhat hazy patches and be in sharp contrast with the lines of uniform thickness building up the picture in the remaining areas. As a rule, this defect can be remedied without any drastic alterations to the set, but an assurance is necessary that there will be no recurrence. Even illumination over the whole picture must be looked for. This may arise from the fluorescent screen thickness lacking uniformity. At the thick sections of the screen some of the picture

brilliance will be lost. Again, unless the screen grain is particularly fine, the picture detail will be partially destroyed. See that the tube face is not too bulbous, or if enlarged by lenses that the picture does not "round off" at any of the mask corners. This will produce a distortion somewhat like a reflection in a curved mirror, and becomes rather trying when watching programmes for any lengthy period.

Several other features could be mentioned, such as accessibility of controls, angle of view, correct picture height and the absence of any interaction between the sound and vision chassis which shows as a pattern of wavy lines on the picture screen, but sufficient of the major points have been detailed to enable the critical viewer to draw up a satisfactory report on the performance of any receiver he is able to see demonstrated.

### Lack of Co-operation

IN the United States there are three leading firms who are concentrating on the development of television, namely, R.C.A., Farnsworth and Philco. Each have their own particular type of scanner, which incidentally is wholly electronic in action, and also different forms of receivers, although cathode-ray tubes are in each case the final picture reproducers. The standards of picture definition employed by these firms are not unified at the moment, and the combined effect of this situation is that any pictures radiated by one company through their ultra-short-wave radio transmitter cannot be received by the other company. This apparent lack of co-operation will not assist the television industry as a whole in that country, and prospective American viewers, as well as the large number of experimenters, are hoping that an acceptable scheme can be propounded for a pooling of resources to expedite development, and the inauguration of a public service.

### High Speed Scanners

BIG screen television shown through the medium of mechanical scanners has been in the news again of late, and many readers have expressed interest in the speeds at which the moving members of mechanical scanners have to rotate. In the case of the Scopophony receiving equipment of the Science Museum the standard of picture definition is 240 lines, 25 frames, 25 pictures per second. For this purpose two inter-related scanning members are used. The first is a thin stainless steel polygon having 20 facets round the edge, and this has to revolve at the enormous speed of 18,000 revolutions per minute. The other scanner, very much larger in size, but having the same number of reflecting surfaces revolves at only 75 r.p.m. Supersonic light control and split focus are employed to modulate the light source—a standard 100 amp. cinema arc—and in this way 80 elements of the picture are employed simultaneously. In the smaller type receiver a similar optical system is used, but the light source is a half kilowatt arc of the microscope type. It is hoped to replace this last named, however, with a high pressure mercury arc which it is claimed will give a two to four times increase in light value.

### A German Extension

THE television telephonic service which has been in operation for such a long time between Berlin and Leipzig has proved very popular, not only with the Germans

themselves, but also with visitors to that country. It has also enabled a considerable amount of research work to be undertaken on the question of propagating signals at television frequencies along cables. It is possible that the expensive coaxial cables of low capacity may ultimately be dispensed with for this specific purpose, but in any case the Gerinans are to be congratulated on their foresight in undertaking a service of this nature. Not content with linking these two cities only, the Minister of Posts has now made it known that this service is to be extended to embrace four other large towns, namely, Frankfurt, Kiel, Hamburg and Munich. The significance of this is very apparent, for not only will it have a novelty appeal to the general public, but business men will avail themselves of the service to carry out certain transactions which the ordinary telephone cannot do, because the person being spoken to can be both seen and heard.

### A C.R. Tube Suggestion

SINCE the modern cathode-ray tube is completely exhausted in order to give the best picture reproducing results in television reception, the glass envelope has to stand very high pressures—from one ton upwards according to size. There is always the risk, therefore, that an implosion may occur, although with modern methods of manufacture and testing this is very remote. To still further reduce the risk, however, proposals have been brought forward to make a tube whose body is constructed of metal, and the face of glass to allow visible spot fluorescence. The main difficulty is fusing the glass and metal together so that there is no undue strain at the join. An intermediate cylinder having the same coefficient of expansion as glass can be interposed between the glass face and the metal body, and it will be interesting to see whether a commercial scheme of this nature can be brought to fruition. The suggested advantages attaching to a scheme of this character, apart from the question of minimised breakage risks, is that repairs or electrode assembly replacements can be undertaken at a very small cost, and this could offset any high first charge that may accrue.

### A Multiplier Modification

THE application of the principles of electron multiplication to photo-electric cell working is well known. Not only is the magnitude of the output signal increased enormously but the signal to unwanted noise ratio shows a material improvement also. Three different types of multiplication principles are used, these being due to Zworykin, Weiss and Farnsworth. In the case of the last named, however, where the electrons oscillate between two cathode surfaces placed at opposite ends of an evacuated glass cylinder, the device can be modified to extend its applications. By having perforated cathodes behind which are solid collector plates, the electrons can be made to surge to and fro, and some of these pass through the perforations to be collected by the plates. When these are connected externally to some form of tuned circuit, and provided the cathodes are kept in phase opposition, the device can be made to act as a generator of sustained oscillations. This is particularly useful in transmitter circuits, and quite large oscillatory powers have been obtained by Farnsworth when working in this way.

### Italy Looks Ahead.

FOR some time now the Italians have been experimenting with television, and developing a system of their own for transmitting and reception purposes. That the work undertaken has been of a satisfactory character is borne out by the announcement that three television centres are to be established at Rome, Turin and Milan. A wavelength in the neighbourhood of seven metres is to be used for the radiated signals, and the cities are to be linked by coaxial cable having the requisite low attenuation of the video frequencies. Programme distribution will in this way be settled satisfactorily, while the receiving sets are known to be incorporating cathode-ray tubes as the picture reproducers. The radius of the signals has yet to be ascertained, and the station powers settled, but it is stated authoritatively that at the earliest possible moment the service will be extended to other cities so as to provide the maximum coverage throughout the country.

**RADIOLYMPIA!**

**OUR STAND No. 10**

**Same Stand — Same Spot**

# Constructional Details of "Practical Wireless" Receivers—13

IN this series of articles we are giving the main constructional features of receivers which are available in blueprint form, but in respect of which the issues describing construction are now out of print. Blueprint P.W. 64 shows the wiring for a simple three-valve receiver which is admirably suited to the beginner, as it is a simple baseboard assembly calling for very little constructional work. It resolves itself, more or less, to the mere wiring of a few parts, all of which are fitted with terminals for connection and which therefore only calls for the use of a screwdriver and a pair of pliers. The few items not so provided are the resistors and fixed condensers, but these have wire ends which, in the case of this receiver, are ample in length to permit of their being attached to terminals on the components associated with them. As will be seen from the theoretical diagram, the circuit incorporates an S.G. valve followed by a triode detector which feeds an output triode through an L.F. transformer. A pair of matched tuning coils are employed, although these are not ganged together. A two-gang condenser is, however, employed for tuning purposes and the wave-change switching is controlled by a single switch.

The Main Features of the Centaur Three Receiver are Described in this Article

this type. When the pick-up is connected, radio signals will be considerably reduced in volume should the receiver be adjusted to a point where a signal is received. Therefore, to guard against a background of radio whilst a record is being played, all that is necessary is to turn the tuning condenser to a point on the dial where only a weak signal is obtained, or to a point where signals cannot be heard. In some cases it may be found useful to have this radio background as, for instance, when a record of a play or similar feature is being used, and the radio will then provide a quite musical background.

## BLUEPRINT P.W. 64

### Main Features

It will thus be seen that this is a very good receiver for general home use by non-technical members of the family and it lends itself admirably to a first effort in home receiver construction. Connections for a gramophone pick-up are provided in the second stage, and the receiver will therefore give adequate volume from normal records when a good standard type of pick-up is employed. It will be noted, however, that no provision has been made for a change-over switch for radio or gramophone reproduction, but this is not a very important point with a receiver of

### Change-over Switching

If, of course, it is thought desirable to cut out the radio entirely, it is an easy matter to fit a simple change-over switch, such as was shown in our issue last week. The connection to the detector valveholder grid terminal should be removed and a single-pole change-over switch mounted on a bracket at the rear of the chassis. The ends of condenser C6 and resistance R1 should then be joined to one contact on the switch, whilst the arm or moving pole of the switch should be joined to the grid terminal of valveholder V2. The wire at present joined from the pick-up terminal to the valveholder should then be joined to the remaining contact

on the switch, and the modification is complete.

A point of importance in connection with the coils used in this receiver is that they are the new type Unigen coils, and these are, in outward appearance, very similar to the older Universal or Universal Type A coils. Unfortunately, these are not all interchangeable. In the case of the Universal coils, there is no connection to the centre of the primary winding and terminal 8 is missing. In place of this terminal is an earthing connection, and therefore the two coils cannot be used indiscriminately. Make quite certain that you obtain the Unigen models, therefore, and we must remind readers that we cannot give instructions for modifying this, or any other receiver of our design, to employ alternative parts. We have had several requests in the past for instructions for using the Universal coils, but it should be remembered that the Unigen model has been produced by the makers to provide an improvement upon the original Universal models, and it is obviously in the listener's interest to make full use of the improvement which is obtained by the modified design and the tapped primary winding.

### Additional Selectivity

It will be noted that the primary winding of the H.F. transformer is not switched, and this is on account of the difficulty of arranging a satisfactory switch to bridge contacts 8 and 5, and it has been found in practice that the results in this particular receiver are quite satisfactory without switching in the second transformer. If it is felt desirable to obtain the additional selectivity, a four-pole switch will have to be used and two of the contacts will have to be joined to terminals 8 and 5 of the coil farthest from the panel. The long leads will, however, probably destroy the slight gain obtained by the switching.

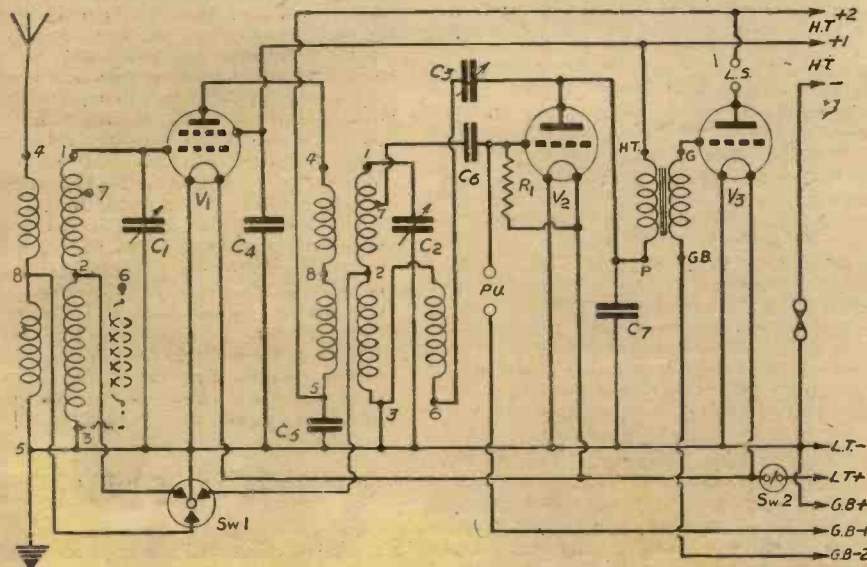

The simplicity of the Centaur Three is apparent from this theoretical diagram.

- LIST OF COMPONENTS**
- Two "Unigen" coils (Wearite).
  - One Baby .0005 mfd. two-gang condenser (C1 and C2) (J.B.).
  - One Airplane Dial (J.B.).
  - One Dilecon .0002 mfd. reaction condenser (C3) (J.B.).
  - One 5-1 L.F. transformer (L.T. 150) (B.T.S.).
  - One .5 mfd. tubular condenser (C5); one .1 mfd. tubular condenser (C4); one .0001 mfd. tubular condenser (C6); one .0002 mfd. tubular condenser (C7) (Dubilier).
  - One 2-megohm grid-leak (R1) (Dubilier).
  - One five-way (30in.) battery cord; three terminal mounts; six Type "R" terminals (A, E, LS, LS, and two P.U.); three wander plugs (Bowspring) G.B.+ , 1 and 2 (Belling and Lee).
  - One three-point wavechange switch (SW1) (B.T.S.).
  - One on-off switch (SW2) (B.T.S.).
  - Three component-mounting brackets (Peto-Scott).
  - One Microfuse (100 mA) (Microfuse).
  - Three Vibroders (Benjamin Electric).
  - One Metaplex baseboard, 12in. by 9in. (Peto-Scott).
- ACCESSORIES**
- One S.G.215 valve (V1); one D.210 valve (V2); one P.220 valve (V3) (Hivac).
  - One Rola type F5B, PM-268 Loudspeaker.
  - One H.T. battery (120-volt) (Siemens).
  - One L.T. accumulator (2-volt) (Exide).
  - One 9-volt G.B. battery (Siemens).

# Radiolympia—My Forecast

## By Thermion

IT is perhaps fitting that a critic should be invited to delve into the realm of vaticination, and to suggest what Radiolympia is likely to reveal. Apparently, the principle is that if you are able to criticise you must be able to forecast. If you are able to say why a thing is wrong you should be able to anticipate so that it cannot be wrong. In a word, you should be able to look into the future through the mirrors of the past and the present in the hope that coming events may cast their shadows and their reflections before them. In any case it provides me with an opportunity of saying, "I told you so," if my forecast comes off, and if it does not, I am able to tell you how mistaken everyone is, and why my forecast did not prove correct. Not so many days will elapse before you are able to judge what sort of a prophet I am. There are those who may wish that I shall be a better prophet than I am critic. If that is possible I must be a very good prophet indeed—I hope!

Now most of the prophecies I read in the Sunday papers are based upon a reading of the stars, and as I have no astrological attainments I have to use a more practical basis for my forecast. I am more accustomed to giving stripes than reading stars, and my remarks must, therefore, be based upon what I have gleaned in my peregrinations round the trade. For a couple of months before the Show the average manufacturer is about as open regarding his plans as a paralytic clam. They suspect that journalists may spill the beans, and forewarn their competitors. My optics are more than usually observant, and it is not necessary for a manufacturer to say much providing that I am permitted to see.

### Increased Prices!

Therefore, I envisage, and with some justification, a general increase in the price of wireless sets and components. Large quantities of metal are absorbed by the radio trade each year, and I cannot believe that they have discovered some method of purchasing metal cheaply which the bicycle and motor industries have been unable to find. The prices of bicycles and motor-cars have been increased by five per cent., owing to the shortage of material and the rise in costs of labour which our armament programme has forced upon us. Therefore, I say that we must expect a price increase of at least five per cent., and I hope that in that particular case I am a bad prophet. Although it is my opinion that wireless sets have become too cheap and that a price increase can be justified, I think to some extent the price level could be maintained if the manufacturer elected to cut the quality, but this I do not think he will do. It is better for him to increase the price. It is possible that where large stocks of raw materials are already in hand no increase will be made, but in other cases increases may vary from 2½ to 15 per cent. This applies to components and sets.

### All-world Radio

It will be observed that the theme of Radiolympia is to be All-world Radio. At first blush this may appear to be a

variant of all-wave radio. It is a resultant of it. It was one thing to design an all-wave set, and quite another to make it so efficient that it would reach out to the stations it was designed to receive. This year I believe that commercial sets will live up to their title of all-wave sets and all-world sets. Next year I expect to see a

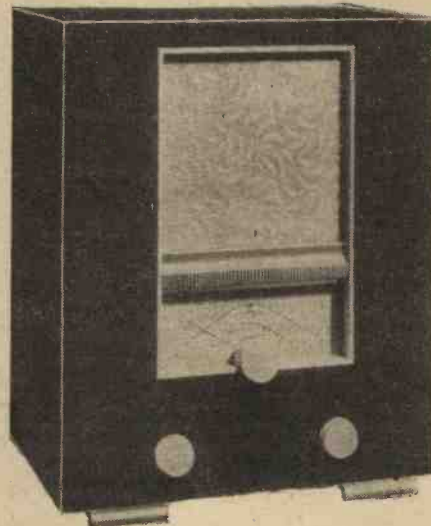

A new G.E.C. receiver in which novelty is found in the colour-scheme.

OUR STAND  
No. 10  
GROUND FLOOR

greater proportion of sets which will tune to the ultra-short wavelengths, for, whilst everyone may not by that time possess a television receiver, many will wish to listen to the sound portion of the programmes. A large proportion of the all-wave sets to be offered will not tune to the ultra-short wavelengths. We may, therefore, expect to see some surprisingly original all-wave tuners on the component makers' stand. The screened Triogen coil of Wearite and the new B.T.S. unit have already been disclosed, but I know that many others are being kept hush-hush until Olympia. In conjunction with these tuners new drives are needed to obtain the necessary vernier movement. The Polar people are redesigning the Micro-horizontal dial to give a 50 to 1 and a 10 to 1 ratio with the usual knob.

Cabinet design seems to supply designers with the greatest degree of latitude for the play of their imagination. There is a distinct tendency to copy the American style. I observe that some manufacturers have kept in mind the requirements of the owners of small houses, for radiogram cabinets are smaller. You may expect to see automatic tuning arrangements, and

larger speaker openings to avoid resonance, and special cabinets designed to fit in corners, or close up to easy chairs, will be seen.

### Television

Perhaps the greatest advance will be manifest in the television section. I have always held that some optical system enabling the picture to be projected or enlarged instead of relying upon the end of the cathode-ray tube, which must limit the size of the picture would eventually arrive, and such will prove to be the case. For apart from the simplification in the control of television receivers due to the pre-setting of adjustments by the makers, big screen models will be on view utilising the cathode-ray tube. Great interest will centre in the Philips receiver, which gives a picture much larger than those formerly obtainable. Interest will also be aroused by the exhibit of another company which up to the present has been rather in the background, although wide claims have from time to time been made for its system. It is too much to hope that the component section will form a separate portion of Radiolympia, and the constructor may therefore have to wade through a lot of exhibits in which he is not interested. I do hope that next year the components will be in a separate part of the exhibition—no matter how small.

There will be nothing staggeringly new, yet a vast amount to interest every listener; the hobby will always be greater than the apparatus, and I have no doubt that thousands of radio constructors will gravitate to Olympia as a matter of course. There are still many tens of thousands of home constructors, and the trade would do well to remember that *in toto* they spend more *per capita* than the average purchaser of a complete set. This is not a prophecy, but fact. I hope I shall see you there!

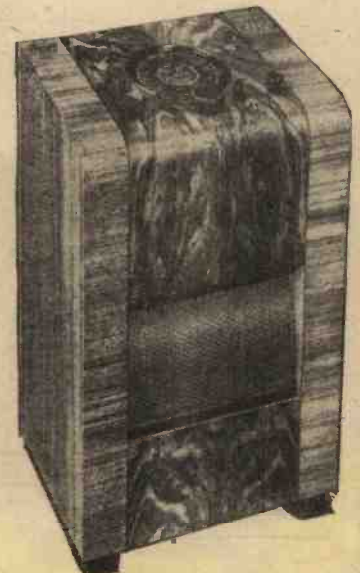

R.G.D. are producing this new cabinet model, with easy tuning arrangements.



A PAGE OF PRACTICAL HINTS

SUBMIT YOUR IDEA

READERS WRINKLES

THE HALF-GUINEA PAGE

A Record-selector System

WHILST reconstructing my radiogram it occurred to me that I might more advantageously make use of the spare section of the cabinet for stacking

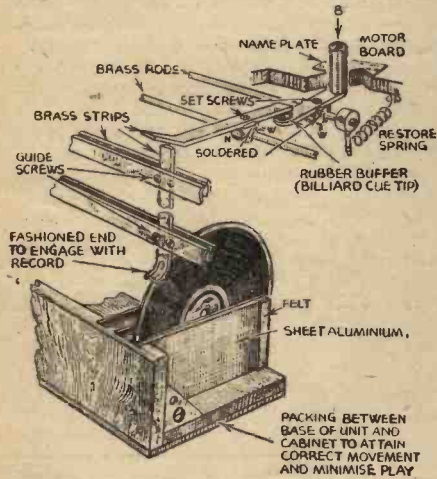

A novel record filing and selector system.

records, but I realised that the only possible method for safe filing would be in the incorporation of felt-lined sections. I therefore constructed the base as illustrated. At a later date I had an idea that a "selector" system would be rather novel, at the same time facilitating the extraction of a record, say, from the middle of the closely filed batch, and this necessitated the perfection of a number of individual movements. Finally, I adopted the method illustrated, and its simplicity possibly supplies the reason for its efficiency.

The rocker strips are prevented from sliding along the brass rod by a turn of copper wire "W" each side of the converted nuts "N," and soldered to the rods.

The four brass guide strips are individually fixed by small brackets to the cabinet sides, and likewise the rods; in their case, however, collars were first soldered to the brackets to accommodate the ends of the rods. The control plunger (B) for each mechanism was fashioned from a length of wood rod and finished with a coat of enamel.—S. R. RUSSEL (Redcar).

Remote Control Condenser Unit

I HAVE just made up a two-station remote control condenser unit, having been encouraged by your recent article on this subject, and whilst assembling the apparatus I decided to make use of the semi-transparent nature of thin bakelite. The accompanying sketch shows the resultant fitment.

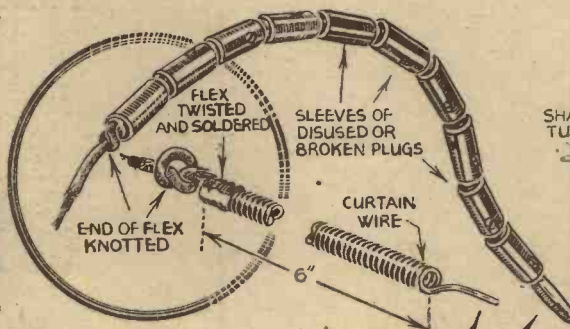

A simple method of making flexible test prods.

THAT DODGE OF YOURS!

Every Reader of "PRACTICAL AND AMATEUR WIRELESS" must have originated some little dodge which would interest other readers. Why not pass it on to us? We pay £1-10-0 for the best wrinkle submitted, and for every other item published on this page we will pay half-a-guinea. Turn that idea of yours to account by sending it in to us addressed to the Editor, "PRACTICAL AND AMATEUR WIRELESS," George Newnes, Ltd., Tower House, Southampton Street, Strand, W.C.2. Put your name and address on every item. Please note that every notion sent in must be original. Mark envelopes "Radio Wrinkles." DO NOT enclose Queries with your wrinkles.

I utilised an old metal-case type torch, and after a little trouble I managed to cut this in half and mount same on a metal bracket in the position indicated, thus providing the illumination for the bakelite disc on which I previously marked the respective station settings for both the .0003 mfd. condenser employed in the unit

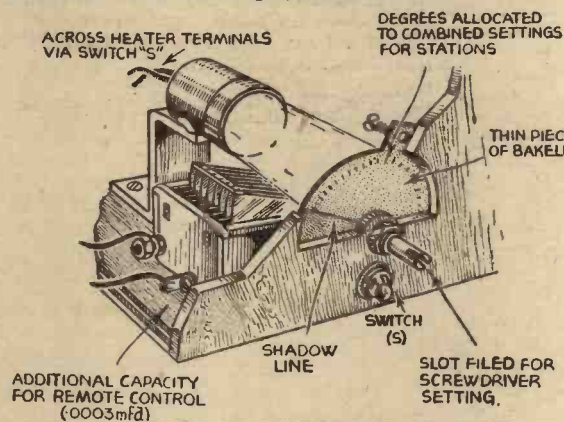

General arrangement of a remote-control condenser unit.

and the .0005 mfd. condenser in my receiver.

The sketch, I hope, will sufficiently show the principle adopted.—W. E. WESTON (Withernsea).

Flexible Test Prods

IT is not always possible when testing a set to reach the various components with the

ordinary test prods. The writer, having a complicated mains set to examine, overcame this difficulty by making a pair of flexible ones. These proved so successful that they are now used in preference to the rigid type. To make the prods, as illustrated, cut a 6-in. length of spring-type curtain rod and straighten out the first spiral. At the other end twist or solder a length of flexible wire tightly in the spirals, and tie a double knot in the flex just above the join. Next, slip on the spring the red tops of six disused or broken banana plugs. Stretch the spring slightly and, holding it in this position with the blade of a knife pushed between the coils, fix a banana plug on the straightened end. When the knife is removed the spring should tighten just enough to hold all straight. The other prod is made in a similar manner but using black tops. —A. DAVIE (Edmonton).

A Set-cleaning Device

HERE is a simple device for cleaning sets and components, which can be made quite easily with a cycle pump, a "football friend" connector, a length of rubber tubing, and a piece of glass tubing. Into the end of the cycle pump is screwed a "football friend" connector, the ball valve of which is removed. To the connector is fixed a suitable length of rubber tubing into which is pushed the "tool." This is simply a short piece of glass tubing (as used in chemical experiments) which is evenly heated at the required point by holding it in a gas jet and revolving it.

When the glass is red hot, it is drawn out and broken off at the required diameter by nicking it first with a file.

Several shapes of these tools may be made by bending them in the gas flame.

The pump is placed in a vice

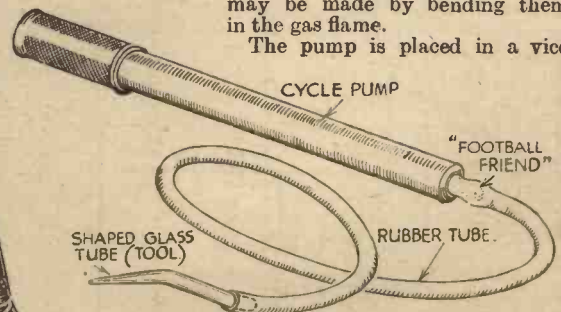

A handy cleaning device for dusty sets.

horizontally, and is worked with one hand, while the other holds the tool, directing it upon the components to be cleaned. A powerful jet of air issues from the end of the nozzle, and it has proved invaluable to me whilst cleaning two very dusty sets.—H. A. BENTLEY (Walsall).

# OVER TO THE

## Suggestions for Bringing Old Receivers Including a Short-wave Tuning Range

THE present vogue in receiver design is that termed commonly "all-wave." As we have pointed out before, however, this is a mis-nomer as the modern receiver does not tune on all waves. It indicates to the modern listener that the receiver covers a short-wave range (or in some cases two short-wave ranges), in addition to the normal broadcast medium and long waves, and the majority of receivers now in use are designed for the latter bands only. Therefore, in order to bring such receivers up to date it is necessary to include short-wave tuning circuits. Luckily, with the approach of the Radio Exhibition certain

tains its own tuning devices. This arrangement, although very popular, is often objected to on the ground that it increases the space required for the receiver, and also that it has to be connected and disconnected in order to give the receiver the normal adjustments. For instance, the short waves may only be required late in the evenings and the receiver may have to be left during the day for the remaining members of the family to use for broadcast reception. It is possible to fit a switch to make the change over, but we are hardly concerned in this article with methods such as these. We really wish to show how a set may be converted so that it follows the normal modern trend of tuning on all waves with the single tuning control which is now fitted.

or used as a single coil. Quite good results should be obtained in ordinary straight receivers by a simple replacement of the tuning coil. By straight receivers, we refer to the detector or detector-L.F. sets, and in some cases to the H.F.-Det.-L.F. type of apparatus. In the latter case, however, it may be necessary to carry out some slight change in the method of coupling the H.F. to the detector stage. There are three or four normal methods of H.F. coupling met with in ordinary receivers, and these are shown in Figs. 2 to 5. In the first case a normal H.F. transformer is employed, the primary being joined in the anode circuit of the H.F. valve and the

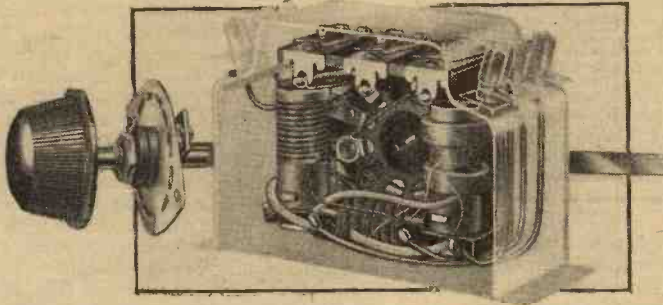
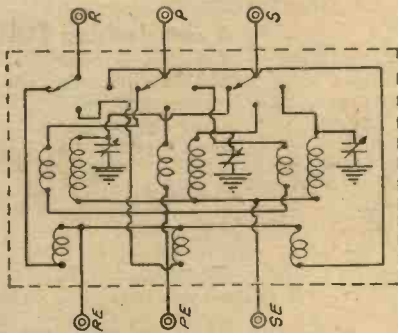

Fig. 1.—The new Wearite all-wave coil and, below, the theoretical circuit employed in it.



components are becoming available to the home-constructor, with the aid of which it is not a difficult proposition to convert an old set in order to make it tune on the desired ranges, although it is not essential that the receiver wiring should be altered.

### Using a Converter

One of the oldest schemes for obtaining short-wave signals on an existing set is by the use of a short-wave adapter or converter, a piece of apparatus which is connected to the receiver and which con-

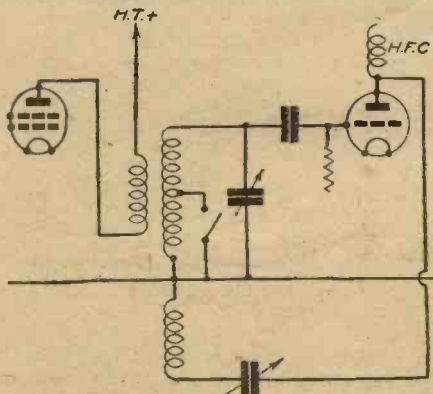

Fig. 2.—The normal H.F. transformer coupling.

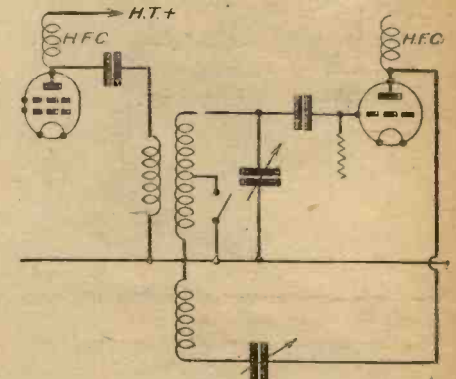

Fig. 3.—In this circuit the transformer is parallel-fed.

secondary in the detector grid circuit. A modification, using the same type of coupling component, is shown in Fig. 3, where the transformer is parallel-fed.

### All-wave Coils

At the moment there are three or four very good constructor-type all-wave coils available in which the necessary switching is incorporated. Thus, these may be used in place of an existing broadcast coil retaining the ordinary .0005 mfd. tuning condenser for the short-wave tuning range. The latest coil of this type is shown in Fig. 1, and it will be seen that it is screened and may be assembled in ganged units

SOME interesting new superhets are announced by Ferranti, and the accompanying illustrations show Model 1137, together with a detailed illustration of the special magnascopic dial which is fitted to the receivers. The illustration of Model 1137 shows that this part of the tuning indicator is a separate section, arranged above the normal scale, which is divided into two sections. The medium-wave scale, marked in wavelengths and with many station names engraved in green, occupies the upper segment of the scale round the top edge of which the short-wave band is marked in wavelengths. The bottom of the dial carries the long-wave indications and station names. Apart from the circuit design and chassis lay-out, the most important detail of these receivers is the Magnascopic dial, in which

## NEW FERRANTI

is extended, in effect, to a length of over six feet.

### A Magnified Dial

As will be seen by the diagrammatic illustration, the magnification is carried out by means of a small bulb, lenses and mirror, so disposed as to direct on to the back of

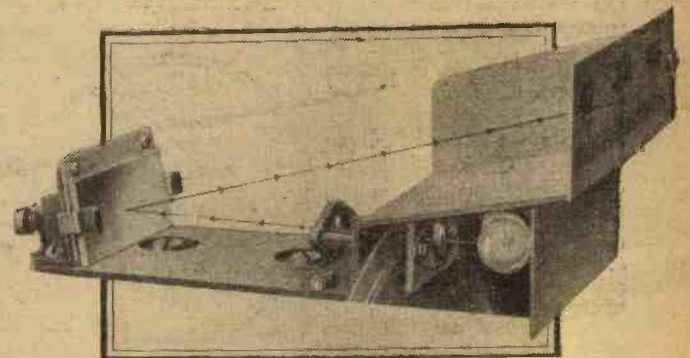

This is the Magnascopic dial, which is fitted to the latest Ferranti set.

# SHORT WAVES

into Line with Modern Practice by  
By W. J. DELANEY

Here an H.F. choke is joined in the anode circuit and the transformer primary is joined between the anode and earth. When the primary is taken away the tuned circuit becomes known as a tuned-anode circuit, and again it may be employed direct or parallel-fed, as shown in Figs. 4 and 5. Consequently, it may be necessary, in view of the type of coil which is adopted in the all-wave tuner, to modify the wiring so as to make full use of the new

ganged tuning condensers are sufficiently well designed to warrant their use in a short-wave tuner of the types referred to, where the minimum wavelength does not go lower than, say, 12 metres. The additional wiring to switches and other components, however, prevents a lower range being effectively covered without more drastic modifications and the use of special short-wave components, but as we are dealing with a direct modification these need not worry us at the moment. The wiring to the coils should, however, be kept as short as possible, and a heavy gauge of wire should be used. If a simple detector stage is employed, make certain that the grid leak and condenser are joined as close as possible to the detector valveholder, and make quite certain that this component is of good quality. If the receiver is very old, and an old bakelite valveholder is being used, change it for one of the modern paxolin or ceramic components.

### H.F. Choke

In some cases the detector H.F. choke may prove unsuitable for short-wave reception, and it should be exchanged for one of the modern all-wave components. An alternative is to obtain a good modern short-wave H.F. choke, and join this between the anode and the existing choke so that the two are in series as shown in Fig. 7. Make certain that the short-wave component is joined next to the anode and, if possible, connect it right up close to the anode terminal on the valveholder. In some circuits it may be desirable to modify the capacity of the anode by-pass condenser or even to remove

it entirely, but this will have to be tried out when the receiver is tested.

### Trimming

The trimmers on the majority of ganged condensers may be found to have rather a high minimum, and in the Triogen coil at least it is advisable to remove the trimmers entirely from the condenser—the makers of the coil having thoughtfully provided special trimmers on that component for matching purposes. Where a single coil is used, of course, the trimmers will not be of much importance, although they should not be screwed right down as they will increase slightly the minimum wavelength to which the coils will tune.

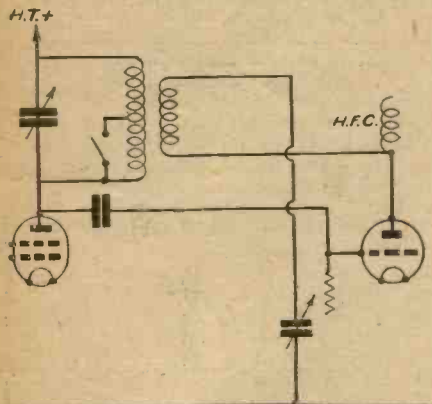

Fig. 4.—A tuned-anode H.F. coupling which is not employed very often in modern receivers.

coil. Obviously, each receiver must be considered on its merits, and the changes carefully carried out.

### Short-wave Components.

The majority of modern .0005 mfd.

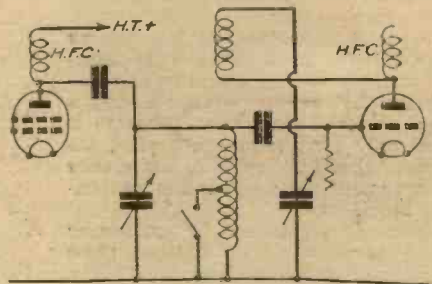

Fig. 5.—The parallel-fed tuned-anode coupling.

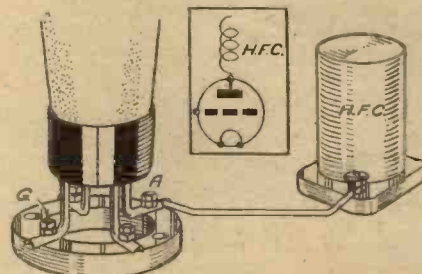

Fig. 6.—The normal H.F. choke as employed for reaction purposes.

To remove the trimmers on the ganged condenser simply unscrew the trimming screw, bend up the top metal plate which will thereby be exposed, and take away the disc or strip of mica which will be found beneath it. Do not replace the screw or bend back the top plate or you will short-circuit the condenser section.

It is obviously impossible to deal with every type of receiver individually, but the details which are given should enable anyone with a standard type of receiver to incorporate the all-wave feature with very little trouble, and thus obtain many more hours of enjoyment from their existing apparatus at the minimum of expense.

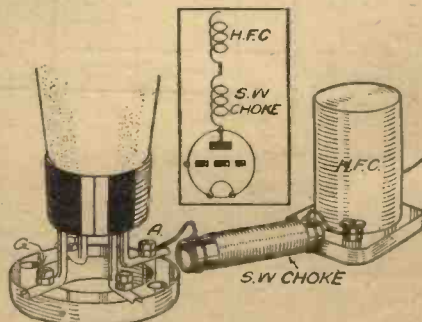
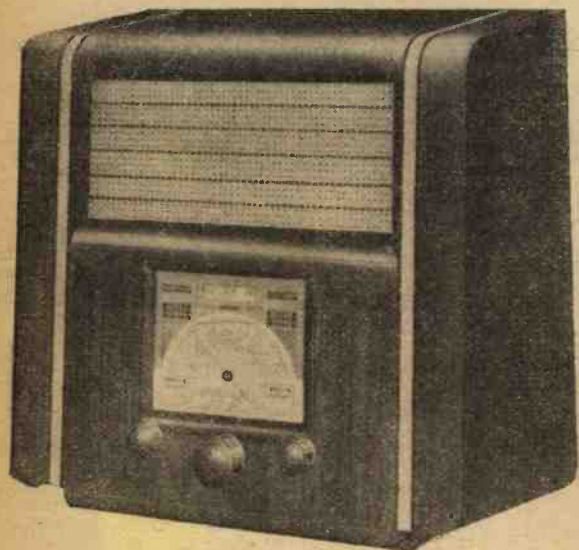

Fig. 7.—For all-wave reception, a short-wave H.F. choke should be joined between the anode and the ordinary choke.

## TI RECEIVERS



Ferranti Model 1137 receiver.

a ground-glass screen the markings on a circular transparent scale carried by the main condenser spindle. This is marked in wavelengths, the markings being divided up and subdivided to form a very effective tuning dial. A hair line in the centre of the window serves as an indicating point, and thus tuning on the short waves is made even simpler than the ordinary broadcast tuning. The tuning pointer is double-ended to enable the single dial to indicate the medium or long-wave stations, and in certain models a separate indicator is fitted to show to which band the receiver is adjusted.

### READY SHORTLY!

Wireless Coils, Chokes and TRANSFORMERS and How to Make Them. 2/6, by post 2/10 from GEO. NEWNES, LTD., Tower House, Southampton St., Strand, London, W.2.

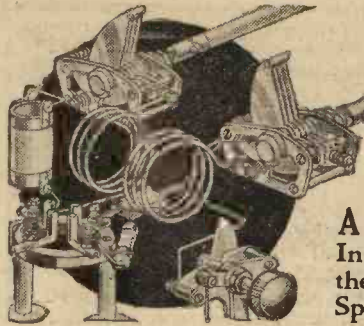

# Short Wave Section

**A TWO-VALVE S.W. CONVERTER**  
 In This Article, Specially Written for Beginners, the Construction of An Efficient Unit From Spare Parts is Described by RADIO ENGINEER.

**A**N efficient short-wave converter is one of those pieces of apparatus which should form part of every constructor's equipment.

It does not follow that it is necessary for one to be a most enthusiastic short-wave "fan" before one makes up and uses such gear. Even if the interest is only a passing one, or if short-wave reception is required only for one month a year, the apparatus takes up very little room, does not cost anything to keep, and is inexpensive to build.

With the great increase in programme value of the world's S.W. stations, those many odd times when the long and medium waves have nothing tempting to offer, need no longer be idle moments for the receiver, providing that one has an efficient S.W. converter or adapter ready to be put into action.

Apart from programme matter, considerable interest, amusement and instruction can be obtained from S.W. reception, and such reception need not, as so many people think, necessitate special aerials, earths and other accessories.

### Types of Units

There are two types of S.W. units which will enable use to be made of a normal broadcast receiver for the reception of the short waves. They are usually known as (a) an S.W. Converter, and (b) an S.W. Adapter. It is possible to combine both types in one unit; but that does not concern us at the moment.

The converter works on the superhet method, and is designed for use with any type of receiver employing one or more

The adapter, on the other hand, is the most simple arrangement possible, but as it only utilises the broadcast receiver from the detector stage to the output,

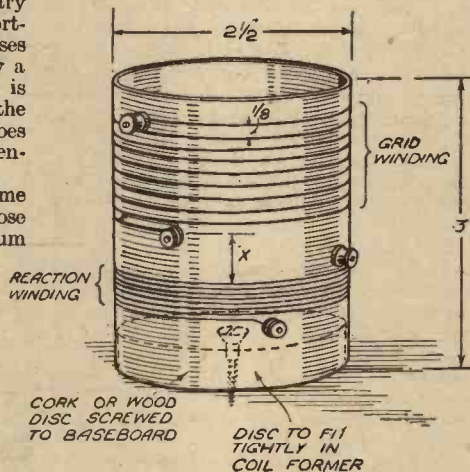

Fig. 2.—Details of the coil. WINDINGS

Wave-lengths	GRID. 22 S.W.G.	Distance X	Reaction 34 S.W.G. Enam. & Cotton Cov.
14-25M	3 Turns	1/8"	4 Turns
24-40M	6 Turns	1/8"	5 Turns
35-75M	10 Turns	1/8"	8 Turns

it is, naturally, not so selective or sensitive, and the results obtained might not always be good. If you have been using an adapter and you are inclined to condemn short waves because of the results you did or did not get, I would say, have another try with the unit described below and then compare notes.

Some converters use a single triode valve as a combined detector and oscillator—two functions necessary in this type of unit—and although such an arrangement is cheap and simple, it is far from perfect in operation. A better method makes use of a heptode, or a heptode and a triode, but once again the constructor runs up against cost, and more valves for stock, so the heptode must be

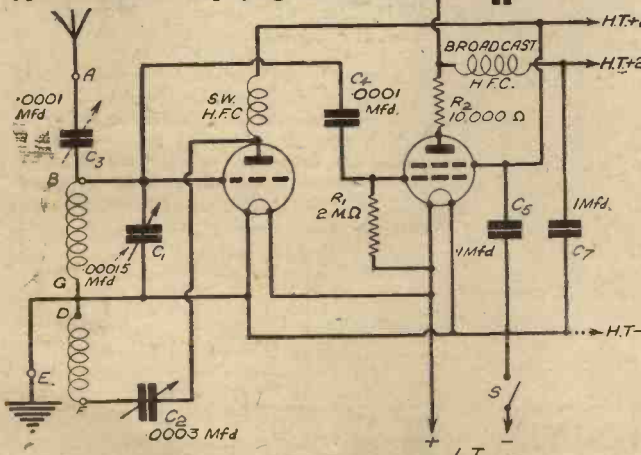

Fig. 1.—Theoretical circuit of the 2-valver. The connections B, D, F, and G are made to the coil by crocodile clips or flex wire.

stages of high-frequency amplification—a superhet receiver being included. It possesses the following worth-while features: it has a good degree of selectivity—very essential nowadays on the short waves—and it forms, in conjunction with any good receiver, a very sensitive outfit.

ruled out on that score.

### An Alternative Circuit

An alternative system—which can be used without any loss of efficiency—is shown in Fig. 1, which is the circuit of the unit under discussion, and which makes use

of a triode and an ordinary S.G. valve, both being likely occupants of the spares box.

The triode is used as an oscillator, the S.G. as a detector, and the combination lends itself to easy operation, good selectivity and sensitivity.

The tuning or grid condenser C1 should have a capacity of .00015 mfd., while the reaction control C2 has a value of .0003 mfd. The values are not too critical, providing the coil-winding details are adjusted to suit any variation. For example, if a .0002 mfd. reaction condenser is used, it may be necessary to add a turn or two to the reaction winding before a satisfactory effect is produced. If a larger tuning condenser is employed, fewer turns must be used for the grid coil, and so on, but don't go to the extreme and use, say, a .0005 mfd. condenser.

### Coil Windings

The details for the coil windings are given with the illustration, and it will be noted that there is nothing difficult about them. Should it happen that other two-circuit S.W. coils are available, there is no reason why they should not be used, so long as the values of C1 and C2 are selected to suit. It should be noted, at this stage, that the whole secret of the circuit depends on smooth and satisfactory reaction being obtained, otherwise the triode circuit will not be maintained in the required state of oscillation.

Two high-frequency chokes are required, one wound for S.W. work, and the other a normal broadcast type. The first, if not found in the spares box, can be wound in the manner advised in the details of the "One Valver for America," published in our issue for January 23rd, 1937, while the latter can be of the screened or unscreened type for medium and long waves.

The other components need no explanation as they are standard, but it is advisable to adhere to the values shown and use a triode valve of the H.L. type and a screened grid of the "straight" variety.

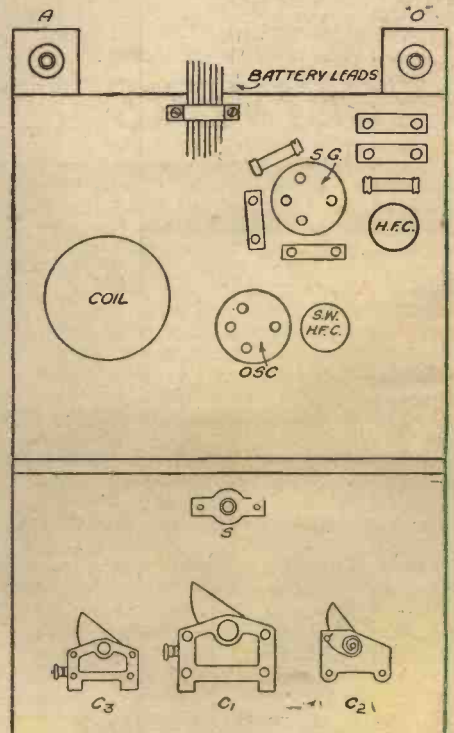

Fig. 3.—Suggested layout of baseboard and panel.

**SHORT-WAVE SECTION**

(Continued from previous page)

**Operation**

With the valves and coil in position, the batteries all connected and switched on, connect the actual aerial to terminal A and the output (terminal O) to the aerial terminal of the broadcast receiver, after making sure that the receiver is switched over to the long waves. The broadcast receiver is then switched on and the volume or reaction control set to, say, just below maximum output, care being taken to see that the circuit is not oscillating or unstable.

The reaction condenser C2 of the converter is then adjusted until the circuit sounds alive or when a steady rushing—but not whistling—sound is produced, after which the tuning condenser C1 can

be rotated—very slowly—through its travel or until a station carrier is heard.

Be careful and patient with the tuning, as it is so easy to pass over transmissions on the short waves without being aware of their existence if the tuning is adjusted too quickly.

It will be found that it is possible, by adjusting the aerial series condenser and the H.T. feed, to find a setting of C2 which will hold good for all settings of C1 for the coil concerned, thus allowing one-dial tuning to be obtained. Once a station is received the volume can be adjusted by the reaction and/or volume controls of the broadcast receiver.

Providing the existing aerial is not longer than, say, 60ft. and a long lead-in is not used through the house, it will be quite satisfactory for use with the converter, though one that is well clear of all obstruction and having a good height will, naturally, be more efficient.

**Leaves from a Short-wave Log**

**Mexico City on the Air**

**X**EWV, a transmitter with a 10-kilowatt output installed at Mexico City (Mexico), may now be heard nightly at good strength from midnight onwards on 31.65 m. (9.43 mc/s). The call in Spanish includes the slogan: *La Voz del America Latina* (The Voice of Latin America). As an interval signal the studio uses four chimes on a descending scale.

**Stockholm Tries Out New Channel**

In addition to the two frequencies used for the relay of the Swedish national programme, tests are also now being carried out on 15.155 mc/s (19.80 m.), for which the call-sign is also SBG. As this transmission is purely experimental, listeners desiring the full Stockholm radio entertainment must turn to 49.47 m. (6.065 mc/s) and 25.63 m. (11.705 mc/s) as per published schedule of times.

**Rio de Janeiro on Short Waves**

Through PSE, Marapicu (Brazil), you may, from time to time, listen to Rio de Janeiro on 20.07 m. (14.935 mc/s). This commercial transmitter is brought into action for the broadcast every Friday at G.M.T. 21.00 of a news bulletin issued by the Brazilian Ministry of Propaganda.

**Cuban Broadcaster Settles Down**

COGF, Matanzas (Cuba), previously reported on 27.8 m. (10.79 mc/s), is now carrying out regular daily broadcasts on 25.45 m. (11.79 mc/s) until the early hours of the morning. Correspondents report reception of these musical programmes until G.M.T. 06.30. As the transmitter relays the CMGF medium-wave programme, the full call given out is as follows: *Emisora CMGF onda larga* (long wave) y *COGF onda corta* (short wave) en *Matanzas, Republica de Cuba*. The channel adopted seems to be the one already used by a station COKG, of Santiago de Cuba, which adopts the slogan: *La Voz de los Provincias y Cultura Nacional* (The Voice of the Provinces and National Culture). Another newcomer recently logged is COBC, Havana, working on 32.22 m. (9.31 mc/s). Here again the station has been heard between G.M.T. 04.00-05.00, giving its address as Apartado Postal (P.O. Box), 22, Havana. Similarly to many other Cuban

and South American broadcasters, a bugle call denotes an interval in the programme.

**Belgrade's Allotted Call-sign**

So far, of the numerous European short-wave stations, that of Belgrade (Yugoslavia) was the only one without call-letters. YUA has been allotted to the transmitter on 49.18 m. (6.1 mc/s). The daily schedule for August and September is G.M.T. 06.00-08.00; 11.30-13.30; and from 17.00-23.30, when the station closes down. The call heard is: *Ovde Radio Beograd* (phon: *Bay-o-grard*), and a musical box melody (Serbian Folk song) may assist in its identification. The power of the transmitter will shortly be increased to 2.5 kilowatts.

**Eiffel Tower Television**

Television transmissions from the Paris Eiffel Tower have been resumed on 42 mc/s (7.14 m.), with sound accompaniment on 206 m. (1.456 kc/s).

**Trujillo City Comes Through Again**

During the past week broadcasts from HIG, Trujillo City (Dominican Republic), on 47.74 m. (6.28 mc/s) have been regularly picked up from G.M.T. 22.30 onwards. The station, which gives out its call in both English and Spanish (HIG, as in Germany, and Achay-ee-hay en Ciudad Trujillo), may be heard closing down as late as G.M.T. 02.30. At present, this is the only Dominican Republic transmitter appearing in our log.

**PR48, Pernambuco, Definitely Closed Down**

As the transmitter placed at the disposal of the Radio Club of Pernambuco, on 49.76 m. (6.028 mc/s), has now been taken over for other duties, special broadcasts by this organisation destined to listeners overseas are now transmitted at irregular intervals through PSG, Marapicu (Brazil), on 27.88 m. (10.76 mc/s), a commercial station usually handling traffic with the United States.

**WIRELESS CONSTRUCTOR'S ENCYCLOPEDIA**

5/- or 5/6 by post from George Neaves, Ltd., Tower House, Southampton St., Strand, London, W.C.2.

**PETO-SCOTT**

**New 5-valve ALL-WAVE A.C. SUPERNET CHASSIS**

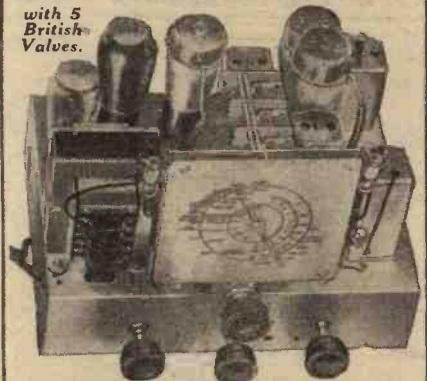

Dimensions: 10" high; Cash or C.O.D. £5:19:6  
11 1/2" wide; 8 1/2" deep. Carr. Paid  
● 3 Wavebands: 18-50, 200-550, 900-2,000 metres. ● Automatic volume control on 2 stages. ● Bandpass on all stages. Circuit: Aerial inductively coupled to bandpass input Triode Hexode as Detector and Oscillator, bandpass transformer coupled to Variable-mu H.F. Pentode as I.F. Amplifier. I.F. stage bandpass transformer coupled to Double-Diode-Triode for second detection, A.V.C. and 1st L.F. amplification. Triode section resistance capacity coupled to high slope output pentode. 4 position wavechange switch for 3 bands and grammo. Each band separately dial lighted. Provision for extension speaker. Combined on-off switch and volume control. Separate tone control. Each chassis tested. For A.C. Mains, 200-260 volts, 50-100 cycles. Output 3 watts. With 5 British Valves, ready to play. £5/19/6, or 10/- down and 11 monthly payments of 11/-. If required with High-Fidelity Field-Emerald 8" cone Moving Coil Speaker, add £12/6 to Cash Price or 2/6 to Deposit and 2/7 to each monthly payment.

12 Months' Guarantee with Each Chassis  
All Postal Orders must be crossed and currency registered  
**PETO-SCOTT Co. Ltd.,** Established 1919  
77 (Pr.W.47), City Road, LONDON, E.C.1.  
Clissold 9875-6-7

**BARGAINS!**

**S.G.3 CHASSIS**

With 3 BRITISH VALVES  
LIST PRICE £4:4:0 BARGAIN 42/-  
● LATEST SCREENED-GRID CIRCUIT. Comprising ● Screened Grid H.F. Detector and Pentode Output Valves. ● Screened wave-wound coils. ● 2-Gang Air-Dielectric Condenser. ● Metal Chassis. ● Only 9 m.a. H.T. Consumption ● Illuminated and Wave-length Calibrated Dial. ● Wave range 200-2,100 metres. ● Complete with Valves, black escutcheon and all knobs.  
This wonderful chassis will bring you a wide choice of English and foreign programmes with amazing purity of tone and remarkable volume. Available at this astonishing bargain price only from N.T.S. 2/6 down secures balance in 12 monthly payments of 4/-. Also available with 3 Concor Valves at 45/-, or 3/- down and 12 monthly payments of 4/3.



**FREE!** Write for free Booklet to-day describing in full, with actual photographs, a 4-valve Bandsread S.W. Kit and 4 other entirely new N.T.S. Bargain Short-Wave Kits, and range of Short-Wave Components. SEND FOR BIG LIST OF BARGAIN SETS BY ATLAS, BRITISH RADIOPHONE, B.T.S., K.B., LISSEN, McMICHAEL, PETO-SCOTT AND ZONO-PHONE.

All Postal Orders must be crossed and currency registered.

**New Times Sales Co.**

56 (Pr.W.28), LUDGATE HILL, LONDON, E.C.4  
EST. 1921



# STABILITY

Stability, n. The quality of being steady or constant, having durability or permanence. —Dictionary

Let the dictionary guide you in the choice of your

# CONDENSERS

MANY have been the makes of condensers... all good to look at... some good performers—for a time. (Why aren't they on the market now? Because they lacked the quality of permanence... Inadequate experience, doubtful materials or unskilled workers left the job in some way incomplete... they failed in the test of time. T.C.C. Condensers are the product of over 28 years' specialisation in condenser design and manufacture. That experience—that solid foundation is behind every T.C.C. Condenser. The result is a range second-to-none plus a reliability that is pre-eminent. For safety's sake use T.C.C.

# T.C.C.

ALL-BRITISH  
CONDENSERS

The Telegraph Condenser Co. Ltd., Wales Farm Road, N. Acton, W.3.

2424 (A)

## DEATH OF COSSOR'S CHIEF

IT is with the deepest regret that we have to announce the death at the early age of fifty of Mr. W. R. Bullimore, Managing Director of A. C. Cossor, Ltd., who passed away on the evening of July 27th.

Mr. Bullimore had a very distinguished career in the electrical and radio industries. Born in Australia, he came to London as a boy on the death of his father, a Whitworth scholar who had been sent to Australia to lay the first trams for the City of Adelaide.

On leaving Technical College 30 years ago he joined the X-ray tube manufacturing concern of A. C. Cossor, Ltd., and soon after acquired the controlling interest. From early work on X-ray, cathode-ray tubes and surgical lamps, it was a logical step to the manufacture of wireless valves, and Mr. Bullimore was the inventor of the



The late Mr. W. R. Bullimore.

first Cossor valves marketed, his new hooded anode and arched filament patents making a revolutionary advance in radio technique. He was also responsible for the idea of the constructor's kit of parts, known as the Melody Makers, which did much to popularise radio.

Mr. Bullimore took a deep interest in the welfare of his workers, and under his guidance the company grew from a small family concern to one of the largest radio manufacturing concerns, and one of his last works was to put into operation a pension scheme which particularly recognised those who had worked with him for many years.

In addition to his steadfast character he combined the qualities of a first-class commercial man with those of an able engineer and scientist, and his demise creates a gap which will be difficult to fill.

Mr. Bullimore leaves a widow and one son, aged 14.

## Join Newnes' Practical Group!

### PRACTICAL MOTORIST

The owner-driver's journal which tells you how to repair, overhaul, and obtain the best performance from your car.

3d.—every Friday.

### PRACTICAL MECHANICS

The only English journal of its type. It deals with every branch of Science, Mechanics, Invention, Model-Making, Chemistry, Astronomy, Photography, Television.

6d.—Every Month.

### THE CYCLIST

The leading weekly for every Cyclist, Clubman, Utility Cyclist, or Tourist.

Join "The Cyclist" Road Club and also take advantage of the FREE Insurance offered.

2d.—Every Wednesday.

## BRIEF RADIO BIOGRAPHIES—18

By RUTH MASCHWITZ

### Davy Burnaby

LIKE many stage and radio stars Davy Burnaby is a victim of the autograph hunter. A short while ago, when walking along the street he was recognised by a crowd of small boys who surged round him with books and pencils. He obligingly signed his name a dozen times or so, and then noticed that one of the boys whose book he had already autographed presented it again.

"But I've given you one signature!" protested Davy.

"I know," said the youngster. "But if I can get three of them I can exchange them for one of Tommy Handley's!"

Since childhood Davy's ambition had been to go on the stage, and at the age of seven he was acting in amateur theatricals. His first professional appearance was an auspicious one, for he played William in "The Crossways" at a command performance given by Mrs. Langtry which King Edward attended. He then went with the same play for a tour of the United States. On his return he toured with George Edwardes' company, and in 1903 appeared as Roderick O'Griff in "The Flood Tide." Since then he has appeared in numerous shows, including "Sugar Bowl," "Belle of Brittany," "Hullo, London," and in 1914 again went to America with "Tonight's the Night." Back in London in the same show success followed success, including, "Yes, Uncle," "Baby Bunting," "Oh, Julie," and "The Co-Optimists." In 1933 he broke into films, and the following year made his debut in pantomime as Widow Twankey in "Aladdin."

Davy is one of the earliest broadcasters—in fact, he was heard over the air two years before the B.B.C. was formed. He broadcast from a place in Dean Street to the Eagle Hut, where a charity entertainment was being given. On that memorable occasion listeners paid ten shillings for headphones for ten minutes of radio!

He has always been intensely interested in wireless, and was one of the first experimenters in short-wave listening. After his performance in "The Co-Optimists" he used to tune in every day in his dressing-room to the Pittsburg Tea Hour.

He was one of the first people to listen to a broadcast from the *Leviathan*, 500 miles out at sea. In fact he organised an enormous party packed with celebrities to hear one of her concerts. Unfortunately just as the audience had assembled, and was waiting with bated breath for the performance to begin, a telephone message came through to say that there was a storm at sea and a broadcast was impossible.

## RADIOLYMPIA

Remember the dates

Aug. 25 to Sept. 4

# NEW PHILCO RECEIVERS

**A**LL-WAVE Radio, the theme of the Radiolympia Exhibition, has influenced the production of the Philco receivers for some time. In the present range of Philco receivers there are no fewer than 28 different models, ranging in price from £6 to 120 guineas. There are two important additions included in this range, the Empire Five, and Empire Twenty-Two in several different models. It will be noted from the accompanying illustration of Model 2258 RG that a new design in cabinets has been introduced. This particular design, known as the "Buckingham," follows more closely American practice, and, apart from the large open style adopted for the speaker opening, the automatic dial is the most interesting feature. An important point with all of the new Philco models seems to be the placing of the controls on the cabinet front instead of having them covered as in the majority of modern radiograms. This does, of course, permit the lady of the house to place a bowl of flowers or electric lamp on the cabinet top without the annoyance of having continually to remove it in order to tune to a station.

## Automatic Tuning

This particular form of tuning has been perfected in the Philco laboratories, and it is as simple to use as the ordinary telephone. Foreign stations are located accurately by the aid of this device and the station numbers are placed at least six times as far apart as on most sets. The receiver illustrated is a 22-valver and the tuning covers five wavebands: 145-350 kc/s, 520-1,600 kc/s, 1.5-4.7 mc/s, 4.5-11.6 mc/s and 11.5-18.2 mc/s. The reproduction is effected through three speakers, a single 14in. model coupled to two additional high-frequency or "tweeter" models. The output is rated at 18 watts, obtained from two triodes in

Class A push-pull. The power supply is obtained from two separate power units, and ample storage space is provided for gramophone records.

In addition to the particular cabinet style shown, this model may also be obtained in two other styles, the Windsor and the Balmoral, the prices of these models starting at 120 guineas. The Balmoral cabinet is particularly interesting in view of the fact that the customary loudspeaker opening has been fitted with sloping louvres across the lower part of the

cabinet, and at the sides thin slots have been cut, thus lending not only an attractive appearance to the complete assembly, but also something out of the ordinary. The tuning dial and four controls are, in this model, mounted at one side of the cabinet front, the top portion above this being fixed, but the remaining portion of the top being hinged to expose the gramophone turntable and record-changing mechanism.

The Windsor is not quite so large and the record-storage cupboard occupies a section of the front, although in this model the louvre-covered speaker fret is also fitted.

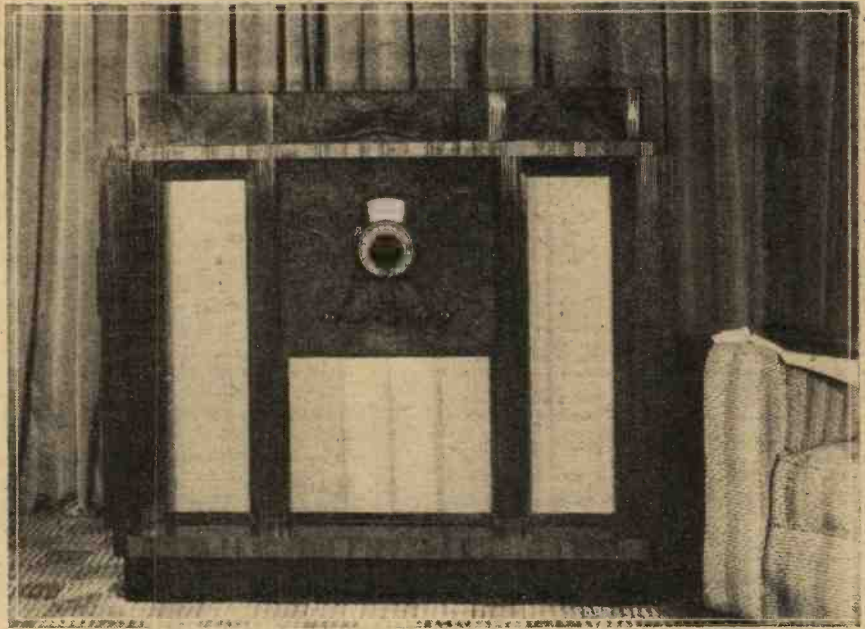

Here is Philco Model 2258 in the "Buckingham" Cabinet.

## ITEMS OF INTEREST

### Powerful Radio Station for a Russian Icebreaker

**W**E are informed that a powerful radio station is being designed and constructed for the giant icebreaker, *Joseph Stalin* (the largest icebreaker in the world), soon to be launched by the Baltic Orjonikidze Shipyards. The icebreaker will be a floating radio centre, and in power of radio equipment she will surpass any of the vessels of the Soviet civil fleet. She will have a short-wave radio transmitter of 1 kilowatt capacity for long-distance communications, which will enable her to maintain direct communications with Moscow, and any of the polar centres from any point of the Northern Sea Route. A second long-wave transmitter of 2-kilowatt capacity will be installed for the purposes of the meteorological service, and for communication with ships sailing the Northern Sea route. By means of this transmitter, the *Joseph Stalin* will be able to maintain telephonic communications with the stations of the Northern Sea Route, and through them with other centres of the Union. The icebreaker will also carry a distress transmitter of small capacity for communication with the nearest ports and coastal stations in the event of mishap, also to be used for communications with

the caravan of vessels for which she may be acting as convoy. A special receiving and transmitting station will be provided for use by expeditions. It will be portable, able to work on any range, and to be fed by any machine, including a hand-operated one.

### Orchestral Music

**O**N August 22nd (Regional) May Harrison will be the soloist in Max Bruch's Violin Concerto, with Julius Harrison conducting. Warwick Braithwaite, the conductor from Sadlers' Wells, will conduct the B.B.C. Orchestra on August 23rd (National) in a programme including three excerpts from Chabrier's "Le Roi malgré lui," and Constance Willis will sing arias by Mozart, and other songs. On August 25th (Regional) Arnold Trowell, the New Zealand cellist, will play the Symphonic Variations, Opus 23, by Boellmann, with the Empire Orchestra, conducted by Eric Fogg.

### Massed Bands from Shrewsbury

**T**HE Midlands will provide a concert for the National programme on August 19th, given by the Massed Bands of the Irish Guards, Welsh Guards, and Royal Air Force from the Quarry, Shrewsbury where the Shrewsbury Musical and Floral

Fete is to be held. The Flower Show is one of the largest and most famous in the country with £1,600 in cash prizes and numerous cups and trophies. It was begun in 1875, and in fifty-five years (no show was held during the War) the takings have totalled over £366,000. It is the only show in the provinces at which concerts are given by Massed Guards Bands of 120 players. The present programme includes "Vivat! George the King," by Peter Rex; the Finale of Tchaikovsky's Fourth Symphony; and Finlandia, by Sibelius.

### Tennis At Scarborough

**T**HE well-known tennis writer, E. J. Sampson, will be at the Leeds station on August 21st, to give an eye-witness account for Northern listeners of the Scarborough Lawn Tennis Tournament. The Scarborough Tournament is one of the big events in the North of England tennis calendar; there is a good entry and play should be of a high standard.

### Potted Opera

**T**HE experiment of broadcasting an opera complete on gramophone records has been tried more than once from Northern Ireland and has proved successful. The programme on August 18th is of "Manon," by Massenet, and the extracts given will include some of the most famous arias, duets and choruses, while the story of the opera, told by a narrator, will link up the records.

# ELECTRADIX BARGAINS

TELEPHONES for HOUSE, OFFICE, GARAGE, and Field Sports. Table, Wall and Waterproof Portable, from 10/-. Headphones for short-wave radio, etc., 2/6 pair. Telephone wire 55/- mile.

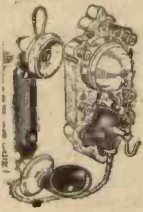

**SWITCHES.** We have some super-grade ultra-short switches. Contacts on ribbed pedestals D.P.C.O., 7/6. Resistance Box Switch Panels, boxcase, B.L. 8-way arm, 7/6. Larger type with two sets of mounted 10-way studs and arms, 9/-. Light duty Switches for Wave-change and Semi-rotary D.P.C.O., 6d. R.A.F. Switch Boxes for 3 circuits, rocker type, 1/3. 6-way Rocker-toggle, 2/-. 8-way ditto, 3/6. Taxley and Rex Wave-change D.P., 3-way, roller contact, npw, 1/3. Bulgin 3-point Wave-change, 9d. Tunwell 8.P. on-off semi-rotary, 8d.

**CONTROLS.** 20-way Stud Switches on panel, two contact arms and ring for 10 amps. 7-way Stud Switches on 3/4in. panel, in and out sockets. 1/9. 10-way D.F. ebonite mounted, 8 amps., 5/6. 12-way D.P. ditto, 5 amp., 4/6. Aerial D.P.C.O. on ebonite, 3/6.

**MAGNETIC SWITCHES. MINIMUM or OVERLOAD CIRCUIT BREAKERS.** Automatic. 2 to 4 amps., 7/6; 6 amps., 10/-; 10 amps., 12/-; 15 amps., 14/-; 20 amps., 16/-, 7/6 for all purposes.

## MICROPHONES

"W.W." No. 11 TABLE MIKE. A splendid Microphone for speech and music. Bakelite case, containing a 2in. transmitter and transformer on bronze pedestal, detachable Switch and plug. Unrivalled for quality and price. 15/-. Other types: Leslix No. 10B Pedestal, 10in. high, 12/6; Leslix Superior No. 12BB Ring 14in. Pedestal, 18/6. Hand Mikes in 2in. case, No. 11 at 5/6; Superior type No. 11A, 7/6. Buttons, 2/-. Eisel public address and hand Mike (Relax principle), 55/-. Ask for Illustrated Mike List "W" of 25 models.

## AND PARTS

Our Famous PARTS for making your own mike. Carbon Granules in glass capsule; Grade No. 2, 1/-; No. 3, fine, 1/6; No. 4, extra fine, 2/-. Carbon back Blocks, 4d. 2 Diaphragms, thin carton, 6d.; Button in 1 1/2in. hard wood case with 2in. mica diaph., 2/6; 3/6; 5/6. 30-1 Transformers, chassis type (Philips), 1/9. 3 Ratio Output transformers 13, 24 and 33 to 1, 3/6. West. Elec. HP Chokes, 3in. x 2in. PPax for interference units, etc., 9d. 12in. Hot Plates for 110 v., 7/6. Electric Waistcoats 12v. wash-leather, 7/6. Fur Helmets, 2/6.

**MAINS RECEIVERS** new 4-valve A.C. chassis sets. Band pass circuit, very selective. Complete less valves at the low clearance price of 30/- each. Leaflet free.

**TWO RADIO-GRAM CABINETS.** Vertical console type, nice condition mahog. and walnut, 22/6 each. Carriage and packing at cost.

**2-VALVE METAL B. CHASSIS.** Drilled and fitted 2 valve holders, transformer, coil, etc. 2/6 each.

**SLOPE FRONT TEAK CABINETS.** New, make fine instrument panel, 10 x 7 x 1 1/2. 3/- each.

**OAK CABINETS** for Short-wave Battery Receivers, 2 or 3 valve, polished Jacobean finish, 12 1/2in. x 7in. x 6 1/2in. deep, oval front, crackle black aluminium panel fitted geared .0005 mfd. condenser, with sunk dial, 3-way coil switch and a single plate condenser. Sliding back and 10 terminal Strip, new, manufacturer's liquidation stock, 16/-.

**PANELS.** Aluminium, 16 and 18 gauge, one side enamel, 12in. x 12in., 3/-. 16in. x 18in., 5/6. 6in. Ebonite, 24in. x 24in., 5/6.

**EXPERIMENTERS 150 WATT TRANSFORMERS,** 150 watts. For any input or output 40v. to 200v. 19 taps, fitted 2 panels with 11 stud switch, 45/-. Other transformers to 5 Kw.

**PROJECTION LANTERNS,** on Stand, with 250-watt focus bulb, 25/-. Arc lamps, slide lanterns. Film projectors, and sound heads cheap.

**A.C. ELECTRO-MAGNETS** for 220 volts 30 mA, holds 14oz., 2/6. **SOLENOIDS** for remote work or relay, 4 and 6 volts, 1/2in. stroke and 1oz. pull, silk covered coil, metal frame, 3/6.

**MOTORS, DYNAMOS, BLOWERS & FANS**

## GRAMO-MOTORS

UNIVERSAL Gramo. Recording Motors with 12in. turntable, 200/250 volts, 23/10/6. Standard A.G. Gramo-motors, and turntable, 25/- and 50/-. GARRARD RECORD CHANGER AND GRAMO-MOTOR, A.C., 55/7/6. NO-MAINS H.T. UNIT, Vibrator type with metal rectifier for 2v. DC to 80v. DC, 37/6.

Send for Radio-Electrical-Scientific Illus. List "N" Free

# ELECTRADIX RADIOS

218, Upper Thames Street, London, E.C.4

Telephone: Central 4611.

**ALL THE LATEST RADIO EQUIPMENT**  
to be shown at  
**RADIOLYMPIA**  
will be available on the  
**LOWEST EASY TERMS**

WE GUARANTEE COMPLETE SATISFACTION. PROMPT DELIVERY. All goods carr. paid. CASH OR C.O.D. ORDERS delivered by return of post.

★ REMEMBER—WRITE US ABOUT YOUR NEXT REQUIREMENTS —We will quote the best possible terms. **McCarthy CHASSIS** always in Stock. New Demonstration Room now open. Estd. 1925

**THE LONDON RADIO SUPPLY COMPANY**  
11 OAT LANE—NOBLE STREET—LONDON, E.C.2

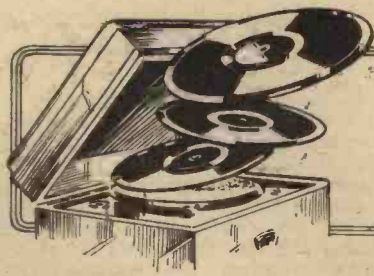

# Impressions on the Wax

**PAUL ROBESON**, with Lawrence Brown at the piano, has this month made a record in aid of the Basque Refugee Children's Fund. It consists of two songs and a short poem. The songs are "Sometimes I feel like a Motherless Child" and "The Wanderer," and the poem is Langston Hughes' "Minstrel Man"—*H.M.V. B 8604.*

Peter Dawson has recorded "Invictus"—"My Head is Bloody But Unbowed, I Am the Master of My Fate." Having settled Fate's business satisfactorily, he sings on the other side of the record "Give Me the Spice of Life"—*H.M.V. B 8600.*

Two very charming ballads, one American and one English, are sung by Derek Oldham, who was so successful in the United States during the recent tour of the D'Oyly Carte Opera Company that he has been invited to return when his engagements permit. The songs are Oley Speak's "Morning" and Graham Peel's successful setting of "In Summertime on Bredon"—*H.M.V. B 8603.*

The Comedy Harmonists have chosen "Congo Lullaby" from the Robeson film "Sanders of the River" for their latest recording on *H.M.V. B 8602.* It is coupled with "Love Me a Little Today."

Other film numbers are "Blue Hawaii" and "Sweet is the Word for You," sung by Al Bowlly on *H.M.V. BD 440*, and "They Can't Take That Away from Me" ("Shall We Dance") coupled with "Where Are You?" ("Top of the Town"), sung by Hal Yates on *H.M.V. BD 436.*

# RADIOLYMPIA

AUGUST 25th to SEPTEMBER 4th, 1937

**OUR STAND, No. 10 Ground Floor**

Vivian Ellis is represented by "A Little White Room" from the new musical show "Foodlight," and a short medley from the same show on *H.M.V. BD443*, while Reginald Dixon continues to explore the possibilities of the B.C.C. organ in "Cloister Shadows" and "The Lost Chord" on *H.M.V. BD 441.*

The imposing array of twenty-two new titles prove an interesting contrast in the treatment of "The Merry-go-round Broke Down" by Roy Fox and Eddie Duchin. Both are good, but Roy's imitation of the steam organ of the roundabout is original. This list includes "Fifty Million Robins can't be Wrong," and the "Merry-go-round Broke Down"—*H.M.V. BD 5239*, and "Blue Hawaii" coupled with "Sweet is the Word for You"—*H.M.V. BD 5230*, both played by Roy Fox and his Orchestra. Orlando and his Orchestra at Gleneagles Hotel play "A Sailboat in the Moonlight"

and "Love is Good for Anything that Ails You" on *H.M.V. BD 5236.* Jack Harris and his Orchestra play "Wake up and Live" and "I'm Gonna Kiss Myself Goodbye"—*H.M.V. BD 5241*, and Fats Waller and his Rhythm play "Sweet Heartache" and "Back up to Me" on *H.M.V. BD 5225.* Henry Jacques (Britain's champion dancer of 1934-6) and his Correct Dance Tempo Orchestra have recorded four titles, "The Greatest Mistake of My Life" and "I Saw a Ship A-sailing"—*H.M.V. BD 5234*, and "Broken-hearted Clown" and "A Sailboat in the Moonlight"—*H.M.V. BD 5244.*

Among the new swing numbers the Quintette of the Hot Club of France have recorded "Body and Soul" and "A Little Love, a Little Kiss" on *H.M.V. B 8598*, and Tommy Dorsey and his Orchestra "Black Eyes" and "Blue Danube" on *H.M.V. B 8592.*

## Decca

**GERALDO'S** "Music Shop" features have for a long time been one of the most popular of radio entertainments and in his latest record—*Decca F 6436*—he has succeeded in getting six of the outstanding hits of the moment.

When Gracie Fields was honoured with the freedom of Rochdale, she broadcast during her programme "Will you Remember." In response to many requests she has now recorded this number on *Decca F 6426.* It is coupled with "On a Little Dream Ranch."

The "Merry-go-round Broke Down" is one of the No. 1 hits of America, and Lew Stone has recorded this number on *Decca F 6434.* It is backed with "Carelessly," a tune which is rapidly finding favour.

Arthur Tracy, better known as "The Street Singer," has recorded two new hits on *Decca F 6438.* "In a Little French Casino" is paired with "Will you Remember." What new can one say of Charlie Kunz? On *Decca F 6440* is another of this popular pianist's medleys played in his usual unimitable style.

## New Brunswick Labels

I WOULD draw your attention to an innovation in which I am sure you will be interested. I refer to the new records of Bing Crosby and Grace Moore. After some weeks of experiment the Decca Company have produced a new type of label. These new labels take the form of scenes from the film in which the artist sings and the actual picture shown coincides as nearly as possible with the singing of the recorded song. So, besides the recorded voice, the purchaser has interesting portraits of their favourite stars as they will remember them in the film.

Of the two artists featured on these new labels we have Bing Crosby singing numbers from his new film "Waikiki Wedding," "Blue Hawaii" and "Sweet is the Word for You"—*Brunswick 02444*, and "In a Little Hula Heaven" and "Sweet Lailani" on *Brunswick 02443.* The other artist, Grace Moore, sings "Serenade" and "Vissi D'Arte" on *Brunswick 0136.* Both of these songs are from her new film "For You Alone."



# TRANSMITTING TOPICS

American Valves and Circuits, the Jones Exciter, Tritet and 12A7, and Unusual Rectifier Circuits, are Dealt with in this Article - - By L. ORMOND SPARKS

**C**ERTAIN American valves are very popular with amateurs, and while admitting that their low price is responsible in many instances for their use in preference to British products, it does not follow that such considerations apply to every user. If one examines the range of characteristics, it will be noticed that there are certain types which have no British counterpart, though certain manufacturers are now producing valves which have very similar specifications. It is, no doubt, in connection with transmitting work that the American valves find most

indicated on the usual diagrams for the type concerned. In such instances, the extra pins should be ignored as it appears that they are there purely for manufacturing convenience. Rather different from our manufacturers' methods. One other item, remember that the H.T. supply is always known as the "B" battery or supply; the L.T. as the "A," and the G.B. as the "C" supply.

### A Simple Tritet Transmitter

I have already mentioned the Tritet oscillator, but as I have been talking about American valves, it is a good chance to give the details of a simple Tritet arrangement which makes use of the 6L6 valve (Fig. 1).

There is nothing complicated about the layout; in fact, it can be made sufficiently compact to be portable, providing, of

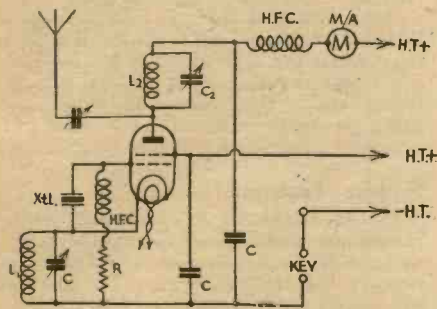

Fig. 1.—A Tritet circuit using the 6L6 valve.

favour, although the constructors of power L.F. amplifiers use them extensively. At the risk of the remark being thought—quite unnecessary, I would advise all beginners, when substituting American valves in an existing circuit, or building a circuit round one or more of the valves, to pay particular attention to the operating conditions required by each valve, the type of valveholder necessary, and the correct connections for the various valve pins. Don't overlook the fact that the filament and heater voltages are different from the normal British types; with A.C. valves it will be necessary to use a special heater transformer, or have a suitable winding embodied in the mains transformer. The following values will give some idea of the general filament and heater requirements. Two volts at .06 amps., 2 volts at .12 amps., 6.3 volts at .3, .6, and .9 amps., 5 volts at .25 amps., and 7 volts at 1.25 amps. These do not cover all types; for instance, no mains rectifier voltages are given in the above figures. The lettering on the American literature may cause a little confusion, though the majority of the connections are designated after our style. There are, however, several which will be new to the beginner, for example, "Sup" denotes suppressor grid, "D.P." diode plates or anodes, "S.H." shield—the metal envelope of the valve which is always connected to valve pin No. 1, "N.C." means no connection to the pin thus marked. It is rather interesting to note that some valves may be provided with more pins than those

of writing, there is no British counterpart. It is the 53 valve, which has a 2.5 volt filament, or the 6A6, which requires 6.3 volts on the filament.

In plain terms, these valves are really mains operated Class B valves, the cathode being indirectly heated.

One triode section is used as a crystal oscillator, while the other is made to function as a "doubler." The circuit, Fig. 2, can be compared to our 2½ Watt Transmitter the chief differences being that the 240B is a battery operated valve, and that one triode is used for modulating.

Another valve which is unobtainable in the British types is the 12A7. The actual arrangement of the electrodes sounds rather peculiar at first, but it is quite satisfactory; in fact, the valve lends itself to the development of a simple low-powered stand-by transmitter. I understand that it is quite widely used for such purposes in America.

The circuit, which is shown in Fig. 3, shows that it is nothing more than a pentode and a half-wave rectifier assembled in one bulb. When using the 12A7, it must be remembered that it is designed for use on the average American supplies, i.e., 110 volts A.C., therefore it will be necessary to insert a suitable transformer between the heater circuit and our 200/250 volt mains.

### Unusual Rectifier Circuits

As one's transmitting station develops, and as the power rating is increased, the question always crops up of how to obtain the required increase in H.T. power, without involving a considerable outlay.

It is rather interesting to note how the Americans get over the difficulty by using various arrangements of, comparatively-speaking, low-powered rectifiers. It must be remembered, when considering the circuits shown, that the rectifiers mentioned can be secured for a matter of a few shillings against the relative high cost of a large single rectifier.

The circuits shown are suitable for the type 83 rectifiers, but there is no reason why they should not be modified to suit valves having other characteristics.

The system used is known as the "bridge" method (Fig. 4), and apart from the advan-

(Continued on next page)

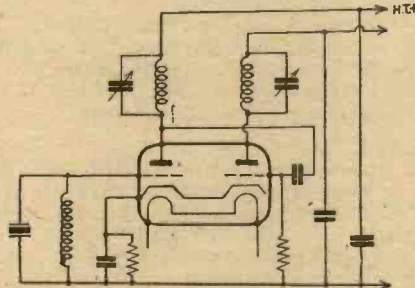

Fig. 2.—This is the Jones Exciter circuit in which the 53 or 6A6 valve is used.

course, that the required H.T. supply is available. The circuit can be operated with 250 volts or 350 volts, the latter giving the higher output, but I would suggest that 250 volts will be ample for the initial experiments.

A simple "end fed" aerial will be quite satisfactory, so long as it is cut to the correct length for the crystal used.

### The Jones Exciter

Another very efficient circuit, and one which gives even greater output than the Tritet, is the Jones Exciter—named after its designer. This arrangement has been developed around another American valve, for which, at the time

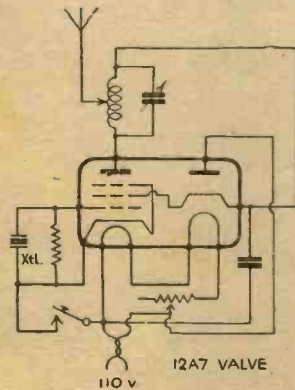

Fig. 3.—A low-power transmitter using the 12A7 valve.

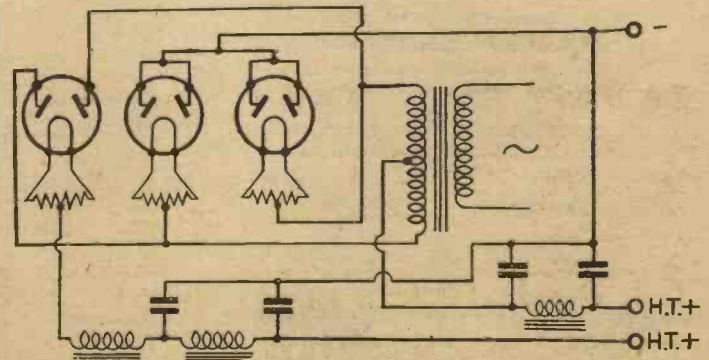

Fig. 4.—Bridge rectifier circuit with three type 83 valves.

### TRANSMITTING TOPICS

(Continued from previous page)

tages of the arrangement which have already been mentioned, it allows two distinct voltage supplies to be available for, say, one circuit requiring high voltage, and another requiring only medium or low values of H.T.

The mains transformer must, of course, be provided with the necessary windings and taps, while it is essential to see that all insulation is beyond suspicion.

#### Series Connection

Another system often used over the other side, is the "series" connection of rectifiers (Fig. 5), the object being to connect two medium voltage rectifiers in series to provide a total output voltage of approximately double their normal output. Actually the final figure will be slightly under that.

For example, two rectifiers capable of

giving, say, 500-volts in normal connection, could be used in series to provide an output near the 900-volt mark. In this method—even more than the "bridge" arrangement

—transformers must be selected with perfect insulation, as one of the H.T. secondaries has to stand higher voltages than for which it was designed.

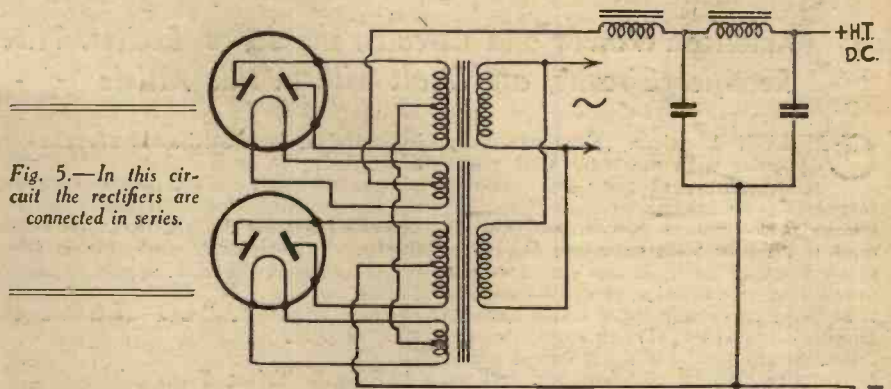

Fig. 5.—In this circuit the rectifiers are connected in series.

## THE BRITISH LONG DISTANCE LISTENERS' CLUB

#### Verification Cards

A LARGE number of members still apparently experience dissatisfaction regarding the acquisition of verification cards and there are one or two points which we should like to make clear again. It is the aim of many listeners to cover the wall of the listening or experimenting den with an array of the cards, and it must be admitted that some of these cards are most interesting pictorially. Experience shows, however, that these cards are not sent out indiscriminately. Many listeners send off a report of reception immediately they hear a call-sign, and expect to receive a card by return of post. In a large number of cases they address an envelope to us with the request that we re-direct the report to the station in question, as they are unable to trace the address. It must be remembered, however, that we do not hold a complete directory of all amateur and broadcast stations in all parts of the world and in very many cases we ourselves are unable to locate a transmitter from the call-sign which is given.

In addition to this difficulty, many of the stations do not reply unless some unusual fact emerges from the listener's report. Some stations are received so well in this country that it is of no interest to the owner that another English listener has succeeded in hearing him and he accordingly ignores the report. If, therefore, you are anxious to get such cards you must be able to supply the station with very complete data, and if possible endeavour to provide some piece of information which is unlikely to be given by other listeners. Remember to give atmospheric data, such as wind velocity, cloud heights and similar details which might be of great use to an enthusiastic amateur transmitter who is compiling some data regarding his transmissions.

#### Signal Strength

Do not be too casual in your reference to signal strength. A mere "Signals at R5" is not always reliable. One listener may judge a signal to be R5, whilst another would only give the signal R3, and, therefore, if some comparison can be made at the same time it will be of added value. Fading and details of the station with which the transmitter is working might also in many

cases provide some useful clue regarding the transmission, and therefore, you must not be disappointed if you fail to obtain a reply or a verification card, but must look to the drawing up of your future reports.

#### A. E. L.

Remember that you can still obtain the All Empire Listener's letter when you have received verifications from five continents. Send to us the five cards proving your successful reception, and we will by return send you a confirmatory letter from the Secretary "conferring" the A.E.L. upon you. This may be framed and pinned up along with your cards to add prestige to your listening post. It is a more interesting detail of your short-wave listening if you classify your cards. For instance, suppose you are just starting serious short-wave listening, and have only a modest receiver for the purpose. Draw up a neat circuit diagram, date it, and, if possible, have a photograph taken of the receiver. Place this in one corner of the wall, perhaps along with your Certificate of Membership, and as the cards arrive place them round this corner. As soon as the receiver is modified, draw up a fresh diagram, with another picture of the

listeners in your district you can not only form an interesting social club, but by an interchange of visits to your individual listening posts you can learn much regarding construction and listening. Mr. R. West, of 3, Grosvenor Avenue, East Sheen, S.W.14, is anxious, in this connection, to get into touch with other listeners in his district with a view to forming a local club.

#### Empire Transmissions

Mr. A. W. Mann, in reporting on the results obtained with his directional aerial, writes: "Experiences relative to the reception of Empire transmitters produce peculiar effects and are interesting; GSC, GSE are examples. Usually they skip us here in this location, at others are weak for some hours and strong later for a while. During this year the following effects have been noted in daylight and towards dusk using 0-v-1 and 0-v-2 sets. With aerial due south-west but clear signals, readjustment to due north produces a 25 to 50 per cent. gain in some instances, which appears to show that a long path directional signal around the globe is received, not ground wave. Volume in such instances can be swung for increase and decrease at will by revolving aerial. The same effects have been noticed on 2XAF during darkness, also 2XAD at dusk.

"With reference briefly to 25 and 19 metres bands, directional effects are greater on one or another transmission within both bands, always showing greater effects than the rest at one time. On 16 metres and below the increase is most marked."



The acquisition of QSL cards makes a most interesting side-line and lends an air of importance to your den.

#### Local Clubs

Remember that by getting into touch with other



# Letters from Readers

The Editor does not necessarily agree with the opinions expressed by his correspondents. All letters must be accompanied by the name and address of the sender (not necessarily for publication).

## A Valve-testing Panel

**SIR**,—In your various articles on the construction of meters, oscillators, wavemeters, etc., you have covered practically all the requirements of the keen experimenter, and, indeed, the service engineer. I beg to suggest that you add to this list of apparatus a mains valve-testing panel. Something that would test, say, half a dozen of the most common valves. The average commercial unit, excellent as it is, I am sure, rather too much for the average pocket, and I feel sure that a home-constructed unit would be welcomed by many readers.

Thanking you for an excellent magazine.  
H. E. CHAMBERLAIN (Farnborough).

[What do other readers think of this suggestion?—Ed.]

## Back Issues Wanted

**WE** have a request for a copy of *Amateur Wireless* dated March 31st, 1934, containing particulars of the "One-Valver for America"; and also for a copy of *Practical Wireless* dated July 15th, 1933, containing particulars of a "Radio Robot." Will any readers having these copies to spare kindly forward them to our office address given at the foot of this page?

## A Short-wave Log from Abercarn

**SIR**,—I have seen many letters on this page from readers giving logs over different periods, and I now give mine over a period of two hours, between 01.30 to 03.30 B.S.T., July 21st, 1937. I logged 44 amateurs on 20 metres, and out of the nine land divisions of America I received eight, represented by W1BLO (working G6BW), W2JT, W3EWW, W4BYY (working GW5KJ), W5BVA, W6AM, W8KVJ, and W9AJS. Of the five divisions of Canada I received four, namely: VE1LR, VE2EE, VE3SM, and VE5NY. I may say that out of 150 20-metre amateurs I have not yet received a W7 or VE4. Six months ago I built the untuned 1-v-1 circuit out of Newnes' Television and Short-wave Handbook, and it is giving excellent results. I can recommend it to anyone who is looking for a good short-wave circuit. I made my own coils and chokes. My aerial is an ordinary inverted-L type. This is the second time this year I have received over 40 20-metre amateurs in a period of two hours.—  
W. R. BURTON (Llanfach, Abercarn).

## Our Short-wave Log: A Few Corrections

**SIR**,—Being a regular reader of PRACTICAL AND AMATEUR WIRELESS, and taking special interest in your short-wave features, perhaps I may be allowed to point out one or two small errors which I have recently noticed in "Leaves from a Short-wave Log."

In your issue dated July 24th I see a

reference to the new Cuban station COGF. Although this station has apparently not yet been reported to you, I have personally heard it since the early part of June, and a friend of mine first logged it some little time before that. Incidentally, this station operates on 11,800 kc/s, and not on 10,790 kc/s as stated. I have received a verification from them which confirms the frequency as 11,800 kc/s, and also gives the following details: COGF relays the long-wave station CMGF, and is located at Gral. Betancourt 51, Matanzas. The power of COGF is 1,000 watts, but no schedule is given. However, I have heard this station as early as 22.00 G.M.T., and it usually appears to sign off at 04.00 G.M.T.

Some weeks ago a reference was made in your journal to the power of another Cuban station—COCQ, and doubt was expressed as to the truth of a report that they were increasing their power to 25 kilowatts. This statement would appear quite feasible, as, according to a verification card sent to me some ten months ago, their power has always been 4 kilowatts.

Incidentally, a new Cuban station is now working on approximately 9,350 kc/s, using a call which appears to be COCB. This station is heard quite well in the early mornings until 05.30 G.M.T., at which time they usually close down. It is located at Havana.

In the July 31st issue of PRACTICAL AND

CUT THIS OUT EACH WEEK.

## Do you know

- THAT ordinary high-resistance headphones may be joined in series with a low-resistance speech coil, with a shorting switch to enable L.S. signals to be heard.
- THAT a neon lamp may be used as a condenser tester and fault-finder.
- THAT modern all-purpose valve-testers often include a neon lamp as an additional fault-locator.
- THAT the tapplings on the primary side of a mains transformer provide useful low-voltage A.C. ranges for test purposes.
- THAT smoothing may be improved in a mains receiver by adding additional smoothing chokes, but the H.T. voltage will be modified by so doing.
- THAT for H.F. screening polished metal is preferable to the frosted or matt type.

The Editor will be pleased to consider articles of a practical nature suitable for publication in PRACTICAL AND AMATEUR WIRELESS. Such articles should be written on one side of the paper only, and should contain the name and address of the sender. Whilst the Editor does not hold himself responsible for manuscripts, every effort will be made to return them if a stamped and addressed envelope is enclosed. All correspondence intended for the Editor should be addressed: The Editor, PRACTICAL AND AMATEUR WIRELESS, George Newnes, Ltd., Tower House, Southampton Street, Strand, W.C.2. Owing to the rapid progress in the design of wireless apparatus and to our efforts to keep our readers in touch with the latest developments, we give no warranty that apparatus described in our columns is not the subject of letters patent.

AMATEUR WIRELESS mention is made of YV5RI, "La Voz de la Esfera," on 6,250 kc/s. I first logged this station on May 8th last, and according to their announcements he call YV5RI belongs to the long-wave station, the short-wave call being YV5RJ.

As a regular and enthusiastic listener to the Latin-American short-wave broadcast stations, I mention these points in the hope that they will be of some interest to other readers.—J. R. GARRETT PEGGE (Chesham, Bucks).

## REPLIES IN BRIEF

The following replies to queries are given in abbreviated form either because of non-compliance with our rules, or because the point raised is not of general interest.

**E. T. (Bolton).** We regret that there is no book in our series dealing with the subject you mention.

**C. D. B. (Bournemouth).** The H.F. receiver will obviously have greater range, but there may be difficulty due to overloading of the output stage. The 0-V-2 would, therefore, be the most effective, especially for a beginner.

**L. S. B. (Stratford).** We regret that we cannot supply a blueprint of a car-radio receiver. The Listener's 5-watt amplifier (WM 302) would suit your other requirements.

**I. F. van A. (Buckhurst Hill).** The transformer is simply an ordinary aerial coil, consisting of an aperiodic aerial circuit and grid circuit. It is the same as an H.F. transformer.

**G. S. C. (Machen).** There can be several causes of the trouble mentioned. The H.T. or G.B. batteries may need replacing; a valve may have become defective, or a component. A stage by stage test is indicated.

**J. R. (Leigh).** We do not recommend the fitting of new coils, and these would be unlikely to cause the trouble mentioned. A component such as a resistance is probably defective. The makers are Climax Radio Electric, Ltd., Brent Crescent, North Circular Road, N.W.10.

**G. M. (Wick).** The receiver in question is a 5-valve battery set of the superhet type with separate triode oscillator and double-diode second detector-A.V.C.-L.F. valve. The output valve is a pentode with tone control of the panel-adjusting type across the speaker.

**W. H. J. (Bettws-y-Coed).** The meter would not be suitable as it has too high a reading. You need a 1 millilamp. meter for the purpose mentioned.

**N. E. (Walsend).** We do not know what set you are using and therefore cannot state whether it is a peculiarity of the design or a local fault. An I.F. image suppressor is often fitted in a modern set to prevent the trouble mentioned, but it can also be caused by local earthed metal bodies near the aerial. We do not advise the use of phones in conjunction with the mains receiver of this type.

## BOOKS RECEIVED

**ELECTROLYTIC CONDENSERS, THEIR PROPERTIES, DESIGN AND PRACTICAL USES.** By Philip R. Coursey, B.Sc., M.I.E.E., F.Inst.P., etc. 172 pp. 112 illustrations. Published by Messrs. Chapman and Hall, price 10s. 6d.

**AS** its title implies, this book deals with all aspects of the modern electrolytic condenser. The increasing use of this component in wireless apparatus and other electrical equipment has led to much difficulty due to failure to understand the principles upon which it is designed, and many of these misunderstandings will be cleared up after reading the book. It explains very clearly how the different types of electrolytic condenser are designed, the uses to which the different types should be put, the precautions to take in special circuits and other similar details. The nine chapters are well illustrated and include such details as the method of testing these condensers, the differences between the wet and the dry condensers, the electrical characteristics and so on. The book is reasonably free from complicated mathematical data, but includes all the necessary calculations which are introduced in the design and manufacture of these components.

# Practical and Amateur Wireless BLUEPRINT SERVICE

PRACTICAL WIRELESS	No. of			
Date of Issue.	Blueprint.			
<b>CRYSTAL SETS</b>				
<b>Blueprint, 6d.</b>				
1937 Crystal Receiver	9.1.37	PW71		
<b>STRAIGHT SETS. Battery Operated.</b>				
<b>One-valve: Blueprint, 1s.</b>				
All-wave Unipen (Pentode)	—	PW31A		
<b>Two-valve: Blueprints, 1s. each.</b>				
Four-range Super Mag Two (D, Pen)	11.8.34	PW36B		
The Signet Two	29.8.36	PW76		
<b>Three-valve: Blueprints, 1s. each.</b>				
The Long-Range Express Three (SG, D, Pen)	24.4.37	PW2		
Selectone Battery Three (D, 2 LF (Trans))	—	PW10		
Sixty Shilling Three (D, 2LF (RC & Trans))	—	PW34A		
Leader Three (SG, D, Pow)	22.5.37	PW35		
Summit Three (HF Pen, D, Pen)	8.8.34	PW37		
All Pentode Three (HF Pen, D (Pen), Pen)	20.5.37	PW39		
Hall-mark Three (SG, D, Pow)	12.6.37	PW41		
Hall-mark Cadet (D, LF, Pen, RC)	16.3.35	PW48		
F. J. Camm's Silver Souvenir (HF Pen, D (Pen), Pen)	13.4.35	PW49		
Genet Midget (D, 2 LF (Trans))	June '35	PM1		
Cameo Midget Three (D, 2 LF (Trans))	8.6.35	PW51		
1936 Sonotone Three-Four (HF Pen, HF Pen, Westector, Pen)	17.8.35	PW53		
Battery All-Wave Three (D, 2 LF (RC))	—	PW55		
The Monitor (HF, Pen, D, Pen)	—	PW61		
The Tutor Three (HF Pen, D, Pen)	21.3.36	PW62		
The Centaur Three (SG, D, P)	14.8.37	PW64		
The Gladiator All-Wave Three (HF Pen, D (Pen), Pen)	20.8.36	PW66		
F. J. Camm's Record All-Wave Three (HF Pen, D, Pen)	31.10.36	PW69		
The "Colt" All-Wave Three (D 2 LF (RC & Trans))	5.12.36	PW72		
<b>Four-valve: Blueprints, 1s. each.</b>				
Sonotone Four (SG, D, LF, P)	1.5.37	PW4		
Fury Four (2 SG, D, Pen)	8.5.37	PW11		
Beta Universal Four (SG, D, LF, Cl. B)	—	PW17		
Nucleon Class B Four (SG, D (SG), LF, Cl. B)	6.1.34	PW34B		
Fury Four Super (SG, SG, D, Pen)	—	PW34C		
Battery Hall-Mark 4 (HF, Pen, D, Push-Pull)	—	PW46		
F. J. Camm's "Limit" All-Wave Four (HF Pen, D, LF, P)	20.9.36	PW67		
<b>Mains Operated.</b>				
<b>Two-valve: Blueprints, 1s. each.</b>				
A.C. Twin (D (Pen), Pen)	—	PW18		
A.C.-D.C. Two (SG, Pow)	—	PW31		
Selectone A.C. Radiogram Two (D, Pow)	—	PW19		
<b>Three-valve: Blueprints, 1s. each.</b>				
Double-Diode-Triode Three (HF Pen, DDT, Pen)	—	PW23		
D.C. Ace (SG, D, Pen)	—	PW25		
A.C. Leader (HF Pen, D, Pen)	—	PW29		
A.C. Leader (SG, D, Pow)	7.4.34	PW35C		
D.C. Premier (HF Pen, D, Pen)	31.3.34	PW35B		
Ubique (HF Pen, D (Pen), Pen)	28.7.34	PW36A		
Armada Mains Three (HF Pen, D, Pen)	—	PW38		
F. J. Camm's A.C. All-Wave Silver Souvenir Three (HF Pen, D, Pen)	11.5.35	PW50		
"All-Wave" A.C. Three (D, 2 LF (RC))	17.8.35	PW51		
A.C. 1936 Sonotone (HF Pen, H.F. Pen, Westector, Pen)	—	PW56		
Mains Record All-Wave 3 (HF Pen, D, Pen)	5.12.36	PW70		
<b>Four-valve: Blueprints, 1s. each.</b>				
A.C. Fury Four (SG, SG, D, Pen)	—	PW20		
A.C. Fury Four Super (SG, SG, D, Pen)	—	PW34D		
A.C. Hall-Mark (HF Pen, D, Push-Pull)	24.7.37	PW45		
Universal Hall-Mark (HF Pen, D, Push-Pull)	9.2.35	PW47		
<b>SUPERHETS.</b>				
<b>Battery Sets: Blueprints, 1s. each.</b>				
£5 Superhet (Three-valve)	5.6.37	PW40		
F. J. Camm's 2-valve Superhet Two-valve	13.7.35	PW52		
F. J. Camm's £4 Superhet	—	PW58		
F. J. Camm's "Vitesse" All-Waver (5-valver)	17.7.37	PW75		
<b>Mains Sets: Blueprints, 1s. each.</b>				
A.C. £5 Superhet (Three-valver)	—	PW43		
D.C. £5 Superhet (Three-valve)	1.12.34	PW42		
Universal £5 Superhet (Three valve)	—	PW44		
F. J. Camm's A.C. £4 Superhet 4	31.7.37	PW59		
F. J. Camm's Universal £4 Superhet 4	—	PW60		
"Qualitone" Universal Four	16.1.37	PW73		
<b>SHORT-WAVE SETS.</b>				
<b>Two-valve: Blueprint, 1s.</b>				
Midget Short-wave Two (D, Pen)	—	PW38A		
<b>Three-valve: Blueprints, 1s. each.</b>				
Experimenter's Short-Wave Three (SG, D, Pow)	—	PW30A		
The Protect 3 (D, 2 LF (RC and Trans))	7.8.37	PW63		
The Bandsread S.W. Three (HF Pen, D (Pen), Pen)	29.8.36	PW68		
"Tele-Cent" S.W.3 (SG, D (SG), Pen)	30.1.37	PW74		
<b>PORTABLES.</b>				
<b>Three-valve: Blueprints, 1s. each.</b>				
F. J. Camm's ELF Three-valve Portable (HF Pen, D, Pen)	—	PW65		
Parvo Flyweight Midget Portable (SG, D, Pen)	19.6.37	PW77		
<b>Four-valve: Blueprint, 1s.</b>				
Featherweight Portable Four (SG, D, LF, Cl. B)	15.5.37	PW12		
<b>MISCELLANEOUS.</b>				
<b>S.W. Converter-Adapter (1 valve)</b>	—	PW48A		
<b>AMATEUR WIRELESS AND WIRELESS MAGAZINE CRYSTAL SETS.</b>				
<b>Blueprints, 6d. each.</b>				
Four-straight Crystal Set	12.12.36	AW427		
1934 Crystal Set	—	AW444		
150-mile Crystal Set	—	AW450		
<b>STRAIGHT SETS. Battery Operated.</b>				
<b>One-valve: Blueprints, 1s. each.</b>				
B.B.C. Special One-valver	—	AW387		
Twenty-station Loudspeaker One-valver (Class B)	—	AW449		
<b>Two-valve: Blueprints, 1s. each.</b>				
Melody Ranger Two (D, Trans)	—	AW388		
Full-volume Two (SG det., Pen)	—	AW392		
B.B.C. National Two with Lucerne Coil (D, Trans)	—	AW377A		
Big-power Melody Two with Lucerne Coil (SG Trans)	—	AW338A		
Lucerne Minor (D, Pen)	—	AW426		
A Modern Two-valver	—	WM409		
<b>Three-valve: Blueprints, 1s. each.</b>				
Class B Three (D, Trans, Class B)	—	AW386		
New Britain's Favourite Three (D, Trans, Class B)	15.7.33	AW394		
Home-built Coil Three (SG, D, Trans)	—	AW401		
Fan and Family Three (D, Trans, Class B)	25.11.33	AW410		
£5 5s. S.G.3 (SG, D, Trans)	2.12.33	AW412		
1934 Ether Searcher: Baseboard Model (SG, D, Pen)	—	AW417		
1934 Ether Searcher: Chassis Model (SG, D, Pen)	—	AW419		
Lucerne Ranger (SG, D, Trans)	—	AW422		
Cosser Melody Maker with Lucerne Coils	—	AW423		
Mullard Master Three with Lucerne Coils	—	AW424		
£5 5s. Three: De Luxe Version (SG, D, Trans)	19.5.34	AW433		
Lucerne Straight Three (D, RC, Trans)	—	AW437		
All-Britain Three (HF, Pen, D, Pen)	—	AW448		
"Wireless League" Three (HF Pen, D, Pen)	3.11.34	AW451		
Transportable Three (SG, D, Pen)	—	WM271		
£6 6s. Radiogram (D, RC, Trans)	—	WM318		
Simple-tune Three (SG, D, Pen)	June '33	WM327		
Economy-Pentode Three (SG, D, Pen)	Oct. '33	WM337		
"W.M." 1934 Standard Three (SG, D, Pen)	—	WM351		
£3 3s. Three (SG, D, Trans)	Mar. '34	WM354		
Iron-core Band-pass Three (SG, D, QP21)	—	WM362		
1935 £6 6s. Battery Three (SG, D, Pen)	—	WM371		
PTP Three (Pen, D, Pen)	June '35	WM389		
Certainty Three (SG, D, Pen)	—	WM393		
Minutime Three (SG, D, Trans)	Oct. '35	WM396		
All-wave Winning Three (SG, D, Pen)	Dec. '35	WM400		
<b>Four-valve: Blueprints, 1s. 6d. each.</b>				
65s. Four (SG, D, RC, Trans)	—	AW370		
"A.W." Ideal Four (2 SG, D, Pen)	16.9.33	AW402		
2HF Four (2SG, D, Pen)	—	AW421		
Crusaders' A.V.C.4 (2 HF, D, QP21)	18.8.34	AW445		
(Pentode and Class B Outputs for above: Blueprints, 6d. each)	25.8.34	AW445A		
Self-contained Four (SG, D, LF, Class B)	Aug. '33	WM331		
Lucerne Straight Four (SG, D, LF, Trans)	—	WM350		
£5 5s. Battery Four (HF, D, 2LF)	Feb. '35	WM381		
The H.K. Four (SG, SG, D, Pen)	Mar. '35	WM384		
The Auto Straight Four (HF Pen, HF Pen, DDT, Pen)	April '36	WM404		
<b>Five-valve: Blueprints, 1s. 6d. each.</b>				
Super-quality Five (2HF, D, RC, Trans)	May '33	WM320		
Class B Quadradyne (2 SG, D, LF, Class B)	Dec. '33	WM344		
New Class-B Five (2 SG, D, LF, Class B)	Nov. '33	WM340		
<b>Mains Operated.</b>				
<b>Two-valve: Blueprints, 1s. each.</b>				
Consoelectric Two (D, Pen) A.C.	—	AW403		
Economy A.C. Two (D, Trans) A.C.	—	WM286		
Unicorn A.C.-D.C. Two (D Pen)	—	WM394		

These blueprints are drawn full size. Copies of appropriate issues containing descriptions of these sets can in some cases be supplied at the following prices, which are additional to the cost of the blueprint. A dash before the Blueprint Number indicates that the issue is out of print.

Issues of Practical Wireless .. 4d. Post paid  
Amateur Wireless .. 4d. " "  
Practical Mechanics .. 7d. " "  
Wireless Magazine .. 1/3 " "

The Index letters which precede the Blueprint Number indicate the periodical in which the description appears; thus PW refers to PRACTICAL WIRELESS, AW to Amateur Wireless, PM to Practical Mechanics, WM to Wireless Magazine.

Send (preferably) a postal order to cover the cost of the blueprint and the issue (stamps over 6d. unacceptable), to PRACTICAL AND AMATEUR WIRELESS Blueprint Dept., Geo. Newnes, Ltd., Tower House, Southampton Street, Strand, W.C.2.

<b>Three-valve: Blueprints, 1s. each.</b>				
Home-Lover's New All-electric Three (SG, D, Trans) A.C.	—	AW383		
S.G. Three (SG, D, Pen) A.C.	—	AW390		
A.C. Triodyne (SG, D, Pen) A.C.	19.8.33	AW399		
A.C. Pentaquester (HF Pen, D, Pen) A.C.	23.6.34	AW430		
Mantovani A.C. Three (HF Pen, D, Pen) A.C.	—	WM374		
£15 15s. 1936 A.C. Radiogram (HF, D, Pen)	Jan. '36	WM401		
<b>Four-valve: Blueprints, 1s. 6d. each.</b>				
All-Metal Four (2 SG, D, Pen)	July '33	WM326		
Harris Jubilee Radiogram (HF Pen, D, LF, P)	May '35	WM386		
<b>SUPERHETS.</b>				
<b>Battery Sets: Blueprints, 1s. 6d. each.</b>				
Modern Super Senior	—	WM375		
Varsity Four	Oct. '35	WM395		
The Request All-Waver	June '36	WM407		
1935 Super Five Battery (Superhet)	—	WM379		
<b>Mains Sets: Blueprints, 1s. 6d. each.</b>				
1934 A.C. Century Super A.C.	—	AW425		
Heptode Super Three A.C.	May '34	WM359		
"W.M." Radiogram Super A.C.	—	WM386		
1935 A.C. Stenode	Apl. '35	WM385		
<b>PORTABLES.</b>				
<b>Four-valve: Blueprints, 1s. 6d. each.</b>				
Midget Class B Portable (SG, D, LF, Class B)	20.5.33	AW389		
Holiday Portable (SG, D, LF, Class B)	1.7.33	AW393		
Family Portable (HF, D, RC, Trans)	22.9.34	AW447		
Two H.F. Portable (2 SG, D, QP21)	June '34	WM363		
Tyers Portable (SG, D, 2 Trans)	—	WM367		
<b>SHORT-WAVE SETS—Battery Operated.</b>				
<b>One-valve: Blueprints, 1s. each.</b>				
S.W. One-valver converter (Price 6d.)	—	AW329		
S.W. One-valve for America	23.1.37	AW429		
Home Short-Waver	—	AW452		
<b>Two-valve: Blueprints, 1s. each.</b>				
Ultra-short Battery Two (SG det., Pen)	Feb. '36	WM402		
Home-made Coil Two (D, Pen)	—	AW440		
<b>Three-valve: Blueprints, 1s. each.</b>				
World-ranger Short-wave 3 (D, RC, Trans)	—	AW355		
Experimenter's 5-metre Set (D, Trans, Super-regen)	30.6.34	AW433		
Experimenter's Short-wave (SG, D, Pen)	Jan. 19, '35	AW463		
The Carrier Short-waver (SG, D, P)	July '35	WM390		
<b>Four-valve: Blueprints, 1s. 6d. each.</b>				
A.W. Short-wave Trans-Beater (HF, Pen, D, RC, Trans)	—	AW436		
Empire Short-Waver (SG, D, RC, Trans)	—	WM313		
Standard Four-valver Short-waver (SG, D, LF, P)	Mar. '35	WM383		
Superhet: Blueprint, 1s. 6d.	Nov. '35	WM397		
Simplified Short-waver Super	—	—		
<b>Mains Operated.</b>				
<b>Two-valve: Blueprints, 1s. each.</b>				
Two-valve Mains short-waver (D, Pen) A.C.	—	AW453		
"W.M." Band-speed Short-waver (D, Pen) A.C.-D.C.	—	WM368		
"W.M." Long-wave Converter	—	WM380		
<b>Three-valve: Blueprint, 1s.</b>				
Emigrator (SG, D, Pen) A.C.	—	WM352		
<b>Four-valve: Blueprint, 1s. 6d.</b>				
Standard Four-valve A.C. Short-waver (SG, D, RC, Trans)	Aug. '35	WM391		
<b>MISCELLANEOUS.</b>				
Enthusiast's Power Amplifier (1/8)	June '35	WM387		
Listeners' 5-watt A.C. Amplifier (1/8)	—	WM392		
Radio Unit (2v) for WM392	Nov. '35	WM398		
Harris Electrogram (battery amplifier) (1/-)	Dec. '35	WM399		
De-Luxe Concert A.C. Electrogram	Mar. '36	WM403		
New-Style Short-Wave Adapter (1/-)	June '35	WM388		
Trickle Charger (6d.)	Jan. 5, '35	AW462		
Short-Wave Adapter (1/-)	Dec. 1, '34	AW456		
Superhet Converter (1/-)	Dec. 1, '34	AW457		
B.L.D.L.C. Short-wave Converter (1/-)	—	—		
Wilson Tone Master (1/-)	May '36	WM405		
The W.M. A.C. Short-Wave Converter (1/-)	June '36	WM406		



# QUERIES and ENQUIRIES

## Cathode-ray Tubes

"I recently saw an advertisement for a very small cathode-ray tube—it was 3in., I believe. Am I right in assuming that I could build a television receiver round this so that I could enlarge it on to a screen and get a big picture? Would not a small tube like this take smaller H.T. and eventually give better results from the amateur point of view?"—R. F. (Enfield).

THE small tubes are not made for television receivers, but for small testing equipment of the oscillograph type. The projector type of tube is not identical with these small tubes, and you would find it very difficult to project the image owing to light loss and other factors. The voltages used in some of the small oscillographs are just as high as those in a modern television receiver. For the amateur, therefore, it is desirable to use one of the specially-designed large tubes for a television receiver.

## Amateur Call Signs

"I have just started listening on the short waves and on going round the dial I heard 'Hello, hello, this is G6IQ calling.' After some more searching I heard GHEW (G8EW?), G6IP, TS6, Z5. Could you tell me what they are?"—F. L. H. J. (Kelsall).

THE letters and numbers are the call signs of various stations, and in the case of the G index letter the letter indicates that the station is British. A TS station is situated in the Saar, but several countries have the letter Z as a prefix, followed by another letter. In order accurately to identify a station it is essential to listen carefully for the call sign, and in this connection it must be remembered that amateurs often adopt words instead of the letters in order to prevent misunderstanding. Thus instead of saying "P" which might be mis-heard as "T" or "B," they may refer to Paris or Pimlico.

## Converting a Receiver

"I wish to convert my three-valve mains screen-grid set into a three-valve amplifier. Can you advise me as to the alterations? Can I use the S.G. valve as an L.F. valve? I want the amplifier for a small hall to provide dance music."—E. T. (Lancaster).

IT may be possible to convert the receiver, but it will be necessary to cut out the tuning circuit in the detector stage, and to include a bias resistor in the cathode circuit of the detector valve. R.C. coupling would have to be provided between the S.G. and detector stage and this means that an anode resistance would have to be fitted in the S.G. stage, and an alternative H.T. feed would become necessary in all probability in order to ensure that adequate H.T. reaches that valve. It would, therefore, be most satisfactory to include your pick-up in the detector grid circuit as this would not necessitate so many alterations. If you are proposing to use gramophone records for your dance music we would remind you that a licence is required and you should write to the Performing Rights Society regarding this matter.

## Using a Tetrode

"I should be glad if you could tell me the price of the Cossor 40PPA as used in the one-valve L.F. amplifier in your issue dated March 7th, 1936. I wondered if the new Cossor Tetrode 4020T could be used in the place of the 40PPA. Is this so? The information would help me considerably in constructing my amplifier."—A. H. R. (Cleethorpes).

THE 40PPA valve costs 18s. 6d. The tetrode would not, in this particular case, be interchangeable with the 40PPA owing to differences in characteristics. The bias required for the tetrode is only six volts, whilst the 40PPA requires 25 volts. Furthermore, the load is slightly greater for the tetrode, and if you made the necessary circuit modifications to suit the tetrode we do not think, in this particular case, that any decided advantage would be found in practice.

## Winding H.F. Choke

"Would you please state the size of former, the wire gauge and number of turns

of cardboard rings spaced equally along it. These should be attached with ordinary adhesive so as to leave six spaces, each roughly 1/4in. wide. Into these spaces wind approximately 200 to 300 turns of fine wire—any gauge from 28 to 36. Messrs. Telsen's present address is Fitzgeorge Street, Collyhurst, Manchester, 9.

## H.F. Instability

"When I turn my volume control just over half on I get distortion and vibration from the speaker. Would you please give me some idea how to set about correcting it. The set is an S.G. Def. Pen, and the speaker a moving coil."—J. W. W. (Bristol).

IT is not possible accurately to diagnose your trouble as you fail to state what form the volume control takes. It is, however, most probable that this is a variable bias control for the H.F. stage and thus the trouble you are experiencing would appear to be due to H.F. instability. This may be due to wrong voltages applied to the H.F. valve or to a poor layout resulting in interaction between leads, etc. If, however, the volume control is an L.F. component, then the trouble would indicate that the L.F. stage is overloaded or some form of L.F. instability exists. A circuit diagram is indicated in order to give more accurate information in a case of this nature.

## The Record All-wave Three

"A few months ago I built the Record Three and I am very pleased with the performance. I am afraid, however, that selectivity is hardly good enough for me and I should be very pleased if you would kindly let me have particulars of a four-valve set using the parts that I have in the Record."—H. J. P. (Darlaston).

THE degree of selectivity in this particular receiver is due to the design of the coils, which, you must bear in mind, are of the all-wave type. Therefore, it is not possible to incorporate this particular unit in any other receiver with an improvement in selectivity. The only suggestion we can make is that you fit a variable condenser of good quality with a maximum capacity of .0003 mfd. in the aerial lead and adjust this for the degree of selectivity required in your particular locality.

## Calibrated Dials

"I have just bought one of the new tuning dials with the station names marked on it, but I find that with my Mullard Three the names do not come in line at all. I can get them right with the trimmers at one point, but not at the ends of the dial, and if I put them right at one end they go out at the other. What type of trimmer will I have to fit to enable me to get them all to read right?"—G. R. F. (Ilford).

WE are afraid you will not be successful in getting the new dial to give you correct indications with the coils you are now using. The dial is designed for use with condensers following a certain law, and for use in conjunction with coils of a given inductance. When your coils were made the inductance value had not been standardised for wireless receivers and the condenser you are using does not follow the present law. Therefore, the only way to obtain correct station indications would be to buy a modern condenser designed for use with the dial you have bought, and to fit modern dual-range coils in place of those now in use.

**RULES**

We wish to draw the reader's attention to the fact that the Queries Service is intended only for the solution of problems or difficulties arising from the construction of receivers described in our pages, from articles appearing in our pages, or on general wireless matters. We regret that we cannot, for obvious reasons—

- (1) Supply circuit diagrams of complete multi-valve receivers.
- (2) Suggest alterations or modifications of receivers described in our contemporaries.
- (3) Suggest alterations or modifications to commercial receivers.
- (4) Answer queries over the telephone.
- (5) Grant interviews to querists.

A stamped addressed envelope must be enclosed for the reply. All sketches and drawings which are sent to us should bear the name and address of the sender.

Requests for Blueprints must not be enclosed with queries as they are dealt with by a separate department.

Send your queries to the Editor, PRACTICAL AND AMATEUR WIRELESS, George Newnes, Ltd., Tower House, Southampton Street, Strand, London, W.C.2. The Coupon must be enclosed with every query.

to wind for an H.F. choke for a battery 2-valver. I should also like to know whether Messrs. Telsen are still in business and, if so, their present address."—J. H. (Chesterfield).

THE ordinary reaction choke, which is presumably the component you require to make, is not very critical. Provided that the self-capacity is sufficiently low to prevent the H.F. from being by-passed and that there is sufficient wire to provide an adequate choking effect, the component may be made up in many different styles. Probably the simplest from the home-construction point of view is to obtain a piece of ordinary dowel rod about 1/4in. or 1/2in. in diameter and to affix a number

**READY SHORTLY!**  
**WIRELESS COILS, CHOKES**  
**AND TRANSFORMERS,**  
**AND HOW TO MAKE THEM**

2/6, by post 2/10 from the Publisher, Geo. Newnes, Ltd., Tower House, Southampton Street, W.C.2

The coupon on page 528 must be attached to every query.

Miscellaneous Advertisements

Advertisements are accepted for these columns at the rate of 3d. per word. Words in black face and/or capitals are charged double this rate (minimum charge 3/- per paragraph). Display lines are charged at 6/- per line. All advertisements must be prepaid. All communications should be addressed to the Advertisement Manager, "Practical and Amateur Wireless," Tower House, Southampton Street, Strand, London, W.C.2.

RECEIVERS, COMPONENTS AND ACCESSORIES

Surplus, Clearance or Secondhand, etc.

RADIOMART SHORT-WAVE MANUAL

Packed with short-wave information and circuits of mains and battery receivers, including straight, superhet and 5-metre transmitters, modulators, etc. Information on transmitting licences, aerials, Class B amplifiers, neutralizations, superhet alignment, etc. The most comprehensive manual published, written by practical engineers, price 6d., post free, 7d. including catalogue. 1937 Short-wave Catalogue only (3 times enlarged) price 1 1/4d., post free.

44, HOLLOWAY HEAD, BIRMINGHAM 1

ALL goods previously advertised are standard lines, still available. Post card for list free. VAUXHALL UTILITIES, 163a, Strand, W.C.2. Over Denny's the Booksellers, Temple Bar 9338.

CONVERSION UNITS for operating D.C. Receivers from A.C. Mains, improved type, 120 watts output at £2/10/0. Send for our comprehensive list of speakers, resistances and other components. WARD, 46, Farringdon Street, London, E.C.4. Telephone: Holborn 9703.

REPAIRS to Moving Coil Speakers, Cones and Coils fitted or rewound. Fields altered. Prices Quoted including Eliminators, Loudspeakers, Repaired, 4/-, L.F. and Speech Transformers, 4/- post free. Trade invited. Guaranteed. Satisfaction. Prompt Service. Estimates Free. L.S. Repair Service, 5, Ballham Grove, London, S.W.12. Battersea 1321.

SPECIAL Summer Sale now proceeding at our Holborn premises. All lines previously advertised still in stock.

RADIO CLEARANCE, 63, HIGH HOLBORN, W.C.1. Tel.: Hol. 4631.

THE largest stock of components in England, over 500 lines, new catalogue now ready 1 1/4d.—J. Bearfield, 105, Upper Street, London, N.1.

BANKRUPT Bargains List Free. All new goods. Burgoyne 4v. S.G. portables, complete batteries, 52s. 6d. Decca 1937 6v. A.C. superhets, £6. Halcyon A.C. S.W. converters, list 3 gns., 20s., with valve. 40 other sets. Large stock valves, components. State requirements.—Butlin, 6, Stamford Avenue, Brighton, Sx.

VALVES

BIGGER AND BETTER VALUE IN AMERICAN VALVES, 3/- any popular type. 6/- each, 210, 250 and 81. Variety of Octal Base Tubes, 3/- to 4/-. All types transmitting tubes in stock. Majestic and Spartan Types, 4/6 each.—Radiographic, Ltd., 66, Osborne Street, Glasgow, C.1. Bell 848.

The HOME MECHANIC ENCYCLOPEDIA

by F. J. CAMM

(Editor of "Practical and Amateur Wireless" etc.)

An up-to-date and comprehensive guide to the Mechanical, Scientific and Technical Interests of the day—with expert articles on Aircraft, Television, Models, Astronomy, Electricity, Photography, Chemistry, Woodwork, Motor Cars, Wireless, Home Cinema, with over 600 illustrations.

Only 3/6 net

4/- post free from the Publishers—Book Dept., George Newnes, Ltd., Tower House, Southampton Street, Strand, London, W.C.2.

NEWNES : LONDON

PREMIER SUPPLY STORES

All goods guaranteed perfect; carr. paid over 5/-; under 5/- postage 6d. extra.

ALL POST ORDERS to JUBILEE WORKS, 167, LOWER CLAPTON RD., LONDON, E.5. 'Phone : Amherst 4723.

CALLERS, AS USUAL, TO 165 & 165a, FLEET ST., E.C.4 (Next door to Anderton's Hotel), Central 2833. New Branch: 50, HIGH ST., CLAPHAM, S.W.4 (Macaulay 2381).

Have you had our GIANT ILLUSTRATED CATALOGUE AND VALVE LIST? Send 4d. IN STAMPS FOR THIS BARGAIN LIST.

NEW 1937 1-VALVE SHORT-WAVE RECEIVER OR ADAPTOR KIT, 13 to 86 Metres without coil changing. Complete Kit and Circuit, 12/6. VALVE GIVEN FREE! DE LUXE MODEL 14 to 150 Metres, complete Kit with Chassis, 4 Coils and all parts, 17/8.

SUPERHET CONVERTER KIT, 12/6. De Luxe Model, 18/6. S.W. SUPERHET CONVERTER KIT, for A.C. Mains Receivers, 20/-, A.C. Valve given FREE!

NEW 1937 2-VALVE S.W. KIT, 13 to 86 Metres without coil changing. Complete Kit and Circuit, 19/6. VALVES GIVEN FREE. DE LUXE MODEL, 14 to 150 Metres, complete Kit and Chassis, 4 Coils and all parts, 25/-. VALVES GIVEN FREE. 3-VALVE S.W. KIT, S.G. Det. and Pen., 42/-. VALVES GIVEN FREE.

SHORT-WAVE COILS, 4- and 6-pin types, 13-26, 22-47, 41-94, 78-170 metres, 1/9 each, with circuit. Special set of 3 S.W. Coils, 14-150 metres, 4/- set, with circuit. Premier 3-band, S.W. Coil, 11-25, 19-43, 25-86 metres. Simplified S.W. receiver construction, suitable any type circuit, 2/6.

COIL FORMERS in finest plastic material, 1 1/2 in. low-loss ribbed, 4- or 6-pin, 1/- each.

The New "Premier" Short Wave CONDENSERS, with Trolitol insulation. Certified superior to Ceramic. All-brass construction. 15 mmfd., 1/4; 40 mmfd., 1/7; 100 mmfd., 1/10; 100 mmfd., 250 mmfd., 2/6. S.W. H.F. Chokes, 9d.; screened, 1/8. All-Brass S.W. Condensers with integral slow-motion, 00015 Tuning, 3/9; 00015 Reaction, 3/3.

Famous EUROPA MAINS VALVES, 4 v. A.C. and 20 v. 18 Universal. All standard types, 4/6. I.H. Pentodes and P.W. Rectifiers, 5/6.

BATTERY VALVES, 2 volts, H.F., L.F., 2/3. Power, Super-Power, 2/9. S.G., Var-Mu-S.G., 4- or 6-pin Pentodes, H.F. Pens., V-mu-H.F. Pens., 5/-, Class B, 5/-.

AMERICAN VALVES. Genuine American HYTRON and TEJAD first-grade Valves, 3 months guarantee. All types in stock, 5/6 each. 210 and 250, 8/6 each. New Metal-Glass Valves all types, 6/6 each. Genuine American DUBOTRON Valves, all types, 3/6 each. Valve holders for all above types, 6d. each. OCTOL bases, 9d. each.

3-WATT A.C. AMPLIFIER, 2-stage for mike or pick-up. Complete kit of parts with 3 valves, 40/-. Wired and Tested, £2/5/0.

7-WATT A.C./D.C. AMPLIFIER, 3-stage high-zen. push-pull output. Complete kit of parts with 5 specially matched valves, 44/6. Completely Wired and Tested, £5/5/0.

COSMOCORD PICK-UPS, with tonearm and volume control, 10/6 each. PICK-UP HEADS only, 4/6 each.

PREMIER MAINS TRANSFORMERS, wired-and type with screened primaries, tapped 200-250 v. Centre-tapped Filaments. Guaranteed one year. E.T. 8 & 9 or E.T.10 with 4 v. a. C.T., and 4 v. 1 a. C.T., 8/6. 250-250 v. 60 m.a., 4 v. 1 a., 4 v. 2 a., and 4 v. 4 a., all C.T. 5/6. 350-350 v. 120 m.a., 4 v. 1 a., 4 v. 2 a., and 4 v. 4 a., all C.T. 12/-. Any of these transformers with engraved panel and N.P. terminals 2/6 extra. 500-500 v. 150 m.a. 4 v. 2-3 a., 4 v. 2-3 a. 4 v. 2-3 a. 4 v. 3-4 a., tall C.T., 17/8. SPECIAL OFFER PHILIPS MAINS TRANSFORMERS. 250-250 v. or 300-300 v. at 80 m.a., 4 v. 3 a. C.T.; 4 v. 1 a. Tapped Primary 100-250 volt., 6/11. 450-450 v. at 150 m.a. or 500-500 v. 100 m.a. 4 v. 4 a. C.T. 4 v. 4 a. and 4 v. 3 a. Screened Primary. Tapped input 100-250 v., 12/6. AUTO TRANSFORMERS, step up or down, 60 watts, 7/6; 100 watts, 10/-. SMOOTHING CHOKES 25 m.a., 2/9; 40 m.a., 4/6; 60 m.a., 5/8. 150 m.a., 10/6. Speaker Replacement Chokes, 2,500 ohms, 60 m.a., 5/6.

Electric SOLDERING IRONS, 200-250 v., A.C./D.C., 2/3.

SPECIAL OFFER LISSEN TWO-GANG SCREENED ALL-WAVE COILS, 12 to 2,000 metres, complete with switching and wiring diagrams, 6/11 per set.

Special Offer BTH Energised Moving Coils 10 1/2 in. diam. 1,650 ohms field Power or Pentode transformer (state which), 14/6.

ROLA latest type P.M.S., 15/-, B. & A. mains energised 2,500 ohms field, 10/6 each; Jensen P.M.S., 10/6.

W.B. 1936 STERTORIAN SPEAKERS. Standard model (list, 32/6), 22/6. Brand new in original sealed cartons.

OUTPUT TRANSFORMERS for Power or Pentode, 2/6; Multi-Ratio, 4/6.

TUBULAR CONDENSERS, non-inductive all values up to 5 mfd., 6d. each. 1 Watt Resistors, 6d. 4 Watts, 1/-.

All Goods previously advertised, still available.

ENGINEERING OPPORTUNITIES Free! This unique Handbook shows the easy way to secure A.M.I.C.E.E., A.M.I.Mech.E., A.M.I.E.E., A.M.I.A.E., A.M.I.W.T., A.M.I.R.E., and similar qualifications. WE GUARANTEE—NO PASS—NO FEE. Details are given of over 150 Diploma Courses in all branches of Civil, Mech., Elec., Motor, Aero, Radio and Television Engineering, Building, Government Employment, etc. Write for this enlightening Handbook to-day FREE and post free. British Institute of Engineering Technology, 409, Shakespeare House, 17, 18, 19, Stratford Pl., W.1

M.P.R. CARBON MICROPHONE The ideal microphone for all P.A. stage work, and transmitting. High sensitivity, with excellent frequency response. Microphone in chromium-plated case, complete with 4 suspension springs. Price 15/-. Send for full particulars M.P.R. Electrical Co., 252, Victoria Rd., Romford, Essex.

FREE ADVICE BUREAU COUPON This coupon is available until August 21st, 1937, and must be attached to all letters containing queries. PRACTICAL AND AMATEUR WIRELESS, 14/8/37.

MISCELLANEOUS "NEWNES TOURIST ATLAS of Great Britain and Route Guide." Edited by John Bartholomew & Son, Ltd., 120 pages of fully coloured contour maps for the whole of England, Scotland, Ireland and Channel Islands, with index to the principal Motoring and Cycling centres and distances, 2s. 6d. from all Booksellers.—George Newnes, Ltd., Tower House, Southampton Street, Strand, London, W.C.2.

VISITORS TO LONDON should get Newnes Handy Pocket Atlas and Street Guide to London, Edited by John Bartholomew & Son, Ltd., 18 coloured Maps, General Index to Streets and Railway Stations, 2s. from all bookstalls.—George Newnes, Ltd., Tower House, Southampton Street, Strand, London, W.C.2.

"WIRELESS FOR THE MAN-IN-THE-MOON," by Columbus and Decibel, 2s. 6d. net.—Writing about the book the "Midland Daily Telegraph" says: "It is both good fun and sound theory."—At all booksellers and Libraries, or from George Newnes, Ltd., Tower House, Southampton Street, Strand, London, W.C.2.

"THE OUTLINE OF WIRELESS," by Ralph Stranger, Fifth Edition, 8s. 6d. net.—This book, which covers the subject from A to Z, is to be recommended to all who desire to master the theory of Modern Wireless. At all Booksellers and Newsagents.—George Newnes, Ltd., Tower House, Southampton Street, Strand, London, W.C.2.

A DICTIONARY OF WIRELESS TERMS, by Ralph Stranger. A Wireless Work of Reference that should be on the bookshelf of every keen amateur. Compiled by a master of lucidity, it gives the meanings of all Technical terms in general use. Price 2s. 6d. from all Booksellers and Newsagents.—George Newnes, Ltd., Tower House, Southampton Street, Strand, London, W.C.2.

FIFTY TESTED WIRELESS CIRCUITS, by F. J. Camm, 2s. 6d.—This handbook contains every modern circuit complete with instructions for assembling, component values, and notes on operation. Obtainable at all Booksellers and Newsagents.—George Newnes, Ltd., Tower House, Southampton Street, Strand, London, W.C.2.

MORE THRILLING THAN FICTION.—Newnes Wide World Library contains the finest true-life travel and adventure books, great literature and exhilarating reading. Each 2s. 6d. net from all Booksellers.—George Newnes, Ltd., Tower House, Southampton Street, Strand, London, W.C.2.



**MCCARTHY**

**OUTSTANDING 9-VALVE  
FOUR-WAVE SUPERHET**  
*For all-wave reception  
at its very best*

To the all-wave enthusiast, this exceptional receiver offers a number of interesting features, with quite unusual range, and power output. Few receivers at present on the market can claim so high a standard of design and performance.

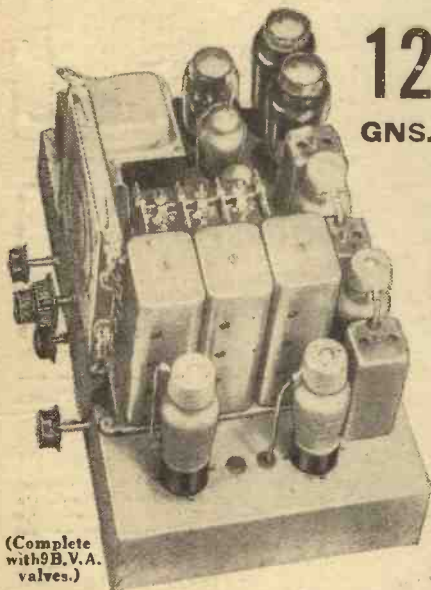

**12  
GNS.**

(Complete with 9 B.V.A. valves.)

4 wavebands: 12.8-33, 29-80, 190-550, 800-2000 metres. Illuminated dial with principal station names. Separate coloured lights for each waveband.

Circuit in Brief.—Aerial input to pre-selector circuit, radio frequency amplifier, latest type triode-hexode frequency changer, 2 band-pass I.F.T. coupled I.F. amplifiers, double diode detector, L.P. amplifier, parafeed transformer-coupled push-pull triode output giving 6 watts. Heavy cadmium-plated steel chassis. Finest components and workmanship throughout.

**DE LUXE MODEL 14 GNS.**

Many additional refinements—full particulars on application.

Controls.—A feature of the receiver is the number of independent controls fitted, making it extremely interesting to operate. These include: sensitivity control (varying bias on R/F stage), Q.A.V.C. with manual muting control, and switch for inter-station noise suppression. 5-position wave-change and gramophone switch. Progressive variable tone control operative on radio and gram.

A.C. models ready for immediate delivery. A.C./D.C. models also in production, and will be available for delivery shortly.

**IMPORTANT**

The prices at which McCarthy Chassis are advertised include Marconi Royalties. "Practical and Amateur Wireless" readers should, for their own protection, make sure before purchasing any receiver that the quoted price includes the Royalty payment.

All McCarthy receivers supplied complete with valves, knobs, pilot lamps, leads, mains cable and plug. 12 months' guarantee.

Deferred terms on application, or through London Radio Supply Co., 11, Oat Lane, E.C.2.

Cash with order on 7 days' approval. Also write for illustrated catalogue of complete range of all McCarthy receivers.

**MCCARTHY RADIO LTD.**  
44a, Westbourne Grove, London, W.2

Telephone: Bayswater 3201/2.

**MISCELLANEOUS**

**PERPLEXITIES and TANTALISERS.**—"The Strand Problem Book" is the finest collection of puzzles of all kinds ever assembled, mathematical, geographical, literary—acrostics and codes, by W. T. Williams (Tantalus) and G. H. Savage. Only 2s. 6d. net from all Booksellers.—George Newnes, Ltd., Tower House, Southampton Street, Strand, London, W.C.2.

**EVERYMAN'S WIRELESS BOOK**, by F. J. Camm, 3s. 6d. net. An invaluable book of reference, explaining the operation, upkeep and overhaul of all types of wireless receiver. 200 illustrations. From all Booksellers and Newsagents.—George Newnes, Ltd., Tower House, Southampton Street, Strand, London, W.C.2.

**TELEVISION.**—Newnes Television and Short-wave Handbook, by F. J. Camm, deals authoritatively with Scanning Systems (Drums, Mirror Screws, Discs, etc.), Neon Lamps, The Cathode-Ray, Oscillograph. How to build Short-wave and Ultra-short-wave Receivers. Fully illustrated, 3s. 6d. net. From your bookseller.—George Newnes, Ltd., Tower House, Southampton Street, Strand, London, W.C.2.

**THE PRACTICAL MOTORIST'S ENCYCLOPEDIA**, by F. J. Camm, 3s. 6d. net. A lucid exposition of the principles, upkeep and repair of every part of the car. 442 illustrations. From booksellers everywhere.—George Newnes, Ltd., Tower House, Southampton Street, Strand, London, W.C.2.

**PRIZES For Your  
PHOTOGRAPHERS**

Special Competitions  
Every Month in

**The HOME  
PHOTOGRAPHER**

**THE HELPFUL MONTHLY  
FOR AMATEURS**

On sale 1st of each month at all Newsagents and Bookstalls, or by post 7d. from the Publisher, George Newnes, Ltd., Tower House, Southampton St., Strand, London, W.C.2.

**6<sup>d</sup>  
MONTHLY**

**ADVERTISEMENT INDEX**

	Page
Automatic Coil Winder and Electrical Equipment Co., Ltd. . . . .	Inside Back Cover
British Institute of Engineering Technology . . . . .	528
Electradix Radios . . . . .	522
Fluxite, Ltd. . . . .	Inside Back Cover
London Radio Supply Co. . . . .	522
M.P.R. Electrical Co. . . . .	528
McCarthy Radio, Ltd. . . . .	Inside Back Cover
New Times Sales Co. . . . .	519
Peto-Scott Co., Ltd. . . . .	519
Premier Supply Stores . . . . .	528
Telegraph Condenser Co., Ltd. . . . .	520

*That's it!*



Radio faults are quickly revealed by the D.C. Avomitor. No guessing! No calculations! Thirteen meters in one, this accurate instrument gives direct readings of current, voltage and resistance . . . Milliamp ranges for testing all valves and apparatus; Volts for L.T., H.T., Grid Bias, Mains and Eliminator Voltages; Ohms for all resistance tests. A radio test-bench in a single instrument! In case with leads, testing prods, crocodile clips and instruction booklet.



13 Meters in ONE	CURRENT	VOLTAGE	RESISTANCE
	0—6 millamps	0—5 volts	0—10,000 ohms
	0—30 "	0—12 "	0—10,000 "
	0—120 "	0—120 "	0—1,200,000 "
		0—240 "	0—3 megohms
		0—300 "	
		0—600 "	

**45/-**

Deferred terms if desired

BRITISH MADE

The D.C.

**AVOMINOR**

Write for descriptive pamphlet  
AUTOMATIC COIL WINDER & ELECTRICAL EQUIPMENT CO. LTD.  
Winder House, Douglas Street, London, S.W.1. phone: Victoria 3404-7



As he finished his short-wave set, Platt, With a satisfied air, said, "That's that." But his friend said, "Dear me, You've no FLUXITE, I see; You'll be lucky to get London Nat. . . ."

See that FLUXITE is always by you—in the house—garage—workshop—wherever speedy soldering is needed. Used for 30 years in government works and by leading engineers and manufacturers. Of Ironmongers—in tins, 4d., 8d., 1/4 and 2/8.

Ask to see the FLUXITE SMALL-SPACE SOLDERING SET—compact but substantial—complete with full instructions, 7/6. Write for Free Book on the art of "soft" soldering and ask for Leaflet on CASE-HARDENING STEEL and TEMPERING TOOLS with FLUXITE.

**TO CYCLISTS!** Your wheels will NOT keep round and true, unless the spokes are tied with the fine wire at the crossings AND SOLDERED. This makes a much stronger wheel. It's simple—with FLUXITE—but IMPORTANT.

**THE FLUXITE GUN**

is always ready to put Fluxite on the soldering job instantly. A little pressure places the right quantity on the right spot and one charging lasts for ages. Price 1/6.



ALL MECHANICS WILL HAVE

**FLUXITE**

IT SIMPLIFIES ALL SOLDERING

FLUXITE LTD. (Dept. W.P.) DRAGON WORKS, BERMONDSEY STREET, S.E.1.

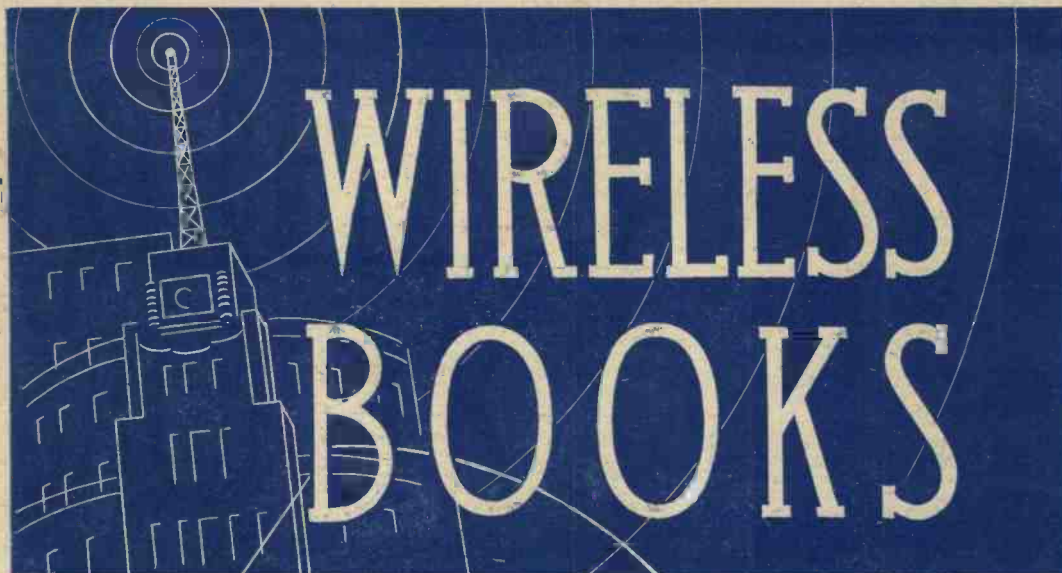

### THE OUTLINE OF WIRELESS

By RALPH STRANGER

8/6 net (9/-)

A book which covers the theory and practice of Reception from A to Z.

### WIRELESS CONSTRUCTOR'S ENCYCLOPEDIA

By F. J. CAMM

5/- net (5/3)

The whole field of wireless construction is covered, in description and diagram in this book.

### THE MATHEMATICS OF WIRELESS

By RALPH STRANGER

5/- net (5/5)

A simple introduction to arithmetic, algebra, geometry, trigonometry and calculus as they affect wireless calculations. 256 pages. *Fully Illustrated.*

### NEWNES TELEVISION AND SHORT-WAVE HANDBOOK

By F. J. CAMM

3/6 net (4/-)

The first really complete and authoritative work on this subject.

### EVERYMAN'S WIRELESS BOOK

By F. J. CAMM

3/6 net (4/-)

### THE ELEMENTS OF WIRELESS

By RALPH STRANGER

3/6 net (3/11)

The whole working of wireless receivers made clear to all.

### FIFTY TESTED WIRELESS CIRCUITS

By F. J. CAMM

2/6 net (2/10)

### DICTIONARY OF WIRELESS TERMS

By RALPH STRANGER

2/6 net (2/10)

A valuable synopsis of technical terms that everybody can understand.

Obtainable from all booksellers or send a P.O. for the amount indicated in brackets after each price and the book will be delivered to you post free . . . . write to Wireless Book Department, George Newnes, Ltd., Tower House, Southampton Street, Strand, London, W.C.2.





**A TWO-VALVE MIXER-AMPLIFIER—See page 545.**

# Practical and Amateur Wireless

**3<sup>d</sup>**  
EVERY  
WEDNESDAY

Edited by F.J. CAMM

a GEORGE  
NEWNES  
Publication

Vol. 10. No. 257.  
August 21st, 1937.

**AND PRACTICAL TELEVISION**

# The SHOW



NATIONAL  
RADIO  
EXHIBITION

## Exclusive Details

### THE WIRELESS CONSTRUCTOR'S ENCYCLOPÆDIA

By F. J. CAMM (Editor "Practical and Amateur Wireless.")

Wireless Terms and Definitions stated and explained in concise, clear language by one of the best known and most popular designers and writers of the day. Profusely illustrated. A veritable treasury of wireless knowledge and literally invaluable to all who are interested in the science whether as amateurs or experts.

Fully  
illustrated

NEWNES

FROM ALL BOOKSELLERS  
or 5/6 post free from Tower House, Southampton Street, Strand, W.C.2.

LONDON

Only  
**5/-**  
net



# No Holiday Complete Without Them!

Here are the Biggest and Best Holiday Magazines you can buy—packed with jolly Seasonable Stories and large numbers of Humorous Drawings and Cartoons. Also a lavishly illustrated Summer Annual for every filmgoer.

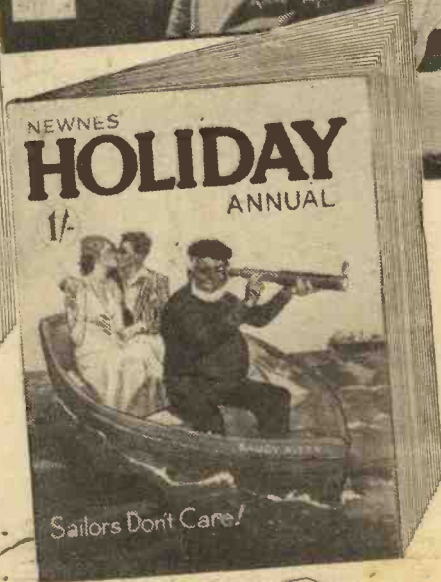

Be sure you get one or more of these special Holiday Mags:

- HAPPY HOLIDAY EXTRA** 1/-
- SCREEN PICTORIAL SUMMER ANNUAL** 6d.
- LONDON OPINION SUMMER ANNUAL** 1/-
- TIT-BITS SUMMER EXTRA** 6d.
- NEWNES' HOLIDAY ANNUAL** 1/-

Obtainable at all Newsagents and Bookstalls, or by post from the Publisher, Newnes and Pearson's, Tower House, Southampton Street, Strand, London, W.C.2. Shilling Numbers 113d each. Sixpenny Numbers 8d. each.

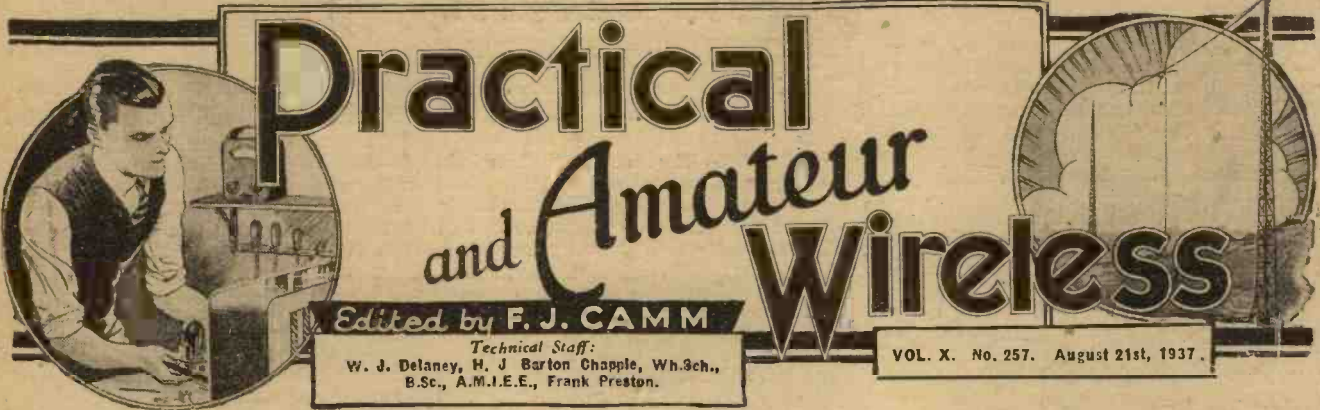

**NEXT WEEK: Complete Guide to the Show.**

# Practical and Amateur Wireless

Edited by **F. J. CAMM**

Technical Staff:  
W. J. Delaney, H. J. Barton Chapple, Wh. Sch.,  
B.Sc., A.M.I.E.E., Frank Preston.

VOL. X. No. 257. August 21st, 1937.

**ROUND *the* WORLD of WIRELESS****Radio Progress Abroad**

**T**HE German Radio Exhibition has recently finished, and in this issue we give a special report from our correspondent with a few illustrations of some of the exhibits. It is interesting to note the developments in radio and television in other countries, and it is of especial interest to note that no other country has yet instituted a regular high-definition television programme and sells television receivers to the public. An interesting point regarding the television experiments being carried out abroad is that in the majority of cases a much higher definition is being employed. Does this mean that, in spite of the fact that we now lead the field by having instituted the regular television broadcasts, we shall eventually be behind in that we shall be using lower definitions?

Although in America the amateur has much more scope, and the commercial programmes provide, according to some authorities, a much higher entertainment value than our programmes owing to the competitive element, we believe that the general design of receivers is investigated much more thoroughly by manufacturers in this country, although there appears to be a tendency to follow American design in cabinet construction. However, the Exhibition which will open at Olympia next week will enable those who are keenly interested in modern receiver design to study to the full the products of the English manufacturers.

**Radio and Fire Brigade**

**S**HORT-WAVE transmitting apparatus has been employed on several occasions in this country by the fire brigades, and at a rick fire in Chippenham, Wiltshire, recently, the short-wave transmitter was put to novel use. The pumping engine was forced to take up its position three-quarters of a mile away from the burning rick, and the chief fire officer employed a portable transmitter with which to keep in touch with the men at the pumping engine in order to control their activities. On previous occasions it has been necessary to send runners with instructions back to the engine and the time saved by the wireless transmission greatly assisted in getting the fire under control with the minimum of damage.

**Radio Spies**

**A** SECRET wireless station has been discovered in France by the counter-espionage service. It is stated that the station was built and operated by a dealer in electrical apparatus who had been making frequent trips to Switzerland and Germany, and messages in code had been tapped from his station.

**Short Waves and Fading**

**O**FFICIALS of the Australian Commonwealth Radio Research Bureau, working in collaboration with the Canberra Solar Observatory, are stated to have discovered the cause of fading on the short waves. They claim that it is due to a sudden burst of radiation from masses of hydrogen

new extension to Broadcasting House, occupying a further area in Portland Place, will practically double the existing space available. In Belfast, a warehouse has been taken over and a contract has been placed for its demolition and the erection of new offices and studios.

**Lifeboat Radio**

**T**HE Clacton-on-Sea lifeboat is fitted with an efficient portable transmitter and receiver with which it is possible to keep in touch with her home station when she puts to sea. By means of this apparatus it will, of course, be possible to inform the shore should any special first-aid or hospital facilities be needed, and thus assistance should be available by the time the lifeboat returns and life may thereby be saved.

**Captain Kettle's Radio Début**

**A** FAMILIAR figure in fiction has so far not put in an appearance in the radio programmes. The situation is to be rectified on August 20th, when that popular personage, Captain Kettle, will appear in a programme entitled "To Capture an Heiress," in the National programme. Produced by Max Kester, the part of Capt. Kettle will be played by Abraham Sofaer.

**Tom Jenkins at B.B.C. Organ**

**T**HIS popular organist, who gave his 220th broadcast on the third of this month, will broadcast in the National programme on August 26th from St. George's Hall, giving a recital on the B.B.C. organ. He is at present manager and organist at the Plaza Cinema, Swansea, and receives a large Empire fan-mail.

**Big Fight Broadcast**

**A**CCORDING to a recent report listeners in this country possessing short-wave sets will be able to hear a "blow-by-blow" commentary of the Farr-Louis fight in New York on August 26th. Arrangements have been completed by the National Broadcasting Company for a broadcast running account over one of the most extensive American networks ever used for a sporting event. This broadcast will be relayed to England by a station operating on a wavelength of 49.1 metres.

The B.B.C. will make records which will be put on the air a few hours later.



**ORDER  
NEXT WEEK'S  
BIG SHOW  
NUMBER  
NOW!**

MANY SPECIAL FEATURES  
AND CONSTRUCTIONAL  
DETAILS OF THREE SETS

OUR STAND: No. 10 GROUND  
FLOOR—SAME SITE AS LAST YEAR!

in the sun's atmosphere, and a detailed report has been sent to this country and is to be published in the journal of the Royal Society of the Institute of Physics.

**New B.B.C. Offices**

**E**XTENSIONS to the B.B.C. premises are announced both in London and in Belfast. In London it is stated that the

# ROUND the WORLD of WIRELESS (Continued)

## Promenade Concerts

ON August 31st (Regional) the programme will be devoted to Liszt and Busoni, and the works to be broadcast are Busoni's Comedy Overture, and Violin Concerto in D. The soloist in the latter will be Joseph Szigeti, who will also broadcast a recital from a studio on August 29th (National).

Clifford Curzon will be the soloist in the Brahms first pianoforte Concerto on September 1st (National). On September 2nd (Regional), Isobel Baillie will sing the "Wife of Bath" air from Dr. Dyson's "Canterbury Pilgrims," and William Primrose will play the "Suite" for Viola and Orchestra by Ernest Bloch.

## "Evening in Cheddar"

THIS is the title of a sound picture of this famous Mendip beauty spot, which will be broadcast from the Western Regional on August 28th. The programme will include a tour of one of the caves by a well-known comedian.

## Radio Rodeo

THE August edition of Radio Rodeo, to be presented by Harold Ramsay from the Union Cinema, Kingston, and broadcast on the Regional wavelength on August 11th, will include Cecily Courtneidge, Claude Dampier and Billie Carlyle, Billy Costello (Popeye the Sailor), the Four Aces, Rusty and Shine, and four well-known organists—



Navarre, the well-known mimic of stage, screen and radio fame, who has been engaged for the second year in succession to appear at the Radiolympia show. He will broadcast from there on September 4th.

Sidney Torch, Phil Park (who has also written the continuity and special lyrics), Robinson Cleaver, and Harold Ramsay. Production will be by Leon Pollock.

## Military Band Music

THE Cheltenham Municipal Military Band will give a popular programme from the Winter Gardens on August 22nd. The Band consists of twenty-six professional players and was formed four years ago.

## INTERESTING and TOPICAL NEWS and NOTES

Arthur Cole is its Director. In the interlude there will be songs by the Clef Trio, which consists of two original members of the old Midland Regional Choir—Isabel Tebbs and Edith Paddock—with Dorothy Byrt.



Al Bowlly, who has recently returned from America, is here seen making his latest record for "His Master's Voice" at the company's London studios. The record is entitled "Carelessly" and "On a Little Dream Ranch" (H.M.V. B.D. 434).

## Music from Austria

WHEN the B.B.C. Northern Orchestra, conducted by Arnold Perry, plays in the National programme on August 29th, a concert of music from Austria will be presented. Johann Strauss's overture, "The Gypsy Baron," starts the programme, and "Tales from the Vienna Woods," by the same composer, follows. Then come seven Austrian Peasant Dances by Max Schönherr. The Northern Orchestra will also be heard by the larger audience on August 30th and September 4th, when concerts from Manchester will come into the Regional and National programmes respectively.

## A Blackpool Night's Entertainment

ANOTHER big outside broadcast programme from Blackpool on August 25th will take listeners on a trip round entertainments-land. The stops will include the Empress Ballroom, the North Pier, and the Palace Theatre.

## "Variety of Instruments"

A HAWAIIAN trio, piano duettists, a harmonica player and an impersonator will be heard in the programme, "Variety of Instruments" which Robin Russell will present on August 28th. To collect unusual instruments or unusual combinations of instruments is one of the aims of this feature, which will be broadcast in the Scottish programme.

## Organ Recital

HAROLD COOMBS will broadcast on the organ of the Capitol Cinema,

Aberdeen, on August 19th. He will play Selection, "Shall we Dance,"; "The Stream by the Wood"; Foxtrot, "La Barcarolle"; Selection, "Old Timers."

## Radiolympia Calling

IN a broadcast on the National wavelength on August 25th listeners will hear many of their radio favourites taking part in "A World of Radio," a vaudeville ensemble from the Theatre at the sixteenth Radiolympia. Among them will be Bobby

Howell and his Orchestra; Paula Green; Vine, More and Nevard; Beryl Orde; the Two Leslies; Sandy Powell; Eric Coates and his Orchestra, Jan van der Gucht, and the Royal Mastersingers. The organists will be Donald Thorne and Harry Farmer, and the compère Sutherland Felce. The programme has been devised and will be produced by Jack Swinburne.

## SOLVE THIS!

### PROBLEM No. 257

Distortion and motor-boating when tuned to a strong signal were being experienced on Beal's receiver. Current and voltage tests were made and readings were practically normal. It was eventually found, however, that when a wire was connected across the 100-ohm bias resistance of the I.F. valve, the motor-boating ceased. What was the fault? Three books will be awarded for the first three correct solutions opened. Address your solutions to the Editor, PRACTICAL AND AMATEUR WIRELESS, George Newnes, Ltd., Tower House, Southampton Street, Strand, London, W.C.2. Envelopes must be marked Problem No. 257 in the top left-hand corner, and must be posted to reach this office not later than the first post on Monday, August 23rd, 1937.

### Solution to Problem No. 256

The emission of the output valve had become low, with consequent low anode current consumption and high smoothed voltage.

The following three readers successfully solved Problem No. 255, and books are accordingly being forwarded to them: G. Budd, 78, Caernarvon Rd., Norwich, Norfolk; L. M. Rawlings, 28, Buriel St., Cambridge; J. Shanahan, 22, February St., Manchester, 13.

# The Berlin Radio Exhibition

AT the radio exhibition recently held in Berlin some 146 firms, along with various government exhibits, filled five of the halls in the very spacious exhibition grounds.

Although there were many exhibits of complete receivers, the home constructor appeared to be quite well catered for, and there were some very interesting exhibits of components and small parts.

Considerable progress appears to have been made in the use of highly efficient mouldings, and some particularly attractive components for short and ultra-short-wave receivers were seen. One firm was showing a number of components, including valve sockets and plug-in coil formers in a trans-

## A Brief Account of Some of the Chief Exhibits, by a Special Representative

to be released shortly, probably during September. Most of the components to be seen were of the "stripped" type, or manufacturers' type, thus taking up an absolute minimum of space, and available at the lowest prices.

### A Novel Pick-up

The firm of Telefunken was showing an extremely interesting new type of gramophone pick-up. The whole device being very light, weighing only about 25 grammes.

NEXT WEEK

SPECIAL ENLARGED  
OLYMPIA NUMBER

ORDER NOW!

A special needle is used which is made of emerald and ground to an extremely fine point. This needle is fixed permanently in the chuck, and can be used to play several thousand records. It is claimed that with this instrument there is very much less wear on the record owing to its extreme lightness. It is claimed that the pick-up has extremely good response characteristics.

### Portables

One or two firms were showing portable receivers, but the manufacturers seem to

have concentrated rather on the amount of output than on the actual portability, as the sets appear to be considerably heavier than our small portables, although they are mostly very sensibly designed as regards ease of operation, the controls being immediately available in most cases without the necessity of opening the case. No "suitcase" portables were to be seen.

One or two firms were showing some very large non-directional loudspeakers for outdoor public-address use. Speakers of this type are frequently used in Germany for addressing political meetings, etc.

### Television Receivers

There were many television exhibits, although not all the receivers actually in

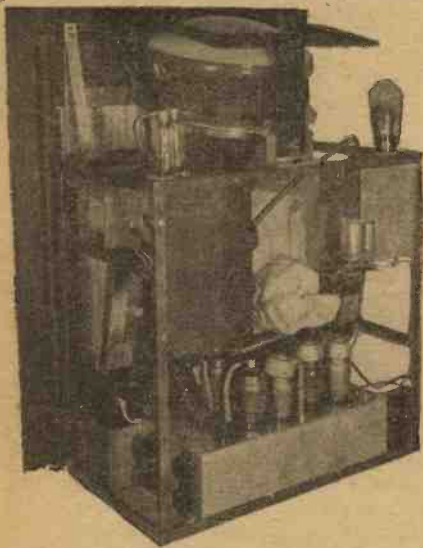

The interior of a Telefunken television receiver, showing the tilted cathode-ray tube.

parent material called Trolitul. This is not exactly a new material, and it has been used in this country to some extent, but it seems to have attractive possibilities for short and ultra-short-wave working.

### Small Components

Many compact and ingenious types of switches were to be seen—switches which would delight the really enthusiastic set builder. One particularly useful component which should be very handy to the constructor took the form of a very compact solid di-electric differential condenser, ganged together with a mains type on-off switch. In smaller receivers this is often the best type of volume control to use, but previously nobody seems to have thought of combining the two controls.

Most of the current valve types now in use in Germany use the 8-pin side contact type of socket which had a short run of popularity in this country some time ago. The "Magic Eye" tuning indicator was much in evidence and has been introduced for the first time in many of the season's new receivers.

German valves are typically of the "European" type, and no American types were to be seen, although one firm was showing a valve tester which had provision for dealing with American valves.

The "Volksempfänger," or people's receiver, was much in evidence on several stands, although a new model is expected



"Magic Eye," or visual tuning indicator with side contact base.

use were receiving pictures by radio as some of them were connected to the transmitter by cable. Several models of complete receivers were to be seen, all working on the new standard of 441 lines, and on many of these receivers the reproduction was excellent and with one exception free from flicker. Various models were showing pictures in the familiar blue tint, although some were in black and white. It was learnt upon inquiry, however, that there are no television receivers actually on sale to the public at the present time in Germany although several different experimental transmitters are actually working or are in the course of erection in various parts of the country.

## "AFTER DINNER."

A CONCERT party, "After Dinner," will be presented by George Thomas (with original libretto and music by Hastings Mann and George Thomas) from the Victoria Pavilion, Ilfracombe, on August 23rd. The cast will include Pat Crowther, Wilfred Burnand, John Lovering, Mary Jordan, Betty Winn, Cynthia Wall, Gwen Somers, Teddy Harley, Doreen Eyres-Hill and Ena Broughton. This broadcast will be given in the Western programme.



A compact table model radiogram by the Telefunken Company.

# The Experimenters Open Their Post-bag

And Pass on a Number of Hints, Ideas and Suggestions Received from Readers. Among These are Several Interesting Circuits, and a Design for an Unusual S.W. Coil

THREE weeks ago we briefly discussed a few short-wave circuits, and asked if readers would let us have their "pet" diagrams. To be perfectly frank, when we wrote that we had no idea that there would be such an excellent response. Anyhow, the many interesting letters which have since come to hand provide ample proof of the wonderful popularity of short-wave reception and short-wave receivers. We also feel not a little pleased to find that we have such a large number of friends ready to co-operate with us, and to send suggestions which will be appreciated by their fellow readers. One of the first points which is very evident after reading through a batch of the letters received is that the Det.-L.F.

condenser. Presumably, a high-ratio slow-motion tuning drive is employed to ensure reasonably easy tuning at the higher frequencies. The complete receiver, without accumulator but including high-tension battery, is housed in a case measuring

*by The Experimenters*

only 10in. by 10in. by 7in. from front to back. Another interesting feature is that the receiver was made almost entirely from "junk-box" parts, and cost about 25s. It is used in conjunction with a 30ft. V-aerial, this being near the ceiling of the

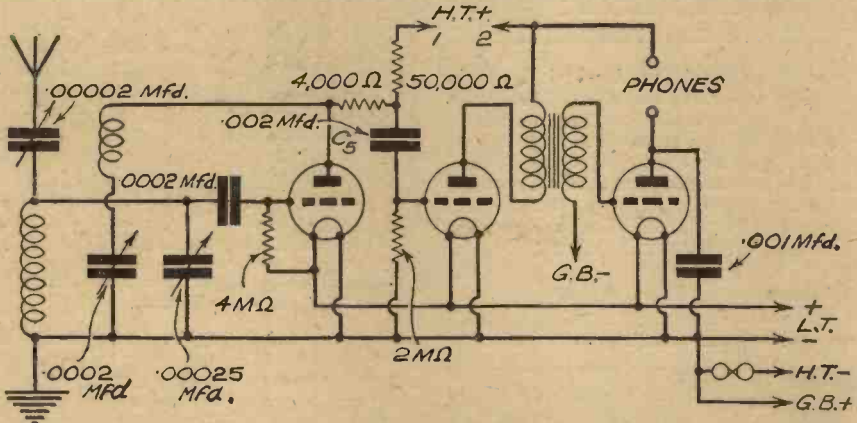

Fig. 1.—Favourite S.W. circuit of a Whitby reader. Note that the usual H.F. choke is replaced by a resistance.

circuit is by far the most popular with our readers. But that does not mean that all of the circuits which have accompanied the letters are alike—far from it. In fact, there are many variations on the theme of "detector with Reinartz-type reaction control, followed by a transformer-coupled L.F. stage."

### Three-valver For 25s.

Where shall we start to deal with the excellent ideas which we are glad to acknowledge? It's difficult, because there are so many, all of which are sure to appeal to others. However, let us commence with the circuit sent by Mr. N. Streeting, of Whitby; a PRACTICAL AND AMATEUR WIRELESS draughtsman has prepared the illustration shown in Fig. 1 from our correspondent's pencil sketch. The circuit is simple enough, but the component values will certainly be of interest to others. Note also that there is no H.F. choke in the detector anode circuit; instead, there is a 4,000-ohm resistance, which acts as an H.F. "stopper." Mr. Streeting uses four-pin coils, along with a .00025-mfd. tuning

bedroom, where the set is installed. Mr. Streeting apparently likes to listen to the remote corners of the earth from the comfort of his bed. Unfortunately the snaps which he sent with his letter are not quite clear enough to permit of reproduction.

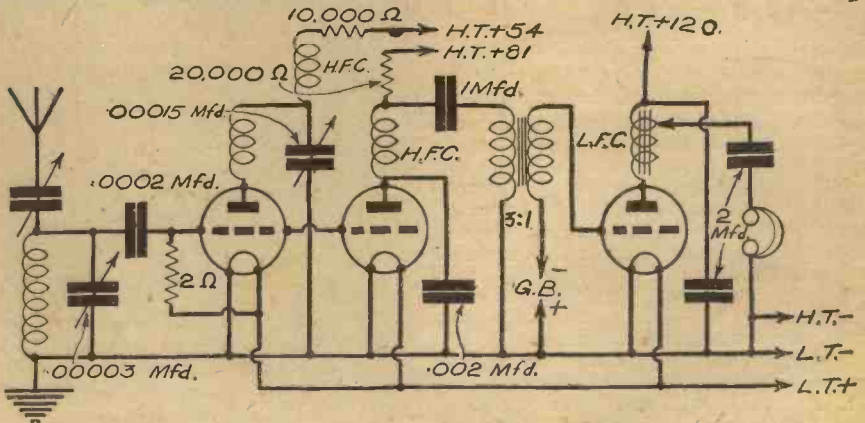

Fig. 2.—This circuit has a separate reactor valve, and has received stations in 54 countries.

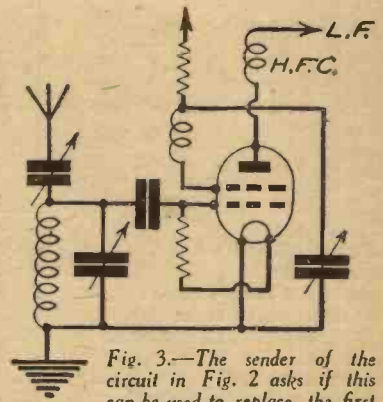

Fig. 3.—The sender of the circuit in Fig. 2 asks if this can be used to replace the first two valves (reactor and detector). It can.

From that showing the front of the set we notice that there is a large celluloid chart attached to the panel with tuning graphs for the various coils—a good idea.

### Separate Reactor Valve

Mr. J. H. White, of Slough, Bucks, favours the circuit shown in Fig. 2. This, in his opinion, could not be beaten, for it has afforded reception of six continents and 54 (yes, fifty-four!) countries. To those readers who are comparatively new to S.W. work, the circuit might appear rather like "double-Dutch," for there are two "detector" valves, followed by a transformer-coupled L.F. stage. Actually, of the two initial valves, the first is used for reaction or regeneration, whilst the second acts as a detector pure and simple. Advantages claimed for this system are: perfectly smooth reaction control; tuning unaffected by reaction adjustments; better rectification than is usual with an oscillating detector; better quality due to the use of a .002-mfd. by-pass condenser between the detector anode and earth. Our correspondent asks if we have ever seen anything like this circuit, because he hasn't.

We must confess that it is unusual, but a similar circuit has been given in these pages on one or two occasions in the past. The use of a separate regenerating valve is an excellent idea, however, and we share Mr. White's enthusiasm for it. This fellow experimenter obviously favours the principle of arranging the tuning circuit so that there is a maximum of inductance and a minimum of capacity, for he uses no less than six coils to tune between 15 and 50 metres. He uses separate coils for the following bands: 16 metres; 19 and 20 metres; 25 metres; 31 metres; 40 metres; and 49 metres. The condenser used with these has a maximum capacity of only .000033 mfd., and even that is

controlled through a 100:1 reduction drive. To use our correspondent's own words concerning this tuning system, "difficulties of tuning just vanish." Probably there are few of us, however, who are not too lazy to change the coil as often as five times when covering a range of 15 to 50 metres.

**Tuning-condenser Hint**

This letter contains a hint which we must pass on. The .000033-mfd. tuning condenser was made from a standard .0001-mfd. component by removing a number of vanes, and giving wider spacing to the remainder. In concluding his letter, Mr. White points out that he does not claim to have "designed" the set, although he has put in a considerable amount of experimental work in connection with the layout "and by now the metallised base-board is quite riddled with holes." Along with his circuit he gives another (shown in Fig. 3), and asks if this will work. The idea underlying the suggestion is that a tetrode valve is used for detection and oscillation to replace the two in the original diagram. Our reply is that it will operate satisfactorily and, in some cases, as well as the separate triodes, although it is sometimes likely to turn out rather more "tricky."

**Two Pentodes**

Another neatly-drawn and interesting circuit comes from "N. Thusiast," of Chesham—why the anonymity, sir? It comprises two pentodes, one H.F. and the other L.F., in the two-valve arrangement shown in Fig. 4. Basically, the circuit is conventional, but, like all "extra-specials," the details have been carefully worked out by trial and careful experiment. We are told that the set operates very well on all wavelengths from 6 to 200 metres, when using standard commercial six-pin coils.

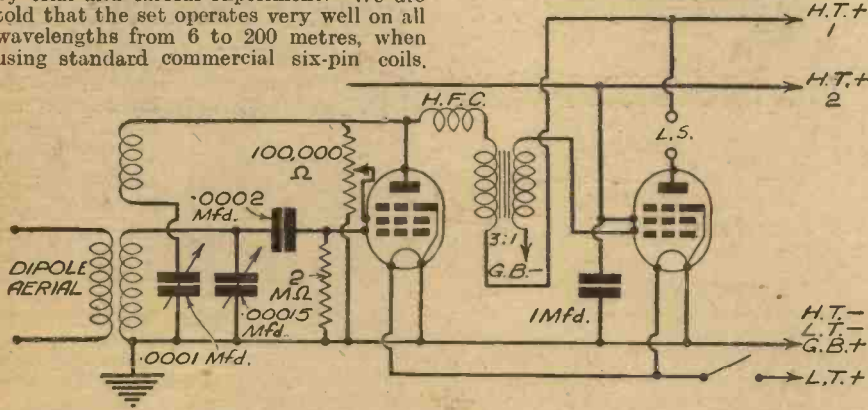

Fig. 4.—Two pentode valves are employed in this circuit from "N. Thusiast," of Chesham.

**Smoother Reaction**

"Super-smooth reaction is obtained by the use of the .0001-mfd. reaction condenser in conjunction with the 100,000-ohm potentiometer." The latter is used to feed the screening grid of the H.F. pentode, and is normally connected to the 60-volt tapping on the H.T. battery. We should have expected that better results would have been obtained by connecting the screening grid of the second valve to H.T.+1, instead of H.T.+2 as shown, but this might have been a slip on the part of our correspondent when drawing out the circuit diagram.

**Dipole Aerial**

"N. Thusiast" uses a half-wave dipole aerial for wavelengths up to 25 metres, but for the higher wavelengths the earth line is connected to one end of the aerial winding, a 30ft. inverted-L aerial being joined to the end other. We are told that

the lowest wavelength range—6 to 13 metres—is covered by using an ordinary 12-26-metre coil "less one winding." This point is not quite clear to us, so perhaps you, Mr. "N. Thusiast," will give us more details? When we have been employing circuits of this type, we have found it better to connect a .1-mfd. fixed condenser between the detector screening grid and earth; we certainly suggest that this be tried.

**Novel Coil Design**

Leaving circuits for the moment, we have received a long letter from Mr. W. Tucker, of Godrer Graig, near Swansea, in connection with a short-wave coil design which he has found unusually satisfactory. The main constructional details are given in Fig. 5. From this it can be seen that the main feature is that the grid winding consists of side-by-side turns, whilst the aerial winding has spaced turns. This is contrary to usual practice, and on the face of it one might imagine that the coil would be no better than if the aerial turns were side-by-side and well spaced from the grid winding, to give very loose coupling. However, its

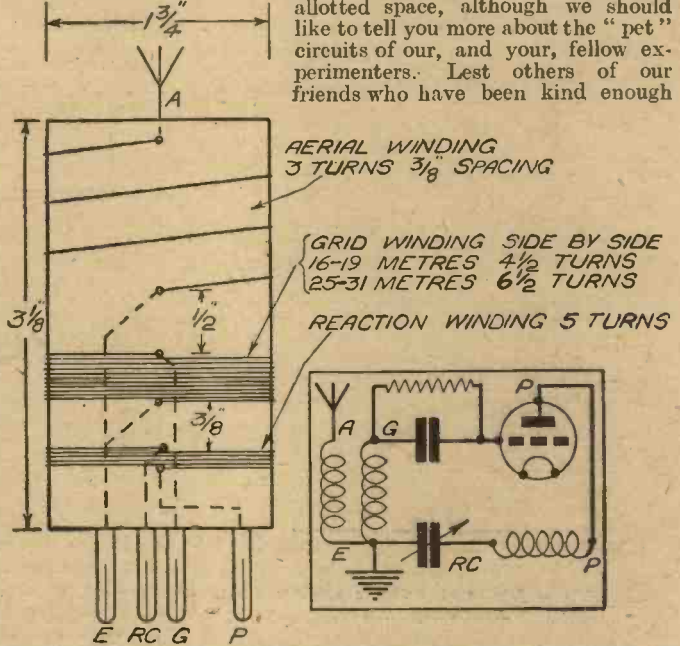

Fig. 5.—The unusual feature of this coil design, from a reader in Wales, is side turns, whilst the aerial-winding turns are spaced, the grid turns being side-by-side.

advantageously." Now, you other keen short-wavers, go to it!

**—and the Others**

We have used almost the whole of our allotted space, although we should like to tell you more about the "pet" circuits of our, and your, fellow experimenters. Lest others of our friends who have been kind enough

to pass on their suggestions wonder why we have not included details of their letters, let us state that it is not because they lack anything in interest, but simply because we cannot "put a quart into a pint pot." No doubt we shall be able to include their suggestions in later articles; whether that is possible or not, we are very grateful for every one of the numerous letters received. Please let us have still more letters. We shall not tire of hearing from you, and are always ready to learn. It is only by exchanging views that we can make the best of the best of all hobbies. None of us will ever have learned all that there is to learn of radio, and any one of you readers might be a future Marconi. Thanks, again, and cheerio for now.

**Join Newnes' Practical Group!**

**PRACTICAL MOTORIST**

The owner-driver's journal which tells you how to repair, overhaul and obtain the best performance from your car.

3d.—Every Friday.

**PRACTICAL MECHANICS**

The only English journal of its type. It deals with every branch of Science, Mechanics, Invention, Model-making, Chemistry, Astronomy, Photography, Television.

6d.—Every Month.

**THE CYCLIST**

The leading weekly for every Cyclist, Clubman, Utility Cyclist or Tourist. Join "The Cyclist" Road Club and also take advantage of the FREE Insurance.

2d.—Every Wednesday.

# Pre-detector Amplification

Concluded from Last Week, This Article Deals with the Alternative Sequences of Stages in the Superhet, and also with the Choice of Intermediate Frequency

By FRANK PRESTON

LAST week, under the above title, I dealt with high-frequency amplification, referring to the different circuit arrangements which are available. But H.F. is not the only kind of pre-detector amplification; in fact, its use is diminishing with the growing popularity of the superhet. I am not going to enter into an argument concerning the relative merits of "straight" and superhet circuits, for that would require more space than can here be devoted to the subject. Nevertheless, it is probably de-

and the signal oscillations are combined with other oscillations produced by the oscillator. When the two frequencies are "mixed," the resultant is a signal on a frequency equal to the difference between the two originals. This is known as the intermediate frequency.

important that the selectivity of the I.F. circuits remains absolutely constant, because the tuning of these is fixed.

### Multiple Tuned Circuits

The custom in present-day superhets is to employ a single valve for first detection and oscillation, this being a pentagrid, heptode, triode pentode, triode hexode, or similar "double" valve. Its output is passed through a form of band-pass filter, known as an I.F. transformer, to the L.F. valve. This is simply an H.F. valve tuned by means of the I.F. transformer to the intermediate frequency—generally of 110, 126 or 465 kc/s. From this valve, the signal is passed through another I.F. transformer to the second detector, which acts in exactly the same manner as the detector of a "straight" set. Consequently, it can be a triode, pentode or diode; alternatively a high-frequency metal rectifier can be employed.

### Different Stage Sequences

There are several other alternative sequences of stages, some of these being shown in Figs. 2, 3, 4 and 5. In Fig. 2, a H.F. stage precedes the frequency-changer, and this has the effect of extending the

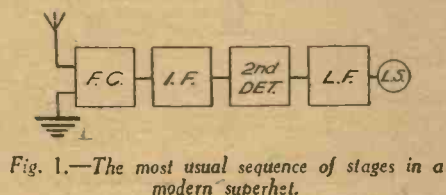

Fig. 1.—The most usual sequence of stages in a modern superhet.

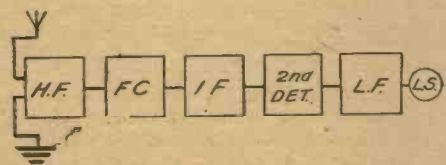

Fig. 2.—In this arrangement an H.F. valve precedes the frequency-changer to give increased range.

sirable that a few of the pros and cons should be explained.

One of the important "pros" of the superhet is that the average constructor can generally obtain more satisfactory results by its use, when building a highly-sensitive receiver. This will perhaps come as a surprise to many of those who have always felt that the superhet was beyond them. There is no doubt that it is nearly always possible to ensure absolute stability without the need for super-accurate design when using the superhet circuit. Stability is, in fact, one of its greatest virtues.

### Selectivity and Quality

Another—and really important—factor in favour of the superhet is the high degree of selectivity which can be had without making any great sacrifice of quality. Again, this is a point with which many readers will probably disagree; but only those who have had little experience of really modern designs. Additionally, variable selectivity is more easily obtained with a superhet, through the use of suitable intermediate-frequency transformers.

As this article will, no doubt, be read by both beginners and more experienced constructors, it might be desirable briefly to run over the sequence of operations in the superpersonal heterodyne (let's give it its full name for once). Fig. 1 shows the arrangement of stages in the most-usual type of receiver. First, there is the frequency-changer, which combines what is rather vaguely referred to as the first detector, and an oscillator. The signals are applied to the first detector from the aerial system,

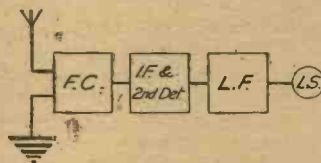

Fig. 3.—Sequence of stages in a three-valve superhet using a double-diode H.F. pentode.

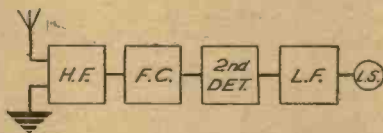

Fig. 4.—In this arrangement the frequency-changer feeds straight into the second detector.

Following the second detector is the usual L.F. amplifier.

In the type of circuit briefly dealt with there might be as many as seven tuned circuits: a band-pass input filter (two); oscillator coil (one); first I.F. transformer (two); and second I.F. transformer (two). This fact alone is indicative of a high degree of selectivity, but it is equally

useful range of reception. Selectivity would be still further increased if a band-pass tuner were employed between the H.F. and F.C. valves, or it would remain practically unaltered if single-circuit tuners were employed before and after the H.F. valve. One useful advantage of the high-frequency valve is that a more complete measure of automatic volume control can be had, due to the A.V.C. voltage being applied to the H.F., F.C. and I.F. valves.

Fig. 3 shows a method of using only three valves in a modern superhet circuit. First is the frequency-changer, this being followed by a double-diode H.F. pentode, which acts as I.F. amplifier and second detector, and the L.F. amplifier. Connections for a double-diode screen pentode, used for I.F. and detection are indicated in Fig. 6. In this case, the output from the diode would be fed into a high-efficiency output pentode through a high-ratio coupling unit or resistance-fed L.F. transformer.

Fig. 4 shows a sequence of stages which is unusual, but which is sometimes employed successfully. In this example, there is no I.F. stage, instead of which the frequency-changer feeds directly into the second detector. There are many who claim that if the number of valves is to be reduced to a minimum without appreciable sacrifice in sensitivity it is better to use an H.F. stage instead of the more usual I.F.; this view appears to be justified by recent

Fig. 6.—Schematic diagram, which is in skeleton form only, showing how a double-diode H.F. pentode can be used for I.F. amplification and second detection.

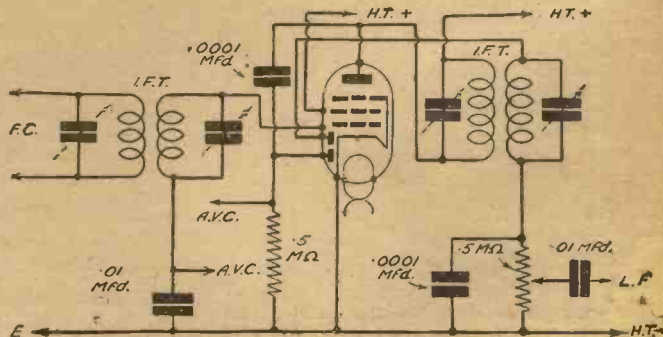



experiments, but the matter is still open to debate and more-conclusive proof.

**Two-valve Superhet**

In Fig. 5 the idea is carried a step further by feeding the output from the F.C. stage into the second detector, and dispensing with a pre-F.C. H.F. amplifier. It would be taken to the ultimate by using a double-diode-output pentode valve in the second position and so eliminating the need for a separate L.F. valve. In this manner a two-valve superhet, of simple form is made possible, a skeleton circuit of this being shown in Fig. 7.

After considering the different sequences briefly described, the reader might feel disposed to enquire as to their relative merits. There can be no doubt that when selectivity, sensitivity and volume are all required at the same time, the arrangement shown in Fig. 2 is representative of the ideal, but a combination of the circuits in Figs. 3 and 4 might provide almost equally good results. On the other hand, the circuits without an H.F. stage have the merit of greater simplicity of design and preliminary adjustment. What is more, a well-designed receiver having the arrangement shown in Fig. 1 is perfectly adequate for most requirements, especially when a moderately-good aerial is available; if only a poor indoor aerial can be employed, and long range combined with reliable reception is required, an H.F. amplifier is well worth the extra trouble and expense which it entails.

**Intermediate Frequency**

What of the intermediate frequency? Any figure between about 100 and 500 kc/s can be used, and various receiver manufacturers have adopted all kinds of frequencies between these limits. But the constructor must use a "standard" I.F. if he is to avail himself of single-knob tuning by using a readily obtainable gang condenser. In most cases the choice comes down to that of 110 or 465 kc/s. Which is better? The higher frequency has come into widespread use during recent years,

largely because it is more suitable when the set is to tune to short, as well as to medium and long waves. One important advantage of 110 kc/s, however, is that it gives greater selectivity with any given number of tuned circuits. In consequence of this, it is to be preferred for a purely "broadcast" set having no H.F. stage and a single I.F.; it is still more valuable if the I.F. stage is eliminated.

One slight disadvantage is that it is practically essential to employ a signal-frequency band-pass tuner to minimise

But if the I.F. transformers have to be adjusted for maximum selectivity there must be a loss of sensitivity, and quality is in danger of being sacrificed.

**Trimming**

Another point which cannot be overlooked by the less-experienced constructor is that there are generally fewer trimmers which require careful and accurate adjustment in a set with 110 kc/s I.F. than in one with 465 kc/s I.F. Thus, if we are to

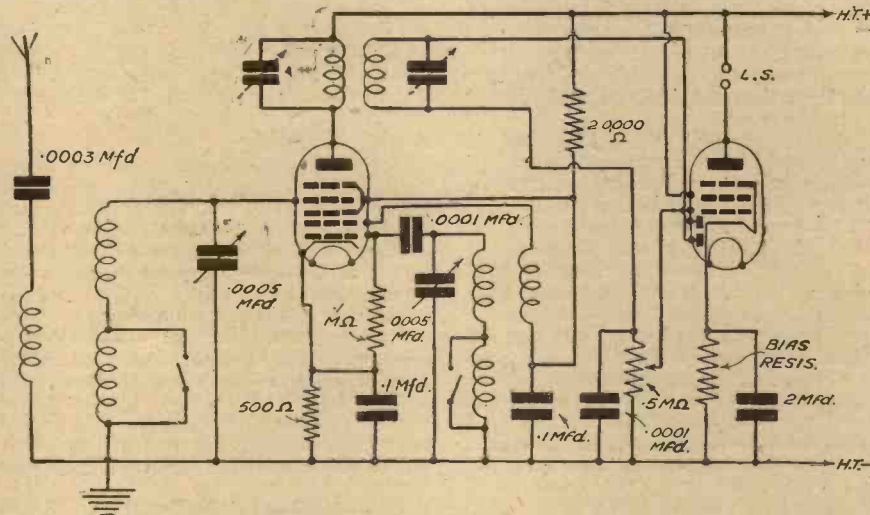

Fig. 7.—This simplified diagram shows how a superhet of moderate efficiency could be made by using only two valves, and without "reflexing."

second-channel interference. This, however, cannot be considered a disadvantage when reasonable selectivity is required—and this is essential to-day. When using 465 kc/s, a single-circuit input tuner is adequate, especially if this is combined with a simple filter, but variable-selectivity I.F. transformers are then desirable unless an H.F. stage, or a second I.F. stage is employed.

generalise we can conclude that the lower frequency is to be preferred when simplicity of construction and preliminary adjustment are important, and when the set is to tune to long and medium waves only. The higher frequency, of 465 kc/s, is better if there is a preliminary H.F. stage or two I.F. stages; and it is practically essential when the set is to cover short waves.

**"LITTLE PRINCESS" PORTABLE**

**A New Lightweight Portable for All-round Use**

THE accompanying illustration gives an idea of the neatness and compact form adopted in the B.T.S. portable, to which the name "Little Princess" has been given. The illustration unfortunately gives no idea of the attractive appearance of the receiver, as it is finished in a blue morocco-grained leatherette, and this, together with the silvered escutcheon and chromium bars across the speaker grille, lend a most pleasing style to this new receiver. A self-contained aerial is fitted, and the receiver chassis incorporates a 4-valve circuit in which an S.G. valve is employed for H.F. amplification, followed by a triode with reaction, which is in turn coupled to an L.F. valve. This is fed, by means of a parallel-fed L.F. transformer into an output pentode of the Harries type, and the general circuit arrangement has been so designed that the total H.T. consumption has been brought to the low value of 6.5 mA. A phone jack is fitted so that headphone reception may be employed when required, and the speaker is then automatically cut out of the circuit. Tuning is carried out by means of a two-gang condenser of the airspaced type, and the

tuning range of the coils fitted is from 200 to 2,000 metres. The left-hand control switches the set on and off, and also selects the wave-range, whilst the right-hand control governs the volume. A ball-bearing turntable is fitted beneath the cabinet to enable the receiver to be turned easily in order to take full advantage of the directional properties of the frame aerial. An external aerial and earth may be fitted if desired.

**Test Report**

The receiver was tested and found to provide adequate volume on a large number of stations, the twenty-five which are guaranteed by the makers being received with no difficulty when the test was carried out. The name dial was found to be very accurate and those stations which were heard were located at the exact setting indicated on the

dial. Volume was sufficient for normal requirements, and the tone was free from resonance or boxiness. The price is 8 guineas complete with L.T., H.T., and G.B. batteries.

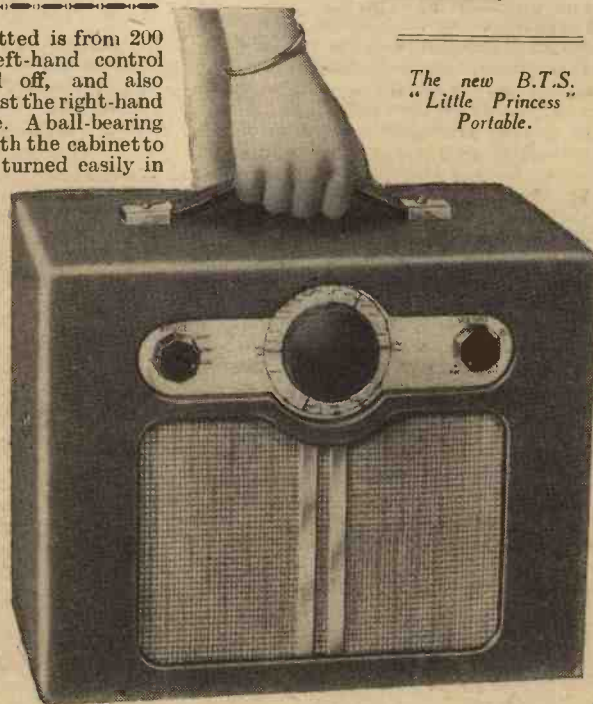

The new B.T.S. "Little Princess" Portable.

# TRANSMITTING TOPICS

Licence Applications and the "Collins Coupler" are Dealt  
With in this Article - - - - By L. ORMOND SPARKS

**B**EFORE discussing any other matters, I would like to mention one letter in particular which I received this week from S. S. of Liverpool, as its contents deal with a problem which I am frequently called upon to solve, and I feel that it is of general interest.

My correspondent asks if I can put him on the right road towards obtaining the necessary licence to allow him to become the owner of a radiating station.

Well, I may as well say right away that I cannot do anything in that direction other than offer the advice I have given in previous articles and state the regulations governing the granting of a "full" licence.

Although the reader in question has rather exceptional knowledge and experience regarding the operation of high-power transmitters, and is fully conversant with the Morse code, I am afraid that his application for a licence will not meet with any more success than that of a reader of less experience unless he can give some definite experimental reason to warrant the granting of a licence. The reason must also prove—so to speak—that the experiments he wishes to conduct are of such a nature that they cannot be carried out with an A.A. licence.

To quote the vital paragraphs in the regulations:—

"Applicants must satisfy the Postmaster-General as to their qualification and intention to conduct experiments of scientific value or public utility. If scientific investigation is intended they should be certified as competent investigators by a Government Department or some recognised scientific body. Authority to use wireless sending apparatus, even with an artificial aerial can be granted *only if the nature of the proposed experiments and other circumstances warrant that course.*"

The chief snag in the above is "the nature of the experiments." You see, there are so many tests and experiments which can be carried out equally as satisfactory with an A.A. as with a radiating aerial; therefore, every applicant must use his own initiative, and make his case as water-tight as possible. Although the regulations look very stiff and—to many—impassable when viewed in cold print, I would mention that the officials concerned are very human and are always ready to give every application all possible attention and consideration.

## Delay

At the time of writing there is some little delay in the granting of licences, and I have it on very good authority that this is entirely due to the great increase in applications since March last. In view of this

it behoves every budding transmitter owner to get busy and fill in the necessary forms, after polishing up his Morse with all possible speed. Getting the necessary permission from the P.M.G. may take as long as two to three months, so don't delay.

## Aerial Coupling

I have had several queries lately about the "Collins Coupler," and therefore, in case other amateurs are interested in this arrangement, I propose giving a few details herewith.

Many coupling arrangements are designed for use with a certain type of aerial, and at a certain frequency. Such methods, while being very efficient under a given set of operating conditions, are often troublesome when it is desired to use some other form of aerial, or transmit on another wavelength. It is in such cases as these that the Collins Coupler scores, as it can almost be regarded as a universal arrangement, and one of the most flexible coupling systems known.

Admitted it is a little trouble to make up

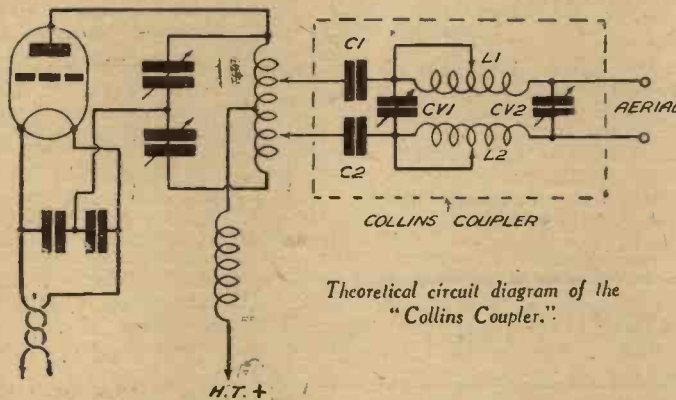

and adjust in the initial stages, but once it is set for any particular operation it is an easy matter to record such settings for future use.

The theoretical circuit is shown above. It is advisable to include the two fixed condensers "C1," and "C2," as they serve the purpose of isolating the coupler and aerial system from D.C. high-tension. They should be of the mica dielectric type, and of a capacity as large as possible. A reasonable capacity—bearing in mind cost—is 0.01mfd.

The two variable condensers "CV1" and "CV2" can be between 250 and 500 micro-micro-farads, and for power up to, say, 50 watts they can be of the ordinary good make of receiving condenser, but for higher powers properly spaced, transmitting types must be used.

The two inductances "L1" and "L2" are space-wound on a 2½ inch former, tapings being provided every three to five turns.

For frequencies between 1.75 and 14 m.c., inclusive, 30 turns of 16 S.W.G. wire will be required, the winding to take up approximately 5 inches along the former.

As a guide to the setting of L1 and L2 the following number of turns should be in circuit for the frequencies mentioned.

The full coil for 1.75 mc/s, 15 for 3.5 mc/s, 10 for 7 mc/s, and 5 turns for 15 mc/s.

## Operation

With the coupler disconnected, the output tank circuit is adjusted for minimum feed, i.e., minimum plate current. The tapings on L1 and L2 are then set for the frequency concerned, and the coupler connected to the tank circuit, the connections being made, approximately, half-way between the centre tap and the ends of the tank coil.

The condenser CV2 [is then set to, say, its mid-position and, with the transmitter running, adjust CV1 for minimum feed again. Should it happen that the resonance point is not found throughout the rotation of CV1, try another setting for CV2; and, should that fail to bring about the desired conditions, fresh adjustments must be made to the tapings on L1 and L2.

It should be noted that when a two-wire feeder is used, the number of turns of L1 and L2 in circuit [must be identical, and once the tank circuit has been adjusted to resonance with the coupler disconnected, it should not be touched.

For those interested in reception only, I would mention that the Collins Coupler is very efficient under those conditions, especially if a twin-feeder half-wave aerial system is in use.

## TELENOTES

### A Standard Decision

IT is learned that the German television authorities have at last made up their minds concerning the picture standard which is to be employed for the public television programme service. The choice is the same as the American, namely, 441 lines with a format ratio of 6 to 5. The pictures are to be interlaced to give 50 frames, 25 pictures per second, but whether picture signal modulation is to be positive or negative is not yet stated. It will be seen that the number of lines for picture dissection is the next prime number to the B.B.C. standard giving the requisite multiplication between odd harmonics. It has been suggested that this may eventually become an international standard, thus permitting an easy interchange of receiving sets.

### A Simple Precaution

IT is well known that if the electron beam impinging on a cathode-ray tube's fluorescent screen is left as a stationary bright focused spot, the screen will be burnt at the point of impact. Precautions are therefore taken in different sets to prevent such an occurrence, and one of the most interesting to be devised concerns electro-magnetically operated tubes. The same power supply feeds the external focusing coil, whose current adjustment alters the spot's focus, the anode of the final valve handling the picture modulation, and also the modulating electrode of the C.R. tube itself.



# On Your Wavelength

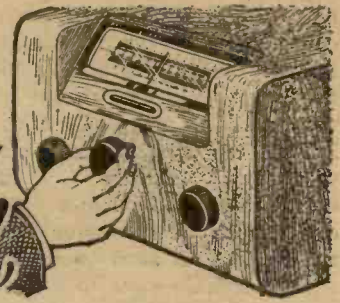

By Thermion

**Old Sets**

AUCTION sales are responsible for bringing to light from the dusty limbo of lofts and cellars the relics of bygone days, hoarded by their owners against possible use, or because they have sentimental value. There is no sentiment pulsing beneath the cold exterior of an auctioneer—no responsive chord is struck with his hammer. "Going . . . going . . . gone," and the cherished item changes hands for a few shillings or pence. A friend of mine who haunts auction rooms in the hope of picking up bargains recently staggered home with a bath of junk, among which was a completely assembled receiver minus cabinet and batteries. I had no difficulty in identifying the receiver, which was the very first described in this journal—the Long-Range Express, which was dealt with in the very first issue. Remember it? Right!

My friend wanted to know whether it was worth dusting and putting in order, so he brought it round to try out on my aerial. Believe it or not,



The helpful rhythm of radio.

that old receiver (five years old!) burst into pleasant song immediately it was connected to aerial, earth, batteries and speaker. Moreover, it has amazing selectivity and ropes in dozens of stations.

My friend now has it installed in his den, housed in a nice cabinet, and is most pleased with his bargain!

**My Big Bargain!**

WHICH reminds me of the fact that a few years ago I bought

a similar box of junk at an auction room. It consisted of odds and ends of metal, drills, files, and a very old accumulator. It was the latter which interested me, for in spite of its evident age it was *not sulphated!* I suspected therefore that it was a Groves cell—one of the earliest of the storage cells. Examination proved this to be so, and my luck was indeed in, for the plates of those early cells were made of solid platinum and silver. My acquisition was at a time when platinum was £20 per ounce, and silver about 3s. an ounce. There was a goodly weight of both metals and I made a large profit out of that transaction. Auctioneers do not know everything!

**Vacuum Cleaners**

THE maid who "does" for an acquaintance likes to work to the tempo of the weather reports or anything which happens to be going when she is wearing out the carpets with a vacuum cleaner. She complained the other day that the set was very bad in the mornings when she was using the vacuum cleaner, but was much improved in the afternoon when she was laying the tea!

I think that the makers of all domestic electric apparatus should use suppressors. The first firm to do so will have a useful sales argument, and a valuable basis for its advertisements. The interference caused by vacuum cleaners, electric fans, sewing machines, refrigerators and the other impedimenta of the all-electric home is a menace to listening, for it can often be picked up streets away. Sooner or later it will be an offence. Why not tackle the problem now?

**Use a Mike**

EVERY constructor should own a mike. Think of the fun you can have on Willy's birthday. No need to get the B.B.C. to wish him "Many happies." You can do it yourself, and add a few remarks which will lead

him to think that he is being specially favoured. You can also cure bad little boys of the tantrums, send them to bed, or make them take the castor oil by a suitable admonition via the loudspeaker.

**At the Show**

I OFFER my usual prize to anyone who successfully challenges me at the Wireless Exhibition—and I shall play fair! Just say "You are Thermion!" and if you say it to me I shall hand you a voucher.

**Amateur Code**

WE recently published in these pages some of the abbreviations used in amateur and commercial code signalling, and I was most amused to note in an Australian radio magazine the way in which these abbreviations were reported once to have been used. Of course, many young amateurs incorporate these abbreviations whenever they can, no doubt just to create an air of mystery when they write to other people, but here is the little story I refer to. On a hiking trip a few members of the party were enthusiastic radio amateurs, and one of them had a slight mishap with his luggage. He was standing around expressing himself in no uncertain language regarding the railway company when one



Fun with a mike.

of his friends suddenly called out "QRT! QRM! T9 YLs 30 Metres!" Of course, only his friend and the other amateurs knew that he was saying "Be quiet—somebody is coming! Good-looking young ladies about 30 yards away!"

**Listeners' Views on Radio Plays**

WHAT does the public think of radio drama and features? Three hundred and fifty men and

women drawn from all parts of the country and from all walks of life recently helped the B.B.C. to answer this question. Those who took part were asked to answer questions about forty-seven wireless plays or feature programmes. Altogether 8,000 forms were completed. The object of this experiment in collective criticism—the first of its kind to be sponsored by the B.B.C.—was to help the new policy of keeping listeners and broadcasting producers in closer touch with one another. Press criticism and letters from individuals have been found very useful, but something more was wanted to give a fuller "box office" reaction. Members of the drama panel were sent weekly questions about plays and features in the National and main Regional programmes. The answers were analysed and sent in each case to the Features and Drama Department.

Productions covered a very wide range. Shakespeare, famous modern plays by Barrie and Galsworthy, Eugene O'Neill and Tchekov, and plays specially written for the radio.

All these very different types of programme were given some good points, and, from the point of view of the B.B.C., extremely useful criticisms on details of production were given. Light was thrown on the listener's attitude towards the much-discussed question of music and voice which is sometimes difficult for the producer with a comparatively perfect set to assess. Classical plays, especially Shakespeare, were popular. Listeners felt that there was a place for Victorian melodrama, provided that it was only broadcast occasionally. There was a feeling that comedy had not been allotted a fair share of programme time. The most important problem of production still to be solved was how to make a play easy to follow. That this is still a difficulty is shown by the welcome which was given to the announcement of scenes in the broadcast of "Anthony and Cleopatra" and to the employment of a "speaker" to read the author's stage directions in "Dear Brutus." Part of the problem is the need to make it easier to distinguish between the characters. Listeners asked for the selection, where possible, of plays with small casts. It was suggested that the characters should be announced in order of their appearance at the beginning as well as at the end of a play, and the B.B.C. was urged to make frequent use of names in dialogues.

On the whole, listeners supported the policy of using sound effects, including incidental music, with re-



## Notes from the Nest Bench

### Using Old Coils

**C**OILS designed over five years ago are seldom suitable for use in modern receivers, except in the very simplest types of set. This is especially true of superhet coils. The old type coil was designed for use in conjunction with a separate oscillator valve and cannot be relied upon to work satisfactorily with a pentagrid or triode-hexode frequency changer. Even if the receiver is of the straight type having one or two H.F. stages, the high efficiency of modern H.F. pentode valves would cause instability. With this type of valve very effective screening of the H.F. components is essential if optimum results are to be obtained. In the old type S.G. receivers the coils were often of the un-screened type, screening being effected by inserting a metal sheet between the aerial and H.F. coils. This method of screening is not sufficiently effective for modern H.F. valves, however, and therefore, unless the coils themselves are completely screened, new coils of modern design should be incorporated.

### Extension Speakers

**W**E receive numerous inquiries from readers concerning the addition of extension speakers to mains-operated receivers. Many of these querists are under the impression that if the receiver is mains operated the extension speaker should also be of the mains energised type. This is quite incorrect, however—a permanent magnet model is more suitable than the mains energised type for extension purposes. If an energised type is used it must be separately energised from the mains, and if the mains are A.C., rectifying equipment must be added, of course. When a permanent magnet model is used it is only necessary to ascertain that it has the correct impedance for matching the receiver output valve. In some cases the extension sockets are joined to the speech coil on the set speaker, and therefore the extension speaker should be of the low impedance type—approximately 2 ohms. In most cases, however, a high impedance type is necessary—approximately 2,000 ohms. When buying an extension speaker it is therefore advisable to obtain a type which incorporates a switch for high or low impedance matching.

### An Ideal Book for the Beginner! Everyman's Wireless Book

By F. J. CAMM  
3/6, or 4/- by post from George Newnes, Ltd.,  
Tower House, Southampton St., Strand, London,  
W.C.2.

straint. It seems that listeners have learnt to expect and grown accustomed to first-class production. The same applies to acting.

Subjects chosen for feature programmes were, on the whole, interesting to listeners; but the construction of these programmes was often criticised. Criticism was made from two points of view—that features were not dramatic enough, and that they were too scrappy and disjointed. One programme—"Louisa Wants a Bicycle"—was specially commended, because it was said to avoid these weaknesses.

Finally, and this applies to all forms of dramatic production, there is a real relationship between the length of a production and its entertainment value. Most people thought that a production of longer than an hour was at a serious disadvantage. Many found not only that it was difficult to concentrate for longer than an hour, but also that domestic circumstances usually made listening for much more than this time difficult. It was frequently urged, however, that productions, such as Shakespeare, which cannot be compressed into an hour, should not be abandoned on this account, but that the play should be broken up by a short interval as is done to the longer symphony concerts.

### New Cabinet Designs

**I**HAVE been looking at some novel cabinet designs which will be shown at the Radio Exhibition, and one of the latest ideas is the use of woven fibre as shown here.

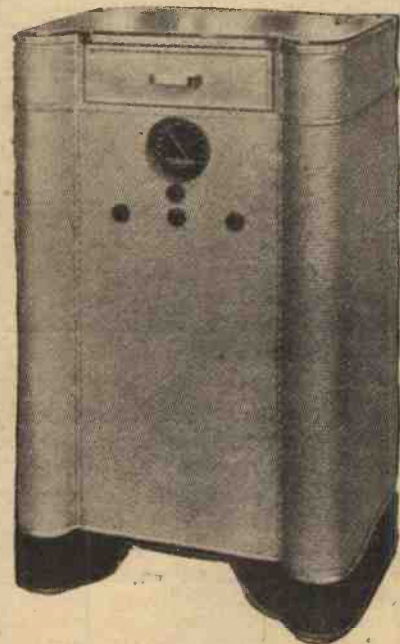

One of the latest woven-fibre cabinets for radio apparatus.

A PAGE OF PRACTICAL HINTS

SUBMIT YOUR IDEA

READERS WRINKLES

THE HALF-GUINEA PAGE

A Novel Series-aerial Condenser

IN the operation of short-wave receivers, it is often desirable to include a small condenser in the aerial lead-in in order to reduce the length of the aerial, and for this purpose an ordinary S.P./D.T. switch may be made to fulfil the duties of a small condenser and aerial earthing switch. A piece of paper or fibre is inserted between the two blades of the contact, as shown in the sketch, so that the arm of the switch is insulated from them. The arm of the switch and the contacts act as the plates of the "condenser," and the capacity can

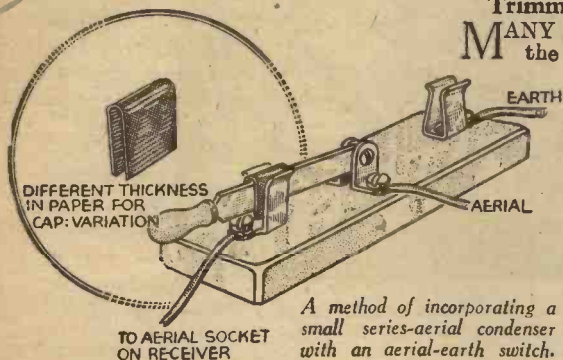

A method of incorporating a small series-aerial condenser with an aerial-earth switch.

be varied by sliding the arm up or down. When the arm of the switch is thrown over to the other contact, the aerial is short-circuited to earth. The aerial lead-in is connected to the arm of the switch, and a wire is taken from the contact not insulated from the arm, to earth, the remaining contact being connected to the aerial socket of the set. The base of the switch should preferably be of porcelain to avoid losses.—STANLEY COUSTON (Glasgow).

An Adjustable Work-bench Lamp

READERS may be interested in the adjustable lamp holder which I have constructed, and which I find very suitable for work on all parts of the bench. A long, thick pole is fixed at right-angles to the wall, the length varying according to requirements, and a box is constructed with holes slightly larger than the diameter of the pole, at each end. The lamp holder is then screwed to the bottom of the box, and the box fitted on the pole so that it slides up and down quite easily. The cord is fitted up as illustrated and runs through screw-eyes to a handle, which when turned causes the light to move up or down the bench according to the position required.

Connections to the lamp holder are, of course, made in the usual way, and the lamp will be found very useful for work which cannot easily be moved.—J. C. EVANS (Blackheath)

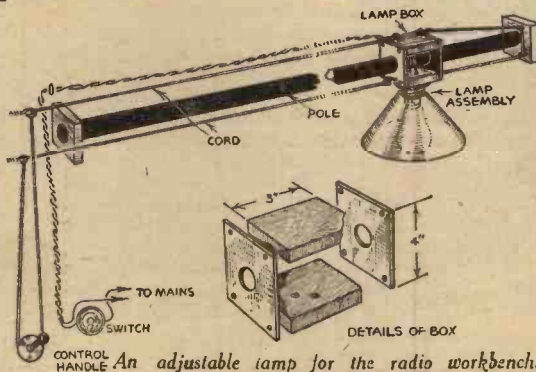

This easily-made anti-capacity screwdriver will be found useful for trimming purposes.

A Serviceable Morse Key

NO doubt readers of THE PRACTICAL AND AMATEUR WIRELESS who constructed the recently-described transmitters, require a cheap and efficient Morse key. This one shown in the accompanying sketch has

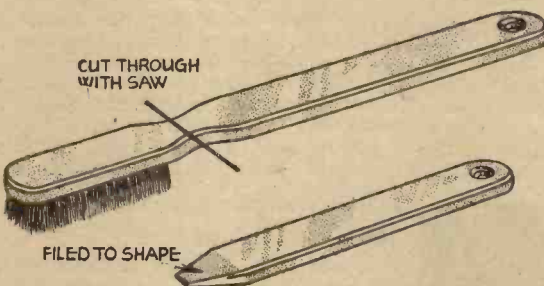

This easily-made anti-capacity screwdriver will be found useful for trimming purposes.

A Serviceable Morse Key

NO doubt readers of THE PRACTICAL AND AMATEUR WIRELESS who constructed the recently-described transmitters, require a cheap and efficient Morse key. This one shown in the accompanying sketch has

THAT DODGE OF YOURS!

Every Reader of "PRACTICAL AND AMATEUR WIRELESS" must have originated some little dodge which would interest other readers. Why not pass it on to us? We pay £1-10-0 for the best wrinkle submitted, and for every other item published on this page we will pay half-a-guinea. Turn that idea of yours to account by sending it in to us addressed to the Editor, "PRACTICAL AND AMATEUR WIRELESS," George Newnes, Ltd., Tower House, Southampton Street, Strand, W.C.2. Put your name and address on every item. Please note that every notion sent in must be original. Mark envelopes "Radio Wrinkles." DO NOT enclose Queries with your wrinkles.

An Easily-made Screwdriver for Trimming

MANY readers have, no doubt, found the trimming of ganged-condensers and intermediate frequency coils rather difficult, due to the capacity of an ordinary metal screwdriver. I use a screwdriver which is insulated, and possesses no capacity.

A toothbrush is taken and sawn off near the bristles, the celluloid handle being filed to the shape of a screwdriver blade, as shown in the sketch.—E. REGAN (Bury).

undergone a four months' test, and has proved very satisfactory. To make the key, first of all cut pieces of ebonite, one 1/2 in. by 2 1/2 in. by 4 1/2 in., and two 3/4 in. by 1/2 in. by 2 1/2 in. Bolt the two last-mentioned

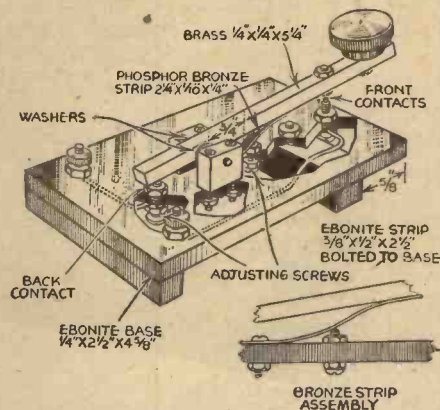

A cheap and efficient Morse key.

pieces to the larger piece, as illustrated, one being at one end and the other being 1/2 in. from the other end. Now cut three pieces of brass, two for the pivot (1/2 in. by 1/2 in. by 1/2 in.) and one for the rocker arm (1/2 in. by 1/2 in. by 5 1/2 in.). The pivot pieces are bolted 1/8 in. apart. The rocker arm is supported between them by means of a bolt passing through a hole drilled in the arm at 1 in. from one end, and through holes drilled at a convenient height in the pivot blocks.

A knob is fastened on the end of the arm, as illustrated, and a spring is made with a piece of phosphor bronze strip, 2 1/4 in. by 1/16 in. by 1/2 in. The spring is bolted beneath the rocker arm on to the base, and is adjusted by means of a screw which forces up the spring to the arm until the required tension is produced.

Fix an adjusting screw on the base under the short end of the arm so as to alter the contact gap. The contacts consist of two bolts, one with a round head, which is used for the contact on the rocker arm, and the other with a sharp end, which is used as the contact on the base. These should both have a piece of silver soldered on the actual tips.—R. Q. HARRIS (Boston, Lincs.).

NOW READY!

WIRELESS COILS, CHOKES AND TRANSFORMERS, AND HOW TO MAKE THEM.

2/6, or 2/10 by post from Geo. Newnes, Ltd., Tower House, Southampton Street, Strand, London, W.C.2.

OLYMPIA will soon open its doors for the annual exhibition of new radio lines, and so far, there is much which is secret. There is always a certain amount of "hush hush" in the camps of certain of the manufacturers, and in many cases some products are kept secret right until the exhibition opens. The amateur is concerned, however, in knowing just what to expect, and in accordance with our usual policy, we give in advance certain of the features which have been made public or which are so far released by the various manufacturers. The simplification of tuning, due to the fact that the majority of receivers now tune over a short-wave band in addition



A comprehensive interference eliminating kit, consisting of an all-wave aerial and mains connector.

to the ordinary broadcast wavelengths, has resulted in some novel forms of drive. The latest model is released by Ekco, and will be seen at the exhibition on certain models this year. It has been christened "Spin-wheel tuning" and avoids the usual projecting knobs which are usual in a modern wireless receiver. The method of tuning is stated to be such that the pointer may be sent right across the entire scale by a mere flick of the finger, and permits of both rapid and fine tuning. The Spin-wheel is 14in. in diameter, is mounted

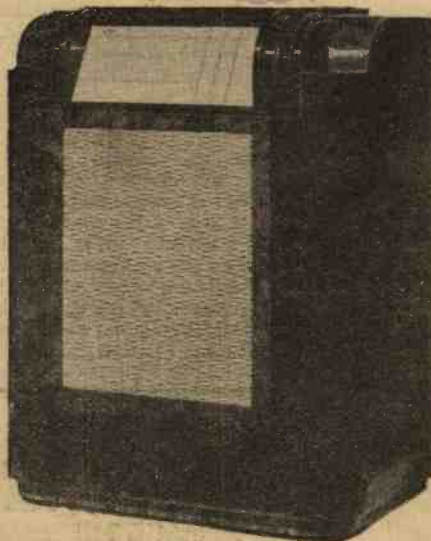

One of the new Ekco receivers, showing how all the controls have been apparently dispensed with. See also the illustration on the opposite page.

# RADIOLYMPIA-EX

Advance Information of S  
be Seen at This Y

on ball bearings, and is free from backlash or involuntary movement. A special clutch and tensioning spring ensure correct registration and the accurate setting of the control.

## Interference

The main bugbear of modern radio reception, especially where the shorter waves are concerned, is interference, and this is carried to the receiver not only from the aerial and earth systems, but also through the mains supply leads. Several



The increased use of ceramic material is evident from this group of radio mouldings to be seen on Stand No. 152.

anti-interference aerial kits will be seen at this year's exhibition, the majority of them designed for use on all wavelengths. Messrs. Belling and Lee will be showing a complete interference-eliminating kit, consisting not only of an all-wave anti-interference aerial system, but also of a mains set lead suppressor, and thus provides complete protection from background noises caused by electrical apparatus. Other all-wave systems will be seen, together with the separate parts of this type of equipment.

## Cabinet Designs

Apart from the new style in cabinets many listeners will no doubt be very interested in the new types of woven-loom cabinets which will be seen on the Texaloom stand. These models are available in small console as well as in large radiogram styles and are made up from coloured woven fibre similar to the popular easy chairs and tables which are already on the market. Certain models on this stand will incorporate sideboards and cocktail cabinets into which all-wave receivers are built, and will be available in green, gold, blue or brown. Another point in connection with cabinet design is the elimination of the silk backing behind the speaker opening. Instead of this we shall see several alternative schemes. Some firms are using plaited string in various colours, or some similar method of making an open-work grille, whilst others are incorporating plaited metallic braid. In some cases, the speaker opening is covered with the usual gauze, but the opening is masked by wooden louvres in colours to contrast with the remainder of the cabinet work, or in the same material.

## Components

In the component market there will be many new lines for the home constructor—the majority of which will be seen, as usual, on the Bulgin stand. This firm announces several new vibrator-rectifiers, transformers, measuring units, condensers, and other items totalling twenty-seven separate

components. The most interesting from the constructor's point of view is undoubtedly the neon output measuring unit in which a neon lamp is used to give an indication of

## Important

- NATIONAL (261.1 m. and 1,500 m.)**  
 Wednesday, August 18th.—Palace of Varieties programme.  
 Thursday, August 19th.—The Mill on the Floss, a radio play by Janet Keith, adapted from the novel by George Eliot.  
 Friday, August 20th.—Promenade Concert, from Queen's Hall, London.  
 Saturday, August 21st.—Running Commentary on the Sixteenth International Ulster Grand Prix Motor-cycle Race over the Clady Circuit, County Antrim.

- REGIONAL (342.1 m.)**  
 Wednesday, August 18th.—So this is Blackpool, feature programme.  
 Thursday, August 19th.—Promenade Concert, from Queen's Hall, London.  
 Friday, August 20th.—The Mill on the Floss, a radio play by Janet Keith, adapted from the novel by George Eliot.  
 Saturday, August 21st.—Walhamstow Band Festival.

- MIDLAND (296.2 m.)**  
 Wednesday, August 18th.—Exploring with a Cycle: A Dane's English tour.  
 Thursday, August 19th.—Dance music programme.  
 Friday, August 20th.—The Mill on the

# EXCLUSIVE DETAILS

## Some of the New Exhibits to Year's Radio Exhibition

the output for use when ganging or adjusting certain receivers. It is connected direct in the output circuit, without disconnecting the loudspeaker. Other items in this particular group will be needle scratch filters, mains connectors, and wire-wound resistors.

All-wave tuning coils will also be a great attraction to the home-constructor, providing him with a ready means of converting

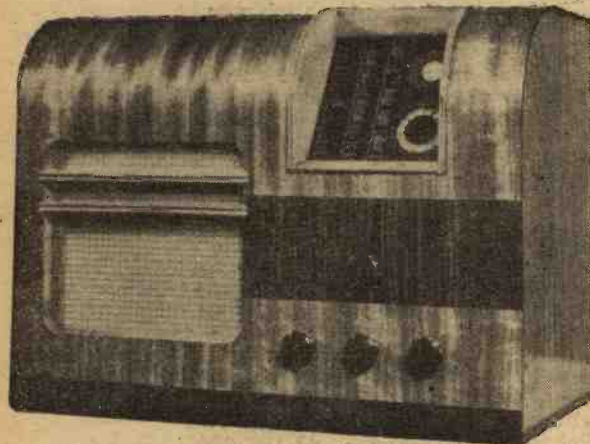

Note how the manufacturer has arranged the tuning dial in this Bush receiver.

any existing receiver, or building a new receiver to cover the short and the medium wavebands with an ordinary tuning con-

denser. Some of the new units are extremely interesting, not only from the point of view of all-wave tuning, but also from the mechanical view-point. The ingenious way in which the necessary tuning coils and multi-point switches have been incorporated in a simple unit, in many cases not as large as the ordinary screened broadcast coil, will well repay study when you visit Olympia. The tuners may be seen on the stands of B.T.S., Wright and Weaire, Varley, and other firms.

### "Feature" Circuits

So far there appears to be a reluctance on the part of the majority of set manufacturers to incorporate certain circuit details which might be termed "features." In the past we have had A.V.C., squelch, and similar arrangements, some of which have been dropped and others of which have been modified and standardised. There are now available certain features which, whilst not popular,

are certainly worthy of incorporation, when they can be made to function efficiently. One instance of a feature of this type is the Contrast Expansion circuit, and at the moment we are only able to trace that two manufacturers are

standardising this feature. Its purpose, as has already been explained in these pages, is to give stronger contrast between loud and quiet passages, the balance of which is often upset by the balance engineer at the broadcasting station or in the recording studio.

### Dials

The tuning dial is constantly being modified, and the all-wave feature has rendered some of the usual dials very complicated to read. Various manufacturers have endeavoured to overcome this difficulty in different ways and some novel

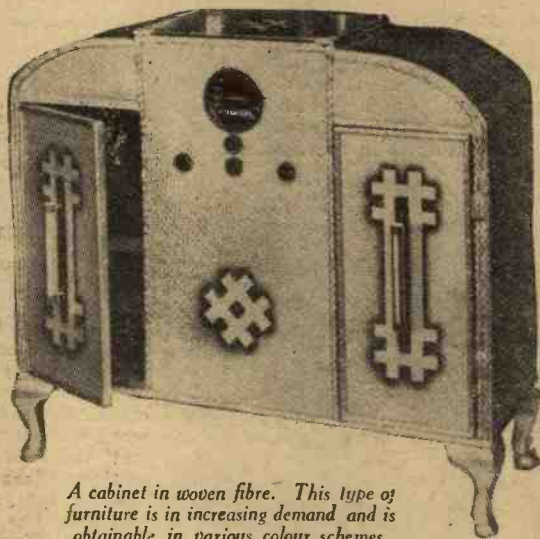

A cabinet in woven fibre. This type of furniture is in increasing demand and is obtainable in various colour schemes.

dials will be seen on this year's models. In some cases, the dial is of glass with side lighting, giving the names a phosphorescent effect; and by selective coloured lights the names in use are separately illuminated when the wave-change switch is operated. In other cases the dial has been converted into a large oval or rectangle and divided at the rear so that only one portion at a time is illuminated. Another firm will be showing a receiver in which the dial is moved with the wave-change switch and this feature—known as the Rotomatic—will only expose that particular wavelength scale and names of stations which are being tuned. At least two firms will be showing receivers in which the dial is mounted in such a manner that its position may be adjusted.

## Broadcasts of the Week

*Floss*, a radio play by Janet Keith, adapted from the novel by George Eliot.  
 Saturday, August 21st.—*The Making and Flying of Model Aeroplanes*, feature programme.

**WEST OF ENGLAND (285.7 m.)**  
 Wednesday, August 18th.—*West from Bristol*, a programme of songs and stories of the West.

Thursday, August 19th.—*Show Places: Pendennis Castle*, a talk.

Friday, August 20th.—*Organ recital from the Regal Cinema, Torquay.*

Saturday, August 21st.—*Cricket Match between New Zealand and Hampshire at Bournemouth—an eye-witness account.*

**WELSH (373.1 m.)**  
 Wednesday, August 18th.—*Prize Onions*, a play by E. Eymon Evans.

Thursday, August 19th.—*Instrumental programme.*

Friday, August 20th.—*Choral and organ programme from Siloh Chapel, Aberystwyth.*

Saturday, August 21st.—*Sailing the Seven Seas*, adventure stories by Sea Captains from Llangrannog, Cardiganshire.

**NORTHERN (449.1 m.)**  
 Wednesday, August 18th.—*So this is Blackpool*, feature programme.

Thursday, August 19th.—*Viennese Orchestral programme.*

Friday, August 20th.—*New Tunes for Old*, Light Orchestral programme, from Morecambe.

Saturday, August 21st.—*Concert Party programme, from Scarborough.*

**SCOTTISH (391.1 m.)**  
 Wednesday, August 18th.—*Summer Suns: a reflective miscellany.*

Thursday, August 19th.—*Concert Party programme, from Barrfields Pavilion, Largs.*

Friday, August 20th.—*A Scots Concert.*

Saturday, August 21st.—*Tobermory Treasure*, feature programme.

**NORTHERN IRELAND (307.1 m.)**  
 Wednesday, August 18th.—*Potted Light French Opera*, a programme of gramophone records.

Thursday, August 19th.—*Stop Dancing*, a programme of very light music.

Friday, August 20th.—*The McKiltricks at the Seaside*, a comedy of errors, by Harry S. Gibson.

Saturday, August 21st.—*Promenade Concert*, from Queen's Hall, London.

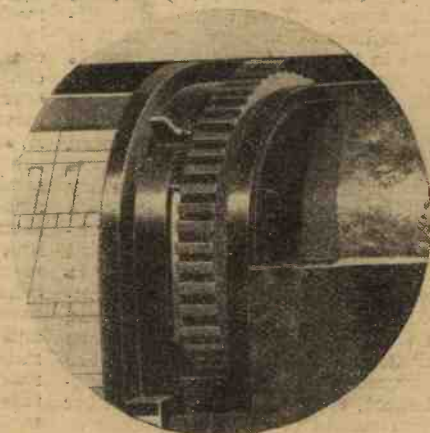

This is the "Spin-wheel" tuning device incorporated in the Ekco receivers. One of the several controls may be seen at the side of the Spin-wheel.

# The All-automatic Receiver

FOR a brief period before the annual exhibition of new radio apparatus at Olympia the man-in-the-street spends much time in speculation as to the tendency to be adopted in the new models. Many listeners, of course, believe that the new models are simply the old receivers, with the lay-out slightly modified and new cabinet designs incorporated, produced by the manufacturers simply to provide something new to offer. Such is far from the case, as a study of the specifications of the new receivers will show. Each year some new feature is incorporated in the complete receivers which are offered, and the improvement is always of such a nature that it offers to the listener some advantage, either in handling or in the results which

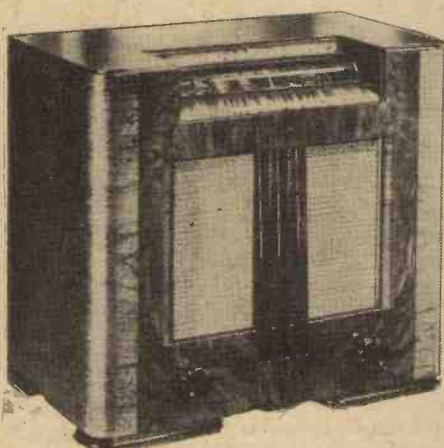

The modern receiver has a large station-named dial.

are given. As has already been stated in these pages, the main feature of this year's radio exhibition is the introduction of the "all-wave" tuning circuit in practically every receiver. This enables the single tuning control which is fitted to bring in stations on certain short-wave bands as well as the ordinary medium and long-wave broadcast stations.

## Automatic Tuning

In many cases it will be found that the tuning is not quite such a simple matter as in the older type of receiver, for several reasons. The intermediate-frequency amplifier of the superhet has been improved in the past few months, and it is now possible to offer sharper tuning without the consequent loss of quality which might be expected. In certain receivers, special circuits are now employed so that the selectivity in the I.F. stages may be modified and the best quality obtained from local stations, and maximum selectivity introduced when distant searching is to be carried out. All this has led to the need for the user of the receiver to be supplied with some very reliable indication of the more easily received stations, and in the past two years we have seen the transition of the tuning scale from the simple degree-marked dial to the station-named chart, upon which a large number of station names is engraved—either in alphabetical order or in the order of location. Even so, this is not a simple process for quite a number of people, and the makers of certain receivers have, therefore, introduced automatic tuning devices, one very well-known type of which

An Interesting Forecast of Modern Receiver Design With a Reference to Receivers to be Seen at the Forthcoming Radio Exhibition. By W. J. DELANEY

consists of a circular dial with holes similar in form to the automatic telephone tuning dial. This provides automatic tuning for a certain number of stations, the method of locating the station varying in different receivers.

## Motor-driven Condensers

One form utilises a small electric motor which drives the condenser spindle, and round this is fitted a number of cams. These are set by the dial on the front of the receiver, each cam having a contacting piece which bears against a jack connected to the motor supply. The position of these contacts is set by the makers of the receiver when the set is tested in the laboratory, and when turned the motor is set into motion, drives the condenser spindle and also the cam, and when the jack is contacted by the cam (at the station setting previously found) the motor is switched off and the station is thus automatically tuned in. To compensate for slight differences in the setting an automatic tuning circuit is generally fitted in the I.F. stage, and this pulls the circuits into exact tune, so that when the dial is operated it will sometimes be found that the signal which is heard is very distorted, due to the fact that the circuits are not quite in resonance. After a second or so, however, the signal will be heard to clear itself, as the automatic tuner pulls into correct setting.

## Auto-grams

We have already seen the automatic record-changing mechanism, which, in addition to changing the record, also turns over each disc and plays both sides. A step further in the automatic receiver is the automatic needle-changing mechanism, which, so far as we can trace at the moment, is not yet to be placed on the English market. Invented by a Frenchman, it has been in use on the Continent for some time, and was featured at the recent Berlin radio exhibition. A close-up of an enlarged model of this apparatus may be seen on this page. When the pick-up comes back to the rest position, the needle is ejected and a new needle driven up into the chuck, which is of the self-gripping type—no locking screw being provided for the needle. Thus the records may be expected to last longer, due to the fact that the needle is changed regularly after each playing, and

the user is provided with a machine which requires no attention whatsoever.

## Future Designs

Is it, therefore, too much to expect that we shall soon see the completely automatic receiver, which will switch on at the required moment, and switch off when an item has ended? Ordinary time-switches are quite old, of course, and have been incorporated in at least one commercial receiver. Suggestions have also been made for a device whereby the tuning note sent out by the B.B.C. stations will switch on the receiver. But the ordinary listener does not want the receiver to be switched on all the time, and may only require one or two separate items, and therefore the all-automatic receiver must be made capable of discrimination. Probably the only way in which this can be done is by means of a microphone circuit, where the operator will simply give the word of command and the mains-switch will be automatically operated. Another method would be by means of a photo-electric cell arrangement, where the directing of a beam of light from a pocket torch, for instance, would operate the necessary mechanism to switch the set on or off. It might even be possible to arrange that a selection of stations could be carried out by modifying the number of light flashes directed from the torch or by the particular code word spoken to operate the mechanism. At the present rate of development it does not seem that such a scheme would be impossible, and the incorporation of the television equipment with the radio apparatus should perhaps simplify matters by enabling the screen of the cathode-ray tube to be used as the source from which the apparatus is put into

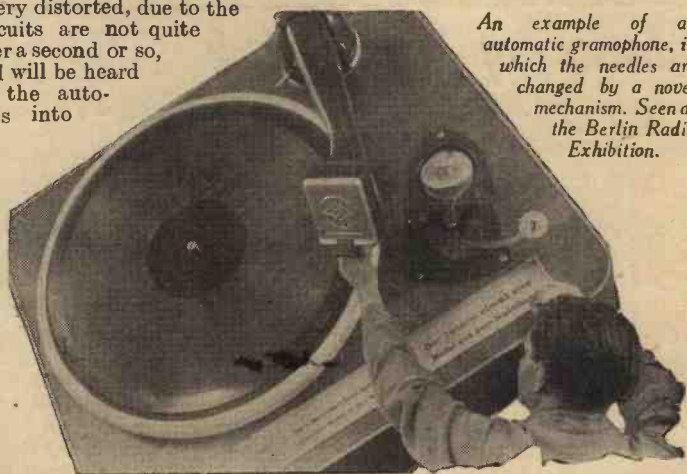

An example of an automatic gramophone, in which the needles are changed by a novel mechanism. Seen at the Berlin Radio Exhibition.

action—either utilising the transparency of the glass end of the screen or utilising the fluorescent coating itself, with some inter-connection to the relay apparatus which would be needed for switching the set on and off. Who knows what the next radio exhibition will bring to light?

**RADIOLYMPIA!**  
Our Stand No. 10  
Ground Floor



# Leaves from a Short-wave Log

## New Japanese Programme Schedule

**D**URING the months of August and September the Broadcasting Corporation of Japan is initiating an extended series of radio programmes destined to listeners abroad. For this purpose the two 60-kilowatt short-wave stations situated at Tokio-Atago-Yama are being brought exclusively into operation; they are JZJ, on 25.42 m. (11.8 mc/s) and JZK, 19.79 m. (15.16 mc/s). For Europe a daily transmission is made from G.M.T. 20.00-21.00; for the United States and South America from 21.30-22.30; for the Pacific Coast, Canada, Hawaii, etc., from G.M.T. 05.30-06.30; and for Java, Sumatra, New Guinea, and so on, from G.M.T. 13.00-14.00. News bulletins will be broadcast regularly every day from G.M.T. 20.45, in English, French, or German, and special musical programmes have been arranged for these transmissions. All reception reports should be addressed to: Overseas Section, The Broadcasting Corporation of Japan, Tokio (Japan).

## Broadcasts from the North Pole

Correspondents report having logged signals emanating from UPOL, the U.S.S.R. Arctic Expeditionary station installed at the North Pole. It would appear that a channel in the 20-metre band is being used as well as 17.94 m. (16.72 mc/s).

## Interesting Broadcasts from the Arctic Regions

The N.B.C. (U.S.A.) propose to relay for re-broadcast through the WEAJ-WJZ network, as well as through the corresponding short-wave stations, a series of transmissions during the next fifteen months in connection with the Macgregor Arctic Expedition. The first relay will be carried out this month from the Schooner *Greely* on its way to Fort Conger on Ellesmere Island, where a meteorological station is to be installed. Listeners may expect to pick up through W2XAD, W2XAF, Schenectady, and through the Boundbrook short-wave transmitters, a full description of aeroplane flights over the ice floes and details of how a winter camp is established, while in December, a special programme comprising Christmas Greetings from the Home of Santa Claus will be broadcast.

## Changes in Wavelengths

The following are notified: VPB, Colombo (Ceylon), 6.11 mc/s (49.06 m.), and ZGE, Kuala Lumpur (Federated Malay Straits), 6.23 mc/s (48.15 m.). Ceylon may now be heard working from G.M.T. 12.00-14.30 and ZGE, on Sundays, Tuesdays, and Fridays, from G.M.T. 11.40-13.40.

## Curaçao's New Channel

So far PCJ1, the short-wave station at Curaçao, has been working on 50.45 m. (5.946 mc/s) daily between G.M.T. 23.30-02.30, and it is reported that in future it will operate on 31.25 m. (9.6 mc/s).

## Schenectady Increases Its Power

Alterations have been carried out to the W2XAD plant, the power of the broadcast

on 19.56 m. (15.33 mc/s) has been increased to 18 kilowatts in the aerial. The station is on the air daily from G.M.T. 15.00-23.00.

## Macao Calling

CQN, Macao (Portuguese China), hitherto operating on 9.6 mc/s (31.25 m.) has now chosen a more favourable channel, namely, 10.1 mc/s (29.70 m.). The station broadcasts twice weekly only, on Mondays and Fridays from G.M.T. 12.00-13.30.

## The WIXAL Autumn Programmes

WIXAL, Boston (Mass.), U.S.A., owned by the World Wide Broadcasting Foundation, and licensed to use 6.04 mc/s (49.67 m.); 11.79 mc/s (25.45 m.); 15.25 mc/s (19.67 m.); and 21.46 mc/s (13.98 m.), in October will start a new series of programmes in Spanish, Portuguese, and English. WIXAL is one of the only U.S.A. stations providing radio entertainments without the aid of advertisers. Most of these transmissions are mainly destined to South America, and will be beamed towards the equator. The channels most used are 11.79 mc/s (25.45 m.) and 15.25 mc/s (19.67 m.).

## THE EGYPT'S GOLD

**W**HEN this broadcast was first given in 1934 it was widely acclaimed as a thrilling actuality feature. Listeners who come fresh to it will no doubt agree with this verdict, and those who hear it for the second time, in the National programme on August 29th, cannot fail to recapture their excitement as the dramatic story again unfolds itself.

Fifteen years ago the P. and O liner *Egypt*, carrying a million pounds of gold bullion, was sunk twenty-five miles from Cape Ushant in dense fog. A certain Commandatore Quaglia decided against all known precedent that it might prove possible to salvage this immense fortune that lay four hundred feet below the surface of the sea. A company was formed and two salvage vessels, the *Artiglio* and the *Rostro*, set out for the supposed position of the wreck.

There followed many months of dreary trawling, interrupted by Atlantic gales which rendered all work impossible, before the *Egypt's* position was established. It was then necessary to penetrate through six inches of thick steel plates and interlocked bulkheads before the bullion room could be reached. That success finally crowned the efforts of Quaglia and his intrepid divers was only due to their dogged perseverance in the face of difficulties that expert opinion had, up to then, considered insuperable.

Terence Horsley, the author of the programme, has brilliantly brought out all the drama inherent in such an undertaking. Listeners first hear the breaking of the news; its immediate repercussions in the City of London; the early plans for the salvage; and, finally, the actual diving operations themselves. A vivid picture of the weird atmosphere sixty fathoms below the surface of the sea is presented; and the moment when one of the divers, owing to an accident, is linked to the ship only by a slim telephone line, is one of almost unbearable tensivity. The programme will be produced by John Cheate.

## WIRELESS CONSTRUCTOR'S ENCYCLOPÆDIA

5/- or 5/6 by post from

George Newnes, Ltd., Tower House, Southampton St., Strand, London, W.C.2.

# PETO-SCOTT

6-7 Watts High Fidelity

## P.A. AMPLIFIER

A Super - Efficient General - Purpose Amplifier to earn you extra money!



MODEL A.C.67. — 4 valves; Triode, Resistance Transformer-coupled to 2 triple Grid Power Amplifier Valves, in Push-Pull, Full Wave Rectifier. Special precautions have been taken

in design to avoid parasitic oscillation in output stage. Fixed and pleasing tone balance. Pressed Steel chassis. Tapped and Screened Mains Transformer. Electrolytic condensers. Volume Control. Mains consumption approx. 60 watts. With microphone, speech easily heard at over 500 ft. Tapped for A.C. Mains 200-250 volts. 40/100 cycles. Output 6-7 watts undistorted. Complete with Valves Ready to connect to microphone or pick-up. Cash or C.O.D. **£4:10:0**

Or 7/6 down and 11 Monthly Payments of 8/6.

COMPLETE AMPLIFYING SYSTEM, comprising above Model A.C.67 Amplifier, Transverse Current Type Carbon Microl Phone and Transformer, 10" Field Energized Speaker and Transformer, 25ft. microphone flex, 40/100 cycles. Output 6-7 watts and 50ft. 4-way speaker lead. Cash **£9:10:0** or C.O.D.

Or £1 down and 11 monthly payments of 17/6.

## HERE'S NEWS!

A revolutionary advance in Short Wave Home Construction. Peto-Scott's Short-Wave Experts have produced the PILOT "SHORT-WAVE EXPERIMENTER" a booklet of 24 pages, illustrating and describing 9 wonderful new PILOT kits. Each of these incorporates a standard chassis and panel. Commencing with a modest but super-efficient 1-valve Adaptor-Converter, you may build 4 up, on the same chassis, into varying forms of 1, 2, 3 and 4-valve Short-Wave Receivers, complete in steel cabinet. No short-wave fan can afford to miss the fascinating hours this booklet will bring him.

Send 1/6 in stamps for free copy of this 6d. Booklet. All postal orders must be crossed and currency registered.

**PETO-SCOTT Co. Ltd.**, Established 1919, 77 (Pr. W. 48), City Road, LONDON, E.C.1.

62 (Pr. W. 48), HIGH HOLBORN, LONDON, W.C.1. Holborn 3248.



For a good job well done

## TOP SOCKET WANDERPLUGS

There is an increasing demand for such a plug particularly in the case of Q.P.P. & G.B. circuits where it is at times required to take two tappings from a single battery socket.

No. 1229. Each, 2½d.



## "MIDGET" & "BOWSPRING" WANDERPLUGS

Both these plugs now have bakelite handles in colours. Hexagon top flange to facilitate tightening and withdrawal. Threads unstrippable. The "Midget" type has hard drawn 3-point spring contacts.

No. 1295. Each, 2d.

The "Bowspring" type is of patented construction and is next best for resilience.

No. 1112. Each, 1½d.

## BELLING-LEE FOR EVERY RADIO CONNECTION

**BELLING & LEE, LTD.**, Strike out item not required. Cambridge Arterial Rd., Enfield, Middx. Please send FREE pocket-catalogue: "Radio Spares and Connections." Please send catalogue, "Radio and Electrical Accessories;" 8d. remittance enclosed. NAME ..... ADDRESS ..... Pr. W. 21.8.37.

## A New 40-Page Booklet—Free



This booklet gives particulars of the many opportunities open to trained men engaged in the Radio industry. It also gives full information about the specialized instruction offered by the I.C.S. This instruction includes American broadcasting as well as British wireless practice, and provides ambitious men with a thoroughly sound training.

Here are the I.C.S. Courses :

**Complete Radio Engineering**  
**Complete Radio**  
**Radio Servicemen's**  
**Elementary Radio**  
**Radio Service and Sales**  
**Television**

Preparatory Courses for :

**I.E.E. Graduateship Exam.**  
**I.W.T. Exams.**  
**C. & G. Exams. in Radio Communication.**  
**P.M.G. Certifcs. in Wireless Telegraphy.**

The Complete Radio Course covers equipment and radio principles as well as practice.

Efficient Servicing is of first importance to every wireless dealer and his assistants.

The Service and Sales Course enables the salesman to hold his own with the most technical of customers.

Television will soon be a tremendous branch of the industry. Our Course deals adequately with this subject.

*I.C.S. Courses do not cost more than those of other reputable schools teaching by correspondence; indeed, in some cases they cost less. An important consideration lies in the fact that all I.C.S. instruction books and special textbooks are supplied without extra charge. The students of many postal concerns have to buy the books required, that often involving an additional expenditure of several pounds.*

**SEND FOR OUR "RADIO" BOOKLET**

And, if you wish, ask for our free advice.



Dept. 94, International Buildings,  
 Kingsway, London, W.C.2.

# Practical Television

August 21st, 1937

Vol. 3.

No. 64.

## An Important Decision

IT is confidently expected that after the stimulus to the television service which will accrue following the Radiolympia demonstrations a decision of far-reaching importance will be made by the Postmaster General's Television Advisory Committee concerning the establishment of the first provincial television station. There seems little doubt that Birmingham will achieve this distinction, primarily because of the Post Office co-axial cable which runs between this city and London. Considerable experience in feeding the television signals along special cables has already been obtained by the B.B.C. engineers, and the results secured have so far exceeded the most optimistic expectations. In view of the cost involved in producing satisfactory television programmes it seems certain that the provincial stations will have to rely on the London station for a fair percentage of their programme requirements, in which case distribution problems will assume major importance. Very material improvements in both the transmitting and receiving systems have been effected since the original committee made their investigation and subsequent recommendations as to equipment, and it is likely that a further enquiry will have to be made before contracts are called for. The question has already been raised in Parliament as to whether the B.B.C.'s income is adequate for the conduct of the services entrusted to it, and the P.M.G.'s reply was to the effect that the matter is under consideration. Once this has been settled development will be expedited.

reception over extended periods. Provided the programme has good entertainment value, picture size becomes of rather secondary importance although naturally more people would be attracted to installing sets if the size of the picture area was increased to a certain extent. New York and Los Angeles are looked upon as the two principal centres for American television developments. The physical nature of the immediate environments in both cities are quite different, for whereas the former has a number of extremely high buildings the latter is favoured with naturally high sites for transmitter installations, with fairly low structures and countryside.



The latest Baird television receiver incorporating a high-fidelity all-wave radiogram and automatic record changer.

## A U.S. Report

THE Scientific Committee of the Research Council of the U.S. Academy of Motion Picture Arts & Sciences recently presented its second annual report and, as anticipated, a considerable section was devoted to the subject of television. The activities in England, Germany and America were covered very fully and certain conclusions drawn up as a result of the observations and analysis of this work. It was stressed that the time is rapidly approaching when all those engaged in the motion picture industry would have to acquire intimate knowledge of the characteristics and methods employed in the science of television. The day was foreshadowed when the two industries would be allied in some form or another, and to delay investigation would only be harmful to both sides. The present picture size for home receivers was criticised but it is felt that this criticism was based on home cine work, and in view of the absence of a public television service in the United States the committee members have not had the opportunity of watching home

## An Opportune Remark

THE very cautious attitude which has been adopted towards television by the radio companies in America was offset recently by President Roosevelt's comments when he inaugurated the new Washington Studios, which it is stated are to be equipped for television transmissions at the earliest possible moment. Alluding to progress being the watchword of science, he stated that no obstacles must be placed in the way of ordered development. American radio executives are keen to withhold television from the public until in their opinion it is sufficiently advanced technically to be marketed on a big national scale. The reason for this is not stated and bearing in mind the progress which has been made in certain European countries, the Americans are forced to the conclusion that research is lagging in their own laboratories. The American president continued by saying that in his opinion television will be established in the home at a much earlier date than generally realised, and visualised the widespread dissemination of news through this important medium.

# A Two-valve Mixer Amplifier

A Useful Unit for Obtaining Realistic Effects, Perfect Blending of Microphone and Pick-up, and Adequate Amplification Without Forcing or Distortion, is Described in This Article By RADIO ENGINEER.

**T**HIS unit is not intended as a final amplifier, and therefore it must not be used to feed a loudspeaker if its real object is to be fulfilled.

In many instances, the broadcast receiver in use does not provide sufficient amplification for microphone or pick-up work; it does not always provide that "little bit in reserve" which so often makes all the difference between passable and satisfactory results. Again, there are times when it is desired to use the pick-up or microphone at some point remote from the receiver or amplifier, and unless an intermediate amplifier and its associated output transformer is used, results are likely to be most disappointing.

The unit is not costly to make; probably many of the parts are resting in the spares box.

## Construction

The circuit is such that one need not be bothered with finicky details regarding the constructional work or the placing of the components. When it is a question of a more elaborate circuit involving specific screening, wiring and components, then, of

If the depth of the box or chassis permits, the potentiometers can be mounted through the front strip, thus keeping them clear of the screening cover and making the wiring neater (Fig. 2). For the two

instances, sufficient control is provided on the receiver or amplifier, therefore the constructor must use his own initiative whether it is embodied in the unit or not. It certainly makes the unit more complete and likewise more applicable to experimental work.

With the battery version, but not with a mains outfit, the microphone transformer and battery can be mounted on the chassis, the switch S2 being used to break the supply to the primary. When mains are used it is strongly advisable to house the microphone transformer and battery in a separate

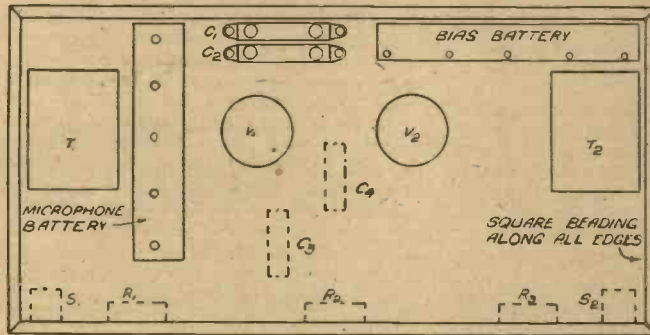

Fig. 2.—Layout plan for the complete amplifier.

inputs and the one output, I would advise the use of single-circuit jacks. For the battery model, one of the jacks, as shown, can be of the two-circuit type, thus allowing the filament of V1 to be switched off when it is not in use. With a mains job, such procedure is both unnecessary and inadvisable owing to risks of hum.

The tone control is optional. In many

box—metal-covered or lined for preference—and keep it a little distance away from the unit, the connections being made by screened leads the covering of which should be earthed.

The screening and protection cover is made from stout perforated zinc. It is quite simple to make and, while serving a very useful purpose, it also adds a neat and professional touch to the final assembly (Fig. 1). The zinc should be cut to shape while flat and before making any bends it should be well rubbed with metal polish

(Concluded on page 549)

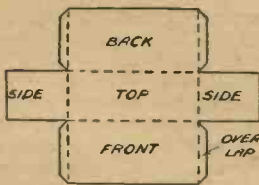
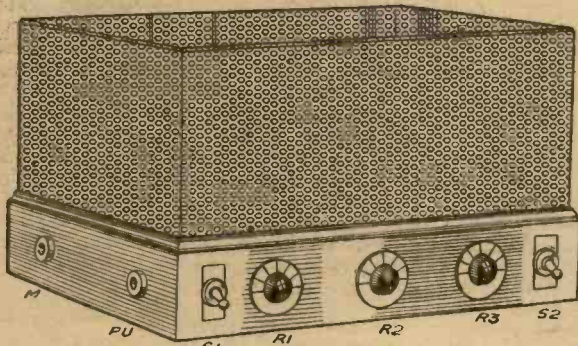

Fig. 1.—The complete unit and method of cutting out the perforated metal screening cover.

course, it is strongly advisable to adhere to the designer's specification in all details.

This unit can be made up on a chassis or baseboard, but personally I would advise chassis construction, especially in the case of a mains-operated apparatus. The details given are for a chassis.

It can be made from ply, or if you happen to have a wooden box the right size—for example, a large, strong cigar-box—then that will save a certain amount of labour, and may prove stronger. Another very good thing to use, providing you are handy with a soldering-iron, is one of those oblong biscuit boxes fitted with a flat push-on lid.

The valveholders can be of the chassis or baseboard type, the former being neater, but as they are not visible it is really immaterial.

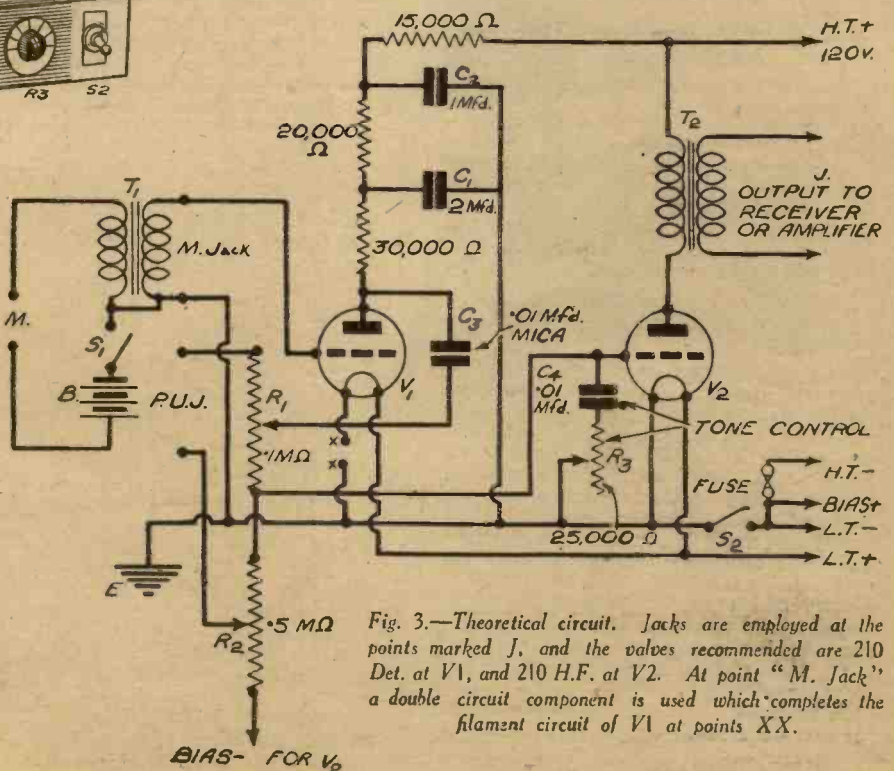
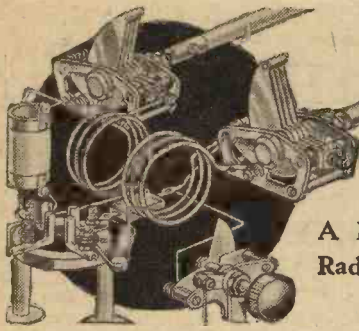

Fig. 3.—Theoretical circuit. Jacks are employed at the points marked J, and the valves recommended are 210 Det. at V1, and 210 H.F. at V2. At point "M. Jack" a double circuit component is used which completes the filament circuit of V1 at points XX.



# Short Wave Section

A Brief Account of how Ultra-Short-Wave Radio is Used in Connection with the Transatlantic Air Services

THE successful inauguration of the first two-way survey North Atlantic flight, in which the Imperial Airways flying boat *Caledonia*, G-ADHM, and the American *Clipper III*, have made the double journey dead on schedule, is now a matter of history, to be long remembered in the annals of flying.

Much has been written about the aircraft themselves, and their technical performance, and much, no doubt, remains to be said in this connection. But radio enthusiasts will be interested to learn that this memorable flight was also noteworthy as being the first occasion on which ultra-short-wave instruments, working on the  $4\frac{1}{2}$ -metre band, have been used for commercial flying communication, combined transmitting and receiving equipment operating on this band having been employed at the seadrome for control and other purposes.

## Mains-operated Transceiver

As a matter of fact, a mains-operated "Transceiver," manufactured by Transreceivers, Ltd., Surbiton, had been in use

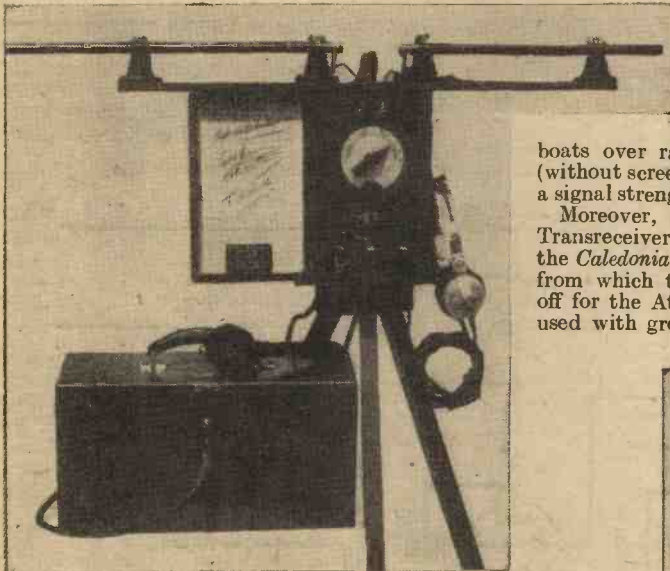

One of the Hermes Transreceivers supplied to the Imperial Airways, Ltd., and used on the occasion of the historic London-America return flight.

for some months at the Hythe Seadrome, installed in the Control Room. A similar instrument, but battery operated, and enclosed in a solidly constructed watertight case, was also permanently fitted to the embarkation raft lying out in Southampton Water, and equipped with a telescopic di-pole aerial which can be retracted when the plane is about to land, thus preventing the aerial from fouling the wings of the seaplane.

In addition, the passenger speed-boats plying between the quay and the embarkation raft are also fitted with similar

instruments, so that complete inter-communication between Control, raft and speed-boats can be obtained, a service which very



Imperial Airways Flying Boat, "Caledonia," G-ADHM, lying at anchor at Hythe Seadrome, after her historic flight from England to America return.

greatly facilitates all the numerous detailed arrangements, such as passing instructions, re-fuelling, repairs, and so forth.

These instruments, both on test and in service, have given an exceedingly good account of themselves, and have been operated at sea on the passenger speed-boats over ranges up to 15 miles (without screening of engines), with a signal strength of R8.

Moreover, two of the portable Transreceivers were taken over by the *Caledonia* to the Irish terminus, from which the flying boats took off for the Atlantic hop, and were used with great success during all

that as a result of the reliability and high utility of the Hermes Transreceivers, similar instruments are being installed at other points on the Imperial Airways Empire Routes.

## Combined Transmitter and Receiver

The Hermes Transceiver is a combined transmitting and receiving instrument, using a patented circuit incorporating a triode and a low-frequency pentode, both of which are employed for both transmitting and receiving. For reception, a super-regenerative reflex arrangement is used, and for transmitting, the pentode acts as the modulator and the triode as the oscillator, the radio frequency power to the aerial being of the order of 0.5 watt.

Instruments designed to work together are adjusted for a particular wavelength, but a small trimmer condenser is fitted for accurate tuning, and to correct any slight variations due to valve characteristics, temperature conditions, and the like. There is also a three-way switch with a "transmit," "receive" and "off" position, a volume control, and a calling device of the buzzer type.

One of the portable instruments used in connection with the flight, and signed by the Pilot, Assistant Pilot, Chief Radio Officer, and Assistant Radio Officer, is reproduced in one of the accompanying illustrations, and will be treasured as a memento of an historic occasion. This view shows clearly the simple nature of the controls, and the compact design of the equipment.

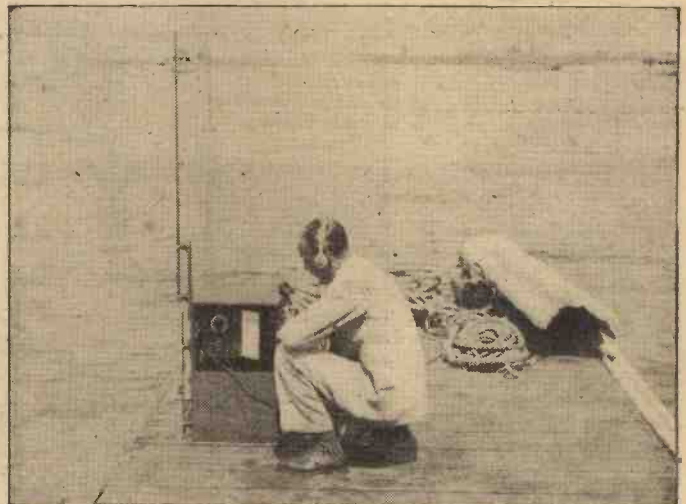

The watertight model Hermes Transceiver permanently fixed to the embarkation raft, situated in the middle of Southampton Water. Used for the transmission and reception of messages on a waveband of  $4\frac{1}{2}$  metres.

the preliminary arrangements.

It is interesting to note that Imperial Airways and the B.B.C. used five of these Transreceivers on the inauguration of the first penny-half-penny Empire Air Mail Service recently broadcast. It is understood

# A ROTARY 5-WAY PUSH SWITCH

**T**HIS switch is constructed from odd parts possessed by almost every constructor, but will be found very efficient in use, if carefully assembled.

Two ebonite plates, 1 and 2, are drilled as shown in Figs. 1 and 2 and fitted with  $\frac{1}{4}$ in. bushes. Plate 1 is also fitted with five valveholder clips, or springy brass contacts as in Fig. 3, and four 4BA countersunk bolts as in Fig. 4. A spring safety pin is pushed into a small hole in the edge of a  $\frac{1}{4}$ in. condenser washer, and a loop is formed on the opposite end, as in Fig. 5.

A brass plate, Fig. 6, is made as shown, and fitted with a valve pin. It is then soldered to a 3in. length of  $\frac{1}{4}$ in. brass rod as in Fig. 7.

## Assembly

The safety pin and washer, Fig. 5, are mounted on one of the 4BA bolts of Plate 1, Fig. 4, together with a soldering tag for connections.

The  $\frac{1}{4}$ in. rod, Fig. 7, is pushed through the washer on the safety pin and the  $\frac{1}{4}$ in. bush on Plate 1; a condenser washer is then placed on the long end of the rod, followed by a compression spring, and Plate 2 is pushed over the 4BA bolts, rod 7 is then clamped with nuts.

The plates 1 and 2 should be adjusted by means of the bolts, so that the tip of the valve pin just engages with the

holes in Plate 1, thus giving a locating indication.

## Using the Switch

In use, turn the switch to the desired location, press the knob, and the circuit is made via the valve pin and appropriate socket. On releasing the knob the circuit will be broken by the action of the safety pin and spring socket combined.

By fitting more valve clips to Plate 1

any number of meters or other pieces of apparatus may be switched.

## Modifications

Several methods of modifying this primary idea will, no doubt, occur to the keen experimenter. For example, it would be quite a simple matter to gang two or more similar units together, using for the centre rod a length of ordinary round steel or brass, and with shoulders soldered to prevent unnecessary movement in one direction. Similarly, a separate plate may be drilled, and a small ball bearing pressed by means of a flattened end to the safety pin against the holes to form a separate locating plate.—D. H.

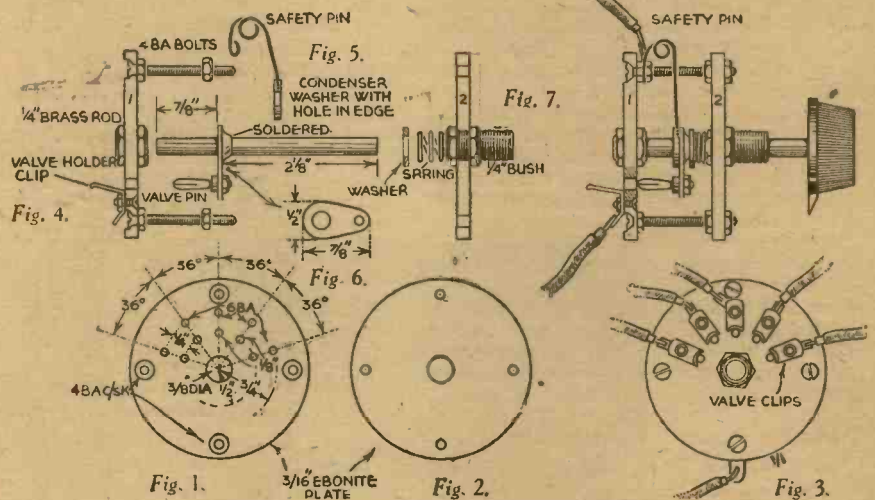

Details of construction of a 5-way push switch.

# THE ELECTRICAL ENGINEER POCKET BOOK

Some of the Contents:

- |                         |                    |
|-------------------------|--------------------|
| ACCUMULATORS            | RECTIFIERS         |
| A.C. THEORY             | SPACE HEATING      |
| BATTERY CHARGING        | TABLES             |
| FUNDAMENTALS            | (MATHEMATICAL)     |
| LIGHTING                | TRANSFORMERS, A.C. |
| MAGNETISM               | TRANSMISSION       |
| MOTORS                  | WATER HEATING      |
| POWER-FACTOR CORRECTION | WIRING TABLES      |

**Illustrations:**—This handy pocket volume contains a profusion of diagrams and sketches together with graphs. Also included for convenience is a small section of blank pages for notes and calibrated pages for graphs, so that the pocket book can contain information of a particular or personal nature as well as being a reference book of general facts.

**The Book Itself:**—The Pocket Book is strongly bound in durable art. leather—deep red, richly grained and embossed in gold. The book measures approximately 6 $\frac{1}{2}$  x 4 inches, and has rounded corners, so that it is in the truest sense of the word a pocket book. The paper has been specially chosen to give the minimum bulk consistent with good printing, again making for convenience in handling.

★ The Electrical Engineer Pocket Book can be obtained from all good newsagents and booksellers at 3/6 net, or in cases of difficulty direct from the publishers, George Newnes Ltd., Book Dept., Tower House, Southampton Street, Strand, London, W.C.2, at 3/8 post free.

## Left Bank

The average pipe smoker can get along comfortably on a moderately-priced tobacco provided he chooses his brand carefully. When he feels 'off his course' in the matter of a suitable tobacco, he will do well to make a 'left bank' in the direction of Player's 'Airmen'. Consistency is one of the qualities which smokers appreciate in this excellent tobacco. It combines a high standard of quality with modest price and there are four varieties to suit every type of smoker.

# PLAYER'S AIRMAN MIXTURE



# LETTERS FROM READERS

The Editor does not necessarily agree with the opinions expressed by his correspondents. All letters must be accompanied by the name and address of the sender (not necessarily for publication.)

## Service by the Trade

SIR,—I have been a regular reader of your excellent paper for the past few years, and find its contents most interesting and helpful. I find Thermion's articles delightful reading and very frank. I have especially noted his article in your issue dated July 10th, 1937, referring to the bad treatment constructors receive from various firms, especially inconvenience caused by delay.

If all firms were so considerate as one well-known firm in the trade constructors would derive a great deal more pleasure from their very fascinating hobby. I have on several occasions returned speakers to them for overhaul, also for repairs which have been made necessary through mishaps, and they have treated me remarkably well and their charges are very reasonable.

Service of this kind is naturally appreciated by readers.—ERIC SUTTON (Alford, Lincs).

## A Reader's Station

SIR,—I enclose a photograph of my station in the hope that it may be of some interest to my fellow-readers. The transmitter is a crystal oscillator using an ACO44 valve capacity-coupled to a Tungram 015/400 frequency doubler, which, in turn, is capacity-coupled to a Mullard DO24 in the PA stage.

The receiver is an SG-v-Pen operated from mains supply. A selection from the list of stations received on the 20-metre band between 03.30 and 04.30 G.M.T. on July 29th last on the above receiver is as follows:—

W1IFD, W2IDQ, W3EWW, W4BYR, W5DEW, W6EDZ, W7BST, W8LPD, W9PZH, VE1DK, VE1LR, VE2NR, VE4EC, VE5NY, LU6AP, CO5HY, VK5JB, K6DDN, and U9MF.

All of these, with the exception of the last, were on telephony.—F. W. GUNN, 2CBP (Halstead, Essex).

## A Five-valver for Overseas!

SIR,—On page 381 of your July 3rd issue you invited other readers overseas to say what they think about the recommendation of Mr. Wiggill for a five-valver for overseas. I think I can tender a little advice

on this subject on account of my 15 years' wireless experience.

Every keen amateur overseas looks at such sets from two angles; the one is the straight or the superhet, and the other the battery driven or the one fed from the mains. For most of the overseas listeners the straight set is preferable as against the superhet, because it is not so tricky in operation and is easier to keep in order.



A corner of station 2CBP, operated by a reader, Mr. F. W. Gunn, of Gosfield, Halstead, Essex.

But a large number of readers overseas have mains supply available, and it would be wise to design one version for mains and one for batteries. The mains version can be built in the set itself, and the output divided so that the currents for the first two valves may be stabilised, which can be done cheaply by neon bulbs.

Overseas reception conditions, together with the vast distances to be covered, make it necessary to make use of the most sensitive and selective valves and parts, and this leads to a division on these lines. As far as valves are concerned, the first valve should be an H.F. pentode or var-Mu S.G., with variable grid resistance, and this valve is followed with an S.G. detector with variable resistance in grid and anode for obtaining the very best working conditions. Precautions should be taken against creeping of H.F. into the next stage. The amplifying stages are a much simpler matter. There is a power pentode, single or ordinary pentode in push-pull, and with the newly-designed negative feedback, it is the thing to recommend for amplification to suit everybody for volume and quality. The link between the detector mentioned and this output stage would be a small L.F. valve, single or also in push-pull, but the latter is not so necessary if it has to handle the detector output without distortion.—W. POLLMANN (Nairobi, S. Africa).

## Another Snag

SIR,—I read with interest Mr. D. D. Wiggill's letter in your issue of July 3rd, and am also interested in a set such as he describes; although I think he has struck a snag in so far as the Bulgun Vibratory converter is concerned, as it is unobtainable in this country, and the makers will not supply direct as they have no licence to export such a kit. I wrote to them for particulars. I would also like to express my appreciation of your fine weekly.—D. DANNIGAN (Glenroy, S. Africa).

## Logged on Our Single-valve Short-waver

SIR,—Just before last Christmas a friend of mine passed along to me a copy of PRACTICAL AND AMATEUR WIRELESS, and since then I have been a regular reader. I enclose a log of stations received on your One-valve Short-waver, which I built from the details published in the December 12th issue. The components were taken from an old dismantled set, and the coils were home-made.

Americans. W2XAF, W2XAD, W2XE, W3XAL, W1XAL, W8XK, and W2XGB.

Japan. JSI, JVN, JZJ, and JZK.

South America. COCH and COCQ.

Czechoslovakia. OLR3A, OLR4A and OLR5A.

Miscellaneous. CT1AA, 2RO, DJN, PCJ, F1QA, HAT4, and HAS3.

I have also received several English amateurs in Coventry, Liverpool, Newport (S. Wales), and the Isle of Wight.—A. W. Tate (Yeovil, Somerset).

## Heard on the Tele-cent

SIR,—I have not seen a log from my district, so I submit mine. All stations are on 20 metres and my receiver is a 1-V-1, S.G., D., Pen. (the PRACTICAL AND AMATEUR WIRELESS Tele-Cent), Antenna, 30ft. indoor, well spaced from walls.

H17P, PY2BA, VE1PR, W2EUI, YV5AE, YV5AVE, CE1AI, LU4BH, CO7HF, W6MR, VK4MR, CO2MT, HJABF, K5AZ, KA1ME, K7VH, K6KGA, VK2KM, VK5IR, SU1CH, SU1SG, SU1RK, and OA4AK.

All the above stations were heard on 'phones and L.S. during last month.—J. WALKER (Manchester).

## CUT THIS OUT EACH WEEK

# Do you know

—THAT the electric eye, or tuning indicator, may be fitted to any receiver employing A.V.C.

—THAT automatic tuning circuits may be fitted to a receiver to pull into tune after the condenser has been roughly set.

—THAT the international distress wavelength used for S O S signals is 500 kc/s (500 metres).

—THAT modern American radiogram cabinets are fitted with baffles, sound-amplifying chambers, and other devices to modify the speaker response.

—THAT the logarithmic horn type of speaker provides a more even frequency response provided that the surroundings are suitable.

—THAT hum troubles can sometimes be caused by a microphonic valve which is affected by the vibrations from a mains transformer or smoothing choke.

The Editor will be pleased to consider articles of a practical nature suitable for publication in PRACTICAL AND AMATEUR WIRELESS. Such articles should be written on one side of the paper only, and should contain the name and address of the sender. Whilst the Editor does not hold himself responsible for manuscripts, every effort will be made to return them if a stamped and addressed envelope is enclosed. All correspondence intended for the Editor should be addressed: The Editor, PRACTICAL AND AMATEUR WIRELESS, George Neveles, Ltd., Tower House, Southampton Street, Strand, W.C.2.

Owing to the rapid progress in the design of wireless apparatus and to our efforts to keep our readers in touch with the latest developments, we give no warranty that apparatus described in our columns is not the subject of letters patent.

# RADIO CLUBS AND SOCIETIES

Club Reports should not exceed 200 words in length and should be received first Post each Monday morning for publication in the following week's issue.

## Slough and District S.W. Club

A MEETING of this club was held at 16, Buckland Avenue, on August 3rd. A suggestion that a Morse class should be started was put forward by J. Tuckfield, seconded by J. Gilbert, and passed. It was then decided that all members should learn the code by the next meeting, when the matter would be discussed further.

An interesting discussion arose from a point put forward by F. Thorn, a new member, on whether receiving conditions are getting worse. Following this, Mr. Paine suggested that a club receiver should be built and experiments carried out on it. A start will be made on this item at the next meeting.

The membership is now 15, but we still want new members. Anyone interested is invited to write to the secretary, J. Gilbert, 26, King Edward Street, Slough.

## Maidstone Amateur Radio Society

THE first meeting of the above society was held at Fossil House, 244, Upper Fant Road, Maidstone, on Saturday evening, July 31st, 1937, with six members present.

During the first half-hour, various points were decided, amongst which came the decision that the society should purchase PRACTICAL AND AMATEUR WIRELESS week by week. Then Mr. D. W. Carr gave an interesting talk on simple detectors, the diode and triode, dealing both with their evolution and applications.

Among its members the society has already one full transmitting licensee, Mr. D. W. Carr, two artificial aerial licences (2BFW and 2BMP), and two members who are applying for licences in the near future.

Meetings will be held from 6.30 till 9 p.m. approx. on Saturdays, at the address mentioned previously. A monthly magazine containing articles of interest to amateurs, entitled *Mars* (M.A.R.S.) is being published at the cost of 2d. (The issue for August is already being distributed) and the subscription is only 6d. entrance fee and 3d. per week.

Everybody in the Maidstone district interested in radio is urgently requested to get in touch with the hon. secretary, Michael Hedgeland, 8, Hayle Road, Maidstone.

## The British Short-wave League

AN informal gathering of the above society will take place at Radiolympia on Saturday, August 28th. For various reasons, several members have found it impossible to attend at the originally proposed time of 13.00, therefore the following arrangement has been decided upon:—

All interested members are requested to gather in the region of the PRACTICAL AND AMATEUR WIRELESS stand, No. 10, Ground Floor, at 13.00, where they will be met by the secretary, and possibly other officials of the League. For those unable to arrive there at 13.00 a second gathering will take place at 14.00, this time actually just outside the stand of this journal. All members are requested to wear the league badge, and to bring along anything of interest, such as QSL cards, photos, etc.

At the conclusion of the tour of the Show, it is hoped that members will adjourn to a neighbouring restaurant for tea.

The secretary, F. A. Beane, 2CUB, of Ridgewell, Halstead, Essex, earnestly requests that all desiring to be present should write to him immediately. Any non-members interested in the league are invited to write to the above address for full particulars of membership. A 2d. stamp should be enclosed to cover postage, etc.

## The British Sound-recording Association

THE association, now firmly established, is shortly to issue the first number of its journal, which will contain articles by amateur and professional recordists dealing with various aspects of sound recording. A series of visits has been arranged, including a tour of the B.B.C.'s Recording Departments at Broadcasting House and Maida Vale one day this month. It is also hoped to arrange visits to a film studio and a commercial recording studio where sponsored programmes for Continental radio stations are produced.

A leaflet describing the activities of the association and stating conditions of membership is obtainable from the hon. secretary, Jas. F. Butterfield, B.S.R.A., 44, Valley Road, Shortlands, Kent.

## A TWO-VALVE MIXER AMPLIFIER

(Continued from page 545)

—the outer side only—which will give it a fine lasting-polished surface.

After soldering the ends, be sure all surplus flux is removed and that all edges are straight and clean. The cover fits inside the rectangle formed by the beading shown, and it can be held in position—if so desired—with a couple of small wood screws driven into the beading.

It is a good idea to give the exposed sides of the chassis a coat of good black enamel, such as Chinese lacquer or any other good make of quick-drying lacquer, the bottom being covered with green baize or supported by small rubber feet at each corner.

## The Circuit

The most outstanding feature of the circuit is the mixing arrangement. It will be noted that separate valves are actually used for the two inputs (Fig. 3). This method has much to commend it; not only does it allow perfect control of the two inputs to be obtained, but it also provides very even amplification of the two signals. It will be readily appreciated that the output of an average transverse current microphone is nowhere near that obtained from a modern pick-up, therefore it is very desirable to provide compensating amplification to level up the inputs. This is obtained in the circuit in question by the valve V1. The tone control being fitted to V2 is operative on the total output, this being found to be quite satisfactory for all general work.

The output of V1 is passed on to V2 via a low gain resistance coupling; it not being necessary to provide a high amplification, otherwise true balance will be upset, and there will be the risk of overloading V2, with consequent distortion.

The anode circuit of V2 receives its H.T. supply through the primary of the output transformer T2, the secondary of which is used to connect the unit to the main amplifier or receiver.

# ELECTRADIX BARGAINS

## BATTERY PORTABLES AT BARGAIN PRICES.

Complete with valves 45/-, less valves and minor items, 30/-, Kit and case partly assembled, 22/6.

PANELS. Aluminium 16 and 18-gauge one side enamelled. Parolin and Ebonite, any size, from 24in. x 24in.

CONDENSERS. 2-gang variable .0005, new, 2/6; single, 1/8. FLEX CORDS. 3-way, 6ft. long, 6d. 4-way, 12ft. 1/- 4-way, 6ft., with plug and socket, 1/6. Govt. 6ft. headphone cords, with plug, 1/-.

COILS. H.M.V. band-pass, 3-wave, slight defects, 9d. Philips Superbet set of 3 in makers carton, 3/- set. 8.W. coils plug-in, 1/6. Ribbed formers, 9d. Long-wave and B.C. 2-pin, 1/- Reaction tuners, 9d. H.F. twin chokes, mains, 9d. Rugby and other coils in stock.

SPARK COILS. 1in., 1in. and 1in. gap, with condensers, 10/6. Short wave spark transmitters for boat model control, 17/-.

SOUND RECORDING at home on your own grammo. with 40 discs. The FEIGH centre geared recorder costs 37/6 only.

MICROPHONE PICK-UPS. Brown's Microbox Tone Arm with button mike reproducer, 10/6. GRAMO MOTORS, for recording, universal 100/240v. with turntable 25/10/0.

SPEAKER BARGAINS in high grade M.C. Speakers. All offered at less than half price. Finest quality reproduction.

D.C. ENERGISED 8" Celestion M.C. 2,500 ohm field, speech transf., as new, 7/6. E. A. C. 2,500 ohms, 7/-, Marmaxox 6" No. 144, 12/6.

A.C. SPEAKERS with rectifier, 100/250 v., 11" dia. with transf., 25/- Jensen, 220 v., 7" dia., 22/6. 100 volt ditto, 7' 18/6.

BATTERY SPEAKERS. Brown 6 1/2 volts 11', 14/6. P.M. SPEAKERS, Sonochoke Class B with transf., 20/- P.M. in Cabinets: Hydra, Oak, 12 x 12, 25/- Heavy Duty 5/8 watt with transf., 35/- A.C. Rect. Speaker, 200/250 v., 5 watts with transf., 60/- Small Cone speakers for extension: Siemens magnet table, 5/- H.M.V. Cone Units, 2/6. Brown's 12" cones, for mov. coil repairs, 1/-.

FILM PROJECTORS & TALKIES. Empire Kneigh 13.5cm. Portable 100-watt projector, completely steel clad for L.C.M. rules on any film, 100 picture. Automatic on 230 volt mains. Trade price 45/2. New condition, 42/2.

Kernemann Professional No. 1 Projector with 10-amp. mirror arc lantern and films. Had little use and throws a very brilliant picture. Bargain at 41/0.

Zelez Mirror Arc and Lantern, less reflector, 44. Cinephone and other arc lanterns, 55/- each. Two B.T.P. Talkie soundheads, fit any projector only want photocells, 44 each. Brown soundheads with cell amplifiers and p.e. complete, 42/2. Film Cleaning Machine, 50/- UX807 R.C.A. Photocells, 25/- C.M.G.8, 70/-.

MICROPHONES.—We are makers and carry the largest and most varied stock in London. Prices are low and there are models for all purposes.

Table Model "W.W.11" For home broadcasting. Bakelite square body on bronze base, containing transformer, switch and plugs, is a marvellous production at a low price. Worth 2 guineas. Only 15/- Lesdix No. 108 Pedestal, 10s. high, 12/6. Lesdix Superior No. 12BB Ring, 14in. pedestal, 18/6. Hand mikes in 2in. case, No. 11 at 5/6. Superior type, No. 11a, 7/6. Home microphone No. 11 is a solo general-purpose robust mike, with solid bakelite body, back terminals, from metal grille, hand or sting design, 5/6.

GRAMO-MOTORS & RECORD CHANGERS. Garrard Universal A.C.D.C. with turntable and auto switch, 43/10. B.T.H. Universal model YM, turntable and autostop, 45/- A.C. Gramo motors and turntable H.M.V. 110 volts, 25/-, 230 volts, 37/6, motor only 30/- B.T.H. Golden Disc, 37/6. Record Changers, Garrard A.C. Automatic Record Changers for Gramo, 25/7/6.

SWITCHGEAR. Auto Selector Switches. 25 ways, 6 arms, 8/6. Battery Auto-Cutouts. Dix 10 amp. Min., 15/- N.C.S., 30 amp. 35/- Crawley 100 amps, 45/- Stud switches, 20 on slate panel, 5/6. FANS, PUMPS and COMPRESSORS cheap.

PARCELS of experimental odd coils, magnets, wire, chokes, condensers, switches, terminals, etc., post free; 10 lbs., 7/-; 7 lbs. 5/-.

1,000 more Bargains in large Illustrated List "N."

# ELECTRADIX RADIOS

218, UPPER THAMES ST., LONDON, E.C.4

'Phone: Central 4611

When writing to Advertisers please mention "Practical and Amateur Wireless"

FREE 268 PAGES

ENGINEERING OPPORTUNITIES

This unique Handbook shows the easy way to secure A.M.I.C.E., A.M.I.Mech.E., A.M.I.E.E., A.M.I.A.E., A.M.I.W.E., A.M.I.R.E., and similar qualifications. WE GUARANTEE—NO PASS NO FEE. Details are given of over 150 Diploma Courses in all branches of Civil, Mech., Elec., Motor, Aero, Radio and Television Engineering, Building, Government Employment, etc. Write for this enlightening Handbook to-day FREE and post free.

British Institute of Engineering Technology, 409, Shakespeare House, 17, 18, 19, Stratford Pl., W.1

When writing to Advertisers please mention "Practical and Amateur Wireless"

# Practical and Amateur Wireless BLUEPRINT SERVICE

These blueprints are drawn full size. Copies of appropriate issues containing descriptions of these sets can in some cases be supplied at the following prices, which are additional to the cost of the blueprint. A dash before the Blueprint Number indicates that the issue is out of print.

Issues of Practical Wireless .. 4d. Post paid.  
 Amateur Wireless .. 4d. " "  
 Practical Mechanics .. 7d. " "  
 Wireless Magazine .. 1/3 " "

The index letters which precede the Blueprint Number indicate the periodical in which the description appears; thus PW refers to PRACTICAL WIRELESS, AW to Amateur Wireless, PM to Practical Mechanics, WM to Wireless Magazine.

Send (preferably) a postal order to cover the cost of the blueprint and the issue (stamps over 6d. unacceptable), to PRACTICAL AND AMATEUR WIRELESS Blueprint Dept., Geo. Neaves, Ltd., Tower House, Southampton Street, Strand, W.C.2.

PRACTICAL WIRELESS		No. of	Three-valve : Blueprints, 1s. each.	
Date of Issuc.		Blueprint.	Experimenter's Short-Wave Three (SG, D, Pow) .. PW30A	
<b>CRYSTAL SETS</b>				
Blueprint, 6d.				
1937 Crystal Receiver .. 9.1.37	PW71			
<b>STRAIGHT SETS, Battery Operated.</b>				
One-valve : Blueprint, 1s.				
All-wave Unipen (Pentode) ..	PW31A			
Two-valve : Blueprints, 1s. each.				
Four-range Super Mag Two (D, Pen) .. 11.8.34	PW36B			
The Signet Two .. 20.8.36	PW76			
Three-valve : Blueprints, 1s. each.				
The Long-Range Express Three (SG, D, Pen) .. 24.4.37	PW2			
Selectone Battery Three (D, 2 LF Trans) ..	PW10			
Sixty Shilling Three (D, 2 LF RC & Trans) ..	PW34A			
Leader Three (SG, D, Pow) .. 22.3.37	PW35			
Summit Three (HF Pen, D, Pen) .. 8.8.34	PW37			
All Pentode Three (HF Pen, D (Pen), Pen) .. 20.5.37	PW39			
Hall-mark Three (SG, D, Pow) .. 12.6.37	PW41			
Hall-mark Cadet (D, LF, Pen, RC) .. 16.3.35	PW48			
F. J. Camm's Silver Souvenir (HF Pen, D (Pen), Pen) (All-Wave Three) .. 13.4.35	PW49			
Genel Midget (D, 2 LF Trans) .. June '35	PM1			
Cameo Midget Three (D, 2 LF Trans) .. 8.0.35	PW51			
1936 Sonotone Three-Four (HF Pen, HF Pen, Westector, Pen) .. 17.8.35	PW53			
Battery All-Wave Three (D, 2 LF RC) ..	PW55			
The Monitor (HF, Pen, D, Pen) ..	PW61			
The Tutor Three (HF Pen, D Pen) .. 21.3.36	PW62			
The Centaur Three (SG, D, P) ..	PW64			
The Gladiator All-Wave Three (HF Pen, D (Pen), Pen) .. 29.8.36	PW66			
F. J. Camm's Record All-Wave Three (HF Pen, D, Pen) .. 31.10.36	PW69			
The "Colt" All-Wave Three (D 2 LF RC & Trans) .. 5.12.36	PW72			
Four-valve : Blueprints, 1s. each.				
Sonotone Four (SG, D, LF, P) .. 1.5.37	PW4			
Fury Four (2 SG, D, Pen) .. 8.5.37	PW11			
Beta Universal Four (SG, D, LF, Cl. B) ..	PW17			
Nucleon Class B Four (SG, D (SG), LF, Cl. B) .. 6.1.34	PW34B			
Fury Four Super (SG, SG, D, Pen) ..	PW34C			
Battery Hall-Mark 4 (HF, Pen, D, Push-Pull) ..	PW46			
F. J. Camm's "Limit" All-Wave Four (HF Pen, D, LF, P) .. 20.9.36	PW67			
<b>Mains Operated.</b>				
Two-valve : Blueprints, 1s. each.				
A.C. Twin (D (Pen), Pen) ..	PW18			
A.C.-D.C. Two (SG, Pow) ..	PW31			
Selectone A.C. Radiogram Two (D, Pow) ..	PW19			
Three-valve : Blueprints, 1s. each.				
Double-Diode-Triode Three (HF Pen, DDT, Pen) ..	PW23			
D.C. Ace (SG, D, Pen) ..	PW25			
A.C. Three (SG, D, Pen) ..	PW29			
A.C. Leader (HF Pen, D, Pow) .. 7.4.34	PW35C			
D.C. Premier (HF Pen, D, Pen) .. 31.3.34	PW35B			
Ubique (HF Pen, D (Pen), Pen) .. 28.7.34	PW36A			
Armada Mains Three (HF Pen, D, Pen) ..	PW38			
F. J. Camm's A.C. All-Wave Silver Souvenir Three (HF Pen, D, Pen) .. 11.5.35	PW50			
"All-Wave" A.C. Three (D, 2 LF RC) .. 17.8.35	PW54			
A.C. 1936 Sonotone (HF Pen, H.F. Pen, Westector, Pen) ..	PW56			
Mains Record All-Wave 3 (HF Pen, D, Pen) .. 5.12.36	PW70			
Four-valve : Blueprints, 1s. each.				
A.C. Fury Four (SG, SG, D, Pen) ..	PW20			
A.C. Fury Four Super (SG, SG, D, Pen) ..	PW34D			
A.C. Hall-Mark (HF Pen, D, Push-Pull) .. 24.7.37	PW45			
Universal Hall-Mark (HF Pen, D, Push-Pull) .. 9.2.35	PW47			
<b>SUPERHETS.</b>				
Battery Sets : Blueprints, 1s. each.				
£5 Superhet (Three-valve) .. 5.6.37	PW40			
F. J. Camm's 2-valve Superhet Two-valve .. 13.7.35	PW52			
F. J. Camm's £4 Superhet ..	PW58			
F. J. Camm's "Vitesse" All-Waver (5-valver) .. 27.2.37	PW75			
Mains Sets : Blueprints, 1s. each.				
A.C. £5 Superhet (Three-valver) ..	PW43			
D.C. £5 Superhet (Three-valve) .. 1.12.34	PW42			
Universal £5 Superhet (Three valve) ..	PW44			
F. J. Camm's A.C. £4 Superhet 4 .. 31.7.37	PW50			
F. J. Camm's Universal £4 Superhet 4 ..	PW60			
"Qualitone" Universal Four .. 16.1.37	PW73			
<b>SHORT-WAVE SETS.</b>				
Two-valve : Blueprint, 1s.				
Midget Short-wave Two (D, Pen) ..	PW38A			
<b>PORTABLES.</b>				
Three-valve : Blueprints, 1s. each.				
F. J. Camm's ELF Three-valve Portable (HF Pen, D, Pen) ..	PW65			
Parvo Flyweight Midget Portable (SG, D, Pen) .. 19.6.37	PW77			
Four-valve : Blueprints, 1s.				
Featherweight Portable Four (SG, D, LF, Cl. B) .. 15.5.37	PW12			
<b>MISCELLANEOUS.</b>				
S.W. Converter-Adapter (1 valve) ..	PW48A			
<b>AMATEUR WIRELESS AND WIRELESS MAGAZINE CRYSTAL SETS.</b>				
Blueprints, 6d. each.				
Four-station Crystal Set .. 12.12.36	AW427			
1934 Crystal Set ..	AW444			
150-mile Crystal Set ..	AW450			
<b>STRAIGHT SETS, Battery Operated.</b>				
One-valve : Blueprints, 1s. each.				
B.B.C. Special One-valver Twenty-station Loudspeaker One-valver (Class B) ..	AW387			
Two-valve : Blueprint, 1s. each.				
Melody Ranger Two (D, Trans) ..	AW388			
Full-volume Two (SG det., Pen) ..	AW392			
B.B.C. National Two with Lucerne Coil (D, Trans) ..	AW377A			
Big-power Melody Two with Lucerne Coil (SG, Trans) ..	AW388A			
Lucerne Minor (D, Pen) ..	AW426			
A Modern Two-valver ..	WM409			
Three-valve : Blueprints, 1s. each.				
Class B Three (D, Trans, Class B) ..	AW386			
New Britain's Favourite Three (D, Trans, Class B) .. 15.7.33	AW394			
Home-built Coil Three (SG, D, Trans) ..	AW404			
Fan and Family Three (D, Trans, Class B) .. 25.11.33	AW410			
£5 5s. S.C. 3 (SG, D, Trans) .. 2.12.33	AW412			
1934 Ethel Searcher: Baseboard Model (SG, D, Pen) ..	AW417			
1934 Ethel Searcher: Chassis Model (SG, D, Pen) ..	AW419			
Lucerne Ranger (SG, D, Trans) ..	AW422			
Coscor Melody Maker with Lucerne Coils ..	AW423			
Mullard Master Three with Lucerne Coils ..	AW424			
£5 5s. Three: De Luxe Version (SG, D, Trans) .. 19.5.34	AW435			
Lucerne Straight Three (D, RC, Trans) ..	AW437			
All-Britain Three (HF, Pen, D, Pen) ..	AW448			
"Wireless League" Three (HF Pen, D, Pen) .. 3.11.34	AW451			
Transportable Three (SG, D, Pen) ..	WM271			
£6 6s. Radiogram (D, RC, Trans) ..	WM318			
Simple-tune Three (SG, D, Pen) .. June '33	WM327			
Economy-Pentode Three (SG, D, Pen) .. Oct. '33	WM337			
"W.M." 1934 Standard Three (SG, D, Pen) ..	WM351			
£3 3s. Three (SG, D, Trans) .. Mar. '34	WM354			
Iron-core Band-pass Three (SG, D, QP21) ..	WM362			
1935 £6 6s. Battery Three (SG, D, Pen) ..	WM371			
PTP Three (Pen, D, Pen) .. June '35	WM389			
Certainty Three (SG, D, Pen) ..	WM393			
Minutube Three (SG, D, Trans) .. Oct. '35	WM396			
All-wave Winning Three (SG, D, Pen) .. Dec. '35	WM400			
Four-valve : Blueprints, 1s. 6d. each.				
65s. Four (SG, D, RC, Trans) ..	AW370			
"A.W." Ideal Four (2 SG, D, Pen) .. 16.9.33	AW402			
2HF Four (2 SG, D, Pen) ..	AW421			
Crusaders' A.V.C.4 (2 HF, D, QP21) (Pentode and Class B Outputs for above : Blueprints, 6d. each) .. 25.8.34	AW445A			
Self-contained Four (SG, D, LF, Class B) .. Aug. '33	WM331			
Lucerne Straight Four (SG, D, LF, Trans) ..	WM350			
£5 5s. Battery Four (HF, D, 2LF) .. Feb. '35	WM381			
The H.K. Four (SG, SG, D, Pen) .. Mar. '35	WM384			
The Auto Straight Four (HF Pen, HF Pen, DDT, Pen) .. April '36	WM404			
Five-valve : Blueprints, 1s. 6d. each.				
Super-quality Five (2HF, D, RC, Trans) .. May '33	WM320			
Class B Quadradyne (2 SG, D, LF, Class B) .. Dec. '33	WM344			
New Class-B Five (2 SG, D, LF, Class B) .. Nov. '33	WM340			
<b>Mains Operated.</b>				
Two-valve : Blueprints, 1s. each.				
Consoelectric Two (D, Pen) A.C. ..	AW403			
Economy A.C. Two (D, Trans) A.C. ..	WM286			
Unicorn A.C.-D.C. Two (D Pen) ..	WM394			
<b>THREE-VALVE : BLUEPRINTS, 1s. each.</b>				
Home-Lover's New All-electric Three (SG, D, Trans) A.C. ..	AW383			
S.G. Three (SG, D, Pen) A.C. ..	AW390			
A.C. Triodyne (SG, D, Pen) A.C. .. 19.8.33	AW399			
A.C. Pentaquester (HF Pen, D, Pen) A.C. .. 23.6.34	AW430			
Mantovani A.C. Three (HF Pen, D, Pen) A.C. ..	WM374			
£15 15s. 1936 A.C. Radiogram (HF, D, Pen) .. Jan. '36	WM401			
Four-valve : Blueprints, 1s. 6d. each.				
All-Metal Four (2 SG, D, Pen) .. July '33	WM326			
Harris Jubilee Radiogram (HF Pen, D, LF, P) .. May '35	WM386			
<b>SUPERHETS.</b>				
Battery Sets : Blueprints, 1s. 6d. each.				
Modern Super Senior ..	WM375			
Varsity Four .. Oct. '35	WM395			
The Request All-Waver .. June '36	WM407			
1935 Super Five Battery (Superhet) ..	WM379			
<b>Mains Sets : Blueprints, 1s. 6d. each.</b>				
1934 A.C. Century Super A.C. ..	AW425			
Heptode Super Three A.C. .. May '34	WM359			
"W.M." Radiogram Super A.C. ..	WM366			
1935 A.C. Stenode .. Apl. '35	WM385			
<b>PORTABLES.</b>				
Four-valve : Blueprints, 1s. 6d. each.				
Midget Class B Portable (SG, D, LF, Class B) .. 20.5.33	AW389			
Holiday Portable (SG, D, LF, Class B) .. 1.7.33	AW393			
Family Portable (HF, D, RC, Trans) .. 22.9.34	AW447			
Two H.F. Portable (2 SG, D, QP21) .. June '34	WM363			
Tyers Portable (SG, D, 2 Trans) ..	WM367			
<b>SHORT-WAVE SETS—Battery Operated.</b>				
One-valve : Blueprints, 1s. each.				
S.W. One-valver converter (Price 6d.) ..	AW329			
S.W. One-valver for America .. 23.1.37	AW429			
Rome Short-Waver ..	AW452			
Two-valve : Blueprints, 1s. each.				
Ultra-short Battery Two (SG det., Pen) .. Feb. '36	WM402			
Home-made Coil Two (D, Pen) ..	AW440			
Three-valve : Blueprints, 1s. each.				
World-ranger Short-wave 3 (D, RC, Trans) ..	AW355			
Experimenter's 5-metre Set (D, Trans, Super-regen) .. 30.6.34	AW438			
Experimenter's Short-wave (SG, D, Pen) .. Jan. 19, '35	AW463			
The Carrier Short-waver (SG, D, P) .. July '35	WM390			
Four-valve : Blueprints, 1s. 6d. each.				
A.W. Short-Wave World-Beater (HF, Pen, D, RC, Trans) ..	AW436			
Empire Short-Waver (SG, D, RC, Trans) ..	WM313			
Standard Four-valver Short-waver (SG, D, LF, P) .. Mar. '35	WM383			
Superhet : Blueprint, 1s. 6d.				
Simplified Short-waver Super .. Nov. '35	WM397			
<b>Mains Operated.</b>				
Two-valve : Blueprints, 1s. each.				
Two-valve Mains short-waver (D, Pen) A.C. ..	AW453			
"W.M." Band-spread Short-waver (D, Pen) A.C.-D.C. ..	WM368			
"W.M." Long-wave Converter ..	WM380			
Three-valve : Blueprint, 1s.				
Emigrator (SG, D, Pen) A.C. ..	WM352			
Four-valve : Blueprint, 1s. 6d.				
Standard Four-valve A.C. Short-waver (SG, D, RC, Trans) .. Aug. '35	WM301			
<b>MISCELLANEOUS.</b>				
Enthusiast's Power Amplifier (1/6) .. June '35	WM387			
Listeners' 5-watt A.C. Amplifier (1/6) ..	WM392			
Radio Unit (2v) for WM392 .. Nov. '35	WM398			
Harris Electrogram (battery amplifier) (1/-) .. Dec. '35	WM399			
De-Luxe Concert A.C. Electrogram .. Mar. '36	WM403			
New Style Short-Wave Adapter (1/-) .. June '35	WM388			
Trickle Charger (6d.) .. Jan. 5, '35	AW462			
Short-Wave Adapter (1/-) .. Dec. 1, '34	AW456			
Superhet Converter (1/-) .. Dec. 1, '34	AW457			
B.L.D.L.C. Short-wave Converter (1/-) .. May '36	WM405			
Wilson Tone Master (1/-) .. June '36	WM406			
The W.M. A.C. Short-Wave Converter (1/-) ..	WM403			



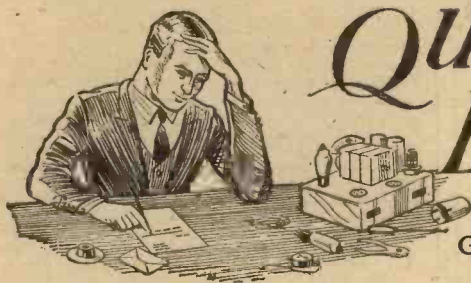

# QUERIES and ENQUIRIES

## The Quench Valve

"Would you please explain what a quench valve is, and a self-quenching detector? What do these quench valves do? Also, what is a regenerative circuit?"  
—R. G. T. (Mundesley).

REGENERATION is simply another word for reaction, and means that H.F. energy is fed back from the anode to the grid circuit of a valve. In the ordinary reacting valve there is a limit to the amount of feed-back or regeneration which can be used, owing to the fact that the circuit bursts into oscillation. In the super-regenerative circuit, the feed-back is permitted to take place until this oscillation occurs, and is carried even further. To enable signals to be received, however, the oscillation is quenched, or interrupted, by means of a further series of oscillations at a different frequency, obtained from another valve (the quench valve) or by means of a special circuit arrangement in the reacting valve circuit. The quenching takes place so that the note produced by the oscillation is above audibility and the technical term for this is "supersonic." This is abbreviated to super and thus the term "super-regenerative" is obtained.

## D.C. Test Supply

"I have a certain amount of service work to carry out in my district, which is now A.C. after having been D.C. for a considerable time. Some of the residents are not yet changed over and I now and again have D.C. sets to service and find a certain amount of difficulty in obtaining the necessary high voltage and high current required for testing. I want up to 200 watts so that I can test radiograms, and wonder if it could be obtained cheaply, as expense is not justified in view of the small amount of work done in this connection."—G. R. (Harrow).

A VERY effective scheme for your purpose is recommended by the service department of H.M.V., and consists of the employment of a discarded A.C. mains transformer and some rectifying valves. The A.C. supply is fed to the primary and one side is also taken out to the D.C. plug, to which you will connect your receivers for test. The other side of the A.C. supply is joined to one side of a 4-volt winding on the mains transformer which feeds the heaters of, say, four rectifiers connected in parallel; the two anodes of each rectifier are strapped together so that the assembly functions as a heavy-current half-wave rectifying unit. The anodes are, of course, the negative D.C. output feed and a large capacity electrolytic condenser should be joined across the D.C. output to remove the ripple which is left. This arrangement permits each rectifier to function within its limits, and when a very large radiogram, for instance, is to be tested, the gramophone section should be disconnected and tested separately to avoid overloading the rectifiers.

## Getting the Short Waves

"I have a Ferranti receiver which only works on the medium and long waves. This is an A.C. model only. I should like the receiver to work on the short waves, but I am somewhat confused by the "adapter" and "converter" systems. Could you explain which I should require to make this an all-wave receiver?"  
—D. W. F. (Preston).

IN your case you would use a converter. This is a single valve unit in the simplest form, provided with a short-wave tuning

### RULES

We wish to draw the reader's attention to the fact that the Queries Service is intended only for the solution of problems or difficulties arising from the construction of receivers described in our pages, from articles appearing in our pages, or on general wireless matters. We regret that we cannot, for obvious reasons—

- (1) Supply circuit diagrams of complete multi-valve receivers.
- (2) Suggest alterations or modifications of receivers described in our contemporaries.
- (3) Suggest alterations or modifications to commercial receivers.
- (4) Answer queries over the telephone.
- (5) Grant interviews to querists.

A stamped addressed envelope must be enclosed for the reply. All sketches and drawings which are sent to us should bear the name and address of the sender.

Requests for Blueprints must not be enclosed with queries as they are dealt with by a separate department.

Send your queries to the Editor, PRACTICAL AND AMATEUR WIRELESS, George Newnes, Ltd., Tower House, Southampton Street, Strand, London, W.C.2. The Coupon must be enclosed with every query.

circuit and so arranged that it functions as a frequency changer. Consequently, when connected to your present set, the combination becomes a superhet receiver and your Ferranti receiver has then to be tuned to a point on the long-wave band—about 2,000 metres—and all tuning for short waves then carried out on the separate converter unit. We have published several designs which you could make up, or you could purchase a ready-made A.C. converter. Some of these are provided with a switch so that the unit may be left permanently connected to your receiver and the switch operated to bring in the short-wave tuning band when required.

## The Tutor Three

"I am having trouble in ganging my condensers with the coils in the Tutor Three. I have re-wired the receiver and find that reception is louder by using the end terminal as well as the aerial connected together."—L. G. H. (Ilford).

WE advise you to make quite certain that you have the correct type of ganged condenser. You require a straight type of condenser, not a superhet model, and should confirm this point. When you couple the terminals mentioned you are cutting out the primary winding of the aerial coil and this will naturally improve signal strength, although it will also reduce selectivity and thus broaden the tuning.

## Replacing Speaker

"I have an A.C. mains receiver which has given good service for over four years. I have had it overhauled, new valves and one or two new components put in, and my service man tells me that I would do well to have a new speaker to complete the repair. I believe this would be an advantage but should like your confirmation, and also to know the best type of speaker for the job. The output is 6 watts and I am keen on getting better quality than at present."—G. F. E. (Crewe).

THE replacing of the speaker may not be a simple matter. If the present model is an ordinary permanent-magnet speaker, then any good modern P.M. speaker could be used to replace it provided that a suitable matching transformer is fitted so that the correct load for the output valve could be obtained. If, on the other hand, an energised model is used, it will be necessary to find the resistance of the field winding, and to obtain an equivalent model with a similar inductance value to provide the correct degree of smoothing. If you prefer a P.M. model a special L.F. choke of the same inductance and resistance could be used to replace the field winding.

## What Wattage?

"I wish to build a small amplifier for use in a small dance hall. I am uncertain regarding the power needed to fill the hall from gramophone records while the people are dancing. There will be about 100 people present and I should like to know what power you recommend and if you have a suitable design which I could make up. The apparatus will be needed permanently."—F. R. (New Brighton).

YOU do not mention the size of the hall, and we can therefore only give you a rough indication. When 100 people are dancing, the background noise will be quite considerable and will naturally demand that a larger output is needed than would be required for addressing a sitting crowd of that size. We suggest 10 to 15 watts, if the hall is of medium size, although you may find that in a large hall even more volume than that would be needed. We shall be publishing details of a powerful P.A. amplifier in the next week or two, and think the design there given (12 watts from a push-pull PX25A stage) will be adequate for your purpose.

## Servicing Superheterodynes

"I am running a small service department in my shop and find that the majority of assistants are not sufficiently well up in superhet technique to be able to get down to the job of servicing these sets. What is the best way to go about it? Is there any book which will be of assistance in understanding the modern complicated superhet, especially where visual tuning and variable-selectivity devices are fitted."—F. G. (York).

A VERY good book for your purpose has recently been placed on the English market. Although it deals with the American receivers (being published in America and written by an American) the general treatment is such that it will be of the greatest use in understanding the modern superhet. The book is very practical and is classified into various sections. It may be obtained from Messrs. Holiday and Hemmerdinger, of Holmer Works, Dolefield, Bridge Street, Manchester; price 5s.

The coupon on page 552 must be attached to every query.

**Miscellaneous Advertisements**

Advertisements are accepted for these columns at the rate of 3d. per word. Words in black face and/or capitals are charged double this rate (minimum charge 3/- per paragraph). Display lines are charged at 6/- per line. All advertisements must be prepaid. All communications should be addressed to the Advertisement Manager, "Practical and Amateur Wireless," Tower House, Southampton Street, Strand, London, W.C.2.

**RECEIVERS, COMPONENTS AND ACCESSORIES**

Surplus, Clearance or Secondhand, etc.

**RADIOMART SHORT-WAVE MANUAL**

Packed with short-wave information and circuits of mains and battery receivers, including straight, superhet and 5-metre transmitters, modulators, etc. Information on transmitting licences, aerials, Class B amplifications, neutralizations, superhet alignment, etc. The most comprehensive manual published, written by practical engineers, price 6d., post free, 71d. including catalogue.

1937 Short-wave Catalogue only (3 times enlarged) price 11d., post free.

**44, HOLLOWAY HEAD, BIRMINGHAM 1**

ALL goods previously advertised are standard lines, still available. Post card for list free. VAUXHALL UTILITIES, 163a, Strand, W.C.2, Over Denny's the Booksellers, Temple Bar 9338.

CONVERSION UNITS for operating D.C. Receivers from A.C. Mains, improved type, 120 watts output at £2/10/0. Send for our comprehensive list of speakers, resistances and other components.

WARD, 40, Farringdon Street, London, E.C.4. Telephone: Holborn 9703.

REPAIRS to Moving Coil Speakers, Cones and Coils fitted or rewound. Fields altered. Prices Quoted including Eliminators, Loudspeakers, Repaired, 4/-. L.F. and Speech Transformers, 4/- post free. Trade invited. Guaranteed. Satisfaction. Prompt Service. Estimates Free. J.S. Repair Service, 5, Balham Grove, London, S.W.12. Battersea 1321.

SPECIAL Summer Sale now proceeding at our Holborn premises. All lines previously advertised still in stock.

RADIO CLEARANCE, 63, HIGH HOLBORN, W.C.1. Tel.: Hol. 4631.

THE largest stock of components in England, over 500 lines, new catalogue now ready 11d.—J. Bearfield, 105, Upper Street, London, N.1.

BANKRUPT Bargains. List free. All new goods. Decca 1937 6v. A.C. superhets, 16. Ditto, all-wave, £7. Ditto, 18gn. A.C. superhet radiograms, 12gns. Burgoyne 4v. S.G. portables, complete batteries, 52s. 6d. 4v. A.C./D.C. American table models, 70s. 1937 Pilot 12 gn. A.C. all-wave, £8 10s. Ditto 14 gn. A.C./D.C., £10. Many others. Large stock replacement valves, components, etc., all kept prices. State requirements.—Butlin, 6, Stanford Avenue, Brighton.

**VALVES**

THE Simplest Equation. Price+Quality—Radiographic Ltd. Satisfaction guaranteed. American Valves 3/-. Lineords 350 OHMS. Midget Speakers, Electrolytic Condensers, Resistors, Volume Controls, etc.—Radiographic, Ltd., 66, Osborne Street, Glasgow, C.1.

**MISCELLANEOUS**

MOVIES at Home. How to make your own Cinema Projector. Particulars, stamp.—Moviescope (L), Pear Tree Green, Doddinghurst, Essex.

**PREMIER SUPPLY STORES**

All goods guaranteed perfect; carr. paid over 5/-; under 5/- postage 6d. extra.

ALL POST ORDERS TO JUBILEE WORKS, 167, LOWER CLAPTON RD., LONDON, E.5. 'Phone: Amherst 4723.

CALLERS, AS USUAL, TO 165 & 165a, FLEET ST., E.C.4 (Next door to Anderson's Hotel), Central 2833. New Branch: 50, HIGH ST., CLAPHAM, S.W.4 (Macaulay 2381).

Have you had our GIANT ILLUSTRATED CATALOGUE AND VALVE LIST? Send 4d. IN STAMPS FOR THIS BARGAIN LIST.

NEW 1937 1-VALVE SHORT-WAVE RECEIVER OR ADAPTOR KIT, 13 to 86 metres without coil changing. Complete Kit and Circuit, 12/6. VALVE GIVEN FREE! DE LUXE MODEL 14 to 150 Metres, complete Kit with Chassis, 4 Coils and all parts, 17/6.

SUPERHET CONVERTER KIT, 12/6. De Luxe Model, 18/6. S.W. SUPERHET CONVERTER KIT, for A.C. Mains Receivers, 20/-. A.C. Valve given FREE!

NEW 1937 2-VALVE S.W. KIT, 13 to 86 Metres without coil changing. Complete Kit and Circuit, 19/8. VALVES GIVEN FREE. DE LUXE MODEL, 14 to 150 Metres, complete Kit and Chassis, 4 Coils and all parts, 25/-. VALVES GIVEN FREE. 3-VALVE S.W. KIT, S.G. Det. and Pen., 42/-. VALVES GIVEN FREE.

SHORT-WAVE COILS, 4- and 6-pin types, 13-26, 22-47, 41-94, 78-170 metres, 1/9 each, with circuit. Special set of 3 S.W. Coils, 14-150 metres, 4/- set, with circuit. Premier 3-band, S.W. Coil, 11-25, 19-40, 38-80 metres. Simplices S.W. receiver construction, suitable any type circuit, 2/6.

COIL FORMERS in finest plastic material, 1 1/2in. low-loss ribbed, 4- or 6-pin, 1/- each.

The New "Premier" Short Wave CONDENSERS, with Troituit insulation. Certified superior to Ceramic. All-Brass Construction. 15 mmfd., 1/4; 40 mmfd., 1/7; 100 mmfd., 1/10; 160 mmfd., 250 mmfd., 2/8. S.W. H.P. Chokes, 9d.; screened, 1/6. All-Brass S.W. Condensers with integral slow-motion, .00015 Tuning, 3/9; .00015 Reaction, 3/3.

Famous EUROPA MAINS VALVES, 4 v. A.C. and 20 v. 18 Universal. All standard types, 4/6. I.H. Pentodes and F.W. Rectifiers, 5/6.

BATTERY VALVES, 2 volts, H.F., L.F., 2/3. Power, Super-Power, 2/9. S.G., Var-Mu-S.G., 4- or 5-pin Pentodes, H.F. Pens., V-mu-H.F. Pens., 5/-. Class B, 5/-.

AMERICAN VALVES. Genuine American HYTRON and TRIAD first-grade Valves, 3/- each guarantee. All types in stock, 5/6 each. 210 and 250, 8/6 each. New Metal-Glass Valves all types, 6/6 each. Genuine American DUOTRON Valves, all types, 3/6 each. Valve holders for all above types, 6d. each, OCTOL bases, 9d. each.

3-WATT A.C. AMPLIFIER, 2-stage for mike or pick-up. Complete kit of parts with 3 valves, 40/-. Wired and Tested, £215 0.

7-WATT A.C./D.C. AMPLIFIER, 3-stage high-gain, push-pull output. Complete kit of parts with 5 specially matched valves, 24/6. Completely Wired and Tested, 26/5 0.

COSMOCORD PICK-UPS, with tonearm and volume control, 10/8 each. PICK-UP HEADS only, 4/8 each.

PREMIER MAINS TRANSFORMERS, wired-end type with screened primaries, tapped 200-250 v. Centre-tapped Filaments. Guaranteed one year. H.T. 8 & 9 or H.T.10 with 4 v. 4 a. C.T. and 4 v. 1 a. C.T., 8.6, 250-250 v. 60 m.a., 4 v. 1 a., 4 v. 2 a., and 4 v. 4 a., all C.T., 8/6. 350-350 v. 120 m.a., 4 v. 1 a., 4 v. 2 a., and 4 v. 4 a., all C.T., 11/-. Any of these transformers with engraved panel and S.P. terminals, 1/6 extra. 500-500 v. 150 m.a., 4 v. 2-3 a., 4 v. 2-3 a., 4 v. 2-3 a., 4 v. 3-4 a. all C.T., 17/6. SPECIAL OFFER PHILIPS MAINS TRANSFORMERS. 250-250 v. or 300-300 v. at 80 m.a., 4 v. 5 a., C.T.; 4 v. 1 a. Tapped Primary 100-250 volt., 6/11. 450-450 v. at 150 m.a., or 500-500 v. 100 m.a., 4 v. 4 a., C.T.; 4 v. 4 a., 4 v. 4 v. 2 a., Screened Primary. Tapped input 100-250 v., 15/6. AUTO TRANSFORMERS, step up or down, 60 watts, 7/8; 100 watts, 10/-. SMOOTHING CHOKES 25 m.a., 2/9; 40 m.a., 4/-; 60 m.a., 5/8. 150 m.a., 10/6. Speaker Replacement Chokes, 2,500 ohms, 60 m.a., 5/6.

SPECIAL OFFER LISSÉN TWO-GANG SCREENED ALL-WAVE COILS. 12 to 2,000 metres, complete with switching and wiring diagrams, 6/11 per set.

MAGNAVOX MOVING COILS. Mains energised. "154," 7in. cone, 2,500 ohms 4 watts, 12/8; "152" 9in. cone, 2,500 ohms, 17/8; "152 Magna," 9in. cone, 2,500 ohms 6 watts, 37/6. Magnavox P.M.'s—"204," 7in. cone, 16/6; "252," 9in. cone, 22/6.

ROLA latest type P.M.'s, 15". GOODMAN'S 8in. mains energised, 1,000 ohms field, 10/6 each.

JENSEN P.M. Speakers, 10/8. R. and A. energised Speaker, 7in. diameter, 2,500  $\Omega$  field. Pentode Transformer, strongly recommended, 11/6.

Special Offer BTH Energised Moving Coils 10in. diam. 1,450 ohms field Power or Pentode transformer (state which), 14/6.

OUTPUT TRANSFORMERS for Power or Pentode, 2/6; Multi-Ratio, 4/6.

TUBULAR CONDENSERS, non-inductive all values up to 5 mmfd., 6d. each. 1 Watt Resistors, 6d. 4 Watts, 1/-.

All Goods previously advertised. Still available.

**MISCELLANEOUS**

A DICTIONARY OF WIRELESS TERMS, by Ralph Stranger. A Wireless Work of Reference that should be on the bookshelf of every keen amateur. Compiled by a master of lucidity, it gives the meanings of all Technical terms in general use. Price 2s. 6d. from all Booksellers and Newsagents.—George Newnes, Ltd., Tower House, Southampton Street, Strand, London, W.C.2.

FIFTY TESTED WIRELESS CIRCUITS, by F. J. Camm, 2s. 6d.—This handbook contains every modern circuit complete with instructions for assembling, component values, and notes on operation. Obtainable at all Booksellers and Newsagents.—George Newnes, Ltd., Tower House, Southampton Street, Strand, London, W.C.2.

PERPLEXITIES and TANTALISERS.—"The Strand Problem Book" is the finest collection of puzzles of all kinds ever assembled, mathematical, geographical, literary—acrostics and codes, by W. T. Williams (Tantalus) and C. H. Savage. Only 2s. 6d. net from all Booksellers.—George Newnes, Ltd., Tower House, Southampton Street, Strand, London, W.C.2.

**ALL THE LATEST RADIO EQUIPMENT to be shown at RADIOLYMPIA**

will be available on the LOWEST EASY TERMS

WE GUARANTEE COMPLETE SATISFACTION. PROMPT DELIVERY. All goods carr. paid. CASH OR C.O.D. ORDERS delivered by return of post.

★ REMEMBER—WRITE US ABOUT YOUR NEXT REQUIREMENTS —We will quote the best possible terms.

MC CARTHY CHASSIS always in Stock. New Demonstration Room now open.

Estd. 1925 THE LONDON RADIO SUPPLY COMPANY 110 AT LANE NOBLE STREET LONDON, E.C.2

**FOYLES**

Booksellers to the World.

Special department for Wireless Books. 119-125 CHARING CROSS RD., LONDON, W.C.2 Telephone: Gerrard 5000 (12 lines).

**M.P.R. 6/7 WATT AMPLIFIER**

6-VOLT CAR BATTERY MODEL. The M.P.R. Car Battery Model obtains all its energy from a 6-volt car battery, and is particularly suitable for Fetes, Sports meetings and Portable advertising service where mains supply is not available. Complete amplifier, with valves and volume control, ready for connecting to pick-up, or microphone. Price £6 0s. 0d. net. Send for full particulars. M.P.R. Electrical Co., 252, Victoria Road, Romford, Essex.

**FREE ADVICE BUREAU COUPON**

This coupon is available until August 28th, 1937, and must be attached to all letters containing queries. PRACTICAL AND AMATEUR WIRELESS, 21/8/37.

**ADVERTISEMENT INDEX**

Belling and Lee, Ltd.	Page 543
British Institute of Engineering Technology	549
Electradix Radios	549
Foyle	552
International Correspondence Schools	544
London Radio Supply Company	552
M.P.R. Electrical Co.	552
McCarthy Radio, Ltd.	Inside Back Cover
Peto Scott Co., Ltd.	543
Player's Airman Tobacco	547
Premier Supply Stores	552

# STANDARD WIRELESS BOOKS

## EVERYMAN'S WIRELESS BOOK

By F. J. CAMM

A Radio Consultant for the Listener, Expert and Amateur Constructor explaining the Operation, Upkeep and Overhaul of all types of Wireless Receivers, with Special Chapters on the Principles of Radio Telephony, Installation and Systematic Fault-finding.

With 200 Illustrations and Diagrams.

3/6 net

(4/- post free)

## THE WIRELESS CONSTRUCTOR'S ENCYCLOPEDIA

By F. J. CAMM

Wireless terms and definitions stated and explained in concise, clear language by one of the best-known and most popular designers and writers on the practical side of wireless construction. Profusely illustrated. A veritable treasure of wireless knowledge.

5/- net

(5/3 post free) Inland

## FIFTY TESTED WIRELESS CIRCUITS

By F. J. CAMM

Modern circuits of practically every type from crystal to superhet. Diagrams and instructions for assembling and wiring. Details of components and notes on operation.

2/6 net

(2/10 post free)

## THE OUTLINE OF WIRELESS

By RALPH STRANGER

Here is a book which covers the theory and practice of Wireless Reception from A to Z, and makes everything plain even to the most "non-technical" reader.

WORLD RADIO: "Step by step, line upon line, precept upon precept, it teaches you everything you want to know about wireless."

816 pages: Lavishly Illustrated.

8/6 net

(9/- post free) Inland

## THE MATHEMATICS OF WIRELESS

By RALPH STRANGER

This brilliant and experienced writer on Wireless has a happy knack of making even the driest and most abstruse topic interesting—and amusing! He has a characteristic way of handling mathematics which appeals irresistibly to those to whom previously the subject has seemed both difficult and dull.

5/- net

(5/5 post free)

**GEORGE NEWNES, LIMITED**

Tower House, Southampton Street, Strand, W.C.2.



**MCCARTHY**

## OUTSTANDING 9-VALVE FOUR-WAVE SUPERHET

*For all-wave reception at its very best*

To the all-wave enthusiast, this exceptional receiver offers a number of interesting features, with quite unusual range, and power output. Few receivers at present on the market can claim so high a standard of design and performance.



**12 GNS.**

(Complete with 9B.V.A. valves.)

4 wavebands: 12.8-33, 29-80, 190-550, 600-2100 metres. Illuminated dial with principal station names. Separate coloured lights for each waveband.

Circuit in Brief.—Aerial input to pre-selector circuit, radio frequency amplifier, latest type triode-hexode frequency changer, 2 band-pass I.F.T. coupled I.F. amplifiers, double diode detector, L.F. amplifier, parallel transformer-coupled push-pull triode output giving 6 watts. Heavy cadmium-plated steel chassis. Finest components and workmanship throughout.

**DE LUXE MODEL 14 GNS.**

Many additional refinements—full particulars on application.

Controls.—A feature of the receiver is the number of independent controls fitted, making it extremely interesting to operate. These include: sensitivity control (varying bias on R.F. stage), Q.A.V.C. with manual muting control, and switch for inter-station noise suppression. 5-position wave-change and gramophone switch. Progressive variable tone control operative on radio and gram.

A.C. models ready for immediate delivery.

A.C./D.C. models also in production, and will be available for delivery shortly.

### IMPORTANT

The prices at which McCarthy Chassis are advertised include Marconi Royalties. "Practical and Amateur Wireless" readers should, for their own protection, make sure before purchasing any receiver that the quoted price includes the Royalty payment.

All McCarthy receivers supplied complete with valves, knobs, pilot lamps, leads, mains cable and plug. 12 months guarantee.

Deferred terms on application, or through London Radio Supply Co., 11, Oat Lane, E.C.2.

Cash with order on 7 days' approval. Also write for illustrated catalogue of complete range of all McCarthy receivers.

**MCCARTHY RADIO LTD.**  
44a, Westbourne Grove, London, W.2

Telephone: Bayswater 3201/2.

A WONDERFUL WORK FOR ALL ENGINEERS . . .

# NEWNES' "ENGINEERING PRACTICE"

A MONEY-MAKING INVESTMENT

47 EXPERT CONTRIBUTORS

With the publication of "ENGINEERING PRACTICE" everyone interested in engineering matters can now avail himself of the experience of 47 PRACTICAL EXPERTS. These men have written down in simple language the results of their years of experience, and at a very nominal cost you can take advantage

of this wonderful collection of expert knowledge.

Hundreds of special photographs, line drawings and diagrams show in detail all kinds of engineering operations, from the rolling of a locomotive tyre to the packing of a gland, and to the correct method of fitting a driving pulley on a shaft.

A STANDARD REFERENCE WORK FOR

- WORKS ENGINEERS
- CHARGE ENGINEERS
- MOTOR MECHANICS
- DRAUGHTSMEN
- PATTERN MAKERS
- MOULDERS
- FITTERS
- TURNERS, ETC.



A Purchaser writes: "I appreciate the clear way in which the processes are described and illustrated. It is easy to see that your contributors are practical men who have been through the mill."

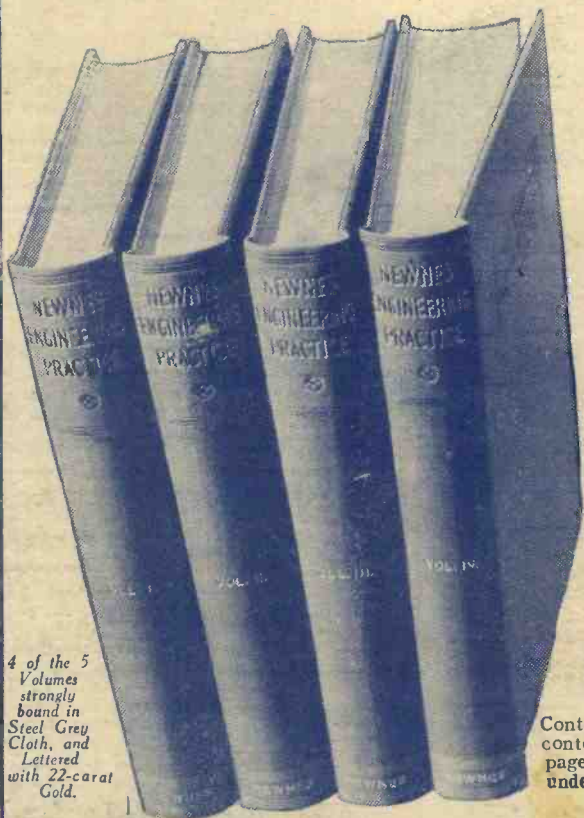

4 of the 5 Volumes strongly bound in Steel Grey Cloth, and Lettered with 22-carat Gold.

POST COUPON TO-DAY FOR FREE BOOKLET

To the HOME LIBRARY BOOK COMPANY Tower House, Southampton Street, London, W.C.2.

Please send me, without any obligation to purchase, full particulars of ENGINEERING PRACTICE and details of your scheme of Easy Payments with immediate delivery.

Name .....

Address .....

P. Wire. 21837

If you do not wish to cut your copy, send post card mentioning "Practical Wireless" to address above.

Containing full list of contents, specimen pages, etc. You are under no obligation whatsoever!

George Newnes, Ltd.

Published every Wednesday by GEORGE NEWNES, LIMITED, Tower House, Southampton Street, Strand, London, W.C.2, and Printed in England by THE NEWNES & PEARSON PRINTING CO., LTD., Exmoor Street, London, W.10. Sole Agents for Australia and New Zealand: GORDON & GORCH, LTD. South Africa: CENTRAL NEWS AGENCY, LTD. Practical and Amateur Wireless can be sent to any part of the World, post free, for 17s. 8d. per annum; six months, 8s. 10d. Registered at the General Post Office as a newspaper and for the Canadian Magazine Post.

GREATLY ENLARGED NUMBER :--COMPLETE GUIDE TO THE SHOW.

# Practical 3<sup>D</sup> and Amateur Wireless

EVERY  
WEDNESDAY

Edited by F.J. CAMM

AND PRACTICAL TELEVISION

A GEORGE  
NEWNES  
Publication

Vol. 10, No. 258.  
August 28th, 1937.



Prizes - 25 "W.B." SPEAKERS

THREE SETS for  
CONSTRUCTORS  
ALL-WORLD RADIO

TELEVISION at OLYMPIA

Many Special Features!



**NEW Stentorian** speaker—

**"AN IMMENSE STEP FORWARD"**

Says Mr. Camm

# G.E.C. makes Radiolympia news

**NEW STANDARDS OF SHORT-WAVE RECEPTION**

World listening available to all.

**EXTRA VALVE THAT MAKES ALL THE DIFFERENCE**

**NO EXCUSE NOW FOR NOISY RECEPTION**

New device kills mains-borne interference

**ENGINEERS PERFECT 'CHILD'S-PLAY' TUNING SYSTEM**

Marvels of Chromoscopic dial and Tuneray indicator

*and that's only a part of G.E.C. progress this year*

WRITE for booklet number B.C. 8123, which gives full particulars of the full range of G.E.C. Radio.



*A complete new range*

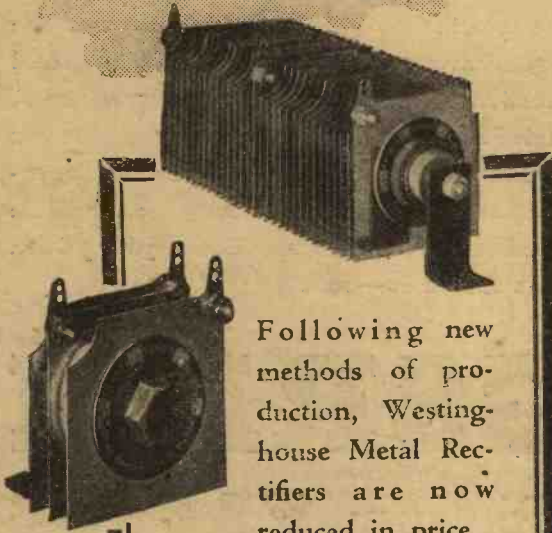

Following new methods of production, Westinghouse Metal Rectifiers are now reduced in price.

The complete new range of H.T. and L.T. units will be exhibited on

# STAND 77 RADIOLYMPIA,

and full details are given in the new 1938 edition of "The All Metal Way." Get a copy at the Stand, or use the attached coupon.

## WESTINGHOUSE METAL RECTIFIERS

---COUPON---

Westinghouse Brake & Signal Co. Ltd.,  
82, York Road, King's Cross, London, N.1.

Please send me a copy of "The All Metal Way, 1938." I enclose 3d. in stamps.

Name.....

Address.....

Prac. 28/8/37.

# POLAR

## SPECIFIED

for the

### "ORACLE All-Wave THREE"

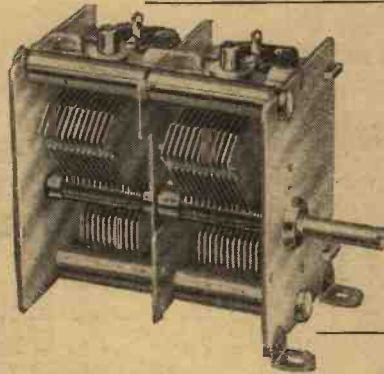

#### POLAR BAR Type 2-GANG CONDENSER

Steel frame ensuring great rigidity. Aluminium vanes. Low minimum capacity.

Price 12/-  
(Also made in 3-gang 17/6)

#### POLAR "COMPAX"

Solid dielectric condenser for tuning or reaction. One hole fixing. Complete with knob. One .00015 required.

Price 2/6

(Also obtainable in cap.: .0005, —.0003 —.001 & .00005 — 2/6 each.)

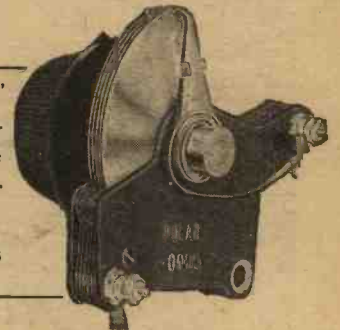

#### POLAR V.P. HORIZONTAL DRIVE

Slow motion with vertical moving pointer. Scale calibrated with station names and degrees. Moulded escutcheon. Lamp-holders.

Price 6/6

Send for fully illustrated Catalogue of Polar and Polar N.S.F. Components.

## WINGROVE & ROGERS, Ltd.

188/189, Strand, London, W.C.2.

'Phone: Temple Bar 2244.

Works: Old Swan, Liverpool.

# There's a TUNGSRAM for every circuit!

From the superhet multi-valve to the short-wave one — Tungstram have a type for every circuit. All standard English and American type valves (pin and octal bases) are included in the Tungstram range. When once you have fitted Tungstram you can sit back in confident expectation that they will give you a long life of reliable working. Remember—Tungstram do everything that a good valve should do — well.

STAND No. 36  
Grand Hall  
Ground Floor  
Olympia

# TUNGSRAM

MANUFACTURED AT  
TOTTENHAM, LONDON

Barium **VALVES**

*The valve with the name behind it!*

**HERE** RADIOLYMPIA VISITORS are INVITED TO SEE the Latest Short Wave DEVELOPMENTS.



## EDDYSTONE RADIO

STRATTON & Co., Ltd., Eddystone Works,  
Bromsgrove Street, BIRMINGHAM.

\* ASK FOR 1938 ILLUSTRATED CATALOGUE  
FREE ON REQUEST



**OLYMPIA**  
STAND **93**

## PRECISION COMPONENTS SPECIFIED by Mr. F. J. CAMM for the ALL-WORLD ACE

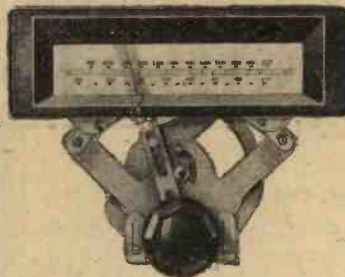

### J.B. BABY GANG CONDENSER

Very compact design. Rigid construction, perfect bearings and complete screening. Ball-bearing spindle.  
Two-gang, .0005 mfd. Price **10/6**

### J.B. STRAIGHT LINE DRIVE

As illustrated. Calibrated degrees and wavelengths. Hair-line cursor and travelling lamp-holder. Black or brown bakelite escutcheon. Single ratio 8 to 1. Price **5/9**  
Type S.L.4.

### The New J.B. ALL-WAVE "LINACORE"

The All-Wave version of the ever-popular J.B. "Linacore" Tuner Unit, creator of vivid all-world radio of an entirely new order, will be fully described in our next week advertisement. Make a note to look out for it. See the New "Linacore" on Stand 93, Olympia.

JACKSON BROS. (LONDON) LTD. 72, ST. THOMAS ST., LONDON, S.E.1.  
Telephone: UOP 1687



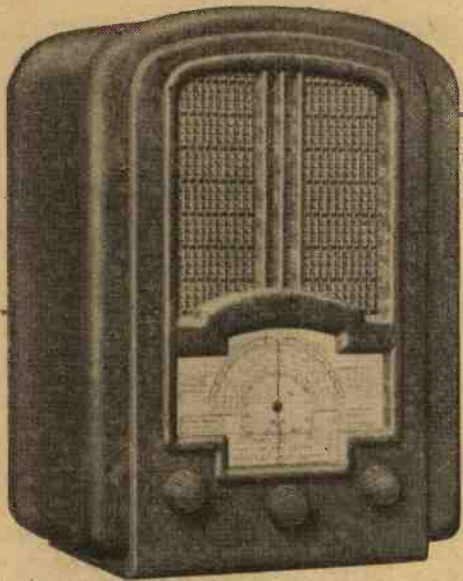

# Ferranti "837" challenges comparison

Look and compare FERRANTI 1937 value, reliability and performance with the corresponding features of any other radio whatsoever. The Ferranti 837 Receiver has been designed to be reliable. Rugged, simple construction and new production methods guarantee a dependability and freedom from failure never before obtainable. By the use of new and simplified circuits the general performance has also been made better than in previous sets costing much more. Examination of the rust-proof steel chassis indicates the excellent and simple construction.

A new multiple valve circuit is used, employing iron cored coils on medium and long waves, giving 9 kilocycle selectivity, the 450 kilocycle I.F. greatly reducing second channel interference on short waves. The performance on short waves from 16.7 to 52 metres is such that whenever short wave programmes may be satisfactorily received on any set the 837 reproduces them well.

A special double concave reflector ensures uniform illumination of the multi-coloured dial, on which a 180 degree scale is provided to assist short wave logging.

The Ferranti energized moving coil speaker gives powerful, good-quality reproduction, being fed from a compensated double diode output pentode giving 2½ watts *undistorted* output, with a maximum of 3½ watts.

**FERRANTI ALL-WAVE SUPERHET**

**"837" - 9 GNS.**

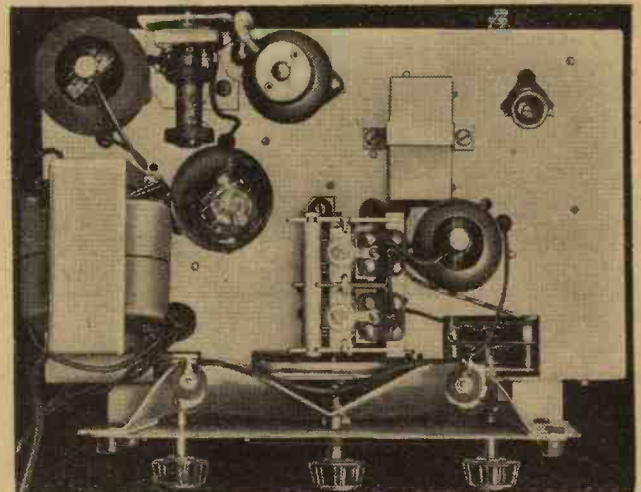

837 Chassis, viewed from above

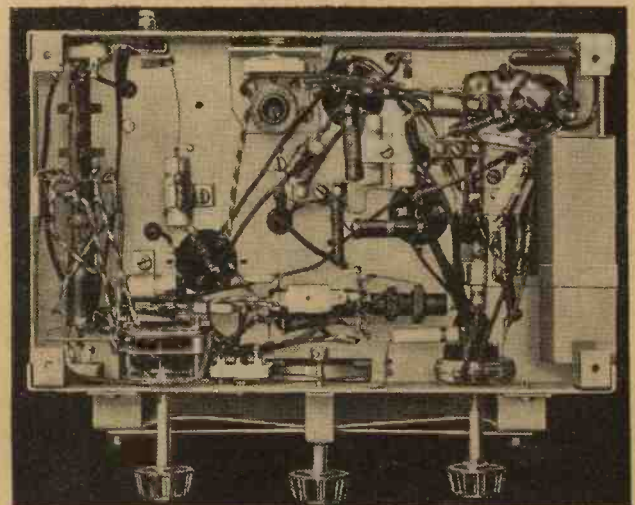

837 Chassis, viewed from below



# "HIS MASTER'S VOICE"

## 1937/38 All-World Radio at RADIOLYMPIA, Stands 66 & 76



Model 655—AC Armchair Radio, incorporating revolving bookcase and glass-topped table. 10 Valve Model—5 Wavebands—10 Watts Output—Fluid Light, Vernier Scale, Two-speed tuning. Variable selectivity. Separate Bass and Treble Tone Controls. **36 GNS.**



Model 660—AC Autoradiogram—10 Valve Model—5 Wavebands—10 Watts Output. Fluid Light. Vernier Scale. Two-speed tuning. Variable selectivity. Separate Bass and Treble Tone Controls. **2 speakers. 6.2 GNS.**



Model 650—AC Receiver—10 Valve Model—5 Wavebands—10 Watts Output. Fluid Light. Vernier Scale. Two-speed tuning. Variable selectivity. **24 GNS.**



Model 801—AC High Fidelity Autoradiogram—10 Valve Model—5 Wavebands—10 Watts Output. Fluid Light. Vernier Scale. Two-speed tuning. Separate Bass and Treble Tone Controls. **3 speakers. 80 GNS.**

### AC 6 VALVE MODELS—5 WAVEBANDS



Model 582 Bureau Autoradiogram. Fluid Light. Vernier Scale. Two-speed tuning. Separate Bass and Treble Tone Controls. **50 GNS.**



Model 496 Receiver. Fluid Light. Vernier Scale. Two-speed tuning. Separate Bass and Treble Tone Controls. **19 GNS.**



Model 498 Autoradiogram. Fluid Light. Vernier Scale. Two-speed tuning. Separate Bass and Treble Tone Controls. **40 GNS.**

Model 485a Autoradiogram. Vernier Scale. Two-speed tuning. Separate Bass and Treble Tone Controls. **35 GNS.**

Model 488 Similar model without Auto-Changer. **29 GNS.**

### 8 VALVES-4 WAVEBANDS 5 WATTS OUTPUT



Model 469—AC—Receiver. Fluid Light. Vernier Scale. Two-speed tuning. Variable selectivity. Separate Bass and Treble Tone Controls. **19 GNS.**

### AC 6 VALVE MODELS—3 WAVEBANDS



Model 495 Radiogram. Two-speed tuning. Continuous Tone Control. **23 GNS.**

Model 492 Radiogram. Two-speed tuning. Three position Tone Control. **22 GNS.**

Model 494 Receiver. Two-speed tuning. Continuous Tone Control. **12 GNS.**



Model 499 Receiver. Fluid Light. Two-speed tuning. Continuous Tone Control. **14 GNS.**

Model 490 Compact autoradiogram form of Model 499. **34 GNS.**

### AC 7 VALVE MODEL 3 WAVEBANDS

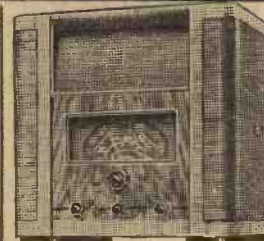

Model 482 Receiver. Fluid Light. Two-speed tuning. Vernier Scale. Six position Tone Control. **16 GNS.**



Model 479—AC—Radiogram. Fluid Light. Vernier Scale. Two-speed tuning. Variable selectivity. **38 GNS.**

### AC/DC 5 VALVES—3 WAVEBANDS



Model 487 Radiogram. Three position Tone Control. Two-speed tuning. **26 GNS.**

Model 493 Autoradiogram. Similar to Model 487, with automatic record changer. **33 GNS.**



Model 486 Receiver. Three position Tone Control. Two-speed tuning. **13 GNS.**

### "H.M.V." LOUDSPEAKERS

Model 172. All-purpose Permanent Magnet Loudspeaker with inbuilt Volume Control. **3 GNS.**  
 Model 184. Wide Angle Sound Distribution speaker with inbuilt Volume Control. **£5-17.6**

### "H.M.V." PICK-UP

with remote volume control and screened connecting leads **32/6**

### ECONOMICAL BATTERY MODELS



Model 166 Five-valve Superhet. Three wave ranges. Two-speed tuning. Three position Tone Control. **13 GNS.**



Model 167 Three-valve Receiver. 170-580 and 800-2000 metres. Moving Coil Loudspeaker. **7 GNS.**



Model 149 Three-valve Receiver. Three wave ranges. Two-speed tuning. Two-speed volume. **9 GNS.**



Model 464 Six-valve Superhet Transportable. 200-550 and 900-2000 metres. Three position Tone Control. **15 GNS.**



7-2,200 metres. New Type **45/1-**

**VISIT ALSO THE "H.M.V." TELEVISION THEATRE — No. 14**

# NEXT WEEK: STAND-TO-STAND REPORT

# Practical and Amateur Wireless

*First Souvenir Number*

Edited by **F. J. CAMM**

Technical Staff:  
**W. J. Delaney, H. J. Barton Chapple, Wh. Sch., B.Sc., A.M.I.E.E., Frank Preston.**

**VOL. X. No. 258. August 28th, 1937.**

### 25 Loudspeakers as Prizes

**I**N accordance with our usual policy, we are celebrating the Radio Exhibition by making a presentation of twenty-five of the latest 1938 W.B. speakers to our readers. These speakers are awarded to the winners of an interesting free-for-all competition, of such a nature that every reader stands an equal chance. Turn to page 575 and read the details now. Remember, there is nothing to pay and there are no irksome restrictions. The Editor of this journal will act as judge, in conjunction with the W.B. Engineers, and the result of the competition will be published shortly after the closing date.

### Stratosphere Transmitters

**T**O report upon the weather conditions in the stratosphere, miniature transmitters have been designed which are capable of being carried by small gas-filled balloons. The transmitter sends out a series of dashes at regular intervals, interrupted by means of a special barometrical device so that the height and speed of travel may be accurately recorded on the ground. The balloon bursts at a certain height and the transmitter descends by parachute. A reward is offered for its safe return.

### Concert from Cheltenham

**T**HE Cheltenham Municipal Military Band, Reginald New (organist) and Michael North (entertainer), will give a concert at the Town Hall, Cheltenham, on August 30th. The Band is conducted by Arthur Cole, musical director to Cheltenham Corporation. Mr. New, famous for

Trio (Ida, Zara and Anna Nelson) will broadcast Trios by Arensky and Beethoven, and Arthur Catterall and John Wills will be heard on the same day (National) in Beethoven's Sonata in C minor for Violin and Pianoforte, and a Ballade by B. J. Dale.

### "The Rocky Mountaineers"

**A**NTHONY HALL, of the B.B.C. Variety Department, who will be responsible for the production in the Regional programme on August 30th of the Rocky Mountaineers in "Swing that Axe," once worked in a timber camp in Sweden for a year. The new show, written and presented by Bill Campbell, opens, aptly enough, with the tremendous crashing of an axe-swinging competition, after which the characters retire to the old bunkhouse where the "boys" make music with their fiddles and guitars.

## ROUND the WORLD of WIRELESS

his long series of recitals on cinema organs, has frequently been guest organist at Cheltenham. Mr. North is well known for his original songs at the piano; he wrote the music for a number of Midland radio shows.

### Chamber Music

**A**LEXANDER BOROVSKY will give a recital of piano music by Liszt on September 5th (National), and on September 6th (Regional) Sophie Wyss will sing songs by contemporary Swiss composers: Volkmar Andrae, Pierre Maurice and Othmar Schoeck. On the same day (National) Edmund Rubbra will play works for the piano by three of Bach's sons: Carl Philip Emanuel, Wilhelm Friedrich, and Johann Christian. On September 7th (National), the Canadian

### Satire on "Jerry Building"

**O**FFICIALLY styled a humorous cantata, "The Builders of England," which is to be broadcast in the Regional programme on September 1st, is really a clever satire on "jerry building." Written by Hugh E. Wright, the well-known actor (who in the radio production will also play the part of builder's foreman), it tells, to the music of T. C. Sterndale Bennett, the story of Jack and Jill and the house they built.

Editorial and Advertisement Offices:  
 "Practical and Amateur Wireless," George Newnes, Ltd.,  
 Tower House, Southampton Street, Strand, W.C.2.  
 Phone: Temple Bar 4363.  
 Telegrams: Newnes, Rand, London.  
 Registered at the G.P.O. as a newspaper and for transmission  
 by Canadian Magazine Post.



# ROUND the WORLD of WIRELESS (Continued)

## From Radiolympia

WE understand that two further broadcasts will be given from the Radiolympia theatre: one on August 30th in the Regional programme, and the other on September 4th in the National.

Each will run for one hour, and each will include Bobby Howland and his Orchestra, Paula Green, Louis Levy and his Symphony with Janet Lind and Gerry Fitzgerald, the Dagenham Girl Pipers and Drummers, and Donald Thorne and Harry Farmer at the organ.

The earlier show will also bring to the microphone the Royal Mastersingers, Murray and Mooney, Phyllis Robins, Mr. Flotsam and Mr. Jetsam, and Ethel Revnell and Grace West who, by the way, write all their gags in little school copy books. Among the stars in the second show will be the Heron Sisters; Mamie Soutter; Forsythe, Seamon and Farrell; Payne and Hilliard; and Leonard Henry.

The programmes have been devised and will be produced by Jack Swinburne; and Sutherland Felce will be the compère.

## Noel Coward's Music

ON September 2nd Reginald Burston will conduct the Revue Orchestra and B.B.C. Midland Revue Chorus in a diagonalised programme of Noel Coward's music from the Midland transmitter. The broadcast for National listeners will be on September 1st. Mr. Burston was Music Director of "Cavalcade" and other Cochran-Coward productions. Martyn C. Webster will present the programme. Marjorie Westbury will be the soprano soloist.



The new Cossor All-wave A.C. Mains Radiogram, Model 538.

## Police Band Concert

RICHARD WASSSELL will conduct the Birmingham City Police Band in a popular programme on August 31st. P.C. Lyon will be the oboe soloist, and P.C. Tibbenham flute soloist for the "William Tell" overture. The vocalist will be Margaret Severn (contralto).

## INTERESTING and TOPICAL NEWS and NOTES

### Wireless and the Blind

"WIRELESS has increased the appetite for news," says the National Institute for the Blind. Far from affecting adversely the circulation of the "Braille Mail," it has proved itself that journal's friend.



Florence Desmond, the well-known actress, with her new Mullard M.A.S.8 receiver.

### "Glamour" from Weymouth

HARRY BENET will present a Concert Party, "Glamour," from the Alexandra Gardens, Weymouth, on September 2nd. The cast will include: Bunny Doyle (comedian), Adrienne Brune (soprano), Marie Makino (comedienne), Robert Kepple (baritone), Cecil Frederick (light comedian), Bunty Meadows (soubrette), Chris Weede (comedian), and the Cosmopolitan Band, directed by Cyril Dawson.

### Private View

SUMMER visitors are never tired of complaining about seaside boarding houses and the shortcomings of their landladies. Western listeners will hear the other side of the question from a landlady on August 27th.

### Organ Recital from Aberdeen

HAROLD COOMBS, the popular Sheffield organist, will be heard at the organ of the Capitol Cinema in Aberdeen on September 2nd. He will play, among other pieces, a paso doble, Le Touquet, by Evans; a selection of Wilfred Sanderson's popular songs; and Amy Woodforde-

Finden's Four Indian Love Lyrics. Coombs made his first concert appearance as a pianist at the age of six. Later he became a church organist and musical director in various cinemas.

### Illuminations Broadcast

DESCRIPTIVE commentaries by John Polwarth on the Sunderland illuminations will be given to Northern listeners on August 31st, when the programme will also include interludes by Mantovani and his Tipica Orchestra from Roker Park.

Sunderland. Unusually interesting pictures in lights, which "speak" as well as move, are a feature of Sunderland's illuminations this year.

### Midland Band Concert

THE Leicester Imperial Band, which is to play a popular programme on August 30th, had its beginnings nearly seventy years ago. It has won numerous prizes at the Crystal Palace, Belle Vue and Midland Contests. S. S. H. Iliffe, for many years its conductor, was a boy prodigy on cornet and trumpet. In the interludes John Arnold will play pianoforte solos. He was pianist on the "Majestic," and has broadcast from New York.

### Melody and Rhythm

MARTINI and his Music will provide the Melody, and Eric Jeffcote and his Quartet the Rhythm in the programme entitled

"Melody and Rhythm," to be broadcast on August 31st from the Midland Regional.

## SOLVE THIS!

### PROBLEM No. 258

The Cossor 210 VP1 valve in Howard's receiver burnt out so he replaced it by a Mullard VP2, as he was told that this valve has approximately the same current consumption and impedance as the 210 VP1. Why were results unsatisfactory after the substitution had been made? Three books will be awarded for the first three correct solutions opened. Address your solutions to the Editor, PRACTICAL AND AMATEUR WIRELESS, George Newnes, Ltd., Tower House, Southampton Street, Strand, London, W.C.2. Envelopes must be marked Problem No. 258 in the top left-hand corner and must be posted to reach this office not later than the first post on Monday, August 30th, 1937.

### Solution to Problem No. 257

The bypass condenser connected across the bias resistance of the I.F. valve was internally open-circuited.

The following three readers successfully solved Problem No. 256, and books are accordingly being forwarded to them: J. M. Mathers, 18, Stair St., Glasgow, N.W.; D. Babcock, 2, Bedford Rd., Harrow, Middx.; G. R. Turlington, 44, New Bridge St., Leicester.

# An Open Letter to Our Readers and the Trade

By THE EDITOR



## Gentlemen,

THE history of radio is largely interwoven with Radiolympia, for interlarded with the best known of all Exhibitions are the names of those who have been responsible for its development. Marconi, most famous of all associated with our industry, has passed on. Though dead, his name will live for ever and the work he so ably led will go on. Fortunately he lived to see the consummation of his ideals within the comparatively short space of 15 years. It is fitting at this time, when manufacturers are looking hopefully towards good sales and good profits during the next season, that we should pay a mental tribute to the one above all who was responsible for it. We are a young industry, so young, in fact, that many changes can be foreshadowed within the next 10 years, and to the gentlemen of the industry I would issue a warning note that progress and long vision are not entirely divorced from eventual profits.

## Absurd Tuning Scales

I would urge you, therefore, not to be satisfied with existing designs and not to spend too much time on titivating cabinets and elaborating the tuning dials. A little of your time, if I may be allowed to suggest it, might usefully be employed in ensuring that the set will receive from any location in England the stations whose names are so tastefully engraved on those dials. Many sets there are which do so, but a number fail to give satisfaction. Nothing is to be gained by overstating the case. If you smother the dial with station names, the customer has a right to be discontented if such stations cannot be received. It is much better to use fewer names and let the customer discover that he

can receive more than you have shown. I congratulate you manufacturers on your wise step in increasing the prices of your products rather than cutting the quality to maintain the old price level. You had a good case for a greater increase, for the cost of almost every other commodity had risen before you decided to increase yours. I see that the average increase is about  $7\frac{1}{2}$  per cent. Prices beforehand had reached a cut-throat stage where it was impossible for the profits to allow ample margin for development. The public will not complain, for it is my opinion that this year's wireless receivers will mark a vintage year in radio, just as certain cars have vintage years. Whilst you have concentrated your attention on marketing receivers, once again it is my bitter complaint that you have neglected the constructor. I am their advocate, and I wish to advise you on their behalf that they are by no means a noisy minority. The circulation of this journal, I can assure you, provides tangible evidence of the fact that interest in home construction is maintained. It is one of those few hobbies, like photography, which will remain. Each year a new generation springs up which wishes to learn all about radio. Do not neglect it; it can provide you with profits, just the same as it did in the early days when you were only too anxious to use constructors as the foundation of your businesses. You will not be unaware of the complaints of constructors regarding deliveries during the past year. I would ask your assurance that you will do better next. I am disappointed that so many of you have neglected television. In this I think you show a lack of business acumen, for television is as inevitable as talking pictures.

## Sightless Radio

I say that in 10 years sightless radio will be as obsolete as silent films are to-day. I also say that it is upon home constructors that you will depend for what I might term local information, when the chain of television transmitters is eventually erected throughout the country. You may imagine that you have the best technical brains that money can buy, but such is of little avail without an expert army of testers in the form of amateur constructors. Therefore, I would ask you to produce a range of television components. It will save you an enormous amount of costly experiments when you decide later on to market television receivers. We are only on the fringe of television. It is a local service at present. Eventually colour television must come, and, in fact, it is easier of production than colour films. You require the services of the experimenter, and you will not be able to solve all of the difficulties in your own laboratories. I would urge the dealer not to neglect the constructor and to stock a reasonable range of components. As it is, many readers are compelled to purchase direct through the post, and money which should be spent locally comes to London. A cycle dealer or a motor agent does not confine his attention merely to the selling of bicycles or motor cars; he stocks accessories, and you must do so if you are to remain in the business. My

(Continued on page 564)

# THE TREND OF DESIGN

THE improvement in the external appearance of the 1938 receivers as compared with the 1937 models indicates that the manufacturers are alive to the fact that the cabinet sells the set in the majority of cases. It cannot be said that any firm has drastically altered the shape of its cabinets, but there has been a tendency to lower the height in most cases. A marked improvement is noticeable in the external finish, however, especially in models priced over £10. For the cheaper models moulded bakelite is being used by several firms; it has probably been realised that a well-designed bakelite cabinet looks decidedly better than a roughly finished wooden type.

## Dials

Tuning dials have gradually increased in size every year since 1932, and 1938 brings further worthwhile improvements in dial design. In fact, it is the improvements in this direction that are the most noticeable on this year's receivers. Apart from the fact that they have been made clearer and larger on most receivers, dial position has been altered to advantage in many models. Several well-known makes of receiver have the dial above the speaker, sloping inwards at the top. There is no doubt that this method of mounting is a step in the right direction, as it places the scale at the best reading level if the set is resting on a table of the average height. Philips are retaining the Adaptovisor dial which they incorporated in several of their models last year. With this type the angle of the scale with respect to the top of the cabinet is variable from approximately 20 to 80 degrees, so that the level can be altered to suit the listener's height or the height of the table on which the set is placed. At least two manufacturers will be exhibiting receivers with what they term a "disappearing" dial—the dial protrudes above the cabinet and can be slid inside the cabinet when the set is not in use. I cannot say that this type appeals to me as being an improvement on the normal sloping type, but it is certainly an innovation, and as such will probably create a good deal of interest.

## Controls

Some manufacturers, notably Cossor, are introducing side controls this year. This method of mounting has probably been adopted in order to facilitate tuning with the new "top-of-cabinet" dials. Side controls were quite commonly used about five years ago, but for some reason have fallen into disuse during the past three or four years. Their re-adoption cannot be termed a retrograde step, however—they are at a more natural position for operation than the front-of-cabinet type, and if recessed they give the cabinet a cleaner appearance. Solo-knob control was introduced by a few firms two or three years ago, and is being retained on some of the higher-priced 1938 models. This type is not likely to be universally popular as the average listener is quite prepared to twiddle three or four knobs, and the service engineer certainly prefers to have separate controls, but as in the case of the recessed side control the solo-knob control gives the cabinet a cleaner appearance, and is likely to appeal to a large percentage of listeners.

## Circuit Design

The most important improvement in circuit design this year is probably the

*Indicating the Main Improvements Which Will be Found in the 1938 Receivers*  
By IDRIS EVANS



General view of one of the latest Cossor receivers in the "48" series.

universal incorporation of the so-called all-wave tuner. I say so-called because most of the all-wave receivers cover only three wavebands—viz., approximately 16

**VISIT OUR STAND**  
**No. 10**  
**GROUND FLOOR**

to 50 metres, 200 to 550 metres, and 900 to 2,100 metres. Some of the more expensive types have a fourth band covering approximately 6 to 12 metres, however, and can therefore tune to the television transmitter's wavelength. A large number of all-wave sets were available last year, but this year it would seem that the two waveband receiver is definitely in the minority—even the lowest priced mains receivers are of the three-band type.

The predetector section of most of the 1938 models incorporates a standard superhet circuit arrangement employing a frequency changing valve and an intermediate frequency amplifier. Cossor have introduced a somewhat novel circuit arrangement in this section of their low-priced receivers, however. They use a

frequency changer coupled by means of a special intermediate frequency transformer to a reacting pentode rectifier. This circuit arrangement was used on the Continent about two years ago, but did not meet with a great measure of success. Cossor seem to have overcome the difficulties experienced then, however, and their receivers of this type give a very good performance.

## Output Stage

Last year a large number of superhets employed a double-diode detector, resistance coupled to a pentode output valve. It is rather surprising that very few receivers having this circuit arrangement are to be found this year—the double-diode triode takes the place of the double-diode in most receivers. This modification provides a higher degree of low-frequency amplification, of course, but necessitates more effective decoupling if the quality of reproduction is to be maintained at the same level. In most receivers priced under £18 the output valve is a high-slope pentode or a tetrode—the output tetrode has recently been introduced by several valve manufacturers, and it is claimed that this type provides better quality of reproduction than the pentode. The higher-priced sets use various combinations in the output stage—pentodes in parallel, pentodes in push-pull, triodes in push-pull, and there is one at least with a double push-pull output stage using triodes.

## Speakers

The listener who attaches great importance to quality of reproduction should have no difficulty in satisfying his needs this year. The more common use of console cabinets for their standard chassis has enabled several manufacturers to fit a larger sized speaker than is normally used for table models. This naturally tends to improve quality of reproduction, as apart from the fact that the large type of speaker is better able to handle a heavy input, better bass response is obtained owing to the large baffle area of the cabinet face. In some of the R.G.D. models a single twelve inch speaker operates into a special sound pressure balancing chamber. In the most expensive H.M.V. models, on the other hand, three special elliptical speakers are used. Dynatron, like R.G.D., favour a single speaker unit, however, but in their most expensive model the single unit is fitted into a special corner cabinet.

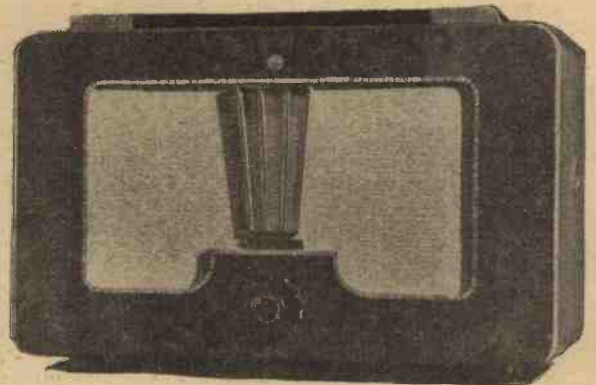

The new Philips 7-valve all-wave superhet. Model 787.



An all-purpose mains transformer by Wearite. This provides output for English or American valves.

THE home-constructor will obviously wander round the stands at Olympia and study the new styles of design which are being used this year, and note points regarding layout, etc. His chief concern, however, will be "What new components are available for me?" He will thus pay particular interest to such stands as those of Bulgin, Peto-Scott, Wearite, Telsen, and others who cater for the home-constructor. This year, Messrs. Bulgin will be showing no fewer than 27 new lines on their stand, and the other manufacturers will also be able to show completely new lines.

No doubt the main item of interest to be seen on these stands is the all-wave tuning coil. In the past we have had various types of screened coil obtainable from different sources and in various designs to suit practically any type of circuit. This year, the all-wave feature has resulted in the component manufacturers producing coils, which, although very little larger than the present type of coils, will cover the short waves as well as the normal broadcast wavelengths. In fact, in one case, the new coil is smaller than the ordinary type of dual-range coil.

#### All-wave Coils

The full programme of many firms is not yet available, but the following have already released details of their all-wave coils: B.T.S., Varley, and Wearite. Each of these incorporates the necessary multi-contact wave-change switch, and is available in a single unit for ganging into various combinations. In addition to these, Messrs. Bulgin will be showing their existing 5-range coils, for which separate switching has to be arranged. They are, of course, able to supply the necessary switch and control rod in various combinations.

#### Tuning Condensers

For use with tuning coils, ganged condensers may now be obtained with very low minimum capacities, and owing to the fact that the inductance of coils has now been standardised, it is possible to purchase tuning dials or scales upon which station names are engraved. Components of this type may be seen on the stands of Bulgin, B.T.S., Jackson Bros., Polar, and others. It is very important to note the manufacturer's instructions regarding the use of the all-wave coil and tuning condenser, as in some cases the recommendation is made to remove the trimmers on the condenser unit in order to obtain a sufficiently low minimum setting on the short-wave tuning range.

# Components at Olympia

A Review of Some of the Home-constructor Component Parts which will be On View at this Year's Exhibition

By W. J. DELANEY

#### Mains Apparatus

An interesting new item for mains receivers is a transformer supplied by Messrs. Wright & Weaire (Wearite). This has a tapped secondary winding so that it may be used to provide 250 to 350 volts H.T. at 80 mA. The low-voltage heater windings are also tapped so that it is possible to obtain 4 amps. at 4 volts or 6.3 volts, and 2.5 amps. at 4 volts or 5 volts. It will thus be seen that either English or American valves may be used, and with a component of this type the experimenter is well-equipped to carry out a large number of experiments at the minimum of expense. This component costs 25s.

Messrs. Bulgin will be showing some new Vibrator Rectifier units and the associated transformers, by means of which high-tension

firms such as H.M.V. and Marconiphone are supplying all-wave aerial kits in which a section is arranged for the reception of television. Component parts for the construction of television receivers are to be seen on the stands of Bulgin, B.T.S., and Haynes. B.T.S. are also supplying complete kits of the television receivers as well as the completed receiver. On the Westinghouse stand will be seen the various types of rectifier which may be used in the television mains packs. For connection to the high-voltage systems needed for television, Messrs. Bulgin and Belling-Lee are supplying special connectors and other insulated components designed to afford ample protection to the user.

#### Sundry Items

So far we have dealt with specialised items, but in addition to these will be found dozens of other items which will interest the constructor. For instance, on the Bulgin stand will be found some interesting devices known as "liners" used for lining-up or trimming the superhet type of receiver. There are, of course, special oscillators which may be used for the same purpose, but which are of wider application. These will be seen on the stands of the Automatic Coil Winder company, Bulgin, and many other firms. Meters, with which no real experimenter can dispense, will be found in many parts of the exhibition. There are low-priced instruments, suitable for rough and ready tests of L.T. and receiver voltages, and high-class moving-coil instruments which may be used for servicing the most efficient and elaborate receiver. Such firms as Avo, Bulgin, Everett Edgecumbe, Weston and others can supply these. By using a single milliammeter it is possible to build up an all-purpose test instrument capable of carrying out all the tests needed by the experimenter. To enable it to be used for measuring A.C. a special rectifier has to be used, and rectifying instruments suitable

(Continued on page 605)



This is the useful 46 range Universal Avometer.

may be obtained from a low-tension accumulator. They are also able to supply a complete battery eliminator utilising this principle, designed to deliver 150 volts at 50 mA, with three tappings delivering 120 volts, 75 volts and a variable 0-100 volts.

#### Television Parts

The increased interest in television has resulted in quite a number of television parts being put on the market for the constructor, and these range from the necessary aerial system to complete kits for the construction of a television (sound and vision) receiver. Aerials may be seen on the stands of Belling & Lee, Bulgin, B.T.S., and Telsen, and in some cases it is possible to obtain a special aerial system designed to obviate interference. In addition, of course, certain

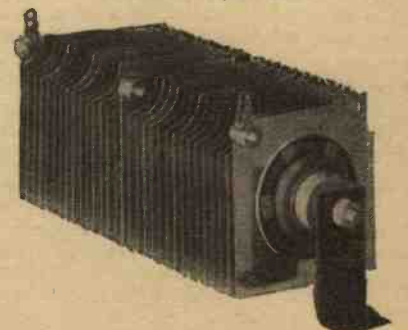

The Westinghouse rectifiers are now available in uncased form, and will simplify construction.

# Outstanding Receivers

Brief Details of a Few of the Outstanding Exhibits at This Year's Radiolympia

**I**n the low-priced class the Philips V7 receiver is a very interesting type. Theoretically this set is a standard four-valve superheterodyne, but the manufacturers have employed a very unique method of construction. The normal chassis has been dispensed with and the components are mounted on the sides and bottom of the cabinet, some of the valves lying horizontally and some vertically. By this means the receiver has been made very compact for a five-valver, and at its price of 7 guineas the performance is exceptionally good.

## Unusual Cossor Circuit

The Cossor 48 Series receivers are also worthy of note in the inexpensive class. Recessed side controls are used in these sets and the dial is a good example of the large clear type used in most of the 1938 models. The unusual feature of the 48 receivers is the circuit arrangement—three valves (plus rectifier) are used, the I.F. amplifying valve being omitted. The frequency changer is coupled to an H.F. pentode detector by means of a special type of I.F. transformer having a reaction winding. With the aid of this winding the detector can be made to oscillate and therefore C.W. morse can be received on the short-wave band. The reaction can also be made good use of to improve selectivity and sensitivity on the medium

plate. This wheel runs on ball bearings and spins the tuning indicator across the scale with the slightest touch. The receivers employing the spin-wheel system

model 1221 in their range is certainly worthy of especial note. It is an all-wave radio-gramophone employing 12 valves and tuning down to 16.5 metres. A resistance coupled push-pull output stage is used, and the massive 12in. moving-coil speaker feeds into a special sound pressure balancing chamber.

A still more elaborate instrument is the Dynatron Ether Empress. This employs 17 valves and 14 tuned circuits, five wave-bands down to 6.5 metres being covered. A special feature of this receiver is the visible tuning system. The station name is illuminated on tuning and is controlled by the signal. When the station is correctly tuned in the scale lights are dimmed and the station name lights up. A double push-pull output stage is used, giving an output of 15 watts, the output valves being fed into a Voigt loudspeaker housed in a special cabinet.

Most firms will be exhibiting television receivers this year, of course, and these are dealt with on page 596.

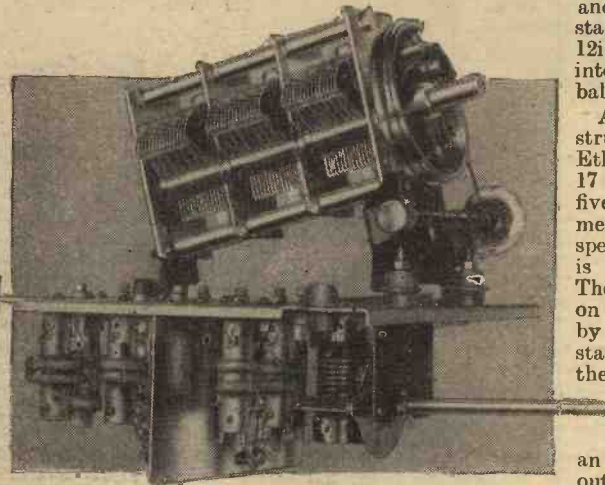

A novel shock-proof assembly used in the chassis of the latest range of Cossor receivers.

can be switched on and the tone and volume adjusted to the level required by the use of one finger.

## Woven Fibre Cabinets

In the medium-priced class we also have the new Texaloom receivers. These have standard all-wave chassis housed in woven fibre cabinets, and it is probable that this is the first time that fibre has been used for this purpose. It is certain that these receivers will create a great deal of interest, as, apart from the fact that a new material is used in making the cabinets, their design is unique. For example, there is a combination side-board bookcase and set, a radio cocktail cabinet, and a radio bookcase.

## High-priced Models

In the expensive receiver class there are at least three outstanding models this year. H.M.V. are exhibiting a very ambitious radiogram at 120 guineas. This incorporates an all-wave superhet tuning down to 7 metres, thus covering the wavelength of the British television sound transmitter. Two PX25 valves are connected in push-pull in the output stage, giving an output of 10 watts, and these feed into three elliptical cone speakers.

As usual, R.G.D. also have several expensive models, and

**ORDER NEXT WEEK'S  
ISSUE NOW!**

**Complete Stand-to-  
Stand Show Report**

**SAME PRICE, 3d.**

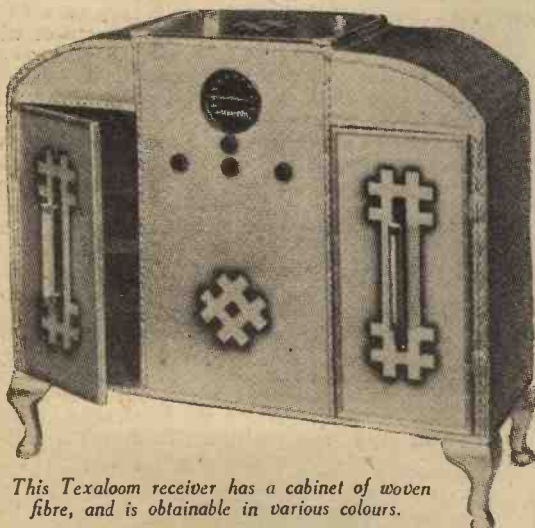

This Texaloom receiver has a cabinet of woven fibre, and is obtainable in various colours.

and long-wave bands. Automatic volume control is not incorporated in these models, and volume is manually controlled by means of a bias voltage potentiometer.

## Ekco Spin-wheel Tuning

In the £10 to £20 class cabinets and circuits are very similar to the 1937 models, except in one or two cases. Ekco spin-wheel tuning is likely to create a good deal of interest in this class. This tuning system somewhat resembles the old thumb drive, tuning being effected by spinning a milled wheel at the side of the escutcheon



The new H.M.V. eight-valve radiogram, model 479, which incorporates fluid-light tuning.



# The Oracle All-World Three

A Most Efficient All-wave Receiver Employing Two Tuned Circuits on the Three Wavebands. Highly Selective and Sensitive. By F. J. CAMM

It is appropriate that in a Show Issue produced at a time which coincides with the opening of Radiolympia, I should present a design which epitomises the spirit of Radiolympia. This year it is all-world radio which forms the theme of the Show, but yet I notice that some of the receivers do not quite live up to the title, for they do not receive the ultra short-waves. Neither does the Oracle, and as, therefore, it seems correct to describe as an all-wave receiver one which tunes from about 9 to 50 metres with a gap between 50 and 200 metres and 550 and 900 metres, but covers up to 2,100 metres on the long-wave band, I feel that I am erring in good company if I do err, in describing the Oracle as an all-world receiver. Some day we shall get down to some standard of definition. What is an all-wave set, and when it does it cease to be an all-wave set? What is the difference between an all-wave set and an all-world set? It is one thing to design a set for given wavebands, and quite another to design it so that you actually can receive those stations.

Whichever way you argue the Oracle is as good as the best commercial receiver in its class, and a good deal better than most. Its wavelength ranges are 19-50 metres, 200-550 metres, and 900-2,000 metres. These wave-ranges are covered without coil changing, which latter is a nuisance even though it may in some cases be more efficient. You will observe from the circuit diagram that there are two tuned circuits controlling the three wavebands—an arrangement which ensures a very high degree of selectivity and sensitivity.

The triode detector is coupled to the output pentode by an L.F. transformer, providing a very high degree of amplification without distortion. The moving-coil speaker specified perfectly matches the output valve chosen. It will be seen that the three valves are: H.F. pentode as H.F. amplifier, a triode as detector, and an L.F. pentode in the output stage. I can assure my readers that they cannot buy better than they can

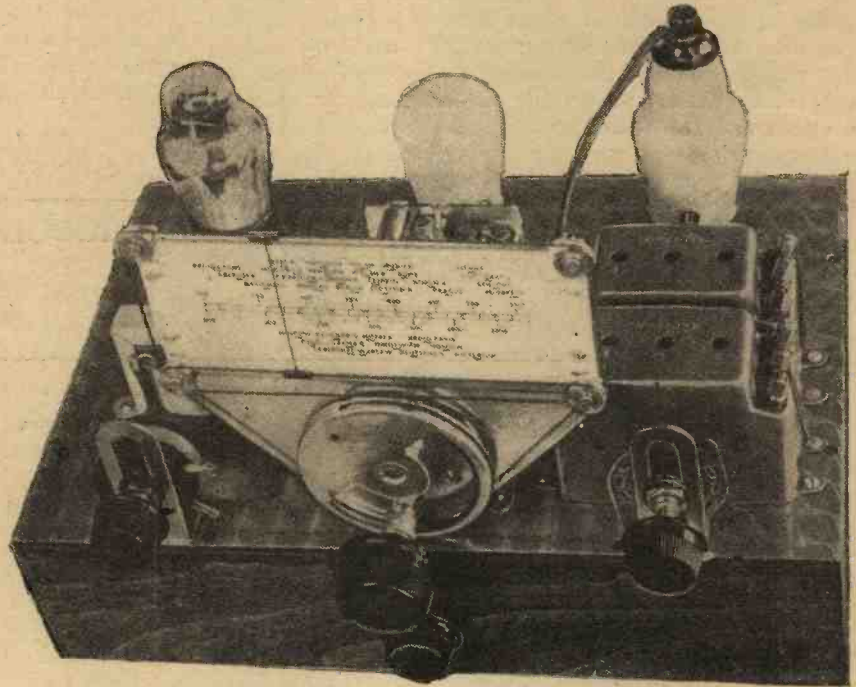

A simple and efficient layout characterises this simple three-valver.

build, and, of course, this receiver carries my guarantee.

It will be observed that instead of using the usual metallised wooden chassis I have employed metal-covered wood. This gives a cleaner and more professional appearance, and does not greatly add to the work of construction. The receiver is reasonably cheap, for Kit A costs only £4-5-0. The receiver may be built (I carefully timed this) in four hours. The theoretical circuit and the wiring diagram together with the illustrations of the receiver, will enable you to complete it without lengthy description, but for those who are making this their first

attempt at receiver construction I would point out that the joints or junction points between wires and components must be soundly made, especially as the receiver is used for short-wave reception. Badly-made joints may be all right for a time, but they soon give rise to all sorts of weird noises, and greatly interfere with the enjoyment which you can obtain from a well-made receiver. Of course, if you are able to solder—and every worth-while constructor should master this simple practice—you will make your connections with the aid of soldering tags and no troubles should arise. The makers of the coil have gone to

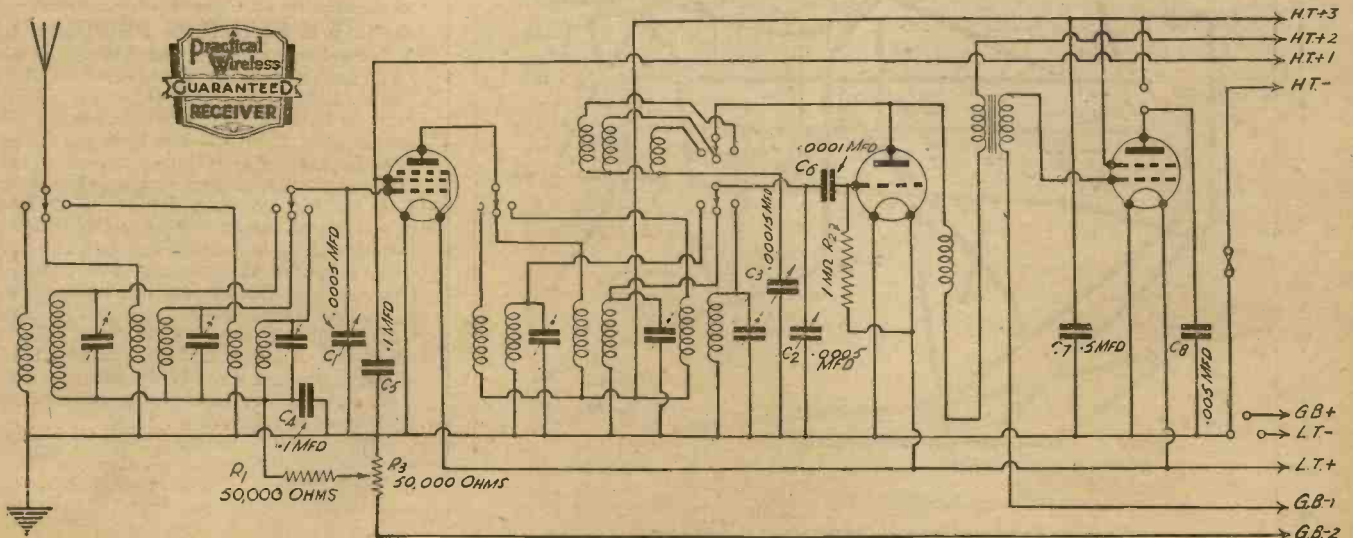

Theoretical circuit of the Oracle All-World Three.

TO OUR READERS AND THE TRADE

(Continued from page 559)

readers complain of the inordinate amount of time you take to execute orders, and I am well aware of the spurious excuses which you give to them. I am also aware of the shocking service and apparent ignorance of some of the so-called service engineers. I would ask the manufacturer of complete receivers to ensure before passing an agency that the manager of the service part of the business is qualified to handle and adjust a receiver costing several pounds. We do not take our watches to the blacksmith for repair, and yet the average person will entrust an expensive wireless set to the unskilled mercy of some draper's assistant who happens to know a terminal from a transformer and can thus impress the average dealer who knows even less.

Family Atmosphere

May I assure my readers that the policy of this journal will be continued with energy and enthusiasm and sincerity throughout the years. Its success is due to their loyalty and to their enthusiasm, and it is because there is a family atmosphere between Editor, Staff and Readers that it has so firmly established itself as the leader in its particular sphere. The fact that it has the largest net sales and the largest advertisement revenue of any journal in its class is tangible evidence of the esteem in which it is held by its readers and of its value as an advertising medium.

I am, Gentlemen,  
Yours faithfully,  
THE EDITOR.

WIRING DIAGRAM OF THE ORACLE ALL-WORLD THREE

THE ORACLE ALL-WORLD THREE

(Continued from page 563)

a great deal of trouble to make a fool-proof unit, and have avoided losses in the switching assembly. Do not, therefore, spoil their good work by making a haphazard job of the wiring up.

Next week I will deal at length with the various points met with in the construction, and will describe the process of tuning and operating this simple and efficient receiver.

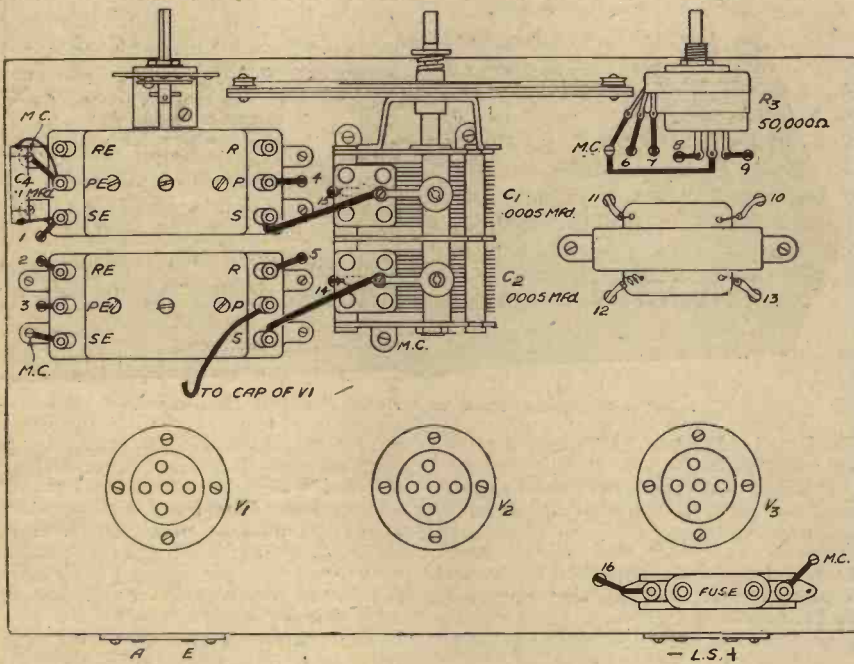

LIST OF COMPONENTS.

- Two all-wave coils, type Triogen, with ganging spindle (Wearite).
- One two-gang condenser, .0005 mfd. bar type (C1, C2) (Polar).
- One S.M. drive, V.P. horizontal (Polar).
- Five fixed condensers: .0001 mfd. (C6), .005 mfd. (C8), two .1 mfd. (C4, C5), .5 mfd. (C7)—tubular (T.C.C.).
- One reaction condenser, .00015 mfd., Compax (C3) (Polar).
- Two resistances: 1 meg. (R2), 50,000 ohms (R1) (½ watt) (Erie).
- One volume control with switch, 50,000 ohms (R3), V.M. 60 (Bulgin).
- One all-wave H.F. choke, H.F.15 (Bulgin).
- One L.F. transformer 4/1, L.F. 37 (Bulgin).
- Two component brackets (Peto-Scott).
- Three chassis valveholders: two 4-pin, one 5-pin (Clix).
- Seven wander plugs: H.T.1, H.T.2, H.T.3, H.T.—, G.B.+ , G.B.—1, G.B.—2 (Belling-Lee).
- Two spades: L.T.—, L.T.+ (Belling-Lee).
- Three valves: 210 V.P.T. (4-pin), 210 Det., 220 H.P.T. (Cosmor).
- One chassis: Plymax, 12in. x 8in. x 2½in. (Peto-Scott).
- One speaker, Stentorian Junior (W.B.).
- One fuse-holder with 60 mA fuse (Microfuse).
- Two socket strips, A.E. and L.S. (Clix).
- 120 v. H.T. battery (Exide).
- 9v. G.B. battery (Exide).
- 2v. L.T. accumulator (Exide).

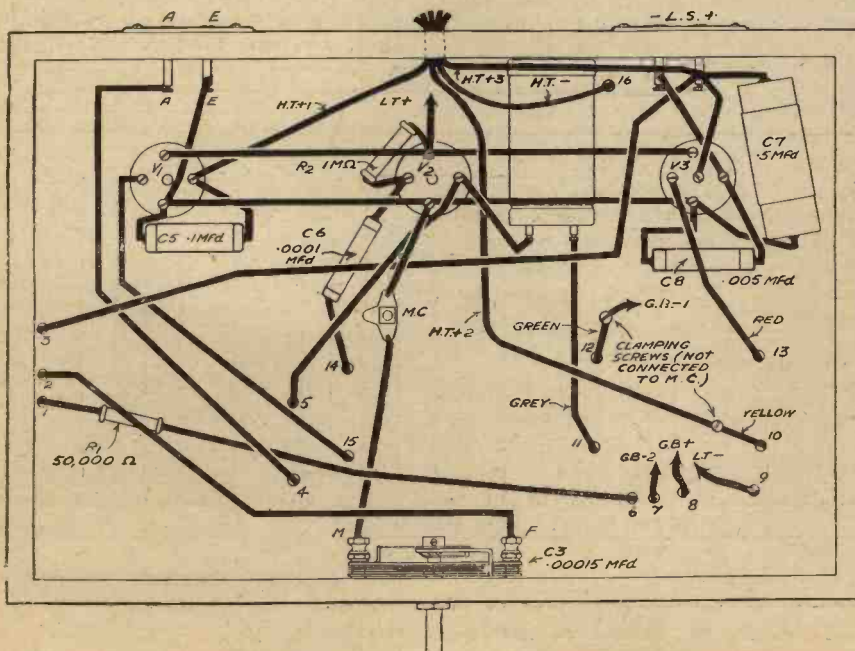

ARE WE MAKING PROGRESS ?

Yesterday's wonder was television, but from the basic point of view television means the cathode-ray tube, and as far back as 1911 Campbell Swindon said in his presidential address to the Röntgen Society that in his opinion the cathode-ray tube offered the only means of success in television. But we can go even further back than this, because the tube used in the 1870's to measure the relationship between the mass and charge of the electron was curiously similar in principle to the cathode-ray tube. Although to-day the cathode-ray tube is doing some marvellous jobs of work, it has still successfully baffled every effort to produce a really worth-while beam current, the maximum obtainable being measured in microamps.

It was about 1900 that Professor Fleming gave to us the valve. Later De Forest put a grid in it. Since then one or two other people have put one or two more grids, improving them mechanically so that you can throw them out of aeroplanes (but who wants to) without damaging them.

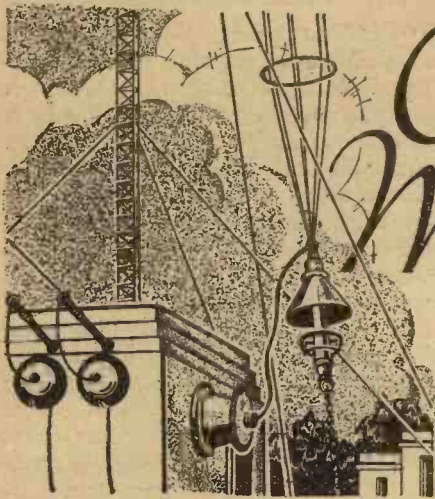

# On Your Wavelength

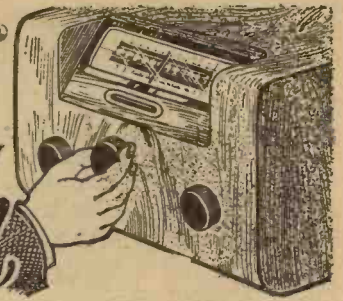

By Thermion

## Another Show

THOSE of us associated with radio mark the milestones in our lives between the cradle and the grave by the Wireless Exhibition. We are all one year older since the last show, and I hope wiser as a result of the passage of 365½ days. I am, and I am sure you must be, for we have all had the benefit of perusing 52 issues of this paper since last Radiolympia, issues which have faithfully reflected the mosaic of scientific change which constitutes our hobby; issues which have been loaded with facts and figures and designs and photographs and news; issues which are stored for possible reference, and issues which provide me with a weekly platform upon which to address you. There is something sad yet inspiring about a birthday. We live according to our allotted span for only 840 months—and when you look at it like that it is a surprisingly short time in which to do all of the things we wish to do. I try to crowd into my life as much interest and as much occupation as I can, and I try to do with as little sleep as possible. Life is too interesting to spend one-third of it in an unconscious form. I loathe going to bed and nothing can keep me in it once I am awake.

And so when Olympia opens its portals this year I shall have been one of the very first to have trodden the aisles, to have circumnavigated the serried ranks, and to have inspected the generalities and the minutiae which constitute an Exhibition. I shall not waste time by telling you what you are going to see. You will undoubtedly go, and on the principle that no one likes to sit in a theatre with a friend who persists in telling you what is coming next I shall occupy my pew this week in silence. Elsewhere in this issue is a valuable digest of all that is interesting at the Show. If you do not go, this issue

will bring Olympia into your home. If you do go, it will guide you round the Show in orderly fashion so that you do not waste your time.

In reply to many kind inquirers, including the pro-croonerites and the pro-jazzites, and the rest of that small minority who disagree with my outspoken views, I shall be there, clothed and unashamed. I shall see you there, I hope; and just a reminder that to anyone who successfully challenges me I shall hand a prize voucher. This is an offer I make annually, but I am still in possession of the vouchers.

## Braille Dials

I AM interested to see that one firm has introduced a tuning dial with the station names embossed in braille characters, so that those listeners who are blind, and who more than ordinary individuals find radio a blessing, can tune in a particular station without assistance. Inserted in the station windows of the tuning dial the braille call-letters can be as easily "read" by the blind as the customary printed letters are by those who can see. This innovation has been introduced by Philco, and because automatic tuning can be thus easily adapted for use by the blind it is no longer necessary for the sightless to explore the range of the dial of the tuning system every time a station is tuned. Although braille raised equipment is not regular equipment, Philco will gladly furnish such a dial for any owner of its sets which are equipped with the automatic tuning device.

## Moving Troubles

ONE of the troubles of removal from one district to another is that the set quite often does not function so well in its new location. It is true that sometimes it operates better, but it is the exception rather than the rule. This reduction in performance can be due to several causes; one reason for the apparent loss of efficiency may be that in the old home

the mains were D.C., while in the new residence they are A.C. ! Before removal make sure ! In installing the set in the new home the installation of the aerial and earth provides you with an opportunity of putting right the defects which existed in the old aerial-earth system but which you could never quite find the time to do. I suggest, with the popularity of all-wave radio, that you should install one of the special all-wave aerial systems recently described in this journal. If it is found that the new district is one in which electrical interference is pronounced, I recommend you to get into touch with the local head post office, whose engineers will investigate the problem for you.

## Lead-Acid Batteries

I WAS interested in an article in *The Chloride Chronicle and Exide News* by Mr. E. C. McKinnon, M.I.E.E., the Chief Engineer to the Exide people. He says that time and time again correspondence from battery-users shows a prevailing difficulty to appreciate the inter-relation of capacity, voltage, and specific gravity and volume of electrolyte.

The rated capacity of any cell is the amount it will yield on discharge at a definite rate, down to a pre-determined final voltage. This final voltage is the difference of potential between the two electrodes—positive and negative—each possessing electrical potential when immersed in sulphuric acid. No current will pass unless the sulphuric acid enters into combination with the active materials of the electrodes.

The electrolyte is thus a reservoir feeding the electrodes with that means without which their pent-up energy cannot be liberated. As with most power producers, gauges and low-level indicators have been devised to enable the user to check the point beneath which the cell ought not to be exhausted. We know the danger arising from running a boiler dry, and that to avoid this the low-level water-line purposely provides a margin of safety. Similar margins are provided in battery design. The positive electrode is purposely designed to

have less capacity than the negative, and there is sufficient electrolyte to ensure that an ample margin of sulphuric acid (indicated by specific gravity) is still left in the electrolyte when the cell has yielded its full rated capacity. If the electrolyte be exhausted first, this is analogous to running the boiler dry.

#### Power Output

**T**HE power exerted by an automobile engine is dependent upon the extent and rate at which gas is admitted to the cylinder. Similarly, the power exerted by a battery is dependent upon the rate of flow (diffusion) of electrolyte into the pores of the active material.

The running of a water-driven turbine has sometimes to be suspended until the exhausted lake or dam has been refilled with enough water to give the requisite "head." A battery may appear exhausted on discharge, but if then left idle for a short time it will give further discharge, because in the meantime the exhausted electrolyte in contact with the porous active material of the plates has been replenished through diffusion by sulphuric acid-bearing electrolyte. Thus, a battery will give a higher capacity at intermittent discharge than on a continuous discharge, particularly at high rates, just on account of this question of diffusion.

There is some argument, therefore, for giving a cell an intermittent rate capacity as distinct from a capacity on continuous discharge. It is not sufficient to have an ample volume of electrolyte. The initial specific gravity must be high enough to ensure that the final specific gravity at the end of the discharge is still high enough to avert the troubles set up if the plates stand in a discharged condition in exhausted electrolyte (practically water). This value can be readily determined because the fall in specific gravity on discharge bears a direct relation to the number of ampere-hours discharged.

The voltage curve of the cell on discharge will depend on its shape and magnitude, upon the rate of discharge in proportion to the number, size, thickness and spacing of the plates, the method of separation, the temperature and the specific gravity of the electrolyte; in other words, on the cell's internal resistance, which is affected by so many of those factors.

#### Short-wave Conditions

**S**HORT-WAVE conditions during the daytime have been a little better than during the past weeks,



#### Short-wave Tuning

**M**OST short-wave and all-wave receivers using an H.F. stage have an aperiodic aerial stage on the short-wave band. By using a simple coupling of this type between the aerial and the first valve, constructional work is simplified and only a slight loss of sensitivity is experienced as compared with a tuned coupling. Experiments prove that selectivity can be greatly improved by using a tuned aerial circuit, however, and if a modern H.F. valve is employed a definite degree of amplification is obtained from the H.F. stage. If optimum results are to be obtained from an all-wave set using two or more tuned circuits on the short-wave band, the coils must be very correctly matched and stray capacities must be accurately balanced, however. The 1938 all-wave coil units, as used in the PRACTICAL AND AMATEUR WIRELESS Radiolympia sets, therefore incorporate a separate trimmer for each tuned winding. If these are correctly adjusted correct matching is obtained on all bands and an exceptionally high degree of amplification can be obtained from the H.F. stage provided that the screening of the H.F. components is effective.

#### Valve Replacement

**T**HERE is such a variety of valves available to-day that it is dangerous for the home-constructor to effect replacement without consulting an accurate valve guide or consulting a reliable radio engineer. Until about two years ago battery type valves could be interchanged without fear of doing any damage, but to-day even these differ considerably for different makes. Some H.F. pentode valves require 120 to 150 volts on the screening grid whereas others only require 60 to 72 volts. There are also special short-wave valves available having the grid connected to the top cap, and these cannot, of course, be substituted for the normal type without altering the wiring of the set. Mains valves are much more varied than the battery types, however, and it is difficult for the expert even to memorise all the different pin connections. Some H.F. pentodes have the grid connected to the top cap and others have the anode joined to this point. The same applies to the output pentode types, and some triodes are available having a top cap and seven pins although only four of these pins are actually in use!

If one of these is used in place of the normal 5-pin type it is necessary to screen the cap lead.

W<sub>3</sub>XAL (17.78 mc/s) being received at useful strength during the afternoon. W<sub>2</sub>XE (21.52 mc/s), although fairly intelligible at this time, has been affected with rather deep fading. W<sub>2</sub>XGB, at Hicksville, has returned to the air again and can be heard testing on 17.31 mc/s on week-days around 5.0 p.m. Usually this station is much stronger than W<sub>3</sub>XAL. W<sub>2</sub>XAD is a good signal during the evenings, but deteriorates towards 11.0 p.m. W<sub>2</sub>XAF is heard fairly well about this time, but is badly interfered with by DJN and a Soviet station, while W<sub>2</sub>XE (11.83 mc/s) provides good reception of the Columbia Broadcasting System programmes from midnight. If you are able to listen in the early hours of the morning you should tune around the 6 mc/s band. At about 4.0 a.m. you should be able to receive several American and Mexican stations in this band, among them being W<sub>8</sub>XAL, W<sub>9</sub>XF, and XEUW.

#### Severe Static

**A**T this time of the year reception of the European medium-wave broadcasting stations is usually affected by severe static. Good clear reception of these stations can be obtained by listening to the short-wave relays of the German, Italian, and other European stations. The programmes of the Prague station, for instance, are very fine. Those who enjoy opera can get the very thing they appreciate from Rome. Also, the European short-wave stations broadcast news in English at regular intervals so that one can compare the opinions of foreign countries with that of their own.

A very attractive part of the dial of one's receiver is that which covers the amateur bands. In the 1.7 and 3.5 mc/s bands local and European amateurs can be heard conducting experiments. The 7 mc/s band is very useful also for distances of about 500 miles. For distant amateurs you should tune to the 14 mc/s band on which you will hear stations in far-off countries, such as Australia, New Zealand, and America, etc. These stations provide much interesting data, several covering great distances with very low power. The Radio Amateur Call Book, which can be obtained from the International Short-Wave Club, 100, Adams Gardens Estate, London, S.E. 16, price 6s., contains the names and addresses of amateur stations in all parts of the world, besides much other useful information for those interested in transmitting.

# COSSOR

introduces the



*A new conception of*

## ALL-WAVE SUPERHET RADIO

**B**RIMFUL of sparkling new features and ideas, everything is new in the series '48'—a new double-floating sub-chassis that ends microphony—new type permeability-balanced I.F. Transformer that secures lasting efficiency—new high "Q" coils for maximum sensitivity and selectivity—new 30 to 1 full-vision dial, with nearly fifty stations—new volume control that automatically increases selectivity on distant stations. Here is the attainment of new standards of superhet performance. Ask your dealer for details.

### Special '48' features

- AUTOMATIC INCREASE OF SELECTIVITY ON DISTANT STATIONS
- PERMEABILITY-BALANCED I.F. TRANSFORMER
- FULL-FLOATING ANTI-MICROPHONIC SUB-CHASSIS
- SPECIAL HIGH Q COILS
- FULL-VISION SCALE WITH 30-1 DOUBLE REDUCTION DRIVE

see the full range of  
**COSSOR RADIO**

on

**STANDS 61 & 163**

RADIOLYMPIA

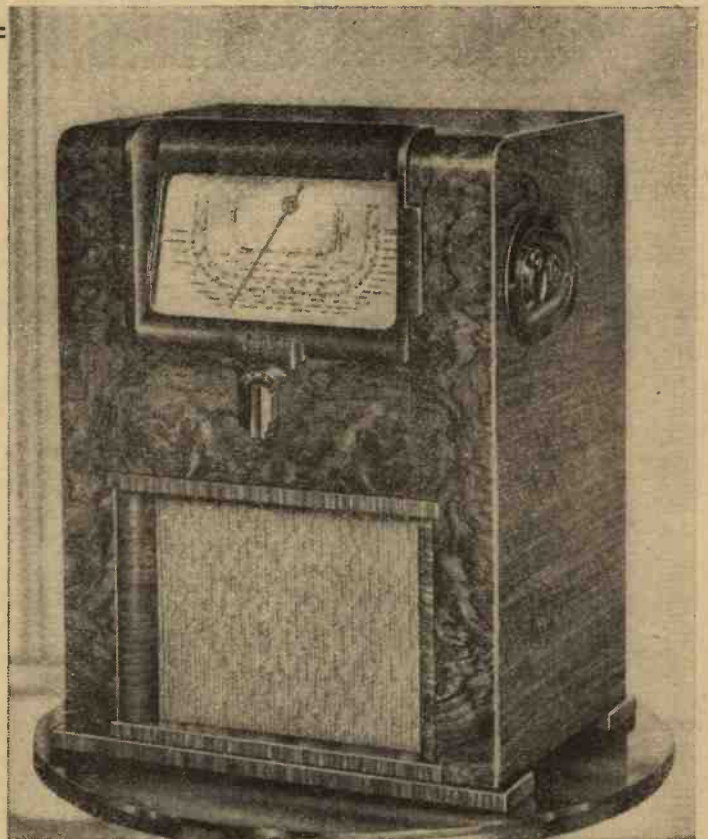

### F I V E M O D E L S

#### BATTERY MODEL 483

With Frequency Changer, Regenerative Pentode 2nd Detector, and Special High Slope Output Valve. 8" M.C. Speaker. (Less Batteries.) **£7 19 0**

#### BATTERY MODEL 485 (4 Valves)

With Frequency Changer, I.F. Amplifier, Detector / Amplifier and Q.P.P. Output Valve. 8" M.C. Speaker. **9 1/2 GNS.** (Less Batteries.)

#### A.C. MAINS MODEL 484

With Frequency Changer, Regenerative Pentode 2nd Detector, Special High Slope Output Valve and Full Wave Rectifier. 8" Energised M.C. Speaker. **9 1/2 GNS.**

#### D.C./A.C. MAINS MODEL 484 U

With Frequency Changer, Regenerative Pentode 2nd Detector, and Special High Slope Output Valve. Half Wave Rectifier. 8" Energised M.C. Speaker. **10 GNS.**

#### A.C. MAINS de luxe

#### CONSOLE MODEL 438

Similar to Model 484 but with 10" Concert Grand Energised M.C. Speaker, and magnificent console cabinet. **11 GNS.**

*All Cossor Receivers are available on Hire Purchase Terms.*

*Prices do not apply in the I.F.S.*

British Made by A. C. COSSOR LTD., Highbury Grove, London, N.5.  
Depots at Birmingham, Bristol, Cardiff, Glasgow, Newcastle, Leeds, Liverpool, Manchester, Nottingham, Plymouth, Belfast and Dublin.



# Now's your chance—

## Don't miss it !!!

Come to Stand 81 and take one of our catalogues—and an opportunity. You see, you can study our catalogue, choose the components you'll be needing for your next set and then inspect the workmanship on the actual components on the stand.

Of course, if you're an "old Dubilier user" you won't have to do this—you'll take our high quality for granted.

*The Dubilier Components specified in the Practical Wireless All World Ace are as follows:*

Thirteen fixed condensers: two .0001 mfd., two .002 mfd., one .005 mfd., .05 mfd., .01 mfd., .5 mfd. (tubular), one 4 mfd., two 8 mfd. (wet electrolytic), two 25 mfd. (25v. dry electrolytic).

Eleven fixed resistances: two 500,000 ohms, one 100,000 ohms, 2,000 ohms ( $F\frac{1}{2}$ ), 100,000 ohms, 50,000 ohms, 25,000 ohms, 10,000 ohms, 600 ohms, 300 ohms, 150 ohms (F.1).

# DUBILIER

DUBILIER CONDENSER CO. (1925) LTD., DUCON WORKS, VICTORIA ROAD, NORTH ACTON, LONDON, W.3



# All-World Radio

All-World Reception is so Closely Linked with All-wave, and Particularly Short-wave, Reception that the Terms have Become Almost Synonymous, and the Development of Short-wave Transmission and Reception forms one of the Most Fascinating Chapters in the History of Wireless

By FRANK PRESTON



This is our 1936 All-wave Gladiator, produced at last year's Radio Show.

**T**HERE can be no doubting the fact that short-wave radio has made the world smaller. And who can say that it has not done more than anything else to create better feeling as between nation and nation? Nevertheless, the ultimate has not been reached, and radio might well prove a more potent factor for peace than a whole army of pacifists and a League of Nations could ever be.

It is only a few short years since the reception of American, Australasian and Oriental low-power broadcast transmissions was looked upon as a feat which could be indulged in by only the select few. Yet to-day the average listener who has a modern all-wave receiver enjoys these privileges and thinks comparatively little of them. Without the development of short-wave technique, round-the-world radio would still be impossible, for the medium and long waves have a very limited range unless propelled by a tremendously high power. In fact, it is probable that if there were but a dozen or so transmitters in the world, each capable of maintaining regular contact on the so-called broadcast wavelengths, thousands of the older commercial equipments would be rendered obsolete. This is because the power of the few transmitters would be so great that interference could be prevented only by employing modern, super-selective receivers.

## Low Range—Low Power

On short waves, a power of 50 watts has proved to be adequate for sending easily-received signals right round the globe. More than this, amateur transmitters are frequently in touch with each other over distances of many thousands of miles when using a power of less than 10 watts, or a tenth of the power required to feed the electric-light bulb in the average drawing room.

It is impossible to predict what will be the future of short-wave radio, but it is certain that the wavelengths employed will become lower and lower. As a result, the power required at the transmitter will decrease, besides which, a far greater number of

freedom from interference.

These facts are of interest now that the majority of commercial receivers are of the so-called all-wave type, and also because PRACTICAL AND AMATEUR WIRELESS has consistently recommended its readers to take up short-wave reception for the past five years. This journal has always catered for short-wave enthusiasts, and has for years predicted the popularity of all-wave radio which now exists. More than this, it has regularly published constructional details of all-wave sets; many of these appeared long before the public could buy a ready-made all-wave set at a modest price.

## Easily-made All-wave Sets

In this issue constructional particulars are given for three complete receivers—of types to suit all requirements and all pockets—which tune to short waves, as well

as the medium and long-wave bands. These sets are sure to meet with an even warmer welcome than have those described in the past. One good reason is that they are no more costly to build than are the older types of receiver designed for two wave-bands only. Another is that they will bring all-world radio into the homes of those thousands of constructors who will build them.

We believe also that they will be a means of increasing the numbers of home constructors. The reason is not far to seek; the sets can be built at a lower cost than most commercial receivers of similar quality, and they bring back the fascination of home construction which was at one time showing a tendency to flag due to the fairly stereotyped design of the receivers of the past few seasons.

We believe also that they will be a means of increasing the numbers of home constructors. The reason is not far to seek; the sets can be built at a lower cost than most commercial receivers of similar quality, and they bring back the fascination of home construction which was at one time showing a tendency to flag due to the fairly stereotyped design of the receivers of the past few seasons.

## Amateur Endeavour

It is only right that the constructor should be the first to share the advantages of all-wave, all-world radio, for it was he who did more than anybody else to bring it to its present state of perfection. The experimenters and amateur transmitters pioneered short-wave radio from the earliest days. After they had shown the possibilities of communication on wavelengths around 180 metres, amateur transmitters were allotted wavelengths on the lower band around 80 metres. And then they were "pushed down" to 40 metres; then 20 metres; and now 5 metres. They set the pace, and commercial and government operators followed. The amateurs are still setting the pace, and will probably continue to do so for a long time to come.

When amateur transmitters were given the waveband around 5 metres it was

(Continued overleaf)

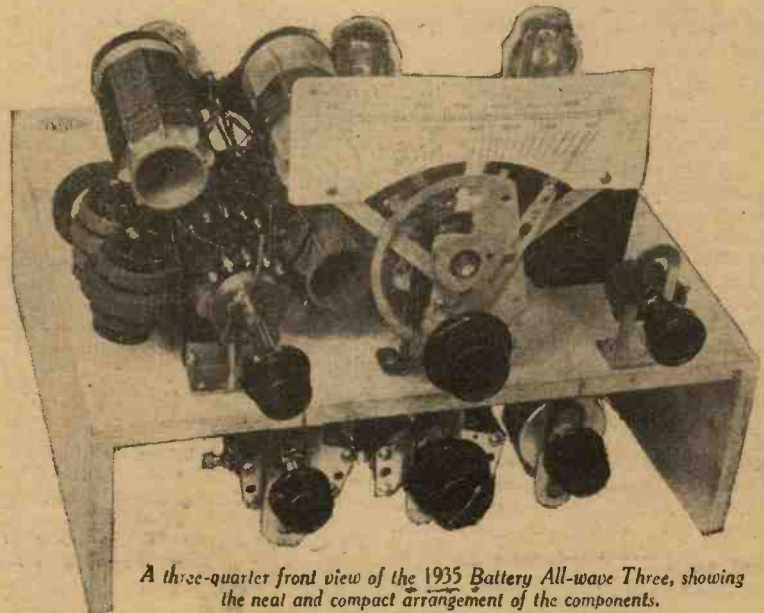

A three-quarter front view of the 1935 Battery All-wave Three, showing the neat and compact arrangement of the components.

## ALL-WORLD RADIO

(Continued from previous page)

considered that transmissions on such high frequencies could be sent over "optical" distances only. Keen experimenters soon disproved this idea by establishing two-way working over considerably greater distances. Although there do not as yet appear to have been any authentic reports of regular trans-Atlantic two-way working on the 5-metre band, it is not too much to expect that this will come. When it does, it will be another triumph of the amateur's enterprise. And it is by no means unlikely that it will be followed by the allocation and use of still lower wavelengths.

## The Constructor's Advantages

Again, the constructor will be in a better position than the owner of a commercial receiver to take advantage of the new wavelengths, because it will be an easy matter to modify an existing home-made set to tune "down" still further. In the meantime, constructors are being well catered for by the makers of components, many of whom now make three-range tuners which the amateur can employ with ease and certainty of obtaining good results. It might be argued that time has been lost in making this type of tuner available to the constructor, but this has probably been due in part to the fact that the keen constructor has not hesitated to make his own tuner, or to use an efficient short-wave adapter in conjunction with his broadcast receiver. The time lag has, however, enabled the manufacturers to see that an all-wave tuner was in demand, and to

perfect their designs before offering them to the public.

In case there are still a few readers who think that short-wave reception is of little entertainment value, it should be explained that the forms of interference and fading which once proved deterrents to the more-general adoption of short-wave reception are now far less in evidence. The design of new aerial systems, the improvement in receiver and component design and the better understanding of short-wave problems have all helped enormously to increase the fascination of short-wave radio.

## Choosing the Wavelength

We have learned that certain wavelengths are more suitable at certain times of the

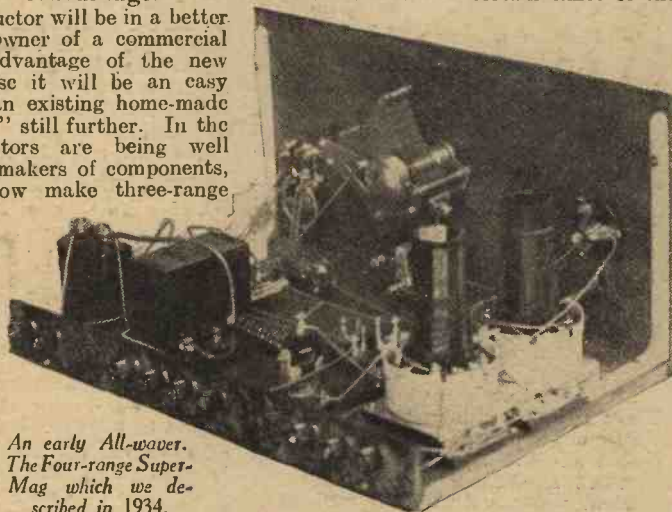

An early All-waver. The Four-range Super-Mag which we described in 1934.

day and in certain conditions. As a result, the listener can be almost sure of obtaining good reception at any time during the twenty-four hours by tuning on the most suitable wave-band. This is facilitated by the use, by many S.W. broadcasting

stations, of two or more wavelengths. In some instances two or more wavelengths are used simultaneously for the same programme, and in others the wavelength is changed throughout the day and night.

Generally, wavelengths below 20 metres have the best range during the middle of the day, whilst higher wavelengths up to 50 metres are more satisfactory as darkness falls and deepens. This alone provides ample scope for research and experiment by the experimenter and enthusiastic amateur. It might be that one day a means will be found of ensuring good reception of certain short wavelengths at any time; on the other hand, the use of ultra-short waves might eventually offer a solution to all transmission and reception problems. Support for this theory is to be found in the fact that interference and fading are practically unknown on the ultra-shorts. The silent background comes rather as a shock to those who have previously been accustomed only to the higher wavelength ranges.

## Real All-wave

In the meantime, it remains for the component manufacturer—and the constructor—to produce a real all-wave tuner. At present, this name is generally wrongly given to a tuner designed to cover three ranges of about 16 to 50, 200 to 600 and 900 to 2,000 metres. It seems certain that we shall sooner or later have to go "below" 16 metres, and experiments lead one to believe that it might not be a very long time before we shall be working in centimetres instead of metres. Who knows? Ten years ago the regular use of wavelengths below 10 metres appeared more incredible than the use of 10 centimetres does to-day.

At any rate we can see that the experimenter who is to keep abreast of his fascinating hobby will have to accustom himself to the use of shorter and shorter wavelengths. The process will be gradual, but evolution will have its way.

## Important Broadcasts of the Week

**NATIONAL (261.1m. and 1,500 m.)**  
Wednesday, August 25th.—Radiolympia Variety programme.

Thursday, August 26th.—Concert Party programme.

Friday, August 27th.—Music from the West: Instrumental concert.

Saturday, August 28th.—Promenade Concert from the Queen's Hall, London.

**REGIONAL (342.1 m.)**

Wednesday, August 25th.—Promenade Concert from the Queen's Hall, London.

Thursday, August 26th.—Cornish Sports at Camborne, feature programme.

Friday, August 27th.—Variety programme, from the Argyle Theatre, Birkenhead.

Saturday, August 28th.—Evening in Cheddar, feature programme.

**MIDLAND (296.2 m.)**

Wednesday, August 25th.—Band concert.

Thursday, August 26th.—Choral programme.

Friday, August 27th.—Variety programme, from the Concert Hall, Bournville.

Saturday, August 28th.—English Song Writers: C. W. Orr, vocal programme.

**WEST OF ENGLAND (285.7 m.)**

Wednesday, August 25th.—South Molton

Sheep Fair: interviewing farmers and conversations between those who have taken part in the day's activities.

Thursday, August 26th.—Cornish Sports at Camborne, feature programme.

Friday, August 27th.—Off the road in Wiltshire, feature programme.

Saturday, August 28th.—Evening in Cheddar, feature programme.

**WELSH (373.1 m.)**

Wednesday, August 25th.—Dr. Abernethy, a Welsh play by Alicia Ramsey and Rudolph de Cordova.

Thursday, August 26th.—A programme by the Ceydd Dant Society, from the Memorial Hall, Harlech.

Friday, August 27th.—Cyngerdd o Faledi: A ballad concert.

Saturday, August 28th.—Concert Party programme, from Callin's Arcadia, Llandudno.

**NORTHERN (449.1 m.)**

Wednesday, August 25th.—Blackpool Night's Entertainment, feature programme.

Thursday, August 26th.—Concert Party programme, from the New Pavilion, Redcar.

Friday, August 27th.—Variety programme, from the Argyle Theatre, Birkenhead.

Saturday, August 28th.—Cinema organ recital.

**SCOTTISH (391.1 m.)**

Wednesday, August 25th.—Time Muddles On, or Making Progress, by G. K. Young and J. Wilfred Taylor.

Thursday, August 26th.—Visitors to Variety (fourth batch), a North-East Novices Night with artists who are new to the microphone.

Friday, August 27th.—Silly Season, a revue of Summertime Follies.

Saturday, August 28th.—Scottish Dance Music.

Friday, August 27th.—Silly Season, a revue of Summertime Follies.

Saturday, August 28th.—Scottish Dance Music.

**NORTHERN IRELAND (307.1 m.)**

Wednesday, August 25th.—Light Orchestral programme, from The Chale, Crawfordsburn.

Thursday, August 26th.—Concert Party programme, from the Floral Hall, Bellevue, Belfast.

Friday, August 27th.—Instrumental programme, from Caproni's Dance Salon, Bangor, County Down.

Saturday, August 28th.—Choral and instrumental programme.





# NEWS

## FOR 'FIDELITY FANS'

### Planoflex NEW SPEAKER FOR 'QUALITY SPECIAL' SETS

30 cycles to 14 kilocycles—the widest range of frequencies yet covered by a speaker of "domestic" proportions—this new W.B. product covers the band without departing more than a few decibels from the datum line anywhere. BUT—you must have a very high quality special receiver to operate it. Particulars of a suitable set, capable of assembly at reasonable cost, are included with each speaker. For those who can only enjoy the sort of radio which is hardly distinguishable from a personal performance, this new speaker and its set will open up new prospects.

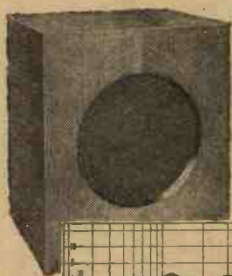

30 cycles  
to 14  
kilocycles

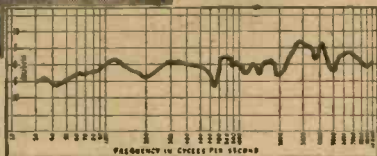

The new Planoflex speaker for special "local station" sets will make a stir among technicians. Price £5 5s. od.

### RADIOLYMPIA STAND

75

Shows these and other items

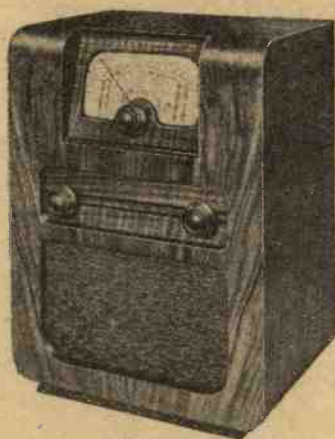

### Stentorian ALL WAVE SETS

For those who buy  
'ready made' radio

For listeners who are critical, but have not time to build the sort of set they like, this new range of set is marketed.

Although not special "onestation" receivers—on the contrary they have world-wide range—their quality of reproduction is well ahead of normal standards.

Prices are extremely moderate as will be seen on examination:—All-Wave Superhet, 9½gns. for A.C. operation; 8gns. for battery operation (less batteries): All-wave A.C. "straight", 4 valve receiver, 8gns. Self-contained battery sets, 7½ gns. and 6 gns. respectively, including full-size batteries. Attractive H.P. terms are available on all.

### Fidelity and Precision

The makers, in their determination to maintain high quality and precision workmanship, are deliberately restricting output irrespective of demand. There will, however, be enough Stentorian sets to provide stocks for many good dealers.

### FOR NORMAL RECEIVERS

Modified Stentorian  
brings increased  
fidelity

The New Stentorian and its response curve.

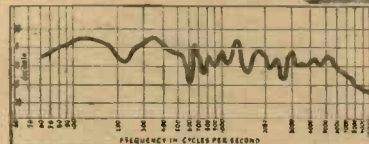

Any improvement on the well-known Stentorian's amazing ability to "straighten" a long range set's output curve has by many been considered unlikely. This feat has, however, been achieved this year in an unmistakable manner—as a few minutes' listening will show you. Prices remain extremely reasonable.

Senior (Type 38S) 42/- Junior (Type 38J) 32/6  
Baby (Type 38B) 23/6 Midget (Type 38M) 17/6

The Senior, Junior and Baby are also available in handsome cabinets; the Senior and Junior cabinets incorporate distortionless constant impedance, volume control and push buttons for "Long Arm" remote switching. Your dealer will gladly show them.

### HIGH PRAISE FROM WELL KNOWN EXPERT

Mr. F. J. Gamm, the well-known scientist, has expressed the following opinion:—  
"In search for the ideal a product remains the best of its class only whilst there is no other standard by which to judge it. In the design of speakers, as in all scientific matters, we must either progress or regress—we cannot stand still. The measure of progression is the degree of improvement over previous efforts. Once again it is my pleasure to congratulate your engineers on the immense step forward which you have made with the new 1938 Stentorians. This is an even greater improvement on your 1937 models than the latter were over the 1936 models, and the listener is fortunate indeed in having at his command a speaker sensitively responsive from the lowest to the highest frequencies encountered in radio. Good and bad sets will be improved by it. It is an important advance in speaker technique."



# AVO Precision TESTING INSTRUMENTS

Regd. Trade Mark

BRITISH MADE

RADIOLYMPIA STANDS Nos. 30 MAIN HALL and 166 gallery

Only precision instruments enable you to test accurately and trace radio faults efficiently. "AVO" Instruments are outstanding for precision. They are the outcome of a constant effort to provide amateur enthusiasts and radio engineers with instruments of high accuracy and maximum utility at a moderate cost. See the comprehensive range of "AVO" Testing Instruments at Radiolympia.



## THE D.C. Avominor

This accurate moving-coil instrument is 13 meters in one. It has 13 ranges, covering volts, current and resistance—voltage ranges sufficient for measuring H.T., L.T., Grid-Bias, Mains and Eliminator Voltages; Milliamp ranges for testing receiving valves and apparatus; Resistance ranges for all resistance measuring. In case, complete with testing prods, crocodile clips, leads and instruction booklet.

45/-



## UNIVERSAL Avominor

This compact precision moving coil instrument provides facilities for all A.C. and D.C. testing. It has 22 ranges covering A.C. volts, D.C. volts, current, and resistance. All readings are direct. Total resistance of meter, 200,000 ohms—ensuring accurate readings. Complete with testing prods, crocodile clips and instruction booklet.

Price £5 10s. Leather Carrying Case, 10/-

## Entirely New Edition RADIO SERVICING SIMPLIFIED

A complete guide to radio testing. This book is a new and greatly enlarged edition of a valuable manual that has sold in thousands. It explains in a clear and interesting manner how to take all radio measurements, how to trace and rectify all radio faults, how to get best results from all apparatus. 150 pages. Numerous diagrams and illustrations. Tests are described in an extremely lucid manner, making them absolutely straightforward. Every amateur radio enthusiast should get this book.

2/6 POST FREE 2/10

## THE AVODAPTER

Simplifies valve testing! Enables all valves to be tested under working conditions. Eliminates the need for severing connections and grovelling about inside the set. Instantly adaptable for 4-pin, 5-pin and 7-pin valves.

27/-  
9-PIN AVOCOUPLER Attachment (not illustrated) for rendering Avodapter suitable for 9-pin valves. 12/6



## "AVO" TESTING ACCESSORIES

A valuable adjunct to your testing kit. The boxed set of accessories comprises insulated testing prods, interchangeable crocodile clips, connecting leads, etc., etc. Easier, safer and quicker to use than nondescript lengths of wire.

2/6



Illustrated pamphlets giving full details of "AVO" Instruments Post Free.

# THE TRIDENT

A Beginner's All-wave Three-valve Battery Operated Receiver—Circuit Description and Constructional Details

THE Trident has been specially designed in response to numerous requests from beginners for a simple all-wave three-valve receiver. A baseboard has been used in preference to a chassis as this simplifies the wiring diagram and the wiring without materially affecting the efficiency of the finished instrument. In order to ensure effective earth-line connection for short-wave reception, however, a metal covered type has been chosen.

## Circuit Arrangement

Although the receiver is primarily intended for beginners, it must not be imagined that efficiency has been sacrificed to provide a simple design. The Trident employs a well-tried straight-three circuit arrangement, and the specified components are all of a reliable type. The all-wave coil used is sturdily constructed and all the internal wiring is completed by the manufacturers; it is only necessary for the constructor to attach the necessary external leads to the terminal board. The switch attached to the coil unit has four positions—short-wave band, medium-wave band, long-wave band, and off. In the "off" position the L.T.—lead from the accumulator is disconnected from the valve filaments, so that no current will be consumed from the L.T. accumulator or from the H.T. battery. A .0005 mfd. condenser is used for tuning, and with this capacity in use the wavebands covered will be approximately 19 to 48 metres, 200 to 550 metres, and 900 to 2,100 metres. The tuned circuit is fed to a triode detector of the metallised type, and reaction is obtained by connecting the anode of this valve to the reaction winding of the coil unit.

## L.F. Amplifier

The coupling between the detector and the first L.F. valve is of the resistance-capacity type, the grid leak of the L.F. valve taking the form of a variable potentiometer. This control will be found very useful, especially when listening on the short-wave band. By reducing its setting, headphones can comfortably be used in place of a loudspeaker when desired. It will be noted that an H.F. choke has not been used in the anode circuit

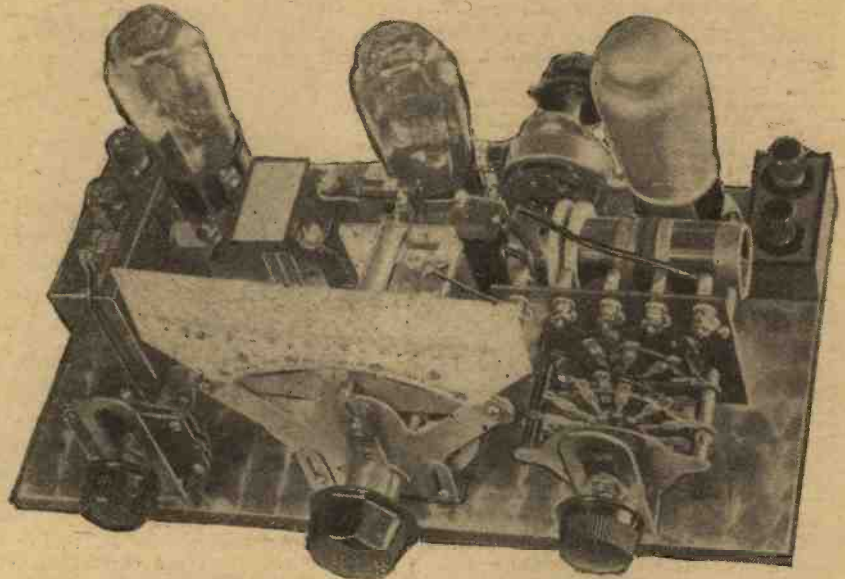

A bird's-eye view of the Trident shows the simplicity of the layout.

of the detector valve. It was found that a resistance of high value connected in the grid circuit of the first L.F. valve served the same purpose—this is the 100,000 ohm resistance R4.

The detector anode circuit is effectively decoupled by means of the 10,000 ohms resistance R3, and the 1 mfd. condenser C5.

Coupling between the L.F. valve and the output triode is effected by means of an L.F. transformer having a ratio of 3.5 to 1. This ensures adequate amplification in this stage without producing instability. A pentode could have been used in the output stage, but better quality is generally obtained in a straight three of this type

with a power triode in this position. It will be noticed that a 2 mfd. condenser is connected between the H.T.+2 lead and the metal covering of the baseboard. This component is not essential if a new H.T. battery is used, but will prove very helpful in keeping the receiver stable when the battery is running down.

## Constructional Work

The position of all the components and wiring is clearly shown on the wiring diagram, and no difficulty whatever should be experienced with the constructional work. There are a few points which need emphasising to beginners, however. A block of wood will be supplied with the baseboard which should be used to raise the tuning condenser spindle to the level of the tuning drive. It will be advisable to remove the left-hand front leg of the tuning condenser to ensure exact mounting of the drive, and the other three legs should then be securely screwed to the wooden block. It is essential, however, that the frame of the condenser be in contact with the metal covering of the baseboard, therefore a lead must be taken from one of the back legs to M.C., as shown on the wiring diagram—M.C. is, of course, the abbreviation normally used for the metal covering of the baseboard.

## Battery Connections

Another precaution which should be taken is in connection with the coil unit; this must be mounted sufficiently high on the component bracket to ensure that the switch tags are well clear of the baseboard. The bracket itself must, however, make good contact with M.C. as the earth return leads of the coil are connected to the switch frame, and if good connection is not made between the bracket and M.C., the earth end of the coil windings will not be in contact with the tuning condenser and valve filaments.

(Continued overleaf)

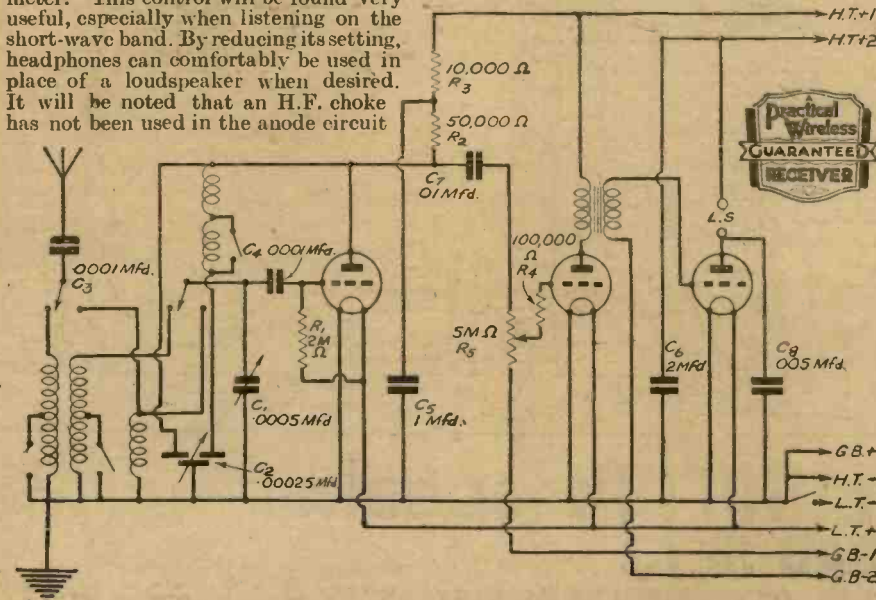

Here is the theoretical diagram of the circuit employed in the Trident.

**THE TRIDENT**

(Continued from page 573)

After the wiring has been carefully examined the battery leads should be con-

**LIST OF COMPONENTS**

- One all-wave coil, type G (B. T. S.).
- One tuning condenser, .0005 mfd., type C.V. (C1) (Bulgin).
- One tuning drive, No. 2,134 (J. B.).
- One reaction condenser, .00025 mfd. (C2) (B. T. S.).
- One volume control: 500,000 ohms (R5) (Eric).
- Four fixed resistances: 2 meg. (R1); 100,000 ohms (R4); 50,000 ohms (R2); 10,000 ohms (R3)— $\frac{1}{2}$  watt (Eric).
- Six fixed condensers: 2 mfd. (C6); 1 mfd. (C5) (type 65); .01 mfd. (C7); .005 mfd. (C8) (two .0001 mfd. (C3, C4) (tubular) (T. C. C.).
- One L.F. transformer—Nictet 3.5, 1 (Varley).
- Two terminal brackets with L.S. and A.E. terminals (Belling-Lee).
- One fuse holder with 60 mA fuse (Microfuse).
- Three valveholders, 4-pin, baseboard type (B. T. S.).
- Six wander plugs: H.T.1, H.T.2, H.T.—, G.B.+ G.B.—1, G.B.—2 (Clix).
- Two spades: L.T.—, L.T.+ (Clix).
- Three component brackets (Peto-Scott).
- One Plymax baseboard (11in. by 6in.) with condenser block (Peto-Scott).
- Three valves: D.210, L.210, P.215 (Hivac).
- One speaker—Stentorian Junior (W. B.).
- One pair headphones (Ericsson).
- 120 v. H.T. battery
- 9 v. G.B. battery
- 2 v. L.T. accumulator (Exide).

G.B.+ lead to the + socket of the 9-volt G.B. battery and the H.T.— lead to the —socket of the H.T. battery. G.B.—1 is the bias lead for the L210 valve and should be inserted into the —3 socket of the G.B. battery. The P215 valve requires a bias of 9 volts for an anode

tory model best results were obtained with this plug inserted in the 108-volt socket. H.T.+2 requires the full voltage of the battery and should therefore be inserted in the 120-volt socket.

The aerial and earth leads may now be connected to the terminals marked A and E and the loudspeaker leads to the L.S. terminals. The position of the valves is, of course, very important and

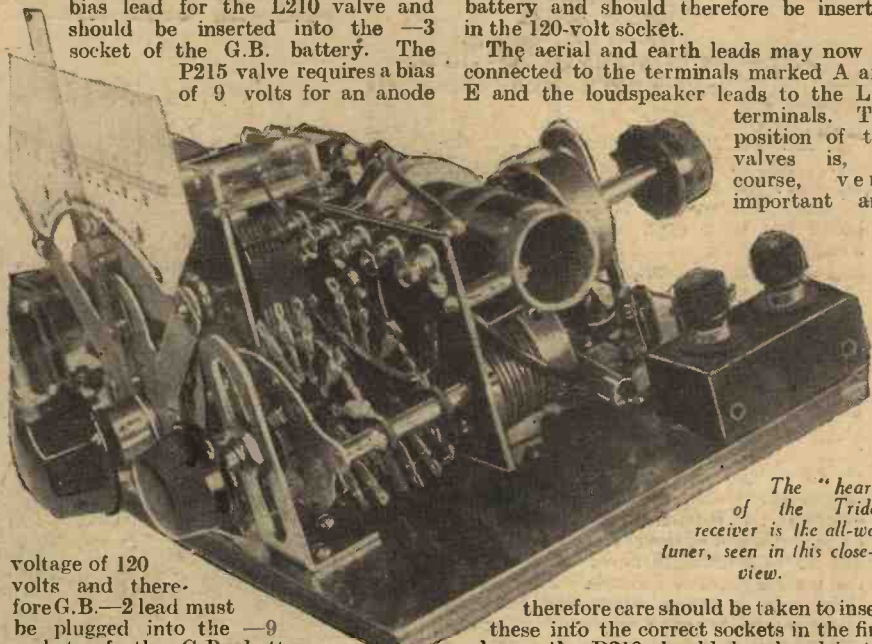

The "heart" of the Trident receiver is the all-wave tuner, seen in this close-up view.

nected up. The L.T.— and L.T.+ leads should, of course, be joined to the — and + terminals of the 2-volt accumulator, the

voltage of 120 volts and therefore G.B.—2 lead must be plugged into the —9 socket of the G.B. battery. The voltage required for H.T.+1 is somewhat critical and the correct socket can best be found by experiment—in the labora-

therefore care should be taken to insert these into the correct sockets in the first place; the D210 should be placed in the holder nearest the terminals A and E, the L210 into the centre holder, and the P215 into the holder next to the L.S. terminals.

**WIRING DIAGRAM OF THE TRIDENT**

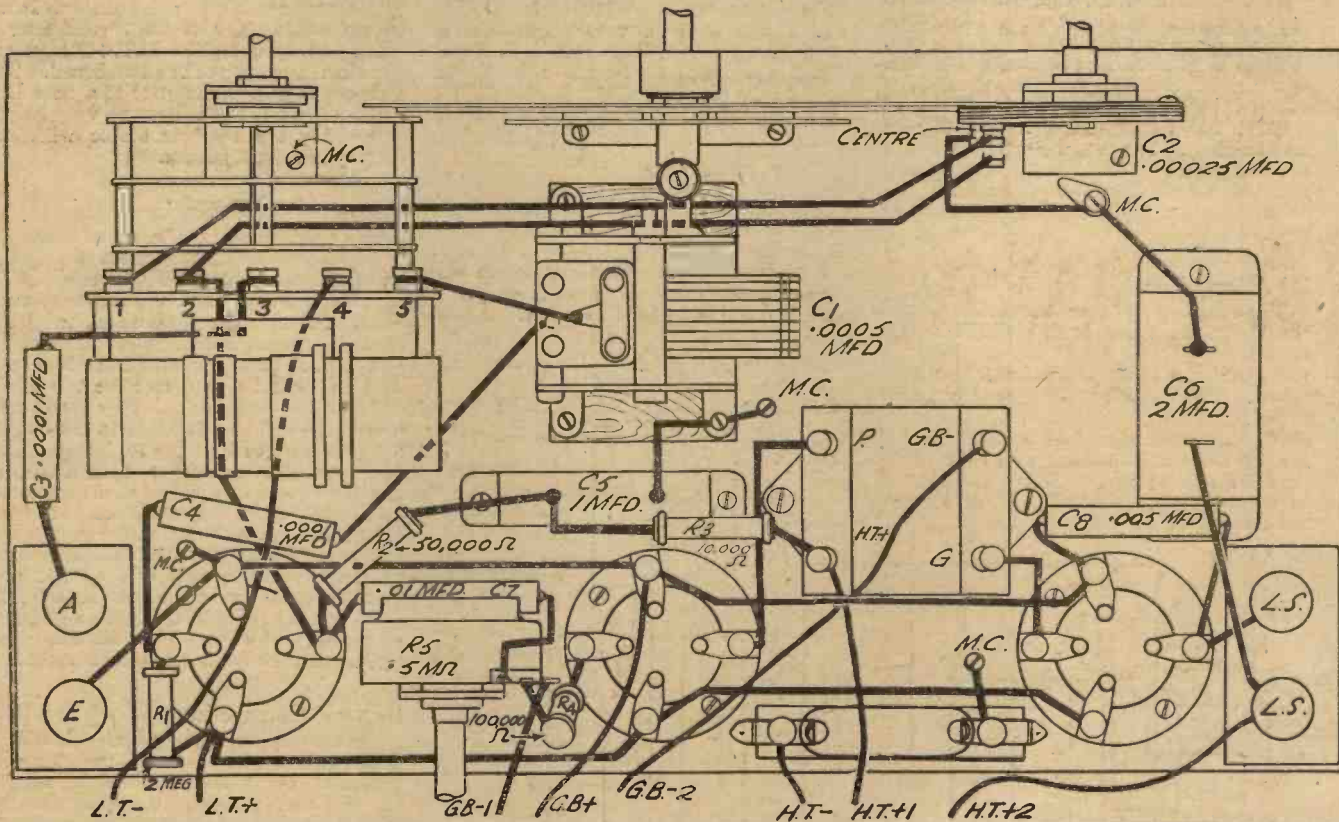

**NEW Stentorian speaker—**

**“GOOD & BAD SETS**

**WILL BE IMPROVED BY IT”** Says Mr. Camm

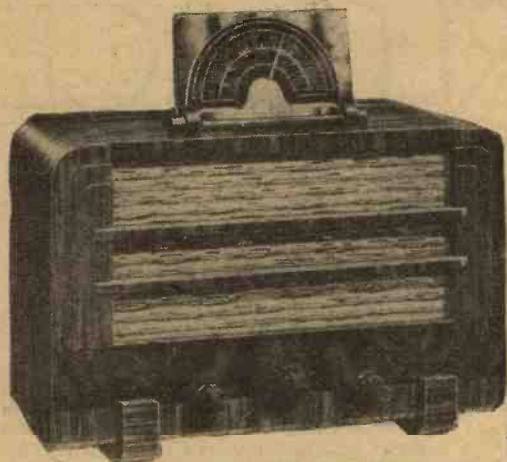

A novelty in tuning scales on the Ultra Model 121.

# CABINETS AND TUNING DIALS

Some Contrasts  
To Be Seen  
at  
**RADIOLYMPIA**

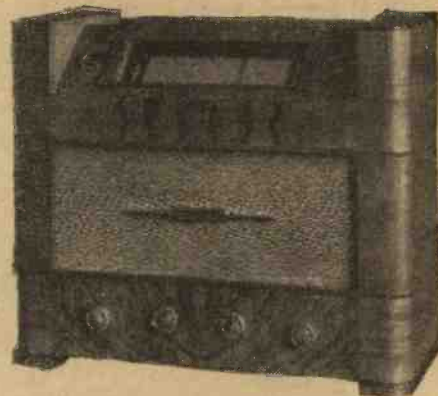

An Aerodyne model with an unusual fret.



This is Ultra Model 49

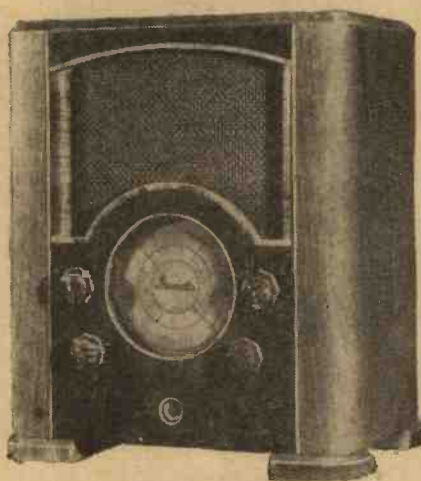

Inivicta Model 330, with a clock-face dial.

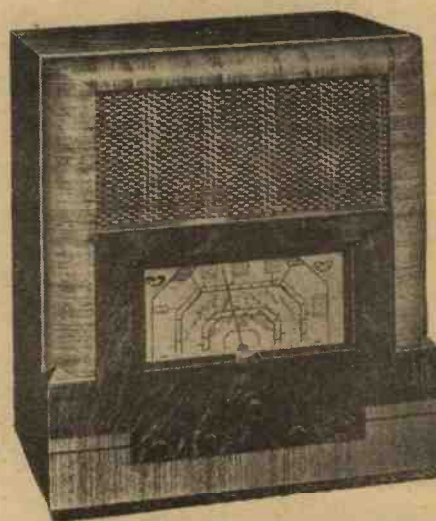

A 10-valve Marconiphone receiver, Model 561.

## 25 W.B. SPEAKERS FREE IN A SIMPLE FREE-FOR-ALL COMPETITION!

This year we again give every reader a splendid opportunity of obtaining one of the new W.B. Stentorian speakers entirely FREE OF CHARGE. The competition is extremely simple, and there is *no entrance fee*. Every entrant has an equal chance of winning one of the 25 speakers of the latest 1938 type, illustrated on page 571 in this issue.

The simple and straight forward rules are as follow:—

1. On the right is given a list of 5 of the most popular features of present-day receivers. You are asked to mark, in the space provided, the order in which you think these features appeal to the present-day listener.
2. On the line provided, enter the type of receiver which you would like to see described in these pages.
3. After filling in the coupon, complete it with your name and address in block letters in the space provided, and post it in a sealed envelope addressed to: The Editor, PRACTICAL AND AMATEUR WIRELESS, Geo. Newnes, Ltd., Tower House, Southampton Street, Strand, London, W.C.2.
4. Mark the word **COMPETITION** in the top left-hand corner of the envelope, and post to reach us not later than September 13th, 1937.
5. Readers may send in as many attempts as they like in one envelope, provided that each attempt is completed on a separate coupon, bearing the full name and address of the sender.
6. The prizes will be awarded to the 25 readers who succeed in placing the most popular features in the order as decided by the entries received in this competition.
7. Only one speaker can be awarded to any one reader.
8. The result will be published in our issue dated September 25th, 1937.
9. The Editor's decision is final and legally binding, and this is an express condition of entry. No correspondence of any kind can be entered into regarding this competition.

WHAT ARE THE MOST IMPORTANT FEATURES OF THE MODERN RECEIVER ?	
1. (a) All-wave tuning. (b) Broadcast wavelengths only.	
2. (a) Output over 5 watts. (b) Output below 5 watts.	
3. (a) Self-contained loudspeaker. (b) Separate loudspeaker.	
4. (a) Designed for quality. (b) Designed for station getting irrespective of quality.	
5. Minimum number of controls.	
The set I would like to see described in "Practical and Amateur Wireless" is:—	
.....	
Name.....	
Address.....	
.....	

# THE ALL-WORLD ACE

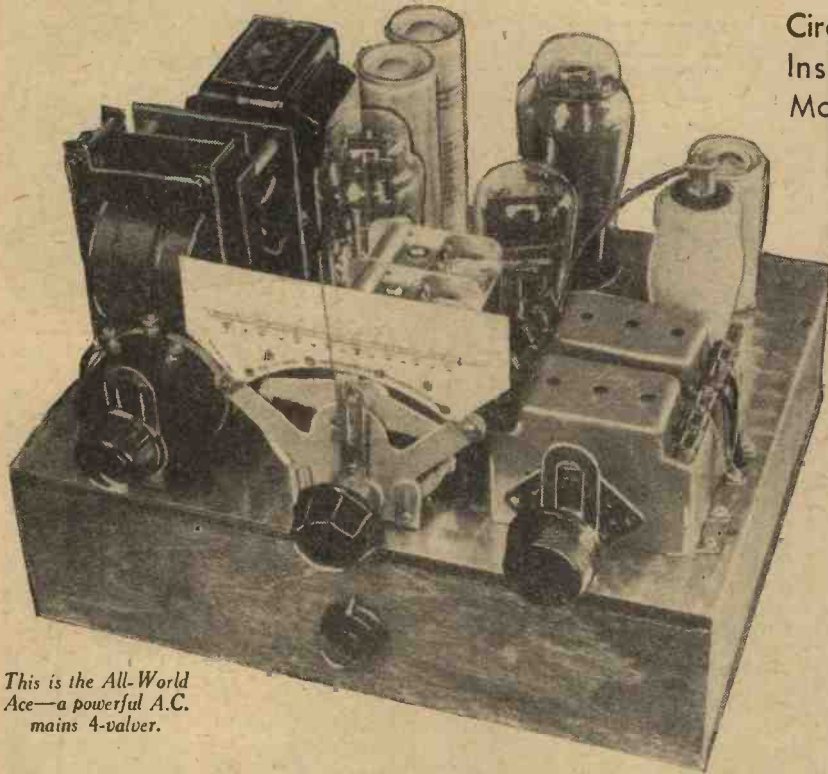

This is the All-World Ace—a powerful A.C. mains 4-valver.

Circuit Details and Preliminary Instructions for Constructing a Modern and Efficient All-wave Four-valve A.C. Mains Receiver

of 19 to 48 metres, 200 to 550 metres, 900 to 2,100 metres are obtained.

### Detector Circuit

Several types of detector were tried when experimenting with this design, but it was found that best results on the three wavebands were obtained when the specified valve (a medium impedance triode) was used. It will be noticed that a 600-ohm resistance and a 25 mfd. condenser are connected in the cathode lead of this valve. On radio these two components have no effect on reception, but if the receiver is to be used in conjunction with a pick-up for gramophone record reproduction the 600-ohm resistance biases the detector valve, thereby converting it into an efficient L.F. amplifier. The two pick-up leads should be connected to the grid socket of V2 and the M.B. bolt respectively.

### The L.F. Amplifier

The anode circuit of the detector valve is decoupled by means of the resistance R8 and the condenser C8—the condenser has a higher value than is normally used, but it has been found that a high capacity is very desirable in this position in an

THE All-World Ace is an all-wave receiver of ultra-modern design which should meet with the requirements of the most critical listener as regards sensitivity, selectivity, and quality of reproduction. 1938 coils and a special low minimum capacity tuning condenser are used in conjunction with specially chosen valves and associated components.

### The Circuit Arrangement

A straight circuit arrangement has been chosen because, apart from the fact that constructors who do not possess a signal generator experience more difficulty with a superhet than with the straight type of set, the latter type generally provides a better all-round performance on the short-wave

band than a superhet. Unless the superhet is fitted with special I.F. transformers having a reaction winding, continuous wave morse transmissions cannot be picked up. This is, of course, a big drawback to constructors who wish to use the receiver for morse reception. The majority of home-constructor straight receivers described in the past have used two tuned circuits on the medium and long-wave bands with an aperiodic aerial stage on the short-wave band. With this arrangement selectivity on the short waves is somewhat poor, and therefore it was decided to tune both stages on all wavebands in the Ace. Well-designed all-wave coil units have been chosen, and when these are used in conjunction with the specified .0005 mfd. two-gang condenser wavelength coverages

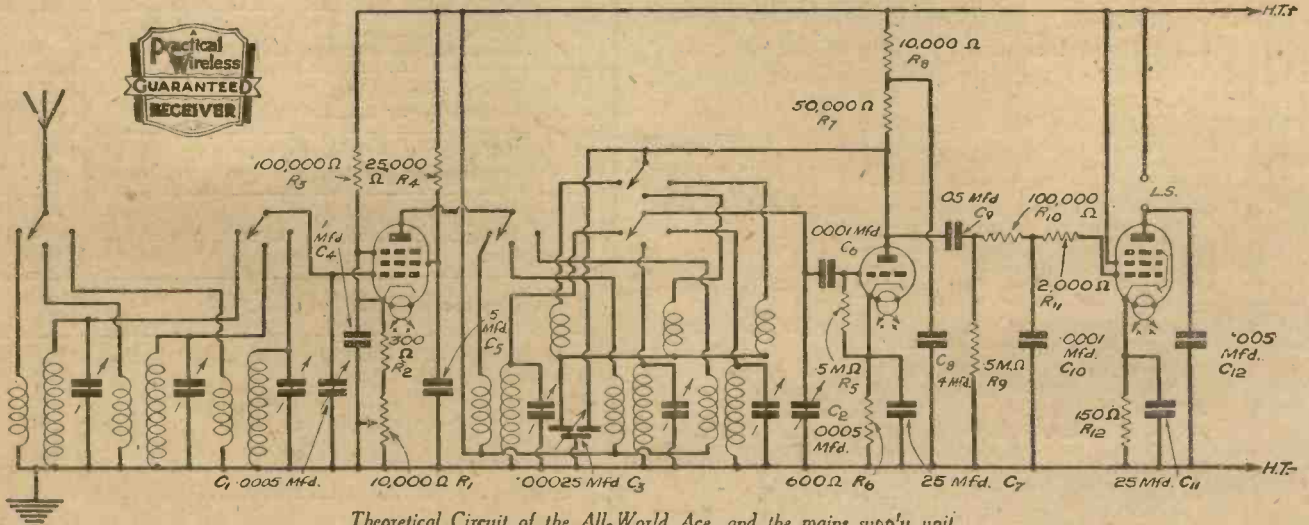
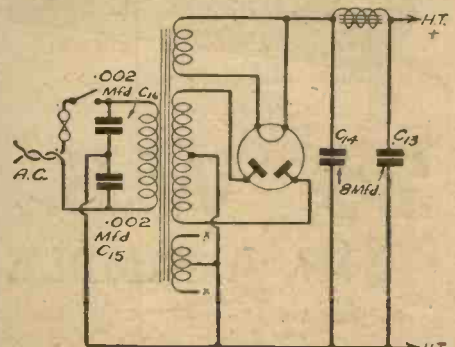

Theoretical Circuit of the All-World Ace, and the mains supply unit.



# The Experimenters Chat About the New Radio Season

And Discuss Just a Few of the Items of Constructor Interest which will be On View at Olympia

**A**LTHOUGH we still have a number of interesting letters which we wish to deal with, we are afraid that they will have to stand over for a little time. The fact is that Radiolympia being almost on top of us—as we write, it rightly claims our first attention. Will those of our friends who have been good enough to pass along their hints and suggestions therefore please excuse the delay this time?

Although the show is not open at the time of our writing this week's article, it will be when you read this page. Fortun-

## Accurate Matching

The position is not very involved when there are only long and medium waves to be considered, but considerable skill—

*by The Experimenters*

and not a little apparatus—is required to make compact short-wave coils with identical characteristics. And if the

characteristics vary it means either that separate tuning condensers have to be used for the different circuits, or that enormous efficiency losses must be contended with. The method which has been adopted in overcoming this trouble is to fit a small-capacity pre-set condenser for each coil in the tuning unit. Thus, you can match up the coils for the various

wavebands by means of these, and set the trimmers on the gang condenser to their minimum capacity, or, better still, disconnect these entirely.

## Transformers

But we must not let our keen interest in coils take our attention from some of the other items which we are simply itching to test. For example, there is a new output transformer tapped for all ratios between 120 to 1 and 10 to 1, which has a constant impedance with primary currents up to 80 mA. This can be used with push-pull, power or pentode output, and will solve many problems connected with powerful L.F. amplifiers. It will be very convenient for use in experimental amplifiers, and as a standard piece of test-bench equipment.

Another similarly-useful component for a different purpose is the new type of mains transformer, costing no more than previous and less-useful units, with outputs for feeding 4-volt, 5-volt and 6.3-volt valve-heaters. Many experimenters will want to buy one of these for general use. There is another mains transformer that tickles our fancy, for it is specially made for chassis mounting, and has sub-chassis connections. This is going to simplify the wiring of chassis-built mains sets, besides avoiding some of those short-circuits which have not been unknown when leads have had to be passed through the top of the chassis.

## Cheaper Mains Sets

Hundreds of constructors have often wished to obtain metal rectifiers without metal containing cases. The makers have satisfied this demand in the new range, with the result that it has been possible to reduce prices by a useful margin. This is another of the new season's lines which is going to help to bring down the cost of home construction, and to emphasise the advantages in this direction which the home constructor enjoyed until about two years ago.

For car-radio and similar sets receiving their total input from accumulators, the additional range of self-rectifying vibrators now available is helpful. These can now be obtained for operation from 4-volt, as well as 6-volt and 12-volt accumulators. The first-mentioned type will enable those whose houses are not wired for electricity to use all-mains-types of receiver without the need for a 6-volt accumulator. These

(Continued on page 599.)

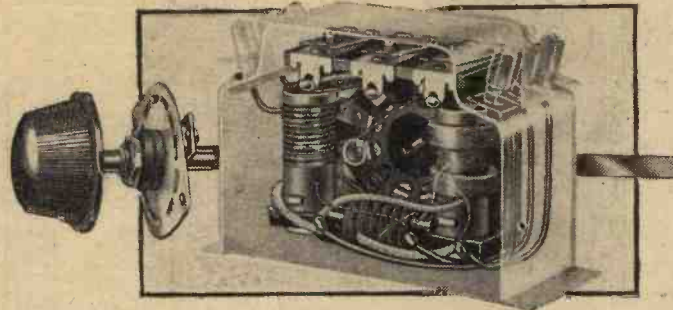

The new Wearite all-wave coil.

ately, we have been able to see in advance some of the proposed exhibits, and we have been able to carry out at least a few preliminary tests with some of the more interesting of the new components. Our first impression is that the coming season is going to be a better and more interesting one for the constructor and experimenter. Reason: because there are several interesting new components at remarkably low prices, whilst the cost of ready-made receivers is increasing.

## New All-wave Tuners

We do not propose to describe the new items in any great detail, since no doubt full particulars will be given in another part of this issue. But we must tell you how pleased we are that manufacturers have at last introduced all-wave tuners which are no more bulky—and no more expensive—than many previous models of two-range coils. What is more, the tuners that we have examined appeared to be remarkably well made, and to be of a real precision nature.

In the past the constructor has been at a slight disadvantage as compared with the user of commercial sets, as far as all-wave working is concerned, but that disadvantage has now been entirely removed. As those of you who have tried your hands at making all-wave coils are fully aware, it is by no means a simple job to make a set that can be used successfully with a gang condenser; matching presents very awkward problems, and stray capacities cannot easily be balanced out. It is all very well to have trimmers on the sections of the gang condenser, but these must be adjusted to a setting which affords a compromise on the different wavebands covered.

The new Bulgin output testing unit using a neon tube.



The forms of construction differ in detail, but the idea of using iron-cores for the two longer-waveband coils and an air-core tube for the short-wave coil appears to have found favour. By this means the overall dimensions of complete, screened all-wave tuners have been brought down almost to those of ordinary midget coils.

Problems of wave-change switching have also been tackled in a thorough manner by fitting reliable, anti-capacity rotary switches inside the coil cans themselves. Two or more switches can be operated by the same knob, since the arms of the switches are slotted to take a single spindle of suitable length. All of the new all-wave tuners that we have tested are very well made, and we are looking forward to trying out a few circuits using them. That is a matter on which we hope to be able to report later. In the meantime we learn that some of the new tuners are being used in new "Show" receivers being described on other pages; the Technical Staff tell us that they are well pleased with them.

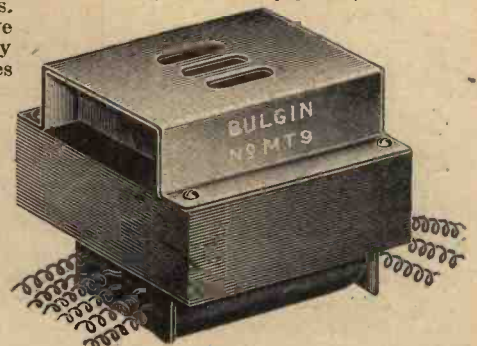

This new Bulgin transformer is arranged for chassis mounting, and is provided with sub-chassis connections.





**ACE RADIO, 2-5, Dingley Place, City Road, E.C.1. Stand No. 103.**

THE receivers exhibited on this stand consist of three- and four-band superhets and radiograms. Probably the most interesting model is No. AW91, which is a 9-valve receiver covering four wavebands from 11 metres upwards. The output stage consists of 2 double triodes in push-pull, delivering a total undistorted output of 12 watts. It costs 15 guineas and is also obtainable in a universal mains version, or as a radiogram.

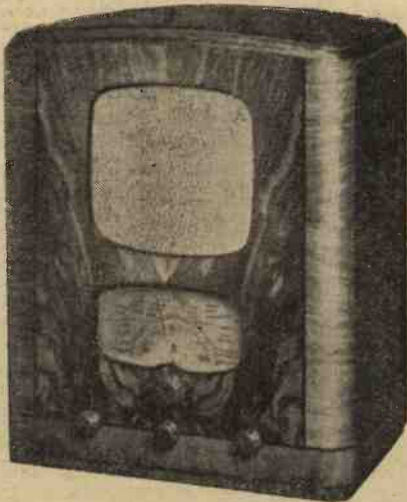

This is one of the Ace receivers, model AW 53B.

**AERIALITE, LTD., Castle Works, Etalybridge, Cheshire. Stand No. 28.**

AMONG the many items on this stand will be seen a massless aerials, aerial wires, batteries and special types of aerial. Amongst the aerial devices are those which are designed to enable the listener to erect such an essential item without the necessity for fixing a pole in the ground, and some novel forms have been developed by this company. For use on the short waves the new Coilite Dipole aerial, costing 12s. 6d., is of great interest. The special Percolite H.T. batteries at 5s. 6d. for 120 volts are bound to interest visitors, and a lower-priced battery is also to be seen on this stand.

**AERODYNE RADIO, LTD., Aerodyne Works, Tottenham, N.17. Stand No. 52.**

THE all-wave receivers shown on this stand are designed to provide high quality, together with fine examples of the modern cabinet-maker's art. In addition to superhet models, this firm will be featuring straight all-wave models, a 3-valve battery portable, and a 3-valve battery receiver covering the ordinary broadcast bands only. The lowest wavelength covered by the Aerodyne receivers is 13 metres, although certain models incorporate two short wavebands extending up to 170 metres.

## Complete Guide to the Exhibits

In some cases details of exhibits have not been released at the moment of going to press.

**ALL POWER TRANSFORMERS, LTD., 8a, Gladstone Road, Wimbledon, S.W.19. Stand No. 209.**

THE home-constructor will be interested in the wide range of transformers and chokes exhibited on this stand. There are components for all purposes, from the simple "stripped" models to the all-shrouded items designed to afford full protection from all points of view. Among the new lines will be two

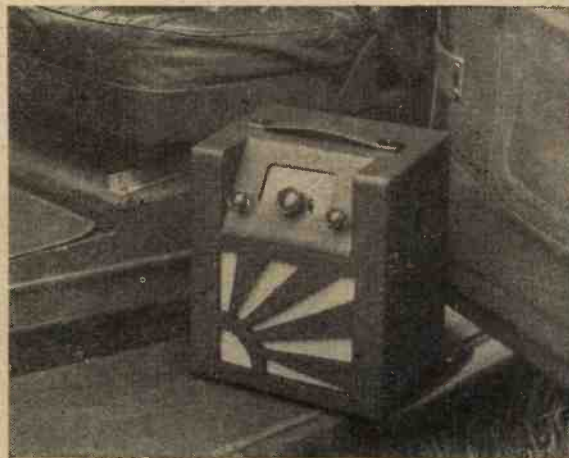

A handy portable, seen in a car setting, taken from the Aerodyne range.

conversion units from A.C. to D.C., one giving an output of 230 volts at 550 mA., and the other 230 volts at 275 mA. Vibrator units, L.T. chargers, and special small mains transformers for use in such processes as welding, soldering, etc., will also be featured.

**ARDENTE ACOUSTIC LABORATORIES, 309, Oxford Street, W.1. Stand No. 2.**

MESSRS ARDENTE specialise in deaf-aid and public-address equipment, and accordingly the exhibits on this stand consist of microphones, loud-speakers, and amplifiers of all types. Many cinemas, churches and other public buildings are fitted with

Floor Plan appears on page 583.  
Bus and other Transport Facilities page 585.  
"Stand-to-Stand" Report next week.

Ardente apparatus, and the equipment shown on this stand will give a good idea of the wide range of their activities. We illustrate one of the amplifiers from which the novel method of providing protection and screening will be seen. A very comprehensive 48-page catalogue may be obtained on this stand, in which photographs of the equipment taken on the exact location where the instruments are installed will be found, together with a full technical section.

**ARMSTRONG MANUFACTURING CO., 100, King's Road, Camden Town, N.W.1. Stand No. 220.**

THIS firm specialises in the supply of complete chassis, as distinct from a finished receiver in cabinet, and thus provides the listener with means for arranging a form of housing to suit his individual domestic requirements. Among the chassis on view will be seen 6-, 7- and 9-valve models, all superhets, and covering short waves as well as the normal broadcast wavelengths. The lowest wavelength covered is 11 metres, and push-pull stages are provided to deliver an output of 12 watts in the 9-valve model.

It is interesting to note that Octal (British) valves are employed in some of these chassis.

**ASSURANCE FINANCE TRUST, LTD., Commerce House, 72-86, Oxford Street, W.1. Stand No. 219.**

THIS stand will be devoted to an exhibit of literature relative to Radio Hire Purchase, and is therefore mainly of interest to manufacturers and dealers.

**AUTOMATIC COIL WINDER AND ELEC. EQUIPMENT CO., LTD., Winder House, Douglas Street, S.W.1. Stands Nos. 30 and 166.**

A MOST interesting range of measuring instruments will be shown here, and the popularity gained in the past for the Avometer and Avo minor will no doubt be shared in the future by the Avo Capacity Meter and Avo Valve Tester. In addition to these devices, all of which utilise a very high-class meter movement, this firm also supplies photographic light and exposure meters employing the photo-electric principle. The service engineer should make a point of



One of the interesting power amplifiers to be seen on the Ardente Stand, No. 2.



# "PRACTICAL & AMATEUR WIRELESS" GUIDE to the SHOW



obtaining details of the range of test equipment, including the Avo-Oscillator, whilst a new edition of the publication "Radio Servicing Simplified" will also be on sale on this stand.

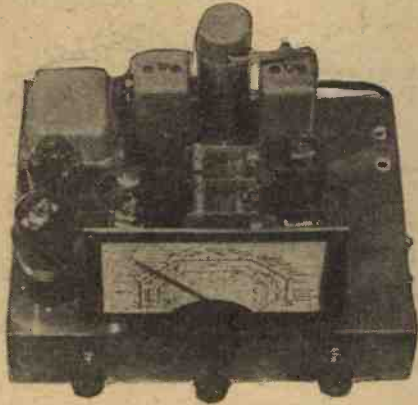

An interesting chassis selected from the Armstrong range, to be seen on Stand No. 220.

**BAIRD TELEVISION LTD.,** Crystal Palace, Anerley Road, S.E.19. Stand No. 87.

THE main feature of this stand will, of course, be the Baird Television receivers, in which the Baird Cathodisc tube, of the all-magnetic type, is incorporated. In addition, will be seen special samples of the equipment which has been used by the company in Flat installations, together with a complete layout of a modern block of flats. Vision and sound are provided "on tap" in any room and technical advice will be given by the company's experts on all points in this connection. Another new development is the Multiplier Photo-Electric Cell available in two mains types, either for a concentrated light beam or diffused light. In addition to other television equipment, working models showing the principles of operation will be on view.

**BALCOMBE, A. J., LTD.,** 52-58, Tabernacle Street, E.C.2. Stand No. 55.

AMONG the many new Alba receivers seen on this stand one of the most interesting will be the Armchair model which is designed for comfortable tuning. As will be seen, it has been designed to fit close to an easy chair, has sunk controls so that a tray or any other object may be placed on the top and it incorporates an all-wave superhet. The other models include battery and mains-operated superhets and straight circuits and the lowest wavelength covered is 16.5 metres.

**BARRATT & ROBINSON, LTD.,** 288-310, York Road, King's Cross, N.7. Stand No. 201.

THIS exhibit will consist of miniature, upright, grand and player pianos, including the smallest grand and player pianos which have ever been successfully marketed.

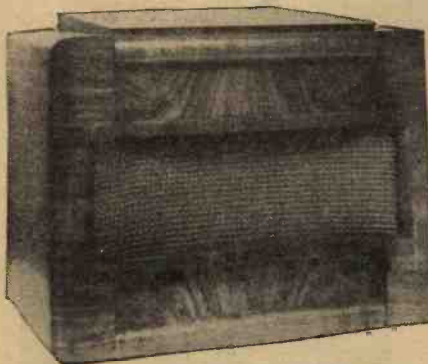

In this Beethoven receiver, to be seen on Stand No. 34, the novel arrangement of the loudspeaker opening is the main external feature.

**BEETHOVEN RADIO, LTD.,** Chase Road, North Acton, N.W.10. Stand No. 34.

AMONG the exhibits on this stand will be what is claimed to be the smallest, lightest and most compact moving-coil loudspeaker battery portable ever produced. Although very little larger than a box camera, it is stated to compare with full size instru-

ments. It will cost 7 guineas and no aerial is required. A canvas case and shoulder strap is also available at a slight extra charge. Among the other receivers to be shown are all-wave portables and radiograms, and the lowest wavelength covered is 16 metres.

**BELLING & LEE, LTD.,** Cambridge Arterial Road, Enfield, Middlesex. Stand No. 42.

THE main portion of this exhibit will consist of interference suppressing devices, ranging from the "Elimnoise" anti-interference aerial system, to the small suppressors designed for connection in the leads of electrical apparatus. Other items will include noise measuring instruments, noise locators, television aerials and valvoholders, loudspeaker extension plugs and sockets, the new mag-nickel delay fuse and a full range of terminals, plugs and other interesting lines for the home constructor and radio experimenter.

**BENJAMIN ELECTRIC, LTD.,** Brentwood Works, Tarrif Road, Tottenham, N.17. Stand No. 17.

A LARGE number of small items for the amateur will be shown on this stand, and these include resistance-fed L.F. transformers, chokes, valve-



A comprehensive kit supplied by Bellings and Lee to cut out the interference which is often picked up by the aerial and mains leads.

holders, switches, etc. In addition a wide range of Magnavox loudspeakers will be shown. These range from small models for home use to large projection models for outdoor public address work, and the Duodec model, with the double speech coil is especially worthy of attention. This model is available with various field resistances and costs £5 5s.

**BIFURCATED AND TUBULAR RIVET CO., LTD.,** c/o 13-14, Golden Square, S.W.1. Stand No. 151.

ON this stand there will be seen a full range of rivets and eyelets such as are now generally employed in modern radio chassis assemblies. By means of the machines designed by this firm these eyelets and rivets may now be inserted in the most awkward places.

**BOWMAKER, LTD.,** Bowmaker House, Lansdowne, Bourne-mouth. Stand No. 217.

THIS is a Finance corporation and therefore the exhibit will be mainly of interest to the dealer and shopkeeper.

**BRIDGER, R. O., & CO., LTD.,** No. 4 Factory, Shelford Place, Church Street, Stoke Newington, N.16. Stand No. 150.

THIS exhibit consists of a display of seamless moulded paper diaphragms for loudspeakers and microphones.

**BRITANNIA BATTERIES, LTD.,** Union Street, Redditch, Worcs. Stand No. 83.

ON this stand will be seen a wide range of batteries for all purposes. These are of the Pertrix type and include not only H.T. and G.B. batteries for radio apparatus, but also cycle lamp, torch and flash-lamp cells, and special types for use in police and fire brigade lamps. Two interesting batteries are the air depolariser and the alkaline model, the latter being guaranteed to last for eight years.

**BRITISH BELMONT RADIO, LTD.,** 4 & 5, Ridgmount Street, W.C.1. Stand No. 79.

THE receivers which will be exhibited on this stand include portables, table models and radiograms. Model 700, which is illustrated, is a 7-valve superhet extending down to 15.5 metres, and costing 13 gns. It is an A.C. receiver with Octal valves and magic eye tuning. The 9 valve superhet which will be exhibited tunes down to 6.2 metres so as to embrace the television programmes.

**BRITISH G.W.Z. BATTERY CO., LTD.,** Falmouth Road, Trading Estate, Slough. Stand No. 82.

THE exhibit on this stand will include G.W.Z. H.T. batteries and G.B. batteries for wireless receivers; refill batteries for pocket lamps and torches; over 60 different replacement models for commercial wireless receivers, a special range of H.T. and G.B. batteries for overseas purposes and a special group of heavy-duty H.T. units with clip terminals for overseas requirements.

**BRITISH MECHANICAL PRODUCTIONS, LTD.,** 79a, Rochester Row, S.W.1. Stand No. 94.

ON this stand will be featured the many Clix products which have proved so popular among home constructors and manufacturers. These include valvoholders, terminal and socket strips, plugs, connectors and switches. Among the new items to be shown will be Long Reach plugs, Plug-socket with horizontal insulator, and a dual-purpose crocodile clip.

**BRITISH METAL ENGRAVING CO., LTD.,** St. Margarets Works, St. Margarets, Middlesex. Stand No. 158.

THIS firm manufactures scales and dials for a number of commercial receivers, together with nameplates, and will exhibit some representative ranges of their products.

**BRITISH PIX CO., LTD.,** Pix House, 118, Southwark Street, S.E.1. Stand No. 211.

ON this stand will be seen the famous Pix Invisible Aerial, Selectivity Device, metallised earth, glass lightning arrester, tubular earth and the self-fitting outdoor aerial. Many of these items are already familiar to our readers, and the novel invisible indoor aerial has been mentioned on many occasions in our pages. In addition to these items the Pix valves, which cost from 2s. 6d. upwards, will also be on view.

**BRITISH RAILWAYS,** District Passenger Manager's Office, Seymour Street, N.W. Stand No. 9.

**BRITISH ROLA CO., LTD.,** Minerva Road, Park Royal, N.W. Stand No. 41.

TWO new Rola models are certain to attract attention this year. They are the F742-PM and the F1050-PM. The former is a 9in. speaker with a very high flux density and with an Alnico magnet system. It costs 49s. 6d. The F1050-PM is a slightly larger model with a 10in. diameter cone and will handle

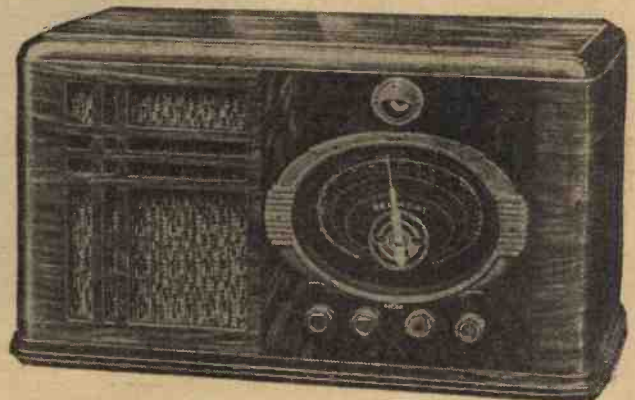

One of the British Belmont receivers in which an unusual shape of tuning dial is employed.

## NOW READY!

**WIRELESS COILS, CHOKES AND TRANSFORMERS, AND HOW TO MAKE THEM.**

2/6, or 2/10 by post from Geo. Newnes, Ltd., Tower House, Southampton Street, Strand, London, W.C.2.

8watts. Among the smaller Rola speakers to be shown is a 6½ in. model and cabinet models of various types, designed for use at extension listening points or as separate speakers where the receiver does not incorporate its own reproducer. The giant G12 model, with a 12 in. dia. phragm, should certainly be inspected.

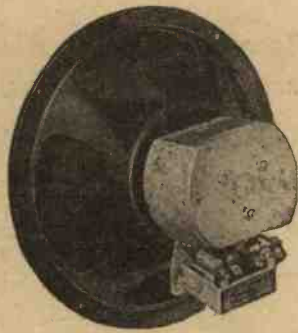

This is the Rola Model F.742-P.M., one of the many novel speaker chassis to be seen on Stand No. 41.

**BRITISH TELEVISION SUPPLIES, LTD.,** Faraday House, 8-10, Charing Cross Road, W.C.2. Stand No. 47.

ON this stand there will be the Little Princess Portable, a Multi-valve superhet chassis for all-wave reception, two amplifiers, and a wide range of B.T.S. components for short-wave work. In addition, the B.T.S. television receivers and kits of parts for home construction will also be exhibited. The amplifiers will provide outputs of 6 and 14 watts, the latter delivered by two triodes in push-pull.

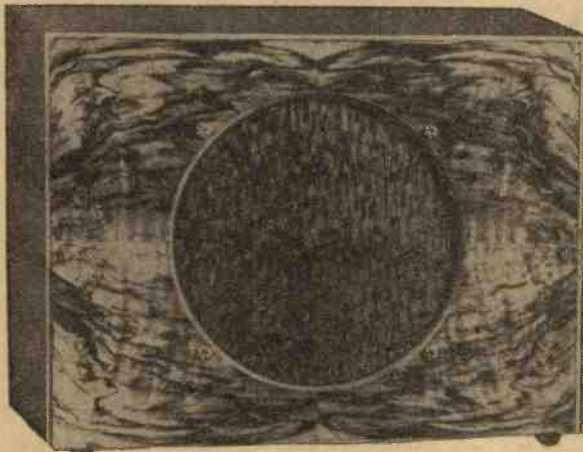

Celestion speakers may be obtained in cabinets for use at extension points. This is one of the models.

**BRITISH TUNGSRAM RADIO WORKS, LTD.,** West Road, Tottenham, N.17. Stand No. 36.

SEVERAL new Tungram valves are to be shown on this stand at this year's exhibition. These include a variable-mu Magic Eye, a special 2-volt triode detector valve with non-microphonic structure



Batteries of all types may be seen on the Chloride Storage company's stand No. 32.

and a large magnification factor, and a vari-mu Hexode for use in car radio apparatus.

**BRITISH WIRELESS FOR THE BLIND FUND,** 224, Great Portland Street, W.1. Stand No. 46.

**BROWN BROS., LTD.,** Gt. Eastern Street, London, E.C.2. Stand No. T.18.

THIS will be a wholesale exhibit and will feature complete products of many well-known firms.

**BULGIN, A. F. & CO., LTD.,** Abbey Road, Barking. Stand No. 1.

ABOUT 30 new components will be exhibited on the Bulgin stand, which, as usual, will be the centre of interest for the home constructor. Among the many old favourites which this firm will be exhibiting will be switches, transformers, chokes, coils and so on. Among the new lines will be a Television Aerial kit in a simple and a de luxe version; a square-can aerial coil and associated coils; multi-ratio output transformer, and neon output measuring unit. The separate items are, of course, too numerous to mention, but every amateur should make a point of examining the vast range which is available.

**BURNDIPT, LTD.,** Light Gun Factory, Erith, Kent. Stand No. 85.

SEVERAL new receivers are to be shown by Burndept, and these will include portables, table models and radiograms. Model 250, which will be shown on this stand, is claimed to be the first British receiver to employ electron-coupled output valves and aural tuning. With this device nothing is left to the skill of the operator, the receiver bringing in all transmissions of programme value absolutely without sideband distortion, passing silently from one station to another as the dial is rotated, and automatically eliminating all stations not of programme value. The lowest wavelength covered in the Burndept range is 13.5 metres.

**BUSH RADIO, Ltd.,** Power Road, Chiswick, W.4. Stand No. 70.

ALL-WAVE receivers will be seen on this stand, and some interesting features will be seen in the design of circuits and cabinets. In addition to the short-wave tuning ranges, the dials are clearly identified and novel forms of indication are adopted in certain of the models.

**CADISCH, R. & SONS, 5-6, Red Lion Square, W.C.1.** Stand T9.

THIS is a trade exhibit and consists of representative collections of standard apparatus.

**CELESTION, LTD.,** 29, High Street, Hampton Wick, Kingston-on-Thames. Stand No. 26.

THIS exhibit will consist of the many popular Celestion speakers, ranging from the Junior models up to the large public-address equipment. The speakers are available in chassis form, or mounted in cabinets, and all P.M. models are supplied without transformers for

use with receivers of 1 to 5 ohms impedance output. Alternatively, they may be obtained with a standard universal transformer. Certain models incorporate a constant impedance volume control. In addition to the speakers, this firm will also be exhibiting a pick-up which is supplied complete with volume control, for 29s. 6d.

**CHLORIDE ELECTRICAL STORAGE CO., LTD.,** Exide Works, Clifton Junction, nr. Manchester. Stand No. 32.

FOLLOWING the Exide "Mass" type L.T. cells incorporating the invisible charge indicator, a new range of Hycap accumulators, especially designed



This is one of the pick-ups manufactured by the Cosmocord Company, and it is available with a motor in the form of a complete gramophone unit.

**WIN A W.B. SPEAKER!**  
Turn to page 575.

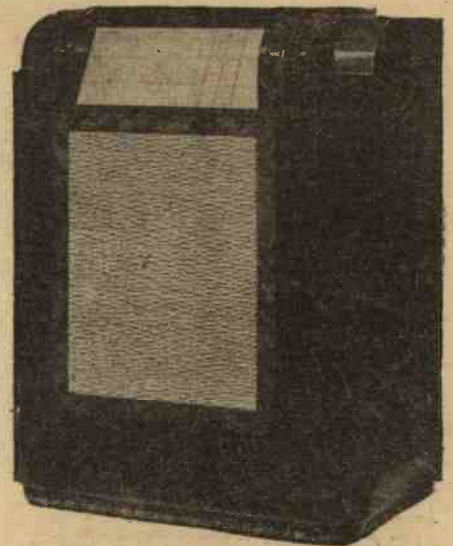

Note how the controls have been masked in the design of this new Ekco receiver. Tuning is carried out by means of a fly wheel device. See it on Stand No. 69.

to meet the demands of high-powered radio receivers has been produced. These will be exhibited on Stand No. 32 together with unspillable cells, wet H.T. batteries and dry batteries of all types. Continuing the policy of having available a suitable H.T. battery for every radio receiver, Drydex have augmented their range to cover all the latest commercial receivers, and in addition can supply alternative batteries for a number of popular sets.

**COLE, E. K., LTD.,** Ekco Works, Southend-on-Sea, Essex. Stand No. 69.

ONE of the most interesting features of the receivers to be shown on this stand, is the novel tuning device. In some of the Ekco receivers this year it would appear, at first sight, that all external tuning, volume and tone controls have been dispensed with. For tuning, a large knob is now used, and this is made

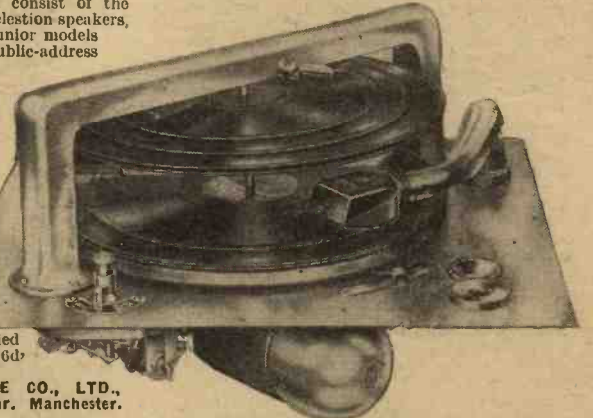

An automatic record changer which will accommodate mixed sizes of records and is faultless in operation. This is a Collaro product.

to follow the contour of the cabinet, rendering it inconspicuous, and the remaining controls are set in with this device. The balance of the control is very fine and the makers have applied the term "spin-wheel" tuning to the arrangement. In addition, Mystic Eye tuning devices, novel cabinets and a pick-me-up portable will also be well featured.

**COLLARO LIMITED,** Culmore Works, Culmore Road, Peckham, S.E.15. Stand No. 101.

ON this stand will be a full range of gramophone-reproducing apparatus, amongst which will be the Automatic Record changer, illustrated on this page. It plays eight 9in., 10in. and 12in. records, mixed in any order without adjustment. In addition, the automatic record-player is available in either

(Continued on page 584)



**Planoflex—** Astounding new speakers for QUALITY AMPLIFIERS

# Guide to the Exhibitors

Full List of Exhibitors arranged in Alphabetical Order, with Addresses and Stand Numbers.



NAME	ADDRESS	STAND No.	NAME	ADDRESS	STAND No.	NAME	ADDRESS	STAND No.
Acc Radio, 2, Dingley Place, City Road, E.C.		103	Eastick & Sons, Ltd., J. J., 118, Bunhill Row, E.C.1		T3	Mercantile Credit Co., Ltd., 39-45, Finsbury Square, E.C.2		215
Aerialite, Ltd., Castle Works, Stalybridge, Ches.		28	Eavestaff & Sons, Ltd., W. G., Ashfield Road, Harringay, N.4		204	Mica & Micanite Supplies, Ltd., Mica House, Barnsbury Square, N.1		154
Aerodyne Radio, Ltd., Aerodyne Works, Tottenham, N.17		52	Ecognsign Co., Ltd., 92, Victoria Street, S.W.1		222	Milnes Radio Co., Ltd., Church Street, Bingley, Yorks		88
All Power Transformers, Ltd., 8A, Gladstone Road, Wimbledon, S.W.		209	Edison Swan Electric Co., Ltd., 155, Charing Cross Road, W.C.2		57	Mullard Radio Valve Co., Ltd., 225, Tottenham Court Road, W.1		72, 161
Ardente (B. H. Dent), 309, Oxford Street, W.1		2	Efficiency Magazine, 87, Regent Street, W.1		221			
Armstrong Mfg. Co., 100, King's Road, Camden Town, N.W.1		220	Elf, Ltd., Gordon, 17a, Hanover Square, W.1		95			
Assurance Finance Trust, Ltd., 72-80, Oxford Street, W.1		210	Ensign, Ltd., 88, High Holborn, W.C.1		T19	New Era Publishing Co., Ltd., 12-14, Newton Street, Holborn, W.C.2		8
Automatic Coil Winder & Electrical Equipment Co., Ltd., Winder House, Douglas Street, S.W.1		30, 166	Ever-Ready Co. (G.B.), Ltd., Hercules Place, Holloway, N.7		58	New London Electron Works, East Ham, E.6		80
			Everett Edgecombe & Co., Ltd., Colindale Works, Hendon, N.W.9		164	Newnes, Ltd., George, Tower House, Southampton Street, Strand, W.C.2		10
Baird Television, Ltd., Greener House, 66, Haymarket, S.W.		87	Ferranti, Ltd., Radio Works, Moston, Manchester		21, 74	Olds Discount Co., Ltd., Equitable House, South Parade, Nottingham		218
Barratt & Robinson, Ltd., 288, York Road, King's Cross, N.7		201	Film Industries, Ltd., 60, Paddington Street, W.1		4	Partridge Wilson & Co., Ltd., Evington Valley Road, Leicester		29
Balcombe, Ltd., A. J., 52, Tabernacle Street, E.C.2		55	Flinners (Wholesale), Ltd., 14-20, St. Peter's Street, Ipswich		T7	Practical and Amateur Wireless		10
Beethoven Radio, Ltd., Chase Road, North Acton, N.W.10		34	Fuller Accumulator Co. (1926), Ltd., Woodland Works, Chadwell Heath, Essex		100	Philips Lamps, Ltd., 145, Charing Cross Road, W.C.2		63
Belling & Lee, Ltd., Cambridge Arterial Road, Enfield, Middlesex		42	Gambrell Electrical Equipment Co., Ltd., 3, St. James's Square, S.W.1		14	Pilot Radio, Ltd., 87, Park Royal Road, N.W.10		84
Benjamin Electric, Ltd., Brantwood Works, Tariff Road, N.15		17	Garrard Engineering & Mfg. Co., Ltd., Newcastle Street, Swindon, Wilts		37	Plessey Co., Ltd., Vicarage Lane, Hford, Essex		22
Bifurcated & Tubular Rivet Co., Ltd., c/o Exhibitors Service, Ltd., 13-14, Golden Square, W.1		151				Pye, Ltd., Africa House, Kingsway, W.C.2		60
Bowmaker, Ltd., 26, St. James's Street, S.W.1		217				Radio Gramophone Development Co., Ltd., Globe Works, Newton Row, Birmingham		67
Bridger & Co., Ltd., R.O., 4, Shelford Place, Church Street, N.16		150				Radiometers, Ltd., Eagle House, Jernyn Street, S.W.1		162
Britannia Batteries, Ltd., Union Street, Redditch, Worcs.		83				Radio Society of Gt. Britain, 53, Victoria Street, S.W.1		214
British Belmont Radio, Ltd., 4-5, Ridgmount Street, W.C.1		70				Rawplug Co., Ltd., Rawplug House, Cromwell Road, S.W.7		91
British G.W.Z. Battery Co., Ltd., Falmouth Road, Trading Estate, Slough, Bucks		82				Reslo (Sound Equipment), Ltd., 97, Hampstead Road, N.W.1		24
British Mechanical Productions, Ltd., 79A, Rochester Row, S.W.1		94				Rists Wires & Cables, Ltd., Freemantle Road, Lowestoft		159
British Metal Engraving Co., Ltd., St. Margaret's Works, St. Margarets, Middlesex		153				Rose (Electrical) Ltd., Norman, 94, Tottenham Court Road, W.1		207
British Pix Co., Ltd., 118, Southwark Street, S.E.1		211				Salford Electrical Instruments, Ltd., Magnet House, Kingsway, W.C.2		168
British Railways, District Passenger Manager's Office, Seymour Street, N.W.		9				Scott Insulated Wire Co., Queensland Works, Holloway, N.7		156
British Rola Co., Ltd., Minerva Road, Park Royal, N.W.		41	General Electric Co., Ltd., Magnet House, Kingsway, W.C.2		54, 62	Selecta Gramophones, Ltd., 81, Southwark Street, S.E.1		T13
British Television Supplies, Ltd., Faraday House, 8-10, Charing Cross Road, W.C.2		47	Gilbert & Co., Ltd., C., 73, Arundel Street, Sheffield		T17	Shaftesbury Microphones, Ltd., 24, Aldersgate Street, E.C.1		92
British Tungsram Radio Works, Ltd., West Road, Tottenham, N.17		36	Goodmans Industries, Ltd., Lancelot Road, Wembley, Middlesex		43	Siemens Electric Lamps & Supplies, Ltd., 39, Upper Thames Street, E.C.4		31
British Wireless for the Blind Fund, 224, Great Portland Street, W.1		46	Gramophone Co., Ltd., 98, Clerkenwell Road, E.C.1		66, 76	Sound Sales, Ltd., Marlborough Road, Upper Holloway, N.19		89
Brown Brothers, Ltd., Great Eastern Street, E.C.2		T18				Steatite & Porcelain Products, Ltd., Stourport-on-Severn		152
Bulgin & Co., Ltd., A. F., Abbey Road, Barking, Essex		1	Halcyn Radio, Ltd., Sterling Works, Dagenham, Essex		35	Sterling Batteries, Ltd., Sterling Works, Dagenham, Essex		5
Burndept, Ltd., Light Gun Factory, Erith, Kent		85	Harries Thermionics, Ltd., 233, Shaftesbury Avenue, W.C.2		3	Stratton & Co., Ltd., Bromsgrove Street, Birmingham		23
Bush Radio, Ltd., Power Road, Chiswick, W.4		70	Harris & Russell, Ltd., 91, Tottenham Court Road, W.1		T12	Tannoy Products, Canterbury Grove, West Norwood, S.E.		86
Cadlsh & Sons, R., 5-6, Red Lion Square, W.C.1		26	Haynes Radio, Queensway, Enfield, Middlesex		11	Telegraph Condenser Co., Ltd., Wales Farm Road, North Acton, W.3		33
Celestion, Ltd., London Road, Kingston-on-Thames		32	Hayberd & Co., Ltd., F. C., 10, Finsbury Street, E.C.2		25	Telsen Electric (1935), Ltd., Fitzgeorge Street, Manchester		90
Chloride Electrical Storage Co., Ltd., 231, Shaftesbury Avenue, W.C.2		69	Henleys Telegraph Works, Ltd., Holborn Viaduct, E.C.1		20	Texaloom Radio, Ltd., 806, High Road, Tottenham, N.17		15
Cole, Ltd., E. K., Ekco Works, Southend-on-Sea		101	High Vacuum Valve Co., Ltd., 111, Farringdon Road, E.C.		27	Thompson, Diamond & Butcher, 34, Farringdon Road, E.C.		T5
Colliaro, Ltd., Culmore Works, Culmore Road, S.E.15		48	Hobday Brothers, Ltd., 21, Great Eastern Street, E.C.2		T10	The 362 Radio Valve Co., Ltd., 324, Liverpool Road, N.7		210
Cosmocard, Ltd., Cambridge Arterial Road, Enfield		61	Hunt, Ltd., A. H., Bendon Valley, Garratt Lane, S.W.18		155	Tucker Eyelet Co., Ltd., George, Cuckoo Road, Birmingham, 7		102
Cossor, Ltd., A. C., Cossor Works, Highbury Grove, N.5		163				Ultra Electric, Ltd., Western Avenue, Acton, W.3		63
Crypton Equipment, Ltd., North Acton Road, Park Royal, N.W.10		202	Invicta Radio, Ltd., 79A, Parkhurst Road, N.7		56	Varley (Oliver Pell Control, Ltd.), Cambridge Place, Burrage Road, S.E.18		99
			Jackson Brothers (London), Ltd., 72, St. Thomas Street, S.E.1		93	Vidor, Ltd., West Street, Erith, Kent		33
Davies (Slough), Ltd., D. M., Trading Estate, Slough, Bucks		16	Kolster-Brandes, Ltd., Cray Works, Sidcup, Kent		65	Webber & Co., Ltd., J. M., 39, Great Eastern Street, E.C.		T11
Davis & Timmins, Ltd., Brook Road, Wood Green, N.22		213	L. E. S. Distributors Ltd., 15, Alfred Place, Tottenham Court Road, W.1		T6	Westinghouse Brake & Signal Co., Ltd. 82, York Road, King's Cross, N.1		77
Decca Gramophone Co., Ltd., 1-3, Brixton Road, S.W.9		71	Lissen, Ltd., Angel Road, Edmonton, N.18		73	Weston Electrical Instrument Co., Ltd., Kingston By-Pass, Surbiton, Surrey		167
De La Rue & Co., Ltd., Thos., 90, Sthernhall Street, Walthamstow, E.17		6	Lugton & Co., Ltd., 203, Old Street, E.C.1		T15	Whiteley Electrical Radio Co., Ltd., Victoria Street, Mansfield, Notts		75
Dew & Co., Ltd., A. J., 33, Rathbone Place, W.1		T20	Manufacturers' Accessories Co. (1928), Ltd., 85, Great Eastern Street, E.C.2		T4	Wingrove & Rogers, Ltd., 188-89, Strand, W.C.2		44
Dibben, Ltd., Ilorace, 34, Carlton Crescent, Southampton		T8	Marconiphone Co., Ltd., 210, Tottenham Court Road, W.1		53, 64	Wright & Weaire, Ltd., 740, High Road, Tottenham, N.17		165
Dubilier Condenser Co. (1925), Ltd., Ducon Works, Victoria Road, N. Acton, W.3		81	May & Baker, Ltd., 42-43, St. Paul's Churchyard, E.C.4		157			
Dynaport Radio & Television, Ltd., Portadyne Works, Gorst Road, N.W.10		18	McMichael Radio, Ltd., Wexham Road, Slough, Bucks		69			
Dynatron Radio, Ltd., Perfecta Works, Ray Lea Road, Maidenhead		104						
Dyson & Co., Ltd., J., 2, Coleman Street, E.C.2		T14						
East London Rubber Co., Ltd., 29, Great Eastern Street, E.C.2		T16						

For the Best Books, Blueprints, Periodicals, and Reader Service, visit our Stand, No. 10, Ground Floor!

# FINDING YOUR WAY ROUND RADIOLYMPIA

Floor Plans Showing Positions, Names of Firms and Corresponding Numbers of Stands

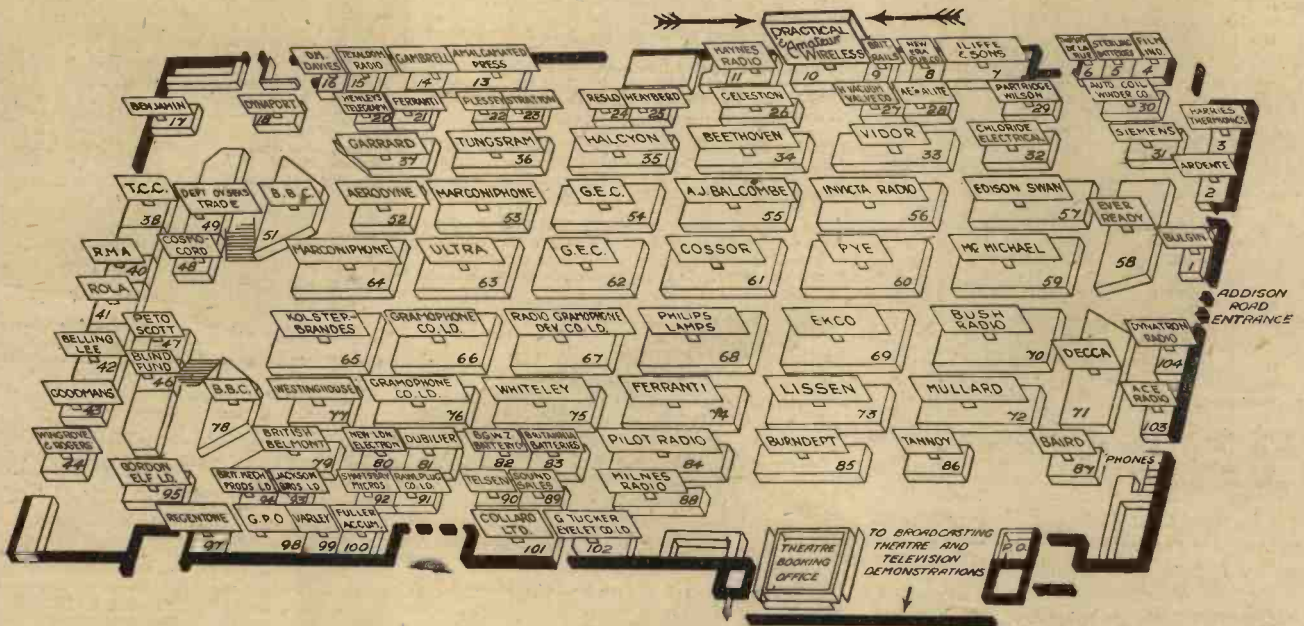

GROUND FLOOR PLAN

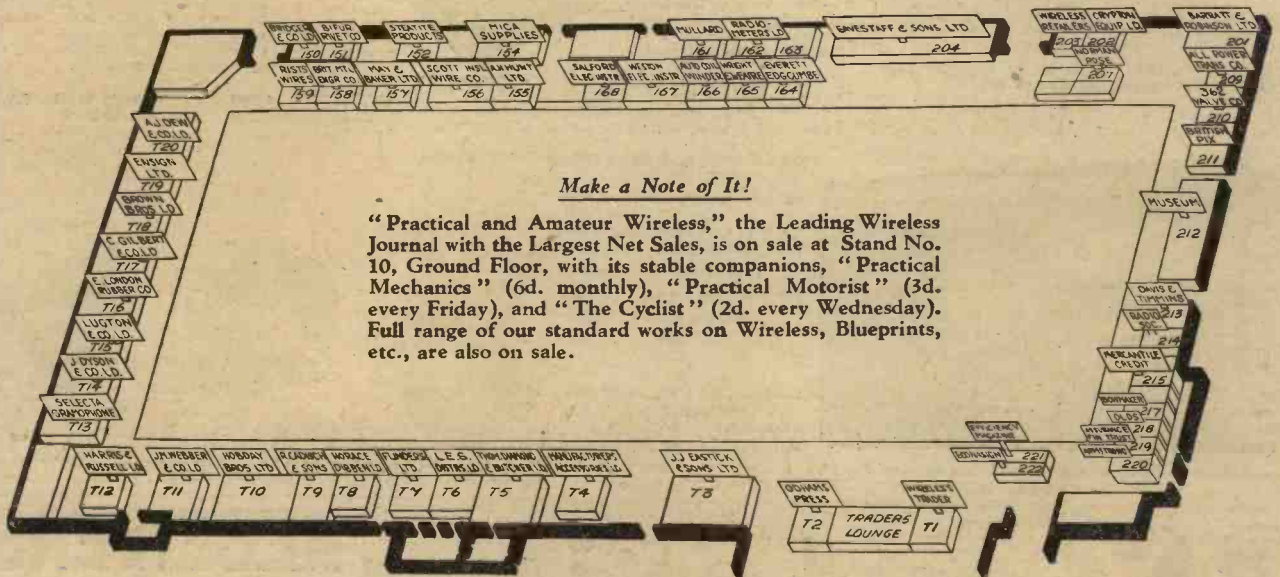

GALLERY PLAN

"PRACTICAL & AMATEUR WIRELESS"  
**GUIDE to the SHOW**

chassis or cabinet form. Magnetic and crystal pick-ups will also be shown, together with radiogram units embodying A.C. and universal motors, combined with pick-ups on rectangular unit plates with fully-auto-

The receivers are of the all-wave and superhet types, and the lowest wavelength covered is 16 metres. Several battery receivers will be seen, and these also embrace the all-wave feature. The popular Melody Maker receivers will be seen in their 1938 form, and the cathode-ray oscillographs will attract considerable attention. The television receiver will also be on view and may be seen working in the special television section.

**DUBILIER CONDENSER CO. (1925), LTD.,** Ducon Works, Victoria Road, North Acton, W.3. Stand No. 81.

HERE will be seen a most comprehensive range of condensers, including small mica dielectric components, wire-end tubulars, metal-cased oil-dielectric



This illustration shows how the variable-selectivity device has been fitted into the I.F. transformers of the Cossor receivers.

matic start-and-stop mechanism. Double and single-speed motors will also be exhibited.

**COSMOCORD, LTD.,** Cambridge Arterial Road, Enfield, Middlesex. Stand No. 48.

ONE of the main items to be featured on this stand will be the novel playing desk, available in different patterns. It consists of a motor, turntable and pick-up built into a small cabinet so that it may be added to an existing table model receiver. It is also obtainable with a record-storing cabinet beneath. In addition to this, there will be motors and pick-ups on view, one of which is shown on page 531. The portable playing desk will also be prominently featured. This costs £4 5s., and is available for Universal (A.C. or D.C.) use without alteration, as well as for A.C. use.

**COSSOR, A. C., LTD.,** Cossor House, Highbury Grove, London, N.5. Stand Nos. 61 and 163.

ON the Cossor stands the exhibits will consist of radio receivers, radiograms, valves, cathode-ray tubes, measuring devices and television receivers.

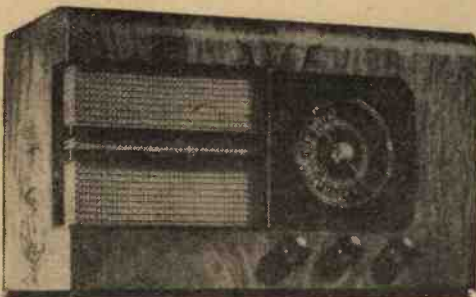

One of the new Portadyne receivers to be seen on Stand No. 18. Note the large clock-face tuning dial.

**CRYPTON EQUIPMENT, LTD.,** North Acton Road, Park Royal, N.W.10. Stand No. 202.

ON this stand will be seen a full range of charging equipment suitable for the radio dealer, service engineer and car-owner. For the latter, a full 6-amp. automatic charger for 6- or 12-volt batteries may be obtained, and this requires no charging resistances, no barretter lamps and no adjustments.

**DAVIES D. M., (SLOUGH), LTD.,** Trading Estate, Slough. Stand No. 16.

**DAVIS & TIMMINS, LTD.,** Brook Road, Wood Green, N.22. Stand No. 213.

**DECCA GRAMOPHONE CO., LTD.,** 1-3, Brixton Road, S.W.9. Stand No. 71.

AMONG the receivers to be shown on this stand are table models, radiograms and a novel portable. This is illustrated on this page and is known as the Portrola receiver. It is a superhet for either A.C. or



This is the Portrola, a Decca portable radio-gramophone which may be seen, with the other Decca receivers, on Stand No. 71.

D.C. supplies, and covers three wavebands. An internal aerial is fitted and a high-fidelity P.M. speaker. It weighs 27lbs. and costs 16½ guineas. The lowest wavelength covered in the Decca range is 12 metres.

**DE LA RUE, T., & CO., LTD.,** 90, Shernhall Street, E.17. Stand No. 6.

THIS exhibit will show the advance which has been made in moulded plastic technique as applied to radio.

**DEW & CO., LTD.,** A. J., 33, Rathbone Place, W.1. Stand No. T.20.

**DIBBEN, H., LTD.,** 34, Carlton Crescent, Southampton. Stand No. T.8.

THIS is a trade exhibit and will consequently consist of representative apparatus.

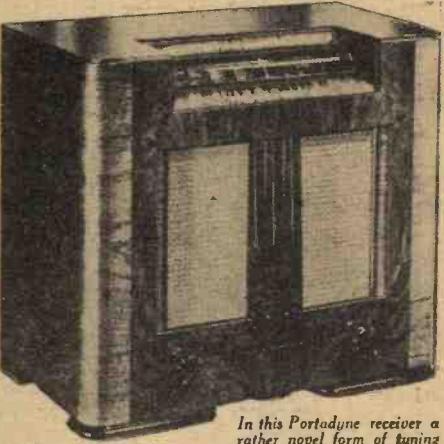

In this Portadyne receiver a rather novel form of tuning dial has been incorporated and greatly facilitates tuning.

and electrolytic condensers of all types. In addition, to the many popular items which have already been placed on the market, there will be a number of new lines, many of which are of the high-voltage type designed for use in television and other high-voltage circuits. Blocks of condensers, incorporating several condensers with common connections, to reduce internal circuit wiring, will also be shown.

**DYNAPORT RADIO & TELEVISION, LTD.,** Portadyne Works, 18-19, Gorst Road, N.W.10. Stand No. 18.

ON this stand will be seen various model receivers, incorporating mains and battery-operated models. The latest release is an all-wave superhet for A.C. operation with triple-tuned 450 kc/s intermediate frequency transformers. The lowest wavelength covered is 16.5 metres. A novel feature is the "Rotomatic" tuning scale which turns with the wave-change switch and thus only exposes the appropriate tuning scale, thus avoiding confusion.

**DYNATRON RADIO, LTD.,** Perfecta Works, Ray Lea Road, Maidenhead. Stand No. 104.

THE main feature underlying the Dynatron receivers is the incorporation of the highest possible quality, and receivers will be found on this stand rang-



Three of the variable controls from the Dubilier range. The centre component is a "Fadover" designed for changing over from radio to gramophone reproduction.



# Stentorian

**RECEIVERS-**  
for Critical  
listeners

ing in price from 35 guineas to 155 guineas. These are built solely for the music-lover, radio enthusiast, and those seeking to obtain the very best, and who are prepared to pay a little more for that purpose. All-wave reception is incorporated, and there are 5 wave-bands going down to 6½ metres. A novel tuning system is introduced in which, when correctly tuned in, the scale lights are dimmed and the station name lights up. The chassis of all the Dynatron receivers may be obtained separately if desired.

**DYSON, J., & CO., LTD.,** 2, Coleman Street, E.C.2. Stand No. T.14.

THIS is a trade exhibit.



This is one of the pick-ups from the range to be seen on the Edison Swan stand.

**EAST LONDON RUBBER CO., LTD.,** 29, Great Eastern Street, E.C.2. Stand No. T.16.

THIS also is a trade exhibit.

**EASTICK, J. J., & SONS, LTD.,** 118, Bunhill Row, E.C.1. Stand No. T.3.

ON this stand, which is a trade exhibit, representative receivers and apparatus will be shown.

**EAVESTAFF, W. G., & SONS, LTD.,** Ashfield Road, Finsbury Park, N.4. Stand No. 204.

ON this stand will be shown the miniature pianos and other products of this firm. These include a new upright and the "Minigrand."

**ECONASIGN CO., LTD.,** 92, Victoria Street, S.W.1. Stand No. 222.

**EDISON SWAN ELECTRIC CO., LTD.,** 155, Charing Cross Road, W.C.2. Stand No. 57.

ON this stand will be shown many interesting B.T.H. components, such as pick-ups and loudspeakers, as well as the full range of Mazda valves and television accessories. These include new types of valve and the cathode-ray tubes. The Pezolectric pick-up is one of the outstanding items in the remaining ranges, and the 1938 model reaches a high standard of efficiency in the reproduction of modern records. In addition on this stand, the Lungar Radio Battery chargers and the "Extra-Life" accumulators will be shown.

**EFFICIENCY MAGAZINE,** 87, Regent Street, W.1. Stand No. 221.



A very useful gramophone motor and pick-up to be seen on the Garrard stand.

**ELF, GORDON, LTD.,** 172, Hanover Square, W.1. Stand No. 95.

**ENSIGN, LTD.,** 88, High Holborn, W.C.1. Stand No. T.19.

THIS is a trade exhibit.

**EVER READY CO. (GT. BRITAIN), LTD.,** Hercules Place, Holloway, N.7. Stand No. 58.

IN addition to the Ever Ready batteries and valves to be seen here, there will be a comprehensive range of receivers. These include a neat portable which has a hinged speaker fitting in the lower portion, unlike the usual scheme of including it in the lid. When the lid is raised the speaker is lifted at an angle and is thus in a suitable position to give good sound distribution. The lowest wavelength covered in the Ever Ready sets is 13 metres.

**EVERETT, EDGUMBE & CO., LTD.,** Colindale Works, Hendon, N.W.9. Stand No. 164.

IN addition to the "All Purpose Tester," the double pointer multi-range A.C. and D.C. moving-coil meter, and the Service Valve Tester, which was introduced last season, two new lines will be seen on this stand. These are the Valve Gauge, a simple emission and mutual conductance tester, handling all types of valve, and an All-Wave Oscillator with a continuous range from 10 to 3,000 metres. The Visual valve tester has been modified to include a more elaborate power pack and voltage stabilisation. In addition a wide range of dwarf testing instruments will be shown, together with power output metres and other radio equipment.

**FERRANTI, LTD.,** Radio Works, Moston, Manchester. Stand Nos. 21 and 74.

ON these two stands Messrs. Ferranti will be showing their new range of all-wave receivers and also their new Television receiver. Full details have not yet been released regarding these items, but the all-wave feature is obviously to be incorporated, and to facilitate tuning on the short-waves a novel projection dial is fitted. This gives an equivalent of about 8ft. of tuning scale and renders the short-wave tuning as simple as the ordinary broadcast tuning.

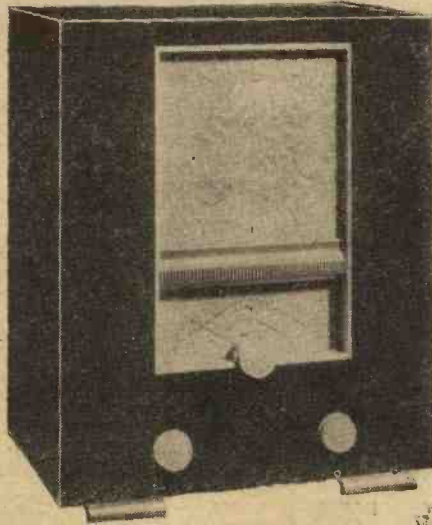

A new idea in cabinet design and colour schemes, to be seen in the new G.E.C. range of receivers.

**FILM INDUSTRIES, LTD.,** 60, Paddington Street, W.1. Stand No. 4.

PUBLIC Address loudspeakers and microphones will be featured on this stand and the latest addition is the type L.S.S. loudspeaker unit. This has a considerably improved diaphragm assembly and will handle 35/40 watts speech power when used in conjunction with the company's 70in. exponential horn. The M2 moving-coil microphone will also be featured with some amplifiers ranging from 3½ watts upwards. In the domestic speaker range a point of interest is the patented parallel action centring device which has the merit of completely sealing the air gap.

**FLINDERS (WHOLESALE), LTD.,** 14-20, St. Peter's Street, Ipswich. Stand No. T.7.

THIS is a trade exhibit.

For covering a large area a loud-speaker horn of this type is very desirable. This model may be seen on the Goodman Stand No. 43.

**FULLER ACCUMULATOR CO. (1926), LTD.,** Woodland Works, Chadwell Heath, Essex. Stand No. 100.

AMONG the many new accumulators and H.T. batteries to be seen on this stand are jelly and free-acid unspillable types and high capacity

units. The 10 volt H.T. accumulator units are available in various capacities ranging in price from 5s. 9d., and H.T. dry batteries are available from 3s. for 60 volts. Fuller batteries are also available for use in torches, flashlamps, cycle lamps and other devices and a special range of portable units is to be shown.



Included in the range of B.T.H. components which are exhibited on the Edison stand No. 57 are pick-ups, head-phones and valves, together with loudspeakers. This is one of the headphone sets which are obtainable in a special lightweight pattern for those who do a considerable amount of listening through the phones.

**GAMBRELL ELECTRICAL EQUIPMENT CO., LTD.,** 3, St. James's Square, S.W.1. Stand No. 14.

**GARRARD ENGINEERING & MGF. CO., LTD.,** Swindon, Wilts. Stand No. 37.

THE main feature on this stand will be the R.C.4 record changer unit. In addition, an improved R.C.1 record changer will be on view and this will be available for either A.C. or A.C./D.C. use. It is designed, to play batches of eight 10in. or 12in. records in any combination. In addition various other gramophone motors and gramophone units will be on view, and the type B.A.C.6 is illustrated on this page.

**GENERAL ELECTRIC CO., LTD.,** Magnot House, Kingsway, W.C.2. Stands Nos. 54 and 62.

ON these two stands will be displayed not only the latest G.E.C. receivers, but also the range of batteries and Osram valves. The receivers will be displayed on stand No. 62, and is claimed to be the most comprehensive range yet brought out by the G.E.C., including both battery and mains apparatus. Prices range from 7½ guineas to 80 guineas for an autoradiogram with a 10-watt output stage. In addition to the Osram valves and H.T. batteries the television receivers will undoubtedly be a great attraction. The instruments provide pictures 10in. by 8in. and details are given in our special television review this week.

**GILBERT, C., & CO., LTD.,** 73, Arundel Street, Sheffield. Stand No. T.17.

THIS is a trade exhibit.

**GOODMANS INDUSTRIES, LTD.,** Lancelot Road, Wembley, Middlesex. Stand No. 43.

ON this stand will be seen some interesting P.A. loudspeakers, an illustration of one being given on this page. In addition Messrs. Goodman will be showing a new volume control designed to meet the demand for a loudspeaker control, which does not materially alter the load reflected back to the primary of the transformer. It eliminates distortion usual with

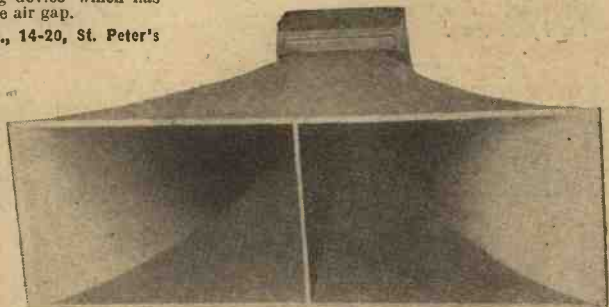

some types of loudspeaker volume control. It costs 7s. 6d. A very interesting domestic speaker is the model which incorporates an elliptical diaphragm, occupying only the space taken by a 6in. speaker, but giving reproduction equal to a 10in. unit.



**"PRACTICAL & AMATEUR WIRELESS"**  
**GUIDE to the SHOW**

**GRAMOPHONE CO., LTD.**, 98, Clerkenwell Road, E.C.1. Stands Nos. 66 and 76.  
 ON one of these stands will be displayed 22 all-world radio receivers and radiograms, and on the other the new Television receivers, together with a series of exhibits showing how closely the world famous H.M.V. trade mark has been linked with the develop-



A novel idea is incorporated in this H.M.V. Armchair receiver. The mirror on the wall reflects the other side of the cabinet and shows the arrangement of the controls.

ment of the successful system of television operated by the B.B.C. The radio receivers range in price from 7½ guineas and in some models provision is made for the reception of the television sound programmes. Otherwise, the lowest wavelength covered is 11 metres.

**HALCYON RADIO, LTD.**, Sterling Works, Dagenham, Essex. Stand No. 35.

A COMPLETE range of receivers will be seen on this stand, including battery and mains models. The all-wave feature is, of course, incorporated, and

the lowest wavelength covered is 16.5 metres. Television receivers will also be shown, and these include one model in which an all-wave radio chassis is built, whilst another model receives television sound and vision only. This will cost 55 gns.

**HARRIES THERMIONICS, LTD.**, Britannia House, 233, Shaftesbury Avenue, W.C.2. Stand No. 3.

THE exhibits here show valves and receivers covered by patents under which licences are granted by the company. The newly released Hivac Harries all-stage valve is also to be shown. A high-performance 6-valve and rectifier chassis using all-stage valves will also be shown. In addition there will be an exhibit showing the patent history of receivers and valves and a silent demonstration of the power handling capabilities of the new Hivac Harries Ae/Q critical distance 60 watt tetrodes.

**HARRIS & RUSSELL, Ltd.**, 191, Tottenham Court Road, W.1. Stand No. T.12.

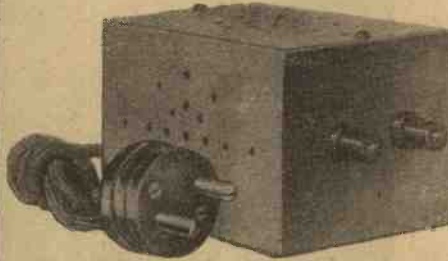

An ingenious midget charger to be seen on the Heayberd stand. This useful piece of apparatus costs only 12s. 6d.

**HAYNES RADIO, LTD.**, Queensway, Enfield, Middlesex. Stand No. 11.

ON this stand will be seen chassis and receivers designed on novel lines. Straight quality circuits, employing H.F. amplification and diode rectifiers, and special amplifiers employing the Duophase circuit, will also be seen, and the makers are also able to supply various pieces of television apparatus. There is a "Viciver," giving complete sound

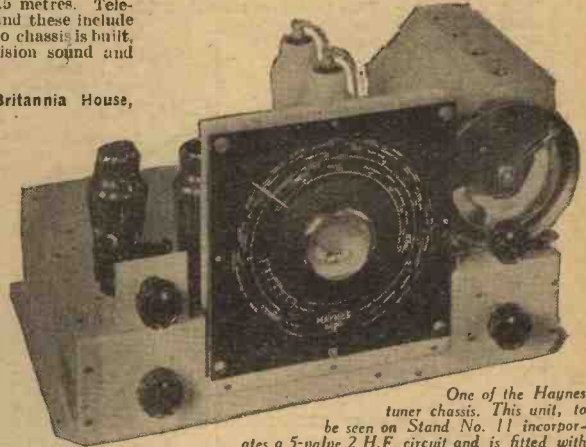

One of the Haynes tuner chassis. This unit, to be seen on Stand No. 11 incorporates a 5-valve 2 H.F. circuit and is fitted with separate valves for L.F. and A.V.C. There are four tuned circuits and a variable sensitivity control.

and vision plus gramophone reception, and loudspeakers, microphone, and various mains transformers and chokes are also to be seen.

**HEAYBERD, F. C. & CO.**, 10, Finsbury Street, E.C.2. Stand No. 25.

AS makers of mains equipment of all types this exhibit will consist mainly of transformers, chokes and associated apparatus. In addition there will be several battery chargers and rectifying equipment. These include the neat little Tom Thumb charger illustrated on this page which is ideal for charging 2-volt accumulators at ½ amp. It costs only 12s. 6d., and is only 3½ in. long by 2½ in. wide. In addition there will be a full range of battery chargers suitable for radio service stations.

**HENLEY'S TYRE & RUBBER CO., LTD.**, 11, Holborn Viaduct, E.C.1. Stand No. 20.



For soldering in awkward places this Solon iron, with the Pencil point bit will prove of the utmost value to the constructor. See it on Stand No. 20.

ON this stand the popular Solon soldering irons will be displayed together with radio wires of all types. Among the many patterns of Solon iron the most

**A**DJOINING Olympia and linked to the Main Hall by a private covered way, the huge garage which was opened recently will provide ideal car parking facilities for visitors to Radiolympia. There is parking accommodation for 1,200 cars.

**FOR YOUR CAR**

Each of the ten parking floors is 100 yards long and the whole building of six storeys is served by two internal spiral roadways, one serving as an entrance

and the other as an exit. This enables visitors to reach or leave any part of the garage with a minimum of delay, and Metropolis Garages, Ltd., who are running the garage, state that it is possible to empty all floors in under twenty minutes.

The lower ground floor houses a workshop specially equipped for rapid service. Open day and night, charges are from 1s. a car.

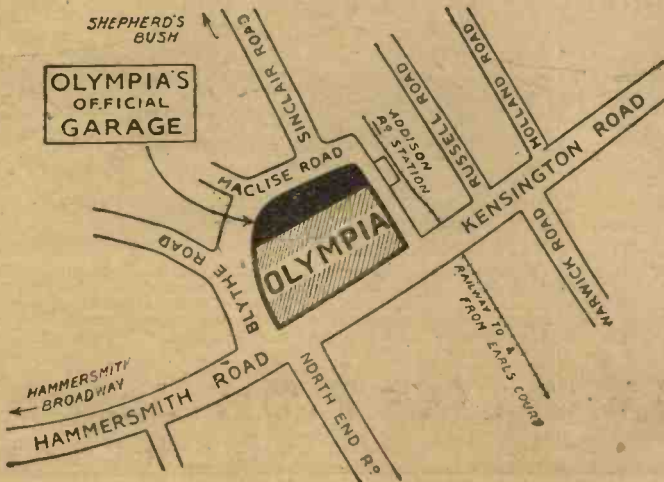



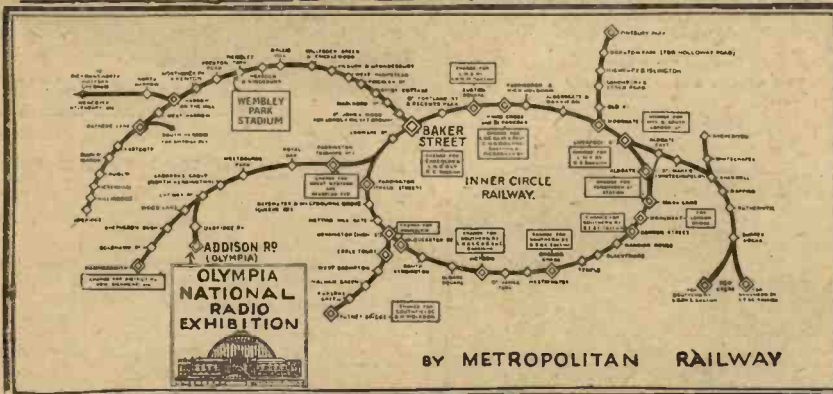
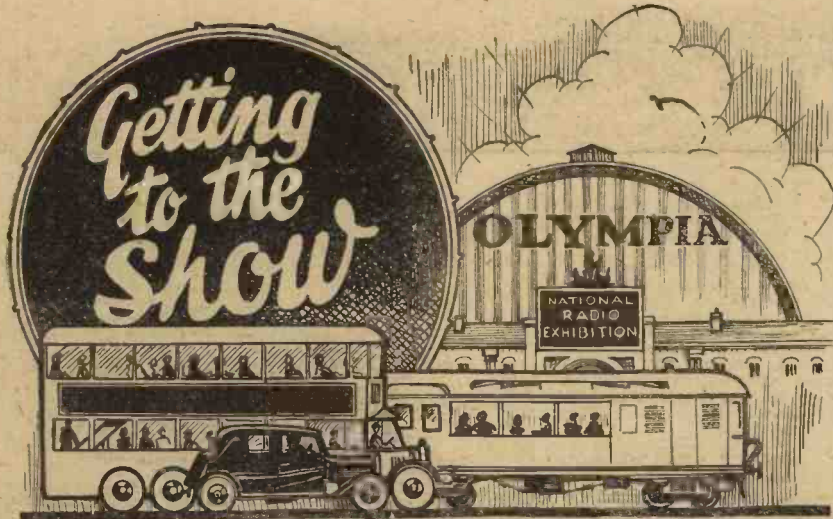

popular, from the point of view of the home constructor is the pencil point model, where the working surface is in the form of a long thin bit which easily reaches down into otherwise inaccessible points of a radio receiver and enables repairs to be carried out easily. There are several new models, and one is illustrated on page 586.

**HIGH VACUUM VALVE CO., LTD.,** 113-117, Farringdon Road, E.C.1. Stand No. 27.

EACH year Hivac are able to show something exclusive, and this year the new Harrios All-stage valve in its commercial form will be featured. This valve is capable of being inserted into any stage in a receiver, even a superhet, and removes the need for different valve types. Other exhibits will be a range of special 2-volt short-wave valves and a complete range of battery and mains valves. There will also be models of the Wayfarer portable receivers which are now marketed by Hivac.

*A novel portable to be seen on the High Vacuum Valve Company's stand (Hivac). This is the Wayfarer Grand, and the tuning panel is shown inset.*



**HOBDAY BROS., LTD.,** 21, Gt. Eastern Street, E.C.2. Stand No. T10.

THIS is a trade exhibit.

*This is the Wayfarer Major portable to be seen on Stand No. 27.*

operated portable instrument covering a frequency range of 30 megacycles to 100 kilocycles in five bands. A sixth band covering 20 to 60 megacycles is obtainable by utilising the second harmonic of band 5, a useful range for the alignment of television receivers.

**INVICTA RADIO, LTD.,** 79a, Parkhurst Road, N.7. Stand No. 56.

SIX all-wave superhets (one a radiogram), three standard broadcast sets and a television receiver comprise the new programme of the Invicta company, and will be seen on this stand. The lowest wavelength covered is 6.5 metres, in a six-band de-luxe receiver which tunes from that point up to 2,000 metres with only a small gap between 550 and 800 metres. In the popular receivers the lowest wavelength is 16.5 metres. Details are not released concerning the television receiver at the time of going to press.

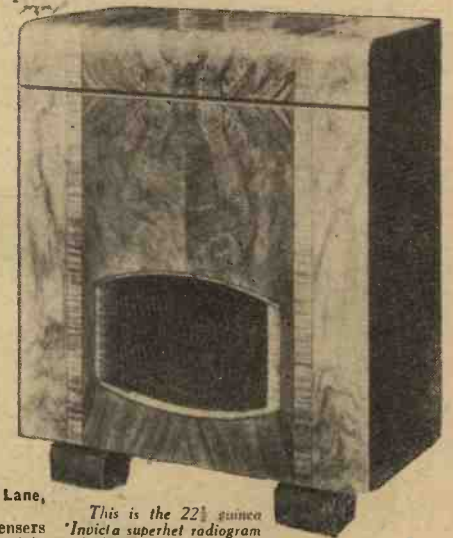

*This is the 22 guinea Invicta superhet radiogram which houses a 4 waveband receiver. See it on Stand No. 56.*

**HUNT, A. H., LTD.,** Bendon Valley, Garratt Lane, Wandsworth, S.W.18. Stand No. 155.

ON this stand the makers will display condensers and service test equipment. The latter consists of a Capacitor Analyzer, and an All-wave Signal Generator. This is a compact self-contained battery-



**NEW Stentorian speaker—**

**“AN IMMENSE STEP FORWARD”**

Says Mr. Camm



# "PRACTICAL & AMATEUR WIRELESS" GUIDE to the SHOW



**JACKSON BROS. (LONDON), LTD.,** 72, St. Thomas Street, S.E.1. Stand No. 93.

IN addition to the range of standard precision components which are already so familiar to the home constructor, Messrs. Jackson Bros. will be showing a new all-wave version of the popular Linacore Tuner Unit, with a constructor's kit for an all-wave receiver embodying the Linacore.

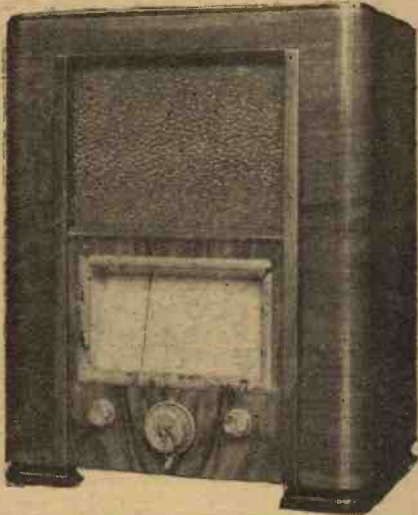

In this Kolster Brandes receiver a large open scale is provided and the control knobs have been toned to provide an unusual appearance.

**KOLSTER-BRANDES, LTD.,** Gray Works, Sidcup, Kent. Stand No. 65.

A RANGE of all-wave receivers is to be seen on this stand, and the lowest wavelength covered is 16.5 metres. The receivers include battery and mains-operated models, and many are provided with facilities for the use of a Rejectorstat aerial system.

**L.E.S. DISTRIBUTORS, LTD.,** 15, Alfred Place, Tottenham Court Road, W.1. Stand No. T6.

THIS is a trade exhibit.

**LISSEN, LTD.,** Angel Road, Edmonton, N.18. Stand No. 73.

IN addition to the Lissen short-wave components to be shown on this stand there will be a range of receivers. These include battery and mains-operated models and the lowest wavelength covered is 19 metres. An interesting model is the four-valve battery "Picnic" portable with built-in frame aerial and pentode output stage.

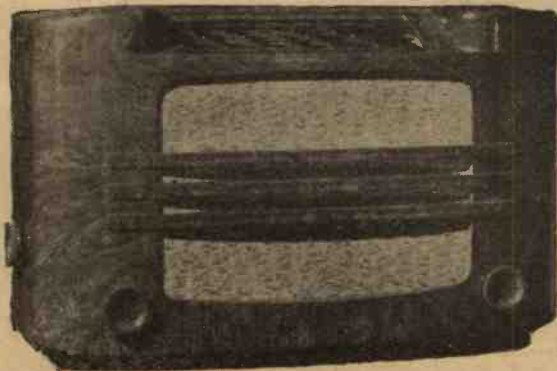

**LUGTON & CO., LTD.,** 203, Old Street, E.C.1. Stand No. T15.

THIS is a trade exhibit.

**MANUFACTURERS ACCESSORIES CO. (1928), LTD.,** 85, Gl. Eastern Street, E.C.2. Stand No. T4.

THIS is a trade exhibit.

**MARCONIPHONE CO., LTD.,** 210-212, Tottenham Court Road, W.1. Stand Nos. 53 and 64.

ON these stands receivers and television apparatus will be displayed. There are 25 models (excluding the television apparatus) of which 11 are radiograms

or auto-radiograms, one a console, seven mains table grands, one battery transportable, and three battery table grams. Seven of these receivers are designed to tune in the television sound transmission. Only two of the receivers (battery models) have no short-wave tuning range. The all-wave receivers tune down in some cases to 4.85 metres and the only gaps, which are quite small, are between 107 and 195 metres. The television apparatus is described in our special television section.

**MAY & BAKER, LTD.,** Dagenham, London. Stand No. 157.

THE exhibit here will consist of a display of articles made from Rhodoid. This is a cellulose acetate material available in various forms and is used for making radio scales, dials, etc. In a powder form it is injected into moulds for such items as control knobs, and small insulation parts.

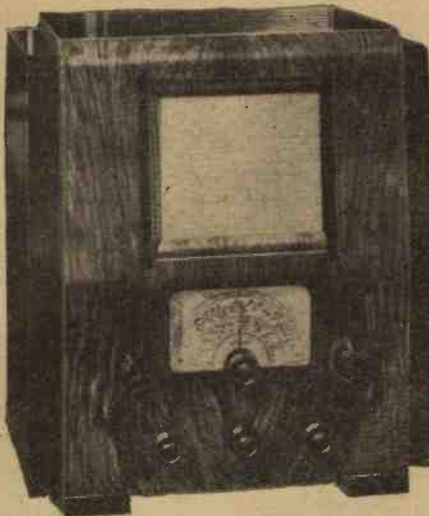

This is the Milnes "Onyx" 5-valve battery superhet receiver which is on view on stand No. 88.



A rather novel control panel and tuning scale design is incorporated in this Lissen receiver.

**MERCANTILE CREDIT CO., LTD.,** 39-45, Finsbury Square, E.C.2. Stand No. 215.

THIS is a trade exhibit and deals with hire-purchase agreements and similar facilities.

**MICA & MICANITE SUPPLIES, LTD.,** Mica House, Barnsbury Square, N.1. Stand No. 154.

THIS exhibit will consist of various mica, micanite and bakelite parts as used in modern radio apparatus. Such items as condenser plates, valve bridges, stampings, formers, commutator rings and similar items will be displayed.

**MILNES RADIO CO., LTD.,** Victoria Works, Bingley, Yorks. Stand No. 88.

A NEW range of receivers will be displayed on this stand, consisting of all-wave models for battery and mains operation. The lowest wavelength covered is 12.5 metres. A novelty included in the Onyx receiver is a single control which, in one knob, combines tone control, variable selectivity, noise suppression, correct tuning device, and dial lamp switch. In addition, the popular Milnes H.T. unit will be shown.

**MULLARD RADIO VALVE CO., LTD.,** 225, Tottenham Court Road, W.1. Stand Nos. 72 and 161.

ON these stands you will see the complete range of Mullard receivers, valves, and associated apparatus. Among the receivers some novel cabinet designs and controls will be featured, whilst the range of Mullard valves is augmented by some interesting new types.

**NEW ERA PUBLISHING CO., LTD.,** 12-14, Newton Street, W.C.2. Stand No. T2.

The makers of this receiver, Philips, had the cabinet designed first, and then arranged for a receiver chassis to be incorporated. As a result the receiver is built on three separate chassis in this particular model.

**MCMICHAEL RADIO, LTD.,** Wexham Road, Slough, Bucks. Stand No. 59.

ON this stand there are six table models, five floor models, and two portables. High quality of reproduction is one of the keynotes of the McMichael receivers, and it will be noted that dual loudspeakers play a large part in their design. As a result, two loud-speaker openings are provided on certain models. Another interesting feature is the new self-tilting Giant Dial showing station names three times their usual size. McMichael are also featuring Polychrome Flying Tuning throughout the range. The lowest wavelength covered in the all-wave receivers is 16.5 metres.



A distinct departure from standard practice. This is one of the latest Marconi phone receivers, Model 563. It is a ten-valve all-wave superhet auto-radiogram tuning from 4.85 to 2,000 metres.

# 1919 PETO-SCOTT 1938

## Our 19th Season Heralded with Wonderful Range of 1938 Quality Radio

We feature here a few of the new season's Peto-Scott productions. Post Coupon for complete Catalogue. We also give IMMEDIATE DELIVERY of EVERYTHING at OLYMPIA—Receivers, Components and Accessories—for CASH, C.O.D. or H.P. Quotations for any item on request.

**Peto-Scott "DOUBLE 2" S.W. Kit**

- Amazing new circuit, obtaining 4-valve performance from only 2
- Waverange 9-50 metres
- Bandspread tuning simplifies world-wide reception
- Easy to build, will bring you hours of thrilling entertainment.



**KIT "A"** All parts, including ready-drilled panel and chassis, four 6-pin and four 4-pin coils, drawings and instructions, less valves, 'phones, cabinet. List Value £1:5:4. Our Price **£2:19:6**

Cash or C.O.D. £2:19:6  
 or 5/6 down and 11 monthly payments of 5/6. **5/6 DOWN**

**Peto-Scott ULTRA-SHORT WAVE 3 Kit**

- Waverange 4.75 to 7.7 metres
- Receives Alexandra Palace television sound programmes with amazing quality
- Many amateur stations operate on the 5-metre band—this wonderful kit will enable you to pick up these interesting transmissions
- Very latest 3-valve Ultra-Short-Wave Circuit.



**KIT "A"** All parts, including ready-drilled chassis and panel, drawings and instructions, less valves. List Value £2:10:8. Our Price **£1:17:6**

Cash or C.O.D. £1:17:6  
 or 2/6 down and 11 monthly payments of 3/6. **2/6 DOWN**

**PILOT AUTHOR KITS ALL-WORLD ACE**

**KIT "A"** Cash or C.O.D. Carriage Paid **£7:7:0**

Or 12/6 down and 11 monthly payments of 13/6.

Author's Kit of First Specified parts, including Peto-Scott Plymax chassis, less valves and speaker.

**KIT "B"** as Kit "A" but with set of specified valves. Cash or C.O.D. Carriage Paid, £9:13:0 or 12 monthly payments of 17/9.

PETO-SCOTT Specified Plymax Chassis 12" x 10" with 4 3/4" wood runners, front board special thickness, ready-drilled for 4 valve-holders. **7/6**

W.B. Senior Speaker, Model 388. £2:2:0

**Peto-Scott SHORT WAVE A.C.4 Kit**

- Waverange 10-52 metres.
- Wonderful new World-wide circuit
- Peto-Scott Duplex Epicyclic tuning simplifies long-distance reception
- 9:1 and 80:1 slow motion dial
- Air-space condensers
- For A.C. Mains, 200-250 volts, 40/80 cycles.



**KIT "A"** All parts, including ready-drilled steel chassis, switched coil, drawings and instructions, less valves. Cash or C.O.D. or 7/6 down and 11 monthly payments of 8/3. List Value £8/0/0. Our Price **£4:10:0**

**7/6 DOWN**

**TRIDENT ALL-WAVE 3**

**KIT "A"** Cash or C.O.D. Carriage Paid **£3:6:6**

Or 6/- down and 11 monthly payments of 6/0.

Author's Kit of First Specified parts, including Peto-Scott Plymax Baseboard, less valves and speaker.

**KIT "B"** as Kit "A" but with set of specified valves. Cash or C.O.D. Carriage Paid, £3:18:9 or 7/3 down and 11 monthly payments of 7/3.

Peto-Scott Specified Plymax Baseboard 11" x 6" x 1". 3/-  
 B.T.S. All-Wave Coil, Type G, as specified. 12/6  
 Ericsson Headphones. 15/-  
 W.B. Junior Speaker, Model 383. £12/6  
 Peto-Scott Lightweight Headphones. 7/6

**Peto-Scott STRAIGHT 3 ALL-WAVE KIT**

- 3 Wavebands: 18-52, 200-550, 900-2000 metres.
- Entirely new design for the DX Fan located more than 50 miles from the main broadcasting station.
- 3-valve efficiency as never before
- Ready-assembled all-wave tuner with double bank coil unit facilitates building.



**KIT "A"** All parts, including ready-drilled chassis, drawings and instructions, less valves and cabinet. List Value £3/1/0. Our Price **£2:5:0**

Cash or C.O.D. £2:5:0  
 or 4/- down and 11 monthly payments of 4/2. **4/- DOWN**

**1938 Stentorian SPEAKERS**



**MODEL 385** (illustrated). Further improvement on the famous W.B. Senior 378. New higher flux density and increased sensitivity. Microlode device for matching any receiver. Cash or C.O.D. Carr. Pd. £2/2/0 or 2/6 down and 11 monthly payments of 4/-.

**MIDGET MODEL 38M.** A new thoroughly efficient permanent magnet moving-coil speaker in extremely compact form. Complete with 3-ratio transformer. Cash or C.O.D. Carr. Pd. 17/6 or 2/6 down and 7 monthly payments of 2/6.

**W.B. "ELLIPSIS" MODEL.** With elliptical cone for receivers where height of speaker opening restricted. Nipernag magnet, Whiteley speech coil, Microlode universal matching device. Cash or C.O.D. Carr. Pd. £2/2/0 or 2/6 down and 11 monthly payments of 4/-.

**All the new W.B. Chassis, Pedestal and Cabinet Models on similar Easy Terms.**

**2/6 DOWN**

**"ORACLE" ALL-WAVE 3**

**KIT "A"** Cash or C.O.D. Carriage Paid **£4:5:0**

Or 12 monthly payments of 7/9

Author's Kit of First Specified parts, including Peto-Scott Plymax Chassis, less valves and speaker.

**KIT "B"** as Kit "A" but with set of specified valves. Cash or C.O.D. Carr. Pd. £5/11/9, or 12 monthly payments of 10/3.

Peto-Scott Specified Plymax Chassis, 12" by 8", with 4 2 1/4" wood runners, special thickness for front runner, drilled for 3 valve-holders. 6/8.

W.B. Junior Speaker, Model 38J. £12/6.

## FREE! TWO INVALUABLE ILLUSTRATED BOOKS FREE!

**Peto-Scott RADIO and TELEVISION CATALOGUE**

ONCE AGAIN for nineteenth years past, Peto-Scott heralds another new radio season with a comprehensive range of apparatus covering the needs of every type of listener. No matter whether you require a small condenser or a 9 Valve All-Wave Superhet Receiver, Peto-Scott will supply you by post, either for Cash, C.O.D., or on easy terms, at astonishingly low prices, made possible only by this direct-to-customer method of trading.

Every item in this new range of quality apparatus, including the Kits featured above, is described and illustrated in a 12-page, two-colour art catalogue sent free to all who post the Coupon. The following are but a few of the items dealt with in this useful little book, "a complete radio shop in itself" enabling you to choose your radio purchases from the comfort of your arm-chair.

**A Brief Outline of the Contents:**

All-Wave Kits	Deaf Aids	Pick-ups
All-Wave Chassis	Eliminators	Radio-gram-Converter Unit
All-Wave Receivers	Extension Speaker System	Short-Wave Pre-Selector
All-Wave Aerial Amplifiers	Gramophone Motors	Television Kits
Broadcast Kits	Gramophone Pick-ups	Speakers
Components	Microphone	Trickle-Charger
Chargers	Portable Receiver	Valves

**"THE SHORT-WAVE EXPERIMENTER"**



PETO-SCOTT'S famous Short-Wave Experts have worked together and produced the **PILOT "Short-Wave Experimenter"**, a booklet of 24 pages, illustrating and describing a range of nine wonderful new PILOT Short-Wave Kits. Each of these designs incorporates a standard chassis and panel. Commencing with a modest but super-efficient 1-valve Adapter-Converter, you may, whenever you please, build this up, on the same chassis, into varying forms of 1, 2, 3, and 4-Valve Short-Wave Receivers, complete in steel cabinet. No short-wave fan can afford to miss the fascinating hours this booklet will bring him. Post the Coupon, for your free copy of this 6d. booklet.

**PILOT 4-valve SHORT-WAVE RECEIVER MODEL 664** (illustrated). One of the super-efficient world-wide receivers described in the "Short-Wave Experimenter." Employing 4- and 6-pin coils in a wonderful new circuit design, covering 8.5 to 97 metres. **KIT "A"** List Price £3/12/6. Our Price **£2:12:6**

Or 4/6 down and 11 monthly payments of 4/10.

**POST THIS COUPON NOW FOR TWO FREE BOOKS**

PETO-SCOTT CO., LTD., 77 (Pr. W. 49), City Road, London, E.C.1, or 62 (Pr. W.49), High Holborn, London, W.C.1.

Please send me \_\_\_\_\_ for which I enclose £ \_\_\_\_\_ Cash/H.P. Deposit. Please send also the Peto-Scott Radio and Television Catalogue and the Pilot "Short-Wave Experimenter." I enclose 2d. (stamps) to cover postage.

NAME \_\_\_\_\_  
 ADDRESS \_\_\_\_\_

All P.O.'s must be crossed and currency registered.

When at  
**RADIO LYMPIA**



MADE IN ENGLAND

...DO NOT FAIL  
TO VISIT THE

**Osram  
Valves**

**STAND...**

where you will see the complete range of Valves for broadcast reception on all wavelengths, the most up-to-date Valves for Television, Tuning Devices, and Valves for Commercial and Industrial purposes of every description.

**NEW LONDON ELECTRON WORKS, LTD.,** East Ham, E.6. Stand No. 80.

**A**LTHOUGH the majority of the exhibits on this stand consist of various wires, there will be some novel aerial devices. These include the Globe aerial, in which a copper ball is suspended from a bracket with a leading-out wire from the lower part. Another interesting product to be seen here is the "Simple-

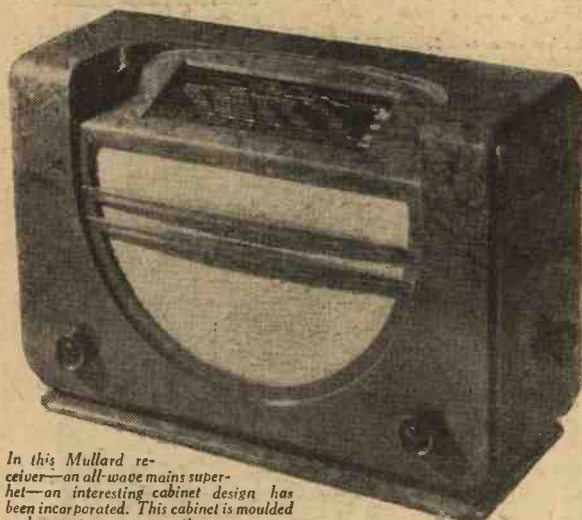

In this Mullard receiver—an all-wave mains superhet—an interesting cabinet design has been incorporated. This cabinet is moulded and presents a most attractive appearance.

strip," a perforated copper strip for wiring purposes. An earth mat, a variable-selectivity device ("Varial"), and an all-wave aerial kit will also be shown.

high-note response. In the large floor models special deflector plates are included in the speaker opening to give more even radiation of the musical scale. Mono-knob control is also a prominent feature of the new Philips receivers. The new projection-type television receiver, utilising a screen 20in. by 16in., will be one of the high-lights of the Exhibition, and it is fully described in our special television article this week.

**PILOT RADIO, LTD.,** 87, Park Royal Road, N.W.10. Stand No. 84.

**A**NUMBER of table models and radiograms will be exhibited on this stand, and the main feature in these receivers is the short-wave performance. The makers have aimed at obtaining a really good short-wave section, and in some of the receivers four separate bands are provided. The lowest wavelength covered is 16 metres, and an important feature of certain models is the selective dial lighting which is operated with the wavechange switch.

**PLESSEY CO., LTD.,** Vicarage Lane, Ilford, Essex. Stand No. 22.

**T**HIS exhibit will consist of manufacturer's chassis and components as well as completely assembled radio units.

**PYE, LTD.,** Africa House, Kingsway, W.C.2. Stand No. 60.

**O**N this stand there will be a complete range of receivers including portables, and the all-wave feature is prominently displayed. Messrs. Pye will also be exhibiting their new television receiver, but full details of the complete range have not yet been released.

**RADIO GRAMOPHONE DEVELOPMENT CO., LTD.,** Globe Works, Newton Row, Birmingham. Stand No. 67.

**A**VERY high standard is set in the R.G.D. receivers to be seen on this stand. Stereoscopically



One of the public address loudspeakers to be seen in the Reslo range of public address equipment on Stand No. 24.

Illuminated dials and a special sound-pressure balancing chamber for the loudspeaker are two of the interesting features worth examining, and the lowest wavelength covered in these receivers is 16.5 metres.

**RADIOMETERS, LTD.,** Eagle House, Jermyn Street, S.W.1. Stand No. 162.

**T**HE high light on this stand is the Ideal Valve Tester, which enables both emission and mutual conductance of (British or American valves (including A.C./D.C. and Side Contact types) to be checked against standards published by the makers. It is also possible to check inter-electrode insulation. An adapter panel is also available for use to accommodate the Octal type of valve. Some further valuable testing instruments will also be on show on this stand.

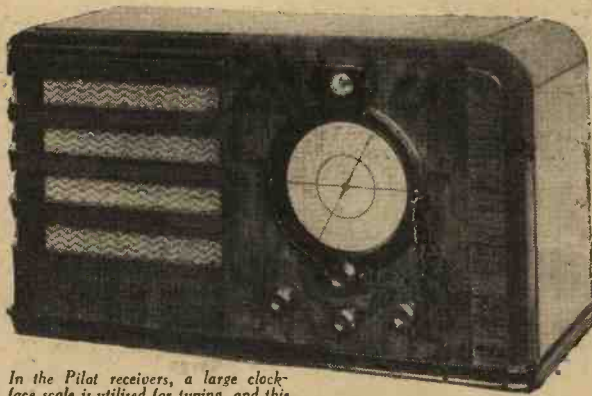

In the Pilot receivers, a large clock-face scale is utilised for tuning, and this is illuminated in sections, the lights being controlled by the wave-change switch. Tuning is thus greatly simplified.



This is one of the interesting receivers to be seen on the R.G.D. Stand No. 67. High quality of reproduction is the main feature of these receivers.

**RADIO SOCIETY OF GT. BRITAIN,** 53, Victoria Street, S.W.1. Stand No. 214.

**T**HIS exhibit will consist of a special crystal transmitter, frequency metres, and other apparatus and publications of interest to transmitters and members of the society.

**"Wireless Coils, Chokes, Transformers and How to Make Them,"** 2/6, by post 2/10, from George Newnes, Ltd., Tower House, Southampton St., Strand, London, W.C.2.

**GEORGE NEWNES, LTD.,** Tower House, Southampton Street, Strand, London, W.C.2. Stand No. 10, Ground Floor.

**M**ESSRS. GEORGE NEWNES, Ltd., probably publish more technical wireless handbooks, blueprints, and wireless and television periodicals than any other publisher. On this stand, therefore, you are bound to find a book or a periodical which appeals to you.

**PRACTICAL AND AMATEUR WIRELESS, Practical Mechanics, Practical Motorist, and The Cyclist** are but a few of the leading journals on show here. A full range of blueprints of wireless receivers ranging from crystal sets to multi-valve superhets will be on sale, as well as a full range of technical books, including "The Wireless Constructor's Encyclopaedia," "Everyman Wireless Book," "Television and Short-Wave Handbook," "The Practical Motorist's Encyclopaedia," "The Home Mechanic's Encyclopaedia," "Ralph Stranger's Wireless Library." You will also be able to inspect Mr. Camm's new series of receivers described in the present issue of **PRACTICAL AND AMATEUR WIRELESS**. Mr. F. J. Camm and the technical staff will be available to answer readers' queries free of charge. Call and see us.

**LD'S DISCOUNT CO., LTD.,** Equitable House, South Parade, Nottingham. Stand No. 218.

**PARTRIDGE, WILSON & CO., LTD.,** Davenset Works, Evington Valley Road, Leicester. Stand No. 29.

**T**HIS firm will be exhibiting their full range of Davenset accumulator charging apparatus. This includes large units for service stations, together with associated accessories for this type of service.

**PHILIPS LAMPS, LTD.,** Philips House, 145, Charing Cross Road, W.C.2. Stand No. 68.

**I**N the new receivers to be exhibited on this stand, the main feature which the makers have incorporated is known by them as "New Listening." To achieve this end cabinet design has been modified and novel circuits and components are incorporated. In the table models the cabinet has been made long and shallow, to help to avoid cabinet resonance, and the speakers which are fitted are designed to provide better

**NEW Stentorian speaker—**  
New High Fidelity from normal receivers

**"PRACTICAL & AMATEUR WIRELESS"**  
**GUIDE to the SHOW**

**RAWPLUG CO., LTD.,** Rawplug House, Cromwell Road, S.W.7. Stand No. 91.

ON this stand a number of interesting accessories, such as the popular Rawplugs, heat-proof adhesives and so on, will be exhibited.

**RESLO (SOUND EQUIPMENT), LTD.,** 97, Hampstead Road, N.W.1. Stand No. 24.

A DYNAMIC microphone, and special loudspeakers, will be shown on this stand, together with other associated apparatus. This will include microphone stands, loudspeaker horns, and other types of microphone.



A Dynamic Microphone to be seen in the range of public address equipment on Reslo Stand No. 24.

**RIST'S WIRES & CABLES, LTD.,** Waveney Works, Lowestoft. Stand No. 159.

ON this stand the makers will be displaying "Super Range" aeriels, 7/25 aeriels, twin flat extension cord for loudspeakers, leading-in wires, flexible and connecting wires, and other similar lines.

**ROSE NORMAN (ELECTRICAL), LTD.,** 94, Tottenham Court Road, W.1. Stand No. 207.

A RANGE of test equipment will be shown on this stand, including the "Omnisection" Valve Emission Tester, an Analyser and similar items. In addition a range of electrolytic condensers will be shown, together with cartridge fuses and similar components of interest to the service man.

**SALFORD ELECTRICAL INSTRUMENTS, LTD.,** Magnet House, Kingsway, W.C.2. Stand No. 168.

A COMPLETE range of miniature voltmeters and ammeters will be shown on this stand, together

with a "Q" meter, and "L" meter and other measuring apparatus. The "Q" meter measures direct the Q factor and frequency, whilst the "L" meter is intended for rapid measurement of inductance. The "C" meter is similarly designed for the measuring of capacities and is mains operated.

**SCOTT INSULATED WIRE CO., LTD.,** Queenstand Works, Holloway, N.7. Stand No. 156.

THIS stand will be designed to display a complete range of wires of all types, including the special Litz wire which is now used for coil winding where high selectivity and amplification is required. In addition, single conductors and resistance wires will also be shown, amongst which is a sample of wire "two-thirds of the diameter of the average human hair." This is insulated with two separate insulations, enamel and silk, and in the finished product is very little thicker than the human hair. One pound of this wire has a length of twenty-four miles.

**SELECTA GRAMOPHONES, LTD.,** 81, Southwark Street, S.E.1. Stand No. T.13.

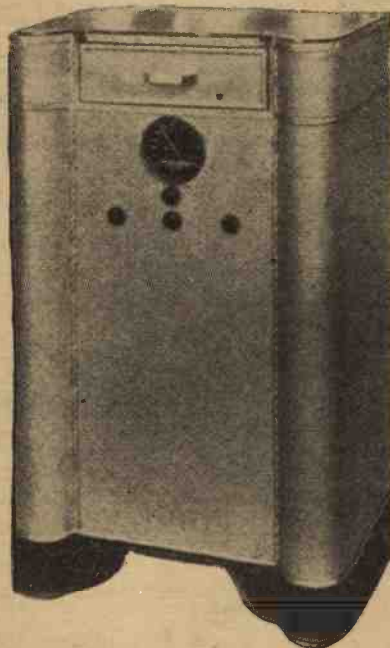

An original cabinet in the Texaloom range. This is constructed from woven fibre and is obtainable in various colour schemes.

**SHAFTESBURY MICROPHONES, LTD.,** 24, Aldersgate Street, E.C.1. Stand No. 92.

INCLUDED in the range of public address equipment to be exhibited on this stand is what is claimed to be the largest horn speaker ever shown at Olympia.

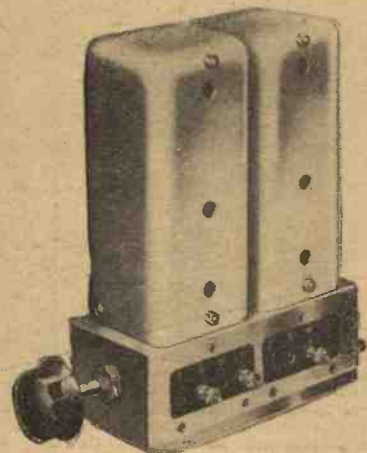

One of the new all-wave two-gang tuner units which is being produced by Messrs. Varley.

In addition there will be seen microphones of all types, a self-contained portable equipment and various public-address amplifiers.

**SIEMENS ELECTRIC LAMPS & SUPPLIES, LTD.,** 38-39, Upper Thames Street, E.C.4. Stand No. 31.

A COMPLETE range of the well-known Siemens batteries will be seen on this stand, the exhibit comprising types and sizes suitable for practically every make of battery-operated receiver. These include the Cadet types designed for an emission from 6 to 7 mA, the Super types for 9 to 10 mA, and the Triple Capacity types for 12 to 15 mA. In addition, there are special models for receivers utilising Class B or Q.P.P. circuits. Torch and other batteries, together with special accumulators, will also be shown.

**SOUND SALES, LTD.,** Marlborough Road, Upper Holloway, N.19. Stand No. 89.

**STEATITE & PORCELAIN PRODUCTS, LTD.,** Stourport-on-Severn, Worcester. Stand No. 152.

HERE will be seen a display of the various ceramic mouldings used in modern radio apparatus. As may be gathered from the illustration on this page, this will include insulators for aeriels, condenser spacers, terminal strips, bushes, and so on. Most exhibits are in material known as Frequentite, although a material known as Faradex will also be shown.

**STERLING BATTERIES, LTD.,** Sterling Works, Dagenham, Essex. Stand No. 5.



A group of condensers from the T.C.C. range. Examine these on Stand No. 38.



Some idea of the various mouldings produced by the Steatite and Porcelain Products Company, and exhibited on Stand No. 152.



# Rumba looking Chaps

R.7

*As a matter of fact, they're called  
"temple blocks." They make the rattle in West  
Indian music. If they sound as weird on your radio as they look  
in this picture, it's high time you changed to an Exide.*

# Exide BATTERIES FOR RADIO

*'Still keep going when  
the rest have stopped'*



**EXIDE 'HYCAP' BATTERY (High Capacity L.T. Battery)**  
For modern multi-valve sets — lasts longer on one charge. For small sets use the Exide 'D' Type. Both have the Exide Charge Indicator. Your dealer will tell you which to use. For High Tension use Drydex.

*From reputable dealers and Exide Service Stations. Exide Service Stations give service on every make of battery. Exide Batteries, Exide Works, Clifton Junction, near Manchester. Also at London, Manchester, Birmingham, Bristol, Glasgow, Dublin and Belfast.*

**FAULTLESS  
DEPENDABLE**



# TRANSFORMERS WHICH HAVE ALWAYS BEEN *THE* TRANSFORMERS

Ferranti have been making good transformers since 1882. The pioneering work of Ferranti in transformers for all purposes has never been surpassed. Thousands and thousands of Ferranti audio transformers are still providing **NEARLY PERFECT REPRODUCTION** after ten to fifteen years of continuous use.

Ferranti transformers and components are used by The B.B.C., the Post Office, the War Office, the Admiralty, the National Grid Scheme, in Relay Services, in Public Address Systems, on board Ship and overseas in all climates and are specified by radio designers and used by engineers for any apparatus where first class performance and freedom from breakdown are essential.

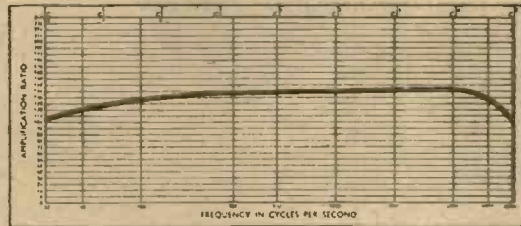

**TRANSFORMERS**  
Audio . Output . Line . Mains  
or Special  
**CONDENSERS**  
Electrolytic and Paper  
**RESISTANCES**  
**VALVES • ETC.**

# FERRANTI

Ask for latest literature.

*If any difficulty in obtaining supplies do not hesitate to write direct.*

**FERRANTI LTD., Radio Works, MOSTON,  
MANCHESTER, 10**

Ferranti's new booklets, "Radio Valves" and "Components" will be sent for 3d. post free. "Electrolytic Condensers" is for Radio Engineers, designers and other executives, to whom it will be sent post free on receipt of business card. To students and others it costs 1s. post free. All these are also obtainable at Stand 74 Radiolympia.

# STAND 74 RADIOLYMPIA

Don't forget to see the new Ferranti Superhets, Televisors and Car Radio.

**IMPORTANT  
PUBLICATION**



**BY AN  
AUTHORITY**



**STRATTON & CO., LTD.**, Eddystone Works, Bromsgrove Street, Birmingham, 5. Stand No. 23.

**I**NCLUDED in the many special short-wave components to be shown on this stand are some new transmitting condensers, low-loss frequentite valveholders, a new control knob and a two-piece metal cabinet. All of the Eddystone products have been designed especially for high efficiency on the lower wavelengths and some complete receivers with these components incorporated will be on view.



Whiteley Electrical are now producing complete receivers, and this is one of the new models. It may be seen on Stand No. 75.

**TANNOY PRODUCTS**, Canterbury Grove, West Norwood, S.E. Stand No. 86.

**H**ERE will be seen a comprehensive range of public address equipment, including amplifiers and loudspeakers for all requirements.

**TELEGRAPH CONDENSER CO., LTD.**, Wales Farm Road, N. Acton. Stand No. 38.

**T**HE T.C.C. exhibit will consist of varied ranges of all types of mica and paper fixed condensers, including non-inductive paper tubulars, together with special types for use under tropical conditions and for car radio work. In addition electrolytic condensers and moulded mica condensers will be shown, with transmitting and other high-voltage types.

**TELSEN ELECTRIC (1935), LTD**, Fitzgeorge Street, Manchester. Stand No. 90.

**A**PPROXIMATELY 36 new lines will be shown on this stand, including Universal receivers, valve testers, output meter, signal generator, analysers, meters and other apparatus of use to the experimenter and service man. A range of short-wave plug-in coils and a dipole aerial kit will complete this exhibit.

**TEXALOOM RADIO, LTD.**, 806, High Road, Tottenham, No. 17. Stand No. 15.

**N**OVELTY is introduced on this stand by the cabinet designs carried out in woven fibre. Some original designs will be seen and it will be noticed that various items of domestic furniture have been incorporated in the cabinet designs.

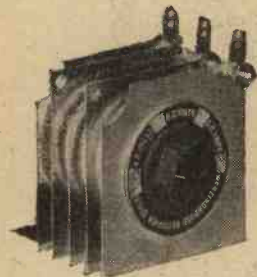

The metal rectifiers manufactured by the Westinghouse Company are now supplied without the perforated metal cases, and thus prices are reduced. This is one of the L.T. models.

**THOMPSON, DIAMOND & BUTCHER**, 34, Farringdon Road, E.C. Stand No. 75.

**T**HIS is a trade exhibit.

**THE 362 RADIO VALVE CO., LTD.**, 324/6, Liverpool Road, Highbury, N.7. Stand No. 210.

**T**HE valves to be shown on this stand will range from transmitting to public-address and similar high-powered types. Among the new types will be the SR.2, a 2-volt 3 amp. super-regenerative battery valve, the SR.4, an indirectly-heated A.C. mains version of this valve, and an MP.4, which is an indirectly heated top-grid tetrode. This valve has a split anode and the connections are taken to a seven-pin base so that it can alternatively be used as a single diode tetrode, double diode triode, or a split anode magnetron.

**TUCKER EYELET CO., LTD.**, Cuckoo Road, Birmingham 7. Stand No. 102.

**O**N this stand there will be an exhibit of metal press wares, including eyelets, solder tags, etc. The exhibit is primarily of interest to manufacturers.

**ULTRA ELECTRIC, LTD.**, Western Avenue, Acton, W.3. Stand No. 63.

**A** COMPLETE range of all-wave receivers, mains and battery-operated, is to be shown on this stand, together with three new television receivers. One of these is a television sound and vision receiver only, whilst the others both include a radio section. The lowest wavelength covered in the receivers is 10.8 metres.

**VARLEY (OLIVER PELL), LTD.**, Cambridge Place, Burrage Road, S.E.18. Stand No. 99.

**A**N interesting range of components for the home-constructor will be shown on this stand, including some of the new all-wave coils. There will also be some I.F. transformers, an I.F. suppressor, and some mains equipment.

**VIDOR, LTD.**, West Street, Erith, Kent. Stand No. 33.

**A** RANGE of all-wave, battery and mains-operated receivers will be shown on this stand, including a new 5-valve battery all-wave superhet listed at 9 gns.



A comprehensive Analyser from the range of Weston measuring instruments to be seen on Stand No. 167. This has been designed so that it may be used for television servicing in addition to ordinary radio purposes.

A neat portable will also be seen on this stand and the lowest wavelength covered in the all-wave models is 13.5 metres.

**WEBBER, J. M. & CO., LTD.**, 39, Gt. Eastern Street, E.C.2. Stand No. 111.

**T**HIS is a trade exhibit.

**WESTINGHOUSE BRAKE & SIGNAL CO., LTD.**, 82, York Road, Kings Cross, N.1. Stand No. 77.

**O**N this stand some of the new constructor-type H.T. metal rectifiers will be seen. These are now available without the metal casing and consequently prices are lower. On the L.T. side five new units are introduced giving outputs from 2 volts .5 amps up to 12 volts 2 amps. A full range of "Westectors" and the high voltage (television) type rectifiers will also be on view. Complete charging equipment will also be displayed.

**WESTON ELECTRICAL INSTRUMENT CO., LTD.**, Kingston By-Pass, Surbiton, Surrey. Stand No. 167.

**A** NEW super sensitive Analyser will be seen on this stand, and it has been designed to meet not only the complex requirements of radio servicing but also



On the left is a new Varley I.F. transformer and on the right a pedestal loudspeaker produced by W.B. This is a novel idea and no doubt will be found very useful under many conditions.

to serve as a basis for television testing gear. Many other interesting measuring instruments will be displayed on this stand.

**WHITELEY ELECTRICAL RADIO CO., LTD.**, Mansfield, Notts. Stand No. 75.

**A**LTHOUGH the main items on this stand will be the W.B. speakers, this year there will be several complete receivers. W.B. has now entered this market and accordingly will be showing a representative range of the receivers they intend to produce. An improved extension speaker will be seen, together with the Long Arm remote control device. The Stentorian speakers will be seen in various styles, both as chassis models and complete in cabinets.

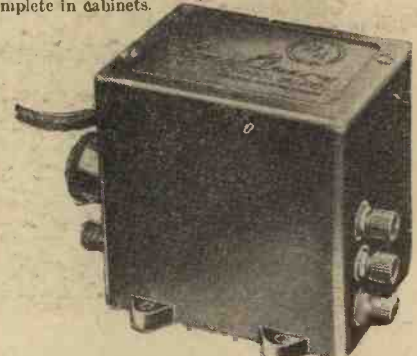

This is the ingenious Long Arm remote control unit supplied by W.B. for distant-listening purposes.

**WINGROVE & ROGERS, LTD.**, 188-189, Strand, W.C.2. Stand No. 44.

**T**HE well-known Polar products will be shown on this stand, in company with the N.S.F. components. The Polar gang condensers will include Bar 2 and 3-gang types, together with a Midget 4-gang model, all available as straight or superhet types for 465 or 110 kc/s I.F. A new Micro Horizontal Drive has been produced having dual ratios of 50 to 1 and 10 to 1, and is marked with station names, wavelengths and degrees. There will also be seen trimmers, drives, volume controls, resistors, tubular, and electrolytic condensers, and short-wave components.

**WRIGHT & WEAIRE, LTD.**, 740, High Road, Tottenham, N.17. Stand No. 165.

**A**MONG the many components shown on this stand the new Triogen 3-range tuning coil is one of the most interesting. We have already mentioned this coil and it is also referred to on other pages in this issue. In addition to this, there is an all-purpose mains transformer which renders it a simple matter to use any types of valve in a receiver, including those of American characteristics. A new series of test equipment will also be seen and these include an all-wave oscillator, valve testing unit, and a condenser analyser.

# The Latest Television Receivers

Details of Some of the Latest Apparatus, With Especial Reference to the New Projection Receiver. By W. J. DELANEY

ALTHOUGH all of the firms who are manufacturing television receivers for sale are not exhibiting at this year's radio exhibition, it would appear that there will be 14 firms showing new models at Olympia. These are Baird, Cossor, Ediswan, Ekco, Ferranti, G.E.C., Halcyon, H.M.V., K.B., Marconiphone, Philips, Pye, R.G.D., and Ultra. With the exception of two of these, all make use of a large cathode-ray tube and the picture is viewed upon the end of this—either direct or by reflection in a mirror. In the two exceptional cases, one firm—Ekco—will be showing a projection

pleasing sepia tone is adopted by the makers, whilst in the remaining examples an attempt is made to obtain a black and white picture.

## Tube Types

The colour is, of course, due to the tube which is employed, and in the case of some of the exhibits the tubes are not made by the makers of the receiver. Thus the picture tone will be that given by the receivers which are made by the makers of the tube, and it will be noticed that in one or two cases an extremely vivid white tone is obtained due to the use of a blue tone in the darker parts of the picture. The term "electric white" has been applied to this particular example. Unfortunately, certain manufacturers appear reluctant to release information before the exhibition opens, and thus we are only able to judge from previous demonstrations which we have attended, and from the details which are already available. The Marconiphone H.M.V., and G.E.C. receivers are more or less the same as last year, with the exception

of improvements in the details of the finished picture. Other receivers have been modified considerably since the last exhibition, and a study of the specifications which are already available show that there has been a rather marked change in the method of obtaining the picture and line deflection. Last year, the majority of receivers were provided with electrostatic deflection systems, whilst this year it would appear that a changeover to electro-magnetic deflection has taken place. The advantage of this is that the apparatus is not restricted to the make-up of the tube, and the deflecting magnet systems may be adjusted to provide the correct picture area and shape. Where reliance has to be placed upon the electrostatic system, it is not possible to counteract any slight malalignment of the deflector-plate assembly inside the tube. In other words, additional controls are available so that the best may be obtained from the tube.

## Cabinet Sizes

One important point regarding the new models seems to be the reduction in the size of the cabinet. Previously the cabinets were all rather on the large side, but improved layouts and methods of assembly have enabled the makers in some cases to make a reduction in the size of the finished instrument, and this is very noticeable in one particular case. Other makers have endeavoured to make the television receiver a complete source of entertainment, combining in one cabinet an automatic record changer and a record-storage cupboard.



One of the new Ultra television receivers.

## Picture Sizes

An analysis of the specifications so far received shows that the average picture size is 10in. by 8in. This is obtained in most cases by utilising a 12in. cathode-ray tube, although in one case a slightly smaller tube is employed and a lens magnifies the image for reflection inside the lid. In the case of the Philips receivers, however, a picture approximately 20in. by 16in. is obtained on a glass screen, and by removing this screen, and placing the receiver near a wall a picture up to 3ft. square may be obtained. This is probably the most interesting receiver which will be on view,

(Continued on page 598)

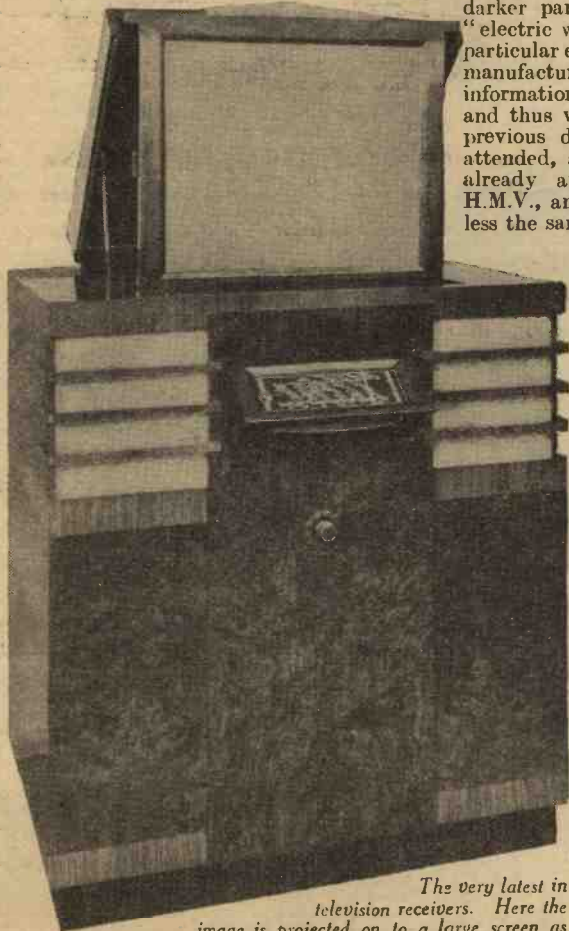

The very latest in television receivers. Here the image is projected on to a large screen as shown in the diagram below.

type apparatus in which an optical-mechanical scheme is utilised, whilst the other—Philips—will show a receiver in which a small cathode-ray tube is used to project an image through a lens system so as to provide a large picture on a glass screen. It is not known, at the time of going to press, whether these two examples will be exhibited in the special television demonstration theatre, although all of the other models may be seen there and the differences judged. One of the first points which will strike the observer is the difference in the colour of the picture. In two cases a rather

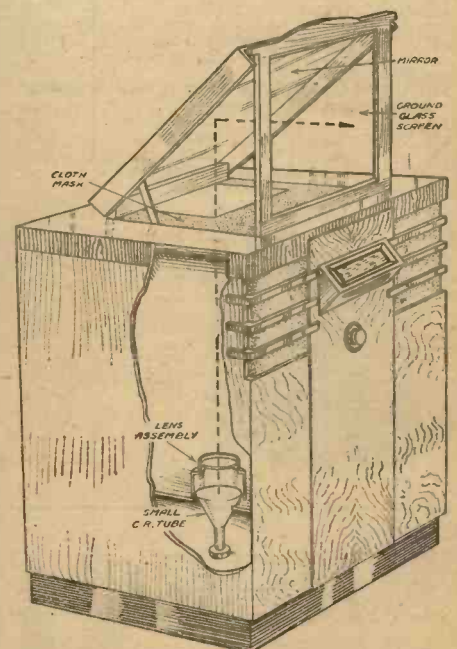

This diagram shows the main lines upon which the Philips receiver is designed.

## STOP PRESS!

For months we at Varley have been working at top pressure turning out more and more of our popular components (radio people always have liked Varley products) so we haven't had time to write a really clever advertisement. However, we extend our usual cordial invitation to the public and the trade to inspect our new 1937/38 components on Stand 99. If you can't possibly come along do send for our new catalogue.

*Yours in haste*  
**Varley**

**VARLEY (Oliver Pell Control Ltd.)**  
 Bloomfield Rd., Woolwich, S.E.18. (Tel: Woolwich 2345.)

## Selected and Specified for the **TRIDENT** SHORT WAVE **3**



No wonder the designers of the Trident Short Wave 3 [featured in this issue chose Ericsson Telephones as indispensable. They are simply perfect for the 100 per cent. functioning of this set.

Wonderfully sensitive, comfortable in wear and very pure in tone, they have come to be regarded as standard for the keen short-wave enthusiast's equipment.

Use them with *your* TRIDENT SHORT WAVE 3 or any set on which you are using headphones and want the very ultimate in results.

Three Resistances—one price: 1120, 2,000 and 4,000 ohms.

15/-

At all good radio dealers. If you have any difficulty in procuring, write direct to:

**ERICSSON TELEPHONES LTD.,**  
 Head Office: 22 Lincoln's Inn Fields, W.C.2

**Ericsson**

**SUPER  
 SENSITIVE  
 TELEPHONES**



# SPECIFIED

for the  
**TRIDENT ALL-WAVE 3**

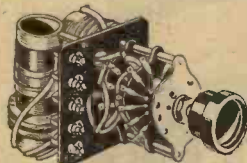

**B.T.S. ALL-WAVE COIL**  
A highly-efficient 3-band tuner unit incorporating rotary switch with silver-plated contacts. Type G ... **12/6**  
1 B.T.S. Solid Dielectric Reaction Condenser, .00025 mfd. **2/6**  
3 B.T.S. 4-pin Valve-holders, baseboard type, Each **6d.**

**ALL-WORLD ACE**  
1 B.T.S. Solid Dielectric Condenser, .00025 mfd. Type **2/6**  
2 B.T.S. Component Brackets, Per pair **8d.**  
From All Dealers. If any difficulty, send cash direct with name of nearest dealer.

See the NEW B.T.S. PRODUCTS at **OLYMPIA Stand 47**

- Many interesting new B.T.S. products are about to be released. Write for free folder containing fully descriptive leaflets on
- B.T.S. HIGH-FIDELITY SPEAKERS
  - ALL-WAVE CHASSIS
  - 7 and 14 watt P.A. AMPLIFIERS
  - AMPLIFYING (P.A.) SYSTEMS
  - High-Fidelity MICROPHONE
  - "Little Princess" PORTABLE RADIO COMPONENTS

**BRITISH TELEVISION SUPPLIES, Ltd.**  
Faraday House, 10, Charing Cross Rd., London, W.C.2.  
Temple Bar 0134.

## ELECTRADIX

Our advertisements that have appeared in PRACTICAL AND AMATEUR WIRELESS since No. 1, comprise typical selections from our extensive stock of bargains.

These are only a few of the thousands and different items in our stock, and would take the whole of these pages to describe. Send us your enquiries. Prompt delivery to any part of the world.

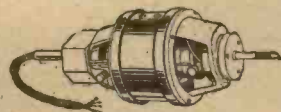

H.T. DYNAMO, 22/6.

It will pay you to post us at once a stamped addressed envelope for our 12-page, 100 illustrations Sale List "N," free.

## ELECTRADIX RADIOS

218, Upper Thames Street, London, E.C.4

Phone: Central 4611

# FOYLES

Booksellers to the World.  
Special department for Wireless Books.  
119-125, CHARING CROSS RD., LONDON, W.C.2  
Telephone: Gerrard 5060 (12 lines).

## THE LATEST TELEVISION RECEIVERS

(Continued from page 596)

and represents the latest development in modern television reception. The receiver is illustrated on page 596 and it will be seen that the screen is attached to the front edge of the lid. When the lid is raised the screen is lifted with it, and a mirror affixed to the inside of the lid directs on to the back of the screen an image thrown on to it by a lens mounted over a small cathode-ray

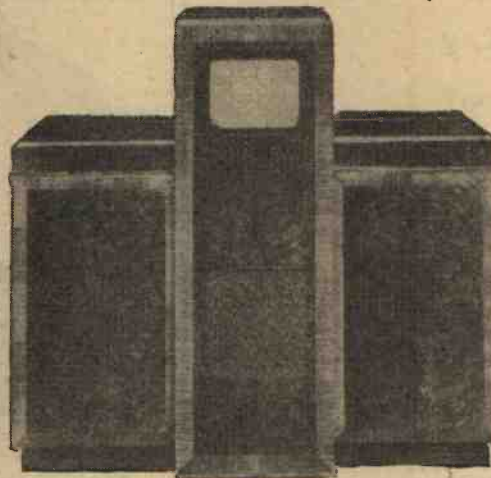

This is the Haynes "Viceiver."

tube on the bottom of the cabinet. A cloth mask is interposed to cut off extraneous light and render the image sharp and clear. A diagram has been prepared by our artist to show the general arrangement, and one of the most important features about this system, apart from the enlarged image, is the absence of a peculiar form of distortion seen in other receivers. The end of the cathode-ray tube is slightly curved and thus when a picture is made to fill the end of the tube it must be viewed from a position direct in front in order to appear flat. If viewed from one side or the other, the edges, due to the convexity, provide a distorted picture. In addition, the sweep of the electron beam is defocussed slightly due to the shape, although in certain cases correcting circuits are employed to retain the focus.

In the Philips receiver a 4in. tube is employed, but the picture is allowed to occupy only a small space in the centre of the tube, and this is, to all intents and purposes, quite flat. Consequently the image on the screen is free from any "curvature" distortion and a large crowd may view the screen without any difficulty in arranging the seating accommodation. One suggested drawback to the suggested enlargement of a picture on the end of a cathode ray tube was that the lines would become very noticeable, but in a demonstration of the Philips receiver which we attended the lines were no more prominent than in the ordinary arrangement. One reason for this appears to be that with the ordinary tube one has to sit rather closer than is needed when a large picture is produced, and thus at the increased distance from which we viewed the screen, the picture detail is such that the lines are not

noticed. Only when a blank screen is produced, such as when no transmission is being received, were the lines clearly picked out. To prevent damage to the reflecting mirror and screen of this new Phillips receiver a novel automatic lid mechanism has been fitted. When finished with, the lid is started on its downward journey and it completes the act of closing automatically in very slow time—actually taking nearly a minute to become completely shut. The screen folds under the lid and it is impossible to force the lid or drop it down and break either mirror or screen.

## Ultra Receivers

Messrs. Ultra Electric are making three different models, one a television receiver only, and the other two both incorporating all-wave sound receiver chassis. One of these is housed in a radiogram cabinet, whilst the two remaining models are made in much smaller dimensions than those previously available. In the television receiver only, which is illustrated on page 596, it will be noted that the design has been reduced to the utmost simplicity. The cathode-ray tube which is employed has been specially produced for Messrs. Ultra and provides a picture measuring only 7½ ins. by 6½ ins., and it is black and white. This tube is unusually short, and this assists in keeping down the cabinet size. Full magnetic deflection is employed in these receivers. In two of the receivers the end of the tube is viewed direct, whilst in the larger model a mirror is fitted inside the cabinet lid and the picture is viewed by reflection.

An important point in regard to the new season's television receivers is the reduction in the number of external controls. Whereas in last year's models the makers provided a certain number of controls on the panel, it has now been found possible in many cases to make certain adjustments in the laboratory, and, consequently, a



A de-luxe television receiver and auto-radiogram by Marconiphone. This is known as the "Mastergram."

"pre-set" control suffices for these adjustments. This has led to the removal of certain controls and those which have to be pre-set are now in most cases covered by a small, hinged flap on the cabinet.

**THE EXPERIMENTERS CHAT ABOUT THE NEW RADIO SEASON**  
(Continued from page 578)

vibrators must, of course, be used in conjunction with a transformer to step up the A.C. voltage produced by the first vibrator to a figure suitable for H.T. use, and appropriate transformers for the various patterns of vibrator unit are available.

**Comparing Signal Outputs**

All experimenters have for a long time wanted a simple type of measuring instrument for comparing outputs from a receiver. This is a practical essential when ganging and trimming many types of receiver, for aural comparisons of output are insufficiently accurate. Some time ago we described the construction of a unit of this type employing a miniature neon tube in conjunction with a potentiometer and small transformer. It is now possible to obtain the essential components assembled together in a neat unit suitable for connection to any type of receiver. The idea is that the signal output from the set is applied to the potentiometer, fed through a step-down transformer, and the potentiometer feeds the neon. If the potentiometer is set so that there is only a short glow in the tube, any adjustment of the set which results in greater output (such as more accurate adjustment of trimmers) causes the length of the glow to increase. The new unit is quite inexpensive and capable of many applications.

**Compact Design**

Turning to components in general, it is of particular interest that many of them are following the trend which has been sponsored by PRACTICAL AND AMATEUR WIRELESS—they are being made more and more compact. This means that the construction of efficient portables is being simplified. Besides, the smaller components in many cases lead to greater efficiency in receivers of the "fixed" type, because they permit of more compact assembly and shorter connecting leads, as well as smaller external fields, which increase any tendency towards instability and feed-back.

It seems that 465 kc/s I.F. transformers are becoming still more popular at the expense of 110 kc/s, but most makers continue to make both types, so there will be no need to sacrifice the advantages of the lower intermediate frequency which were set out in a recent article which was published in these pages.

**See You There**

We must leave any further chatter about new components until we have had an opportunity of looking round the stands at Olympia. During coming weeks we will keep you informed of our tests and experiments with the new apparatus, and let you know of anything which has a particularly strong appeal. In the meantime we are looking forward to the Show just as much as you are, for we are certain that it is going to herald a new era in home construction and give every keen experimenter ample food for thought.

No doubt we shall have the pleasure of meeting many of you at Radiolympia, even if we retain our anonymity. After you have looked round the stands we hope that you will give us your views, so that we can exchange notes in this feature.

A pleasant visit to Radiolympia and good experimentin'.

**N.T.S. SHORT WAVE BARGAINS!**

**New 2-valve BANDSPREAD SHORT KIT LIST VALUE 59/6 BARGAIN 32/6**



Assembled in an evening, this wonderful receiver, of entirely new and unique design, will bring you a lifetime of fascinating short-wave entertainment. Delivery from stock. ● Reacting Detector and Transformer coupled circuit, Power Output. ● Slow-motion bandspread tuning SIMPLIFIES WORLD RECEPTION! ● Low-loss reaction condenser. ● Air-spaced bandspread and tank condensers. ● SPECIAL ANTI-BLIND SPOT CONDENSER. ● 3 scales calibrated in degrees and tenths. **KIT "1"** comprises every part, including 3 4-pin coils, wiring and assembly instructions, less valves only. Cash or C.O.D. Carr. Pd. 2/6, or 2/6 down & 11 monthly payments 3/-. Kit "2" With 2 British Valves, £2/15/0, or 4/- down and 11 monthly payments 3/6.

**2/6 DOWN**

**3-valve BANDSPREAD \* SHORT WAVE KIT \* LIST VALUE £3 BARGAIN 37/6**

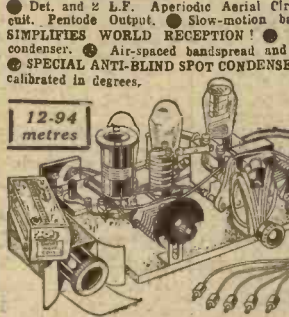

● Det. and 2 L.F. Aperiodic Aerial Circuit. Pentode Output. ● Slow-motion bandspread tuning SIMPLIFIES WORLD RECEPTION! ● Efficient reaction condenser. ● Air-spaced bandspread and tank condensers. ● SPECIAL ANTI-BLIND SPOT CONDENSER. ● 3 SCALES calibrated in degrees. **2/6 DOWN** and 11 monthly payments of 3/6. Each kit complete with drawing and instructions.

**NEW DESIGN! WONDERFUL PERFORMANCE!** The latest Bandspread world-wide tuning system incorporated into an ultra-modern aperiodic aerial short-wave circuit... and this amazing kit is yours at almost half the list value! **KIT "1"** comprises every part, including 3 6-pin coils, wiring and assembly instructions, less valves only. Cash or C.O.D. 37/6, or 2/6 down and 11 monthly payments 3/6. **KIT "2"**—With 3 British valves, £2/15/0, or 12 monthly payments 5/-.

**Something Entirely NEW! "3-in-1" SHORT WAVE KIT Adaptor—Converter—Receiver LIST VALUE 37/6 BARGAIN 25/-**

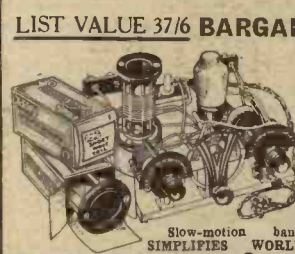

● Adapts or converts your battery set for short-wave reception, or may be used as 1-valve Short Wave Receiver. ● Reacting Detector Circuit. ● Slow-motion bandspread tuning SIMPLIFIES WORLD RECEPTION! ● Low-loss reaction condenser. ● Air-spaced bandspread and tank condensers. ● SPECIAL ANTI-BLIND SPOT CONDENSER. ● 3 scales calibrated in degrees. The N.T.S. "3-in-1" Short-Wave Kit is entirely unique in short-wave technique. This amazing combined Adaptor-Converter-Receiver is offered you for the first time... at an astonishingly low price. **2/6 DOWN**

**KIT "1"** comprises every part, including 3 4-pin coils, wiring and assembly instructions, less valve only. Cash or C.O.D. Carr. Pd. 25/-, or 2/6 down and 10 monthly payments 2/6. **KIT "2"**—With 2-volt valve, £18/9, or 2/6 down and 11 monthly payments 2/9.

**D. X. FANS' A.C. 4 SHORT-WAVE KIT List Value £5:10:0 BARGAIN 75/-**

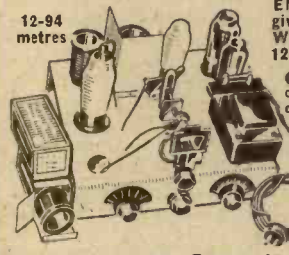

**ENTIRELY NEW DESIGN giving UNIQUE ALL-WAVE WORLD-WIDE RECEPTION 12-94 METRES** ● Variable Mu H.F. pentode, leaky grid reacting detector, pentode output and valve rectification. ● Bandspread tuning with air-spaced condensers. ● Slow motion bandspread dial. ● 3 calibrated scales 0-180, 0-180, 0-10. ● For A.C. Mains 200-250 volts, 40-100 cycles. **KIT "1"** comprises every part for assembly including 3 pairs 4 and 6-pin coils (12-94 metres), wiring and assembly instructions, less valves only. Cash or C.O.D. 75/- or 5/- down and 11 monthly payments of 7/-.

**KIT "2"** with 4 British Valves, Cash or C.O.D. £5/12/6 or 10/- down and 11 monthly payments 10/6. **KIT "3"** with Valves, and 2,500 ohms Field Energised Speaker. Cash or C.O.D. £6/12/0 or 12/6 down and 11 monthly payments 12/-.

Post Coupon for Free Booklet describing above Kits in detail.

**COMPONENT BARGAINS**



**N.T.S. SHORT-WAVE COILS.** Interchangeable plug-in coils. Low-loss material ribbed formers. N.T.S. coils are expertly wound with high-grade copper wire to ensure accurate distributed self-capacity, 100% efficient. 4-pin: 12-28, 22-47, 41-94, 70-170 metres. List Value 2/9. Bargain Price 1/9. 6-pin wavelengths as for 4-pin types. List Values 3/6. Bargain 2/-. For prices of Coils for higher wavelengths, post coupon for free N.T.S. Catalogue. **1/9 EACH**

**COIL Bases for above:** 4-pin 1/-; 6-pin 1/6 **ANTI-BLIND-SPOT CONDENSER.** Type AB. List value 2/-. Bargain 1/-. Expressly designed to overcome "blind-spots" always present in ordinary aerial systems. Ensures smooth reaction and maximum H.F. gain at "blind-spots" otherwise devoid of short-wave signals.

**BANDSPREAD AND TUNING CONDENSERS.** Type 2/16.00016 mid. List value 5/9. Bargain 3/6. Type 4/16.00016. List value 4/9. Bargain 2/9. For all short and ultra-short-wave circuits. Brass vanes and spindle and ceramic compound end-plate. Extended spindle for ganging. For minute accuracy and efficiency on short-wave tuning always use N.T.S. condensers.

**SLOW-MOTION DIAL.** List Value 2/8. Bargain 1/9. 10°-1° slow motion. Illuminated scale. 0-180 degrees. Burnished acetone. For all 1" spindle condensers. With bracket for single condenser and with knob.

**Special Offer! HEADPHONES** List Value 15/-. Bargain 8/6. New lightweight adjustable model, highly recommended for short-wave work.

**A.C. BANDPASS S.G.4 CHASSIS**



With 4 British Valves. LIST PRICE £6:6:0 **BARGAIN £3:10:0** Wonderful selectivity and sensitivity. 4 matched British valves. Screened Bandpass Coils. Slow Motion Tuning. Illuminated dial. Wavelength calibrated. Gramo pick-up sockets, 24 watts output. Wave range 200-500, 1,000-2,000 metres. For A.C. Mains ONLY 200-250 volts 40/80 Cycles. Cash or C.O.D. £3:10:0, or 5/- down and 12 monthly payments 6/6. Also available in beautiful walnut veneered cabinet complete with Celestion Field Energised Moving Coil Speaker and Airplane dial, ready to play. List price £8:8:0. Bargain Price £5:5:0, or 5/- down and 18 monthly payments of 6/6. **5/- DOWN**

**New Times Sales Co.**

56 (Pr.W.29), Ludgate Hill, London, E.C.4.

Please send me.....

For which I enclose £.....; Cash/H.P. Deposit.

Please send also your Free Booklet describing in detail 5 new Short Wave Kits, and General Bargain Catalogue of Components, Valves, Receivers, etc., etc.

NAME.....

ADDRESS.....

Please cross all P.O.'s and register currency. Overseas orders must be accompanied by full cash and approximate postage.

A PAGE OF PRACTICAL HINTS

**SUBMIT YOUR IDEA**

**READERS WRINKLES**

**THE HALF-GUINEA PAGE**

**A Novel Illuminated Map**

THE accompanying illustration shows a simple but attractive method of making an illuminated map with provision for variation in colouring for medium and long-wave bands. The two illumination tubes "X" and "Y" were fashioned from sheet tin by moulding round a broom handle and allowing sufficient lap for the flanges. Prior to this moulding operation, and after the size of tin, per tube, has been

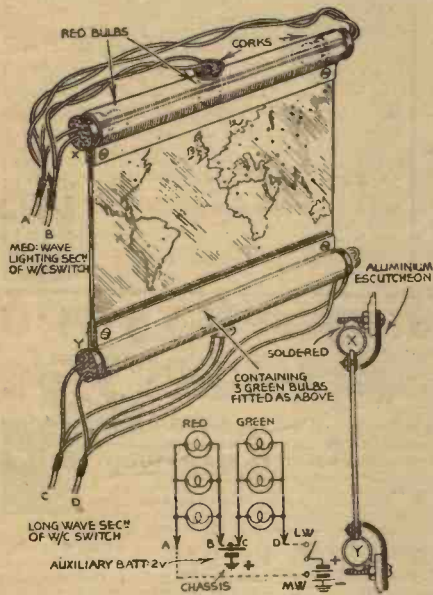

A method of making an illuminated map with "stereoscopic" lighting.

ascertained, a hole—sufficient to accommodate a large cork into which has been fitted a 2.5v. bulb (for 4v. heater circuit)—is drilled in each tube. The next part of the assembly is a little difficult; it constitutes the drilling of four holes to take 4 BA screws. Marks were made with the countersinking bit, then small drills were used increasing up to 4 BA. The operation was then repeated.

I used white paint (applied with a nib) when drawing the map, and the various stations were indicated with red ink which, when dry, left a greenish tint around each station. I painted—this time with a fine brush—a white circumference, and the station names were finally printed on strips of paper and stuck down with glue.—T. C. HENTWORTH (Sheffield).

**Coils for the Simplest Short-waver**

I HAVE noticed that several readers are anxious to extend the range of the "Simplest Short-waver." The accompanying sketch shows how I solved the problem without any expense. An old valveholder was taken of the type which had side contacts instead of pin sockets. I stripped off these contacts, bent the part for the bolt in the opposite direction, and

**THAT DODGE OF YOURS!**

Every Reader of "PRACTICAL AND AMATEUR WIRELESS" must have originated some little dodge which would interest other readers. Why not pass it on to us? We pay £1-10-0 for the best wrinkle submitted, and for every other item published on this page we will pay half-a-guinea. Turn that idea of yours to account by sending it in to us addressed to the Editor, "PRACTICAL AND AMATEUR WIRELESS," George Newnes, Ltd., Tower House, Southampton Street, Strand, W.C.2. Put your name and address on every item. Please note that every notion sent in must be original. Mark envelopes "Radio Wrinkles." DO NOT enclose Queries with your wrinkles.

screwed five of them to a wooden bobbin, arranging them as shown in the sketch. Around each screw I also fixed a loop of 18 S.W.G. tinned copper wire for soldering connections to other components. I then fixed this to a small square of plywood by screwing them together from below. This formed a socket over which I could easily plug the coils. These were made as described in PRACTICAL AND AMATEUR WIRELESS (December 12th, 1936), only that the ends were brought down the inside of the former, pulled tight and turned up on the

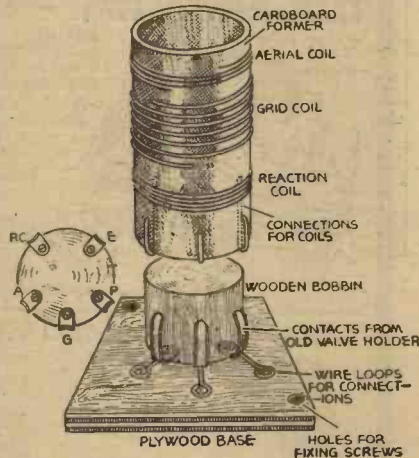

Interchangeable coils for the simplest short-waver.

outside. This was then pressed firmly into the cardboard with pliers. When the coil was pushed on top of the bobbin the wires on the inside (at the foot of the former) made firm contact with the valve contacts on the bobbin. The former I used was 1 1/2 in. diam.—FRANCIS HARMON (Glasgow).

**An Improvised Accumulator**

WHEN testing out some new circuits recently my low-tension supply suddenly gave out. As it was too late to visit a charging station I adopted the following dodge.

All I needed was an old accumulator which I located in my shed. I removed the negative plates and in their place I put a few sheets of tinplate, about the same size, and cut from an old can. Then I connected the improvised accumulator to the A.C. mains in series with a load consisting of a small electric fire and a large electric lamp.

After about ten minutes' charging in this

way, I obtained a supply of low-tension current—which lasted several hours.—E. C. ADAMS (Rhydyfelin).

**Fixing Chassis-mounting Valveholders**

A SIMPLE but very efficient method of fixing chassis-mounting valveholders—particularly the midget type—

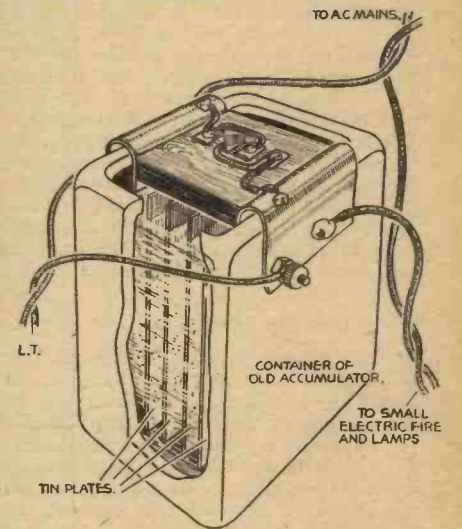

A novel arrangement of an improvised accumulator

may be accomplished in the manner indicated in the accompanying sketch. It will be seen that the only materials required for a number of similar fittings consist of a length of strip brass—for the midget type, as shown, 4 in. by 1/4 in. by 1/16 in.—and a number of 6 BA nuts and bolts, together with a few large brass washers.

The resilience of the assembly illustrated obviates possible damage to electrodes by jarring the apparatus.—A. R. W. JONES (Durham).

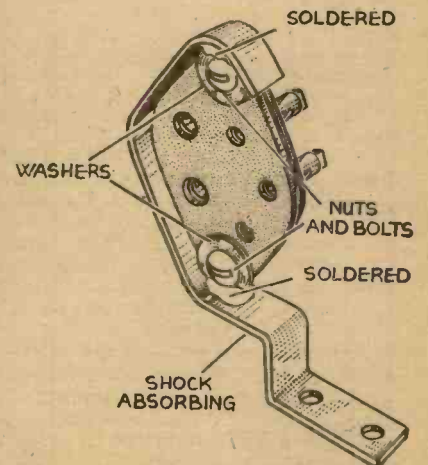

Fixing chassis-mounting valveholders to avoid the effects of vibration.

## BROADCASTS TO SCHOOLS

It is revealed that a year ago there were 4,415 schools in England, Wales and Northern Ireland on the B.B.C.'s register. To-day this figure has increased to 6,466. Much of this increase is due to the lively interest of education authorities, most of which wire their new schools for reception.

The use of school broadcasting is defined as the drawing into service by the teacher of something which is part of the average child's normal home life. Youngsters trained in classroom listening will be able to listen critically and selectively when they grow up. They may, for instance, join Listening Groups; and Mr. A. C. Cameron, Secretary of the Central Council for School Broadcasting, was lately appointed Secretary to the Central Committee for Group Listening.

Altogether twenty-seven courses will be broadcast to schools during the coming year. These range from a course in Music and Movement for the very young children to talks for Sixth Forms which have in the past been given by such speakers as J. B. S. Haldane, Sir Richard Livingstone, Dame Rachel Crowley, and T. S. Eliot.



Miss Radiolympia, who was selected out of 2,000 applicants to be this year's Radio Queen. See her at Olympia.

Feature programmes and topical talks, the object of which, it is stated, is to "bring the world to the classroom," will again be broadcast every Friday afternoon. Some of these will be outside broadcasts, others programmes of recorded material. The topical talks will deal with inventions, discoveries, films and anything else that is in the news.

Modern History will be dealt with week by week in the "History in the Making" series. These talks tell schoolchildren of the big events of the day in relation to similar events in history.

Listeners to Senior English will hear talks on books, on speech and language, on poets and poetry, and on words. Dramatic readings will also be broadcast. Professor A. Lloyd James, Mr. Desmond MacCarthy and Mr. S. P. B. Mais are among broadcasters in this series.

Full particulars of the complete syllabus for the season are given in the recently published Annual Programme of School Broadcasting for the year 1937-8. The book may be obtained free on personal application to the B.B.C. Publications Department, 35, High Street, Marylebone, London, W.1, or to any B.B.C. provincial office. Applications by post should be accompanied by a three-halfpenny stamp.

### A NEW "PRACTICAL AND AMATEUR WIRELESS" HANDBOOK!

An important new Handbook of great interest to every home constructor and, in fact, to anyone interested in radio, has just been published from the offices of this journal. It is entitled "Wireless Coils, Chokes, and Transformers: And How To Make Them." It fills a gap in technical literature which has existed from the earliest days of home construction. For as far as we are aware a book has not yet been published which gives complete practical information on the making of every type of coil. This handbook is not a mere theoretical treatise on the principles of induction and capacity, although these subjects are dealt with as introductory to the practical side of the book. It contains chapters dealing with coil types and principles; resistance inductance and capacity; choice and use of coils; a simple tubular coil; screened coils; materials and construction; circuits; a band-pass unit; ganging and switching; superhet coils; short-wave coils; adjusting and testing coils; coil troubles and remedies; I.F. transformers; an all-wave tuner; coil winders and how to make them; selectivity; aerial and earth systems; breakthrough and its prevention; making H.F. chokes; L.F. and smoothing chokes; low-frequency transformers; making mains transformers; coil data and formulae; symbols; abbreviations; the R Code; di-electric constants; wavelength conversion table; coil-winding tables; wire and sheet metal gauges; copper wire data; metric equivalents; useful formulae, etc. etc.

The book contains 180 pages, is cloth bound with attractive jacket, illustrated by nearly 150 diagrams, and costs 2s. 6d., or 2s. 10d. by post.

"Wireless Coils, Chokes and Transformers," with "Everyman's Wireless Book," the "Wireless Constructor's Encyclopaedia," "Television and Short-Wave Handbook," and "50 Tested Wireless Circuits" form a complete technical library on the practical and theoretical sides of radio.



R. Heath Bradley; Principal of T.C.R.C.

All T.C.R.C. Training is conducted by correspondence. You study in your own home, at your own pace. You need not know anything about radio or mathematics; a T.C.R.C. Course will take you from the elementary theory to advanced practice by easy stages. T.C.R.C. Courses do not waste your time with a lot of useless and out-of-date subjects; you enjoy studying and make rapid progress.

### TELEVISION

New and "up-to-the-minute" Courses now ready on Modern Television, Short-Waves and Ultra-Short Waves.

## TECHNICAL & COMMERCIAL RADIO COLLEGE

FAIRFAX HOUSE,  
HIGH HOLBORN, W.C.1.

(Phone: Holborn 7453.)

If you are already employed in Radio a T.C.R.C. Course will help you to qualify for promotion and better pay.

## My students get good jobs

"Thanks to your excellent training, valuable introductions and good advice, I am now getting twice as much as when I enrolled only six months ago."

That is an extract from just one of the hundreds of grateful letters from successful students, and here are just a few of the reasons why T.C.R.C. training is so successful:—

The T.C.R.C. Specialises in RADIO. All its energies are concentrated on helping its students to become successful Radio Engineers.

The T.C.R.C. Courses are prepared by practical experts who have proved their ability in the radio world. The Courses are praised by leading manufacturers and the Technical Press.

Every T.C.R.C. student is under my personal supervision and is given individual help in obtaining well-paid spare-time work or full-time employment.

The T.C.R.C. offers indisputable proof that its students can and do get well-paid posts solely as a result of their training.

The T.C.R.C. can help you as it has helped others. Take the first step to success and better pay by sending at once for free copy of book entitled RADIO AS A CAREER. Post coupon below.

Post in unsealed envelope; 1d. stamp.

(P.R. 701)

To: T. & C. RADIO COLLEGE,  
Fairfax House, High Holborn, London, W.C.1.

Please send, IN PLAIN ENVELOPE, Free Copy of "Radio as a Career," which tells me how I can qualify for well-paid radio employment or profitable spare-time work. NO CANVASSERS.

NAME .....

ADDRESS .....



**LEGISLATION IS ON THE WAY**

**INTERFERENCE SUPPRESSION**

It is anticipated that legislation will soon be introduced to compel owners of electrical appliances (domestic and commercial) to fit Interference Suppressors to their offending appliances.

The noise-reduction effected will ensure comparative freedom from interference on local stations, provided your set is equipped with a reasonably efficient outdoor aerial and earth system. For a mains receiver you may have to fit to the set a special filter; the All-Wave Set Lead Suppressor No. 300. Price 25s.

To enjoy the full capabilities of your set in picking up distant stations, it will perhaps be found necessary to fit the "Eliminoise" (trade mark) All-Wave Anti-Interference Aerial. Price 37s. 6d. and 1s. per yard for screened down lead.

For informative booklet, **FREE**, send coupon.

**BELLING-LEE SUPPRESSION SERVICE**

**BELLING & LEE, LTD.,**  
Cambridge Arterial Rd., Enfield, Mdx.

Please send, free, 8-pp. booklet, "Electrical Interference."

Name .....

Address .....

Pr. W. 28.8.37 .....

Improved Short-wave reception is assured if you erect an



As used in the R.G.D. Laboratories. Leaflet post free.

**Anti-static All-wave Aerial System**

Radio Gramophone Development Co. Ltd., Globe Works (Section B), Birmingham, 6.

**CHARGE YOUR OWN BATTERY!**

With the Heayberd "Tom Thumb" Battery Charger you can charge your own low-tension battery at 3 amp. for less than 1d. per week! Think of it, with the "Tom Thumb" you can charge your own batteries the whole year round for 2/6d.1 Simply connect the battery to the charger, and insert the mains lead into the nearest light or power point. All metal parts—No Valves—No inconvenience—Guaranteed for 12 months.

Price **12/6**

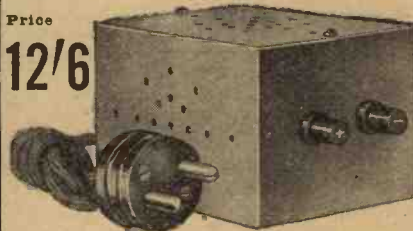

You can see this midjet battery charger on Stand No. 25 at Radiolympia. Send now for List No. 996, describing Heayberd components and the "Tom Thumb."

**F. C. HEAYBERD & Co.,** 10 Finbury St., London, E.C.2.

**ALL THE LATEST RADIO EQUIPMENT to be shown at RADIOLYMPIA**

will be available on the **LOWEST EASY TERMS**

WE GUARANTEE COMPLETE SATISFACTION. PROMPT DELIVERY. All goods carr. paid. CASH OR C.O.D. ORDERS delivered by return of post.

★ REMEMBER—WRITE US ABOUT YOUR NEXT REQUIREMENTS —We will quote the best possible terms.

**MCCARTHY CHASSIS** always in Stock. New Demonstration Room now open.

Estd. 1925 **THE LONDON RADIO SUPPLY COMPANY**

11 OAT LANE, NOBLE STREET, LONDON, E.C.2

**HOME SOUND RECORDING at low cost**

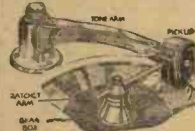

Electric FEIGH set has ball bearing centre gear box and geared traverse rod. Set with Tracking Gear, Pick-up and Tone-arm fitted diamond, 37/6 For experimenters re-quiring gear only, less Pick-up and Tone-arm, this is 21/6. Diamond Cutter Needles, fit all pick-ups, 7/6. Blank Discs, 4/- dozen. Complete Acoustic Sets de Luxe, 18/-; No. 2, 10/8; Junior type, 5/6 each complete.

Send Stamp for Radio-Electrical Scientific Illus. List "N" Free.

**ELECTRADIX RADIOS,** 218, UPPER THAMES STREET, LONDON, E.C.4.

Telephone: Octral 4011.

**RADIO CLUBS AND SOCIETIES**

Club Reports should not exceed 200 words in length and should be received First Post each Monday morning for publication in the following week's issue.

**Ealing and District Short-wave DXers' Club**

A SHORT-WAVE club under the above heading is now being formed, and all applications for membership, etc., should be made to the hon. secretary. It has been proposed to hold meetings once a month, and these will take the form of lectures, etc. The secretary would be glad to hear from anyone who would care to give a lecture or demonstration.—Hon. Sec., W. J. Colclough, 31, Lancaster Gardens, W. Ealing, W.13.

**Proposed Club for Finchley**

WILL any readers interested in the formation of a short-wave and television society in the Finchley district please communicate with E. C. Cusack, 2, Victoria Grove, Friern Park, North Finchley.

**The Eastbank Research Society**

THE above society is interested in serious research work, in so far as an artificial aerial licence permits, and will welcome the collaboration of any experienced amateurs in the district. Readers interested are invited to communicate with the secretary, James P. Blackwood, 23, Braidfauld Street, Tolcross, Glasgow, E.2.

**Dulwich Radio Club**

WILL all readers who are interested in joining the Dulwich Radio Club please communicate with the organiser, C. E. Newton, 105, Underhill Road, S.E.22. The club has a large room for practical work where more advanced members will be in attendance on certain evenings. The club is running outings to places of interest, also social events such as swimming, football, etc. The clubroom is situated at the rear of 55, Upland Road, S.E.22 (near Barry Road).—Hon. Sec., Eric Wells.

**The Hackney and District Wireless Club.**

A MEETING of the above club was held on Monday, the 9th inst., at 226, Graham Road, when the secretary read a letter received from the Radio Signal Survey League. All members present were interested in a local chapter being formed. Full particulars of the club may be had from Mr. E. Penrose, 2, Coopersale Road, Homerton, E.9.

**REPLIES IN BRIEF**

The following replies to queries are given in abbreviated form either because of non-compliance with our rules, or because the point raised is not of general interest.

V. P. P. (Liskeard). There are many coils bearing the description you give in your letter and connections are not standardised. A good local radio dealer may be able to trace them out for you.

D. S. (Rochdale). A valve fault can give rise to the trouble, or a defective grid resistance in the L.F. stages. Test each anode circuit in turn with a good milliammeter.

P. K. (Slough). A back number may be obtained from this office, price 4d.

J. G. (Watford). We regret there is no blueprint for the receiver referred to.

G. A. T. (Godalming). You can use the parts but it would be better to build to a published diagram and use parts which have been tested and follow details closely.



## Leaves from a Short-wave Log

### Panama Tries Out a New Channel

HP5J, Panama City, previously reported on 31.22 m. (9.61 mc/s), is now to be found on 25.63 m. (11.7 mc/s), or slightly above HP5L, David, Chiriqui, also in the Republic of Panama. The call given out in Spanish includes the slogan: *La Voz de Panama*, but announcements are made both in that language and in English. Schedule—Weekdays: G.M.T. 16.45-18.15; and midnight to 03.30; on Sundays from G.M.T. 15.30-18.15; 20.00-21.00 and the later concert. Address: *La Voz de Panama* (HP5J), Apartado Postal 867, Panama City (Republic of Panama).

### Special Transmission from Curacao

Advice has been received that PCJ1, Wilhelmstad (Curaçao), will broadcast a special programme for listeners abroad between G.M.T. 00.35-01.35, on 50.59 m. (5.93 mc/s). The channel usually adopted by this station is 31.67 m. (9.475 mc/s).

### New Cuban Station

I am informed that a new transmitter giving the call-sign COBZ, and announcing its location at Havana (Cuba), has been logged when broadcasting a concert in the early morning hours. As the call letters are not found in the official lists it is possible that it has been confused with COBC, previously logged on 32.22 m. (9.31 mc/s). The address given is: P.O. Box 132, Havana (Cuba).

### Vienna Programme Schedule

OER2, on 25.42 m. (11.801 mc/s), is now on the air every Monday and Friday from G.M.T. 14.00-22.00, and on Saturdays from G.M.T. 14.00-23.00. The power is 1.5 kilowatts. It is on most occasions a good medium through which to capture some excellent concerts from the Austrian capital and which, owing to interference, are not so easy to tune in on the medium-wave channel.

### Another Mystery Station

Listeners report having heard broadcasts by a French communist station announcing itself as *Radio Liberté*, Paris. It is stated to be giving a simultaneous transmission on 31.5 m. (9.523 mc/s), and 40.65 m. (7.38 mc/s). The programmes consist of gramophone records and short talks in French and Italian, but no definite address is given for obvious reasons.

### Broadcasts from the Normandie

On the occasion of the Paris 1937 International Exhibition the French liner *Normandie* is carrying out test transmissions of music with the National Broadcasting Company of America with a view to the establishment of a regular service of radio programmes in the near future. Transmissions from the liner can be logged at odd times on 66 m. (4.546 mc/s); 34 m. (8.824 mc/s); and 22.6 m. (13.275 mc/s).

### Radio Programmes from Hawaii

KKP, KIO, and KKH, Kahuku, on 18.71 m. (16.03 mc/s), 25.68 m. (11.68 mc/s), and 39.89 m. (7.52 mc/s) respectively, are relaying almost nightly musical programmes from the medium-wave station in Hawaii for the benefit of listeners in the United States. They are heard working until G.M.T. 06.00.

## BRIEF RADIO BIOGRAPHIES—19

By RUTH MASCHWITZ

### Navarre

NAVARRÉ, the "Prince of Mimies," was for years an opera singer, and his career as an impersonator began quite by chance. At a party one night he gave an imitation of one or two worn-out opera singers which amused the guests so much that he got the idea of doing impressions of world-famous singers. An agent heard him and got him an audition at Broadcasting House. After doing two impersonations of Tauber and Chaliapine, Navarre was asked to wait



whilst officials from other departments were called in to listen. He repeated the performance and producers from St. George's Hall were summoned. His first broadcast followed almost immediately, when many listeners refused to believe that gramophone records were not being used.

Navarre was born in Australia about 100 miles from Melbourne. His family were all enthusiastic amateur musicians, but he received no training whatsoever. His first stage appearance was in "The Maid of the Mountains," and he was later engaged to sing the part of Figaro in "The Barber of Seville." He then joined a concert party as assisting artist to a world-famous prima donna and toured Australia until 1927. On his first visit to Paris he met Dame Nellie Melba, who introduced him to the great mystery man of Europe, Sir Basil Zaharoff. The latter, after hearing Navarre sing, consented to finance his studies for training on the Continent. He worked for a year in Milan and sang in many of the principal cities of Italy in leading operatic tenor rôles.

He first came to England in 1933 and sang in concerts for six months; then went to Paris, and returned in 1934 when he appeared in the non-stop production at the Prince of Wales.

One of Navarre's most treasured possessions is an Egyptian ring many hundreds of years old.

Quaint IDEAS YOU ACCEPT WITHOUT QUESTION....

NUMBER ONE

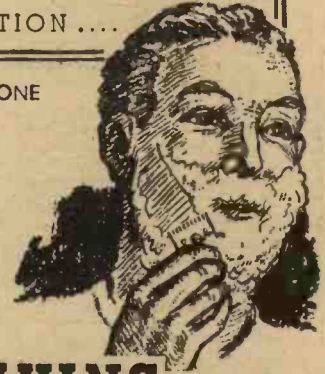

that SHAVING makes the hair grow faster

Of course, the idea is all wrong, and has been proved a mere misconception. Fortunately whether you accept the idea or not no penalty results, but when it's a question of condensers, to imagine one is as good as another can lead to endless trouble. Condenser design and manufacture is a specialised job. So it's wiser to ignore hearsay and to rely on established fact.

## ● A PROVED CONDENSER FACT

T.C.C. CONDENSERS ARE THE ACCEPTED STANDARD OF CONDENSER EFFICIENCY—THE NATURAL OUTCOME OF 30 YEARS' SPECIALISATION

See the complete range on

STAND

38

Radiolympia



T.C.C. ALL-BRITISH CONDENSERS

The Telegraph Condenser Co. Ltd., Wales Farm Road, N. Acton, W.3.



As he finished his short-wave set, Platt, With a satisfied air, said, "That's that." But his friend said, "Dear me, You're no FLUXITE, I see; You'll be lucky to get London Nat. . ."

See that FLUXITE is always by you—in the house—garage—workshop—wherever speedy soldering is needed. Used for 30 years in government works and by leading engineers and manufacturers. Of Ironmongers—in tins, 4d., 8d., 1/4 and 2/8.

Ask to see the FLUXITE SMALL-SPACE SOLDERING SET—compact but substantial—complete with full instructions, 7/6. Write for Free Book on the art of "soft" soldering and ask for Leaflet on CASE-HARDENING STEEL and TEMPERING TOOLS with FLUXITE.

TO CYCLISTS! Your wheels will NOT keep round and true, unless the spokes are tied with the fine wire at the crossings AND SOLDERED. This makes a much stronger wheel. It's simple—with FLUXITE—but IMPORTANT.

## THE FLUXITE GUN

is always ready to put Fluxite on the soldering job instantly. A little pressure places the right quantity on the right spot and one charging lasts for ages. Price 1/6.



ALL MECHANICS WILL HAVE

# FLUXITE

IT SIMPLIFIES ALL SOLDERING

FLUXITE LTD. (Dept. W.P.) DRAGON WORKS, BERMONDSEY STREET, S.E.1.

# Replace with CHAMPION

The Valve with the real guarantee

Write for full details.

CHAMPION VALVE CO.  
13, City Road, London, E.C.1.

Tel. NAT. 4756, 4372

NOW IN A THIRD EDITION

## THE SUPERHETERODYNE RECEIVER

By ALFRED T. WITTS, A.M.I.E.E.

"Gives all the information necessary for a complete understanding of the superheterodyne receiver."—*Practical Wireless*.

"A comprehensive manual, thoroughly up-to-date."—*Wireless Trader*. 192 pp. 3/6 net.

From a bookseller, or 3/9 post free from  
PITMAN, Parker St., Kingsway, W.C.2.

When writing to Advertisers

please mention

"Practical and Amateur Wireless"

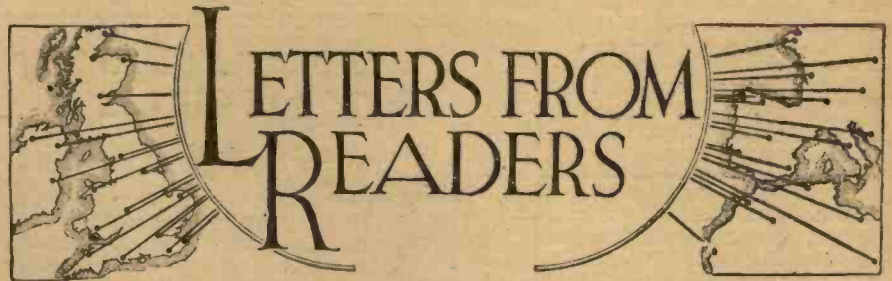

The Editor does not necessarily agree with the opinions expressed by his correspondents. All letters must be accompanied by the name and address of the sender (not necessarily for publication.)

### An Interesting Broadcast

SIR,—While searching the short waves on the 12th inst. about 10.20 B.S.T., I came across an English voice emanating from W3XAL, Bound Brook, New Jersey, which proved to be a well-known correspondent of a London daily paper giving his views on Tommy Farr and the World's Heavy-weight Championship. Then came the representative of a London evening paper, together with the donor of the £800 belt to the winner, giving their opinions. After that we heard the other side—some of the greatest sports writers in America expounding to us everything about Joe Louis and the coming battle. Then Joe Louis himself informed us how he was going to win. To finish this very interesting broadcast Louis' cook stated that his charge keeps "in the pink" all the time by eating lots of ice cream.—G. LANE (Combe St. Nicholas, Somerset).

### A Receiver for Overseas

SIR,—I read with great interest Mr. Wiggill's letter in your issue of July 3rd. I must say that he has hit the nail on the head when he talks about a battery-operated 6-volt short-wave receiver. I, for one, would greatly appreciate to see in your fine paper an article which would describe a receiver of this kind. I note he does not say whether he would prefer a receiver of the straight or superhet type, but I should like to suggest that a receiver of the straight variety would be preferable, with plug-in coils, as I have found that they eliminate dead-spots. I am situated in a very bad locality so am looking for a really HOT receiver.—J. C. INNES (Lusaka, Northern Rhodesia).

### Portuguese Station Veri

SIR,—With reference to the unknown Portuguese Station "Radio Renascença," mentioned in the Leaves from a Short-wave Log in a recent issue of your paper, I have received a verification from this station which gives the following data: Frequ., 5.977 mc/s; Power, 200 watts; Schedule, Daily 20.30-22.30; and address 5, Rua Capelo, Lisbon.

The station has apparently not obtained any call-letters yet, but during the intervals the announcement: Emissora Catolica de Lisboa. Portugal, is given, and the station designates itself officially as: Emissora Catolica Portuguesa.—K. E. CLARE (Wimbledon).

### A Valve-testing Panel

SIR,—As a regular reader of PRACTICAL AND AMATEUR WIRELESS I would like to endorse Mr. Chamberlain's request for a valve-testing panel—mains driven—but I should like it to be able to test more than half a dozen types.

Also, after that, I should like to see published a condenser tester, one that will test condensers under a high voltage, as I

have a capacity meter which works on 230 v., and I have damaged it twice owing to insulation breakdown at 230 v.—J. H. OLDROYD (Sale, M/C.).

SIR,—I agree with the suggestion made by H. E. Chamberlain with regard to a valve-testing panel. But why only a mains valve-testing panel? If you supply one type that is successful, some of us would clamour for one to test battery valves; and why not, unless you can suggest a universal test-panel, which I think would satisfy the majority. Hoping you have sufficient letters on this subject to justify you publishing details in PRACTICAL AND AMATEUR WIRELESS.—P. WATKINS (Wolverhampton).

### Station CR7AA

SIR,—In your issue of July 10th, 1937, page 399, you state that CR7AA, Lourenço Marques, has changed its wavelength to 25.6 m. It has actually started using this as an additional wavelength for CR7BH, the former 48.88 m. programme being S.B. with the call CR7AA. In Capetown we listen to the 25 m. transmission during the daytime and the 49 m. at night, when the other has faded out.

You may be interested in the transmission equipment—a Collins' type 300 B.A. The power is 250 watts, crystal

CUT THIS OUT EACH WEEK

# Do you know

- THAT as the dipole aerial gives improved results on a given waveband a multi-dipole aerial is a valuable accessory to all-wave listening.
- THAT to enable experiments to be carried out with transmitting apparatus without interference, an artificial aerial system is employed.
- THAT a licence for an artificial aerial is less expensive than for a full outside aerial.
- THAT an ordinary flash-lamp bulb will not always provide protection when used as a fuse in a battery receiver.
- THAT care is required when using long leads for a distant listening point with a low-resistance speaker.
- THAT fixed I.F. transformers may be converted to obtain a variable-selectivity effect by joining a small variable condenser between the primary and secondary windings.

The Editor will be pleased to consider articles of a practical nature suitable for publication in PRACTICAL AND AMATEUR WIRELESS. Such articles should be written on one side of the paper only, and should contain the name and address of the sender. Whilst the Editor does not hold himself responsible for manuscripts, every effort will be made to return them if a stamped and addressed envelope is enclosed. All correspondence intended for the Editor should be addressed: The Editor, PRACTICAL AND AMATEUR WIRELESS, George Neeson, Ltd., Tower House, Southampton Street, Strand, W.C.2.

Owing to the rapid progress in the design of wireless apparatus and to our efforts to keep our readers in touch with the latest developments, we give no warranty that apparatus described in our columns is not the subject of letters patent.

controlled. Half-wave Zepp aerial (6,137 kc/s). Times of transmission are: weekdays (G.M.T.)—5.15 to 6 a.m., 9.30 to 11.30 a.m., 2.30 to 4 p.m., and 5.30 to 9 p.m.; Sundays—10 a.m. to 12 noon, 3 to 5.30 p.m., and 7 to 9 p.m.—A. H. C. NICKLIN (South Africa).

**I.F.S. National Radio Society**

SIR.—Having recently been appointed I.F.S. representative of the National Radio Society, I shall be pleased to get in touch with any person in the Irish Free State who is interested, with a view to forming an I.F.S. Section.

Any communications to the address below would be much appreciated.—J. G. WHITE, 18, St. David's Terrace, N.C. Rd., Dublin.

**COMPONENTS AT OLYMPIA**

(Continued from page 561.)

for different meters will be found on the Westinghouse stand. They are designed for use with 1, 5 or 10 mA meters. Messrs. Westinghouse can also supply mains rectifiers for the construction of H.T. units and battery chargers, whilst Messrs. Heayberd can supply transformers specially designed for use with these rectifiers, and complete kits of parts for the purpose.

**Fixed Condensers**

On the Dubilier stand will be found dozens of fixed condensers, suitable for practically any type of receiver or amplifier. These will include many of the old existing types already familiar to the experimenter, but this year a number of new lines are to be shown. Many of these are of the oil-immersed type, designed for use in television equipment or in high-powered amplifiers, where a really high degree of insulation is required. Electrolytic condensers are also to be found on this stand, and are being used more frequently in modern apparatus. On the Telegraph Condenser Company's stand (T.C.C.) similar ranges of components will be found, and the small wire-ended components designed for inclusion in the actual wiring of a receiver greatly reduce the constructional work and in many cases give increased efficiency owing to the reduction in the number of joints and the shortening of the connecting leads.

It is, of course, impossible to deal with every item and every manufacturer in an article of this nature, but the above details give some indication of the many facilities which are available to the home constructor, and it will be found that there is no lack of components for the construction of modern radio receivers, radiograms, and television equipment.

**THE WIRELESS CONSTRUCTOR'S ENCYCLOPAEDIA**

By F. J. GAMM | 4th Edition 5/- net.

Wireless Construction, Terms, and Definitions explained and illustrated in concise, clear language.

From all Booksellers, or by post 5/6 from George Neumes, Ltd., Tower House, Southampton Street, Strand, London, W.C.2.

**QUALITY COUNTS**

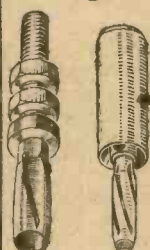

(36) (34)

35. PLUG SOCKET. A dual-purpose master plug .. 2½d.

36. COIL PIN. Power type for mains work .. 3d.

34. LONG REACH PLUGS for recessed A and E sockets. 1in. insulator 3d. 2in. insulator 4d.

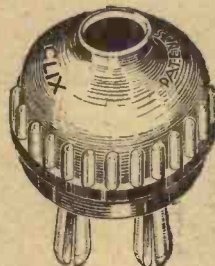

(30)

30. WALL PLUG. Type M, 5 amps. 6d.

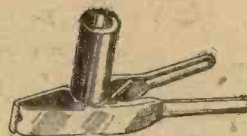

(32)

32. CROCODILE CLIP. For short-wave and service work .. 4½d.

2. HEAVY DUTY. Master Plug for A.E. work .. 3d.

33. MASTER PLUG. With special lin. insulators. Used in certain well-known sets .. 2d.



(33)



(2)

STAND 94 RADIOLYMPIA

STAND 94 RADIOLYMPIA

BRITISH MECHANICAL PRODUCTIONS LIMITED 79a ROCHESTER ROW LONDON S.W.1

**1ST AND FOREMOST NEW 120 PAGE**

**ILLUSTRATED CATALOGUE**

Every type of modern component for All-wave Sets, Television, and Scientific Servicing, is illustrated and described in this compact volume.



STAND No. 1 RADIOLYMPIA COME AND SEE THE COMPONENTS THAT ARE USED IN THE FINEST MAKES OF RADIO-RECEIVERS!

**BULGIN**

SEND FOR THIS CATALOGUE NOW

COUPON  
A. F. BULGIN & CO., LTD., ABBEY RD., BARKING, ESSEX.  
Please forward, post free, a copy of your 120 page Catalogue No. 157, for which I enclose 3d. stamps.  
Name.....  
Address.....  
[N] PLEASE USE BLOCK LETTERS

# Practical and Amateur Wireless BLUEPRINT SERVICE

PRACTICAL WIRELESS Date of Issue.	No. of Blueprint.	Three-valve: Blueprints, 1s. each.	
<b>CRYSTAL SETS</b>			
Blueprint, 6d.		Experimenter's Short-Wave Three (SG, D, Pow)	— PW30A
1037 Crystal Receiver	9.1.37	The Perfect 3 (D, 2 LF (RC and Trans))	7.8.37 PW63
<b>STRAIGHT SETS. Battery Operated.</b>			
One-valve: Blueprint, 1s.		The Bandspread S.W. Three (HF Pen, D (Pen), Pen)	29.8.36 PW68
All-wave Unipen (Pentode)	—	"Tele-Cent" S.W.3 (SG, D (SG), Pen)	30.1.37 PW74
Two-valve: Blueprints, 1s. each.		<b>PORTABLES.</b>	
Four-range Super Mag Two (D, Pen)	11.8.34	Three-valve: Blueprints, 1s. each.	
The Signet Two	29.8.36	F. J. Camm's E.L.F. Three-valve Portable (HF Pen, D, Pen)	— PW65
Three-valve: Blueprints, 1s. each.		Parvo Flyweight Midget Portable (SG, D, Pen)	19.6.37 PW77
The Long-Range Express Three (SG, D, Pen)	24.4.37	Four-valve: Blueprints, 1s.	
Selectone Battery Three (D, 2 LF (Trans))	—	Featherweight Portable Four (SG, D, LF, Cl. B)	15.5.37 PW12
Sixty Shilling Three (D, 2 LF (RC & Trans))	—	<b>MISCELLANEOUS.</b>	
Leader Three (SG, D, Pow)	22.5.37	S.W. Converter-Adapter (1 valve)	— PW48A
Summit Three (HF Pen, D, Pen)	8.8.34	<b>AMATEUR WIRELESS AND WIRELESS MAGAZINE CRYSTAL SETS.</b>	
All Pentode Three (HF Pen, D (Pen), Pen)	29.5.37	Blueprints, 6d. each.	
Hall-mark Three (SG, D, Pow)	12.6.37	Four-station Crystal Set	12.12.36 AW427
Hall-mark Cadet (D, LF, Pen (RC))	16.3.35	1934 Crystal Set	— AW444
F. J. Camm's Harris Souvenir (HF Pen, D (Pen), Pen) (All-Wave Three)	13.4.35	150-mile Crystal Set	— AW450
Genet Midget (D, 2 LF (Trans))	June '35	<b>STRAIGHT SETS. Battery Operated.</b>	
Cameo Midget Three (D, 2 LF (Trans))	8.6.35	One-valve: Blueprints, 1s. each.	
1936 Sonotone Three-Four (HF Pen, HF Pen, Westector, Pen)	17.8.35	B.B.C. Special One-valver Twenty-station Loudspeaker	— AW387
Battery All-Wave Three (D, 2 LF (RC))	—	One-valver (Class B)	— AW449
The Monitor (HF Pen, D, Pen)	—	Two-valve: Blueprint, 1s. each.	
The Tutor Three (HF Pen, D, Pen)	21.3.36	Melody Ranger Two (D, Trans)	— AW388
The Centaur Three (SG, D, P)	—	Full-volume Two (SG det., Pen)	— AW392
The Gladiator All-Wave Three (HF Pen, D (Pen), Pen)	29.8.36	B.B.C. National Two with Lucerne Coil (D, Trans)	— AW377A
F. J. Camm's Record All-Wave Three (HF Pen, D, Pen)	31.10.36	Big-power Melody Two with Lucerne Coil (SG, Trans)	— AW338A
The "Colt" All-Wave Three (D 2 LF (RC & Trans))	5.12.36	Lucerne Minor (D, Pen)	— AW426
Four-valve: Blueprints, 1s. each.		A Modern Two-valver	— WM409
Sonotone Four (SG, D, LF, P)	1.5.37	Three-valve: Blueprints, 1s. each.	
Fury Four (2 SG, D, Pen)	8.5.37	Class B Three (D, Trans, Class B)	— AW386
Beta Universal Four (SG, D, LF, Cl. B)	—	New Britain's Favourite Three (D, Trans, Class B)	15.7.33 AW394
Nucleon Class B Four (SG, D (SG), LF, Cl. B)	6.1.34	Home-built Coil Three (SG, D, Trans)	— AW404
Fury Four Super (SG, SG, D, Pen)	—	Fan and Family Three (D, Trans, Class B)	25.11.33 AW410
Battery Hall-Mark 4 (HF, Pen, D, Push-Pull)	—	£5 5s. S.G. 3 (SG, D, Trans)	2.12.33 AW412
F. J. Camm's "Limit" All-Wave Four (HF Pen, D, LF, P)	26.9.36	1934 Ether Searcher: Baseboard Model (SG, D, Pen)	— AW447
<b>Mains Operated.</b>			
Two-valve: Blueprints, 1s. each.		1934 Ether Searcher: Chassis Model (SG, D, Pen)	— AW419
A.C. Twin (D (Pen), Pen)	—	Lucerne Ranger (SG, D, Trans)	— AW422
A.C.-D.C. Two (SG, Pow)	—	Coscor Melody Maker with Lucerne Coils	— AW423
Selectone A.C. Radiogram Two (D, Pow)	—	Mullard Master Three with Lucerne Coils	— AW424
Three-valve: Blueprints, 1s. each.		£5 5s. Three: De Luxe Version (SG, D, Trans)	19.5.34 AW435
Double-Diode-Triode Three (HF Pen, DDT, Pen)	—	Lucerne Straight Three (D, RC, Trans)	— AW437
D.C. Ace (SG, D, Pen)	—	All-Britain Three (HF Pen, D, Pen)	— AW448
A.C. Three (SG, D, Pen)	—	"Wireless League" Three (HF Pen, D, Pen)	3.11.34 AW451
A.C. Leader (HF Pen, D, Pow)	7.4.34	Transportable Three (SG, D, Pen)	— WM271
D.C. Premier (HF Pen, D, Pen)	31.3.34	£6 6s. Radiogram (D, RC, Trans)	— WM318
Ubique (HF Pen, D (Pen), Pen)	28.7.34	Simple-tune Three (SG, D, Pen)	June '33 WM327
Armada Mains Three (HF Pen, D, Pen)	—	Economy-Pentode Three (SG, D, Pen)	Oct. '33 WM337
F. J. Camm's A.C. All-Wave Silver Souvenir Three (HF Pen, D, Pen)	11.5.35	"W.M." 1934 Standard Three (SG, D, Pen)	— WM351
"All-Wave" A.C. Three (D, 2 LF (RC))	17.8.35	£3 3s. Three (SG, D, Trans)	Mar. '34 WM354
A.C. 1936 Sonotone (HF Pen, H.F. Pen, Westector, Pen)	—	Iron-core Band-pass Three (SG, D, QP21)	— WM302
Mains Record All-Wave 3 (HF Pen, D, Pen)	5.12.34	1935 £6 6s. Battery Three (SG, D, Pen)	— WM371
Four-valve: Blueprints, 1s. each.		PTP Three (Pen, D, Pen)	June '35 WM389
A.C. Fury Four (SG, SG, D, Pen)	—	Certainty Three (SG, D, Pen)	— WM393
A.C. Fury Four Super (SG, SG, D, Pen)	—	Minitube Three (SG, D, Trans)	Oct. '35 WM396
A.C. Hall-Mark (HF Pen, D, Push-Pull)	24.7.37	All-wave Winning Three (SG, D, Pen)	— Dec. '35 WM400
Universal Hall-Mark (HF Pen, D, Push-Pull)	9.2.35	Four-valve: Blueprints, 1s. 6d. each.	
<b>SUPERHETS.</b>			
Battery Sets: Blueprints, 1s. each.		65s. Four (SG, D, RC, Trans)	— AW370
£5 Superhet (Three-valve)	5.6.37	"A.W." Ideal Four (2 SG, D, Pen)	16.9.33 AW402
F. J. Camm's 2-valve Superhet	13.7.35	2HF Four (2SG, D, Pen)	— AW421
F. J. Camm's £4 Superhet	—	Crusaders' A.V.C.4 (2 HF, D, QP21) (Pentode and Class B Outputs for above: Blueprints, 6d. each)	18.8.34 AW445
F. J. Camm's "Vitesse" All-Waver (5-valver)	27.2.37	Self-contained Four (SG, D, LF, Class B)	25.8.34 AW445A
Mains Sets: Blueprints, 1s. each.		Lucerne Straight Four (SG, D, LF, Trans)	Aug. '33 WM331
A.C. £5 Superhet (Three-valve)	—	£5 5s. Battery Four (HF, D, 2LF)	Feb. '35 WM350
D.C. £5 Superhet (Three-valve)	1.12.34	The H.K. Four (SG, SG, D, Pen)	Mar. '35 WM384
Universal £5 Superhet (Three-valve)	—	The Auto Straight Four (HF Pen, HF Pen, DDT, Pen)	— April '36 WM404
F. J. Camm's A.C. £4 Superhet 4	31.7.37	Five-valve: Blueprints, 1s. 6d. each.	
F. J. Camm's Universal £4 Superhet 4	16.1.37	Super-quality Five (2HF, D, RC, Trans)	May '33 WM320
<b>SHORT-WAVE SETS.</b>			
Two-valve: Blueprint, 1s.		Class B Quadradyne (2 SG, D, LF, Class B)	— Dec. '33 WM344
Midget Short-wave Two (D, Pen)	—	New Class-B Five (2 SG, D, LF, Class B)	— Nov. '33 WM340

These blueprints are drawn full size. Copies of appropriate issues containing descriptions of these sets can in some cases be supplied at the following prices, which are additional to the cost of the blueprint. A dash before the Blueprint Number indicates that the issue is out of print.

Issues of Practical Wireless .. 4d. Post paid.  
Amateur Wireless .. 4d. " "  
Practical Mechanics .. 7d. " "  
Wireless Magazine .. 1/3 " "

The index letters which precede the Blueprint Number indicate the periodical in which the description appears: thus PW refers to PRACTICAL WIRELESS, AW to Amateur Wireless, PM to Practical Mechanics, WM to Wireless Magazine.

Send (preferably) a postal order to cover the cost of the blueprint and the issue (stamps over 6d. unacceptable), to PRACTICAL AND AMATEUR WIRELESS Blueprint Dept., Geo. Newnes, Ltd., Tower House, Southampton Street, Strand, W.C.2.

Three-valve: Blueprints, 1s. each.		Home-Lover's New All-electric Three (SG, D, Trans) A.C.	— AW383
S.G. Three (SG, D, Pen) A.C.	—	A.C. Triodyne (SG, D, Pen) A.C.	19.8.33 AW399
A.C. Pentaquester (HF Pen, D, Pen) A.C.	23.6.34	Mantovani A.C. Three (HF Pen, D, Pen) A.C.	— WM374
£15 15s. 1936 A.C. Radiogram (HF, D, Pen)	—	Jan. '36	WM401
Four-valve: Blueprints, 1s. 6d. each.		All-Metal Four (2 SG, D, Pen)	July '33 WM326
Harris Jubilee Radiogram (HF Pen, D, LF, P)	—	May '35	WM386
<b>SUPERHETS.</b>			
Battery Sets: Blueprints, 1s. 6d. each.		Modern Super Senior	— WM375
Varsity Four	—	Oct. '35	WM395
The Request All-Waver	—	June '36	WM407
1935 Super Five Battery (Superhet)	—	—	WM379
Mains Sets: Blueprints, 1s. 6d. each.		1934 A.C. Century Super A.C.	— AW425
Heptode Super Three A.C.	—	May '34	WM359
"W.M." Radiogram Super A.C.	—	—	WM366
1935 A.C. Stenode	—	Apr. '35	WM385

<b>PORTABLES.</b>			
Four-valve: Blueprints, 1s. 6d. each.		Midget Class B Portable (SG, D, LF, Class B)	20.5.33 AW380
Holiday Portable (SG, D, LF, Class B)	—	1.7.33	AW393
Family Portable (HF, D, RC, Trans)	—	22.9.34	AW447
Two H.F. Portable (2 SG, D, QP21)	—	June '34	WM363
Tyers Portable (SG, D, 2 Trans)	—	—	WM367
<b>SHORT-WAVE SETS—Battery Operated.</b>			
One-valve: Blueprints, 1s. each.		S.W. One-valver converter (Price 6d.)	— AW329
S.W. One-valver for America	23.1.37	—	AW429
Rome Short-Waver	—	—	AW452
Two-valve: Blueprints, 1s. each.		Ultra-short Battery Two (SG det., Pen)	Feb. '36 WM402
Home-made Coil Two (D, Pen)	—	—	AW440
Three-valve: Blueprints, 1s. each.		World-ranger Short-wave 3 (D, RC, Trans)	— AW355
Experimenter's 5-metre Set (D, Trans, Super-regen)	30.6.34	—	AW438
Experimenter's Short-wave (SG, D, Pen)	—	Jan. 19, '35	AW463
The Carrier Short-waver (SG, D, P)	—	July '35	WM390
Four-valve: Blueprints, 1s. 6d. each.		A.W. Short-Wave World-Beater (HF Pen D, RC, Trans)	— AW436
Empire Short-Waver (SG, D, RC, Trans)	—	—	WM313
Standard Four-valver Short-waver (SG, D, LF, P)	—	Mar. '35	WM383
Superhet: Blueprint, 1s. 6d.		Simplified Short-waver Super	Nov. '35 WM397
<b>Mains Operated.</b>			
Two-valve: Blueprints, 1s. each.		Two-valve Mains short-waver (D, Pen) A.C.	— AW453
"W.M." Band-spread Short-waver (D, Pen) A.C.-D.C.	—	—	WM368
"W.M." Long-wave Converter	—	—	WM380
Three-valve: Blueprint, 1s.		Emigrator (SG, D, Pen) A.C.	— WM352
Four-valve: Blueprint, 1s. 6d.		Standard Four-valve A.C. Short-waver (SG, D, RC, Trans)	— Aug. '35 WM391
<b>MISCELLANEOUS.</b>			
Enthusiast's Power Amplifier (1/6)	—	June '35	WM387
Listeners' 5-watt A.C. Amplifier	—	—	WM392
Radio Unit (2r) for WM392	—	Nov. '35	WM398
Harris Electrogram (battery amplifier) (1/-)	—	Dec. '35	WM399
De-Luxe Concert A.C. Electrogram	—	Mar. '36	WM403
New Style Short-Wave Adapter (1/-)	—	June '35	WM383
Trickle Charger (6d.)	—	Jan. 5, '35	AW462
Short-Wave Adapter (1/-)	—	Dec. 1, '34	AW456
Superhet Converter (1/-)	—	Dec. 1, '34	AW457
B.L.D.L.C. Short-wave Converter (1/-)	—	May '36	WM405
Wilson Tone Master (1/-)	—	June '36	WM406
The W.M. A.C. Short-Wave Converter (1/-)	—	—	WM403



# QUERIES and ENQUIRIES

## A Permanent Detector

"Can you please tell me which type of crystal I should require to make a permanent crystal receiver, and where I could obtain same?"—R. M. (Kidderminster).

THERE is no crystal combination which may be regarded definitely as permanent, but there are certain crystals which will retain their sensitivity over a long period when placed together or used in conjunction with a metal. For instance, carborundum, with a plate of steel pressing on it, and with a small applied potential, will not require adjustment over a very long period. On the other hand, zincite in conjunction with tellurium gives in many cases a louder signal and the readjustment simply consists in moving one crystal slightly. This combination is obtainable ready assembled in a dust-proof cartridge under several different trade names, and we recommended an article known as the Red Diamond for our 1937 Crystal receiver. It may be obtained from the Jewel Pen Company of 21, Gt. Sutton Street, E.C.1, price 2s. 6d.

## Flat-tuned Coils

"I am preparing to make a television receiver from details recently given in your pages, but am at a loss regarding one point. I know that I require a flatly-tuned I.F. stage, but am not certain how to get the selectivity and other features. The superhet will ensure the selectivity, no doubt, but how do I arrange for the flatly-tuned I.F. transformers? I would rather buy these, but they do not appear to be on the market."—H. T. F. (Dalston).

COILS for your purpose are now on the market and are supplied by two or three firms. The method generally adopted for obtaining the flatness of tuning, or broad peak required, is to wind the transformer or coil with resistance wire, or to connect a resistance across a component wound with ordinary wire. We cannot give you constructional details, as you have not supplied a circuit and give no indication of the lines upon which you have decided to work.

## The Output Stage

"I am proposing to build a power amplifier for use with our band, and should like some hints on design. Is it desirable to use push-pull in order to obtain the high volume and quality, or do you recommend a single power valve of the high-voltage type, say one taking 500 volts and giving 10 watts output? What are the advantages of these two systems?"—G. E. (Rhyl).

SOME designers prefer the push-pull stage on account of the freedom from hum and the absence of second harmonic distortion, whilst others prefer the single valve owing to the quality which that delivers. It is really a matter of personal choice, as the various forms of distortion are not all discernible by every listener in the same degree. Furthermore, there is the question of cost. Smoothing circuits may certainly be less ambitious in a push-pull circuit, but there are two valves to obtain, and in the event of an accident there may be two valves to replace. Against this, the single high-voltage type of valve may cost almost as much, but will take up less space on the chassis and is not so critical regarding the selection of associated components.

### RULES

We wish to draw the reader's attention to the fact that the Queries Service is intended only for the solution of problems or difficulties arising from the construction of receivers described in our pages, from articles appearing in our pages, or on general wireless matters. We regret that we cannot, for obvious reasons—

- (1) Supply circuit diagrams of complete multi-valve receivers.
- (2) Suggest alterations or modifications of receivers described in our contemporaries.
- (3) Suggest alterations or modifications to commercial receivers.
- (4) Answer queries over the telephone.
- (5) Grant interviews to querists.

A stamped addressed envelope must be enclosed for the reply. All sketches and drawings which are sent to us should bear the name and address of the sender. Requests for Blueprints must not be enclosed with queries as they are dealt with by a separate department.

Send your queries to the Editor, PRACTICAL AND AMATEUR WIRELESS, George Newnes, Ltd., Tower House, Southampton Street, Strand, London, W.C.2. The Coupon must be enclosed with every query.

## Cabinet Resonance

"I recently built a mains four-valver with a pentode output stage. I was fairly satisfied with the reproduction when used with a W.B. speaker standing on the table, but there was not much bass. A friend who helped me in the building said that was due to the fact that no baffle was being used. I therefore made a table model cabinet and allowed ample baffle area, but now find that it is too boomy. Is there any way I can cure this without making another cabinet?"—F. W. (Aldenharn).

IT is hardly likely that the boomy reproduction is due to wrong component values, as this would have been distinguishable when coupled to the speaker in the first place. It is, therefore, safe to assume that the trouble arises from the cabinet design and layout of the chassis. Two facts must be considered. Firstly, the speaker may be so arranged that the sound

waves at maximum volume are sufficient to make the glass envelope of the detector valve vibrate, and this will give rise to the booming sound which is fed to the speaker and back to the valve. To test if this is your trouble, grip the glass bulb firmly with your hand and note if the boom stops. If not, then the trouble is due to the cabinet design. The back should be as open as possible, preferably enclosed only by thin fabric to keep out dust. The depth from front to back should be made as small as possible, and you may find that in your case you will be able to cut quite a large amount of wood away to obtain this end. Finally, mount the speaker about 1in. behind the front, inserting thick rubber washers between the front of the cabinet and the speaker chassis.

## All-wave Tuner Conversion

"I have a well-known dual-range tuner combined with condenser on a base-plate. I am anxious to get the short waves and although I have used a short-wave converter I should prefer to use the single set for all purposes. Would it be feasible to add standard short-wave tuning coils to the present dual-range coils with some form of switch to cut out the latter so that I could use all-wave tuning? Also, could I get a station-named dial to go with the combination?"—G. F. (Exeter).

IT should be possible to add good short-wave coils in the manner outlined but the switching may present some difficulty. It might prove preferable to disconnect the dual-range coils and to replace them by modern three-range coils which are supplied with a self-contained wavechange switch. Modern dials may be obtained engraved with station names, but they are only of use when used with a condenser designed on modern lines and used with coils having an inductance of 157 u/H on medium waves and 2,200 u/H on the long waves.

## Radio-gram. Switching

"I am going to fit a change-over switch to go from radio to gram. I believe it is possible to make this gradual or to fade out and should like to know the simplest way to do this. I do not want to buy a lot of components and alter the set too much. Perhaps you can suggest a simple way of doing the job."—J. O. (Carlisle).

A SPECIAL control may be obtained for the purpose mentioned by you. This is known as a fader, and in the Dubilier range it is called a Fadover. Three connections are made to one side and a single connection to the other, corresponding with a centre-tap on the resistance element. The centre terminal on the other side is joined to the grid of the L.F. valve (which may be the detector in some circuits) and the other two contacts are joined to pick-up and radio, with the centre (single) contact to G.B. or earth. Thus, it is possible to fade out either radio or gramophone and build up the other reproduction.

The coupon on page iii of cover must be attached to every query.

THE ONE AERIAL FOR THE MODERN SET

**PIX INVISIBLE AERIAL**

Neat  
Efficient  
Blends with furnishings  
Self-Adhesive



2/-

Double Length 3/6

STAND 211 OLYMPIA.

PIX, LONDON, S.E.1.

**Miscellaneous Advertisements**

Advertisements are accepted for these columns at the rate of 3d. per word. Words in black face and/or capitals are charged double this rate (minimum charge 3/- per paragraph). Display lines are charged at 6/- per line. All advertisements must be prepaid. All communications should be addressed to the Advertisement Manager, "Practical and Amateur Wireless," Tower House, Southampton Street, Strand, London, W.C.2.

**RECEIVERS, COMPONENTS AND ACCESSORIES**

Surplus, Clearance or Secondhand, etc.

**RADIOMART SHORT-WAVE MANUAL**

Packed with short-wave information and circuits of mains and battery receivers, including straight, superhet and 5-metre transmitters, modulators, etc. Information on transmitting licences, aerials, Class B amplifications, neutralizations, superhet alignment, etc. The most comprehensive manual published, written by practical engineers, price 6d., post free, 7d. including catalogue.

1937 Short-wave Catalogue only (3 times enlarged) price 1d., post free.

**44, HOLLOWAY HEAD, BIRMINGHAM 1**

**CONVERSION UNITS** for operating D.C. Receivers from A.C. Mains, improved type, 120 watts output at £2/10/0. Send for our comprehensive list of speakers, resistances and other components.

WARD, 46, Farringdon Street, London, E.C.4. Telephone: Holborn 9703.

**REPAIRS to Moving Coil Speakers, Cones and Coils** fitted or rewound. Fields altered. Prices quoted including Eliminators, Loudspeakers, Repaired, 4/-. L.F. and Speech Transformers, 4/- post free. Trade invited. Guaranteed. Satisfaction. Prompt Service. Estimates Free. L.S. Repair Service, 5, Balham Grove, London, S.W.12. Battersea 1321.

**THE largest stock of components in England, over 500 lines, new catalogue now ready 1½d.—J. Bearfield, 105, Upper Street, London, N.1.**

**ALL goods previously advertised are standard lines, still available. Post card for list free. VAUXHALL UTILITIES, 103a, Strand, W.C.2, Over Denny's the Booksellers, Temple Bar 9338.**

**BANKRUPT Bargains. List free. All new goods. Continual advertiser since 1920. Write for all radio requirements. Following are some of my bargains. Plessey 5v A.C./D.C. chassis, Mullards, M.C. speakers, latest models 90s. Ditto battery models 5v superhet 47. Decca 1937 6v A.C. superhets 46. Ditto all-wave 47. American 4v consolette A.C./D.C. 70s. Truphonic 1937 5v A.C./D.C. superhet 56. Ditto all-wave 47. Latest Ferguson and Truphonic 1938 all-wave superhets in stock. 1937 16½gn. Ferguson all-wave 11 valve complete 10gn. 1937 14gn. A.C./D.C. Pilot complete 110. Halcyon short-wave converters A.C. with valve 20s. Ormond 5v A.C. superhet, list 11gn., for 25 5s. Large stock components, replacement valves, speakers, etc. Whatever you require write—Butlin, 6, Stanford Avenue, Brighton.**

**RADIO** turned Radiogram; Electric motor, 26s.; Pick-up, 9s.; Pick-up-Head, 4s. 3d.; 5,000 sprung motors, 4s. 6d., dozen, 30s.; Pedestal radio Anaxgram, 25. Ditto table, 68s.; Gramophones from 12s.; Cabinets, Horns, tonearms, soundboxes, needles, springs, gears, accessories, cabinet fittings, violins, cheapest. Established 1903. Trade supplied. Catalogue free.—Regentam, 120, Old Street, London, E.C.1.

**LOUDSPEAKER REPAIRS**

**LOUDSPEAKER** repairs, British, American, any make, 24-hour service; moderate prices.—Sinclair Speakers, Alma Grove, Copenhagen Street, London, N.1.

**RADIO BARGAINS**

**ALCO ELIMINATORS AND CHARGERS.** Standard outputs, 18/-. With charger, 25/-. Charger, 7/6. Year's guarantee. Details free.—P. and D. Radio, 1, Gooding Road, N.7.

**VALVES**

**THE Simplest Equation. Price+Quality=Radio-graphic Ltd. Satisfaction guaranteed. American valves, 3/-. Lineords 350 OHMS. Midget Speakers, Electrolytic Condensers, Resistors, Volume Controls, etc.—Radio-graphic, Ltd., 66, Osborne Street, Glasgow, C.1.**

**PREMIER SUPPLY STORES**

All goods guaranteed perfect; carr. paid over 5/-; under 5/- postage 6d. extra.

**ALL POST ORDERS TO JUBILEE WORKS, 167, LOWER CLAPTON RD., LONDON, E.5. Phone: Amherst 4723.**

**CALLERS, AS USUAL, TO 165 & 165a, FLEET ST., E.C.4 (Next door to Anderson's Hotel), Central 2833. New Branch: 50, HIGH ST., CLAPHAM, S.W.4 (Macaulay 2381).**

**Have you had our GIANT ILLUSTRATED CATALOGUE AND VALVE LIST? Send 4d. IN STAMPS FOR THIS BARGAIN LIST.**

**NEW 1937 1-VALVE SHORT-WAVE RECEIVER OR ADAPTOR KIT, 13 to 80 metres without coil changing. Complete Kit and Circuit, 12/6. VALVE GIVEN FREE! DE LUXE MODEL 14 to 150 Metres, complete Kit with Chassis, 4 Coils and all parts, 17/6.**

**SUPERHET CONVERTER KIT, 12/6. De Luxe Model, 12/6. S.W. SUPERHET CONVERTER KIT, for A.C. Mains Receivers, 20/-. A.C. Valve given FREE!**

**NEW 1937 2-VALVE S.W. KIT, 13 to 80 Metres without coil changing. Complete Kit and Circuit, 19/6. VALVES GIVEN FREE. DE LUXE MODEL, 14 to 150 metres, complete Kit and Chassis, 4 Coils and all parts, 25/-. VALVES GIVEN FREE. 3-VALVE S.W. KIT. S.G. Det. and Pen., 42/-. VALVES GIVEN FREE.**

**SHORT-WAVE COILS. 4- and 6-pin types, 13-26, 22-47, 41-94, 78-170 metres, 1/8 each, with circuit. Special set of 3 S.W. Coils, 14-150 metres, 4/- set, with circuit. Premier 3-band, 8-W. Coil, 11-25, 19-43, 38-86 metres. Simplifies S.W. receiver construction, suitable any type circuit, 2/6.**

**COIL FORMERS** in finest plastic material, 1½in. low-loss ribbed, 4- or 6-pin, 1/- each.

**The New "Premier" Short Wave CONDENSERS, with Troilut insulation. Certified superior to Ceramic. All-brass Construction, 40 mmfd., 17; 100 mmfd., 1/0; 160 mmfd., 2/6; 250 mmfd., 2/6; Double Spaced 15 mmfd., 2/9; 40 mmfd., 3/8. S.W. H.P. Chokes, 9d.; screened, 1/6. All-Brass 8-W. Condensers with integral slow-motion. 00015 Tuning, 3/9; .00015 Reaction, 3/3.**

**Famous EUROPA MAINS VALVES, 4 v. A.C. and 20 v. 1½ Universal. All standard types, 3/6. 1.H. Pentodes and P.V. Rectifiers, 5/6.**

**BATTERY VALVES, 2 volts, H.F., L.F., 2/3. Power Super-Power, 2/9. S.G. Var-Mu-3.G., 4- or 6-pin Pentodes, H.P. Pens., V-mu-H.P. Pens., 5/-. Class B, 5/-.**

**AMERICAN VALVES. Genuine American HYTRON and TRIAD, first-grade Valves, 3 months guarantee. All types in stock, 5/6 each. 216 and 230, 8/6 each. New Metal-Base Valves all types, 6/6 each. Genuine American DUGTRON Valves, all types, 3/6 each. Valve holders for all above types, 6d. each. OCTOL bases, 9d. each.**

**3-WATT A.C. AMPLIFIER, 2-stage for mike or pick-up. Complete kit of parts with 3 valves, 40/-. Wired and Tested, £2/15/0.**

**7-WATT A.C./D.C. AMPLIFIER, 3-stage high-gain, push-pull output. Complete kit of parts with 5 specially matched valves, 24 4s. Completely Wired and Tested, 25/5/0.**

**COSMOCORD PICK-UPS, with tonearm and volume control, 10 6 each. PICK-UP HEADS, 4/6 each.**

**PREMIER MAINS TRANSFORMERS, wired-end type with screened primaries, 7 tapped 200-250 v. Centre-tapped Filaments. Guaranteed one year. H.T. 8 & 9 or H.T.10 with 4 v. 4a. C.T. and 4 v. 1a. C.T. 8, 8, 250-250 v. 60 m.a., 4 v. 1a., 4 v. 2a., and 4 v. 4a., all C.T., 8/6. 350-350 v. 120 m.a., 4 v. 1a., 4 v. 2a., and 4 v. 4a., all C.T., 11/-. Any of these transformers with engraved panel and N.P. terminals 1/6 extra. 300-500 v. 150 m.a., 4 v. 2-3 a., 4 v. 2-5 a., 4 v. 2-5 a., 4 v. 3-4 a., all C.T., 17/6. **SPECIAL OFFER PHILIPS MAINS TRANSFORMERS, 250-250 v. or 300-300 v. at 80 m.a., 4 v. 5 a., C.T.; 4a. 1 a. Tapped Primary 100-250 volt., 6/11. 450-450 v. at 150 m.a., or 500-500 v. 100 m.a., 4 v. 4a. C.T. 4 v. 4a. and 4 v. 3a. Screened Primary. Tapped input 100-250 v., 12/6. **AUTO TRANSFORMERS, step up or down, 60 watts, 7/6; 100 watts, 10/-. SMOOTHING CHOKES 25 m.a., 2/9; 40 m.a., 4/-. 60 m.a., 5/6. 150 m.a., 10/6. Speaker Replacement Chokes, 2,500 ohms, 60 m.a., 5/6.******

**SPECIAL OFFER LISSEN TWO-GANG SCREENED ALL-WAVE COILS, 12 to 2,000 metres, complete with switching and wiring diagrams, 6/11 per set.**

**MAGNAVOX MOVING COILS. Mains energised, "154," 7in. cone, 2,500 ohms, 4 watts, 12/6; "152," 9in. cone, 3,500 ohms, 17/6; "152 Magna," 9in. cone, 2,500 ohms, 6 watts, 37/6; Magnavox P.M.'s—"234," 7in. cone, 18 6; "292," 9in. cone, 22/6.**

**ROLA latest type P.M.'s 15/-, GOODMAN'S 8in. mains energised, 1,000 ohms field, 10/8 each.**

**R. and A. energised Speaker, 7½in. diameter, 2,500 ohm field. Pentode Transformer, strongly recommended, 11/6.**

**Special Offer BTH Energised Moving Coils 10½in. diam. 1,650 ohms field Power or Pentode transformer (state which), 14/8.**

**OUTPUT TRANSFORMERS for Power or Pentode, 2/6; Multi-Ratio, 4/6.**

All Goods previously advertised, still available.

**RADIO CLEARANCE**

**63, HIGH HOLBORN, W.C.1. Holborn 4631.** We thank all our past customers for their support during the last season. Once again we are offering Brand New and Surplus goods at very keen prices. We are the sole agents for the American Constructrad Co., of New York, and this season we are offering Short Wave Kits, complete with valves, at prices that defy competition. These Kits cover a wavelength from 15-600 metres by means of 6 Interchangeable, Plug-in Coils. The Kits are easily assembled and are sent out sealed as from the makers. They incorporate a stamped metal chassis, metal panel, and all necessary parts to make up a successful Short Wave Receiver. 15/11d. 1 Valve Battery Kit, complete with Valve. 22/11d. 2 Valve Battery Kit, complete with Valves. 37/6d. 3 Valve Battery Kit, complete with Valves. 22/11d. 1 Valve AC/DC Kit, complete with Valve. 42/6d. 3 Valve Battery Kit, complete with Valves. 42/6d. 3 Valve A.C. Kit, complete with Valves. Orders for the above Kits must be accompanied by 1/- as part payment for postage.

**LIMITED QUANTITY. ALBA UNIVERSAL ALL-WAVE AC/DC RECEIVER.** Originally listed at 17 gn. This Receiver represents the best in modern Superhet design. Wavebands covered, Short Wave 10-49 metres, Medium 200 to 550 metres, Long Waves 800 to 2,000 metres. 2 Speed Drive is incorporated, First-Class Visual Tuning, fitted one side of the Main Tuning Dial, the other side of the dial is balanced by an illuminated Window showing the various positions of the switch, i.e., Short Wave, Medium Wave, Long Wave and 'grau, Combined Volume Control and Mains On/Off Switch, Provision for Extension Loud-speaker and, of course, Pick-up which as explained above is switched. Mains Aerial etc. Valve combination as follows: URIC, C1, Pen 30C, 2 D13C, V130C, V131C, FC13C. Here is your chance to buy a first-class All-Wave, All Mains Receiver at a reasonable price. To clear, £7 12s. 6d. Carr. Paid. **FEW ONLY, BUSH A.C.23, 4-Valve A.C. Mains Band Pass Receiver, fitted in a Handsome Cabinet finished Dark Walnut. This little Receiver is selective and provides plenty of volume from many stations. Our price to clear 4 gn., Carriage Paid.**

**BRUCE MAINS TRANSFORMERS AND CHOKES, standard for the season. These Transformers are British made and are fully guaranteed for 6 months. A comprehensive range of all types are carried in stock. 250-0-250, 80 m.a., 2-0-2 volts, 2.5 amp, 2-0-2 volts, 4 amp, 8/6. 350-0-350, 120 m.a., 2-0-2 volts, 2.5 amp., 2-0-2 volts, 4 amp, 10/6. 350-0-350, 150 m.a., 2-0-2 volts, 2.5 amp., 2-0-2 volts, 4 amp. 2-0-2 volts, 2 amp., 11/6. 500-0-500, 150 m.a., 2-0-2 volts, 2.5 amp., 2-0-2 volts, 6 amp. 2-0-2 volts, 2 amp., 2-0-2 volts, 2 amp, 15/6. **H.T.3 TRANSFORMER, 250 volts, 60 m.a., 2-0-2 volts, 4 amp, 8/6.****

**BRUCE MAINS CHOKES, 40 m.a., 30 Hys, 500 Ohms, 3/6. 60 m.a. 40 Hys, 500 Ohms, 5/-. 60 m.a., 80 Hys, 2,500 Ohms. for Speaker replacement, etc., 5/3.**

**4 and 5-pin Chassis mounting Valveholders, first-class make, 3d. each. 7-pin ditto 6d. each. 4 and 5-pin Chassis or Baseboard mounting type Valveholders, 3d. each. 7-pin Ditto, 3d. each. Large quantity of POLAR 1 TUBULAR CONDENSERS, 3/- a Dozen. 0003 Mica Dielectric Reaction Condensers, 9d. each. (Coscor.) **Wearite All-Wave Chokes, 12-2,000 metres, Iron Coiled, listed 6/6, 1/- each.****

**Lissen 1-1 Driver Transformers, 1/- each. Lissen 126 K/C, I.F. Transformers, fully screened, 1/3 each.**

**LIMITED QUANTITY OF CENTRALAB VOLUME CONTROLS, in the following sizes: (Medium size spindle) 500,000; 1 meg; and 100,000, 9d. each. Twin Centralab Pots, 5,000 and 100,000, 1/6 each. Lissen R.C.C. Units, boxed, Brand New, 6d. each. Lissen H.F. By-pass Units, Brand New, Boxed, 6d. each. Universal Chassis fitted with 2 coils (Aerial and H.F.), 2 7-pin Valveholders and 2 5-pin Valveholders, H.F. Choke, Aerial and Earth Strip, Mains Aerial Strip, 3/6 each.**

**Handy Size, Metal Chassis, Drilled for Valveholders, etc., 8d. each. Special clearance of Bryce Transformers, ex. large manufacturer's order. 300-0-300, 180 m.a., 4 volt, 4 amp, C/T, 4 volt 2 amp, Mains Input 200-250, Adjustable, 6/- each.**

**PLESSEY 2,500 Ohms Field, Energised Speaker, fitted Pentode Transformer, 7½" Cone, splendid job, 4/6 each. Rola P.M. Moving Coil Speaker, latest type, Circular Magnet, 10" Cone, fitted Power or Pentode Transformer, 21/-.**

**W.B. Manufacturer's type, P.M. Moving Coil Speaker, 7½" Cone, Pentode Transformer, 11/6.**

**Limited Quantity of American Valves. Types available, 12Z3, 6B7, 6F7. To Clear, 1/- each. Enquiries 1½d. stamp if reply expected. Hours of business, 9 a.m. to 7 p.m., Saturdays, 9 a.m. to 1 p.m.**

**All orders 5/- or over, Post Free, orders under 5s. must be accompanied by a reasonable amount for postage. C.O.D. orders under 5s. cannot be accepted. Orders from Ireland and Special parts of Scotland are subject to certain increased postage rates and customers are advised to apply for details of postage before ordering.**

**RADIO CLEARANCE, 63, HIGH HOLBORN, W.C.1. HOLBORN 4631.**

## STANDARD WIRELESS BOOKS

### THE OUTLINE OF WIRELESS

By RALPH STRANGER 8/6 net (9/-)

A book which covers the theory and practice of Reception from A to Z.

### WIRELESS CONSTRUCTOR'S ENCYCLOPEDIA

By F. J. CAMM 5/- net (5/3)

The whole field of wireless construction is covered, in description and diagram, in this book.

### THE MATHEMATICS OF WIRELESS

By RALPH STRANGER 5/- net (5/5)

A simple introduction to arithmetic, algebra, geometry, trigonometry and calculus as they affect wireless calculations. 256 pages. Fully Illustrated.

### NEWNES TELEVISION AND SHORT-WAVE HANDBOOK

By F. J. CAMM 3/6 net (4/-)

The first really complete and authoritative work on this subject.

### EVERYMAN'S WIRELESS BOOK

By F. J. CAMM 3/6 net (4/-)

### THE ELEMENTS OF WIRELESS

By RALPH STRANGER 3/6 net (3/11)

The whole working of wireless receivers made clear to all.

### FIFTY TESTED WIRELESS CIRCUITS

By F. J. CAMM 2/6 net (2/10)

### DICTIONARY OF WIRELESS TERMS

By RALPH STRANGER 2/6 net (2/10)

A valuable synopsis of technical terms that everybody can understand.

Obtainable from all booksellers or send a P.O. for the amount indicated in brackets after each price and the book will be delivered to you post free . . . write to Wireless Book Department, George Newnes, Ltd., Tower House, Southampton Street, Strand, London, W.C.2.

**GEORGE NEWNES, LTD.**



**MCCARTHY**

### OUTSTANDING 9-VALVE FOUR-WAVE SUPERHET

For all-wave reception at its very best

To the all-wave enthusiast, this exceptional receiver offers a number of interesting features, with quite unusual range, and power output. Few receivers at present on the market can claim so high a standard of design and performance.

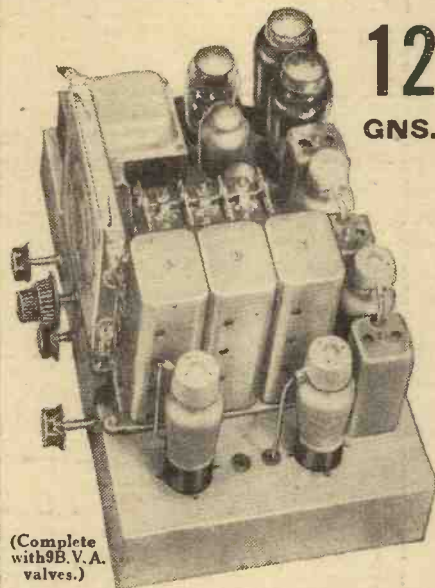

**12 GNS.**

(Complete with 9B.V.A. valves.)

4 wavebands : 12.8-33, 29-80, 190-550, 800-2000 metres. Illuminated dial with principal station names.

**Circuit in Brief.**—Aerial input to pre-selector circuit, radio frequency amplifier, latest type triode-hexode frequency changer, 2 band-pass I.F.T. coupled I.F. amplifiers, double diode detector, L.F. amplifier, parafeed transformer-coupled push-pull triode output giving 6 watts.

Heavy cadmium-plated steel chassis. Finest components and workmanship throughout.

#### DE LUXE MODEL 14 GNS.

Many additional refinements—full particulars on application.

**Controls.**—A feature of the receiver is the number of independent controls fitted, making it extremely interesting to operate. These include : sensitivity control (varying bias on R/F stage). Q.A.V.C. with manual tuning control and switch for inter-station noise suppression. 5-position wave-change and gramophone switch. Progressive variable tone control operative on radio and gram.

A.C. models ready for immediate delivery. A.C./D.C. models also in production, and will be available for delivery shortly.

#### DEFERRED TERMS

on application or through our City Agents  
**LONDON RADIO SUPPLY CO.,**  
11, Oat Lane, E.C.2.  
Demonstrations daily.

All McCarthy receivers supplied complete with valves, knobs, pilot lamps, leads, mains cables and plug. 12 months' guarantee.

The prices at which McCarthy Receivers are advertised include Marconi Royalties.

Cash with order on 7 days' approval. Also write for illustrated catalogue of complete range of all McCarthy receivers.

**MCCARTHY RADIO LTD.**  
44a, Westbourne Grove, London, W.2

Telephone : Bayswater 3201/2.

### VALVES

**BUY VALVES DIRECT.**—Save 50% ; 2-volt, H2, L2, 2s. 3d. ; power, 3s. ; screen-grids, 4s. 6d. ; H. F. and L. F. Pentodes, 5s. 6d. ; A. C. Mains, 4-volt, general purpose, 4s. 6d. ; power triode, 6s. 6d. ; screen-grids, H. F. and L. F. pentodes, 6s. 6d. ; full-wave rectifiers, 4s. 6d. ; postage 3d. one valve, 4d. two, 6d. three and over.—Luminous Electric Appliances, Ltd. (Dept. 8), Phoenix Works, Tyburn Rd., Erdington, Birmingham.

### MISCELLANEOUS

**REVOLUTIONARY** principles and circuits, revolutionising existing ideas and apparatus.—Book 1s. 1d.—D'Arcy Ford, Gandy Street, Exeter.

### IDENTIFICATION



of amateur wireless transmitters can be found in the **RADIO AMATEUR CALLBOOK**. This book is essential to owners of short-wave, or all-wave sets. Contains complete lists of amateur transmitters with names and addresses) from Alaska to Zanzibar, also short-wave commercial stations, lists of International Abbreviations (the "Q" code), International Prefixes, etc. Price 6/- per copy, post free. Send for lists of other books dealing with amateur transmitting.

G5KA (Dept. PW), 41, Kinfauns Rd., Goodmayes, Ilford, Essex.

### M.P.R. 3-WATT BATTERY PUSH-PULL AMPLIFIER

For Cets, Danes, Socials, etc.—Amazing volume, with excellent quality. Supplied complete with 3 British Valves, and Volume Control, ready for connecting to pick-up, etc.

Complete Amplifier (less batteries), price 45/-, or 31 deposits and 3 payments of 10/- Matched MO Speaker, 20/- extra.

Send for full details, also A.C. 7-watt model, 105/- Car Portable model, 120/- Phone : Romford 838. M.P.R. ELECTRICAL CO., 252, Victoria Road, Romford, Essex.

### FREE ADVICE BUREAU COUPON

This coupon is available until September 4th, 1937, and must be attached to all letters containing queries.

PRACTICAL AND AMATEUR WIRELESS,  
28/8/37.

### ADVERTISEMENT INDEX

	Page
Automatic Coil Winder and Electrical Equipment Co., Ltd.	572
Belling and Lee, Ltd.	602
British Institute of Engineering Technology	Back Cover
British Mechanical Productions, Ltd.	605
British Television Supplies, Ltd.	598
Bulgin, A. F., and Co., Ltd.	605
Champion Valve Co.	604
Cosser, A. C., Ltd.	567
Dubilier Condenser Co. (1925), Ltd.	568
Electradix Radios	558 and 602
Ericsson	597
Exide	593
Ferranti, Ltd.	555 and 594
Fluxite, Ltd.	604
Foyles	598
G5KA	Inside Back Cover
General Electric Co., Ltd.	590 and Inside Front Cover
H.M.V.	556
Heayberd, F. G., and Co.	602
Jackson Bros. (London), Ltd.	554
London Radio Supply Co.	602
M.P.R. Electrical Co.	Inside Back Cover
McCarthy Radio, Ltd.	Inside Back Cover
New Times Sales Co.	599
Peto-Scott Co., Ltd.	589
Pitman	604
Pix	607
Radio Gramophone Development Co., Ltd.	602
Stratton and Co., Ltd.	554
Technical and Commercial Radio College	601
Telegraph Condenser Co.	603
Tungram Valves	554
Varley	597
Westinghouse Brake and Signal Co., Ltd.	553
Whiteley Electrical Radio Co., Ltd.	571, 574, 581, 584, 587, 591, 595
Wingrove and Rogers, Ltd.	553

# FREE!



## This IMPORTANT GUIDE to SUCCESSFUL ENGINEERING CAREERS

After months of intensive effort and research, we are pleased to announce that the 1937 edition of our Handbook, "ENGINEERING OPPORTUNITIES," is now out of the publishers' hands and ready for free distribution. Containing 268 pages of practical guidance, this book is, beyond argument, the finest and most complete handbook on Successful Engineering Careers ever compiled. It is a book that should be on the bookshelf of every person interested in engineering, whatever his age, position or experience.

The Handbook contains, among other intensely interesting matter, details of B.Sc., A.M.I.C.E., A.M.I.Mech.E., A.M.I.E.E., A.M.I.A.E., A.M.I.W.T., A.M.I.R.E., CIVIL SERVICE, and other important Engineering Examinations: outlines courses in all branches of CIVIL, MECHANICAL, ELECTRICAL, AUTOMOBILE, RADIO, TELEVISION and AERONAUTICAL ENGINEERING, BUILDING, GOVERNMENT EMPLOYMENT, etc., and outlines the unique advantages of our Employment Department.



**WE DEFINITELY GUARANTEE**  
**"NO PASS--NO FEE"**

If you are earning less than £10 per week you cannot afford to miss reading "ENGINEERING OPPORTUNITIES." In your own interests, we advise you to send for your copy of this enlightening guide to well-paid posts by filling in and posting the coupon NOW. There is no cost or obligation of any kind.

**BRITISH INSTITUTE OF ENGINEERING TECHNOLOGY**

409A, SHAKESPEARE HOUSE,  
 17, 18 & 19, STRATFORD PLACE, LONDON, W.1

**FREE COUPON** (written diagonally across the coupon area)

TEAR OFF HERE (written along the top edge of the coupon area)

To B.I.E.T., 409A, SHAKESPEARE HOUSE,  
 17, 18 & 19, STRATFORD PLACE, LONDON, W.1.

Please forward, free of cost or obligation of any kind, your  
 268-page Handbook, "ENGINEERING OPPORTUNITIES."

NAME.....

ADDRESS.....