

FEBRUARY 1980

Australia 95c; Malaysia \$2.75; New Zealand 95c

55p

# TELEVISION

SERVICING-VIDEO-CONSTRUCTION-DEVELOPMENTS

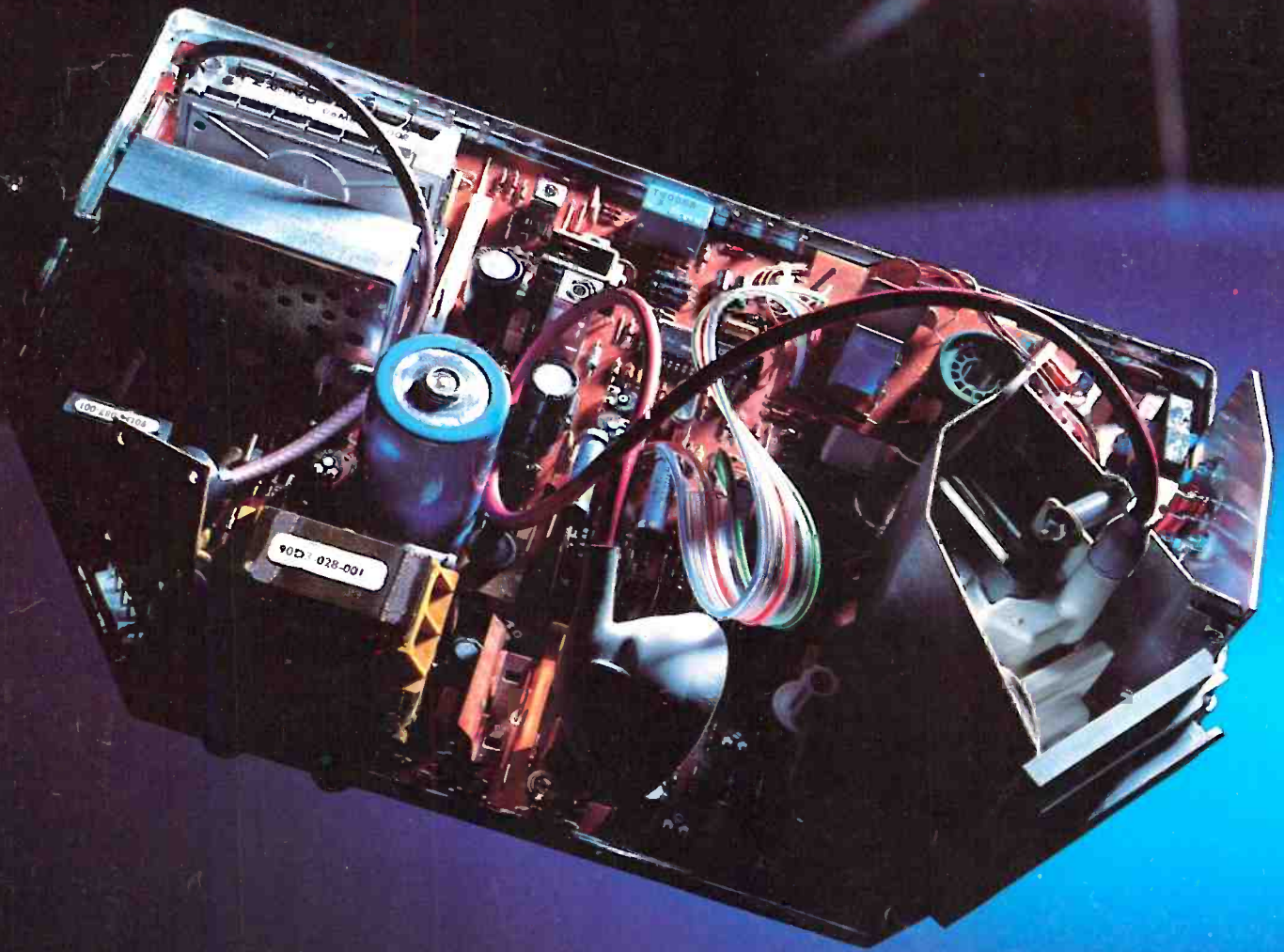

**ASSESSING THE TX9**

**SERVICING HINTS**

**LED CHANNEL DISPLAY**

**VINTAGE TV**

**PHD COMPONENTS**  
**RADIO & TV COMPONENT DISTRIBUTORS**  
**UNIT 7 CENTENARY ESTATE**  
**JEFFRIES RD ENFIELD MIDDX**  
**MAIL ORDER ONLY TELEX 261295**

**ALL COMPONENTS OFFERED SUBJECT TO AVAILABILITY. WE RESERVE THE RIGHT TO SUBSTITUTE REPLACEMENTS SHOULD THE ORIGINAL PART BE OUT OF STOCK OR UNAVAILABLE!**  
**PLEASE ADD 0.35p per parcel post and packing.**

**SEMICONDUCTORS**

AA113	0.16	BC117	0.20	BU208 02	3.00
AA116	0.16	BC118	0.20	BU2265	1.50
AA117	0.16	BC119	0.20	BU406	2.00
AA119	0.16	BC125	0.20	BU406D	2.50
OA91	0.12	BC126	0.20	BU407	2.50
OA95	0.12	BC136	0.20	RZ068B	2.50
OA202	0.18	BC137	0.40	RZ0108	2.50
BA100	0.18	BC138	0.40	R2540	3.00
BA102	0.10	BC139	0.40	ME0402	0.20
BA130	0.15	BC142	0.40	ME0412	0.20
BA154	0.10	BC143	0.40	ME4003	0.15
BA155	0.20	BC147	0.15	ME8002	0.20
BA164	0.12	BC148	0.10	ME8001	0.20
BAX13	0.16	BC149	0.15	MJE2995	1.50
BAX16	0.08	BC153	0.15	MJE3005	1.30
BA Y38	0.16	BC154	0.15	MP8113	1.00
BY206	0.20	BC157	0.15	MPSU05	1.20
IN4148	0.04	BC158	0.15	MPSU55	1.20
BY126	0.20	BC159	0.15	TIP2955	1.30
BY127	0.15	BC160	0.40	TIP3055	0.60
BY133	0.22	BC161	0.40	T1S90M	0.60
BY164	0.50	BC170	0.15	T1S91M	0.15
SK82 08	0.10	BC171	0.10	T2N904	0.50
BY238	0.15	BC172	0.20	2N2905A	0.50
BYX10	0.18	BC177	0.20	2N2905	0.50
IN4001	0.10	BC178	0.20	2N3053	0.50
IN4002	0.10	BC179	0.20	2N3703	0.20
IN4003	0.12	BC182L	0.15	2N3705	0.20
IN4004	0.12	BC183L	0.15	2N3710	0.20
IN4005	0.12	BC184L	0.15	2N3055H	0.75
IN4006	0.14	BC184L C	0.30	TAA350	0.80
IN4007	0.16	BC185	0.30	TAA550	0.60
IN5407	0.33	BC187	0.80	TAA570	1.80
BR100	0.50	BC203	0.15	TAA611	1.75
BR101	0.60	BC204	0.15	TAA630S	2.50
BR Y39	0.60	BC205	0.15	TAA661B	2.00
TIC1160N	1.50	BC206	0.15	SN76540N	1.50
BT119	2.50	BC207	0.15	TAD100	1.50
BT120	2.50	BC208	0.15	TBA120AS	1.75
BYX/71 600	0.80	BC209	0.15	TBA231	0.20
2N444	1.50	BC212L	0.15	TBA480Q	2.20
TV106 2	1.00	BC213L	0.15	TBA520Q	2.00
BYX88C2V7	0.10	BC214L	0.15	TBA530	2.00
BZ Y88 3V0	0.10	BC225	0.40	TBA530D	2.00
BZ Y88 3V3	0.10	BC237	0.15	TBA540	2.20
BZ Y88 3V6	0.10	BC238	0.15	TBA540Q	2.20
BZ Y88 3V9	0.10	BC251A	0.15	TBA550	3.00
BZ Y88 4V3	0.10	BC301	0.40	TBA550Q	3.00
BZ Y88 4V7	0.10	BC303	0.50	TBA560C	2.20
BZ Y88 5V1	0.10	BC307	0.15	TBA560CQ	2.20
BZ Y88 5V6	0.10	BC308	0.15	TBA570	2.50
BZ Y88 6V2	0.10	BC327	0.15	TBA570Q	2.50
BZ Y88 6V8	0.10	BC328	0.15	TBA6418X	3.00
BZ Y88 7V5	0.10	BC337	0.15	TBA641811	4.00
BZ Y88 8V2	0.10	BC338	0.15	TBA651	3.00
BZ Y88 9V1	0.10	BC547	0.15	TBA720A	1.50
BZ Y88 10V	0.10	BC141 10	0.80	TBA730	1.50
BZ Y88 11V	0.10	BD115	0.50	TBA750	2.00
BZ Y88 12V	0.10	BD124	2.00	TBA750Q	2.00
BZ Y88 13V	0.10	BD131	0.70	TBA800	1.00
BZ Y88 15V	0.10	BD132	0.60	TBA810S	1.50
BZ Y88 18V	0.10	BD133	0.70	TBA820	1.50
BZ Y88 20V	0.10	BD134	0.10	TBA920	2.00
BZ Y88 22V	0.10	BD144	2.50	TBA920Q	2.00
BZ Y88 27V	0.10	BD159	0.80	TBA990	2.00
BZ Y88 33V	0.10	BD238	0.70	TBA990Q	2.00
BZ X61 7V5	0.25	BD380	0.50	TC A2705A	2.00
BZ X61 8V2	0.25	BD441	0.70	TC A900	1.00
BZ X61 9V1	0.25	BD537	0.70	TC A940	2.00
BZ X61 10V	0.25	BD538	0.70	TD A1170	2.00
BZ X61 11V	0.25	BD507	0.70	TD A120	3.00
BZ X61 12V	0.25	BD508	0.75	TD A1270	4.00
BZ X61 13V	0.25	16181	1.00	TD A1412	1.00
BZ X61 15V	0.25	16182	1.20	TD A2020	4.00
BZ X61 16V	0.25	BD709	1.00	SN76115N	2.00
BZ X61 18V	0.25	BD710	1.00	SN76227N	1.20
BZ X61 20V	0.25	BD442	0.70	SN76530P	1.50
BZ X61 22V	0.25	BD3719	0.50	SN76651N	1.50
BZ X61 24V	0.25	BF115	0.60	SN76003N	3.00
BZ X61 27V	0.25	BF118	0.60	SN76013N	2.00
BZ X61 30V	0.25	BF152	0.40	SN76013ND	2.00
BZ X61 33V	0.25	BF154	0.25	SN76013ND	2.00
BZ X61 36V	0.25	BF157	0.70	SN76023N	2.00
BZ X61 39V	0.25	BF158	0.70	SN76023ND	1.00
BZ X61 47V	0.25	BF160	0.60	SN76033N	2.00
BZ X61 72V	0.25	BF163	0.60	SN76110N	2.00
AC107	0.35	BF167	0.50	SN76226ND	2.00
AC127	0.50	BF173	0.50	SN76227N	1.20
AC127 01	0.60	BF177	0.50	SN76532N	2.00
AC128	0.60	BF179	0.50	SN76533N	2.00
AC128 01	0.60	BF180	0.50	SN76544N	2.00
AC141	0.50	BF181	0.60	SN76650	1.00
AC141K	0.60	BF182	0.50	SN76665N	1.50
AC142	0.40	BF183	0.50	SN76666N	1.20
AC142K	0.60	BF184	0.60	SL901B	6.00
AC176	0.60	BF185	0.50	SL917B	8.00
AC186 01	0.40	BF194	0.15	TBA395Q	2.00
AC187	0.40	BF195	0.15	TD A440	2.50
AC187K	0.60	BF196	0.15	SN76001N	1.50
AC188	0.40	BF198	0.15	TBA120S	1.00
AC188K	0.60	BF199	0.15	UA7824	0.50
AD140	1.50	BF200	0.15	TBA396	2.00
AD142	1.50	BF224	0.15	TC A2705Q	2.00
AD143	1.50	BF240	0.15	TD A2030	8.00
AD145	1.50	BF241	0.15	TD A2140	6.00
AD149	1.00	BF256LC	0.50	TD A2150	6.00
AD153 2	1.50	BF257	0.50	TD A2160	6.00
AD162	0.70	BF258	0.50	TD A1230	3.00
AD262	1.50	BF271	0.60	TD A3089	2.00
AF114	0.60	BF273	0.20	TD A1054M	2.00
AF115	0.60	BF274	0.25	MC1349N	1.50
AF116	0.60	BF336	0.50	SAA661	0.60
AF117	0.80	BF337	0.50	SAS560S	2.00
AF118	0.60	BF338	0.50	SAS570S	2.00
AF121	0.60	BF355	0.80	SN7400N	0.40
AF124	0.60	BF458	0.60	SN7413N	0.90
AF125	0.60	BF459	1.00	SN74122N	1.00
AF126	0.60	BF474	0.50	SN74141N	1.00
AF127	0.60	BFX29	0.50	TBA396	1.80
AF139	0.60	BFX84	0.50	TBA395Q	4.00
AF239	1.00	BFX89	0.50	TBA880	4.00
AL102	3.00	BFY89	0.50	TC A800Q	4.00
AL107	3.00	BFY51	0.50	TD A1180	3.30
AL110	3.00	BFY52	0.50	TD A1190	3.30
AL103	3.00	BFY90	0.50	TD A2020H	3.60
AY102	3.00	BF381	0.50	TD A2590Q	5.00
BC107	0.20	BFR39	0.30	TD A2600	5.00
BC108	0.20	BFR79	0.30	TD A2640	3.30
BC109	0.20	BFR81	0.30	TD A395Q	3.00
BC113	0.15	BFR89	0.30	TAA621 AX1	3.30
BC114	0.15	BF255	0.25	TBA625X5	2.00
BC115	0.20	B0X32	2.50	TC A830S	2.00
BC116	0.20	BU206	1.60	TD A2020 AZ	5.00

TDA2020P	5.00
TDA2030V	3.60
TDA2010 BD2	4.50
TDA2002V	5.00
TC A940E	3.00

**VALVES - ALL VALVES  
"MAZDA" BRAND**

DY 86 87	1.20
DY802	1.00
ECC82	1.10
ECC84	1.35
EH83	1.00
EH84	2.00
ECL80	1.50
ECL82	1.30
ECL86	1.50
EF80	1.20
EF95	0.70
EF183	1.10
EF184	1.10
EL34	0.30
EL84	1.40
GY501	2.40
PC37	1.60
PC300	1.75
PCF80	3.50
PCF802	1.50
PCF806	2.50
PCL82	1.50
PCL84	1.50
PCL85 805	1.50
PCL86	1.50
PD500 510	5.00
PL1200	3.00
PL36	2.00
PL81	1.00
PL504	1.60
PL508	2.00
PL509	3.50
PL802	3.20
PY88	1.80
PY900A	2.40
PY800 801	1.50
UC182	1.40
30F1.1	1.60
PCF805	1.50
PCF808	1.50

**DIRECT REPLACEMENT PARTS**

173 Tuner (Repl Etc 1043 05)	8.00
4.43MHz Crystals	2.00
Cut Out TCE 3500	2.00
Cut Out TCE 8500	2.50
TV18 Rectifier Stick	2.00
TV20 Rectifier Stick	2.00
VA 1104 Thermister	0.60
Transducer TCE 3000	1.50
AEG Tuner (Repl Etc 1043 06)	9.00
Aeriel Isolator Kit	10.00
Philips G8 Lopt	12.00
PYE 691 597 Lopt	14.00
Philips A 774 Lopt	15.00
Decoder Panel Autovox 2282	3.00
Degaussing Panel Autovox 2282	2.00
Sounf O P Panel Autovox 2282	4.00
PS Panel Autovox 2282	6.00
Rtimp Cool Unit Autovox 2282	3.00
Field TB Panel Autovox 2282	5.00
IF Tuner Assembly Autovox 2282	7.50
TCE 850 Lopt	3.00
TCE 900 Half Wave	1.00
Delavine SDF 141	0.40
PYE 95 Tuner	1.50
GCE 2110 Degauss Panel	1.50

**EHT MULTIPLIERS**

TCE950 Doubler	2.00
TCE950 1400 Tripler	4.00
TCE1400 Pipred System Only	4.00
TCE1500 Doubler	2.00
TCE1500 Tripler	4.00
TCE1600 1 2 Wave	4.50
DECCA CS 1730 1830 Doubler	6.00
DECCA CS 1910 2213 Tripler	6.50
DECCA 30 Series Tripler	6.50
DECCA 80 Series Tripler	6.50
DECCA 100 Series Tripler	6.50
GEC Hybrid 2028 Tripler	6.50
GEC 2110 Tripler PRE JAN77	7.00
GEC 2110 Tripler Post JAN77	6.50
ITT CVC 5 8 9 Tripler	6.50
ITT CVC 20 25 30	6.50
Philips 520 Tripler	6.50
Philips 550 Tripler	6.50
Philips G9 Tripler	6.50
PYE 691 693 697 Tripler	5.50
PYE 731 725 Tripler	6.50
RR1 823 Tripler	7.00
RR1 219 823	6.50
TCE 3000 3500 Tripler	7.00
TCE 4000 Tripler	8.00
TCE 8000 Doubler	3.00
TCE 8500 Tripler	6.00
TCE 9000 Tripler	7.00
TVK 76 13 Continental Sets	5.00
TVK 52 ITT Replacement	6.50
Korting 90% Tripler	6.50
Autovox Tripler	6.50
Redifusion MK 1 Tripler	8.00
RR1 TV 25 Quadripler	8.00
Tripler Mounting Kit	1.50
RR1 T20	6.50

**PHD COMPONENTS**

**MULTISECTION CAPACITORS**

DECCA 400 400 350	3.72
DECCA 80 100 400 350 - 800 250	4.00
GEC 200 200 150 50 350	3.00
GEC 1000 200 350	1.10
GEC Philips G8 600 250	2.10
GEC Philips G8 600 300	2.50
ITT KB 200 200 75 25 350	3.00
ITT CVC 20 200 400	2.20
Philips G11 470 250	1.80
PYE 691 200 300 350	2.80
PYE 1000 1000 40	0.90
PYE 731 800 250	2.50
RR1 2500 2500 30	1.30
RR1 600 300	2.50
RR1 300 - 300 300	2.55
TCE 950 100 300 100 16	1.00
TCE 1400 150 100 100 100 150	

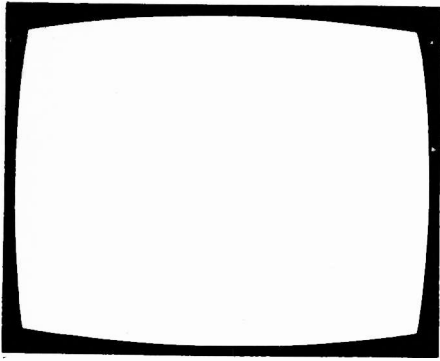

# TELEVISION

February  
1980

Vol. 30, No. 4  
Issue 352

## COPYRIGHT

©IPC Magazines Limited, 1980. Copyright in all drawings, photographs and articles published in *Television* is fully protected and reproduction or imitation in whole or in part is expressly forbidden. All reasonable precautions are taken by *Television* to ensure that the advice and data given to readers are reliable. We cannot however guarantee it and we cannot accept legal responsibility for it. Prices are those current as we go to press.

## CORRESPONDENCE

All correspondence regarding advertisements should be addressed to the Advertisement Manager, "Television", King's Reach Tower, Stamford Street, London SE1 9LS. Editorial correspondence should be addressed to "Television", IPC Magazines Ltd., Lavington House, Lavington Street, London SE1 0PF.

## SUBSCRIPTIONS

An annual subscription costs £9.50 in the UK, £10.50 overseas (\$21 Canada or USA). Send orders with payment to IPC Services, Oakfield House, Perrymount Road, Haywards Heath, Sussex.

## BINDERS AND INDEXES

Binders (£3.75) and Indexes (45p) can be supplied by the Post Sales Department, IPC Magazines Ltd., Lavington House, 25 Lavington Street, London SE1 0PF. Prices include postage and VAT. In the case of overseas orders, add 60p.

## BACK NUMBERS

Some back issues are available from the Post Sales Department, IPC Magazines Ltd., Lavington House, 25 Lavington Street, London SE1 0PF at 75p inclusive of postage and packing.

## QUERIES

We regret that we cannot answer technical queries over the telephone nor supply service sheets. We will endeavour to assist readers who have queries relating to articles published in *Television*, but we cannot offer advice on modifications to our published designs nor comment on alternative ways of using them. All correspondents expecting a reply should enclose a stamped addressed envelope.

Requests for advice in dealing with servicing problems should be directed to our Queries Service. For details see our regular feature "Service Bureau". Send to the address given above (see "correspondence").

## this month

- 177 **Leader**
- 178 **Teletopics**  
News, comment and developments.
- 180 **Assessing the Thorn TX9 Chassis** *by Eugene Trundle*  
The Thorn TX9 is a remarkable chassis – the most compact colour receiver to date, making extensive use of i.c.s to keep the component count to a minimum. There are nevertheless some interesting features: a novel though simple power supply, an elaborate anti-breathing system, and switch-off spot suppression for example. We passed our review set on to E. Trundle who gave it a thorough test and reports on its performance and the interesting new bits of circuitry.
- 187 **Fault Round-up** *by John Coombes*  
Notes on fault conditions in a wide variety of TV sets – in particular the various Rank solid-state colour chassis. Valuable assistance for the busy fault-finder!
- 190 **Vintage TV: The English Electric Model 16T11D** *by Vivian Capel*  
Interest in old equipment seems to be spreading from one field to another. Perhaps old TV sets will be the next to be rescued and lovingly restored. This new series will look at some of the more interesting sets of yesteryear, starting with the English Electric 16T11D of 1953. If you've never come across a Barretter or a metal-cone c.r.t., read on...
- 191 **Next Month in Television**
- 192 **Oh Dear What Can the Matter be?** *by Les Lawry-Johns*  
Once upon a time there was a bright fellow who could diagnose faults without taking the back off the set. No longer! This, so he says, explains the endless series of cock-ups reported for your entertainment and enlightenment.
- 194 **Computerised TV, Part 1** *by David K. Matthewson, B.Sc., Ph.D.*  
It's all microprocessors and microcomputers nowadays. They're now getting into TV sets and VCRs. So it's time to take a look at them, with a view to finding out what they can do and how they can be used in domestic TV equipment.
- 196 **VCR Troubles** *by Steve Beeching, T.Eng.(C.E.I.)*  
The aim is to pass on useful gen to those new to video servicing. Apart from the machines themselves, Steve has had problems with the cassettes.
- 198 **Colour Receiver Options, Part 4** *by Luke Theodossiou*  
Constructional details of the teletext plus remote control option. Also how to add LCD channel indication to this option.
- 201 **Letter**
- 202 **TV Servicing: Beginners Start Here... Part 29** *by S. Simon*  
This time the awkward bit: what to do when you encounter a colourless colour set. Plus other colour faults.
- 206 **Long-distance Television** *by Roger Bunnay*  
Reports on DX reception and conditions, and news from abroad. There's been more spectacular F2 reception. Also, in the beginners' section, notes on preamplifiers and filters for removing interference.
- 209 **Readers' PCB Service**
- 211 **Service Bureau**
- 213 **Test Case 206**

OUR NEXT ISSUE DATED MARCH WILL BE  
PUBLISHED ON FEBRUARY 18

# THE UNBEATABLE BRIARWOOD SERVICE

## EX-EQUIPMENT SPARES

MISC. S/Output Trans.  
£1 + VAT + £1 P&P  
F/Output Trans.  
£1.25 + VAT + £1 P&P.  
Scancoils £1.50 + VAT  
+ £1 P&P. Other  
spares available, please  
write or phone for details.

**MONO TUBES**  
(tested)  
19" Ringuard £3.00  
23" Ringuard £4.00  
20" Ringuard £5.00  
24" Ringuard £6.00  
+ £5.00 P.&P.

**MONO TUNERS**  
6-button integrated all  
at £4.00  
U.H.F. P/Button D/S  
£3.50. U.H.F. P/Button  
S/S £4.00. Rotary £3.00  
+ £1 P&P.

**MONO LOPTS**  
All D/Standard Lopts  
at £4.00 + £1 P.&P.  
All S/Standard at  
£4.00 + £1 P.&P.

**MONO PANELS**  
i.e. Philips, Bush etc.  
£3.50 + £1 P.&P.  
Quotations for  
complete  
S/hand chassis if  
required. (Diff. prices)

PLEASE ADD 15% V.A.T.  
TO ALL ITEMS AND  
OVERSEAS AT COST.  
CASH WITH ALL ORDERS.

### VALVES (MONO & COLOUR)

PCL82	0.10	30C1	0.10	PCC189	0.10	EF183	0.10	PL504	0.25	ECL80	0.10
PCL83	0.25	30C17	0.10	30C15	0.10	EF184	0.10	6/30L2	0.10	PL509	1.00
PCL84	0.10	PCF802	0.10	30C18	0.25	6BW7	0.10	30PL1	0.25	PY500	1.00
PCL85	0.10	PCF805	0.25	PC97	0.20	EH90	0.10	30PL13/4	0.10	GY501	1.00
PCL86	0.10	PCF806	0.10	PC900	0.10	DY802	0.10	30FL1/2	0.25	PL508	0.50
PFL200	0.10	PCF808	0.25	EF80	0.10	PY800/1	0.10	ECC82	0.10	PCF200	0.50
PCF801	0.10	PCF80	0.10	EF85	0.10	PL36	0.25	ECC81	0.10	EY51	0.15

Please note there is 25p Postage and Packing per order.

WE DO NOT SELL RUBBISH  
AT BRIARWOOD TV

### D/STANDARD COLOUR SPARE PANELS

	IF	LUM	CHROMA	EHT	REG	CON	S/OUTPUT	POWER	L/TB	F/TB
Bush/Murphy	5.00	5.00	6.50	—	—	5.00	1.50	5.00	—	—
GEC/Sobell	5.00	5.50	—	—	—	5.00	—	—	—	7.50
Philips	5.00	7.00	—	—	—	5.00	—	—	—	5.00
Decca	5.00	9.00	9.00	—	—	5.00	2.00 (19" only)	6.00	—	5.00
Thorn 2000	5.00	5.00	5.00	6.50	6.50	7.00	—	6.50	10.00	5.00
Pye	7.00	6.00	7.00	—	—	5.00	—	—	—	5.00
Baird	6.50	8.50	7.00	—	—	5.00	—	—	—	5.00

Postage & Packing £1.25

### S/STANDARD COLOUR SPARE PANELS

	IF	LUM	CHROMA	VIDEO	CON	POWER	L/TB	F/TB
Bush 184	9.50	—	12.00	—	6.00	6.00	12.00	—
GEC Hybrid	6.00	6.50	9.00	—	5.00	—	—	12.00
Philips G6 S/S	9.50	—	10.00	—	5.00	—	—	6.00
Thorn 3000	6.00	6.00	6.00	—	5.00	20.00	20.00	6.00
Pye 691/693	6.00	6.00	8.00	—	5.00	—	15.00	5.00
Thorn 3500	6.00	6.00	6.00	6.50	7.50	20.00	20.50	6.00

Postage & Packing £1.25

Korting and other foreign  
panels available on request.

### COLOUR TUBES

19"	£18.00
19" A49, 192	£20.00
20"	£20.00
22"	£22.00
25"	£18.00
26"	£28.00

Plus P&P £5.00

**NEW**  
Rebuilt tubes  
available on request.

### COLOUR TUNERS

Bush	£5.00
GEC	£5.00
Philips G6 S/S	£5.00
Thorn 3000	£5.00
Pye 691	£5.00

Some new tuners in stock,  
can supply on request. Many  
Foreign Tuners also available  
on request. Plus P&P £1.

### COLOUR LOPTS

Most Lopts available  
from £5.00. Both  
British & Foreign  
makes. Please ring  
or write.  
P&P per Lopt £1.

### MISC.

S/Output transformer  
from £1.50.  
F/Output from £1.25.  
Scancoils from £5.00.  
P&P £1.  
Other spares available on  
request.

### THORN 1500 TUNERS

NEW SPECIAL OFFER  
AT £8.00

Postage & Packing £1.00

## MAIL ORDER T.V.s. IN GOOD WORKING ORDER

COLOUR		COLOUR		COLOUR	
Pye	19" £60.00	22" £65.00	26" £75.00	20" & 24" S/S	£16.00
GEC	19" £60.00	22" £65.00	26" £75.00	20" & 24" D/S	£14.00
Bush	19" £80.00	22" £80.00	26" £90.00	19" & 23" D/S P/button	£12.00
Philips	G6 —	22" £63.00	26" £70.00	19" & 23" D/S Rotary	£8.00

Many other makes & models available.  
Please ring or write for information.

**PERSONAL CALLERS  
WELCOME.**

**MONO**  
20" & 24" S/S £16.00 Pye, GEC, Bush etc.  
20" & 24" D/S £14.00 Pye, GEC, Bush etc.  
19" & 23" D/S P/button £12.00 Pye, GEC, Bush etc.  
19" & 23" D/S Rotary £8.00 Pye, GEC, Bush etc.

Please note there is 15% V.A.T. on all the above prices.  
Plus £8 P&P. England, Wales & Scotland for colour T.V.'s.  
Inland N. & S. Ireland P&P £15. P&P £5 for mono T.V.'s  
to England, Wales & Scotland. Inland N. & S. Ireland £7  
per set.

Briarwood T.V. Limited  
Britain's Mail Order  
T.V. Specialists

# BRIARWOOD

# THE PROFESSIONAL CHOICE. NATIONWIDE

## NEW SPARES

TYPE	PRICE £	TYPE	PRICE £	TYPE	PRICE £	TYPE	PRICE £	TYPE	PRICE £	TYPE	PRICE £	DIODES	E.H.T. TRAYS MONO		
AC107	0.20	AF170	0.25	BC172	0.08	BD222/T1P31A	0.37	BF260	0.24	OC45	0.20	1N4001	0.04	950 MK2 1400	2.00
AC113	0.17	AF172	0.20	BC173	0.12		0.37	BF262	0.28	OC46	0.35	1N4002	0.04	1500 18" 19" stick	
AC115	0.17	AF178	0.49	BC177	0.12	BD225/T1P31A	0.39	BF263	0.25	OC70	0.22	1N4003	0.06		2.37
AC117	0.24	AF180	0.60	BC178	0.12		0.39	BF271	0.20	OC71	0.28	1N4004	0.07	1500 24" 5 stick	2.48
AC125	0.20	AF181	0.30	BC179	0.12	BD234	0.34	BF273	0.12	OC72	0.35	1N4005	0.07	Single stick Thorn TV	
AC126	0.18	AF186	0.29	BC182L	0.09	BD222	0.50	BF336	0.28	OC74	0.35	1N4006	0.08	11.16K 70V	0.75
AC127	0.19	AF239	0.43	BC183L	0.09	BDX22	0.73	BF337	0.24	OC75	0.35	1N4007	0.08	TV20 2 MT	0.75
AC128	0.17	AU113	1.29	BC184L	0.09	BDX32	1.98	BF338	0.29	OC76	0.35	1N4148	0.03	TV20 16K 18V	0.75
AC131	0.13			BC186	0.18	BDY18	0.75	BF42	0.26	OC77	0.50	1N4751A	0.11		
AC141	0.23	BA130	0.08	BC187	0.18	BDY60	0.80	BFT43	0.24	OC78	0.13	1N5401	0.12	IC's	
AC142	0.19	BA145	0.14	BC209	0.11	BF115	0.24	BFX84	0.27	OC81	0.20	1N5404	0.12	3N76013N	1.20
AC141K	0.29	BA148	0.17	BC212	0.09	BF121	0.21	BFX85	0.27	OC810	0.14	1N5406	0.13	3N76013ND	1.00
AC142K	0.29	BA155	0.08	BC213L	0.09	BF154	0.12	BFX88	0.24	OC82	0.20	1N5408	0.16	3N76023N	1.20
AC151	0.17	BAX13	0.05	BC214L	0.09	BF158	0.19	BFY37	0.22	OC820	0.13			3N76023ND	1.00
AC165	0.16	BAX16	0.08	BC237	0.07	BF159	0.24	BFY50	0.15	OC83	0.22			3N76226DN	1.50
AC166	0.16	BC107	0.10	BC240	0.31	BF160	0.23	BFY51	0.15	OC84	0.28			3N76227N	1.20
AC168	0.17	BC108	0.10	BC281	0.24	BF163	0.23	BFY52	0.15	OC85	0.13			TBA341	0.97
AC176	0.17	BC109	0.10	BC262	0.18	BF164	0.17	BFY53	0.27	OC123	0.20			TBA520Q	1.10
AC176K	0.28	BC113	0.09	BC263B	0.20	BF167	0.23	BFY55	0.27	OC169	0.20			TBA530Q	1.10
AC178	0.16	BC114	0.12	BC267	0.19	BF173	0.21	BHA0002	1.90	OC170	0.22			TBA540Q	1.45
AC186	0.26	BC115	0.10	BC301	0.22	BF177	0.26	BR100	0.20	OC171	0.27			TBA550Q	1.40
AC187	0.21	BC116	0.10	BC302	0.30	BF178	0.24	BSX20	0.23	OA91	0.05			TBA560CQ	1.50
AC188	0.20	BC117	0.11	BC307	0.10	BF179	0.28	BSX76	0.23	RRC4443	0.65			TBA570Q	1.00
AC187K	0.30	BC119	0.22	BC337	0.11	BF180	0.30	BSY84	0.36	R2008B	1.50			TBA810	1.50
AC188K	0.30	BC125	0.12	BC338	0.09	BF181	0.34	BT106	1.18	R2010B	1.50			TBA800	1.00
AD130	0.50	BC126	0.09	BC307A	0.10	BF182	0.30	BT108	1.23	R2305	0.38			TBA810	1.50
AD140	0.65	BC136	0.12	BC308A	0.12	BF183	0.29	BT109	1.09	R2305/BD222	0.37			TBA920Q	1.50
AD142	0.73	BC137	0.12	BC309	0.14	BF184	0.23	BT116	1.23	SCR957	0.65			TBA990Q	1.50
AD143	0.70	BC138	0.21	BC547	0.09	BF185	0.29	BT120	1.23	TIP31A	0.38			TCA270SQ	1.45
AD145	0.70	BC139	0.21	BC548	0.11	BF186	0.30	BU105/02	1.50	TIP32A	0.36			TCA270SA	1.45
AD149	0.64	BC140	0.24	BC549	0.11	BF194	0.09	BU105/04	2.00	TIP3055	0.53			TCA1327B	1.00
AD161	0.40	BC141	0.22	BC557	0.11	BF195	0.09	BU126	1.40	T1590	0.19			E.H.T. TRAYS COLOUR	
AD162	0.40	BC142	0.19	BD112	0.39	BF196	0.12	BU205	1.20	T1591	0.19			Pye 731	5.20
AD161 }		BC143	0.19	BD113	0.65	BF197	0.10	BU208	1.60	TV106	1.09			Pye 691/693	4.50
AD162 }	1.30	BC147	0.07	BD115	0.30	BF198	0.11	BY126	0.09					Decca (large screen)	
AF106	0.42	BC148	0.07	BD116	0.47	BF199	0.14	BY127	0.10					CS2030/2232/2630/	
AF114	0.23	BC149	0.07	BD124	1.30	BF200	0.28							2632/2230/2233/	
AF115	0.22	BC153	0.12	BD131	0.32	BF216	0.12	OC22	1.10					2631	5.00
AF116	0.22	BC154	0.12	BD132	0.34	BF217	0.12	OC23	1.30					PL84	0.74
AF117	0.30	BC157	0.10	BD133	0.37	BF218	0.12	OC24	1.30					PL504	1.10
AF118	0.40	BC158	0.11	BD135	0.26	BF219	0.12	OC25	1.00					PL509	2.45
AF121	0.33	BC159	0.11	BD136	0.26	BF220	0.12	OC26	1.00					PY8B	0.63
AF124	0.33	BC160	0.22	BD137	0.26	BF222	0.12	OC28	1.00					PY500A	1.60
AF125	0.29	BC161	0.22	BD138	0.26	8F221	0.21	OC35	1.00					PY81/800	0.57
AF126	0.29	BC167	0.09	BD139	0.40	BF224	0.12	OC36	0.90						
AF127	0.29	BC168	0.09	BD140	0.28	BF256	0.37	OC38	0.90						
AF139	0.39	BC169C	0.09	BD144	1.39	BF258	0.27	OC42	0.45						
AF151	0.24	8C171	0.08	BD145	0.50	8F259	0.27	OC44	0.20						

All transistors, IC's offered are new and branded. Manufactured by Mullard, I.T.T., Texas, Motorola etc. Please add 15% VAT to all items and overseas at cost P & P U.K. 25p per order, overseas allow for package and postage. Cash with all orders. All prices subject to alteration without notice.

## TELEVISION SALE DISCOUNT FOR QUANTITY

Please note all mono sets sold as 100% comp. No broken masks, no broken panels etc. Colour sets sold with good c.r.t.s and 100% comp.

Working Mono £3.00 extra. Working Colour £15.00 extra. Supplied in 1's or 100's.

### MAINS DROPPERS

Mono	
Bush 161	60p
Philips 210 30+125+2K85	50p
Philips 210 118R+148R	48p
Thorn 1400	75p
GEC 2018	58p
Thorn 1500	70p

Colour	
Bush A823	72p
Pye 723 27Q+56Q	57p
GEC 2110 -41Q	45p
GEC 2110 -12R5+12R5	47p
GEC2110 -27R5	45p
Thorn 3500	58p
Thorn 8000	58p
Thorn 8500	54p
Philips G8 47R	30p
Philips G8 2.2+68	42p

All plus VAT at 15%

### MONO Rotaries 19" & 23"

GEC	£3.00
Thorn 950 etc.	3.00
K.B.	3.00
Pye	3.00
Thorn 1400	4.50

### D/S P/B 19" 23"

Thorn 1400	7.00
Bush 161 etc.	7.00
Baird 660 etc.	7.00
Philips 210 etc.	7.00
Pye Olympic etc.	7.00

### D/S P/B 20" 24"

Bush	10.00
GEC	10.00
Philips	10.00
Pye	10.00
Thorn	10.00

### S/S 20" 24"

Bush 313 etc.	£12.00
Pye 169 chassis	12.00
Thorn 1500	12.00
GEC series 1 & 2	12.00
Decca MS series	12.00

### S/S COLOUR

	19"	20"	22"	25"	26"
	£	£	£	£	£
GEC	40	40	40	40	40
Philips	—	—	40	40	40
Thorn	55	—	60	45	65
Korting	—	—	55	—	60
Pye Mechanical	40	—	40	40	40
Pye Varicap	45	—	45	45	45

WHY NOT TRY OUR EXPRESS MAIL ORDER ON ANY OF THE ITEMS LISTED.

EXPORT COLOUR & MONO T.V.S AVAILABLE READY FOR USE OVERSEAS

# TELEVISION

Briarwood House Preston Street  
Bradford West Yorkshire BD7 1NS  
Tel. Bradford 306018 (STD code 0274)

# BRIARWOOD TELEVISION LTD

Britain's Mail Order TV Specialists

BRITAIN'S LARGEST SUPPLIERS OF  
BRITISH AND CONTINENTAL  
LINE OUTPUT TRANSFORMERS

12 Months Guarantee. Please add 15% VAT  
to all items. P & P £1.00.

Various other models available on request

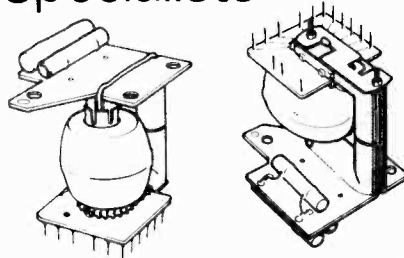

Set Manufacturer	Chassis/Model	Price. £	Set Manufacturer	Chassis/Model	Price £
Pye	731	12-50	Scantic	2621-1/2621-2	12-50
Philips	G8	9-50	Scantic	Chassis 32.631 - Series 2	
Philips	K70	18-75		2635-1/2635-3/ 2636/2636-2/ 2636-4/2637/ 2638/2639/ 2645/1805-6482	12-50
Decca	30 (Bradford)	9-25	B & O (Beovision)	3100/3300/3400	13-00
Decca	1730	9-25	B & O (Beovision)	3100/3300/3400	
Decca	80	9-00		EHT Transformer	14-50
Decca	100	9-00	B & O (Beovision)	3500/3600/4000/ 5000/6000	12-50
Decca Mono	MS1700/2020/ 2001/2401	8-00	Tandberg	CTV 1/2/2-2/ Colour 102/103/ 104/105/106	12-50
Korting	51763/51765 - 22"			CTV 55552	
	52665/52666 - 26"	12-00		Chassis 711A	12-00
	52865/52866 - 26"		Telefunken	Chassis 2682/2683/ 2684/2282/2283/ 2284	12-00
Korting	53701/02/08/09		Autovox 90°	2684/2282/2283/ 2284	12-00
	54701/02/07/08/547	11-20	Autovox 110°	Chassis 2693/2694	12-00
	55606/55700/02/ 711/735/747		Siemens	2221-1/222-2/ 2621-1/2621-2/ 2622-1/2622-2/ 2623-1/2623-2/ 2624-1/2624-2	12-50
ITT	CVC25/30/32	9-00	Zanussi	B2222-2/3	11-20
Grundig	1500/2000/2500/ 3000/3010	12-50	Baird	B2223-2/3	11-20
Grundig	5010	13-00	Salora	27" 110°	11-20
Grundig	5010 EHT Transformer	14-50	Indesit Mono	BP-CTV 225 & 265	
Luxor	Series 5005/ 2222/6000/6010/8000	12-50		BP-7-663291/ BP-7-663691	12-00
	Chassis 32.617 - Series 2			ED/B24	
	2031-1/2031-2/ 2227-1/2227-2/ 2229-1/2229-2			EG/B	8-50
	Chassis 56.307 - Series 1 & 2				
	22307/22309/22317				
	26305/26307	12-00			
	Chassis 56347 - Series 1				
	TV 22347-2217-1				
	22349-2219-1				
	26345-2615-1				
	26347-2617-1				
	26349-2619-1				
	26347-2227-1				
Luxor	Chassis 32.621 - Series 1	12-50			

## 6 MONTH GUARANTEE

p & p 1-00

### INSERTS (WINDING)

PYE 691 or 697	Small	3-65	Decca CTV 25	(Non Tripler Type)	
PYE 691 or 697	Large	5-10		Overwind	8-50
Bush CTV 25 Mk 3	Underwind	7-25	Philips G6 S/S or D/S	Underwind	7-90
Philips K70	Underwind	8-00		Overwind	8-50
				Philips G6 Overwind on Exchange basis only	
			EMO 90° Winding		7-90

### MONO

Bush 161V Series	8-45	Philips 210, 300	8-45
Bush 313 Series	8-45	PYE 368	8-45
Decca DR1 to DR24	8-45	PYE 169 or 569	8-45
GEC Series 1-2	8-45	BUSH 816	12-00
ITT K13 VC 200	8-45		

Briarwood House, Preston Street, Bradford  
West Yorkshire BD7 1LU  
Tel: (0274) 306018

# CAMPBELL ELECTRONICS Limited

Unit E5, Halesfield 23  
Telford, Salop  
TF7 4QX

Tel: Telford (STD 0952)  
585799/584373

Telegrams CAMELEC  
Telex CHAMCOM 35191

DISTRIBUTORS OF SPECIALIST SPARES TO RADIO & TELEVISION SERVICE DEPTS; NATIONWIDE

## Your source to better components

ITEMS SHOWN WITH \* INDICATES THESE ARE SOLD IN PACKS OF 5

### TRANSISTORS

BC108		BC107		BC106		BC105		BC104		BC103		BC102		BC101		BC100		BC99		BC98		BC97		BC96		BC95		BC94		BC93		BC92		BC91		BC90					
AC127	78	AF238	1.03	BC119	1.49	BC173	1.47	BC464	1.00	BD1508	1.29	BF123	23	BF222	23	BF450	42	BU111Y	2.50	R1038	2.10	TIP126	73																		
AC128	58	AF2785	1.20	BC125	2.07	BC178	1.97	BC485	1.20	BD150C	.84	BF154	20*	BF224	18*	BF458	1.00	BU128	2.10	R1039	2.10	TIP127	1.12																		
AC141	48	AL102	2.90	BC126	2.0*	BC179	1.9*	BC547	1.4*	BD163	.73	BF156	43	BF240	18*	BF459	1.00	BU204	1.50	R2008	1.50	TIP205	1.29																		
AC142	40	AL113	2.90	BC135	2.0*	BC182L	1.4*	BC548	1.4*	BD166	.48	BF158	39	BF241	18*	BF481	.32	BU205	1.50	R2009	1.99	TIP206	1.29																		
AC153	57	AU103	2.11	BC136	2.0*	BC183L	1.4*	BC549	1.4*	BD181	.77	BF180	59	BF255	25	BF482	.33	BU206	1.59	R2010	1.80	TIS43	.40																		
AC178	59	AU106	2.69	BC137	2.0*	BC184L	1.4*	BCX31	.26	BD182	.59	BF187	48	BF256	50	BF483	.31	BU208	2.50	R2028	1.90	TIS91	.60																		
AC187	38	AU107	2.06	BC139	.39	BC186	2.0*	BCX32	.24	BD183	.78	BF173	50	BF257	49	BF484	.30	BU208/02	2.99	R2030	1.93	TIS92	.59																		
AC188	38	AU108	2.06	BC140	.39	BC187	.29*	BCX33	.22	BD187	.66	BF177	50	BF258	49	BF485	.29	BU209	2.41	R2265	2.05	ZTX300	.22																		
AD149	1.00	AU110	2.90	BC141	.33	BC212L	1.5*	BCX34	.27	BD201	.76	BF178	26	BF259	45	BF486	.28	BU407	2.90	R2305	.80	ZTX500	1.9*																		
AD161	.75	AU111	2.90	BC142	.39	BC213L	1.5*	BCX36	.27	BD222	.35	BF179	49	BF262	49	BF487	.29	BU407	2.90	R2306	.80	ZTX500	1.9*																		
AD182	.75	AU112	2.40	BC143	.39	BC213L	1.5*	BCY70	.18*	BD225	.45	BF180	49	BF263	52	BF488	.28	ME8001	.26	R2540	3.00	2N687	.40																		
AF115	.80	AU113	2.90	BC147	.15*	BC214L	1.5*	BCY71	.24	BD232	.47	BF181	59	BF271	49	BF489	.28	MJE340	.40	TIP29	.43	2N2905	.51																		
AF167	.80	AU114	2.40	BC148	.15*	BC237	1.5*	BCY72	.19*	BD233	.47	BF182	50	BF273	19*	BF490	.28	MJE520	.45	TIP30	.58	2N3053	.50																		
AF178	.59	CI107	1.8*	BC149	.15*	BC238	1.4*	BD115	.49	BD234	.45	BF183	50	BF274	24	BF491	.28	MJE2955	1.49	TIP31	.37	2N3065	.74																		
AF178	.59	CI107	1.8*	BC153	.15*	BC239	1.2*	BD118	.71	BD237	.58	BF184	49	BF274	43	BF492	.28	MJE3066	1.29	TIP32	.40	2N3103	.23																		
AF125	.59	CI108	1.8*	BC154	.15*	BC307	1.4*	BD131	.69	BD238	.50	BF185	49	BF275	49	BF493	.28	OC28	.20	TIP33	.81	2N3704	2.0																		
AF126	.61	BC113	1.5*	BC157	.15*	BC327	1.4*	BD132	.60	BD435	.78	BF194	18*	BF337	49	BF494	.28	OC35	2.00	TIP34	.74	2N3705	1.9*																		
AF127	.60	BC114	1.5*	BC158	.15*	BC337	1.4*	BD133	.69	BD437	.75	BF195	14*	BF338	49	BF495	.28	OC36	2.10	TIP41	.43	2N3706	.89																		
AF139	.80	BC115	2.0*	BC159	.15*	BC338	1.4*	BD135	.58	BD509	.58	BF196	14*	BF355	80	BF496	.28	OC44	.40	TIP42	.80	2N3707	1.9*																		
AF178	1.54	BC116	2.0*	BC160	.39	BC384L	.22	BD136	.58	BD510	.49	BF197	14*	BF362	47	BU105/01	1.69	OC45	.43	TIP47	.94	2N5296	.89																		
AF180	1.60	BC117	1.9*	BC170B	.20	BC481	.27	BD140	.58	BDX32	2.17	BF198	14*	BF363	47	BU105/02	1.64	OC71	.49	TIP112	.90	2N5296	.77																		
AF181	1.61	BC118	1.9*	BC171	.15*	BC482	.65	BD144	2.49	BF115	.59	BF199	14*	BF422	47	BU108	1.80	OC72	.49	TIP117	1.00	2N5496	.61																		
				BC172	1.9*	BC483	.65	BD150A	.69	BF121	.21	BF200	21*	BF423	.51	BU110	3.00	OC76	.37	TIP121	.66	2N5496	.61																		

### THYRISTORS, SILICON SWITCHES, DIACS

BFT42	.49		
BFT43	.49	BT100	1.20
BR100	.49	BT116	1.24
BR101	.59	BT119	2.49
BR102	1.30	BT120	2.49
BR103	.59	CI065	1.10
BT106	1.50	OT112	1.60
BT108	1.30	TIC46	.80

### BRIDGE RECTIFIERS

B40	1.05	BY164	.60	KB501	1.40
BY179	.83	WO2	.58		
BYW21	1.96	WO4	.54		
BYW24	2.50	WO6	1.28		
BYW61	3.20	BR1	.52		
BYW62	3.20	BR2	.74		
BYW64	4.70	BR3	.88		
ITT3CD	.80	BR4	.82		

### DIODES AND RECTIFIERS

AA112	20*	BA115	22	BAX16	08*	BY206	19*	BYX10	20*	IN4007	16*
AA118	18*	BA145	16*	BY126	20*	BY207	22*	OA47	18*	IN4148	.06
AA119	18*	BA156	20*	BY127	20*	BY210/400	40	OA91	18*	IN4448	.34
AA143	20*	BA202	18*	BY176	16*	BY210/800	50	IN4001	10*	IN5401	.24
AA144	14*	BA219	18*	BY182	1.03	BY251	.35	IN4003	12*	IN5408	.42
AY102	2.30	BA316	.40	BY184	.84	BY255	.38	IN4004	12*	ITT44	.08*
AY106	2.30	BA317	.44	BY187	1.00	BY298	.70	IN4005	12*	ITT2002	.38
BA102	.25	BAX13	16*	BY199	.33	BY299	.72	IN4006	14*		

### ZENER DIODES

400Mw 82V8E TYPE	.12*
Values 2.4V 62V	
1W 82X81 TYPE	.25*
Values 3.3V 200V	
10W (STUD MOUNTING)	1.30
Values 4.7V 200V	

### INTEGRATED CIRCUITS

BRCM200	3.34	SN72723L	2.20	TBA851	3.00
BRCH300	3.42	SN7603N	2.90	TBA873	2.19
BR1330	.80	SN78013N	1.90	TBA890	2.85
BT122	5.21	SN78013ND	1.90	TBA100	1.61
BT15018	2.57	SN78023N	1.90	TBA120A	2.84
CS00	3.87	SN78023ND	1.51	TBA720	2.00
CA270A	3.80	SN76033N	1.90	TBA800	1.22
CA270BE	3.70	SN78110N	1.90	TBA101AS	2.62
CA505	1.61	SN782260N	1.98	TBA105	2.22
CA758E	4.10	SN78227N	1.70	TBA820	2.10
CA920A	2.58	SN78228N	1.85	TBA890	3.94
CA2121	2.40	SN78530P	1.60	TBA920	3.23
CA3089E	4.48	SN78532N	2.00	TBA940	3.09
CA3090Q	1.98	SN78533N	2.00	TBA9502A	3.07
ETT6016	3.20	SN78544N	2.00	TBA970	4.09
ETT6016B	3.20	SN78546N	2.90	TBA980	2.93
LM1351	2.00	SN76866	1.30	TBA1440G	3.33
LM1370	2.38	TAA350A	2.80	TAA1441	3.33
MC1307P	2.80	TAA550A	.60	TCA270	3.00
MC1310P	2.40	TAA550B	.60	TCA270S	4.09
MC1327AP	3.27	TAA550C	.60	TCA290A	3.23
MC1327P	1.50	TAA570	1.98	TCA420A	2.04
MC1330P	1.00	TAA591	2.77	TCA440	1.98
MC1348P	1.98	TAA611B	2.83	TCA840	2.97
MC1351P	1.98	TAA630S	2.80	TCA850	3.42
MC1352P	1.65	TAA681B	2.83	TCA730	3.22
MC1358P	1.60	TAA700	3.91	TCA750	2.43
MC7724CP	1.80	TBA231	1.29	TCA800	3.12
ML237B	2.80	TBA240A	4.67	TCA820	2.17
SAA570	2.68	TBA325	1.57	TCA830S	2.13
SAA700	4.90	TBA395	3.34	TCA900	3.00
SA560S	3.30	TBA396	2.79	TCA910	2.90
SA5670S	3.30	TBA440C	3.30	TCA940	1.90
SA580	3.84	TBA480	2.20	TDA440	3.54
SA590	3.84	TBA480	2.20	TDA440	3.54
SA5660	4.20	TBA500	2.83	TDA440N	3.33
SA5670	4.20	TBA510	2.63	TDA1170	3.81
SC9503P	1.				

### QUARTZ LCD 5 Function

Hours, mins, secs., month, date, auto calendar, back-light, quality metal bracelet.

**£6.65**

Guaranteed same day despatch. Very slim, only 6mm thick.



M1

### SOLAR QUARTZ LCD 5 Function

Genuine solar panel with battery back-up. Hours, mins., secs., day, date. Fully adjustable bracelet. Back-light. Only 7mm thick.

**£8.65**

Guaranteed same day despatch.



M2

### QUARTZ LCD 11 Function

SLIM  
CHRONO

6 digit, 11 functions. Hours, mins., secs., day, date, day of week. 1/100th, 1/10th, secs., 10X secs., mins., Split and lap modes. Back-light, auto calendar. Only 8mm thick. Stainless steel bracelet and back. Adjustable bracelet. Metac Price



**£10.65** Thousands sold! Guaranteed same day despatch.

M3

### QUARTZ LCD ALARM 7 Function

Hours, mins., secs., month, date, day. 6 digits, 3 flags plus continuous display of day and date or seconds. Back-light. Only 9mm thick.

**£12.65**

Guaranteed same day despatch.



M4

### MULTI ALARM 6 Digits 10 Functions

- Hours, mins., secs.
- Months, date, day.
- Basic alarm.
- Memory date alarm.
- Timer alarm with dual.
- Time and 10 country zone.
- Back-light.
- 8mm thick.



**£18.65**

M5

### FRONT-BUTTON Alarm Chrono Dual Time

6 digits, 5 flags, 22 functions. Constant display of hours and mins., plus optional seconds or date display. AM/PM indication, month, date. Continuous display of day. Stop-watch to 12 hours 59.9 secs., in 1/10 second steps. Split and lap timing modes. Dual time zones. Only 8mm thick. Back-light. Fully adjustable open bracelet.



**£22.65**

M6

Guaranteed same day despatch

### SOLAR QUARTZ LCD Chronograph with Alarm

Dual Time Zone Facility  
6 digits, 5 flags. 22 functions. Solar panel with battery back-up. 6 basic functions. Stop-watch to 12 hours 59.9 secs., in 1/10 sec., steps. Split and lap timing modes. Dual time zones. Alarm. 9mm thick. Back-light. Fully adjustable bracelet.



**£27.95**

M7

### ALARM CHRONO with 9 world time zones

- 6 digits, 5 flags.
- 6 basic functions.
- 8 further time zones.
- Count-down alarm.
- Stop-watch to 12 hours 59.9 secs. in 1/10 sec. steps.
- Split and timing modes.
- Alarm.
- 9 mm thick.
- Back-light.
- Fully adjustable bracelet.



**£29.65**

M8

### SOLAR QUARTZ LCD Chronograph

Powered from solar panel with battery back-up. 6 digit, 11 functions. Hours, mins., secs., day, date, day of week. 1/100th, 1/10th, secs., 10X secs., mins. Split and lap modes. Back-light, auto calendar. Only 8mm thick. Stainless steel bracelet and back. Adjustable bracelet. Metac Price



**£12.65**

Guaranteed same day despatch.

M9

### SEIKO Alarm Chrono

LCD, hours, mins., secs., day of week, month, day and date, 24 hour Alarm, 12 hour chronograph, 1/10th secs., and lap time. Back light, stainless steel, HARDLEX glass. List Price £130.00



METAC PRICE

**£105.00**

M10

### SEIKO MEMORY BANK

Calendar watch M354  
Hours, mins., secs.  
Month, day, date in 12 or 24 hour format all indicated continuously. Monthly calendar display. Monthly, year and all dates for any selected month over 80 year period. Memory bank function. Any desired dates up to 11 can be stored in advanced. 2 year battery life. Water resistant. List Price £130



Metac Price **£79.50**

M11

### SEIKO-STYLE Dual time-alarm Chronograph

Mineral glass face. Battery hatch for DIY battery replacement. Top quality finish with fully adjustable bracelet.



**£35.00**

M12

### HANIMEX Electronic LED Alarm Clock

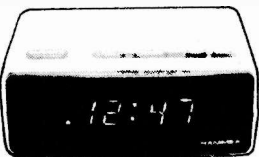

Features and Specification:  
Hour/minute display. Large LED display with p.m. and alarm on indicator. 24 Hours alarm with on/off control. Display flashing for power loss indication. Repeatable 9-minute snooze. Display bright/dim modes control. Size: 5.15" x 3.93" x 2.36" (131mm x 11mm x 60mm)  
Weight: 1.43 lbs (0.65 kg). AC power 220V.

**£9.65** Thousands sold!

Mains operated.

Guaranteed same day despatch.

M13

### HANIMEX portable LCD clock radio

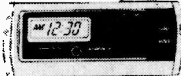

- Time set & alarm controls.
- Snooze & sleep controls.
- Wake to music or alarm.
- AM/PM indicator.
- Battery operated. No plug required.
- Receives all standard AM radio broadcasts.
- Drawstring carrying case included.
- Back-light.
- Batteries supplied free.
- Quartz crystal controlled.

**£17.95**

M14

#### HOW TO ORDER

Payment can be made by sending cheque, postal order, Barclay, Access or American Express card numbers. Write your name, address and the order details clearly, enclose 30p for post and packing or the amount stated. We do not wait to clear your cheque before sending the goods so this will not delay delivery. All products carry 1 year guarantee and full money back 10 day reassurance. Battery fitting service is available at our shops. All prices include VAT.

Trade enquiries: Send for a complete list of trade prices - minimum order value £100.  
Telephone Orders: Credit card customers can telephone orders direct to Daventry or Edgware Rd., 24 hour phone service at both shops: 01-723 4753 03272-76545.



### QUARTZ LCD Ladies 5 Function

Only 25 x 20mm and 6mm thick. 5 function. Hours, mins., secs., day, date and back light and auto calendar. Elegant metal bracelet in silver or gold. State preference.



**£9.95**

Guaranteed same day despatch.

M15

### Price breakthrough only £18.95



#### OUTSTANDING FEATURES

- **DUAL TIME.** Local time always visible and you can set and recall any other time zone (such as GMT). Also has a light for night viewing.
- **CALENDAR FUNCTIONS** include the date and day in each time zone.
- **CHRONOGRAPH/STOPWATCH** displays up to 12 hours, 59 minutes, and 59.9 seconds.
- On command, stopwatch display freezes to show intermediate (split/lap) time while stopwatch continues to run. Can also switch to and from timekeeping and stopwatch modes without affecting either's operation.
- **ALARM** can be set to anytime within a 24 hour period. At the designated time, a pleasant, but effective buzzer sounds to remind or awaken you!

Guaranteed same day despatch. **M16**

# Metac

ELECTRONICS  
& TIME CENTRES

North & Midlands  
67 High Street, DAVENTRY  
Northamptonshire  
Telephone: 03272 76545

South of England  
327 Edgware Road  
LONDON W.2  
Telephone: (01) 723 4753



ARE YOU IN THE DARK?  
...ABOUT OUR



## COLOUR T.V. PANEL EXCHANGE REPAIR SERVICE

FULL RANGE OF  
THORN · RBM · PHILIPS  
PYE · INVICTA · GEC  
DECCA · TELPRO  
AND MANY OTHER MAKES

90 DAY GUARANTEE ON ALL REPAIRS  
SAME DAY POSTAL SERVICE

We employ a large skilled Staff, who utilise some of the most sophisticated Test equipment available, inclusive of AUTOMATIC FAULT FINDING COMPUTERS together with specially designed SERVICING JIGS which in short means to you —

HIGH QUALITY REPAIRS — AT LOW COST



ONE OFF  
OR



100 OFF · NO ORDER TOO  
LARGE OR SMALL

SEND FOR PRICE LIST

SEND FOR CATALOGUE  
BLOCK DISCOUNTS FOR TRADE CONTRACTS

TO

### Campbell Electronics Ltd.

Factory Unit E5, Halesfield 23, Telford · Shropshire · TF7 4QX  
Telephone: Telford (0952) 584373, Ext. 2. Telex 35191 Chamcon

## TV LINE OUTPUT TRANSFORMERS

by FAST RETURN OF POST SERVICE

### MONO LOPTS

Most makes supplied

£7.90 TRADE

£8.50 RETAIL

p&p 70p each item

### COLOUR LOPTS

Philips G8, ITT CVC5-9, Decca Bradford series 10 & 30

£8.35 TRADE

£9.50 RETAIL

p&p 70p each item

WINDINGS p. & p. 50p each item

Bush colour. (Hybrid quadrupler version)

£6.25

Decca CTV19/25 (non-tripler version)

Primary £6.25

EHT £7.20

Philips G6 (dual & single standard)

Primary £6.25

(EHT winding on exchange basis only)

EHT £7.20

Pye 691, 693 & 697 (please state which)

Primary £4.60

EHT £3.10

EMO 90 degree

Primary £6.25

PRICES INCLUDE 15% VAT

S.A.E. all enquiries

All lopts and windings are new and guaranteed for 6 months.

### PAPWORTH TRANSFORMERS

80 Merton High Street  
London SW19 1BE

Barclaycard and  
Access welcome



01-540 3955

## Technical Training in Radio, Television and Electronics

Start training TODAY and make sure you are qualified to take advantage of the many opportunities open to trained people. ICS can further your technical knowledge and provide the specialist training so essential to success.

ICS, the world's most experienced home study college has helped thousands of people to move up into higher paid jobs — and they can do the same for you.

Fill in the coupon below and find out how!

**There is a wide range of courses to choose from, including:**

### City and Guilds Certificates:-

Telecommunications Technicians,  
Radio, TV and Electronics Technicians,  
Electrical Installation Work,  
Technical Communications,  
Radio Amateur,  
MPT General Radio Communications  
Certificate.

### Diploma Courses:-

Electronic Engineering,  
Electrical Engineering,  
Computer Engineering,  
Radio, TV, Audio Engineering, Servicing and  
Maintenance. (inc Colour TV)  
New Self-Build Radio Courses with Free Kits.

### Colour TV Servicing

Technicians trained in TV Servicing are in constant demand. Learn all the techniques you need to service Colour and Mono TV sets through new home study courses which are approved by a leading manufacturer.

### The ICS Guarantee

If you are studying for an examination, ICS will guarantee coaching until you are successful — at no extra cost.

POST OR PHONE TODAY FOR FREE BOOKLET.

I am interested in.....

Name.....

Address.....

..... Phone No: .....

### ICS

International Correspondence Schools,  
Dept. R285, Intertext House,  
LONDON SW8 4UJ. Tel 622 9911  
(all hours)



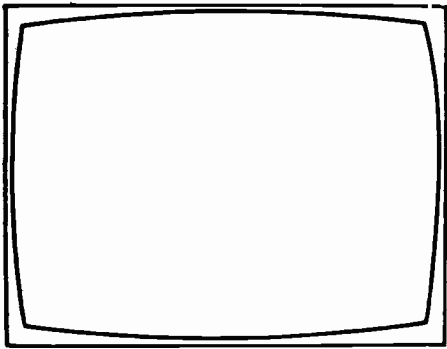

# TELEVISION

## EDITOR

John A. Reddihough

## ASSISTANT EDITOR

Luke Theodossiou

## ART EDITOR

Roy Palmer

## ADVERTS MANAGER

Roy Smith 01-261 6671

## CLASSIFIED ADVERTS

Colin R. Brown 01-261 5762

## CORRECTIONS

An error occurred in Fig. 7, page 148 last month in connection with converting the Sony Model KV2000 Mk. II for use as a receiver/monitor. IC301 at the top left of this diagram should have been shown as IC201. IC201 is the i.f./video/a.g.c. i.c., type CX100D in the earlier version of the chassis and type CX177 in the later version. IC301 is the chroma/luminance signal processing i.c., type CX108 in both versions.

For those who wondered what the gap in the right-hand column on page 138 was about, the sidehead "Chroma Demodulators" apparently fell off before the page was photographed for platemaking.

## The \$64,000 Question

"I'm thinking of buying/renting a new TV set" he/she says. Excellent you think. Do the trade no end of good. That's the sort of thing we like to hear. Sir Jules will be pleased. Then it comes. What you should have expected from the start. "What do you suggest?" Er, you start (we'll assume you're not a salesman, who's supposed to be trained to deal with this sort of thing), well, ah, um, let's see . . . Your mind races round, remembering that the last set you actually bought was five years ago and secondhand then, though a jolly good buy. Come on, think, there must be something obvious to suggest! The mind seems to be getting blanker however. Perhaps to be helpful one could suggest a couple of makes to avoid? Not so easy as a few years back. Meanwhile he/she's still waiting, beginning to wonder no doubt why the person who's supposed to know about TV can't give an instant answer to a simple question like that. Amazing how we get caught out by it, isn't it?

We had a reader write in the other day. "Why don't you do reviews of TV sets?" he asked. People would certainly sit up and take notice. "Double the sales of that issue" he said. But (to sidetrack for a moment) that wouldn't be very helpful to us. Magazine publishing could not adjust to sales jumping up and down in such a manner. It assumes a fairly steady sale, increasing a bit if you spend a little on advertising an issue, print orders otherwise being based on what was sold the month before. There just aren't the facilities for slapping the print back on the presses and running off a few thousand more. But I digress.

Next came a cruel jibe. If *Which?* can do it, surely with your experience . . .? Well now, we have a high regard for *Which?* It fulfills an extremely useful role, and has without doubt contributed no little to the standards of consumer goods and services. But: when you plough through (some of them need it) a *Which?* report and get to the recommendations at the end, you may sometimes feel that you haven't exactly been vouchsafed a divine revelation on the subject. A couple of duds may have been exposed, and some recommendations within a certain price range made. Really, *Which?* scores with those who have the time to study their findings and don't have much idea to start with about what they want and what's available. So, TV wise, you'd get a run-down on the various facilities offered by different types of set, and the prices they sell for. Plus some indication of performance – with TV sets this will inevitably be rather vague.

With a publication such as *Television* we have to assume that our readers are reasonably familiar with the currently available chassis and the "extras" on offer – teletext, remote control and so on. If not, you haven't been paying attention, have you? So you should be way ahead of the *Which?* reader. If you really think we can come up with a snap recommendation however, you must think we've got some vital inside information. But we haven't, and there isn't any.

All we can say is: make sure to start with you know what you want and, having done so, look for a good offer from a reputable outlet. The fact is – and this probably applies to most consumer goods nowadays – that sets are much of a muchness. They have to be, if setmakers are to stay in business. You won't find junk, and you won't find a set that's vastly superior technically because it would cost so much to make that no one would buy it. It'll have either a PIL type tube or a 20AX/30AX tube. Probably a U321 tuner unit and a TDA2540 i.f. strip. There'll be circuit diversity elsewhere, but you'll get solid-state reliability. The picture won't vary all that much between sets, while the sound will obviously depend on the speaker used. Some imported sets may have higher than average gain, but unless you live in a remote area this fact will be quite irrelevant to your viewing.

So what are we doing publishing a long article on the Thorn TX9 chassis? Well, we think this is a notable achievement as a piece of careful engineering aimed at a certain section of the domestic market – smaller screen colour sets. The idea primarily is to examine the technical features. As to what you eventually buy – we must hand you over to the salesman!

Ah yes, and that opening question, still unanswered. How do you deal with it? Well, you can hum and ha, as we've done. You can outline the main features of today's sets. You can then turn the tables: "You'll have to make you're own mind up" you say. "Decide what you want, then check up on what's on offer". Only we never do. We just hum and ha and look silly. It's an unfair world, isn't it?

# Teletopics

## TELESOFTWARE

Whatever next? Well, it seems that ITV and Mullard have been working for some time on a project, called Telesoftware, that would add to the teletext system a home computing facility. The idea is logical enough. Given a teletext receiver, you've already got a computer display system and a certain amount of computer storage capacity. What you haven't got is something to do the computing and computer programmes. In this age of the microprocessor the former is simple and cheap enough to provide, while simple computer programmes could be transmitted as extra teletext pages and stored in the receiver for use as required. In fact the IBA has for a couple of years been carrying out experimental transmissions to test the viability of the system, while Mullard have been working on the extra chips that would need to be added to the teletext receiver. The advantages then are that for little extra cost a teletext-equipped receiver could be adapted to act as a home computer, with a range of computer programmes that would otherwise be expensive to obtain available off-air at no extra cost. The cost of adding this computing facility to a teletext equipped receiver is, in mass production terms, expected to be about £50.

The Department of Industry has provided funds to enable Brighton Polytechnic to instal ten specially equipped receivers so that further tests and experiments with the system can be carried out. The proposed computer programmes would be suitable for making simple calculations and could provide a wide variety of TV games, educational courses etc. off-air. According to the IBA, the basic system has already been proved to be workable and the next step is to decide upon a standard format. In this connection, talks are being held with BREMA, the Post Office and the BBC. The chairman of the steering committee is Bernard Rogers, who was very much involved in the development of teletext.

A further user requirement would be a keyboard, though this is already part of a viewdata installation. The computer programmes would be decoded off-air for immediate use or stored for later use. According to the IBA, users would require no special computing knowledge – in fact operating Telesoftware would be “as easy as selecting Oracle pages”.

The IBA is also carrying out a series of trials, in conjunction with the National Maritime Institute, to assess the usefulness of teletext as a navigational aid. The Dover transmitter is being used to provide ships with details of wrecks and hazards in the English Channel, one of the most congested shipping lanes in the world.

## MORE MICROCOMPUTERS

Sorry if it seems to be all computers this month, but that seems to be the way things are going at present. Last month we mentioned the systems being proposed by Philips and ITT, using a microcomputer as the basis of a flexible TV receiver control system. The idea is that using an off-the-shelf microcomputer chip enables such systems to be realised more cheaply than using complex i.c.s specially developed for the purpose. At the recent Electronics '79 exhibition, Mullard were demonstrating an up-market “all-electronic” radio, in which a microcomputer chip is used as the centre of a system providing digital control of both the r.f. and a.f. sections of the

receiver. No need to touch the set any more: just send it some signals from the remote control transmitter unit and the set will tune itself as required and adjust its volume/treble/bass/stereo balance – with numerical read-out so that you can see it's done what you asked it to do.

Meanwhile GI Microelectronics have introduced a low-cost system called Teleview, giving access to both teletext and viewdata in conjunction with a normal TV set. The system is controlled by a microcomputer chip of course, GI's PIC1650. This, together with two other LSI chips and some interfacing components, can be mounted on a printed board measuring about 4 x 6in. GI claim that the system offers significant performance advantages over existing teletext and viewdata systems using special-purpose chips. The system is compatible with GI's existing TV chips for digital tuning, channel indication, remote control – and also with external accessories such as copy printers and keyboards. Because the system uses a standard microcomputer chip, GI hope that the cost will be low enough to attract manufacturers of TV add-on equipment as well as setmakers.

Texas Instruments have introduced in the UK a home computer, Model TI-99/4, which can be used by beginners and skilled users alike. All they need is a power supply source – and a TV set to provide the display. The programmes are held in solid-state modules which can be snapped into position. The cost of these varies from £14.95 to £44.95 depending on the complexity of the programme. The TI-99/4 itself comes at a price of about £665 including VAT. Various accessories, including a speech synthesiser, remote control and a printer, will be made available later this year.

In view of all this activity, it's as well that we're starting a two-part article this month on Computerised TV. This explains how a typical microcomputer chip, a version of the Texas TMS1000, is used to control various operations in Sanyo's Betamax VCR. Well now, what would you expect to find in the new range of TV sets just introduced in the UK by Finnish setmaker Salora, the F range? You guessed it of course: another version of the Texas TMS1000 chip, used here to control a digital search-tuning system and to make provision for additional facilities which can be added later – for example remote control with a standard set, video input/output, teletext and viewdata. Incidentally, Salora refer to the chip as a microprocessor, though it's actually a microcomputer chip. There seems to be some general looseness about the use of these terms at present. The difference is explained in our Computerised TV article.

Finally, if you want to teach yourself computer programming, Cambridge Learning Enterprises have just published a four-part self-teaching course at £7.50. This is available from Cambridge Learning Enterprises, Rivermill Lodge, St. Ives, Cambridgeshire PE17 4EP. You don't need to have a computer to follow the course, and at a quick glance we thought we might even be able to follow it ourselves...

## TOSHIBA TO LAUNCH LVR VCR IN THE UK THIS YEAR

Toshiba's fixed-head, longitudinal-scan VCR, which uses an endless loop cassette and was unveiled in prototype form only last June at the Chicago Consumer Electronics Show, is scheduled for launch in the UK this September – at a “target price” of £250. The machine will have a two-hour recording capability, and a three-four hour cassette is under development. At the sort of price envisaged, the Toshiba LVR machine must be considered a very serious contender in the domestic VCR market. As to the viability of the LVR system, it's interesting that Toshiba's fixed-head VTR technology is already in use in a microcomputer controlled document filing

system which was announced in Tokyo last November: equipped with an electronic printer/copier, the system stores information on cassettes which can each handle 3,000 A4 pages of information.

The first "Made in Britain" Toshiba colour sets are now being produced at the Rank-Toshiba Plymouth plant – just eleven months after the joint venture and manufacturing agreement were announced. The new production line for the sets is the first phase of a £3 million modernisation programme. A second line, boosting production to 350,000 sets a year, 40 per cent of which will carry the Toshiba brand name for both home and export sale, is scheduled for phase two of the programme. The first sets incorporate a Toshiba black-stripe, 90° 20in. SSI tube: production of 22in. sets will start this month (February). The chassis is the Rank T24E, and we'll be including more details of this next month.

In Japan, Toshiba have shown a talking TV set! The receiver will accept thirty commands, such as select channel four or switch off, giving the message OK if the command has been received and understood.

Scheduled for release by Toshiba in the UK late this summer is a 45in. screen colour projection system priced at "around £2,000".

### **RANK'S VIDEOCASSETTE LIBRARY**

Rank is the latest firm to enter the pre-recorded videocassette field. The first twenty titles in the Rank Video Library include such well-known films as "The 39 Steps", "Bugsy Malone", "Brief Encounter" and "Doctor in the House". Every title is available in the VHS, Beta and Philips VCR/LP formats. At the moment Rank is signing up dealers to handle the cassettes.

### **MONO PORTABLE WITH REMOTE CONTROL**

A new version of the Pye/Philips TX 12in. monochrome portable receiver is being launched, featuring the addition of a remote control handset. It will be the world's first monochrome portable with remote control, and is being produced, along with the existing TX receivers, at the Lowestoft plant. The new version is expected to sell for around £72, about £12 more than the basic version, and will be known as the TX+.

### **NEW COLOUR CAMERA FROM THORN**

A new colour camera, Model 3V17, has been added to the Thorn range of video equipment. The camera is based on the JVC GX33, and incorporates a newly-developed single 2/3in. vidicon tube with integral colour-stripe filter. It weighs only 1.4kg, has a ×3 zoom lens with TTL (through-the-lens) viewfinder and a built-in split-image range finder as an additional check on focusing. The auto iris control can be overridden for manual adjustment under difficult lighting conditions. There's also a three-position colour compensation switch (with additional manual control for fine adjustment) to ensure that natural colours are obtained in any lighting conditions without the need for optical filters. Using the sensitivity select switch, recording in light conditions as low as 100 lux is possible.

### **TRADE FIGURES**

The latest figures issued by BREMA cover the first nine months of 1979. The total number of colour sets delivered during the period was 1,272,000, of which imports accounted for 354,000. This represented a very slight increase in total

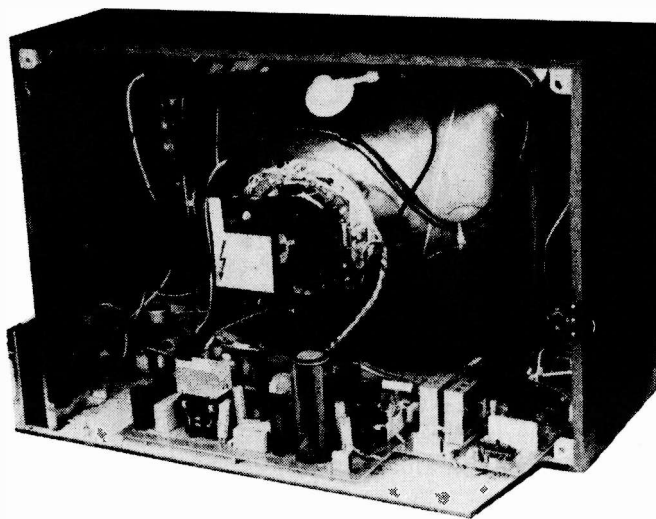

*The "Television" colour receiver project – Manor Supplies' version which can be seen at 172 West End Lane, London NW6.*

deliveries compared to the same period in 1978, with imports taking a slightly higher proportion. Deliveries of small-screen monochrome sets totalled 925,000, of which just over half were UK produced. There was a substantial decline (38 per cent) in deliveries of large-screen monochrome sets.

The biggest growth was in VCR deliveries, where the total rose to 129,000, 180 per cent higher than in 1978. This increase was somewhat higher than general expectations in the trade.

We're inclined to doubt however the suggestion made in one quarter that by the end of 1979 over 250,000 VCRs will have been installed in UK homes. Though this claim was arrived at after "an analysis of import figures over the last five years", it would assume that all the VCRs imported have actually been sold/rented out – and that all have gone to domestic users! Prior to 1977 the number of VCRs supplied to domestic users was minimal – a few thousand. 1978 saw the full impact of the Philips N1700 and the introduction of the SVR, VHS and Betamax systems. VCR deliveries in that year were in the region of 60-65,000. Exact figures are not available since some machines are re-exported and the totals include professional VTR equipment. The educational and industrial market is understood to total around 20,000 machines annually.

In the first four years of Ceefax/Oracle transmissions, only some 4,500 teletext equipped sets were sold. There was a substantial improvement during 1979, with the total number of sets sold/rented rising to over 35,000 and the prediction that 40,000 sets would be in domestic use by Christmas. Sales of around 200,000 are predicted for 1980.

### **SIBILANTS – KT3 CHASSIS**

A few Pye/Philips colour sets fitted with the KT3 chassis have produced complaints of excessive sound sibilants. The recommended modification is to increase the value of the de-emphasis capacitor C5177 from 0.0082µF to 0.022µF.

### **IBA'S DIGITAL DEVELOPMENTS**

The IBA has drawn up specifications for an experimental two-hop, two-way 11GHz microwave TV link using digital techniques. The aim is to provide a test bed for the further evaluation of digital TV techniques and bring to light any problems that may arise when a digital link is used with existing analogue links.

The feasibility of practical video recording in digital form

*– continued on page 210*

# Assessing the Thorn TX9 Chassis

*Eugene Trundle*

SINCE the start of colour TV in the UK, Thorn have always been amongst the first in the field with technical advances. The world's first solid-state colour receiver (the 2000 chassis); the first use of a switch-mode power supply in a TV chassis (the 3000/3500); the use, right from the start, of modular chassis construction; and the Syclops integrated line timebase/power supply system (9000 chassis) – all these are outstanding examples. Much of Thorn's technology has been concerned with cost reduction and simplified field servicing, reflecting the fact that with only a few exceptions the receivers produced by the company have been for the rental and the bread-and-butter type of market – a sort of Volksvision one might say.

We have the greatest respect for Thorn as technical innovators, despite many a workbench skirmish with one or other of their products, and many a muttered oath when we should have known better . . . Those of us in the servicing trade have necessarily got to know Thorn colour sets well over the years: they've often been featured in these pages, and there can be few engineers who are not familiar with the 3000/3500 and 8000/8500/8800 series of chassis.

World-wide excess colour television receiver production capacity and the saturation of most of the main domestic TV markets in the developed world have led to a period of harsh competition. In the past many UK setmakers have produced a multiplicity of chassis types and variations to cater for different presentations and tube types. Such extravagance is no longer feasible, and many of the chassis that have become familiar in recent years are now being phased out.

A major part of Thorn's plans for survival as a large-scale setmaker in these difficult circumstances is the TX9 chassis, which is intended to drive any size of 90° PIL type tube up to and including 20in. It's understood that larger sets will be fitted with the forthcoming TX10 chassis – for 22 and 26in. 30AX tubes. The TX9 requires only one simple modification for different tube sizes – a shorting link in the beam limiter circuit – and will operate on mains voltages in the range 185-265V with no adjustment.

## **Basic Features**

Gone is the metal chassis – the TX9 consists of a single braced PCB with one daughter board containing the i.f. strip. Since the chassis is intended for export as well as the home market, the pluggable i.f. panel simplifies production. The power consumption is way down on previous Thorn chassis, being only 45W at zero beam current. An inverter which fits inside the cabinet is available, enabling the set to be operated in a boat, car or caravan from 12 or 24V d.c. supplies. The very compact board layout has been made possible by the use of seven i.c.s, including a 28-pin chip which handles the luminance signal and carries out the complete decoding process. There's a diode-split type line output transformer, and a new full-wave thyristor power supply circuit: these two areas should represent a vast reduction in complexity and an improvement in reliability compared to current designs.

A great deal of money has been invested by Thorn in setting up the production line for the TX9, whose name we're told stems from the T of Ford motor car fame, since the

production philosophy and intended market are similar, X for extra technology and 9 for the tube's deflection angle. Much of the production line is automated and under computer control. New flow-soldering techniques are used on the single PCB which, because of its construction, brings other advantages. The total component count for the TX9 is 410, compared with 618 for the 9000 chassis it replaces. This implies greater reliability, especially as there are 400 or so fewer soldered joints to worry about and a corresponding reduction in plugs, sockets and wiring. There are fewer internal adjustments in the TX9 compared to its predecessors – and visually the set is less complex than the monochrome receivers of fifteen years ago.

These then are the bare bones of the TV chassis on which Thorn is pinning its future. The techniques used are not completely new: some Japanese colour sets have for a time used a single PCB; SAW filters and diode-split line output transformers have been used in other setmaker's chassis for some time now; while our own colour receiver project very nearly had a single-chip decoder (and a modified version soon will have – editor). Nevertheless the chassis as a whole represents a well thought out use of the latest in TV receiver technology. So let's take a closer look at some of the more interesting departments.

The tube used in the initial models is a 90° black-matrix PIL (precision in-line) type made by Hitachi. It incorporates soft-flash and other recent developments in tube technology, and has a sealed on, self-converging saddle/toroidal deflection yoke. No NS raster correction is required, while a diode-modulator provides EW raster correction and width stabilisation. The type used in the 14in. models (the 3755 and 3790) is designed to run at a higher than normal focus voltage (7kV) in order to minimize spot size. The tubes are guaranteed for two years, with an optional extension.

## **Signal Stages**

The first models (14in.) to use the TX9 chassis employ a conventional six push-button assembly for programme selection, though there'll no doubt be many variations on later

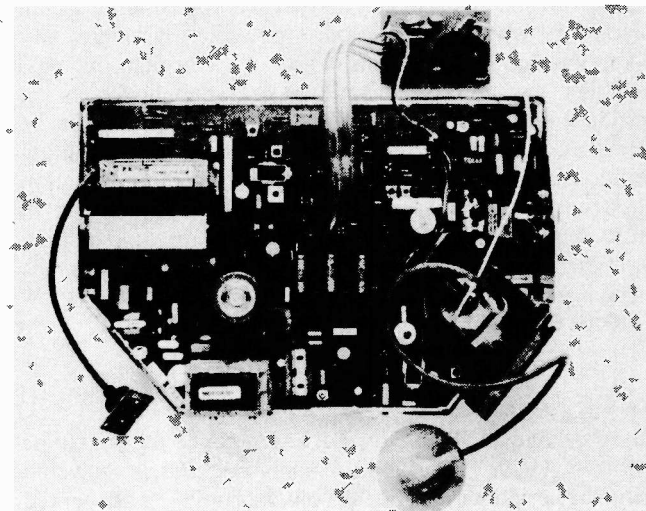

*Thorn's TX9 single-board colour chassis.*

# MANOR SUPPLIES

## PAL COLOUR BAR GENERATOR

plus CROSS HATCH KIT (Mk. 4)

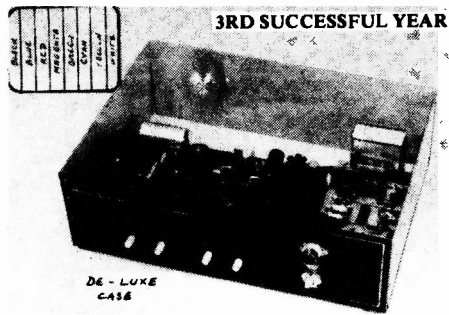

- ★ Output at UHF, applied to receiver aerial socket.
- ★ In addition to colour bars R-Y, B-Y etc.
- ★ Cross-hatch, grey scale, peak white and black level.
- ★ Push button controls, battery or mains operated.
- ★ Simple design, only five i.c.s. on colour bar P.C.B.

**PRICE OF MK4 COLOUR BAR & CROSS HATCH KIT £40.25 + £1.25 P/Packing. DE-LUXE CASE £5.95. ALUMINIUM CASE £2.95, BATT HOLDERS £1.70, ALTERNATIVE STAB. MAINS SUPPLY KIT £5.55.**

ALSO THE MK3 COLOUR BAR GENERATOR KIT FOR ADDITION TO MANOR SUPPLIES CROSS HATCH UNITS. £28.75 + £1.15 p.p. CASE EXTRA £2.00. BATT. HOLDERS £1.70.

- ★★ Kits include drilled P.C. board, with full circuit data, assembly and setting up instructions.
- ★★ All special parts such as coils and modulator supplied complete and tested, ready for use.
- ★★ Designed to professional standards.
- ★★ Demonstration models at 172 West End Lane, NW6.
- ★★ Every kit fully guaranteed.

MK4 DE LUXE (BATTERY) BUILT & TESTED £66.70 + £1.50 P&P. VHF MODULATOR (CHI to 4) FOR OVERSEAS £4.00. INFORMATION ON VIDEO TAKE-OFF FOR C.C.T.V. (ABOVE PRICES INCLUDE 15% VAT)

# MANOR SUPPLIES

## TELETEXT KIT (MK2)

(INCORPORATING MULLARD DECODER 6101VML)

INFRA RED REMOTE CONTROL

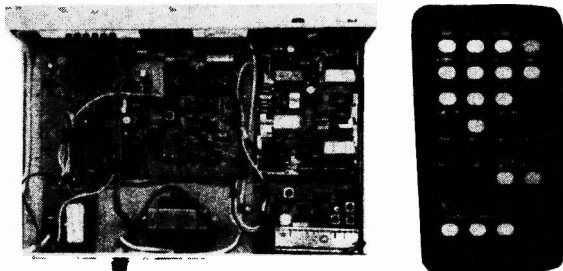

- EXTERNAL UNIT. PLUGS INTO AE SOCKET.
- LATER SPEC (DOUBLE HEIGHT BACKGROUND COLOUR ETC).
- INFRA-RED REMOTE CONTROL (MULLARD 5000 SYSTEM) STATION SELECTION, TEXT, MIX, TIME, DOUBLE HEIGHT, HOLD, CLOCK, REVEAL RESET ETC, ETC.
- INCLUDES COMPLETE & TESTED 6101 VML (MULLARD) DECODER, SAW FILTER IF PANEL & 32 BUTTON REMOTE CONTROL HANDSET.
- SUITABLE FOR BBC DEAF SUB-TITLE TRANSMISSIONS REMODULATES PICTURE.
- CONVERTS ANY UHF RECEIVER TO STATION SELECTION REMOTE CONTROL AND TELETEXT.
- EVERY KIT EASY TO ASSEMBLE & FULLY GUARANTEED.
- WORKING MODEL AT 172 WEST END LANE, N.W.6.

FURTHER DETAILS ON REQUEST

## COLOUR. UHF & TELEVISION SPARES

NEW 'TELEVISION' COLOUR RECEIVER PROJECT ALL PARTS AVAILABLE AT PRESENT. POWER, SIGNAL & TIMEBASE. SEND OR PHONE FOR LIST. WORKING DEMONSTRATION SET NOW ON SHOW WITH TELETEXT.

NEW SAW FILTER IF AMPLIFIER PLUS TUNER COMPLETE AND TESTED FOR T.V. SOUND & VISION £32.80 p.p. £1.10. T.V. PORTABLE PROJECT PARTS AVAILABLE. SEND OR PHONE FOR LIST. WORKING MODEL AT 172 WEST END LANE, NW6.

TV TEST GENERATOR UHF MODULATOR £4.60 p.p. 40p.

CROSS HATCH UNIT KIT, AERIAL INPUT TYPE, INCL. T.V. SYNC AND UHF MODULATOR. BATTERY OPERATED. ALSO GIVES PEAK WHITE & BLACK LEVELS. CAN BE USED FOR ANY SET £12.65 p.p. 50p. (ALUM CASE £2.30 p.p. 80p.) COMPLETE TESTED UNITS READY FOR USE (DE LUXE CASE) £26.00 p.p. £1.25.

ADDITIONAL GREY SCALE KIT £3.35 p.p. 35p.

UHF SIGNAL STRENGTH METER KIT £20.00 (ALSO VHF VERSION) ALUM CASE £1.95 p.p. £1.25.

CRT TESTER & REACTIVATOR PROJECT KIT FOR COLOUR & MONO £25.80 p.p. £1.60.

"TELEVISION" COLOUR SET PROJECT (1974) SPARE PARTS STILL AVAILABLE. ALTV. IF COMPL. & TESTED £16.80 + £1.25 p.p.

THORN 9000 TOUCH TUNE, REMOTE CONTROL RECEIVER UNIT PLUS TRANSMITTER HANDSET £18.40 p.p. £1.40.

THORN 9000 FASCIA INCL. CHANNEL SELECTOR, INDICATOR SET CONTROLS, SPEAKER £6.90 p.p. £1.50.

PHILIPS 210 300 Series IF Panels £2.90 p.p. £1.25.

PHILIPS 210, 300 Series Frame T.B. Panels £1.15 p.p. 75p.

BUSH A823 CONVERGENCE PANEL £7.60 p.p. £1.25.

BUSH A823 (A807) Decoder Panel £8.65 p.p. £1.25.

BUSH A823 SCAN CONTROL PANEL £2.90 p.p. 80p.

BUSH A823 IF PANEL (EXPORT VERSION) £3.25 p.p. 95p.

BUSH Z718 BC6100 SERIES IF PANEL £5.75 p.p. 80p.

BUSH A816 IF PANEL (SURPLUS) £1.90 p.p. 80p.

BUSH 161 TIMEBASE PANEL A634 £4.40 p.p. £1.25.

GEC 2010 SERIES TIMEBASE PANEL £1.15 p.p. 95p.

GEC 2040 Surplus Panels, ex-rental. Decoder £5.75, T.B. £2.88 p.p. £1.25.

DECCA CTV25 Single Stand. IF Panel £4.40 p.p. 75p.

DECCA Colour T.V. Thyristor Power Supply. HT, LT etc. £4.40 p.p. £1.40.

BUSH TV 312 IF Panel (Single I.C.) incl. circuit £5.75 p.p. 75p.

BUSH TV Portable Eleven Volt Stab. Power Supply Unit £4.40 p.p. £1.10.

PYE 697 Line T.B. P.C.B. for spares £3.68 p.p. £1.25.

THORN 3000 IF Panel £9.78 p.p. £1.00.

THORN 3000 POWER LINE TB PCB £5.75 each p.p. 85p.

THORN 3000 VID. IF, DEC, FTB Ex Rental £5.75 ea. p.p. £1.00.

THORN 8000/8500 POWER/SALV. SPARES £2.88 p.p. 60p.

THORN 8000/8500 TIME BASE, SALV., SPARES £5.52 p.p. 90p.

THORN 9000 LINE T.B. SALV., SPARES £8.62 p.p. £1.38.

MULLARD AT1022 Colour Scan Coils £6.90 p.p. £1.30, AT1023/05 Convergence Yoke £2.90 p.p. 95p, AT1025/06 Blue Lat. 90p p.p. 40p.

PHILIPS G9 Signal Board Panels for small spares £4.80 p.p. £1.00.

PHILIPS G6 convergence panels £2.90 p.p. £1.20.

G8 Decoder panels salvaged £4.25. Decoder panels for spares £2.00 p.p. £1.15.

VARICAP UHF MULLARD U321 £8.97, ELC 1043/05 £6.35 p.p. 40p., G.I. type (equiv. 1043/05) £4.00 p.p. 40p. Control units, 3PSN £1.40, 4PSN £1.75, 5PSN £2.00, 6PSN £2.10, Special Offer 6PSN £1.15 p.p. 40p.

TAA 550 58p p.p. 20p. Salv. UHF varicap tuners £1.75 p.p. 40p.

BUSH "Touch Tune" assembly, incl. circuit £5.75 p.p. 85p.

VARICAP UHF-VHF ELC 2000S £9.80, p.p. 75p.

UHF/625 Tuners, many different types in stock. UHF tuners transisted. incl. s/m drive, £3.28. Mullard 4 position push button £2.88 p.p. £1.10 etc.

TRANSISTORISED 625 IF for T.V., sound, tested. £7.82 p.p. 75p.

RBM 774 250R Mains Droppers, four for £1.15 p.p. 40p.

LINE OUTPUT TRANSFORMERS. New guar. p.p. 95p.

### SPECIAL OFFER

BUSH 145 to 186SS series .....	GEC 2114J/FINELINE .....	£5.50
BUSH, MURPHY A816 series .....	GEC 448/452 .....	£1.75
DECCA DR 121/123, 20/24, MS1700, 2000, 2401 .....	THORN 1590/1591 .....	£5.50
	KB VCI, VCIH (003) .....	£3.25
FERG., HMV, MARCONI, ULTRA 850, 900, 950 Mk. 1 95011, 1400, 1500, 1580 .....	COLOUR LOPTS p.p. £1.10.	
	BUSH 182 to 1122 etc. ....	£11.30
GEC 2000, 2047 series, etc. ....	MURPHY Equivalents .....	£11.30
INDESIT 20/24EGB .....	DECCA "Bradford" (state Model No. etc) .....	£10.15
ITT/KB VC2 to 53, 100, 200, 300 .....	GEC 2028, 2040 .....	£11.30
MURPHY 1910 to 2417 series .....	GEC 2110 Series .....	£12.20
PHILIPS 19TG170, 210, 300 .....	ITT CVC 5 to 9 .....	£8.50
PYE 368, 169, 769 series .....	PYE 691, 693, 697 .....	£20.50
PAM, INVICTA, EKKO .....	PHILIPS G8 .....	£10.15
FERRANTI equivalents as above.	THORN 3000/3500 (Scan or EHT) .....	£7.85
SOBELL 1000 series .....	THORN 8500 .....	£12.50
STELLA 1043/2149 .....		

OTHERS AVAILABLE. PRICES ON REQUEST.

THORN MONO SCAN COILS (850 to 1500) £3.25 p.p. 95p.  
 THORN 950 3 Stick Tray £1.15 p.p. 55p. Most others available.  
 THORN 3000/3500 MAINS TRANSFORMER £10.15 p.p. £1.40.  
 6-3V CRT Boost Transformers £3.70 p.p. 85p., Auto type £2.10 p.p. 50p.

CALLERS WELCOME AT SHOP PREMISES (Tel: 01-794-8751)

**MANOR SUPPLIES**  
 172 WEST END LANE, LONDON, N.W.6.

NEAR: W. Hampstead Tube Sta. (Jubilee) Bus 28, 158 pass door  
 W. Hampstead British Rail Sta. (Richmond, Broad St.) (St. Pancras, Bedford)  
 W. Hampstead (Grit.Road) access from all over Greater London.

Mail Order: 84 GOLDERS MANOR DRIVE, LONDON N.W.11.  
 ALL PRICES INCLUDE VAT AT 15%

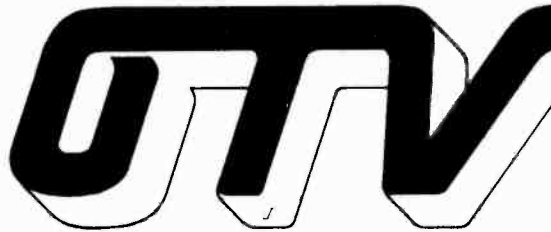

THE LARGEST STOCKS OF

GENUINE PART-EXCHANGED COLOUR T.V.'s IN THE COUNTRY - UNDER ONE ROOF.

REGULAR LARGE DELIVERIES EVERY WEEK INCLUDE—

Philips 511/512/G8 etc., Bush, Murphy, Thorn 3000/3500/8000/8500, GEC all models, Pye Varicap, Grundig, Telefunken, Saba, Decca Bradford, Nordmende, B. & O., Emo, Finlux, Luxor, Korting, Hitachi, Sanyo, Toshiba, etc., etc., etc.

STOCK UP NOW FOR THE COMING BUSY PERIOD.

SINGLE STANDARD T.V.'s FROM £20 + VAT

SPECIAL OFFER WHILE STOCKS LAST. ASSORTED DUAL STANDARD COLOUR T.V.'s IN LOTS OF TEN, ALL AT £5 EACH.

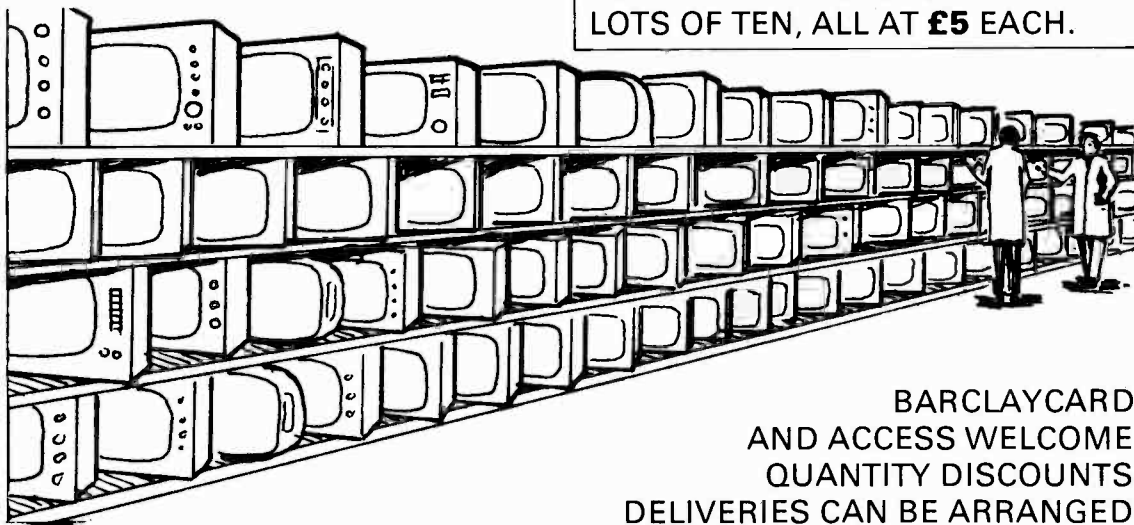

BARCLAYCARD AND ACCESS WELCOME QUANTITY DISCOUNTS DELIVERIES CAN BE ARRANGED

SUPERB TESTING FACILITIES AVAILABLE

OTV TELEVISION LTD, 144A Lea Bridge Rd, London E5 9RB. Tel: 01-985 6111/8687

OPEN MON.-SAT.

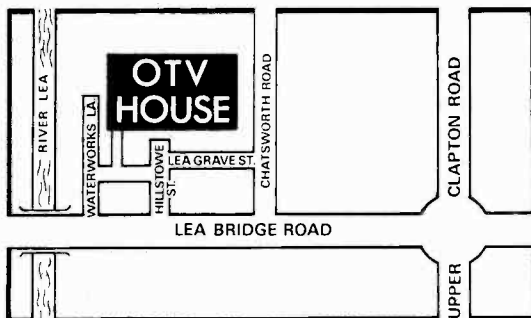

We specialise in Export

Enquiries invited from the Middle East and Third World Countries.



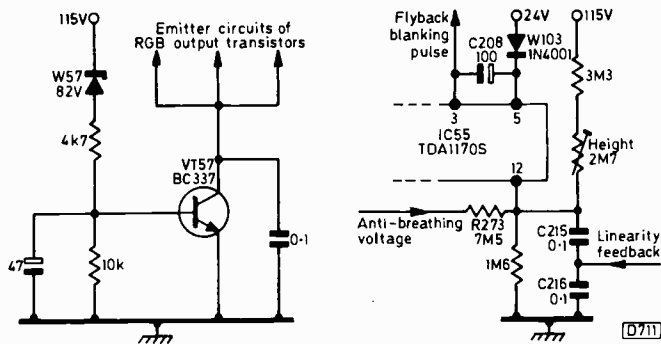

Fig. 1 (left): Switch-off spot suppression circuit.  
 Fig. 2 (right): The height and field flyback circuits.

models. The varicap tuner is followed by a Plessey SL1430 i.f. preamplifier i.c. which provides a differential output to drive the SW153 surface acoustic wave filter. The latter forms the i.f. pass band, and in turn provides a differential output to the i.f. amplifier/demodulator chip. This is the current favourite amongst setmakers, the TDA2540. There are two novel features here. First the provision of a "video defeat" line to pin 14, for possible future use with sweep tuning. And secondly the presence of an odd capacitor (C44, 10pF) in series with the a.f.c. tank coil. This capacitor effectively inserts a notch at about 37MHz in the a.f.c. circuit's response, compensating for a.f.c. asymmetry due to filtered noise.

The sound department – intercarrier sound amplifier/demodulator plus audio amplifier and output – consists of a single TDA1035S i.c. driving a 15Ω loudspeaker. A feature of the chip is a silent warm-up arrangement consisting of an internal zener diode connected to supply pin 10. This forestalls the sound output until the supply voltage, which is obtained from the line output transformer, has built up to about the normal working level. The nominal audio output is 1W.

### Single-chip Decoder

Probably the most novel feature of the TX9 chassis is the UPC1365C single chip colour decoder, which is manufactured by NEC in Japan and has been developed from a very successful NTSC version. The decoding system itself is quite conventional – a detailed block diagram is included in the TX9 circuit diagram. Only one additional transistor is used – the chroma delay line driver. A single line-frequency pulse of the sandcastle type is fed in at pins 19 and 23 and is used for all the gating, clamping and triggering operations in the i.c. It's obtained from the TDA9503 "line processor" i.c.

### RGB Output Stages

The RGB matrix in the chip drives the three RGB output transistors. The output stages operate in the class A mode, with very hairy 12kΩ collector load resistors. These resistors are very prominent in the middle of the chassis, and at first sight appear to represent a power loss and source of heat. In practice they normally dissipate less than half a watt each, and are heavily rated to comply with BEAB requirements in the event of one or other of the BF460 output transistors going short-circuit.

### Switch-off Spot Suppression

The emitter circuits of the RGB output transistors are returned to chassis via the spot suppression transistor VT57 (see Fig. 1). This transistor is normally held fully conductive,

its base being taken to the 115V h.t. rail via the 82V zener diode W57. Once the h.t. voltage, following switch off, falls below 80V the zener diode and in turn VT57 cease to conduct. The RGB transistors will also cease to conduct of course, so the c.r.t.'s cathode voltages rise and the tube cuts off. This removes the usual coloured-ball effect following switch off. It also provides protection against the effects of "hot switching", i.e. off and then immediately on again. Without this protection, the decoder i.c. can drive the RGB output transistors and thus the tube into heavy conduction after hot switching.

### Field Timebase

A single TDA1170S i.c. provides all the field timebase functions. No field hold control is required, but a removable link is provided to take up tolerances if necessary. To maintain height stability with e.h.t. variations, pin 12, to which the field charging circuit (C215, C216 etc.) is connected, is linked via R273 to the picture size stabilising circuit (see Figs. 2 and 3). The 24V supply to the i.c. is fed to pin 5 via W103; during the flyback this diode switches off, and the associated electrolytic capacitor C208 provides bootstrap action. Field flyback faults such as teletext lines at the top of the screen or top foldover should lead to a check on these components therefore – repeated failure of the i.c. can be due to C208 being open-circuit.

### Line Timebase

The TDA9503 "line processor" i.c. contains a noise-suppressed sync separator, the line oscillator and the flywheel line sync circuit with switched time-constant for VCR operation. The chip also provides the sandcastle pulse for the decoder i.c., and incorporates an under-voltage switch which forestalls any output until the supply to the i.c. exceeds about 4V. This ensures that no damage can occur in the line driver or output stage due to an under-size or misshapen drive pulse, and produces a clean kick start. The line shift control supplies a d.c. voltage to pin 14, operating on one of the phase comparators in the i.c. This pin also receives a picture position correction voltage from the earthy side of the e.h.t. system (see below).

The output pulse from the TDA9503 is a.c. coupled to the line driver transistor which, as in the 9000 chassis, also provides the start-up supply for the line oscillator. Once the line output stage comes into operation, the oscillator is powered from a scan-derived 12V rail.

The line output stage itself is straightforward, with a high-level diode modulator circuit and using a diode-split output transformer which incorporates the thick-film focus potentiometer. The diode modulator is driven by a Darlington compound transistor (VT72, type TIP110) which receives its input from a differential amplifier. There are some nice touches here. The differential amplifier receives not only the field frequency waveform required for EW raster correction but also an anti-breathing input to correct for variations in width with changes in the e.h.t. and a ripple input from the h.t. supply to cancel residual hum on the raster. (Hum cancellation is also applied to the c.r.t grids incidentally.)

### Beam Limiting and Anti-breathing

The beam limiting and anti-breathing arrangement is particularly intriguing (see Fig. 3). Instead of being taken directly to chassis, the tube's external aquadag coating is a.c. coupled to chassis by C205. Thus the voltage (nominally 6.4V) at the junction of the aquadag coating and C205 is

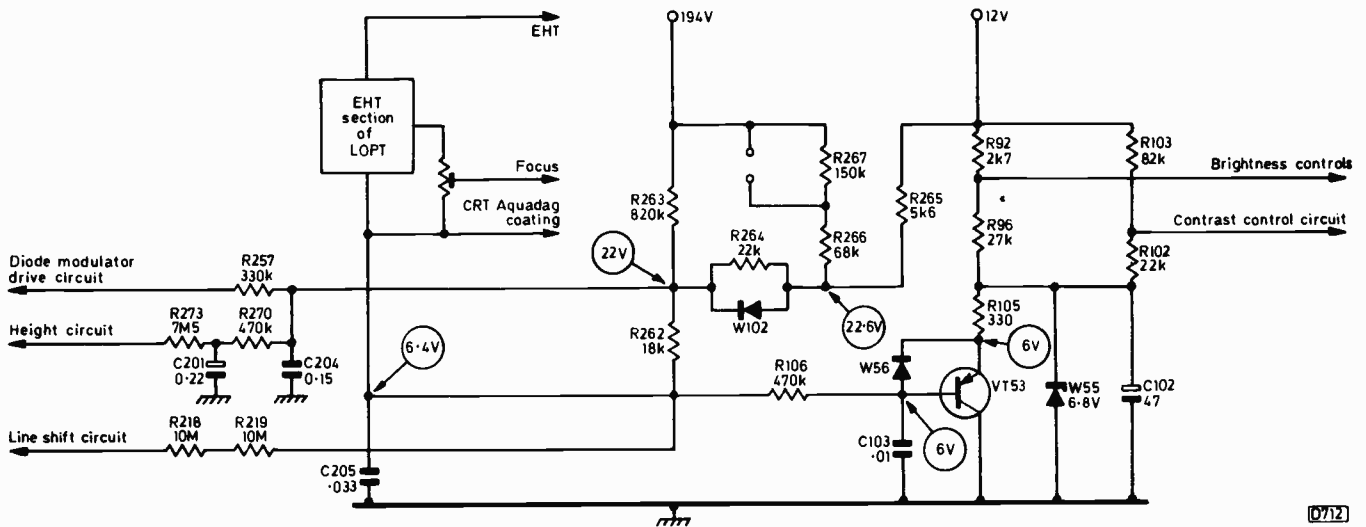

Fig. 3: The beam limiting/anti-breathing circuitry.

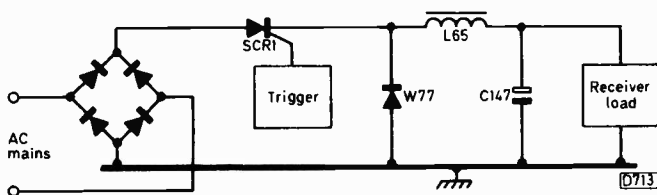

Fig. 4: Skeleton circuit of the power supply.

proportional to the beam current. This voltage is linked via R218/R219 to the line shift circuit for picture centring correction, and to the anti-breathing network R262/R263 etc. The voltage at the junction of R262/3 is fed via R257 to the diode modulator circuit and via R270/R273 to the field charging circuit.

The active element in the beam limiting circuit is VT53, which is normally held non-conductive. When the beam current exceeds  $600\mu\text{A}$  (for 14in. tubes – for larger sizes R267 is shorted out so that the tubes will operate at a higher maximum current), the base voltage of VT53 falls sufficiently

for it to conduct. In consequence it shorts the zener diode W55, which normally clamps VT53's emitter at 6.8V. With VT53 conductive, the brightness/contrast levels are reduced via R102 and R96. To prevent short-duration highlights activating the beam limiter circuit, the time-constant network R106/C103 is included in the base circuit of VT53. Picture emphasis is thus retained. Once the limiter comes into operation, the time-constant is made much longer by C102, thus preventing shading over the field. At low beam current levels (less than  $50\mu\text{A}$ ) W102 cuts off. This increases the gain of the beam sensing network to compensate for the higher output impedance of the e.h.t. system.

## POWER SUPPLY

The power supply is one of the few areas in modern TV receiver design where a great diversity of approaches is to be found – not only amongst different manufacturers, but between successive chassis from individual setmakers. Like

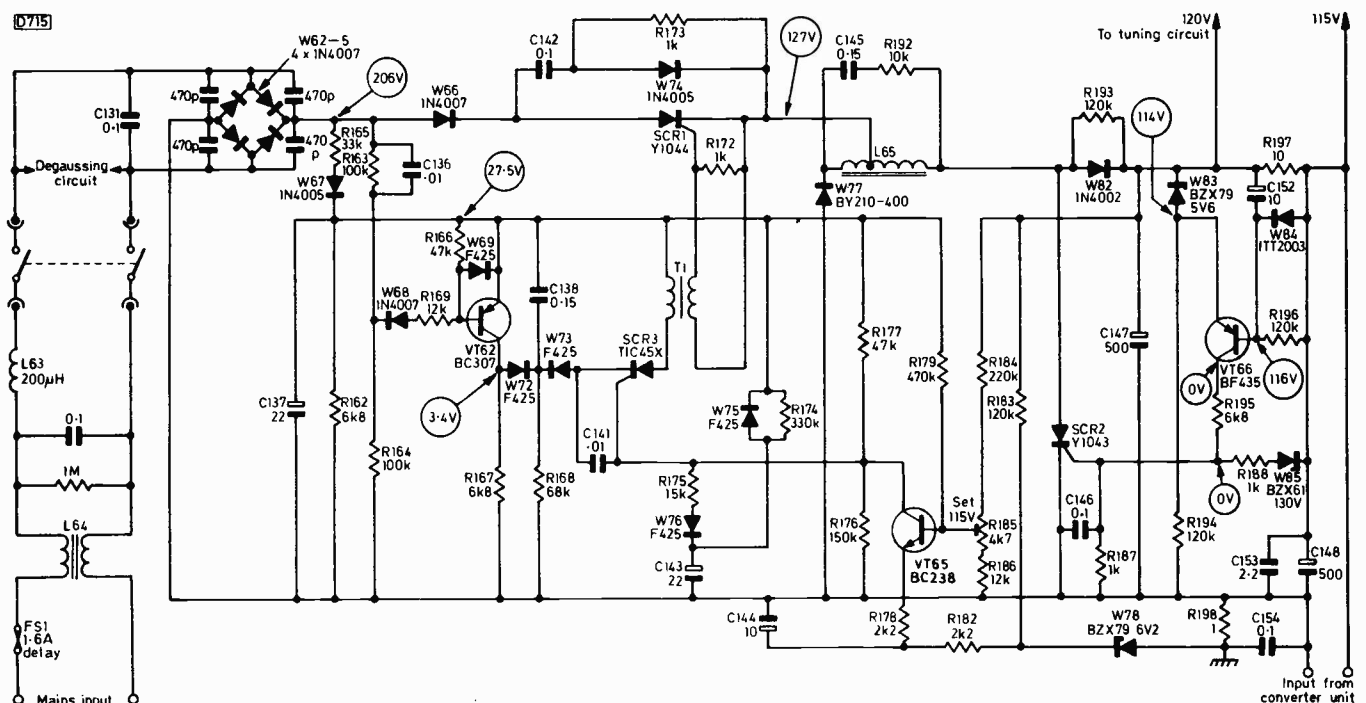
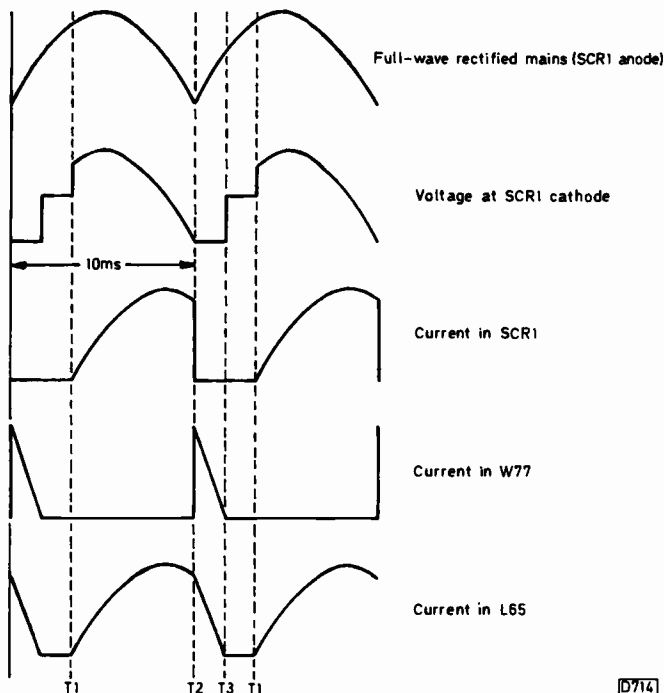

Fig. 5: Complete circuit of the power supply.



**Fig. 6: Power supply waveforms.** The thyristor is triggered on at T1. Point T2 is the mains zero crossing point, and T3 the point at which W77 turns off. During T1-T2 the thyristor feeds energy into the circuit. From T2-T3 the receiver draws on energy stored in L65 as magnetic flux. From T3-T1 the reservoir capacitor C147 maintains the output voltage.

Sony, Thorn have in the past used many power supply techniques – series regulators in the 2000 chassis, a series chopper in the 3000 chassis, a thyristor circuit in the 8000 chassis, a parallel chopper in the 4000 chassis, and Syclops in the 9000 chassis. The new circuit used in the TX9 seems to be a very well engineered, cost-effective design which should keep everybody happy.

It's based on the use of a thyristor as the regulating element, but the resemblance to earlier designs ends here! In the past, thyristor power supplies have been justly criticised on the grounds of r.f. radiation and the huge, short-duration bites they take from the mains supply – in early designs, on one half cycle only. The TX9's power supply circuit overcomes these problems by the use of a large inductor downstream from the thyristor, which in turn draws on both half-cycles of the mains input.

The circuit is shown in skeleton form in Fig. 4. The full-wave bridge rectifier presents the thyristor's anode with a train of half-sinusoid pulses at 100Hz. As each pulse approaches peak voltage, the thyristor is triggered into conduction, feeding energy into the inductor L65, the reservoir capacitor C147 and the receiver load. When the input voltage drops to zero at the end of the half cycle, the thyristor cuts off and W77 switches on, clamping the input end of L65 to chassis. The energy stored in L65 as magnetic flux then maintains the flow of current, sustaining the output voltage. The operation is much the same as with the 3000's chopper, but this time at 100Hz. When the magnetic field around L65 has collapsed to zero, W77 turns off and the energy stored in C147 maintains the current flow until the thyristor is once again triggered on to restart the cycle. The waveforms in Fig. 6 show the timing.

A neat idea, but with the circuit as shown in Fig. 4 we cannot guarantee that at the end of each half cycle the thyristor's anode voltage will drop below that at its cathode. If this requirement is not met, the device won't turn off. The solution is to move the thyristor's injection point along the

choke towards the reservoir capacitor (see Fig. 5). This has the effect of forcing W77 to conduct before the input voltage drops to zero at the end of the half cycle. In fact the tapping point is fixed so that W77 starts to conduct when the input voltage is still 15V above earth, thus ensuring that the thyristor is well and truly cut off until the next trigger pulse arrives. C142/R173/W74 protect the thyristor against transients, while C145/R192 damp the choke L65.

The trigger circuit is quite simple. An unregulated supply of about 28V is developed across C137, which is fed via the potential divider R165/R162. As a result, C138 begins to charge via R168. Let's assume that the gate of the trigger thyristor SCR3 is at a fixed positive potential. As C138 charges, a negative-going voltage will be developed at its lower plate. When this voltage is less than the voltage at the gate of SCR3, W73 and SCR3 will switch on. As a result, the charge developed by C138 will produce a current pulse in the primary winding of T1. The pulse appearing across the secondary winding fires SCR1. At the end of each input half cycle, the pnp transistor VT62 conducts briefly to ensure that C138 is fully discharged ready for the next cycle of operation.

### Regulation

To obtain regulation, the voltage at the gate of SCR3, and thus its firing time, are varied. The control action is provided by VT65, which operates in the normal error detector fashion – its emitter voltage is held steady by the zener diode W78, while its base is fed with a potted down voltage obtained from the main 120V h.t. rail. R179 monitors variations in the mains voltage via the unregulated 28V line.

### Soft Start

It's desirable that the h.t. voltage should rise gradually to the normal working level over a period of a second or so after the set is switched on. C143 provides this soft-start facility. At switch on, C143 starts to charge via R175 and R177. The values of these resistors are selected so that SCR3 cannot conduct to start with. As C143 charges, the voltage at the gate of SCR3 rises and it's fired progressively earlier. This results in a gradual rise in the h.t. voltage. W76 isolates C143 once normal receiver operation has been established.

The delay introduced by C143 also ensures that the automatic degaussing is completed before the tube starts to be scanned.

To reset the slow-start circuit quickly, C143 is discharged via W75 and VT62, which remains conductive until C137 has discharged. This ensures that the slow-start action occurs even when the set is switched off and on again quickly.

### Power Supply Source Impedance

As colour chassis become more efficient, so the current demand on the power supply becomes progressively more dependent on beam current. Modern power supply circuits in fact have to cope with a current demand ratio approaching 2:1 between full and zero beam current. In consequence the power supply must have a low effective source impedance if picture breathing is to be avoided, i.e. the voltage regulation must be good!

The use of RC smoothing (C147/R197/C148) downstream from the thyristor-choke combination means that the power supply's source impedance will not be less than 10Ω (R197). This is not good enough, so the feed-forward technique is used to lower the effective source impedance of the power supply. The receiver's current demand is monitored by the 1Ω sampling resistor R198, which is in series with the

earthy side of the power supply. The voltage developed across this resistor is proportional to the current demand and is added to the voltage at the emitter of the error detector transistor VT65. R182/C144 smooth this voltage so that the circuit is immune to ripple components at 50Hz or above. The effect of the feed-forward arrangement is to give the power supply an effective source impedance of less than  $1\Omega$ .

### Protection

Apart from the mains fuse, the protection in the TX9 is based on the crowbar thyristor SCR2. To provide over-voltage protection, the gate of SCR2 is connected via the 130V zener diode W85 to the 115V h.t. line. Should the h.t. voltage exceed the zener voltage, W85 and SCR2 will conduct, earthing the cathode of the regulator thyristor SCR1 and thus blowing the mains fuse. Excess current protection is initiated by VT66. Under normal operating conditions the set's current consumption is around 500mA, resulting in a voltage of about 5V across the smoothing resistor R197. Should this voltage rise significantly, indicating an overload, VT66 will turn on and fire SCR2. To avoid false alarms due to flashovers or transients, the time-constant network C152/R196 is included to delay the response.

### Power Supply Summary

To sum up, a good power supply, and provided the components are reliable it should be a winner! We did some comparative measurements on the TX9 and the earlier 8000 chassis power supply circuits. With our none-too-stiff mains supply in a Sussex village, the 8000 gulped a huge, steep-sided 7.5A spike from the positive mains half cycle only: the TX9 took a gentle 800mA swell at a 100Hz rate – see Fig. 7. We also discovered that our review set worked happily with a mains input voltage as low as 152V.

## SERVICING

A great deal of attention has been paid to the servicing aspect of the TX9. The single PCB can be withdrawn from the cabinet and mounted vertically, locating in a slot at the bottom of the cabinet moulding. This gives simultaneous access to both sides of the board. The i.c.s are not pluggable, for reasons of reliability – there have been many problems in the past with i.c. holders in various makes and models, and they are often less reliable than the chip itself.

For testing the operation of the power supply, the load presented by the set can be simulated by a resistor of about  $384\Omega$ , rated at 34W. This can be made up of heavy wire-wound resistors or old heating elements.

The service manual is excellent and includes a circuit description. In addition, component functions are included in the parts list – something we've not had since the 1590/1591

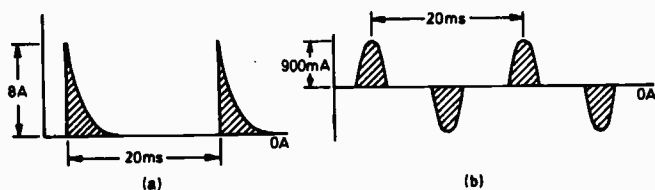

Fig. 7: (a) Mains-current waveform with the earlier 8000 series chassis, which also used a thyristor power supply. The sharp rise time and heavy transient current pulse caused interference radiation, stress in the power supply components and a d.c. drain on the mains supply. (b) The more civilised mains-current waveform with the TX9 chassis.

series manual was published in 1972. The list also reverts to quoting part numbers – a good thing as far as we're concerned, having come unstuck many times for various reasons since Thorn dropped part numbers some years ago.

Spares prices are surprisingly low. At the time of writing, we've been quoted the following which are approximately net trade: line output transformer/e.h.t./focus unit £12; luminance/chrominance i.c. £4; SAWF i.f. module £9; complete chassis assembly £110. The components are guaranteed for one year. The c.r.t. guarantee is two years, with an optional extension to four years.

## CONCLUSIONS

The set we had for evaluation was the first model to be released – the 14in. Model 3755. We sought several opinions, both technical and lay, while we had the set.

We were impressed by its apparent lightness. In fact it weighs 13kg (29lb), marginally lighter than other comparable models. The illusion is due to the provision of recessed carrying grips at the sides rather than the usual single handle. These and the folding u.h.f. loop aerial, plus the optional battery facility, make the 3755 truly portable, though for use when travelling around a rotary tuning knob covering the whole u.h.f. band would save a lot of fiddling.

On test, the picture was found to be slightly green tinted. This was put right with a tweak on the G background control. The sound was a little distorted on some programme material, but slight readjustment of the sound detector coil soon cured this.

Earlier Thorn sets often suffered from a fierceness of customer control operation – the slider controls on the 8000 and 8500 chassis are notorious in this respect. The rotary controls on the TX9 are not so bad as earlier models. The brightness and contrast can be set fairly easily, though most of the business is done over little more than half the track range. The volume control did nothing until advanced almost a quarter turn, the next quarter turn increasing the sound virtually to full. The saturation control was a little better, but zero to full saturation occupied only the middle half of the available knob travel.

The set was placed alongside an ITT 16in. colour portable. It was difficult to put a pin between the two pictures from the performance point of view. Slight differences in the phosphor colour were noticeable with the sets side by side, but not otherwise. Most observers agreed that the sound from the ITT set was marginally better, even after our adjustment of the sound detector coil in the TX9. Critical appraisal of the relative performances of the two sets on test card, also with a 14in. Decca Model CN0701 (70 chassis), showed that the picture performance was virtually identical, though neither the ITT nor the Decca set matched the picture breathing v. brightness performance of the TX9. It must be added that these remarks should be read in the light of the relative prices of the sets concerned.

Inside the set, we noticed that the e.h.t. lead and cap have been given much beefier insulation. This should score in adverse environments, and is very relevant to a portable which may see service anywhere from a boat to a kitchen. The only really heavy component, the power supply choke, is braced by the peripheral metal chassis reinforcing rib. Such sources of heat as exist, and there are very few of them, are well distributed around the chassis.

By way of conclusion, we are convinced that the TX9 represents a milestone in TV receiver design. Congratulations are due to the Thorn design team. On a more personal note, we were very sorry to lose the review model: it makes our 1970 vintage Bush set look very tired indeed! ■



R334 was intermittently open-circuit. When it goes completely open-circuit, there's severe non-linearity. It's worth changing both R334 and R333 to prevent a call-back. The field linearity controls R326 and R335 are also occasionally responsible for flickering at the top and bottom – look for burn marks where the wiper rests on the carbon track.

If you find it necessary to keep replacing the PCL805 field timebase valve in these sets due to field roll, check the heater chain. Some sort of internal short seems to occur in the PY500 boost diode, as a result of which its heater voltage falls to about 25V a.c. instead of 40V a.c. Replace the PY500 and PCL805 and all should be well. For some reason no fault other than field roll shows up.

## Mitsubishi

**Model CT200B:** One of these sets came in with the complaint small picture – lacking in width and height. There was a slight hum on sound (the give-away) and also a weak, grainy picture. The trouble was due to loss of capacitance in the main reservoir electrolytic C907 (820 $\mu$ F). The replacement has to be a genuine Mitsubishi one since it has four earthing tags, with the positive terminal almost in the centre.

A fault we've had on several occasions with this set is the picture size varying – it's more noticeable on test card. The picture suddenly increases in size, then just as suddenly returns to normal. This may happen quite often or only a couple of times an hour. The cause each time has been the zener diode D923 (type EQ401-12) in the regulator error amplifier circuit.

**Model CT202B:** We've had several cases of sound but no picture on these sets, due to either the second (Q202, type 2SC710C or 2SC454A) or third (Q203, type 2SC620C) luminance amplifier transistor being faulty. The two stages are d.c. coupled, so if the voltages in both stages are wrong replace Q202 while if only the voltages in the later stage are wrong replace Q203.

The procedure for dealing with colour noise on a monochrome picture on these sets is as follows. First see whether the colour noise disappears when the colour-killer control VR604 is rotated (see Fig. 2). If it does, check the condition of the track or better replace the control (1k $\Omega$ ). If the colour noise is still present, check the a.c.c. amplifier's drain voltage. This should be 5.2V (Q612). If this is correct,

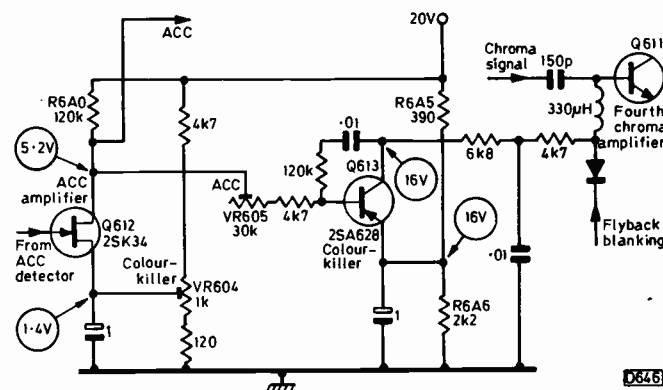

Fig. 2: The a.c.c. amplifier and colour-killer circuits used in the Mitsubishi Model CT202B. Similar circuitry is used in other Mitsubishi models of the period. The a.c.c. detector is of the synchronous type, producing an output when the colour burst is present. This output is fed to Q612, which in turn drives Q613 into saturation, thus providing Q611's base with forward bias. Note that the output from the collector of Q613 also activates the 4.43MHz trap in the luminance channel during colour reception.

replace the colour-killer transistor Q613 (2SA628). If Q612's drain voltage is incorrect, check the voltage at its gate (should be 1.1V). If this is normal, replace Q612 (type 2SK34): if not, check for a fault in the a.c.c. detector circuit (D611, D612, D605 etc.).

## Perdio

**Model RP206CS:** When switched on, the sound came up with a gurgling effect and there was no raster. The voltages around the regulator were all over the place, so attention was turned to the line output transistor Q403 (2SC508). The voltages here were also wrong. It turned out that the line section of the deflection yoke was open-circuit between tags 26 and 27. A replacement yoke restored normal operation.

## Philips

**G8 chassis:** In the event of no sound plus field collapse, check whether the 45V supply from the line output stage is present at pin 4 of plug U. If not, the 1.25A fuse F5512 will probably be found blown, due either to the rectifier diode D5540 (BY210-800) or its reservoir capacitor C5537 (800 $\mu$ F) having gone short-circuit.

In the event of no results except for a slight hum when the set is first switched on, proceed as follows. Check whether the 205V h.t. supply is present at TP61 in the line output stage. If so, check for voltage at the collector of the upper line output transistor T5531. If everything is in order thus far, check with a scope whether the line oscillator input is present at pin 2 of socket G. If not, check whether the 205V supply is reaching TP49 on the timebase panel. If 205V is present here, check wirewound resistor R4516 (10k $\Omega$ ) which could be open-circuit. If the resistor is intact and warm, suspect the zener diode D4531 (BZY88/C18) or the smoothing electrolytic C4518 (47 $\mu$ F) of being short-circuit.

**G9 chassis:** One of these sets came in with the dead set symptom. There was a.c. at the anode of the thyristor rectifier but nothing at its cathode. A check of the voltage at the collector of the control transistor T7 (BC147) revealed zero instead of 14.7V, due to the charging capacitor C15 (0.22 $\mu$ F) being short-circuit.

## Rank

**A823 chassis:** The pincushion distortion correction transducer 6T3 on this chassis gives a fair amount of trouble. On one set the report was that it had started to smoke. The set was switched on and worked, but there was pincushion distortion. On examination, the fusible resistor 6R15 was found to be open-circuit. This is connected between the line-frequency windings on the transducer: a new transducer stopped the burning and restored normal results. The transducer can also be responsible for intermittent field collapse, or even intermittent field bounce, due to dry-joints on the board.

Problems not infrequently arise in the c.r.t. first anode circuitry. 4R3 (220k $\Omega$ ) on the c.r.t. base panel tends to increase in value, causing excessive brightness and a poor grey scale. The first anode potentiometers (7RV11/12/13) also tend to change value. In a recent case one of them had fallen from 2.2M $\Omega$  to 400k $\Omega$ . The odd thing is that the effect of this may not be noticeable until an attempt is made to set up the grey scale. It's best to replace all three controls.

Another fault one sometimes encounters on this chassis is excessive brightness with flyback lines due to 6R8 (820k) in the coupling between the line output transformer and the e.h.t. tripler going open-circuit. This resistor is not easy to

change, being behind the line output transformer. The symptoms that are evident arise due to the effect of the fault on the c.r.t.'s grid circuit (via the beam limiter). Uncontrollable or varying brightness can be due to 8C11 (0.1 $\mu$ F) which couples the clamp pulses to the decoder/RGB drive panel.

One of these sets with the two-chip decoder came in recently with the complaint loss of colour. A replacement decoder panel made no difference, so attention was turned to the i.f. panel – the first two chroma amplifier stages, plus the a.c.c. transistor, are housed in module Z on this panel. The trouble was due to the supply line smoothing electrolytic 2C48 (10 $\mu$ F) being short-circuit. Note that any of the three transistors (2VT7/8/9) in this module can be responsible for loss of colour: if this is suspected, change all three as they don't always read faulty when checked.

**Z179 chassis:** Lack of width on one of these sets was traced to 4C41 (4.7 $\mu$ F) in the EW modulator circuit being open-circuit. Another capacitor in this area, 4C68 (1.5 $\mu$ F), causes bowing at the sides when it goes open-circuit.

**Z718 chassis:** Bad sound distortion is usually due to the transistors in the sound output stage. There are two, the output transistor itself 3VT14 (BD166) and 3VT15 (also BD166) which acts as a constant-current source. They are mounted on the decoder panel (Z905). The trouble may simply be a dry-joint: if it's necessary to replace them however, it's important to adjust the set audio current control 3RV9. The procedure is simple. Connect the meter across 3VT14's emitter resistor 3R88 (2.2 $\Omega$ ), and adjust 3RV9 for a reading of 0.44V – corresponding to 200mA through the audio output stage.

Very bad distortion on one occasion was found to be due to 3R88 being open-circuit. On another set the sound would disappear almost to nothing, even with the volume control turned fully up. This was traced to the TBA120SB intercarrier sound i.c. 2SIC2. The voltages around the i.c. varied slightly from cold to when the set had warmed up, and a spray of freezer would restore the sound for a short time.

The complaint on a couple of occasions has been "burning". On the first occasion the trouble was due to 4R39 (56 $\Omega$ ), the base bias transistor for the field convergence output stage. One of the transistors (4VT11, BD509) in this stage was found to be short-circuit. Replacing 4R39 and 4VT11 restored normal operation. On the second occasion 4R30 (13 $\Omega$ ) was found to be cooking. This is the emitter resistor of one of the two field driver transistors (each field output transistor has its own driver). The cause of this sort of trouble is usually a leaky diode in the field output stage. There are four diodes, 4D4, 4D5 and 4D6, all type 1N4001, and 4D7 which is type 1N4148. Replace all four to be on the safe side.

Intermittent field collapse on these sets can usually be cured by resoldering the tags on the NS correction transducer 5T4 (on the line output panel). On one occasion however we were led quite a dance, until we discovered that a spray of freezer on 4VT22 in the field scan generator circuit would open out the picture to normal height. Replacing 4VT22 (BC158) completely cured the trouble. Another fault in this area was traced to 4C7 (2.2 $\mu$ F): the symptom was slight field bounce.

The dead set symptom on one of these receivers turned out to be due to an unusual fault. The fusible resistor 5R6 (68 $\Omega$ ) which provides the supply to the line driver stage was found to be open-circuit. The supply is obtained from the centre point of the line output stage, so I suspected the line output transistors. These were replaced and the base balance adjustment carried out. The setting up seemed to be

o.k. but I left the meter in place to monitor the conditions and noticed that every now and then the voltage reading would jump right off the scale (15V a.c.). With the aid of a scope, it was found that the line driver transformer 5T1 was faulty, replacement stopping the voltage variations and giving correct balance.

Lack of width after the set had warmed up, the width then slowly reducing, was traced to a dry-joint at the collector of the EW modulator output transistor 4VT19 (2N5296).

A case of fluctuating signals was traced to 2C18 (0.01 $\mu$ F) in the a.g.c. circuit.

An inoperative brightness control with some shading at the bottom of the picture turned out to be due to a defective diode in the burst gating/black-level clamp pulse generator circuit – the culprit was 3D5 (1N4148).

**T20 chassis:** Intermittent mains fuse (7FS2) blowing has been a problem with this chassis. Rank dealt with it by changing 7FS2 from a 1.6AT fuse to one rated at 2.5AT.

Where the fault is no h.t. output from the T114A switch-mode power supply panel, first check the h.t. rectifier diode 7D1 (BY299) in case it's open-circuit, then if necessary check diodes 7D3/4 in the chopper transistor's base circuit. If either of these is found to be short-circuit, check zener diode 7D7 (BZY79/C10) which could also be short-circuit.

If the switch-mode power supply won't start (again no h.t. output), check the two fuses (7FS1 and 7FS2), then 7D8 (1N4148) for being short-circuit and zener diode 7D9 (BZY88/C6V8) for reverse leakage: if these are all o.k., check 7R9 (220 $\Omega$ ) for being high-resistance – I've had this one on several occasions, replacing the resistor restoring normal results. Note that if the start-up circuit is in order an audible clunk will be heard at switch on: check as suggested in the previous paragraph.

Note that 7FS1 must be a HRC type (1.6A), and that if either the chopper transistor 7VT2 (BU326) or the trigger SCS 7THY1 (BR103) is defective both must be replaced. Rank comment that 7R15 (8.2 $\Omega$ ), which is in series with the crowbar thyristor, should always be checked for being open-circuit whenever the power supply is serviced, and if necessary replaced. Rank also point out that the power supply module can be serviced outside the set by providing a mains input and a suitable dummy load – two 60W lamps in parallel to simulate the normal load (600mA) and three 60W lamps in parallel to simulate full load (870mA).

### Thorn

**8000 chassis:** We had one of these in the other day with the dead set symptom. This was quickly traced to W704 (BY127), the protection diode in series with the thyristor controlled rectifier, being open-circuit.

**9000 chassis:** Crinkly verticals on this chassis are usually due to C431 (10 $\mu$ F), which seems to dry up: it decouples the emitter of the line oscillator transistor VT411. If the grey scale is unstable, check C174/5/7: these 560pF capacitors provide emitter decoupling in the RGB output stages.

### Toshiba

**Model C800B:** We were called to a strange fault on this set – there was no sound or raster, with the tuner neons flickering on and off in an odd manner. A quick voltage check in the line oscillator stage revealed that the trouble was due to line oscillator failure. The circuit is a bit unusual for a colour receiver, consisting of a pair of transistors (T401 and T402, both type 2SA495Y) in an emitter-coupled multivibrator stage. The trouble was due to one of the cross-coupling capacitors, C408 (0.0043 $\mu$ F).

# Vintage TV: The English Electric 16T11D

Vivian Capel

THE vogue for vintage cars has been in existence for many years. Now an interest in products that have passed from the obsolete stage into comparative rarity, and are thus becoming sought after collectors' items, is rapidly expanding. Old optical and scientific instruments, typewriters and radios are among the items that are hunted down, lovingly renovated and assembled into collections. Their value often climbs dramatically, and not a few find their way across the Atlantic after making a handsome profit for their discoverers.

Early TV sets now seem set to join the list of sought after vintage items. Pre-war ones already have, but these are rare indeed. The sets of the late forties and early fifties are now some thirty years old however and are rapidly gaining vintage status. In this new occasional series we'll be taking a look at some of these early models. The idea will be to interest those who weren't around at the time, provide a little nostalgia for those who were, and give some guidance to would-be restorers and collectors.

What better set to start with than the English Electric 16T11D? Yes, English Electric, then an independent company, made their own sets up to about 1956. The 16T11D was a handsome table model with doors, and was released in January 1953 – at a price of £64 19s 7d plus purchase tax. It was a single-channel model, and two further versions appeared later in the same year – the 16T18 (no doors!) and the console 16C19D. In fact the same basic chassis design was retained by English Electric until they pulled out of the TV market, the final version being fitted with a Band I/III turret tuner.

The 16T11D was an interesting model with several unusual features. Its appearance was quite distinctive, with what was called a "double D" mask, i.e. the top and bottom of the screen's viewing area were straight, with semi-circular sides. This gave one of the largest pictures of the time, as almost the full width of the circular tube face was used, though there was some loss of corner information. The tube

itself was not greatly liked by engineers. It was produced by English Electric themselves, and was a 16in. type with a metal cone. This cone was connected to the e.h.t., which meant there was an awful lot of area where you had to be careful! True the cone was covered by a loose plastic sheath, but the e.h.t. could still jump out at you at the edges and often did!

## The Line Output Stage

The e.h.t. in fact was quite high: 14kV. In those days 10kV was usual, with sometimes 12kV for the "large" 15in. tubes, and in many 9 or 12 in. sets it was 8-9kV. The line output stage (see Fig. 1) is quite modern looking, the only unusual feature being the voltage doubler circuit that produced the e.h.t. This employed a couple of EY51 rectifiers – those small, tubular wire-ended e.h.t. rectifiers.

In the earlier sets an open type line output transformer was used. This gave rise to many complaints of line whistle, so an enclosed assembly that improved matters somewhat was fitted in later versions. A nice touch was protection of the line output stage by means of a fuse. In early sets this was a standard 250mA type, connected in series with the cathode of the PL81 line output valve, but was none too reliable. In later versions a 150mA thermal cut-out was used instead, connected in series with the h.t. feed to the line output stage. This had the additional advantage of protecting the other valves in the event of the PY81 boost diode developing a heater-cathode short, since for some reason it was way down at the earthy end of the heater chain. The cut-out could be reset simply by pushing a wire arm back into a grip contact, and I've often wondered why this never caught on. I removed one from a scrapped set and soldered it across a blown fuse cartridge. It served for many years as a bench replacement for testing sets with intermittent fuse blowing.

## Features of the Chassis

A feature that was to prove many engineers wrong was the use of a vertical chassis. Hitherto sets had been constructed with a conventional horizontal chassis – either separate from the tube or supporting it. While we approved of the better accessibility of the valves with the vertical chassis, it would never catch on we said. The valves would keep on dropping out!

A very unusual feature of all but the earlier versions was the use of a Barretter in series with the heater chain. For readers who may never have seen one of these, it looked very much like a low-wattage lamp, with a cage of resistance wire mounted in a glass envelope. It became incandescent in use, and the idea was to exercise a degree of control over the heater current. If the current increased, the Barretter glowed brighter and increased its resistance, thus reducing the current. Barretters were mainly used in a.c./d.c. radio receivers.

This current limiting was a good point and no doubt prolonged valve life. The Barretter itself however was not a

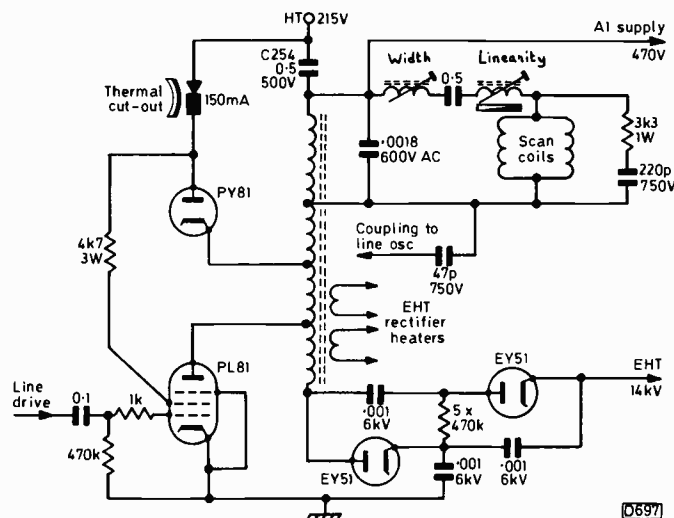

Fig. 1: The line output stage circuit.



very reliable component, and frequent calls had to be made to replace it. You're unlikely to be able to get one now, but a 140Ω resistor rated at 15W at least will do as a replacement.

### Metal HT Rectifier

The h.t. was supplied by a metal rectifier. This can of course be replaced by a silicon diode, with a series resistor (21Ω, 10W is suitable) to provide surge limiting. Nowadays rectifier replacement is usually required because of catastrophic failure of the silicon diode – a short- or sometimes an open-circuit. In the days of the metal rectifier however the most common fault was a gradual increase in the rectifier's forward resistance with age, thus lowering the h.t. voltage. You'd get various symptoms, the most common being reduced height and width, often accompanied by field rolling.

Occasionally there would be a short to the mounting rod and bracket, as a result of which the unit would overheat. This could be quickly diagnosed without removing the back from the set, since it produced a dreadful smell like a blocked drain! The rectifier would sometimes go on working in this condition, and many a householder was mystified as to the source of the smell. I used to know two old ladies who would bring in a bucket of water with Jeyes fluid added every time they watched TV. It eventually got so bad that they would turn the set round to face the window and take their chairs out into the garden to watch!

### Signal Stages

Anyway, back to the English Electric 16T11D. Note that the earthy end of the volume control does not go to chassis but via a screened lead to the junction of the two resistors in the cathode circuit of the ECL80 audio amplifier/output valve (see Fig. 2). Since the triode/pentode ECL80 has a common cathode, the idea of this arrangement is to enable a higher bias voltage to be applied to the pentode than to the triode section of the valve. Watch this point therefore when replacing the volume control.

The front end of the receiver is of interest. To start with, provision is made for using balanced twin, screened balanced twin or coaxial feeder. Then there are two r.f. amplifier stages before the pentode frequency changer. A sensitivity control varies the cathode voltage of both the r.f. amplifier valves (see Fig. 3), enabling a wide range of reception conditions to be covered without the need for attenuators or boosters. The tuning is fixed to just one of the five Band I channels, by means of four plug-in coils mounted along the bottom right-hand corner of the chassis.

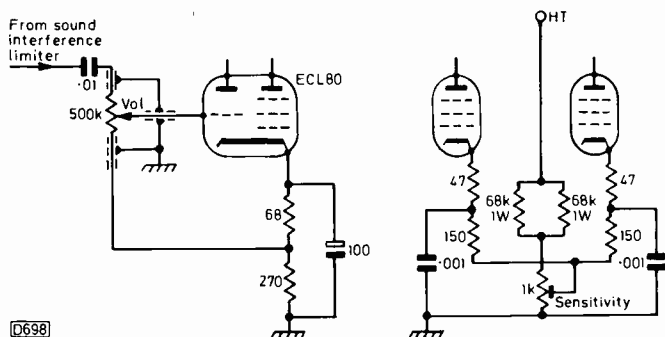

Fig. 2 (left): The volume control connections can be confusing if you don't know where the earthy end should go.

Fig. 3 (right): Method of varying the gain of the two r.f. amplifier valves to provide sensitivity control. An identical arrangement was used in the vision i.f. stages for contrast control.

# next month in

# TELEVISION

### ● 50 YEARS OF TV

Fifty years ago TV was poised to become part of the domestic scene. Rapid progress was being made in several countries, but Baird in the UK was in the lead – with his original mechanical TV system. In March 1930 the BBC provided Baird with the facilities to demonstrate the simultaneous transmission of vision and sound programme material, and in the same year TV receivers first went on sale – at £18. To commemorate the achievements of the time, the Science Museum is holding a special exhibition. The technical history will be summarised in our cover feature.

### ● TV/VDU CONVERSION

TV sets can be adapted for use as VDU displays, while still providing off-air reception, if suitable signal switching and interfacing is provided. Alan Kitching presents a suitable circuit, with details of how to adapt several common TV chassis.

### ● SERVICING ZANUSSI COLOUR RECEIVERS

Yet another of the foreigners that came into the UK in appreciable numbers during the great colour boom of the early seventies. The set is a 26in. 110° one, using a solid-state chassis with a thyristor line output stage, and many have appeared on the ex-rental market. Faults and servicing are described by Mike Phelan.

### ● BEAM LIMITING SYSTEMS

To prevent damage to the tube and e.h.t. system, colour receivers incorporate beam current limiting. George Wilding takes a look at some typical arrangements.

## PLUS ALL THE REGULAR FEATURES

ORDER YOUR COPY ON THE FORM BELOW:

TO.....  
(Name of Newsagent)

Please reserve/deliver the March issue of TELEVISION (55p), on sale February 18th, and continue every month until further notice.

NAME.....

ADDRESS.....

# Oh Dear What Can the Matter Be?

Les Lawry-Johns

ONCE upon a time there was a chap who was quite good at his job. When sets came in for repair he would have bets with himself that he could not only diagnose the cause of the trouble from the customer's description of the symptoms, he could also rectify the fault before the set was switched on for test. No longer. Now he has a furtive air about him, and is evasive and wary, hedging his bets with "ifs" and "buts". Now and again some of his old confidence returns, after a day of bull's-eyes or near misses, but it doesn't last long and the next day brings the usual catalogue of minor disasters, wrong conclusions and general cock ups.

## Widely Varying Colours

For example. A Pye CT222. The 725 chassis – solid-state with vertical panels. Customer's complaint: widely varying colours. Sometimes red, sometimes green, sometimes blue, with combinations of each. Diagnosis: a faulty thick-film unit (R428 etc). Voltage tests revealed wide variations at the collectors and bases of the three RGB output transistors.

We turned to the pile of thick-film units, only to find that they all had five legs (Thorn 3500 type). We then remembered that all recent invoices have said that the Pye units are out of stock. The fool is nothing if not stubborn, and decided to make up the unit himself with wire wounds and carbon resistors – patiently and with infinite care. In they went, one after the other, until the circuit was complete. But the colour variations continued.

It was mainly red now and checks directed suspicion to the TBA530Q matrixing i.c. In went another. Now mainly green. In went another. Perfect colour. The first two i.c.s went into the bin. Tap the panel to make sure. Colour mainly blue, then a combination of variations. Retrieved i.c.s from bin. Carefully tapping around brought us to the TBA990. Remove it from its holder and refit it. Trouble cleared and no amount of tapping would bring back the variations. Why didn't we do this in the first place?

## Loud Arcing and Spitting Noises

Next a GEC C2111. Customer's complaint: loud arcing and spitting noises. Diagnosis: excessive e.h.t. due to high h.t. Probably a faulty thyristor. In fact the h.t. was high at the top right side droppers – 230V instead of 190V. Change

SCR701 (see Fig. 1). No difference. Check setting of P701. Little variation. Cannot leave set on with high h.t. as there's a risk to the tripler, line output transformer, transistor etc. (remembering recent expensive losses).

Check components cold. All read right, including all resistors. Change diac D701, BC147 and 7.5V zener (just in case). Fit 33Ω dropper section in place of fuse FS1. H.T. now below 180V, as expected, but P701 still not producing the variation it should. Experiment with values of resistors in series with P701. Find single 820Ω resistor works better.

Remove 33Ω resistor and fit fuse. H.T. can now be set correctly, and there's no discharge. Check grey scale and suddenly e.h.t. starts to spit viciously. Excessive width and h.t. up to 240V. Back to square one, and P701 now has minimal effect.

Squirt P701 with freezer. No effect. Squirt R706. No effect. Squirt R709 and h.t. drops to correct figure. R709 (270kΩ) going high when mains applied, had read correctly when checked cold. Replace with 1W type to be sure. Panic over and now remember that we had had similar trouble, with an open-circuit R709, a couple of years previously. Had forgotten of course.

## No Results with Plasticity Smell

Next a Bush T20A. This is the current Bush chassis, with the centre field timebase etc. swing-down panel. Set only just out of guarantee, but not one we'd sold. Customer's complaint: no results with plasticity smell. Diagnosis: faulty tripler. The warm line output transformer overwinding seemed to confirm this. Fit new tripler. No change. Fit new line output transformer and all is well. Faulty line output transformers not uncommon on this chassis. Ponder. The earlier A823 series used a lovely transformer, never any trouble. The monochrome TV161, TV181 etc. series transformer, murder.

Shopping list for line output transformers. Monochrome: Bush-Murphy all models TV161 on; Philips 210, 300 series; Indesit T24. Colour: Philips G8; Thorn 3000/3500 e.h.t. transformer T503 (usually killed by tripler); now add Bush T20.

## Varying Focus

Next a Bush Z718 chassis. Continue in our bumbling

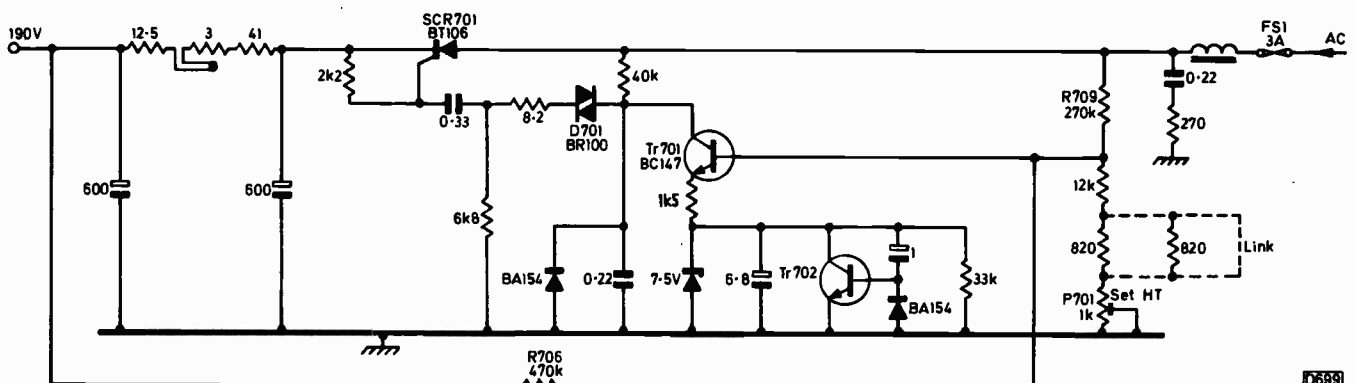

Fig. 1: H.T. supply circuit, GECC2110 series. Early versions differ in several ways.

way. Customer's complaint: very poor focus for the first half hour, gradually improving; no variation in picture size. Diagnosis: faulty thick-film focus unit.

Now it should be pointed out that there's no tripler in this chassis. Instead, a large overwinding feeds a single stick rectifier (see Fig. 2). The full e.h.t. is applied to the focus unit, which reduces it to the 4-5kV required at pin 9 of the tube. There are two 100kΩ resistors in the circuit, but both seemed to be in order. A meter check confirmed that the voltage at pin 9 of the c.r.t. was low, while fully advancing the focus knob produced little improvement. So a new focus unit was fitted. No improvement.

We wept bitter tears until we recalled our friend Ray moaning and groaning about the type of tube base socket used in these sets. "Makes you think the bloody tube has clapped out" he'd said, "until you take the tube base off and find the tube's pins pitted and corroded." So we removed the base socket and found pin 9 pitted. The quick meter check had not taken into consideration the very high resistance of the thick-film unit, and the 3kV in fact was some 5kV.

Carefully cleaning the pin and fitting a new tube base socket restored normal focus, and we resolved to write it down so that others would not be similarly fooled.

### A Thorn 1590 with No Results

A Thorn 1590. Now any fool can diagnose the faults that occur on these well known portables. Only an idiot could get mixed up. We did.

"It doesn't come on" said the customer.

"Blown l.t. fuse" we correctly diagnosed, in a blinding glimpse of the obvious.

Cold checks on the line output transistor and the associated diodes and electrolytics revealed nothing amiss, and we didn't even notice the spidery black lines across the top of the line output transformer. A meter in place of the fuse read 3A when the set was switched on, with pretty blue arcing across the top of said transformer. Now we didn't immediately condemn the transformer to the rubbish bin: it occurred to us that the set was probably used in the kitchen, and that the top insulating material had probably suffered as a result. The conductive paths were scraped away therefore, and the fresh surface treated to a dose of silicone. A 2.5A fuse was fitted, and the set switched on. Pop went the fuse, after only a very brief period. The meter was brought back and showed 3A as before, but there was no sign of life around the line output transformer.

"It must be bugged after all" we thought. It wasn't of course, but we touched it to see if it was warm and were struck by the warmth coming from the e.h.t. stick. "Well I never" we said. "Either the stick is faulty or the 1kpF disc e.h.t. reservoir capacitor is short-circuit (C115, 1590 chassis only). So we disconnected the capacitor and found it short-circuit. "Oh well" we said, "if it's left out of the 1591 it can be left out of this one too."

In went another fuse, and we switched on. Pop went the fuse, just as before. "Goodness gracious me" we murmured, "the stick is still sick." So we changed this and the 1590 lived happily ever after, because before we wrapped it up we checked the supply line and found it a little high, resetting the regulator to reduce the supply to 11.5V.

### VHFOK, NoAM

A Fidelity radio, type 23. Just for a change we thought we'd tackle a radio. "V.H.F. o.k., no a.m." said the customer. The diagnosis was swift and wrong: faulty a.m.

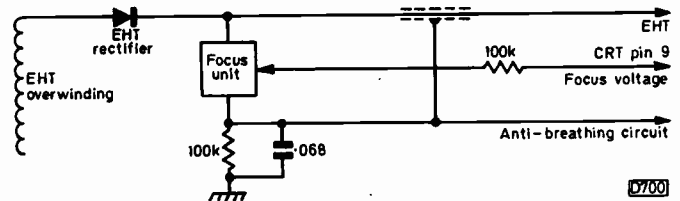

Fig. 2: Focus circuit, Rank T20 chassis.

mixer-oscillator transistor (BF194).

The back was off in a trice, but the panel took a little longer because when we took out all the screws the tuning dial fell off. Eventually the panel was in one piece and out.

Sure enough, touching the base of the BF194 restored medium and long wave reception, so the suspect was removed and a new one fitted – without melting the dial cord (our usual forte). The a.m. reception was now good, so the panel was manfully refitted and secured, together with the rear cover. Recheck to be sure. No a.m. Remove rear cover and explore area of the BF194. The 4.7kpF capacitor at the top of the panel was tapped and the signals returned. As we fitted a new capacitor the cat watched intently, probably wondering why we seem to have to do everything twice.

### The Day the VAT man Came

On the morning the VAT man came to check the books and figures the daily comedy was already in progress. We were on the phone trying to find out if there should be some form of tube guarantee form with the new Pye/Philips colour portables (KT3 series) with the 14in. tube. As the 16in. version comes complete with said form or card, it seemed reasonable that there should also be one with the 14in. version – at least it did to our befuddled mind.

We were put through to one department after another of the mighty Philips organisation.

Service: "We don't know. Try new sales."

New sales: "We don't know. Do you want a card sent to you?"

"No, I only want to know if there should be one or not."

"We don't know. Hang on, we'll put you through to P.R." (I think that's what he said).

On it went, from pillar to post, all for the want of a yes or no. Finally it must have been the managing director who said "we'll ring you back." But he never did. We now know that there's no separate guarantee card with the 14in. version, simply because none have had one.

The Vatman sat with the books and found all the mistakes we've made over the past couple of years, whilst we attended to the customers.

Small boy. "Can you mend my torch?"

Tall man with pointed teeth. "I put the battery you sold me in my clock but it doesn't work, so I've brought the clock in for you to look at."

Local vet. "The auto-pilot on my boat keeps sending me round in circles. I think it's this 12 to 24V power unit. Can you check it at 100mA?"

Local vicar. "This slide projector isn't working properly. Just have a quick look will you?"

And so the morning passed. "Can you come and look at the telly, all the buttons get ITV." The frustration built up and the Vatman looked on pityingly. "No wonder you make mistakes in the books. If I'd to contend with that lot I'd be barmy too. When are you going to put some money in the till?"

Smarting under this, we decided to vent our spite on a

dear little old lady who crept quietly in and stood hesitantly, looking from me to the Vatman.

"Television" she said in a very small voice. Thinking she'd come to ask daft questions about her no doubt clapped out old set, we started an imitation John Cleese/Basil Fawlty tirade.

"Television, television. Of course television. No doubt you want to buy a nice new one. How about a splendid new 22in. colour set with all the trimmings?"

"Yes please" she murmured. "How did you know what I wanted?"

The Vatman collapsed with laughter, while we were made to look dafter than ever.

### **Solly, Velly Solly**

Finally an apology. Apparently one or two readers wrote to say they found our far eastern adventures (December issue) vulgar and offensive (and probably dull too). We're sorry, and to prove it we cut out the succeeding account of our adventures in the frozen north, where we travelled to meet Solo Joe and Eskimo Nell. We try to have our bit of fun, but apparently it doesn't always come off.

# Computerised TV

## Part 1

MICROPROCESSOR and microcomputer i.c.s seem to be cropping up everywhere nowadays. It's hardly surprising therefore that TV manufacturers have found uses for them. First, what's the difference? Well, they both enable a great deal of digital signal processing to be carried out in a single chip. The differences relate to the internal memory arrangements. Clearly the chips require memories so that they can remember what they're supposed to do and how to do it, and to store data as necessary during the processing operations. A microprocessor's memory is of the ROM (read-only memory) type, i.e. it provides outputs as required but you can't feed data in and get it back later. Typical examples of ROMs are the character and graphics generator i.c.s used in VDUs and teletext decoders. A microcomputer is more flexible because it also incorporates a RAM (random-access memory) which will hold and release data as instructed. The data store in a VDU and the page memory device in a teletext decoder are of the RAM variety.

The use of digital techniques in domestic TV sets started a few years back – with a rather expensive, up-market Barco colour receiver. This had an automatic tuning system – similar to the arrangement used in the Grundig SVR videocassette recorder, described in these pages last July. Digital tuning and remote control systems are becoming increasingly common in TV sets, and are also found in the latest VCRs. Once you start using digital control systems, it's logical to employ a microcomputer i.c. to control the system. Both Philips and ITT have published details of microcomputer TV receiver control systems recently, and we shall doubtless find these in the more complex TV sets featuring teletext and viewdata facilities before long.

One of the first items of domestic TV equipment I've had an opportunity to examine using a microcomputer chip is the Sanyo VTC9300P, a Beta format VCR. This uses a microcomputer to act as an off-air timer and tape counter. In other VCRs these functions are carried out by a mixture of special-purpose i.c.s, standard TTL i.c.s and electromechanical devices.

It's worth taking a look at the techniques used in the VTC9300P, since the microcomputer system Sanyo use is fairly simple yet has all the features found in more complex systems. In fact it provides a good introduction to the microcomputer.

The microcomputer chip itself is the Texas TMS1070, a variant of the TMS1000. Before delving into it however, let's briefly outline what a microcomputer is and can do. It's a simple computer of course, and has been described as a

very large-scale integrated circuit (VLSIC) which, by performing a sequence of programmable (in manufacture) operations, can fulfil a wide range of different electronic functions. The advantages of using a microcomputer are its low cost (less than £5), the low component count achieved, and the ease with which the instructions (and thus the functions the device will perform) can be changed by the i.c. manufacturer to cater for different applications.

### **The TMS1070**

Like the other microcomputers in the TMS1000 series, the TMS1070 is basically intended for calculator applications, use in cash registers, and to control microwave ovens and simple industrial processes. The TMS1070 contains all the essential elements of a microcomputer in a single 28-pin package. Fig. 1 shows the basic elements of a microcomputer. The data enters via the input/output interface, is modified or acted upon in the central processing unit in accordance with the programme held in the memory (ROM), and is then fed out. The microprocessor is basically the same, with the omission of the store (RAM) which increases the flexibility of the processing system. The TMS1070 is a p-channel MOS device and is equivalent to some 125–150 TTL i.c.s.

A block diagram of the TMS1070 is shown in Fig. 2. The following is a simplified account of what goes on in it.

### **Programme Memory**

The ROM holds the basic programme material, i.e. the operating instructions. It's constructed in accordance with the basic specification for the device, using a single-level masking technique. Once programmed therefore the TMS1070 cannot be altered. In other microprocessor/microcomputer systems an external instruction ROM can be used to increase system flexibility.

The ROM in the TMS1070 can contain up to one thousand and twenty four instructions, arranged in eighteen pages, i.e. sixty four instructions per page. The microcomputer can taken any one of these instructions from the ROM and carry it out in twice ten to the minus six seconds – pretty fast!

Each instruction consists of eight bits (binary digits). So the ROM contains eight thousand one hundred and ninety two bits. Why these rather odd numbers especially as, in Fig. 2, the ROM is labelled one k but contains one thousand and twenty four instructions? The answer is that since this

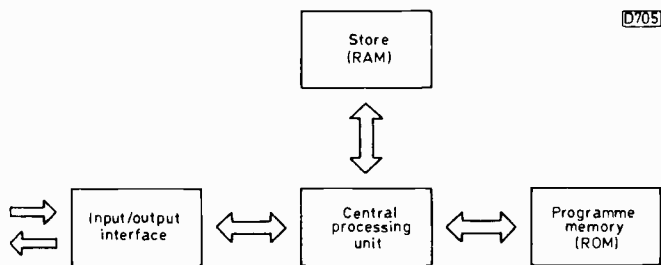

Fig. 1: Basic elements of a microcomputer i.c. A microprocessor i.c. is similar, with the omission of the RAM store.

is a binary system everything is based on powers of two, and two to the power of ten is one thousand and twenty four, etc. The binary system is ideally suited to electronic processing of course since numbers can be represented by 0s and 1s, i.e. a pulse or no pulse. In microprocessor/microcomputer jargon each group of eight bits is called a byte, which so far as the TMS1070 is concerned is equivalent to an instruction "word". The ROM can be said to contain one thousand and twenty four words therefore, each of eight bits or one byte.

### The Store

The RAM is the other memory section of the TMS1070, and is used to hold data obtained from the chip inputs and also to hold information during intermediate steps in the operating processes. You can envisage it as a sort of buffer and scratch pad! It consists of two hundred and fifty six bits, with access to each (i.e. each can be "addressed") without going through any irrelevant storage cells. The bits are arranged in four files, each containing sixteen four-bit data words, i.e. a total of sixty four words.

### Arithmetic Logic Unit

The central "working" part of the microcomputer is the ALU (arithmetic logic unit) which performs logic comparisons, arithmetic comparisons and carries out addition and subtraction. More on this later.

### Inputs and Outputs

There are four data inputs to the TMS1070 called, by

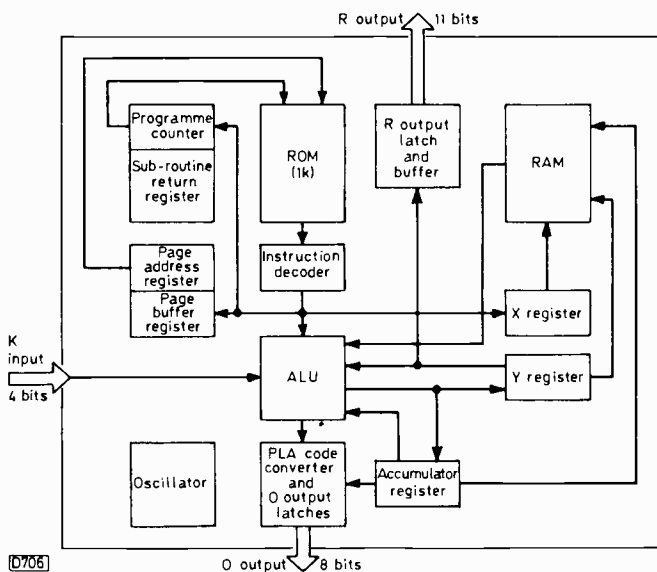

Fig. 2: Block diagram of the Texas TMS1070 microcomputer i.c.

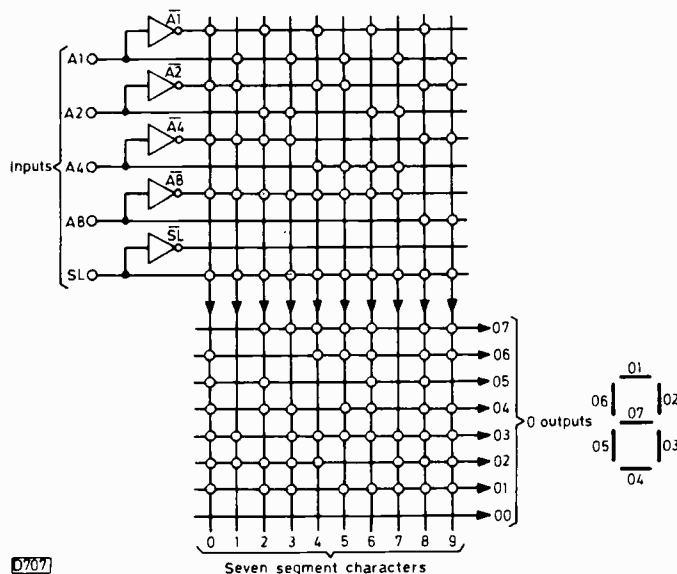

Fig. 3: How the O output programmable logic array turns a five-bit input into an eight-bit output. Inputs A1, A2, A4 and A8 come from the accumulator, SL from the status latch. The O encoding for a seven-segment display is shown on the right.

convention, K1-K4. These feed directly into the ALU. The rate at which data – in the form of four-bit words – is fed into a microcomputer is usually controlled by one of the R outputs acting as either a "clocking signal" or as a multiplexing system. In the TMS1070 the internal clock (oscillator) supplies the timing pulses for this purpose.

The device's outputs are taken via two multipurpose channels designated, again by convention, R and O. The R outputs are fed via thirteen latches which store the information until required (a latch is basically an unlocked flip-flop). The eight parallel O outputs come via the five-bit to eight-bit code converter shown as the PLA (programmable logic array) in Fig. 2. The O outputs also have latches. A typical use for the O outputs is to send data to drive a seven-segment display. The information is coded by the PLA as required for the particular application. Fig. 3 shows how the O output PLA can encode a five-bit input, converting this to provide an output to drive a seven-segment display device.

### Instruction Decoder

The instruction decoder (see Fig. 2) is another PLA, consisting of thirty programmable input NAND gates. These are used to decode the eight-bit instruction words (i.e. parts of the programme) from the ROM. After decoding, each word will have provided a combination of sixteen microinstructions which in turn control the ALU, send data to the RAM and so on.

### The Rest of the Four-bit Microcomputer

The other sections of the TMS1070 consist of various registers which are used for short-term information storage – rather like latches. A flip-flop can be considered as a one-bit register.

That really sums up what's in the TMS1070, a typical four-bit microcomputer. The latter term is used because the microcomputer handles data in four-bit chunks. We'll look at the operation of the various sections of the TMS1070 in greater detail next month, and will also show how the device is employed in the VTC9300P.

# VCR Troubles

Steve Beeching, T.Eng.(C.E.I.)

THE first faults to be dealt with this time relate to Sony Betamax VCRs. Before going further however I'd like to discount any impression that these machines are unreliable. The fact is that one of my clients has a large number of them out in the field, so we're beginning to get quite a bit of experience of them. The purpose of these notes is, hopefully, to save fellow engineers with less video experience some time and perhaps a nervous breakdown...

## A Betamax that Wouldn't Play

The first time a Sony Betamax VCR came in with the fault "the play button will not stay down", I must admit to going round the houses a bit before finding the cause of the trouble. This is bound to happen when you get new faults on new equipment, and at the moment every fault on domestic VCRs seems to be a different one.

Anyway, after removing the top from the VCR, inserting a tape and pressing the play button, sure enough it wouldn't latch down. An optimist might look for a broken latch spring, but this is a VCR, not an audio cassette deck, and anyway I'm a bit of a pessimist. A quick check underneath revealed that a stop/release solenoid was operating as fast as the button could be depressed. I also noticed that the head drum was not rotating. Now every VCR has a safety circuit to bring everything to a halt if the head drum is not revolving, and this seemed a likely cause of the stop solenoid operating. Wrong! A thorough check on the head drive motor and relay showed no obvious fault. What we did find was that there's a microswitch, operated by the stop solenoid, in series with the head motor. Maybe this was why the head wasn't rotating: the motor was being switched off immediately.

Time to apply Spock type logic. The stop solenoid is operating not because the head motor is not revolving. The stop solenoid is preventing the head motor revolving via the microswitch. So there must be some other cause of the fault. Brilliant!

The most sensible approach seemed to be to work back from the system control board, muting the operation of the stop solenoid to ascertain why it comes into operation. Pin 15 of

IC701 (see Fig. 1) is normally in the high-voltage state; in the stop mode it goes low, switching off Q701. To override the system, connect the base of Q702 to chassis. Now one shouldn't override safety circuits without due consideration of the effect the action will have. Having considered, we shorted the base and emitter of Q702. The play button stayed down, the head drum revolved - but pin 15 of IC701 remained low. This proved that the fault did not lie in the head safety circuits: the r.f. switching pulses from the head servo were arriving at pin 22, so everything was in order here unless the chip was faulty.

The other system feeding the and gate which provides the output at pin 15 of the chip is the end-of-tape stop circuitry. The sensors are two little inductors in close proximity to the tape, one for stopping at the end of a cassette in the fast forward or play mode, the other for stopping the cassette at the beginning in the rewind mode. Both operate in the same way, and in fact share a common oscillator and low-pass filter. In the play mode, 12V is applied to R708 from the forward switch. The 200kHz output from the oscillator within the i.c. appears at pin 13. The level is set to 3V peak-to-peak at TP701 by means of the 22kΩ preset. The sensor coil sits lightly on the tape, and is tuned to 200kHz by the parallel 3,300pF capacitor. When the end of the cassette is reached, a metal foil comes into proximity with the coil altering the tuning so that the oscillations cease. In fact even a reduction in the level of the oscillations at TP701 results in the stop solenoid operating.

The problem was found to be no oscillations when the play button was pressed, so that the end of tape stop action was initiated. Now the oscillator was working, monitored at TP702, and the rewind action was normal. There was also 12V at R708 and about 6V at TP701. But no oscillations. At least at first. While checking through, the oscillations suddenly appeared and all attempts to find out why were defied!

There are several PCB links between pin 10 of IC701 and the socket connection to the sensor coil, so all the joints were resoldered, and the plug and socket and sensor leads were checked. No obvious reason for the trouble could be found. I tend to worry a bit with a situation like this, since there's usually a return visit with the same fault.

Some time elapsed, and my client then phoned to say that he had another faulty Betamax but this time the rewind button would not latch down. Now Beeching is not one to be caught twice. The machine was sent over, and a check was immediately made at TP702. Sure enough, no oscillations, though they were present at TP701. Again we went over all the joints concerned, though none of them looked particularly bad, and cleared the fault. Up to now there's been no recurrence of the fault on either machine.

## Intermittent Loss of Colour

Two more Sony Betamax VCRs came along recently. Both had been running for some time, and both suffered from the same problem. Perhaps they fail in pairs! The fault was intermittent loss of colour, accompanied by horizontal lines. Clogged heads we thought. Wrong again! The heads

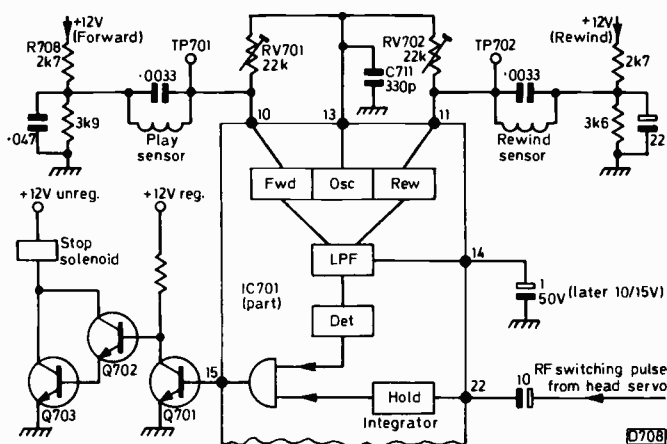

Fig. 1: The end-of-tape stop system used in the Sony Betamax Model SL8000 (simplified circuit).

were cleaned, but the fault reappeared at varying intervals. So being of a gentle nature, I gave one of the machines a bash. The picture cleared. Bash again. Noisy picture. Same with the other machine. The temptation was to send them both back with a couple of rubber hammers, but instead we stripped one down to investigate.

The f.m. replay signal loss was traced right back to the video head record/playback switch S101, which can be got at only after removing the complete tuner unit. A cure was effected using lubricant switch cleaner, but if the trouble appears again we'll replace the switch.

### A Philips Cassette Problem

Now a Philips cassette problem. Something rather annoying, since I object to spending a lot of time looking into faults brought about by production changes.

There was a panic call to an N1502. In the past, this had suffered from threading problems, as a result of which a new threading motor, belt and gearbox had been fitted. The complaint was that the machine had been left on the timer to record a programme but had failed to operate, switching off without any recording taking place – after releasing the record and start buttons. The fault in fact was that the VCR would not thread up when used on “timer start”, but worked all right when operated manually. In the fault condition the head assembly would start to thread, then jam up, putting considerable pressure on the head drum which slowed down, eventually initiating the unthread operation via the safety circuits. Why?

I eventually noticed that the mechanism that releases the turntables within the cassette was not moving far enough to release the reels. This prevented tape being withdrawn from the cassette of course, and consequently the head drum assembly from rotating. Again no problem was present or could be found in the manual mode – or in any mode if a cassette was not inserted. Great consternation all round! Close inspection of the leverage didn't reveal any clues: it was quite free of any impediment.

Attention was then turned to the cassette, which was a recently purchased new one, and it was noticed that the slot into which the brake release lever is inserted is not the same as with older cassettes. Fig. 2 shows the slot in the old moulding, and the position of the release lever: Fig. 3 illustrates the small undulation (lump) found on all new cassette mouldings. It was this small lump on the new moulding that was causing the trouble. As the lever's arc of travel is towards the lump, it pressed against the surface of the lump and would not travel over the lump. The lever itself is powered by a spring which activates the lever after being released by the threading system. In the manual mode this release is sudden, and the lever jumps over the lump (most of the time). In the timer mode, when the start button

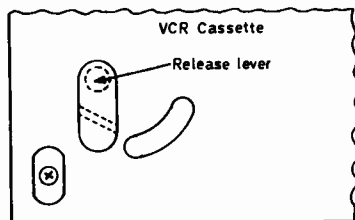

Fig. 2 (left): Bottom view of a Philips VCR cassette, showing the position of the reel brake release slot.

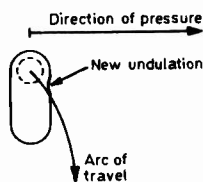

Fig. 3 (right): Position of the undulation in the brake release cut-out in recent cassettes.

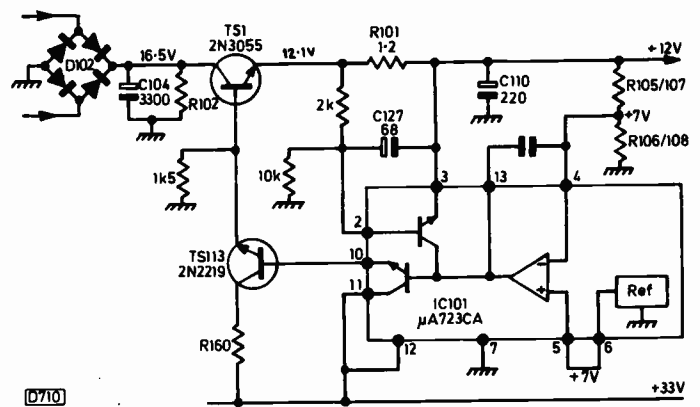

Fig. 4: 12V power supply circuit, Philips N1700 VCR.

is pressed the release is slower and the lever is impeded by the lump. The cure is to bend the lever away from the lump slightly – i.e. to the right-hand side of the VCR, viewed from the front.

Obviously the slot in question had straight sides when this N1502 was made. The additional bit on the new moulding is thus causing problems. If you're sceptical about this, compare new Philips' cassettes with those purchased a year or so ago – I don't know exactly when the moulding was changed. BASF cassettes are not affected incidentally.

It's worth noting that serious damage to the heads and threading components – the motor, belt and gearbox – can occur if the matter is left unattended.

### Timer Record Problem

There was a note with a Philips N1700 I recently serviced – new heads and belts and a general tidy up – to the effect that it blew 13A fuses when left on the timer to do a recording. As usual, I was sceptical: any fault that would blow a mains fuse would burn the VCR somewhat! The timer circuit was tried by setting it and advancing the clock manually. No fault showed. Next I set the clock for a minute in advance, and left the machine for more important activities like drinking coffee.

The VCR obliged by switching on and going dead. No clock, nothing. The same thing happened two or three times in succession, leaving the machine in the dead condition, and investigation revealed that there was no 12V supply as a current limiter in IC101 had operated. The excess current switch is held on by C127 (see Fig. 4), so power has to be removed for a short time or C127 shorted out to restore the machine to normal operation. So the question to be answered was, why does the current trip operate only with the timer?

Crowbar tactics were tried next: link out C127 and try again. The machine operated perfectly. So the VCR was left running while I finished by coffee. Time next to try out my new Philips digital voltmeter. A few measurements later I was as confused as ever. The only voltage that was incorrect was 14V at the emitter of the series regulator transistor TS1. Then the penny dropped. The 12V supply was correct, so there was 2V across R101. But R101 is 1.2Ω, which means that 2A must be flowing. Impossible. Check R101 and find it's 136Ω.

While chatting to a friend at Philips Service, it transpired that this fault is not exactly uncommon. “Wait till you get one that's only 4Ω” he said! It seems that the machine then shuts down every so often on timer record as an intermittent fault. So if you get one that does this sort of thing, check R101 ...

# Colour Receiver Options

## 4: Teletext, Remote Control and Channel Display

Luke Theodossiou

CONSTRUCTION of the interface board is quite straightforward using the double-sided p.c.b., ref. no. D070.

The only exception is the top soldering required on some components, including i.c.s. Ordinary i.c. sockets cannot be used for this reason, so constructors have the choice of either being brave and soldering the i.c.s straight in or using "soldercon" sockets. The other difficult area is the top soldering on the collectors of Tr16-Tr31. The easiest way we found of doing it is to solder one transistor at a time instead of inserting them all at once. Don't forget to put the through-hole links in where indicated.

The Tifax XM11 module is mounted on top of the interface board using suitable spacers and the mounting holes provided. Connections between the two boards are on a point-to-point basis and a very neat job can be achieved

using ribbon cable which is soldered on the interface board and terminated on the sockets provided with the Tifax module. Connections to the receiver are shown in Table 1. The video signal connection to B9 on the interface board should be made with screened cable with the screen earthed at the signals board end only. The same applies to the line pulse connection to D1 with the screen earthed at the timebase board end. This avoids earth loops which can cause jitter, hum bars, line pulling and other undesirable phenomena.

As with the teletext only option, R49 on the signals board is changed from 2k2 to 68Ω.

The remote control transmitter unit is available from ITT Consumer Products Ltd., Service Dept., Eldon Way, Paddock Wood, Kent. The stock number is 16554.

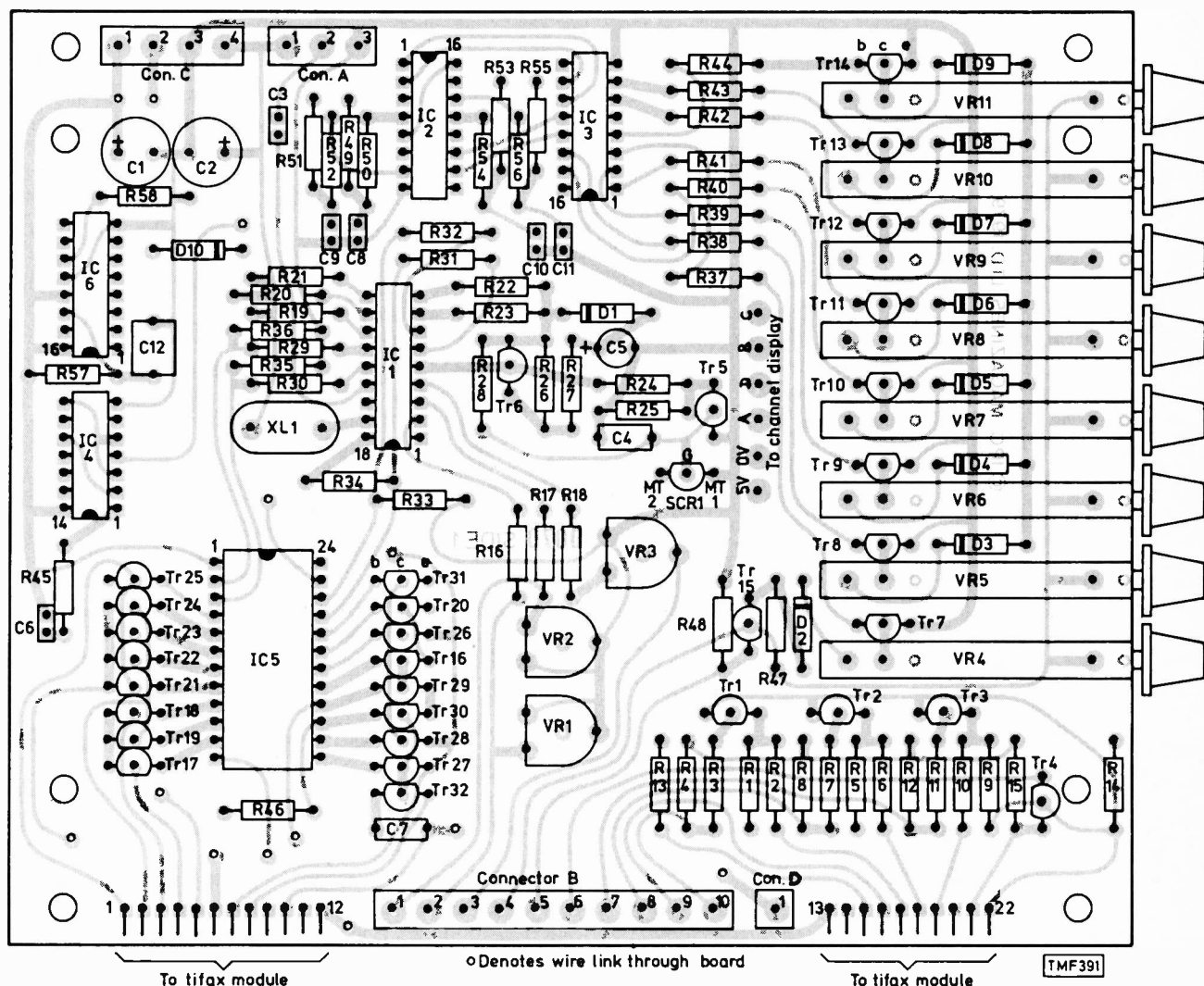

Fig. 1: Layout of the teletext plus remote control interface board.



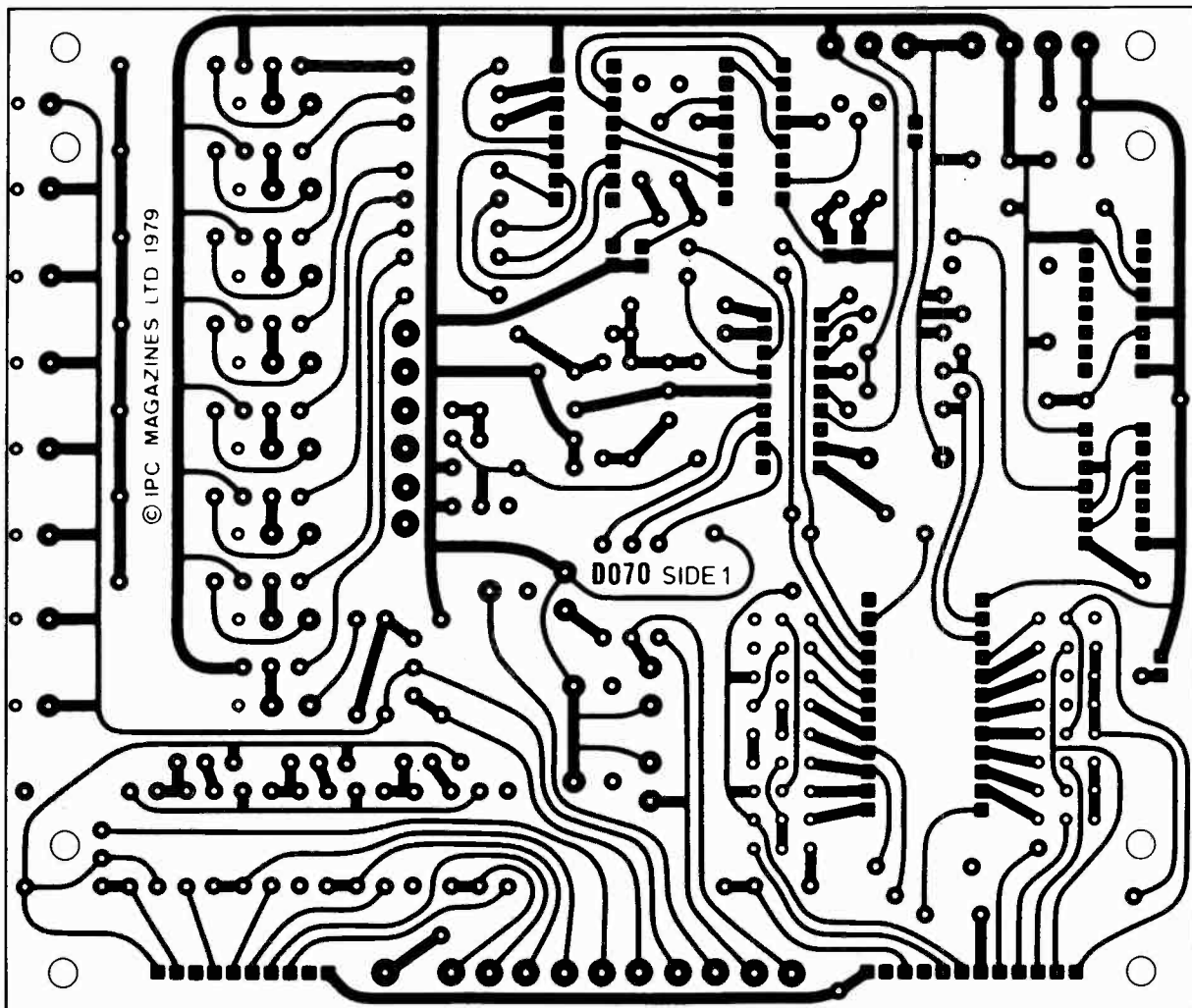

Fig. 2: Interface board print pattern, side 1.

**Capacitors:**

C1	100 $\mu$ 16V pluggable electrolytic
C2	100 $\mu$ 25V pluggable electrolytic
C3	2n2 ceramic plate
C4	100n Siemens 100V polyester
C5	2 $\mu$ 2 35V tantalum bead
C6	10n ceramic plate
C7	100n Siemens 100V polyester
C8	10n ceramic plate
C9	10n ceramic plate
C10	10n ceramic plate
C11	10n ceramic plate
C12	680n Siemens 100V polyester

**Semiconductors:**

D1-D9	1N4148
D10	BZX83 C13V
Tr1-Tr3, Tr6	BC212L
Tr4, Tr5, Tr7-Tr32	BC182L
SCR1	TRI400-0.35 triac
IC1	SAA1130
IC2	4042
IC3	4028B
IC4	4001
IC5	4514
IC6	4528

**Resistors: all 0.25W carbon film,  $\pm 5\%$ .**

R1	1k	R26	100k	R51	100k
R2	3k3	R27	22k	R52	22k
R3	270	R28	2k2	R53	100k
R4	68	R29	100k	R54	22k
R5	1k	R30	100k	R55	100k
R6	3k3	R31	100k	R56	22k
R7	270	R32	100k	R57	1M
R8	68	R33	39k	R58	100k
R9	1k	R34	39k		
R10	3k3	R35	39k		
R11	270	R36	39k	VR1	10k
R12	68	R37	10k	VR2	10k
R13	15k	R38	10k	VR3	1k
R14	2k2	R39	10k	VR1-VR3 are miniature skeleton types.	
R15	1k5	R40	10k	VR4-VR11 100k Helical multiturn tuning potentiometers	
R16	5k6	R41	10k		
R17	5k6	R42	10k		
R18	5k6	R43	10k		
R19	100k	R44	10k		
R20	100k	R45	22k		
R21	100k	R46	100k		
R22	100k	R47	470k		
R23	10k	R48	27k		
R24	22k	R49	100k		
R25	10k	R50	22k		

**Miscellaneous:**

XL1	4.43MHz crystal
0.2"	Molex pin connectors
PCB	D070

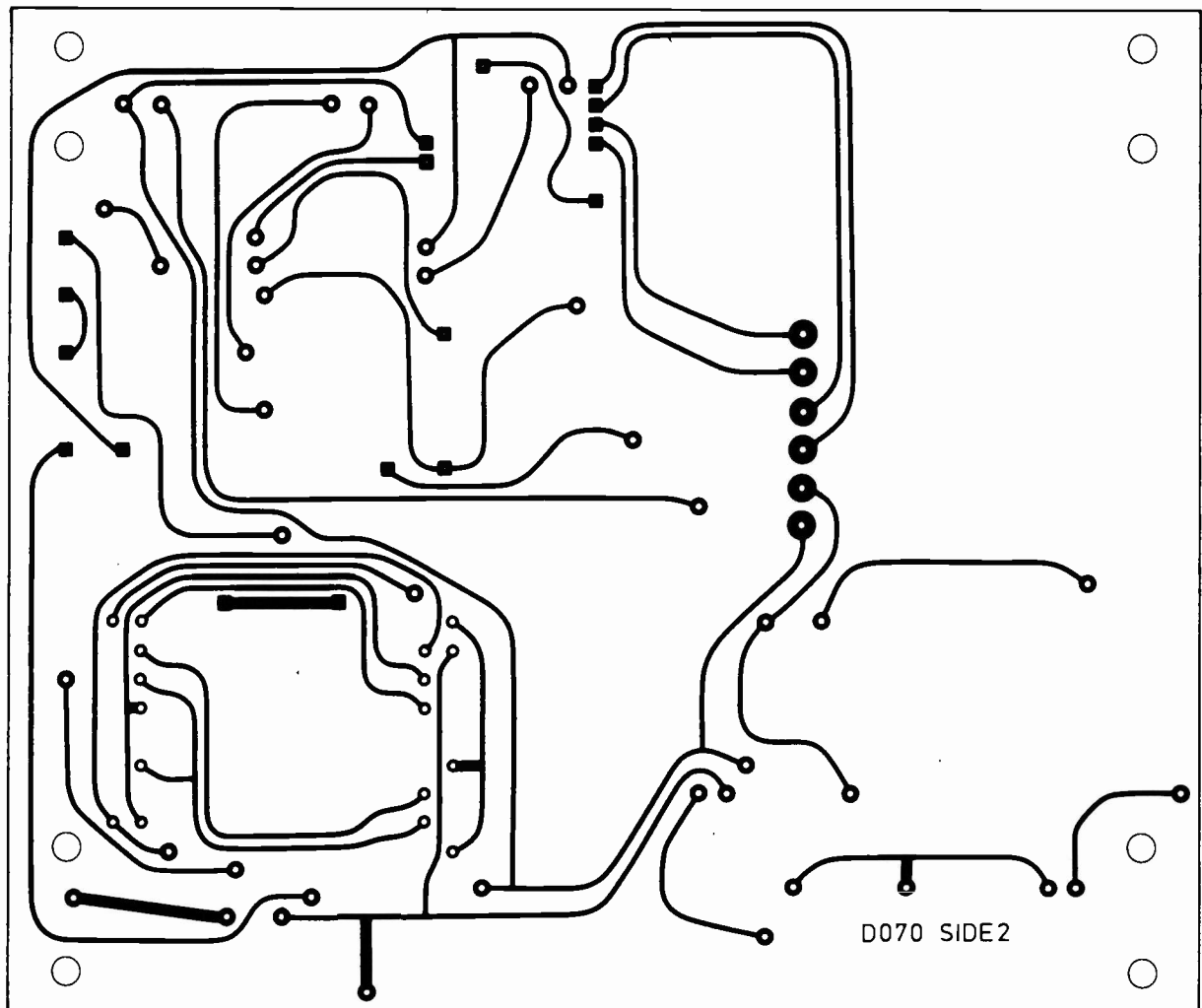

Fig. 3: Interface board print pattern, side 2.

Table 1

A1 →	} To preamplifier
A2 →	
A3 →	
B1 →	A6 on signals board
B2 →	A5 on signals board
B3 →	A9 on signals board
B4 →	A12 on signals board
B5 →	A18 on signals board
B6 →	A1 on signals board
B7 →	A4 on signals board
B8 →	A3 on signals board
B9 →	A20 on signals board
B10 →	A2 on signals board
C1 →	F3 on PSU board
C2 →	F1 on PSU board
C3 →	F4 on PSU board
C4 →	F2 on PSU board
D1 →	E3 on timebase board

### Channel Indication

We originally considered using an on-screen display for channel indication, but the idea was discarded in favour of the very simple i.e.d. circuit shown in Fig. 4. The heart of the system is the Motorola type MC14493 i.c. which is a binary to seven segment latch, decoder, and driver. The decoding is binary plus one which matches the SAA1130

output code. The latch is not used in our application since the programme outputs from the 4042 i.c. are already latched.

The MC14493 is designed to drive common cathode i.e.d. displays, but we chose a common anode type which in fact takes more current than the i.c. can provide.

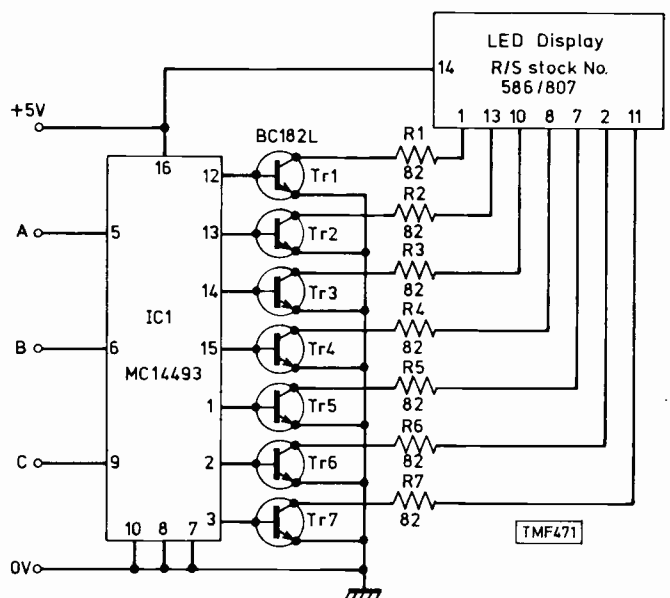

Fig. 4: LED channel display circuit.

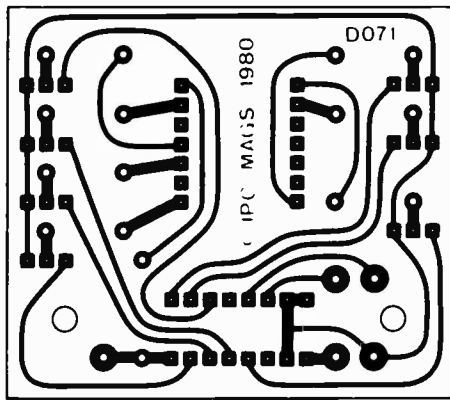

Fig. 5: Display board print pattern.

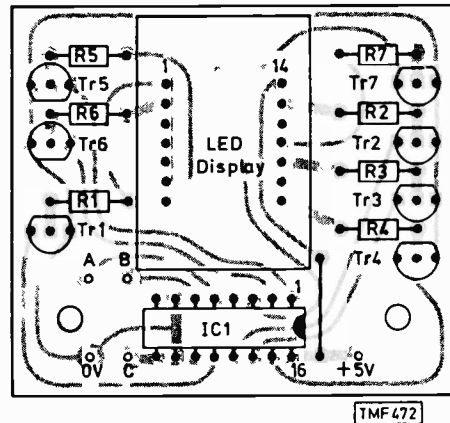

Fig. 6: Display board component layout.

Transistors Tr1-Tr7 act as inverters and current amplifiers for each segment, whilst resistors R1-R7 limit the current to around 20mA.

The copper pattern for the display board is shown in Fig.

5, whilst Fig. 6 shows the component location. Wiring is to the points provided on the interface board. Note that since we only use 8 channels, control bit D is not used, although it is available on the interface board.

# Letter

## A DANCE WITH KÖRTING

We had a real awkward fault recently on a Körting hybrid colour set. I recount the tale in case it may help others confronted with this confusing problem.

The symptoms were a blank raster and low sound, at first intermittent. One of our field technicians first encountered the trouble, and got as far as finding that the voltage at the cathode of the video detector diode D102 (see Fig. 1) was 26V, biasing it off, before the fault cleared. The fault would not return, at least until several weeks later. Meanwhile C142 was changed "on spec". When the set finally arrived in the workshop, the fault was permanent. The detector diode was biased off, also the video preamplifier transistor T105 because of its high base voltage (26V). Since T105 was biased off, its collector was at chassis potential and there was no luminance signal.

As there was another of these sets in for repair, we swapped over the i.f. panels and found, to our surprise, that the fault was not in the i.f. strip at all. At this point I decided to double check the voltages. The 24V supply was spot on, and sure enough there was 26V at the cathode of D102. Where was it coming from? A scope at the anode of D102

revealed all – a 2.5V peak-to-peak signal since with T105 cut off there was no a.g.c. action. The 26V seemed to be due to C138 and other stray capacitances, including the Avo, charging to the peak value (20.8V plus 5V).

Since there was no a.g.c. action the i.f. strip was working flat out and the whole thing seemed to be something of a vicious circle. Lack of a.g.c. gating pulses was suspected, but they were present and correct. A bias voltage is fed to the a.g.c. circuit from a potential divider in the timebase panel, so these two resistors were checked – and found to be o.k. We seemed to be getting nowhere.

After scratching head and lighting pipe, another go at voltage checks was made. This revealed that the emitter of T105 was at 19V. Strange, since with it cut off by the high voltage at its base, its emitter voltage should have been at something approaching 24V. We then remembered that the fault was not in the i.f. strip itself. Now in addition to driving the a.g.c. gate, the emitter of T105 provides the video input to the decoder panel. A measurement was made at the junction of C746 and R758, where a reading of 8V was recorded. All was now clear: C746 on the decoder panel was leaky, and since this pulled down T105's emitter voltage there was no a.g.c. action. In retrospect, the 26V reading was a bit of a red herring, T105's emitter voltage providing the real clue to the fault. Quite an interesting one!

Mike Phelan  
Holmfirth, Yorkshire.

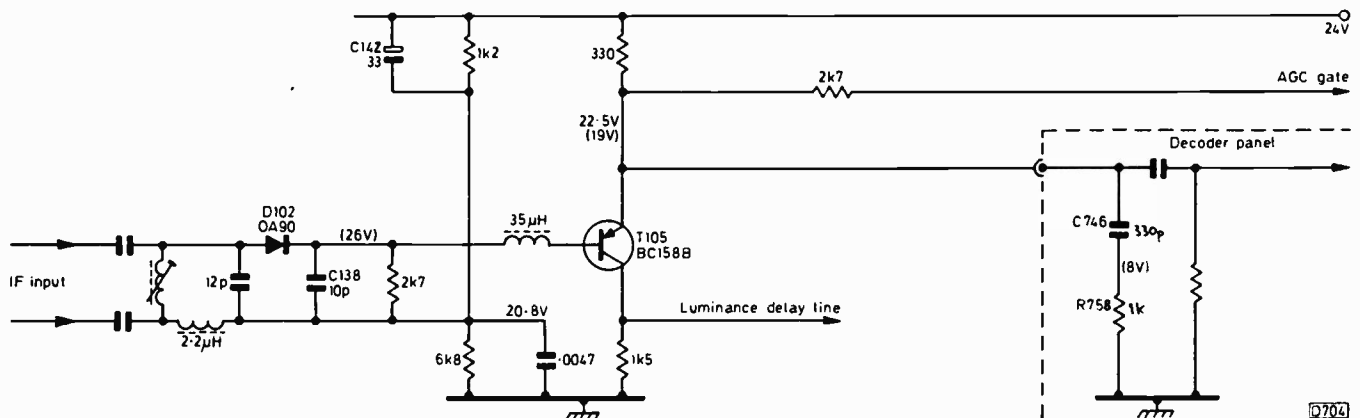

Fig. 1: Video detector and preamplifier stages used in Körting hybrid colour sets. The incorrect voltages in the faulty set are shown in brackets.

# TV Servicing: Beginners Start Here...

Part 29

S. Simon

ONE point worth making clear before we go any farther is the fundamental difference between the luminance and the colour-difference signals. Say we want to drive the cathode of a monochrome tube from peak white to black. The voltage swing required would be from maybe 50V (peak white) to 200V (black). The point about such a signal change is that it is a d.c. one, i.e. the signal has only positive values, not positive and negative ones (with respect to a datum point, which may or may not be zero) as with an a.c. signal. The RGB signals used to drive the cathodes of a colour tube are of the same type. As we've seen however the colour-difference signals are used to supplement the basic brightness signal, so that we can obtain more or less red, blue and green as required. This means that the colour-difference signals must be a.c. signals, i.e. with both negative and positive values so that they can add to or subtract from the luminance (brightness) signal.

This is the reason why we have to use a synchronous demodulator to detect the colour-difference signals. A simple diode will not do since it will provide only a positive- or a negative-going output depending on which way round it's connected. A synchronous detector however acts as a switch, allowing the input signal, whether positive- or negative-going, to pass through at the instant it's switched on by the reference signal.

Let's take a closer look at one of the chroma demodulators in the Pye circuit shown last month (see Fig. 1). The reference signal switches the diodes D34-37 on once during each reference signal cycle. With the reference signals as depicted – of opposite polarity at each end of the secondary winding on T16, the negative-going half cycle on the left will switch on diodes D35 and D36 while the positive-going half cycle to the right switches on D34 and D37. During the succeeding half cycle all the diodes remain cut off. When the diodes are switched on, the signal at the input, whether positive- or negative-going, appears at the output. This system works because the rate at which the signal modulation varies is much less than the reference signal frequency. The amplitude of the reference signal has to be significantly greater – say five times – than that of the

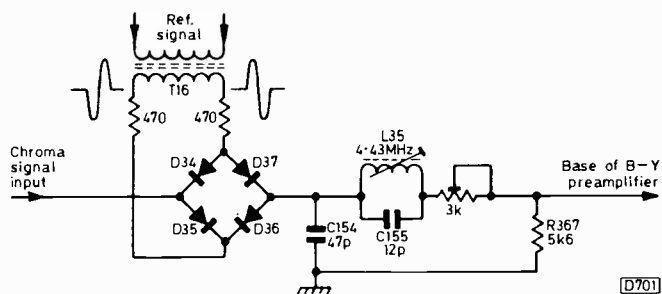

Fig. 1: One of the synchronous chroma demodulators (B-Y) used in Pye hybrid colour chassis. The four diodes are switched on once during each full subcarrier cycle. The series trap L35/C155 presents a high impedance at 4.43MHz, so that the subcarrier signal is not passed on to the base of the B-Y preamplifier.

202

input signal so that only the reference signal controls the switching of the diodes. The reference signal itself is filtered out by L35/C155.

If this is the case you might ask, how does the chroma signal get through the single diode detector commonly used to demodulate the i.f. signal? The answer to this is that the i.f. signal is a double sideband one, with the chroma signals carried pick-a-back style on each sideband. So whichever sideband is passed by the vision detector, both the luminance and the chrominance signals appear at its output.

The burst detector operates in a similar, though not identical, manner. The point here is that we require from the burst detector a positive- or negative-going output to pull the reference oscillator back into phase lock. So the outcome is much the same.

## Automatic Frequency Control

This talk of positive- and negative-going control voltages is leading up to something else – automatic frequency control (a.f.c.). The object here is to control the oscillator in the tuner. Accurate tuning is more important in a colour receiver than a monochrome one since the colour information is carried by a subcarrier which is towards one end of the channel bandwidth. So the vast majority of colour receivers feature a.f.c. The a.f.c. action is effected by the use of varicap diodes in the tuner unit, the control voltage being used to adjust the tuning.

The basic idea is shown in Fig. 2. The signal appearing at the collector of the final i.f. amplifier transistor is fed to a separate amplifier stage which drives a frequency discriminator circuit. This detects variations in the i.f., and produces a positive- or negative-going control voltage which is added to the tuning voltage applied to the tuner unit. The result is that any drift in the oscillator frequency is corrected. The discriminator itself consists of a rather complex tuned circuit and a couple of diodes: its operation depends on any phase difference between the i.f. and the signal provided by the i.f. amplifier. To enable the channel to be tuned in correctly, the a.f.c. has to be disabled – otherwise it would counteract the attempt at accurate tuning. For this reason an a.f.c. disable switch is incorporated in the system.

## When You Meet a Faulty Set

We're sorry for all the theory we've been serving up over the last couple of parts in what's intended to be an essentially practical series. But with a complex thing like colour decoding the basic processes involved have to be sorted out before any logical attempt at fault finding can be made. Now for the awkward part – when you actually meet a set which is faulty from the colour point of view.

## No Colour

Probably the most common fault is no colour. It often presents a trap for the uninitiated. What to do? It's what

TELEVISION FEBRUARY 1980

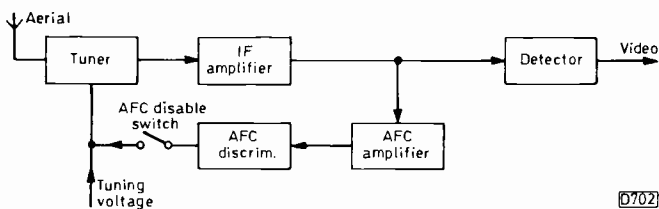

0702

Fig. 2: Basic idea of automatic frequency control. The a.f.c. discriminator produces an output proportional to any signal deviation from the nominal i.f. This output is added to the tuning voltage applied to the tuner, restoring correct tuning.

you don't do to start with that's more important. You don't disturb the decoder in any way. You don't even take the back off the set. What you do do is to take a good look at the picture displayed. In all probability it is not a very good monochrome picture, but this condition is a side track and has probably been present for some time, due possibly to the tube wearing or the grey scale not being correctly set up.

Note whether there's a "colour off" button at the front or the rear (fitted mainly on some older sets), and ensure that the colour/saturation control has not been turned right down. Check the tuning carefully. If there is colour at one point when the button is tuned, but it cannot be held when the button is released (exact arrangements depend on the set), check the a.f.c. disable system which may be a slide switch at the front or a push-on/push-off switch at the front or rear. If you find that the colour can be held with the a.f.c. system disabled, you've established the probable source of the trouble – the a.f.c. circuit. It's likely that the adjustment of one or more coil cores in this department is all that's required. Consult the appropriate circuit diagram to find out which small section of the set provides the a.f.c. action – it will almost certainly be on the i.f. panel.

### Preliminary Checks

If the tuning is not at fault, the picture is well contrasted (not weak and grainy – check the aerial and feeder/connections in this event) and there are no hidden colour-off buttons, it's time to remove the rear cover and make a few preliminary checks. First ensure that the decoder section is receiving its power supply, and that the burst gating pulses are present. Whilst a multimeter will record the presence of the d.c. voltage supplies, some sort of diode probe is required, in conjunction with the multimeter, to record the presence of the gating pulses (the diode rectifies them, charging a capacitor to produce a measurable d.c. voltage).

In many cases you'll find the gating pulses absent, and in all probability restoring them will produce full colour – if someone else hasn't been making hopeful adjustments to the preset controls and coil cores in the decoder in an attempt to get the colour back. You'll have to refer to the circuit to find out where the pulses are fed into the decoder and where they come from (probably the line output stage). Check any series feed resistors (a likely cause on some chassis) and capacitors (less likely) plus such mundane things as dry-joints at the line output transformer leadouts or tags, the plugs and sockets and if necessary the continuity of the print tracks involved.

### Overriding the Colour-killer

If the gating pulses are present, disable the colour killer so that the chroma amplifier can amplify any signals that are presented to it. The method of overriding the colour-

killer varies from chassis to chassis. In some sets you link two points together, in others you add a resistor to bias on one of the chroma amplifier transistors, whilst in a few you rotate a control fully to one end (e.g. in some Bush/Murphy sets you turn the ident control 3RV4 fully clockwise). Follow the maker's instructions in all cases.

### Colour-killer Faults

If this simple action of overriding the colour-killer restores normal colour, the killer circuit itself obviously requires attention. The fact that you've been able to get normal colour means that the colour burst is present, the reference oscillator is working and the chroma channel is otherwise in order. This narrows the possibilities to a very small area. The checking list includes the killer circuit components such as the rectifier diode and/or switch transistor, the reservoir capacitor, print contacts and so on. The ident stage could be producing a 7.8kHz signal of inadequate amplitude – check the tuning of the coil and in some cases the transistor's emitter decoupling capacitor. In the case of the ITT hybrids (CVC5-CVC9 chassis) the bistable circuit could have stopped operating, since the colour turn-on voltage is obtained by smoothing the output from one of the two transistors. In this case you'll have to check the two transistors, the presence or not of the triggering pulses, the colour detector circuit and the tuning of the ident stage.

### Still no Colour

If overriding the colour-killer does no more than produce some coloured noise (confetti like) on the screen, it probably means that the chrominance/burst signals are not reaching the decoder or once there are not travelling along their respective paths, or alternatively the reference oscillator is not working. We say probably because there are other possibilities depending upon the particular chassis, and by this time we would have taken the set and model number into consideration and started to proceed according to our previous experience of it, checking the signal input to the decoder and if this is absent checking back to the i.f. panel as there are often one or more chrominance amplifier stages here. If the decoder is receiving its signal input (checking this with our scope or a diode probe), we'd check the reference oscillator stage – the transistor, tuning capacitors and maybe the crystal (this is not often at fault, but is a possibility). Polystyrene (see through) capacitors are a common cause of a non-operative reference oscillator. If in doubt and there are two or more suspects in the stage, replace the lot. Voltage checks on the chroma and burst amplifier transistors are usually enough to identify which is inoperative and for that matter why. You can treat the chroma amplifier and the a.c.c. system in exactly the way you would tackle the i.f. amplifiers and the a.g.c. circuit, checking voltages to find the source of the trouble.

### Weak Colour

More often disabling the colour-killer will produce weak colour, unlocked colour or both. Weak, correctly locked colour merely means a repeat of what we've just said, i.e. check the chroma signal path from the i.f. through the early stages of the decoder. The fault would not normally be in the later stages of the decoder, since the colour-killer had to be overridden to show it up. If there's an a.c.c. preset, check the setting of this. If everything seems in order so far, the fault is probably around the killer, the burst amplifier, the

burst gate etc. — it depends on the particular design, and there's a certain amount of interaction between these stages.

At this point the effect of adjusting any other relevant preset controls and cores can be tried, being extremely careful to return each to its original position if no improvement is obtained. In all probability however you will find that something produces an improvement, since you've already checked the d.c. conditions and found the stages to be working normally, and it's now the phasing or timing that require setting up. Do it as laid down in the manufacturer's instructions.

### Unlocked Colour

Bands of colour drifting across the screen mean that although the reference oscillator is working it is not operating at the correct frequency, probably due to a fault in the burst detector or the d.c. amplifier stage. Adjust the "set oscillator frequency" control to see if this improves matters. Follow this up with adjustment of the reference oscillator's collector coil. Check the voltages in the d.c. amplifier circuit — note that a field effect transistor is sometimes found here, for example in the Thorn 8000/8500 series. Check the components in the burst detector circuit, including any electrolytics and zener diodes used to stabilise the voltages in the control loop, and set up the burst detector circuit (bridge balance etc. according to the circuitry employed).

### Defective ICs

Where i.c.s are used in the decoder, they are a common cause of no colour, weak colour and various defects which seem to differ from occasion to occasion and for which no hard and fast rules can be laid down. The SL917A i.c. used in the Z584 decoder fitted in the Rank A823A chassis is particularly prone to producing one or more of these symptoms, and is the first suspect if the chroma signal is reaching the decoder board from the i.f. panel (check the transistors in the upper can, marked chroma amp, of the i.f. panel if the signal is weak or absent). When a new SL917A has been fitted, turn the ident control 3RV4 back from its fully clockwise position (where you put it to override the colour-killer) until a fully identified picture is obtained. Hold it in this position and change channels several times to prove that the faces remain flesh colour and don't turn to green (incorrect ident). If there is a tendency to change, readjust the control slightly until correct operation is obtained after every channel change.

This digression on to the Rank A823A chassis illustrates how the same fault may require rather different treatment in different chassis, as did our earlier mention of the unusual colour-killer arrangement in the ITT hybrid chassis (CVC5 on).

### Basic No Colour Routine

In a nutshell, the basic routine to follow in the event of no colour consists of first checking the user controls and tuning, making sure that the aerial and its connections are adequate, checking the operation of the colour saturation control and the colour-off control if present; next checking the decoder supplies and the presence of gating pulses; and if these are present overriding the colour-killer, or check the chroma amplifier stages to see whether these are biased on or off.

The results of these checks should indicate whether the chroma amplifier, the colour-killer or the reference

oscillator is at fault. It should also be appreciated that it's no good the gating pulses arriving to open the burst gate if the burst is not there at the same time. We don't mean simply that there's continuity of the chroma/burst signal path. Suppose that the burst is there, but the burst gating pulse doesn't arrive at the same time? How come, you may say? Well, if the pulses come from the line timebase, the setting of the line hold control can have an appreciable effect on their timing.

### Incorrect Burst Gating

Line drift due to component changes (resistor values, leaky semiconductor devices or capacitors) can sometimes result in loss of colour, and it's instructive on chassis such as the Thorn 3000/3500 to rotate the line hold control and observe the result. You might think that there would be loss of line hold to draw attention to the cause of the trouble, but this is not always so — though some horizontal picture shift may be noticed.

In some sets the gating pulses are derived from the line sync pulses — the main example is the Pye hybrids whose decoder we described last month. In this decoder coil L28 tunes the gating pulses to ensure that they coincide with the burst. Large amplitude pulses from the line timebase are still required for other purposes — to drive the bistable circuit etc. — so the line timebase will always have some effect on the decoder as a whole even where it's not the origin of the all important burst gating pulses.

### Intermittent Colour

Quite often the complaint is of loss of colour after the set has been on for some time, or that the picture appears in monochrome for a period before the colour appears. Once again this could be due to tuner drift or faulty a.f.c. action, and the effect of retuning should be the first check.

If the tuning is not at fault, it's instructive to note the effect of using a hair dryer to warm up suspect areas of the decoder, and/or a freezer aerosol to achieve the opposite effect. A fruitful area for this warming and cooling is around the reference oscillator, where it may be found that a half turn on the relevant coil core is all that's required to achieve reliable colour operation.

### CDA No Colour Faults

In some hybrid sets it's quite possible for the decoder to be operating correctly but still with no colour on the screen. We refer in particular to the Pye 691 and the GEC hybrid sets, also dual-standard models from Decca and Bush/Murphy, where the common screen grid feed resistor

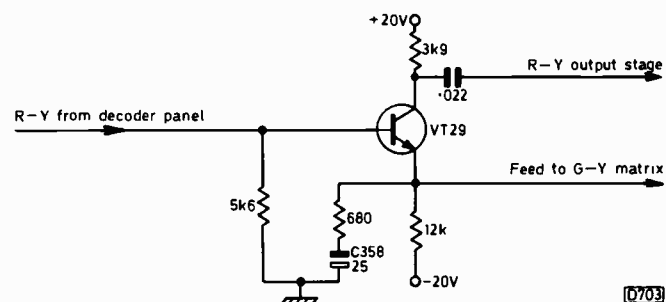

Fig. 3: The colour-difference preamplifier stages in Pye hybrid colour receivers are unusual in being connected between + and -20V supplies. In the absence of either supply there will be no outputs from the preamplifiers. The circuit above shows the R-Y preamplifier.

to the three PCL84 colour-difference output valves can go open-circuit. With no screen grid voltages, the PCL84s fail to amplify the signals presented to them. You don't get quite the same effect with the later Pye hybrids (693 and 697 chassis), since the resistor concerned in these sets also feeds the varicap tuner tuning system – so you don't get any sound or luminance either. It may not be the resistor itself that's open-circuit: you may find a hair-line crack on the print.

Another point is that the three colour-difference signal preamplifier stages in the Pye hybrid chassis are mounted on the colour-difference amplifier panel. So no supply to these would again remove the colour. Two supplies are involved here, the 20V supply to the three collectors and a –20V supply to the three emitters (the three transistors are operated without forward base bias – see Fig. 3). While on the subject of these transistors, note that two of them have a 25µF emitter decoupling capacitor. These electrolytics can leak, removing the bias to the transistor concerned. Say the R – Y preamplifier transistor's emitter decoupling capacitor goes short-circuit: red goes, and green is reduced since there's no contribution from this stage to the G – Y matrix. So you may have to check the transistor or its electrolytic emitter decoupler for this sort of fault. It's not, we hasten to add, one of the more common defects.

### Wrong Colour

This last point has taken us from no colour to wrong colour. Before going farther, we must emphasize that the majority of wrong colour faults are due to defects in parts of the set other than the decoder – the RGB or colour-difference amplifier stages and the controls which provide the tube's first anode supplies in particular. We've tried to outline these troubles in previous issues.

As far as the decoder is concerned, there are several colour errors that can be puzzling to the new arrival on the servicing scene. For example, the centre of the picture may be in perfect colour, but the sides – usually one side or the other – completely wrong. In this case you say to yourself: timing. Something is clearly not happening at the right time. The trouble in fact is probably due to incorrect PAL switching, and the usual cause is mistuning of the 7.8kHz coil which controls this. Sometimes the coil slips down its former – something that happens with the Thorn 3000/3500 chassis from time to time. In the Thorn 8000/8500 chassis, if tuning the coil fails to produce a cure, perhaps only moving the incorrect colour from one side of the screen to the other, it may be necessary to replace the i.c. that contains the PAL switch (the MC1327PQ, SN76227N or T2079).

Then there are Hanover bars – horizontal bands of incorrect colour. If the effect is severe, the PAL switch has stopped, probably due to a defective transistor in the bistable circuit. If the effect is not so severe, i.e. alternate lines miscoloured (take a close look at the screen), the trouble is due to incorrect alignment of the chroma delay line circuit and/or incorrect phasing of the reference signals. Coils and presets are provided to enable all this to be set up accurately, but it's best to leave these alone unless you have a colour-bar generator and an oscilloscope, plus the maker's alignment instructions. In the absence of these, adjustment can be tried if the circuit and layout are to hand and a steady test card pattern is being transmitted. Readers are strongly recommended to refer to our January 1979 issue where Mike Phelan, in his article on *Renovating Colour Receivers*, gives a comprehensive decoder alignment check for most of the common hybrid sets, including the

Pyes, with diagrams illustrating the key points where the diode probe should be connected and listing the adjustments to make in the correct order.

Quite a common fault is green faces, with the greens in the picture taking on a reddish hue. We've already referred to this in discussing the setting up of the ident control on the Rank A823A chassis. While it's fairly common, on some sets you don't see it until the colour-killer is overridden because the fault (incorrectly synchronised PAL switching) brings the colour-killer into operation. The things to check are the ident stage and the coupling components between it and the bistable.

### Different Chassis

The colour decoders used in different chassis have their own peculiarities, both from the design and the fault point of view, which makes it impossible to give a more detailed practical outline of decoder faults. For example, we've said that the reference oscillator crystal is a possible though not a common cause of no colour. In the Thorn 8000/8500 series however the crystal is a common cause of this fault. The preceding f.e.t. d.c. amplifier (type BC256LC) is another suspect.

So you just have to accept that different decoders have to be tackled in different ways. The only alternative to practical experience is avid reading of the various servicing articles published in this magazine and also attention to the problems pages, where many decoder faults have been dealt with in the past.

Finally, if all this talk of different faults in different decoders is beginning to depress you, remember that the decoder remains one of the most reliable sections of a colour receiver.

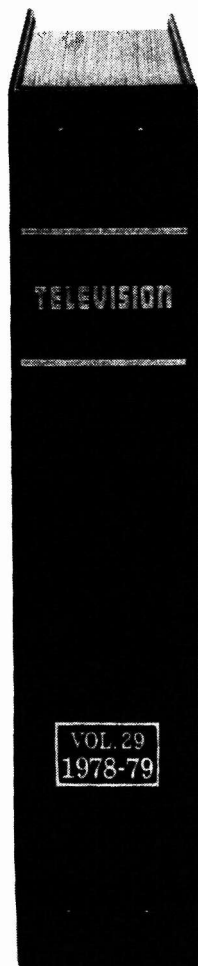

## Bind it

It's so easy and tidy with the Easibind binder to file your copies away. Each binder is designed to hold approximately 12 issues and is attractively bound and blocked with Television logo. Gold letraset supplied for self blocking of volume number and years.

Price £3.75 including postage, packing and V.A.T. Why not place your order now and send the completed coupon below with remittance to: IPC Magazines Ltd., Post Sales Dept., Lavington House, 25 Lavington St., London SE1 0PF.

it's easy with **EASIBIND**

### Order Form

I enclose p.o./cheque value 28.29 for Vol's 24, 25, 26, 27, 28, 29 binders

Years required.....  
(BLOCK LETTERS PLEASE) 1974, 75

Name..... 76, 77, 78, 79

Address..... 6 x 3 3/4 = 22.50

= 3 x 7.50

Date..... 27/1/80

# Long-distance Television

*Roger Bunney*

On Sunday, October 4th I received ch. E2 signals from Ghana. Written a couple of years ago, this would have been a remarkable event, even more so perhaps than receiving Gwelo ch. E2 from Rhodesia. At present however African reception is regarded as commonplace. The final week in October and the first two weeks of November produced signals that have certainly been record breaking. In the last column I wondered what would be reported next? Reception from North America maybe? In fact the North Atlantic has been bridged in a spectacular manner!

Following reports from Australian enthusiasts of reception of BBC TV towards the end of October, the BBC has confirmed that the ch. B2 sound and vision signals Anthony Mann received in Perth, Western Australia were from Holm Moss (zero offset). I gather that this is a record distance for reception from a ch. B2 transmitter. Meanwhile, Crystal Palace ch. B1 has been continuing its "World Service" transmissions, and Australian vision signals were received here in South Hampshire on October 31st and November 1st. Mike Allmark (Leeds) received Australian vision as late as the 9th (0850-1030). I've very carefully tuned to just below ch. A0 in the hope of receiving the New Zealand ch. 1 vision, but alas with no success. This could be due to NZ being some +12 hours GMT, with suspected early closedowns due to economic problems, so that signals aren't available when the propagation path is open.

Attempts are being made to identify some of the Australian signals. Fortunately in the case of the ch. A0 signals received on the 1st, the programme could be identified (namely "Mash"). Two stations were transmitting this at the time - ATV0 which carries an hour's "double feature" and TVQ0 with a single programme. Hugh Cocks

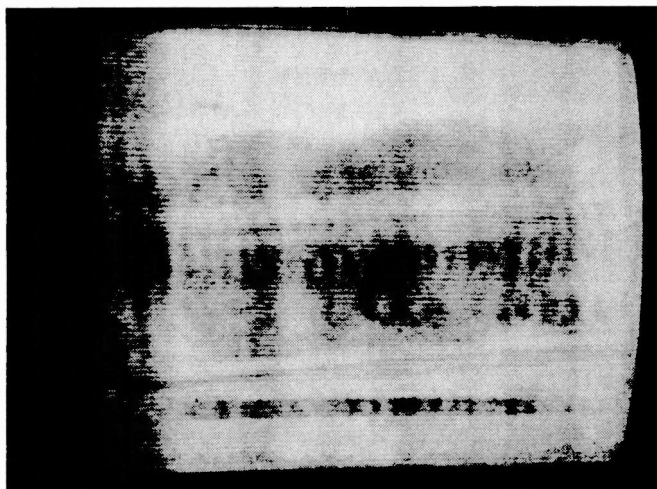

*American television, received in Holland by Ryn Muntjewerff at 1330 on November 7th last. The ch. A2 transmission was carrying adverts at the time.*

(East Sussex) observed captions just after 0900 UK time, suggesting that the signals came from TVQ0. He's waiting confirmation from the station. The signals were very strong, with commercials at 0915-0919 and further ads at 0930. The 51.75MHz sound channel appeared at this time, but by 1000 all signals had gone. Incidentally, Hugh mentions F2 backscatter, with Auroral type signals (rumbling and hum) from directions other than the correct one - CST (Czechoslovakia) from the West etc.

Clive Athowe noted definite Chinese captions on ch. R1 on November 12th!

At about 1230 UK time on November 7th, North American TV (ch. A2) was seen at fair strength in both the UK and Holland. What's surprised us is the relatively large number of people who have reported this signal opening, especially as it was a midweek workday! There was sustained reception during the period, and at some locations two or three signals were sometimes present. The quality was similar to that of the Russian F2 signals commonly present during the past six weeks, i.e. strong but with ghosting and very smeary - so much so that no definite indication of transmitter origin has been possible.

Ryn Muntjewerff monitored communications signals on ch. E2 from mobile transmitters in the New York/Boston area during this period. Much of the programme material from 1300 seemed to be a news/breakfast show interspersed with commercials (Andrew Tett noted a soap ad for "Shape"). From photographs sent in by both Ryn and Cliff Dykes (Potters Bar) it certainly appears that identification is going to be difficult if not impossible: unfortunately the m.u.f. didn't rise sufficiently for the ch. A2 sound to appear. Ch. A2 operates with 55.25MHz vision and 59.75MHz sound, 525 lines and 60 fields. Those who received the signal(s) all report reduced height and a rolling picture. Correct locking was usually possible, with no adjustment of the line hold control. As Brian Fitch commented, it was necessary to adjust the field hold control for steady locking.

Ch. A2 was observed on subsequent days, but not reaching the same intensity as on the 7th nor for such a prolonged time.

F2 signals from deepest Russia on ch. R1. have been present almost daily. On some days a variety of test patterns have been seen - crosshatch, the "letterbox" electronic pattern, the Leningrad and 0249 patterns, with floaters most of the time. At times the signals have been very intense - BBC Caversham measured upwards of 1mV field strength.

In concluding this report of the month's activities, I'm sure you will forgive my missing for once mention of the MS and tropospheric signals that usually entertain us this time of the year.

## FROM OUR CORRESPONDENTS . . .

The continuing exceptional F2 conditions have resulted in the biggest post bag ever. Though I can't mention all correspondents in the column, letters are nevertheless always welcome, whether on a reception report or a problem! Please include an s.a.e. however.

Robert Copeman (Sydney) received ch. B1 vision on November 17th, at fair strength. He tells me that George Palmer (Queensland) has received both Hawaiian and American Samoan TV via F2 in recent times. Robert has pulled off another first - reception of WIN ch. 58 (a u.h.f. transmitter link between WIN4 and a mountain near Wollongong where the WIN3 transmitter is situated). He monitored conditions in New Zealand during a holiday



there. Both Auckland and Wellington have many low-powered relays, and the Band I situation seems to be very saturated.

John Cowan (Ayr) has noted the recent excellent F2 conditions and mentions a very unusual smudgy F2 signal, with severe ghosting/multipath effects, from Switzerland in Band I – evidence of backscatter. On October 22nd he received a very strong ch. R1 TVP (Poland) signal, in the midst of F2 activity. This suggests that almost all countries in Europe are likely to be received via this propagation mode (F2 backscatter).

David Burton is another of the enthusiasts who received American TV on November 7th. He suspects that the programme was the NBC's "Today" show, a breakfast show with news, interviews etc. The signals at his Tolworth (Surrey) location were sufficiently clear for him to be able to make out a vague station identification consisting of a circle breaking into three or four smaller ones with several letters inside the circles, the last one being C.

Anthony Mann (Perth, Australia) has received a Fubk pattern on ch. E2. He measured the exact carrier frequency and from a study of known transmitter offsets suggests that the signal was either from Grunten (W. Germany) or from one of the Finnish transmitters! This was on October 24th. The photograph shows that the identification was unfortunately smeared into a white band.

Another first for Geoff Perrin, now in the Sultanate of Oman where he received Forest Side, Mauritius ch. E4. The reception has been confirmed by the Mauritius Broadcasting Corporation, who comment that it's the farthest known reception to date of their transmitter.

Cliff Dykes (Potters Bar) received a total of four ch. A2 signals on November 7th. Like Hugh, he also saw strong but short-lived ch. A2 signals on the 16th, at 1618 GMT. Cliff has sent us a photograph showing a weak PM5544 pattern he received on ch. E2 at 1400 on the 25th. This suggests origination in Dubai State on the Gulf.

Finally, the Solar Flux on November 9/10th reached record figures, giving a roughly smoothed sunspot count of 300/360, something recorded only a few times since 1947.

#### GHANA TV

Costa van der Linden (Holland) has sent information supplied by a friend at GBS. There are plans to phase out the existing Band I services in favour of Band III. At present, the three main transmitters operate in Band I – Kissi near the Cape Coast on ch. E2 at 20kW e.r.p. (directional); Yamasi in the Ashanti region on ch. E3 at 20kW e.r.p.; and Adjankote near Accra on ch. E4 at 20kW e.r.p. Transmission times (GMT) are 1730-2030 weekdays, 1700-2045 Saturdays and 1515-2100 Sundays.

#### NEWS ITEMS

**Burma:** Colour transmissions in the capital, Rangoon, are to start this year. The service is being established with Japanese help and is to be extended across the whole country during the next ten years.

**New Zealand:** The TV1 and TV2 networks are to be merged into a single two-channel network known as "TV New Zealand".

**Sri Lanka:** Regular TV transmissions are due to start later this year.

**South Africa:** A programme channel aimed at the coloured community is to be fully operational by 1982, financed by advertising and government grants. There will be at least three hours' transmissions daily, more at the weekends.

**CONTINENTAL AERIAL SPECIALISTS, RETAIL AND TRADE.  
GOLDEN ANODISED, WEATHER PROTECTED, SUPERB ARRAYS.  
GUARANTEED FOR FIVE YEARS.  
GOLDEN QUALITY IN A PLASTIC AGE.  
ALL PARTS (EXCEPT COAX) EXCHANGEABLE FOR 7 DAYS.  
10% DISCOUNT OFF MOST AERIALS  
SPECIAL PROMOTION OFFER  
15% + DISCOUNT ON PLEMI RANGE**

For new glossy, highly graphic lists & brochures send 40p & stamp only 40p credit on 1st order.

AGENTS FOR  
FUBA & PLEMI

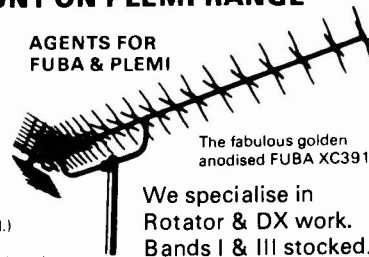

The fabulous golden anodised FUBA XC391

Stockists of the finest aerials available in Britain:

STOLLE FM aerials (W.Ger.)  
FUBA TV & FM aerials (W.Ger.)  
MARGON/PLEMI TV aerials (Hol.)  
UKW FM aerials (E.Ger.)  
ANTIFERRENCE TV & FM aerials (U.K.)

We specialise in  
Rotator & DX work.  
Bands I & III stocked.

### ASTRA (GOLDEN D.I.Y.) AERIALS

A friendly family firm. Our 25th. Jubilee Year.

D.I.Y. AERIAL SPECIALISTS FOR ALL DOMESTIC TV & FM RECEPTION

Weather exposed part of U.K.? Scotland, Wales, West Country etc. Gales, salt air corrosion problems? Want to install your aerial and forget it?

The continental aerial range from Germany and Holland having proved so fantastically successful, we are in future recommending continental aerials (especially Fuba) as our first choice for customers. In short we offer quality in a plastic age.

Anodised against corrosion, guaranteed for five years, robust, high gain, easy to assemble, eye-catching superb aerials, what else, in truth could we recommend?

Over 3,000 aerials stocked: All Bands: Masts: Lashings: Wall Brackets:

Rotators: Televertas: Diplexers and Triplexers: You can now mix Band 4 and Band 5, or lower Band 5 with higher Band 5, or mix FM with either,

1.5db loss approx.: Padded outlets: Directional splitters: Coax, white or brown: 300 ohm cable.

Many of our customers come from recommendation.

53 WHITEHORSE ROAD, CROYDON, SURREY.

Nr. Spurgeons Bridge

Tel: 01-684 4300

Open 9.00-5.30 TUE-SAT.

01-684 5262

Closed 12.30-1.30 Closed All Day Mon.

24 hr. answering service

FM & TV AERIALS AND ROTATORS ON DISPLAY

**LOOK!** Phone: LUTON  
BEDS. 38716

## OPPORTUNITIES TRADE SALES

**ALL SETS GUARANTEED  
COMPLETE**

**OVER SIX HUNDRED SETS**

**ALWAYS IN STOCK**

Pye 20T, Philips G8;

Ferguson 3-3k5

Murphy, Bush, Decca, GEC

All from

**£35.00 £50.00**

Square Screen, Mono's from

**£5.00 ALL MODELS**

Sets for spares from

**£2.00**

All include VAT

**OPPORTUNITIES**  
9A, Chapel Street, Luton, Beds.  
LUTON 38716

9.30-6.00 p.m. Weekdays, 10.30-1.00 p.m. Sundays.

## DX-TV FOR THE BEGINNER – 6

The aerial preamplifier is used between the aerial and the receiver and provides a signal voltage gain with, hopefully, a minimal contribution of noise and, where used near a local high-power transmitter, minimal interference from this.

Preamplifier gain is quoted in decibels (dBs), similarly to aerials, but whereas the latter will be a measured power gain relative to a half-wave dipole an amplifier gain figure is usually a voltage gain. If the amplifier has a voltage gain of two, this is quoted as a 6dB gain; a voltage gain of four is quoted as 12dB. Where an aerial provides a voltage gain of two with respect to a half-wave dipole, this is a power gain of 3dB.

The amplifier's noise figure indicates the quality of the signal it provides. All amplifiers contribute some noise, something we can well do without where the signal itself is very weak. Commercial aerial preamplifiers are now available with gains up to 25dB and noise figures below 3.5dB – the lower the noise figure the better.

Cross-modulation occurs when an amplifier is presented with one or more very high input signal voltages. These strong signals mix, producing spurious signals on frequencies other than the carriers, or two or three signals superimposed on each other with characteristic overload buzzing and vision distortion. The Labgear single-stage CM6000 u.h.f. preamplifier can handle a single signal of up to 25mV before overloading effects occur, but with three signals present overloading may occur at 14mV. Its higher-gain two-stage counterpart will safely handle a single 63mV signal, or 35mV in the case of three signals.

Manufacturers often quote figures relative to 1mV, 6dBmV representing a doubling from 1mV to 2mV. It's as well to have a reference book that includes a discussion of decibels, since gains, losses and other characteristics are usually quoted in dBs.

There are many commercial preamplifiers available, covering Bands I-V inclusive, v.h.f., u.h.f. or parts of the u.h.f. broadcasting spectrum. In addition, many designs have been published in the magazine from time to time, while my DX-TV book (published by Babani Publishing Ltd.) also includes suitable designs.

The enthusiast who wants to make an amplifier covering Bands I-V inclusive (30-900MHz), for indoor use, is strongly advised to consider the design featured in the July 1978 issue of *Television*. This incorporated a hybrid i.c. made by SGS – in two versions, the 24V SH221 and the 12V SH120A. This gives a voltage gain of 18dB (eight times) over the bandwidth, with a noise figure of 5dB at 30MHz and 4dB at 900MHz. The cost of the device, which is available from Maplin Electronics, is about £9, and in addition a 12 or 24V power supply will be needed. Photostats of the two-page article can be supplied for 50p.

When constructing a v.h.f. or u.h.f. amplifier, great care must be taken to keep lead lengths to a minimum – too much lead length can introduce sufficient inductance to degrade performance.

Masthead amplifiers are commonly used, particularly at u.h.f., where losses in the downlead would otherwise result in very little signal reaching the receiver. They also improve the overall noise performance of the system. Most aerial manufacturers produce or have available a range of weatherproofed units with medium or high gain, covering various bandwidths. The more adventurous constructor could follow the design by Hugh Cocks featured in the December 1975 issue of *Television*, using a varicap u.h.f. tuner as a remotely tuned masthead amplifier.

Perhaps the most difficult reception problem is

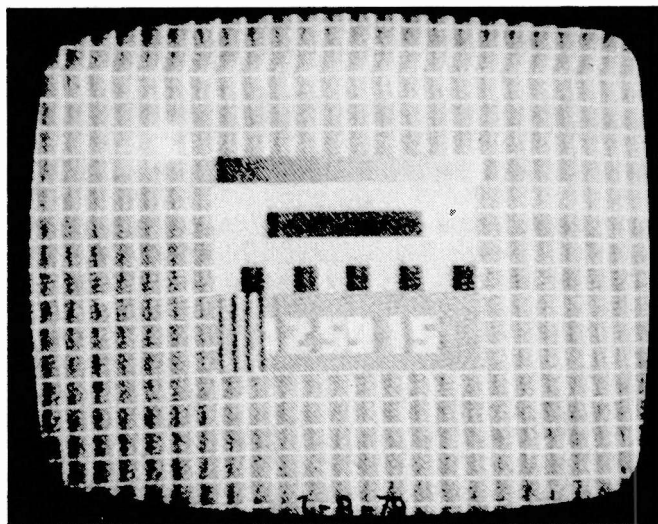

*The Russian letterbox type test pattern, with numbers, received by Ryn Muntjewerff on ch. R2.*

interference from a strong local TV transmitter. This is particularly trying when the wanted signal is a weak one. A receiver with a wide i.f. bandwidth, i.e. an unmodified u.h.f. one, is likely to be more susceptible to such adjacent channel interference. Reducing the i.f. bandwidth will improve matters, but unfortunately this is not a simple thing to adjust on modern receivers. An easier approach to narrowing the bandwidth is to include a narrowband stage at the input to the i.f. strip: the stage could well be switched into or out of circuit to give switched selectivity. The simplest way of going about this is to add one of the Philips G8 selectivity modules, adjusting the coils for optimum results. Enthusiasts have been known to use two such units, one after the other, to get sharper selectivity. Such a modification should enable you to receive say ch. 23 or 25 as a fringe signal in the presence of a strong local signal on ch. 24.

Low-cost v.h.f. and u.h.f. notch filters are available with a rejection level of some 24dB down, and will also assist with the "local" problem. With the i.f. input modification the improvement is available throughout the tuning range, a notch filter resolving the problem on one channel only. In the main however a single notch filter of proven design will remove that annoying sound splatter or vision spread – simply tune the notch to the unwanted carrier frequency. Depending on how well the filter is constructed (by making the coil absolutely symmetrical) a notch as deep as 40dB can be obtained. One enthusiast designed a double notch filter to remove both the sound and vision carriers, completely clearing his problem.

A notch filter will obviously not help where the problem is that the wanted vision signal is on ch. E2 and the local interference is the ch. B2 sound carrier, since the two carriers are both at 48.25MHz. A lot of thought and effort have been put into trying to overcome this difficulty. One approach that's produced a degree of success is to use a special aerial array with a null pick-up point, aligning this null with the local signal. This can reduce the level of the local signal sufficiently to enable the distant signal to be received. Another approach is to use two aerials, adjusting the level and phasing of the signals thus obtained so that the unwanted one cancels out.

A problem with the use of a wideband preamplifier at v.h.f. is that Band II f.m. signals can be present at the lower end of Band III (second harmonic breakthrough). The

solution to this is to use a GPO type 35A bandpass filter, or alternatively a home constructed bandstop filter resonant in Band II.

Electrical interference can arise due to badly suppressed/designed equipment such as thermostats, cleaners etc., and car/motor cycle engines. Suppression components are available and the cure is usually easy once the source of the interference has been traced. Unfortunately this can be difficult, while some types of equipment may present problems. I've personally had trouble with r.f. diathermy from the outpatients surgery at a local hospital; a rasping Band I hum which turned out to be due to an electric pump in a large oil-fired heating system at an old people's home some 120 yards distant; high-level patterning across ch. E4 due to r.f. welding equipment some two miles away (I can still receive this effect at a distance of some 11 miles!); and, a current problem that's lasted for three years, radiation at 1.55MHz intervals between 27-200MHz due to a VDU/terminal installation some 60 yards away.

Problems with domestic equipment are usually easy to resolve on a personal basis, but difficulties due to industrial equipment may not be so easily dealt with. This may be particularly so if the interference has become "established",

i.e. has continued for some time. It's in your interest therefore to object at the earliest opportunity if you notice a new source of interference. The GPO will help where difficulty is experienced in tracing the source of the trouble, but only where the interference affects local transmissions. The fact that reception on ch. R1 is difficult due to interference from say r.f. welding equipment will not interest the GPO, but if the welding equipment also disrupts the local BBC f.m. service action will be forthcoming.

Since starting this brief series for beginners I've received several letters querying various points. If sufficient queries arrive I may be able to put together a "questions and answers" section. Off-screen photography seems to be one subject that causes uncertainty. There have also been queries about the reception of paging station calls in Band I (at approximately 54MHz) in the Surrey area. In this area there's also apparently a pirate radio station that swamps ch. E2. Once again, a stamped, addressed envelope with any queries will help!

Finally, anyone experiencing difficulty with adjacent channel reception will find much useful information in Hugh Cocks' article on the subject in the November 1977 issue of *Television*. This includes details of suitable filters etc.

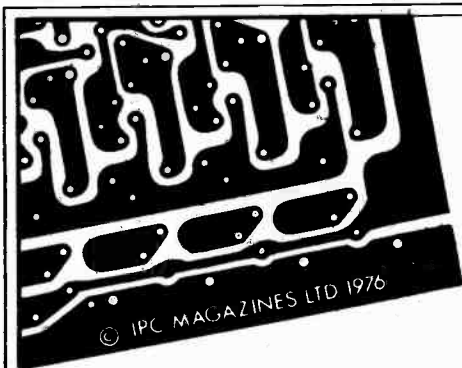

All boards are epoxy glassfibre and are supplied ready drilled and roller-tinned.

Any correspondence concerning this service must be addressed to **READERS' PCB SERVICES LTD**, and not to the Editorial offices.

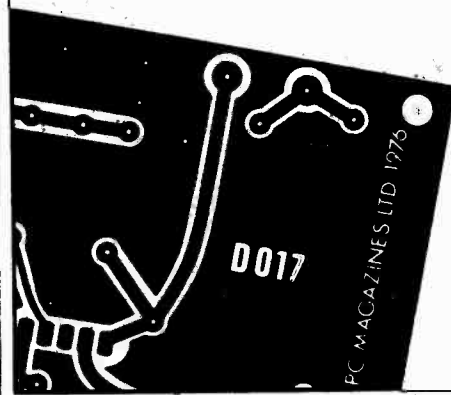

# TELEVISION READERS PCB SERVICE

Issue	Project	Ref. no.	Price
November 1976	Ultrasonic Remote Control	D007/D008	£3.24 per set
December 1976	IC Sound Circuits for the Constructor	D009	£1.44
		D017	£1.44
March 1977	Teletext Decoder Power Supply	D022	£3.24
May 1977	Teletext Decoder Input Logic	D011	£10.53
May 1977	Single-chip SPG	D030	£3.30
June 1977	Wideband Signal Injector	D031	£0.79
June 1977	Teletext Decoder Memory	D012	£8.51
July/Aug 1977	Teletext Decoder Display	D013	£8.62
August 1977	Logic State Checker	D038	£1.70
September 1977	Teletext Decoder Switch Board	D021	£1.43
September 1977	Teletext Decoder Mother Board	D027	£4.36
October 1977	Teletext Decoder IF Board	D041	£6.50
Feb/March 1978	On-Screen Clock	D045	£7.03
April/May 1978	CRT Rejuvenator	D046	£2.76
May/June 1978	Test-Pattern Generator	D048	£9.15
Aug/Sept 1978	Diagnostic Pattern Generator	D051	£8.62
October 1978	Colour Receiver PSU Board	D052	£3.83
January 1979	Colour Receiver Signals Board	D053	£10.75
February 1979	Commander-8 Remote Control System	D054/5	£5.43 per set
March 1979	Colour Receiver Timebase Board	D049	£17.13
July 1979	Colour Pattern Generator	D062	£13.50
		D063	£9.15
September 1979	Teletext Decoder Options Board	D064	£8.50
August 1979	Teletext Decoder New Mother Board	D065	£5.00
August 1979	Simple Sync Pulse Generator	D067	£4.00
September 1979	New Teletext Signal Panel	11331	£8.00
October 1979	Teletext Keyboard	D057	£3.50
October 1979	Teletext Interface Board	D058	£5.00
November 1979	Colour Receiver Remote Control	D066	£5.00
January 1980	Remote Control Preamplifier	D061	£3.75
February 1980	Teletext/Remote Control Interface	D070	£9.50
February 1980	LED Channel Display	D071	£4.00

To: **Readers' PCB Services Ltd. (TV), Fleet House, Welbeck St., Whitwell, Worksop, Notts.**

Please supply p.c.b.(s) as indicated below:

Issue	Project	Ref.	Price

Prices include VAT and post and packing. Remittance with order please.

NAME \_\_\_\_\_

ADDRESS \_\_\_\_\_

Post Code \_\_\_\_\_

# Teletopics

— continued from page 179

was demonstrated by the IBA at the last International Broadcasting Convention: the IBA's prototype experimental recording system uses no more tape than the latest types of analogue machine. Development of a practical digital video recorder is regarded as the key to the all-digital TV studio.

## TRANSMITTER OPENINGS

The following relay transmitters are now in operation:

**Camperdown** (Tayside) Grampian Television ch. 23, BBC-2 ch. 26, TV4 ch. 29, BBC-1 ch. 33. Aerial group A.

**Chambercombe** (Devon) BBC-1 ch. 21, Westward Television ch. 24, BBC-2 ch. 27, TV4 ch. 31. Aerial group A.

**Clettravel** (Hebrides) Grampian Television ch. 41, BBC-2 ch. 44, TV4 ch. 47, BBC-1 ch. 51. Aerial group B.

**Clun** (Salop) BBC-1 ch. 55, ATV ch. 59, BBC-2 ch. 62, TV4 ch. 65. Aerial group C/D.

**Daliburgh** (Hebrides) TV4 ch. 53, BBC-1 ch. 57, Grampian Television ch. 60, BBC-2 ch. 63. Aerial group C/D.

**Donhead** (Wiltshire) Southern Television ch. 41, BBC-2 ch. 44, TV4 ch. 47, BBC-1 ch. 51. Aerial group B.

**Durham City** BBC-1 ch. 40, Tyne Tees Television ch. 43, BBC-2 ch. 46, TV4 ch. 50. Aerial group B.

**Keighley** (W. Yorkshire) Yorkshire Television ch. 23, BBC-2 ch. 29, TV4 ch. 29, BBC-1 ch. 33. Aerial group A.

**Kilbride** (Hebrides) BBC-1 ch. 39, TV4 ch. 42, BBC-2 ch. 45. Grampian Television ch. 49. Aerial group B.

**Newry** (Co. Down) Ulster Television ch. 41, BBC-2 ch. 44, TV4 ch. 47, BBC-1 ch. 51. Aerial group B.

**Till Valley** (Wiltshire) BBC-2 ch. 40, Southern Television ch.

43, BBC-1 ch. 46, TV4 ch. 50. Aerial group B.

All the above transmissions are vertically polarised. The IBA transmitter installed at the Clettravel site incidentally has an e.r.p. of 2kW and is the highest power all solid-state u.h.f. transmitter so far installed in the UK.

## AERIAL CATALOGUE

South West Aerial Systems of 10, Old Boundary Road, Shaftesbury, North Dorset, proprietors Roger Bunney and David Martin, have produced a comprehensive catalogue of aerials, fittings etc. they can supply. Copies are available provided 20p in stamps is sent to cover postage.

## FIRST ANNIVERSARY FOR SOUNDS VINTAGE

The bi-monthly subscription magazine *Sounds Vintage* is celebrating its first anniversary. Our congratulations! This independent magazine is dedicated to things close to the heart of your editor — old records and equipment, and interesting historical articles. The subscription is £6 for a year, from Sounds Vintage Subscription Dept., 28 Chestwood Close, Billericay, Essex. Airmail subscriptions cost £9.50 Zone B, £10.50 Zone C.

## IBC-80

The 8th International Broadcasting Convention, IBC-80, will be held during September 20-23 at the Metropole Conference and Exhibition Centre, Brighton. It's the first time the convention will be held outside London, but the organisers say that it's outgrown the London venues previously used.

★ NEW ★

# COLOUR BAR GENERATOR

## U.H.F. AERIAL INPUT PATTERN GENERATOR CPG6-RF

All Facilities of our PG6RF

### PLUS COLOUR BARS.

Produces 7 invaluable patterns.

**Robust, Battery Powered, Pocket Sized Unit,  
Plugs Straight into Aerial Socket.**



W H I T E	Y E L L O W	C Y A N	G R E E N	M A G E N T A	R E D	B L U E	B L A C K
-----------------------	----------------------------	------------------	-----------------------	---------------------------------	-------------	------------------	-----------------------

## FEATURES:

- ★ CROSSHATCH GRID
- ★ DOT MATRIX
- ★ VERTICALS
- ★ HORIZONTALS
- ★ WHITE RASTER
- ★ GREYSCALE
- ★ PLUS PAL COLOUR BARS;  
ONLY 3 SIMPLE ADJUSTMENTS.
- ★ PG6RF OWNERS; Buy Add-On 'C6' Unit!

## ORDER NOW!

**PG6RF KIT £25.87 BUILT £33.35 — As per TV Review, Jan. 1979**

**C6 KIT £18.98 BUILT £26.45 — Add-on Colour to PG6RF**

**CPG6RF KIT £42.55 BUILT £63.25 — Both above combined.**

These prices INCLUDE P & P and 15% VAT. Export VHF versions available.

## MAIL ORDER ONLY

Quantity Discount  
on application

In response to demand we have produced an add-on Colour Bar unit C6 to upgrade the PG6RF to PAL COLOUR. A MUST for TV construction or servicing! Available as a KIT or BUILT & TESTED. Kit includes all components and ready built modulator etc. Hundreds sold, reliable design.

**Full 12 month guarantee on built units.**

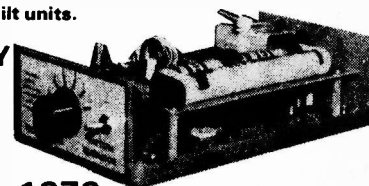

**ACCESS  
ORDERS  
WELCOME**

ALSO AVAILABLE:

## TECS: TECHNALOGICS EXPANDABLE COMPUTER SYSTEM.

**Full Colour Teletext;** full facility Microprocessor-based, Aerial Input Decoder with extensive computing facilities. The most versatile decoder on the market. Expandable from a simple teletext decoder to a full professional computer/information centre. Send large S.A.E. for details.

**SEND ALL ORDERS OR ENQUIRIES TO TECHNALOGICS LTD. (DEPT. TV):  
8 EGERTON STREET, LIVERPOOL L8 7LY. Tel: 051-724 2695.**

# Service Bureau

*Requests for advice in dealing with servicing problems must be accompanied by a 75p postal order (made out to IPC Magazines Ltd.), the query coupon from page 213 and a stamped addressed envelope. We can deal with only one query at a time. We regret that we cannot supply service sheets nor answer queries over the telephone.*

## **THORN 3500 CHASSIS**

Four white bars about an inch wide, spaced some five inches apart, run from the top to the bottom of the screen, right across the picture. When anyone passes through these lines they appear to go out of focus and the picture goes wavy.

If the bars are brighter on the left-hand side of the screen, check the line linearity coil's damping resistor R521 (should be 1.2k $\Omega$ ). If the bars are of even brightness and extend evenly across the screen, check the plug and socket connections between the line timebase and beam limiter boards, also the electrolytics (C901/2) on the latter board. This sort of trouble is normally caused by a poor connection, as a result of which there's interaction between one part of the circuit and another.

## **DECCA MODEL MS2000**

With no signal input, there's a dark band half an inch wide down the centre of the screen. With a signal tuned in this appears as a bright band, about a quarter of an inch wide, still in the same place. On close examination it can be seen that this band is actually severe cramping at the centre of the picture, although the width seems to be about right. The line timebase valves have been changed.

These sets use an ECC82 anode-to-grid cross-coupled multivibrator as the line oscillator. We suggest you check the values of the two anode load resistors R132 (15k $\Omega$ ) and R133 (56k $\Omega$ ). If these components are in order, check the line drive coupling capacitor C123 (0.01 $\mu$ F) and the drive waveform shaping components R141 (120k $\Omega$ ) and C121 (1,500pF).

## **HITACHI MODEL CSP680**

The trouble with this set is a shrinking picture. First, a gap of about an inch occurred at the top and bottom, with a quarter inch gap at the left-hand side and a half inch gap at the right-hand side. When the brightness is turned up the volume falls and there's a slight reduction in the picture size. The contrast is at maximum. Adjusting the timebase controls only results in non-linearity.

All these problems indicate a low h.t. line with poor regulation. The set uses a conventional series regulator circuit. Check the h.t. at fuse F905. If less than the correct 120V, first try adjusting R911. If a large adjustment is needed, or 120V can't be obtained, the suspects are R912 (18k $\Omega$ ) which is in series with R911, the error amplifier transistor TR43 (2SC458), and the diodes in this stage – the zener CR39 (AW01-07), CR37 (1N34A), VA901 and VA902 (both type HV23).

## **THORN 9000 CHASSIS**

R724 and R725 in the beam limiter circuit have burnt out, and severe arcing is apparent between the right-hand degaussing screen (viewed from the rear) and the tube's graphite coating. The resistors were replaced, but the arcing persists.

The trouble is due to the e.h.t. tripler having failed. Replace it along with the two resistors.

## **SANYO MODEL 10-T150H**

The trouble with this set is no field scan, just a horizontal white line across the screen. The sound is normal.

The usual cause of field collapse on these sets is damaged preset controls at the rear, due to the use of too large a screwdriver and too much pressure. Check these and replace as necessary. If the controls are in order, check the field output transistors Q118 (2SC1024 or 2SD315) and Q119 (2SB474), the driver Q117 (2SC536) and oscillator Q116 (2SC536), and the voltages in these stages.

## **ITT CVC5 CHASSIS**

The problem with this set is no colour. I changed the colour-killer reservoir capacitor C162 without improving matters, then discovered that disconnecting the emitter of the bistable transistor T37 produces a blue and yellow picture. The voltage at each side of the colour detector diode D37 is the same – about 5V.

Since the output from T37 is smoothed to give the colour turn-on voltage, disconnecting its emitter so that its collector voltage remains high will have a similar effect. The key to the problem seems to be that the ident stage is not supplying a signal to the colour detector diode D37. The voltage across its reservoir capacitor C218 should be 11V with a colour signal present. Since this is apparently not the case, see whether an improvement can be obtained by adjusting the tuning of the ident coil L75d, then suspect the ident transistor T35d and the burst detector assembly L74d.

## **THORN 1590 CHASSIS**

The trouble with this set is no field hold, though the line sync is o.k. The supply line is slightly low, but this doesn't seem to have led to any other observable faults. The field timebase transistors and diodes, and the variable controls, have been tested, but the trouble persists.

We don't think the fault is in the timebase. Our first suspect would be the 3.3M  $\Omega$  resistor R41 which biases the base of the sync separator transistor. If this is correct in value, check C44 (0.01 $\mu$ F) which couples the sync pulses from the sync separator to the sync amplifier/phase splitter transistor, then suspect signal clipping in the i.f. strip. This could be caused by the 4.7 $\mu$ F a.g.c. smoothing capacitor C17 or a faulty i.f. transistor. Emitter voltage checks should reveal whether there's a faulty i.f. amplifier stage. Make sure that the preset contrast control R2 is not over-advanced.

## **PYE 725 CHASSIS**

The problem on this set would seem to be due to dirty channel change switches. I'd like to clean or replace these, but can't see any way of removing them – they appear to be moulded into the cabinet.

The switchbank is a single plastic moulding which is held in position by clips round the side. The knobs must be removed before dismantling. Be careful what sort of cleaning solvent you use, as the plastic frame is readily attacked. Electrolube for instance can turn the assembly into a gooey mess.

### **BEOVISION 3400 CHASSIS**

The red in the top half of the screen seems to be washed out, and there's a faint hum bar (predominantly red) that travels from the bottom of the screen to about half way up, then fades. I've tried valve replacement without success.

This condition is symptomatic of hum on the 32V line. If the peak-to-peak hum level exceeds 60mV, there's probably a fault in the regulator circuit. Suspects are the driver transistor 2TR28 (use a BC107B) and the series regulator transistor 0TR8 (2N3055), either of which could be leaky. A less likely possibility is failure of one of the diodes in the bridge 2D15-18.

### **THORN 8000 CHASSIS**

When the set is switched on the sound and vision appear for about a minute then the raster goes off. On checking I discovered that R727 gets very hot, but nothing else in this area seems to be faulty.

R727 is the anti-breathing resistor in the h.t. feed to the line output stage, where the fault must lie. The line output transistor or flyback tuning capacitor could be responsible, but heavy damping on the line output transformer is a more likely cause. Try disconnecting the e.h.t. tray and checking whether R727 still overheats. If it doesn't, fit a new tray.

### **PYE 368 CHASSIS**

The picture is too dark to watch in daylight, and when the brightness control is advanced the picture balloons. Another fault is poor line hold. The valves in the line output stage have been replaced, also the boost reservoir capacitor C118.

The low e.h.t. is most likely to be the result of insufficient heater supply to the DY802 e.h.t. rectifier valve, due to deterioration of the 1-2Ω resistor R163 which is in series with pins 1 and 9 of the base. The poor hold could well be due to the PCL85 valve – the triode section acts as a phase splitter, driving the flywheel sync discriminator circuit.

### **ITT CVC9 CHASSIS**

The screen is entirely green for about three minutes after the set is switched on. The picture then appears. Most of the time it's o.k., but occasionally there's more green than usual.

Check for dry-joints and similar print defects around the green drive transistors T25d and T26d – a common weak point is the printed circuit land adjacent to R176d, via which the collector of T25d is earthed to the metal chassis strip. If these points are in order, the green output transistor T26d or, less likely, its load resistor R179d are suspect.

### **GEC SERIES 1 CHASSIS**

The fault shows up as three dark vertical bands on the right-hand side of the screen. When the tuner is disconnected however there's a clear, full raster. Is the tuner suspect, or is there anything else that should be checked?

We don't suspect the tuner. There are several things to check, as follows: poor bonding of the tuner to the chassis; the c.r.t.'s external coating not efficiently connected at either the tube coating or the c.r.t. base; poor decoupling (smoothing) of the 18V supply line (check C224/C225); the tuner's i.f. output coaxial lead not properly connected either at the tuner end or after the bandpass filter (at connection PL1/3 to the PCB); or a poor chassis earth connection.

### **THORN 1613 CHASSIS**

The initial symptom was low output from the voltage regulator circuit, with the TIP42A series regulator transistor and its two base resistors R203/R210 overheating. These were replaced, restoring normal operation of the set, but the TIP42A runs so hot that the heatsink can barely be touched, and I fear for its early failure.

It seems that the BC337 driver transistor is passing excessive current. We suggest replacing it with a BFT84, which is more reliable.

### **PHILIPS TS7 CHASSIS**

This set (Pye Model 173) developed a tuning fault, with vision buzz on sound. After replacing the tuner unit and the TAA550 voltage stabiliser i.c., good pictures can be obtained on all six buttons but I can't get rid of the buzz. When the buzz is at maximum, the sound is much reduced, even at full volume, though the picture is steady. This is so on all six buttons. Slight tuning adjustments decrease the buzz on some selectors, but not much.

This could be a difficult problem to deal with. We'd be inclined to check the cores of the sound i.f. coils U15, U6 and U7 to see if they've been disturbed. If they have, they'll have to be returned to their original settings. Then check the ratio detector reservoir capacitor C121 (10μF). If all is well with the 6MHz sound channel, check C179 (22μF) which decouples the video bias supply and C151 (100μF) which smooths the a.g.c. to the tuner. The a.g.c. is produced by the TBA890 jungle i.c., which could be at fault. We presume that the alignment of the i.f. strip has not been disturbed.

### **THORN 8500 CHASSIS**

The trouble with this set is pulling on captions – mainly white lettering. The picture is otherwise perfect.

First ensure that the aerial system is in order and is supplying a clean signal. If so, it's likely that the MC1330 vision detector i.c. is faulty. Check voltages around it for any clues. It would be worth checking the 3-3μF coupling capacitor C196 in the video section.

### **TRANSISTOR EQUIVALENTS**

Could you suggest suitable replacements for the following transistors used in the Sony Model KV1800UB – the regulator driver transistor Q601, type 2SC1124, and the error detector transistor Q602, type 2SC926A?

The 2SC1124 can be replaced by a BF380, BD232 or a BD410; the 2SC926A by a BF298, BF422, BFT58, BFR88 or 2N5550.

### **THORN 8000 CHASSIS**

I've an Alba set fitted with this chassis. The trouble with it is a red "ghost" to the right of objects, i.e. the red seems to run on. The red spreading is reduced if the brightness is decreased, but the brightness level is then too low for normal viewing. Could it be the tube?

Unfortunately yes. We're inclined to suspect that the red gun is soft. Reactivating it might help for a while, but replacing the tube is the only long term solution. Colour spreading can be caused by an open-circuit frequency compensating capacitor in the appropriate output stage, C193 (330pF) in this case, but this spreading would not be affected by the brightness level.

## PHILIPS G8 CHASSIS

The problem is intermittent foldover at the bottom of the raster. This is occasionally present continuously until the set is switched off, but is usually present for only a few seconds at a time, generally after the set has been on for an hour or so. I've changed the field charging and bootstrap capacitors.

The trouble is most likely to be due to a dry-joint or other poor connection associated with the field output transistors. The solder connecting the body of the BD124 types used in earlier panels to the collector tags was a prime source of this sort of trouble. Check all soldered connections associated with the output transistors, then check the field bias and linearity presets if necessary.

## THORN 3000 CHASSIS

The set works perfectly except that at irregular intervals the cut-out operates. This may happen anything from once a week to three times a night. On resetting the cut-out the set may operate for several hours but occasionally cuts out again immediately.

It's quite likely that the cut-out itself is faulty. For test purposes replace it with a 2A anti-surge fuse. If this holds, replace the cut-out. If the fuse fails, check the over-voltage zener diode W617 (BZX61/C72) which can short intermittently. Also check whether the h.t. is too high, the condition of the chopper transistor's insulating washer, and the crowbar thyristor W621 for corrosion.

# TEST CASE

## 206

Each month we provide an interesting case of television servicing to exercise your ingenuity. These are not trick questions but are based on actual practical faults.

A colour set (Sobell Model 1040) fitted with the GEC single-standard hybrid chassis would suddenly lose line sync. Tests proved that the cause was a decrease in line oscillator frequency, since adjusting the line hold control so as to increase the frequency slightly restored the lock, though with slight loss of picture width. This condition would remain stable for a while, then the oscillator would jump back to its original frequency, calling for a further adjustment of the line hold control.

This is another of those chassis using a PCF802 sine-wave line oscillator, with the tuned circuit connected between the screen and control grids of the pentode section of the valve while the triode section acts as a variable reactance, controlled by the flywheel sync circuit, to adjust the oscillator's frequency. So the cause of the fault could be either in the line oscillator stage itself or in the flywheel sync and the variable reactance part of the circuit.

As a first step, the valve was changed. This made no difference however. Next, in an attempt to save time and considering the age of the set, a blitz was made on the components around the valve – the oscillator feedback capacitor C509 and all the resistors in the valve's grid circuits were replaced. Still the problem persisted.

Attention was turned to the flywheel sync circuit therefore, where the diodes, the coupling capacitors and the load resistors were replaced. Once again there was no significant change in the fault condition, and it was concluded that there must be an intermittent fault in the oscillator coil assembly. A replacement was not in stock however, so the set was put on one side for further appraisal by another technician.

This technician spent about half an hour probing in the

oscillator circuit, eventually tracing the component responsible (not the coil). Which component had the first technician overlooked? See next month for the answer and another item in the series.

### SOLUTION TO TEST CASE 205

– see page 156 last month –

The sets fitted with the Pye 691 chassis have been around for quite a time now, and many of the components are beginning to protest. Resistors can go up or down in value, while capacitors can change their  $Q$  (goodness factor), decrease in value, or go intermittently open- or short-circuit in a random manner. Some of the smaller components in the timebase circuits are particularly vulnerable, and when there's an intermittent fault a small pulse or transient may be sufficient to temporarily clear it, the capacitor concerned testing correctly when checked.

You'll remember that the trouble reported last month was that the picture sometimes took a long time to appear after the set had been switched on, and that there was intermittent loss of line hold.

Whilst checking the line oscillator stage, the picture vanished completely – due to the oscillator stopping.

The technician discovered that the oscillator could be triggered back into activity simply by connecting the voltmeter's prod to the PCF802's screen grid pin. It seemed likely therefore that the oscillator's feedback capacitor C211 (320pF, connected between the screen and control grid circuits of the pentode section of the valve) was responsible, and on replacing this the intermittent fault vanished.

In cases of intermittent line timebase operation with the 691/693/697 chassis therefore it's a good idea to replace this capacitor before carrying out further tests.

## QUERY COUPON

Available until 18th February, 1980. One coupon, plus a 75p (inc. VAT) postal order, must accompany EACH PROBLEM sent in accordance with the notice on page 211.

## TELEVISION FEB. 1980

Published on approximately the 22nd of each month by IPC Magazines Limited, King's Reach Tower, Stamford Street, London SE1 9LS. Filmsetting by Trutape Setting Systems, 220-228 Northdown Road, Margate, Kent. Printed in England by Carlisle Web Offset, Newtown Trading Estate, Carlisle. Distributed by IPC Business Press (Sales and Distribution) Ltd., 40 Bowling Green Lane, London EC1R 0NE. Sole Agents for Australia and New Zealand – Gordon and Gotch (A/sia) Ltd.; South Africa – Central News Agency Ltd. Subscriptions: Inland £9.50, Overseas £10.50 per annum payable to IPC Services, Oakfield House, Perrymount Road, Haywards Heath, Sussex. "Television" is sold subject to the following conditions, namely that it shall not, without the written consent of the Publishers first having been given, be lent, resold, hired out or otherwise disposed of by way of Trade at more than the recommended selling price shown on the cover, excluding Eire where the selling price is subject to VAT, and that it shall not be lent, resold, hired out or otherwise disposed of in a mutilated condition or in any unauthorised cover by way of Trade or affixed to or as part of any publication or advertising, literary or pictorial matter whatsoever.

TV LINE OUTPUT TRANSFORMERS (Prices include VAT at 15%)					Discount to Trade	Post and Packing 70p
<b>BUSH</b> TV123 TV124 TV126 or U TV128 TV134 TV135 or R TV138 or R TV139 TV141 TV145 TV148 TV161 TV165 TV166 TV171 TV175 TV176 TV178 TV181 or S TV183 or D TV183S TV183SS TV185S TV186 or D TV186S TV186SS TV191D TV191S TV193D TV193S TV198 TV307 TV313 TV315 Price <b>£8.50</b>	<b>MURPHY</b> V843 all models to V979 V153 V159 V173 V179 V1910 V1913 V1914 V2014 or S V2015D V2015S V2015SS V2016S V2017S V2019 V2023 V2027 V2310 V2311C V2414D V2415D V2415S V2415SS V2416D V2416S V2417S V2419 V2423 A774 All complete with valve base Price <b>£8.50</b>	<b>DECCA</b> MS1700 MS2000 MS2001 MS2400 MS2401 MS2404 MS2420 Price <b>£8.50</b>  <b>PHILIPS</b> 23TG170a all models to 23TG176a G24T230a ... all models to G24T310 19TG170a ... all models to 19TG179a G19T210a G19T211a G19T212a G19T314a G19T215a G20T230a Price <b>£8.50</b> G24T324 G24T326 G24T329 Price <b>£10.00</b>	<b>PYE</b> 58 64 59 88 60 75 61 76 62 77 63 80 81 93 83 94 84 95/4 85 96 86 97 92 98 150 161 151 170 155 170/1 156 171 160 171/1 Chassis 169, 173 RV293B 368 569, 573 769 Price <b>£8.50</b>  <b>KB-ITT</b> By Chassis: VC1 VC2 VC3 VC4 VC11 VC51 VC52 VC52/1 VC100 VC100/2 VC200 VC300 Price <b>£8.50</b>	<b>GEC</b> BT454 BT455 BT455DST 2000DST ... all models to 2044 2047 ... all models to 2084 2104 or /1 2105 or /1 Price <b>£8.50</b>  <b>SOBELL</b> ST196 or DS ST197 ST290 ST297 1000DS ... all models to 1102 Price <b>£8.50</b>  <b>THORN GROUP</b> Ferguson, H.M.V., Marconi, Ultra. By Chassis: 800, 850, 900, 950/3, 960, 970, 950/1, 950/2, 1400, 1500, 1500, 1580, 1590, 1591, 1612, 1712 Or quote model No. Price <b>£8.50</b> 1600, 1615 1690, 1691 Price <b>£10.20</b>	<b>COLOUR TRANSFORMERS</b> DECCA CS1730, 1733, 1830, 1835 <b>£9.51</b> DECCA 30 Series Bradford Chassis <b>£9.51</b> DECCA 80, 100 Series <b>£9.51</b> GEC Dual STD Hybrid <b>£11.59</b> GEC Single STD Hybrid <b>£11.59</b> GEC Single STD Solid State <b>£9.51</b> ITT CVC 1 to CVC 9 <b>£9.51</b> ITT CVC 20 <b>£10.53</b> ITT CVC 30, CVC 32 <b>£9.51</b> PYE/EKCO 725 Chassis <b>£9.51</b> PYE/EKCO 731, 735, 737, 741 Chassis <b>£9.51</b> PYE/EKCO 713, 715 Chassis <b>£11.35</b> PHILIPS G8, G9 Chassis <b>£9.51</b> PHILIPS 570 Chassis <b>£11.35</b> THORN 3000, 3500 EHT and SCAN <b>£8.50</b> THORN 8000, 8000A, 8500, 8800 <b>£10.02</b> THORN 9000 <b>£12.14</b> TELPRO All Models <b>£9.51</b> RANK A823, A823A, A823B <b>£11.35</b> TANDBERG CTV 2-2 AT2063/00 <b>£9.51</b> PYE/EKCO 691 to 697 Printed circuit type <b>£15.26</b> PYE/EKCO 691 to 697 Wired Type <b>P.O.A.</b> NORDMSINDE Solid State <b>£9.51</b>  <b>WINDINGS Post &amp; Packing 40p</b> BUSH Colour Hybrid Quadripler type <b>£6.25</b> RANK T20A, Z179 chassis <b>£6.83</b> PHILIPS G6 EHT Overwind <b>£7.20</b> PHILIPS G6 Primary <b>£6.00</b> PYE 691 to 697 EHT Overwind* <b>£3.07</b> PYE 691 to 697 Primary Winding* <b>£4.60</b>  *Please state Printed Circuit version or Wired version. Korting, B & O, Grundig, Autovox in stock.	
<b>BUSH MURPHY</b> A816 Chassis TV309 TV311 V2029 V2427 Price <b>£10.30</b>	<b>INDESIT</b> 20EGB 24EGB with rectifier holder Price <b>£9.51</b>					

**Tidman Mail Order Ltd.,**  
236 Sandycombe Road,  
Richmond, Surrey.

Approx. 1 mile from Kew Bridge.

Phone: 01-948 3702

MON-FRI 9 am to 12.30 pm.

1.30 pm to 4.30 pm.

SAT 10 am to 12 pm.

Closed Wednesday afternoon

**Hamond Components (Midland) Ltd.,**

416, Moseley Road,  
Birmingham B12 9AX.

Phone: 021-440 6144.

MON-FRI 9 am to 1 pm.

2 pm to 5.30 pm.

Contact your nearest depot for service by-return. Callers welcome. Please phone before calling.

# The NEW Marshall's 79/80 catalogue is just full of components

*and that's not all . . .*

. . . our new catalogue is bigger and better than ever. Within its 60 pages are details and prices of the complete range of components and accessories available from Marshall's.

These include Audio Amps, Connectors, Boxes, Cases, Bridge Rectifiers, Cables, Capacitors, Crystals, Diacs, Diodes, Displays, Heatsinks, I.Cs, Knobs, LEDs, Multimeters, Plugs, Sockets, Pots, Publications, Relays, Resistors, Soldering Equipment, Thyristors, Transistors, Transformers, Voltage Regulators, etc., etc.

Plus details of the NEW Marshall's 'budget' Credit Card. We are the first UK component retailer to offer our customers our own credit card facility.

Plus — Twin postage paid order forms to facilitate speedy ordering.

Plus — Many new products and data.

Plus 100s of prices cut on our popular lines including I.Cs, Transistors, Resistors and many more.

If you need components you need the new Marshall's Catalogue

Available by post 65p post paid from **Marshall's, Kingsgate House, Kingsgate Place, London NW6 4TA**. Also available from any branch to callers 50p.



Retail Sales: London: 40 Cricklewood Broadway, NW2 3ET. Tel: 01-452 0161/2. Also 325 Edgware Road, W2. Tel: 01-723 4242. Glasgow: 85 West Regent Street, G2 2QD. Tel: 041-332 4133. And Bristol: 108A Stokes Croft, Bristol. Tel: 0272 426801/2.



## Manufacturers Surplus Components FIT THE RIGHT PART

300 mixed  $\frac{1}{2}$  and  $\frac{1}{4}$  watt resistors £1.50  
 150 mixed 1 and 2 watt resistors £1.50  
 300 mixed Capacitors, improved pack, most types £3.75  
 100 mixed Electrolytics £2.20  
 300 mixed Printed Circuit mounting Components for various TVs, resistors, caps etc. £1.50  
 300 printed circuit Resistors  $\frac{1}{2}$  to 4 watt £1.00  
 100 High Wattage TV resistors, Wirewound etc. £2.75  
 100 mixed miniature Ceramic and Plate Caps £1.50  
 100 mixed polystyrene capacitors £2.20  
 25 mixed Pots and Presets £1.20  
 25 mixed TV Presets £1.00  
 20 assorted TV VDRs and Thermistors £1.20  
 10 assorted TV Convergence Pots £1.00  
 20 assorted TV knobs, includes push button, chrome, control types etc. Mostly Thorn and ITT £1.00  
 10 assorted Valve Bases, B9A, ceramic, EHT, etc. £1.00  
 20 assorted Sync Diodes blocks for various TVs £1.00  
 25 assorted Pulse Caps high voltage £1.25  
 10 Spark Gaps £1.00  
 20 assorted Zener Diodes 1 watt and 400MW £1.50  
 100 Mixed Diodes, includes zener, power, bridge, varicap, germanium, silicon etc. All full spec. £4.95

### NEW

4-433 C.T.V. Crystals  
 Long Leads £1.00 each  
 3 for £2.50

**Why Buy Expensive Triplers!**  
 Repair your old 5 and 3 sticks at a Fraction of the Cost.  
 10 Replacement Rectifier Sticks (Thorn). £1.00

### Special TV Bargain Parcels

Lots of useful parts including damaged panels, tuners, components etc. 10lb for £7.50  
**Hardware Pack**  
 Includes BA nuts and bolts, nylon, posidrive, self-tapping "P" clips, cable markers, clamps, fuse holders etc. £1 per lb.

### THORN SURPLUS

**3500 Series Scan Coils**, new and boxed, complete with convergence yoke, purity assembly, static controls, leads and sockets £5.25  
**3500 Focus units** with metrosil £1.50  
**3500 "625" line VHF Kit** for wired systems £9.50  
**4 Knobs** black with chrome caps to fit ITT, Thorn, GEC and most small diam. shafts 60p per set  
**950 bottom panel** complete with i.f.'s switch etc. £3.00  
**950 line transformer** (not Jellypot) £2.50  
**Convergence Pots** with knobs. 5 $\Omega$ , 10 $\Omega$ , 20 $\Omega$ , 30 $\Omega$ . 8 of 1 type £1.00. 8 of each £3.50

### SAVE THAT TUBE.

Fit our **C.R.T. Isolating Transformer**. Ideal for HTR./Cath. Shorts. 200-220-240 inputs. 750-900 MA outputs with thermal cutout. Made for **Thorn 4000 C.T.V.** but works O.K. on other sets. £2.00 each 3 for £5.00

## ULTRASONIC TRANSDUCERS

Transmitter and receiver. 40 kHz 14 mm diam. £4.25 pair

### PUSHBUTTON KNOBS

**Type 1** 15mm long x 11mm diam. Brushed Aluminium Finish 10 for £1  
**Type 2** 10mm long x 10mm diam. Chrome Finish 10 for £1  
 Both types fit standard  $3\frac{1}{2}$ mm square shafts as used on most music centres etc. 100 for £7  
 1000 for £50

### STANDARD STEREO JACK PLUG

on 6 feet of 4 core lead 5 for £1

BD131 4 for £1  
 BD132 4 for £1  
 BF181 6 for £1

## PROTECT YOUR PROPERTY

Buy a "SENTINEL" Smoke and Gas Detector. Uses TGS105 plug in sensor, housed in  $3\frac{1}{2}$ " diameter diecast box. 24V. Convertible to 12V. Will activate lamp or relay.

With Data and Circuit £16.95  
 Suitable 24V Relay £1.00

**De Luxe Fibre Glass Printed Circuit Etching kits**  
 Includes 150 sq. ins. copper clad F/G. board. 1 lb ferric chloride 1 dalo etch resist pen. Abrasive cleaner. Etch tray plus instructions.  
**Special Price £4.95.**

1 lb F.E. C1 To mil. spec. £1.25  
 5 lb FE. C1. To mil. spec. £5.00  
 150 sq. in. Single sided board £2.00  
 150 sq. in. Double sided board £3.00

### 500 Watt Dimmer Switch

Toroidal mains suppression, fused with satin aluminium knob, white.

ONLY £3.45.

## MISCELLANEOUS

**Philips G8 Tube Base Panels**  
 Complete, but PCB's cracked, ok for spares. Focus, base, leads, plugs etc. 2 for £1

**Bush CTV 25 Quadrupler** Remo type Q25B. equiv. to ITT. TU25 3QK. with mounting brackets. £4.25 each. 3 for £10

**GEC single standard**, hybrid chassis. convergence panel. Brand new, complete with plugs and leads £2.50

**Focus unit** with lead, for above chassis £1.50

**ITT Featherlight Super**. Side Chassis, with controls, V. Cap Tuning Panel, Regulator, P/Button Switches, Bridge Rec. etc., etc. £3.50  
 I.C. for above £1.00

### SPECIAL OFFER

GEC transistor rotary tuners with slow drive, AE Skt. and leads 2010 Series £1.50

**KB VC3** VHF tuner with valves £1.50

**KB VC3** transistor tuner "UHF" £1.50

**ITT VC200** transistor tuner (Philips type) £1.50

**ITT CVC5** power panel. New but five resistors never fitted £1.50

**Pye 697** line and power panels, damaged or some bits missing but invaluable for spares £2.00

**Pye mono mains droppers** with fusible link. 147 $\Omega$  + 260 $\Omega$  50p 3 for £1.00

69 $\Omega$  + 161 $\Omega$  50p 3 for £1.00

**Decca "Bradford" C.T.V.** triplers 25KV £3.00 each 4 for £10

**Portable TV EHT Sticks** "Siemens TV 18 KV". Fit most portables 50p each 3 for £1.00

**Pye 18" CT200** V. Cap P/B Assembly with leads and plug £3.90

**G.E.C. S/S Hybrid Focus** Assembly with lead £1.50

**2 x Coax Sockets** on plates suitable for various Continental T.V.s 50p

**1.5 Amp T.V. Cutouts** Suitable for DECCA and THORN sets. 60p each. 3 for £1.50

### White Ceramic TV Resistors

200 16W, 180 $\Omega$  11W, 13 $\Omega$  11W. 10 of any one type £1.20  
 10 of each type £3.00  
**2-2k fusible, vertical mounting Screen Feed** resistors 9 watt 8 for £1.00

**Q.47N**  $\frac{1}{2}$  watt emitter resistors 40 for £1.00

**10 $\mu$ F 400V modern Small** Type 8 for £1.00

**4.7 $\mu$ F 63V** 20 for £1.00

**1000 $\mu$ F 16V** 10 for £1.00

**Bias Caps**

**330 $\mu$ F 25v** 10 for £1.00

**470 $\mu$ F 25V** 10 for £1.00

**4,500 $\mu$ F 35V** cans 80p each

**R.B.M. 100 $\mu$ F + 32 $\mu$ F + 32 $\mu$ F 300V** 50p each

**Avoid Lethal Shocks**  
 Buy our specially designed

**EHT Probe**, removes high voltage charges from tubes, caps, etc. Heavily insulated with lead and earth connector 60p each

**B9A P.C. valve bases** 20 for £1.00

**EY87/DY87 EHT bases** 10 for £1.00

**C.T.V. Tube bases** 5 for £1.00

**20mm Antisurge Fuses** 630Ma 800MA, 1A, 1 25A, 1 6A. 12 for £1.00

**2A, 2 5A, 3 15A** 100 for £7.00

**TH1 thermistors** 6 for £1.00

**TH3 thermistors** 10 for £1.50

**Aluminium Coax Plugs** 8 for £1.00

**Metal Coax Couplers** 6 for £1.00

**200V 1A Diodes 10D2** (equivalent to 1N4003) 20 for £1.00

**Miniature "Terry" clips** ideal for screwdrivers and small tools etc. 40 for £1.00

**Low profile 16 pin quill**

**I.C. Sockets** (to fit most "Q" series I.C.) 12 for £1.00

**Cassette Motors** self regulating, 9V, make unknown type 9FM 90p

**Rediffusion/Doric Mk 13** 5 stick Triplers can be modified for other sets £1.00

**Miniature Level/Batt. Meters** as fitted to many cassette recorders 90p

Also:- **Miniature Mains Transformers** 4 5V-0-4 5V at 250Ma 90p each. 3 for £2.50

### ZENERS

**400MW**. 4-3V, 4-7, 6-8, 7-5, 30V 10 of one type 80p  
 10 of each type £3.00

**1-3W**. 12V, 13V, 18V. 10 of one type £1.00  
 10 of each type £2.50

**DIACS** BR100 6 for £1.00

**TAA550** STABILIZERS 4 for £1.00

**GEN. PURPOSE DIODES**

IN4000 30 for £1.00 IN4003/10D2 20 for £1.00

IN4002 25 for £1.00 IN4148 20 for £1.00

## TRANSISTOR PACKS

Our Transistor Packs are even better than before! **100 NEW AND MARKED TRANSISTORS** including BC238, ME0412, BF274, BC148, BC182L, BC338 and, or other similar types. A random analysis of these packs yielded between 98 and 106 transistors of 17 to 20 different types with an average total retail value of £14 - £16. **OUR PRICE ONLY £4.95**

**200 transistors** as above but including BD131, 2N3055, AC128, BFY50, BC154, BF394, BC184L, etc. **ONLY £9.95**

**BY476 (BY176) 18kV. 2-5Ma EHT REC** 60p each 3 for £1.50

Send **40p P. & P.** on all above items; send Cheque or P.O. with order to:-

### SENTINEL SUPPLY DEPT. TV

149a Brookmill Rd., Deptford, London SE8

(Mail Order address only. Callers by appointment)  
 Trade enquiries for quantity welcome.

Surplus stocks purchased for cash.

**BUSH 2211/14/15 AU 863**  
**GEC 2110/2110 SOLID**  
**STATE**  
**DECCA 22/30 SERIES**  
**FERGUSON 3713**  
**PYE 18'' 200-713**  
**SERIES**  
**KB 703/704**  
**MITSUBUSHI CT**  
**200B/202B**  
**HITACHI CMP 190/20**

## SPECIAL OFFER!

### PYE 205 VARICAP

(Sold as checked complete, good cabinet, tested tube, many working)

	22''	26''
Singles	£28.00	£24.00
5's	£26.00	£22.00
20's	£24.00	£20.00
100's	£18.00	£18.00

(mainland delivery free)

**All prices plus VAT**

## SPECIAL OFFER!

**COMPLETE COLOUR SETS**  
**(but minus tube)**  
**MANY CHASSIS WORKING**  
**ALL MODELS AND SIZES**

**First Come! First Served!**

**Quantity Discounts**

**Deliveries Arranged**

**We are taking orders now**

**BATCHES OF 12 FOR £115 INC VAT**

PLUS THOUSANDS OF SPARES IN STOCK – RING OR WRITE FOR QUOTATIONS

# TRITEL GROUP

#### NORTHERN

Thornbury  
Roundabout  
Leeds Road  
Bradford 3.  
Tel: (0274) 666070

#### SCOTLAND

Peacock Cross  
Industrial Estate,  
Burnbank Road  
Hamilton.  
Tel: (0698) 282141

#### LONDON

395/397 Albany Road  
Off Watworth Road  
LONDON SE5  
Tel: (01) 703 4040

#### WEST

Unit 4a  
Bulwerk Industrial  
Estate, Chopetow,  
Nr. Bristol.  
Tel: Chopetow  
(02912) 6862

#### MIDLAND

48/52 Pershore  
Street,  
Birmingham 6.  
Tel: (021) 622 1023

#### SOUTHERN

Watling Street  
Heckcliffe, North  
Dunstable (on A5)  
Tel:  
Leighton Buzzard  
(0625) 210788

MAIL ORDER SEND CWO (CHEQUES OR UNCROSSED PO'S) TO ANY BRANCH

## Spares Service from W.M.T.V. Ltd.

#### Tested Ex-Equipment

<b>Valves</b>	
DY802/86/87	10p
ECC82	10p
ECL80	8p
EF80	8p
EF85	8p
EF183	8p
EF184	8p
EY86/87	10p
PCC85	15p
PCF80	10p
PCF802	12p
PCL82, PCL86	12p
PCL84	15p
PCL85/805	15p
PFL200	15p
PL36	20p
PL504	25p
PL508	30p
PL509	80p
PL519	£1.00
PL802	£1.20
PY500	40p
PY800/81/801	15p
6F23	20p
30FL1/2	25p

Many more available.  
15% V.A.T. to be added to  
prices shown.

Postage paid on orders  
over £2.00.

Orders under £2.00,  
please add 10p per  
valve, p&p.

Discount of 10% on  
orders over £20.00.  
Large quantities of  
untested valves sold,  
prices on request.

#### Ex-Equipment Colour

<b>Tubes</b>	
19" A49 120x	£18.00
20"	£20.00
22" A56-120x	£22.00
25" A63-120x	£15.00
26" 90°	£24.00

Please add £4.00 p&p  
per C.R.T.

Please add 15% V.A.T.  
to all items ordered,  
then add postage indicated.

MANY MORE SPARES  
AVAILABLE  
PLEASE WRITE OR PHONE  
NOW.

**PERSONAL CALLERS  
WELCOME.**

### W.M.T.V. TRADE SALES LTD.

92, High Street, Kings Heath,  
BIRMINGHAM, B14 7JZ

## MAIL ORDER PROTECTION SCHEME

#### INTRODUCTION

The Office of Fair Trading have agreed that the notice of the Mail Order Protection Scheme to appear in periodicals carrying mail order advertising should appear as follows:—

#### "MAIL ORDER ADVERTISING

#### British Code of Advertising Practice

Advertisements in this publication are required to conform to the British Code of Advertising Practice. In respect of mail order advertisements where money is paid in advance, the code requires advertisers to fulfill orders within 28 days, unless a longer delivery period is stated. Where goods are returned undamaged within seven days, the purchaser's money must be refunded. Please retain proof of postage/despatch, as this may be needed.

#### Mail Order Protection Scheme

If you order goods from Mail Order advertisements in this magazine and pay by post in advance of delivery, Television will consider you for compensation if the Advertiser should become insolvent or bankrupt, provided:

- (1) You have not received the goods or had your money returned; and
- (2) You write to the Publisher of Television summarising the situation not earlier than 28 days from the day you sent your order and not later than two months from that day.  
Please do not wait until the last moment to inform us. When you write, we will tell you how to make your claim and what evidence of payment is required.

We guarantee to meet claims from readers made in accordance with the above procedure as soon as possible after the Advertiser has been declared bankrupt or insolvent.

This guarantee covers only advance payment sent in direct response to an advertisement in this magazine not, for example, payment made in response to catalogues etc., received as a result of answering such advertisements. Classified advertisements are excluded."

# Build your child an exciting world of knowledge



**NEW**

World of Knowledge magazine is the most exciting new development in learning aids for children. All mankind's achievements – past and present – are presented week by week in 10 stimulating and absorbing streams of learning using the most up-to-date graphic and illustrative techniques available. With the authoritative backing of a team of distinguished academic advisers, headed by Lord Asa Briggs, Chancellor of the Open University, World of Knowledge is structured to provide a complete understanding of the world about us and is a unique opportunity for your children to discover the adventure of finding out.



## The ten streams of learning

1. Nature's Kingdom
2. Great Beginnings
3. Our Island's Story
4. The Mysterious Earth
5. This Modern Age
6. The Arts
7. Finding Out
8. Other People's Countries
9. Great Men and Women
10. Our World in the Making

So build your child's

# World of Knowledge

**EVERY WEDNESDAY 30p**

## QUALITY TV'S ALWAYS AVAILABLE

GOOD STOCKS OF MODERN COLOUR QUANTITIES OR SINGLES

COME TO THE BEST IN THE WEST

## TELETRADERS

ST. LEONARDS WAREHOUSE  
ST. LEONARDS ROAD, NEWTON ABBOT, DEVON  
Telephone: (0626) 60154

## SOUTHERN IRELAND DEALERS

We are the largest stockists in the south of Ireland of clean used T.V. sets.

**PYE – BUSH – PHILIPS – FERGUSON – KORTING DECCA ETC.**

UHF/VHF Mono from **£18.00** each  
Colour from **£125**

All Sets Tested & Cabinets Polished.  
Over 2,000 sets in stock.

Visit our warehouse and see for yourself.

Irish stockists for the new 'Tyne' colour sets.

**T.V. WHOLESALE DISTRIBUTORS LTD.**  
E.D.I. House, Kylemore Park West Industrial Estate,  
Dublin 10. Tel. 264139 or 267995.

# ARE YOU

## USING YOUR SPARE TIME PROFITABLY?

If not, you're losing money. Money that you could be making by selling **used colour televisions from home** in the evenings. In fact, provided you start correctly and know exactly how to operate, you can easily earn a substantial CASH INCOME with a starting capital of less than £20. Our new unique publication "**How to Deal Successfully in Used Colour Televisions**" enables you to follow in the footsteps of many experts who have a great deal of combined experience in this lucrative home business, and who have 'pooled' their knowledge to help you. After all, to follow the advice of someone who has travelled the ground before you, is to be given the best possible start. And the hundreds of valuable trade secrets, hints, tips and suggestions in the guide show exactly how anyone of average intelligence can **succeed immediately**.

Every aspect, from securing the first television right through to rapid expansion of sales, is covered with the detailed knowledge of experts to ensure **certain success**. Indexed information on almost all makes of television is presented in clear tabular form, describing performance, reliability, price and service. In particular, the tips on 'expanding the business' are very practical, and are almost automatic when put into practice. Pages of unique advice on advertising ensure that maximum sales are secured, and sources of supply are described in detail – for both televisions **and** new/used spares. Monochrome sets are also covered, as are "invisible" cabinet repairs. **Plus FREE on-going advice and FREE regular up-dating service.**

**You can start tomorrow – but you'll need our guide.** The latest big illustrated edition is out now, and costs just **£4.95** – a small price to pay for financial independence!

ORDER TODAY FROM:

CITY PUBLISHING, HAYWORTH ROAD, SANDIACRE, NOTTINGHAM NG10 5LL

To: City Publishing, Hayworth Road, Sandiacre, Nottingham NG10 5LL.  
Please send by return post "How to Deal Successfully in Used Colour Televisions".  
I enclose cheque/p.o. for **£4.95**.

NAME.....  
ADDRESS.....  
.....

## CASIO WATCHES THE NEXT STEP FORWARD IN TIME. NEW LITHIUM BATTERIES LASTING UP TO 5 YEARS

### LATEST MODEL 83QS-27B

Displays hours, minutes, seconds date AM/PM or hrs, mins, secs, alpha day date AM/PM with automatic 28-30-31 day calendar. 4 year battery 1/10th sec chronograph to 12 hrs with net lap and 1st and 2nd place times. 24 hour alarm. Stainless steel encased, mineral glass. Water resistant to 66ft. Optional hourly chime facility **£26.95**



**81 QS-33B** as above with 5 year battery plated case, water resistant to 66ft 1/100th second chronograph 12 or 24 hour display, 24 hour alarm with chime facility **£26.95**

**81 CS-33B** as above with all solid stainless steel case, water resistant to 100ft, mineral glass, accuracy  $\pm 10$  secs per month **£33.95**

### OTHER MODELS FROM THE CASIO RANGE

**F8C** Time 6 digit hour, minutes, seconds with date and day AM/PM display three year battery illustrated **£9.95**

**F200** Similar to F8C with month and date display stopwatch 1/100th second net and lap time 1st and 2nd places **£14.50**



**95 QS-32B** Hours, mins, secs chrono. **£21.95**

**95 QS-31B** Hours, mins, secs, chrono. **£21.95**

**95 CS-31B** Hours, mins, secs, chrono. **£28.95**

ALL OTHER CASIO WATCHES P.O.A.

## SEIKO WATCHES CURRENT MODELS MINIMUM 25% DISCOUNT

Order details please note all Casio products price includes V.A.T. P.P. and insurance. Please send cheque P.O. made payable to B. Bamber Electronics C.O.D. by phoning (0353) 860185  
Callers welcome Tues-Sat 9am-5pm

## CASIO POCKET AND CLOCK CALCULATORS

**AQ2000** Calculator with clock in hrs, mins, sec, stopwatch, calendar and alarm, also countdown alarm 1 year battery life **£23.95**

**MELODY 80** Calculator with clock hours, mins, secs, calendar stopwatch alarm buzzer and musical 1 year battery life **£22.95**

**CQ82** Desk calculator clock with multi alarm, battery life 1 year continuous **£18.95**

**FX80** Scientific 39 functions 8 digit 4000 hour battery life **£14.95**

**FX68** Scientific card 39 functions with 500 hours battery life **£18.95**

**FX2600** Ultra slim scientific 6+2 LCD 43 functions latest model **£18.95**

**FX3200** Ultra slim scientific 10 digit 43 functions latest model **£20.95**

**FX310** Ultra slim scientific 6+2 LCD 50 functions latest model **£16.95**

**FX510** Ultra slim scientific 10 digit 50 functions latest model **£18.95**

## CASIO SCIENTIFIC PROGRAMMABLES

**FX501P** World's first LCD pocket sized complete programmables. Uses Algebraic Computer Language. Has 128 steps with 11 memories. Optional FA1 program adaptor available - permits programs to be recorded on standard tape cassette recorder and stored for re-entry later. FA1 adaptor also contains a music switch which converts calculator into musical synthesizer. Key 1-8 contain pre-programming for a full musical octave. Calculator has automatic power off after 14 minutes non-use. With the programme stored in 11 non-volatile registers: Complete in leatherette wallet.

**FX502P** As above with 256 steps and 22 memories.

**PRICES** **FX501P** **£52.95**

**FX502P** **£72.95**

**FA1** **£18.95**

## BUMPER 1980 CATALOGUE

A selection of items below from our 1980 catalogue, the products we stock are by EAGLE, WELLER, DRAPER, SPIRALUX, KNIPEX, SERVISOL, BARNARD'S & BABANI, NEWNES, JAYBEAM, VERO AND MANY OTHERS. Send £1.35 and you will receive our catalogue plus five bi-monthly shortform catalogues to keep you up to date with prices and special offers. A FREE PACK OF BLOB BOARD COMES WITH THIS MONTH'S ISSUE.

**EAGLE MA780T** Electric fully automatic 6 section retractable car aerial with built-in voltage sensor. Remote drive system makes fitting easier. Aerial length 1.000mm, below wing 200mm, lead length 9,000mm, flexible drive link 700mm. **£18.95 + VAT**

**EAGLE D07** Paging microphone, impedance 600 ohm or 50K ohms, sensitivity, 2.25mV at 50K ohms, frequency response 300-9000Hz. Desk or wall mounted **£14.85 + VAT**

**EAGLE MULTIMETER EM50** 50,000 OPV DC volts: 0-1200 volts, AC volts: 0-1200 volts, DC current 0-6A, resistance 0-10megohms. **£19.95 + VAT**

**DRAPER SUPER CHROME** 1" square drive socket sets. 38 pieces, 9 AF hexagon, 3 AF bi-square sockets, 11mm hexagon sockets, 9 BA hexagon sockets, and 6 accessories. **£12.75 + VAT**

**SPIRALUX** Metric nut spinner sets. Contains 8 nut spinners 4, 4.5, 5, 5.5, 6, 7, 8, 9, 10mm - packaged in a plastic wallet with cellulose acetate carrying handle **£7.53 + VAT**

**WELLER TCP3** Trons 24 volt series, 3 wire power units, for applications requiring earthed TIP. Also PU3D power units. **£13.84 + VAT**

**WELLER INSTANT HEAT GUNS** Model No. 8100D **£13.21 + VAT**

**WELLER CORDLESS** Model No. WC100 **£25.47 + VAT**

**SUPA** Servisol switch cleaner **£0.72 + VAT**

**MARYPLASS** Storage boxes SP2 combination draw pack (contains 1x6D 1x2x2D 5x1D) interlocking storage boxes. Per pack **£4.40 + VAT**

**JAYBEAM** Stereobeam VHF/FM antennas model SBM2. Folded dipole and reflector with universal mast clamp. Full range ex stock **£8.00 + VAT**

**TERMS OF BUSINESS.** Cheque or P.O. with order remember please add 15% VAT for above goods.

**CARRIAGE** Packing and carriage charges for orders under £5.00 nett invoice value 75p. Orders over £5.00 but less than £20.00 invoice value 50p. Orders over £20.00 carriage paid.

B. BAMBER ELECTRONICS DEPT TV 5, STATION ROAD, LITTLEPORT, CAMBS., CB610QE

## The Professional COLOUR BAR GENERATOR kit

ONLY  
**£59.50**  
inclusive



TRULY  
PORTABLE

\*Compare the specifications with any kit or manufactured Colour Bar Generator on the market. Then compare the price.

### \*SPECIFICATION

- (a) Line Frequency: 15.625 Hz  $\pm 0.1\%$
- (b) Field Frequency: 50 Hz  $\pm 0.1\%$
- (c) Interlace: 2:1
- (d) Subcarrier Frequency: 4.43361875 MHz
- (e) Colour System: PAL
- (f) Standard 75% Saturated 100% Amplitude Colour Bars, left to right: White, Yellow, Cyan, Green, Magenta, Red, Blue, Black

(g) Size 8" x 5 1/2" x 1 1/2" and weighs a mere 500g

\*Push Button Selection provides:

- (i) Peak White Raster
- (ii) Linearised Grey Scale
- (iii) Crosshatch
- (iv) Colour Bars
- (v) Red Raster

\*Direct connection to Television Aerial Socket

\* All kits are complete with a **PROFESSIONALLY FINISHED** Case, tinned, drilled and screen-printed P.C.B., step by step assembly instructions, and a simple setting up procedure (only **TWO** adjustments)

\* No extras to buy, not even Batteries. It comes complete with its own re-chargeable battery and charger (Approx. 10 hours running time per charge)

\* The backing of our After Sales Service Department

\* V.H.F. Modulator also available

\* Ready-built, aligned and tested for only £88.25, with a full twelve months guarantee

Prices inclusive of  
V.A.T. and Postage



**INTRACPT ELECTRONICS LTD.**

203 PICTON RD, LIVERPOOL L15 4LG  
Tel: 051-733 3042

## TELEVISION ELECTRONIC DISTRIBUTION (SPARES) LTD.

412a Hanworth Road, Hounslow, Middlesex  
Telephone: 01-572 4668

### PANEL REPAIR/EXCHANGE SERVICE TRADE ONLY

**BERRYVISION 510**

**EMO**

**THORN** 2000 Series, 3000/3500 Series,  
8000/8500/8800/9000 Series.

**GEC** Solid State 2110 Series.

**PHILIPS** G8 G9

**RBM** A802/823 AV (Ultrasonic)

**DECCA** Solid State 80 Series/Hybrid 30 Series.

**GRUNDIG** 5010/6010 GB

**PYE** 691, 697, 713, 723, 731

**SONY** 1800UB

**TRADE REPAIRS ON ALL SONY COLOUR T.V.'s**  
VERY COMPETITIVE PRICES.

3 MONTHS WARRANTY ON PANELS FROM  
DATE OF OUR INVOICE.

DISCOUNT FOR BULK PANEL ORDERS.  
CATALOGUE AVAILABLE ON REQUEST.

## TELEVISION TUBE SHOP

NEW TUBES AT CUT PRICES

### EUROPEAN TYPE Nos.

	Price £	VAT £
A28-14W.....	18.95	2.84
A31-19W/20W.....	19.95	2.99
A31-120W/300W.....	17.95	2.69
A31-410W/510W.....	17.95	2.69
A34-100W.....	18.50	2.77
A38-160W.....	17.50	2.63
A44-120W.....	18.75	2.81
A50-120W.....	17.95	2.69
A59-23W.....	18.95	2.84
A61-120W.....	18.95	2.84

### U.S.A./JAP. TYPE Nos.

9AGP4.....	19.50	2.92
190AB4/C4.....	17.50	2.62
230ADB4.....	28.50	4.28
230DB4/CT468.....	24.00	3.60
240AB4A.....	17.95	2.69
CT507.....	17.95	2.69
CT512.....	27.50	4.12
310DGB4/DMB4.....	23.00	3.45
310EUB4.....	19.95	2.99
310EYB4.....	18.75	2.81
310FDB4.....	19.95	2.99
310FXB4.....	17.50	2.62
310GNB4A.....	23.50	3.52
310HCB4.....	23.50	3.52
340AB4.....	19.50	2.92
340AYB4.....	25.25	3.79
340Rb4/CB4.....	24.50	3.68
340AHB4.....	24.50	3.68

**Some Rebuilt Japanese  
& European Types  
Available at  
£14.00 + VAT £1.75**

### COLOUR TUBES (New & Coloured)

12VARP22.....	62.50	9.37
330AB22.....	65.00	9.75
470FUB22B.....	85.00	12.75
A44-271X.....	65.00	9.75
A47-342X.....	69.50	10.42
A47-343X.....	69.50	10.42
A49-191X.....	59.50	8.92
A51-220X.....	64.00	9.60
A56-120X.....	58.50	8.77
A63-120X.....	69.50	10.42
A66-120X.....	65.00	9.75
A66-140X/410X.....	70.50	10.57
A67-120X.....	65.00	9.75
A67-140X/200X.....	69.50	10.42
A67-150X.....	75.00	11.25

ALL TUBES TESTED BEFORE  
DESPATCH & GUARANTEED  
FOR 12 MONTHS! 4 YEAR  
GUARANTEES AVAILABLE ON  
MOST TYPES

### CARRIAGE

Mono £3.00 Colour £4.00

Mainland only. Overseas Rates on  
Application.

### TELEVISION TUBE SHOP LTD.

52 BATTERSEA BRIDGE RD.,  
LONDON, SW11.  
Tel. 228 6859/223 5088

**EMO - EUROSONIC - GRUNDIG - TELETON + ALL BRITISH MAKES  
ETC., ETC. ● ALL SPARES READILY AVAILABLE ● REBUILT TUBES  
CREDIT AVAILABLE - TRADE ONLY**

Almost any TV Component supplied by return "off the shelf" e.g. LOPTX -  
EHT trays - droppers - OSC coils - switches - cans - smoothers - I.C.'s, etc., etc.  
NEW - COMBI LOPTX NOW AVAILABLE.

**YOU CAN BE 95% SURE WE CAN SUPPLY ANY  
TV COMPONENT BY RETURN  
IF YOU NEED SPARES FAST - RING NOW!**

ACCESS AND BARCLAYCARD ACCEPTED.

S.A.E. FOR FREE SERVICE CATALOGUE.

**TELE-PORT (WTON) THE TELECENTRE, WORCESTER ST.,  
WOLVERHAMPTON (0902) 773121**

PLEASE MENTION  
**TELEVISION**  
WHEN REPLYING  
TO ADVERTISERS

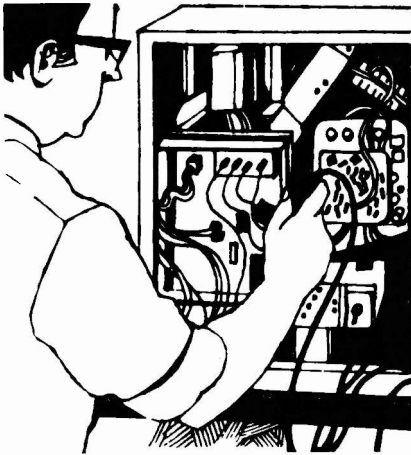

### SETS & COMPONENTS

## URGENT TRADE NOTICE

Large quantities of good quality mono and colour TV receivers for sale, at competitive prices.

WHY not come to us where your custom will be welcomed and appreciated.

WE supply receivers to all parts of the UK, and to EIRE. All export enquiries welcomed.

### TV WHOLESALE SUPPLIES

35 Shipston Road, Stratford-on-Avon.  
TEL: 0789 4424

### Southern Valve Co.,

2nd Floor, 6 Potters Road, New Barnet, Herts.

Tel: 01-440 8641 for current prices & availability, all popular valves stocked. NO CALLERS, SAE Lists. Cash with order. Same Day Postal Despatch.

Valves, Tubes, Aerials etc by LEADING-MAKERS. Send SAE Lists or Phone for current prices. Counter or MAIL ORDER. NO COD. Speedy Despatch assured. No order under £1.

Philip Beaman, 6 Potters Road, New Barnet, Herts.  
Tel: 01-449 1934/5 (1934 Recording Machine).

## HURNGATE LTD.

SERVICED AND WORKING

**PHILPS G8  
SOLID STATE G.E.C.  
THORN 3000/35000**

AND OTHERS

CONTACT:

**UNIT 3 THE QUARRY,  
WESTERLEIGH, YATE  
BRISTOL**

**Tel: CHIPPING SODBURY  
316056**

## TELECARE T.V. DISTRIBUTION LTD. BRISTOL AND NORTHERN IRELAND

Due to a New Policy in purchasing we are able to OFFER most makes of Colour & Mono at Lower Prices than ever before.

We can supply any quantity, nothing too big or too small. *Trade only.*

**TELECARE BRISTOL**  
Unit 3 Whitby Road,  
Brislington,  
Bristol.  
Phone 0272 712569

**NORTHERN IRELAND**  
Bellanaleck  
Co' Fermanagh,  
Northern Ireland.  
Phone Florencecourt 388

## SMALL ADS

The prepaid rate for classified advertisements is 21p per word (minimum 12 words), box number 60p extra. Semi-display setting £4.00 per single column centimetre (minimum 2.5 cms). All cheques, postal orders etc., to be made payable to Television, and crossed "Lloyds Bank Ltd". Treasury notes should always be sent registered post. Advertisements, together with remittance, should be sent to the Classified Advertisement Manager, Television, Room 2337, IPC Magazines Limited, King's Reach Tower, Stamford St., London, SE1 9LS. (Telephone 01-261 5846).

## NOTICE TO READERS

Whilst prices of goods shown in classified advertisements are correct at the time of closing for press, readers are advised to check with the advertiser to check both prices and availability of goods before ordering from non-current issues of the magazine.

### RE-BUILT COLOUR TUBES

19" £29.50 MONO 20" £30.50  
22" £32.50 20" 24" 25" £34.50  
26" £38.50 £16

One Year Guarantee.

**MATRIX TV LTD.,**

112 Essex Road, London N1. Tel: 226 1111

TELEVISIONS to the Trade. Large quantities of Mono from £2.00; Square Screen from £6.00. Colour T.V.s Working from £65. R.B.M., GEC, PYE, Thorn etc. Phone Scarborough 0723-68087-65451. Scarborough T.V. Trading, Ridings House, Depot Lane, Seamer Road, (A64) Scarborough.

### COLOUR TUBES

Rebuilt with new electron gun, to British Standard. High temperature pumping.

Here is what you pay. VAT

17-18-19 inch.....	£29	4.35
20 inch.....	£30	4.50
22 inch.....	£31	4.65
25 inch.....	£34	5.10
26 inch.....	£35	5.25

Guarantee 2 years.

Exchange basis.

Carriage charged at cost.

### TELESTAR TUBES

575c Moseley Road, Birmingham B12 9BS.  
Tel: 021-440 5712.

RECONDITIONED Pye Hybrid Colour TV's, to the following spec: New regunned tube (2 year Gtee.) Solid state CDA panel, new boost caps, new tower valves, new thermistors, etc, trade price £149 including VAT. CASTLEGATE TV, 64 Castlegate, Grantham, Lincs. Tel: 0476 66869.

### STS

For Good Quality Colour and Mono T.V.'s Ex-Rental, Part Exchanges, Re-possessions, etc.

COLOUR T.V.'s from £11 inc. V.A.T.

MONO T.V.'s from £3-30 inc. V.A.T.

Why not Call or Phone now to Londons Established Wholesaler

**SOUTHERN TRADE SERVICES,**

21 Colindale Avenue,  
London NW9.  
Tel: 01-200 7337.

## VALVE BARGAINS

ANY 1-20p, 5-80p, 10-£1.25, 50-£5.50

ECC82, ECH84, EH90, PFL200, EF80, EF183, EF184, PCF80, PCF802, PCL82, PCL84, PCL85/805, PY81, PY800, PY88, PL36, PL504, 6F28, 30PL14.

COLOUR VALVES 65p EACH

PY500/A, PL508, PL509, PL519.

Postage & Packing 30p, no VAT

### VELCO ELECTRONICS

9 Mandeville Terrace, Hawkshaw, Via Bury, Lancs.

### EX EQUIPMENT PANELS

Pye 693. Decoder £14. I.F. or convergence £9. Line Panel £20. Tuner £9; CDA £10; Frame Panel £8. BRC 3500: Power Supply £20 Line Board £20; Decoder £14; Video £14; I.F. £10. Frame Sound £12. All prices VAT inc. P&P £1.50 on any item. Cheque or PO with Order.

### ROBIN RENTALS LTD.,

28 Lorne Road, Northampton. 33730

TURN YOUR SURPLUS capacitors, transistors, etc., into cash. Contact Coles-Harding & Co., 103 South Brink, Wisbech, Cambs. 0945 4188. Immediate settlement.

## QUALITY REBUILT TUBES

HIGH TEMPERATURE PUMPING

COLOUR (2 year Guarantee) from £34  
MONO (Including thin necks) from £12.50

4 year Optional Guarantee

Agents in Harrow, West London, Croydon, Anglia.

Send or phone for full list and terms.

**WELTECH PICTURE TUBES**  
Unit 3-10 Wembley Commercial Centre,  
East Lane, Wembley, Middx.  
01-908-1816

## TV TUBE REBUILDING

Faircrest Engineering Ltd., manufacture a comprehensive range of equipment for processing all types of picture tubes, colour and mono. Standard or custom built units for established or new businesses. We export world-wide and have an excellent spares service backed by a strong technical team.

Full training courses are individually tailored to customers requirements.

For full details of our service contact Neil Jupp

### FAIRCREST ENGINEERING LTD.

Willis Road, Croydon CR0 2XX  
Tel: 01-689 8741 01-684 1422/3

### TELEVISION AERIALS

The full range of quality BASIC aerials, amplifiers, lashing kits, cables, masts, rotators and accessories can be supplied at extremely competitive prices, normally from stock. Representative examples are shown. For quotations on specific items or general and technical application queries, please write enclosing S.A.E. For new comprehensive 6-page catalogue and price list, send 20p stamps.

Imported 75ohm notch filters—single notch for either Band 3, 4, or 5, -20dB depth, 10B loss £28.90  
Double notch filters — coverage as above, -36dB depth, 10B loss £14.85

Numerous other filters available including F.M. Band  
TELENG 27dB High Gain VHF Wideband Amplifier 40-300MHz £12.33  
STPUZ2 Matching Power Supply for above Amplifier £25.81  
WOLSEY 'Supra Nova', 22dB High Gain Wideband UHF Amplifier £11.81  
Matching Power Supply for above Amplifier £11.81  
LARGEAR CM7053 mains powered set-back Wideband UHF Amplifier £12.52  
MAXVIEW 'Trimax' UHF High Gain long vagi (state group) £18.75

All prices include VAT, post and packing  
The proprietors Roger Bunney and David Martin will be happy to advise on specific installations and allied problems, drawing on their in-depth knowledge of reception engineering. S.A.E. with all queries, please.  
BASIC: Aerialite, Antiference, Jaybeam, Maxview, Wolsey, Premier Industries.

**SOUTH WEST AERIAL SYSTEMS**  
10 Old Boundary Road, Shaftesbury, Dorset. Tel: (0747) 4370

## VALVE LIST

ALL VALVES FULLY TESTED

Five valves or over postage paid  
Under five valves postage 6p each

DY86/87	15p	PC900	8p	PCL85/805	20p
EB91	12p	PCC84	8p	PL36	20p
ECC82	10p	PCC85	20p	PL504	25p
ECL80	8p	PCC89	8p	PY32/33	15p
EF80	8p	PCC189	8p	PY81/800	15p
EF85	8p	PCC805	15p	PY801	20p
EF183	10p	PCF80	8p	U191	15p
EF184	10p	PCF86	15p	6F23	15p
EH90	13p	PCF805	20p	6/30L2	15p
EY86/87	13p	PCL82	15p	30F5	10p
PC86	15p	PCL83	15p	30FL1	20p
PC88	15p	PCL84	15p	30PL14	15p

AND MANY MORE AVAILABLE

**S. W. ELECTRONICS**

114 Burnley Road, Rawtenstall, Rossendale, Lancs.

## T.V. SPARES, PANELS AND MANUALS

PHILIPS · GRUNDIG

TELEVIEW 01-994 5537  
194, Acton Lane, London W.4.

## LLOYD ELECTRONICS

63 North Parade, Grantham, Lincolnshire

PL802/T Top Quality Solid State Valve @ £2.50 each.

Solid State C.D.A. Panel for 'Pye' 203/205 series @ £19 each.

I.F. Gain module for 'Pye' 713/731-series @ £9.50 each.

Motor speed control module for 'Hoover' washing machines. Types 3234/5/43 D.C. @ £9.50 each.

VAT & P/P included  
QUANTITY DISCOUNTS

# SUFFOLK TUBES LIMITED

214 Purley Way, Croydon, Surrey.  
Tel: 01-686 7951/2/3/4

SUPPLIERS OF MONO AND COLOUR TUBES TO MAJOR RENTAL COMPANIES.

ALL COLOUR TUBES HOT PUMPED AT 385c AND REBAND TO BRITISH STANDARD. 415 1972 CLAUSE 18-2.

19" and 22" TUBES APPROVED. OTHER TYPES PENDING.

BRITAINS LARGEST INDEPENDENT REBUILDER FOR 21 YEARS.

DXTV. PHILIPS selectivity modules, tested less cans 95p post paid. Gain modules 95p post paid. Other DXTV items supplied. H. Cocks, Bre Cottage, Staplecross, Robertsbridge, E. Sussex. Tel: 058083-317.

### MAINS DROPPERS AND CAN CONDENSERS

Philips G8 47!	43p
Philips G8 2-2-68!	63p
Philips 210 118-148-Loop!	63p
Philips 210 30-125-2K85!	74p
Philips GT23 6-124-84!	74p
Thorn 3500	74p
Thorn 1500 350-20-148-1500-317!	90p
Thorn 1400	80p
Thorn 8000 56-1K-47-12!	90p
Pye 725 27-56!	63p
R.B.M. TV161 250 14-156!	70p
GEC 2010 8-15-17-70-63-188!	90p
2010 Covers 2013 2014 2017 & Sobell 1010 10A 13 & 1014	
Bush IV165-166-171-175-176-178	70p
Murphy V1910-1913-1914-2014-2310-2311-2312 2314	70p
Bush A823 68-56!	90p
TV Condensers: - 200 + 200 + 100 mfd 300V	45p each
150-100-100-100-150M 325V	£2.00
150-150-100M 300V	£1.60
175M 400V 100-100M 350V	£2.05
400-400M 350V	£2.65
All 2500-2500M 30V	80p
2500-2500M 63V	£1.45
Can 4700m 25V	85p
1000m 63V	63p
Cond 2200m 40V	65p
PL802T Special	£3.00
BDX32	£1.98
100-300-100-16m 300V	

Post Free, Cash with order, VAT paid.

**Durham Supplies**

367 Kensington Street, Bradford 8, West Yorkshire

### 20 AX & P.I.L. TUBE

Colour Tubes.....	from £25
20 AX all sizes.....	from £25
Toshiba P.I.L. All Sizes.....	from £25
S/S COLOUR SETS.....	from £60
S/S & D/S MONO.....	from £5

RING: JEFFRIES 01-845 2036

G6 SPARES. Panels £2. - £4. New Valves. No callers. List SAE. Sole, 37 Stanley Street, Ormskirk, Lancs. L39 2DH.

### COLOUR PANEL EXCHANGE SERVICE

BRC 3000 - 3500 8000 - 8500  
Philips G8 and GEC 2110 series.

Free delivery in London area on Exchange Panels. Large stock of BRC 3500 series spares. New and S/H BRC Panels for sale. Immediate exchange on repairable panels.

Catalogue available on request.

**KAY JAY TV SERVICE**

34, Clouston Avenue, Northolt. Phone 884 0350.

PYE HYBRID CDA panels, tested and working. £2.50 incl. P. & P. Castlegate TV, 64 Castlegate, Grantham, Lincs.

### REBUILT CATHODE RAY TUBES IN

## S. WALES

All tubes are now guaranteed for 2 years	Exchange Price	V.A.T. @ 15%
A44 270X-A44 271X	£30.00	£4.50
A47 342X-A47 343X	£30.00	£4.50
A49 120X-A49 192X	£30.00	£4.50
A51 110X-A51 220X	£30.00	£4.50
A55 14X	£33.00	£4.95
A56 120X-A56 140X	£33.00	£4.95
A63 120X-A63 200X	£36.00	£5.40
A66 120X-A66 140X	£36.00	£5.40
A67 120X-A67 150X	£36.00	£5.40

20AX and P.I.L. tube prices are available on application.

For further details contact: **C.R.T. Services**  
Tel. Llanwern (0633) 412112

PLEASE MENTION

TELEVISION

WHEN REPLYING TO ADVERTISEMENTS

### LOOK! THORN 3000/3500 TRIPLERS

High Quality Silicon Replacement Units  
One Year Guarantee: Same Day Despatch  
ONLY £3.95 inc. P.P. Add 59p V.A.T.  
Quotes for larger quantities on request.

**WING ELECTRONICS**  
13 Middle Road, Harrow HM, Middx.

### WANTED

NEW VALVES and CRT's required, PCL805, PL504, PL509, PY500A etc. Cash waiting, Bearman, 6/8 Potters Road, New Barnet, Herts. Tel: 01-449 1934/5.

**RADIO AND TV Servicing** books, 1968 onwards. Offers to Haywood. 0793 824963.

**NEW VALVES REQUIRED.** Please ring (0254) 36521. P. V. Tubes, 38A Water Street, Accrington, Lancs.

**MULTI-STANDARD** Portable DX-TVs required, e.g. Sony UM112. Harris, 24 Hampton Grove, Farcham, PO15 5NL.

**WANTED: CIRCUIT** And/or manual for Old Philips Oscilloscope Type GM 5660. Brown, 105 South Farm Road, Leeds 9.

**LEADER LBO-5B** oscilloscope manual or copy of circuit. Write to Box 151.

**EDUCATIONAL**

**TELEVISION & VIDEO SYSTEMS SERVICING**

**18 MONTHS full-time Diploma course to include a high percentage of practical work.**

- ELECTRONIC PRINCIPLES
- MONO & COLOUR TELEVISION
- CLOSED CIRCUIT TELEVISION
- VIDEO CASSETTE RECORDING
- DIGITAL TECHNIQUES & TELETEX
- COMPUTERS & MICROPROCESSORS

**Shortened courses for applicants with suitable electronics background.**

*Next session starts April 21st.*

(Also available 2½ year course in Marine Electronics & Radar for employment as ships Radio Officer.)

Prospectus from:

**LONDON ELECTRONICS COLLEGE**

**Dept: TT2, 20 Penywern Road, London SW5 9SU. Tel. 01-373 8721.**

**BETTER JOB! BETTER PAY!**

**GET QUALIFIED WITH ICS IN: COLOUR & MONO TV SERVICING COLOUR & MONO TV ENGINEERING COLOUR & MONO TV MAINTENANCE**

**PLUS:** Telecommunications, radio, electronics, electrical engineering, technical communications, radio communications, etc., etc.,

**NEW: Self-build radio courses with free kits**

Train in your own home, in your own time with ICS, the world's most experienced home study college.

**RETURN THIS COUPON TODAY FOR FREE BROCHURE!**

**ICS** Int Correspondence Schools  
R284 Intertext House, Stewarts Rd.  
London SW8 4JJ. Tel: 01-622 9911

Name .....

Address.....

**SERVICE SHEETS**

**LARGE SUPPLIERS OF SERVICE SHEETS AND COLOUR MANUALS**

**TV Monos, Radios, Tuners, Tape Recorders, Record Players, Transistors, Stereograms, all at 75p each + S.A.E., except Colour TVs from £1 and Car Radios £1.25.**

State if Circuit will do, if sheets are not in stock. All TV Sheets are full length 24 x 12, not in Bits & Pieces. All other Data full lengths. Free Fault Finding Chart or TV Catalogue with order. Crossed PO's Returned if Sheets Not in Stock.

**C. CARANNA, 71 BEAUFORT PARK, LONDON NW11 6BX. 01-458 4882. MAIL ORDER**

**SERVICE SHEETS, Radio, TV, etc., 10,000 models. Catalogue 24p plus SAE with orders-enquiries. Telray, 154 Brook Street, Preston, PR1 7HP.**

**SERVICE SHEETS** from 50p and S.A.E. Catalogue 25p and S.A.E. Hamilton Radio, 47 Bohemia Road, St. Leonards, Sussex.

**G.T. THE TECHNICAL INFORMATION SERVICE 76 CHURCH STREET, LARKHALL, LANKS ML9 1HE.**

Over 200 different colour T.V. service manuals in stock. 1000's of other manuals in stock for immediate delivery.

S.A.E. brings quotations, newsletter, bargains, details these and other T.V. offers by return. Any service sheet £1 + large s.a.e. by return.

**FREE £4 OFF VOUCHERS** send very large s.a.e. and £2 for our 2 GIANT SERVICE SHEETS & MANUALS CATALOGUES

**NEW PUBLICATIONS FROM T.V. TECHNIC . . . plus extra manuals.**

Complete British Colour T.V. Repair System **£52** (£65 abroad).

(3 Repair Manuals & 3 Giant Circuit Diagram/layout collections in luxury binders).

Complete Mono T.V. Repair System **£42** (£53 abroad).

(4 Repair Manuals & 2 Giant Circuit Diagram/layout collections in luxury binders).

**ORDER FORM PLEASE WRITE IN BLOCK CAPITALS**

Please insert the advertisement below in the next available issue of Television for .....

insertions. I enclose Cheque/P.O. for £ .....

(Cheques and Postal Orders should be crossed Lloyds Bank Ltd and made payable to Television)

NAME.....

ADDRESS .....

Send to: Classified Advertisement Manager. TELEVISION, GMG, Classified Advertisement Dept., Rm. 2337, King's Reach Tower, Stamford Street, London SE1 9LS. Telephone 01-261 5846. Rate 21p per word, minimum 12 word. Box No. 60p extra.

Company registered in England. Registered No. 53626. Registered Office: King's Reach Tower, Stamford Street, London SE1 9LS.

**FOR SALE**

**PHILIPS V.C.R. 1520.** Electronic Editing, 2 sound channels, studio model. Video 1/P and 0/P + UHF. Perfect order. Offers around £250 or P.X. Electronic Organ any condition. 0329 281406.

**NEW BACK ISSUES** of 'Television' available 80p each post free. Open P.O/Cheque returned if not in stock - **BELL'S TELEVISION SERVICES**, 190 Kings Road, Harrogate, N. Yorkshire. Tel: (0423) 55885.

**BOOKS & PUBLICATIONS**

**FULL REPAIR** data any named T.V. £5.30, with circuits, layouts, etc. £7. (AUST) 76 Church Street, Larkhall, Lanarks ML9 1HE.

**MISCELLANEOUS**

**RIGONDA AGENTS.** For all spares and repairs. Fast despatch trade service available. 01-476 1928. Star Radio, 272 Barking Road, London, E13.

**VIDEORECORDER SERVICE** and Technical consultancy - B & B Electronics, Newark 76895. Call Steve Beeching.

**C.T.V. Panels** Ect lists S.A.E. No Callers. Sole, 37 Stanley St., Ormskirk, Lancs. L39 2DH.



# SERVICE SHEETS. SERVICE MANUALS PRACTICAL AND TECHNICAL BOOKS

COVERING COLOUR & MONO TELEVISIONS, RADIOS,  
RECORD PLAYERS, TAPE RECORDERS, ETC.

**SERVICE SHEETS £1.00 PLUS S.A.E. SERVICE MANUALS ON REQUEST.**

## BOOKS

PRICES INCLUDE POSTAGE U.K. ONLY

TVT '78 TRANSISTOR EQUIVALENT & DATA BOOK. (A TO Z). 272 Pages .....	£3.25
TVT '78 TRANSISTOR EQUIVALENT & DATA BOOK. (2N, 2S, ETC.). 392 Pages .....	£4.25
NEWNES COLOUR TELEVISION SERVICING MANUAL by G. J. King. Vol. 1 .....	£8.50
NEWNES COLOUR TELEVISION SERVICING MANUAL by G. J. King. Vol. 2 .....	£8.50
NEWNES COLOUR TELEVISION SERVICING MANUAL by G. J. King. Vol. 3 .....	£9.50
COLOUR TELEVISION SERVICING by G. J. King. 2nd Edition .....	£9.80
COLOUR TELEVISION THEORY by G. H. Hutson .....	£7.50
LONG DISTANCE TV RECEPTION FOR THE ENTHUSIAST by R. Bunney .....	£1.70
COLOUR TV WITH REFERENCE TO THE PAL SYSTEM by G. N. Patchett .....	£6.40
VIDEOTAPE RECORDING: THEORY AND PRACTICE by J. F. Robinson 2nd Edition .....	£9.95
TELEVISION SERVICING HANDBOOK by G. J. King. 3rd Edition .....	£7.25
BEGINNERS' GUIDE TO TELEVISION by G. J. King. 5th Edition .....	£3.45
BEGINNERS' GUIDE TO COLOUR TELEVISION by G. J. King. 2nd Edition .....	£3.45
CATHODE-RAY OSCILLOSCOPE AND ITS USES by G. N. Patchett .....	£4.40
SERVICING WITH THE OSCILLOSCOPE by G. J. King. 2nd Edition .....	£6.65
TOWERS' INTERNATIONAL TRANSISTOR SELECTOR. 2nd Update .....	£10.35

## COLOUR TV MANUALS

COVERING FOLLOWING MAKES  
PLEASE SEND S.A.E. FOR QUOTATION

ALBA, BRC, BUSH, DECCA, GEC,  
DEFIANT, MARCONI, EKCO, PYE,  
FERGUSON, DYNATRON,  
NATIONAL, HITACHI, INVICTA,  
ITT/KB, RGD, GRUNDIG, SOBELL,  
STELLA, SONY, MURPHY,  
PHILIPS, HMV, ULTRA & OTHERS.

## CIRCUIT DIAGRAM MANUALS

We supply circuit diagrams for televisions in Giant Binders, covering most British 'Single' and 'Dual Standard' models, consisting of 2 volumes on colour and 1 on black & white. Price £12.50 each plus £2 post or all 3 for £37.50 post free.

WE STOCK NEW AND SECONDHAND EDITIONS OF "RADIO AND TELEVISION SERVICING" BOOKS.  
FROM 1965-66 EDITION UP TO DATE. PRICES ON REQUEST.

BACK ISSUES OF FOLLOWING MAGAZINES AVAILABLE. CURRENT PRICE PLUS 25p POSTAGE PER COPY.  
P. WIRELESS, P. ELECTRONICS, E. ELECTRONICS, TELEVISION, ELECTRONICS TODAY, ELEKTOR

## BELL'S TELEVISION SERVICES

**190, KINGS ROAD, HARROGATE, N. YORKSHIRE. TEL. HARROGATE (STD 0423) 55885**

OPEN TO CALLERS DAILY 9.00 a.m. TO 5.00 p.m. (HALF DAY WEDNESDAY) PLEASE INCLUDE AN S.A.E. WITH ENQUIRIES

## N.G.T. COLOUR TUBES

**First Independent Rebuilder with**

**B.S.I. CERTIFICATION**

*(Certificate No. 004)*

**12 month's guarantee: 4 year option**

Tubes are processed using high temperature pumping schedules giving high definition and long life. They are then fitted with an implosion safety system approved by the British Standards Institution.

**N.G.T. ELECTRONICS LTD.,**

**120, SELHURST ROAD., LONDON S.E.25**

**Phone: 01-771 3535.**

*20 years experience in television tube rebuilding.*

**We're giving away**

**Trade  
secrets**

**FOR EX-RENTAL COLOUR  
AND MONO TELEVISION**

**West Midlands T.V.  
Trade Sales Ltd.**

**021-444-6464**

**92 HIGH STREET**

**KINGS HEATH**

**BIRMINGHAM B14 7JZ**

**★ NOW OPEN ★**

**New Warehouse at**

**37-39, Jamaica St.**

**Bristol.**

**0272-48266**

Why not call in and see us. . . .  
A relaxed friendly atmosphere, together with a choice of hundreds of sets at low, low prices. Colour from £15. Mono from £2. Also stands, spares, etc. Send an S.A.E. or phone, for our current price lists and area map showing how to find us. Export enquiries welcome.

## EX RENTAL COLOUR TV's. THE BEST DEAL IN LONDON

OVER 2,000 in STOCK. MANY WORKING.

**THORN BUSH DECCA PYE GEC PHILIPS KORTING GRUNDIG**

Delivery arranged ★ Working sets available ★ Complete lorry loads available

★ Excellent stocks of Mono ★ Export our speciality.

Low, Low prices for genuine trade buyers, call and see for yourself, we would like to meet you  
or phone 01-997 8833/2298

**Colin Butler TV Wholesale, Servier House, Horsenden Lane South, Perivale, Middx.**

(New industrial estate behind Perivale underground station)

## ELECTRONIC MAILORDER LTD.

### VALVE BARGAINS

Any 5-80p, 10-£1.50, 50-£6.00 Your choice from the list below.

ECC82, EF80, EF183, EF184, EH90, PCF80, PCF802, PCL82, PCL84, PCL85, PCL805, PL504, PY81/800, PY88, 30PL14, 6F28, PFL200.

Colour Valves - PL508, PL509, PL519, PY500/A. All tested, 65p each.

Aerial Splitters: - 2 way, 75 OHMS, Inside Type, £2.50

### AERIAL BOOSTERS

Aerial boosters can produce remarkable improvements on the picture and sound, in fringe or difficult areas.

B11 - For the stereo and standard VHF/FM radio.

B12 - For the older VHF television - Please state channel numbers.

B45 - For Mono or colour this covers the complete UHF Television band.

All boosters are complete with Co-ax plugs & sockets. Next to the set fitting. Price £5.70 each.

### SIGNAL INJECTOR

AF/RF, which emits signals up to the UHF band. Price £4.70

ALL PRICES INCLUDE VAT. P&P 30p PER ORDER. EXPORTS WELCOME AT COST. SAE FOR LEAFLETS.

62 BRIDGE STREET, RAMSBOTTOM,  
BURY, LANCS.  
TEL: RAMS (070 682) 3036.

## DISPLAY ELECTRONICS

### REGUNNED COLOUR TUBES 2 YEAR GUARANTEE

Up to 19" .....	£29.50
20" .....	£31.50
22" .....	£33.50
25" .....	£35.50
26" .....	£37.50

The above prices are for standard 38mm Delta Gun Types. Prices on application for P.I.L. Tubes etc. Some types available without pre-supply of glass at extra cost.

Carriage/Packing £5 up to 75 miles from works. £6.50 over. Please add 15% VAT

### REGUNNED MONO TUBES 2 YEAR GUARANTEE

20" .....	£11.00
24" .....	£13.00

Carriage/Packing £4.00 up to 75 miles from works. £5.00 over. Please add 15% VAT.

## COLOUR T.V. SPARES

Most parts for Decca's stocked

<b>LOPT</b>		
DECCA	10/30	£10.80
	80/100	£10.20
	Mono	£12.00
PHILIPS G8		£12.90
ITT	20/25/30	£11.90
BUSH	A774	£15.00

### TUNER CONTROL UNITS

DECCA		
4 Button		£7.90
6 Button		£8.90
7 Key		£14.50

Exchange 2230 Tuner Unit £10 (5 Butt - New for old)

Complete working  
THORN 3000 models  
£79 (callers only)

**Ex-equip panels**  
for 3000 and BRADFORD  
See our NEW Catalogue  
for details.

Hundreds of correct spares listed.

Send stamp for free copy.  
New 1590 or 1591 speakers £4.90.

Prices include 15% VAT

Package/Posting 30p per order but Transformers and Panels 80p.

### BOTTOMLEY'S TELEVISION

11 Leeds Road, Hipperholme,  
HALIFAX (0422) 202979

Callers Phone first. Exit 26 M62

## BIRMINGHAM AND DISTRICT DEALERS/ENGINEERS

# NEWS FLASH

HIGH VACUUM  
QUALITY  
REBUILT TELEVISION  
PICTURE TUBES

COMPETITIVE PRICES

CONTRACT TERMS  
AVAILABLE

2 YEAR GUARANTEE

E.G.		
17" 18" 19"	£29.50 + VAT	£4.43
20"	£32.50 + VAT	£4.86
22"	£34.00 + VAT	£5.10
25"	£37.00 + VAT	£5.55
26"	£40.00 + VAT	£6.00

**PIL Tubes our speciality.**  
All Prices For Tubes available on a Sound "Glass for Glass" basis otherwise £20 surcharge

C.W.O. Carr./Ins. £6.50

"Old Glass Purchased"

### TUBESURE LTD.

Unit 111, Middlemore Industrial Estate,  
Middlemore Road, Smethwick,

West Midlands. Telephone: 021-558 7777.

## CALLERS WELCOME

Late night Thursdays until 8pm  
Saturdays until midday.

N.B. Customers intending to collect orders are requested to telephone in advance:— even popular types may be out of stock for short periods.

## V.D.U./RADAR TUBES

We have supplied British and Foreign Airlines with rebuilt V.D.U. Tubes for several years and also have Radar Display Tubes operating on British Airfields.

Home and export enquiries for Radar Display Tubes manufactured from new (with phosphors to specification) are invited.

**WATERLOO ROAD,  
UXBRIDGE,  
MIDDLESEX**

Telephone: Uxbridge 55800

## VIEW WELL WITH WELLVIEW TV TUBE REBUILDS

### Exchange Mono

	our price	+ VAT	15%	total price
CME 1601-1602	£9.30		£1.39	£10.69
A44/120WR	£9.30		£1.39	£10.69
A50/120WR	£9.30		£1.39	£10.69
AW59/23W	£11.00		£1.65	£12.65
A61/120WR	£11.00		£1.65	£12.65

### NEW MONO TUBES

20" = £15.80 inc. VAT 24" = £17.20 inc. VAT

### Exchange Colour

	our price	+ VAT	15%	total price
A44/270X-271X	£27.00		£4.05	£31.05
A47/342X-343X	£27.00		£4.05	£31.05
A49/120X	£27.00		£4.05	£31.05
A51/110X	£27.00		£4.05	£31.05
A55/14X	£32.00		£4.80	£36.80
A56/120X	£32.00		£4.80	£36.80
A63/120X	£36.00		£5.40	£41.40
A66/120X	£36.00		£5.40	£41.40
A67/120X	£36.00		£5.40	£41.40
A67/200X	£36.00		£5.40	£41.40

18 month full guarantee (Established ten years).

Send cash or cheque together with old tube with your order.

Carriage=£4.50 including VAT

**ALSO YOUR VALVE SUPPLIER  
NEW AND BOXED  
(inclusive of VAT)**

DY802=74p	ECC82=64p	EF183=78p
EF184=64p	PCC89=72p	PCF802=98p
PCL82=78p	PCL84=92p	PCL805=97p
PFL200=£1.15	PCL86=97p	PL504=£1.38
PL509=£2.82	PL519=£2.92	PY88=70p
PY800=70p		PY500A=£1.52

Postage and Packing 10p per valve. All orders over £10 Free of charge.

### WELLVIEW TUBES LTD.,

Unit 7, KING ROAD,  
CHARFLEET INDUSTRIAL ESTATE,  
CANVEY ISLAND,  
ESSEX

TELEPHONE CANVEY ISLAND 65372

BD253/B	35p	G8 TYPE PYE UHF V/cap T/units & VHF unit on Panels	New £6.00	Hitachi 12" tubes new	A31/300W	£12.00	Used in G.E.C. T/V small neon lamps	NE-2B6H-2	3p
3 amp 1 1/4 Fuses	2p	with Reg 25kV Tripler 5 Diode	£1.50	2200/35		15p	TCE527		20p
Long Wires		EHT S.Stick 18 or 20KW Triplers (ITT)	£1.50 new	2000+2000/35		25p	TCE340		20p
300 Mixed Carbon Film Resistors		3 amp Diodes approx. voltage 1200	7p	2500+2500/63V		50p	TCE157		20p
5 of each type 1/4 Watt		3500 6 push button units for Thorn 3500 Varicap tuning	£1.00	4700/25		25p	Y716		20p
1R to 2 Meg - ITT	£1.50	Varicap F.M. Tuner		4700/30		35p	SN76226		50p
Red & Green L.E.D.s mixed large and small	14 for £1.00	Tuning range 78.5 to 108MHz (I.F. Panel with circuit)	£2.00	4700/40		50p	BD253		£1.00
Convergence Panel for GEC 2040 11 pots 5 coils		6 position 12.5K V/Resistor Unit for Varicap	50p	1250/50		10p	BY190		50p
2-Resistors E.T.C. New	£1.50	Thorn Mains Lead & ON/OFF switch & Control Panel with Slider Pots	75p	33/350		6p	Plug and Sockets 3 & 6 Pin Printed Circuit Type	pair	10p
(Reject Varicap Units)		TBA 120A	30p	100/63		8p	<b>FRONT END FOR MUSIC CENTER</b>		
ELC1042/ELC1043	50p	TBA 120B	30p	10/350		8p	VHF/M.W./L.W. Size 13" x 3 1/4"		
ELC2000	£1.00	TIP 161NPN	50p	47/50		5p	4 Push Button, Unit 7 Transistors, V/Condenser, 10 Coils, Rod Aerial, I.C. Decoder CA758E. (No Power Supply and O/P Stage).		
10 Watt LP1173	£1.00	EHT Lead & Anode Cap	75p	Bush Rank 6 push button unit for V/cap		£2.50	Circuit Supplied	£6.00 (New)	
IF LP1170	50p	GEC I.F. Panel 2110	£7.50 New	1000+2000m/35V		25p	TCA830S		£1.00
AM/FM T/Unit (Seconds)	50p	.01MFD 600V	5p	TBA 520		£1.00	.05/100		3p
AT1025/08 Blue Lateral Tip P31 A/B	15p	.01MFD 1000V	8p	.47/100V		5p	4.7/50V		5p
10 Watt Mullard Amps New	£2.00	.0047/500V	8p	TCA 275Q		£1.00	4/350		5p
BD 207	30p	.0022 1500V	8p	CA 270		75p	1000/25		10p
TIP 31 or TIP 31A	20p	.47 250 A/C	8p	TBA 720A		£1.50	4.7/100		6p
TIP 2955	50p	.47 1000V	35p	TBA 510Q		£1.50	2.2/100		6p
2N3583 250V/1A Output Transistor	40p	.047 1000V	8p	SN76115N		50p	1000/10		5p
BY190 (MJE2021) (SJE5451) NPN 80V/5A	40p	.22/250AC	8p	TAA 700		£2.00	8/350		5p
(661 pair 80W/5A pair 28p)		1500/100V	25p	TAA570		£1.50	1/250		5p
(660 90V)		10/500V	15p	TBA 396		£1.00	1/100		5p
40V 2A O.P. Trans		330/25V	5p	SAS 570S		£1.50	6MHz Filters		25p
B0375/6 pair	20p	680/40V	8p	SN76666		£1.00	3300/40		15p
BZV 15/12R PYE	30p	22/350V	7p	SN76660		50p	3300/25		5p
BD228	25p	330/100V	10p	SN76544N		75p	1500/25		10p
BD238	25p	15/450V	10p	TBA641BX1		£1.50	1/350		5p
MJE 1661	25p	47/450V	12p	CA920 AW		£1.00	220/10		5p
XTALS T/V		470/16V	8p	TBA 750		£1.00	680/100		10p
4.433.610KHz	50p	470/25V	8p	TAA 550		20p	220/16		5p
BYX 38/600R	50p	470/40V	10p	SN76131N		50p	47/63		5p
BT138 Triacs 10a/600V	65p	470/63V	15p	SN76001		£1.00	33/63		5p
RCA40506 Thyristors	50p	470/100V	15p	TBA560CQ		£1.00	2.2/63		5p
MJE 2955/15A	50p	220/25V	6p	SN76530P		50p	22/100		8p
TIP 41A-42 pair	40p	220/40V	6p	SN76650N		50p	4.7/63		5p
G11 Phillips Thyristors	60p	220/63V	10p	TDA1170		85p	1000/40		10p
PYE Thyristors	85p	160/25V	5p	TBA 651		75p	100/450		30p
2N4444-0T112 BT116		330/16V	5p	BTT822		£1.50	22M 350V		20p
SP8385 Thorn	25p	100/16V	5p	BTT8224		£1.50	33.000		20p
5 amp 300V Thyristors	25p	2.2/160V	5p	22/40		5p	PUA758PC		£1.00
BRC 4443	65p	10/40V	5p	1500/40		10p	MC1349P		50p
SCR 957	65p	TBA 920	£1.00	.005/1500V		5p	TCEP100		£1.00
BD561-2 pair	30p	TBA 920Q	£1.50	47/100V		8p	TCE120CQ		£1.00
BC365	10p	TBA 480Q	£1.00	BU124 Portable T/V Line Scan Trans.		50p	22/100V		5p
BD 131	25p	5 x 3 Speaker 80R or 50R	50p	UHF Aerial Socket and Leads		35p	100/350V		20p
BD183 PYE FRAME O/P	50p	G9 Speakers 70R	£1.00	PYE, ITT & THORN		35p	.47/250V		8p
AC187-8K pair	40p	TBA 625	£1.00	BD386		30p	10/350		10p
6 Way Ribbon Cable	20p per meter	TBA 550Q	£1.50						
210PF/8KV	10p	TBA 540	£1.00						
330PF/8KV	10p	TBA 5400	£1.00						
4.7NF5KV	10p	TBA 530Q	£1.00						
6200PF/2000V	10p	TBA 990	£1.00						
180PF/6KV	10p	SBA 550B	£1.50						
1000PF/10KV	10p	SN76003	£1.00						
1000PF/12KV	10p	No Heat Sink							
1200PF/12KV	10p	SN 76003N	£1.75						
270PF/8KV	10p	SN 76023N	£1.50						
160PF/8KV	10p	SN 76033	£1.50						
.1MFD 400V	5p	TBA 800	60p						
.1MFD 800V	8p	TBA 810S	£1.00						
.1MFD 2000V	15p	TCA 270	£1.00						
		TCA 270Q	£1.00						
		DE Solder Pumps	£4.00						

# SENDZ COMPONENTS

2 WOODGRANGE CLOSE,  
THORPE BAY, ESSEX  
Reg. Office Only.

Callers by appointment only.

Add 15% VAT.

Add 30p P. & P.

Add postage for all overseas parcels.

New Circuit Supplied G.E.C. VHF/UHF 8 C.H. Tuch. Tune Units 4 I/C 1 SN29862N, 2 CBF16848N 1 SN16861NG <b>£5.00</b> 100 mixed 20mm Fuses <b>£2.00</b>	Belling Lee CO AX Plug Non Solder Type <b>14p</b> AU113 <b>£1.00</b> BU 205 <b>£1.00</b> BU 108 <b>£1.00</b> BU 208 <b>£1.00</b> BU 500 <b>£1.00</b> BU 126 <b>£1.00</b> R2008B <b>£1.00</b> R2010B <b>£1.00</b> BU208/02 <b>£1.00</b> BU208A <b>£1.00</b> EHT Rectifier BY212 <b>10p</b> 3 OFF G770/HU37 EHT <b>10p</b> 12KV ? M/A Small <b>20p</b> EHT RECS 12KV 2 M/A Large <b>30p</b> EHT RECS EHT REC USED IN THORN 1400.1500 Triplers (x80/150) <b>10p</b> CSD 118xMH Rec THORN 3500 <b>10p</b> 220M/450V THORN <b>50p</b> 700M/250V THORN <b>35p</b> 175+100+100 350V 3500 THORN <b>£1.50</b> 400+400.350V DECCA <b>80p</b> 470+470.250V <b>40p</b> 100+200 325V <b>40p</b> 200+200+100+32 350V <b>70p</b> 150+200+200.300V <b>70p</b> 200+200+100 325V <b>60p</b> 731 PYE 600/300V & BUSH <b>75p each</b> 200+200 350V <b>60p</b> 400M 400V <b>40p</b> 400M 350V <b>50p</b> 800M 250V <b>30p</b> AE Power supplys 15V <b>£1.00</b> BF 127 BC 303 BF 264 BRC 2108 BF 180 BC 336 BF 181 BF 157 BF 182 BC 161 BC 300 BC 460 AC 128 BC 350 BC 350 E1222 BF 178 BSY95A BF 257 BFT 43 BF 137 with heat sink BF 185 TIP 29A BF 200 TIP 32 AC 153K <b>20p each</b> GEC Sound O.P. Panel L.C. O.P. <b>£2.50</b> AC 176K AC 153K  Pair <b>40p</b> UHF Varicap Units+VHF NEW ELC 1043/05 <b>£4.00</b> ELC 1043/06 <b>£4.00</b> THORN Varicap UHF 3.500 <b>£3.50</b> New EQV ELC 1043/05 DECCA UHF Varicap New eqv EIC 1043/05 <b>£4.00</b> VHF/UHF AEG Varicap (New) <b>£3.50</b> G8 PHILLIPS <b>£3.50</b> UHF Varicap replacement	NEW VHF/UHF on panel ELC2060 <b>£4.50</b> Phillips T/Units UHF New <b>£2.00</b> New Circuit Supplied UHF 8 C.H. Light action unit 4 I/C for V/cap tuning G.E.C. <b>£5.00</b> VHF Varicap Units NSF AEG removed from Print Panels <b>£1.00</b> New 49.00 21.900MHz VHF Varicap (NSF) AEG New 49.00 21.900MHz <b>£2.00</b> 4 Push Button T/Units UHF MULLARD <b>£2.00</b> AE Isolating Sockets UHF & Lead PYE & THORN ITT <b>35p</b> DECCA 1730 Doubler <b>£1.00</b> Transistor UHF Units with AE Socket and leads GEC 2000 Rotary type NEW <b>£2.00</b> 7 button Varicap tuning heads Variable Resistor with Fascia Plate 7 Lamps G.E.C. <b>£3.00</b> PYE 6 push button unit for Varicap Tuning <b>£2.50</b> 6 Push Button VHF/UHF units for V/cap <b>£2.50</b> New N.S.F. UHF/VHF V/cap units <b>£3.50</b> G.E.C. 6 Push Button UHF for V-cap tuning <b>£2.50</b> 4 push button unit (for Varicap Tuning) 20K New <b>50p</b> DECCA Bradford Tuner 5 Button New <b>£2.75</b> BB 105 UHF BB 103 VHF BA 182 Varicap diodes <b>5p each</b> BTY80 <b>20p</b> 3 amp Diodes 300V <b>10p</b> 3 amp Diodes 100V <b>7p</b> 1 amp Bridges 100V <b>20p</b> 1 amp 400V <b>20p</b> 3 amp Bridge <b>25p</b> W005M Bridge <b>15p</b> 194-N30 Replacement for BU204 <b>75p</b> 121-1015 Replacement for BU208A <b>£1.00</b>	BY296 <b>10p</b> BY299 <b>10p</b> BY 206 <b>7p</b> MR501 3 amps/100V <b>7p</b> MR508 3 amps/800V <b>12p</b> IN4006 <b>5p</b> IN4007 <b>5p</b> BY210/400 <b>5p</b> BY210/800 <b>10p</b> BY176 <b>50p</b> BY133 <b>10p</b> BA159 <b>10p</b> BY184 <b>25p</b> BY187 <b>50p</b> TV 20 <b>50p</b> TV 18 EHT <b>40p</b> Rectifiers Sticks & lead & Anode Cap BYF3214 20KV Rectifier Sticks <b>25p each</b> BYF3123 18KV Wire ends <b>25p</b> BA 248 <b>6p</b> BSS 68 <b>20p</b> BYX55/350 <b>10p</b> BT106 S/Type <b>50p</b> BT 106 <b>95p</b> BT 116 <b>95p</b> BT 119 <b>95p</b> BT 109 <b>70p</b> BT 146 750V <b>25p</b> Thyristors 8A/800V 2N6399A <b>30p</b> Thyristors 8A/400V 52600D <b>30p</b> Y827 Diodes <b>30p</b> Bridge Rec B30C 600A6 <b>12p</b> B30C 500 <b>12p</b> BC147C 2N3566 BC148B BF198 BC149C BF274 BC195 BSY79 BC108 BC327 BC107 BC213LA BF594 BC212LT BC158 BF195 2N2222 BC182L 2N390 BF594 2N4355 BC183 T1591 BC238A 2SK30A BC454 BC455 <b>7p each</b> TIS90 <b>15p</b> 200+200+100 325V <b>70p</b> BY 127 <b>10p</b> IN4005 <b>4p</b>
---	--	--	---

# SENDZ COMPONENTS

2 WOODGRANGE CLOSE,  
THORPE BAY, ESSEX

Reg. Office Only.

Callers by appointment only.

Add 15% VAT.

Add 30p P. & P.

Add postage for all overseas parcels.