

TELEVISION

25p

SERVICING · CONSTRUCTION · COLOUR · DEVELOPMENTS

OCTOBER
1974

EXTRA

FULL COLOUR FEATURE

GETTING THE MOST FROM THE TEST CARD

digital touch tuner unit



Also:

SOLID-STATE
(CHARGE-COUPLED) VIDEO

SERVICING THE
ITT VC100 CHASSIS

LOGIC LEISURE LTD

build Your
own t.v.
game

COMPLETE KIT AVAILABLE
OR P/C BOARD ONLY

FIRST TIME AVAILABLE, THE REAL T.V. GAME IN KIT FORM AS SUPPLIED TO THE AMUSEMENT TRADE WITH FIVE BAT ANGLES, FULLY AUTOMATIC BALL, DIGITAL SCORE READ OUT ON SCREEN AND ALSO SIMULATED SOUND.
PLEASE SEND STAMPED ADDRESSED ENVELOPE FOR DETAILS AND PRICES TO:-

LOGIC LEISURE LIMITED, KINGFISHER HOUSE, 68 PARK ROAD, NEW BARNET, HERTS.
TELEPHONE: 01 - 440 - 9173/4 TELEX: 264397

THE MARK TWO GENERATOR



This is our Mark Two, vastly improved Cross Hatch Generator

- * With plug in I.C.'s and a more sensitive sync. pick-up circuit.
- * Virtually unbreakable—designed with the engineers tool-box in mind. Size 3" x 5¼" x 3".
- * Supplied to large T.V. Rental companies for service engineers

Ready built unit only **£10.92**

Kit only **£8.72**

Above prices include V.A.T. and p. & p. but do not include batteries

BI-PRE-PAK LTD

Co Reg No 820919

Dept. G 222-224 WEST ROAD, WESTCLIFF-ON-SEA, ESSEX.
TELEPHONE: SOUTHEND (0702) 46344.

Please send me the NEW free BI-PRE-PAK Catalogue

Please send me complete ready built Mark Two Cross Hatch Generators

Please send me kits of Mark Two Cross Hatch Generators

I enclose cheque/P.O./M.O. for.....

Name

Address

T.V.'S TO THE TRADE

BBC 2 from £2.00

Others: G.E.C. 2000 from £6.00; 950's Mk. II and Mk. III £6.00; Baird 660's £5.00; Bush 141U £4.50; Style 70's £6.00; Baird P/B Tuner £9.00; Thorn 1400 P/Button & Rotary £12.00; Integrated, i.e. Pye, Ecko, Ferranti (Olympics, Europa, etc.)

Bush 170's, Philips 210 Series, etc. £12.50

To the Trade only we will undertake to supply all Spare Parts Free.

Discount for Quantity, deliveries anywhere in the country.

Colour: Bush-Murphy	19"—25"	} from £40.00
G.E.C.	19"—25"	
Decca	19"—25"	
Philips	25"	
Baird	25"	
Thorn	19"—25"	

Alberice 10p Slot Meters from £1.50

Please note that there is V.A.T on all items mentioned

MAIL ORDER SERVICE

(Stamped addressed envelopes appreciated for your queries)

T.V.'s Tested Working	19" at £8.50	} plus p & p £1.50
" Untested	19" at £4.00	
" Tested Working	23" at £10.50	
" Untested	23" at £5.00	

Tubes any 19" £3.00—23" £4.50 plus p & p £1.50

ALL TUBES IN GOOD WORKING ORDER

L.O.P.T.'s from £2.00 plus 50p

UHF Tuners P/Button at £3.00 plus p & p 50p

UHF Tuners Rotary at £2.00 plus p & p 50p

Integrated Tuners at £4.50 plus p & p 50p

Valves any at 12p plus p & p 5p. (Free p & p for orders of 10 or over)

Complete Working Panels for T.V.'s such as Philips Style 70's, Bush 141U, 170's

I.F. Panels for Integrated (Pye, Ecko, Olympic and Europa models)

Spares for colour, i.e. for Baird, Bush, Murphy, Decca, Philips G6. (includes Tubes (19" & 25"), Panels, Lopts, Tuners, etc.)

No connection whatsoever with any other company

TRADE DISTRIBUTORS (I.M.O.S.)

5 COMMERCIAL ST., HARROGATE

Tel. Harrogate (STD 0423) 3498



"I MADE IT MYSELF"

Imagine the thrill you'll feel! Imagine how impressed people will be when they're hearing a programme on a modern radio you made yourself.

Now! Learn the secrets of radio and electronics by building your own modern transistor radio!

Practical lessons teach you sooner than you would dream possible.

What a wonderful way to learn - and help qualify yourself for a new, better-paid career! No dreary ploughing through page after page of dull facts and figures. With this fascinating Technatron Course, you learn by building!

You build a modern Transistor Radio... a Burglar Alarm. You learn Radio and Electronics by doing actual projects you enjoy - making things with your own hands that you'll be proud to own! No wonder it's so fast and easy to learn this way. Because learning becomes a hobby! And what a profitable hobby. Because opportunities in the field of Radio and Electronics are growing faster than they can find people to fill the jobs!

No mathematics, no soldering - yet you learn faster than you ever dreamed possible.

Yes! Faster than you can imagine, you pick up the technical know how you need. Specially prepared step-by-step lessons show you how to: read circuits - assemble components - build things - experiment. You enjoy every minute of it!

You get everything you need. Tools. Components. Even a versatile Multimeter that we teach you how to use. All included in the course AT NO EXTRA CHARGE! And this is a course anyone can afford. You can even pay for it in easy payments - in fact you could make extra cash from spare-time work when you've turned yourself into a qualified man through B.I.E.T. training.

So fast, so easy, this personalised course will teach you even if you don't know a thing today!

No matter how little you know now, no matter what your background or education, we'll teach you. Step by step, in simple easy-to-understand language, you pick up the secrets of radio and electronics.

You become a man who makes things, not just another of the millions who don't understand. And you could pave the way to a great new career, to add to the thrill and pride you receive when you look at what you have achieved. Within weeks you could hold in your hand your own powerful radio. And after the course you can go on to acquire high-powered technical qualifications, because B.I.E.T.'s famous courses go right up to City & Guilds levels.

Send now for FREE 76 page book - see how easy it is - read what others say!

Find out more now! This is the gateway to a thrilling new career, or a wonderful hobby you'll enjoy for years. Send the coupon now. There's no obligation.

POST TODAY FOR FREE BOOK



To: **BRITISH INSTITUTE OF ENGINEERING TECHNOLOGY**
Aldermaston Court, Reading RG7 4PF

BTV 85
QH

Yes, I'd like to know more about your course. Please send me free details—plus your big, 76-page book that tells about all your courses.

NAME _____

ADDRESS _____



BIET

BRITISH INSTITUTE OF ENGINEERING TECHNOLOGY

Heathkit televisions begin as they mean to go on.

At Heathkit we go to great lengths to make sure that the kits we produce represent the ultimate in quality and reliability.

And, in order to achieve that end, every kit has to be right. Right from the beginning.

Our GR-9900 black and white television is no exception. It has a factory pre-assembled and aligned UHF tuning unit which gives you low cross modulation, no overload on strong signals and sensitivity which is much higher than most.

It also has exceptionally good frequency stability. And the use of four highly advanced integrated circuits ensure performance and reliability second to none.

We haven't forsaken looks either. The GR-9900 comes in a beautifully finished white cabinet that would look good anywhere.

At home, or in the caravan or boat. (The GR-9900 can be operated

from the mains or a 12V battery.)

For more details and a free Heathkit catalogue showing the rest of our wide range of kits, just post the coupon.

Or call into the London Heathkit Centre, 233 Tottenham Court Road, or our showroom in Bristol Road, Gloucester.

And we'll show you exactly what the end result of a Heathkit television kit looks like.

Heath (Gloucester) Limited,
Dept. TV-104, Bristol Road,
Gloucester, GL2 6EE. Telephone:
Gloucester (0452) 29451.

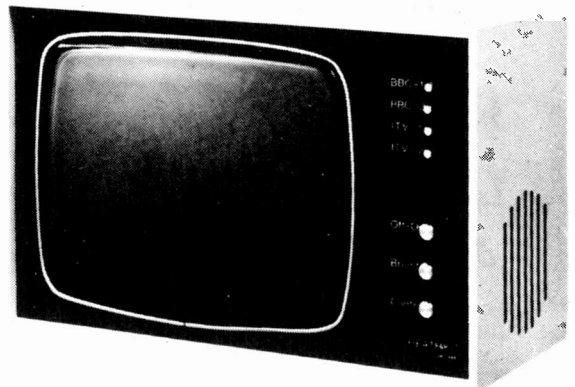

To: Heath (Gloucester) Limited, Dept. TV-104, Gloucester, GL2 6EE.
Please send me my free Heathkit catalogue.

Name _____

Address _____

Remember easy terms are available with the Heathkit Monthly Budget Plan

HEATH
Schlumberger

TELEVISION

SERVICING · CONSTRUCTION · COLOUR · DEVELOPMENTS

VOL 24 No 12
ISSUE 288

OCTOBER 1974

THE ANNAN COMMITTEE

By the time this issue is on sale the Committee of Enquiry into the Future of Broadcasting, under the chairmanship of Lord Annan, will have become deeply involved in their task of collecting and studying information, opinion, and evidence from a wide variety of sources. At the press conference held at the start of this enquiry we asked Lord Annan about the enquiry's technical aspects, feeling that in spite of his assurances on the degree of technical representation on the Committee there was apparently little room for skilled and experienced television engineers' views or advice on the future planning of both television and the sound broadcasting services being given sufficient weight. The first technical matter that looks as if it will be in the Committee's thoughts is cable television, probably because of its growth on the continent where it seems to be more successful than in the UK.

On other technical matters the Committee is openly inviting considered comment. In reply to our question about the allocation of a fourth television channel Lord Annan hinted that such a decision may be postponed until after the Committee has reported to the Government by early 1977, though he was quick to add that the Government of the day would be free to ignore any recommendations and to make a decision at any time it chooses.

So it seems that the UK television service must continue for a while as it is at present. From the list of members it would appear that the Committee will be mainly concerned with the programme side of television and radio. Lord Annan said that technical matters would be considered by Professor G. D. Sims, Head of Electronics at the University of Southampton, and Mr. Tom Jackson, General Secretary of the Union of Post Office Workers and a former Governor of the BBC.

Whilst some may question the reasons for selecting individual members of the enquiry the important point is the effectiveness of the Committee as a whole. This in turn depends on representations being made to it by individuals and groups. Lord Annan has suggested that he would be keen to hear from readers of Television, whether writing as viewers, constructors, designers, planning or service engineers, giving any constructive comments or suggestions on any aspect of broadcasting in the UK. The address to write to is: The Committee of Enquiry into the Future of Broadcasting, Waterloo Bridge House, Waterloo Road, London SE1 8UA.

THIS MONTH

Teletopics	536
Digital Touch Tuner	<i>by A. Willcox</i> 538
Modern TV Power Supply Circuits, Part 2	<i>by E. J. Hoare</i> 541
Some Foreigners—Faults in Imported Colour Receivers	<i>by Dewi James</i> 544
Colour CRT Replacement Guide	546
Letters	547
Solid-State Video—Image Sensing Using CCD Technology	<i>by I. R. Sinclair</i> 548
Special Supplement—Using Test Card F	
Servicing Television Receivers—KB-ITT VC100 Chassis	<i>by L. Lawry-Johns</i> 553
Closed Circuit Television, Part 7, Sync Pulse Generators	<i>by Peter Graves</i> 556
TV Football and Other Games, Part 4	<i>by P. Busby, B.Sc.</i> 560
Long-Distance Television	<i>by Roger Bunney</i> 565
Your Problems Solved	568
Test Case 142	571

THE NEXT ISSUE DATED NOVEMBER IS
DUE FOR PUBLICATION ON OCTOBER 21

TELETOPICS



FUTURE OF BROADCASTING

The Committee of Inquiry into the Future of Broadcasting (Chairman Lord Annan) is now meeting to receive and consider evidence on radio and TV broadcasting in the UK. The Committee is to consider the future of the broadcasting services (including cable distribution services), also the implications of possible additional services and new techniques, and to make proposals on the constitutional, organisational and financial arrangements and the conditions applying to the conduct of services. The Committee is expected to take about two and a half years to report and a further similar period of time is likely to be needed for considering the Committee's recommendations and framing any new legislation that may be decided upon. The IBA Act and BBC Charter have been extended to cover this period and the licences of the experimental local cable TV operations are also to be extended. The Government is understood to be considering setting up an additional experimental cable TV operation run on a public service basis, possibly at Milton Keynes. This would be run by trustees appointed by the community and would use funds raised from non-commercial sources.

THE TeD VIDEODISC

There have been indications that an updated version of the Teldec (Telefunken/Decca) videodisc system is to go into production shortly. Various versions of this have been described in these pages before (see December 1971 pages 68-71 for example) and readers may recall that the signal is recorded as frequency modulation in the form of vertical undulations in the groove

in a flexible disc and that a pressure-sensitive pickup mounted at a fixed height is used to scan the disc which is maintained in contact with the pickup by air pressure from beneath. As with the Philips VLP disc the system is for playback only and is fully colour capable. The TeD disc has a playing time of ten minutes but a magazine system is being developed to give over an hour's playing time without a break. The groove concentration is 280 to the millimetre and the playing speed 1,500 r.p.m. (1,800 r.p.m. in the case of 525-line, 60Hz television systems).

Because of the inevitably restricted bandwidth (< 3MHz) standard PAL (or NTSC) encoding cannot be used. Instead a system called 3-PAL has been developed and an advantage claimed for this is that it is very tolerant of timing errors. In addition to the sound and luminance (Y) signals, three primary-colour signals are recorded in sequence line by line in the band below 0.5MHz. The basic replay signal processing is shown in Fig. 1. The pickup provides a composite vision plus sound signal of about 20mV amplitude. The sound signal is separated by means of a bandpass filter while the video signal channel has a high-pass filter at its input. After demodulation and amplification the h.f. component of the video (Y) signal is separated by means of a high-pass filter and fed to the adder. A low-pass filter separates the l.f. video signals and feeds them to the l.f. Y matrix and to the 3-PAL switch. Since the three colour signals are recorded sequentially line by line two line duration (64µS) delay lines are used to make them available to the l.f. Y matrix and the 3-PAL switch simultaneously. The Y matrix delivers the l.f. component of the luminance signal to the adder while the 3-PAL switch delivers simultaneous R, G, B signals to the colour-difference signal

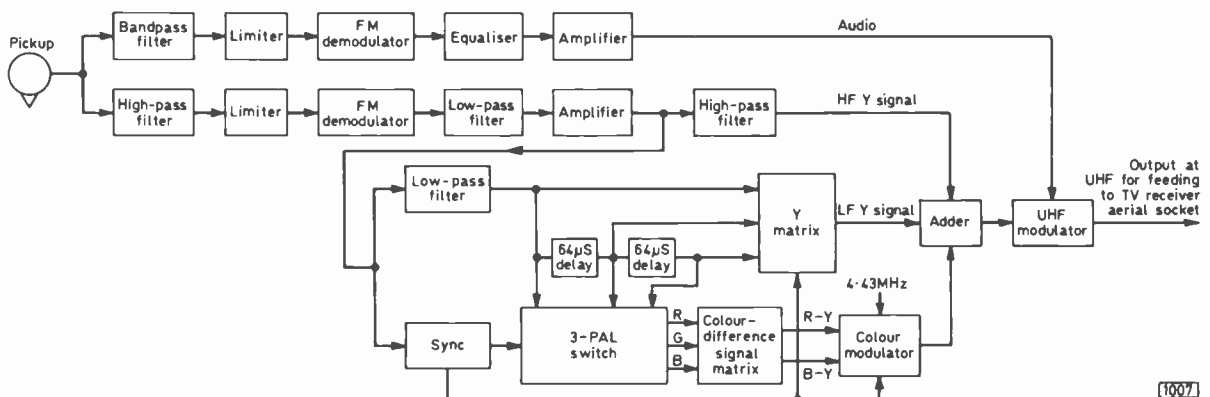

Fig. 1: Block diagram of a TeD videodisc player

matrix which produces standard R-Y and B-Y colour-difference signals. These are fed to the colour modulator where they are imposed in quadrature on a 4.43MHz subcarrier. The output from this is fed to the adder which thus assembles a video signal of the standard PAL form. This together with the sound signal is modulated on to a u.h.f. channel to provide a signal which can be fed to the aerial socket of a colour receiver. Separating the h.f. and l.f. components of the video signal and carrying out the matrixing processes at l.f. ensures that the picture detail is preserved.

To improve the quality of the recorded signals recording is done at a fraction of the playback speed—at 60 r.p.m. instead of 1,500 r.p.m. This involves the use of special equipment to provide high-quality, low-speed signals. The video signals are provided by a telecine machine developed for the purpose by Rank Cintel.

The TeD system has always been a relatively simple and potentially inexpensive method of providing video recordings for replaying in the home. There is unlikely to be room for more than one videodisc system alongside the various videotape systems however. It is much too early at present to be able to predict whether the TeD or VLP system will eventually be adopted for the mass consumer market. Quite likely they will both be launched to see which or whether either has a market.

RECOMMENDED SERVICE CHARGES

The RTRA has revised its recommended minimum service charges as follows: for a call within a radius of 5-6 miles £3.50; minimum charge for repair or estimate (whether accepted or not) £3; workshop charge £4 up to one hour, £3.50 for each subsequent hour. Collection and delivery charges may be additional.

OPTOELECTRONIC SIGNAL COUPLING

We wrote last month mentioning the use of optoelectronic couplers to feed video signals safely—since they provide mains isolation—into and out of TV receivers and have since learnt that Mullard have developed an optoelectronic coupler, together with the necessary associated circuitry, to feed a composite PAL video plus intercarrier sound signal into a TV set. The coupler itself consists of a light-emitting diode which converts the signal to a modulated light output and a photodiode or phototransistor which detects this light signal and converts it back to an electronic waveform. The light-emitting diode requires a driver stage at its input and the supply for this is obtained from the mains via a floating power supply circuit. The photodiode output is amplified, clamped and fed to the receiver's video and sound circuits. The generation of light by a light-emitting diode results from electron-hole recombination and is consequently a fast process—in fact a light-emitting diode can be modulated at frequencies up to several MHz.

SYNC GENERATOR IC

Ferranti's Electronic Components Division now has in production a digital TV sync pulse generator which uses the company's collector diffusion isolation (c.d.i.) semiconductor technology. The device—type number ZNA103E—is driven by a 5V signal at 656.25kHz from a crystal oscillator and produces from this all the

line, field, composite, blanking and sync pulses required for 625-line raster generation. Its operating temperature range makes it suitable for military and industrial use as well as for normal television applications. In addition to the standard outputs (composite video blanking, composite cathode blanking, line drive and "clamping" signals, field drive and composite sync) there are two 32µs pulse outputs synchronous with field outputs one and two and two outputs at the line and field frequencies respectively. The device—an example of large-scale integration—is fully compatible with TTL logic. If the price is right it could help towards inexpensive high-quality CCTV.

PCB UHF TUNERS

Two u.h.f. tuners, Models MTS925 and MTS926, using printed circuit design instead of coaxial cavities or strip lines have been introduced by GTE Sylvania NV (Belgium). They are believed to be the first tuners of this type to be manufactured in Europe and are intended for use in colour sets. Since the tuners are plug-in types they can be easily replaced without need to unsolder any connections. Good overall noise performance is claimed and the tuners are said to be the first such units to have a nearly true resistive output impedance. They can be used in conjunction with touch-sensitive control systems.

PHILIPS CCTV CAMERA

Philips have introduced a hand-held TV camera for CCTV use including operation in conjunction with their VCR. The camera, type LDH8300, is being marketed by Pye Business Communications and is priced at £300 plus VAT. It can be operated from the mains or a 12V battery and comes complete with a 6:1 zoom lens, incorporating a reflex-coupled viewfinder, modulator, power supply unit and microphone. Philips say that no special skills are required to use the camera successfully.

A774 CHASSIS MODIFICATIONS

Rank Radio International (Bush/Murphy) report the following modifications to their A774 chassis which was covered in our *Servicing Television Receivers* series in the April and May issues 1973. To improve the a.g.c. action a 1µF tantalum capacitor has been added between the collector and base of the a.g.c. amplifier transistor 3VT2 (positive connection to 3VT2 collector). The capacitor can be fitted to the print side of the panel. As more sensitive deflection coils are used on later production receivers the value of the resistor (3R58) in series with the slider of the line stabilisation control (3R62) has been increased from 3.3MΩ to 4.7MΩ in order to maintain the width adjustment.

NEW RELAY SERVICES

The following relay transmitters are now in operation: **Llangeinor** (South Wales) ITV channel 59 carrying HTV Wales programmes. **Luton** (Bedfordshire) ITV channel 59 carrying Anglia programmes. **Peterhead** (NE Scotland) ITV channel 59 carrying Grampian programmes.

Vertically mounted group C/D receiving aerials are required for reception from these three stations.

digital touch tuner

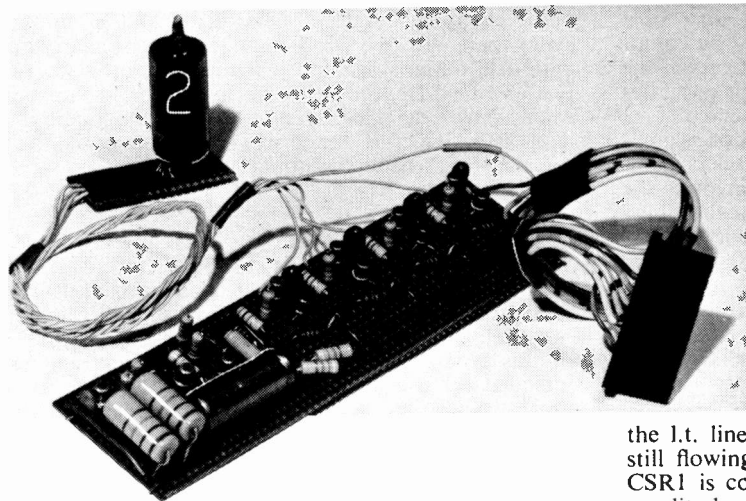

A.WILLCOX

THIS article describes a solid-state digital touch tuner which can be incorporated in a TV set already fitted with a varicap tuner or used together with a varicap tuner to convert a set with a mechanical tuner to electronic operation.

Repeated operations of the single touch switch result in the tuner switching sequentially through the channels, the channel number being displayed on the numericator tube. In this respect the unit differs from existing commercial touch tuner circuits that make use of a separate set of touch contacts for each station, a feature which involves complications if the addition of remote control—either by direct or by ultrasonic link—is required.

The heart of the unit is a shift register composed of silicon controlled switches. The use of these devices enables the numericator tube to be switched directly, thus avoiding the use of relays or high-voltage transistors. The method of switching the tuner control voltage from the tuning potentiometers eliminates the temperature drift problems normally associated with solid-state switching. The complete circuit is shown in Fig. 1.

Circuit Operation

A 12V supply for the shift register is provided by R26 and zener diode Z1. Upon switching on CSR1 conducts because its cathode gate is connected to the 12V supply via R10. When CSR1 is in the conducting state all its connections are at near to earth potential and due to the nature of the device this is a stable condition. Digit 1 in the indicator tube strikes and Tr1 is biased to cut off.

This state of affairs continues until the touch circuit is operated whereupon the common line to the SCSs is "shorted" out for a brief instant due to C2 charging. The voltage on this common line is thus reduced below the level required to maintain CSR1 in conduction. It promptly switches off therefore, a positive pulse appearing at its anode gate. This pulse is transferred to the cathode gate of CSR2 by C4.

CSR2 is now switched on (selecting station 2) because

the l.t. line returns to 12V while charging current is still flowing in the coupling capacitor C4. Although CSR1 is connected to the 12V rail by R10 the large amplitude pulse through C4 "wins" and CSR2 turns on: once it is on the other SCSs are prevented from turning on because the 12V line is brought down to earth potential in the process. At this time Tr1 is switched on hard by a positive voltage picked up on cathode 1 of the tube and applied to its base via R15. Tr2 is switched off because its base is returned to chassis via CSR2 which is now conducting. Thus successive operations of the touch circuit cause each SCS to conduct in turn down the line; when the last SCS turns off the pulse at its anode gate is fed back to the first SCS via C3, turning it on.

It is clear that three of the transistors Tr1-Tr4 are conducting, the exception being the one associated with

★ components list

Resistors:

R1	15M Ω 1W	R10	33k Ω
R2	15M Ω 1W	R11-14	3.9k Ω
R3	470k Ω	R15-19	1M Ω
R4	470k Ω	R20-23	33k Ω
R5	100k Ω	R24-25	47k Ω (300V HT)
R6	270 Ω		33k Ω (250V HT)
R7	10k Ω		22k Ω (200V HT)
R8	2.2k Ω	R26	30k Ω 5W or
R9	220k Ω		two 15k Ω 2W

All $\frac{1}{2}$ W unless otherwise shown

Capacitors:

C1	0.01 μ F 15V	C3-6	100pF ceramic
C2	0.047 μ F 15V	C7	10 μ F 250V

Semiconductors:

CSR1-4	BRY39
D1-5	1SJ50, OA200 etc.
Tr 1-8	BC107
Z1	12V 400mW zener

Miscellaneous

V1	ZM1080 (Mullard) or RS number valve
Veroboard	6.3 x 1.7 in., 0.1 in. matrix

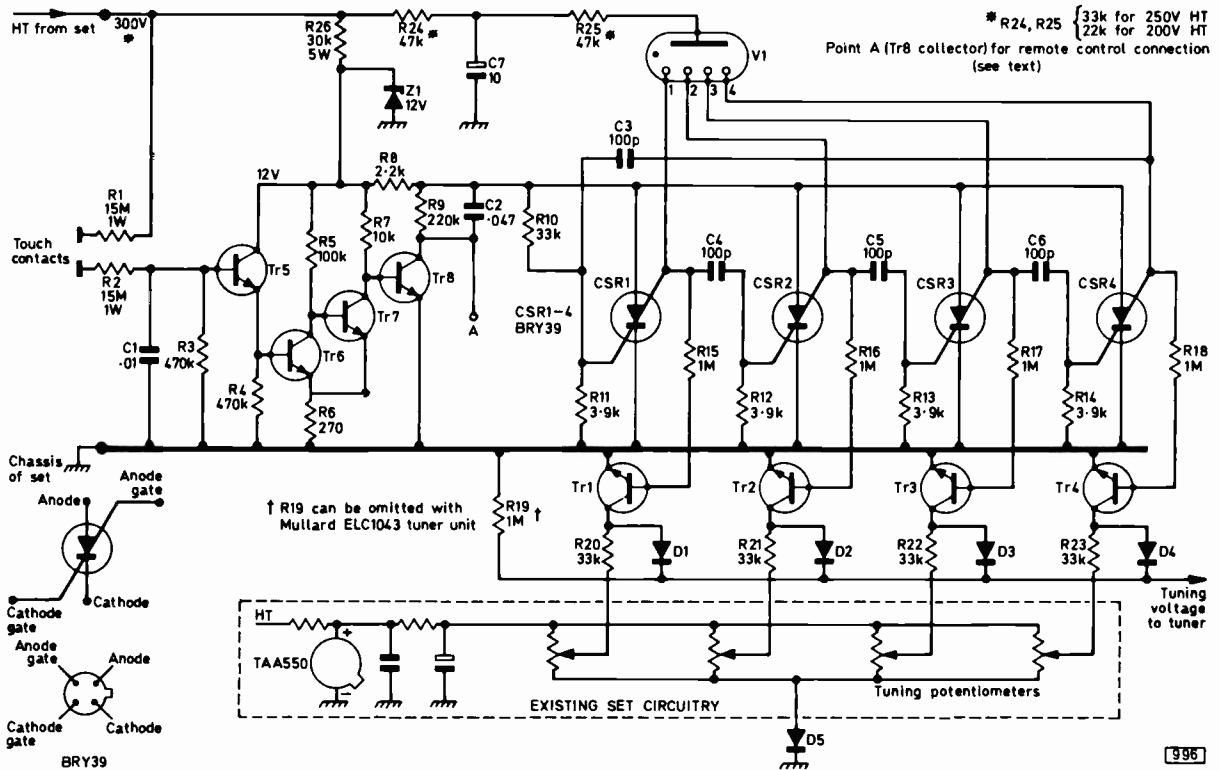

Fig. 1: Circuit diagram of the digital touch tuner unit.

the conducting SCS. Thus the voltages at the sliders of the unwanted tuning potentiometers are bypassed to chassis by the respective transistors.

Diodes D1 to D4 isolate the potentiometers from one another. All are reverse biased except the one connected to the turned off transistor. Thus the required tuning potential is passed via this diode to the line to the tuner unit.

R24 and C7 in the h.t. supply ensure that the circuit turns on slowly from switch on, avoiding spurious triggering of the SCS.

It will be seen that a diode has to be inserted in the common earth lead of the tuning potentiometers. The reason for this is that a small voltage is subtracted from the tuning voltage by whichever of the gating diodes D1 to D4 is in circuit, and this voltage will vary with temperature. A similar voltage is added to the tuning voltage by D5, temperature stability thus being achieved.

If a varicap tuner is already fitted to the TV set you will find that there is usually a resistance in circuit between the 33V stabilizer and the tuning controls. If this resistance is of a high value it must be replaced by one of 100Ω or so. If this is not done there will be some interaction between the potentiometers. This is because the unused channels are clamped down by transistors Tr1 to Tr4 and the voltage on the common line would vary with the positions of each potentiometer, making initial tuning a difficult operation.

Touch Circuit

When the touch contacts are bridged by the body resistance a small current is allowed to flow. This current is amplified by Tr5 and is sufficient to saturate

Tr6, thereby removing the bias from Tr7 which thus turns off. Tr8, which was previously turned off by Tr7, now conducts and allows C2 to charge, providing the temporary short across the 12V line. R6 provides feedback which ensures that the circuit switches rapidly.

The touch contact can consist of two pieces of brass mounted about 1/4 in. apart on a small piece of paxolin or some other efficient insulator. The high-value resistors R1 and R2 in the leads to the touch contacts are included for safety reasons and must not be left out. They are best mounted at the rear of the touch contacts. Good quality components must be used because of the safety factors involved.

Remote Control

The simplest form of remote control would consist of a pair of touch contacts on an extension lead wired in parallel with the touch contacts on the set.

If an ultrasonic transmitter and receiver are available

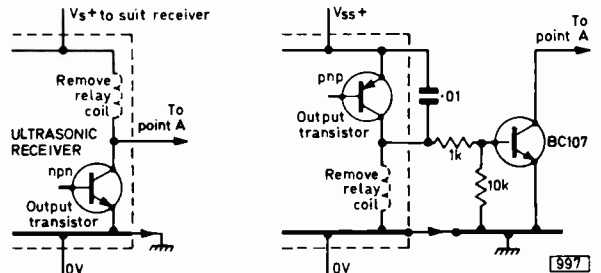

Figs. 2 and 3: Methods of adapting an ultrasonic receiver to operate with the digital touch tuner unit.

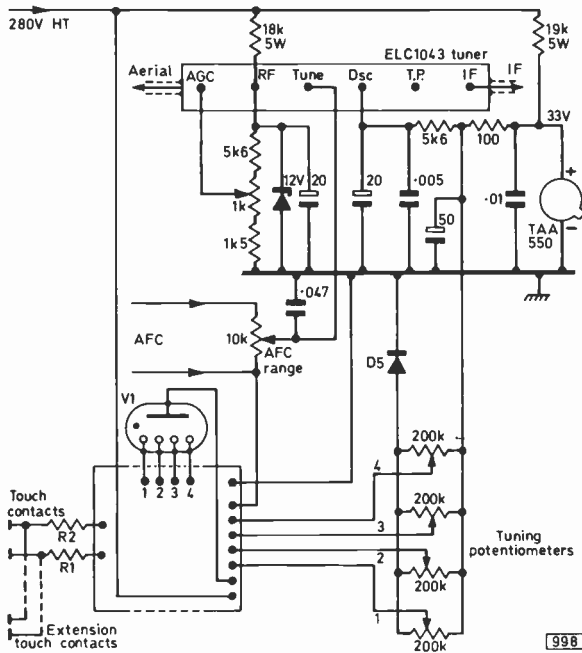

Fig. 4: The digital touch tuner unit installed with a varicap tuner, showing typical associated circuitry.

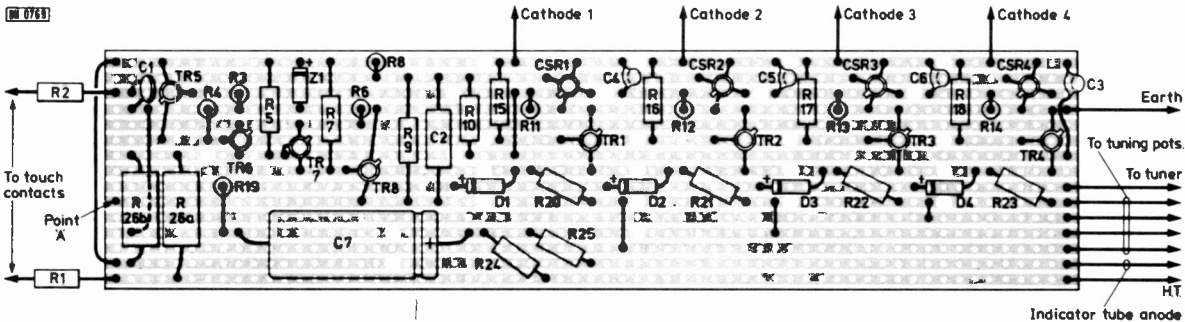

Fig. 5: Layout of the digital touch tuner unit on Veroboard. Note that R1 and R2 should be mounted off the board behind the touch contacts.

these can be used. The receiver supply cannot be taken from the 12V line because no smoothing can be introduced on this line. A separate feed via a suitable dropping resistor must be taken from the h.t. supply therefore. The receiver relay contacts should be connected between point A and chassis.

Alternatively the relay can be removed and the output taken from the collector of the final transistor to point A if the output switch is an npn device (Fig. 2) or via another transistor (Fig. 3) if it is a pnp device.

Components

The time-constant of R8, C2 has been chosen to suit the indicator tube characteristics and the value of the coupling capacitors C3-C6. If other tubes, or perhaps separate neon indicators, are used for a display device C1 might need to be changed in value. If it is too small the circuit will fail to switch from station 1, and if it is too large the circuit will appear to switch but 1 will

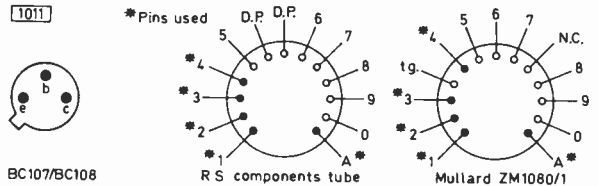

Fig. 6: Active device connection data—viewed from below.

remain illuminated along with partial illumination of some other digit.

Resistors R20 to R23 are included because it is possible at times for a potentiometer slider to be at the top of its travel. Thus when its associated transistor conducts the 33V line would be shorted out.

The circuit has proved very reliable in use, but the following precautionary measure must be observed. All construction should be properly completed and all wires to the receiver etc. soldered before testing. Failure to do this could be detrimental to the SCSs which are susceptible to damage by sparking, etc. caused by poor connections and shorting.

The indicator tube used in the prototype was the Mullard ZM1080 which is available on the surplus market mounted on a decade counter board for around 50p. Alternatively the RS components cold-cathode number tube would be suitable. Separate neon indicators could also be used but an additional resistor would have to be included in the common lead. The

value which gives correct operation varies with different neons: it would have to be found by experiment, and could be anything from 100kΩ to 800kΩ.

BC107 or BC108 transistors can be used for Tr5 to Tr8. BC107s are used for Tr1 to Tr4 because of their higher collector voltage rating.

AFC

If the unit is fitted to a colour TV receiver a.f.c. will probably be incorporated in the set. If the pull-in range is excessive it is possible that when changing channel the required station will fail to appear, being locked out by a.f.c. action. With a manual channel selector this effect is prevented by incorporating a switch in the push-button assembly to short out the a.f.c. until the button is released. The problem can be overcome with this circuit by including in the a.f.c. circuit a potentiometer (see Fig. 4) to reduce the range of the a.f.c. Some sets, such as those in the Bush/Murphy ranges, already have such a potentiometer in circuit.

MODERN TV POWER SUPPLY CIRCUITS

Part 2

E. J. Hoare

A wide range of stabilising circuits is available and they come in a bewildering variety of forms. Some circuit techniques can be engineered in many different ways, the differences being matters of detail rather than of basic principle and adopted in order to achieve particular compromises of cost and performance or certain engineering advantages. Sometimes the differences are fortuitous and depend upon how the designer happens to "see" the circuit: they may not produce any special improvements. When designing power supplies however it is essential to understand very clearly how the circuit works since in some cases it is possible to make substantial improvements in performance through very small but subtle changes.

In other instances differences are more apparent than real because poor layout of circuit diagrams has obscured the basic form of the circuit and made it look different when in fact there is nothing new about it at all. This point applies to many circuit diagrams of course but is perhaps rather more the case with power supplies than most other circuits. It is certainly a matter to be on your guard against.

Types of Stabilising Circuits

For TV purposes stabilised power supplies can be divided into four categories. First comes the series regulator. In this a high-power transistor is used as a variable h.t. dropper resistor. A control circuit inspects the h.t. voltage and adjusts the conduction of the transistor to maintain a constant voltage. Next come switch-mode power supplies—series or parallel circuits. The third category consists of thyristor controlled circuits which also have a switching action. Both these types of circuit need a detailed description. The last type of power supply is also a switch-mode type but in this case the switching of the incoming mains energy is coupled with the switching of the line time-base. There are two types beginning to gain acceptance, known as thyristor and Wessel circuits. They are not

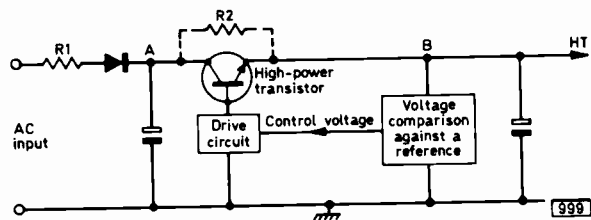

Fig. 4: A series regulator power supply.

yet in common use and a description of their mode of operation is outside the scope of this article because of its complex nature.

Let us consider briefly some of the more common types of stabilised supply, then finally describe one of them in greater detail.

The Series Regulator

The series regulator is really a modified form of the very simple kind of power supply with which we began this article and which was shown in Fig. 1. If we can vary the effective value of the series dropping resistor R1 in sympathy with changes of load or changes of the incoming mains supply we can achieve a constant h.t. voltage.

One way of obtaining a "variable resistor" is to use a high-power transistor and to vary its current conduction by means of a control voltage applied to its base—see the diagrammatic representation shown in Fig. 4. Ignoring for the moment the resistor (R2) shown dotted, it is clear that the transistor is merely an extension of R1.

The nominal mains input voltage is assumed to be 240V. The value of R1 is chosen so that when the mains voltage is 240V -10% and the transistor is turned hard on, i.e. bottomed, the right value of h.t. voltage is obtained with the load at maximum. This will normally occur—in the case of a monochrome receiver—when the brightness and contrast controls are at the maximum usable setting. The circuit is also suitable for small-screen colour receivers and here of course the saturation will also be set to its correct level. When the mains input voltage is at its top limit of 240V $+10\%$ the transistor is partly turned off so that the h.t. voltage remains unchanged. The increased h.t. voltage at point A does not appear at point B because it is dropped across the impedance presented by the transistor.

If a $+10\%$ mains input gives 330V at A and a -10% mains input gives 270V then $330-270=60V$ has to be dropped across the transistor. If a monochrome receiver has a load current of 0.3A the power dissipation in the transistor becomes $60 \times 0.3=18W$. This is a lot of power for a transistor to dissipate but matters can be greatly improved by adding resistor R2. The value of this resistor is chosen so that when the d.c. input at A is 330V the transistor is cut off and 60V is dropped across R2. Its value for a load current of 0.3A is $R2 = \frac{V}{I} = \frac{60}{0.3} = 200 \Omega$. The power dissipation is 18W as before. At minimum mains input the transistor is bottomed and only a volt or so is dropped across the combination of the transistor and R2 in parallel. Virtually all the load current flows through the transistor.

At the nominal mains input 30V is dropped across the combination, half the current flowing through the transistor and half through R2. The power dissipation in the transistor is therefore $0.15A \times 30V = 4.5W$ —a considerable reduction, especially as this is the worst condition. There is no dissipation in the transistor when it is cut off in one case and bottomed in the other.

In order to obtain a constant value of h.t. it is necessary to add a control loop. This compares a potted down fraction of the h.t. voltage against a reference potential—for example the voltage across a zener diode. Any difference between the two voltages

is applied to a driver transistor which amplifies this error signal and applies it as current drive to the series regulating transistor—in the appropriate sense to achieve negative feedback action. Thus an increase of h.t. voltage causes the transistor to be made less conductive and the h.t. is then restored to its correct value. This action also provides smoothing of the 50Hz ripple, but increases the power dissipation.

Advantages and Disadvantages

This is a nice, simple circuit. What are the snags? First of all a transistorised monochrome receiver might well have an h.t. line of about 160V. So at maximum mains input the total power dissipation in the series regulator and dropper resistors will be $(330-160) \times 0.3 = 51W$. This amount of heat in a very slim cabinet may be too much to be compatible with good engineering practice. In larger cabinets it may be permissible.

Snag number two is that the series regulator transistor is at more than 160V above chassis. This means that in addition to being a medium-power type the driver transistor must also be capable of withstanding a collector-emitter voltage of at least 180V and preferably a bit more (remember the safety margin). Both the transistors required are expensive types then, and the series regulator will need quite a large heatsink.

Snag number three, which is common to all stabilised circuits, is that failure of the series regulator or its control circuit can cause the h.t. to rise by up to 60V. This can prove fatal to quite a large number of semiconductor devices scattered throughout the receiver. One cannot design economically to cater for an h.t. line of 160V which may rise to 220V!

In any case the requirements of BS415 will almost certainly make it essential to add some sort of safety circuit that will disconnect the h.t. line, or blow the mains fuse, if the h.t. voltage rises above a predetermined value.

In spite of these disadvantages however a series regulator supply will often prove a suitable choice for monochrome receivers and small-screen colour receivers. Supplies of this type are also commonly used in better quality audio amplifiers and many professional l.t. supplies.

To sum up its characteristics: it is best suited for receivers with low h.t. current requirements; it provides good stabilisation; has a low internal impedance; needs an h.t. safety circuit; has high heat dissipation; is almost immune to disturbances on the mains; does not generate interference; makes suppression of mains borne interference relatively easy; needs unsophisticated circuitry; and is of moderate cost.

Switch-Mode Supplies

There are two types of switch-mode circuit using the same basic techniques. They are known as series and parallel switch-mode supplies. There are also many variations of both types, but the main differences lie in the choice of control circuits. An example of a series switch-mode supply is that used in the BRC 3000 chassis—though BRC prefer to call it a “chopper” power supply.

Series Circuit

The basic series circuit is shown in Fig. 5, but without any confusing detail. The first point to note is that the

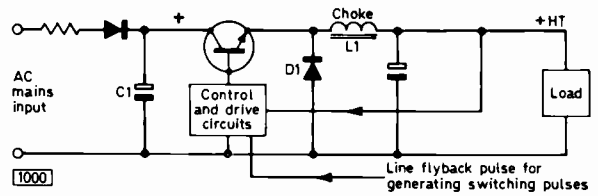

Fig. 5: Diagrammatic representation of a series switch-mode power supply.

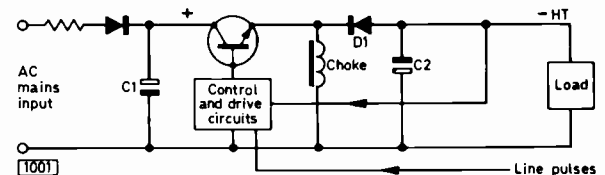

Fig. 6: Diagrammatic representation of a parallel switch-mode power supply.

transistor is switched on and off at a high frequency: usually at the line scanning rate. The transistor is either hard on, i.e. bottomed, or else turned completely off.

When the transistor is switched on a rapidly increasing current flows through choke L1, building up a magnetic field. When enough energy has been transferred to the choke the transistor is turned off. The left-hand end of the choke then becomes connected to chassis via diode D1 and as the magnetic field collapses the energy is transferred to the load.

If the transistor is turned on for a shorter period of time less energy is transferred to the load and the h.t. falls. If on the other hand the on-to-off time is increased more energy is transferred and the h.t. rises. Thus the h.t. line voltage can be controlled by varying the on-to-off time of the transistor. Note that the transistor has to be a high-power, high-voltage, high-current type capable of dissipating several watts.

A control circuit has to be provided to inspect the h.t. line, compare it against a reference voltage, decide whether the h.t. is too high or too low, and provide an error voltage to vary the on-to-off time (mark-space ratio) of the squarewave train supplied to the base of the switching transistor.

A convenient way of obtaining this switching squarewave is to integrate a line flyback pulse to produce a sawtooth which can then be clipped at the appropriate level and amplified to give a squarewave. A change of bias on the clipper stage will vary the on-to-off ratio, so this stage can be controlled by the error voltage.

The switching is carried out at line frequency partly because this is a convenient frequency from the point of view of designing the choke (it keeps the inductance down to a reasonable value) and partly because any interference generated will appear as a stationary vertical line on the picture. This will be much less obtrusive than a moving pattern. Also there is no need to provide a separate oscillator.

It is worth noting that this high-frequency switching is very beneficial from the point of view of h.t. filtering. A ripple at 15,625Hz needs only quite low values of smoothing capacitor for filtering purposes. Also, the control circuit has a fast action and “sees” mains hum as a change in h.t. voltage—as indeed it is—and varies the switching action to cancel it out. This process is

known as "active filtering" and can easily be incorporated in series regulator supplies as well.

Parallel Circuit

The parallel switch-mode supply operates on the same principle as the series switch-mode circuit and is shown in Fig. 6. Current flows through the choke when the transistor is switched on and as before a magnetic field builds up. When the transistor is switched off current continues to flow as the magnetic field collapses, passing through diode D1 into the load circuit. The ripple is smoothed by capacitor C2. The cycle then repeats when the transistor is switched on again.

Performance

The choice between series and parallel circuits is not very clear-cut; both are capable of giving a good stabilising performance. Factors in favour of the series circuit are the smaller size of choke and the lower values of peak voltage and current in the transistor. The ripple voltage is also smaller.

An important factor in favour of the parallel circuit concerns the matter of protection. If the transistor fails, going either short- or open-circuit, no power is delivered to the load. Thus the circuit is fail-safe. It is also a simple matter to build in over-current and over-voltage protection: all that needs to be done is to disable the switching circuit when the load current or voltage exceeds certain predetermined levels.

In the case of the series circuit current will build up rapidly if the transistor becomes short-circuited and the h.t. voltage will rise to an unacceptable level. Some kind of crowbar is needed which will blow the mains fuse, or a circuit breaker can be added. Both tend to be expensive.

The fact that the receiver's entire load current is being switched very rapidly at a repetition rate of 15,625Hz means that high-energy, high-order harmonics of this frequency will be generated. Problems inevitably arise due to these harmonics causing interference within the receiver itself and also to their being fed back into the mains supply.

Great care is needed in the layout of the circuit to keep the path of the switched currents as short as possible and without any radiating loops. Earth paths must be carefully designed so that these same currents are not coupled into other circuits. Careful filtering will also be needed at the input to the receiver in order to limit mains-born radiation.

We can summarise the characteristics of switch-mode supplies as follows: they are capable of providing high load currents; they have a good stabilising performance; they have a low internal impedance; circuit protection is cheap in the parallel circuit but expensive in the series circuit; heat dissipation is very low; h.f. interference is generated and needs careful attention to prevent mains-borne radiation or picture defects; the control circuit is in practice rather complex; cost is moderate for a high-power supply; mains ripple filtering is cheap and simple.

Next Month

In the concluding part next month we will take a detailed look at thyristor stabilised power supply circuits.

NEXT MONTH IN

TELEVISION

BUILD A BLACK-LEVEL CLAMP

Most monochrome receivers use a.c. coupling at some point in the video circuits. The result of this is that the black level shifts as the average picture content changes. In consequence the contrast range is compressed as dark areas become lighter and dark detail is lost. D.C. restoration can help but the best answer to the problem is to use a driven clamp. The circuit to be described—with full constructional details—was devised for use in the Thorn 950 Mk II chassis but should work in almost any monochrome receiver using a valve video output stage. Accurately timed pulses derived from the line output stage are used to drive the clamp.

RASTER CORRECTION IN 110° COLOUR RECEIVERS

New circuits have had to be devised for pin-cushion distortion correction in the new generation of 110° colour receivers. This means extra knobs for the devoted knob-twiddler to try out. As the methods of correction used are quite novel however it is important to know what the circuitry is doing. The message from Harold Peters next month is reassuring however: "don't panic, it's easy!"

CHANNEL IDENTIFICATION WITH VARICAP TUNERS

One of the problems of the DX-TV enthusiast or those seeking extra channels with a varicap tuner is that no accurate indication of the channel selected is provided. Accurate channel identification in electronically tuned sets can be provided however by means of the simple and inexpensive meter circuit to be described next month.

PLUS ALL THE REGULAR FEATURES

ORDER YOUR COPY ON THE FORM BELOW

TO
(Name of Newsagent)

Please reserve/deliver the NOVEMBER issue of TELEVISION (25p) and continue every month until further notice.

NAME

ADDRESS.....

SOME 'FOREIGNERS'

FAULTS ON FOREIGN COLOUR SETS

DEWI JAMES

THE following brief notes on faults experienced with imported colour receivers may be of help to other service departments.

SONY KV1320UB

This is possibly the most reliable colour set on the market. It has however been known to fail, albeit infrequently. Faults encountered so far have included:

(1) Failure of fuse F801 (1.6A) for no apparent reason. The fuse is omitted in later models and can in fact be shorted out whenever the trouble is experienced.

(2) Bent verticals, predominantly on the left-hand side. This is caused by the 115V series regulator transistor Q903 (2SC807A) being short-circuit.

(3) No sound or vision, raster OK. Due to the first i.f. transistor Q201 (2SC1129) being short-circuit.

(4) Colour altering. Usually due to misalignment of the ident circuits (adjust on test card unless an expensive colour bar generator is available). The adjustments are T701, VR701 and VR702.

(5) No colour, due to a fault in the colour killer circuit (see Fig. 1). The operation of this circuit is worth noting. In the absence of a colour signal Q316 is biased on by R383; its low collector voltage is insufficient to turn on the final chroma stage Q317. On colour the sinewave signal from the U reference signal driver stage, fed to the colour killer circuit via the buffer stage Q321, is rectified by D307 to produce

a positive potential at Q316 emitter, thus cutting it off so that its collector voltage rises and Q317 turns on. In the faulty set turning up VR302 produced horizontal, locked bands of colour while tuning through the channel produced colour briefly. The voltages in the colour killer stage Q316 were incorrect, due to C370 being leaky.

(6) Sound faults. The intercarrier sound i.c. IC201 (M5142P) can fail. Intermittent sound can be due to poor soldered joints in this area.

SONY KV1800UB

The general practice in both colour and mono-chrome receivers is to derive the e.h.t. supply from an overwinding on the line output transformer. Thus many faults in the line timebase will result in loss of e.h.t. and no brightness. For this reason it is most unusual to encounter the symptom of a vertical white line on the screen. In a minority of colour chassis however the e.h.t. generator and line output stages are separate. With these it is possible to find the e.h.t. system functioning correctly whilst a fault condition exists in the line output stage. The Sony 18in. colour Model KV1800UB is amongst the sets with separate e.h.t. and line output stages and we have encountered the vertical white line fault symptom in one of these. The arrangement of the line output and e.h.t. circuits in this chassis is most unusual in fact and is outlined in the accompanying block diagram (Fig. 2).

The fault itself was easily traced to the line output transistors Q801A and Q801B. Whilst delving into this part of the receiver however we felt that it might be helpful to engineers without access to the full manual to set down the following notes.

The supply for the line oscillator is obtained from a rectifier which is fed from a winding on the flyback transformer. To start the line oscillator the supply rail is returned via C531 and R555 (see Fig. 3) to the 110V line: at switch on C531 charges and powers the line oscillator. Once C531 has charged fully the two rails are effectively isolated. In the event of a fault in the line output/e.h.t. circuits a supply for the line oscillator can be obtained by connecting a 3.9k Ω , 5W resistor across C531 and R555 as shown in Fig. 3.

If the line output transistors fail R622 (see Fig. 4) which is included to provide protection should be checked. It is also important that the gain (h_{FE}) rating of the transistors fitted is the same—see Fig. 5. This rating is indicated by the third figure below the Sony transistor type number. Resistor R807 in series

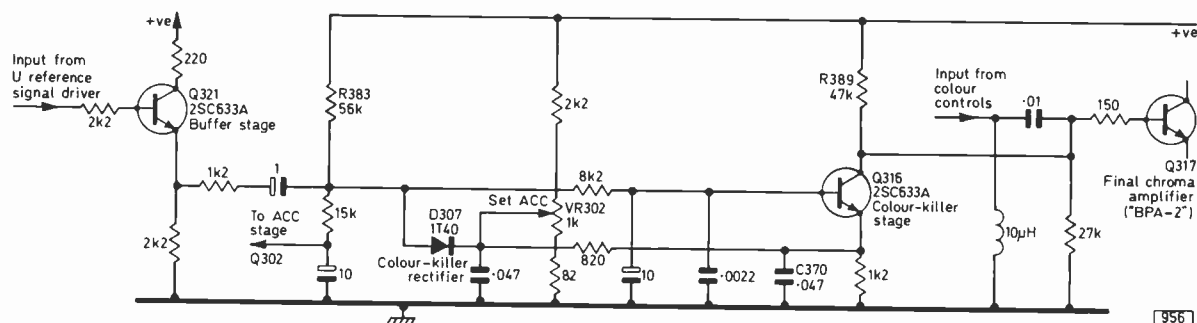

Fig. 1: Colour killer circuit used in the Sony Model KV1320UB (the small screen model).

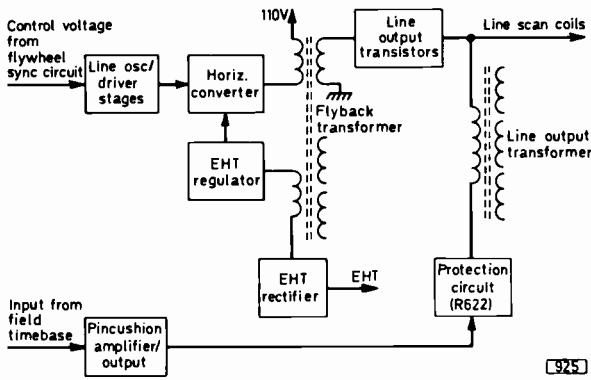

Fig. 2: Block diagram of the line timebase/e.h.t. generator arrangements used in the Sony Model KV1800UB.

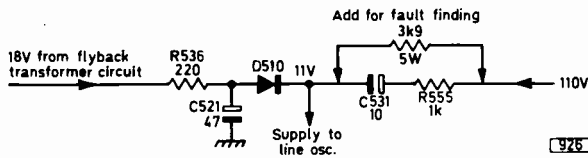

Fig. 3: Line oscillator power supply circuit.

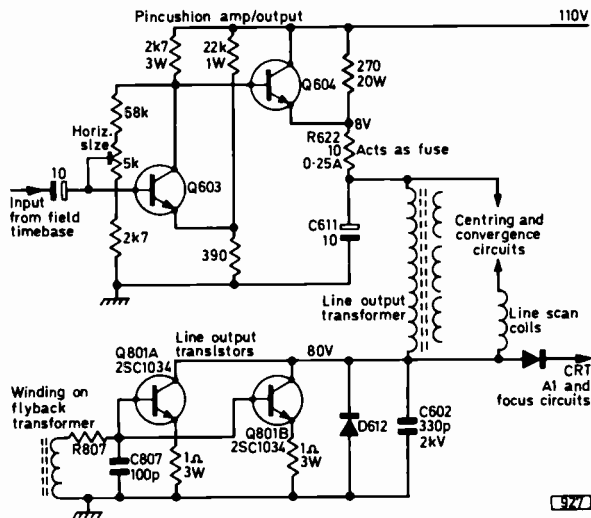

Fig. 4: The line output/pincushion drive circuits used in the Sony Model KV1800UB, shown simplified.

	Rating	R807 up to Serial No. 25300	R807 Serial No. 25301 and above
	3	0.68	1.5
	4	1.2	1.8
	5	1.8	2.7

Fig. 5: The gain rating of the line output transistors (Q801a and b) is indicated as shown on the left. The value of base feed resistor R807 required with transistors of different gain ratings is indicated on the right. A similar system of varying the base feed resistor value to suit the gain of the transistor is used for the horizontal converter transistor Q802.

with the bases of the line output transistors may need to be replaced since its value depends on the h_{FE} rating of the transistors. In our experience when the line output transistors become faulty the protection resistor R622 goes open-circuit.

Some of the chassis used in this model incorporate a sound noise-suppression circuit mounted on a small board—the SQ board—and fed from the same pin of the 6MHz intercarrier sound i.c. (IC201, pin 8) as the volume control. Unfortunately it responds to the BBC's 22kHz data signals, cutting off the sound when they are present. The symptoms are that you can get a monochrome picture plus weak sound on BBC-1 and -2, or with correct tuning a colour picture without sound. The problem is overcome by simply removing the SQ board—it is worth knowing that this is not a fault condition.

These sets become faulty only infrequently however and we have found them easy to service—once the back has been removed!!

HITACHI MODELS

Hitachi colour sets have also proved to be extremely reliable, requiring little attention. The following troubles have been experienced however:

Models CAP160, CEP180 and CNP190.

- (1) Plain white raster: beware of broken wire from luminance delay line.
- (2) Excessive colour saturation when changing channels. Check light sealing and characteristics of the decoder reference oscillator varicap diode VC501.
- (3) Line timebase not working with R720 (2.2kΩ 1W) overheating. Generally caused by faulty line driver transistor (TR39, 2SC685A).
- (4) Small picture, increasing or decreasing in size as the brightness control setting is altered. It will be found that the 120V line is low. One has to decide whether the fault lies in the power supply or in the line timebase, bearing in mind the other symptoms. Removing plug K5 will isolate the line driver and output stages, and if the fault is in this section the 120V line will rise to 180-185V. The most likely fault here is a collector-emitter leak in the driver transistor TR39 (2SC685A)—this in turn will result in its 2.2kΩ 1W collector feed resistor R720 overheating but since this resistor is in a sleeve the condition may not be immediately obvious. If the 120V line remains low when the line output section is isolated the fault is almost certainly in the power supply—CR39 and the zener diode CR40 in series with it are likely candidates. First and foremost however check the 315mA fuse F903 since if this is open-circuit the symptoms will be exactly the same.
- (5) Colour slow appearing and horizontal bands of colour. Since the problem is lack of colour lock once the colour has appeared attention should be directed to the reference oscillator circuit. We have traced the trouble to the 400pF capacitor in series with the varicap diode in the reference oscillator circuit. The burst channel phase detector diodes CR8 and CR9 are sometimes the cause of no colour initially.

Model CFP470. Causes of no colour with this set have proved to be:

- (1) Reference oscillator collector coil L1005 open-circuit.
- (2) Faulty colour killer transistor TR20 (2SA15V). To over-ride the colour killer short out CR13.
- (3) L1004 in the collector circuit of TR1002 (2SC460) being open-circuit. This transistor amplifies the

reference signal fed back to the phase detector in the reference oscillator control loop.

Model CSP680. Hum on sound in this model has been traced to C407 (220 μ F) which decouples the supply to the CA3065 intercarrier sound/audio preamplifier i.c.

The sync separator circuit used in these Hitachi colour receivers is somewhat unusual. The circuit used in Models CAP160/CEP180/CNP190 is shown in Fig. 6—with minor variations the same circuit was used in earlier models.

A disadvantage of the negative-going vision modulation system used with u.h.f. transmissions is that high-amplitude interference pulses are of the same polarity as the sync pulses. This Hitachi sync separator circuit employs a noise-canceller stage to overcome the problem.

As Fig. 6 shows, the video signal—with positive-going vision and negative-going sync pulses—is fed via diode CR3 to the base of the sync separator Tr5. CR4 is normally forward biased and since Tr5 is a pnp device the positive-going vision signal cuts it off while the negative-going sync pulses drive it into full conduction, positive-going sync pulses appearing at its collector.

The npn noise-canceller transistor Tr4 is normally fully conducting—as the voltages show—while CR3 in its base circuit is reverse biased. When large negative-going noise pulses arrive CR3 conducts and since Tr4 is an npn device the negative-going pulses applied to its base cut it off. Its collector voltage then rises and the voltage at the junction R255/R257 is sufficient to cut off CR4, thus ensuring that the pulses are not applied to Tr5 base. In consequence the output from the sync separator is noise free. It will be seen that the a.g.c. detector is also fed from CR4 cathode and since CR4 is cut off in the presence of noise pulses the a.g.c. level is unaffected by noise. The burst gating pulses are obtained from the collector circuit of the sync separator (not, as is more usual, from the line output transformer) and these are also unaffected by noise. An advantage of using sync pulses for burst gating is that this operation is not affected by the setting of the line hold control—in fact in these models there is no separate horizontal shift control, the line hold control being used for this purpose (the purity magnets should be used to shift the picture vertically, provided the movement required is not too great, since there is no separate vertical shift control).

When faults arise in television circuits diodes are

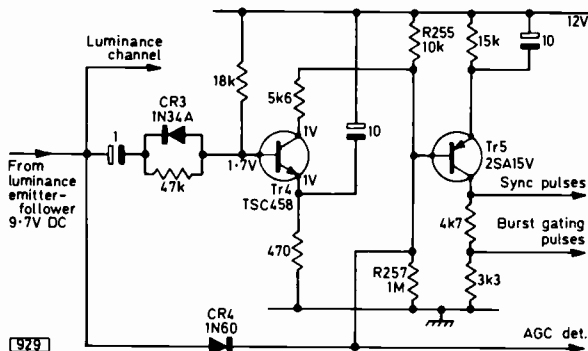

Fig. 6: Sync separator circuit used in Hitachi colour receivers, with noise canceller stage Tr4.

among the most suspect components. Should CR3 become open-circuit the only effect would be that the noise-cancelling circuit will be inoperative. Should CR4 become open-circuit however there will be several symptoms. The first of course will be loss of sync. Secondly, the gain will be increased owing to the feed to the a.g.c. detector disappearing. And since the burst gating will also cease the colour-killer circuit will no longer produce a turn-on bias for the chrominance channel and there will be no colour. In the event of lack of sync, high gain and no colour therefore check CR4.

KUBA FLORENCE

We have recently encountered a number of these sets which are made in Italy. They seem to work quite well and the service and spares organisation is speedy and efficient. To date we have encountered a small number with dry-joints around the sound output transistors (TR54/TR55), and one or two dry-joints in the line timebase circuits. A case of intermittent loss of picture was traced to a faulty VDR (VDR501) in the PL519 line output valve control grid circuit.

Apart from a slightly suspect line output transformer we have found these sets quite reliable with easy access for servicing. It has been our experience however that sets manufactured on one large vertical panel are prone to printed circuit fracture as the horizontally mounted components tend to droop after a while, particularly large components such as transformers.

COLOUR CRT REPLACEMENT GUIDE

The latest colour c.r.t. replacement list issued by Mazda is of particular interest in listing replacements for many Japanese colour tubes including Nippon, Hitachi and Toshiba types, also SEL, RCA and Sylvania etc. types. Details are as follows:

<i>Mazda type</i>	<i>Replaces</i>
A44-271X	440AXB22, A44-270X, A44-271X
A49-192X	490AXB22, 490BK B22, 490BK B22A and B, 490BTB22, 490BTB22A, 490BUB22, 490CJB22, 490CVB22, A49-11X, A49-120X, A49-191X, A49-192X, A49-200X, CTA1950, CTA1951
A51-110X	510AEB22A, 510ARB22, 510AUB22, 510AUB22A, 510BMB22, 510CKB22, 510CLB22, 510DB22, 510DB22A, 510DJB22, 510ELB22, 510HB22, 510LB22, 510ZB22, A51-110X, A51-112X.
A55-14X	550CB22, 550CB22A, A55-14X, A55-141X, CTA2250
A56-120X	A56-120X
A63-200X	25UP22, A63-11X, A63-16X, A63-17X, A63-120X, A63-200X, CTA2550
A67-120X	A67-100X, A67-120X, A67-130X

Mazda point out that in some cases there might be slight differences in the light transmission of the glass, also that there may be variations in the implosion protection metalwork around the edge of the faceplate though the positions of the mounting lugs are unaffected by this.

LETTERS

Some readers may wish to "hot up" the simple field effect transistor voltmeter I described in the February issue this year. There seems no reason why the resistors in the input circuit should not be increased in value ten times: I would suggest the input circuit shown in Fig. 1(a) however as this enables C1 to be omitted, and the use of a 3N153 field effect transistor which is designed for electrometer use—adjust the value of the source bias resistor R8 as necessary so that half the supply voltage is obtained at the drain. Alternatively the input circuit shown in Fig. 1(b) could be used: this increases the input impedance on the 10V and 100V ranges to 20M Ω .

I have constructed a version of your colour receiver and this has given about six months' trouble-free viewing so far. One fault I originally had was with L2 in the decoder. The effect was a picture with three colours from left to right, and was traced to trouble with L2. I replaced this with 120 turns of 42 s.w.g. wire on a similar former to those used elsewhere in the decoder and changed C13 to 1,000pF. A slug was used to tune the coil.

A couple of other points. I suggest turning round the core of L408 (pincushion N-S phase) and pushing it in reverse to overcome the need to drill a hole in the board to enable optimum adjustment to be made. Also the layout accompanying the line oscillator modification shown in the January issue is a little misleading since it does not indicate that the earthy side of C325 should be swung round from its previous position to connect to the junction of R339/R340 (earth).—R. MacClay (Cheshire).

Editorial comment: Other readers had trouble with L2 which seems to be rather critical. They may care to try the modification suggested.

I am building a similar colour receiver to David Robinson's (March-May 1974) and would appreciate guidance on the following points:

(1) What is the source of the $-80V$ line flyback blanking pulse (Fig. 12)? Such a pulse does not seem to be available from the Pye line output stage used.

(2) My power supply requirements differ. First I propose to use RGB output stages operating from a 200V rail as in the RBM chassis: can I get this simply by dropping from the 280V rail? My audio circuit (RBM i.f. panel) requires a 25V supply and my decoder an 18V line. I propose to divide the 47 Ω dropper shown in your circuit (Fig. 13) to obtain 25V plus a zener stabilised 18V rail. Also I notice that in the

original RBM timebase the field charging circuit (height control etc.) is fed from the same h.t. line as the line output stage instead of from a 40V rail as in your receiver.

(3) I have had difficulty with the line oscillator circuit shown in Fig. 11.—A. Lovell (Rochdale).

David Robinson writes: (1) I used a $-80V$ pulse for line flyback blanking for the simple reason that a $-80V$ pulse is required in the decoder and it is convenient to use the same one for blanking. To get this pulse I added an extra winding on the lower limb of the Pye line output transformer, with the number of turns in proportion to the 47V pulse winding, i.e. 80/47 times as many turns to the nearest whole turn. In the absence of a 'scope this was the only way of getting the right pulse amplitude but it is quite accurate enough. Polarity is easily found by trial and error—obviously if it is wrong the blanking becomes bright-up.

(2) Deriving a 200V line for the RGB output stages by dropping from the 280V rail would cause problems due to regulation. A heavy current drain by the R output stage for example would cause the 200V line to drop thus disturbing the black level at the other two guns. The results obtained might be acceptable but would not be optimum. To provide a stabilised 200V rail on the other hand would be expensive. After considering this matter carefully I decided to alter the RBM video output circuits to operate from the 280V rail which they do perfectly well with the few altered resistor values shown in Fig. 9. The only penalty is increased dissipation in the BF179 collector load resistors. Note that the value of the resistor in series with the base of the BF194 brightness pulse inverter also has to be changed (see Fig. 7).

I would use separate droppers from the 40V rail to obtain the 25V and 18V supplies in order to avoid interaction. The audio amplifier on the RBM i.f. panel will since it is a class B type take a current which varies with the volume. This brings two problems. First it would result in the 25V line voltage varying widely if derived by a resistive dropper from the 40V line. Secondly it would cause the other l.t. lines to vary, thus interfering with the picture, in the circuit you propose. Incidentally I am now using a TAA570 intercarrier sound i.c. feeding a 2W class A amplifier. This is far more satisfactory than the previous arrangement.

Regarding the 200V feed to the height control network in the RBM chassis, this is done to reduce picture breathing due to the e.h.t. regulation problems when a tripler is used. If you are using the Pye shunt stabilised e.h.t. supply as in my set this stratagem is unnecessary and it is convenient to feed the height control from the 40V line. What I did was to change the height control from 50k Ω to 22k Ω and connect it via a 22k Ω resistor to the 40V rail (i.e. remove 5R44, 5C32 and 5R45 in the original RBM circuit).

(3) There was a mistake unfortunately in the line oscillator circuit shown (Fig. 11). The BC186 stage in my modified circuit adds capacitive loading to the oscillator tuned circuit. The tuning capacitance has to be reduced therefore to maintain the correct frequency. This is easily done by removing the 2,700pF tuning capacitor shown in Fig. 11 (5C20 on the RBM board). Line phasing can be adjusted within limits by using the core in the line sync discriminator transformer (5T1) on the RBM timebase board—not the oscillator tuned circuit itself or the discriminator balance control 5RV2. I found it helpful to reduce the tuning capacitor (5C7) across 5T1 primary from 1,500pF to 1,000pF.

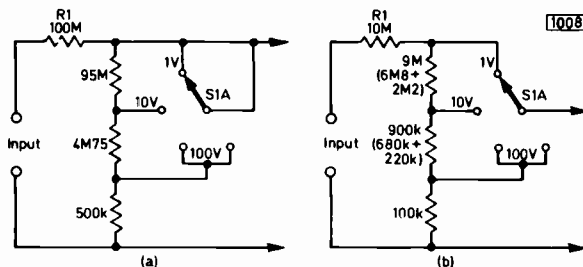

Fig. 1: Alternative voltmeter input circuits.



**SOLID-STATE
VIDEO**

I.R. SINCLAIR

THE all solid-state TV camera has been a possibility which has seemed a reasonably attainable proposition—though not exactly just around the corner—ever since integrated circuit techniques developed to the extent that panels of silicon photodiodes could be made. The main problem has been to find a scanning mechanism that could be used in a solid-state panel. The capabilities of silicon photodiodes themselves have been proved through their application in the silicon vidicon camera tube (see TELEVISION February 1974). In this tube the scanning is provided by a conventional electron beam. The final step to the solid-state camera optical sensing device has now come however with the use of charge-coupled shift techniques to provide scanning and read-out of the information stored by the photodiodes.

Charge Coupling

Charge coupling is a fairly new technique which has yet to find its way into the text books, while charge-coupled devices (CCD) are so far at the development and pilot run stages rather than in full production. Low-resolution cameras using CCD image sensors have been demonstrated however and the aim of current work is to achieve the standard of performance of the conventional vidicon camera tube.

It will help us to understand the principles and uses of charge coupling if we think of two well established but quite dissimilar devices which carry out a similar set of operations. First the clocked bistable shift register (see Fig. 1). This is a series of connected bistables each of which can store a one or a zero at one collector—meaning that this collector is at either a high or a low voltage. When a clock pulse is applied to such a bistable shift register each bistable shifts on to the next bistable the number (1 or 0) which it is storing so that the

total stored number shifts one place along the register and a digit is read out at the end. A shift takes place with each clock pulse so that the clock pulses control the rate at which numbers can be read in and out of the shift register.

If the information stored by each bistable came from a separate photodiode—one photodiode for each bistable—then the shifting operation would be a form of scanning, with all the information shifted out by the clock pulses. The arrangement would incidentally be a much more linear form of scan than we could ever hope to achieve with electron-beam tubes. Such a form of scan would be useless for our purposes however: the information provided would be digital, with only two voltage values (peak white and black level if you like), while what we require is an analogue signal with its many possible voltage values to indicate the amount of light reaching each photodiode. In addition the photodiodes could not add information while the shifting took place so that it would be necessary to use some form of gating between the photodiodes and the shift register. Although there are solutions to these problems—such as having enough shift registers to cope with the number of signal levels required, thus converting the signal into digital form—the complexity of all this would make a working panel with more than a few lines of resolution very difficult to achieve.

The second device is our old friend, now in honourable retirement, the dekatron tube (see Fig. 2). This was a gas-filled tube which produced an orange glowing spot at one of ten positions marked around the periphery of the tube face. Each time suitably processed pulses were applied to electrodes in the tube the spot was shifted to the next cathode. The shifting action was based on the simple principle that electrons will move towards a more positive voltage.

The piece of technology for which we have had to wait is the solid-state equivalent to this process, charge coupling, though this is by no means as simple as the operation of the dekatron. Charge coupling makes use of two principles well established in semiconductor work. The first is that free electrons in semiconductor material will move in the direction of an applied field; the second is that the movement can be closely controlled by changing the quantity of mobile electrons in

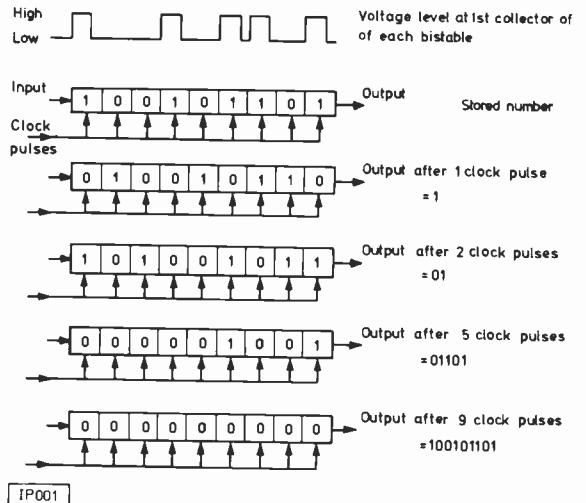

Fig. 1: Action of a clocked shift register.

IP001

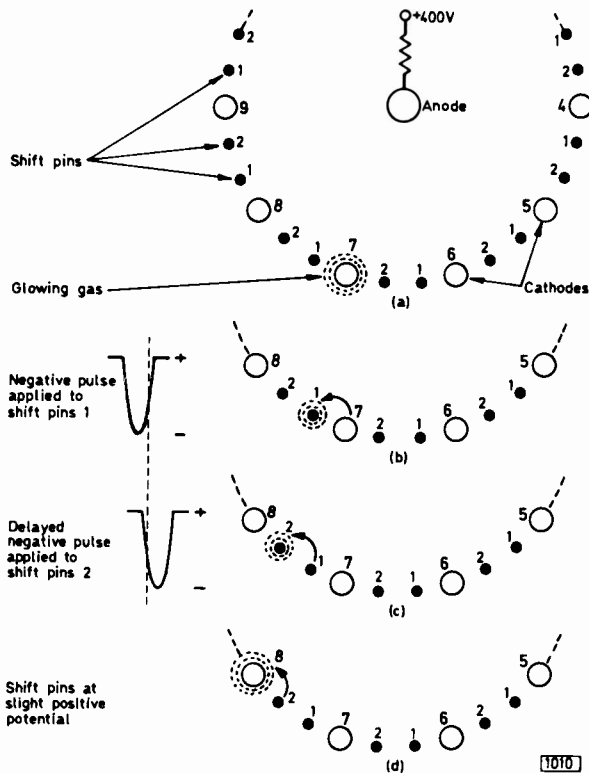

Fig. 2: Transferring the glow in a dekatron tube. The glow is a gas discharge between the anode and one cathode, showing up bright at the cathode. The glow will shift to the most negative adjacent electrode at any time. All the "1" shift pins are connected together and all the "2" shift pins are connected together, negative-going pulses being applied to the "1" shift pins and delayed negative-going pulses to the "2" shift pins. If the glow is at cathode 6 a negative-going pulse will shift it to the adjacent "1" pin. The delayed negative-going pulse will subsequently shift it to the adjacent "2" pin and at the termination of the pulse, when the pins are slightly positive, the glow will move to the next cathode. A sequence of pulses will result in the glow shifting from cathode to cathode in a clockwise direction therefore.

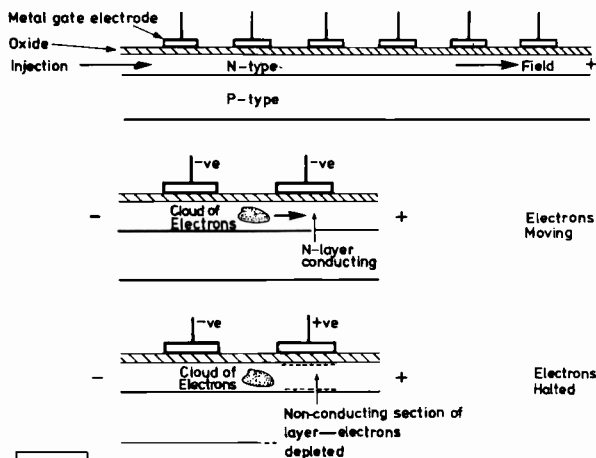

Fig. 3: Basic principle of charge coupling.

the semiconductor material—by depleting the material of free electrons so that it becomes almost non-conducting. These principles are used in m.o.s. field-effect semiconductor devices in which the movement of electrons through an n-type region is controlled by a gate electrode. The potential applied to this electrode results in electrons in the material beneath being either trapped or released: thus varying the gate bias varies the conduction through the device.

Charge coupling makes use of these effects to move a "packet" of charge through a semiconductor and to keep the charge packet intact as it moves through the material. Consider an extended m.o.s.f.e.t. (see Fig. 3) with a large number of gate electrodes to which pulses can be applied. If bunches of electrons are injected into the main n-type region—say from a heavily doped n region at one end—these injected electrons will remain bunched together and will travel along the semiconductor material in bunches in the direction of the applied field. We can control the movement of the electron bunches by applying pulses to the gates. If such a pulse depletes the semiconductor material of electrons in the region beneath a gate just as a bunch of moving electrons arrives the electron bunch will be "frozen" in position—it will be unable to move forward. If the control pulses are then applied so that the region beneath the next gate is depleted while that beneath the previous one is released the charge bunch will move towards the next gate and so on. Thus by applying pulses to alternate gates charge packets can be moved along the semiconductor material—at a rate controlled by the frequency of the pulses. The resistivity of the semiconductor material must be of a value that allows electrons to travel at the required speed of course.

Analogue Shift Register

We thus have a form of shift register in which information in the form of groups of electrons can be moved along by a set of clock pulses—scanned and read out in fact. What makes the technique so valuable is that we can vary the number of electrons injected—the number in each packet—and that the quantity injected, or pretty close to it, will travel along together without spreading out or getting lost. In other words this is an analogue shift register. We do not have to rely on 0 and 1, i.e. digital, signals: instead we have signals whose strength is represented by the number of electrons per packet. If the total charge per packet represents the video signal and this can be scanned out of the register under the control of clock pulses we have what we are after—solid-state scanning. All we have to do then is to devise some arrangement through which electrons from an array of photodiodes can be injected, scanned out by charge coupling and converted into a voltage signal. That's all!—though the technology is far from easy to put into effect. In particular the semiconductor technology employed may be rather more complex than that described above—the charge packets for example may consist of minority carriers (electrons in p-type semiconductor material) moving in a "buried channel".

Fairchild CCD201 Image Sensor

One of the first solid-state image sensors announced was the Fairchild CCD201. This consists of a tiny transparent panel measuring 0.16×0.12in. with 100 photosensitive silicon diodes along each side of the

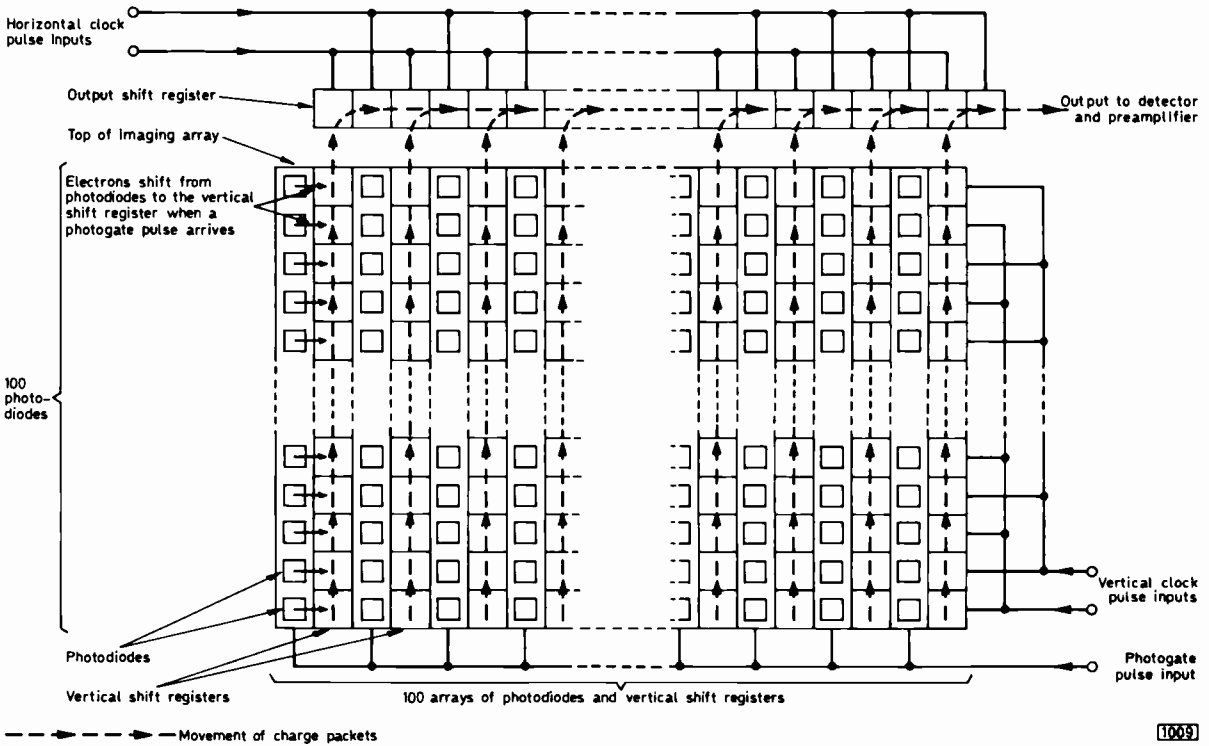

1009

Fig. 4: Basic arrangement of the Fairchild CCD201 image sensor. Once each field when the photogate pulse arrives half the photodiodes discharge into the adjacent shift registers. The action of the vertical clock pulses then moves the charge packets along the vertical shift registers into the horizontal (output) shift register which is emptied—read out—between the arrival of each set (line) of charge packets from the vertical shift registers.

rectangle, making a total of 10,000 diode elements, laid beside a set of CCD shift registers. There are 100 columns of analogue shift registers (see Fig. 4), with gating strips so that signals can be gated from the photodiodes into the registers and also from the 100 registers into the 102 element analogue output shift register. In addition there is an output detector to convert the stored charges into an output signal, a preamplifier, and circuits to remove the gating signals from the final video output. The whole chip is contained in a 24-lead dual-in-line package measuring only 1.25×0.52 in. The video output is fully interlaced and although the resolution is low by today's camera tube standards the principle is sound and the development of panels with much larger numbers of elements is in progress. The charge packets consist of minority carriers.

The circuitry needed to drive the unit consists of pulse generators to supply the main clock pulses, reset pulses and photogate pulses together with a video amplifier for the output signal.

When an image is focused on the glass window of the CCD201 each silicon photodiode will respond to the light by generating electron-hole pairs. The number of pairs generated is proportional to the light intensity and the time of exposure. As with conventional camera tubes a good signal-to-noise ratio can be obtained only if the charge on the photodiodes is allowed to build up over the comparatively long time of one frame.

Each photodiode is coupled to a position along one of the 100 vertical analogue shift registers—there are 100 diodes to each shift register and the shift registers run the entire vertical length of the panel.

At the end of each field a photogate clock pulse is

applied as a bias potential between the diodes and the vertical shift registers. This allows the electrons which have accumulated by the action of the light to transfer into corresponding positions in the shift registers—provided the field between the register and the photodiodes is sufficient to shift the electrons across. The photogate clock pulse occurs at the same time that a pulse is applied to the shift registers, but the shift register pulse has a different voltage value on alternate scans. As a result in one field only half the diodes (alternate horizontal lines) discharge into the vertical shift registers while the other diodes continue to charge through the action of the light. At the end of the photogate pulse the first set of diodes starts to charge again. In this way the outputs from the photodiodes consist of bunches of electrons each representing the light intensity on a diode averaged over a whole frame of two fields—just as would be the case in a camera tube. As we can keep the electrons bunched in the same groups until they are read out by the detector we get an output video signal proportional to the amount of charge at each photodiode.

The vertical shift registers are clocked so that the electron bunches at each of fifty positions in each register—remember that only half the photodiodes discharge into the registers on each field—are shifted vertically by one position as each set of clock pulses is applied. Thus fifty vertical clock pulses shift one field of electron bunches. With all 100 vertical shift registers working the result is that each set of vertical clock pulses places a line of information—in the form of electron bunches—into the output shift register at the top.

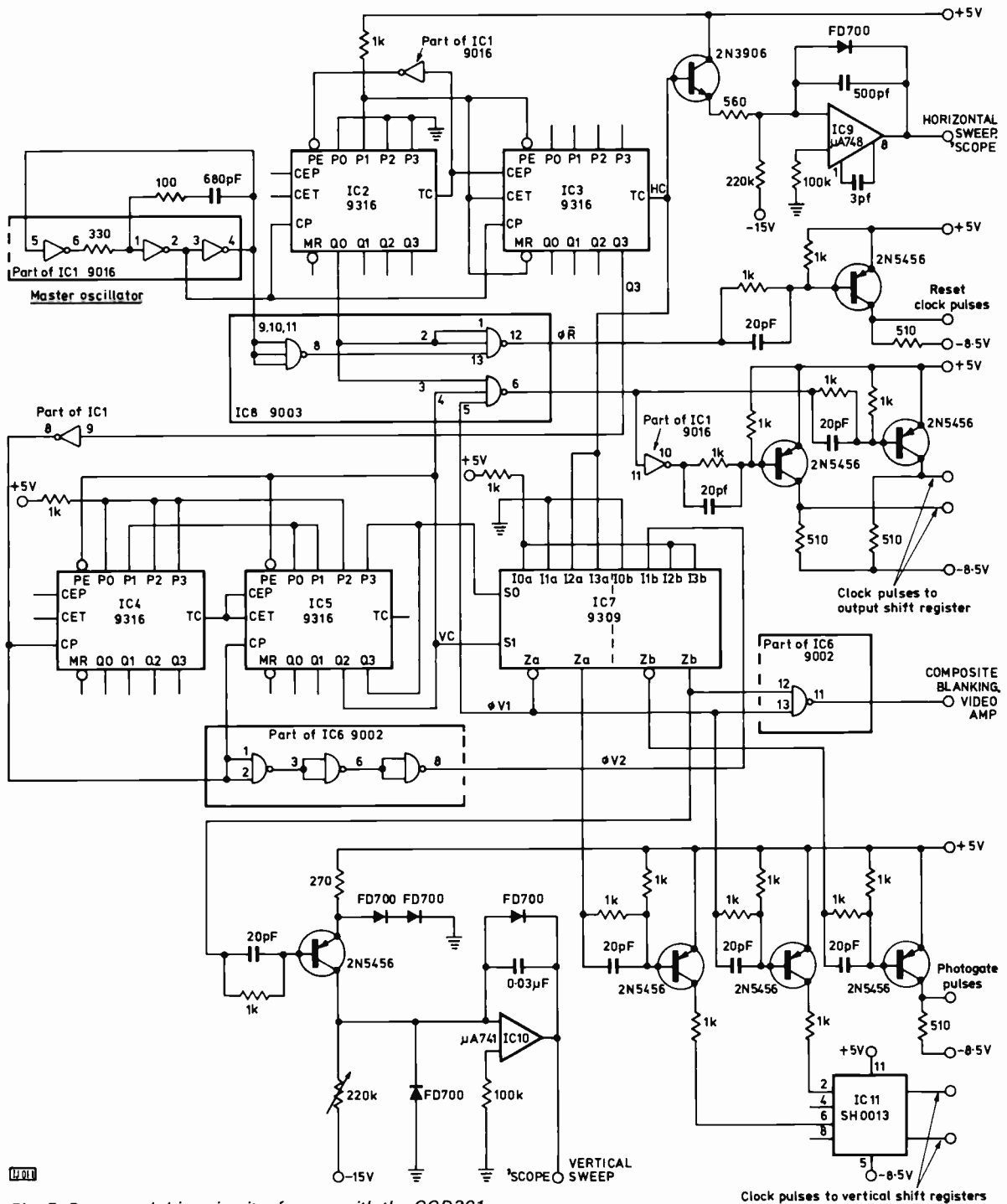

Fig. 5: Suggested drive circuitry for use with the CCD201.

The output shift register must be clocked very much faster than the vertical shift registers—over 102 times more in this case—so that between each vertical shift the charge packets corresponding to one line of information are shifted out to the detector and pre-amplifier. Since there are 100 vertical shift registers only 100 horizontal clock pulses are required to shift a line of signal information—the other pulses are used to clear the register during the blanking period between

each line.

At the end of a field the photogate pulse coincides with different vertical shift register clock pulse voltages: the other set of photodiodes—for the second field of the frame—then discharges into the vertical shift registers and is clocked up line by line into the output shift register.

The “signals” being shifted out of the horizontal—i.e. output—shift register are charge signals and have

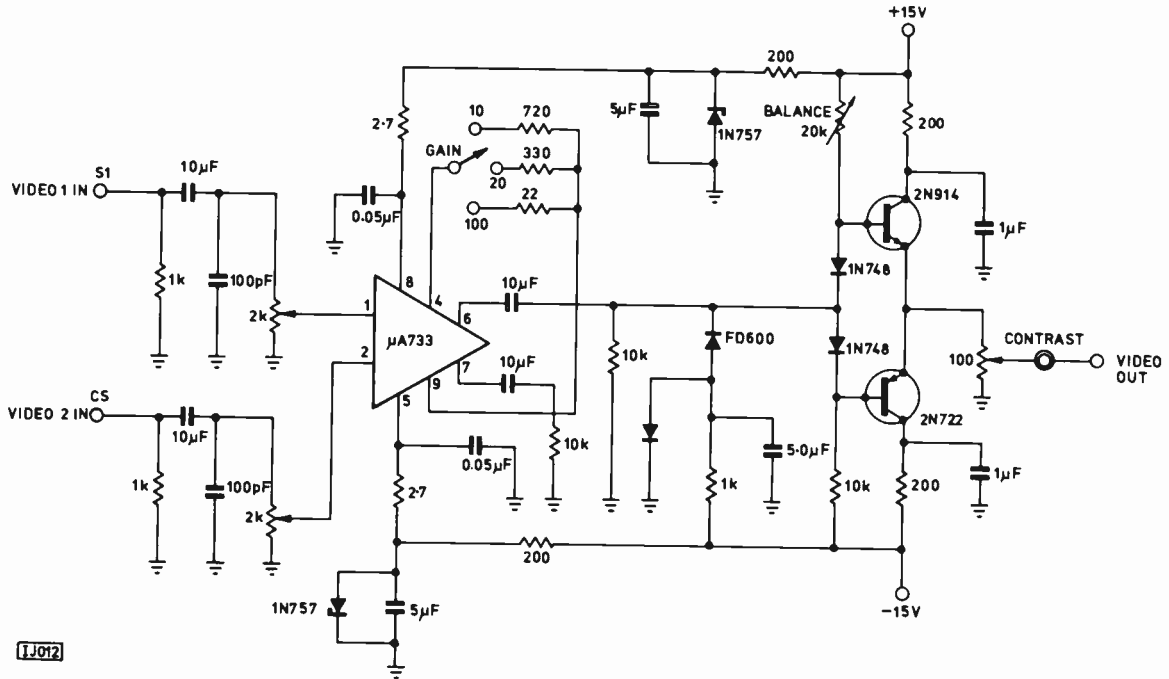

Fig. 6: Video amplifier circuit for use with the CCD201. Input S1 is from the output amplifier in the CCD201 and consists of the video signal plus reset pulses. Input CS is from the compensation amplifier in the CCD201 and consists of reset pulses only. The reset pulses are cancelled in the μ A733 i.c.

to be converted into voltage signals before they can be amplified. For conversion the well known relation between the voltage and the charge in a capacitor ($Q=CV$) is used— C represents the capacitance (in farads), V the voltage (in volts) and Q the charge (in coulombs). When a capacitor charges, the voltage across it is proportional to the charge. If we feed each charge packet into a small-value capacitor which starts off uncharged the voltage across the capacitor when the charge is fed in is our video signal and this can then be amplified in the usual way. The capacitor must be fully discharged between each charge so that the next charge signal can be read accurately.

The capacitor used for this purpose in the CCD201 consists of a reverse-biased diode. The potential developed across this changes linearly when an electron packet is delivered to it and this change in potential is then used to bias the gate of a m.o.s.f.e.t. preamplifier. To prepare the capacitance diode for the next signal a reset pulse is applied to it at the start of each horizontal clock pulse. This makes the diode conduct and thus removes the stored charge.

The output from the m.o.s.f.e.t. preamplifier will consist of the reset pulse plus a video signal voltage. The reset pulses are also fed on their own to a second m.o.s.f.e.t. By subsequently mixing the two outputs in a differential amplifier the reset pulses can be cancelled and the video signal on its own obtained.

The circuits suggested by Fairchild for driving the CCD201 are shown in Fig. 5. They provide all the timing and drive signals needed to operate the image sensor, also outputs to control the vertical and horizontal deflection of an oscilloscope so that with the CCD201 video signal used to provide brightness modulation the oscilloscope will display the video signal as a picture.

The suggested master clock frequency is 4MHz and this is obtained by using three sections of a 9016 i.c. as an oscillator. The 9316 i.c.s IC2 and IC3 convert the master clock output into horizontal clock pulses—105 shift pulses plus a seven-pulse flyback at a pulse rate of half the master clock frequency. The reset pulse is a shorter one generated by gating a master clock pulse with a horizontal shift pulse. To equalise the delay times one section of a 9003 gate is placed in the line from the master pulse unit. The 9316 i.c.s IC4 and IC5 count the vertical lines so that the odd and even fields can be scanned. The vertical sweep generator IC7 (9309) is held back by one line at the start of each second vertical sweep: the other half provides the photogate pulses.

Fig. 6 shows the video amplifier circuit suggested, using a μ A733 i.c. as differential amplifier fed with both the video (with reset pulses) and the reset pulse train on its own as mentioned earlier.

The CCD201 has the spectral response normal for silicon photodiodes and resolution corresponding to the 100 diodes per picture side. The small size of each diode should make it possible to raise the resolution considerably without raising the size of the assembly too much, and a 120,000 element (400 lines \times 300 lines) sensor has already been announced by RCA though no details are available at the time of writing. There seems no doubt that this solid-state type of panel will eventually offer very serious competition to the camera tube, particularly in closed-circuit and monochrome work. There is known to be a great deal of development effort going on into making panels of higher resolution and in adapting the system for colour video signals.

The author acknowledges the assistance of Fairchild Semiconductor for information provided. ■

USING TEST CARD F

Most readers will be aware of the significance of the more obvious features of the Test Card transmitted in the UK—the resolution gratings and the central circle for example. But there is far more to the test card than that. It was designed jointly by the BBC, BREMA, EEA and IBA to provide checks on almost every function in a domestic television receiver. This supplement refers mainly to colour receivers but should also prove useful to monochrome set owners.

Before you examine in detail the reproduction of the Test Card on your set it is essential to check that the normal user controls are correctly adjusted. These normally consist of some or all of the following:

Brightness: Set this so that the black areas such as the letter box and the blackboard have just some very faint illumination.

Contrast: Within limits this is a matter of personal preference. It should not be so low that the picture is faint nor so high that peak white areas are excessively defocused however.

Tuning: It is an unfortunate fact that there are still many receivers which do not have high short-term and long-term tuning stability, or alternatively an efficient a.f.c. system. Consequently, instead of being a preset adjustment at the back of the set the tuning is in the hands of the viewer. In this case the usual method is to set the tuning to a point just before that where sound-on-vision interference begins. On colour transmissions this interference normally takes the form of sound-chroma beat patterning.

Saturation: This is best set at zero initially so that the luminance signal can be checked.

It is important to remember that the luminance signal (monochrome display) must be correct before it is possible to obtain a correct colour picture. We shall deal first therefore with using the Test Card to check a monochrome display on a colour receiver.

(1) **Border Arrowheads:** These are used to check width, height and centring. On a modern picture tube with the correct 4:3 aspect ratio the picture edges at the left, right and bottom should correspond to the arrowheads. There is no arrowhead at the top due to the superimposed colour bars which should just slightly overlap the edge of the screen. With the older type of 5:4 aspect ratio tube probably the easiest method is to set the height and centring first, then set the width for a truly round centre circle.

Many receivers do not have a separate width control as the width and e.h.t. are both set by a "line drive" control. In this case the manufacturers' instructions must be followed to the letter. The e.h.t. adjustment must never be touched unless a reliable e.h.t. meter is connected. It may be necessary to accept a slightly incorrect width setting on such sets—also on those which have only an adjustment in discrete steps. Err on the high side with the width setting and then set the height to match so that the aspect ratio is correct.

The issue is further complicated by the fact that some sets are subject to picture breathing, that is variation of picture size with brightness. As a result if the width and height are set on the Test Card—which has an overall brightness level in the mid-grey region—the picture edges may come into the viewing area on dark scenes. This point can be checked on the Test Card by turning down the brightness and if necessary setting the width and height a little higher.

(2) **Background White Grid:** The white squares are used to check line and field linearity.

(3) **Grey Scale Rectangles:** The brightness difference between any two adjacent rectangles should be the same. The lighter spots within the top and bottom rectangles should not merge into the surrounding area. Grey scale can be checked by examining these rectangles or by examining—with the colour off—the colour bars at the top of the card. Adjustment of the dark grey end of the scale (usually by voltage controls connected to the c.r.t. first anodes) is quite easily done on almost any monochrome picture in a darkened room. It is helpful to turn down the brightness for this. If the receiver has been previously set up and the adjustments are being "touched up" leave one of the three controls untouched and remove any colour tints with the other two.

Setting the peak white colour is not so easy. The only correct method is to use some sort of reference white source or alternatively a photoelectric meter. In the absence of these the only method—and a rather approximate one—is to set up for the best flesh colour.

RESOLUTION AND BANDWIDTH

(4) **Frequency Gratings:** These are equivalent to square-wave signals at the frequencies marked on the photograph. It is important to note the difference between the ideal and the actual in this matter.

On a monochrome receiver all the gratings should be clearly reproduced. But equally important is the *relative contrast* of the various gratings since this is an indication of the *smoothness* of the amplitude/frequency response and this is at least as important as the overall bandwidth. The fact for example that all the bars are clearly visible does not indicate that all is well if the 3.5MHz grating (say) is significantly stronger than the others: this would indicate a peak in the response at around that frequency and the overall standard of resolution would not be satisfactory.

We must be careful however to distinguish between a peak (or trough) at some point in the response—this is undesirable—and a slight *smooth* roll-off at the h.f. end which is much more acceptable. It is common for example to find that the top four gratings are equally strong but that the 4.5MHz grating is a little weaker and the 5.25MHz one weaker still. This is perfectly normal.

Ideally of course a monochrome set would have a perfectly level amplitude/frequency response from d.c. to about 5.5MHz. But conflicting with this is the need for adequate attenuation of the 6MHz intercarrier sound signal. It is very difficult to get a sharp enough roll-off in the response to satisfy these requirements without producing ringing, the subjective effect of which is worse than a simple lack of bandwidth.

With a colour receiver the situation is more complicated because there is always a colour subcarrier rejector in the luminance channel. This is tuned to 4.43MHz and is usually effective over a bandwidth of about 0.5MHz. Hence the top four gratings should be little affected but depending on the depth of the rejection notch and on the h.f. roll-off mentioned above the 4.5MHz and 5.25MHz gratings may be anything from rather weak to totally invisible. Fortunately this reduced resolution is counteracted by the added detail due to the colour information.

When the colour is turned on there will always be a certain amount of colour patterning (cross-colour) over the gratings, and indeed on all non-horizontal sharp edges. This is because the luminance signal in these areas has frequency components which fall within the passband of the chroma circuits. This will be most obvious on the 4.5MHz gratings which tend to take on a blue tint because

GETTING THE MOST FROM THE TEST CARD

SPECIAL
FEATURE to
'TELEVISION'
October 1974

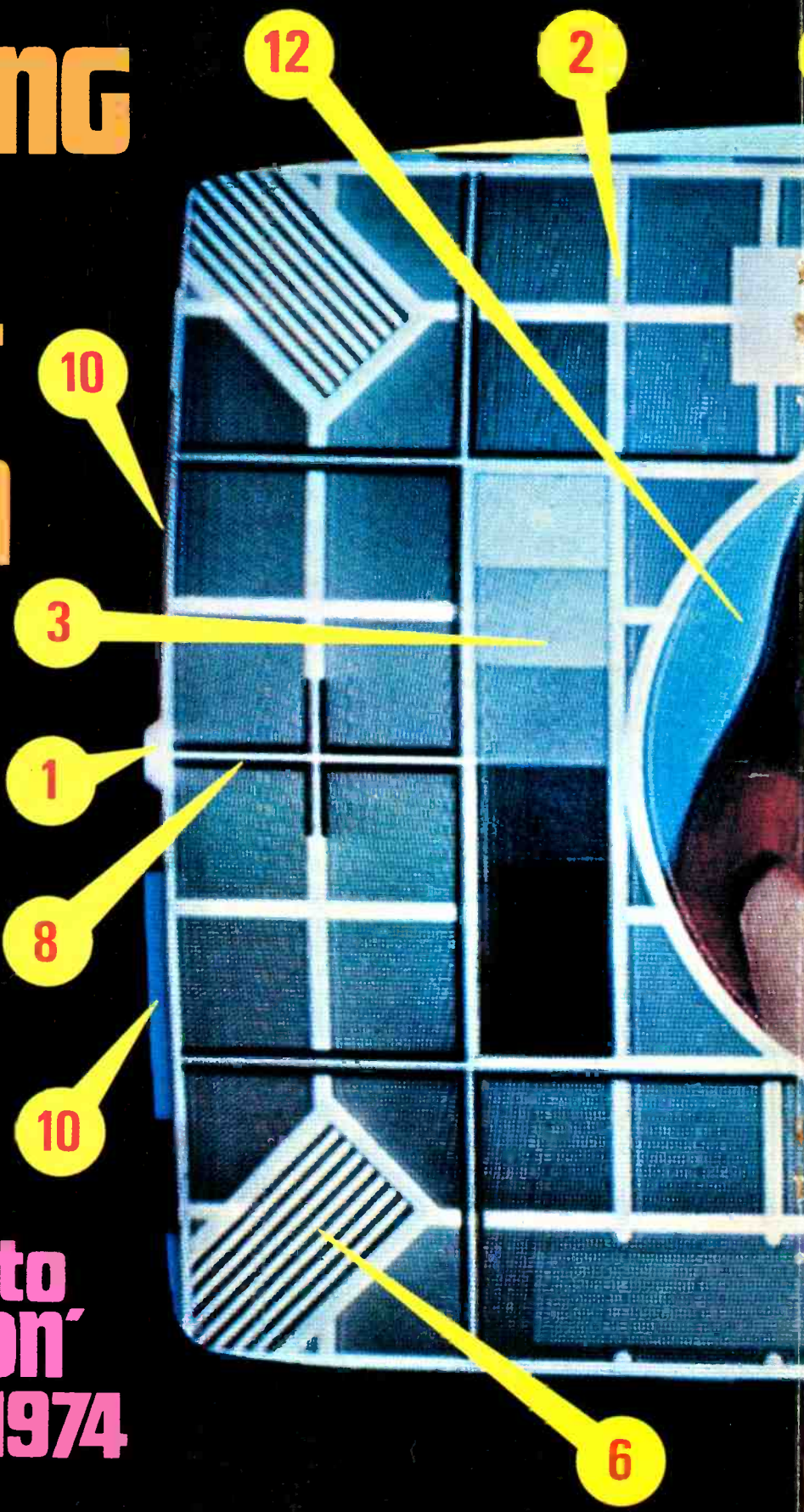

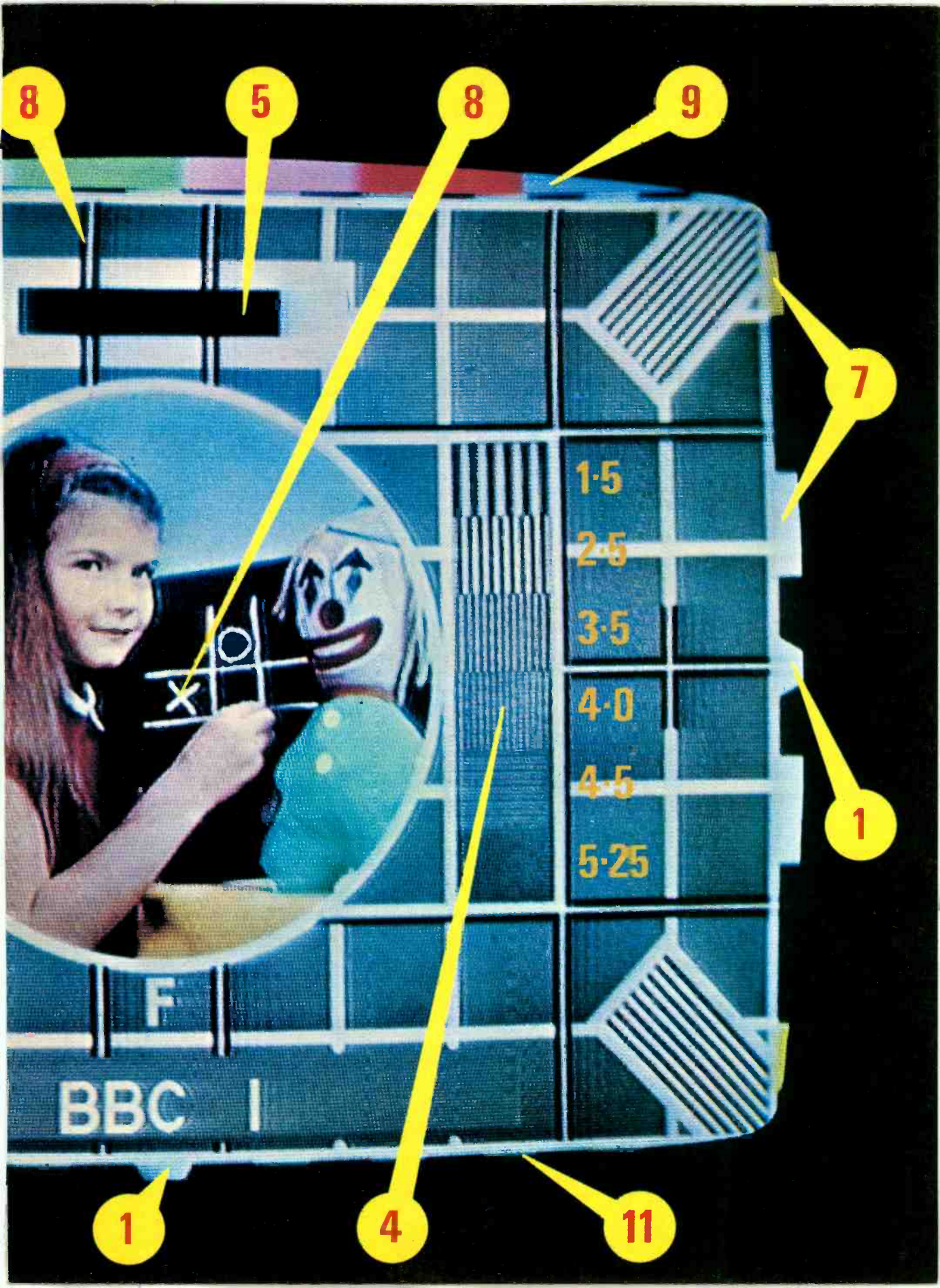

8

5

8

9

7

1

1

4

11

1.5

2.5

3.5

4.0

4.5

5.25

F

BBC I

their frequency is so close to that of the subcarrier. But it is also true of the lower-frequency gratings, due to their squarewave form.

The vertical lines (2) of the white background squares are useful for checking the overall standard of resolution. Phase distortion shows up as smearing of the line on the right-hand side or as overshoot (a black outline to the right of the white line). A very slight overshoot is much preferable to smearing and may subjectively improve the definition. Ringing shows up as a multiple image close to the right-hand side of the lines. This is usually accompanied by increased contrast in one of the frequency gratings compared to the others, indicating the approximate frequency at which the ringing is occurring.

Note that on small colour tubes (say below 22in.) and on all colour tubes at high levels of brightness and/or contrast the resolution may be limited by the tube rather than the circuitry.

(5) *Letter Box Pattern*: Used to show up poor low-frequency response which causes streaking to the right at the right-hand edges of the black and white rectangles.

(6) *Diagonal Corner Stripes*: Used to check uniformity of focus. The focus is never quite as good in the corners as at the centre, especially with 110° tubes. Since the main interest of the picture is usually at the centre however it is best when setting the focus to concentrate on this area—the noughts and crosses are useful—rather than trying to compromise with the corner focus.

SYNCHRONISATION

(7) *Right-side Castellations*: Faulty sync separator operation will by allowing picture information to pass through cause horizontal displacement of the picture in line with the yellow and white castellations. Displacement caused by the yellow castellations but not by the white ones indicates interference to the sync separator action as a result of excessive colour subcarrier. Disturbance on the white castellations as well indicates excessive bandwidth reduction in the video feed to the sync separator.

Since all colour sets have flywheel line sync the disturbance will be a gradual bending of verticals rather than an abrupt displacement.

CONVERGENCE

(8) The central white cross provides a check of static convergence and some of the white lines in the background grid are outlined in black as a check of dynamic convergence. If any adjustment is needed however there is no substitute for a crosshatch generator.

COLOUR PERFORMANCE

First we must obtain the correct saturation setting. There is only one such setting, even though most sets have the saturation as a user control. This appears to be done for one or more of the following reasons: (a) the chroma gain may not track adjustments of the luminance gain (contrast) control; (b) there may be no (or inadequate) chroma a.g.c. so that saturation varies with fine tuning, propagation effects etc.; (c) it seems to be the fashion to have a front panel "colour" control—even if only to advertise the fact that the set is a colour one—and this is turned up by viewers to counteract the effect of excessive ambient lighting.

The correct method of adjustment however is to switch off the green and blue guns and set the control so that the two pairs of red bars seen at the top of the test card are of equal brightness.

Now for a review of the colour performance checks on the Test Card.

(9) *Electronic Colour Bars*: By observing the individual red, green and blue signals on the colour bars the accuracy of the decoding can be checked. This can be done fairly accurately on the c.r.t. by switching on one gun at a time. On the blue gun the bars will appear alternatively bright and dark: all the bright bars should be of exactly the same brightness, as should all the dark bars. The same applies to the red picture except that there are two pairs of adjacent bright bars. On the green picture the left half of the colour-bar display will be uniformly bright and the right half uniformly dark. Note that the term dark does *not* mean black.

On sets with RGB tube drive a more accurate check can be made by displaying each of the RGB signals in turn on an oscilloscope. A useful display, although with some flicker and possibly lack of brightness, can be obtained on the Test Card by triggering the 'scope at field rate. It is better however to wait for BBC-2 to transmit the colour bars over the whole screen, when the 'scope can be triggered from the line scan. The waveforms should have values of 100% or 25% of the value—depending on the colour of the bar—of the peak white (left-hand) bar, taking the black (right-hand) bar as a zero reference.

Uncorrected chroma phase errors due to maladjustment of the chroma delay line circuit show up as Hanover Bars on the c.r.t. or as differences in adjacent lines (double image when using line triggering) on an oscilloscope.

There is no colour burst during the field sync period so it is possible for the reference oscillator phase to drift during this time. This shows—assuming a PAL-D receiver—as a reduction in saturation of the colour bars towards the extreme top.

(10) *Left-side Castellations*: These are red and blue and are used to check whether the burst gating circuit allows picture information to pass through. Since the subcarrier phase on the castellations is very different from that during the burst the reference oscillator phase will be disturbed if this fault is present. The result on a PAL-D receiver is horizontal bands of reduced saturation in line with the left-side castellations.

(11) *Bottom Castellations*: These provide a means of checking reference oscillator performance at the end of the field as compared with the start. They also, along with other features such as the left- and right-side castellations and the central colour picture, provide a check of registration between the luminance and colour-difference signals. An error in this respect, resulting in the colour appearing to one side of the luminance image, indicates that the luminance delay and the chrominance bandwidth are not correctly matched to each other.

(12) *Central Colour Picture*: This contains flesh tones and bright colours for overall assessment. The bright colours show up Hanover Bars while the noughts and crosses show up ringing. Having high luminance and saturation the doll and the yellow tablecloth show up sound-chroma beats which can occur when an excessive amount of sound carrier reaches a diode detector used for luminance demodulation.

This then is the full story on Test Card F. No receiver is perfect of course, but if any of the imperfections mentioned above are visible on Test Card at normal viewing distance it is time for action!

Text by David Robinson, B.Tech. (Hons.). Our test card photograph was taken from a Forgestone 400 receiver. Ghosting—images to the right—can be clearly seen: this is due to the difficult reception conditions in the locality where the photograph was taken. The raster was set for slight horizontal overscan to conform with the correct e.h.t. setting.

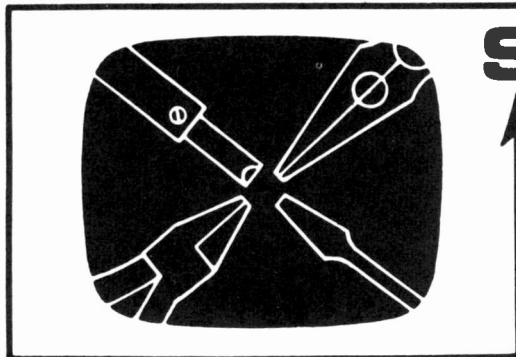

SERVICING television receivers

L. LAWRY-JOHNS

ITT-KB VC100 CHASSIS

THE last of the wired chassis, this receiver can be looked upon as being a single-standard version of the VC51 chassis which we dealt with four years ago. Some of these notes will naturally overlap with what was said in the previous article but this is no bad thing since many readers may have missed the issues or may find a recap of some value. Receivers using the VC100 chassis may be fitted with 19in., 20in., 23in. or 24in. tubes, the only difference being that the 20in. and 24in. models do not have C146.

IF Preamplifier

As these are single-standard sets there is no v.h.f. tuner. The absence of the two valve heaters is compensated in the heater chain by a 40 Ω , 5W resistor (R180) which is wired between the PCL86 and PCF80 valve bases. The absence of the v.h.f. tuner also results in a loss of i.f. amplification. This is made up by the addition of a small panel containing a BF197 pre-amplifier transistor and its associated components, coils etc., also the u.h.f. tuner supply resistor Rk7 and the stabilising voltage-dependent resistor Rk8. It is worth bearing in mind that the 12V tuner supply does not come directly from the main chassis but from the i.f. preamplifier.

AGC Inverter

Another addition is the a.g.c. inverter stage which consists of a BC109 transistor and its associated components. The idea of this is to invert the negative-going i.f. a.g.c. line to a positive-going forward bias for the r.f. amplifier stage in the tuner. In addition the high-impedance negative a.g.c. bias becomes a low-impedance source suitable for transistor application.

VC100/2 Chassis

A variation of the VC100 is the VC100/2 which reverts back to a v.h.f. tuner for v.h.f. relay work. Thus the transistors etc. just mentioned are not required.

Mains Input

The mains input is taken direct to the on-off switch, the single fuse being in the supply to the h.t. rectifier. We mention this point because of a common failing with this and many other sets—the tendency of the mains input filter capacitor to short thus putting an infinite load directly across the mains via the on-off switch. The effect with this chassis depends upon the

fuse fitted in the mains supply feed. If the usual three-pin square plug is used the fuse fitted should be not more than 3A. It is often the case however that the fuse fitted is 13A. In this event one of three things can happen. Obviously the 13A fuse can fail (if you're lucky), but all too often the on-off switch disintegrates instead. The third thing is that the capacitor blows apart and the set continues to function ("we heard a noise like a pistol shot so we switched off straight away"). If the volume/on-off control has to be replaced it is a 500k Ω log. type with double-pole switch. The mains filter capacitor (C142) is 0.1 μ F and rated at 300V a.c.

No HT Supply

The mains supply is taken from the on-off switch to the dropper. This has several sections, some of which remain at a.c. while some (the top three) are at d.c. This must be understood to avoid making a wrong diagnosis when the heaters are glowing but there is no h.t. Look at the circuit and note that the a.c. is presented to the dropper just below the middle, is taken to the small 1A delay fuse then back to the dropper via R165 (13 Ω 10W) and the rectifier, thus arriving back as d.c. on the upper sections. Thus the drill in this situation is to check the fuse, then R165, then the 7 Ω section R169 and up, remembering that the reservoir capacitor (C145) may still be charged and only waiting an opportunity to discharge, if necessary through you if one of the top dropper sections is open-circuit. Remember also that these top sections are an essential part of the smoothing and that a reduction in their value will result in a ripple which can affect the picture.

No Heater Supply

Quite often however the fault may be not lack of h.t. but of heater supply. The lower sections of the dropper may not be responsible and in fact rarely are. Most often the trouble is due to resistor R166 (135 Ω). This is located on the front right-hand side, behind the screened line output section. If this resistor turns out to be in order the next most likely causes of the failure are the PY801 (which blows its heater when it has a heater-cathode short) or resistor R180 which as previously mentioned is fitted to take the place of the v.h.f. tuner valve heaters in the VC100 only. It is connected from pin 4 of the PCF80 to pin 5 of the PCL86 sound output valve. If mains voltage is present at this point however you can start to sweat until you have proved that the supply is not at pin 8 of the c.r.t.

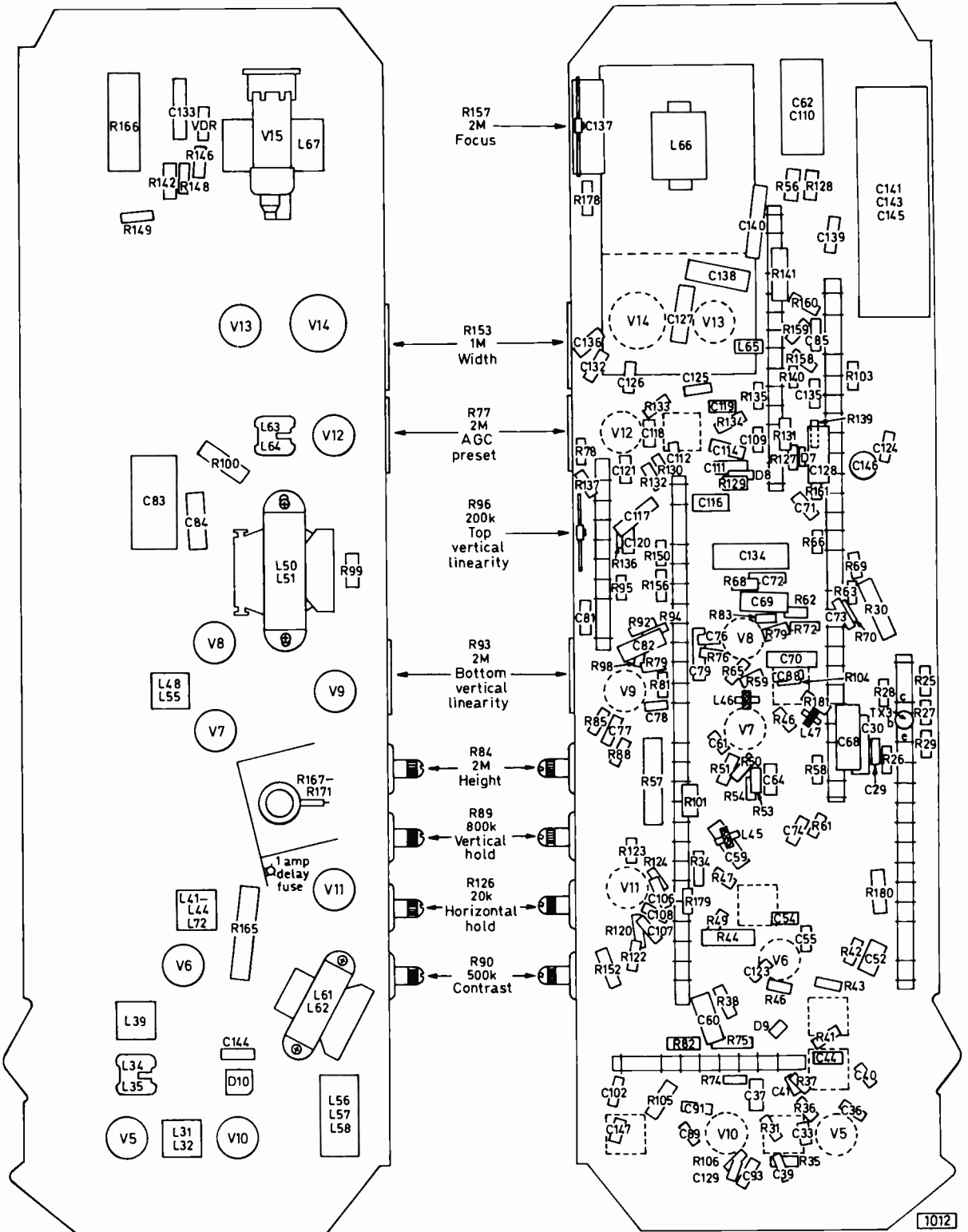

Fig. 1: Component layout above and below chassis (ITT VC100).

base, because if it is and pin 1 is properly connected to chassis a new tube is the next item on the agenda instead of "any other business". It is not unusual to

find that the heater of the PCF802 is open-circuit however and this of course is a happier conclusion to reach.

HT Shorts

Reverting to h.t. supply troubles, a blown fuse or open-circuit resistor associated with it or the dropper can be the result of an h.t. short in some part of the receiver.

Quo Vadis

I'll tell you where my son, you go straight to the PCL84 video amplifier valve base and look at its screen grid supply resistor R51. If this resistor is a mess, take out the PCL84 and throw it to Rome! The value of R51 is 3.9k Ω but the exact value is not at all critical. Also check the 330 Ω resistor R56 which is up near the electrolytics C62/C110—it may be severely damaged. The PCL84's cathode resistor (R54) which has a value of 68 Ω also needs to be checked or better replaced since although it may read right it could well give trouble later due to chemical decomposition.

Fortunately these single-standard models have a capacitor (C59) in the control grid circuit and this of course blocks d.c. Without this the detector diode would be ruined together (probably) with associated resistors in the event of a short to the control grid. This is what happened so often on the earlier dual-standard versions when the set was used on 405 lines, making the repair far more extensive. You may well say that as the blocking capacitor is rated at only 125V the sudden application of full h.t. will probably cause it to short and leave us with this more extensive damage anyway. The answer to this is that the full h.t. doesn't get a chance to be applied to the capacitor due to the dropping action of the various resistors as the current rises and the subsequent failure of the delay fuse which shuts off the supply.

If the PCL84 stage is not at fault, R51 presenting a cheery orange-white-red appearance (uncharred), move along to the EF184 stage and check R44. This 2W resistor is of the same value as R51 and should thus have the same colour bands. If it is blackened or otherwise looks the worse for wear check the EF184 for shorts before suspecting C54.

These are the most probable causes of h.t. shorts: there are many other possibilities but they do not seem to occur very often.

Sound Faults

One very common complaint is that the sound becomes distorted. Before carrying out any signal injection tests to see where the distortion is occurring check the condition of the PCL86 valve. If it is overheated change the valve and check its 120 Ω cathode resistor R123. This resistor will not stand too much current and if the valve has been misbehaving will most certainly need to be replaced. Whilst leakage through C108 could be the cause of this it rarely is, the valve nearly always being the villain of the piece. A voltage check at pin 8 when the new valve has been fitted will however show if a slight positive voltage is leaking through this capacitor.

The loudspeaker is another cause of distortion, due to the cone rubbing. This is a different type of noise which becomes more obvious at low volume levels.

Correct alignment of L56-L58 is necessary in order to avoid vision buzz and it is always as well to check the back-to-front resistance of each AA119 diode (D1, D2) as well as the preset R111 and the capacitor C103.

A very noisy volume control is often caused by leakage through C102.

The Field Timebase

The field timebase consists of a PCL85 working as output and part oscillator and a PCF80 working as part oscillator (triode section—the pentode is the sync separator). Whilst the PCL85 is most often the cause of field faults—ranging from non-operation (horizontal white line) to bottom fold up, lack of height and rolling—the PCF80 should not be overlooked. The PCF80 will not be responsible for bottom compression etc. but can be suspected in cases of no field scan or a rolling picture where the PCL85 is in order.

Weak Field Hold

If weak or varying field hold is experienced and the valves are not at fault (include the PCL84 in this valve check) attention is drawn to the presence of several low-wattage, fairly high-value resistors in the sync separator and field sync pulse amplifier circuits. R63 and R66 are the most troublesome, their normal 330k Ω and 220k Ω values rising way up into the megohm range at the drop of a hat. When taking a resistance reading it is necessary to disconnect one end of each resistor as some low values are associated. Apart from this, voltage checks will reveal which resistor is at fault—approximately 70V is required at pin 6 of the PCF80 and 26V at pin 3. Resistor R70 (390k Ω) should not be overlooked as this and R72 (1M Ω) have been found to have gone high on more than one occasion. When the hold control is at the end of its travel check R88 which is in series with it.

Loss of Height

When loss of height is even at the top and bottom check R85 which is connected to pin 1 of the PCL85. Lack of height in early VC series chassis was due to an 0.1 μ F capacitor which decoupled the boost line feed to the height control. This shorted to the h.t. line (thus overheating the 100k Ω feed resistor). Since the circuit was revised the feed to the height control has been taken direct from the boost line and the only capacitor present is the boost capacitor itself (C134). If this shorts there is no picture anyway.

Field Linearity Faults

When the loss of height is markedly more severe at the bottom C84 will almost certainly be at fault. This can be proved by shunting another electrolytic of approximately the same value across it. C83 is less often at fault, but when checking this remember its voltage rating (275V).

Top compression is less often encountered but is more noticeable nowadays since Ceefax and Oracle rush about at the top and tend to be distracting as soon as they come into view. Whilst there can be several causes, such as the PCL85, C81 or R96 being faulty, the presence of R99 across the primary winding of the field output transformer should not be overlooked. After a period this can fall in value producing top compression. Whilst this does not happen so often on these receivers as it did on some of the earlier Pye group models it is something to bear in mind.

CONTINUED WITH FULL CIRCUIT NEXT MONTH

CCTV

PART 7

Peter Graves

THIS MONTH: SYNC PULSE GENERATORS

DESPITE its name a typical synchronising pulse generator (alternatively sync pulse generator or SPG) generates line drive, field drive, and blanking pulses in addition to synchronising pulses. At this stage we are concerned with the generation of line and field drive pulses only. The other pulses (as will be seen in a later article) are derived from these. An SPG must be a stable source of accurately timed pulses. This calls for high quality engineering and circuit design so that SPGs tend to be expensive. Reliability on the other hand is very high.

When high resolution is required from a single camera, say when a camera and its monitor are used to enable a whole class of students to view a specimen through a microscope, the camera may be fitted with an internal SPG that uses parts of the existing circuit (such as the random interlace line oscillator) and is linked into appropriate points. Typically the extra components required are supplied as an "add-on" printed circuit board which can be purchased separately from the basic camera. These boards are often referred to as 2:1 interlace boards but the operating principles are the same as those of an external SPG feeding a whole studio.

Master Oscillator

The heart of an SPG is the master line oscillator (referred to simply as the master oscillator) which for reasons we shall discuss later normally runs at twice line frequency: all the other pulses are ultimately derived from the output of this oscillator. Since they have a common source the pulses are electrically locked together. Most commercial circuits use a blocking oscillator or a crystal oscillator for the master oscillator stage. Occasionally other circuits, such as the Armstrong oscillator, may be used but these are rare. In fact any stable circuit could be used. Here we are going to discuss in detail only the first two types.

The Blocking Oscillator

Fig. 1 shows a simplified circuit of a typical blocking oscillator. Alternative arrangements have the transformer connected between other electrodes of the transistor (e.g. between the collector and the emitter) but the principle of operation is much the same. The $-12V$ supply forward biases the transistor's base-emitter junction and at switch on the base current will rise causing a corresponding increase in the collector current and hence the current through the primary winding of the transformer. The primary and secondary windings are connected so that a change of primary current in this direction induces current in the secondary circuit and hence into the base such that the transistor turns on further, that is an increase in collector current causes an increase in base current. This further increase

in base current causes the collector current to rise and there is a rapid regenerative action with both the collector and base currents increasing very rapidly.

As the collector current increases, the voltage across R1 (and hence the voltage across C1 which charges) also increases until it approaches the voltage of the h.t. rail ($-20V$ less the drop across the transformer primary and the transistor itself). The regenerative action cannot continue indefinitely however: when the transistor is driven into saturation further increase in base current has no further effect on the collector current. Since the collector current is then no longer changing, the magnetic field built up around the transformer primary winding during the time the current was increasing collapses, inducing a heavy current pulse in the secondary winding in the opposite direction to previously (as a consequence of Lenz's law). The transistor is thus turned hard off and its collector current drops to zero.

The base will then be at approximately $-12V$ and the emitter (due to C1 being charged) at approximately $-20V$. The base-emitter junction is thus reverse biased and the transistor will not turn on again until C1 has discharged sufficiently through R1 for its base-emitter junction to be once more forward biased. Conduction will then restart and the process repeats itself. It will be seen that the collector current consists of a series of pulses.

The point at which the transistor turns on again and thus the repetition frequency of the output pulses can be adjusted by changing the $-12V$ rail voltage or the value of C1 or R1.

Practical Circuit

Fig. 2 shows a more practical circuit. A tertiary winding has been added to the transformer to provide the output and a diode (D1) is connected across the transformer's primary winding to eliminate ringing. This is a damped high-frequency oscillation that can occur when the current changes suddenly. When the

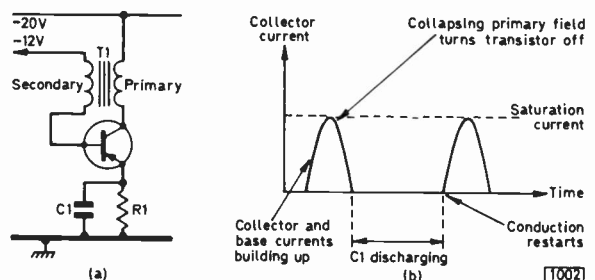

Fig. 1: Basic blocking oscillator circuit (a) and waveforms (b).

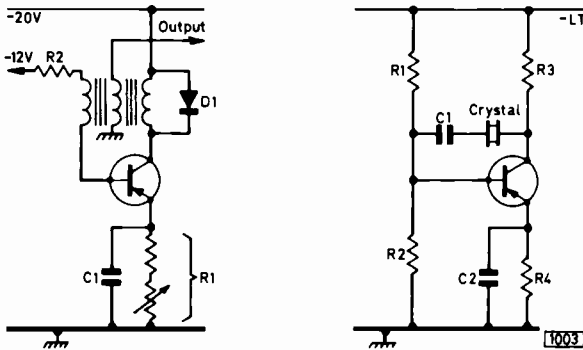

Fig. 2 (left): Practical blocking oscillator circuit.

Fig. 3 (right): One form of crystal oscillator.

polarity of the voltage across the transformer's primary winding reverses D1 will be forward biased, damping out the oscillation. R1 is made partly variable to give fine frequency adjustment for setting up while R2 is added as a base current limiter to prevent damage to the transistor.

The chief disadvantages of the blocking oscillator are that it needs a comparatively heavy and expensive iron-cored transformer and that its operation depends on the characteristics, which may change with age and temperature, of the transistor. The crystal oscillator is not dependent on this.

Crystal Oscillator

Although the frequency of a crystal oscillator can be adjusted by very small amounts (a process known as pulling) the crystal oscillator must be regarded as a fixed-frequency circuit. We will be discussing some of the reasons for choosing between the blocking oscillator and crystal oscillator circuits next month. Frequency changes are carried out by changing the crystal. The crystal itself is a thin, accurately cut slice from a larger, complete quartz crystal of high purity. Metal electrodes (often gold) are deposited on opposite sides of the slice, and lead-out wires—which are also used to support the crystal—are soldered to the centre of the electrodes. Often the whole assembly is mounted inside a B9A valve envelope to protect the crystal from damage or contamination. For very accurate frequency control the crystal oscillator with its crystal is mounted in a temperature-controlled oven. This refinement is rarely encountered in CCTV work however.

The crystal will oscillate mechanically at the mechanical resonant frequency of the slice when an a.c. voltage is applied across the electrodes. Conversely if the crystal is oscillating mechanically an a.c. voltage appears across the electrodes, generated by the mechanical flexing of the crystal (this is known as the piezoelectric effect and is also exploited in the crystal gramophone pick-up). It is possible to make a self-sustaining oscillator therefore by picking off this voltage, amplifying it and feeding it back to maintain the crystal in oscillation. Under these conditions the crystal exhibits a very sharp resonant peak, much sharper than can be obtained with practical LC components: the crystal acts as if it was a conventional tuned circuit of exceptionally high quality.

This implies that the arrangement can be used to produce an oscillator with excellent frequency stability.

One type of crystal oscillator circuit is shown in Fig. 3. If the crystal and C1 are removed it will be seen that the circuit is a simple common-emitter amplifier. The crystal and C1 provide a positive feedback path between the collector and the base of the transistor and the feedback energy keeps the crystal in oscillation.

Deriving the Field Pulses

Whichever circuit is used the field pulses are derived from the master oscillator output by a process of frequency division. It is theoretically possible to use an oscillator operating at field frequency as the master oscillator stage and to multiply up to line frequency: practical frequency multipliers have insufficient phase stability to make this method feasible however.

Let's consider the most common system in use in this country—625 lines, 50Hz field, 2:1 interlace. For this system 625 lines corresponds to a line repetition frequency of 15.625kHz. Starting from the beginning of the odd field the next field pulse (the one that ends the odd field) must occur after $312\frac{1}{2}$ lines. So if we take the start of the odd field as zero (i.e. the first line is number 1) the frequency divider must count $312\frac{1}{2}$ line pulses before it delivers a field pulse which signifies the beginning of the field blanking/field sync period. After a further $312\frac{1}{2}$ lines it must deliver another field pulse—at the end of the even field. And so on. But practical frequency dividers can divide only by whole numbers, say 312 or 313, not $312\frac{1}{2}$. If the master oscillator runs at twice line frequency however its output pulses will occur at half line intervals so that to count $312\frac{1}{2}$ lines the frequency divider counts 625 half lines. 625 is a whole number as required.

Equalising Pulses

In some SPGs an output is taken at twice line frequency to provide equalizing pulses—pulses added to the camera output waveform during the field blanking period to keep the monitor line oscillator running at the correct speed over the whole frame without having to distinguish between the end of the odd and the even fields. By this method correctly timed pulses are automatically supplied.

Frequency Division

Fig. 4 shows in block diagram form the arrangement of master oscillator and frequency divider. A more sophisticated version—allowing for mains lock—will be described next month. An additional divide-by-two stage generates line frequency pulses from the master oscillator output.

The frequency divider chain or counter chain usually consists of blocking oscillator frequency dividers or bistables—commercial circuits favour bistables. Although the use of blocking oscillators requires fewer stages for the same overall division ratio they are heavier (because of the transformer) and more prone to characteristic shifting with age and temperature. They also need setting up and are less flexible than the bistable circuit when it comes to selecting a different line standard.

Blocking Oscillator Frequency Divider

The circuit of a blocking oscillator frequency divider is shown in Fig. 5. Unlike the free-running blocking

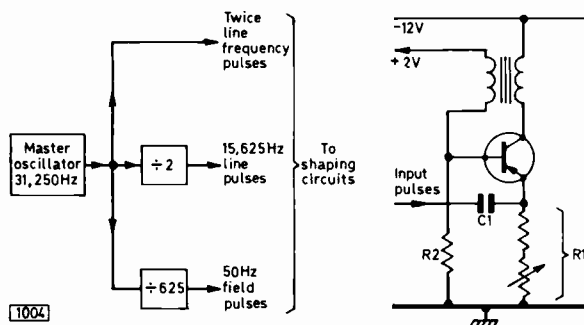

Fig. 4 (left): Block diagram of a master oscillator plus frequency divider arrangement.

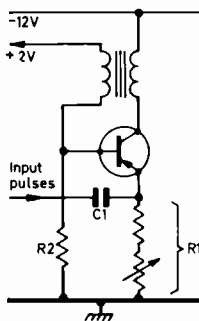

Fig. 5 (right): Blocking oscillator circuit which acts as a frequency divider.

oscillator (Fig. 1) the divider is normally cut off. Positive-going pulses applied to C1 gradually build up a charge on the capacitor and at some stage after a certain number of pulses have been applied the transistor's base-emitter junction will become forward biased and conduction will start, initiating the regenerative rise in currents described before which drive the transistor into saturation. During the time the transistor is conducting C1 will discharge through the transistor: when the transistor is driven off by the collapse of the primary field, the base-emitter junction will no longer be forward biased and the transistor will not turn on again until sufficient charge from the input pulses has been built up on C1. By choosing suitable values for C1 and R1 it is possible to make the transistor turn on after say 5 or 7 pulses have been received. By making R1 variable it is possible to get the circuit to divide by any (whole) number between 2 and about 7. The upper limit is set by the need for reliable switching: it's no good having a circuit that divides by 7 at one time and 8 at another! As the capacitor charges, each successive charge has less effect on the voltage across the capacitor (as a percentage of the total voltage) and it becomes more difficult for the circuit to distinguish between the effect of one pulse and that of the next. This leads to unreliable switching. A blocking oscillator divider also needs to be set up initially and again for each change of line standard.

Divider Chain

In practice individual stages are strung in a line, the output of one feeding the input of the next. For our example, 625 is made up of the factors $5 \times 5 \times 5 \times 5$ so that four stages each dividing by five are needed. For the American 525-line, 60Hz field, 2:1 interlace the factors are $5 \times 5 \times 7 \times 3$: four stages are again needed, but different stages have different division ratios. Using blocking oscillators, change of line standard involves setting up the stages to divide by a different amount—a bistable frequency divider simply needs some links changed.

The Bistable Circuit

Fig. 6 shows a bistable circuit with its characteristic cross-coupling in the middle. Essentially a bistable is an electronic see-saw and is capable of being switched between two stable states—that is, the circuit will

remain in one or other state, depending on which one it is switched to, until the next switching pulse arrives. Keep the image of a see-saw in mind because at first reading the description of a bistable's operation can be rather confusing, with the voltages and currents flying up and down on both sides.

We will ignore to start with D1, D2, C1, C2, R7 and R8. When the power is switched on to the supply rails the circuit will switch itself into one or other of its two stable states—either Tr1 on (saturated) and Tr2 off (cut off), or Tr2 on and Tr1 off—because of unbalance between the two sides of the circuit (i.e. the resistor values will not be exactly the same because of tolerance variations and the transistors will not be exactly matched). Suppose Tr1 is on and Tr2 is off. Two points arise. First, as the circuit is (normally) symmetrical it does not matter which state is initially chosen; secondly, if Tr1 is on then Tr2 must be off and vice versa.

If Tr1 is on a high collector current (saturation current) will be flowing and there will be a large voltage drop across R1. The voltage at Tr1 collector will to a first approximation be at the same voltage as the emitter, 0V. R3 and R6 form a potential divider supplying the base of Tr2. The top end of R3 is at 0V and the bottom end of R6 at -6V. By suitable choice of resistor values the base-emitter junction of Tr2 will be reverse biased so that it is cut off. Conversely since Tr2 is off no collector current will be flowing and the collector potential of Tr2 will be about that at the h.t. rail, +12V. R4, R5 also form a potential divider, with the top end under these conditions at +12V and the bottom end at -6V. The base of Tr1 is thus forward biased and Tr1 is held on. This is a stable state and the transistors will remain in this condition as long as the supplies are on.

If a positive-going pulse is applied to the base of the off transistor Tr2 via terminal T2 and is of sufficient amplitude to start turning Tr2 on (i.e. the base-emitter junction is forward biased for the duration of the pulse) the switching action will start. This, as in the blocking oscillator, continues after the initiating pulse has finished. When the pulse is applied collector current starts to flow in Tr2 and its collector potential drops towards the 0V rail. This change is coupled across to the base of Tr1 by the action of R4 and R5 and is in the direction to turn Tr1 off. So the collector current of Tr1 starts to decrease and its collector voltage rises towards the +12V rail. This change is in turn coupled back to the base of Tr2, turning Tr2 further on. There is a rapid regenerative action (which is why the multi-vibrator—one of this family of circuits—is used to produce squarewaves) which only stops when Tr2 is in saturation (fully on) and Tr1 is fully cut off. The

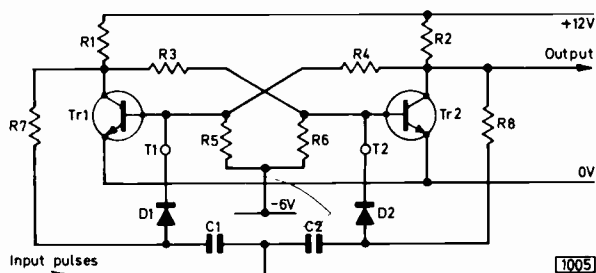

Fig. 6: The bistable frequency divider circuit.

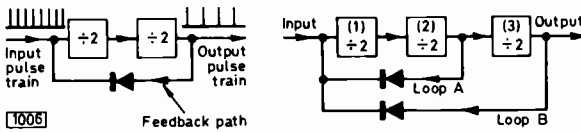
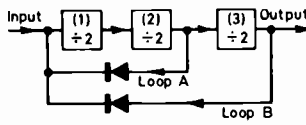

Fig. 7 (left): Divide by three arrangement.

Fig. 8 (right): One method of division by five.



see-saw has thus swung over to its other position. This position is again stable and the circuit remains in this state until a positive-going pulse is applied to the base of the now off transistor Tr1. The circuit will then revert to its original state.

Pulse Steering

When the circuit is triggered by a train of pulses it is preferable to guide or steer successive pulses to the base of the off transistor. Applying a positive-going pulse to both bases simultaneously means that the on transistor is turned harder on and the switching action may not be initiated. The components previously ignored form a pulse steering network. Note that the circuit shown is just one possible arrangement: in others the pulses may be applied to the collectors or negative-going pulses may be applied to the on transistor to start turning it off. The final effect is the same whichever method is employed.

Suppose again that Tr1 is on and Tr2 off. D1 will be reverse biased since the collector potential of Tr1 is close to 0V (the diode is biased via R7). Conversely since Tr2 is off its collector potential will be nearly at +12V and D2 will be forward biased via R8. If a positive-going pulse is applied to the junction of C1, C2 it will be blocked by D1 and thus unable to reach Tr1 base. It will on the other hand be coupled to the base of Tr2 by the low-resistance path of D2. Conversely if Tr2 is on and Tr1 is off D2 will be reverse biased and D1 forward biased and the next input pulse will be routed to the new off transistor Tr1.

Division Ratios

Bistables are sometimes referred to as flip-flops or Eccles-Jordan circuits. Whatever state the circuit is in initially it will take two input pulses to return it to that state—one to flip it into the other stable position and another to flip it back. If as shown we take an output from one of the collectors we will get one output pulse for every two input pulses. If a continuous train of input pulses is supplied the output pulse train will be at half the frequency of the input. The circuit thus divides by two. If two identical stages are connected in series (that is the output of one stage is connected to the C1, C2 junction of the second stage) there will be one output pulse for every four input pulses since there are two frequency divisions by two. Adding a third stage gives an overall division ratio of 8. In general if "n" stages are connected in series there will be one output pulse for every 2^n input pulses. Alternatively stated the circuit will divide the input frequency by a factor of 2^n . If "n" is 3 for example (i.e. there are three stages in series) the arrangement will divide by $2^3 = 2^3 = 2 \times 2 \times 2 = 8$.

For our SPG we want a chain which divides by 625. Nine bistables in series will divide by $2^9 = 512$ which is too low: ten bistables will divide by $2^{10} = 1024$ which

is too high. Note that although something like $2^{9.4}$ has a strict mathematical meaning it has no meaning here since "n" must be a whole number—it indicates the number of bistables used, and there is no such thing as 0.4 of a bistable! This suggests that we cannot use a string of simple bistables for our SPG divider chain.

Use of Feedback

Look at the block diagram shown in Fig. 7 however. Here the final output from a chain of two bistables is fed back to the input via a diode. The diode isolates the input from the output in one direction—input pulses cannot get to the output since the diode is reverse biased in this direction for positive-going pulses; output pulses can be returned to the input however. Without the feedback loop the circuit will divide by four ("n"=2). When the feedback loop is connected, every time an output pulse appears it will be fed back to the input and will act as an additional input pulse. Since one output pulse appears for every four input pulses it will require only three more pulses from the input train before the next output pulse occurs. The process will then be repeated. The circuit is still dividing by four but is supplying one of the four pulses itself. Thus the overall effect on the input pulse train is division by three—one output pulse for every three input pulses. By choosing the stages over which feedback is applied and allowing feedback loops within feedback loops we can obtain a wide variety of division ratios. The system is very flexible as alternative division ratios can be quickly selected by linking feedback paths in and out.

Division by Five

We want to divide by 625, which is $5 \times 5 \times 5 \times 5$. So if a circuit capable of dividing by five can be devised the problem is solved. Fig. 8 shows one way of doing this. If loop B and bistable 3 were removed the circuit would divide by 3 as before. Adding bistable 3 alone would give a division ratio of $3 \times 2 = 6$. Adding loop B lowers the overall count ratio by one, i.e. the overall division ratio is $6 - 1 = 5$ as required.

Different manufacturers use their own selection of circuits and loops—the circuit is versatile and the aim is for component economy. It is important that the correct links and the correct links alone are connected. Incorrect linking may give pictures and as all the pulses may be present the cause of picture twitches or odd rolls may go unrealised.

Faults

As previously mentioned reliability is high: occasionally however a component fails along the divider chain and this calls for logical working down the chain from the master oscillator output, using a 'scope. Some designs use metal-cased transistors that have the collector connection made to the case (for better cooling): with these it is just a question of touching with the 'scope probe each can in turn down the line. Perhaps it would be well to note here that the output pulses of these circuits are in the form of "spikes" at the correct time intervals. They have to be processed by other circuitry before taking on the nice rectangular forms so familiar in television work. We shall be looking at the various circuits used for this purpose and their operation in a subsequent article.



FOOTBALL & other GAMES

P. BUSBY* B.Sc

ON THE TELEVISION SCREEN

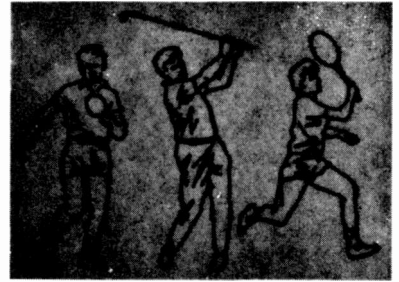

*IPC SERVICES LTD.

PART
FOUR

This month we describe the circuitry for generating the touch and bye lines for the football game. We also include the modifications to a particular colour receiver, enabling you to display the full game on the TV screen as featured on the cover of the July issue.

Touch and Bye Lines

In Fig. 16 the touch lines W and X and the bye lines Y and Z are shown together with the waveforms necessary to produce them. Referring to Fig. 19 we see that the circuitry is similar to the man and ball circuits outlined in the first article.

The resistive chain VR202, R202 at the input to the Schmitt trigger IC201a serves to pull down the line ramp so that IC201a triggers at a preset position along each line. The wiper of VR202 should be set near the top (line ramp end) so that it determines the start of lines W and X. The second Schmitt trigger IC201b is set to switch near the end of each line: it will then terminate lines W and X by feeding a zero input to pin 2 of IC201a.

The output of IC201a ("h" in Fig. 16) is differentiated by C208, R208 and the positive-going edge produces a pulse ("j" in Fig. 16) which is used to determine the thickness of line Z. A negative-going pulse will be generated by the zero-going edge, but this will be suppressed by the following logic gates. IC206a inverts waveform "h" and C207, R207 differentiate the leading edge to give a pulse ("k" in Fig. 16) controlling the width of line Y.

Goal Mouths

If we move on to IC203 we see that an identical arrangement defines the width of the goal mouths, except that in this case the field ramp is applied to the top of VR205 and VR206.

The circuitry to generate the lengths of lines Y and Z and the width of lines W and X differs in that the output of the Schmitt trigger (IC202b) defining the end of the line is not fed back to the first Schmitt trigger IC202a. The output of IC202a ("a" in Fig. 16) is inverted by IC206b and fed to the NAND gate IC205b together with the output of IC202b ("b" in Fig. 16). The output from IC205b is shown at "c" in Fig. 16.

Note that IC205 is a quadruple NAND gate with open-collector outputs: thus pull-up resistor R211 is required at its output.

As before, the leading and trailing edges of the pulse are differentiated—by C209/R209 and C210/R210—to give pulses which determine the widths of lines W and X. The reason for using the extra gate IC205b here will become clear later when we deal with the logic for reflecting the ball from the touch lines.

Gate IC207a subtracts the pulse controlling the goal mouth width ("f" in Fig. 16) from the pulse defining

★ Components list

TOUCH & BYE-LINE GENERATORS & LINE/MEN/BALL MIXER (MONO FOOTBALL)

Resistors: (all $\pm 5\%$, $\frac{1}{2}W$)

R209, R210	220 Ω	R211, R212, R213	1k Ω
R207, R208	390 Ω	R201—R206	1.5k Ω

Preset Potentiometers:

VR 201—VR206	500 Ω miniature carbon
--------------	-------------------------------

Capacitors:

C201—C206	1nF ceramic	C211—C213	0.1 μF ceramic
C207, C208	1.5nF	C209, C210	0.33 μF

Semiconductors:

D201—D206	1N914 or 1N4148		
IC204, IC205	7401	IC206	7404
IC207	7402	IC 201—IC203	7413

COLOUR FOOTBALL TV DRIVE CIRCUITS (additional components)

Resistors: (all $\pm 5\%$, $\frac{1}{2}W$)

R213	680 Ω	R214	2.2k Ω
------	--------------	------	---------------

Preset Potentiometers:

VR207—VR210	1k Ω miniature carbon
-------------	------------------------------

Semiconductors:

D207, D208	1N914 or 1N4148	IC219	7410
------------	-----------------	-------	------

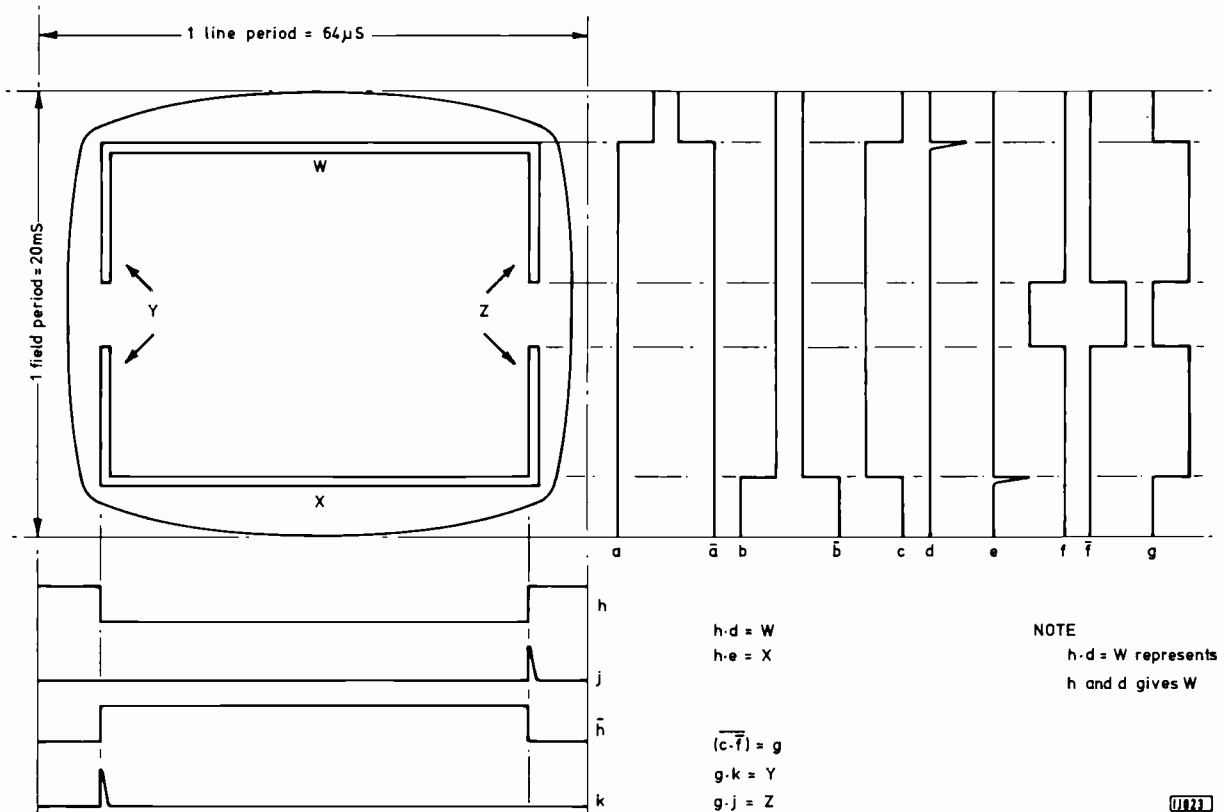

Fig. 16: Generation of the football pitch outline.

the bye lines Y and Z ("c" in Fig. 16). It is convenient to use a NOR gate here for a NAND function as the input pulses are inverted. The output ("g" in Fig. 16) is produced when waveforms "c" and "f" are present at the inputs (remember that a NOR gate only produces a high output when both inputs are low).

Finally, each pair of pulses controlling the width and length of a line is combined in an AND gate in exactly the same way as described in the first article when dealing with the man and ball circuits. For example, waveforms "k" and "g" are combined in NAND gate IC204a to produce line Y.

Output Mixing

All that remains is to mix these outputs together so that all four lines plus the man and ball outputs appear together on the screen. Here we see the advantage of using the open-collector type of gate, as by connecting all the collector outputs to a single load resistor R212 we have in effect a five input OR gate. This is usually known as a WIRED-OR gate. With the value of load resistor chosen a maximum of seven gates can be wired together provided the output is not driving more than seven gates. Here we feed into a single inverter, which drives the video amplifier Tr20 (Fig. 8).

Colour Drive

If you intend to use a colour receiver the various outputs will have to be divided between the three colour channels. By using straightforward logic mixing, where

the signals in each channel are either at maximum level ("on") or black level ("off"), you have a choice of six colours plus black and white. The colours are the primary colours red, green and blue plus the secondary colours cyan, magenta and yellow.

The way the colours are allocated to the different parts of the display is quite arbitrary of course. The author chose cyan for the right man, yellow for the left man, magenta for the ball, white for the boundary lines and green for the background.

Fig. 17 shows how the circuit is modified for colour and how the colours are mixed using the three gates in IC219. The secondary colours represent simultaneous outputs on two channels; thus a yellow man requires outputs on both the red and green channels. Extra wiring is necessary to bring out separately the signals representing the two men, the connections for which are shown on the diagram.

The green background is produced by applying inverted line blanking pulses to the green channel. These pulses are obtained from the complementary output of the monostable IC11 (pin 1) on the ramp generator board. The analogue gate consisting of diodes D207, D208 and resistor R214 is necessary to allow the green background to be turned down to a comfortably low level. The gate output is a composite signal which is at a maximum level for the pulses representing the boundaries and players, an intermediate level for the background and zero level during line flyback blanking.

Potentiometers VR207, VR208 and VR209 are for balancing the signals in the three channels to enable

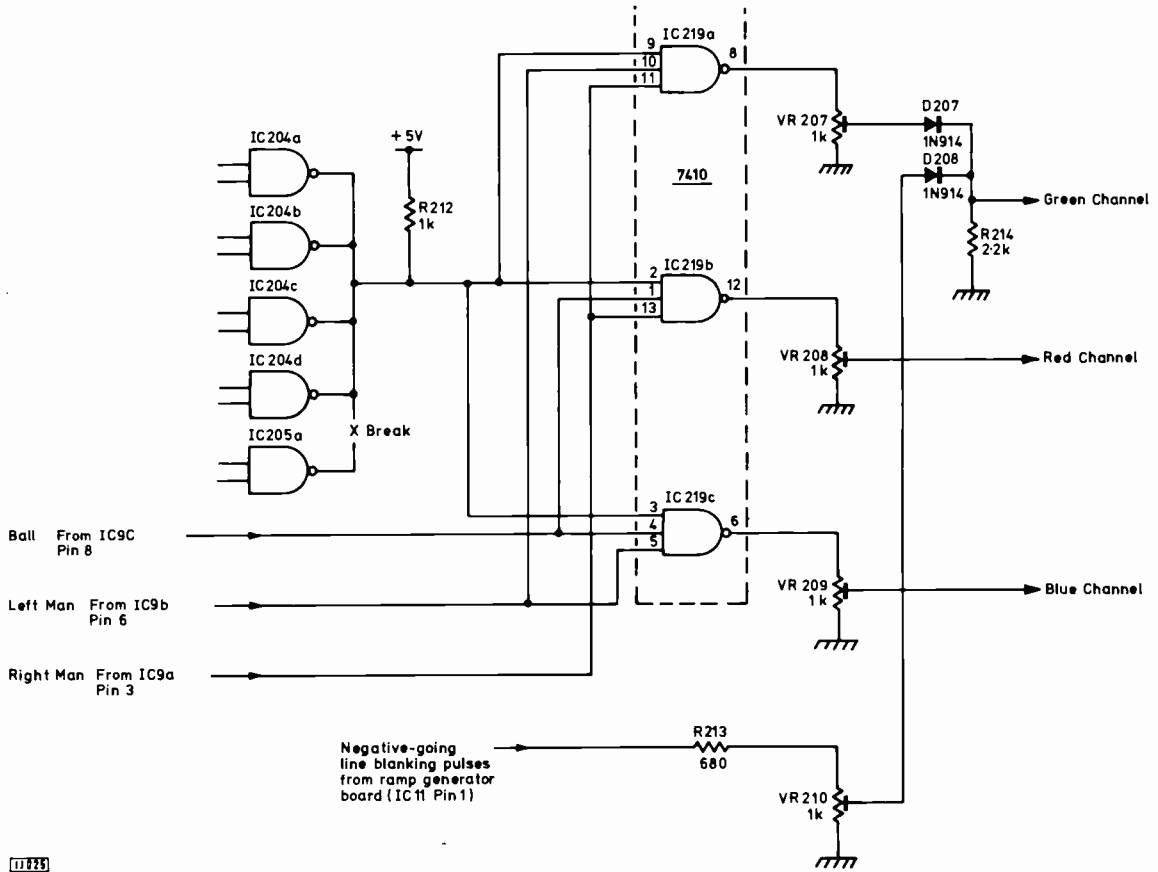

Fig. 17: Modifications required to Fig. 19 to drive a colour receiver (KB-ITT CVC5 chassis).

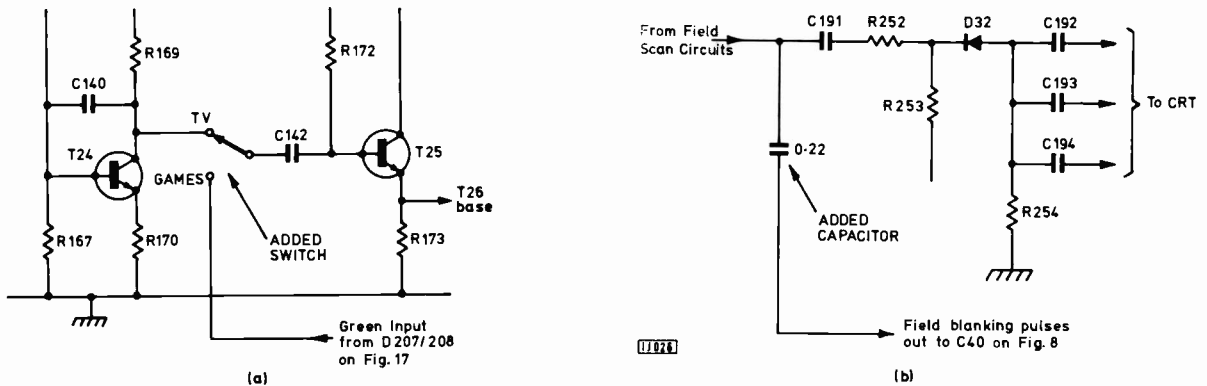

Fig. 18: Connections to the KB-ITT CVC5 chassis.

clean white boundary lines to be obtained. Potentiometer VR210 should work independently to adjust the background illumination.

There is plenty of scope for individual choice of colours. Should you prefer the right man to be red for example simply disconnect the input from the right man to the green channel (IC219a pin 11). Pin 11 should be connected to the +5V rail, or it can be tied to an adjacent driven input such as pin 10. Or you may prefer to have a blue background and call your game Water Polo. For this you would transpose the outputs to the blue and green channels.

Colour Receiver Connections

At this stage we must again give some words of caution. The modifications described in this article refer to a particular colour TV chassis, the KB/ITT CVC5 chassis. We cannot guarantee that these modifications will be suitable for any other type of set. In fact it is quite possible that some sets will not be suitable at all.

Neither the author nor the staff of TELEVISION can enter into correspondence regarding the use of other types of TV receiver for the purposes of this game.

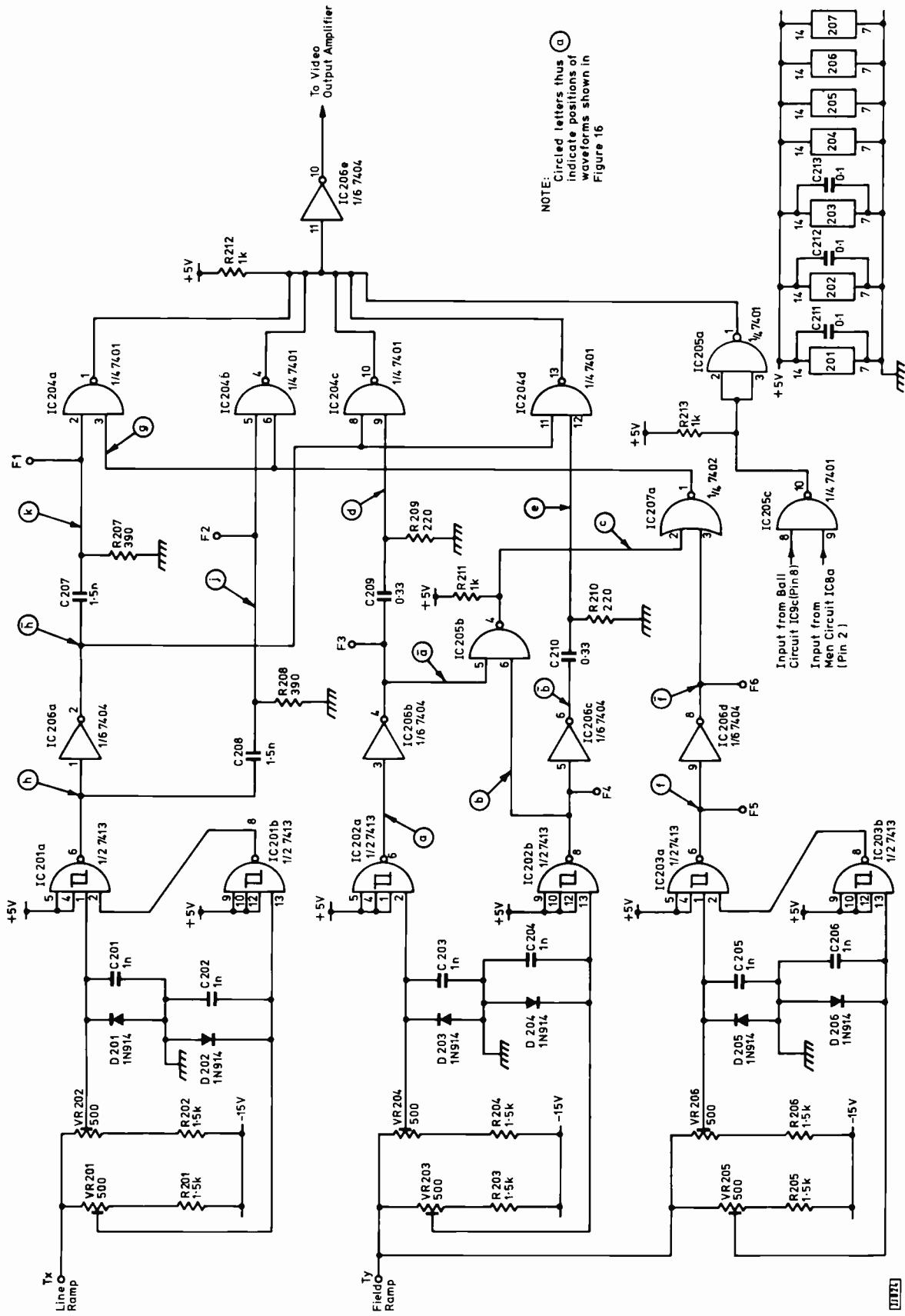

Fig. 19: Monochrome football pitch generators and line/ball/man mixer.

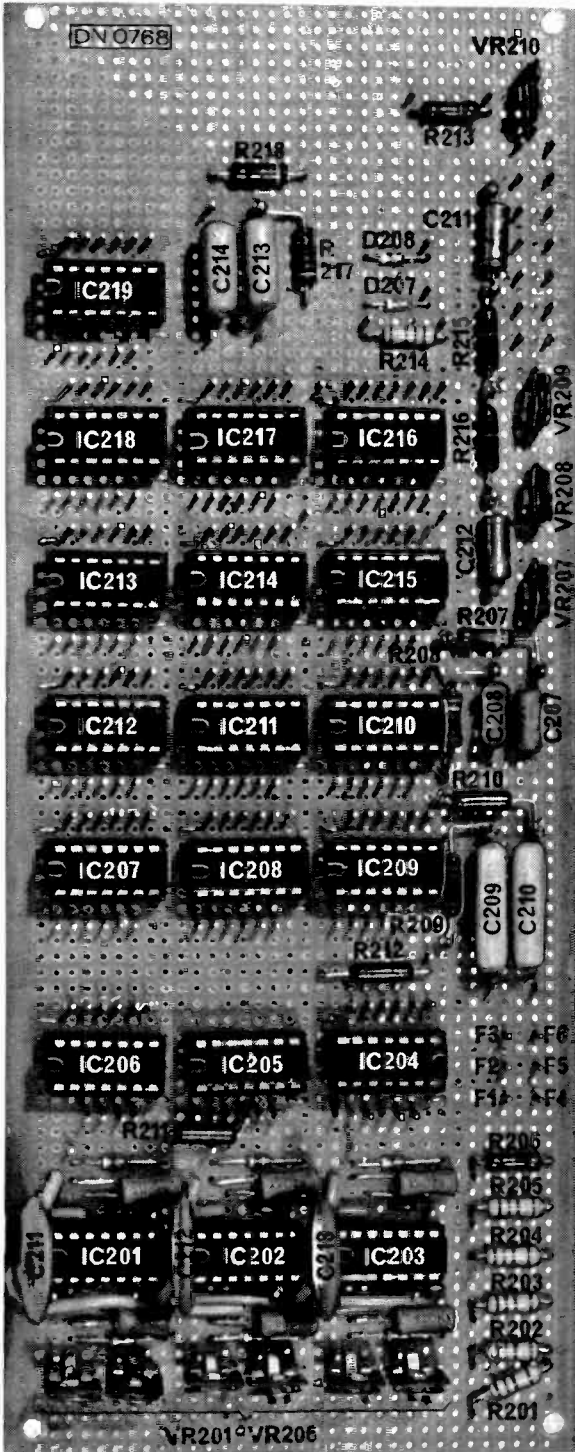

Fig. 20: Football pitch generator board.

Most regular readers of TELEVISION will be well acquainted with TV circuitry however and many will be able to devise their own modifications. We shall be pleased to hear from those who cope successfully with the more common chassis.

The three outputs shown in Fig. 17 require no further amplification as the output swing of a few volts is

ample to drive the set's video amplifiers. Part of the green channel is shown in Fig. 18(a); break into the circuit between T24 collector and the $2.2\mu\text{F}$ coupling capacitor C142. We then use this capacitor to a.c. couple the game circuits into the emitter-follower T25. The corresponding capacitors in the other channels are C82 (red) and C187 (blue).

The field pulses are obtained in a similar way to that outlined for a monochrome receiver. Rather than connecting directly to the c.r.t. grid however they are picked up from C191 via a $0.22\mu\text{F}$ coupling capacitor—see Fig. 18(b). Should the signals prove too large and cause erratic firing of the field ramp generator R41 on the ramp generator board can be reduced to about $10\text{k}\Omega$.

Line blanking signals are picked up as before, with the capacitive pick-up plate well secured to the inside of the line output section cover adjacent to the PL509 line output valve.

Construction

The components are mounted on stripboard as shown in Fig. 20. The control logic for reflecting the ball from the touch lines and the man/ball interception, to be described in a later part, will also be included on this board. The i.c. packages are laid in a regular matrix with the +5V supply and earth connections linked to strips running between them.

Apart from the three Schmitt trigger i.c.s (IC201, IC202, IC203) the pin connections to each package are brought out to pcb pins and all interlinking is done on the back of the board with thin equipment wire. Although the end result may look like a mare's nest this method has much to recommend it: each interconnection will be by the shortest route and the criss-crossing of the wires will minimise interference.

Testing

Once the receiver modifications have been carried out the partially completed board comprising the circuit shown in Fig. 19 (plus Fig. 17 for the colour version) can be tested. Adjust VR201 to VR204 to give the dimensions of the football pitch. Note that these potentiometers have considerable latitude and it is possible for a line to be terminated before it has started, giving no line at all. Adjust the width of the goals with potentiometers VR205 and VR206.

Next month we will describe the circuitry governing the ball motivation of the football game.

NEW WIDEBAND UHF AMPLIFIER

A new low-noise, wideband u.h.f. aerial amplifier designed for TV distribution head-end applications in areas of low signal strength and where trouble is experienced with strong interference signals has been introduced by Wolsey Electronics (Cymmer Road, Porth, Rhondda, Glamorgan). Called the Orbit, the amplifier has a typical noise factor of 2.6-2.8dB, covers the range 460-860MHz and has a gain of typically 18dB. The Orbit is line powered at 24V d.c. from a stabilised power unit also available from Wolsey. An extremely weather-resistant housing is provided. The amplifier is being used by our long-distance TV correspondent Roger Bunney who has written enthusiastically about it. (See page 451 August.)

LONG-DISTANCE TELEVISION

ROGER BUNNEY

THE 1974 Sporadic E season has been quite unusual. As I type this column on Sunday morning July 28th one receiver is displaying a very noisy NOS (Holland) EBU test bar and, musing on this signal level and indeed the signals over the past month, I recall that there have been very long periods when just a glimpse of such a weak signal would have been welcome. Certainly the number of openings has been down this season compared with previous seasons. The most significant aspect of the 1974 season however has been the reception of really long-hop signals while the shorter-hop signals have been lacking. Distant signals have been received in comparative abundance—Lebanon, Jordan, Crete, Albania, Ghana, Canary Islands and a possible North/South American signal!

Month's Round-up

Startling news came in from two separate DX enthusiasts relating to a 525-line, 60Hz field signal on ch. A2 at 0020-0035 CET on the morning of July 19th. Fortunately RTP (Portugal) were still on the air, giving an immediate confirmation of the different transmission standard. Both Ryn Muntjewerff (Holland) and Keith Hamer (Derby) noted the signal which consisted of a programme with two men talking in a large garden/park. This signal will be almost impossible to identify but on an off-chance a letter has been sent to the AFRTS transmitter (TV) on the Azores in case they have changed from ch. A8 to ch. A2 (Crete carried out a similar change).

Jordan has definitely been seen by a number of enthusiasts. For my part the news announcer complete with fez has still to be identified—fortunately the photo is clear. Exciting news for yours truly came this month with a letter from CLT (Lebanon) confirming that my test grid/cross-hatch originated from their ch. E4 outlet at Maasser el Chouf. Hugh Cocks also received this pattern at the same time.

The famed CST electronic pattern type "CS U 01" has been seen with still more variations. Hugh Cocks has sent in a photo showing this pattern with an identification to the right-hand side (as usual), another to the left—somewhat longer—and beneath the latter information a digital clock readout. Garry Smith (Derby) noted another identification—DVA-1—and still another variation on the EBU bar from TVR (Rumania). This was received on ch. R2 with the usual "TVR Bucharesti" and included the date to the left of the main identification.

The WTFDA (Deerfield, Illinois) write to say that some 18 months ago a large meteor "skimmed" within 36 miles of the Earth's surface over Western USA. Estimated to be some 13ft. in diameter and weighing over 1,000 tons, it would have had an impact similar to that of the World War Two atomic bombs and is thought to have been the largest meteor ever observed. Apparently the US Air Force has only recently declassified the story, hence the lateness of this news.

Important news from our Arabian Gulf contact Dr. A. Fadel who reports that the Qatar Television Service commenced colour transmissions on June 15th.

Depressing (?) news from Clive Athowe. Norwich! The

5544 strikes again: this time CST (Czechoslovakia) has been seen using this pattern on ch. R2 with the identification "CST" at the top and "Bratislava" at the bottom. Similarly the DFF (GDR) has been seen using a form of the NOS blockboard type 5552.

Finally in this short news round-up Graham Deaves rang one afternoon recently to report that BRT (Belgium) is now using the Telefunken T05 test card prior to the start of programme transmissions. The card carries the identification "BRT" at the bottom in white.

Log for July

- My log for the period follows:
- 1/7/74 DFF (East Germany) ch. E4—MS (meteor scatter).
 - 2/7/74 TVE (Spain) E2—MS.
 - 3/7/74 DFF E4—MS.
 - 4/7/74 RA1 (Italy) 1B; WG (West Germany) E4—both MS.
 - 5/7/74 TVE E2; RTP (Portugal) E2—both SpE (Sporadic E).
 - 6/7/74 DFF E4—MS.
 - 7/7/74 TSS (USSR) R1; TVP (Poland) R1; CST (Czechoslovakia) R1 twice; TVE E2, 3, 4—all SpE. An unidentified signal consisted of the Fubk test card on ch. E2a/R1 (ORF?).
 - 8/7/74 DFF E4—MS; improved tropospherics from France and Belgium at u.h.f.
 - 9/7/74 TSS R1, R2, R3; TVR (Rumania) R2; TVP R2; SR (Sweden) E2, 3; TVE E3—all SpE; DFF E4—MS.
 - 10/7/74 DFF E4—MS; TSS R1—SpE.
 - 11/7/74 DFF E3, 4—MS.
 - 12/7/74 DFF E4—MS; unidentified SpE R1 signal; TSS R1 also SpE.
 - 13/7/74 DFF E4—MS; TVE E2, 4; RTP E2, 3—SpE.
 - 14/7/74 Improved tropospherics from Belgium.
 - 15/7/74 DFF E4—MS; RTP E2 3; TVE E2—all SpE.
 - 16/7/74 TSS R1, 2; RA1 1A, 1B—all SpE.
 - 17/7/74 DFF E4; TVE E2—both MS.
 - 18/7/74 DFF E4—MS.
 - 19/7/74 DFF E4; TVE E2—both MS.
 - 20/7/74 DFF E4; TVP R2—both MS.
 - 21/7/74 DFF E4; WG E2; CST R1—all MS; improved tropospherics from ORTF (France).
 - 22-23/7/74 DFF E4—MS.
 - 24/7/74 DFF E4—MS; TSS R2, R3; TVP R3; many unidentified signals—all SpE.
 - 25/7/74 DFF E4—MS; TSS R1, 2; TVR R2; MT (Hungary) R1, 2; JRT (Yugoslavia) E3; RA1 1A, 1B; NRK (Norway) E2—all SpE.
 - 26/7/74 DFF E4—MS.
 - 27/7/74 DFF E4; WG E2; RA1 1B—all MS; improved trop from BRT, ORTF.
 - 28/7/74 DFF E4; CST R1—both MS.

The opening on the 25th brought JRT ch. E3 at fair levels carrying the 5544 card: additional wording/letters can be seen to the left of "Beograd", apparently "TVI".

I have now removed the wideband Band III array and

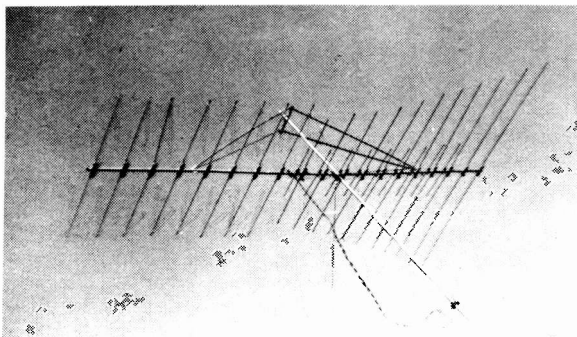

Anthony Mann's wideband (covering Bands I and III) log-periodic array.

replaced this with a new aerial from Telerection, type M10X. This is a ten-element export array covering the CCIR Band III spectrum and seems to perform exceedingly well. The dipole is the "Tru-Match" type i.e. an active straight dipole (to which the cable is connected) plus a closely adjacent parasitic dipole.

News Items

Mongolia: A TV centre has been completed and now runs two programmes. Intervisio programmes are received via four Orbita satellite receiving stations and in the near future Mongolia will commence transmitting a national TV programme via communications satellite.

China: The decision is expected shortly as to whether the Peoples' Republic of China will adopt PAL or SECAM colour. AEG Telefunken demonstrated the PAL system in Peking last year and report strong interest by the Chinese: PAL is well suited because of its long-distance transmission capability while the political climate at present favours its use. Both Sony and Matsushita have despatched colour tubes to China.

Zanzibar: Pye TVT Ltd. have supplied major items for the colour TV service in Zanzibar. Included in the order were two transmitters—both of 4kW and operating at v.h.f. and u.h.f. This is the first fully operational colour TV service in Africa.

New Zealand: Marconi have received a large order for transmitting equipment for the NZBC 2nd chain which is due to come into operation in the latter part of 1975. Two paralleled pairs of 10kW Band I units and three paralleled pairs of Band III units have been ordered together with large quantities of coaxial feeder. The transmitters will be located at Auckland, Wellington, Christchurch, Hamilton, Rotorua and the Manawatu.

Space: The ATS-F satellite is now in operation providing signals on a test basis to the Western parts of the USA. In July 1975 the satellite will be moved along the Equator to the Indian area when it will receive signals from an Indian ground station for the commencement of educational TV programmes to the vast Indian land mass.

Holland: Goes ch. E29 NOS-1 and ch. E32 NOS-2 both reduced in e.r.p. from 250kW to 125kW. We also understand that the future NOS-3 transmitters will be Goes ch. E7 and Lopik ch. E30, the latter with 1000kW.

Brest Mast Collapse

The EBU has released details recently about ORTF actions after the collapse of the Roc Tredudon mast following an explosion. This deprived a million people of broad-

cast programmes from the night of February 14th 1974. The upper stays snapped, folding the 200 metre high mast at 60 metres and causing serious damage to the transmitter building and relay equipment as the mast hit the ground. Special light weight equipments were installed the next day to maintain the basic links. The 16th brought restoration of the circuit to the Pleumeur-Bodou Earth station for International traffic and by the 19th full link operation was available.

The 10kW ORTF-1 ch. F8 transmitter was completely destroyed but the second chain 50kW klystron unit was undamaged as were the v.h.f. f.m. transmitters. Temporary arrays were mounted on the remaining 60 metre section of the mast and a lower power second chain programme service commenced on March 9th. In May a 160 metre temporary mast carrying first and second chain programmes plus the v.h.f. f.m. services went into operation, radiating at half power. This restored the service to most of the original coverage area. During the first few days following the collapse of the main mast a number of low-power gap-filling transmitters were commissioned and strategically placed in the area. These accepted and re-radiated off-air signals from distant transmitters.

From Our Correspondents . . .

A. Papaeftychiou (Cyprus) has written to tell us about the methods used in the island for relaying the recent World Cup football matches. Cyprus Broadcasting (RIK) installed high-gain receiving arrays at the North-West part of the island (Morphou Bay) and received off-air signals from the ch. E9 Rhodes transmitter. The signals were by all accounts of good quality, indicative of the excellent ducting conditions in the area (the signal path length is some 240 miles!). Cyprus Broadcasting is apparently making plans to connect with Eurovision and also to go colour.

Peter Vaarkamp (Holland) has reported on Danish test transmissions. These are daily from 0800 until start of programmes except for Sundays when transmission is for one hour only prior to programmes. SWF-1 is at times using the "old" circular electronic test card (as RUV—Iceland). "Summer pauses" are in operation at the moment on NDR-3, SWF-3 and HR-3 but WDR-3 is continuing with programmes. Kleve ch. E46 has been using a new pattern: Peter has sent an excellent shot of this—it resembles an affluent EBU bar!

Anthony Mann (Western Australia) has sent a photograph of his log-periodic wideband array (covering the whole of Bands I and III). Ribbon feeder is used. Anthony has been most fortunate in receiving TV Malaysia Network 1 on ch. E3—Johore Bahru—with strong signals at 2,000 miles. Even there the tendency for long-hop signals has been noted.

Ryn Muntjewerff has sent a startling—though noisy—photograph of the 0249 card received from Yerevan, USSR (Armenia). This is between the Black and Caspian Seas. Interesting to note the identification at the top of the photo.

Finally we welcome another new reader and TV DX enthusiast, Dave Dobson of Leyland, Lancs. He has done extremely well this past season with excellent loggings of many distant stations. One caused a problem however, a news announcer with the "DTV" emblem. We can confirm that this originates from TVP (Poland).

Lightning Scatter Reception

Some years ago we mentioned the phenomenon of lightning scatter reception. The time seems appropriate to resurrect the subject since summer usually brings a considerable

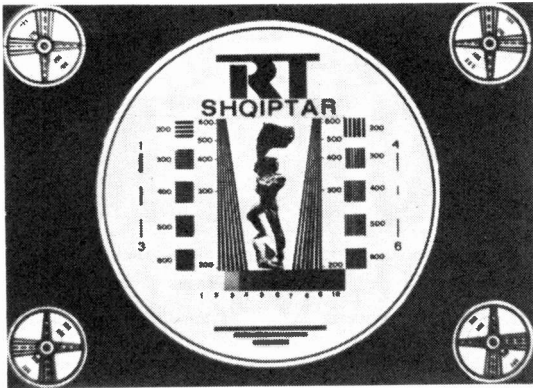

The Albanian (Radiodiffusion Television Albanaise) test card.
Courtesy Keith Hamer.

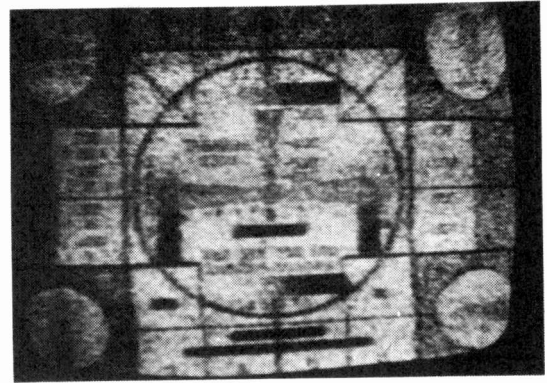

0249 test card received on ch. R1 from Yerevan (Armenia)
by Ryn Muntjewerff.

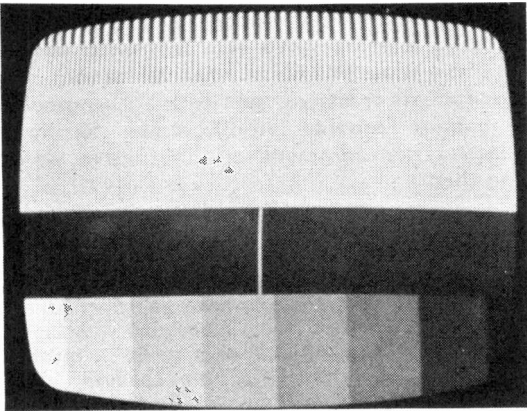

Test pattern received by P. F. Vaarkamp from Kleve on
ch. E46.

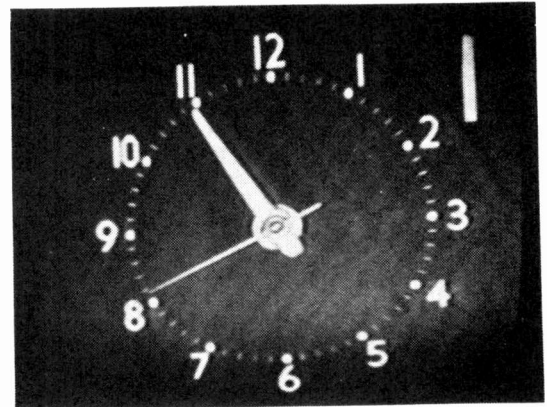

The MT-1 (Hungary) clock.

increase in thundery weather. This propagation mode was discussed at some length in the WTFDA VHF-UHF Digest for March 1969 where several articles on the subject originally published by QST (October 1954), *Nature* magazine (May 28th 1955) and the IRE Proceedings (December 1957) were summarised.

The first reports date back to August 1954 when a radio amateur noted high-level bursts of signal at his Rensselaer, Indiana location from another amateur at Shiloh, Ohio. Signals peaking S8-9 from an average S3 were received at a distance of 240 miles, well under the normal meteor scatter range. The signals resembled the short, sharp peaking characteristic of MS however. *Nature* noted results of experiments at 49MHz, 91MHz and 173MHz using five-element Yagi arrays and at 492MHz using a 12ft. dish. Thunderstorms in the vicinity of monitoring receivers brought normally slow-fading signals (tropospheric) up to a series of rapid impulses on all frequencies. The IRE reported the observations of two Midwest scientists using a 915MHz signal over a 400 mile path: a storm at the midpoint of the transmission path produced lightning bursts of 20-30dB above the median level. "Evidence points to forward-scatter type ionized areas caused by cloud-to-cloud discharges."

The following year TV signals on ch. A2 from KPRC-TV (Houston) and KMID-TV (Midland) were received in San Antonio (200 and 300 miles respectively). Nearby lightning flashes "greatly increased the signal for the duration of each flash; there were more but weaker bursts as a result of more distant storms—most of these lasted less than a second but

some lasted for many seconds." WTFDA members (and the previous AIPA) have also noted this phenomenon. More recently Rod Luoma of Detroit noted WFLD-32 Chicago over 250 miles with short one second bursts during lightning flashes "apparently due to ionization of the air around the strike. There was no signal between strikes". V.H.F. was also affected.

In QST November 1968 u.h.f. activity was again noted (at 432MHz) between radio amateurs—in Arkansas and Oklahoma—during an intense thunderstorm. Signals were received for up to 25 seconds at +40dB above the noise over a path distance of around 500 miles.

To summarise, it seems that all frequencies can be affected. Signals are normally of short duration—resembling MS—and the lightning flash itself needs to be on or near the transmitter/receiver path. Consequently a storm tracking across the reception path at 90° at the midpoint of the path would provide the optimum condition and indicate how far from the "true" direction signals can be reflected. Sheet lightning would undoubtedly give more positive results.

We have often noted the relation between thunderstorms/general thundery weather and the incidence of Sporadic E. It would seem that we can take advantage of higher frequencies (up to 600MHz) at such times. I would discourage the use of DXing equipment when a storm is overhead—in the interests of safety, both of the operator and transistor aerial amplifiers! In conclusion we would be extremely interested in hearing of any observations, reports of signal reception etc. by this mode and hope to report on these in due course.

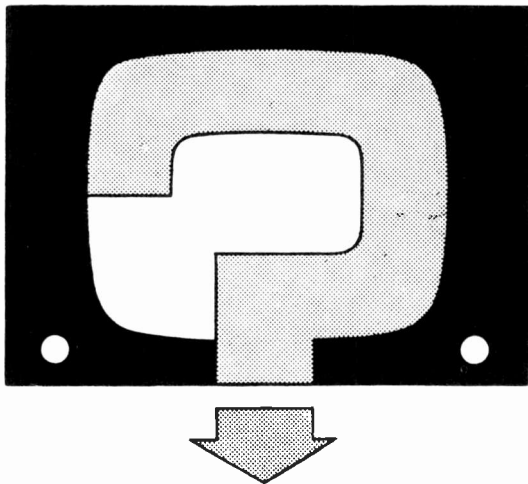

YOUR PROBLEMS SOLVED

BUSH TV125

The problem with this set is sound but no picture. The line whistle is absent. The valves in the line output stage and the boost capacitors have been changed and the chokes in the efficiency diode anode and cathode leads and their connections checked.—T. Guthrie (Sidcup).

If the PL36 line output valve is overheating check the line oscillator circuit—the valve (PCF80), the preset trimmer (sometimes goes short-circuit), the cathode capacitor (560pF), also the flywheel line sync discriminator diodes. If the PL36 runs cool check its screen grid feed resistor (2.2k Ω) and that h.t. is present at pin 9 of the efficiency diode.

PHILIPS T-VETTE

We are unable to tune in the sound and vision together on v.h.f. When the sound is tuned in it is loud but when the vision is tuned in it is impossible to resolve a clear picture. U.H.F. reception is perfect however. I suspect a broken tuning wand in the v.h.f. tuner: if so, how should it be replaced?—R. Coker (Eltham).

The fact that the v.h.f. tuning can be varied means that the wand is not broken—the metal sleeve on it could be loose however. If so unscrew the wand, fix the metal band in position and replace. The tuning point is determined by the amount of wand screwed in. The fault you have could be due to incorrect i.f. alignment however.

MARCONIPHONE 4801

Even with the brightness turned fully up the picture is very dull and flat. Also the scan has expanded to such an extent that the test card centre circle fills the screen. I have changed the valves in the line output stage and checked all voltages except the e.h.t. which I am unable to check.—L. Bedford (Crook).

Your problem is due to low e.h.t.—this reduces the c.r.t. beam velocity and thus increases the deflection sensitivity, resulting in an over-wide picture. You will have to replace the e.h.t. tripler tray therefore. Make sure that you get the right one—Thorn part number 00D4-083. It should have a 22in. yellow lead with white e.h.t. cap. A different tray is used in the smaller-screen versions of this chassis. (BRC 1500 chassis.)

★ Requests for advice in dealing with servicing problems must be accompanied by an 11p postal order (made out to IPC Magazines Ltd.), the query coupon from page 571 and a stamped, addressed envelope. We can deal with only one query at a time. We regret that we cannot supply service sheets or answer queries over the telephone. We cannot provide modifications to circuits published nor comment on alternative ways of using them.

FERGUSON 3654

The picture on this set is very weak and lacks contrast—in fact the contrast controls have no effect at all on either system. The two diodes associated with the a.g.c. line have been checked and seem to be in order. The 6F29 and 6F28 valves have been changed, also the valves in the line output stage, but the problem remains. Another fault is a 6in. grid pattern on the right-hand side of the screen.—J. Emery (Pontypool).

The most likely cause of the weak contrast fault is change of value of the two high-value resistors (R4 and R7) which are in series with the sliders of the contrast controls. Also check R8 and R9 (both 1k Ω) on the main chassis assembly—the feed to the mixer pentode in the v.h.f. tuner is taken via these resistors. If they look distressed check C225 and C221 for leakage—these are ceramic feedthrough capacitors on top of the tuner. Note that the second i.f. amplifier is the 30FL14—it might be in need of replacement. Another possibility is the PCF805 mixer valve in the tuner. For the right-hand side patterning change C115 (may be 0.1 μ F or a 1 μ F electrolytic) which decouples the screen grid of the line output valve (pins 6, 7). (BRC 1400 chassis.)

PHILIPS 534

There is an irritating fault on this colour set—a faint grey-white band approximately 1in. deep is always visible along the top edge of the tube face, particularly at the two top corners. Height adjustment makes no difference and the picture is otherwise perfect. The white band is more prominent when the background is dark—the picture is visible “under” it. The band disappears when there is no picture.—T. Gilmore (Droylsden).

The trouble is due to reflection within the tube from phosphor around the edge of the faceplate. This can be proved by substantially reducing the height—the band should then disappear. This is a characteristic of some c.r.t.s and unfortunately the only cure is to fit another.

BUSH TV166U

The fault with this set is absence of e.h.t.—the DY802 e.h.t. rectifier heater does not light up and the arc from its anode is smaller than the one from the PL504 line output valve. The line oscillator and output valves have been replaced and the flywheel sync discriminator diodes, boost capacitor and output valve screen grid components checked and found to be in order. Does the line oscillator employ cathode coupling—it stops if 3C11 (560pF) is shunted with an 0.1 μ F capacitor? The line output transformer has been tested for continuity and insulation but not for shorted turns. The line output valve and boost diode seem to be running hot but are not glowing.—R. Bucknel (Sunderland).

The line output transformer could be the cause of the trouble—it is not unknown in this model. Check for around -40V at the control grid of the line output valve however—if missing the fault is probably in the line oscillator and all capacitors in this circuit—including the coupler 3C13 (0.01 μ F) to the output stage—should be checked for value and leakage. The line oscillator is a cathode-coupled multivibrator and will stop if its cathode capacitor 3C11 is shunted.

STELLA ST2149A

Vision is perfect on both systems but the sound very poor. Fine tuning improves the sound slightly but at the expense of the vision which on v.h.f. is lost completely. The valves in the sound channel and the voltages have been checked and found to be OK. There are no discoloured components to be seen.—T. Boyle (Newhaven).

The fact that the sound is poor on both systems suggests that the fault is after the detectors. Clean and check the system switch contacts. Suspect a faulty coupling capacitor—i.e. C228 between the triode and pentode sections of the PCL83. Check the loudspeaker, the output transformer and the volume control—especially check the continuity and earthing of the volume control leads. Try connecting an electrolytic across the pentode cathode decoupler (C227, 100 μ F). Note that the triode anode components form an interference limiter network, with R257 (2.7M Ω) fed from the boost rail. Check this resistor and the associated 560pF capacitor (C225). (Philips 152A series.)

McMICHAEL MT762

The picture stays for say quarter of an hour after switching on then goes off with loss of line whistle, the line output valve glowing red hot when this happens. I have changed all the line timebase valves, including the ECC82 line oscillator. When the picture goes the h.t. voltage drops. The sound is not affected.—G. Jones (High Wycombe).

The fact that the line output valve glows red hot suggests that there is no drive to it—the excess current reducing the h.t. voltage. If the ECC82 line oscillator valve is in order check the h.t. supplies to it (pins 1 and 6) then suspect a faulty capacitor. If the coupling capacitor C126 (0.01 μ F) to the output valve is leaky the h.t. at pin 6 will be reduced and a positive voltage will appear where the negative drive should be on the PL36 output valve control grid (pin 5). The other capacitors to check are C124 and C125 (both 150pF) across which the drive waveform is generated, the multivibrator anode-grid cross-coupler C120 (330pF) and its cathode capacitor C123 (800pF).

PHILIPS G24T230A

On turning the contrast or brightness controls to darken the picture an effect like loss of sync occurs at the top and bottom of the picture—further alteration of the controls increases the area over which this is present until the whole screen is affected by a Venetian blind effect.—R. Cullimore (Grantham).

The trouble is oscillation in the line output stage. Try adding extra capacitance across the line drive waveform shaping capacitor C2062 (220pF), if necessary to chassis instead of to the 82k Ω resistor R2172 in series with C2062. The added capacitance should not exceed another 220pF. A 100k Ω resistor in series with the PL504 line output valve control grid—from the junction of C2062/R2168 to pin 1 of the valveholder where the ferrite bead is fitted—may help. Sometimes it is only necessary to redress the leads in the vicinity of the line oscillator ECC82 (V2004) to cure the trouble. (Philips 210 chassis.)

EKCO T418

The line hold is poor, with line slipping, and the field hold is also poor. The conditions in the sync separator stage appear to be correct.—R. Shaw (Pontefract).

Weak synchronisation such as you describe is generally due to trouble in the video amplifier section of the PCL84 (V9). Check especially the screen grid feed resistor (R26 5.6k Ω), the cathode bias resistor (R28 220 Ω) and the control grid stopper resistor (R27 330 Ω). All these resistors tend to change value in this chassis. (Pye 11U series.)

HMV 2616

There is sound but no picture. The e.h.t. is almost non-existent and the e.h.t. rectifier heater does not light up. The valves in the line output stage have been replaced without success. The line whistle is strong and the line output pentode grid waveform seems to be correct. The boost voltage is present, but low. Disconnecting the line coils makes no difference to the conditions in the line output stage. Suspecting that the e.h.t. rectifier heater winding was faulty—as the heater voltage was only 0.25V—I replaced the winding with five turns of e.h.t. cable. There is still no raster however though the heater voltage has increased to 1.3V r.m.s. Do you think that the line output transformer is faulty, or can I increase the number of turns on the heater winding? The line output transformer d.c. resistances all read correct, including the e.h.t. overwinding.—J. Goddard (Putney).

The supply voltage waveform to the EY86 e.h.t. rectifier heater consists of a series of pulses at line frequency, their average amplitude corresponding to the valve's heater voltage. It is impossible therefore to measure either the heater voltage or current with a conventional meter. Restore the original heater winding. If the e.h.t. (and the EY86 heater glow) is restored on removing the c.r.t. anode cap check the voltages at pin 7 (140V) and pin 6 (0-130V) of the c.r.t., then suspect the tube. If removing the c.r.t. anode cap makes no difference, and assuming that the fault is present on both systems, check the boost reservoir capacitor C89 (0.1 μ F 1kV) and smoother C88 (1 μ F) for leakage, R101 (2.2M Ω) in the width circuit and the pulse feedback capacitor C87 (100pF, 2kV pulse). If all these points are OK the line output transformer has probably developed short-circuit turns despite the apparently correct readings. (BRC 850 chassis.)

**THE UM4
"COLOURBOOSTER"**
UHF/625 LINE

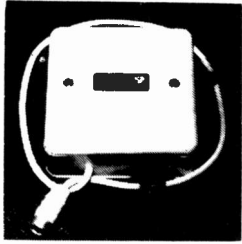

CAN PRODUCE
REMARKABLE
IMPROVEMENTS IN
COLOUR AND
PICTURE QUALITY
IN FRINGE OR
DIFFICULT AREAS
WITH SIGNIFICANT
REDUCTION IN
NOISE (SNOW).

HIGH GAIN—VERY LOW NOISE
FITTED FLY LEAD—INSTALLED IN SECONDS
HIGHEST QUALITY COMPONENTS
IVORY PLASTIC CASE 3½ x 3¼ x 1½ CORK BASE
CHANNELS: Group A, Red code 21-33
Group B, Yellow code 39-51
Group C-D, Green code 52-68

EQUALLY SUITABLE FOR BLACK AND WHITE

Also the M4 DUAL BAND VHF UNIT

BOOSTS ALL BAND III and ANY SPECIFIED
BAND I CHANNEL SIMULTANEOUSLY
NOMINAL GAIN 16-18 DB BOTH BANDS

PRICES BOTH TYPES:

Battery model £4.17 Mains version £6.50
Including VAT p/p 18p

TRANSISTOR DEVICES LIMITED
6 ORCHARD GDNS., TEIGNMOUTH, DEVON
Telephone: Teignmouth 4757

BUSH TV181S

There is a variable frequency warbling tone on the sound, arising prior to the volume control. The picture is good on all channels but the warbling tone is also present on all channels and is very evident above the programme sound.—T. Cotton (Esher).

If the fault is arising before the volume control it is likely to be due to lack of decoupling or poor earthing. Check the decoupler 2C44 inside the intercarrier sound can E, the earthing of this can, plug and socket P/S4 to the volume control and the soldering generally in this area. (RBM A774 chassis.)

HMV 2800

The contrast on this set is very poor—the control itself is at one end of its travel and cannot be used to improve conditions.—H. Bryant (Colchester).

Our first suspicion is the electrolytic capacitor C37 (64µF) which couples the contrast control to the base of the video output transistor VT9. Try the effect of shunting a test capacitor across C37—say anything from 32µF to 100µF for test purposes. If this makes no difference C37 is in order and you will have to check the emitter voltages of VT8, VT7, VT5 and VT4—also if necessary the collector voltage of VT6. One of these readings is likely to be incorrect, denoting a faulty transistor or a fault in the associated circuitry. Note that VT4 obtains its bias from VT5 so that incorrect VT4 emitter voltage could be due to a fault in the VT5 stage. If VT5's emitter voltage is incorrect the trouble is likely to be in the a.g.c. circuit. (BRC 1500 chassis.)

SOBELL SC370

The field hold on this set is very weak—the hold control has to be very carefully adjusted to lock the picture at all. The height and linearity controls both affect the field hold and will roll the picture rapidly in both directions. When the field can be held there is a slight jitter on the picture. I have changed the PCL85 field timebase and PCL84 video/sync valves, also the resistor in series with the field hold control and the two 0.02µF capacitors in the field linearity feedback loop—the field collapsed on two previous occasions due to one of these capacitors going short-circuit. The line lock is affected only when the setting of the contrast control is reduced.—C. Butcher (Dagenham).

There is a field sync pulse amplifier stage using one triode of an ECC82 between the sync separator and field timebase valve. We suggest you try a new ECC82 and increase the value of C48 which couples its output (pin 1) to pin 2 of the PCL85 from 150pF to 400pF. It is advisable to check that the two linearity controls are not intermittent.

KB WV20

The picture on both standards appears to limit at peak whites, creating vision distortion. The sound on both standards is also distorted.—E. Chambers (Rugby).

Sound distortion on both standards should direct attention to the PCL86 sound output valve and its 120Ω pentode cathode bias resistor. The clipping on peak whites could be due to a fault in the video amplifier stage—check the PCL84 and its associated resistors and capacitors—or to the detector diode or the c.r.t. itself which could well be ageing as the set is now about ten years old.

ENGINEERS
FREE
YOURSELF FOR A
BETTER JOB WITH MORE PAY!

Do you want promotion, a better job, higher pay? "New Opportunities" shows you how to get them through a low-cost home study course. There are no books to buy and you can pay-as-you-learn.

This helpful guide to success should be read by every ambitious engineer. Send for this helpful 76 page FREE book now. No obligation and nobody will call on you. It could be the best thing you ever did.

CUT OUT THIS COUPON

CHOOSE A BRAND NEW FUTURE HERE!
Tick or state subject of interest. Post to the address below.

Electrical Engineering	<input type="checkbox"/>	Radio Servicing, Maintenance and Repairs	<input type="checkbox"/>
Electrical Installations and wiring	<input type="checkbox"/>	Transistor Technology	<input type="checkbox"/>
Electrical Draughtsmanship	<input type="checkbox"/>	CITY AND GUILDS Installations and Wiring	<input type="checkbox"/>
Electrical Mathematics	<input type="checkbox"/>	CITY AND GUILDS Electrical Technicians	<input type="checkbox"/>
Electronic Engineering	<input type="checkbox"/>	CITY AND GUILDS Telecommunications	<input type="checkbox"/>
Computer Electronics	<input type="checkbox"/>	Radio Amateurs' Exam. etc. etc.	<input type="checkbox"/>
Computer Programming	<input type="checkbox"/>		
General Radio and TV Engineering	<input type="checkbox"/>		

To ALDERMASTON COLLEGE Dept BTY95. Reading RG7 4PE
NAME (Block Capitals Please)
ADDRESS
Other subjects Age

Accredited by C.A.C.C. Member of A.B.C.C.

BRITISH INSTITUTE OF ENGINEERING TECHNOLOGY

HMV 2808

When the set is switched on it is necessary to adjust the field hold control in order to lock the picture: after a time it starts to roll again. Lock can be restored by further adjustment of the field hold control, but lock is subsequently lost again. This continues until the hold control is hard over. Rolling can then be stopped only by switching the set off for a while and then on again. The picture is perfect when it is not rolling. I have changed the 30FL2 sync separator valve and checked the associated components.—B. Craymore (West Wickham).

This fault is in the field timebase, not in the sync separator circuit. The first action should be to try a new PCL805. Also check the pentode cathode resistor (300Ω) and decoupling capacitor (160μF). If the fault is still present look for discoloured resistors in the field timebase circuit, also leaky capacitors—especially the cross-couplers C75, C70 and C73, and the linearity feedback capacitor C81. (BRC 1500 chassis.)

PHILIPS G22K511

The fault on this colour set is brightness instability, accompanied by white hum bars going up the picture, ringing and lack of sharp definition. The brightness

either becomes full white or fades to black. Temporary stability can sometimes be achieved by adjusting the accessible controls.—S. Reynolds (Chester).

The fault is in the luminance output stage and the first suspect is the valve itself, a PFL200 (V2001). Since the brightness is set by a driven clamp circuit there could well be a fault here—prime suspects are the diode X2152 (BA154) and the transistor T2146 (BC148). There are various decoupling capacitors in the stage that could be faulty—C1002 (10μF) which decouples the brightness control slider, C2047 (12.5μF) which decouples the screen grid and C2057 (50μF) in the anode circuit. The input coupling capacitor C2045 (0.15μF) should also be checked and if necessary the feed components to the clamp circuit. Print faults are also possible. (G6 single-standard chassis.)

QUERIES COUPON

This coupon is available until October 21 1974 and must accompany all Queries sent in accordance with the notice on page 568. Don't forget the 11p (inc. VAT) postal order!

TELEVISION OCTOBER 1974**142**

Each month we provide an interesting case of television servicing to exercise your ingenuity. These are not trick questions but are based on actual practical faults.

? Intermittent picture distortion was reported by the owner of a Bush Model TV135R. Fault examination in the home revealed that while the picture could be locked vertically and horizontally the locking points were very critical and any slight electrical or signal disturbance caused the picture either to start rolling or to pull horizontally (or both).

This model uses a PFL200 valve as video amplifier and sync separator. In the past this valve has given similar fault symptoms so before making any further tests a replacement was fitted. There was certainly some improvement, particularly to the line lock, but the field lock still remained rather critical. The receiver was transported to the workshop therefore for more detailed analysis.

Tests were made of the voltages and components in and around the sync separator stage, including coupling capacitors, but all tested normally. The signal input to

the sync separator was correct, and 'scope tests revealed the presence of sync pulses of useful amplitude. After carefully muting the timebases and examining the field sync pulses however it was seen that these were more like differentiated squarewaves than "solid" field pulses.

The technician then turned his attention to the video amplifier stage and soon found the cause of the trouble, the receiver providing a hard lock after changing but one component. What was the most likely cause of the trouble and why did the technician suddenly divert attention to the video amplifier? See next month's TELEVISION for the answer and for a further item in the Test Case series.

SOLUTION TO TEST CASE 141

Page 523 (last month)

The small neon mentioned last month is part of an overvoltage protection circuit. When the h.t. voltage is correct and the line timebase working normally the voltage across the neon is insufficient to make it strike. When the h.t. line rises about 10% above the correct figure however the neon strikes. 5VT3 then conducts and in short-circuiting the line oscillator's base circuit stops the line timebase operating.

Since disconnecting 5VT3 base circuit restored operation of the timebase and the voltages involved were normal it was clear to the technician that a fault somewhere in the protection circuit was holding 5VT3 on. The neon is the most vulnerable component of course and it was found that by flicking it with a finger the timebase could be brought into operation temporarily. The trouble proved to be intermittent shorting between the neon's two electrodes.

BELL'S TELEVISION SERVICES

SERVICE SHEETS • MANUALS • BOOKS

SERVICE SHEETS 40p plus S.A.E. ★ SERVICE SHEET CATALOGUE 25p
OVER 12,000 SERVICE SHEETS & MANUALS IN STOCK ON COLOUR/MONO TELEVISIONS
RADIOS, RADIOGRAMS, T/RECORDERS, R/PLAYERS, ETC. S.A.E. WITH ENQUIRIES

NEW BOOKS & PUBLICATIONS

	PRICE
COMPREHENSIVE COLOUR TV REPAIR MANUAL by J. McCourt. Volume 1.....	£2.80
COMPREHENSIVE COLOUR TV REPAIR MANUAL by J. McCourt. Volume 2.....	£2.80
COMPREHENSIVE BLACK & WHITE TV REPAIR MANUAL by J. McCourt. Volume 1.....	£2.80
COMPREHENSIVE BLACK & WHITE TV REPAIR MANUAL by J. McCourt. Volume 2.....	£2.80
COLOUR TELEVISION PICTURE FAULTS by K.J. Bohlman. Faults illustrated in colour.....	£2.50
COLOUR TELEVISION THEORY by G.H. Hutson. PAL-System principles & receiver circuitry.....	£4.10
NEWNES COLOUR TV SERVICING MANUAL by G.J. King. Volume 1.....	£4.90
BEGINNERS GUIDE TO COLOUR TELEVISION by G.J. King. 2nd Edition.....	£1.95
MAZDA BOOK OF PAL RECEIVER SERVICING by D.J. Seal.....	£4.80
BEGINNERS GUIDE TO TELEVISION by G.J. King. 5th Edition.....	£1.60
TELEVISION SERVICING HANDBOOK by G.J. King. 3rd Edition.....	£3.80
TV TECHNICIANS BENCH MANUAL by G.R. Wilding.....	£2.50
RADIO TECHNICIANS BENCH MANUAL by H.W. Hellyer.....	£3.00
AUDIO TECHNICIANS BENCH MANUAL by John Earl.....	£3.00
UNDERSTANDING ELECTRONIC CIRCUITS by Ian R. Sinclair.....	£3.50
UNDERSTANDING ELECTRONIC COMPONENTS by Ian R. Sinclair.....	£3.50
BASIC TELEVISION by The Technical Press Ltd. (Common Core Series) 3 parts combined.....	£3.50
BASIC ELECTRICITY by The Technical Press Ltd. (Common Core Series) in 5 parts.....	£5.50
BASIC ELECTRONICS by The Technical Press Ltd. (Common Core Series) in 6 parts.....	£6.60
BASIC ELECTRONIC CIRCUITS by The Technical Press Ltd. (Common Core Series) in 2 parts.....	£2.20
WORLD RADIO TV HANDBOOK 1972. 26th Edition. 384 pages. Special reduced offer.....	£0.90
TUNERS & AMPLIFIERS by John Earl.....	£2.10
PICKUPS AND LOUDSPEAKERS by John Earl.....	£3.00
IMPROVING YOUR HI-FI by John Earl.....	£3.00
CREATIVE TAPE RECORDING by Vivian Capel.....	£3.50

NEWNES RADIO & TELEVISION SERVICING books bought & sold (all years) good prices paid.

Please add 10% for Postage and Packing on all books. Send large S.A.E. for FREE booklists.
OPEN UNTIL 6pm DAILY & 8pm SATURDAY. CALLERS WELCOME TO COME AND BROWSE.

B.T.S (Mail Order Dept.) 190, KINGS ROAD, HARROGATE, YORKS. Tel. 55885

LARGE SUPPLIER OF SERVICE SHEETS

All at 40p each

(T.V., RADIO, TAPE RECORDERS,
RECORD PLAYERS, TRANSISTORS,
STEREOGRAMS, RADIOGRAMS,
CAR RADIOS)

**"PLEASE ENCLOSE LARGE S.A.E.
WITH ALL ENQUIRIES & ORDERS"**

Otherwise cannot be attended to

(Uncrossed P.O.'s please, original
returned if service sheets not available.)

PLEASE NOTE

We operate a "by return of post" service. Any
claims for non-delivery should be made within
7-days of posting your order.

C. CARANNA 71 BEAUFORT PARK LONDON, NW11 6BX

We have the largest supplies of Service
Sheets (strictly by return of post). Please
state make and model number alternative.

Free T.V. fault tracing chart or T.V. list on
request with order.

Mail order or phone 01-458 4882

SERVICE Sheets for over 6,000 models of
Televisions, Radios, Transistors, Stereo,
Tape Recorders, Record Players etc., at only 30p plus
S.A.E. with free Fault-Finding Guide. Over
50,000 sheets in stock for 10,000 models.
S.A.E. enquiries. Catalogue 20p plus S.A.E.
Hamilton Radio, 47 Bohemia Road, St.
Leonards, Sussex. Telephone Hastings 429066.

SERVICE SHEETS, Radio, TV etc. 8,000
models. Catalogue 20p. S.A.E. enquiries.
Telray, 11 Maudland Bank, Preston.

SETS & COMPONENTS

Top 20 Plus Electronically Tested TV Valves

PL504	18p	30FL1/2	15p
PCF801	15p	PCL84	10p
DY86/7	15p	PCL82	10p
PL36	15p	PD500/A	50p
PC88	15p	ECC82	10p
PC86	15p	EH90	10p
PC97	15p	EY86	15p
PCL805/85	15p		

Colour Valves Fully Tested

PL509	40p	PY500/A	30p
PL508	30p	GY501	50p
PL802	40p	PCF802	15p

Many others available including
Mazda Types.

P. & P. 4p per valve, over 12 2½p per valve,
orders over £4 post free.

Prompt service. S.A.E. for New free list
Mail order only.

L. & D. COMPONENTS LTD.,
71 Westbury Ave., London N22 6SA.
Tel. 01-888 2701.

COLOUR—COLOUR—COLOUR

19" DECCA £90.00
25" DECCA £100.00
25" RBM/PHILIPS £110.00
25" THORN £115.00
22" DECCA & PHILIPS single standard £130.00
Fully serviced, one month's guarantee. Delivery
and Terms can be arranged. Non-workers
available. S.A.E. Details please.

T.E.S.T.

P.O. Box 1, Kirkham, Preston, PR4 2RS
Telephone 077-48 2796 any time.

COVENTRY COLOUR

25" Colour Televisions

Serviced in our Workshops £80 or with
regunned tubes fitted £110. (One Year
Guarantee). Non Workers from £40.

25" wired (piped) Colour sets £45.

Conversion kits (6 mhz.IF. and AF. OP)
built and tested £15.

COLOURCARE TV

Arden Street,
Coventry (0203) 79400

25" regunned tubes £25. (One year warranty)

MAINS DROPPERS.

37-31-97-26-168 Ω 50p.
25-35-97-59-30 Ω 50p.
14-26-97-160 Ω 50p.
14-26-97-173 Ω 50p.
15-19-20-70-63-28-63 Ω 50p.
Post free. C.W.O.

Durham Supplies, 367 Kensington Street,
Bradford, 8, Yorkshire.

Components Galore. Pack of 500 mixed
components, manufacturers' surplus plus
once used. Pack includes resistors, carbon
and W.W., capacitors various, transistors,
diodes, trimmers, potentiometers etc. Send
£1 + 10p P. & P. C.W.O. To: Caledonian
Components, Strathore Road, Thornton,
Fife.

250—New Resistors well assorted $\frac{1}{4}$ —2 watts. Carbon—Hi-Stab Oxide etc. £1.00 Post Free. Whitsam Electrical, 33 Drayton Green Road, London W.13.

MARCONI 19" (2000 chassis) £75. Decca 19" (poor C.R.T.) £60. Bush 22" £125. All good working, all plus VAT. D. A. Jones, Tel. Worthing 35907.

EDUCATIONAL

TELEVISION TRAINING

16 MONTHS' full-time practical and theoretical training course in Radio & TV Servicing (Mono & Colour) for beginners.

13 WEEKS' full-time Colour TV Servicing course. Includes 100 hours practical training. Mono revision if necessary. Good electronics background essential.

NEXT SESSION commences on January 2nd.

PROSPECTUS FROM:
London Electronics College, Dept. TT10
20 Penywern Road, London SW5 9SU.
Tel. 01-373 8721.

C. AND G. EXAM

Make sure you succeed with an ICS home study course for C and E Electrical Installation Work and Technicians, Radio/TV/ Electronics Technicians. Telecommus Technicians and Radio Amateurs.

COLOUR TV SERVICING

Make the most of the current boom! Learn the techniques of servicing Colour and Mono TV sets through new home study courses, approved by leading manufacturers

TECHNICAL TRAINING

Home study courses in Electronics and Electrical Engineering, Maintenance, Radio, TV, Audio, Computer Engineering and Programming. Also self-build radio kits.

Get the qualifications you need to succeed. Free details from:

INTERNATIONAL
CORRESPONDENCE SCHOOLS
Dept. 750U, Intertext House,
London SW8 4UJ. Or phone 01-622 9911

MISCELLANEOUS

Build the Mullard C.C.T.V. Camera

Kits are now available with comprehensive construction manual (also available separately at 80p)

Send 5" x 7" S.A.E. for details to

CROFTON ELECTRONICS

15/17 Cambridge Road, Kingston-on-Thames, Surrey KT1 3NG

TELEVISION Colour Receiver constructor, north western area seeks assistance to complete project. Phone 051 427 6209 (evenings).

TELEVISION Colour project constructor would welcome contact with others. 01-500 4551, evenings.

BRC, 2000, 3000, 3500

Panel Repairs

Singles or Bulk.

MODULAR ELECTRONICS-

All Details Tel: 01-897 0976

PLEASE MENTION
TELEVISION
WHEN REPLYING
TO ADVERTISEMENTS

SITUATIONS VACANT

WIRELESS TECHNICIANS

There are vacancies at the Home Office Central Communications Establishment and London Region Depot both of which are situated at Headstone Drive, Wealdstone, Harrow, Middlesex, also at Rochester Row, London, SW1 for Wireless Technicians to assist with the installation and maintenance of VHF and UHF systems. Ability to drive a car and possession of current driving licence is desirable.

PAY: inclusive of an optional interim addition is £1,370 (at 17) and £1,965 (at 25) rising to £2,309 (plus £110 Outer London Weighting at Harrow and £228 Inner London Weighting at Rochester Row).

Generous leave allowance, good pension scheme and good prospects of promotion.

QUALIFICATIONS: City and Guilds, Intermediate Telecommunications Certificate or equivalent.

Vacancies also occur from time to time in various parts of the country.

For further details phone or write to:

Mr. C. B. Constable

Directorate of Telecommunications

60 Rochester Row, LONDON SW1P 1JX

Telephone Number: 01-828 9848 Extension 734

SOUTHERN VALVE CO. P.O. Box 144 BARNET, HERTS.

All new and boxed, Mazda & Mullard wherever possible. Lists s.a.e. Mail order only

AZ31	62p	EZ80	35p	PL83	45p	SZ4	50p	30PL15	80p
DY86/7	35p	EZ81	25p	PL84	45p	6/30L2	60p	30P4MR	88p
DY802	40p	GY501	75p	PL500	1	6AT6	30p	35W/4	35p
EB91	15p	GZ30	40p	PL504	70p	6BW7	60p	ETC., ETC.	
ECC81	34p	PC86	61p	PL508	75p	6CD6G	80p		
ECC82	28p	PC88	61p	PL509	£1.40	6F24/5	60p		
ECC83	28p	PC97	38p	PL802	85p	6F28	60p		
ECC85	36p	PC900	45p	PL805	82p	6K7/8	45p	PD500	£1.25
ECC88	45p	PCC84	33p	PL805	82p	6V6	45p		
ECH42	70p	PCC85	25p	PY32/3	50p	6X4	30p		
ECH81	34p	PC888	60p	PY81	3	6X5	40p		
ECH84	50p	PCC89	45p	PY800(Br)	35p	9D7	40p		
ECL80	40p	PCC189	48p	PY801(Br)	35p	10C2	75p		
ECL82	45p	PCF80(Br)	38p	PY500(A)	80p	10F1	45p		
ECL83	57p	PCF82	50p	UBF89	35p	10P13	70p		
ECL86	40p	PCF86	48p	UCC85	40p	12BA6	40p		
EF80	28p	PCF200/1	70p	UCH42	50p	20L	80p		
EF85	36p	PCF801	48p	UCH81	40p	20P3	80p		
EF86	50p	PCF802	50p	UCL82	40p	20P4	80p		
EF89	30p	PCF805	70p	UCL83	55p	20P5	95p		
EF183	35p	PCF806	55p	UF41	60p	30C1	38p		
EF184	35p	PCF808	70p	UF85	35p	30C15	70p		
EH90	45p	PCF200	70p	UF89	35p	30C18	70p		
EL34	58p	PCL82	38p	UL41	60p	30F5	75p		
EL41	50p	PCL83	45p	UL84	42p	30FL1	68p		
EL84	33p	PCL84	45p	UY41	35p	30FL2	68p		
EL86	38p	PCL85	55p	UY85	30p	30L1	33p		
EL90/1	40p	PCL805	55p	U25	62p	30L15	75p		
EL95	40p	PCL86	48p	U26	66p	30L17	70p		
EM80/1	40p	PFL200	70p	U191	60p	30P12	70p		
EM84	40p	PL36(Br)	55p	U193	35p	30P19	70p		
EY51	45p	PL81	45p	U404	40p	30P11	60p		
EY86 7	35p	PL81A	48p	U801	90p	30PL13	75p		
EZ40	40p	PL82	37p	5Y3	50p	30PL14	80p		

All prices subject to market fluctuations

PD500 £1.25

Service & Civility.

The above types,

and many others,

are in stock at

time of going to

press.

These are new

lower prices,

including V.A.T.

Transistor lists

s.a.e.

All valves new

and boxed but

we cannot always

guarantee any

specific make.

Post free over

£5.00. POST 4p

each valve.

30L17 70p

30P12 70p

30P19 70p

30P11 60p

30PL13 75p

30PL14 80p

Tel. (Office):
440 8641

Closed Thursday
& Saturday
afternoons.

TELEVISION TUBE SHOP

BRAND NEW TUBES AT
REDUCED PRICES

A31-18W	£12.50
A47-11W	£9.95
A47-13W	£12.50
A47-14W	£8.25
A47-26W	£10.75
A50-120WR	£12.50
A59-11W	£12.95
A-59-13W	£13.50*
A59-15W	£9.95
A59-23W	£14.75
A61-120WR	£16.50
AW43-80	£6.95
AW43-88, 43-89	£6.75
AW47-90, 47-91	£7.50
AW53-80	£7.50*
AW53-88, 53-89	£8.25
AW59-90, 59-91	£9.00
CME1201	£12.50
CME1601	£10.50
CME1602	£12.00
CME1705	£7.75
CME1713/A44-120	£14.50
CME1901, 1903	£7.50
CME1906	£12.50
CME1908	£7.75
CME2013	£12.50
CME2101, 2104	£8.25
CME2301, 2302, 2303	£9.00
CME2305	£14.75
CME2306	£13.50*
CME2308	£9.95
CME2413R	£16.50
MW43-80	£6.75
MW53-20, 53-80	£7.50
TSD217, TSD282	£14.00†
13BP4 (Crystal 13)	£14.00†
190AB4	£9.25
230DB4	£11.25

* These types are fully rebuilt.

† Rebuilt tubes also, at £7.00 plus carriage and old bulb.

COLOUR TUBES	NEW	R/B
19" Unprotected	£ 25	£ -
A49-120X	45	-
A56-120X	72	48
A61-15X	78	52
A63-11X	-	52
A66-120X	82	55
A67-120X	85	-

SHOP-SOILED COLOUR TUBES

19", 22" & 26" NOW AVAILABLE
Brand new, with slight scratches.
Prices from £20. Callers only.
Add Carriage and Insurance! Mono-
chrome 75p, Colour £1.50.

ALL PRICES SUBJECT TO V.A.T.

TELEVISION TUBE SHOP

48 BATTERSEA BRIDGE ROAD,
LONDON, S.W.11. BAT 6859
WE GIVE GREEN SHIELD STAMPS

AERIAL BOOSTERS £3.30
We make three types of Aerial Boosters:
B45-UHF 625, B12-VHF 405, B11-VHF
RADIO

VALVE BARGAINS

Any 5—50p, 10—75p, 50—£3.30—
ECC82, ECL80, EB91, EBF89, EF80, EF85,
EF183, EF184, EY86, PCC84, PCC89, PCC
PCC189, PC97, PCF80, PCF86, PCF80S,
PCF808, PCL82, PCL83, PCL84, PCL85,
PFL200, PL36, PL81, PL504, PY33, PY82,
PY800, PY801, 30L15, EH90, PC86, PC88.

COLOUR VALVES

P7500/A PL508 PL509 25p each

Press Button U.H.F. Tuners—£2.50.

Rotary U.H.F. Tuners—£2.00.

PLUGS—SOCKETS

Price per item, in brackets for ten
CO-AX PLUGS 6p (50p) Socket surface
7p (60p). Connectors 4p (35p).

D.I.N. PLUGS

2 pin, 3 pin and 5 pin 20p (£1.65).

JACK PLUGS. Standard 18p (£1.50).

3.5 mm 10p (80p), 2.5 mm 10p (80p).
All prices include V.A.T. p. & p. 10p
per order. Money back refund, S.A.E. for
leaflets.

ELECTRONIC MAILORDER (BURY) LTD.

62 Bridge St., Ramsbottom, Bury,
Lancs. Tel. Rams 3036.

REBUILT T.V. TUBES FOR MEN OF VISION

Current types

17"	£4.00	21"	£5.00
19"	£4.00	23"	£5.00

Panorama & Ringuard types

19"	£6.00	23"	£8.00
-----	-------	-----	-------

Twin panel

19"	£7.50
-----	-------

Cash or P.O. with order, no C.O.D.
Carriage 75p in England, Scotland, Wales.
Add £1.25 for carriage Northern Ireland.
For all enquiries please send S.A.E.
Each tube fitted with new electron gun
assembly. Fully guaranteed for two years
against any fault except breakage.

k.s.t. ltd.

Providence Mills, Viaduct St., Stanningly,
Nr. Leeds, Yorks. Tel. Pudsey 78177

REBUILT TUBES!

YOU'RE SAFE WHEN YOU BUY FROM RE-VIEW!

HERE IS WHAT YOU PAY:

Mono	Rimband & Twin Panel	Colour			
15-17"	£5.00	19"	£7.00	19"	£25.00
19"	£5.50	23"	£9.00	22"	£25.50
21"	£6.50	24"	£10.00	25"	£30.00
23"	£7.50			26"	£32.50

Carriage £1.00

INC. V.A.T.

Exchange Basis
(carriage-ins. £2.00)

Cash or cheque with order, or cash on delivery

- ★ Each tube is rebuilt with a completely new gun assembly and the correct voltage heater.
- ★ Each tube comes to you with a guarantee card covering it for one year against all but breakage.
- ★ Each tube is insured on the journey.
- ★ Each tube is rebuilt with experience and know-how. We were amongst the very first to pioneer the technique of rebuilding television tubes.

RE-VIEW ELECTRONIC TUBES

237 LONDON ROAD, WEST CROYDON, SURREY Tel. 01-689 7735

PHILIP H. BEARMAN

(VALVE SPECIALISTS) SUPPLIERS TO
H.M. GOVT. Etc.

NEW valves by Mullard, Mazda, Telefunken, Tungram

IMMEDIATE POSTAL DESPATCH, LISTS S.A.E., DISCOUNT PRICES

ALL PRICES SUBJECT TO ALTERATION WITHOUT NOTICE.

PRICES FROM SEPT. 1974 (INCL. V.A.T. @ CURRENT RATE)

DY86.7	38p	PCC84	40p	PCL86	58p	6F23	80p	ENQUIRIES
DY802	42p	PCC89	52p	PFL200	74p	6F28	67p	WELCOMED
ECC81	38p	PCC189	58p	PL36	80p	20P4	88p	ON
ECC82	40p	PCF80	47p	PL84	60p	30C1	47p	OUR
ECL80	60p	PCF86	62p	PL504	77p	30C17	84p	VAST
EF80	37p	PCF200	84p	PL509	£1.45	30FL1	67p	RANGE
EF183	54p	PCF801	52p	PL802	£1.20	30FL2	67p	
EF184	54p	PCF802	64p	PY81	40p	30L15	86p	
EH90	56p	PCF805	83p	PY800	45p	30L17	86p	
EY51	66p	PCF808	78p	PY801	45p	30PI2	87p	
EY86.7	34p	PCH200	96p	PY500(A)	98p	30PL1	87p	
GY501	70p	PCL82	47p	U25	80p	30PL13	95p	BY100/127 etc.
PC86	72p	PCL83	52p	U26	80p	30PL14	£1.10	all 17p each
PC88	72p	PCL84	46p	6/30L2	80p	30PL15	94p	with 10W
PC97	38p	PCL805/85	58p	6BW7	74p	ETC., ETC.		resistor.

See separate Component, CRT and Transistor Lists. Many obsolete types available.
SAE with enquiries please. Please verify current prices

(Adjacent to Post Office) **6 POTTERS RD., NEW BARNET**
HERTS. Tel: 449/1934-5 any time.

PHILIP H. BEARMAN, 6 POTTERS RD., NEW BARNET, HERTS.

We offer one of the finest range of new or rebuilt makers tubes in the Country, tubes are tested before despatch. Delivery usually ex stock and despatched daily securely packed; deliveries arranged world wide. Prices available on application. We regret any alterations which are subject to circumstances beyond our control.

Colour Tubes, 4 year warranty

17" @ 20" 90° types	£54.00 + cge
19" A49/11X & A49/120 A49/191X	£52.92 + cge
22" A55/14X, A56/120X A56/140X	£57.24 + cge
25" A63/11X, A63/120X A63/200X	£61.56 + cge
26" A66/120X, A67/120X	£63.72 + cge
Note 20" with 1-yr. g'tee	£47.00 + cge
Mullard 22" A56/120X ..	£54.00 + cge
Mullard 26" A66/120X ..	£56.16 + cge
Mullard 26" A66/140X ..	£57.00 + cge

All tubes tested before despatch.

PRICES ALL SUBJECT TO ALTERATION
WITHOUT NOTICE

We often have Mullard A56 & A66/120X electrically perfect with very minor screen marks from £40.00 upwards. Availability etc. on application. Also 20° Toshiba similar seconds. All excellent value, guaranteed.

PRICES INCLUDE 8% V.A.T.

TELEPHONE: 01-449 1934/5

TWO YEAR WARRANTY (with certain exceptions).

17" CME1713 rimband	£14.00 + 66p cge
17" mono. all types except CME1713	£6.35 + 66p cge
19" CME1903, CME1902, CME1901, AW47-90, AW47-91, A47-14W, C19AH	£10.80 + 66p cge

(all tubes extra 99p for short sea journeys) SAE with enquiries.

19" A47/25W (CME1905/7) fully rebuilt	£10.80 + 71p cge
20" A50/120WR (CME2013) fully rebuilt	£12.28 + 71p cge
19" A47/11W, A47/26W etc. NEW tubes	£13.65 + 71p cge
19" Twin panels A47/13W (CME1906)	£13.50 + 77p cge
23" CME2303, CME2301, AW59-90, AW59-91, A59-15W, CME2308 New	£10.80 + 77p cge
24" A61/120WR (CME2413) New	£16.20 + 77p cge
24" A61/120WR (CME2413) fully rebuilt	£12.65 + 77p cge

ALSO other types as follows:—

TSD282(217) 1-year warranty	£13.50 + 55p cge
MW31/74 2-year warranty	£3.24 + 55p cge
TSD290/CME1201 2-year warranty	£10.80 + 55p cge
A31/120W (CME1220) 2-year warranty	£10.80 + 55p cge
13BP4 1-year warranty	£15.20 + 60p cge
MW36/24 (36/44) 2-year warranty	£5.13 + 55p cge
CME1601 2-year warranty	£10.26 + 60p cge
CME1602 2-year warranty	£11.34 + 60p cge
CME1713 2-year warranty	£14.00 + 60p cge

REBUILT COLOUR TUBES

19"	£25.00	22"	£28.00
25"	£30.00	26"	£32.00

OTHER SIZES AVAILABLE

Exchange prices, subject to V.A.T.
Tubes supplied without exchange
glass at extra cost, subject
to availability.

Colour Tubes demonstrated
to callers.

Carriage extra
all types.

Full range of rebuilt mono
tubes available, Standard,
Rimband and Twin Panel

- ★ Complete new gun fitted to every tube.
- ★ 12 months' guarantee
- ★ 17 years' experience in tube rebuilding.
- ★ Trade enquiries welcomed.

N.G.T. ELECTRONICS LTD.
22-24, Anerley Station Road,
London S.E.20

Telephone: 01-778 9178/0528

COLOUR TUBES STANDARD TUBES

METAL BAND TUBES

TWIN PANEL TUBES

Rebuilt with new Electron
Guns to British Standard
415/1/1967.

SUFFOLK TUBES LIMITED

261 CHURCH ROAD
MITCHAM, SURREY CR4 3BH
01-640 3133/4/5

Britain's Largest Independent
TV Tube Rebuilder

color TV

Fabulous 25" tube, Teak, COLOUR TVs
Working—Cash 'n Carry from our
warehouse NOW!

Non-working sets as available from £25.

MONO UHF TVs

Sold complete but unserviced with good
cabinets.

Valve tuner type include:

BUSH 128 SOBELL 1000
GEC 2000 THORN 900

etc., etc., one for £4.50 (add £2.50 carr.).

Transistor tuner type include:

THORN 950 BUSH 141 GEC 2010
PHILIPS '70

etc., etc. One for £9.50 (add £2.50 carr.).

Quantity Discounts.

Plenty of sets in stock. Pick your sets,
some available from 50p.

25" CRT x-ray shields with degaussing
coils £1.25 p & p 50p.

DL1 (& DL1E) Delay lines at 25p + 20p p & p
U.H.F. Tuners—brand new, untested
4 button, £4.50.

Add VAT

SUMIKS

1532 Pershore Road,
Stirchley, BIRMINGHAM B30 2NW

(Main A441 from City centre,
Look for the 'COLORCARE' sign)

Which of these 165 career opportunities could earn you £10... £15...even £30 extra a week?

In a job you really enjoy

How to qualify in your spare time for a better job

Make yourself *worth* more and you'll earn more. It's as simple as that. There are always plenty of people to do the routine work - but, right now, key jobs are going begging for lack of suitably qualified men to fill them. *The basic qualification is technical know-how.* When you've got that, you're in demand - out in front.

Are you ambitious - willing to set aside about 60 minutes a day for home study? If you are, B.I.E.T. can give you the technical knowledge you need - change your entire future prospects.

It's easier than you think...

Make no mistake about it - you *could* do it. Most people have unused ability. A low-cost B.I.E.T. course helps you discover this hidden ability - makes learning enjoyable and so much easier than it used to be. The B.I.E.T. simplified study system gets results fast.

We've successfully trained thousands of men at home - equipped them for higher pay and better, more satisfying jobs, steered them safely through City and Guilds examinations - enabled many of them to put letters after their name.

With the help of B.I.E.T., you too could soon be on your way to better things.

That's how long it will take you to fill in the coupon. Mail it today and we'll send you full details and a free book. We have successfully trained thousands of men at home—equipped them for higher pay and better, more interesting jobs. We can do as much for YOU. A low-cost home study course gets results fast—makes learning easier and something to look forward to. There are no books to buy and you can pay-as-you-learn. Why not do the thing that really interests you? Without losing a day's pay, you could quietly turn yourself into something of an expert. Complete the coupon (or write if you prefer not to cut the page). No obligation and nobody will call on you . . . but it could be the best thing you ever did.

Others have done it, so can you

"Yesterday I received a letter from the Institution informing that my application for Associate Membership had been approved. I can honestly say that this has been the best value for money I have ever obtained, a view echoed by two colleagues who recently commenced the course."—Student D.I.B., Yorks.

"Completing your course, meant going from a job I detested to a job that I love, with unlimited prospects."—Student J.A.O., Dublin.

"My training quickly changed my earning capacity and, in the next few years, my earnings increased fourfold."—Student C.C.P., Bucks.

These letters, and there are many more on file at Aldermaston College, speak of the rewards that come to the man who has given himself the specialised know-how employers seek. There's no surer way of getting ahead or of opening up new opportunities for yourself. It will cost you a stamp to find out how we can help you. Write to

Aldermaston College
Dept BTV80, Reading RG7 4PF, Home of B.I.E.T.

Tick or state subject of interest.
Post to address below.

- MECHANICAL**
- Society of Engineers—
- A.M.S.E. (Mech)
- Institute of Engineer & Technicians (A.M.I.E.)
- CITY & GUILDS
- Gen. Mech. Eng.
- Maintenance Eng.
- Welding
- Gen. Diesel Eng.
- Sheet Metal Work
- Eng. Inspection
- Eng. Metallurgy

- ELECTRICAL & ELECTRONIC**
- CITY & GUILDS
- Gen. Electrical
- Engineering
- Electrical
- Installations
- Electrical Maths
- Computer
- Electronics
- Electronic Eng.
- Practical Radio & Electronics (with kit)

- MANAGEMENT & PRODUCTION**
- Institute of Cost & Management
- Acctnts.
- Computer
- Programming
- Works M'tment
- Work Study
- Gen. Production
- Eng.
- Estimating & Planning
- Storekeeping
- Management
- Skills
- Quality Control

- DRAUGHTSMANSHIP**
- Institute of Engineering Designers (A.M.I.E.D.)
- General
- Draughtsmanship
- Elec. Draughtsmanship
- Architectural
- Draughtsmanship
- Technical Drawing

- RADIO & TELE-COMMUNICATIONS**
- City & Guilds
- Telecoms.
- Gen. Radio & TV Eng.
- Radio Amateurs Exam.
- Radio Servicing

- AUTOMOBILE & AERONAUTICAL**
- Institute of the Motor Industry
- A.M.I.I.
- M.A.A./I.M.I.
- City & Guilds
- Auto Eng.
- Gen. Auto Eng.
- Motor Mechanics
- Auto Diesel Eng.
- Garage M'tment
- AEC Aero
- Eng. Exams
- Gen. Aero Eng.

- CONSTRUCTIONAL**
- Institute of Building
- L.I.O.B.
- A.B.T. Clerk of Works

- Construction
- Surveyors Institute
- L.C.S.I.
- City & Guilds
- General Building (all branches)
- Heating & Vent. Inst. Clerk of Works
- Site Surveying
- Health Engineering
- Road Construction
- Quantities
- Estimates
- Hydraulics
- Structural Eng.

- GENERAL**
- Agricultural Eng.
- Council of Eng. Institutions
- Farm Science
- Plastics

Supplimentary courses for Nat. Certificates.

G.C.E. —choose from 58 'O & A' level subjects.

IT PAYS TO BE QUALIFIED! POST TODAY FOR A BETTER TOMORROW

To Aldermaston College, Dept. BTV80, Reading RG7 4PF

QN BTV80

NAME

Block capitals please

ADDRESS

OTHER SUBJECTS

Accredited by C.A.C.C.

AGE
Member of A.B.C.C.

BRITISH INSTITUTE OF ENGINEERING TECHNOLOGY

