

# Practical TELEVISION

DECEMBER 1966

2/-

TELEVISION  
AERIAL  
ERECTION

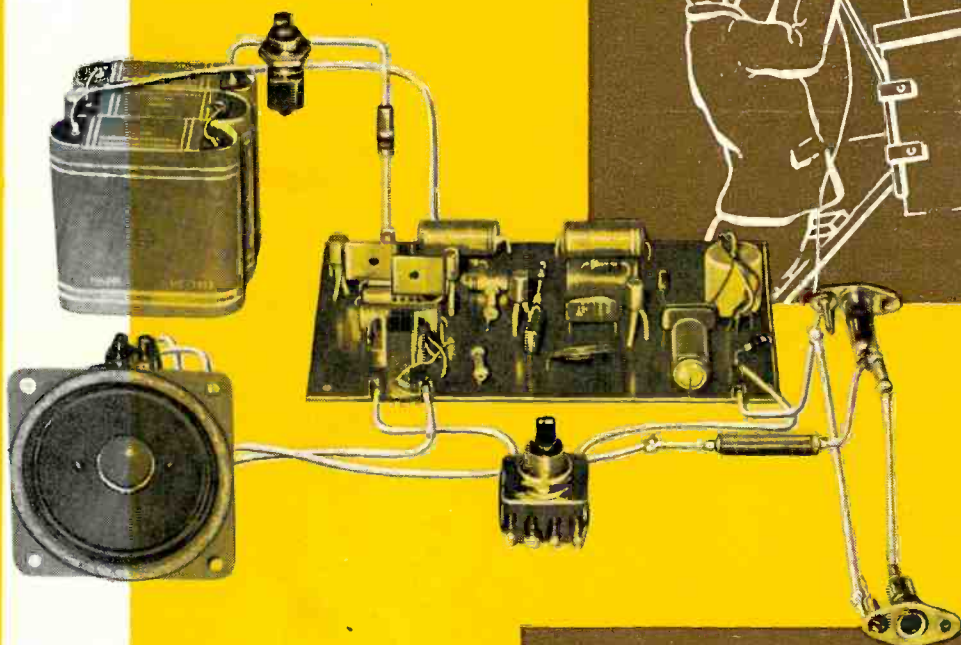

**INTERCOM  
UNIT**

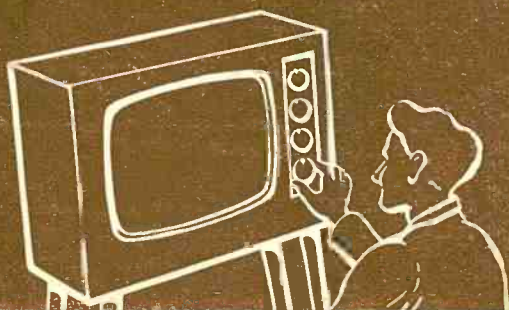

# CRT'S *Rebuilt*

- RESCREENED
- RE-ALUMINISED

*Regular buyers of Suffolk and Midland Tubes have learnt to rely on their outstanding quality. Every Tube fully guaranteed with proved performance reliability.*

PRICES FROM £4.0.0 EACH  
The largest independent rebuilders in the U.K.



### SUFFOLK TUBES LTD

1/3 UPPER RICHMOND ROAD  
PUTNEY LONDON S.W.15  
Tel: Vandyke 4304/5267

### MIDLAND TUBES LTD

477/483 OLDHAM ROAD  
MANCHESTER 10  
Tel: Collyhurst 4412

## ADCOLA

*(Regd. Trade Mark)*

### SOLDERING EQUIPMENT

**DESIGNED FOR ALL RADIO ENGINEERS**

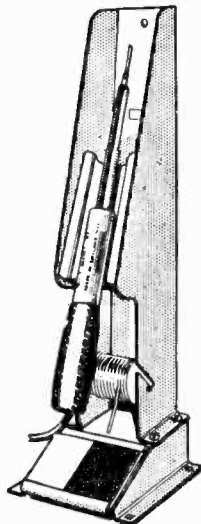

APPLY CATALOGUES:—  
**ADCOLA PRODUCTS LTD.**  
ADCOLA HOUSE,  
GAUDEN ROAD,  
LONDON, S.W.4.

TELEPHONE: MACAULAY 0291/3  
TELEGRAMS: SOLJOINT, LONDON, S.W.4.

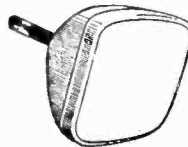

## "SABRINA" STILL WELL IN FRONT

### COMPLETELY REBUILT C.R. TUBES ALL TYPES

12" now	..	..	£5. 0.0	} For Single Tubes
14" to 17" now	..	..	£5.10.0	
19" now	..	..	£6.15.0	
21" now	..	..	£8. 0.0	

ALL C.W.O.—TRADE SUPPLIED

### Special Bonus Scheme for Service Engineers—Reducing to:

12"—87/6 ; 14"/17"—97/6; 21"—147/6  
FREE Pass. transit & Ins. anywhere in British Isles or N. Ireland (12 months' guarantee).

ALSO FULL RANGE OF VALVES  
(Guaranteed 12 months)

## SABRINA C.R. TUBE CO.

Electron Works, North Bar  
BANBURY, OXON  
Telephone 2390

# Practical Television

PRESENTING COLOUR

DECEMBER  
VOL. 17

1966  
No. 3  
issue 195

SPEAKING at a recent trade conference, David Attenborough, BBC-2 chief, made some cogent points on the programming aspects of colour TV.

"You have only to look back", he said, "at the history of the arrival of colour and you saw that the organisers became drunk with the sense of colour. This is not what the public would want—they won't want to be stunned by the flamboyance". Those who remember early colour films will take the point.

Mr. Attenborough took a tilt at those whose thoughts immediately drift to "spectaculars" when thinking of colour TV presentations. He pointed out that at the start of the service, 99 per cent of the audience will be watching colour programmes on monochrome receivers and that if the BBC puts out programmes that are meaningless unless they are seen in colour then they would be breaking faith with the majority of viewers.

We are delighted that Mr. Attenborough is taking this realistic assessment of the situation and that he will not be one of those who, in their enthusiasm for exploiting the possibilities of the new dimension, blind themselves to the fact that colour must be regarded and treated not as a separate entity but basically as an enrichment of an existing scene.

Colour TV will inevitably get off to a fairly slow start in terms of viewers and this in itself may be a blessing in disguise. For, with the knowledge that most people will be seeing the programmes in monochrome, programme organisers will learn early on to discipline themselves to the condition that the programme itself must not be the sacrificial lamb on the altar of Colour.

On the question of time, Mr. Attenborough said "We must get the maximum hours of colour as soon as possible. You can't sell colour TV sets on the basis of three or four hours of colour spectaculars a week."

He said there would be at least 14 hours of colour per week, two hours each evening. But within a year 90 per cent of BBC-2 programmes would be in colour. "It will be my ambition to achieve 100 per cent colour as soon as possible," he proclaimed.

We trust that his energies and enthusiasms will not be thwarted. For until the colour service can offer more than a token appetiser it will never be able to give the industry the shot in the arm it so desperately needs.

W. N. STEVENS—*Editor*

## THIS MONTH

Teletopics	98
Stock Faults—Part VI <i>by H. W. Hellyer</i>	100
Tuner for the Olympic II <i>by A. Melville</i>	105
Field Sync Supply Systems <i>by G. R. Wilding</i>	106
DX-TV <i>by Charles Rafarel</i>	108
Servicing TV Receivers— Bush TV80 <i>by L. Lawry-Johns</i>	110
Reactivating Valves and Cathode Ray Tubes <i>by K. T. Wilson</i>	113
Underneath the Dipole <i>by Iconos</i>	114
TV Terms and Definitions Explained—Part VII <i>by Gordon J. King</i>	116
Colour Conference	119
Aerial Riggers' Intercom <i>by M. L. Michaelis, M.A.</i>	120
Fibres, Crystals and Pipes <i>by I. R. Sinclair</i>	127
The Peregrine <i>by W. Twyford</i>	129
Letters to the Editor	131
625-line TV Sound Circuits <i>by G. R. Wilding</i>	132
Your Problems Solved	137
Test Case—49	140

OUR NEXT ISSUE DATED JANUARY  
WILL BE PUBLISHED ON DECEMBER 22

# TELETOPICS

## Title Royal for The Television Society

IT was announced on Friday, October 21, 1966, that Her Majesty The Queen has been graciously pleased to command that The Television Society shall now be known as "The Royal Television Society".

The Society is especially pleased that this honour has been bestowed at the beginning of its 40th Anniversary year and it highlights the contributions which members of the Society have made to the development of British television.

This also means that, for the first time, the art of television has been officially and separately recognised in this way.

## EMI DEMONSTRATE EDUCATIONAL TV

EMI ELECTRONICS recently provided a complete studio to demonstrate the use of educational TV to members of the Hillingdon Borough Council Education Committee. The committee meeting had been called to finalise aspects of the Borough's pilot plan to link eight schools within the area with Brunel University which will be the transmitting centre.

On three monitor screens in the main committee chamber, the audience of about 50 committee members and teachers saw a 20 minute programme presented by a local headmaster. The programme was relayed from the studio which EMI Electronics had completely equipped in another part of the building. The whole production was carried out by EMI technical staff.

## No price increase from Radio Rentals

MR. J. W. C. ROBINSON, M.B.E., M.A., Chairman of Radio Rentals Limited, stated recently: "Radio Rentals and Rentaset have no intention at present, of increasing television rental charges for either existing or new subscribers".

## NEW AVO PLANT OPENED

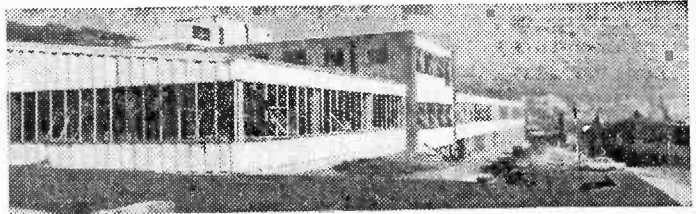

ADMIRAL OF THE FLEET EARL MOUNTBATTEN OF BURMA, in his capacity as chairman of the National Electronics Research Council, recently opened the new Avo factory at Dover.

Avo is a member of the Metal Industries Group and produces electrical, electronic and nucleonic test instruments and coil winding machines of which 40 per cent are exported. Its headquarters were previously in Westminster where a small section still remains.

The new factory, built at a cost of £400,000, has brought much needed jobs to Dover: it already employs 770 people of whom 450 are women.

The plant stands on a six-acre site which allows ample room for expansion. A notable feature is the 18,000 square feet clean air zone where delicate instruments are assembled.

## Herts schools to have TV

HERTFORDSHIRE County Council is to equip all its schools and other educational establishments with television.

Following negotiations with various manufacturers and service organisations, the County Supplies Department has awarded the contract to Radio Rentals who will supply an initial 100 Baird television receivers before the end of March next year, and to Raybrights of Berkhamsted who are to install the aerial systems throughout the county.

This decision is the first step towards implementing a five to seven year plan, involving the expenditure of approximately £40,000, which will enable viewing of programmes transmitted by the BBC and ITV and meet the growing need for closed circuit television.

## BBC-2 SERVICE FROM REIGATE RELAY STATION

THE Reigate BBC-2 relay station was brought into service on Monday, October 24 to serve some 200,000 people in an area which includes most of Reigate and Redhill, Horley, Godstone and Crawley and parts of Dorking and East Grinstead. Transmissions are on u.h.f. Channel 63 with vertical polarization.

This station receives its programmes from the Crystal Palace transmitter, there may be interruptions to the trade tests because modifications are being carried out on the Crystal Palace aerial.

As the transmissions from Reigate are vertically polarized, it is important that u.h.f. receiving aerials with vertical elements and designed for reception on Channel 63 are used.

The Reigate relay station is one of a number which are being built to fill in the gaps in the coverage of the main BBC-2 transmitters. Other BBC-2 relay stations for the London area are already in operation at Hertford and Tunbridge Wells and another to serve the Guildford area is nearing completion.

## *Should the Independent Television Authority have colour ?*

**S**PEAKING at the Radio and Television Retailers Association's Annual Dinner in London (Dorchester Hotel) on 4th October, Mr. Howard Steele, Chief Engineer, Independent Television Authority, said:

"Everybody, I think, wants to see ITV in colour. The Authority certainly wants it and has asked the Post Office to have examined, as a matter of extreme urgency, all the technical ways in which this might be achieved as soon as possible.

"The Programme Companies certainly want it, indeed need it, if the level of programme exports is to be maintained let alone expanded. The advertisers want it, for who ever sees a black and white advertisement in the cinema these days.

"The receiver manufacturing industry want it, indeed they want ITV in colour so badly that they are even proposing that the existing BBC-2 channel be shared by ITV on a day about basis if all else fails. The capital goods side of the industry (the makers of cameras and transmitters) want it and you want it, I know.

"And the great long-suffering British public, what do they say? Well, according to a recent independent market survey commissioned by the Authority, they say that the demand for colour receivers would be approximately 30 times as great if colour were available on all services than it would be if colour was only available on BBC-2—that is, of course, on the basis of the present number of u.h.f. sets.

"Well then, what is the problem?

"Put very simply, it is this. Independent Television is on 405 lines. The Government have been advised to allow colour only on 625 lines. And we don't yet know how to change over.

"On an average evening about three out of four of all television homes are watching television and of these about 98 per cent are watching either ITV or BBC-1 whilst on average rather less than two per cent are watching BBC-2 if we may judge from recent TAM London figures.

"Thus, despite the enormously rapid spread of BBC-2 throughout the country (considerably aided, it is fair to say, by the ITA who have built transmitter halls, masts and so on for the BBC at our Winter Hill, Emley Moor, Belmont, Black Hill, Durriss and Dover stations already and are currently engaged on many more)—yet despite all this, over 98 per cent of all viewing is still in the BBC-1 and ITV 405 line v.h.f. services.

"What has gone wrong?

"One of the things that has gone wrong is that the dual standard 625-line sets in the field are not yet showing the improvement in picture quality which some people had expected. I say some people, because it has long been the Authority's belief, indeed it is in the published evidence given to Pilkington, that and I quote [While it cannot be doubted that the quality of transmission will be improved by the change from 405 to 625 lines, equally it cannot be doubted that the quality of reception must suffer in the change from v.h.f. to u.h.f. transmission.]

"At the moment, in the London area where u.h.f. transmissions have been available for 2½ years now, this picture quality of our only u.h.f. service (BBC-2) has been found to be *much worse* than ITV in 21 per cent of all u.h.f. homes, *worse* in 23 per

cent, the same in 42 per cent and only better in 13 per cent and much better in one per cent. In other words 14 per cent say it's better or much better, 42 per cent say it's six of one and half a dozen of the other while 44 per cent actually say it's worse or much worse. The comparison between BBC-1 and BBC-2 gives almost identical results.

"Now there are all sorts of arguments and excuses put up for this sorry state of affairs and many of them have validity, but unfortunately time does not permit me to go into them in detail.

"Suffice to say of 4.4 million dual standard receivers that have been sold up until last May when the survey was carried out, only 1.1 million (or 1 in 4) were found to be actually receiving viewable u.h.f. pictures, and the results in those homes were as I have described.

"So you will see u.h.f. does not look very attractive to us at the moment, and we are beginning to have the most serious doubts about whether it is ever going to prove practicable at all for us to change over from 405 to 625 lines—leaving aside the question of the complexity and cost of such a changeover.

"The Authority sees it as its first duty to advance the interests of its viewing public on which both it and the Programme Companies depend for their livelihood. If somebody can produce an absolutely viable scheme for changeover to 625 lines without taking the telly away from many thousands of homes, we'll change and be happy to change. But if not, there is no option, as we see it, to admitting that the changeover is just no longer practicable in which case the sooner we stop talking and put colour on 405 lines the better.

"I am happy to announce tonight that (subject to obtaining all the necessary permissions) the Authority is planning to build the first of its second generation transmitting stations. A brand new building in harmony with the architecture of the "new Croydon" with a transmitter hall built entirely of glass to allow a full view from the roof of all the high power transmitters inside."

BY H. W. HELLYER

# STOCK FAULTS

PREVALENT TROUBLES IN COMMERCIAL RECEIVERS

NEW SERIES

PART 6: Control Systems

THE circuit of Fig. 26 shows a skeleton control circuit which could be used for a typical television receiver. A.G.C., pure and simple, is derived from the negative potential at the grid of the sync separator stage. We have discussed this circuitry in previous articles, and should not need to elaborate.

But the "simple" method usually brings in its train a number of improvements, modifications, compensating arrangements and controls. We find widely varying circuit styles, with part negative, part positive voltages from different sources, backing each other off to provide a residual a.g.c., plus preset controls for some pretty tricky setting up, and the inevitable clamps and safety circuits. Like all protective devices, they are fine when they work, but a waggon-load of extra trouble when they do not.

Figure 26 is a relatively simple circuit, used in many Thorn Group dual-standard receivers. A negative control voltage is derived from the grid of the sync separator valve and applied to the vision i.f. amplifier grid via a filter circuit, and also to the tuner unit valves, with another filter. The filters are necessary to decouple the signal frequencies from the separate stages and also to regulate the a.g.c. voltage so that sync pulses have no effect. Thus, the time constant of these components is critical, and adding capacitance across the a.g.c. to "improve" it can upset matters.

## TWO LEVELS OF A.G.C.

The separation of the two a.g.c. lines has another purpose: to achieve good signal-to-noise ratio, it is desirable to have the tuner valves working near their maximum gain. Normal a.g.c. would bias them back too far, so a reduced value, but still in proportion to the control (source voltage) is fed to the "front end". This is preset, see Fig. 26, by a positive voltage fed from the Local/Distant control, which backs off part of the negative a.g.c. Some receivers use fixed resistors with tapping points, others dispense even with the latter facility.

The main a.g.c. control is to the grid of the vision i.f. amplifier, but this deceptively simple arrangement also carries its burden of protection and compensation. If the varying negative voltage were applied willy-nilly, mistuning would occur as the bias altered. This is because the input capacity of the valve alters with the bias applied. To overcome this effect, some negative feedback is needed in the cathode circuit. This can be achieved by omitting the cathode bypass capacitor

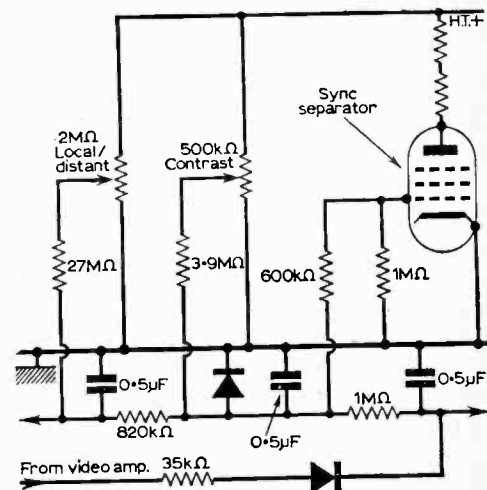

Fig. 26—Typical a.g.c. control circuit, suitable for mean-level control of a dual-standard receiver. Based on a Thorn design but similar to many other models, with variations discussed in the text.

—remembering that some resistance is needed in the cathode to bias the controlled valve to its correct operating point.

## NEGATIVE FEEDBACK

Vari-mu valves operate with a small negative grid bias to obtain the best use of the gradually tailing slope of the  $I_a/V_g$  curve. A small positive cathode voltage is needed to maintain this bias in the absence of a signal or any control. Positive voltage at the grid, which could occur if, for any reason, sync pulses were absent, would cause the stage to over-run. The normal practice of decoupling the bias resistor to signal voltages is partly or wholly omitted, even at the cost of some reduction in gain. To get the best of both worlds, some manufacturers split the cathode load and fit a comparatively large capacitor across the lower section, and a smaller one across the upper resistor.

Also note the diode across the bias line in Fig. 26. This "Clamp" diode is used to shunt any positive voltage on the a.g.c. line to chassis thus protecting the controlled stage. More than one clamp diode may be found, and in some cases, odd circuits are used to achieve the same effect.

such as using the suppressor grid of a pentode as a regulator.

The other diode, in the circuit from the grid of the video amplifier, also has a protective function, but in a very different way. Dual-standard receivers will have such a device, its purpose being to feed a supplementary rectified voltage to the a.g.c. line in the right sense to reduce gain. This is necessary because on 625 line reception, the opposite polarity of the signal means that the video valve is biased back hard on a strong negative signal from a dark picture. This clips the sync pulses and can reduce the a.g.c. bias at the very time when it is most needed. On 405 lines, the strong signal is positive to the video grid and this diode will not conduct. (One possible fault occurs when it develops a leak and *does* conduct on 405 lines.) Overall control of the a.g.c. in this circuit is by alteration of the contrast control which, like the Local/Distant control or other a.g.c. preset, or sensitivity control affecting the front end, applies a backing-off positive voltage to the a.g.c. line.

## FAULTS

A common cause of trouble on sets with this type of circuit is failure of these controls, which have full h.t. across them. If the control burns out and open-circuits at its earthy end, full h.t. is put on the a.g.c. line and almost invariably the clamp diode is ruined. The immediate symptom is an uncontrollable overload—the familiar “negative picture”.

Other faults can occur, such as varying contrast or weak picture with only slight control, if the variable resistor develops “hot-spots” at the rivet ends of the track or at the slider-to-track contact. On the Pye 11U, an o.c. contrast control usually gives a limiting effect, whereas on the Cc50r 948, a poor track contact always results in low gain. As this model is prone to vision diode failure, much fruitless dismantling of final i.f. transformer cans may result before attention is directed to the real source—the contrast control or its 2.7 M $\Omega$  limiting resistor.

Although the faults that can occur in the control circuits, even so simple a design as our example, are as numerous as the models of receiver we may encounter, remember that it all boils down to a greater or lesser negative voltage than required. The circuit should be studied, obvious causes exonerated, and then one can get down to winking out the less obvious.

First, the more obvious ones: negative picture, the common symptom, denotes overdrive to the video amplifier and thus a lack of negative bias voltage on the a.g.c. line. If the contrast control is feeding a positive backing voltage, failure here can cause too much positive rather than not enough negative, as explained earlier. Other styles use the contrast control to divide the 30 or so volts available at the sync separator grid and an open circuit or high resistance track can cause similar symptoms.

A direct short-circuit across the a.g.c. line is obvious, and usually happens after an overload. Replacing a damaged clamp diode should always lead to an investigation of the rest of the circuit.

Positive voltage which is fed back to the a.g.c. line from the grid section of a controlled stage is another common cause of overload. The valve itself may be faulty. On the Pye CTM17 the sound and vision were known to fade because the sound i.f. stage became unstable. The sound and vision a.g.c. circuits are coupled, hence the symptoms of first strangled then weak sound, rapidly followed by fading picture. On the Murphy 470F and similar models, the screen grid resistor of the EF183 tended to reduce from its correct 39k $\Omega$  value and the symptoms were that the vision increased to a certain point, then abruptly decreased as the contrast control was advanced. The prime cause of the resistor failing in these cases is usually the valve itself. On the 430 model for some reason faulty decoupling of the vision i.f. stage produced excessive a.g.c., while on the 410, a poor anode decoupling capacitor caused intermittent action of the contrast circuit.

A “simple mean level” circuit is shown in Fig. 27, with a triode valve connected as a diode across

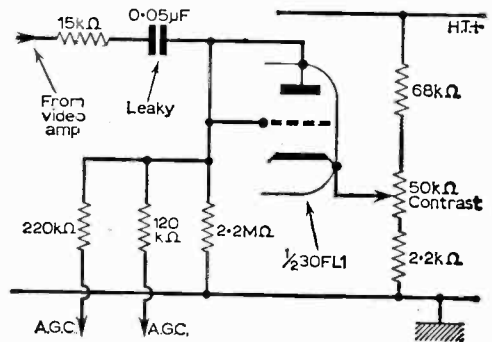

Fig. 27—Simple mean-level circuit used by Ultra.

the negative line, but with its cathode taking a preset positive voltage from the contrast control. This is the method used by Ultra in the 1781 and associated sets. The curious symptom is that the contrast control apparently works in reverse. The clue is the source from which the a.g.c. is derived, and its method of application. Instead of from the sync separator grid, we obtain the source signal from the video amplifier anode, and there is a blocking capacitor in series with the feed. Leakage at this point puts a positive voltage on the anode of the diode, and under certain conditions, this is enough to cause the contrast control to apply an opposite compensation to that intended. A queer fault, but not so difficult when we think about a.g.c. in terms of applied voltages.

## CHECK VOLTAGES

Voltages in the wrong places can come from various sources. One puzzler, the first time it is met, occurs on the Thorn 850 chassis, where the printed circuit track of the a.g.c. line runs around the edge of the panel parallel with an h.t. line. When the panel gets dirty, or the varnish chips and traps moisture, a leakage can occur, putting positive voltage on the a.g.c. line.

such an obvious source happens when a fault develops in the tuner unit. Often, this is simply valve failure.

There is also the possibility of breakdown of a feedthrough capacitor—more of a physical fault than an electrical, but having the same effect. Again, the delay components in the separate chain to the r.f. valve may give trouble. On some Ultra circuits, such as the 2171, a pair of high value resistors,  $10M\Omega$  and  $2.7M\Omega$ , act as delay splitters, providing the proportionate voltage for the front end to maintain full gain on weak signals. When these go "high", as high value resistors are prone to do when heated by high currents or proximity of hot parts, the balance of the a.g.c. is upset, and the result is a biasing-off action that may very well mislead. Often, the symptoms are of low gain on one channel—usually the channel with the weaker signal.

Before leaving the subject of increased value of meg-size resistors, the circuit used by several receivers in the C.R.T.S. (Combined Radio and Television Service, Ltd.) Group, Regentone, K-B and R.G.D., are worth studying. Figure 28 shows the a.g.c. circuit of the VC3 chassis, typical dual-standard receiver. One factor immediately springs to our attention—the coupling to the grid circuit of the PL36 (30P19 or PL302) line output valve. This is a protection device, ensuring that the a.g.c. will be fully operative while the set warms up, to prevent overload of the vision amplifier valves, especially the video amplifier, in the absence of a bias-producing signal. The action is also akin to that of the keyed-a.g.c. circuits, in that the bias is tied more closely to black level.

The presence of the V.D.R. (Voltage Dependent Resistor) in this circuit is to stabilise the line output stage, a rectifying action due to its characteristic, in conjunction with the  $1.8M\Omega$  resistor and  $0.022\mu F$  capacitor, applying a direct voltage to the PL36 grid in proportion to the amplitude of the flyback pulse, obtained from the line output transformer.

## CONTRAST CONTROLS

Contrast controls are provided for both standards and a single a.g.c. preset determines the standing bias. The clamp diode is across the i.f. control line and instead of the diode protector circuit for 625-line operation that we have noted before, a series R-C filter is fitted, switched so that on 405-lines this feed is returned to chassis. Looking through this circuit, we note several high value resistors that could cause trouble.

So far, we have dealt with mean-level a.g.c. systems, and noted that their apparent simplicity can cover a number of servicing pitfalls. Conversely, the more complicated circuitry of the keyed or gated a.g.c. system can be easier to service. There are many versions, and, perhaps happily, modern receivers employ an adaptation of the mean-level system, with some of the control circuits we have noted. While flywheel sync is in and out of fashion like the length of ladies' dresses, it is no longer thought imperative to fit gated a.g.c. to obtain a "better-quality" set. Readers who wish to brush up are therefore referred to previous articles which dealt with these

Cancellation of the bias voltages from not quite

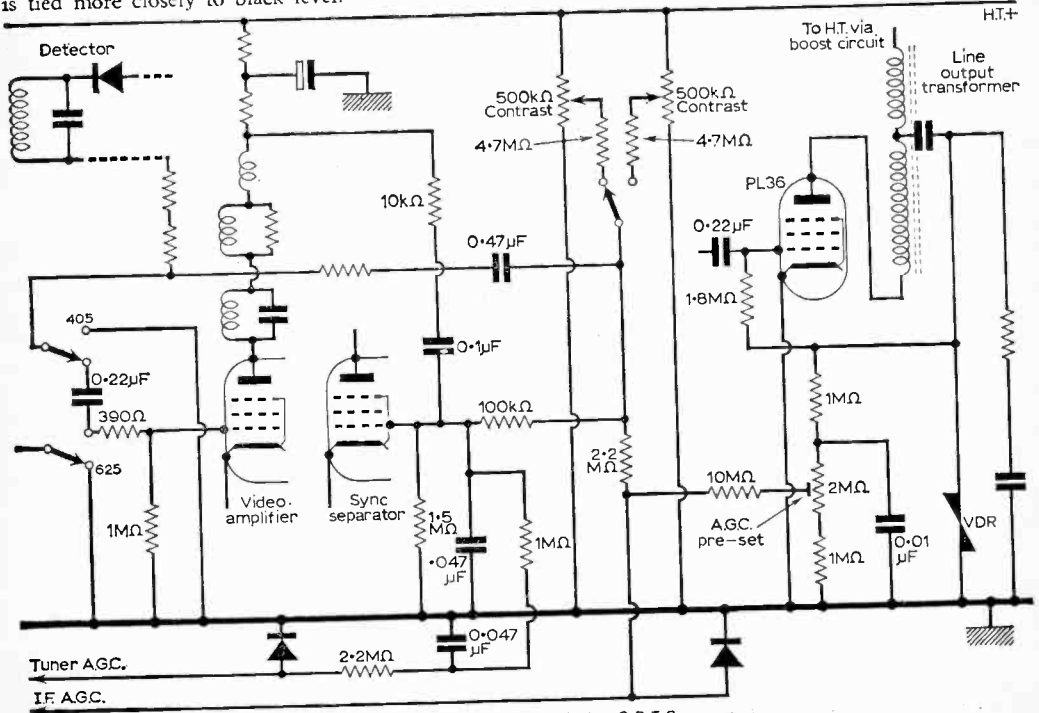

Fig. 28—A.G.C. circuit of the C.R.T.S. range.



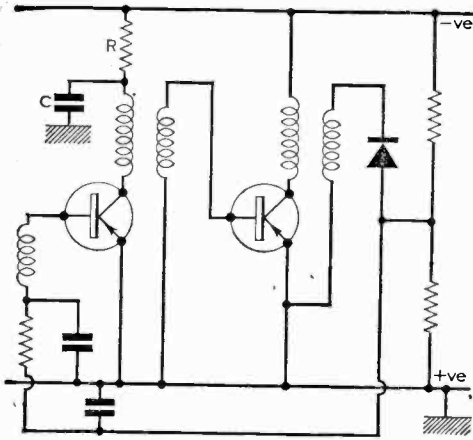

Fig. 29—Forward-a.g.c. applied by taking a negative voltage from the detector to control the base potential of a transistor amplifier, and thus the current flow through the collector load.

gated systems, and gave examples of the most popular commercial circuits to illustrate the discussion.\*

## TRANSISTOR CIRCUITS

With transistorised television receivers coming on apace, the rest of our space must be devoted to a look at typical circuitry.

The difficulty of arranging for a.g.c. in transistor circuits arises from their being very susceptible to bias changes, causing a varying impedance and thus affecting the tuning of vision amplifier circuits, and the basic fact that the transistor is a current-operated device, so that power is needed to obtain any variation in gain. It is not a feasible proposition to feed back a proportionate negative voltage, as we can with valve amplifiers.

Transistor gain is varied by changing the emitter current while keeping the collector voltage constant, or by varying the collector voltage. The first method produces what is known as "reverse a.g.c." and the latter method, "forward a.g.c.". To consider how this is achieved, we need to look also at the video amplifier conditions, and note the method of tube drive employed. These three things are closely dependent; after all, the a.g.c. depends on the detected and amplified video signal, and the polarity of the video signal is determined by the method of tube drive. A grid drive needs a positive-going video and negative-going sync, as we have seen, and a cathode drive uses the opposite

sense. To obtain the maximum collector potential at the video, the sync separator and the a.g.c. systems obtain their take-off signal at the video input.

Forward a.g.c. was mentioned above, and the circuit of Fig. 29 shows one simple, theoretical, way of obtaining this. This is very like a conventional valve detector-cum-a.g.c. circuit, except for the important fact that the detector diode is opposite to its normal sense of connection. This gives a negative a.g.c. bias—and its purpose is to make the controlled transistor conduct *more* as the bias is applied. Using the opposite bias, i.e., reverse a.g.c., brings the base voltage nearer the emitter voltage as the signal increases and the positive bias also increases. There comes a point when these are equal and the transistor cuts off. But the action of the circuit, for reasons that are a little too abstruse to concern us at this point, still allows some breakthrough of signal, and cross-modulation occurs. Using forward a.g.c. the cross-modulation is considerably reduced, and as a bonus, the control range is widened.

The important factor is the collector load R, which has the effect of lowering the collector voltage as the conduction increases. Capacitor C decouples R from signal currents and there is thus the condition of a varying load—which, as we have stated is one method of controlling a transistor stage gain.

However, this is *only* theoretical, for such a crude method would not do for the range of control needed in a transistor amplifier. More realistic is the amplified a.g.c. circuit of Fig. 30, which is the basic section of a specimen G.E.C. circuit or, more accurately, four sections of the circuit. The signal from the detector is passed to a valve video amplifier in the normal fashion, and a control voltage is taken from the cathode of this stage. Making this source variable provides

\* Stock Faults, October, 1964. Video AGC Systems, January and February, 1965. First-Time Tests, January, 1966. All in PRACTICAL TELEVISION.

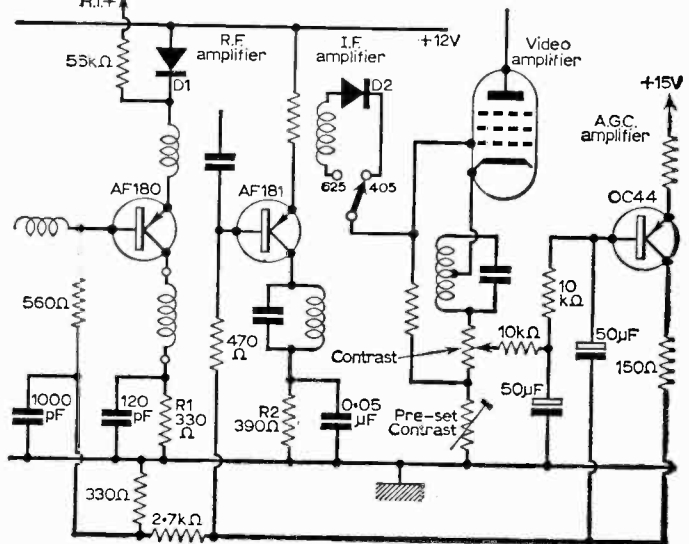

Fig. 30—Method of forward-a.g.c. used by G.E.C., and similar to many other makes of receiver.

a contrast control, which does not affect video conditions directly, as the whole resistor, and the preset series a.g.c. control, is unaltered. In effect, a portion of the cathode voltage is tapped off, the steady d.c. varying according to signal level. The stronger the signals, the more positive the control voltage.

Note that the transistors in this diagram (Fig. 30) are drawn "upside-down" for convenience, the chassis being the negative line and the collector load resistors R1 and R2 of the controlled stages being returned to chassis. The collector load of the a.g.c. amplifier is part of the feed to the tuner section, 2.7k $\Omega$  and 330 $\Omega$  in series. When the signal is weak, the OC44 passes fairly heavy current, low base voltage with respect to chassis. The a.g.c. line is positive to chassis and the r.f. and i.f. amplifier transistors are at maximum gain.

A signal increase raises the positive base voltage, decreases the a.g.c. line positive voltage, increases the current through the amplifier transistors, and reduces the gain, as mentioned earlier—despite its upside-down appearance, this is still a forward-a.g.c. system. To allow the r.f. stage to operate at full gain on weak signals, in other words, provide a.g.c. delay, a slightly different current limiting arrangement is made.

The 56k $\Omega$  resistor in the emitter circuit is returned to h.t. positive, and it thus has a much greater voltage-varying effect than the collector load R1. The r.f. transistor thus acts like a constant-current device and it seems at first as if the a.g.c. is ineffective. But the hidden persuader is D1, which conducts heavily when the signal gets strong enough for the current through the 56k $\Omega$  to cause the emitter voltage to fall below the 12 volt positive rail, virtually switching the emitter to a constant 12 volts, and converting the circuit to a normal forward a.g.c. type, with the variations provided by the voltage change across R1.

The foregoing, more descriptive than concerned with faults, can be used as a launching point for diagnosis. Instead of looking for relative voltages, we must consider the effect of current change, and test for possible causes that might prevent it. Once again, the contrast control itself, and the resistive coupling, will be high on our list. Failure of the decoupling electrolytics will cause fluctuation of the a.g.c. amplifier base control and the i.f. amplifier will show signs of instability. Values of resistors are fairly critical, and where possible, the manufacturer's stated figures for transistor voltages should be used as a reference. ■

## UNLICENSED STATIONS

**I**F it is true, as the Post Office claims, that over a million television sets are operated without licences it is another example of the law that guilt diminishes in direct proportion to the impersonality of the crime. Relatively few people will steal from their friends and neighbours. Rather more will steal from big department stores and insurance companies. Many more will steal from the Government, usually by the negative method of withholding taxes. In the case of television licences the remoteness is increased by the fiction that the licence money is not payment for the programmes but for permission to operate a set.

The Post Office is now pressing for legislation that would force retailers to report the names and addresses of their customers. It could then swoop down and gather in its £6M with ease. But the retailers object to being drafted as unpaid auxiliary policemen, even for the sake of £6m. They do not wish to become embroiled in the crimes of their customers. Rental and hire-purchase firms have the additional fear that the sets of delinquent customers might be seized more often than at present.

The retailers' attitude will find a good deal of sympathy among those who dislike the proliferation of penal laws, the encouragement of snooping, and anything that further invades the privacy of the ordinary citizen. But £6M is a lot of money and it might just possibly be used to improve the service. What is the Post Office to do?

Rumour already has it that some of the detector vans that cruise the streets are either dummies or useless in densely populated urban areas. True or false, they do send a fair number of people rushing to the Post Office. Bluff is as old as the art of warfare and history is full of wily

commanders who managed to persuade the enemy to overestimate the number of their troops or weapons. The essence of most bluff is credibility but uncertainty also plays a part. The licence-less viewer cannot know if the van in the street is a dummy or not, and with a bit of luck he will go to the Post Office just the same.

Like crying "wolf", the effect would wear off gradually, but it might be a start. The only trouble is that the next step, inevitably, would be the waxwork policemen at street corners, and cardboard police cars parked on main roads. Perhaps, on second thoughts, honesty is preferable on both sides of the law. The only simple way is to increase the severity of the penalties, and to publicize the increase widely, possibly over television itself.—THE TIMES, October 4.

**Have you thought of sending your friends a gift subscription to "Practical Television"?**

They will thank you for it time and time again in the months ahead!

All you have to do is send us their names and addresses, together with the appropriate remittance, and we will do the rest. Just send the details to our Subscription Manager (Z2), Practical Television, Tower House, Southampton Street, London, W.C.2.

We will despatch first copies to arrive before Christmas—if we get your go-ahead—and send an attractive greetings card in your name to announce each gift.

Annual rates are as follows: U.K. and Overseas £1 9s. 0d. U.S.A. \$4.25.

To make sure of your own copy, why not place a regular order with your local newsagent?

# TUNER FOR THE OLYMPIC II

A thirteen channel turret for this popular transistorised receiver

By A. Melville

THE writer was keen to extend the coverage of the Olympic II transistorised television receiver since the original design catered for only six channels.

After a fruitless search, there suddenly appeared on the market, a transistorised thirteen-channel turret at a very modest price which looked a promising solution.

Subsequent tests with this unit proved satisfactory in every way, and the tuner is confidently recommended for use with the Olympic II receiver.

It has also been successfully fitted to a valve type receiver.

The tuner uses three AF102 transistors

operating in common base mode. From Fig. 1 it will be observed that there are two a.g.c. inputs, which, in the original Perdio circuit, were used to damp the input to the r.f. amplifier, and the output from the mixer.

It is quite feasible to operate the tuner with these inputs disconnected, i.e., in a fixed gain mode. This works very well and both BBC-I and ITV have been received satisfactorily using this method.

It would doubtless be possible to devise an a.g.c. circuit which would permit operation of both the a.g.c. damping circuits incorporated, but this has not been attempted. The writer feels that a.g.c. is not worth while unless either a line or field pulse amplitude sampling method is used, and this is neither simple nor cheap.

—continued on page 136

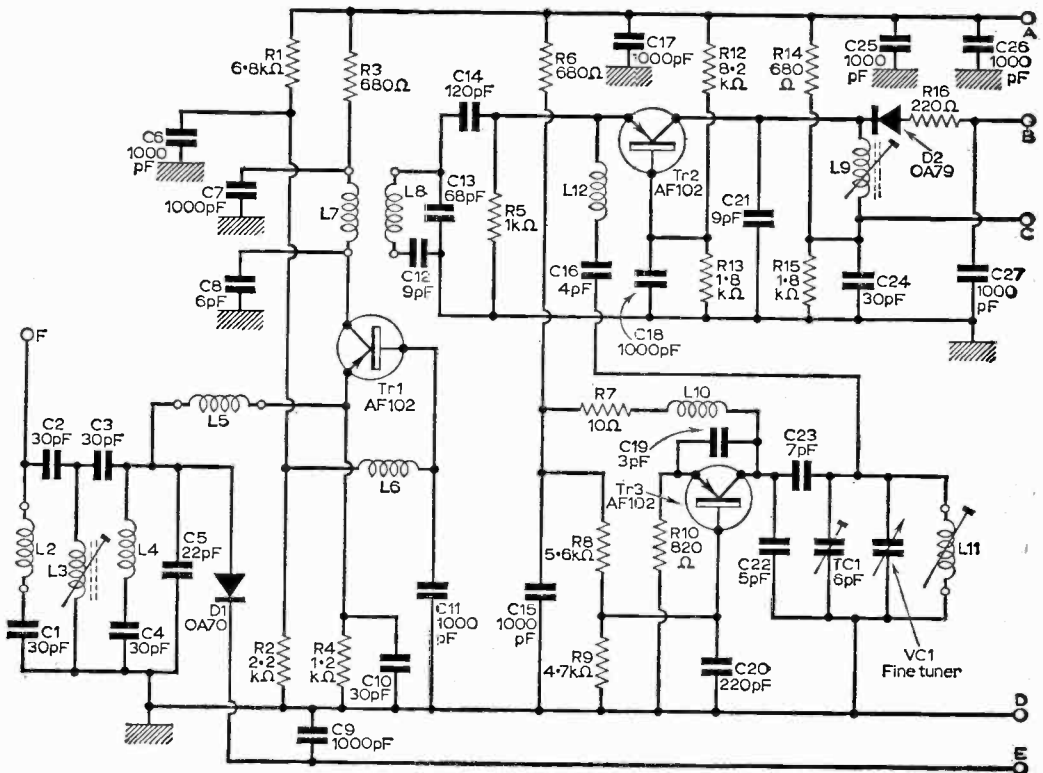

Fig. 1—Circuit diagram of tuner. Note: For clarity only one set of coils shown.

# FIELD SYNC SUPPLY SYSTEMS

By G. R. Wilding

THE serrated waveform of the integrated field sync pulse train causes a lot more trouble to television designers than do the line sync pulses which have very steep fronts. Many different circuits are used to sharpen and/or amplify the field sync pulse train to bring it up to scratch.

The field sync pulse train comprises a succession of eight  $40\mu\text{Sec}$  pulses with a  $10\mu\text{Sec}$  interval between each, in which the integrating capacitor charges and discharges to produce the characteristic serrated edge rising curve. This, however, is far from the ideal triggering shape and is exactly opposite to that produced by the differentiator on the line sync pulses. Differentiator and integrator circuits are similar since they comprise a series combination of resistor and capacitor; the only difference being the point of obtaining the output. If the output is obtained from the resistor, it is a differentiator; if from the capacitor it is an integrator. When a square wave or a sync pulse is applied to such a circuit, the full voltage appears across the resistor instantaneously and falls away exponentially as the capacitor charges up. Once the capacitor is fully charged, there is no voltage across the resistor. This waveform, an almost ideal timebase triggering shape, is the reversal of that developed across the capacitor, which is zero when the pulse is first applied and rises exponentially to maximum. Since the interval between pulses is only a quarter that of the actual pulse, the capacitor only fractionally discharges and thus produces the usual serrated edge voltage curve. If the amplitude of this curve is such that the field timebase "fires" only towards the end of the pulse train when it tends to flatten, there is increasing danger that successive frames may be triggered off at different points or even different pulses on the curve. This results in varying interlace at best and pronounced "jitter" at worst.

To improve the rising waveform many designers incorporate field pulse shaping and/or amplifying circuits. These, as the name implies, sharpen and increase the leading edge of the pulse steps so that they become steeper and cause the timebase to trigger early in the train.

There are many types of pulse shaping circuits, all based on partly differentiating the incoming pulse train. A typical example is that used in the Thorn 900 Series (shown in Fig. 1). This employs two series connected CR pulse shapers between the sync pulse input and the triode-pentode PCL85, which doubles as a multi-vibrator generator and field output stage. Another popular way to improve field locking is to "hold off" the rising pulse

waveform from the timebase until it reaches a pre-determined level, preventing line sync "blips" and spasmodic noise pulses from tripping it prematurely. This is usually accomplished by using a reversed biased germanium diode, sometimes called the limiter or gate diode, which only conducts when the amplitude of the rising curve exceeds its bias. A typical example of such a circuit is that used in the 101 to 505 range of Decca dual-standard models (shown in Fig. 2). Resistors R1/R2 and R3/R4 form two separate voltage dividers and hold the gate diode

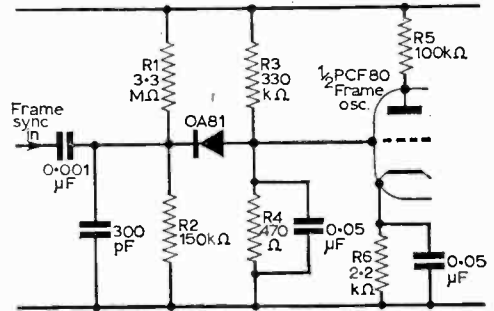

Fig. 2—Field sync feed circuit used in the 101 range of Decca receivers.

non-conductive in the absence of a signal by keeping its anode voltage slightly lower than its cathode. Once the rising integrated waveform makes the diode cathode less positive than its anode, the diode conducts and passes on a sharp triggering pulse. Although in the circuit illustrated, the fixed potentiometer R3/R4 will put a slight positive bias on the PCF80 triode grid. This is more than offset by the negative voltage developed

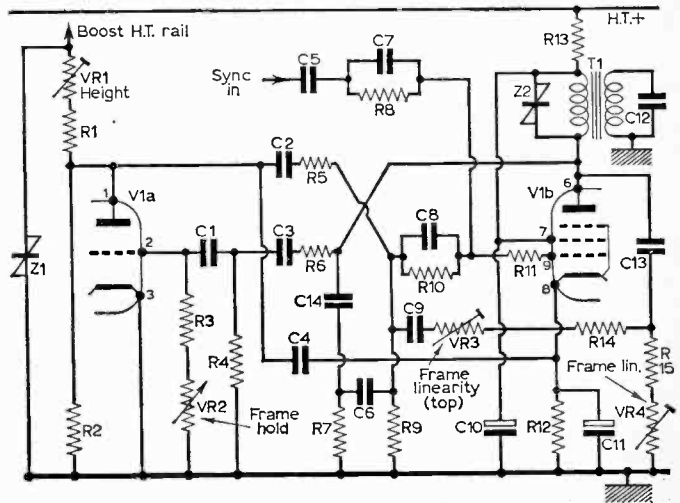

Fig. 1—Complete field circuit of one of the receivers in the Thorn 900 Series.

across the cathode resistor R6.

Naturally the whole success of the scheme depends on the correct biasing given to the gate diode. In cases where field sync is weak, the first move after checking the diode itself will be to ensure that the high value current-carrying resistors have not changed in value. Some manufacturers have used a separate triode valve to amplify the field pulses after normal sync pulse separation. K-B, for example, successfully employed such an arrangement for many years, using a duo-triode; one half as the conventional sync separator and the other as an RC coupled vertical sync amplifier. Similarly in many early Pye/Invicta models a triode was used as the sync separator, but directly coupled to the grid of an ECC82 vertical pulse amplifier.

Coming right up to date, many current STC receivers (RGD, Regentone, K-B, etc.) have field sync amplification but in quite a novel manner. A normal pentode PCF80 sync separator is used, but with direct coupling via a resistive network to the cathode of a grounded-grid triode (PCL84) acting as the pulse amplifier, whose anode output feeds the grid of one of the field multivibrator triodes in the usual way. Using a cathode-driven

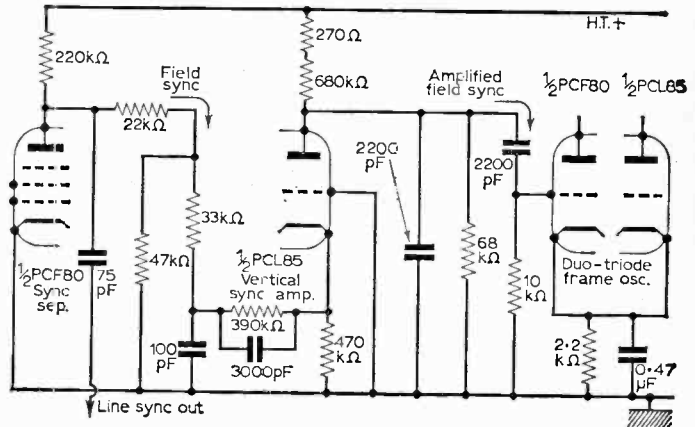

Fig. 3—Triode vertical sync amplifier used in many dual-standard K-B, Regentone and RGD receivers.

triode in this manner leaves the phase of the sync pulse unaltered and maintains the d.c. level.

Finally, when investigating cases of weak field lock with good line lock, remember that this does not necessarily indicate a fault in the field-only sync circuitry. It could be due to a defect in the common sync separator, the video stage, inadequate h.t. supply smoothing, or even in the field generator circuit.

## A new Television Aerial from J-Beam

**M**OST Band I television transmissions in the United Kingdom are vertically polarised, notably in Southern England to avoid mutual interference with Continental stations. The conventional vertical aerial is often inconveniently large, making the design of loft aerials difficult and, moreover, a vertical dipole has no polar diagram in the horizontal plane and thus no rejection of ghosts, unlike the horizontal dipole with its figure-8 polar diagram with very sharp nulls off the ends and the advantage of no pickup on the vertically run feeder of horizontally polarised signals.

The presence of the feeder in vertical aerials materially affects performance and feeder pick-up tends to destroy the sharp nulls necessary for adequate ghost rejection. Provision of a balun on Band I frequencies is impractical on economic grounds and end-fed systems have fallen into disuse.

The conventional method of achieving high rejection performance on Band I is to increase the number of elements, progressing from the H or X to multi-element arrays. In many cases, however, the extra gain introduced requires the use of an

attenuator to avoid overloading and unbalance between Band I and Band III.

A loop aerial would be fine, for it has two exceptionally sharp nulls at right angles to the plane of the loop, but its size (when resonating at TV frequencies) precludes adequate signal pickup.

J-Beam Aerials Ltd., however, have now introduced a new approach to Band I aerials in their new "Q Beam", a loop aerial which meets the conflicting requirements. The loop is split at the centre opposite to the feed point becoming resonant when the circumference is approximately half-wave. This gives a diameter of about 3 ft. on Band I. The makers claim that tests show highly directive properties and adequate gain for most TV receivers. To prevent the feeder pick-up reducing the nulls, a Gamma match is used which effectively ensures rigidity, provides a direct earth for the outer feeder connection (thus eliminating pick-up) and distorts the normal figure-8 response to give a small reduction at the back in addition to the complete rejection from the sides.

Price will be approximately 35s. retail.

# DX-TV

A MONTHLY FEATURE  
FOR DX ENTHUSIASTS

by Charles Rafarel

## CONDITIONS

**R**ECEPTION for the period 7/9/66—20/9/66 has been severely curtailed by holidays, but it would seem that the Sporadic E season is now practically over for this year. All that remains at the end of the period is some East Europe activity early mornings from 08.00 onwards, but even this has been of short duration.

This is the usual dismal "end of the season" story, but the Tropospherics are already showing signs of considerable improvement. Reception by this method really proves if our installations are as good as they ought to be!

## NEWS

(1) **G. J. Deaves** has had his confirmation from Nigeria for his reception of Enugu E2. Heartiest congratulations.

(2) We have just received from **Caporal Maden**, of Cyprus, the following information on additional "exotic" DX possibilities in the Middle East. I give Band I information only, where reception could be possible by Sporadic E.

(a) *Saudi-Arabia*. Channel A2 525 lines, station operated by the Arab American Oil Co., two test cards U.S.A. type, one with "Red Indian" head (remember the early BBC/USA Early Bird relays). This is interesting as we have reports of USSR TV/DX reception of this type of card, and DX'ers there are suggesting it might be USA but I feel that this could be the answer.

(b) *Iran*. Ch A3 Teheran 4kW Hor. 525 lines. No test card, but Persian script captions. Starts about 14.00 GMT weekdays.

(c) *Egypt/Syria (United Arab Republic)*. Port Said E3 5kW Hor. Monday-Friday 13.45-14.00 GMT Test Card, the same as Poland/Hungary except that the main circle has 4 black rectangles making up a square instead of the usual 4 graded ones.

(d) *Lebanon*. Fih E2, and Maaser-El-Chouf/Bekaa E4, 50kW Hor. No test card, but test grid like TVE Spain, Monday-Friday 15.00-16.15 GMT. Slides showing scenes of Lebanon to 16.25. Clock at 16.30 GMT, then station identification in Arabic (sometimes in French as well). Programmes 16.30—approximately 21.30 GMT, and "Commercials" in Arabic and French, even in English at times. Sunday programmes 16.00-21.30 approximately GMT.

If anyone has received any signals that they suspect might have come from any of the above stations please send me details and I will try to

help with identification. Caporal Maden has kindly sent test card and opening caption photographs so we may be able to help in sorting out your queries.

(3) Bad news for all those who have not yet logged Cyprus Nicosia E2. **A. Papaeftychiou**, of Cyprus, tells us that this station ceased transmission on 15/9/66, leaving only stations on E6 and E8 operational in Cyprus. He, too, has kindly sent us details of the Saudi-Arabian "Red Indian" test card.

(4) **R. Bunney** tells me that Albania is at last operational in Band I, with Tirana R2, 50kW Hor, so we have a chance for another new country here. He also says that Bucharest is now up to 100kW power.

(5) My wife and I were back in Paris on 17/10/66 for the O.R.T.F. reception and official opening of the Radio and Television Museum. You will remember that my 1932 vintage 30-line TV was given to O.R.T.F. earlier this year. The museum is beautifully laid out and well worth a visit if you are ever in Paris.

We had a wonderful time as guests of the French Government, champagne flowed like water, we met M. Jacques-Bernard Dupont, the Directeur General of O.R.T.F., himself, who was most interested to hear of French TV reception in many parts of the British Isles, and we also met many well-known French TV personalities. Some of you may have seen our debut on French TV in the late night news at 23.30 on 17/10/66, repeated at 13.00 on 18/10/66; we appeared together with the old "bacon slicer."

(6) O.R.T.F. confirm that Lille-Bouvigny u.h.f. is now as from 26/9/66 operating on Ch21, not 27, the reason being trouble with co-Channel interference with N.T.S. Lopik, Holland. U.H.F. will give rise to this type of "trouble," and we will get increasing DX successes because of it.

## READERS' REPORTS

**Mrs. Mary Doyle**, of Dublin, Eire, (yes, we have some lady DX'ers), has been proving what the fair sex can do, with reception of USSR, Czechoslovakia, France, Poland, West Germany and Sweden, and an inquiry about a "G" type test card that proves she has received Norway as well.

**G. J. Deaves**, of Hitchin, has now received TVE Canary Island E3, apart from his confirmation of Enugu, so he has been doing very nicely with the "Exotics"!

Other readers' reports must unfortunately be held over until next month as I want to tackle the trouble with the Polish and Hungarian test cards. **R. Bunney** and I have been spending a lot of time over this, and now with the help of readers' photographs, kindly sent in at our request, we hope that at last some progress has been made towards a solution. Refer to this month's Data Panel.

## DATA PANEL 16

## HUNGARY &amp; POLAND

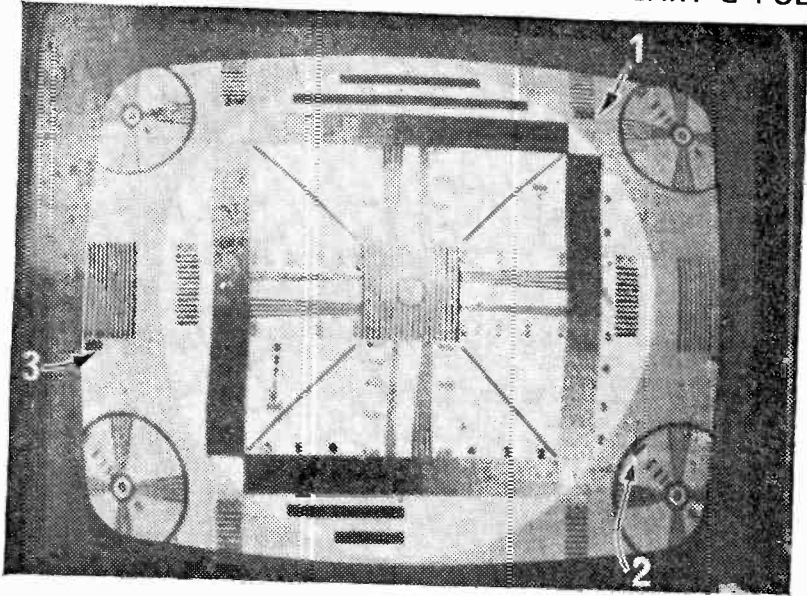

**Test Card:** Some confusion has existed owing to the similarities of the test cards. The actual differences are small but definitive. They are as follows:

- (1) Radial bars in corner circles are black for Poland and white for Hungary.
- (2) The figures "200" above the pile of bars above and below the main square contrast wedges are black for Poland and white for Hungary.
- (3) The figures "200" below strip

of vertical bars on the left- and right-hand sides of test card are black for Poland and white for Hungary.

**Channels:**

Poland—Bydgoszcz	R1
Warsaw	R2
Gdansk	R3
Hungary—Budapest	R1
Pecs	R2
Tokaj	R4

## Tool Kit for Transistorised Circuits

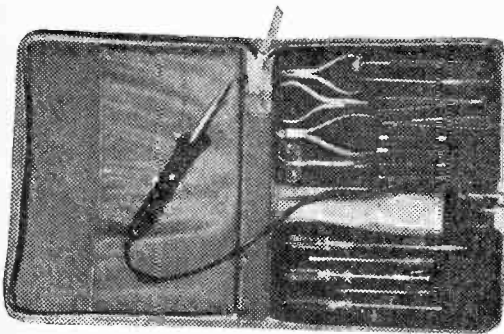

In the building, maintenance and repair of transistorised circuits, the small size and inaccessibility of many of the components creates

special problems for the technician. With this in mind, many new tools have been devised in recent years and a selection of those most frequently in demand is now available, in a neat zip-case, from Henri Picard and Frère, Ltd., 34/35, Farnival Street, London, E.C.4.

This Transistor Tool Kit, 1900 TR, contains 18 tools held in cut-out plastic foam to eliminate retaining straps. The selection includes a 14mm magnifying contact mirror, a 30W soldering pencil, a flexible screwdriver, a screw-positioner, hook tweezers for removing excess solder and a special side cutting nipper. Amongst the more conventional tools are miniature screwdrivers in five sizes, two sizes of grub screw screwdrivers and one for Phillips screws, a crown shear and two pairs of specially shaped electrician's pliers.

The complete kit weighs just over 2lb and measures 10 x 13 x 1½ in. A large pocket is provided for documents and there is ample room for small additional accessories. The price is 10 guineas.

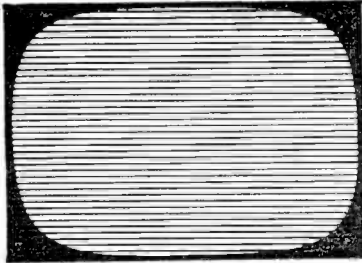

# Servicing TELEVISION Receivers

No. 129 - BUSH TV80

by L. Lawry-Johns

**W**E have been asked to include this receiver in the servicing series as it contains some features not found in other Bush models of the period which were covered in the April-May, 1962, issues (TV77 series).

The TV80 is a 14in. transportable for a.c. mains only housed in a fibre cabinet. It has a push-button tuner unit with four selectors, two for Band I and two for Band III.

## The Tuner Unit

The buttons may be set to receive any channel from 1 to 5 by pressing one of those marked BBC, bringing the receiver to the edge of the bench or table so that buttons overlap the edge. The button is then withdrawn by hooking a fingertip under it and pulling it out along the spindle and rotating until it engages on the splines and can then rotate the spindle. Both buttons can be set to select the same channel in this way.

When the desired programme is received, push in the button to clear the spline and check the adjustment by selecting another button and then returning to the first. A slight adjustment may be required if the spindle has been accidentally rotated when the button was pushed in to align with the others. The two buttons marked ITA are similarly adjusted to receive any channel 6-13. Now quite often the complaint is that buttons do not operate properly, the selected station varying in strength (fading) or not coming in at all. This fault can usually be cleared quite easily by applying switch cleaner to the slider contacts inside the tuner. The operation should not be left at this, however, since some of the trouble, or perhaps future trouble, could be due to sluggish movement of the tuning slugs inside the coil formers. These are pushed in by the button mechanism and returned by an end spring. It should be ensured that the slugs move freely, lubricating the slug ends if necessary. Clean away any dirt or thick grease which may impede free movement.

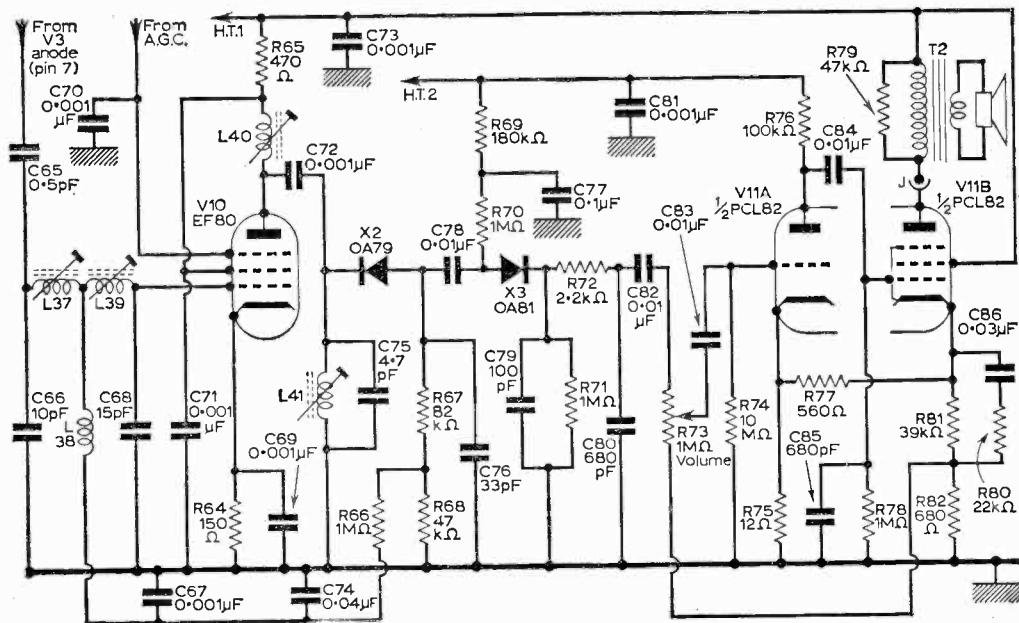

Fig. 1—The sound strip.



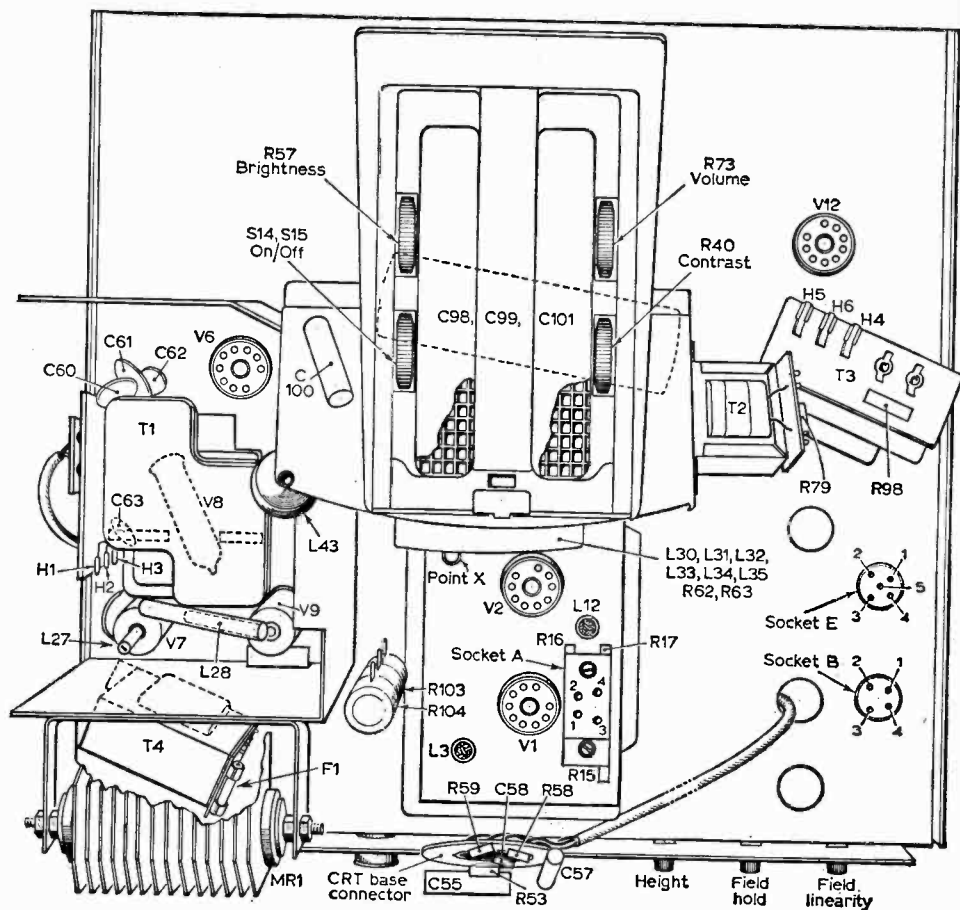

Fig. 2—Plan view of chassis as seen with c.r.t. and receiver unit moved.

Once good electrical contact on the sliders has been ensured and the mechanical side is working properly, there is no reason why the unit should not function over long periods without trouble. If reception is weak or absent check the PCC84 and PCF80 valves.

### Unboxing

Close the top control panel cover and lay the receiver face down on a soft surface. Remove the three screws from the back of the cabinet and lift the shell bodily from the chassis. This exposes nearly all parts for servicing.

### Tube Removal

Leave the receiver face down as above, remove the c.r.t. base socket, ion trap magnet and centring magnet. Remove the e.h.t. connector to the side of the tube. Remove the e.h.t. unit cover (two screws). Remove the deflection coils plugs.

Remove the two 2B.A. screws on the underside of the chassis which hold the moulded c.r.t. frame. Remove the four screws which secure the moulded handle and top panel to the c.r.t. frame. Loosen the tube mask clamping band screws sufficiently to allow the chassis to be lifted from the c.r.t. Slacken the deflector coils clamp and remove the coils and the closed loop linearity sleeve from the tube neck. Take the tube away from the rubber mask.

### Common Faults

This is one of the few sets which uses an auto transformer. This dispenses with the more usual mains dropper resistor which is a nuisance in small enclosed receivers due to the heat dissipated. The advantage of a transformer is that the mains input can be stepped up as well as stepped down. In addition it can also be used as a smoothing choke with a separate winding, thus permitting more efficient smoothing with less capacity which is necessary if only resistors are

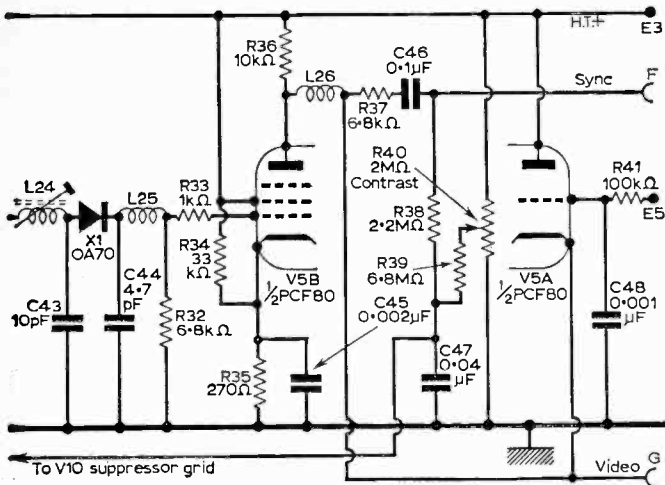

Fig. 3—The video circuit

used. What then is the snag? The most obvious one is the restriction of use to a.c. mains only. A more obscure snag is the magnifying effect a transformer has on transient mains pulses. This is usually only noticed when the originally fitted metal rectifier is replaced by a silicon diode. This may function perfectly for some time but may suddenly short, blowing the 750mA h.t. fuse. To prevent this a filter capacitor of some 0.05μF 1kV should be wired across the diode to absorb these short duration pulses with a series resistor of not less than 20Ω between the fuse and the diode. This resistor should, of course, be of adequate wattage; not less than 10 watt.

The indications of a failing LW15 metal rectifier are lack of width and bottom compression somewhat more noticeable than overall loss of height.

The correct d.c. output of the rectifier is 260V, the normal receiver h.t. line standing at 200V.

If the voltage is well up to these

figures the rectifier need not be suspected and attention should be directed to the valves, the PL81 for the lack of width, the PCL82 (field time-base) for the bottom compression. The 2.2kΩ screen feed resistor to pin 8 of the PL81 does not cause much trouble in this receiver as it is adequately rated at 6 watt. A less common cause of lack of width is a change in value of the 100kΩ resistor to pin 1 of the PCF80 (part line oscillator) and a reduction in capacity of the 0.001μF coupling capacitor. Both conditions can lead to overheating of the PL81.

**Raster Only, No Picture**

This assumes the sound is in order, the brilliance is working, perhaps at a different level to normal, but no picture content can be resolved. First, check the PCF80 video amplifier which is most likely to be at fault.

Then check the associated resistors; the 270Ω bias resistor pin 7 to chassis and the 33kΩ loading resistor to pin 7. The 33kΩ can change value, damaging the 270Ω without necessarily blowing the h.t. fuse. It may be found that the 33kΩ is quite in order and presents its original colours but that the 270Ω is still a little charred as may be the 6.8kΩ grid lead—diode load. This should immediately lead one to suspect that the PCF80 had developed a G<sup>2</sup> to G<sup>1</sup> short (pins 3 and 2) causing a heavy current flow with the attendant certainty that the OA70 crystal diode vision detector (demodulator) has been ruined. Thus although the valve may be replaced and the resistors checked no picture can be obtained until the OA70 is replaced.

The vision i.f. amplifier rarely gives trouble but if the voltages are present and the raster is overbright check the 0.001μF decoupling capacitor pin 8 to chassis.

**PRACTICAL WIRELESS — JANUARY**

**'TEN-FIVE' TRANSMITTER**

A pocket-sized phone transmitter covering 160 and 80m bands for use under fixed station portable or mobile conditions. By the designer of the popular Ten-Five transistor communications receiver.

**"EXPLORER" V.H.F. RECEIVER**

A four-transistor portable Rx/tuner for a.m. and f.m. reception on the v.h.f. bands. It covers 65–120Mc/s and 110–170Mc/s which take in the 2m and 4m amateur bands, BBC band II and many other transmissions.

**POWER SUPPLIES**

Examining mains power supplies in detail and drawing attention to several fundamental requirements not always appreciated when designing a power supply to fulfill a particular role.

**on sale December 8th—2s. 6d.**

# REACTIVATING VALVES AND CATHODE RAY TUBES

Most cases of  
low emission  
can be cured

K. T. WILSON

**W**HEN a valve or a cathode ray tube loses emission, it may be due to one or more of the following reasons: loss of vacuum; cathode exhaustion; cathode poisoning; high cathode interface resistance; or mechanical damage, such as peeling.

Generally the experimenter is not all that interested in the cause of loss of emission and is willing to replace the faulty component. In some cases, however, a valve or c.r.t. may not be easy to replace; either being obsolete or an industrial type not handled by retailers. Then it might pay the experimenter to try and reactivate it.

So long as no mechanical damage has occurred and the valve still has its vacuum, it is generally possible to restore it to good working order.

## CATHODES

Firstly it is advisable to have an understanding of the cathode. Leaving aside certain of the special purpose valves, the cathode is composed of oxides of strontium, barium and calcium sintered on to a core of nickel. Its performance is very dependent upon the way the nickel core is prepared and upon the composition of the mixture of the oxides. Precise details are carefully guarded by the manufacturers, but the net effect is that when the whole cathode is raised in temperature by the heater wire, electrons can be drawn from its surface by a small attracting field. If it were not for the fact that the oxides are conductive when raised in temperature by the heater wire, the electrons leaving the cathode would make it go positive.

**Cathode exhaustion** occurs when the chemical structure of the cathode changes. This effect does not happen overnight, but is gradually noticed by loss of emission. In time, the life of any valve must be limited by this change, but usually other factors terminate its life long before this happens.

**Cathode poisoning** is generally caused through contamination of the sub-assemblies during manufacture, but can occur by over-running a valve and causing the electrodes to overheat.

**High cathode interface resistance** is often encountered in valves which have to pass little or no cathode current, such as some of those used in pulse triggering circuits and in some u.h.f. tuners. (Several u.h.f. tuners have resistors arranged so that the valve is not completely cut-off when the receiver is being operated on v.h.f.)

The effect of high cathode interface resistance is similar to inserting a large resistor in the cathode circuit. It is caused by chemical changes in the surface of the cathode, which forms a film of resistance to electrons surrounding the cathode. Often this is much more troublesome when the valve is used in high frequency and pulse circuits.

Generally it is undetectable on a valve tester, unless one does a pulse test and measures the difference in current readings.

## REACTIVATION

The reactivation procedure is a carbon copy of the activation procedure used by the manufacturers. Once a valve has been evacuated and sealed, the emission is generally very low and has to be boosted. The manufacturer does this in three stages:

- 1 A short run with the heater current much higher than normal.
- 2 A long run with the heater current above normal and current being drawn from the cathode.
- 3 A long run with normal valve voltages applied, except for the heater which is run slightly higher than normal.

A typical schedule for a valve whose heater is rated at 6.3V, 0.3A and which should pass 10mA cathode current under normal conditions, might be as follows:

- 1 Run the valve for one minute with the heater voltage set at 10V.
- 2 Reduce the heater voltage to 8V and apply a positive potential to the grid to obtain 1mA cathode current. Cathode readings should be taken every ten minutes. When the readings level off, step the grid voltage up until 10mA flows from the cathode. Observe changes in current again for a while and gradually step up the grid voltage until 50mA flows in the cathode circuit. Retain this level for 30 minutes.
- 3 Reduce the heater voltage to 7V and apply normal voltages to the other electrodes, then run for 12 hours.

A valve which shows no sign of recovery after this treatment is at the end of its life, though the results are sometimes obscured by the release of gas within the valve. This latter case is indicated when the valve functions better after it has not been in use for some time.

In a stubborn case, the first two steps may have to be repeated several times before emission starts to rise to a level which justifies the final step. It is very rare for a valve not to respond to this treatment.

Some difficulty may be experienced with high current valves, such as those which operate in line output stages under pulsed conditions. With these valves, the gear used for activation must be able to cope with grid currents of up to 1A, and suitable limiting resistors should be inserted to prevent excess current. ■

# UNDER NEATH



## THE DIPOLE

**W**HAT a curious body the Arts Council is! It is a collection of well-meaning persons who, in the great cause of art and culture, award substantial subsidies to the most odd minorities, wicdies, do-gooders, do-badders, cranks and nut cases. I don't know who must take the blame for the large sums of money poured down the kitchen-sink in the live theatre of cruelty, so-called "fact", horror, degradation, pornography and sadism.

I don't know into which of the above categories *US*, the Aldwych Theatre production falls, but one of the national Sunday newspapers referred to it as an anti-American pro-Communist diatribe and asked "who ever would pay to see such deplorable muck put on to the stage".

Well, I didn't pay for a seat to see it at the theatre, neither did I see the extracts of it on the David Frost programme *The Look of the Week* on ITV on one Thursday night. I saw

the same disgraceful material later, when it was made available in the following Sunday's BBC-1 programme *The Look of the Week*, with Robert Robinson as Chairman of a so-called "brains trust" of three persons (two supporters of *US* and one against).

The fact that the odds were in favour of the subsidised cranks seems utterly unfair and undemocratic. Foreign propagandists should not be invited to take over the freedom of radio or television, and one is entitled to ask why a subsidised body like the Royal Shakespeare Company gets television advertising free gratis and even plus possible fees for the scatterbrains for saying their pieces.

The Aldwych and other extreme left-wing theatres are subsidised by the Arts Council but the money comes from taxation—and that means from *US*, that is, you and I, to pay for *US* of the Aldwych Theatre.

### Censorship

There are several arty-crafty groups of theatrical people who wish to eliminate censorship in the theatre. They are mainly persons of an irresponsible type who endeavour to titillate the jaded tastes of blase theatrical critics of newspapers by shock treatment.

The British Board of Film Censors is liberal enough—far too liberal, in fact. The Lord Chamberlain has permitted a lot of live theatre plays which are often offensive without quite sinking to the new lower levels, likely to happen if his job is given to someone else.

It is all very well for the cranks to talk blithely about Freud, Wren-Lewis, Brecht, Gorer, Toyne and others in the mixed-up world of fashionable psychoanalysts, but they make no contribution whatever to the standard of living. Most of us have had enough of the down-beat by the deadbeats, and this applies to many playwrights of television plays.

### Uptake and Upbeat

Now is the time to forget the horrors of the Arts Council television promotions and think about something pleasant, such as ATV's new Sunday night series *Secombe and Friends*, a

successor to *Sunday Night at the London Palladium* which had become stale and lacking in new ideas of presentation.

*Secombe and Friends* was a fresh presentation in every sense, full of laughs and put over with Secombe's "top of the bill" bracket of talented friends: Richard Burton, actor; Roy Castle, comedian; Peter Sellers (himself); Ray Ellington (and his music); Donald Houston; Geraint Evans and — quite definitely—an all-star cast. But you can't always achieve a perfect balance with a star-studded top-heavy troupe of theatrical personalities.

John Schofield, the producer, did achieve a good balance and it turned out to be a show which deserved an immediate encore. Same again, please!

### Photo Finish

First shown on BBC-2, and recently repeated on BBC-1, *Photo Finish* was the television adaption of Peter Ustinov's play, which ran successfully at the Saville Theatre—which is exactly opposite the premises of the Television Society and also the British Kinematograph, Sound and Television Society.

It was a good play as seen in that theatre, well acted by a fine cast in a one-scene background, old Sam's living room, where he renewed acquaintance with the figures of himself at the ages of 20, 40, 60, his mother at 20, 40 and 80 and his father at 50. With the principal actor mainly lying in bed during the whole of three acts, it might have become a study in still-life—but Ustinov's amusing dialogue held attention.

Television presentation was naturally a more flexible medium for such a subject, with beautifully composed close-ups of each of the characters. These revealed the smallest of subtleties in a feast of superb character acting.

### Sibilants and Transients

The motion picture film has always played an important part in television programmes. Television for reproducing both 16 mm. and 35 mm. films for transmission has always been one of the most important items of equipment in a television station. With colour TV, it will be of even greater importance.

Most of the prints of old

cinema features are of the standard 35 mm. gauge, with a photographic sound track alongside the frames of picture. The perforations have changed very little since the days of Edison, excepting when the Fox Cinemascope pictures were first introduced and which carried four stereophonic tracks of magnetic sound on 35 mm. film with very small "Foxhole" perforations. The small perforations gave space for more sound track and more picture too. This was in 1953.

Stereophonic sound on the normal cinema feature film was not very successful, its failure being due to the very fact that it was stereophonic. This restricted the activities of the film directors and their editors. The rapid changes of voices from left to right of screen to match the reverse angle shots was annoying to the audience.

Quickly the problems of stereophonic recording on the studio stage was changed to normal single microphone operation and the voice was returned to appropriate channel with the dialogue coming from the centre loudspeaker.

## Monophonic Sound Goes Magnetic

The BBC, ITA and Independent Television Companies have avoided the use of magnetic tracks for 35 mm. films on telecine up to now. The photographic (sometimes called "optical") sound track has continued for years but there is likely to be a gradual change to the use of a single magnetic stripe and a new British standard has almost been completed for 35 mm. film prints.

Having normal perforations, the picture print will carry a magnetic stripe in the exact position formerly occupied by the photographic track. The synchro-

nising position of the sound on magnetic stripe will be 28 frames *behind* its associated frame of picture, instead of the 20 frames *in front* of the picture, that was its synchronising position for optical sound.

Unfortunately, it is not possible for the sound to be exactly opposite the relative picture, because (except for flying spot telecine machinery) the transport mechanism moves the picture intermittently.

## Baker Street Back Chat

"Goodness gracious, Holmes! What will they think next?" "This is all pretty elementary and obvious, my dear Watson! Magnetic recording and its reproduction is generally accepted to be superior to photographic (optical) recording. But in this modern age of high quality photographic printing and procession, improved film stock and an excellent optical sound system on a projector, is the improvement of magnetic recording worth the high extra cost per foot of film, Watson?"

"Yes! Decidedly! In my opinion, Watson, the improvement in the ground noise ratio and especially in the more accurate reproduction of transient sounds make it worthwhile." Holmes had said his piece and rapidly played a few scales on his violin.

## Ground Noise Reduction

Optical sound tracks have a ground noise reduction system which is quiescent. The clear part of the track (with a variable area system) or the light densities of the track (on a variable density system) are kept dark when modulation is low—or when there is no sound at all. This ground noise reduction still remains

"shut" until a sound modulation opens it up, and the first few peaks are thereby clipped. The clipping, though of a very short period, rectifies the first few modulations.

## Elementary My Dear Watson

Then, you say, (as Dr. Watson would have said), "Why is it, Holmes, that magnetic recording has been so little used in the cinema?"

"The answer, my dear Watson, is that the cost of magnetic striping plus the cost of making individual transfers from a master magnetic track to the stripe is also high. This is because it is a "one off" job. It cannot be treated like modern high speed simultaneous printing of picture and photographic sound tracks on to the combined print for release printing for the cinema or for television."

Hundreds of prints are required for cinema release. Two or three prints only will suffice for television release, when 35 mm. gauge film is used. If the sound quality—particularly from music—justifies the extra cost for television use—then it will be gradually introduced. The magnetic "penthouses" 28 frames behind the relative picture will begin to be attached to telecines, as an addition, not a substitute, to the present optical tracks.

Rediffusion already have magnetic heads fitted on one or two telecines. "See for yourself, Watson!" said Holmes, "let's take a hansom cab up to Wembley TV Studios immediately!"

*Icons*

# PRACTICAL ELECTRONICS

January Issue

On sale December 15

2/6

REMOTE TEMPERATURE MEASUREMENT

TAPE RECORDER CONTROL UNIT

INTEGRATED STEREO AMPLIFIER-2

Special Series: THE ELECTRONIC ORGAN-2

# TV TERMS AND DEFINITIONS EXPLAINED

Gordon J. King

## Part VII

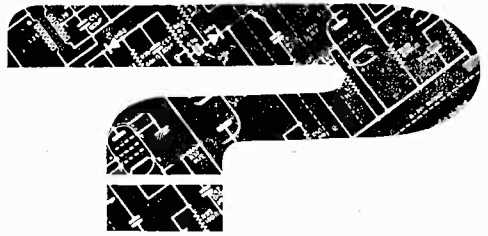

### Linearity

From basic television principles, the term linearity refers essentially to the geometric linearity of the picture on the screen of the picture tube. Linearity appraisal is given by the various Test Cards, good linearity being judged by the symmetry of squares or rectangles at the centre and extremes of the card.

If the rectangles towards the sides of the screen are elongated or compressed horizontally relative to rectangles in correct proportions at the centre of the screen, then the horizontal linearity is in error. By similar token, the vertical linearity is in error if the rectangles are expanded or compressed in a vertical sense. Sometimes other forms or figures are used as a linearity check.

The current waveform through the line and field scanning coils must rise steadily from zero to maximum value to provide a linear deflection of the tube electron beam. However, owing to the flat nature of the modern screen, the scanning spot on the screen's surface demands certain compensations to the scanning currents for linear deflection. These are provided by linearity correcting circuits in the receiver, and preset controls are usually available to optimise this linearity.

Most modern receivers have two field (or vertical) linearity controls, one which affects mainly the bottom and centre of the screen and the other that affects the top of the screen. The idea is carefully to adjust these in conjunction with the height control on a Test Card for the best possible vertical linearity.

Horizontal linearity is often fixed by a special sleeve operating inside the scanning coils. This sleeve is not easily adjustable, it being accurately positioned at the time of manufacture or subsequent to tube replacement.

There are very few sets which can be said to have one-hundred per cent linearity of picture, but small non-linearity does not show on the picture proper, provided it is not too bad on a Test Card.

### Low Emission

Emission is the term given to a valve or picture tube to describe the production (or emission) of electrons by the cathode. Electrons are produced when the cathode is heated (by the heater) and these are attracted to positively charged electrodes within the vacuum of the valve or tube.

The efficiency of the cathode in producing electrons may also be described by the term

emission. A new valve or tube can produce adequate quantities of electrons to satisfy the full demands of the circuit.

However, as the cathode wears, so the quantity of electrons produced diminishes, and the circuit is not able to be fully satisfied. In a valve, this can cause excessive distortion, lack of picture width or height, low h.t. voltage and so forth. In a picture tube, the picture gradually lacks brilliance, the contrast ratio suffers and the picture assumes a dull, flat appearance.

### Magnetic Deflection

The raster of 405 or 625 lines upon which a television picture is formed is produced by suitable vertical and horizontal deflection of the picture tube's electron beam. While early picture tubes and the majority of oscilloscope cathode-ray tubes have built-in electrostatic deflection in the form of deflector plates, it is the current television practice to cause the beam to be deflected by magnetic means.

This is accomplished by the deflector coils (sometimes called scanning coils) placed on the tube neck, near to the flare. There are two sets of coils on one assembly, one for vertical and one for horizontal deflection, called respectively the *field* and *line* deflector coils. Each set of coils produces a magnetic field across the tube neck axis, the two fields being at right-angles to each other.

In this way the electron beam, and thus the

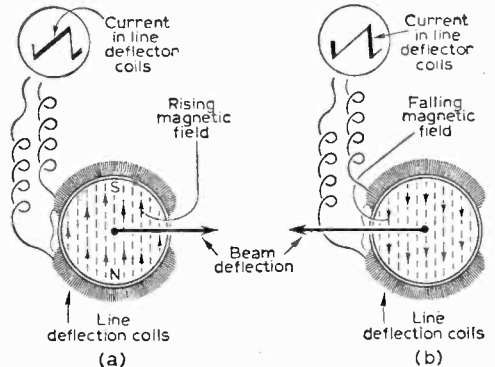

Fig. 31—Magnetic deflection. (a) how the beam is deflected over a line scan and (b) how the beam is swiftly returned on the retrace. The field coils are placed at right-angles to the line coils.

scanning spot on the tube screen, can be deflected both vertically and horizontally by arranging for the current in the coils to rise at a rate which is equal to the required speed of spot deflection.

Fig. 31(a) shows how the linear rising current in the line coils, for instance, produces a magnetic field that deflects the beam horizontally. At the finish of the scanning stroke the current collapses very rapidly and causes a change in field conditions, resulting in the swift return of the beam to its starting position, as shown in Fig. 31 (b).

The same things happen relative to the field coils, but in this case the beam is deflected vertically at 50 times per second on both line standards. The line deflection rates are 10,125 times per second for 405 lines and 15,625 times per second on 625 lines.

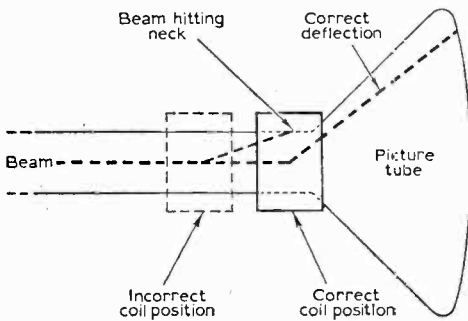

Fig. 32—This diagram illustrates how the electron beam is cut off by the tube neck if the coils are not pushed fully along the neck hard against the flare

Rotation of the deflector coils on the tube neck results in corresponding tilting of the whole picture on the screen, while corner shadowing will occur due to beam cutting if the coils are not pushed fully along the tube neck, hard against the flare. The reason for this is shown in Fig. 32.

### Mains e.h.t. System

It was common for early sets to incorporate a large step-up mains transformer for e.h.t. production. This had a secondary winding delivering about 5kV r.m.s. at a dangerously high current. The high voltage winding was connected to a half-wave e.h.t. rectifier, the output giving a peak d.c. around 6kV across a relatively large value reservoir capacitor, necessary because of the 50c/s supply frequency.

This system is no longer used commercially. Instead the high peak voltages generated in the inductive elements of the line output stage are stepped up by an overwind on the line output transformer and used as the e.h.t. source. The peak voltages which, in effect, are pulses at line frequency, are rectified by the e.h.t. rectifier and then applied direct to the tube final anode.

The reservoir capacitance is formed by the inner and outer conductive coatings of the tube, with the glass sandwiched between acting as the dielectric. This need not have such a large value as that for mains e.h.t. systems because the supply frequency is 10,125c/s or 15,625c/s on 405 or 625 lines respectively.

Care must be taken when handling old sets

with mains e.h.t., for this voltage is really lethal owing to its relatively low source impedance and fairly high value reservoir, thereby allowing high discharge currents.

Although the modern e.h.t. system can give a nasty jolt, it is rarely responsible directly for lethal electric shock because of its high source impedance and small value reservoir capacitor, these factors considerably limiting the discharge current available.

### Multichannel Sets

This term was coined some years ago following the advent of Band III television. Prior to that period, most sets were fixed tuned or pre-tuned to a single Band I, BBC channel. Then came the models capable of receiving two or more stations. These incorporated some arrangement for channel switching and selection and represented the first multichannel sets. Turret and switched tuners arrived a little later, after which came the true multichannel models which we know today.

Contemporary sets designed for reception on all the v.h.f. and u.h.f. channels are called *dual-standard* models.

### Multipath Interference

This is the technical term given to ghost interference. On vision, of course, such interference gives rise to a secondary image to the right-hand side of the main image, usually of smaller intensity. On f.m. sound it can cause a distortion similar to that produced by a loudspeaker in which the cone is out of centre or by a transistor class B output stage running into crossover distortion. This, incidentally, applies to the sound of the 625-line standard, which uses f.m.

The trouble arises from the signal sent out by the transmitter arriving at the receiving aerial by two or more routes. These are (i) the direct route and (ii) a route via a reflecting object. Of course, there may well be more than just one reflecting object, the receiving aerial then picking up the direct signal plus a number of signals via reflecting objects.

Because the reflected signal always arrives a very small fraction of a second after the direct signal, it tends to produce the whole sequence of picture to which it relates all over again, and consequently does this in the form of a ghost image to the right-hand side of the main image. The displacement of the ghost image from the main image is a measure of the *extra* time taken by the reflected signal relative to the direct signal. The time effectively being "measured" by the movement of the scanning spot from left to right across the screen.

If there are several reflected signals, then there will be an equivalent number of ghost images, displaced one from the other and from the main image by the various time differences. If the extra time of the reflected signal is very small, the ghost image may not be displaced sufficiently from the main image to be easily observed. What happens then is that the definition of the main image is reduced. Very small horizontal picture detail is thickened by the corresponding ghost information.

If the phase of the reflected signal is opposite to that of the direct signal, the ghost image will appear as a "negative" of the main image, the black parts being white and the white parts black. Signal reflections of changing phase are often displayed in this manner when the reflection is from a passing aircraft.

The cure for earthbound multipath interference lies in the choice of a highly directional aerial system orientated for maximum discrimination between the direct signal and the unwanted reflected ones. For curing aircraft reflections, the aerial should have a small vertical response, which can be obtained by stacking arrays, one above the other and then coupling them all to a common downlead.

Prior to the commencement of u.h.f. television, it was thought that u.h.f. multipath interference would cause a great deal of trouble. This, however, has not proved to be true, firstly because highly directional aerial systems are fundamental to the u.h.f. bands and secondly because it would seem that reflected u.h.f. signals are more easily attenuated than reflected v.h.f. signals.

**Multivibrator**

This is a circuit arrangement which employs either a pair of transistors or valves to produce current or voltage pulses of specific wave shape to drive the line and field timebase amplifiers.

A typical multivibrator timebase generator is shown in Fig. 33. This works as follows: When first energised, a momentary increase in anode current of one of the triodes, say, triode (a), causes an increase in the voltage dropped across the anode load R2. This random change in condition is reflected to triode (b) grid, through C2, as a negative pulse. This results in triode (b) anode current falling and a reducing voltage drop across the load R3.

This is communicated back to triode (a) grid, through C1, as a positive pulse, causing a rapidly rising current in triode (a). The effect rapidly builds up—the handing of an amplifier negative pulse to triode (b) grid, and a positive pulse to triode (a) grid. Grid current is soon drawn from triode (a), while triode (b) grid is driven well beyond anode current cut-off.

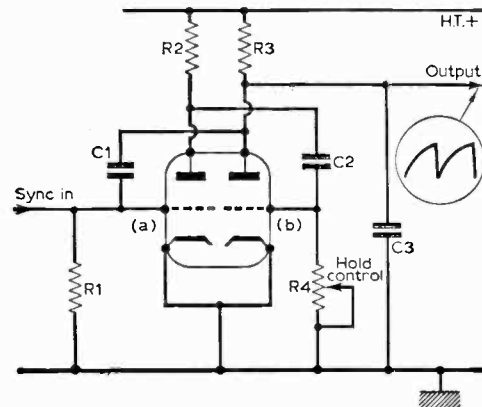

Now, during the period that the charge developed in C2 is leaking away through R4—eventually returning triode (b) to its conductive condition—triode (a) continues to pass heavy anode current. This valve, in effect, is switched "hard on".

When the grid of triode (b) rises sufficiently, anode current begins to flow and triode (b) anode potential falls, causing a fall in triode (a) grid voltage and a rise in its anode potential.

The whole cycle then starts all over again, but this time in the opposite direction; that is, C1 charges and triode (a) cuts off, the discharge being through R1. Alteration in value of the discharge resistor (R4 in Fig. 33) alters the repetition rate of the generator, as also, of course, would alteration in value of a capacitor.

The action of the circuit can thus be likened to the alternate switching on and off of valve sections (a) and (b) at a rate governed by the time-constant or charging/discharging cycle.

To produce a suitable drive for the line or field amplifier, a capacitor is usually connected in the position of C3 in Fig. 33. This charges through R3 and gives an exponentially rising output voltage, but is then suddenly discharged when triode (b) conducts, thereby producing the retrace or flyback action. The waveform produced across C3 is shown.

The correct line frequency should be obtained with the hold control at about range centre. If this control needs to be far over towards one of its stops to lock the timebase, alteration in value of R2, R3, C1 or C2 should be suspected. Sometimes, however, a bad valve can cause the effect.

If R2 goes high, but not sufficient to put R4 out of range, a series of closely-spaced white, horizontal lines may appear at the top of the picture when the generator is in the field timebase. Too high R3 can reduce the scan amplitude.

**Negative-going Picture Signal**

In the 405-line system, the polarity of the composite video signal rises in a positive direction from the base of the sync pulses. In the 625-line system, however, the reverse is true, and the picture signal is said to be negative-going.

Such signal is shown in Fig. 34, which shows the sync pulses rising to a positive value from picture peak white. It is for this reason why switching is required in the vision detector and, sometimes also, in the video amplifier of dual-standard receivers.

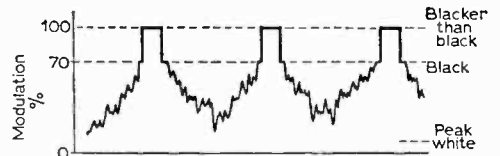

Fig. 33 (left)—A typical multivibrator circuit used as a timebase generator.

Fig. 34 (above)—The negative-going picture signal of the 625-line standard

Part VIII follows next month



# COLOUR CONFERENCE

at Mullard's

AS a prelude to the run-in for the start of colour television, scheduled to start on BBC-2 u.h.f. channels in the autumn of 1967 (subject, of course, to any changes resultant on the publication of the much overdue Government White Paper on Broadcasting), Mullard Limited recently organised a conference at Mullard House. At this conference, speakers drawn from the BBC, industry and trade associations, provided food for thought to the audience of the press and radio and TV dealers. Some of the comments by David Attenborough, head of BBC-2, are referred to in this month's leader.

Mr. S. E. Allchurch, director of BREMA, claimed that the PAL system would be more reliable and likely to need less servicing and would also be much easier to instal (an apparent turn-around from the previously highly pro-NTSC line taken by BREMA).

## FIFTY THOUSAND SETS FIRST YEAR?

About 50,000 colour sets were expected to be sold or rented during the first year of the service, said Mr. Allchurch. The sets, only slightly larger than conventional receivers, would sell at from 260-310 guineas and would be rented at around 35-40 shillings per week.

He said that colour TV should open a new market which may become the major growth factor in the industry for the next decade.

Cheerful news for service engineers came from Mr. A. J. Kenward, secretary of SERT who thought that colour receivers would not present many more servicing difficulties than an ordinary set. "The chap who is competent with black and white equipment should be able to find his way about a colour receiver given a service manual and a little instruction", he claimed. We hope he is right!

## ONE CAMERA TO EVERY RECEIVER?

Some inside facts on the programming side were given by Mr. F. C. McLean, Director of Engineering, BBC. At the start of the service 30 colour cameras will be in use, with half a dozen telecines, videotape recorders, etc. Plans for colour have been progressing since the start of BBC-2. Transmitters will radiate a colour picture irrespective of the system, the GPO programme links will accept a colour signal, studio equipment has been built with colour in mind.

In the monochrome service, there are probably 60,000 receivers for every camera or picture-originating device. With colour the initial ratio is likely to be one receiver per camera. Handling this type of equipment calls for more than a knowledge of the basic theory and Mr. McLean implied that it is necessary to have a kind of inbuilt sympathy to the medium of colour to obtain maximum handling efficiency. He stressed that very great care and skill will be required by operators.

To deal with this sort of problem a large training scheme is envisaged. At the Engineering Training School at Evesham, training will be given in basic colour principles, the use of test equipment, vectorscopes and in the use of cameras, monitors, etc. Lime Grove will also be used for training programme and engineering staff.

Some 200 men are to undergo this training which has to be completed by the spring.

## PUBLIC MORE CRITICAL OF COLOUR

Mr. McLean stressed that the public is likely to be much more critical of picture quality in colour. In monochrome, people are not usually critical of grey shades in a scene but if colour does not look natural viewers are likely to be very disturbed. He went on to underline the importance of the white balance in setting up in order to maintain accurate colour values.

Elaborating on this theme, Mr. McLean drew attention to the slow start of colour in the USA, where the service drifted along from 1954 to 1962 before really getting off the ground. He thought that although the receivers were expensive and that only one company was marketing them (and incidentally making a loss), the real reason for the cooling off of the American public was the picture quality—sometimes good, sometimes very bad, but always variable.

## AMERICA: INSUFFICIENT TRAINED STAFF

One reason, claimed Mr. McLean was not the cameras but insufficient staff which had not been trained to keep them up to the top level at the studio end. Contributory factors were poor colour recording facilities, poorly lined up transmitters and distribution networks and receivers with poor electrical stability.

We have learned a lot from these early American experiences and our receivers will not only be better than the early American ones but should be better than the current models. This is due to our 8Mc/s channel (against the American 6Mc/s) and the advantages of the PAL system in receiver tuning and design.

## FIRST CLASS SERVICEMEN NEEDED

Mr. McLean wound up his talk by going over the aspects of the effects of receiver misadjustments and faults. It can be summarised in that a receiver defect will produce much more striking and disturbing phenomena than in conventional sets and that the viewer will be far more demanding of perfection. This, of course, stresses the great importance of ensuring not only that studio equipment and receiving equipment is good but that the service and distribution side of industry makes an early start in training people to appreciate what is what in a colour system and giving them adequate training and practical experience in lining-up and handling colour receivers. ■

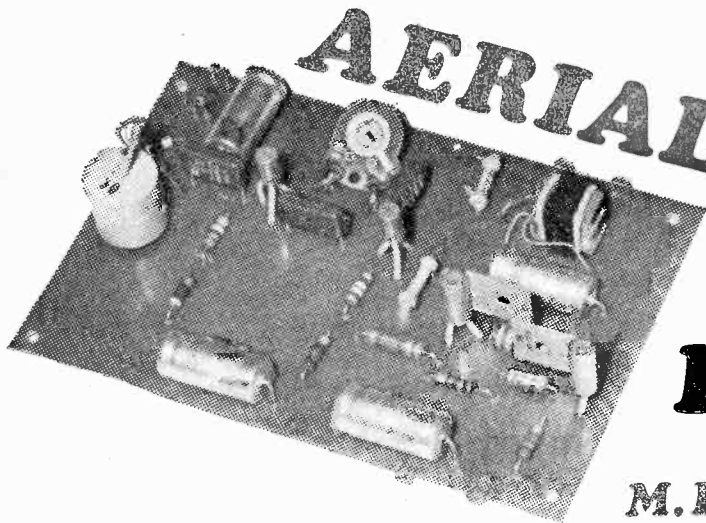

# AERIAL RIGGED INTERCOM

M. L. Michaelis, M.A.

WITH the high input sensitivity of modern television receivers, and good area coverage by the television organisations, maximum possible signal pick-up is not necessarily the sole aim when installing and adjusting an aerial system. Multi-element television aerials are highly directional and are needed in areas where tall buildings, hills or other obstructions can impede the direct signal and give rise to a number of reflected signals. The various reflected signals arrive along paths which are slightly longer than the one for the direct signal straight from the transmitter and cause ghost images to appear to the right of the main image. In some cases the

reflected signal is stronger than the "line-of-sight" signal; then the ghost images will be to the left of the principal display.

The closer a reflecting obstruction is situated to the line-of-sight path between transmitter and receiver, the less noticeable the resulting ghost image will be. Principally those obstructions which lie well to the side of the line-of-sight to the transmitter (or behind it) are the most troublesome. A highly directional aerial, in the

Fig. 1—(below) Circuit diagram of the intercom amplifier; Fig. 2—(right) Component layout of component board which is actual size of author's prototype

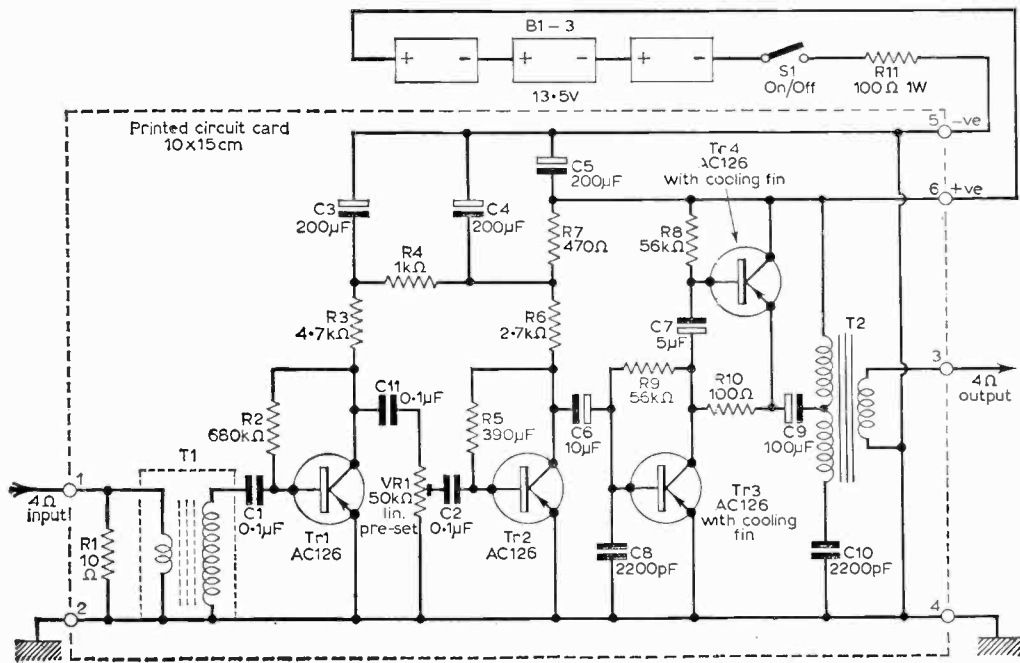

# R'S DM

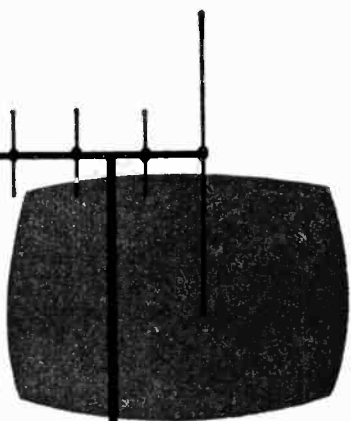

ideal case aimed straight at the transmitter, will combat ghosting very effectively, because it is designed to be unresponsive to signals from the side or rear.

### Practical Conditions

If practical conditions were really as simple as this it would be easy to align a newly-erected television aerial, since the geographic location of the transmitter is known and the aerial can be aimed at it accurately using a compass. However, conflicting requirements often rule out the possibility of any such simple procedure.

In obstructed areas, it may well be that some strong reflection is the dominant, or even the only, signal. The correct beam direction for the aerial may then be completely different from the line-

of-sight path to the transmitter. It is not possible to predict the strength of such major reflections from pure geographic and topographic considerations, since, among other factors, they give rise to standing waves in valleys and between buildings, so that signal strengths can vary enormously over distances of only a few yards. Neither is it possible to judge the effectiveness of some intermediate alignment of the aerial between two transmitter directions, as far as response to the wanted signals and rejection of any ghosts is concerned, unless one actually makes observations on a receiver.

### Assessment of Picture Quality

For the best possible results the aerial system should be installed as high up as possible on the roof of a building or on a self-supporting mast. In most areas, however, it is possible to put an aerial in one's loft. In either of these locations it is not possible to see a picture and generally it needs a middle man to run back and forth from the aerial to the receiver while adjustments are made. As a result, many good aerial arrays are left in some setting which is not giving the optimum performance.

### Signal Strength Meters

Television signal strength meters are quite frequently used by aerial erectors. These basically consist of a channel tuner, detector and moving coil meter indicating the rectified carrier voltage. Such instruments may be connected directly to the aerial on the roof or at the other end of the downlead. The former arrangement is useful for determining a position

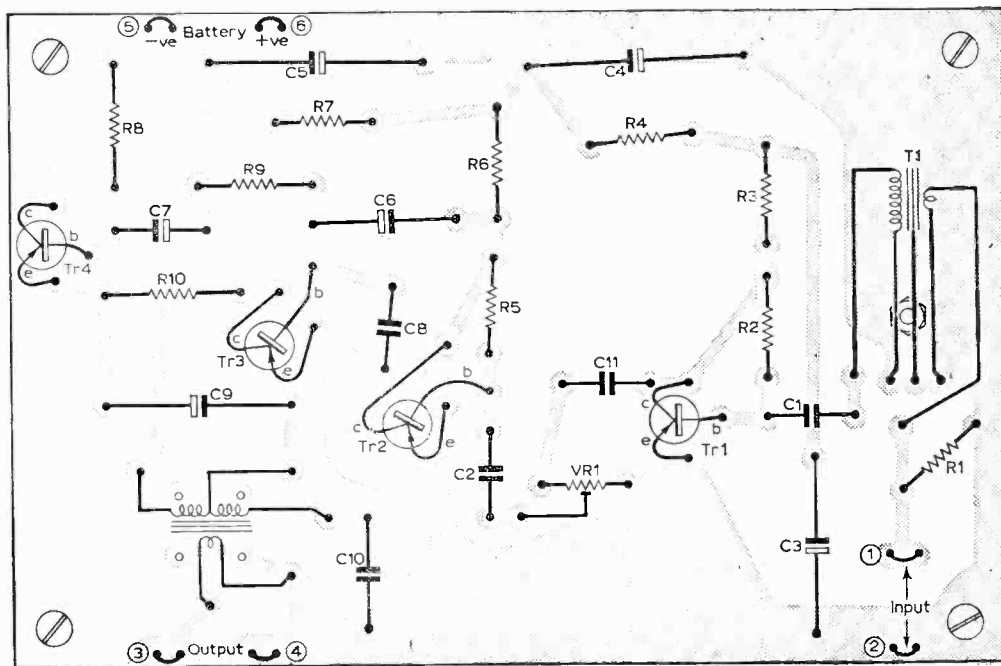

for the aerial mast giving adequate signal strength; the latter arrangement for checking feeder lines and determining the most suitable feeder in cases of doubt. However, it is important to point out that a signal strength meter cannot be used satisfactorily for aerial beam alignment, except in the simplest case of a fully unobstructed rural area free of ghosts. In all more complicated cases, and it is just these which are concerning us in this article, the signal strength meter can give no guide as to picture quality, because it is quite unable to distinguish between the direct signal and reflected signals (ghosts); always indicating a resultant voltage without taking any account of time differences and relative intensities. The use of the signal strength meter is thus confined to the choice of a site for erecting an aerial and to the choice of a suitable type of feeder in cases of doubt. Correct beam alignment of the aerial, the far more tricky problem, must be achieved by other means.

### **Beam Alignment Intercom**

The second instrument which a well-equipped aerial erection team requires is some form of voice-intercom unit enabling two-way communication between a person at the receiver and another at the aerial. This communication can be made through the feeder and downlead of the aerial to avoid an additional communications cable. It should be done at audio frequency to avoid complications and additional expense involved with alternative radio-frequency systems.

It is the subject of this article to bring constructional details for a suitable intercom unit. The outfit comprises a small amplifier and battery power supply, a crossover-network at either end of the feeder line and a small loudspeaker at each end which is also used as a microphone.

### **Amplifier**

An amplifier design for this purpose must satisfy a number of special conditions. Firstly, its input and output impedance must be very low matching a 3- $\Omega$  loudspeaker directly when used as microphone or as loudspeaker. The feeder line may then be used as desired for loudspeaker signals at high level as well as for microphone signals at low level, without introducing appreciable mains hum or instability even if unscreened (twin feeder) and of considerable length. Secondly, the gain must be very high, so that the crossover networks may be adjusted in favour of minimum interference with the television signal, at the expense of audio efficiency. Thirdly, the circuit should be as simple and reliable as possible, with no critical or vibration-sensitive adjustments.

Finally, the circuit must be inherently stable and able to withstand input and output variations according to the particular aerial installation being worked on. One of the factors enhancing such general stability is a reduction of the output power to the minimum really necessary for clarity; about 100mW. This avoids large a.f. currents on the feeder line.

The only manual control needed apart from the on/off switch is a toggle (or pressbutton) switch at the receiver end for selecting the "listen" or "speak" function for the person making observations at the set. It is a matter of taste whether a toggle switch, pressbutton or keyswitch is used for the listen/speak changeover. A toggle switch is normally cheapest and quite satisfactory.

### **Circuit Principles**

Figure 1 shows the theoretical circuit of the amplifier. In spite of its simplicity, this circuit offers extremely high gain considering the number of transistors used. However, it is very important to use the specified transistor Type AC126 (Mullard). Most other audio transistors are unsuitable, giving either inadequate gain or severe instability. The AC126 has very high current gain ( $\beta$  of between 150 and 200) and a low cut-off frequency (around 17 kc/s). If transistors of higher cut-off frequency are used it may be necessary to select ones with such low  $\beta$ -values to maintain stability that the gain is then inadequate for the intended purpose. The circuit of Fig. 1 with the specified transistors is just on the verge of instability with VR1 turned full up and the switching, crossover network, feeder and aerial-end loudspeaker connected. At this setting, 100 $\mu$ V r.m.s. from the speaker functioning as microphone will give full output at the other speaker (100mW). This is more than adequate even under the most adverse conditions, since the e.m.f. from the miniature loudspeaker used as microphone for close speech is normally 1mV (3-5 $\Omega$  impedance). The preset gain control may thus be turned well down under all normal conditions of use, making the system quite stable. The correct setting for VR1 is determined by the sensitivity of the particular speakers (when used as microphones) and by the losses introduced by the crossover filters.

### **Preamplifier Stage**

Tr1 is the preamplifier stage. Resistor R1 prevents instability during switching or if the input is disconnected. T1 may be any small microphone transformer, preferably encapsulated in mumetal screen especially if the intercom is combined with another item of test equipment. The ratio should be about 1 : 30 and the impedance rating should be between 5 and 200 $\Omega$ .

The type of base bias used in the preamplifier stage, and for that matter, in the other three stages, consists of a high-value resistor between the collector and base. This gives adequate d.c. and a.c. negative feedback for temperature stabilisation and minimises distortion without requiring emitter resistors and shunt electrolytics.

### **Gain Control and Driver Stage**

The low values of C11 and C2 in conjunction with the value of VR1 and the low input impedance of Tr2 gives bass attenuation, which improves speech intelligibility and minimises amplification of any residual mains hum which may be picked up. The driver stage Tr2 is

otherwise similar in function to the preamplifier stage. Its low collector load resistance R6 permits adequate drive of the push-pull output stage Tr3/Tr4.

### Push-Pull Output Stage

The transistors Tr3 and Tr4 form a push-pull output stage which is series-connected for d.c. currents. This arrangement obviates the need for a driver transformer and does not require critical temperature stabilisation.

The action on a.c. signals is as follows: Single-ended drive from the driver stage Tr2 is applied to the base of Tr3 only; the collector load for Tr3 is R10 in series with the parallel connection of the emitter-collector path of Tr4 and the top half of the output transformer primary via C9. Of this total load, R10 is a negligible fraction, but it alone is connected between base and emitter of Tr4 and is thus producing the small antiphase drive signal for the top transistor Tr4. Now consider a drive applied to Tr3 base which is going more negative at the moment in question, i.e., the current through Tr3 is increasing. This will also make the current through T2 primary increase. But Tr4 is being driven antiphase from R10, so current through Tr4 is actually decreasing, allowing more current to flow through T2 primary. The action is reversed when the input drive at Tr3 base is going less negative. Tr3 is then driven closer to cut-off, reducing the current through T2 primary directly and again because Tr4 is being driven to increased conduction by the antiphase signal and is thus increasingly shunting residual current away from T2 primary. The total current swing in T2 primary is equal to the peak current of one of the transistors alone (theoretically, assuming a linear characteristic right to cut-off), i.e., exactly the same as for a single-ended stage of the same standing current.

One might ask where this push-pull stage is deriving the additional power, since conventional push-pull stages give twice the current swing of a single transistor in the total primary of the output transformer. The answer is to be found in the fact that the d.c. series connection halves the voltage applied to each transistor, so that twice the standing current may be used without overloading the transistors. Thus the stage gives twice the output power of a single transistor within its ratings. True, the output power is no more than a single transistor will develop at the same current and full supply voltage, but such operating conditions would exceed the maximum permissible power dissipation and destroy the transistor.

The choice of output transformer T2 is not very critical but the optimum ratio is 5 : 1 between each half-primary and the secondary. The secondary should be rated for a 3-5Ω speaker. Thus the half-primary would ideally be rated at about 100Ω, the full primary at 400Ω. A miniature 100mW or 250mW type is adequate and screening is not required.

### Adjustments to the Output Stage

It is essential to adjust the output stage correctly, to safeguard the transistors and to obtain the rated output power of 100mW which is just right for conveniently intelligible loudspeaker

intercom operation without making undue noise. First of all, Tr3 and Tr4 must be fitted with small cooling fins. These need only be exposed freely to the air; clamping to some larger metal structure is not necessary. Now connect-up the amplifier via terminals 5 and 6 to the batteries, S1 and R11 as shown in Fig. 1, but leave S1 switched off. Connect a milliammeter momentarily across S1 (range 50mA f.s.d.). If the immediate current is less than 22mA, decrease the values of R8 and R9 slightly (large-value resistors in parallel) in order to aim at exactly 25mA upon switch-on via the milliammeter. If the immediate current was greater than 27mA, increase the values of R8 and R9 to obtain 25mA upon switch-on.

Leave the milliammeter connected and observe the current. All is correct if the current does not exceed 30mA after half an hour. If it does exceed 30mA, then increase the values of R8 and R9 until the current after half an hour of continuous running without a signal is 30mA. Now measure the d.c. voltage between Tr3 collector and the chassis line, also between Tr4 collector and emitter. If the ratio of these two voltages falls outside the limits 0.85—1.2, then increase the value of the base resistor (R8 and R9) of that transistor across which the smaller voltage was measured. If this adjustment calls for large differences between R8 and R9, try exchanging the transistor with the larger voltage reading with Tr1 or Tr2. After any such transistor swap, repeat the current adjustment described at the outset before taking the new voltage symmetry readings. All these adjustments are not over-critical and the circuit will probably work correctly right away with the specified values for R8 and R9 and most samples of AC126. If maximum undistorted power is desired, R10 may need to be modified. For this purpose, connect a loudspeaker and an oscilloscope to the output terminals 3 and 4 (in parallel) and feed an audio signal (about 400 c/s to 1 kc/s) from a signal generator to the secondary of T1. Adjust the signal (a few mV) so that Tr1 does not overload and full output is obtained with VR1 set about mid-way. Now turn-up VR1 until clipping of the sinewave occurs. If this is not simultaneous on the positive and negative peaks, adjust the value of R10 by trial and error. The required sense of adjustment depends on the phasing of T2 and must also be established by trial and error. Note that if other transistors are used in this output stage, the resistor values may need drastic modification.

### Stability

Capacitors C8 and C10 improve the stability of the amplifier by shunting high frequency signals at which the transistors could otherwise oscillate. If it is found that high-pitched squeaks or motor-boating result when the listen/speak switch, crossover network and speaker are connected (Fig. 3), or even with the amplifier input open-circuit and merely a speaker connected directly to the output, then increase the capacitance value of C8 and, if necessary, also of C10. In the prototype, the specified values brought the amplifier to the verge of oscillation (but still not oscillating) when VR1 was turned full up and the external circuitry shown in Fig. 3 was connected.

### Power Supplies

When building the intercom unit to operate on its own, battery operation is strongly recommended since there is very little battery drain and a really safe mains power supply is expensive. The author used three "flat" batteries giving a nominal supply voltage of 13.5V. The series resistor R11 shown in Fig. 1 is essential for safeguarding the transistors when the batteries are fresh and may temporarily have a high voltage. This resistor may be mounted on the printed circuit board, but was not put on the prototype board because its value and arrangement will be different for a mains power supply. The prototype is being built into a composite unit which also contains the small television pattern generator described last month and will be operated off a common mains power unit. Details of this composite unit will be given later.

### "Set-End" Connections

Figure 3 shows the external connections to be made to the amplifier board at the "set-end" of the aerial feeder cable. The amplifier board, batteries, speaker, switches and other components may be mounted in a small metal case which will carry the two coaxial sockets P1 and P2.

For use, the aerial downlead is then simply plugged into P1 on the intercom unit instead of into the aerial socket of the television set, whilst a small extension cable is used to connect P2 to the aerial terminal on the television set. C12 establishes continuity for the TV signal proceeding to the receiver, but prevents the audio signal from being shorted-out by certain arrangements of the receiver input circuits.

Resistor R12 and the choke L1 prevent the TV signal from reaching the intercom circuits, but offer negligible impedance to the audio signals. The resistor is merely a former for the coil L1. A fairly long 47k $\Omega$  2W carbon resistor is ideal, and about 80 to 100 turns of 36 s.w.g. enamelled copper wire should be close-wound on to its body.

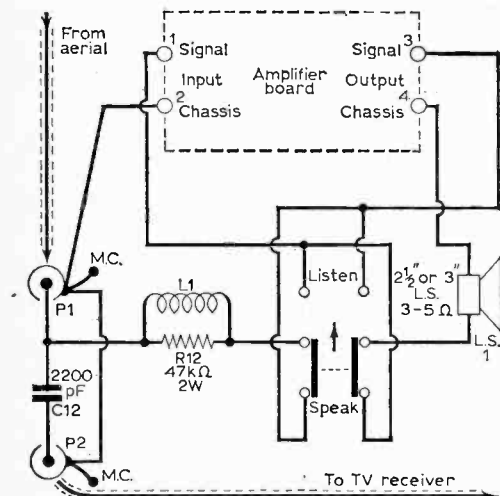

Fig. 3—"Set-end" connections of the intercom.

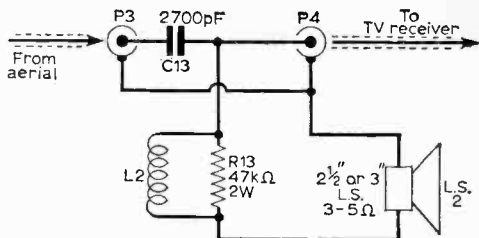

Fig. 4—"Aerial-end" connections of the intercom.

The ends of this winding should be soldered on to the leads of the resistor, close to the body.

With many types of enamelled copper wire it is not necessary to scrape off the enamel first. If a blob of solder is run on to the resistor lead close to the enamelled wire and the soldering iron applied for some 15 to 30 seconds, supplying more solder; the flux of modern cored solder will often eat away the enamel and produce a clean soldered joint without damage to the wire or resistor. A small low-voltage iron which is not run at an excessive temperature is most successful for this operation, which can also be useful when soldering thicker connecting wires to the ends of transformer windings for other purposes.

The listen/speak toggle switch (or pressbutton) S2 is a double pole changeover type and is wired to change over the internal speaker and the TV aerial feeder line between the input and output of the amplifier (Fig. 3). Due to the very low impedance used on both lines, no trouble should be experienced with instability at normal settings of VR1.

### "Aerial-End" Connections

Figure 4 shows the required crossover and loudspeaker connections at the aerial end. The arrangement and function of the crossover network is similar to that at the set-end. Capacitor C13 providing continuity for the TV signal passing straight through from P3 to P4, but preventing the aerial from shorting-out the audio signal. The latter can pass with little impedance via L2 to the speaker/microphone LS2; choke L2 prevents shunting of the TV signal. No switching is required this end, since the person at the set-end determines the direction of the conversation. L2 is identical to L1, being wound on a similar (resistor) former. The exact diameter and number of turns for L1 and L2 is not critical.

The downlead will be cut to the correct length for subsequent direct attachment to the aerial array, but a coaxial plug should then be fitted temporarily and connection made to P4 of the aerial-end intercom unit. A temporary link is then made from P3 to the aerial array.

### Loudspeakers

Do not choose loudspeakers with a cone diameter greater than 3 inches, because these would give a rather deep and muffled response when used as microphones. A pair of 2.5 or 3 inch loudspeakers (3 to 5 $\Omega$ ) are probably the best since they give crisp intelligibility of speech when used as a microphone and good intelligibility when used as a loudspeaker.

**Balanced Twin Feeder Lines**

The arrangement shown in Figs. 3 and 4 is for the more common coaxial feeder. This has the advantage of permitting a common return for the TV signal and for the audio signal, so that only one crossover choke is required at each end, reducing audio losses. Figure 5 contains some modifications which may be made to cope with twin feeder systems. The conversion transformer between twin feeder and coaxial line may be used either way round after fitting appropriate plugs and sockets. Capacitors C16, C15 and choke L4 can be omitted if v.h.f. signals alone are present.

The respective symmetry windings (Baluns, as they are often called) should be wound bifilar fashion, see Fig. 5 for details. Two lengths of wire are taken for this purpose and wound on simultaneously in a single layer, with alternate turns belonging to each wire. The end of one wire is then connected back to the start of the other to constitute the centre tap of the winding in the theoretical circuit, whilst the remaining two ends are the outer connections (which way round is immaterial). The windings should be wound on small twist drill shafts of the specified diameters, which are then removed, leaving air-cored coils.

A small piece of printed wiring board mounted in a non-metallic casing provides a suitable skeleton for the unit. Apart from the details given, the construction is not particularly critical, but keep all connections very short. Such a transformer may be interposed at the "set-end" where the twin feeder is to enter P1, and again where the coaxial feeder comes out from P2. In principle, another pair of transformers could be used with the "aerial-end" unit. However, a total of four transformations of the line symmetry would lead to rather heavy losses in the TV signal, and could possibly even introduce mismatches and alter the directional response of the aerial, especially when used at the aerial-end of the feeder line. The arrangement shown in Fig. 5 is thus preferable at the aerial end. The circuit shown in Fig. 5 is actually intended for optional twin-feeder or coaxial use and interposes three chokes in series with the speaker, leading to quite heavy audio losses. Whether this is tolerable or not will depend upon the efficiency of the speaker. With good-quality high-flux magnet speakers, it should still give adequate audio

performance and would be the ideal arrangement as far as television requirements are concerned, because either kind of feeder may be encountered by a large aerial erection concern.

If the unit is to be used for twin feeder only, then the coaxial plugs, C13, R13 and L2, may be omitted in Fig. 5, with the loudspeaker connected directly between the free ends of R14/L5 and R15/L6. In principle, a similar arrangement can then be adopted at the set end instead of using two transformers there for temporary conversion to a coaxial feed. In other words, in Fig. 3 P1 and P2 would then be replaced by twin feeder sockets, interlinked internally by a pair of 2700pF capacitors, and two resistor/choke combinations would branch respectively to connection 2 on the amplifier board and to S2.

A few experiments with symmetry transformers and dual arrangements (Fig. 5) should be made with an existing aerial installation known to be giving good performance, noting the signal attenuation (TV signal strength meter) and the audio performance of various arrangements in order to decide which one is best for general adoption. A lot will depend upon the quality of the speakers, the efficiency of the particular audio transformers on the amplifier circuit board, the diameter of wire used for the crossover chokes and personal preferences regarding minimum acceptable intercom volume.

**Using the Intercom**

The author assumes that several transmissions can be received at the site in question and it is required to orientate the aerial system to obtain optimum pick-up with acceptable or negligible ghosting for all television stations in question. It may or may not be possible to satisfy this condition; but the following procedure will definitely and systematically establish whether it is possible to within acceptable tolerance limits.

If the various transmitters operate on different bands requiring separate aerial arrays, then the entire procedure should be carried out independently for each array and its associated programmes. We will confine the discussion to a single array with which at least two programmes are to be picked-up, i.e., to the establishment of some single beam direction which gives good

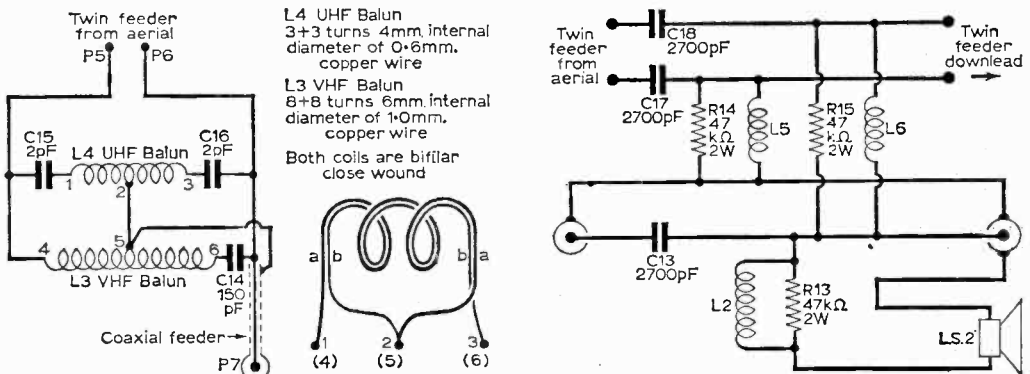

Fig. 5—Arrangements for twin-feeder systems 'a' shows the "set-end" and 'b' "aerial-end".

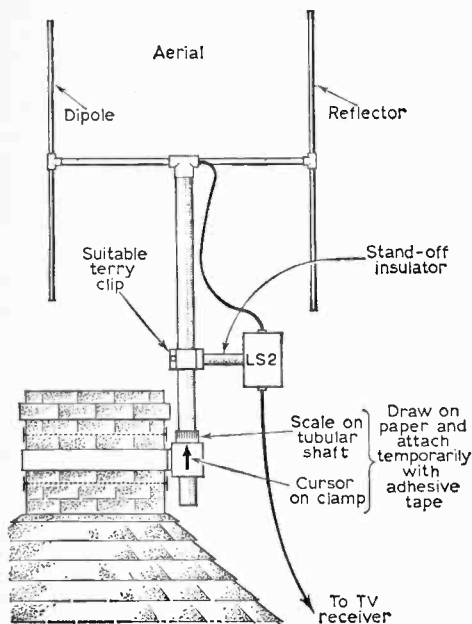

Fig. 6—Suggested method for television alignment.

response to two or more programmes which may be arriving along different directions.

Figure 6 shows a convenient arrangement at the aerial-end. The loudspeaker and crossover network here may be mounted most conveniently in some non-metallic case (bakelite or plastic) with a stand-off insulator and terry clip or some other form of bracket for quick and temporary attachment on to the aerial mast near its lower end. A piece of paper is cut to a strip whose length is equal to the circumference of the aerial mast. This strip is uniformly marked with some form of graduation, e.g., 0 to 360 deg. and is then attached around the mast directly adjacent to a main clamp, or near the upper end if the array alone is rotated. Sellotape affords a convenient means for temporary attachment of this scale. The clamp or some other stationary part of the fittings should carry a piece of paper marked with an arrow as pointer, also attached with sellotape.

The working procedure is now as follows: The intercom is normally left set so that any remarks made by the man at the aerial are heard by the man at the television set. The latter will start by switching the receiver to one of the programmes. As soon as the man at the aerial announces that the aerial is now in position "A" (stating scale setting), the observer at the set will note the reception quality and the scale setting. He will then briefly switch over and tell the man at the aerial that he is ready for the next setting. The man at the aerial turns it gradually to the next setting, speaking as he is doing so "10—20—30 degrees shift." The observer at the set will note the changes in reception quality during the motion, and the new scale setting, then confirming back and requesting the next setting.

After completing a full circle turn of the aerial array in this manner, the procedure is repeated for

## ★ components list

### Resistors:

R1	10Ω ½W	R9	56kΩ ½W
R2	680kΩ ½W	R10	10Ω 1W
R3	4.7kΩ ½W	R11	100Ω 1W
R4	1kΩ ½W	R12	47kΩ 2W
R5	390kΩ ½W	R13	47kΩ 2W
R6	2.7kΩ ½W	R14	47kΩ 2W
R7	470Ω ½W	P15	47kΩ 2W
R8	56kΩ ½W		(Carbon, ± 10%)

### Capacitors

C1	0.1μF MF	C10	2200pF C
C2	0.1μF MF	C11	0.1μF MF
C3	200μF E	C12	2200pF C
C4	200μF E	C13	2700pF C
C5	200μF E	C14	150pF C
C6	10μF E	C15	2pF C
C7	5μF E	C16	2pF C
C8	2200pF C	C17	2700pF C
C9	100μF E	C18	2700pF C

MF= Micro-foil 250V  
C=Ceramic 500V  
E= Electrolytic 30V

### Potentiometer:

VR1 50kΩ lin preset

### Semiconductors:

Mullard:

Tr1 AC126 Tr3 AC126  
Tr2 AC126 Tr4 AC126

Two with cooling fins

### Loudspeakers:

LS1, LS2, Miniature loudspeakers 2½ or 3 in.  
3–5Ω impedance

### Inductors:

L1–L6 (see text)

### Switches:

S1 s.p.s.t. } Toggle or pushbutton  
S2 d.p.d.t. }

### Miscellaneous:

Four coaxial sockets, three "flat" batteries (4.5V), material for printed circuit, casing, etc.

the next programme. This is much better than running through all programmes in succession at each setting, because such a procedure would distract attention from the essential need to note carefully improvements or deteriorations with respect to small angles of beam change on any one programme.

When the process has been completed for each programme, the optimum beam settings as well as the ranges of reasonable response are read-off for each programme. Points of coincidence or sector overlap which are mutual to all programmes

—continued on page 136



# FIBRES, CRYSTALS

and

# PIPES

— I. R. Sinclair

SOME of the most unlikely things seem to turn up in the rapidly-growing world of television. A few years ago, the element Europium was an academic curiosity, of interest to only a handful of research chemists. Now it is the basis of improved red phosphors for colour c.r.t.'s and means brighter colour pictures—when we get them. Examples like this can be found in any branch of engineering, but some of the most spectacular examples have been concerned with the transmission of modulated laser beams, a subject described by the title, *Fibres, crystals and pipes.*

The fibres of the title are, of course, glass fibres. The discovery that glass fibres could be used to contain and direct a beam of light is a fairly recent one; in fact, glass fibres themselves are of recent origin. A fibre of glass as normally prepared is of no use in forming a light-pipe; there is nothing to stop light leaking in and out of the transparent fibre. It is rather like trying to conduct microwaves along a piece of lighting flex, radiation is easier than conduction. One way, however, of conducting microwaves

The refractive index of a material measures the amount of change of direction of a light beam when it passes from a vacuum to another transparent substance. When a glass fibre is coated with another glass of higher refractive index, a ray of light travelling so as just to hit the wall of the fibre will be changed in direction, or refracted, so as to travel into the fibre again. Since any ray of light in a fibre must travel nearly parallel to the walls, no light is lost, and the combination of the two glasses makes an excellent light pipe.

## Fibre Manufacture

We can obviously make this fibre as thin and as flexible as manufacturing processes permit us. These manufacturing processes are rather similar to the making of Blackpool rock. A thick rod of the centre glass is made, and coated with a sheath of the second glass of lower refractive index. The whole composite rod is then taken up to a temperature at which both glasses are fairly soft, and then drawn rapidly out so as to form a fibre before the glass has had time to solidify.

We can then use the fibres in the form of a bundle as a long "cable" for light, or we can chop the fibres into shorter lengths and use them to make "lenses" of rather unique properties, but that is a story which must be told at another time.

The crystals are the next item, and the material is gallium arsenide. Until recently, there was hardly any use for the metal, gallium. It is a very soft metal, rather like lead, to which it is chemically related, but with a melting-point so low that it will melt in hot water. Probably no one would have ever thought of forming the compound of gallium and arsenic but for the fact that arsenic is a close neighbour, chemically speaking, of germanium; and at one time all possible compounds of elements which might have some semiconductor action were being carefully investigated. As it turned out, gallium arsenide wasn't likely to challenge germanium as a material to make transistors, but its chemical and physical properties were carefully documented.

After the invention of the ruby rod laser (which also is another story) the rag-bag of materials was being turned over again, this time in search of substances which might show laser action when excited by intense light.

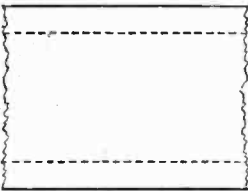

Fig. 1—Coated glass rod ready for "pulling out".

Fig. 2—Complete fibre showing path of light beam.



along a piece of wire is to make the wire the inner of a coaxial cable. It is a construction very similar to a coaxial cable which makes the fibre light-pipe successful. The inner fibre is coated with a glass of different composition to form a coaxial fibre which prevents light loss. This in turn is often coated with a dark material to prevent light from entering the fibre from outside; the dark coating can be thought of as the insulation of the "cable".

How good a conductor of light a fibre is depends on how well the operation of forming the coaxial fibre is carried out. The outer glass is usually about 10% of the thickness of the inner one, and has a lower refractive index.

Physicists knew the sort of atomic structure which might be useful, and the temporarily-discarded gallium arsenide was investigated again. The result was quite unexpected, though. The material was useless as a ruby-rod type of laser, but emitted laser light when current was passed through a p-n junction. Not only was there good laser action (though at low power), but the amplitude of the light could be controlled by varying the current through the junction and the laser action was continuous. The ruby laser, by contrast, could only be pulsed, and control, that is to say modulation, could be carried out only by indirect means involving polarising the output and modulating by changing the polarisation of a liquid cell electrically. The gas laser could be operated continuously but was equally difficult to modulate.

The importance of the ease of modulation of the crystal laser lies in the bandwidth which can be modulated on it. We are familiar with the idea that higher frequency waves can accept wider bandwidths; we modulate the 5kc/s of audio on our 1Mc/s carrier, the  $3\frac{1}{2}$ Mc/s of TV 405 line picture and sound on carriers of 50Mc/s upwards, and the very large bandwidths of pulse and f.m. radar on carriers of several thousands of megacycles. The sensation which we call light is a wave of much higher frequency, about a million times the frequencies which we call "ultra-high". The amount of information which could be contained on such a beam of light is therefore enormous, all our present communications could theoretically be carried on a single light beam and leave room for lots more—if we could code and modulate them on suitably.

The gallium arsenide laser leads us to hope that the theory may be put into practice. Already, gallium-arsenide lasers have been used to convey a TV signal, but the experiment was limited to

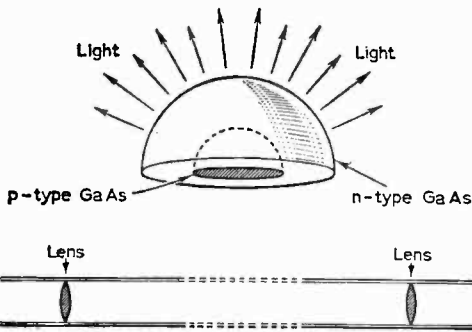

Fig. 3 (top)—Shape of Gallium Arsenide pellet for laser operation  
Fig. 4 (bottom)—Pipe for light transmission.

using the laser to form a beam through air. The next step is to convey the light through a closed channel.

This brings us back to our fibres. The output of the gallium arsenide laser can be coupled into a fibre light guide with very little loss, and the signal, carrying all the information which we can modulate on to it, taken along the fibre to a receiver. Here we come up against snags. At the front end of any receiver, we must use either a

device which will amplify light itself, or we must detect the light and recover the modulation from it at that point. The first course would require an article to itself, the second is the usual course taken, and the usual detector is a photoconductive cell cooled in liquid nitrogen so as to obtain the highest possible signal-to-noise ratio. Despite all this, the best obtainable signal-to-noise ratios at the moment are about a hundred times worse than those of good microwave receivers; worse still, the glass fibre cables attenuate the signals rather drastically, so that they can be used only for short lengths where their advantage of flexibility overcomes the disadvantage of attenuations of about 200dB per km at the best.

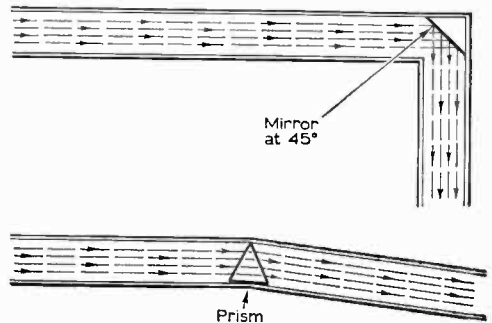

Fig. 5—Pipes with varying degrees of bend showing two methods of bending rays in the pipe itself.

At this point we introduce our bits of pipe. The best ideas are often the simplest ones, and the idea of carrying light signals through pipes fitted at intervals with lenses to prevent the beam spreading excessively seems simple to the point of being impossible. It works, though, and attenuations of as little as 0.5dB per km are being reported, and that's an improvement on 200dB per km no matter how you look at it.

As usual, there's a snag. The pipe must be dead straight, or sharply bent with a prism or reflector at the junction. However, we can lay pipes dead straight using a laser to guide us, as the beam of a gas or ruby laser is itself dead straight and parallel, and considerable work is being done at the moment on methods of compensating for slight bends in the pipe.

On the whole, it looks as if we are at the beginning of a revolutionary new communications system which will be of immense benefit to TV, the entertainment medium which demands most precious bandwidth, and it could well mean an end to the present system of television broadcasting. One can imagine pipes carrying many colour-casts, stereo sound programmes and video-telephone channels linking our cities. Each telephone exchange would be fitted with optical demodulators to recover the signals and send them by coaxial cable to each house, eliminating the unsightly aerials on the roofs. Possibly even, the exchange would merely convert from pipe to fibre, the final change from optical signal to electrical signal being in our own sets, giving us the choice of as many channels as could be broadcast with the studio and financial resources available. ■

# Peregrine

A NEW AGILE  
TV CAMERA  
MOUNTING

described by  
W. Twyford

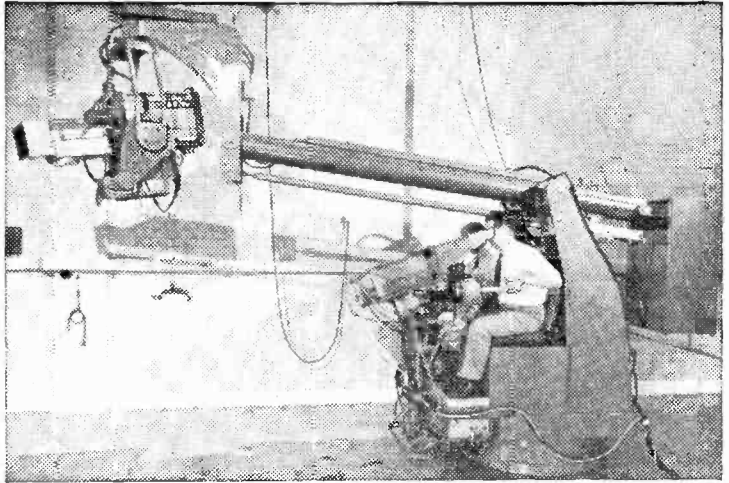

**H**OW often does the viewer actually notice spectacular camera movements? Generally speaking, these go almost unnoticed, as the very smoothness and ease of movement that make for pleasant viewing disguises the efforts needed. As in so many things, experts make it look so very easy.

In the past, very large movements or flowing shots have been performed using a camera on a large crane jib mounted on a cumbersome base. At least three men per crane were needed and for the larger ones six or seven men operated just one camera. This was quite satisfactory for film work where only one camera was used to take one shot, followed by a break for moving lights and camera ready for the next shot. However, in television, with three or four cameras on each

scene, each one taking different shots at the same time, the situation is rather different. Often, there was just not room available to manoeuvre a large crane along with three other cameras.

For use in television, W. Vinten, of Bury St. Edmunds introduced a simplified camera crane called the Heron. This is operated by a crew of two people and all movements of the camera platform are made by hydraulic power. Its great simplicity and flexibility of operation have made the Heron very popular with both directors and operators.

Now Vintens, in conjunction with the BBC, have built a completely new camera mounting called the Peregrine. The Peregrine system has a circular base about four feet in diameter. The machine moves on six wheels equally disposed around the circumference of the base; alternate wheels are fitted with brakes or hydraulic motors, permitting speeds of four miles per hour in any direction. On this base a rotatable platform is mounted. The cameraman, who controls the pan, tilt, focus and zoom movements of the camera, sits alongside the tracker, who drives the Peregrine around the studio. The movement of the jib and rotation of the platform can be controlled by either operator.

By moving the cameraman's position from the end of the jib the height previously taken by his leg room is no longer needed, allowing a minimum camera lens height of 1ft. 6in. Hence, although the Peregrine can also reach a height of 11ft. 6in. it can produce low level shots previously requiring a special mounting.

The zoom lens used is an Angenieux power operated lens, which is in common use already. Power operation allows remote control of zoom, whilst focus and iris controls are combined in the same unit. The pan and tilt are performed by electrical servos of a conventional type, but all the rest of the functions are hydraulically operated with electrical control.

The control levers operate a potentiometer, as does the movement of the corresponding part; for example, the jib. These potentiometers are connected in a Wheatstone Bridge circuit, with

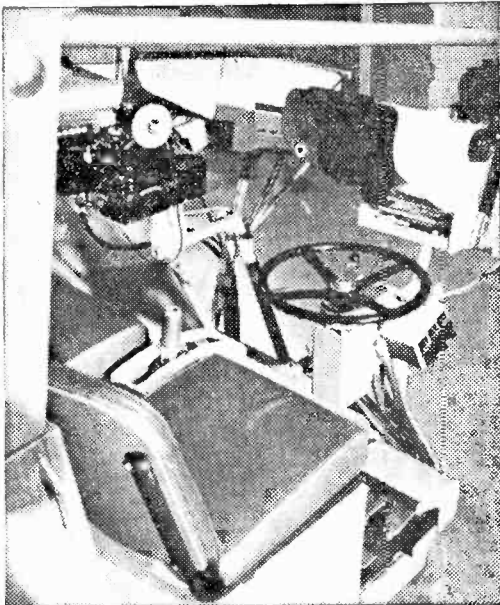

—continued on page 130

a hydraulic control valve in place of the meter in the familiar circuit. Thus a movement of jib control unbalances the bridge so current flows through the hydraulic valve. This allows hydraulic power to be applied to the jib till the bridge is balanced again and the jib stops. Thus movement of the control to any point causes the jib to move to a corresponding point. The turntable movement is similarly controlled. The driven wheels are operated by a hydraulic motor also controlled by a potentiometer. As this controls the velocity, extreme sensitivity of movement is achieved, such that the Peregrine can be moved imperceptibly in any direction.

The hydraulic power is stored up in a hydraulic "accumulator"; this is a cylinder containing nitrogen, pressurised by oil from a pump driven by an electric motor. This system allows the power cable to be removed and the Peregrine driven to storage space overnight.

A number of safety features are employed; for, example, if the Peregrine is switched off during a break in rehearsal, the jib control may be moved accidentally and when power is applied on switching on, the jib may swing violently to its new position. To avoid this, the control lever must be moved to within a few degrees of the corresponding position of the jib when normal operation can be restored, thus the controls are simply moved until the machine 'comes back to life' and follows the controls.

Some operators find at first that the use of remote servos is difficult to master but after familiarisation with the new technique they are soon impressed with the Peregrine. In use, the Peregrine is able to produce unique movement with great smoothness and precision even in the most cramped studio conditions, surrounded by scenery and other cameras. No doubt this camera mounting will take its place alongside its popular predecessor, the Heron. ■

The author wishes to thank all the staff of W. Vinten Ltd. who helped him to prepare this article.

## PLEASE NOTE

You can keep your copies clean and safe so that they will always be to hand just when you need them, and all it will cost you is 12/6d., and this includes the postage too. The Practical Television Easibinder is especially designed to hold twelve issues. If you tell us the volume number we'll stamp it on your binder in gold free of charge, otherwise we'll send you a blank.

P.S.—Like to know exactly which page that article is on? For 1/6d., you can get an index to volume 15 post paid from our Post Sales Department.

Go on—spoil yourself, send 14/-d. and have both.

Send your order to:

*Binding Department, George Newnes Ltd.  
Tower House, Southampton Street,  
London, W.C.2.*

# NEXT MONTH IN Practical TELEVISION

## COMBINED TEST UNIT

The bar and pattern generator described in the November issues and the Aerial Riggers' unit in the current issue are combined into a compact single unit, together with a mains power supply are other auxiliary circuitry, forming a versatile and neat servicing aid.

## SYNC LINE SELECTOR

Sync faults are often very difficult to diagnose, but this simple piece of equipment will make life easier. Using a monostable delay circuit, the sync line selector can be attached to any standard oscilloscope as an aid to fault finding and circuit development in the TV receiver.

## CIRCULAR TV AERIAL

An idea for an easily constructed circular TV aerial for the home constructor.

## THE WORLD OF SERVICE

A new series of articles covering the wide field of service in the TV field. Part One describes the life of the Outside Engineer.

ORDER YOUR COPY ON THE FORM BELOW

TO \_\_\_\_\_  
(Name of Newsagent)

Please reserve/deliver the JANUARY issue of PRACTICAL TELEVISION (2/-), on sale December 22nd and continue every month until further notice

NAME \_\_\_\_\_

ADDRESS \_\_\_\_\_



# LETTERS TO THE EDITOR

**SPECIAL NOTE:** Will readers please note that we are unable to supply Service Sheets or Circuits of ex-Government apparatus, or of proprietary makes of commercial receivers. We regret that we are also unable to publish letters from readers seeking a source of supply of such apparatus.

The Editor does not necessarily agree with the opinions expressed by his correspondents.

## ABERFAN DISASTER

SIR,—With reference to my letter on page 89 in the November issue, I am reducing size of parcels to try to give something to the majority of requests. May I point out quite a few readers have shown their generosity in stating that if all my surplus has gone I should give the carriage POs to charity. If this should be so no greater cause would be than to the Aberfan Disaster and this I will certainly do on behalf of PRACTICAL TELEVISION readers.—J. GOULDING.

## ISSUES FOR DISPOSAL

SIR.—I have the following issues of PRACTICAL TELEVISION for disposal. Jan, Feb, Mar, Apl, May, June, July, Aug, Sept, Oct, Nov and Dec 1952; Jan, Feb, Mar, Apl, May, June, July, Aug, Sept, Oct and Dec 1953; May, July, Aug, Sept, Oct, Nov and Dec 1954; Feb and Nov 1955; Jan, Feb and Dec 1956; Jan, Feb, Mar, Apl, May, June, July, Aug, Sept, Oct, Nov and Dec 1957; Jan, Feb, Mar, Apl, May, June, July, Aug, Sept, Oct, Nov and Dec 1958; Apl, May, July, Aug, Oct and Dec 1961; Jan, Feb, Mar, Apl, May, June, July, Aug, Sept, Nov and Dec 1962; Mar and Nov 1963.

If any readers are interested would they please contact me.—ERNEST L. LEWIN (8 The Knoll, Hayes, Bromley, Kent).

## CAN ANYONE HELP?

SIR,—Would any reader be kind enough to supply me with the May and June 1966 issue of PRACTICAL TELEVISION.

Also, if any reader has any old unwanted issues of PRACTICAL TELEVISION, I would be very glad to have them.—DAVID TURNER (Earnley School, Earnley Place, Near Chichester, Sussex).

## HAS ANYONE A SPARE TUBE?

SIR.—I have been given an old Murphy television set, type V240 (serial number 946321), which needs a new 12in. tube. Could any readers please inform me where I could obtain a second-hand tube, CRM 141/2.—R. ARRUEL JONES (Hyfrydle, Corwen, Merionethshire, North Wales).

## I NEED TIME!

SIR,—With regard to my offer in the November issue of PRACTICAL TELEVISION, I have been overwhelmed with requests. I would like to state that any reader not having heard from me, please give me time as I am having a full-time job making up parcels and sorting out. I still have about a ½-ton to go through and I am doing my best to give all readers their wants.—J. GOULDING (Lancaster C, Lancashire).

## C.R.T. INFORMATION

SIR,—In the October episode of "Ideas for Amateur TV", Mr. M. D. Benedict states that cathode ray tube 5FP5 has a white trace, when discussing suitable tubes for a viewfinder. This is incorrect, as a P5 phosphor is one having a very short blue trace, being ideal for photographic work. The white trace tube is the 5FP4, which has been used extensively as the viewfinder tube in early Marconi equipment, the 7CP4 being used in an early CCU.

Mr. Benedict goes on to say that the 5FP7 and 7BP7 have long persistence yellow phosphors, which is correct, but omits the fact that they also have a short blue-white persistence. These tubes are suitable for slow scan work, using the yellow phosphor, or for flying spot work, using the short blue trace, to which many photo multipliers are sensitive to. The 5FP5 which he mentions is admirable for the latter work, being only of a blue trace. It may not be known to many newcomers to TV work that these tubes can often be directly substituted in many early sets, such as the Bush TV22/24 series, where the scancoil size etc. is just right.

The following list gleaned from the ARRL Amateur Handbook may be of interest to readers:

P1	Green medium	Oscilloscope
P2	Blue-green medium	Special Oscilloscopes and Radar
P4	White medium	Television
P5	Blue—very short	Photographic recording of high speed traces
P7	Blue-white short	
	Yellow long	Radar
P11	Blue short	Oscilloscope
P12	Orange long	Radar

I am at the moment using a 5FP11 in a flying spot scanner, this tube being obtainable quite cheaply, in good condition, as can the other tubes mentioned.—STEPHEN J. GILBERT, G30AG (Manchester, Lancashire).

## CAN ANYONE SELL OR LOAN?

SIR.—I would be grateful if any reader could sell or loan me the following copies of PRACTICAL TELEVISION: the series starting on October, 1963, containing information for building the CCTV unit and issues after that which may contain any improvement, etc. I also require the copies before August, 1966, containing the series on "Ideas for Amateur TV."

If readers do not wish to sell the above copies, I will let them have them back within a week of receiving them.—T. D. WILLS (Wyastone Hotel, Porabala Road, Cheltenham, Gloucestershire).



without any circuitual addition. It is for this reason that in the early days of the radio superhet the actual signal rectifier was referred to as the "second detector" since the frequency-changer formed the "first detector." The fact that the vision i.f. valves simultaneously handle the 625 sound throughout the i.f. strip (although there is usually one additional sound-only i.f. valve), contributes to receiver design economy. Also, as the 6Mc/s inter-carrier signal is so rigidly fixed it makes it possible for designers to work to minimum circuit tolerances in the f.m. section.

Apart from any other considerations, if the conventional 405-sound system was used at u.h.f. carrier frequencies, the bandwidth of the sound i.f. circuits would have to be very broad to accommodate the unavoidable drift of the receiver's local oscillator.

## The disadvantages

However, there are disadvantages with inter-carrier sound. The main one is that as the vision i.f. amplifiers are handling an amplitude modulated signal, on detection, the accompanying f.m. signal can become slightly amplitude modulated in unison. This is because the amplitude modulated picture carrier is taking the place of the normal constant output of a mixer's local oscillator. To keep the effects of such a varying carrier to a minimum, the voltage level of the sound i.f. signal at the video detector is very much less than the lowest instantaneous value of picture signal.

The "beat" amplitude should therefore be fairly constant. Then the transmitted sound carrier is 24dB lower than the vision carrier while the receiver's overall i.f. response curve is carefully tailored to maintain this disparity.

The vision carrier is never permitted to reduce to less than about 10% of peak value where the negative modulation equates to "peak white." Also, due to the simultaneous handling of sound and vision throughout the i.f. strip, care must be taken to ensure that cross-modulation does not occur due to overloading any of the stages.

The second disadvantage of inter-carrier sound is that complete failure of the vision carrier also results in failure of sound at the receiver, since it is the heterodyning of the two transmitted frequencies that produces the 6Mc/s difference frequency to which the f.m. sound-only i.f. circuits are tuned to on 625. Absence or breakdown of picture modulation will not prevent sound reproduction, only complete absence of carrier.

It should be apparent at this stage that the term "inter-carrier sound" is a misnomer since the sound is not transmitted in any complex or unusual way, but merely transmitted 6Mc/s higher than the vision carrier and f.m. modulated. By applying the two signals to the one non-linear device—the vision detector—the 6Mc/s beat frequency is produced by normal mixer action. Although this "inter-carrier sound" is produced by the non-linearity of the vision detector, it can be directly tapped off from there or tapped off from the anode circuit of the video

amplifier after its subsequent amplification by that stage.

Current design practice seems to favour the latter system with one separate sound-only i.f. amplifier to handle both the 38Mc/s 405 and 6Mc/s 625 sound signals, although the Decca DRI model, almost exclusively in dual-standard design, employs two consecutive sound-only i.f. stages.

## Ratio detectors

Conventional ratio detectors are invariably used as the demodulator on f.m. since they have an inherent amplitude limiting action, although there is a growing tendency to use the EH90 type of valve as a "locked oscillator" detector for its high audio output and simplicity.

Figure 1 shows a complete and typical example of the 625-sound system in a dual-standard receiver where the f.m. sound is taken from the anode of the video pentode (Alba T230). A low impedance link coil picks up the 6Mc/s signal from a tuned circuit in the anode lead and feeds it via a co-axial lead to a similar low-impedance link coil inductively coupled to a further 6Mc/s tuned circuit in the grid of the EF183 sound i.f. amplifier. In series with this latter tuned circuit is the 38Mc/s tuned circuit fed from a tapping on a coil in the post anode circuitry of the combined vision/sound i.f. amplifier on 405. Similarly, in the anode circuit of the EF183 solus sound i.f. amplifier are two

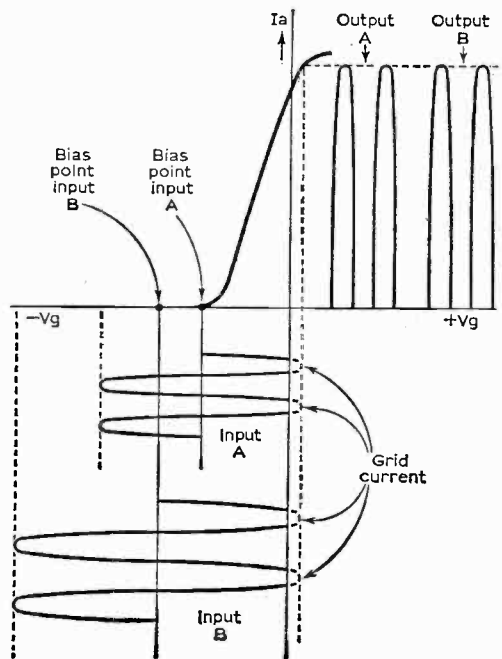

Fig. 2—Illustrating action of i.f. amplifier/amplitude limiter with 2 differing inputs. Functioning depends on restricting valve grid base by lowering screen voltage and producing grid-leak bias according to the amplitude of the input signal.

such tuned circuits, connected in series and feeding their respective a.m. or f.m. detectors.

As the two frequencies concerned are so widely separated there is no need for coil change-over switching in the anode circuit since which ever frequency is being handled by the grid will be developed in an amplified version across the appropriate tuned circuit.

A simple S.P.D.T. section on the system switch selects the correct detector output on change-over, while additionally a 100kΩ resistor is placed in series with the h.t. feed to both the screen and anode of the EF183 to lower their respective potentials from 168V and 93V on 405 to 22V

and 14V on 625. By so lowering these voltages, the valve then functions as an amplitude limiter as well as an i.f. amplifier on 625 to remove the slight amplitude modulation that often develops on the f.m. signal due to the factors previously outlined.

Not all designs follow this practice, and many manufacturers rely purely on the self-limiting qualities of the f.m. ratio detector. Other manufacturers, such as Thorn for example, simply lower the sound i.f. amplifier screen voltage from 62V on 405 to 31V on 625. Such shortening of the valve's grid base, that is the restricting of the voltage necessary to drive a

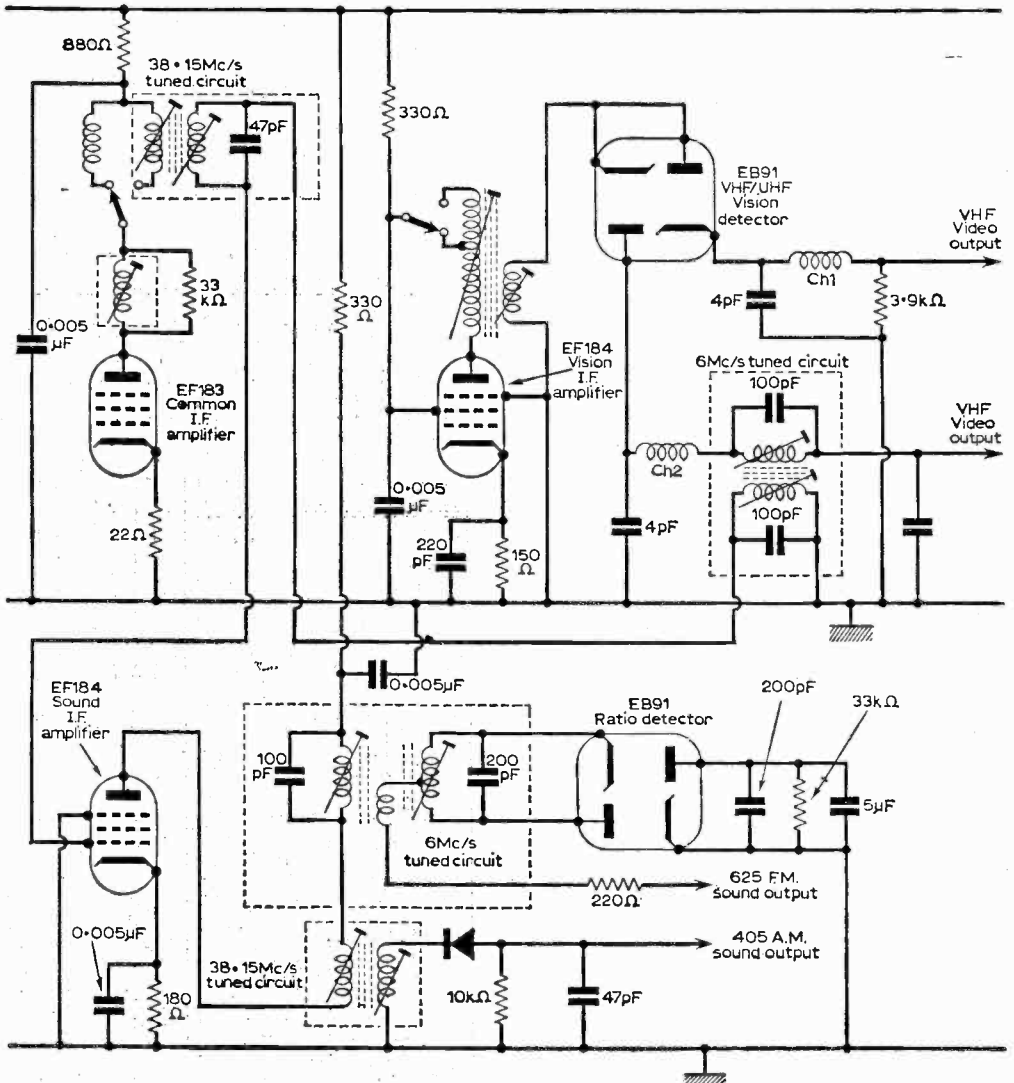

Fig. 3—Dual-Standard sound system taking 625 sound i.f. from 625 vision detector and 405 sound from 38Mc/s tuned circuit coupled to anode circuit of common sound/vision amplifier (Decca 606). Note series connection of both 38Mc/s and 6Mc/s tuned circuits to grid and anode of sound i.f. amplifier without change-over switching.



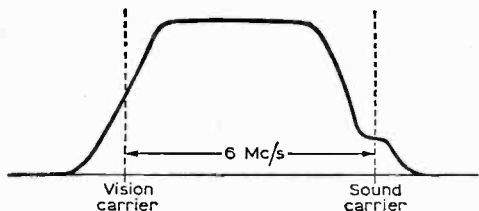

Fig. 4—Ideal response curve of receiver on 625. Mal-adjustment of the tuned circuits or drift of the local oscillator from optimum setting can result in the sound carrier being on the slope of the curve instead of the "step" thus imposing amplitude modulation on the f.m. signal as it approaches or recedes from the correct position.

valve to the commencement of grid current from anode current cut-off, must also be accompanied by the use of the conventional grid capacitor/grid leak in the valve's input circuit. With zero or very slight fixed bias, the application of an a.c. signal charges up the grid capacitor on the positive half-cycles to almost peak value. This voltage produced is therefore proportional to the amplitude of the input signal and biases back the valve so that only the peak tips of the positive

point of the valve to a position closely equivalent to, and wiping out, their signal voltage difference.

On 405 in this particular model, grid current never develops due to full anode and screen voltage producing normal bias across the cathode resistors. Also, the application of a.g.c. voltages from the a.m. detector increasing this bias when high amplitude signals are received.

### Vision detector tapping

Figure 3 shows another 625-sound system in which the 6Mc/s is tapped directly from the vision detector instead of from the video amplifier as in the previous example.

This arrangement is used in many Decca receivers, but again as in the Alba system, the 405 38Mc/s and 625 6Mc/s sound i.f. tuned coils are simply connected in series in both the grid and anode circuits of the sound-only i.f. amplifier with no change-over switching.

The f.m. ratio detector follows conventional design although it will be noted that it has not been found necessary to include a "Ratio Balance Control" to minimise the risk of vision "buzz" breakthrough. Undoubtedly, although

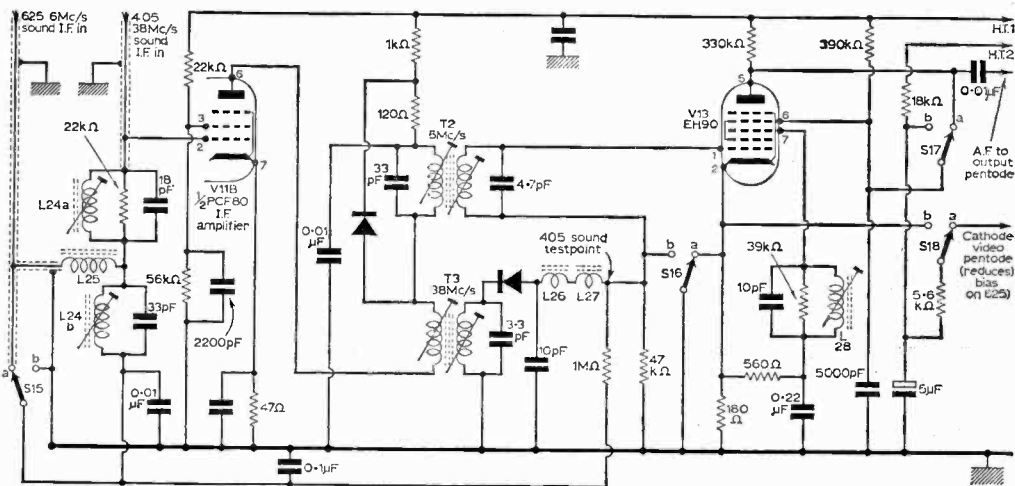

Fig. 5—Dual-standard sound system used on many Dynatron models incorporating EH90 heptode as a "locked oscillator" f.m. detector on 625 and as an a.f. amplifier on 405.

half-cycles draw grid current. The slight current then drawn compensates for the constant drain through the grid leak. Within limits, all inputs are positioned from this point. This means that varying amplitude inputs produce a varying bias to move the operating point of the valve proportionately away from the zero bias point so that the outputs will be substantially equal.

### Varying bias

Figure 2 demonstrates this effect clearly with two vastly differing inputs producing virtually identical outputs due to the greater bias produced by the larger signal biasing back the operating

the sound i.f. amplification afforded by the video stage on 6Mc/s is considerable, tapping off this frequency prior to this stage lessens the risk of picture content at the top end of the spectrum from getting through the sound tuned circuits and causing this annoying complaint.

Conventional 625 sound circuitry today involves one i.f. amplifier (two in the Decca DRI); a duo-diode ratio detector; triode a.f. amplifier and pentode output, the last two stages being also, of course, common to the 405 system. However, there is a growing tendency to use the Mullard EH90 heptode as the f.m. demodulator in dual-standard receivers since it is both simple and gives a high audio output. For instance, in many Dynatron models the 625-sound system is i.f.

## 625-Line TV Sound Circuits

—continued from page 135

amplifier, EH90 heptode and pentode output, the sensitivity of this new type of detector not requiring the usual triode a.f. stage.

On 405, in contrast, the same i.f. amplifier is used to feed the usual germanium crystal a.m. detector but whose output is then taken to the EH90 which, on this system, functions as an a.f. amplifier in the conventional manner. This EH90 is operated in what is known as a "locked oscillator" mode on 625, and its functioning is briefly outlined as follows.

The 6Mc/s sound i.f. is applied to  $G_1$  in the customary manner, but due to the "space charge coupling" between this grid and  $G_3$  caused by the electron stream flowing through the valve, an e.m.f. at the applied frequency develops on the latter grid and builds up in a 6Mc/s tuned

circuit connected between the latter grid and a cathode connection. This "space charge coupling" is present in all multi-grid valves and, in fact, many American receivers use a conventional pentode as such an f.m. demodulator, but the EH90 has been specially designed for optimum internal coupling in this respect.

However, the signal abstracted by the  $G_3$  electrode, although at input frequency, normally lags behind by  $90^\circ$  and can be said to be "locked on" to the  $G_1$  frequency providing it does not deviate too far from the frequency of its own tuned circuit. Hence the term.

When the modulation of the f.m. carrier causes its frequency to increase or decrease, the normal  $90^\circ$  phase difference between the two signals no longer exists and the resulting disparity is reflected in the valves anode current. The audio content is then developed across a resistor in the anode circuit of the valve for power amplification in the usual way. ■

## TUNER FOR THE OLYMPIC II

—continued from page 105

Connection points are identified as follows: A—Battery negative; B—A.G.C.; C—Output to television receiver; D—Battery positive; E—A.G.C. These tuners are described as transistorised

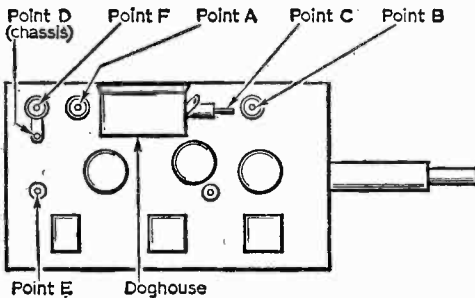

Fig. 2—Top chassis view showing location of connection points.

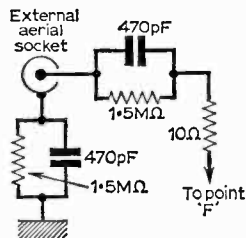

Fig. 3 (right)—Attenuator circuit for areas of excessively high signal strength

v.h.f. model 2, and are obtainable from Messrs. Lasky's Radio, 3-15 Cavell Street, Tower Hamlets, London, E.1, and all branches. The cost is 37/6d., plus 2/6d. postage and packing. Note, Messrs. Lasky's are unable to supply circuitry or interconnection data.

The tuner draws 17mA from a 12-volt battery supply and is thus quite economical to run.

If necessary an aerial attenuator circuit can be fitted. Suggested circuitry for this is shown in Fig. 3. ■

## Aerial Rigger's Intercom

—continued from page 126

then represent suitable final settings of the aerial. If no mutual overlaps are present, then the desired programmes are not receivable with a single array and more arrays must be added and aligned individually. If a mutual overlap of satisfactory reception is obtained, the observer at the set can communicate this to the man on the roof, telling him to turn the aerial array on to some particular scale reading. Final checks can then be made on all programmes in succession at this aerial setting.

If several arrays are mounted on a single shaft and are to be aligned independently, then the following procedure is simple and direct. It is equally applicable, whether the separate arrays are different and operating on different bands, or whether they are identical and intended to pick-up different programmes in the same band which cannot all be picked-up with a single array. First of all, mount all arrays pointing in the same direction on the shaft. Then run through the full-circle observation procedure described above for each programme. From the recorded observations at the receiver, it will then be possible to take one array as reference and specify a mast-scale setting to bring it into its optimum position. For all other arrays, an angle can then be specified through which each must be turned with respect to the reference array. These instructions can then be reported up to the man on the roof, who will thereupon set and secure the aerial system accordingly. The usual precautions regarding maintenance of adequate spacing between separate arrays, especially if working on closely adjacent frequencies, must be observed. ■

## IDEAS FOR AMATEUR TV.

WE REGRET DUE TO CIRCUMSTANCES BEYOND OUR CONTROL, THAT PART VII OF THIS SERIES IS HELD OVER UNTIL NEXT MONTH. WE APOLOGISE TO ALL THOSE READERS WHO ARE FOLLOWING THIS SERIES

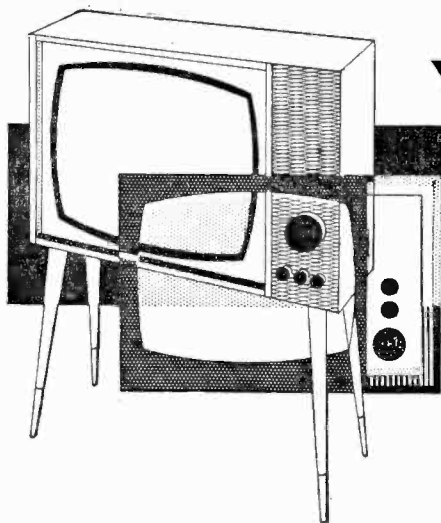

# Your Problems Solved

*Whilst we are always pleased to assist readers with their technical difficulties, we regret that we are unable to supply diagrams or provide instructions for modifying surplus equipment. We cannot supply alternative details for constructional articles which appear in these pages. WE CANNOT UNDERTAKE TO ANSWER QUERIES OVER THE TELEPHONE. The coupon from page 140 must be attached to all Queries, and a stamped and addressed envelope must be enclosed.*

## **PHILIPS 1758U**

The top of the picture pulls to one side at times and the verticals are ragged. The screen voltage on the line output valve is 135–140V. Increasing the contrast causes the picture to roll and also increases the line trouble.—A. Tomlinson (Wigan, Lancashire).

Ragged verticals accompanied by poor line lock often indicate either a weak aerial signal or reduced sensitivity in the vision i.f. stages. If the sound is normal, the vision i.f. stages are the most likely cause; but if the sound is also a little below normal, first check the aerial system and then, if this is proved to be in order, the tuner especially the valves. These are best checked by substituting with replacements known to be in good order.

## **FERGUSON 306T**

During the programme, the picture started to shrink in size with a black margin on the screen of approximately just over  $\frac{1}{2}$  in. top, bottom and both sides. The set was switched off that night. Next day upon switching on, there was no picture and the sound was poor. I changed valves 10, 8, 9, 5, 13 and 7 with no result. I then changed V14 (PY32) whereupon sound was corrected and the picture came back but still with margins top, bottom and sides. I again changed the other valves but with no improvement. I notice however, that normally I used to switch from BBC to ITA with nothing other than channel switch and a slight adjustment to the sound. Now, on this reduced picture, I have also to adjust the line hold quite considerably.—L. F. Schneider (Neasden, London, N.W.10).

It is possible that one of the surge limiting resistors to the anodes of the PY32 has broken down. Check this possibility, for low h.t. voltage is most likely and the h.t. rectifier has been proved by replacement. However, also check, if necessary, the electrolytic smoothing capacitors, especially if the hum on sound is above normal level.

## **FERRANTI 17K4**

Over the last month the brightness has deteriorated. The picture then started to slip to the left and now shows about  $\frac{1}{2}$  in. blank space up the side. Turning the brightness up makes the picture go darker and the bottom of the picture starts to move.—T. Smith (Oldham, Lancashire).

First ensure that the ion trap magnet on the rear of the tube neck is set for maximum brilliance. Then reset the shift knobs to centre the picture and slightly adjust the ion trap magnet again for maximum brilliance. Check the PL81 line output valve if necessary.

## **PYE VT4**

This set suffers from uncontrollable brightness. For example, when the background is a clear sky in an outdoor setting, like a Western and there is perhaps one person or an object in view, the picture very quickly goes to the same condition as advancing the brightness control; it goes dark and off focus until sometimes the dark part (the person or object) disappears in the gloom.—A. Sammons (Solihull, Warwickshire).

The symptoms you describe suggest low e.h.t. usually due to a defective EY51 e.h.t. rectifier. Alternatively, if width is lacking, we advise you to check the PL81 line output valve and its 3.3k $\Omega$  screen grid feed resistor.

## **BUSH TUG34A**

There is a bar at the bottom of the picture which is also folded up and the upper half of the picture is greatly expanded. The frame output valve has been replaced to no avail.—W. James (Preston, Lancashire).

There is a 50 $\mu$ F electrolytic capacitor associated with pin 3 of the ECL80 and an 8 $\mu$ F associated with pin 8. Check both of these and also the 0.02 $\mu$ F capacitors in the height circuit.

# LAWSON BRAND NEW CATHODE RAY TUBES



The rapidly increasing demand for a complete range of new tubes of the very highest quality is now being met by the new Lawson "CENTURY 99" range of television tubes.

**SPECIFICATION:**

The new "Century 99" range of C.R.T.s are the products of Britain's premier C.R.T. manufacturers. All types are exact replacements, manufactured to the original specification but incorporating the very latest design improvements to give superb performance, coupled with maximum reliability and very long life.

"Century 99" C.R.T.s, available as direct replacements for the following makes and types

MULLARD		MAZDA		BRIMAR		EMISCOPE & EMITRON		GEC & COSSOR also ENGLISH ELECTRIC	
MW43/69	AW36-80	CRM121	CME1901	C12FM	C17SM		4/14		141K
MW43/64	AW36-21	CRM123	CME1902	C14FM	C19/7A		4/15		171K
MW36/24		CRM122	CME1903	C14GM	C19/16A		4/15G		172K
MW31/74		CRM124	CME2101	C14HM	C19 10AD		5/2		173K
MW31/16	<b>Twin Panel Types</b>	CRM141	CME2104	C14JM	C19AH		5/2T		212K
MW43/80		CRM142	CME2301	C14LM	C19AK		5/3		7102A
MW36/44	A47-13W	CRM143	CME2302	C14PM	C21/1A		5/3T		7201A
MW53/80	A59-16W	CRM144	CME2303	C171A	C217A		14KP4		7203A
MW53/20	A59-13W	CRM153		C174A	C21AA		17ARP4		7204A
MW43/43		CRM171	<b>Twin Panel Types</b>	C175A	C21HM		17ASP4		7205A
AW59-91		CRM172		C177A	C21KM		17AYP4		7401A
AW59-90		CRM173		C17AA	C21NM		21CJP4		7405A
AW53-89		CRM211	CME1906	C17AF	C21SM		SE14/70		7406A
AW53-88		CRM212	CME2306	C17BM	C21TM		SE17/70		7501A
AW53-80		CME141		C17FM	C23-7A				7502A
AW47-91		CME1402		C17GM	C23-TA				7503A
AW47-90		CME1702		C17HM	C23AG				7504A
AW43-89		CME1703		C17JM	C23AK				7601A
AW43-88		CME1705		C17LM					7701A
AW43-80		CME1706		C17PM					

12" ..	£4.10.0
14" ..	£5.10.0
17" ..	£5.19.0
19" ..	£6.19.0
21" ..	£7.15.0

Terms:  
C.W.O.  
Carr. and  
Ins. 10/-

**2 YEARS' FULL REPLACEMENT GUARANTEE**

Complete fitting instructions supplied

**LAWSON TUBES**  
STATION ESTATE, MALVERN.  
Offices  
18 CHURCHDOWN ROAD,  
MALVERN, MALVERN 2100

## NEW RANGE U.H.F. AERIALS FOR BBC 2 (625) line transmissions

All U.H.F. aerials now fitted with tilting bracket and 4 element grid reflectors.  
**Loft Mounting Arrays, 7 element, 35/-, 11 element, 42/6, 14 element, 50/-, 18 element, 57/6. Wall Mounting with Cranked Arm, 7 element 60/-, 11 element, 67/-, 14 element, 75/-, 18 element, 82/6. Mast Mounting with 2in. clamp, 7 element, 42/6; 11 element, 55/-; 14 element, 62/-; 18 element, 70/-.** Chimney Mounting Arrays, Complete, 7 element, 72/6; 11 element, 80/-; 14 element, 87/6; 18 element, 95/-.

Complete assembly instructions with every unit. **Low Loss Cable, 1/6 yd.**  
**U.H.F. Preamps, from 75/-.** State electric channel number required on all orders.

## BBC • ITV • F.M. AERIALS

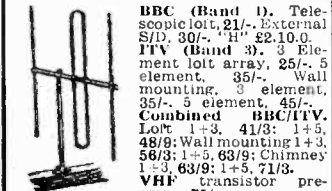

**BBC (Band 1).** Telescopic 10ft, 21/-; External S/D, 30/-; "H", £2.10.0.  
**ITV (Band 3).** 3 Element loft array, 25/-; 5 element, 35/-; Wall mounting, 3 element, 35/-; 5 element, 45/-.  
**Combined BBC/ITV.** Loft 1+3, 41/3; 1+5, 48/9; Wall mounting 1+3, 56/3; 1+5, 63/9; Chimney 1+3, 63/9; 1+5, 71/3.  
**VHF transistor pre-amps, 75/-.**

**F.M. (Band 2).** Loft S/D, 12/6; "H", 30/-; 3 element, 52/6. External units available. Co-ax cable, 8d. yd. Co-ax plugs, 1/3. Outlet boxes, 4/6. Diplexer Crossover Boxes, 12/8. C.W.O. or C.O.D. P. & P. 4/6. Send 6d. stamps for illustrated lists.  
**Quotations for special arrays available on request**

**K.V.A. ELECTRONICS (Dept. P/T)**  
27 Central Parade, New Addington  
Surrey  
LOD 2266

## FIRST-CLASS RADIO AND T/V COURSES... GET A CERTIFICATE!

After brief, intensely interesting study—undertaken at home in your spare time—**YOU** can secure a recognised qualification or extend your knowledge of Radio and T.V. Let us show you how.

### FREE GUIDE

The New Free Guide contains 120 pages of information of the greatest importance to both the amateur and the man employed in the radio industry. Chambers College provides first rate postal courses for Radio Amateurs' Exam., R.T.E.B. Servicing Cert., C. & C. Telecoms., A.M.I.F.R.E. Guide also gives details of range of diploma courses in Radio/TV Servicing, Electronics and other branches of engineering, together with particulars of our remarkable terms of

### Satisfaction or refund of fee

Write now for your copy of this invaluable publication, it may well prove to be the turning point in your career.

**FOUNDED 1885—OVER 150,000 SUCCESSSES**

**CHAMBERS COLLEGE**  
(Incorp. National Inst. of Engineering)  
(Dept. 884W), 148 HOBORN  
LONDON, EC.1.

## NEW VALVES

Guaranteed Set Tested  
24 HOUR SERVICE

IR5, 185, 1T4, 3S4, 3V4, DAF91, DF91, DK91, DL92, DL94, SET OF 4, 14/9.					
DAF96, DF96, DK96, DL96, SET OF 4, 23/6.					
IR5	4/-	DY87	8/9	PCL82	6/3
185	3/9	EABC80	5/6	PCL83	8/9
1T4	2/9	EAP42	7/-	PCL84	7/3
3S4	4/3	KBC41	6/6	PCL85	7/9
3V4	5/-	EBF80	5/9	PL36	9/3
5Y3GT	4/6	EBF89	5/9	PL81	6/6
6P1	6/3	ECC81	3/3	EL82	5/-
6K7C	1/3	ECC82	4/6	EL83	5/11
6K8G	3/3	ECC83	4/6	PL84	8/-
6L1H	7/3	ECC85	5/3	PY32	8/9
6G7G	5/6	ECH35	5/9	PY33	8/9
6V6G	3/-	ECH42	8/9	PY81	5/-
10C2	11/-	ECH61	5/6	PY82	4/9
10F1	9/6	ECL90	5/9	PY83	5/3
10P13	8/3	ECL82	6/3	PY800	5/11
20F2	8/9	ECL86	7/6	R19	6/6
20P1	8/9	EF39	3/6	U25	8/9
20P3	6/9	EF41	5/9	U36	8/6
20P4	12/6	EF80	4/3	U191	10/-
30F5	8/3	EF85	5/-	U301	11/6
30P4	11/6	EF86	6/6	U801	16/-
30P19	11/6	EF89	4/9	UABC80	5/-
DAC32	6/6	EL33	6/3	UAF42	6/11
DAF91	8/9	EL41	8/-	UBC41	8/6
DAF96	5/11	EL84	4/3	UBF80	5/6
DF33	7/6	EY51	5/11	UBF89	5/9
DF91	2/9	EY86	5/3	UCC85	8/6
DF96	5/11	EZ40	5/6	UCC86	8/-
DK32	7/-	EZ80	3/6	UC81	6/6
DK81	4/-	EZ81	4/-	UCL82	7/-
DK96	6/3	KT61	6/3	UCL83	8/8
DL33	6/6	N78	14/6	UF41	7/9
DL35	4/9	PCC84	5/3	UF89	5/6
DL92	4/3	PCB89	6/9	UL41	7/9
DL94	4/3	PCF80	6/3	UL84	5/3
DL96	5/11	PCF82	5/9	UY41	4/9
DY86	6/3	PCF805	8/-	UY85	4/9

Postage on 1 valve 9d. extra. On 2 valves or more, postage 6d. per valve extra. Any parcel insured against damage in transit 8d. extra.

Office address, no callers.  
**GERALD BERNARD**  
83 OSBALDESTON ROAD  
STOKE NEWINGTON  
LONDON N.16

**EKCO TC313**

Is it possible to adjust the fine tuner as this set was used down south and I found that the travel is not quite enough to allow the best results in this area. I have checked the tuner but can find no adjustment.

Could you also give me the date of manufacture of this set?—C. Earl (Middleton, Manchester).

There is a separate local oscillator adjustment at the front end of each set of tuner biscuits. This becomes accessible via a hole in the tuner side when the appropriate station is tuned in.

The date of your receiver is approximately 1959.

**FERGUSON 725**

There was a complete failure of picture but the sound was perfect. I replaced valve EY86 but there was still no picture and upon removing the valve I found that I could obtain 6V across the pins of the valveholder. After cleaning and adjusting same, I obtained a picture with the top half the full width of the screen and the bottom half only half-size. Could this be due to faulty scan-coils?—V. J. Beckett (Hayes, Middlesex).

The symptom described certainly appears to be the result of shorting turns in a section of the scanning coils.

**PILOT PT452**

On switching on, the picture equally centres top and bottom. After an hour or two the picture gradually shrinks at the bottom and stretches at the top. Replacement of valve No. 13 (frame output) has only very slightly improved this.

The frame hold and line hold have become very unstable with very little lock on either.—N. G. Carragher (Aberdeen, Scotland).

The gradual field compression and expansion effects are characteristic of this model to a certain degree. However, that could be aggravated by (a) poor rear and bottom ventilation and (b) sunning at the incorrect mains voltage tapping. Poor field hold should lead to a check of the field sync pulse circuits from the sync separator stage to the field oscillator valve. It is, of course, impossible to say exactly which components—if any—are at fault, as tests will have to be made to establish their condition.

**KB PVP20**

The picture rolls when the set has just been switched on, but can be locked with the frame hold control. After warming up (approximately 10 minutes) the picture resumes rolling but can again be locked with the frame hold control. The picture then remains stable. This fault occurs every time the set is used.—R. Weids (Clevedon, Somerset).

You should check by replacement valves V11 (12AX7) and V10 (PCL82). Check R99 (150k $\Omega$ ) and R100 (120k $\Omega$ ) if necessary.

**MARCONI VT68DA**

Channels 2 and 7 are good but on channel 10, the sound comes in at one end of the fine tuner and only a very dim picture at the other end. I assume the coils need adjusting on this channel but I am not certain which, as there are four sets of coils.

Can you also tell me if I can get inside the tuner unit without disconnecting it and taking it out, as there does not appear to be a cover to remove.—W. Hall (Withernsea, Yorkshire).

The cover of the tuner is secured by a number of small PK screws. The tuner must be released to gain access to these screws. This is not difficult but not actually necessary if you can adjust L46 oscillator screw which is inset in the middle of the front end of the tuner, i.e. below the i.f. output coil can. This can be adjusted with a short tool from beneath the chassis. The screw on the other side is for BBC.

**KB QV30/1**

I can hear the line timebase oscillator, but I cannot get the EY86 to light up. I have tried the heating windings on the meter and find they seem to be intact. In desperation I put a battery to the EY86 and got full line scan.—C. Brooker (Hanwell, Middlesex).

It would seem that something is amiss in the line output transformer. The line pulses must be present otherwise a raster would not be obtained when the e.h.t. rectifier is heated by a battery.

**PHILIPS 23TG**

The line hold is very critical. When adjusted, it holds for a second then starts pulling into an "S" shape. The brightness and contrast seem to affect the line hold. I have replaced all the valves which would affect this, also a number of capacitors and the grid resistor on the PL36. I have also bridged the main smoothing capacitors.—R. Smith (Oswestry, Salop).

Check the PL33 video amplifier for heater/cathode leakage. Then check V410 (ECL80) and the components to pins 6 and 2, also those to pin 6 of V402.

**PYE VT4**

This set has exhibited a negative picture. This used to happen only when first switching on, but has now become permanent. If the sensitivity control is turned down by about one-half (this is a fringe area and sensitivity is normally at maximum) then the picture becomes normal although tending to go negative as time goes on.—H. Hosking (Blandford Forum, Dorset).

The fault appears to be in the a.g.c. circuits. We advise you to check thoroughly around the V12B, V13 circuitry, suspecting particularly leakage of coupling capacitors such as C42 (0.01 $\mu$ F) and C43 (0.01 $\mu$ F).

**HMV 1870**

When switching on this set, the sound and vision are quite good but after about ten minutes the picture disappears just leaving a raster. By switching off and leaving for a few minutes, then switching on again, the picture returns.—C. Smith (Huyton, Lancashire).

This trouble could be in the vision detector or in its coupling to the video amplifier, assuming that the sound is unaffected by this fault. Also try tapping the picture tube neck when the symptom is present. If this results in the picture reappearing, the tube should be suspected.

**ULTRA V2170**

There seems to be no control over focus on this set. There is a control marked as R93 on the service sheet and the value of this should be 2.2M $\Omega$ . As far as I can gauge, the one in the set measures 1.5 meg. and movement of the slider produces not the slightest effect on the picture.—T. P. Ford (Peacehaven, Sussex).

There is not meant to be a control over focus on this set. The tube is the latest electrostatically focused type and once the preset is adjusted to suit the tube characteristics no more adjustment is required until the tube is replaced.

**PYE 13U**

The sound and picture are normally very good, but occasionally the height suddenly judders. This is accompanied by a brighter but elongated picture. This then jumps back, leaving a black line up to 1in. wide at the top and bottom of the screen, with a corresponding lack of brightness.

These "oscillations" of height can occur almost immediately after switch-on and several times during an evening's viewing. This fault is the same on both standards.—T. Pattison (Thurmarston, Leicestershire).

The symptoms you describe suggest a fault in the cathode bias circuit of the PCL85 valve, V15A. We suggest that you check particularly resistor R77 and Capacitor C74 as marked on the printed circuit.

**QUERIES COUPON**

This coupon is available until DECEMBER 22nd, 1966, and must accompany all Queries sent in accordance with the notice on page 137.

PRACTICAL TELEVISION, DECEMBER, 1966

**TEST CASE -49**

Each month we provide an interesting case of television servicing to exercise your ingenuity. These are not trick questions, but are based on actual practical faults.

? The set was a recent model of the Thorn 850 series and the symptom was lack of picture coupled with distorted sound. Tests proved that the h.t. supply voltage was normal, but that the line output valve was running hotter than normal.

No trace of line whistle could be heard when the horizontal (line) hold control was turned over its range with the aerial disconnected from the set. The line output valve and associated components were checked and found in good order, as also were the sound output and audio valve and associated components.

What would be the possible cause of these two symptoms and how could they be related? The solution will be found in next month's PRACTICAL TELEVISION and also another Test Case item.

**SOLUTION TO TEST CASE 48****Page 93 (last month)**

One component that was overlooked by the enthusiast when investigating for the field timebase trouble was the ECL80 valveholder. After several years of service, the underside of the valveholder tends to become rather brittle due to

the heat of the valve and dust accumulations may sometimes impair the insulation between the pin sockets.

Ordinary cleaning may not solve this trouble as the dust sometimes ingresses between the laminations of the holder. The reduction of insulation may be insufficient to promote arcing or sparking across the valveholder, but bad insulation between a pin socket carrying h.t. voltage, such as an anode or screen grid, and a control grid socket can severely disturb the operating conditions of the stage, especially in field circuits of high control grid impedance. Not only the general biasing, but also the linearising feedback can be disturbed, thereby giving the typical symptom of picture inversion.

The arcing in the valve could have been caused by excessive conduction during the warming-up period, when the control grid is almost at the h.t. line potential.

Replacing the valveholder completely cleared the trouble. It is worth remembering that similar trouble can occur on printed circuit boards between adjacent conductors in the screen grid, anode and control grid circuits. Very slight leakage on the control grid of the field output pentode affects first the vertical linearity, developing progressively to the serious condition described in Test Case 48.

# FREE TO AMBITIOUS ENGINEERS

— THE LATEST EDITION OF ENGINEERING OPPORTUNITIES

**Have you sent for your copy?**

ENGINEERING OPPORTUNITIES is a highly informative 156-page guide to the best paid engineering posts. It tells you how you can quickly prepare at home for a recognised engineering qualification and outlines a wonderful range of modern Home Study Courses in all branches of Engineering. This unique book also gives full details of the Practical Radio & Electronics Courses, administered by our Specialist Electronics Training Division—the B.I.E.T. School of Electronics, explains the benefits of our Employment Dept. and shows you how to qualify for five years promotion in one year.

## SATISFACTION OR REFUND OF FEE

Whatever your age or experience, you cannot afford to miss reading this famous book. If you are earning less than £30 a week, send for your copy of "ENGINEERING OPPORTUNITIES" today—FREE.

**BRITISH INSTITUTE OF ENGINEERING TECHNOLOGY**  
(Dept. 301B), Aldermaston Court, Aldermaston, Berkshire

### WHICH IS YOUR PET SUBJECT

Mechanical Eng.,  
Electrical Eng.,  
Civil Engineering,  
Radio Engineering,  
Automobile Eng.,  
Aeronautical Eng.,  
Production Eng.,  
Building, Plastics,  
Draughtsmanship,  
Television, etc.

### GET SOME LETTERS AFTER YOUR NAME

A.M.I.Mech.E.  
A.M.I.C.E.  
A.M.Prod.E.  
A.M.I.M.I.  
A.I.O.B.  
E.Sc.  
A.M.I.E.R.E.  
City & Guilds  
Gen. Cert. of Education  
etc., etc.

### PRACTICAL EQUIPMENT

Basic Practice and Theoretical Courses for beginners in Radio, T.V., Electronics Etc., A.M.I.E.R.E., City & Guilds  
Radio Amateur's Exam.  
R.T.E.B. Certificate  
P.M.G. Certificate  
Practical Radio  
Radio & Television Servicing  
Practical Electronics  
Electronics Engineering  
Automation

### INCLUDING TOOLS!

The specialist Electronics Division of B.I.E.T. NOW offers you a real laboratory training at home with practical equipment Ask for details

**B.I.E.T. SCHOOL OF ELECTRONICS**



### POST COUPON NOW!

Please send me your FREE 156-page "ENGINEERING OPPORTUNITIES" (Write if you prefer not to cut page)

NAME .....

ADDRESS .....

SUBJECT OR EXAM THAT INTERESTS ME ..... 301B

## THE B.I.E.T. IS THE LEADING INSTITUTE OF ITS KIND IN THE WORLD

*Basic guides for the enthusiast — a new series in question and answer form:*

### Q. & A. ON AUDIO

Clement Brown

104 pages

80 line diagrams

### Q. & A. ON ELECTRONICS

Clement Brown

112 pages.

60 line diagrams.

### Q. & A. ON TRANSISTORS

Clement Brown

96 pages.

60 line diagrams.

### Q. & A. ON RADIO AND TELEVISION

H. W. Hellyer

128 pages.

70 line diagrams.

*each 8s. 6d.*

from booksellers or 9s. 6d. by post from **GEORGE NEWNES, Tower House, Southampton Street, W.C.2**

### TWO YEAR GUARANTEED TUBES

14 in. 59/6  
17 in. 79/6  
21 in. and all Slimline Tubes 99/6



100% REGUNNED Add 10/- or old tube.

Ex-Maintenance Tested Tubes  
17" 35/- 14" 15/-  
Most Makes and Types (Not Slimline)  
Carr. 5/-

### TWO YEAR GUARANTEE EX-RENTAL TELEVISIONS

17 in. — £11.10.0

3 star Guarantee

★Tube ★Valves ★Components

#### FREE ILLUSTRATED LIST

covering a wide range of models, sizes and prices  
17in.—19in—21in—23in.

Demonstrations daily

Personal collection or insured  
Carr. 17in. 30/-

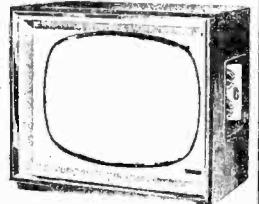

### LATEST RADIOGRAM CABINETS £9.10.0

Brand new low design in veneered English walnut dia. 40 x 16 x 15 1/2 in. Carr. 30/- Also Small Cabinets £6.19.6. Radiogram Cocktail Cabinets (Personal Shoppers.) Send for Free List.



Record Player Cabinets 49/6. Latest designed covered cabinets. Take any modern Autochanger. Single Player Cabinets 19/6. P. & P. 5/6. T.V. Turret Tuners 2/6 less valves. Slim Models 5/- Press Button Models 19/6 P. & P. 2/6

### DUKE & CO. (LONDON) LTD.

621/3 Romford Road, Manor Park, E.12  
Liverpool St.—Manor Park.—10 mins.  
Phone: ILFord 600-1-2-3 Stamp for free list

**MISCELLANEOUS**

**CONVERT ANY TV SET** into an Oscilloscope. Instructions and diagrams 12/6. **REDMOND**, 42 Dean Close, Portslade, Sussex.

**SETS & COMPONENTS**

**TV TUBE BARGAINS.** 17in., 19in., 21in., 23in. 110 slim line tubes. Also 70 and 90 none slim line. All the above are brand new tubes which had slight scratches on the screen and have been removed at our factory. Fully guaranteed 12 months. All at one fantastic price, £3 each plus 15/- P. & P. Old glass not required. Cash with order, no C.O.D. **ATLAS TV SERVICES (BRADFORD) LTD.**, 124 Barkend Road, Bradford 3, Yorkshire.

**STOP**

**FULLY GUARANTEED L.O.P.T. REWINDING SERVICE**

A few of the types are listed below:-  
**BUSH TV 53-66. TV 79.115R, etc.**  
**K.B.P.V.P.20 etc.**  
**PHILIPS 1768U, 17TG100U, etc.** All at 50/-  
**NEW FROM STOCK**  
**U25 Type EKCO, state model.**  
**FERGUSON 306-308.** All at 45/-  
**F.O.P.T. REWINDS 30/-.**  
 We manufacture all types of transformers.  
**S.A.E. Enquiries P. & P. 4/-, C.O.D. 6/-**  
**WITWORTH TRANSFORMERS Ltd.**  
 26 All Saints Road, North Kensington  
 W.11 Telephone: **BAY 9071**

**R. & R. RADIO & TV SERVICE**

44 MARKET STREET

BACUP, Lancs. Telephone: 465

Selected Valves 5/- each, Min. order 1 doz., PCF80, PCC84, EF80, PY800, 30P19, PL36, ECL80, EY86. Most other types available, see previous advts.

Silicon rects, BY100 & similar types, complete with Resistor and Mounting tag 5/-.

EKCO line output trans., U25 type 30/-; U26 Type 35/- Post paid.

New Valves 6K8, 6R7, 4/6; 6K7, 6F6, 6B8g, 3/- Post 6d per valve.

Video panels, printed circuits suitable for stripping, 5 for £1, post pd.

Transistor pre-amps for bands 1, 2 and 3, £3 12s 6d, post paid, these will amplify one channel and pass the other, i.e. amp. any channel, band three and pass band one, or vice versa. 14dB gain.

Speakers 6 x 4 and 5 in. round, 3/6, post 2/3.

8 in. speakers 6/-, post 2/3.

Line output trans., scan coils, etc. S.A.E. with all queries.

**RATES: 4/- per line or part thereof, average five words to line, minimum 2 lines. Box No. 1/- extra. Advertisements must be prepaid and addressed to Advertisement Manager, "Practical Television", Tower House, Southampton Street, London W.C.2.**

**SETS & COMPONENTS**

(continued)

**THIS MONTH'S SCOOP!**

New, Boxed and Tropicalised, in Beautiful Cabinets, 525-625 line

**EXPORT T.V. SETS**

19 in. £33 23 in. £39

**TELEVISION TUBE SHOP**

48 Battersea Bridge Road, SW.11

**TV SPARES**, fully guaranteed. Makers' Parts. Telephone orders sent same day C.O.D. Line O.P. Trans: Murphy V270/280 99/6, Ekco T311, 330, 221, 231, 327 series and Pye VT4 etc., all 62/6. Most types stocked. Send S.A.E. for quote. Add 4/- p.p. Ekco/Ferr. Plastic Hsgs, 15/- **KINGS (ORPINGTON) LTD.**, 8 Cray Parade Main Road, St. Paul's Cray, Kent. Orpington 30566.

**TUBES, AERIALS, VALVES**

U.H.F. aerials. Bands I, II & III aerials. U.H.F. transistorised boosters. I.T.V. boosters. Regunnet T.V. tubes. Valves, etc. New and second-hand T.V. sets, Transistor Radios and all types of Electrical Appliances. Quotations without obligation. Coaxial cable, fluorescent light fittings, all at special prices to the trade and Home Engineers. S.A.E. for list.

**G. A. STRANGE**

**BROADFIELD, NORTH WRAXHALL.** nr. Chippenham, Wilts. Tel. Marshfield 236

**GUARANTEED IDEAL for ANY RECORDER.**

**TAPE** World Famous make. PRICES SLASHED. APPROX. HALF PRICE!

By enormous purchase we can offer you fully tensilised Polyester/Mylar and P.V.C. tapes of Identical Hi-Fi wave range recording characteristics as top grade tapes. Quality control manufacture. Not standard in any way. **TRY ONE for YOURSELF. THEY ARE TRULY WORTH A FEW MORE COPPERS.**

**STANDARD PLAY DOUBLE PLAY**

3"	150'	2/3	3"	300'	4/-
4"	300'	4/6	4"	600'	8/-
5"	600'	7/6	5"	1200'	15/-
5 1/2"	900'	10/6	5 1/2"	1800'	19/6
7"	1200'	13/6	7"	2400'	27/-

**LONG PLAY TRIPLE PLAY**

3"	225'	2/9	4"	800'	13/-
4"	450'	5/6	5"	1800'	25/-
5"	900'	10/6	5 1/2"	2400'	34/-
5 1/2"	1200'	13/-	7"	3600'	44/-
7"	1800'	18/6	<b>QUADRUPLER PLAY</b>		
			3"	600'	8/-

Postage 1/- per reel.  
 Post free and less 5% on three.  
 Trade and quantity enquiries welcomed.

**TECHNICAL TRADING CO.**

All Mail Orders to Brighton Please.  
**Devonian Court, Park Crescent**  
**Place, Brighton 680722, 67606**  
 350/352 Fratton Road, Portsmouth 22034  
 72 East Street, Southampton 25851  
 132 Montague Street, Worthing 2639

**TELEVISION TUBE SHOP**

THE

**NEW TUBE Specialists**

A47-13 W	£12.10.0
A59-13 W	£15.10.0
AW36-20, 21	£5.12.6
AW36-80	£5. 7.6
AW43-80	£6. 7.6
AW43-88, 43-89	£6.12.6
AW47-90, 91	£7.10.0
AW53-80	£7.12.6
AW53-88, 53-89	£7.17.6
AW59-90, 59-91	£9.10.0
C14B M, F M	£5.15.0
C17B M, F M, H M	£6. 7.6
C17L M, P M, S M	£6.12.6
C21H M, S M, T M	£7.17.6
CME1402	£5.17.6
CME1702, 1703	£6.12.6
CME1705	£7. 7.0
CME1901, 1903	£7.10.0
CME2101, 2104	£7.17.6
CME2306	£15. 0.0
CRM93	£5.10.0
CRM124	£5.10.0
CRM141, 2, 3, 4	£5.17.6
CRM152	£5. 0.0
CRM153	£3.19.6
CRM171, 2, 3	£6. 7.6
CRM211, 212	£7.17.6
MW31-16, 74	£5.12.6
MW36-24, 44	£5. 2.6
MW43-64, 69	£6. 7.6
MW43-80	£6. 7.6
MW53-20	£7.12.6
MW53-80	£7.12.6
14KP4A, 141K	£5.12.6
171K, 172K, 173K	£6. 7.6
7201A, 7203A	£5.12.6
7240A	£5.10.0
7401A	£6. 7.6
7405A	£6.12.6

Manufacturers' Reprocessed Tubes available at £1 each less than the above prices.

All tubes tested before despatch and guaranteed for 12 months.

**CARRIAGE 10/-**, via B.R.S. or 15/- via passenger train. Add 2/6 for Comprehensive Insurance.

**TERMS £2 down** (plus carriage) balance £1 per month.

Midland Stockists:-

Amateur Electronics Co.,  
 240 Lichfield Road, Aston,  
 Birmingham.

**TELEVISION TUBE SHOP**

48 BATTERSEA BRIDGE ROAD  
 LONDON S.W.11. BAT 6859

JUST SOUTH OF THE BRIDGE  
 OPEN SATURDAY UNTIL 4 p.m.





**WANTED**

**NEW VALVES WANTED** . . . EY51, EY86, PL84 PCC84, PCF80, PCL82, PCL83, PY81, R19, 30P19, U25 etc. Best cash price by return. **DURHAM SUPPLIES**, 175 Durham Road, Bradford 8, Yorks.

**WANTED**—Popular Brand New Valves—R.H.S., Stamford House, 538 Great Horton Road, Bradford 7.

**SERVICE SHEETS** purchased. **HAMILTON RADIO**, Western Road, St. Leonards, Sussex.

**DAMAGED AVO METERS WANTED**. Models 7 and 8. Any condition. Any quantity. **HUGGETTS LTD.**, 2-4 Pawson's Road, West Croydon.

**SITUATIONS VACANT**

**RADIO AND TV Exams. and Courses** by Britain's finest home study School. Coaching for Brit.I.R.E., City and Guilds Amateur's Licence, R.T.E.B., P.M.G. Certificate etc. Free brochure from British National Radio School, Russell Street, Reading.

**T.V. and Radio A.M.I.E.R.E., City & Guilds, R.T.E.B.Cert., etc.** on "Satisfaction or Refund of Fee" terms. Thousands of passes. For details of exams and home training courses (including practical apparatus) in all branches of radio, T.V. and electronics, write for 132 page handbook—**FREE**. B.I.E.T., (Dept. 172K) Aldermaston Court, Aldermaston, Berks.

**TECHNICAL TRAINING**

**CITY & GUILDS** (electrical, etc.) on "Satisfaction or Refund of Fee" terms. Thousands of passes. For details of modern courses in all branches of electrical engineering, electronics, radio, T.V., automation, etc. send for 132 page handbook—**FREE**. B.I.E.T. (Dept. 173K) Aldermaston Court, Aldermaston, Berks.

**SERVICE SHEETS**

**SERVICE SHEETS**. Radio, TV 5,000 models. List 1/-, S.A.E. enquiries. **TELRAY**, 11 Maudland Bk., Preston.

**SERVICE SHEETS** (75,000) 4/- each. Callers welcome. **ALWAYS OPEN**. 5 South Street, Oakenshaw, Bradford.

**SERVICE SHEETS**

For all makes of Radio, Television, Tape Recorders, 1925-1966. Prices from 1/-. Catalogue of 6,000 models, 2/6. Free fault-finding guide with all Service Sheets. Please send Stamped Addressed Envelope with all orders and enquiries.

**HAMILTON RADIO**

Western Road, St. Leonards, Sussex

**SERVICE SHEETS**

(continued)

**RADIO 2/-, TV 3/-, Manuals 5/-, C.W.O. S.A.E. Model No. HOPKINS, 44 Dale Valley, Poole.**

**SERVICE SHEETS**

4/- each, plus postage

We have the largest supply of Service Sheets for all makes and types of Radios and Televisions, etc. in the country (speedy service).

To obtain the Service Sheet you require please complete the attached coupon:

Name: .....  
 Address: .....  
 .....

To: S.P. DISTRIBUTORS

30 Baker Street, London, W.1

Please supply Service Sheets for the following:

Make: .....  
 Model No..... Radio/TV...

Make: .....  
 Model No..... Radio/TV

Make: .....  
 Model No..... Radio/TV

I also require new 1966 List of Service Sheets at 1/6 plus postage.

(please delete items not applicable)

I enclose remittance of .....  
 (which includes postage)

MAIL ORDERS ONLY (Dec. PT.)

**EDUCATIONAL**

**A.M.I.E.R.E., A.M.I.Mech.E. City & Guilds, G.C.E., etc.** Become a technician or technologist for high pay and security. Thousands of passes. For details of exams and courses in all branches of Engineering, Building, Electronics, etc., write for 132 page book—**FREE**. B.I.E.T. (171K) Aldermaston Court, Aldermaston, Berks.

**A concise guide for only 6s. 6d. BEGINNER'S GUIDE TO ELECTRONICS T. L. Squires**

This book provides a "short-cut" for those wishing to obtain a quick acquaintance with modern electronics. It describes as simply as possible the basic concepts in electronic engineering. No prior technical knowledge is assumed, mathematics being avoided and emphasis placed on numerous illustrations.

6s. 6d. paperback, limited supplies only. By post 7s. from Newnes, Tower House, Southampton Street, London, W.C.2

**PADGETTS RADIO STORE**

OLD TOWN HALL

LIVERSEDGE, YORKSHIRE

Telephone: Cleckheaton 2866

**Motors, Single Phase, 240v., 1 H.P. 26/- each, 1400 revs. Fully guaranteed, ex washing machines. Carr. 8/6.**

**Special Offer. Garrard Record Players. Auto Changers. Model AT6 £8.2.6. Model 1,000 £5.12.0.**

**Single Player. Model S.P.25 £8.2.6. Carriage of Cabinet on any Model 10/-.** All complete with cartridge and maker's guarantee.

**19 Set with outer case. Receiver section complete with valves.**

**Parts Removed. 500 micro-amp meter, all transmitter parts. Relay and 807 valve. Condition fair. No dry rot 10/-, Carr. 10/-.** Bush TV53 14in. 13 Channel TV Set. Perfect working order £6. Carriage 10/-, N.Z. £4.0.0 cart.

**Pye VT4 14in. TV 13 channel, fitted with new tube and in good working order. Condition of Cabinet, fair £5.10.0. Carriage 10/-, N.Z. £4.0.0.**

**Reclaimed Tubes. Six months' guarantee. AW4380, 30/-, MW4380, 30/-, MW 4386, 30/-, CRM12, 30/-, CRM142, 17/-, 12in. Tubes 10/-, 17in. Tubes perfect but without guarantee. 17/- each. Carriage on any Tubes in G.B. 10/-.**

**Specially Selected Nearly New Valves. 6 months' guarantee. Single Valves, Post 7d.**

PY33	6/-	ARP12	1/6	EL38	5/-
PCC84	5/6	ECL80	3/6	5U4G	4/-
PCP80	5/6	ECC83	5/-	6K7	1/9
PL81	5/6	ECC82	4/3	6V6	1/9
807	5/-	EF91	2/-	185BT	8/6

**VALVE LIST**

**Ex. Equipment. 3 months' guarantee. Single Valves, Post 7d.**

EF80	1/6	PCF80	2/-	10P13	2/6
ECL30	1/6	PCC84	2/-	10P1G	5/-
EF91	9d.	PCL82	4/-	20D1	3/-
EB91	9d.	PCL83	3/-	20L1	5/-
EF80	3/-	PCL85	3/-	20P1	4/-
ECC81	3/-	PY30	5/-	20P4	8/6
ECC82	3/-	PY31	1/6	U3C9	5/-
ECC93	4/-	PY82	1/6	U801	8/6
EL84	5/-	PL81	4/-	U301	5/-
EF50	1/-	PL36	5/-	U191	5/-
PY86	5/-	PY33	3/-	U281	5/-
6K25	5/-	6B8	1/6	U282	5/-
6U4	5/-	6F1	1/-	U25	5/-
6P25	5/-	6P14	5/-		
KT36	5/-	10C2	5/-		

**Breaking up 19 Sets. Relays 100 Ohm Coil 2/-, Post 2/6. 1 Doz. 26/-, Post Paid. Jack Sockets 7/6 doz. Post Paid.**

**Toggle Switches 7/6 doz. Post Paid.**

**Pointer Knobs 7/6 doz. Post Paid.**

**Top Grade Diodes 3/6 doz. Post Paid. No dues.**

**Perfect Speakers. Removed from TV sets. Goodmans 7 x 4, 5/-, Goodmans 8 x 5, 7/6. 6 x 4 and 5ins., 3/-, Plus Post on any Speaker. 4/-.**

**NYLON - P.T.F.E.**

ROD, BAR, SHEET, TUBE, STRIP WIRE

No quantity too small  
 List on application

**ALUMINIUM, LIGHT ALLOYS BRASS, COPPER, BRONZE**

**H. ROLLET & CO. LTD**

HOWIE STREET, S.W.11  
 BATtersea 7872

Branches at Liverpool, Manchester, Birmingham, Leeds, Glasgow.

# REBUILT TUBES!

*You're safe when you buy from RE-VIEW!*

- ★ Each tube is rebuilt with a completely new gun assembly and the correct voltage heater.
- ★ Each tube comes to you with a guarantee card covering it for two years against all but breakage.
- ★ Each tube is delivered free anywhere in the U.K. and insured on the journey.
- ★ Each tube is rebuilt with experience and know-how. We were amongst the very first to pioneer the technique of rebuilding television tubes.

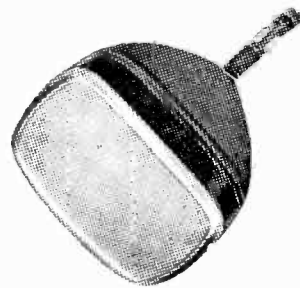

## HERE IS WHAT YOU PAY:

12in. ...	£4.15.0
14in. ...	£5. 0.0
15in. ...	£5. 5.0
17in. ...	£5. 5.0
19in. ...	£5.15.0
21in. ...	£7. 5.0

*Cash or cheque with order, or cash on delivery*

**Discount for Trade**

*Old Tubes Purchased*

## RE-VIEW ELECTRONIC TUBES

237 LONDON ROAD, WEST CROYDON, SURREY. Tel. THORnton Heath 7735

## BBC2, TV, RADIO & TAPE REC. SPARES

**UHF/625.** Modify your set to BBC2. 1955 to 1963 models covered. Selection of new manufacturers conversion kits and tuners at reduced prices. List available.

**SPECIAL OFFERS:** FERGUSON 625 IF amp. chassis. New, incl. 6 valves, 39/8 (dies valves 19/8). Circuit and instr. 3/8. p/p 4/6. PHILIPS 625 conversion kit incl. Tuner and IF Amp. etc. New, £5.10.0. p/p 6/.

**TV SIGNAL BOOSTER UNITS.** Some gain all stations. PVE/LARGAR trans'd. BBC/ITA or UHF Battery "plug in" 75/-. CHF Mains "plug in" 97/6. UHF Masthead 105/-. Post free.

**FIREBALL TUNERS.** New/tested (KB RGTN, RGD, PVE, ULTRA, PILOT, etc.) suitable for other models. 75/-. p/p 4/6.

**TURRET TUNERS.** New. Cyclon off 38 Mc/s 30/-, Brayhead 10, 16, 30 Mc/s 25/-, KB MV/F 38 Mc/s 15/-, EKCO 16 Mc/s 10/-, p/p 4/6. Many others available. Two. Repl. services for special types incl. Pve, Ferguson, Sobell, Philips, GEC, McMich. Large Selection Channel Coils, etc.

**ORTs.** Rebuilt. 12 month guarantee. 14, 17 inch; 70°, 90° 4-5-0. 17, 19 inch 110°. 5-5-0. Callers only.

**LINE OUTPUT TRANSFS.** Popular types available. brand new exact replacements fully guar. A selection which can be supplied:—

PHILIPS 1768 etc. STELLA 8617 etc. ... 98/6  
 EKCO 221 to 331 (U25) types ... 42/6  
 FERRANTI 1601 to 1011 (U25 types) ... 42/6  
 EKCO FERRANTI (U25 types) 70°/90° ... 58/6  
 FERGUSON 506, 508, 404, 408 ... 59/6  
 FERGUSON 506, 508, 404, 508/8, later models ... 74/6  
 MARCONI VT157, 159, 160, 164 59/6  
 Others ... 74/6

GEC 232, 1749, 2745 range 52/8 later models ... 72/6  
 HMV 1865, 1869 42/6, 1890/1894 55/-  
 Others ... 72/6  
 SOBELL T817, 346 48/6; other models ... 72/6  
 PVE, PAM, INVICTA from ... 62/6

Also, ALBA, COSSOR, KB, McMIC, PHILCO, P/SCOTT, REG, RGD, ULTRA etc. Postage and Packing for I.O.T.s 4/6. C.O.D. 3/6 extra.

**SCAN COILS.** Frame off frame osc. transf., with linearity coils, sound off transf., mains droppers, control knobs, dual val., controls, line osc. transf., resistors, condensers, etc.

**TAPE REC/CHANGER.** Drive Belts, Heads Pinch Wheels, Idlers, Motors for most British (incl. WALTER) and Continental.

**SALVAGED COMPONENTS.** Large selection for popular models, clean, serviceable condition. Turrets, transformers, etc.. ENQUIRIES Invited quotations given. C.O.D. despatch available.

## VALVES SAME DAY SERVICE

NEW! TESTED! GUARANTEED!

SETS	1R5, 1R5,	1T4,	3R4,	3V4,	DAF91,	DF91,	DK91,	DL92,	DL94,
	set of 4 for 18/-, DAF96, DF96, DK96, DL96, 4 for 24/8.								
1A7GT	7/8	7H7	7/8	9063	12/6	ECF82	6/8	N18	5/8
1H5GT	7/8	7C5	8/5	AZ31	8/8	ECF86	9/-	N78	14/9
1N5GT	7/8	706	6/8	B36	4/8	ECF45	6/-	PC97	6/8
1R5	4/8	7H7	5/-	B729	10/-	ECF42	9/-	PC94	5/8
184	4/8	7Y4	5/-	DAC32	7/8	ECF81	5/8	PC99	9/8
185	3/8	918W6	6/8	DAF91	3/8	ECF84	8/8	PC199	9/8
1T4	2/8	1622	11/8	DAF96	6/-	ECF80	6/8	PC190	6/8
3A5	7/-	10F1	9/8	DC980	7/-	ECF82	6/8	PC98	6/8
3Q4	5/8	10F13	8/8	DF33	7/8	ECF85	7/8	PCF86	8/8
3R4	4/8	12A7	3/8	DF91	2/8	ECF99	3/8	PCF80	10/8
3V4	5/8	12A06	4/8	DF96	6/-	EF41	6/8	PCF81	9/8
614G	4/8	12A07	4/8	DF76	3/8	ECF80	8/-	PCF81	16/8
5X4G	7/8	12A07	4/8	DH77	4/-	ECF85	5/-	PCF82	6/8
5Y3GT	4/11	12K7GT	3/8	DH81	12/8	ECF86	6/8	PCF83	9/8
5Z4G	6/8	12K8GT	8/8	DK32	7/8	ECF89	5/-	PCF84	7/8
6J3012	9/8	12Q7GT	3/8	DK91	4/8	DF91	3/8	PCF85	8/8
8AL5	2/3	26C2	9/-	DR92	8/-	DF92	2/3	PCF86	8/8
6AM6	3/8	30L17	11/8	DK96	6/8	ECF87	7/8	PCF84	9/8
6AQ5	4/8	20P1	9/8	DL33	8/8	EF182	6/8	PCF86	5/8
6AT6	4/-	20P3	9/-	DL35	5/8	EF184	6/8	PCF86	5/8
6BA6	4/8	20P4	13/8	DL92	4/8	EL33	6/8	PCF83	8/8
6BE6	4/3	2214GT	11/8	DL94	5/8	EL38	11/8	PCF80	14/8
6BX6	5/8	36C15	10/-	DL96	6/-	EL41	4/8	PCF86	9/8
6BW6	1/6	40L17	12/8	EB91	2/8	ECF81	7/8	PCF81	6/8
6P1	7/8	40L18	8/8	DSK7	6/8	EL44	4/8	PCF82	7/8
6P13	3/8	36P5	8/8	EAC80	6/8	EL48	4/8	PCF83	8/8
6P14	9/-	3CFL1	10/8	EAF42	6/8	EL55	5/8	PCF81	8/8
6P29	9/8	30L15	11/8	EBA41	4/8	E8M80	5/8	PCF80	14/8
6K7G	3/8	30L17	12/8	E8M81	7/8	PCF81	7/8	PCF80	5/8
6K8G	4/8	30P4	13/8	E8C33	6/8	E8M84	5/8	PCF85	7/8
6K8GT	7/8	30P12	9/8	E8C41	7/8	E8M87	6/8	PCF81	15/8
6L18	7/8	30P19	13/8	E8F90	6/8	PCF82	9/8	PCF82	9/8
6Q7G	5/8	30P11	11/8	E8F89	3/8	EY86	6/8	PCF83	9/8
6Q7GT	6/8	30P13	11/8	E8C81	4/8	EY80	6/8	PCF80	5/8
6V6G	3/8	35MCT	11/8	ECY82	4/8	EZ41	6/8	PCF81	5/8
6V6GT	6/8	35V4	4/8	ECY83	7/8	EZ80	3/8	PCF82	5/8
6X4	3/8	35Z4GT	4/8	ECY84	6/8	E281	4/8	PCF83	5/8
6X5GT	6/8	35Z4	5/8	ECY85	5/8	E282	9/8	PCF80	7/8
7H6	10/8	18B1T	20/-	ECY86	6/8	ET36	9/8	PCF81	6/8

## MANOR SUPPLIES

64 GOLDERS MANOR DRIVE, LONDON, N.W.11

(Callers: 5898, HIGH ROAD (nr. Granville Road), N. Finchley N.12).  
 Open all week inc. Sat., HIL 9118 (Day) SPE 4032 (Evg.).

## READERS RADIO

85 TORQUAY GARDENS, REDBRIDGE, ILFORD, ESSEX. CRE 7441

Postage on 1 valve 9d. extra. On 2 valves or more, postage 6d. per valve extra.  
 Any Parcel Insured against Damage in Transit 6d. extra.

**Planned as the reference book on the subject . . . 400 data-filled pages for only 30s. Just published**

# OUTLINE of RADIO and TELEVISION

by J. P. Hawker

This book has been specially written by an author whose day-to-day concern has — as Communications Correspondent of the industry's weekly newspaper for several years — been the reporting of progress in the field of radio and television transmission and reception, to help the keen enthusiast to understand the principles and operation of the types of radio and television receiving equipment found in our homes to-day.

Major changes in recent years, such as stereophonic sound and colour television, the changeover to the use of semiconductor devices such as the transistor, the use of new constructional techniques such as printed circuitry, the use of higher frequencies for broadcasting and frequency modulation, and a great deal of development to provide improved performance in the fields of materials and components, have made many existing introductory books on the subject obsolete; hence the need to look at the subject afresh, providing an explanatory text that fully takes into account from the outset the major advances that have occurred.

The book is designed to give the reader an up-to-date overall understanding of the principles and practice of radio and television reception.

## CONTENTS

*Fundamentals, Electric Currents, Alternating Current, Radio Waves, Radio and Television Components, Transducers, Circuit Diagrams and Printed Circuits, Valves, Semiconductors, Valve Amplifiers, Transistor Amplifiers, Radio Receivers, Frequency Modulation Receivers, Power Supplies, Stereo Sound Systems, Short-Wave Radio, Principles of Television, Television Receivers: Receiver Sections, Television Receivers: Timebases, Colour Television, Tape Recorders, Aerials.*

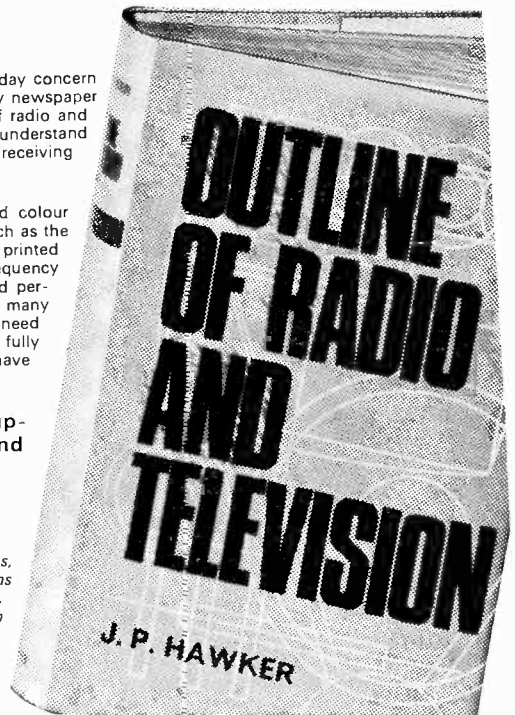

**408 pages  
Over 300  
diagrams  
including  
numerous  
circuits  
ONLY 30s.**

**Buy this book NOW at your bookseller, W. H. Smith, Boots, Wyman or Menzies branches—  
or fill in and post coupon below—**

To: Odhams Books, Dept. SAC 126  
Basted, Sevenoaks, Kent.  
Please send me . . . copy/ies of OUTLINE OF RADIO & TELEVISION  
30/- (32s. 6d. by post)

Name .....

Address .....

I enclose remittance of £ : s. d.

Published by  
**NEWNES**