

97 June

PRACTICAL MECHANICS AND SCIENCE

FEB 1963

2/-



SCALE MODEL
COASTAL MOTOR BOAT

Also Inside

SIMPLE BRAKE TESTING
FIBREGLASS TELESCOPE TUBE
WEATHER FORECASTING BY SATELLITE

SAVE MONEY AND
ENJOY YOURSELF



BUILDING ANY
OF OUR MODELS

Even if you are an absolute beginner,
you can build any Heathkit model!

We guarantee that NO electronic or soldering experience is necessary. Our simple well illustrated manual guides you step-by-step.



S-33

6 W. STEREO AMPLIFIER. Model S-33. A versatile, high-quality, self-contained STEREO/MONAUROAL Amplifier. 3 watts per channel. 0.3% Distortion at 2.5 w. per Channel. Inputs for Radio (or Tape). Gram ... £13.7.6

AUDIO SIGNAL GENERATOR. Model AG-9U. 10 c/s-100 kc/s, switch selected. Distortion less than 0.1%. 10 v. sine wave output metered in volts and dB's ... £21.9.6

VALVE VOLTMETER. Model V-7A. Measures volts to 1,500 (D.C. and R.M.S.) and 4,000 pk to pk. Res. 0.1Ω-1,000 MΩ. D.C. impedance. 11 MΩ, with test prods, leads and standardising battery ... £13.18.6

TELEPHONE AMPLIFIER. Model TTA-1. "Free-hand" operation; portable and self-contained. 9 v. battery. Elegant ivory-toned cabinet ... £7.9.6

5in. OSCILLOSCOPE. Model 0-12U. Wideband amplifiers ideal for TV servicing. F.M. alignment, etc. Vertical frequency response 3 c/s-5 Mc/s without extra switching. T/B covers 10 c/s to 500 kc/s. ... £38.10.0

PORTABLE SERVICE SCOPE. Model OS-1. A compact, portable oscilloscope, ideal for servicing and general laboratory work. Uses printed board circuitry. 2½in. CRT. Size 5 x 8 x 14½in. long. £19.19.0

SHORTWAVE TRANSISTOR PORTABLE. Model RSW-1. Two short bands, trawler and medium. £19.17.6

SINGLE CHANNEL AMPLIFIER. Model MA-12. 10-12 watt Hi-Fi amplifier. Extremely low distortion and wide frequency range ... £11.9.6

HI-FI AM/FM TUNER. Model S.99. Tuning range: FM:83-103 Mc/s. AM: 16-50, 200-550, 900-2,000 m. Tuning heart (£4.13.6 incl. P.T.) and I.F. Amplifier (£20.13.0) sold separately. Printed circuit board ... Total £25.6.6

HI-FI 18W STEREO AMPLIFIER. Model S.97. 9 w. per channel. Ganged controls. Stereo/Monaural. Gram, Radio, and Tape Recorder inputs. Push-button selection. Grey metal cabinet. Printed circuit construction ... £27.19.6

TAPE RECORDING/PLAYBACK AMPLIFIER
Stereo (TA-15) £24.10.0 Monaural (TA-1M) £19.2.6

6-TRANSISTOR PORTABLE Model UXR-1. Pre-aligned I.F. Transformer, printed circuit and a 7 x 4in. high flux speaker. Covers both Med. and Long Wavebands. Has attractive leather case with gold relief. Can be assembled in 4 to 6 hours ... £12.11.0



UXR-1

THE "MOHICAN" GENERAL COVERAGE RECEIVER, Model GC-1U. Fully Transistorised. Frequency coverage. 580 kc/s min., 30 Mc/s max., in 5 bands ... £39.17.6

AMATEUR TRANSMITTER. Model DX-40U. From 80-10 M. Crystal controlled. Power input 75 W. C.W., 60 W. peak, controlled carrier, phone. Output 40 W. to aerial ... £33.19.0

SINGLE SIDE BAND ADAPTOR. Model SB-10U. May be used with most A.M. Transmitters with certain provisions ... £39.5.0

HI-FI F.M. TUNER. Model FM-4U. Available in two units which for your convenience are sold separately. Tuner unit, FMT-4U £2.15.0. Amplifier and P.S. FMA-4U £12.6.0. ... Total £15.1.0

ELECTRONIC WORKSHOP KIT. Model EW-1. Will help your child to understand electronics, by making at least 20 exciting experiments, including Transistor Radios, Intercom, Burglar Alarm, etc. £7.13.6

VARIABLE FREQUENCY OSCILLATOR. Model VF-1U. Calibrated 160-10 m. Output on 160 and 40 m. ... £11.17.6

TRANSISTOR INTERCOM. Models XI-1U and XI-R-1U. Ideal for office or home. Each Master operates up to 5 remotes. 9 v. battery operated.

Model XI-1U (Master) ... £10.19.6
Model XI-R-1U (Remote) ... £4.7.6

HI-FI SPEAKER SYSTEM. Model SSU-1. Easily assembled. Twin speakers and balance control in a ducted port reflex cabinet, suitable for STEREO or MONO. (Legs 14/6 optional extra). ... £10.17.6

STEREO CONTROL UNIT USC-1. Luxury model with inputs to suit any pick-up ... £19.10.0



TTA-1



0-12U



S-99



AM/FM Tuner



TA-IS



MALVERN

Assembled models also available — prices on request.
Deferred terms available over £10. Free Delivery U.K.

HI-FI EQUIPMENT CABINETS. Range available to meet various needs. Details on request. (MALVERN equipment cabinet illustrated on the left) from £11.12.6 to £18.10.0.

STEREO HEAD PREAMPLIFIER USP-1. Ideal for boosting tape-head output and low output pick-ups (e.g. Decca ffs) £7.7.6

AUDIO & DO-IT-YOURSELF accessories also available

"COTSWOLD" HI-FI SPEAKER SYSTEM. Acoustically designed enclosure "in the white" 26 x 23 x 15½in. 12in. bass speaker with 2in. speech coil, elliptical middle speaker. Complete with cross-over unit, level control, etc.

COTSWOLD MFS SPEAKER SPEAKER. A minimum floor space model. Size: 36in. high x 16½in. wide x 14½in. deep, with performance similar to the standard model. Specially designed for small rooms. Either model ... £23.4.0



COTSWOLD

FREE BRITISH HEATHKIT CATALOGUE

Please send me FREE CATALOGUE (Yes/No)
Full details of model(s)
NAME
ADDRESS

PM-2

DAYSTROM LTD.

Dept. PM.2, GLOUCESTER, ENGLAND

A member of the Daystrom Group, manufacturers of the
WORLD'S LARGEST-SELLING ELECTRONIC KITS



**IN THE DARK
ABOUT
DEVELOPING?**

It is much easier than you think to develop your own films and this new UNIVERSAL tank from Johnsons makes it easier still. You only have to load the film in the dark, the rest of the job—developing, fixing and washing—is carried out in the light. Everything has been designed for ease of manipulation and the tank is adjustable for several widths of film—120/620, 127, 35 mm./828 or 16 mm. (6 feet.) With fully illustrated instruction book. At your dealers' now, 32/6.

**JOHNSONS
OF HENDON LTD**

English of Brentwood for the finest Telescopes

- List No. T.10 **The FAMOUS SCOUT MK. II.** 25 x 50. Three draw light-weight, only 2 1/2 lbs. Superb object glass made for government regardless of cost puts this scope in a class of its own. A collector's piece. All brass, leather covered, with case and sling. 2" dia. O.G. Mint condition. 29 ea. Used from 26.10.0.
- T.17 **50X or 75X eyepieces** to fit above 50/- ea. extra. 3 ft. tripods to fit. New 15/- ea.
- T.17 **Ross 20 x 75. Elbow type. Built-in filters.** Near New. 212 ea.
- T.19 **7 x 50. C.T.S. Elbow. Bloomed, lightweight, lever focus.** with neutral filter. New and boxed. Definition and brilliance out of this world. The finest 7 x 50 we have yet seen regardless of price. Only 25 ea.
- T.18 **7 x 50 C.T.S. Screw focus, unbloomed.** 23.15.0. New.
- T.3 **VARIABLE POWER TELESCOPE. 7-21X. ZOOM ACTION.** As specified in A.C.W. for long range bird photography with cine cameras. Weight 10 lbs., length 30". As new and in fitted hardwood case with lock and key. 26.10.0 ea. Used from 24.10.0.
- T.5 **As above but 5-15X angle type. 2" O.G. Length 28". Weight 13 lbs.** As new in fitted case, 25 ea. Used from 23.15.0.
- T.1 **6" PARABOLIC REFLECTING TELESCOPE. 48" focus. 80-400X. Infinitely variable. Complete on equatorial or altazimuth mounting with circles and geared drives, 255 ea. EX-WORKS. Also available in Kit form or sep. parts. Plans 2/- ea., with full parts list.**
- T.25 **FINDER TELESCOPE. 6 x 30. Astro type. Fixed focus. (incl. O.G.) with or without crosshairs. Grak. 45/- ea.**
- P.2 **PROJECTOR KIT.** For 35mm (2 x 2"). Triple condenser in mounts. 4" lens in push focus mounts. Uses 100w 20v lamp. Gives 3-ft. picture at 8 ft. We guarantee this kit when made up as per our plans, to give results equal to if not better than any other projector up to 300 watts and costing up to 225. This applies to brilliance of image, evenness of illumination, definition from centre to far corners, low heating of slides, and correct colour rendering due to the fact that no heat filter is required and lenses throughout are best quality white glass and last but not least "It is properly designed". Optics only in mounts, 87/6. Plans for above and 5 other types with full parts list 2/- ea.
- Booklets, "How to use Ex-Govt. Lenses and Prisms", Nos. 1 and 2, 2/6 ea. Lists Free for S.A.E.
- FOR OPTICAL EQUIPMENT DESIGNED BY EXPERTS AT PRICES YOU CAN AFFORD. CONSULT**
- H. W. ENGLISH, 469 RAYLEIGH ROAD, HUTTON, BRENTWOOD, ESSEX. Brent. 1685.**



M&W

Screwdrivers

* PRECISION BUILT FOR CRAFTSMEN

Manufactured to exacting standards by Moore & Wright (Sheffield) Ltd, world famous for precision and hand tools.

WRITE FOR OUR LEAFLET NOW

Please send me details of your SCREWDRIVERS.

NAME _____

ADDRESS _____

MOORE & WRIGHT (Sheffield) LTD.
Handsworth Road, Sheffield, 13.

AW68 PM

VALUABLE NEW HANDBOOK FREE TO AMBITIOUS ENGINEERS

Have you had *your* copy of "Engineering Opportunities"?

The new edition of "ENGINEERING OPPORTUNITIES" is now available—without charge—to all who are anxious for a worthwhile post in Engineering. Frank, informative and completely up to date, the new "ENGINEERING OPPORTUNITIES" should be in the hands of every person engaged in any branch of the Engineering industry, irrespective of age, experience or training.

We definitely Guarantee
"NO PASS—NO FEE"

This remarkable book gives details of examinations and courses in every branch of Engineering, Building, etc., outlines the openings available and describes our Special Appointments Department.

**WHICH OF THESE IS
YOUR PET SUBJECT?**

MECH. ENGINEERING
Gen. Mech. Eng.—Maintenance Eng.—Diesel Eng.—Press Tool Design—Sheet Metal Work—Welding—Eng. Pattern Making—Inspection—Draughtsmanship—Metallurgy—Production Eng.

RADIO ENGINEERING
General Radio—Radio & TV Servicing—TV Eng.—Telecommunications—Electronics—Sound Recording—Automation—Practical Radio—Radio Amateurs' Exam.

CIVIL ENGINEERING
General Civil Eng.—Municipal Eng.—Structural Eng.—Sanitary Eng.—Road Eng.—Hydraulics—Mining—Water Supply—Petroleum Tech.

ELEC. ENGINEERING
General Electrical Eng.—Installations—Draughtsmanship—Illuminating Eng.—Refrigeration—Elem. Elec. Science—Elec. Supply—Mining Elec. Eng.

AUTO ENGINEERING
General Auto. Eng.—Auto. Maintenance—Repair—Auto. Diesel Maintenance—Auto. Electrical Equipment—Garage Management.

BUILDING
General Building—Heating & Ventilation—Plumbing—Architecture—Carpentry—Painting—Decorating—Specifications & Quantities—Surveying—Architectural Draughtsmanship.

WE HAVE A WIDE RANGE OF COURSES IN OTHER SUBJECTS INCLUDING CHEMICAL ENG., AERO ENG., MANAGEMENT, INSTRUMENT TECHNOLOGY WORK STUDY, MATHEMATICS, ETC.

Which qualification would increase your earning power?
A.M.I.Mech.E., A.M.S.E., A.M.I.C.E., A.M.Brit.I.R.E., A.F.R.Ae.S., B.Sc., A.M.I.P.E., A.M.I.M.I., A.R.I.B.A., A.I.O.B., A.M.I.Chem.E., A.R.I.C.S., M.R.S.H., A.M.I.E.D., A.M.Mun.E., CITY & GUILDS, GEN. CERT. OF EDUCATION, ETC.

BRITISH INSTITUTE OF ENGINEERING TECHNOLOGY
410A COLLEGE HOUSE, 29-31 WRIGHT'S LANE, W.8

THIS BOOK TELLS YOU

- ★ HOW to get a better paid, more interesting job.
- ★ HOW to qualify for rapid promotion.
- ★ HOW to put some letters after your name and become a "key-man" . . . quickly and easily.
- ★ HOW to benefit from our free Advisory and Appointments Depts.
- ★ HOW you can take advantage of the chances you are now missing.
- ★ HOW, irrespective of your age, education or experience, YOU can succeed in any branch of Engineering.

156 PAGES OF EXPERT
CAREER - GUIDANCE



You are bound to benefit from reading "ENGINEERING OPPORTUNITIES," and if you are earning less than £25 a week you should send for your copy now—FREE and without obligation.

POST NOW!

TO B.I.E.T., 410A, COLLEGE HOUSE, 29-31 WRIGHT'S LANE, W.8.

2yd. stamp if posted in an unsealed envelope.

Please send me a FREE copy of "ENGINEERING OPPORTUNITIES." I am interested in (state subject, exam., or career).

NAME _____

ADDRESS _____

WRITE IF YOU PREFER NOT TO CUT THIS PAGE

THE B.I.E.T. IS THE LEADING INSTITUTE OF ITS KIND IN THE WORLD

PRACTICAL MECHANICS AND SCIENCE

Vol. XXX

February, 1963

No. 346

TALKING POINT

Editorial and Advertisement
Offices
"PRACTICAL MECHANICS
AND SCIENCE"

George Newnes Ltd., Tower
House, Southampton Street,
Strand, W.C.2.

© George Newnes Ltd., 1963

Phone: Temple Bar 4363

Telegrams:

Newnes, Rand, London

SUBSCRIPTION RATES

including postage for one year

Inland - - - £1 8s. per annum
Abroad - - - £1 6s. 6d. per annum
Canada - - - £1 5s. per annum

Copyright in all drawings, photographs and articles published in "Practical Mechanics and Science" is specially reserved throughout the countries signatory to the Berne Convention and the U.S.A. Reproduction or imitations of any of these are therefore expressly forbidden.

CONTENTS

Talking point	195
The fastest man on wheels ...	196
Lathe gadgets	198
Anti-turbulence coatings ...	200
A drill powered lathe	202
Simple brake testing	204
The Gozunda	207
Picture news from the world of science	208
A fibreglass telescope tube ...	210
Weather forecasting by satellite	212
Model Thornycroft coastal motor boat	214
Ultra close-up device	219
Test your knowledge	221
An illuminated address	223
Four bronze horses have cancer	224
Make your own button dies ...	225
Earthquake-proof flats	226
Choosing the right motor	227
Trade news	230
Making small mouldings	231
Lawn aerator and garden roller	233
How to mark out clock dials ...	236
A new method of model control	238

CONTRIBUTIONS

The Editor will be pleased to consider articles of a practical nature suitable for publication in "Practical Mechanics and Science". Such articles should be written on one side of the paper only, and should include the name and address of the sender. Whilst the Editor does not hold himself responsible for manuscripts, every effort will be made to return them if a stamped and addressed envelope is enclosed. All correspondence intended for the Editor, should be addressed: The Editor, "Practical Mechanics and Science", George Newnes, Ltd., Tower House, Southampton Street, Strand, London, W.C.2.

New magnetic coils

SCIENTISTS have discovered a way to create extremely strong magnetic fields while using a very small amount of electrical power. The discovery makes possible the development of powerful magnetic coils which operate at super-cold temperatures.

This development, originated at the U.S. Bell Telephone laboratories, is significant in its possibilities for improving the operation of some electron tubes, and other electronic devices, such as those used in ultra-high frequency radio relay systems. It may extend their use to extremely high frequencies. It may also make practical many new devices requiring high magnetic fields.

The discovery has encouraged scientists' dreams of harnessing nuclear fusion to peaceful purposes by providing a way to create the necessary strong magnetic fields. Nuclear fusion is the source of energy of the H-bomb, and experts in the field of nuclear energy have expressed enthusiasm.

The current through the new superconducting magnetic coils will be started with small amounts of electrical power, and once the coil is energised, current will continue to flow without any power at all. Any coil of wire acts like a magnet when it carries an electric current. Such a device is called a solenoid. Coiled around a metal core, it becomes the familiar electromagnet that is used to ring a telephone bell.

In the field of thermo-nuclear physics, large electromagnets have been used by scientists in attempts to control fusion, which is the source of power in the sun, as well as in the H-bomb. Most experiments have used extremely high magnetic fields to contain high-speed atomic particles in a magnetic "bottle". Unfortunately, some scientists have estimated that the input power needed to create a successful magnetic "bottle", with conventional electromagnets, would exceed the power output of the fusion that they seek to obtain, unless the machines were enormous.

The new material will permit the construction of a solenoid which has a volume large enough for fusion experiments, and which can produce the high fields necessary. The solenoid requires little electrical power because it is made of a material that becomes a "superconductor" at very low temperatures. Superconductors are material whose behaviour alters sharply at temperatures near "absolute zero" (-459.6 °F). They show no resistance to electricity. And once an electrical current is started in a superconducting circuit, it can continue to flow indefinitely. Compared with the tons of power-supply equipment now associated with large electromagnets, for the new magnetic coils it will be small—perhaps a few hundred pounds.

The Luton Major

Readers are familiar with the series of articles we published from September 1959 to August 1960 on building a small light aircraft called "The Luton Minor".

We are now planning a further series on a two-seater development of this machine, "The Luton Major", and it is hoped to commence publication within the next two months.

The aircraft was designed by Phoenix Aircraft Ltd., and many have already been successfully built and flown by amateurs.

The Editor would be interested to hear from readers who have had previous experience with this type of project.



The Fastest Man on Wheels

By Donald S. Fraser

MICKEY THOMPSON—America's fastest man on wheels and chief rival to our own Donald Campbell—has retired from the contest. He wrote his resignation in records as he bowed out of speed driving last summer.

Thompson, who drove his four-engine Challenger 1 at 406.6 m.p.h. on the Bonneville Salt Flats in 1960 for the fastest measured mile in history, brought the sleek blue car back in the hope of making the two-way run required to break the official world land speed record.

Rough salt at one end of the approximately 11-mile course shattered that dream, but Thompson took a 1962 Pontiac to etch out an impressive list of new stock car records in the sizzling salt desert. The 33-year-old speedster used two arenas for his assaults on the stock car marks. One was the same straight course where he had intended to run Challenger 1. The other was a 10 mile circle.

In two days, on the two courses, he claimed just about every record available to the stock car. But just as it snatched the world land speed record from his grasp two years ago, mechanical trouble stopped him short of his ultimate stock car goal—1,000 miles on the circular track.

In 1960, after he piloted the Challenger through the traps at 406.6 m.p.h., a broken drive shaft kept him from making the return trip needed to topple the land speed record of 394.2 m.p.h. set by the late John Cobb in 1947. Last summer, an oil leak halted the Pontiac after 76 laps, 240 miles short of 1,000 miles, and 12 minutes short of a six-hour

record set earlier. Even to the most casual of spectators, the long grind around the circular track had its thrilling moments. On several miles of the circle, the salt was quite wet, causing the car to drift sideways with spectacular twin sprays of white spinning off the rear wheels.

Thompson's last decision against opening up the Challenger for another attempt at the land speed record was a reluctant one. Inspecting the course and noting that the first 2½ miles were cracked and rough, he asked Bonneville officials whether the stretch could be put in shape. The consensus was that only an extended period of watering and then waiting for the salt to dry out again could improve the course. They said the process might take weeks. An alternative course was considered, but one end of it was too wet. In either case, Thompson did not have the distance he needed to accelerate and bring the car to a safe stop. And so, he finally announced that he would retire without making another attempt for the world record that had eluded him.

To demonstrate how the cracks, even at low speeds, made his Challenger 1 bounce, he permitted several newsmen to steer it while the vehicle was pushed over the course at about 35 m.p.h.

With no shock absorbers on the Challenger, the jolting was terrific. The car literally bounced off the salt. To a man, the guest "drivers" agreed the first part of the course was no place for speeds in the 400 m.p.h. range.

If Thompson sticks to his decision to retire, it

may well be the end of an era for piston-driven cars in quest of the land speed record, as far as America is concerned. The jet age has begun on the salt as well as the sky. Last August, Mr. N. Ostrich attempted to break the land speed record with a jet-powered car. However, at a speed of 320 m.p.h. he lost a wheel. A three-wheeled, jet-powered car is also scheduled to attempt to break the record, and doubtless, there may be others.

For his final attempt, Thompson had planned to use a Jato rocket—usually attached to planes for a quicker take-off—mounted on the rear of the Challenger. “The fascinating thing about the Jato”, Mr. Thompson said, “is that once I push that button, I’ve got 15 to 18 seconds of rocket whether I want it or not”. He planned to “push that button” about a mile and a half before hitting the measured mile, calculating that the rocket assistance would last just past the finish line and quit in time for him to stop by drag chutes while there was still solid salt under his wheels.

The Challenger has four Pontiac engines which produce approximately 3,200 American horsepower. Each has a 430 cubic inch displacement. Each engine drives a 21in. magnesium wheel, carrying a 30in. tyre specially designed by Goodyear for the car.

To qualify for the absolute land speed record, a car must be driven through a measured mile, in two directions within an hour. An average of the two runs is then taken.

It is, however, doubtful if a jet-powered vehicle, even if it broke the record, would be recognised. Motive power must be applied via the road wheels, according to the present rules and regulations.

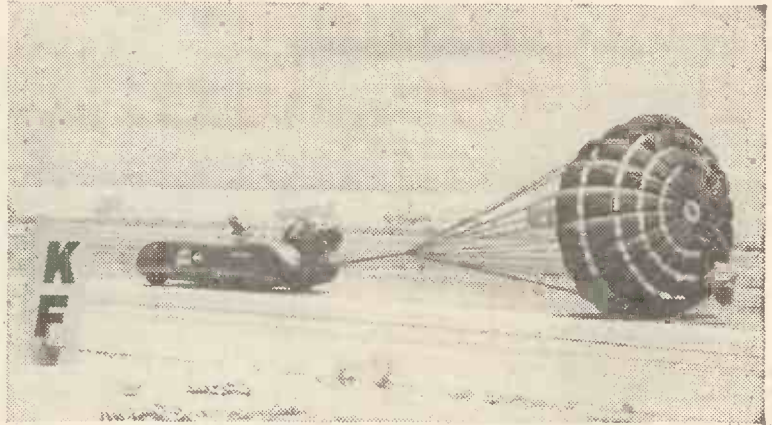

Mickey Thompson in “Attempt”, using a similar braking parachute to that which he intended using on “Challenger 1” at Bonneville Salt Flats.

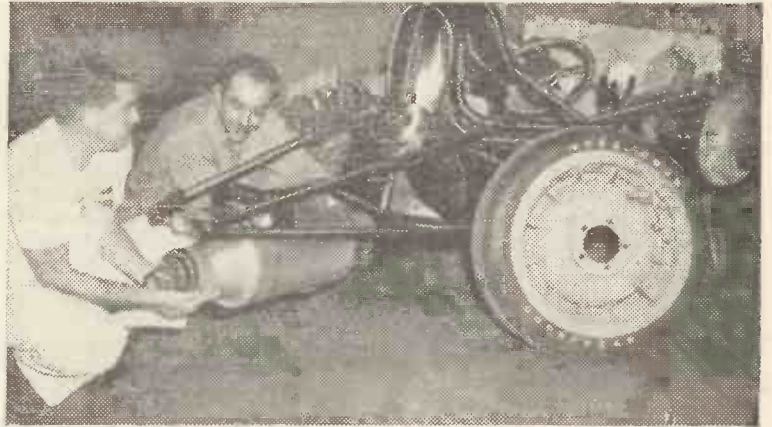

“The Bonneville Booster”. Mickey Thompson hoped to use this JATO rocket in his attempt on the world land speed record.



A tyre for “Challenger 1” being tested at a speed exceeding 500 m.p.h. Such tests are observed on this closed-circuit television screen.

LATHE GADGETS

Part 14 FILING REST

By L. C. MASON

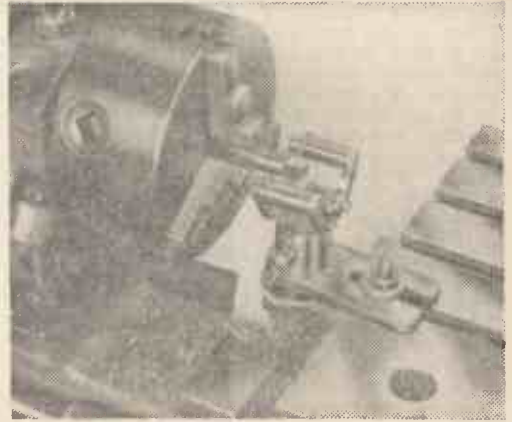

Filing a square on a shaft end.

FILING in the lathe as a means of obtaining the right size or finish is rather frowned on by the expert turner. However, filing a workpiece in the lathe to produce a different shape on part of it is as reasonable as filing in the vice. Hexagons for spanners, squares on shaft ends, or other flats, can all be produced accurately and truly flat by the aid of a filing rest without disturbing the job in the chuck.

The rest consists of a horseshoe-shaped cradle held in an adjustable mounting bolted to the cross slide. The cradle carries a pair of hardened rollers positioned either side of the job. The workpiece is filed down until the file rides on the rollers, which stops further cutting at that level and leaves a true flat, the size of the flat depending on the height setting of the rest. Regular hexagons and squares can be produced by using some sort of indexing gear on the mandrel, while a simple flat to mike measurements—as for a D-bit—can be filed by simply locking the mandrel.

The cradle is assembled on the top of a short screwed stem. This is free to slide vertically in a bored column and is keyed to prevent rotation. Its lower end is fitted with a captive wheel nut, so that turning the wheel raises or lowers the stem in its mounting.

The wheel is a convenient item to make first as, after tapping it $\frac{1}{2}$ in. B.S.F. (16 t.p.i.), it can be used as a gauge to produce a nicely fitting thread on the stem. The wheel is a plain turning job from a stub of $1\frac{1}{2}$ in. rod. Turn it with the collar side

outwards, drilling and tapping it whilst still in the chuck. Partially part it off before knurling the edge, which makes it easier to knurl only the narrow rim required. On completion of the knurling, part right off and face the parted surface if necessary.

The stem should be turned from $\frac{7}{8}$ in. square bar, the head end held in the four-jaw chuck and the other end supported on the tail centre. Screwcut the thread 16 t.p.i. to almost finished size and chase to finished size, using a die in the tailstock dieholder. Adjust the die to produce a smooth fit in the wheel nut. The $\frac{1}{4}$ in. wide keyway can be produced in a number of ways and in this case was actually cut with a Woodruff cutter with the job mounted in the machine vice on the cross slide.

The two cradle plates should be made from $\frac{1}{8}$ in. plate and the ones shown were bored together on the faceplate after roughing out for the sake of a neat finish on the inside edge. Clamp them together and drill all the holes 4 B.A. tapping size. Thread all the holes in one plate 4 B.A. Then open up to clearance size all those in the plate which will be nearest to the tailstock.

The rollers are plain turning and drilling jobs

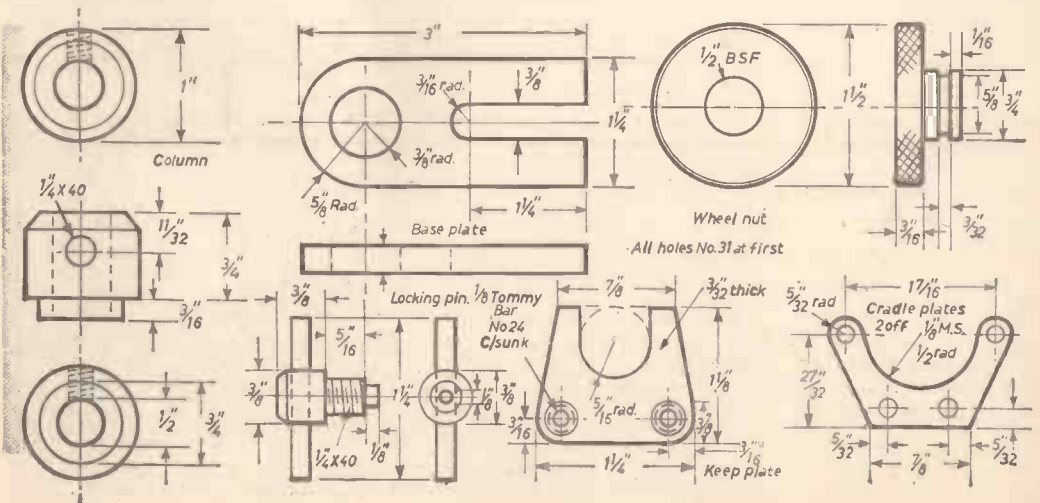

from silver steel rod. It will be seen that each has a small flange at one end. This end goes next to the chuck so that the side of the file can ride against the flange, thus positioning all the flats at the same distance along the job. When completed, harden the rollers dead hard and clean up the outside. The rollers should have brass or bronze bushes pressed into their bores, to run on the stationary pins, and these bushes should be turned with a thin flange at each end to take any end thrust produced when filing. This means that each roller has two flanged bushes, one pressed into each end, with a slight gap between the inner ends which helps lubrication. After pressing in the bushes run a reamer or D-bit through the pair in case the pressure has contracted them a trifle.

Turn up the roller bearing pins—mild steel will do—and assemble pins, plates and rollers as a complete cradle. Clamp this assembly on the square top of the stem and centre pop through the lower holes for the cradle mounting bolts. Drill the stem top and bolt the cradle to the stem.

Next to be made is the baseplate, which is a plain shaping and boring job from $\frac{1}{4}$ in. mild steel plate or strip. The column is another straight turning job. Bore the hole to a snug fit for the threaded stem. When turning the spigot to be a press fit in the base take tiny cuts off just the tip end when nearing finished size, to avoid accidentally turning the whole spigot too small. When the outer end will just jam tightly in the hole leave this as a "lead" and turn the rest of the spigot about 1 thou. larger. Drill and tap the hole for the locking pin $\frac{1}{4}$ in. x 40 t.p.i. The locking pin is a plain screwed plug and should be cross-drilled through the head to take a press-fit $\frac{1}{4}$ in. tommy bar. The other end should be reduced to $\frac{1}{4}$ in. diameter to fit the keyway in the stem. Make the $\frac{1}{4}$ in. diameter part slightly longer than the depth of the keyway so that on screwing the pin in, the pressure comes on the bottom of the keyway. This avoids bruising the threads on the threaded elevating stem.

Slip the cradle and stem assembly through the column, screw in the locking pin and lock the stem at about the mid-point of its travel. Offer up the spigot of the column to the hole in the baseplate and position the column to bring the rollers in line

with the edges of the baseplate. Without moving the column remove the stem assembly. Press the column into the base, squeezing it home in the vice, using soft packing such as scraps of copper or aluminium in the jaws.

The wheel keep plate should be filed up from $\frac{3}{32}$ in. steel strip. Do all the shaping and drilling while it is still part of the strip. Leave cutting it off till the very last operation, which makes it much easier to clamp to the baseplate when spotting through to mark the positions for the 4 B.A. securing-screw holes. Locate it so that the wheel is quite free to turn. Drill and tap the holes in the base, countersink the holes in the keep plate and lastly cut it to length and finish off the cut end and corners.

The filing rest should be mounted for use with an ordinary stud and T-nut in one cross-slide slot so that the wheel overhangs the edge of the cross slide far enough for easy operation. To file squares and hexagons it is best to first set the roller height so that the file doesn't quite take off enough; lowering it a fraction at a time till the right depth is reached. File two adjacent flats at each setting

(Continued on page 211)

Sub-assemblies comprising the filing rest.

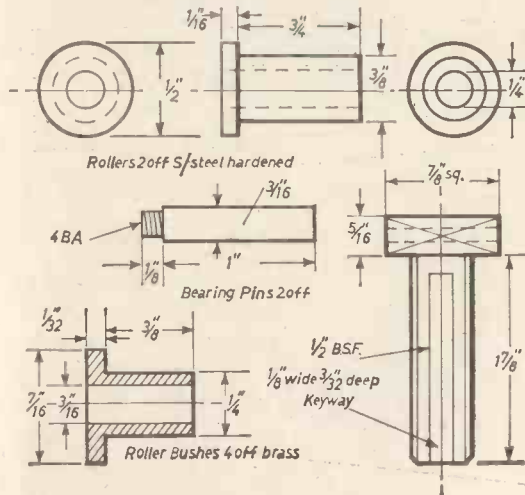
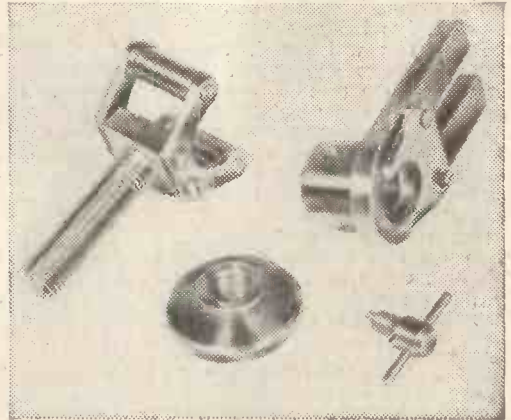

The assembled filing rest.

by our science correspondent

Anti-Turbulence Coatings

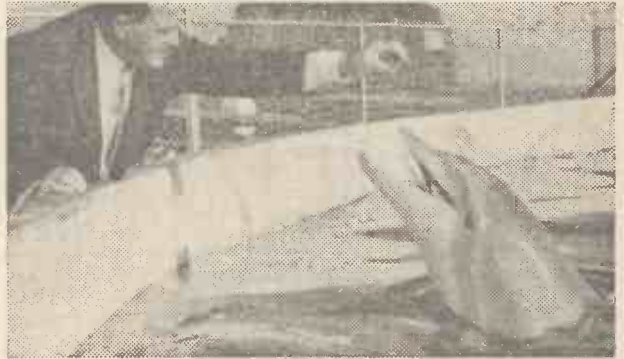

The abnormally high swimming speed of the porpoise has led to a revolutionary method of reducing the drag of boat hulls.

AN era of dramatic advances in water transportation may result from the ideas of a scientist who wondered why porpoises can swim so swiftly with so little apparent effort. This thought has led to the development of a rubber coating that will permit vessels to travel faster with no increase in power. Applied to an object, it reduces the turbulence normally created as the object moves through the water. Workers interested in boundary layer stabilisation, report that an object being propelled through the water, actually uses from 70% to 90% of the propulsive energy to overcome the drag due to turbulence created by the object itself. Any reduction of this turbulence thus reduces the power required for propulsion. The two main factors in achieving maximum speed through water have hitherto been the smoothness and shape of the object. These are now joined by the elimination of turbulence by damping.

Dr. Max O. Kramer, of Los Angeles, is the scientist and inventor of the coating, and is a leading authority on the theory of anti-turbulence, otherwise called "boundary layer stabilisation by distributed damping". He began his anti-turbulence research before World War II while he was heading the Aerodynamic Institute of the German Research Centre for Aeronautics near Berlin. Here he studied boundary layer stabilisation, using wind tunnels. He obtained the first German patent on high-speed drag reduction by damping, but was not satisfied with his test results. Following the war, he accepted an invitation to work for the U.S. Navy.

It was while on a sea voyage that Dr. Kramer happened to notice a school of porpoises passing the ship. Based on his observations and calculations, he came to the conclusion that the porpoise must have only about one-tenth the drag that would normally be expected from an animal of its size and

TURBULENT FLOW

Underwater object is slowed by Turbulence



LAMINAR FLOW

Porpoise eliminates Turbulent currents



SCHEMATIC VIEW OF LAMIFLO COATING

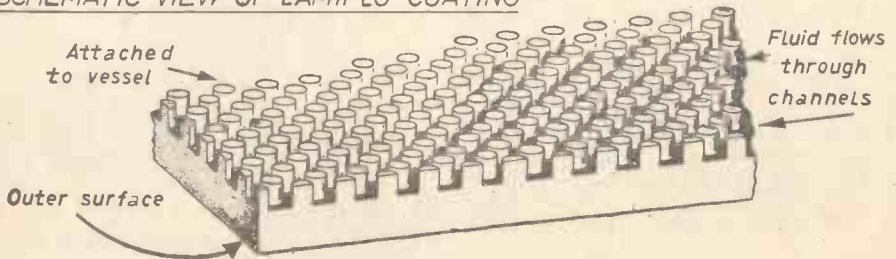



The new coating being tested by Dr. Kramer prior to trials in water.



Covered with the new coating, these test devices are used in underwater testing.

shape. He therefore concluded that turbulence could not form along the porpoise's body and that Nature had solved the problems of boundary layer stabilisation by distributed damping in some way. Eventually, he obtained samples of a porpoise's skin, and discovered that the porpoise is completely covered with a $\frac{1}{16}$ in. thick hydraulic skin that is both elastic and full of fluid ducts.

Dr. Kramer then joined forces with the U.S. Rubber Research Centre, together they experimented with many coatings to reproduce the porpoise's hydraulic layer of skin. The most practical development so far, is a thin layer of rubber supported by a multitude of tiny rubber pillars. The inter-connecting channels thus formed face the surface of the object. The outside, or water side, of the coating is smooth. The channels give the coating flexibility, and the liquid in the channels provides the necessary damping.

The United States Rubber Company believes this development will be as important to water

transportation as the pneumatic tyre now is to land transportation, and their technologists have actually developed coatings which can reduce drag by about 50% on underwater craft. They are now experimenting with the material on the hulls of motor boats, to determine how much effective power can be expected. They are much encouraged by the 50% reduction in drag obtained to date on completely submerged bodies, but are working toward the greater reduction that is theoretically possible. Streamlined test bodies, towed at the side of a small motorboat, have been utilised in experiments.

Vice Admiral Charles B. Momsen, retired Naval submarine expert, and co-developer of the Momsen lung escape apparatus, believes that submarine speeds of 60 knots should be possible with the development of a successful submarine "skin". With further improvement in power plants, he predicts, underwater objects might travel at speeds as fast as 180 knots (about 207 m.p.h.).

Preparing for a trial run with the torpedo-like test device alongside a high-speed motor launch.

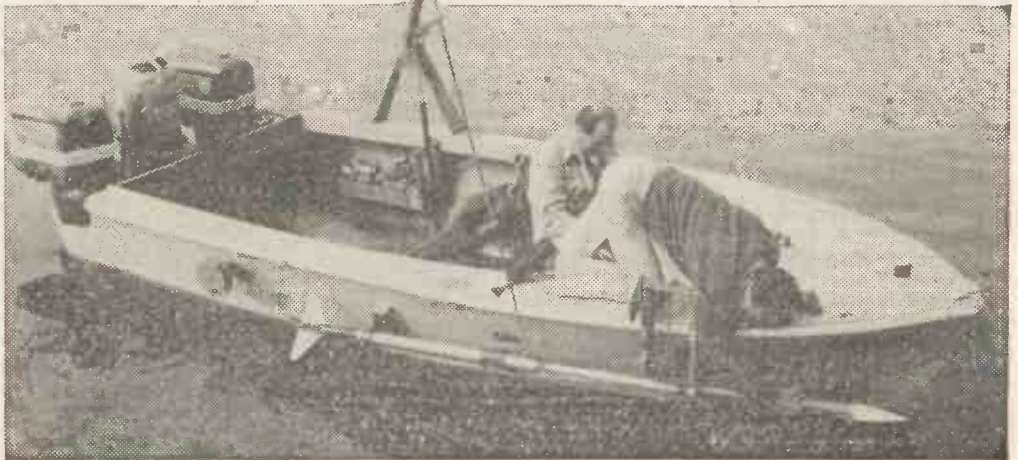

a **DRILL** powered **LATHE**

ANYONE having average mechanical ability and a few simple tools, including taps and dies, can make this lathe without difficulty. The material required is usually to be found in the handyman's workshop, and with a certain amount of care in fitting a reasonably accurate and serviceable tool will result.

The bed should be made from two 24in. lengths of steel angle measuring 1½in. across. These should

be filed and dressed flat along one side to serve as the lathe table. In the opposite flats a ¼in. diameter hole should be drilled 3in. from each end, through which bolts and nuts will be fitted when the wood feet are mounted. These should be made from hardwood about 2in. square and 12in. long. Mounting and fitting are shown in Fig. 1.

Once the base has been completed, a tailstock, also of hardwood, should be made as in Fig. 2, having a tight-fitting brass or steel bush with its centre 2½in. up from the lathe table. This bush is to take the tail spindle, which should be made from a piece of ¼in. round steel rod, threaded ½in. Whit. for ¾in. A ½in. Whit. nut should be screwed hard up to the end of the thread and the end of the rod filed to a dull point. Alternatively, if a hand or breast drill is available it should be mounted in the vice and the unthreaded end of the tailstock inserted

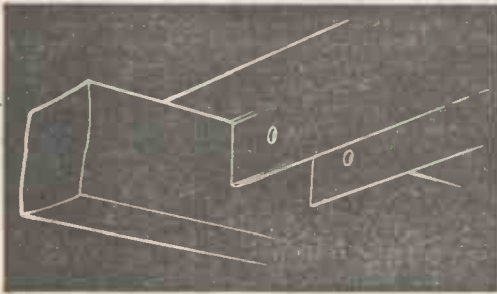

Fig. 1.

Fig. 3.

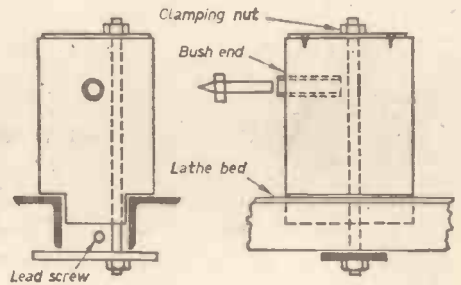
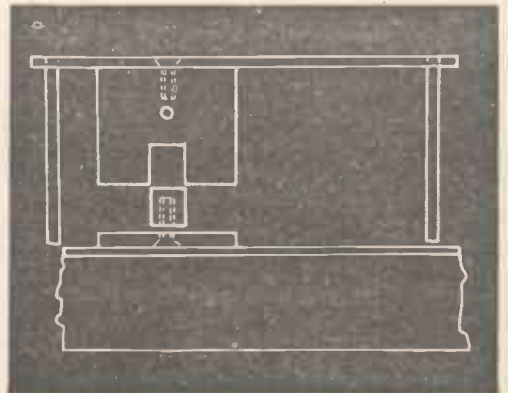
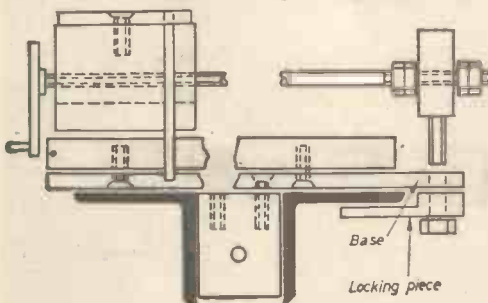

Fig. 2.

Fig. 4.



into the chuck. The point can then be shaped by hand with a file. A piece of thin sheet metal should be screwed to the top of the tailstock body as shown. The full details of the tailstock are shown in Fig. 2. It is essential that it is perfectly square with the bed and it should be checked for consistent centre height at all points of travel.

The tool post is the most difficult part to make, but care taken over the drilling and tapping will be repaid by an accurate machine. In the lathe which I built the gap between the angles is 1in. The gap takes a brass block attached to the tool-post base. I made it this size simply to fit a piece of brass I had. The block should be a good sliding fit between the angles for their full length, and should be drilled and tapped $\frac{1}{16}$ in. Whit. as shown. The base for the tool post, 1in. wide by $\frac{3}{4}$ in. thick steel bar, should be fitted to the block at right angles to the bed, with two countersunk bolts. At one end of the base a short length of $\frac{1}{2}$ in. square rod, filed round and threaded $\frac{1}{2}$ in. Whit. at one end, should be attached. The threaded portion must be long enough to pass through the hole in the base and into a locking piece as in Fig. 3. This is to prevent movement of the tool post when in use. The fit of the locking piece should be just tight enough to allow the post to be moved easily by hand along the bed without up or down play.

An exploded view of the tool post parts is given in Figs. 3 and 4. The feed screw should be 6in.

long, threaded for a little more than half its length at one end, and for about 1in. at the other. A $\frac{1}{16}$ in. Whit. thread is suitable although a B.S.F. thread will give a finer feed.

The lead screw should be made from $\frac{1}{2}$ in. round rod, 14in. long and threaded for nearly its full length. It should pass through the wood base at the tailstock end and through the threaded hole in the brass block between the angles (Fig. 5). It should be anchored in a similar fashion to the feed screw, by check nuts and washers.

The writer uses a Black and Decker drill to operate his lathe. This was mounted with two suitable bolts screwed into the body of the drill, which attach it to two upright brackets fitted to the bed. A shaped wooden block provides additional support underneath the drill.

For simplicity a right-handed thread has been specified for the cross-slide feed screw. As a result, clockwise movement of the handle *withdraws* the tool from the work. If left-handed taps and dies are available the use of these is to be preferred, to give a more normal action.

This lathe is not intended for heavy or precision turning, but is suitable for making soft brass and aluminium parts, and excellent for wood turning, although for the latter the feed screws will seldom be used. If average care is taken in its construction and assembly a useful addition to the workshop will be the reward.

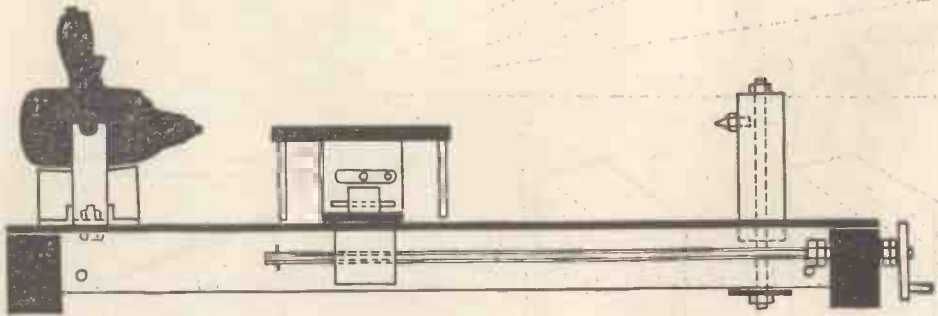

Fig. 5.

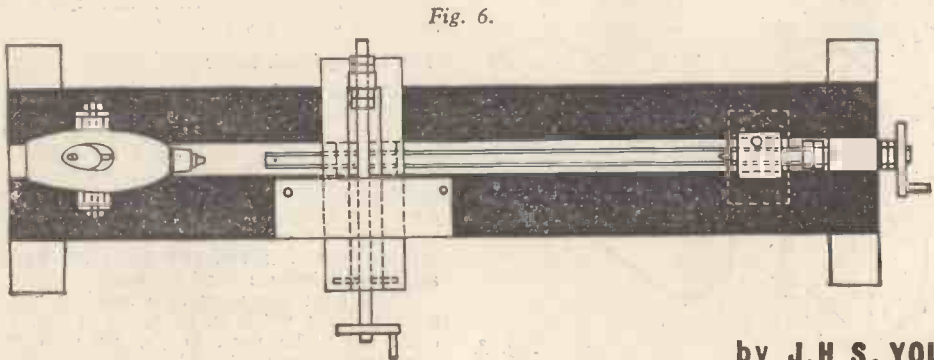

Fig. 6.

by J.H.S. YOUNG

Simple Brake Testing

described by E. V. King

MANY motorists do not realise how simple it is to test their brakes efficiently. In this article E. V. King gives our motorist readers some useful ideas and means for brake testing on their own vehicles.

Braking efficiency

If a stone is dropped it accelerates downwards at an acceleration (g) which will give it a speed of 22 m.p.h. in one second. This fact is used as the basis for comparing braking efficiencies. If a car travelling horizontally at this speed of 22 m.p.h. could be braked to a stop in one second the

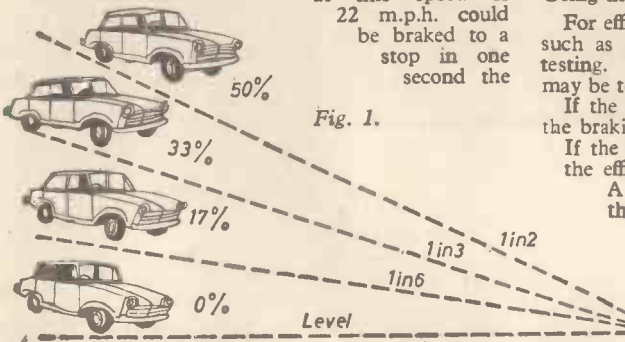

braking efficiency would be called 100%. Such braking is not possible on roads since no tyres will grip to this extent. Braking in excess of 100% is, however, quite possible on tracked vehicles such as rack and pinion mountain railways and in lifts and mine cages. At the time of writing the Government Motor-Vehicle Test requires the primary braking system of motor-cars to have a braking efficiency of not less than 50%, while the hand-brake must show an efficiency of at least 30%. Full details of the test requirements are obtainable from H.M. Stationery Office.

Using hills as a test

For efficiencies of less than about 50% a gradient such as a steep hill or drive-in may be used for testing. Thus handbrakes and motor-cycle brakes may be tested by reference to Fig. 1.

If the brakes will hold the car on a slope 1 in 2 the braking efficiency is $\frac{1}{2} \times 100$ —i.e., 50%.

If the brakes will only hold on a slope of 1 in 6 the efficiency is $\frac{1}{6} \times 100$ —i.e., 16%.

A spirit level and a ruler will soon give the gradient of a uniform slope (Fig. 2).

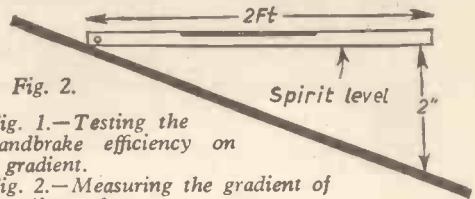

Fig. 1.—Testing the handbrake efficiency on a gradient.

Fig. 2.—Measuring the gradient of a uniform slope.

Fig. 3.—The top two falling block brake testers can be made in wood, concrete or any rigid material. The lower two show the use of a standard flat-faced building brick.

The falling block tester

Although the last test can give useful results, a dynamic test with the car in motion is generally preferable. A simple dynamic device which gives good results when used on a level road is the falling block type of tester. Even a standard solid building brick with flat sides will do. The weight does not matter. If such a block or brick is standing on a level surface in a car travelling at, say, 40 m.p.h., it will fall when the brakes are applied—if they are good enough.

The correct way to mark a building brick with sides of 2½, 4 and 8½ in. is shown in Fig. 3. The brick should be stood in the car with the face corresponding to the hoped-for efficiency across the

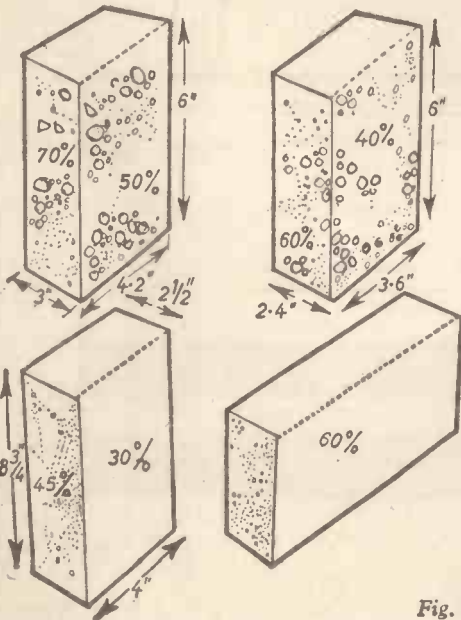

Fig. 3.

car. Note that the long edge should be vertical for 30% and horizontal for 60%. For convenience, position the brick so that the marked side faces backwards. It will then be visible on top when the brick falls. Drive the car along a straight and level road at about 40 m.p.h. and brake to about 10 m.p.h. (look in the mirror first!). The actual speeds are not important but do not brake to a complete stop as the brake shoes tend to grip the drums more fiercely just before the car stops and this will give an over-optimistic reading. Another point is that the nose of the car dips most at this time and this also upsets the reading. This applies equally when using the other types of tester described later in this article.



Fig. 4.—A ball and ramp brake tester. The ramp is a piece of bent curtain rail

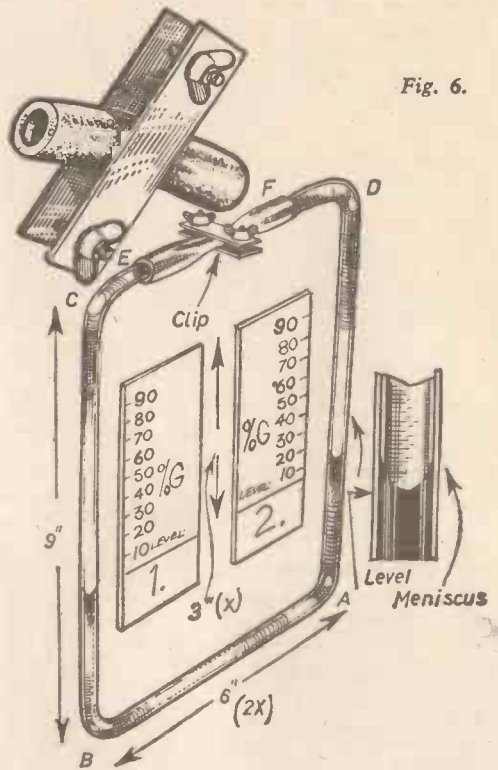

Fig. 6.

If the brick falls the brake efficiency is at least that on the marked face. If it does not fall, position the brick for a more realistic figure and repeat the test till it does fall from one position. If it doesn't fall in the 30% position drive home very carefully and get the tool kit out! The handbrake can be tested in the same way. A good handbrake should be capable of about 45% efficiency. If a suitable brick is not available make a block to the same dimensions in wood, concrete or indeed any rigid material. Alternatively a pair of blocks to the dimensions of Fig. 3 will give a wider range of values.

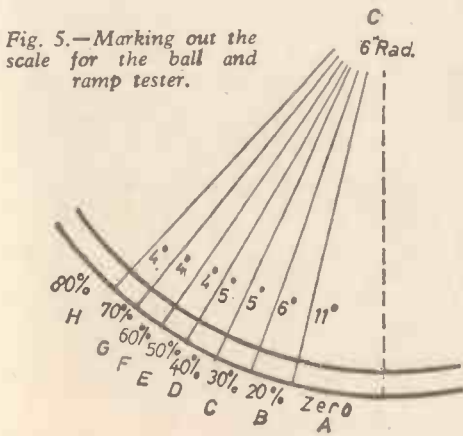

Fig. 5.—Marking out the scale for the ball and ramp tester.



Fig. 7.

The ball and ramp tester

To make this tester about 9in. of brass curtain rail should be carefully bent to a 6in. radius and mounted on a wooden stand as in Fig. 4. Place a large ball-bearing at the bottom of the ramp. When placed on a level car floor the ball will rise as the vehicle is braked. The degree of rise is dependent on the braking efficiency, which can be read off from a scale along the ramp. For those readers who are mathematicians we need only state that the efficiency is the tangent to the curve (i.e., the slope) at the particular point to which the ball rises. To help readers who are not able to work this out Fig. 5 gives details of how to mark out the scale using a protractor. Provided the latter is large this is the most accurate way of working, but it is also possible to use the following information (it will be useful as a check anyway): Zero sector A, $1\frac{1}{8}$ in. long; B, $\frac{3}{4}$ in.; C, $\frac{1}{8}$ in.; D, $\frac{1}{2}$ in.; E, $\frac{3}{4}$ in.; F, $\frac{1}{2}$ in.; G, $\frac{3}{4}$ in.; H, any length (you won't exceed 80%). The radius of the bend must be 6in. exactly.

This tester will measure within a few per cent, and any error will be on the "safe" side, i.e., the meter will under-read efficiencies slightly.

The U-tube brake meter

This is a most accurate type of meter, but it requires an observer to watch it with some degree of skill. The author describes one that he made for his own use, but readers could use plastic tube instead of glass and introduce other modifications to suit their needs. The instrument will be as accurate as the scale, and it should be easy to read efficiencies within 5%. It can in fact be as accurate as many very expensive instruments used by garages, if carefully made and used.



Fig. 8.—The U-tube brake tester in position.

Bend a 28in. length of $\frac{1}{4}$ in. bore soda-glass tubing (obtainable from most large chemists) to the shape of a rectangle as shown in Fig. 6. The bends should be made in the order A, B, C, D. It may be bent easily in the flame of a bunsen burner, gas poker, builder's blowlamp or large spirit burner, and less easily on an ordinary gas stove or butane burner of the picnic type. Where possible heat the glass first in a yellow flame, and then, while it is still hot hold it in a hotter blue flame, turning the glass all the time, until it feels soft. It is best to let the tube bend under its own weight. When the shape is correct cool it off for a minute or two in a yellow flame again. If the glass is not cooled slowly like this it will be brittle and may snap when fitting the rubber tube etc. Readers who have not done any glass bending should obtain some glass with which to practise in the first instance. The commonest fault is to overheat the glass so that the bend collapses. However it is not necessary to

Fig. 9.—The ball and socket clamp.



obtain rounded bends, and bends with "kinks" in them will do just as well in this instrument.

The tube should now be slightly less than half-filled with water, ink, or methylated spirit and dye. In the prototype I used water with green food dye as used for cake icing. The density of the liquid does not matter, but if water is used it must not be allowed to freeze in the winter. The gap E to F of Fig. 6 should now be bridged with a piece of rubber tubing.

The assembly should be mounted on a square of a non-warping board such as Weyroc, using small Terry clips (Fig. 7). A camera ball and socket tripod head should be fitted to the board at the rear (Fig. 9). A metal clip should then be attached to the ball and socket head so that the tester may be clipped over the window of the car being tested.

The general method of marking out the scale is shown in Fig. 6. If the gap between A and B is 6in. then half this (3in.) should be divided into 10 parts, each representing 10%. Two scales are required, one on each side, and they should be very carefully placed so that the zero line (LEVEL) is coincident with the bottom of the meniscus of the water in the tube (Fig. 6). From this you will see that the tester can in fact be made any size you like as long as the scale is half the length AB.

The fitting of a damper makes reading the instrument much easier and minimises small fluctuations in braking intensity. The average braking efficiency is thus recorded rather than the maximum peak efficiency. The damper (Fig. 6) takes the form of a metal clamp fitted with a wing nut and bolt which squashes up the rubber tube to a very fine bore which will only just allow air to move from tube CE to FD. The best setting will soon be found in use.

The tester should be used with the car on a level road. Fix it on a window (or other part of the car) with the tube AB in line with the motion of the car (Fig. 8). Drive the car at about 30 m.p.h. and brake to about 10 m.p.h. The liquid will rise to a steady maximum on one side of the tube, indicating the braking efficiency of the brakes being tested.

(Continued on page 229)



The Gozunda

By G. HAYDOCK

FOR some time British Railways have been using a hydraulically operated, rail-mounted, viaduct inspection unit which has slashed the cost of inspecting and maintaining bridges and viaducts. The contraption, known to railwaymen as a "Gozunda", was originally developed by the Civil Engineer's Department of the North-Eastern Region of British Railways in conjunction with Simon Engineering, Dudley, Ltd., and the Auto-Mower Engineering Co. Ltd.

The Simon Viaduct Inspection Unit enables inspections to be carried out on bridges and viaducts to a depth of 29ft below rail level and up to 15ft under the inside of the arches. Before it came into use such inspections had to be made with field glasses and could only indicate where more detailed inspection was needed. Where closer inspection had to be carried out it was necessary to erect scaffolding or undersling a cradle from the superstructure. To make a close inspection of a large bridge or viaduct the gear had to be dismantled and erected from span to span. The adoption of the inspection unit by the North-Eastern Region five years ago, and more recently by the London Midland Region, dispensed with this costly and laborious job. Mounted on a bogie-bolster wagon which is ballasted to give stability, the inspection unit can carry a load of 600lb on its inspection platform and operates without restriction to traffic on adjacent lines.

The inspection unit is made up of three parts, an "A" frame with a slewing gantry, an upper and a lower boom. In the centre of the "A" frame is a gate-type hinge mounted on 2½in. diameter bearings for slewing the gantry. The triangular cantilever frame of the gantry is 12ft 6in. long and

carries an operator's platform 2ft wide on each side of the main frame to give access to the "Gozunda's" inspection platform and to its duplicate controls. The slewing motion of the gantry platform is controlled by a lever operating a hydraulic ram which can rotate the gantry and booms through 180° to either side of the viaduct or bridge parapet. As well as the slewing control there are two levers on the gantry platform to operate the upper and lower booms which form the "arm" of the unit. The boom control lever valves, which raise and lower each boom, are of a type that can be used singly or together to provide independent or simultaneous action.

The upper boom is 21ft long with the "shoulder" end connected to the gantry unit, while the other end forms an "elbow" to carry the lower boom. A hydraulic ram controls the movements of the upper boom from a horizontal position through 85° in a downward direction. The movements of the 17ft-long lower boom are controlled by another hydraulic ram mounted beneath the upper boom. When the upper boom is in the lowest downward position the lower boom can travel 30° above, or 60° below, the horizontal. At the extremity of the lower boom is mounted the inspection platform. 7ft long by 2ft 10in. wide, it is capable of carrying two or three inspectors. The platform is always maintained in a horizontal position by a simple parallelogram system of levelling rods attached to the platform and running along the booms. To allow the inspection engineers on the platform to control all the movements of the unit, duplicate operating controls are fitted on the platform.

(Continued on page 234)

PICTURE NEWS

FROM THE WORLD OF SCIENCE

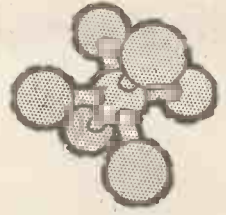

X-15 research airplane

AN unusual close-up rear view of the rocket-powered X-15 research aircraft. America's "fringe of space" accomplishments with this craft have been a classic example of a most effective method of conducting a research programme on flight at extreme speeds and altitudes. All original design goals have been reached.

The X-15, which is launched from a B52 carrier plane at varying altitudes around 45,000ft has already reached an altitude of 314,750ft and a top speed of 4,159 m.p.h. (Mach 6.09). The average burning time of the rocket engine is about 80 seconds, and actual flight time 11 to 12 minutes, during which period the craft covers 200 to 225 miles.

Salt of the sea

SCIENTISTS the world over are still working to find the perfect way to remove salt from sea water. In Australia however, there are no natural deposits of rock salt, so the reverse procedure is practised there. Their needs are salt, rather than water. On 5,000 acres of reclaimed mangrove swampland, 25 million tons of sea water are pumped through a series of evaporation ponds. From the final 430 acre crystallisation beds, nearly 400,000 tons of salt are harvested. The harvest begins in March each year, after months of dry, sunny weather. Two specially designed harvest machines move across the hardened salt. Each clears a swathe 14ft wide by means of large augers that break the 6in. thick salt bed into granular form for stacking. In one hour, each harvester can gather 850 tons.

The salt, which is for use in the Imperial Chemical Industries plant at Osborne, is then dissolved again in fresh water to produce saturated brine that is pumped six miles through a pipeline to the plant. The plant produces enough soda ash, bicarbonate of soda, and caustic soda to supply the entire Continent's industrial needs. None of this supply of salt reaches the dinner table, but produces ingredients for the manufacture of glass and soap powders that do reach the home.

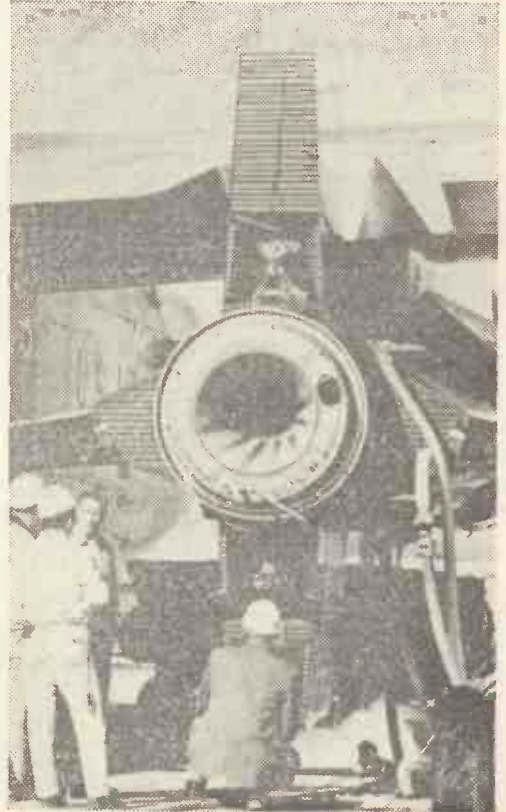



Frostbite in the summer?

NO, but a scientist testing plastic bags at a temperature of 20 degrees below zero. The bags are weighted with rice and then rolled over and over to test the bags' strength under conditions simulating the extremes of winter weather in North America, which could be encountered during shipping. At the Goodyear Tyre and Rubber Company's research laboratory in Akron, where this picture was taken, a year-round temperature of 20 degrees below zero is constantly kept. No wonder the scientist looks like an Eskimo!

Deceleration of re-entry space vehicles

COATED fabric balloons, which inflate in one-tenth of a second, have been developed for a high-altitude recovery system, designed to control deceleration of re-entry space vehicles. The spherical drag balloons are to be used to retard tumbling, and to control the speed of instrumented nose cones, manned escape capsules, and other orbital vehicles during re-entry through the "heat barrier" of the earth's upper atmosphere. A parachute is ejected at a lower altitude to complete the recovery.

Specially modified test missiles will evaluate the recovery system. One shot, will seek a velocity of Mach 2 at an altitude of 150,000ft, and a second firing of Mach 3 velocity will be made at 200,000ft. During tests, the 9ft balloon will be deployed and inflated behind the missile. Once the missile is stabilised, the balloon will be reeled out until it reaches the flow region which gives maximum drag. When the re-entry vehicle is slowed, the parachute will be ejected at a lower altitude to complete the recovery.

During recent wind tunnel tests of 25% scale models at two NASA facilities, the balloons were tested at simulated altitudes of 155,000ft and speeds approaching Mach 3.5.

According to reports, the tests simulated actual ejection, inflation and deployment of the drag balloon under high-speed flow conditions. The balloons proved to be perfectly stable in subsonic, transonic and supersonic flow conditions.



Dry box

THIS device, called a "Dry Box", allows scientists to experiment with chemicals requiring an absolutely dry and inert or sterile atmosphere. The air and moisture are extracted from the box through valves, and dry nitrogen is pumped in. Dried chemicals are placed in the small "lock", shown in the foreground of the illustration without its locking device. Then the atmosphere is withdrawn and replaced with nitrogen. The chemist, working through rubber glove ports, then opens the inside lock and transfers the chemicals into the box.





MAKING the tube for a large reflecting telescope can be quite a problem on its own. This complicated task can be considerably simplified using fibreglass cloth, an epoxy resin and a simple mould. The finished product will combine considerable strength with lightness, will be proof against the elements, will require no subsequent maintenance and will need no finishing other than trimming the ends.

The method consists of winding the glass cloth on a suitable former and impregnating it with an epoxy resin. After a period the resin sets hard, so bonding the glass cloth, whereupon the mould is removed, leaving a tube the required shape and size.

Materials

Glass cloth is made in a variety of widths and thicknesses, the thickness being referred to in thousandths of an inch. The thicker the cloth the fewer number of layers will be required for a given thickness. A suitable wall thickness for say a seven inch diameter tube, would be $\frac{1}{16}$ in., so that eight layers of 12 thou. cloth would be required.

The bonding resin is a thick viscous liquid which only sets after the addition of a "hardener", another liquid compound. The period required for setting varies with temperature and the type of resin, but may be anything up to a few days. This period can be very considerably reduced by the addition of small quantities of another compound, an "accelerator". The resin may thus be made to set in an hour or so, depending on the amount of accelerator added. Though the setting time can be further reduced, the resin becomes unworkable that much more quickly. It is better to choose a longer curing time, thus giving the resin a longer working life. Manufacturers supply tables with their resins,

A FIBREGLASS TELESCOPE TUBE

By LESLIE HUGGARD B.Sc.

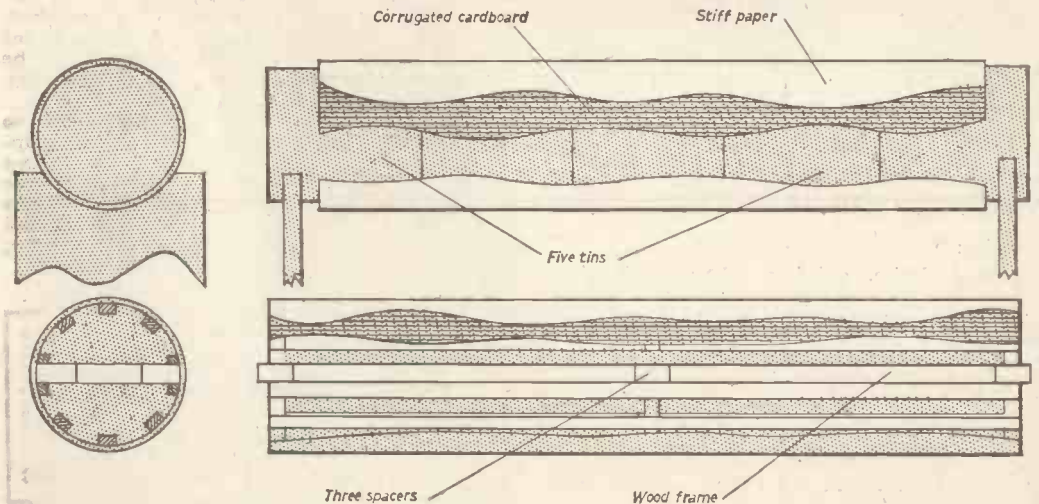

giving the proportions of hardener to be used and the amount of accelerator to be added to achieve different setting times. Sometimes the hardener and accelerator are combined as a single liquid. The resin may be coloured with special pigments, the resulting colour being permanent though some resins tend to darken with age.

Epoxy resins bond firmly to practically anything, so that the mould must be covered with a release agent to allow its removal after curing. Silicone floor polish liberally applied works well, but leaves a poor finish on the job as it is difficult to spread the resin evenly over it. A proprietary brand of release agent, such as "blue mould release" is much better. It can be thinned with methylated spirits and painted on, drying rapidly to leave a thin plastic skin to which the resin will not bond.

When working with resin and glass cloth, it is advisable to wear very old overalls, rubber boots and plastic gloves, since hardened resin is almost impossible to remove, and the glass cloth and resin can cause serious irritation or even dermatitis. The resin should be worked into the glass cloth with an old, stiff paint brush, which can be discarded afterwards without loss, as it may be impossible to clean. Cellulose thinners can be used to clean off unhardened resin in the event of an accident, though the result will not be very satisfactory.

The mould

Two types of mould which can be simply made are shown in the drawings. In each case the mould should be some inches longer than the required finished length of the tube.

The first simply consists of five empty tins of the required diameter, round which a tube of corrugated cardboard should be tightly rolled. This should be covered with a layer of thin cardboard or thick paper. This final covering forms the finished surface of the mould and should therefore be free from wrinkles and creases which, if present, show up on the finished surface of the tube. The finished outside diameter of the mould should be equal to the required inner diameter of the tube. The end tins should rest in V blocks so that the whole mould can be rotated. Finally the mould surface should be given a coating of prepared resin, with enough accelerator to ensure a quick setting time. When this has set hard the surface should be lightly rubbed down with glasspaper. The mould then has a smooth hard surface to work on. A reasonably thick coat of release agent should next be painted on, care being taken to ensure that the whole mould surface is covered. When this has dried the mould is ready for use.

The second mould sketched consists of a light wooden framework, made in two halves which are held apart by spacers. The whole is covered and finished in the same way as the previous one. The spacers must be easily removable, especially the centre one, so that the mould can be dismantled by removing them and collapsing the two halves inwards, before drawing the sections out of the tube.

Moulding the tube

First prepare only sufficient resin to just cover the whole mould, adding sufficient accelerator to ensure gelling (partial setting) in about twenty minutes. If the internal surface of the tube is to be black, mix in plenty of black pigment. Paint this mix evenly over the mould and allow to gel. Whilst this is happening the glass cloth can be cut to

suitable lengths for winding on. Prepare sufficient resin for two more coats, adding colour pigment if desired, though this is not essential, but adding only enough accelerator to give a curing time of about a day. When the initial coat has gelled, commence winding on the glass cloth, making sure that it goes on smoothly and tightly. Whilst winding on, thoroughly impregnate with the prepared resin, using the paint brush with a dabbing action. Make sure that no air bubbles are trapped. Continue winding on glass cloth and impregnating until the required thickness is obtained. If joints have to be made the ends should butt against each other, not overlap. Avoid making joints on top of other joints as this weakens the tube. When complete, set aside to cure.

Finishing

Inspect the tube after about twenty-four hours, by which time the resin should have set completely hard. If it has not, restrain your impatience and leave it for a further twelve hours. The curing time depends a great deal on the temperature of the surroundings, warmth speeding up the process and cold retarding it.

When, and only when, completely hard, remove the mould and tear out any adhering cardboard and paper. Strip off any release agent sticking to the inside of the tube and trim the ends square using a hacksaw and shaper. The inside of the tube should be a smooth matt black, whilst the outside, if no pigment has been added to the outer coats of resin, will be a light brown or green which will darken considerably during the next few weeks.

LATHE GADGETS

(Continued from page 199)

in this way; the size of the rounded corner remaining after each trial will then give a good indication of how much more has to come off. When once set correctly for two sides all the rest must come right without further adjustment.

The capacity of the rest when made to the sizes given cannot be expressed as a straight dimension. The number of flats required—and therefore their size—is related to the job diameter. However, some idea can be obtained from the fact that it can be used to file hexagons on diameters from 0— $\frac{1}{2}$ in. and squares on diameters from 0— $\frac{1}{2}$ in.

Incidentally, as a final thought it may serve to show how much a part of the normal lathe equipment the accessories described in this series become when it is realised that no less than six of those already described helped in the production of this one. They were: adjustable height toolpost, tool height gauge, centre extractor, tailstock dieholder, back parting-off toolpost and knurling tool.

"Practical Mechanics and Science" Advice Bureau. COUPON

This coupon is available until February 28th, 1963, and must be attached to all letters containing queries, together with 6d. Postal Order. A stamped and addressed envelope must also be enclosed.

Practical Mechanics and Science. Feb. 1963

Weather forecasting by Satellite

by R. J. SALTER



THE day will soon come when scientists hope to be able to give long-term weather forecasts which will allow holiday-makers to catch our elusive summers. What is more, if the weather does not look as if it is going to come up to expectations the scientists think they may be able to modify the natural course of events.

Advance weather forecasts are not new but, in the future the use of meteorological satellites promises to make weather science much more accurate. Whilst it may take several years before a weather man in any part of the world will be able to predict the future weather accurately, very rapid strides have already been made in that direction.

From the weather men's point of view our planet is just a heat machine. This is because the heating and cooling of the earth as it revolves in its path around the sun forms the clouds which produce our weather. They believe long-range weather forecasting and weather modification hinges on how much heat the earth absorbs every day from the sun and how much heat it loses. This gain and loss of heat is very delicately balanced, for if the world temperature should rise, the polar ice would begin to melt, so flooding vast areas of the land.

Satellites far out in space can gain a much more complete picture of the cloud cover around our earth than it is possible to obtain from the ground.

Called the Tiros I because it contained television and infra-red equipment, the first weather satellite

was launched in 1960. It has been followed into space by five more satellites of the same series.

The last Tiros sent into space was launched on September 18, 1962, and was soon searching out hurricanes in the Atlantic and Pacific oceans and gave valuable weather information for the space flight of Astronaut Walter Shirra. Two of this type of satellite are to be kept at work in space until more advanced Nimbus satellites take over the space watch.

How then do these tiny satellites give the information needed for accurate forecasting? All that the television cameras in the satellites see are the tops of the clouds, with the earth appearing in the gaps. It is the temperature of these clouds which gives the vital clue as to their thickness and the amount of water they contain. This temperature reading is obtained by infra-red sensors on the satellite which transmit their observations down to earth with the television pictures of the clouds.

Useful as the Tiros satellites have been—Tiros III discovered one hurricane and observed 18 tropical storms and six easterly tidal waves between July and October of 1962—a great deal more information will be given by the Nimbus satellites, the series next to be launched.

Weighing about 650lb each, a Nimbus satellite will pass over every point of the globe in 24 hours. As it circles the globe it will turn itself around so that its television cameras are always pointing towards the earth. Pictures covering an area of 400 miles by 1,200 miles will be taken every 100 seconds and will be stored within the satellite on magnetic tape.



Assembling *Tiros* photographs to make a mosaic composite.



Drawing the cloud patterns on a map placed over the mosaic.

After each 106-minute orbit the satellite will send out this information to ground stations; one in Alaska and the other in Northern Canada. From here the information will be sent by land cable to the satellite headquarters near Washington.

Here computers will help to analyse the information, which must all be dealt with and distributed to various weather centres throughout the world before the next set of pictures and information arrives 106 minutes later.

Two wireless transmitters will send out the information from the satellite headquarters. One will be at New York and broadcast to Europe, North Africa

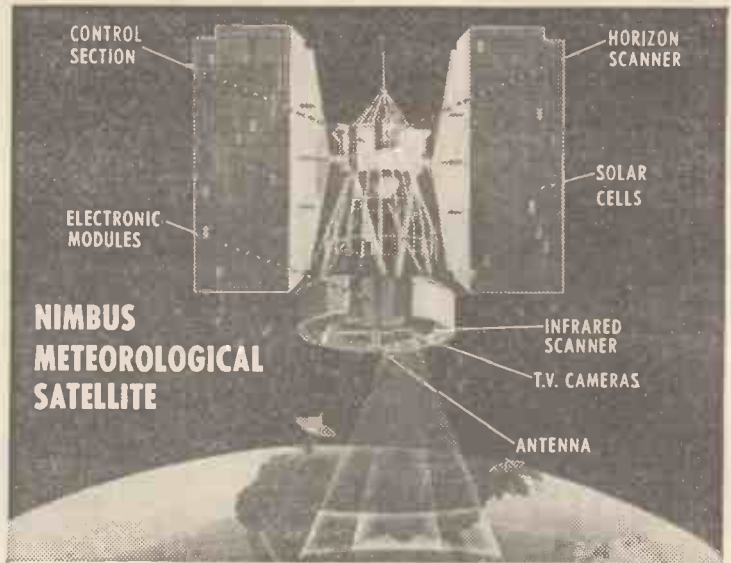

The lay-out of the *Nimbus* satellite. Note the large area of solar cells needed to power the equipment.

This *Tiros IV* photograph shows Britain completely covered by cloud.

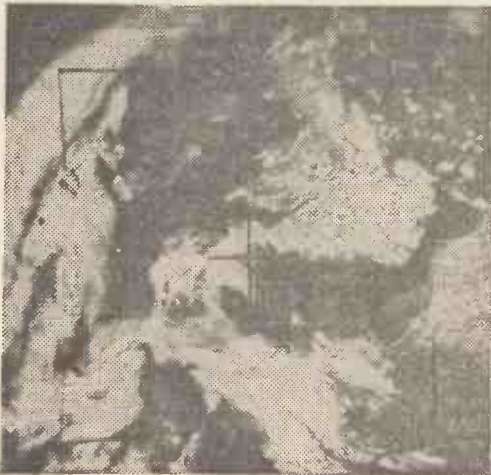

and South America. The other transmitter will be at San Francisco and will beam its information to Australia and Japan. Other weather centres in the Philippines, India and Russia will continue to obtain their information through radio teletype networks.

To keep a complete eye on the earth from space it is hoped eventually to have four *Nimbus* satellites out in space and also two *Aero* satellites. These will be placed in a "stationary" orbit at 22,300 miles above the earth and will be placed over the Equator on either side of the earth. It will be possible to focus the lenses of the television cameras in these satellites from the control centres on earth, so that cloud patterns of special interest can be investigated.

Whether this ambitious target will ever be achieved depends very largely on the co-operation of other countries, for clearly weather conditions are global and it is of benefit to all the people of the earth to receive warning of the floods, tidal waves and hurricanes which bring so much tragedy.



By L. G. WARNER

BEFORE launching into a description of this model C.M.B. of the 1914-18 war a few notes on the origin of these boats and their construction and work may be of interest. These particulars are taken from an article published in "The Engineer", March 30, 1923, written by Sir J. E. Thornycroft, K.B.E., and Lieut. Bremner, R.N., D.S.O.

At the opening of the war it seemed that anything in the nature of a small torpedo carrying boat was a thing of the past. However, in 1915 Lieutenants Hampden, Bremner and Anson suggested the use of small high-speed motor craft for attacking enemy submarines as well as passing over minefields and attacking German boats. The boats were to be equipped with 18in. torpedoes and were not to exceed 4½ tons weight all up, so that they could be handled by the davits installed on light cruisers. The first boats were 40ft long with a 250 h.p. engine which gave them a speed of 30 knots. A hull with a single step amidships was decided on as this was considered the best form to drive at this speed, carrying a torpedo weighing three-quarters of a ton. Experience with racing motor boats had shown that a lighter hull could be made of wood rather than steel. American elm was considered the best as it would bend easily.

Owing to the limited displacement, conventional methods of launching the torpedo were out of the question and some other method had to be devised. Preliminary experiments showed that the torpedo might be launched from the stern of the boat tail first. To discharge the weapon satisfactorily it was found that it must leave the boat at a velocity of 17 knots. As the craft would be travelling at at least 30 knots this would mean that the torpedo

would enter the water tail slightly downward and at a forward velocity of 13 knots or more. The torpedo was therefore carried on a trough built into the hull and fitted with bronze-faced rails extending some distance over the stern. The impulse to discharge it was obtained by burning cordite in an enclosed vessel fitted with a propelling ram. This ram was provided with a bell-like head which pressed on the nose of the torpedo.

The small 40ft boats were so successful that larger ones 55ft long were built and fitted with two 250 h.p. motors, and later with 375 h.p. motors which enabled them to maintain a speed of 40 knots fully loaded. Some of these larger boats were equipped with one torpedo and four depth charges as is the model, some with two torpedoes and two depth charges, whilst others were used as mine layers. A special propeller was fitted to some of them so that they could pass over obstructions such as wires and booms. The motors of these early boats were not very satisfactorily silenced, but this was not so detrimental as would be supposed as they were often mistaken for aircraft.

These C.M.B.s did particularly well in the attack on Zeebrugge. They were responsible for the smoke screens and also for placing the flares showing the turning points for the block ships. All but one of the boats succeeded in getting away, although sorely battered and with many officers and men wounded.

An interesting illustration of the strength of the hulls of these C.M.B.s occurred at Ostend. A torpedo fired from one of them exploded under its stern. The hull was badly distorted and many of the pipe connections were fractured. Nevertheless the boat was able to run out of action and was

picked up by another vessel and towed back to Dover.

The illustrations in "The Engineer" were a side elevation and plan of the 40ft and 55ft boats. The larger one seemed the more attractive, so this one was chosen for modelling. The only cross-section shown was at the step, so the shape of the hull had to be imagined. Several photographs were obtained from various sources and used in making the model. There is a very fine model of this craft in the Imperial War Museum, unfortunately not seen by me until after my model was completed, but the shape of the hull was not far out. It could have been a little fuller in the forward sections but on the whole looks very well. The early boats were built with open cockpits protected by canvas dodgers but later ones were provided with various patterns of shelter. The one shown on the model is called a Portsmouth type.

The hull

This was made from American whitewood, bread and butter fashion. Now that hard balsa and obechi are obtainable they would be more suitable. Each layer should be $\frac{3}{16}$ in. thick. There are five layers, which should be glued together with Croid Aero glue. Of course, at the modest speeds expected of the model the step serves no useful purpose, rather the reverse, but it has to be there for appearance sake. Four thin strips should be pinned to the deck to form foot rails. A rubbing strake should be pinned on each side of the hull, and another strip to form a beading at deck level.

Rudders

Twin rudders should be fitted and linked together. They are adjusted by a small wire strainer or rigging screw. The one I used was actually taken from a violin chin rest.

Shelter

This should be made from thin tinplate, soldered together. The windows can be cut from $\frac{1}{8}$ in. Perspex and there should be a sliding hatch on top. Inside there is a chart table with the steering wheel placed in a horizontal position in the centre.

Ventilators

These can be made from the back half of small brass bells with a ring of brass wire soldered round the

edge. A piece of light brass tubing should be soldered on to form the shaft.

Depth charges

Four depth charges should be fitted. They are simply $1\frac{1}{2}$ in. lengths of $\frac{7}{8}$ in. diameter dowel. The brackets should be built up from thin tin. The charges should be held in position with fairly stout fuse wire. On the real boats they are held by cables with quick release devices which permit them to roll over the side.

Torpedo

This was originally made from a child's cricket stump but a better one has now been made from an aluminium cigar container. An aluminium tail-piece was turned and fitted to it. It should be fitted with vertical and horizontal rudders and twin two-bladed propellers.

Jamming beams

These can be made from a brass ring turned on the lathe to a T section. The ring should be cut in half and small feet soldered to each half to make a pair. Alternatively the beams may be fabricated by soldering. Screw clamps with crossbar handles should be added. These were used to hold the torpedo firmly on the rails until the time came to release it.

Torpedo trough

A box-like structure built into the stern of the boat and extending over the stern. Two wire supports are fixed to the ends of the runners and extend to the corners of the transom. Lifting hooks are fitted on each side of the trough.

Masts

These were of an unusual type, being cut down the middle and then spread out with small stretcher

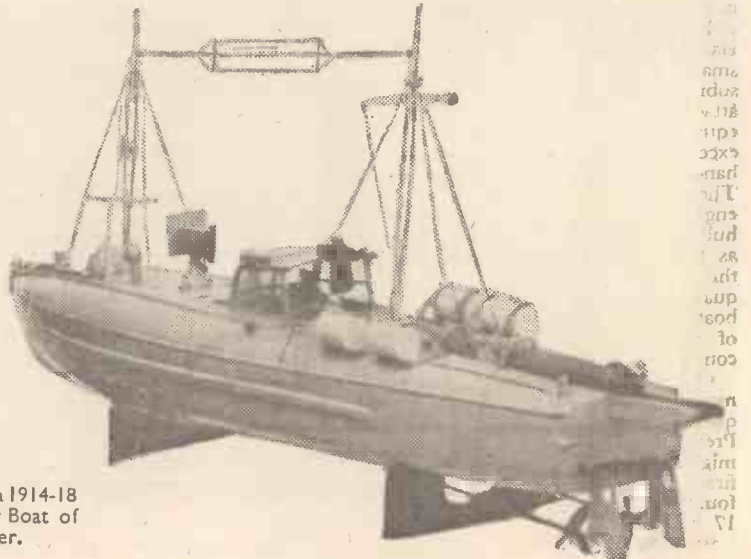

Mr. Warner's excellent model of a 1914-18 Thornycroft 55ft Coastal Motor Boat of the type shown on our cover.

Model Thornycroft Coastal Motor Boat

From Plans by L.G. WARNER

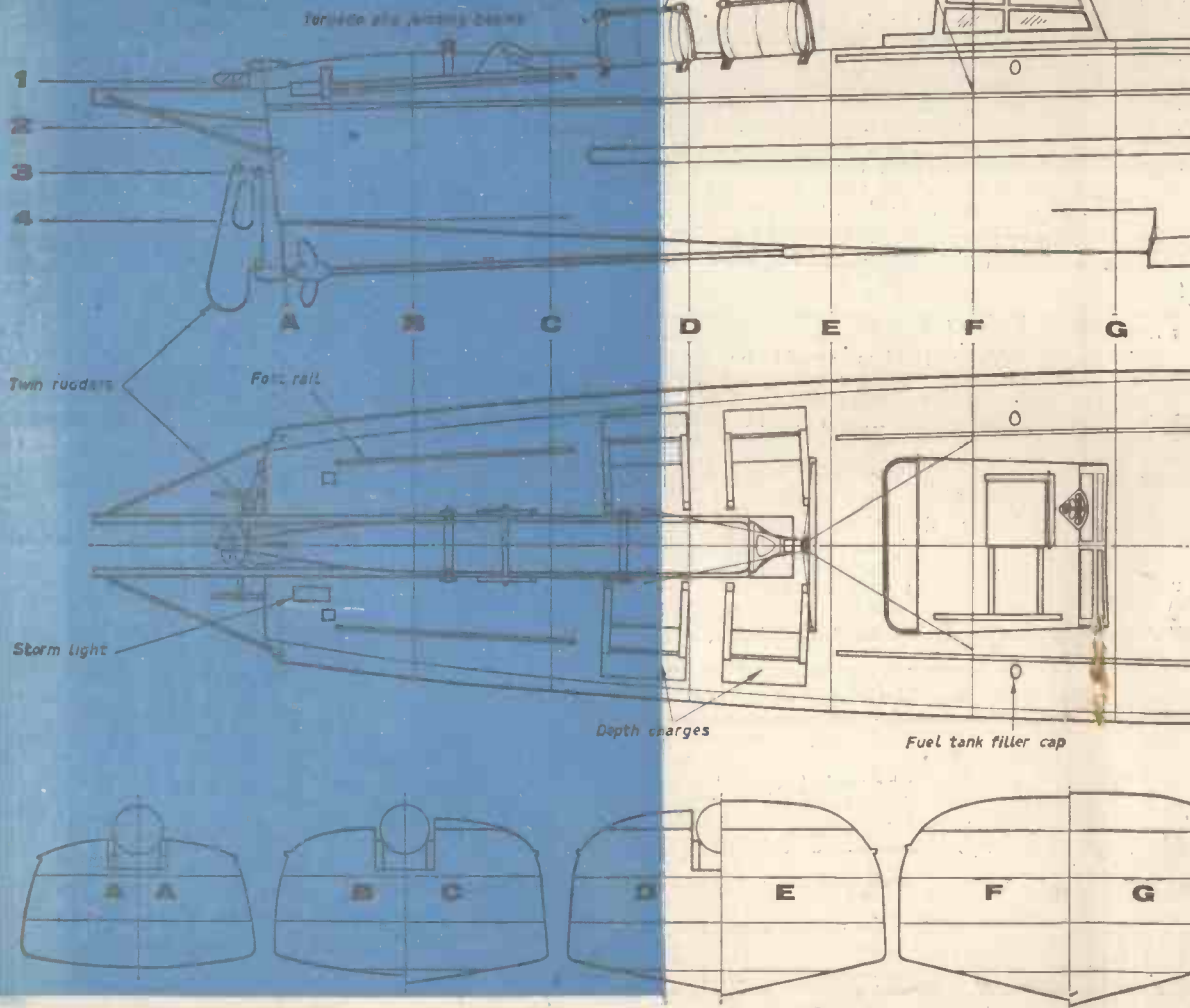

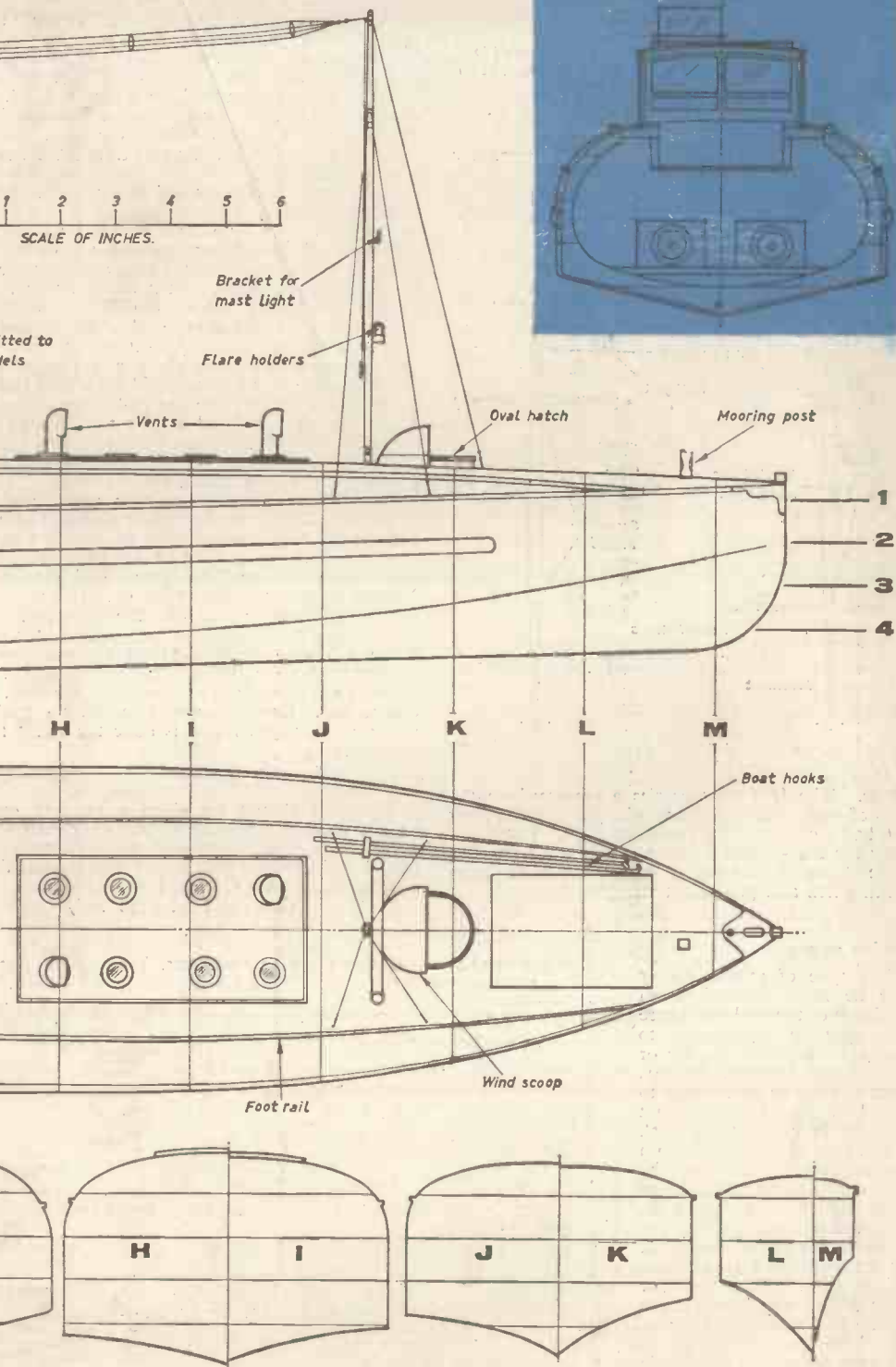

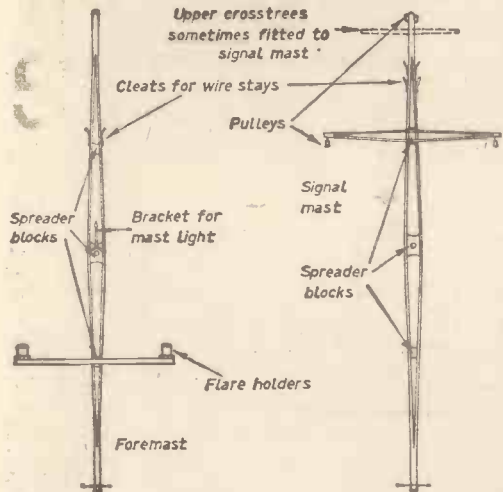
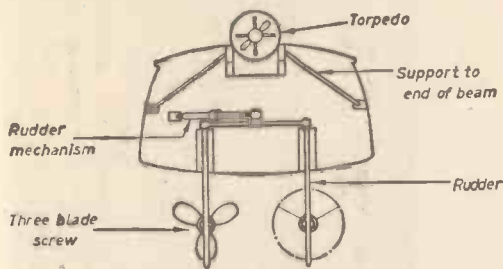

pieces. The fore-mast carries a crossyard on the ends of which flares could be placed. The aft mast also had a crossyard for signalling flags. The masts carry the four-strand wireless aerial, which may be made from fine copper wire unravelled from lighting flex and pulled out straight.

Motive power

Any type of motive power may be fitted depending on the fancy of the builder. There are many on the market to choose from, either electric or compression ignition. At this point it may be of interest to record some of my first attempts to power the model. It was first of all fitted with a steam plant which gave the most encouraging performance when tried in a testing tank. Unfortunately when taken out of doors the blowlamp could not be persuaded to perform satisfactorily. Somehow or other I find small blowlamps never can be, so this form of propulsion was abandoned. In any case the model was made for show rather than per-

formance, so a Stuart Turner permanent magnet electric motor was substituted. This gave a steady and reliable performance but not breathtaking. The motor was placed towards the stern of the hull and drove forwards to a small gearbox which reduced the motor speed by about a third. The shaft passed back under the motor. This method is preferable as it avoids making the shaft enter the water at a steep angle. At this time there was only a single propeller.

Some years later a small compression ignition engine was given to the writer and it was decided to put it in the C.M.B. and give it a realistic performance. Before being installed it gave the most dazzling performance and a really spectacular turn of speed was expected. But it was not to be. After getting everything ready, the motor obstinately refused to start and despite all efforts never burst into song again. In disgust it was thrown away and a return to electric drive was decided upon. This time the hull was stripped for a refit and twin propellers fitted just like the real thing. The twin rudders were also fitted at this time. Two small permanent magnet motors were obtained from an M.E. exhibition. In order to keep them synchronised the two shafts were connected with a crossed rubber band running in grooved pulleys. It worked all right in the testing tank but up to the present the boat has not been tried on a pond. It is finished as an exhibition model and certainly looks very attractive. The basic model has not been without adventures during its life. It was severely damaged by enemy action on the night of May 10, 1941. A large bomb fell in the garden of the house, doing extensive damage to all the neighbouring property. A large chunk of ceiling fell on the boat, crushed the superstructure and split the deck from end to end. However, it was carefully coaxed into shape again, reglued, and is none the worse for its adventure.

Painting

The hull should be given a priming coat of shellac, rubbed down and then several coats of lead paint, each coat being well rubbed down. My model was finally finished with Valspar but during its career has been repainted many times.

(Continued on page 229)

This and our heading picture show later versions. The 55ft hull was used unaltered until about 1936. (Photos courtesy of J. Thornycroft).

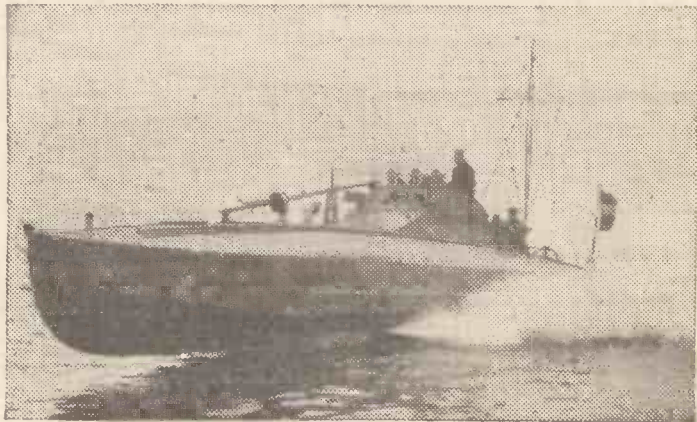

Improved Design for Ultra Close-up Device

by A. E. BENSUSAN

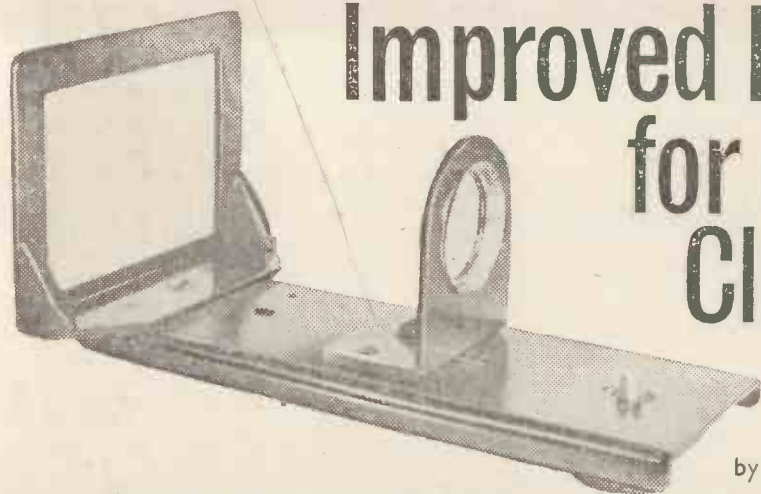

Fig. 1.—The device set up to use one close-up lens with the large frame.

THE author's article on ultra close-up photography, published in the May 1962 issue, gave details of the photography of small objects at a large scale of reproduction with the aid of a watchmaker's glass. The ability to carry out this type of work, with the equipment described, resulted in such a volume of ultra close-up photography being undertaken that a more precise unit became well worth while developing.

It was decided to make the present device readily adaptable to two fixed reproduction scales; i.e., ratios of subject to negative image sizes. The first step was to obtain two identical single cell, double-convex lenses, each of 4in. focus. These are, in fact, precision ground magnifying glasses, and were specially ordered from the supplier mentioned below, at a cost of only a few shillings. The diameter of the lenses should be kept reasonably large to avoid vignetting (cut-off) at the corners of the negative. In the writer's case, glasses of the same diameter as the outside of the lens mount were chosen.

Using one of these glasses only, in conjunction with a 35mm Super Silette camera having a 45mm focal length lens, the scale of reproduction was found to be 1:2.15. That is, an object sized 51.5mm x 75mm (2.03in. x 2.95in.) would just fill the 24mm x 36mm (0.95in. x 1.42in.) negative. The subject to close-up lens distance was exactly that of the close-up lens, i.e., 4in., with the camera focused at infinity. These conditions hold true for any 35mm camera having a 45mm lens. For those readers who intend to use a camera having a frame size other than 24mm x 36mm, or which is fitted with a lens of focal length other than 45mm, the method of finding the area of subject covered was given in the previous article mentioned above. The distance between the close-up lens and the subject with

the camera focused at infinity will, however, remain unaltered if the former still has a focus of 4in. Briefly, a sheet of graph paper is set up at the correct distance from the camera and close-up lens and photographed. By comparing the number of lines registered on the negative, with the graph paper, the area covered can be seen immediately.

The completed device is shown in Fig. 1. The drawings give dimensions for a 35mm camera with 45mm lens using a 4in. close-up lens. The height of the centre line of the close-up lens and frame above the bed depends on the height of the centre of the camera lens from the bottom face of the camera body. This distance must be measured with great care to avoid any risk of straining the camera lens mounting. Light weight with rigidity and absolute ease of assembly and use are the key-notes of this unit. The bed is made from 18 S.W.G. half-hard aluminium, flanged along each side for stiffness.

The frame is $\frac{1}{4}$ in. thick aluminium with the two parts (frame and foot) made separately and butt joined with Araldite epoxy resin. It can be seen from the drawing that the rectangular cut-out in the frame is slightly larger than the area recorded

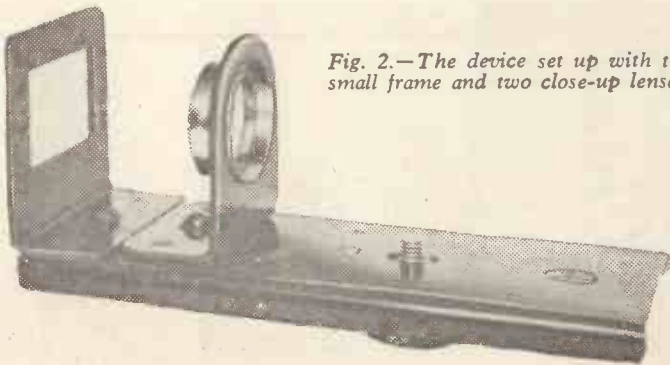
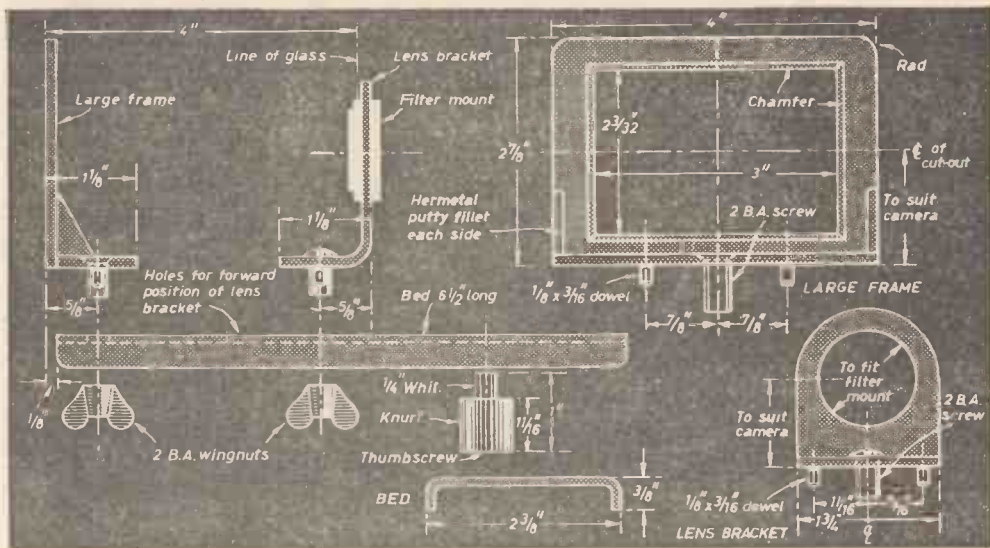

Fig. 2.—The device set up with the small frame and two close-up lenses.



on the film, and that its edges are chamfered. This is done to prevent any intrusion into the camera's field of view, and to lessen the possibility of shadows being thrown on the subject. Additional fillets, made from Hermetal putty, were added to give extra strength to the corner. The frame is held square to the bed with two 1/8 in. diameter silver steel dowels, and retained with a 2 B.A. countersunk head screw; these three parts being secured in the frame foot with Araldite. A wingnut under the bed holds the frame securely but allows it to be removed when desired.

The lens bracket is bent up from 18 S.W.G. half-hard aluminium, care being taken to get the bend square. To save time and trouble, a filter mount of the correct diameter to suit the close-up lens, but slightly too large for the camera lens mount, was bought for a few shillings and cemented into the hole in the bracket with Araldite. Take great care to support the bracket and mount dead square to each other while the adhesive is setting hard. It is fixed to the bed exactly as for the frame, but a round head screw may be used since there is no possibility of encroaching on the camera's field of view.

In use, the camera should be attached to the bed by means of the thumbscrew, so that its lens mount

penetrates the filter mount in the lens bracket as far as possible. The thumbscrew has a tapped hole for tripod-mounting the entire unit. The camera lens scale should be set to infinity, the frame held in the same plane as the subject, so that the required area shows through the cut-out, and the photograph taken. Unless the whole unit is mounted on a tripod, a shutter speed of at least 1/100th of a second is desirable to avoid shake. The lens should be stopped down as far as possible since the depth of field at such short range is very limited.

The ability to cover two scales of reproduction with basically the same equipment is a particularly novel and useful feature. By using two 4 in. focal length glasses, the field covered is reduced to 25.5mm x 38mm (1.0 in. x 1.5 in.), while the scale of reproduction increases to 1:1.06 (i.e. almost full-size reproduction). The arrangement is shown in Fig. 2. A subject can thus be photographed almost life-size with the two glasses in place. To facilitate mounting, the second lens is held in a filter mount similar to that cemented into the bracket but of a size which will fit on the front of the first one. It merely needs to be clipped over the first mount to form the combination. A second frame is required and as shown in the small drawing, has a cut-out slightly larger than the area covered. As it is quite small it may be made from 18 S.W.G. aluminium alloy bent to shape. As usual, the bend is best made across the grain of the metal to avoid cracking.

This smaller frame uses the same screw and dowel holes as the larger one. The lens bracket needs to be moved nearer to the subject frame to obtain sharp focus, and the precise point can be determined by attaching a printed sheet to the back of the frame and moving the lens bracket and camera to and fro until a sharp image is obtained on a ground glass screen in the camera film plane. To do this, the shutter should be set to "time" and the iris opened right up. The correct point of focus having been found; in the writer's case 2 1/8 in. from the subject to the nearest close-up

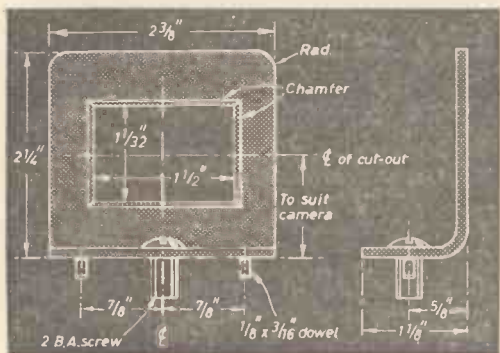

(Continued on page 222)

THE device described in this article is really meant for use in the junior school, although if constructed on a smaller scale it can be used in the house as a general quiz game. If used on the scale shown here—each quiz sheet is 21in. x 20in.—then two children, using a question and answer technique, can work together.

When one of the test prods is placed on any question and the other prod is placed on the answer to that question, then a bulb on the headboard will light up. If the answer prod is placed on an incorrect response then, of course, nothing happens. The quiz sheets are removable and are held on to the wired baseboard by paper clips.

First of all a master card should be marked out (see sketch). From this the baseboard and the quiz sheets can be prepared, thus ensuring accurate alignment when a quiz sheet is placed on the

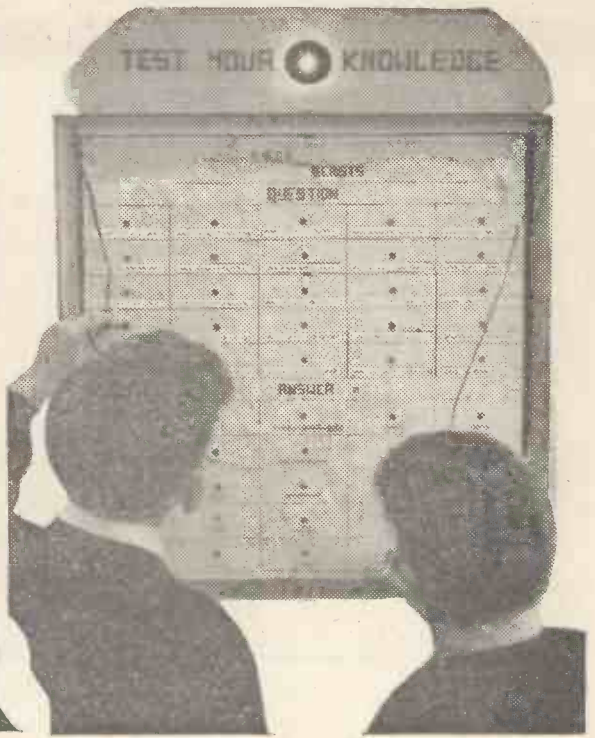

TEST YOUR KNOWLEDGE

By **SCHOOLMASTER**

baseboard. Draw up a master card and find the centre of each rectangle by drawing crossed lines from the corners. Place this master card on the baseboard, which can be made from thick cardboard, and push a scriber or divider point through each centre. This will leave a series of marks on the baseboard. Through each of these push a $\frac{1}{2}$ in. brass-headed drawing pin. Connect the pins in pairs with insulated copper wire according to the numbers on the master card. The pin points should be hammered over and the wires soldered on to ensure a good contact.

The next step is to mark out the quiz cards. Place your master card on any suitable coloured card and mark out as for the baseboard. This time, where every prick point is, punch out a $\frac{1}{4}$ in. diameter hole with a hollow punch. When the quiz card is in position on the baseboard a test prod will thus be able to touch the drawing pin contact. To complete the quiz card the questions and answers should be written directly on the card or typed on slips of gummed paper and stuck on.

The electrical layout (right) is mostly hidden behind the "Test Your Knowledge" headboard and simply consists of a pair of prods, battery and bulb, connected in series. When continuity is obtained—by linking a question with its correct answer—the bulb will light.

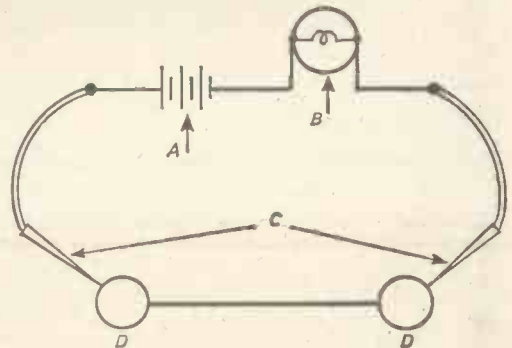

- A** 4½ volt torch battery.
- B** Torch bulb.
- C** Prods on flexible leads.
- D** Studs linked by wire.

TITLE				
QUESTION				
1	2	3	4	5
6	7	8	9	10
11	12	13	14	15
16	17	18	19	20
21	22	23	24	25
ANSWER				
7	11	10	8	14
13	4	24	21	3
15	9	2	5	18
12	23	6	20	22
17	1	25	16	19

The master card.

By this means the subjects can be consolidated by play and not by less interesting ordinary classroom routine methods. Titles should be made attractive, such as "Birds and Beasts", "Inventors and Inventions", or "Persons and Places", to name but a few which spring readily to mind.

The completed board.

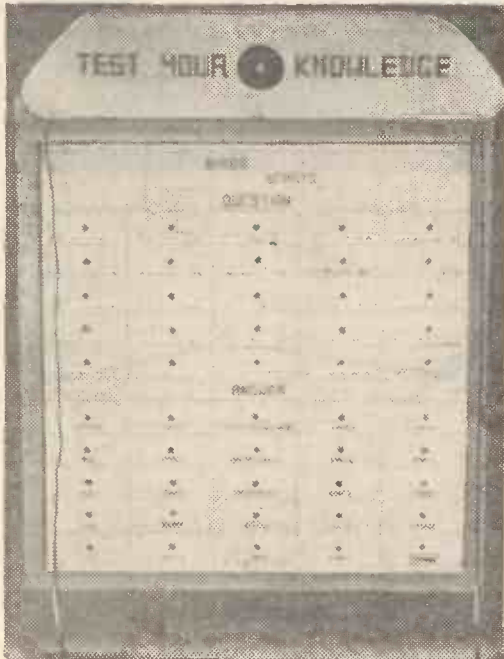

ULTRA CLOSE-UP DEVICE

(Continued from page 220)

lens, the holes to match the dowels and screw in the lens bracket should be drilled. The camera is, again, located by the screw protruding through a 1/4 in. wide slot in the bed. All aluminium parts should be finished matt black.

At such a short range there is slight curvature of the image towards the edges of the frame but this generally passes unnoticed and is a small price to pay for the otherwise unobtainable facility of taking extreme close-up photographs with a non-interchangeable lens camera. Fig. 3 shows a photograph of a midget flashbulb taken by this method.

The entire unit weighs only a few ounces, can



Fig. 3.—Close-up photo of midget flash bulb.



Fig. 4.—The unit accommodated in its wallet.

be assembled in a matter of seconds and may be stored in a wallet made from p.v.c. cloth and fitted with a zip fastener (Fig. 4). The components are held in place by elastic straps, and the closed wallet measures only 4in. x 7 1/2 in. x 1 1/2 in.

Suppliers

The close-up lenses of 4in. focal length can be obtained from Gowllands Ltd., 176 Moreland Road, Croydon, Surrey. A quotation should be obtained for lenses of the appropriate diameter to suit the camera. It is advisable to purchase the lens mounts before actually ordering the lenses, to be sure the correct diameter lenses are obtained.

In case of difficulty in obtaining Hermetal Putty, this can be obtained from the manufacturers, Kenilworth Manufacturing Co. Ltd., West Drayton, Middlesex.

AN ILLUMINATED ADDRESS

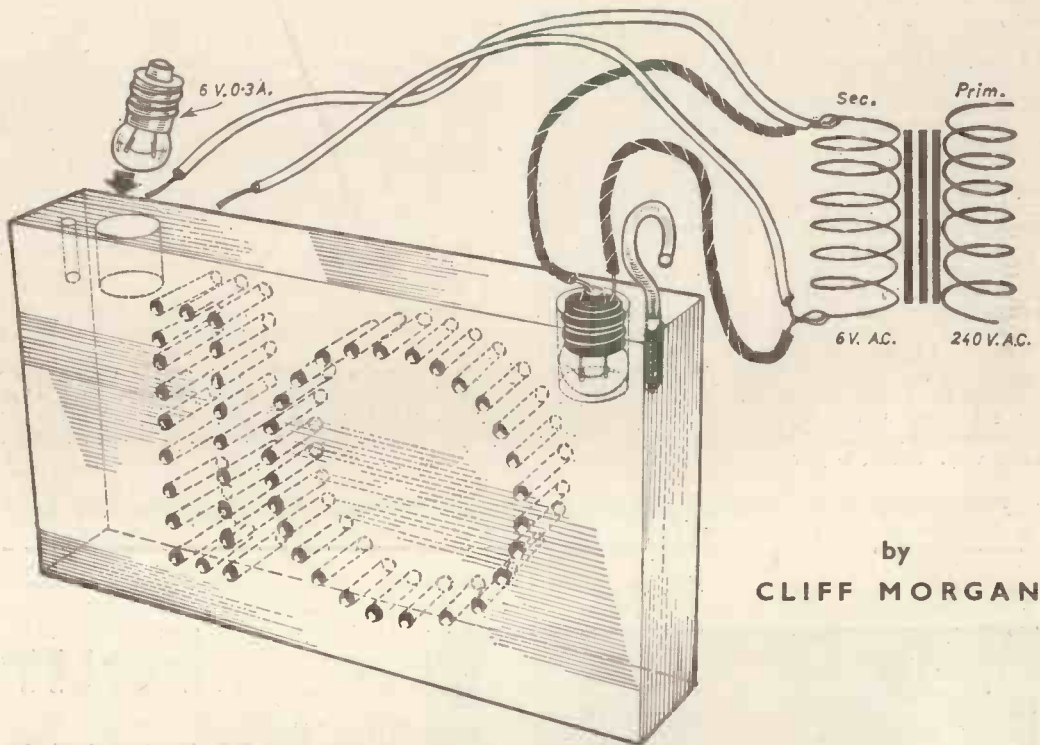

by
CLIFF MORGAN

IN an effort to please the "Lady of the House", the postman, and several late callers, and to try to reduce the size of the electricity bill by doing away with a porch light, the following idea was evolved. The result was that the "fair sex" was delighted, the electricity bill considerably reduced, while all late callers were assured of finding the right number of the house, no matter how dark it was, or what the condition of the caller!

The idea is that light, when passed through a length of glass or Perspex, as in this case, will not emerge anywhere on the surface of the material, providing that it is not scratched. Wherever the surface is roughened however, the light can escape and this area thus appears to glow.

Material required

A piece of $\frac{1}{8}$ in. thick Perspex, clear or coloured, size according to the shape and size of numbers desired; two 6 volt, 0.3 amp radio dial pilot bulbs; solder; 22 or 20 gauge insulated wire; two small screw-eyes; bell transformer (6 volt secondary); and tools such as are used in the everyday home workshop. A sheet of graph paper with $\frac{1}{16}$ in. squares could also be used to advantage. This does facilitate the drawing of the lines needed in marking out the illuminated address.

Procedure

On a sheet of the graph paper draw the shape and size of the numbers to be illuminated. Draw a border round this number leaving at least $1\frac{1}{2}$ in. clear all round.

Cut the Perspex to the same size as the graph paper template; taking great care not to scratch the surface in the process. One good way to ensure that the edges are clear, is to smooth down first with a medium file, then follow with very fine sandpaper, and lastly scrape gently with the edge of an old razor blade or piece of broken glass. Hold this in a gloved hand, or protect your fingers with a length of rag.

Paste the graph paper on the Perspex, using a paste that will stick well yet can be soaked off in water. The reason for this is that after drilling holes, which will form the outline to be illuminated, the paper has to be removed without scratching the already polished surface of the Perspex.

With a spring punch, punch-mark evenly spaced hole centres round the outline of the number. Do not position them too close together, one-tenth of an inch apart is plenty, otherwise the drill will force the swarf up and under the paper. When this has been completed, very carefully drill all the holes $\frac{1}{16}$ in., through the Perspex. Use no lubrication on the drill, drill slowly, and clear the drill often. Do

not let the drill overheat as this tends to distort the Perspex. When the final hole has been drilled, soak off the paper, and carefully clear any blocked holes.

The plate is now ready to have the lamp holes drilled. On the top edge of the plastic, draw a centre line along the whole length of the edge. Measure in 1 in. at each end and make a small centre-pop mark. Drill this to a depth equal to the length of the glass portion of the bulbs to be used, with a $\frac{1}{8}$ in. drill. It is essential that care be used in this process. Clamp the Perspex tightly, but in doing so, ensure that the clamps do not mark the material. When the pilot holes on the top edge have been drilled, a $\frac{1}{8}$ in. drill should replace the pilot drill and the hole should be drilled out to the depth of the pilot hole. Water is a very good lubricant for Perspex, and should be used frequently when drilling the larger holes. Make sure the holes are dry, place a torch bulb in each and glue them into place with any clear glue. Leave to dry according to the instructions on the glue label and when dry, commence with the wiring up of the lamps.

The two lamps should be connected in parallel with the 6 volt output terminals of the transformer. Connect the screw caps of the two bulbs together by soldering a length of thin, insulated wire between them. Connect the centre contacts in the same way. Solder a pair of wires, long enough to

reach the transformer, to the screw cap and centre contact of one bulb. Connect these wires to the transformer output.

If now the lamps are connected to a 6 volt supply and viewed in the dark, the holes that were drilled to represent the numbers will stand out loud and clear, while the remainder of the Perspex will be invisible at a distance of three or more feet.

The method of securing the device over the door is left to your own imagination. The original was supported by two lengths of fine chain, the wires supplying the power for the lights being woven in and out of the links. Two small eyelets were screwed into the top of the Perspex to take the chains.

To improve the appearance of the sign, the filaments of the lamps could be blacked out or covered up. This has the effect of making the lettering stand out even more.

The final assembly being almost completed, all that remains to be done is to give the exposed parts of the lamps a coating of shellac, or any other waterproof varnish. This will keep the soldered contacts from weathering, and prevent any electrical leak due to damp.

As the sign is only operated at a low voltage from a transformer, contact with the bulbs or wires is not serious and cannot result in any injury. This is not so with the higher voltage type of outside number illumination.



Four bronze horses have cancer

OUR photograph shows the four great bronze horses in the Piazza San Marco in Venice which are being cleaned and restored. The horses, which are more than 2,000 years old, have succumbed to "bronze cancer". They have been affected by minute particles of sulphurous compounds in the air which, assisted by the rainfall of centuries, have penetrated the outer layer of gilt to the bronze, resulting in corrosion and disintegration called "bronze cancer". Their "disease" is being cured by modern scientific methods. The ~~bronze surfaces~~ surfaces will be thoroughly cleaned inside

and out to remove all traces of copper sulphate before the horses are repaired. The horses will then be covered with a protective skin of nylon or some other plastics material which can be removed or replaced in the event of further surgery. Created by a Greek artist about the second century, the horses were removed from Trajan's Arch in Rome to Constantinople after the Fourth Crusade and then to Venice. After six centuries in Venice they were transported by Napoleon to Paris and were returned to Venice after the Battle of Waterloo. There they have stayed since.

Make your own BUTTON DIES

Says John Waller

EVERY user of a home workshop must have been faced at some time or other with the problem of trying to find a screw to fit an existing tapped hole. Although, where Whitworth or B.A. threads are concerned, it simply means finding an appropriate screw and perhaps cutting off a portion to bring it to the required length, there are many occasions when an American or metric thread is required or the item to be replaced cannot be bought because Sunday closing puts all such shops out of action. It is surprising how quickly a die can be made if a suitable tap is available—surprisingly, most engineers have a range of taps in their tool kit but button dies always appear absent when wanted—so select a piece of steel that will harden. It does not matter what section it happens to have as you can generally arrange to hold it easily later.

The drawings show the steps necessary to produce an efficient die and though for the larger sizes more cutting edges are necessary, this simply means that a greater number of small holes must be drilled round the threaded portion. The principle is exactly the same and, if the holes are reasonably equally spaced, good cutting edges will result. Cut off a piece of bar—I have on at least two occasions used an old file which had been annealed and

allowed to cool slowly—and dress this either to a circular shape or file it to whatever shape is most convenient. It is advisable to anneal any piece of bar you intend using because some steels are tough and tapping a fine thread is not always an easy operation if you happen to lack engineering experience. So heat it to a really bright red colour in the domestic fire or boiler and allow it to cool in the ashes overnight.

Having cleaned up the metal disc, find the centre as near as you can, centre pop it and scribe a circle corresponding to the radius the holes marked "X" lie on. With the aid of dividers or compasses divide this circle into four parts to give the necessary spacing. Centre pop and drill through at these points. Although it is not strictly necessary I find that reaming the holes afterwards is useful in providing a good basis for the next stage. This, surprisingly, requires you to straight away plug the holes you have just drilled! However, let me hasten to explain that this is only temporary and is necessary to assist the final drilling of the centre thread. Reaming each hole, if such a tool is available, means tight plugs, and there is little chance they will be disturbed during the next process. If a reamer is not in the tool kit simply file the plugs to the correct diameter for a tight fit and drive them

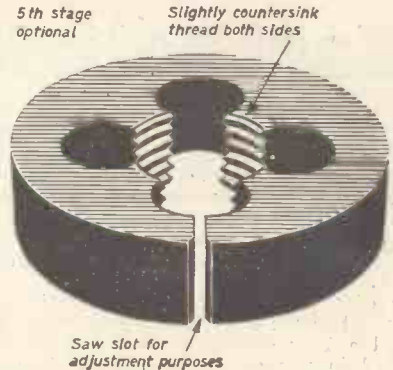
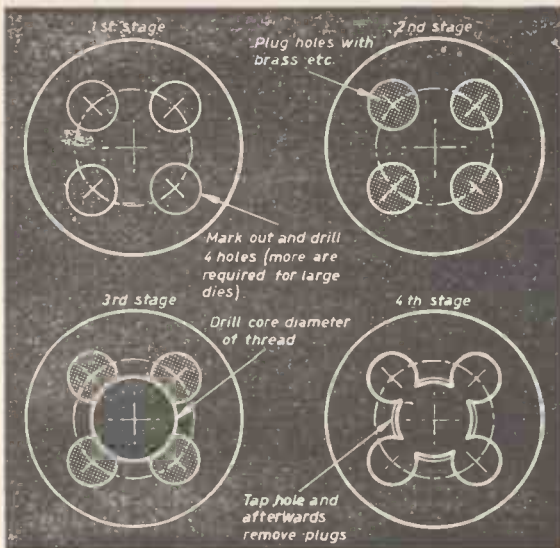

The five stages in making a button die. Round stock is shown but any shape can be used as available.

in carefully. Any soft material is suitable for these and I have made them from brass, steel, aluminium and phosphor bronze and they all give good results.

Now look up the core diameter of the tapped hole—most engineers' text books give the required diameter in the reference tables. Choose a drill just a tiny bit smaller than the required finished diameter, two or three thousandths of an inch less is ample. This will allow the drill to cut oversize slightly without removing too much of the threaded portion; few amateur drills cut to size properly. Centre the material under the drill spindle and see that the drill is rotating concentrically and that it is sharp. Hold the die securely in a clamp or vice and lay it on a piece of scrap flat metal while the work proceeds. A true hole through the thickness is then assured. A minute or so spent on this initial setting-up process produces a correct hole which is both at right-angles with the die faces and the proper diameter, so exercise a little care.

Next tap the thread, using the tap in a lathe if one is available; if not simply tap the hole by hand. Carefully observe that the tap enters the hole square

in all directions, use oil as a lubricant and clear the swarf frequently while performing this operation and a first-class thread will result. Now gently drive out the plugs. Inspect the cutting edges to see that no burrs exist on the threads—a very fine file will soon remove them—or pass a tiny oilstone slip through the four holes. This leaves an excellent cutting edge in each hole. Heat the die to a bright red heat and quench in oil or water. If you only want to make a single thread in a soft metal such as brass or aluminium the hardening operation can be dispensed with because with care the die will produce such a screw without being too badly damaged. After hardening, polish the flat faces of the die and gently clean out any scale that has accumulated in the holes.

This work may appear lengthy in order to make a single screw to complete a job, but not every town has a good tool shop where you can purchase any type of screw you wish and it may mean several days' delay while you wait to pay a visit to a neighbouring town. So make your own dies from bright steel bar and save time.

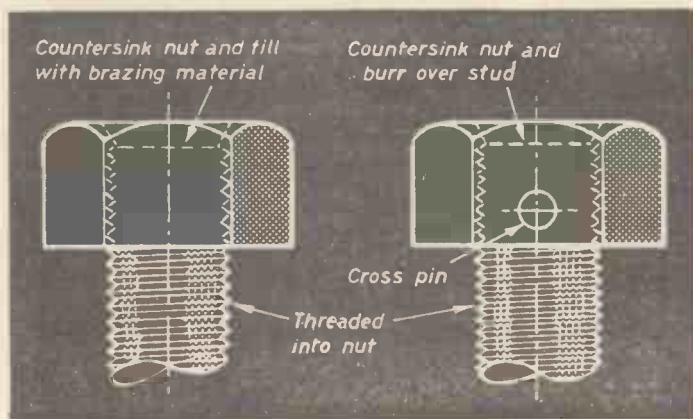

An unobtainable bolt can be made if a tap is available. Drill and tap a similar sized nut to the required thread. Make a die as described, and thread a length of rod. Screw on the nut and secure by either method shown. Brazing is best but the cross-pin method is satisfactory if not over-tightened.

Earthquake-proof flats

A BLOCK of flats with anti-seismic foundations, designed by three Soviet engineers, has been built in Ashkhabad, Turkmenia. It does not stand on the ground, but rests on metal suspensions which absorb the seismic shocks. The Moscow board of the Building Industry Research Society has recommended the designers of this house for a Lenin Prize.

One of the inventors, Fyodor Zelenkov, who has worked in the building industry for 50 years, has told a *Tass* correspondent that he has been interested in this aspect of building all his life. "In 1923, when the world was shocked by news of a devastating earthquake in Japan", he said, "I promised myself I would find a means of safeguarding people from this terrible calamity".

The engineers have designed a foundation which separates the building from the earth by a layer of

air, which serves as the absorber of the seismic waves. A building weighing nearly 1,500 tons and standing on anti-seismic foundations costs only seven or eight per cent. more than a conventional one. In the engineers' opinion it is highly economic to build houses of this type. If only two devastating earthquakes occur in a century, it means that three houses on conventional foundations have to be built instead of one house on the anti-seismic foundation.

Soviet seismologists believe that the construction of buildings on bedrock is the most effective way to protect them from earthquakes, which in the Soviet Union occur mainly in mountain areas. Buildings erected on bedrock in Ashkhabad and some other seismically active localities have withstood force seven earthquakes. With additional reinforcement by the new method they could withstand force nine earthquakes.

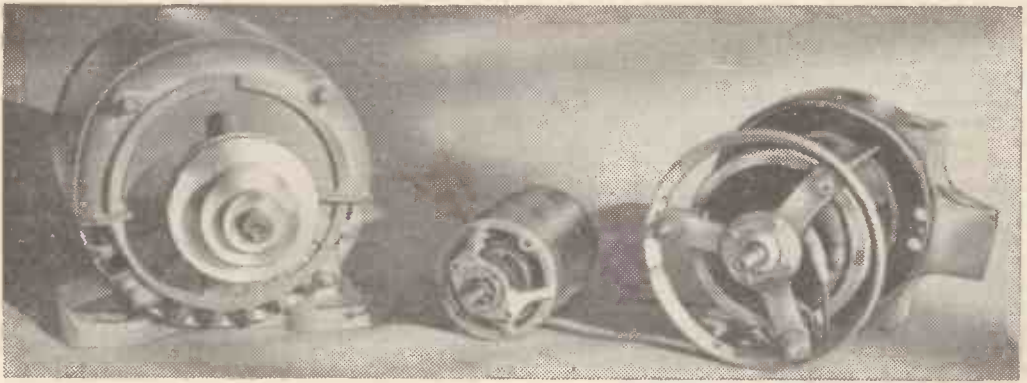

Choosing the right Motor

By Electrician

THE electric motor provides an excellent source of mechanical power for driving many gadgets, from toys to lathes and drilling machines such as are now often found in home workshops. There are many different motors available and it is sometimes difficult to choose the most suitable type for the job. There are several factors to be borne in mind. First of all, what horsepower is necessary? Here is a rough guide.

Synchronous clocks require about 2 watts or 0.003 h.p.

Gramophone turntables require about 22 watts or 0.03 h.p.

Refrigerators require about 124 watts or 0.17 h.p.

Vacuum cleaners require about 150 watts or 0.2 h.p.

Drilling machines ($\frac{1}{4}$ in.) require about 320 watts or 0.43 h.p.

Washing machines require about 373 watts or 0.5 h.p.

This will give an idea of the power required for the work in hand. A small lathe, for instance, will be roughly on a par with a drill and will need a motor giving 0.43 horsepower or drawing 320 watts. In practice a $\frac{1}{2}$ h.p. motor would be the nearest to this. Seven hundred and forty-six watts is equal to 1 horsepower and for practical purposes multiplying the horsepower required by 746 will

give the wattage. There are such things as power factor and efficiency which affect this calculation but for general purposes they may be omitted.

The next point is speed. A lathe, for instance, rotates rather slowly but most motors run at between 1,500 and 3,000 revolutions per minute. These are good speeds for vacuum cleaners, centrifugal pumps and drills but far too fast for a metal-working lathe. This can, however, be overcome by using suitable pulley drives which will be discussed later.

Starting torque is a factor which is often overlooked. This is the power that the motor is able to produce in order to start it rotating. Some motors have a good starting torque and therefore they can be directly connected to loads such as pumps, where the load is applied as soon as the motor is switched on. Other motors have a poor starting torque and are therefore only suitable for fans and such loads, which do not need much force to start them moving.

Most electricity supplies are alternating current (a.c.) but small motors for working models often run on direct current (d.c.) and are therefore suitable for battery operation. Motors for d.c. have the great advantage that they can be made to run at a wide range of speeds, which is not always the case with a.c. apparatus. Very small motors have a permanent magnet field and operate from a low

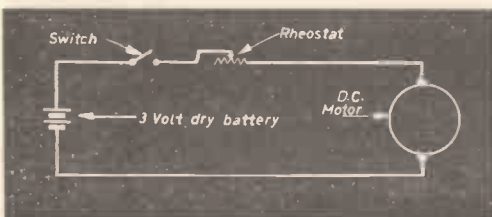

Fig. 1.

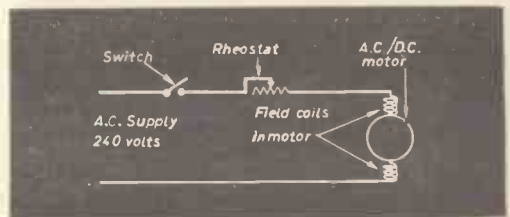

Fig. 2.

voltage battery. Their speed can be controlled by a simple rheostat as shown in Fig. 1. They produce about 0.008 horsepower and are very useful for driving small toys.

The universal motor is very popular in the home. It runs on d.c. as well as a.c. and a reasonable amount of speed variation can be achieved with a rheostat connected in series with it (Fig. 2). It has a good starting torque but is not very suitable for constant speed machinery such as lathes because its speed would alter considerably with variations in the load. This type is usually used to operate drilling machines, vacuum cleaners and sewing machines. The performance on d.c. is usually better than on a.c.

There are many types of "a.c. only" motors on the market. These must *never* be connected to a d.c. supply. They are very reliable but one disadvantage is that variation of the speed of the motor itself is almost impossible. However, its constant speed tendency can, at times, be an advantage.

The most popular a.c. motor is the induction type, which is sub-divided into split-phase, capacitor start, shaded pole and other types. They are all of robust construction and require very little maintenance.

The split-phase motor (Fig. 3) consists of a stator which has running and starting windings attached to it and an iron rotor with thick copper conductors mounted on the shaft. When power is applied to the windings it creates a magnetic field which induces currents in the rotor conductors. These then produce their own field and are repelled by the stator field. Thus the rotor revolves. When the motor has accelerated, an automatic switch disconnects the starting winding, which draws a heavy current, but the running winding remains in circuit. These motors have rather a low starting torque and they also draw a heavy current initially which drops to normal at running speed.

A more expensive but better arrangement is the capacitor-start system shown in Fig. 4. A capacitor is placed in series with the starting winding and gives a high starting torque but lower starting current. There is also the capacitor-start-run motor which has a transformer as well as a capacitor. An automatic switch changes the transformer connections during acceleration (Fig. 5). These motors are suitable for operating lathes, pumps and any other machine that requires a steady speed.

There are two main types of automatic switch for disconnecting the starting winding once the motor is running. The centrifugal switch is a commonly used method. It is fitted to the motor spindle, and weights which fly out as this speeds up operate the switch during acceleration. A much simpler arrangement is the relay switch (Fig. 6) which has the great advantage that it can be more easily "got at" for repairs than the centrifugal type, which is usually built into the motor. When the motor is switched on, the current is high enough to close the relay contacts and bring in the starting winding. During acceleration the current drops and the relay contacts open, thus disconnecting the starting winding.

The shaded-pole motor has no starting winding, capacitor, or auto switch. Starting is brought about by copper rings permanently fitted to the poles. It is a simple motor, but unfortunately the starting torque is very low and it is therefore only suitable for driving fans, gramophone turntables, and other very low power equipment.

Finally, the synchronous motor. This should only be considered when constant speed is absolutely necessary. Clocks, and time-switches fall into this category. Synchronous motors rotate at a constant speed which is entirely dependent upon the frequency of the supply. In this country, and in many other places, the frequency is very reliable so they can be used satisfactorily for time-keeping. If the motor is overloaded it will stop. In other words it either runs at its correct speed or not at all. They are obtainable in small sizes, of about 0.003 horsepower which is quite sufficient for driving timing mechanisms. There are two types, self-starting and non-self-starting. The latter is usually started by spinning it by hand.

Fractional horse-power motors such as the ones described here do not require complicated control switches, but it is advisable to have some sort of protection in the form of a fuse or circuit breaker in case of overloads or short circuits. Both of these conditions draw heavy currents that could damage the wiring or the motor. The fuse is the simplest device, but for larger motors ($\frac{1}{2}$ h.p. and upwards) a circuit breaker is more reliable. It is really an automatic switch that turns off the supply on its own accord if an excessive current is drawn. Fig. 7 illustrates a typical type. They usually work on thermal or magnetic systems.

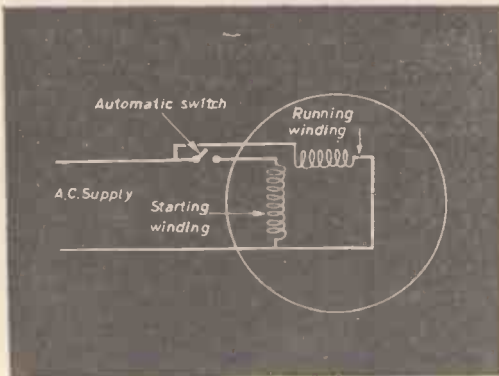

Fig. 3.

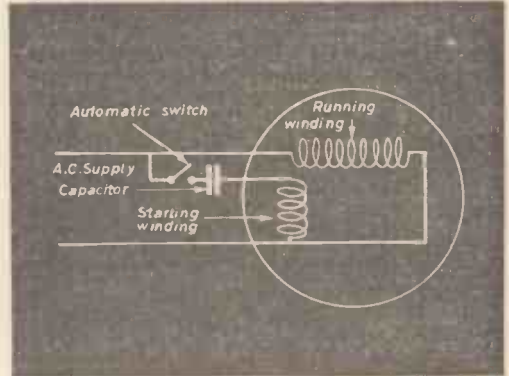

Fig. 4.

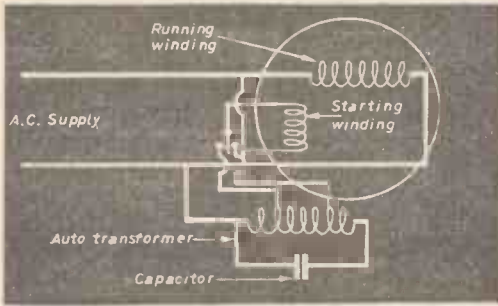

Fig. 5.

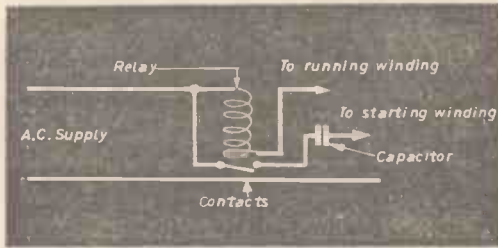

Fig. 6.

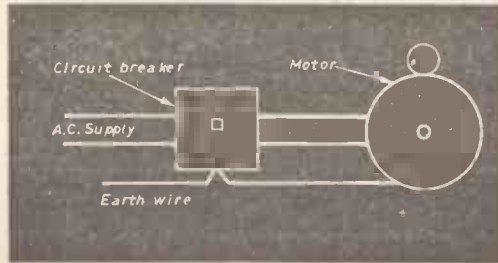

Fig. 7.

The speed of the machine being driven can be correctly adjusted by using different size pulleys. Pulley belts should not be too tight but at the same time they must not be so loose that they tend to slip. It is a simple matter to calculate the sizes required from the following formula.

$$d = \frac{DS}{s}$$

- d=diameter of machine pulley.
- D=diameter of motor pulley.
- S= speed of motor (r.p.m.).
- s= speed of machine (r.p.m.).

For example, a pump is required to rotate at 1,000 r.p.m. The motor rotates at 1,500 r.p.m. and it has a 2in. pulley. What size pulley is required for the pump?

$$d = \frac{DS}{s} = \frac{2 \times 1,500}{1,000} = 3\text{in.}$$

If the machine already has a pulley and it is required to fit one to the motor then the formula is:—

$$D = \frac{ds}{S}$$

Taking the same example:—

$$D = \frac{3 \times 1,000}{1,500} = 2\text{in.}$$

There are three main motor faults to watch for, short circuits, open circuits, and overloading. Short circuits are usually indicated by the fuse blowing or the circuit breaker tripping. Sometimes there are also signs, or a smell, of burning. Open circuits (breaks in the wiring, etc.) prevent the motor from running at all, but the fuses or circuit breakers remain in operation. Overloading causes the motor to run slowly or not at all. It may also overheat and the fuse or circuit breaker will probably operate due to the rise in current. Small synchronous motors will not be damaged by overload. They just stop.

If an induction motor does not start unless it is rotated by hand, this means that the capacitor is out of action, or there is a break in the starting winding, or the automatic switch is not functioning. There will also be a humming noise. A damaged starting winding or capacitor may indicate a faulty automatic switch which has failed to switch out the starting winding after the motor has attained normal speed.

All motors except the double insulated types should be properly earthed so that there will be no danger of the metal casing becoming live due to a short circuit.

MODEL THORNYCROFT COASTAL MOTOR BOAT

(Continued from page 218)

Lights

A mast light was fitted which showed white ahead and port and starboard through openings in the sides. A stern light was also fitted. I fitted both with electric pea bulbs.

The gun

The gun fitted to the model is actually not correct. The original boats were armed with Lewis guns. The one on the model represents a 37mm Maxim. It was made for another model but when tried on this one looked so good it was fitted to it.

Crew

The model carries a crew, as scale model boats like this should never be seen on the water without one. Unmanned they look very unreal. But if you decide to put a figure on board do not attempt to dress it; it will look like a doll. Use a carved or plastic figure and paint it with flat paint. This way it will look realistic.

SIMPLE BRAKE TESTING

(Continued from page 206)

The instrument will also measure accelerations as a percentage of g. If, on accelerating, the liquid rises to 10% on one scale the car is accelerating at 3.2 feet per second every second, i.e. 2.2 m.p.h. per second. This is useful for getting optimum tune as the effect of slight adjustments to timing, tappets etc. can be measured. The instrument can thus be an aid to good tuning, but will not replace a good manifold vacuum gauge as a tune indicator.

TRADE NEWS

Universal woodworking machine

DESIGNED originally for the professional craftsman, the Swiss-built Inca Woodworker has for years filled a need in many branches of the woodworking industry for a compact multi-purpose machine.

Serious home woodworkers have, however, been quick to see in the Inca a means of producing a professional finish without the limitations generally imposed by portable power tools, and at only a moderate outlay. For this reason the Inca Woodworker is now offered in unit form to enable the home handyman to purchase only those units and attachments he requires. As all units and attachments are fully interchangeable this means that the complete machine may be built up over any period of time, thus providing a spread-over of cost.

Built around the most-used machine in any woodwork shop—the sawbench—the Inca Multi-purpose woodworker in its fully equipped version will cope adequately with the following operations:—

- Rip, crosscut and mitre to 2½ in. depth.
- Bevel and cut compound angles.
- Groove to ½ in. width.
- Mould (nine standard patterns).
- Tongue and groove.
- Tenon.
- Mortise to 3½ in. length in one pass.
- Bore to 4½ in. depth.
- Cut corner lock joints.
- Drum-sand profiles.
- Disc-sand flats.

Adequately protected for safe operation and especially suitable for students of wood machining, the Inca Woodworker is constructed to give years of trouble-free service and is backed by guarantee and full ex-stock facilities for all accessories, attachments and tools.

The combinations of units and attachments are numerous and all start with the sawbench with 16½ in. x 25½ in. tilting table—the heart of the

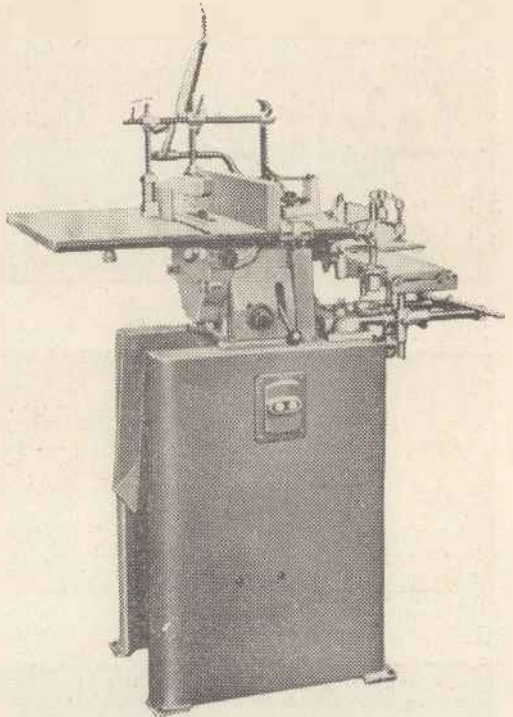

machine—which sells complete with blade, guard, full length fence, grooving washers and tools for £25. 0. 0. This may be powered by the user with the motorising kit, comprising ¾ h.p. single phase motor, starter gear, motor pulley and belt for £16. 0. 0. All other units and attachments may be added as required at a later date.

The fully motorised version mounted on the totally enclosed floor stand and equipped with most of the units and attachments normally required, sells for about £75. 0. 0. A 5ft flexible shaft for power take-off and grinding wheels for tool grinding are also available.

Practical men know that they save time, and trouble and money, by tackling a job in a practical way.

For every practical man who's seeking a home, or planning a holiday, or looking for a business to buy, here's the modern practical way of going about it. It's a great new weekly called *Property Advertiser and Holiday Guide* and every week it offers you hundreds of opportunities for homes, holidays and businesses from all over the country.

What's more, a new easy-reference system makes sure you find what you want quickly.

Property Advertiser and Holiday Guide is the really practical paper with the national coverage. It's from Newnes—the publishers of the famous "Practical" series. Price 4d every Friday, everywhere!

Making Small Mouldings

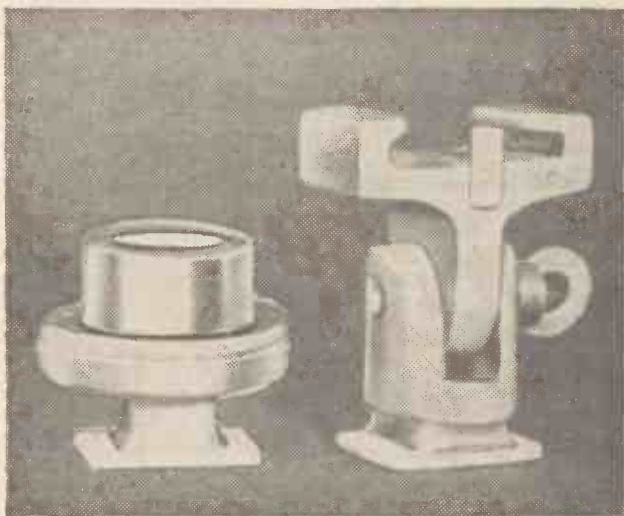

Fig. 1.

A JOB which generally defies the efforts of most home workshop enthusiasts is the production of small mouldings. Mouldings are particularly useful on two counts. Firstly, they can be given, in a single operation, smoothly flowing lines which are difficult or even virtually impossible to obtain by simple fabrication. Secondly, they require no machining facilities; some fettling and general cleaning up being all that is usually needed.

Since most amateur projects are one-off propositions the mould can be discarded after a single use and, in fact, the method described here entails the breaking of the mould to release the component. The moulding material employed by the writer is a metal-loaded putty known as Hermetal. This can be obtained in larger quantities but a sample pack costing 7s. 6d. direct from the manufacturers, the Kenilworth Manufacturing Co. Ltd., West Drayton, Middlesex, contains sufficient putty to produce half a dozen or more small mouldings. The pack also contains a thinner, paste-type material which is ideal for filling small imperfections.

Equal quantities of the two constituents are kneaded together in the hands. After a curing period which depends on the ambient temperature the material hardens and can be finished with hand tools and fine emery cloth where required. Drilling, filing, sawing and tapping can be carried out without difficulty. It is wise to avoid very thin sections as these have low strength. If a thin section is essential to the functioning of the component, an aluminium alloy sheet insert can be moulded in or attached with screws, rivets or epoxy resin adhesive.

Fig. 1 shows, on the left, a circular spirit level mounted on a foot for sliding into a camera shoe. Useful for levelling the camera and avoiding converging verticals when carrying out architectural photography or photo-copying, and an accessory impossible to buy at photo shops. At the right of Fig. 1 is a tilting head for similar attachment to the camera, and intended to hold a flashgun or range finder. Drawings for the spirit level and tilting

head are given in Figs. 2 and 4 respectively, since these items are likely to have wide appeal to readers.

The spirit level is of the circular type, in a raised pattern mount, and made by Cooke, Troughton & Simms Ltd., York. Sizes from $\frac{7}{8}$ to $1\frac{1}{4}$ in. flange dia. are available, the 1 in. model (No. E985) being shown here. These levels are produced by a number of manufacturers and can be ordered from tool shops at a cost of four to five shillings. With the foot-mounted level in the camera shoe, alignment is obtained in all planes when the bubble is centralised within the engraved circle on the glass top.

The tilting head enables a rangefinder or flashgun axis to be lowered to intersect the lens axis during close-up photography, as well as permitting the flashgun to be tilted upwards for bounce-flash applications. The angular setting is by friction, with a screw lock for final tightening.

The moulds should be made from cardboard, as shown in Fig. 3, laminated or shaped to obtain the required profile. The parts of the mould may be stuck together with any warm-water soluble glue, and the interior of the mould should also be given a thin coating of glue. Lamination is suitable for shallow items, such as the foot for the spirit level, which is shown being filled with moulding putty in Fig. 3. The putty must be rammed down as hard as possible with a spatula or similar tool.

It is unwise to rely on the outside profile of the mould laminations for alignment, since there are certain to be minor differences between one layer and another. When assembling the mould, line up each lamination so that the interior profile of one matches those on either side and ignore the exterior edges. The mould is best made with no top or bottom closure as filling may need to be carried out from both ends, especially where there is a centre constriction which would prohibit easy passage of the putty from one end to the other.

Having rammed the mould full, glue-coated strips of card should be used to level off both openings and should be left in position. After a minimum

of twenty-four hours at room temperature, immerse the entire mould in warm water to dissolve the glue and permit the pieces of card to float free. The moulding will then be left ready for finishing. Fig. 5 shows the lower section of the tilting head after release from the mould.

At least a further twenty-four hours should elapse before any further work on the moulding is undertaken, as hardening is gradual and progressive. All

finishing operations may then be performed. Since these mouldings are not solid metal in the normal sense, they need handling with a certain amount of care during finishing and in use. However, they are quite suitable for many lightly stressed components.

Although two small photographic accessories have been described here, the process can be used equally well for any other object of a similar nature. Other applications can easily be found.

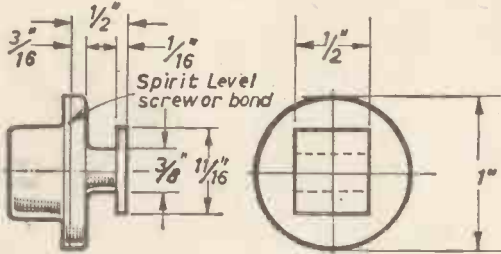

Fig. 2 (Above).—The accessory shoe spirit level.

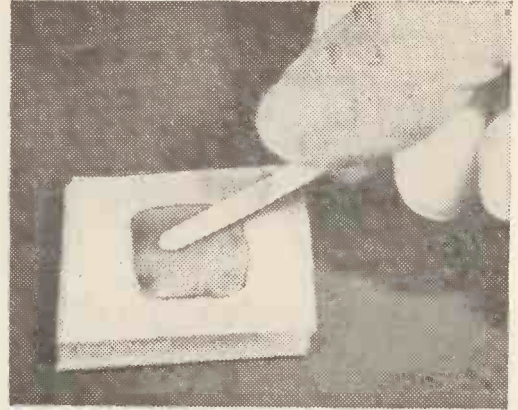

Fig. 3 (Right).—The putty should be pressed down firmly with a spatula to ensure that it is solid and fully fills the mould.

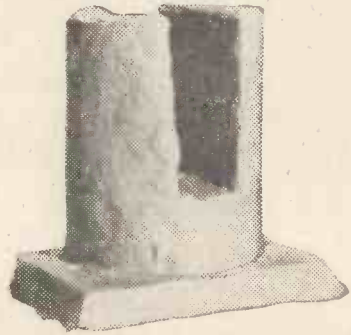
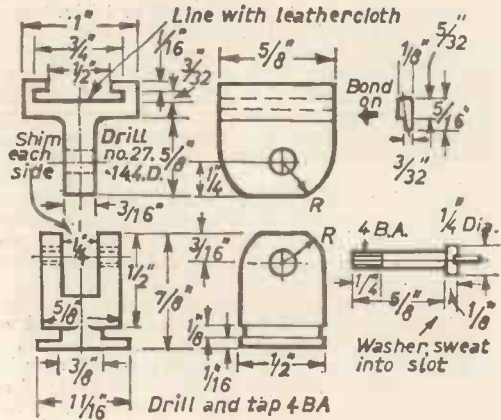

Fig. 4 (Left).—The tilting accessory head.

Fig. 5 (Above).—The base of the tilting head removed from the mould, before finishing.

THE P.M. BLUEPRINT SERVICE

- 12 FT. ALL WOOD CANOE. New Series. No. 1, 4s.*
- COMPRESSED-AIR MODEL AERO ENGINE. New Series. No. 3, 5s. 6d.*
- AIR RESERVOIR FOR COMPRESSED-AIR AERO ENGINE. New Series. No. 3a, 1s. 6d.
- "SPORTS" PEDAL CAR. New Series. No. 4, 5s. 6d.*
- F. J. CAMM'S FLASH STEAM-PLANT. New Series. No. 5, 5s. 6d.
- SYNCHRONOUS ELECTRIC CLOCK. New Series. No. 6, 5s. 6d.*
- ELECTRIC DOOR-CHIME. No. 7, 4s.*
- ASTRONOMICAL TELESCOPE. New Series. Refractor. Object glass 3in. diam. Magnification x 80. No. 8 (2 sheets), 7s. 6d.*

- CANVAS CANOE. New Series. No. 9, 4s.*
- DIASCOPE. New Series. No. 10, 4s.*
- EPISCOPE. New Series. No. 11, 4s.*
- PANTOGRAPH. New Series. No. 12, 2s.*
- COMPRESSED-AIR PAINT SPRAYING PLANT. New Series. No. 13, 8s.*
- MASTER BATTERY CLOCK.* Blueprints (2 sheets), 4s. Art board dial for above clock, 1s. 6d.
- OUTBOARD SPEEDBOAT. 11s. per set of three sheets.
- P.M. TRAILER CARAVAN.* Complete set, 11s.
- P.M. BATTERY SLAVE CLOCK, 2s. 6d.
- P.M. CABIN HIGHWING MONOPLANE, 1s. 6d.
- THE MECHANIKART, 15s.*



Lawn Aerator and Garden Roller

A TWO-IN-ONE GARDEN IMPLEMENT

by J. R. EVANS

THE majority of readers of PRACTICAL MECHANICS AND SCIENCE have to allot some of their time to gardening and the two implements about to be described are simple to construct and should prove to be worthy of a place in the tool-shed.

A lawn will benefit from an occasional aeration of the surface to allow air, moisture and fertilizer to get to the roots, which is the purpose of the first implement. Actual dimensions at the business end of the implement have been omitted, as these will depend upon the size of the containers used by the constructor. As a guide the spiked rollers shown in the photograph were made from two baby-food tins which measured $4\frac{1}{2}$ in. diameter by 7 in. long. These sizes are not critical, but it is suggested that 4 in. diameter should be the minimum size. Furthermore, to ensure that the spikes are firmly held by the concrete filling, the two outer lines of spikes should be positioned not less than 1 in. from each end. The plain roller is constructed out of a metal drum (or drums) of similar length to the spiked rollers, in order that both units can be used with the same handle.

It is worth while also to make a tubular metal sleeve to fit over the aerator roller. This will allow the spiked rollers to be safely stacked on end in a corner of the tool shed when not being used. Those spikes are really sharp and otherwise will just lay in wait for an unwary ankle!

Lawn aerator

Having obtained two suitable size tins, carefully centre-punch the centres of the bottoms and lids. With a hole-saw cut holes in these positions to take $\frac{3}{4}$ in. diameter steel conduit. Cut a piece of plain paper to the length and circumference of the tin and mark on it the positions of the spikes as shown in Fig. 3. Attach the paper template to the surface of the tin with adhesive tape. Cut a piece of $\frac{1}{2}$ in. thick

scrap timber the same width as the inside diameter of the tin, slightly rounding the edges as shown. Use this as a packing block and punch-mark the position of the spikes (Fig. 4). After removing the template drill holes in the marked positions, the same diameter as the spikes (approximately $\frac{1}{8}$ in. diameter). Cut off two lengths of $\frac{3}{4}$ in. steel conduit about $\frac{1}{4}$ in. longer than the tins.

Mix the concrete in the proportion of 1:1:2, i.e., 1 part cement, 1 part sand, 2 parts small shingle (or stone or granite chippings). Using a container the same size as the rollers as a measure, mix $\frac{1}{4}$ tin cement, $\frac{1}{4}$ tin sand, $1\frac{1}{2}$ tins shingle; this will yield sufficient concrete to fill the two rollers. Thoroughly mix together the dry material on a flat clean surface then add clean water, a little at a time, and mix to a thick porridge-like consistency.

Insert the spikes (3 in. masonry pins) through the lower line of holes, leaving the points projecting $1\frac{1}{2}$ in. Insert one end of the piece of steel conduit in the drilled hole at the bottom of the tin and pour in about a 3 in. layer of concrete. This should then be thoroughly rammed down with a steel rod.

Place the middle row of spikes in position then add a further 3 in. layer of concrete, rammed as before. The final row of spikes should then be put in and the concrete brought up level with the top, rammed and smoothed off level. Fit the lid, leaving the $\frac{3}{4}$ in. tube projecting about $\frac{1}{4}$ in.

Finally place the rollers somewhere where they can remain undisturbed until the concrete has set, and adjust the spikes so that they all project $1\frac{1}{2}$ in. radially and lie in the same planes horizontally. A few gentle taps around the rim of the tin with the handle of a screwdriver or similar will consolidate the concrete after these adjustments have been carried out. The filled rollers should be left for 2-3 weeks before being used. In the meantime resist the temptation to waggle the spikes to see if they are firm, for once loosened, little can be done to make them solid again.

The handle

The tee-shaped handle should be made of $1\frac{1}{2}$ in. square oak or other hardwood, morticed and tenoned and wedged and glued together after the cross-piece has been turned or carved to shape.

The two $1\frac{1}{2}$ in. or $1\frac{1}{4}$ in. x $\frac{1}{4}$ in. mild steel flat strips should be heated and bent to the required shape in a vice. Drill holes for the $\frac{1}{2}$ in. diameter spindle and the $\frac{1}{2}$ in. diameter bolts as Fig. 5. Bolt the bent brackets to the handle with $2\frac{1}{2}$ in. x $\frac{1}{4}$ in. diameter bolts. Drill a $\frac{1}{4}$ in. diameter hole at each end of the spindle to take suitable split pins.

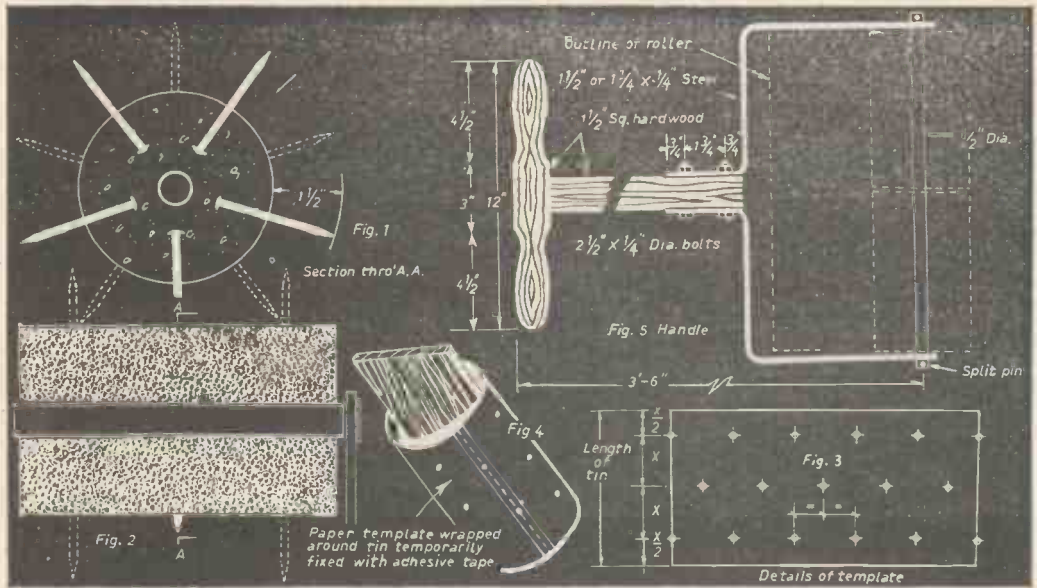

Two or three coats of paint on all exposed metal-work and a couple of coats of varnish or linseed oil on the handle will protect and improve the appearance of the implement.

Plain roller

This is constructed in a similar manner to the aerator using a metal drum 10 in. to 12 in. diameter and of a suitable length to fit between the steel brackets. The ends should be drilled and fitted with $\frac{3}{4}$ in. steel conduit as before.

The concrete filling in this case is a much weaker mix consisting of 1 part cement, 2 parts sand, 4 parts shingle (or stone chippings), mixed and placed

in the same way as previously. As a guide to the weight of the finished roller, a 12 in. diameter by 15 in. long roller would weigh approximately $1\frac{1}{4}$ cwt.

Method of use

The method of using the aerator depends on the texture of the lawn. If the ground is reasonably soft it is usually sufficient just to pull the implement along, but where the surface is inclined to be hard, pushing on the handle is suggested. The degree of penetration is controlled by the angle made by the handle with the surface. A steeper angle gives deeper penetration.

THE GOZUNDA

(Continued from page 207)

To provide lateral movement of the inspection unit along the bridge a special type of hydraulic bollard winch is fitted to the underframe of the rail wagon. A steel wire rope is attached to anchor points on the track ahead of and behind the rail wagon on which the unit is mounted and passes round the drum of the winch. The wagon can be hauled along the 100yd length of steel rope at speeds up to 40ft per minute when controlled from the gantry platform and 20ft per minute when controlled from the inspection platform. A Klaxon horn on the gantry gives a warning to the men on the track when the engineers on the inspection platform are to operate the winch gear to move the wagon along the track.

A 3kW generator provides power for electric tools for breaking out defective masonry or brick-work and for 300W swivel floodlights fitted on the platform. Above the headstocks at each end of the

rail wagon, spotlights are fitted to provide lighting along the length of track. Lighting is also provided over the winch gear, on the slewing gantry platform, over the power unit and in the cab at the end of the wagon. This cab is provided with seats, lockers for tools and equipment, brackets for stowing floodlights and a table on which plans can be examined. Communication between the cab and the men on the inspection platform is provided by means of two telephones which enable information to be passed up direct from the platform for recording on the plans.

The economies made by using the Simon Viaduct Inspection Unit have paid for the cost of it within three years. It has also enabled the North-Eastern Region engineers to complete the inspection of every arch of the Royal Border Bridge between trains during two Sundays. By the old method this job would have occupied many weeks.

Interest in the inspection unit has also been aroused abroad. In 1961 a unit was supplied to the German railways and one to the French railways. A further order was then received to provide a Simon Viaduct Inspection Unit to the French railways by the end of 1962.

PARKER'S SHEET METAL FOLDING MACHINES

NEW BENCH MODEL



Capacity 36in. wide x 18-gauge mild steel. Forms channels and angles down to 45 deg., which can be flattened to give safe edge. Depth of fold according to height of bench. Will form flanges.

Weight approx. 2 cwt. for general purposes. 49° for very soft materials. 50° for drilling wood, ebonite and formica.

Price £23/0/0, carr. free. Also the well-known vice models of:
 36 in. x 18-gauge capacity ... £11 10 0
 24 in. x 18-gauge capacity ... £6 15 0 } Carriage
 18 in. x 16-gauge capacity ... £6 15 0 } free

One year's guarantee: money refunded without question if not satisfied. Send for details:

A. B. PARKER, Wheatcroft Works
 WELLINGTON STREET, BATLEY, YORKS. Tel: 426

GAMAGES

DRILL GRINDING JIGS

VERTICAL DRILL STAND



Capacity 1/2in. to 1/2in Has scale of five angles: 88° for thin sheet, hard materials and counter sinking. 68° for 1/2in. drills and smaller. 50° for general purposes. 49° for very soft materials. 50° for drilling wood, ebonite and formica.

Post & pkg. 2/-

GAMAGES PRICE 30/-

This press provides extra leverage, accuracy and control for any of the famous Electric Drills. "Tee" slotted cast iron base.



ONLY 70/-
 If outside our van area Part Carr. & Pkg. 4/9 Adaptor for Woll Cub or Bridges Tool Power drills 3/- extra. Adaptor NOT required for B. & D. drill.

PICADOR 'PUP' UNIVERSAL LATHE

This excellent unit can be purchased as a complete Lathe, as shown, or separate parts as required. Robustly constructed to give good service. For Sawing, Sawing, Sanding, Drilling, etc. Fitted with graphite impregnated Bronze Bushes, weight approx. 12 lbs., size approx. 25 x 8 1/2 x 6 1/2 in. with 24 Tube Bed.

£7.7.0

or 9 monthly payments of **17/3**

3 1/2 in. 4-Jaw Independent Chuck 60/- extra. If outside our van area Part Carr. & Pkg. 5/6



SPECIAL OFFER TO DRIVE LATHE

1 h.p. G.E.C. ELECTRIC MOTOR 1440 R.P.M.—230V, A.C. Mains Needs to be adapted to bench, motor has plain round body. Motor Pulley 3/8 extra—send 9d. for broad sheet on above Lathe. 13/3 for 1960 complete Picador Catalogue and 2/10 for Picador 1963 New supplement, to 1960 catalogue.

79/6 Carriage & pkg. 7/6

GAMAGES, HOLBORN, LONDON, E.C.1. HOLborn 8484

The book for the serious model-maker . . .
RADIO-CONTROLLED MODELS

The remote control by radio of models—whether aeroplanes, boats, locomotives, tanks or steam rollers as well as stationary models—is an important post-war development with a keen, wide-world following of hundreds of thousands of enthusiasts. This practical book is the result of numerous experiments and long research on the subject and includes information already published in the nationally read "Practical Mechanics" plus additional material. Contents include steering control gear; receivers; transmitters; control box; tuned reeds; model actuators; tuning transmitting aerials; details for model battleship and aircraft, etc. Fully illustrated with circuit details, diagrams, etc. 192 pages.

12s. 6d. FROM ALL BOOKSELLERS
 or, in case of difficulty, 13s. 6d. by post from
C. ARTHUR PEARSON, LTD. Tower House,
 Southampton Street, London, W.C.2.

FREE THIS BOOK WILL INTEREST YOU!

EARNING the PRACTICAL WAY

Radiostructor EQUIPMENT COURSES

FOR

- .. Your Career
- .. Your Own Business
- .. An Absorbing Hobby

A NEW-PRACTICAL WAY of UNDERSTANDING

RADIO • TELEVISION • ELECTRONICS

Including: Transistors; VHF/FM; Hi-Fi equipment; Computers; Servo-mechs; Test instruments; Photo-electrics; Nucleonics, etc.

Radiostructor—an organisation specialising in electronic training systems—offers a new self-instructional method using specially designed equipment on a "do-it-yourself" basis. You learn by building actual equipment with the big kits of components which we send you. You advance by simple steps performing a whole series of interesting and instructive experiments—with no complicated mathematics! Instructional manuals employ the latest techniques for showing the full story of electronics in a practical and interesting way—in fact, you really have fun whilst learning!

RADIOSTRUCTOR
 LEADS THE WORLD
 IN ELECTRONICS TRAINING

POST NOW

To **RADIOSTRUCTOR** (Dept. G28) READING, BERKS. Please send brochure, without obligation, to:—

*Name.....

*Address

(We do not employ representatives) *Block Caps Please

How to mark out clock dials

By G. W. PARTRIDGE

THE practical man may well be called upon to make a simple clock dial. This kind of work crops up when clock toys are to be made for small children or it may be desired to make up a time switch and replace the metal dial of a clock with other material so that contacts can be arranged around the dial to operate alarms, etc., at certain hours. It might also be decided to make a large decorative clock dial and fit an old but still useful clock movement to it. Or, of course, it may simply be necessary to replace a damaged dial.

First of all choose a suitable material and draw a circle with a pair of compasses to the required size. With metal dials a pair of machine shop dividers will be preferable. Mark the 12 o'clock position on the top of the circle. Now with the compasses or dividers still set at the same radius mark off the 2 and 10 o'clock positions with the compass point set on the 12 o'clock point (Fig. 2a). Now starting with the point on 2, move around the circle with the same radius and mark the 4, 6 and 8 o'clock positions (Fig. 2a). With the compasses again set to the same radius and the point on 2 draw an arc outside the circle. Now with the compass on 4 draw another arc crossing the first one (Fig. 2b). With a rule draw a line from the intersection of these arcs through the centre of the circle. This marks the 3 and 9 o'clock positions (Fig. 2b). With the compass point on 3 o'clock mark the 1 and 5 positions. Now move round the circle with the compasses and mark the 7 and 11 o'clock points. The hour figures from 1 to 12 can now be drawn, painted or stencilled in.

Start drawing the minute markings by first placing a protractor so that its baseline runs through the 3 o'clock and 9 o'clock points and the 90-degree line through the 12 o'clock position (Fig. 4). Now carefully mark off 6° up from 3 o'clock on the dial. Draw a line through this point and the centre of the circle (Fig. 2c). This

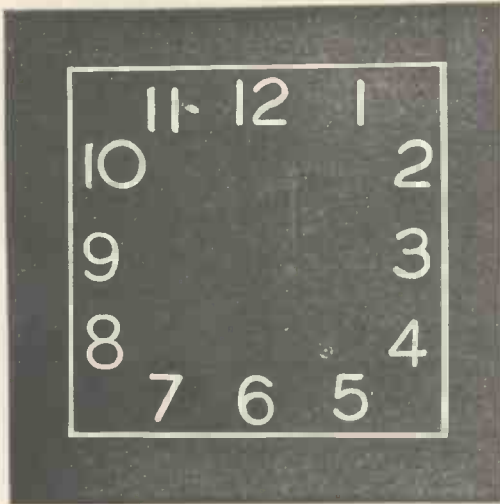
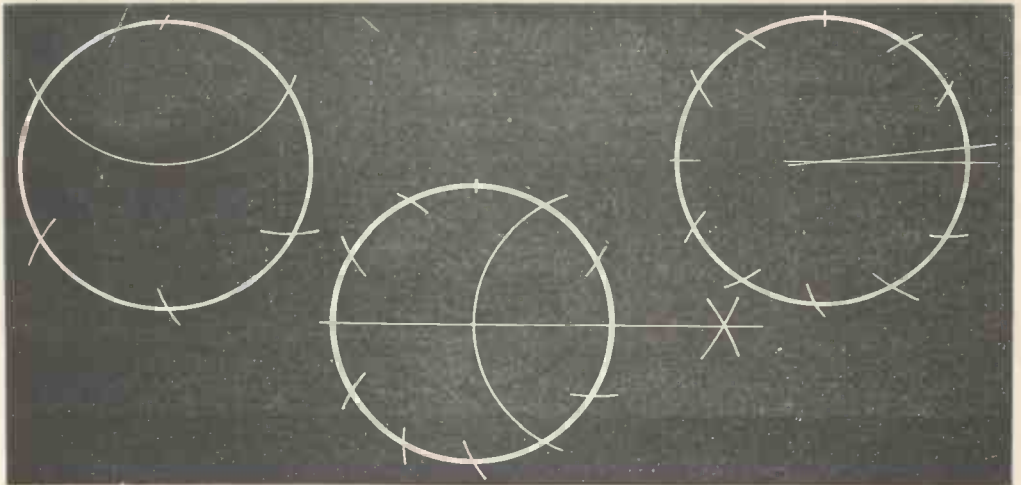

Fig. 1.—A typical square clock dial with hour markings.

Fig. 2a.—Marking the 2, 4, 6, 8 and 10 o'clock positions.

Fig. 2b.—Finding the 3 and 9 o'clock positions.

Fig. 2c.—The first five-minute division.



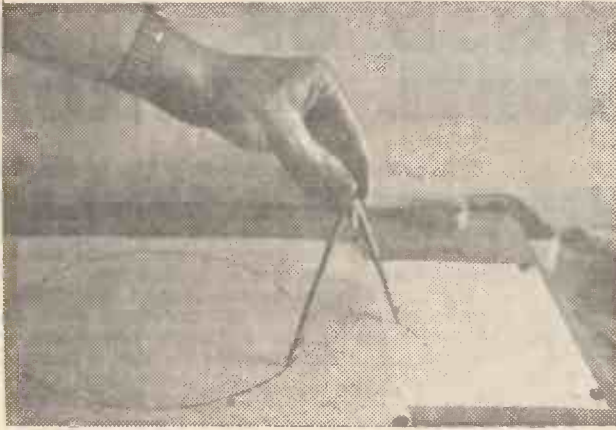

marks the 14-minute position on the circle. Set the compasses or, better still, a pair of dividers to this width and carefully mark five one-minute divisions between each hour point.

Square-faced dials are marked out differently. The 12, 3, 6 and 9 o'clock positions are found by simply dividing the face into quarters (Fig. 5). Then each of the quarters should be divided

Fig. 3.—Marking two intersecting arcs outside the circle, from the 2 and 4 o'clock positions, to find the 3 o'clock and 6 o'clock positions.

Fig. 4.—Laying a protractor with its base along the 9-3 o'clock line to mark the first five-minute division. This is 6° above 3 o'clock. The remaining divisions are marked with dividers set to this width.

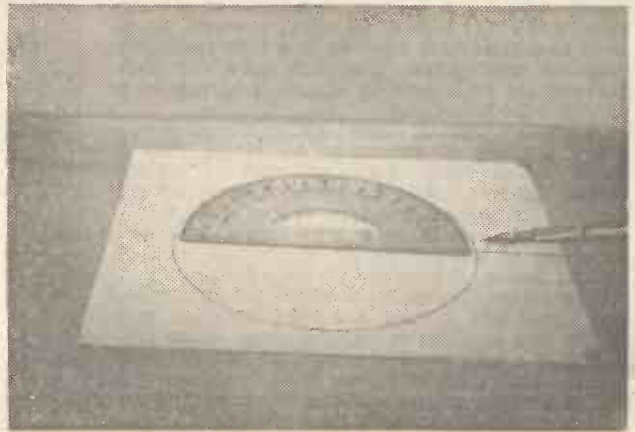
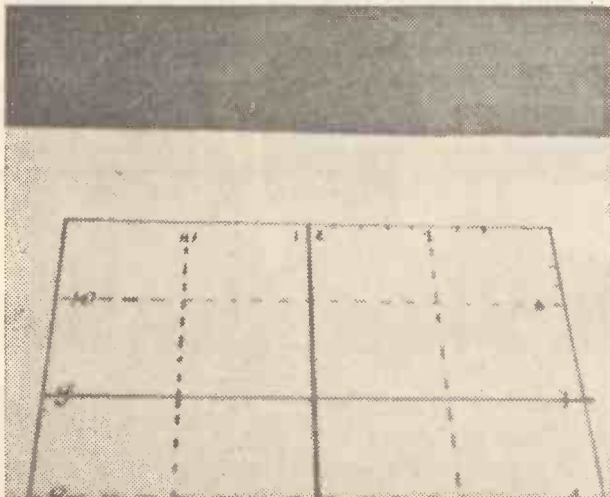

Fig. 5.—Marking out a square clock dial. The 3, 6, 9 and 12 o'clock positions are obtained by quartering the square, the rest by quartering these quarters.



into four again to give the remaining hour points.

One-minute divisions are often not used around square dials but can be marked out as follows: Draw a circle inside the square and mark out the one-minute divisions as for a round dial. Draw line through the centre of the dial and these points, marking where they cross the square.

A NEW METHOD OF MODEL CONTROL

THE use of ultrasound for control purposes has increased considerably during the last year or so, due to the range of new ultrasonic components available. With ultrasonic control, instead of using radio waves to transmit commands, the control signals are carried by ultrasonic (very high frequency) sound waves. Two great advantages are that no radio transmitting licence is required and interference by other control systems operating nearby is completely eliminated. Now the introduction of new ultrasonic transducers for use in transmitting and receiving units has brought ultrasonics for remote control within the range of all model makers.

For the simple ultrasonic control system the same transducer is used both as transmitter and receiver. When used as a transmitter it operates as a loud-speaker at a very high sound wave frequency. When used as a receiver it operates as a high frequency response microphone. The unit used for both transmitting and receiving signals is known as a Gulton 1404 transducer.

A simple ultrasonic control system comprises two units, typically a transmitter no bigger than a small pocket torch and a receiver of similar dimensions mounted in the model. The transmitter has two transistors driving a Gulton 1404 transducer and operates as a high frequency sound generator at a frequency of 40kc/s (the limit of human hearing is normally between 10-15kc/s).

The receiver comprises a transducer picking up the signal and feeding a simple transistor unit which then amplifies the control signal before passing it to a relay or other control device within the model. Both these units can be easily constructed by the amateur with no specialist knowledge (typical circuit details are available from the makers).

To control a model train a small press key mounted on the transmitter unit is depressed, sending out the ultrasonic control signal. When the control signal is received by the train, it operates the relay, switches on the current to the motor and the train moves, the power being permanently switched on to the rails.

The same technique can be used to control most type of models, whilst many engineers and model makers will think of other uses such as alarm systems and control of household equipment. The transducers can also be used to transmit speech using the ultra-sonic frequency as a carrier.

The transducers measure only 1in. in diameter and $1\frac{3}{4}$ in. in length. The basic model 1404, with a centre frequency of 40kc/s, has a wide directional beam width of 65° to the 6dB points. The bandwidth is 4kc/s but narrower bandwidths can be arranged by the use of a series capacitor.

For multi-channel control systems the circuitry can be arranged so that one transducer alone can be used, but Gulton ultrasonic transducers of different centre frequency are available if required.

Further information is obtainable from: Gulton Industries (Britain) Ltd., 52 Regent Street, Brighton 1, Sussex.

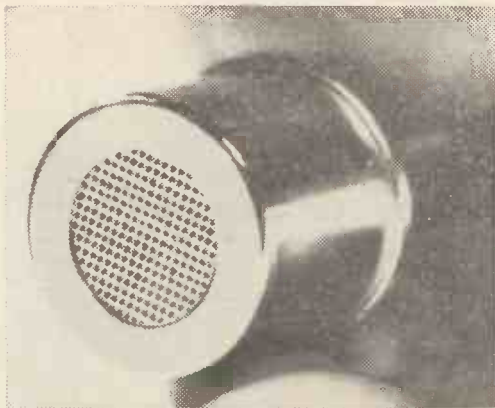

Close-up of the transducer.

Demonstrator controls a model railway.

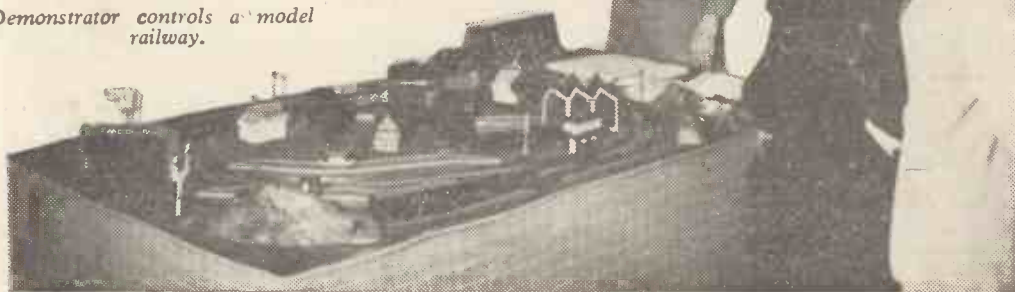

SALES AND WANTS

The prepaid charge for small advertisements is 9d. per word, with box number 1/6 extra (minimum order 9/-). Advertisements, together with remittance, should be sent to the Advertisement Director, PRACTICAL MECHANICS AND SCIENCE, Tower House, Southampton Street, London, W.C.2.

PERSONAL

INVENTORIOUS LIMITED

Our team of consulting experts is available to advise and assist you in all technical and commercial phases of the successful development of your inventions.

Write to:

The Commercial Director
INVENTORIOUS LIMITED
278/282 High Holborn, W.C.1.

PATENTS

PATENTING SERVICES. Advice qualified Agent. C. L. BROWNE, 114 Greenhayes Avenue, Banstead, Surrey.

FOR SALE

CLUB, CAR and Lapel Badges at realistic prices from: **TESTER HATCHER & CO. LTD.**, Oliffe, Rochester, Kent.

RAILWAY PHOTOGRAPHS. Steam and Diesel, thousands to choose from. Postcards 8d. each send 1/- (in stamps). R. O. COFFIN, 57 Landrail Walk, Renchay, Bristol.

Make your own 2in. Slide Projector. Leech 3in Lens with Focusing Mount £2.15.0, post 1/6. Pre-Focus Lampholder 5/-, post 6d. Double Condenser Assembly with Carrier 15/-, post 1/6. Lamphouse with Mirror 10/-, post 1/6.

All the above parts are removed from Brand New Ex-Government Ellis & Newton 35mm. Strip Projector. The projector complete less lamp, containing all the above parts and many more can be purchased for £4.15.0. Post 4/-.

Similar but Heavier Built Strip Projector Adioscope by Metalair. 3 Element Condenser system. Beck 3 1/2in. lens. Lighting by 110 volts. 200 watt pre-focus lamp, inbuilt transformer to operate from 200-220 volts A.C. in wooden carrying case, used but good condition. £5.15.0, plus 3/- carriage (spare lamps 3/- ea. plus 1/- post).

EX A.M. G45 Gun Camera. 24 volt, 2in. fixed focus lens 50 ft. magazine loading, complete with magazine, new £2.15.0, ditto used £2. Both post 2/6. Brand new Kodak (ex Admiralty) 7 x 50 Prismatic Telescopes, focussing in fitted wooden case with binocular eyepiece, fitted filters, cost over £50; due to another huge purchase lower than ever price £4.10s, each, carriage 5/-.

Brand new (ex A.M.) 12 volt 25 amp, batteries. These are R.A.F. general purpose lead acid accumulators, and are similar in construction to normal car battery. Very suitable for cars and vans, will start any vehicle. Never been filled and in original tropical packing. First charge instructions included, cost about £11, only £2.10.0 each, carriage 5/-.

All Metal Projector Stands. Lightweight, fold flat when not in use. Model 1. Height 3ft. Table 20 x 13in. Grade 1 £4. 2ft. 4ft. £2. Both post 1/6. Model 2. As above but height variable between 2ft. 9in. and 3ft. 3in. Platform 21 x 13in. Grade 1 £5. Grade 2 £3. Both carr. 7/6. All are in good condition, used but paintwork is very good on Grade 1 models.

EX R.A.F. Aerial Film. 9 1/2in. x 300ft. Pan. £3. 160ft. 35/-, 5 1/2in. x 47ft. 5/-, 24ft. 5/-. Ideal for cutting to smaller sizes. Perfect condition. Post 1/6. EX A.M. G68 Mark 3 Recorder Camera. 16mm. made by Specto. Latest model with three shutter speeds, 2 or 16 f.p.s., bicoomed 1 1/2in. lens F1.9 with iris to F1.6, 24 volt 50ft. magazine loading, complete with magazine in original tropical packing, absolutely brand new, only £5, post 2/6. Ditto used £3.10.0, post 2/6.

All goods supplied on 14-day money back guarantee.

R. SANKEY Regal Cinema, ATHERSTONE
WARWICKS. Tel.: Atherton 2220, 2210

FOR SALE

(continued)

OXY-ACETYLENE Home Welder. Build your own, instructions 2/6. **DRESDENA,** The Harrow Way, Basingstoke, Hants.

CATALOGUE NO. 45. About 5,000 items. Materials, Electrical and Mechanical Gear. Very interesting. **K. R. WHISTON** (Dept. P.M.S.), New Mills, Stockport.

BLACKSMITHS PORTABLE FORGES! Brand new Government from £5/15/- carr. paid. Particulars free. **GREENS,** 937 Albert Street, Lytham.

WASHING MACHINE Spares, new and second-hand. **J. AND D. ELLISON,** Barkerhouse Road, Nelson.

ASTRO TELESCOPE making Standard Ramsden push-in eye-pieces. 1 1/2in., 1 1/4in., 1 1/2in. focus 35/-; with R.A.S. thread 42/6 each. S.A.E. list. Object Glasses. Newtonian Mirrors, Diagonal Mounts, Focusing Mounts, Altazimuth Mountings and Tripods for Refractors and Reflectors. **W. BURNET,** 99a West St., Boston, Lincs.

WATCHMAKERS

NEW WATCHES, watch movements, Watchmakers' tools and materials, instructional books, etc. at unbeatable prices. Also watch repairs undertaken. Send 1/- for Bumper Bargain Catalogue. **THE WATCHMAKERS' SUPPLY COMPANY,** "Time House", Carterton, Oxford.

WATCH REPAIRERS. Send 9d. for Catalogue of Watch parts and New Watches at lowest Wholesale prices, also Used Movements, Instructional Books, Special Kit for Beginners. **T. G. LOADER & CO.** (Dept. B) 36 Milestone Road, Carterton, Oxford.

HOBBIES

NEWTONIAN TELESCOPE making. 6in., 8 1/2in., 11 1/2in. Glass discs, Grinding Kits. Aluminium Parabolic Mirrors. Optical Flats, Ramsden Eye-pieces, Barlow Lenses. S.A.E. for list. **L. J. MAYS,** 20 Clover Road, Timperley, Altrincham, Cheshire.

CATALOGUE NO. 15. Government surplus Electrical and Radio equipment. Hundreds of items at Bargain Prices for the Experimenter and Research Engineer. 2/6 post free. Catalogue cost refunded on purchase of 50/-. **ARTHUR SALLIS RADIO CONTROL LTD.,** 93 North Road, Brighton.

HANDICRAFTS

MARQUETRY VENEERS. 12 assorted 6/-. post free. List 3d. **FRANK COLES (VENEERS) LTD.,** 76 Rivington Street, EC2.

JEWELLERY SIMPLY MADE. Rings, Brooches, Catalogue free. **WEBBS,** 105 Upminster Road, Hornchurch.

PHOTOGRAPHY

PROJECTORS. Home Assembly Kits, all types and sizes and stereo from £6/2/6. Fan Base Kit £3/7/6. Opticals, Screens. S.A.E., **MARSHALL SMITH LTD.,** 64 Norwich Avenue, Bournemouth.

ELECTRICAL

ALL TYPES OF Electrical Goods at extremely competitive prices. e.g., 5-amp Twin Cable, 35/- 100yd; Lampholders, 7/- doz; 5ft. Batters, 49/-. Quality and immediate dispatch guaranteed. Request list. **JAYLOW SUPPLIES,** 93 Fairholt Road, London N16. (Tel.: Stamford Hill 4384.)

SMALL ELECTRIC CIRCULATING PUMP

for hot or cold water, fish tanks, ornamental fountains, waterfalls, milk cooling, greenhouse watering, pot washers, etc., comprising 120 watt unshrouded type, shaded pole, A.C. motor, coupled to centrifugal die-cast pump. Output 250 g.p.h. Maximum head - feet, 220/250 volts, silent continuous running.

New Price £3.3.0. Post paid.
H. MIDDLETON, 639 ABBEYDALE RD., SHEFFIELD, 7.

BRAND NEW

BROOK ELECTRIC MOTORS
Single Phase, 1/2 h.p., 1,500 r.p.m. £7 13 9
1/4 h.p., 1,500 r.p.m. £10 7 6
H.P. TERMS 1/2 h.p., 3,000 r.p.m. £10 7 6
AVAILABLE 1/2 h.p., 1,500 r.p.m. £11 16 9
1/4 h.p., 3,000 r.p.m. £11 16 9

Fully guaranteed by makers, approval against cash. Carriage paid mainland. State voltage.

P. BLOOD & CO.
ARCH STREET, RUGELEY, STAFFS.

WOODWORKING

ANGLIAN RANGE Saw Spindles, 10in. R/F Sawbenches, 6in. and 8in. Planers, 6in. Sawplanes and Woodworking Lathes. Send 6d. postage for brochures and price list to: **THE EAST ANGLIAN TRADING COMPANY,** 5 Guardian Road, Norwich, Norfolk. NOR55A.

HOME BOAT BUILDING

FULLY PREFABRICATED Kits to assemble a boat at home for two-berth Cabin Cruisers, fast Runabouts, Canoes, Prams, Enterprise Signet Sailing Dinghies. Leaflets from: **WYVERN BOATS (WESSEX) LTD.,** Milborne Port, Sherborne.

BROMLEY BOATS, Kits, Mahogany, Silver Spruce, American Boat plans. 3d. list. Southlands Road, Bromley, Kent.

TOOLS

LARGEST STOCKS OF Bargain new Cutting Tools. Send for free list. **ENGINEERING TOOLS LTD.,** 313 New North Road, London N.1. Phone: Canonbury 9977. Cables: Gepetra Londonal.

MISCELLANEOUS

AQUALUNG AND COMPRESSOR
Equipment, Ballraces and Miscellaneous items Lists 3d. PRYCE, 157 Malden Road, Cheam, Surrey.

EDUCATIONAL

"HOW AND WHY" of Radio and Electronics made easy by a new non-maths practical way. Postal instructions based on hosts of experiments and equipment building carried out at home. New Courses bring enjoyment as well as knowledge of this fascinating subject. Free brochure from: Dept. 12, P.M., **RADIOSTRUCTOR**, Reading.

POSTAL TUITION in Technical Drawing, tracing and blueprint reading. Drawing and design in wood or metalwork for Handicraft Teachers Examinations. Details from: C. PANNELL, 145 The Crossway, Portchester, Hants.

G.C.E. in Geometrical Drawing Postal tuition to "O" level. C. PANNELL, 145 The Crossway, Portchester, Hants.

ENGINEERING DRAWINGS. Learn how to prepare and read them by simplified postal tuition. No previous technical education required. Complete course £2. Single lesson 10/- Write for free prospectus to: **SPEEDI-DRAFT**, 2 Norwood High Street, London SE27.

It's MADE

By repairing Radio and TV Sets as a job or as a spare time business. Our practical course will show you the way. No previous experience is required.

SEND FOR FREE BOOK TO-DAY

RADIOSTRUCTOR

Dept. G.90 READING, BERKS.

SITUATIONS VACANT

A.M.I. Mech.E., A.M.BrIt.I.A.E., City and Guilds G.C.E., etc. bring high pay and security. "No pass—no fee" terms. Over 95% success. For details of exams and courses in all branches of Engineering, Building, Electronics, etc., write for 148-page handbook free. B.I.E.T. (Dept. 967B) London W8.

RADIO

RADIO, TELEVISION Service Sheets. All types Valves. S.A.E. list. JOHN GILBERT TELEVISION, 1b Shepherd's Bush Road, London W6. SHE 8441.

MATCHBOX SIZE Crystal Sets, all parts, instructions 3/3. BAILEYS (P.M.), 23 Fir Lane, Royton, Lancs.

NEW POCKET MANUAL "PRACTICAL STEAM TRAPPING"

New unique guide to correct selection and installation of steam traps for mains drainage, heating systems, process steam units of all kinds; including best condensate-lifting installations. Concise directions; clear illustrations. Copies free on request to:

SPIRAX-SARCO LTD.
(TECHNICAL DEPT.) Cheltenham, Glos.

ROGERS 31/83 NELSON ST. SOUTHPORT

Fibre Washers, 144 Assorted ..	3/6
Mercury Switches ..	8/6
Timer Motors, 1 r.p.m. ..	28/-
Rectifiers 6/12 v. at 5 amps. ..	17/-
Transistors, GT11 Braided ..	2/6
Motorised Water Pumps ..	95/-
Instrument Cases, 12in. x 8in. x 6in. New	7/3
Thread Gauges ..	4/9
Races, Belts, Valves, Pulleys, Pumps, Brass, Steel, Aluminium, etc.	By Arr.

10 PAGE LIST FREE, STAMP PLEASE



THE "ADEPT" BENCH HAND SHAPER
Length of stroke of ram 3 1/2 in.; or No. 2 R.H. model, 6 1/2 in. stroke. Also for Power-drive—extra.

Ask your dealer Manufactured by



The "SUPER ADEPT" LATHE
1 1/2 in. centres 6 1/2 in. between centres. A good range of accessories is available.

F. W. PORTASS MACHINE TOOLS LTD.
Adept Works, 141a Nicholson Road, Heeley, Sheffield, 8.

INTRODUCING A NEW PORTASS LATHE
3 3/4" x 16 1/2" B.G.S.C. bench lathe complete with faceplate, catchplate and backplate, change-wheels, etc., flat or vee drive. Complete satisfaction or remittance refunded in full. Ex-works write:
CHARLES PORTASS & SON
Buttermere Works, Sheffield 8
Est. 1889 Cash or terms

Everyman's guide to astronomy—a fascinating book—

FOCUS ON STARS

Julius D. W. Staal, F.R.A.S.

Today, probably more than ever before, astronomy is a vital study. This fascinating book by a distinguished astronomer is an account of the universe which will be a practical inspiration to both the layman and the amateur astronomer. The reader will experience a real pioneering excitement as astronomical calculations are made step by step and the wonderful workings of the heavens are unfolded. Clear and simple diagrams are used to illustrate the cause of the tides, the complex motion of the earth, the seasons of the other solar planets, eclipses, the nature of galaxies. Monthly star charts give a unique all-the-year-round guide. The author was previously at the London Planetarium.
292 pages, 16 plates, numerous figures and 12 star charts.

40s. FROM ALL BOOKSELLERS
... or, in case of difficulty, 41s. 6d. by post from George Newnes Ltd., Tower House, Southampton St., London, W.C.2

NEWNES

BRASS, COPPER, BRONZE, ALUMINIUM, LIGHT ALLOYS

Rod, Bar, Sheet, Tube, Strip, Wire

3,000 Standard Stock Sizes
NO QUANTITY TOO SMALL.
List on application.

H. ROLLET & CO. LTD.
6 CHESHAM PLACE, LONDON, S.W.1
Also at BELGRAVIA 4300
LIVERPOOL, LEEDS, MANCHESTER, BIRMINGHAM

WE WILL SUBMIT—ON APPROVAL

- PROJECTION MICROSCOPE. An amazing new instrument designed by Charles Frank. £28.10.0
- Ex-M.O.S. HARDENED CHESTERMAN COMBINATION SET No. 92, with 12" rule. Brand new cond. £6.15.0
- TOOLROOM CLINOMETERS (Micrometer Bubble-Type) 35/-
- The NEW RUSSIAN MICROSCOPE. Worth £70. £47.10.0
- Ex-R.A.F. ILLUMINATED MAGNIFIERS with 3" diam. lens. 38/6
- GERMAN DRAWING INSTRUMENT SETS: Brand new in velvet lined case. £2.19.6

CHARLES FRANK LTD. Phone: BELL 2000
67/75 SALTMARKET, GLASGOW, G.1. Est. 1907
Britain's greatest stocks of new, used and Ex-Government Optical and Scientific Equipment. Send for Illustrated Catalogue.

IF YOUR INTERESTS ARE LATHEWORK or WELDING take advantage of this Free Offer

● Every technician knows —and you know—that there are big opportunities for skilled craftsmen. Newnes' proved and trusted **TECHNICAL AIDS** will help you to make your future **SECURE**. Use the set you need at home for a week—you send no money and there is no obligation.

NEWNES

Complete Lathework

This technical work provides all the essential information for the efficient operation of CENTRE, CAPSTAN, TURRET and AUTOMATIC LATHES. It is designed to assist the lathe man to become highly skilled and fully conversant with various types in present-day use.



OVER 500 PAGES

2 Volumes and Case of 16 Data Charts

Free copy of "Turret Lathe Setters' Pocket Book"

plus Postal Advice for 2 years

Contents include:—

Differential Threading. Floating-blade reamers. Trepan boring. Back facing. Deephole boring. Boring bar cutters. Tool design. multicut. Turning universal-joint flange. Camshafts, machining. Gear cutting on lathes. Right-angle lathes. Profile turning. Grinding carbide tools. Chip breakers. Turning compound tapers. Acme threads. Norton quick-change gearbox. End-train. Eccentric turning. High-speed screwcutting. Designing cams, etc.

NEWNES COMPLETE

Gas and Arc Welder

Written by leading experts, it gives you all the specialised knowledge that would take you years to gain. This means higher pay! Packed with illustrations, it explains the welding theory, methods and techniques used in general engineering, aircraft industry, railway and shipyard. Incorporates U.S.A. techniques.

OVER 500 PAGES

2 Volumes and Case of 14 Data Charts

Free copy of "Welding Engineer's Pocket Book"

Postal Advice for 2 years

Contents include:—

Gas Welding and Cutting: Assembly and operation of equipment. Weldable metals. Rods. Fluxes. Joints. Welding sheet steel, cast iron, alloy steels, aluminium, magnesium, copper, etc. Hand, Machine and Underwater cutting. Oxygen Lance. Oxy-thermic Drilling, etc. Electric Welding and Cutting: Equipment, transformers, generators. Electrodes. Joints. Carbon Arc. Atomic Hydrogen and Inert-Gas Welding. Automatic Welding. Testing, etc.



You are invited to apply now - it is to your advantage. All you do is complete coupon on right and post to-day and the set of your choice will be sent to you for a week. Act Now!

Post to: George Newnes Ltd., (Dept. RSL), 15-17 Long Acre, London, W.C.2

To: George Newnes Ltd., 15-17 Long Acre, London, W.C.2.

Please send: COMPLETE LATHEWORK GAS AND ARC WELDER

(Tick your choice here)

without obligation to purchase, I will return it in 8 days or send 10/- deposit 8 days after delivery, then 12 monthly payments of 10/-, paying 130/- in all. Cash in 8 days £6. 5s.

Name and Address in block letters please.

Name

Address

Occupation

Signature

(Parent signs if you are under 21)
(CL) 568/10 (GA) 567/10

Tick V where applicable

The address on left is—

My Property	<input type="checkbox"/>
Rented unfurnished	<input type="checkbox"/>
Parents' Home	<input type="checkbox"/>
Furnished Accom.	<input type="checkbox"/>
Temporary Address	<input type="checkbox"/>

EARN

There's plenty of room at the top for technically trained men—room for YOU if you want quick promotion or a better-paid more interesting career. N.I.E. can quickly give you a *guaranteed* spare-time Postal Training, in the comfort of your own home and open up a whole new world of opportunity for you.

Find out, as thousands of others have done, how easy it is to learn at home with N.I.E. Send for *Success in Engineering*—120 pages of information you can use—and details of pay-winning Courses in all branches of Engineering, Building, Local Government, etc. Get your copy today—FREE!

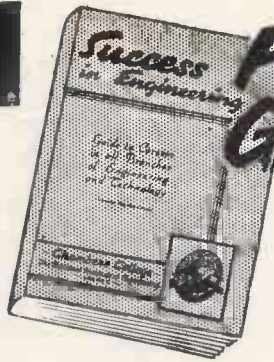

FREE GUIDE!

One of the following Courses taken quietly at home in your spare time can be the means of securing substantial well-paid promotion in your present employment, or entry into a more congenial career with better prospects.

MORE

This remarkable FREE GUIDE explains:

- Openings, prospects, salaries, etc., in Draughtsmanship and in all other branches of Engineering and Building.
- How to obtain money-making technical qualifications through special RAPID FULLY-GUARANTEED COURSES.

A.M.I.Mech.E., A.M.I.M.I., A.M.Brit.I.R.E., A.M.I.Prod.E. A.M.I.C.E., A.M.I.Struct.E., A.M.I.Mun.E., M.R.S.H., A.M.I.E.D., A.F.R.Ae.S., London B.Sc., Degrees.

Fully guaranteed postal courses for all the above and many other examinations and careers. Fully described in the New Free Guide.

SOON

We definitely guarantee that if you fail to pass the examination for which you are preparing under our guidance, or if you are not satisfied in every way with our tutorial service—then your Tuition Fee will be returned in full and without question. This is surely the acid test of tutorial efficiency.

If you have ambition you must investigate the Tutorial and Employment services we offer. Founded in 1885, our success record is unapproachable.

ALL TEXTBOOKS ARE SUPPLIED FREE PROMPT TUTORIAL SERVICE GUARANTEED NO AGENTS OR TRAVELLERS EMPLOYED



BECOME A DRAUGHTSMAN - EARN BIG MONEY

Men and Youths urgently wanted for well paid positions as Draughts-men, etc., in all Branches of Engineering. Our Guaranteed "Home Study" courses will get you in. Those engaged in the General Drawing Office should study some specialised Branch, and so increase their earning capacity.



NATIONAL INSTITUTE OF ENGINEERING

THE GATEWAY TO BETTER LIVING

A.I. POSTAL COURSES

ENGINEERING, RADIO, AERO, ETC.

Aero. Draughtsmanship	Elec. Draughtsmanship
Jig & Tool Design	Machine ..
Press Tool & Die Design	Automobile ..
Sheet Metalwork	Structural ..
Automobile Repairs	R/F Concrete ..
Garage Management	Structural Engineering
Works M'gmt. & Admin.	Mathematics (all stages)
Practical Foremanship	Radio Technology
Ratefixing & Estimating	Telecommunications
Time & Motion Study	Wiring & Installation
Engineering Inspection	Television
Metallurgy	Radio Servicing
Refrigeration	Gen. Elec. Engineering
Welding (all branches)	Generation & Supply
Maintenance Engineering	Aircraft Mainten. Licence
Auto Engine Technology	Aerodynamics
Diesel Engine Technology	Electrical Design

BUILDING AND STRUCTURAL

A.I.O.B.	A.I.A.S.	M.R.S.H.
A.M.I.P.H.E.	A.A.L.P.A.	A.I.Q.S., A.R.I.C.S.
Building Construction	Costs & Accounts	Builders' Quantities
Surveying & Levelling	Clerk of Works	Carpentry & Joinery
Quantity Surveying		Building Inspector
		Building Draughtsmanship
		Heating & Ventilating

GENERAL, LOCAL GOVERNMENT, ETC.

Gen. Cert of Education	A.C.I.S., A.C.C.S.
Book-keeping (all stages)	A.C.W.A. (Costing)
College of Preceptors	School Attendance Officer
Woodwork Teacher	Health Inspector
Metalwork Teacher	Civil Service Exams.
	Housing Manager (A.I.Hsg.)

POST COUPON FOR FREE BOOK

Please send me a FREE copy of "Success in Engineering".

NAME

ADDRESS

Subject or exam of interest

NATIONAL INSTITUTE OF ENGINEERING
(Dept. 29) 148-150 Holborn London EC1

901