

# Practical MECHANICS

JUNE  
1961

1'6



**Man in Space**

**JUNIOR'S  
LAWNMOWER**

**TAPE  
RECORDER  
MAINTENANCE**

**BRITAIN'S  
LATEST  
WINDTUNNEL**

# THE "54"

## DRAWER UNIT ALL STEEL

stove  
Enamelled  
DARK  
GREEN

•  
OVERALL  
SIZE  
42" HIGH  
35" WIDE  
11½" DEEP

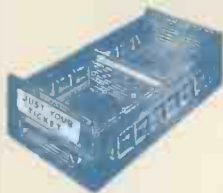

Contains 54 of these drawers, each 5" wide 3" high 11½" long. 54 dividers and 54 drawer cards with each unit. Extra dividers 6d. each.

**£18**

Deliveries **FREE** to England  
Scotland and Wales

SEND FOR SAMPLE DRAWER

**N. C. BROWN LTD.**  
GREEN LANE WING, HEYWOOD, LANC

Telephone:  
HEYWOOD  
69018 (5 lines)

# The Hand Drill with a DIFFERENCE



Pat. No.  
587049.

See it  
at your  
Tool Shop

**Leytool**  
PRECISION  
HAND DRILL

Even at a glance, the improvement on the conventional type of hand drill can be seen. Compact in size, light in weight, well balanced and comfortable to hold. The one-piece die-cast body totally encloses the precision-cut gears. Accurate self-centring nickel-plated chuck with ground jaws. Ball thrust race takes up drilling pressure eliminating necessity for pushing with the body. Made for the craftsman—good for a lifetime.

**FREE 32/9**

Write for illustrated  
catalogue of complete  
range of "Leytools"

**LEYTONSTONE JIG & TOOL CO. LTD.**  
LEYTOOL WORKS · HIGH ROAD · LEYTON · LONDON · E.10  
Telephone: LEYTONSTONE 5022-3-4

## BRING YOUR OLD RADIOGRAM RIGHT UP TO DATE FOR ONLY £14 (Carr Paid)



### BRAND NEW 2 WAVE BAND PLUS VHF RADIOGRAM CHASSIS

Fit the latest type chassis to that treasured old cabinet, or one of our own design. A quality receiver built by a famous maker, as fitted to an expensive commercial model. Ready to fit. Complete with 6 valves. Size 15 x 6½ x 5½ in. (Dial 14½ x 4 in.). Mains/trans 200-250v. A.C. Five "plano key" controls (Long, Medium, V.H.F., Gram, OD), plus tone, volume and tuning. **BEAUTIFUL TABLE MODEL CABINET (AND SPEAKER) TO FIT, 47/8 (post 3/6), 10 x 6 in. ELLIPTICAL SPEAKER, 20/-** to purchasers of this chassis. **TERMS:** (chassis) £5.10.0 down and 6 Monthly Payments of 39/-, or with Cabinet and Speaker £5.17.0 down and 7 Monthly Payments 32/-.

## BUYING A NEW RADIO? SAVE ££'s

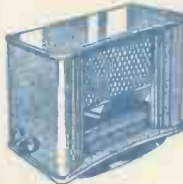

**COMPLETE V.H.F./A.M. RADIO—VALUE OVER £20 OUR PRICE £13.10. (Carr. paid)**  
Brand new set by famous maker, in superb walnut cabinet (size 19 x 8½ x 14½ in high). 4 waveband, Long, Med, Short and V.H.F. (F.M.). Mains input 200-250 v. A.C. Ferrite rod aerial for A.M. Controls: volume on/off, tone, tuning, w/change. Gram and ext. speaker position provided. 5 valves and metal rectifier. Ready to use. Fully guaranteed. Terms available.

**B.S.R. "MONARDECK" SINGLE SPEED TAPE DECK.**  
Our price only £8.10.0 with 850 ft. 1st grade tape, carr. paid.

### GLADSTONE RADIO

58a HIGH STREET, CAMBERLEY, SURREY (Tel. 22791).  
247 NEW RD., PORTSMOUTH and 56 STOKES CROFT,  
BRISTOL, 1. (Camberley closed Sats, Bristol and Ports-  
mouth Weds.). Mail Orders to Camberley, Catalogue 6d.

Ex-M.O.S.

## PRECISION TOOLS

14 DAYS  
FREE  
TRIAL



**TOOLROOM  
CLINOMETERS (Micrometer Bubble Type) 35/-**

An Engineer's Clinometer of great precision. Main scale is divided 0-20 deg. in 1 deg. divisions and angles to within ¼ minute can be read speedily on the micrometer thimble. For their original military purpose a clip was fitted to the base but this clip can be easily removed in the Machine Shop. Nett weight 22 oz. Length of base 3½ in.

### Ex-M.O.S. WALTHAM STOP WATCHES

A high quality ½ second recorder with minute recorder reading 0-30 minutes. Offered at fraction of cost. **£3.15.0.**

### OPTICAL TEST SET

Containing 36 carefully graded lenses of Crown glass. Focal lengths from 4 in. to 120 in. Dia. 47 mm. All in the new Vu-File transparent pack. **42/-.**

## CHARLES FRANK LTD

67-75 SALTMARKET, GLASGOW, C.1  
Phone: BELL 2106/7

Established 1907  
Britain's greatest stocks of new, used and Ex-Govt. Optical and  
Scientific Equipment. Send for illustrated catalogue.



# EXPERIMENTAL SPRINGS?

Don't grope here... Select your springs here



That spring you want... in a hurry... where is it? Pick what you want, when you want it, from **TERRY'S BOXES OF ASSORTED SPRINGS**—our fine range of small boxed assortments of experimental springs. We can show you only a few from the range here. Send a postcard for our full list—and if ever you're stuck with a spring problem send it along to our Research Department—they'll gladly help you out.

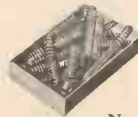

**No. 760**  
Three dozen Assorted Light Compression Springs. 1" to 4" long, 22 to 18 S.W.G.,  $\frac{1}{8}$ " to  $\frac{1}{2}$ " diam. 7/6



**No. 98A**  
Three dozen Assorted 1" to 4" long,  $\frac{1}{2}$ " to  $\frac{3}{4}$ " diam., 19G to 15G. 6/6



**No. 757**  
Extra Light Compression, 1" gross Assorted,  $\frac{1}{2}$ " to  $\frac{3}{4}$ " diam.,  $\frac{1}{2}$ " to 2 $\frac{1}{2}$ " long, 27 to 19 S.W.G. 18/-

Have you a Presswork problem?

If so, the help of our Design Staff is yours for the asking.

Really interested in Springs? "Spring Design and Calculations" 10th Edition tells all post free 12/6

Cut Production Costs with Terry's Wire CIRCUPS. We can supply immediately from stock—from  $\frac{1}{8}$ " to  $\frac{1}{2}$ "



**CLIPS**  
80 & 81

in sizes to grip from  $\frac{1}{4}$ " to 2"



Looking for good Hose Clips? Send for a sample of Terry's Security Worm Drive Hose Clip and price list.

## TERRY'S

for SPRINGS

**HERBERT TERRY & SONS LTD.**  
Redditch, Worcs.

(Makers of Quality Springs, Wireforms and Presswork for over 100 years)

HT318

# PHOTOGRAPHERS!

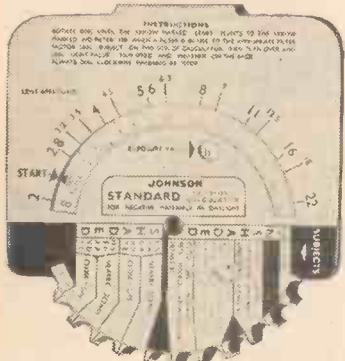

Get the right exposure every time!

Do your pictures ever come out over-exposed or under-exposed? You need a Johnson Standard Daylight Exposure Calculator! It's only 4/6d. With this calculator, you just 'dial' for the correct exposure. It's easy! You 'dial' the sort of subject you are photographing, the light conditions, the weather, and the speed of the film you are using—then read off the exposure details. Other calculators for colour cine, artificial light, and flash are also available. Ask your local photographic shop about Johnson calculators.

**JOHNSONS**  
OF HENDON LTD

# YOUR THIRD HAND



THAT HOLDS ON



WITH HANDS OFF

THE  
**MOLE**  
TRADE MARK  
**SELF-GRIP**  
**WRENCH**

Nowadays, Handymen, Housewives, Engineers, Motorists and the like have an opportunity to use the Mole Wrench as their 'third hand'. This tool, world famous for its versatility, locks on to work and remains there, with hands off, until the release lever is touched. A hand vice, clamp, super-pliers, and so on, are but a few of its uses for the inevitable repairs and maintenance jobs in home, workshop, garage and garden. Two sizes: 7", 12/6 and 10", 15/-.

Make sure you get a genuine Mole Wrench—look for the name on it.

FROM IRONMONGERS,  
MOTOR AND MOTOR  
CYCLE ACCESSORY  
DEALERS

If in any difficulty write to:  
**M. MOLE & SON LTD., BIRMINGHAM, 3.**

**Two new books for the serious HI-FI enthusiast and engineer . . .**

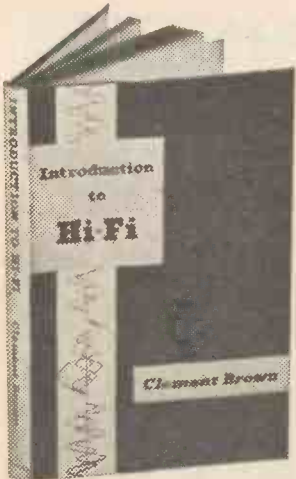

**INTRODUCTION TO HI-FI** by Clement Brown

A clear introduction to what we can and cannot do in the world of hi-fi, what is and is not important, which items of equipment can be bought cheaply, and for which this would be false economy. **CONTENTS:** Introducing High Fidelity - Records and Pick-ups - Amplifiers and Radio Tuners - Loudspeakers - Listening Room Acoustics - Stereophonic Sound - Tape and High Fidelity - Choosing Your Equipment - Installing Your Equipment - Hi-Fi in the Future - Further Reading - Useful Data. List of Recommended Records and Tapes. Glossary of terms used in hi-fi. 21s. net (22s. by post) 208 pages · 85 illustrations

**HIGH FIDELITY SOUND ENGINEERING**

by Norman H. Crowhurst

Provides the reader with basic concepts and design procedures of proved and lasting practical value. The material comes from a hitherto unpublished library of design data and information. **CONTENTS:** Basic Requirements of Systems - Electrical Transfer in Simple Passive Circuits - Simple Active Circuits - Transformers and L-C Filters - Power Amplification - Feed-back Transducers - Transducer Matching - Oscillators and Sound Generators - Test Equipment - System Design - Control of Acoustics - Design Data. 50s. net (51s. 6d. by post) 336 pages · 262 illustrations



FROM ALL BOOKSELLERS . . . or, in case of difficulty, at the best prices shown from the publishers, GEORGE NEWNES LTD., Tower House, Southampton Street, London, W.C.2.

NEWNES

**CASTINGS WHICH SET THE STANDARD BY WHICH OTHER CASTINGS ARE JUDGED**

★ **EVENING STAR**

for 3½-In. Gauge DESIGNED BY L.B.S.C.

- |                           |          |
|---------------------------|----------|
| Frame steel               | 17/11    |
| Buffer beam angle         | 2/3      |
| Main horns                | 17/- set |
| Main axleboxes            | 18/- set |
| Bogie wheels              | 4/- set  |
| Drivers                   | 32/- set |
| Cylinder castings         | 65/-     |
| Pony bolster              | 3/-      |
| Pony king pin stay        | 3/-      |
| Pump and rear frame stays | 8/-      |
- Postage extra. These and other castings will be available as the "serial" progresses.

**OUTSTANDING IN ITS CLASS**

MYFORD M.L. 7 LATHES (FOR EARLY DELIVERY) AVAILABLE ON THE MOST REASONABLE "OUT OF INCOME" TERMS. Cash price £67.10.0. Deposit £6.15.0 followed by 12 monthly payments of £5.9.10 OR 18 monthly payments of £3.16.3 OR 24 monthly payments of £2.19.3. ILLUSTRATED LITERATURE WITH PLEASURE.

A 1/- stamp will bring you a copy of our comprehensive lists of blueprints and castings for many small steam loco's, workshop equipment, etc.

"THE CHOICE OF EXPERIENCE"

**A. J. REEVES & CO. (Birmingham) LTD.**  
(Dept. E.S.) 416 MOSELEY RD., BIRMINGHAM, 12  
Phone: CALthorpe 2554.

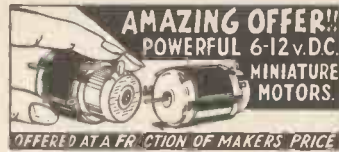

Size 1½" x 1½" diam. Latest development. Extremely powerful with low consumption. Weighs as little as two ounces and totally enclosed in polythene case. Three position switch; forward, reverse, stop. 7,000 r.p.m., self-lubricating and long life sintered bronze bearing; 15/6, post 1/-. Ask for free flexible drive. **MORSE KEYS.** Totally enclosed in bakelite case with easy access for all adjustments. Shrouded terminals. Overall size 5" x 1½" x 2" with mounting holes. 10/6, post 1/-. **REMOTE CONTROL SWITCH.** Double Pole Changeover in tubular hand-operated case. 4" x 1" 5/- each, post 1/-. **1 h.p. CAPACITOR MOTORS.** 230-240 volts, 50 cycles, 1,420 r.p.m., ½" shaft, standard foot mounting. Or ½" shaft, resilient mounting. Either type £5/10/0, carriage 10/-.  
**L. WILKINSON (CROYDON) LTD.**  
19 Lansdowne Road, Croydon, Surrey CROYdon 0839

**DUKE & CO. (LONDON) LTD.**  
621/3 ROMFORD ROAD, MANOR PARK, E.12 ILF 6001/3

**LATEST FREE LIST**  
Liverpool Street Station, MANOR PARK—10 min.

**SUPER CHASSIS**

79/6

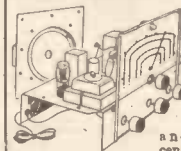

5 valve a/h e t chassis, including 8in. P. M. speaker and valves 4 central knobs (tone, volume, tuning and wave change). 4 w/bands with position for gram P.D. and extension speaker. A.C. Ins: carr: 5/6.

**EXTENSION SPEAKERS**

19/9



8in. P.M. Speakers fitted into polished cabinets (complete). P. & P. 3/9

**SPEAKER 8/9 SALE**

Ex-manufacturers, salvage. "Money Back Guaranteed." 5, 6, 8in. and 7 x 4in. P. & P. on 1, 2/9.

Price £13.17.8 Carr. Extra



**THE "ADEPT" BENCH HAND SHAPER**  
Length of stroke of ram 3¼in.: or No. 2 B.H. model, 6¼in. stroke. Price £25.5.0. Also for Power-drive—extra.

Ask your dealer Manufactured by



Price £8.10.0.

Postage and packing 4/6 (U.K.). The "Adept" 2¼in., 6in. B.S.F. 4-jaw independent chuck, reversible jaws, 5/7/8.

F. W. PORTASS MACHINE TOOLS LTD.  
Adept Works, 141a Nicholson Road, Heeley, Sheffield, 8

The "SUPER-ADEPT" LATHES 1½in. centres. 6in. between centres.

A good range of accessories is available.

**Automatic (Time) Switches**

New and reconditioned 16 day clockwork and electric switches

from 35/-

Send S.A.E. for illustrated details to:

**DONOHUE (TIMERS)**  
1 & 2 UPPER NORFOLK ST., NORTH SHIELDS, NORTHUMBERLAND



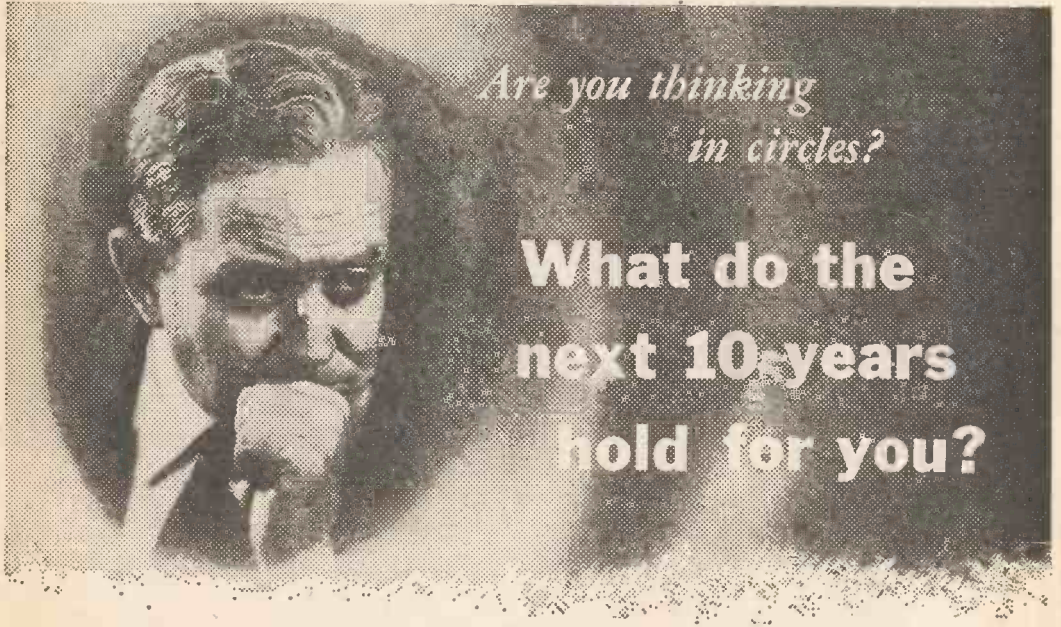

*Are you thinking  
in circles?*

**What do the  
next 10 years  
hold for you?**

Do you ask yourself, "Where do I begin—what shall I do next?" Have you a confusion of ideas? Mastery of life, success in any enterprise, comes from the subtle ability to marshal your thoughts and to call to the fore, when an emergency arises, the proper mental powers. Mentally, you are an aggregate of forces. Why dissipate them because of lack of knowledge of how to properly use them? Learn to control them and you will have at your command, a *tremendous power* for accomplishment.

### SEND FOR FREE BOOK

The Rosicrucians, a group of thinking men and women, have preserved for centuries the knowledge of a secret method for the development of mind power and the direction of man's unused inner faculties. This wisdom, not strange or mysterious, has changed the course of life for many men and women throughout the world. Write for the free book, "The Mastery of Life," which explains how you may join with the thousands who now have *and use* this helpful information. Address: Scribe B.L.N.

## **The ROSICRUCIANS** (AMORC)

25 Garrick St., London W.C.2, England  
(NOT a religion)

Scribe B.L.N.  
The Rosicrucians  
25 Garrick St., London W.C.2, Eng.

I am sincerely interested in an intelligent method for attaining a greater mastery of life. Send me, without obligation, a FREE copy of "The Mastery of Life" which explains how I may receive this valuable information.

Name \_\_\_\_\_

Address \_\_\_\_\_

City \_\_\_\_\_

# VALUABLE NEW HANDBOOK FREE TO AMBITIOUS ENGINEERS

Have you had *your* copy of "Engineering Opportunities" ?

The new edition of "ENGINEERING OPPORTUNITIES" is now available—without charge—to all who are anxious for a worthwhile post in Engineering. Frank, informative and completely up to date, the new "ENGINEERING OPPORTUNITIES" should be in the hands of every person engaged in any branch of the Engineering industry, irrespective of age, experience or training.

**We definitely Guarantee  
"NO PASS—NO FEE"**

This remarkable book gives details of examinations and courses in every branch of Engineering, Building, etc., outlines the openings available and describes our Special Appointments Department.

## WHICH OF THESE IS YOUR PET SUBJECT ?

**MECH. ENGINEERING**  
Gen. Mech. Eng.—Maintenance Eng. — Diesel Eng. — Press Tool Design — Sheet Metal Work — Welding — Eng. Pattern Making — Inspection—Draughtsmanship — Metallurgy — Production Eng.

**RADIO ENGINEERING**  
General Radio — Radio & TV Servicing — TV Eng. — Telecommunications — Electronics—Sound Recording—Automation—Practical Radio —Radio Amateurs' Exam.

**CIVIL ENGINEERING**  
General Civil Eng. — Municipal Eng. — Structural Eng. — Sanitary Eng. — Road Eng. — Hydraulics—Mining—Water Supply — Petroleum Tech.

**WE HAVE A WIDE RANGE OF COURSES IN OTHER SUBJECTS INCLUDING CHEMICAL ENG., AERO ENG., MANAGEMENT, INSTRUMENT TECHNOLOGY, WORK STUDY, MATHEMATICS ETC.**

Which qualification would increase your earning power  
A.M.I.Mech.E., A.M.S.E., A.M.I.C.E., A.M.Brit.I.R.E., A.F.R.Ae.S.  
B.Sc., A.M.I.P.E., A.M.I.M.I., A.R.I.B.A., A.I.O.B., A.M.I.Chem.E.  
A.R.I.C.S., M.R.S.H., A.M.I.E.D., A.M.I.Mun.E., CITY & GUILDS,  
GEN. CERT. OF EDUCATION, ETC.

**BRITISH INSTITUTE OF ENGINEERING TECHNOLOGY**  
410A, COLLEGE HOUSE, 29-31, WRIGHT'S LANE, W.8.

**ELEC. ENGINEERING**  
General Electrical Eng. — Installations—Draughtsmanship — Illuminating Eng. — Refrigeration — Elem. Elec. Science — Elec. Supply — Mining Elec. Eng.

**AUTO. ENGINEERING**  
General Auto. Eng. — Auto. Maintenance & Repair — Auto. Diesel Maintenance — Auto. Electrical Equipment—Garage Management.

**BUILDING**  
General Building — Heating & Ventilating — Plumbing — Architecture — Carpentry — Painting & Decorating — Specifications & Quantities — Surveying — Architectural Draughtsmanship.

### THIS BOOK TELLS YOU

- ★ HOW to get a better paid, more interesting job.
- ★ HOW to qualify for rapid promotion.
- ★ HOW to put some letters after your name and become a "key-man" . . . quickly and easily.
- ★ HOW to benefit from our free Advisory and Appointments Depts.
- ★ HOW you can take advantage of the chances you are now missing.
- ★ HOW, irrespective of your age, education or experience, YOU can succeed in any branch of Engineering.

**156 PAGES OF EXPERT  
CAREER - GUIDANCE**



You are bound to benefit from reading "ENGINEERING OPPORTUNITIES," and if you are earning less than £25 a week you should send for your copy now—FREE ar without obligation.

## POST NOW!

TO: B.I.E.T. 410A, COLLEGE HOUSE, 29-31, WRIGHT'S LANE, W.8.

Please send me a FREE copy of "ENGINEERING OPPORTUNITIES." I am interested in (state subject, exam., or career).

NAME .....

ADDRESS .....

WRITE IF YOU PREFER NOT TO CUT THIS PAGE

**THE B.I.E.T. IS THE LEADING INSTITUTE OF ITS KIND IN THE WORLD**

2d. stamp if posted in an unsealed envelope.



# MECHANICS

Vol. XXVIII

June, 1961

No. 326

## Editorial and Advertisement Offices

"PRACTICAL MECHANICS"  
George Newnes Ltd., Tower  
House, Southampton Street,  
Strand, W.C.2.

© George Newnes Ltd., 1961

Phone: Temple Bar 4363  
Telegrams:

Newnes, Rand, London

## SUBSCRIPTION RATES

including postage for one year

Inland - 22s per annum  
Abroad - 20s. 6d. per annum  
Canada - 19s. per annum

Copyright in all drawings, photographs and articles published in "Practical Mechanics" is specially reserved throughout the countries signatory to the Berne Convention and the U.S.A. Reproduction or imitations of any of these are therefore expressly forbidden.

## CONTENTS

Fair Comment	425
Britain's Latest Supersonic	
Wind Tunnel	426
Light as you Like It	428
Space, Deep Sea and Other	
Cameras	430
3 1/2 in. Gauge Evening Star	432
Puzzle Corner	434
Science Notes	435
Simple Tape Recorder	
Maintenance	436
Spy System Weighing Machine	439
Making a Toy Lawn Mower	440
Puppets on Film	442
Man in Space	444
Make this Burglar Alarm	448
Books for the Motor Cyclist	450
Making a Jeweller's French	
Blowpipe	451
Stereoscopic Colour Transparencies	452
Chemical Laboratory Apparatus	454
A Cascade Print Washer	457
Finishing Photographic Prints	458
Letters to the Editor	460
Trade Notes	461
Your Queries Answered	465

## CONTRIBUTIONS

The Editor will be pleased to consider articles of a practical nature suitable for publication in "Practical Mechanics." Such articles should be written on one side of the paper only, and should include the name and address of the sender. Whilst the Editor does not hold himself responsible for manuscripts, every effort will be made to return them if a stamped and addressed envelope is enclosed. All correspondence intended for the Editor, should be addressed: The Editor, "Practical Mechanics," George Newnes, Ltd., Tower House, Southampton Street, Strand, London, W.C.2.

## FAIR COMMENT

### BRITAIN LOOKS SPACEWARDS

OUR main feature article this month deals with the subject of manned space flight, with particular reference to the recent magnificent achievement of the Russian scientists in putting a man into orbit and then landing him again safely. Also in the article we review the progress of U.S. scientists towards the same goal and it is almost certain that before this issue is published they will have launched a man into space and recovered him, this being part of the preparations for putting a man into orbit later this year.

This race between the world's two greatest powers for the conquest of space is being watched by every nation but just outside the spotlight's glare, less spectacular preparations are being made, which we hope will be of great significance to Britain. The preparations concern the entry of this country to the field of space research. At last Britain is to take a part, albeit a small one, and her initial contribution will be a satellite known as U.K. Scout I. Careful planning is ensuring that the work carried out by Scout I will be entirely original and it was probably with this thought in mind that the electrical properties of the ionosphere were selected as the field of research. Pioneer work in this sphere was carried out initially by Sir Edward Appleton and British scientists have since contributed much careful study of the subject.

The Scout I satellite is intended as a basic vehicle which can be modified as required to carry a variety of equipment into orbit. The main body is a 2ft. diameter, 10in. long, cylinder with domed ends. To one of the domed ends will be attached four "paddles" on which will be mounted solar cells to provide power.

The equipment to be carried includes a Birmingham University experiment to measure spatial electron density and equipment for an electron temperature experiment promoted by University College. Another device is being developed by Messrs. McMichael Radio for the purpose of plotting the distribution of heavy cosmic particles round the earth. Theories regarding the magnetic fields round planets can be tested by the information collected by this device. Other firms concerned in the provision of satellite apparatus are Bristol Aircraft's Guided Weapons Division, who are responsible for an electronics package, and Messrs. Pye who are the designers of circuitry for the experiments on electron density and temperature.

This 150lb. satellite is perhaps, in comparison with the huge satellites orbited by the Russians, a very modest project, but marking as it does the start of a new British scientific endeavour, it will be welcomed with enthusiasm, not only by those who are scientifically interested, but all those to whom Britain's prestige is important.

The atom bomb has practically nullified the importance of huge armies and war potential as a prestige factors and it is to be hoped that as time goes on the urge for competition between nations will be increasingly channelled into fields of scientific research. The achievements of scientists may possibly become the status symbols of the future, but whether they do or not, it is certain that no nation that wishes to retain its influence in the world can neglect the technological and scientific improvements resulting from space research.

The potential benefits which can accrue in the field of communications alone make it imperative that Britain enter the lists. Whether the motive be prestige or whether the importance to Britain's technological and scientific future has at last been recognised, our initiation into the adventure of space has come not a day too soon.

The July, 1961, issue will be published on June 30th, 1961. Order it now

# BRITAIN'S LATEST SUPERSONIC WIND TUNNEL

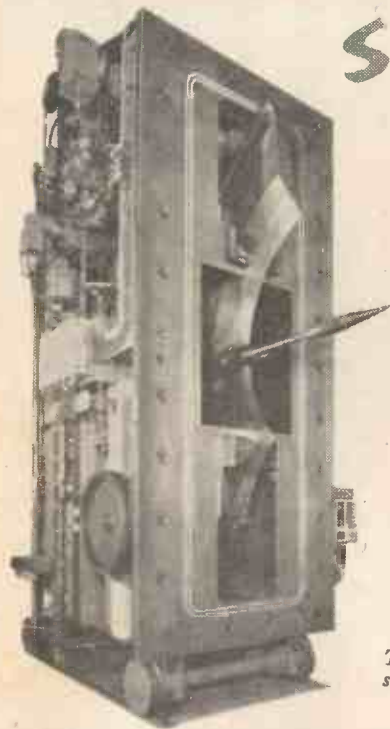

*The model-support section.*

**A** NEW 4ft.  $\times$  3ft. closed-circuit wind tunnel at the Royal Aircraft Establishment, Bedford, was opened recently.

The working-section leg, which is over 150ft. long, comprises, in order, the inlet and contraction sections, nozzle, bridle structure, model-support section, supersonic and subsonic diffusers and outlet section. In addition there is a calibration section for examining the air flow pattern. This unit is interchangeable with a model-support section in the line of the tunnel.

At present the tunnel is operating with a fixed throat gap and contour nozzle made by the Ministry of Aviation, and giving a nominal air speed corresponding to Mach number 4. A flexible plate nozzle, now being built, will, when installed, cover the speed range between Mach numbers 2.5 and 5. The 8ft.  $\times$  8ft. wind tunnel at Bedford which was commissioned a few years ago has a maximum Mach number of 2.8.

To provide maximum availability of the tunnel for testing work, the time consuming mounting, manipulation and instrumentation of models is carried out in a number of separate and interchangeable model-support sections or trucks, which can be quickly disconnected and removed bodily from the air current to an adjacent rigging bay.

Another important feature of the tunnel is that the whole of the working-section leg is anchored only at the model-viewing position, and both upstream and downstream of this point the various casings are mounted on wheels running on machined rails.

## **Inlet and Contraction Sections**

The fabricated inlet casing consists of a long pipe varying from 5ft. dia. at the compressor end up to 9ft. dia. at the settling chamber. This houses five close-meshed screens which smooth the air flow. Beyond the screen is the contraction section which serves to transform the cylindrical shape of the settling chamber to the rectangular 4ft.  $\times$  3ft. cross-section of the nozzle with streamlined air flow.

*General view of the tunnel taken from the outlet section end. The Schlieren beam equipment can be seen in the centre of the picture.*

9ft. dia. at the settling chamber. This houses five close-meshed screens which smooth the air flow.

Beyond the screen is the contraction section which serves to transform the cylindrical shape of the settling chamber to the rectangular 4ft.  $\times$  3ft. cross-section of the nozzle with streamlined air flow.

## **Flexible Plate Nozzle**

Because of the conditions under which the tunnel would be operating several unusual features had to be adopted in the design of this section.

The maximum inlet pressure will be about 12 atmospheres absolute and, to prevent liquefaction in the nozzle at the high Mach numbers, the temperature of the air will be allowed to rise to 150 deg. C. Under some operating conditions the pressure in the tunnel may be below 0.1 atmosphere absolute. It was decided at an early stage that, with the high temperatures and high rates of change of temperature, coupled with the degree of accuracy required for the nozzle control devices, it would be inadvisable to enclose these devices within a pressure shell.

This decision introduced the difficult problem of providing a very efficient sliding seal between the fixed and moving walls of the nozzle. The double seal to be used for this purpose will be packed with dry air to prevent the ingress of moist atmospheric air into the circuit. This system of dry-air packing of all seals has already been employed on all joints in casings, and on all entries for drive shafts, etc., which penetrate the pressure shell.

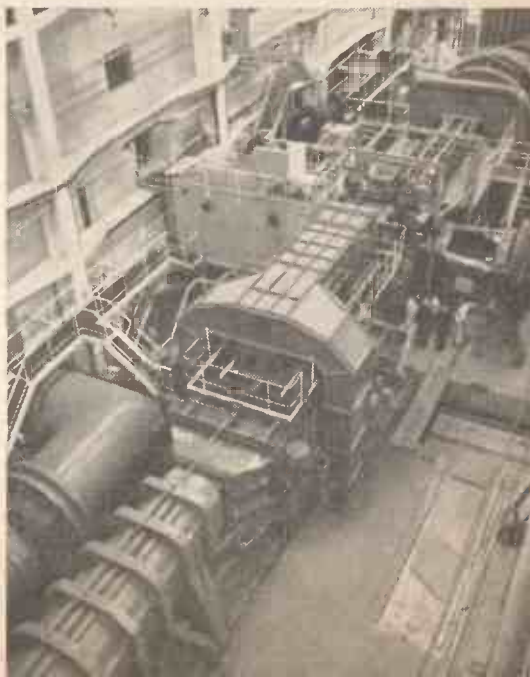



Essentially the nozzle will comprise two fixed side walls and movable top and bottom walls. Each of the moving walls of the nozzle is carried by a pair of extremely stiff fabricated steel beams pivoted at the downstream end. At the upstream end each pair of beams carries a throat block of fixed contour which is driven upwards and downwards to vary the throat gap. The variable contour top and bottom walls of the divergent sections of the nozzle are formed by flexible plates each attached to one of the throat blocks at the upstream end and also to the supporting beams through 17 pairs of motor-operated ball screw jacks.

The position of the flexible plate at the jack stations throughout the range of the Mach numbers is controlled by the nozzle controller, a separate piece of equipment located in a nearby room. Throat dimensions can be varied from 18in.  $\times$  3ft. at Mach number 2.5 to 1 $\frac{1}{2}$ in.  $\times$  3ft. at Mach number 5.

**Bridle Structure**

When the flexible plate nozzle is installed, its downstream end is to be fixed into the bridle structure which will be the only part of the working-section leg anchored to the foundations. This section will house the high- and low-temperature viewing windows, each with specialised illumination for use in conjunction with a remotely controlled television camera.

**Model-Support Section**

This is a structure on which the models to be tested can be conveniently mounted and manoeuvred in the airstream. It consists of four fabricated sections bolted together to form a rectangular shell. The whole of the structure can be removed from the line of the tunnel and taken to an adjacent rigging bay on a motor-driven cross-traverse transporter, and another model-support section or the calibration section can be inserted in the tunnel.

The main components of the model-support section are the moving quadrant and the sting shaft on which the model is mounted. The quadrant is used to alter the pitch of the model within the limits of 5 deg. depression and 27 deg. elevation, while the sting can rotate the model through  $\pm 180$  deg. from a mean position. These movements can be remotely controlled when the model-support section is in the line of the tunnel. When the section is in the rigging bays, it is sometimes necessary to be able to reproduce the movements of the sting which occurred when the section was in the tunnel, and portable control cabinets are provided for this purpose.

**Calibration Section**

This is similar in shape and dimensions to the model-support section with which it is interchangeable

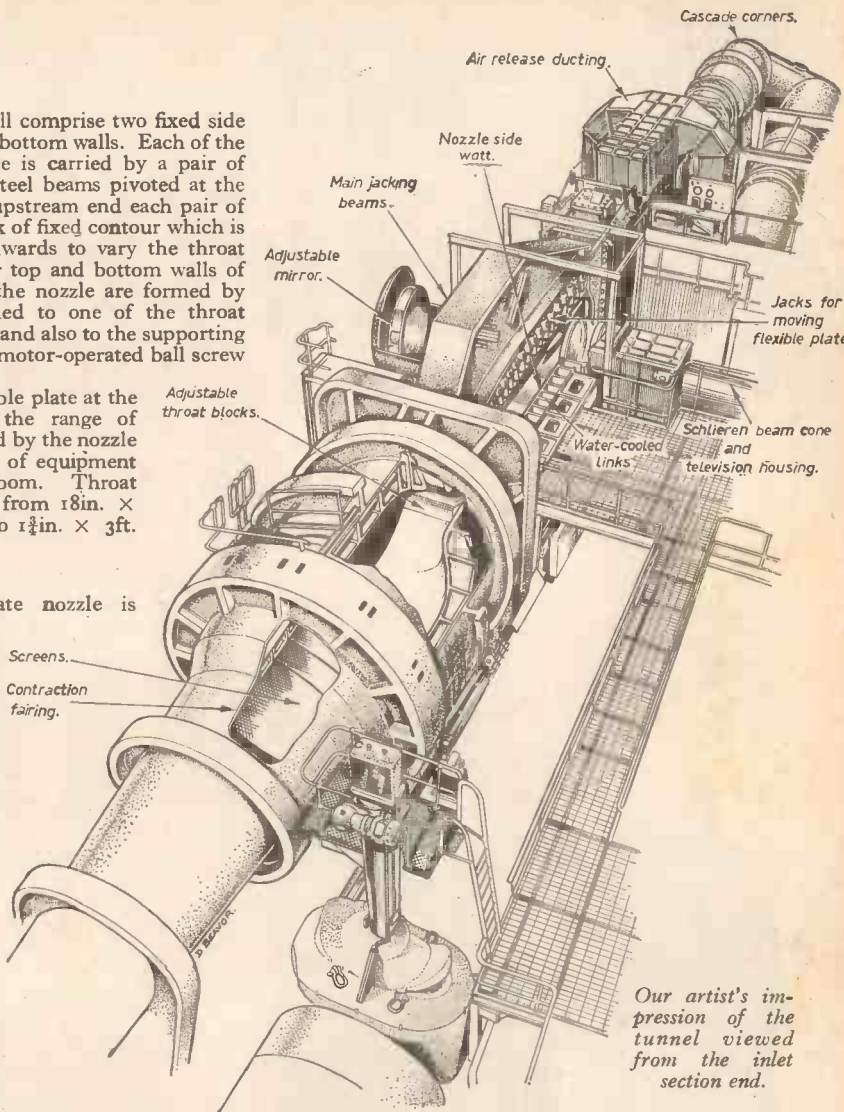

able in the air current. The main difference is that the moving quadrant and sting are replaced by a probe housing which has a 2ft. traverse across the airstream. Inside this housing are two hollow probe arms carrying a common probe head fitted with pitot tubes and yaw meters. The probe head is capable of being moved 3ft. upstream and downstream of the window centre line, so that a plot of the airflow can be made in the vicinity of the model.

In order to obtain maximum operational efficiency of the tunnel the speed of the air emerging from the nozzle is gradually reduced with a minimum loss of energy, first by the supersonic diffuser and then by the subsonic diffuser. It is then recirculated through the tunnel via the compressors.

The outlet section is virtually a U-shaped 7ft. dia. pipe housing two cascade corners to turn the air flow through 180 deg. and a further catch net.

Adjacent are the motor generator, observation and data reduction rooms.

Messrs. G.E.C. were awarded the £1,000,000 contract to build the tunnel and associated controls.



# LIGHT as you LIKE IT

By  
E. W. Monarch

THIS device uses a specially made auto-transformer which consumes current only in relation to the light given out. The user pays only for the light he is getting as there is very little waste as heat. The wattage of the lamp is variable between 5 and 60 using one 60W. lamp. This is obtained by varying the voltage fed to the lamp from 70V. to the full mains 240V. by means of S2. The circuit is shown in Fig. 1.

## Transformer Construction

Any old radio *mains* transformer is stripped completely. Generally it will look like Fig. 2, with some means of keeping the laminations together and of mounting to a chassis. Cut away the *windings* with a hacksaw, keeping the cardboard or bakelite former. Remove the laminations and inspect them to make

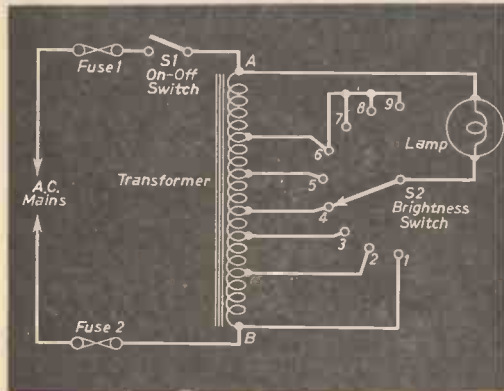

Fig. 1.—Theoretical circuit of lamp.

sure that the sectional area of the centre part which goes in the former is at least 1 sq. in.

## The Windings

Use cellulose tape to hold the start of the windings. Leave 6in. of 28g. enamelled wire (copper) for connections and wind on 490 turns. Make the windings as close and neat as possible and when one layer is done, cover the windings with one layer of thin paper and continue in the *same direction* all the time. After the required number is on make a tapping as shown in Fig. 3 by folding the wire, gently twisting, and covering with sleeving.

Continue to wind on 700 turns, i.e. another 210 and make another tapping as before. It is a help in

## A unit to vary the

wiring to have the start and finish wires coming out on one side and the tappings on the other side of the former and near together. They *must not* come out where they will foul and short on the laminations when they are replaced.

Refer to the chart of transformer below and complete the 1750 turns. Replace the laminations, as in Fig. 2, reversing the position of B and A laminations in each separate layer. Wedge the laminations tight if necessary with wood wedges.

## Testing the Transformer

Using a flash lamp and bulb check that there is no circuit between any wire and the laminations. Connect the mains via a 60W. lamp to the inner and

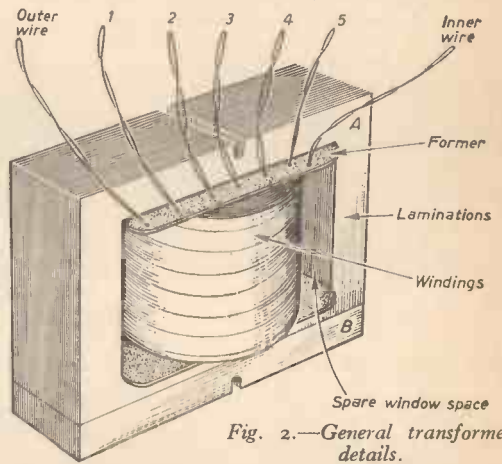
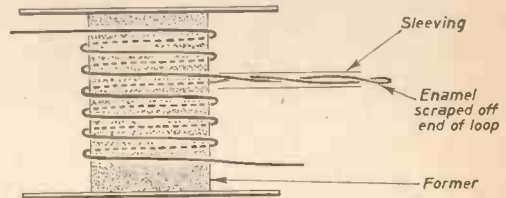

Fig. 2.—General transformer details.

Fig. 3.—How the tappings are made.



## TRANSFORMER DETAILS, USED WITH 60W. LAMP

TURNS (from start)	TURNS (from last tappings)	Voltage (from start)	Wattage of "light"
490	490	70v	5.0
700	210	100	10
1,015	315	145	20
1,195	175	170	30
1,400	210	200	40
1,750	350	240	60

Turns per volt, approx. 7.0.

Input 240V, 200V. is also suitable, must be A.C. Laminations 1 sq. in. or more area of centre cross section.

Windings with 28g. enamelled copper wire.



# Brightness of your lamp

outer wire, having scraped off the enamel (see Fig. 5). The lamp should NOT light. A very slight humming may be heard. If the lamp lights, the windings are shorting. This may indicate need for rewinding, but careful examination may reveal the cause. Insulation tape may be used on top of the windings if plenty of window space is available (Fig. 2).

Connect the transformer inner and outer wire to the mains direct and the lamp from the inner (two wires on this lead) to each of the taps in turn (Fig. 6). Switch off at the mains before each trial. The lamp should light at various brightnesses according to the number of windings in circuit. Do not worry about humming at this stage. Leave on one of the middle



Fig. 4.—The parts mounted in the box.

mains leads to the fuse holders (Bulgin F 26/1 or Home Radio FH2), and insert 1 or 2A. fuses (Bulgin F127 or types obtained from any T.V. dealer). Number the fuses and take No. 2 to the outer end of the transformer. Tape the connection. Take fuse No. 1 to one tag of the switch (S1). The prototype uses Bulgin S 128, but Arcolectric S645 makes a very neat job and is ideally suitable). Fit a knob if the S 128 is used (Bulgin K.58, pointer knob). Wire the other switch terminal to the inside end of the transformer.

Plug in and switch on. Humming should be heard, or may be "felt" by touching the laminations. If all is well switch off and inspect the rotary switch (the prototype uses a surplus 1-pole ten-way type available from Radio Clearance Ltd., but a more suitable long-life switch would be Bulgin S 430, with one tapping unused). Note which tag of the switch is the "rotor" and connect it to the lamp holder. Connect each of the other tags in turn to the tappings taken in order

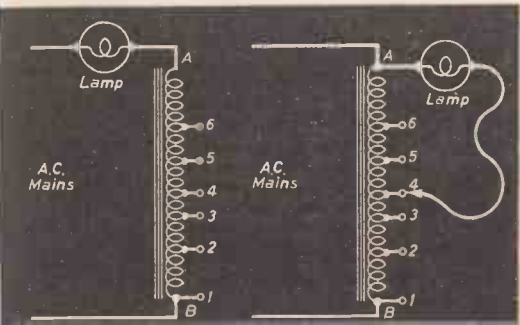

Fig. 5.—(Far left) Test circuit to ensure transformer efficiency.  
Fig. 6.—(Left) Test circuit to make sure the transformer is giving output on the tappings.

Fig. 7. (Right)—Details of the box and lay-out of parts.

tappings for about an hour and verify that the transformer is not hot, but only slightly warm to the touch. If it is hot then some windings are shorting.

### Wiring Up

A trial wiring is advisable before putting in a case. Wire the

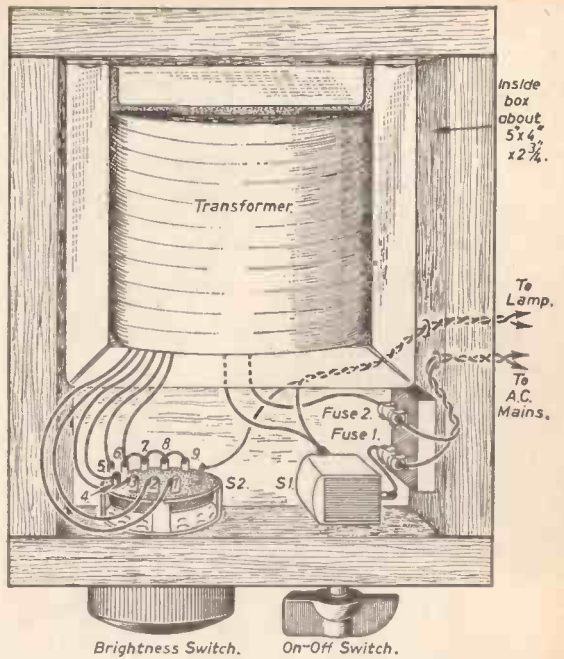

from the outside noting that the first tag joins on to the outer transformer lead together with the lead from fuse No. 2. The remaining tags may be left unused or they may all be soldered to the last used tag as shown in Figs. 1 and 7. Join the lamp to the side of S1 already joined to transformer inner wire. Fit a knob to S2 (Bulgin K. 284).

Switch on at mains and keeping the fingers away from all bare wires, etc. rotate S2 making sure the lamp does vary in brightness as required.

### Housing and Layout

No ventilation is required. The unit may be housed inside a "box based" table lamp, bedside cabinet, cupboard, etc. or in a small box to be placed under any conventional reading lamp. The simple construction is shown in the various figures and the layout should be approximately followed.

The transformer, whatever the type of mounting, must be firmly fixed or it will "hum" when in use.

Where 200V. A.C. mains is available 240V. may be obtained by taking the lead from fuse 2 of Fig. 1 directly to the first tap on the transformer from "B" and leaving the rest intact. When S2 is at contact No. 1 the lamp (or other device) will receive 240V. A.C.

It is dangerous to leave any wires exposed, to work with electrical gear on wet or concrete floors and to leave metal parts exposed to touch not earthed.

Fig. 8.—The unit in use on an office desk.



# SPACE, DEEP SEA and OTHER

## A subject of topical



Fig. 1.—A photographer prepares a Kerr camera prior to an explosion.

Fig. 2. (right) The Brixner camera being adjusted.



WITH the conquest of space just around the corner, and underwater craft circling the globe without coming to the surface, cameras are playing an ever-increasing part in scientific research. Several new types of camera have been developed in recent years which can take pictures in a number of new and extraordinary ways.

There are cameras which can, for instance, photograph great areas of the earth from orbiting satellites, reach billions of miles into outer space, take pictures of the deepest ocean floors, or take photographs even when there is no light. One new camera can take pictures so small that the entire Bible could be recorded in the space of one square centimetre (Fig. 3). Others are so fast that they can show how explosives behave during detonation.

The amazing abilities of these cameras contrast strikingly with the early daguerreotype cameras, which first came into general use in 1839. In those days, people who were photographed had to sit motionless in bright sunlight for as long as 20 minutes. In addition, they had to whiten their faces with flour to reflect more light.

### Satellite Cameras

The cameras that can take pictures from a satellite, showing a vast expanse of the earth's surface, are two television cameras mounted on the United States Tiros II weather reporting satellite. Each is about the size of an ordinary tumbler and weighs only two pounds. When taking photographs of the earth, they use a picture tube smaller than a man's finger.

One of the cameras, fitted with a wide-angle lens, focuses on an area of 640,000 square miles. The other photographs, in greater detail, an area 75 miles square. Both store their photographs on magnetic tape and transmit them to the ground when activated by a signal.

### Tracking Camera

Another remarkable camera developed in recent years is the huge Baker-Nunn satellite tracking camera (Fig. 4). Equipped with an intricate system of lenses, it photographs satellites as they speed around the earth, with a tracking error of less than one per cent. A similar camera can photograph meteors that are as small as buckshot, that is, about  $\frac{1}{2}$  in. diameter.

The Baker-Nunn satellite-tracking camera is a wide-angle telescopic camera of the Schmidt type, 10ft. high, 9ft. wide and 6ft. deep. It weighs almost 3 tons.

The optical system consists of a 31in. spherical mirror and three 20in. correcting lenses. Strip film is stretched over a curved surface at the focus of the mirror. The camera can be turned to face any part of the sky, and operation is automatic once the controls have been set in accordance with the satellite's expected orbit.

The camera takes two pictures on each strip of film. The first is taken while the camera is fixed on and following the satellite, with the time to the nearest 0.001 second recorded on the picture by a crystal clock. The second exposure is made while the camera is fixed on background stars and moves with them, thus providing a point of reference for locating the satellite.

Fig. 3.—Camera used for taking miniature photographs. (Extreme left) A square centimetre shown in comparison to one page of the Bible



# CAMERAS

## Interest by D. S. C. Fraser

### "Big Schmidt"

At the Palomar Observatory, near San Diego, California, there is the 48in. Schmidt telescope, familiarly known as the "Big Schmidt," which is even more powerful. Actually a very wide-angle camera, it could photograph a candle flame 10,000 miles away.

The "Big Schmidt" was used to make the photographs for a Sky Atlas published recently by the National Geographical Society and Palomar Observatory. This atlas shows the stars and other celestial bodies in the heavens up to approximately 1,000,000,000 light years away. (A light year is the distance over which light can travel in a year, or approximately 6,000,000,000,000 miles.)

### Deep Sea Cameras

At the other extreme, a camera designed and built by Dr. H. E. Edgerton, with help from the U.S. National Geographical Society, recently took pictures of the deepest part of the Atlantic Ocean ever photographed. This is the Romanche Trench, 24,600 feet deep, near the equator, and between the "bulges" of eastern Brazil and West Africa.

The Romanche Trench is as yet the only known break in the great Atlantic Ridge—the major feature of the Atlantic Ocean's floor. The Ridge extends from Iceland to beyond the latitude of Cape Horn at the southern tip of South America.

Dr. Edgerton's camera used an electronic flash to pierce the undersea darkness. While near the bottom of the Romanche Trench, the camera's lens—1½in. thick—cracked under the tremendous pressure; fortunately no water seeped through the crack into the inside.

### Needs no Light

Still another recently developed camera, called the evaporograph (Fig. 6), can take pictures of the proverbial black cat sitting on a pile of coal on a moonless night. This camera needs no light whatsoever in order to take pictures. It makes its photographs by gathering the heat radiation given out by the objects upon which it is focused.

The evaporograph focuses these radiations on a thin oil film. This causes oil molecules to evaporate to a varying degree, in accordance with the temperatures on different parts of the film. By this method, the camera makes a colour image of the object photographed (Fig. 6).

The camera which takes microscopic pictures has been developed by the U.S. National Bureau of Standards for film resolution studies. It will be used to establish new standards for measuring the resolving power of photographic films, plates and papers.

It is said to be capable of projecting parallel line patterns as fine as 50,000 lines per inch, and the ability of photographic film to record the lines distinctly is taken as a measure of its ability to render fine details in pictures.

In actual practice, a Bureau spokesman has said, "the films to be measured will not come close to resolving the finest patterns which can be produced by the apparatus. However," he added, "the equipment must be able to out-perform the materials to be tested in order that any limitations determined will be

(Concluded on page 457)

Fig. 6.—A photograph taken by an evaporograph camera. (Extreme right, the actual camera.)

Fig. 4.—The Baker-Nunn Schmidt-type telescope camera.

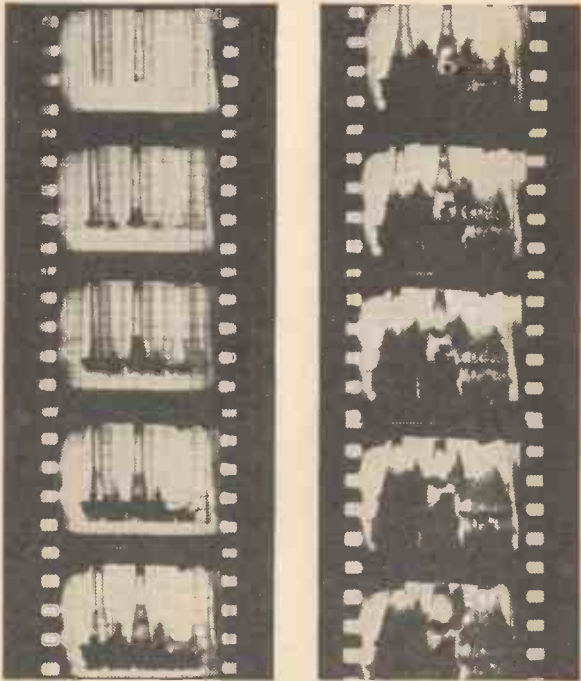

Fig. 5. (Above)—A sample sequence of still photographs of an explosion.



L.B.S.C.'s 3½ in. Gauge

**EVENING STAR**

**Part 4 is all about the coupling rods.**



**E**ACH coupling-rod is made up of four sections (Fig. 21) connected by fork-and-tongue knuckle joints, to provide sufficient flexibility to allow the wheels to follow an uneven line. This is more necessary on a small line than a full-size one, as the "umps and 'ollers" are far greater in proportion. I do my best to keep my own line level, but the British climate plays Old Harry with the timber longitudinals.

Four pieces of ½ in. × ½ in. mild steel bar are needed for the end sections, each 4½ in. long; two 5½ in. lengths for the driving sections, and two 4½ in. for the intermediates. For clearness, I have drawn the sections separately in Fig. 21. Coat the pieces which will form one complete rod with marking-out fluid, mark them off as shown, and drill a No. 31 hole at each end, through the pin or bush holes. These holes must go through dead square. File off any burring, clamp each section to its "opposite mate"—line them up carefully—and drill the latter, using the holes in the marked sections as guides. Drive in bits of ½ in. steel to keep the pieces together, and file these flush, so that the sections can be held in either bench or machine vice.

**Removing Surplus Metal**

If a regular milling machine is available, the surplus metal top and bottom can be removed by setting the pair of blanks level in a machine-vice on the table, and running them under a cutter on the arbor; but the wasp in the jampot is that the small radius at each end of the cut, precludes the use of an ordinary cutter. I get over that by using a special

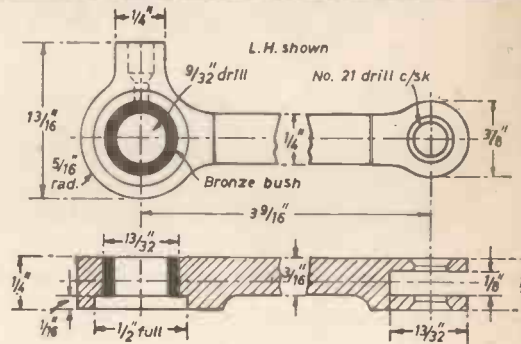

1st section

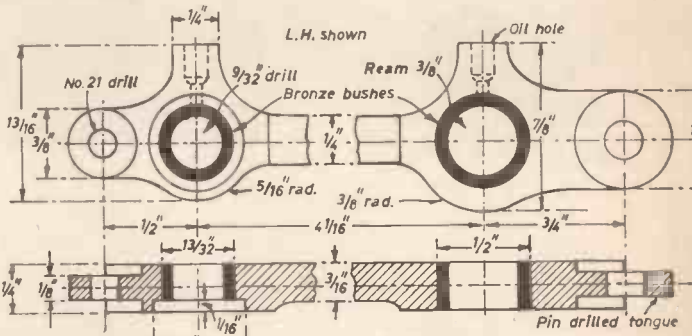

2nd section

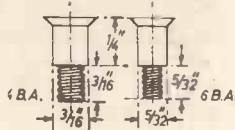
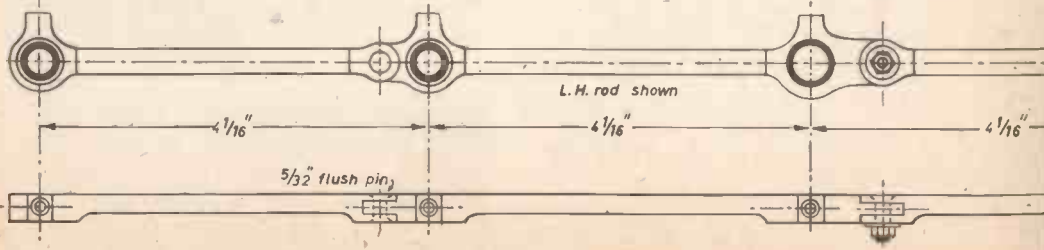

Fig. 21.—Details of the coupling rods. (Below) general arrangement; (above and right) enlarged detail of the various sections.





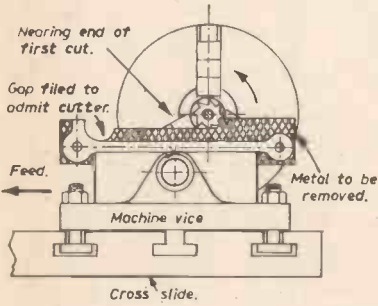
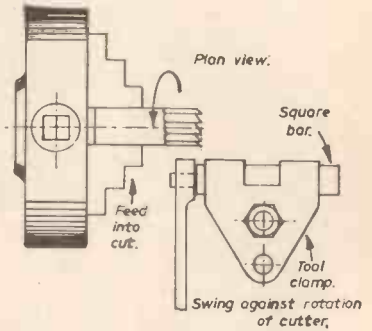

Fig. 22. (Left)—Removing surplus metal, using an endmill cutting with its side teeth.

Fig. 23 (Right)—Rounding the ends using an endmill in the lathe chuck.



endmill (Govt. surplus) 3in. long and 3/8in. dia. used as a slabbing cutter, with its shank in the mandrel socket, and its outer end supported by a centre-point in the overhanging arm of the machine. Lubricated from a drip-can on the arm, the way it mows off the unwanted steel is just nobody's business. This antic can be imitated by using an ordinary 3/8in. endmill, cutting with its side teeth as shown in Fig. 22.

**Using the Lathe**

There are two ways of doing the job in the lathe. Bolt a long angle-plate to the vertical slide, set it level, and clamp the pair of blanks to it. Put a 3/8in. endmill in the chuck, and adjust the lathe saddle until the blanks are directly under it. Feed into cut by moving the vertical slide upward, at the start of cut which is nearest to the operator, and traverse the cross-slide slowly towards you, using plenty of cutting oil.

Way No. 2 is to use the lathe as a regular milling-machine, but the unfortunate thing about modern small lathes is that the saddle has no height adjustment. The old 4in. round-bed Drummond had it, and very useful it was, too. However, where there's a will, there's a way! File a gap 3/8in. wide at the end of the pair of blanks, to the full depth of the required cut. Bolt a machine-vice to the cross-slide, and set the blanks horizontally in it, at a height that will allow a 3/8in. endmill in the chuck, to lie 1/8in. down in the gap. This will allow a cut of that depth to be taken right along the blanks, by traversing the cross slide. Return to starting-point, set the blanks 1/8in. higher up, take another cut, and ditto-repeat until the surplus metal is all removed.

After doing the top and bottoms, the faces of the blanks can be recessed 1/16in. by the same methods, on the outsides; and this will automatically give you the right-hand and left-hand rods. The left-hand one is shown in the drawing of the assembled rod.

**By Hand**

The job can also be done by hand, but it is rather laborious! Grip the blanks in the bench vice with the line of cut just level with the jaw tops. File a gap at one end, just wide enough to take a hacksaw blade on its side. Put a coarse-tooth blade, say about 14 per inch, sideways in the hacksaw frame, rest it in the gap, and saw along the line, letting the jaw tops guide the saw. Cutting oil applied to the blade is a great help. File away the saw marks with a flat file, and finish the radius at each end with a round one. I used that method in my early days when in a perpetual state of "financial embarrassment." The faces of the rods can be recessed by filing only, as there isn't much metal to remove, and a big flat coarse-toothed file will soon do the trick. Finish with a fine one.

To round off the ends, knock out the pins and part the sections. Chuck a piece of 1/2in. square steel rod truly in the four-jaw, and turn a pip on the end about 1/2in. long, to a diameter that will fit nicely in the end holes in the blanks, without shake. Set this crosswise under the slide-rest tool holder. Put the end of a rod over the pip, and run it up to a 3/8in. endmill held in the chuck (Fig. 23). Hold the outer end as tightly as

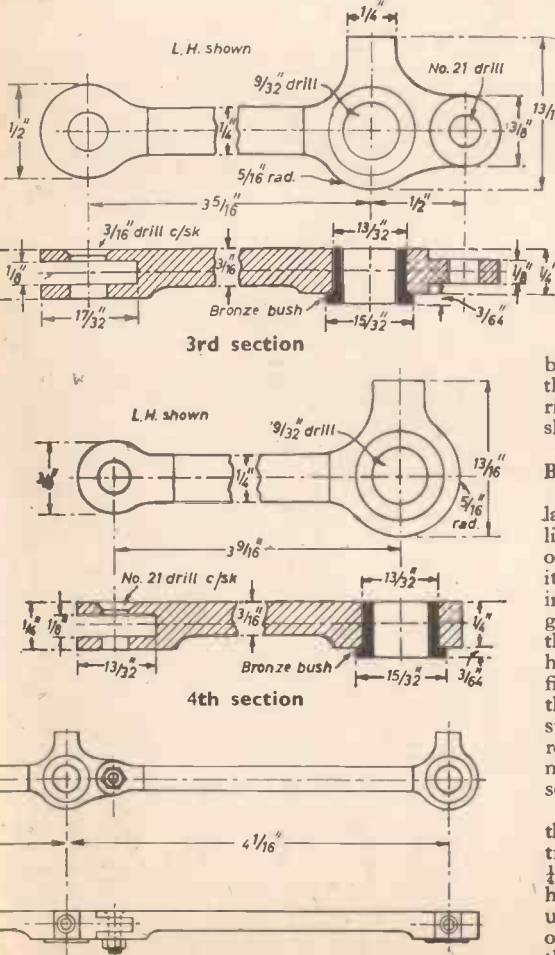

you can, then feed carefully into cut, and swing the end of the rod slowly round, so that the cutter removes the surplus metal and leaves the end of the rod nicely rounded. Be careful to avoid swinging the rod too far, or the cutter will take off the projections which form the oil boxes. The irregular parts of the bosses can be finished off with a file.

To slot the forked ends, clamp each rod under the slide-rest tool-holder at right angles to lathe centres. Put the cutter used for slotting the buffer and drag beams in the chuck, and feed the rod on to it in the same way, running at slow speed and using plenty of cutting oil. The tongues are formed with a pin drill,  $\frac{3}{16}$  in. dia. for the outer joints, and  $\frac{1}{8}$  in. for the middle one. Pindrill away  $\frac{1}{16}$  in. of the boss on each side, so that a  $\frac{1}{8}$  in. tongue is left in the middle. When the surplus metal around the recess left by the pindrill has been filed away, the tongue should be a nice fit, without side-shake, in the fork of the adjoining section of rod.

#### Assembly

The holes in the  $\frac{3}{16}$  in. forks and tongues can be opened out with a No. 21 drill. Those in the  $\frac{1}{2}$  in. ditto can either be drilled  $\frac{3}{16}$  in. or drilled No. 14 and reamed  $\frac{3}{16}$  in., putting the tongue in place in the fork, and poking the reamer through the lot, as I usually do. Countersink all the holes in the forks on the plain side of the rods, and on the recessed side of the front sections as well. The holes in the bosses are drilled out to the sizes shown in Fig. 21. Those in the front sections of the rods, and the leading ends of the driving sections, are also pindrilled to  $\frac{1}{16}$  in. full depth, to the given dimensions, so that the retaining washers will lie flush.

If you want the engine to run perfectly for a long time without undue wear, don't use anything softer than best-grade phosphor-bronze for the bushes. The Stroudey engines on the L.B. & S.C.R. had p-b bushes which ran trouble-free, and showed little wear after years of service.

Turning them is a simple job; the first and second can be turned from  $\frac{1}{16}$  in. rod held in the chuck. Face off, centre, drill  $\frac{3}{16}$  in. to  $\frac{1}{4}$  in. depth, then turn  $\frac{1}{4}$  in. of the outside to a press fit in the hole in the boss. Part off at  $\frac{3}{16}$  in. from the end. When pressed in, the bushes should be flush with the bottom of the recess. The driving bushes are turned from  $\frac{1}{8}$  in. rod. Face, centre, drill  $\frac{3}{16}$  in. for  $\frac{1}{8}$  in. depth, turn  $\frac{1}{8}$  in. length to a press fit in the big boss, and part off at a full  $\frac{1}{4}$  in. from the end. After pressing in, put a  $\frac{3}{16}$  in. parallel reamer through. The driving bushes should be a nice running fit on the pins, but all the others must be easy, to allow the wheels to "follow the road," as in full-size practice.

At the Southern works at Eastleigh, the bushes in the coupling-rods of all wheels except driving wheels, were bored  $\frac{1}{16}$  in. bigger than the diameter of the pins; to allow for the up-and-down movement of the wheels when running through crossing-frogs and other rail gaps. This was the cause of the ringing rattle frequently heard when the engines were coasting with steam off. Without the extra play, the rods would bend or break. This was found out by experience, in the early days of railways, and experience is the best of teachers!

The bushes in the fourth and fifth bosses are flanged. Chuck a piece of  $\frac{1}{2}$  in. rod, face, centre, and drill  $\frac{3}{16}$  in. for  $\frac{3}{16}$  in. depth. Turn  $\frac{3}{16}$  in. of the outside to  $\frac{1}{2}$  in. dia. and further reduce  $\frac{1}{4}$  in. of the end, to a press fit in the boss. Part off at a bare  $\frac{1}{16}$  in. from the shoulder, and press in from the recessed side of the rod. Drill a  $\frac{1}{16}$  in. oil hole in the projection at the top of each boss, right through into the hole in the bush, and counterbore it with a No. 30 drill as shown by dotted lines in the drawing.

Mild steel will do quite well for the knuckle pins, as very little wear takes place here. They can be turned from  $\frac{1}{8}$  in. round rod held in the chuck. Use a pointed tool with the cutting edge ground off to the same angle as the countersink, and slightly round off the point so that it gives a smooth finish without scratching. Turn the ends with a knife tool, and screw them with a die in the tailstock holder. The parallel part should be a nice push fit, without shake, in the forks and tongues; use plenty of cutting oil for both turning and screwing. The distance from the top of the head to the shoulder should be  $\frac{1}{4}$  in. full, so that when the nuts are screwed up tightly the jaws of the fork won't grip the tongue and prevent free movement. This is very important. Ordinary commercial nuts and washers can be used.

The pin in the front knuckle joint isn't screwed as there must be no projection beyond the boss where the connecting-rod passes it. Put a  $\frac{3}{16}$  in. length of  $\frac{3}{16}$  in. round rod through the fork and tongue and hammer the projections carefully into the countersinks, but not tightly enough to make the joint stiff. File flush each side.

(To be continued)

## PUZZLE CORNER

#### Fair Shares

THREE tramps met and decided to partake of a meal by the roadside. The first tramp had three loaves and no money; the second two loaves and no money; and third no bread at all but 1s. 5 $\frac{1}{2}$ d. in money. It was agreed that the loaves should be divided equally among them, the third tramp surrendering his money to the other two.

Since the first tramp had half as much bread again as the second, it is obvious he should receive more money. In what proportion should the money be paid?

#### Answer

As the total of five loaves were divided equally, each pay-out should be 1s. 2d. to the first tramp and 3 $\frac{1}{2}$ d. to the second. While the second contributed only  $\frac{1}{3}$  of a loaf. The first contributed  $\frac{2}{3}$  of a loaf to the tramp with the money, contributed 1 $\frac{1}{2}$  loaves. Therefore, the first must have consumed 1 $\frac{1}{3}$  loaves. Therefore, the first

## P.M. BINDING OFFER

Self-binders, in which copies of P.M. can be inserted as received, cost 10s. 6d. post free, from: Publisher (Binding Dept.), Geo. Newnes Ltd., Tower House, Southampton St., Strand, W.C.2. The binders are in black waterproof and greaseproof cloth, attractively lettered in gold. When the volume is complete our annual index, published at 1s. 3d. can be inserted.



# SCIENCE NOTES

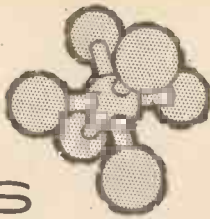

## Giant Coal Breaker

TO give it its full title it is a Pennsylvania spider-mounted Bradford breaker and it is to be used for crushing coal in the coking plant being built near Newport, Monmouthshire. The suppliers are G.E.C. through Mitchell Engineering Ltd. Coal enters straight from the mine at a rate of 600 tons per hour. The breaker rotates and shelves

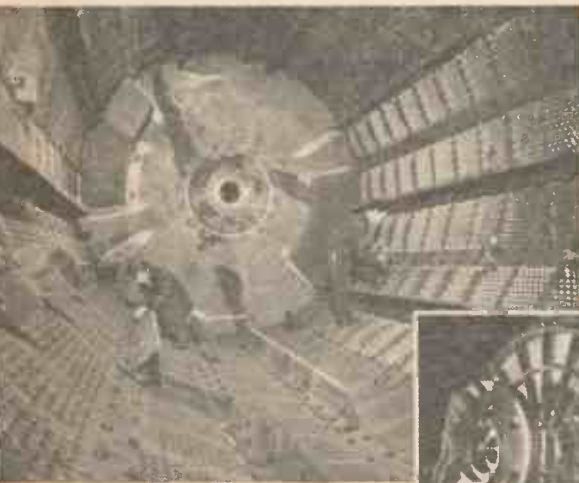

lift the large lumps which then drop on to heavily perforated screen plates, shatter and pass through. The screened size is 1½ in. dia. The above two photos show inside and outside views.

## New Trace Reader

THIS is currently reducing time and fatigue in the analysis of data displayed as a changing variable, such as pressure against time on a moving paper trace. The area of the trace is projected and magnified and controls are fitted to enable the co-ordinate scales to be adjusted independently. The instrument, shown in the photo below, has been developed by scientists of Shell International Petroleum Ltd.



## 600 h.p. "Taurus" Diesel-hydraulic Loco

DESIGNED as an economical unit for heavy shunting and transfer or trip working by Yorkshire Engine Co. Ltd., Sheffield, in collaboration with Rolls-Royce Ltd., this locomotive, shown above, has a novel combination of hydraulic and differential transmission. Two automotive engines are installed and drive through torque converters into a differential gearbox; a cardan shaft drives to the final gearbox. The second engine comes into use only at the higher speeds. One engine only can produce a very high starting tractive effort.

## Unique Dome

A HOUSE for a moon dweller? No, its very much an earthly structure, the chief point of interest being that it's made of wood. The outside is two layers of T.

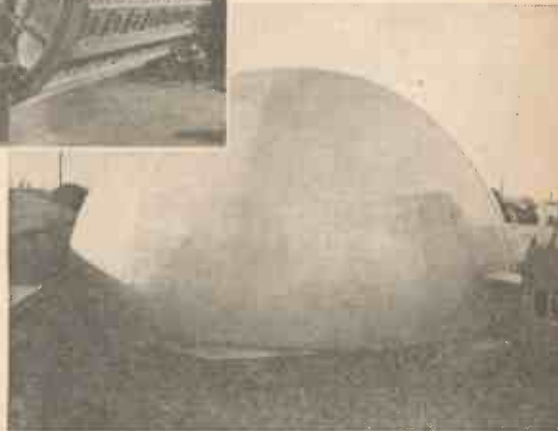
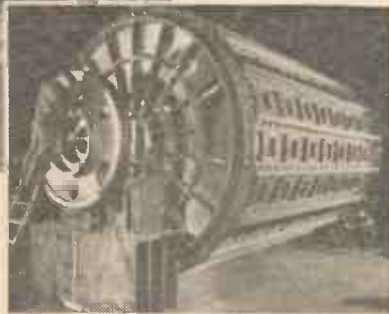

and G. boarding on laminated timber ribs. The inside is lined with plywood. It was built to enable a special form of insulation to be made and fitted for an atomic reactor.

## Sitting on It!

TO help in assessing public transport requirements, some bus companies have installed weight operated counting devices under the seats. The information thus supplied is used to compute future schedules.

# SIMPLE TAPE RECORDER MAINTENANCE

By B. Wilkinson



THE other day I had occasion to repair a tape recorder, the complaint made being simply that it would not work. On being plugged into the mains and switched on, the motor came up, and the magic eye lit up, but when switched to play or record, it refused to move. Around the head and capstan mechanism was a small clip-on cover, which, when removed, revealed the "fault." The belt driving the take-up spool via a slipping clutch, had become so stretched that it finally slipped off the pulley. As there was thus no drive to the take up spool, the tape merely cascaded into the mechanism until the whole thing jammed up.

Now this fault could have easily been avoided, by a little occasional attention to the mechanism immediately under the deck. The quantity of dust, fluff, and magnetic oxide powder around the head, bore silent witness to the amount of maintenance that had ever been carried out. Although many recorders seem to run indefinitely without any attention at all, the ingress of dirt and the wear of working parts tend to lower its performance (although the rate at which this falls off is so slow that it is rarely noticed until it is seriously impaired) and render it more susceptible to faults. Many of the faults, as the above example is intended to show, occur as the result of neglect, and could have been avoided. Fortunately, faults which are complicated and difficult to find are generally concerned with the amplifier and oscillator systems, and do not occur often.

The maintenance of a tape recorder is not difficult, and requires only a modest aptitude for mechanics. To keep the process in a systematic form, we will deal with it in two parts, mechanical and electrical.

## Mechanical

The mechanical system is far more likely to become faulty than the electrical system, because of wear in

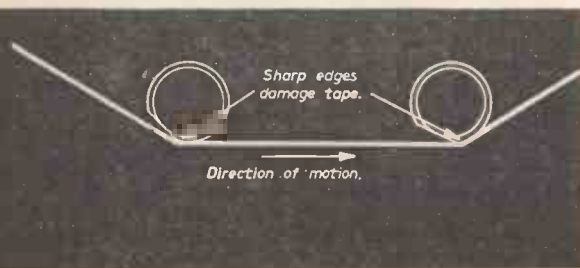

Fig. 1.—Possible effect of adjusting worn tape guides.

the moving parts. While wear is inevitable, it is certainly much increased by the presence of abrasive materials such as dust. Most tape recorders incorporate a cover which hides the head and capstan drive mechanism, and while this may prevent the ingress of foreign matter, there is always a gap along which the tape is laid. It is always possible to either remove this cover or gain access to the capstan and head, so this should be one of the first jobs. Much of the dust will

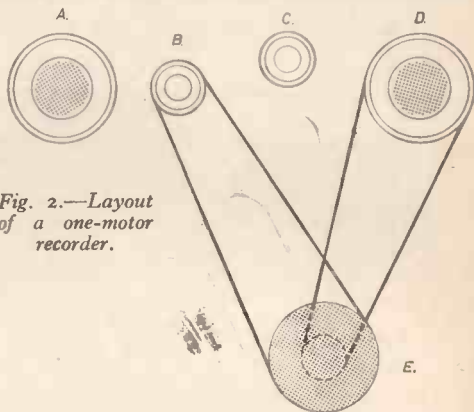

Fig. 2.—Layout of a one-motor recorder.

be red oxide from the tape, while the rest will have come from carpets, furniture, and the atmosphere. It should all be brushed away with a small camel hair brush.

## Bearings

There are several bearings in the region under discussion, and the dust here will mix with any oil to form a dark residue which should be washed out with a solvent such as benzene. If the tape recorder has any parts made of polystyrene, commercial cleaners based on carbon tetrachloride should be avoided as they will dissolve the plastic. The pinch wheel, which keeps the tape pressed against the capstan during play and record, is not only likely to pick up dust in its bearings, but also to become shiny and inefficient due to powdered oxide collecting on its circumference. It should thus be removed, the bearings being washed with a solvent, and the rubber circumference with soap and warm water. If this wheel shows any irregularities in its circumference perhaps due to being left in the record or play position when switched off, it should



be replaced as this will cause "wow" and "flutter."

While many recorders use small pillars which move forward and press the tape against the head, most instruments employ pressure pads, stuck to spring-loaded arms. When the recorder is switched to "play" or "record" the pressure pad moves forward and ensures a good contact between the tape and the head. It is not only necessary to ensure that the spring-loaded arm is free to provide a reasonable pressure but also to see that the pad itself is clean. Dust particles eventually clog up the felt, and sometimes the surface of the pad becomes hard so that it "rings" as the tape passes across it, producing a high frequency whistle that is often difficult to trace. If this occurs the surface of the pad should be roughed up with a sharp point, such as that of a needle.

The surface of the capstan will tend ultimately to become uneven due to a deposit consisting of the magnetic oxide from the tape and rubber from the pinch wheel. This should be removed by means of a cloth soaked with a solvent. On no account should it be scraped off. The tape guides, of which there are generally two, are also worthy of attention. The con-

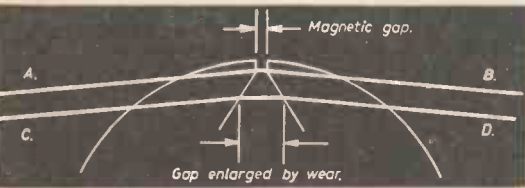

Fig. 3.—Effect of wear on head pole pieces.

tinual passing of tape across them, wears flats in the metal, and while this in itself does not affect the performance of the recorder, adjustment to the height of the tape by raising and lowering the guides, may well cause the tape to pass over a sharp corner (Fig. 1). Thus if the guides are removed or rotated they should have any sharp corners taken off with a fine file.

### Belts

While some recorders use as many as three motors, and do not have belt drives, the majority use one to provide all the functions. Fig. 2 shows a typical layout where two belts are used to transmit drive from the motor pulley B. The capstan which drives the tape is connected to the motor pulley by means of the belt shown. Since the capstan wheel is generally of a high inertia to eliminate "wow" and "flutter," starting tends to stretch the belt. At the same time, heat generated by the valves and other components which may dissipate power, tends to harden and reduce its flexibility.

In one particular recorder, mechanical noise became noticeable after six months from new. A year later when the noise became considerably worse, it was found to be due to the belt rubbing on a spring. Replacement of the belt which was over one and a half inches longer than it should have been, completely cured the mechanical noise. It may also be found that if this belt has become stretched or perhaps has taken oil on to its surface, the drive will slip so that "wow" and "flutter" may result. The slipping might even be such that there is no "wow" and "flutter" but the capstan runs slower than its correct speed. The pulleys carrying the belt should be inspected to see that belt material is not sticking to the surface.

The second belt, driving from E to the take-up spool D, via a slipping clutch is necessary to ensure that the tape winds on at the correct tension. Failure of this belt will result in the tape cascading into the mechanism. This belt is lighter than the capstan drive, but should not be loose on the pulleys or have a hard or cracked surface.

In the layout shown in Fig. 2, the fast forward function is effected by connecting the rubber tyred jockey pulley C, between B and D. If it is found that with the take-up spool almost full, the fast forward function is ineffectual, it may well be due to grease or dirt impeding the friction drives between B and D. The surfaces of these drives should therefore be cleaned, either with a grease-solvent or, if it is suspected that the surfaces may be of plastic, with soap and water. The same applies to the fast rewind function, which operates when the drum A, which carries the supply spool, is connected to the motor pulley B. If slipping occurs it will generally be manifested by difficulty in rewinding when the supply spool is nearly full.

### Brakes

While the covers are removed, it is a good plan to examine the brakes. In a tape recorder these should operate so that, regardless of which function the instrument is switched from, the spools come to rest almost instantaneously. There should be no jerking which may stretch or even break the tape, and the tape should not run off one reel without being taken up by the other. Sudden jerking, when the function is changed from fast to forward off, is due to excessive binding of the supply spool brake, or lack of bite on the take-up spool brake. The cause is *vice versa* if the function is fast rewind. If when switched from fast forward, the tape reels off, and has to be taken on to the take-up spool manually, then either the take up spool brake is binding excessively, or the supply spool brake is ineffective. The cause is *vice versa* if the function is fast rewind. Brakes vary considerably from type to type, so that it is not intended to go into any detail, but merely to state that the offending brake should be adjusted.

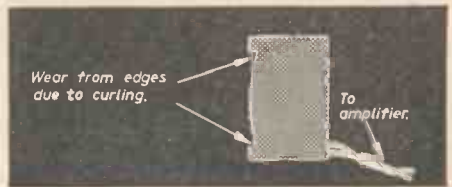

Fig. 4.—Side view of head, showing wear.

### Electrical

The quality of reproduction will gradually fall off due to:

- wear of the head gap
- magnetisation of the head
- misalignment of the head
- inter channel crosstalk.

The fall off however is normally so gradual that it is rarely noticed until it becomes very bad, or the reproduction is compared with that of a recorder in condition.

### Head Gap Wear

Fig. 3 shows the pole pieces of a typical play/record head. When a considerable length of tape has passed

across the head, the pole pieces will have become worn down to AB. At this point, the head is at its most efficient. There is no leakage across the parallel faces of the pole pieces, as they have been worn away, and all the flux developed is concentrated in the tape. Any further wear, however, causes the gap to enlarge (CD) with a consequent fall off of frequency response. In tension, the tape tends to curl slightly and the wear becomes as shown in Fig. 4. It is easily detected by means of a fingernail, which can be made to catch in the shoulder. If the shoulder is such that a fingernail

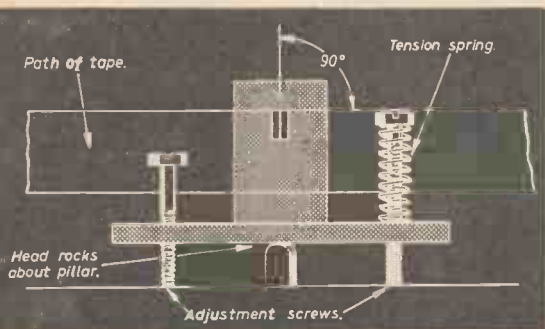

Fig. 5.—Head alignment.

can be held firmly against it, the head should either be replaced, or lapped down, the gap being viewed through a microscope to ensure that it has not reached the AB level (Fig. 3).

### Head Magnetisation

It may be that while the wear on the head is acceptable, the quality of reproduction has depreciated. This may well be due to magnetisation of the head, and generally shows itself as a background of hiss, odd clicks, and partial erasure of tiny sections of tape which have been allowed to remain against the head, where the tape has been stationary for any length of time. Demagnetisation is effected by placing the head in an alternating magnetic field of decreasing amplitude. Unless one has a defluxer which is especially for the purpose, the tape recorder should be taken to a dealer who can do the job in a matter of minutes.

### Head Misalignment

If it is suspected that the response has fallen off, and yet the head does not appear worn to excess, the trouble may be due to azimuth misalignment of the play/record head. This trouble, which gives the reproduction a woolliness, is more often found in instruments with separate play and record heads, and is cured by adjusting the offending head. Fig. 5 shows a typical head adjustment. The head pivots about the hump underneath the support, and the azimuth of the gap is adjusted by rotating the two screws. One is longer and carries a coil spring to provide tension. To adjust the head move only the plain screw. The recorder should be set to "play," a piece of music with a fair amount of high frequency component being the most suitable if a test tape is unobtainable. The plain screw is rotated until a point of maximum clarity is found. If the head adjustment seems to have become misaligned through a lack of tension, the spring-loaded screw should be tightened down first.

### Channel Crosstalk

Adjustment of the tape guides has already been mentioned and this may be necessary due to the presence of channel crosstalk. Fig. 6, shows the track details on a tape used with a dual track machine. The tape is .25in. wide, and each track is .1in. wide. This leaves .05in., .04in. of which provides two .02in. fringes at the edge, and a path .01in. separating the tracks. After some time, wear in the guides or shifting of the head perhaps may cause the head to overlap the second track, or perhaps to make the separating gap so small that both tracks can be heard at replay, although the interfering one is at a much lower level. This effect is much more likely to be observed when a tape made on one machine is played on another, or perhaps when a tape is played several months or years later on the same machine that recorded it. If it is suspected that this fault exists, it should be corrected by adjusting the tape guides, or moving the replay head up or down as necessary.

### Fault Switching

Most tape recorders use one amplifier for both recording and replay, so that complex switching is required to provide the necessary functions. After a long period of use, grease from the working parts of the switches may become deposited on the contacts, and this, together with the possibility of oxides forming on the contacts, causes faulty connections to be made. The symptoms of this kind of fault are clicks, and grating noises in the loudspeaker when the function switch is operated, or the necessity to work the function switch several times before good contact can be made. Without taking the switches to pieces

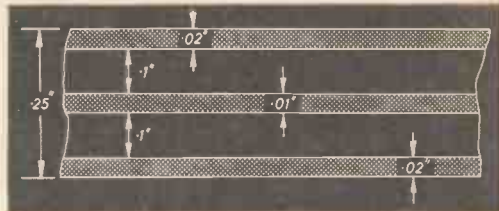

Fig. 6.—Track details (not to scale).

(which is unwise anyway), the best remedy is to squirt switch-cleaner into the switch working it several times as this is done.

### Volume Control and Leads

One of the most common electrical faults to occur is the failure of the volume control. It seldom fails completely, but becomes extremely noisy, so that it may be difficult to set a particular level. If this has happened it would be just as well to replace the component while the covers are off. However, it may be that the volume control is of a special type which is not easily replaceable. The old one may be given a new temporary lease of life by a little cleaning. I have known a very noisy volume control completely cured by being dipped in a cup of switch cleaner. This is very crude and it is much better, having removed the component from the tape recorder, to take it apart and clean the carbon track with switch cleaner. Finally one should check the mains and microphone leads for signs of fatigue or pulling away at plugs, etc. The microphone cable, usually of the co-axial variety, is particularly susceptible to breaking at plugs and connectors. Any lead which shows signs of wear or deterioration should be replaced.





# MAKING A TOY LAWN MOWER

By B. J. Dracey



**T**his toy mower closely resembles the grown-up version of the roller type. The absence of a bottom blade makes it completely safe for a child to use, whilst retaining a realistic action. It can be made quite cheaply from scrap or odd material.

## Side-Plates

These are cut from 12 B.G. sheet steel to the dimensions given in Fig. 3. This can be done on a guillotine at your local garage. One plate is then marked out for drilling, as shown. Clamp the two side-plates together to ensure accurate alignment of all corresponding holes, and drill a  $\frac{1}{4}$  in. dia. hole for front roller, and  $\frac{3}{8}$  in. dia. for the other three. Trim up all rough edges, round corners, etc., and finish by painting green.

## Rear Roller

This is made from a luncheon meat tin of approx. 4 in. dia. and about 11 in. long. It is a commercial size, and can be obtained from your local grocer. The next step is to cut two end discs from 12 B.G. sheet steel to fit tightly inside the tin. Scribe two circles about a centre dot, to a dia. to suit your tin (in my case  $3\frac{1}{2}$  in. dia.). These can be cut roughly by your local steelworker's guillotine, and finished off by filing to fit. Drill through the centre of each disc a  $\frac{3}{8}$  in. dia. hole to take the brass bearing tube, which is  $\frac{3}{8}$  in. o.d.  $\times$   $\frac{5}{16}$  in. i.d.  $\times$   $7\frac{1}{2}$  in. long.

One end disc must now be marked off, drilled with a No. 34 drill and tapped 4BA at 90 deg. intervals on the same pitch circle dia. (P.C.D.), as the driving pulley (dealt with later). The bearing tube is then pushed into one end disc (force fit) and the assembly pushed into and down to the bottom of the tin, the disc being located square by resting against four nuts, previously placed at the bottom of the tin.

A cement mix can now be poured into the tin, taking care not to get any inside the brass tube. The other end disc is pushed on to give an overall roller length

of 6  $\frac{1}{2}$  in. This disc can be held in position by roughly tapping over the end of the tin. The whole assembly can be left to harden for a day or two and then all surplus tin cut away with a small hacksaw. The bearing tube is cut off, leaving  $\frac{1}{4}$  in. protruding at each end of the roller. This surplus is then rolled over with a ball pein hammer to hold the end discs securely in position. With a file smooth any rough edges.

Obtain two pulleys—preferably, but not necessarily, of differing diameters—about 1  $\frac{1}{2}$  in. dia.  $\times$   $\frac{3}{8}$  in. wide. The larger (if of different dia.'s.) will be fitted to the roller. Drill four holes, No. 26 at 90 deg. intervals on a suitable P.C.D. and countersink for 4BA screws (drilling in end disc must line up with this). Drill a  $\frac{3}{8}$  in. dia. hole through the centre which must be countersunk on one side to enable it to fit flush against the roller side. Fit the pulley into position, and finish roller ends by painting grey.

## Front Roller

This can be made from a broom handle 1  $\frac{1}{2}$  in. dia. and cut to a length of 7 in. A  $\frac{3}{8}$  in. dia. hole must then be bored through the centre. Slightly chamfer the ends of the roller and varnish. As an alternative, the roller can be made from a steel tube of similar dimensions, with a  $\frac{1}{8}$  in. thick steel disc welded in each end. Drilling would be the same. Finish by painting grey.

## Cutter Assembly

Two end discs; one steel spindle; and six cutter blades comprise this unit. Make two 2  $\frac{1}{2}$  in. dia. end discs from  $\frac{1}{2}$  in. brass in a similar manner as for rear roller. Scribe an inner circle of 1  $\frac{1}{2}$  in. dia. and mark off centre lines at 60 deg. intervals—see Fig. 3. Cut

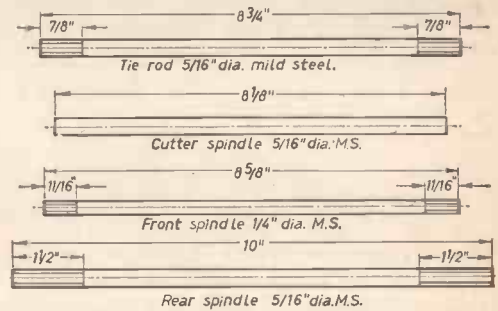
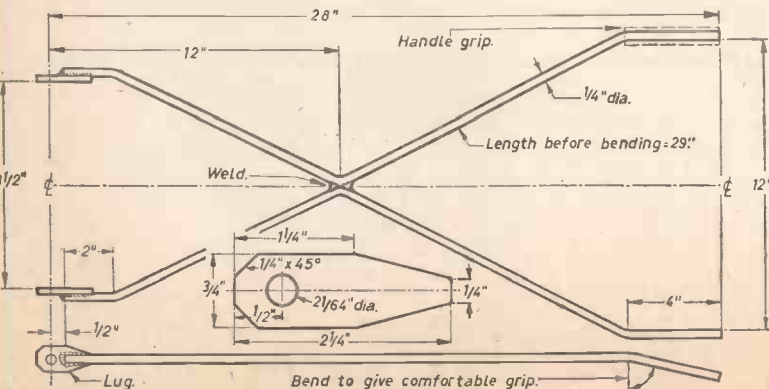

Fig. 2.—Dimensions and details of the spindles.

slots along centre line down to the inner circle with standard hacksaw, giving a  $\frac{3}{8}$  in. depth of cut approx. 0.042 in. wide. The cutter blades are made of  $\frac{1}{2}$  in.  $\times$  0.48 in. thick brass—6  $\frac{1}{2}$  in. long.

To assemble, drill each end disc at the centre  $\frac{1}{8}$  in.

Fig. 1.—Details of the handles and lugs.





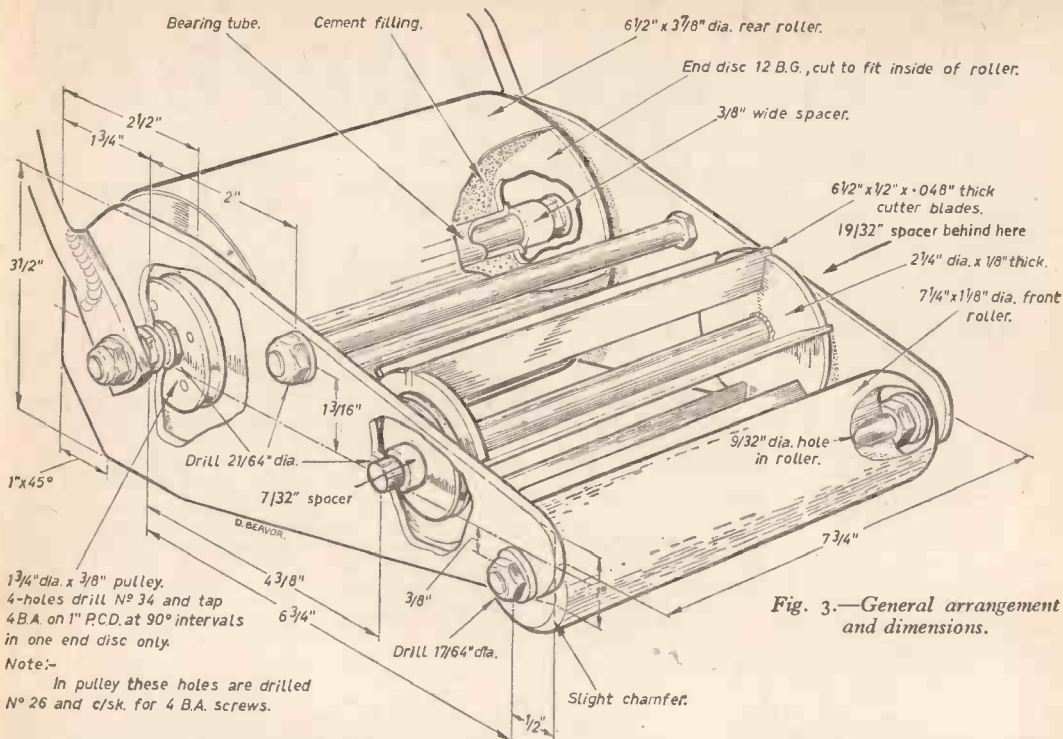

Fig. 3.—General arrangement and dimensions.

1 3/4" dia. x 3/8" pulley.  
4-holes drill N° 34 and tap  
4 B.A. on 1" P.C.D. at 90° intervals  
in one end disc only.

Note:—  
In pulley these holes are drilled  
N° 26 and c/sk. for 4 B.A. screws.

dia. and push on to the 5/16 in. dia. × 8 1/2 in. long spindle as shown. The ends of the cutter blades can be filed to a slight taper and forced into the slots in the end discs. Square the job up and solder all joints. To give a more realistic look, the blades can be given a twist before the second end disc is soldered to the spindle. The driven pulley can then be fitted flush against one end disc, and either be a tight fit, bolted or soldered in position. Finish by painting red.

**Spindles and Ties**

Details are given in Fig. 2. The rear spindle is 5/16 in. dia. steel × 10 in. long and threaded 1/8 in. Whit. or B.S.F. × 1 1/2 in. at each end. The front spindle is 1/4 in. dia. steel × 8 1/2 in. long and threaded 1/4 in. Whit. or B.S.F. × 1 1/8 in. at each end. The cutter spindle is 1/8 in. dia. steel × 8 1/2 in. long—plain. The tie-rod is 1/8 in. dia. steel × 8 1/2 in. long and threaded 1/8 in. Whit. or B.S.F. × 3/8 in. at each end.

**Assembling the Mower Body**

Run locknuts on to one end of both spindles and tie-rod—followed by plain washers, and place into position on one side-plate. Place on plain washers, and lock with Simmonds self-locking nuts for front spindle; tie-rod, and locknut for rear spindle.

Place in position front roller; cutter assembly and rear roller with suitable spacers on the latter two, to compensate for pulleys and locknuts. Fit driving belt (vacuum cleaner spare was used), run locknuts on to spindles and tie-rod, followed by plain washers and side-plate. This can then be fixed in position with washers, and nuts as before. Adjust all inner locknuts to give free running of rollers, and cutters, and tighten all outer nuts.

**Handles**

The mower body is now ready to receive the handles which are made up from two pieces of 1/2 in. dia. steel rod, bent as shown in Fig. 1 and welded together at the centre. Cut two lugs (inset) from 1/2

steel and drill a 3/4 in. dia hole in each. Weld one lug on to the handle, then, using a length of 5/16 in. dia. steel rod to get correct alignment, weld on the second lug. Brush all welding clean, and finish by painting green. Push on rubber or plastic tubing about 4 in. long for handgrips and the handle assembly is ready to be placed in position on the rear spindle. Spring on to spindle using plain washers as spacers, and hold in position with plain washers and Simmonds self-locking nuts, allowing handle to pivot freely. The result is a very realistic toy, made at only a fraction of shop cost, ready for handing over to junior.

**List of Materials**

Side plates	9 in. × 3 1/2 in. × 12 B.G. mild steel	2 off
Handles	1/2 in. dia. × 29 in. long mild steel	2 off
Lugs	2 1/2 in. × 1/2 in. × 1/2 in. thick mild steel	2 off
Hand grips	1/2 in. inside dia. × 4 in. long, plastic or rubber	2 off
Front spindle	1/8 in. dia. × 8 1/2 in. long mild steel	1 off
Cutter spindle	1/8 in. dia. × 8 1/2 in. long mild steel	1 off
Tie rod	1/8 in. dia. × 8 1/2 in. long mild steel	1 off
Rear spindle	5/16 in. dia. × 10 in. long mild steel	1 off
Front roller	1 in. dia. × 7 1/2 in. long wood	1 off
Cutter discs	from 1/2 in. thick brass	2 off
Cutter blades	0.048 in. × 1/2 in. × 6 1/2 in. long brass	6 off
Rear roller	luncheon meat tin—approx. 3 1/2 in. inside dia. × 11 in. long	1 off
Cement filling		
Bearing tube	5/8 in. inside dia. × 1 in. outside dia. × 7 1/2 in. long brass	1 off
End discs	from 12 B.G. mild steel	2 off
Pulleys	suitable outside dia. × 1/2 in. wide brass	2 off
Drive belt		
Spacers		
Locknuts	1/2 in. B.S.F. or B.S.W. plated steel	2 off
Locknuts	3/8 in. B.S.F. or B.S.W. plated steel	8 off
Plain washers	1/2 in. standard brass	4 off
Plain washers	3/8 in. standard brass	12 off
Simmonds nuts	1/2 in. B.S.F. or B.S.W. plated steel	2 off
Simmonds nuts	3/8 in. B.S.F. or B.S.W. plated steel	4 off
C/sk. screws	4 B.A. × 1/2 in. long brass or steel	4 off
Paint	green; grey and red	

# PUPPETS on film

By C. C. Somerville

## The Puppets

The simple type of puppet I advocate is illustrated in Fig. 3. It is reasonably simple to construct and proves very versatile in performance. Basically it is a series of wooden shapes mounted on a flexible armature. Twisted galvanised wire, copper wire or 3/32in. welding rod being used for this purpose. For the wooden shapes, rather like large beads, you will require the help of a wood turner if you do not possess a lathe. Actually a very simple puppet could be constructed using the larger wooden beads sold in handicraft stores (Fig. 4).

I would recommend a puppet of 12in. as the ideal size. Many properties, musical instruments, telephones and crockery, can be bought as toys. These may well be not quite to the scale of the puppets but this is all to the good. Puppets are ludicrous creatures and a little incongruity in scale will add to the effect.

The heads of the puppets are also based upon turned wood shapes, with the features built up with wooden beads, plastic wood, bits of fur and crêpe hair, and, of course, paint. A selection of stock character heads is illustrated in Fig. 2.

The puppets are dressed, for the most part, in felt. This is very easy to work with as it gives beautifully clean shapes and requires no hemming.

ATTEMPTS have been made in the past to film a live puppet show, but with little success.

Experiments in animating puppets using the "stop and start" technique, however, produced a much more satisfactory effect and this type of puppet filming is well within the scope of the enthusiastic amateur. Knowledge of films, cameras and the presentation in the orthodox fashion can be easily obtained from suitable books and from one of the many ciné clubs around the country. There is a difference between the "stop-action" technique for cartoon work and the "stop-action" technique for puppetry. Cartoons require hundreds of drawings accurately superimposed over the backgrounds and painstakingly filmed, but a simple animated puppet film can be tackled by one person without recourse to drawing or elaborate equipment.

## Equipment Required

You will, of course, need a ciné camera; 16 mm. or a smaller gauge is best. It is essential to have a camera fitted with single picture action. If you intend to use a sound track (as opposed to striping) then 16 mm. is obviously the gauge to use.

The only lens really necessary is a 1in. which will focus down to about 12in., but a wide angle 15 mm. lens will also be useful for filming a big set in a small room. A firm tripod and a lengthy cable release will also be required. A good quality light meter will prove an invaluable addition.

Space to make your film is of course another essential, together with a firm table and wall on which to attach scenery. A simple set-up incorporating a makeshift tracking wagon is illustrated in Fig. 1.

## Animation

The characters are fixed by a screw through one of the feet, to the base board or table-top on which you are working. The animation is largely a matter of experiment depending upon the action which your character is to undertake. But to illustrate the basic process I have analysed the most common action; that of walking. The secret of successful animation is to use a single frame per movement, and make the movements as small and gradual as possible. An invaluable aid to timing is a stop watch. Perform an action yourself and time it. If this indicates that you require 20 frames for that action use 24 frames, in other words, err on the side of smoothness.

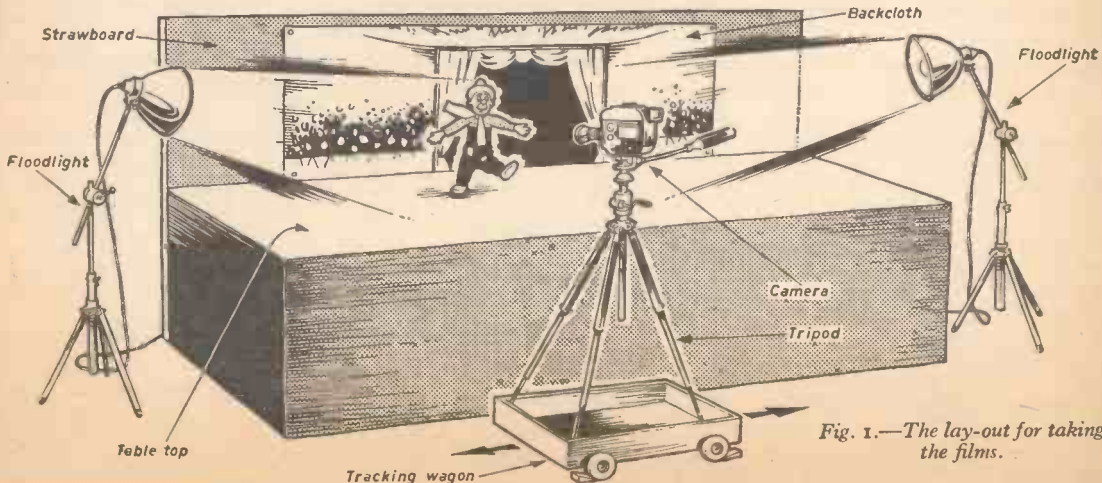

Fig. 1.—The lay-out for taking the films.



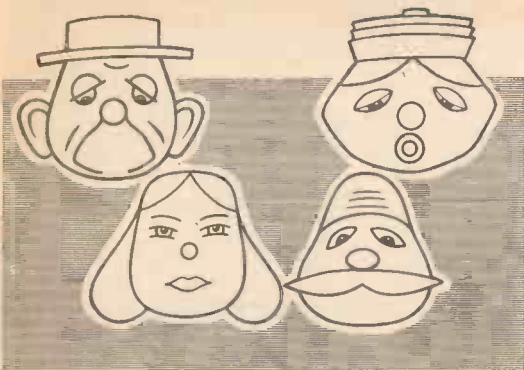

Fig. 2.—Stock character heads.

The basic procedure is to fix a puppet in position, take one frame, move the puppet slightly and refix in position then take the second frame. This is a laborious business, but with practice an average of 200 frames per hour can be achieved. Before you attempt any animation be sure that everything on the set is as rigid as possible since one accidental movement of camera, puppet or scene can ruin a "take" or length of film.

This next paragraph refers to the walking analysis illustrated in Fig. 6. and must be read in conjunction with the drawings.

**Frame 1.** Right leg screwed down. Take one frame.

**Frame 2.** Left leg bent and moved slightly forward. Slightly move the arms in the opposite direction.

**Frame 3.** Bend left foot and leg moving slightly forward.

**Frame 4.** Move left leg beginning to pass the right leg.

**Frame 5.** Right leg bent slightly. Do not move left leg.

**Frame 6.** Left leg further forward arms moving in opposite direction.

**Frame 7.** Move left leg forward, putting heel of left foot to the ground.

**Frame 8.** Screw down left foot and release the right foot.

After this the movement is a repetition of frames 1 to 8, only with the right foot instead for the left. Fig. 5 shows a puppet foot screwed down.

Scenery can consist of painted backcloths and setpieces. Details of the construction of these can be found in one of the numerous books on puppetry or model theatres. The writing of the script is not quite so straightforward. Basically, it should tell a story, no matter how simple; plots of the fairy tale or melodrama calibre are most suitable for animated puppets. Remember the puppet is a ludicrous creature who should not try to ape life, but to lampoon it. In the next column is a short excerpt from my own script "Motley," which may give some idea of layout.

Fig. 6. (Right)—Walking analysis.

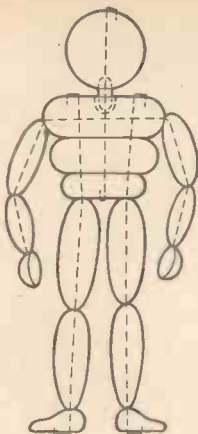

Fig. 3.—Puppet made from wooden shapes.

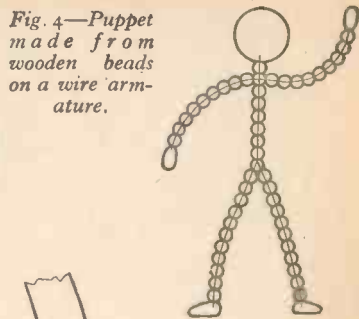

Fig. 4—Puppet made from wooden beads on a wire armature.



Fig. 5.—The foot of a puppet screwed down.

#### SHOOTING SCRIPT

**TAKE I.** Scene: Backcloth showing Circus posters. "Busker" character is speaking into microphone.

1/a—3 sec. Establish Scene. Medium shot.

1/b—11 sec. Busker walks across stage trailing mike, gesticulating all the time.

1/c—12 sec. Track camera to close-up to show only face. Effect of moustache twitching.

1/d—8 sec. Track camera back to medium shot.

1/e—6 sec. Horizontal.

Track camera to big bass drum with word "Motley" painted on.

N.B. Here fade in Titles.

**TAKE II.** Scene: Circus ring (solid) with background of crowd. Clown juggling at centre.

11/a—12 sec. Clown juggling. Medium camera shot from front.

11/b—12 sec. Repeat 11/a with new camera angle.

11/c—6 sec. Track to close-up of Clown's hands.

11/d—7 sec. Ball effects.

etc.

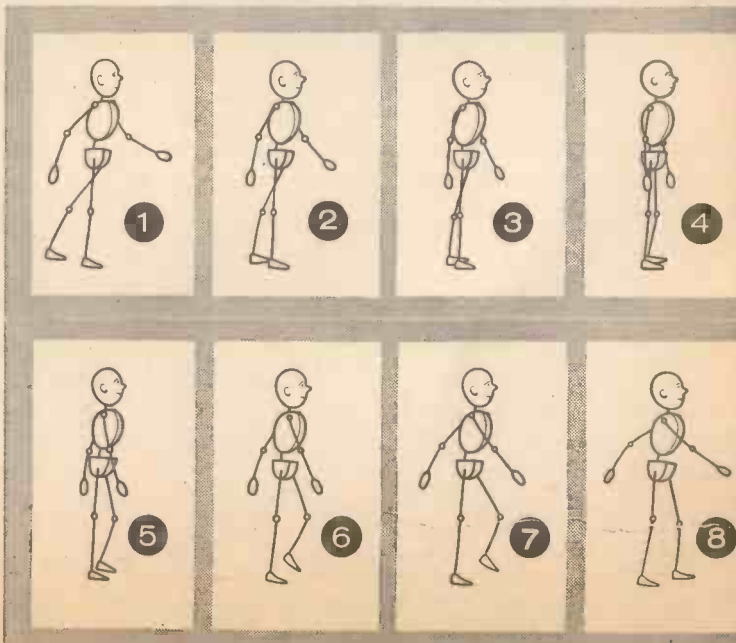

## The U.S. Mercury project

**F**ROM outer space the earth looks blue. This is information which we have on the very best authority from the man—the only man—who has seen it, Major Yuri Alekseyevich Gagarin of the Russian Air Force. Many eminent men have tried to visualise how our earth appears from space, but Major Gagarin *knows*—he has been into space, he has seen and he has returned to tell the world of earth-bound men his experiences.

His flight by this time is, of course, no longer news, but it is in no danger of being forgotten either. This Russian achievement and the name of Gagarin will be recorded in history. However many follow, nothing can dim the lustre of being the first man in space.

Little information has been released as to how the flight was achieved but it is certain that a multi-stage rocket was used. Its total height on the launching pad would be about 150-200ft. and its weight well over 100 tons. No details of the Russian space capsule are available but in general principles it is probably similar to the American Mercury capsule shown in Fig. 3.

The take off must have been the same as hundreds of others with an involved checking procedure and final tense count-down—even more tense than usual on this occasion with everyone thinking about the lone astronaut in his tiny pressure-sealed cabin.

His sensations must have been most unenviable. A sweating tense anxiety up to take off, followed by almost unbearable G forces which nearly drown the feeling of relief gained by the knowledge that the rocket had not failed at take off. After the first and second stages have fallen away, the last act of the final rocket was to eject the capsule with its human payload. The main change for the man inside would have been the discomfort of the G-forces being replaced by the exactly opposite feeling of weightlessness, but while the ship was in orbit the astronaut was able to make radio contact with his base and to look around him as his fabulous journey continued.

When the time came for the descent back to earth his feelings must have been strangely mixed. Vying with his reluctance to end the wonderful experience of gazing at sights man had never seen before would have been a very natural longing to get his feet back on solid earth. All in all, however, the realisation that the ship's retro rockets had fired must have come with relief. The following discomfort of G forces and heat as the rocket bores through the earth's atmosphere would be expected as also would the jerk as the descent changed to parachute. The bewildered and dazed astronaut's feelings on being released from his capsule are probably beyond description but relief and pride must have been predominant.

The details about the orbit so far released are shown in Fig. 2.

### America's Mercury Project

Reaction across the Atlantic to the Russian success was of disappointment, although it was already widely realised that they were several years behind the

Fig. 1. (Left)—A Redstone missile, carrying a Project Mercury space capsule, blasts off the launching pad at Cape Canaveral, Florida, December 19th, 1960.

# MAN IN SPACE



minutes

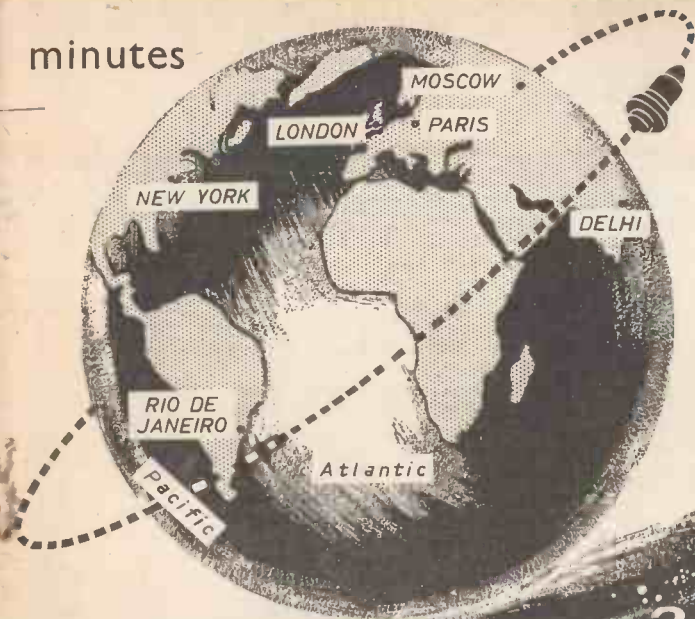

Key:

- 1 — Roll jets;
- 2 — Entrance hatch;
- 3 — Parachute;
- 4 — Pitch and yaw jets;
- 5 — Horizon scanner;
- 6 — Navigation periscope;
- 7 — Heat shield;
- 8 — Manual control;
- 9 — Communications system;
- 10 — Retro-rockets.

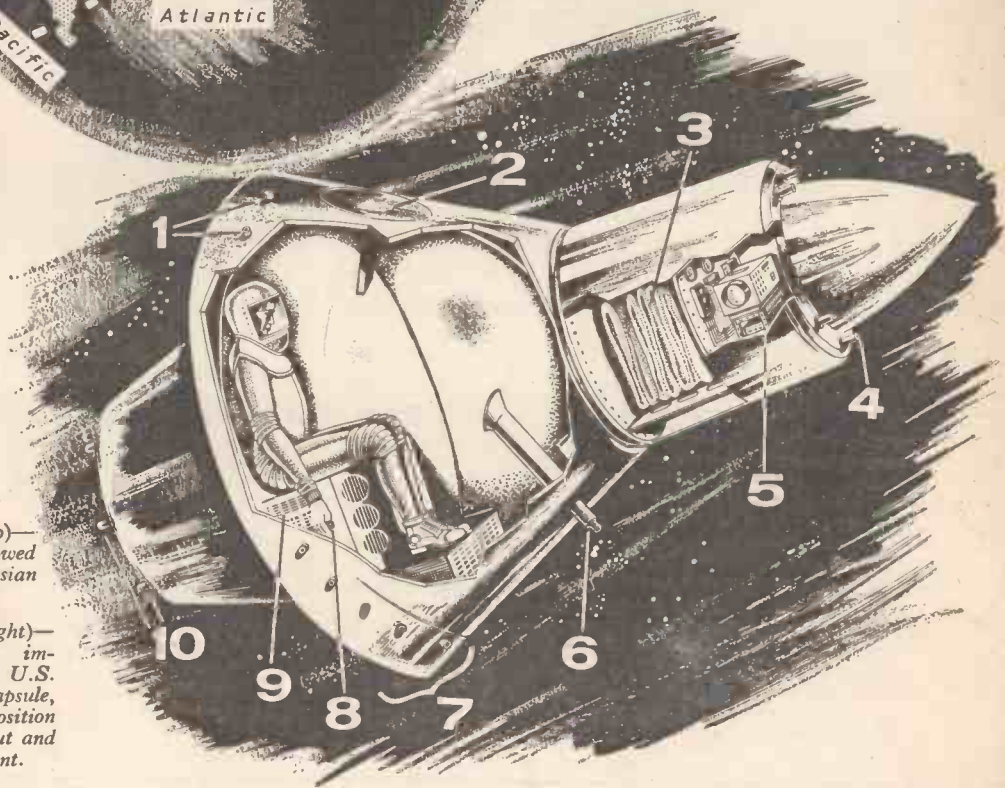

Fig. 2. (Top)—  
The orbit followed  
by the Russian  
space capsule.

Fig. 3. (Right)—  
Our artist's  
impression of the U.S.  
Mercury capsule,  
showing the position  
of the astronaut  
and the equipment.

Russians in this particular field. The knowledge that manned space flight was coming closer all the time had been emphasised by the successful recovery of the chimpanzee Ham in a Mercury space capsule. However, there is much more to space flight procedure than the recovery of a capsule.

### Miscalculations

While the Mercury recovery was accomplished, it was by no means perfect. By the same token, allied aspects of this flight left much to be desired. True, the chimpanzee returned alive and well, after his 5,000 m.p.h. flight, but he was picked up, fortunately, 130 miles beyond the original target area. Owing to miscalculations somewhere, the rocket travelled 1,000 m.p.h. faster than was intended; rose to a height of

Fig. 4. (Below)—Stages in the recovery of a space capsule from orbit.

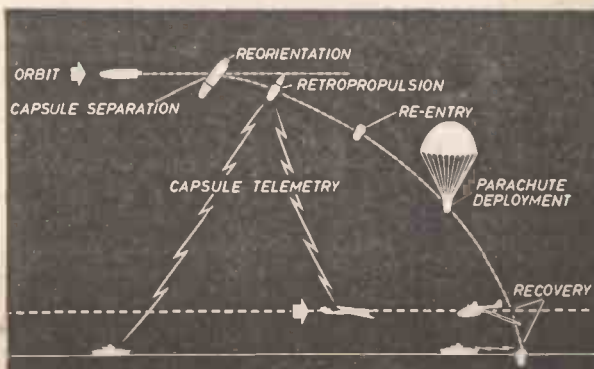



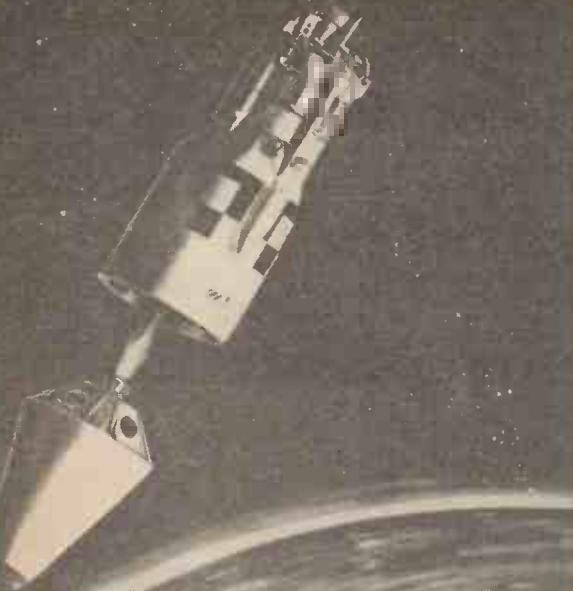

Fig. 5.—How the instrument capsule was separated from the Discoverer XIII satellite. The 85lb. capsule was recovered safely from the Pacific.

155 miles when it was scheduled to rise only 115, and it journeyed 430 miles in place of the planned 290 miles.

Obviously, before any definite attempt is made to put a man into space—especially into an orbiting satellite—discrepancies of this nature must, and undoubtedly will, be eliminated.

This is a problem which must have already been solved by the Russians. Their manned spaceship is believed to have landed very near indeed to the spot where it was intended it should.

### Mercury Project History

The immediate objectives of this project which started in October 1958 include uninhabited, animal inhabited and manned sub-orbital ballistic flights preparatory to manned earth-orbital flights. Only after extensive testing will the spacecraft be used to put a man into space.

Tests include ground testing, development and qualification flight testing as well as astronaut training (see Figs. 6, 7 and 8). Numerous rocket-boosted Mercury test flights of research and development

Fig. 6.—Mercury astronaut in the Wright centrifuge prepares for a test to measure his ability to cope with multiple gravity forces.



models have been made to-date and have provided much information, but more tests have to be conducted including manned sub-orbital flights before a man can be put into orbit from America.

On December 19th, 1960 a Mercury capsule was launched by a Redstone rocket from Cape Canaveral (Fig. 1). After a 16 minute flight it landed on target 235 miles down the Atlantic Test Range and was recovered. It reached an altitude of 135 miles and a speed of over 4,000 m.p.h. The sequence of events is shown in Fig. 4.

This was followed by the flight of the chimpanzee Ham, already mentioned, and the attendant miscalculations.

### The Mercury Capsule

The general layout and main details of the Mercury space capsule can be seen in Fig. 3. It is designed to withstand any known combination of acceleration, heat and aerodynamic loads that might occur during boost or re-entry, as well as land or water landing.

The craft has an extremely blunt leading face covered with beryllium heat shield. Its on-board systems include environmental (life support) and attitude controls, retrorockets to initiate descent from orbit, an escape device which provides complete escape capability during the boosted portion of flight, communications, landing systems and recovery aids.

This, then, is the position regarding project Mercury which has as its prime objective manned orbital flight. The Americans are at least a year behind the Russians in this particular aspect of space research. However, the Americans have endured a long and varied programme to perfect the penetration of space. The first successful American satellite Explorer I (launched 1st February, 1958), is still circling the earth, and is one of 21 U.S. earth satellites now in orbit. The Russians have successfully launched eleven earth satellites, of which one—Sputnik IV—is still in orbit.

With the Discoverer series, American scientists have sought, among other things, to control a satellite in its orbit and guide its capsule back to recovery, undamaged at a predetermined point on earth.

Of the first 12 Discoverers launched, seven were placed into a polar orbit, and six out of the seven, on an electronic command, released their instrument capsules. But none of these capsules was recovered.

Then, twice within eight days, two capsules were

Fig. 7.—Astronauts experience weightlessness of free fall conditions simulated by plane pilot flying a segment of an arc, like an orbital path.



picked up. The first of these, from Discoverer XIII, was circling the earth for the 17th time at 18,000 m.p.h. before the capsule release command was given as it passed at a height of 200 miles over Alaska (Fig. 5).

The capsule was aimed at a patch of the Pacific Ocean 60 by 200 miles in extent, and it parachuted down dead on target. Cloud prevented the waiting C-119 "flying boxcar" planes from catching it in their snares, but a naval helicopter picked it up soon after it had been spotted floating in the ocean (Fig. 9). Its instruments were not damaged.

The capsule from Discoverer XIV achieved a spectacular "first" when it was caught in mid-air by a "flying boxcar" on 19th August last. Like its predecessor, it was released as the satellite made its seventeenth orbit of the earth.

This time the weather was good, and one of the C-119s watching for the capsule caught it at 8,500ft. by snaring the shrouds of the parachute in a trapezoidal hook dangling from the plane. The capsule from Discoverer XV was sighted but lost in stormy seas but No. XVII was caught (Fig. 10).

Some 35 launchings have been programmed in the Discoverer series, which began in 1958 under the Defence Department's Advanced Research Projects Agency. According to Lieut. General Bernard Schriever, Air Force Chief of Research and Development, launchings from now on will proceed at the rate of about two a month.

#### "Life Shot"

Planned for the near future are a series of "life shots" which will launch monkeys and other live animals into space so that their reactions and physical tolerances to orbiting the earth in a capsule can be studied. The first such animal will probably be a chimpanzee weighing between five and 10lb. The "Ham" flight, mentioned earlier, was a N.A.S.A. recovery exercise.

General Schriever said that the Discoverer programme was "strictly complementary" to the National Aeronautics and Space Administration's Project Mercury—the programme which aims to put a man into orbit around the earth some time this year. He said that all relevant information gathered by the Air Force was being exchanged with N.A.S.A.

"The technique of recovery, plus the life specimens, will bring us definitely closer to success in the man-

Fig. 8.—Here a capsule is being tested for comfort, survivability, mobility, etc., by one of America's potential astronauts.



Fig. 9.—Mercury capsule launched from Cape Canaveral, December 19th, 1960 is lowered on to the deck of the U.S.S. Valley Forge by a helicopter after being picked out of the Atlantic.

in-space programme," he added.

The instruments in the Discoverer capsules monitored the significant events of the rockets' stages and will provide detailed information on rocket behaviour. Other instruments gathered data on temperature, pressure and deceleration problems that must be solved to achieve a manned space flight programme.

With both the National Aeronautics and Space Association and the U.S. Defence Department's Advanced Research Projects Agency combining their findings on space problems (together they have put a total of 30 earth satellites into orbit, and sent two instrumented space probes into orbit round the sun), Manned Space Flight should not be too far distant for the Americans.

Fig. 10.—A U.S.A.F. C-119 plane catches the capsule ejected from Discover XVII in mid-air by hooking its parachute.



## Part 16 in the Automatic House Series by E. V. King



WHEN any burglar alarm system is operated momentarily the bell should continue to ring until muted by the occupier with a special switch. A latching relay (May, 1960 issue) or the electric relay switch of Fig. 141a may be used.

A circuit incorporating this relay switching is given in Fig. 146. It will be explained later.

### A Simple System

The simplest system possible is that shown in Fig. 144. A secret switch of some type is represented by S1 and the setting switch by S2. It is battery operated to stop the thief using the mains switch to avoid detection. The bell should be in a convenient place (or may be plugged in at various points) and S2 with the batteries and wiring should be hidden. Unless S1 is of a special type the bell will not ring continuously, but only as the thief operates the secret switch.

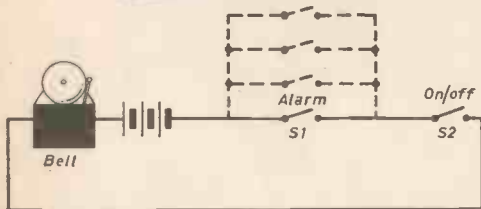

Fig. 144.—The simplest circuit. Additional optional alarm switches are dotted.

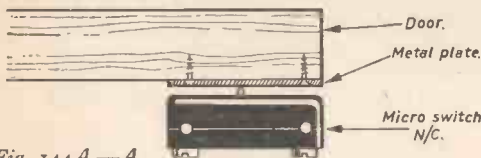

Fig. 144A.—A microswitch arranged to come on if a door is opened.

Fig. 145.—(Below) A pad-operated switch to be mounted level with the floor.

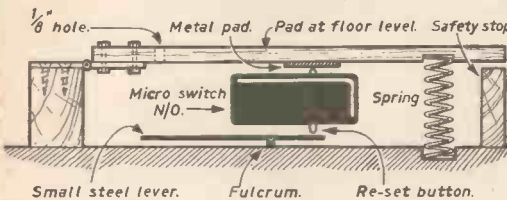

Fig. 146.—(Below) A circuit which will continue to ring once an alarm switch is tripped.

### Secret Switches

Micro-switches are small and fairly easily concealed in slots in woodwork. Fig. 144A shows a microswitch of the Burgess BR type being kept "open circuit" by a door. If the door is opened the contacts make and the bell will ring as long as the door is open. Other switches may be wired as shown in Fig. 144 to come on when any of the doors or windows in a house are moved. S2 is the setting switch which must not be put on until all the doors, etc., are closed.

### Pad-operated Switch

Pad-operated switches may be fitted under carpets in places likely to be trodden on (i.e. bottom of the stairs) Fig. 145 shows the idea. The pad is hinged at one side and rests on a spring at the other. It is compressed by weight until it rests on a stop of wood. A micro-switch is mounted underneath so that weight will just, but only just operate the plunger. Only 0.005 in. of overtravel after the switch clicks is permissible to avoid possible damage to the switch. If used as S1 in Fig. 144 the alarm will only ring when the pad is pressed. Any number of pads may be wired as shown by the dotted lines in Fig. 144, or any combination of door, window and pads may be wired in the same way.

If a special "locking" microswitch is used for pad operation continual operation of the bell after pressure is possible. In Fig. 145 a small hole has been drilled through

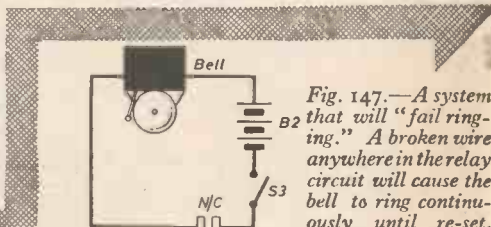
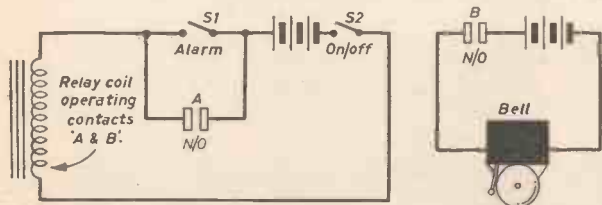
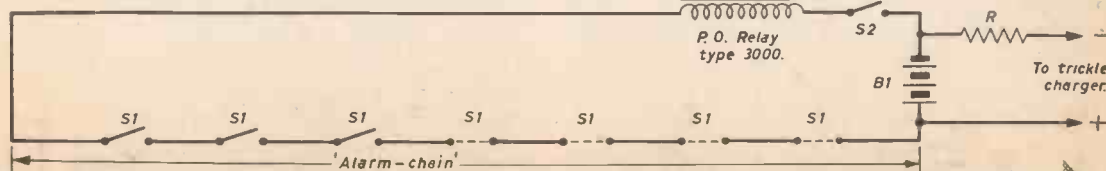

Fig. 147.—A system that will "fail ringing." A broken wire anywhere in the relay circuit will cause the bell to ring continuously until re-set.





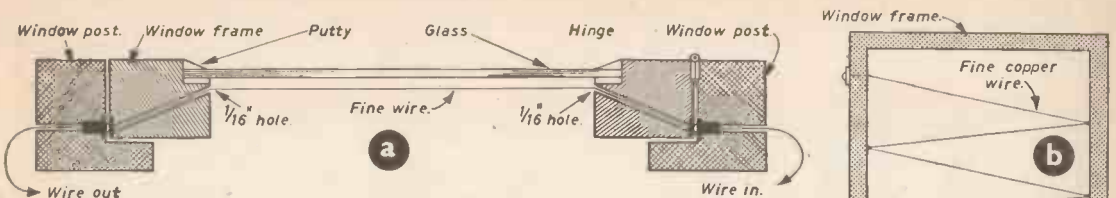

Fig. 148.—Method of fitting a wooden window frame with fine "Alarm Chain" wiring. Contact will be made automatically when the window is closed.

**PARTS REQUIRED**

- 2ft. 2in. x 1in. deal.
- 1 sq. ft. hardboard. Panel pins. Wood screws.
- Electric Bell 4V. operation. Obtained from Messrs. Halfords Ltd.
- Terminal Block (5C/430) Messrs H. Franks, 58 New Oxford St., London, W.C.1.
- On/off Switch (S2) Arcoelectric T.216, Messrs. Arcoelectric Switches, Ltd., West Molesey, Surrey.
- Micro-switch or other secretly operated device to make contact momentarily when disturbed. Type BR (Messrs. Burgess Products Co. Ltd., Team Valley, Gateshead, 11) will suit.
- Relay 100 to 200Ω, P.O. type 3,000, with two pairs of n/o contacts. Other contacts may be cut off if present. No. R3/2A from Messrs. Whistons, New Mills, Stockport, will suit.
- Batteries. Two flat type 4½V. torch batteries.

or less resistance can be operated from a battery of about 10V. If S2 is put on and a thief operates S1 (or many more as in Fig. 144) the relay will pull in. The (normally open) contacts "A" close and even if the thief closes the door (etc.) again the relay will still stay in. Contacts (normally open) "B" also close and cause the bell to ring from the same or another battery. Re-setting is only possible by putting S2 off. The re-set is then automatic.

**A Typical Relay Operated Layout**

Fig. 149 shows the appearance of a suitable layout for this system, it is ideal for small scale work in private houses and is easy to build.

**Making the Control Unit**

The circuit is as Fig. 146 and the unit is shown in the heading. The box is made as in Fig. 149 and the two panels made to fit; one is pinned on for a bottom.

The relay is mounted under the panel by bending some thin metal round the coil and bolting it down with four small B.A. nuts and bolts. The bell is now mounted, taking care not to puncture the relay coil. The switch is mounted in a small hole cut with a chisel and mallet, and the terminal block with two nuts and bolts.

The wiring is done in two stages. The bell circuit first. This should then work when the relay is pressed manually. The relay circuit is then wired. When the alarm contacts (i.e. terminal block terminals) are shorted momentarily the bell should continue to ring until S2 is put off temporarily.

the operating pad, this hole must take a steel knitting needle freely. A small piece of mild steel strip is mounted on an axle under the switch (see-saw fashion). The re-set button rests on one end of the strip.

When retiring for the night a needle is pushed through the 1/8 in. hole until the click is heard. S2 is put on. Any intruder pressing the pad will cause the bell to ring continuously. A suitable switch for use in this manner is the Burgess type BX made by Messrs. Burgess Products Co. Ltd., Team Valley, Gateshead, 11.

**The Relay System**

Fig. 146 shows how a P.O. type 3,000 relay of 200Ω

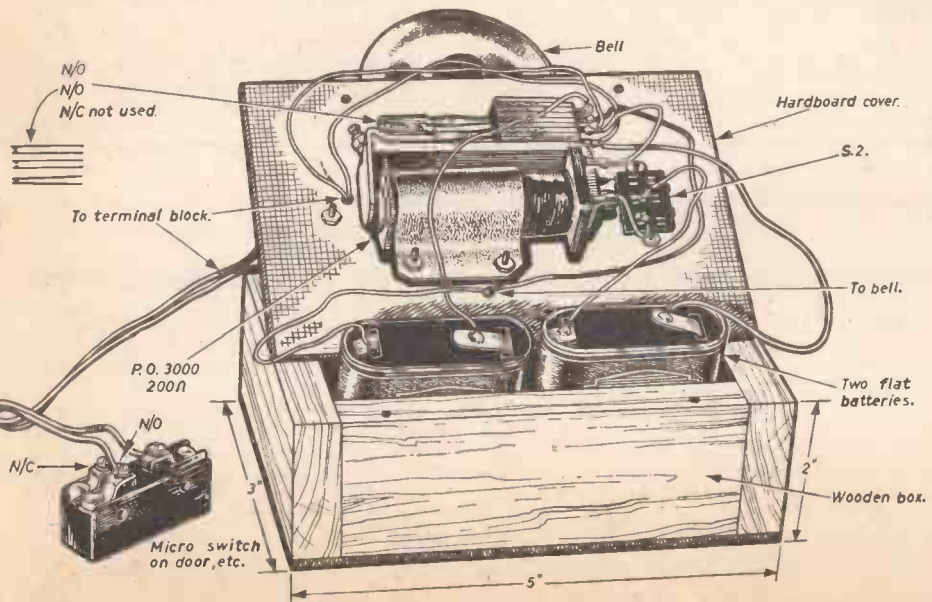

Fig. 149.—The underside of the panel and the wiring of the burglar alarm unit. Also shown are details of the framework to house the unit.

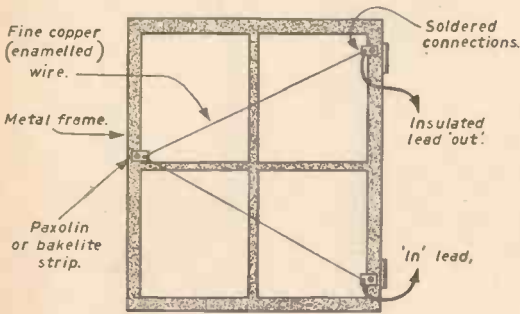

Fig. 150.—A method of insulating thin conductors across metal-framed windows.

### The "Fail on" System

This means that if an intruder should spot the system and remove a wire the bell will ring. It is possible to cover breakage of windows with this system (see Fig. 147).

The alarm chain of switches is made up of door-operated n/o switches, pad-operated n/c switches and thin wires of about 34 s.w.g. copper stretched across windows behind lace curtains. If the windows open contacts must be provided or the wire must go from window post to window post loosely to avoid breakage.

### How the System Works

When all the doors and windows, etc. have been closed, S<sub>2</sub> of Fig. 147 is put on. The relay is energised and consumes continually about 0.1A. of electricity. Large dry batteries would give long service, but motor cycle accumulators and a trickle charger would be best. The relay is thus held in. Contacts C, which are normally closed, are kept apart. Any failure of the alarm chain or relay circuit will cause the bell to ring until the circuit is completed again. A switch S<sub>3</sub> may be fitted for muting purposes, and it is convenient to gang it with a S<sub>2</sub>, using a 2-pole 1-way switch. For test purposes a changeover 2-way single pole switch may be connected to a lamp circuit so as to avoid ringing the bell on retiring if a door, etc., has been forgotten. The circuit used would be as for

Fig. 147 with alteration to the bell circuit as in Fig. 140 (May issue).

### Window Wires

Fig. 148 shows a suitable system using small cabinet ballcatches so that the wires (34 s.w.g.) may be stretched across the window and the windows open when required. Holes are drilled to take the catches, the tops countersunk. Sometimes a brass plate with a hole in it is used on one side, this is quite suitable. Wires are soldered to the catches as shown. The wires are led through small holes carefully drilled through the window frame to come out level with the inside of the glass. The wire may be tightly stretched across, left loose, stuck to the glass or taken zig-zag fashion backwards and forwards or up and down terminating at the catches. This is shown in Fig. 148b.

If a great length of wire is used to cover all the windows in a house an increase in battery voltage may be necessary to pull in the relay or the relay "leaves" may have to be adjusted to an easier tension. Suitable P.O. type relays of under 200Ω resistance with one set of n/c contacts may also be obtained from Messrs. A. T. Sallis, 93 North Road, Brighton. Thin enamelled copper wire suitable for the windows is obtainable from radio repair dealers, armature winders or Messrs. Post Radio Supplies, 33 Bourne Gardens, London, E.8. The catches are obtainable at most "do-it-yourself" stores.

An easier system, rather more obvious, is to take in and lead out a wire from the hinge side of the window leaving a few inches of flexible cable so that opening the window will not break the wire. (Fig. 150.)

### Metal Window Frames

Small bakelite or similar tags must be fixed to the metal by drilling right through and using nuts and bolts or partially drilling and tapping a thread. The idea is shown in Fig. 150 and since ball catches are not suitable flexible leads are used on the hinge side.

If enamelled wire is used it may be taken over any metal struts in its path, alternatively sleeving may be slipped over at such places and stuck in position with cellulose adhesive. Any number of insulators may be used on each window.

## Books for the MOTOR CYCLIST

Published by C. Arthur Pearson Limited, Tower House, Southampton Street, London, W.C.2.

**LAMBRETTA** by Raymond Broad. 184 pages. Price 10s. 6d. net.

AS THE prime intention of this book is to provide servicing data both for the owner-rider and the service mechanic, all but the first and last chapters are devoted to various aspects of this subject. The first chapter describes the various types and models, the whole range from Model C to the TV 175 and Li models being covered. The final chapter is devoted to the activities of the British Lambretta Owners' Association. If you own or intend owning, a Lambretta scooter, this volume is a must for your bookshelf.

**ROYAL ENFIELD Motor Cycles** by C. A. E. Booker. 213 pages. Price 10s. net.

WRITTEN by the Royal Enfield Service Manager, this handbook covers the complete range of Royal Enfield motor cycles from 1937 to 1960. The

procedure adopted in laying out the book has been to group machines with similar engine characteristics together and chapters on engine dismantling and reassembly are followed by others devoted to specific components. The many excellent diagrams and the useful index make this book of certain interest to the Royal Enfield owner.

**PASS YOUR MOTOR-CYCLE DRIVING TEST** by L. Franklyn, revised by Insp. E. Taylor (Metropolitan Police Motor Driving School, Hendon). 64 pages. Price 3s. 6d. net.

ALL that needs to be known by motor cyclists and scooterists alike, is contained in this handy little book. The first section summarises all that the candidate for the test is expected to know and do, and the steps that must be taken in applying for the test. In the second section will be found a series of typical questions in preparation for the oral part of the test. The questions will assist the reader in becoming fully conversant with the essentials of safe driving. Information on the new Motorways has been included in this 4th edition.

# Making a Jeweller's

# French Blowpipe

By L. T. Hansen

THE materials required are a piece of brass sheet approximately 3in. square, 22 or 24 gauge; two pieces of brass or copper tube about 9in. long, one of  $\frac{1}{8}$  in. outside diameter and the other  $\frac{3}{16}$  in. outside diameter; a small brass gas tap and a farthing.

### Construction

From the brass sheet cut a strip 1in. wide and form it into a cylinder round a  $\frac{3}{8}$  in. dia. bar. Silver solder the joint (see the final paragraph below) and trim the ends square. Slide the cylinder on the bar to within  $\frac{1}{4}$  in. of the end and carefully tap it inward all round leaving the opening about  $\frac{3}{8}$  in. dia. Next flatten a piece of sheet brass about 1in. square, silver solder the cylinder on this and trim off all round to form the top of the blowpipe (see Fig. 1).

Cut the  $\frac{1}{8}$  in. tube in two and make another tube from the brass sheet about 1in. long and a good-push fit on the  $\frac{3}{16}$  in. tube. Cut this in half. The gas tap will most likely have a short length of threaded tube on each side. If this is so, file the thread away until the  $\frac{1}{2}$  in. length of tubes are a good push fit on them.

Unscrew the plug from the gas tap and solder  $\frac{3}{16}$  in. tubes to the plug (Fig. 1). This may be done with soft solder though silver solder is better. Cut off the finger-piece from the tap plug, file it flat and replace with a disc such as a farthing. Again-soft solder may hold it but silver solder is more suitable.

### The Jet

Gently tap the end of the  $\frac{3}{16}$  in. tube, turning it round and round until a large darning needle will fit the hole. Hammer the tube all round the needle then withdraw it and anneal the end of the tube. Bend it round as shown in Fig. 2. Drill two holes in the head: one  $\frac{1}{16}$  in. at  $\frac{3}{8}$  in. from the front and another  $\frac{1}{16}$  in. at  $\frac{1}{2}$  in. from the front. Silver solder the two tubes in position. When the gas tap is reassembled, the blowpipe is complete, apart from the strut connecting the two tubes together about 1  $\frac{1}{2}$  in. from their ends.

In use the larger tube is connected to a gas supply with a rubber tube and the narrow one by 18in. of rubber to a pipistem mouthpiece.

### Silver Soldering

Silver soldering small items can quite easily be accomplished with the aid of a Bunsen burner or a gas ring, or even a blow lamp. The flux is a little borax made into a thin paste with a drop or two of water. The joint is well fluxed and tiny pieces of solder (also fluxed) placed along it. Gently warm the whole job first and the borax will effervesce and swell up. If it dislodges the solder continue the heating and coax the solder back into place with a needle. The flux will melt as the heat increases and at low red heat the solder will suddenly flash into the joint. The secrets of silver soldering are:—Ensure a good (but not perfect) fit of the parts; Well flux the place where the solder is wanted; Use as little solder as will fill the joints; Bring the whole work slowly up to the required temperature; Do not direct the flame on to the solder but heat from behind. After silver soldering the job should be allowed to soak for about 15 minutes in a 10 per cent. solution of sulphuric acid (obtainable at a garage) to clean it.

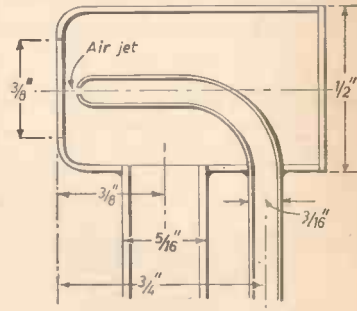
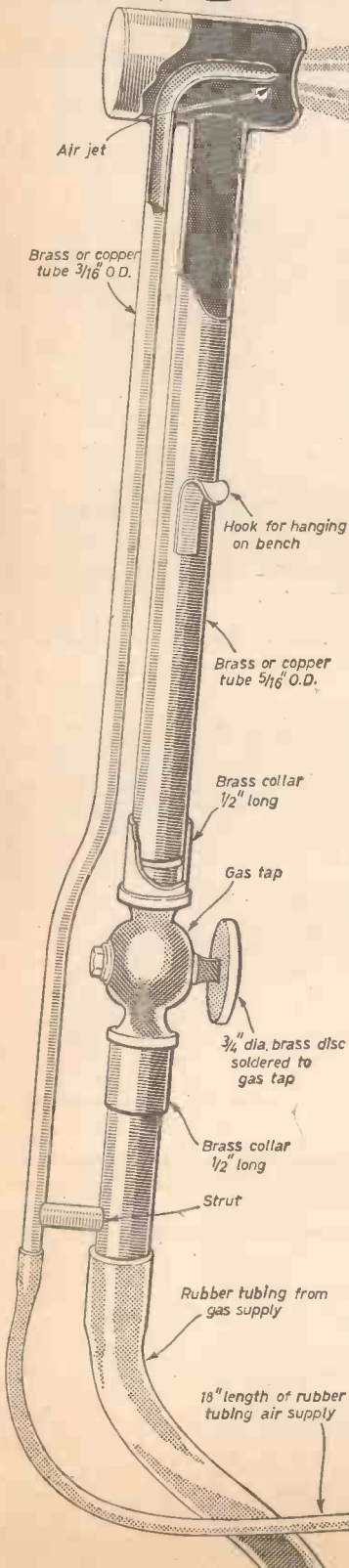

Fig. 2.—Dimensions of the jet.

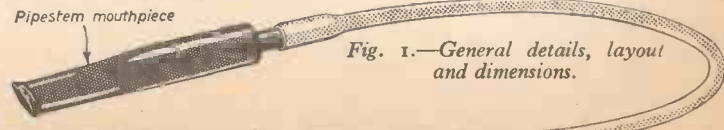
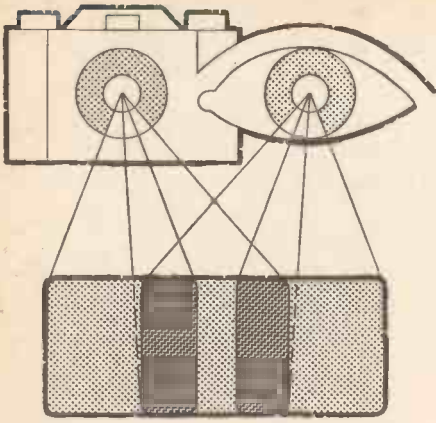

Fig. 1.—General details, layout and dimensions.



# STEREOSCOPIC COLOUR TRANSPARENCIES



E. Spencer explains how these can be taken with an ordinary 35 mm. camera and shown to advantage

**E**XAMINED in a well-designed viewer, a single-colour transparency often gives a much greater sense of depth than is obtainable with an ordinary bromide print. The effect is even more impressive when a pair of stereoscopic colour transparencies are viewed. Provided that one avoids photographing moving objects, an ordinary 35 mm. camera can be used to take stereo pairs; the additional equipment required is simple and inexpensive to make.

Two views are required of the subject in which the viewpoints should be separated by a distance equal to the separation of the eyes. Of course, some people's eyes are further apart than others but fortunately the separation of the two viewpoints is not critical: about 3 in. gives satisfactory results. The lens axes for the two shots should be parallel and in the same horizontal plane.

## Camera Tray

All these requirements can be satisfied by supporting the camera on a small tray fixed on top of a tripod (Fig. 1). The length of the tray should be 3 in. longer than the base of the camera so that the required

separation is obtained by taking successive exposures with the camera, first at one end of the tray and then at the other. The tray should have a beading round the edge and, before making each of the exposures, the back of the camera should be pressed against the rear beading. The tray I use with my Agfa Silette consists of a piece of  $\frac{3}{8}$  in. plywood  $8\frac{1}{2}$  in.  $\times$   $2\frac{3}{4}$  in. with a  $\frac{3}{8}$  in. square bead round the edge. In order to be able to screw it on to the tripod, a 2 in. square steel plate  $\frac{1}{2}$  in. thick with a central hole drilled and tapped  $\frac{1}{2}$  in. Whitworth was bolted beneath the middle of the tray.

For critical shots use a small spirit level to ensure that the tray is horizontal. On the other hand it is possible to take satisfactory stereo pairs without using the tray and tripod. The first shot has been taken as usual with the camera hand-held and with some small distant object in the middle of the viewer. Then lean slightly to one side to take the second shot, lining up on the distant object as before. Small errors are inevitable this way, but usually it is possible to correct them when mounting the transparencies in cardboard mounts—in which the area of the cut-out is slightly less than the area of the picture.

## The Viewer

As a temporary measure, a pair of stereo transparencies can be viewed using two ordinary viewers side by side, but transparencies can be viewed much more conveniently through a proper viewer. The one in Figs. 2 and 3 was designed for use with transparencies mounted in ordinary 2 in. square mounts.

The transparencies are observed through a pair of watchmaker's eyeglasses mounted above a box supplying the illumination. The light from a 15W. 230V. pigmy bulb is diffused by means of a piece of flashed opal; a pair of mirrors, one on each side of the bulb help to provide even illumination. The box is painted



Fig. 1.—The camera supported by the tray.

white inside and black outside and has a pair of ventilation holes at each end. The opal glass and the two mirrors are held in place by thin strips of tinplate cut from a fruit can; they should not be gripped too tightly or they may splinter.

The eyeglasses have a focal length of 3in. and were bought for a few shillings from a well-known multi-branch chemists. Ideally, it should be possible to adjust the distance between the eyeglasses and also their distance from the transparencies. In this viewer, however, the distance between them is fixed at 2½in. and this seems to suit most people. However, it is advisable to check by experiment the gap between the transparencies and also the distance between them and the eyeglasses. When the box and its internal fittings have been completed, a temporary support for the eyeglasses can be made out of cardboard and the essential dimensions checked before completing the job in wood.

One final word about the choice of subject. Don't forget—no moving objects! Make sure before you make the first exposure that you will have time to make the second before people, animals, cars, etc. come into view. Otherwise you may have a tedious wait while the coast is clear again—by which time the sun is sure to be obscured by a long slow moving cloud. Avoid including water (unless it is absolutely

still) and watch out for the movement of trees if there is a strong wind. On the other hand, buildings, gardens and woodland scenes make excellent subjects when the conditions are right and you will be surprised how clouds will stand out in the sky and how the undulations in rough ground convey the impression of distance.

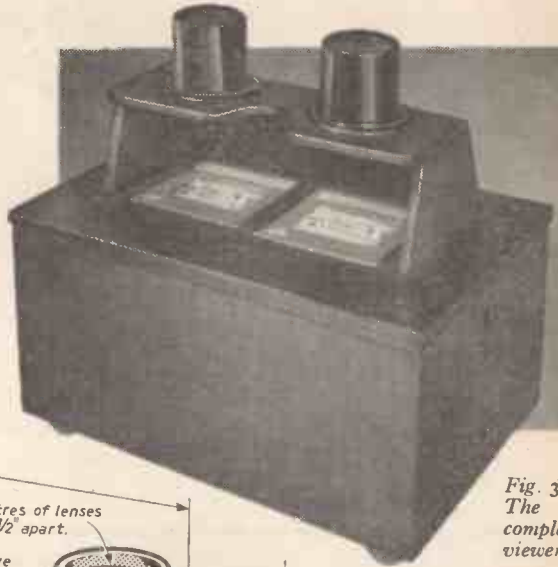
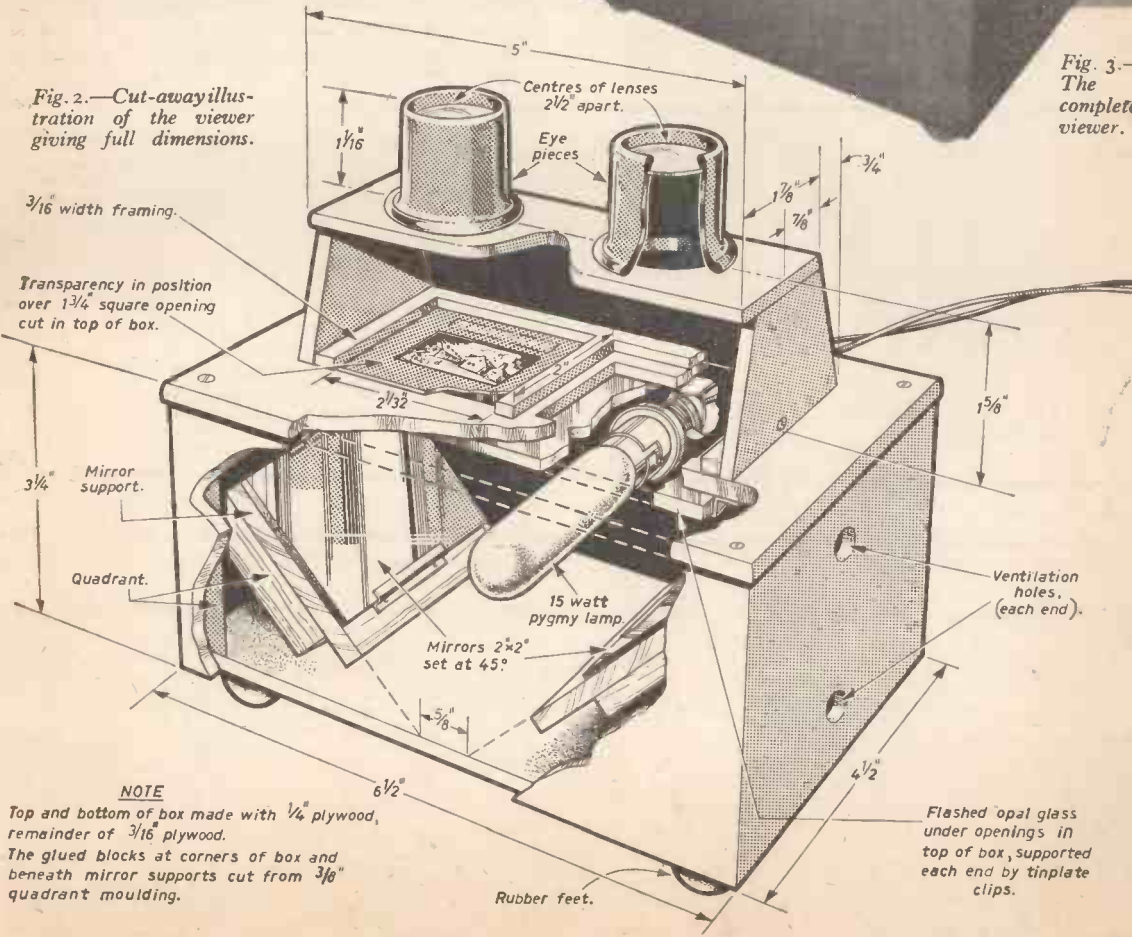

Fig. 3.—The completed viewer.

Fig. 2.—Cut-away illustration of the viewer giving full dimensions.



NOTE

Top and bottom of box made with 1/4" plywood, remainder of 3/16" plywood. The glued blocks at corners of box and beneath mirror supports cut from 3/16" quadrant moulding.

# home-made

## CHEMICAL LABORATORY APPARATUS

### Part 10—Making Pipettes and Kipp's Apparatus

56.—Various types of home-made pipette.

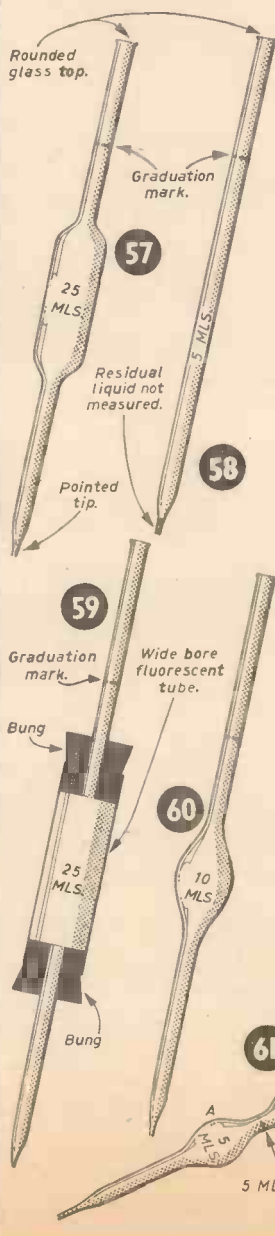
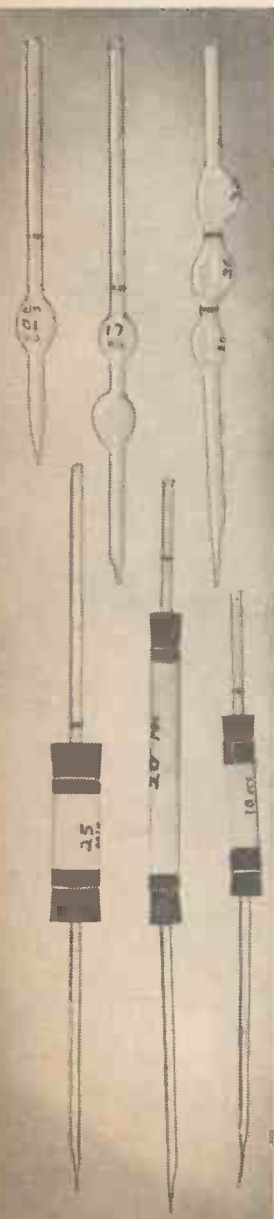

**P**IPETTES are usually of the types shown in Fig. 57, but some commercial types are similar to that of Fig. 58. The method of operation is to suck the liquid up through the pointed tip by placing the rounded end in the mouth. Naturally, **CAUTION** is required when sucking up dangerous liquids such as the caustic soda solution or hydrochloric acid.

Once the liquid is sucked up well into the top tube a wetted finger is quickly placed over the rounded end and by carefully allowing air to bleed in past the finger the level of liquid is allowed to fall until the meniscus (lowest point) is level with the graduation mark.

The pipette is then held over the vessel to receive the metered liquid and the finger removed. The last drop of liquid is **NOT** always removed by blowing or by tapping the glass tip on the receiving vessel, it is often left inside the pipette (Fig. 58) which is graduated accordingly.

#### Home-made Pipettes

A very accurate and fine type can be made from glass tubing with a bore of up to 10 mm. The end is pulled out to a point (Fig. 63e shows this), broken off and slightly rounded. The other end is rounded off in the roaring flame. The rounding must be carefully done so that the finger may make an airtight joint when pressed on it. Remember not to try the pipette until the glass is cold, a burn on the lips is very painful and dangerous.

#### Home Graduation of Pipettes

Once one pipette has been *accurately* graduated to a value of say 5 Mls. it may be used to graduate the rest. The primary one may be graduated in the following manner.

Suck up some water into the pipette. Let it run out leaving the residual amount (Fig. 58). Fill a fine (small dia.) measuring cylinder or burette with water up to some known mark (Fig. 64). Now place the *extreme end* of the pipette in the water and suck up the required amount. A second observer is a help

Fig. 57.—A typical commercial pipette. Fig. 58.—A tube type low capacity pipette. Fig. 59.—Home-made tube and bung pipette. Fig. 60.—Home-made bulb type pipette. Fig. 61.—Home-made multi-reading type pipette. Fig. 62.—A home-made dual-reading pipette.

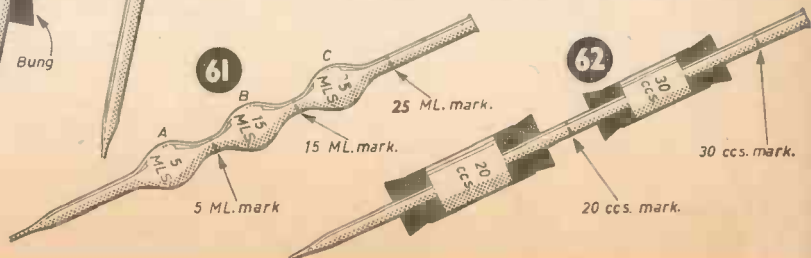



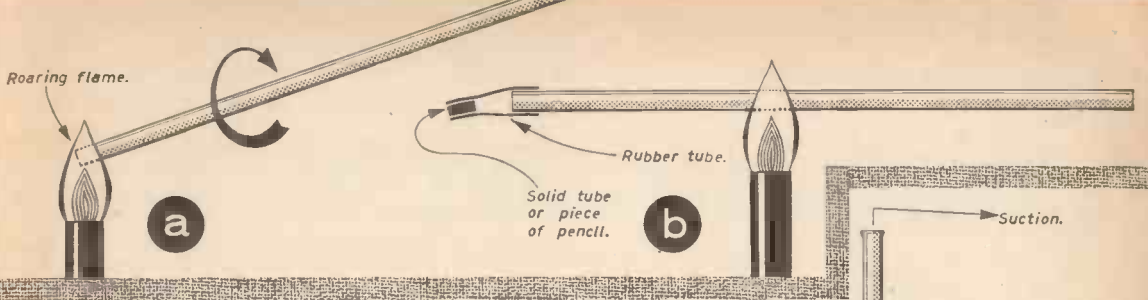

Fig. 63.—(a) Rounding the end of the tube; (b) Heating the centre of the glass tube; (c) Tube held vertically while blowing the bulb; (d) Heating the other end of the glass preparatory to making the jet; (e) Pulling out the jet.

here. A mark is then made on the upper part of the pipette as in Fig. 58.

The burette is now refilled to any known level. The pipette is used to run in its calibrated amount of liquid. The level of the burette is checked to see if it has risen exactly the required amount.

After checking, the graduation mark is scribed with a glass cutting diamond or pen and glass marking ink. The value of the pipette is then marked on the glass. Usually the values used are in multiples of 5 Mls. (ccs). The finer the tube used the more accurate the result, but tubes under about  $\frac{1}{4}$  in. dia. should not be used as capillary attraction of the liquid becomes a nuisance.

#### Glass Bulb Type Pipette

If a pipette of greater capacity than about 5 ccs. is required the length of the tube becomes inconvenient and it is best to blow a bulb in the glass. One such pipette is illustrated in Fig. 60.

The process of making it is shown clearly in Fig. 63. Remember to heat glass firstly in a yellow flame, then in a really hot roaring flame and to keep the glass revolving all the time. After cutting and rounding off one end (a) put a piece of blocked up rubber tube on the other end and when cool commence to heat as in (b). Get the tube really hot and pliable and hold it as in (c) and blow strongly down the rounded end. A bulb should develop as in (c). Reheating once or twice may be necessary and some practice will be necessary to get a good shaped bulb. It is not possible for the amateur to get easily the cylindrical shape of Fig. 57, but this does not affect the final accuracy, only the utility, of the pipette. The bulb is annealed and then the end of the tube is drawn out as in (d) and (e).

Calibration is exactly as for the type already described. Experience will tell the operator how big to blow the bulb. Great accuracy is not required as the final graduation mark (see Fig. 60) may be moved up or down the tube to compensate.

#### A Home-made "Tube Type" Pipette

Where no coal gas is available or the worker feels that making the glass bulb described is too difficult, a rather less satisfactory pipette may be made by cutting some wide bore tubing (fluorescent tubing, etc.) with the hot wire technique and rounding the ends in a flame. Bungs are then fitted as shown in Fig. 59. Two glass tubes are prepared, one with the pointed and the other the rounded end.

Fig. 64.—A method of graduating pipettes using a small diameter measuring cylinder or burette of water.

Calibration is as before, but care must be exercised to hold the pipette *absolutely* vertical when in use or a trapped air bubble under the top bung will introduce an error in the reading.

**Larger Capacity Pipettes**

Where it is desired to make a pipette of larger capacity than 15 ccs. the bulb cannot be made strong enough. The best way of getting this is to blow a series of bulbs as in Fig. 61, or a series of tubes and bungs may be made up as in Fig. 62.

A rather unconventional arrangement which has great utility is to make a number of bulbs (or cylinders) as in Figs. 61 and 62 and to use a series of graduation marks. The amount written on the bulb is the amount held by that bulb and the LOWER bulbs. Thus bulb (b) is labelled 15 mls. Bulb (a) holds 5 Mls and (b) 10 Mls, but when let out 15 Mls will be metered. Likewise bulb c holds 5 Mls, but when emptied 5 + 15 + 5 Mls, i.e. 25 Mls, will be metered.

**Kipp's Apparatus**

Where a gas is prepared by the action of a cold liquid on a solid this is a very useful piece of apparatus as without having a compressed cylinder of the gas one can turn it on at will (see Figs. 65 and 67).

To make hydrogen the stopper F is removed, dilute sulphuric acid is poured into the bottle J and it flows down the tube in the bottom to the base of the bottle A. If the burette clip is open air is expelled and the acid rises through the glass (broken) layer D and eventually to the granulated zinc layer E. Hydrogen is thus evolved and is expelled through the tube in the bung marked K. If the clip is done up the gas pressure within H causes the acid to be pushed up the long internal tube back again in J. When finished with for the time being the stopper F may be replaced.

Two prototypes were made and tested. The large one was very satisfactory and would deliver large quantities of gas quickly, but with H<sub>2</sub>S it was inclined to be smelly when shut off as the container J was open. For use in the garden shed or fume cupboard it was satisfactory. The smaller one was better although the amount of gas obtainable from one filling was somewhat limited.

**The Small "Kipp"**

A bottle holding about ½ litre with a good large ground glass stopper is drilled with a ¼ in. hole Fig. 65 K. The hole is best drilled with the technique described in the Oct. 1960 issue with the method shown in Fig. 12 and redrawn Fig. 66. This hole is fitted with a rubber bung, delivery tube, rubber tube and burette clip as already described. The bottom of the jar is filled with a zin. layer of broken glass or pumice. The finer, within reason, the better, bearing in mind a sand-like texture will cause acid to rise by capillarity. The upper bottle of about the same capacity is drilled with a similar hole in the bottom centre. Another hole is then drilled right through the large glass stopper of the bottle H. This hole has to go through a thick piece of glass, but there should be no difficulty.

A small rubber stopper of the type with a small differential is fitted so that it holds both the stopper B and the bottle J together and the long glass tube extends downwards. The stopper B should have a thin layer of petroleum jelly applied. The apparatus should be tested with water for air tightness, then carefully put together. When upright and shaken

(Concluded on page 460)

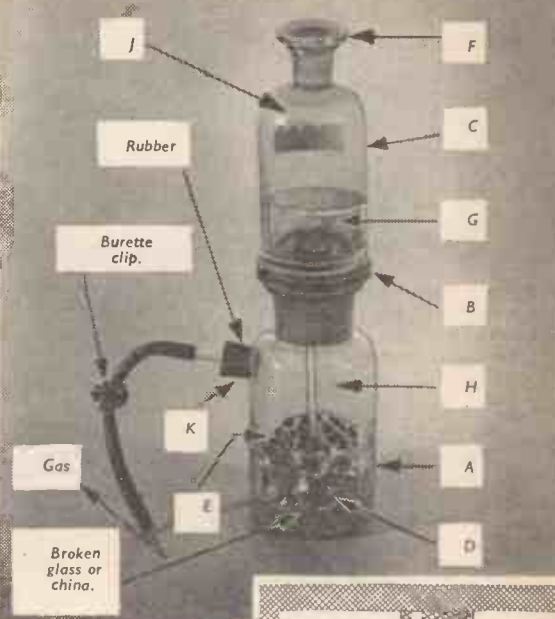

Fig. 65.—A miniature Kipp's apparatus.

Fig. 66.—(Right) Method of drilling hole in bottle.

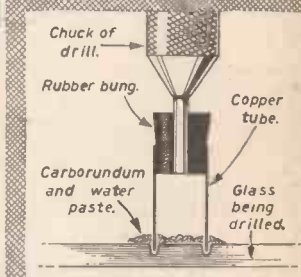
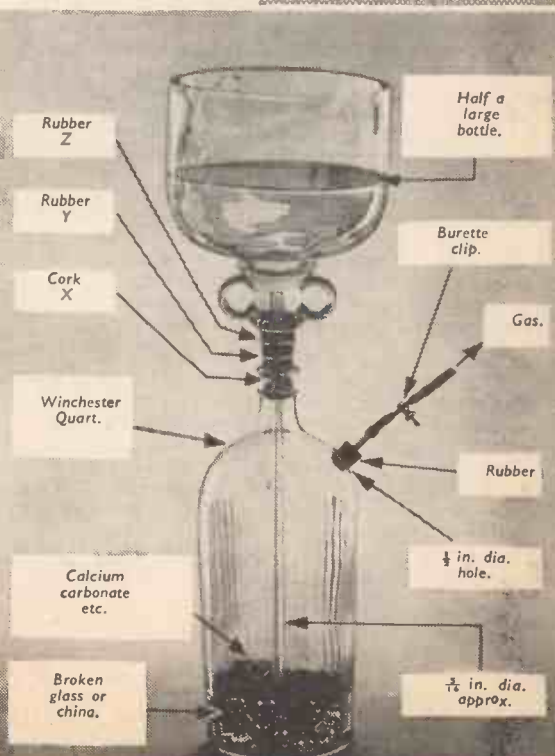

Fig. 67.—A large Kipp's apparatus.







# A Cascade Print Washer By R. Gilham

Fig. 1.—The print washer in use.

**H**ERE is a print washing system, that requires the minimum of attention, while washing prints as soon as they are out of the fixer. It is known as the cascade method and is shown in Fig. 1.

## The Framework

Make a framework of hardboard and wood to form three steps big enough to hold 10in. × 8in. dishes, or large enough to take the size print you normally produce. Finish by painting with a good gloss paint. Fig. 2 gives constructional details.

## The Dishes

Three 10in. × 8in. plastic dishes are drilled along one side where it joins the bottom. Fix a piece of dowel rod across the top, near the side of one of the dishes. A piece of ¼in. rubber tubing, with one end sealed off is fixed along this rod, using transparent plastic tape. This is punctured at about ¼in. intervals by snipping small pieces out of the tube. The other end of the tube is connected to a Paterson force film washer which has a moulded push-on end to fit most taps.

## Method of Use

In use the first print out of the fixer goes into the top dish, the second print into the middle dish, and the third into the bottom.

The first print, if single weight paper, is taken out for drying after 45 minutes. The other prints are moved up at quarter-hour intervals from the top, whilst unwashed prints are fed in from the bottom. These times are adjusted for double weight papers to give 1½ hours' washing time.

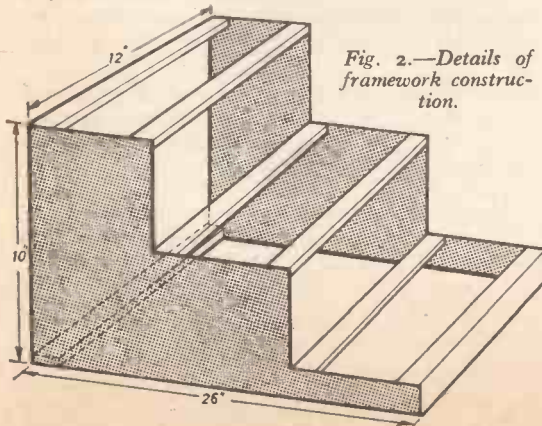

Fig. 2.—Details of framework construction.

# Space Deep Sea and Other Cameras

(concluded from page 431)

those of the materials rather than of the equipment.

This camera, which utilises a modified microscope optical system, was designed by Mr. C. S. McCamy, chief of the Bureau's photographic research section. The entire camera, and the object to be photographed, are mounted in a massive steel cylinder which is suspended by springs to insulate it from vibrations.

"The classic example of fine printing," McCamy told a recent meeting of photographic scientists and engineers, "is putting the Lord's Prayer on a grain of rice." With the reduction ratio used in the new camera, the entire Bible could be printed twice in that area. "And" he added, "that's not counting the ends of the grain, where we might put a Concordance and perhaps a few maps of the Holy Land."

## Looking at Explosions

Two of the fastest cameras ever built are helping American scientists to develop new and improved explosive materials for both military and industrial purposes. These cameras have provided basic information on the behaviour of explosives during detonation, of explosion shock waves and the interaction of explosives with other materials. The secrets revealed have made it possible to utilise new, highly efficient explosive materials and to develop improved methods for fabricating and storing high explosives.

One of these two photographic instruments is the Brixner camera designed, perfected and operated by scientists at Los Alamos Scientific Laboratory, Los Alamos, New Mexico (Fig. 2). The camera makes 35 mm. films in colour of high-speed events at the rate of 15 million frames per second—625,000 times the rate of standard film. It can make up to 96 consecutive pictures of a single explosion. Contained in a strong aluminium frame, the camera has a three-sided mirror which revolves 23,000 times a second, sweeping a beam of light across a row of lenses. Since no shutter could be devised to prevent double exposures, the camera uses an electric detonator to shatter a glass block in the light path during the period required to close a mechanical shutter.

## The Kerr Camera

The other high-speed camera, the Kerr camera (Fig. 1), was developed for the United States Army by Electro-Optical Systems, Inc., Pasadena, California. It has an exposure speed of one five-thousand-millionth of a second and has made still photographs of explosion shock waves travelling as fast as 18,000 miles an hour. The camera is being used to study all types of explosive materials, including some that are quite new and little understood. The detonation devices, and the camera itself, are operated by remote control.

Photographs, a sample sequence of which are given in Fig. 5, are made through a shatter-proof glass porthole in a large steel-encased cell, open at one end to allow the blast to escape. The explosive material detonated in the cell is a block about the size of a man's clenched fist. Light is provided by setting off an argon gas bomb simultaneously with the explosion being photographed. By fully recording detonations, the camera is yielding basic knowledge necessary to make new and conventional explosive materials reliable and useful.



# FINISHING PHOTO

**Professional tips  
for the amateur  
given by  
A. E. Bensusan**



*Fig. 1.—Removing a circular white spot.*



*Fig. 2.—A longer blemish is removed by slanting the brush.*

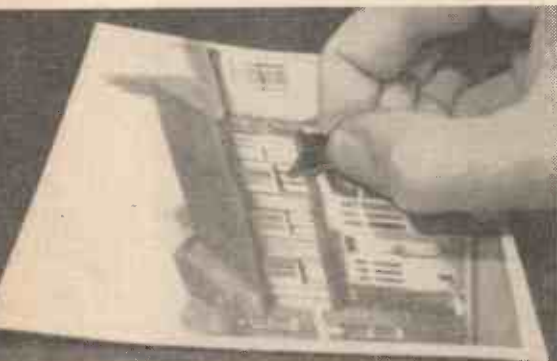

*Fig. 3.—Using a blade for removing black spots.*



**T**HE term "finishing," applied to photographic prints, includes such operations as spotting out white marks, knifing the emulsion away where a pinhole in the negative has caused a black spot on the print, and waxing or doping lustre surfaced papers to improve the brilliance. Other, more specialised, tasks such as blocking out backgrounds, and cutting out prints for pasting on to plain backgrounds or for use in montages are also included.

## Removing White Spots

For the removal of white blemishes, which may be caused by dust on the negative or the paper while printing or enlarging, it is necessary to use either water colour or a retouching dye of a colour to match the tone of the print. Although less permanent, the water colour is easier to use as it can be removed by swabbing the print with a wad of damp cotton wool if a mistake has been made. It is available in a range of colours and a choice of solid or liquid forms.

Retouching dye cannot be sponged away, but many users insist that it gives a far more satisfactory result. It is available in liquid form in a range of colours and is very economical in use. It is essential that the print to be worked on is properly washed. Any trace of fixer in the emulsion will cause the dye to turn green in a short while.

Whichever medium is employed, the technique remains the same. A small quantity of colour is taken on the extreme point of a fine sable brush, either No. 0 or 1. The brush point is twirled lightly on a clean piece of linen, at a slight angle so as to remove most of the colour, and the tip is applied lightly to the white mark on the paper. To remove a circular spot, the brush should be held almost upright (Fig. 1). A longer blemish is best removed by slanting the brush (Fig. 2). If the colour is not sufficiently dense, the first application should be allowed to dry before repeating the process. Large areas can be stippled in until they match their surroundings.

## Removing Black Spots

Black spots on a print are almost impossible to avoid, particularly when the print is made by the enlarging method. Small pinholes and snags in the negative emulsion, which would be too small to be noticeable in the contact print, become quite obvious when enlarged and must be removed from the print.

*Fig. 4.—Method of applying wax or dope.*

# GRAPHIC PRINTS

The most satisfactory way to achieve this is to scratch the surface of the print very gently until the spot matches the surrounding area in tone.

This operation requires an extremely keen cutting edge, and a discarded safety-razor blade is ideal for the purpose. It should be carefully snapped down the centre, and only half of the blade used at a time. The half blade should have one end broken off at an angle and the point so formed is used to shave down the black spot. The blade is held at right angles to the print surface and moved to-and-fro until the desired result is obtained (Fig. 3). It is advisable to try this technique on a scrap print first.

## Waxing or Doping

Glossy prints require no surface improvement as they already display the maximum brilliance. However, prints made on a lustre paper; that is, a paper having a rough surface and a gelatine supercoating, can be improved by adding to the reflective qualities. It is essential to remove all the black and white blemishes before waxing or doping the surface. Dope can be bought ready mixed from all photographic dealers, or a household, white, unscented furniture wax can be used. Take a small quantity of the selected preparation on a wad of cotton wool and, starting at one end of the print, work it well into the surface with a circular motion (Fig. 4). Move progressively along the print and, when the surface has been covered, lay the print aside for at least a day for the finish to harden.

## Removing Backgrounds

Prints of a specialised or technical nature, particularly those for reproduction or for display under glass, frequently need to have sky and other backgrounds removed. If the outline of the subject is elaborate it is necessary to do this entirely by hand, using a suitable brush and process or poster white colour obtainable in liquid form. The subject is carefully outlined with a fine brush, and the parts required to be blocked out are filled in with a larger brush (Fig. 5). If the colour is applied evenly, the background should be entirely eliminated. It is, of course, by no means essential to use white paint although this is the normal colour.

Should the outline of the subject be relatively simple and, preferably, consist only of straight lines, it is quicker to make a cardboard cut-out mask and use this to shield the subject while painting or spraying the unprotected area. In the illustration, the mask is shown slightly displaced from the subject to show how the outlines match (Fig. 6). The mask is made by taking a light tracing from the print, attaching the tracing paper to the cardboard, and then cutting out the profile with a sharp knife held against a steel rule. Hold the mask firmly against the print while applying the colour, and lift it off vertically to prevent seepage and smearing.

An alternative method of obtaining a plain background is to cut out the subject from the print, using a well-sharpened pair of scissors (Fig. 7). The part is then turned over and the edges thinned down with fine glasspaper, before being stuck down on to a plain sheet of card. As can be seen, the system lends itself well to montage work where the subject of the photograph is cut out and stuck on to a new background which may be either a photographic print or a drawing.

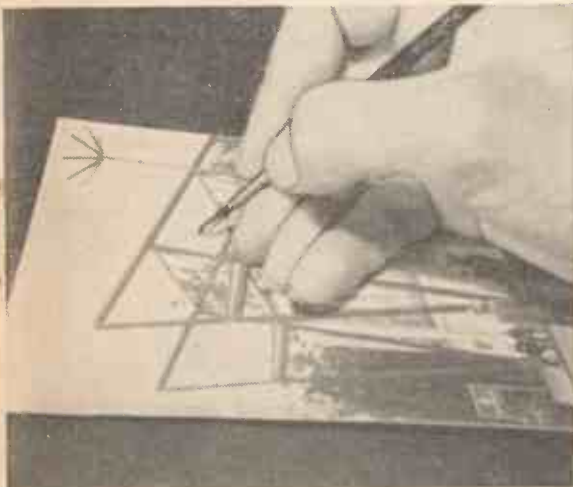

Fig. 5.—Removing background.

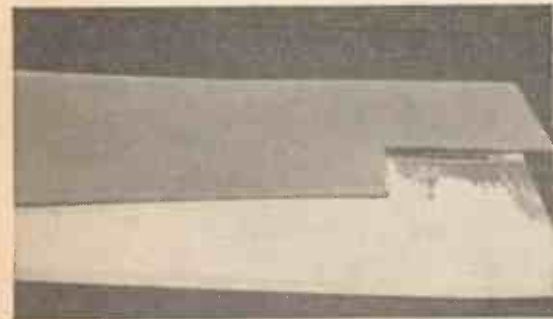

Fig. 6.—Method of masking.

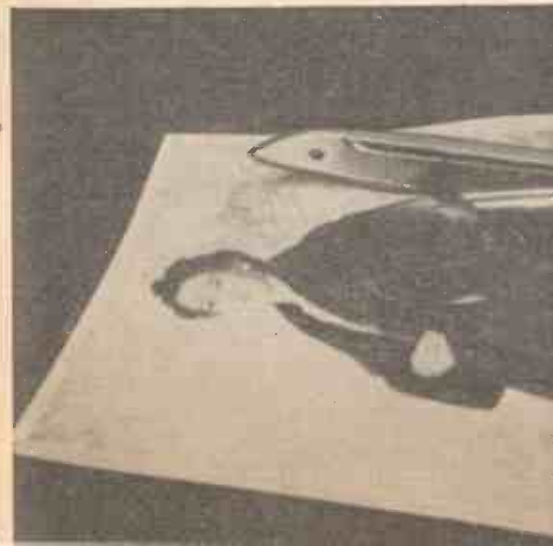

Fig. 7.—Cutting out for use in a montage.

## LETTERS TO *The Editor*



The Editor does not necessarily agree with the opinions expressed by correspondents

### Hints for Drill Users

SIR,—Since you published my article "A Power Bench Drill" in the April 1961 issue one or two readers have asked for some hints about using it. Others contemplating construction might also be interested in the following:

No special instructions are necessary over and above those which apply to all power drilling machines, but too much emphasis cannot be laid on the need for constant oiling and light greasing, and for liberal application of suitable drill lubricants, particularly when drilling hard materials or using the larger drills.

When starting drilling from a centre-punched hole, file the burr flat before engaging the drill. This will prevent the point "wandering" on the burred edge and possibly finally settling down in a non-central position. This is important when holes in separate pieces of metal have to align accurately.

All work which cannot be held firmly by hand should be cramped to the table or held in a drilling vice which in turn, and if occasion demands, can itself be fastened to the table. If being held by hand, watch out for a final kick which the drill imparts at the moment it completes its work. This final action of the drill—just before emerging—is a counter-sinking one which results in the sudden removal of the burr thus created.

Do not attempt to drill a deep hole by removing part of the drill shank from the chuck; this procedure places too much strain on the substance of the drill. Drills of extra length are obtainable for really deep holes and range for 6in. overall up to  $\frac{1}{8}$ in. dia. and from 8in. to 15in. long for sizes between  $\frac{1}{8}$ in. and  $\frac{1}{4}$ in. A few are even made 18in. long.

Always support the work as near as possible to the point of the drill. Excessive distance between supports causes the work to flex and spring and will result in an irregularly shaped hole and, when the point of the drill is about to emerge, may cause it to break if of small diameter.

The following points should also be borne in mind: The smaller the drill the faster the speed permissible.

Speeds may range from roughly 3,000 r.p.m. with small drills to 500 r.p.m. with a  $\frac{1}{2}$ in. drill.

Pressure of feed should never be unduly forced; just maintain enough to make reasonable progress.

Lubricants: Mild steel—soluble oil; copper and brass—dry or paraffin; aluminium—paraffin; cast iron—dry, and proceed slowly in order to keep tip of drill cool.

Clear drill flutes to prevent them becoming choked with drillings.

Keep drills sharp; always sharpen before they become dull.

Remember that when drilling a blind hole which is to be tapped that it is essential to have adequate clearance at the bottom, *i.e.* drill deeper than you are going to tap.—Jameson Erroll (London).

### Colour Transparencies in 3D

SIR,—With reference to the article on the above subject which appeared in the February 1961 issue of P.M., I suggest the box be made with one end only and a block of wood 2 $\frac{1}{2}$ in. long used to space the camera for the second picture. If the box is made at least 2 $\frac{1}{2}$ in. longer than the largest camera likely to be used, then the gadget will be suitable for use with any camera.—R. Corse (Perthshire).

### Home-made Chemical Laboratory Apparatus

(concluded from page 456)

level, the pieces of zinc etc. may be put in either through the hole "K" or by carefully lifting B. The best method is to put them in through K and to even out the distribution over the glass with a small piece of wire.

#### Suggested Uses and Limitations

Kipp's Apparatus is ideal for testing for elements with the gas sulphuretted hydrogen or hydrogen sulphide (bad egg smell). The gas is bubbled through a solution and if it contains certain elements a precipitate appears. Any text book on traditional inorganic analysis will give full details. For hydrogen sulphide place pieces of iron sulphide on the top of the glass and use dilute sulphuric in the upper container. Never use this gas in an ill-ventilated room or one in which people sleep or dine.

Hydrogen may be made as already described. Never light the issuing gas unless it has first been tested for purity by a tubeful not exploding on being lit. Failure to follow this instruction will result in an explosion with possible glass and acid being flung about.

Carbon dioxide may also be prepared. Marble chips of sea-shell are placed on the glass and dilute hydrochloric acid in the upper container.

Gas at low pressure only may be delivered, the water head being less than 1ft. with this model.

#### The Large "Kipp"

This is shown in Fig. 67. A large Winchester Quart or similar bottle is used for the bottom container, a gallon lemonade bottle would suit. A hole is drilled as described towards the top of the bottle.

Another similar bottle has to be cut in half using the hot wire technique. A fairly stout central tube is necessary,  $\frac{1}{8}$ in. being the minimum considered safe. Glass chips are introduced as before and the central tube is located by means of an ordinary dry bark cork "X", rendered gas tight by part of a rubber bung "Y", and attached to the upper part with another bung "Z". The two bottle necks rest on one another so that the  $\frac{1}{8}$ in. tube takes little bending force. The apparatus is used exactly as the smaller version and the limitations and warning given apply.



A REVIEW OF NEW TOOLS, EQUIPMENT, ETC.

## Adjustable Back Tool Post

**L**ATHE users will be interested in the back tool post shown opposite which, although designed for use with a Myford ML7, can be used on any similar slide rest. The robust mild steel unit has a parkerised finish and cadmium plating is used on the tee-bolt and hexagon nut. The height of the tool is adjustable relative to the lathe centre and the wide base and firm fixing arrangement ensure stability in use. The cost is £35, plus 2s. post and packing, from the makers, Canonbury Engineering Co., 283 Essex Road, London, W.1.



## Plasti-kote Aerosol Spray Paint

**T**HE handyman will find many uses for this quick and simple painting technique in the home, garage and workshop. Plasti-kote enamels and lacquers are ready after replacing the top of the can by the detachable metal spray head and shaking hard. Finger pressure on the trigger regulates the flow. The enamels dry in two to four hours; the lacquers are dust dry in five minutes and completely dry in 20 minutes. They are oil, petrol and saltwater resistant and heat resistant to 240 deg. F. The price is 16s. per approx. one pint can and the makers are Plasti-kote Ltd., Silbury Street, London, N.1.

## New Bandsawing Machine

**A**NY of the popular electric drills may be used to power the Selecta bandsaw machine on the right. The narrow multi-purpose blade cuts all kinds of wood, plastic, hardboard, etc., and allows small diameter radii to be sawn. The tilting table may be locked at any angle up to 45 deg. and a table-fence and graduated protractor are available as extras. In addition, other accessories may be screwed to the drill spindle, such as a flexible shaft, sanding plate or a drum sanding attachment. The maximum throat depth is 11½ in. and a maximum thickness of 3 in. can be accommodated under the top plate guide. The price (without electric drill) is £11 19s. 6d. and the makers are Selecta Power Tools Ltd., Elmgrove Road, Harrow, Middlesex.

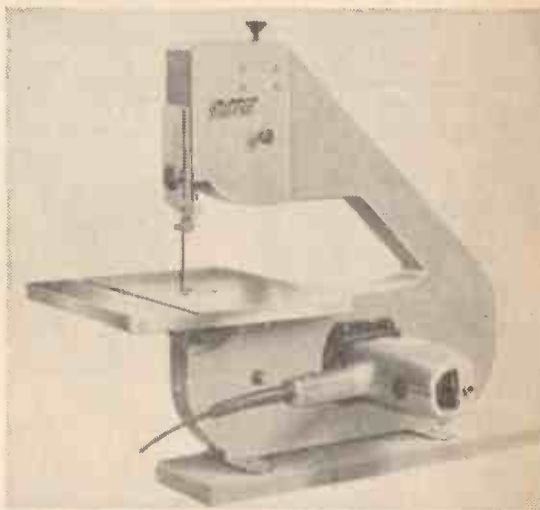

## Table-top and Shelf-edge Finishing

**T**HAT kitchen table and set of shelves you have just made for the kitchen can be immeasurably improved by the addition of practical and easy-to-fix Herzim decorative edging. The flexible aluminium moulding will bend smoothly round corners and is attached as shown on the right. The edging is finished off by the addition of coloured plastic insert which hides the screw heads. The moulding is supplied with or without a lip and in sizes from 7/8 in. to 1 in. wide and the plastic insert can be had in a variety of colours. The makers are Metal Mouldings Limited, Park Royal Road, London, N.W.10. and the edging materials are stocked by S. Leboff, Ltd., 1-19 Virginia Road, Shoreditch, London, E.2.

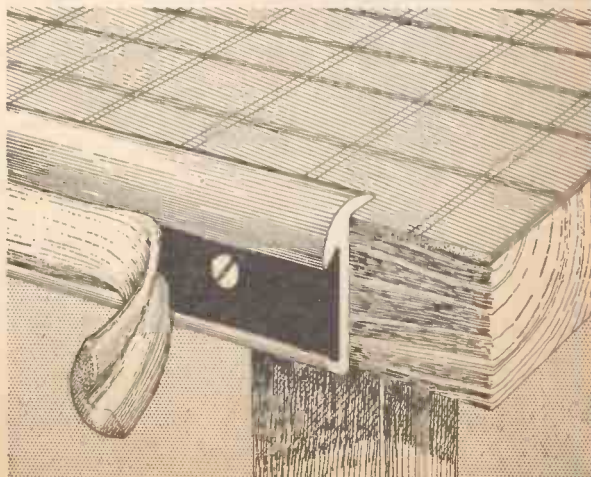

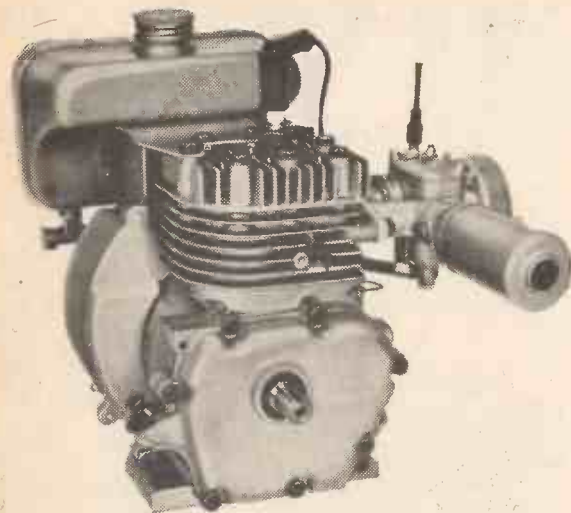

## New Industrial Engines

THE engine shown on the left will be the first of a new range of agricultural and industrial engines to be made by the Villiers Engineering Co. Ltd. It is a 50 c.c. single cylinder, blower cooled horizontal shaft engine, developing 0.92 b.h.p. at 4,000 r.p.m. Designed on the over square principle, the engine weighs only 14lb. The full range of engines will cover capacities from 50 c.c. to 150 c.c. with power ratings from  $\frac{1}{2}$  to  $3\frac{1}{2}$  b.h.p. All enquiries regarding these new engines should be made to the Villiers Engineering Co. Ltd., Marston Road, Wolverhampton.

## The Minipac

A NEW addition to their range of glass fibre repair packs has been introduced by Bondaglass Limited, of 53-55 South End, Croydon, Surrey. This new Minipac enables minor repairs to be carried out economically. The kit is priced at 8s. 9d. and contains: 5oz. Bondaglass resin and catalyst; polythene catalyst measure; 2oz. mixing cup;  $1\frac{1}{2}$  sq. ft. glass fibre mat; 1 pkt. brush cleaning powder and an 8 page illustrated instruction leaflet.



## Ray-O-Vac Lanterns

POPULAR with motorists, campers, yachtsmen, etc., for the past two years in America, these American made lanterns are now available in Britain. There are three types. The one shown in the photograph on the left is the sealed beam spotlight which costs £4 os. 2d. Another type is similar, with the addition of a red flasher warning light; this costs £4 1s. The versatile third model costs £2 18s. 1d. The standard 6V. battery for all three lamps costs 21s. It is all metal, leakproof and disposable after use. The lanterns are marketed by Alpha Accessories Ltd., Halifax House, 51-55 Strand, London, W.C.2.

## Studio in a Box

THE Tape Mixing Ade manufactured by Electronic Ades (London) Limited, 6 Alpha Road, Teddington, Middlesex, is a small control instrument which will enable the user of tape recorders to superimpose his or other voices, musical instruments or noise effects on to any recording being made from a gramophone, radio set or sound output of a television set. The instrument is housed in a white plastic box 4in. by 3½in. by 1½in. and controlled by three switches. Very simple connections need to be made with the recorder using telephone switch plugs. The retail price is £5 5s.

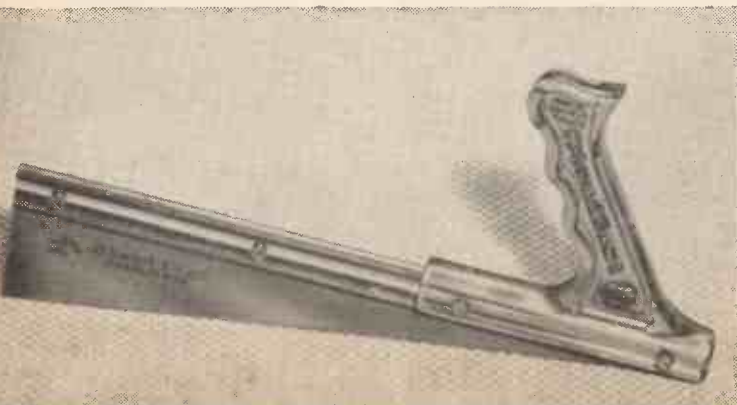

## Steadfast Sheet Saw

THIS new saw comprises a polished alloy spine, holding a 12in. triangulated blade of "Cobaltcrom" special abrasion resisting steel, and is fitted with a shatterproof amber plastic handle. 14 and 24 T.P.I. blades are supplied and the tool is intended to cut asbestos, plastics, wood, steel and other metals. The price is 16s., including two blades of different pitch. Spare blades cost 3s. 3d. each. The tool is available from most hardware and tool shops.

**SPECIAL HEAT RESISTING GRADE P.V.C. HEATING CORDS**, Nylon centre, Copper/Nickel conductor, woven glass braided. For soil warming, under-carpet heating, frost-free pipes, etc., etc. Supplied in 12, 15, 25 and 30 ohms/yard. Price 1/- per yard, post free.



**NEON ILLUMINATED INDICATOR SWITCH**. 2 amps, 240 v. A.C. 10/6 each, post free.  
**FIT THIS TO YOUR ELECTRIC BLANKET AND BRING IT UP TO DATE**

**THERMOSTATS**. BW/1, 5 amps, 15/6. Post 8d. SN/40 1/2 amp., 5/6. Post 6d. C.S. Convector Thermostat, 15 amps 25/- Post 10d. Model MB for Immersion Heaters, 15 amp., £2. Post 2/-. PF Room Thermostat, 15 amps, £2. Post 1/-. M.L. Greenhouse Thermostat, 10 amps, 35/- Post 1/-. P.J. Miniature Thermostat for Hotplates, 5 amps, 9/3. Post 9d.

**REPLACEMENT ELEMENTS** for electric fires, irons, toasters, kettles, convector heaters, washboilers, etc.

**TELEVISION SUPPRESSOR KIT**, for appliances up to 1 amp., 3/6. Post Free.

**BI-METAL**. Hi-Flex 45 3/16 in. x .010, 6d. per foot. Standard 1 1/2 in. x 3/8 in. x .036, 6d. Plus postage.

**MAGNETS**. Sintered Bar Magnets of great power and stability 1/2 in. x 3/16 in. x 1/16 in., 9d. each. 8/- doz. Post 9d.

**CAR HEATER ELEMENT**. 6 in. x 1 1/4 in. 200/250 v. 100 w. 6/- each.

**THE TECHNICAL SERVICES COMPANY, Banstead, Surrey**  
 We can list only a few items in this space. Send 6d. in stamps for Catalogue and S.A.E. for enquiries.

## TAKE UP PELMANISM And Develop Power

**PELMANISM** is a training in power. It is a means by which knowledge is more easily acquired, retained and used; a means through which natural aptitudes find greater expression and by which individual facilities are developed. The main idea is all the time on use, for with practice and use more knowledge comes, and skill, wisdom and power grow.

The general effect of the training is to induce an attitude of mind and a personal efficiency favourable to the happy management of life. The emphasis throughout the Pelman Course is on the harnessing and proper use of energy.

Pelmanism eliminates the feelings of Frustration and Inferiority, and many other weaknesses as well. So why suffer from these mental failings any longer?

*Remember—Everything you do is preceded by your attitude of mind.*

Pelmanism develops and strengthens your Will-Power, your Determination and your powers of Initiative and Concentration. Whatever your age, whatever your occupation, Pelmanism will free your mind from unhappy conditions and change for the better your whole outlook on life.

**Send for Free Book Today**

The Pelman Course is simple and interesting and takes up very little time. The books are printed in a handy pocket-size enabling you to study them in spare moments during the day. You can enrol on the most convenient terms. The Course is fully explained in "The Science of Success" which will be sent you, gratis and post free, on application. WELbeck 1411.

**PELMAN INSTITUTE**

130, Norfolk Mansions, Wigmore Street, London, W.1.  
 Pelman (Overseas) Institutes: Delhi, Melbourne, Durban, Paris

## A NEW-PRACTICAL WAY of UNDERSTANDING

**RADIO • TELEVISION • ELECTRONICS**

Including: Transistors; VHF/FM; Hi-Fi equipment; Computers; Servo-mechs; Test Instruments; Photo-electrics; Nucleonics; etc.

Radiostructor—an organisation specialising in electronic training systems—offers a new self-instructional method using specially designed equipment on a "do-it-yourself" basis.

You learn by building actual equipment with the big kits of components which we send you. You advance by simple steps, performing a whole series of interesting and instructive experiments—with no complicated mathematics! Instructional manuals employ the latest techniques for showing the full story of electronics in a practical and interesting way—in fact, you really have fun whilst learning!

### POST NOW

To RADIOSTRUCTOR (Dept. G28) READING, BERKS.  
 Please send brochure, without obligation, to:—

\*Name.....  
 \*Address .....

.....6/61  
 (We do not employ representatives) \*Block Caps Please

**FREE** THIS BOOK WILL INTEREST YOU!

FOR .. Your Career  
 .. Your Own Business  
 .. An Absorbing Hobby

Radiostructor EQUIPMENT-COURSES

# RADIOSTRUCTOR

LEADS THE WORLD  
IN ELECTRONICS TRAINING



## BRASS, COPPER, BRONZE, ALUMINIUM, LIGHT ALLOYS

Rod, Bar, Sheet, Tube, Strip, Wire

3,000 Standard Stock Sizes.  
NO QUANTITY TOO SMALL.  
List on application.

### H. ROLLET & CO. LTD.

6 CHESHAM PLACE, LONDON, S.W.1  
Also at BELGRAVIA 4300  
LIVERPOOL, LEEDS, MANCHESTER, BIRMINGHAM

## PARKER'S SHEET METAL FOLDING MACHINES NEW BENCH MODEL



Capacity 36 in. wide x 18-gauge mild steel. Forms channels and angles down to 45 deg., which can be flattened to give safe edge. Depth of fold according to height of bench. Will form flanges. Weight approx. 2 cwt.

Price £17/15/0, carr. free. Also the well-known vice models of:  
36 in. x 18-gauge capacity ... £8 10. 0. } Carriage  
24 in. x 18-gauge capacity ... £5 5. 6. } free  
18 in. x 16-gauge capacity ... £5 5. 6. }

One year's guarantee: money refunded without question if not satisfied. Send for details:

**A. B. PARKER Wheatcroft Works**  
WELLINGTON STREET, BATLEY, YORKS. Tel.: 426

## WATSON'S SPECIAL OFFERS

**PRISMATIC ELBOW TELESCOPES 57/6.** Post 3/6. Very fine instruments. 7 x 50 magnification.  
**ASTRO COMPASS.** Precision instruments, optical sight, four scales, two spirit levels. 22/6. Post 3/-.  
"NIFE" **NICKEL ALKALINE STARTER OR LIGHTING BATTERIES, TYPE L.R.7.** 6v. 75 amp. hour. Comprising five cells in hardwood crate. Ex-Government, and we believe **UNUSED.** They have been filled with electrolyte for initial charge. £7.10.0. Carr. 15/-.  
**SMALL D.C. MOTORS.** 12v. 5,000 r.p.m. 3 1/2" x 1 1/2" diam. 9/-. With 6:1 reduction gear 11/6. Post 2/-.  
**FLEXIBLE SHAFTS.** Brass outer casing and unions. 7/16" outside diam., 6' 10" long. 15/-. Post 2/-.  
Hundreds of other Bargains. Send 6d. for Illustrated List



Eastern Motors, Aldeburgh, Suffolk Phone 51

A money-saving book for every Morris owner . . .

## MORRIS CARS

by **T.B.D. Service** A practical maintenance and repair book for Morris owner-drivers covering models produced between 1934 and 1960, including the new Morris Mini-Minor—with 112 do-it-yourself diagrams, 232 pages. Covers regular maintenance, engine lubrication, fuel systems, electrical, engines, clutch, gearboxes, brakes, wheels and tyres, steering and suspensions, rear-axle assemblies, propeller shafts, body care, table of S.U. Jet Needle settings.

Also in the same series . . . only 12s. 6d. each: Austin-Healey • Austin • Ford • Humber • Landrover • M.G. • Riley • Rover • Standard • Triumph • Vauxhall • Volkswagen • Wolseley  
12s. 6d. from all booksellers, or, in case of difficulty, 13s. 6d. by post from C. ARTHUR PEARSON LTD., Tower House, Southampton Street, London, W.C.2.

A Pearson Motor Car Maintenance and Repair Book

## FREE CORRESPONDENCE COURSES IN STEAM

TWO COURSES: (1) A simplified Course for the practical man in need of basic information about steam and steam applications; (2) An *Advanced Course* for those with a background of technical training. There is no charge or obligation. Details on request to:

SPIRAX-SARCO LTD.  
(TECHNICAL DEPT., Cheltenham, Glos.)

20,000 Metal Slitting Saws, 1-3/4" dia., 5/8" hole, .015" to .060" thick, 6 ass'd. 8/9, Cozen 15/-. Still cheap at double this price.  
100 Sets 2-1/4" dia. Circular Split Dies, 9/16", 5/8", 3/4", 7/8", 1" B.S.F. American N.F., also 26 Brass thread, 30/- per set any thread, 3 sets £4. Actual value £5 per set.  
5,000 Hardened and Ground H.S. Tool Bits, 1/4" square, 2-1/2" long, 15/- doz.; 5/16" square, 3" long, 20/- doz.; 3/8" square, 3" long, 25/- doz.; 7/16" square, 3-1/2" long, 30/- doz.  
3,000 H.S. Straight Shank End Mills, approx. 3/32"-1/2" dia., outstanding value, 8 assorted. £1 the lot.  
2,000 Small Twist Drills, approx. 1/32"-3/32", 4/- doz. Approx. 1/16"-1/4", 7/6 per doz. Approx. 9/32"-15/32", six for 10/-.  
3,000 Circular Split Dies, 1" dia. cutting 1/4", 5/16", 3/8", 7/16", 1/2" White B.S.F. also brass thread, 26 thread and all sizes and American N.F. 12/- per set of 5 sizes, 2 sets 22/6; 4 sets 42/6. Taps to suit 12/6 per set, either taper or second or plug. 1" dia. stocks 6/- each.  
Metal Marking Punches, sizes 3/32", 1/8" and 1/4", figures 8/6 per set, letters, 25/- per set, any size; 1/2" figures, 15/- set.  
Six Tons Precision Ground Silver Steel, 36" lengths: 1/4", 9/32", 3/8", 1/2" dia., 10/9 lot. Also 13" lengths 1/16" to 15/32" dia., doz. assorted, 5/6.  
1,000 H.S. Inserted Blade Expanding Reamers, 27/32" to 31/32", 18/6 each; 31/32" to 1-1/8", 22/6 each; 1-1/8" to 1-9/32", 27/6 each; 1-9/32" to 1-15/32", 35/- each.  
H.S. Parting Tool Blades, 3/32" x 3/4" x 5", 5/- each.

£2 ORDERS POST PAID

J. M. BURKE

192 Baslow Road, Totley, Sheffield

## SURPLUS BARGAINS

**MULTI-PURPOSE MOTORS.** Low voltage, with gearbox, 24 v. D.C., but good at 12 v. or lower. Two shafts, 4 and 16 R.P.M. at 12 v., 6 and 24 R.P.M. at 24 v. Operate 3 sets of cams and also plunger giving powerful lateral thrust. Takes under 1 amp. Wonderfully versatile motor. Each 25/-, post 2/-.

**BATTERY CHARGING TRANSFORMERS,** 11 v. and 17 v. A.C. (for 6 and 12 v. Charging at 1 1/2 amp.) Each 17/6, post 1/9.

**RECTIFIERS** to suit above. Each 6/6, post 1/-. (These transformers and rectifiers will run above motors.) Send 3d. stamp for list of other motors, transformers, pumps, lamps, switches, etc.

## MILLIGANS

2 Harford Street, Liverpool, 3  
Money Back Guarantee

## ROGERS 31/33 NELSON ST. SOUTHPORT

Fibre Washers, 144 Assorted . . . 3/6  
Meter Rectifiers, A.C. to D.C. . . 3/6  
Self Tap Screws, 100 Assorted . . . 3/-  
Rectifiers, 6/12 v. at 6 mps . . . 18/-  
Winker Units, 6 or 12 volt . . . 6/6  
Motorised Water Pumps . . . 75/-  
Instrument Cases, 12in. x 8in. x 6in. New 7/3  
Telephones, New, Modern . . . 16/-  
Races, Belts, Valves, Pulleys, Pumps, Brass Steel, Aluminium, etc.  
10 PAGE LIST FREE. STAMP PLEASE

Better Buy a **betaBENCH**



£9 19 6  
Complete  
Carr. Paid

Patent pending  
High quality folding bench, 2ft. 9in. high x 4ft. 6in. long x 1ft. 6in. wide. Fitted with adjustable tin dia. steel thrust rod. Brochure on request.

**BENSON LADDERS**

Dept. PM1. Greenway, Gairthorpe, Nr. Leeds

## GENERAL CERT. OF EDUCATION

THE KEY TO SUCCESS & SECURITY

Essential to success in any walk of life! Whatever your age, you can now prepare at home for the important new General Cert. of Education Exam, on "NO PASS—NO FEE" terms. You choose your own subjects—Educational, Commercial or Technical. Recently announced big extension of subjects gives everyone the chance to get this valuable Certificate.

SEND FOR FREE 136 PAGE BOOK

Full details of how you can obtain the General Cert. are given in our 136-page Guide—Free and without obligation. Personal advice on request.

Write today, School of Careers, Dept. 101, 29-31, Wright's Lane, London, W.8.

The School of Careers

# YOUR

# Queries ANSWERED

## Crystal Growing

**W**ILL you kindly advise me on the method of growing crystals on coal for decorative purposes.—E. Baker (Dorset).

**T**O grow crystals upon a piece of coal is quite simple. The lump of coal should be suspended in a vessel by a thread so as to hold it roughly in the middle of the liquid containing the particular salt selected. It merely acts as a nucleus upon which the crystal structure builds. There are numerous solutions from which crystals of different shapes and colours can be grown.

Copper sulphate forms nice crystals. All you have to do is to make a supersaturated solution of copper sulphate in water. Warm the water to near boiling point and keep on adding crystals of copper sulphate until no more will dissolve. Now remove the vessel, which conveniently can be a pyrex glass beaker, from the source of heat, suspend the lump of coal in the middle of the liquid and allow to cool very slowly. Crystal growth will continue for as long as there is a sufficiently high concentration of copper sulphate in the solution in relation to the crystal growth upon the lump of coal. Ultimately equilibrium of concentration will result and no more growth will take place. Other salts will give different geometrical shapes of crystal. For example: If instead of a lump of coal you were to suspend a crystal of dark violet chromium alum in a saturated solution of ordinary potassium alum a transparent colourless coating of potassium alum is deposited as an overgrowth over the dark coloured chromium alum.

Similarly, a crystal of colourless zinc sulphate can be coated with an overgrowth of green nickel sulphate. Also, crystals of sodium nitrate grow on Iceland spar. In each case the solution containing the salt that is required to be deposited upon the nucleus, be it coal or another crystal, must be a saturated solution in order to get vigorous growth.

### THE P.M. BLUEPRINT SERVICE

12 FT. ALL WOOD CANOE. New Series. No. 1. 4s.\*  
COMPRESSED-AIR MODEL AERO ENGINE. New Series. No. 3. 5s. 6d.\*

AIR RESERVOIR FOR COMPRESSED-AIR AERO ENGINE. New Series. No. 3a. 1s. 6d.  
"SPORTS" PEDAL CAR. New Series. No. 4. 5s. 6d.\*  
F. J. CAMM'S FLASH STEAM-PLANT. New Series. No. 5. 5s. 6d.\*

SYNCHRONOUS ELECTRIC CLOCK. New Series. No. 6. 5s. 6d.\*  
ELECTRIC DOOR-BELL. No. 7. 4s.\*

ASTRONOMICAL TELESCOPE. New Series. Refractor. Object glass 3in. diam. Magnification x 80. No. 8 (2 sheets), 7s. 6d.\*

CANVAS CANOE. New Series. No. 9. 4s.\*  
DIASCOPE. New Series. No. 9. 4s.\*  
EPISCOPE. New Series. No. 11. 4s.\*  
PANTOGRAPH. New Series. No. 12. 2s.\*

COMPRESSED-AIR PAINT SPRAYING PLANT. New Series. No. 13. 8s.\*

MASTER BATTERY CLOCK.\* Blueprints (2 sheets), 4s. Art board dial for above clock, 1s. 6d.

OUTBOARD SPEEDBOAT. 11s. per set of three sheets.  
P.M. TRAILER CARAVAN.\* Complete set, 11s.  
P.M. BATTERY SLAVE CLOCK, 2s. 6d.\*  
P.M. CABIN HIGHWING MONOPLANE, 1s. 6d.

THE MECHANIKART, 15s.\*

The above blueprints are obtainable, post free from Messrs. George Newnes, Ltd., Tower House, Southampton Street, Strand, W.C.2.

\* denotes constructional details are available free with the blueprints.

## RULES

**Our Panel of Experts will answer your Query only if you comply with the rules given below**

A stamped addressed envelope, a sixpenny crossed postal order, and the query coupon from the current issue which appears at the foot of this page, must be enclosed with every letter containing a query. Every query and drawing which is sent must bear the name and address of the reader. Send your queries to the Editor, PRACTICAL MECHANICS, Geo. Newnes Ltd., Tower House, Southampton Street, Strand, London W.C.2.

## Recording Radio Programmes

**W**ILL you please tell me how to switch a tape recorder on and off by ringing my telephone when I am away from home? I wish to record radio programmes I miss whilst at work.—J. Hyde (Lancs.)

**I**T is a comparatively easy job to arrange for the switching you require.

Basically we suggest a small valve amplifier (say a 6V6) arranged so that it is working somewhere near the zero anode current position by using a large value cathode resistor. The anode load will be a relay coil. A small voltage input to the grid will operate the relay as an increase in anode current is caused.

The voltage input is obtained from a carbon P.O. Microphone and a transformer of about 100 to 1 ratio, or from a crystal microphone using a 1MΩ grid resistor if one is not included in the instrument. Thus when the telephone bell rings near the microphone the relay will pull in.

It is inconvenient to keep the bell ringing all the time the relay is wanted to be kept in so the relay may be wired to a good D.C. supply and a "Stepping Relay." Thus with a Longdex FS/HD/2 type stepper two complete rings will work the contacts once. The FS/HD/SEL would, if wired correctly give on/off for each continuous ring. Stepping relays are available surplus for about 10s.

In order that slightly intermittent rings may not start and stop the radio a large value electrolytic condenser may be fitted across the primary relay windings.

Polarising voltage for the carbon microphone may be obtained from the bias of the valve if it is suitable smoothed with a bias type electrolytic condenser.

## Re-threading Sparking Plug Hole

**A**T the moment the sparking plug hole in the cylinder head of my motor cycle is threaded to take a 14mm. plug. I wish to clear the hole and re-thread it to take an 18mm. sparking plug. Can you tell me the taps to use also the size drill required to clear the hole.—E. Wilkinson (Berks.)

**S**PARKING plug threads are metric, therefore if you wish to tap for an 18mm. plug you need an 18mm. metric tap. The tapping drill size required would be 39/64 (15.5mm.) The work must be done accurately, or the plug will not seat correctly.

The best method to use to overcome the difficulty would be to fit a 14mm. steel coil thread insert, thus retaining the original thread size and avoiding possible re-occurrence of the trouble.

Most, if not all, manufacturers now fit these thread inserts in alloy cylinder heads. A special tap is

"Practical Mechanics" Advice Bureau. **COUPON**

This coupon is available until June 30th, 1961, and must be attached to all letters containing queries, together with 6d. Postal Order. A stamped addressed envelope must also be enclosed.

Practical Mechanics. **June, 1961**

required to enable such an insert to be fitted. It is possible that the makers of your engine would undertake the work for you, in which case it is not likely that the cost would be great, and would possibly be less than the cost of the taps.

## Destroying Moss

**C**AN you please tell me how to remove moss from an asphalt path. It is difficult to remove this completely by scraping owing to the nature of the surface.—A. Eve (Edenbridge).

**T**REAT with a solution of sodium chlorate; 20z. to a gallon of water is strong enough.

## Comparator Microscope

**I** AM keenly interested in forensic ballistics and am thinking of making a comparison microscope. I have already one S.E.L. type microscope. Would it be possible to mount two side by side using a comparator eyepiece?—W. M. Smart (Beds).

**T**HE microscope consists essentially of two parts:

- (1) The objective is a lens combination, usually of small aperture and short focal length, which forms a real, inverted and much enlarged image of the object at a point high up in the microscope tube.

The objective lens system is composed of several positive lenses, the first of which is hemi-spherical with its plane surface facing the object. Following this is a larger convex-concave or "meniscus" lens.

- (2) The eyepiece is placed beyond with its focal plane coinciding with this image and acts as a collimator, so that one looking into it sees a virtual image, apparently at an infinite distance, and subtending a wide angle.

The magnifying power of the microscope depends upon the relative focal length of objective and eyepiece; its resolving power depends upon the dominant wavelength of the light used.

In measuring microscopes, a transparent scale or a filar micrometer may be introduced into the ocular focal plane; or a pair of cross-hairs may be used and the whole instrument moved laterally by a micrometer screw, thus forming a comparator.

We do not think it would be practicable to mount two S.E.L. type instruments side by side.

## Battery Charging

**I** HAVE a selenium rectifier D.C. output 12V. 3A. If I use this with a transformer giving 15V. 3A. A.C., will it be really satisfactory for charging a car battery of 12V? I have been told that it is essential to have 13 or 14V. D.C. output for the purpose. Can you give a circuit drawing also?—R. F. Rich (Bristol, 4).

**T**HERE will be a volt drop through the rectifier when passing the charging current to the battery, so that if the 15V. transformer is used the charging current will flow for only a limited portion

of each cycle of the A.C. supply. The average value of the charging current will, in consequence, be quite small; in fact the battery will only be trickle charged and it will not be possible to bring it up to a state of full charge.

For fully charging a lead-acid battery from a steady D.C. supply we advise 2.75V. per cell or about 16.5V. for the 12V. battery. The A.C. voltage applied to the rectifier should exceed this value in order to allow

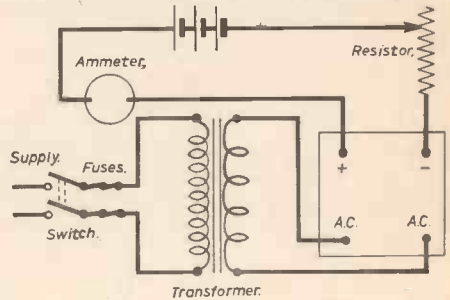

*Circuit for battery charging*

for the volt drop in the rectifier and in a series resistor used to control the current. The 12V. 3A. rectifier might be satisfactory if supplied from a transformer having a secondary output of 3A. at about 22V. with a variable resistance of about 1Ω in circuit as shown.

## Camera/Monocular Combination

**I** HAVE been trying to take some photographs by using a 8 × 30 monocular in front of the lens on my Pentacoon 35mm. single lens reflex. So far I haven't been able to obtain a full format, getting only a ring or a hexagonal. How can I overcome this?—W. H. Davies (Glam.)

**C**OMPLETE coverage cannot be obtained because the angle of view of the monocular is not sufficient to cover the negative area. This is quite usual. No simple way of overcoming the difficulty exists. If the camera lens is removed, and a negative lens substituted, it may be possible to obtain coverage, but definition is likely to suffer. If the lens is fixed, this cannot be attempted. For complete coverage the whole system requires to have a wide enough angle of view, and this would require a monocular of very much larger aperture than 30 with 8 magnification.

## Sawdust Mastic

**I** require a formula for a mastic made from sawdust. It should be waterproof and capable of holding securely bolt heads imbedded in it.—R. MacKinley (Glasgow).

**A**N excellent, hard-setting and waterproof mastic can be made from an admixture of sawdust and Araldite 103. This is a liquid resin. The mixture of sawdust and "103" will not set until it is mixed with "Hardener 951," and after adding the hardener the mass will remain pliable or workable for ½ hr. after addition. After this period of time it will set like iron.

The resin mentioned above is a product of: CIBA Ltd., Duxford, Cambs.



# SALES AND WANTS

The pre-paid charge for small advertisements is 9d. per word, with box number 1/6 extra (minimum order 9/-). Advertisements, together with remittance, should be sent to the Advertisement Director, PRACTICAL MECHANICS, Tower House, Southampton Street, London, W.C.2.

## MODEL PARTS

### "EVENING STAR" in 3½" G.

'Wilwau' will make the complete range of castings for this fine L.B.S.C. 2-10-0 loco. S.A.E. with enquiries appreciated.

W. K. Waugh, 31 Hillfoot Drive, Bearsden, Nr. Glasgow. Bea 2985.

## HOBBIES

CATALOGUE NO. 14 Government Surplus and Model Radio Control, over 500 illustrated items. 2/6d. (refunded on purchase).—Arthur Sallis Radio Control, North Road, Brighton.

NEWTONIAN TELESCOPE MAKING Kits, Glass Blanks and Tools, Grinding Kits, Plano-convex Lenses, Optical Flats, Ramsden Eye-pieces, Barlow Lenses. S.a.e. for lists.—L. J. Mays, 20 Clover Road, Timperley, Altrincham, Cheshire.

ASTRO TELESCOPE MIRROR DISCS Edged and bevelled. Per pair with abrasives, polish, etc., 6" x 1" £2.15.0; 8" x 1" £4.15.0. Cash refund guarantee.—H. Gibbs, 75 Portnamoor Road, Cardiff, S. Wales.

METAL JOINTING. Our Service can help you. All Materials supplied for: Silver Brazing, Bronze Brazing, Soldering, Low Temperature Aluminium Welding, Gilmour-Vale Torches for Town and Color Gas, 19/6d., 25/6d. and 33/6d. each. Small or large orders welcome, enquiries from Schools invited.

Illustrated list on request. 3d. stamp please. G. M. VALE & Co., 55 Park Road, Wellingborough, Northants.

## WOODWORKING

SAWBENCHES.—Cast Iron. Rise and Fall. 6in., £6/19/6. 8in., £10/10/-. Carriage extra.—Drysdale, 58 Commerce Road, Wood Green, London, N.22.

6IN. SAWPLANE £16 10s., write for brochure from East Anglian Trading Co., 5 Guardian Road, Norwich.

## HOME BOAT BUILDING

FULLY PREFABRICATED KITS TO ASSEMBLE A BOAT AT HOME, for two-berth Cabin Cruisers, fast runabouts, canoes, prams, ENTERPRISE sailing dinghies. Leaflets from Wyvern Boats (Wessex) Ltd., Milborne Port, Sherborne.

BROMLEY BOATS, Kits, Mahogany, Silver Spruce, American Boat Plans, 3d. List.—Southlands Road, Bromley, Kent.

## PATENTS

PATENTING SERVICES.—Advice. Qualified agent.—C. L. Browne, 114 Greenhayes Ave., Banstead, Surrey.

## TOOLS

### SELECTA 2 SPEED DRILL

plus 13 attachments. Everything new. Full maker's guarantee. £12 10s. 0d. the lot. Carriage 3/6.

### DRYSDALE

58, Commerce Road, London, N.22 BOWes Park 7221

### FANTASTIC TOOL KIT OFFER

Six Surform tools plus six Stanley tools in handy rack, plus nest of five saws.

### BARGAIN 95/- LOT

### DRYSDALE

58, Commerce Road, London, N.22 BOWes Park 7221

### FANTASTIC SOCKET SET OFFER

Genuine Hand Forged Chrome Vanadium 27 Piece King-Hawk Socket Set in fitted steel carrying case.

LIST PRICE £10.19.6 OUR PRICE 6 gns.

### DRYSDALE

58, Commerce Road, London, N.22 BOWes Park 7221

## MULTIPLE SWIVEL SOCKET WRENCH

"EIGHT IN ONE"



DROP FORGED SELECTED STEEL

35/- POST PAID

Choice of Specification:

Whitworth:	1/8"	1/4"	3/8"	1/2"	5/8"	3/4"	1"
A/F.:	1/8"	1/4"	3/8"	1/2"	5/8"	3/4"	1"
Metric:	11	13	14	15	16	17	19 22

### ARTHUR DRYSDALE & CO. LTD.

58 COMMERCE RD., WOOD GREEN LONDON, N.22 BOWes Park 7221

## TOOLS continued

GRINDING LAWN MOWERS PAYS, other people's or your own. The New Simplan 14in. grinding machine—powered by your electric drill, costs only £13 5s.—carriage paid, and it's on approval. Details from—A. W. ROEBUCK, LTD., Turvey, Bedfordshire.

### BLACK & DECKER D.500 jin.

### ELECTRIC DRILL

Plus 10 attachments, everything new. Full maker's guarantee.

BARGAIN £7 8s. 6d. LOT.

### DRYSDALE

58, Commerce Road, London, N.22 BOWes Park 7221

## PHOTOGRAPHY

BELLOWS, Camera, Enlarger, Process, Industrial Collapsible Machine Guards.—Beers, 4 St. Cuthbert's Road, Derby. (Tel. 41263.)

PROJECTORS. Home Assembly Kits from £6 2s. 6d. Fan Base Kit £3 7s. 6d. Optical: Screens. S.a.e. Marshall Smith Ltd., 64 Norwich Avenue, Bournemouth.

GR photometers. Build the latest high sensitivity photometer with the new cadmium sulphide resistor cell and miniature nickel-cadmium secondary cell. Basic component kit suitable for colour densitometer, photo-enlarging and exposure meter. Price 55s. s.a.e. details. G.R. Products, 22 Runnymede Avenue, Bristol, 4.

## WATCHMAKERS

### WATCH PARTS

For all makes of watches, tools, instructional books, etc. Special Kits for beginners. Send 6d. for "Super Bargain Catalogue" T. G. LOADER (Dept. B.), Watchmakers' Mail Order Service, Milestone Road, Carterton, Oxford.

THE FIRM that brought you Main-springs at 6/6d. Gross now brings you Friction Fitting BALANCE STAFFS, E.B., Oris, etc.—3 DOZEN NAMED (12 Calibres) in box. ONLY, 5/- box, all popular. Numerous other bargains. All Watch Materials, Watches, Tools, Bracelets supplied. All repairs undertaken. Send for FREE lists—J. J. LAWSON, 95 Godwin Street, Bradford 1.

## SITUATIONS VACANT

A.M.I.Mech.E., A.M.Brit.I.R.E., City and Guilds, G.C.E., etc., bring high pay and security. "No pass—no fee" terms. Over 95% successes. For details of exams and courses in all branches of Engineering, Building, Electronics, etc., Write for 148-page handbook—free —B.I.E.T. (Dept. 9G78), London, W.8.

Continued overleaf.

EDUCATIONAL

"HOW AND WHY" of Radio and Electronics made easy by a new, non-maths. practical way. Postal instructions based on hosts of experiments and equipment building carried out at home. New courses bring enjoyment as well as knowledge of this fascinating subject. Free brochure from: Dept. 12.P.M., Radio-structor, 40 Russell Street, Reading, Berks.

LEARN RADIO & TV SERVICING for your OWN BUSINESS/HOBBY

by a new exciting no maths system, using practical equipment recently introduced to this country. FREE Brochure from:

RADIOSTRUCTOR DEPT. G80, READING, BERKS. 6/61

ELECTRICAL

SELF-starting synchronous mtrs., 200/250 v. 50 cycles complete with detachable geared mechanisms. 10s. each.—James S. Graham, 73 Acre Road, Kingston-on-Thames, Surrey.

BRAND NEW BROOK ELECTRIC MOTORS

Single Phase, h.p. 1,500 r.p.m. £7 13 9 h.p. 1,500 r.p.m. £10 7 6 h.p. 3,000 r.p.m. £10 7 6 AVAILABLE h.p. 1,500 r.p.m. £11 16 9 h.p. 3,000 r.p.m. £11 16 9

Fully guaranteed by makers, approval against cash. Carriage paid mainland. State voltage.

P. BLOOD & CO. ARCH STREET, RUGELEY, STAFFS.

ALL TYPES OF ELECTRICAL GOODS at extremely competitive prices, e.g. 5 amp. Twin Cable, 35s. 100 yards; Lampholders, 7s. doz.; 5ft. Batters, 49s.; quality and immediate dispatch guaranteed. Request list.—Jaylow Supplies, 93 Fairholt Road, London, N.16. (Telephone: Stamford Hill 4384.)

MISCELLANEOUS

AQUALUNG and Compressor Equipment, Ballraces and Miscellaneous items. Lists 3d.—Pryce, 157 Malden Road, Cheam.

DO YOUR OWN SIGNWRITING. Black and gold transfer letters, 2in., 3d., 1in., 1½d.—BCM/Rondo, London, W.C.1.

Protect your home with "LITON" Photoelectric Burglar Alarm Easy to build, Safe, Foolproof. Kit of parts, £4, 12.6; built, £5, 10.0. Battery model: Kit, 65/-; built, 72/6. Also Garage Door Opener, Light Saver. Customer Announcer etc. Send Is. stamp for NEW CONSTRUCTION MANUAL 12 pages. 20 illustrations. 156 St. John's Hill, London, S.W.11

FOR SALE

ASTRO TELESCOPE MAKING.—Standard Ramsden Push-in Eyepieces, ¼in., ½in., ¾in., focus, 35/-, with R.A.S. thread, 42/6 ea. S.A.E. list. Object Glasses, Newtonian Mirrors, Diagonal Mounts, Focusing Mounts, Tripods, Mountings and Terrestrial Telescopes.—W. Burnet, Grand Sluice, Boston, Lincs.

SEND 6d. for list of 1,000 snips. Valves, Radio and Television spares—Technical Trading Co., 350-352 Fratton Road, Portsmouth.

HYPODERMIC SYRINGES, branding new 2 c.c. SIMA, excellent for oiling etc., 4/9 each. Also needles, sizes 12, 17 and 18 at 4/- per dozen.—G. Roger Smith, 16 Clyde Street, Liverpool 20.

STAINLESS STEEL CONTAINERS with lids, 6 gallons, 75/—Thos. Foulkes, Lansdowne Road, London, E.11.

MODERN STEAM SPORTS CAR COLOUR PLATE. Steam at turn of switch, two pedal control, silence and economy. Boats and small stationary power units described. Lists of drawings, castings, etc., complete power units, 5s. post free. "Light Steam Power", Kirk Michael, Isle of Man, U.K.

FEW unused 1/3 h.p. "Brook" motors, 99/6d.—also others, larger. New portable Sprayplant, veebelt drive, 40 lbs. pressure, airhose, spraygun complete, £29 19s. 6d., or 30/- deposit and eight monthly payments of £4. Numerous clearance items for Callers. S.A.E. literature and enquiries.—Bellangers, 306 Holloway Road, London, N.7. North 4117.

GOVERNMENT SURPLUS AND CLEARANCE

MAINS 230V. ELEC BELLS. Twin 6" 35/- F.W. METAL RECTIFIERS. 12V., 1 amp. 5/- 2 amp 9/- 3 amp 12/6 4 amp 16/- 6 amp 22/6. FERRITE ROD AERIALS, 5/- L. & M. 7/6. VANNER SILVER ZINC ACCUMULATORS. H.105. 15/- Six for 85/-. FURNACE. 200/230V. 1,000 C. MUFFLE 6" x 6½" x 4" high. Weight 2½ cwt. £12.10.0. ATLAS ¼" AIR DRILLS. £4.10.0. VACUUM PUMPS. HAMMOND ENG. CO. £5.10.0. TAPS, Taper 1½" Whit. 5/- each. S.A.E. for Latest List 74.

HUGGETT'S LTD. 2/4 PAWSON'S ROAD WEST CROYDON, SURREY

WANTED

WANTED

FOR SALE IN U.S.A. & CANADA THROUGH LARGEST MAIL ORDER HOUSE WITH 740 SHOPS AND LARGE 1,500 PAGE PROFUSELY ILLUSTRATED CATALOGUE ISSUED TWICE YEARLY:

Small new (pref. Pat. appd. for), domestic and workshop items and clever toys (pref. educational). Also negotiate Licences to make in U.S.A. and tool exchanges.

DOUGLAS O. BREMNER, A.M.I. Mech.E. LONDON NEW YORK 19 Beaufort Gdns., Knightsbridge, S.W.3 Interviews by appointment only.

T.V. Chassis 5/6 Plessey. Less Valves and Tube. Carr. and Ins. 7/6d. Circuit incl. VALVES 9d. 2D21, 4D1, 6A1.5, 6C6, 6D2, 6H6, 7/8 per 6D2, 10C2, 10F3, doz. 12Y4, 15D2, 75 CV6R, D1, EA50, ER34, EB91, EF34, EF36, EF50, HL41DD, LP2, KT36, P41, P61, R19, SP61, SP61, T41, TT11, VR35, VR37, VR51, VR107, VR137, VT201, VT501, W150, W76. 2/9 11C6, 6AK6, 6AM6, 6C4, 6D6, 6F1, 6F3, 6F12, 6F13, 6F14, 6F15, 6K7, 6K25, 7A7, 7B7, 7C7, 7Q7, 10D1, 10F1, 30/- per 10P13, 10P14, 12BE6, 12BH7, 12SJ7, doz. 12SK7, 12H7, 14H7, 25A6, 25L6, 25Z5, 25RE, 35Z4, 42, 43, 50CD6, 50L6, 874, 8D3, APV4, APV4, B56, CL33, CY1, CY31, DH76, DE77, EAB80, EB39, EB41, EBL21, ECC84, KCC91, EF39, EF41, EF80, EF91, EF92, EL32, EY51, KT81, KTW61, N142, PEN45, PEN46, TH41, TH233, U22, U31, UAF42, UB41, UCH42, UF41, UF42. More at 2/6d. Z152, EY68U104, 6AB8, 6BW7, EY66, U404, ECF78, few only ECL60, ECC81, ECC82, ECC84, ECF80, ECH35, 60/- per EL33, EL38, EL41, EL42, EL91, doz. E240, many more. Post for 1, 7d.; 6, 1/6d.; 12, 2/6d. Vol/Tone control 2/6d. per doz. Assorted and stripped from working chassis. P & P 2/-.

P. P. COMPONENTS LTD. 219 ILFORD LANE, ILFORD, ESSEX Stamp for FREE Catalogue

ULTRA Hi-Power TELESCOPES INTRODUCING OUR LATEST Super "Moonscope" from £9.19.6 (Mag. 53 to 200X. Early Moonscopes modified. Larger 3" dia. models, etc. Moon maps, star charts, etc. Send 6d. stamps for lists. Numerous Testimonials from 5/6 WEEKLY. Photos Available

J.K.M. HOLMES & CO. LTD. Dept. P.M. 81 (Scientific Instrument Makers) MARTINS BANK CHAMBERS, NORTH SHIELDS NORTHUMBERLAND

BOOKS for CONSTRUCTORS NEW PICTORIAL APPROACH TO LEARNING

BASIC ELECTRICITY, 5 parts. BASIC ELECTRONICS, 6 parts. The Complete Set sent on payment of first instalment. LEARN WHILE YOU PAY FOR ONLY 2/6 PER WEEK Write for FREE Illustrated Prospectus giving details of instalment plan. BOYS' BOOK OF CRYSTAL SETS AND SIMPLE CIRCUITS. 3/- 36 pages, 29 illustrations and plans. The know-how on constructing 12 different sets without any previous knowledge.

SEND STAMP FOR LISTS SELRAY BOOK CO. DEPT P.M., 60 HAYES HILL, HAYES BROMLEY, KENT. Tel.: HURStway 1818

The finest portable telescope available today. Scout Mk. II. Ex-Gov. 2 in. O.G. 25x, £8 10s. each. High-powered eyepieces and astro kits available. See our lists. Projector Kits, 35mm. Gives 500w. results from 100w. lamp. 15 ft. candles on 3 ft. screen guaranteed. From 38s. set (unmounted lenses). 2½ sq. from 31s. Plans 2s. each. Dozell Lens. Ex-Gov. Suits any camera, as telephoto lens 3x micro and macrophotography, projection enlarging and magnifying lenses, stereo, etc. 55s. each. Send for details. Mirror type Viewer for 35mm. Perfection. Plans 1s. Mirror and Flat 37s. 6d. Astro Mirrors. 6 in. Parabolic. First grade £9 5s. each. 6" dia. x 40" focus spherical mirrors, unsilvered on ⅝ plate. £2 each. 4" x 40" focus aluminized 45s. each. Telescopic eyepieces. The world's best. ⅝ W.A. Erfle, focusing 58s. each. 1 in. and 1½ in. W.A. Erfle. £3 each. Orthoscopes ⅝ focus, plain sleeve 17s. 6d. and 35s. 1 in. 27s. 6d. 1½ in. 30s. 2 in. 30s. Variable power eyepieces, ortho, ⅝ to ⅞ R.A.S. £4 5s. each. Any eyepiece fitted R.A.S. thread 7s. 6d. extra. Kepler eyepiece 1½ in. focusing mount 8s. 6d. each. First Grade Prisms from 18s. 6d. Most types available. Aluminized Flats from 3s. 6d. Polarised spectacles 6s. 6d. pr. Liquid Compasses 55s. each. Clinometers Mk.IV 25s. each. 6 x 30 Binoculars. Ex-Army £6 10s. Hundreds of useful items for the scientific experimenter in optics, electronics, radio and scientific equipment. See our lists or call. How to use ex-Govt. Lenses and prisms. Nos. 1 and 2. 2s. 6d. each.

**H. W. ENGLISH** 469 RAYLEIGH RD. HUTTON BRENTWOOD, ESSEX

# GAMAGES

## famous '16' ELECTRIC ARC WELDERS



Suitable for garage and maintenance work, agricultural machinery, heating engineers, ornamental iron or blacksmith's work, handi-crafts or the home workshop.

For joining Ferrous Metals not less than 16 gauge (or ⅜ in.) thick, and, if necessary, up to ¼ in. thick by repeat runs after preparation. Robustly constructed throughout. Air cooled. Dimensions approx. 10 x 13 x 8 in. Weight approx. 50lb. Incorporates a heavy-duty transformer and is complete with cables, welder's equipment, electrodes and instructions. Will not weld thinner than ⅜ in. For 190/250v. single-phase A.C. 10 to 15 amps domestic supply. Runs 16 S.W.G. rods continuously.

BARGAIN  
PRICE

**£15'10'0**

Or 12 Monthly  
Payments of **27/3**

*If outside our van area, part carr. and pkg. G.B. 7/6*

### COMBINED ARC WELDING AND BRAZING MACHINE

New and improved model. Brazes light sheet down to 26 S.W.G.—invaluable for work on car bodies. Even a novice can operate this carbon brazing contact method.

**£25** Or 12 Monthly Payments of **43/9**

CARR. PAID in G.B.

Tool and Car Accessory List FREE

GAMAGES, HOLBORN, LONDON, E.C.1 - HOL 8484

## Used by famous loco model **Myford** builders

the lowest priced and finest  
precision metal-working  
lathes in their class



Send for details of the **ML7 & Super 7**  
and the full range of accessories:

3- & 4-Jaw Chucks  
Fixed and Travelling  
Steadies

Dividing Attachment  
Quick Change Gearbox  
TRI-LEVA Speed Selector, etc.



**Myford** ENGINEERING CO LTD  
BEESTON-NOTTINGHAM  
TELEPHONE NOTTINGHAM 25-4222

## every door tight shut!

- SIMPLE TO FIX—
- NO WOODWORKING ALTERATIONS
- PERMANENT IN POWER—WILL NOT FATIGUE OR FALL
- SELF-ALIGNING FLOATING MAGNET
- NO WORKING PARTS TO OIL OR SERVICE
- ALUMINIUM CASING & PLATED KEEPER AVOID RUST

No. 870 For use on kitchen or bathroom cabinets & cupboard doors

No. 871 For use on heavier hinged or sliding doors

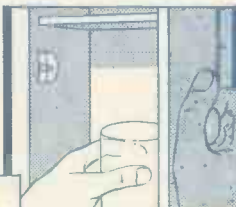

**Magnetic**

## DOOR CATCH

Made by James Neill & Co. (Sheffield) Ltd.  
and obtainable from all tool distributors



# Free Guide — SUCCESS IN ENGINEERING

One of the following Courses taken quietly at home in your spare time can be the means of securing substantial well-paid promotion in your present calling, or entry into a more congenial career with better prospects.

## ENGINEERING, RADIO, AERO, ETC.

Aero. Draughtsmanship	Elec. Draughtsmanship
Jig & Tool Design	Machine " "
Press Tool & Die Design	Automobile " "
Sheet Metalwork	Structural " "
Automobile Repairs	R/F Concrete " "
Garage Management	Structural Engineering
Works M'gmt. & Admin.	Mathematics (all stages)
Practical Foremanship	Radio Technology
Ratefixing & Estimating	Telecommunications
Time & Motion Study	Wiring & Installation
Engineering Inspection	Television
Metallurgy	Radio Servicing
Refrigeration	Gen. Elec. Engineering
Welding (all branches)	Generators & Motors
Maintenance Engineering	Generation & Supply
Steam Engine Technology	Aircraft Mainten. Licences
I.C. Engine Technology	Aerodynamics
Diesel Engine Technology	Electrical Design
	Ordnance Survey Dr'ship

## BUILDING AND STRUCTURAL

L.I.O.B.	A.L.A.S.	A.R.S.H.	M.R.S.H.
A.M.I.P.H.E.	A.A.L.P.A.	A.F.S.	A.R.I.C.S.
Building Construction	Builders' Quantities		
Costs & Accounts	Carpentry & Joinery		
Surveying & Levelling	Building Inspector		
Clerk of Works	Building Draughtsmanship		
Quantity Surveying	Heating and Ventilating		

## GENERAL, LOCAL GOVERNMENT, ETC.

Gen. Cert of Education	Common. Prelim. Exam.
Book-keeping (all stages)	A.C.I.S., A.C.C.S.
College of Preceptors	A.C.W.A. (Costing)
Woodwork Teacher	School Attendance Officer
Metalwork Teacher	Health Inspector
Housing Manager (A.I.Hsg.)	Civil Service Exams.

## BECOME A DRAUGHTSMAN — LEARN AT HOME AND EARN BIG MONEY

Men and Youths urgently wanted for well paid positions as Draughtsmen, Inspectors, etc., in Aero, Jig and Tool, Press Tool, Electrical, Mechanical and other Branches of Engineering. Practical experience is unnecessary for those who are willing to learn—our Guaranteed "Home Study" courses will get you in. Those already engaged in the General Drawing Office should study some specialised Branch such as Jig and Tool or Press Tool Work and so considerably increase their scope and earning capacity.



★ OVER SEVENTY YEARS OF CONTINUOUS SUCCESS ★

## NATIONAL INSTITUTE OF ENGINEERING

(In association with CHAMBERS COLLEGE—Founded 1885)  
(Dept. 29)

148, HOLBORN, LONDON, E.C.1

SOUTH AFRICA: E.C.S.A., P.O. BOX NO. 8417, JOHANNESBURG  
AUSTRALIA: P.O. BOX NO. 4570, MELBOURNE

**132-PAGE BOOK FREE!**  
**SEND FOR YOUR COPY**

This remarkable **FREE GUIDE** explains:

- ★ Openings, prospects, salaries, etc., in Draughtsmanship and in all other branches of Engineering and Building.
- ★ How to obtain money-making technical qualifications through special **RAPID FULLY-GUARANTEED COURSES**.

### MANY INTERESTING COURSES TO SELECT FROM!

A.M.I.Mech.E., A.M.I.M.I.,  
A.M.Brit.I.R.E., A.M.I.P.E.,  
A.M.I.C.E., A.M.I.Struct.E.,  
A.M.I.Mun.E., M.R.S.H.,  
A.M.I.E.D., A.F.R.Ac.S.,  
London B.Sc., Degrees.

Fully guaranteed postal courses for all the above and many other examinations and careers. Fully described in the *New Free Guide*.



## THE ACID TEST OF TUTORIAL EFFICIENCY—SUCCESS—OR NO FEE

We definitely guarantee that if you fail to pass the examination for which you are preparing under our guidance, or if you are not satisfied in every way with our tutorial service—then your **Tuition Fee will be returned in full** and without question. This is surely the acid test of tutorial efficiency.

If you have ambition you must investigate the Tutorial and Employment services we offer. Founded in 1885, our success record is unapproachable.

**ALL TEXTBOOKS ARE SUPPLIED FREE**  
**PROMPT TUTORIAL SERVICE GUARANTEED**  
**NO AGENTS OR TRAVELLERS EMPLOYED**



## Free Coupon

To: NATIONAL INSTITUTE OF ENGINEERING  
(Dept. 29), 148-150, Holborn, London, E.C.1

Please Forward your Free Guide to

NAME .....

ADDRESS .....

.....

.....

.....

.....

.....

.....

.....

.....

.....

.....

.....

.....

.....

.....

.....

.....

.....

.....

.....

.....



My general interest is in: (1) ENGINEERING  
(2) AERO (3) RADIO (4) BUILDING  
(5) MUNICIPAL WORK

(Place a cross against the branches in which you are interested.)

The subject of examination in which I am especially interested is

.....

.....

.....

.....

.....

.....

.....

.....

.....

.....

.....

.....

.....

.....

To be filled in where you already have a special preference.  
(2d. stamp only required if unsealed envelope used.)

**FOUNDED 1885 - FOREMOST TODAY**