

ALTITUDE TESTING CHAMBERS

NEWNES

9<sup>D</sup>

# PRACTICAL MECHANICS

EDITOR: F. J. CAMM

AUGUST 1949

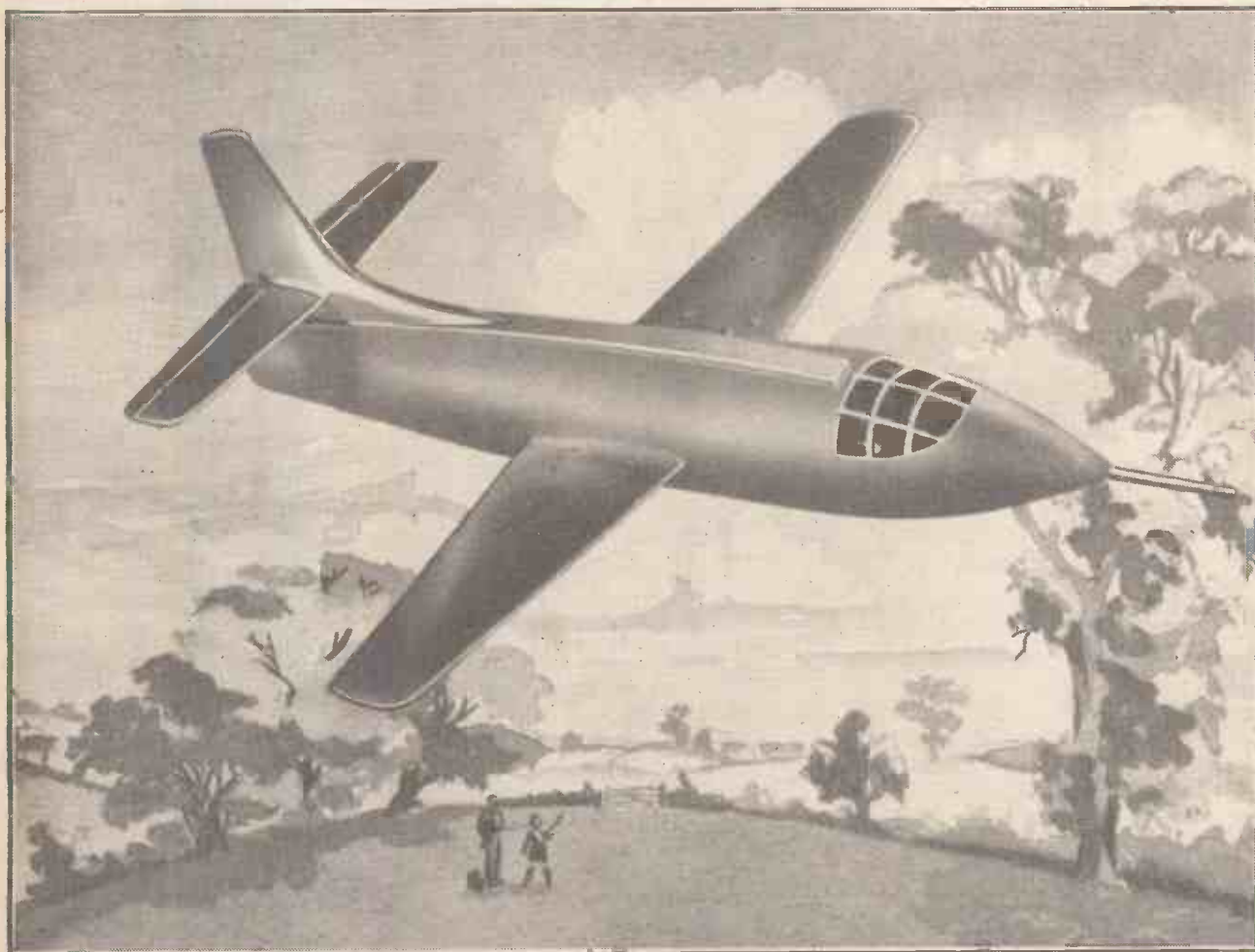

A CONTROL-LINE JET-PROPELLED MODEL AIRCRAFT IN FLIGHT. SEE PAGE 346.

## PRINCIPAL CONTENTS

Studies in Electricity and Magnetism  
Jet Reaction Power Models  
Model Engineering Practice

Elements of Mechanics:  
Woodturning  
Simple Electronics

World of Models  
Letters from Readers  
Cyclist Section

**YOU NEED CLIPS**

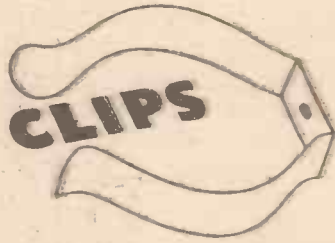

**TERRY'S MAKE CLIPS**

in every shape and size — steel clips, bronze clips, stainless clips, etc., etc.  
 Here we show a tiny selection from the enormous range we have produced.  
 Our Research Department can design any clip to your own specification.  
 (33 years of clip-making experience is at your disposal.)

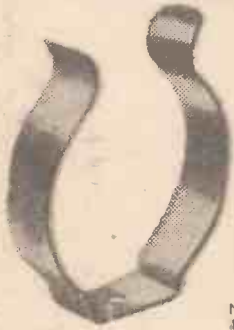

No. 81

Two popular types. In a range of sizes to grip from 1" to 2". Delivery from Stock.



No. 80



No. 300

A drawing board clip. Plated finish, delivery from Stock. 4/- doz. plus P.T.

The most comprehensive and informative text book on springs yet published. 10/6 post free.



**TERRY**



Sole Makers:

HERBERT TERRY & SONS LTD. REDDITCH. London · Birmingham · Manchester

**IF** YOU TAKE PHOTOGRAPHS GET THIS JOHNSON J-20 TANK AND DEVELOP YOUR FILMS IN DAYLIGHT

You lose half the fun of photography if you do not develop your own negatives and make your own prints. It is much cheaper to do the work yourself and you see your results more quickly.

J-20 TANK, as illustrated below, is for all size-20 roll films. Holds 10-oz. of solution. Enables you to develop, fix and wash a film in daylight. Price 21/-.

JOHNSON ADJUSTABLE TANK for amateurs who require a tank for more than one type of camera spool. This tank takes six sizes of film: 16 mm., 35 mm., 1½ x 2½, 2½ x 2½, 2½ x 3½ and 2½ x 4½. Price 27/6. Ask for it at your dealers.



**SPECIAL OFFER**

For three pence in stamps we will send you a book on *Home Photography*. It will interest all amateur photographers, for it tells how to develop films, how to make contact prints and how you can do your own enlarging. There is a chapter on taking portraits by artificial light.

Mark your envelope clearly *Practical Mechanics offer*.

JOHNSONS OF HENDON LTD. LONDON N.W.4  
Established 1743

**THE "ZYT0" 15in. MOTORISED SAWBENCH WITH TOTALLY ENCLOSED MOTOR FOR CROSSCUTTING, RIPPING, MITREING, BORING, GROOVING, etc.**

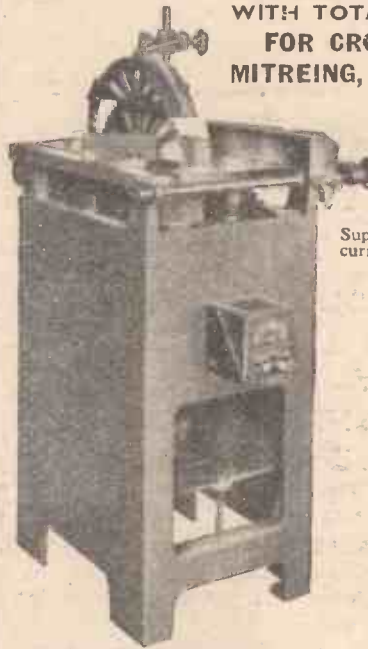

**Brief Specification:**  
Saw-table 24in. x 18in., with rise and fall motion for grooving, etc. Takes 15in. saw. Long ripping fence with fine adjustment.  
Heavy spindle bored to take dowel bits, etc.  
2 h.p. motor provided.  
Supplied single three-phase or D.C. current.

PLEASE STATE VOLTAGE, PRICE AND FULL DETAILS FREE ON APPLICATION.



Production of S. TYZACK & SON, Ltd.  
**THE "ZYT0" BENCH HAND-FEED DRILLING MACHINE**  
Drills to centre of 8in. circle.  
Chuck to table, 7½in.  
Hand-feed depth, 2in.  
Weight, 15lbs.  
Chuck capacity, 0-½in.

PRICE 57/- (carriage paid)

**S. TYZACK & SON, Ltd.,** 341-345 OLD ST., LONDON, E.C.1.

Telephones: CLERKENWELL 8301 (Ten lines).

Telegrams: TYZGAR, FINSQUARE.

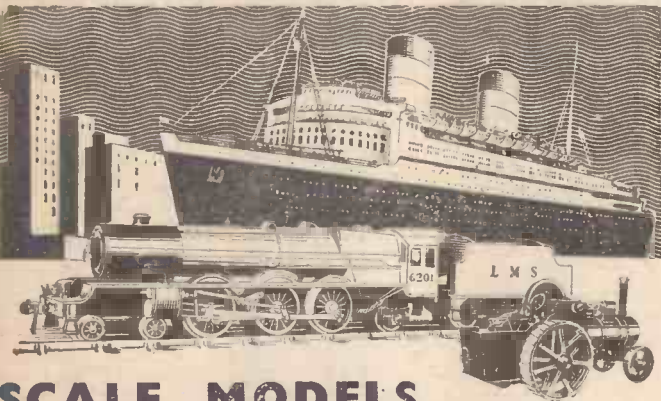

**SCALE MODELS of every description for every purpose**

Are you INTERESTED in . . . Model locomotives, railway equipment, ships (full-hull and waterline), motor-boats, sailing yachts, engines and boilers; architectural, display and museum models; drawings, castings and parts for the amateur model-maker? If so . . . send 1d. stamp for (BP112)

**"BASSETT-LOWKE PUBLICATIONS"**  
a NEW Brochure giving details of all catalogues, booklets etc. devoted to models and modelmaking.  
Drawings, Castings and Parts supplied by Bassett-Lowke Ltd. are of the finest quality.

**BASSETT-LOWKE LTD**  
NORTHAMPTON  
LONDON SHOWROOMS: 112, HIGH HOLBORN, W.C.1.  
MANCHESTER: 28, CORPORATION STREET.  
Visit our London and Manchester Branches, where our staff is at your service.

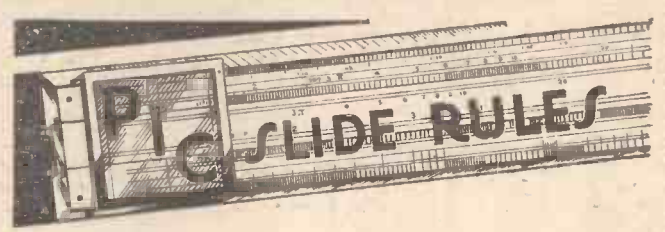

Manufacturers of  
**DRAWING and SURVEYING INSTRUMENTS**

SLIDE RULES

DRAWING MATERIALS

DRAWING OFFICE STATIONERY

**A. G. THORNTON LTD**  
*Drawing Instrument Specialists*  
41 GARTSIDE ST. MANCHESTER 3

# I.C.S. TRAINED MEN are in Greater Demand than Ever—Maximum production depends on high technical skill, such as that acquired by I.C.S. Students

TENS OF THOUSANDS MORE  
TRAINED MEN ARE URGENTLY  
NEEDED NOW—BUT THERE IS  
NO WORTH-WHILE PLACE FOR  
THE UNTRAINED

*Ambitious men everywhere have succeeded through  
I.C.S. Home-Study Courses. So also can you.*

The man with an I.C.S. Training in any one of the subjects  
listed below knows it thoroughly, completely, practically.  
And he knows how to apply it in his everyday work.

- |                         |                         |                        |
|-------------------------|-------------------------|------------------------|
| Accountancy             | Diesel Engines          | Mining Engineering     |
| Advertising             | Draughtsmanship         | Motor Engineering      |
| Aero Engineering        | (State which branch)    | Motor Mechanic         |
| Air and Vacuum          | Drawing Office Practice | Motor Vehicle Elec.    |
| Engines                 | Electrical Engineering  | Municipal Eng.         |
| Air-Conditioning        | Electric Power, Light-  | Plastics               |
| Architecture            | ing, Transmission,      | Plumbing               |
| Architectural Drawing   | Traction                | Quantity Surveying     |
| Auditing                | Eng. Shop Practice      | Radio Engineering      |
| Boiler Engineering      | Fire Engineering        | Radio Service Eng.     |
| Book-keeping            | Free-Lance Journalism   | Refrigeration          |
| Building Construction   | Fuel Technology         | Sales Management       |
| Building Specifications | Heating and Ventilation | Salesmanship           |
| Bus ness Training       | Hydraulic Engineering   | Sanitary and Domestic  |
| Business Management     | Hydro-Electric          | Engineering            |
| Carpentry               | Illumination Eng.       | Sheet-Metal Work       |
| Chemical Engineering    | Industrial Management   | Short-Story Writing    |
| (Chemistry, I. & O.)    | Joinery                 | Steam Engineering      |
| Civil Engineering       | Lettering               | Structural Steelwork   |
| Clerk of Works          | Machine Designing       | Surveying              |
| Coal Mining             | Machine-Tool Work       | Telegraph Engineering  |
| Colliery Examiner's     | Marine Engineers        | Television Technology  |
| Colliery Overman's      | Mechanical Drawing      | Welding, Gas and Elec. |
| Commercial Art          | Mechanical Engineering  | Woodworking Drawing    |
| Concrete Engineering    | Mine Surveying          | Works Engineering      |

And most of the Technical, Professional, Commercial and Civil Service  
Examinations; also U.C.T.A. Exam. in Salesmanship.

(I.C.S. students preparing for Examinations are coached till successful)

If you need technical training, our advice on any matter concerning  
your work and your career is yours for the asking—free and without  
obligation. Let us send you our special free booklet on the subject in which you  
are specially interested. DON'T DELAY Make ACTION your watchword

The successful man DOES to-day what the failure  
INTENDS doing to-morrow. Write to us TO-DAY

Use this Coupon

## INTERNATIONAL CORRESPONDENCE SCHOOLS LTD.

Dept. 95, International Buildings, Kingsway, London, W.C.2

Please send me the free booklet describing your Courses in

Name..... Age.....  
(USE BLOCK LETTERS)

Address: .....

### Addresses for Overseas Readers

- Australia: 140, Elizabeth Street, Sydney.  
Egypt: 40, Sharia Malika Farida, Cairo.  
Eire: Anglesea Street, Dublin, C.4.  
India: Lacksmi Bldgs., Sir Pherozsha Mehta Rd., Fort,  
Bombay.  
New Zealand: 182, Wakefield Street, Wellington.  
N. Ireland: 26, Howard Street, Belfast.  
South Africa: 45, Shortmarket Street, Cape Town.



Largest stocks,  
best selections

# CLYDESDALE

and Bargains in Ex-Services Radio and Electronic Equipment

## Brand New in maker's carton. "SIROCCO" BLOWER, WITH SHUNT MOTOR

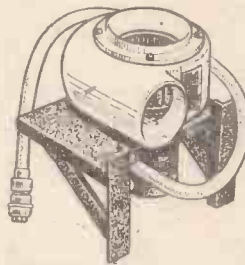

27 volts D.C. 1.5 a.  
1/50 h.p. 3,000 r.p.m.  
continuous running, multi-  
bladed fan, outlet dia.  
2 1/2 in. Size overall 7 x 5 x  
6 in., mt. size 7 1/2 x 5 x  
4 1/2 in. on rack 16 x 12 in.  
with fixing screws,  
aluminium construction.

CLYDESDALE'S  
PRICE  
ONLY  
17/6d. each. POST  
PAID

## Brand New MINIATURE 230 v. A.C. MAINS MOTOR

Not a converted unit,  
operates from 230 v.  
A.C. mains. Single  
Phase, 50 c/s. A  
beautifully made  
synchronous frac-  
tional H.P. miniature  
motor. Dimensions,  
body: overall length  
2 1/2 in.; dia. 2 1/2 in.;  
spindle length, 1 in.;  
dia. 1/2 in; black crackle  
finish.

CLYDESDALE'S  
PRICE ONLY  
21/- each  
POST PAID

VOLT-OHMMEETER, Brand New, Portable. E336, with Sling. Scale 0-5,000 ohms,  
0-60 ma. 0-1.5 v. 0-3 v. Range 0-500 ohms, 0-5,000 ohms, 6 ma. 1.5 v. In  
black plastic case, size 3 1/2 x 3 1/2 x 2 1/2 in. Instructions on back.

CLYDESDALE'S  
PRICE ONLY

16/6 each.

POST  
PAID

## Brand New in tropi- cal packing. EX-R.A.F. MINIA- TURE ELECTRIC MOTOR

E524, for 24 volts  
D.C. Small dimen-  
sions: length 2 1/2 in.,  
diam. 1 1/2 in.

CLYDESDALE'S  
PRICE  
ONLY  
5/11 each  
POST PAID

## Brand New in maker's cartons. A UNIVERSAL MOTOR

By simple external wiring, full data supplied, for 220-250  
volt A.C. or D.C. mains. New method gives better than  
1/6 h.p. Ideal for light bench  
work, a 1 in. spindle is available  
(when the fan is removed) for  
driving. Motor Generator type  
29, size 11 x 5 1/2 x 5 1/2 in. Input  
24 v. 16 a. Output 1,200 v.  
200 ma.

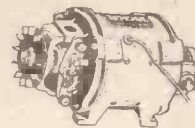

CLYDESDALE'S  
PRICE ONLY  
25/- each  
CARRIAGE PAID

All goods advertised or in our list can be ordered from any of our branches, in England  
and Northern Ireland, or direct from:—

## CLYDESDALE SUPPLY 2 BRIDGE STREET CO. LTD. GLASGOW . C.5

Phone: SOUTH 270619.

Send now for new Illustrated Lists.

Please print Name and Address.

# M.O.S.

offer you more  
for your money

## MINE DETECTOR AMPLIFIERS

A complete R.C. 3-stage amplifier in  
aluminium case with battery compart-  
ment. Less valves but chock full of  
components, including 12-1 Midget  
transformer, ceramic button bases, con-  
densers and resistors. BRAND NEW.  
Reduced in price to 4/6 Post  
Free

## DUAL LOUDSPEAKERS

A Parmeko 10-watt speaker as used by  
the Admiralty on board all types of craft.  
Two 8 in. dia. P.M. Speakers mounted  
back to back and complete with matching  
volume control. Housed in black  
moulded frame and fitted with base  
fixing plate. Ideal for all purposes  
£2 10 0 to callers. Add 10/- for carr.  
and pkg. if required by rail.

## FOOT CONTROL SWITCH

just what you have been waiting for . . .  
and offered at a fraction of the original  
cost. Made to Government specifications  
from heavy brass casting, accurately  
machined, will take the heaviest load, and  
can be used to control machinery, model  
engines, etc. Ideal for the amateur and  
professional  
photographer. ONLY 22/6 Carr.  
Paid

## FOLDING AERIALS

A very useful aerial comprising seven  
sections of copper tube aerial, which  
extends to 14 feet. The aerial folds down  
to a compact parcel of approx. 2ft. length.  
Each section is permanently connected  
to the adjacent one by a flexible cable  
running through the centre of the tube.  
The aerial is assembled by push-fitting  
one section into another and the assembly  
is painted khaki green. We supply in  
addition a solid rubber insulated base  
into which the aerial fits. This base will  
fit anywhere as it is provided with a

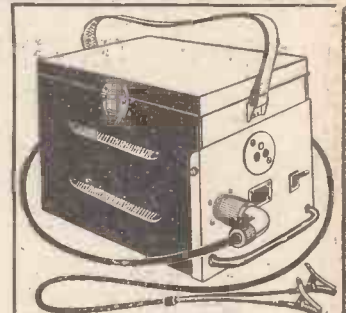

## ROTARY CONVERTERS Type 195

in BLUE-GREY STEEL CABINET  
as illustrated. Input 24v. D.C.  
Output 230v., 50 c/s., 100  
watts Single phase. Complete  
with plug, leads, clips, and  
fitted with 3-way 15 amp.  
socket and control switch.

BRAND NEW £4 . 10  
Carriage Paid.  
Slightly soiled (Exterior) Models  
at £3 10 0.

circular metal disc with 3 fixing holes.  
A connecting terminal is also pro-  
vided. THE WHOLE  
ASSEMBLY FOR ONLY 10/- Post  
Free

## INTERIOR LIGHTS

A robust lamp approx. 3 1/2 in. dia., with  
pearl domed glass cover and fitted with  
standard B.C. fitting for low power  
illumination. A heavy duty on-off  
switch of the push type projects through  
the case. Black BRAND 7/6 Post  
enamel finish. NEW 7/6 Post  
Free

## M.O.S. NEWSLETTER

the paper for the handyman. Packed  
with genuine bargain items and useful  
"gen." Send 6d. for specimen copy or  
5/- for a year's subscription.

Terms: Cash with Order.

33, Tottenham Court Road, London, W.1  
Telephone: MUSeum 6667-8-9.

# MONTHLY NEWSLETTER



Redbrook Works,  
Gawber,  
BARNLSLEY.  
August, 1949.

## HAIL!

Perhaps the hardest thing in advertising is to convey pride of achievement without betraying a vestige of smugness. However, we are no strangers to "P.M." and hope to prove worthy of the confidence of a widening circle of friends. "Friendliness" is the operative word in all our dealings, we are privileged to share the engineering hobby of countless enthusiasts at home and overseas.

Our particular pleasure is the supply of first quality hand and machine tools direct to users, backed by policy of sound service. For instance, our Lathe Department concentrates solely on MYFORD products backed by stocks of accessories and replacements second only to those of the factory. Similarly, the same test is applied to every item of stock with the accent on speedy and safe delivery. A further step has been the provision of our Personal Hire Purchase Plan which operates on any transaction over £25 value; a sane commonsense arrangement for those who wish to pay out of income.

Space does not permit further details but we would like to extend this brief acquaintance. A copy of our house journal "Tool News" or "Current Machinery Quotations" will gladly be sent free on request (stamp will be appreciated) to any address in the world. Alternatively, should you have any immediate requirements, we shall be pleased to quote upon receipt of details.

We look forward to hearing from you.

Yours Sincerely

T. GARNER & SON LIMITED

Hand & Machine Tool Division

## HOUSE TELEPHONES WALL OR DESK MOUNTING

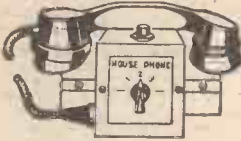

Suitable for intercommunication between Offices, Workshops, Stores, Garages, Big houses, Kitchens, etc. Each station consists of normal size Bakelite handsets as illustrated, and desk or wall mounting cabinet with built-in Selector switch, buzzer and push. All stations can communicate with one another independently. Each installation is absolutely complete and internally wired. All you do to instal is to run the multi-core cable between stations, join green wire to terminal A, reds to Terminal B, blacks to terminal C, etc., etc.

- 3 station installation complete with 50 yds. 5 core cable, £6/10/0. Ref. 318.
- 4 station installation complete with 50 yds. 6 core cable, £8/10/0. Ref. 319.
- 2 station installation complete with 25 yds. 4 core cable, £3/17/6. Ref. 320.

Absolute satisfaction guaranteed or money refunded.



## KLAXON HORNS

**PULL STRAP OPERATED.**—Ideal for Boats, Scaring Crows, Street Vendors-works signals for alarms, etc. List price, £6/6/0, our price, 25/-. Unused, perfect.

**CHAINS/BATTERY MOTOR FITTED WITH GEARBOX.** Ideal for driving large-sized models or with gearbox removed for operating a small buffing wheel, or similar. These motors measure 7 1/2 in. x 3 1/2 in. high, they will run off D.C. between 6 and 24 volts or from A.C. or D.C. mains, any voltage. Speed is 2,000 revs. approximately. Price, 15/-, post free. Order item No. 134.

### A ONE-VALVE RADIO RECEIVER

If you are anxious to make a set for your den or to listen in at night when the main radio cannot be used, then you will be interested in the One-Valve Radio Kit which we have available at the exceptional price of £1, plus 2/6 postage and insurance. The set works entirely from dry batteries and gives good headphone reception on the medium wave band. The complete Kit consists of: Chassis, Tuning Condenser, Trimmers, Volume Control, Valve, Valve Holder, small Condensers, small Resistors, Flex Wire and Earphones, everything, in fact, except batteries. We also supply detailed instructions showing you how to assemble wire, and work the Receiver.

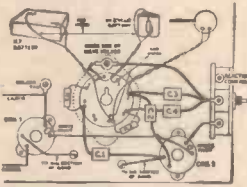

(Note—the diagram below is part of these instructions reproduced here to show you how clear the diagrams and instructions are.) This is an offer which cannot be repeated once all stocks have been cleared, so you should order by return of post.

**YOU CAN MAKE A TELEVISION RECEIVER** It cannot be denied that there is a lot of work in making a Television Receiver, but if you are sufficiently keen, there is no reason why you should not be able to successfully complete a really good Television which will give you and your family hours of enjoyment.

We are certain that you could follow the diagrams if they were all presented in the same easy and straightforward manner, as the one of the One-Valve Receiver above; and this is the way we are presenting the data for our new Mark III Television. If you feel you would like to make this up, then send 7/6 immediately for the the constructional data.

Even if you haven't any of the components, the total cost will be less than £20 and these can be purchased H.P. if desired.

**PRECISION EQUIPMENT, (1) Electron House, WINDMILL HILL, RUISLIP MANOR, MIDDLESEX**



Get this book - make these MODELS

HOUSES · SHIPS · ASHTRAYS · BOOK- ENDS · SIGNAL CABINS · RAILWAY STATIONS · AIRPORTS · DOCKS RELIEF MAPS · PLAQUES · MODEL FURNITURE · INKSTANDS · PAPER WEIGHTS · MODEL FIGURES AND ANIMALS ETC.

**SIMPLE TO HANDLE · INEXPENSIVE**

The Instruction Book illustrated tells you how to make such models as above, without special tools or skill, in Sankey's "Pyruma" Plastic Cement. This material, modelled while plastic, dries or bakes to stone-hardness, ready for painting according to instructions. Obtainable at local ironmongers, hobbies shops and art material dealers.

Get Instruction Book by sending 4d. in stamps to the address below



Dept. 4

**J.H. SANKEY & SON, LTD.**

ILFORD Est. 1857 ESSEX

# IT'S HOME ENGINEERING



## WITH MACHINE-SHOP TECHNIQUE

• Build your own radio chassis and 101 other gadgets for the home; construct perfect working models to your own plans. In fact, create to your heart's content; you'll see your work materialise into perfect precision productions. The Prestacon Press is the instrument that, for the first time, brings home engineering to the handyman.

• Prestacon is the COMPLETE Press with all necessary attachments including

Guillotine for shearing metal from  $\frac{1}{2}$ " to 2" and up to 12" long. Also attachments for piercing round and square holes and for cutting circular and rectangular slots as well as for bending metal to almost any angle. All with absolute accuracy.

• PRESTACON PRESS, 55/- Complete model making outfit with working drawings, 84/- Speciality kits also available.



Obtainable from the Toy Department of leading Stores and Model Supplies Dealers

Illustrated leaflet detailing in full the scope of the PRESTACON PRESS available on request from

Sole Concessionaires: L. REES & CO. LTD. (Dept. 20), 31/35, WILSON STREET, LONDON, E.C.2.

THE BRITISH MADE PRECISION SMALL TOOLS

## BRIDGES



**Drills**  
Bridges Drills are electronically hardened, and scientifically checked and tested, to satisfy the most exacting needs of the watch-maker and engineer.

**PIVOT DRILLS**  
For drilling very small holes. Range of sizes: .05 mm. (.002") to .5 mm. (.0197").

**FLAT DRILLS**  
Similar to pivot drills. Range of sizes: .25 mm. (.0098") to 3 mm. (.1181").

**STRAIGHT FLUTE DRILLS**  
Recommended for brass. Range of sizes: .35 mm. (.0138") to 3 mm. (.1181").

**STANDARD SPIRAL FLUTE DRILLS**  
Improved design for easy ejection of swarf. Range of sizes: 1 mm. (.0039") to 3 mm. (.1181").

**SINGLESPIRAL FLUTE DRILLS**  
For drilling to extremely fine limits. Range of sizes: 1 mm. (.0039") to 3 mm. (.1181").

Obtainable from your usual supplier; in case of difficulty write for name of your nearest stockist. Details of Bridges precision Tools and Speciality Instruments, sent on request.

S. N. BRIDGES & CO., LTD., Parsons Green Lane, London, S.W.6

Air Ministry Surplus

### ALTIMETER

Reading to 20,000ft. An accurate British instrument by Smiths, Kelvin, etc. Diameter 3 1/2 in. Depth, 2 1/2 in. Convertible to barometer pressure switch, etc. Made to top R.A.F. standard.

5/6

(Post and packing, 6d.)



### HIGH POWER TELESCOPE

Brand new. Ex-Army-Navy triple extending type. Power approx. 40, object glass 50 mm. Ideal for rifle ranges from 25yds. to 1,000yds. (22 shots at 100yds. easily visible.) Eminently suitable for bird watchers military and naval cadets, coastal observation and a hundred and one other uses. This telescope is a solidly constructed instrument built to rigid government specifications by leading British optical manufacturers. Brand new, complete with leather case. Length closed, 11ins., open, 31in. £6 10 0 (Post and packing, 2/6.) Carrying strap, 3/6 extra.



### 12 VOLT ACCUMULATOR

Capacity at 10 hour rate 13 A.H. to 1.75 v., capacity at 5 hour rate 10 A.H. to 1.7 v. Weight 21 lbs. Fine value, heavily made. Brand new. £15 0 (Carriage and packing, 3/-.)



### VOKES OIL FILTER

Heavy duty, suitable for all types of vehicles, launches, etc. 10/6 (Post and packing, 1/3.)

### FLEXATEX TUBING

Brand new in 14ft. 6in. lengths and ideal for fuel, oil, water, paint, etc. Outer cover of strong P.V.C. enclosing thick reinforcing spiral and bonded P.V.C. on canvas inner lining. 1 1/2 in., 1 3/4 in., 2 in. bores at 17/6, 21/- and 27/6 (carriage paid.)

### CHART BOARD

17in. square with hinged perspex sheet and elbowed parallel arm, giving complete coverage. Board strongly reinforced and the whole makes a fine, light portable drawing machine. 25/- (Post and packing, 1/3.)

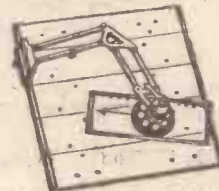

### AERO SPARES CO

(Dept. 215)

71, HIGH HOLBORN, LONDON W.C.1

Tel.: AMBassador 4856 (all depts.)

## WILKINSON'S OF CROYDON

**A.C. INDUCTION MOTORS.** Single phase. 1,425 r.p.m. All voltages. Ideal for workshop and industrial uses. Heavy duty. Silent running. No radio interference. 1/2 h.p., £6-5-5; 1 h.p., £6-15-8; 1 1/2 h.p., £8-7-0 Carr. & pkg., 10/-

**CONTACTOR UNIT.** A precision clock movement 3 1/2 in. x 2 1/2 in. mounted on a 3-stage filter used for sending impulses by means of a switch operated by the escapement. This valuable instrument is fitted in a sound-proof case; 12 or 24 volts; With thermostatic control of heater to maintain constant temperature. Brand new, 15/8.

**THERMOSTAT SWITCH.** Bimetal type in sealed glass tube, 2 1/2 in. x 1/2 in. 30 deg. cent. 5/- each.

**MICROAMMETER.** Full scale deflection 25 microamps, scaled 0-500. Dial 2 1/2". 57/6 Post free.

**MICROPHONE and HEADPHONE SET.** Moving coil with switch. 7/6.

**GOODMAN SPEAKERS** in wall case with transformer. 21/-.

**ROOM THERMOSTAT.** Adjustable 45 to 75 Fahrenheit. 42/6 each.

**THERMOSTAT.** Satchwell 12in. stem. 0.250 volts A.C. D.C. 10 to 90 deg. cent. 35/-.

**24 VOLT MOTOR** with reduction gear and cam-operated switches suitable for Model Work. 15/6.

**COCK PIT LAMPS** with obscured domed glass for S.B.C. Bulbs. Brand new with switch. Diam. 3in. 5/- each.

**VOLTMETERS.** 0/300 A.C. Moving Iron. 2 1/2 in. flush. 17/6 each. 0/15 vt. 15/-.

**TELEPHONE SETS** at a fraction of their original cost, will operate up to 5 miles, suitable for office, garage, farm, etc. Complete with calling buzzer, batteries, etc. 37/6 per set. 75/- per pair.

**HIGH SPEED RECORDER.** Marconi type UG9 with Klaxon geared Motor 220/240 volts. 80 r.p.m. variable resistance. Westinghouse Rectifier type HT15, etc. £5-5-0.

Complete List of Electrical and Radio Goods available. 4d.

L. WILKINSON

204, Lower Addiscombe Road Croydon



# “THE MODEL ENGINEER” EXHIBITION

AUGUST 17th — 27th 1949

*Special Attractions include:*

Enlarged competition section showing the year's best models • Fully equipped workshop carrying out a daily programme of work • Model cars, boats, and aircraft in action on the circular track • Radio controlled models • Working model railways with full scenic effects • Steam traction engines of all types operated under working conditions • Two passenger-carrying model railways.

**NEW ROYAL HORTICULTURAL HALL, WESTMINSTER, LONDON.**

Admission 2s. 3d. (inc. tax). Children under 14, 1s. Weekdays 11 a.m. (12 noon Aug. 17)—9 p.m.

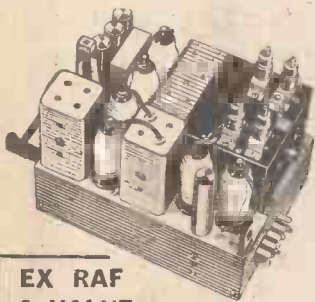

**EX RAF 6 VALVE SUPERHET** *With Valves* **29/6**  
Easily converted to Broadcast Receiver. 2/6 Post & Pckng. Complete with valves. Full circuits and modification details—2/3. Above set, less valves, 10/- post free.

**EX-RAF ALTIMETER** contains Aneroid Barometer Movement. **5/6** Plus 9d. Post & Pkg.

**12 ASSORTED MAGNETIC RELAYS** for experimental purposes. Post free. **12/9**

**NUTS, BOLTS, WASHERS,** small sizes for model making. Three gross assorted. **7/6**

**MIDGET TYPE GLASS PRISM,** beautifully ground, per pair. **1/6**

**EX-GOV. UNIVERSAL POWER PACK,** giving 120v. H.T. 7v. L.T.; ideal as an eliminator and trickle charger. Can be used on any voltage between 90-250v. A.C./D.C. **41/-** post free.

**SEALED GLASS TYPE THERMOSTATIC SWITCH** Breaks automatically at 86 deg. Fah. Post Free. **3/6**

Write (Dept. K)  
**INSTRUMENT CO.**  
244 HARROW ROAD, LONDON, W.2

## HIGH FIDELITY REPRODUCTION



TYPE 'K'

**S. G. BROWN, Type 'K'**

Moving-Coil Headphones supply that High Fidelity Reproduction demanded for DX work, monitoring and laboratory purposes, etc.

### OUTSTANDING CHARACTERISTICS

D.C. RESISTANCE 47 Ohms.  
IMPEDANCE 52 Ohms at 1,000 c.p.s.  
SENSITIVITY, 1.2 x 10<sup>-12</sup> watts at 1 kc. .0002 Dynelcm<sup>2</sup>.

PRICE **£5.5.0** PER PAIR  
Descriptive Literature on request.

Your local dealer can supply.

★ For details of other S. G. Brown Headphones (prices from 30/- to 77/6) write for illustrated Brochure "P.M."

**S.G. Brown, Ltd.**

Telephone: Watford 7241

SHAKESPEARE STREET, WATFORD, HERTS

## The Modelcraft PLANBOOKS

**MODEL OIL ENGINE** 2/2 POST FREE

An entirely new model engineering technique has been evolved for making this model. Only tools that are in every home and materials that are always to hand are needed. The model runs on air.

**MAKE-A-CLOCK** 3/9 POST FREE

Most people would tell you that an "ordinary man," without fine tools and much skill and experience can't make a clock. Well, the "Flipclock" is different! Many have been made on the kitchen table with the help of this plan book.

**A SIMPLE MODEL LOOM** 2/8 POST FREE

There is something deeply satisfying in handling a device you have made yourself which also does something. Ties, scarves, table mats, etc. can be made on this perfect little working model.

**BUILDING A GALLEON** 13/- POST FREE

This book has become a classic and is now known to modelmakers the world over. Plans for the Golden Hind, the ship in which Drake sailed round the world, are included.

★ Many other planbooks are included in the Modelcraft Complete List for 1949, which, for 1/- post free or from your model shop, lists over 600 items of vital interest to modelmakers.

**MODEL CRAFT LTD.**  
77(L), Grosvenor Rd., London, S.W.1.

# FREE! TO AMBITIOUS ENGINEERS

## This enlarged and entirely new edition of the valuable Handbook "ENGINEERING OPPORTUNITIES"

For 21 years this unique book has been a guiding light to Engineers all over the world. More than 1,000,000 copies have been distributed . . . there have been 104 editions. Still the demand continues! After months of research, we have been able to produce a better and even bigger "ENGINEERING OPPORTUNITIES" packed from cover to cover with vital, up-to-the-minute information that every engineer requires—information *you* must have if you want rapid promotion, higher pay, and one of the many worth-while appointments open to technically trained men.

### 176 PAGES OF PRACTICAL GUIDANCE

"ENGINEERING OPPORTUNITIES" explains the modern, quick way of preparing in your spare time for recognised engineering examinations, outlines hundreds of examination and non-examination courses in all branches of Engineering, describes the benefits of our Employment Dept., and enables you to visualise a secure, better paid and more important position for yourself.

### We definitely Guarantee "NO PASS—NO FEE"

B.I.E.T. has helped thousands of ambitious men. We can and will help you. It will cost you no more than a stamp to inquire, and in any case "ENGINEERING OPPORTUNITIES" is well worth having. It will reveal many opportunities you are now missing and, if you are earning less than £10 a week, will be of special interest to you. Make sure of your FREE copy by posting the coupon now.

#### POST THIS COUPON TODAY!

(Write if you prefer not to cut page)

Please send me FREE and entirely without obligation a copy of the new and enlarged edition of "ENGINEERING OPPORTUNITIES."

NAME .....

ADDRESS .....

I am interested in .....

(State subject, exam., or type of appointment that appeals to you.)

BRITISH INSTITUTE OF ENGINEERING TECHNOLOGY  
410A Shakespeare House, 17-19 Stratford Place, London, W.1

#### WHICH IS YOUR SUBJECT?

##### Mechanical Engineering

A.M.I.Mech.E.—CITY & GUILDS—General Mechanical Eng.—Maintenance Eng.—Diesel Eng.—Sheet Metal Work—Welding—Metallurgy—Machine Drawing & Design—Refrigeration, etc.

##### Electrical Engineering

A.M.I.E.E.—CITY & GUILDS—General Electrical Eng.—Installations—Illuminating Eng.—Electrical Science—Electricity Supply—Meters & Measuring Instruments—Mains Eng., etc.

##### Radio & Television

A.M.Brit.I.R.E.—SERVICING—CERTIFICATE—C. & G. Telecommunications—General Radio Eng.—Radio Servicing—Television Servicing—Sound Film Projection—Electronic Eng., etc.

##### Production Engineering

A.M.I.P.E.—Works Management—Foremanship—Staff Supervision—Planning Eng.—Costing, etc.

##### Automobile Engineering

A.M.I.M.I.—CITY & GUILDS—General Automobile Eng.—Automobile Repairs—High Speed Diesels—Garage Management, etc.

##### Building & Civil Engineering

A.M.I.C.E.—F.R.I.C.S.—L.I.O.B.—General Building—Architectural Drawing—Sanitary Eng.—General Civil Eng.—Surveying—Specifications & Quantities—Heating & Ventilating—Painting & Decorating—Plumbing—Carpentry & Joinery—Timber Technology, etc.

PLASTICS—DRAUGHTSMANSHIP—AERONAUTICAL ENG.—FORESTRY

##### SOME LETTERS AFTER YOUR NAME

A.M.I.Mech.E. A.M.I.E.E. A.M.I.C.E.  
F.R.I.C.S. A.M.I.Struct.E. L.I.O.B.  
A.M.Brit.I.R.E. A.F.R.Ac.S. A.M.I.P.E.

HUNDREDS OF OTHER COURSES

(Tell us what interests you)

# BIET

THE B.I.E.T. IS THE LEADING INSTITUTE OF ITS KIND IN THE WORLD



# PRACTICAL MECHANICS

Owing to the paper shortage "The Cyclist," "Practical Motorist," and "Home Movies" are temporarily incorporated.

Editor: F. J. CAMM

VOL. XVI

AUGUST, 1949

No. 190

## FAIR COMMENT

By THE EDITOR

### The Novelty of Patents

THE death of Mrs. Charles Kingston Welch recently and the celebration of the diamond jubilee of the marketing of the pneumatic tyre remind me of a curious position in patent law disclosed soon after the pneumatic tyre was launched on the market.

Dunlop had patented his tyre in 1888, and it had not been on the market very long before it was discovered that R. W. Thompson had patented substantially the same idea in 1845. Thompson's pneumatic tyre was in connection with horse-drawn carriage wheels, and they were actually marketed and sold as a commercial product for a number of years. They did not, however, catch on, and they finally disappeared from the market.

Some may wonder how it was that with only one other patent for air tyres on file at the Patent Office it was possible for Dunlop to obtain a patent without Thompson's patent being discovered by the examiners.

The fact is that at that time an inventor did not have to prove originality, nor did the Patent Office make a search. Thus it was possible for several people to patent the same idea and they were left by means of litigation to sort out in the Law Courts who was the true and real first inventor. In fact, unscrupulous people took full advantage of this loop-hole in the Patent Law, and a poor inventor aggrieved by this flagrant infringement had little redress unless he could find the thousands of pounds necessary to fight a powerful company.

### Change in Patent Law

It was the seriousness of the position disclosed by the Dunlop imbroglio that virtually caused a change in the patent law. For, of course, the Dunlop patent was proved to be worthless. It was the addition of the wired-edge to pneumatic tyres, plus the fitting of the Wood's valve-rubber valve which fortified the position of the Dunlop Rubber Co. The wired-edge tyre fitted to Westwood-type rims was the invention of Charles Kingston Welch, and Harvey du Cros, the founder of the Dunlop Rubber Co., who bought up the Welch and the Wood's patent which, for practical purposes, gained patents of addition to the Dunlop patent.

To-day an inventor states his claims and a very rigid search is conducted by the Patent Office examiners before a patent is granted. If any of the claims have been anticipated in prior patents such claims must be struck out, or a disclaimer inserted.

Even so, occasionally a patent is granted to-day which is later found to be invalid. It is not possible to sue the Patent Office for negligence. The invalidation of a patent can place a company in a serious financial position. It launches its business upon what it considers to be a hall-mark of originality, namely, the granting of Letters Patent. A

patent can be contested in the Law Courts and set aside, and this has often been done.

So when the Patent Law was changed it did not go quite far enough. A patent should be allowed to lie open for a much longer period before the grant is made to allow possible contestants to state the basis of their opposition. Failure to do so within the specified time should disqualify them from further action. The pending changes in patent law and procedure, which I explained in a previous issue, will go a long way towards eliminating some of the anomalies to which I have referred.

### Whitworth Scholarships

DETAILS of the Whitworth scholarships in engineering to be offered for competition in 1950 were recently announced by the Ministry of Education.

Two senior scholarships and five scholarships will be available for candidates of British nationality who are not more than 26 years of age. They are required to have had practical experience in engineering before taking up an award.

Whitworth senior scholarships are for candidates who possess an engineering degree or a higher national certificate with two distinctions, or are in the last year of a course leading to one of these qualifications. The annual value of the awards is £325, and they will be tenable for two years for a course of further training in industry or for research work. Candidates are required to submit a thesis on one of a number of specified subjects.

Whitworth scholarships are for students whose further education has been limited to evening classes. Their annual value is £200, though this amount may be increased, depending on the cost of the course and the means of the holder. They are tenable for three years either in industry or at an educational establishment. They will be awarded on the results of the Whitworth Scholarships Examination to be held in April, 1950.

Further details of the awards may be obtained from heads of colleges of further education or from the Ministry of Education, Curzon Street, London, W.1. The closing date for the competition is January 15th, 1950.

### New British Diesel Locomotive

THE interesting news is announced by the Railway Executive that there is now under construction at the Derby Locomotive Works a new type of main line diesel locomotive, in which the power from the engines is transmitted mechanically to the driving wheels instead of being electrically transmitted as in the majority of other existing main line diesel-driven locomotives.

The locomotive will be operated by four engines, each capable of developing 500 h.p. It will have two driving cabs, so that it can be driven from either end, and a 4-8-4 wheel arrangement.

By comparison with comparable diesel locomotives, the new locomotive will be lighter in weight and the power losses in transmission will be less.

The locomotive is expected to be ready for trials in the early part of next year. It has been numbered 10,100, and will have a maximum speed of 84 m.p.h.

Due to the comparatively light load on the axles, the locomotive will be able to run over most main line routes and will be readily adapted for a wide range of duties from heavy goods to high speed express passenger services.

The locomotive is being constructed to the design of Mr. H. G. Ivatt, chief mechanical engineer, London Midland Region, in collaboration with the Fell Developments, Ltd., and Ricardo and Co.

The system of transmission, as well as various ancillary features, have been patented by the inventor, Lieut.-Colonel L. F. R. Fell.

### SUBSCRIPTION RATES

including postage for one year

Inland	- - -	10s. 6d. per annum.
Abroad	- - -	10s. 6d. per annum.
Canada	- - -	10s. per annum.

Editorial and Advertisement Office: "Practical Mechanics," George Newnes, Ltd., Tower House, Southampton Street, Strand, W.C.2  
Phone: Temple Bar 4363

Telegrams: Newnes, Rand, London.  
Registered at the G.P.O. for transmission by Canadian Magazine Post.

Copyright in all drawings, photographs and articles published in "Practical Mechanics" is specially reserved throughout the countries signatory to the Berne Convention and the U.S.A. Reproductions or imitations of any of these are therefore expressly forbidden.

### NOTICE TO INTENDING CONTRIBUTORS

THE EDITOR OF PRACTICAL MECHANICS is always pleased to consider manuscripts suitable for publication in the columns of this journal. As a general guide, articles should be about 1,200 words in length, although where the subject warrants it, the article may be extended to 2,000 words. Short articles of 500 to 750 words are also accepted.

To avoid the possibility of overlapping, intending contributors are advised to write in the first instance to the Editor, giving a brief outline of the article they intend to write, and at the same time enclosing details of their qualifications.

MSS. should be typewritten, using one side of the paper only, and double spacing. Preferential consideration will be given to those MSS. which are accompanied by sketches and/or photographs, and these should be properly captioned.

The Editor does not hold himself responsible for the safe custody of manuscripts, but every effort will be made to return unaccepted contributions, if a stamped and addressed envelope is enclosed. All correspondence intended for the Editor should be addressed: The Editor, PRACTICAL MECHANICS, Tower House, Southampton Street, Strand, W.C.2.

# Altitude Testing Chambers

Technical Details and Operating Notes

By H. E. HATTER, A.M.I.E.E.

**T**HE problems of high altitude flight are of great importance in connection with military aviation and can be divided into two spheres, man and machines. The man problem has been overcome in commercial aviation by the use of pressurised cabins, but this solution is not applicable to single-seater and other machines too small to allow pressurised cabins.

At 20,000ft. the pressure of the oxygen in the air is less than half that at sea level, and so a smaller amount is absorbed at each breath and, further, the oxygen is not so efficiently absorbed through the lining of the lungs. The cold at high altitudes—67 degs. Fahr. at 35,000ft.—can be overcome by heated clothing, but the limit as regards oxygen in the air is assumed at about 18,000ft. to 20,000ft., above which consciousness is lost. The modern oxygen mask under the control of the wearer at all times and fitting closely around the mouth and nose has overcome this particular trouble.

high degree of efficiency and instrumentation.

## Low Temperature Effects on Materials

The effect of low temperatures on some materials is remarkable. Ordinary rubber will shatter on impact and some metals will become as brittle as glass, while the difference in coefficients of expansion can cause endless trouble. Apparatus made with similar metals in close fit may be subject to ambient temperatures of over 100 degs. on the ground, and at temperatures of -60 degs. and below the difference in their diameters may

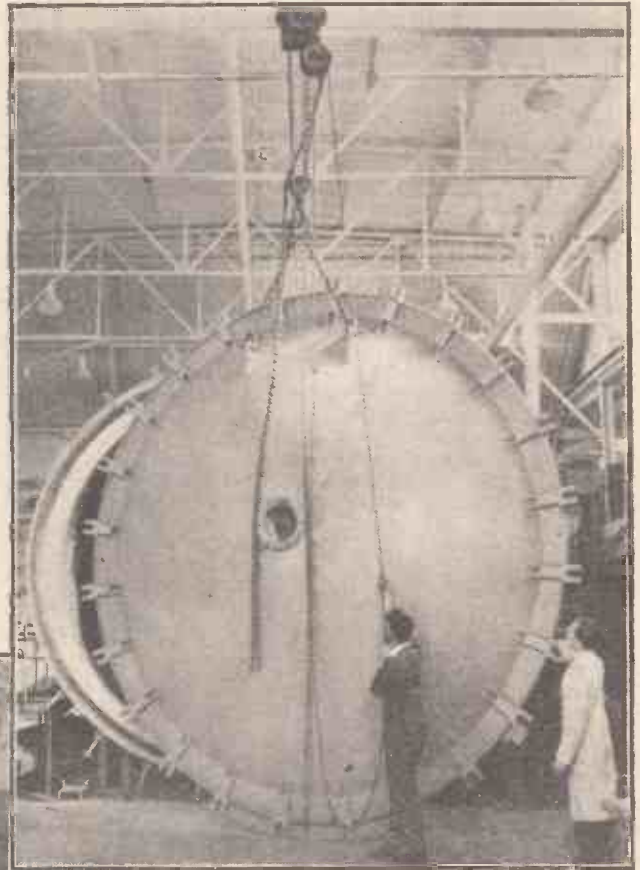

Fig. 2.—Main door of chamber.

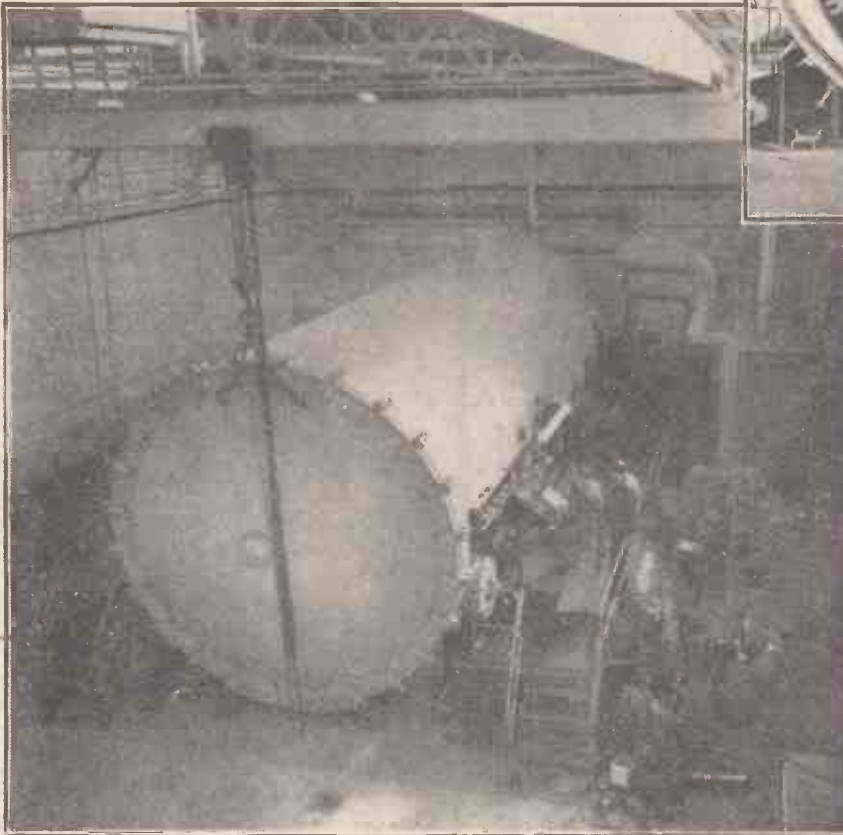

Fig. 1.—General view of De Havilland testing chamber.

Investigations covering both man and machine can be carried out by actual flights, a method most expensive as regards time and money. The obvious solution to this is the testing at ground level in a suitable chamber where temperatures and pressures can be varied at will. The first tests were made a very long time ago, and much development work has been required to bring the modern altitude chamber to its present

change to such an extent that vital parts of gun-turrets, etc., may seize solid.

Lubricating oils and hydraulic fluids may be equally subjected to such temperature changes with considerable effects on their viscosities to such an extent that they are useless at high altitudes, and very extensive research work has been needed to enable suitable grades to be produced for use in aircraft under any conditions.

Electrical equipment suffers in a similar way, greater clearances having to be provided to prevent sparking over and corona discharge in the rare air, heavy insulation being frequently required. In the case of electrical machines excessive wear of brushes has been found to be due to the extreme dryness of the air. Normally the moisture in the air would appear to act as a lubricant and reduce this wear. Many other problems can be tackled in suitable equipment chambers, such as icing and fogging of windows, seals for pressurised aircraft and also super-charging problems.

## De Havilland Altitude Testing Chamber

A very fine high altitude testing chamber in this country is that built by the De Havilland Aircraft Co., which is capable of being evacuated to a pressure equivalent to that of operating at 80,000ft., while the internal temperature can be controlled within the limits of +40 degs. C. and -70 degs. C.

A general view of the complete equipment can be seen in Fig. 1, and to give a better indication of the size of it Fig. 2 shows the large door being placed in position. The overall length is 35ft. and the diameter 14ft., but the internal dimensions are only 12ft., the other being lagging. One end of the chamber is provided with a suitable air-lock to allow men to enter or leave the chamber without loss of pressure, while to permit large fuselage to be inserted the other end of the chamber is completely removed, as shown in Fig. 2.

As can be seen from Fig. 1, a number of men are engaged when a test has to take place. Full recording and control of all gear is actually carried out from the control

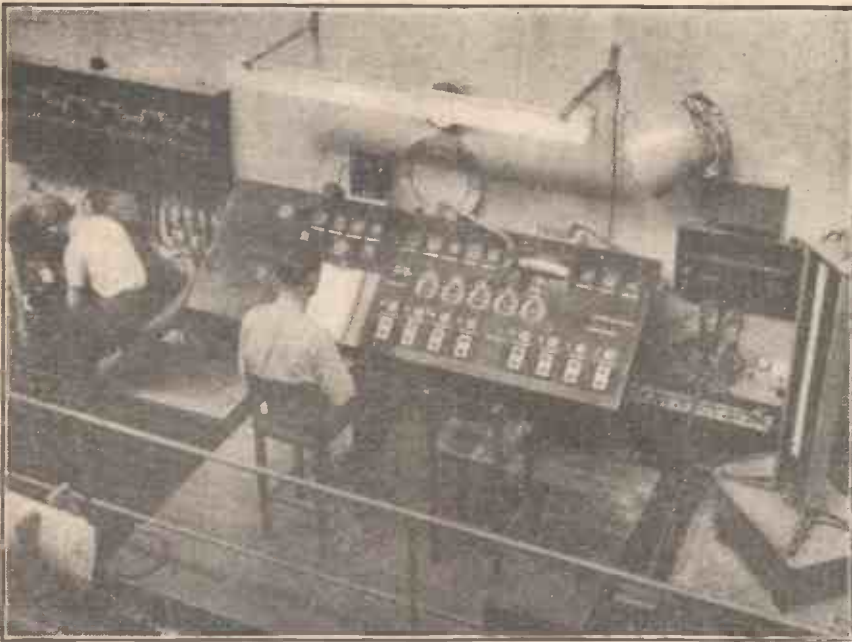

Fig. 3.—The control desk of the De Havilland altitude testing chamber. Note the pipe entry gland in the right-hand corner.

desk, shown in Fig. 3, and this permits operation of all the valves for the refrigeration and vacuum systems to be worked by push-buttons, while indicating lights and instruments show pressure, rate of climb, temperatures, etc. A further detachable unit incorporates instruments which may be required for one particular test only. Communication between the operators inside of the cabin and outside is done by means of loudspeaker equipment and, should an emergency arise, the internal operators have priority over any communication.

A large number of components have to enter into the chamber, and for this purpose a special entry panel—the position of which can be seen in Fig. 3, and which is shown in more detail in Fig. 4—is provided. This enables electrical connections, oxygen piping and other required services to be passed into

the chamber. Full provision is also made inside for connections for the operators: electrically heated clothing, oxygen supply and intercommunicating telephone system. A 24-volt DC supply is also provided to enable aircraft units to be tested under operating conditions.

**Insulation**

The insulation of the chamber is carried out by fitting a wooden framework to provide a support for the thick kapok lining, the whole insulation then being faced with cedar

wood boarding. The refrigeration system adopted is not mechanical, but employs solid CO<sub>2</sub>, a method widely employed in the United States with great success. In this system methylated spirit is sprayed over crushed, solid CO<sub>2</sub> which is contained in a large insulated cooling tank; this tank is shown in Fig. 5 with the CO<sub>2</sub> crusher unit mounted above it. At the bottom of the tank is a sump containing the cooled methylated spirit. Circulation of the spirit is from the bottom of this tank, through a gilled cooler inside of the chamber and back again to the top of the cooling chamber. The air inside of the chamber is circulated at the rate of 31,000ft. per min. over these two coolers. Sufficient allowance has been made so that the chamber can be cooled to -60 degs. C. in 80 mins. and at the same time allow a dissipation of 80,000

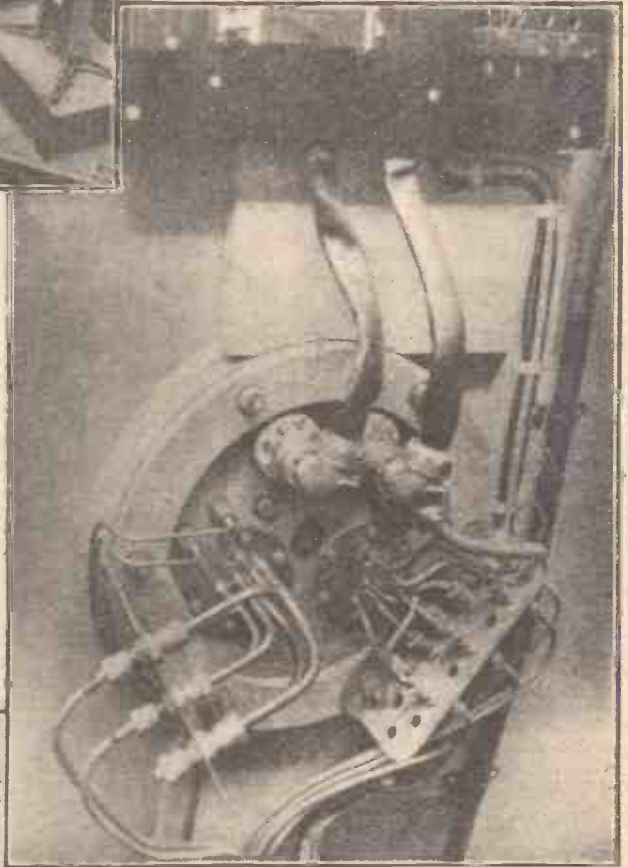

Fig. 4.—Pipe entry gland which enables electrical connections, etc., to be passed into the chamber.

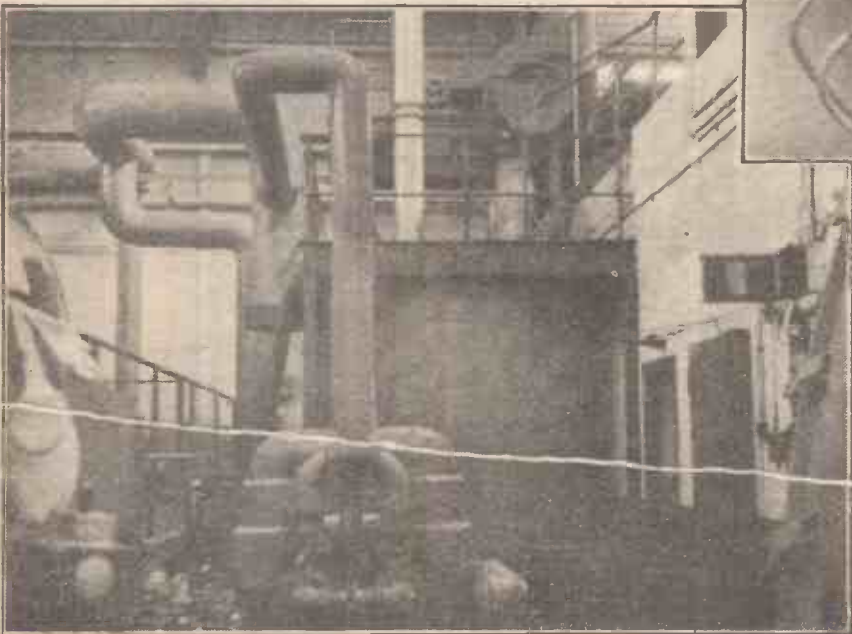

Fig. 5.—The refrigerating unit, showing the large insulated cooling tank, with the CO<sub>2</sub> crusher unit mounted immediately above it. The tank contains the crushed solid CO<sub>2</sub> over which methylated spirit is sprayed.

BTU. Intermediate temperatures are obtained by controlling the rate of circulation of the spirit.

A considerable source of trouble in these tests is the excessive formation of ice, and to overcome this, air which is allowed to enter the chamber is first passed over a cooler so that sufficient dehumidification is obtained to prevent excessive icing up. To simulate the tropical conditions steam heaters are provided over which the air is circulated by the fans previously mentioned.

The artificial simulation of altitude is obtained by the use of a double-acting vacuum pump with the capacity of 2,000ft. per min. Control of this degree of vacuum is obtained by double sets of mechanically operated valves giving fine and course adjustment. By prior setting of these any degree of rate of climb can be easily obtained. Reduction back to atmospheric pressure is obtained by allowing filtered air to re-enter at the required rate to simulate diving conditions.

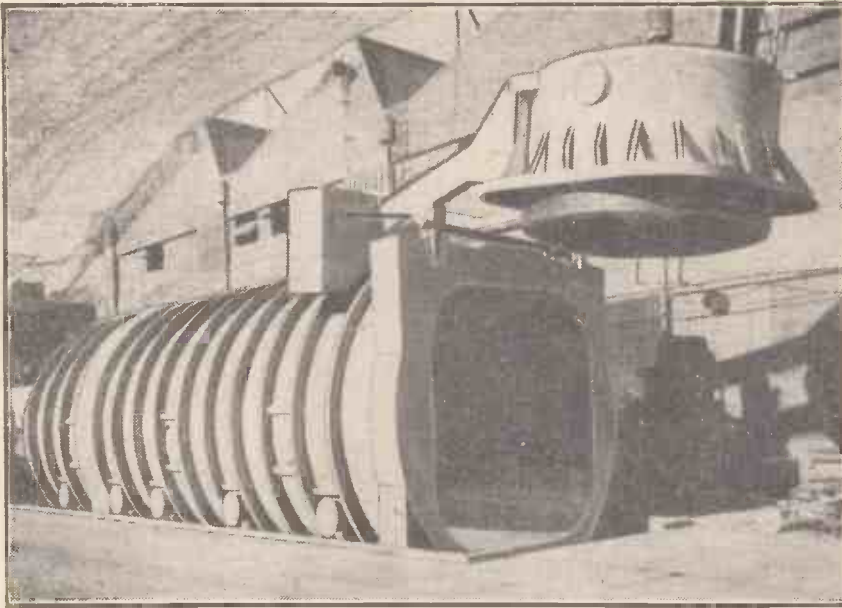

Fig. 6.—General view of the North American chamber.

### Largest Altitude Chamber

What would appear to be the largest altitude chamber at present in existence is that built by the North American Aviation Co. and in operation in 1946. The chamber as finally constructed was made of steel plate, but considerable investigation was made first as to the use of reinforced concrete. The doubts as to the reliability of this material when subjected to severe changes of temperature, combined with vacuum conditions, forced the final decision in the use of steel.

The overall dimensions of the unit are very large, the shell being 17ft. diameter by 53ft. long, built up of  $\frac{1}{2}$ in. plate with external stiffening at frequent intervals, additional reinforcements provided at the point of support. An idea of the overall dimensions can be obtained from Fig. 6, which shows the main door in open position.

The equipment associated with this chamber was designed to permit dive tests at the rate of 7,500 ft. per min., with an auxiliary arrangement to permit a reduction at the rate of 20,000 ft. per min. Should any of the operators be in difficulties the ceiling limit was set at 60,000ft., equivalent to a vacuum of 27.8in. A temperature range was fixed at  $-100$  deg. F. with a top limit of  $+200$  deg. F. this gave a considerable margin for any future developments. Due to the wide range of temperatures permitted this would appear to be one of the few chambers in which provision has been made for humidity control, and desert conditions can be reproduced as easily as fogs. Artificial conditions of snow and sleet can also be provided.

As much work will be done on pressurisation of cabins, air for the pressurising and heating is provided by atmospheric air, which is filtered, dehumidified by refrigeration, compressed in a special compressor free of water and oil, and finally passed to a receiver in which the required conditions can be obtained.

### Refrigeration

The method of refrigeration adopted in this chamber is the same as in the previously mentioned unit, with the exception that methyl alcohol is used instead of methylated spirit.

The liquid from the refrigeration system is passed to cooling coils which are mounted above and below the fan. The total face area of 47 sq. ft. was based on the design

requirements of a capacity of 500,000 BTU per hour when cooling 3,500 lb. of air per min. from  $-90$  degs.F. to  $-100$  degs.F. Inside of each heat exchanger is mounted a battery of electric heaters, there being a total of 18-36 kW units, permitting a total maximum heating rate of 736,000 BTU per hour.

The high rate of circulation of air over the heat exchanger was essential to maintain uniform conditions throughout the chamber when holding a fixed temperature. Further provision is made by means of ducting from the fan outlet for delivery of 10,000 cu.ft. per min. at a suitable pressure for icing and heat exchanger tests. Over a very small area an air velocity of 150 m.p.h. can be obtained.

The main door into the chamber is 12ft. square in the form of a large box, and this is shown in more detail in Fig. 7. Inside of this box construction are two smaller doors, one of which can be seen as an opening, and these form an air-lock for entering the chamber. The door is pivoted, as seen in Fig. 6, and the counterweight shown there is a 15 ton steel block. Opening and closing of this main door is done by means of a geared motor, rubber sealing being adopted to make the face airtight. The windows, of which there are a number along each side, consist of six panes of glass, the inner pane being  $\frac{1}{2}$ in. thick of safety glass with five others  $\frac{1}{4}$ in. thick with  $\frac{1}{4}$ in. spacing in which is contained a dessicant.

### Vacuum Pump

A reciprocating pump of 100 h.p. is provided for the production of the required vacuum and has a displacement of nearly 3,000 cu.ft. per min., which may be compared with the 8,600 cu.ft. volume of the chamber. The fan is of the double inlet centrifugal type driven by a 150 h.p. motor, and has a

maximum capacity of 49,000 cu.ft. per min. The double inlets serve to connect to the two ducts which are formed one by the floor and the other by the ceiling. Each duct is large enough to give a 9 sq. ft. area. Due to the large internal volume and the very rapid circulation of air there exists a considerable danger from fire because of the large amount of combustible cork used in insulating, and to protect against this a complete  $\text{CO}_2$  fire extinguisher installation of the automatic type is fitted inside.

While both these chambers described have been of large size there is a considerable field for small units used for testing instruments and smaller components. Some of these are simple refrigeration equipments to provide varying degrees of cold, while others are

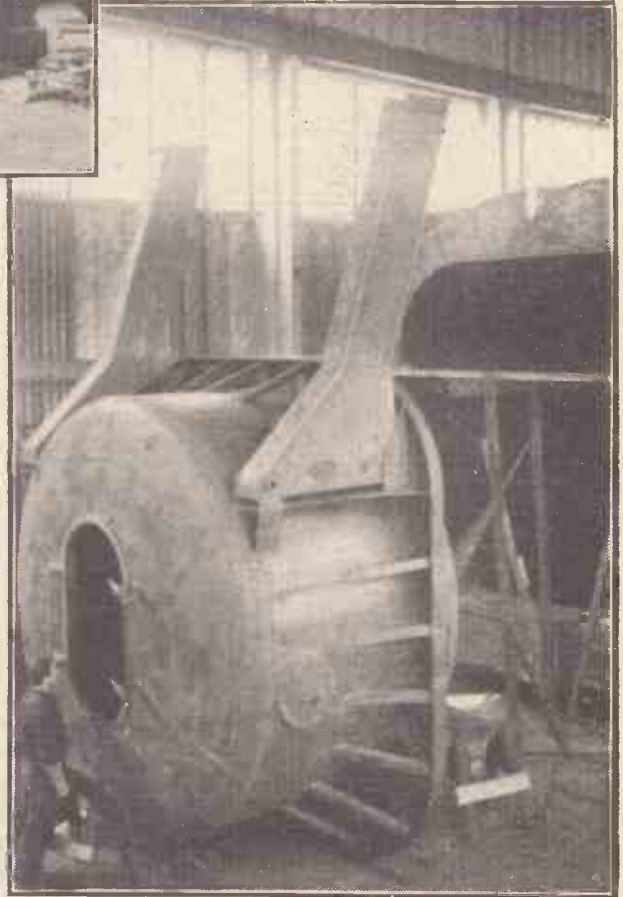

Fig. 7.—Door and air-lock unit for the testing chamber shown in Fig. 6.

small chambers of 2 or more cu. ft. in which varying degrees of cold, heat and humidity can be obtained within fairly close limits. It should be mentioned that in some cases it is much more difficult to obtain satisfactory control of humidity and temperature combined in a small chamber than it is with a much larger unit, due to the minute amount of water which has to be provided to raise the humidity because of the limited amount of air present.

## REFRESHER COURSE IN MATHEMATICS

By F. J. CAMM.

8/6, by post 9/-

2nd Article of a New Series

# MODEL ENGINEERING PRACTICE

by J. J. Camm

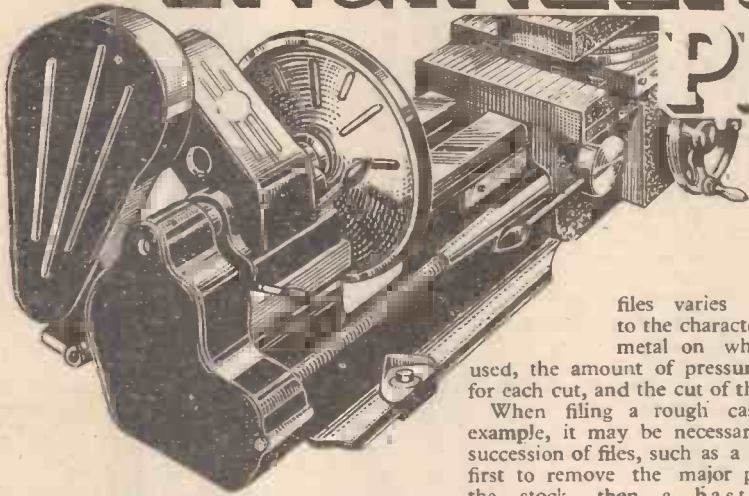

## II.—BENCH TOOLS

files varies according to the character of the metal on which it is used, the amount of pressure exerted for each cut, and the cut of the teeth. When filing a rough casting, for example, it may be necessary to use a succession of files, such as a rough file first to remove the major portion of the stock, then a bastard file,

ready for filing. There is a correct file for every class of work.

Each type of file is generally supplied in four different cuts, namely, bastard, second cut, smooth, and dead smooth. There are also rough and middle cuts, but these are less frequently used.

Special handles are available for files and it is important to see, whatever handle is used, that the tang is well driven into or gripped by the handle. A loose handle can cause injury if when using it comes off, and the tang is driven into the palm of the hand with the full force used to thrust the file.

**B**EFORE explaining workshop processes it is necessary to deal with the tools mentioned in the previous article. The commonest of all the workshop tools is the file, and these are made in a variety of sizes, shapes and cuts to suit various purposes. The usual shapes are flat, hand, knife-edge, square, round, rat-tailed, triangular or three-square, half-round and rifflers. Additionally, there are very fine Swiss files, so fine indeed that they do not appear to have teeth. These are used for extremely fine cuts and for giving a burnished finish.

### Types of Files and Cuts

The ordering of files requires attention. Do not confuse a bastard file with a rough file. They are two distinct types, the rough file having about five teeth an inch fewer than the bastard type file. Also do not confuse flat files with hand files. Files for brass are of a different cut from those used for steel. All files are made in varying lengths, so when ordering keep this point in mind. A 6in. file, for example, would be almost useless for filing a large surface, say, one more than 2in. wide. The nature of the work to be undertaken must decide the lengths, the quantity and the type of files. A small selection is useful to start with, adding to them as the work progresses. Do not make the mistake of using one file for all metals, for tests have shown that the work done by

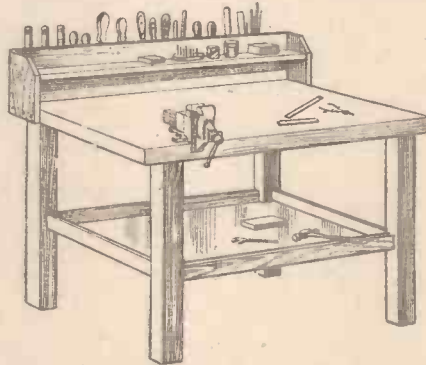

Fig. 1.—Typical model engineer's work bench. It should be of such height that the elbow with the arm bent just touches the top of the vice. A drawer for tools is an advantage.

### Filing Faults

One of the first faults encountered in filing is the dragging of the file blade backwards over the metal on the return stroke, with the exertion of filing pressure. This is as bad as to run a circular saw the wrong way round. Filing should always be done forward, never backward. It is often difficult to convince the beginner, and sometimes even the experienced man, of the weakness of this practice of filing on the return stroke. The reason is probably that the large number of teeth on a file blade make the occasional fracture of one or two of them appear insignificant. Nevertheless, it cannot be too strongly emphasised that every tooth of a file is valuable and does good work.

The next common failing is the leaving of the teeth without protection, when they are put away after use or purchase. Thrown into a tool bag or drawer, they are almost bound to come sooner or later into contact with hard metallic surfaces, and this will result in cracked or fractured teeth. Each tooth of a file has a part to play in efficient filing, and whenever a file tooth is broken or damaged, a point where no metal is cut is created. In consequence, not only will more time be needed to complete the work in hand, but also excess labour cost will be incurred. It must be remembered that it is not a matter of one tooth only. If these bad practices are

then a hand file and finally a smooth file. In some cases it may be necessary to use a hammer and cold chisel to chip away excrescences and roughly to level the surface

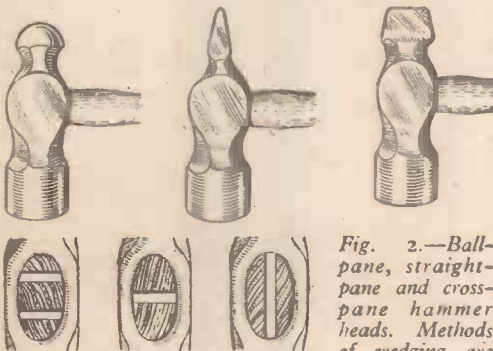

Fig. 2.—Ball-pane, straight-pane and cross-pane hammer heads. Methods of wedging are shown above. A handle wedged as on the right soon works loose. Methods shown at the centre and left are best.

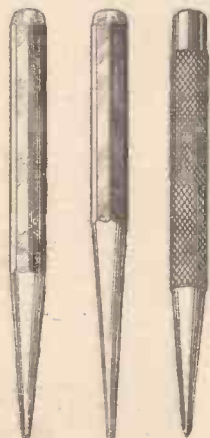

Fig. 3.—Three punches. Left, a round pin punch; centre, a taper drift; and right, a centre punch. Automatic centre punches which do not need the use of a hammer are available.

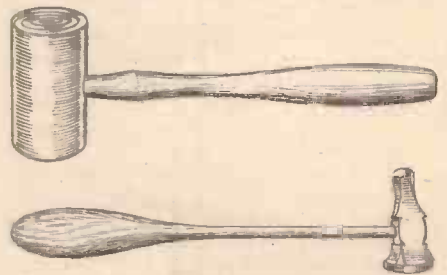

Fig. 4.—Above, a raw hide hammer, used on polished or finished parts to avoid marking. Below; a repossé hammer.

indulged in, a tooth or teeth will go on each occasion, until soon the blade is but a jagged wreck of what it should be.

**Brushing the File Teeth**

It is always good practice to brush the file teeth carefully before the tool is placed aside at night or when its work is finished for the moment. Only a careless worker leaves his files with pieces of metal clogging all the teeth. To leave them in this condition means that their efficiency will be seriously impaired when next they are put to work. Pieces sticking to file teeth frequently cause pinning, resulting in deep scratches on the work. If there is no other means of preventing it, this can be reduced by thoroughly chalking the file, though in this condition it is hardly likely to cut so freely. If a brush will not serve to eliminate the filings from between the teeth, the best plan is to rap the edge of the file against the vice, which will probably shake out the majority. Otherwise, a piece of file carding will prove effective. When filing wrought iron and steel, the best plan is to employ a soft iron or copper scorer.

If the files become completely clogged with dirt and grease, a wire brush should be used. This comprises a wooden backing to which is affixed a piece or strip of file carding. In efficient workshops, drawers are provided in which files may be placed with some protective covering round them.

The majority of files in ordinary use are double cut, i.e., the teeth are serrated by a diagonal cutting. Only too often the novice uses a file too large or too small for his work. For example, he will use a medium size 6in. to 8in. in a medium cut or second cut, whereas it would be far better to buy a 10in. second cut and a 6in. smooth file. The first will enable him to eliminate metal rapidly, while the second will put a good finish on the work.

**Using a New File**

When a file is new, it is advisable not to bear too heavily upon it with each stroke, as this may lead to fracture of a number of teeth at their bases. The correct method is to file lightly until the fine points are worn down, after which a greater pressure can be exerted with the increasing bluntness of the teeth. If the file is pressed too heavily at the outset, it may be completely ruined. It is likewise bad practice to employ a brand new file on a weld, where borax or some vitreous flux has been used, and it is equally unwise to use it on the chilled and gritty skin of castings. It is more expedient to employ an already rather worn file for this work, so that the hard scale can be filed off, after which the new file can be employed to finish off.

The correct method is, in short, to remove the scale with an old file, then follow up with a bastard file for removing the main bulk of the material, and to finish up with a 2in. cut or smooth file, according to the degree of finish desired. Should it be necessary to end with a very fine finish, then a dead smooth file can be used.

As stated in the previous section, the right file should be chosen for the right material. Thus, a file that has been used

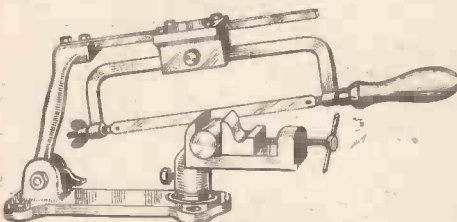

Fig. 7.—Hand-power machine hacksaw.

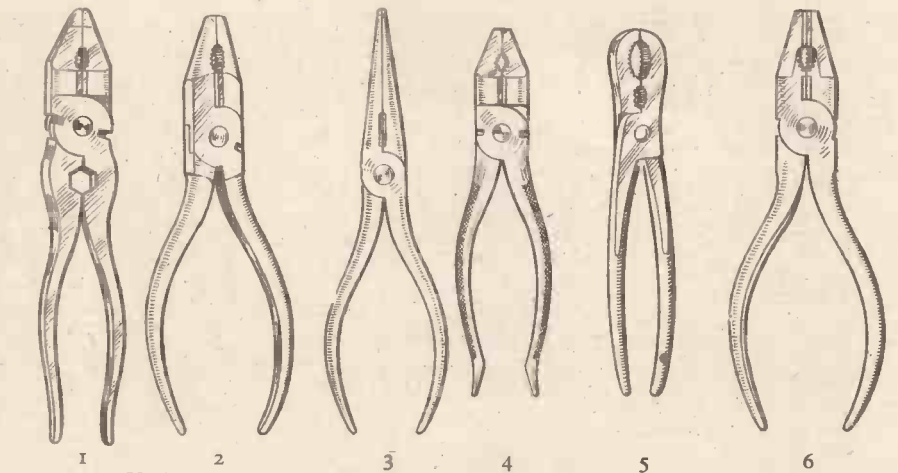

Fig. 5.—Various pliers. 1, side-cutting pliers; 2, round-nosed pliers; 3, long-nosed or snipe-nosed pliers; 4, taper-nosed pliers; 5, gas pliers; 6, another type of round-nosed pliers.

with complete success for iron and steel will not meet with the same success if used on brass. Steel is best filed with second-cut files rather than those with coarser teeth, while if, on occasion, an extra finish is

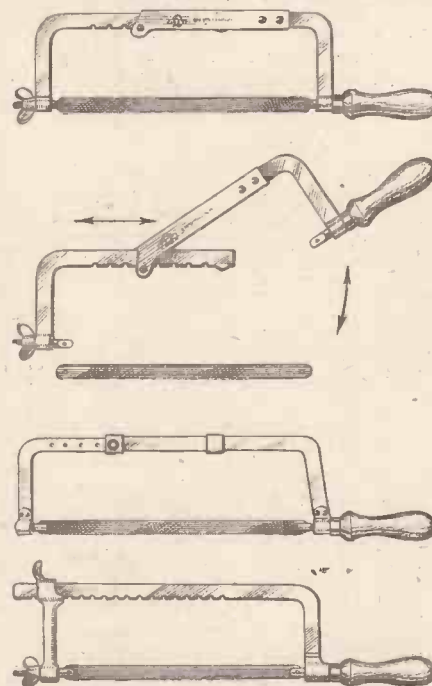

Fig. 6.—Hacksaws. Above, adjustable hacksaw frame; below, two other types.

desired, the finer cuts will be found indispensable.

**Milling File for Lathe Filing Work**

For normal lathe filing work, a milling file is the most satisfactory, and it is sound policy to retain this type of file specially for its own work, carefully cleaning it after each period of use. When good work is needed, it is bad practice to put a file that has been used for vicework on to lathe work, while the lathe file should not be used for vice work.

A standard bastard file is more economical, as a rule, than a wider bastard file for the majority of work for which a bastard file is used. With identical weight applied, it files off a greater quantity of metal in a given period.

The non-fibrous materials, such as brass and cast iron, call for a sharper file than do wrought iron and steel. In fact, the reader should note that there are files specially cut for operation on brass and other

non-ferrous metals. A sharper file is also advisable for a broad surface, less sharp serving for narrow surfaces. The new file should, therefore, be employed, in the first instance, for broad cuts on brass or cast iron, and then only on narrow surfaces of these metals, and on edges. No new file should be put to work on edges, because the teeth bite into the metal too quickly and firmly and may be wrenched off, thus damaging the tool.

The next use of the now somewhat worn file should be on steel, and it will give better results here, as stated, than a perfectly new file. When its life is coming to an end it can be put aside for use on removing sand and scale from castings and forgings, a job that would rapidly destroy new files without any improvement in results. The scale on these parts is extremely hard, and as a rule only a rough finish is needed. The edges of a flat file, rarely employed for anything else, will efficiently perform this work.

It has been stated that all filing should be done in the forward direction, but this does not mean that the worker must lift the file off the metal with every stroke, unless special files are being used. The principal point to watch is that as the file is drawn back for the return stroke, no pressure is exerted on it. The most effective work will be done on the forward stroke if the file is given a slight motion sideways, alternating to right and left with every few strokes.

**Correct Method of Holding a File**

One of the first things any beginner must learn is how to hold the file. Bad habits acquired early will take a great deal of eradication later, and will cause much waste of time and effort. The proper filing grip is attained in the following manner. Look for

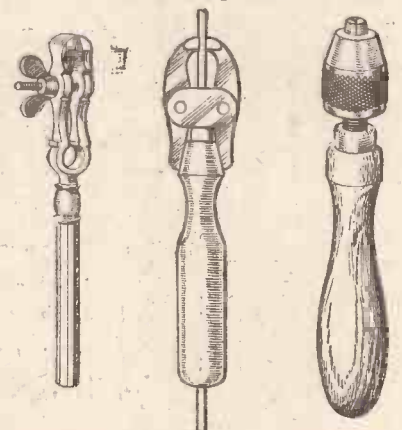

Fig. 8.—Pliers.

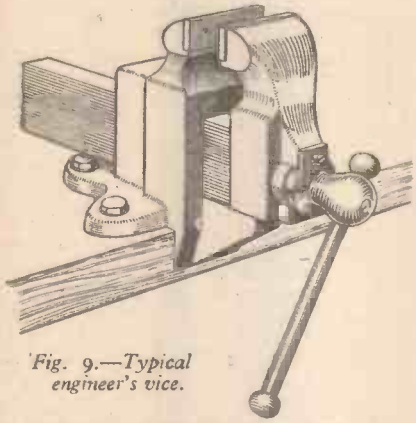

Fig. 9.—Typical engineer's vice.

the thick part of the file, allow it to rest on the work, with the first two fingers or the base of the thumb directly over the work. The handle is then grasped with the other hand, and filing begun. The hand resting on the work must not leave it either at the beginning or at the end of the stroke.

Files should be so gripped that the end of the handle fits into and rests against the fleshy part of the palm below the joint of the little finger, with the thumb lying along the top of the handle in the direction of its length and the finger-ends pointing upwards.

When the job to be filed is held in a vice, the height of the holder from the floor is important. As a rule, the vice jaws should be on a level with the elbow of the filer. A good average height is 42in. from the floor, and this will prove suitable for the majority of operators. If the work to be fitted is small and delicate, so that the filer need only move his arms slightly, or may need to move only one hand and arm, the vice should be higher. The reason is that this makes it possible for him to hold himself more erect, and also makes it easier for him to inspect the job. If, on the other hand, the work is heavy and bulky, calling for considerable exertion, its surface should be below the elbow joint. In this manner the weight of the body is brought to bear on the stroke of the file.

**Hack-saw Types**

The hack-saw is the only type of saw generally associated with metal working, but there is another type which is widely used for more delicate work, and especially when producing an ornamental finish in sheet metal. This is the piercing saw. The use of both types will be dealt with, but the hack-saw claims first attention.

If a saw of this type is to be bought there is a wide choice of patterns. As with all other tools, the higher-priced article is the better value if it is intended for hard and continuous use. A few of the principal pat-

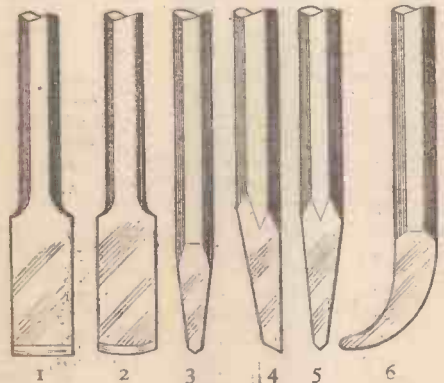

Fig. 12.—Types of chisel. 1, chisel for light chipping; 2, chisel for heavy chipping; 3, round-nosed chisel; 4, cape chisel; 5, diamond-point chisel; 6, chisel for working in close places.

terns are illustrated in Fig. 6, and of these the tubular one is generally considered the best, provided that it is of good make.

In nearly every case the frame is made adjustable in length, to receive blades from 8in. to 12in. long, and the different methods of adjustment will be evident from the illustrations. Besides the main length adjustment, provided by moving the two parts of the frame or by sliding the handle along the backbone of the frame, there is a wing nut or similar adjustment for altering the tension on the blade. A certain amount of experience is necessary to judge the most suitable tension, but in general the blade should be so taut that there is little tendency towards bending, and yet not so tight that slight twisting while sawing causes it to snap. This matter is regulated to a certain extent by the

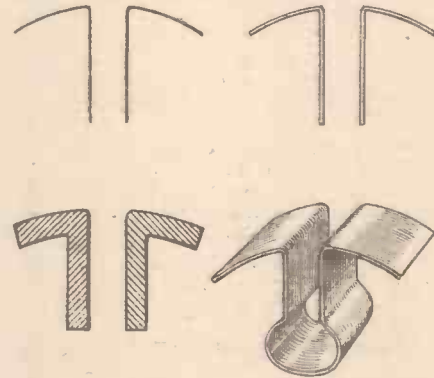

Fig. 10.—Soft vice jaws or clams, used to prevent the serrations between the vice jaws marking the work. Top left are made of tin or sheet iron; top right of 18-gauge sheet brass; bottom left, of thick brass or copper; bottom right, of spring steel.

type of blade in use; this point will receive more attention later.

**Hack-saw Blades**

Blades are generally made in three lengths: 8in., 10in., and 12in., and are of two principal types. One is hardened throughout the width, the other having hardened teeth and a soft back. Alternatively, the latter may be a double-sided blade with a soft centre; this

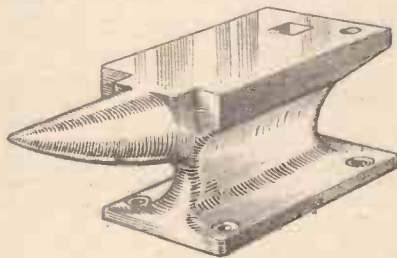

Fig. 11.—Small bench anvil.

is widely used for sawing brass tubing, but among other things the all-hard back has a longer life, of course, but is more brittle and therefore less suitable for the semi-skilled worker; the soft back blade is better when sawing in an awkward place, where there is difficulty in keeping the saw in a perfectly straight line.

The teeth of all blades are given a certain amount of "set"—that is, the teeth are bent slightly outward in opposite directions—so that the kerf, or cut, made is wider than the thickness of the back of the blade. This prevents the blade from jamming in its cut. Blades intended for use with mild steel have 18 teeth to the inch; those for hard steel and brass have 22 teeth to the inch; and those for tubing, sheet and less robust material have 32 teeth to the inch. These are general figures and there may be slight deviations from them in some cases.

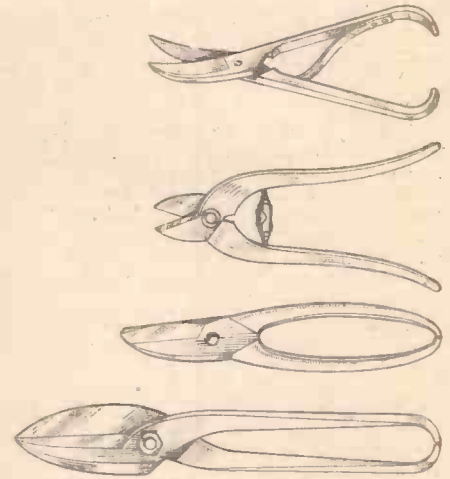

Fig. 14.—Various types of shear.

The usual width of hack-saw blades is 1/2in., and the thickness .025in.; here again, however, there are variations according to make. Additionally, there is an extra-thick pattern which is intended for slotting screw heads and similar work. One make is obtainable as 8in. blades, 14 teeth per inch, and in four thicknesses from .049 to .109in.

**Correct Use**

In using a hack-saw it is first necessary to decide on the most suitable type of blade, according to the details given above, and then to fit it to the frame and carefully adjust the tension. The blade should be fitted so that the teeth point toward the front of the frame; that is, so that the cut is made on the forward stroke.

Where possible, set up the metal in the vice so that it is held rigidly and prevented from vibrating. Hold the handle with the right hand so that the forefinger points down the blade. Hold the front of the frame with the left hand and take up a position similar to that for filing, but preferably with the work at a rather lower level. It is generally agreed that the best rate of sawing is about 30 strokes a minute, but there cannot be any hard and fast rule about this.

It is of the utmost importance to keep the saw in a straight line on both forward and backward strokes, for not only does this simplify the work but it reduces the chances of the blade being broken. Apply weight with the left hand during the forward stroke, removing pressure when drawing the saw back. When the cut has been taken almost through the metal the downward pressure should be reduced until it is only that provided by the weight of the saw.

(To be continued.)

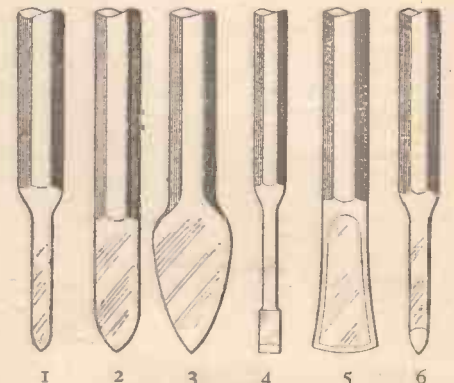

Fig. 13.—Further types of chisel. 1, chisel for general use; 2, chisel with cutting edge slightly circular; 3, side view of 2; 4, diamond-point chisel as shown at 5 (Fig. 12); 5, chisel for cutting-oil-grooves in bearings; 6, side view of 5.

# A Radio-controlled Model Battleship

Further Constructional Details

By JOHN J. CHANTRILL, A.M.I.E.E.

(Concluded from page 301, July issue.)

A SIX-VOLT 15 ampere hour "Gel-cel" accumulator supplies current for the three motors and the stud-switch solenoid, a two-volt supply for valve filaments being tapped off the same battery. A separate switch is provided for the two- and six-volt supplies, and each is independently fused. Average running time on one battery charge is about six hours.

H.T. for the receiver is supplied by a miniature 69-volt battery, with an additional 45-volt battery in series for the supply to the anode-bend rectifiers. This latter battery, as it is only called upon to supply 3 m/a for very short intermittent periods, is of the deaf-aid type. Bias for the output tetrode and rectifiers is obtained from a small 12-volt battery made up from pen-torch cells. The receiver, including the acceptor circuits and rectifiers, is built on a wooden chassis and is easily removed for adjustments, if necessary. Supplies are picked up via an eight-pin plug and socket.

## Shore Equipment

This is divided into two parts contained in identical carrying cases 14in. x 10in. x 7in. The first contains the transmitter and L.F. oscillator, while the second contains the batteries and controls, with compartments for tools, spares and an Avomitor. An eight-core flexible cable connects the two units, Jones-type plugs and sockets being used on the cable ends.

## Transmitter Unit

The R.F. section of the transmitter uses a conventional crystal oscillator (LP2), followed by two frequency doublers (LP2 and P2). The second doubler, which is modulated, feeds the aerial via a single-turn coupling coil. The aerial used may be either a vertical  $\frac{1}{2}$ -wave or horizontal dipole; both types have been used with equal success. Choke modulation is employed with a PT2

pentode as modulator; H.T. to all stages is 108 volts. The anode current of each stage can be measured by means of a switched milliammeter on the front panel.

## L.F. Oscillator

This uses two PM2DX type valves and consists of a two-stage R.C. amplifier with output coupled back to input. The oscillating frequency is determined by a tuned circuit connected across the grid circuit of the second valve, one of these tuned circuits being provided for each of the three frequencies used. Output from the anode circuit of the second valve is fed through

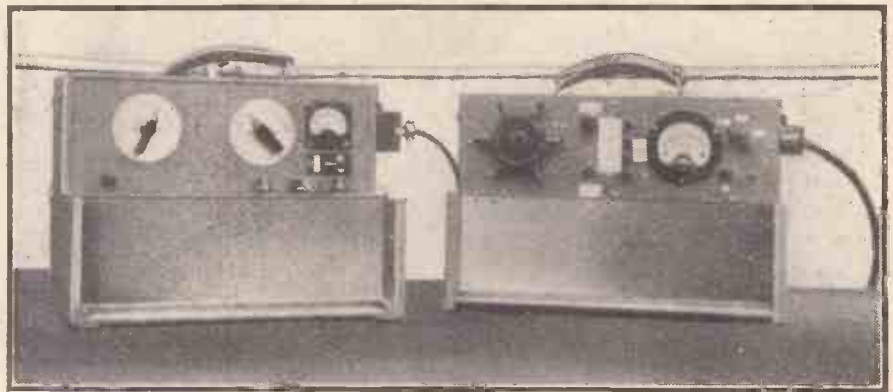

The transmitter (left) and the control box.

a transformer to three volume controls, one associated with each oscillator frequency.

Three relays contained in the transmitter unit are used to connect the required tuned circuit to the oscillator, and additional contacts on these relays connect the oscillator output, via the appropriate volume control, to the modulator input. Thus, the modulation level on each tone is adjustable. A fourth relay, which operates when any of the other three is operated, serves to apply cut-off bias to the L.F. oscillator valves when no tone is being transmitted; this prevents random oscillation and economises in H.T. consumption. A monitoring jack is provided so that the transmitted tone may be checked with headphones.

## Control Unit

This contains a two-volt "Gel-Cel" accumulator for filament supply, a 108-volt H.T. battery, an 18-volt dry battery for relay operation and bias, control mechanism, and tools, etc. A switched meter on the front panel measures L.T. and H.T. voltages and total H.T. consumption.

A small spring-loaded steering wheel controls the steering. This consists, in effect, of two separate make-and-break switches, so that turning the wheel 30 degrees to the left (when it reaches a limit-stop) operates the 3,500 cps. relay in the transmitter and turning to the right operates the 400 cps. relay.

Four push-buttons control the ship propulsion motor and the turret motor is switched on by means of a push-pull D.P.D.T. switch. The operation of both of these controls is as follows: Associated with the push-buttons is an impulse motor similar to that used in the ship but energised by the 18-volt dry battery. This has been modified by the addition of a six-position Yaxley switch so that it will "home" to any one of six equally spaced positions—moving, of course, in one direction only. The buttons are connected so as to "home" the impulse motor on to the following positions:

Button 1 ("Stop")—Position 1; Button 2 ("Half speed forward")—Position 3; Button 3 ("Full speed forward")—Position 5; Button 4 ("Half-speed astern")—Position 6.

Pushing the turret motor switch to the "ON" position changes buttons 1 and 2 over to positions 2 and 4 respectively. (It

will be noted that these 6 positions correspond to those on the stud-switch on the ship.)

A six-point cam carried on the impulse-motor shaft momentarily closes a pair of contacts half-way between the "home" positions: these contacts supply current to the 1,500 cps. relay in the transmitter unit. Thus, if a push-button is pressed or the turret-motor switch moved from one position to the other the control-box impulse motor will "home" to the corresponding position, and a pulse of 1,500 cps. tone will be transmitted for each position passed through. It follows that, if this motor and the stud-switch aboard ship start off in the same position, then they will keep in step and the stud switch will move to the correct position to give the conditions selected by the controls. The stud-switch moves slightly faster than the control-box impulse motor, so that in operation it pauses at each position until the arrival of the next impulse.

This may sound a rather slow process, but in actual fact the most lengthy operation, i.e., moving the switch through five positions, takes less than two seconds.

## General

The ship clips into a wooden crate for transport, this crate also containing the aerial rods for the transmitter and a spare stud-switch for the ship. It has been operated for many hours and has proved, after the usual "teething troubles," to be perfectly reliable. No serious "snags" arose during construction, which occupied 15 months of spare-time work—most of this being carried out on the inevitable kitchen table.



Rear view of the control box. The impulse motor is seen at the top left with the associated push-buttons (top centre). The flat boxes mounted on the inside of the opened lid contain tools, and a selection of spare parts.



# Simple Electronics

## A Brief Explanation of the Theory Involved

By A. LINFORD

**D**URING the war the vital importance of "Radar" resulted in rapid strides in the science of electronics and, during recent years, these developments have been applied with success to the production of electronic instruments for peace-time requirements in almost all branches of engineering.

The reasons for the ever-widening uses which are being found for electrical apparatus of this description may be summarised briefly as follows: 1. Purely electronic apparatus has no moving parts and hence there are no source of wear. 2. Generally speaking, electronic instruments operate so fast that they may be regarded as instantaneous in action. However, when required, time delays can be introduced into the electric circuit. 3. With electronic valves, it is readily possible to obtain very great power amplification. That is to say, a very small power input can be converted into a large power output, which is directly proportional to the input. By mechanical means, such power amplification is not easy to obtain and necessitates a large number of moving parts.

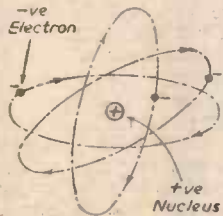

Fig. 1.—An atom, showing the positive nucleus and negative electrons.

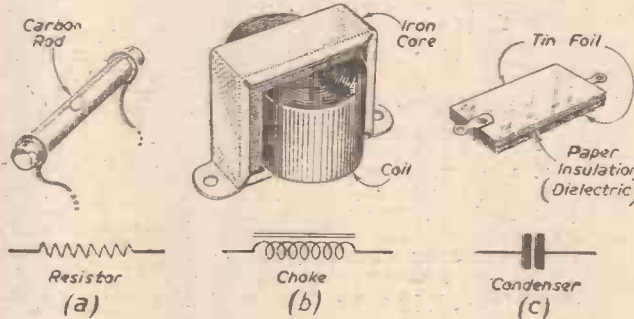

Fig. 2.—Circuit components, showing (underneath) the symbols used to represent them in circuit diagrams.

4. Nearly all electronic circuits consist of a combination of resistances, condensers, coils and valves, and these components are mass-produced in large quantities. Therefore, they can be bought cheaply from stock, and once an electronic device has been designed, its manufacture, to a very great extent, is a series of assembly operations.

The above remarks are not intended to convey the fact that an electronic instrument is always preferable to a mechanical or electro-mechanical one, but there are many instances where an electronic device can perform the required function more quickly, cheaply and efficiently than any other form of apparatus. In fact, as is the case with all mechanical and electrical mechanisms, the choice of the most suitable type of apparatus finally depends upon the particular application. For example, in some cases the risk of electric shocks or sparks, which may cause a fire or explosion in an atmosphere containing inflammable vapour, may weigh heavily in favour of mechanical instruments, or even preclude any apparatus which needs electrical power for its operation. It must not be overlooked that an electronic valve may fail without any previous warning, and this is a disadvantage which cannot be ignored.

Electric circuits, and especially those making use of electronic devices, tend to appear somewhat complicated to all but those who are professional electrical engineers. However, the principles of electronics are not difficult to comprehend and the following is a brief consideration of the theory involved:

It will be understood that, when dealing with these theoretical considerations, it is necessary to start from the basic principles of electrical technology.

### Planetary System

An atom consists of a positively-charged nucleus around which spin a number of electrons, in a similar manner to the planets revolving round the sun (Fig. 1). The electrons are negatively-charged and may be regarded as minute particles of negative electricity. It should be noted that the terms "positive" and "negative" are used merely to distinguish between the two kinds of electrical nature shown by the nucleus and the electrons; in fact, it would have made no difference to the theory if the electron had been referred to originally as a positively-charged particle and the nucleus as a negatively-charged one.

The planetary system forming an atom is held together by the electric force; any two particles with unlike charges, attract one another and vice versa, thus the positively-charged nucleus attracts the negatively-charged electrons, this attraction balancing the centrifugal force of the electrons, so preventing them from flying off at a tangent. In other words, the charge carried by the electrons is equal and opposite to that carried by the nucleus and the atom, as a whole, is electrically neutral.

In metals, some of the electrons are held together by weak forces so that it is not difficult to detach them from their nuclei and that is what happens when a battery is attached to the ends of a wire. The battery applies an electric field (also known as a potential difference or an electro-motive force) to the atoms in the wire. This field detaches some of the electrons and starts them moving down the wire. This results in some of the atoms which have lost electrons being left with a net positive charge, and these attract more electrons from the neighbouring atoms to restore the electric balance. The process is continuous and a steady stream of electrons flows down the wire and back through the battery. The battery functions as an "electron pump," the process being very similar to that of a fluid being pumped through a pipe. The rate of flow of electrons is measured in amperes and is referred to as an electric current.

The magnitude of the current produced in the wire or other material by applying given electro-motive force (e.m.f.), depends upon

the nature of the conductor, but for a given material, the current is proportional to the e.m.f. This fact is summarised in the familiar Ohm's Law, which states that the ratio, e.m.f. divided by current, is constant for a given conductor. The constant is called the resistance of the conductor and is measured in ohms while the e.m.f. is measured in volts.

In practice, various forms of resistors, i.e., conductors with a known resistance, are utilised; the most familiar, of course, is a coil of fine wire, but rods of carbon are also used (Fig. 2a). The latter material conducts electricity in the same way as a metal, but has fewer loosely bound electrons and, therefore, a higher resistance for a given diameter.

### A.C. and D.C.

So far only electric currents which flow continuously in one direction have been considered, that is to say, direct (D.C.) current, but of course alternating (A.C.) current is also used to a very great extent and, as the name suggests, this form of current results from electrons surging backwards and forwards in the conductor.

A generator of A.C. produces an e.m.f. which, starting from zero, builds up to a maximum or peak, falls to zero and then becomes negative in sign, reaching a maximum negative value, which has the same magnitude as the peak positive value, and returns to zero ready to start on a new cycle. In the usual A.C. main supply, the cycles follow each other at a frequency of fifty per second.

The graph of the A.C. voltage variation has the same characteristics as a sine curve and the voltage can be expressed by the equation  $V = V_0 \sin 2\pi ft$ , where  $f$  is the frequency (say 50 cycles per second as mentioned above),  $t$  is the time in seconds, and  $V_0$  is the height of the peak reached by the e.m.f. and is measured in volts (Fig. 3a).

The effective or "root mean square" (R.M.S.) value of the voltage,  $V_r = \frac{V_0}{\sqrt{2}}$

When an A.C. voltage is applied to a resistor, the alternating current set up also varies in a sine wave form. The peaks of current occur at the same instants as the voltage peaks and the current is said to be "in phase" with the voltage. Ohm's Law still applies, providing the R.M.S. value of both current and voltage are used in the formula.

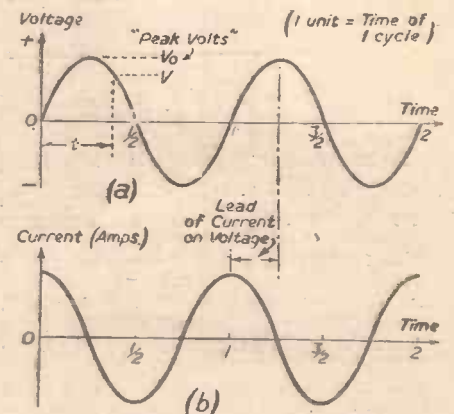

Fig. 3.—Graph showing an A.C. voltage, with the current it would produce in a condenser.

**Capacity and Inductance**

The use of alternating current brings into play two additional properties of conductors, these being capacity and inductance. Capacity is the most important property of a condenser, which consists of two plates of metal mounted close together but separated by an insulating material or dielectric (Fig. 2c). The commonest type of condenser is made by rolling together two strips of tin foil separated by wax paper.

When an e.m.f. is applied across a condenser, the plate on the negative side collects electrons, and these repel electrons from the other plate. As the number of electrons on the first plate increases this plate becomes more negatively charged, while the other plate becomes more positively charged. A state is eventually reached when the applied e.m.f. cannot force any more electrons into the condenser owing to the repulsion of those held there. In this condition, the charges on the condenser plates exert an e.m.f. exactly equal and opposite to the applied e.m.f. and no further change takes place.

The time taken for a condenser to become fully charged depends upon the magnitude of the current which is allowed to flow into it, and hence upon the resistance of the circuit applying the e.m.f.; usually the time is a small fraction of a second. When a D.C. voltage is applied, there is an initial rapid surge of current, and then the condenser behaves as an open circuit. However, when a condenser is placed into a circuit supplied with an A.C. voltage, it no longer acts as an open circuit but behaves as a kind of resistance, the action being as follows:—The voltage first tends to charge the condenser in one direction, then to discharge it and start charging it in the other direction, so there is a continual flow of electrons back and forth from one plate to the other, resulting in an alternating current.

On A.C. the condenser differs from a simple resistance in two aspects. In the first place, the current it will pass, using a given voltage, varies with the frequency of the voltage.

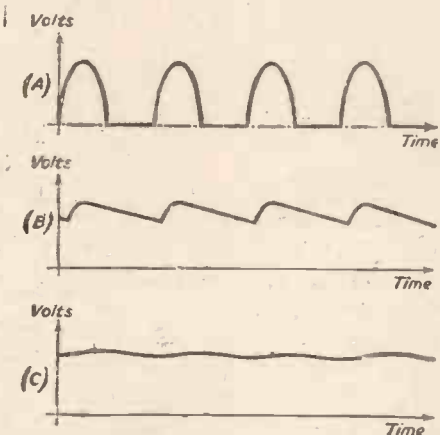

Fig. 5.—Rectification of A.C. to D.C., showing A—Half sine waves produced by a diode valve. B—The effect of adding a condenser. C—The D.C. output after passing through a choke.

Ohm's Law must be altered, replacing resistance by the impedance of the condenser

which has the value of  $\frac{1}{2\pi f C}$ , where f is

the frequency in cycles per second and C is the capacity in farads. Secondly, the current is not in phase with the voltage, the peaks of currents occurring when the voltage across the condenser is zero and vice versa. (Figs. 3a and b.)

Condensers are often used for separating A.C. from D.C. by making them of sufficient

capacity to be a low impedance to the A.C. while they are open circuit to D.C.

Coils of wire are used in A.C. circuits to introduce inductance, which property results from the relationship between electricity and magnetism. When a current is passed through a loop of wire, a magnetic field is produced at right angles to the loop. On the other hand, if a magnetic field is directed through the centre of a loop of wire, then any change in that field introduces an e.m.f. round the loop. When an A.C. voltage is applied to a coil, the current flowing through the coil sets up a magnetic field, which varies in proportion to the current. The variation of the magnetic field induces an e.m.f. in the coil, which is in the opposite direction to the original applied voltage. This reduces the effect of the applied voltage, and the current which flows is, therefore, smaller than would otherwise be the case. Hence, a coil has greater impedance to A.C. than D.C. A pure inductance would be a short circuit to D.C. but, in practice, a coil always has some resistance.

As in the case of a condenser, the impe-

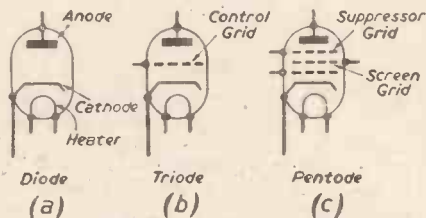

Fig. 4.—Diagram of the three basic types of electronic valve.

dance of a coil varies with the frequency, and the coil also puts the current "out of phase" with the voltage; the phase change is in the opposite direction from that produced by a condenser. The value of the impedance of a pure inductance is  $2\pi f l$ , where l is inductance measured in henries, and that of a coil is  $\sqrt{R^2 + (2\pi f l)^2}$  where R is the D.C. resistance in ohms.

Large inductance values are often obtained by putting an iron core through a coil, which increases the magnetic field. Coils of this type are usually called chokes (Fig. 2b) and they are used in opposing sudden changes of current. A simple extension of the choke is a transformer, which is constructed in the same way, but has two (or more) separate coil windings. An A.C. current passed through the primary winding sets up an alternating magnetic field in the iron core and this induces an A.C. voltage in the secondary winding. If the two windings have different numbers of turns of wire, a voltage change results. Thus, if a transformer has a primary winding of a 100 turns and a secondary winding of 50 turns, then if 20 volts A.C. are applied to the primary, 10 volts A.C. will appear in the secondary. The power in each winding is the same, so that if one ampere is drawn from the secondary, only half an ampere is taken from the primary. The figures given above refer to a perfect transformer, but since it is not difficult to make a transformer with an efficiency of 95 per cent., very similar results are obtained in practice.

**The Electronic Valve**

Having dealt with the part played by electrons in the basic circuit elements, the operation of an electronic valve may be considered. Most valves are based on the phenomenon called "thermionic emission," which takes place when a metal is raised to a high temperature in a vacuum. The heat energy agitates the atoms in the metal to such an extent that some of the loosely held electrons are thrown out of metal into the space surrounding it.

A diode (Fig. 4a) which is the simplest type of valve, consists of a cathode and an anode, mounted in a glass bulb which has been highly evacuated. The cathode is a metal tube containing a heating filament. A current passed through the filament generates heat, which raises the temperature of the cathode surface until electrons are emitted. The anode is a metal plate, usually in the form of a hollow cylinder, surrounding a cathode. When a voltage is applied between the anode and the cathode making the anode positive, the electrons emitted by the cathode are attracted by the anode, where they are collected. An electric current, therefore, passes through the valve which then behaves as a resistance. This current, called the anode current, must be distinguished from the filament or heater current, which latter is used only to heat the cathode and is not passed through the vacuum as is the anode current.

If the anode is made negative, the electrons are repelled by it and remain close to its surface, so the anode current is then zero. This property is used when the diode is applied to rectification, i.e., for changing A.C. to D.C.

If an A.C. voltage is connected across a diode through a load resistance, current only passes during alternate half cycles of the supply. This current is in the form of pulses, i.e., intermittent, but all in the same direction and it can be considered as a D.C. current with an A.C. current of distorted wave form added to it. A choke is put in series with the load and one or two condensers are connected across the load.

Due to the special properties of these components, explained in the foregoing, the A.C. part of the current takes the easiest path through the condensers and the load passes a D.C. current. The reason for referring to the choke and condensers as a "smoothing network" will be apparent. (Fig. 5 (A), (B) and (C).)

**The Triode**

The next type of valve, in order of complexity, is the triode (Fig. 4b) which incorporates three electrodes, these being a cathode, an anode and a control grid. The cathode and anode are similar to those in a diode, but the control grid is a spiral of fine wire, interposed between the other two electrodes. The introduction of this grid causes a considerable modification to the manner in which the valve operates and considerably increases its value.

To explain the operation of the triode, it may be supposed that the grid is made a

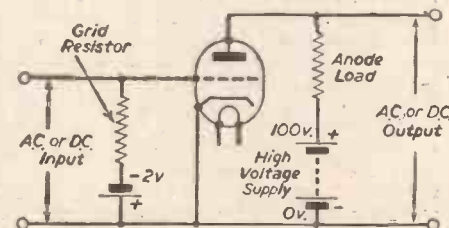

Fig. 6.—Circuit diagram of a simple triode amplifier with battery supplier.

few volts negative to the cathode, while the anode is kept at a constant positive potential of a few hundred volts. The high voltage on the anode still draws electrons from the cathode but the grid, being negative, attempts to repel these electrons back again. The result is that the anode current is much smaller than it would be if there were no grid. If the grid is made more negative, the anode current becomes still less until the point is reached when the anode current

ceases altogether; this is referred to as the "cut-off" point. Changes in the grid voltage between cut-off and zero grid volts, cause changes in the anode current, which are almost proportional.

The importance of the triode lies in the fact that the grid itself, so long as it remains negative to the cathode, does not collect any electrons and passes no current. Theoretically, it requires no power to change the grid voltage, whereas the changes of anode current enable power to be drawn from the anode. In practice, it is necessary to connect a resistor or grid leak between the grid and the cathode, to prevent electrons lodging on the grid and causing it to collect a charge. The resistor can have a high value, however, and will not pass much current, so a low power input is sufficient to cause comparatively large power variations in the anode circuit. This is the basis of power amplification with a triode. (Fig. 6.)

**The Pentode**

Another valve, which is very frequently used, is the pentode (Fig. 4c), having two more grids, making a total of five electrodes. The extra grids, which are again spirals of fine wire, are placed between the control grid and the anode.

The control grid of a pentode modifies the anode current in the same way as in the triode. The next grid is termed the screen grid and is connected to a constant positive voltage, a condenser frequently being connected from the screen grid to earth or to the cathode, to prevent any change in voltage. The purpose of the screen grid is to accelerate the electrons which pass through the control grid and assist them on their way to the anode. In the process, some electrons are collected by the screen grid itself which, therefore, passes a small current, but most of the electrons are moving so fast by the time they reach the screen, that their

momentum carries them on. Due to the screen's accelerating effect, the anode current change produced by a given control grid voltage change, is increased and amplification is higher.

The third grid, known as the suppressor, is connected directly to the cathode. It is used because, with a screen grid, the electrons strike the anode with such force that they knock more electrons out of it. The "secondary" electrons would, if the suppressor were absent, fly back to the screen grid and the anode might lose nearly as many electrons as it collected. The suppressor repels the secondary electrons back to the anode surface.

The method of operation of a pentode, described above, is the normal one and is used in the majority of circuits. However, other methods are also utilised; for example, the screen current is sometimes used to give the output power.

# Scale Prevention and Corrosion Control

## Particulars of the Micromet Treatment

**T**HE formation of scale in hot water systems is often a serious problem, especially in districts where the water supply is hard. The presence of scale causes waste of fuel; increased maintenance and cleaning costs, and sometimes actual damage to boilers and heating equipment. On the other hand, with soft water supplies, corrosion of pipework and hot water tanks frequently occurs.

These problems of scale and corrosion have been solved by the use of Calgon (sodium metaphosphate) in many water undertakings and industrial plants.

In smaller hot water systems, such as are found in some hospitals, factories, pit-head baths, schools, hotels and private houses, it is more convenient to use another form of metaphosphate known as Micromet, which is marketed by Albright and Wilson, Ltd., 49, Park Lane, London, W.1.

The effect of Micromet treatment in hard water districts is to prevent the formation of hard deposits of scale or "fur" in water heaters of all kinds, e.g., hot water boilers heated by coal, coke or oil, steam-heated calorifiers, gas and electric water heaters. (Micromet is not recommended for steam-raising boilers for which a special method of water treatment using Calgon and other phosphates has been developed; see the booklet, "Phosphates for Boiler Water Conditioning.")

In soft water districts, where corrosion troubles replace scale formation, the use of Micromet will control corrosion and thus lengthen the life of water heaters and pipes.

A small vessel or dispenser charged with Micromet is connected to the water main at some convenient point. The water passing through the Micromet will dissolve a small amount of metaphosphate; three or four parts per million are sufficient to prevent the formation of scale. When corrosion is the problem, greater amounts of metaphosphate are required; the amount is regulated by variations in the charge of Micromet.

Micromet dissolves very slowly in water; the grade which is usually employed dissolves at the rate of about 30 per cent. per month. The rate is largely independent of the flow of water over the Micromet.

Medical authorities, hospitals, water engineers and municipalities in Great Britain and America have satisfied themselves that the presence of metaphosphate in drinking water is harmless to health.

**How to Use Micromet**

The treatment is most conveniently applied by the installation of a Micromet dispenser at some suitable point in the water system.

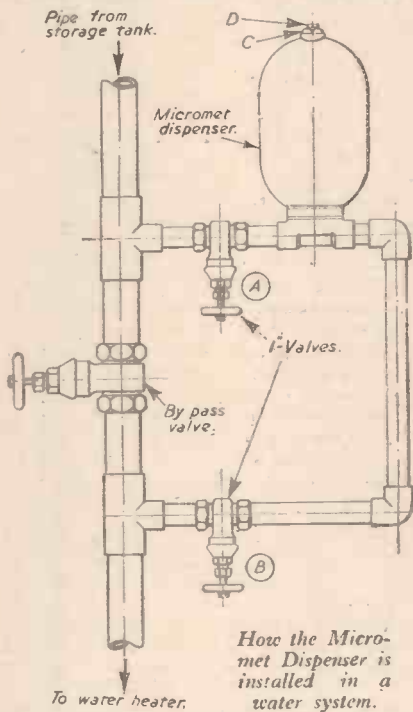

How the Micromet Dispenser is installed in a water system.

We can supply a dispenser (see diagram) which consists of a gun-metal cylindrical vessel with connections to the water main and an opening at the top for charging the dispenser with Micromet.

The size of the Micromet charge depends on the amount of water to be treated. The following table gives a range of quantities for the dispenser described above:

**Scale Prevention**

Quantity of Water used per day	Initial Charge of Micromet	Additional charge of Micromet per month
500 galls.	2½ lb.	12 ozs.
1,000 "	5 "	1½ lbs.
2,000 "	10 "	3 "

**Corrosion Control**

250 galls.	2½ lb.	12 oz.
500 "	5 "	1½ lb.
1,000 "	10 "	3 "

If the daily consumption of water is greater than the maximum quantities given above, then two or more Micromet dispensers can be connected either in series or in parallel to give the required capacity, e.g., two dispensers with an initial charge of 10 lb. each, would treat 4,000 gallons of water per day for the prevention of scale. Smaller feeders, known as scale reducers, are also available. These are suitable for private houses.

An alternative method is to put the Micromet in the cold water storage tank, preferably in a basket made of perforated metal or wire gauze, which can be hung over the side of the tank and suspended in the water. Unless the storage tank is easily accessible, however, the Micromet dispenser is to be preferred.

**How to Install the Micromet Dispenser**

The diagram shows how the Micromet dispenser is installed. This is a simple job and is usually done by an engineer or plumber.

The dispenser is installed at some convenient point on the water main supplying the water heater, calorifier or condenser. The point chosen should be such that the dispenser is readily accessible, and can easily be recharged with Micromet. Two isolating valves are fitted, one at the outlet and one at the inlet, as shown, and it is good practice to fit a by-pass so that the water supply could not be interrupted in the event of the dispenser having to be dismantled or repaired.

**Recharging the Micromet Dispenser**

It is necessary to replenish the Micromet regularly once every month. The quantity to be added is given in the table above. For example, if a dispenser is fitted to a water heater to prevent scale formation and the daily consumption of water is 2,000 gallons, 3 lb. of Micromet should be added each month.

Close the isolation valves A and B (see diagram) and open the filling plug at the top of the dispenser. Pour in the required amount of Micromet, close the filling plug C and open the air release cock D. Slowly open valve A and shut air release cock D as soon as water begins to flow from it. Open valve B. The dispenser is now recharged.

**PLANT ENGINEER'S POCKET BOOK**

An invaluable work for all engineers responsible for the installation, operation or supervision of engineering plant and equipment in works and factories.

Of all Booksellers, 6/- net, or by post 6/6

From **GEORGE NEWNES, Ltd.** (Book Dept.),  
Tower House, Southampton St., Strand, W.C.2.

New Series

# Wood-Turning - I

The Lathe

By FREDERICK JACE

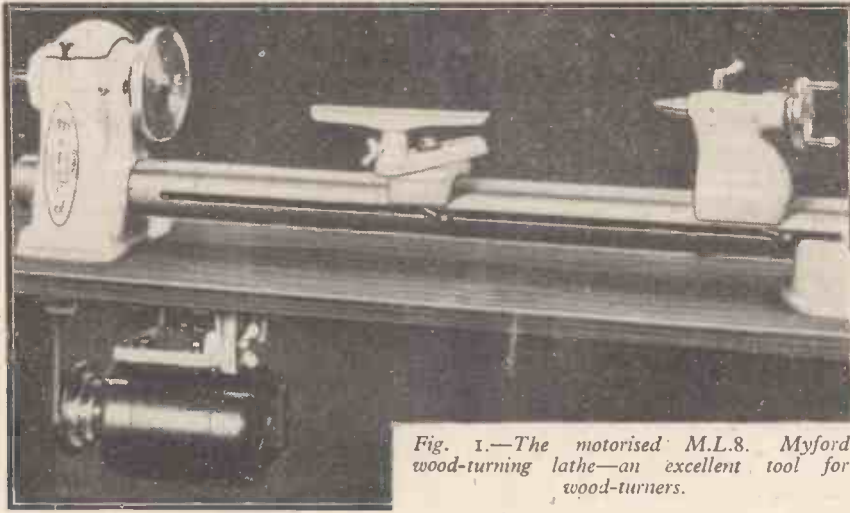

Fig. 1.—The motorised M.L.8. Myford wood-turning lathe—an excellent tool for wood-turners.

**T**HERE is a considerable difference between the methods employed in wood-turning and metal-turning, not only as to the methods of cutting the work, which is, of course, rotated between centres, but also concerning the methods of mounting the work.

In metal-turning, for example, the cutting tool is usually fixed in the slide-rest which is traversed along by means of a lead screw. Moreover, the cutting edge of the tool is mounted at centre height or just below it.

With wood-turning, however, most of the cutting is done by hand tools, except in the case of mass production factories where the tool is fixed as with metal-turning.

The cutting tools used for wood-turning are really wood-workers' tools, and the cutting angles are similar to those used for chisels, plane-irons, etc. Also the cutting edge of the tool is applied to the work considerably above centre, and the cutting consists rather of a shaving action than a direct shearing action as with metal-turning.

The wood-turning lathe is, of course, much simpler in design. A good commercial example of a motorised wood-turning lathe—the Myford M.L.8—is shown in Fig. 1, and where electric power is available it is recommended that a lathe of this type is used, for it saves the considerable amount of labour necessary when a treadle or foot motor provides the power, and also one does not have to acquire the knack of treadling and operating the cutting tool at the same time. Of course, it is possible to have an assistant to do the treadling, but this is not always desirable, as with certain work he would be in the way.

A simple wood-turner's lathe is shown in Fig. 2, and its various parts are named in the caption. It will be seen that the construction is of simple character, so simple,

indeed, that one may easily be constructed by the amateur.

The position of the lathe should be such that a good light will fall in front of the worker and on to the work. A window with a northern aspect would be best as

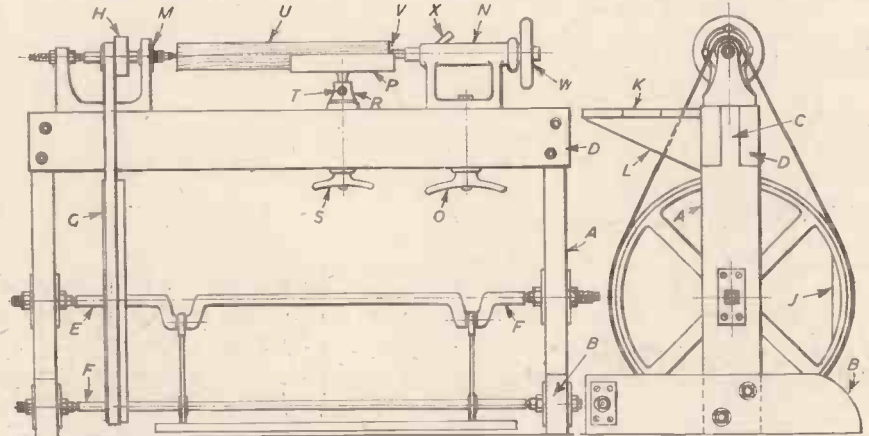

Fig. 2.—Front and side elevations of simple treadle-operated wood-turning lathe; A, standards; B, feet; C, upper ends of standards; D, bed; E and F, bearings; G, leather belt; H, mandrel; I, counterpoise; K, board platform; L, brackets for platform; M, lathe headstock; N, tailstock; O, holding-down bolt; P, T-rest; R, socket; S, T-rest clamping wing nut; T, pinching screw; U, work mounted between centres; V, back centre; W, tailstock feed wheel; X, tailstock clamping lever.

being free from the glare of sunshine which can be trying to the eyesight.

Briefly, a wood-turning lathe consists of a horizontal wooden or iron framing termed the lathe bed, which is supported on wooden or iron standards, and carries the headstock and tailstock. The standards are provided with bearings to carry the flywheel (in the case of treadle-driven lathes) and also feet prolonged at the back to carry the tail-pins for the treadle pivot-bar, and these feet are splayed to form an efficient base to ensure that the entire framework stands rigid and steady when work is being performed on it. For additional security it is also advisable to fix the lathe feet to the floor, either by means of angle plates or by means of letting them into the cement.

The lathe may be conveniently rigged up at the back with a bench or table attachment, which is useful for keeping chucks and other small appliances at hand.

Turning tools cannot be used without a support or rest for them to bear on, for the downward pressure on the cutting edge is much more than could be resisted by the hands alone. The work, of course, revolves towards the operator, and the support should be as near the cutting edge as possible. If too far back there is more or less leverage

on, and from there its surface slopes downwards away from the work. It is provided with a post which fits into a socket in the base, and when adjusted for height and for horizontal angle it is clamped by a set-screw. The base can also be adjusted to any angle on the lathe bed, and moved in or out to suit the diameter of the work. It has a socket, as shown, which receives a suitable bolt for clamping. Adjustments for height do not vary much, but some amount of adjustment is necessary.

On face-plate work, that is, flat disc-shaped articles, the top of the rest must usually coincide with, or be very slightly below, the lathe centre height, when the face of the work is being operated on. In turning the edges of such work and in cylindrical articles between centres, the turner adjusts to any height he finds convenient, his own height in relation to the lathe having something to do with it. Usually the top of the rest is kept a little above the lathe centre height.

The T-rest P which supports the turning tool is adjustable for height in the socket, by means of the pinching screw T, and the socket R is also movable both longitudinally and laterally to suit the work, which is locked by means of the wing nut S.

(To be continued)

Fig. 3.—The T-rest.

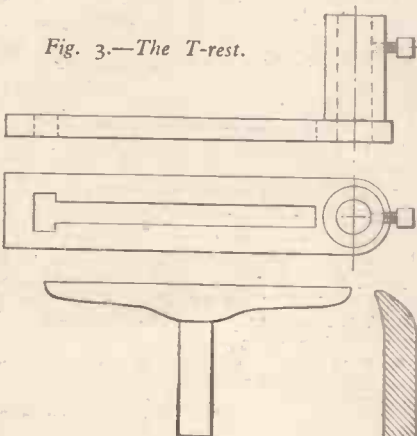

# Studies in Electricity and Magnetism

"Maximum Power" : High-resistance Load : Constant-voltage Sources

I CAME across a hoary old problem the other day—one of those that constantly crop up in one form or another.

Someone had read that a "generator" (an "imaginary" one of a type never found in practical work !) would supply "maximum" current to a load, if the resistance of the load was made equal to the internal resistance of the source.

Whether or not this was the actual statement made in a book, I cannot say. As it stands, I daresay, you can easily see why the theory is ridiculous.

A battery—and some types of "generators"—or, generally, any "supply source," will deliver greatest current when the two terminals are short-circuited with a piece of wire—a highly foolish proceeding!

## "Maximum Power"

What was probably said is that, under certain conditions, the power in a circuit will be maximum when external resistance = the internal resistance of the source.

That is a very different principle. As I have often explained to readers: Power = volts × amperes, though, if the "volts" can be kept constant, greatest power will be the same as maximum "amperes."

Hence the reservation above, "under certain conditions." The principle applies to apparatus whose output voltage is far from constant; where a large drop occurs in internal resistance; or where, therefore, the terminal volts fall rapidly with load current.

In such cases, largest current would be got under short-circuit conditions. But, then, almost all the volts would be dropped internally, leaving little "watts" in the outside circuit.

Let us look at a typical example.

## Dry Batteries

In Fig. 1a is shown a single "cell" having an internal resistance  $r = 1$  ohm.

Primary cells ("dry," or "wet," Leclanche, etc.) have resistances of this order—much more, if they become really "dry" or otherwise deteriorated. Also, "internal resistance" is not a very constant figure, but varies with the state of a battery, polarisation, and so forth.

We shall suppose our 1 ohm to be the same at all load currents.

First, let us inquire what sort of results might be expected if we shorted the terminals with a piece of wire of zero resistance. Every piece of wire has some resistance, but it can be 0.000 . . . something of an ohm—near enough to zero, compared with 1 ohm, as will make no difference.

If we had an ammeter in circuit, it would show maximum current. Thus, if the e.m.f. of the cell is 1.5 volts, the short-circuit

By H. REES, A.M.I.E.E.

current is approximately 1.5 volts ÷ 1 ohm = 1.5 amperes (still forgetting effects like polarisation).

## No Dropped Volts

But 1.5 amperes in a wire of zero resistance will cause no voltage drop, and no conversion of power into heat. The current is at a maximum, but encounters no opposition in the external circuit: no volts are "dropped" in the short-circuiting wire, and no energy is expended in driving current through it! Alternatively:

$$\begin{aligned} \text{Watts} &= \text{volts} \times \text{amperes} \\ &= (\text{amperes} \times \text{resistance}) \times \text{amperes} \\ &= (\text{amperes})^2 \times \text{resistance} \\ &= I^2 R. \end{aligned}$$

$R = 0$ , so the power is nil, however large

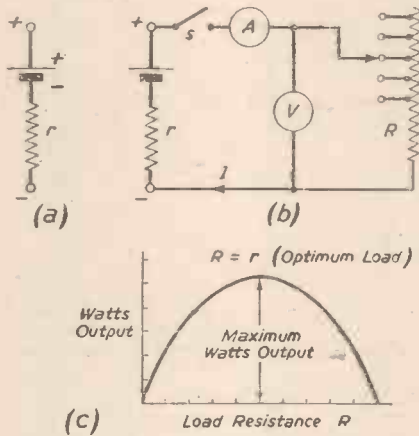

Fig. 1.—Is there an "optimum load" which will take greatest power from a battery or a generator? The question is discussed fully in this article.

the amperes. The "volts" referred to are the volts dropped across a resistance, which is here nil.

But the battery itself has 1 ohm of internal resistance—the resistance of the electrolyte and chemical constituents.

Hence the whole of the e.m.f. (1.5 volts) will be dropped internally, in driving 1.5 amperes through 1 ohm. The heat generated internally will be the equivalent of a power of 1.5 watts.

This is a "maximum power"—the greatest power which can be lost in internal resistance! We would hardly buy batteries for verifying that fact experimentally, so let us inquire how to get maximum energy expenditure where we want it—in the external circuit.

## High-resistance Load

Suppose we go to the other extreme, connecting a high resistance across the terminals, i.e., moderately high—say 1,000 ohms.

The current discharge would now be quite small—a mere 0.0015 ampere or 1.5 milli-amperes (actually a little less). The drop across internal resistance will be somewhat less than 0.0015 volt. We are getting almost the full 1.5 volts across our external resistance.

But it does no good from the power point of view. There are plenty of "volts"—as many as a given battery can supply—but the current is negligible.

Watts = volts × amperes, which works out to something like 0.0025 watts or 2.25 milli-watts.

This is hardly "maximum power," compared with the 1½ watts wasted internally under short-circuit conditions.

Small dry cells cannot be expected to deliver much power, but it is possible to obtain a more impressive figure than this—at least, for brief intervals.

## The "Optimum" Load Resistance

The foregoing suggests there must be a "best" or "optimum" load resistance: one not too small or too large, but of an exact value which will give maximum product of volts × amperes.

While difficult to carry out an experiment on ordinary cells, Fig. 1b shows a set-up for verifying the fact.

Starting with a fairly large value of  $R$ , readings of terminal volts ( $V$ ) and amperes ( $I$ ) are taken for various load resistances, and multiplied to give the watts output.

$R$  might consist of separate known resistances, or a decade box where values are indicated. Short-period discharges should be made on the cell by closing switch  $S$  only during the brief intervals when taking readings.

A variable factor will be the internal resistance  $r$ . If the e.m.f. is accurately known in the first place, any changes of internal resistance may be noted by using the relation:

$$\text{internal resistance, } r = \frac{\text{e.m.f.} - \text{terminal volts}}{\text{amperes discharge}}$$

A power curve (Fig. 1c) of watts output against load resistance  $R$  would show (if measurements could be accurately carried out) that the power is a maximum when  $R = r$ : the optimum load is one whose resistance is exactly equal to the internal resistance of the supply source.

Note, however, that this curve falls off slowly from the maximum—or is fairly "flat"—meaning the power will not be much less than the maximum if, for example,  $R = 2r$ —twice

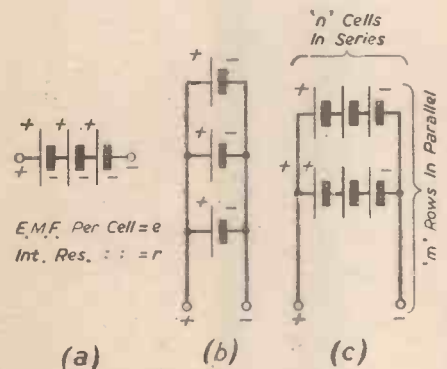

Fig. 2 (left).—Methods (b) and (c) of grouping primary cells are apt to cause a lot of trouble owing to unequal sharing of load current, but are sometimes used for supplying larger currents than is possible with (a). Here we are interested in "maximum power" output.

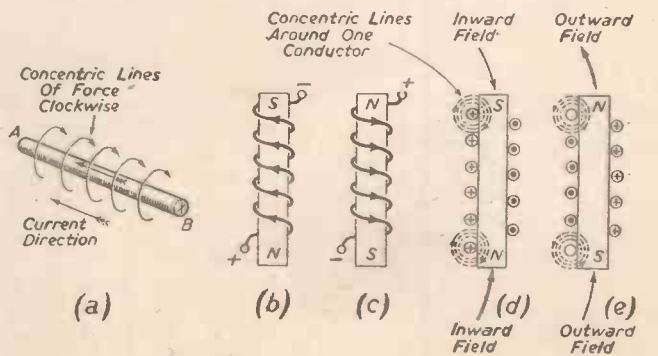

Fig. 3 (right).—More "Fundamentals": Finding the polarity of a magnet.

the internal resistance. Thus, the resistance need not be very accurately adjusted to get a power near enough to the maximum.

**Arrangements of Cells**

If you have a number of cells available (Fig. 2) they may be arranged (a) in series, (b) in parallel, or (c) in series-parallel.

Which particular arrangement is "best" depends on the ratio of your circuit resistance to the internal resistance of the entire battery.

Suppose it is a question of obtaining maximum power—let us say, generating the greatest amount of heat in a resistance element, "heat" being directly proportional to the watts dissipated.

A battery should be made up (series, parallel, or series-parallel) whose total internal

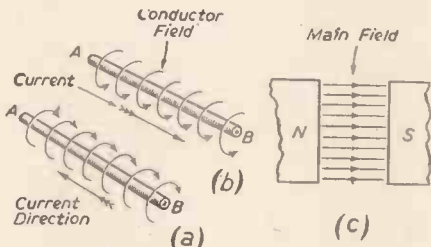

Fig. 4.—What will happen if the conductor AB having a concentric field as shown, is placed in an independent "main field" due to a pair of poles NS?

resistance is as near as possible equal to the resistance of your element.

In the general case (series-parallel) we have N cells, grouped in m parallel rows, with n cells in each row (Fig. 2c). Let the internal resistance of each cell be r ohms, and the e.m.f. of each e volts.

Then :

e.m.f. = that of one row = ne volts

Total internal resistance = nr/m ohms

External resistance = R

For greatest power :

$nr/m = R,$

or,  $n = mR/r$

Also,  $m = N/n,$  giving finally,

$n^2 = NR/r,$  or  $n = \sqrt{NR/r},$

where n is the number that must be put in series in each row. If R is considerable compared with r, the answer will work out to such a number in series as to permit only of one row, i.e., in effect, all the cells should be connected in simple series (Fig. 2a).

In fact, calculations of "cell groupings" are of more theoretical interest than any real practical utility, but the principles of optimum loads are quite important in other branches:

Thus, as in the battery case, radio and audio-frequency loads have to be "matched" to the internal resistances of power valves—sometimes for maximum power, but usually for maximum undistorted power, which is equivalent generally to  $R = 2r$  (a power slightly less than the maximum).

Telephone and music lines, radio-frequency feeders, and so forth, have generally to be matched to the inputs or outputs of amplifiers for maximum "power transfer," i.e.,  $R = r.$

**Constant-voltage Sources**

So, altogether, the principle we have been discussing has highly important applications: primary cells are useful as a d.c. illustration.

But we have already given a warning about generalising too far—extending the principle to cases where it does not apply.

For instance, an accumulator cell has an extremely low internal resistance. For all loads within its capacity it is almost a constant-

voltage source. The same is true of d.c. generators, etc., having constant-voltage characteristics.

We may say that such sources will deliver "maximum power" if a load resistance was connected across the terminals equal to the internal resistance.

Theoretically it is perfectly true, but no one would dream of connecting such a "load" to any generator or accumulator. Think of a 2-volt accumulator whose internal resistance is perhaps considerably less than 0.05 ohm. What sort of "load" would have this resistance?

Clearly it means shorting the terminals! No secondary cell is designed to supply anything approaching the maximum current and power expressed by  $R = r.$  Neither are any real generators.

So when you do read in radio textbooks of "imaginary generators" whose loads must be matched to equal the internal resistance, remember that they are largely fictitious things—or, rather, generators which (if made) would have an internal resistance of some thousands of ohms.

Still, when amplifying, a radio valve is an exact equivalent of a high-impedance a.c. generator.

**About the "Corkscrew Rule"**

Turning now to magnetic questions.

The first is the familiar rule connecting current-direction with magnetic polarity.

The "positive direction" of a magnetic field (the N to S direction) is related to the current-direction in the same way as the motion of a right-handed screw is related to the direction of turning the screwdriver—or a corkscrew, or a spanner.

Inward or downwards motion (a current flowing away from the observer) requires that the screw shall be turned in a clockwise (right-hand) direction: also the positive direction of a magnetic field around a wire.

Thus, looking at end B of the conductor in Fig. 3a, the current is going downwards (towards A), hence the field is clockwise as shown; an imaginary isolated N pole would be repelled in a clockwise direction.

Alternatively, looking at end A, the current is upwards (towards us), equivalent to turning

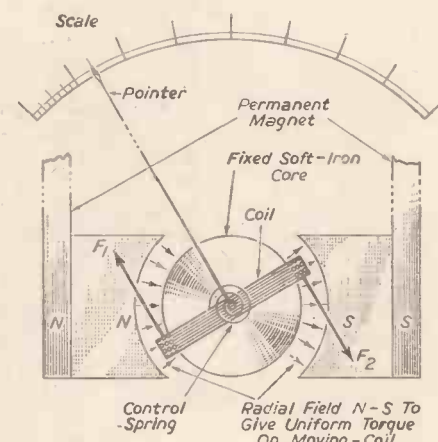

Fig. 6.—The simplest application (in theory!) of the motor principle. A coil, carrying the current to be measured, will be acted upon by forces F1 and F2 to give clockwise rotation. Because of the radial field-distribution, the sides of the coil will always be moving at right-angles to the flux.

a screw anti-clockwise, with upward motion of the screw itself. Hence we reach the same result as looking at end B—a field whose direction is anti-clockwise (relative to end A)—clockwise at end B.

**Magnetic Polarity of Coils**

When drawing coils wound on iron cores, we may show complete turns with current-direction, as in 3b and 3c, or imagine the wires cut in section as in 3d and 3e.

In this latter case, a + denotes the tail-end of an arrow—a downward current; . shows a current coming towards the observer. At end B (Fig. 3a) we have a + sign, and at A a . sign.

To find the magnetic polarity of the iron in the examples shown we may either consider individual turns or conductors, or apply the screw-rule to the coil as a whole.

In Fig. 3b we have a current going from right to left in the parts of the turns shown. Looking at either "end" of this piece of a turn, we have a clockwise magnetic field, one whose lines of force enter the iron at its top end.

Lines of force enter S poles, hence the top end is a S pole. Alternatively, looking at the bottom end, lines of force emanate, giving us a N pole.

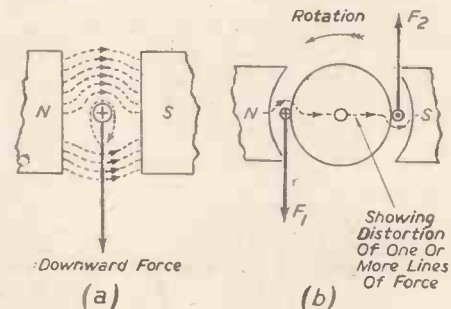

Fig. 5.—Magnetic forces which cause a motor armature to rotate.

Actually, what we are doing is considering single conductors. In Fig. 3d is shown exactly the same coil, where a few lines of force are drawn to show more clearly that they enter at the top end and "emanate" from the bottom end of the iron. Of course, the total field will be due to all the concentrated "lines" around each conductor (or "turn"), combining to act upon the magnetism inherent in the molecules of the iron, i.e., the permeability of the latter greatly augments the total "flux."

But as far as finding the resultant magnetic polarity is concerned, it is sufficient to consider individual conductors, as explained.

Fig. 3c and 3e similarly show the reversed polarity when the current is reversed, or if the "sense" of the winding is reversed, or if the coil is turned upside down.

Alternatively, we may apply the screw rule to the entire coils.

In Fig. 3b, the current is circulating downwards, from the top end. Here, our screw-rule "reverses" its conventions.

To turn a screw downwards requires clockwise motion. In Fig. 3a, this clockwise motion was the positive direction of the field. Here, in Fig. 3b, however, the clockwise motion denotes the direction the current is circulating; "downward motion" (of a right-handed screw), then indicates that the top end of the magnet is a S pole—lines of force going inwards.

In the same way if we regard the bottom end: current is circulating anti-clockwise (left-handed motion), equivalent to drawing out a screw, hence lines of force emanate from this end.

It is all very simple once grasped. The change in conventions is a little confusing, and it should be noted when considering individual "turns" or "conductors" that we are applying the convention of Fig. 3a. It is for the whole-solenoid that the assumptions based on a right-handed screw are switched over.

**The "Motor Principle"**

I have dealt at some length with generator principles. The electric motor is equally interesting as an application of fundamental magnetic rules.

Consider a single conductor carrying a current of 1 ampere (Fig. 4a). It will be surrounded by concentric lines of force—a clockwise field, by the above rule; if the current is reversed, the positive direction of the field will be reversed as in Fig. 4b.

Next, we have another strong field, positive direction N to S (Fig. 4b). This is set up by an electromagnet such as the shunt field circuit of a motor.

What will happen if we place the current-carrying conductor, Fig. 4a, in this independent field?

It will be found that a magnetic force acts downwards, tending to push the conductor out of the field, its magnitude (in dynes) being given by:

$$F = \frac{BLI}{10}$$

or,

$$F = \frac{BLI}{10 \times 453 \times 981} \text{ lbs. wt.}$$

(1 lb. wt. = 453 grams, and 1 gram "gravitates" with a force of 981 dynes.)

In this equation:

B = magnetic density lines per sq. cm.

L = active length of conductor in cms.

I = current in amperes.

For example: if a piece of wire 10 cms. long, carrying 100 amperes, was placed in a field of intensity 10,000 lines per sq. cm., it would be acted upon by a force (at right angles to the field) of approximately 2 lbs. weight.

Evidently a large number of such conductors embedded on the periphery of a motor armature can give rise to a very large "torque" (= Force × Radius at which it acts).

If the current in the conductor was reversed, or if, keeping this current-direction the same, the main field polarity (positive direction of the main flux) was changed, the direction of F would be reversed.

Obviously, if, having reversed the main flux, we also reverse the current in the conductor, the direction of the force will be the same as we started with.

Here we have the magnetic principles governing reversal of rotation of a motor: reverse either the armature current, or the field current, but not both.

**Interaction of Fields**

Fig. 5a shows roughly what happens in the case of a single conductor—that of Fig. 4a.

The main field is directed N—S; the field around the conductor has a clockwise

(positive) direction. Therefore, the conductor field will be in the same direction as the main field on top—strengthening the resultant field, but opposing it underneath the conductor—causing a weakening of flux on this side.

Lines of force will be bent or distorted out of their normal straight-line paths, to take "the path of least resistance" from the N pole to the S pole. Also, because lines of force going in the same direction mutually repel, this distorted flux will tend to straighten out—again, to take the shortest possible path from N—S.

Clearly this is equivalent to a force acting on the conductor—a downward force (Fig. 5a). In Fig. 5b are shown two conductors of an armature, respectively carrying downward and upward current, e.g., the two "sides" of a "turn."

The field will be altered in the manner shown, giving equal forces F<sub>1</sub> and F<sub>2</sub> tending to turn the armature anti-clockwise.

A fairly simple example of a single coil in a two-pole field is an ordinary moving-coil instrument, Fig. 6. With the current directions shown, a clockwise torque is developed.

To conclude this article: draw separate sketches for these various cases, showing why rotation will be reversed by changing the direction of either field—the main flux, or the concentric field around the conductors.

(To be continued)

# Electrified Fence Construction

Details of Installation and Working

By FORBES M. MILNE, A.M.I.C.E.

WHILE still somewhat of a novelty on this side of the Atlantic, the electrified fence has achieved great popularity in America. This is due, principally, to its many useful qualities as well as to its ease of erection. While it is possible to buy the fence ready-made, home construction is both cheap and simple.

The supply for the fence may be taken either from an accumulator or, via a transformer, off the A.C. mains. Voltages supplied by the accumulator run from 6 to 12 and from mains transformers from 2 to 12 volts. If possible, it is better to use a transformer as this saves the trouble of re-charging accumulators.

**Using a Spark Coil**

The fence depends for its action on an induction or "spark" coil. This increases the voltage in the line considerably, the amperage being, of course, very low. The high voltage imparts a sharp sting to any animal coming in contact with the wire. While the effect is, of course, entirely momentarily, after one experience animals studiously avoid approaching the line. To owners of easily-raided orchards an electrified fence may prove a boon.

Coming down to costs, a 6-12 volt induction coil can be bought for about 12s. 6d., a transformer with three taps—2, 6, 12 volts—will cost about 25s., copper wire for the fence at 2s. per 50ft. coil, insulators 4d. each, while 2-volt accumulators will cost approximately 9s. each.

In the cable carrying the A.C. current from the mains a low-value fuse should be inserted to ensure that under no circumstances can the dangerous position arise of mains voltage passing through the fence. Near the proposed fence a switch should be inserted in the mains wires, so that the current may be switched on and off when required. From this switch the cable goes to the transformer and hence to the spark coil. Most

6-12 volt coils will run quite well on 2 volts A.C. current, though if it is desired to use D.C. it is probable that a slightly higher value will be needed. In the latter case a selenium rectifier is inserted between the transformer and spark coil.

The "live" wire of the spark coil is then joined to the copper wire which is to be electrified and a connection from the frame of the spark coil lead to a well conducting earth. If the fence has twin wires, say, a barbed wire above and the insulator-carried copper wire below, the "earth" wire may be connected, if desired, to the barbed wire, the "live" connection going, of course, to the copper one.

**Testing**

After switching on the current the fence should be tested by holding a rake or other tool with a wooden handle between the wires. With one end of the iron rake touching one wire hold the tool so that a small gap is left between it and the other wire. If the fence is in working order a continuous spark should be seen across the gap. If this does not occur the trouble is probably due to faulty insulation of the "live" wire. No attempt should be made to obtain "fat" sparks by heavily increasing the voltage or amperage. The fence would then become dangerous and might involve its owner in serious consequences.

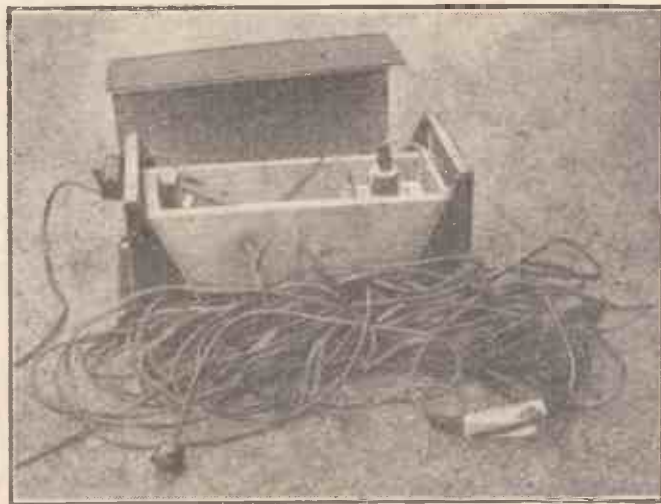

Components for a home-constructed fence, including plug for A.C. mains, watertight low-value fuse, transformer and spark-coil in waterproof box.

Finally, the transformer and spark coil must be protected from the effects of rain or damp, and an easily-read notice, such as "CAUTION—ELECTRIFIED FENCE," erected in a prominent position.

**NEWNES' RADIO ENGINEER'S POCKET BOOK**

By F. J. CAMM

3/6, or by post 3/9

Obtainable from booksellers, or by post from George Newnes, Ltd., (Book Dept.), Tower House, Southampton Street, Strand, W.C.2.

# Jet Reaction Power Models

## Various Types of Jet Power Engines for Model Aircraft and Boats

By C. E. BOWDEN, A.I.Mech.E.

FULL-SIZED military aircraft are rapidly becoming jet-powered and there is already an airliner flying with jet engines. This development is not surprising when it is considered how fundamentally more simple a jet engine is than the complicated reciprocating piston engine. Both are internal combustion engines, but the jet engine eliminates many moving parts besides getting away from that limiting factor of the propeller at speeds of approximately 450 m.p.h. and over, when propeller drag becomes a serious problem. Furthermore, a jet engine has no torque reaction trying to turn the aircraft around the propeller's axis. This latter point is most important from the aero modeller's angle, for at least 80 per cent. crashes are due to the upsetting forces of propeller torque. It is simple to design a model glider to have great stability, but as soon as an engine with its propeller is added, stability problems occur due to torque reaction.

Apart from this advantage of jet propulsion for models, the fact that full-sized craft will mostly be flying by jet propulsion in the next few years, with perhaps the exception of the smallest personal plane, is bound to cause the modeller to follow suit.

Unfortunately there are at the moment certain limitations, for the model jet engine is in its infancy and has lagged behind its full-sized brother, not so much in efficiency, which is high, but in a useful size and power output to suit this country's peculiar overcrowded conditions. There is not the safe space to fly high-powered model free-flight jet aircraft in safety, and most of the model

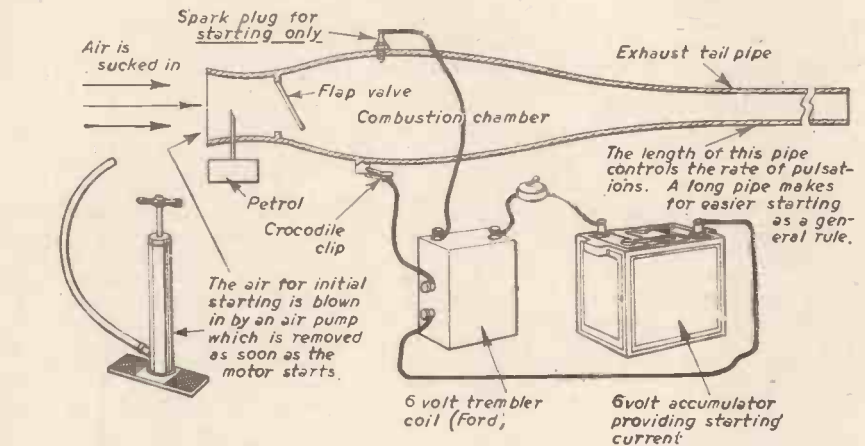

Fig. 2.—The basic principle of the model pulse-flap valve jet motor.

right lines instead of trying to ban free-flight jets, for the fact must be faced up to, that whatever obstacles are placed in its way, the jet is the coming power

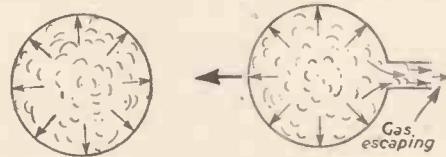

Fig. 1.—The basic principle of jet forward reaction.

(Left) An explosion in a sphere creates an equal force on all sides internally.  
(Right) If a vent at one side is opened there is a low pressure here, and the force will remain momentarily high at the opposite side, thus giving the sphere a push in the direction of the large arrow. This is the force of reaction employed by jet engines.

unit and cannot be suppressed in the future. The old "red flag" failed to stop the motor-car and motor-cycle. It should not be diffi-

cult to encourage a suitable low-powered jet engine, apart from the rocket type, by sensible rules.

There are one or two ventures at the moment which will doubtless provide smaller and less powerful jet motors in the future. Our present engines have developed from the very powerful American jet motors, and all at present offer over 3½ lbs. static thrust which builds up to greater thrust due to ram effect as the model flies or travels faster. Such a thrust is vastly more than we require in this country, except for racing speeds in control-line flight, when a record is being sought. This ultimate speed craze has evidently appealed to the Americans who have put the world's speed record for control-line flying model aircraft up to over 170 m.p.h. by a jet engine.

When we consider that the most popular sized piston reciprocating (propeller) engine in this country to-day is the diesel, having a thrust of approximately 15 to 200z., it will be clear what I mean. Such a thrust suits our model purposes in general. Naturally greater thrusts are required for special purposes such as free-flight and control-line models of the large type, and also for radio-control models, but it has been found that the average boy or young man is best suited by the lower-powered engines, and this in my opinion is the power that the jet engine should be designed to produce at a low weight.

### Principle of Jet Reaction

There are many people who still do not understand the general principle of jet reaction. They think that the eflux or exhaust gases roaring out from the tail push on the air and so propel the craft.

A jet reaction motor operates on the principle of Newton's third Law of Motion, which states that to every force there is an equal and opposite force. A flow of gas through a nozzle, or jet, requires a force to give its high velocity, and there is thus an equal force on the container, driving it forward in the opposite direction to the jet outlet. In other words we may say that the force of the expanding gases is actually taken by the

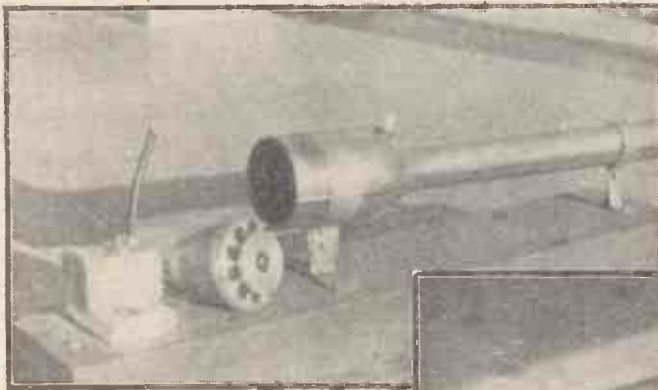

Fig. 3.—The Dynajet flap-valve engine is here shown with the nose removed. Behind the nose can be seen the flap or "flutter" valve which has ten petal-like arms of spring steel which open and shut with rearward movement controlled by a radiused "button."



Fig. 4.—The writer's American Dynajet is seen mounted on a test block with fuel tank. The British Juggernaut is resting on the ground below. The starting air nozzle is beside the fuel pipe in front of the air intake which is firmed to keep the flutter valve cool.

jet units of the internal combustion type as opposed to rocket, are of a very powerful and noisy set up. The power is so great that even control-line flying can be dangerous to spectators if the operators are not careful about the strength of lines and so on. Naturally, most local residents object to the noise which, although stimulating to the enthusiast, is annoying to those without any interest in the subject.

This is, however, a matter of development, and in my opinion it would be better if the F.A.I. and S.M.A.E. were to control development along the



engine's body and thence transmitted to the airframe or the boat's hull. Fig. 1 shows the general principle by the well known sphere or balloon idea.

In this sketch it will be noticed that if an expansion or "explosion" of gas takes place in a sphere, an equal pressure takes place internally on all sides. If one side is opened suddenly the gases will rush out from that side, and the pressure will drop, but is momentarily maintained at the opposite side.

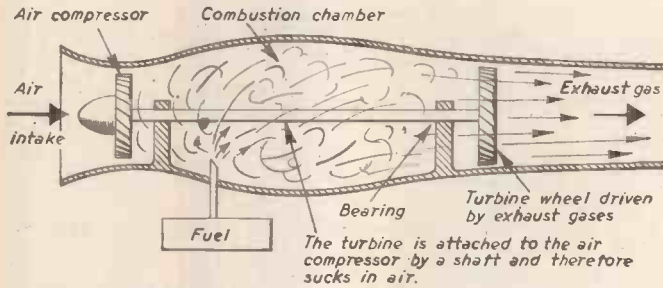

Fig. 7.—The principle of the "turbo-jet" or gas turbine engine.

Therefore, the sphere gets a kick in the opposite side from the open vent.

Every boy will have noticed that when a child's toy balloon is blown up and the vent suddenly released, the balloon will shoot violently off in the opposite direction to the released vent. This is the principle of jet reaction, for the front of a jet engine is virtually closed in varying ways and the rear is open.

Last year I gave the first B.B.C. Television broadcast on model jet engines, in which I showed the reaction principle by a toy balloon which duly leapt across the camera's front as the vent was released. I then flew a small jet-engined model across the studio much to the interest and amusement of the operators. Fortunately it flew to order, landing among the rafters of the studio!

**A Popular Type of Model Jet Engine**

The most usual engine for full-size work is the gas turbine, because this type can be run up on the ground and throttled back within reasonable limits in the air.

The Athodyd, or the Ram Jet, is the most simple jet engine and, in fact, the most simple prime mover in the world; it is suitable for supersonic speeds, but has the very big limiting factor that in order to start, it has to be moved through the air at between 200 to 500 m.p.h. This is generally done by the means of rockets. Naturally, such a jet is not suitable for normal aircraft. The Athodyd is just a tube with a diffuser at the forward end and a ring of fuel jets behind the diffuser. There is no air compressor and turbine to drive the compressor as in the gas turbine (see Fig. 7.)

A further type of jet motor is on the lines of the German "Buzz Bomb" in the last war. This is the Pulse Resonance Flap-Valve jet engine, and is the one which has been developed by the Americans for model work. The British have followed their lead, which has resulted in the very powerful and noisy engine I mentioned at the beginning of this article.

This type of engine is a highly scientific achievement although it is so simple in construction. It is a most efficient power producer giving over 3½lbs. static thrust on the ground for an approximate weight of 1lb. As the speed rises through the air there is a considerable rise in thrust. There are no complications of compressor or turbine as in the turbo-jet, and yet we have this most important thrust from rest which makes it useful for model aircraft. How is it done?

The general principle is shown in Fig. 2. The engine is essentially a tube, the length

of which affects ease of starting and power output as well as the exhaust note. Air is sucked into the nose where there is a venturi (i.e., a restricted tube) which creates suction over a fuel jet. The suction created raises fuel from a tank situated just below the jet. The fuel is ordinary car petrol, and there is no lubricating oil used, for there are no other moving parts than a springy steel flap-valve. Petrol is easily vaporised and burns sufficiently fast to suit the high pulsation rate. The flap-valve, or flutter-valve as the Americans call it, is located in the nose behind the fuel jet.

The petrol / air mixture, in the form of an explosive gas, is sucked or blown by a pump for starting into the combustion chamber through this valve. There is a spark plug fitted in the wall of the combustion chamber facing the intake orifice. This is for starting only. Behind the flutter-valve there is a radiused "button" to limit the movement of the valve's petal-like arms. The combustion chamber is extended into a long exhaust pipe which is restricted in diameter. This long pipe gives an extractor effect like the long pipe of a racing motor-cycle's exhaust. Fig. 3 shows the nose of an American Dynajet engine taken off and the flutter-valve's ten little petals in view.

A trembler coil is generally used to create the initial starting spark after which the engine runs by its own heat. An old T Ford trembler coil using six volts makes a useful unit as there is then no need for a make-and-break and contact breaker, for the Ford coil gives a constant stream of sparks when the current is switched on. A car hand-pump is used to introduce the initial blast of air.

To start, the air pump is connected to the starting tube on the engine nose, and air is pumped by hand in steady blasts which draws up the fuel from the fuel jet and, mixing with the petrol, forms an explosive mixture. This mixture is forced through the

Fig. 6.—A Dynajet-powered model is seen being started up by hand-pump to introduce the initial blast of air. Note the starting Ford trembler coil and its six-volt accumulator is carried in a box by these young men.



Fig. 5.—The British Decojet is an exceptionally easy starter, having a long tail pipe which usually assists this feature. These jet motors have a greater power than the "hot" 10 c.c. type of model petrol engine seen below the jet engine as a comparison for size. The fuel consumption is approximately three times greater.

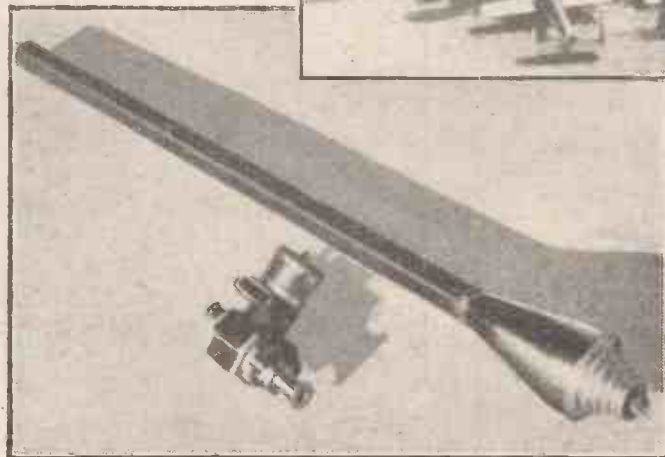

flutter-valve which is opened by the air blast where it meets the stream of sparks from the coil. An "explosion" results which shuts the flutter-valve and gives the forward reaction push to the engine's internal body, at the same time the expanded gases rush out of the open rear tube thus causing an extractor effect or a partial vacuum in the combustion chamber. This opens the flutter-valve petals and draws in a further charge which is fired this time by heat created from the first "explosion." The air pump and the electrical gear are removed and the motor runs until the fuel ends or becomes too weak or too rich through possible maladjustment.

It is hard to think up a more simple engine giving greater efficiency. Certainly there is far less complication than the reciprocating petrol motor with its piston, connecting rod, crankshaft and bearings to be carefully fitted and lubricated. But, on the other hand, the pulse-jet engine has to be carefully designed to get the right harmonic balance between length and thickness of pipe, flutter-valve thickness and springiness, and limiting stop, etc. Any one of these features if out of phase may stop the engine working. The only moving part is the flutter-valve springing back and forth.

The length of the tail-pipe control, the frequency of the pulsations, and therefore the time of ignition, is controlled by this resonance frequency, subject to subsidiary factors such as fuel strength and the thickness and springiness of the thin tempered steel flutter-valve. If the tail pipe is shortened the frequency of the explosions increases. A long pipe usually means easier starting and a little less power. The American Dynajet (see Fig 4) has a pulsation frequency of 280/300 per second, which accounts for the noise!

**Pulse-jet Engines Available**

There are two pulse-jet motors on the American market which have lead the way. Both are the same in general principle but vary conspicuously in the form of flutter-

valve used. The Dynajet is perhaps the best known to modellers in this country. I have one of these motors which I use on my models. Fig. 4 shows my Dynajet mounted on a test block with a British Juggernaut lying below it. The Juggernaut is approximately the same length and has a petal flutter-valve reminiscent of the Dynajet.

A recent comer on the British market is the Decojet, which I have found to be an exceptionally easy starter. One or two pumps and the engine is booming away. This motor has a longer and thinner tail pipe which probably accounts for its outstanding easy starting. There is a shrouding disc fitted behind the flutter-valve on the Decojet which protects the valve from excessive heat when the engine is fitted to a slow model or run up on the ground. This can be removed if the engine is fitted to a fast model, giving

adequate cooling. These engines all run very hot and rely upon forward motion to keep reasonably cool. They therefore should not be run up for more than a few seconds on the ground. In the failing light of evening they emit a lurid red glow with licking short flames from the exhaust as they fly around on a control-line model. This glow added to by the noise makes the whole performance most intriguing and adds a spice of excitement to the high speed at which the models fly. Fig. 5 gives a view of the Decojet which I use, with a "hot" 10 c.c. petrol motor below, to show a comparison between size, etc. The 10 c.c. motor is generally considered to be the racing class for control-line work in the reciprocating engine line. Speeds have been reached around the 140 m.p.h. mark against the 170 mark of the jet in America.

The model seen in Fig. 6 is shown being started up by two young men, and at the time when I took the photograph they had done over 30 hours flying using the same flutter-valve. Even then there was no sign of ragged edges through excessive heat. The Americans use some excellent steel for the purpose.

The following dimensions of leading jets may interest readers:—

American—Dynajet: Length 21½ ins., max. diam. 2½ ins., tail pipe diam. 1¼ ins.; Mini-jet: Length 28½ ins., max. diam. 2 ins., tail pipe diam. 1 in.

British—Juggernaut: Length 21½ ins., max. diam. 2½ ins., tail pipe diam. 1¼ ins.; Decojet: Length 30½ ins., max. diam. 2½ ins., tail pipe diam. 1½ ins.

(To be concluded)

## Club Reports

### Preston and District Society of Model Engineers

SINCE the beginning of the year the Society has enjoyed the use of a room kindly rented to us by the W.E.A. This has been quite a change after the uncertainty of the previous year. For the benefit of any model engineers in the Preston district who may be intending members, the society now meets every alternate Friday at 23, Chapel Walks, Preston, at 7.30 p.m.

So far this year, visits have been made to a cotton mill, the Ribble power stations, and Preston locomotive running sheds. Shortly, a Sunday visit will be made to the British Railways locomotive works at Horwich. Further visits to places of interest are being arranged to take place after the society visit to the M.E. Exhibition on the 26-27th August. This trip will be made by motor coach, specially booked for the occasion.

A start has been made on a 5in. gauge locomotive by various members of the society, with the idea of a running track of our own. At the present moment the society does not possess a workshop, and members are machining the loco in their own workshops.

Future meetings: 5th and 19th August; 2nd and 16th September. Hon. sec., M. A. COLLARD, 46, Brackenbury Street, Preston.

### Shrewsbury and District Society of Model and Experimental Engineers

THE above society was formed in May, 1946, and has a membership of over 40. Meetings are on Monday evenings, 7-9 p.m., at the Technical College. Our president is A. Moore, Esq., Principal of the College. We have the use of the very extensive workshops, including 7 centre lathes, shaper, universal and vertical milling machines, ½ in. capstan lathe, radial and pillar drilling machines, engraving machine, precision circular grinding machine, fly-press, etc. In addition, both oxy-acetylene and electric welding equipment is available to members. The total annual subscription is 19/6 for members over 21, reducing to 3/6 at 15.

Exhibitions were held in 1946 and 1947, supported by the Oswestry and Wrekin Societies. Our exhibition this year will be in the Walker Hall of the College on Friday, 28th October, 7-9 p.m., and Saturday, 29th October, 2.30-9 p.m. Approximately 100ft. of 2½ in., 3½ in. and 5 in. gauge track will be in operation. The exhibition is non-competitive, and entries are invited from all model engineers in the locality.

Particulars should reach the secretary by 17th September.

The society is a member of the S.M.E.E. affiliation, and the support of the affiliation has also been promised. Hon. sec., W. T. HOWARD, Technical College, Shrewsbury.

### Portsmouth Model Engineering Society

THIS Society now has in hand the publication of a periodical newsheet magazine which it is hoped will contain articles of interest for all members. A monthly bulletin informing members of the business transacted at council meetings is already in circulation.

At the moment, a very ambitious programme is being executed. The gauge "O" railway used in the 1947 exhibition has been dismantled, and a new track is being constructed by the model railway section. New stations, signals, permanent way and scenic effects are gradually being introduced, and it is hoped that the plans will be fully realised before the end of the year, in time for the 1950 exhibition. The layout will be portable, being divisible into eight interlocking sections. Much of the trackwork

has been completed and limited train operation is possible.

Lecture meetings are held on the first Wednesday in each month, in the Lecture Room, Central Library, Portsmouth, at 7.15 p.m.

Further information is obtainable from the hon. sec., F. J. ALLISON, 21, Carmarthen Avenue, Cosham, Portsmouth.

## Books Received

**Lathe and Shaping Machine Tools.** By "Duplex." Published by Percival Marshall and Co., Ltd. 72 pages. Price 3s. net.

IN order to produce accurate and well-finished work in the lathe or shaping machine the tools must be of correct form for the operations undertaken, and they must also be properly sharpened. The object of this book is to deal primarily with the practical side of this important subject, and interested readers, desirous of improving the quality of their work, will find in this handy little book much that is both helpful and instructive. The book is illustrated with numerous line drawings.

**Newnes Engineer's Reference Book.** 3rd Edition. Greatly enlarged and fully revised, 45/-, or 46/- by post from George Newnes Ltd., Tower House, Strand, W.C.2.



Final assembly stages of the superstructure of the ½ in. to the foot scale model of the R.M.S. "Queen Elizabeth," made by Bassett-Lowke, Ltd., of Northampton. This fine example of British craftsmanship is reputed to be the world's largest ship model.

# The Elements of Mechanics and Mechanisms—22

## Water Wheels (continued)—Applied Mechanics—Geneva Mechanisms

### Alteration of Wheel Acceleration

TENTATIVE methods of decreasing the acceleration of the wheel in the Geneva mechanism considered must necessarily aim at the reduction of the value  $C-r$ , since the maximum velocity ratio is given by  $r(C-r)$ , and the crank radius  $r$  is constant. In other words, the locus of the roller centre must intersect the common centre-line of driving and driven shafts at a point more remote from the wheel centre. This is fulfilled by a shallow curve between the roller centre positions at slot engagement and disengagement, which is tangential to the centre-lines of the two slots at these positions.

A method of realising the above requirements is illustrated in Fig. 10. The roller is mounted on a pin fixed to one corner of a triangular frame which is pivoted at one other corner to a link pivoted to the fixed frame of the machine. The triangular frame is actuated by the pin of the driving crank and the resultant locus of the roller centre, which is indicated by the continuous chain-dotted line, fulfills the requirements outlined above.

The method of incorporating a locking plate shaped as a circular sector is illustrated in Fig. 11. The locking plate is keyed to an auxiliary shaft which is driven from the main driving shaft by means of three spur wheels 1, 2 and 3. The numbers of teeth in the spur wheels must be arranged to effect correct relative motions of locking plate and driven wheel in opposite directions.

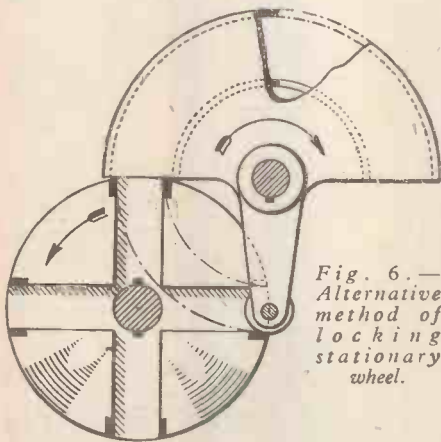

Fig. 6.—Alternative method of locking stationary wheel.

### Alternative Methods of Locking Wheel

Two alternative methods of locking the wheel during its stationary period of the intermittent motion are illustrated in Figs. 6 and 9.

The locking plate D (see Fig. 9) is in the form of a sector with a circular arcuate groove which is engaged during the crank idling period by rollers mounted on the outer face of the wheel. This arrangement has great disadvantages; it is rather bulky and the wheel must be placed on the end of the driving shaft, otherwise the locking plate would foul the shaft extension. Also, the locking effect of the roller contacting a circular-arc surface described about a centre considerably off-set from the roller pitch centre is much reduced and consequently

By F. J. CAMM

(ALL RIGHTS RESERVED)

great care is needed in the fitting of rollers and groove and in the location of the rollers.

A second method of locking the wheel is

TABLE I. (REFERRED TO LAST MONTH) DESIGN FACTORS FOR STANDARD DRIVES.

Configuration at roller entry	Centre distance $C$	Maximum velocity ratio $\frac{C-r}{r}$
	$= \frac{2r}{\sqrt{3}}$ $= 1.154r$	$= \frac{\sqrt{3}}{2-\sqrt{3}}$ $= 6.4630$
	$= \sqrt{2}r$ $= 1.414r$	$= \frac{1}{\sqrt{2}-1}$ $= 2.4139$
	$= 1.701r$	$= 1.426$
	$= 2r$	$= 1.000$
	$= 2.613r$	$= 0.6203$
	$= 2.923r$	$= 0.5208$
	$= 3.236r$	$= 0.4472$

illustrated in Fig. 6. The above objections are overcome by this design, which is much cheaper to manufacture; the use of lugs

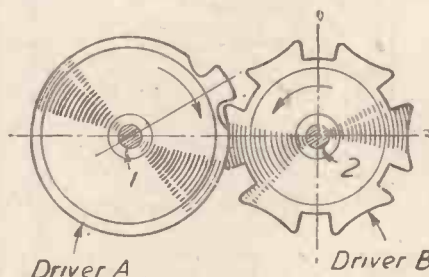

Fig. 8.—Geneva mechanism in a simple form.

projecting from the slotted face of the wheel enables a much smaller locking plate to be employed and effects efficient locking. Accurate location of the lugs on each side at the extreme outer ends of the slots is easily effected and the load on a lug when resisting a particular torque is about 30 per cent. smaller than the corresponding load on a roller in the arrangement of Fig. 9, since the locking is more efficient.

### Uniform Wheel Velocity

When the movement of the driven wheel of intermittent gearing is required to be at constant speed bevel or spur gearing of the form shown in Fig. 7 can be employed.

Such gearing is kinematically identical to the Geneva mechanism, since the rolling of the roller along the slot corresponds to the rolling action of mating spur teeth. The method of locking is also the same. It represents a convenient method of effecting intermittent rotary motion at very short intervals which may be regular as at (a) or irregular as shown at (b). Fig. 8 shows the Geneva mechanism in a simple form.

### The Inverse Geneva Mechanism

The above title refers to a form of intermittent gearing based on the Geneva principle, in which the directions of rotation of driven and driving shafts are the same. A typical example of a mechanism employing a four-slot wheel is illustrated in Fig. 12, which gives the configurations of the mechanism. The corners formed by the intersections of the slots must be cut away at least to a radius

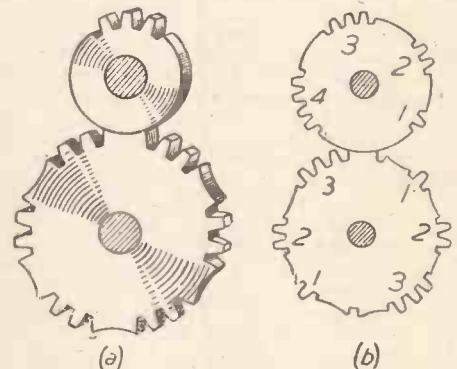

Fig. 7.—Types of intermittent gearing.

equal to the distance of the driving shaft axis from the crank pin or roller. For ease of manufacture the surplus material between the slots is cut away as indicated by the dotted straight line.

The action of the inverse mechanism is kinematically identical to that of the ordinary Geneva mechanism; the crank pin or roller engages successive slots in the wheel and drives it through a fraction of a revolution according to the number of slots employed. No drive is transmitted while the roller is traversing the circular arc connecting successive slots.

The roller enters and leaves each slot tangentially, and hence the idling angle  $\phi$  of the crank rotation during which period no drive is transmitted is  $(180-90)$  deg. A general formula for the crank idling angle is

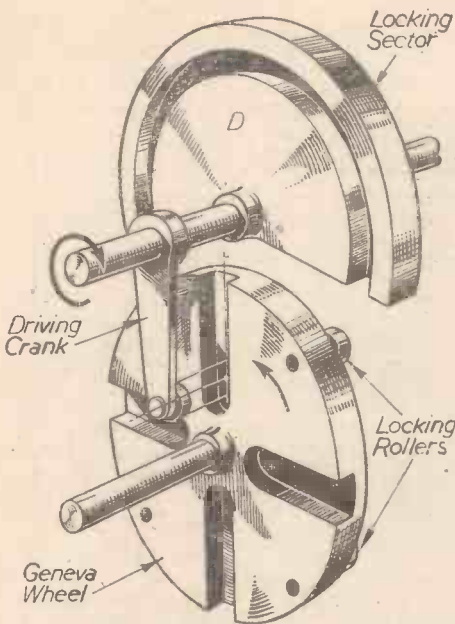

Fig. 9.—Exploded diagram of a compact form of Geneva mechanism.

$$\phi = 180 - \frac{360}{n} = 180 \left\{ \frac{n-2}{n} \right\} \text{degrees} \dots (8)$$

where n=number of wheel slots.

For example, the idling angle for an eight-slot wheel is

$$\phi = 180 \left\{ \frac{8-2}{8} \right\} = 135 \text{ deg.}$$

As with the ordinary Geneva mechanism, a circular-segmental plate integral with the driving crank can be used to rigidly locate the driven wheel during the crank idling period. The convex edge surface of the locking plate mates with the wheel face, located midway between each pair of slots, and effects locking of the wheel. It should be noted that the arcuate mating surfaces must be described about a centre at the crankshaft axis, and must subtend an angle  $\phi$  (see equation 8) at the same axis. The method of locking inverse Geneva mechanism is shown in Fig. 13.

The direction of the roller thrust, which is perpendicular to the centre-line of the slot, is indicated on a diagram of the configuration illustrated in Fig. 14a. The velocity ratio, as with the ordinary form of Geneva mechanism already considered, is the ratio of the distances of the line of action from the crank and wheel centres.

The maximum velocity ratio, which occurs at mid-position when crank and slot are collinear (see Fig. 12a) is given by :

$$\text{V.R. max.} = \frac{\text{Angular velocity of wheel}}{\text{Angular velocity of crank}} = \frac{r}{C+r} \dots (9)$$

where r = crank radius  
C = centre distance of shaft axes.

The maximum velocity ratio can be found by the method used in the determination of the maximum velocity ratio for the ordinary Geneva mechanisms. Since

$$C = r \cos A + \left( \frac{r \sin A}{\tan B} \right) \text{ where}$$

A=angle of crank from common centre-line, and  
B=angle of wheel slot from common centre-line, both at the instant of roller engagement or disengagement.

Also  $B = \frac{1}{2}$  angle between two successive slots, and  
A+B=90 deg.

Therefore

$$C = \frac{r}{\cos A} = \frac{r}{\sin B} \text{ and}$$

$$\text{V.R. max.} = \frac{\cos A}{1 + \cos A} = \frac{\sin B}{1 + \sin B} \dots (10)$$

Note that the angle A is one-half the angle between two successive slots.

For example, for a five-slot wheel the angle between two successive slots is  $360 \div 5 = 72$  deg., and the maximum velocity ratio given by

$$\text{V.R. (5)} = \frac{\sin 36^\circ}{1 + \sin 36^\circ} = \frac{.5878}{1.5878} = 0.3701$$

Maximum velocity ratio values for several wheel types are given in Table II.

To determine the velocity ratio at any intermediate position, consider a general configuration of the mechanism, such as is shown diagrammatically in Fig. 14b. The velocity ratio is the ratio of the distances of the line of action of the roller thrust from the crank and wheel centres, and therefore can be expressed as

$$\text{V.R.} = \frac{oA}{OB}$$

where o is the crank centre and O is the centre

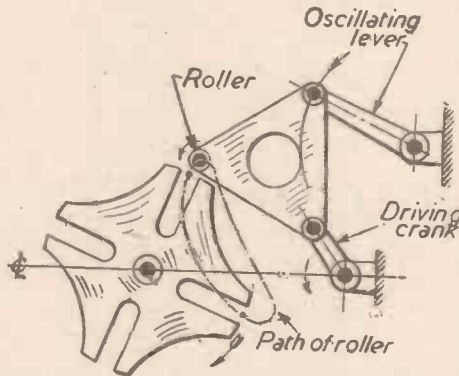

Fig. 10.—Method of reducing acceleration of wheel.

of the wheel. Since the lines oA and OB are parallel, then

$$\text{V.R.} = \frac{ok}{Ok} = \frac{ok}{C+ok} \dots (11)$$

$$ok = oB \cos a + Ek \dots (12)$$

Since r=oB=crank radius  
a=angle of crank from mid-position.

Also  $\theta$ =angle of wheel from mid-position  
=angle BOk or Aok or plate EBk

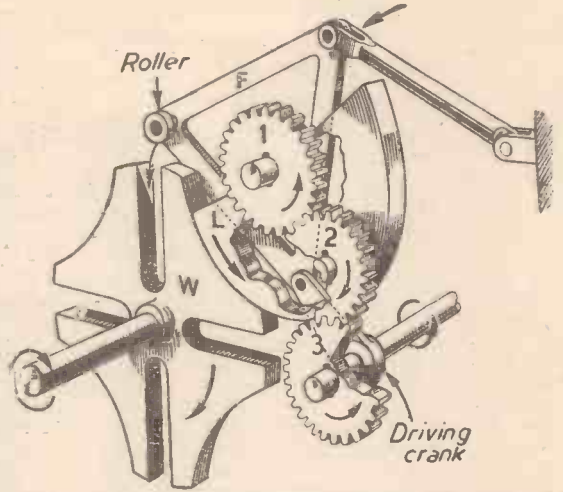

Fig. 11.—Method of incorporating a locking plate in a modified Geneva mechanism.

$$Ek = EB \tan \theta = r \sin a \tan \theta \dots (13)$$

It remains to determine the value of  $\tan \theta$  in terms of C, r and angle a

$$\sin \theta = \frac{r \sin a}{OB} = \frac{r \sin a}{\sqrt{r^2 + C^2 + 2rC \cos a}}$$

and since  $\cos \theta = \sqrt{1 - \sin^2 \theta}$

$$\tan \theta = \frac{r \sin a}{C + r \cos a}$$

$$\therefore Ek = \frac{r^2 \sin^2 a}{C + r \cos a} = \frac{r^2(1 - \cos^2 a)}{C + r \cos a}$$

$$\text{V.R.} = \frac{r \cos a + Ek}{C + r \cos a + Ek} = \frac{r(C \cos a + r)}{C^2 + 2rC \cos a + r^2} \dots (14)$$

As a check consider the mid-position of the configuration, that is, when angle a=0. The velocity ratio calculated from equation (14) gives the maximum value of equation (9).

The similarity of equations (4) and (14) for the ordinary and inverse Geneva mechanism should be noted. The wheel velocity for the inverse form is obtained from

$$W = w \left( \frac{rC \cos a + r^2}{C^2 + 2rC \cos a + r^2} \right) \dots (15)$$

and the acceleration equation obtained by differentiation is

$$\text{Acc} = w^2 \left[ \frac{Cr \sin a (c^2 + r^2)}{C^2 + 2rC \cos a + r^2} \right] \dots (16)$$

where W=angular velocity of wheel, w=uniform angular velocity of crank.

(To be continued)

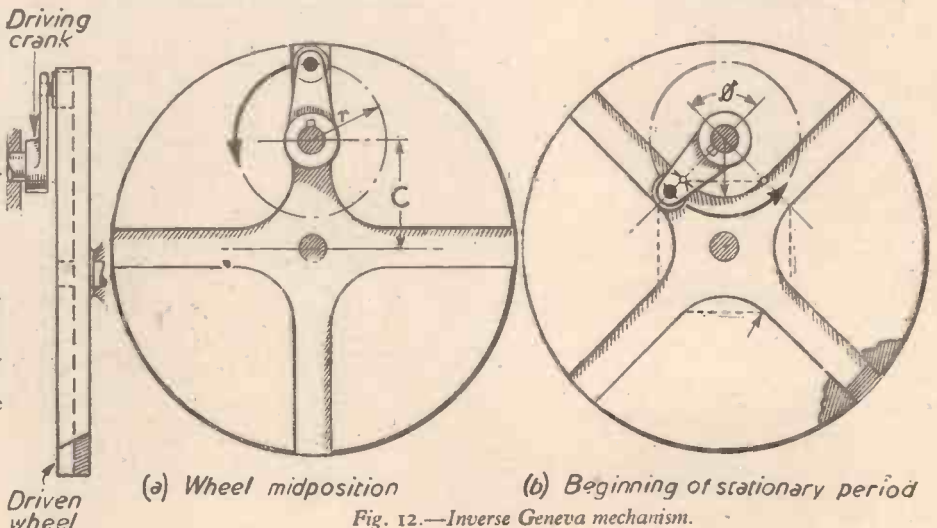

Fig. 12.—Inverse Geneva mechanism.

# THE WORLD OF MODELS

The "Barnes Model Shipyard":  
An Electrically Controlled "O"  
Gauge Railway

By "MOTILUS"

**P**ASSERS-BY alongside the Leeds and Liverpool Canal at Maghull during the last two years have occasionally seen electrically-controlled model ships skimming through the water, zealously watched by two or three schoolboys, in company with a man who was criticising or appraising the performance as keenly as the boys themselves. Had anyone stopped to enquire, they would have discovered that they were witnessing trials of one or more of the products of the "Barnes Model Shipyard."

This unusual venture was started sometime in 1947 by Mr. W. E. Barnes, an engineer's fitter, who was then living in Maghull. His idea was that his 12-year-old son, William Martin, together with two or three schoolfriends, should make model ship-building their hobby, under his own guidance. Part of the Barnes' home was turned into a miniature shipyard, equipped with the usual workshop tools. Before long it was flourishing, the boys and Mr. Barnes doing the whole of the work themselves,

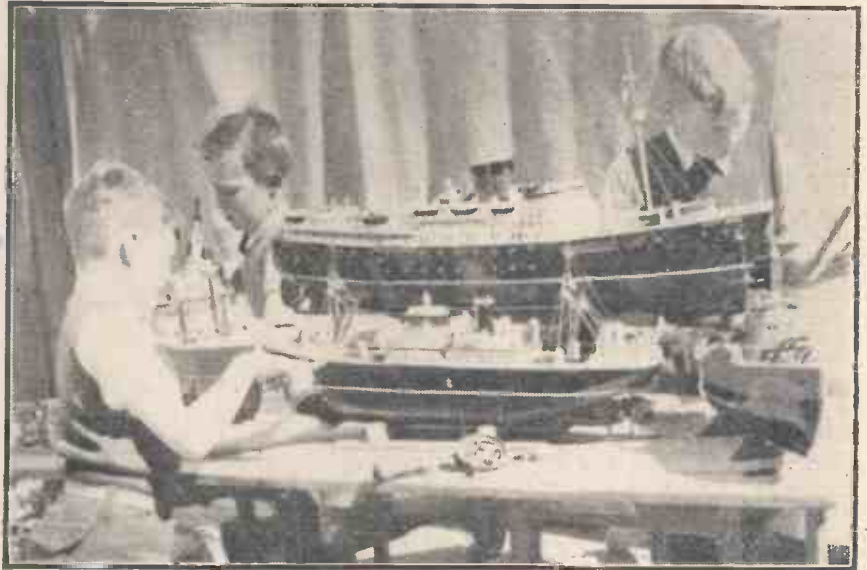

Fig. 1.—The "Barnes Model Shipyard": the team goes "full speed ahead." Master William M. Barnes is on the far right.

hull. The ultimate thickness of the hull is  $\frac{3}{16}$  in., calipers set to this measurement being used continuously during the hollowing-out process: chisel and glasspaper ensure a smooth finish.

## Superstructure and Fittings

Superstructure is built up from 16 s.w.g. aluminium sheet, windows being drilled and then filed square and backed with green celluloid. The decks are of plywood, fixed to the superstructure with panel pins, as no glue is used. Tinplate (24 s.w.g.) is used for the funnels, which have bands of wire soldered on. Lifeboats the boys carve from solid wood. In the interests of economy, Mr. Barnes collects as much "scrap" tinplate, wood and other useful odds and ends as he can. The power units, propellers and shafts and small fittings, such as vents, navigation lights, anchors, chains, sidelights, etc., have to be purchased, as the shipyard has no facilities for making these items.

Mr. Barnes insists on the best possible finish for the models, and sees that his workers use plenty of glasspaper. From three to five even coats of paint are applied to the models with camel hair brushes, the plywood decks being lined and then varnished. One of the difficulties Mr. Barnes has had to overcome is finding an easy method to help the boys determine scale proportions when dealing with the super-

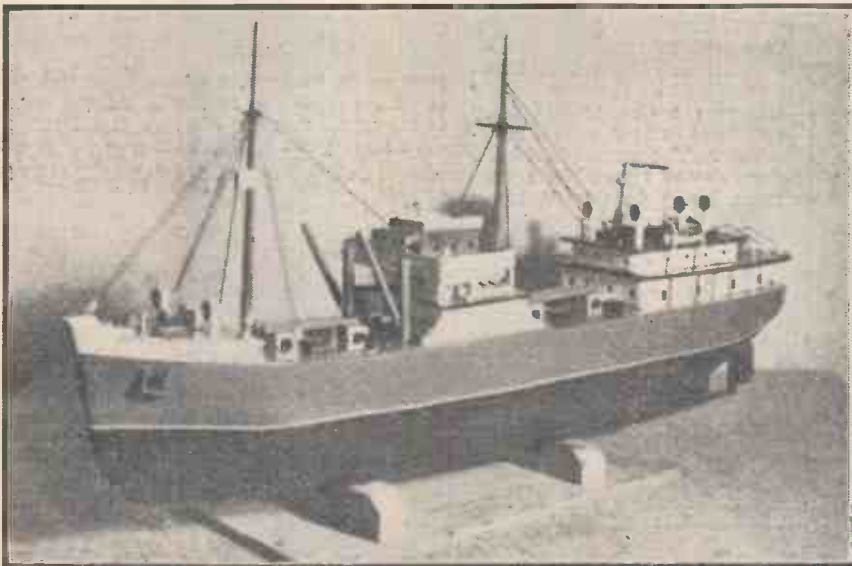

Fig. 2.—S.S. "Albil," a free-lance design from the model shipyard. This oil-tanker is 2 ft. 6 in. long and electrically-driven.

from designing and building the vessels to the launching and water trials on the canal.

Before the boys start building any model, Mr. Barnes schools them well in nautical terms, ensuring that they know the difference between bow and stern, what is meant by displacement and sheer of hull, the names for the numerous deck fittings they will have to make and where they are placed on a ship. Next he suggests that they build a ship to the boys' own design, bearing in mind that it is to be a working model, yet with as much true detail as possible.

The model hulls they usually make from white pine, using templates of card, cut in half-patterns, so that they are reversed for the second half of the hull. Card templates are again used for shaping the sides of the

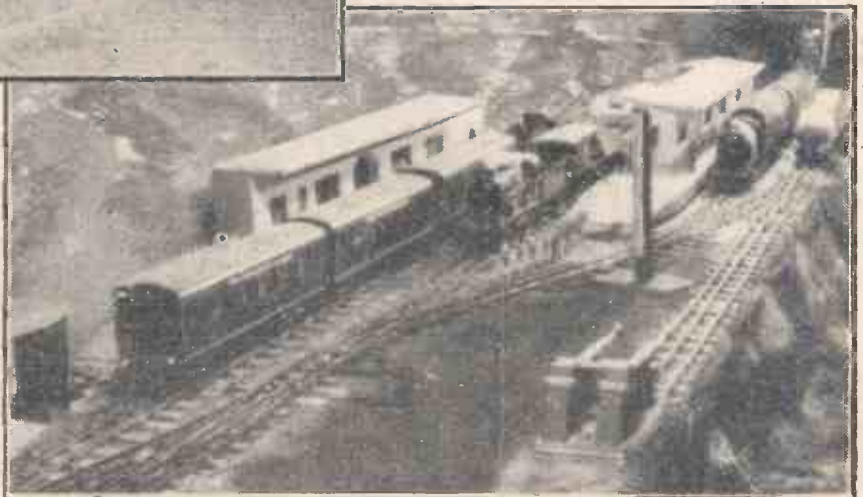

Fig. 3.—A general view of a portion of Mr. G. Stainton's gauge "O" model railway, showing one of the stations.

structure and fittings. His ingenious solution to this problem is to cut up matchsticks to represent a scale-size man: with the aid of tweezers, the model-makers can insert the matchstick alongside their work for comparison on any part of the ship.

**Model Liner "Ocean Queen"**

Mr. Barnes had made the construction of these ship models so smooth-running and efficient that it only took the team three weeks of evening and week-end work to complete the free-lance liner, "Ocean Queen," shown in the illustration (Fig. 1). During the two years that the shipyard was operating at Maghull they built models of tramp steamers, paddle steamers, cargo boats, ocean liners, tug boats, oil tankers, a clipper after the style of the well-known "Cutty Sark," and a model warship designed by 12-year-old William Barnes.

In May this year the Barnes family moved to Wilmslow, Manchester, where they look forward to renewing modelmaking activities and increasing the range of their work. When I last heard from Mr. Barnes he was busy drawing plans for a model of the magnificent Dutch liner, "Nieuw Amsterdam," so that I anticipate with pleasure further news from the "Barnes Model Shipyard."

**An "O" Gauge Model Railway**

Some time ago I was pleased to receive



Fig. 4.—Mr. Stainton's "o" gauge railway: the mouth of the tunnel that passes under the model village.

a letter from Mr. G. Stainton, of Liverpool, who has been developing a gauge O, electrically-controlled, model railway at his home in the Liverpool suburbs. The whole scheme Mr. Stainton has in mind is not likely to be complete for another 18 months or two years: even then, I do not suppose it will really be "finished," as I never knew a model railway owner who was not always planning further additions or improvements to his lay-out.

Mr. Stainton started his model railway hobby some 30 years ago at the age of six and his enthusiasm has never waned with passing years. Unfortunately, at the begin-

ning of the last war, he lost all his original outfit through enemy action. Like many other modelmakers, however, he was undaunted, and as soon as circumstances allowed he set to work to build up a new gauge O railway.

At the time I last heard, the lay-out was 30ft. long and about 6ft. wide, a portion at one end being extended to 10ft. in width to take the main railway station, engine sheds, turntable, etc. The two main tracks were 2ft. 6in. radius, although later it is hoped to extend the lay-out to provide for tracks of 5ft. radius curves. Before this can be done, however, Mr. Stainton will have to make some structural alterations in the portion of his home where the railway is housed!

All the track is permanent way, installed with wooden sleepers on a base-board and slide-on chairs. The sleepers (2in. by 1/2 in) were cut from old Venetian blinds, as Mr. Stainton's aim is, as far as possible, to make all the lay-out himself. The two main tracks are divided into four sections, each controlled by section switches in circuit, with transformer and rheostats. The sidings are also controlled by switches in circuit, with a transformer. The control board has three control areas: No. 1 main track, No. 2 main track, No. 3 sidings. The three roads through the main station can be cut out individually with switches and the same applies to the sidings. The signals, made by Mr. Stainton, are two light type and are operated from the control board.

Mr. Stainton is keen to have good scenic effects for his railway, so has covered the brick walls of the room with wall boards on which he has painted a realistic background. In addi-



Fig. 6.—A skilled craftsman puts final details on four models of the new Argentine-owned vessel, "Presidente Peron." The scale of these models is 32ft. to 1in.

tion, he has built up distant hills and mountains with the aid of mortar and cement; other scenery is built round the outside, and in the centre of the layout, including a small model village with a school, house, shops, a church and an hotel.

After much perseverance on the part of himself and a keen model-making friend, Mr. Stainton has made this layout reliable for electrical operation. The photographs I have been able to obtain do not, I fear, really do justice to this excellent railway layout, of which all but the rolling stock has been built by the owner himself. The pictures do, however, give readers some idea of this comprehensive scenic railway that is the result of so much time and interest devoted to patient craftsmanship.

**Model "Royal Scot" Loco. in Hollywood**

It is interesting to note that many model enthusiasts outside this country are keen on having models of the popular types of locomotive that run over British Railways. One of the most popular is the *Royal Scot* of the London and Midland Region. This is often the choice of Swiss model-makers, and there are also several such models in the U.S.A.

One of the well-known *Royal Scot* models is operated in the U.S.A. on a 7 1/2 in. gauge railway owned by Mr. C. N. Rineck, of Easton, Pennsylvania, who is most enthusiastic about his British-made model locomotive. Another is to be found in the far West, owned by Mr. David Rose, of Hollywood, California. In Mr. Rose's sub-tropical garden he has a fine 7 1/2 in. gauge layout, on which he runs a *Royal Scot* model locomotive made specially to his order by Bassett-Lowke, Ltd., of Northampton. Most of Mr. Rose's passenger-carrying wagons and other vehicles, however, are of American production.

In the illustration, Fig. 5, Mr. Rose is seen with his British-made locomotive on the track. I am indebted for this photograph to Mr. C. Derry, who, during a recent visit to U.S.A., called on Mr. Rose and took the opportunity of photographing



Fig. 5.—Mr. David Rose, of Hollywood, standing by his British-made 7 1/2 in. gauge "Royal Scot" locomotive.

this layout and the various locomotives.

**Scale Models of the "Presidente Peron"**

A modern liner of unusual external design has been built recently at the Barrow shipyard of Vickers-Armstrong, Ltd. This is the first of three new Argentine-owned ships for a fast passenger-cargo service between London and Buenos Aires. The name of

this first ship is the *Presidente Peron*, and she has accommodation for 74 first-class passengers and large, insulated cargo capacity. Her overall length is 629ft., breadth 71ft. She has twin screws, each driven by Parsons double reduction geared steam turbines, developing about 14,500 s.h.p., with steam supplied by two oil-fired water-tube boilers.

**Water-line Models**

The illustration, Fig. 6, shows four water-line models of this new ship being made by a professional craftsman, to a scale of 32ft. to 1in. By the time this magazine reaches readers it is expected that the *Presidente Peron* will have made her maiden voyage.

# Trade Notes

**A Side-filling Battery**

ON many commercial and passenger vehicles there is often little head-room above the battery, and access from above for filling or topping up is difficult, or impossible. Operators must have yearned for an easier battery-filling arrangement under these conditions.

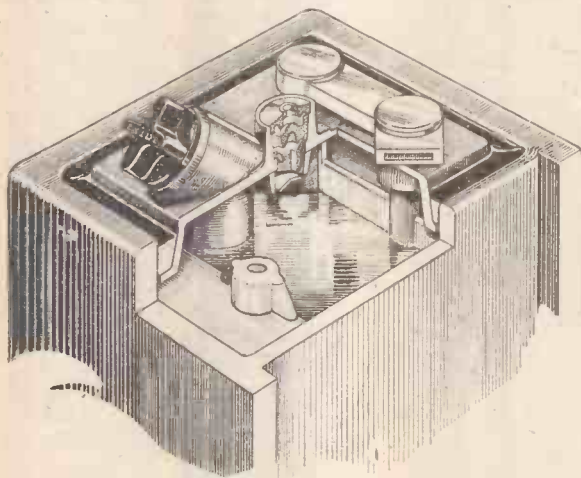

The new Exide side-filling battery.

Mindful of this inaccessibility of the battery on many vehicles, The Chloride Electrical Storage Co. Ltd., have designed a new lid for Exide-Ironclad and Exide-batteries. This embodies an inclined filling aperture so that it is easy to top or fill up from the side.

In this new lid the filling opening is located at one side and is inclined outwards to facilitate side filling, while the gas vent is centrally situated. As the side-filling plug is blind there is no risk of acid splash when the vehicle is cornering.

Batteries with the normal vertical filling opening arrangement will continue to be made and operators will be able to fit batteries with either central or side filling, depending on the location of the battery on the vehicle.

**Ripmax Ltd.**

MR. C. A. RIPON, who has over 40 years' experience of air modelling and is one of the leading lights of the Northern Heights Model Flying Club, has recently commenced business under the title of Ripmax, Ltd., 39, Parkway, London, N.W.1. He can supply all model-makers' requisites.

**Synchro Switch Handlebar Gear Control**

PRODUCTION of this precision-engineering component, successfully introduced by the Hercules Cycle Co. last year, has now reached a point where the synchro switch can be offered through the trade as a separate unit for fitment to any make of cycle, in addition to being fitted as standard to Hercules 3-speed machines.

It is claimed for the synchro switch that it has proved highly successful in operation, that it clicks easily into each position, being ratchet-operated for exact, positive and easy action.

It is finished in Hercules high-lustre chromium plating of the same high standard as all other Hercules chromium-plated parts.

Special features are that the synchro switch is suitable for any make of cycle and for any 3-speed variable gear, and that it fits any handlebar, and can be secured to the handlebar in any position to suit the rider.

This fitment, now available to any cyclist as a separate unit, is priced at 8s. complete with pulley.

**Garner's Tool**

THE May issue of this handy booklet, published

by T. Garner and Son, Ltd., of Redbrook Works, Gawber, Barnsley, contains a review of small tools and equipment, each class of tool being presented in alphabetical order for easy reference. There is some useful information about the Garner hire purchase plan and several detailed quotations for lathes and other tools. Owing

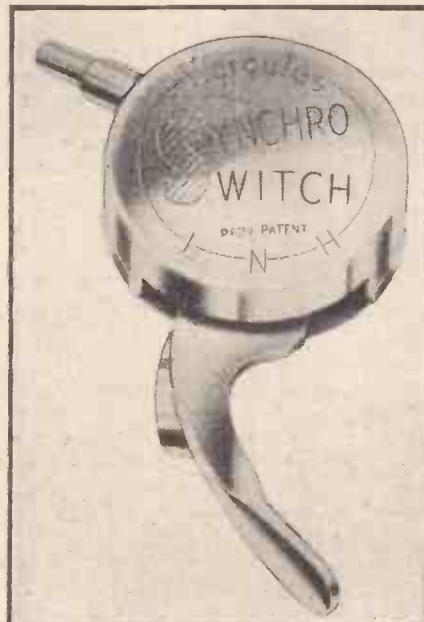

The Synchro Switch handlebar gear control.

**World's Largest Ship Model**

A VERY attractive and well illustrated brochure giving a comprehensive account of the construction of a large model of the R.M.S. *Queen Elizabeth*, has been issued by Bassett-Lowke, Ltd., of Northampton, the makers of the model. Intended for exhibition in the offices of the Cunard White Star Co. in New York, the model is built

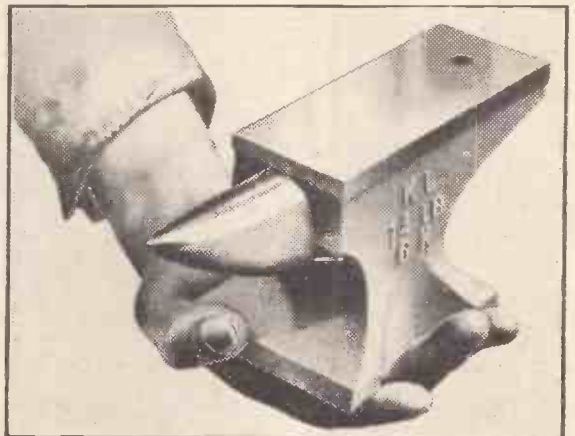

Especially useful for the small workshop is this 14lb. cast steel arvil marketed by the K. and L. Steelfounders and Engineers, Ltd., and T. C. Jones and Co., Ltd., 25-29, Bulwer Street, Shepherds Bush, London, W.12.

to a scale of 1/4 in. to the foot, and is 21ft. 7in. long overall. The weight of the model is 1 ton 7 cwt., and the total man hours expended in building the model was 6,900. The text and illustrations, showing the model liner in various stages of construction, give the reader a good idea of the work involved in producing such a fine example of the model-maker's craft.

**THE MODEL AEROPLANE HANDBOOK**

An Important New Work

By F. J. CAMM

312 Pages, 303 Illustrations, 12/6, by post 13/-.

A Short History of Model Aeronautics ; Principles of Design ; Airscrews ; Wings ; Undercarriages ; Folding Airscrews—Retractable Undercarriages ; Fuselages ; The Elastic Motor ; Gearring and Special Mechanisms ; Making Model Wheels ; Geared Winding Devices ; Model Aeroplane Stability ; Downthrust ; Model Petrol Engines ; Adjusting Model Petrol Engines ; Compressed Air Engines ; How to Form and Run a Model Aero Club ; F.A.I. and S.M.A.E. Rules ; S.M.A.E. Competition Cups ; A Lightweight Duration Model ; A Wakefield Model ; A Farman Type Model Monoplane ; A Composite Model ; Ornithopters—or Wing-flapping Models ; A Low-wing Petrol Monoplane ; A Duration Glider ; Winch-launching Model Gliders ; A Streamlined Wakefield Model ; A Model Autogyro ; A Super Duration Biplane ; Flying Model Aeroplanes ; A Flash Steam Plant ; Model Diesel Engines ; Weights of Wood ; Plane Wire Sizes, Areas and Weights ; Schedule of British Records. Fully Indexed.

Published by

GEO. NEWNES LTD, TOWER HOUSE, SOUTHAMPTON ST., STRAND, LONDON, W.C.2.

# Letters from Readers

## Cycle Rear Lights

SIR,—With reference to A. R. Jones' letter in the May issue of PRACTICAL MECHANICS on the question of rear lights, I have thought of an idea which does not entail much work and which eliminates the uncertainty of wondering whether the rear lamp is alight. It is to connect the rear lamp in series with the front lamp, as shown in the sketch. A dynamo rear lamp which is insulated from the frame is used and a lead attached which is connected to a battery in the saddle bag, the other lead being taken to a switch mounted on the handlebars, then to a front lamp, which is a battery-type converted by fixing a wooden block in place of the battery with a brass contact strip screwed to it; the circuit is completed via the frame.

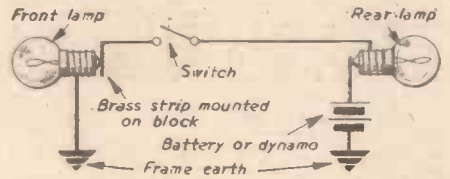

Front and rear lamps of a cycle connected in series.

Failure of the rear lamp will be noted by the front lamp also going out. There is just one more point—if a 3-volt battery is used two 1.5-volt lamps should be used, or if a 6-volt dynamo, two 3-volt lamps. The current rating should be the same for both lamps.—R. VERLANDER (Theydon Bois).

## Methanol as a Fuel

SIR,—May I draw attention to certain inaccuracies which appeared in a letter from Mr. S. Asher, Gorleston-on-Sea, in the June issue. I feel prompted to do this in view of the large number of your readers who may be misled as to the capabilities of methanol as a fuel for motor-cycles.

Mr. Asher's carburation figures are theoretically unsound, and I suggest that he is using far too low a compression ratio. The equations for the relevant reactions may be represented as follows:

(1) *Petrol*: This is a mixture of hydrocarbons, but the main constituents are pentane (C<sub>5</sub>H<sub>12</sub>) and hexane (C<sub>6</sub>H<sub>14</sub>).

(a) C<sub>5</sub>H<sub>12</sub> + 8O<sub>2</sub> oxidises to 5CO<sub>2</sub> + 6H<sub>2</sub>O. Hence, substituting the molecular weights: 72 parts of pentane combine with 256 parts oxygen.

∴ 1 part of pentane combines with approximately 3.5 parts oxygen.

(b) 2C<sub>6</sub>H<sub>14</sub> + 19O<sub>2</sub> oxidises to 6CO<sub>2</sub> + 7H<sub>2</sub>O.

Again, substituting the molecular weights: 172 parts hexane combine with 304 parts of oxygen.

∴ 1 part hexane combines with approximately 2 parts of oxygen.

Since it may justifiably be assumed that petrol, a mixture of approximately half pentane, half hexane, will require a proportion of oxygen intermediate between the above values, it follows that

1 part petrol combines with 2.75 parts of oxygen, since air is 1/5th oxygen

1 part petrol combines with approximately 14 parts of air.

(2) *Methanol* or methyl alcohol (CH<sub>3</sub>OH) oxidises to form carbon dioxide and water, viz.:

2CH<sub>3</sub>OH + 3O<sub>2</sub> oxidises to 4H<sub>2</sub>O + 2CO<sub>2</sub>. Substituting the molecular weights

64 parts of methanol combine with 96 parts of oxygen.

∴ 1 part of methanol combines with 96/64 parts of oxygen.

And, since air is 1/5th oxygen 1 part of methanol combines with approximately 7 parts of air.

It may be inferred therefore from the above figures that methanol mixtures for internal combustion engines require twice the recommended fuel concentration for petrol.

However, it is inaccurate to effect a comparison between the two fuels unless each is compressed to the maximum possible pressure before ignition. This reduces the proportion of unburnt gases to a minimum, and thus the explosions more nearly approximate to the ideal equations given above. It is common knowledge that beyond certain pressures fuels have a tendency to detonate, giving rise to the phenomenon known as pre-ignition. The limiting pressure in the case of petrol is approximately 90lb. per sq. in., whereas methanol may safely be compressed to as much as 180lb. per sq. in. Hence to run a petrol engine efficiently on methanol it is essential to raise the compression ratio until the compression pressure approaches 180lb. per sq. in. This point, I feel sure, has been neglected by your correspondent and is the cause of the poor starting, slow running and low mileage to the gallon he mentions. It also accounts for the rich mixtures he has to use to get his engine to run at all. I am aware that it is difficult to increase the compression ratio of two-stroke engines with a deflected top piston without altering the position of the top of the piston relative to the ports, but Mr. Asher makes no mention of the point at all. I can only assume, therefore, that he has not considered it.

In conclusion, my own experiences with methanol have shown that my motor-cycle will run much quieter, cooler and give me greater acceleration than petrol. I can obtain a little over half the mileage to the gallon that I used to obtain with petrol.

Hoping the above information will be of use to any of your readers contemplating the conversion of their motor-cycles to methanol.—S. A. SPOUSE (Chippenham).

## Workshop Soldering Stand

SIR,—The accompanying sketches show a simple soldering outfit for those having workshops without gas or electricity. The device is a most useful, almost indispensable,

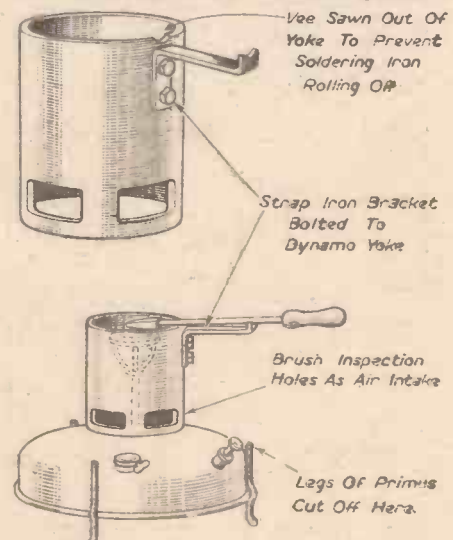

A handy soldering stand for the workbench.

device, being very easily made. It gives years of trouble-free service. The only materials required are an old dynamo yoke and a strip of mild steel or strap iron 10in. by 1in. by 1/16in. Minc has been in constant use for over 10 years, with different pressure stoves.

I have been, since 1936, an admiring reader of PRACTICAL MECHANICS and look forward to every issue.—G. W. HOUGHTON (Chester).

## Repairing Broken Records

SIR,—Here is a method I use for repairing broken records, and it is much cleaner than the sticky paper method. Take four pins and cut the heads and points off with a pair of pliers. Get someone to hold the pieces together (the grooves can be adjusted under a magnifying glass) and then hold one of the

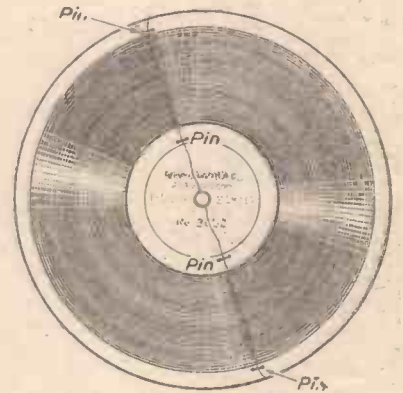

A simple method of repairing broken records.

pins in the gas with the pliers until red hot and push it into the outside of the record, making sure not to touch the grooves. Repeat with other side of the record, and then do the same on the inside near the paper, again making sure not to touch the grooves; the repair is then completed. It will be found after four or five playings that the clicking noise reduces considerably.—A. COOMBER (Wallington).

## Fountain Pens

SIR,—I feel I cannot let a statement of Mr. E. W. Baigent (June issue) go unchallenged.

He says—"why not pour the ink into the barrel—petrol lighters do not have self-filling gadgets, so why fountain pens?"

I am a user of both fountain pen and lighter and my wife does not care to see patches of ink on the carpets, nor do I care to fill my pen over the kitchen sink every time this requires doing. When I fill my lighter by pouring in petrol I frequently drop petrol on the carpet but this does not bother me a scrap—it soon dries up.—C. B. LANCASTER (Lattenbury Hill).

A NEW VEST POCKET BOOK

NEWNES METRIC & DECIMAL TABLES

By F. J. CAMM

3/6 or 3/9 by post from

Geo. Newnes, Ltd., Tower House, Southampton St., Strand, W.C.2.



SPECIALISTS  
IN LIGHT  
MACHINE  
TOOLS

*Myford*  
ENGINEERING CO. LTD.

CABLES  
MYFORD  
BEESTON  
NOTTINGHAM

ENGINEERING CO. LTD. BEESTON NOTTINGHAM ENGLAND

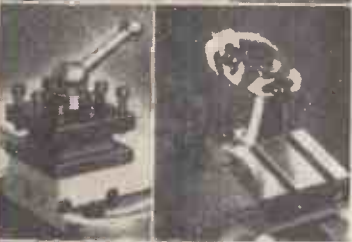
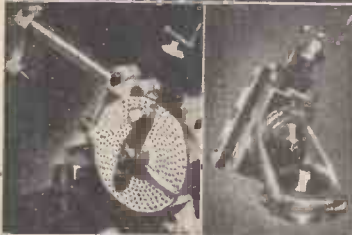

DO NOT FAIL TO VISIT  
THE 24th ANNUAL

# MODEL ENGINEER EXHIBITION

NEW ROYAL HORTICULTURAL HALL, WESTMINSTER

AUG. 17th to AUG. 27th inclusive

## DEMONSTRATIONS OF MYFORD

METALWORKING AND WOODWORKING  
LATHES AND ATTACHMENTS WILL BE GIVEN DAILY

**MYFORD**  
3½ HEAVY DUTY LATHE  
TYPE M.L.7

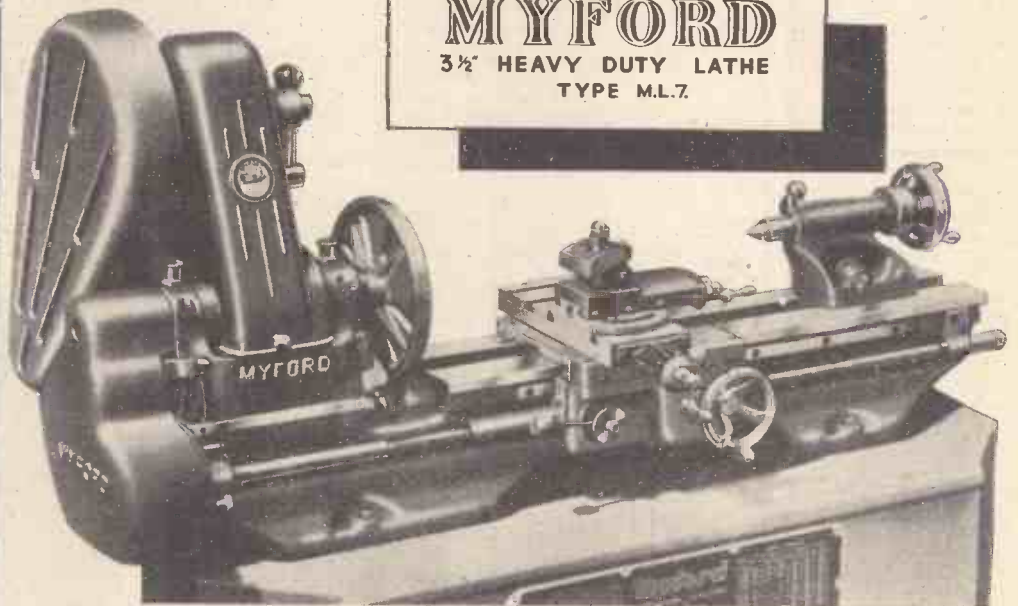

SEE OUR **STAND 6.**

# GALPINS

ELECTRICAL STORES

403 HIGH STREET, LEWISHAM, LONDON, S.E.13

Telephone: Lee Green 0309. Near Lewisham Hospital

TERMS: CASH WITH ORDER. N.O.C.O.D. THURSDAY EARLY CLOSING

**MAINS TRANSFORMERS**, input 200-250 v., 50 cycles, in steps of 10 v. Output 450/1450 v. 250 mla., 4 v. 4 a., 5v. 4 a., 6.3 v. 8 a., 6.3 v. 8 a., 62/6. Ditto 450/1450 v., 250 mla., 6.3 v. 8 a., 5 v. 4 a., 4 v. 8 a., 4 v. 8 a., 60/-. Another 500/350/1350/500 v., 250 mla., 6.3 v. 8 a., 0, 4, 5 v. 4 a. twice. 6.3 v. tapped at 2 v. 2 a., 4 v. 4 a. 350/1350 v., 300 mla., 4 v. 8 a., 4 v. 4 a., 6.3 v. 4 a., 6.3 v. 8 a., 6.3 v. 8 a., 4.4 a., 5 v. 4 a., 67/6.

**EX-R.A.F. MICROPHONE TESTERS** (new). These consist of a Ferranti 0 to 450 mamp. 2 1/2 in. scale meter shunted to 1 mla incorporated Westinghouse Rectifier, the whole encased in polished teak case, calibrated at present 0 to 10 v., 25/- each.

**ELECTRIC LIGHT CHECK METERS** (Watt-Hour). A.C. 50 cys., 200/250 v. 5 amp. load, 18/6, post 2/-, 10 amp., 21/-, post 2/-, 20 amp., 25/-, post 2/-; also a few only Pre-Payment 1 1/2 slot type, 20 amp. load, less coin box, complete with synchronous motor, 35/- each, carriage 3/6.

**SPECIAL OFFER METERS**, all new, boxed. Moving Coil first grade instruments, 0 to 20 v., 10/- each, or 3 for 25/-; 0 to 40 v., 12/6 each; 0 to 10 amps., 15/- each, all 2 in., scale, 0 to 20 v., A.C., calibrated 50 cycles, 25/- each; 0 to 40 amps., thermo-coupled, 25/- each.

**MAINS TRANSFORMERS**, all 200/250 v., 50 cys., 1 phase, input, output 700/1700 v., 70 mla., 4 v. 2 1/2 a., 12 v. 1 a., 30/- each. Another 525/525 v., 150 mla., 6.3 v. 5 a., 5 v. 3 a., 37/- each. Another 2,350 v. at 500 mla., 85/- each. Mains Smoothing Chokes, 10 Hy. 100 mla., 6/-; 150 mla., 8/6; 350 mla., 25/-; 5 Hy., 250 mla., 17/6.

**EX-R.A.F. ROTARY CONVERTERS**, 12 v., D.C., input 230 v. A.C., 50 cys. 1 phase at 100 w. output, 85/- each, carriage 3/6. Ditto 24 v. input, 65/- each, carriage 3/6.

**PRE-PAYMENT 1 1/2 SLOT ELECTRIC LIGHT CHECK METERS**, 200/250 volts, 50 cys. 1 ph. 2 1/2 amp. load, 30/- each, carriage 3/6; 5 amp. load, 35/-, carriage 3/6. 10 amp. load, 42/6 each, carriage 3/6.

**MAINS TRANSFORMERS INPUT**, 200/250 volts in steps of 10 volts output tapped 6, 12 and 24 volts at 25 amps., 65/- each, carriage 3/6. Another 230 volts input with 3, 4 volt windings at 5 amps., 25/- each. Another 200/250 volts input output 6, 12 and 20 volts at 4 1/2 amps., 27/6 each, post 1/6.

**MOTOR ALTERNATORS**, ex-R.A.F., as new, 230 v. A.C. 50 cys. 1 ph. input. Output 250 v. 625 cys. 1 ph. at 24 amps., 75/- each. Ditto 1,725 cys. output, 85/- each. Please note both these machines require a 24 v. D.C. excitation.

**SYNCHRONOUS MOTORS** 200/250 VOLTS, 50 cys. 1 ph., convertible as Clock Movement, 12/6 each. Resistances 350 ohms to carry 25 amps. (fixed) but can easily be fitted with a slider, 8/6 each.

**EX-R.A.F. I.F.F. UNITS CONTAINING 10 VALVES**, EF50s, SP61s, EA50s, etc., power supply Motor generator 12 volts D.C. input 450 volts, 50 Mamps. output, and many other useful components as new, 32/6 each. Ditto with a 24 volt input Generator Valve sequence slightly different. Generator can easily be converted to run as a Motor off A.C. mains, 30/- each.

**SHORT WAVE COUPLING AERIAL UNITS** (Wavemeters), absorption type wound with 20 and 12 gauge Silver plated wire, 2 1/2 to 5 1/2 meters, 3/6 each. No. 19 VARIOMETERS containing H.V. Condenser Instrument Rectifier, useful for parts, 3/6 each.

**EX-NAVAL TELEPHONE HANDSETS** BAKELITE PATTERN (self-energised), no battery required, complete with wall bracket (new), 15/- per pair, post 1/6. Ditto complete with Buzzer ringing mounted in weather proof box, 24 volt required for energising Buzzer only, complete with Hand-set, 15/- each, or 25/- per pair.

**EX-NAVAL NAVIGATION INSTRUMENT** Containing F.H.P. 230 volt A.C./D.C. Motor, first grade 3 1/2 in. scale ohmmeter. Standard Potentiometers 2, other Resistances both variable and fixed also some very useful 10-in. Metal Gears (new), 65/- each, Carriage 10/-.

**MAINS VARIABLE STUD SWITCH-ARM TYPE**. Resistances 25 Studs, 50 ohms to carry 1.4 to 9 amps., 30/- each. 10 ohms, to carry 9/14 amps., 32/6 each, many other types in stock, please forward your enquiries.

# —TAKE UP PELMANISM—

## For Courage and Clear-Thinking

**The Grasshopper Mind.**

**YOU** know the man with the 'Grasshopper Mind' as well as you know yourself. His mind nibbles at everything and masters nothing.

At home in the evening he tunes in the wireless—tires of it—then glances through a magazine—can't get interested. Finally, unable to concentrate on anything, he either goes to the pictures or falls asleep in his chair. At his work he always takes up the easiest job first, puts it down when it gets hard and starts something else. Jumps from one thing to another all the time.

There are thousands of these people with 'Grasshopper Minds' in the world. In fact, they are the very people who do the world's most tiresome tasks—and get but a pittance for their work. They do the world's clerical work, and the routine drudgery. Day after day, year after year—endlessly—they hang on to the jobs that are smallest salaried, longest houred, least interesting, and poorest futured!

**What is Holding You Back?**

If you have a 'Grasshopper Mind' you know that this is true. And you know why it is true. Even the blazing sun can't burn a hole in a piece of tissue paper unless its rays are focused and concentrated on one spot. A mind that balks at sticking to one thing for more than a few minutes surely cannot be depended upon to get you anywhere in your years of life!

**What Can You Do About It?**

Take up Pelmanism now! A course of Pelmanism brings out the mind's latent powers and develops them to the highest point of efficiency. It banishes such weaknesses and defects as Mind Wandering, Inferiority and Indecision, which interfere with the effective working powers of the mind, and in their place develops strong, positive, vital qualities, such as Optimism, Concentration and Reliability, all qualities of the utmost value in any walk of life.

The general effect of the training is to induce an attitude of mind and a personal efficiency favourable to the happy management of life.

Half-fees for serving and ex-Service members of His Majesty's Forces. (Apply for Services Enrolment Form.)

The Pelman Course is fully described in a book entitled, "The Science of Success." The Course is simple and interesting, and takes up very little time; you can enrol on the most convenient terms. The book will be sent you, gratis and post free, on application to—

**PELMAN INSTITUTE,**  
130, Norfolk Mansions

Wigmore Street, London, W.1  
(Established over 50 years) Callers welcomed  
**PELMAN (OVERSEAS) INSTITUTES: PARIS** 176 Boulevard Haussmann, AMSTERDAM: Damrak, 68. **NEW YORK:** 271 North Avenue, New Rochelle. **MELBOURNE:** 288, Flinders Lane. **JOHANNESBURG:** P.O. Box 4928. **DURBAN:** Natal Bank Chambers (P.O. Box 1489). **DELHI:** 10, Allpore Road. **CALCUTTA:** 102, Clive Street.

## THE LATEST TYPE FIXED CRYSTAL DETECTOR THE CRYSTAL VALVE

as used in radar receivers.

Overall size 2 1/2 in. x 1 1/2 in.

### AMAZING RESULTS

3/- each, postage 2 1/4 d.

Protective Tube and Fixing Brackets, 3d. each.

Wiring instructions for a cheap, simple but high quality Crystal Set included with each Detector.

## CRYSTAL SET INCORPORATING THE LATEST CRYSTAL VALVE

Adjustable Iron Cored Coil

### RECEPTION GUARANTEED

Polished wood cabinet, 15/- post 9d. Send S.A.E. for lists of copper wires, screws, nuts, paxolin tubes, ebonite, tumof rod and panels, etc.

## POST RADIO SUPPLIES

33 Bourne Gardens, London, E.4

## CHEMISTRY APPARATUS

Send Stamp for COMPLETE PRICE LIST



Booklets:  
"Experiments" 7d.  
"Formulas" 10d.  
"Home Chemistry" 2/3  
Post Paid

**BECK** (Scientific Dept. A)  
60 HIGH STREET,  
Stoke Newington, London, N.16

## Mail Orders to: WALTON'S WIRELESS STORES 203, STAVELEY ROAD, WOLVERHAMPTON

Remember all is Carriage Free to any address in Great Britain.



Industrial Type Adjustable Lamp, complete with Reflector, less Lampholder and Wiring, 22/6.



50v. 50 cycle 3 ph. Motor, complete in Transit Case, 15/-.



Magnificient Gun Sighting Telescope, complete in Stowage Box, 67/6.

Send S.A.E. for our latest Illustrated Bargain List. You will be amazed at the value we offer.

Callers only: WALTON'S WIRELESS STORES, 48, Stafford Street, W. ton.

## Jubilee PATENTED WORM DRIVE CLIP

\*Wholesale dealers please use this form. All orders are subject to credit being made by bank transfer.  
Drive Clips. They are up to my price.



THE FINEST CLIP IN THE WORLD.

\*Write for details, quoting reference RP/12.

L. ROBINSON & CO. (LILLINGHAM) LTD.  
Lillingham Lane

**ELECTRIC ENGRAVERS.**—Powerful instruments in flat case. Suitable for dot collars, tool marking. Writes on glass, metals, plastics. Plugs into any lampholder. A.C. Mains model, 200-240 volts or 6v. battery. Price 42/6. Post 3d.  
**TELEPHONE SETS**, comprising 2 G.P.O. hand phones, 2 bells, 2 pushies and 80ft. twin wire. Price 48/6, post free. Makes an excellent inter-office, works or domestic installation. Really professional instruments. Brand new, not rubbish. Single instrument, 11/6.  
**MOTOR**—4-6v. dry battery driven, well made, powerful, 11/6. Illustrated list, 3d.

**BATTERY CHARGERS** for A.C. MAINS. FOR CHARGING 2-volt accumulators at 1 amp. Parts with diagram, 15/-, Complete, 21/6. Postage 10d.  
**FOR TRICKLE CHARGING CAR CELLS**, parts with diagram. Output 1 1/2 amps. for 6v. cells, 26/6 set. For 12v. cells, 28/6 set. Post 10d. Complete on Open Metal Base, 35/6. Post 1/-, See List for larger sizes.  
**PHOTO-ELECTRIC CELLS**—For all sound films, high fidelity production, speech and music. Small tube size, 2in. x 1 1/2 in. dia., 26/6. Midget tube, 1in. x 1 1/2 in., 22/6.  
**COMPLETE OPTICAL SYSTEM** for 35 or 16 mm. sound film, 2in. long, 1 1/2 in. diam., projects 0.0005in. light line. Price 22/6.

**ECONOMIC ELECTRIC CO.,**  
64, London Road, Twickenham, Middlesex. Tel.: POPesgrove 1313

## A SUPER POLISHING HEAD



AS ILLUSTRATED.  
27/6  
CARRIAGE PAID.  
(without chuck 20/-)

Dual Driving Pulley, fully shrouded, Self Lubricating Bushes, 3 Jaw Lin. Capacity Chuck. (The case is sprayed an attractive metallic blue). From  
**MORTONS,**  
13, CAMDEN ROAD,  
WALTHAMSTOW, LONDON, E.17.

## THE WORLD'S GREATEST BOOKSHOP

**FOYLES**  
\* FOR BOOKS \*

New and secondhand Books on every subject. Stock of 3 million volumes

Large Dept. for Technical Books

119-125 CHARING CROSS RD. LONDON, W.C.2

Gerrard 5660 (16 lines)  
Open 9-6 (inc. Sats)

## PERFECT PASTIMES FOR PLEASURE AND PROFIT

The Magazine *Craftworker* lists Tools, Materials, Equipment & Fittings for all profitable Crafts at Home; and Instruction Books, Booklets, and Leaflets on Leatherwork, Lamp shades, Plastics, Toys, China and Glass Painting, Art Jewellery, Toys, Models and a host of other Crafts that are Different.

Send 11d. for specimen and full lists to—  
**Dept. 2, HOMECRAFTS,**  
Albion St., Broadstairs, Kent

## INSULATED COPPER WIRE.

Enamel, silk or cotton covered, all gauges 13 S.W.G. to 44 S.W.G. Leatheroid insulation, Empire cloth, armature sleeving, commutators, etc.

**SPECIAL OFFER.**—A.C. Single Phase Electric Motors. New, 1 h.p. £5 10s. 1 h.p. £6 10s. 1 h.p. £7 12s. Send S.A.E. for List.

L. C. NORTALL, 16, Holly Road, Quinton, Birmingham, 32.

# QUERIES and ENQUIRIES

A stamped addressed envelope, three penny stamps, and the query coupon from the current issue, which appears on page 88 (THE CYCLIST), must be enclosed with every letter containing a query. Every query and drawing which is sent must bear the name and address of the reader. Send your queries to the Editor, PRACTICAL MECHANICS, Geo. Newnes, Ltd., Tower House, Southampton Street, Strand, London, W.C.2.

## Glazing Plaster Casts

COULD you please give me some information regarding plaster casts, and in particular: (1) What is the process of glazing plaster casts? Also, do the glazed casts have to be baked in a kiln? (2) Are there any books on the subject?—H. Phillips (London, N.W.)

(1) PLASTER casts (and by the term "plaster" we presume you refer to plaster of Paris) are not usually glazed in a kiln. Their glaze is merely an applied enamel, a base or ground enamel being brushed or sprayed on, and the decoration hand-painted on the cast.

To prevent the absorption of too much of the enamel it is a good plan to brush over the cast a warm gelatine solution, one containing, say, 10 parts of gelatine dissolved in 90 parts of water. After the cast has dried, it should be painted with a flat white paint, and, after that, with any enamel paints which you may have available either as oil paints or as cellulose enamels.

For glazing purposes the base material must be of baked clay, which is much more enduring at high temperatures than mere plaster.

(2) There are no books specifically on the subject of painting plaster casts, but the following books will, most likely, be of interest and use to you: S. W. Antonies: Pottery and Modelling. C. F. Binns: The Potter's Craft: A Practical Guide for the Studio and Workshop. R. Lunn: Pottery: A Handbook of Practical Pottery for Art Teachers and Students. Modelling with Self-Setting Clay. (Dryad Leaflet). Modelling and Casting for Children. (Dryad Leaflet.) H. and D. K. Wren: Pottery: Finger-built methods. It is possible that Dryad Handicrafts, Ltd., St. Nicholas Street, Leicester, may also have some pamphlets of the same or allied subjects.

## Treatment of Old Furniture

I HAVE an old chest of drawers which was mahogany stained and polished. To remove this colour I washed the chest with strong caustic soda dissolved in warm water. The drawers now are dry and perfectly free from stain and polish, but on examining the wood I find the grain is comparable to that of ash or elm. The information I require now is how to treat the wood so as to get as reasonable a furniture finish as possible, so that the chest of drawers will have a light oak appearance.—A. Ridley (Birtley).

IT is not common to find these chests in ash or elm, but possibly it may be made of birch which was, at one time, used for furniture-making in this country. Since the chest is an old one, we do not think that you will ever get it back to a light oak shade. In fact, in our opinion it would be a pity to make any such attempt, since by so doing you would destroy whatever antique value the chest may have.

By treating the chest with strong caustic soda you will have lightened the wood almost to a maximum extent. You must now give it a thorough and patient sandpapering all over until you smooth down the rough surface which the caustic soda treatment must have given to it. Then, if you wish to keep the wood at its lightest colouration, simply give it two thin coats of a clear cellulose varnish.

On the other hand, if the chest has to have an antique appearance, give it a liberal treatment with a mixture of raw linseed oil and turpentine (applied hot). Let the oil soak in for a week or more, then give the wood a light varnishing with shellac polish. Finally, give it a rubbing down with any good household wax polish or, better still, with a solution of beeswax in turpentine. This treatment will, of course, darken the wood.

If you insist on the wood being whitened brush over the bare woodwork a thin paste of chloride of lime and water. Let this dry on. Then brush over the surface either dilute hydrochloric acid or dilute acetic acid. One part acid in three parts water is the strength to use. Do this out of doors and preferably in the sunshine, since the latter facilitates the bleaching action. Repeat the process if necessary, then swirl off thoroughly with plenty of water. Allow to dry slowly. Sandpaper well, then finally give a light coating of a clear cellulose varnish. This will give the lightest possible effect on the woodwork.

At the same time, if your chest is of any artistic or antique value, this bleaching treatment will ruin it from these standards.

## Removing Carbon Deposits from I.C. Engines

I BELIEVE that certain preparations are obtainable for removing carbon deposits from the interior of internal combustion engines without dismantling.

I shall be glad if you will inform me where I can get one of these preparations. I should also be interested to know how they work, as I have always understood that carbon can only be removed by burning with an oxygen flame or by mechanical methods.—D. G. Preston (Bury).

THERE are no preparations which are capable of dissolving carbon from the interiors of internal combustion engines. At the best, any such preparations can only loosen loosely adherent carbon masses and thereby dislodge them. There is no known solvent of carbon (apart from molten iron and a few other similar impossibilities), so do not be deluded by statements to the contrary.

The carbon "solvents" to which you refer comprise nothing more than alkaline solutions. They vary from strong solutions of caustic soda to mildly alkaline solutions such as various mixtures of sodium metaphosphates, metasilicates and percarbonates, with or without suitable admixture with a wetting agent, such as Teepol-X. Such solutions are effective inasmuch that they serve to dislodge loose carbon particles, but they do not dissolve such particles. Hence, the loosened matter has to be removed by swilling or by scraping.

If you want to experiment with one such preparation, here is a suitable formula:  
Sodium carbonate .. 6oz.  
Caustic soda .. 2oz.  
Trisodium phosphate .. 2oz.  
Sodium silicate .. 1oz.  
Water .. 1 gallon.  
To the above may also be added 1 fluid oz. of a wetting agent such as Teepol-X, which is now being produced by Shell Chemicals; Ltd., Strand, London, W.C.2.

## Laying Cement Paths

I AM contemplating the laying of cement paths around my house and garden, but I cannot estimate the amount of material which will be required to complete the work.

Readers are asked to note that we have discontinued our electrical query service. Replies that appear in these pages from time to time are old ones, and are published as being of general interest. Will readers requiring information on other subjects please be as brief as possible with their enquiries.

The area to be laid is approximately: Length, 100yds.; width, 2ft. 6in.; depth, 2in.

Can you give me an estimate of the amount of material required, also a mixture which would make strong and durable paths?—S. Copeland (Ilford).

A GOOD cement mix for your purpose will be:  
Portland cement .. 1 part (by volume)  
Sharp sand .. 2 " "  
Fine sand or grit .. 1 " "

Half the depth should be filled loosely with irregularly-shaped stone fragments, but each fragment must not be more than approximately 1/2 in. diameter or width.

Before attempting the path proper try out the above mix on a spare piece of ground, this being 1 sq. ft. in area. Find out the weight of the trial sample and, remembering that one-quarter of this is composed of cement, you will be able to work out the amount of cement needed for the whole job. We cannot do this for you in view of the fact that you will be using larger stones, which will reinforce the material and whose presence in the concrete will render less of the material necessary.

## Colour Photography

I WISH to undertake a little experimenting in colour photography, and shall be pleased if you will inform me on the following point:

What is the formula for the active emulsion used on films and plates (all colours), and the method of applying this emulsion to glass plates?—F. K. Morton (Leyton).

IT will be impossible for you to prepare for yourself photographic emulsions for natural colour photography. In the first place, all successful emulsions of this type are made up to highly secret formulae, and their method of preparation is also secret. Again, plates and films for natural colour-work are mostly of the "composite-emulsion" type. That is to say that the film or glass substratum receives several separate emulsions, one on top of the other, with all sorts of inter-layers of varnish, etc., between them. Unless an individual was highly skilled in this delicate work, and was in possession of factory methods and secrets, he would not be able to prepare any such emulsions for himself. Even textbook descriptions of principles will hardly help in this connection.

Again, the processes of developing and fixing of the natural-colour emulsions depends greatly on the actual nature of the emulsions and the process which is being used. There is no general process for developing colour emulsions. Each type of emulsion needs special conditions of development.

You should read one of the several modern textbooks on the principles of colour-photography, such as: D. A. Spencer: Colour Photography in Practice. R. M. Fanstone: Colour Photography. K. Heney: Colour Photography for the Amateur. These should be available in your nearest reference library.

## Fireproofing Fabrics

CAN you supply me with the names of chemicals used for fireproofing clothes, also instructions how to use same, and where they can be obtained.—T. Menamay (Millerston).

THERE are various chemical solutions which may be used for fireproofing fabrics. Some are better than others for any given type of fabric, but since you do not mention the type of fabric which you have in mind we can only advise you to make your own trials. In every case, the fabric material is soaked in the cold solution for four or five hours, after which it is withdrawn, passed through a mangle and hung up to dry. Note particularly that no chemical solution will confer absolute fire resistance on a fabric. If the surrounding temperature is high enough the fabric may smoulder and thus become destroyed, but it will not ignite. The only 100 per cent. fireproof fabrics are those which are woven from asbestos fibre. These will withstand white heat.

Any of the following solutions may be used for your purpose:

(1) Sodium tungstate .. .. .	1 part
Water .. .. .	9 "
(2) Borax .. .. .	12 parts
Epsom salts .. .. .	9 "
Water .. .. .	80 "
(3) Alum .. .. .	3 parts
Sodium phosphate .. .. .	1 "
Water .. .. .	20 "
(4) Sal ammoniac .. .. .	15 parts
Boric acid .. .. .	6 "
Borax .. .. .	3 "
Water .. .. .	100 "

When making up any of these solutions use hot water and dissolve the ingredients one by one.

All the above ingredients can be obtained from a local pharmacist. If you have difficulty in obtaining sodium tungstate apply to your nearest chemical wholesaler or to Messrs. Vicsens, Ltd., 148, Pinner Road, Harrow, Middlesex.

## Lens for Home Cinematograph

I AM desirous of making a home cinematograph. Could you advise me as to the type of lens required to make a picture about 4ft. square at a distance of about 10ft. from the lantern? Also, could you tell me if any ex-Service gadget now on the market would provide a suitable lens?—A. Troupe (Sunderland).

### THE P.M. BLUEPRINT SERVICE

12 FT. ALL-WOOD CANOE.\* New Series. No. 1. 3s. 6d.  
10-WATT MOTOR. New Series.\* No. 2. 3s. 6d.  
COMPRESSED-AIR MODEL AERO ENGINE.\* New Series. No. 3. 5s.  
AIR RESERVOIR FOR COMPRESSED-AIR AERO ENGINE.\* New Series. No. 3a. 1s.  
"SPORTS" PEDAL CAR.\* New Series. No. 4. 5s.  
F. J. CAMM'S FLASH STEAM PLANT.\* New Series. No. 5. 5s.  
SYNCHRONOUS ELECTRIC CLOCK. New Series. No. 6. 5s.\*  
ELECTRIC DOOR-CHIME. No. 7. 3s. 6d.\*  
ASTRONOMICAL TELESCOPE. New Series. No. 8 (2 sheets). 7s.\*  
CANVAS CANOE. New Series. No. 9. 3s. 6d.\*  
DIASCOPE. New Series. No. 10. 3s. 6d.\*  
EPISCOPE. New Series. No. 11. 3s. 6d.\*  
PANTOGRAPH. New Series. No. 12. 1s. 6d.\*  
£20 CAR\* (Designed by F. J. CAMM). 10s. 6d. per set of four sheets.  
MASTER BATTERY CLOCK\* Blueprints (2 sheets). 3s. 6d.  
Art board dial for above clock, 1s.  
OUTBOARD SPEEDBOAT. 10s. 6d. per set of three sheets.  
SUPER-DURATION BIPLANE\* Full-size blueprint, 2s.  
The 1-c.c. TWO-STROKE PETROL ENGINE\* Complete set, 7s. 6d.  
STREAMLINED WAKEFIELD MONOPLANE—3s. 6d.  
LIGHTWEIGHT MODEL MONOPLANE Full-size blueprint, 3s. 6d.  
P.M. TRAILER CARAVAN\* Complete set, 10s. 6d.  
P.M. BATTERY SLAVE CLOCK\*—2s.  
The above blueprints are obtainable, post free, from Messrs: George Newnes, Ltd., Tower House, Southampton Street, Strand, W.C.2.  
An \* denotes constructional details are available, free, with the blueprint.

YOU can use any type of projection lens or objective for your purpose, and since you ask for useful data on this matter, we append below three formulæ from which you will readily be able to calculate projection requirements under any varying conditions.

Let:

- D = Distance of lens from screen.
- F = Focal length of lens.
- X = Diagonal of frame (i.e., of single picture) of film.
- Y = Diagonal distance of projected picture.

Then:—

$$D = \frac{Y \times X}{F}$$

$$Y = \frac{D \times X}{F}$$

$$F = \frac{D \times X}{Y}$$

A projection lens from any available ex-Service optical device would suit your purpose, provided that its focal length is not too great, say, not more than 4in. You should consult our advertisers for particulars of any such lenses, or, alternatively, try Messrs. Broadhurst Clarkson, Ltd., Farringdon Road, London, E.C.4.

**Ultra-violet Light: Focusing Infra-red Rays**

WOULD you please give me details of an inexpensive method of producing ultra-violet light?

Also, do any substances become fluorescent under infra-red light? If so, which substances? Is there an inexpensive method of producing infra-red light?

How can these rays be focused, as I believe glass would absorb at least the ultra-violet rays?  
—B. Rosen (Streatham).

ULTRA-VIOLET rays are produced by (a) an arc lamp or (b) by a mercury-vapour lamp. In each case the U.V. rays are accompanied by visible light rays. Hence, to obtain pure U.V. rays from either source you would require an ultra-violet filter before the lamp and through which the rays would pass. This filter would suppress all visible rays and would pass only U.V. rays. Filters of this nature are very expensive.

Infra-red rays do not excite fluorescence, although endeavours have been made to prepare chemical materials which will fluoresce under these rays.

Any source of heat automatically produces infra-red rays. An electric iron, a small bowl fire (electric), an electric soldering-iron, indeed, any heated object, is a producer of such rays. The higher the temperature of the object the smaller the wave-length of the rays and the more visible they become. True infra-red rays are invisible. They are merely heat rays.

By placing an infra-red filter in front of, say, an electric bowl fire or any red-hot object the visible rays are suppressed, and only the invisible infra-red rays are passed. Such filters can be obtained from Ilford, Ltd., Ilford, or from Kodak, Ltd., London, W.C.2. Filters of this type are used for photographic purposes.

To some extent, both ultra-violet and infra-red rays can be focused and manipulated by ordinary glass lenses, although it is true that glass absorbs both of them to some extent. A rock-salt lens is transparent to infra-red rays, and a quartz lens to ultra-violet rays. Both these are very expensive, and are only supplied to special order. For all ordinary work ordinary lenses are quite suitable.

**Laying Lino on a Tiled Floor**

CAN you advise me regarding the laying of lino on a red-tiled kitchen floor?

Presuming that, however well-built the house, there is bound to be a slight rising of moisture from such a floor, I have been advised to sprinkle a layer of sawdust on the tiles, on which to lay the lino, but I should imagine this would tend to attract, rather than contract, any moisture. Would a layer of thin roofing felt or an under-layer be satisfactory?—K. W. Cooke (Birmingham.)

A SPRINKLING of sawdust under the lino would certainly attract and hold uprising damp. Roofing felt, however, would be very satisfactory as an under-layer, and, what is more, it would tend to reduce the wear on the lino.

To get maximum damp-resisting efficiency give the tiles a coating of a good bituminous paint (black). When this is dry (but not before) lay down the roofing felt and then the lino. Since the roofing felt will more or less adhere to the coated tiles, it must be considered to be permanently in position. Hence, it should be cut very accurately to fit walls, etc. To make doubly sure of checking uprising damp you may place between the felt and the lino sheets of kraft union paper. This is a strong brown paper comprising two sheets with a layer of bitumen or tar between them. It can be obtained from any builders' suppliers. When laying down the kraft union do not lay the sheets edge to edge, but have a good overlap between them. This paper is sold in rolls about a yard wide, but your local supplier should be willing to let you have any measured quantity from a single roll.

**Removing Tar from Woodwork**

I HAVE a country bungalow, some of the wood of which has been smeared with tar. On applying flat paint, the tar penetrated the paint. I was advised to apply lime to the affected parts, but finding this unsatisfactory the surface was treated with a sealing compound, after which a finishing coat of hard gloss paint was added. This is now peeling off, possibly due to the intense heat of the sun.

What further treatment do you recommend?—K. Holdsworth (Bradford).

YOU have been wrongly advised in applying either lime or a sealing compound to remove tar from a woodwork surface. The tar should have been scraped or dissolved away before any fresh paint was applied, since the oils in tars are very penetrative and will make their way through most paints.

The only radical way open to you now is to remove the whole of the paint, tar, etc., by stripping the entire wood surface and exposing the bare wood. To do this you can make use of a proprietary paint-stripping composition, which softens the paint and thus allows it to be scraped off readily, or, alternatively, you can use a solution of caustic soda made by dissolving one part of caustic soda in four parts of water. Add a little ammonia to this solution so that it smells faintly. Then dab the solution on to the surface by means of a cloth tied at the end of a stick. This will soften the paint so that you can scrape it away. The task is admittedly a tedious one, but you have no alternative.

After you have got down to the bare wood, make up a fresh solution of caustic soda of the above strength, and scrub this on to the bare wood, using an old yard brush for the purpose. The object here is to get rid of all tar oil which may have soaked into the wood. Finally, give the wood surface a thorough washing with plenty of clean, cold water. After drying, give it a thin coat of a lead priming paint, and when this coat is dry proceed to build up the surface in the type and colour of paint of your choice. You will then have no further trouble.

**Magnetising a Permanent Magnet**

I HAVE had considerable difficulty in magnetising a 12-pole Alnico magnet of the size indicated in the small sketch given below (Fig. 2). My

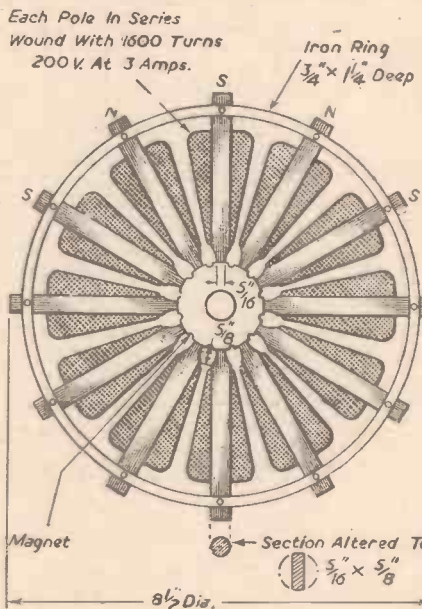
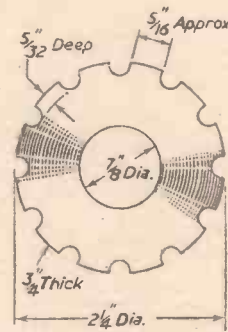

Fig. 1.—(Above) Details of a magnetiser for a permanent magnet.

Fig. 2.—(right) Dimension of the Alnico permanent magnet.



experimental magnetiser, shown in Fig. 1, is not very satisfactory. I have current available as follows: 12v. 4,000 amp. generator or 200 v. D.C. I shall be pleased to have your comments and any ideas as to modification of the magnetiser in order to ensure successful results.—G. Dungsworth (Sheffield).

WHEN magnetising a permanent magnet we consider that, after switching off the current, the magnetic circuit of the permanent magnet should not be interrupted until this is placed in the apparatus in which it is to be used. In your case this might be accomplished by placing a soft iron or mild steel disc on each side of the magnet before removing it from the magnetiser, or sliding the magnet into a mild steel or soft iron cylinder. We presume the poles of the magnetiser are in contact with the Alnico. As the current is only required for very brief periods it may be possible to increase the magnetising force considerably by arranging the coils in series-parallel instead of series.

Another suggestion is that you construct a powerful

magnetiser which will magnetise one pair of adjacent poles only. The poles of this magnetiser should be as closely as possible to those of the Alnico magnet and should have an area practically as great as those of the magnet. The distance between the poles of the magnetiser could be made as small as 1/16in. or 1/32in., the magnetiser being shaped so as to allow for a very large number of ampere-turns being used.

**Plaster Mould Lubricants**

I HAVE been making ornamental models from plaster of Paris, and am experiencing considerable difficulty over the "greasing" of the moulds. The latter are also made of plaster of Paris. I have been using soap and water for greasing the moulds, also a mixture of soap, water and oil, but the models are either sticking or I have great difficulty in removing them from the mould. Have you any suggestions as to how I can overcome this trouble?

Can you also inform me how I can lengthen the "life" of a plaster of Paris mould? Would thorough drying and then painting with shellac give the desired effect?—H. C. Swann (Winscombe).

ONE or other of the following plaster mould lubricants will be found to fulfil your requirements:

- (a) Stearic acid dissolved in petrol, paraffin or white spirit.
- (b) Thick solution of soap (semi-jelly) containing some glycerine and/or dextrine.
- (c) Tallow dissolved in paraffin.
- (d) White Vaseline dissolved in butyl phthalate or butyl stearate or any other heavy organic liquid, such as tricresyl phosphate.

A plaster mould may be given greater durability by incorporating some powdered asbestos into it during the mixing of the plaster. Mix the plaster with, say, about 20 per cent. of fine asbestos powder and then slake it with water in the usual way.

Fine asbestos powder can be obtained from Turner Brothers Asbestos Co., Ltd., Rochdale, Lancs, or from Messrs. A. M. MacCarthy, 37, Sandford Road, Mosely, Birmingham, 13.

You can also strengthen a plaster mould by dissolving 10 parts of ordinary gelatine in 90 parts of hot water. Using this solution hot (it will set to a jelly when cold) brush it on to the plaster surface so that the plaster absorbs as much of it as possible. When the plaster surface is dry brush over it a coating of formalin and allow it to dry again. The formalin hardens the gelatine and renders it quite insoluble. Finally, give the mould a thin coating of shellac solution made by dissolving good quality shellac in about an equal weight of methylated spirit.

**Artificial Stone**

CAN you please supply me with formula for making the following?

1. Garden ornaments in imitation stone. (I find a coating of cement with sand is not successful.)
2. Garden curbs in red cement.
3. The mixture for making a white or near-white curb for a grave.—W. Rayner (Morpech).

CONCRETE, when properly made, is as good as anything else for artificial stone making. Use the following proportions (by measure):

Portland cement, 1; clean washed sand (not sea sand), 2; grit or gravel, 4. The grit should be light-coloured and attractive-looking. If you wish to colour the mixture red use less gravel and add red oxide in its place. Mix the ingredients well in the dry state and then slake the mixture to mortar consistency with water. An imitation granite can be made by mixing together slaked lime, 100 parts; sodium silicate (waterglass), 35 parts; fine quartz sand, 120-150 parts; coarse sand, 180-200 parts. This sets slowly but produces a very solid mass.

An imitation marble may be produced by mixing 100 parts of chalk or whiting with 20 parts of ground glass and eight parts of slaked lime. Colouring matter may be added if required. The mixture is then worked up with sodium silicate solution (waterglass) until of mortar consistency.

In making these products with sodium silicate water may be added to the latter if it is found to be too stiff.

A dead white, smooth, hard, stone-like mass may be made by mixing together equal parts of sand and calcined magnesite and by slaking the mixture to mortar consistency with a 40 per cent. solution of magnesium chloride (made by dissolving 40 parts of magnesium chloride in 60 parts of water). This mixture takes 36 hours to set, but since it expands very slightly on setting it gives particularly sharp casts. Its drawback is that it is rather expensive and that magnesium materials are not easy to obtain at the present day. The product may, of course, be coloured by admixture of any dry powder colour of a mineral nature.

Any of the above products are suitable for grave-stone curb making. It should be remembered, in this connection, that the incorporation of up to 10 or 12 per cent. of powdered asbestos into any of the mixtures imparts strength to the products and greater freedom from cracking, although a rougher surface is produced.

Powdered asbestos may be obtained from Messrs. Turner Brothers Asbestos Co., Ltd., Rochdale, Lancs, or from Messrs. Jas. Milne Cooper and Co., Ltd., Kobar Works, Bradford, Yorks.

Other stone-making materials (lump or powdered) may be obtained in relatively small amounts from Messrs. A. M. MacCarthy, 37, Sandford Road, Mosely, Birmingham, 13.

# Acralac O.P.P. MODEL DOPE

*Specially formulated*  
FOR ALL POWER MODELS



Other extremely good ACRA finishes are:—  
ACRALAC ART ENAMEL  
2 oz. Jar 1/4 and ACRALAC  
POLYCHROMATIC  
METALLIC CELLULOSE  
LACQUER, 2 oz. jar 1/9

You will get brilliant results with these fine dopes in Blue, Yellow, Vermilion, Marigold, also Black, Ivory, Gold and Silver. Supplied by your usual Model Shop with detailed instruction folder  
2 oz. Jar 1/7½ and ¼ pint Tin 2/6

ACRALAC  
CLEAR "HIGH FLASH"  
SHRINKING DOPE  
2 oz. jar 1/6

Ask to see them, and for the very best Glueing job, always use ACRA BOND

Highly Resistant to Petrol, Diesel Oil, Ether.

The last word in Model Dopes. Made by the makers of **Acra-bond**

ACRA PRODUCTS LTD. ACRA HOUSE, SHEPLEY, NEAR HUDDERSFIELD

## MIDLAND INSTRUMENT CO.

Brand New Govt. Surplus Stock.

**IMMERSION HEATERS**, for water, etc., 230 v. 250 watt., fitted thermostat to cut out at 111 deg. F., 2in. dia. hole fitting with securing flange, depth of element 4 1/2in., superior job, 15/-, post 9d.  
**FLEXIBLE DRIVES**, 4ft. long, dia. outer casing 1 1/2in., will transmit 4 h.p., exceptional value, 3/9, post 9d. **MAINS MOTORS**, 200-250 v. A.C./D.C., fitted gearbox, powerful, final drive of 60 r.p.m., 15/-, post 1/-, motors less gearbox, fitted shaft, 12/6, post 11d., gearboxes only 6s-1 reduction with 1in. wide gears, 5/-, post 9d. **MAINS TRANSFORMERS**, all 200-250 v. input, output 20 v. 3 amp., 10/-, post 11d., output 40 v. 4 amp., 5/-, post 11d., output 30 v. 1 amp., 5/-, post 9d. **ELECTRIC PUMPS**, Immersible self-priming centrifugal type, lift 25ft., delivery 10 g.p.m., ideal for water supply, bilge pumps, garden fountains, etc., 24 v. A.C./D.C., 25/-, post 1/4. **ACCUMULATOR CUT-OUTS**, in bakelite cases with cover, two models, 12 or 24 v., both 60 amp., each 7/6, post 9d. **BURGLAR ALARMS**, closed circuit type, will protect large or small premises with high efficiency, superior to those now on the market at £5 and over, our price with instructions, 30/-, post 1/-; see our current lists for further data. **GEARBOXES**, 1-1, single to dual drive, enclosed, 1/3, post 9d. **BURGLASS MICRO SWITCHES**, 4 different types, 5/-, post 9d. **TELEPHONE SETS**, consists of two combined microphones and telephones, 25ft. twin connecting flex, provides perfect 2-way communication, self-energised, no battery required, set complete ready for use, 7/6, post 9d. **BOX KITES**, dinky antenna type, aluminium tube frame, opens up to 36in. x 17in. x 17in., closed to approx. 19in. long, 2 1/2in. dia., a grand flier, brand new, 12/6, post 9d. **SANTON ROTARY SWITCHES**, mains 20 amp., single pole 5-way and off position, panel mtr., fitted arrow pointer knob, bargain, brand new boxed, 3/6, post 9d. P.V.C. covered 1/044 (18 s.w.g.) cable, in red or black, remarkable value, 100 yd. coils, 5/-, post 1/-, **WALKIE TALKIE AERIALS**, copper collapsible, 9 sections, total 7ft. long, 1in. dia. tapers to 3/32in., also makes an ideal fishing rod, 2/6, post 6d, 3 for 9/9, post 9d. Also hundreds of other interesting Radio Electronic and Mechanical items: send for our new July-August lists, 2d., with S.A.E. Orders 30/- and over, up to 15 lbs. post-paid. Carriage orders extra in all cases. Our C.O.D. service is cancelled for the time being. **MOORPOOL CIRCLE, BIRMINGHAM 17.** Tel.: Harborne 1308 or 2664.

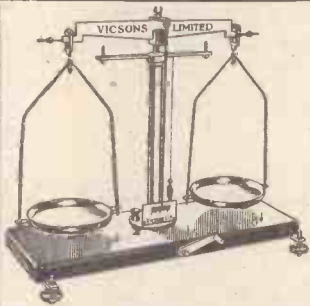

CHEMICAL BALANCE FROM STOCK 24.5.0. SEND FOR FULL DETAILS. NEW ILLUSTRATED **CHEMICAL APPARATUS CATALOGUE** SEND 2/6 POST FREE. **VICSONS LTD.** for all Laboratory Apparatus, 148, PINNER ROAD, HARROW, MIDDLESEX

## CAPITAL REALISATION SALE

New, guaranteed valves: EF50, ECH35-6K8, 6K7, 6C7, 6V6, 25A6, 25Z6, 6F6, 6L7, 6SN7, 6J7, KT33C, 5Z4, 5U4, MU14, F/W450, 7/6 each; HVR2, 6L6, 10/6. New Gramophone Equipment: Collaro AC47 induction motors, var. speed with 12in. turntable, £5 each. Collaro AC49 complete gram, unit with mag. pickup and autostop, £5 2/6. Collaro new super A.C. Mixed Autochangers in black and chrom. with hi-fi crystal pick-up—our special offer—only £14. The N.R.S. No. 1 Audio amplifier—4 watts output, pick-up and tuner inputs, volume, tone and feedback controls—a quality job.—Price £5/19/6. No. 2, ditto, but 15 watts output twin inputs (gram and mike), push-pull 6V6's, 10 gns. Quality T.R.F. 2-wave Tuner, £5. Quality plus exceptional range 3-wave Superhet Tuner, with large horizontal dial assembly, £8/10/-. Full Constructional Manuals of above Amplifiers: No. 1 2/6; No. 2, 4/6. Tuners: T.R.F. or Superhet, 3/6. N.R.S. 3-wave iron-cored Coil Packs, a very high "Q" 100, 21-, iron-cored I.F.'s 465 kc/s, 13/6 pair. "Mighty Midget" 4-valve A.C./D.C. radio receivers in polished walnut cabinet, 200-550 metres, 12 mths. guarantee, 6/19/9, carr. 2/6. All the parts for the E.E. Television Set. Bargain List, 24d. Terms: C.W.O. or C.O.D. any amount.

**NORTHERN RADIO SERVICES,** 102, PARKHILL ROAD, LONDON, N.W.3.

## HIGHSTONE UTILITIES

Meters, 0-7v, 2 1/2in., m/c. 9/6; 15v., 2 1/2in., m/c. 9/6; 150v. 2 1/2in., m/c. 10/-; 300v. 2 1/2in., m/c. 13/6; 3,500v. 3 1/2in., m/c. 20/-; 6,000v., 3 1/2in., m/c. 5/7/6; 15,600v., 2 1/2in., m/c. double reading, 8/-; 100 m/a., 2 1/2in., m/c. 7/6; 40/200 m/a., 2 1/2in., m/c. double reading, 8/-; 3.5 amp. T.C., 5/-; 4 amp., 2 1/2in. T.C., in case with switch, 7/6; 20 amp., 2 1/2in., m/l, 9/6. Meter Movements, 2in. size with magnet and case (500 microamp), 2/6. Units containing two movements, 5/-, or with one 100 microamp and one 500 5/6. All meters post extra. **Bell Transformers.** These guaranteed transformers work from any A.C. Mains, giving 3, 5, or 8 volts output at 1 amp., operate bulb, buzzer or bell. Will supply light in bedroom or ladder, etc. PRICE 8/-, post 6d. **BELLS** for use with either the above or batteries, 6/-, post 6d. **EX-R.A.F. 2-valve (2-volt) Microphone Amplifiers** as used in "plane inter-com." in self-contained metal case; can be used to make up a deal and outfit, intercommunication system, or with crystal set, complete with valves, 20/-, post 1/6. Useful wooden box with partitions to hold amplifier, 2/- extra. Ditto, less valves, 10/-. One valve amplifier, complete with valve, 9/6, post 1/-, **Band Microphones**, with switch in handle, and lead, 4/-. Similar instrument, moving coil, 7/6, post 6d. **Mike Buttons (carbon), 2/-.** **Moving Coil, 4/6; Transformers, 5/-.** All post 4d. each. **Sparking Plug Neon Testers**, with vest-pocket clip, 3/6, and with gauge, 3/6, post 3d. **S.B.C. Neon Indicator Lamps**, for use on mains, showing "live" side of switches, etc., 3/6, post 4d. **Soldering Irons.**—Our new streamlined iron is supplied with interchangeable bits, one each straight and curved; 200/250 v. 50 watts, 9/-, **Standard Iron** with adjustable bit, 200/250 v., 60 watts, 9/6. **Heavy Duty Iron**, 150 watts, 12/6, all post 6d. **Crystal Sets.** Our latest Model is a real radio receiver fitted with a permanent crystal detector. Have a set in your own room, 9/6, post 6d. **De Luxe Receiver** in polished oak cabinet, 18/6, post 1/-. **Spare Permanent Detectors**, 2/-, each. When ordered separately, 2/6, with clips and screws, 2/10, post 3d. **Headphones**, brand new, S. G. Brown, G.E.C., etc., 15/-, 23/-, and super-sensitive, 30/- a pair, post 8d. **New Headphones**, 10/- a pair, balanced armature type (very sensitive), 12/6 a pair. Both post 6d. **New Single Earpieces**, 3/6. **Ear, armature type**, 4/6; **EX-R.A.F. earpiece**, 2/-, post 4d. **Headphones**, in good order, 4/6 and 5/6 (better quality, 7/6), all post 6d. **Headphone Cords**, 1/3 a pair, post 3d. **Replacement Bands**, 1/3, post 4d. **Wire Bands**, 6d. (All Headphones listed are suitable for use with our Crystal Sets.) Money refunded if not completely satisfied. 58, New Waukeston, London, E.11. New Illustrated List sent on request with 1d. stamp and S.A.E. Letters only.

## MODEL ENGINEERS

**FOR THE TURNER:**  
Lathes, 3 1/2 and 4 1/2 S.S. Bench Millers, Drilling Machines, Hand Bench Shaping Machines.

**FOR THE WOODWORKER:**  
Wood Turning Lathes, 2 1/2 and 5 1/2 centres, 4in. Planers, Saw Benches, Sanders, Spindle Moulders, Pedestal Jig and Fret Saws, Perspex—All sizes and colours in stock.

**NUTTALL'S (LATHES) LIMITED,**  
MANSFIELD, NOTTS.

## SOMETHING DIFFERENT!

Radio Remote Control for Model Aircraft, Boats, Trains, etc. With no previous radio knowledge whatsoever, you can build your own control. Complete instructions, circuits and wiring diagrams for only 2/6. Also price list. All necessary parts in stock.

**MIDGET ENGINES**—petrol, diesel and compression ignition, for model aircraft, boats, hydroplanes, etc., in stock from 45/- Send stamp for price list.

**YOUR VERY GOOD RECORDS** made at home to your very good liking! Make your own wire or tape recorder for only £15, or anything up to £5 if you already have an amplifier. Constructional data 5/-. All parts in stock, including "Crown" high fidelity recording wire and "Diamond" plastic backed—no paper—tape.

**R.A.F. MOVIE CAMERAS**—16mm., brand new in sealed cartons. Work from a 9v. battery, which can be carried in your pocket. Each camera complete with one film, 47/6, post 1/6. Spare films 2/- each.

**FANS**—converted ex-Govt. stock, 230v. A.C./D.C. These fans need mounting on a stand (wooden block) and a wire guard for the blades. If the blades are removed, the motor can be used during the winter months to power models. 12/6 each, post 1/-.

**PARK RADIO OF MANOR PARK, 676/8 Romford Road, London, E.12.**

## YOU

## can become a first-class RADIO ENGINEER

We are Specialists in Home-Study Courses in Radio Engineering, Servicing, Transmission, Television, Mathematics and Radio Calculations!

**T. & C. RADIO COLLEGE,** KING EDWARD AVE., AYLESBURY.

Post coupon now for free booklet and learn how you can qualify for well-paid employment or profitable spare-time work

Please send me free details of your Home-Study Courses in Mathematics, Radio and Television

Name .....

Address .....

M.50 .....

(Post coupon in unsealed envelope—1d. stamp.)

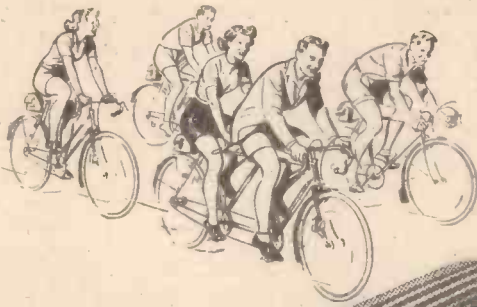

# The right kind of TYRES for your kind of cycling—

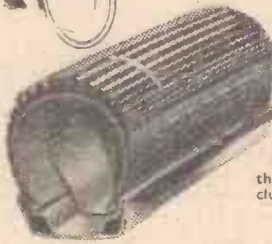

### SPRITE

The ups and downs of club-work? Reliability without the sacrifice of speed? Then fit the translucent-sided Dunlop Sprite, the first choice of knowing clubman. Cover 8/9



### SPRITE TANDEM

Effortless dual-harness work at speed calls for a tyre designed to minimise rolling resistance and prevent slip—the Dunlop Sprite Tandem. Cover 10/6

SOLO . . .

OR TANDEM

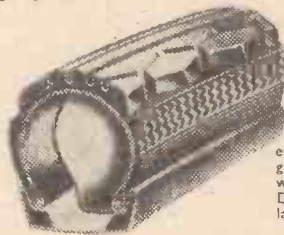

### SPORTS

If your sport embraces everything from an energetic evening spin to a hard week-end's miling, use the Dunlop Sports. Long-lasting and lively. Cover 7/4

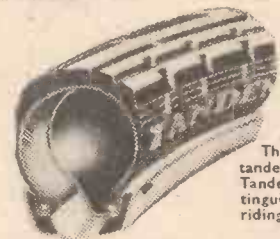

### TANDEM

The tyre for more general tandem work. The Dunlop Tandem has gained a distinguished name both for easy riding and durability. Cover 10/2

# All by DUNLOP

9H/327



The Soft Block with the **FIRM GRIP**

Yes — it's the new soft **FIBRAX** red brake block—specially designed to be kind to alloy rims! Just as tough and hard-wearing as the **FIBRAX** black block, it gives safe stopping and smooth action at any speed. Coloured red for easy identification—an ideal partner for alloy rims.  
NOTE.—The new **FIBRAX** red block is made for a special job—for steel rims the black block is still the best.

FIT

## Fibrax BRAKE BLOCKS

and get there safely!

FIBRAX LTD., 2 TUDOR ST., LONDON, E.C.4

## Valvespout

THE OILER THAT'S DIFFERENT



A twist to open  
A twist to close

An oiler that is quite different and wonderfully helpful. A twist of the screw at the end of the spout enables the oil to flow—a reverse twist closes it hermetically. No cap to lose. A choice of the shapes and five spouts.

Sole Distributors: **MARKT & Co. (London) Ltd.**, Portpool Lane, Grays Inn Rd., London, E.C.1. **Of all good dealers and ironmongers**



it's realistic

## it's 'Plasticine'

Made only by **HARBUTT'S**

Almost any type of model can faithfully be modelled in 'PLASTICINE,' which is so easy to handle that modifications can rapidly be made as the work proceeds. For prototypes, "mock-ups" and other uses there is no more practical medium. Long-lasting, hygienic and available in 16 attractive colours.

**HARBUTT'S PLASTICINE Ltd., BATHAMPTON, BATH, SOM.**

**MORE than a toy!**



VOL. XVII

AUGUST, 1949

No. 329

All letters should be addressed to the Editor, "THE CYCLIST," George Newnes, Ltd., Tower House, Southampton Street, Strand, London, W.C.2.

Phone : Temple Bar 4363

Telegrams : Newnes, Rand, London

## Comments of the Month

By F. J. C.

### Sixty Years of Air Tyres

SIR ARTHUR DU CROS was the guest of honour at the Roadfarers' dinner at the Savoy Hotel on June 21st to celebrate the diamond jubilee of the marketing of pneumatic tyres. Sir Arthur is the sole surviving member of that famous family: Harvey Du Cros, Senior, and his four sons, Harvey, George, William and Arthur (now Sir Arthur). There were many distinguished guests, including Lord Courtauld Thompson, K.B.E., C.B. (son of R. W. Thompson, the original inventor of air tyres, who patented the pneumatic tyre principle in 1845); Lord Kenilworth, one of the early employees of the Dunlop Rubber Co., Sir Miles Thomas, Sir Richard Jenks (son of a former Lord Mayor of London), Colonel J. J. Saunders, O.B.E., Mr. George L. Du Cros (nephew), William Blackwood, C.B.E., Dr. H. A. Bulman, Douglas C. Ingram, Richard Viner, H. A. Willes, H. R. Cook, T. W. Knox, P. Allardyce, B. O. Davis, Stanley Burchett, James A. Wilson, Bob Carlisle; whilst members present included Lord Brabazon of Tara, the president, the Marquis of Donegall, The Marquess Camden, Lord Waleran, Roy Du Cros (Sir Arthur's son), Major F. Bale, O.B.E., Mr. C. G. Grey, Professor A. M. Low, Donald Campbell (son of the late Sir Malcolm Campbell), W. G. James, Jack Barclay, Harold Lambert, L. W. Lambert, A. H. Bentley and Harry Payne.

It was indeed a memorable evening, notable not only for the standing of the members and guests assembled, but also for the quality of the speakers. Lord Brabazon, in introducing Sir Arthur, paid a glowing tribute to the great work of the Du Cros family in commercialising the idea of the pneumatic tyre, an invention which had benefited the whole of mankind. The Du Cros's displayed their genius not only in the world of commerce, but the sons went forth into the sphere of competitive sport, and by their successes broke down the apathy towards the new idea. There was plenty of opposition in those days, for the early tyres were not the perfect examples which we use to-day. Some of the guests, including Bob Carlisle, were not only present at the birth of air tyres, but had been associated with the company ever since. It was an historic occasion in another respect—Sir Arthur Du Cros, the only survivor of the Du Cros family which pioneered the tyres, sitting next to Lord Courtauld Thompson, now over eighty and son of the man who took out the first patent for air tyres in 1845!

Lord Brabazon went on to detail the great experience of Sir Arthur, the adversity of the early years, and the developments, such as the motor-car, the cycle industry and the aeroplane, all of which owe their present state of advanced development to pneumatic tyres.

### The Tyre Industry

Sir Arthur, in his reply to the toast with which was coupled also the tyre industry, said that we are now, in fact, in the hundred and fourth year of the invention and the

sixtieth of the foundation of the industry. The principle was invented twice: first by Robert William Thompson, at the age of 23, in 1845, when our railways were still having their teething troubles. He patented it in France in 1846 and in America in 1847, but unfortunately or fortunately disguised his patent under the names of "elastic bearings" or "hollow belts for wheels." The word pneumatic did not occur to him.

Thompson overlooked nothing. His patent covered all rolling bodies, and he could have controlled everything from a railway train to a hobby horse. The original scroll of the letters patent issued to Thompson was presented by Sir Arthur recently to the City of Coventry, where it hangs in the public library. Contrary to popular belief, Thompson's tyre was marketed, and it was under constant trial on heavy vehicles from 1845 onwards. He used it on his own brougham, and in 1871 demonstrated it to the Emperor of Brazil in

on the grounds of anticipation. Dunlop was not a cyclist then, and stated publicly that had he known of Thompson's patent he would not have taken the trouble to register his own. Yet, while its publication was a knock-out blow for him and the pioneer company, it was to the crude re-invention of this Scotsman that the world owes the pneumatic tyre. The founder company did a great deal to amend and to validate the Dunlop patent, but without success. It was the Thompson tyre, but that does not lessen the debt we owe to him as the pioneer of air tyres. Thompson's tyre, although perfect in principle, was clumsy in practice. It languished and died of inanition. It remained dormant until its second debut in Belfast 44 years later. It was not a new invention by Dunlop but a discovery designed for a new purpose. The cycle provided the answer. Dunlop stated that his tyre would not be practicable for heavy vehicles. It was Dunlop who pressed the button which started

the machine and set many minds to work on the problem. He found the missing market in the bicycle, the only silent vehicle on the road, and later in the ever-expanding motor industry. Thompson and Dunlop present a typical case of the first being last and the last being first. Thompson was a loser on his valid invention, while by a margin of less than six months Dunlop made a fortune from his.

William Harvey Du Cros was 43 when he was converted to the new idea by his son's successes on the race track.

The coming of age of the pneumatic tyre was celebrated 40 years ago by a banquet to do

honour to him as founder of the industry.

All pneumatic tyres all over the world have emanated from this source, and it is pleasant to recall that its advent harmed no other industry and gave birth to vast new enterprises.

But it was Charles Kingston Welch, whose widow died almost on the eve of this diamond jubilee celebration, who supplied the missing link which successfully harnessed the principle of compressed air by a series of basic inventions which are still in general use. It was he who first made them detachable. Had he not

(Continued on page 82, column 3.)

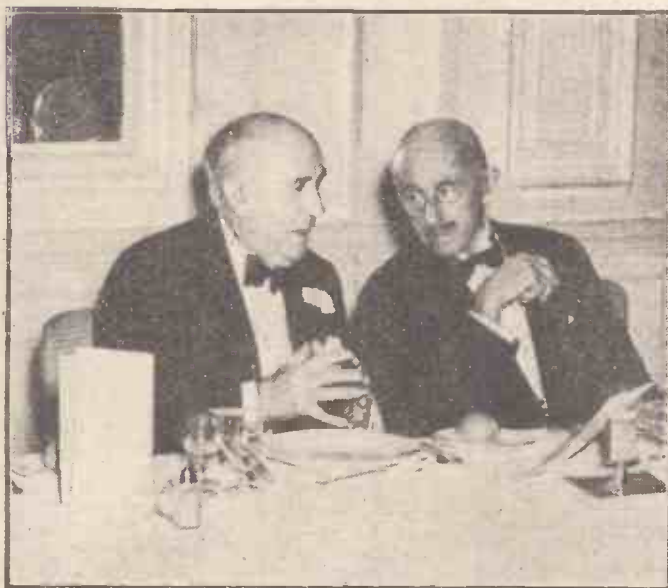

An historic picture. Sir Arthur Du Cros, sole survivor of the pioneer tyre company, and Lord Courtauld Thompson.

Edinburgh. Carriage users, however, did not take kindly to pneumatic tyres and it was withdrawn from the market, although if horses could have spoken results would have been very different! Thompson's patent was not altogether forgotten, said Sir Arthur, for it was published in leaflet form one or two years before the date of Dunlop's patent in 1888, but it did not come into Dunlop's possession until some months after the flotation of his tyre in 1889.

### Foreign Patent Applications Rejected

Dunlop's applications for patents in Belgium, France and America were rejected



### Weekley

Northamptonshire.

A picturesque small village a few miles from Kettering. The church is mainly Early English but also contains some Norman work.

# Peragrams.

saddle shaft the "Aquacyclist" steers the boat.

### Pedal Outboard for Boat

A KENTUCKY firm, the Aquacycle Co., Inc., of Covington, has just put on the market a light type of outboard motor for small boats which is pedal-driven. Pedals working a circular gearcase drive the propeller through bevel gears and a shaft. The Aquacycle is attached to the boat by clamps, in the same way as ordinary outboard motors, and by moving his weight in the attached above the driving shaft the "Aquacyclist" steers the boat.

### From Wales to Walsingham

AFTER reading a newspaper report of cures said to have taken place at the Shrine of Our Lady, Walsingham, 16-year-old Robin James left his home in Abercynon, Glamorgan, without telling anyone and cycled the 250 miles to Norfolk to get a bottle of water from the shrine in the hope of being able to cure his 77-year-old grandfather who was dying. No news was received at his home until the boy stopped at a cottage in Guyhirn, in the Isle of Ely, for a drink. A telegram was sent to his home, while Robin went on, without waiting for any food, in an attempt to complete his self-imposed task, but he had barely reached Walsingham when his grandfather died.

### A Little Learning!

WHEN a 16-year-old boy cyclist appeared before Oakham Juvenile Court the Chief Constable said the charge was brought because of the boy's attitude to a constable who called on him to stop. The boy went on for 50 yards before stopping and then gave the constable a wrong address. When the constable took out his note-book the boy asked if he was on duty, as he could not have someone "pulling" him who was not on duty, and he also asked the constable why he had his cycle with him. He said he would go and see the Chief Constable. The boy, who told the magistrates he thought that when a policeman left the police station he was off duty, was said by his school report to have rather a high opinion of himself. The usual fine was increased to £1, and the boy's knowledge of the law was also increased.

### No Falling Off

SO that the young idea can get used to a bicycle and have no fear of falling off the Huffman Manufacturing Company, of Dayton, Ohio, have put on the market an outrigger device to be attached to the rear wheel of a bicycle ridden by a child between the ages of 3 and 7. The attachment carries two light wheels, about 6ins. in diameter, and of the type used on kiddiecars, and one wheel is on either side of the rear cycle wheel. By means of this device it is claimed that children can teach themselves to ride in a very short time.

### Who Can Blame Them?

MARKET RASEN (Lincs) Urban District Council have been receiving complaints about the habit of local cyclists riding on the footpath in Mill Road, to the danger of pedestrians. During a discussion of improvements necessary to roads in the town the chairman of the council said Mill Road gave any cyclist who rode down it an alarming few minutes. "There are potholes so big," he said, "that they might cause you to break your neck or legs," and another councillor said the only safe place for a cyclist there was on the footpath, and so everyone seemed to use the footpath. The Highways Committee is to be presented with the problem.

### Hinckley Road Racing

THOUSANDS of spectators were attracted to the road-racing events held over a 16½ miles course at Hinckley, Leics, on June 12. The East and North Midland Section of the British Racing Cyclists chose Hinckley

for the 1949 senior, junior, and ladies' championships, and representatives from most of the Midland clubs took part. The senior championship was won by E. Thompson (Derby Mercury) in 3h. 50m. over 82½ miles, with B. Craig (Notts Olympic) second, and J. Walsh (Woodville) third. The winner of the junior event was H. Page (Leicester Pegasus) first, followed by E. Furniss (Woodville C.C.) second, and C. Talbot (Trent Olympic) third; the winner's time being 2h. 19m. G. Clements (Wolverhampton R.C.) won the ladies' championship in 49m., followed by J. Humphreys (Stonebridge) and D. Welsh (Woodville C.C.). There were close finishes in both the ladies' and the junior events, while in the senior event the winner got in two minutes before the second rider home.

### New Zealand to Leicestershire

MR. JACK WRIGHT, well-known in cycle-racing circles in Leicestershire some 40 years ago, is back visiting his home town of Coalville from New Zealand, where he now lives. Mr. Wright regularly acted as pacemaker for George Harry Hardy, a Coalville cyclist, who broke many records and was well known for his speed on the track all over the country. Mr. Wright's impressions of his home town? He thinks it has shrunk—and when he saw the narrow streets, after the wide roads of New Zealand, he thought he had got out of the train in the wrong town!

### COMMENTS OF THE MONTH

(Continued from previous page)

intervened on the side of the pioneer company it would have been snuffed out at birth. Later, he was first to apply weftless fabric to tyre linings and to introduce the non-skid cover. He was the first to put wire into tyres.

### The Non-return Valve

FREDERICK WOODS contributed his excellent non-return valve in 1891 and Frederick Westwood his perfect cycle rim in 1893. The inventions of these three "W's" are still in standard use and survived all assaults upon the patents. There was plenty of litigation in those days, and it cost the pioneer company about £150,000, so that even a valid patent is hardly a poor man's dowry. To show its appreciation of the unbeaten record of Welch's invention the company in September, 1904, celebrated its expiration by making a bonfire of the patent at a banquet attended by over 500 leading members of the cycle and motor industries.

Sir Arthur went on to trace the history of the company from 1889 up to the present time, and gave many hitherto unrecorded facts of the vicissitudes through which the company passed. The company, of course, moved from Ireland to Coventry as it grew in strength, but chiefly because of the complaints from local residents of the smell of rubber. His speech was packed with anecdotes concerning all those whose names have become famous in the spheres of cycling, motoring and aviation. He went on to state that there is no memorial at present to Charles Kingston Welch, and he suggested that it would be a graceful act if the Roadfarers' Club were to move the city fathers of Coventry to commemorate this great man by an appropriate plaque upon the house in which he lived and worked and died. Telegrams in appropriate terms were sent to Dunlop's daughter, Mrs. Jean McClintock, and to Mrs. Charles Kingston Welch.

Judged by past achievements and the certainty of more to come the pneumatic tyre and all that flowed from it was only just one more advance in an age of tremendous activity. We preserve the records of our great sailors, soldiers, explorers and statesmen, yet comparatively little is recorded of inventors and industrialists who provide the benefits which are indispensable in our daily lives. Pioneers, in whatever field, are among the benefactors of their times, and their achievements should rank as highly as those in any other field of national service.

The toast of the Roadfarers' Club was proposed by Sir Miles Thomas, D.F.C., who drew attention to the importance of its work, and Professor A. M. Low replied in a witty speech. The guests were toasted by Lord Donegall with responses by various guests, including Bob Carlisle, who has been with the pioneer company from its inception. The toast of the president and chairman was in the capable hands of C. G. Grey.



# DIAMOND JUBILEE of the PNEUMATIC TYRE 1889-1949



Speakers at the Diamond Jubilee Dinner given by the Roadfarers' Club at the Savoy Hotel on June 21st, when Sir Arthur Du Cros was the guest of honour : 1, Sir Miles Thomas proposing the toast to the club; 2, Sir Arthur Du Cros; 3, Professor A. M. Low; 4, Lord Brabazon, president; 5, C. G. Grey; 6, Bob Carlisle; 7, Marquis of Donegall; 8, Lord Kenilworth.

# Wayside Thoughts

By F. J. URRY



## A Good Example

I HAVE been riding a bicycle most days for 60 years. So has Mr. Victor Breyer, the doyen of French cyclists, but the jolly old Parisian is nearly a decade my senior. Listen to his latest letter:—

“With the help of the Almighty I will be 80 years old next September, and hope to pedal as long as I live, having never found a more exhilarating, healthful and joyous exercise than cycle touring. Many years ago, as with most young people, I went in for amateur racing and thoroughly enjoyed it; but nowadays scorching is, of course, out of the question. On give and take roads my average speed per hour is 15 to 16 kilometres (rather under ten miles an hour), and I can always run up 100 kilos (63 miles) in a day without undue exertion; and at that take things leisurely, two hours for lunch with a quiet drink before eating, and a stroll round the place when there is anything worthy to visit. Nothing finer exists, I say again.”

Do you believe it? I do, and my hope is that when and if another decade has gone over my head, I can still do these things and revel in them. It is a refreshing thing to read such a testimony to cycling from an individual who has practised it for sixty years, for it gives me the desire to run on along time until I have completed seventy years of cycling, and then I expect I shall not be satisfied. Most of the people with whom I am in touch in the cycling sense are of the later generation, and therefore have to discover still the delight of cycling when speed and distance have become matters of secondary consideration, when the individual freedom of the game has developed into a priceless acquisition. Yet the promise of that development is within the compass of every one of you, and if you care for it and cherish it you will not grow older than your years, but mellow into a wanderer seeking beauty by the wayside and carrying some of it home with you to comfort rest and make memory a very charming background to life.

## Do Doctors Know?

HOW enlightening it is to read of fellows who, in the face of illness, have on recovery and against doctor's advice, taken to cycling, and found a sense of fitness and well-being which has astonished them and their

The White Hart Inn,  
MORETON-IN-THE-MARSH  
Glos.

The unique hall—once the cobbled  
coachway entrance to the inn yard.  
Charles I lodged here on the night  
of July 2, 1644.

friends. The fact is, of course, that only the folk who hate to lose their activity and that individual freedom of movement associated with cycling are keen enough or brave enough to defy the medical advice and prove to themselves that quiet, sensible riding is amongst the greatest healers extant. It is natural that it should be, for here you have gentle exercise, fresh air in abundance properly inhaled, sunshine and the scents of a countryside added to its sights to make

life much more of a smiling progression than the self pity that might so easily overtake you if the advice to desist had been accepted. I know nothing about medical matters, except that no medical men of my acquaintance ride a bicycle with any degree of

regularity; but I do know enough to realise that seven weeks' absence from the saddle last year brought home to me, as nothing else could, the kindly health value I obtain from the pastime, to say nothing of the pleasure of which I shall never be able to tell enough. I do think some doctors are inclined to look upon cycling as the last resort of the impecunious and to treat it accordingly. Because I am an enthusiast my recommendations in this matter are given warily; I know it is good for me, and so I think it must be equally good for other people, always providing they will use the pastime with discretion, gear moderately, pedal correctly and sit comfortably. It is not always easy to act counter to a doctor's advice; there are the family folk to consider besides your own desire to remain an inhabitant of this earth as long as possible; but I do seriously believe that much such advice is given without knowledge of the excellence of cycling, and the very delight of the freedom on the mental condition of a patient under the handicap of health recovery.

## Going Without

I RECENTLY went along on a recuperative holiday without a bicycle, one of the few times in my life when I have been so circumstanced. Illness at home and the hope of a recovery made the journey necessary, and indeed desirable, even from my point of view, for the process of witnessing the return to reasonable fitness of an affectionate companion for 44 years is a joy beyond the telling. We were not without travel facilities, for the powers that be recognised the need for the journey and granted the necessary fuel, so I have seen a little more of the South Downs when the spring made them a perfect picture of the peaceful English scene. And how beautiful they are! No wonder the poets who live and have lived under their shelter sang their praises, and the books on Sussex teem on the theme of their loveliness. Because my companion was an old cyclist she was content to use the

car as an old cyclist, for the purpose of seeing, hearing and smelling the countryside, watching the great cloud shadows sail across the weald from the summits of the downs, and lingering in the comely villages that nestle among the hollows and are so often embraced, as it were, by the gentle rivers. Some day I must roam this land when the corn has been harvested and all the tinted fields run in joyous colour schemes to the tawny strand; but in the meantime I have assignations to fill in Scotland, and the introduction of the Wye country to some of my young friends, and for the moment my commitments are going no further. How I longed for a bicycle—but I daren't say so, indeed it would not have been kind, for the memory of the old days was with us whenever we went out, those times when a tandem was our mode of wandering from one end of the land to the other. Old cyclists can get a lot of quiet joy out of their holidays of yore, even if the method of travel has changed for them, and that is an acquisition denied to the folk whose touring and journeying has been confined to the car. I always feel on such occasions as this how fortunate I am and how grateful I should be to the bicycle that has kept me fit and fairly nimble right up to the three score and ten and, I hope, for long beyond that measure. But how good it was to get back to the saddle, to go roving round the home lanes welcoming the spring, making contact with the grace of it all; and with the knowledge that the southern sunshine had worked a small miracle, for the breath of the season was a balm to my partner, so that both of us are happier and, each in our sphere of interest, more contented.

## The Old Trail

HUMAN nature is very frail, even after the experience of three score years and ten. I should know better, but preferring to be optimistic than otherwise I half expected the Easter weather to preface a summer of glorious sunshine and warm showers, and the nip that followed those delightful days gave the “old miseries” the satisfaction of saying, “I told you so; sure to have to pay for it,” and so made them happy in retrospect. I believe in taking the good things as they fall and finding in the enjoyment of them any needed solace for the things to come, which may not be a wise way to live, but it is at least a happy one. I went into the Cotswold country with an old friend, a man connected with the trade, and after a lapse of nearly a decade found that area as delightful as ever. I warned my companion that my passage would be annotated as it were with frequent stops to stand and stare, and, if the weather was favourable, many a road-side lounge to better hear the birds sing and see “cherry hung with snow.” Further I said I would introduce him to the drumming-up method of lunch and tea if he would carry his portion of the necessities; he agreed before he saw the necessities, created an additional burden of under four pounds, made a horrible job of packing, but at the end of the adventure became enthusiastic. The meals were better, you had them where and when you desired; a Primus can cook things, and the delight of this nomadic sense of freedom made you forget the few additional pounds of baggage. Besides it is so much cheaper; such were his reactions, and I concur. After one trial under instruction he managed to pack the appurtenances without rattle and in the minimum of space, and the minimum of time, so our little journey started propitiously after the first arguments had been composed and order restored to a rather agitated mind.

**APEX  
'SUPERLITE'  
CELLULOID PUMP**  
15 x 7/8" BLACK

Thick Celluloid  
Beautifully Polished

Light of Weight but of  
robust construction

'SUPERLITE' 15in.  
CELLULOID (with  
solid drawn brass  
plunger tube) each **4/9**  
IN WHITE AND  
COLOURS ... 5/3

'LASTWEL' CELLULOID  
(with steel split  
plunger tube) 15in., **4/6**  
each

The World Famous  
**BAILEY'S  
'SUPER'  
PUMP**  
15 x 7/8" BLACK

Steel Lined Celluloid Covered

Lining is Solid drawn  
cartridge fashion, the ends  
being solid with the barrel.

Cannot warp nor leak  
BAILEY'S 'SUPER' (Steel  
lined and Celluloid  
covered) 15in. each **5/6**  
IN WHITE AND  
COLOURS ... 6/-

BRASS PUMP, Nickel  
Plated or Black enamelled  
(with steel split  
plunger tube) each **3/9**  
Coloured, same price.

**Prices  
Reduced**  
of APEX  
CELLULOID  
MUDGUARDS

WHITE OR BLACK

Wide Section &  
Narrow Section **10/6**  
PAIR

Wide Section  
with Reflector **11/3**  
PAIR

**APEX  
INFLATOR**

Co. Ltd.

ALDRIDGE ROAD,  
PERRY BARR,  
BIRMINGHAM 22B



**SAFE BRAKES**  
rain or fine

Ferodo All Weather Brake Blocks are made of a special friction material that is practically unaffected by weather and can be relied on to give you safe, positive control for long hills or emergency stops.

The price of standard sizes is now

**6<sup>d.</sup> A PAIR**

**HUB BRAKES.** Ferodo Linings are supplied in boxed sets, complete with rivets, for all makes of hub brake. The size is exact, and the friction characteristics correct, for each type. Also available in roll form.

**FERODO**

**ALL WEATHER BRAKE BLOCKS  
AND LININGS FOR HUB BRAKES**

FERODO LIMITED, CHAPEL-EN-LE-FRITH  
A member of the Turner & Newall Organization

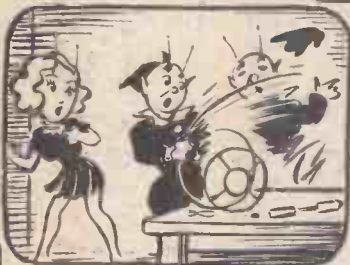

THE "FLUXITE QUINS"  
AT WORK

"I'm making a lampshade,"  
said OO.  
"Come on and help me, you two.  
Hold that wire nice and  
tight  
While I get our FLUXITE  
Don't let go whatever you do."

For all SOLDERING work—you need FLUXITE—the paste flux—with which even dirty metals are soldered and "tinned." For the jointing of lead—without solder; and the "running" of white metal bearings—without "tinning" the bearing. It is suitable for ALL METALS—excepting ALUMINIUM—and can be used with safety on ELECTRICAL and other sensitive apparatus.

With Fluxite joints can be "wiped"  
successfully that are impossible  
by any other method

Used for over 40 years in Government works and by leading engineers and manufacturers. Of all Ironmongers—in tins, 10d., 1/6 and 3/-.  
● TO CYCLISTS! For stronger wheels that will remain round and true, here's a time-tested tip. Tie the spokes where they cross with fine wire AND SOLDER. It's simple—with FLUXITE—but IMPORTANT.

THE "FLUXITE"  
GUN puts "FLUX-  
ITE" where you  
want it by a simple  
pressure.

Price 2/6 or filled  
3/6

ALL MECHANICS WILL HAVE

**FLUXITE**

IT SIMPLIFIES ALL SOLDERING

Write for Book on the ART OF "SOFT" SOLDERING and for Leaflets on CASE-HARDENING STEEL and TEMPERING TOOLS with FLUXITE. Also on "WIPED JOINTS." Price 1d. Each.

FLUXITE LTD., Dept. P.M., Bermondsey Street, S.E.1

**NOW  
AVAILABLE**



**THE BRILLIANT**

# **SYNCHRO SWITCH**

(PROV. PATENT)

**Handlebar Gear Control**

Now you can bring your Cycle right up-to-date with Synchro-Switch Handlebar Gear Control—responsive to a finger-touch, flashing easily into position—with brilliant finish.

RETAIL PRICE  
COMPLETE WITH  
PULLEY

**8/-**

*Ask your Dealer about it!*

THE HERCULES CYCLE & MOTOR CO. LTD., ASTON, BIRMINGHAM

# CYCLORAMA

By  
H. W. ELEY

The Talbot,  
Chaddesley Corbett,  
Worcestershire.

A fine half timbered inn set on a high sandstone base. Across the wide street stands the church, the finest example of 14<sup>th</sup> cent. work in the county.



## Call of the Sea

EVERY year one reads complaints about the concentration of holidays into the month of August. And every year it is patiently pointed out that as August is the school holiday month, it is inevitable that most families will select the month for their annual trip to the seaside. It is an awkward business, but nobody has yet succeeded in solving the problem, and I am afraid that Foamville-on-Sea will continue to receive its hordes of holiday-makers in August, and beaches will be crowded, and boarding-houses full. But for the happy cyclist, who can slip away when he will, August is perhaps as good a month as any. True, some of the freshness has departed from the countryside, and the green of June gives way to the dusty-brown of later summer; but it is summer still, and it is good to ride down to the coast, and find some spot where the waves lap lazily against the rocks, and the seagulls cry overhead, and the little fishing boats set out, manned by tawny-faced old men who know the ways of wind and tides, and whose eyes are clear with long gazing out to sea.

This year, I plan to ride down into Dorset, where there are coastal villages which have remained unspoiled—where "development" is unknown, and where, in some little inn rejoicing in some such name as "The Lobster Pot," one may drink good ale, and chat with men of the sea, and forget for a time the frets and fumes of the city. Salute to August, and the restless sea!

## The Indispensable Bike

SINCE my retirement from the Dunlop Service my plans for residence in the heart of my beloved Derbyshire have been progressing, and I have recently spent a couple of happy weeks not far from ancient Ashbourne, almost under the shadow of the Peak . . . preparing for the days when I shall be a villager, caught up in all the varied activities of a little community where every-

one knows everyone else, and "parish pump" politics assume an enormous significance. And I have found, as I knew I should, that the bicycle in the country is no luxury, but a sheer necessity! Impossible to contemplate life in a village without a bike, and I am glad that I am as keen a rider as ever, for I look forward to many happy rides around that good country along the Derbyshire-Staffordshire borders, with Uttoxeter and Derby as centres for my runs. Retirement from the hurly-burly of London Town has its compensations, I find!

## Those Old Catalogues.

MY recent references to an old "Mead" cycle catalogue which I unearthed have brought me one or two letters from cycling men who evidently share my own love for old papers and documents and price-lists and the like. One refers to an old Dunlop leaflet published about 1898, wherein the virtues of the pneumatic principle are described in quaint language, and where the address of the Company is given as Alma Street, Coventry. This is going back indeed! But of all our great companies and industrial enterprises, I suppose that none has a more romantic history than the Dunlop Company . . . and few folk in 1898 could have foreseen the gigantic development of the concern, or visualised its present-day ramifications. Among great inventions which have revolutionised human habits the invention of the pneumatic tyre must always have an honoured place.

## The Best County?

I HAVE lost count of the number of times I have listened to discussions about the varied virtues of the counties of England. In little old-fashioned inns, in tea-shops in remote villages, and at club meetings I have heard riders extolling the beauties of Sussex, and Devon, and Warwickshire, and Kent, and Westmorland . . . and I have smiled at times at the passion with which this question

of "the loveliest county in England" can be debated. Of course, it is all a little fatuous, for the truth is that almost every English county is beautiful; all have charm; all have scenic gems which entrance according to season and mood. The other day, while sipping ale in a cosy inn in a village just off the Great North Road, I heard the old topic ventilated again . . . and the vote went to Devon. I did not grumble with the verdict, although I did put in my word for the glories of Yorkshire, with special reference to the Dales, and to Wharfedale in particular. And another member of the party, just back from a tour in Shropshire and Herefordshire, stood up valiantly for the matchless beauty of those shires. But Devon carried the day . . . and there was much talk of Lynmouth and Lynton, and Clovelly, and of all the romance of Drake's land, and the glamour of Plymouth Hoe. As I rode away from the inn, in the purpling dusk, I thought of other shires, and fell to musing upon tours I had made, in the long ago, in quiet, homely Suffolk, where the spirit of Constable broods upon the meadows, and his genius seems to haunt the streams and lanes. . .

## Welcome Return

HOW good it is, after so much indifference (and even discourtesy) during the war years, to see a return to civility and good manners in our shops! In a small cycle dealer's shop the other week, I was pleasantly struck by the courteous manner in which customers were served and attended to. One man required only a pair of trouser clips, but his need was met with a smile. I have always felt that efficient shop-keeping rested on courtesy . . . and it is good indeed to see this return to former modes and manners. Life can be drab enough without the added and unnecessary burden of impoliteness in our shops.

## This is Our Heritage

EVEN in this age of scientific planning, the vandal is still with us, and it is still possible to see areas of England which are being needlessly spoiled. Our heritage of scenic beauty is something more than a romantic thing: it is one of our best commercial assets. We read much of the "Come to Britain" movement, and of the efforts to attract tourists to our shores. But we must remember that they come, largely, to see our panorama of scenic grandeur; they want to see rolling fields, and little farmsteads, and noble trees in ancient parklands, and stately homes . . . and all that makes the essential English scene. Let the vandal destroy these gems, and the lure to see England is no more . . . and we lose a most valuable source of revenue. Every cyclist who loves beauty, and has memories of the real England, should support the excellent work of those bodies which battle for the preservation of our heritage.

## Workshop Calculations Tables and Formulæ

Ninth Edition

by F. J. CAMM

A handbook dealing with methods of calculation, solution to workshop problems, and the rules and formulæ necessary in various workshop processes. It contains all the information a mechanic normally requires.

From all booksellers, 6/- net,  
by post 6/6 from the publisher,

GEORGE NEWNES, LTD.

(Book Dept.)

Tower House, Southampton Street,  
W.C.2.

# My Point of View

By "WAYFARER"

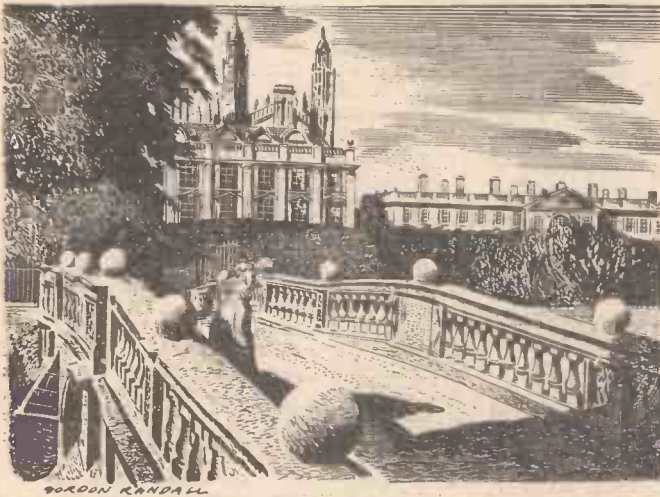

A glimpse of King's Chapel from the lovely Clare Bridge dating from 1640.

## Objectless

IT must be admitted that while I have always had a liking for the process known as "messaging about in boats," I deplore the same process in its application to bicycles. Please do not mistake my meaning. What I condemn is the aimless activity of adolescents who, very often possessed of attractive new bicycles, seem to be content with a cycling programme which can best be described as "twice round the block and home." To my mind this sort of cycling programme is a prostitution of a magnificent pastime which offers infinite delights and advantages to anybody who will use the bicycle properly, and I must say that the sight of young people "messaging about on bicycles"—content with a run round the houses, followed by indulgence in a few more or less "clever" tricks—peevs me. What waste of time; what loss of opportunity—when just beyond the corner is to be found the Romance of the Open Road . . . the joy of the lanes . . . the sublime beauty of the countryside . . . and the constant possibility of adventure. Adventure? Yes! all sorts of little adventures befall the cyclist—provided he does not confine his activities to "twice round the block and home."

## Ubique

WE cyclists do get about, don't we? Visitors' books kept by the cottages, farms and little inns at which we put up are an interesting study, for therein, as a general rule, we shall find familiar names. "Old Bill" was staying at this place last week, was he? And "Dusty's" name recurs so often in another book that one imagines him never to spend any time at home. Here are the names of a familiar married couple and their two boys (the latter having now reached the stage when they ride their own singles and are no longer carted about by the parents), while another page carries the names of an enthusiastic band of club stalwarts who, at Bank Holiday week-ends, indulge in an ironing-out of

roads on a large scale. Thus if we cyclists should ever seek a motto, it might well be "Ubique," meaning "Everywhere."

These thoughts are prompted by a chance meeting with an old friend last Good Friday. He is a brother-Anfielder whom I first encountered in my Birkenhead days over 25 years ago. Afterwards he trekked in search of bread and butter to Scotland and then to Yorkshire, and now he lives in Essex. Well, I was very busy sunning myself, sitting on the garden wall of the little Herefordshire inn where I was staying, when this still young man (one of the last of the fixed-gear brigade) rolled along the road and gently drifted to a standstill. He looked up at the

inn sign and then at me, and we both said: "Well! Dash me!"—or words to that effect. He sought lunch and I saw to it that he did not seek in vain. When did we last meet? Just a year ago, according to the Church's calendar. On the day before Good Friday, 1948, I was making my way towards Chirbury, along the Wolverhampton-Bridgnorth road, when I was overtaken by my friend (an easy enough job to overtake me nowadays!), who thought he recognised from a distance "those shoulders." And three or four years before that we met again by chance on the Ludlow-Leominster road, when, under the protection of his wife, he mildly remonstrated with me for "dancing" (as it is wrongly called) on the pedals in the negotiation of a little hill.

## Discovery

THE other day I read an advertisement issued by the London Transport Executive which ended as follows: "You will find that the country is nearer than you think." That is a thought which all cyclists might fitly bear in mind: the country is nearer than you think, and how much nearer it is, and how quickly it can be reached, if we use our bicycles sanely.

On the evening before I saw this advertisement, I had a chat with a friendly bus driver, who professed to be astonished because I was not, as usual, riding a bicycle. He said that he had just had a run into the country, taking advantage of the opportunity which split duty gave him, and he had thoroughly enjoyed himself, pottering about some of the lovely spots within very easy reach of the city. He asked: "But how many people know about them?" and the question was pertinent. Yes; what percentage of the million-odd folks who dwell in the city where I live know that within such ready access is a great mass of loveliness, with delightful lanes, glorious long-distance views, and a ring of shapely hills to inspire the passer-by? What is true of Birmingham

is true, in varying degrees, of many other populous places.

## The Borrowed Bicycle

I HAVE always maintained that borrowed or hired bicycles do not, as a rule, give one cycling fever. Probably they don't fit, and it may be too much trouble to carry out such adjustments as will make the mount more suitable to one's purpose. And, in the case of the borrowed bicycle, it would be only right to make the necessary readjustments, so that, in returning the machine, it is in the same condition as when taken away. Recently, however, I borrowed a bicycle which might very well have brought on cycling fever, had I not already possessed it. I was away from home, and, confronted with the need for making a few calls in out-of-the-way places, I looked round for some way of avoiding the cost of hiring a car. A friend to whom I spoke willingly agreed to lend me her bicycle. For one horrid moment I thought it would be a lady's model, but it was not. It was a quality male bicycle with free-wheel and a rather steeply dropped handlebar. The saddle was not quite my choice, but then I can ride any sort of saddle without discomfort. So off I went, and thoroughly enjoyed the experience, doing my business quickly with a minimum of expense, whereat I was gratified. I must confess that I do not like cycling in long trousers, but better than that than not cycle at all!

## Flaw

OUR Parliamentary draughtsmen have a great deal to answer for, and it is to be presumed that they are the best friends possessed by members of the legal profession. Take the case of that motorist who was "pardoned" for a sin he did not commit. He had been fined £2 for driving a motor-van with negligence, his offence being that, when stationary, he had opened the door of the vehicle and a boy cyclist ran into it. The Lord Chief Justice has held, on appeal in a similar case that, as the vehicle was at a standstill, the man could not be held to be driving it. Of course, it was never the intention of Parliament that thoughtless motorists should "get away with it" in this manner—and the careless draughtsman achieves another victory. On a strict reading of the Act, the Lord Chief Justice was right, and there can be no manner of doubt that Acts of Parliament (and Orders in Council, for the matter of that) must be so read; and I, for one, cannot quarrel with the decision to pardon a person who has not committed any offence in law. But the law must be altered as quickly as possible, for the protection of cyclists against those social pests who fling open their car doors without the slightest regard for other road-users.

From the cycling point of view, I suppose that the most famous example of faulty draughtsmanship is contained in an Act of Parliament which I think is no longer in operation. It said that the cyclist must give warning of his approach, in named circumstances, "by bell, whistle, or otherwise." It was never intended, of course, that the cyclists could do the needful by word of mouth, but the law is—or, rather, was—quite clear. There was no compulsion to carry a bell: there was compulsion to let people know you were coming. If you did this in a way included in the category of "otherwise," you were safe!

### "Practical Mechanics" Advice Bureau COUPON

This coupon is available until Aug. 31st, 1949, and must be attached to all letters containing queries, together with 3 penny stamps. A stamped, addressed envelope must also be enclosed.

Practical Mechanics

August 1949

Published about the 30th of each month by GEORGE NEWNES, LIMITED, Tower House, Southampton Street, Strand, London, W.C.2, and Printed in England by W. Speaight & Sons, Ltd., Exmoor Street, London, W.10. Sole Agents for Australia and New Zealand—Gordon & Gotch (A/asia), Ltd. Sole Agents for South Africa—Central News Agency, Ltd. Subscription Rate (including postage): For one year, Inland and Abroad, 10s. 9d. (Canada 10s.). Registered at the G.P.O. for transmission by Canadian Magazine Post.

CONDITIONS OF SALE AND SUPPLY: This periodical is sold subject to the following conditions, namely, that it shall not, without the written consent of the publishers first given, be lent, re-sold, hired out or otherwise disposed of by way of Trade except at the full retail price of 9d.; and that it shall not be lent, re-sold, hired out or otherwise disposed of in a mutilated condition or in any unauthorised cover by way of Trade, or allowed to or as part of any publication or advertising, literary or pictorial matter whatsoever.

**ELECTRADIX RADIOS**  
*for Best British Burgains*

**TRANSFORMERS.** Double wound, shrouded "Foster" transformers 230 volts 50 cy. to 50 volts 2 amps. 25/- B.T.H. 230 v. 50 cy., input 2 volts 20 amps. and 75 v. 6 amps. with 15 taps. 40/-

**AUTO TRANSFORMERS** 230/110 volts 85 watts, 25/- 150 watts, 35/- 1 kW., 57/10/0.

**TRANSFORMERS** for rewind, ex G.P.O., with laminations and wire, 500 watt size, 17/6.

**WIRE.** D.C.C. magnet wire, 19 gauge, 46 lb., 36 gauge 2 1/2 lb.

**MOTOR PUMP.** 400-v. 3 ph. A.C., motor fitted submersible pump, 600 g.p.h., 35. 12 volt D.C. for Caravan or boat lift. 3ft. throw, 10ft. handle, 100 g.p.h., 24/15/-

**TELEPHONES.** House and office. Constructors' parts for your own set up. Ex-G.P.O. wall type comprising bracket mike transformer and condenser, magneto bell, in walnut case Bin. x 6in. x 3 1/2in., fitted terminals and connections switch hook and contacts, hand magneto generators and single receivers, 25/- per pair, with wiring diagram; carriage and packing 5/- extra.

**DIMMER RESISTANCES.** Totally enclosed, panel type, 100 ohms, 1/2 amp. or 50 ohms, 1/2 amp., 2/6 each, post 6d. Open type, wire wound, porcelain base, 10 ohms, 1 amp., 2/6.

**RELAYS.** ex-G.P.O. stock, 100-ohm coil, operate from 2 1/2 volts, 15 m.a. bank of 20 relays, in case, 15/- G.P.O. type 3,000, as new, 150 ohms, 2 m. I. C.O. contact, 4/6. P.O. relay in circular case, 30 ohms, 500 ohms, 1,000 ohms, etc., 2/6 each.

G.P.O. Table type magneto ring telephone with hand com. Telephone on rest, mag. bell generator, with wiring diagram, 40/-, carriage 5/-.

**MORSE KEYS.** Precision made ex-W.D. on bakelite base with heavy insulated knob, 1/6, post 6d. Practice buzzer 2/-

**THE DEM. CONTINUITY TESTER,** self-contained Govt. model, 6 1/2 x 3 1/2 x 2 1/2, useful for all electrical circuits, totally enclosed in polished wood box carrying strap and contact switch, 8/6 with battery.

**LIGHTING AND CHARGING SETS.** Villiers 550 watt sets 2 h.p., single cylinder, air cooled, vertical petrol engine direct coupled to 18-volt, 20.5 amp. D.C. Crypto generator, speed 2,000 r.p.m., with petrol tank and guard rails, 17/10/-. 3-circuit charging switchboard for above plant, in pressed steel cabinet fitted variable charging resistances, Field regulator for dynamo, 3 circuit ammeters and main current ammeter, voltmeter, 3 enclosed cut-outs, terminals and 3-pole coupling plug, 5/6. All as new. Immediate delivery.

**HEADPHONES.** Single L.R. phones with headband and cord, 1/6, post 6d. Double headphones for crystal reception, 5/-, 9d. postage.

**WIRELESS CONTROL UNITS,** ex-R.A.F., contain Yaxley switch and knob, connection strips, fuse and holder, coil socket and connections, 2/-, postage 9d. Larger model with 2 Yaxley switches and pilot lamp, 3/-, plus 1/- postage.

**PRESSURE GAUGES.** Bourdon Boost Gauges plus 8 minus 7 lbs., luminous scale, bakelite case, new and boxed, 5/-

**DYNAMOS.** C.A.V. 12 volt 10 amp, 600/1,000 r.p.m. totally enclosed, shaft extension at both ends for prop. for windmill work, 40/-, carriage 5/- Leece Neville 30-volt 5-amp. shunt dynamo, 1,500 r.p.m., 35/-, carriage 5/-

**VARIABLE RESISTANCES,** slider type, 3 ohms 10 amps. 12/6, 6 ohms 6 amps. 15/-, 1.2 ohms 15 amps. 7/6. Rotary resistances, comprising resistance mats and radial stud switch and contact arm, 10 ohms 18 amps., 22/6 carriage 2/6.

**TERMINAL BOXES.** Bakelite power terminal boxes 3 1/2in. x 2 1/2in. x 2 1/2in. highly polished black with 1/4in. centre fillet and screwed cover connection studs and nuts. Admirable terminal or branch top on large transformer, 2-pole lights, power or charging circuits 10/50 amps. Wall or ceiling fixing, 1/6 each, 15/- per dozen.

**PARCELS.** 10lb. useful oddments for the junk box. All clean, dismantled from Government and other surplus apparatus, 7/6 post free. (Not for Overseas buyers.)

Please include postage for mail orders

**ELECTRADIX RADIOS**  
214, Queenstown Road, Battersea, London, S.W.8

Telephone: MACaulay 2159

**NO MAN CAN KNOW TOO MUCH OF HIS PRODUCT**

For the close scrutiny of every conceivable object, metals, tools, fabrics, fibres, minerals, precious stones, paint, print, manu-



The Ultra Lens is a revealing eye of six actual diametrical magnifications, which brings out points of strength or weakness, and enables the most minute measurements to be gauged accurately. Whether you are engaged in manufacturing, buying or selling, it is an ally of real value. No instrument you can buy will more quickly justify and pay for itself.

**THE ULTRA LENS COMPANY,**  
75, Finsbury Court, Finsbury Pavement, London, E.C.2.

**GREAT SUMMER OFFER**

Sets of clear Diagrams and Instructions for making easily from readily obtainable materials only.

1. Toy and Model Makers' Lathe 3/6
2. Toy and Table Model Fret Jing Saw Machine ... 3/6
3. Ball Bearing Circular Saw .. 3/6
5. Table Model Torch Battery Operated Cigarette Lighter and 6 Lengths of Element Wire ... 3/6
6. Tubular Furniture (all kinds) 2/6

Any TWO for 3/6 only. Post to-day to:

**P. M. BARHAM,**  
BRIDGE AVENUE,  
ST. SAMPSONS, GUERNSEY, C.I.

**BOOKS:**

- "Railway Modellers Handbook ... 2/6
- L.M.R. & Sc.R. Shed Nos. ... 3/-
- "Civil Engineering Work" ... 4/6
- "Min. Loco. Construction" ... 8/6

Sample L.M.S. or G.W.R. Train Postcard & List 7d.

**USEFUL PARTS**

- Scale Bakelite Wagons ... 00 0
- Scale Bakelite Vans ... 12/6
- Green Grass Paper, 22in. x 11in. ... 1/- 1/6
- Scale Station Figures ... 5d. 7 1/4
- Pea Bulbs on Base 2.5 v. ... 6d. 6d.
- 20-v. Lamps for Hornby ... 12/1
- 5 SW. Block 20 Amp. ... 2/6 2/6
- Model Shrubs ... 6d. 6d.

Postage extra. "OO" or "O" Parts List 3d. per post.  
**TYLDESLEY & HOLBROOK (M.E.T.A.)**  
109, DEANS GATE, MANCHESTER, 3

**SAILOR SAM'S SECRET**

How to Make SHIPS IN BOTTLES  
Kits, 5/6 and 6/-  
Flying Fish Solid Gliders  
The Super Kit, 4/3

Stocked by Model, Sports and Toy Stores  
Please write for details  
**COOPER - CRAFT, LTD.**  
The BRIDEWELL, NORWICH

**EARN MONEY**

making Scale Models at home. We supply Plans, Instructions, and buy your work. Details free. Write Box C19.

**BILTEX MODELS**  
**CHISWICK, LONDON, W.4**

**MYFORD LATHES AND ACCESSORIES (Ex-Stock)**

ML7 Model, 3 1/2in. x 20in. Bench Model, 242/5/8, or with two fitted chucks and motor, 559/19/6; ML8 Model Wood or Plastic, 9in. Swing x 30in., 118/15/6; "Super Adept" 1-5/8in. Lathes, 44/10/-; "Flexispeed" Ditto, 47/5/-; 2 1/2in. Chucks, 32/-; "Adept" Hand Shapers, 27/10/-; "Burner" and "Crown" Chucks. All Model Engineers' Tools.  
**L. TERRY, FISHERS LANE, GOLD ASH, NEWBURY. HERmitage 254.**

**BOMB-SIGHT SIGHTING HEADS** in original steel cases. Weight 40 lbs. 15/- carr. paid.

**BROWN**  
**102, CLEVELAND STREET**  
**DONCASTER**



**EASILY MADE FROM OUR CASTINGS**  
**J. HALLAM & SON**  
UPTON, POOLE, DORSET.  
MINIATURE PETROL ENGINES for Aeroplanes, Boats and Race Cars.  
Send 6d. for New List.

**ADANA PRINTING MACHINES**

Print in the odd hours with an Adana—still the most absorbing of crafts. No. 1 H/S Machine 24/10.0. No. 2 H/S Machine 29.15.0. Will quickly pay for itself. Send for illustrated folder to Dept. P.M. 25.

Adana (Printing Machines), Ltd. 15/18, Church St., Twickenham, Mdx.

**RATCHET & REVOLUTION COUNTERS**

Ask for Leaflet No. 18/6 Speed up to 6,000 r.p.m.  
**B. & F. CARTER & Co., Ltd., Bolton 5**

**WEBLEY AIR PISTOLS**

Marvellously accurate for target practice. No licence required to purchase.  
Senior Mark I Junior Webley Air Rifle  
Write for List. **WEBLEY & SCOTT LTD., 106, Weaman Street, Birmingham, Eng.**

**\* Multicraft CATALIN Material \***

Rods, Cylinders, Sheets, Sections, Kits for Book-ends, Table lamps, etc. The most versatile of all materials. Beautiful colours, easily worked. Sample Box 10/- Parcels 25/- & 50/-  
Details, Stock List, Sample 6d.  
**Dept. PM, COULDEN & SMITH, 17, The Mead, West Wickham, Kent.**

**The "THAMES VALLEY" BATTERY CHARGER**

2 - 6 - 12 VOLTS 1 AMP. with AMMETER  
for 200-250 volts 50 cycle mains  
42/6 post free  
Thames Valley Products  
28 Camden Avenue, Feltham, Middx.

**FOR SALE**  
Cycle. Gents Raleigh Sports. 3-Speed. Gear case. Dynamo Lighting from Front Hub. Cable Brakes. Special Saddle. Used few times; as new. Cost £20, price £15.-  
Peerless, 58, Gloucester Place, W.1. WELbeck 1288.

**Announcing THE "CORVETTE"**

**ALL-DRY ALL-WAVE SUPERHET PORTABLE**

A design specially produced for those who want an efficient all-dry trouble-free compact receiver. Ideal for any area. Simple to construct and adjust. Midget Valves; Slow-motion Drive. Chassis size 5 1/2in. x 4 1/2in. A.G.B. and A.V.C. Data Sheet, 3/-, post free.

**MANY OTHER TESTED AND GUARANTEED DESIGNS AVAILABLE**

Send 2ld. stamp for Latest List, or see previous issues of P.M.

**WINTER EVENINGS**

Now is the time to start on that Radiogram you have promised yourself so that you will obtain perfect enjoyment of your favourite broadcasts and records. If you want the best, without paying dearly for it, you should consider my "CORVETTE" RADIOGRAM. This design is for Quality Reproduction of radio and records, the circuit incorporating 2 T.R.F. stages; Infinite Impedance Detector; High and Low Note Tone-correcting Stage (with Constant Output); Voltage Amplifier; Phase Splitter and Two Triodes in Push-pull in the Output Stage, giving 8 watts; Negative Feedback; Medium and Long-waves; A.C. only; 3 Large Sheets of Full-size Plans, plus full descriptive matter and all component values, 7/6.

BEGINNERS HAVE ACTUALLY MADE THIS DESIGN WITH COMPLETE SATISFACTION

**PROMPT COMPONENT SERVICE**

What they say: "YOU ARE SURE OF A SQUARE DEAL FROM SPARKS"

**L. ORMOND SPARKS (M)**

9, Phoebeth Road, Brockley, S.E.4. (Nearest Station: Lydwell S.R.) (Phone: Lee Green 0220)

**FOR PRINTING**

LETTER HEADINGS, BILL HEADS, FOLDERS, LEAFLETS, CARDS, Etc.

THE FORREST PRINTING WORKS, 240, Holloway Rd., London, N.7  
Opposite Tube Station NOR 2004

**REYNOLDS RADIO.** Mail order specialists for all spares, testgear, television, and gram equipment. Send for Lists. All brand new equipment by reputable makers at the right price. Latest Plessey mixer-changer, 218/- Amplifiers 4 watt, 6/6; 10 watt, 21/-; 25 watt, 228/5/0. B.V.A. and surplus valves of all types, pickups, motors, etc.—**H. C. REYNOLDS, 21, Heath Street, London, N.W.3.**

**TRANSFORMERS**

Thompson Transformers of various outputs to suit your requirements. Special Sizes for Trains and Motors.  
12 v. or 20 v. 11 amps. ... 21/-  
12 v. or 20 v. 21 amps. ... 26/-  
6 v. 7 amp. Ground Heater ... 26/-  
Step-up or Down 60 watts ... 21/-  
Rectifiers from 13/6.

Stamp for List and quotation.  
**T. W. THOMPSON & CO., 176, Greenwich High Road, Greenwich, S.E.10.**

Weatherproof, Aluminium, Two Blade WIND CHARGER PROPELLERS  
Length, 4 ft. 10 ins. Weight, 23 ounces. Price 20/- each, including full set of constructional details for making Turntable Mast-head and other parts. Careful packing and postage, prompt dispatch. No duty, nor P.T. to pay.  
**P. Robert, 63 Hauteville, Guernsey, C.I.**

# Free Guide - "Success in Engineering"

One of the following Courses taken at home in your spare time can definitely be the means of securing substantial promotion in your present calling, or entry into a more congenial career with better prospects.

## ENGINEERING, AERO, ETC.

Plastic—Radio—Aero Engines—Aircraft Design—Welding—Aerodynamics—Electrical Engineering—Television—Electric Wiring—Diesel Engineering—Generation and Supply—Works Management—Metallurgy—Refrigeration—Planning. Estimating. Rate-fixing—Time and Motion Study—Aero Inspection—Automobile Engineering—Sheet-metal Work—Engineering Draughtsmanship—Aero Draughtsmanship—Jig and Tool Draughtsmanship—Press Tool and Die Draughtsmanship—Structural or R/F Concrete Draughtsmanship—Sanitary Engineering.

## GENERAL

Matriculation—College of Preceptors—A.C.C.S.—A.C.I.S.—Aircraft Apprentice.

## MUNICIPAL SERVICE

School Attendance Officer—Handicraft Teacher—Registrar—Housing Manager—Sanitary Inspector—Weights and Measures Inspector—Inst. of Mun. Engineers—A.R.I.C.S.—L.A.B.S.S.

### THE BUILDING BOOM— SECURE YOUR SHARE!

The Free Guide also gives particulars of our extensive range of modern Building and Structural Courses, Building Draughtsmanship, etc. The great post-war Building programme offers unlimited prospects to technically trained men.

### BECOME A DRAUGHTSMAN— QUALIFY AT HOME AND EARN BIG MONEY

Men and Youths urgently wanted for well paid positions as Draughtsmen, Inspectors, etc., in Aero, jig and Tool, Press Tool, Electrical, Mechanical and other Branches of Engineering. Practical experience is unnecessary for those who are willing to learn—our Guaranteed "Home Study" courses will get you in. Those already engaged in the General Drawing Office should study some specialised Branch such as Jig and Tool or Press Tool Work and so considerably increase their scope and earning capacity.



## NATIONAL INSTITUTE OF ENGINEERING

(Dept. 29)

148, HOLBORN, LONDON, E.C.1

OVER SIXTY YEARS OF  
CONTINUOUS SUCCESS

SOUTH AFRICAN BRANCH: E.C.S.A. P.O. BOX 8417 JOHANNESBURG.

FOUNDED 1885—FOREMOST TODAY.—OVER 100,000 SUCCESSSES

## "PRACTICAL ENGINEERING" said—

We recommend all readers interested in improving their position to apply for a copy of this valuable book. "Success in Engineering" is not a pamphlet. It is a 132-page book, containing valuable and vital information on all branches of engineering. . . . There are many engaged in engineering who owe their success to The National Institute of Engineering.

The FREE GUIDE explains:

- Openings, prospects, salaries, etc., in Draughtsmanship, Inspection, and opportunities in all other branches of Engineering and Building.
- How to obtain money-making technical qualifications through special RAPID FULLY-GUARANTEED COURSES.

Write now for your copy of this remarkable publication.

A.M.I.E.E., A.M.I.Mech.E.,  
A.M.Brit.I.R.E., A.M.I.P.E.,  
A.M.I.C.E., A.M.I.Struct.E.,  
A.M.I.Mun.E. M.R.San.I.,  
A.M.I.E.D., A.F.R.Ae.S.,  
London B.Sc., Degrees.

Fully guaranteed postal courses for all the above and many other examinations. Fully described in the Free Guide.

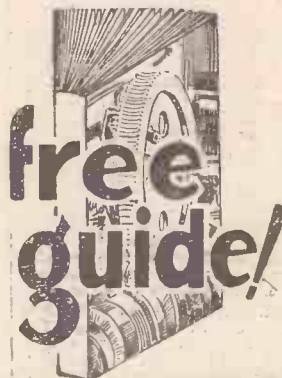

## THE ACID TEST OF TUTORIAL EFFICIENCY SUCCESS—OR NO FEE

We definitely guarantee that if you fail to pass the examination for which you are preparing under our guidance, or if you are not satisfied in every way with our tutorial service—then your Tuition Fee will be returned in full and without question. This is surely the acid test of tutorial efficiency.

If you have ambition you must investigate the Tutorial and Employment services we are able to offer. Founded in 1885, our success record is unapproachable.

Why not fill in and post the attached Coupon NOW for further details and Free Authoritative Guide to openings in Engineering and Building? This book contains a mine of valuable and exclusive information and may well prove to be the turning point in your career.

PROMPT TUTORIAL SERVICE GUARANTEED

### FREE COUPON

To NATIONAL INSTITUTE OF ENGINEERING  
(Dept. 29), 148, Holborn, London, E.C.1.

Please Forward your Free Guide to

NAME .....

ADDRESS .....

My general interest is in: (1) ENGINEERING (Place a cross against the branches in which you are interested.)  
(2) AERO (3) RADIO (4) BUILDING  
(5) MUNICIPAL WORK

The subject or examination in which I am especially interested is .....

To be filled in where you already have a special preference.  
(Id. stamp only required if unsealed envelope used.)