

*Palmer*  
THE ELECTRON MICROSCOPE

NEWNES

9<sup>D</sup>

# PRACTICAL MECHANICS

EDITOR : F. J. CAMM

OCTOBER 1948

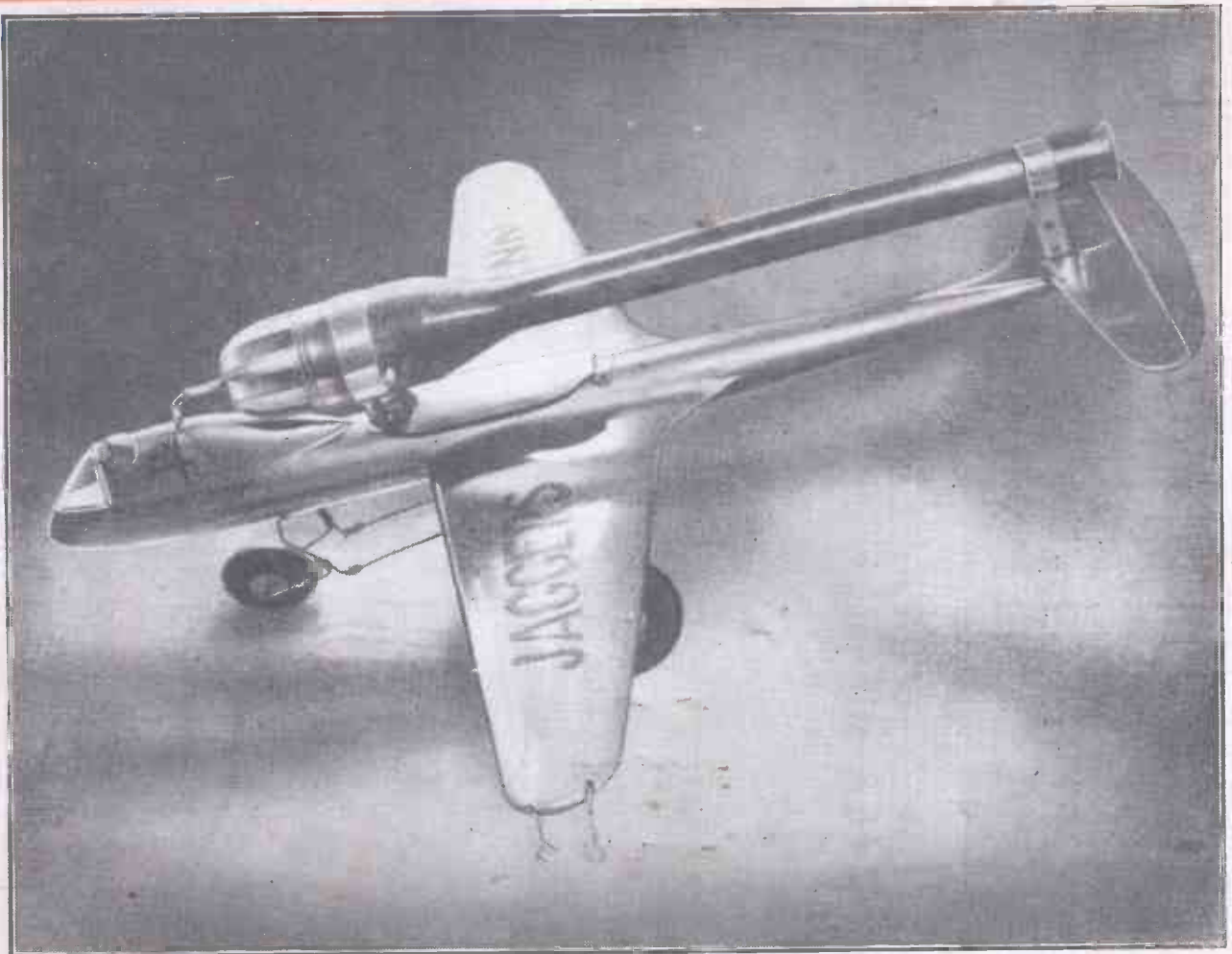

A RECORD-BREAKING JET-MODEL AIRCRAFT (SEE PAGE 27)

## PRINCIPAL CONTENTS

Small Electric Motor  
Calling CORINTHIAN !  
Power Model Aircraft

World Air News  
Elements of Mechanics  
Twenty Years from Now

Trade Notes  
World of Models  
Cyclist Section

LET **TERRY'S**  
 SOLVE YOUR *Clip* PROBLEMS

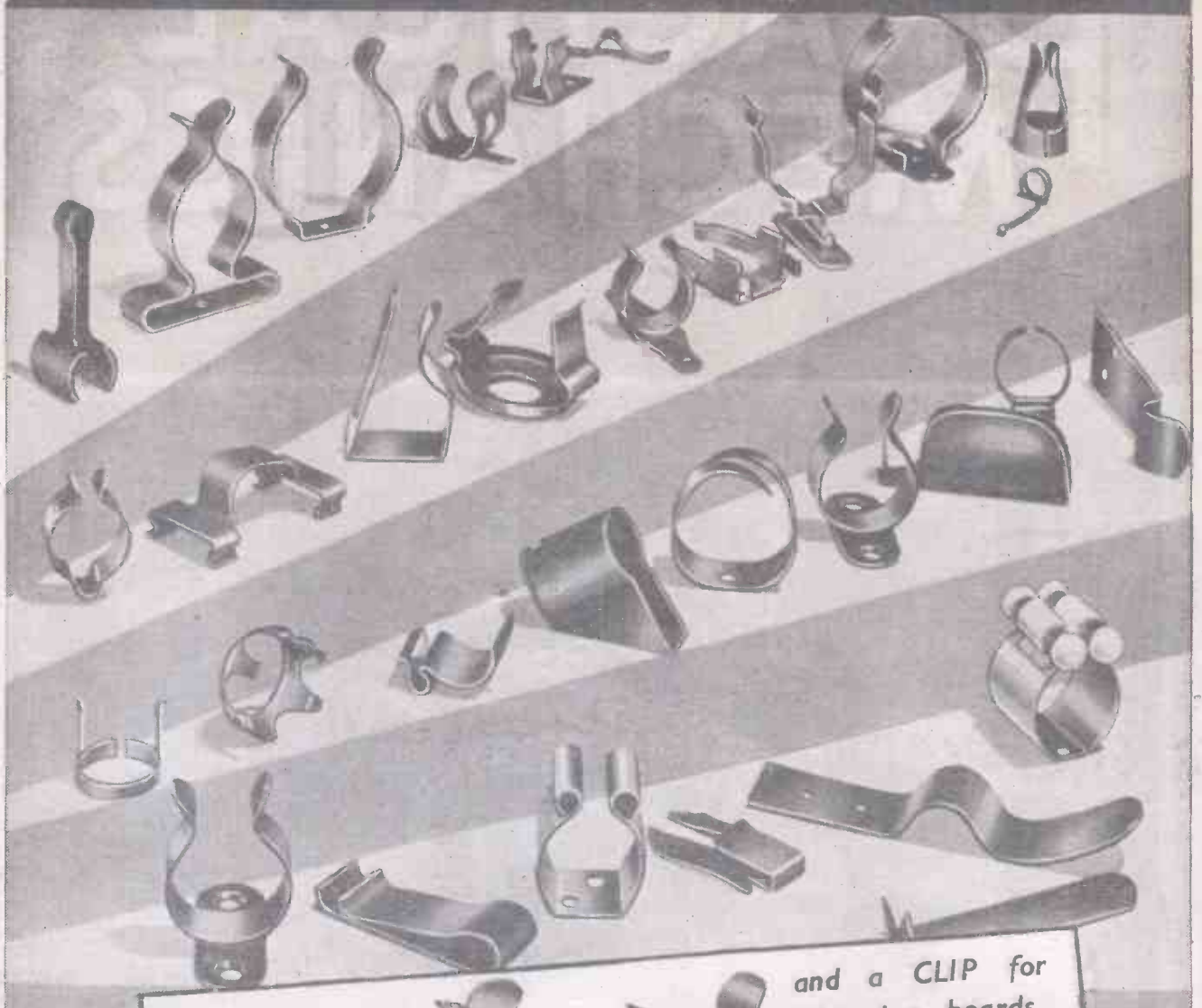

Two stock patterns  
 always in supply  
 —80 and 81—  
 made in a range  
 of sizes to grip  
 from  
 $\frac{1}{4}$ " to 2"

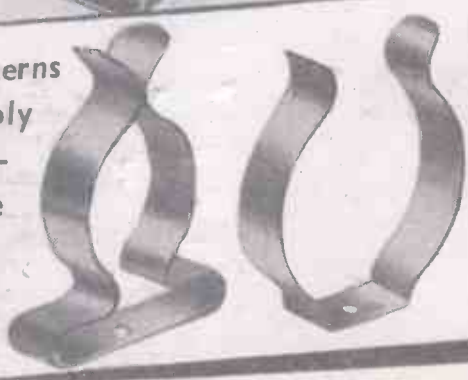

and a CLIP for  
 drawing boards  
 (No. 300)



The most authoritative  
 text book  
 on springs  
 published.  
 10/6 post  
 free.



★ We show here just a few from our enormous selection of specially made clips  
 . . . . . our research department can design any clip you require to your own  
 specification (93 years of clip-making is at your disposal).

HERBERT TERRY & SONS LTD. REDDITCH • London • Birmingham • Manchester

**SCALE MODEL  
PERMANENT WAY**  
for Gauge 'O' Railways

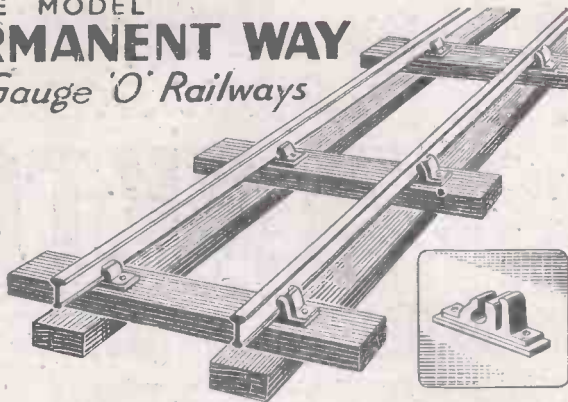

**Now Available from Stock**

Easily the most realistic, durable and quietest running track made. (Note the new slide-on chair—an exact fit on rail.) Available with book of instructions and special jigs for easy assembly.

Scale Track parts for Gauge 'O' Railways.

RAILS, Steel 36in. lengths	5/- per doz. lengths	BATTENS, longitudinal 36in. lengths	4/6 per doz.
RAILS, Brass 36in. lengths	12/- per doz. lengths	PANEL PINS	6d. per packet
CHAIRS, Slide-on Pattern	2/6 per 100	CONDUCTOR RAIL CHAIRS for electrifying the track	8/6 per 100
FISHPLATES	7d. per dozen	INSTRUCTION BOOKLET	6d. each
SLEEPERS, 3in. long	3/6 per 100	TRACK LAYING GAUGE	1/6 each
HOLDING-DOWN SPIKES	6d. per 500	CHAIR FIXING JIG	2/9 each

Complete set of parts for constructing 18 feet track: With brass rails, £1 6s. 6d. With steel rails, 19/6. Postage on either set, 1/3.

Brass conductor rail and parts for electrifying the above sets, 9/6. (Postage if ordered separately, 9d.)

**"BASSETT-LOWKE PUBLICATIONS"**

Send 1d. stamp for BP/12 a new brochure giving details of all catalogues, booklets, etc., devoted to models and model-making.

**BASSETT-LOWKE LTD.**  
**NORTHAMPTON**

London: 112, High Holborn, W.C.1.  
Manchester: 28, Corporation Street.

**TOY-MAKING, MODELS  
OR FRETWORK**

A Hobbies Outfit provides all tools for useful and ornamental things to make in wood. There are hundreds of full size plan sheets to choose from and kit of materials for each. A happy hobby for the handyman is to be found in one of

**HOBBIES**  
BRITISH FRETWORK OUTFITS.

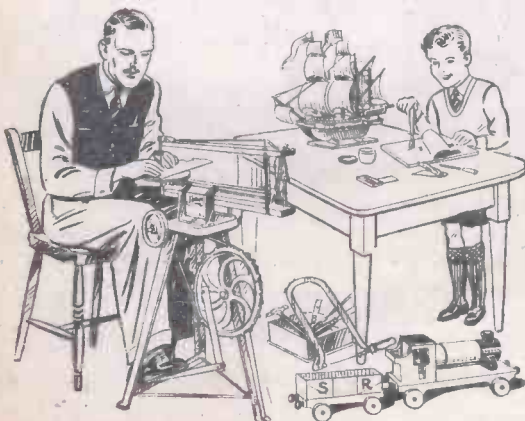

Outfits at all prices from Hobbies branches in London, Glasgow, Manchester, Birmingham, Sheffield, Leeds, Hull, Southampton, or stores and ironmongers everywhere. Illustrated lists of tools and things to make from Dept. 7, Hobbies, Ltd., Dereham, Norfolk.

JOHNSONS OF HENDON ARE AGAIN ABLE TO OFFER A RANGE OF PHOTOGRAPHIC CHEMICALS IN SMALL AND HANDY PACKAGES UNDER THE BRAND NAME OF

**PACTUMS**



★ The most popular pactum package is M-Q Developer (Metol-Quinol) containing all the chemicals required to make 10 oz. of solution for dish development. This M-Q pactum will also make 16 oz. of solution for using in a tank.

JOHNSON PACTUMS are exceptionally useful for those amateur photographers who like to make up small quantities of solution at a time. Toners, Intensifiers and Reducers are only needed occasionally and to have the chemicals at hand in this convenient form saves time and trouble. Get a few PACTUMS of each kind. Keep them ready in your dark room.

The following packings are available.

- ★ M-Q DEVELOPER (Metol-Quinol) BLUE TONER for making 10 oz.
- COPPER INTENSIFIER for 8 oz. SEPIA TONER to make up 8 oz.
- REDUCER sufficient for 8 oz. GREEN TONER for making 10 oz.

Ask your Dealer for Scales Brand Pactums.

**JOHNSONS OF HENDON**

HENDON, LONDON, N.W.4.

ESTABLISHED 1743

**"SPECIAL OFFERS IN TOOLS"**



Super quality Grinding Heads, bronze bearings. Vee pulley. Suitable for round or Vee belts. 6in. height of centres. Spindle, 8in. x 1/4in., one end for grinding wheel, other tapered spindle for polishing mops. Price 19/3 Post Paid.



Combination Grinding Head, as shown, with 3-jaw self-centring chuck. 8in. centres. Price 38/-



American type adjustable from Planes, with best Sheffield irons. Size 9in. x 2in. Price 26/6 Post Paid



Genuine "All-ball" Grinders. Treadle action. Tremendous speed obtained in quick time, both hands free to manipulate work. A necessity for the engineer and work-shop. Price complete. 75/9 carr. Paid.



Highly geared Hand Bench Grinders, with 6in. x 1 1/2in. wheel. Extra fine quality machine cut gears, adjustable tool rests. Price complete, 36/6



Best quality Sheffield made steel Scissors. Extra heavy quality for home or factory use. 7 1/2 Post double point. Overall length, 7in. Price 7/9 Paid.



One-pint Paraffin Blow-lamps. Brass container, best British manufacture, specially suitable for painters, plumbers, engineers. Price 27/6 Post Paid.

We have large stocks of tools for all trades. Please send us your enquiries.

**S. TYZACK & SON LTD.** TOOL & MACHINERY MERCHANTS  
341-5, OLD STREET, LONDON, E.C.1.  
Telephone: CLERKENWELL 4004-5-6. Telegrams: Tyzack, Finsquare.

# I.C.S. TRAINED MEN are in Greater Demand than Ever—Maximum production depends on high technical skill, such as that acquired by I.C.S. Students

**TENS OF THOUSANDS MORE  
TRAINED MEN ARE URGENTLY  
NEEDED NOW—BUT THERE IS  
NO WORTH-WHILE PLACE FOR  
THE UNTRAINED**

*Ambitious men everywhere have succeeded through  
I.C.S. Home-Study Courses. So also can you.*

The man with an I.C.S. Training in any one of the subjects listed below knows it thoroughly, completely, practically. And he knows how to apply it in his everyday work.

Accountancy	Diesel Engines	Motor Engineering
Advertising	Draughtsmanship	Motor Mechanic
Aeronautical	(State which branch)	Motor Vehicle Elec.
Engineering	Drawing Office Practice	Municipal Eng.
Air and Vacuum	Electrical Engineering	Plastics
Brakes	Electric Power, Light-	Plumbing
Air-Conditioning	ing, Transmission,	Quantity Surveying
Architecture	Traction	Radio Engineering
Architectural Drawing	Eng. Shop Practice	Radio Service Eng.
Auditing	Fire Engineering	Refrigeration
Boiler Engineering	Free-Lance Journalism	Sales Management
Book-keeping	Fuel Technology	Salesmanship
Building Construction	Heating and Ventilation	Sanitary and Domestic
Building Specifications	Hydraulic Engineering	Engineering
Business Training	Hydro-Electric	Sheet-Metal Work
Business Management	Illumination Eng.	Short-Story Writing
Carpentry	Industrial Management	Steam Engineering
Chemical Engineering	Internal Comb. Eng.	Structural Steelwork
Chemistry, I. & O.	Joinery	Surveying
Civil Engineering	Lettering	(State which branch)
Clerk of Works	Machine Designing	Telegraph Engineering
Coal Mining	Machine-Tool Work	Textile Designing
Colliery Examiner's	Marine Engineers	Welding, Gas and Elec.
Colliery Overman's	Mechanical Drawing	Woodworking Drawing
Commercial Art	Mechanical Engineering	Woolen and Worsted
Concrete Engineering	Mine Surveying	Manufacturing
Cotton Manufacturing	Mining Engineering	Works Engineering

And most of the Technical, Professional, Commercial and Civil Service Examinations.

(I.C.S. students preparing for Examinations are coached till successful)

If you need technical training, our advice on any matter concerning your work and your career is yours for the asking—free and without obligation. Let us send you our special free booklet on the subject in which you are specially interested. **DON'T DELAY. Make ACTION your watchword**

**The successful man DOES to-day what the failure  
INTENDS doing to-morrow. Write to us TO-DAY**

..... Use this Coupon .....

**INTERNATIONAL CORRESPONDENCE SCHOOLS LTD.**

Dept. 95, International Buildings, Kingsway, London, W.C.2

Please send me the free booklet describing your Courses in

Name..... Age.....  
(USE BLOCK LETTERS)

Address .....

Addresses for Overseas Readers  
Australia: 140, Elizabeth Street, Sydney.  
Egypt: 40, Sharia Malika Farida, Cairo.  
India: Lakshmi Bldgs., Sir Pherozsha Mehta Rd., Fort,  
Bombay.  
New Zealand: 182, Wakefield Street, Wellington.  
South Africa: 45, Shortmarket Street, Cape Town.



## Make your JUNEERO a precision tool with the "XAKTO" SLIDE GAUGE & PROTRACTOR

Accuracy guaranteed, quickly and easily fixed, it gives INSTANT VISUAL LOCATION OF EXACT MEASUREMENTS FOR ALL CUTTING, PUNCHING AND BENDING.

No marking out required. Get an "XAKTO" to-day and be sure of greater precision for the "one off" job plus a real saving of time in repetition work.

From All  
Registered  
Dealers  
PRICE

**7/6**

JUNEER LTD.,  
Stirling Corner,  
Boreham Wood,  
Herts.

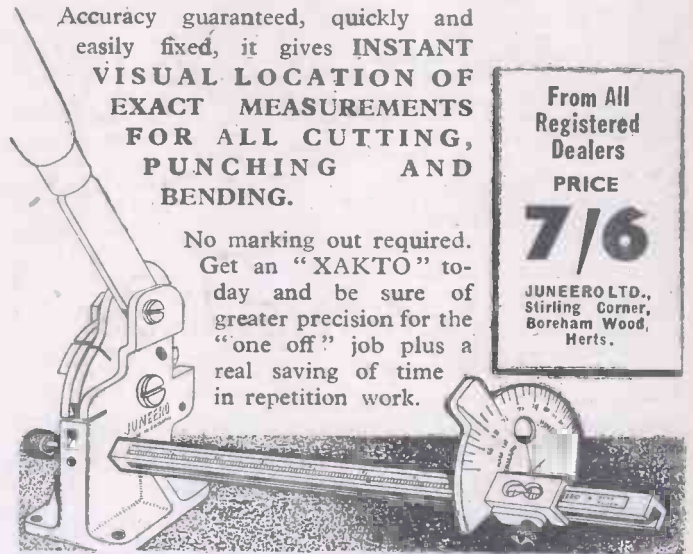

## HEADPHONES WHICH UPHOLD BRITISH PRESTIGE

**S. G. BROWN, Type 'K'**

Moving Coil Headphones, supply that High Fidelity Reproduction demanded for DX work, monitoring and laboratory purposes, etc.

**OUTSTANDING  
CHARACTERISTICS**

D.C. RESISTANCE 47 Ohms.

IMPEDANCE 52 Ohms at 1,000 c.p.s.

SENSITIVITY, 1.2 x 10<sup>-12</sup> watts at 1 kc  
.0002 Dynel/cm<sup>2</sup>.

PRICE **£5.5.0** PER PAIR

Your local dealer can supply.



TYPE 'K'

Descriptive Literature on request.

For details of other S. G. Brown Headphones (prices from 30/- to 63/-) write for illustrated Brochure "P.M."

**S. G. Brown, Ltd.**

Telephone: Watford 7241

**SHAKESPEARE STREET, WATFORD, HERTS.**

# You have only to press the trigger!

No longer is it necessary to go about jobs of painting, distemping, whitewashing, etc., in the old laborious way.

Now you only need to connect the "Crystal" Spray Gun to your electric cleaner, and press the trigger, to complete such jobs without mess or effort and at the same time obtain a much superior finish. For re-cellulosing cars, cycle frames, etc., it is ideal.

The "Crystal" Spray Gun will be forwarded by return, post free, on receipt of remittance with order stating, make and type of cleaner. A special connector, desirable with all and essential with some cleaners, is available at 3/6d. extra.

**75/-**  
complete

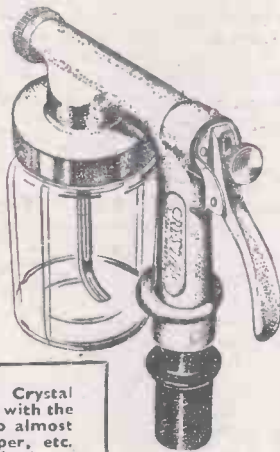

Write for full details of the NEW Crystal "Flock" Gun. You will be intrigued with the finish imparted by this new process to almost any material—wood, glass, metal, paper, etc. Many HOME uses—no skill required.

Dept P.M  
**DOMESTIC SUPPLY COMPANY**  
341, REGENT'S PARK ROAD, LONDON, N.3  
(Near Finchley, Central Station) Tel: FInchley 5193

## VOLTAGE REGULATOR AND FILTER UNIT (CONTROL PANEL 5U/363)

This equipment as illustrated comprises filter unit, block condensers, carbon pile voltage regulator, fuse panels, mains switch, pilot lamp, holder, rheostat, rectifier, etc., etc., all contained in metal cabinet. It was originally designed for a Radar equipment and has an input of 80 v. A.C. and an output of 90 v. 30 m/a. D.C. Adaptation for other voltages may be made. The value of the components only is extremely high, but we can offer the whole unit complete at the low price of 12/6 (carriage and packing 5/-).

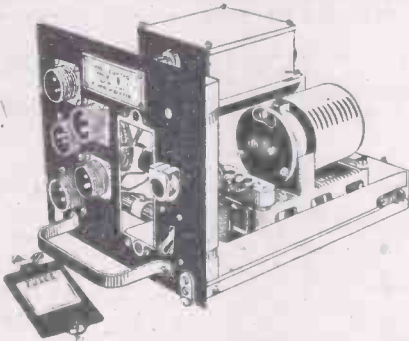

## REMOTE CONTROL MAGNETIC SWITCH

An interesting remote control device comprising a 1 pole 2 way 1 inch break, with D.C. bobbin and rectifier. For use on 230 v. 50 c/s. A.C. mains, as used by the Admiralty. Type W576B. Ideal for remote control of machinery, etc., etc. ONLY 9/11 each (carr. & pkg. 3/-). BRAND NEW.

## HARDWARE KIT

A necessity for every mechanic. A kit comprising 5 gross assorted steel bolts, nuts, flat and shakeproof washers, soldering tags—mainly BA threads; tag panels; crocodile clips; solder; insulating tape; wire; sleeving; spade terminals; brackets; clips; etc., etc. ALL FOR 29/6, you would normally have to pay £5 for this parcel!

## UNIVERSAL MOTORS

A 1/2 H.P. motor to operate on 200-250 v. A.C. or D.C. mains. Will give 5,000 r.p.m. and is ideal for use with grindstone, polishing mop, etc. End of spindle

Terms: C.W.O. Remittances payable to E. & G. Distributing Corporation Ltd. MAIL ORDER SUPPLY CO., Dept. P.M., 3, Robert Street, Hampstead Road, London, N.W.4. Stepney Green 2760-3906.

threaded. Complete and ready for use with 4 fixing feet for bench or table. ONLY 22/6. POST FREE. BRAND NEW.

## MAINS TRANSFORMERS

A first-grade transformer, input 230 v. 50 c/s. A.C. with an output of 4 v. 2 1/2 amps. Size 3 1/2 in. x 2 1/2 in. x 4 in. Weight 3 1/2 lbs. Fixing feet incorporated. ONLY 10/- (Post & pkg. 1/6.) BRAND NEW.

## POWER UNIT TYPE 87

These units comprise a 3 commutator rotary transformer with a smoothing system consisting of screened suppressor units and an L.F. choke and condenser. Input 24 v. D.C. Output 250 v. 65 m/a H.T. and 6.3 v. 2.5 amps. L.T. Housed in sound-proof cabinet. Will operate continuously at 30 m/a. H.T. or intermittently at 65 m/a. The rotary transformer has a bi-polar permanent magnet field. These have many uses, including that of a D.C. battery charger by using the H.T. winding for mains input and charging 6 v. batteries at one or two amps. from the L.T. side. Brand new—ONLY 10/- (Post & pkg. 2/6.)



Get this book  
make these  
**MODELS**

HOUSES · SHIPS · ASHTRAYS · BOOK-  
ENDS · SIGNAL CABINS · RAILWAY  
STATIONS · AIRPORTS · DOCKS  
RELIEF MAPS · PLAQUES · MODEL  
FURNITURE · INKSTANDS · PAPER  
WEIGHTS · MODEL FIGURES AND  
ANIMALS ETC.

**SIMPLE TO HANDLE · INEXPENSIVE**

The Instruction Book illustrated tells you how to make such models as above, without special tools or skill, in Sankey's "Pyruma" Plastic Cement. This material, modelled while plastic, dries or bakes to stone-hardness, ready for painting according to instructions. Obtainable at local ironmongers, hobbies shops and art material dealers.

Get Instruction Book by sending 4d. in stamps to the address below



Dept. 4

**J.H. SANKEY & SON, LTD.**

**M.O.S.**

Callers to: 24, New Road, London, E.1.  
Money refunded if not satisfied.

ILFORD

Est. 1857

ESSEX

## GALPIN'S

ELECTRICAL STORES

408, HIGH STREET, LEWISHAM,  
LONDON, S.E.13

Telephone: Lee Green 0309.  
Near Lewisham Hospital.

TERMS: CASH WITH ORDER. NO  
C.O.D.

**EX-NAVAL CATHODE RAY RECTIFIER UNITS.** New, consisting of the following components, High Voltage Condensers, Chokes, approx. 150 assorted Resistances, and Condensers, solid brass Chassis, 42/6 each. C.I.F.

**EX-R.A.F. I.F.F. UNITS 10 VALVE SHORT WAVE,** complete with Valves and Motor Generator, 12 volts input 450 volts 40 ma output, 35/- each; with 24 volt Motor Generator, 30/- The latter can also be used as an A.C. Motor direct from 200/250 v. mains.

**ROTARY CONVERTERS EX-ADMIRALTY** 110 volts D.C. to 230 volts A.C. 50 cyc. 1 phase rated at 200 watts but capable of 550 watts continuous rating, weight approx. 100 lbs., £81/0/- each, carriage 10/- Another Ex-R.A.F. 12 volts D.C. input, 220 volts A.C. 50 cyc. 1 ph. at 100 watts output approx. weight 15 lbs., as new, 85/- each, carriage 3/6.

**VARIAC TRANSFORMERS.** Input variable between 200/240 volts output constant at 220 volts at 7½ amps., 90/- each, carriage 5/-.

**MAINS TRANSFORMERS,** all 200/250 volts 50 cyc. 1 ph. input, output 700/10700 v. 70 ma., 4 v. 2½ a., 12 v. 1 a., 30/- each. Another 525/525 v. 150 ma. 6.3 v. 5 a. 5 v. 3 a., 37/- each. Another, 350/0/350 v. 250 ma. 4 v. 8 a., 4 v. 3 a., 6.3 v. 6 a., 6.3 v. 2 a. tapped at 2 v., 65/- each. Another 500/0/500 v. 300 ma. 6.3 v. 6 a., 4 v. 6 a. 5 v., 62/6 each. Another tapped output 6, 12, at 24 volts at 10/12 amps., 47/- Another 350/0/350 v. 180 ma. 4 v. 4 a., 6.3 v. 4 a., 5 v. 3 a., 39/- Another 2,350 volts at 500 ma., 85/- each. Mains Smoothing Chokes, 10 Hy., 100 ma., 6/-; 150 ma., 8/6; 350 ma., 25/-; 5 Hy., 250 ma., 17/6.

**EX-GOVERNMENT (G.E.C.) ELECTRIC FANS,** 12 volts, A.C./D.C. laminated field, complete with 5in. impeller. New, boxed, 20/- each, post 1/- Transformer to suit, 230 volts, input, 12/16 volts at 4 amps. output, 32/6 each.

**MAINS VARIABLE RESISTANCES,** ex-Govt. (new) 4,000 ohms, .25 amps., 35/- each. Worm wheel control, slider type, 60 ohms, to carry 1½ amps., 17/6 each; 5.7 ohms, 8 amps., 25/- each. Dimmer resistances stud switch arm type, 2,700 ohms to carry .27 amps., 25/- each.

**MAINS VARIABLE RESISTANCES** (slider type), new, ex-Govt., 14 ohms, carry 1 to 4 amps. graduated, useful as dimmers, etc., 17/6 each; another, 0.4 ohms, carry 25 amps., 17/6 each, post 1/6. Ex-Govt. Moving-coil Cell Testers, 3-0-3 volts (new), 20/- each.

**MAINS TRANSFORMERS (Auto-Wound).** Voltage Changers tapped, 10, 20, 25, 90, 130, 150, 190, 210 and 230 volts, all at 1,000 watts, a combination of 24 voltages can be obtained from this transformer, new ex-Government Stock, £51/0/- each, carriage 5/- Mains Booster Transformer, tapped 0, 6, 10, 19, 175, 200, 220, 225, 240 and 250 volts at 1,500 watts (new, ex-Government), £55/- each, carriage 5/- Another 200 volts input, 240 volts output at 2,500 watts, £71/0/-, carriage 7/6. Another 2 to 1 ratio, 110 volts input, 220 volts output, or vice versa, at 4,000 watts, £12/10/-, carriage 10/- Another 230 volts input, tapped output 40, 41, 42, 44, 46, 47, 49 and 52 volts at 100 amps., £15/- each, carriage 10/- The latter two are double wound. Another Auto Wound, tapped 0, 110, 150, 190, 210 and 230 volts at 1,500 watts, £61/0/- each, carriage 5/- Ditto, 2,000 watts, £75/-, carriage 5/-.

**EX-R.A.F. MICROPHONE TESTERS** (new). These consist of a Ferranti 0 to 450 mlamp. 2½in. scale meter shunted to 1 ma. incorporated Westinghouse Rectifier, the whole encased in polished teak case, calibrated at present 0 to 10 volts, 32/6 each. 27/6 each.

**EX-NAVAL (SELF-ENERGISED) TELEPHONE HANDSETS,** 10/6 each, or complete Telephones, Magneto Ringing with Neon Light, 35/- each, post 2/6. Another with BUZZER ringing, 15/- each, post 2/-.

**EX-R.A.F. CRYSTAL CALIBRATORS UNITS.** Type 18, R.A.F. serial No. 10a/15237. These units contain 100 kc/s. xstal 2-EF 50 valves and numerous other items all new and unused, 35/- each.



### THE "FLUXITE QUINS" AT WORK

"At last! A day by-the sea!  
And now for a nice cup of tea,"  
Cried OO, "Yes, we might,  
If we had some FLUXITE,  
We've brought the old kettle, you see."

For all **SOLDERING** work—you need **FLUXITE**—the paste flux—with which even dirty metals are soldered and "tinned." For the jointing of lead—without solder; and the "running" of white metal bearings—without "tinning" the bearing. It is suitable for **ALL METALS**—excepting **ALUMINIUM**—and can be used with safety on **ELECTRICAL** and other sensitive apparatus.

**With Fluxite joints can be "wiped" successfully that are impossible by any other method**

Used for over 40 years in Government works and by leading engineers and manufacturers. Of all Ironmongers—in tins, 10d., 1/6 and 3/-.

● **TO CYCLISTS!** For stronger wheels that will remain round and true, here's a time-tested tip. Tie the spokes where they cross with fine wire **AND SOLDER**. It's simple—with **FLUXITE**—but **IMPORTANT**.

THE "FLUXITE" GUN puts "FLUXITE" where you want it by a simple pressure.

Price 1/6 or filled 2/6

ALL MECHANICS WILL HAVE

# FLUXITE

IT SIMPLIFIES ALL SOLDERING

Write for Book on the **ART OF "SOFT" SOLDERING** and for Leaflets on **CASE-HARDENING STEEL and TEMPERING TOOLS with FLUXITE.**  
Also on "WIPED JOINTS." Price 1d. Each.

**FLUXITE LTD., Dept. P.M., Bermondsey Street, S.E.1**

## MYFORD TYPE ML7

### 3½" HEAVY DUTY LATHE

The finest Lathe in its class.

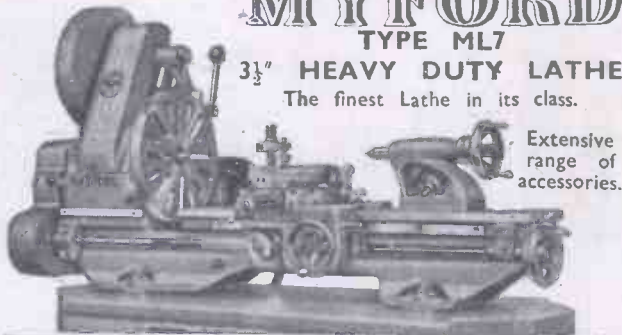

Extensive range of accessories.

**MYFORD ENGINEERING COMPANY LIMITED**

BEESTON · NOTTINGHAM · Phone: 54222 (3 lines)

07.148B

## EVERYTHING FOR THE HANDYMAN

Wood Mouldings, Dowelling, Table and Chair Legs.  
Ornamental Pressings.

Plastic and Metal Handles and Knobs.

Sheet, Strip and Tubular Metal.

Hinges, Screws and Cabinet Fittings Of All Kinds.

Saws, Planes, Vices, Braces, Drills, Etc.

Special Fittings Obtained To Order Within A Few Days.

Send For Price List and Sample Wood Mouldings.

IT WILL PAY YOU TO PAY US A VISIT

**B. KOSKIE (Dept. B)**

75 Leather Lane, Holborn, E.C.1.

Closed 1 o'clock Sat.

Phone: Holborn 4777

## PELMANISM

for  
Courage and Clear-Thinking

The Grasshopper Mind

**YOU** know the man with a "Grasshopper Mind" as well as you know yourself. His mind nibbles at everything and masters nothing.

At home in the evening he tunes in the wireless—gets tired of it—then glances through a magazine—can't get interested. Finally, unable to concentrate on anything, he either goes to the pictures or falls asleep in his chair. At his work he always takes up the easiest job first, puts it down when it gets hard, and starts something else. Jumps from one thing to another all the time.

There are thousands of these people with "Grasshopper Minds" in the world. In fact, they are the very people who do the world's most tiresome tasks—and get but a pittance for their work. They do the world's clerical work, and the routine drudgery. Day after day, year after year—endlessly—they hang on to the jobs that are smallest-salaried, longest-houred, least interesting, and poorest-future!

What is Holding You Back?

If you have a "Grasshopper Mind" you know that this is true. Even the blazing sun can't burn a hole in a piece of tissue paper unless its rays are focused and concentrated on one spot! A mind that balks at sticking to one thing for more than a few minutes surely cannot be depended upon to get you anywhere in your years of life!

Half fees for serving and ex-Service members of His Majesty's Forces (Apply for Services Enrolment Form)

The tragedy of it all is this; you know that you have within you the intelligence, the earnestness, and the ability that can take you right to the high place you want to reach in life! What is holding you back? One scientific fact. That is all. Because, as Science says, you are using only one-tenth of your real brain-power. What Can You Do About It?

Take up Pelmanism now! A course of Pelmanism brings out the mind's latent powers and develops them to the highest point of efficiency. It banishes such weaknesses and defects as Mind Wandering, Inferiority, and Indecision, and in their place develops strong, positive, vital qualities such as Optimism, Concentration, and Reliability, all qualities of the utmost value in any walk of life.

The Pelman Course is fully explained in *The Science of Success*. The Course is simple and interesting and takes up very little time. You can enrol on the most convenient terms. The book will be sent you, gratis and post free, on application to-day to:

**PELMAN INSTITUTE**

(Established over 50 years)

136 Norfolk House, Wigmore St.  
London, W.1

# IT'S HOME ENGINEERING

WITH MACHINE-SHOP TECHNIQUE



● Build your own radio chassis and 101 other gadgets for the home; construct perfect working models to your own plans. In fact, create to your heart's content; you'll see your work materialise into perfect precision productions. The Prestacon Press is the instrument that, for the first time, brings home engineering to the handyman.

● Prestacon is the COMPLETE Press with all neces-

sary attachments including Guillotine for shearing metal from  $\frac{1}{2}$ " to 2" and up to 12" long. Also attachments for piercing round and square holes and for cutting circular and rectangular slots as well as for bending metal to almost any angle. All with absolute accuracy.

● PRESTACON PRESS, 55/- Complete model making outfit with working drawings, 84/- Speciality kits also available.



MODEL ENGINEERING

Obtainable from the Toy Department of leading Stores and Model Supplies Dealers.

Illustrated leaflet detailing in full the scope of the PRESTACON PRESS available on request from

Sole Concessionaires: L. REES & CO. LTD. (Dept. 20), 31/35, WILSON STREET, LONDON, E.C.2.

## 2 AMAZING OFFERS!

IDEAL FOR  
CRYSTAL  
SETS,  
VALVE  
SETS,  
HOSPITALS  
ETC.



EX-ARMY HEADPHONES  
BRAND NEW AND BOXED  
Post Free 5/6 Pairs 10/- Lots of 3/-  
Per Pair 100

PRECISION MADE INSTRUMENTS,  
BALANCED ARMATURE UNITS,  
REED DRIVEN CORRUGATED  
ALUMINIUM DIAPHRAGMS,  
DOUBLE HEADBANDS, 8ft.  
CORDS and PLUG. D.C. RESIST-  
ANCE 60 ohms, High Impedance.  
Enormous purchase by us from the  
Govt. enables us to offer these at a price  
which barely covers cost of Cords and  
Plug. All these Headphones have been  
carefully stored in air-heated Army  
Stores, and they are therefore as new  
as when they left the Makers. Satis-  
faction guaranteed or money refunded.  
They are worth about 42/- per pair.

Fractional H.P. ex-R.A.F.  
ELECTRIC MOTORS.  
1th H.P.  
BRAND  
NEW, made  
by Hoovers.



ONLY  
45/-  
each.  
Carriage Free.

NOT TO BE CONFUSED WITH  
SMALLER AND CHEAPER TYPES.  
Size 11in. x 5 1/2in. x 5 1/2in. Weight 18lbs.  
Volts 200/250 A.C., 2,000 r.p.m.

IDEAL FOR  
POLISHING, GRINDERS, SHOE  
REPAIRS, WOODWORKING, Etc.  
Converted by us from Rotary Trans-  
formers (Input 24 v. D.C. and Output  
1,200 v., 200 m/A. and supplied as such  
at 40/- if preferred). These Mains Motors  
are worth trouble and have a dozen uses.  
Existing Spindle is 5/16in. diam. 1in.  
long. All-purpose Extra. Spindles,  
to screw on, 7/8 pair extra.

AUTO COLLECTIONS LTD.  
15, LAWRENCE ST., Northampton.  
Send 1d. S.A.E. for our Radio/Electric List.



Manufacturers of  
DRAWING and  
SURVEYING  
INSTRUMENTS

SLIDE RULES

DRAWING MATERIALS

DRAWING OFFICE  
STATIONERY

A. G. THORNTON LTD  
Drawing Instrument Specialists  
41 GARTSIDE ST. MANCHESTER 3.



Higher and  
Higher

stands the reputation of  
Harbutt's "Plasticine." For  
more than fifty years it has  
been the only reliable material  
for model makers of all ages.  
Whether for home amusement  
— designing — experimenting  
— or the handyman, "Plasti-  
cine" is indispensable. Be-  
cause it is ever-plastic and  
hygienic, "Plasticine" has  
hundreds of other uses, and it  
never deteriorates.

'Plasticine'

HARBUTT'S PLASTICINE LTD.,  
BATHAMPTON, SOMERSET.  
LONDON: 68, Victoria Street, S.W.1.

# ENGINEERING

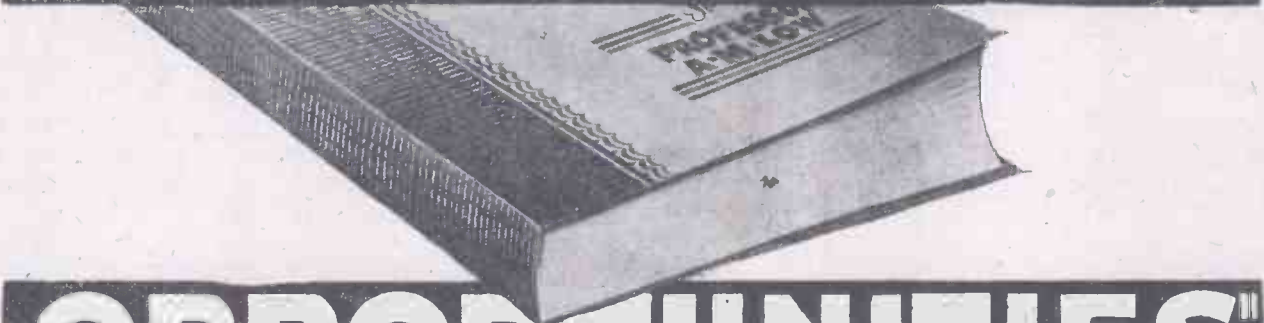

# OPPORTUNITIES

## PREPARE FOR COMPETITION—NOW!

As the Engineering Industry swings into its normal stride, the inevitable competition for the *secure* and well-paid posts will return. It is the man who stands out from the rest because he is *technically trained* who will be in the happy position of taking over the more responsible, more *secure*, and better paid positions. "**ENGINEERING OPPORTUNITIES**" will show you how to get this all-important technical training quickly and easily in your spare time. This 100-page book is full of valuable information and explains the simplest way of preparing for recognised Examinations. Among the courses described are :

### MECHANICAL ENGINEERING GROUP

A.M.I.Mech.E.  
A.M.I.E.D.  
City & Guilds  
General Mechanical Eng.  
Diesel Engines  
\*Draughtsmanship & Tracing  
Works Management  
Press Tool Work  
Pattern Making  
Foundry Practice

Mining Practice  
Estimating  
Foremanship  
Jig & Tool Design  
Viewing & Inspection  
Welding  
Sheet Metal Work  
Maintenance Eng.  
Metallurgy  
Refrigeration

### COMMERCIAL ENGINEERING GROUP

A.M.I.P.E.  
Commercial Eng.

Cost. Accounts  
Languages

### CIVIL ENGINEERING GROUP

A.M.I.C.E.  
Inst. Mun. Engineer  
A.M.I.Struct.E.  
M.R. San.I.  
City & Guilds  
Sanitary Inspector  
Specification  
Structural Design

Mining Surveying  
Road Eng.  
Hydraulics  
Municipal Eng.  
General Civil Eng.  
Structural Eng.  
Reinforced Concrete  
Railway Eng.

### SURVEYING AND BUILDING GROUP

A.R.I.B.A.  
F.R.I.C.S.  
A.M.I.H. & V.E.  
L.I.O.B.  
F.A.I.

Costing & Valuations  
Heating & Ventilating  
Clerk of Works  
Surveying & Levelling  
Building (all branches)

### ELECTRICAL ENGINEERING GROUP

A.M.I.E.E.  
City & Guilds  
General Electrical Eng.  
Alternating Currents  
Power House Design  
Traction  
Mains Eng.  
Mining Electrical Engineering

Electricity Supply  
Electrical Meters  
Electrical Design  
Illumination  
Installations  
Telegraphy  
Telephony

### WIRELESS GROUP

A.M.Brit.I.R.E.  
C. & G. Telecommunications  
General Wireless  
Short-wave Wireless

Advanced Wireless  
Radio Servicing  
Television  
Sound-film Projection Eng.

### AUTOMOBILE ENGINEERING GROUP

A.M.I.M.I.  
City & Guilds  
Automobile Repairman  
Course

General Automobile Eng.  
Garage Management  
Electrical Equipment  
High Speed Diesels

### AERONAUTICAL ENGINEERING GROUP

A.F.R.Ae.S.  
R.A.F. (Maths.)  
Pilots' Licences  
A.R.B. Licences

Aero Engines  
Navigators' Licences  
Aeroplane Design  
Meteorology

### UNIVERSITY DEGREES

London Matriculation  
School Certificate

University Entrance  
Intermediate B.Sc.

\* Our Diploma is accepted for Graduateship of the Inst. of Engineering Draughtsmen and Designers.

**WE DEFINITELY GUARANTEE**  
**“NO PASS—NO FEE”**

If you are earning less than £10 a week you cannot afford to miss reading "**ENGINEERING OPPORTUNITIES**"; it tells you everything you want to know to *make your future secure*, and describes many chances you are now missing. In your own interest we advise you to write for your copy of this enlightening guide to well-paid posts **NOW—FREE** and without obligation.

**BRITISH INSTITUTE OF ENGINEERING TECHNOLOGY**

410A, SHAKESPEARE HOUSE, 17, STRATFORD PLACE, LONDON, W.1

**THE B.I.E.T. IS THE LEADING INSTITUTE OF ITS KIND IN THE WORLD**



## SUBSCRIPTION RATES

(including postage)

Inland	- - -	10s. 6d. per annum.
Abroad	- - -	10s. per annum.
Canada	- - -	10s. per annum.

Editorial and Advertisement Office: "Practical Mechanics," George Newnes, Ltd.

Tower House, Southampton Street, Strand, W.C.2  
Phone: Temple Bar 4363

Telegrams: Newnes, Rand, London.

Registered at the G.P.O. for transmission by Canadian Magazine Post.

Copyright in all drawings, photographs and articles published in "Practical Mechanics" is specially reserved throughout the countries signatory to the Berne Convention and the U.S.A. Reproductions or imitations of any of these are therefore expressly forbidden.

# PRACTICAL MECHANICS

Owing to the paper shortage "The Cyclist," "Practical Motorist," and "Home Movies" are temporarily incorporated.

Editor: F. J. CAMM

VOL. XVI OCTOBER, 1948 No. 180

## FAIR COMMENT

By THE EDITOR

### The Model Engineer Exhibition

THE twenty-third Model Engineer Exhibition at the New Horticultural Hall, Westminster, worthily upheld and even enhanced the tradition of its predecessors. I missed the face of the late Percival Marshall, the architect of the Exhibitions and whose hand guided the work of model makers throughout the world and provided them with the means of exhibiting their work for the inspection, criticism and instruction of fellow enthusiasts, and of stimulating interest among those new to model engineering.

### Wanted—a Larger Hall

The exhibition, year by year, has expanded, both as to the numbers of exhibits and trade stands, and the attendances each year have steadily increased. In this connection I should like to make the suggestion that future exhibitions be held in more commodious premises. The Horticultural Hall was adequate in the days when the adherents to mechanical hobbies were small in numbers, and the trade which supplied their needs was correspondingly minute. But to-day the industry is a large one and it is growing. The model engineer is represented by a large number of technical journals, catering for particular branches of model making, and as new hobbies have cropped up the numbers of enthusiasts increased. Twenty-three years ago, for example, there were very few people interested in model aircraft, which were then almost entirely confined to those of the rubber-driven type. To-day, model aircraft are propelled by jets, by diesels and by petrol engines. One or two have produced miniature-turbines, and the radio control of models is well on the way. The hobby of model railways, which formed the hard core of the model-making movement, to-day is quite small in comparison with hobbies such as model aircraft,

model boatbuilding, and all of the other model making hobbies shown in such plenitude at the Horticultural Hall. There were models of old horse-drawn vehicles, buildings and bicycles, in fact, models of almost everything capable of being reproduced in miniature. All of the models exhibited a high degree of skill, high-class craftsmanship and patience, and overseas visitors and buyers who this year visited the exhibition in greater numbers than ever before must have been impressed with the fact that British craftsmanship has gained in the years, and has lost nothing as a result of the war. For the first time models were shown from Denmark, Norway, Sweden, Holland, France, Switzerland, Austria, Spain and Canada.

### Circular Track

The circular track proved a great success. Throughout the run of the show power-driven boats, aircraft and racing cars could be seen operating at high speeds. Within the arena steam traction engines and other models were shown running under their own power. The multi-gauge track for live steam passenger hauling, which was omitted last year, was reintroduced and proved a great success.

### Braille Reading Micrometer

Among the trade exhibits I was interested in the braille reading micrometer and bevel protractor, the miniature jet engines, the 10½ gauge two-ton locomotive for light railway operation, and (for the first time in this country) the radio control equipment which was offered for sale to the public. There were multi-cylinder petrol engines of 10, 15 and 30 c.c. capacity, as well as a .2 c.c. two-stroke diesel engine.

Altogether a noteworthy exhibition, but we hope that next year it will be housed in a larger building, where it will be possible to give more space to each exhibit.

### The "P.M." Master Battery Clock

ON the PRACTICAL MECHANICS stand I was exhibited the PRACTICAL MECHANICS master battery clock which I constructed especially for the exhibition. In view of the enormous demand for the blueprints for this clock and the great interest aroused at the exhibition, I shall in a later issue devote further space to it.

### The Model Aeroplane Handbook

THE Model Aeroplane Handbook, upon which I have been engaged for some time, will be published shortly. It costs 12s. 6d., or 13s. by post, and orders should be sent to the publisher, address as above. The book contains a short history of model aeronautics, principles of design, airscrews, wings, undercarriages, folding airscrews and retractable undercarriages, fuselages, the elastic motor, gearing and special mechanisms, making model wheels, geared winding devices, model aeroplane stability, downthrust, model petrol engines, adjusting model petrol engines, compressed air engines, how to form and run a model aero club, F.A.I. and S.M.A.E. rules, S.M.A.E. competition cups, a lightweight duration model, a Wakefield model, a Farman type monoplane, a composite model, ornithopters, or wing-flapping models, a low-wing petrol monoplane, a duration glider, winch-launching model gliders, a streamline Wakefield model, a model autogiro, a super-duration biplane, flying model aeroplanes, a flash steam plant, model diesel engines. The book extends to 310 pages and has no less than 303 illustrations. It is fully indexed.

### New Volume Commences

THIS issue commences Volume XVI. Indexes for Volume XV are available for 1s. each from the Publisher, George Newnes, Ltd., Tower House, Southampton Street, Strand, London, W.C.2.

# The Electron Microscope

Its History and Underlying Principles

By FRANK W. COUSINS, A.M.I.E.E.



Fig. 6.—Metrovick new electron microscope in use.

THE electron microscope is the most outstanding achievement of the science of electron optics, and behind the excellent instruments now made for industrial and medical research there is a story of continuous critical examination of the known and newly discovered phenomena relating to light and the properties of matter. To give a clear idea of the magnitude of the task which has culminated in the modern electron microscope, it is desirable to approach the subject historically and to show in what manner the light microscope had reached its limit of usefulness in its own particular sphere; and to record the birth of the science of electron optics from the hypotheses and experiments of the great minds of the past.

The light microscope was invented by Jansen in Holland about 1590 and by Galileo in Italy in 1610. With advances in the study of optics and the discovery of the laws of refraction in 1624 microscopes with double glasses were introduced and these were improved upon by Benjamin Martin, Henry

### Resolution of Optical Microscope

In the middle of the 19th century it was found that the limit of the optical microscope was decided by the wavelength of the light used, and was not decided by defects in the lens system.

The wave nature of light sets a limit to what is termed the resolving power of the microscope, that is to say its ability to distinguish between two separate details in very close relationship to each other. The resolution limit is defined as the minimum distance or dimension which can separate two minute or point particles while they still remain separate in the image. Increase in magnification, contrast or intensity are of no avail in changing this limitation.

E. Abbé, a famous optician showed that the resolution limit for one condition of illumination was :

$$\Delta d = \frac{0.61\lambda}{\mu \sin \alpha}$$

where  $\lambda$  = wavelength of light in vacuo

$\mu$  = refractive index of the medium in the object space.  
 $\alpha$  = the semi-angle of the cone of rays leaving an object point and entering the objective lens.

For visible light the limit is about  $2,500 \text{ \AA}^*$ .  
 (\*  $1 \text{ \AA} = 10^{-8}$  cms. or  $10^{-4}$  microns.)

It followed that the wavelength of light placed a difficult obstacle in the path of advancement and future observations in the submicroscopic domain. One more improvement, however, was yet to come, and this was obtained by using electro-magnetic waves in the ultra violet band and fused quartz lenses; this combination gave a resolution limit of the order of  $1,500 \text{ \AA}$ . Here it seemed the investigators must pause and take breath, looking backward upon their labours. We shall see, however, that attention was turned toward new channels of thought, and a

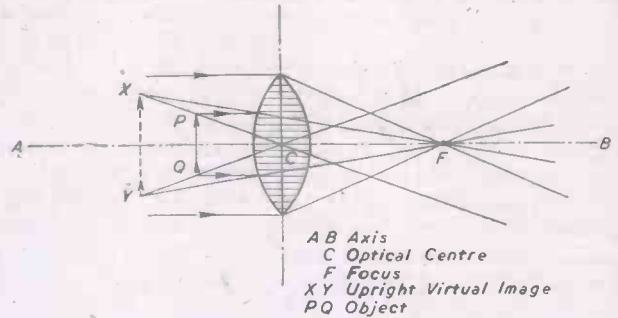

Fig. 1.—Converging lens.

digression is profitable to see how this came about.

### The Nature of Light

Two theories of the nature of light caused great controversy right up into recent years and the controversy was no mean one; it had involved such men as Newton, Huygens, Young and Einstein. Newton held the opinion that light consisted of particles shot out into space and travelling in straight lines. This was known as the Pythagorean idea or corpuscular theory. Huygens proposed the wave theory of light, although Aristotle's pellucid was perhaps the real origination of this idea. Huygen's proposal was not given much consideration until the early 19th century, when the corpuscular theory broke down owing to the discovery of new phenomena regarding the nature of light. Newton's theories were then replaced by the theory that light was propagated in waves through a medium termed the ether. The exact properties of ether were difficult to define and

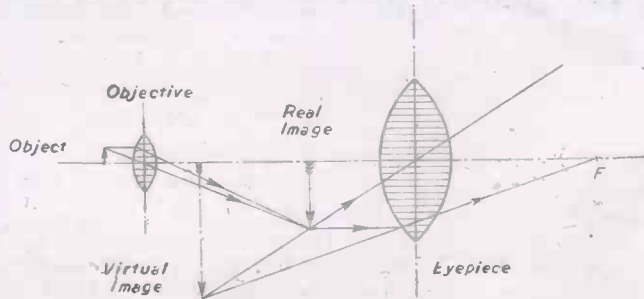

Fig. 2.—Compound microscope.

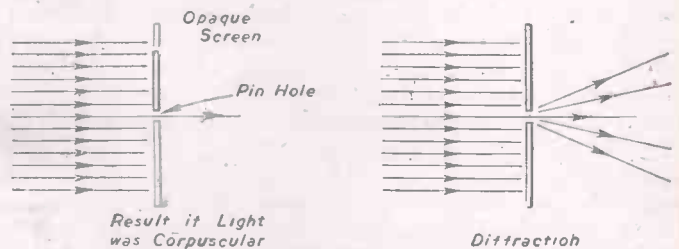

Fig. 3.—Corpuscular effect and diffraction fringes.

appreciate, but at least the wave concept was able to explain satisfactorily the phenomena of diffraction and interference, the *sine qua non* of a wave motion, already appreciated in the analogous study of sound.

**Diffraction** is the small-scale spreading of light beyond the limits of the geometrical shadow which is observable when the source of light is small. At the edge of the shadow and parallel to it a few alternatively light and dark bands are seen which are called diffraction fringes, Fig. 3.

**Interference** is the effect of superposing two or more trains of waves of equal wavelength; the resultant amplitude is the algebraic sum of the amplitudes in the interfering trains. Fig. 4 shows Young's classical interference experiment.

Now, light manifests these phenomena very strikingly, so much so that the science of spectroscopy and a clear theory of vibrations in the ether has been constructed upon them to include heat, radio waves and X-rays. Maxwell put this into mathematical form, and in 1887 Hertz found that electromagnetic waves could be reflected, diffracted, refracted and focused exactly as light waves; this confirmed Maxwell's theory.

Other discoveries concerning light, however, still made its exact nature somewhat obscure; for instance, it was difficult to appreciate that gentle vibrations in the ether, from a distant star, could cause the atomic rearrangement on a photographic plate exposed thereto.

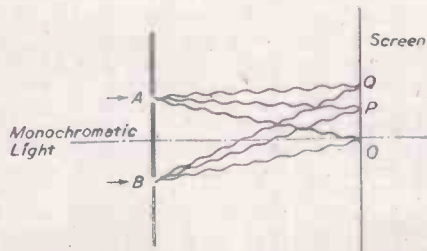

Fig. 4.—Young's interference experiment. *O* is equidistant from *A* and *B*. *P* half wavelength nearer to *A* than *B*. *Q* one wavelength nearer to *A* than *B*. Result: *O*, Bright. *Q*, Bright. *P*, Dark.

this manner (a migration of ions). Knowledge was carried a stage forward with the great researches of Helmholtz, Hittorf and Crookes, but it was to J. J. Thomson that the truth was to be revealed by his classical and meticulous experiments at the Cavendish Laboratory in 1897.

Thomson announced that cathode rays were matter in a new state of subdivision carrying negative charges of electricity. He went further and calculated the ratio of the mass "m" of the particles to the charge "e" and launched the electron upon the world of physics. Thomson prophetically stated that these particles were the substances from which all chemical substances are built

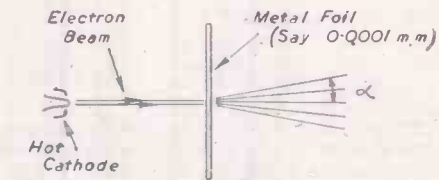

Fig. 5.—Electron beam diffracted by gold foil and the like.

Thomson, passed a thin beam of electrons through gold leaf on to a photographic plate, Fig. 5, obtaining a well-developed diffraction pattern consisting of concentric rings. This, then, meant that electrons were corpuscular in form but moving as a train of waves; the analogy with the dual nature of light was now complete and the birth of electron optics had taken place.

**The Application of Electron Optics**

It is now possible to return to our consideration of the electron microscope, the crowning achievement of electron optics. Since electron paths and rays of light are shown to be analogous, it was only to be expected that science would suggest an electron lens, and this was announced by Bush in 1926.

It is the use of electrons ejected from an electron gun—receiving intelligence from

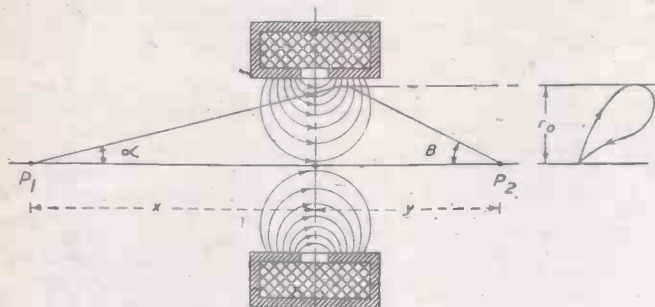

Fig. 7.—Short magnetic lens.

In such a case it would appear more logical to accept the corpuscular concept. Other phenomena of a similar kind showed that "weak" light would perform everything that "strong" light would perform, if the time period was suitably adjusted.

**Introduction of the Quantum Theory**

In 1900, Planck found that the absorption and emission of radiant energy by hot bodies could not be reconciled with their observed temperatures when explained by the wave concept, and he was forced to introduce his quantum theory. Einstein proposed in 1905 that we consider light particles or light quanta, and, although it has taken some imbibing, scientists now accept a dual theory of light, which, stated broadly, means that light must be considered as travelling in a wave motion, but when associated with photo-electric effects and radiation problems, it must be considered as particles of light quantum which we term a photon. By definition, a photon is a particle of mass  $h\nu/c^2$  where "v" is the frequency of vibration, "h" is Planck's constant and "c" is the velocity of light.

**The Electron as a Constituent of Matter**

Having attempted to elucidate, in a few words, the complex nature of light, we must turn to a consideration of the structure of matter, and the electron as a constituent thereof. The electron had its real beginning as a part of our knowledge with Faraday's work on electrolysis and his enunciation of the laws governing the transfer of matter in

(protons, electrons). On Thomson's work Millikan made more precise measurements and we now know that the electron has a mass at rest of  $9.042 \times 10^{-28}$  gm. and a charge of  $-4.774 \times 10^{-10}$  E.S.U. These discoveries opened the study of free electrons, which we now term electronics.

**Electron Optics**

In 1924 De Broglie postulated that a train of waves is associated with a free electron in motion, the wavelength being given by the equation

$$\lambda_e = \frac{12.24}{\sqrt{V}} \text{ \AA}$$

where V is the voltage by which the electrons have been accelerated.

Einstein appreciated the De Broglie result and immediately realised that this would mean the possibility of electron diffraction—you will remember we agreed that diffraction was one of the phenomena associated with wave motion. J. J. Thomson's son, Sir George



Fig. 10.—General view of Metrovick electron microscope EM2.

passage through a specimen and entering an electron lens system to be made visible to the eye of an observer upon a fluorescent screen—that has produced the electron microscope of to-day (Fig. 6). The resolving power of such an instrument is vastly superior to that of the light microscope, since the wavelength of the electron is inversely proportional to the square root of the potential applied to accelerate it, and may be of the order of 50,000 times shorter than that of light.

**The Electron Lens**

To appreciate the theory of the electron lens it is essential to discuss the basic principles of electron optics.

An electric field of force acting upon an electron at rest causes it to move along the lines of force and in a direction opposite to the motion of a positive charge, and it will bend a beam of electrons into regions of higher potential.

A magnetic field has no effect upon a static electron, and no effect if the electron moves parallel with the lines of magnetic force; but it will cause an electron to move in a circular path if the direction of motion of the electron was initially at right-angles to the lines of magnetic force.

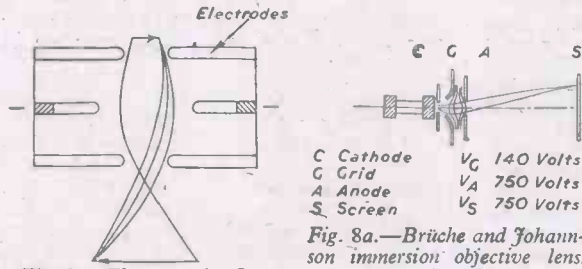

Fig. 8.—Electrostatic Lens.

In more precise language, for those readers who are acquainted with the electrostatic and electromagnetic units, it is known (1): "that an electric field accelerates a free electron in the direction anti-parallel to the electric intensity and with a force equal to  $10^{18}$  dynes in which X the intensity is in volts/cm. and 'e' the electronic charge in coulombs. The acceleration is therefore  $10^{18}Xe/m$  where 'm' is the electronic mass. Since for an electron the charge mass ratio e/m is  $1.76 \times 10^8$  coulombs per gram the acceleration of an electron in a field of intensity X volts/cm. is  $1.76 \times 10^{18}X$  cm/sec.<sup>2</sup>

"If there is a component 'X' of the field at right-angles to the electronic motion, the electron moving with speed 'V' cm/sec. follows a curve whose radius of curvature is  $r_x = 5.66 \times 10^{-16} v^2/X$  cm.

"A magnetic field produces no acceleration in its own direction, but if there is a component of it, H oersteds, at right-angles to the electronic motion the electron is deflected at right angles to both its motion and to the component H, following a curve of radius  $r_h = 5.66 \times 10^{-8}V/H$  cm."

Bush showed that his electron lens would so act upon an electron ray as to cause all electrons departing in different directions to converge at a point, and that the aberrations and characteristics of the lens were analogous to those experienced in the glass lens. Once Bush had disclosed his magnetic electron lens the discovery of an electrostatic lens was only a matter of time, for it transpired that every electrostatic field with axial symmetry behaved as an electron lens. It has now been shown that either an electro magnetic, or an electrostatic field having axial symmetry will act as an electron lens provided the electron ray is close to the axis.

The focal length (2) of an electromagnetic lens is given by the equation:

$$\frac{1}{f} = \frac{K}{V_0} \int H^2 dz.$$

where f = focal length of lens in cm.  
K = constant.  
 $V_0$  = electron velocity in volts.  
 $H_x$  = magnetic field intensity along the E axis in oersteds.

The focal length (2) of an electrostatic lens is given by the equation:

$$\frac{1}{f} = \frac{-K}{\sqrt{v_0}V}$$

where V = the lens potential.  
A diagram of a typical thin magnetic

electron lens (3) is shown in Fig. 7, the left-hand portion of the diagram being a projection on a plane through the axis of symmetry and the right-hand portion of the diagram being a projection on a plane perpendicular to this axis. The lines of force drawn characterise the magnetic field of the lens. The electrons leave the axis at  $P_1$  and reach it again at  $P_2$ . The distances from  $P_1$  and  $P_2$  to the middle plane of the lens are "x" and "y" respectively; the angles which the electron ray makes with the axis at  $P_1$  and  $P_2$  are  $\alpha$  and  $\beta$  respectively. The maximum distance of the electron from the axis is r.

"The force arising from the longitudinal motion of the electron across the radial field is normal to both these directions (Fleming's Left-hand Rule) and gives rise to an angular velocity about the axis. This rotary motion, cutting the longitudinal field, gives rise to a radial force on the electron and this, by Lenz's law, is directed toward the axis no matter from which side of the field the electron is incident. The electron is therefore both rotated about the axis and deviated towards it as it passes into a short magnetic lens" (4). It is of interest to note that it is not necessary to use the wave properties of the electron ray to explain the lens action; the conclusions may be arrived at from a consideration of the electron trajectory in the force field.

An electrostatic lens (5) is shown in Figs. 8 and 8a. The principle may be understood if we consider the electron in its simple form, i.e., a negative particle, and remember that a positively charged surface will attract it and that a negatively charged surface will repel it. Electrons arriving at the outer plate which is at anode potential pass freely through its aperture and then come under the influence of the negative converging field of the negative electrode. The rays now pass through the third electrode plate and travel in the form of a divergent cone until another electrostatic lens is reached. The focusing is a function of the strength and form of the electrostatic fields existing between the various lens electrodes. From a consideration of the electrostatic lens equation

$$\left(\frac{1}{f} = \frac{-K}{\sqrt{v_0}V}\right)$$

it will be readily appreciated that if the lens potential is made proportional to the electron

velocity potential the value  $V_0/V$  becomes a constant and would give the lens a constant value for  $\frac{1}{f}$ ; this is desirable in that a constant focal length will produce a well-focused image. This problem of the voltage adjustment is peculiar to the electron lens, the geometry of the glass lens deciding the focal length of the finished lens.

Electron lenses have all the defects of optical lenses, viz., spherical aberration, chromatic aberration (the focal length of the electron lens being different for electrons of different velocities) and coma. Optical lenses may be suitably corrected but electron lenses cannot (except in the case of coma). These errors may, however, be reduced by a reduction in the aperture angle of the lens. The apertures used are very small, 1/500th of those that can be achieved with optical lenses. It is only fair to mention here that researches are continually progressing and the pessimistic note above may well be toned down; as one example Gabor (6) has disclosed a method of correcting spherical aberration with simultaneous reduction of the focal length of the objective, the invention consisting of a dispersing lens for an electron beam, the lens being constituted by a region of axially symmetrical electronic space charge produced by an auxiliary cathode, and confined to the region by electric and magnetic fields, the beam being directed co-axially into the region.

**The Electron Microscope, Per Se**

Having discussed briefly the lens arrangements and theory, it remains to show the disposition of the lenses within the actual microscope.

Fig. 9 shows the magnetic and electrostatic instruments in comparison with the well-known light microscope; the "optical" systems will be seen to be exactly analogous.

The first emission type microscope was made by Knoll and Ruska in Germany in 1932 and up until 1940 Allgemeine Electricitäts Gesellschaft was the only company engaged in the development of the electron microscope. In 1936 an instrument was built in Britain by Martin, Whelpton and Parnum and the first commercial instrument was produced by Messrs. Siemens in Berlin, to be followed by one from the Radio Corporation of America two years later. A remarkably fine instrument (7) has been constructed in recent years by the Metropolitan-Vickers Electrical Co., Ltd.; it is known as the Type EM2, and it is the first British-built electron microscope to be commercially supplied for use in an industrial research laboratory.

(To be continued)

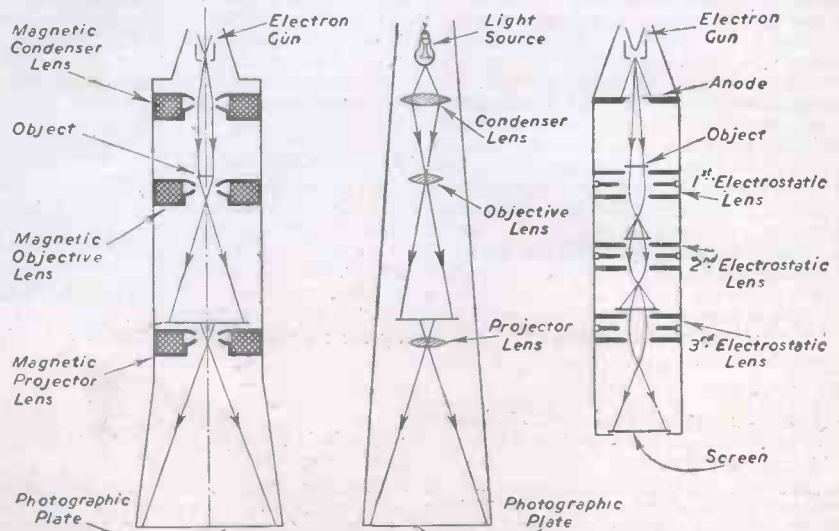

Magnetic electron microscope. Optical microscope. Electrostatic electron microscope. Fig. 9.—The magnetic and electrostatic instruments compared with an ordinary optical microscope.

# Calling CORinthian!

Behind the Filming of the XIVth Olympiad

By THE MARQUIS OF DONEGALL



One of the towers specially designed and built for the Olympic Games Technicolor Film, by Scaffolding (G.B.), Ltd.

WHEN they discovered that all-over filming of the Olympic Games involved the laying of eight miles of telephone wires in and around Wembley Stadium and Swimming Pool it became certain that a new telephone exchange would be advisable. Somebody with the obvious solution in mind suggested OLYmpic. Everybody might have been happy except the operator.

(Incidentally, I have always wanted to know why, for some less glaring technical reason, Scotland Yard Emergency could not be III—the ideal choice, as it is the quickest and can be dialled with ease in the dark.)

So they hit on CORinthian which, anyway, has a good Ancient Greek flavour.

In this article I will try to show a little of what went on to make CORinthian.

For this purpose I went down to Wembley. I entered the large marquee restaurant-bar, which formed part of the film centre, watched the games on the television and asked Mr. Castleton Knight a lot of questions:

This was best done in one of his two super-luxury, plastic roofed, chromium-plated, white trailers. One served as an office and the other as his home during the preparations and filming—television, radio, switchboard, hot and cold, kitchen, etc.

## Technicolor Film

In order to make the Technicolor film, 1,000,000ft. of film was brought in an

American cargo boat from Rochester, New York. The ship had to be diverted to Antwerp owing to the London docks strike. But it got here 'all right eventually and I believe that already half a million feet were used in the making of this film. It had to be ready to be Press previewed three weeks after the close of the Games.

What complicated matters considerably was that each version sent abroad had to give special prominence to the athletes of each particular country with commentaries in 16 foreign languages. One advantage of Technicolor that one might overlook is that the millions who see it abroad will easily recognise the colours of their own competitors.

So 100 cameramen (70 for the colour film and 30 for black and white) milled round this luxuriously appointed film centre, with Castleton Knight's two caravans in the forecourt of Wembley's administrative building, and the Press centre.

Ex-air-raid shelters came in handy as stores for cameras and films. Some were converted into dark rooms.

As far as the actual filming went, there were several major problems to be faced:

(1) The erection of a suitable mobile tower for the centre of the arena.

(2) The erection of camera-sites that would not obstruct the view of the spectators.

(3) The positioning of camera sites in relation to the position of the sun at the time of each event to be filmed.

No rehearsals, no re-takes!

With regard to the mobile tower, requirements were somewhat exacting.

## Mobile Tower

The tower had to be mobile and easily man-handled into position. The platform on which the camera was to stand had to be rock-firm. The stem had to be as thin as possible.

Scaffolding (G.B.) Ltd. solved the problem. They constructed a special tower, as seen in the accompanying illustration, 24ft. high, of steel tubing, fabricated by electric arc-welding. The base measured 13ft. across and was mounted on two 26in. pneumatic and one trailer wheel. When in the required position it was jacked up on spade-like feet.

The tower lay in a horizontal position for transport and an additional trailer wheel was fitted at platform level to enable it to be wheeled in this position. It could be hoisted into a vertical position by means of a rope and specially constructed chocks.

Tall and thin with a minimum of bracing and stays, it was rigid, and I was told that there was no vibration in the wind.

The platform at the top was 8ft. in diameter and included a pulley system for hoisting camera and equipment. I got up by means of ladder rungs built into the stem and reached the platform through a trap door.

The complete tower weighed about 11 cwt. and it could be handled by one man. Communication between the camera crew and the ground was by means of telephone.

## Transporting Equipment

To transport film equipment into the centre of the Stadium a special bridge had to be constructed to span the 40ft. running track. It had to be sufficiently strong to allow the passage of the three-wheeled electric wagons used for transporting equipment. This bridge was designed and constructed in three segments assembled into one box girder, the upper cord of each segment being designed to act as guide and track for each of the three wheels. Two floating axles and pneumatic wheels were built into the assembly, the axles having a jacking device which allowed the wheels to retract into the depth of the bridge, allowing it to stand on its own springing when in use but to be wheeled on and off the track by two workmen. The total weight of the structure when fully assembled was 16 cwts.

Dealing with problem (2), other camera positions were erected above the entrance tunnels to the Stadium, where they did not obstruct the view. They were also constructed of steel tubing, pinched between the tunnel walls and suspended from special stirrups and hanging wires. Camera-pits with lids were built into the arena.

So much for the problems peculiar to the arena. In the case of the Empire Pool, for the swimming and boxing, similar considerations governed the positioning of gantries, etc. But throughout the winter, the pool had been used as an ice-rink, of which the glass roof was painted to prevent melting of the ice by the sun's rays.

This had to be scraped. It consists of 14 panels with 90 windows in each. Scraping was a dangerous job because the workmen had to stand on the narrow steel window-frames.

All the camera positions were connected by telephone through CORinthian to enable Castleton Knight, from a central control point, to keep in touch.

One feature, as an "Old Man of the Mountains," that I am eagerly anticipating is the inclusion in the Olympic Film of the Winter Games at St. Moritz six months ago. The ski-jumping should be thrilling, and I have memories of the jump that they built for the winter games in St. Moritz in 1928.

If there is one notable fact about ski-jumping it is that the worse you do it, the safer it is. One morning, Roger Bushell and I set out to practise on the Olympic jump. I went off first, missed my take-off, landed on my back about 90ft. down the almost perpendicular slope, rolled over and over to the bottom, got up and—like the pig—slowly walked away.

Not so Roger. He jumped so well that he over-jumped the slope, landed on the flat and broke both his ankles.

#### Incidental Music

One other feature of the Olympic colour film is the incidental music. This was being written by Guy Warrack. He derived his main material from the Parade of the Nation's March, which he wrote for the film. This leads into symphonic arrangements of the National Anthems of the 61 nations—except Pakistan which apparently has not yet acquired one.

There is a fugue for full orchestra for the Marathon, a waltz for the figure skaters, and the lot was recorded by Sir Thomas Beecham's Royal Philharmonic and conducted by Muir Mathieson. Considering the thing runs for 130 minutes I should judge that Mr. Warrack had a busy day.

Distribution of the film to Europe was scheduled as a matter of hours by British European Airways—the longest being the two prints for Istanbul in 15 hours.

As for the rest of the world, British Overseas Airways (and Associated) reckoned that the last place to get it would be

Shanghai, in five days. By far the largest Empire customer for prints is Canada with 20, as compared with Australia's eight and South Africa's three.

A word about Castleton Knight, the producer of "Fourteenth Olympiad—The Glory of Sport." He has pretty well run the gamut of films from A to Z, starting as office boy at the Kingston County Theatre.

Altogether, I think you will agree with me that the best summing-up of the whole shooting-match is:

CORinthian! What A Game!

# Rotary Transformers

## Hints on Their Mounting and Uses

By WM. NIMMONS

AT the present time it is possible to buy for ten shillings or so a rotary transformer which cost ten times as much to produce. These rotaries are surplus war-stock, and are new and unused.

which are to be found there—passing the screws through the rubber and thence back into place, with a washer to spread the pressure. Get a friend to hold the rotary while you fasten the other end of the rubber

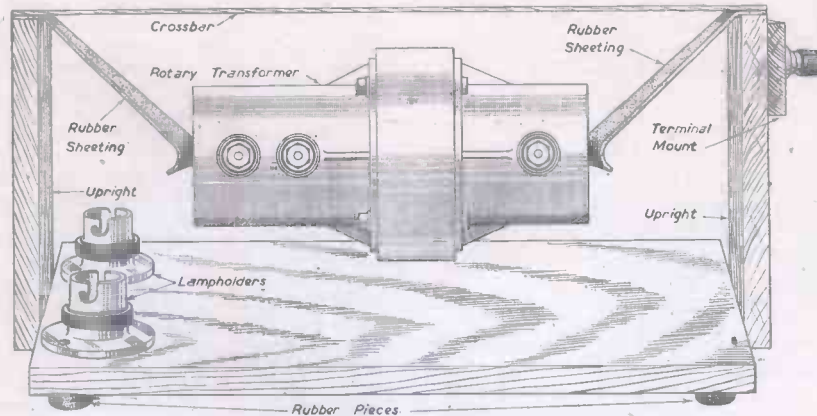

Fig. 1.—How rotary transformers are mounted.

They are very useful for charging accumulators when the supply is D.C. Up to four 2-volt cells can be charged at one time. The battery wireless user, particularly if he is an experimenter, would be well advised to procure one of these rotaries before they are all gone; the rotary will pay for itself in a short time, and the experimenter will have the satisfaction of seeing that his accumulators are properly charged—which is not always the case at charging stations.

Car accumulators, too, can be charged, since the unit will deliver up to three or four amps.

The first thing that strikes one on receiving the rotary is the "rolliness" of the unit. It is about 8in. long and 4in. in diameter, and being perfectly round, seems determined to roll off any bench on which it is placed. The obvious thing to do, therefore, is to mount it in a framework of some kind.

#### Mounting the Machine

Procure a thick board 12in. by 6in., also two shorter pieces, 6in. by 6in. Nail the shorter pieces at either end of the long piece, and you have your framework. If desired, cross-pieces may be stretched from each upright (at the top) in order to strengthen the whole (Fig. 1).

You will next need two pieces of rubber sheeting. Pieces from an old motor inner tube are ideal for the purpose. These should be 4in. by 2½in. Fasten them to either end of the rotary by undoing two of the screws

bands to the tops of the uprights, by means of screws with washers, and the mounting is complete. The rotary will sag somewhat, after the style of the old magnetic microphones once used by the B.B.C.

#### Interference Suppressors

In fairness to your neighbours, the unit should be fitted with interference suppressors. To do this six .1 mfd. tubular condensers are required, one for each brush. Commencing with the high-voltage side, connect one side of each of two condensers to each H.T. brush,

and join the remaining sides of the two condensers together. This junction of the two condensers should be connected to the frame of the machine. Do the same with the 12-volt and 6-volt brushes. The machine can now be run without causing wireless interference with neighbours' sets.

By wiring a couple of lampholders (Fig. 2) in series with the mains lead to the rotary it is possible to control the charging current by inserting various sized lamps in the holders. A 25-watt lamp will just cause the machine to "tick over" without charging. A 40-watt lamp is useful for small charging currents, such as the half ampere required for small mass type cells. A 60-watt lamp will charge at 1 amp., a 100-watt at 2 amps., 150-watt at 3 amps., while by short-circuiting the lamp a current of about 4 amps. at 6-volts is obtained, i.e., 24 watts, which is the maximum for continuous running to take off the L.T. winding.

#### Economical Running

The wattage rates of the lamps by no means indicates what the rotary is consuming on the H.T. side, because the back E.M.F. of the machine cuts down the wattage considerably. For example, I have noted the machine charging at 3 amps. with the 150-watt lamp in series. The machine, however, was travelling so fast that the back E.M.F. cut down the primary current so that the lamp barely glowed. I do not think it was consuming more than 50 watts.

This is a measure of the economy of the machine, for 50 watts with the customary mains voltage is about .2 amp. We put .2 amp. in and get 3 amps. out. Again, 50 watts is 1/20th of a unit, so that the machine will run for 20 hours at the cost of ½d. It is unlikely that an accumulator will take more than 40 hours to charge, at a cost of 1d., and we can charge four cells at this cost, which at a charging station would cost at least 2s. It will be seen, therefore, that one of these rotaries is a well-worth-while investment.

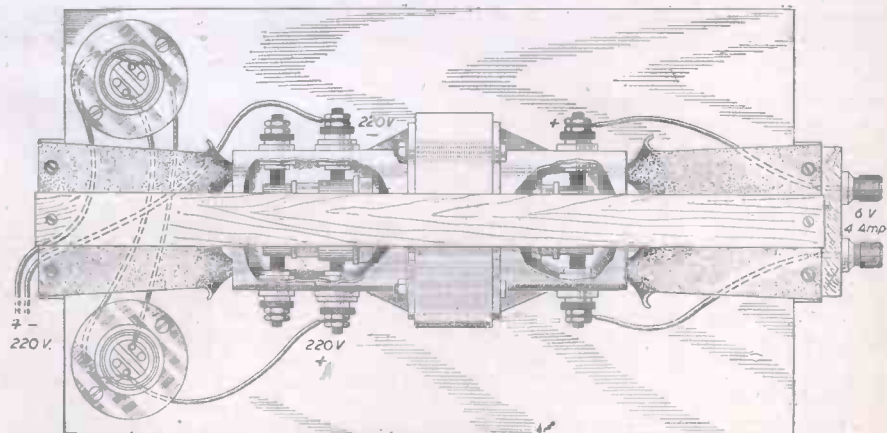

Fig. 2.—Part sectional view, showing how the lampholders are wired up.

# Power Model Aircraft—2



Fig. 8.—A model of simple but effective lines for speedy flying and manoeuvrability to suit medium size engines of 5 c.c. (diesel) and 4-5 c.c. to 9 c.c. glow-plug motors' is the author's, "Bowden Stunt Bus" designed on American lines with the effective symmetrical wing section and a large elevator. The span is 38in., and the model flies very smoothly.

(Continued from page 386, September issue)

**L**ARGE diesels such as the 5 c.c. Eta, and the American 5 c.c. Drone, both engines used in my models, fit very well into control line models of 36in. to 40in. or 45in. span.

A propeller of about 10½in. diam. with a pitch of 8in. to 9in. is suitable. I find that the American "toothpick" thin frontal area prop creates less drag for a speedy control-line model than the wide bladed props so often used over here.

## Large Stunt Models

There is a recent tendency in America to make even larger speed and stunt models than the model I designed and show in Fig. 8. Thus "Madman" Yates flies what is probably one of the most successful stunt models over there, and which has a wing span of 52in. The Americans mostly use very powerful 10 c.c. motors such as the Dooling, the McCoy, the Ohlsson 60, and the Atwood Champion. I have the last two mentioned engines, and their power is really outstanding, in fact definitely on the fierce side for a newcomer to power modelling.

Now we come to the larger "sports" machine which is very nice to fly and great fun, but is a little too heavy for violent stunting when fitted with the larger type of engine. This is a type that suits many British power control-line men who normally fly or have been brought up on large free-flight models.

## A Versatile Model

Fig. 9 shows the sort of thing I mean. It is a model I built some time ago, and looks well and imposing in the air, for its large chord elliptical wing has a span of 48½in. Central chord is 11½in. The length of the model is 37½in. This model has proved most versatile and shows what can be done if a wing section of the built-up type is used on a large model, for it has flown slowly on only a 2.2 c.c. Majesco diesel in spite of its weight. It flies fast and with an exciting performance when fitted with a 5 c.c. diesel or a large petrol or 9 c.c. glow-plug motor. The model has a planked monocoque fuselage, and the wing is entirely covered with 1/16in. sheet balsa as most of my models are, for it makes them really strong. All my engines are fitted on detachable

Control-line Models : Scale Models : "Goats"  
Fuel Feed : Fuselage Construction

By C. E. BOWDEN, A.I.Mech.E.

engine mounts, for I can change engines to try different types. An unhappy prang seldom does damage if the engine and its mount are attached by rubber bands that give instead of the crankshaft. However skilful the owner may be, he or one of his visiting friends will occasionally do a bad landing. I usually cover my power control-line models with nylon or thin medapollum, and sometimes a fine lawn over the

control which is normally slack. One pull, when the model is in flight, raises the retractable undercarriage legs. A second pull releases the two dummy bombs hung on their racks below the wings, and yet a third tweak on the line just before landing time comes along, drops the undercarriage legs for the landing. Fig. 11 gives a view of the retractable undercarriage in its up position. The bombs can be seen off their racks lying on the ground. A good deal of fun can be had bombing a target laid out in the control circuit. Most people would be satisfied if they could achieve bomb dropping without retracting the undercarriage as well. I often fit a third line to control the engine speed of my models. The line is normally kept slack and a gentle pull closes the throttle, a second pull opens the throttle.

The same designer is responsible for the very nice 2.2 c.c. diesel - engined Tiger Moth of the scale type (see Fig. 12). The compression adjustment lever can be seen just protruding from the inverted cylinder inside its engine cowling. This model flies exceedingly well as a control-line machine and gives an excellent idea of the suitability of scale types for control-line work. The control lines automatically look after lateral stability and the owner can nurse his longitudinal trim in a good take-off, level flight and a damage-free landing by means of his elevator.

A free-flight model of the old-fashioned braced biplane type would not usually be considered a suitable type for damage-free flight, but with rea-

sonable skill on the part of the pilot such a model if flown control-line from smooth grass or concrete should suffer no damage.

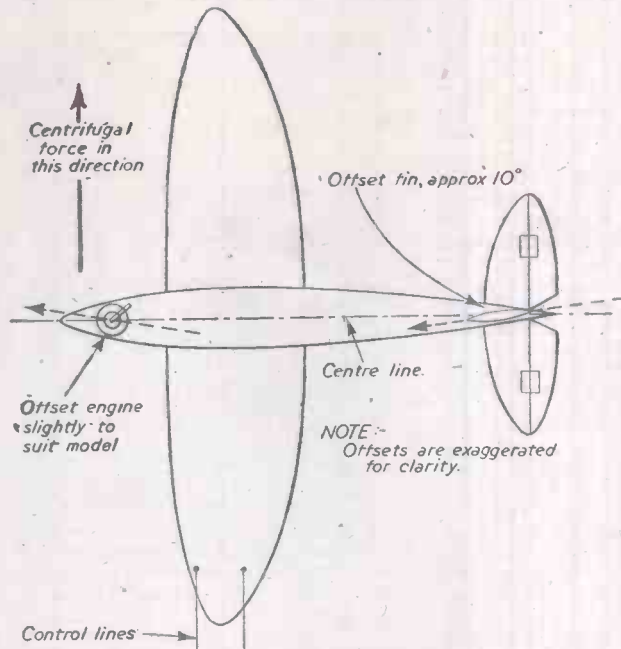

Fig. 7.—Offsets to assist centrifugal force in keeping control lines taut.

sheet balsa. This is doped with genuine Cellon full strength clear full size glider dope, and makes a model to last. Such dope is difficult to get, as so many model shops sell only thin model stuff, sometimes calling it full strength glider dope. Thin model dope never makes such a tight and lasting job.

## Scale Models

Scale model enthusiasts will be interested in Dr. Thomas's two control lines shown in Figs. 10, 11 and 12. Fig. 10 carries one back to the war. The model is powered by a 2.2 c.c. diesel and has an ingenious third line



Fig. 9.—The author's general-purpose sport control-line model shown in this photograph has a monocoque fuselage and a large surface elliptical wing with a section of his own. Engines from 2.2 c.c. diesel to hot 10 c.c. petrol fly this model at varying speeds. Engines are all on detachable mountings held to the fuselage nose by elastic bands, which save damage in the event of any "wizard prangs."

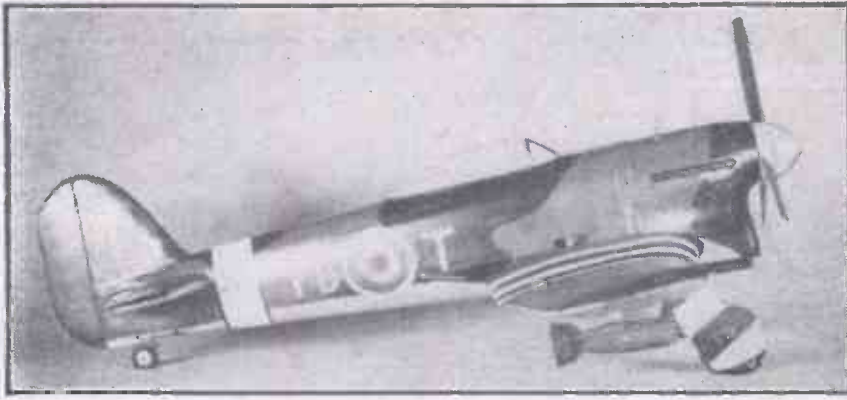

Fig. 10.—This ingenious control-line model built by Dr. Thomas has a third line. One pull on the line when in flight retracts the undercarriage. A second pull drops two bombs, and a third tweak on the line lowers the undercarriage for the landing.

### The "Goat"

Before we consider constructional and flying details, let us for a few moments examine what is termed in America, the "Goat." A "goat" is a free-flight model that is converted to a control-line model, and because of its light wing loading usually makes a nice slow-flying control-line model for beginners in light winds. In fact, I recommend the free-flight man to start off with a "goat."

There is a great deal of fun to be got from these converted models, provided the owner realises that because of their slower speed they may be rather more tricky to fly in windy weather due to the fact that centrifugal force is not so determined in pulling the model outwards. Practically every free-flight model can be converted to a "goat," but remember that the model must be re-weighted so that the C.G. position comes just behind the leading edge of the mainplane and not as for free-flight about one third to one half of the chord back. Figs. 13 and 14 give two examples that will serve to explain the idea.

I am often asked the question: "Can I convert my free-flight model of such and such a make to control line?" The answer is definitely yes. For instance, Fig. 13 shows a small 45½ in. span model of my design that has proved a popular kit model. This model is called the "Meteorite" and is powered by the Frog and Mills size of diesel and several of the great number that have been built in Britain have been converted to control-line where people wanted to try their hand, or wanted to fly in a confined space. All that is required is the fitting of a simple flap elevator to the tail plane, attached by three fabric hinges as described later. An external control plate of three-ply and its



Fig. 12.—This medium size scale Tiger Moth, built by Dr. Thomas, is powered with a 2.2 c.c. diesel engine.

connecting wires are mounted on the bottom of the port wing, i.e., the left wing looking forward from the tail. A three-ply control handle and two fishing lines complete a couple of evenings' work, and the owner is initiated into the mysteries of control-line

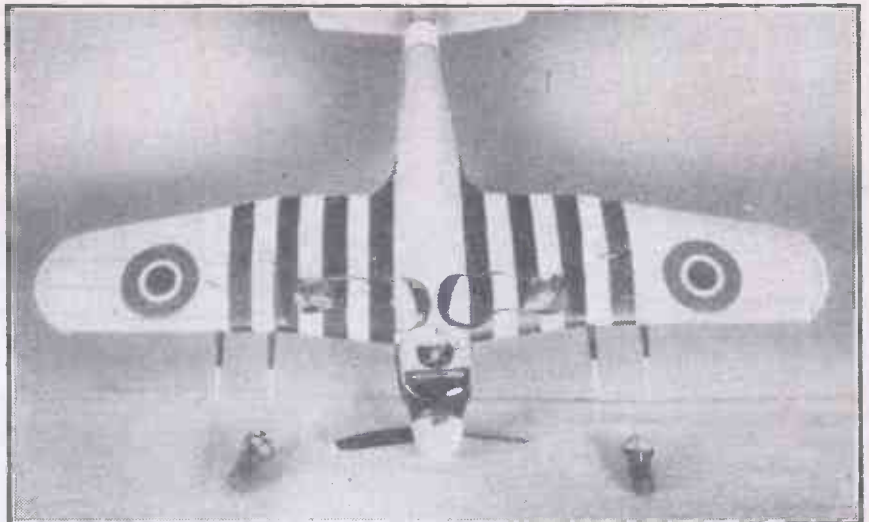

Fig. 11.—The undercarriage can be seen retracted, and the two bombs off their racks lying on the ground. Good fun and a test of aiming and flying skill can be had bombing a target laid out in the control-line circuit.

flying, not forgetting, of course, to add a little weight to the nose as described above. Garden or park flying can then be carried out, or the owner can nip into a convenient small field and put the model through its

paces for, being lightly loaded, it will take off from reasonably rough ground.

In Fig. 14 we have a large and ancient "goat" conversion from an early low-wing petrol model of mine. The wing span is over seven feet, and I now control-line this old machine powered by a 5 c.c. Eta diesel which slowly takes the model off and flies it majestically round my person. The model is fitted with external wing-tip slots, one of which can be seen in the photograph. I am able to observe the effect of these slots in action, and can land the old model at absurdly low speeds much to my satisfaction and the amusement of my flying friends who visit me at the garden circuit.

It is also possible to fly this slow model quietly around, with myself in a crouching posture, whilst a friend with a faster model flies around with his lines above mine. He can then bomb the ancient lumbering crate as he speeds round above her. It is amusing, and requires quite a lot of bomb aiming skill, not to mention a little flying care.

Note the simple flap elevator that has been tacked on to the trailing edge of the tail plane with small cloth hinges. Incidentally cloth hinges last indefinitely, and

are most effective in freedom of operation. They never tear out of balsa sheet tail planes as I have known metal hinges do. The control rod can be seen running below the fuselage from the triangular three-ply control plate to the elevator horn which is made of piano wire anchored securely by plastic wood and glue to the elevator. (See Fig. 1a, September issue.) On a large model like this the long connecting rod is stiffened with a length of birch wood. Small models can be operated by a 12 s.w.g. piano wire rod, which is sufficiently stiff for the job.

The control plate is pivoted on a bolt that is securely anchored to the underside of the wing through a piece of three-ply wood let into the wing, with the whole well reinforced by plastic wood and glue, because the whole strain of centrifugal outward force is taken through this plate. Two wires of 20 s.w.g. piano wire are carried from the ends of the control plate to the wing tip through two brass tube guides located in a laminated balsa guide piece cemented and reinforced by plastic wood to the wing tip. Stout fishing line is used for lines to the operator's three-ply control-line handle.





Fig. 13.—The author's small free-flight diesel-engined model "Meteorite" with span of 45½ in. can be converted to a control-line "Goat" in a few hours. The engine in this model is a 1 c.c. Frog diesel or a 1.3 c.c. Mills.



Fig. 14.—The author's ancient free-flight petrol low-wing 'plane now relegated to a control-line finish of its life. The 'plane is over 7ft. wing span and is fitted with wing tip slots. It can be flown very slowly and landed at absurdly low speeds with nose right up.

**Fuel Feed**

Centrifugal force tends to fling the fuel outwards away from the engine pick-up fuel tube to the jet. Most standard tanks fitted to model engines for free flight are in the form of a simple tank below the fuel jet, the fuel being sucked up to the fine adjustment needle of the jet. If this tank is retained on a fast model the engine suffers from fuel starvation as the speed rises. A special fuel tank has therefore to be fitted for fast models. This is in the form of a wedge shape with the deep end near the pilot and the thin edge of the wedge located outwards, as seen in Fig. 1a. The fuel tube of brass is then taken from the thin end so that centrifugal force pushes the last drops of fuel up the pipe. A few of the slower models will fly with the normal tank if the filler orifice is arranged inside the circle. Canting the tank outwards helps. The Frog cone tanks seem to work without alteration.

**Fuselage Construction**

The fuselage can be made up if desired as a "slab-sider" with rectangular shape on the lines of many free-flight models. This is easily and robustly done on the system that I introduced a number of years ago. The sides are cut from 1/16 in. balsa sheet. On to these the balsa longerons are cemented. The two sides are then put upright and crosspieces are added. The top and bottom are then sheeted with 1/16 in. balsa, thereby producing a very strong but light box. This method will be illustrated with photographs in a subsequent article dealing with free-flight models. The method is also described in my book "Petrol-Engined Model Aircraft."

Alternatively, a monocoque fuselage, which suits control-line models well, can be constructed either from solid balsa block or by the cheaper method of planking. Many people think that planking in balsa must be difficult. In actual fact it is very easy if approached in the right way.

I am therefore showing some photographs of the various stages of making a planked fuselage, which if followed in the order given, will be found to get over all the imaginary terrors of planking in balsa, and will enable modellers to have pleasant looking free-flight monocoque models as well as control-line machines. Following these photos is a series showing the method of building a monocoque fuselage from solid balsa. This is hollowed out and is also easier than some modellers imagine.

Let us build the fuselage and wing of my "Bullet" together, starting off with Fig. 15. I have traced out the side elevation of the model's fuselage with the aid of carbon paper on to a sheet of balsa 1/8 in. or 3/16 in. thick, and then cut away the centre to lighten. This forms a backbone

to build upon. I cut around the outline with a safety razor blade of the single edge kind. I then trace the formers on to 1/8 in. sheet balsa and cut these in half longitudinally,

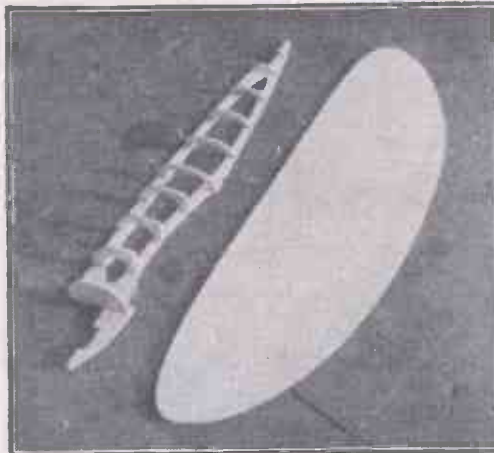

Fig. 15.—The backbone is laid on a building board or the kitchen table. The half oval formers of balsa are cemented in position, being temporarily retained by pins until the cement is dry.

ally, for my next move is to cement one-half of the formers on to the balsa backbone which can be seen lying on the ground. I keep these half formers in position by ordinary household pins, until the cement is dry, when I remove them. I use pins for many similar purposes throughout building operations.

The elliptical sheet of 1/16 in. balsa, seen in Fig. 15, forms the bottom of the wing and is made wide enough by the simple expedient of smearing the edges of more than one sheet of balsa with cement and then butt-jointing and allowing to dry with weights such as old irons placed on the sheets to prevent them curling up whilst the cement is drying.

Now look at Fig. 16 and you will see that I have laid on balsa planks, in this case 1/8 in. thick and ¼ in. wide so that I have half my monocoque fuselage planked up. I start by putting a touch of cement on each former at a line along the top. I then pin down my first master plank. Now I smear, along one edge of this plank some cement from a tube with little drops of glue on each

former close to the master plank. Number 2 plank is then pinned in beside the master plank so that the glue keeps both together.

The next process is to put in my third plank on the opposite side of the master plank in the same way, and so I go adding planks on alternate sides. It is surprising how quickly one finds the side of the fuselage is completed, and what a restful and yet pleasing task this planking becomes! One wants to go on and see the thing grow. As the quick-drying cement sets, the pins are withdrawn and put on one side.

In the same photograph will be seen half the wing made up and the solid balsa tail plane cut from 3/16 in. sheet balsa. You will notice that the sheet outline of the wing seen in Fig. 15 has now got an outline of 1/8 in. by 1/8 in. balsa strip cemented around its edge and then the ribs, which have been traced on to 1/8 in. sheet and cut to shape, cemented in place. This easy method has automatically built you up a wing of great strength with stressed sheet covering, for all we have to do now is to add the control plate inside the wing, and then cement on a balsa 1/16 in. sheet top covering. The finished wing, if covered with paper or, better still, with nylon or fabric such as fine lawn, will be indestructible. Pins are used to keep the sheet in position whilst the cement is drying during the covering operation, and plenty of cement should be used over each rib, etc.

(To be continued)

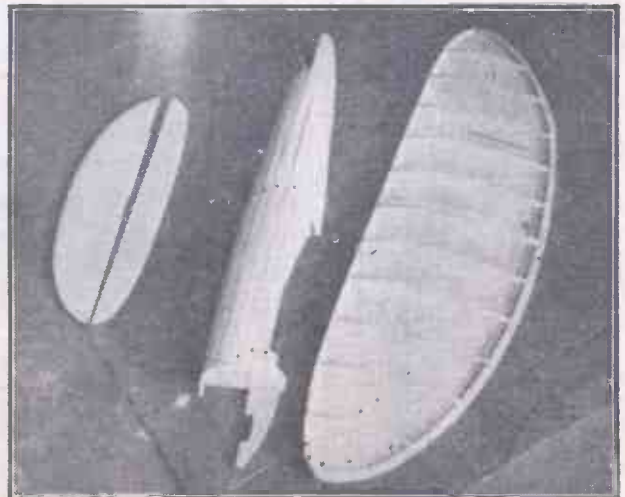

Fig. 16.—The half side of the fuselage is planked up. Pins are then withdrawn and work proceeds on the other side. The wing has its outline spars cemented in and also the balsa ribs. The solid sheet balsa tail plane is cut to streamline, and the cloth hinges added.

# A Small Electric Motor

Constructional Details of an Efficient Motor for Driving Model Boats

By R. R. HUTCHISON

**T**HIS simple electric motor is designed to produce a relatively high power on a very low voltage (1½-6) for small model motor-boats, and can be built quickly and easily by any handyman with the minimum of tools. It has been tried out and works efficiently.

First of all a small "Eclipse" magnet must be bought, which is obtainable in most tool shops or model makers' supply stores. This

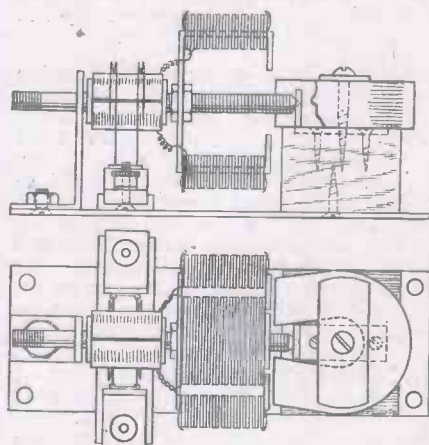

Fig. 1.—Side elevation and plan of the completed motor.

is clamped to a small block of wood, which in turn is screwed to a metal base, as in Fig. 1.

The armature core is cut from a piece of soft iron sheet about 1/32 in. thick (Fig. 4) and bent at right angles on all dotted lines to the form shown at A (Fig. 5). Small, thin pieces of brass are bound on with insulating tape or gummed paper, as shown at B, for keeping the armature windings in position when these are completed.

A centre hole is drilled to take the axle and tapped 4 B.A. Each arm is carefully wound with eight layers of No. 26 D.C.C. copper wire all in the same direction, leaving a loop of wire between each arm for connection to the commutator. The two finishing ends are joined together to form the fourth loop. When the windings are all neatly finished, cover with a liberal coating of shellac varnish and bend the brass pieces up and over the ends of the windings to prevent them from slipping. (See Figs. 1, 2 and 3.)

### The Commutator

To make the commutator, take about 2ft. of thin gummed paper and cut this to 7/16 in. in width, damp or, better still, gum along its entire length and roll this tightly and evenly on to a slightly vaselined 1/4 in. piece of rod (the smooth shank of a drill will do), slide off, and leave to dry for 24 hours. Before sliding this off, however, make sure it is going to fit fairly tightly into the short length of brass tubing that is to be used for the commutator. This tubing should be about 3/16 in. diameter and about 7/16 in. long, of light gauge. A piece of old brass gas tubing will do. When the paper roll is perfectly dry and hard gum the surface with a strong adhesive and force into the tubing again leaving to dry very thoroughly with a little of the paper roll protruding at each end. When quite dry, cut the brass lengthways into four equal segments with a fretsaw. This forms the commutator, the hole for the axle being exactly down the centre.

The axle is a piece of steel rod 9/64 in. in diameter, and is threaded 4 B.A. half-way along its length to take the armature, and at the other end to take some form of coupling to the propeller.

For those readers who have no taps and dies both the armature and the coupling to the axle can be soldered with equally good results, but it is not so handy for taking to pieces or for final adjustments.

The armature is now screwed on to the axle with a nut on each side to keep it square with the axis, and the commutator is forced on close to it (Fig. 1). In the top half of this illustration the two side arms of the armature are omitted in the sketch to show the nuts and screwed axle.

The end of the axle nearest to the field magnet is carefully filed to a point of about 45 deg., which is pivoted into a bearing made of a piece of odd brass, bent at right angles, countersunk into the block of wood supporting the field magnet, and drilled half-way through on its vertical surface to take the point of the axle (Figs. 1 and 2). The other bearing is just a piece of brass bent at right angles, bolted to the base and drilled 9/64 in. to fit the plain part of the axle.

The windings are now soldered to the commutator sections by twisting each loop of wire tightly and soldering to the commutator segment nearest to it. Finally the commutator is adjusted to the position shown in Fig. 3—the cuts opposite each respective leg of the armature. (The outer bearing is left out here to show the brushes and commutator details.)

### The Brushes

Many ways of making the brushes have been tried and the following method has been found most effective. An exploded view is shown in Fig. 6. This consists of a few inches of thin piano wire about 24 gauge carefully bent as shown with a single turn at the top to make the brush more springy.

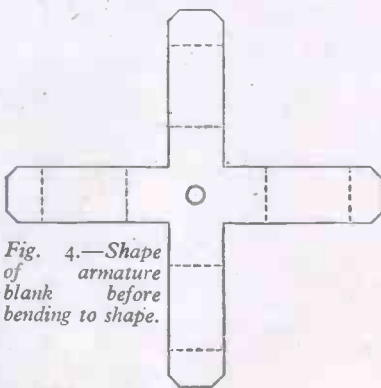

Fig. 4.—Shape of armature blank before bending to shape.

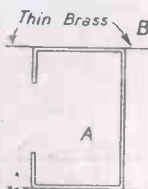

Fig. 5.—Details of armature and brass clamping strips.

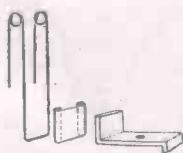

Fig. 6.—An exploded view of the wire brushes and holder.

A small piece of very thin brass or tin is now bent round each leg and the flat side of the brass is then soldered to the brush-holder and terminal strip (Figs. 1 and 3).

A small thick strip of ebonite, hard wood, or fibre is now cut and drilled and the terminals fitted which clamp the brush-holders firmly down, the whole unit being securely bolted to the base plate.

One method of connecting the motor to the propeller shaft is by making a close-wound spring from piano wire, screwing one end to the motor axle and the other to the propeller shaft. This makes an excellent universal joint.

Using a single "unit" cell (1½ volts), this little motor has driven a 16in. model boat very easily across a boating pond many times one afternoon, and the battery was still quite useful at the end of the run. If three or four "unit" cells are used a surprising turn of speed and power is developed.

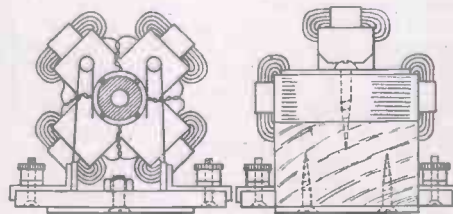

Figs. 2 and 3.—Front view of the motor (with bearing plate removed), and rear view.

## International Scientific Film Congress

**T**HE second congress of the International Scientific Film Association will be held in London from October 4th-11th, 1948.

The Association was constituted last year in Paris by delegates from 22 countries who had accepted the joint invitation to the inaugural congress from the Scientific Film Associations of Great Britain and France. The primary aim of the Association is:

"To raise the standard and to promote the use of the scientific film and related material throughout the world in order to achieve the widest possible understanding and appreciation of scientific method and outlook, especially in relation to social progress."

This year's congress is being convened by the Scientific Film Association of Great Britain, with the help of the British Film Institute, and invitations have already been issued to countries throughout the world. The congress will open with a formal reception to the delegates on October 4th, and the following three days will be devoted to business meetings of the International Scientific Film Association. On October 8th, 9th and 10th there will be a Festival of Scientific Films, when it is hoped to show many contributions from all the participating countries to members of the general public. The congress will close with a general assembly of the delegates on October 11th.

The widespread public interest in this country in the scientific film, makes it particularly appropriate that this congress should be held in Great Britain.

Further details may be obtained from the Scientific Film Association, of 34, Soho Square, London; W.1.

# The Elements of Mechanics and Mechanisms—12

## The Inclined Plane—The Wedge—The Screw

By F. J. CAMM

(All Rights Reserved)

A PLANE surface is one on which if any two points be taken and joined by a straight line, that line will everywhere touch the surface. When the plane surface is like that of water at rest it is a horizontal plane. When at right angles to this or upright it is a vertical plane, and if disposed at any angle between these two positions it is an inclined plane.

The angle of inclination of an inclined plane is found by measuring the number of degrees between it and the horizontal plane.

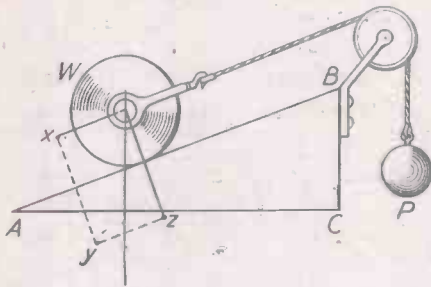

Fig. 1.—The inclined plane, with force acting parallel to face of plane.

Another way is to find how many units of length we must ascend along the inclined plane to reach one unit of height above the horizontal. This is usually expressed by saying that the inclination or gradient is, say, one in two, one in six, and so on. By the side of a railway may be seen boards bearing figures such as  $\frac{1}{250}$ . These are intended to indicate to engine drivers that the line of rails at that point rises at the rate of 1 yard for every 250 yards.

Now, we have already seen that the weight of a body acts downwards along a straight line which theoretically joins its centre of gravity with the centre of the earth. When a body lies on a horizontal plane it is completely supported by the reaction or upward pressure of the plane which is then equal and opposite to the downward pressure of the body. When a body rests on an inclined plane it is supported, more or less, according to the inclination or gradient of the plane surface. If the surface be perfectly smooth and rigid the body will roll down the plane, no matter how small the angle at which the plane is inclined. But all bodies possess a certain amount of friction, and so it is possible for a body to rest on an inclined plane. It is the friction between the body and the plane which causes the former to remain at rest. In calculations relating to the force required to produce equilibrium, it is always presumed, however, that the surfaces are perfectly smooth and rigid. In Fig. 1 for example let the line XY represent the total weight of the body W acting vertically downwards due to the force of gravity. It will be seen that this force may be resolved or divided into two other forces, one acting at right-angles to the plane AB, and the other acting downwards and parallel to the surface of the plane. By completing the parallelogram the length of the vertical will show the proportion of the

weight of the body which is suspended by the surface of the plane, while the distance of X to the centre of the weight will represent the force tending to urge the body to roll downwards towards A.

To produce equilibrium, it is obvious that we must introduce a force equal to this, but acting in the opposite direction. The figure XYZ is a parallelogram and the vertical is its diagonal. We know that if any given force be represented by the diagonal then the two adjacent sides represent two other forces whose joint effect is equal to that of the single force acting on the diagonal.

By assigning units beforehand, for example, that in. shall represent 1lb., it is only necessary to measure the line XO to find the force which would be required to produce equilibrium. Taking an inclined plane with a greater inclination, it will be found that less of the weight of the body is supported by the plane and consequently a greater force will be required to produce equilibrium.

But instead of drawing a parallelogram, we can ascertain the force required to produce equilibrium when acting parallel to the length of the plane, by finding the proportion that the height bears to the length. For example, if BC equals 3ft. and AB equals 5ft., then to prevent a body weighing 100lb. from sliding down the plane we must employ a force of  $\frac{3}{5}$  of 100lb., namely 60lb.

In Fig. 2 is shown a force supporting the body E and acting from D to E parallel to the base. In this case the force required to

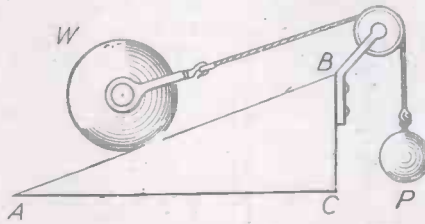

Fig. 3.—The elements of the inclined plane.

support the body is found by experiment to bear the same relation to the weight of the body as the height does to the base. Force is applied in this manner when a man wheels a truck up an incline or pushes a barrow in

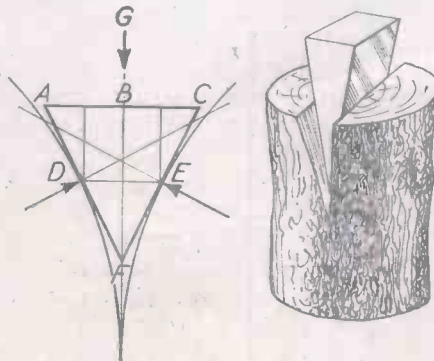
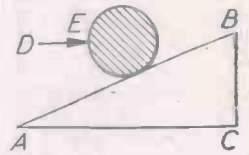

Fig. 4.—The principle of the wedge.

front of him up a plank into a dray. It should be obvious that it is a mechanical advantage for the force to act parallel to the length of the plane.

Having investigated the conditions necessary to produce equilibrium, it will be seen that the least additional force applied to the body will cause it to ascend the plane. In Fig. 3 is shown a roller weighing, say, 100lb. placed at the lower end of the inclined plane AB and connected by a rope passing over a pulley with the weight P, say 40lb. If the length of the plane is 7ft. and the height 2ft. then if the parts be considered to work without friction and the rope to be without weight, there will be equilibrium and the least additional weight to P will cause the weight to roll up the plane. Apparently a

Fig. 2.—The inclined plane, with force acting parallel to base.



force of 32lb. balances a weight of 112lb. Consider the motions of P and W in a vertical direction. It will be seen that while W has been elevated vertically to a height of 2ft. P has descended downwards 7ft. Applying our knowledge of leverage we see that  $32 \times 7$  equals 224ft./lb. and  $112 \times 2$  equals 224ft./lb.

In other words, the smaller weight has had to move through a correspondingly greater distance—another example of the rule given earlier that what we gain in power we lose in space.

There are many examples of the application of the inclined plane. The stairs in a house are really only inclined planes, the steps merely being notches to provide a foothold.

### The Wedge

The wedge is a body having a triangular section, the top and sides being parallelograms, and the bottom edge being sharp.

It is an example of an adaptation of the inclined plane. If two inclined planes of the same size be fixed together, as in Fig. 4, they will form a wedge. The action of a wedge is based on the principle of the inclined plane, the difference being that the action is reversed, for in the case of the simple inclined plane the surface remains at rest while the body, whose resistance is to be overcome, is made to move up or down the plane, whilst in the case of the wedge the body remains at rest while the plane moves. Consider Fig. 4, and assume that the wedge ACF is being forced into the block of wood, the direction of the force being represented by G, while the resistances to be overcome, represented by the cohesion of the fibres of the wood, are represented by D and E, acting at right-angles to the faces of the wedge. It can be shown that when the force is applied at a steady pressure on the face of the wedge, there is equilibrium when the three forces D, E and G are in proportion to the three sides of the wedge. It will be seen that it must be an advantage to have the wedge as narrow as possible.

In using a wedge the force is applied, however, by percussion usually and not as a steady pressure.

**Friction Has Its Usés**

Friction, of course, compels us to use more force than would otherwise be necessary, but in many ways it is of assistance. We could not walk unless there was friction between our feet and the ground. In using a wedge it is the

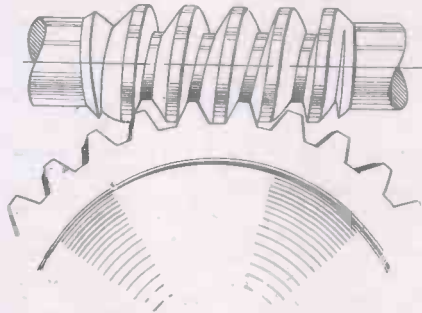

Fig. 5.—Worm and worm wheel.

friction between its sides and the body which it is entering that keeps the wedge in place between the hammer blows.

Now the main use of a wedge is to overcome a resistance through a small space. If a heavy weight needs to be lifted to a considerable height, pulleys would be used or the inclined plane, but to raise a heavy body a comparatively small distance the wedge provides the simplest solution.

**The Screw**

If a piece of paper be cut into the shape of a right-angle triangle (a section of an inclined plane), and it be wrapped round a pencil, it will be noticed that the hypotenuse traces out the spiral of a screw thread. A screw thread is really a movable spiral-inclined plane wound round an axis or cylinder. We have seen that it is not necessary for an inclined plane to be straight. If, for example, it is desired to reduce the proportion between the force and the resistance, the length of the plane must be as great as possible in comparison with the height. That is the reason why roads are made to wind round a hill so that we only very gradually reach the top. A spiral staircase is a further example.

The distance between one thread of a screw and another is called the pitch. There are many forms of screw thread which need not be dealt with here.

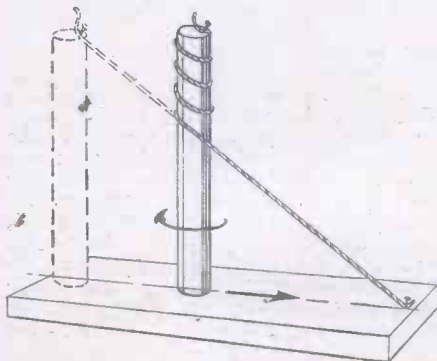

Fig. 6.—The screw thread—an example of the inclined plane.

Of course, a screw thread is useless without a corresponding nut in which to work. The nut is a hollow cylinder on the inside of which spiral grooves or internal threads are cut corresponding to the pitch of the external screw thread.

Apart from very small screws which may be operated by means of a milled nut, power is generally applied to the head of the screw by means of some form of lever, such as a spanner or, in the case of a capstan screw, by means of

the capstan itself. In the case of wood screws a screwdriver is used.

Now when the head of a screw makes one complete revolution, the point of the screw is advanced by the distance between any two adjacent threads. If the power applied to the head of the screw is applied through a circle whose circumference is, say, 3ft. (as in the case of a very long spanner), the end of the screw and any weight attached to it will be raised or depressed a distance equal to the pitch. It will be seen that the power moves, presuming the pitch of the screw thread to be  $\frac{1}{16}$  in., 36 times the distance moved by the weight or resistance. In other words, the force need only be  $\frac{1}{36}$  of the load or weight. The force applied to a screw thread is found by the formula  $F = \frac{WP}{2\pi r}$ , from which  $W = \frac{F2\pi r}{P}$ , where P equals the pitch of the screw, r the radius on which the force F acts, and pi equals 3.1416.

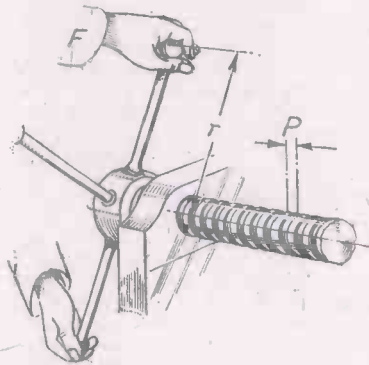

Fig. 7.—Force exerted by a screw.

There is considerable friction in the case of screw threads and a large proportion of the power applied is expended in overcoming it; even with modern methods of cutting screw threads it is estimated that at least 60 per cent. of the force is wasted in this way.

The screw is similar to the wedge in that it enables a great force to be exerted over a small distance. Enormous pressures can be obtained by means of the screw and many metal presses are operated by means of it. The vice is a further example of the application of the screw.

The micrometer is an application of the screw thread for purposes of making measurements. It consists of a forged steel frame (sometimes cast ones are used) to which a graduated sleeve is attached. It is screwed inside 40 threads per inch to receive the spindle, which is rigidly attached to the inside of the thimble. The spindle is a good fit within the sleeve. The contact faces of the spindle and the anvil are, of course, ground dead flat. For ease in using, the thimble is knurled for about an inch, as shown in the illustration. Now, since there are 40 threads to the inch, it follows that if we turn the spindle (by means of the thimble)

one complete revolution we have moved it a distance from the anvil equal to  $\frac{1}{40} = .025$  in.; and if we move it  $\frac{1}{25}$  of a revolution it also will be clear that we have moved the spindle  $\frac{1}{25} \times \frac{1}{40} = \frac{1}{1,000}$  in. This, in brief, is the principle of the micrometer. The graduations along the sleeve are in

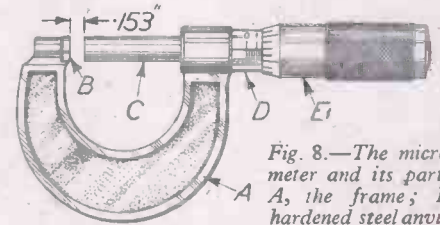

Fig. 8.—The micrometer and its parts. A, the frame; B, hardened steel anvil; C, spindle; D, sleeve; E, thimble. The reading is 0.1531 in.

fortieths of an inch—that is, one division represents .025 in.

Since, also,  $4 \times .025 = .1$  in., or  $\frac{1}{10}$  in.,

the divisions are numbered in series of four, as 0, 1, 2, 3, and so on, up to the full inch. The thimble is graduated into 25 divisions, each representing  $\frac{1}{25} \times .025 = \frac{1}{1,000} = .001$  in.

That is to say, when the zero line on the thimble has rotated exactly one division from the zero line on the sleeve the distance between the spindle and anvil faces are in perfect contact so that there is no space at all between them, the zero mark on the thimble exactly coincides with the zero mark on the sleeve. So much for the principle; now for the method of reading.

Assume, for the purpose of explanation, we require a micrometer setting of .527 in. This measurement, split up, is equal to five-tenths, two-hundredths, and seven thousandths. Since, therefore, the numerals along the sleeve represent tenths of an inch, unscrew the spindle (by turning the thimble) until zero on the thimble corresponds to the figure 5 along the sleeve. Now unscrew the spindle another complete revolution, until zero again coincides with the line along the sleeve; we have now opened the micrometer  $.5 + .025 = .525$  in.;  $.527 - .525 = .002$ , and, therefore, the second division past zero on the thimble must be brought to coincide with the line on the sleeve. The micrometer illustrated in Fig. 8 is set to .1531 in., because the thimble has uncovered No. 1 along the sleeve and there are also two more complete divisions showing. Reading round the thimble we have three divisions showing (representing thousandths); hence  $.1 + (2 \times .025) + .003 (= 3 \text{ thousandths}) = .153$ . No difficulty in reading this instrument will be experienced once these fundamental principles have been grasped.

(To be continued.)

## British Clock and Watch Exhibition

THE technical development of the British clock and watch industry will be revealed for the first time at an exhibition to be held at the Goldsmiths' Hall, Foster Lane, E.C.2, on October 28, in conjunction with the ninetieth annual general meeting of the British Horological Institute—the oldest trade association in the world, the president of which is The Astronomer Royal, Sir Harold Spencer Jones, F.R.S., M.A., Sc.D., F.R.A.S., F.B.H.I.

The exhibition will be of intense technical interest, disclosing the latest products of all the British manufacturers and the craftsmen-

ship of the master Tompion, "The Father of English Clockmaking," and his contemporaries.

Other features will be examples of the work of the National Horological College, the Ministry of Labour training colleges, and other horological training institutions throughout the country. In addition, Fellows and Craft-members of the British Horological Institute will be showing selected pieces of mechanism of their own construction.

The exhibition will be free to the public from 11 a.m. to 5 p.m. on October 28.

# Practical Pottery Repairing—2

## Repair Technique and Moulding Materials

By J. F. STIRLING

(Continued from page 397, September issue)

and was quite incapable of being replaced. Patiently cutting and grinding another piece of pottery to fit the gap and cementing and/or riveting it up was impossible owing to the difficulty in matching the shade of the material and, also, in getting the peculiar rim-curve of the jug. The only feasible repair method was an actual moulding operation.

First of all, a couple of very fine holes were drilled about  $\frac{1}{16}$  in. down into the broken edge of the jug. In these were inserted steel pins—fine gramophone needles, as a matter of fact—the purpose of these being to reinforce the moulding material which was to be laid over them, and thus to provide an additional “key” for the inserted material.

It was now necessary to obtain the correct curvature of the outer and inner sides of the jug. This was effected by taking a quantity of children’s play-wax, a material which becomes plastic when rolled between the hands. This was rolled into a flat sheet and pressed on to the inner and undamaged side of the upper edge of the jug so that a correct replica of the inner surface and curvature was obtained. The same was carried out with another piece of the moulding wax on the outer jug side. The two moulded pieces of wax—outer and inner sides—were then slid round on the upper edge of the jug until they covered the gap, thereby providing “walls” for the latter. Between these

jug. The level of the moulding material was raised slightly above the level of the jug edge.

After the moulding material had set and hardened, the wax “walls” were pulled away, and the upper edge levelled down to the height of the remainder of the jug rim, this being done by gentle sandpaper treatment. The hardened “inset” was then very gently smoothed off with fine glasspaper and given a couple of coats of cream cellulose paint to match the rest of the jug at that area.

Now this technique can be adapted to a host of different pottery repairs. Holes in the side of valuable jugs, dishes and other ceramic articles can be filled in and built up neatly, making the repair only visible on the very closest examination. The repaired parts, particularly if reinforced, have considerable strength and will usually well withstand normal wear.

### Moulding Materials

The moulding materials which can be used for this purpose may comprise any type of fine-grained waterproof luting or cement. Plaster of Paris may be used; but it is very brittle, even when a little powdered asbestos is incorporated with it to give it additional strength.

A much harder material is magnesium oxychloride, which is similar to dental cement. Such stuff is readily made by slaking finely powdered calcined magnesia with a 40 per

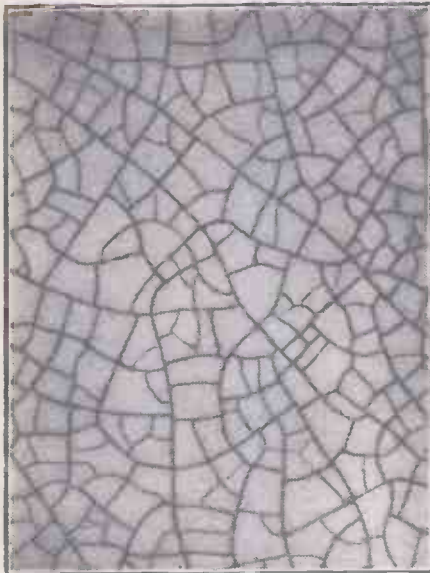

The crazed surface of a domestic plate which has become dirty. This is a magnified photograph of approximately one inch of surface.

**E**ACH small piece of surface-crazing is bounded by three or four cracks, down into which gradually seep some of the dirt, dust and grease which the surface of the plate or dish necessarily collects. When the pot is washed, some of this surface dirt is removed, but a little of it is drawn down into the cracks by capillary forces. Once in the cracks it is retained there. Hence the “dirty” appearance of such an article.

Something can be done to clean up a crazed crock by placing it in water which is very slowly brought up to the boil (there is a risk here of the pot disintegrating), or by soaking it in a hypochlorite solution or in a solution of chloride of lime, followed by immersion in a dilute solution of hydrochloric or sulphuric acid. This, of course, is properly a bleaching process, and, generally, except in the case of valuable articles, it is, perhaps, hardly worth the trouble—and risk—of applying.

Often enough a dish or a jug gets a piece knocked out of its side, the piece being so hopelessly fragmented that cementing it back is quite out of the question. In this event the piece of crockery is either immediately discarded, or, at least, used in the secret hope that it will quickly become smashed up altogether!

### An Outline of Repair Technique

There is, however, quite a good repairing technique for this sort of trouble. Here, indeed, is pottery surgery proper, the idea being to fill up the offending gap in the vessel’s side in something like the manner in which a patient dentist slowly fills up a defective molar or a careful surgeon delicately implants a new fragment of bone substance.

The actual technique of this pottery surgery must naturally vary a good deal, each case having to be considered and treated according to its individual circumstances, but the following description of an actual piece of work will enable the reader to put the method into practice.

A valuable antique Italian spouted jug happened, by accident, to get a piece knocked out of its upper rim. The piece was shattered



An early china “handleless cup” of the late eighteenth century. It has met with a bad accident, but, fortunately, the break is a clean one, and there are only two parts. (Below) The same cup joined up again by cellulose cementing and careful crack filling.



moulded wax walls, the moulding material was carefully poured, being gently prodded and compacted down with a blunt stick, particular care, also, being taken to see that the material was compressed evenly around the two reinforcing pins which had been previously fitted into the broken edge of the

cent. solution of magnesium chloride (made by dissolving 40 parts of magnesium chloride in 60 parts of water). This cement hardens in two days. It expands very slightly on setting and therefore exerts a good grip. Unfortunately, all these magnesium compounds are difficult to obtain these days.

### Silicate Moulding

The latest cements of this nature are those which are based on an alcoholic solution of ethyl silicate containing a trace of acid. Ethyl silicate is now obtainable from most chemical suppliers. It is a clear liquid, water-white. When treated with acid, it gradually sets to a jelly and then to a hard mass of pure white silica, which is waterproof and inert.

The mode of preparation of the ethyl silicate is to take 19 parts of the latter and to add to it 8 parts of alcohol (surgical spirit will do) and 3 parts of very dilute hydrochloric acid (0.06 per cent. HCl). This mixture is shaken or stirred until the liquid does not separate into two layers. One hour after this stage, a further 15 parts of ethyl silicate are added to the mixture. In this “hydrolysed solution” form it will keep for several weeks, but will, in time, set to a jelly. Now, if sand,

(Continued on page 27).

## New Series

# World Air News

This Month's Topics Include Hawker Fighter Production and the Commercial Uses of Boost Rockets

By KENNETH W. GATLAND

**H**AWKER AIRCRAFT, LIMITED, is another firm doing well in the export line. Sea Furies are being supplied to the navies of Canada and the Netherlands (Fig. 1), and there are also land-based Furies for Iraq and Pakistan, among them dual-seat trainer versions. Moreover, the Dutch are building the latest Sea Fury F.B. Mk. XI under licence in the Fokker works at Amsterdam.

A formidable Sea Fury strike force is becoming available to our own Royal Navy, and here, too, a special dual-trainer model has been introduced, known as the Sea Fury T. Mk. XX.

The two trainers, though basically the same, can be readily identified by their different cabin configurations for, whilst the Iraqi machine embodies separate hood canopies (as seen in the illustration, Fig. 2), the Mk. XX has a clear-view Perspex "tunnel" linking the two cabins. One other feature about the latter is that a mirror has been mounted above the gunsight of the rear cabin which, with the reflector glass of the sight itself, forms a periscope, enabling the instructor to "sight" over his pupil.

### The Standard Sea Fury

With a top speed of over 450 m.p.h., the Sea Fury is perhaps the most versatile aircraft in naval service to-day (Figs. 3 and 4). It is armed with four 20 m/m. guns and, by way of disposable armament, can carry either two 1,000 lb. bombs, two 500 lb. depth charges, twelve rocket projectiles, or a large variety of other stores. For increased range, there is the usual provision for rocket-assisted take-off and two drop fuel tanks which con-



Fig. 1.—Sea Furies are now flying with the Royal Netherlands Navy. This one awaits delivery from the Hawker factory airfield at Langley, Bucks.

tribute a further 180 gallons over the normal 200 gallon fuel load.

A Bristol Centaurus XVIII engine transmitting its power through a five-blade Rotol airscrew, supplies 2,480 b.h.p. at take-off. The maximum rate of climb is 4,520ft. per minute whilst to reach 20,500ft., the Fury takes only 5.4 minutes. Its maximum range with 380 gallons is 2,080 miles when flying at optimum speed and height (over 450 m.p.h. at 30,000ft.).

It will be apparent from the above that the Sea Fury possesses many advantages not shared by naval jet fighters, namely, superior range and duration, which make it especially valuable for reconnaissance, and a display of offensive armament that at once places it in an entirely different class.

It is a common tendency these days to dismiss any propeller-driven fighter as obso-

lete, but it is not until the precise capabilities of the machine in question are weighed point by point against those of a corresponding jet machine that any true analysis can be made.

In its own way, the Sea Fury is as unique and as necessary to the modern carrier as the latest "jet." Many naval pilots will tell you that its special qualities make it, in fact, more desirable than present jet machines, but its ideal place is alongside the faster jet-fighters where it may be called upon to share the duties of fighter or to take up any of those "strike" or reconnaissance duties for which it is fully provisioned.

As a fighter-bomber, the Fury is fast and manoeuvrable, whether it carries bombs, rockets or depth-charges, and its robust construction and protecting armour for the pilot and fuel system contribute to make it a most difficult aeroplane to destroy. It is equally at home on reconnaissance duties, when special cameras are carried with drop fuel tanks for added range.

### Rocket-assisted Take-off

The use of R.A.T.O.G. on military aircraft is now standard practice, but its commercial possibilities have still to be properly explored. Perhaps the need for a supplementary power device for civil types is not so great in this country as abroad, but nevertheless, there are certain occasions when assist rockets might be profitably employed.

The take-off of aircraft engaged in scheduled airline operations is one, especially where runway lengths are too short for a machine to be loaded to maximum gross weight and clear the airfield boundary with any degree of safety. Normally, when a suitably long runway is not available, the payload must be reduced with loss to the operator.

### Emergency Use of Rockets

Another use for rockets might be as a standby source of power in the event of engine breakdown. One serious accident occurred not so long ago when an engine of a Dakota suddenly failed just after take-off. This is obviously the most critical time for power failure, as there is a heavy fuel load and the machine has not yet gained a safe flying speed. Moreover, there may be obstacles in the path and even if the 'plane is still controllable, the pilot may have no room to turn.



Fig. 2.—Off on the road to Iraq. W. Humble, Hawker's chief pilot, and J. Gale, Service Manager (rear cabin), pictured before setting out on their flight to deliver the first Iraqi-Fury dual-seater trainer.

A single solid-fuel rocket of the type manufactured by the Aerojet Engineering Corporation of Azusa, California, giving from 300 to 500 lbs. thrust for 25 seconds to insure an appreciable margin of safety, might easily avert disaster in the case of an aircraft of the Dakota class. The fittings for mounting the rocket unit could be simple and light, whilst the unit itself would be quickly and easily replaceable by one man. Its added weight would not reduce payload.

Power would be available instantly at the flick of a switch, enabling a machine with a faltering or "dead" engine to accelerate to a safe single-engine flying speed and gain height, when the pilot would have every chance of making a safe forced landing.

Thirdly, there is the possibility of using



Fig. 3.—An experienced pilot makes a Sea Fury deck-landing look simple.

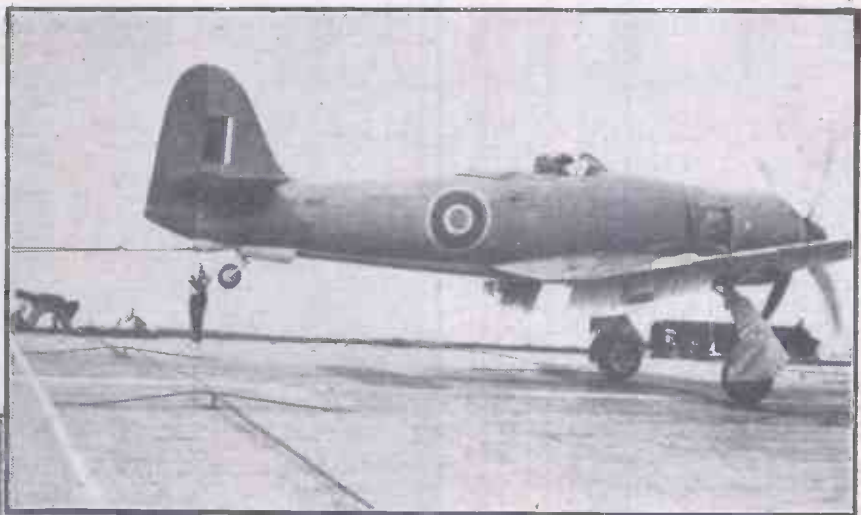

Fig. 4.—Safely down. A Sea Fury hooks up on H.M. Carrier "Illustrious."

Guggenheim Aeronautical Laboratories, California Institute of Aeronautical Technology, under the direction of Dr. Frank J. Malina, and its production was subsequently put into the hands of the Douglas Aircraft Company at Santa Monica, California.

The first free-flight tests took place during the summer of 1945 at the Army Ordnance Department's White Sands Proving Ground at Las Cruces, New Mexico, with a missile known by the code "WAC Corporal."

These compact missiles offer for the first time a means of obtaining data on the state and nature of the atmosphere at really high altitudes, being designed to carry instruments which record temperature, pressure, density, humidity, as well as more specialised devices for the investigation of electronic phenomena. Some have been fitted with radio transmitters to enable data on the changing conditions of the rocket's flight to be flashed direct to ground receiving stations, whilst others merely parachute their readings to earth.

forward-firing rockets as "brakes" to shorten the landing run of fast or large aircraft.

It will be realised that R.A.T.O.G. has unique virtues in special cases. It would have a great many more if it were not for the one main drawback—cost. Present Aerojet units are priced at \$125 apiece and since at least two are normally required for a take-off, their limited commercial appeal is not so surprising.

#### Rocket Power for Models

Speaking of rocket boosters, aero-modellers will be interested to learn that a firm has recently been incorporated to manufacture a rocket propellant specially for model use. The charges are not of the usual black-powder variety but come in the form of plastic-like sticks which can be safely cut to any desired length.

All concerned will welcome this development which should put model rocket flying on a more practical basis. The charges, developed in the laboratories of the Explosives Division of the Imperial Chemical Industries, Ltd., are now available.

#### Altitude Sounding

The news that sounding rockets, barely 16ft. long and weighing only 1,000 lbs., have reached heights of over 43 miles, has put an entirely fresh complexion on the problems which have hitherto called a halt to investigations of the upper atmosphere.

The project was initiated in 1944 at the

## "Royal Designers for Industry"

Royal Academy Exhibition of Industrial Design

THE first exhibition of the work of Royal Designers for Industry (R.D.I.s), will be held at Burlington House, Piccadilly, London (by permission of the President of the Royal Academy), in October.

The exhibition is being organised jointly by the Royal Society of Arts and the Council of Industrial Design. It will show, by practical demonstration and example, the commercial importance of good design and the vital contribution to industry which designers are making. The exhibition will appeal as much to the customer as the manufacturer, for the public will see for the first time the stages in the creation of a new product from the first sketches, through models and prototypes, to the finished article as it comes off the production line.

The distinction "Royal Designer for Industry" (R.D.I.), which may at no time be held by more than 40 designers, is recognised as the highest award to be obtained in the field of industrial design. The distinction was instituted by the Royal Society of Arts in 1936, and the Faculty (Designers for Industry of the Royal Society of Arts), was formed in 1938; its present Master is Gordon

Russell, C.B.E., M.C., R.D.I., F.S.I.A., Director of the Council of Industrial Design.

#### Scope of work

The final selection of the work to be exhibited has been made, and an idea of the scope of the exhibition can be gathered from the work of R.D.I.s which includes the famous jet aircraft De Havilland 108, designed by Sir Geoffrey De Havilland, C.B.E., the Alanbrooke Sword of Honour, by Robert Y. Gooden, the interior fittings and furniture of the s.s. *Orcades*, the Coronation Scot and the Vickers Viking airliner, by Brian O'Rourke, equipment for London Transport, by Charles Holden, and Perpetua type designed by the famous typographer, the late Eric Gill. Their work ranges from mobile cranes to powder boxes; it includes stage and exhibition decor, school furniture, posters and packaging, and the great variety of furnishings and equipment used in the home.

It is hoped that this 1948 exhibition of the work of the R.D.I.s will stimulate production of British goods of outstanding design in time for showing to the world during the 1951 Festival of Britain.

# Another Mechanical Paradox

Particulars of a Novel Mechanical Unit

By H. J. ANDREW

SOME time ago, it was necessary to make an attachment which would convert a uni-directional rotary motion into one that was mainly clockwise and, during the remainder of the revolution, anti-clockwise. The sequence was to be repeated indefinitely so long as the power was available. The objective to be achieved without the use of

believe it until they had personally examined the device.

The accompanying sketches give some idea of the kind of device finally made, but are not strictly to scale.

Fig. 1 is a sectional elevation and Fig. 2 is a sectional plan at XX.

Fig. 3 is a diagram of the motion obtained at the terminal shaft.

The primary shaft

"a" is firmly fixed to the disc "b," which is the upper portion of a kind of cage, the lower portion being marked "b1."

Item "c" is a case which protects the gearing and item "d" is the cover of the same.

Both the case and its

machine on which the device is being used.

Item "e" is a sun spur gearwheel mounted loosely on the primary shaft and firmly fixed to the cover by a feather or key "o." A planet spur gearwheel "f" is keyed to the secondary shaft "g" and meshes with the sun gearwheel.

## Secondary and Terminal Shafts

Item "h" is another secondary shaft, and item "j" is the terminal shaft running free in bearings formed in both the cage and the case. An elliptical gearwheel "k" is keyed to the secondary shaft "g" and meshes with a similar elliptical gearwheel "l," which is keyed to the secondary shaft "h."

Item "m" is an ordinary spur gearwheel, also keyed to secondary shaft "h" which meshes with another spur gearwheel "n," and this is keyed to the terminal shaft "j."

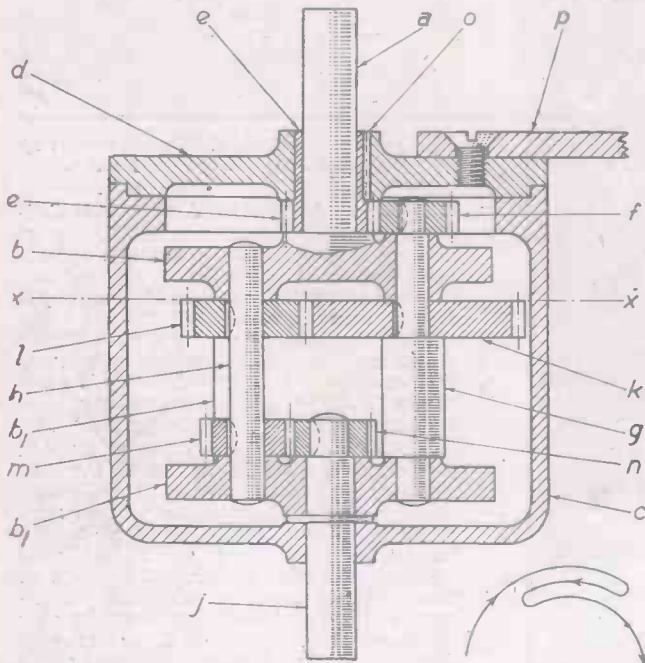

Fig. 1.—Sectional elevation of the unit described in the text. (Inset) Fig. 3.—Diagram of the motion obtained at the terminal shaft.

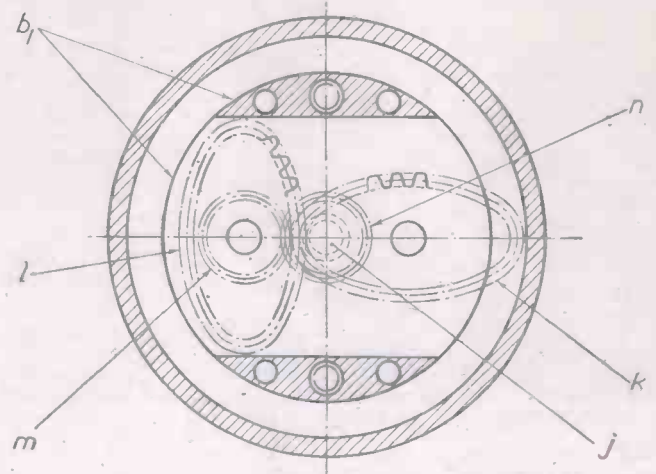
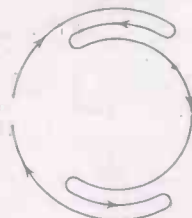

Fig. 2.—Sectional plan on line XX.

cams, clutches, or springs, and to be entirely automatic.

It is well known that a positive force can be neutralised, modified or overcome by a negative force, this depending on the ratio between the two forces. Adopting this theory, the basis of the design was for the primary shaft to be running clockwise at, say, 100 r.p.m., and upon this to superimpose another motion running anti-clockwise at a variable speed with a maximum of, say, 150 r.p.m. and a minimum of, say, 50 r.p.m., thus, when the anti-clockwise motion was running at 150 r.p.m., the resultant of the two motions would be anti-clockwise at 50 r.p.m. When both motions were running at the same speed of 100 r.p.m., they would cancel out each other, and the resultant motion would be nil.

On the other hand, when the anti-clockwise motion was running at 50 r.p.m., the resultant motion would be clockwise at 50 r.p.m.

## Elliptical Gears

The mechanism finally evolved consisted mainly of six spur gearwheels, two of which were of elliptical form, the remainder being ordinary concentric gearwheels.

All the various gearwheels were to be constantly in mesh with one another and thus no part of the mechanism changed its direction of motion except the terminal shaft.

This is apparently a 'mechanical paradox, and many clever draughtsmen could not

cover are prevented from rotating by an arm "p" fixed to the cover, the said arm engaging with some fixed portion of the

The teeth of the elliptical gearwheels were equivalent to 22 D.P. and, of course, are cut by hand.

## The "Bristol" Centaurus 663 Engine

THE Centaurus 663, latest addition to the range of "Bristol" Centaurus engines, has been specially designed to suit the newest types of civil aeroplanes.

Employing an engine compression ratio of 8:1, and operating on 115/145 grade fuel, it enhances still further Bristol's reputation for fuel economy, the specific consumption over the major portion of the cruising range in "M" gear being below 0.40lb./b.h.p./hr. In spite of its high compression ratio, its sea-level take-off power is 2,810 b.h.p. rising to 2,985 b.h.p. at 8,500ft. The ability to deliver its maximum power at 8,500ft. makes it particularly suitable for high-altitude aerodromes in the tropics.

The engine is fitted with a two-speed blower and drive for cabin blower in order to cater for the high-altitude flying demanded by modern pressurised aircraft.

The maximum continuous power output is: 2,405 b.h.p. at 7,750ft., "M" gear. 2,280 b.h.p. at 16,000ft., "S" gear.

The maximum continuous power in lean mixture is:

1,830 b.h.p. at 15,500ft., "M" gear.

1,745 b.h.p. at 23,250ft., "S" gear.

With a weight of 3,170lb., including the "Bristol" torque-meter, the engine has an attractive specification and has already been scheduled for fitment to the new medium-range aeroplane for Empire Air Routes. It is a development of the Centaurus 630 already built for the Airspeed "Ambassador" aeroplane.

A NEW VEST POCKET BOOK  
NEWNES METRIC &  
DECIMAL TABLES

By F. J. CANN

3/6 or 3/9 by post from

Geo. Newnes, Ltd., Tower House,  
Southampton St., Strand, W.C.2.



# THE WORLD OF MODELS



Fig. 1.—Mr. Ellis stops to admire his 2½in. gauge model of the Caledonian Railway locomotive "Dunalastair No. 3," on show at the Plymouth Society's Exhibition.

IT is not often we hear a great deal of the activities of model enthusiasts in the West of England, so I am glad to be able to record news of the second annual Exhibition of the Plymouth and District Society of Model and Experimental Engineers, held last May. This Exhibition was an outstanding West Country model event and was staged in the Barton Motor Showrooms, Mutley Plain, Plymouth, with an auspicious opening by Lord Roborough, and presided over by the Lord Mayor of Plymouth (Ald. H. J. Perry). Commenting on the world-wide fame of English engineering, Lord Roborough said that model engineering societies could help to maintain this hard-earned tradition.

This active Society has a good membership of seventy strong supporters, including some juvenile members (the youngest exhibitor, Master Patrick Le Pla, is eleven years old), and they can also boast one woman member, Miss Judith E. Hughes, of Tavistock. All profits from this second annual Exhibition were to go towards providing new headquarters for the club, and plans for the proposed new building were displayed at the Exhibition.

A wide variety of models was to be seen :

Ships, locomotives, railway layouts, racing cars, stationary engines, and an aircraft section organised by the Plymouth Model Flying Club.

The President of the Society, Mr. S. Gordon Monk, contributed an excellent novelty model. This was a miniature, working reproduction of Tower Bridge; I cannot remember ever having seen a model of this outstanding London landmark in any previous exhibition. Congratulations to Mr. Monk on both workmanship and an unusual choice of subject.

Turning from the Society's "first gentleman" to one of its youngest supporters.

Plymouth Model Exhibition : British Railways Model Display : Architectural Models

By "MOTILUS"

Master Patrick Le Pla won the prize in the "under 12 years" section for his splendid model of the battle cruiser *Hood*. Master Le Pla evidently has a love for ships, as he

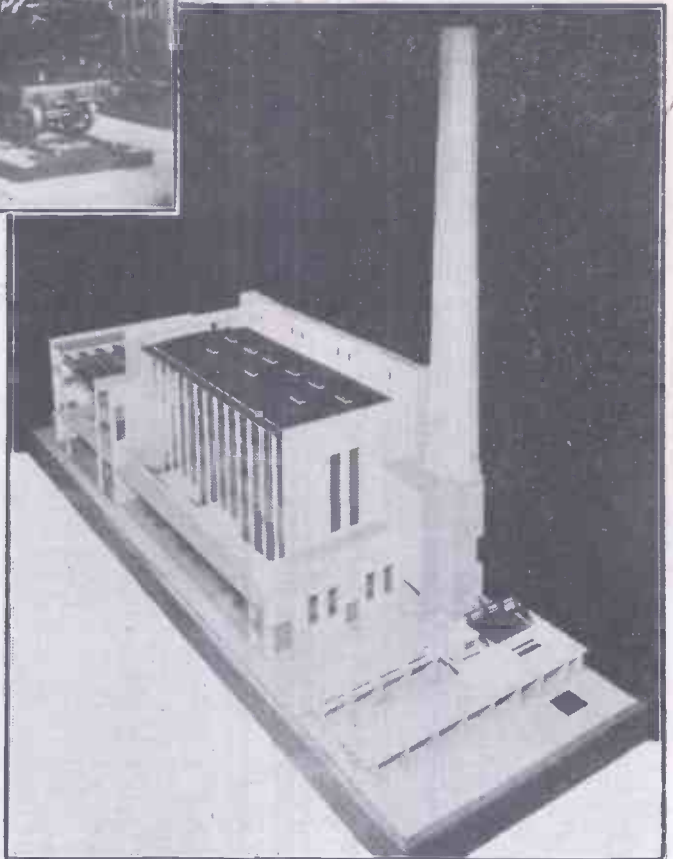

Fig. 3.—Exterior view of the sectional model of Staythorpe generating station, showing one complete unit. The coal-handling plant and tipping gear can be seen in the foreground.



Fig. 2.—Mr. C. Scapplehorn's bronze medal winner : a model Great Western Scammell and dray. Photograph by courtesy of Western Region Staff Association (London Division) of British Railways.

had two other ship models exhibited: an aircraft carrier and a modern liner.

Miss Judith Hughes, previously mentioned, is well known among art and craft societies, and has an established reputation for fine woodwork and, also for model-making. Her contribution to this Exhibition was two cases of waterline models of warships of many nations and a number of well-known liners.

In the locomotive section, one of the centres of attraction was Mr. S. Wollington's partly finished 2½in. gauge model "Pacific"-type locomotive. This is based on L.B.S.C.'s "Fayette," the design for which was published some twenty years ago. Work on the model was started before the war, but that does not mean Mr. Wollington has spent all this time on it; he was obliged to discontinue his model work during the war years. Most of the fittings were cut from the solid, and the only castings used were for the cylinders and wheels, work being carried out on a 3½in. treadle lathe. Mr. Wollington has continued work on the boiler and tender since the Exhibition. Judging from the excellent workmanship already shown in

this model, it should be a successful locomotive when completed.

### Model Dunalastair No. 3 Loco

A 3in. scale model of the Caledonian Railway locomotive, "Dunalastair No. 3," built to the design of Mr. E. L. Pearce, was exhibited by Society member Mr. Ellis. The model originally belonged to a member of the famous Kodak Society of Model and Experimental Engineers, and was purchased by Mr. Ellis last January, when, as he comments, "Change of ownership" seemed to be in the fashion." At that time the locomotive had not been in use for many years and required a complete overhaul, which was accomplished by her new owner, assisted by a fellow Society member, Mr. Middleton, the work being finished after many hours of concentrated "hard labour," just in time for the Exhibition. The model has a coal-fired boiler, a hand-pump in the tender and injector under the footplate; it also has Stevenson link motion. Mr. Ellis has not yet had the locomotive under steam, although the boiler has been tested to 140lb. water pressure.

The Exhibition included the popular feature so well known to visitors to London model exhibitions, the passenger-carrying model railway, which is always well patronised by enthusiasts of all ages. There was also on view the Society's "oo" gauge layout, built by two young members.

The crowds that visited this Exhibition were the testimony of its success during the whole two weeks it was open. Let us hope that it will not be long before the Society are able to announce that their coveted new headquarters are ready, which will be a well-deserved reward for the enthusiasm and hard work which results in members attaining such high standards in their model craftsmanship.

### British Railways Model Exhibition

I was glad to be able to attend, for a short while, what I believe was the first model exhibition held under the auspices of British Railways, and organised by the Western Region Staff Association (London Division). This was held at 159, Westbourne Terrace, near Paddington, and was called an Exhibition of Arts and Crafts, although naturally the most interesting exhibits to me were those devoted to model work.

Silver and bronze medals were awarded for work of merit, and I would like to men-

tion some of the models that won prizes. A clean, smart model, showing good detail and careful work was that of the sailing ship, "Caliph," of c.1860. This model won a silver medal for Mr. R. E. Wicks, of Paddington. Mr. Wicks also displayed a well-finished and colourful model of the "Golden Hind." Another ship model, which won a bronze medal, was a miniature Barbary felucca, mounted on an imitation sea, in a glass case. An unusual exhibit was a gold-plated model aeroplane, which was awarded a silver medal.

Another silver medal winner which attracted much attention was Mr. T. E. Clowes' model showman's fairground tractor, complete with dynamo over the smokebox, and a bronze medal was given to Mr. C. Scaplehorn for his model of a Great Western Scammel and dray, for motor haulage; this latter model is shown in the illustration,

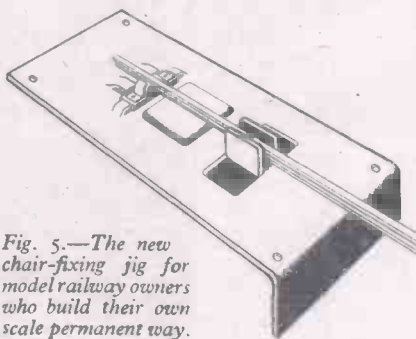

Fig. 5.—The new chair-fixing jig for model railway owners who build their own scale permanent way.

Fig. 2. Mr. H. Thompson, of Theale, near Reading, used nine thousand matches to construct his unique exhibit of a model of St. Mary's Church at Purley.

These models were only part of one section of the Exhibition, which included, among the many displays worth attention, much excellent craftwork, art and photography.

### Architectural Models

If unexpectedly asked to define the phrase "architectural model," most people would generally think first of a small-scale model town or city, a miniature of a proposed building, or possibly a model house showing either exterior or interior aspects. Of recent years, however, this branch of modelmaking in the commercial world has developed along ever-broadening lines into a combin-

ation of architectural and engineering models, usually incorporating exterior architectural design and interior engineering machinery and plant.

This month, I am able to show two photographs of a very good example of a model of this character: a sectional model of a unit of a British Electricity Authority generating station at Staythorpe. The model was built by Messrs. Bassett-Lowke, Ltd., of Northampton, to a scale  $\frac{3}{16}$ in. to 1ft. (or 64th actual size), to the order of the British Thomson-Houston Co., Ltd., Rugby. On the exterior of the model is shown the coal-handling plant and tipping gear, a sectional representation of the chimney, and the offices and entrance hall.

Internally, all the plant and equipment is shown in full detail. The coal elevator, the Babcock and Wilcox boilers with automatic coal feed, the high-powered B.T.H. turbo-alternators of 60,000 Kw capacity, and the condensers by Worthington Simpson, Ltd. Included in the turbo-alternator house are all the various auxiliaries that complete the unit, and also the overhead crane, with two separate lifts for light and heavy loads.

Encased in Perspex and internally lighted, the model was originally shown at the Birmingham Engineering Section of the British Industries Fair held in May this year.

### Chair-fixing jig

The threading of slide-on chairs on bull-head section rail for scale model permanent way has always been something of a problem for model railway fans. The chairs must be a tight fit, and the ends of the rail must always be slightly tapered and all burrs removed. This done, the usual practice is to push on the chairs by hand, and any model railway builder will vouch for the patience necessary on this tedious work.

I was in the London shop of Messrs. Bassett-Lowke, Ltd., recently and noticed that a member of their Northampton staff, Mr. W. H. Rowe, has devised a very simple yet effective tool for this operation. As can be seen from the illustration, Fig. 5, this chair-fixing jig consists of an oxidised brass bed-plate which can be fastened on the edge of a bench or table. The chair is placed in a recess and the rail steered through the guides into the correct position to engage the chair. The rail and chair are then moved into a second position, a further chair placed in the recess and the procedure repeated. This placing also spaces the chairs on the rail correctly to scale.

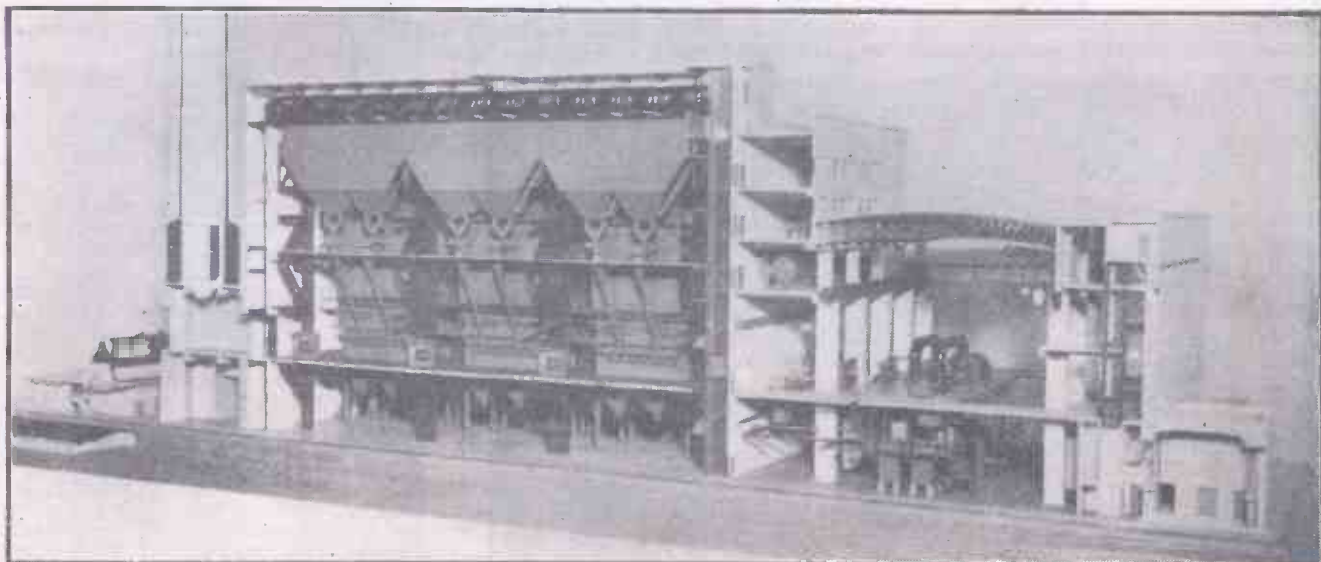

Fig. 4.—Interior view of the sectional model of Staythorpe generating station, showing all plant and machinery contained in one station unit. From left to right can be seen the coal-handling plant, the chimney, coal elevator, three boilers with automatic coal feed, the turbo-alternator house, showing all details of auxiliaries that complete the unit, and the overhead crane. The entrance hall and offices are on the extreme right.

# Twenty Years from Now

## Shall We Have Atomic Energy?

By Prof. A. M. LOW

(Continued from page 335, July issue.)

UP to the moment the only tangible result of the great scientific achievement of atomic fission has been entirely destructive. "Splitting the atom" has resulted in the deaths of thousands, in scaring hundreds of millions and in making the nations of the world suspicious of each other—not very creditable results for one of the great scientific triumphs of all time. But I think that when we look back in 20 years' time we may see the use of the atom bomb just as an incident in the history of atomic energy. Without being cynical, we may take the view that the explosion at Hiroshima was like an explosion in a high explosive works or a child cutting itself when learning to use a knife.

For in 20 years' time I believe that atomic energy will be "harnessed" and supplying us with millions of horse-power of energy a year. I do not rule out the possibility of it being used as a military explosive, but fully developed atomic energy could bring about an industrial revolution hardly less important than the harnessing of steam power.

### Research Work

Britain is spending £30,000,000 simply on preliminary steps in research on atomic fission for "peaceful" purposes, and other nations are also spending vast sums. In 20 years we shall have the fruit of this research. In the House of Commons, Ministers have been at some pains to damp down the idea that atomic power could lead to the Utopia of a four-hour working day, but the reasons for this are probably psychological. Of course there are immense technical difficulties—that is why we are spending £30 millions. But if the result of overcoming these difficulties is not to be a supply of abundant cheap power, why trouble to tackle them?

The principle by which it is assumed that atomic energy will be harnessed is that atomic piles will be made to run so that they heat water, which in turn will drive gas or steam turbines. Research may show that there are more direct methods by which the energy can be harnessed, just as it is likely to reveal methods of utilising the atomic energy of elements less expensive than uranium, which has hitherto been used.

In the light of our present knowledge the disadvantages of atomic power are: the very high cost of the plant and "fuel"; the fact that an atomic pile must be large and, thirdly, the poisonous gases and by-products of atomic fission which have to be disposed of. The last two disadvantages are taken to mean that it will never be possible to utilise atomic power for transport—the energy generator would be too large except, perhaps, for a ship, and the impossibility of disposing of the dangerous by-products would make it impossible to use atomic power in street vehicles or even trains.

### Controlled Atomic Power

But it would be wrong to assume that this disadvantage will always exist. Just as we may find cheaper atomic "fuel," so we may find methods of utilising atomic energy indirectly, turning it into a synthetic fuel that could be used by comparatively small power units and with no danger from by-products. You will not, in 20 years, stop at a garage and fill up your car with uranium—radioactive materials are too dangerous to use

in densely populated places even when they are in "foolproof" containers. But you may fill up with a fuel whose potential energy has been derived from an atomic power generator.

The first practical use of controlled atomic power is, paradoxical as this may sound, likely to be in countries which are not greatly industrialised. With our present methods atomic power is rather more expensive than power derived from coal. Research will undoubtedly bring down the cost so that atomic power becomes much cheaper than power from coal. But the fundamental fact remains that in this generation of electricity and the manufacture of goods, the cost of power is only one item. Fuel accounts only for about 40 per cent. of the cost of our electricity—as against 60 per cent. for distribution and administration: In many manufactures the expenditure on fuel represents only about 10 per cent. of the total cost.

It will be seen, therefore, that even if we could get atomic power for nothing, it would not make such an enormous difference. The importance of atomic energy, in my view, lies in the fact that we can look forward to obtaining it in quantities inconceivable for coal or oil-derived power, and that the fuel is comparatively light and easily transported. This means that we shall undertake gigantic engineering feats that would be impossible with our present sources of power, and that we shall be able to obtain power cheaply in places remote from present industrial centres. For instance, with atomic power it is possible to consider great irrigation pumping plants in the heart of deserts, where the cost of transporting fuel would at the moment make the use of power pumps quite uneconomic. In the arid regions of Australia and Africa there is water if the boring is deep. Atomic power offers the possibility of getting it.

### Gigantic Engineering Feats

We shall be able to contemplate gigantic engineering feats which may change the climate and even the weather. Twenty years ago the idea of removing—or making—mountains in order to change the rainfall seemed ridiculous. Using the power of atomic fission it becomes a practical possibility. We can contemplate melting polar ice or warming the soil over hundreds of square miles. The Americans have already talked, even if only half seriously, of diverting the Gulf Stream so that it gave them more warmth. That may become a real possibility. It is in such ways, perhaps, rather

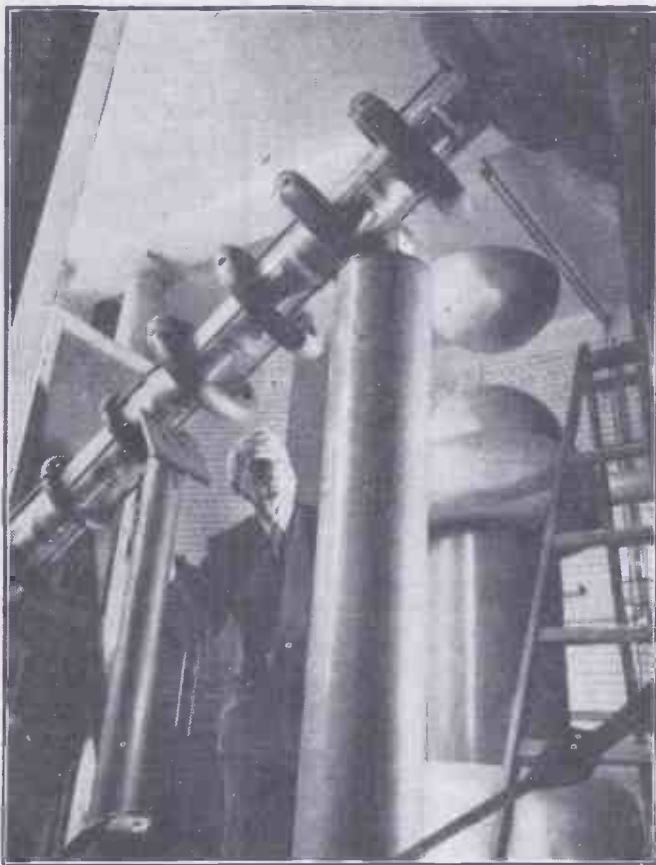

Professor Sir George Thomson, F.R.S., looks at the accelerating tube of a Van de Graaff generator in the Imperial College of Science laboratory. This type of machine produces deep-penetrating X-rays which are of great help in experiments for the treatment of cancer.

than in replacing coal and oil as fuels, that atomic power will be used.

Atomic power may prove to be the key to inter-planetary flight of which I have written in my first article. A few tons of atomic "fuel" will provide more energy than thousands of tons of oil. We may even discover methods of renewing the fuel by making use of the atomic fragments—cosmic rays—which we know are abundant in space.

The difficulties of the dangerous radiation will, I believe, be overcome more quickly than anticipated, and the present tremendous concrete walls may seem as clumsy as mediaeval armour in twenty years. It is worth noting that in the short history of atomic energy the experts have constantly had to revise their ideas of the future. After Hiroshima they were at pains to say we could expect no peaceful developments for twenty years. Then they began to talk about ten years. Now they admit that the first "pilot" commercial atomic piles are ready to begin work and that we can expect practical results in five years.

Plentiful and cheap power is not the only benefit from atomic energy we shall be getting in twenty years. Medicine will benefit very greatly as atomic fission makes it possible to obtain great quantities of radioactive substances for tracers and medical purposes, so that we can think of "radium treatment" in a new way. In less than twenty years' time the cost and shortage of radium which handicapped surgeons will have disappeared.

### Radioactive Elements

In addition, atomic fission enables us to create radioactive elements and compounds, like

"heavy water," in which the ordinary hydrogen of plain water is replaced by a special form. A whole new field opens up for chemistry. The number of possible substances is immensely multiplied. We have not yet had time even to contemplate what some of these new "materials" may be like, or what magic we can perform with them. But already a number are being used for medical research and treatment, offering new possibilities of cures in hitherto incurable diseases. These radioactive elements could, in many cases, be made before atomic fissure, but only in minute quantities at immense expense. Now they are mere by-products of atomic piles and should become plentiful.

In twenty years the results of research based on these new substances should be apparent. They may be very far-reaching. Consider one piece of research alone that may be made

possible with the aid of atomic pile by-products. Scientists have never been able to unravel the process by which plants, with the aid of sunshine, turn water, carbon-dioxide and mineral substances into living tissue. Before twenty years are passed, with "activated" materials the mystery may be solved. In twenty years we may be setting up food factories in which starches and sugars are really synthesised on the same principles as plants work. The effect would be revolutionary. It would mean the end of the danger of famine anywhere in the world. And this is only one of the possibilities that emerge from research based on atomic fissure.

Atomic energy will bring new responsibilities which are not limited to its use as an explosive. If we obtain energy to change climate and weather, we shall be forced to work in co-operation with other nations to

avoid disaster. Warming the polar regions, for instance, might have far-reaching effects on the weather in the rest of the world.

Many people say it would have been better if the scientist had failed in his effort to "split the atom," and that the world would have been a happier place. Myself, I like to think that this great achievement is the beginning of an adventure, perhaps the greatest adventure on which the human race has ever embarked. For the first time man can contemplate changing his environment, really being master of his own condition. Whether the adventure ends in disaster or in triumph may well be decided in the next twenty years. Disaster will come through failure to realise our responsibilities. But triumph cannot come simply by negative action. Research for the exploitation of the atom is as necessary as avoiding its use for destructive purposes.

## Letters from Readers

### Exhaust Gas Analyser

SIR,—In the July issue of PRACTICAL MECHANICS you published a letter describing an exhaust gas analyser as used on certain American aircraft during the war. Here are a few more details of such an instrument which may be of further interest to readers.

As stated in the letter referred to, the composition of the exhaust gases depends on the original mixture strength. Rich mixtures form more carbon monoxide, whereas weak mixtures mean that more carbon dioxide and excess oxygen are found in the exhaust. Water vapour is present in any case.

As the composition of the exhaust gas varies so does its thermal qualities, i.e., specific heat and thermal conductivity. If these thermal qualities can be measured, then the composition of the exhaust gas, and so the original mixture strength, can also be estimated.

The apparatus consists of a Wheatstone Bridge. The bridge has two standard arms "a" and "b" and two others "c" and "d" (Fig. 1). These latter are enclosed in two chambers separated from each other by a thin metallic wall (Fig. 2). Resistance "c" is surrounded by a standard gas (atmospheric air saturated with water vapour by means of wick) and resistance "d" is surrounded by the exhaust gas to be analysed.

Current passing through the bridge heats both wires "c" and "d" to a temperature higher than that of their surrounding gases. The arm "c" is cooled (by conduction and convection) through the standard gas and settles down at a steady temperature and resistance; "d" is cooled by the exhaust gas and settles down at a temperature dependent upon the heat-removing properties of the exhaust gas which, once again, varies with the mixture strength. The difference in temperature between "c" and "d" upsets the balance of the Wheatstone Bridge giving a reading of the galvanometer. This reading varies according to the mixture strength in use. The galvanometer is calibrated to read mixture strength direct.

For greater sensitivity all four arms of the bridge could be placed in the two gas chambers, "b" and "c" in the standard chamber and "a" and "d" in the exhaust chamber.

The temperature of the exhaust gas plays no part in the operation since the hot exhaust also heats up the standard air chamber via the thin metal wall which has a high conductivity. After a short period of running, both chambers have the same temperature so that both resistances "c" and "d" are affected to

the same extent. In any case, the wires are warmer than the surrounding gases and are "cooled" by the same.

The resistances are usually of platinum or stainless iron.

The stainless steel wool in the exhaust

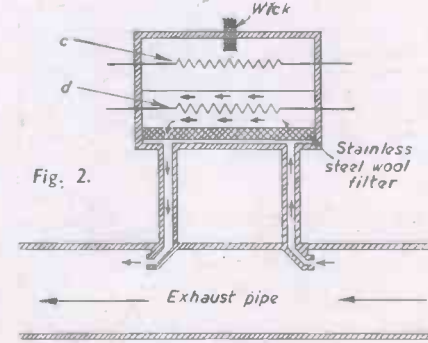
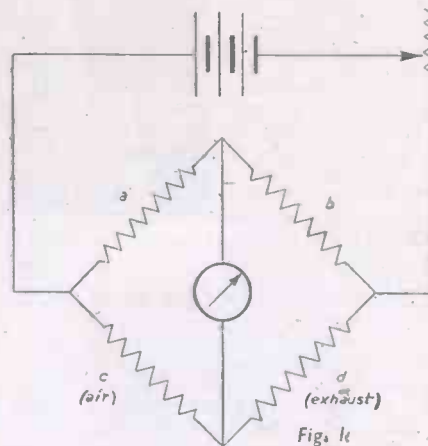

Fig. 2. Circuit diagram and sectional view of an exhaust gas analyser.

chamber needs to be washed occasionally in petrol and then thoroughly dried out before replacing. Soap should not be used since it tends to leave a "scum" behind. This scum is fatty and under working conditions it may, for quite a long time, give off a vapour which affects the accuracy of the instrument.

As your previous correspondent remarked: although not extremely accurate, the analyser provides a very useful check on the mixture strength in use.—H. S. PERRY (Beeston).

### Detecting Refrigerant Leakages

SIR,—Referring to an enquiry in the July issue of PRACTICAL MECHANICS regarding leak detection of methyl chloride refrigerant, it may be interesting to this reader to mention that our official organ "Modern Refrigeration" (June issue) contains an article which explains a red colour tracer for leak detection.

Another test is the moistening of absorbent wool with a test solution containing 3 grains of alpha-naphthylamine and sulphanic acid. If this moist wool is placed for a few minutes near the suspected leak, a red spot will appear on the wool. (Moyer & Fitty).—JAMES PARTINGTON, A.M.Inst.R. (Bolton).

### Cellulose Lacquers

SIR,—We were very pleased to see your reference to our name as a source of supply for cellulose lacquers and for paint materials generally under "Queries and Enquiries."

During the recent war our old premises at Cornwall Road, S.E.1, were completely destroyed by enemy action and, as a result, the activities of the company have been transferred entirely to its subsidiary factory, which has now been greatly enlarged, and the address of which is Woodbridge Works, Kingston Road, Leatherhead. We feel sure you would wish to know that as one of the oldest established manufacturers of paints and varnishes and allied products in the country, we are continuing our activities at this address.—NOBLES & HOARE, LTD. (Leatherhead).

### Re-cellulosing a Car

SIR,—With reference to the reply given to reader J. Jacklin (Grimsby) in the July issue of PRACTICAL MECHANICS on how to re-cellulose his car.

As a coach-painter, I cannot agree with the method suggested.

I should like to outline a procedure to be followed by an amateur on a repaint. This may be of some value to other readers.

(1) In the first place I do not advise any beginner to strip a car completely. This is very difficult and very often disastrous because the rough spots on a car body are usually camouflaged with very thick layers of putty, and the surface will have to be built up again if this putty is stripped off.

A simple test can be made to find out if the original paint will carry new cellulose. Take a small piece of thin cloth, roughly 2in. square, and soak in cellulose thinners. Lay on a horizontal surface and allow to dry (10 minutes). If the cloth can be lifted off without pulling any paint, the cellulose can be applied safely.

I have found that only one car in fifty need be stripped completely.

The first operation is to remove all traces

of rust with a scraper and coarse emery paper used dry, making sure that the broken paint edges are chamfered down to the metal.

(2) Rub down the entire surface of the car with medium and fine emery paper, using plenty of water (a special waterproof emery paper is obtainable for this) and just the slightest trace of soap.

(3) Dry off completely, using a perfectly clean chamois leather, then mask all chrome parts with adhesive-tape.

(4) Spray on one thin coat of cellulose primer all over (without this the lacquer cannot adhere to bare metal). Allow at least 24 hours for this to harden. If the initial rubbing down was done well, the surface should now be quite smooth and have a flat dull finish. If not, the rough spots can be

rubbed down again and re-primed. Remember that cellulose does not "flow" like oil paint and will not hide the slightest flaw.

(5) Spray on two coats of paint, allowing two hours between coats. Allow to harden for at least eight hours, then rub down all over with fine waterproof emery paper (No. 400 grit), using plenty of water and a light touch of soap, until the whole surface is smooth and dull. Dry off completely.

(6) Spray on the final coat; the paint should be slightly thinner for this. Allow to harden for at least 12 hours.

(7) The whole of the surface should be rubbed down with cellulose buffing compound, applied with a soft cloth, until it is glass smooth. Finishing off with a good brand of car polish.

The cellulose lacquer, primer, thinners, rubbing compound, "wet and dry" emery paper can be obtained through motor trade supply channels.

The following hints may be useful to the amateur:

The work cannot be rushed, and ample drying time must be allowed.

Cleanliness is essential, and care must be taken to remove all traces of water.

Cheap paint is a waste of time and money.

Of all colours, black is the most difficult to apply. Grey, light blue and green are the easiest.

It is not necessary to mask window glass; a new razor-blade will remove paint without scratching the glass.—F. DAWBER (Liverpool).

## Trade Notes

### "Araldite"

"ARALDITE," a new synthetic resin adhesive for bonding metals, glass, porcelain, china and other materials is now available for many industrial purposes.

Two advantages of this process of bonding are of special interest. First, "Araldite" sets under the application of heat alone, without addition of hardener. Secondly, no water or other volatile substance is evolved during the setting process and non-porous materials can therefore be successfully bonded. It is claimed that this adhesive possesses exceptional endurance under severe conditions and that it is often stronger than the materials which it bonds.

"Araldite" was developed originally by Messrs. Ciba Limited, Basle, and is marketed in Great Britain by Aero Research Limited, Duxford, Cambridge.

### Leytonstone Jig & Tool Co., Ltd.

WE are informed that the above firm now has an office in Canada, the address of which is:—31, Willcocks Street, Toronto, 5, Ontario, Canada.

The Resident Director is Air Vice-Marshal D. F. Stevenson, C.B., C.B.E., D.S.O., M.C.

All "Leytool" productions can now be obtained at this address.

### Burroughs Wellcome & Co. Photographic Products.

BURROUGHS WELLCOME & CO. announce that from 1st September, 1948, Johnson & Sons, of Hendon, will act as sole distributors of all "Tabloid" Photographic Products.

The manufacture of these products will remain in the hands of Burroughs Wellcome & Co., and formulae will be unaltered.

Burroughs Wellcome & Co. have also arranged that Johnson & Sons shall take over the sole publication and selling rights of the well-known "Wellcome" Photographic Year Book, commencing with the 1949 edition. Under this new arrangement, the publication will be known as the "Johnson Wellcome" Photographic Year Book."

From 1st September, all orders and enquiries in regard to "Tabloid" Photographic Products and the Photographic Year Book should be addressed to Johnson & Sons, Hendon Way, London, N.W.4.

### "Melco" Wheel-nut Wrenches

THOS. MELDRUM, LTD., of Freedom Works, John Street, Sheffield, have been manufacturing tools and accessories for the motor trade industry since 1920, and have recently commenced production of six-arm and four-arm wheel-nut wrenches. These are being manufactured under their trade name "Melco," and are being distributed in the home market through wholesalers. They are being primarily made for the export trade, but a small percentage will be available for the home market.

The "Melco" wheel-nut wrenches are

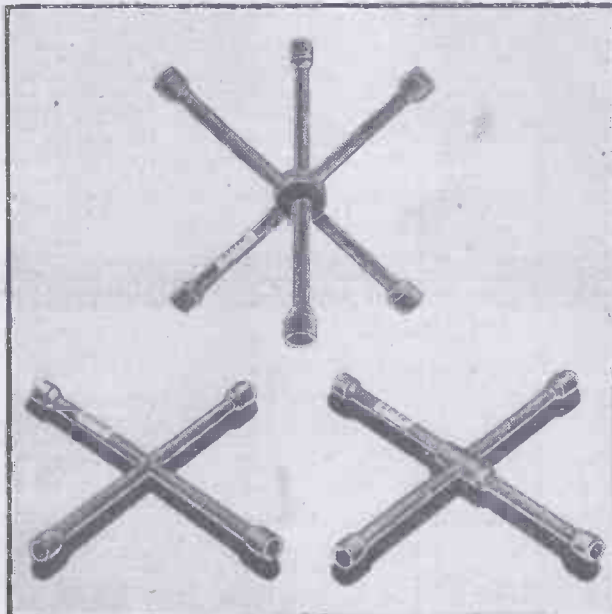

"Melco" Six- and Four-arm Wheel-nut Wrenches.

sturdily constructed of high carbon steel, with arms sweated into centre body, countersunk, and electric arc welded. The sockets are drop-forged, and there are no rivets or nuts to work loose. The attractive new wrinkle finish, similar to that used on typewriter bodies, is both friendly to the touch and gives a good grip, no matter how greasy the hand of the user. Both the six- and four-arm wheel-nut types are supplied in car and lorry models.

## Book Received

Cycling Touring Guide No. 2 (Wales). By Harold Briercliffe. Published by English Universities Press, Ltd. 108 pages. Price 2s. 6d. net.

THIS book provides a useful guide to Wales from the cyclists' point of view. It is divided into three parts, the first dealing with Approaches, An Eight-day Tour in North Wales, A Six-day Tour, and Mountain Climbs. In the second part two Nine-day Tours, and Mountain Climbs in Central and South Wales are described. Part three deals with the Shropshire Highlands and South Wales. The book is illustrated with photographs and a number of line drawings by the well-known artist Frank Patterson.

### PRACTICAL POTTERY REPAIRING

(Continued from page 19.)

3 parts; fine silica powder, 1 part; and (optionally) asbestos powder, 1 part, are slaked with the hydrolysed ethyl silicate solution as above prepared, the resulting white mass will set hard within about 24 hours. The incorporation within the mass of 1 per cent. of calcined magnesia will considerably decrease the setting time of the mixture.

For pottery-repairing purposes, particularly in the case of high-grade work, this modern ethyl silicate method has many possibilities.

Incidentally, of course, any of these moulding mixtures can be used for filling-in small intervening gaps which may exist when pottery pieces are riveted and/or cemented together.

Finally, a rough but quite serviceable method of prolonging the life of an almost broken dish, plate, bowl or saucer may be described. It is assumed that the article is so badly cracked that it is "almost in two."

Using any waterproof cement, glue down a piece of strong fabric (clean, thin sacking will do) over the cracked area. Let the cement set. Then apply several layers of paint over the glued-down fabric. Such a "join" will often hold wonderfully well. It will have adequate tensile strength and will resist washing and, indeed, complete immersion for lengthy periods even in hot water.

## Our Cover Subject

THIS year's Model Engineer Exhibition, which was held recently at the New Horticultural Hall, Westminster, London, S.W.

Regarded as the finest exhibition of its kind in the world, this year it showed for the first time model craftsmanship from many parts of the world. Our cover picture this month shows a record-breaking jet model aircraft which was on view at the Exhibition. Powered by a "Juggernaut" miniature British jet engine, this model holds the record British speed of 144.8 m.p.h.

# QUERIES and ENQUIRIES

A stamped addressed envelope, three penny stamps, and the query coupon from the current issue, which appears on page 8 (THE CYCLIST), must be enclosed with every letter containing a query. Every query and drawing which is sent must bear the name and address of the reader. Send your queries to the Editor, PRACTICAL MECHANICS, Geo. Newnes, Ltd., Tower House, Southampton Street, Strand, London, W.C.2.

## Repairing Leaking Rubber Dinghy

**CAN** you advise me on the following matter? I have an R.A.F. rubber dinghy, which after being used about a month has begun to leak air. The holes are too numerous to patch in the normal way. Is there any solution with which I can paint it to rectify the fault? Would Bostik dissolved in petrol do?—M. Baron (Sidmouth).

IT is probable that your dinghy is made of synthetic rubber or that it contains a good proportion of that material, in which case there is no cure for the condition in which you find it, this being due to the slow ageing (and perishing) of the synthetic rubber.

If the dinghy is of natural rubber you could make a thick solution of pure rubber (powdered) in warm naphtha and paint this over the affected areas. After drying, the areas would have to be French chalked to prevent residual tackiness.

It is quite possible that a petrol solution of Bostik might remedy matters, but we cannot say with certainty.

If you cannot obtain raw rubber, thin down ordinary rubber solution with warm naphtha.

Do not waste time on synthetic rubber material. Once ageing has set in, it has finished. You might, however, be able to cement some old fabric over the surface and to put a layer or two of paint over this. In this way an additional life could be given to the dinghy.

## Cleaning Galvanised Iron

I HAVE a 5 gallon galvanised iron fish kettle which has become badly soiled inside with a deposit from food scraps for poultry which had been kept in it, and I wish to clean it thoroughly. The galvanising appears to be in perfect condition and I do not want to use an abrasive substance on it. Can you please tell me how best to remove the deposit?—D. Shoppee (Chichester).

A HOT, strong solution of ordinary washing soda should remove the deposit from the interior of your fish kettle, and this treatment may be recommended.

Alternatively, employ the following solution, using it hot:

Sodium metasilicate	5 parts
Teepol X (synthetic detergent)	1 part
Water	50 parts

The metasilicate is obtainable from Messrs. B. Laporte, Ltd., Luton, Beds., price about 3s. per lb. Teepol X is supplied, price about 13s. per gallon, by Shell Chemicals, Ltd., 112, Strand, W.C.2.

A 2 per cent. solution of caustic soda could also be used for the purpose, but care would have to be exercised here, since if the caustic soda solution were allowed to remain very long in contact with the metal it would attack the zinc coating.

## Plastic Moulding Material: Gelatine Capsules

**CAN** you give me a formula for making a pliable permanent mould? I find that gelatine melted in water is not permanent but contracts and deteriorates.

Are the small petrol containers for petrol lighters made of gelatine?

Could you give me the formula for making them?—A. Lester (Birmingham).

THE following plastic moulding material should be quite satisfactory in your case. It is a liquid when hot, plastic when warm and dead hard when cold. It can be used over and over again.

Paraffin wax	50 parts (by weight)
Carnauba wax	5 "
Resin	35 "
Sulphur	10 "

Melt all the ingredients together. Stir well and then pour out in trays to set.

The petrol lighter capsules are usually made of a toughened gelatine. Here is a suitable formula:—

Gelatine	16 parts (by weight)
Glycerine	15 "
Water	20 "

Add the glycerine to the water. Then dissolve the gelatine.

To make the capsules, provide yourself with a smooth iron or wooden rod having a pear-shaped end.

This is slightly greased with vaselin and is dipped in the above warm solution. The dipping process is repeated until a thick skin of gelatine is built up on the pear-shaped end. The capsule thus formed on the rod is dipped in a solution made by mixing 1 part of formalin solution with 3 parts of water. This hardens the gelatine and makes it insoluble in water. The capsule is then removed from the rod by cutting it around its neck and then by pulling it gently off the rod. It is then allowed to dry out thoroughly, and, after filling, its open upper end is sealed by a drop of the above gelatine solution.

In the commercial manufacture of gelatine capsules, the above process is carried out mechanically, but the procedure outlined above should be quite satisfactory in your case.

## Producing High Gloss on Photo Prints

I SHALL be gratified for information concerning the following subject:

What is the chemical formula and method of obtaining a gloss on home printed snaps?—S. Westwood (Ormesby).

A HIGH gloss is readily obtained on glossy bromide and gaslight papers (not on matt or semi-matt grades) in the following way:

Obtain a sheet of plate glass somewhat bigger than the sheet of paper to be glazed. Clean it thoroughly and polish it well, making quite sure that it is entirely grease-free.

The prints, after their final washing, must be dried. This is essential. The prints are then soaked for 10 minutes in a mixture of formalin (one part), water (seven parts). They are then laid face downwards on the glass, and squeezed thereon, care being taken to see that no air bubbles remain between the print and the glass. The prints are then allowed to dry overnight.

Readers are asked to note that we have discontinued our electrical query service. Replies that appear in these pages from time to time are old ones, and are published as being of general interest. Will readers requiring information on other subjects please be as brief as possible with their enquiries.

They can then be stripped off the glass and will have a highly glazed surface.

Some workers prefer to use ox-gall instead of formalin. If so, this can be made up about the same strength with water.

Various proprietary glazing solutions (mainly of ox-gall), can be obtained from your photographic stores. We believe that Messrs. Johnson and Co., Ltd., Hendon, London, N.W.4, make a very useful and reliable photographic glazing solution.

## Glue for Broken Pottery: White Paste

**CAN** you give me some information on the following:

(1) Can you inform me of a glue suitable for sticking together such things as, broken fountain-pen barrels, china, pottery, etc.? I have a quantity of the so-called "plastic glues."

(2) Can you give me a formula and the necessary quantities for making a good office paste?—T. W. Neill (Caversham).

(1) TRANSPARENT Perspex dissolved in trichloroethylene, chloroform or a mixture of equal parts of acetone and amyl acetate makes an excellent cold glue for the articles you mention. The solution of the Perspex is slow, taking several days to accomplish, but ultimately a thick, clear varnish-like liquid is obtained.

Alternatively you can use for the same purpose a solution of celluloid in a mixture of equal parts of acetone and amyl acetate. The solution used should be very thick.

(2) We presume that you refer to one of the white

pastes, not an actual gum. An excellent paste may be made by heating together white dextrine with just a little more than its own weight of water. Stir the dextrine into the water, breaking down any lumps with a clean spoon. Heat gently until a clear liquid is obtained. Then add a few drops of glycerine and one or two drops of carbolic acid or oil of cloves to prevent the paste from becoming mouldy. Pour the liquid into suitable containers and allow to cool and to set.

A paste similar to the above but darker in shade can be used by employing yellow dextrine, which is cheaper than the white dextrine.

You should be able to obtain one of the grades of dextrine ("British Gum") from your local chemical supply house, or Messrs. Vicons Ltd., Pinner Road, Harrow.

## Cement for Lead Strip Work

**COULD** you please give me a formula for making cement for sticking lead strip work on glass?—J. McHugh (Oldham).

EITHER of the following formulae will provide a good, enduring cement for lead strip work such as you describe:

(A)	Pitch	3 parts (by weight)
	Resin	10 "
	Beeswax	5 "
	Brick powder (fine)	3 "

(B)	Marine glue	12 parts (by weight)
	Slaked lime	25 "
	Turpentine (not subs.)	15 "
	Copal oak varnish	35 "
	Boiled linseed oil	15 "

Also, please note that a very simple adhesive consists of a mixture of medium-soft bitumen and resin, with, perhaps, a little boiled linseed oil added. The trouble, however, about this cement is that it tends to soften in hot weather and under such conditions is hardly to be relied on.

## Calcium Phosphate

**WOULD** you kindly inform me how to obtain calcium phosphate from bones, and the apparatus and chemicals needed (if any)?—C. J. Sanger (Templecombe).

IF the bones are carefully cleaned in the first place, the powder which remains after they have been heated to red heat for several hours will be nearly pure calcium phosphate,  $Ca_3(PO_4)_2$ . For practically all purposes, chemical and agricultural, the calcined bones may be used as pure calcium phosphate.

To make absolutely pure calcium phosphate you must add a solution of sodium phosphate to a solution of calcium chloride containing a little ammonia. Pure calcium phosphate will be precipitated.

## Evaporative Cooling for Food Safe

I WISH to construct a food safe out of metal and shall be glad if you could tell me of any way to keep it cold. I could, of course, use ice packed round the safe, but as this would melt it would be rather a nuisance, as well as difficult, to get regular supplies of ice.

Could you tell me if there is any other means of keeping it cold, say, some chemical which would not need replenishing very often?—H. Crabtree (Bradford).

THERE is absolutely no practical method of keeping a food container cold over long periods by chemical means alone. You could use a freezing mixture of certain chemicals, but this would be expensive, short-lived, messy and generally unsatisfactory.

Apart from the use of ice, or some method of mechanical refrigeration, your only alternative is the cheap and simple method of "evaporative cooling." This is based on the fact that when a liquid evaporates it utilises the heat energy of its surroundings to do so and, therefore, the surroundings become colder.

To apply this method, all you have to do is to take your food safe and to wrap it loosely all round with two or three layers of an absorbent material such as a thin

## THE P.M. LIST OF BLUEPRINTS

- "PRACTICAL MECHANICS" 12 FT. ALL-WOOD CANOE.\* New Series. No. 1. 3s. 6d.
- "PRACTICAL MECHANICS" 10-WATT MOTOR. New Series.\* No. 2. 3s. 6d.
- "PRACTICAL MECHANICS" COMPRESSED-AIR MODEL AERO ENGINE.\* New Series. No. 3. 5s.
- "PRACTICAL MECHANICS" AIR CONTAINER FOR COMPRESSED-AIR AERO ENGINE. New Series. No. 3a. 1s.
- "PRACTICAL MECHANICS" "SPORTS" PEDAL CAR.\* New Series. No. 4. 5s.
- F. J. CAMM'S FLASH STEAM PLANT. New Series. No. 5. 5s.
- "PRACTICAL MECHANICS" SYNCHRONOUS ELECTRIC CLOCK. New Series. No. 6. 5s.\*
- "PRACTICAL MECHANICS" ELECTRIC DOOR-CHIME. No. 7. 3s. 6d.\*
- "PRACTICAL MECHANICS" ASTRONOMICAL TELESCOPE. New series. No. 8. (2 sheets.) 7s.
- "PRACTICAL MECHANICS" £20 CAR SUPER-DURATION BIPLANE\* (Designed by F. J. CAMM), Full-size blueprint, 2s. 10s. 6d. per set of four sheets.
- "PRACTICAL MECHANICS" MASTER BATTERY CLOCK\* Blueprints (2 sheets), 3s. 6d.
- "PRACTICAL MECHANICS" OUTBOARD SPEEDBOAT 10s. 6d. per set of three sheets.
- A MODEL AUTOGRIO\* Full-size blueprint, 2s.

The above blueprints are obtainable, post free, from Messrs. George Newnes, Ltd., Tower House, Southampton Street, Strand, W.C.2.

An \* denotes constructional details are available, free, with the blueprint.

cloth. This material is saturated with water and the lower end of the material should lie in a trough of water so that the water lost by evaporation can be replaced by water drawn up from the trough. Alternatively, you can arrange for water to drip on to the fabric from above.

Now, the speedier the evaporation of the water from the cloth, the greater will be the degree of cooling. Consequently, this "cold box" will be cooler in summer than in winter, that is to say, relatively so. If you bring an electric fan into action so as to create a forced draught of air around the fabric, the evaporation will be speeded up and the cooling effect will be increased.

This simple method is very effective, unless, of course, a high degree of cooling is required. The method will, at least, cause the temperature of the box to drop about 10 or 12 degrees below that of its surroundings under normal conditions.

**Protective Paint for Galvanised Tanks**

HAVING previously experienced rusting in galvanised iron cisterns used with domestic hot water systems, I am considering giving extra protection to a new cistern before installing it. Several methods have been suggested such as painting it with aluminium or bitumastic paint; but these would appear to have other disadvantages such as increasing the risk of electrolytic action or contaminating the water, which is used for drinking.

Could you please advise me, therefore, what is the best method of giving extra protection to galvanised iron water tanks?—T. R. Hockney (Coventry).

A GOOD bituminous paint made from a pure bitumen will give very good extra protection to a galvanised tank provided that only cold water is used in the tank for, under the influence of heat, the bitumen film would soften and leave exposed areas.

We suggest that you obtained a good bitumen paint, one which is guaranteed not to contain any tar as, for example, "Mariolene," which is manufactured by British Asphalt and Bitumen, Ltd., The Docks, Preston, Lancs, and that you give your tank three coatings with this, allowing the paint to dry out thoroughly between the successive coats. After the hardening of the final coat, the tank should be charged at frequent intervals with water during a period of about a month. This will get rid of any traces of soluble matter which may be present. The tank will now be ready for use, and it will not contaminate drinking water, since the film of pure bitumen left by the paint is not soluble in or affected by water.

Aluminium paint on galvanised iron would not be very protective. A copper plating would be extremely protective, but it would not be desirable for continual contact with drinking water.

As an alternative to bitumen, you could use one of the special protective hard varnishes which are now being supplied by Bakelite, Ltd., 19, Grosvenor Gardens, London, S.W.1. We see no reason why these should not be entirely satisfactory, particularly if applied in two or three coats and allowed to dry thoroughly before the tank is filled.

**Drawing on Metal**

COULD you please tell me the name of a product, used by draughtsmen for drawing on metal? It is obtainable in various colours. The metal is given a coating of this product, and when hardened, it enables one to design freely on polished metals.—L. A. Day (Spalding).

THE product to which you refer is a synthetic resin composition, suitably coloured by means of a wax or oil-soluble dye. It is coated on to the metal, which is afterwards "baked" in a warm oven. Alternatively, the resin coating may be chemically hardened by wiping it over with a weak acid such as dilute acetic or hydrochloric acid.

Products of this nature are manufactured in bulk by Bakelite, Ltd., 18, Grosvenor Gardens, London, S.W.1, but we doubt whether you would find it possible to obtain them from that source. We believe that they are retailed by Messrs. J. Halden and Co., Ltd., Albert Square, Manchester.

**Testing a Water-softener**

COULD you please suggest a method of testing the degree of efficiency of a water-softener?

Would it be a practical proposition to renew the base material (silica)? If so, do you know where this could be obtained?—H. Page (Finchley).

THE only method of estimating the degree of efficiency of a water-softener is by ascertaining the water hardness before and after softening. This is readily done provided you have the necessary apparatus, full particulars of which you can obtain from any book on inorganic chemistry or on water testing, such as "Chemistry for Public Health Students," by E. Gabriel Jones, published by Methuen and Co., Ltd., some years ago, and which, possibly, may now be obtained second-hand from Messrs. H. K. Lewis and Co., Ltd., 136, Gower Street, W.C.1.

Without adopting a laboratory method, a rough idea of the water-softener's efficiency can be obtained in the following manner. Dissolve some pure white soap in water so as to make up a strong soap solution which is liquid when cold. Now take, in bottles, equal amounts of the water before and after softening. Add to each the soap solution, drop by drop, shaking the bottle vigorously between each addition, until a permanent lather is obtained. The harder the water, the more soap solution will be required to give the lather.

The base material of your water-softener is not silica, although it contains silicates as an ingredient. You should be able to regenerate it satisfactorily by passing a solution of common salt solution through it but, if not, you can replace it with fresh material, which can usually be obtained from a laboratory supplier, such as Vicsons, Ltd., Pinner Road, Harrow, Middlesex. Alternatively, the Burgess Zeolite Co., Ltd., 68-72, Horseferry Road, S.W.1, may be able to supply you with the necessary synthetic zeolite material, as it is termed.

**Welding Transformer Details**

CAN you advise me regarding the design of a transformer and choke coil suitable for reducing the mains voltage low enough for welding small jobs?

The supply is 230 volts 15 amps single phase. Could you tell me the cross-sectional area of the transformer and choke cores, the number of turns, gauge, and the tapings of the primary and secondary windings on the transformer and the choke coil? What is the maximum size of welding rod I could use on this set and the thickness of metal I could weld?—N. Walker (Lindal-in-Furness).

WE suggest you build the core of the transformer of Stalloy stampings to the dimensions given in the diagram, (Fig. 1), the stampings being about 0.014in. thick and lightly insulated on one side. A bobbin or former, through which the centre limbs of the stampings will afterwards be threaded, should be wound with the primary having 202 turns of 11 s.w.g. D.C.C. wire; and the secondary having 79 turns of conductor of 0.03 sq. in. cross-sectional area, the secondary being tapped at the 62nd and the 50th turns. When assembling

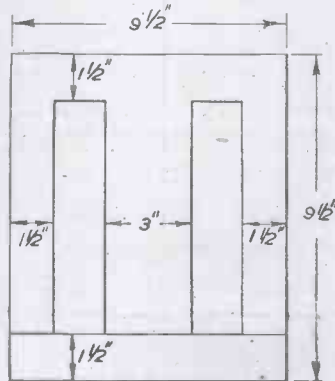

Fig. 1.—Transformer core.

the core the insulated sides of the core should face the same way, adjacent layers of stampings being reversed so that the joints in one layer are covered by the next. The core of the choke coil should also be built of Stalloy stampings about 0.014in. thick, to the dimensions given in Fig. 2. The centre limb should have 60 turns of conductor of 0.03 sq. in. cross-sectional area, tapped at 52, 47, 43, and 38 turns. When assembling the core, stampings should be laid in two piles of the two shapes, with the insulated sides facing the same direction. The core should be assembled with an air gap of about 0.04in. at each of the three points A, B and C. This gap may be filled with hard wood, fibre, or other non-magnetic material so the core can be clamped up solid.

The set could be used with 1/16in.-diameter welding rod to weld mild steel of about 1/16in. thick.

**Petrifying Liquid**

WOULD you please advise me on how to make a petrifying liquid suitable for mixing with distemper for sealing walls.

I believe one of the constituents is water glass.—H. J. Edwards (Dartford).

THE compositions of commercial petrifying liquids are maintained secret. Several of them are protected by patents, so that you would be guilty of infringement if you looked up the patent specifications and made them yourself.

You can make a petrifying liquid by mixing 1 part of sodium silicate (water glass) with 3 parts water, but the trouble with this liquid is that, after drying, it tends to rub and dust away from the wall surface.

Most of these petrifying liquids comprise solutions of soluble caseinates (casein compounds) which, on drying out, become insoluble. You cannot obtain casein at the present day, however.

A good preparation for sealing a wall previous to painting is a solution of 10 parts of glue size in 90 parts of water—applied hot. After semi-drying, the area is brushed over with a mixture of 1 part formalin and 2 parts water. The formalin renders the glue insoluble, and effectively seals the plaster or other wall surfacing.

**Paint for Aluminium Sheets**

I HAVE built a caravan, with the outer skin of aluminium. Can you please advise me as to the correct paints to use? I have been told that an ordinary lead base paint would "disagree" with the aluminium.—W. G. Tonge (Bolton).

ALUMINIUM sheets sometimes have a slightly greasy surface and, because of this, paints often do not take kindly to such surfaces. There is, however, no actual "disagreement" between the paint and the metal surface.

It is often advisable to wipe over the new aluminium sheets with a cloth saturated with a solution of common soda in water, of strength, say, 1 part soda in 6 parts water. Do not use caustic soda for this purpose, since it will dissolve the metal. Common soda (sodium carbonate), however, is safe enough. Be sure that you remove all traces of the soda by following up with clean-water cloths. Then, after the surface has dried out, matt it slightly with sandpaper. On the surface thus prepared, give a thin coat of a grey priming paint. Let the coating be well brushed out and applied as thinly as possible—such as would be the case if you were applying a real gold paint! Let this dry out properly, and then give another coating, rather thicker this time, of the same grey priming paint. Let this dry out, and on top of it place the ordinary paint of your choice. This will make a good job, and you should have no cause to complain about it.

**Black Stain for Wood: Barbola Paste**

I WOULD be much obliged if you could give me information on how I could blacken wood, with a stain that would polish when rubbed with a brush.

Also, could barbola paste be coloured to look like marble?—Geo. MacKenzie (Dublin).

TO blacken wood, you can use a spirit solution of a black aniline dye, and, after impregnating the wood with this, you can polish it up with any ordinary floor polish.

Another way is to boil logwood chips in water, concentrate the solution to small bulk and impregnate the woodwork with it. When nearly dry, brush over the woodwork a solution of potassium bichromate (strength immaterial). This will give a black stain which can afterwards be polished over with wax.

Still another method is to dissolve a quantity of oil-soluble black dye (such as "Berlin black") in boiled

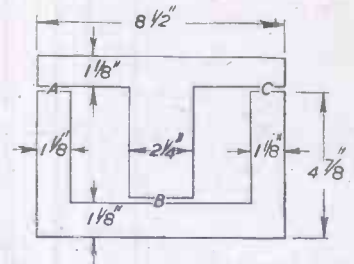

Fig. 2.—Choke coil core.

linsced oil, and to mix this 50 : 50 with turpentine or turpentine substitute. Coat the woodwork liberally with this. When it has soaked in, polish with wax in the ordinary way.

Any of the above methods will give an enduring black—and polished—effect on woodwork.

It would be very difficult to convert barbola paste to a marble-like appearance. You would have to add to it quantities of coloured powders which would have to be combed through the paste in order to give the veined appearance of marble. Even then, we hardly think the general effect would be really satisfactory. However, if you still wish to experiment, the following materials, finely powdered, would suit your needs: carbon, brickdust, zinc white, slate powder, yellow ochre, burnt sienna, amber, green chromium oxide.

**Non-compressor Type Refrigerators**

I UNDERSTAND that several electrical firms are marketing a refrigerator of a non-compressor type. Can you supply any information regarding this as, for instance, the refrigerant, principles of operation, etc., and also your opinion as to whether the manufacture of this would be within the scope of an amateur?—J. C. Waterman (St. Leonards-on-Sea).

REFRIGERATORS of the non-compressor type are not a new introduction. They have been known and made for years. Most of these refrigerators use ammonia as the refrigerant, together with an inert gas, such as hydrogen.

Such refrigerators consist of two main sections, viz., the evaporator, in which the refrigerant is volatilised and in which the cooling takes place, and the condenser, in which the gas or vapour is converted back into liquid. In many of the small domestic refrigerators, no moving parts whatever are used, the inert gas keeping the pressure constant throughout the internal circuit of the apparatus, and the movement of the refrigerant being effected by an ingenious system of heaters and coils.

The making of such a refrigerator is definitely not within the scope of an amateur or even a skilled worker unless he happens to have a specialised knowledge of the mechanics of this type of apparatus.

You can obtain information of these refrigerators from any modern book on refrigeration, which should be available at your County or nearest Reference Library.

## ELECTRADIX BARGAINS

### For Discerning Buyers

**BT.H. TRANSFORMERS.** 200/230/250 volts, 50 cy. input, 2 volts 20 amps, 75 volts 6amps., with 15 taps output, 70/- Carriage, paid England and Wales.

**BATTERY SUPERSEDER.** 6 volts D.C., input 230 volts 40 m.a. D.C. output, for Radio receivers, 5 $\frac{1}{2}$ in. x 3 $\frac{1}{2}$ in. x 3 $\frac{1}{2}$ in., ball bearings, model finish, 55/-.

**BATTERY CHARGERS.** 230 volts A.C. for 6 or 12 volt accumulators; send for special leaflet and keep your car accumulator in good condition while not in use.

**DIMMER SWITCHES.** Small bakelite all-enclosed surface pattern for valves, small lighting controls or safety control on test circuits, neat and strong, 2/6 each.

**LIQUID LEVEL.** Remote indicators, Electrical type, less meter, with variable resistance operated by geared float to vary a reading on a distant dial connected by a pair of wires and a dry battery, 3/6 each, post 6d.

**SOLENOIDS.** Powerful electro-magnetic ironclad type, 1 D.C., pot magnet with screw-in solenoid core. Weight 1lb. 10ozs., 2 $\frac{1}{2}$ in. x 1 $\frac{1}{2}$ in., for use on 6 to 25 volts, lift 7-28lbs., price 4/-. Type 2 has 3 separate windings, price 4/6. Solenoid coils of enamelled wire, 27 gauge, weight 6ozs., 2/- each; excellent as H.F. smoothing filter chokes.

**PRESSURE GAUGES.** Bourdon Boost gauges new, plus 8 lbs. sq. inch to minus 7 lbs. for testing blowers, vacuums, etc. Luminous scale, bakelite case, 7/6. Low-pressure Bourdon gauge movement, complete and new, 5/-. Special prices for quantity orders.

**MOTORS.** New Sewing Machine Motor, 1/25 h.p., 230 volts, A.C./D.C., totally enclosed, square construction, with pulley belt and bracket, 90/-.

**MOTORS.** Electradix Micro Motors for instrument work and models 2in. x 1 $\frac{1}{2}$ in., weight only 10 ozs. 12/24 volts; work from dry cells or A.C. Mains through transformer, laminated fields, ball bearings totally enclosed, small vee pulley, centrifugal relay speed governor on shaft removable for second shaft drive. Precision made ex-W.D. stock. Worth 45/-. Price 21/- each.

**HAND MIKES** in moulded bakelite case, 4/6; transformer, 4/6; Tannoy Hand Mike, multi-cell Carbon types, with neat switch in handle, 12/6. Special transformer, 8/6.

**HEADPHONES.** Single Low-Resistance Headphone with headband and cord, 3/6 each or 5/- per pair, useful for circuit-testing and house telephones. High Resistance double

headphones, 12/6.

**LAMPS.**  $\frac{1}{2}$  watt Neon lamps, 230 volts, miniature type, with small bayonet cap, 3/6, postage 9d. extra; 5-watt Standard Neons, bayonet cap, 3/1, postage 9d.; letter plate Neons with E.S. cap, 2/6, postage 9d.

**METERS.** Ironclad A.C. voltmeters, G.E.C. 4in. switchboard, 0-60 volts, 45/-. Ammeters to match, 0-40 amps., 45/-. Frequency meter 40/60 cy. Crompton F.G. ironclad switchboard 50 volts 6 $\frac{1}{2}$ in. x 6 $\frac{1}{2}$ in. x 4in. with lamp on top to illuminate dial, 85/5/0; transformer for 230 volts A.C., 35/- extra. Ammeter to match, 0-50 amps., A.C., 75/-. Voltmeter to match, 0-75 volts A.C., 65/-. D.C. moving coil, Elliott voltmeter, 3 $\frac{1}{2}$ in. panel with back connection, 130/260 volts, 30/-.

**Ex G.P.O.** 4-pin telephone plugs with solid bakelite base, 1/- each, postage 3d.; 10/- per dozen. Multiple connection strips of Solder tags tele. type, moulded mounting 60-way, 2/6 each, post 9d. R.A.F. 10-way terminal strip, 2/9.

**MAGNETS.** D.C. Electric magnets, weight 10 oz., lift on 2 volts 1 $\frac{1}{2}$  lb. 4 volts 3 lb., 6 volts 4 lb., new, surplus, 7/6 each. Permanent powerful flat bar magnets, 2 $\frac{1}{2}$ in. x 1in. x  $\frac{1}{2}$ in., drilled 2 holes each end, for any pole pieces, 2/- pair. "The wonder Midget magnets. Alni perm. steel disc;  $\frac{1}{8}$ in. diam.,  $\frac{1}{8}$ in. thick, with 3/16in. centre hole, 3/6 each. Large stock of Horseshoe magnets. Send for special Magnet Leaflet "P.M."

**PARCELS.** 7lb. useful oddsends for the junk box. All clean, dismantled from Government and other surplus apparatus, 7/17 post free. (Not for Overseas buyers.) Please include postage for mail orders.

**ELECTRADIX RADIOS**

214, Queenstown Road, London, S.W.8

Telephone: MACaulay 2159.

**Telephone: MACaulay 2159.**

**Telephone: MACaulay 2159.**

**Telephone: MACaulay 2159.**

**Telephone: MACaulay 2159.**

**Telephone: MACaulay 2159.**

**Telephone: MACaulay 2159.**

**Telephone: MACaulay 2159.**

**Telephone: MACaulay 2159.**

**Telephone: MACaulay 2159.**

## THE BOWDEN BULLET

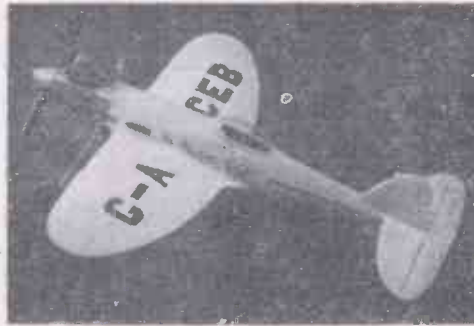

24in. span Sports Control Line Model. Designed by Lt.-Col. C. E. Bowden, A.I.Mech.E. A comprehensive kit containing: Ribs and formers cut to shape, ample good quality balsa wood, cement, paste, wire, etc., and 2in. rubber control line wheels. Price 29/6. Post 1/- extra. Plan only, 5/- post free.

Other Bowden-designed kits include: White Wings (6ft. 6in. span) and Meteorite (45in. span). Send S.A.E. for catalogue to Manufacturers: WELBECK MODEL AIRCRAFT PRODUCTS (H. WELCH), 85, Church Street, Preston, Lancs. Designed by: B.M. Models (C. E. Bowden), 43, Westover Road, Bournemouth.

*Manufacturers SPECIFY IT BECAUSE IT IS THE FINEST CORED SOLDER IN THE WORLD*

**MULTICORE SOLDER**

FOR RADIO, ELECTRICAL MOTOR AND ALL HOUSEHOLD PURPOSES

CONTAINS 3 CORES OF FLUX

NO EXTRA FLUX REQUIRED

*You WILL PREFER TO USE IT BECAUSE IT MAKES PRECISION SOLDERING SO SIMPLE*

SPECIAL HANDY CARTON

**6<sup>D</sup>**

ENOUGH FOR 200 AVERAGE JOINTS

MULTICORE SOLDERS LTD., MELLIER HOUSE, ALBEMARLE STREET, LONDON, W.1

## POST RADIO SUPPLIES

OFFER FROM STOCK:—  
COPPER INSTRUMENT WIRE, ENAMELLED, TINNED AND FUSE, COTTON AND SILK COVERED, LITZ WIRES.

Most gauges available.  
B.A. SCREWS, NUTS, WASHERS, soldering tags, eyelets and rivets. EBONITE AND LAMINATED BAKELITE PANELS, TUFNOL ROD. PAXOLIN TYPE COIL FORMERS AND TUBES, ALL DIAMETERS. COVERED WIRES, FLEXES, etc. PERMANENT DETECTORS, CRYSTALS, EARPHONES, etc.  
Latest Radio Publications. Full Range Available.

Send stamped addressed envelope for comprehensive lists. Trade supplied.

**POST RADIO SUPPLIES**  
33, Bourne Gardens, London, E.4.  
Callers to 395, Queensbridge Road, Dalston, E.8.

## LATHE

Table Model Fret J.g Saw and Circular Saw.

Why wait months for delivery? Build your own from easily obtained parts and material only. Well tested sets of diagrams and instructions.

Price 3/6 each or 9/- the Three (New Channel Islands Liberation Postage Stamps used on all orders—very valuable).

**P. M. BARHAM,**  
Bridge Avenue, St. Sampsons, Guernsey, G.I.

## CRAFTSMAN'S AIDS

Winter production demands early preparation. Equip yourself now for the long nights, by making these machines at little or no cost, specially designed for construction by the average handyman. Clear drawings and instructions supplied for making:

1. **JOINTER and SHAPER** for Perspex (automatically forms true edges for cementing, etc.), at 2/6.
2. **SANDER and POLISHER** for a speedy, professional finish, at 2/6.
3. **Heavy-duty, ball-bearing FOOT MOTOR** (no cranks or bearings to make). Will comfortably drive lathe, circular saw, above machines, etc., at 2/6.

All post free and satisfaction guaranteed from  
**T. SINCLAIR (Dept. M), 5 Buss Craig Road, Eyemouth, Berwickshire.** S.A.E. and 1d. brings leaflet "Hints on Working Perspex."

## TELESCOPIC DINGHY MAST

(ex-R.A.F.)  
Telescopic Aluminium, 15in. long, opens to 9ft. Terrific strength, yet weighs less than 1lb. Makes ideal fishing-rod, etc., 10/6 post free.

**GLASS PRISMS**, small, as fitted in opera glasses, etc., 1/6 pair.

**MAINS OR BATTERY MOTOR** Fitted with reduction gearbox, ideal for driving small to medium size models. Runs off 6 or 12 volt batteries, or 200-230 A.C. or D.C. mains. Size approx. 8in. x 4in. x 4in. Post free, 30/-

**MERRIBULL PRODUCTS,**  
44, Cromwell House, Wood End, Green Road, Hayes, Middlesex.

## ADANA PRINTING MACHINES

Print in the odd hours with an Adana—still the most absorbing of crafts. No. 1 H/S Machine £4.10.0. No. 2 H/S Machine £9.15.0. Will pay for itself in a month or two. Send for illustrated folder to Dept. P.M. 15.

Adana (Printing Machines), Ltd.  
15/19, Church St., Twickenham, Middx



# TOOL NEWS IS OUT

TOOL NEWS is now on sale and a limited number of new subscribers are invited. This handsome quarterly is something entirely new in house journals: chatty, informative and helpful.

To the beginner it offers a valuable guide to practical engineering and modern workshop practice. To the advanced it is a valuable herald of new products of the industry, providing a friendly forum for discussion of production problems. Unfortunately, circulation is limited and early application is essential—5s. Od. per annum, post free to any address in the world. Our latest Stock Bulletins are available for 2½d. stamp.

**T. GARNER & SON, LTD.,**  
Redbrook Works, Gawber,  
**BARNSELY**



## YOU CAN MAKE THESE and make money!

Knights in Armour, Indians, Farmyard Animals, Lions, Elephants, Cannons, etc. toy casting moulds, and fast-drying enamels. Full instructions about this fascinating hobby and profitable pastime with every first order. Send S.A.E. for full details. Write to-day.

### COMPLETE KIT FOR BEGINNERS

We pack a complete working outfit—the "Progress, Special Casting Kit," comprising Two moulds, different models (Moulds in Brass or Hard Aluminium Alloy), Eight jars of Quick-drying, non-poisonous Toy Paint. One Squirrel Painting Brush. Two small Pigs of special Toy Metal. Four Handles (Wooden). Complete with full instructions. Price £2.2.0. Cash with Order.

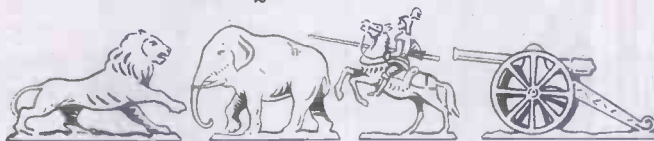

**PROGRESS TOY CO LTD**  
DEPT. 7 KIRBY RD BLACKPOOL S.S.

## MODEL ENGINEERS

### FOR THE TURNER:

Lathes, 3½ and 4½ S.S. Bench Millers. Drilling Machines. Hand Bench Shaping Machines.

### FOR THE WOODWORKER:

Wood Turning Lathes, 2½" and 5½" centres. 4in. Planers. Saw Benches. Sanders. Spindle Moulders.

Pedestal Jig and Fret Saws.

Perspex—All sizes and colours in stock.

**NUTTALL'S (LATHES) LIMITED,**  
MANSFIELD, NOTTS.

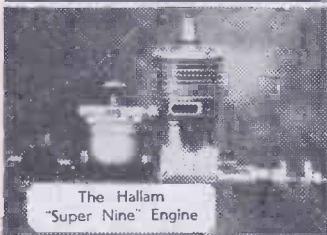

The Hallam "Super Nine" Engine

EASILY MADE FROM OUR CASTINGS  
**J. HALLAM & SON**  
UPTON, POOLE, DORSET.  
MINIATURE PETROL ENGINES for  
Aeroplanes, Boats and Race Cars.  
Send 6d. for New List.

## CHEMISTRY APPARATUS

Send Stamp for COMPLETE PRICE LIST



Booklets:  
"Experiments" 7d.  
"Formulas" 10d.  
"Home Chemistry" 2/3  
Post Paid

(Scientific Dept. A)  
**BECK** 60 HIGH STREET,  
Stoke Newington, London, N.16

### NICKEL PLATING

Complete Equipment, including Nickel Anode, Plating Salt, etc. Full Instructions for Plating Ornaments, Car Fittings, and all Metal Parts. Flash-lamp battery only required.

Price 15/-, post free.

**HOLBOROW & CO.,**  
71, Weymouth Bay Avenue,  
Weymouth.

**ELECTRIC ENGRAVERS.**—Powerful instruments in flat case, on stand with spring attachment, and switch. Suitable for dog collars, tool marking, etc. 4-6 volt model, price 48/6; A.C. Mains model, 200-240 volts, 55/-; A.C. Engraver only, 42/6.

**TELEPHONE SETS,** comprising 2 G.P.O. hand phones, 2 bells, 2 pushes and 80ft. twin wire. Price 60/-, post free. Single instrument, 22/6.

**MOTOR.**—4-6v. dry battery driven, well made, powerful, 1½/6. Illustrated list, 3d.

**BATTERY CHARGERS FOR A.C. MAINS.** FOR CHARGING 2-volt accumulators at 1 amp. Parts with diagram, 12/6. Complete 18/6. Postage 10d.

**FOR TRICKLE CHARGING CAR CELLS,** parts with diagram. Output 11 amps. for 6v. cells, 28/6 set. For 12v. cells, 30/- set.

Complete on Open Metal Base, 42/6. Post 1/- See List for larger sizes.

**PHOTO-ELECTRIC CELLS.**—For all sound films, high fidelity production, speech and music. Small tube size, 2in. x ½in. dia., 28/6. Midget tube, 1½ x ½in., 28/-. Complete with diagram.

**COMPLETE OPTICAL SYSTEM FOR 35 or 16 mm. sound film,** 2in. long, ½in. diam., projects, 0.001in. light image. Price 22 2s.

**ECONOMIC ELECTRIC CO.,**  
64, London Road, Twickenham,  
Middlesex. Tel.: POPesgrove 1318

## LABORATORY APPARATUS & CHEMICALS

A few of the many chemicals in constant demand.

(Approx. 4oz.)	Deposit on bottle
100 grams Charcoal, 5d.	9d.
100 grams Iron Filings, 6d.	4d.
100 grams Manganese Powder, 3/2.	10d.
100 grams Potassium Nitrate, 5d.	6d.
100 grams Potassium Permanganate, 1/5.	6d.
100 grams Sulphur, 6d.	7d.
100 grams Aluminium Powder (fine), 2/7.	1/6

Any chemical can be supplied on request.

100 ml Beaker, 1/6. 150 ml Flask FB, 1/11. 6in. x 1½in. Gas Jar and Plate, 2/1. Beehive Shelve, 1/- 6in. x 4in. Pneumatic Trough, 5/2. 120in. Glass Tubing, 1/-. Bunsen Burners (Student), 2/-. Tripods (Student), 1/6. Allow 1/6 for Carriage and Packing. BOOK, "EASY HOME CHEMISTRY," 2/-. Send stamp for detailed list of students' apparatus and chemicals.

### VICSONS LTD.

(DEPT. E.S.)

148, PINNER ROAD, HARROW,  
MIDDLESEX.

**MOTORS, A.C.,** approx. ¼ h.p., 230 v., 2,800 r.p.m. Single phase. Series wound, brush motors, base plate mounting; shaft 9/16in. dia., 1½in. extension; size 8in. long x 6in. across x 7 in. high; self starting. £3 12s. 6d. plus 5/- postage and packing. D.C., approx. ¼ h.p., similar to above but shunt wound, £3 10s., plus 5/- packing and carriage. A.C. 1/6 h.p., dimensions, etc., similar to the ¼ h.p. A.C. above, £2 10s., plus 5/- carriage.

**MICRO-TELEPHONES,** very sensitive, need no mains or batteries, 2/6 each, or 4 for 9/6.

**CRYSTAL DIODES,** permanent detectors, need no resetting, 2/6 each, B.T.H.'s recommended circuit diagram, 3d. extra.

"Tom Thumb" Headphones, very small earpieces, about size of a cherry, 7/6 pair.

Trickle charger kit, transformer 4/9; rectifier, 4/9; 230 v. input, 6 v. D.C. output, with instructions for assembling. Hydrometers for conditioning batteries, 5/11.

Voltage regulators for model railways, 44 ohms, 24 v. out., 6/6.

Miniature H.T. batteries, ex-Govt., 22½ volts; size 3½in. x 2½in. x 2½in., 2/9.

Cycle dynamos—dynamo only, for replacement purposes, output 6.3 v., 5/11.

Car cutouts, brand new, 12 v., 6/9. Car ammeters, 0-30 double reading, new, 6 v. or 12 v., 6/9.

Rotary transformers, D.C. only, 230 v. D.C. input, 24 v. output. Just right for battery charging or working model railways. Completely housed in steel case, 25/-.

## PARK RADIO

of Manor Park

676/8 Romford Road, Manor Park  
London, E.12.



### PERFECT PASTIMES

Modern Materials for CRAFTS AT HOME

Plastercraft — Leatherwork — Lampshade making — Plastics Models — Toys — Patterns.

Send 1/- for specimen copy of the Magazine Craftworker and Catalogue of instructions, tools and materials.

**HOMECRAFTS (Dept. 2),**

Albion Street, Broadstairs, Kent

## JUBILEE WORM DRIVE HOSE CLIPS

The long-life clip with the ever-tight grip

The Best Known For Radiator Joints, Air, Oil and Water Hose Joints

We guarantee a Tight Joint

**L. ROBINSON & Co.**

25, London Chambers,  
GILLINGHAM, KENT

### \* Multicraft CATALIN Material \*

Rods, Cylinders, Sheets, Sections, Kits for Book-ends, Tablelamps, etc. The most versatile of all materials. Beautiful colours, easily worked. Sample Box 10/-, Parcels 25/- & 50/-.

For details send large stamped addressed envelope.  
Dept. PM, COULDEN & SMITH,  
17, The Mead, West Wickham,  
Kent.

# The sign of a Youth Hostel

# Y

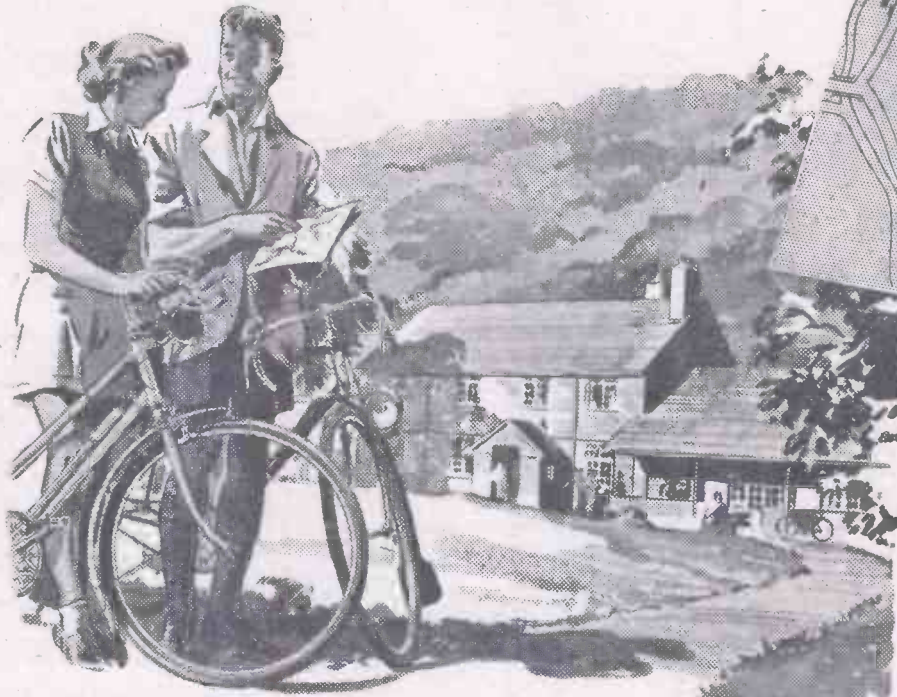

This is the symbol on an Ordnance Survey map of a hostel where accommodation is available to Youth Hostel Association members. The illustration shows the specially built Longthwaite Hostel in Borrowdale, Cumberland, one of over 250 in England and Wales alone. To the north of it lies Derwent Water, westward there is Buttermere. To the South-West tower the 2,900 ft. of Great Gable. In every direction the beauty of the Lake District is within the reach of the cyclist.

## The sign of a good tyre - **DUNLOP**

BH/325



### APEX 'SUPERLITE' CELLULOID PUMP

15 x 7/8 BLACK

Thick Celluloid Beautifully Polished

Light of Weight but of robust construction

'SUPERLITE' 15in. CELLULOID (with solid drawn brass plunger tube) each **5/-**  
WHITE ... .. 5/6

'LASTWEL' CELLULOID (with steel split plunger tube) 15in., each **4/6**

### The World Famous BAILEY'S 'SUPER' PUMP

15 x 7/8 BLACK Steel Lined Celluloid Covered

Lining is Solid drawn cartridge fashion, the ends being solid with the barrel.

Cannot warp nor leak  
BAILEY'S 'SUPER' (Steel lined and Celluloid covered) 15in. each **5/6**  
WHITE ... .. 6/-

BRASS PUMP, Nickel Plated or Black enamelled (with steel split plunger tube) each **4/-**

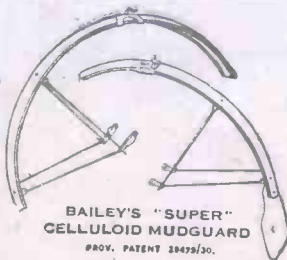

BAILEY'S "SUPER" CELLULOID MUDGUARD  
PROV. PATENT 28429/30.

in Ordinary or Narrow Section. Plain or ribbed, 11/6 pair. Fitted Reflector, 13/6 pair.

**APEX INFLATOR Co. Ltd.**  
ALDRIDGE ROAD, PERRY BARR,  
BIRMINGHAM 22B

### PLEASE NOTE

Apex Celluloid Mudguards are again obtainable.

Every time you have to **STOP**



## Fibrax

famous **BRAKE BLOCKS** and LINERS

will pull you up smoothly and promptly

Known to thousands of cyclists over the past 40 years for their reliability and long wearing qualities. Supplied in various patterns to fit all makes of machine. Ask your dealer.

FIBRAX LTD., 2 TUDOR STREET, LONDON, E.C.4.

## RADIO - CYCLE - SERVICE

**RADIO.**—We specialise in supplying complete kits and individual component parts for all circuits described in this journal, and other technical publications. Send 2d. stamp for list of our Practical How-to-Build-it Books, complete instructions and designs for the HOME CONSTRUCTOR.

**CYCLES.** We undertake complete overhauls, cycles resprayed, bright 11/6 replated. We carry large stocks of accessories. Send S.A.E. for our cycle list.

**LIGHTWEIGHT CARRIERS** (Black), 5/6.

**BLUMEL'S "FEATHERWEIGHT"** Pumps, 5/6.

**BRINLOCK.** The perfect Cycle Lock. Fits to Frame (same as calliper brake), 6/6.

**NON-SPILL** Ashtray and Combined Perpetual Calendar, in Beautiful Black Moulding (approx. 4in. x 6in.). Ideal for the Office and Home, 6/6 (worth double).

**SEWING MACHINE MOTOR.** Complete with foot speed control and needle light, fits all standard machines, 28.

Postage, Packing, etc., on all Orders under £1. 6d. extra.

**5-VALVE A.C. MAINS SUPERHET KIT**, 3 waveband, 16.5-50, 200-550, and 800-2,000 metres, complete with valves and speaker, £14.7.1; also supplied to cover 42.5-37, 36-120, and 200-550 metres. A.C.D.C. version, £13.7.4.

**ETRONIC 6 VALVE A.C. MAINS SUPERHET RECEIVER**, in walnut cabinet, wave range 15-51, 100-550, and 900-2,200 metres, "Magic Eye" tuning, £21.13s. 9d., or on H.P. Terms. Deposit 25 9s. 6d. and 11 monthly payments of £1.12s. 6d.

**ALUMINIUM CHASSIS** (22 gauge), 8in. x 6in. x 2in., undrilled, 5/- drilled to own specification at extra cost.

**HENBEST BROS., LTD.**

26 Green Lanes, London, N.13

Telephone: BO Wes Park 6287



VOL. XVII

OCTOBER, 1948

No. 319

All letters should be addressed to the Editor, "THE CYCLIST," George Newnes, Ltd., Tower House, Southampton Street, Strand, London, W.C.2.

Phone : Temple Bar 4363

Telegrams : Newnes, Rand, London

## Comments of the Month

By F. J. C.

### The Origin of the Cycle Show

FEW of the thousands of enthusiasts who visit the "Cycle Show," which opens at Olympia on November 18th, to admire the marvellous cycles exhibited there, know—or care—anything about the history of cycle shows. "Olympia" had, until the war, become the annual incident in the cyclist's calendar, and he, with his fair tandem or cycling clubmate, attended regularly as a matter of course. Historical happenings and dates regarding ancient events do not interest the average modern youth. "Here is the Show," he murmurs, "let us enjoy it." He is unlikely to soliloquise on the musty past. He revels in the present. Yet the history of cycle shows is vastly entertaining, and it demonstrates, once again, the accuracy of the ancient adage about great oaks springing from little acorns.

A few veterans of the pastime may have heard of "The Stanley Show"; fewer still have personal recollections of that classic institution; but only the grandfathers of the present generation will be able to recall the first of the long series (thirty-four of them) of shows which were organised by the once active Stanley Bicycle Club.

### The Formation of the Stanley Bicycle Show

The club was formed on May 1st, 1876, at a time when the famous explorer, H. M. Stanley was at the height of his fame, and the youthful cyclists, conceiving some analogy with themselves as explorers of the countryside on the new-fangled bicycle, adopted his name, and the "Stanley Helmet" as part of the club's official uniform. It was a fortuitous coincidence that the club's first meeting place was the Lord Stanley Hotel, in Camden Park Road. The Stanley B.C. made a speciality of social gatherings during the winter—or "Off" season—these taking the form of lectures, debates, etc. For instance, on January 25th, 1878, a very prominent member, J. Dring, read a paper on "Luggage carrying." Early in 1878 the members decided to present their hon. secretary, J. Robinson Airey, with a testimonial, which took the very practical shape of a new bicycle—a "Timberlake," a make long since defunct and forgotten, but among the foremost in those far-off days. The presentation was made at a musical evening, held at the club's headquarters, the Athenæum, Camden Road, N.W., on March 12th, 1878, and, as a side-line to the musical items, some genius hit on the idea of inviting cycle makers to send samples of their latest patterns for exhibition in the hall. The committee expected about a dozen machines, but the trade responded with such enthusiasm (being, even then, commercially minded individuals) that seventy bicycles and four tricycles were

staged by thirty firms, and the affair was extended to cover two evenings. The leading bicycling paper of the period announced the function in the following words, "On Tuesday, March 12th, a bicycle conversation and exhibition of bicycles takes place . . . a good programme of music has been obtained for each evening of the exhibition." The same paper reported the "do" in a paragraph of twenty-six lines.

A list of the exhibitors is before me, and in this I can find the names of but two firms which are still engaged in the trade, although the business of another participant is to-day being carried on by an indirect descendant.

### The Second Show

The second Stanley Show was held at the Foresters' Hall, Wilderness Row, in February, 1879, 110 machines being on view. By the by, Arthur Fox joined the club in 1878, and became hon. secretary a few years later; he is still "in the game," being on the committee of the Fellowship of Old Time Cyclists.

The 1880 Show, held at the Holborn Town Hall, was notable for the appearance of H. J. Lawson's first rear-driving "safety" bicycle. One hundred and fifty machines were staged. I will not weary the reader by tabulating the different halls in which following Stanley Shows were housed; they even included (in 1885) a temporary tent on the Thames Embankment, near Blackfriars Bridge. The show prospered beyond the wildest dreams of its originators, and was recognised by trade and public alike as the juncture at which new models appeared each season.

In 1893 certain bicycle manufacturers cut adrift from the Stanley Exhibition (then in the hands of a company called "The Stanley Show, Ltd.") and promoted a show of their own at the Crystal Palace; this, known as the National Show, was held annually for eleven years, but the Stanley carried on, harmed very little by the opposition. In 1910 the present series of shows was inaugurated by the Cycle and Motor Cycle Manufacturers' and Traders' Union, at Olympia, and the old Stanley show died.

### Early Motor Cycles

As the early motor cycles were produced by firms which had previously become famous as makers of bicycles, these, naturally, appeared at the cycle shows; one of the first was the Gladiator tricycle, which was seen at the Stanley Show of 1895.

Bateman's steam tricycle was exhibited at the Stanley Show of 1881.

In 1884 a plan of the floor space was published for the first time. The show was

housed in the Floral Hall, Covent Garden, and J. H. Price, a popular Stanley member and trade celebrity, was honorary secretary.

Messrs. J. Lucas exhibited an electric cycle lamp at the 1888 show at the Royal Aquarium.

Carter's oilbath gearcase appeared at the 1889 show.

The pneumatic tyre was first seen in public at the 1890 show, and the Dunlop-Welch wired-on detachable tyre saw the light at the show of 1892.

The first show manager to arrange a Press view before the official opening day was Frank Peach, of the National Show, November, 1898. Peace to his ashes.

The Minerva engine made its bow to the British public at the National Show in November, 1900, and at the same exhibition, the Singer, with engine in the rear wheel, first appeared.

But it is possible to go on raking out recollections from memory's storehouse till modern readers cry "chestnuts," so I will conclude by prophesying that the show will be as popular and successful as any one of the long series which has preceded it.



The Bottom, Urchfont, Wiltshire. A lovely village in the Pewsey Vale.

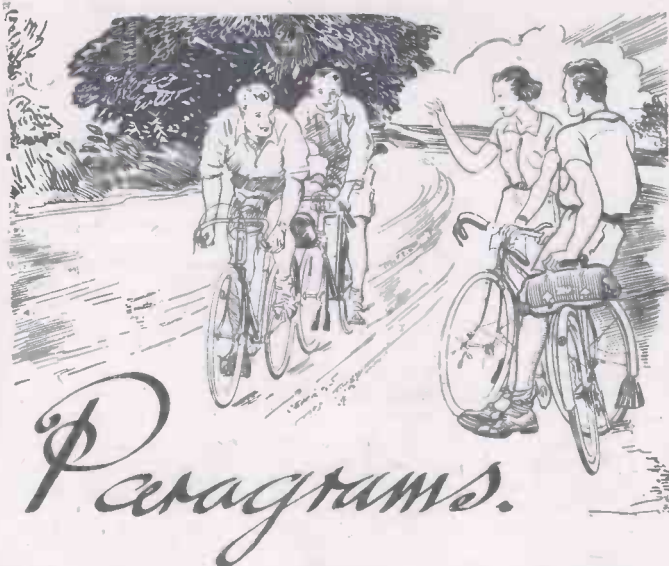

# Paragrams.

## The Missing Medal

MRS. H. H. KNIGHT, of Uxbridge, while digging a root of potatoes the other day in her garden, found the gold medal which was presented to her brother, Mr. W. H. Gough, when he completed 20 years as secretary of the Uxbridge Cycling Club. Mr. Gough lost the medal in the garden 17 years ago.

## Room for Five on Top!

THE caretaker at a Dutch school has fitted a kind of delivery carrier at the front and rear of his bicycle, large enough to hold two children in each. The carriers are railed round and the caretaker delivers to their homes those children who live a long way from the school and have no other means of transport than their own short little legs.

## Just Wooden

IN order to protect children at school crossings in the town of Hawthorne, California, a set of cut-out figures has been provided to act as traffic-stoppers. The cut-outs are life size and hold stop signs. They are mounted on two-wheeled platforms at the end of a 15ft. pole and when the children want to stop the traffic and cross the road they push the figures out into the roadway. It is to be hoped that they are well instructed to look and see that no unwary cyclist is likely to hurl himself to destruction over that long pole.

## Fake Accident Too Dangerous

WHEN members of Daventry and District Road Safety Committee were discussing whether or not any good purpose was served by having fake accidents arranged during road safety demonstrations, the chairman told them: "Last year, when one was held at Weedon, two children on bicycles were so interested that they ran into each other." The Committee eventually decided that they would have no mock accidents this year but would send a loudspeaker van round the district to impress everyone with the need to take care on the roads.

## Vintage Models

INCLUDED in the Safety-First Procession held at Nuneaton, Warwickshire, were what the organisers claim to be the world's oldest bicycles and cars, and it is to be hoped they were well checked before being allowed on the road. The procession was headed by 17-year-old Joyce Lloyd, of Nuneaton, the town's Safety Queen, riding in a horse-drawn and flower-decked landau, probably the safest means of conveyance, apart from a perambulator, she could have found.

## In The Family Tradition

PETER POPPLE, of Wyberton Low Road, Boston, 19-year-old member of the Spalding Cycling Club, whose two brothers are well known in South Lincolnshire for their cycling skill, is keeping the family escutcheon bright. So far this year he has carried off six individual prizes and three team prizes in road-racing events. In addition, at the Club's August Bank Holiday gala at Spalding he took first prize in all five cycling events on the track, including the half-mile and quarter-mile championships.

## Good For 83

MR. DAVID SMITH, of Croydon, Surrey, whose next birthday will be his 84th, took only 12 hours to cycle the 90 odd miles from Croydon to Peterborough, where he had decided to spend a few days holiday. He lived in Peterborough at one time and thought he would like to see the old city once again. After three days in Peterborough he cycled back to Croydon, going by way of Daventry.

## Epidemic

THE police in the Isle of Ely, Cambs, are having a busy time just at present as they are in the middle of an epidemic of cycle stealing. Everyone seems to have taken a fancy to someone else's cycle

and the police ask that cyclists should take all precautions to ensure the safety of their machines and to inform the police if they see any cycles outside houses or premises for an unusual length of time.

## Ride In Discomfort!

WHEN Walter Nilsson, after spending 20 years touring America as a trick cyclist, decided to settle down he picked upon Los Angeles, the city of weird new fads and crazes. He is now making a good living hiring out crazy cycles which he has invented. The less resemblance these things have to ordinary bicycles the more popular they are. Some have wooden casks instead of wheels, some have off-centre wheels, some have ordinary handlebars and some have no handlebars at all and the rider just steers by faith. One cycle that needs a good pair of muscular legs to move it has a large medicine ball instead of a front wheel

and two tiny rear wheels. Walter is still puzzling out the reason why his cycles are so popular.

## Cycle With Retractable Wheels

AN American sufferer from the effects of infantile paralysis, who decided to take up cycling to improve his health, found that he could get along quite well on the road but had difficulty in getting on and off as his legs were not strong enough to balance the machine. He sat down and devised an attachment consisting of two small retractable wheels on a light frame. The wheels fit at the rear of the cycle, one on either side of the back wheel, and can be raised or lowered to support the cycle when starting or stopping, by means of a handlebar control. The inventor has decided to pass his idea on to crippled ex-soldiers' organisations.

## In Convoy

NOW that the public own the railways and only a millionaire can afford to travel by train, cyclists are making the most of their economical transport. One cyclist, seen the other day in an East Coast seaside resort, was riding with one hand and towing with the other a rather shaky pram containing one baby, one dog and an assortment of odds and ends. Riding between the pram and the kerb was a small boy on his cycle.

## 2,500 Centuries!

MR. JOSEPH PLOWRIGHT, of Bridge Cottage, Deeping Gate, Lincs, who has just been awarded the Imperial Service Medal in recognition of his 43 years as a postman, estimates that he has cycled nearly 250,000 miles on his rounds in the Lincolnshire Fens. It is quite possible that he will cycle a few more miles yet in that Fen country of few buses and even fewer trains.

## Watch That Load

ALTHOUGH, it is to be feared, most cyclists are offenders at one time or another, the dangers of carrying awkward loads on bicycles was again emphasised at the inquest at Bedford on a 69-year-old land worker who fell from his cycle while riding home from work. A car had just passed him when he was seen to wobble and fall from his machine, and he died later in hospital. It was stated at the inquest that he was carrying a clumsy pair of thigh boots balanced on his cycle, with a saw and an axe strapped to the cross-bar. The motorist who passed him was quite positive that she did not catch him in any way with her car.

## Did He?

"I SHALL have to speak to the Council about this," said an Earl Shilton (Leics), youth when told by a constable that he would be reported for failing to observe a Halt sign. He had his opportunity of "speaking to the Council" when he was summoned before certain members who are also magistrates. He has now 10s. less pocket money.

## Real Enthusiasts

MR. WILLIAM H. HENSON, of Barwell, Leics, who is 65 years old, and his 70-year-old friend, Mr. Albert Warrington, also of Barwell, spent their summer holiday this year on a cycling trip through Wales, covering nearly 400 miles. Mr. Warrington has been a keen cyclist since he was a young man, but Mr. Henson only started riding when he was about 50, and they have been on similar trips together since the early days of the war. Mr. Henson's new cycle, which he bought nearly 18 months ago, has already covered some 6,000 miles. So that they would be fit for their cycling holiday, the couple made runs of just over 100 miles each on the two week-ends preceding their holiday and now they are back home they say they

feel fitter than ever. Both men are still working at a Barwell factory.

## Polite Horns?

IN a few years' time, when some hurrying motorist wishes to flash through the countryside a little faster, he will probably not give a raucous, abusive blast of his hooter as he does to-day. He will press the button and we shall hear a "pleasant and musical" note, according to technicians at the Birmingham factory of Messrs. Joseph Lucas, Ltd. They have been studying gramophone records made specially for them by members of the Birmingham City Symphony Orchestra, in an attempt to find the best musical note for a new car horn. They are very anxious to find the best combination of notes for a twin horn which will give good warning of a motorist's approach and yet not be so horribly ear-splitting as most horns now are.

## Another Labour Saver

A BRIGHT inventor has now taken out a patent for a device to inflate cycle tyres without using up the energy which, on present-day rations, we can so ill afford. The tyre is blown up with compressed gas which is contained in a bulb similar to the bulbs used in the special syphons for making soda water at home. The special bulb holder is screwed to the tyre valve and the bulb inserted and pressed down to puncture it and release the gas. One bulb contains sufficient gas to inflate completely any ordinary cycle tyre but as the gas cannot be controlled once the bulb is punctured it would be wise to have the tyre completely deflated before commencing operations.

## How Many Miles?

THE ancient and comprehensively inscribed milestone on the wall of the parish church at Holbeach, Lincs, well known to thousands of cyclists passing through the town, has at last been cleaned up and renovated after having been blacked out during the war. The milestone gives the distances to many towns and villages; the most distant place shown being Birmingham (118 miles).

## Safe Enough?

DAVENTRY and District Road Safety Committee has decided, because of the poor response from schools in the area, not to organise safe-cycling competitions for local children. Only five schools appeared to be in favour of the scheme when approached by the Committee for their support.

## "Crackpot" Cyclist

ALBERT REATHER, a musician in Dr. Crock's notorious band of "Crackpots" and a former bandsman in the old Hunts Cyclist Battalion during the 1914-18 war, has been meeting former comrades while appearing at the Embassy Theatre, Peterborough. He joined the band of the Cyclist Battalion early in 1915 and performed on the cornet, euphonium or sax-horn as and when detailed to do so. Several Peterborough men were with him in the band and he had long chats with them. Later he was posted from the band to the Beds and Herts Regt., and served in France. He continued his career as a professional musician on demobilisation and has played with most of the leading bands in this country.

## The Hardest Blow

NOT content with stealing a stock of cigarettes and tobacco which had only just arrived and had not even been unpacked, a thief who broke into the shop of Mr. C. Coles, cycle agent, Catherine Street, Leicester, also stole the proprietor's personal ration of smokes. The thief chose early-closing day for the robbery, but it is thought he was disturbed by a chance caller at the shop and left in a hurry. Mr. Coles first started to sell cigarettes and tobacco many years ago for the convenience of members of a local cycling club who held their meetings at his shop, and he has continued his sideline ever since.

## Cycling Veteran Dies

MR. JOHN YORK, who has died at his home, 11, Overstone Road, Northampton, at the age of 82, was well known throughout Northamptonshire as a cyclist and all-round athlete in his younger days. He started cycling when he was 12 years old and during his career he won over 60 medals in cycling and other sporting events. A number of years ago he set up two cycling records which still stand. He made the 136-mile run from Northampton to the Marble Arch in 8 hrs. 42 mins., and his other record ride was from Northampton to London and back again via Leicester, a total of 200 miles, in 13 hrs. 3 mins.

## King Dick's Well

AN historic Leicesterworth landmark, King Dick's Well, near Bosworth Park, Hinckley, from which King Richard is said to have drunk before his ill-fated battle at Bosworth, is getting into a bad state of repair, and Mr. W. S. Woodward, a local business man, has taken the matter up. Over the well there is a pyramid-shaped stone erection with a doorway to get inside to the well, and at one time there were railings round it, but now the masonry is disintegrating and the railings have completely disappeared, while the well is almost overgrown with rank grass and weeds. The attention of the Society for the Preservation of Ancient Monuments has been drawn to the bad state of the well, and it is likely that in future it will be properly cared for.

# Around the Wheelworld

By ICARUS

## Bicycle Tyres Unaffected

I AM glad to note that bicycle tyres are not affected by the rise in tyre prices which came into force on September 1st. This increase is due to the rise in the cost of Egyptian cotton! The rise in tyre prices is from 7½ to 10 per cent., although the price of Egyptian cotton is 50 per cent. more than it was six months ago.

## The Bicycle Produces the Dollars

MORE than 1,000,000 bicycles have been exported by Britain this year, almost twice as many as for the completed twelve months of 1938. They have brought in more than £7,000,000 worth of foreign currency, including £167,288 from Venezuela, £159,108 from Mexico, £136,834 from Iran, £129,023 from Egypt, and £105,044 from Canada.

More than thrice as many motor-cycles (43,628) have been sold overseas as in 1938, bringing in £577,802 from the United States, £398,654 from Switzerland, and £137,667 from Canada. U.S.A. has bought 6,855 British motor-cycles this year compared with 114 in 1938. All told, our bicycles and motor-cycles have already earned this year more than 3,500,000 dollars from U.S.A. and Canada.

## In Bad Taste

ALTHOUGH I am a keen supporter of the B.L.R.C., they will not mind my criticism of their Brighton to Glasgow Programme. In that programme details are given of some of the riders, from which I gather that A. H. Clarke has an ambition "to marry a cracker with stacks of cash," Ronald Morby is "prone to Socialism," H. J. Burvill is "a body snatcher with an ambition to sign up the field," that Kenneth Taylor has a hobby of "touring Saloon Bars," that J. G. C. Taylor wishes "to marry a blonde; will stop at ten children," and that Norman Taylor has an ambition "to leave Kate and fall in a £20 per week job."

Ben Whitmore wishes to "give up work." Now, allowing for the normal leg pulling which goes on in cycling circles, and that stupid desire to emulate what has come to be known as "the Bath Road spirit," I do not think that an official programme is the place for such remarks. They give the impression that cyclists are a lazy lot of gutter-snipes. There is enough criticism of the conduct of cyclists. A programme should endeavour to remove that impression. I suggest that in future the B.L.R.C. appoint someone with editorial experience to present the catalogue in a dignified way and one worthy of the League. The programme I have quoted should never have been issued in its present form.

## Raleigh Further Education Scheme

I AM glad to notice that the directors of the Raleigh Cycle Company have appointed a further-education committee to administer a scheme of further education and the award of prizes for employees in their works and offices.

All employees in the works and offices between the ages of 15 to 18 years, will be allowed time off on one day per week to attend classes organised by the City of Nottingham Education Committee. Employees will receive their normal basic rate of wages for the day of absence each week attending such classes. It is a provision of attendance

at these classes that apprentices and other employees having specialised training, who are unable to complete the full educational course in the daytime to meet the requirements of their training will undertake to attend other classes on at least one evening a week.

Sympathetic consideration in approved exceptional cases will be given to applications from employees of 18 years and over to attend day classes.

The City of Nottingham Education Committee has agreed to provide Courses of Instruction suitable to the particular needs of employees as under:—

The course for apprentices will provide for three periods of non-vocational subjects and five periods of vocational subjects to be taken on one day per week and the compulsory

film test. This took place at the Marylebone studios.

Twenty-year-old Miss Bourke, one of a family of seven, comes from a long line of theatrical people. She has performed at the Theatre Royal, Dublin, and recently won an important Irish bathing beauty contest.

The recent Dublin Cycle Show, the first ever to be held in Ireland, was organised by the Hercules Cycle Company of Birmingham.

## Olympic Games—Poor Press Arrangements

THE press arrangements for the Olympic Games caused bitter comment amongst those whose duty it is to provide news for their papers. Legitimate press men were denied press facilities, which were freely handed out to large numbers of people not

connected in any way with the press. One small child even was enjoying those facilities, and caused a mild accident at the end of one of the events. No wonder that the Olympics had a poor press. Whoever was responsible for the press arrangements should examine the methods of the B.L.R.C., which has attained nation-wide publicity for much smaller events. Many newspaper men found it quite impossible to report the events and went home. A few others paid for their entrance, but, of course, were remote from the finish and so could not obtain prompt and accurate details. Because of these difficulties we contented ourselves with the bare announcement. There should be an inquiry into this matter.

## A Bureau of Research?

IT is said that the bicycle is incapable of anything except detail improvement, and that it has become, like boots and bedsteads, standardised. I demur. Manufacturers have

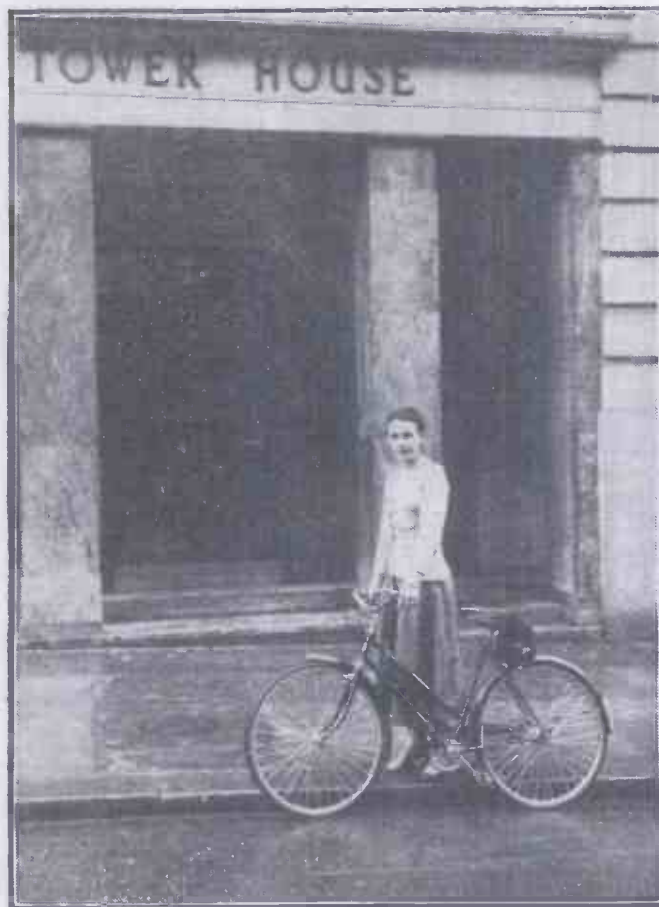

Miss Grace Bourke arriving at Tower House.

attendance in the evening for any other subjects which may be necessary to complete courses qualifying for national certificate or other examinations.

This scheme should help to provide a higher standard of technicians for the cycle and kindred trades.

## Irish Cycle Queen

FOLLOWING the election of an Irish Cycle Queen from 3,000 entrants at the recent Dublin Cycle Show, the winner, Miss Grace Bourke (whom you see in the picture on this page, arriving at Tower House for an interview with the Editor), flew with her mother from Dublin to London for a

not the advantage as other industries of an independent research association which can investigate problems and pass them on to the manufacturers generally. Few firms can afford a costly experimental department, but all firms collectively could. Were there such an association it could investigate a large number of problems the solutions to which are long overdue. For example, are thirty-two spokes really necessary in the front wheel and forty in the back? Is there any advantage in the upright frame? Can the weight of a bicycle be materially reduced? Can an alternative drive, all enclosed, be cheaply incorporated? Is it possible to instal a light, direct current dynamo?

# Wayside Thoughts

By F. J. URRY

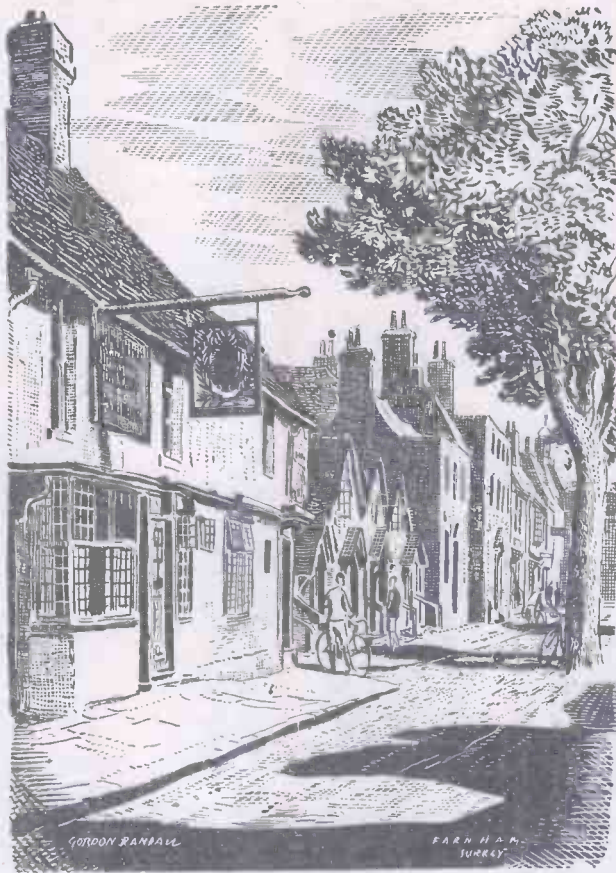

The old Nelson Inn, Castle Street, Farnham, Surrey

## Getting Back

THERE is a consummate pleasure and a rising tempo of enjoyment in the process of recovering after five or six weeks of alteration and repair, and in late June and early July I was feeling the return of full liveliness, and the reconditioned engine was doing well. Soon I was running under my own power, if not with increased speed at least with all the old flair for sitting in the saddle and watching the cool summer soothe the land with all the mystification of the elements, and it was very good to be alive. I confess to feeling a bit of a fraud when advisers sent me away for a cruise on a car, and even gained from a close control a few gallons of petrol for the purpose. This suited my people, and it just had to suit me on the promise that a fortnight so spent would put me in possession of a pair of legs that would then kick me over many thousands of miles of travel and restore the individual freedom that has become so charming a possession through life. Under Snowdonia, in the Vale of Festiniog there is an inn at Tan-y-Bwlch, the Oakeley Arms, which is doing a job of hospitality as richly and delightfully as any spot I have found since 1939, and from thence four of us explored the little roads that curl and climb into the hills within a twenty miles radius of our headquarters. Limitation of the spirit that moves cars restricted our wanderings, there was no dashing from place to place, but instead a searching of the maps to discover which faint lines thereon led through the hills or climbed to upland valleys under their rugged ridges and gave access to the changed visions of the much travelled roads of the Principality.

## The Difference

I DO not like motoring: I become conscious of being pushed around like a bale of goods with a label on, and there is no waiting on route until the package has been duly delivered. But on this occasion I had no choice in the matter, for it was either travel by car or go by train, and I like the car better because it can provide you with a picnic lunch or tea in delectable places. And a life of cycling has not fitted me for a sedentary holiday when one is supposed to rest within a very limited area, absorb the sunshine (if any) and remain contented—like a cabbage. Cycling has made me a nomad when holidaying, and I'm glad it has, otherwise I feel I should never have become quite alive. Actually the shortage of petrol allowance was by no manner of means an unmixed blessing, for our little outings were taken slowly and all the journeys

were of an explorative nature with the inch ordnance of the area to help. And I discovered this, that though I thought I knew the district of Snowdonia very thoroughly, there were still many miles of rough little lanes running high up under the ridges of the hills and leading to remote farms that had a wild charm and often a wonderful vision to render a new picture of a well-known area. There were dozens of gates to open and shut, and the car's speed was never more than ten because it had to pick a careful way over the rock-ribbed surfaces. We would walk to little vantage points, adding another heart beat to our love of Wales, and always could find a wind-sheltered spot where the primus could roar undisturbedly cooking whatever luck, and a trifle of scrounging, brought us, or boiling the kettle. A little motoring and a little scrambling made me fitter every day.

## The Quiet Way

MOST tourists know the climbing road that runs into the hills to Cwmbychan Lake, and lovely as is that way, I think the little lane branching right a mile up is more beautiful still. It leads along the brook Bwlch Drws Arddwy from the glen of Nant Col and runs into a wide vale right under the Rhinogs, Fawr and Fach. There is no more beautiful upland valley in Wales with a scene at once so charming and so wild. From its six hundred feet of elevation a coast vision so attractive with the whole Llwyn Peninsula spilling its diminishing hills into the sea. The way does not go through the gap of the Rhinogs as the outline of the hills seems to invite, but near the last farm but one before it peters into a sheep track, a gated way of grass and boulders swings right along the cornice of the hills and finally drifts down to Dyffryn and the main coast way. Much of the route is rideable, in fact with the aid of a very low gear, all of it, and I know few better spots for a camp site well away from the "madding crowd" with water, river lawns and farm produce at command. The valley of Cwmbychan is beautiful, and of course to the handy cyclist it leads over the Roman Steps to the Dolgelly-Trawsfynydd road and that way through is an attraction: yet I think this Nant Col climb to the fairy valley is a gem with which to fill a lovely afternoon with unforgettable beauty. That is how it struck me; I wanted to stay, I yearned for a snug little camp by one of the musical little falls, with the great rocky flanks of the Rhinogs to shelter me from the north, and in the morning to sip early tea under a clear sky, and then listen to the splutter of eggs and bacon in the pan. And the only folk we met on that ten miles trek were a couple of shepherds with their shy dogs.

## This Summer

THE weather was not good. I met numerous touring cyclists wearing gloves in July; a reflection upon the cool conditions! But they were cheerful people, as indeed the nomadic tribe should be when on holiday, for the damp and cold has little effect on their spirits though it may restrict their visions, and reduce those idle sunny interludes 'twixt lunch and tea when browsing on a bosky bank makes heaven almost a realisation if the ancient prophets are right in promising us rest without pain, anguish or tears. The scanty clothing of the lightweight campers struck me as a trifle meagre with which to meet the unusually low temperatures of late June and early July, but they assured me that with the aid of macks and pullovers even the cold atmosphere of 2 a.m. did not interfere with slumber. How beautiful to be young and full of the warm glory of youth. I had more than a passing glance at the bicycles, and for the main part they were excellent, equipped, nearly all hub or derailleur geared, possessing sturdy carrying equipment, and all the modern ones gay with colour and chrome. I saw one or two still carrying luggage rucksack fashion on their backs while their bicycles were almost free of impedimenta, and though I had no opportunity of asking them why they preferred to burden their bodies instead of their bicycles, I am still curious to know the answer. For it seems that to use a couple of shoulder straps supporting a fairly heavy load would be a most

uncomfortable handicap on a long rise, like the road from Maentwrog to Blaenau Festiniog, for instance, and I have never been able to adduce the reason for loading the man rather than the bicycle. True enough you have to propel the load in any case, but a fit body free from irksome restriction must be a better engine for the pleasant employment of cycling.

## The Growing Roads

ONE day, after a careful counting of petrol coupons, we went through Rhyd towards Beddgelert, along that road skirting the foothills just above the flats of the Glaslyn after its riotous youth through the pass of that name. A mile or so before reaching Pont Aberglaslyn a gated road leads right up the Nant-y-Mor, its only sign being the insignia of the Y.H.A. The hostellers know it and years before the first world war its surface was little better than a river bed. Now it has grown up and has become respectable under foot while retaining its loveliness, yet though we strolled through the hills and had our picnic with Snowdon as a foreground we met no other wanderers. The shepherds were about the fells gathering their flocks for the shearing, the postman was waiting for a lift supplied by the district nurse; and that was all. Beyond the old quarry where the way skips down towards Gwynant the full glory of Snowdon comes into vision with the Watkin-Wynn path stricking from the main road. As a near view of the storied mountain I do not know its peer, and yet how few folk come this narrow way which is one of the little glories of Snowdonia. It may be of some interest to remind people that the Watkin-Wynn track was built in its early reaches by the late Sir Edward of that ilk for the purpose of a great Welsh gathering addressed by Gladstone on the occasion of his third Premiership at the age of 84. It was late in the afternoon when we left our sheltered nook, saw the mist roll off the coned summit of the hill, and the curious effect of the black smoke of the mountain train issuing from the last steep ridge as it puffed to the summit; we could almost hear the engine's anguish in the smoke puffs as it laboured out of sight on the Llanberis side. Through the cool day we drifted up to Pen-y-Gwyrd to the famous inn of the memories of great men of whom Mallory of Everest is one, along the gaunt way to Capel Curig, and into the fair valley of Bettws-y-Coed, and up the ever-beautiful Lledr to the desolation of Blaenau and our comely inn, and the comfort of a fire—in July!

## Storm and Flood

THE fire was needed. Late that night the thump of rain on the window interrupted my sleep. At seven o'clock the floods were out and every hillside pouring in its quota, and still it rained nor ceased till noon with the river five feet over its banks, and the cut hay going out to sea. In the evening we went to see the Lledr foaming through its gorge, and I noticed the gulls were wheeling seaward and the swifts and swallows hawking high. Good signs of a break in this dismal period. Monday was a perfect day with a high wind to blow the remnants of storm away; so in the flattering sunshine we collected some "juice" (what it is to have friends), lunched up the estuary of the Mawddach with all the varied colours aglow, and Cader leaning over the long valley in bright benediction. No wonder the ancients worshipped mountains. Is there a more lovely ten miles in this land of beauty? I doubt it, and seeing it again under a blue sky was a dazzling confirmation of an old experience. We re-visited, too, that rollicking little road running above the ruins of Cymmer Abbey, two miles short of Dolgelly on the left bank of the Mawddach, a road climbing perhaps a couple of hundred feet above the main way on the opposite bank, opening far more extensive views and gathering the afternoon sunshine. A lovely way that makes you linger by its gates, and near its ending dives through a couple of miles of the Jing's Forest to a bridge crossing the river by Tyn-y-Groes. Take it next time you are that way for it provides a refreshment in beauty. The ridges of the Rhinogs against the dropping sun were flamed in colour, and in the cradle of the valley the pattern of the lake relieved the moorland stretches; another instance where artificiality has improved the scene. That was a great day, 39 miles on the clock, an easy ride for a fit man, and as lovely a one as such distance can grant. Then we had to go home, and I was not sorry, for that meant a bicycle again and a fit man to ride it, so fit, indeed, that even the feelings of the family could no longer be outraged when the re-conditioned old thing went sliding off into the summer morning.

A NEW VEST POCKET BOOK

NEWNES METRIC &  
DECIMAL TABLES

By F. J. CAMM

3/6 or 3/9 by post from

Geo. Newnes, Ltd., Tower House,  
Southampton St., Strand, W.C.2.



**A smooth,  
sure GRIP,  
wet or dry**

Ferodo All Weather Brake Blocks are made of a special friction material that is practically unaffected by weather and can be relied on to give you safe, positive control for long hills or emergency stops.

*The price of standard sizes is now*

**6<sup>d.</sup> A PAIR**

**HUB BRAKES.** Ferodo Linings are supplied in boxed sets, complete with rivets, for all makes of hub brake. The size is exact, and the friction characteristics correct, for each type. Also available in roll form.

**FERODO**

**ALL WEATHER BRAKE BLOCKS  
AND LININGS FOR HUB BRAKES**

FERODO LIMITED, CHAPEL-EN-LE-FRITH REG'D TRADE MARK  
A member of the Turner & Newall Organization **FERODO**

**Firestone**  
BEST TODAY ★ STILL BETTER TOMORROW

**Tailor-made  
CYCLE TUBES**



*'No other cycle tube really satisfies me now'*

Firestone Cycle Tubes are made of finest quality rubber, processed to give long, tough service. They are circular moulded—tailor-made to avoid wrinkling—fitted with Rubber Base Valves.



*Announcing a New*

# Hercules

LIGHTWEIGHT SPORTS MODEL  
531 TUBING

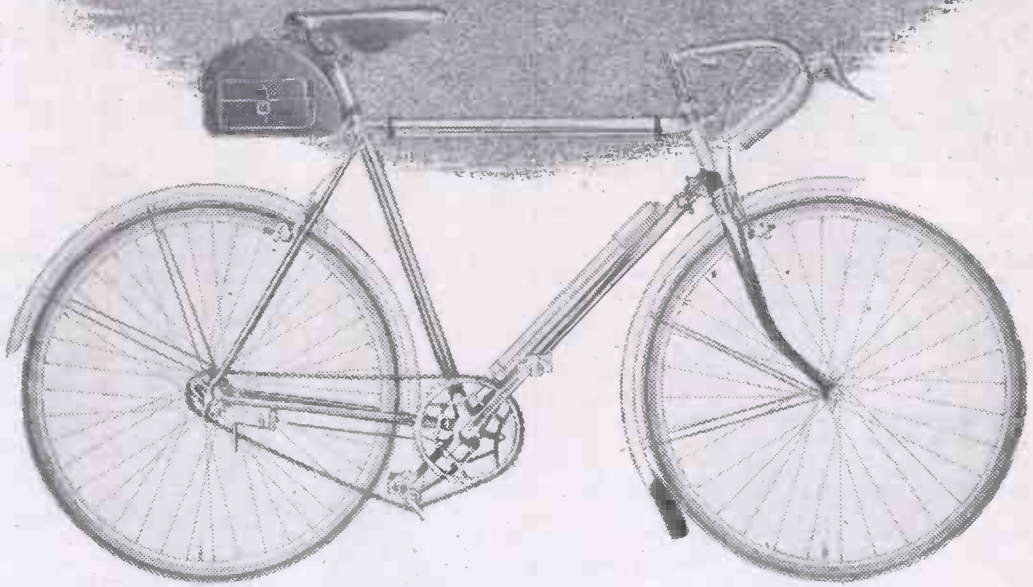

## *The New Kestrel*

Specially constructed frame of 531 tubing. 21" and 23". Frame angles  $70\frac{1}{2}^\circ$  Head and  $70\frac{1}{2}^\circ$  Seat. Finished in unique polychromatic gold.

Price (incl. P.T.) **£14.5.0** Speed gears extra

Prices do not apply in Eire.

THE HERCULES CYCLE & MOTOR CO. LTD.,  
ASTON, BIRMINGHAM



# CYCLORAMA

By  
H. W. ELEY



The MUSIC ROOM  
with its lovely timberwork.

The old Ostrich Inn, Colnbrook, Bucks.

## Cycle Exports Still Rising

THE increasing exports of British cycles made a national newspaper story the other day . . . so noteworthy were the figures. Truly, the British bicycle industry can be proud of its recent achievements! There seems to be no shortage of machines for the home market, and the dealers' shops which I pass on my travels are well stocked, and the machines attractively displayed; and this output for home, together with that for overseas, is very considerable indeed. I should imagine that in any review of British industries which Sir Stafford Cripps may make in the quietude of his study, the position of the cycle industry must impress him as being very healthy and encouraging indeed.

## Into the Storm

AUGUST Bank Holiday . . . and a bright and sunny morning; every sign of continuing fine and warm weather as I stood at the door of a country cottage, waiting for the kettle to boil for my early morning cup of tea; early though it was, the bees were droning along the colourful garden border. Just the hot, sultry day, I thought, for a ride into the cool woodland country, where the trees in the ancient wood make a canopy of green and one may lie among the bracken, shaded from the sun. These were my thoughts as I listened to the singing of the kettle; by evening I was a drenched, bedraggled cyclist, riding through sheets of rain. But I did not complain . . . that rain on my face was very refreshing; the fields drank greedily of the moisture they had yearned for during those sultry days when there was hardly a breath of air over the fields, and when, in the village, one felt drowsy all day . . . and the old spaniel at the inn was content to lie lazily on the worn step of the inn, not bothering even to cock an eye when a customer entered for a cooling draught of "mild and bitter." And my good farmer friend at "Three Elms" rejoiced in the rain . . . as farmers do.

## "High Tea" Again!

IT is one of the very pleasant features of this "Cyclorama" contribution that I receive a goodly bit of correspondence from readers, and I have many interesting letters on my files. One, received the other day, told of a tour in Staffordshire . . . and one of the items of news cheered me not a little. My correspondent had been riding around Rugeley and Armitage and up to the Cheshire border. "At a village near Rugeley," he wrote, "I partook of a real old-fashioned Staffordshire 'high tea,' with pork-pie, scones, brawn, lots of home-made jam, and sausages of old-time consistency." Now, I am not proposing to enter into any controversy about the "how and the why" of this succulent repast . . . I believe in the truth of my correspondent's statements, and have a yearning to journey to that village (which shall be nameless) and eat just such a meal. As a son of Staffordshire, I have happy memories of the county's "high teas"—with tables loaded with good food—and, later in the evening, of visits to a local village inn, there to drink good ale from old pewter tankards. Maybe such days will return, and the glories of the table with them! Let us hope so.

## Checkers On the Road

THERE are so many Government officials to-day . . . so many Ministries watching our behaviour, and our observance of the countless regulations which govern our lives, that I wondered, during the Bank Holiday period, whether cyclists and motorists were being watched for breaches of the "rules." As I rode along the highway I observed the posters—"Mind how you go"; I noticed the many local Road Safety campaigns which were being run by the authorities, and I wondered whether the general standard of riding had improved. My own belief has always been that the cyclists of this country, in the main, do obey the law, and do observe the courtesies of the road which are essential for our safety. There are "black sheep," of course . . . but not many, I fancy.

## October Charm

SO often October is a grand and lovely month; King Winter is not as yet established on his icy throne, and my records of October riding show that the month frequently gives us a lot of sunshine. It is a month of rich colours in the countryside. The berries are many-hued, and the trees at their golden best. That ridge of elms over by Long Roodham is glorious in autumn garb, and I love to wander in the old plantation on an October afternoon, when the sun glints through the branches and the brambles call one to pick those succulent blackberries which provide such a wonderful free feast for all who will gather them. The grey squirrels slip quickly up the smooth trunks of the beeches as I emerge from the glade; a gaudy jay darts by, squawking with raucous note; and the woodland ride is a soft carpet of brown leaves, with many fallen acorns under the old oak.

## A Note for Dealers

WHEN I was young, and learning the business of advertising (and what a fascinating business it is!) I was keenly interested in the question of window display. To the dealer, his shop window is the "silent salesman," and I think that much could be done to improve the standard of display these days. Of course, owing to the war and its aftermath, the cycle and tyre manufacturers have been unable to provide such ample window-display help as formerly. Materials are in short supply still; those fleets of "advertising vans" which used to be so helpful to the trader have disappeared. And, generally, this vital question of window display is rather in the doldrums. But there is much that the individual dealer could do himself. A little ingenuity . . . a little planning . . . and a greater appreciation of the important part which the shop window plays in the sales scheme and we should see some brighter and more attractive windows.

## BOOKS FOR ENGINEERS

- |  |   |
|--|---|
| Screw Thread Tables, 5/-, by post 5/3.                       | Screw Thread Manual, 6/-, by post 6/6.                        |
| Refresher Course in Mathematics, 8/6, by post 9/-.           | Compressed Air in Engineering Production, 17/6, by post 18/-. |
| Gears and Gear Cutting, 6/-, by post 6/6.                    | Newnes Metric and Decimal Tables, 3/6, by post 3/9.           |
| Workshop Calculations, Tables and Formulæ, 6/-, by post 6/6. | Plant Engineers' Pocket Book, 6/-, by post 6/6.               |
| Dictionary of Metals and Alloys, 10/6, by post 11/-.         |   |
| Wire and Wire Gauges (Vest Pocket Book), 3/6, by post 3/9.   |   |

Published by

GEORGE NEWNES, LTD., TOWER HOUSE,  
SOUTHAMPTON STREET, STRAND, W.C.2

# My Point of View

By "WAYFARER"

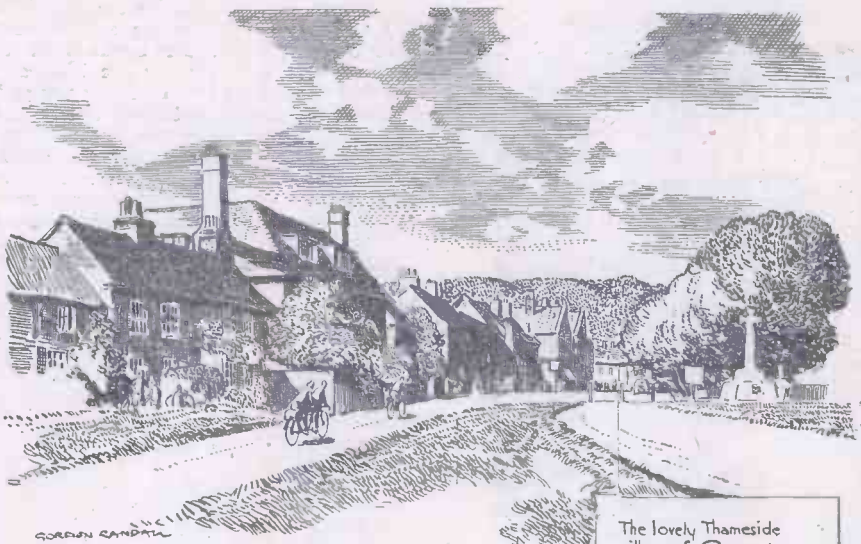

The lovely Thameside village of Cookham with Cliveden Woods in the background.

## Diagnosis

I HAVE just been discussing cycle-touring with an acquaintance, who expressed the opinion that 30 miles was a commendable day's journey. In reply, I said, quietly: "I'm starting off tomorrow for a tour, and if I don't average between 60 and 70 miles a day, without trying, I shall think there's something wrong with my heart." His rejoinder was: "Oh! there's nothing wrong with your heart, but what about your head?"—and we left it at that!

## First Things First

A RECENT Sunday morning jaunt was interrupted by a tyre which suddenly decided to go flabby. Cutting out the projected final detour, I made straight for my lunch destination, intent on doing the repair job under decent conditions. At the second pumping, however, the valve hissed at me, and my hopes were realised. Had it been necessary for me to tackle a repair, my first step would have been to examine the valve, and that is always excellent advice to follow, unless a puncture shouts at you. All I had to do on the occasion here referred to was to fit a new valve tube, which was the work of a moment. And so let "first things first" be the slogan—except (as I say) on those occasions when a perforation is obvious and clamant.

## Goggles

I SOMETIMES feel that the use of goggles is rather overdone, and that they may be worn for effect. Except on one occasion many years ago, I have never found the use of goggles necessary. The sun does not trouble me in the least, and my great objection to smoked or tinted goggles is that they destroy the beauty and the brightness of the day, causing a dullness which gives one an entirely wrong impression as to the state of the weather. In this country of ours we really cannot afford to tone down the rays of the sun. At least, that is my view, and herein lies the source of my prejudice—if it is a prejudice. I observed the other day, in the heart of a great city; a young cycle tourist whose eyes were well protected with coloured goggles complete with wire entanglement. As it was a grey day, I wondered what was the purpose of this elaborate equipment. Of course, the lad may have had weak eyes—but, somehow, I doubt it.

## Agreed

A MOTORIST of fifteen years' experience writes to *The Birmingham Post* to say this: "I am more than ever convinced that every accident can be avoided; and that it is not entirely a question of an acquired road sense, but of a keen sense of anticipation of what is likely to happen ahead of you; and of being ever ready to apply the brake and to start reducing

the speed of the vehicle, car or motor cycle, even before reaching the obstacle, the animal, child, or adult." How right he is! I keep on saying that same thing about the avoidability of accidents, barring, of course, those arising from a sudden mechanical fault. I continue to reiterate that any observer of ordinary intelligence can see accidents being manufactured. It is done deliberately through the medium of taking risks and "chancing your arm." Surely the time has come for a halt to be called, to the end that the majority of those who are killed and maimed in road accidents can go on living out their allotted span, and living it in one piece, physically.

## The Borrowed Bicycle

AS the train hurled me on a sixty-mile journey I studied my day's programme of work in conjunction with a map, and was horrified to realise that I had bitten off far more than I could chew. In other words, I was contemplating a job which should have been spread over three or four days, instead of the one and a half days I had in mind. When the train had disgorged me, a spot of quick thinking led me into a garage. Could I borrow a bicycle—and a pair of trouser clips? The goods were produced, the tyres of the bicycle were filled with air, and off I went. I realised, of course, that hired bicycles do not induce enthusiasm for the pastime. This did not matter, for I possess an enduring love of the game, and a few hours on a borrowed steed could do nothing to affect that.

## Second Thoughts

To start with—it was slightly wet at the time—the tail of my raincoat jammed in between the back wheel and brake, and I had to climb out of the coat before I could secure my release. I took precautions to prevent a recurrence of this. Half an hour later the wire of the back brake, which was working very harshly, broke (owing to gross neglect), and I promptly returned the bicycle to its home, the nature of the country in which I was operating stressing the folly of riding a free-wheel bicycle with only one brake. The garage folks offered me their only alternative—a lady's bicycle which they assured me ran very sweetly. I looked at the steed without enthusiasm and rejected the offer with scorn. I was certainly not going to parade about the country on a lady's bicycle. So I commenced the stamping act, realising that I would get very little work done and that the process of walking from call to call would soon become a burden. That realisation arrived quickly, and, pocketing my pride, I slunk back to the garage, examined the female bicycle, looked with horror at the upturned handlebars—and rode away on the machine! For the remainder of that day and for the whole of the next day I trundled that machine about the countryside, actually, in the end, completing my programme of calls. The sweetness of running, promised by the garage folk, was a fact. I crashed

my ankle every time I mounted or dismounted, and then I decided to get on and off "through the frame," just as though I were a lady. I hated the sit-up-and-beg position which I was compelled to adopt, and hoped that none of my friends or acquaintances would see me! But what a godsend that bicycle was to me! Utility!—thy name is indeed "bicycle!"

I called at the garage a few days later, with a new programme of calls. The brake on the man's bicycle had been repaired and was working satisfactorily, and I took that machine in preference to the female one. It served me well. Yet a third time I went and borrowed the steed, with the result that, in a very short space of time and at quite a negligible expense, I completed the work awaiting me in that area.

## Aftermath

THE curious effect of riding a free-wheel bicycle for a day and a half may fitly be mentioned. For the last 25 years I have used fixed-gear bicycles exclusively, barring those rare occasions when I have ridden "free" for a mile or two. When I mounted my own bicycle three or four days after the experience first above-mentioned, I was conscious of a certain oddness about the machine. To my great surprise, the pedals did not cease revolving when back pressure was applied to them! That oddness continued throughout the day, and was revived on later dates when I reverted to my own machine after using the borrowed bicycle. It is certainly curious that a quarter of a century's experience should be "blanketed" in this way through the medium of a few hours' riding of another sort of bicycle.

## Disparities

I WAS shown a newspaper-cutting the other day, dealing with certain police-court proceedings in a small country town. It was an entertaining mixture of "cycle and dog-licence fines," as per the heading. A farmworker and (presumably) his wife were each fined 10s., including costs, "for riding the same bicycle." There! And I didn't know that was an offence against the law. Then two or three cyclists, charged with riding without lights "during the hours of darkness" (that isn't what the Act of Parliament says!) were each fined 15s. "for each missing light." On the scanty knowledge available, that decision seems to me to be a bit harsh—a fine for the offence, rather than in respect of each light omitted, being surely called for. The probably much more deliberate "crime" of keeping dogs without licences resulted in a fine of 7s. 6d. in each case. These punishment disparities are rather glaring.

## The Way In

THE wonder to me is that more cyclists, making their way to the Ceiriog Valley from the south, do not patronise the very delightful "slip" route which is shorter and easier than the main road, and enables Chirk (for what it is worth) to be avoided. Turning left off the Holyhead Road by Gobowen Church, you then turn sharp right and proceed along a quiet road which gradually edges away from the main road. After going under the railway bridge (once the property of the Great Western, and now partly mine!) you turn left and go through Weston Rhyn and then gently over the hill to Bron-y-garth and down into the Ceiriog Valley, obtaining a magnificent view of Chirk Castle in the process. It is years since I first used this alternative route, and years since I last used it—until July of this present year of grace, when it was my good fortune to traverse those quiet ways on several occasions.

## Every Saturday Off

AS regards work, I am a six-days-a-week man. The happy lot of those who cram the week's work into five days, and thus have two full days in which to play, is not for me (for the time being, anyway). As I trickle down to my office on Saturday mornings I regularly see obviously touring cyclists en route for the country, and, it must be admitted, I feel slightly envious. It is such people as these, it appears to me, who are able to obtain the full advantage from the five-day week, and I feel almost inclined to suggest that such advantage is exclusive to cyclists. Be that as it may, it is good to see these lads and lassies making wise use of their new-found leisure. A weekly break of two full days seems disproportionately more than that of one and a half days (now in course of being outmoded), and, rightly used, it provides a magnificent holiday space every week. How much can be seen and done in a couple of days! It is almost worth a week's holiday in the case of the average non-cyclist, especially as every moment of the time, from the moment of starting off to the moment of arriving back home, is holiday.

## SAVE THAT CARTON

Every empty breakfast food, sugar, cigarette, soap-flake packet is urgently needed for salvage.

### "Practical Mechanics" Advice Bureau COUPON

This coupon is available until Oct. 31st, 1948, and must be attached to all letters containing queries, together with 3 penny stamps. A stamped, addressed envelope must also be enclosed.

Practical Mechanics October, 1948

Published about the 30th of each month by GEORGE NEWNES, LIMITED, Tower House, Southampton Street, Strand, London, W.C.2, and Printed in England by W. Spaight & Sons, Ltd., Ekmoor Street, London, W.10. Sole Agents for Australia and New Zealand—Gordon & Gotch (Asia), Ltd., Sole Agents for South Africa—Central News Agency, Ltd. Subscription Rates (including postage): Inland, 10s. 6d. per annum. Abroad, 10s. per annum. Canada, 10s. per annum. Registered at the G.P.O. for transmission by Canadian Magazine Post.

CONDITIONS OF SALE AND SUPPLY: This periodical is sold subject to the following conditions, namely, that it shall not, without the written consent of the publishers, first given, be lent, re-sold, hired out or otherwise disposed of by way of Trade except at the full retail price of 9d., and that it shall not be lent, re-sold, hired out or otherwise disposed of in a mutilated condition or in any unauthorised cover by way of Trade, or affixed to or as part of any publication or advertising, literary or pictorial matter whatsoever.

## TELEVISION COMPONENTS

SCANNING UNIT to "Electronic Engineering" Spec., 30 - each.  
 LINE TRANSFORMER to match, 30/- each.  
 FOCUSING COIL (Electro Magnet) 36/- each.  
 SET OF THREE ABOVE. £4/15/0. complete, carriage paid.  
 Complete set of Blueprints and Drilling Templates ready shortly for Home Constructors of Television Receivers. S.A.E. for details.  
 EX. R.A.F. ELECTRIC MOTORS. 6,000 revs., approx. 1 h.p. Will work on 12, 27, 200-250 volts A.C. or D.C. Brand New, 35/- post paid.  
 DOUBLE REDUCTION GEARED MOTORS. Size approx. 2in. x 2in. x 3in. Dustproof. Very powerful. Works on 12 volts A.C. or D.C. Ideal for driving models. 17/6 post paid.  
 ALSO RADIO BOOKS AND MANUALS. Send 2/6 stamp for booklet describing over 50. From

**MORTONS**  
 13, Camden Rd., Walthamstow, London. E17

## MATRIC.

WHY needlessly handicap yourself and watch other people winning success and security? Whatever your age, you can now prepare for the all important Matriculation Examination at home on "NO PASS—NO FEE" terms. Write now for our valuable "GUIDE TO MATRICULATION" which explains the easiest and quickest way to matriculate—FREE and without obligation.

**BRITISH TUTORIAL INSTITUTE**  
 (Dept. 160), 356, Oxford Street, LONDON, W.1.

## "NO PASS—NO FEE"

## Make your own TELESCOPE

High Quality materials to make 6in. telescope reflector, as described by T. J. Mulligan in this magazine March and April 1948.

No. 1 kit comprises: Optical Rouge. Sufficient Carborundum powder of seven different grits.

Best Swedish Blank. Mirror Disc Pitch, 6in. dia. x 1in. thick. Plate Tool disc, 6in. dia. x 3/8in.

Detailed illustrated instructions by T. J. Mulligan. Packed in stout box, post free, for 55/-

**A. J. S. McMILLAN**  
 5, Oakfield Rd., Bristol, 8

## CRAIG'S LATEST

Radio Circuit. Personally designed, tested and guaranteed. No experience needed to build this Super T.R.F. 4-valve set. M.W. AC/DC High Quality Output. Clear Diagrams. Detailed Instructions. Parts List, etc., 3/6.

**H. CRAIG**  
 64, CONYERS RD., STREATHAM, S.W.16.

**RADIO BARGAIN CORNER**  
 BRAND NEW VALVES at CUT PRICES. guaranteed: EF35, EF36, EL32, ECH35, EBC 33, 6X5C, 6Z4G, 8/-; 3 for 22/6. 6K3, 6K7, 6Q7, 6V6, 6SN7, 6J7G, KT33C, ECC31, 6N7, 5U4, 5Z5, FW4/500, 10/-; any 3 27/6. PX25's, 30/- matched pair. A.C. gram motor, 9in. table, 75/-; Collaro ditto, 12in. table, 118/4. Collaro Motor/Pickup/autopost, latest model, A.C., 29/-; A.C./D.C., £12/18/9. Super T.R.F. and Superhet Kits (complete). 2/6. for special P.M. Bargain List.  
 N.R.S., 102, Parkhill Rd., London, N.W.3.

## CATALIN

We hold large stocks of the wonder cast resin. Gorgeous colours in rods, cylinders, sheets, shapes, etc. S.A.E. Lists. Sample Table Lamp parcel 9/- post free.

**NEW**  
 Plastic Resin Glue. Heat- and waterproof. Sticks anything. 3/6 post free.  
**TOWN BOOKSHOP, Enfield.**  
 'Phone: ENF. 4948.

## TECHNICAL TRAINING

The Institute of Practical Radio Engineers have available Home Study Courses in every phase of radio and television engineering, specialising in the practical training of apprentices in the retail trade. Enrolments limited. Fees moderate. The Syllabus of Instructional Text may be obtained, post-free, from the Secretary, I.P.R.E., Fairfield House, 20, Fairfield Road, Crouch End, London, N.8.

## NO MAN CAN KNOW TOO MUCH OF HIS PRODUCT

For the close scrutiny of every conceivable object, metals, tools, fabrics, fibres, minerals, precious stones, paint, print, manu-

The Ultra Lens is a revealing eye of six actual diametrical magnifications, which brings out points of strength or weakness, and enables the most minute measurements to be gauged accurately. Whether you are engaged in manufacturing, buying or selling, it is an ally of real value. No instrument you can buy will more quickly justify and pay for itself.

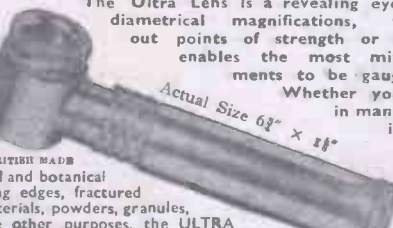

BRITISH MADE  
 scripts, biological and botanical specimens, cutting edges, fractured surfaces, raw materials, powders, granules, and innumerable other purposes, the ULTRA LENS is invaluable, and presents in many instances hitherto unsuspected data which can be used to advantage.  
 FULL PARTICULARS ON REQUEST  
**THE ULTRA LENS COMPANY,**  
 75, Finsbury Court, Finsbury Pavement, London, E.C.2.

### EXTRA CASH IN SPARE TIME

Cutting moulds deep cut. Battle dress Soldiers, Aeroplanes, Farm and Wild Animals, Cars, etc. Stamped envelope for list. Illustrated Catalogue 6d

## TOY-CASTING MOULDS DEEP CUT

Soldiers, sailors, airmen, ships, 'planes, tanks, cars, farm animals, wild animals and keepers. Sample mould 3/6. Plastercraft Metal Moulds.—Wall plaques, galleons, brooches, dog ornaments, etc. Sample mould of brooch 3/6. German flat moulds from 3/6. S.A.E. for List. 9d. for Illustrated Catalogue.

**NUTHALL, 69, ST. MARK'S RD., HANWELL, LONDON, W.7**

**BOOKS:**

"TITANS" L.M.S. 2/-, G.W.R. 1/6
"The 20,000 British Locomotives" 2/6
"Studies in Steam" 3/6
"Model Railway Signals" 3/-
"How to Build Good 00 Loco" 5/6
"Model Railway Hobby" 10/6
New Developments in Railway Modelling 15/-

**USEFUL PARTS**

Round Spring Buffers 7d. 9d.
S.L. or 3 Link Couplings, pair 2/4d.
Corridor Connections, pair 2/-
Motor Bodies 12 v.d.c. 42/6
Ex R.A.F. 5 point Switches 2/6
Ex R.A.F. 16-Switch Panels Now 2/6
Postage extra "00" or "0" Parts List 3d. per post.

**TYLDESLEY & HOLBROOK (M.E.T.A.),**  
 109, DEANSGATE, MANCHESTER, 3

Construct your own **WATER SOFTENER** Easily, from Readily Obtainable Materials Only. Costs shillings. Selling Price—Pounds. SAVES 50 per cent. of **YOUR TEA AND SOAP RATION** Sets of Clear Diagrams and Instructions 3/6d. Included FREE—Sample of Zeolite W.S. Compound (stocked). Prompt posting.

**W. S. ROBERT, "Hollywood,"**  
 Hauteville, Guernsey, C.I.

1 pint Spray Guns ...	£3 10 0
1 pint Spray Guns ...	£2 0 0
3 C.P. Compressors ...	£9 10 0
6 C.F. Twin Compressors ...	£22 10 0
Air Chambers with Gauges ...	£3 10 0
6" Saw Machines ...	£7 10 0
Heavy Duty Jig Saws ...	£20 0 0
Air Hose, V. Belts, Pulleys, Gauges, Valves, etc.	

Illustrated Lists.  
**H. HALL, 2, Glamis Way, Greenford, Middlesex.**

**TRANSFORMERS**  
 Thompson's of Greenwich (Estb. 1897) can now supply their Guaranteed **TRANSFORMERS FOR TRAINS** 12 or 20V. 11A..... 20/-  
 12 or 25V. 24 A..... 25/-  
 Models to suit individual requirements. Step-up or down for American Radios 110V-220V, etc., and Chargers. Send stamp for estimate and List.  
**T. W. THOMPSON & CO.,**  
 176 Greenwich High Road, Greenwich, S.E.10.

**"PERIMET" ELECTRODE SOLDERING and BRAZING TOOL.**  
 Operates from 4 or 6 Volt Accumulator or Transformer.

Price 15/-, post free.  
**MAINS TRANSFORMER.** 4 Heats. 35/-, delivered.  
**HOLBOROV & CO., 71, Weymouth Bay Avenue, Weymouth.**

## SPARKS' DATA SHEETS

Provide detailed Instructions with Clear, Full-size Constructional Prints of Tested and Guaranteed Designs.

**THE "CONQUEST"**  
 My Latest Design. A Very Efficient A.C./D.C. ALL-WAVE SUPERHET Five Valves, including Rect., 3-Wave Bands. Delayed A.V.C. 4 Watts Output. P.U. Connections. Good Range, Selectivity and Quality... 2/9

**THE "CRUISER"** All-dry T.R.F. 3-Valver for use with rod or short aerial. Compact ... 2/6  
**THE "CUB."** A.C./D.C. 2-Valver Plus Rect. Fine results on Med. and Long waves. Good Tone... 2/6  
**THE "CADET."** A.C./D.C. 4 Watt Amplifier. Two Valves, plus Rect. Ideal for P.U. ... 2/6  
**THE "OLD FOLKS TWO."** An A.C./D.C. 2-Valver, plus Rect., having Station Selection by Switch. A fine trouble-free Set. M.L. Waves... 2/9  
**THE "CHALLENGER."** An Outstanding A.C./D.C. Portable for use in any room without aerial or earth; 3-Valve T.R.F. circuit, plus Rect. 2/9  
**A.C. TWO-VALVER (Plus Rect.)** M/L Waves. Fine Power and Tone. Very widely used. ... 2/6  
**A.C. THREE-VALVER (Plus Rect.)** T.R.F. Circuit. M/L Waves ... 2/9  
**A.C. SUPERHET.** 3 Valves plus Rect. All-wave. 4 Watts Output ... 2/6  
**A.C. 8 WATT QUALITY RADIOGRAM.** A.C. M/waves only. Quality rather than range. P.P. Neg. F/Bk. 3/6  
**BATTERY ALL-DRY PORTABLES.** Tiny Two. Med. waves. Local station on 2 1/2in. Sparker ... 2/6  
**THREE-VALVE PORTABLE.** M/L Waves. A very popular Set... 2/6  
**THE PORTABLE FOUR.** Med. waves only. T.R.F. Circuit ... 2/6

MANY OTHER DESIGNS for Sets and Amplifiers. Stamp for List and with order. Prompt Service. Components supplied.

**L. ORMOND SPARKS (M),**  
 8, Phoebe Road, Brockley, S.E.4 (Nearest Station: Ladywell S.R.)  
 ('Phone: Lee Green 0220.)

## TARPAULINS

Genuine Ex-Railway and Ship Waterproof. Guaranteed Good Condition. 70 sq. ft., 20/-; 140 sq. ft., £2 10s.; 280 sq. ft., 25. Approx. 360 sq. ft., 26. Approx. 720 sq. ft., £12. All include carriage, Ex-W.D. Shovels, 3ft. overall, 3/9 each, carr. 1/3. Entrenching Spades, 18in. overall, 1/6, carr. etc., 9d. U.S.A. Waterproof Knee Boots, new, Rubber soles, 2/6, post, etc., 1/-. New Weather-proof Gauntlets, 5 pairs, 2/6, or 4/8-gross, carr. free.  
 Tents, Marquees and all sorts camping equipment in stock. Send 1d. for Bargain List.  
**HEADQUARTER & GENERAL SUPPLIES, LTD., DEPT. PEIT,**  
 196/200 Coldharbour Lane, London, S.E.5. 1 min. from Loughborough Junc. Station, London.

## ZEOLITE

**WATER SOFTENER REFILLS**  
 Refills for water softeners at reasonable charge. This Zeolite is of a high exchange rate value and is guaranteed. Price of refill upon application. State gallons of water to be softened between regenerations. Particulars from **HALL AND HAMBLEN, BCM/ROS, LONDON, W.C.1.**

## WEBLEY AIR PISTOLS

Marvellously accurate for target practice.  
 No licence required to purchase.  
 Senior Mark I  
 Junior Webley Air Rifle  
 Write for List. **WEBLEY & SCOTT LTD.,**  
 106, Weaman Street, Birmingham, Eng.

## ELECTRIC HAWAIIAN GUITAR

In a few winter evenings you can produce a first-class instrument, with the aid of my drawings and full constructional details. Used throughout the World. 7s. 6d., post free.  
**C. W. CRAG,**  
 48, High St., Oakham, Rutland

## SAILOR SAM'S SECRET

How to Make Ships in Bottles, Kits, 5/6 and 6/-  
 Flying Fish Sold Gliders  
 The Super Kit, 4/3  
 Stocked by Model, Sports and Toy Stores  
 Dealers write for terms  
**COOPER - CRAFT, LTD.**  
 THE BRIDEWELL, NORWICH

## ELECTRIC "PIGMY" MOTORS

A.C./D.C. REVERSIBLE  
 Specially Designed for Driving Models.  
 Size 2 1/2 x 2 1/2 x 1 1/2, shaft 3/16, weight 91 ozs.  
 Model No. 1, 4 to 8 volts, 20/- Postage 8d.  
 Ex-Govt. motors, 12/24 v. D.C., 2 1/2 x 1 1/2 x 1 1/2, 1 A., 1/20 h.p., 12/8; 12/24 v. A.C./D.C., 2 1/2 x 1 1/2 x 1 1/2, 1 A., 1/80 h.p., reversible, 19/6.  
 Worm gears, 10-1 in case, 8/-; 10-1, no case, 5/9; 40-1, no case, 5/9. Armature stampings (3-pole), 1in. dia., 3/22in. shaft, 0/20 thick, 2/- per doz. End fibres, 2d. each. Magnets on application. Stamp for leaflet. Satisfaction guaranteed.—E. M. Co., 120, Torrington Avenue, Coventry.

## ARMATURE RE-WINDING

Re-winding of armatures and field coils for Portable Tools, Vacuum Cleaners, Polishers, Hair Dryers, and similar Appliances.  
 Six months guarantee with all complete re-winds. Send to:  
**JOHN F. KNELL, "Sherwood,"**  
 Merry End, Middleton-on-Sea, Sussex.

## RATCHET & REVOLUTION COUNTERS

Ask for Leaflet No. 18/5  
 Speed up to 6,000 r.p.m.  
**B. & F. CARTER & Co. Ltd., Bolton 5**

## it an OILCOIL

For increased power, improved petrol consumption, better starting. Send for interesting booklet Z17.  
**RUNBANKEN MANCHESTER**

## FLOUORESCENT LIGHTING

220-240v. A.C. 80-watt choke-capacitor unit, holders, glow-switch, ready to install less 5ft. tube, 47/6. 4 h.p. single phase 230v. motor, 28 5s. 0d. Transformer 230v.-36v. 2a, 10/- All new, carr. free.—Malden Transformer Supplies, 39, Malden Road, New Malden, Surrey.

# Free Guide — "Success in Engineering"

One of the following Courses taken at home in your spare time can definitely be the means of securing substantial promotion in your present calling, or entry into a more congenial career with better prospects.

## ENGINEERING, AERO, ETC.

Plastic—Radio—Aero Engines—Aircraft Design—Welding—Aerodynamics—Electrical Engineering—Television—Electric Wiring—Diesel Engineering—Generation and Supply—Works Management—Metallurgy—Refrigeration—Planning. Estimating. Rate-fixing—Time and Motion Study—Aero Inspection—Automobile Engineering—Sheet-metal Work—Engineering Draughtsmanship—Aero Draughtsmanship—Jig and Tool Draughtsmanship—Press Tool and Die Draughtsmanship—Structural or R/F Concrete Draughtsmanship—Sanitary Engineering

## GENERAL

Matriculation—College of Preceptors—Chartered Institute of Secretaries—Aircraft Apprentice.

## MUNICIPAL SERVICE

School Attendance Officer—Handicraft Teacher—Registrar—Housing Manager—Sanitary Inspector—Weights and Measures Inspector—Inst. of Mun. and Cy. Engineers—A.R.I.C.S.

"PRACTICAL ENGINEERING" said—

We recommend all readers interested in improving their position to apply for a copy of this valuable book. "Success in Engineering" is not a pamphlet. It is a 132-page book, containing valuable and vital information on all branches of engineering. . . . There are many engaged in engineering who owe their success to The National Institute of Engineering.

The FREE GUIDE explains:

- Openings, prospects, salaries, etc., in Draughtsmanship, Inspection, and opportunities in all other branches of Engineering and Building.
- How to obtain money-making technical qualifications through special RAPID FULLY-GUARANTEED COURSES.

Write now for your copy of this remarkable publication.

A.M.I.E.E., A.M.I.Mech.E.,  
A.M.Brit.I.R.E., A.M.I.P.E.,  
A.M.I.C.E., A.M.I.Struct.E.,  
A.M.I.Mun.E. M.R.San.I.,  
A.M.I.E.D., A.F.R.Ae.S.,  
London B.Sc., Degrees.

Fully guaranteed postal courses for all the above and many other examinations. Fully described in the Free Guide.

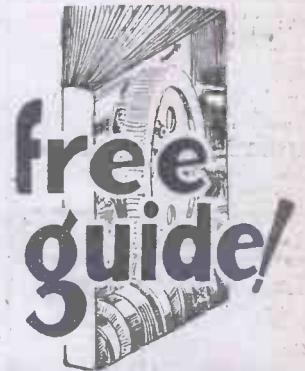

## THE BUILDING BOOM— SECURE YOUR SHARE!

The Free Guide also gives particulars of our extensive range of modern Building and Structural Courses, Building Draughtsmanship, etc. The great post-war Building programme offers unlimited prospects to technically trained men.

## BECOME A DRAUGHTSMAN QUALIFY AT HOME AND EARN BIG MONEY

Men and Youths urgently wanted for well paid positions as Draughtsmen, Inspectors, etc., in Aero, Jig and Tool, Press Tool, Electrical, Mechanical and other Branches of Engineering. Practical experience is unnecessary for those who are willing to learn—our Guaranteed "Home Study" courses will get you in. Those already engaged in the General Drawing Office should study some specialised Branch such as Jig and Tool or Press Tool Work and so considerably increase their scope and earning capacity.



## NATIONAL INSTITUTE OF ENGINEERING

(Dept. 29)

148, HOLBORN, LONDON, E.C.1

OVER SIXTY YEARS OF  
CONTINUOUS SUCCESS

SOUTH AFRICAN BRANCH: E.C.S.A. P.O. BOX 8417 JOHANNESBURG.

FOUNDED 1885—FOREMOST TODAY—OVER 100,000 SUCCESSSES

## THE ACID TEST OF TUTORIAL EFFICIENCY SUCCESS—OR NO FEE

We definitely guarantee that if you fail to pass the examination for which you are preparing under our guidance, or if you are not satisfied in every way with our tutorial service—then your Tuition Fee will be returned in full and without question. This is surely the acid test of tutorial efficiency.

If you have ambition you must investigate the Tutorial and Employment services we are able to offer. Founded in 1885, our success record is unapproachable.

Why not fill in and post the attached Coupon NOW for further details and Free Authoritative Guide to openings in Engineering and Building? This book contains a mine of valuable and exclusive information and may well prove to be the turning point in your career.

PROMPT TUTORIAL SERVICE GUARANTEED

## FREE COUPON

To NATIONAL INSTITUTE OF ENGINEERING  
(Dept. 29), 148, Holborn, London, E.C.1.

Please Forward your Free Guide to

NAME .....

ADDRESS .....

My general interest is in: (1) ENGINEERING (2) AERO (3) RADIO (4) BUILDING (5) MUNICIPAL WORK (Place a cross against the branches in which you are interested.)

The subject or examination in which I am especially interested is

To be filled in where you already have a special preference.  
(Id. stamp only required if unsealed envelope used.)