

LONDON'S NEW AIRPORT

NEWNES

# PRACTICAL MECHANICS

9<sup>D</sup>

EDITOR: F. J. CAMEL

MARCH 1940



# Join the Well-paid Ranks of the I.C.S. TRAINED MEN

THERE IS ALWAYS A GOOD POSITION FOR THE MAN WITH A SPECIALIZED TRAINING, BUT THERE'S NO WORTH-WHILE PLACE FOR THE UNTRAINED

Ambitious men everywhere have succeeded through I.C.S. Home Study Courses. So also can you. We offer you the benefit of our 54 years' matchless experience as the creative pioneers of postal instruction. Since our establishment in 1891, more than 1,000,000 British men and women have enrolled for I.C.S. Courses.



The man with an I.C.S. Training in any one of the subjects listed below knows it thoroughly, completely, practically. And he knows how to apply it in his everyday work.

Accountancy  
Advertising  
Aeronautical Engineering  
Aero Engine Fitting  
Aero Fitting and Rigging  
Aeroplane Designing  
Air-Conditioning  
Aircraft Eng. Licence  
Architecture  
Architectural Drawing  
Boilermaking  
Book-keeping  
Building Construction  
Building Specifications  
Business Training  
Business Management  
Carpentry  
Chemical Engineering  
Chemistry, Inorganic and Organic  
Civil Engineering  
Clerk of Works  
Colliery Examiner's  
Colliery Overman's  
Commercial Art  
Concrete Engineering

Cotton Manufacturing  
Diesel Engines  
Draughtsmanship  
(State which branch)  
Drawing Office Practice  
Electrical Engineering  
Electric Power, Lighting, Transmission, Traction  
Eng. Shop Practice  
Fire Engineering  
Fuel Technology  
Garage Management  
Gas-Power Engineering  
Heating and Ventilation  
Hydraulic Engineering  
Hydro-Electric  
Joinery  
Journalism  
Machine Designing  
Machine-Tool Work  
Marine Engineers  
Mechanical Drawing  
Mechanical Engineering  
Mine Surveying  
Mining Electrical

Motor Engineering  
Motor Mechanic  
Motor Vehicle Elec.  
Municipal Eng.  
Plastics  
Plumbing  
Quantity Surveying  
Radio Engineering  
Radio Service Eng.  
Ry. Equip. & Running  
Refrigeration  
Salesmanship  
Sanitary & Domestic Eng.  
Scientific Management  
Sheet-Metal Work  
Steam Engineering  
Structural Steelwork  
Surveying  
(State which branch)  
Telegraph Engineering  
Telephone Engineering  
Textile Designing  
Welding, Gas & Elec.  
Woodworking Drawing  
Works Engineering  
Works Management

And most of the Technical, Professional, and Matric Exams.

Special terms for members of H.M. Forces and discharged disabled members of H.M. Armed Forces.

If you need technical training, our advice on any matter concerning your work and your career is yours for the asking—free and without obligation. Let us send you full information regarding the subject in which you are specially interested. DON'T DELAY. Make ACTION your watchword.

The successful man DOES to-day what the failure INTENDS doing to-morrow. Write to us TO-DAY

Use this Coupon

**INTERNATIONAL CORRESPONDENCE SCHOOLS LTD.**

Dept. 95, International Buildings, Kingsway, London, W.C.2.

(Use penny stamp on unsealed envelope)

Please send me particulars of your courses in.....

Name..... Age.....

(USE BLOCK LETTERS)

Address.....

Addresses for Overseas Readers

Australia: 140, Elizabeth Street, Sydney.

Egypt: 40, Sharia Malika Farida, Cairo.

India: Lakshmi Bldgs., Sir Pheroosha Mehta Rd., Port.

Bombay.

New Zealand: 182, Wakefield Street, Wellington.

South Africa: 45, Shortmarket Street, Cape Town.



3 CORES OF ERSIN FLUX

Radio Experimenters are now able to use "The Finest Cored Solder in the World," Ersin Multicore. The three cores of extra active non-corrosive flux ensure speedy soldering and eliminate high resistance or dry joints.

Available from electric and radio shops, ironmongers, etc.

Size 2 cartons:	16 S.W.G.	-	6d. ea.
Nominal 1-lb. reels:	13 S.W.G.	-	4/10 ea.
	16 S.W.G.	-	5/3 ea.

**MULTICORE SOLDERS LIMITED**  
Mellier House, Albemarle Street, London, W.1  
Tel.: REgent 1411 (P.B.X. 4 lines)

We still can't give you as much film as you want, the reason being labour shortage. But we're trying hard, and the best film ever made should soon be yours for the asking.

Meanwhile please grant us your kind forbearance.

**ILFORD**

**SELO**  
FILMS

# S. TYZACK & SON LTD., ENGINEERS MACHINERY AND TOOL SPECIALISTS



**GEARED SCROLL LATHE CHUCKS**  
High-grade Nickel Chrome Steel Scrolls.  
Alloy Steel Pinions.  
Complete with 2 Sets of Jaws (Internal and External),  
4in. diam., £3/12/6; 6in. diam., £4/12/6; 7in. diam., £5/5/-.  
Independent 4 Jaw Chucks with Reversible Jaws,  
3in. diam., 39/6; 4in. diam., 41/-; 4in. diam., 48/9.

**DELIVERY EX STOCK**

## British Made PRECISION SENSITIVE BENCH DRILLING MACHINE

Ideal for Engineers, Model Makers, Pattern Makers,  
etc.

Ball Thrust. Sturdy Construction. Fitted with 3-Jaw  
Self-Centring Chuck, Jacobs. 0-1in. capacity. Overall  
height, 16in. Spindle to Back, 2 1/2in.  
Feed Stroke, 1in. Adjustable Table, 5 1/2in.  
1/2 h.p. Motor if required, Single Phase, £4/17/6.  
**£7/11/-**  
Pulley for Motor, 7/6 extra

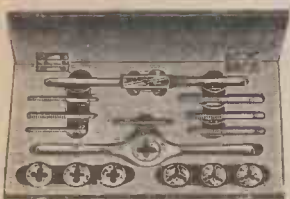

### B.A. Stocks and Dies

Size 0 to 10 inclusive with Taper and Plug.  
Tap to each size, Tap Holder and Diestock. All  
Complete, Fitted in Polished Case. Price 52/6 set.

#### Set 1. Whitworth Stock and Dies

Sizes, 1/16, 3/32, 1/8, 5/32, 3/16, 7/32, 1/4in.  
Complete with Tap and Die Holders and Taper  
and plug Tap to each Size. Complete in Case, 29/6.  
Set 2. 1/4, 5/16, 3/8, 7/16, 1/2 inch. As above. 49/6.

We have good stocks of all types of Taps and Dies. Whit., B.S.F., Model Engineer.  
Please send us your enquiries—

## S. TYZACK & SON LTD.,

341-345, OLD STREET, LONDON, E.C.1  
Telephone: CLE. 4004-5-6



## MASTERPIECES IN MINIATURE

We are happy to announce that our famous hand-made scale models of trains, ships and engines, etc., will soon be in production and available to customers. We can supply castings and parts, materials and drawings for the Model builder.

WRITE FOR  
Wartime Stock List (L/12),  
Price Ad.  
"Building a 2 1/2in. gauge  
Flying Scotsman," Price 11-  
"How to Build a Traction  
engine," Price 6d.  
"Laying Model Permanent  
Way," Price 3d  
"Perfection in Miniature"  
(waterline models), Price 3d.  
The above are post free

## BASSETT-LOWKE LTD. NORTHAMPTON

LONDON: 112, High Holborn, W.C.1. MANCHESTER: 28, Corporation Street, 4.

# P.I.C.



SLIDE RULES  
DRAWING  
INSTRUMENT  
*Specialities*

Manufacturers of

DRAWING and  
SURVEYING  
INSTRUMENTS

SLIDE RULES

DRAWING MATERIALS

DRAWING OFFICE  
STATIONERY

## A. G. THORNTON LTD

*Drawing Instrument Specialists*  
41 GARTSIDE ST. MANCHESTER 3.

*Get this Catalogue NOW!*

3d



**BERRY'S**  
(SHOP) WAVE LTD.

25 HIGH HOLBORN  
LONDON, W.C.1  
(Opposite Chancery Lane)  
Telephone: HOLborn 6231

The House for  
Quality Radio and Electronic products

(Please send 3d. stamps for Catalogue "P.M.")

THIS NEW AND SIMPLE READY-TO-USE SOLUTION WILL BE WELCOMED BY ALL AMATEUR PHOTOGRAPHERS. ONLY NEEDS- THE ADDITION OF WATER

# UNIVERSAL DEVELOPER



INVALUABLE FOR FILMS, PLATES, LANTERN SLIDES, GASLIGHT PRINTS AND BROMIDE ENLARGEMENTS

Prepared from a new and concentrated M-Q formula including the appropriate proportions of the two new chemicals **ONE-FOUR-TWO**, the best developer improver, to brighten prints and make old papers usable, and **THREE-TWO-SIX**, the better wetter, to ensure the even flow of solution and the elimination of all drying troubles.

Sold by all Photographic Dealers

## JOHNSON & SONS

MANUFACTURING CHEMISTS LTD., HENDON, N.W.4. ESTAB. 1743

# OPPORTUNITIES IN PLASTICS

A most informative handbook entitled "OPPORTUNITIES IN PLASTICS" is now available for distribution. This guide discusses in considerable detail the prospect of careers in all branches of the Plastics Industry—knowledge required, salaries, possibilities of promotion, and so on—and explains how you may prepare for these opportunities through our modern home-study courses.

We specialise in Plastics training and our courses are authoritative, up to date and comprehensive. The range of our tuition is wide, covering **Elementary Instruction in Basic Subjects, PLASTICS TECHNOLOGY**, coaching for the **CITY AND GUILDS EXAMINATIONS**, and specialised instruction in such specific branches of the industry as:—

Plastics Mould Design, Plastics in the Paint, Varnish and Lacquer Industries, Plastics Costing and Estimating, Plastics for the Aircraft Industry, Plastics for the Electrical Industry, Plastics for the Building Industry, Plastics in Sales Promotion, Plastics in Textiles, Designing in Plastics, Synthetic Rubber Technology, etc.

All courses are conducted under a guarantee of

**"SATISFACTION OR REFUND OF FEE"**

"OPPORTUNITIES IN PLASTICS" will be sent on request, free and without obligation. The book contains so much useful information and guidance that whatever your interest in Plastics may be, you should make a point of writing for your copy at once.

**BRITISH INSTITUTE OF PLASTICS TECHNOLOGY**

4, SHAKESPEARE HOUSE,

17, STRATFORD PLACE, LONDON, W.1

# MYFORD

## Countershafts for Lathes

There is a countershaft amongst the numerous types that will enable you to choose a suitable layout for your MYFORD Lathe.

Individual Pulleys, Cones, Hangers and Bearings can be supplied when you require alteration or extension. Roof, Wall and Bench Countershafts are supplied for flat belt drive from line shafts or electric motor. Bench Motor Units on which the motor is directly mounted, permit the use of the Vee Rope Drive, and Vee Headstock Pulleys are available to convert present flat drive lathes.

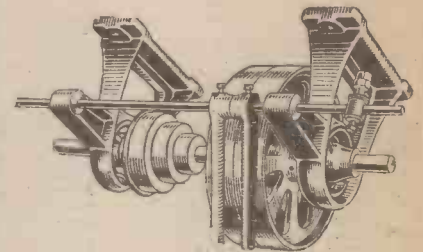

**MYFORD ENGINEERING CO LTD**  
**BEESTON, NOTTS : 'Phone 54222**

878-79

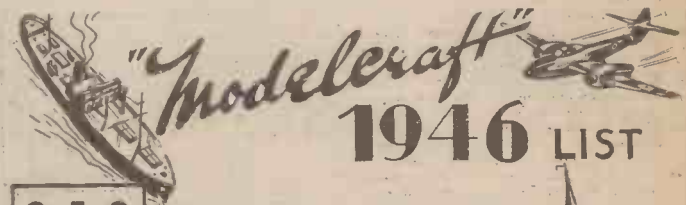

## 1946 LIST

**250  
PLANS  
& PLAN-  
BOOKS**

Working models, racing yacht, galleons, clippers, merchant ships, warships, railside, bus, lorry, car, model houses. *3d. and unstamped addressed envelope brings your copy.*



**MODEL CRAFT Ltd**

77 (PM) Grosvenor Rd., London, S.W.1



## COMPLETE CONTROL

The specially processed Fibrax material gives maximum frictional control of revolutions under all conditions. Fitted as brake liners its retarding effect is sure and definite. Used in clutches it is recognised as the best method for conveying power in a smooth, constant and economical way. Fibrax is made from the finest asbestos, reinforced with zinc

or brass wire (or non-metallic), and supplied as follows:

**FIBRAX FLEXIBLE** supplied in rolls in all widths with selvages.

**FIBRAX DIE PRESSED BRAKE LINERS**, processed to withstand heaviest braking and great frictional heat. Supplied in any radius, length, width and thickness.

**FIBRAX TM2 LINERS**, for the lighter type of brakes used on conveyor plants, etc.

**FIBRAX CLUTCH RINGS**, in all types and sizes.

**Fibrax**

*Brake and clutch linings*

*They always Grip!*

FIBRAX LTD., 2, TUDOR STREET, LONDON, E.C.4

**Electradix Bargains**

A fine selection to choose from

**TRANSFORMERS.** 3 k.w. Crypto 230 v. to 115 v., shrouded, £9 10s. 3 kW Metvick, 50 cy. 400 v. to 600 v., £9 10s. 500 watts, Foster 50 cy. 440 v. to 110 v. 5 amps., £4 15s. 250 v., 50 cy. to 25 v. 10 amps., 230 v. 50 cy. to 20 v. 2 amps., 30/- 230 v. 50 cy. to 12 v. 3 amps., 32/6. 5 watts H.T. test Transformers 110/220 v. to 1,000 v. 5 m.a., 10/-.

**AUTO TRANSFORMERS.** 230 v. to 110 v. 50 cy. 80 watts, 25/- 150 watts, 35/- 300 watts, 60/- 350 watts, 65/- 900/1,000 watts, £7 10s.

**TRANSFORMERS, FOR RE-WIND** 3kW. New type with stampings 4½ x 6 x 7½ in., windings damaged by blitz. Can be taken apart to make a number of smaller units. Weight with damaged wire is 65 lbs. Limited number at 45/-, carriage extra. ½ kW. Transformer for rewind, 35/- 150/200 watt size, 30/-.

**CHARGING DYNAMOS.** We are now able to offer a line of Charging Dynamos for prompt delivery. 6 v. 10 amp., £4; 12 v. 10 amp., £4 10s.; 12 v. 15 amp., £5; 24 v. 40 amp., £10; 30 v. 5 amp., £7 10s.; 32 v. 68 amp., £8 10s. These machines are all in first-class condition, circular body; by leading makers.

**MOTOR BLOWERS.** Small valve cooling or lab blowers, 12 volts input, £5 10s. 32 v. D.C. motor blower, ½ H.P. motor, 500 cub. ft. per min., £8 10s. Table model A.C. or D.C. fans 200/230 volts, 10in. blade and guard, 45/- Large mains motor blowers A.C./D.C.; send us your enquiries.

**METERS.** D.C. Moving Coil Milliammeters 0-1 m/a., 100 ohms resistance, 2½ in. flush panel, bakelite case, 55/- Ditto, 0-1 m/a., 50 ohms resistance, 4½ in. flush panel, bakelite case, 80/- Instrument Rectifier, 1 m/a., 10/6.

**MAKE YOUR OWN CRYSTAL SET** with our Crystal Set Assembly, comprising .0005 mfd. variable condenser, paxolin coil, 2½ in. x 3½ in., coil wire for winding, Crystal detector, .001 fixed condenser and 4 terminals, 10/6 complete.

**CRYSTAL SETS.** The Wall-Nut Model, tapped aerial inductance and condenser tuning, semi-perm. detector, in fine quality walnut box, 42/- Mk. II Converted ex-W.D. type, variable condenser, coil tuning and perm. detector, in box with lid, 55/- The Lesdix Bijou Crystal Set in bakelite case, condenser tuning, semi-perm detector, 15/-.

**RELAYS.** Siemens' High-speed Relays in heavy brass case, £3 5s. Telephone type No. 6. 2-coil polarised, S.P.C.O., 6 v. 25 ma., 325 ohms, 8/6. No. 1A. S.P. on-off, 2 v. 40 ma., 5/- Relay movements 1,000 ohms, less blade and contact, 2/6. Moving-coil relays by Weston, Elliot and Sullivan.

**MAGNETS.** Midget ALNI perm. steel disc magnets, ½ in. dia. with centre hole 3/16 in. dia., of tremendous magnetic force; unlimited uses, 3/6 each. Horse-shoe permanent-steel magnets, various sizes, from 3/6 each.

**SOLENOIDS.** 24 v. D.C. Solenoids, lift 14lb., 15/- Gemi Solenoids, 6 v. 1½ amps., 6/6. 12 v. Rotax type, pull 1 oz. lin., 10/-.

**SEND-RECEIVE Hand Coms.** All-metal Field Hand Coms. for portable or fixed stations. The famous No. 16 Govt. type, used in field telephones; mike and earpiece with damaged finger switch, easily repaired, 7/6.

**BUTTON MICROPHONES** are SOUND TRANSMITTER UNITS. A marvel of acoustic engineering design, as used by G.P.O. For amplification and detection of sound for all purposes. **EVERY BUTTON GUARANTEED.** The 1in. dia. brass body forms the granule chamber and the diaphragm is thin mica. Needs only a pocket battery 4½ volts and a high-ratio transformer. With special transformer, 7/6. Button only, 2/6. Prices include instruction leaflet.

**BUZZERS.** Cambridge Townsend high-note buzzer, the smallest made, used by Government on precision wavemeters, platinum contacts, 10/- Practice buzzers, tunable, in metal case, 7/6; small buzzers in bakelite case, 3/6.

**G.P.O. Connection Strips** of soldering tags, telephone type moulded mounting, 60-way, 3/6 each.

**PARCELS.** 7/6. Parcel of useful oddments for your junk box, all clean and dismantled from Government and other apparatus, 7/6, post free.

**ELECTRADIX RADIOS**

214, Queenstown Road, London, S.W.8  
Telephone MAcaulay 2159

EVERY PRACTICAL MECHANIC should see the PERCIVAL MARSHALL LIST of TECHNICAL HANDBOOKS

The following are a few of the popular titles :

	Price
1001 MECHANICAL FACTS MADE EASY ... ..	2/6
BEGINNER'S GUIDE TO THE LATHE ... ..	2/6
ELECTRIC MODEL RAILWAYS ... ..	2/6
EVERYBODY'S BOOK OF ELECTRICITY ... ..	2/6
HOW TO PREVENT ELECTRICAL TROUBLES ... ..	3/-
LATHE ACCESSORIES ... ..	3/-
MECHANIC'S REPAIR SHOP MANUAL ... ..	3/-
MICROMETERS, SLIDE GAUGES AND CALIPERS ... ..	2/6
MODEL AEROPLANE MANUAL ... ..	7/6
SMALL A.C. MOTORS ... ..	2/-
SMALL ELECTRIC MOTOR CONSTRUCTION ... ..	2/6
SOLDERING AND BRAZING ... ..	2/6
WORKING MODEL RAILWAYS ... ..	2/6
WORKSHOP FACTS AND FIGURES ... ..	2/6

Ask your Newsagent or Bookseller to show you the full list. In case of difficulty write to the publishers :

PERCIVAL MARSHALL & CO., LTD.,  
23, GT. QUEEN ST., LONDON, W.C.2

**TOWER TOOLS**  
BRITISH MADE



Now obtainable from:



WALNUT TREE WALK, KENNINGTON, LONDON, S.E.11.

**PELMANISM**  
For All Times and Circumstances

PELMANISM has stood the test of time. During the last half-century, in peace and war, in times of prosperity and of depression, it has helped and encouraged men and women in all the affairs of life. Now in this time of unprecedented happenings and supreme efforts two facts stand out against a background of evidence—the large number of serving members of H.M. Forces enrolling for the Pelman Course and the continued support of those not in uniform but held closely to civilian occupations.

Half-fees for serving and ex-service members of His Majesty's Forces (Apply for Services Enrolment Form)

This increasing demand proves the creative and re-creative value of Pelmanism. Minds under stress and strain are sorely in need of restful recreation and soothing stimulus. Pelmanism gives all this and more. It is the way to clear thinking and calm but determined action under all circumstances. You cannot be harassed by anxieties, fears and worries, or feel helpless, mute and fearful in times of sudden emergency when imbued and buoyed up by the friendly personal guidance of Pelmanism. Take the Course to-day and possess those self-reliant attributes permanently enjoyed by over half a million grateful Pelmanists.

**A True Philosophy**

Pelmanism is a true philosophy of living for ordinary sensible people who wish to make the best of themselves at all times and under all circumstances. The Pelman Institute has won and held its unique position through all wars and worries, trials and tribulations, during the last half-century. To-day Pelmanism is appreciated as much as ever. The test of time has proved the Power of Pelmanism and in these exceptional and ever-changing times it plays its part in the National Effort.

Remember—Everything you do is preceded by your attitude of mind.

The Pelman Course is fully described in a book entitled "The Science of Success." The Course is simple and interesting, and takes up very little time; you can enrol on the most convenient terms. The book will be sent you, gratis and post free, on application to:—

Pelman Institute,  
(Established over 40 years)

130, Norfolk Mansions,  
Wigmore Street, London, W.1.

Readers who can call at the Institute will be welcomed.

PELMAN (OVERSEAS) INSTITUTES:  
NEW YORK: 271 North Avenue, New Rochelle, MELBOURNE: 306 Plinders Lane, JOHANNESBURG: P.O. Box 4028, DURBAN: Natal Bank Chambers (P.O. Box 1489), DELHI: 10 Aliporo Road, CALCUTTA: 102 Clive Street.

# "ENGINEERING OPPORTUNITIES"



## PREPARE FOR PEACE-TIME COMPETITION

In the more competitive days of peace, technical training will be a vital necessity to the Engineer who wishes to safeguard his position and make advancement. "ENGINEERING OPPORTUNITIES" will show you how to secure this all-important technical training quickly and easily in your spare time. This 100-page book is full of valuable information and explains the simplest way of preparing for recognised Examinations. Among the courses described are :

### MECHANICAL ENGINEERING GROUP

A.M.I.Mech.E. City & Guilds General Mechanical Eng. Diesel Engines Draughtsmanship & Tracing Works Management Press Tool Work Pattern Making Foundry Practice	Estimating Foremanship Jig & Tool Design Viewing & Inspection Welding Sheet Metal Work Maintenance Eng. Metallurgy Refrigeration
---	--

### ELECTRICAL ENGINEERING GROUP

A.M.I.E.E. City & Guilds General Electrical Eng. Alternating Currents Power House Design Traction Mains Eng.	Electricity Supply Electrical Meters Electrical Design Illumination Installations Telegraphy Telephony
--	--

### COMMERCIAL ENGINEERING GROUP

A.M.I.P.E. Commercial Eng.	Cost Accounts Languages
-------------------------------	----------------------------

### WIRELESS GROUP

A.M.Brit.I.R.E. City & Guilds General Wireless Short-Wave Wireless	Advanced Wireless Radio Servicing Television Talking-Picture Eng.
---	--

### CIVIL ENGINEERING GROUP

A.M.I.C.E. Inst. Mun. & Cy. Engineer A.M.I.Struct.E. M.R.San.I. Sanitary Inspector Specifications Structural Design	Road Eng. Hydraulics Municipal Eng. General Civil Eng. Structural Eng. Reinforced Concrete Railway Eng.
---	---

### AUTOMOBILE ENGINEERING GROUP

A.M.I.A.E. M.I.M.T. City & Guilds I.A.E. Repair Certificate	General Automobile Eng. Garage Management Electrical Equipment High Speed Diesels
--	--

### SURVEYING AND BUILDING GROUP

A.R.I.B.A. F.S.I. A.M.I.H. & V.E. L.I.O.B. F.A.I.	Costing & Valuations Heating & Ventilating Clerk of Works Surveying & Levelling Building (all branches)
---	---

### AERONAUTICAL ENGINEERING GROUP

A.F.R.Ae.S. R.A.F. (Maths.) Pilots' Licences Ground Licence	Aero Engines Navigators' Licence Aeroplane Design Meteorology
--	--

### UNIVERSITY DEGREES

London Matriculation School Certificate	University Entrance Intermediate B.Sc.
--	---

**WE DEFINITELY GUARANTEE**

**"NO PASS—NO FEE"**

If you are earning less than £10 a week you cannot afford to miss reading "ENGINEERING OPPORTUNITIES"; it tells you everything you want to know to *make your peace-time future secure*, and describes many chances you are now missing. In your own interest we advise you to write for your copy of this enlightening guide to well-paid posts NOW—FREE and without obligation

**BRITISH INSTITUTE OF ENGINEERING TECHNOLOGY**

410A, SHAKESPEARE HOUSE, 17, STRATFORD PLACE, LONDON, W.1

**THE B.I.E.T. IS THE LEADING INSTITUTE OF ITS KIND IN THE WORLD**

## SUBSCRIPTION RATES

(Including postage)

Inland	- - -	10s. 6d. per annum.
Abroad	- - -	10s. per annum.
Canada	- - -	10s. per annum.

Editorial and Advertisement Office: "Practical Mechanics," George Newnes, Ltd.

Tower House, Southampton Street, Strand, W.C.2

Phone: Temple Bar 4363

Telegrams: Newnes, Rand, London.

Registered at the G.P.O. for transmission by Canadian Magazine Post.

Copyright in all drawings, photographs and articles published in "Practical Mechanics" is specially reserved throughout the countries signatory to the Berne Convention and the U.S.A. Reproductions or imitations of any of these are therefore expressly forbidden.

# PRACTICAL MECHANICS

Owing to the paper shortage "The Cyclist," "Practical Motorist," and "Home Movies" are temporarily incorporated.

Editor: F. J. CANN

VOL. XIII MARCH, 1946 No. 150

FAIR COMMENT

—BY THE EDITOR

## Science is News!

SIR EDWARD APPLETON, secretary of the Department of Scientific and Industrial Research, stated during a recent lecture that science is news to-day as never before. Whilst I agree that science facts, accurately presented, are news, there is a great deal appearing in the daily Press under the guise of scientific news which amounts to warping some trifling scientific fact, newly discovered by the reporter, but well established in scientific circles, in order to provide a flaming headline. In fact, it is one of the daily newspapers' failings that they are deserting their function of news gathering and endeavouring to become daily magazines. In this they can never hope to succeed against the specialist journals. Few of them, indeed, take the trouble to employ qualified scientific people to write scientific articles. If science is news, there are some hundreds of scientific developments which have not been dealt with by the daily Press, merely because they concern drab things, but are none the less highly important. If some crank, however, invents a new mousetrap, or a new seal for jam-jars, it attracts a headline and a half a column of type in our leading newspapers. Of course, the facts are warped to make extravagant claims for the "scientific development," in an effort to pep it up for the delectation of the more gullible readers of the daily Press.

The too-early disclosure of a scientific development is, in my view, wrong. It creates a demand which cannot be satisfied because the development is still in the embryo stage, and by the time it is ready the public have forgotten about it. Popular enthusiasms are apt to wane, and great expectations often lead to great disappointments. Science is knowledge based upon accurate observation of facts and their relation to general principles and known laws. The scientific method is the checking of unbiased observations by reference to existing co-ordinated and experimentally verified knowledge.

Thus, the scientific method begins with observation, advances into reflective thought, as a result of which a theory is evolved, and this, in its turn, must be submitted to the test of carefully devised and reproducible experiments before it is generally accepted as true. This scientific method of approach is entirely English in its conception, and it has been adopted throughout the world—in fact, it forms the basis of all scientific thought and laboratory experiments.

In the steel industry, the main heat consumers are the open-hearth furnaces where the steel is made, and in order to secure economies it was necessary to determine their heating efficiency. For this purpose it

was necessary to know, accurately, the specific heat of the waste gases going up the chimney as well as their temperature, the specific heat of the metal and of the slag over a large temperature range, including the liquid state and the heat value of the various thermo-chemical reactions taking place in the process of manufacturing the steel in the furnace. It was found that only about 25 per cent. of the heat supplied to the furnace was being usefully employed; 25 per cent. of the remainder was lost by radiation from the walls of the furnace and 50 per cent. was lost up the chimney. Boilers were, in some cases, heated by this waste gas, but they were only successful in using 15 per cent. of the available waste heat.

It was decided, therefore, to instal better designed equipment, and the result was that the recovery of heat was increased to 75 per cent.

This, of course, does not interest the daily papers, but it is a most important achievement, especially in these days of coal shortage.

### Traditional Knowledge

TRADITIONAL knowledge, amassed and handed down in course of time from one generation to another, can in certain circumstances be as exact as the knowledge gained by the scientific method. In fact, traditional knowledge still forms the basis upon which many of our older industries are conducted. In other words, it builds up a successful "know how." In an industry welded, however, to traditional methods, new technical knowledge can only be acquired slowly, and so such an industry must be inflexible in its operations, and it is extremely difficult for it to take advantage of any new methods or materials. It remains stagnant and unprogressive.

We are living in an age where new materials continue to replace the old, and science has developed sufficiently for us to be able to say what particular qualities in a material we need for a certain use. New materials and new industries are not created by the waving of a wand. They come by keeping watch on all contributory developments. Before the war, both uncreasable cotton and unshrinkable wool had been produced in this country as a result of prolonged research. During the war, cotton fabrics were produced in large quantities in which the fibres are so twisted that on contact with water they swell so that the cloth becomes immediately waterproof, but still allows the passage of air. Between the wars, England gained all the speed records in the air, on water, and on land, and we hold all those records again.

We are apt to forget that perspex, the transparent, non-splintering plastic, indis-

pensable for aircraft construction, was an English invention, while another was polythene, an essential insulating material for high-frequency cables, without which Radar would have been impossible.

While much can be done immediately by the application in industry of existing scientific knowledge, by way of improving processes, reducing waste and generally in solving the day-to-day problems of production, sustained future progress must depend on the application of new knowledge, which is being now obtained in the laboratories as the result of fundamental or pure research.

In Government or industrial research organisations such research should be objective in its character. By this I mean that it should consist of a long range attack on the basic generic problems that fall in the particular field of the organisation. Usually objective research of this type is not intended to aim at immediate practical results, but to gaining "physical" insight into some basic phenomenon such as corrosion, the oxidation of fats, or the growth of large molecules which form plastics and proteins. Experience has shown, however, that a basic attack of this kind is often the shortest and most fruitful road to the solution of problems of practical importance.

### Academic Research

BESIDES such objective fundamental research there is also the need for academic research. Such work is not academic in the sense that it deals with "pure" science as opposed to "applied." It may involve either or both. Obviously the best conditions for this type of work are those which prevail at universities or similar institutions. Its encouragement is of the greatest importance to-day, as research of this type has been in abeyance in many fields during the war, so that there are nearly six years of progress to be made up.

We must also look to the universities and the technical colleges for the supply of highly trained research workers, upon which the future progress of all kinds of industrial research depends.

General Government support for universities is the responsibility of the University Grants Committee, but the D.S.I.R. makes special grants to individual workers to enable them to employ research assistance or to obtain special pieces of apparatus. The Department also operates a scheme for training young post-graduate students in the methods of research. Several large industrial organisations are also making very substantial contributions to universities; for example, I.C.I. have recently given 80 research fellowships, to which no restrictive conditions are attached.

# An Adjustable Drawing-table

Constructional Details of a Useful Appliance for the Draughtsman or Mechanic

By F. HOOK

**A** DRAWING-TABLE is a most useful article for the practical mechanic to possess if he has to prepare drawings or tracings. This article describes such an accessory which embodies a simple feature which will enable the drawing board to be let down to a horizontal position, when it may serve as a light work table. The table is designed to be large enough to take a sheet of 30in. by 22in. (imperial) size drawing paper, and to leave sufficient margin of board for pinning on notes and sketches.

The timber shortage need not deter an intending constructor as the easel may be constructed from battens available from shops which market wood for the home constructor. In passing, it is interesting to note that the table illustrated here, Figs. 1 and 2, was made entirely from some lengths of secondhand floorboards. Some care was needed to stop the holes with plastic wood. The framework may be painted or stained and varnished, but it is advisable to leave the surface of the drawing-board "in the white."

**Materials**

Materials needed may be listed as follows (all measurements being finished sizes):

- 4 pieces for end cross-frames. 46in. x 2 1/2 in. x 1/2 in.
- 6 pieces for crossbraces. 48in. x 1 1/2 in. x 1/2 in.
- 2 pieces for stays holding cross-frames. 30in. x 1 1/2 in. x 1/2 in.
- 2 pieces for ends of stays. 2in. x 1 1/2 in. x 1/2 in.
- 2 pieces for stays adjusting height of table. 30in. x 1 1/2 in. x 1/2 in.
- 2 packing blocks at hinges. 5in. x 2 1/2 in. x 1/2 in.
- 6 pieces for drawing-board. 42in. x 6in. x 1 in.
- 2 pieces for bracing drawing-board. 30in. x 2in. x 1 in.

- 1 piece for bottom ledge of board. 48in. x 2in. x 1/2 in.
- 2 3in. x 1/2 in. bolts, wing nuts and washers.
- 4 2in. x 1/2 in. bolts, wing nuts and washers.
- 3 1in. x 1/2 in. bolts, wing nuts and washers.
- 6 1 1/2 in. x 6. iron countersunk screws to secure ledge.
- 6 1in. x 6 iron countersunk screws for blocks at hinges.
- 24 1in. x 4 iron countersunk screws to secure cross bracing frame to end frames.

**Constructional Details**

The first step in construction is to plane up the timber for the under-frame. Construct the outer frame shown in Fig. 3. The cross-bracings used to give rigidity are screwed to the uprights with 1in. x 4 iron countersunk screws. The two 5in. long blocks at the top are screwed and glued to the top of the side uprights in order to build up enough width for the 1 1/2 in. back-flap hinges.

Secondly, the inner frame is made fit inside the previous frame, Fig. 4. Only one pair of cross-pieces are used on this frame, as if a lower pair were used they would be

inconveniently situated for the draughtsman's legs when seated at the table.

The angles on the top and bottom of the four uprights are approximately 50 deg. These may be adjusted when the two frames are bolted together with 2in. by 1/2 in. bolts and nuts.

Drill the side pieces for the cross-stay bolt holes (Fig. 5). At one end of each stay is a packing piece 1/2 in. thick, used to make the stay lie parallel to the general construction (Fig. 6). When these stays are bolted on, the



Fig. 1.—Front view of the completed drawing-table.

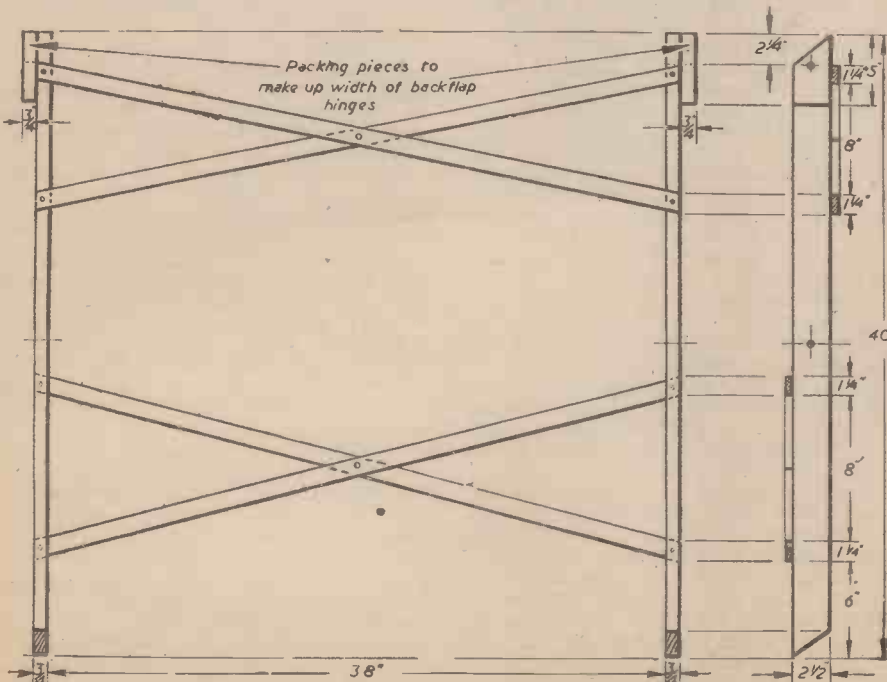

Fig. 3.—Details of the framework.

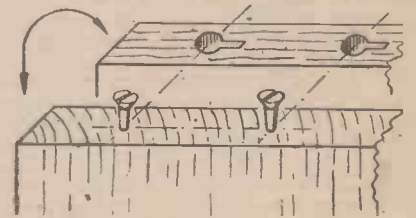

Fig. 8.—Method of slot-screwing.

whole assembly should stand quite rigidly on the floor.

**The Drawing-board Top**

The construction of the drawing-board can be taken in hand next. The essential feature of this part is that the top surface should be smooth and "out of winding." The left-hand edge, along which the T-square moves, should be dead straight.

There are several methods of making up a board of this width and the main problem involved is to make allowance for the contraction (or expansion) of the board.

The five pieces of wood may be glued and joined in several ways (Fig. 7), e.g.:

- (a) A rubbed glued joint;
- (b) A dowelled glued joint;
- (c) A tongued and grooved joint.
- (d) Each board grooved and a common tongue of plywood used.



**Joining**

In jointing up these five pieces it is necessary to use a pair of 3ft. sash cramps. The boards should be jointed in two pairs first of all. When dry these two should be jointed with the remaining piece.

When the assembly is dry, both sides are trued up with a plane. The edges are trued up also and the ends sawn square and smoothed by a finely-set smoothing plane.

The end pieces to the drawing-board may be dowelled and glued, allowing two dowels per board. The disadvantage of this method is that if the board contracts, it is liable to split or warp. Consequently, the method of "slot screwing" is to be strongly recommended. The batten is either screwed to the end of the board (Fig. 8) or across the back of the board (Fig. 9). The latter method is easier.

In the first method lines are squared across the batten and the ends of the jointed boards to mark the position of the screws. Iron c/s screws (2in. x 8) are screwed into the ends of the drawing-board on these lines, leaving 3/4in. of the screws' length protruding. In the batten holes are drilled 3/8in. diameter x 1in. deep to take the heads of these screws. A slot is now cut to each of these holes 3/4in. long x 7/32in. wide (i.e., wide enough to accommodate the shank of the screw) as indicated in Fig. 8.

No glue is used in the assembly of this joint. The batten is placed over the screw heads and held firmly in place, whilst the end (towards which the slots point) is struck with a mallet so that the heads will be forced into the wood about 1/4in. to 3/8in.

The method illustrated in Fig. 9 is even



Fig. 9.—Method of screwing batten to the back of the drawing-board.



Fig. 2.—Rear view of drawing-table.

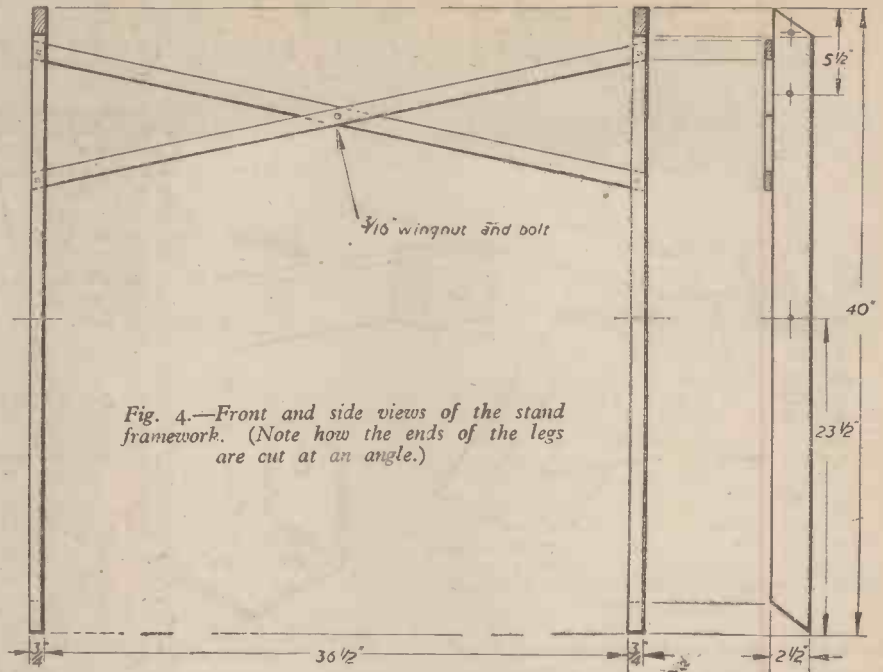

Fig. 4.—Front and side views of the stand framework. (Note how the ends of the legs are cut at an angle.)

simpler. For each screw drill two 7/16in. holes at distances of 3/4in. Now countersink these holes to about 3/8in. diameter (Fig. 9b). Then cut a slot 7/32in. wide with a 3/8in. chisel to join up the two holes. Bevel the sides of the slots to join up with the countersinks.

The screws are put into the centre of the

slots and screwed down to the back of the drawing-board so that the heads bed down nicely into the bevelled groove.

As the board expands or contracts the screws will move in the slots so that the board will remain entirely flat.

The drawing-board may now be hinged to the under-frame. Back-flap hinges are used. If procurable, a pair of hinges which take apart are useful (Fig. 10). By using these the board may be removed rapidly from the under-

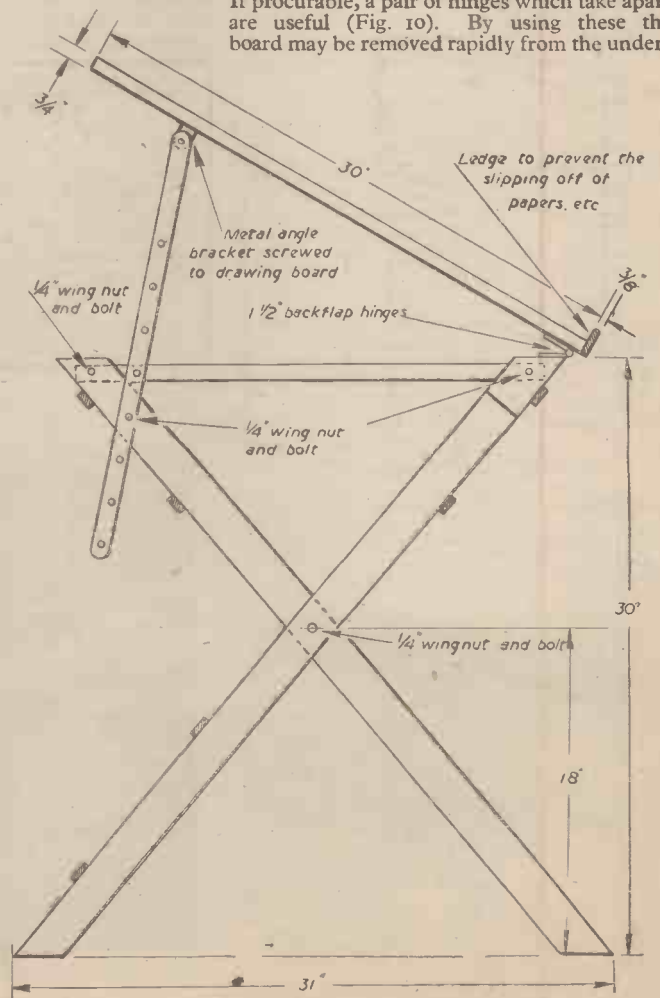

Fig. 5.—Side elevation of the complete assembly.

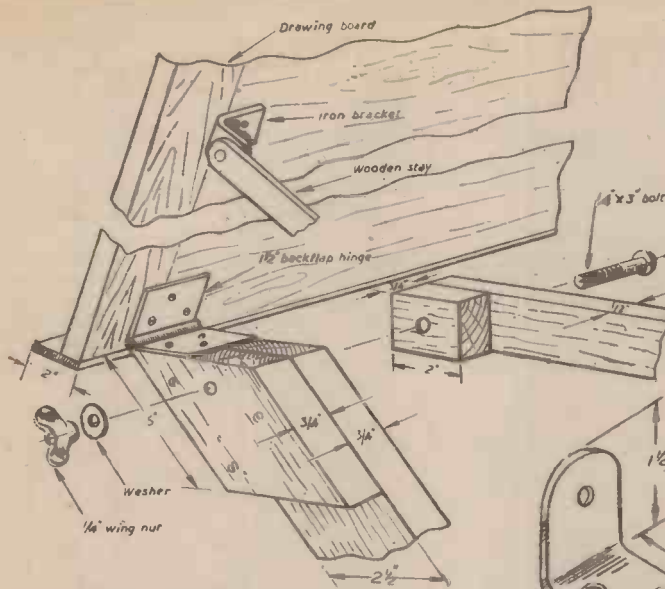

Fig. 6.—Details of hinged corner and winged nuts and bolts.

frame by undoing the height adjusting stays and merely moving the board sideways.

Two angle brackets are needed on the back of the board from which swivel the slope adjusting stays (Fig. 11.)

**Lamp Bracket**

Readers will observe a lamp at the top of the drawing-board in Figs. 1 and 2. This was originally a hasty improvisation, which

A. A plain glued joint

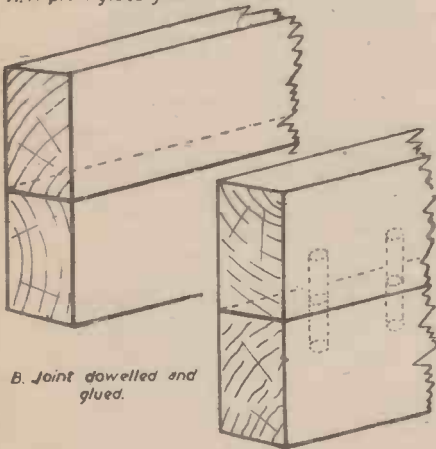

B. Joint dowelled and glued.

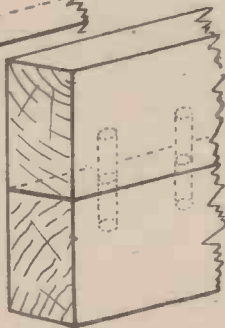

C. Tongued and grooved

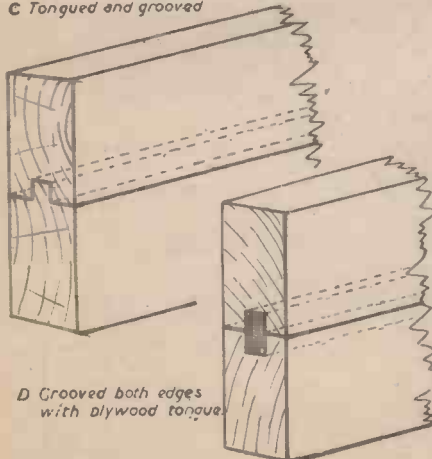

D. Grooved both edges with plywood tongue

Fig. 7.—Four methods of jointing boards.

has since served so well that it has now been made a fixture.

The bracket consists of three pieces of wood jointed by 2B.A. screws and wing nuts and spring washers. The top strip has a batten holder mounted on it (Fig. 12). For a lampshade an 8in. loaf tin was used, a 1in. diameter hole being cut in the end of the tin with a

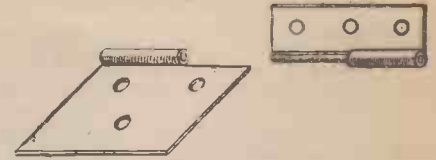

Fig. 10.—Details of hinges for drawing-board

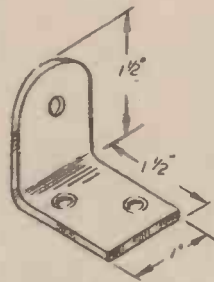

Fig. 11.—Angle bracket.

centre bit so that the tin will fit on to the batten lampholder. This tin nicely accommodates a 60- or 100-watt bulb. A 5 amp. switch is fixed in a convenient place on the lowest strip of the support. This lowest strip is bolted to a block of wood 4in. x 2in. x 1in.), screwed underneath the drawing-board. With this simple contrivance a good light may be obtained

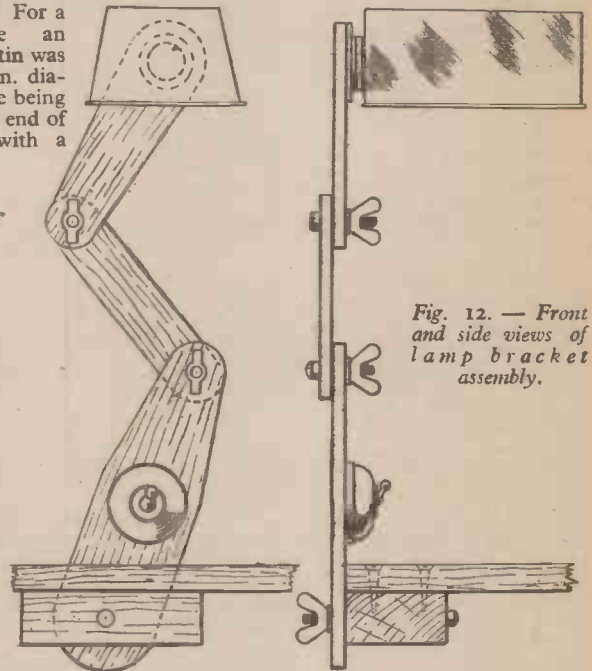

Fig. 12.— Front and side views of lamp bracket assembly.

at any point across the width of the board without glare to the eyes of the draughtsman.

*A New and Monumental Work!*

**NEWNES ENGINEER'S REFERENCE BOOK**

Edited by F. J. CAMM. 1326 pages. Hundreds of Illustrations, £2 2s. (43/- by post).  
*A Concise List of Contents*

- |   |  |
|---|--|
| Heat Treatment and Pyrometry              | Metal Cleaning and Metal Polishing         |
| Drawing Office Practice                   | Workshop Mathematics                       |
| Patents, Designs and Trade Marks          | Production and Quality Control             |
| Plastics and Powder Metallurgy            | Costing and Time and Motion Study          |
| Gear Cutting and Screw Cutting            | Aeronautical Engineering                   |
| Centre, Capstan and Turret Lathe Practice | Tools, Jigs and Fixtures                   |
| Wire Gauges and Wire Drawing              | Compressed Air Practice                    |
| Milling, Planing and Shaping              | Conveyors and Cranes                       |
| Gauge and Screw Thread Measurement        | Coolants and Lubricants. Panel Beating     |
| Soldering, Brazing and Welding            | Boilers, Hydraulics                        |
| Press Tools and Presswork                 | Internal Combustion Engines. Radio Formula |
| Tubes: Manufacture and Calculations       | Workshop Practice. Tables, Etc., Etc.      |



The new Waterloo Bridge, over the Thames, the ceremonial opening of which was recently performed by the Right Hon. Herbert Morrison, M.P.

# Autocycle Care and Maintenance

## How to Keep Machines in Good Running Order

**T**HE autocycle, although an essentially simple machine, nevertheless requires a certain amount of care and attention to ensure a trouble-free, pleasant-running machine.

Being in a distinct class of its own, the autocycle combines features which are common to both the pedal and motor-cycle, and it is hoped that the following notes will be of value and assistance to owners of these popular machines.

Considerable power is often lost through worn, unlubricated and incorrectly adjusted chains. To inspect a chain for wear, remove same from the machine and place on a level surface. By alternately pulling and pushing on the ends, any excessive wear is immediately shown by undue movement between the links. Slight movement is permissible, but a chain that shows much wear should be discarded, as if used in this condition will very soon ruin the sprockets. Likewise, if the sprockets are in a very bad condition, having broken or hooked teeth, it is wise to replace these, to save unnecessary strain and wear on the chain.

### Lubrication

Care and thoroughness in lubrication contributes in no small measure to long chain life and smoothness of running. Thoroughness of lubrication entails the removal of the chains from the machine, and a preliminary washing in paraffin to remove any dirt and grit adhering to same. This is followed by a few minutes' immersion in molten motor-grease, preferably the graphited variety. After removal, and allowing the surplus grease to drain away, they are refitted back on the machine, observing that the spring link is assembled correctly, that is, with the closed end facing the chain's direction of travel.

Adjustment of the chain is made by slackening the spindle nuts, and giving the adjusters the requisite number of turns. In order that the rear wheel is centralised correctly, count the number of turns given on each adjuster. They should both coincide.

As a chain usually wears uneven, a tight point will be found at one position of its run. All adjustments must be made from this point, allowing approximately 1 in. up and down movement in the secondary chain, and ½ in. movement in the pedalling-gear chain. The adjustment for the latter chain is usually made by means of a jockey sprocket. After adjustment has been satisfactorily made, securely tighten all nuts.

The procedure enumerated above should be carried out every 2,000 miles. In between these times, the chains should be regularly lubricated with engine oil slightly thinned with petrol before application.

### Brake Adjustment

As these machines are fitted with internal expanding brakes, a few remarks concerning these will not be amiss.

A brake that judders when applied may usually be cured by rasping the leading edge of the lining, as indicated in Fig. 1.

If, after prolonged use, it becomes necessary to reline the brakes, the following procedure should be followed. Remove the old linings by interposing a screw-driver between them and the shoe face, and levering off. The rivets are next removed by cutting and punching out. The replacement lining is then placed on the shoe, and carefully riveted

By E. S. BROWN

into position with the rivets provided. These rivets are either aluminium or copper. It is not permissible to use rivets of metal other than that specified above, otherwise with the wear of the lining, contact will eventually be made with the surface of the brake-drum, and scoring will be the inevitable result.

The rivets are burred over on the back of the shoe by supporting the head of each rivet on a short length of rod previously held in a vice, and tapping over with a ball-hammer. As each rivet is applied, make

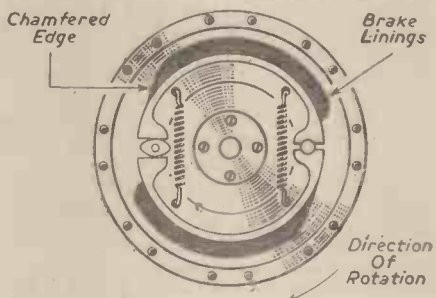

Fig. 1.—A method of curing brake judder by rasping the leading edge of brake shoe.

sure that the head is down snug in the counter-sunk hole in the lining.

When the linings are satisfactorily fitted, the leading edge should be slightly chamfered off, to prevent any subsequent occurrence of fierceness and judder.

Some machines are fitted with back-pedalling brakes. These brakes operate by expanding a phosphor-bronze cone into contact with the hub shell. These brakes are very reliable. The only attention normally required is regular lubrication. Lack of proper and insufficient lubrication is very soon indicated by the brake becoming fierce and erratic in action.

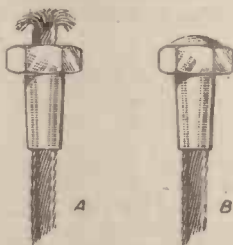

Fig. 2.—Method of repairing a Bowden cable.

- A. The nipple on the Bowden wire ready for soldering.
- B. Nipple soldered in place.

### Bearings

The wheel bearings are adjusted by turning the adjusting cone with the special spanner provided, having, of course, previously loosened the spindle nut adjacent to it. The adjustable cone is usually fitted on the right-hand side of the machine when viewed from the saddle.

Correct adjustment is obtained by tightening the cone until it slightly binds when the wheel is rotated. It is then turned back a quarter of a turn, and the spindle nut securely retightened.

The hubs will, of course, require regular lubrication, this should be done at intervals of 200 miles with a good make of cycle oil. A few drops is all that is required at any one time, otherwise any surplus oil may find its way into the brake-drums, and make their operation ineffectual. Other parts requiring the attention outlined above are

the bottom bracket and pedal bearings, steering-head and the various Bowden wire controls.

The steering-head bearings may be tested for adjustment by standing astride the front wheel, firmly grasping the handle-bars and alternately pushing and pulling on same. Any lateral movement should be taken up by means of the adjuster provided. Should the handle-bars turn erratically with either a grating or clicking noise, suspect either a broken ball-race, fractured ball, or a combination of both. The only satisfactory course to adopt is to dismantle the bearing for inspection and, if required, renew the damaged parts.

The various controls, such as throttle, clutch, handbrake, etc., are actuated by Bowden cable. Acute bends in these cables should at all times be avoided, otherwise additional strain will be placed on both the inner and outer cables, with the eventual failure of same.

### Repairing Bowden Nipple

Should a nipple pull through, the following is the correct method of repairing same. Carefully clean both the cable and the inside of the nipple, and apply a non-corrosive flux to both. Thread the nipple on to the cable and spread over the end of same to form a stop. Then, with a hot iron, run the solder well into the nipple and into the stop made at the end of the cable. With such a repair it will be almost impossible for the nipple to again pull through.

A similar procedure is required to repair a broken petrol union. In this case, owing to the admixture of oil with the petrol, it will be necessary to wash the parts very thoroughly in neat petrol to remove any trace of oil. Afterwards furbish the end of the pipe and the inside of the union with emery paper and apply the flux. Well tin both parts with the soldering-iron, and while the solder is still fluid, bring the pipe and union together, pushing the latter on the pipe as far as it will go. Apply the hot iron for a few seconds to complete the fusion and, after allowing to cool, remove any surplus solder with an old file. Do not forget to see that the union nut is on the petrol-pipe prior to soldering.

Incidentally, should a petrol union break while on the road, a temporary repair is always possible by means of smearing soap around the inside of the union, and afterwards pressing the petrol pipe into place. To prevent any subsequent movement between the two parts, a small length of insulating tape is tightly wound around both.

### Wheel Adjustment

Should it be suspected that one of the wheels is buckled, a simple test may be made for this by supporting the hand on a convenient part of the machine and holding a piece of chalk in close proximity to the rim of the wheel. By slowly turning the wheel, the chalk will mark those places that are out of truth. If the degree of error is very marked it will, of course, be necessary to correct same. Remove the wheel from the machine, and then the outer cover and tube from same. The buckle should now be noted and on the side of the rim where it occurs, the spokes should be slightly loosened, and on the opposite side slightly tightened. This will have the effect of drawing that part of the rim into conformity with the rest.

Replace the wheel on the machine and slowly turn, and observe the result. It is very probable, however, that several adjustments of the spokes will have to be made before the results are considered satisfactory.

It is likely that several spoke heads will be projecting. It will, of course, be necessary to remove these with a file before refitting the inner tube and cover.

In the event of a spill, the pedalling-cranks are the most likely to suffer. With care they can be satisfactorily straightened by placing them in a copper-jawed vice and applying steady pressure with either a twisting wrench or large adjustable spanner. With a badly bent crank it is advisable to heat the damaged part prior to straightening to avoid undue fatigue of the metal. The heating, however, is somewhat apt to spoil the subsequent appearance, especially if the crank is plated, and will necessitate replating or enamelling.

When refitting the cranks, it is advisable to use new cotters, as the old ones may have worn to such an extent that they project too far through the crank boss and so prevent the crank from being fully tightened on the spindle.

#### Power Unit

The power unit fitted to the autocycle is extremely smooth running. Should any

undue vibration be experienced, it is very likely that the bolts securing the engine to the frame have worked loose. It is as well, therefore, to occasionally test these bolts to make sure that they are quite tight. A useful tip to keep these and other bolts secure is to smear the thread with motor gasket cement before tightening.

Other vulnerable places for loose nuts are the mudguard stays, and where the mudguard is bolted to the machine. These parts of the machine are subject to much vibration and tend to loosen.

It is a strange but true fact that many riders pay very little attention to securing the most comfortable riding position on their machines. They will continue riding them exactly as delivered by the makers, although only a few minutes' work with a spanner would make an unbelievable improvement to the riding qualities.

It is impossible to generalise on this subject, as the owner will have to make adjustments to the relative positions of the saddle and handle-bars to suit his own individual requirements. It should be noted, however, that the saddle peak is not poised too high, otherwise there will be a tendency for the rider to lean backwards.

The size of the tyres as fitted to autocycles is 26in. by 2in. by 1½in. When replacement becomes necessary, fit "Carrier

Oversize" if you can obtain them. They have approximately 30 per cent. greater air capacity than the standard size, and give enhanced comfort and wearing qualities. One precaution is necessary before fitting these larger tyres, and that is to see that there is sufficient clearance on the machine for them. The overall increase in size for the larger cover is about ½in., and when verifying the clearance, this should be borne in mind.

#### Protecting Plated Parts

An excellent method of protecting the plated parts of the machine, especially where they are worn thin, is by applying celluloid collodion. If this cannot be obtained locally, it can be easily prepared by dissolving some scrap celluloid in equal proportions of acetone and amyl acetate. This will take about 24 hours, and during this time it should be occasionally stirred. The collodion, when ready for use, should have a consistency similar to varnish.

The plated parts should be prepared for the protective coating by being well cleaned. Where chromium plate has worn thin, it is usual for it to become spotted with rust. This can usually be removed by a brisk rubbing with a damp cloth, and afterwards allowing to dry. The collodion should be applied as quickly as possible, in a full coat with a soft brush.

## London's New Airport

### Layout and Constructional Details of Heathrow Aerodrome

**T**HE reason for Heathrow was the need of the Royal Air Force for an airfield near London capable of handling the heaviest types of aircraft, especially in the closing stages of the war in the Far East as it was expected to develop. In the planning it was taken into account that such an airfield could be subsequently developed for civil aviation as the main terminal airport for London.

On January 1st Heathrow was handed over to the Ministry of Civil Aviation by the Air Ministry. The claims of other airfields near London were considered when the question of a suitable site arose, but none was satisfactory.

Heathrow is only 14 miles from the centre of London, it is outside the built-up area, and is capable of development without extensive demolition of private property. It lies between the Bath Road and the Staines Road, two of the best approaches to London, and is well served by train services, being only two miles from the Waterloo-Staines section of the Southern Railway, and the same distance from Hounslow West Underground Station.

#### Three Runways

The selected area included about 120 acres of ponds and disused gravel workings, and a portion of the main runway would have to traverse these ponds. Special drainage problems were presented, as the discharge of huge quantities of water would have to be regulated so as to avoid flooding the surrounding land. These and many other problems were successfully solved, and in April, 1944, plans were complete for a three-runway airfield of lengths 9,000, 6,000 and 6,000ft., together with a perimeter track 25,000ft. long connecting the ends of the runways. The width of the runway was 300ft. and that of the perimeter track 100ft. The runways are sited so as to be capable of extension to 15,000, 9,000 and 9,000ft. respectively.

The main east-west runway of length 9,000ft. is now complete. The second

runway extending from the north-west to the south-east is practically finished. The arrival and departure apron, together with temporary terminal buildings, is also complete. The installation of apparatus and the completion of the third runway extending from the south-west to the north-east will proceed without delay, and the airport will be ready to accommodate regular passenger services in the summer. It will be the main London airport for transoceanic traffic. The internal and European services will make use of Croydon and Northolt, though eventually some of them also will be accommodated at Heathrow.

#### Accommodation for Largest Aircraft

This three-runway aerodrome will in itself give London a first-class airport, capable of accommodating the largest aircraft now contemplated; but in due course it is planned considerably to extend the area and increase the number of runways. Detailed plans cannot yet be announced because they are still subject to revision, but a thorough study of the neighbourhood has been made in order to safeguard the land and avoid unnecessary interference with dwelling-houses and ancient buildings. It is not anticipated that the number of persons who will be displaced from their homes will be large, and there will be no displacement until five or six years, by which time the housing position will be much easier.

The contractors, George Wimpey and Company, Ltd., Denham, Uxbridge, began work in May, 1944. Throughout the first summer and winter the main operations consisted of pumping out the ponds, and this involved the disposal of 100,000,000 gallons of water, the removal of half-a-million cubic yards of silt, bulk excavation over the area of the first runway and its appropriate perimeter track, the refilling of the ponds and making up to levels in preparation for the actual construction of the runway and perimeter track. Concurrently with this operation, it was necessary to construct the large drainage

scheme required for the collection and disposal of rain water from the concrete paving and involving the laying of some 13 miles of large concrete pipes.

During the first summer and winter a total of two million tons of earth and gravel was excavated, 36,000ft. of multiple ducting for the electric cables were laid, and 60 miles of wire laid through these ducts.

On the main runway, 9,000ft. long by 300ft. wide, the concrete paving is 12in. thick. The laying of this mass concrete paving was begun in April, 1945, and the bulk of the work was completed in three-and-a-half months.

#### Concrete Mixing and Spreading

The most modern mixing plant was installed on a scale not previously provided in airport construction in this country.

The mixed concrete was placed on the runway and perimeter track by modern mechanical spreading and compacting equipment to provide the density of concrete and requisite finished surface. Tests of the quality and strength of samples of the concrete, taken daily, show an average strength of over 30 per cent. above the very high strength demanded by the specification.

When the three runways are completed, more than 1,114,000 square yards of 12in. thick concrete will have been laid.

The foregoing facts give a picture of the scale of operations and magnitude of quantities involved. The results have been possible only because of the high degree of mechanisation developed on other construction projects during the war with the consequent large reduction in the numbers of heavy navy labourers required. At no time has there been more than 700 men in this category employed at Heathrow, the general average being about 400.

Two hundred lorries, 40 mechanical excavators, 50 bulldozers and tractor-drawn excavators, besides many other items of plant of the most modern type, have been used in addition to the elaborate concreting equipment.

Considering the magnitude of the engineering problems and the existence of wartime restrictions and control of labour and materials, all of which was complicated by flying-bombs and rockets, the successful completion of this work is a credit to British engineering skill.

# Heathrow Aerodrome



The huge mixing machine making concrete for the runways.

The Ministry of Civil Aviation recently took over the administration of Heathrow, the designated airport for London, which is being built between the Bath and Staines roads, near Hounslow.

Air Vice-Marshal Donald Bennett, who formed and led the R.A.F.'s famous Pathfinder Force, celebrated the transfer of Heathrow aerodrome from military to civil control by taking off in the Lancastrian air-liner "Star Light" on a survey flight to South America.



Another view of the travelling machine for making the runways.



Building one of the large runways with a continuously-moving machine.



Part of the new airport, showing, in the background, the "Star Light" being loaded prior to leaving for South America.



The Lancastrian "Star Light" taking off for the first flight from the new airport.

# A Camera Enlarger

Base, Print Holder and Focusing Screen

By "HOBBYIST"

(Concluded from page 183, February issue)

IN last month's issue the enlarger case, negative holder and opalising screen were described in detail. To complete the work, the base and adjustable printing easel has to be made, all the necessary details appearing in this issue.

The base is really a "sleeve" for the printing easel arm, the latter allowing the printing easel to be extended to a distance of 2ft. 6ins. The arm keeps the easel in alignment with the lens of the camera.

The base also serves to hold the camera truly in position. As you know, most cameras are fitted with screw sockets at one end and side for connecting to a tripod. This feature is made to suit the enlarger, a screw being fitted to the front, top-end of the base so that the camera can be screwed upon it.

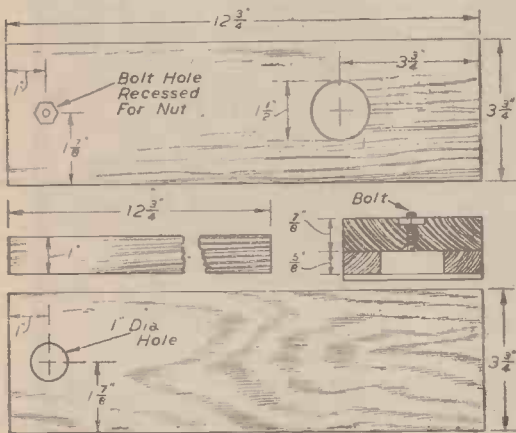

Fig. 11.—Base parts of the enlarger, with sectional end view.

### Base Construction

To make the base, cut out the top piece from 3/4 in. wood. A 3/16 in. hole is bored at one end for the camera socket screw, this being a 1 in. long gutter bolt or any flat-headed bolt of a similar nature which suits the socket threads. Countersink the bottom side of the base top bolt hole and insert the bolt, then fix on the nut.

The nut, of course, must be flush with the surface of the base top, so cut a neat recess for it, as shown in Figs. 11 and 12. Incidentally, it is essential that the bolt is so fixed in the wood that when the camera is screwed upon its projection, the latter is sufficient to allow the camera to be a firm fixture upon the base when facing the front end, i.e., the easel end of the base.

Having glued and nailed the side strips to the underside of the top base piece (these strips must be absolutely parallel at the centre for the extension arm), cut out the bottom piece from 1/4 in. plywood and affix on the strips. The 1 in. diam. hole cut at the end of this piece allows the socket screw bolt to be adjusted, or removed, if necessary.

### The Extension Arm

The extension arm is a piece of 1/2 in.-thick wood 36 in. long by 1 1/4 in. wide, the cross piece being a piece of 3/4 in.-thick stuff 6 1/2 in. long by 1 1/4 in. wide. One end of the arm is half-checked, as shown in Fig. 13, then the cross piece checked similarly in the centre

to make a half-lapped joint. Glue and screw the parts together, as suggested. The cross piece, being an 1/8 in. thicker, projects 1/4 in. at the bottom.

It is being assumed, of course, that the extension arm has been tried in its sleeving to see that it fits in and out smoothly. It is better to have it a trifle slack than a neat fit, since the wood might swell with dampness in the atmosphere, or through applying a stain, thus becoming troublesome to adjust.

### The Print Holder

Instead of the usual plain easel on which the printing paper is attached, the writer preferred to use a holder resembling a printing frame. As a result, one is confined to a certain size of enlargement all the time, unless extra holders are made and attached when occasion demands them.

Experiment showed that the smallest frame was one taking 4 1/2 in. by 3 1/2 in. printing paper, the largest frame being one taking 10 in. by 8 in. printing papers. The "between" sizes of printing papers are 8 1/2 in. by 6 1/2 in. and 6 1/2 in. by 4 1/2 in., holders being made accordingly. The frame holders, of course, ensure a neat, white border all round the print.

The best size of holder for the writer's requirements was one taking half-plate printing papers. The parts for this size of frame holder are detailed in Fig. 14. The front piece is cut from 1/2 in. wood to make an inner aperture 6 1/2 in. by 4 1/2 in.

The back piece is cut from 3/4 in. plywood, the central waste piece being carefully cut out with the fretsaw. A hole, for the entry of the fretsaw blade, is made at one corner, but you should drill tiny holes at all four corners to facilitate turning the blade at these points.

Glue and nail the front piece upon the back piece, and see that the rebate is even all round, for any inaccuracy here will always show on the prints. The waste removed from the back piece is used as a flap, as shown in Fig. 15, it being hinged to the framework.

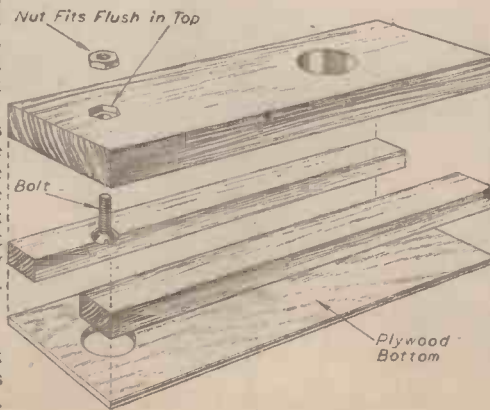

Fig. 12.—Exploded constructional view of base parts.

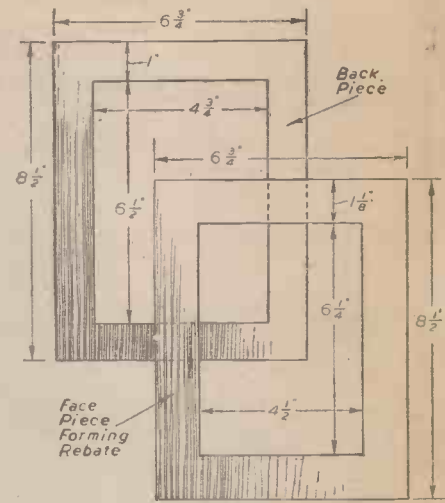

Fig. 14.—Front and back parts of print-holder frame.

### A Focusing Screen

Prior to hinging it in position, however, it is necessary to carefully remove a ply of wood from one side. A piece of thin, white ticket card (or a 6 1/2 in. by 4 1/2 in. printing paper) is adhered on the wood in place of the ply removed. This makes a white focusing screen on which the enlarged image is adjusted satisfactorily before inserting the printing paper.

If you use a printing paper to make a white screen surface, have the back showing, this being pure white. The sensitive side of the paper would, in time, tend to become a yellowish hue owing to exposure to the light. An old, useless, clean print could be used instead of a new, undeveloped one, including a piece of white cartridge paper, if desired.

It ought to be explained here, for the benefit of beginners, that most commercial enlargers are fitted with a swivel cap having an orange-coloured glass which is brought before the lens when focusing enlarged images on the printing paper, the latter being insensitive to orange light. In the case of the home-made enlarger, there is no orange glass fitment, so one must first focus the image on a white background, after which the printing paper is put before the background and the exposure made. This makes little difference to the enlargements; in fact, it is a safer method, since the orange cap can, at times, be accidentally touched with the hand, or it might be a fit-

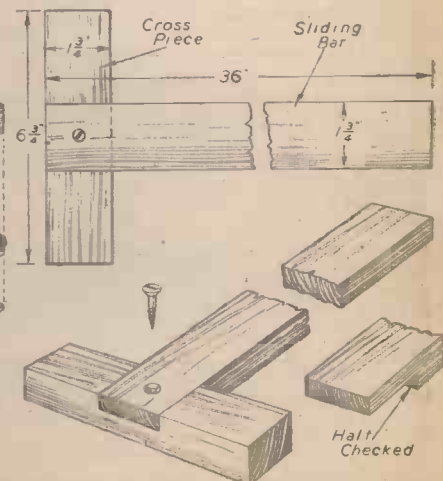

Fig. 13.—Details of the extension arm.

on-the-camera-lens type which could fall off, thereby spoiling the printing paper before the finest adjustment was made.

**Attaching the Print Holder**

The holder frame back can be attached by means of a single butt hinge or two smaller butt hinges, as shown. Moreover,

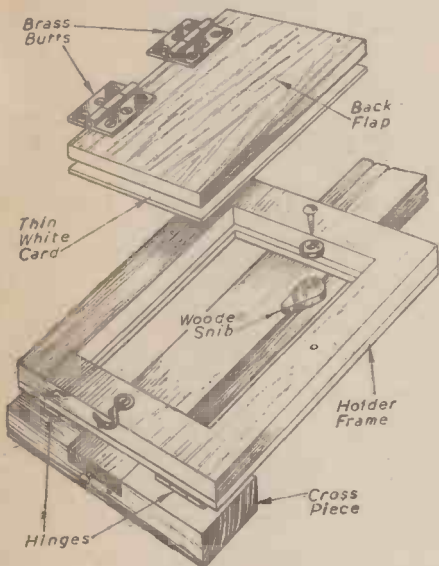

Fig. 15.—Constructional details of print holder, showing how it is hinged on the extension-arm cross-piece.

you can, if desired, have a piece of plain, thin glass fitted in the frame so that "curl" in the printing papers (especially the larger sizes) are flattened out when the back is closed and snibbed. If a sheet of plain glass is used, see that it is free from scores and whorls, as these will reproduce and have a disturbing effect on the print. Further, it will be necessary to remove an additional ply from the hinged back to allow for the thickness of the glass.

The holder, when completed, is attached to the cross piece of the extension arm by a single hinge, as shown in the constructional view in Fig. 15. Have it hinged so that, when sitting upright, the back is flush with the edge of the cross piece. To keep the holder from falling forward, attach a brass hook and eye, or a roundheaded screw could be used in place of the latter.

**A Medium Holder**

A good, useful medium-sized holder is one taking 6½ in. by 8½ in. prints. If this size of holder is fitted with a good piece of thin glass, quarter-plate, and half-plate, including postcard sizes of printing papers can be used. When using the smaller sizes, always make a point of keeping them in the centre of the holder. This becomes a habit in time and keeps you accurate. Naturally, these smaller prints will be without a white border.

**Up and Down Adjustments**

Because the negative holder, nor the easel, can be shifted upwards or downwards, this should not deter you from getting the

enlargements correctly upon the printing paper. Practically all stand cameras possess an up and down adjustment for the lens.

Thus, by moving the lens upwards or downwards, one is able to raise or lower the projected image. This is, naturally, a limit to these movements, but it is surprising what can be achieved on the home-made camera enlarger. It is primitive, in a way, but it should serve its purpose. The various sizes of printing papers which can be used are shown in Fig. 16.

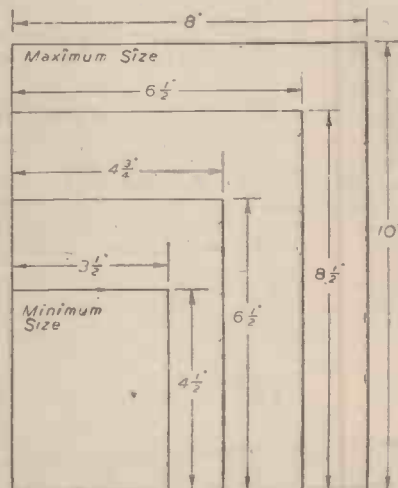

Fig. 16.—The minimum to maximum sizes of printing papers suitable for the enlarger, the holder being made accordingly.

# The Horseferry Road Citadel

## A Description of the Power Plant in One of London's Underground Miniature Cities

IN 1940, at the most critical stage of the war for Britain, three underground buildings were erected at strategic points in London to house the country's executives in emergency. The largest of these was on the already excavated site of an old gasometer in Horseferry Road, and it became generally known as the Horseferry Road Citadel.

Construction, power plant, equipment and supplies were such that under the worst war conditions, including poison gas, the Citadel could be inhabitable for at least three weeks by a maximum of about 2,000 persons. Water supply in an emergency was to be from a deep-bore artesian well through the foundations of the building; and food supplies for many weeks were normally held in store; so that the only supply to come in from outside was air. Under all circumstances the air had to pass through conditioners, but if a gas warning came through a gas filter was brought into circuit at the bottom of the main air intake.

Because of the course of the war, the building was never put to full-scale emergency use. But in view of the extraordinary variety of services—amounting in miniature to those found in any large city, plus others of a special war nature—which had to be provided, the power generation and engineering equipment is of exceptional interest. The Citadel itself has been put to use in housing Government departments, and the power for its services has, in general, been obtained direct from the local electricity supply undertaking. But on occasions of Grid failure the Citadel's services have been maintained with complete success by the diesel-engined plant intended to cope with war emergencies. And in view of the high peak loads at certain times each day,

and the national fuel situation, these diesel-engine sets have been brought into regular operation during winter months for a few hours each day.

**Power Plant**

The heart of the installation is four Petter

two-stroke Superscavenge oil engines set to give 375 b.h.p. at 500 r.p.m., and direct coupled to 250 kW. Brush alternators. Each complete set is mounted on a solid concrete foundation. The four engine generator groups had to be accommodated 50ft. underground within a space of approximately 35ft. long



General view of the four 250 kW. Petter engine generating sets at the Horseferry Road Citadel. The two Heenan and Froude coolers are in the background.

by 20ft. wide, but additional space was available for the switchboard and coolers.

Some of the reasons leading to the choice of the Petter make of engine were the favourable ratio of the space occupied to the power generated, and the low exhaust temperature, both of which factors were of more than usual importance in this sub-surface installation. The engines are started by compressed air stored in steel cylinders at a pressure of 350lb. per sq. in., and pumped into those cylinders by one or other of two small compressor sets, one driven by an electric motor taking its current from the Grid, and the other driven by a small petrol engine and used only when Grid supply is not available.

The Petter engines are cooled by water which has itself to be cooled, and this is done in two Heenan and Froude coolers; through which the engine water is circulated and cooled by an air draught provided by two motor-driven fans. The exhaust gases from the engines are passed through Burgess silencers, which are very well lagged in order

#### Air-conditioning

Most vital of all the services are the ventilation and air-conditioning. Up to 90,000-100,000 cubic ft. of air a minute are drawn into the building under maximum conditions, and this is enough for four complete changes of air in an hour, plus the air needs of the engine and cooler equipment. All the air for the building is taken down a central duct to the bottom of the structure, and then passes through filtering and conditioning equipment before being led to the rooms and the services.

Two points are of particular importance. First, the elimination of all poisonous gas from the atmosphere in the event of a gas attack; secondly, the maintenance throughout the year and throughout each day and night of the correct temperature and degree of humidity. Experience has shown that 55 to 60 deg. of relative humidity in conjunction with an air temperature of 68 deg. F. gives the most satisfactory conditions to the inhabitants. These values are maintained within very close

Ltd., for refrigeration and a multiplicity of fans belt-driven from electric motors.

The gas filters and gas fan motor come into operation through a remotely-controlled electrically-operated damper at the bottom of the building's main air intake; this action puts the air through the gas filter circuit and makes the metal to metal contact needed to close the electric circuit controlling the gas fan motor and to keep that motor running until the damper is lifted.

Though vitally important in a war emergency the artesian well would make little call on the power generated by the Petter engines, its motor taking only 18 h.p. But there are two other pumping operations which are of almost equal importance. First is the sewage disposal plant, the clearing of which is effected by Shone pneumatic automatic ejectors supplied with compressed air at a pressure of 20 to 30lb. per sq. in. The sewage cleared from the two settling tanks is pumped off into the local sewers.

The Citadel is sunk in some of London's marshiest ground; and the seepage trouble which formed one of the principal engineering difficulties in building the present Victoria station, not far away, are ever present in this building. The foundations of the Citadel incorporate a double wall; water leaking through the outer wall is picked up in the cavity between the two walls and pumped out into the mains; similar pumps deal with the water coming from certain springs just outside the walls.

#### Hot-water Supply

Steam to give the hot-water supply throughout the building is supplied by two Paxman Economic boilers designed for a working pressure of 80lb. per sq. in. These boilers are located well underground, on the same floor level as the Petter oil engines, and are fired by coal. Abutting on to the same room are the fuel oil storage tanks for the engine-generator groups, and holding a total of 25,000 gallons.

The working of the complete generating, ventilating, conditioning and pumping plants is under the direct observation of the shift engineer in his office, by means of a comprehensive system of visual and audible warning signals; and all the panels of the switchboard are visible to him through the windows and door of his office. Multi-purpose indicators are installed in the office, so that without leaving his desk the shift engineer can check the air temperature outside; the temperatures in the incoming air duct, after the washing process, and of the water in the condenser sprays. Finally, there is a gauge to indicate that the ventilating plant is maintaining that slight pressure above atmospheric necessary to ensure that no gas leakage into the building can occur.



Nine-panel switchboard; at the extreme left is the hinged panel for the synchroscope then the four generating-set panels; and on the right the five feeder panels for the building.

to prevent heat being transmitted into the engine room and making temperature conditions there intolerable.

The electric generators and all the main electrical equipment was supplied by the Brush Electrical Engineering Co., Ltd. The four generating sets are designed to operate in parallel with each other and with the incoming bulk supply from the Grid. They take over the whole Citadel load within a couple of minutes of the Grid supply being cut off, and there is a Chloride battery installed to maintain the essential services during this small time gap. The switchboard for the engine-generator groups has four panels which line up with five feeder panels controlling definite sections of the building. All the engine speed control operations can be carried out by the shift engineer from the switchboard.

Principal services maintained by these Petter engine-generating groups when the Grid supply has been cut off are: lighting; ventilation; air-conditioning; boiler auxiliaries; artesian well; sewage disposal; surface water pumps; and kitchen cooking loads. With the building fully occupied under emergency conditions these loads are estimated to need at least three-quarters of the installed engine power.

limits, and are under constant observation by the superintendent.

The ventilation and air-washing plant installed by Young, Austen and Young, Ltd., comprises in essence three washer and filtration plants, supplemented by three 175 h.p. CO<sub>2</sub> compressors by J. and D. Hall,

## BOOKS FOR ENGINEERS

Screw Thread Tables, 5/-, by post 5/3.  
 Refresher Course in Mathematics, 8/6, by post 9/-.  
 Gears and Gear Cutting, 6/-, by post 6/6.  
 Workshop Calculations, Tables and Formulæ, 6/-, by post 6/6.  
 Engineer's Manual, 10/6, by post 11/-.  
 Practical Mechanics' Handbook, 12/6, by post 13/-.  
 Engineer's Pocket Book, 10/6, by post 11/-.  
 Wire and Wire Gauges (Vest Pocket Book), 3/6, by post 3/9.

Dictionary of Metals and Alloys, 10/6, by post 11/-.  
 Plant Engineer's Pocket Book, 6/-, by post 6/6.  
 Screw Thread Manual, 6/-, by post 6/6.  
 Newnes Plastics Manual, 17/6, by post 18/-.  
 Newnes Engineer's Reference Book, 42/-, by post, 43/-.

Published by

GEORGE NEWNES, LTD., TOWER HOUSE,  
 SOUTHAMPTON STREET, STRAND, W.C.



# Modern Coal-mining Machinery—2

## Cutting Chains, Gummers and Special Adapters

By G. F. HAMBLETON and S. McCALLUM

(Continued from page 132, January issue)

**T**HE cutting chain is the next part of the machine to be considered. This consists of hardened steel links and boxes with a pitch of 6½ in.

Each box is slotted to carry a pick, which is held in place by a set screw, four or five types of boxes being used with different angles of pick slots, so that the chain can be built with a number of lines of pick points to give the best cutting result.

The chain runs round the jib, which is normally 4ft. 6in. to 6ft. in length. It consists of a high carbon steel frame to which are riveted top and bottom plates to keep the chain on its course.

The jib is carried by a support bar clamped to the jib-head, which can rotate through a distance of more than 180 deg. round the gear-head frame. The chain is tensioned by an adjusting screw inside the jib and working on a nut in the support bar. Where conditions are suitable, the jib can be fitted with a sprocket on the outer end to reduce frictional resistances.

The thickness of the cut is generally from 6in. to 9in., although special thin kerf jibs and chains can be fitted which reduce the cut to 4in.

### Operation

The machine is set with the jib in position ready to start moving into the coal face. The chain is then engaged and the jib is pulled round by the slewing chain which is hooked to the jib-head, and is drawn in by the haulage rope working at its lowest feed.

When the jib is fully under the cut, and at right angles to the machine, a spring-loaded locking pin drops in position in the jib-head. The feed is then transferred to the drum nearest the face, the end of the rope being first run out and held in position by a prop.

The cut is then continued along the face. Up to a few years ago the small holings or gummings thrown out by the chain had

to be shovelled away by a man working at the gear-head end of the machine. Much of this was carried back under the cut, and had to be cleaned out to make shot firing efficient.

### Mechanical Gummers

This work has been eliminated in many cases by the development of mechanical gummers.

There are various types which remove the gummings in different fashion, the most successful working on the spiral worm principle. In the Samson machine the gummer, which is clamped on to the machine in one minute, is driven by a small bevel pinion engaging in the gear-head crown wheel, then through a further bevel gear driving a clutch-shaft on each side of the gear-box.

The removable gummer frame is clamped to this gear-box, and the drive from either side, depending on which way the machine is cutting, is taken up by a spring-loaded clutch through a train of straight-cut gears carried on ball and roller bearings to the gummer worm shaft.

The worm runs in a cylindrical chamber which receives the holings thrown out by the chain, the spiral then pushing the holings



Side discharge gummer being fitted to machine at beginning of shift. The driving gearbox is seen bolted to the gearhead frame.

through the end of the cylinder, leaving them neatly piled along the goaf side of the coal-cutter's path, ready for disposal.

A further advantage is that it safeguards the man behind the machine from any risk of being caught in the chain or should there be any chain breakage.

### Arcwall Working

To fulfil these operations successfully the drums are fitted on an extended drum shaft to give the ropes a clear way to the gear-head end, and a special jib-head fitted with pulley brackets is also required to allow full scope with haulage rope. The fitting speed is also stepped up to 40ft. per minute to save time in moving from one face to another.

The longwall arcwall Samson, as its name implies, can be adapted for either longwall or arcwall working. It is fitted with a longer gear-head to take a jib-head that can be slewed round by the chain and haulage rope in one continuous sweep while cutting in an arc 240 deg. and up to 10ft. in radius.

When arcwalling, the machine is mounted on wheels or crawlers, the drive for same being taken from the large spur wheel on haulage drum shaft, through a reversing gear, box bolted to the upper side of the haulage frame and hence by chain drive to the wheels or crawlers.

### Loading and Conveying

Turning to the handling of the coal, after the cutting and shot firing process, speedier handling is duly carried out by various types of conveyors, e.g., shaker conveyors, belt conveyors, and loaders, some of the latter actually loading on to the coal face conveyor itself.

The modern face conveyor consists of a sectionalised structure carrying idler rollers



Cutting the face with an A.C. longwall Samson. The machine is hauled along by winding in the drum on the face side, the end of the rope being fixed by a prop. The face conveyor is shown in position ready for commencement of the loading shift.

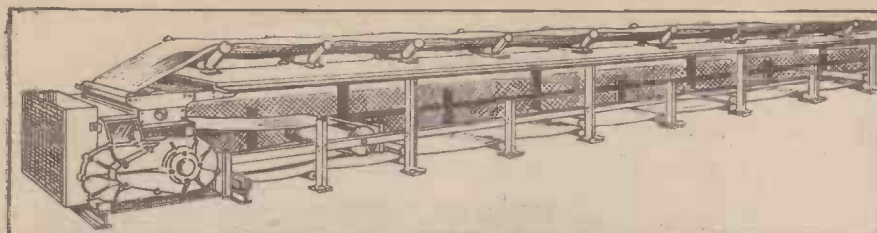

Troughed belt conveyor with underneath drive. Showing loop take-up. The belt is troughed by the side idlers.

for top and bottom belts, the bottom belt being protected from dirt and small coal by inverted troughs. This keeps the return pulley clean, thus reducing friction and wear to a minimum.

The side plates of the structure prevents spillage.

The belt consists of a number of layers or piles of cotton duck impregnated with rubber and protected by a layer of rubber on both sides, and at the edges.

The cotton duck enables the belt to withstand tension and the rubber prevents the cotton rubbing and cutting, and also reduces internal friction by insulating the strands of the fabric from one another.

The width of a face belt is usually from 18in. to 26in. and the length is, maybe, up to 300yds

At the tail end the belt passes round a pulley which is pulled out from the main structure by sylvesters chained to props, thus applying tension to the belt. Finer adjustment is made by a screw device applied to the pulley frame at each side. The trough on the frame is connected to the rest of the conveyor by a telescopic trough which ensures continuous protection for the bottom belt.

#### Face Conveyor

On the M. and C. face conveyor, the driving unit, which stands at the delivery end, consists of two cast steel side cheeks which are held together by cross stays. A pair of driving pulleys, one of which has a hollow shaft, are carried between the cheeks on ball bearings.

On one side the motor is spigoted to the cheek, and spur gearing transmits the drive from the rotor shaft through a solid shaft inside the hollow shaft to the other side, where a further train of gears takes the drive to the pulley shafts.

When the power is compressed air, the unit fitted is usually a turbine working on the same principle as the compressed-air Samson, the flow of air being automatically controlled by a governor fitted to one rotor shaft, this keeping the belt running at a uniform speed.

A reciprocating air engine can be fitted in place of the turbine, Holman Bros. unit being a typical example. This consists of two cylinders set at a V-angle to one another, the pistons of which both drive on to one crank shaft. The belt is wound between the driving pulleys and snub pulleys to give the necessary amount of belt wrap. Delivery is either into the receiving end of a scraper loader or gate belt conveyor, or straight into tubs, and extended delivery head being fitted if necessary.

The complete cycle for operations at the face, viz., cutting shot firing, loading, timbering and turning over face conveyor ready for the next loading shift usually takes 24 hours.

The main gate conveyor is a more permanent structure than the face unit, and can be lengthened by the addition of sections at the tail end as the face recedes from the main haulage road.

To increase the capacity without resorting to the side-plate the belt is formed into a trough shape. This is done by having horizontal idlers in the centre of the belt

and side idlers carried on brackets at an angle to give the suitable depth of trough. The idlers and brackets are bolted on to the pressed steel inverted trough sections which cover the return belt. The side idlers are given a slight tilt in the direction of travel to assist the belt to run centrally.

The driving gear may be placed at the delivery end, receiving end or somewhere in between on the return belt, depending on prevailing conditions.

A receiving end structure is fitted to take the coal from the face conveyor, and as it is moved forward in conjunction with the face each day, it follows that the whole conveyor has to be extended.

#### Loop Take-Up

A loop take-up and telescopic trough eliminate the fitting of extra belt and troughs each day.

The loop take-up has its maximum length

of belt in hand when the troughs are closed; as the face advances the whole structure can be extended by pulling the receiving end along, the telescopic troughs opening out while the extra belt length is taken from the loop and tensioned up again by the pulley and jack arrangement in the loop structure. The loop belt length is in the region of 60ft. which is ample for a week, more troughs and belting being fitted during the week-ends.

Sometimes two or more gate conveyors deliver to a trunk conveyor in which case a system of sequence control may be included in the motor switchgear, so that when the main truck conveyor is stopped all other tributary conveyors automatically come to a halt.

On restarting again the gate and face conveyors follow up on the trunk conveyor at intervals of a few seconds, according to the timing of the relays fitted on each individual switch.

Other types of machine mining plant include scraper chain loaders, Joy loaders, duckbill loaders, shuttle cars and various types of shortwall coal-cutters which, owing to limitation of space, cannot be described at present, but they are mentioned to illustrate the variety of appliances which are used in modern coal mining. Prior to the war a great deal of the mining machinery used in Europe and the Dominions was of British manufacture, and there should be a tremendous field for post-war trade to these and many other countries.

## An Electric Bed-warmer

By Prof. A. M. LOW.

IN these times of fuel and blanket difficulties it is not always easy to keep warm in bed. Hot-water bottles are often unobtainable, and we have no time for the warming of sheets with pans of hot coal as used by our great-grandfathers!

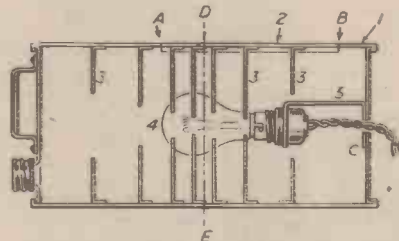

1. One Gallon Oil Tin Or Small Biscuit Tin.

2. Side Cut Out From A-B.

3. Fins - Five Are Attached To 2 & Lift Out Together

4. Bulb.

5. Bent Tin Support For Socket Soldered To Tin At C.



Section At D-E

Sectional views of an electric bed-warmer.

Warm pads contain hot wire resistances which are necessarily thin and repairs can mean weeks or months of delay. Anyone with a few "kitchen materials" or who is willing to spend five shillings on the necessary parts can make a warmer which is unbelievably cheering on a cold night.

The sketch shows the method adopted. Bulbs waste about 97 per cent. of their energy in heat, and a 40-watt type is usually ample. If regulation is desired two can be used and a simple switch is easily fitted. The vanes, or fins, must be carefully made so

that the heat is conducted away, or the bulbs will not last.

The whole device is safe, simple, and breakdowns are a rare occurrence. It can be repaired in 30 seconds. Running cost is merely the normal bulb consumption.

With a cover made from a piece of old blanket, the apparatus is a blessing and will be appreciated during the winter when coal fires are somewhat "under the counter," instead of in the grate!

#### ELECTRICALLY HEATED CLOTHING

THE subject of an invention recently submitted to the British Patent Office is electrically heated clothing which forms part of the equipment of airmen.

The author of this improved device remarks that for connecting a heating element to the source of the electric current a plug and socket arrangement would be most convenient. But this has the disadvantage that the plug and socket are liable to be pulled apart by the movement of the airman or, at high altitudes, owing to contraction due to low temperature.

In the case of the newly invented electrically heated clothing it has a plug and socket connection whereby one member of a readily releasable two-part fastening device is connected to the plug and the other member to the socket. The fastening is so arranged that an indissoluble union is effected.

For this purpose one member of the fastening device may be attached to the plug or socket and the other to a band or strap which is attached to the socket or plug. The band is of such a length that, when the two parts of the snap fastener are engaged, the plug and socket cannot be disconnected.

Obviously the source of the current is of low voltage.

# The Story of Radar—5

Radio Navigation : Altimeters : Fighter Direction : Airborne Radiolocation

(Continued from page 168, February issue.)

**A**N apparent inconsistency in the preceding article is explained by the fact that Coastal Command got its first "radar" navigational aid as an unplanned by-product. It will be clear that if an A.S.V. set can get radiolocation echoes from a ship or a U-boat on the surface of the sea, it will also get echoes from islands, headlands and the like. The range of pick-up varies with the sharpness with which the landmark rises from the sea, and with its size. In general a coastline will be shown on A.S.V. at ranges much exceeding those given by ships. So the A.S.V. set could be used for making landfall in bad visibility, and a crew working on a familiar coast or with some experience in map-reading from the radiolocation standpoint could get very valuable guidance. This free service was so popular that the scientists sometimes wondered whether A.S.V. was not carried mainly for getting about rather than for its official purpose of finding enemy shipping.

A natural development from the fact that the range of the nearest echo from the ground or sea was that from vertically underneath, and therefore measured the instantaneous height of the aircraft above ground, was to fly across country by the aid of the "terrain clearance indicator" thus available. An early experimenter guided an aircraft, flying blind save for his radiolocation information of this special kind, across country in several long flights, including one which simulated a bombing attack on Carlisle after an indirect flight of several hundred miles.

In the same series of experiments it became evident that some discrimination among the different components of a landscape could be based on the returned echoes; the cranes at Harwich, for example, were useful radio landmarks. This kind of discrimination was later exploited in the centimetric aids to bombing, described in the section "Finding the Target."

It will be seen from the foregoing example how interlaced were the many early developments of radiolocation; a device was no sooner developed for one purpose than it was found to provide wholly or in part the solution to some other problem, and a new line of development would be marked down as soon as effort could be spared for it.

But the altimeter is an essential flying instrument and for many years the only indication of "height" was the reading of an aneroid barometer which had been "set" before take-off to the height above sea-level of the aerodrome from which the flight started. Even if the weather conditions did not change during the flight, the best that could be expected was that while over water or land at sea level the aneroid would indicate true "clearance." The same reading would be obtained in level flight if, a few minutes later, the aircraft flew over mountain peaks 10,000ft. high: with disastrous results if the flight altitude were only 9,000ft.

This is not a fanciful possibility—only too often have aircraft flown into mountain-sides in weather so "thick" that disaster was upon them before the pilot could take evasive action.

What was needed, clearly, was an instrument to show "terrain clearance," the true distance from the aircraft to the nearest part of the earth's surface, so that if this clearance became dangerously small the pilot could gain height and avoid danger.

A commercial organisation in U.S.A. had produced before the war a device in which

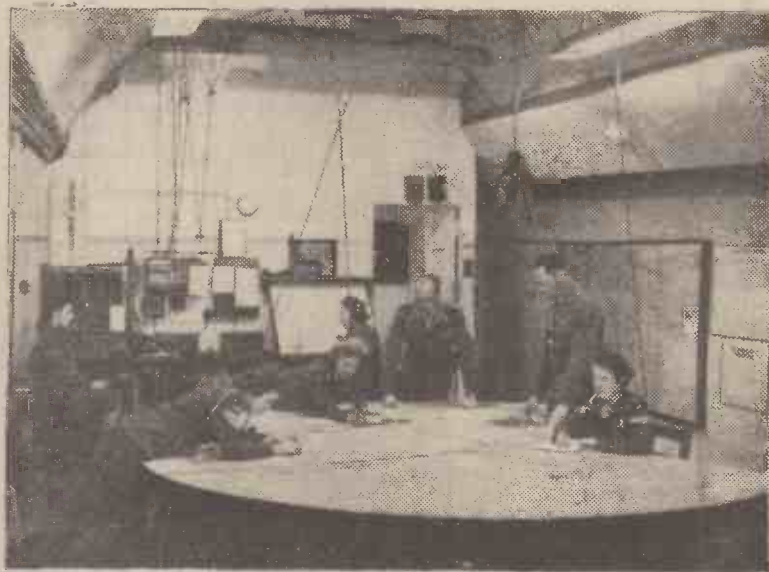

*How radar helped the Dover coastal artillery to sink enemy ships on the darkest nights. Our illustration shows the interior of the coastal artillery operations room, situated in the dungeons of Dover Castle. Here all the radar information was co-ordinated and the heavy and medium coastal guns directed on the enemy. On the right is seen Brigadier C. W. Raw, O.B.E., T.D., who was in charge of the radar operations at Dover Castle.*

continuous electric waves were emitted, with rhythmic variations in frequency, from the underside of the aircraft. The reflected wave from the earth's surface is received in the aircraft and "compared" electrically with the wave then being sent out. The longer the time interval between the emission of the original wave and its reflection back to the aircraft, the more will its frequency differ from that of the wave being emitted when it gets back. This frequency difference was made to show true "terrain clearance" directly on an instrument dial and for small and moderate distances—e.g. up to 5,000ft.—the system works well.

Terrain clearance may involve also the measurement of clearance obliquely ahead (as in approach to, or flying through, steeply mountainous country). In such cases, the indications can be combined, for peacetime use particularly, with a warning that other aircraft are in the vicinity and the apparatus takes on the general character of A.I., already described, but it has not been found necessary to use such equipment in war.

## The Story of Fighter Direction

The growth of the coastal chain of Air Ministry Stations which was the first and most urgent application of radiolocation has just been described as if it had been designed as a purely passive information service. Indeed, had it done no more than give the Air Raid Warnings which it supplied for A.R.P., it would have amply repaid the few tens of millions of pounds which it cost. The elimination of standing patrols from the fighter defence of Great Britain, the elimination of permanent "action stations" from the anti-aircraft gun defences, were in themselves revolutionary economies. Of the former the Air Ministry said in the first instalment of the story of radiolocation (June, 1941): "Although millions of pounds have been

spent on Radiolocators it is safe to say that the entire cost has already been saved. Radiolocation makes it largely unnecessary to maintain standing patrols and so it has saved the country an immense expenditure on petrol, engines and wear and tear of aircraft. It has also obviated the tremendous strain on personnel which, otherwise, would have been unavoidable. In the Battle of Britain, the advantages of Radiolocation were even more apparent. Our sorely overworked fighters had no need to maintain standing patrols. They could rely on the vast Radiolocator system to tell them in plenty of time when the enemy were coming and from what direction. This was of such incalculable help to them that independent observers from the Dominions have stated categorically that the Battle of Britain was won by the Fighter Organisation of the Royal Air Force aided by Radiolocation."

No such narrow limits to their ambitions as mere passivity were set by the pioneers of radiolocation. In particular, the chairman of the scientific Air Defence Committee seized enthusiastically on the possibility of giving to the fighter pilot in the air an accurate stream of information as to the position of the enemy relative to himself and of instructions on the course which he should fly to come within visual range of them, and to come within that range in a relative position favourable to himself in engaging combat. Long before radiolocation equipment was ready to give actual information of this kind, experiments had been started on controlled interception at the Biggin Hill fighter station. There a scientific study was made of the most suitable method for controlling intercepting fighters, making use of the communication equipment at that time available. During these trials at Biggin Hill it was assumed that the results from Bawdsey would eventually be such that the position of an aircraft would

be correctly determined once every minute and that the information could include plan-position and height. By December, 1937, both the location and interception technique had been evolved to a sufficient degree for a programme of interception experiments to be initiated, and from the 1st January, 1938, to the opening of the present war, a very large percentage of civil air liners reaching this country were intercepted by fighters based at Biggin Hill and controlled from the Biggin Hill Operations Room; although in order not to excite too great an interest on the part of their officers, the air liners were never "closed" by the intercepting fighters. During these experiments, a visitor to Biggin Hill was duly impressed by the navigational paraphernalia used to calculate what direction should be given to fighter aircraft. One day, the R.A.F. Officer Commanding came into the Operations Room, mounted the control dais and watched the process for some time, after which he casually announced that he was quite certain he could do just as well by estimating what instructions to give to the fighters instead of making the calculations that were then being worked out. He accordingly instructed that the Operations Room table should be cleared of all but plotters and took charge. His efforts met with such remarkable success that it is not an exaggeration to say that this incident was the birth of the Day Fighter Control system which was universally employed by the R.A.F. through the Battle of Britain.

By the time the war started we plotted cross-channel aircraft so regularly that an investigation was made into every individual case of civil air liners being missed by the sentinel stations.

Had these experiments not been begun before there was a solid foundation on which to establish them, had they not been pursued with skill and zeal by service officers and civilian scientists in the closest co-operation, then the technical readiness of the coastal chain for the day Battle of Britain would almost certainly have been stultified by the inability to attain tactical readiness in the ground and air organisation for controlled interception by day.

#### The Beginning of Airborne Radiolocation

The problem of daylight interception is only the easy part of controlled interception. In spite of the imperfections of the coastal stations it was not difficult to guide the fighter to within a very few miles of his prey. When the prey flies by night the guidance is neither worse nor better, but the pilot's range of useful vision is now restricted to a few hundred yards—sometimes to a few hundred feet. All this was clear to the early radiolocation workers and the scientific Air Defence Committee. The problem before the small group of "airborne radiolocation" experimenters was to go on from R.D.F.I., the coastal station project, to R.D.F.II, the formidable problem of putting a complete radiolocation equipment, transmitter, receiver and indicator, into a night fighter, so that the crew could, from the position to which the ground controller could direct them (a few miles from the night bomber) seek him out and close into visual range by the use of his own radiolocation set—the "smeller," as Mr. Churchill called it.

With the confidence borne of past success and present ignorance the experimenters said they would do R.D.F.II, but the sweat and tears required were not at all proportionate to the smaller size of the equipment or the smaller range required! The proposed solution was amplified to the Air Defence Committee at a meeting on February 2nd, 1936; the promise was then made that six months' work on the ground would suffice as a foundation for flight trials in a light bomber, and it was at the same time forecast that centimetric wavelengths would later be required for a fully satisfactory solution.

In September of 1936 the "airborne" group consisted of three members and in spite of many diversions to give urgently-needed help in other fields these three experimenters set out to devise an equipment, light enough, small enough and taking sufficiently little



*A corner of an operations room, showing heavy anti-aircraft fire-control radar equipment. Many gunners and A.T.S. operators have spent long hours at these controls searching for enemy bombers and directing the fire of A.A. guns.*

power from the meagre aircraft generators then available to go in a fighter aeroplane.

By mid-1937 the equipment was still very crude, but was hopefully put in an Anson, the transmitting dipole being poked through the escape hatch, while the receiving aerial was kept inside the aircraft. To the great joy of the experimenters, echoes from ships were observed at four or five miles. This was an important development of which more later.

A year later, a flight of aircraft was allocated to the airborne experimenters at Martlesham: two Ansons, a Harrow, and later two Battles, some of which were always unserviceable at any given time, but sufficient remained to give opportunities for remarkable experimental progress in successive flights.

In 1939 a period of great activity was followed by so many simultaneously-ripening fruits that it was embarrassing to select one for immediate development at the expense of the others: the device of switching from one aerial to another enabled "port and starboard," "up and down" lobe-switching to give precise "direction-finding" in two dimensions and the success of this method was another milestone and the basis of all early A.I. (and A.S.V.). Also, a rotating dipole and synchronised rotation of the "time base" of the cathode ray tube (as related in the chapter on C.H.L.) was the forerunner of many airborne display systems at present in use.

Again, it was observed that ground echoes from "towns" were stronger than those from the "countryside" and Norwich was

detected at a distance of several miles, while still invisible to the pilot of the "Battle." Here was a first foreshadowing of that aid to precise target location which has made the R.A.F. so devastating in its attacks on industrial Germany.

During the winter of 1939 and the first half of 1940 much concentrated hard work was put into the development of A.I. Improvements were made in minimum and maximum ranges and in the serviceability and reliability of the gear under flying conditions. It was very clear to the experimenters, although it is not obvious on a first casual glance, that the problem of reducing the minimum range at which useful information could still be obtained was much harder than that of extending the maximum range.

By summer 1940 A.I. Mark III was becoming operational in Blenheim's with a minimum range improved to 800ft. and a maximum range of about two miles. The system was, however, still incapable of defining with sufficient accuracy the direction in which the bomber lay relative to the fighter. This problem was very acute and advantage was taken of every minute of daylight for flying experiments on it. The Fighter Interception Unit, which had been formed to work out the tactical utilisation of devices of this kind, began trials in August, 1940. The results were impressively promising and A.I. Mark IV was approved for use in the Beaufighter which, with this great advantage in speed, was replacing the Blenheim as a night fighter.

In July and August of 1940 there were several "chases" by A.I. fighters and the first claim—a "probable"—was made by F.I.U. on the night of 2nd-3rd July, 1940. By October, 1940, Blenheim's fitted with A.I. Mark III had shot down six enemy bombers. In November, 1940, the first kill with the improved version in Beaufighters was made, and from then until the autumn of 1941 the main night fighter was the Beaufighter carrying A.I. Mark IV. The installation in Beaufighters gained much in effectiveness by use of a new modulator produced by an industrial development laboratory. The maximum range rose to 20,000ft. and the minimum range fell to less than 600ft.

#### Radio Lighthouse

Air staff and scientific staff alike were confident that controlled interception by day using the C.H. and C.H.L. systems would drive the enemy into a concentration of his main effort on night bombing. They realised that the technique which was good enough for day control would not suffice for the control of the night fighter even when he had been equipped with the A.I. installations under development. It had long been felt that a considerable improvement in accuracy might be attained by controlling the fighter directly from the ground radar station, thus eliminating the delay necessarily involved in passing information to a Central Filter Room controlling fighters. The improvements attained in practice, however, were not sufficient to solve the problem of night fighter control. The radio lighthouse with its Plan Position Indicator was now essential to success.

The problem of attaining the radio lighthouse was a threefold one and three separate teams at the Research Establishments attacked them. One had to develop an aerial system of the same general nature as that for C.H.L., but capable of being rotated continuously instead of sweeping a limited sector. A second group was attempting to solve the problem of providing more accurate height information than was yet available, while the third was concerned with the production of a suitable display system. The lighthouse dream of 1935 had described the kind of display system that was wanted, and the new team produced

it in an elegant and practical form, which marked one of the most revolutionary advances ever made in radiolocation. The principle was that the distance scale on the cathode-ray tube started with its zero at the centre of the tube and measured radially outwards, so that the distance of an indication from the centre of the tube was the distance from the radiolocation station to the target concerned. This distance scale was rotated about the centre of the tube, so that the angle at which it lay from the north point on the tube was the angle at which the narrow rotating beam from the rotating aerial lay relative to true north at that particular instant. Instead of the older device by which the radio echo made a notch on the distance scale, the echo now produced a bright spot on an otherwise dark background. Thus each target was represented on the Plan Position Indicator by a bright spot in the correct map position of the corresponding target, the map being one showing the slant range and bearing of any point from the radiolocation station.

The practical realisation of the demand for a Plan Position Indicator, which may be said to have come in about May, 1940, was a major revolution in radiolocation technique. From its first application in ground stations for fighter direction it passed to application in almost every significant development of radiolocation, on shore, in ship and in aircraft.

### Ground Control of Night Interception

The solutions of all three problems just mentioned provided the basis of the G.C.I. equipment (for the ground control of Interception, particularly at night). Between May and September, 1940, it was brought to the stage at which actual fighter control could be demonstrated by T.R.E. to senior R.A.F. officers; in July the characteristics of the equipment to be used in the field were officially agreed; and another early "crash programme" in the long series of crash programmes which have assured the timely availability of each new radar device, was undertaken.

On October 15th a site for the first (mobile) G.C.I. was chosen; next day the equipment moved in from T.R.E., where it had been built; on the 18th it plotted its first aircraft track. A gruelling series of trials ensued, failure to cover certain vital zones had to be cured, height-finding properties had to be improved still further. Trials went on night and day, a decision was taken to make six sets even before the improvements had been proven, and T.R.E., with invaluable help from A.D.R.D.E., despatched the first of the six on Christmas Day, 1940, the last of the six on January 6th, 1941.

It was not long before the burghers of Bournemouth, and the guardians of security, were stirred by the passage through the town of a mobile set clearly marked with 48 swastikas "notched on the butt."

Much of the credit for the successful interceptions which now came was due to A.I. Mark IV. New methods of training R.A.F. operators and improved servicing of equipments paid good dividends. Special electronic devices which simulated on the ground the process of interception were developed at T.R.E., and T.R.E. technicians were sent to squadrons to assist in R.A.F. training. These electronic devices were among the first of scores of synthetic "trainers" which T.R.E. was to provide in helping the Service to train the operators of many different equipments, thus simplifying procedure and at the same time eliminating much of the time which had been spent in training in the air. More than 2,000 aircraft and over 100 million gallons of petrol have been saved in this way.

The result of the new control system is seen in the statistics of enemy losses during the first months of 1941. Our night fighters'

success increased steadily. In December, 1940, they destroyed two enemy planes, with six more probably destroyed or damaged. By March, 1941, the figures were 24 destroyed and 50 probably destroyed or damaged; in April, fighters accounted for 52 destroyed and 88 probably destroyed or damaged; in May the results were 102 destroyed and 172 probably destroyed or damaged. In addition to these fighter successes, the number of A.A. successes was increasing and formed a considerable proportion of the total. The number of enemy sorties was about the same in each of the four months mentioned above



*Radar in the Navy. This equipment was designed to provide radar-controlled fire at enemy planes, using the main A.A. batteries, in large modern ships. It can also control the main armament of a destroyer against surface targets. The modulator and receiver are similar to those used in the surface gunnery equipment.*

—and the overall casualty rate rose from less than ½ per cent. to just under 7 per cent. On the night of May 10-11th, the enemy sent 340 aircraft to London, of which fighters destroyed or probably destroyed 28 and damaged a further 10. It was obvious that the night blitz was more likely to result in the destruction of the Luftwaffe than in the elimination of the Londoners and the invasion of Britain. Hitler decided to turn his attentions elsewhere.

### Centimetric

But A.I. Mark IV had many limitations which had worried its designers and its users from the earliest days of A.I. work. It was vulnerable to jamming by the enemy, and it was also vulnerable to a very serious interference by echoes from the ground below it; the maximum range at which it could see any enemy aircraft was in fact limited to the flying height of the A.I. fighter.

By far the largest reflector which sent back echoes to the A.I. receiver was the surface of the earth or sea; therefore the A.I. operator would see depicted on his cathode-ray tube, firstly the transmitted pulse, then a clear space with perhaps an echo from some nearby aircraft, then a relatively huge echo, apparently several "miles" long and often

extending up to the farther edge of the tube. The "near" edge of this "ground return" marked the distance from the aircraft to the nearest part of the earth's surface, which is at the nadir of the aircraft's position, and this distance is (very usefully) the "terrain clearance," or height above ground of the aircraft. (Hence, yet another application of Radiolocation—the Radio-altimeter). Clearly, no small reflecting object, such as another aircraft, could be expected to make its feeble echo perceptible through the enormous "ground return"; therefore, the maximum range at which an enemy bomber could be detected by the 1½-metre A.I. of the fighter was equal to the flying height above ground of the fighter (and the minimum range, that at which his echo disappeared in the "clutter" and the transmitter pulse).

This disadvantage of being limited in range by the "ground return" could be overcome by the use of such short waves that a narrow-beam, no wider than that from a sharply-focussed motor-car headlamp, could be used to illuminate the enemy, while being kept clear of the ground, and so avoiding disturbance of "ground return."

The story of the remarkable developments in technique which have made centimetre waves practicable, and in them, have unified the art of radiolocation, has already been told in a preceding article.

The summer of 1940 brought success to the "centimetric" experimenters. With the danger of night raids looming ever larger, A.I. was chosen as the first application of the newly-won power on centimetre waves.

The first aircraft fitted with centimetric A.I. began flights in February, 1941. The radio beam projected ahead of the aircraft was narrow, and was made to scan a large area of sky by giving a spiral motion to the parabolic mirror which focussed the beam.

The success of these early centimetric equipments was so outstanding that a "crash" programme for a considerable number was given to British Industry: this was a hard-and-fast programme with no hard-and-fast design, the latest innovations being incorporated in production as soon as they became available from the T.R.E. laboratories. At the same time T.R.E. began to make special arrangements for teaching the new centimetre technique to R.A.F. personnel and for introducing the new A.I. (known as A.I. Mark VII) to the operators. A small group of T.R.E. bodies was detailed specially for this purpose and themselves learned the theory of centimetre working and details of A.I. Mark VII from their colleagues who had designed the equipment. The group became known as Post Design Services (PDS); they helped in the design and construction of test gear; they wrote technical manuals for the use of R.A.F. learners; and finally they themselves fitted the first 36 A.I. Mark VII aircraft and accompanied them to the squadrons. This was the beginning of PDS, which expanded rapidly both in size and in functions; over 50 different equipments have been introduced to the Service by PDS.

(To be continued)

# Power from Thermo-electricity

The Possibilities of Thermo-electric Couples By J. A. JOHNSON

**I**N spite of the broughams and river-launches of 40 years ago, and the powered invalid-chairs and tradesman's runabouts of to-day, the long-distance electric vehicle still remains a vision. The motorist still longs to be rid of his gears and cold-starting troubles, and the non-motorist wishes for some cheap and simple way of avoiding the bicycle or bus. Electric power is available from mainly

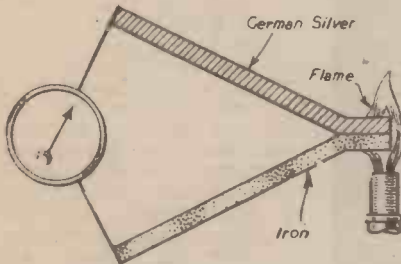

Fig. 1.—A simple thermo-electric couple.

three sources: driven dynamos, chemical battery action, and thermo-electric appliances. Accumulators, in spite of their weight, size, chemicals and deterioration, are still the most efficient portable reservoirs of electrical energy we have. Assuming, perhaps wrongly, that primary and secondary batteries are unlikely to be capable of much further improvement, the only alternative (pending the introduction of atomic energy) is to recognise that, in the

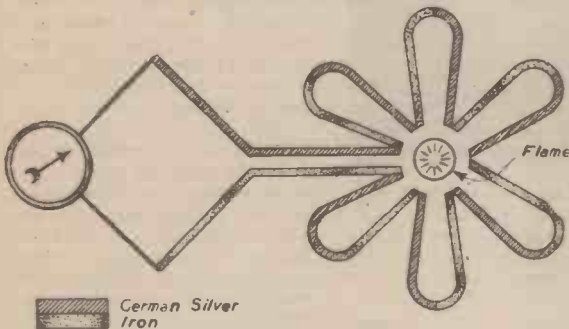

Fig. 2.—A number of thermo-electric couples brazed together.

light of modern knowledge, thermo-electricity is capable of further development.

Since its discovery by Seebeck in 1821, much attention has been given to this interesting subject in an effort to understand its true origin and also to apply it to practical purposes. To-day, it is still used for only very few and relatively unimportant purposes—furnace pyrometers, delicate laboratory heat-detectors, and as gas-heated batteries for radio sets.

If two thick wires (say, 1/16 in.) of dissimilar metals, such as iron and German silver, are joined by brazing in the form of a letter "V" and the two free ends connected to a galvanometer (Fig. 1); on heating the brazed joint, the passage of a very weak current will be shown in the detector. It is apparent that if a number of these couples are brazed together in series and alternate joints heated (Fig. 2), a proportionately stronger current is generated.

### Iron-German Silver Elements

With little trouble a number of such rings can be piled one above the other, separated by flat asbestos rings, and the whole connected in series. So arranged, 120 iron-German silver couples, with the centre at dull red heat

has given the writer sufficient output to drive a small electric motor, which moved a small truck carrying the thermo-pile and spirit-stove—in short, thermo electric-traction!

The thermal efficiency of this or, for that matter, of the most carefully designed units, is very poor; roughly five per cent. or under as compared with about 14 per cent. for steam and about 30 per cent. for internal combustion engines, the majority of the heat being lost by spreading through the elements and uselessly raising the general temperature. Moreover, thermo-piles share with accumulators the disadvantage of great weight per horsepower.

On the other hand, any form of heat can be employed: the household fire, the sun's heat, anything inflammable.

At the end of last century a relatively powerful thermo-electric battery was constructed which burned coal and produced 50 volts at 5 amps. The method recently employed by a manufacturer, in an effort to improve thermal efficiency, was to heat each couple separately by a tiny hooded flame.

The goal is always to improve wattage per couple, with a reduction of weight and fuel consumption. These three factors are, of course, inter-related. The perfect couple should absorb all the heat, without itself getting hot, and deliver it as current. The modern theory of electron pressure assists in clearly focussing the problem. Two metals in contact exercise a neutralising electron pressure on each other (Fig. 3).

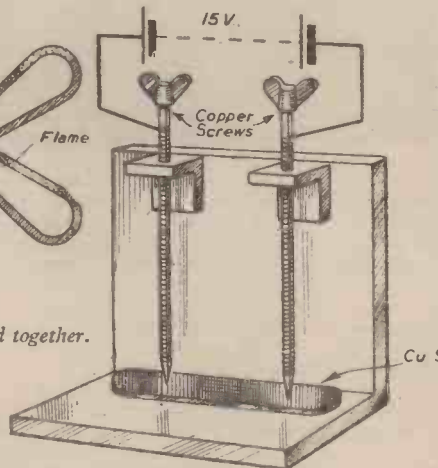
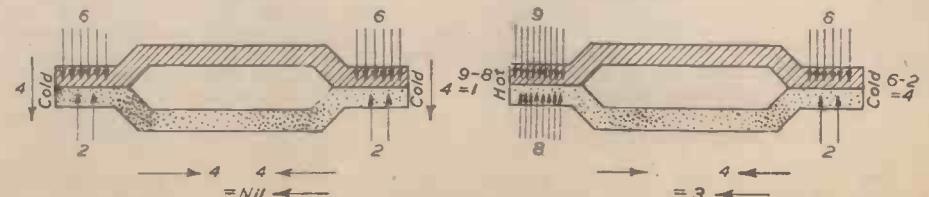

Fig. 6.—Testing the sensitivity of a bar of copper sulphide.

When one of the junctions is heated the balance is disturbed through the well-known fact that, while the electron emission of metals is greatly increased by heating, this varies for different metals and alloys and for even differing crystalline structures of the same metal, so that while one metal may have its emission doubled by a 10 deg. rise in tempera-



Figs. 3 and 4.—How two dissimilar metals exercise a neutralising electron pressure on each other.

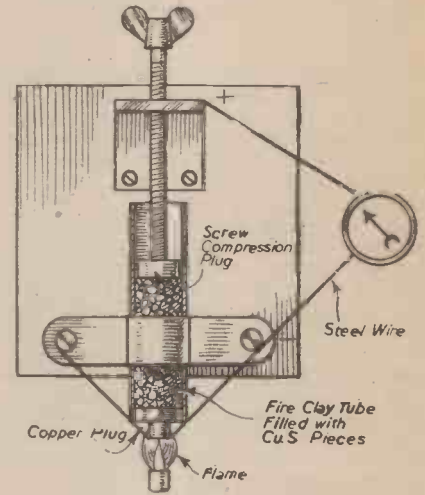

Fig. 5.—Simple apparatus for demonstrating the thermo-electric qualities of various substances.

ture, that of another may be quadrupled by a similar rise (Fig. 4).

### Copper Sulphide Element

Ideal substances would therefore be those which would conduct electricity well, but heat badly, and while one had very high emission with gentle heating, the other emitted not at all. Copper sulphide does go some way to meet these requirements, a bar of this (produced by the direct combination of a copper rod and flowers of sulphur in a heated crucible) being a relatively powerful thermo-electric element when coupled with copper or German silver, five such couples producing 1 volt at 2 amperes. This substance is, however, extremely brittle and friable owing probably to its loose crystalline structure. This latter characteristic is, on the other hand, probably connected with its efficiency as it has no thermo-electric qualities in powder form. If an external current of about 15 volts is passed through one of these bars, via two copper points, it will be found that it not only has sensitive spots, like the galena wireless crystal, but that an area of bright red heat will develop round the positive electrode point with veins of dull red heat radiating therefrom. In a very short time sulphur fumes appear and the bar fractures along these veins thereby breaking the circuit. A microscope shows that a kind of minute inter-crystal arcing is taking place.

Figs. 5 and 6 show simple apparatus by means of which this and other similar interesting substances may be studied.

### Electron Movement

The broader aspect of the inter-relation of heat and electricity in conductors becomes evident the further investigation is carried. At the risk of over-simplification, this may be summarised as the difference between chaotic and orderly electron movement. That the

(Continued on page 219)

# Rocket Propulsion

## Rocket-assisted Take-off : Successive-feed Powder Motors

By K. W. GATLAND

(Continued from page 176, February issue)

A GREAT deal has already been said of the development of successively loaded powder motors, but the units concerned have largely been the outcome of research in the U.S.A.

In Britain, similar research has been conducted by the Astronautical Development Society, and this has involved investigations of the recharging mechanisms for both the slow-burning and rapid-burning powders.

The principal difficulty associated with powder fuels has always been their limited duration of firing, and in the development of the successively loaded motor much hope is held to remedy this deficiency.

### Assisted Take-off Rocket Units

The use of rockets to assist fighter aircraft and heavily laden bombers and transports

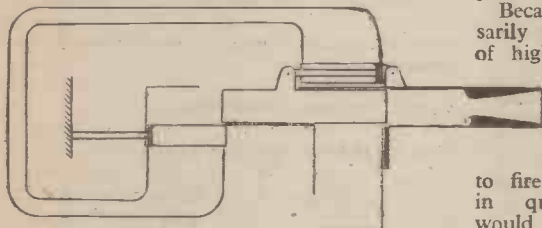

"A" Reaction Carriage at "Forward" Position

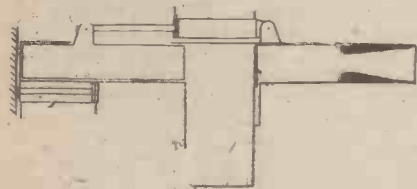

"B" Reaction Carriage at "Rearward" Position

Fig. 56.—Diagrams showing two positions of an improved cartridge injector.

into the air without the need for long runways is to-day common knowledge.

Almost without exception the units employed are simple cordite rockets. The standard charge contains 26lb. of propellant within a steel casing of about 40lb. weight, 40in. long and 5in. in diameter, with a 1/4in. wall thickness. Short nozzles are fitted, 4in. in length, the throat to mouth diameters enlarging from approximately 2in. to 4in.

The thrust yield of these charges is slightly more than 1,000lb., and the energy per lb. of cordite, therefore, a little greater than 41lb.

The rockets are mounted in batteries of two to four, generally either side of the fuselage, close in to the wing roots. They are usually capable of maintaining a thrust constant for about four seconds, and, once expended, automatically release from their mountings and drop away.

In trials carried out in the U.S.A., a navy Avenger, was fitted with four "Jato" assisting rockets, each capable of a thrust of 330 h.p., and it was found that these cut down the take-off run by as much as 60 per cent.

It is of interest to note that the Sander 10lb. powder charges, used by Fritz von Opel in his rocket glider of 1929, each developed a thrust of 53lb., effective for 25 seconds. Other single charges produced by Sander were capable of thrusts exceeding 600lb., but only for three or four seconds.

A high thrust, it will be appreciated, is only possible at the expense of the effective thrust duration and the burning rate can be moderated by the type and consistency of the powder employed.

Because of the necessarily limited duration of high thrust powder charges, it is obvious that some form of constant feed device, able

to fire several charges in quick succession, would be a valuable refinement. Before going on to discuss units of this kind, however, a word about an interesting liquid fuel accelerating gear, developed in 1943 and used extensively by the Luftwaffe.

### The Walter Bi-fuel A.T.O. Gear

The Germans sought to overcome the limitations of the powder charge by the use of a bi-fuel assisted take-off unit, known as the Walter 109-500.

The device employed 80 per cent. pure hydrogen peroxide with a permanganate catalyst, the peroxide being contained in a spherical tank and fed to a single combustion chamber under pressure from air bottles. Its fully charged weight was only 600lb.

The motor operated at an average thrust of 1,200lb., the power lasting from 24 to 28 seconds.

Two of these units were fitted, one below each wing, being jettisoned and parachuted to the

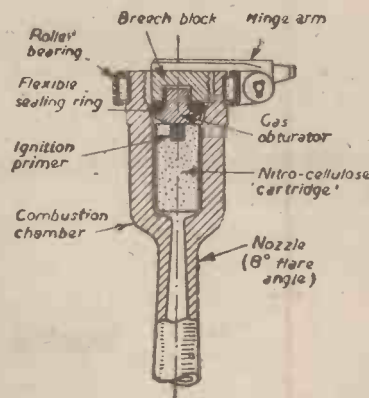

Fig. 58.—Detail of firing chamber and seal mechanism of rapid fire "cartridge" motor.

ground for re-use, once combustion had ceased. Since only "chemical combustion" took place within the chamber, the same unit, recharged, could be used several times before corrosion took serious effect.

A modified version of the Walter 109-500 was fitted in the Hs. 293 "glide-bomb," used for attacks upon Allied shipping.

### A Successive Feed Motor for Slow-burning Powders

An outline of the more critical design problems to be overcome in the evolution of a suitable device has already been given in the references to Professor Goddard's early researches with rapid-burning powders (PRACTICAL MECHANICS, August, 1945, pp. 373-4), and it will be recalled that, although much in detail has been previously conducted concerning chamber and nozzle efficiencies, information is entirely lacking of the reloading mechanism itself.

Work towards evolving a small motor, capable of the repeated injection of quantities of slow-burning powder to a single combustion chamber, was commenced in 1941, and credit for this and subsequent development is largely due to Mr. A. M. Kunesch and the writer. The outcome of an initial survey was a first self-operating design in which powder fuel was intended to be fed in the form of "cartridges" (Fig. 57).

With reference to the diagram, it will be seen that the unit is made up of the following components: combustion chamber, door, breech, cartridge, pump, pneumatic jack, and injector rod.

The "injector" was designed around a specially prepared "plastic cartridge" which had no separate case and burned away com-



"Strut Psychrometer." An instrument used on meteorological aircraft for recording pressure, temperature, and humidity.—Courtesy of the Meteorological Office, Air Ministry.

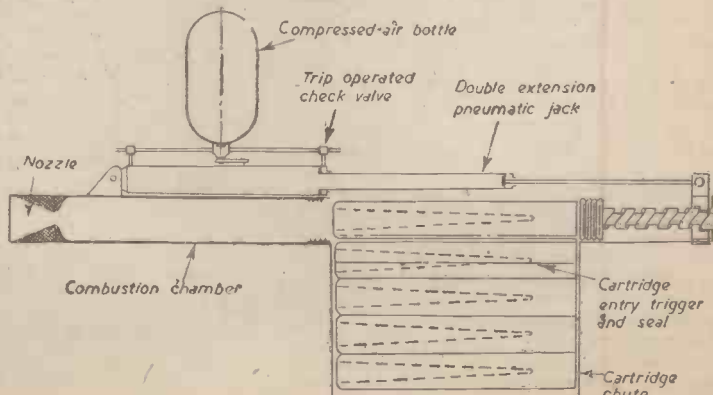

Fig. 57.—The improved cartridge injector for slow-burning charges (Astronautical Development Society, 1943).

pletely. The desired structural form resulted from an organic admixture to certain fuel powders, and using this process it was found that rocke: propellents could be formed readily into any desired shape or size.

of the initial survey gave clear indication that the two types of powder—slow and rapid burning—would require entirely different injection mechanisms. In view of this, it was decided to proceed first with the slow-burning powder motor as the system originally developed was obviously not suitable for rapid firing.

**An Improved "Cartridge Injector"**

The second design was prepared in more detail and

At the rearmost travel of the injector a cartridge is allowed to enter the breech. The air pressure is then applied to return the jack piston, which pushes the injector forwards and inserts the charge. The breech block at the injector head is then screwed in to seal the combustion chamber under the action of the "Archimedes screw," and the cartridge electrically fired.

Immediately the thrust of the charge commences to decline, pressure from the air bottle moves the jack piston backwards, and the injector head automatically unscrews and travels to the rear, allowing a further charge to rise into the breech.

It would probably be necessary to incorporate vents around the chamber seal to prevent "blowback" of thrust pressure as the chamber is opened preparatory to the injection of a fresh charge. Otherwise, the gas temperature may be sufficient to ignite the charge before its entry into the chamber. The unit described is intended to fire five three-second cartridges, but for units employing more charges it would be necessary to jacket the combustion chamber with liquid coolant.

Whether or not an A.T.O. system of this type would be preferable to fixing the same number of single charges to fire in sequence is debatable. The one principal advantage of the reloading device is that the thrust line is constant, and as reloading would be almost instantaneous, the whole question largely resolves into a matter of reliability, weight and installation space.

**The Rapid-fire Rocket Motor**

The rapid-firing cartridge motor is altogether different from the units previously described, having been designed to power a light, high-altitude sounding rocket.

In this arrangement the cartridges are fed at the rate of 20 per second, but each charge weighs only 1/2 oz., as compared with the charges of several pounds specified in the slow-firing designs. Because of this, the mechanism which feeds the cartridges can be appreciably lighter, and it is this factor that largely accounts for the high rate of fire. It has, in fact, been estimated that

Two views of an experimental rocket motor to the design for a rapid-firing cartridge injector. It has been used as a proving motor for testing single charges. (Astronautical Development Society, 1943).

Experiments with charges of this nature have shown that no residue remains after firing, it being found that ash produced in combustion only condensed outside the nozzle. This is particularly important in view of the fouling which occurs after the firing of gunpowder, and which would seriously impede the proper function of a repeating mechanism.

Apart from the special powders tested, it is also possible to bond nitro-cellulose powders—cordite, for instance, may be conveniently formed by the admixture of acetone.

An impression of the "injector" can be best gauged from an explanation of its operation. The firing sequence is as follows: a cartridge is initially primed to the combustion chamber when the "reaction carriage" is at its foremost travel—as shown in Fig. 56. The chamber seal door is then closed by a cam action and the cartridge fired, causing the complete unit to recoil along runners to a bearing plate. During this action air pressure is transferred from the supply pump (situated beneath the carriage) to the pneumatic jack, which actuates the injector rod and retains it at the rear of the carriage. A second cartridge is then free to enter the breech.

Once the thrust of the primed charge has fallen below a certain value, recoil springs return the carriage to its original position, pressure being transferred back to the supply pump, while air is forced out into the other side of the injector jack to move the rod forward. The door is then rapidly opened and closed to allow the second cartridge to enter for combustion. From this point the operating cycle is continued automatically.

The conclusions

presented an altogether more practical solution. Perhaps most important of all, the effective sealing of the firing chamber—a problem ignored in the early design—was most satisfactorily overcome. Another refinement was that the recoiling feed action was eliminated.

The improved "cartridge injector" (Fig. 56), though basically the same as the original, incorporated several entirely new features. It comprised the following main items: combustion chamber, breech, cartridge entry chute, cartridge entry trigger and chute seal, pneumatic jack, check cocks (two required), compressed air cylinder, and breech block/injector.

As may be gathered from the diagram, the motor is designed to operate under controlled pressure from an air bottle. The air is fed through trip-operated control cocks which alternately direct pressure to move the breech block/injector backwards and forwards under the action of a pneumatic jack. As will be seen from the diagram, the breech block, which seals the chamber, also forms part of the injector movement.

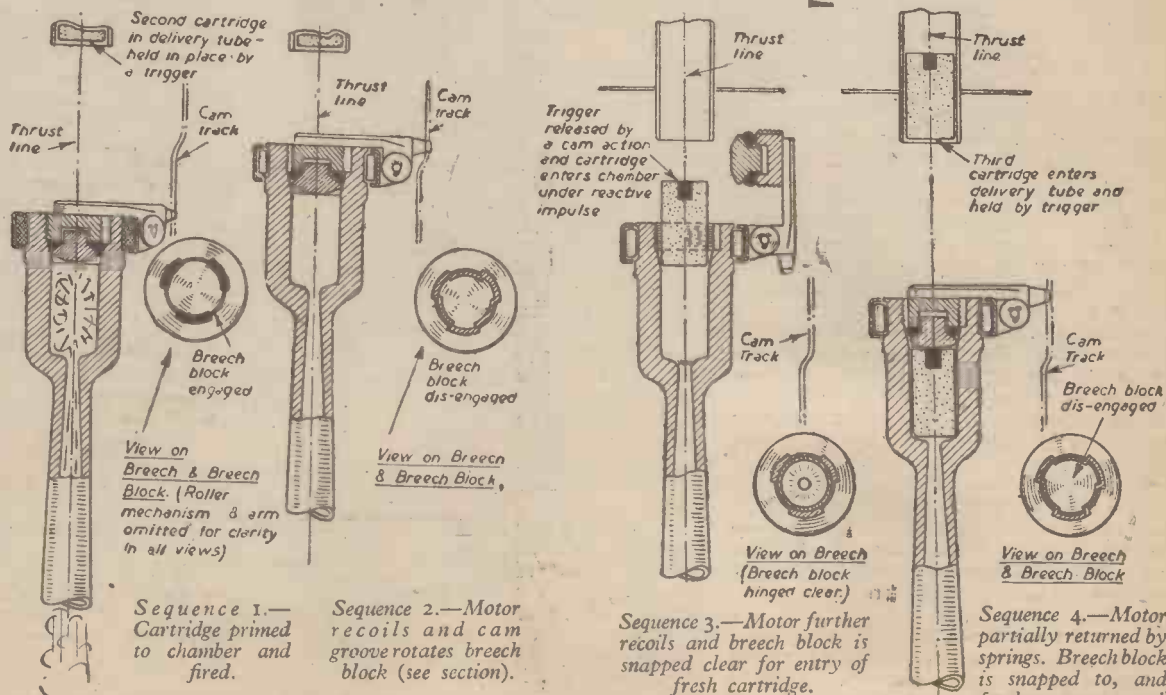

Fig. 59.—Part sectional diagrams showing operation of the rapid-fire "cartridge" rocket motor. (Combined British Astronautical Societies, 1944).

Sequence 4.—Motor partially returned by springs. Breech block is snapped to, and further counter-recoil engages breech and fires cartridge—as sequence 1.



the total weight of the moving parts would not exceed 15oz.

The combustion chamber (Fig. 58) is designed to recoil along runners, and the cartridges are fed by the inertia. There is an opening breech-block to allow the cartridges to enter the chamber, which is rapidly opened and closed under the action of a cam mechanism operated by the recoil.

The chamber is returned by strong springs which compress as the motor recoils under thrust, and the charges, having separate ignition primers, are fired electrically by a simple "make and break" circuit.

The breech-block is constructed with interrupted threads. This enables the breech to be disengaged and re-engaged by a slight turn of the roller bearing to which the hinged arm of the breech-block is attached.

**The Combustion Chamber and Nozzle**

The combustion chamber is particularly small, its internal length being only 1in. by 1/4in. diameter. These surfaces are finely machined and polished to reduce frictional losses, and thus any excessive heating of the chamber is avoided.

A high operating efficiency is therefore maintained over the entire period of combustion, and while it is rare for a liquid-fuelled motor to greatly exceed a chamber pressure of 500lb./sq. in., the rapid firing "cartridge" motor is designed to permit the exceptionally high pressures of 30 to 45 thousand lb./sq. in.

This largely accounts for the high efficiency, which is, of course, due to the rapidity of combustion and the greater expansion and less dissociation of the gases.

To suit these conditions the size of the motor is limited, but, nevertheless, the dimensions of the unit here discussed are well within the bounds of the practical. Indeed, the thermal efficiency would be improved by slightly "scaling up" the chamber, due to the reduced heat loss. This is because the chamber area increases by four to the weight of the charge, eight times.

A high-expansion tapered nozzle, 7.25in. long, is fitted which embodies an 8 degree flare angle, expanding from .125in. at the throat to slightly more than 1in. at the mouth. It is not quite a straight taper, as at the mouth end the angle is decreased to form a short parallel length, and this refinement—originally adopted by Professor Goddard—ensures that the high-velocity gases fill the cross-section throughout the entire nozzle length. Without this change in contour a discontinuity of flow would be produced at the points where the gases leave the wall of the nozzle and result in the formation of eddies with a consequential loss of unidirectional velocity.

In comparison with the machine-gun—a useful guide in this work—heating effects would be less critical. In the gun the bullet creates considerable friction and confines the propelling gases in the barrel (at a temperature of 2,000 deg. C.), whereas in our particular case there is no friction save that of the gas itself, which escapes almost instantly.

It is thus obvious that the rocket motor will permit the firing of considerably more cartridges than a machine-gun before getting to critical heat—the temperature at which the propellant is ignited merely by contact with the combustion chamber.

**Explanation of Diagrams**

The diagrams (Fig. 59) represent the firing sequence of the motor, and is self-explanatory. Sequence "1" shows the motor as it appears at its rearmost travel, a cartridge having just been fired. The breech block is, of course, engaged in this position, and

a fresh cartridge is held in place at the bottom of the feed tube.

In the second view the motor is shown partially recoiled, and it will be seen that the breech-block has been rotated so that it is completely disengaged under the action of the cam track.

The third sequence depicts the motor in full recoil, with the breech-block snapped clear and the feed trigger released to allow the second cartridge to enter the chamber under the inertia of recoil.

Finally, the motor is shown partially returned by the recoil springs (these are omitted in the diagram), the breech-block

than the test types, the maximum figure should be nearer the mark.

Using 1/2oz. cartridges, the jet flow works out at 2 1/2oz. per second, and assuming a jet velocity of 7,500ft./sec., the thrust would be approximately 36lb. Although the jet flow and thrust values are not great in comparison with other motors, the fact that the chamber is of midget proportions and the complete unit so very light ensures a high operating efficiency.

**A Solid-fuelled Sounding Rocket**

The possibilities of the unique cartridge motor in a sounding rocket arrangement are



The combustion chamber of the bi-fuel Walter 109-500 assisted take-off unit described in this article. Note the helical mixing vanes around the central support tube. The propellant enters through a stainless steel nozzle at the head, and thrust is derived through chemical reaction resulting from H<sub>2</sub>O<sub>2</sub> and calcium permanganate.

being snapped to, but the threads not yet engaged in the breech. At this point a selective mechanism allows a third cartridge to enter the delivery tube.

At the rearmost travel the motor appears again as sequence "1," the breech-block re-engaged, and the second charge fired as the first.

**Performance**

Previous tests of single-shot motors of similar chamber and nozzle forms have shown that it is reasonable to expect jet velocities of 7,000 to 7,500ft./sec., and since the chamber proposed is somewhat larger

illustrated in Fig. 60. As will be seen, the unit can be very compactly accommodated, and there appears no reason why such an arrangement should not prove highly effective.

In the projected design the fuel container comprises 19 individual 1/4in. i/dia. cellules, arranged on a honeycomb plan for maximum structural strength and fuel capacity.

Basing the size of the rocket on 10lb. of fuel (or 1,280 cartridges), it should be possible to build the cellules and shell of bonded plastic, as affording a ready finish and greater resistance to denting than a much thinner metal case and tube structure of the same weight. A plastic case and the desired number of cellular feed tubes would weigh about 5lb.

The motor, having a weight of 2lb., plus 1lb. of instruments, makes the total for the main components in the region of 18lb.

The rocket would have an initial acceleration of 1g., and a final acceleration of approximately 3 1/2g., and, using 1,280 charges, the firing duration would be 64 seconds.

(To be continued)

**AUTOMATIC GUN COCKER**

A NEW device which has been submitted to the British Patent Office concerns guns in which cocking during firing is effected automatically by gas pressure obtained from the barrel of the gun.

In the larger guns, it is stated by the inventor, after the supply of ammunition has been exhausted and a fresh supply has been introduced, the initial cocking cannot be effected by hand. It has been subjected to pneumatic treatment, but this method, asserts the inventor in question, is somewhat complicated.

The object of the new device is an improved and simplified means for the initial cocking of the gun.

The invention comprises a hydraulic pump-supplying pressure fluid to a cylinder containing a plunger which performs the cocking operation. There is also a plunger-type automatic valve loaded through a lever having two positions: (1) where the valve is closed and loaded against the pump delivery pressure and (2) where the valve opens a by-pass passage to release the pump delivery pressure and is not loaded to return to its service position, so that such return must be effected by hand.

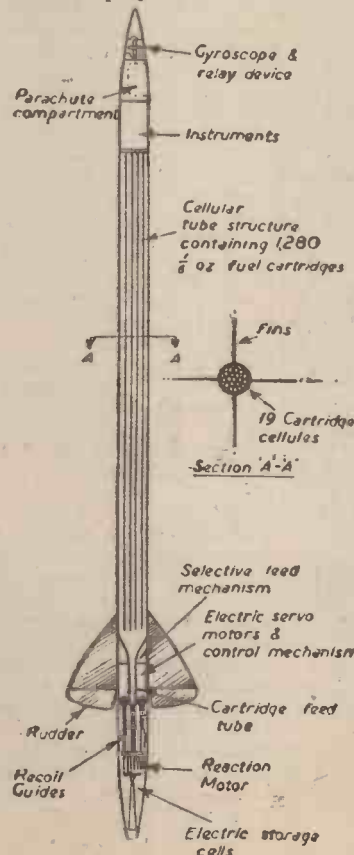

Fig. 60.—Suggested layout for a successively loading "cartridge" rocket.

# The Mechanics of Meteorology—4

Cloudbursts : Snow : Wind Speed and Direction

By G. A. T. BURDETT

(Continued from page 163, February issue)

**C**LOUDBURSTS are nothing more than thunderstorms of an exaggerated form.

We have seen that the cumulonimbus cloud requires strong up-currents of warm air to support it. In fact, such large quantities of water which are contained in the thundercloud can only be supported by strong up-currents. Should these ascending currents for some reason suddenly cease, most of the water content would, by force of gravity, descend to the ground at once. When this happens we have what is termed the "cloudburst."

These occur chiefly in hilly and mountainous districts. When the cloud passes over the hill on these occasions, the ascending currents of air decrease in strength and the cloud releases its water.

This phenomenon of variable air currents is particularly apparent when travelling in a glider towed by powered aircraft over hilly districts. On occasion the glider has been known suddenly to drop 200-300ft. without warning.

Some years ago, as a result of a "cloudburst," the watersheds of a hydro-electric scheme in North Wales were overloaded with water, the dam burst, wrecked houses and caused several casualties, some fatal, in the valley below.

### Hail

Normally, we consider that water turns to ice (freezes) once its temperature drops below freezing point (32 deg. F.). Experience has shown, however, that such is not always the case. Water drops can exist in clouds in liquid form with the temperature

as low as 0 deg. F. These are termed super-cooled water drops. Once they come into contact with anything such as an aircraft, or even a small water droplet, the super-cooled water turns to solid ice.

Clouds of great vertical extent, viz., cumulonimbus, which are separated by large, upward currents of air, usually comprise three, though not distinct, portions (Fig. 26): The top portion, known as the "snow region," where the drops are frozen into ice crystals; the centre portion, which comprises super-cooled water drops; and the lowest portion, which comprises liquid water drops of a temperature above freezing level.

The portion of the cloud between A and B comprises a mixture of both ice crystals and super-cooled drops. When one of the latter impinges against the ice crystal it immediately solidifies into soft ice. In doing so the drop traps a little air, becomes larger and falls through the super-cooled region, still growing. When it reaches the lower region it comes into contact with water drops at a temperature of 32 deg. F. (just above the super-cooled temperature), the water drop is deposited on the ball of soft ice and freezes as a coating of hard, transparent ice. The ball then falls to the ground as hail. If a ball of hail is cut open it will reveal a core of soft ice surrounded by this hard layer.

The hail does not always fall direct to the ground, but is caught up by the strong rising currents of air in the cumulonimbus cloud and is lifted into the top region. It then falls again and goes through the same process, a further layer of soft ice, and then a coating of hard transparent ice. This may happen a number of times until the air currents can no longer support it. If these large hailstones are cut open they will appear as concentric layers of soft and of hard transparent ice.

Hail often falls as soft ice (soft hail) when it has been formed in the region where the temperature of the drops is at 32 deg. F. and no upward currents of air have carried them back into the cloud.

### Snow

Snowflakes are formed from one or more ice crystals. When water vapour condenses at temperatures even below freezing point, liquid drops first form, which crystallise later. In the upper region of the cumulonimbus cloud we have seen this happen, while in the centre regions the droplets remain liquid and are "super-cooled."

Now, water crystallises in hexagonal form. Snowflakes made up of a number of these crystals take on a variety of shapes which, when examined under a microscope, show perfect symmetry of form and



Fig. 27. — Cup-anemometer, a wind indicator. The wind enters the hollow of the cups, which revolve on a spindle. The distance travelled by the cups is measured on the counter. Over an interval of time, e.g., minute, the speed of the wind is obtained by reference to a chart.

(Photograph by Negretti and Zambra.)

often make most beautiful patterns.

When snow falls at high temperature the flakes are large and very moist and are built up of a number of crystals. When the temperature is low the flakes are smaller and "drier." When the temperature is far below freezing point (32 deg. F.) the precipitation is "snow dust," as dry flakes do not readily combine.

### Sleet

Sleet is largely partly melted snow, and is sometimes due to the precipitation of both snow and rain. A temperature increase near the ground is often the reason for the sleet, since the snow, as it reaches the ground, passes through layers of air of higher temperature just above 32 deg. F., which causes the snow to partially melt.

### When Snow May be Expected

Snow, which, as we saw above, is really only frozen water droplets before precipitation, can be expected at any time when at high temperature rain would be due, viz., the passing of a depression, instability of the atmosphere or the condensation of moist atmosphere, due to its coming into contact with cold, high ground.

### Too Cold to Snow

The layman is often heard to remark in winter that "it is too cold to snow." This adage is true in fact, but only when the cold, dry polar air is passing over the area.

If this is followed by a depression from the Atlantic when warm, moist air comes into contact with the colder polar air, the former condenses, forms cloud and either rain or snow descends, depending, of course, upon the temperature.

### Glazed Frost

Sometimes in Great Britain, but on rare occasions only, the roads, pavements, surfaces of the buildings and practically everything are coated with a layer of glassy ice known as glazed frost.

Traffic is brought to a standstill, and it is almost impossible for a pedestrian to proceed with safety. Electric railways which run above ground are particularly susceptible to glazed frost since the ice acts as an insulator on the conductor rail and the train cannot obtain the necessary current to drive it.

One of the worst glazed frosts recorded in Great Britain occurred on December 21st, 1927, when traffic was brought to a standstill and a number of accidents were caused.

Glazed frost is due to the following:

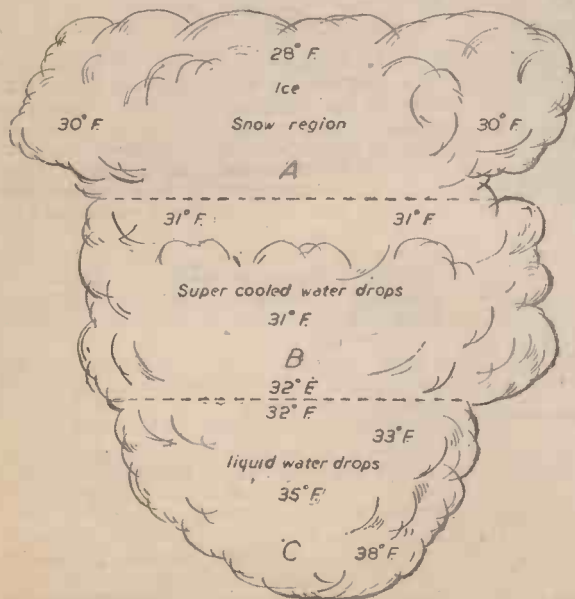

Fig. 26. — Thundercloud (cumulonimbus) showing three distinct portions—snow region, super-cooled water drops, and liquid water drops.

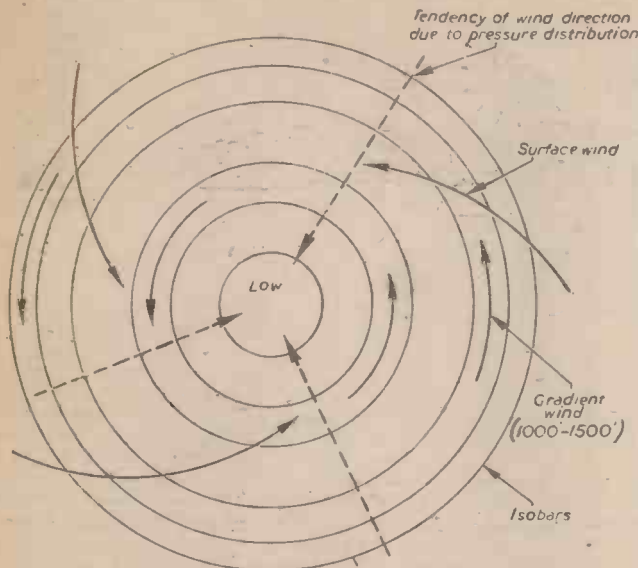

Fig. 28.—Direction of gradient wind, owing to the geostrophic and cyclostrophic effects of the earth's rotation, flowing in an anti-clockwise direction around a depression in the northern hemisphere parallel to the isobars, as indicated by the parallel black arrows, at a height of 1,000ft. to 1,500ft. (Note.—Surface wind flows at an angle of 30 deg. to the isobars due to the friction of the earth's surface.)

The temperature of the ground must be below freezing point. Precipitation in the form of rain at a low temperature collects on the surface and immediately freezes. Sometimes the drops are super-cooled, but generally it is the temperature of the surface (ground, etc.) which determines whether glazed frost will occur or not.

When glazed frost forms there is usually an increase of temperature over the area. The cold water drops pass through a comparatively warmer temperature, but on approach to the ground the temperature decreases. At ground level the temperature is below freezing point. The ground frost which often follows snow, which is melted in the heat of the sun during the day, is frozen and resembles glazed frost. This is not, however, glazed frost, but just a normal ground frost which occurs when conditions are favourable, as pointed out earlier.

**Formation of Rain**

It has been shown that the moisture content of clouds and even large water droplets are supported in a cloud by rising air currents. The nimbostratus cloud, which is a rain cloud of the layer type, does not require strong upward currents to support it. When the moisture in the air has condensed, due to its temperature falling below dew point, and the cloud forms, small water drops which have a diameter in the order of 0.002 mm. are readily supported by the small upward current of air. These are then carried farther up through the cloud, and as the temperature decreases the water drops increase in size until they reach a diameter in the order of 0.2 mm. By force of gravity these fall to the earth in the form of rain, since the upward currents of air can no longer support them.

**The Wind**

In the British Isles the wind is almost constantly changing in both force and direction.

The cyclist will set off on a clear day and before long he will find he is cycling against a head-wind of a fairly high speed. On his return journey he may, to his dismay, find the wind has now changed to the opposite direction, and he again has to cope with a head-wind.

Also, at a given time, the wind or winds,

will be blowing in different directions at varying speeds in different places not far apart.

Direction and force of wind also vary with altitude. At ground level the air may be calm, while at 10,000ft. strong winds will be blowing.

Wind, which is the movement of masses of air, is largely caused by the following:

- (1) Changes in the variation of the temperature of air masses, over land and sea;
- (2) The movement of air from areas of high pressure to areas of low pressure;
- (3) The movement or passage of frontal systems.

Wind, like the formation of clouds, provides a good indication to the meteorologist of the type of weather which may be expected in the immediate future (viz., up to 24 hours in advance).

Before attempting to fit wind into the general weather picture, it is necessary to understand its most fundamental principles.

**Measuring Wind**

The direction of the wind at the earth's surface is usually given by the meteorologist in the points of the compass, viz., north, south, east, west, north-east, and so on. This direction is that from which the wind is blowing and not vice-versa. The common weather vane points in that direction—that is, up-wind. This vane is so constructed that the arrow head offers the least resistance to the wind, and is therefore against the wind, while the thick end will be down-wind, as it offers more resistance.

When observing the general wind direction, it is important not to place too much reliance on the ordinary weather vane unless this is isolated, since it may indicate only the local wind. For instance, should the vane be sited between two high buildings, the wind will generally, irrespective of its true direction, blow between the buildings and give the observer a false reading.

Wind blowing between hills, along a valley, or over the coast may not necessarily coincide with the direction of the general wind, and should therefore be treated as local wind only.

While the winds are light and variable, the weather vane is useless. In these circumstances a good indication of wind direction is that of smoke.

A close observation of the flight of birds is recommended when studying wind direction. It will be noticed that birds, except the smaller and younger ones, always land and take off against the wind. Pilots in aircraft also, of course, manipulate their aircraft likewise.

**Wind Speed**

The speed of wind is measured in miles per hour on the land, and in knots at sea.

Where wind-measuring instruments are not available, more general

terms may be used, such as light, moderate, strong.

To assist in the accurate estimation of wind speeds, the Beaufort Scale is used (see accompanying scale). This scale, which bears his name, was devised in 1805 by Admiral Sir Francis Beaufort, then hydrographer to the Navy. For easy reference, each group of wind speeds is allotted a Beaufort number. From the table it will be seen that Force 3 on the Beaufort Scale refers to a wind speed between eight and 12 miles per hour, and is termed a gentle breeze, indicated by the constant motion of leaves and twigs. Small flags are also extended by wind of this velocity.

Plenty of practice is necessary before accurate estimates may be made. Where possible a check should at first be made with wind-measuring instruments, viz., anemometers (Fig. 27).

Wind velocity usually increases with height. Therefore, that observed at ground level is of little use for estimating that at an altitude of, say, 3,000ft. Here the velocity of the clouds moving across the sky should be noted. One method of doing this is by observing the shadows of clouds moving over the ground.

Not only does the velocity of wind vary at different heights, but also its direction. This may be proved by comparing the direction of the cloud movement with the surface wind. Quite often the wind at high altitude will be blowing in the opposite direction to that at the earth's surface.

**Veering and Backing**

When the direction of the wind changes in a clockwise direction it is said to be veering. For instance, if at 8 a.m. the wind is blowing from the south, and at 10 a.m. from the south-west, the wind has veered from the south to the south-west.

Conversely, when the direction changes in an anti-clockwise direction, it is said to be backing. If, therefore, at 10 a.m. the wind had changed to south-east instead of south-west, it would have backed from south to south-east.

**Wind Direction**

Since wind is largely caused by the movement of air masses from areas of high to areas of low pressure, we would expect the wind to blow in a straight path from one area to the other, as represented by the dotted line in Fig. 28. In practice this is not so, for it is deflected to one side by the rotation of the earth.

In the northern hemisphere the deflection is to the right, and in the southern to the left. This deflection is known as the geostrophic effect. As a result of this curved movement of the air a further force is present, known as the cyclostrophic effect, due to the gyroscopic properties of the moving masses of air, which tend to force the wind off the curved path.

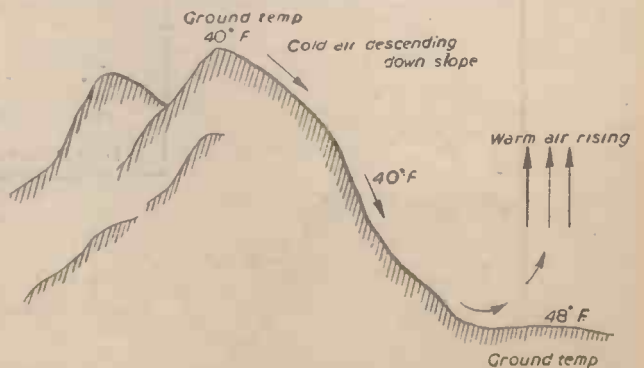

Fig. 29.—Katabatic wind. By night, reaching maximum about 4 a.m. G.M.T., cold air from top of hill falls down slope into valley and forces warm air in the valley to rise, as indicated.

The wind now will move along the isobars, that is, parallel to them and not at right angles, from the areas of high to low pressures. The discovery of these facts led to the formulation in 1853 of a law by Professor Buys Ballot, of Utrecht, now known as the Buys Ballot's Law.

This law states that in the northern hemisphere if you stand with your back to the wind, the area of low pressure is on the left. In the southern hemisphere it is the other way round. From Fig. 28 it will be seen that the wind blows in an anti-clockwise direction around an area of low pressure. Conversely, the wind blows in a clockwise direction around an area of high pressure. This again refers to the northern hemisphere, the reverse being the case in the southern.

Although winds follow the direction of the isobars, this is only strictly true of winds above the height of about 1,000ft. Below this height, friction of the earth's surface, trees and so forth, tend to slow up the wind and, since the cyclostrophic effect is reduced, the wind is freer to follow a more direct path between the two different areas of pressure. The result is that the wind blows across the isobars at an angle of approximately 30 deg. towards the area of lowest pressure (Fig. 28).

From the above, it will be appreciated that wind bears a direct relationship to the difference in pressure of the atmosphere.

Because of this, meteorologists are able to estimate the speed of the wind in different parts of the country (or the world) at given times by observing the atmospheric pressure gradient at these points.

The pressure is observed and recorded at the various observation posts, and particulars are circulated to the meteorological departments. They are then noted on special charts provided, and lines (isobars) are drawn between the points of identical pressure. These isobars, when completed, are similar to contour lines on topographical maps, but represent gradients, not of heights, but of pressure. While on a topographical map lines drawn close together indicate steep gradients, those on the weather map, or synoptic chart, as it is termed, indicate the velocity and the direction of the surface wind. The closer the isobars, the higher the velocity of the wind at that part.

**Diurnal Wind Variation**

Diurnal, which means the passage of time over a period of 24 hours, is used in this case to record the probable wind variation which normally occurs from day to day.

Over a considerable period of time, meteorologists have recorded that during the daytime the surface wind usually veers and increases in speed, while the upper wind, viz., 1,500ft. and above, tends to back and

decrease. As night approaches the reverse happens and the surface wind drops and backs, while the upper wind tends to veer and increase in speed. These variations will, of course, be altered by weather changes, the passing of fronts, seasons, and so forth.

**Effect of Temperature of Air Masses**

It was shown earlier that the sun heating the ground, which in turn heats the air, causes masses of warm air, e.g., thermal currents, to rise into the atmosphere. This displacement of air is, of course, one of the direct causes of wind.

It was further shown that substances such as sand, earth and rock heat up more quickly than woodlands, areas of vegetation and the sea and lakes. Conversely, the former

substances give off their heat quicker than woodland and the sea, etc. This variation in heat dissipation also causes a variation in

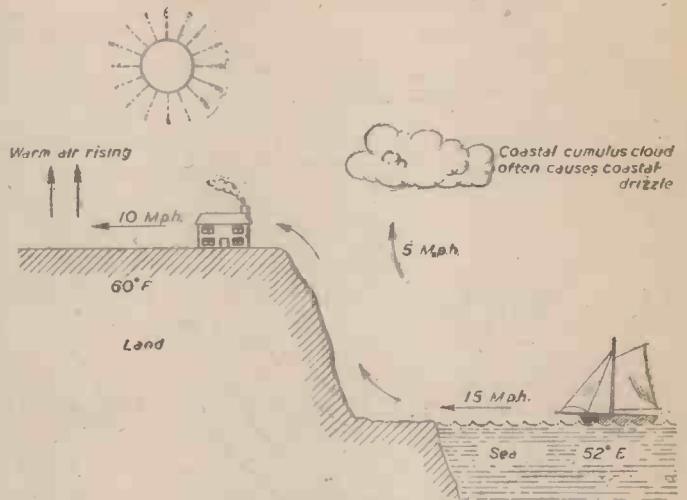

Fig. 31.—Sea breeze. By day, reaching maximum velocity at about 3 p.m.

**THE BEAUFORT SCALE OF WIND FORCE**  
Observed Effects

Beaufort Number.	General description of wind	For use inland	For use at sea	Wind strength in m.p.h. at about 30 feet above ground level.
0	Calm ..	Smoke rises vertically	Sea like a mirror .. .. .	Less than 1
1	Light air ..	Smoke, but not wind vanes, show wind direction	Scale-like ripples .. .. .	1-3
2	Light breeze ..	Wind felt on face; leaves rustle; wind vanes moved	Small wavelets; glassy crests ..	4-7
3	Gentle breeze	Leaves and small twigs moving constantly; small flags extended	Large wavelets; crests begin break; a few white horses	8-12
4	Moderate breeze	Dust and loose paper raised; small branches moved	Small waves become longer; white horses fairly common .. .	13-18
5	Fresh breeze ..	Small leafy trees sway	Moderate waves with pronounced length; many white horses. Some spray	19-24
6	Strong breeze	Large branches in motion; whistling heard in telegraph wires	Large waves form; white foam crests more extensive everywhere	25-31
7	Moderate gale	Whole trees in motion	Sea heaps up and white foam from breaking waves is blown off	32-38
8	Fresh gale ..	Breaks twigs off trees	Moderately high waves of greater length	39-46
9	Strong gale ..	Slight structural damage occurs; chimney removed	High waves; dense streaks of foam along the direction of the wind	47-54
10	Whole gale ..	Trees uprooted; considerable structural damage	Very high waves with long, overhanging crests; foam in great patches	55-63
11	Storm ..	Very rare; widespread damage	Exceptionally high waves; sea completely covered with foam	64-75
12	Hurricane ..	Very rare .. .	Air filled with foam and spray; sea completely white with driving spray	Above 75

NOTE.—The velocity of the winds given is only that for 30ft. Above that height the winds are stronger

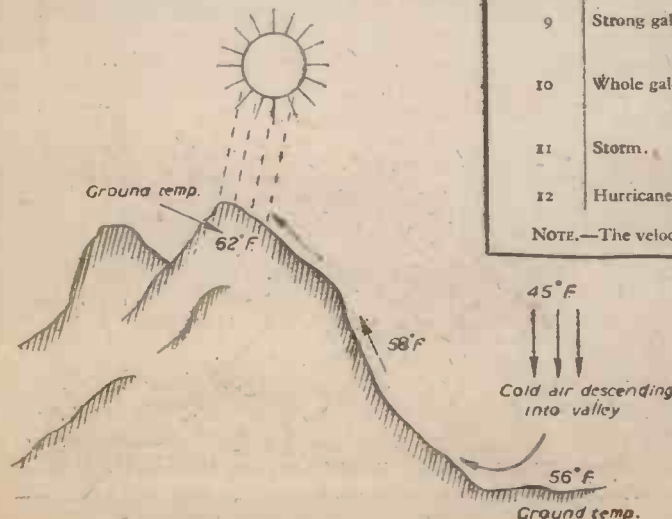

Fig. 30.—Anabatic wind. By day, reaching maximum about 3 p.m. G.M.T., cold air falls into the valley and forces warm, light air up the slope to the warm hill-top.

the thermal currents of rising warm air, the effect of which is to cause variation in wind speed in different places.

Most local wind variations are due to the temperature effect. These "temperature" winds are termed Katabatic, Anabatic and sea and land breezes.

**Katabatic Winds**

Katabatic is the name given to winds which usually blow down the hill or mountain

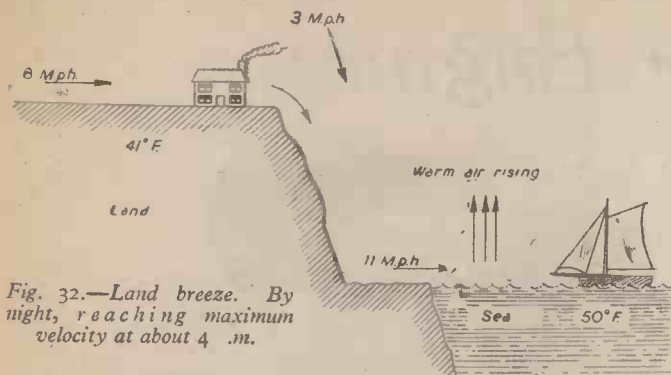

Fig. 32.—Land breeze. By night, reaching maximum velocity at about 4 .m.

side at night, following a hot day. During the day the temperature of the land will have been raised by the heat of the sun. When night falls, the highest points, viz., the tops of the hills and mountains, will cool down more quickly than in the valley. This will cause the air in contact with the peaks to cool, and owing to its increase in density and that it is heavier than the air below, it will roll down the hillside and force the warm air in the valley up into the atmosphere (see Fig. 29).

**Anabatic Winds**

This wind is the converse of the katabatic

and occurs during the earlier part of a hot day.

Normally the hill top will heat up more quickly than the ground in the valleys. Thus the warmer and lighter air will rise and this air will be replaced by the colder air in the valley, which will have the effect of a movement of a mass of air, or anabatic wind, up the side of the hill or mountain, Fig. 30.

**Sea and Land Breezes**

Anyone who has walked along the seashore on even the hottest day will have observed that there is usually a marked breeze (sea breeze) blowing inland, particularly during the morning.

He will have observed also, that as evening approaches the breeze will stop, but at night the breeze will have changed direction from that of the day and will now be blowing out to sea. The latter is termed a land breeze.

When the rays from the sun heat up the land it will soon possess a higher temperature

than the sea. The air in contact with the surface of the ground will then warm up and, being lighter, will rise. The colder air, that is, the air from the sea, will then blow over the shore in order to replace the rising warm air (Fig. 31). The velocity of this day sea breeze rarely exceeds 10-15 miles per hour, extends only a few miles inland, and above an altitude of 1,000ft. has no effect.

At places on the equator the day sea breeze often exceeds a velocity of 30 miles per hour, extends up to an altitude of several thousand feet and goes far inland. This is due to the much higher temperature of the land near the equator.

At night, when the ground rapidly cools to a temperature lower than that of the sea, the cooler air over land will move over the sea to replace the comparatively warmer rising sea air (Fig. 32).

This night land breeze continues throughout the night until the land again rises in temperature.

Land and sea breezes must always be considered as local winds which are noticeable during calm weather. At other times when the general winds, caused by pressure distribution, are strong, the local wind force will be overcome and therefore will be cancelled out.

(To be continued)

# Items of Interest

Electrically driven Torpedo

THE electrically driven torpedo used with so much success by American submarines in the Pacific, was developed by the Westinghouse Electric Corporation, of Pittsburgh, U.S.A. By means of special heat-resisting materials and insulation, a motor was developed weighing only a few pounds per horsepower. This, in conjunction with a high-capacity Exide battery, solved the lightweight power plant problem, and made the torpedo possible.

The motor and battery compartment could not be ventilated, as this would have created a tell-tale wake. This provided several difficult problems, the first being that the powerful motor produced heat intense enough to melt the ordinary solder used to bind the armature coils to the commutator. This was solved by brazing the coils in place. Another problem was that gases generated in the closed body of the torpedo could have damaged the unit. Here the answer was to insert a filament-like wire in the battery-compartment, which when heated burned off the gases as they were generated.

Radar-controlled Ship

SEA history was made last month when H.M.S. *Pollux*, an Admiralty research ship, was navigated through the crowded shipping lane of the Thames Estuary entirely by radar. The officers moved away from the compass, the echo-sounder was switched off, and even the bridge was deserted. Discoveries by British scientists investigating the future of radar navigation in merchant ships made the achievement possible.

The first discovery was the chart comparison unit which, aligned against the screen of the radar set, gives the position of the ship on the chart at a glance. The second was the development of a new type of reflector to be fitted to buoys to increase their radar response. These reflectors increase the range at which the buoys can be detected from two to ten miles, and the patterns in which they were laid

stood out sharply on the screen, contrasting sharply against the illuminated dots which represented ships.

New Short Sunderland Flying-boat

ONE of the first results of Britain's post-war export drive was shown on November 1st when the "Argentina", first of four Short Sunderland civil flying-boats for their passenger service in South America, was launched at Belfast, Northern Ireland.

From Poole, Britain's present flying-boat terminal, these aircraft—the second of which is to be named "Uruguay"—will fly to the Argentine with British crews, under the care of the famous Atlantic pilot, Air Commodore Powell.

The route taken, incidentally, showing the flag of British enterprise, will be via Lisbon, Gibraltar, Bathurst, Natal, Rio de Janeiro to Montevideo. These flying-boats will bring to the extensive air-lines of the Argentine the

performance and reliability which the military version of the Short Sunderland has made world famous.

They are equipped to carry 40 passengers in comfort. On the upper deck a convenient bar, in polished wood, for light refreshments is included, with seating for a further five passengers when operating on busy routes. In addition, 1,000lb. of freight may be carried.

With a range of over 2,000 miles at a speed of approximately 175 miles per hour and an all-up-weight of 59,000lb., these aircraft with their handsome lines and smartly-faired nose and tail, are a credit to British flying-boat design and construction—a sphere in which this country and particularly Short Brothers has always led the world.

**OUR COVER SUBJECT**

THE illustration on the cover of this issue shows the new air liner "Tudor II" in course of construction. This machine is one of 79 similar aeroplanes which Messrs. A. V. Roe are building for Commonwealth and South American routes. With a wing span of 120ft., and weighing 34 tons, the air liner will be equipped with a kitchen, and sleeping accommodation for 60 passengers.



The flying-boat "Argentina" entering the water after the launching ceremony.

# New Petter Engines

Particulars of the New Twin- and Single-cylinder Air-cooled Engines.

**T**WO compact self-contained power plants have recently been placed on the market by Messrs. Petters, Ltd., of Loughborough. One is a twin-cylinder engine, the other a single-cylinder unit.

The new twin-cylinder engine has been developed after extensive research and experiment in the Petter works, and is now ready to take its place in the many fields of industry and agriculture. The proved reliability of the earlier types led to their adoption for every kind of duty with the many Government and Service departments. The new twin Petter is of sturdy design, but achieves a degree of compactness not yet attained in any other engine of similar power and speed, thus giving ease of portability when required. These engines are normally supplied to operate on petrol, but with certain modifications made at the works they are adapted to operate with equal satisfaction on paraffin. High octane fuel may also be used as the engines are virtually lead-proof. In certain territories fuel consisting of a mixture of petrol and gas oil gives good results. Details of such fuel and its correct mixture can be obtained from the technical department at the works.

The steady running of the engine is secured by the close co-ordination of the sensitive governor and the heavy flywheel. One of the many salient features of the new twin is the provision of a half-speed shaft that eliminates the necessity of external gearing. The main shaft drive can be taken from either end of the engine, and the shafts are sufficiently rigid to carry short belt or chain drives of all types.

The power developed is 8 and 10 b.h.p. at 1,500 and 1,800 r.p.m. respectively for the 12-hour rating according to B.S. specification for carburettor-type engines. In accordance with this specification the engine will develop an overload of 10 per cent. above these figures for one hour, and there is an adequate reserve of power above this. The b.m.e.p.

at the 12-hour rating, varies from 73 to 76.5 lbs. per sq. in. over the range. The piston diameter and stroke are 85 mm. and 82.5 mm. (about 3½ in. × 3¼ in.).

## Cam-operated Side Valves

The engine is of the 4-stroke air-cooled type with side valves operated by a camshaft driven by a train of gears, the latter being designed to serve a half-speed shaft drive when required.

The lubrication is by splash from dip-pers fitted on to the connecting rods which dip into the oil sump. The splash effect is augmented by a lubricating oil pump of the plunger type which delivers oil to the main and large end bearings of the connecting rod. The oil sump has a capacity of 12½ pints.

The crank pins are set at 180 deg., which arrangement and order of firing provides excellent balance and good carburation.

Cooling of the engine is effected by means of a flywheel fan of the centrifugal type, with an aerodynamically designed volute and fan casing: even distribution of the cooling air is thus assured under all conditions.

## Sensitive Governing

Sensitive governing is an important feature. A hand speeder control permits a speed adjustment of 15 to 20 per cent. above and below the rated speed. The governor is

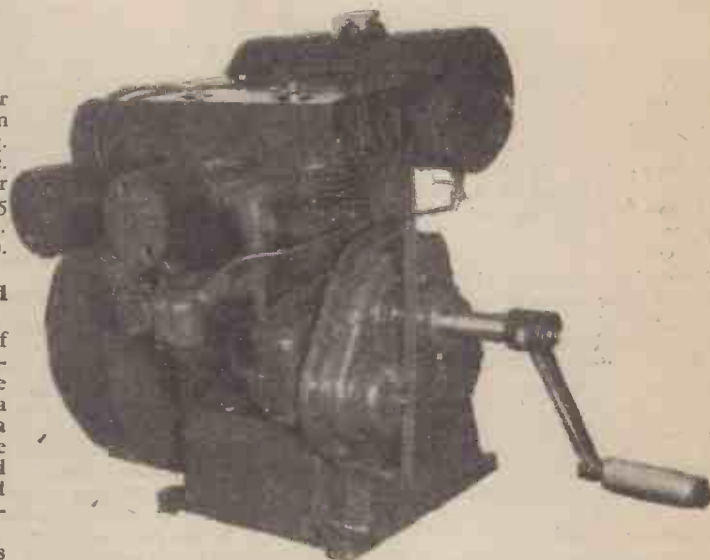

Three-quarter front view of the new Petter air-cooled twin-cylinder engine, showing the two silencers, carburettor, and the cylinder head exit vent for the turbo air-cooling.

connected to the throttle of the Zenith carburettor, this, in conjunction with the Wico-Pacy impulse starter magneto and Lodge B.14 plugs, ensures good starting.

The engine is suitable for many diverse applications. A new feature is the provision of a half-speed shaft, thus eliminating the necessity for an external reduction gear. By a simple operation involving the use of one spanner only the shaft extension may be changed so that an engine speed drive can be provided at the end of the engine remote from the flywheel.

The engine is suitable for electric generating of either direct or alternating current, and where very close voltage regulation or especially low cyclic irregularity is required, a heavy flywheel can be supplied as an extra. This may be desirable on heavy duty or irregular drives such as reciprocating pumps, etc.

The engine can be adapted for light traction and marine propulsion, in which case suitable gearboxes or other forms of transmission will be required about which Messrs. Petters will be glad to advise.

## Single-cylinder Air-cooled Engine

This engine has been produced as a complement to the twin-cylinder model, with which a large number of the parts to the extent of over 90 per cent. are interchangeable throughout the range, including important components such as cylinders, valves, springs, pistons, connecting rods, bearings, governor, etc.

The power developed is 1½ to 5 b.h.p. at 750 to 2,000 r.p.m. respectively for the 12-hour rating for carburettor-type engines.

The engine is of the 4-stroke air-cooled type, with side valves operated by a camshaft driven by a train of gears, the latter being designed to serve a half-speed shaft drive when required.

Lubrication is by the splash method, as in the twin-cylinder model. The oil sump has a capacity of 6½ pints. Ignition is by means of a Wico-Pacy H.T. magneto with an impulse starter—this facilitates cold starting and reduces the effort which is necessary for turning by hand to start up.

Cooling of the engine is effected by the same method adopted with the twin-cylinder engine.

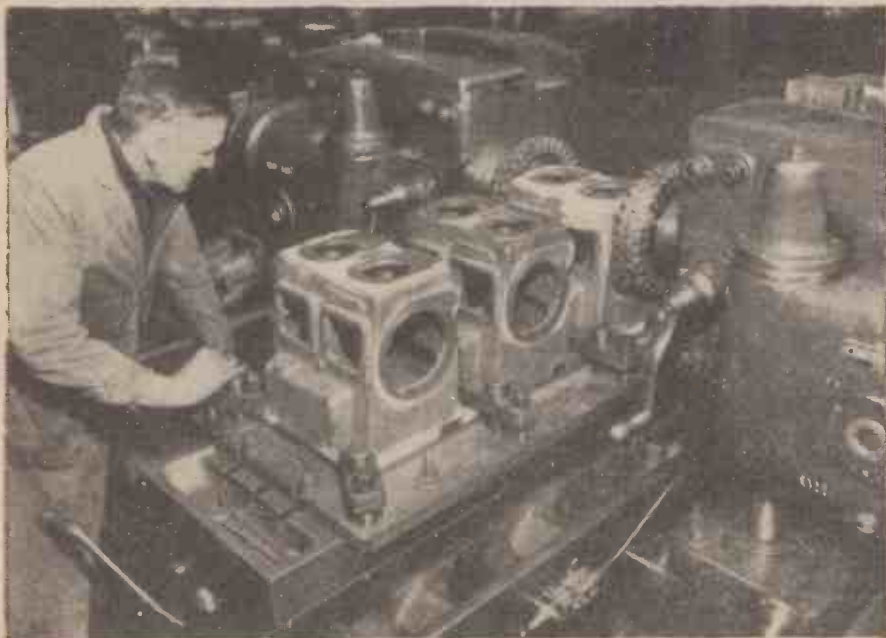

Milling crankcase castings of the twin-cylinder Petter air-cooled engine at the Petter factory at Loughborough.

# The Foundations of Thermodynamics—5

## Entropy : The Gravity and Reversible Cycle

**I**N the previous articles in this series the development of the subject of thermodynamics has been outlined up to the point where the work of William Thomson and Rudolf Clausius, in the middle of the last century, produced a proof of Carnot's principle which made this celebrated heat theorem consistent with the first law of thermodynamics. It has been seen that as a consequence of this union of ideas there emerged a further fundamental heat theorem which was to be described at a slightly later date as the second law of thermodynamics. For some years afterwards both Thomson

By R. L. MAUGHAN, M.Sc., F.Inst.P.  
(Continued from page 172, February issue.)

quantity hitherto unnoticed which does remain the same at the high and low temperature levels? and ended in 1854 when he discovered such a quantity and gave it the name of "entropy."

### Gravity Engine

The approach made by Clausius to the solution of this problem is illustrated diagrammatically in Figs. 20, and 21. Fig. 20 represents the action of a gravity engine in which a quantity of matter of mass  $M$  is lowered through a difference of level  $h_1-h_2$  (where these heights are measured from some standard level), in a region of space where the gravitational field is uniformly intense with an acceleration of free fall denoted by a constant  $g$ . In the operation of the engine, the weight  $M.g$  of the mass moves through a vertical distance  $h_1-h_2$ , and in so doing delivers a quantity of mechanical work given by  $E=M.g. (h_1-h_2)$ .....(1). Fig. 21 illustrates the action of the ideal heat engine working in a forward cycle. An output of work  $W$  is made by the engine by absorbing  $Q_1$  units of heat isothermally and reversibly at the higher temperature  $T_1$  and returning  $Q_2$  units isothermally and reversibly at the lower temperature  $T_2$ , the work  $W$  being equal to the heat balance  $Q_1-Q_2$ . An elementary application of the first law of thermodynamics to the processes of isothermal and adiabatic expansion of an

"Entropie" (which translates directly into English as "entropy"), a word which he coined from two Greek stems meaning "turning into," and which has a form more in keeping with the companion word "energy" which appears so frequently in the literature of thermodynamics.

### "Heat-weight"

Clausius was responsible for many of the reforms in the nomenclature of thermodynamic terms. He was the first to describe the nomenclature of thermodynamic terms. He was the first to describe the Joule principle and the outcome of its union with Carnot's principle as the first and second laws of thermodynamics, and he introduced the adjective "adiabatic" (built from three Greek stems meaning "no passing through") to describe the changes in a system which is prevented from giving out or taking in heat while the change is in progress. At a later date, Professor Zeuner employed the word "heat-weight" to describe the quantity  $Q/T$ , a title suggested by the correspondence between the weight term  $M.g$  in the gravity engine formula  $E=M.g. (h_1-h_2)$ , and  $Q/T$  in the heat engine formula  $W = \frac{Q_1}{T_1} \cdot (T_1 - T_2)$ .

The above definition of an entropy change has been made with reference to the transaction of a finite amount of heat  $Q$  at a constant absolute temperature  $T$ . It can readily be extended so as to include changes in which the temperature of a substance is varying continuously. The physical state of a body, as determined by its instantaneous values of pressure, volume and temperature, can be represented in the conventional manner by a point in the plane of a pressure-volume diagram, and a succession of changes in which pressure, volume and temperature are all varying simultaneously, by a continuous line on the P-V diagram, as represented by AB in Fig. 22. If this line is intersected by a succession of small but finite isothermals and adiabatics, each successive pair forming, so to speak, two adjacent sides of a minute Carnot cycle of work, then the entropy change transacted along any one of the isothermals may be denoted by  $dQ/T$ , where  $dQ$  is the small but finite quantity of heat exchanged reversibly and isothermally at the absolute temperature  $T$ . The entropy change along every adiabatic line is zero, since the heat transacted is zero and the change is performed reversibly. The total entropy change involved in passing from A to B along the irregular course of intersecting isothermals and adiabatics is therefore a sum of terms represented by  $\sum dQ/T$  from A to B. As the lengths of these isothermals and adiabatics shorten, they approach a limiting value which coincides with the continuous curve AB, and at this limit the total entropy change is

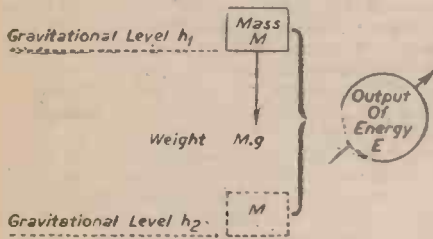

Fig. 20.—Diagram illustrating the action of a gravity engine.

and Clausius continued their independent inquiries into the principles of thermodynamics, but in somewhat different directions. Thomson's researches led him to the conception of the absolute thermodynamic scale of temperature (1848), and to the discovery of the thermoelectric effect (1855), which is named after him, and in 1854 Clausius made the discovery of a thermal property of matter, afterwards called "entropy," which has since assumed a role of considerable importance in pure and applied thermodynamics.

### Entropy

When a stream of water passes over a mill-wheel to generate mechanical power in the shaft of the wheel, no water is necessarily lost or consumed as it makes its descent through the earth's gravitational field. The same mass of water leaves the higher gravitational level in a given interval of time as runs into the lower level at the end of the fall. When a stream of electric charge flows in an electric motor from a high electrical level to a lower one in the presence of a magnetic field, no charge is necessarily lost or transformed in the process of generating mechanical power. But when heat is passed through a heat engine from a high temperature to a lower one, some fraction of the thermal stream necessarily goes out of existence, and in the ideal case the amount of heat which disappears is the energy equivalent of the mechanical work delivered by the engine during the performance of a cycle. All forms of idealised gravity engine and electric motor possess this property in common, that the quantity of energy-producing agent remains conserved in amount as it falls through the difference in levels. By this standard, heat occupies a unique position as a source of mechanical power, and this special peculiarity caused Clausius to seek for some property of the ideal heat engine which would make it conform to the conservation law obeyed by other forms of engine. His search began with the question, "is there, in the ideal heat engine, and in spite of the inevitable disappearance of some of the heat, any other thermal

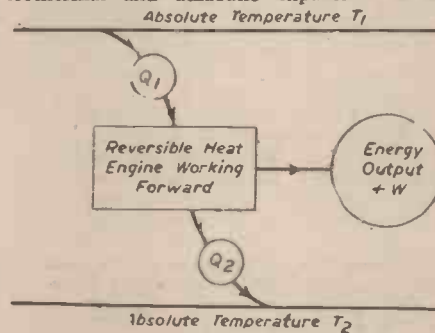

Fig. 21.—Diagram of heat engine action.

ideal gas enables the efficiency of the engine's performance  $(Q_1-Q_2)/Q_1$  to be expressed in terms of absolute temperatures as  $(T_1-T_2)/T_1$ . From the equation  $(Q_1-Q_2)/Q_1=(T_1-T_2)/T_1$ , two other equations follow at once, namely  $Q_1/T_1=Q_2/T_2$  and  $Q_1-Q_2=\frac{Q_1}{T_1} \cdot (T_1-T_2)$ . These combine with the equation  $W=Q_1-Q_2$  to give the result

$$W = \frac{Q_1}{T_1} \cdot (T_1 - T_2) = \frac{Q_2}{T_2} \cdot (T_1 - T_2) \dots (2)$$

A comparison of formulae (1) and (2) shows that just as the weight  $M.g$  of the lowered mass is the same at the high and low gravitational levels in the gravity engine, so is the thermal quantity  $Q/T$  the same in value at the high and low temperatures in the ideal reversible heat engine. In his original exposition of the theorem, Clausius gave the name "Verwandlungsinhalt" (literally "transformation-content") to the quantity  $Q/T$ , and it is considered probable that he described it in this manner since it appeared as a quantity which preserved its content in the process whereby an engine transformed heat into work. Later he changed the name

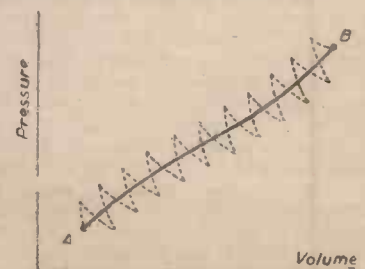

Fig. 22.—Pressure, volume and temperature diagram.

represented by the conventional symbols as

$$\text{an integral } \int_A^B \frac{dQ}{T}$$

If the Clausius description of entropy as a ratio of a quantity of heat to the absolute temperature at which the heat is reversibly and isothermally absorbed or given out by a substance is accepted as a definition, further properties and characteristics of entropy can be at once deduced by taking this definition as a basis. An obvious property which follows from it is that the entropy of a substance is directly proportional to the mass of the substance, since the quantity of heat which a body abstracts or rejects to maintain a given condition of temperature depends upon the body's mass. Consequently, the entropy of a system of bodies is the total sum of the entropies of the individual bodies. Another property of deeper significance which emerges is that the entropy of a substance is a thermal quantity whose value is a function of the instantaneous state of the substance, and is independent of the previous history of the substance. This amounts to saying that if the state of a given body is represented by a point on the pressure-volume diagram, a definite amount of entropy is associated with every point in the plane of the diagram, and that the change in entropy which the body experiences as it passes from one state to another is calculated from the difference between the entropy values associated with the end and initial states, and is quite independent of the particular process whereby the body changes its state. Thus, with reference to Fig. 23, if the points A and C represent two different physical states of a given mass of substance, the entropy change involved in passing from state A to state C is the same for every possible path which may be constructed between these two points, whether the path represents a reversible or an irreversible process. This fact can be expressed more concisely in mathematical terms by saying that the small change in entropy incurred in passing from one state to a closely neighbouring state is a complete or exact differential, and a graphical proof of it may be sketched with the aid of Fig. 23.

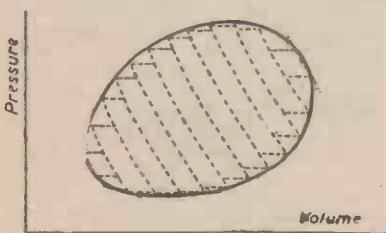

Fig. 24.—Diagram indicating reversible cycle of states.

Any closed loop constructed on a pressure-volume diagram to represent a thermodynamically reversible cycle of states can be considered as the limiting position reached by the extremities of a number of Carnot cycles drawn across the loop so as to occupy its area completely, when the number of Carnot cycles is increased indefinitely (see Fig. 24). Each pair of adjacent Carnot cycles in this system possess one adiabatic line in common, and if each of these cycles is performed in a clockwise direction, the net effect, if their number is sufficiently great, is the same as would be obtained by outlining a path in a clockwise direction along the isothermals only. The entropy change in each Carnot cycle is, by the Clausius theorem, zero, since the ratio  $Q/T$  has the same magnitude at the high and low temperatures in any one cycle, and their algebraic sum  $Q_1/T_1 - Q_2/T_2$  is nought. The total entropy changed summed

over all the component cycles is therefore zero, and thus for any reversible cycle the integral  $\oint \frac{dQ}{T} = 0$ . (The circle drawn through the sign of integration indicates that the calculation is made for a complete cycle of states.) If this fact is applied to any arbitrary reversible cycle ABCD, drawn so as to include an initial state A and an end state C (see Fig. 23), it follows that:

$$\int_A^C \frac{dQ}{T} \text{ (via ABC)} + \int_C^A \frac{dQ}{T} \text{ (via CDA)} = 0$$

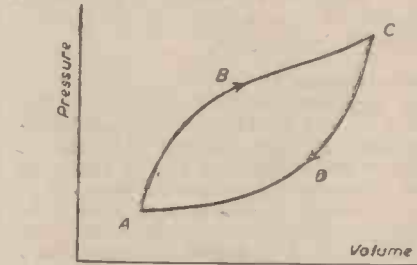

Fig. 23.—Pressure, volume curve.

But

$$\int_A^C \frac{dQ}{T} \text{ (via CDA)} = - \int_A^C \frac{dQ}{T} \text{ (via ADC)}$$

hence

$$\int_A^C \frac{dQ}{T} \text{ (via ABC)} - \int_A^C \frac{dQ}{T} \text{ (via ADC)} = 0$$

or

$$\int_A^C \frac{dQ}{T} \text{ (via ABC)} = \int_A^C \frac{dQ}{T} \text{ (via ADC)}$$

Thus the entropy change, as defined by the quotient of heat and temperature, made by a given mass of material in passing from one state to another, is the same for all paths between the two states, since ABC, ADC are, by hypothesis, any two arbitrarily drawn reversible paths. This implies that the entropy of a substance is determined completely by its instantaneous state, and is independent of the nature of the process which takes it to that state.

It is to be remarked that this result is established by virtue of the fact that an entropy change can be calculated from the

integral  $\int \frac{dQ}{T}$  only when the change of state

is made in a thermodynamically reversible manner. If the change from A to C were made along an irreversible course, the entropy change would have exactly the same value as before, but it would no longer be equal to the

value of the integral  $\int_A^C \frac{dQ}{T}$ . In general terms

when a substance completes a closed cycle of changes in an irreversible manner, its total entropy change is zero, as it is in the case of the reversible cycle, since the substance returns to its initial state, but the value of the integral

$\oint \frac{dQ}{T}$ , calculated for the irreversible cycle, is negative, and no longer represents the entropy change. If a substance passes in an irreversible manner from one state A to another C without completing a cycle of work, its entropy change is still  $S_C - S_A$  (where S denotes entropy) as it is for the reversible change from

A to C, but the value of the integral  $\int_A^C \frac{dQ}{T}$  for

the irreversible path is no longer equal to the entropy change, but has a value less than  $S_C - S_A$ . These two propositions are sometimes referred to as the "inequalities of Clausius," and are formally stated as:

$$\oint \frac{dQ}{T} < 0, \text{ for an irreversible cycle,}$$

$$\int_A^C \frac{dQ}{T} < S_C - S_A, \text{ for an irreversible change.}$$

**Reversible Cycle**

They can be proved by considering the properties of a Carnot cycle, which is first of all performed reversibly, and then irreversibly. In Fig. 25 the reversible cycle is shown as ABCD, and the irreversible one as A'B'CD'. The isothermal line AB represents the absolute temperature  $T_1$  of both the source of heat and of the engine's working substance when in contact with the source, since in the idealised reversible engine no temperature difference need be applied across the material separating source and working substance to promote a heat flow, as this material is considered to be 100 per cent. thermally conducting. Similarly CD is the line of constant temperature  $T_2$  of the heat sink and of the working substance when the latter is in thermal communication with the sink. One way of introducing the quality of irreversibility into such an engine is to replace the ideal thermal conductors by real conductors, which require the maintenance of a finite temperature difference across their extremities to cause heat to flow through them. In this case AB is still the constant temperature line  $T_1$  of the working substance in the cylinder of the engine, but A'B' is the isothermal of the heat source at a slightly higher temperature  $T_1'$ . During the isothermal compression stage of the cycle, the temperature  $T_2$  of the sink exceeds that of the sink  $T_2'$  by a finite amount, in order to cause heat to flow from cylinder to sink.

The Clausius theorem, applied to the reversible cycle, states that  $Q_1/T_1 - Q_2/T_2 = 0$ . It follows that for the irreversible cycle  $Q_1'/T_1' - Q_2/T_2 < 0$ , since  $T_1'$  is greater than  $T_1$ , and  $T_2'$  is less than  $T_2$ . If the principle of Carnot is extended to any general cycle by dividing the latter into a system of small Carnot cycles (as in Fig. 24), and proceeding to the limiting case, the above inequality becomes

$$\oint \frac{dQ}{T} < 0 \dots \dots \dots \text{First inequality of Clausius.}$$

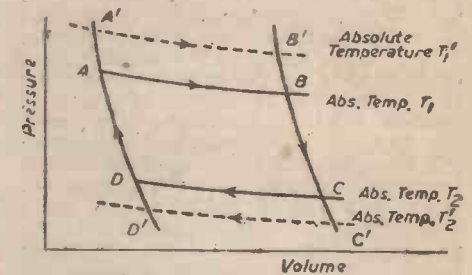

Fig. 25.—Diagram indicating reversible and irreversible cycles.

where T refers to the temperature of the heat reservoir supplying or receiving heat. The second proposition may be established by considering the performance of a cycle (see Fig. 25), in which the stage ABC is conveyed irreversibly, and the return stage CDA reversibly. Since a part of this cycle is irreversible, the character of the cycle as a whole is irreversible, and therefore from the first inequality of Clausius.



$$\int_A^0 \frac{dQ}{T} (\text{irreversibly via ABC}) + \int_0^A \frac{dQ}{T} (\text{reversibly via CDA}) < 0$$

But  $\int_0^A \frac{dQ}{T} (\text{reversibly via CDA}) = S_0 - S_A$ , where S

denotes entropy, since entropy is evaluated by a heat-temperature ratio when the process is reversible. Hence,

$$\int_A^0 \frac{dQ}{T} (\text{irreversibly via ABC}) + (S_A - S_0) < 0$$

or  $S_0 - S_A > \int_A^0 \frac{dQ}{T} \dots \dots$  Second inequality of Clausius.

In an adiabatic change of state, no heat is allowed to leave or enter the system while the

change is in progress. This fact reduces to zero the integral carrying dQ in its numerator. Hence,  $S_0 - S_A = 0$ , for an adiabatic process which is reversible, making  $S_0 = S_A$ , whereas  $S_0 - S_A > 0$  for an adiabatic process which is irreversible, making  $S_0 > S_A$ . Thus an adiabatic change which is made in a reversible fashion is accompanied by no change in entropy (such an adiabatic line is sometimes described as an "isentropic" line), but an irreversible adiabatic process is always associated with an increase in entropy.

The fundamental relation  $(Q_1 - Q_2)/Q_1 = (T_1 - T_2)/T_1$  which applies to a reversible cycle of work, provides yet another viewpoint from which entropy may be considered; a viewpoint which suggests how the concept of entropy may be used more directly in practical problems of heat engine design and operation. From this equation, the quantity of heat  $Q_2$ , which is returned to the low-temperature sink without being converted into useful work, and which may therefore

be suitably described as "unavailable energy,"

may be written as  $Q_2 = \frac{Q_1}{T_1} \cdot T_2$ . The ratio  $Q_1/T_1$  is the entropy acquired by the working substance in drawing heat reversibly and isothermally from the source during the first stage of the cycle of work, and  $T_2$  is the lowest temperature available to the heat engine. By this equation, therefore, the initial entropy of the working substance may be regarded as that quantity which when multiplied by the lowest absolute temperature to which the engine has access, gives the amount of supplied heat which cannot be transformed into useful work. It indicates that two desirable characteristics in any heat engine are the choice of a working substance which acquires a small entropy increase in the process of heating, and the use of a sink to receive the rejected heat at a temperature as low as possible.

(To be continued)

# Notes and News

## Fast Hammer Heads

A RECENTLY accepted application for a patent in this country relates to a means for effectively fastening the head of a hammer to its handle. The contrivance consists of a pair of wedge-shaped serrated metallic keys, and a metallic wedge made to be driven between the two keys. This wedge is serrated on its wide faces and has its edges converging towards each other in the direction of the thin edge of the wedge preferably by forming grooves transversely across the faces. Each key has transverse serrations across its converging faces and its outer edge.

The head of each key has a projecting lug overhanging the outer edge of the key.

The edges of the wedge and the adjacent inner edges of the keys are shaped to effect sliding interlocking grooved and tongued engagement with each other when the wedge

is driven between the two keys. This invention should enable a hammer to keep its head.

## Watertight Flat Roofs

AN inventor has been devoting his attention to houses with flat roofs. He points out that flat roofs are usually provided with a covering of asphalt or some bituminous material with or without layers of felt to render them watertight.

This covering, he mentions, is wholly relied upon to exclude rainwater. If such covering has any cracks or weakness, the roof may not be watertight. The covering ordinarily is black or dark in colour and therefore is non-reflective to solar heat. As a consequence, it provides poor insulation, and may be liable to soften or deteriorate under the sun's rays.

In order to protect the covering from the

direct rays of the sun, a top layer of light-coloured material is often applied to it. This layer serves also to furnish a harder and more enduring walking surface.

The aim of the new device is to provide a flat roof with an entirely different kind of covering which will be waterproof and have a light-coloured surface that will reflect the sun's rays. In addition, it will be hard enough to carry the normal traffic on a flat roof.

The improved covering is made from two decks, each composed of sheets of asbestos-cement or equivalent rigid material. The sheets in the lower deck overlap one another at the sides and ends. They are corrugated to form troughs, the undersides of which have bearing surfaces lying in a single plane and resting on the supporting framework or on a flat surface covering it.

The upper deck is supported by the lower deck, and affords umbrella-like protection over the laps and fixing holes in the lower deck.

## POWER FROM THERMO-ELECTRICITY

(Concluded from page 208).

heat riot can in part be converted to an orderly electrical march every thermo-couple proves, and that the march can at least modify the riot both the Thomson and Peletier effects prove. In the Thomson effect, a hot-point will move along a conductor in the direction opposite to that of a flowing current; it might be said that the positive potential attracts not only the negative electrons but their actual high-temperature manifestations. A big step forward would be to prove the expected reverse to be the case—that a moving hot-spot will evoke a current.

While admitting that much experimental work has been undertaken in this field during the past century, it is inconceivable that the simple examples of its use to-day represent the last word; surely, the clean, simple, silent vehicles it promises, with houses and factories independent of outside supply, are a sufficient inducement for more research into this subject so full of unsolved riddles.



Ordnance factories are now switching over part of their factory space to peace-time production that will eventually benefit road and civil transport. Our illustration shows mechanics busy on motor trucks for Europe, with the last six-pounder anti-tank gun being taken from the shed—a scene at the Royal Gun and Carriage Factory at Woolwich Arsenal. American Sherman tanks were re-gunned in this shed during the war.

## REFRESHER COURSE IN MATHEMATICS

8/6 by post 9/-

From: GEORGE NEWNES LTD.  
Tower House, Southampton Street, Strand, W.C.2

# Inventions of Interest

By "Dynamo"

## Parachute Pack

ONE does not require the vision of a seer to foretell that the complete conquest of the air will soon be a *fait accompli*. And the time will arrive when every occupant of a plane will be equipped with an efficient parachute—that lifebelt of the aircraft.

Devoting his mind to this *sine qua non* of those who travel by aircraft, an inventor has focused his attention principally upon the parachute pack, and chiefly to that form of pack which is strapped to the wearer's back.

The author of an improved contrivance of this description has aimed at a pack which readily accommodates itself to the shape of the body, so that it may be worn with increased comfort.

One characteristic of this pack is that its envelope is composed either wholly or partly of elastic fabric. Another feature is that it has an envelope in which the direction and the degree of the elasticity of the material are controlled to the end that, when the pack is strapped with uniform pressure to the body, a lesser resistance to bending will prevail in that direction in which the greater deflection is needed.

The envelope has a bottom member with fabric side and end flaps attached. The amount of elastic material is different cross-wise of the sheet than it is lengthwise.

Still another object aimed at is so to control the elasticity of the fabric that it will assist considerably in erecting the canopy when released.

## For Travelling Cranes

THE British Patent Office has received an application for a patent relating to electrically propelled vehicles of the description in which current is supplied to the vehicle from a stationary conductor (e.g., an overhead trolley wire). This extends along the track of the vehicle and is traversed by a current collector (e.g., a trolley, brush, etc.) supported by and moving with the vehicle.

The invention is mainly, but not exclusively, concerned with electrically driven

overhead travelling cranes. It is a requirement of certain legislation that, when a workman is liable to be struck by a moving crane, adequate provision shall be made for preventing the crane from approaching closer than a prescribed safety distance. One object of the invention is to satisfy this legal obligation.

Broadly stated, the device provides safety apparatus for automatically stopping an elec-

The information on this page is specially supplied to "Practical Mechanics" by Messrs. Hughes & Young, Patent Agents, of 7, Stone Buildings, Lincoln's Inn, London, W.C.2, who will be pleased to send free to readers mentioning this paper a copy of their handbook, "How to Patent an Invention."

trically propelled vehicle. It comprises an abutment which is secured to the stationary conductor at a predetermined position in relation to the track of the vehicle. And it is adapted by engagement with the current collector to divert the collector off the conductor and so break the current supply and arrest the vehicle.

More particularly the apparatus is in the form of a portable unit, comprising a shoe which embodies a clamping device for securing the shoe to the conductor at any desired position along it. It is arranged so as to form an abutment located in the normal path of the current collector along the conductor and adapted by engagement with the collector to throw the latter, by cam or equivalent action, off and to one side of the conductor.

## Pipe Line

IN modern warfare, and possibly in peacetime, there are occasions when necessity demands the immediate transportation of liquids over considerable distances.

There has recently been accepted by the British Patent Office an application relating to a pipe line of special construction with means for laying such a pipe.

The originator of this invention declares

that he has discovered by experience with existing flexible piping that it fails under high pressure. Either the metallic structure leaks or collapses, or the inner rubber tube is extruded through the seams in the outer metal covering.

The object of the improved device is a pipe line which will withstand high pressure and yet be capable of flexibility sufficient to enable it to be carried in bulk as, for example, in coils of large diameter in the hold of a ship.

The invention comprises a flexible reinforced conduit which has a central cylindrical tube of ductile material. There is a covering formed of one or more ribbons of high tensile strength wound spirally thereon. As a result, the lateral edges of the adjacent convolutions do not abut, but are spaced and are capable of free adjustment of their relative positions at both the inner and outer diametrically opposite places of the bends.

## Power-operated Steering

IMPROVED steering mechanism which has made its advent has claimed for it the characteristic that it reduces the manual effort required in the steering of heavy vehicles. Another purpose is to diminish the shock to the man at the wheel due to the impact on the road wheels when traversing uneven ground.

This is a power-operated steering device which includes co-axial input and output shafts. The shafts carry arms pivotally connected at different points to a reaction lever. One end of the lever is movable with respect to the shafts and has a connection to control valve devices. The other end is connected to the piston of a power cylinder. The rocking movement imparted to the lever by the operation of the input shaft causes the lever to work one of the valve devices. Thereby power is developed in the cylinder, which reacts on the lever to balance it about its pivotal connection to the output arm and to cause movement to be transmitted through the arm to the output shaft and the steering gear.



One of the two light motor-cars to be mass-produced at Grantham by Denis Kendall, M.P. These cars are to be sold at £150 inclusive of purchase tax, etc. On the left is seen the 7 h.p. radial engine housed in the rear of the car. The illustration on the right is a front view of the car, showing the luggage space.

# THE WORLD OF MODELS

By "MOTILUS"

Model Railway Work in a P.O.W. Camp in Bavaria; and Some Commercial Models

**T**HIS month sees us well through the winter and I hear everywhere of the revival there has been during these past few months in peacetime model making, both among amateurs and commercial firms, who are slowly but surely getting into their stride again.

The variety of equipment offered in 1939 was enormous—the result of years of building up stocks—and model manufacturers are starting their post-war programme with models that were most in demand at the outbreak of war; but in the last six years the taste of the model owner may have altered, and there may be a tendency towards models of more modern means of transport—as, for instance, aircraft—as opposed to ships, motor-cars and trains. An important factor, however, in the fascination of the model aircraft hobby is that models are only propelled by two methods—the simple method of elastic, and the small-power petrol engine. The drawbacks to these methods are that the elastic model is not much more than a toy, and the petrol-driven model is difficult to construct satisfactorily, often gets out of control, crashes, and is a total loss.

### Model Railway Work at P.O.W. Camp

It is very heartening to think of the many model enthusiasts who carried on not only in this country during the war but overseas, and as prisoners of war in enemy countries.

ment of the model railway hobby so that by the time the building of the railway was in full swing five to six hundred men were aiding in its construction.

When taken prisoner Corporal Waldron—who, incidentally, lives in Northampton—was transported to Poland, where he remained in a prison camp there for two years. He was then moved to Stalag 383, in Bavaria, where conditions were better and the prisoners were able to think about hobbies and had plenty of time to make plans. From the making of cap badges, etc., the idea of toy-making inevitably found its way in and started the ball rolling for bigger things. At Christmas-time they made simple things and some of the men, who



Fig. 1.—(Left) Photograph of the new G.W.R. signal box for the gauge "O" clockwork line of Mr. Gilbert Thomas at Teignmouth.

Fig. 3.—(Above) A fine example of a model 20-ton gantry crane on the south side of the works of the Motherwell Bridge Engineering Co., Ltd. Also to be seen are shop cranes, gantry, and special goods wagons. Scale of model, 24ft. to 1in.

were model railway hobbyists in peacetime, got together.

Among those in the camp was Sergeant Ray Beale, relative of the Rev. E. Beale, the well-known model railway owner and writer, and Sergeant Beale suggested they should write for railway catalogues, and Corporal Waldron wrote, among others, to Bassett-Lowke, Ltd., for their catalogues and "Model Railway Handbook."

### Gauge "O" Model Railway

The big decision was taken to try to construct a gauge "O" railway. The lines grew from the "raw material" of empty Red Cross tins and eventually about 48ft. of track was made, comprising four roads, crossover and switches. Electric current was



I have already referred to several models made by members of the Forces at home and abroad, and I can now tell you a fine story of how the hobby of model railways was used to create interest and usefulness in Stalag 383 at Hohenfels, near Nuremberg in Bavaria, during many weary war years.

The story was told to me by Corporal Jack Godfrey Waldron, of the Queen Victoria Rifles, who has recently been awarded the D.C.M. in recognition of gallant and distinguished services in the defence of Calais in 1940. He was taken prisoner at Calais and was in German hands for five years, returning to England in May, 1945. Corporal Waldron called to see Mr. W. H. Rowe, of Bassett-Lowke, Ltd., with whom he has been in communication during his years of captivity. He told an amazing story of the develop-

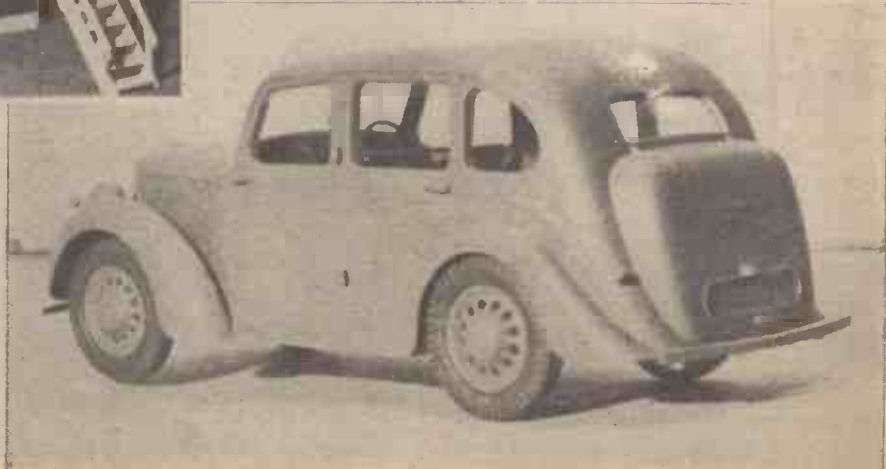

Fig. 2.—Model of the Hillman Minx (1/10 full size) made for Rootes Group by, Bassett-Lowke, Ltd., for wartime production records.

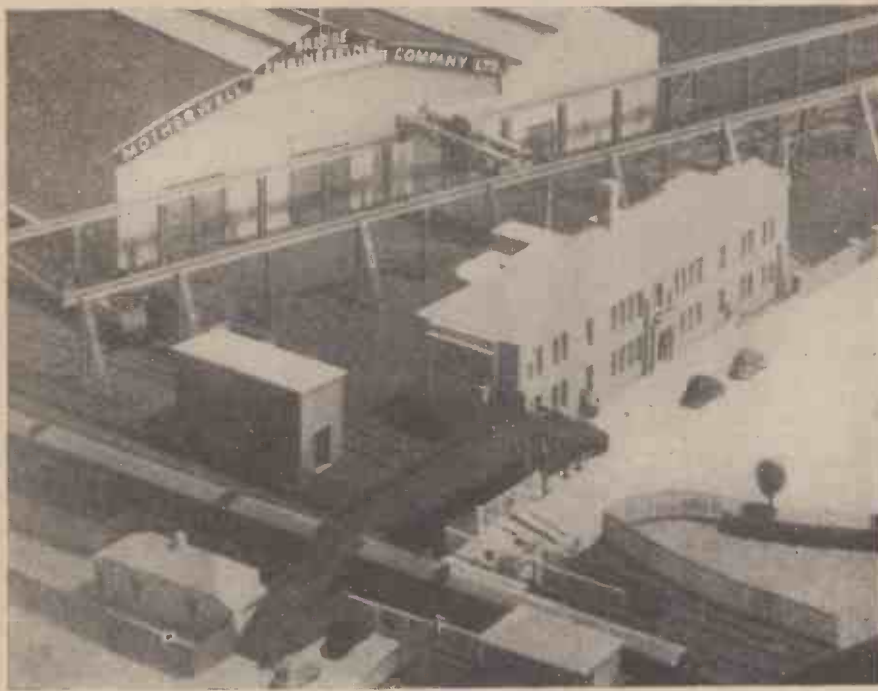

Fig. 4.—Level crossing near the main office entrance, showing gantry on the north yard and a portion of the frontage of the main workshop of the Motherwell Bridge Engineering Co., Ltd.

stepped down from 220 volts to 12 volts, and the motor itself was made out of cocoa tins, while the wire came from such things as old telephone bobbins and some bare wire painted with shellac.

The chassis of the motor was made from the aluminium bottoms of the jugs issued by the Germans (not strictly lawful but very successful).

The switchboard was Corporal Waldron's department. Not having any asbestos for the switchboard, he used a piece of beaver boarding painted over to represent asbestos. Switches and wiring were unobtainable, so knife switches were fabricated out of tin.

Fellow prisoners of war who had previously no model interest promptly developed into model enthusiasts and began listing out the items for their railways. Some earmarked £50 of their post-war credits for model railways. On their return to England, Corporal Waldron ruefully confessed, their hopes were dashed, for on visiting Bassett-Lowke's branch at Holborn they found that the firm had been on Government work the whole of the war and none of their peacetime stock was available.

Still, better luck, boys, in the near future!

#### Model Signal Box

Now for the Home Front. Calling on Gilbert Thomas at Teignmouth the other day I was very pleased to see that he had added to his very attractive layout a fine new 7 mm. scale model of one of the G.W.R. signal boxes near Snowhill Station, Birmingham. It is not an exact model of the actual signal box but reproduces the latest features of this rather extraordinary design—the base being narrow to go between the two tracks, and the extra space required being made available by overhang all round (Fig. 1.)

This model was made specially by Bassett-Lowke, Ltd., and the photograph shows the model before leaving the works.

Mr. Gilbert Thomas is constantly adding to and improving his now well-known gauge "O" G.W.R. clockwork railway, and I hear a rumour that he has written a book shortly to be published on the origin and development of his model railway.

#### Model Engineering Works

Architectural models vary in their attraction and detail and sometimes those which are more spectacular from the point of view of size are not so difficult to make as a small model which contains much mechanical detail. The model (Figs. 3, 4 and 5) of the engineering works of the Motherwell Bridge Engineering Co., Ltd., comes into the latter class. The model is made to a scale of 24ft. to 1in.

This has been produced recently by the architectural department of Bassett-Lowke, Ltd., under the direction of Mr. E. H. Clifton, and covers an area of approximately 5ft. by 3ft. 6in. and is 1/288th actual size.

This is one of the best examples of a model demonstrating the metal working ability of the model maker. The detail is in the machinery—cranes and gantries—and this is the work of craftsman J. Ashby. Besides the buildings, there are many railway sidings and tracks, and the L.M.S. main line to Glasgow is shown with a streamlined express locomotive and train on the down track. Metal work is again to the fore with the models of the company's products—container tanks, caissons, special bridge sections and so forth—made in miniature and placed in the yard, where it is usual to erect them for test before dispatching. Another feature is the amount of rolling stock on view in the sidings—including special type wagons used by this kind of engineering works, modelled by the score.

#### Industrial Model

This is a truly industrial model, with little grass or trees, the ground mostly consisting of the company's yards. The scale of 24ft. to the inch enables sufficient small detail to be shown with precision and is small enough, in the case of a large works, to provide a model of convenient size for transport and display at exhibitions. This model is now in the company's offices at Motherwell.

### THE SLIDE RULE MANUAL

By F. J. CAMM

5/- or 5/6 by post from George Newnes, Ltd.,  
Tower House, Southampton Street, Strand, W.C.2

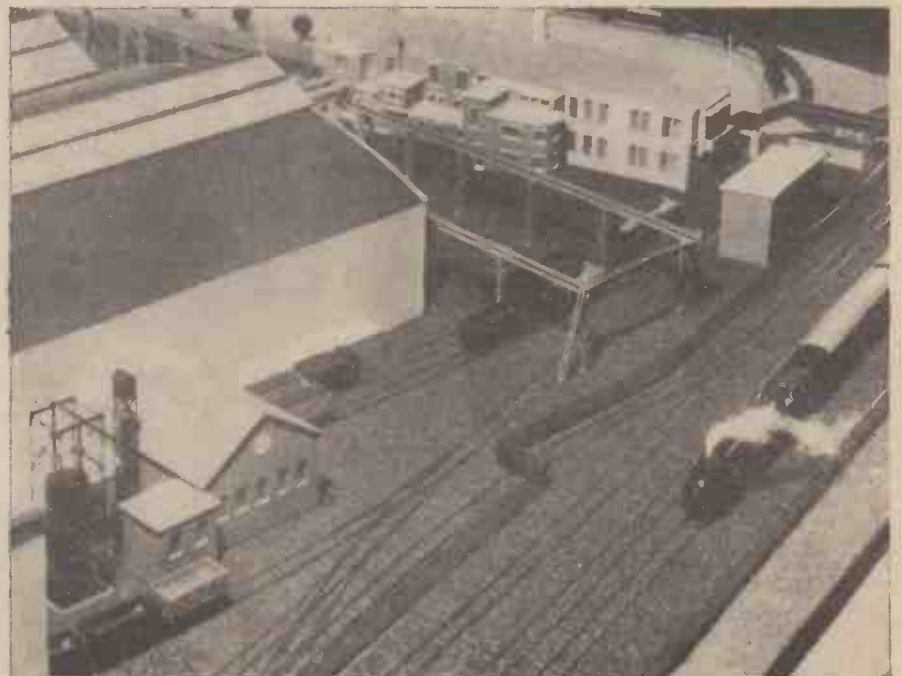

Fig. 5.—In the foreground of this picture is the L.M.S. main line with express on the down line, to Glasgow. In the background can be seen the workshop and the rear of the office buildings.

# QUERIES and ENQUIRIES

A stamped addressed envelope, three penny stamps, and the query coupon from the current issue, which appears on back of cover, must be enclosed with every letter containing a query. Every query and drawing which is sent must bear the name and address of the reader. Send your queries to the Editor, PRACTICAL MECHANICS, Geo. Newnes, Ltd., Tower House, Southampton Street, Strand, London, W.C.2.

## Accumulator Making

I WISH to construct a special accumulator which involves making plates, and I would be glad of your advice in this matter. It is to be the standard type of cell using the oxides of lead (PbO) yellow lead oxide and (Pb<sub>3</sub>O<sub>4</sub>) red lead, and I would be glad of information regarding the binding materials to give the necessary strength and stiffness, and the strength of the sulphuric acid solution required for mixing the paste.—W. H. Leyon (Coventry).

THE precise methods of accumulator making are, in these modern times, more or less trade secrets, and little information has been published concerning these subjects.

Usually, the plate material is formed by hydraulic compression outside the accumulator. For this purpose, up to 5 per cent. of china clay may be added to form a binder. In your case, however, you will not be able to use this form of compression. All you can do is to "trowel" the moist paste into the plates, and to pack it down in position as best you can. It is precisely for this reason that home-made accumulators are never long lasting, for the plate material always tends to fall away.

Regarding the acid used to make the plate pastes. This is dilute pure sulphuric acid—one part acid to 4 parts water. The acid must be pure, since impure acids containing iron and arsenic will seriously inhibit the free chemical actions within the cells.

## Measuring Humidity of Air

IS there any chemical material which indicates the amount of moisture in the air by a change of colour and, if so, where may I obtain a supply of such?—Wm. D. Tattersall (Blackburn).

THERE is no chemical substance which will accurately measure the humidity of the air by means of a colour change, but there are two or three materials which will do so approximately.

For example, when pure copper sulphate is strongly heated, it loses its blue colour and turns to a white powder. This powder, on standing in contact with the air, absorbs moisture and is gradually reconverted into the blue variety of copper sulphate.

Again, when cobalt chloride is heated to about 120 deg. C. for a short time, the pink crystals lose their constituent water and become blue. On exposure to the air, the blue variety of cobalt chloride rapidly absorbs moisture and turns pink again.

Perhaps these methods of moisture indication will serve your purpose. Copper sulphate can be obtained from any druggist. Cobalt chloride is most likely to be obtained from Messrs. Towers & Co., Ltd., Chapel Street, Salford, Lancs.

## Heat Resisting Glass

CAN you please supply me with the formula for the glass known as "Oven Proof" or "Heat Resisting" or "Flame Proof"? I have an electric muffle capable of attaining temperatures in excess of 1,500 degrees Centigrade. Can I produce this glass?—K. J. Field (Erdington).

IF you can readily attain a temperature of 1,500 plus degrees Centigrade, you ought not to have much difficulty in making small batches of various glasses.

The various trade glasses are more or less of secret composition, containing specific ingredients which are only known to their makers. However, the following two formulae are capable of giving heat-resisting glasses of the type which we think you aim at:

Sand	60-70 per cent.
Boric acid	15-30 "
Potassium carbonate	1-2 "
Sodium carbonate	3-6 "
Zirconia	1-3 "
Titanium dioxide	1-3 "
Sand or silica	
Boric acid	70 per cent.
Litharge	16-20 "
Iron oxide	10 "
	3 "

This latter glass is the more easily made. It is resistant to high temperatures and to sudden temperature changes, and it is fairly easily worked.

## Light-weight Concrete

CAN you tell me how to make light-weight or cellular concrete using cement and sand aggregate? I have used aluminium powder with very poor results.

There is, I understand, a number of simple

chemicals that can be used for making this material.

I would also like to know if it is possible to give concrete a high-glazed finish?—A. J. Purcell (Dalkey).

LIGHT-WEIGHT concrete is ordinarily made by employing light-weight aggregates such as blast-furnace slags, burnt clays, pumice, coke-breeze, sawdust etc. If this aggregate contains a small amount, say, 1 per cent., of powdered resin, this acts as an air-entraining agent and tends to the formation of air cells within the concrete, thereby imparting extra lightness to it, together with a cellular structure.

A formula which is stated to be successful for the making of cellular and light weight concrete is:—  
Portland cement . . . . . 1 part (by weight).  
Sand . . . . . 1-6 parts.  
Seed or grain husks . . . . . 2-12 parts.

Mix the above material with water to mortar consistency in the usual way, so as to give sufficient fluidity for casting.

The addition of 1 part of resin powder to the above, will substantially increase the amount of entrapped air in the mixture.

Concrete cannot be given a highly glazed finish, for the reason that it is essentially porous. This applies particularly to the cellular concretes. You can, of course, fill up the surface pores of the concrete with size or some other material and paint or varnish over this sealing coat, but the result will be a glazed applied coat, not a true glaze on the concrete itself.

## Re-winding Small Electric Motor

I HAVE acquired the carcass of a small motor minus all windings. I wish to rewind same, and shall be glad if you will supply the necessary information.

- Particulars are as follow:
- Commutator bars = 16
- Armature slots = 8
- Armature diameter = 1 3/16 in.
- Armature length = 2 in.
- Number of poles = 2
- Voltage = 220/240 A.C./D.C.

Details of slots are as shown in the diagram. I want the machine to run at about 5-6,000 r.p.m.—J. Devine (Brighton).

THE air gap could be made about 0.006 in. on each side of the armature. Each field pole could be wound with 400 turns of 34 S.W.G. S.S.C. enamelled

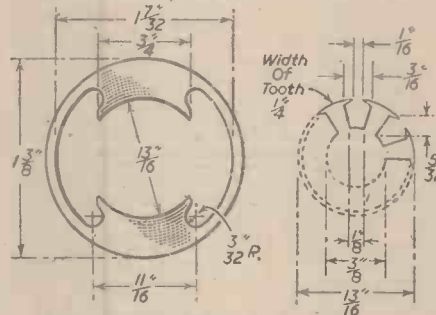

Dimensions of field magnet and armature for a small electric motor.

wire, the two field coils being connected in series so as to create poles of opposite magnetic polarity, and in series with the armature. The armature could have 8 coils, each with 220 turns of 41 S.W.G. S.S.C. enamelled wire, a loop being brought out from the centre of each coil for connection to intermediate commutator segments. Use a coil span from slots 1 to 4 and so on. With the armature placed so that slots 1 and 4 are equi-distant from the centre of one pole face, number the commutator segment which then lies under the nearest brush, number 2. All numbering is considered clockwise at the commutator end.

For reversible operation connect the start of the coil in slots 1 and 4 to segment 1, the loop to 2, and finish of the coil to segment 3. Connect the start of the coil in slots 2 and 5 to segment 3, loop to 4, finish to segment 5, and so on. For fixed clockwise rotation at the commutator end with fixed brushes we suggest you add 2 to the numbers of segments quoted above for the coil

connections, and for fixed counter-clockwise rotation subtract 2.

## "Base-exchange" Material

I AM constructing a water softener and would be pleased if you could supply me with the following information:

The cubic capacity of 1 lb. Zeolite.  
The number of gallons of water 1 lb. Zeolite will soften (approximately) as I know this depends on the degree of hardness, and

How much salt is required to re-activate say 40 lb. Zeolite?

Also, could you please inform me where I can obtain Zeolite?—M. J. Parker (Hatfield).

BY "Zeolite, we presume that you refer to Zeolite which is the "base-exchange" material used in water-softeners.

These zeolites are made in many different forms, so that we cannot possibly estimate the precise cubic capacity of 1 lb. of the material. This depends upon the specific gravity of the material and the grain-fineness or particle size of the mineral. Roughly speaking about 1 3rd its weight of common salt is required to re-activate a zeolite, but, as you yourself point out, the gallonage of water softened by 1 lb. of zeolite depends upon the exact nature and type of the material, the speed of the water's passage through it, the temperature of the water, the degree of permanent hardness of the water and the amount of surface of zeolite exposed to the water. Since these are all variable factors, we cannot possibly give you the figures which you seek.

These zeolite materials have been very stringently controlled and, therefore, unobtainable by the average individual, but it is possible that the control may now have been lifted. For supplies of these zeolites write to:—Permutit, Ltd., Gunnorsbury Avenue, London, W.4. Also, write to Solfon, Ltd., for their booklet on water softening, which may possibly bring you some of the information which you require.

In pre-war days, many chemical supply houses used to stock zeolite materials. Try Messrs. Harrington Brothers, Ltd., 4, Oliver's Yard, 53a, City Road, Finsbury London, E.C.1, or Messrs. A. Gallenkamp & Co., Ltd., 17-29, Sun Street, Finsbury Square, London, E.C.2.

## Anti-steaming Preparation for Spectacles

COULD you please inform me of a suitable anti-steaming preparation for use on spectacles?—N. F. Reed (Cowplain).

ANTI-STEAMING preparations for glass are usually of very simple composition, consisting merely of various solutions of soap and/or glycerine.

A simple formula is: Rectified spirit, 10 parts (by volume); glycerine, 1 part (by volume). Since rectified spirit is expensive, you might possibly replace the above formula by surgical spirit alone. This liquid contains a little castor oil, so that if you wipe the glasses over with this sufficient oil may remain on the lenses to prevent steaming.

Another suitable formula is: Soap, 1 part (by weight); glycerine, 1 part; water, 15 parts. Heat together until a clear solution is obtained. Wipe a little of this over the lenses, and then wipe it off. A minute film of soap will remain on the glass, which film will prevent all ordinary steaming effects.

If, of course, you work in an excessively cold atmosphere, then we are afraid that no preparation will prevent the outside steaming of your spectacle lenses. It is a good plan to warm the spectacles thoroughly before putting them on.

## Enlargement from Cine Film

I WOULD be very much obliged if you could answer the following questions.

I have a roll of 9.5 mm. cine film which has been processed positive (i.e. ready for projection). Is it possible for me to have a frame of this film enlarged and made into a negative so that I can have snapshot-sized prints made from it? If so, could you recommend a firm of photographers who would do this for me?

Could you please explain briefly the method used in the above operation, assuming that it is possible?—W. Addey (Chaddesden).

IT is readily possible for you to have a single frame of your 9.5 mm. positive cine film enlarged so as to form a negative from which enlarged prints can be made, and any competent photographic trade-printing house should be able to do this for you at a reasonable price. Write to Messrs. Wallace Heaton and Co., Ltd., New Bond Street, London, W.1.

## THE P.M. LIST OF BLUEPRINTS

- |   |   |
|---|---|
| The "PRACTICAL MECHANICS" \$20 CAR<br>(Designed by F. J. CAMM),<br>10s. 6d. per set of four sheets. | SUPER-DURATION BIPLANE*<br>Full-size blueprint, 1s.       |
| "PRACTICAL MECHANICS" MASTER BATTERY CLOCK*<br>Blueprints (2 sheets), 2s.                           | The 1-c.c. TWO-STROKE PETROL ENGINE*<br>Complete set, 5s. |
| The "PRACTICAL MECHANICS" OUT-BOARD SPEEDBOAT<br>7s. 6d. per set of three sheets.                   | STREAMLINED WAKEFIELD MONOPLANE—2s.                       |
| A MODEL AUTOGIRO*<br>Full-size blueprint, 1s.   | LIGHTWEIGHT DURATION MODEL<br>Full-size blueprint, 2s.    |
|   | P.M. TRAILER CARAVAN*<br>Complete set, 10s. 6d.           |
|   | P.M. BATTERY SLAVE CLOCK* 1s.                             |

The above blueprints are obtainable, post free from Messrs. George Newnes, Ltd., Tower House, Southampton Street, Strand, W.C.2.

An \* denotes that constructional details are available, free, with the blueprint.

The procedure is simple enough. Instead of projecting the enlarged image of your positive film frame on to a sheet of bromide paper, the image is projected on to a slow-emulsion plate or film. The necessary short exposure is given and the plate or film is then developed up in the ordinary way, the positive film giving a negative image. A projection enlarger is, of course, necessary for the work, and the task itself is somewhat unusual, but there is nothing difficult in it.

**Small Air Compressor**

**CAN** you please help me with the following problem?

I wish to construct a compressor for spraying cellulose paint. For driving the compressor I have a one-eighth h.p. electric motor running at 2,750 r.p.m. The compressor is the type used for pumping up car tyres and has a bore of 1 1/2 in. and a stroke of 1 1/4 in.

What gear ratio will be necessary and will a belt drive be satisfactory?—A. H. Durrant (Basingstoke).

THE suitability of your proposed compressor for some extent by the actual viscosity of the paint and by the volume of the paint material which is actually under compression at any given time. Since your motor has only one-eighth h.p., the paint container will not have to be large, otherwise the motor will become overloaded.

A good belt drive will be quite satisfactory provided that the drive is not too long. Gear ratio is a vexed question. It all depends on the design of the paint spraying plant and, to some extent, on the power of the motor. Since we are not aware of your exact design in the matter of this plant, we cannot give a definite figure for a gear ratio, but we should say that a ratio of 2 or even 3 to 1 will be suitable, particularly with a belt drive.

**Hydrogen Peroxide**

**IS** it possible to obtain pure hydrogen peroxide, and can it be stored without the oxygen evaporating off? What conditions must it be stored under, and where can it be obtained?—R. J. Bremner (Southampton).

PERFECTLY pure hydrogen peroxide, which is a thick, viscid liquid, is not yet an article of commerce. The strongest hydrogen peroxide which is normally obtainable is that listed as "Hydrogen peroxide 90-100 volumes." This may contain about 92 per cent. of the peroxide. It must be stored in amber bottles in a cool, dark place, but, apart from these ordinary precautions, there are no special restrictions to observe in connection with it. If the peroxide remains uncontaminated it will keep in good condition for months under the above conditions.

The above grade of hydrogen peroxide is obtainable from chemical suppliers as, for example, The British Drug Houses, Ltd., Graham Street, City Road, London, N.1., or from Messrs. Harrington Bros., Ltd., 4, Oliver's Yard, 53a, City Road, Finsbury, London, E.C.1. Its price is about 6d. per oz. It is possible that you may be able to obtain this material to order from your local branch of Boots, the Chemists.

**Sprayed Paper Finish on Metal Surfaces**

**COULD** you supply any information concerning the spraying of adhesive, followed by paper particles, on to sheet metal surfaces (steel-aluminium alloys)? What I have in mind is of a similar nature to that employed on shipboard, where cork particles are used to counteract the effects of condensation.

Could you give any advice regarding the possibilities of this process, together with the names of firms likely to help regarding plant, material, etc.?—W. B. McCulloch (Alloa).

SO far as we have been able to ascertain, the coating of surfaces with paper particles ("paper dust") has not been altogether satisfactory, mainly in consequence of the hygroscopic nature of the paper, the paper attracting moisture to itself with consequent deterioration of its under support. However, nothing has been published on this subject, so that if you require detailed information it will be necessary for you to apply to some trade or research association, such as the Paper-Makers Association of Great Britain and Ireland, Shell-Mex House, Strand, London, W.C.2. These people will also put you in touch with a suitable supplier of paper material for your purpose.

The adhesive employed for the paper spraying is an ordinary fish glue, which has been plasticised either with a little glycerine or with a small quantity of urea, and which contains, also, a small quantity of fine resin. The composition of this adhesive has not been published. Nevertheless, it is prepared along the above-mentioned lines. Cork particles are usually cemented to a bituminised surface, but this process is not generally applicable with paper in view of the staining power of the bitumen or bitumen solution. It is essential that the base metal surface must be perfectly clean and free from grease, otherwise the cement will not adhere well.

Spraying plant of various types can be obtained from the following firms: Messrs. A. C. Wells and Co., Ltd., 43, Carnarvon Street, Cheetham, Manchester, 4; Messrs. Drake and Fletcher, Ltd., Kentish Engineering Works, Maidstone, Kent; Hocklyhem, Ltd., Hockley Hill, Birmingham, 18.

Our personal opinion of the process you mention is that, for specialised cases, it may give excellent results, but for general large-scale use its possibilities are not very high in view of the lack of permanence of the paper coating.

**Mains Transformer Details**

**MY** electricity supply is 250 volts A.C. 50 cycles, and I wish to build transformers having the outputs: A, 24 volts 4 amps.; B, 14 volts 2 amps.

Where can I obtain the iron stampings for the cores, and how is the area of the iron calculated?

What gauge, type of insulation and number of turns of wire will be needed for each of the coils, and can you please give any hints on carrying out this work?

Is there any reference book which deals with small transformers?—J. M. (Blairgowrie) Douglas.

THE following formula for the cross-sectional area of transformer cores gives quite a liberal rating:

$$A = \frac{\sqrt{W}}{5.58}$$

where A is the cross-sectional area in square inches and W is the volt-amp. output. Hence for the 24 volt 4 amp. transformer you could use a core of approximately 1.76 sq. in., and for the 14 volt 2 amp. transformer a core of 0.95 sq. in. Stampings of transformer steel 0.014 in. thick and lightly insulated on one side could be used, these being made to the dimensions given in the diagrams. You may be able to obtain such stampings from Messrs. George L. Scott and

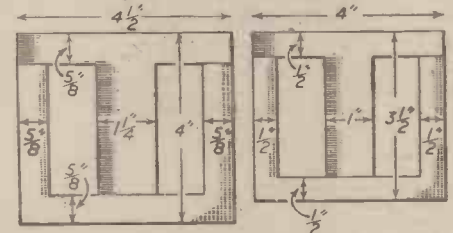

Transformer A 24 Volts Build Up Core To 1/4" Thick. Transformer B 14 Volts Build Up Core To 1" Thick.

**Details of transformer stampings.**

Co., Ltd., of Hawarden Bridge Steelworks, Shotton, Chester.

For the primary of transformer A we suggest 1,080 turns of 25 or 26 S.W.G. enamelled wire and for the secondary 110 turns of 16 S.W.G. D.S.C. For transformer B we suggest 1,900 turns of 33 S.W.G. with 112 turns of 18 S.W.G. D.S.C. wire for the secondary.

Having obtained a suitable bobbin, through which the centre limb of the stampings will afterwards be threaded, this should first be wound with the primary coil, a layer of thin paper being wound on after each layer of enamelled wire. After insulating the primary with empire tape the secondary is wound on the top. When assembling the stampings the insulated side of each should face the same way, the stampings being packed as tightly as possible, and adjacent layers of stampings turned round so the joints in one layer are covered by the next layer. The book "Practical Design of Small Motors and Transformers," by E. Molloy (Geo. Newnes and Co., Ltd.), would no doubt be of assistance to you.

**Telescope Lenses: Books on Optics**

**I** HAVE a small telescope (not very powerful) and three other lenses, all convex, from rin. to 3 in. diameter. I am wondering if by using the latter I can improve the power of the telescope. I do not know the focal length of the lenses.

I would like to learn more about this subject, reflection and refraction, etc., of light. Could you suggest books which would help me in this direction?—R. Lawson (Huddersfield).

SIMPLY speaking, an ordinary telescope may be said to consist of two optical parts, viz.: the light "collector," which is the big lens at the "end" of the telescope barrel, and the object magnifier, which is the smaller eyepiece lens of the instrument. The larger the collecting lens of the telescope the more the instrument will be able to "penetrate" distance, whilst the greater the power of the eyepiece, the greater will be the degree of magnification of the received image.

Unfortunately, from your point of view, as you increase the diameter of the light-collecting lens, you also increase its focal length, that is to say the distance from this lens at which it forms an image to be magnified by the eyepiece lens. Consequently, the greater the diameter of your collecting lens, the longer will have to be your telescope barrel.

You can make an approximate estimate of the focal length of a telescope lens by holding it in the sun's rays and by measuring the exact distance which intervenes between the lens and the sharply-outlined luminous disc (really an image of the sun) which the lens forms on a wall or on the floor.

A book on this subject which would interest you is: J. Stockley, "Stars and Telescopes" (1936) (10s. 6d.), but it appears to us that you require a more general work on light and optics, such as:

- J. Valasek, "Elements of Optics" (1928) (10s.);
- B. K. Johnson, "Practical Optics for Laboratory and Workshop" (12s. 6d.);
- B. K. Johnson, "Lecture Experiments in Optics" (8s. 6d.).

Almost any good up-to-date book on the subject of light and/or optical instruments would fulfil your requirements more or less admirably.

The figures given in brackets in connection with the above mentioned volumes represent their pre-war net prices.

**Gut Reviver**

**I** HAVE a pair of tennis racquets, which are in need of "gut reviver." As this is at present unobtainable in this district, I should be much obliged if you would tell me the substances required and the method whereby I could prepare a small quantity of this substance.—G. R. Perry (King's Stanley).

ORDINARY shellac dissolved to a fairly thick solution in methylated spirit is sometimes used as a gut reviver and stiffener, as is, also, a solution of gum dammar in spirit.

The following preparation, however, is stated by Bennett's "Chemical Formulary" (Chapman & Hall Ltd.) to give much better results than solutions of shellac, dammar, or varnish:

Boil 4oz. of starch in 16oz. of water. Dissolve 64oz. gum arabic in 16oz. water. Mix the two solutions and to the mixed solutions add an equal quantity of a solution made by dissolving 2 parts potassium bichromate in 98 parts of water.

The resulting solution must be kept in the dark, as its contents slowly become insoluble when exposed to bright daylight.

This solution is brushed on to the gut, which is then exposed for an hour to sunlight.

The treatment is said to add from 25 to 100 per cent. new life to the gut, to stiffen it up and to render it damp resistant and enduring.

**Oil Absorption Problem: Air Filtering Material**

**PLEASE** suggest a material that will absorb oil along a straight line a distance of at least 5yds. Similar to 1/2 in. oil wick (not successful) material for filtering air as in a vacuum dust bag.

- Also, can you recommend any books on rewinding small armatures similar to those used in vacuum cleaner motors.—J. Gregory (London, N.).

WE are not at all clear as to the precise conditions under which you wish to make your experiment. However, we take it that you wish to set up a continuous oil absorption from one area to another by means of an absorptive medium, but you do not tell us whether the oil has to ascend or descend, which is an important point. Neither do you tell us the nature of the oil, which is another very essential point. We can only suggest, in the light of our very meagre information, that you experiment with various "lines" of hempen material, soft tow, cotton wool, and ordinary wool. We take it, of course, that you do not wish to use a powder, such as aluminium oxide, which is strongly absorptive. In order to get good absorption, the absorptive material must be absolutely dry before it is used.

The nature of material for filtering air depends upon the air speed and pressure. A light gauge cloth will act as an admirable air filter when dealing with still air, but it is quite useless under pressure conditions.

For average conditions of air current and pressure, a closely-woven cotton material would suit your needs. This is made specially for various technical uses, and we would direct your inquiries for this commodity to Messrs. Tootal, Broadhurst, Lee & Co., Ltd., Oxford Street, Manchester.

For very high pressures, excessive air speeds and for outside working, you might find fine copper gauze more suitable and enduring. A gauge of 300's standard gauge should suit your needs in this respect.

Books on small motor and armature winding which might interest you are:

- D. H. Braymer, "Rewinding Small Motors" (16s. 6d.);
- D. H. Braymer, "Armature Winding and Motor Repair" (19s. 9d.);
- Braymer & Rose, "Rewinding and Connecting Alternating Current Motors" (23s.);
- C. G. Veinott, "Fractional Horsepower Electrical Motors" (23s.);
- H. E. Dance, "Notes on the Induction Motor" (6s.).

Figures given in brackets above are publishers' pre-war net prices. Possibly, some of the above works may be obtainable secondhand from Messrs. W. & G. Foyle, Ltd., Charing Cross Road, London, W.C.2.

**Translucent Cinematograph Screen**

**I** HAVE a 9.5 mm. cinematograph, and am using a silver screen. I wish to obtain a transparent screen for rear projection, and would be grateful if you could tell me what is used for these screens, and if it would be possible to construct one myself.—H. A. Durrant (Edmonton).

MIX together 6 parts methylated spirit and 2 parts di-butyl phthalate. Paint this liquid liberally over the cloth or paper screen and then allow it to dry out slowly. The spirit will evaporate, leaving the di-butyl phthalate behind in the fibres of the screen material. This will render the screen translucent. Di-butyl phthalate is obtainable from most laboratory suppliers, or from Messrs. A. Boake, Roberts & Co., Ltd., Carpenters Road, Stratford, E.14.

A solution of candle wax in castor oil has the same effect when rubbed over the screen, but, in this case, the screen becomes rather sticky and unpleasant to handle.

Raw linseed oil rubbed into the screen will give a similar result.

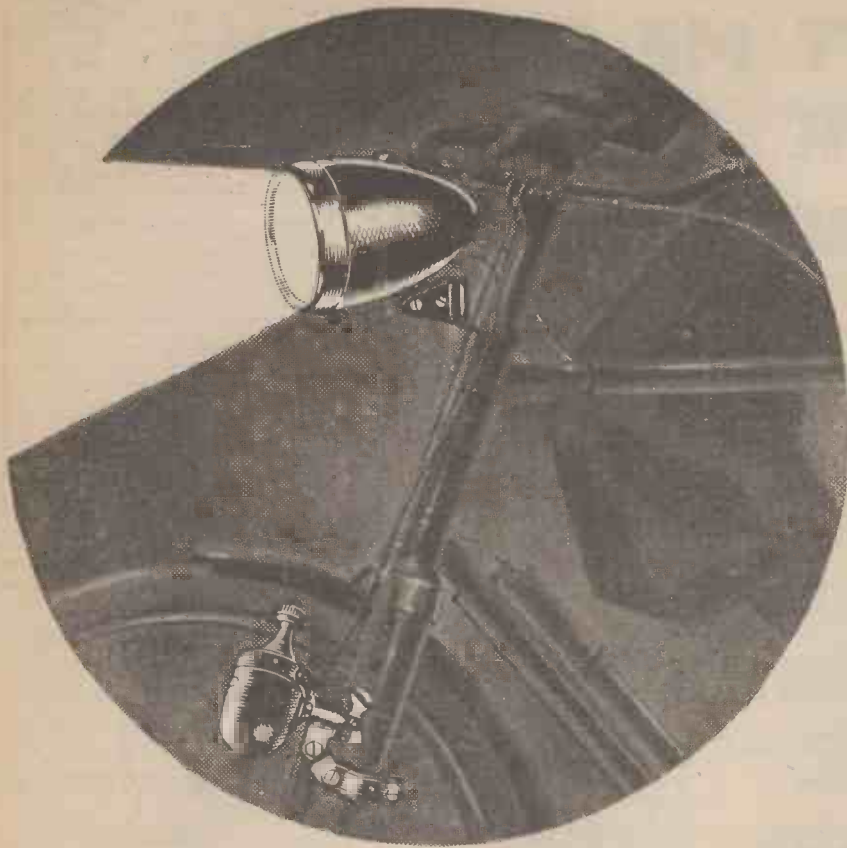

# Service

After years of faithful service in the blackout, it is not surprising if even a Philidyne set needs an overhaul. Should this apply to your set, send it in now and let us overhaul it for you. Post to the Service Department, Philips Lamps Ltd., Waddon Factory Estate, Waddon, Croydon, Surrey.

PHILIPS 

## PHILIDYNE

### CYCLE DYNAMO LIGHTING SETS

PHILIPS LAMPS LTD., CENTURY HOUSE, SHAFTESBURY AVENUE, LONDON, W.C.2 (40)

CONSOLIDATED INDUSTRIAL RESEARCH LABORATORIES, LTD.,

Technical Consultants and Analysts

FINE & PHOTOGRAPHIC

## CHEMICALS

ANALYTICAL REAGENTS

LABORATORY GLASSWARE

Send Stamp for Lists

295, Regents Park Road, Finchley, London, N.3



### THE "FLUXITE GUINS" AT WORK

Cried EH, "Well, dang my old eyes, Our lass should take the first prize. At the fancy dress ball You'll shatter them all... Miss FLUXITE! No, not if you're wise."

For all SOLDERING work—you need FLUXITE—the paste flux—with which even dirty metals are soldered and "tinned." For the jointing of lead—without solder; and the "running" of white metal bearings—without "tinning" the bearing. It is suitable for ALL METALS—excepting ALUMINIUM—and can be used with safety on ELECTRICAL and other sensitive apparatus.

**With Fluxite joints can be "wiped" successfully that are impossible by any other method.**

Used for over 30 years in Government works and by leading engineers and manufacturers. Of all Ironmongers—in tins, 8d., 1/4d. and 2/8. Ask to see the FLUXITE POCKET BLOW LAMP, price 2/6d.

● TO CYCLISTS! Your wheels will NOT keep round and true unless the spokes are tied with fine wire at the crossings AND SOLDERED. This makes a much stronger wheel. It's simple—with FLUXITE—but IMPORTANT.



THE "FLUXITE" GUN puts "FLUXITE" where you want it by a simple pressure. Price 1/6 or filled 2/6.

ALL MECHANICS WILL HAVE

# FLUXITE

IT SIMPLIFIES ALL SOLDERING

Write for Book on the ART OF "SOFT" SOLDERING and for Leaflets on CASE-HARDENING STEEL and TEMPERING TOOLS with FLUXITE. Also on "WIPED JOINTS." Price 1d. Each.

FLUXITE LTD., Dept. P.M., Bermondsey Street, S.E.1

## SCALE MODELS THAT FLOAT

Simple Plans and Detailed Instructions

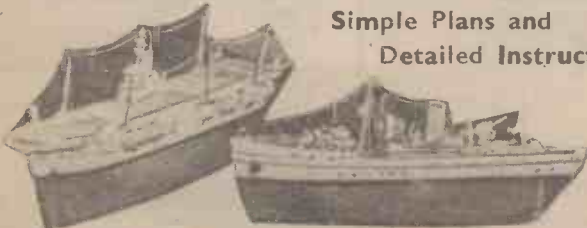

DÜKE OF YORK - ILLUSTRIOUS - ARK ROYAL DESTROYER - SUBMARINE - YACHT SUNDERLAND FLYING BOAT, ETC.

2/8½<sup>D</sup> Post Free.

ALSO PLANS AND INSTRUCTIONS FOR DOLLS HOUSE, WINDMILL, FORT, LIGHTSHIP, ETC., at 1/8½ P.F.

ERIC RICHARDSON, Ltd., 93-94, Chancery Lane, London, W.C.2.

# 226 HIGHSTONE UTILITIES

## CRYSTAL SETS



Our latest Model is a REAL RADIO RECEIVER, and is fitted with a PERMANENT CRYSTAL DETECTOR. WHY NOT HAVE A SET IN YOUR OWN ROOM OR AS A STAND-BY? -9/6, post 6d.

PERMANENT DETECTORS, 2/6, post 3d.  
.0003 Pre-set Condensers, 2/-, post 3d.  
HEADPHONES, 12/6, post 6d.

## MICROPHONES

Just the thing for impromptu concerts, room to room communication, etc. Bakelite table model, 6/9; Suspension type, 8/6. Post 6d. Super Model on stand, 12/6. Fitting instructions included. Mike buttons, 2/6. Transformers, 8/6. Public Address Transverse current Mike, 37/6, post 1/-.

## MORSE KEYS AND BUZZERS

Standard size keys, wired to work Buzzer or Lamp. Chromium plated, 7/6. W.O. Key, heavy brass bar, with an additional front bracket, 9/6. Chromium plated, 10/6, post 6d. No. 2 Single Coil Buzzer, 2/6. No. 3, Heavy Duty Double Coil, 4/9, post 3d.

## BELL TRANSFORMERS



These guaranteed transformers work from any A.C. Mains, giving 3, 5 or 8 volts output at 1 amp., operate bulb, buzzer or bell. Will supply light in bedroom or larder, etc. PRICE 8/6. Post 6d.

## SOLDERING IRONS

Adjustable Bit, all parts replaceable and fully guaranteed. 200/250 v., 60 watts, 9/6; 150 watts, 12/6, post 6d. Small Soldering Irons, for use on gas, 1/4. Post 4d.  
Two flex, for lighting, 6d. yard. Power, 9d. yard, and postage. Toggie Switches, can be used for Vacuum Cleaners, radio sets, table standards, etc., 2/3, post 3d.

SEND 1d. S.A.E. FOR ILLUSTRATED LIST B.P. OF USEFUL ELECTRICAL ACCESSORIES. Money refunded if not completely satisfied. Letters only. Please include postage, any excess will be refunded.

Wholesale and Export Departments,

HIGHSTONE UTILITIES,  
58, New Wanstead, London, E.11

B.A. thread screws, one gross, useful sizes, 2/6; ditto, nuts, 2/6 gr.; assorted gross screws and nuts, 2/6; ditto, brass washers, 1/6 gr.; fibre washers, 1/6 gr.; assorted soldering tags, 2/-; assorted small eyelets and rivets, 1/3 gr. Large stock of screws, etc. State wants. Rubber-covered stranded copper wire, 1d., 1ld., 2d. yard. Tinned copper connecting wire, 20ft. coil, 6d.; ditto, rubber covered, 10ft. 6d.; finest quality stranded push-back wire, 12yds., 2/3; twin bell wire, 12yds., 2/3; ditto, flat rubber-covered, 3d. yd. Cotton-covered copper instrument wire, 1lb. reels, 18, 30, 22, 24s., 1/6; 26, 28s., 1/9; 30, 32s., 2/-; 34s., 2/3. Enamelled, ditto, same prices including 38s., 2/3; 38, 40s., 2/6. Silk-covered ditto, 2oz. reels, 24, 26, 28s., 1/6; 30, 32, 31, 36s., 1/9; 40, 42s., 2/-; 16g. D.S.C. 1lb., 5/-; Laminated Bakelite Panels, 1in. thick, 8in. x 4in., 1/3; 6in. x 8in., 1/3; 8in. x 6in., 2/3; 10in. x 6in., 2/9; 10in. x 8in., 3/6; 12in. x 8in., 4/-; New "Lucerne" permanent crystal detectors, 2/-; "Lucerne" crystal set coil with wiring instructions, 3/6; glass tube crystal detectors, complete, 2/-; reliable crystal with cats-whisker, 6d. Reconditioned headphones, complete, 4,000 ohms, 12/6. All postage extra. S.A.E. with enquiries.

POST RADIO SUPPLIES,  
33, Bourne Gardens,  
London, E.4

"Easily the best soldering fluid obtainable."  
This statement by a regular user of "BAKER'S" expresses the general opinion of motor and engineering trades. Sold in 6d., 1/- and 1/6 tins. Also in Bulk.



SIR WM. BURNETT & CO. (CHEMICALS) LTD.  
Gt. West Rd., Isleworth, Middx. Hounslow TW46

# LET ME BE YOUR FATHER

You need help and Fatherly advice in difficult times like these. I am in the position to give that to you FREE.



We teach nearly all the Trades and Professions by Post in all parts of the world. The most progressive and most successful Correspondence College in the world.

If you know what you want to study, write for prospectus. If you are undecided, write for my fatherly advice, it is free. Distance makes no difference.

## DO ANY OF THESE SUBJECTS INTEREST YOU?

- Accountancy Examinations
- Advertising & Sales Management
- Agriculture
- A.M.I. Fire E. Examinations
- Applied Mechanics
- Army Certificates
- Auctioneers and Estate Agents
- Aviation Engineering
- Aviation Wireless
- Banking
- Blue Prints
- Boilers
- Book-keeping, Accountancy and Modern Business Methods
- B.Sc. (Eng.)
- Builders' Quantities
- Building, Architecture and Clerks of Works
- Cambridge Senior School Certificate
- Civil Engineering
- Civil Service
- All Commercial Subjects
- Commercial Art
- Common Prelim. E.J.E.B.
- Concrete and Structural Engineering
- Draughtsmanship, all Branches
- Engineering, all Branches, Subjects and Examinations
- General Education
- G.P.O. Eng. Dept.
- Heating and Ventilating
- Industrial Chemistry
- Institute of Housing
- Insurance
- Journalism
- Languages
- Mathematics

- Matriculation
- Metallurgy
- Mining, All Subjects
- Mining, Electrical Engineering
- Motor Engineering
- Motor Trade
- Municipal and County Engineers
- Naval Architecture
- Novel Writing
- Pattern Making
- Play Writing
- Police, Special Course
- Preceptors, College of Press Tool Work
- Production Engineering
- Pumps and Pumping Machinery
- Radio Communication
- Radio Service Engineering
- R.A.F. Special Courses
- Road Making and Maintenance
- Salesmanship I.S.M.A.
- Sanitation
- School Attendance Officer
- Secretarial Examinations
- Sheet Metal Work
- Shipbuilding
- Shorthand (Pitman's)
- Short Story Writing
- Speaking in Public
- Structural Engineering
- Surveying
- Teachers of Handicrafts
- Telephony and Telegraphy
- Television
- Transport Inst. Examinations
- Viewers, Gaugers, Inspectors
- Weights and Measures Inspectors
- Welding
- Wireless Telegraphy and Telephony
- Works Managers

If you do not see your own requirements above, write to us on any subject. Full particulars free.

## COUPON. CUT THIS OUT



To Dept. 76, THE BENNETT COLLEGE, LTD., SHEFFIELD

Please send me (free of charge) \_\_\_\_\_ (Cross out line which does not apply)

Particulars of.....

Your private advice about.....

PLEASE WRITE IN BLOCK LETTERS

Name .....

Address .....

## A.C. BATTERY CHARGER

For charging car accumulators, either 6 or 12 volt at 1 amp., in enclosed metal case. Input and output flex, leads and ADAPTERS. A thoroughly efficient job. Price 39/6, post 10/-, state 6 or 12 volt.  
**COMPLETE SET OF PARTS**, including case and blue print. Price 32/6, post 10d.  
**TABLE MICROPHONE** complete with transformer in base. Very sensitive. Price 8/6, post 7d.  
**BELL TRANSFORMER**, 3, 5 and 8 volts at 1 amp. Price 6/6, post paid.  
**HEAT AND LIGHT ADAPTERS**, 4/6, post 6d.  
**ELECTRIC ENGRAVERS**. Powerful instrument in cylindrical cases, on stand, with spring attachment and switch, suitable for dog collars, identity discs, etc. A.C. Mains Model, 200-240v. 75/-; 4-6-volt Battery Model, 55/-.  
**SWITCHBOARD METERS, A.C.-D.C.** N.P. cases, 1 1/2" dial. Any readings up to 0-25 volts, 0-25 amps. Price 15/6 each.  
**TOOLS**. Send 2d. stamp for list of over 200 useful tools of all kinds.  
**ECONOMIC ELECTRIC CO.**, 64, London Road, Twickenham, Middlesex. Tel.: POPesgrove 1318.

## CHEMISTRY



POST FREE APPARATUS OFFER  
**10/6**  
OR INCLUDING CHEMICALS  
**21/-**  
(England, Scotland and Wales only)  
Send 1d. stamped envelope for Price List of other equipment.

## BECK

(SCIENTIFIC DEPT. A), 60, HIGH STREET, STOKE NEWINGTON, LONDON, N.16.  
Booklet: "Experiments in Chemistry," 7d. P.O.

## GIVE THOSE YOU LOVE

A Radio You Have Made Yourself.  
The "JB VICTORY FOUR" is:  
(a) Child's play to build.  
(b) Suitable for work off A.C. or D.C. mains and bang up to date.  
(c) Portable, it needs no aerial or earth.  
(d) Ideally suitable for Bedroom, Nursery, Workshop, etc.  
(e) Guaranteed 6 months and subject during this time to free service.  
Complete kit of parts, including valves and all items, even nuts, bolts, wire, etc., with full detailed layouts and wiring instructions, 57/11/76. Diagrams, etc., only; 5/-; refunded if complete kit bought later.  
**V.E.S., Radio House, Ruislip.**

## JUBILEE WORM DRIVE HOSE CLIPS



The long-life clip with the ever-tight grip  
The Best Known  
For Radiator Joints, Air, Oil and Water-Hose Joints  
We guarantee a Tight Joint  
**L. ROBINSON & Co.**  
25, London Chambers,  
SILLINGHAM, KENT

## LARGE DEPT. FOR TECHNICAL BOOKS

## FOYLES

FOR BOOKS  
New and secondhand Books on Engineering and all other subjects.  
119-125, Charing X Rd., London, W.C.2  
Open 9 a.m.-6 p.m. including Saturday.  
Telephone: Gerrard 3668 (16 lines)





HE used to rumble along, always the last one at the tea-garden, the real lame-duck of the gang. Well, one Sunday morning he turned up as usual, was quickly in the lead and seemed tireless, leaving the rest of us well behind. Finally Harry called a halt. "Have you been taking vitamin pills Jim?" he demanded good-humouredly. "No" said Jim with a grin, "just a bit of sound advice. I've bought a Hercules." "Good for you" said June, "I hereby move that Jim be re-christened 'Post Chaise' forthwith . . . all those in favour . . ."



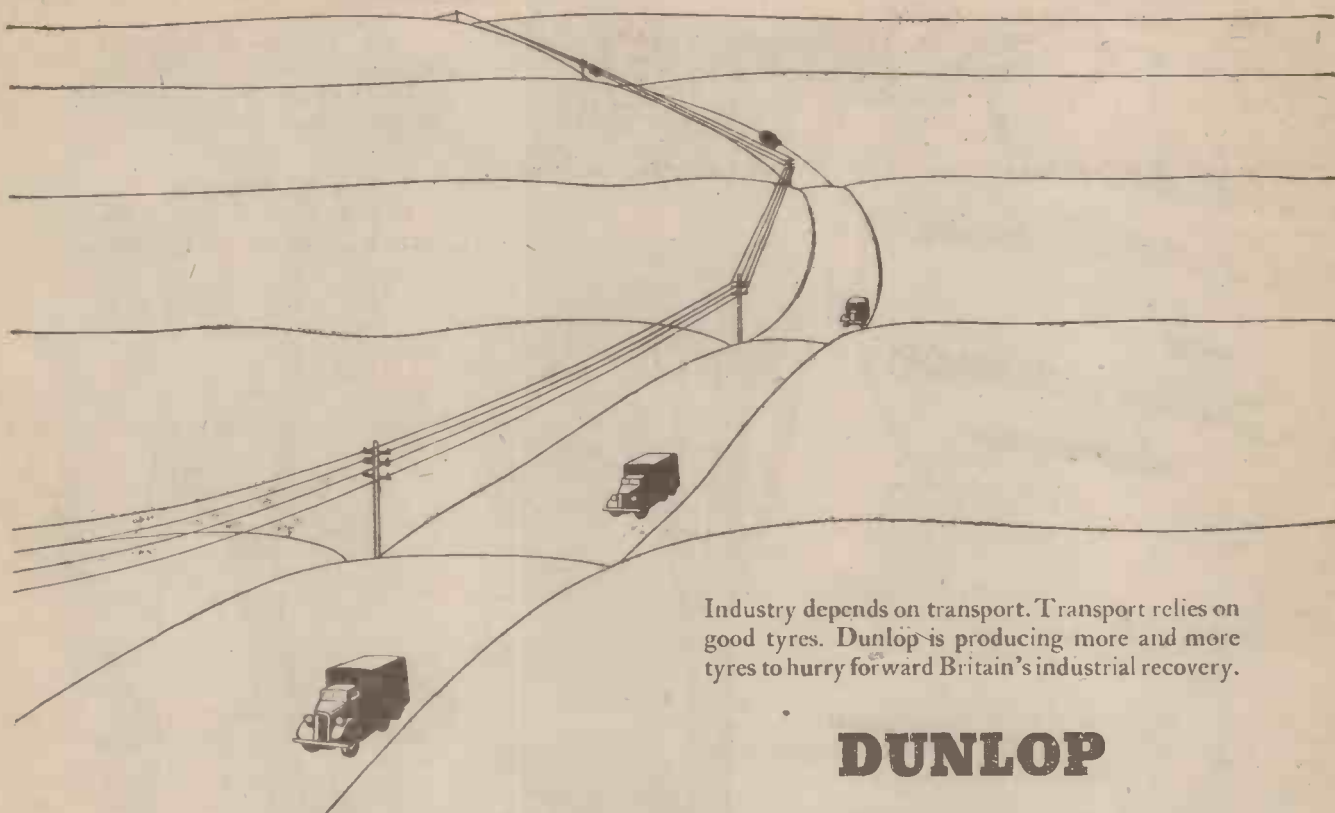

Industry depends on transport. Transport relies on good tyres. Dunlop is producing more and more tyres to hurry forward Britain's industrial recovery.

# DUNLOP

*Backs Britain's Recovery*

5H/189



**APEX  
'SUPERLITE'  
CELLULOID  
PUMP**  
15" 4/-

Thick Celluloid  
Beautifully Polished

Light of Weight  
but of  
robust construction

LASTWEL (Celluloid) 15" 4/-

The World Famous  
**BAILEY'S  
'SUPER'  
PUMP** 15" 4/-  
Steel Lined  
Celluloid Covered

Lining is solid drawn  
cartridge fashion,  
the end being solid  
with the barrel.

Cannot warp nor leak



## APEX PRODUCTS

Are in use in every Country in the world.

They are known and appreciated for their reliability ; long service and efficiency in their job of inflating tyres.

Labour and materials are still very much restricted ; consequently supplies of pumps are scarce ! If you are lucky in owning an Apex Pump, treasure it.

MADE BY

**APEX INFLATOR Co. Ltd.**  
ALDRIDGE ROAD, PERRY BARR,  
BIRMINGHAM 22B.

# CLAUD BUTLER CYCLES

Post-war "C.B." cycles and tandems feature new innovations and accessories plus all the fine workmanship that have made them supreme. The personal touch, even through the difficult war years, has never relaxed and my lads and I are always at your service to give you the finest machines and accessories available. Leave it to Claud !

## "CHAMPIONS' CHOICE"

CLAPHAM MANOR ST.  
LONDON - S.W.4



VOL. XIV

MARCH, 1946

No. 289

Comments of the Month

By F. J. C.

## Straight Words to Strauss

MR. G. H. STRAUSS, who, by a fortuitous electoral circumstance, waltzed into the Ministry of Transport with his new broom, is carrying out the policy which permeates the present Government of tackling last things first. He was sufficiently misguided as to accept an invitation to a small London club whose members totalling forty or so, are all members of either the N.C.U., the C.T.C., or the R.T.T.C. Mr. Strauss could not be expected to know, we suppose, that the club concerned is merely a luncheon club and that it has no influential authority in the cycling world. It seems, therefore, a great pity, when he had to make, as he thought, a momentous announcement about massed-start racing, that he should have selected so flimsy and obscure a platform.

However, having enjoyed the hospitality of the club, Mr. Strauss got up to make his *Most Important Announcement*. He said that massed-start racing was dangerous and contrary to the public interest and should it be continued, although he hoped that those concerned would take voluntary action themselves, the Ministry would be forced to consider taking steps to put an end to this serious menace to the public safety. We challenge Mr. Strauss to produce any evidence that it is a menace or that it is dangerous. With a far greater experience and knowledge of it than Mr. Strauss can possibly have, we say that it is no more dangerous than time trials. He knows perfectly well that his Ministry cannot introduce legislation banning massed-start without also banning time-trials. There is very little difference in these two forms of racing, except in the methods of starting. There have not been any accidents in connection with massed-start, but there have been in connection with other forms of racing on the road.

Usually, however, Ministers adopt Parliamentary language when dealing with matters concerning their office. When Mr. Strauss went on to describe those who take part in these races, as "dangerous and anti-social," he goes too far. There are many of us who think that some politicians are anti-social, especially those who use unparliamentary language. We do not think that massed-starters are anti-social. Massed-start racing will continue in spite of any opposition, just as time-trials have continued for over fifty years. Time-trials were considered dangerous then, but they have continued all these years and proved the police wrong.

### "Danger Bogey"

THE bogey of danger has been promoted by that farcical body, the N.C.U., and by its strange bed-partner, the R.T.T.C. All sorts of forces are being brought to bear to kill this form of sport, because the N.C.U. knows full well that it is killing track racing, with which it should alone concern itself. One prominent midlander has sent a circular letter to all B.L.R.C. officials and known

riders. In it he says that he is worried, because of the intense fear that all forms of road sport will be outlawed by the Government if massed-start racing on the highway continues. Fear, therefore, is at the bottom of the opposition, not fear because of a genuine danger, but fear that their own form of sport will suffer. He goes on to appeal to the recipients of the letters to refrain from further activity.

His appeal, from the point of view of results, has been a waste of paper and has caused not a little amusement. However, if Mr. Strauss, like so many of the new brooms of the present Government, wishes to exercise any powers for reform, which he may possess, we suggest there are other and more pressing road matters to be considered before he endeavours to do battle with the kelpie at the stream.

Let him take a drive down the Bath Road, for example, and observe the different systems of lighting between the Great West Road and Cranford. Let him proceed farther and drive into the darkness of the stretch of the road beyond Heathrow Aerodrome. Let him endeavour to secure uniformity of street lighting and insist that local authorities light their particular section of the roads. He has ample powers to enforce this, since all the trunk roads of the country are now administered by the M.O.T. Let him consider the question of road surfaces, curb heights, the colour of road surfaces and the abolition of road islands, which bottle-neck the road every fifty yards or so and create dangerous conditions.

Let him consider, also, the abolition of about 80 per cent. of the traffic lights which create traffic congestion, instead of keeping the traffic fluid and apart. The more dams you erect in a traffic stream the more will it overflow its banks.

Let him also bring pedestrians within the control of traffic lights—and compel them to use pedestrian crossings, before he strains at gnats and swallows camels.

We do not think that Mr. Strauss would have touched upon this question of massed-start racing had he not been prompted on the subject, but, in any case, we consider that his views, expressed at a private luncheon should not have been published, since it was obvious from the smallness of the gathering that it was a private gathering, and he may have been a little less guarded than he would have been at a public meeting.

If any legislative move is contemplated massed-start racing, at present run open and above board, without any of the furtive sneak-thief methods of the time-trial, will be driven into the same hole and corner methods; but it will continue. We challenge Mr. Strauss to deny (evidence is on record in his own department) that Mr. Noel Baker was compelled to admit that the only complaints that they had received when the controversy started was from the N.C.U. and the R.T.T.C. We also challenge him to produce any evidence outside the figments

All letters should be addressed to the Editor, "THE CYCLIST," George Newnes, Ltd., Tower House, Southampton Street, Strand, London, W.C.2.

Phone: Temple Bar 4363

Telegrams: Newnes, Rand, London

of his own imagination that massed-start racing is dangerous.

The N.C.U., we would remind Mr. Strauss, originally controlled time-trials and attempts at records on the road, but towards the end of the last century they banned it as dangerous and turned their attention to track racing only. Time-trials and road records are now governed by two totally different bodies.

### Road Accidents—December, 1945

CASUALTIES on the roads during December totalled 14,053. Deaths numbered 533 and cases of serious injury 3,226.

Compared with December, 1944, there were 76 fewer fatalities, but the number of injured increased by 1,895.

The following is an analysis of the number of deaths according to the type of vehicle primarily involved:

Type of Vehicle	No. of Deaths
Service (British, Dominion, and Allied of the three Services)	50
Public Service and Hackney	90
Goods	116
Private Cars	154
Motor Cycles	53
Pedal Cycles	55
Others	15
<b>Total:</b>	<b>533</b>

The term "vehicle primarily involved" means where more than one vehicle was concerned, the vehicle to which the accident appeared to be primarily attributable. In no case does it imply that the driver of the vehicle was culpable.

### The Safety Campaign

WE do not know who is responsible for planning the puerile "Keep Death Off the Roads" advertisements, which are going to cost the country a cool quarter of a million pounds, but they have the same imbecilic touch as many of the Government posters had during the war. They reveal an appalling lack of knowledge of the mentality of the public, and presume that we are a lot of unintelligent schoolchildren who can be cajoled and gently chided into mending our ways. Quite apart from their stupidity, some of them condone manslaughter and endeavour to place the blame on the other person for not anticipating that the driver of a car had ineffective brakes. The scheme has been running long enough for us to be able to assess its value; it is nil, as the accident returns show. This Government, which has distinguished itself by promoting schemes for spending money and few, if any, for providing it, could have put that sum of money to far better use in removing danger spots from a number of our roads. When shall we have someone in the Government who really understands the road problems?

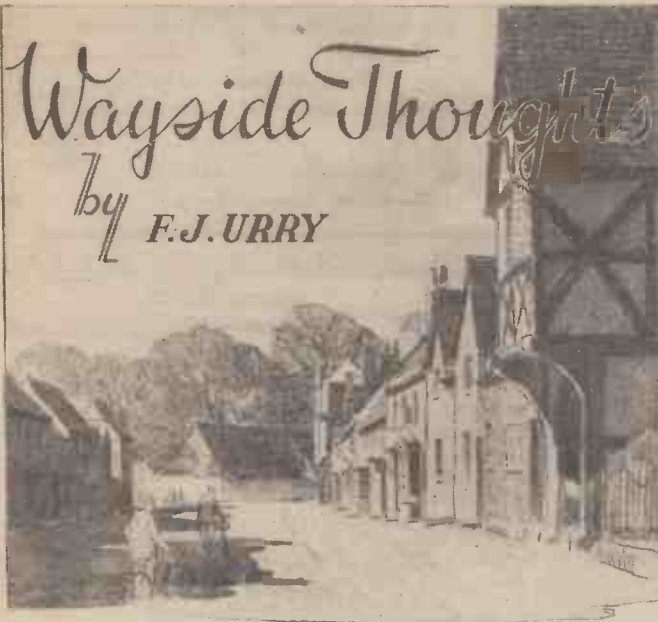

### The Season of Seasons

AS far as I have been concerned the winter solstice has been an agreeable one for my purposes. I have enjoyed some happy journeys, not all of them in fine weather, but nevertheless happy, for there have been bright spots in most of my outing days, and even when it has rained and stormed the company was good, and a few miles along the road awaited tea and a jolly fire with the inconsequent chatter of merry people. I do not think there is any other game that can take the run of the elements with such a wide philosophy as cycling and especially cycling in company. You cannot be gloomy or withdrawn, or feel that you are the sport of circumstance; indeed, you are rather the circumstance of sport even when the driven water drips from the end of your nose and the wind tries to tear the cape from your shoulders. But apart from these oddments of "rainspreading northward," as the weather forecasts say, there are many beautiful

days in winter when the mistily filtered sunshine breathes a benison on you and all the tints of winter sparkle. That frosty morning under the pale blue of the sky, so quiet that the silver patterns of the cobwebs hang on the hedges like frozen breath and the little puddles are crinkled with thin ice; ah! to be out and about then is to take from the English winter one of its greatest pleasures. And now as you read these lines we shall be looking for the footprints of Spring in the sheltered hedgerows, and over the young wheat will blow to us, as we lean on the gate and look towards the emurpling woodlands, the warm breath of the south-wester coming overseas from the spicy isles and faintly laden with their perfume. The season of seasons is almost with us, "the horns of elfin faintly blowing" can be heard if you listen at the edge of some copse over which the white clouds are sailing, trailing their shadows along a lovely land.

### The Way of It

ALL these things are awaiting you if you will but seek them. The way is easy and the method of cycling is within the reach of nearly all people; cycling, that keeps a man active and simple and young, one with the land and all its teeming beauty. You can take it or leave it; there is the invitation; and the like of it had never been given to mankind until he invented the bicycle. But if you leave it for other modes of travel, I tell you frankly you will be unwise, for you will grow older more rapidly, the inhibitions of middle and elder age will settle in you, and the spice of life will lose much of its flavour. I bow to no man's opinion on this matter, for I've proven the truth of it. I can, of course, understand and sometimes sympathise with all the excuses as to why men fall away from cycling; but that knowledge does not alter the fact that a man gets more out of life by the process of simple activity than by indulging in a far more costly manner of travel. I am not "up against" the motor-car—a charge frequently levelled at me—I am just all for cycling because it weaves the spell of travel for me more romantically than other means of movement, and possesses the all-pervading grace of activity, that easy use of the muscles flexing the body to fitness, imposing exercise unconsciously taken. I know men of my own age who ride with me seem to be happier mortals because they are active ones; and I'm perfectly sure I am. However young you who read may be, remember this: you have got to grow older; but if you were given a pleasant method of retaining, both mentally and physically, the boon of a youthful outlook and the grace of easy movement, would you take it? Well, here it is on offer and it costs nothing. The world still has to learn these good tidings, but because they possess no complications and no ritual the unbelief, in a plain fact, is

colossal. Nothing can cure old age, but regular cycling can make it younger.

### You Can't Overstate

HAVING written that in the full belief that it is true, I shall probably be taken to task by some of my friends who will tell me I have overstated the case. I am getting accustomed to that type of criticism, to be dubbed a fanatic because I love a certain way of life that has provided me with the crown of health and surrounded me with an oriel of loveliness all the days of my existence. And then they say to me, "I don't know how you do it!" as if it were a miracle for a man of my years to be active, which, of course, is absurd. I do it because I am active, and I'm still active because I do it; and so can every one of you carry the joy, if you will but remain loyal to the game. And what a dividend it will pay you! And there I speak out of knowledge without the aid of imagination or the emphasis of the advertiser. Of course, there is a measure of wisdom to be used in this cycling progression adown the years, and I think that definition can almost be given in the one word, comfort. Speed, in the racing sense, you can still enjoy by proxy if you so desire, but every other form of cycling is at your disposal. My idea of comfort in these days is a wide four-wire saddle from the seat of which all comfort flows. Easy gears make easy riding, sixty for me as a normal, dropping to forty-three in the low range, and I can then average 10 m.p.h. on a day's journey and enjoy every league of it. Most folk who ride are geared too high (I am not speaking of the racing or the fast clubman) and would trundle their normal pace of ten to twelve miles an hour more comfortably in sixties or sixty-threes, and sit easier in the saddle if they sported a slightly-dropped bar with grips level with the seat top. And I like my saddle peak level and at least three inches behind a vertical line drawn through the bracket axle. These things are important to comfort and—I regret to say it, but it is true—mainly ignored by the average rider, and often sneered at by that type of cyclist whose handlebars are reminiscent of the plough.

### Such a Chance

I WONDER whether the railway people will understand that cyclists, and especially touring cyclists, can and would be their good customers if any regard were shown for their comfort, and the decent handling of their property. I have long felt our rail systems look upon the cyclist, first as a nuisance, and secondly as an individual who has gained freedom of travel at their expense. If we can get by rail to our touring area quickly, reasonably, and free from the fear of damage to our property, I am certain the return to the railway people would be considerable. But it is most difficult to penetrate the hide-bound notion of officials that cyclists would form any considerable part of their customers. Attempts have been made time and again, and the small concessions organised cycling has been able to obtain have never been sufficient to be really attractive, while at the back of the official mind one has always sensed the notion that we are not wanted—only tolerated. Towns are spreading, and will spread more in the next decade; the way to the open country for many of us is via six miles of building canyons. Suppose we could get cheap fares, morning and evening at the week-ends, to carry us beyond the bricks, and bring us home again at night, do you think such concessions would pay the rail folk? I do; and also I believe the round ticket taking you to one area and returning from another would soon become exceedingly popular and introduce a new form and type of week-end travel. If the rail folk do not introduce some such arrangement, I think road transport might easily step in and obtain quite a lucrative business.

### Doing Well

WE are now well launched into 1946, and up to the moment of writing it has not been too bad as far as I am concerned. Physically I have managed my full quota of riding, which has extended in miles as the light has lingered in the west, giving me an hour of easy journeying on the longer way home and the vision of the fields and woods that have been but a memory for the past weeks. How good it is to get back to the evening saunter with its refreshing change from the well-worn way of the direct route. That is the value—or one of them—of being a daily cyclist, you just take the chance of an hour off in your stride, pick up your friends along the road again, and still arrive home in time to hear the "nine o'clock," read a page of history, ancient and modern, digest the domestic news, and supplement that need for living, a comfortable meal. And mechanically I am lucky. My bicycles are running with perfection and silence, and are still airborne on pre-war tyres, a condition of comfort only attained by guessing the shortage-to-be in the early days of 1940. So I am not worrying about the immediate future, being well provided with the machinery to take all the chances of roaming that may come my way during this year of grace. Sometimes I marvel at my fortune in coming through the war years so happily, and in so doing give a few moments of thankfulness to the people who have preserved for me this lovely land, as I lean over a five-barred gate and watch the March mad hares scampering along the shallow ditches and see the last of the light quiver over the quiet mere. I am here, and I may not have been; I am free to pursue these simple pleasures on a simple machine that paces the land from sea to sea when the highdays are all mine, and I feel, stronger than ever before, that this country is so much mine that I can never appreciate it sufficiently.

### The Truant Twicer

MY tandem has just returned home. It has been adventuring in the company of two men of the old 14th Army home from Burma. One of them wrote to me in the late summer to know if I could fix them up with a tandem with which to tour during their long leave and cure the nostalgia of nearly five years absence from the homeland. I suspect they knew of the existence of my old machine and imagined I would fall for the request. And I did. Who wouldn't, when you remember what these lads have done for us? They collected it one day in the late autumn and the next I heard of them was at Lynmouth, from whence a long epistle of joyous adventure arrived, making me feel a trifle jealous of their wanderings by way of Exmoor and the coastline southward, where apparently they found welcome accommodation everywhere; not surprising considering it was then mid-November. They were away a month, partly Indian summer mixed with storm and the glory of great seas coming ashore. Then, on their last day, combing the ridge of the Malverns, the back axle broke (not surprising considering the machine has some 30,000 miles to its credit), so that the train was the only convenience left. And now, after nearly three months that specially long axle has been replaced, and the old twicer seems as fit as ever once again. In the interim my one reliable tandem partner has returned from the wars, so it may be that I'll be part of the crew on numerous occasions, which will certainly be a change after a lapse of nearly five years. For two on tour I think a tandem is ideal, always providing the crew "nick" in pedal action and are reasonably good companions. From my youth onwards I have been a tandemist, for until the close of 1917, when a major operation intervened, my good lady was my constant companion, and she swears now that they were the best holidays ever.



# Around the Wheelworld

By ICARUS

## New Charlotteville President

**C**ONGRATULATIONS to Vic Jenner, who at the recent annual general meeting of the Charlotteville C.C. was elected president of the club. The former club captain and treasurer, who now succeeds to the highest position in the club, has been a protean worker in its interests. It is a distinction which he greatly deserves. The vacancy occurred due to the previous president, Mr. E. F. Mitchell, moving to Birmingham. Vice-presidents elected at the meeting were Harry Woolgar, C. Cripps and Major Lew Kent. D. Grey, of Rockstone, Eashing Lane, Godalming, Surrey, was re-elected race secretary, whilst club race secretary remains W. Stickle. The hon. gen. sec. is D. Staerck, of 16a, Brighton Road, Godalming, Surrey.

## The Interim Report

**T**HE Interim Report of the Committee on Road Safety, which has been so much quoted, particularly the paragraph relating to massed-start racing, is worth a little examination. Let us examine the terms of reference:

"We were appointed by the Minister of Transport in December, 1943, to report on the matters covered by the following terms of reference. To consider and frame such plans as are possible for reducing accidents on the roads and for securing improvements in the conduct of road users in the interests of safety and to review the recommendations of the Select Committee of the House of Lords on the Prevention of Road Accidents, and to advise on those which should be adopted as measures of post-war policy for the reduction of accidents."

As massed-start road racing was not responsible for any death or accident, either before or after the deliberations of the Committee on Road Safety, it is obvious that paragraph 115, page 37, of the Report is entirely out of order and would seem to be an inspired statement. Moreover, the chairman of the Committee abused his powers by permitting the subject to be discussed, as it was outside their terms of reference.

## B.L.R.C. to be Incorporated

**A**T the annual general meeting of the National Executive Committee of the British League of Racing Cyclists held in Leeds on Sunday, January 27th, the decision to incorporate the League into a limited company was ratified. It was decided that the League should be registered under the Permanent Friendly Society Act, and an appeal was made for funds to help carry on. The task of registering the League under this Act will be completed in approximately two months.

Mr. James Kain was again elected general secretary.

A fighting reply was made to Mr. G. R. Strauss, M.P., Minister of War Transport, in regard to a speech reported to have been made recently by him at a meeting of a local club in London and it was decided to oppose and fight him all the way. Proof was put forward to show that no increase in road accidents was being caused by the League, as the insurance company had not yet been asked to pay any compensations for riders having been involved in accidents. Each rider has to pay 2s. per annum, and this sum has not been raised by the insurance company as a result of accidents having occurred.

Mr. James Kain announced that at Easter three racing teams from Ireland would be visiting this country. One team will take part in the track meeting to be held at Hampden Park, Scotland, before the Scottish cup final on April 20th.

A second team will be riding at Paddington on April 20th and the third will take part in the Dover to London race to be held on Easter Monday.

On Easter Saturday the Irish riders will take the opportunity of being in London, and a reunion of the London-Irish will be held in Town.

It was also announced that the 5-day Victory Marathon held during 1945 cost the League £600. A strong recommendation was made that the 6-day, to be held on July 29th to August 3rd, 1946, should be organised by a professional promoter as too much work will be involved for a part-time promoter.

Approval was made on all events drawn up. A resolution for the establishment of an "Independent" class of rider, half-way between amateur and professional, was passed and the licence fee for Amateur, Independent, and Professional riders was fixed at 2/6, 10/-, and £2, respectively.

A new rule to the effect that a log book should be signed by the competitors at the start and finish of each race according to international practice, and another that wherever possible all road race finishes shall take place on a private ground (i.e., stadium, arena, a field, etc.) was passed.

The new Handbook for 1946 will be published in a month's time. The registrar in his report to the executive stated that the League now has 1,000 registered riders on its books.

Delegates to the meeting came from scattered areas throughout the country between Glasgow and Bournemouth. London was strongly represented.

As a result of recent elections the following officials have been announced to conduct the business of the London Section, B.L.R.C., for 1946:

Chairman—W. Summers, 4C, Lower Camden, Chislehurst, Kent. General Secretary—P. L. Marshall, 38, Coopersale Road, London, E. 9. Assistant General Secretary—E. Lawton, 44, Lammas Park Road, Ealing, W. 5. Event Organiser—A. H. Clarke, 7, Chestnut Road, Enfield, Middlesex. Assistant Event Organiser—C. Walker, 24A, Oxford Gardens, Kensington, W. 10. Treasurer—V. Humphrey, 28, Haslemere Avenue, Bath Road, Hounslow. Track Secretary—S. Garrard, 9, Abbott's Crescent, Highams Park, E. 4. Press Secretary—R. Fairman, 61, Chestnut Avenue, Buckhurst Hill, Essex. Social Secretary—C. Owen, 11, Chingford Mount Road, E. 4.

## Roadfarers' Club A.G.M.

**T**HE 3rd annual general meeting of the Roadfarers' Club was held in January and was preceded by a dinner which was presided over by Mr. E. Coles Webb. Mr. J. Dudley Daymond took the chair at the A.G.M. The hon. sec., Mr. R. A. West, reviewed the difficulties of the past year, when V-Days and the General Election upset plans. The club was founded in July, 1942, with a membership of ten and now has a membership of some hundreds. The club is in a sound financial position as shown by the secretary's report. The press secretary, Mr. F. J. Camm, announced No. 1 of the Club journal, *The Roadfarer*, would shortly be published. Mr. Camm was elected a vice-president. The press secretary, treasurer, and secretary of the Council were

re-elected with acclamation and the president, Lord Brabazon of Tara, of course, continues to occupy the presidential chair.

## Release of Service Cycles

**M**ANY Service bicycles which have become surplus are to be exported, and a number will be made available to dealers for re-sale in the home market, Mr. George Wilson, O.B.E., stated in Birmingham on being re-elected 'president of the British Cycle and Motor Cycle Manufacturers' Union.

During the war, he said, they had exported 1,420,806 bicycles and 23,902 motor-cycles. For these and for cycle and motor-cycle parts £14,000,000 had come back to this country.

Britain had made 2,500,000 bicycles for civilians at home in the war years and supplied the Army with 400,000 motor-cycles. Thousands of bicycles had gone to the Navy for coastguards and others, and to R.A.F. stations for pilots and air crews to get from their quarters to their 'planes. The Dutch, who had 20,000 Service machines on order, would be using hundreds of these R.A.F. bicycles. Liberated Europe had received 20,000 new bicycles from Britain since V-Day and it was hoped to make the total up to 100,000 during the year.

Mr. C. Douglas Terry, of Herbert Terry and Sons, Ltd., Redditch, was re-elected senior vice-president and Mr. J. Y. Sangster, of Ariel Motors, Ltd., Birmingham, junior vice-president.

## Dynamo Hub Action

**M**R. JUSTICE VAISEY, in a recent action, brought by the Raleigh Cycle Co., Ltd., asking for an injunction restraining Messrs. Miller and Co. from infringing the Raleigh Hub Dynamo patent, made an order revoking the patent. The judge agreed that the Raleigh Company had made out its case, but they failed on the question of the subject matter of the invention. He thought there was nothing novel in the dynamo, or in placing it in the hub of the wheel. There may be an appeal.

## The Supply Position

**B**ICYCLES will be high in the list of things which many readers would like to get, but cannot.

The situation improves. Britain made 1,600,000 units in bicycles and parts last year and we hope to raise the figure to 5,000,000 units during 1946. If we do, and the number there will largely depend on the number of men and women we can get to make them, two out of three are already booked for overseas.

How many people are aware that the world bought more bicycles from Britain before the war than from all other countries put together? In 1937 we sent 831,113 complete machines overseas and got £2,329,313 for them, with £2,323,664 for cycle parts, a total of £4,652,977. In the same year the rest of the world exported 729,224 machines for £1,418,107 (in some cases their return includes bicycle parts and bare frames).

Japan with 461,951 complete machines and frames (if one could describe any Japanese bicycle as complete) and Germany with 166,864, will not be in the running for some years to come. Even, therefore, when we reach our ultimate aim of 6,000,000 bicycle units a year, there will be more than enough riders clamouring for them in both hemispheres.

# CYCLORAMA

By  
H. W. ELEY



Sonning,  
Berks.  
By the lovely medieval  
bridge across the Thames.

## A World in White

THERE are people who only like to see snow on Christmas cards, and always grumble when, awakening one morning, they find the familiar ground covered with a mantle of white. But there is beauty in the snow, and even though it makes "hard going" for the cyclist, I think there is something to be said for a ride on snowbound roads, for under snow the countryside looks very different; trees take on a new and ghostly beauty, and each familiar field becomes a strange land of white. And when the sun breaks through, and shines on the white landscape, then there is loveliness indeed, and one has memories of Switzerland, and sunshine that almost hurts, and tinkling goat-bells, and all the glory of winter sports. . . .

## A Kipling Memory

A GOOD cycling friend of mine recently took my advice and took his bike into Staffordshire. I had told him that he must forget the grime and smoke of the Potteries, and the ugliness of the Black Country, and set out to find the charm and beauty which the county holds for those who seek it. My friend cycled through good country, kept me advised of his progress, and wrote me an interesting letter from Rudyard—that little place at the end of the famed Rudyard Lake, which is a reservoir some two miles long and 400 acres in extent. And the burden of his letter was that he never knew that it was Rudyard which gave Kipling his baptismal name! Of course, it is true, and I fancied that everyone knew that it was in the lovely surroundings of Rudyard Lake where Lockwood Kipling courted Alice Macdonald; here, amid the leafy beauty, he asked her to be his wife. When their son was born in India, the father and mother, with fond memories of their courtship in the Rudyard district, named the boy Rudyard . . . and so this bit of Staffordshire has a very special link with the poet of Empire.

## Who is Our Oldest Cycle Trader?

AN interesting query—but perhaps difficult to find the answer. Anyway, I recently saw some correspondence from Mr. Prentice,

of Wickford, Essex, who was certainly mending punctures in the year 1889. Now, that was the very year in which the famous cycle race was held at the Queen's College Sports, Belfast, when the famous Du Cros brothers demonstrated the advantage of the pneumatic tyre over the old solid. Going back a bit! But I wonder who can claim to have been in business the longest period as a cycle dealer?

## The "Charlotteville" Club

MY old and good friend, "Ed" Mitchell, who left London for Birmingham a few months ago to take up the position of Dunlop Midland Regional Manager, informs me that he has resigned from the Presidency of the Charlotteville Club, finding it impossible to fill that distinguished office when quartered so far away. "Ed" is followed by Vic Jenner, too well known in cycling circles to need any introduction. The club has lost a good and popular president, but been lucky enough to get a worthy successor—to whom good luck and good fortune!

## The "Apologies" are Nearing Their End

YES! I think that that melancholy note of apology for no supplies, which has been such a familiar feature in British advertising during the war years, is disappearing at long last—even from the cycle makers' announcements. You know the theme: "Some day you will again be able to buy a 'Sentinel' . . ." Well, there seems more and more cycles in the shops, and there is a new note of optimism creeping into the cycle manufacturers' advertising, at which I rejoice greatly. Speed the day when there will be no shortage—the day when one can make a selection, browse through a bulky, well-illustrated catalogue, the day when the ogre of Austerity has been banished for ever!

## Shades of Doctor Johnson

THE great lexicographer was much in my mind during the Christmas holidays, for I spent the days near Ashbourne, and actually regaled myself with ale in that famous old inn, "The Green Man and Black's Head," where one may be shown the identical chair in which the Doctor used to sit and sip his ale in the

long ago. There is another association between ale and the Doctor, for I fancy that he had some connection with the Barclay-Perkins brewery at Southwark, and his "head" appears on some of the bottle labels issued by that famous old firm. Ashbourne, despite bitter winds, seemed full of cycles—but then, if you live in a small country town you find a bike an essential possession! And it still remains the best and cheapest form of locomotion, the ideal mount for man, woman and child.

## Frost . . . and the Birds

WHEN the land is in the iron grip of King Frost, the garden lawn hard and rime-covered, and the ponds all frozen, then is the time for the cyclist who is a lover of bird-life to remember the birds' "food problems," and see to it that the bird-table has a goodly supply of crumbs. I almost said "and bits of fat," but I suppose that under our austerity ration scheme even such trifles are impossible. But crumbs . . . yes; and it is a grand sight to watch the sparrows, the chaffinches, the robins, and the sleek blackbirds twittering and disputing for the dainties which, while the hard frost lasts, must take the place of grubs and worms.

## Come to Coventry

NOT for some months had I been to Coventry and had time to ramble around its streets. But recently I did spend some hours there, thinking of its many trades and manufactures over the years, deploring its sad scars due to the blitz, and musing upon the legend of Peeping Tom, and remembering the good William Ford, the gracious founder of Ford's Hospital. And Peeping Tom brought me to Lady Godiva, the wife of Earl Leofric of Mercia . . . and I recalled that Leominster, in fair Herefordshire, was originally "Leofric's Minster." But I thought chiefly of all the famous makes of cycles for which the City of the Three Spires has been famous; I remembered renowned old "brand-names" and how they had carried the fame of Coventry to the uttermost parts of the earth. And, in view of the vital need to rebuild Britain's export business, I rejoiced that Coventry still made good cycles . . . and sent them overseas to carry the banner of British craftsmanship among the peoples of distant lands.

## It's Good to Keep a Diary

THE New Year . . . and we put away, or destroy, that diary which has been such a faithful companion through the old year . . . we glance at notes we made, recall all kinds of "dates" and events, and write our names and addresses in the new diary for 1946. There is always, I think, a little thrill about starting a new diary, and I hope that many of my readers make a point of recording their riding experiences, noting down their mileage, and in short keeping a "running commentary" of the year's cycling. It is so good to look back on such records; I have kept them for many years, and the other night, over a final pipe before the dying fire, I turned over the pages of a diary for the year 1928. What a year of plenty! More than one note of "ham and egg tea" at some wayside inn or cottage! More than one mention of buttered scones and jugs of cream! Perhaps all such good things will come back during the course of the present year. Anyway, let us salute 1946, and hope that as it runs its course we shall really emerge out of the shadows of war and its aftermath, into the full sunshine of permanent peace. Good riding to all!

*“After what I saw ‘out there’  
no other tyre will really satisfy me now”*



**Firestone**  
BEST TODAY ★ STILL BETTER TOMORROW

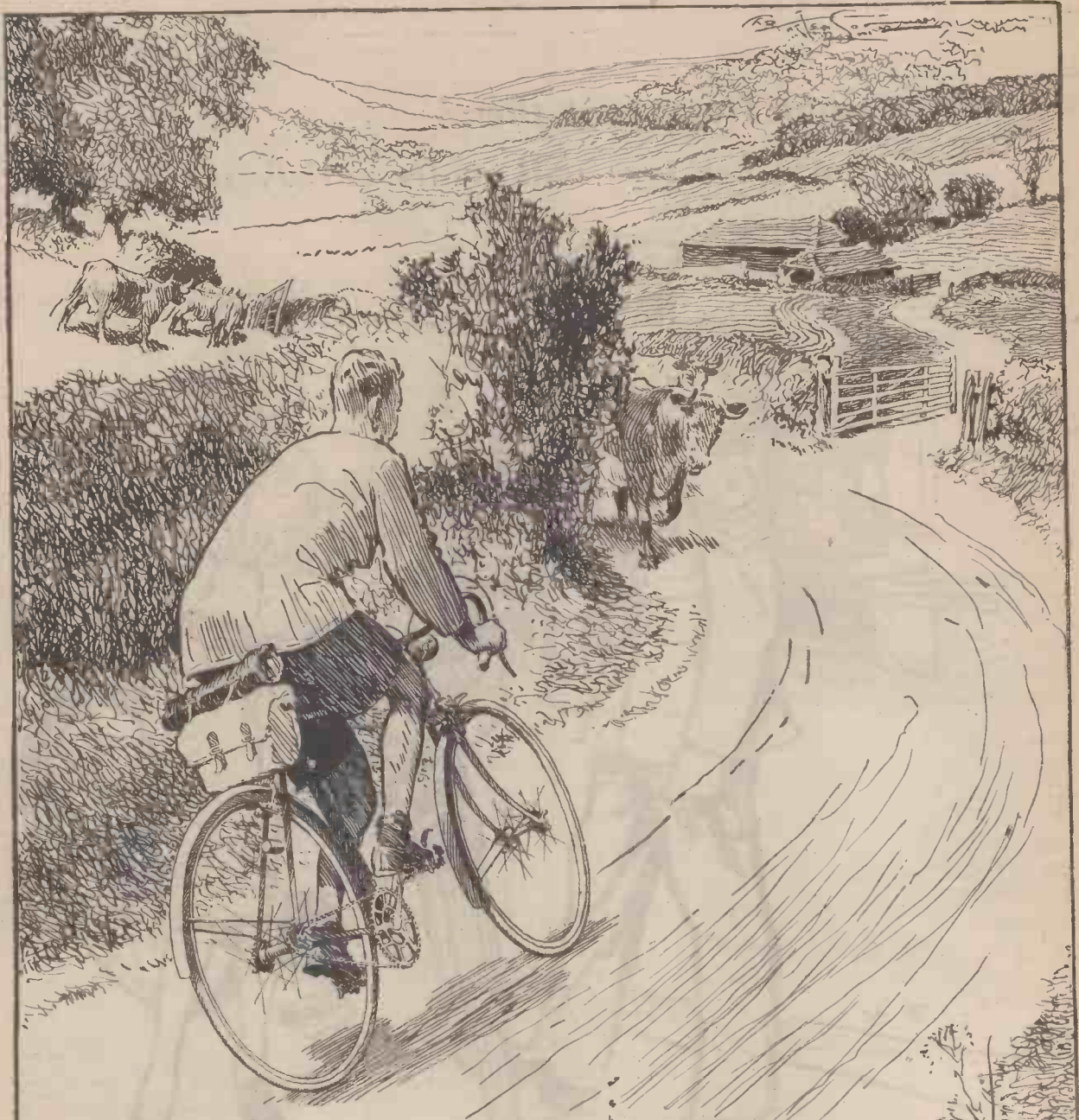

## *The turn in the road*

The turn in the road, ever revealing the unexpected, is one of the fascinations of cycling. But it may also reveal an unexpected emergency: be ready to meet it.

Remember, rain or shine you can cycle in safety if you fit

**FERODO**  
ALL-WEATHER BRAKE BLOCKS

FERODO LIMITED

CHAPEL-EN-LE-FRITH

**FERODO**  
REGD. TRADE MARK



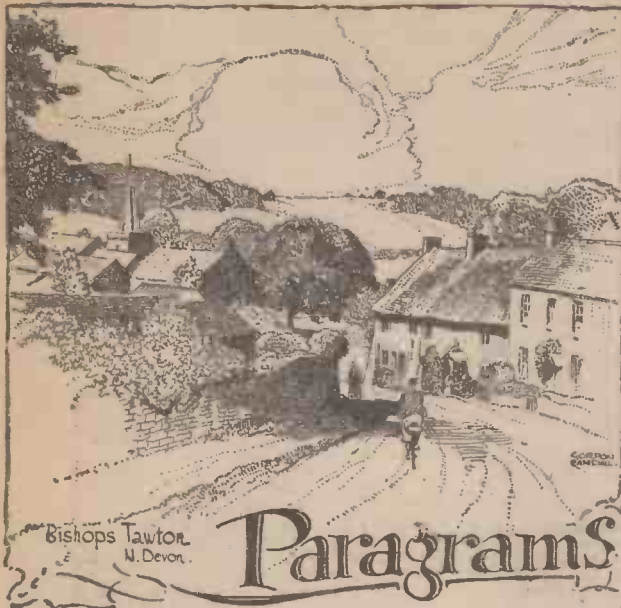

**Fresh Start**

LANARKSHIRE Road Club lost nearly all its members owing to Service calls. The club is now being reformed with J. Leonard, 101, Newarthill Road, Carfin, Motherwell, Glasgow, as secretary.

**Watch on the Rhine**

A CYCLING club has been formed among members of the Rhine Army headquarters

**J. Sibbitt's New Honour**

J. SIBBITT, famous path rider of the Manchester Wheelers, has been elected president of that club. He follows A. J. Bradbury.

**Decorated**

L/CPL. W. COWELL, Ilford Road Club, who is serving with the R.A.S.C., has been awarded the Military Medal for gallantry. He was previously mentioned in dispatches.

**Six-day Race for London?**

IT is suggested that London will have a six-day race this year at Wembley Stadium.

**Octogenarian Presides**

GEORGE JOWITT, 80-year-old president of the Upperthorpe C.C., presided at the club's 65th anniversary celebration.

**Arthur Moss, J.P.**

ARTHUR MOSS, Wessex Road Club, has been appointed a J.P.

**Suggestive**

IN his report to Kesteven (Lines) Standing Joint Committee, the Chief Constable stated that cycle thefts during the past quarter had decreased "in sympathy with fewer offences attributed to members of the Services."

**Don't Do as I Do**

A MEMBER of a Huntingdon local authority has been seen more than once cycling on the pavement. His idea is apparently that other cyclists should do as he says and not as he does.

**Grantham Road Club**

AT the annual meeting of the Grantham Road Club it was stated that the club is now back to its pre-war position as the strongest in Lincolnshire, with an increased membership from 47 to over 90 during 1945. Financially, the year was also stated to have been a good one.

**R.A.F. Club Disbanded . . .**

OWING to Service movements the R.A.F. Club, known as the Dunmow Road Club, which had many fast men in its ranks, has been disbanded.

**But New One Formed**

AT Blinbrook, Lincs, the Blinbrook (R.A.F.) Club which caters for airmen in the vicinity has been established.

**Cozens Home Again**

SYD COZENS, a Flight Lt. in the R.A.F., has been demobbed. He was a member of the famous Manchester Wheelers and rode in a number of Six-Day Races.

**Yorkshire Veterans**

THE Veterans Time Trial Association has extended its activities to Yorkshire, where a section has been formed with C. F. Bause, 11, Fellbrook Ave., Acomb, York, as its secretary.

**Activity in Kent**

THE Kent Cycling Association has been resuscitated with C. R. Fiberton, 163, Rochester Ave., Rochester, Kent, as hon. sec.

**Old Timer Dies**

FORMER well-known official of the N.C.U. Devon and Cornwall Centre, W. Eva, has died. He was 86.

**Champion Killed**

FORMER champion of the Kingston Road Cycling Club, J. Compton, lost his life in an airplane crash when on his way home from imprisonment in Japanese hands.

**Down Under**

MORE cycles are to be permitted to be imported to New Zealand this year.

**No Luxury**

IN France the Luxury Tax on cycles has been lifted and standard prices for machines have been fixed.

**The Industry Moves**

CYCLES are to be manufactured in Montgomeryshire by Tube Investments, Ltd., which is taking over a Government factory.

**Now Mixed**

THE Crest C.C., of Ilford, Essex, have opened their ranks to ladies.

**Road Improvements**

OVER a quarter million sterling has been granted for road improvements in Skye.

**Middle East Record**

L. SMITH, Manchester Clarion C.C., is holder of the Middle East 25-mile record with 1.5.3. He made the ride as a member of the Peninsula C.C.

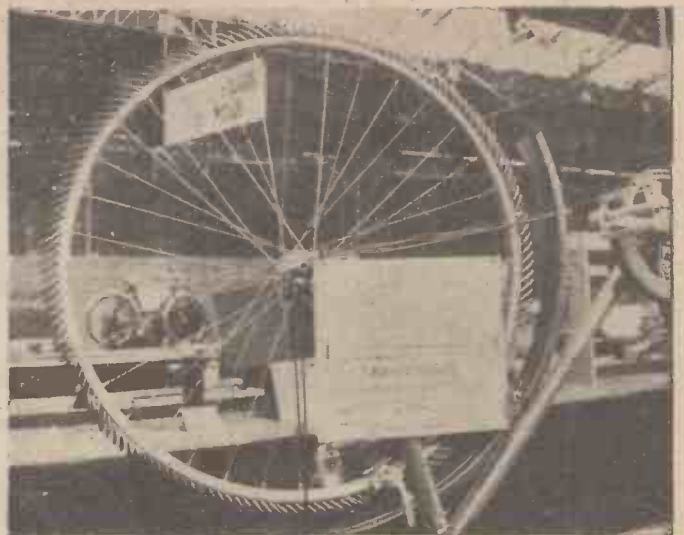

A novel exhibit at the Paris Fair, held last autumn. A spring-like bicycle wheel made to meet the shortage of rubber tyres!

**"Safety First" Pioneer**

SERGEANT HARRY GILBERT HATHER, who instituted special tests for child cyclists in Doncaster and designed badges for those children who passed the tests, has died, aged 49. He had spent 25 years in the Lincolnshire and Doncaster Police Forces and had been retired on pension for less than 12 months.

**Gulls at Scawby**

BECAUSE during the war eggs were taken in very large quantities from the gull breeding ponds at Scawby, Lincs, there is a danger of Scawby losing all its gulls very shortly. For many years this unique breeding ground of gulls, where before the war some 100,000 gulls nested annually, has been a source of interest to cycling visitors from all over the country.

**Road Maintenance**

MAINTENANCE and improvement of the 1,175,960 miles of road and 134 bridges in the County of Holland, Lincolnshire, cost £151,140 during 1945. The road accident rate was halved during the year.

**Road Safety Scheme**

PROVISION is being made by Lindsey (Lincs) County Council for the expenditure of £750 on road safety schemes between now and the end of March, 1947.

**All the Time**

IN the course of a journey the other day, a mother was heard mildly upbraiding her child for not keeping to the left on her bicycle. "Always keep to the left," she said. "Always." The kiddie's reaction to this piece of sound advice was remarkable, for she asked: "Even when going downhill?" The word "always" was then repeated with greater emphasis.

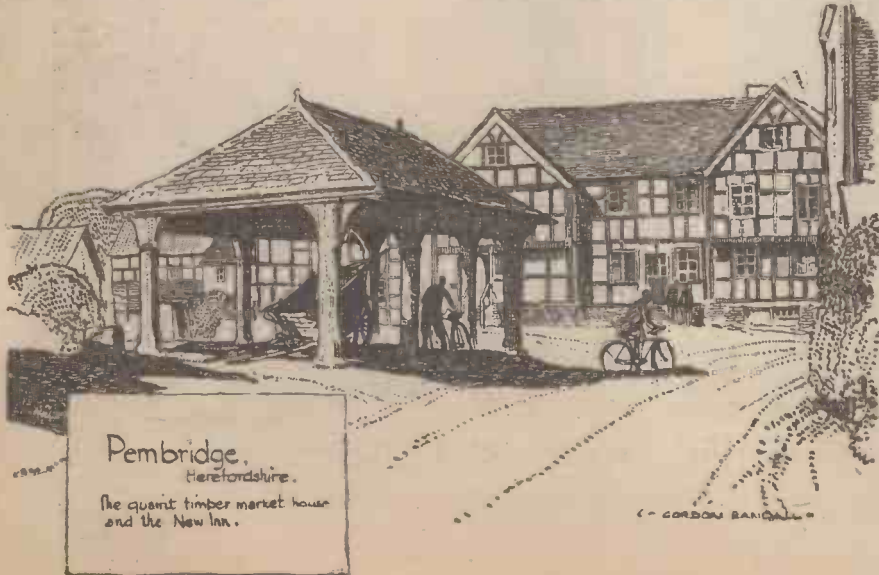

Pembridge, Herefordshire.

The quaint timber market house and the New Inn.

# My Point of View

By "WAYFARER"

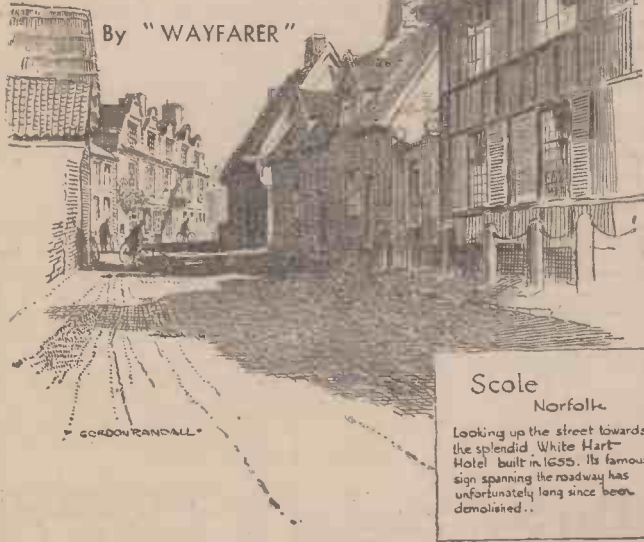

Scale  
Norfolk

Looking up the street towards the splendid White Hart Hotel built in 1655. Its famous sign spanning the roadway has unfortunately long since been demolished.

## Epitaph!

I HAVE just been reading an obituary notice which speaks of the deceased as "an outdoor man who was a romantic at heart to the end." I can hardly think of a better epitaph. Where's my tombstone?

## Asking For It

IN my part of the world, recently, a cycling post-woman rode out of a passage and collided with a lorry. At the subsequent inquest it was stated that her back brake was missing, while her front brake was defective. Any comment on this deplorable state of affairs is unnecessary.

## So Say All Of Us

RATHER belatedly, because other matters have been more pressing, I quote from a speech made by the Minister of War Transport in the House of Commons last November, during the second reading of the Trunk Road Bill: "Our roads must be designed to enable the motorist, cyclist, and hiker not only to reach his destination speedily, easily, and in comfort, but to enjoy every moment of the journey." If we cannot achieve those purposes, I believe it is because of the conduct of the Selfish Few.

## Bad Slip

I HAPPEN to possess a reputation for being a methodical sort of merchant. My maps are kept in apple-pie (and numerical) order, segregated as regards (a) England and Wales, (b) Scotland, and (c) Ireland, Mr. Bartholomew's numbering system being supplemented by the application of plainly-seen dates from disused calendars. Similarly, my travel books are assembled on certain shelves in my bookcase, being again divided into countries as above. As with maps and books, so with my gas lamp. The regular attention it requires is not left until starting-time on Saturday afternoon or Sunday morning. If the job of cleaning-out and recharging is not done on a Friday evening, the reason is—well, merely that the task was carried out earlier in the week. And, it may be added, the process of recharging applies to water as well as carbide, I preferring not to risk being caught napping with regard to a supply of the fluid which is all too common in this country.

So far, so good. The other Saturday, however, I slipped badly. Of course, the lamp required no thought, it having been attended to, as usual, in ample time. Why, then, did it fail me when a bare two miles of my homeward journey in the dark had been achieved? Why was it then necessary for me to take refuge in a friendly garage, dissect the lamp and clean it out, afterwards recharging with carbide and water? Why? Because my method had broken down through sheer forgetfulness. The job which seemed to be as much a part of the routine of my life as eating a meal or going to bed had been completely overlooked.

## Seen in Time

ONE evening recently, in the course of my journey home after tea in the country, I had two experiences which stressed the need for every unit of traffic to light its own way, and for every driver or rider of a wheeled vehicle to "watch his step." In the first place, I came across a large herd of cows just being released after the milking process. In the second place, I found an empty milk-churn lying athwart the road. In each case my speed bore such strict relation to the volume of light I was throwing forward that there was no danger. I saw the cows and the obstructive churn in ample time

to avoid trouble—and that, I suggest, is but an elementary precaution and duty resting on each one of us. It is doubtless an old-fashioned view, but it remains a safe view, and explains one's freedom from serious trouble despite many thousands of miles travelled in the dark.

## Mistaken View

A GIRL cyclist rose from table at a tea-house one cold day recently, gave "Cheerio" to the remainder of the people in the room, and made her exit. "Ugh! shorts!" ejaculated another girl who was sitting opposite to me, and who had arrived after I had commenced feeding. By way of comment I raised a bare knee above the table—and said nothing. The girl opposite gave a little shiver, and I then explained that shorts are not so uncomfortable as they look—granted that they have such an appearance—and that I was in the habit of using them for almost 100 per cent. of my cycling. It is quite a mistaken view that these abbreviated garments are chilly.

## A Bad Word

TWICE within a few days young cyclists have used the word "inevitable" in speaking to me. On the first occasion, my face must have asked a question, for the reply was: "Yes! I've got the inevitable puncture." I can't imagine what word my friend intended to use—"infernal," perhaps—but punctures are not "inevitable." The second youngster was telling me about cycling to work on a skiddy morning. He came round a right-angled bend at speed, and had the "inevitable" crash. Of course, a toss is "inevitable" if you ask for it—and that's a thing to avoid doing. I cycled to business on the same morning, doing twice or three times the distance of my "inevitable" young friend, and my machine did not perform a single dither. But, then, I refrained from applying for a chance to display my gymnastic abilities! It appears to me that "inevitable" is a thoroughly bad word. Punctures occur so rarely that it is ridiculous to speak of them as "inevitable": the same remark applies to skidding.

## Britain-boost

IT was very interesting to read in my newspaper, at the beginning of February, of the plan which is being launched by the Travel Association for making a series of films portraying Britain—its sport, industries, and traditional customs—for display in the U.S.A. and also in Canada and other parts of the Empire and Commonwealth. The first six areas in Britain to be dealt with are London, the Midlands, Devon and Cornwall, Wales, Scotland, and Northern Ireland, a start being made very shortly with either Wales or Devon and Cornwall, followed by the Midlands. This is an attractive scheme: it ought to bring many visitors to a land which, according to recent Yankee "invaders" (quoted by the Director-General of the Travel Association some weeks ago) "has more tourist attractions per square mile than any other country in the world." By the way, I wonder whether cyclists as a whole appreciate Nature's rich endowment of these "islands of the blessed"?

## Dreams Coming True

THIS year of grace, it appears to me, should see some of our cycling dreams coming true—not all of them, because many months must elapse before we reach normality. It does not seem very likely that Continental touring will be possible during 1946, but Scotland ought to be reckoned amongst the possibilities for those of us who live on the wrong side of the River

Tweed, whilst Ireland may be "on the map." I do not feel too sure about the latter country owing to the dearth of shipping, which (if it does nothing else) sets up formalities and causes uncertainty and loss of time. Thus, for the moment, I am inclined to view Ireland as a "starter" for 1947—which is quite a long way off! I say that with considerable regret, yielding to none in my desire to revisit "the ould sod," which has entered so largely into my wartime dreams.

I long to see again all those delights with which my many tours in Ireland have endowed me—Connemara, Killarney, Glengarriffe, the Dingle Peninsula, County Donegal, the Bloody Foreland, the Antrim Coast Road, and all the rest of it—but it looks as though the fulfilment of my dreams will not take place just yet. With regard to Scotland, I have kept away from "the Land of Cakes" during the war years solely because of my reluctance to undergo the expense and the discomfort (especially the discomfort) of the long railway journey from the Midlands to (say) Glasgow, and because I was not prepared, as a pleasure traveller, to occupy train space required by those who could (or thought they could!) answer affirmatively the question: "Is your journey really necessary?" But, with improving train services, the Scotland of which I have dreamed—Galloway, the Trossachs, Mull, Ardnamurchan, Skye, the Great Glen, and "the Road to the Isles"—looks like being within realisation.

## Tram-lines

TRAM-LINES are disliked by most cyclists, and dreaded by some. Yet, given room to manoeuvre, the average steel rail (if there is such a thing as an "average") need not cause very much concern. If you cross the line at a proper angle, and your tyres are correctly inflated, the job can be achieved safely. If, however, you are hampered by other traffic, difficulties may arise. My own policy is one of refusing to be stampeded into doing the wrong thing. I prefer to stand by until (if it is necessary to cross) tram-lines can be approached at an angle which experience tells me carries safety with it.

## The Better Part

VARIOUS harrowing stories have been heard relative to the wartime (and post-war) difficulties over meals as experienced by people who take non-cycling holidays—of the inability of certain company-house keepers to supply more than bed and breakfast, and of the necessity for queuing up at restaurants, etc., in order to obtain lunches, dinners, and teas. As a cycle-tourist who has taken his full quota of holidays, it may be placed on record that no such problems have come my way. I have never queued for a meal: I have never been "driven from home" at places where I have stayed and been asked to get my food out. There have been one or two slight—very slight—difficulties over accommodation, but only on one occasion did I miss a meal, and that was at a seaside resort, where, having regard to my views about such, I had no right to be! Here, after sitting in a restaurant waiting for a meal which was an unconscionable time a-coming—the animal involved was still roaming the mountains when I entered the place, and had to be rounded-up, captured, disrobed and cooked!—I indignantly went on my way, expressing my feelings in suitable language to the proprietor, who had the effrontery to inquire whether I had enjoyed my lunch! An "iron ration" of chocolate kept me going until tea-time, when I made amends for the meal I had missed.

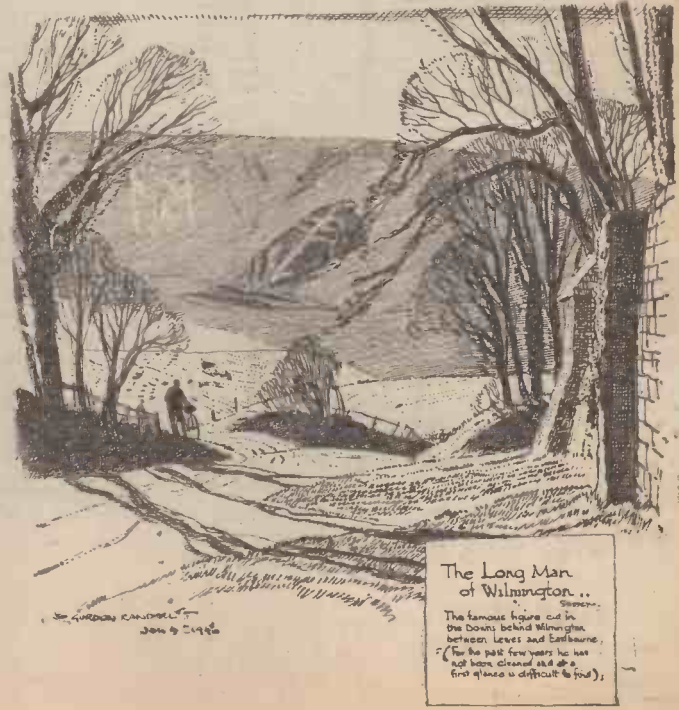

The Long Man of Wilmsington...

The famous figure cut by the Downs behind Wilmsington between Leves and Eastbourne. For the past few years he has not been cleaned and is in first class condition to find!

### Which Professional Qualification for You!

Government and Industry urge you and others like you to train for the highest post-war technical posts within your capacity. Write to-day for "The Engineers Guide to Success"—free—and use the FIRST PLACE COURSES of the T.I.G.B. to attain the engineering knowledge and qualifications necessary to success.

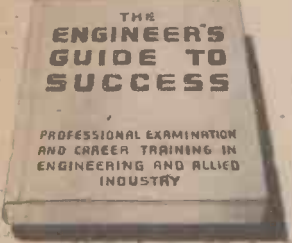

The Technological Institute of Great Britain, 218, Temple Bar House, London, E.C.4

Convert your M.W. TRF set to Long and Medium Waves. Circuit diagrams and specific instructions for our own "Wizard" and "Dorset" conversion, price 1d. "Dorset" Amplifier A.C./D.C., 6-8 watts, circuit and instructions, 5s.

**SPECIAL LINES**  
Weymouth 3-Wave Superhet Coil Pack, complete with circuit and detailed instructions, 38/6. Standard size I.F. Transformers, factory tune to 465 kc/s, High Q, per pair, 15/-.  
H.F. Chokes, 2/- each. 3-Wave Superhet Aerial and Oscillator Coils with circuit. Per pair, 10/-. Separate tuning coils, Medium, Long and Short wave, Aerial, H.F. or Oscillator, 2/6 each.  
Write: **WELDONA RADIO ACCESSORIES, Ltd., 12, Gilbert Rd., Swanage, Dorset.**

### ARC-WELD IT!

Special low-mains-loading oil-cooled sets. 64 output variations, designed for 200 to 240 volt mains. £33.  
Accessories and electrodes stocked, prompt dispatch.  
Whiteheads', 94, Camden Rd., N.W.1.

### SHORTHAND

**DUTTON'S ONE-WEEK SHORTHAND** is used by over 60,000 men and women. Accepted by Services and examining bodies. Test Lesson 3d. Write Dept. P.M., 93 Great Russell St., London, W.C.1.

### IN ONE WEEK

**FABRICATED PLATEWORK CONSTRUCTIONAL AND GENERAL ENGINEERING**  
**WELDING AND REPAIRS IN ALL METALS**  
**ROD ENGINEERING & WELDING CO.,**  
64a, Arkwright St., Nottingham  
Phone: Nottm. 89455

### RATCHET & REVOLUTION COUNTERS

Ask for Leaflet No. 18/4  
Speed up to 6,000 r.p.m.  
**B. & F. CARTER & Co. Ltd., Bolton 5**

### TOOL NEWS

7d. post free.  
**GARNERS**  
Sheffield Road, BARNSELEY  
Phone 2866.

### YOU CAN TIN ANY METAL QUICKLY AND EASILY with

## HOYT'S TINNING COMPOUND!

consisting of fine powdered tin combined with an active flux  
NO SEPARATE APPLICATION OF FLUX, SOLDER OR TIN REQUIRED  
JUST CLEAN THE METAL AND FOLLOW DIRECTIONS

Heat the work and just sprinkle the powder evenly upon surface to be tinned. The flux should "boil" and its cleansing action will be assisted if the surface is scrubbed with a wire brush at this stage. When flux has all melted and the surface is tinned evenly all over remove from heat and wipe with a clean rag.

Now available in 1-lb. tins 7/-, 7-lb. tins 45/6, and 14-lb. tins, 87/6. Carriage paid on all orders of 7-lb. or over.

**HOYT METAL CO. of GREAT BRITAIN Dept. E - DEODAR ROAD PUTNEY - LONDON - S.W.15**

**Varley** ★ 40 YEARS RELIABLE ★ SERVICE TO THE ★ INDUSTRY

## POWER CHOKES TRANSFORMERS

## WIRE WOUND RESISTANCES

## DELAY SWITCHES

MADE BY

### OLIVER PELL CONTROL LTD

CAMBRIDGE ROW, WOOLWICH, S.E.18  
TELEPHONE: WOOLWICH 1422

## SMALL TOOLS

Drills, Reamers, Lathe Tools, Micrometers, etc.

## EVERYTHING FOR THE ENGINEER-MECHANIC

Bench Millers, Lathes, Bench Drills, Electric Motors A.C. and D.C.

Send 4½d. for Lists

### NUTTALL'S (LATHES) LIMITED,

MANSFIELD, NOTTS.

### BUILD YOUR OWN

**TOY MAKER'S or MODEL MAKER'S LATHE** from readily obtainable parts ONLY (costing about 50/-).

SET of clear Diagrams and Instructions for making all parts easily—including alternative types of chuck, headstock, etc., etc. Price 3/6d. Parts stocked.

**P. M. BARHAM, La Hougue, Vale, Guernsey, C.I.** (New address.)

**Fit an OILCOIL**

For increased power, improved petrol consumption, better starting. Send for interesting booklet 2/1.

**RUNBAKEN, MANCHESTER 1**

### MIDLAND INSTRUMENT CO.

Comprehensive range of Lewcos instrument wires, eureka and nickel chrome res. wires, flexes and cables, electrical accessories, sleeving, Empiro tape, rubber grommets, L.T. rectifiers, Avometers, Wee-Meggers, Ohmmeters, speakers, chassis, dual-range and s.w. coils, var. cond., counters, synchronous motors, microphones, plugs and jacks, etc., etc. New Feb. lists, 1d. s.a.e. Trade lists 1d. s.a.e.

18, Harborne Park Road, Birmingham, 17  
Tel. HAR-1308 or 2694.

### BOOKS

A.B.C. OF L.M.S.	2/-
A.B.C. OF G.W.R.	1/6
G.W.R. L.N.E. L.M.S. TITANS each	1/6
A.B.C. WALLETS	1/6
Postage 2½d. each extra.	
HISTORY OF THE G.W.R. IN 3 PARTS	10/6
BRITISH LOCOMOTIVE TYPES	7/6
ISLE OF MAN RAILWAY	7/6
Postage 6d. each extra.	
MODEL RAILWAY CONSTRUCTION	1/6
MODEL SHIPS AND BOATS	1/6
OUR RAILWAY HISTORY, complete	15/-
NEW EDITION, with Map	15/-
Postage 3d. extra.	
PARTS LIST 'O' or 'OO' 3d. each.	

### TYLDESLEY & HOLBROOK

109, DEANS GATE, MANCHESTER, 3.

### CASTINGS FOR OSCILLATING ENGINE, 7/16in. bore, 3/4in. stroke, with detailed blueprint, 6/- p.f.

Detailed boiler blueprint, 2/- p.f.—Hughes, Hopedale Road, Frecheville, Sheffield.

5 m/m. FILMS—Sale, Hire or Exchange. Sound and Silent. Enormous selections, over 3,000 reels. Projection Accessories. Everything for the Cinematographer. Complete literature, 3d.—Watsonian Film Supply, 78, Cox Street, Coventry.

**WANTED**—Model engineer to undertake simple individual metal-work jobs. Turning, brazing essential; welding advantageous.—Write: O. Storey, Plas Nantyr, Glynceiriog, Denbighshire.

**DRAWING, Detailing, Tracing**—The Mechanical & Model Draughting Agency, 38, Belmont Road, Bristol, 6.

### SPARKS' DATA SHEETS

Provide full constructional details, theoretical diagram, component list, and fine full-size black and white prints of Tested and Guaranteed Designs, specially prepared to meet the needs of the amateur.

- MIDGET ONE-VALVE PORTABLE.**—All dry batteries. Own aerial covering Medium and Long waves. 9V H.T. (C) 2/6
  - THREE-VALVE T.R.F. SET.** Batt. Modium and Long-wave. Compact and efficient. Pentode output ... 2/6
  - FOUR-VALVE T.R.F. SET.** (No. 10/8.) Batt. Medium and Long waves. Push-pull output. Powerful with good quality P.U. sockets. ... 2/6
  - THREE-VALVE T.R.F. SET.** (No. 10/9.) A.C. mains. 3½ watt output. Good quality on radio and P.U. Medium and Long waves ... 2/6
  - MIDGET PORTABLE.** All-dry batt. 3-valver. Self-contained L.S. and Aerial. 8 x 6 x 3½in. Medium wave (C) ... 2/6
  - MIDGET TWO-VALVER.** All-dry Batt. 9v. H.T. Med. wave. 5½ x 5½ x 3½in. Powerful "phone sigs. (C) ... 2/6
  - A.C. RADIOGRAM.** A Quality job. Med. waves. H.F. stage plus "Infinite Imped." Detector. 3 watts P.P. output (C) ... 3/6
  - A.C. 8 WATT AMPLIFIER.** Neg. Feed-back. P.P. output. Tone and Vol. controls. Ideal for P.U. ... 2/6
  - RADIO UNIT.** Two-valver for use with a Quality amplifier. A.C. or A.C./D.C. Med. waves. H.F. stage plus "Infinite Impedance" Detector (C) 2/6
  - THREE-VALVE PUSH-PULL AMPLIFIER.** A fine unit for battery operation. Ideal for P.U. ... 2/6
  - ELECTRIC GUITAR UNITS** ... 5/-
  - ELECTRONIC ONE-STRING FIDDLE** ... 3/6
  - A.C./D.C. PORTABLE AMPLIFIER.** Neg. Feed-back. 3 watts. P.P. output. For use with above or P.U. etc. ... 3/6
  - 3½ WATT A.C. AMPLIFIER** ... 2/6
  - A.C. QUALITY TWO-VALVE SET.** Med. waves (C) ... 2/6
  - TWO-VALVE AMPLIFIER.** Battery. Pentode output. Fine Vol. ... 2/6
  - COMPACT STRAIGHT 3 SET.** Batt. Med. Waves (C) ... 2/6
  - SUPER S.W. TWO-VALVER.** Batt. Plug-in Coils ... 2/6
  - HIGH GAIN CRYSTAL SET.** Med. waves (C) ... 2/6
  - A.C. CHANGELER.** 2 and 6 volt ... 2/6
  - SHOCKING COIL** ... 2/6 (C. Denotes coil details provided.)
- Many other Designs. Please send stamp with order or for List.
- L. ORMOND SPARKS (M),**  
9, Phoebeth Road, Brockley, S.E.4  
(Lee Green 0220)

### I WILL MAKE YOU A BRILLIANT PIANIST

I do not say I may, but I say positively that I WILL if I accept you as my pupil. I have taught over 68,500 during 41 years, my class is seldom less than 2,000 pupils, of all ages, occupations and degrees of proficiency to play the piano brilliantly. I CAN TEACH YOU, even if to-day you do not know a note, to read and play at sight any standard musical composition. I grade lessons personally to suit your individual needs, using ordinary musical notation, no trashy methods. SEND P.C. for free book and advice.

Say Moderate, Elementary or Beginner.  
**Mr. H. BECKER** (Dept. 858),  
69 Fleet Street, London.

### "VIBRO-ARC" Engraving Pen

10/- For rapid engraving any metal—hard or soft. Operates from 4-6v. Post Battery or A.C. Transformer.

**HOLBOROW,**  
Boroughbridge, Yorks.

Easily made From Our Castings.

**J. HALLAM & SON,**  
Upton, Poole, Dorset.

### MINIATURE PETROL ENGINES for Aeroplanes and Speed Boats.

Send 3d. for particulars

### BOOKS

"Publishing for Pleasure and Profit" (How to start and run a publishing business), 3/6.  
"How I Toured the World on Nothing," 1/6, by W. Buchler.  
"The Art of Scale Model Aircraft Building" 4/11, by V. J. G. Woodason.  
"Toys from Scrap for Pleasure or Profit," 3/6, by W. Lee.  
"Money in Exports" (Trading in 41 different Markets), 10/6.  
**USEFUL PUBLICATIONS,**  
37, Aldwych, London, W.C.2.

# Free Guide - "Success in Engineering"

One of the following Courses taken at home in your spare time can definitely be the means of securing substantial promotion in your present calling, or entry into a more congenial career with better prospects.

## ENGINEERING, AERO, ETC.

Plastics—Radio—Aero Engines—Aircraft Design—Welding—Aerodynamics—Electrical Engineering—Television—Electric Wiring—Talking Picture Work—Generation and Supply—Works Management—Metallurgy—Refrigeration—Planning, Estimating, Rate-fixing—Time and Motion Study—Aero Inspection—Automobile Engineering—Sheet-metal Work—Engineering Draughtsmanship—Aero Draughtsmanship—Jig and Tool Draughtsmanship—Press Tool and Die Draughtsmanship—Structural or R/F Concrete Draughtsmanship—Sanitary Engineering—R.A.F. AND R.N. PILOTS AND OBSERVERS.

## GENERAL

Matriculation—College of Preceptors—Chartered Institute of Secretaries—Aircraft Apprentice.

## MUNICIPAL SERVICE

School Attendance Officer—Handicraft Teacher—Registrar—Relieving Officer—Sanitary Inspector—Weights and Measures Inspector—Inst. of Mun. and Cy. Engineers—P.A.S.I.

"PRACTICAL ENGINEERING" said—

We recommend all readers interested in improving their position to apply for a copy of this valuable Book. "Success in Engineering" is not a pamphlet. It is a 132-page book, containing valuable and vital information on all branches of engineering. There are many engaged in engineering who owe their success to The National Institute of Engineering

The FREE GUIDE explains:

- Openings, prospects, salaries, etc., in Draughtsmanship, Inspection, and opportunities in all other branches of Engineering and Building.
- How to obtain money-making technical qualifications through special RAPID FULLY-GUARANTEED COURSES.

Write now for your copy of this remarkable publication.

A.M.I.E.E., A.M.I.Mech.E., A.M.Brit.I.R.E., A.M.I.P.E., A.M.I.C.E., A.M.I.Struct.E., A.M.I.A.E., A.F.R.Ae.S., A.M.I.S.E., M.R.San.I., London B.Sc., Degrees.

Fully guaranteed postal courses for all the above and many other examinations. Fully described in the Free Guide.



**THE BUILDING BOOM—  
SECURE YOUR SHARE!**

The Free Guide also gives particulars of our extensive range of modern Building and Structural Courses, Building Draughtsmanship, etc. The great post-war Building programme offers unlimited prospects to technically trained men.

## THE ACID TEST OF TUTORIAL EFFICIENCY SUCCESS—OR NO FEE

We definitely guarantee that if you fail to pass the examination for which you are preparing under our guidance, or if you are not satisfied in every way with our tutorial service—then your Tuition Fee will be returned in full and without question. This is surely the acid test of tutorial efficiency.

**BECOME A DRAUGHTSMAN  
QUALIFY AT HOME  
AND EARN BIG MONEY**

Men and Youths urgently wanted for well paid positions as Draughtsmen, Inspectors, etc., in Aero, Jig and Tool, Press Tool, Electrical, Mechanical and other Branches of Engineering. Practical experience is unnecessary for those who are willing to learn—our Guaranteed "Home Study" courses will get you in. Those already engaged in the General Drawing Office should study some specialised Branch such as Jig and Tool or Press Tool Work and so considerably increase their scope and earning capacity.



If you have ambition you must investigate the Tutorial and Employment services we are able to offer. Founded in 1885, our success record is unapproachable.

Why not fill in and post the attached coupon NOW for further details and Free Authoritative Guide to openings in Engineering and Building? This book contains a mine of valuable and exclusive information and may well prove to be the turning point in your career.

PROMPT TUTORIAL SERVICE GUARANTEED.

## FREE COUPON

To NATIONAL INSTITUTE OF ENGINEERING (Dept. 29), 148, Holborn, London, E.C.1.

Please forward your FREE Guide to

NAME.....  
ADDRESS.....

My general interest is in: (1) ENGINEERING (2) AERO (3) RADIO (4) BUILDING (5) MUNICIPAL WORK (Place a cross against the branches in which you are interested.)  
The subject or examination in which I am especially interested is

To be filled in where you already have a special preference. (rd. stamp only required if unsealed envelope used.)

**NATIONAL INSTITUTE OF ENGINEERING**  
(Dept. 29)  
**148, HOLBORN, LONDON, E.C.1**

**OVER SIXTY YEARS OF  
CONTINUOUS SUCCESS**

SOUTH AFRICAN BRANCH: E.C.S.A., P.O. BOX 2417 JOHANNESBURG.

**FOUNDED 1885—FOREMOST TODAY—OVER 100,000 SUCCESSES**

"Practical Mechanics," Advice Bureau **COUPON**  
This coupon is available until March 30th, 1946, and must be attached to all letters containing queries, together with 3 penny stamps. A stamped, addressed envelope must also be enclosed.  
Practical Mechanics. March, 1946.

Published about the 30th of each month by GEORGE NEWNES, LIMITED, Tower House, Southampton Street, Strand, London, W.C.2, and Printed in England by the Newnes and Pearson Printing Co., Ltd., Exmoor Street, London, W.10. Sole Agents for Australia and New Zealand—Gordon & Gotch, Ltd. Sole Agents for South Africa—Central News Agency, Ltd. Subscription Rates (including postage): Inland, 10s. 6d. per annum. Abroad, 10s. per annum. Canada, 10s. per annum. Registered at the G.P.O. for transmission by Canadian Magazine Post.  
CONDITIONS OF SALE AND SUPPLY: This periodical is sold subject to the following conditions, namely, that it shall not, without the written consent of the publishers first given, be lent, re-sold, hired out, or otherwise disposed of by way of Trade except at the full retail price of 9d.; and that it shall not be sold, hired out, or otherwise disposed of in a mutilated condition or in any unauthorised cover by way of Trade; or affixed to or as part of any publication or advertising, literary, or pictorial matter whatsoever.