

WIND OPERATED CHARGING & LIGHTING PLANTS

NEWNES

# PRACTICAL MECHANICS

OCTOBER 1939

6<sup>d</sup>





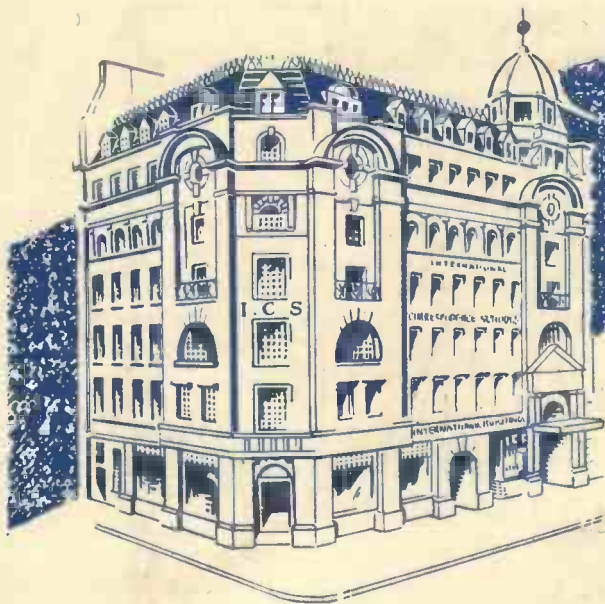

**Your Work -  
AND Your Pay**

The size of your salary is more or less in accordance with the measure of what you know and therefore can do. The more you know, the greater your pay.

Success—progress won by merit—depends on trained ability. Unless you have studied **IN YOUR SPARE TIME** you have little chance of promotion, for knowledge that comes through everyday work is not enough.

You must know the principles underlying your work and be familiar with the many processes closely related to that work. *The one and only means of obtaining such knowledge is specialized study.*

No man need be without that extra efficiency which adds so much to his income, security, and happiness. He can acquire it on easy terms, by the simple I.C.S. method of teaching by post.

If you are in the early stages of your career and have not yet had a specialized training, you should start to get one without delay. Or perhaps you feel that your knowledge is a little out of date and ought to be modernized. In either case

**The International Correspondence Schools can help you.**

*Our expert advice on any matter concerning your work and your career is yours for the asking—free and without obligation. Let us send you a booklet dealing with the subject in which you are especially interested. It is packed with valuable information.*

The I.C.S. offer instruction in the subjects given below.

Write for Special Booklet to-day or use the Coupon

This is  
**INTERNATIONAL BUILDINGS,  
KINGSWAY, LONDON**

Head Offices of the

**INTERNATIONAL  
CORRESPONDENCE SCHOOLS**

It is the centre from which radiates technical, commercial, and professional instruction that has been of great benefit to tens of thousands of ambitious people.

The I.C.S. is the greatest as well as the largest institution in the Empire devoted to spare-time training. Its prestige is unequalled. Several State Departments have entered into working arrangements with the I.C.S. for the training of men.

More than 1,500 I.C.S. text-books, prepared at International Buildings, are marvels of clearness, accuracy, and practical helpfulness.

There are 80 Instructors at Kingsway, many of them Associates, Members, or Fellows of their respective technical or professional bodies. *All are specialists*, and expert in giving the student *individual attention* throughout his Course of Study.

Among the 400 I.C.S. Courses there is one that can qualify YOU for Promotion and better Pay.

**COUPON FOR FREE BOOKLET**

**INTERNATIONAL CORRESPONDENCE SCHOOLS, LTD. (Dept. 95), International Buildings, Kingsway, London, W.C. 2**

Please send me your booklet containing full particulars of the Course of Correspondence Training before which I have marked X. I assume no obligation.

- |   |  |  |   |
|---|--|--|---|
| <input type="checkbox"/> Accountancy              | <input type="checkbox"/> Diesel Engineering        | <input type="checkbox"/> Lettering                       | <input type="checkbox"/> Scientific Management        |
| <input type="checkbox"/> Advertising              | <input type="checkbox"/> Draughtsmanship           | <input type="checkbox"/> Mechanical Drawing              | <input type="checkbox"/> Short-Story Writing          |
| <input type="checkbox"/> Aeronautical Engineering | <input type="checkbox"/> Electrical Engineering    | <input type="checkbox"/> Mining Engineering              | <input type="checkbox"/> Steam Engineering            |
| <input type="checkbox"/> Air Conditioning         | <input type="checkbox"/> Engineering Shop Practice | <input type="checkbox"/> Motor Engineering               | <input type="checkbox"/> Surveying                    |
| <input type="checkbox"/> Architecture             | <input type="checkbox"/> Fire Engineering          | <input type="checkbox"/> Pattern-making                  | <input type="checkbox"/> Telephone and Telegraph Eng. |
| <input type="checkbox"/> Boiler Engineering       | <input type="checkbox"/> Garage Management         | <input type="checkbox"/> Plumbing                        | <input type="checkbox"/> Textiles                     |
| <input type="checkbox"/> Book-keeping             | <input type="checkbox"/> Gas-Power Engineering     | <input type="checkbox"/> Radio Engineering and Servicing | <input type="checkbox"/> Welding, Gas and Electric    |
| <input type="checkbox"/> Building                 | <input type="checkbox"/> Heating and Ventilation   | <input type="checkbox"/> Salesmanship                    | <input type="checkbox"/> Wireless Engineering         |
| <input type="checkbox"/> Chemical Engineering     | <input type="checkbox"/> Hydro Electric            | <input type="checkbox"/> Sanitary Engineering            | <input type="checkbox"/> Woodworking                  |
| <input type="checkbox"/> Civil Engineering        | <input type="checkbox"/> Journalism                |  | <input type="checkbox"/> Works Management             |

**EXAMINATIONS**

Technical, Professional, Matriculation, and Civil Service. State the one you wish to pass .....

NOTE.—If your subject is not on the above list, write it here .....

NAME..... Age.....

ADDRESS.....





# I USE THEM AT WORK-AND AT HOME

## RAWLPLUG

FOR ALL FIXING PURPOSES

"I use Rawlplugs at work for fixing anything from machinery to shelves, and they never let me down. So it's natural that I should use Rawlplugs at home when there's a fixing job to be done. Things like towel rails, hooks, pictures and dozens of other articles can be fixed in a few minutes the Rawlplug way. I find that they save money and always give a neat job. Have you a Rawlplug Outfit in your tool kit?"

Complete Outfits:  
1/6, 3/6, or 5/6.

Illustrated literature  
free on request

The  
**RAWLPLUG  
CO., LTD.**

RawlplugHouse,  
London, S.W.7

## RAWLPLUG PLASTIC WOOD WOOD IN PUTTY FORM

"Here's a line that saves pounds in repair bills. Rawlplug Plastic Wood is like putty to handle, yet when it's dry it is just like ordinary wood. It's wonderful for repairing cracks in tables and floors, filling in holes, making mouldings, and repairing things like knife handles and kiddies' toys. It is a fine adhesive, in addition to its other qualities. When Rawlplug Plastic Wood is dry it can be stained or painted, cut and planed—in fact it can be treated in exactly the same way as ordinary wood."

Available in  
tubes at 6d.  
and 1s. or in  
tins from 9d.  
upwards.

B 178

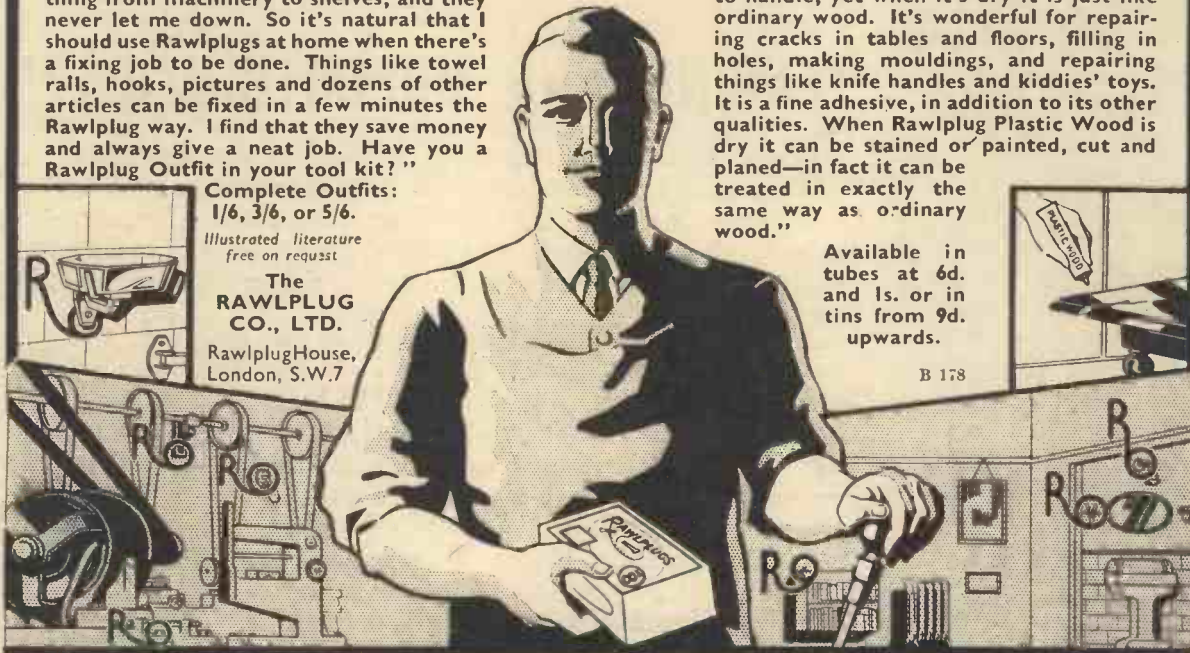

## Here's Amazing VALUE IN SUPER DETAILED FLYING SCALE KITS



**HESTON  
PHOENIX**  
Span 12 in.  
Kit Price only 1/9 p.f.

Famous "FROG" Scale kits containing full-sized detailed plan, instructions, ready punched out balsa parts, formed wire parts, easy to assemble propeller, etc. Tissue, cement, rubber and colouring. Hurricane has special moulded engine cowling.

**OTHER FAMOUS VALUE KITS**

Gl ster Gladiator Span 21 in. Price 3/-	<b>DURATION TYPES</b>
Caudron Racer Length 18 in. Price 3/-	Condor Clipper Span 30 in. Price 8/6
Hawk Pursuit Span 20 in. Price 3/6	Condor Curlew Span 20 in. Price 5/3
Vickers Wellesley Span 17 1/2 in. Price 2/9	Cahill's Clodhopper Span 47 1/2 in. Price 7/6
Westland Lysander Span 25 in. Price 10/6	

Prices are post free  
U.K. Abroad add 2/-  
for extra packing and  
carriage.

**HAWKER  
HURRI-  
CANE**  
Span 12 in.  
Price 2/3 p.f.

Have you a copy of our  
fine illustrated CATA-  
LOGUE? Send 4d.  
stamp please.

**NORTHERN MODEL AIRCRAFT CO.**  
25 LOWER MOSLEY ST., MANCHESTER, 2.



When his model steam boat (a real ripper)  
Sprung a leak, said the wily young Nipper,  
"A spot of FLUXITE  
Will soon put that right,  
Lend me yours, Dad, and you can be  
Skipper!"

See that **FLUXITE** is always by you—in  
the house—garage—workshop wherever speedy  
soldering is needed. Used for 30 years in  
Government works and by leading engineers  
and manufacturers. Of Ironmongers—in tins,  
4d., 8d., 1/4 and 2/8. Ask to see the **FLUXITE  
SMALL-SPACE SOLDERING SET**—compact but  
substantial—complete with full instructions 7/6. Write for Free Book on the  
**ART OF "SOFT" SOLDERING** and ask for Leaflet on **CASE-HARDENING  
STEEL** and **TEMPERING TOOLS** with **FLUXITE**.

**TO CYCLISTS!** Your wheels will NOT keep round and true unless the spokes  
are tied with fine wire at the crossings and **SOLDERED**. This makes a much  
stronger wheel. It's simple—with **FLUXITE**—but **IMPORTANT**.

## FOR ACCURATE WORK AND PERFECT FINISH A "MILNES" LATHE is Essential



7 in.  
diameter  
Centre  
Lathe

**SELF-CONTAINED ELECTRIC OR COUNTERSHAFT DRIVE**  
Robust construction in every detail with easy means of adjustment  
ensure a lifetime's efficient service from "MILNES" MACHINES

Send for full lists to: **HENRY MILNES, LIMITED,**  
**INGLEBY LATHE WORKS, BRADFORD,**  
**YORKSHIRE, ENGLAND**

## THE FLUXITE GUN

Is always ready to put Fluxite on  
the soldering job instantly.  
A little pressure places the  
right quantity on the right  
spot and one charging lasts for  
ages. Price 1/6, or filled 2/6.



ALL MECHANICS WILL HAVE

# FLUXITE

IT SIMPLIFIES ALL SOLDERING

FLUXITE Ltd., Dept. P.M., Dragon Works, Bermondsey St., S.E.1

# AMBITIOUS ENGINEERS



## HAVE YOU HAD YOUR COPY OF "ENGINEERING OPPORTUNITIES?"

Whatever your age or experience—whether you are one of the "old school," or a youngster who is beginning to realise that in Engineering can be found every possible opportunity for real advancement—you cannot afford to miss reading this highly illuminating guide to the best paid engineering posts.

Our handbook contains, among other intensely interesting matter, details of B.Sc., A.M.I.C.E., A.M.I. Mech. E., A.M.I.E.E., A.M.I.A.E., A.M.I.W.T., A.M.I.R.E., Civil Service, and other important Engineering Examinations; outlines over 200 courses in all branches of Civil, Mechanical, Electrical, Automobile, Radio, Television and Aeronautical Engineering, Building, Government Employment, etc., and explains the unique advantages of our Nationally Organised Employment Department.

WE DEFINITELY GUARANTEE  
"NO PASS-NO FEE"

"ENGINEERING OPPORTUNITIES" is not just a pamphlet—it is a 268 page volume and is the most comprehensive work ever compiled on Successful Engineering Careers. If you are in any way interested in Engineering you must make a point of reading this book without any delay.

Write (or send the coupon) for your copy NOW, while you have the matter in mind. There is absolutely no cost or obligation involved and the book is bound to benefit you.

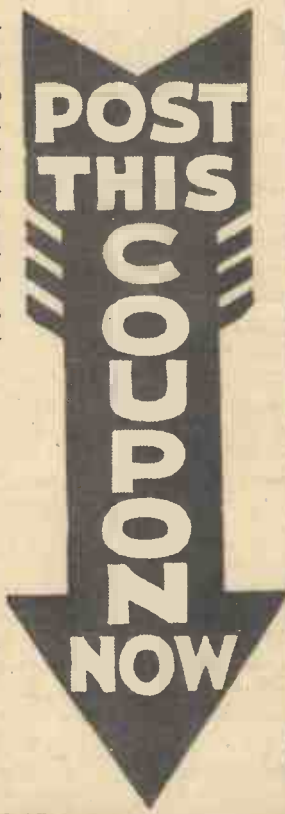

----- TEAR OFF HERE -----  
**FREE COUPON**

**BRITISH INSTITUTE OF  
ENGINEERING TECHNOLOGY**

**410a, SHAKESPEARE HOUSE,  
17, 18 & 19, STRATFORD PLACE, LONDON, W.1**

**BRITISH INSTITUTE OF  
ENGINEERING TECHNOLOGY,**  
410a, Shakespeare House,  
17-19 Stratford Place, W.1.

Please forward, Free of cost or obligation of any kind, your 268-page Handbook. "ENGINEERING OPPORTUNITIES."

Name.....

Address.....

.....  
.....



## SUBSCRIPTION RATES

Inland and Abroad 7s. 6d. per annum

Canada - - 7s. per annum

Editorial and Advertisement Offices: "Practical Mechanics," George Newnes Ltd. Tower House, Southampton Street, Strand, W.C.2.

Phone: Temple Bar 4363.

Telegrams: Newnes, Rand, London.

Registered at the G.P.O. for transmission by Canadian Magazine Post.

Copyright in all drawings, photographs, and articles published in "Practical Mechanics" is specifically reserved throughout the countries signatory to the Berne Convention and the U.S.A. Reproductions or imitations of any of these are therefore expressly forbidden.

# PRACTICAL MECHANICS

Editor: F. J. CAMM

VOL. VI. OCTOBER, 1939. No. 73.

## FAIR COMMENT

## SCIENCE AT WAR

WITHIN the comparatively short space of 25 years this country finds itself again at war, and it is the task of each and all to help to bring it to successful fruition. Within the limitations imposed by the state, it is the duty of each citizen to carry on so as to cause as little disruption to national life as possible; that it will be disturbed is inevitable. It is impossible at this stage to portend the extent of the conflagration. We can only hope that mercifully it will be of short duration. We may be permitted, however, the reflection that as mechanical, electrical, chemical, and scientific knowledge has advanced for the benefit of mankind in his peaceful moments, such must inevitably be drawn in for national defence. This country has led the world in engineering, in chemistry and in science. During the last war vast numbers of Japanese were sent over here to be trained in our methods of education, manufacture and commerce. That is a thought with a moral. The war draws attention to the points I have so often stressed, that technical knowledge is absolutely necessary in the modern battle, whether of life or existence. An army without arms would be unthinkable. We have made great strides in Britain towards enlightened education along sound lines, and degrees and honours to-day do not go to those precocious parrots who in former years were able to obtain them because they could remember the date of the death of Alfred the Great and the story of Bruce and the spider. The mental equipment of a race is of vastly greater importance than anything else. Even in agriculture scientific knowledge has been applied, and we are now able to produce at home many of the things for which we were formerly dependent on other countries. *Scientia est Potentia*—knowledge is power. You may lose your worldly possessions and everything you hold dear. Knowledge is the one

thing which cannot be taken away from you. If you add to it personal characteristics, including integrity, and obedience to the verities which orthodoxy has laid down, there are no limits to what you may achieve.

### A Trained Mind and Body

A TRAINED mind and a fit body is a *sine qua non*. In the past, there has, I regret to say, been too great a tendency for universities and schools to devote too much attention to sport and the modern cult of keeping fit. It is, of course, necessary to keep fit, but I do not approve of the manner in which the world has been taught to believe that unless each person indulges in regular physical exercise, usually of a violent character, they will die. The natural tendency of the body is towards good health, and a reasonable amount of normal exercise is all that is necessary. Slavishly to follow a sport for the purposes of keeping fit is basically wrong, and certainly unnecessary. In the first place, I have observed from a long experience that it destroys the desire to work, and unless my experience has been peculiar, I have seldom found that a person keenly interested in sport achieves any distinction in his profession. Their mind is on sport, even when at work.

It is obvious that industry cannot make use of a man's ability as a footballer, a tennis player, a cricketer, or a rugby blue. They are interesting pastimes which should not be allowed to become the basic interest of life. Too many, I fear, think that because they achieved distinction on the playing fields they are entitled to highly paid posts.

### Technical Qualifications

THE present position has drawn attention to this. The country needs people with technical qualifications in all branches of industry and radio announcements have made it

clear that such positions must go to those possessing proof of their knowledge. Many of my readers will not yet have attained military age. They have time to equip themselves for the important work which the country requires to be done. It is the first duty of every one of us to help the country in its time of need.

During the war this journal will continue to carry on. The services of our experts on all branches within our field will continue to be available to those who seek them. We hope that every one of our readers called to the colours will continue to write to us. We shall reply to each. Our readers will understand that under the new rules regarding the publication of technical matter, particularly relating to aircraft, ships, armament, explosives and the methods of the services, our material is subject to the pencil of the censor.

For the time being the television service has been suspended, and amateur transmitting sets have been confiscated. It will be understood, therefore, that we cannot answer questions relating to transmitting, television, aircraft, and kindred subjects, and moreover, for the time being, we have postponed our service relating to high explosives and queries coming under the heading of chemical warfare. We shall, of course, continue our advisory service on occupations and methods of entering various industries.

### Index for Volume 6

IN view of the enormous number of queries we have received during the past few weeks for information on a wide variety of subjects, we suggest that our readers should, whilst such books are in print, obtain the copies of those which will be of most use to them in their work. A catalogue will be sent free to every reader. They should also purchase the index to this journal.

# WIND-OPERATED LIGHTING SETS

By A. H. Avery, A.M.I.E.E.

*Serviceable Wind Power is Available for an Average of Eight Hours per day in the Majority of Localities, if the Site is Carefully Chosen*

A GOOD deal of interest is being taken now in small electric generating sets driven by wind power, of a size sufficient to supply the needs of bungalows and isolated buildings in outlying parts of the country, out of reach of any public electricity supply. There are, of course, plenty of self-contained lighting sets depending on petrol or oil engines for motive power, some of very excellent design, but with these one cannot

get away from the fact that the petrol or other fuel employed has to be paid for and transport arranged. The great attraction about wind-driven generators lies in the fact of getting one's power for nothing, utilising one of the free gifts of Nature.

Although wind power in these islands is apt to be rather erratic, far too much of it at times and not enough of it at others to provide any useful results, it is a notable fact that taken over a long period careful observations have proved that serviceable wind power is available for an average of eight hours per day in the majority of localities, if the site is carefully chosen.

**Variations in Speed**  
The problem with wind motors is, of course, to control the variations in speed arising from extreme weather conditions, such as periods of calm on the one hand and tempests on the other. A wind motor to be successful must be so constructed as to resist disaster in a gale and yet be sufficiently sensitive to develop useful power in winds of light or moderate velocity.

This brings one to the necessity for some definition as to what constitutes the difference between a breeze and a hurricane. The Meteorological Office has compiled a table known as "Beaufort Scale Numbers" which are attributed to winds of varying force according to their characteristics as below:—

Beaufort Scale	Corresponding Wind	Velocities in Miles per Hour
0	Calm	Under 2
1 to 3	Light Breeze	2 to 12
4 to 5	Moderate Wind	13 to 23
6 to 7	Strong Wind	24 to 37
8 to 9	Gale	38 to 55
10 to 11	Storm	56 to 75
12	Hurricane	Above 75

Any lighting system to be practicable must be so designed as to allow a reasonably constant voltage to be maintained at the lamps, otherwise there will be great fluctuation in the light and a risk of burning out the bulbs. Much the same problem confronts the automobile industry; the considerable variations of engine speed which occur during road use have to be counteracted by some means before lighting from the car dynamo can become satisfactory, and in this there is a definite resemblance between motor-car generators and wind-driven dynamos. In the car, engine speeds must of necessity vary in order to meet the conditions imposed by gear-changing, gradients, traffic conditions, etc. In the wind generator similar speed variations are unavoidable with changes in the wind velocity. In both cases there must be storage capacity to tide over periods when the driving power is not available.

The motor industry solves this problem by the development of the so-called "constant voltage" generator, which permits of

a fairly constant voltage being obtained from its terminals at widely different driving speeds by a special construction, and by the use of a "floating battery" used in conjunction with it.

## Constant Voltage Generator

There are in fact a good many different devices for obtaining constant voltage at varying speeds, but the most popular is the one known as "third-brush control." In the case of the ordinary shunt-wound 2-pole dynamo such as used for stationary lighting sets, engine-driven at a closely governed speed, there are two brushes only at opposite positions on the commutator, see Fig. 3. The windings form two distinct circuits, one through the armature B and brushes to the main terminals B and so direct to the lamps or battery; the other is an independent and separate circuit C through the fields only, a small current being "shunted" from the main terminals for the sole purpose of exciting the field magnet coils. In a dynamo of this type the voltage (the E.M.F.) generated by the armature is almost directly proportional to its speed, and variations in driving speed would cause corresponding fluctuations in the light given by any lamps connected to the terminals. Quite obviously a generator of this class would be unsuitable for lighting



Fig. 1.—A commercial set which relies principally on the self-governing properties of the dynamo, aided by a furling action of the wind-motor tail

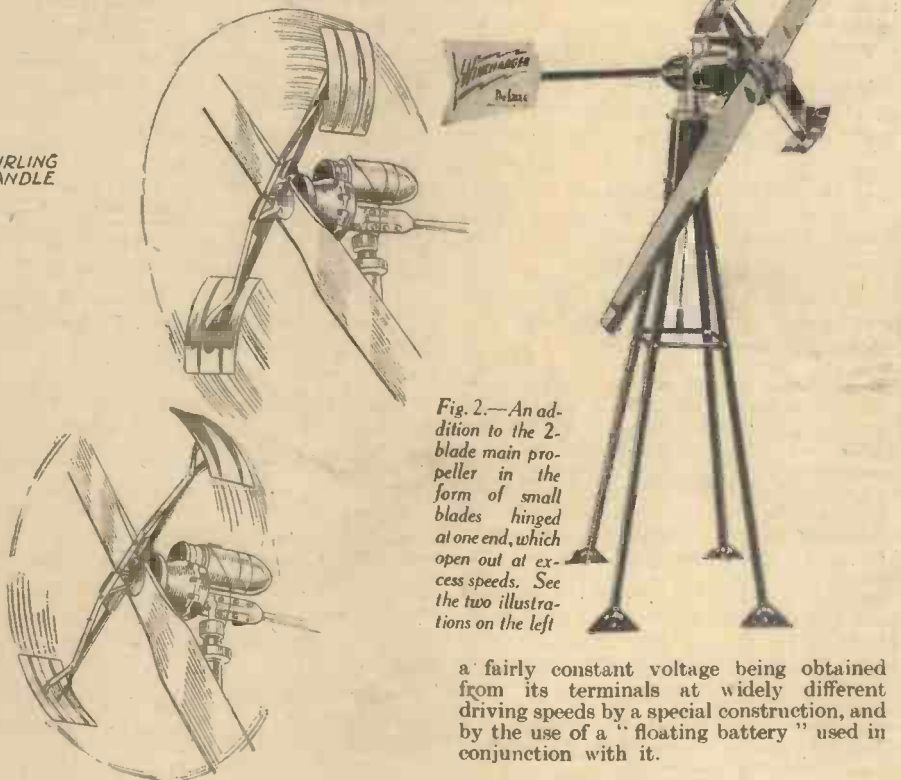

Fig. 2.—An addition to the 2-blade main propeller in the form of small blades hinged at one end, which open out at excess speeds. See the two illustrations on the left

get away from the fact that the petrol or other fuel employed has to be paid for and transport arranged. The great attraction about wind-driven generators lies in the fact of getting one's power for nothing, utilising one of the free gifts of Nature.

Although wind power in these islands is apt to be rather erratic, far too much of it at times and not enough of it at others to provide any useful results, it is a notable fact that taken over a long period careful observations have proved that serviceable wind power is available for an average of eight hours per day in the majority of localities, if the site is carefully chosen.

**Variations in Speed**  
The problem with wind motors is, of course, to control the variations in speed arising from extreme weather conditions, such as periods of calm on the one hand and tempests on the other. A wind motor to be successful must be so constructed as to resist disaster in a gale and yet be sufficiently sensitive to develop useful power in winds of light or moderate velocity.

This brings one to the necessity for some definition as to what constitutes the difference between a breeze and a hurricane. The Meteorological Office has compiled a table known as "Beaufort Scale Numbers" which are attributed to winds of varying force according to their characteristics as below:—

Beaufort Scale	Corresponding Wind	Velocities in Miles per Hour
0	Calm	Under 2
1 to 3	Light Breeze	2 to 12
4 to 5	Moderate Wind	13 to 23
6 to 7	Strong Wind	24 to 37
8 to 9	Gale	38 to 55
10 to 11	Storm	56 to 75
12	Hurricane	Above 75

Any lighting system to be practicable must be so designed as to allow a reasonably constant voltage to be maintained at the lamps, otherwise there will be great fluctuation in the light and a risk of burning out the bulbs. Much the same problem confronts the automobile industry; the considerable variations of engine speed which occur during road use have to be counteracted by some means before lighting from the car dynamo can become satisfactory, and in this there is a definite resemblance between motor-car generators and wind-driven dynamos. In the car, engine speeds must of necessity vary in order to meet the conditions imposed by gear-changing, gradients, traffic conditions, etc. In the wind generator similar speed variations are unavoidable with changes in the wind velocity. In both cases there must be storage capacity to tide over periods when the driving power is not available.

The motor industry solves this problem by the development of the so-called "constant voltage" generator, which permits of

a fairly constant voltage being obtained from its terminals at widely different driving speeds by a special construction, and by the use of a "floating battery" used in conjunction with it.

## Constant Voltage Generator

There are in fact a good many different devices for obtaining constant voltage at varying speeds, but the most popular is the one known as "third-brush control." In the case of the ordinary shunt-wound 2-pole dynamo such as used for stationary lighting sets, engine-driven at a closely governed speed, there are two brushes only at opposite positions on the commutator, see Fig. 3. The windings form two distinct circuits, one through the armature B and brushes to the main terminals B and so direct to the lamps or battery; the other is an independent and separate circuit C through the fields only, a small current being "shunted" from the main terminals for the sole purpose of exciting the field magnet coils. In a dynamo of this type the voltage (the E.M.F.) generated by the armature is almost directly proportional to its speed, and variations in driving speed would cause corresponding fluctuations in the light given by any lamps connected to the terminals. Quite obviously a generator of this class would be unsuitable for lighting



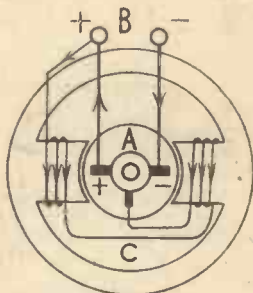

Fig. 3.—A shunt-wound 2-pole dynamo

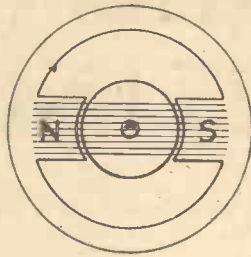

Fig. 4.—Showing the magnetic lines of force fairly evenly distributed over the pole faces

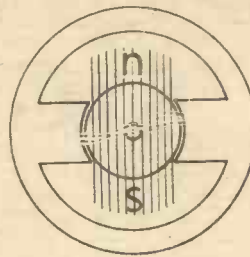

Fig. 5.—A cross "flux" set up by the armature coils

purposes where speeds would be as erratic as in a car engine or a wind motor.

**Theory Explained**

To understand how such voltage variations can be counteracted in the car-lighting dynamo by third-brush-control the theory can be best explained with the aid of the following diagrams. When an ordinary shunt-wound dynamo as Fig. 3 is running light, that is with no lamp load connected to its terminals, the magnetic lines of force or "flux" from the field magnet poles N.S. (Fig. 4) in which the armature coils are rotating, and which are the seat of the E.M.F. generated, are fairly evenly distributed over the pole faces. When the dynamo is loaded however and delivering current from the armature to the lamps the flow of current round the armature coils sets up a cross flux "n.s." (Fig. 5) at right angles to that due to the main field magnet. The joint effect of these two conflicting fields is to distort both from their normal course, so that the field axis as a whole swings round into an intermediate position shown by Fig. 6. It will now be evident that some of the armature coils lie under portions of the pole faces where the field is much weaker than before, and consequently they cannot generate their full E.M.F. The greater the armature current becomes the more will the resultant field be distorted, becoming concentrated in one tip of each pole face and thinned out in the other (Fig. 6). Field distortion due to this armature reaction is taken advantage of in constant-voltage dynamos to compensate for the tendency to increased voltage at increasing speeds by exciting the field coils from a third brush intermediate to the two main brushes, Fig. 7, instead of direct across the two main terminals. This has the effect of reducing the effective excitation of the fields automatically in proportion to the extent by which the field flux is swung across the pole face by the cross flux arising from armature current, and the result is a reasonably effective voltage compensation throughout a considerable range of speed changes.

**Current Output**

Such systems of voltage control are not effective however unless the dynamo is working in conjunction with a battery of accumulators. When supplying a lamp load alone it would require a very considerable rise of dynamo voltage to create any great increase in the current output from the dynamo, upon which the reaction described depends. But when there is a battery of accumulators in circuit the "forward" E.M.F. of the dynamo and the "backward" E.M.F. of the battery are more or less in an opposing state of balance, and a very little excess of the one over the other would cause a considerable increase in the charging current, so enabling the dynamo to exhibit its self-regulating properties.

The foregoing explanation has a direct application to the problem which has to be met in all wind-driven lighting sets, and the presence of a floating battery used with a constant-voltage dynamo is the only known means of obtaining a steady light with the varying driving speeds inseparable from such forms of motive power. In short, the "governor" is an electrical one applied to the generator, instead of a mechanical one

**A Mechanical Governor**

Some attempts have certainly been made to combine the two in aiming at a dual control of speed and voltage by the addition of a mechanical governor or wind-diverter, or even a small wind vane attached to the tail to move the propeller into less effective

which open out at excess speeds by centrifugal effect and cause the wind stream to diverge before reaching the main propeller blades. This device is used in the "Win-charger" outfits manufactured by an American Company. In these the natural regulation of the constant-voltage dynamo is augmented by the action of the air-brake seen at right angles to the propeller when a critical speed is exceeded. An English set is illustrated in Fig. 1, which relies principally on the self-governing properties of the dynamo, aided by a furling action of the wind-motor tail. The operation of this device as supplied by the makers is as follows, the parts referred to being illustrated in Fig. 1. When the furling handle is moved downwards to bring the set into operation, a metal collar B is slid down the shaft against the tension of spring A. The whole of the head gear is free to rotate within the metal collar. A forked member C is engaged with the collar and is moved downwards about its pivot by the collar. A lever arm F attached to the forked member engages the tail bracket E causing it to be moved outwards against the tension of spring D. When furling the reverse takes place. Release of the furling handle relieves spring A and allows the metal collar to slide up the headgear. This lifts the forked member, the lever arm F is disengaged from the tail bracket, and the tail is thus returned to the furled position by spring D. In the event of very strong winds likely to cause excess speeds the tail is swung back and out

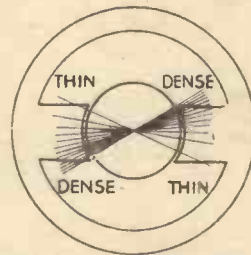

Fig. 6.—Two conflicting fields are distorted from their normal course

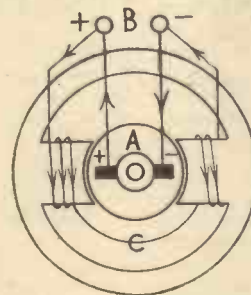

Fig. 7.—A constant voltage dynamo

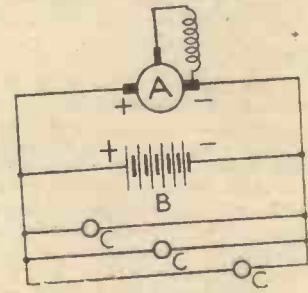

Fig. 8.—The circuit diagram for most types of wind motors

positions with increasing force of the wind. One example is given in Fig. 2 showing an addition to the 2-blade main propeller in the form of small blades hinged at one end

of the wind with a consequent regulation of the dynamo speed.

**The Electrical Circuit**

Apart from details of design, such as typical in the foregoing illustrations, the electrical circuit is similar in all such outfits, and in its simplest form without any switches, instruments, or other complications is arranged as in Fig. 8, consisting of dynamo A, battery B, and lamps C, all in parallel with one another. From this elementary layout it will be seen that the lamps can derive their current either from the dynamo or from the battery, or from both contributing at the same time.

But there must be some automatic means of preventing current from the battery discharging back through the dynamo when the latter is not running fast enough to charge. Also switches are required to control individual lamps, and an ammeter to measure the charge or discharge current in the accumulator circuit.

When these necessary items are added the circuit in Fig. 8 becomes as Fig. 9. The Dynamo A excites the field coils B from the third intermediate brush and one main terminal, independently of the rest of the circuit, and is protected by a fuse C. Should the accumulator become disconnected while the dynamo is running at normal speed the resulting rise in voltage would cause increased current through B and fuse C would then

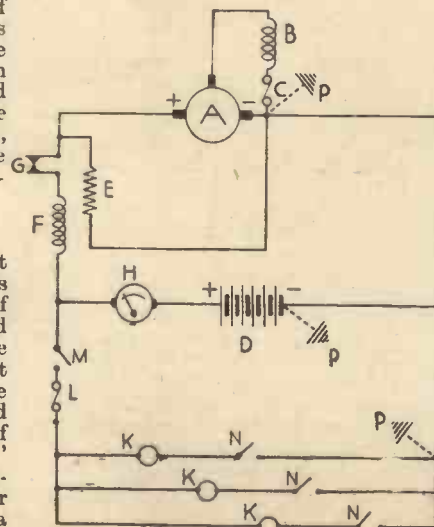

Fig. 9.—How to prevent the current from the battery discharging back through the dynamo when the latter is not running fast enough to charge



protect the field windings from the effects of excess voltage by breaking the circuit. Between the battery D and the dynamo A comes the automatic cut-in and cut-out switch E.F.G. This has two coils, one of which E is a "voltage" or high-resistance coil connected directly across the main dynamo terminals and which serves to "cut in" whenever the dynamo voltage is sufficiently high to overpower the back E.M.F. of the battery, which it does by closing the contacts at G. As soon as these are closed the accumulator begins to charge and this current by passing through coil F of the cut-out adds its effects to that of E, holding the contacts G firmly together. If for any reason the battery voltage should rise beyond that of the dynamo E.M.F., causing current to flow in a backward direction, the reversal of current through F causes the contacts G to separate and so automatically interrupts the circuit between dynamo and battery before any harm can be done.

In series with the battery D is a centre-zero ammeter H which serves to show the amount as well as the direction of whatever current happens to be passing through the circuit. The lamp circuit K is protected by a single pole switch and fuse M and L, while each lamp can be switched in or out by means of its own switch N.

#### Small Lighting Sets

Since many small lighting sets are operated on the "earth return" system instead of being provided with a continuous metallic circuit, an alternative is shown on the negative side of the wiring system by providing earth plates at P, or if a main water supply is available connections can be taken to the nearest pipe. Earth returns are not advised for very low voltage circuits as they sometimes introduce too high a resistance, and as a general thing it is advisable to have an insulated metal circuit throughout for all the wiring.

Readers who feel that the professionally made wind-electric lighting sets are beyond their means, may care to consider those illustrated in the foregoing as suggestions for building up home-made outfits, with such variations as they care to introduce, and making use of such material as happens to be available, modifying the general design accordingly. They will be well advised however to regard simplicity of design as the first essential, and bear in mind that the wind-electric outfit is not always a fine weather equipment, and must be substantially built so as to withstand storm and tempest.

The indispensable parts in any such outfit comprise (1) the constant-voltage dynamo, (2) the propeller, (3) a tailpiece to keep the propeller in the wind, (4) the collector rings for conveying current from the movable head to fixed terminal points, and (5) the mast upon which the whole is mounted.

So far as the generator is concerned there are plenty of good secondhand car lighting dynamos to be picked up cheaply, of a type illustrated in Fig. 11. This is one of the most popular models, and makes a very serviceable unit, cutting in for charging at 850 r.p.m. and giving its full output of 12 volts 13 or 14 amperes at about 1,350 r.p.m. If larger models happen to be available they can of course be used, and the lower the cutting-in speed the more serviceable will they be in light winds.

#### The Propeller

Item (2), the propeller, will no doubt demand some little patience and several modifications before a satisfactory home-made article is arrived at. Lightness and

strength is of course essential as the centrifugal effect and thrust will be considerable at high speeds. A well seasoned piece of straight grained pine or cedar will be required, in one piece 6 ft. long and 1½ in. thick, tapering from 6½ in. wide at the hub to 3½ in. or 4 in. at the tips, fashioned on the lines shown in Figs. 1 and 2, the pitch of the blades being about 35 degrees measured from the plane of rotation. The boss needs strengthening by a flanged double-arm casting, keyed to the dynamo shaft and retained by an end lock nut.

The design and dimensions of the sheet-

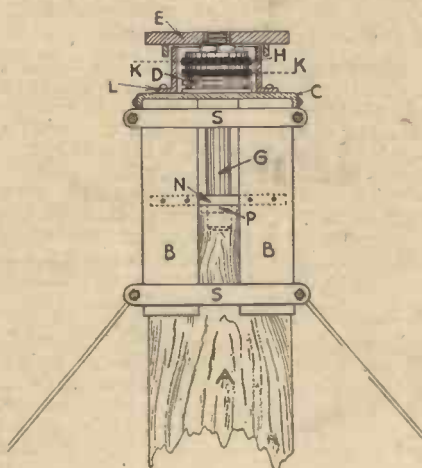

Fig. 10.—Details of the rotatable head

metal tailpiece are obtainable from Fig. 2, the extension arm carrying it consisting of a length of seamless steel conduit about 1 inch diameter such as used in electric wiring, attached to the revolving head by saddles at each extremity.

#### The Rotatable Head

The rotatable head with the collector rings needs planning out with a view to utilising whatever "scrap" happens to be available in the workshop, and dimensions are of secondary importance, so long as the collector is not too small, say 3 in. in

diameter. The main idea is sketched out in Fig. 10, but is not to scale for reasons stated previously. As shown in this figure the wood mast A terminates in four angle pieces of 1½ in. x 1½ in. mild steel B, not less than 12 in. long, which are arranged to grip the mast with four straps and bolts S. These angle pieces stand up six inches beyond the end of the mast, and a flanged steel plate C is screwed to them to form a rigid metal top. Above this is the rotatable table E to which the dynamo is fixed, and from the underside of which extends a central tube G carrying the two insulated sliprings H. From these rings current can be collected whatever may be the position in which the dynamo is pointing, by means of two insulated cartridge type carbon brush-holders K. An outer casing L which serves for their mounting is fixed to C and forms a protection from wet or dust, and is drawn in section to expose the collector rings.

Connections from the dynamo terminals are brought down through the hollow stem G, one being attached to each slipring. Between the underside of the slipring assembly and the fixed head C may be placed a ball thrust washer D to carry the whole weight of the dynamo and propeller. The extremity of the stem at N is guided and supported by passing through a cross strap riveted to the angles B, with a nut P to prevent it from rising.

The design of the head is to be taken as a suggestion, and subject to variation according to means and experience. It forms a workable basis for building up a practicable wind-driven lighting installation capable of providing a good light to four or five bulbs of 25-watt size, when working in conjunction with a 12-volt car accumulator.

### WORKSHOP CALCULATIONS, TABLES AND FORMULÆ

by F. J. CAMM

A handbook dealing with methods of calculation, solution to workshop problems, and the rules and formulæ necessary in various workshop processes. It contains all the information a mechanic normally requires.

From all booksellers 3/6 net,  
by post 3/9 from the publisher:

GEORGE NEWNES LTD. (Book Dept.),  
Tower House, Southampton St., London, W.C.2

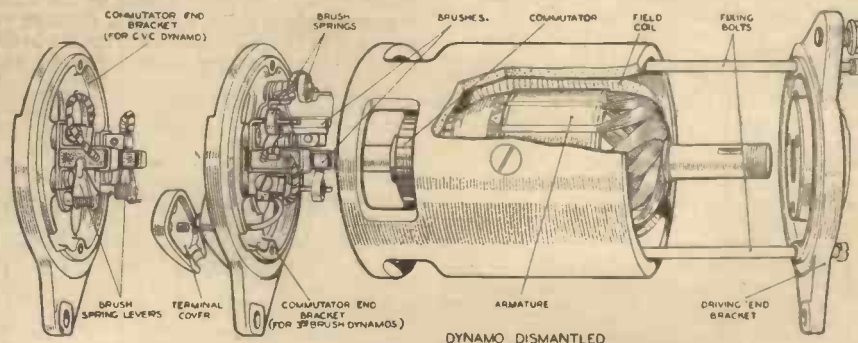

Fig. 11.—A car lighting dynamo showing construction

### BOOK RECEIVED

"The Restless Earth." By R. Gheyselinck.  
Published by The Scientific Book Club.  
286 pages. Price 2s. 6d. to members.

WHEN we glance towards the skies and ponder over the secret world of the stars, or when we probe into the secrets of nature—the wide realm of animals and plants—we are apt to forget the significance of the earth, that giant globe on which we live and have our being. In this interesting book the author has described in non-

technical language the agitated movement going on in the body of the earth, changing it again and again. All these changes are dependent on the rhythm of geological events which are subject to certain laws, and these are clearly explained in this book. There are seven chapters, covering such subjects as The Enigmatic Beginning; The Face of the Earth: Petrified Life; The Great Rhythm; Mountains Grow; The Unsteady Crust, and Wegener's Theory of Continents Drift. The book is illustrated with eight half-tones.



# MAKING AN AIR-RAID

# SHELTER

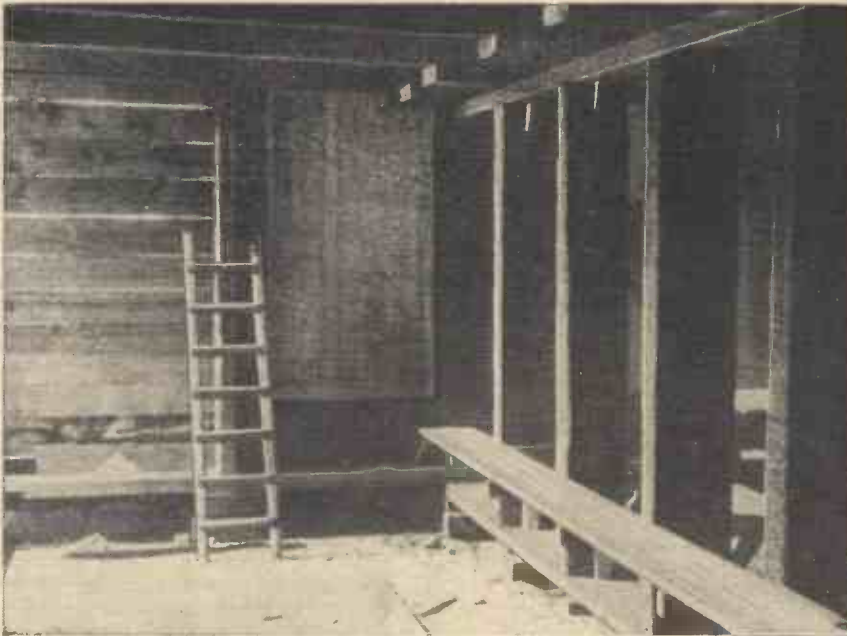

An air-raid shelter capable of accommodating twenty persons. Note the heavy timbring

## Details for Constructing Underground and Semi-Surface Shelters

tory air-raid shelter is by no means a difficult task, although it is apt to be a laborious one, for those unused to heavy manual labour.

No ordinarily-constructed shelter, of course, can be completely proof against a direct hit by a heavy bomb. For such missiles, only the very deep shelter can possibly give complete safety. Heavy bombs, however are expensive articles and, if only in view of this fact alone, they are not likely to be used in any desultory fashion. The ordinary air-raid shelter, therefore, the

**R**EGRETTABLE though the fact may be, it seems evident that in these modern times the air-raid shelter constitutes a structure which, for some years at any rate, has come to stay. Although the countryman may, as a rule, not be in need of any bomb-proof chamber, nearly every town-dweller must necessarily in times of hostilities face the urgent prospect of having hurriedly to take refuge during an air-raid in the best shelter available, for, it must be remembered that not only will the enemy's bombs constitute a danger to life and limb but, also, in a secondary degree, will falling fragments from our anti-aircraft shells, to say nothing of the scattered wreckage of raiding planes!

Hence, in times of modern aerial warfare, there must be a shelter for everybody—at least for every town and city occupant, otherwise a large number of quite unneces-

sary casualties must inevitably result from an enemy raid.

### Simple Task

Despite the provision of the "Anderson" pressed steel shelters by the Government and, also, the erection of public air-raid shelters by the various municipalities and public authorities, there are many individuals who have a mind to erect their own shelters for the use of their families and for any friends who may be with them at the time of an aerial emergency. Provided that a few common-sense principles are adhered to, the building of a satisfac-



(Right) Entrance to an underground shelter. A ladder is lowered from above (not shown in illustration)

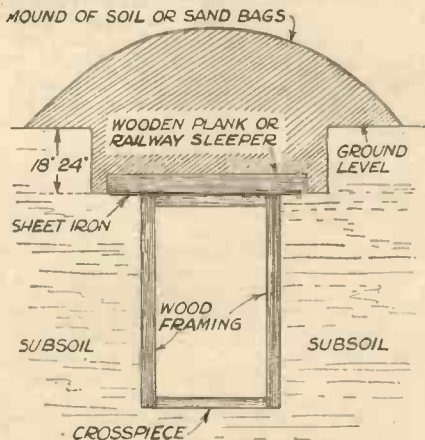

(Above) An underground shelter designed to give maximum protection, and (right) a semi-surface shelter. It is only half buried in the ground, the upper half being protected by a mound of earth

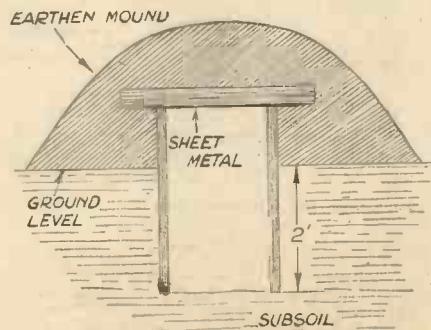

shelter which any handyman can make for himself and for his family, has certainly a high margin of safety, as witness, for example, the tests with the Government's "Anderson" steel shelters, which have proved themselves to be capable of withstanding shock and blast to an astonishing extent.

### An Exploding Bomb

When a bomb explodes on contact with the ground or any other firm object, its "explosion zone" is roughly conical in shape, after the fashion of an inverted umbrella. That is to say, the force and zone of the explosion invariably tends to be upwards in an oblique direction. The minimum



force of the explosion is in a downwards direction. Hence, even if a light bomb does happen to make a direct hit on an underground shelter, the chances are that the occupants of the latter compartment will escape harm, since the bomb will expend its force in an upwards direction, flinging out its debris away from the shelter.

It is, of course, a rule in A.R.P. work that the deeper your shelter is below the ground, the greater the degree of protection it will afford. Even a shelter buried at only a small depth of, say, eighteen inches possesses an extraordinary safety-factor against blast and concussion, whilst, of course, it completely protects its inmates against flying splinters and other metal fragments.

A completely underground shelter which any amateur can make provided he has the necessary ground space is illustrated in the diagram. Here, it will be seen that the roof of the shelter is between 18 inches and 2 feet below the ground level and that further protection is provided by throwing up a mound of earth or of sandbags over the shelter.

### Underground Shelter

A shelter of this type is an efficient one. It must, however, be carefully and properly made, due regard being paid to seeing that the sides cannot possibly fall in or the roof of the shelter collapse under the weight of the soil above it. If strong timbers are employed for lining, cross-piecing and roofing the shelter, this cannot possibly happen, but on no account must weak timber be employed for this purpose.

Old railway sleepers make excellent timbers for shelter-construction, and in most towns there is generally some wood-yard or general dealer's establishment where such useful articles can be purchased cheaply enough.

Owing to the fact that individual requirements vary a good deal and that consideration must be paid to available space, it is not practicable to give in the diagrams accompanying this article actual dimensions for the various shelters. Naturally, if the shelter is not to accommodate standing persons, it need not have the 6-foot height which would be necessary to allow individuals to stand erect in it. It is advisable, however, to make the shelter wide enough to allow of a few seats being put in it.

Instead of employing timber for the framing and roofing of an underground shelter, cast concrete can be used instead. This, of course, is much stronger than wood and, what is more, it is absolutely rot-proof and permanent. Thus it is that a concrete-framed shelter, particularly if it is internally bricked or asphalted in order to render it waterproof, could be employed permanently as a useful place for storing garden tools and a hundred and one other items of domestic utility.

### Cast Concrete

It is not a difficult matter to manufacture cast concrete objects, such as the roofing and framework of an air-raid shelter, at home. All one requires is Portland cement and a quantity of grit. This "grit" must not consist entirely of sand. Rather, about 20 per cent of it should comprise broken stones about 1½ inches across. Another 30 per cent should comprise smaller stones, and the rest of the "grit" should be made up of fine particles, say a mixture of sand and slightly coarser grit particles. Such "aggregate," as this ingredient of the concrete is termed, when mixed with the cement, moistened and allowed to set, will provide an exceedingly strong and durable concrete. Four parts of the "aggregate" (i.e. the grit)

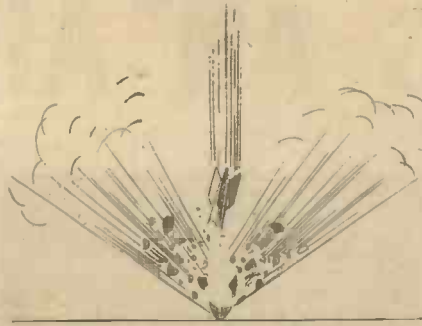

Representation of a bursting bomb showing the roughly conical or "inverted umbrella" shape of the blast zone of the explosion

is mixed intimately with one part of the cement and made just wet with water. It is then packed into moulds made from wooden

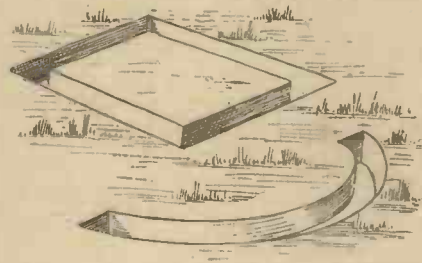

Channels cut in the ground for casting concrete

strips, or, alternatively, it is filled into mould channels made in well-consolidated ground. After setting, the cast concrete article is

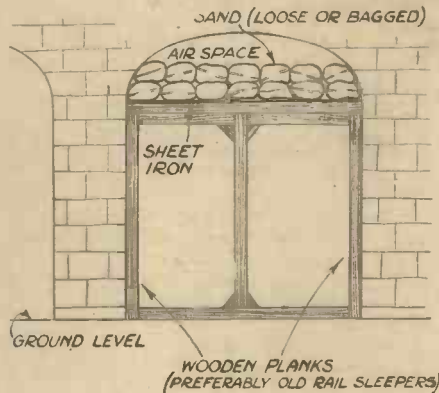

Utilising an arch for a convenient above-ground shelter

simply stripped of its mould and it is then ready for use.

When dealing with concrete or stone roofs of underground shelters the fact should be

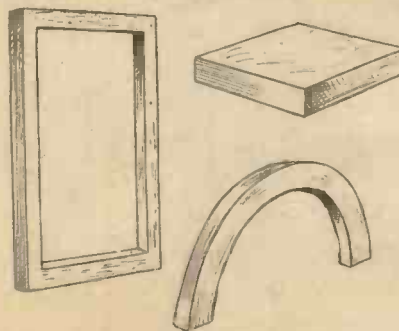

Cast concrete shapes suitable for shelter construction. They can be made at home in earthen or wooden moulds

born in mind that a gently-arched roof is considerably stronger than a flat one, although it is rather more difficult to erect successfully.

An underground shelter must naturally be provided with a suitable entrance. In many cases, this entrance can be effected merely by sloping the ground down from the surface level to the shelter beneath it. This is the best form of entrance to construct in those instances in which the air-raid shelter will afterwards be required permanently for the storage of various articles.

### The Door

An entrance to the shelter can also be effected by digging a vertical shaft and by suitably framing it with wood so that the sides do not fall in, access to the shelter being gained by means of a ladder. Actually, it is always best to have two entrances (or exits) to any underground shelter so that if a bomb fell unpleasantly near and resulted in the blocking up of one entrance, the other would stand a great chance of being available. In any case, however, it is always policy during an actual air-raid to take a strong shovel into any variety of ground shelter so that if the very worst happened and the shelter were covered with fallen debris, one would stand on almost certain chance of being able to dig or force oneself out.

A "semi-surface" shelter is shown on page 7. This comprises a rather simpler type than the previous totally-submerged one, yet its construction is on very similar lines. Stout timber, concrete or brickwork is the best material to construct this type of shelter with. The shelter must, of course, be thoroughly well moulded on all sides but its entrance side, and even here some sort of removable screen, such as a heavy metal sheet, should be provided.

The above type of shelter is much on the same lines as the ordinary Anderson or Government "tin" shelter, in the respects that it is entered in the same way as the latter, and, if properly constructed, is equally as blast-proof. Moreover, such a shelter can be constructed at a tithe of the cost at which the Government shelters may be bought, since all that is required in the way of constructional materials is some stout timber (preferably railway sleepers) and a few sheets of galvanised iron or similar flat metalwork.

### Above Ground

Shelters which are completely above ground, although they will give complete protection from flying fragments, cannot possibly be expected to provide the degree of protection from blast and concussion which is to be obtained from a submerged shelter. Yet, in many instances, above-ground shelters must be relied upon, particularly in congested areas and in yards which do not permit digging into the soil.

In the making of such shelters, personal ingenuity must necessarily play a great role. It is impossible to give directions for all possible types of above-ground shelters. If, however, the sides of such shelters are efficiently earth-mounded or sandbagged and their roofs (if possible) are treated in some similar manner, then a close approach to the theoretical maximum degree of protection will be obtained. Just as garden and underground shelters should be constructed as far as possible from neighbouring buildings which would be likely to collapse if hit by an exploding bomb, so, too, should these "above-ground" shelters be erected in situations which would at least liable to serious damage from falling masonry. An outhouse having its sides earth-mounded or



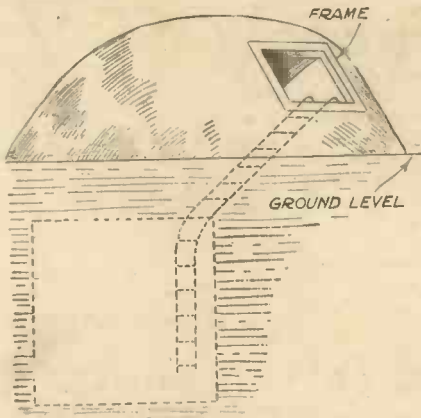

Two methods of providing an entrance to an underground shelter. (Above) By descent from a ladder—a frame opening is constructed on the mound covering the shelter—and (right) by means of a gradual slope

preferably sandbagged and having at least one layer of sandbags on its roof makes a reasonably efficient above-ground shelter. A similar type of shelter can be made at the angle of two yard walls, whilst, with any convenient arch, a very high degree of air-raid protection can be obtained by means of stout timbers and sandbags. Many commercial firms, indeed, have employed railway arches for the construction of their shelters, and although such shelters are by no means the most ideal ones, it is possible to impart to them an astonishingly high safety factor.

Insistence upon effective earth-mounding and/or sandbagging must be made in the construction of all types of shelters. Sandbags should not be filled too tightly. They "bed" down better when they are "floppy" filled and, as a matter of fact, their bullet-stopping propensities in this loosely-filled state are better than when the bags are tightly filled. Dry sand should be used in the filling of the sandbags. Otherwise, the water will evaporate and subsidences may occur.

**Sandbags**

Whether simple earth-mounding is better than sandbagging is a controversial matter. One foot thickness of sandbags, however, is likely to stop a flying fragment more effectively than a foot thickness of compacted soil owing to the greater resistance of the individual hard and partially-separated sand grains. On the other hand, however, sandbags cost more than simple earth-mounding or earth-walling. Hence, in the instance of most amateur-constructed shelters it would seem that the superiority of sandbags is, to a large extent, offset by the much lesser cost of earthing a shelter.

**"Bedding Down"**

After any type of shelter has been constructed it should always, if possible, be given a week or two in which to "bed down," as the saying is. During this time, the floor and sides of the shelter (if it is a below-ground one) will consolidate themselves and the earth-mounding and/or sandbagging will, in like manner, become more homogeneously compacted and united, thus adding greater stability and security to the shelter. Any small subsidences which may have occurred during this period can be made good and the shelter, as a whole, finally completed.

To a large extent, the timber employed in shelter construction can be rot-proofed by being creosoted, the creosote being best

brushed on to the wood in a hot state to ensure maximum penetration. To many people, the smell of creosote is unpleasant, yet, at the same time, it is a decided disinfectant and is permanently obnoxious to beetles, mice and other pests.

For a purely temporary shelter, however, there is, perhaps, no need to go to much trouble in the way of rot-proofing the materials used in its construction. It is only

and neutralised by the earth-mounding of the shelter. All the same, it is best to take one's gas mask into a shelter during an air raid in case some "true gas," such as phosgene, should be used by the enemy.

**Cleanliness**

Naturally enough, an air-raid shelter should, so far as possible, be kept clean and tidy during any period of hostilities. To a

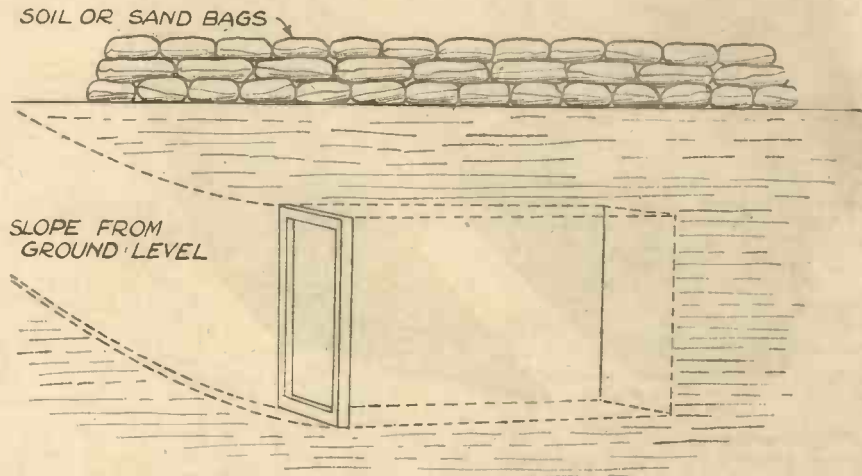

when the shelter is likely to be required permanently for other uses than air-raid protection that attention to its lengthy preservation need be given.

**Not Gas Proof**

None of the shelters mentioned in this article can hope to be gas-proof. At the same time, however, the "gas" employed in modern warfare is in the nature of an oily spray and much of this would be absorbed

certain extent it can be kept dry by putting a layer of sand, sawdust or straw on its floor and by changing this frequently. Large shelters might advantageously be equipped with electric lighting supplied by an accumulator and a miniature bulb. Otherwise individual electric torches may, at times, be required, although during any night-time raid the greatest care must be taken not to allow their beams to penetrate outside the shelter.

**A COMPACT SET OF GOLF CLUBS**



Demonstrating the use of the new golf kit, showing how the head is screwed on the shaft

GOLF experts in America have designed a kit of playing tools requiring only one shaft, to which can be attached the head needed for each shot on the golf course. There is a saving in weight—some four pounds for the kit as compared to fourteen pounds for the bag—a saving in bulk and a saving in initial cost.

In slots on the side of the kit the five iron and two wood heads are held in place. A Zipp fastener provides a compartment for balls, and a half-dozen small slots are convenient for carrying tees. It has been demonstrated that the clubs with their screwed-in heads provide a firm hitting surface. Contact of the club head with the ball does not tend to loosen the head. Rather the impact serves to tighten the head since the golfer is hitting against the groove of the screw.

**Endurance Record**

TWO brothers Hunter and Humphrey Moody, of Decatur, Illinois, are claiming a new endurance record for light aeroplanes. They remained in the air for 343 hours, 46 minutes. For fourteen days they were cramped in their small monoplane and state that they could have carried on much longer but were forced to land owing to bad electrical storms. The previous record for light aeroplanes was 218 hours 43 minutes.



# BEYOND THE GRAVITY FIELD

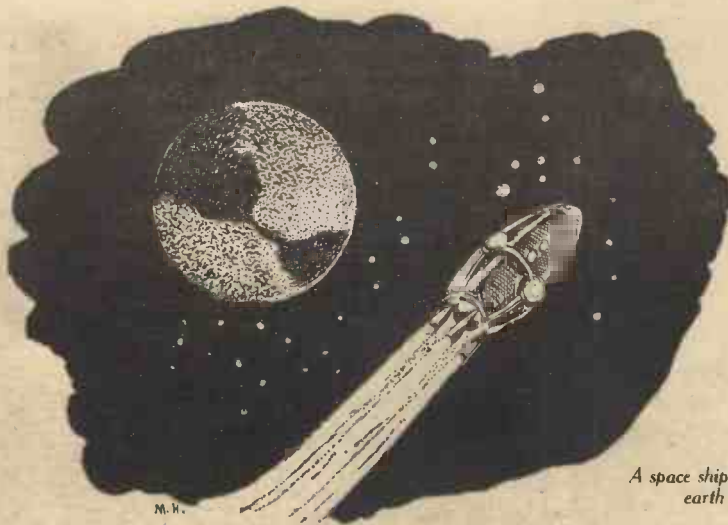

A space ship sets off from the earth for Mars

**O**NE curious fact which becomes apparent in reading through the history of human discovery is the extraordinary prevision which enables men to visualise the actual form of an invention long before anyone has come within miles of realising it as an actual possibility.

Readers who have seen the prints of "Henson's Aerial Steam Carriage," which was patented in the 1840's, will have been struck by the way in which the ingenious Henson anticipated in his design the pusher monoplane of seventy years later.

I mention this ability of the inventive mind to foresee the inevitable course of human ingenuity because there are men working to-day on a problem that has long captured the imagination of mankind; the problem of interplanetary flight.

A number of the most important difficulties in the way of rocket-flight (to which the interplanetary pioneers are pinning their faith) have been overcome. In Europe, Willy Ley is the leading "rocketeer," author of a number of works on the subject of interplanetary flight, and the founder of an international space-travel society.

In Soviet Russia, Tsiolkovsky has interested himself with marked success in the same pursuit. The former air-ace, Major-General Udet, has taken keen interest in the question of rocket-flight, and the movement has received considerable support from the German Government.

Now let us see what are the major problems involved in achieving rocket-flight to the extent where interplanetary travel becomes possible.

First, the question of power. This, unless some genius learns to liberate atomic energy in larger quantities than is at present possible, will be supplied by the high explosive force of (in all probability) a mixture of liquid oxygen and liquid hydrogen, kept under extremely high pressure and released into the firing chambers, from which the ignited gases are expelled through the rocket tubes.

Why rockets stand supreme in the list of all possible motive-agents is because a rocket will travel in a vacuum. A glance at the sketch will show the reason for this. Think of a rocket in flight, with the exploded gases rushing out of the rocket-tube.

When the fuel is ignited it shoots out of

the opening at very high velocity. In a flight through air, the resistance of the atmosphere to the escaping gases *pushes* the rocket forward: in the near or total vacuum of space this resistance does not exist, so that as far as the force of the escaping gases is concerned there is a total loss of energy here.

But, examining the sketch, you will see that on being ignited the fuel explodes in four directions of impact: through the opening, against the sides, and against the front wall of the firing-chamber. In free space, as there is no air for the gases to react against, the gases rush out unimpeded.

In the second and third reactions—against the sides of the firing chamber—the reactions neutralise each other. But with the fourth reaction—against the forward wall—the explosive force actually *pushes*

Diagram illustrating the four directions of impact when the rocket-fuel is ignited

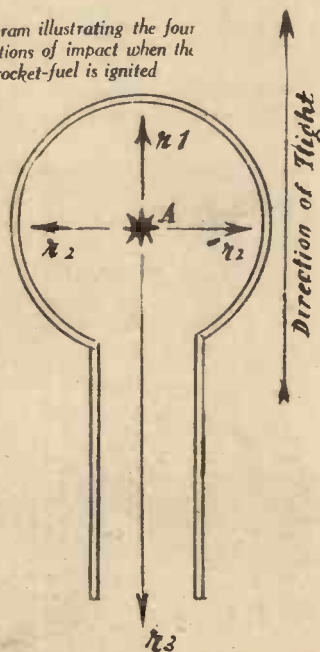

A exploding fuel  
r points of reaction

## The Cold Facts about the Prospects of Interplanetary Travel

the rocket forward. So that even with the loss of energy caused by the absence of an atmosphere the rocket can still travel in a vacuum.

It is probable that when interplanetary flight does arrive rocket-ships will use retractable wings in order to take advantage of the earth's atmosphere while they are still within it.

As to the speed that must be attained in order that the ship may be able to overcome gravitational force and leave the earth's gravity-field—well, this is a simple problem in mathematics, giving the "velocity of escape" as 4.90 miles per second. There is also another important point to be remembered. We should naturally, in attempting to leave the earth, take advantage of the eastward equatorial rotation of .28 miles per second so that, in order to leave the earth in an eastward direction above the equator, we should need to attain a velocity of no more than 4.62 miles per second.

Nor is this figure—high as it seems—impossible to achieve even with ordinary molecular energy, and the rocket-flight pioneers are not discouraged by a necessary speed of four and a half miles per second. Indeed, the main difficulty in establishing interplanetary travel on a sound basis will not arise in any problems of engineering, but through the danger of the asteroid belt—countless mineral particles, ranging in size between pebbles and lumps of ore several miles long.

They are all that remains of what was once a planet, exploded in some cosmic catastrophe. They represent a great danger to the space-traveller of the future, and much ingenuity will be needed to overcome this peril.

The dangerous effects of the "cosmic rays" are well known now, but the space-ship will probably be supplied with a double skin containing ozone, a very thin layer of which is all that protects us here on earth from these rays' harmful effects.

These are the main problems. Modern experience has shown that speed in itself is not dangerous to the human system: only acceleration—or sudden acceleration—rather.

### CHANGE OF NAME

IN the last three issues of "Practical Mechanics" announcements have appeared on behalf of the Delta (Nottingham) Manufacturing Company of Nottingham.

Owing to an infringement, it has been mutually agreed that this firm's name and the name of its products shall be changed. The firm in future, will be known as the Homrux Projector Company, and its products marketed under the name "Homrux"; the address remains as before, 46 High Pavement Nottingham, England.



# Chemistry for Beginners

## No. 7.—Some Interesting Acids. How to Prepare and Experiment with them in the Home Laboratory

THE three most important acids are nitric, hydrochloric and sulphuric acids. In Great Britain alone, this trio of acids is manufactured to the extent of hundreds of thousands of tons per annum, for these acids play a tremendously important and fundamental part in the chemical industry of our country.

Acids like the above-mentioned ones are frequently known as "mineral" acids, in consequence of their being prepared from so-called mineral materials such as common salt, nitre and brimstone (sulphur). Hence, when "mineral acids" are referred to, this term is usually taken to denote one or all of the three acids above mentioned.

Nitric acid,  $\text{HNO}_3$ , one of the most powerful of all the known acids, has always been of very great importance. We may term it the "explosive" acid, for it is used in the manufacture of all modern explosives. It is not, however, in any way explosive itself. Hence, if due precautions are taken to guard against its highly corrosive nature, this acid may be prepared safely by any average experimenter.

### Small Scale Production

In order to make nitric acid on a small

## Practical Experiments for the Home Worker

scale, we require a glass retort, a quantity of saltpetre (potassium nitrate) and some concentrated sulphuric acid. All we have to do in this case is to distil gently a mixture of potassium nitrate with its equal weight of concentrated sulphuric acid and fairly pure nitric acid will collect in the receiver, the residue in the retort consisting of potassium hydrogen sulphate, as will be evident from the following equation:—

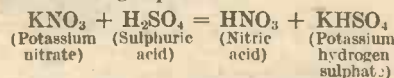

Nitric acid, it will be observed, is a compound of hydrogen, nitrogen and oxygen. It is nowadays made in vast quantities by passing air (which consists of a mixture of oxygen and nitrogen) through a specially-designed electric flame-arc furnace, whereby a portion of the oxygen and nitrogen of the air directly combine to produce various oxides of nitrogen which, when absorbed into water, and further oxidised, form nitric acid. This process of making nitric acid from the air is often referred to as that of the "fixation of atmospheric nitrogen" and it is of the greatest industrial importance, since an adequate supply of nitric acid is required not only for the manufacture of explosives and blasting agents, but, also, in the photographic, dyestuff, drug, plastics, fertiliser and numerous other industries.

As a matter of fact old Mother Nature herself has practised this "fixation of

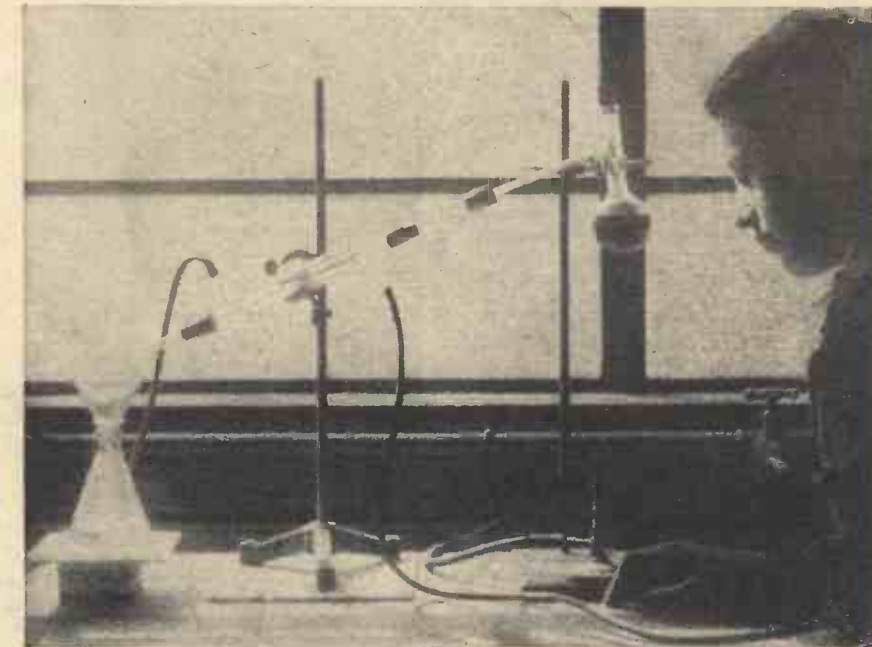

A "herbig's condenser" used in the laboratory distillation of liquids. It consists merely of a water-jacketed glass tube

atmospheric nitrogen" from time immemorial, for every time a lightning flash occurs, a quantity of nitric acid is formed

is a strong-smelling liquid and will be almost colourless. In the strong or the diluted state, it dissolves a large number of metals, forming the nitrates of such metals in solution.

For instance, if we dissolve copper in nitric acid, we shall obtain a blue-green solution, which, when carefully evaporated will produce long, watery crystals of copper nitrate. Great care should be taken not to breathe the reddish-brown "oxides of nitrogen" which are evolved when metals are dissolved in nitric acid, since these are poisonous.

Metals such as gold and platinum are insoluble in nitric acid, and even common iron, too, is seemingly insoluble in concentrated nitric acid, for when placed in this acid, it is said to assume a "passive" condition and is unacted upon.

By merely soaking ordinary cotton wool in a mixture of two parts of strong sulphuric acid and one part of strong nitric acid for 24-36 hours, the cotton becomes "nitrated." In other words, it is changed into nitro-cellulose or "gun-cotton." After this prolonged acid immersion, the cotton wool should be thoroughly well washed in water in order to remove the very last traces of acid, and then allowed to dry without heat. Such nitro-cellulose, when lighted with a match, will flare up instantly but with perfect safety. It must, however, on no account be struck with a heavy object.

Ordinary thin tissue-paper can be nitrated, also, by the above method.

### Sulphuric Acid

Coming, now, to sulphuric acid,  $\text{H}_2\text{SO}_4$ , this, as we explained in the previous article of this series which dealt with the element sulphur, cannot very well be prepared satisfactorily in the home laboratory, except by distilling ferric sulphate (not ferrous sulphate) or sodium pyrosulphate and by dissolving the sulphur trioxide thereby produced in cold water.

Hydrochloric acid,  $\text{HCl}$ , however, is

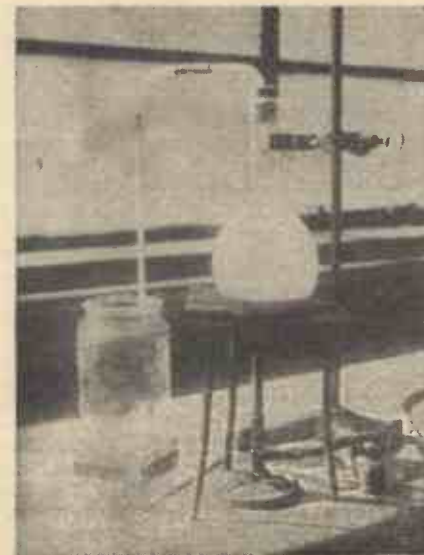

Preparing hydrochloric acid gas by heating common salt with strong sulphuric acid



easily made in the laboratory, both in its gaseous and solution form, as are also its two closely related acids, hydrobromic and hydriodic acids.

Hydrochloric acid was one of the first acids to be made on a large scale in this country. Known commercially as "Spirits of Salt" in consequence of its being manufactured from common salt, the acid enters into a thousand different industries and is of paramount importance in the modern manufacturing world.

As a matter of fact, hydrochloric acid is not a liquid. It is a colourless gas. This hydrochloric acid gas, however, is extremely soluble in water, one volume of water dissolving about five hundred volumes of the gas, and it is the solution of this gas in water which is generally known as "hydrochloric acid," just as it is the solution of ammonia gas in water that is referred to as "ammonia."

To make hydrochloric acid gas in the laboratory we require merely a flask fitted with a delivery tube. In the flask is placed a quantity of common salt (sodium chloride) which is just covered with a quantity of strong sulphuric acid with which rather less than its own volume of water has been mixed. (Note here that when diluting sulphuric acid with water, the acid **MUST** be added to the water, and not vice versa).

#### Collecting Gas

Upon heating the salt-sulphuric acid mixture in the flask, hydrochloric acid gas will be evolved copiously, and it can be collected by displacement of air in jam jars. Alternatively, the gas may be led into cold water, in which it will dissolve, forming the well-known hydrochloric acid solution. When dissolving hydrochloric acid gas in water, it is best to place a small glass funnel on to the end of the gas delivery tube and to arrange matters so that the funnel dips below the surface of the water. By adopting this precaution, the water will not be sucked back up the delivery tube and into the flask, as might otherwise happen.

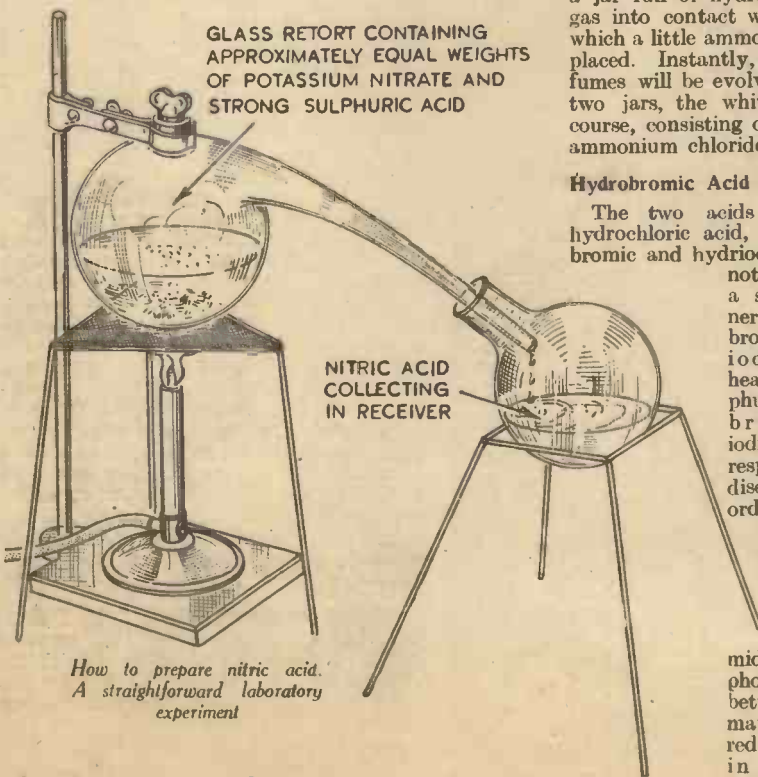

How to prepare nitric acid.  
A straightforward laboratory experiment



White smoke production by the simple interaction of gaseous hydrochloric acid and ammonia

Hydrochloric acid, strong and dilute, dissolves many metals, their oxides, hydroxides and carbonates, forming the chlorides of the metals. Thus, when zinc is dissolved in hydrochloric acid, hydrogen gas is evolved, and zinc chloride is formed in solution.

A mixture of two parts of strong hydrochloric acid and one part of strong nitric acid is known as *aqua regia*, or "Royal Water," since this liquid alone has the power of dissolving the so-called "Royal" or "Noble" metals, such as gold and platinum.

The combination of hydrochloric acid gas with ammonia to form ammonium chloride or sal-ammoniac may be demonstrated in a striking manner by bringing a jar full of hydrochloric acid gas into contact with a jar in which a little ammonia has been placed. Instantly, dense white fumes will be evolved from the two jars, the white fumes, of course, consisting of a cloud of ammonium chloride,  $\text{NH}_4\text{Cl}$ .

#### Hydrobromic Acid

The two acids related to hydrochloric acid, i.e., hydrobromic and hydriodic acids, are

not prepared in a similar manner, since, if a bromide or an iodide were heated with sulphuric acid, free bromine or iodine would respectively be disengaged. In order, therefore, to make hydrobromic acid we may either distil potassium bromide with phosphoric acid or, better still, we may place some red phosphorus in a flask, moisten it with water, and then

drop bromine on to it from a small dropping funnel fitted in the neck of the flask. Hydrobromic acid gas will then be liberated and phosphoric acid will be left behind in the flask in accordance with the equation below:—

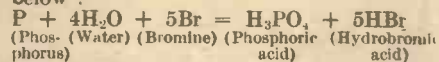

Hydriodic acid, HI, is made by placing in a small flask a mixture of about equal quantities of powdered iodine and red phosphorus and by dropping water on this mixture, whereupon a stream of hydriodic acid will be disengaged, phosphoric acid being again left behind in the flask:—

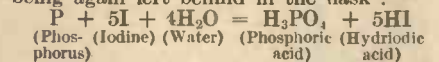

Hydriodic acid, like hydrobromic acid, may, also, be made by distilling potassium iodide with phosphoric acid.

Like hydrochloric acid, hydrobromic and hydriodic acids are both colourless, pungent-smelling gases which are extremely soluble in water, forming corrosive solutions in which some metals, their oxides, hydroxides and carbonates will dissolve with the formation of bromides or chlorides. After standing for some time, hydrobromic and hydriodic acids turn red and brown respectively, owing to the liberation within them of free bromine and iodine respectively. These two acids are of much less importance than hydrochloric acid.

#### Hydrofluoric Acid

There is, however, one other acid of this group of "halogen acids" which is of great importance, and this is the nowadays well-known hydrofluoric acid, HF, which has the property of dissolving glass and which has, therefore, to be stored in hard rubber or lead bottles.

Hydrofluoric acid is made from fluorspar, as its name suggests, by heating a mixture of equal parts of this powdered mineral and strong sulphuric acid, whereby fairly concentrated hydrofluoric acid can be made by passing the evolved hydrofluoric gas into water.

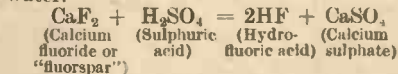

The above preparation cannot be carried out in glass apparatus, since the hydrofluoric acid would attack the glass. It must, therefore, be conducted in a lead apparatus, and the acid stored in lead or rubber bottles.

Just as hydrochloric is more corrosive than hydrobromic and hydriodic acids, so hydrofluoric acid is more active still than hydrochloric acid. Hydrofluoric acid attacks nearly all metals (except a few, such as lead and platinum), together with their oxides, hydroxides and carbonates, forming the fluorides of the metals. Glass, also, as we have seen, is attacked by hydrofluoric acid, and it is precisely on this account that this potent acid finds so much use in the engraving and etching of glass.

When concentrated sulphuric acid is added to a cold saturated solution of potassium dichromate, scarlet crystals of chromium trioxide,  $\text{CrO}_3$ , slowly separate out. These crystals are often called chromic acid, although, strictly speaking, chromic acid is only formed when the chromium trioxide is dissolved in water.

#### Inflammable

The interesting point, however, concerning these crystals is that they are so powerful an oxidising agent that they will char and often actually set fire to paper. Consequently, chromium trioxide (chromic acid) crystals cannot be filtered on to

(Continued on page 16)



# Our Busy Inventors

## To Smother Fire

**S**Ocially, a wet blanket is not a thing to be desired. Akin to this arduous-damping covering is an anti-fire blanket which has recently been devised. If a workman's clothing ignites, he can, by means of this dousing cloth, unaided extinguish the blaze in a few seconds. To unroll the blanket, he has simply to pass his arm through a catch-rope and pull. The workman is then enabled to smother the



A smart ensemble made from mahogany

flames by wrapping himself in the blanket, which is treated with fire-retarding chemicals.

## One-hand Extinguisher

**H**ERE is another fire-extinguishing appliance, which should be welcome in view of the possibility of a rain of incendiary bombs. The characteristic feature of this fire-fighting contrivance is that it can be operated by one hand only. When a trigger is pulled, two pounds of carbon dioxide are suddenly thrust out. This, it is affirmed, will chill and suffocate a fire in its infancy.

## Slumber Curler

**T**HE old-fashioned curl-paper which of yore trained the hair in the way it should go, has another descendant, which has been patented in the United States. Technically, it is described as a one-price resilient hair curler comprising a flexible body having spaced kerfs to define spaced tines and swingable loop means having stay means adapted removably to receive corresponding portions of said tines. This almost interminable terminology is, as a welcome contrast, picturesquely headed "slumber curler."

## Eyelash Trainer

**T**HE theme of artificially created curly locks is not far removed from that of imparting graceful curves to the eyelashes. I am therefore moved to mention a patented eyelash curler, which has made its advent in America. This particular curler has a

frame formed to fit in an eyesocket and to be placed upon the eyelids. There is a guard and a lower edge shaped to contact over the lashes. The frame carries a handle, and a pivotally mounted member exerts

The following information is specially supplied to "Practical Mechanics," by Messrs. Hughes & Young (Est. 1829), Patent Agents, of 9 Warwick Court, High Holborn, London, W.C.1, who will be pleased to send readers, mentioning this paper, free of charge, a copy of their handbook, "How to Patent an Invention."

upward pressure against the lower edge of the guard, which a groove is adapted to receive.

The result should be eyelashes like those of an Odalisque in the seraglio of a Sultan.

## To "Ginger" Fire Brigades

**O**UR British fire brigades cannot justly be accused of lacking in promptitude in responding to a call. But I suppose that the human element is not yet perfect. And so, to keep our worthy living fire extinguishers up to the mark, a newly invented fire alarm-recording apparatus may have a reason for its existence. This device, in the case of electrical signalling systems, is more particularly concerned with arrangements for registering at the central station



A visitor to Switzerland trying out a "keep-cool" machine. We imagine it would cause confusion if used in large numbers at a popular resort

the time elapsing between the receipt of a call and the turning out of the engine. The inventor considers that it is important to have proof that any delay which may occur has not been due to a slow response to a call on the part of the brigade.

The record is made upon a moving tape.

## Anti-draught Sausage

**T**HE exclusion of draughts is an important factor in a room designed for comfort and health. The Victorians were accustomed to keep out unwelcome air by a gigantic red sausage filled with sand or sawdust. A new invention with the same object comprises a flexible tube of rubber or other suitable material made to hold an appropriate fluid. This tube is sealed at

## By "Dynamo"

one end by means of a plug. It is partially closed at the other end by an apertured plug, which is adapted to be sealed. Provided with means enabling it to be attached to a door or window, the tube, owing to its fluid contents, should resist the wildest blasts of Aeolus, the god of the winds.

## Handy Diving Mask

**A**N application from a subject of the Emperor of Japan has been made to the British Patent Office for a patent for an improved diving mask. The objects of the inventor are to provide a mask in which the pressure of the exhaled air can easily be regulated by hand; to furnish one with means to keep the front of the glass clean; and to prepare one which can be used without special skill or knowledge.

The mask in question has the portion which covers the face divided into upper and lower compartments by a partition. The upper compartment is closed tightly with a transparent glass plate. In this compartment there is fixed an air-distributing pipe in such a manner that the air under pressure supplied from an air-feed pipe is sprayed against the surface of the glass.

## To Keep You from Falling

**T**HE next two inventions which I shall notice both have for their aim the prevention of slipping on roads and paths.

In the case of the first, an application has been made to the British Patent Office to protect the following process. When the road has been watered, there is poured over the surface a mortar composed of one part cement and two parts sand, made to the consistency of gruel by adding to the mixture the requisite amount of water. The mortar is well brushed in while it is still in a wet condition. Sand is then sprinkled over the surface and this sand is brushed over the wet mortared road which is allowed to dry. The road must be



A doughnut designed especially for "dunkers." It has a wooden handle so that you may "dunk" in the boiling coffee, or tea, without scalding a finger



stone-faced and rolled firm. It must also be clean and free from exposed tar.

The second device to antidote slipping achieves its end by an appliance fitted on the shoe. It comprises a strip of elastic material. Mounted beneath this is a metal plate having a number of sharp points. The consequence is a shoe which is not a slipper.

### New Use for Coffee Beans

A CUP of coffee in a cup made of coffee appears now to be within the realm of practical politics, owing to the introduction of plastic material produced from the green coffee bean. It has been predicted that one will soon be able to enter a coffee-house literally made of coffee and eat from coffee dishes, being meanwhile entertained by a radio housed in a coffee cabinet.

I learn that one type of coffee hardens under heat, while another kind softens and can be moulded when heat is applied. The latter kind solidifies upon cooling.

### Peanut Reaper

THE peanut, which has been nicknamed monkey nut, is a familiar object. Unfortunately, its shell is unpleasantly familiar, inasmuch as it contributes an unwelcome quota to the litter which is the *bête noire* of the tidy.

It is interesting to note that the pods of the peanut, though first formed in the air, are, as they increase in size, forced into the earth by a natural motion of their stalks.

There they come to maturity three or four inches under the surface.

A peanut harvester has recently been patented in the United States. This apparatus includes a plough and a moving conveyor equipped with plant-engaging and carrying fingers.

### Umbrella Roller

THE rolling of an umbrella is an art in which the average possessor of that portable anti-rain shelter is not proficient. The ideal to be aimed at is the slimmest which characterises the form of the fair, while the pet aversion is a corpulent gingham lineally descended from that of Mrs. Gamp.

The modern Beau Brummel may be intrigued by a self-rolling umbrella to which a patent has been granted in the United States. This umbrella has means to raise, lower and roll up its cover. I am unable to state whether the effect is equal to that produced in a city or West End shop where umbrellas are ironed and rolled by a cunning hand.

### Vision Concentrator

ARTISTS and others when looking at a picture or landscape, frequently cup their hands about their eyes. This action is performed with the purpose of eliminating wide-angle vision. It gives what has been termed "central fixation" and "tunnel vision." A simple device to attain this end has been developed. It is styled a "vision concentrator." Such a contrivance will be not only useful to artists, but will benefit students, typists, golfers, theatregoers and others.

### Looking Back

WHILE upon the subject of shading the vision, my mind reverts to the familiar lines of Sir Walter Scott relating to Melrose Abbey. To "view aright" that venerable

ruin one was enjoined "to visit it by the pale moonlight." But an improved method has been suggested whereby in broad daylight the tourists can behold the famous abbey with almost equal pleasure. The spectator is advised to turn his back upon the ruin, to bend down and gaze upon it through the improvised Gothic archway formed by those twin columns—his legs. This shuts out the superfluous light on the principle of the aforementioned vision concentrator.

### Accommodating Chair

THERE is no novelty in an easy-chair with arms and back containing accom-



The umbrella man. Max Fire, with his umbrella hat during a demonstration

modation for ash-trays, smokers' other requirements, needlework cases, etc. But a new invention specially concerns chairs in hair-dressing saloons. The principal object of this device is to provide for the hair-



A venetian blind mop, invented by Kenneth Wade, of New York. It cleans five slots at one clip

dresser means whereby he can very quickly reach the tools and utensils required in the service of his customers, especially those of the feminine gender. This arrangement dispenses with the necessity for special tables and economises space in the cubicle.

The frame and sides of the chair are fitted with boxes and drawers for the hair-dresser's various implements and bottles. There are shelves or trays which can be lowered for the placing thereon of different articles.

In addition to this comprehensive accommodation a special feature of the chair is a contrivance to receive a closed helmet-made of very light canvas for drying hair. This helmet has a fronted band formed with celluloid and elastic to place round the head, thus ensuring an hermetic closing. Besides being adaptable to any shape of head, the helmet can be made of a material such as a light canvas which will absorb the steam created by the heat acting on wet hair. This steam, owing to the hot air, will be forced to make its exit.

As a sequel, the twentieth-century Venus will emerge from the cubicle with waves as undulating as those from which the original Goddess of Glamour made her debut.

### Novel Way of Keeping Cool

AS soon as we start to experience a heat wave, ingenious persons at once begin to think up ideas for keeping cool. From Switzerland comes rather an elaborate idea. A long pole, with a wheel at one end is fixed to a belt on the person's body, on the end of the pole near the person is a four-bladed fan, and as one walks the fan revolves, worked by connecting belts, and keeps the wearer of the novel machine cool.

### "The Umbrella Man"

BIZARRE headgear may not be confined to the gentler sex if an invention by Max Fire of Los Angeles catches the fancy of the man of the family. The inventor has applied for a patent on a head umbrella, which, he avers, not only protects the wearer, but allows the freedom of both hands. It is a miniature umbrella, with elastic bands attached to the ends of the stays.

### It's Smart in Mahogany

HERE'S a solution to the problem of what to do with old furniture. Convert it into a smart ensemble like that shown on page 13. The hat brim, cigarette case and handbag are all the combined triumph of the lumberman and the milliner. They are carried out in mahogany by the simple process of cutting the wood into a fine veneer, then into strips and weaving it into the desired shape, after which it is treated with a special plastic which makes it durable, weatherproof and brings out the fine beauty of the grain. It comes from New York.

### Nursery Stars

"TWINKLE, twinkle, little star" was, in the artless reign of Queen Victoria, a bed-time jingle which lulled the rising generation when they were settling. The amenities of the nursery are now to be enhanced by a constellation. The wondering youngster is to be intrigued by heavenly bodies which will decorate his room. Thin paper stickers cut out in the shape of stars, moons and comets, are to be coated with luminous paint. As a result, when the light is switched off, the walls and ceiling will present a somewhat feeble imitation of the starry vault.



# A FARMAN TYPE MODEL MONOPLANE

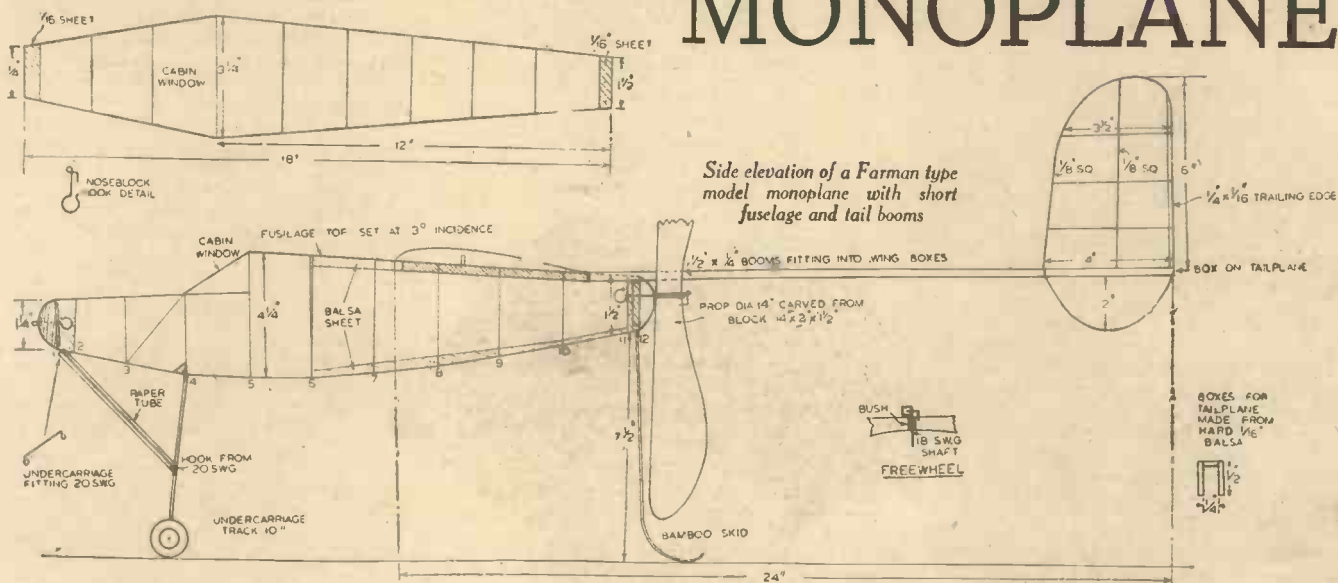

Side elevation of a Farman type model monoplane with short fuselage and tail booms

**N**OTWITHSTANDING S.M.A.E. encouragement, few aero-modellists build models of the Farman type. I am referring, of course, not to the ordinary canard model but to the model with the airscrew interposed between the mainplane and the tail. These make fascinating and very reliable fliers and I am glad to see during the past few months a great revival of interest in them. The S.M.A.E. record for fuselage Farman type models is held by R. W. Mackenzie at 1 min. 54.4 secs.

sure that the fuselage is true and then bind and cement a piece of 18 s.w.g. tubing to the bottom cross-piece No. 4. A small corner piece of 1/8 in. balsa should be fitted as shown on the drawing. A piece of 20 s.w.g. should be bent as shown for the undercarriage, and this should be cemented behind upright No. 1, and a small piece of mm. ply is fitted round it and cemented on the outside of the 1/8 in. sheet.

banana oil, test for balance again, and fit an 18 s.w.g. bush. The noseblock can be carved from a block approximately 1 1/2 in. x 1 1/2 in. x 1 in. and an 18 s.w.g. bush should be cemented firmly in position. Bend a shaft of 18 s.w.g. and fit a ball race between the propeller and noseblock. The freewheel is self-explanatory.

The celluloid cabin windows can then be placed in position and the whole fuselage is covered with tissue. Apply one coat of dope

**The Undercarriage**

Streamline two pieces of bamboo for the undercarriage legs and fit two 1 1/2 in. diameter wheels. Bend two pieces of 18

**Fuselage**

The fuselage is 18 in. long and is built of 1/8 in. x 1/8 in. balsa. Build one side on top of the drawing on a flat board. Pin the top and bottom longerons in position and cement the upright in place. Take care that the top of the fuselage is accurate, as this is set at 3 degrees to give the necessary incidence to the wing. Note the 1/8 in. balsa 1/2 in. wide, which is cemented between uprights No. 6-11 (top and bottom). Also the 1/8 in. balsa is fitted between uprights No. 1 and 2 and 11 and 12.

Then build a second side in exactly the same manner and make sure that both sides are identical.

The cross pieces should then be cemented into position; top and bottom and a piece of 1/8 in. sheet balsa is fitted between the cross pieces No. 1 and 2 and 11 and 12. Make

*A Great Revival of Interest has been shown in this Type of Model during the past few Months*

and then two coats of banana oil. Carve the front nose-block and bend a hook from 18 s.w.g. This should be left long enough to go through the noseblock and the winding hook should be bent as shown on the drawing. This should be firmly cemented, as it has to take the strain of a fully-wound motor.

The propeller and rear noseblock should then be carved. Care should be taken when carving the propeller, as it can be made of fairly soft balsa and can be carved thinner than the normal tractor's propeller, as it is protected by the bamboo skid.

After the propeller is finished and balanced correctly, apply one coat of thick

s.w.g. to fit into the brass tube in the fuselage and bind firmly to the undercarriage legs. A cross piece of 20 s.w.g. should be bound to the bamboo leg to give a track of 10 in. Two hollow paper tubes should then be made by rolling paper round a knitting needle and applying one coat of banana oil. Two small hooks are then made from 20 s.w.g. and bound to the undercarriage legs as shown.

When the undercarriage is fitted, a rubber band is passed through the paper tube and attached to the hook on the bamboo leg and the hook on the front of the fuselage. This provides a very efficient shock-absorbing undercarriage; the bamboo skid should

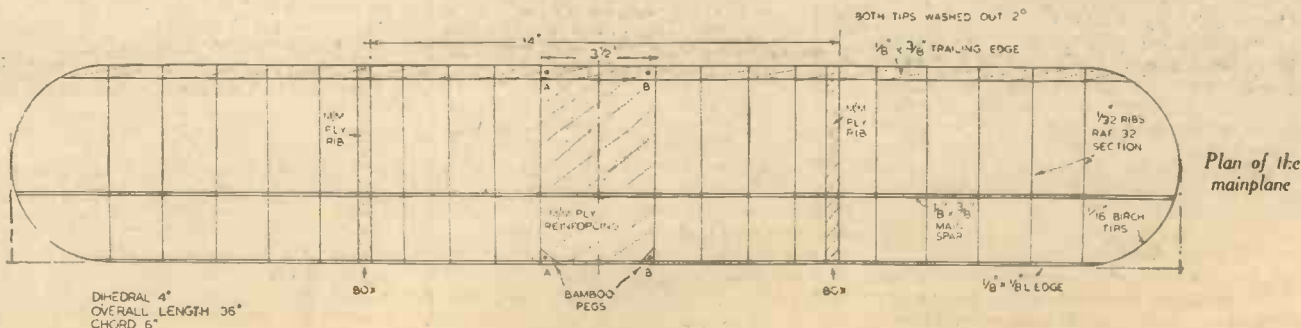

Plan of the mainplane



be strong and flexible, and is firmly cemented in the rear noseblock.

**The Wing**

The wing has a span of 36 in. and a chord of 6 in. Cut the required number of ribs (section R.A.F.32) from 1/2 in. sheet balsa, and also cut two ribs of mm. ply. only the last two ribs should be continued 1/2 in. below the leading and trailing edges, so that the wing boxes for the booms can be cemented to them. The mainspar is of 1/2 in. x 3/8 in. and the leading edge is 1/2 in. square balsa. The trailing edge is shaped from 1/2 in. x 3/8 in. balsa, while the tips are bent from 1/8 in. square birch. Build two boxes of 1/8 in. hard balsa, to accommodate the 1/2 in. x 1/4 in. booms and cement them firmly to the mm. ply ribs, making sure that the boxes are on the outside in order to give the propeller clearance between the booms.

The dihedral is 4 in. and a piece of mm. ply reinforcing is cemented to the mainspar where it is cut each side of the centre section. Four bamboo pegs are cemented at A and B and then the 2 degree washout on each tip should be steamed in. Great care should be taken when this is being done, as it is essential that both wings are identical. The wing can then be covered and one coat of dope and one coat of banana oil should be applied.

**The Tailplane and Rudder**

The tailplane has a span of 14 in. and a constant chord of 4 in. The ribs are cut from 1/2 in. sheet and are biconvex. The mainspar and trailing edges are 1/2 in. x 1/8 in. balsa, and the leading edge is 1/2 in. square balsa. The boxes for the booms are made as shown on the drawing and firmly cemented to the tips of the tailplane. The rudder is made as shown. The leading edge and spar are 1/2 in. square balsa and the



Details of the tailplane and box spar

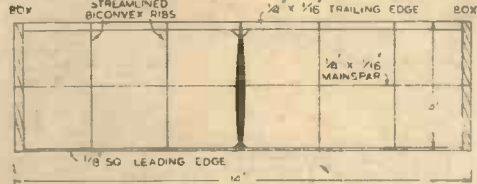

trailing edge is 1/2 in. x 1/8 in. balsa. The ribs are streamlined in section and are cut from 1/2 in. sheet. The tip and the under slung fin are both bent from 1/8 in. birch.

The rudder should be firmly cemented at right angles to the tailplane and corner gussets are cemented at the leading and trailing edges. The rudder and tailplane can then be covered and given one coat of dope and one coat of banana oil. The booms are made of 1/2 in. x 1/4 in. balsa and when

fitted in the wing boxes they are at 3 degrees positive incidence, but they should be steamed in the middle and bent up until the tailplane is at 0 degrees incidence, i.e. when the wing and tailplane are fitted, the wing will be at 3 degrees positive incidence and the tailplane at 0 degrees incidence.

The model flies best with 12 strands of 1/16 in. rubber 30 in. long and tensioned. The rudder should be offset so that the model will climb steeply in wide circles with

torque, but will turn when the power is finished and will glide in large circles in the opposite direction.

Adjustments can be made by moving the wing backwards and forwards along the fuselage, and adjustments to the rudder are made by pushing one boom farther in or out of the boxes. The weight of the model complete with rubber should be about 5 1/2 ozs.

Correctly built, this model is very strong and is a very stable and consistent flier.

**CHEMISTRY FOR BEGINNERS**

(Continued from page 12)

ordinary filter paper. Glass wool must be used instead, and the crystals must not be allowed to touch any paper, fabric or similar organic material.

When alcohol or methylated spirit is dropped on to "chromic acid" crystals, it takes fire at once, and when the crystals are heated to about 250°C, they evolve oxygen, becoming converted into chromium oxide, Cr<sub>2</sub>O<sub>3</sub>, which has a bright green colour. Indeed, this chromium oxide, Cr<sub>2</sub>O<sub>3</sub>, makes its appearance whenever chromium trioxide ("chromic acid"), CrO<sub>3</sub>, takes part in a reaction as an oxidising agent.

Of recent years, chlorsulphonic acid, SO<sub>2</sub>ClOH, has come into great prominence, not only in the manufacture of "intermediates" for dyestuffs, but, also, in view of the fact that, when sprayed into moist air, it forms a "smoke screen."

Chlorsulphonic acid may be made by distilling phosphorus pentachloride with concentrated sulphuric acid, or, better still, perhaps, by the direct union of hydrochloric acid gas and sulphur dioxide gas, these two gases being led into a flask or Wouff's bottle in which they will combine together with the production of the chlorsulphonic acid.

**Corrosive**

The above acid is an extremely corrosive one and it possesses an extraordinary affinity for water, so much so that when it is dropped upon water, it reacts with the latter liquid with almost explosive violence, forming a mixture of sulphuric and hydrochloric acids. When dropped on to powdered quicklime, it gives rise to vast clouds of white smoke, and, in this respect, it has been commercially used as a smoke-producing agent.

All experiments with chlorsulphonic acid, however, should be undertaken with great care, since the acid can inflict painful burns on the skin which are difficult to heal.

The element phosphorus forms many different acids of which, perhaps, ortho-phosphoric acid, H<sub>3</sub>PO<sub>4</sub>, is the most easily

prepared besides being the most useful.

One can readily prepare ortho-phosphoric acid by dissolving phosphorus pentoxide in water and by boiling the liquid for a few minutes subsequently:—

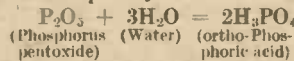

but as phosphorus pentoxide is an expensive chemical, it is more usual to prepare ortho-phosphoric acid in the laboratory by oxidising red phosphorus with nitric acid, to which end a quantity of red phosphorus is boiled in a flask with slightly diluted nitric acid until the phosphorus disappears. For this purpose, the flask will have to be fitted with an upright condenser ("reflux condenser") so that the nitric acid can drop back into the flask.

Red fumes of oxides of nitrogen will be disengaged, and when all the phosphorus has disappeared, the acid liquid should be heated in a porcelain basin at a temperature not exceeding 180°C to drive off the free nitric acid.

The residue in the dish will be composed of fairly pure ortho-phosphoric acid, H<sub>3</sub>PO<sub>4</sub>. It can be dissolved in water to form the usual phosphoric acid solution,

which is corrosive and which possesses the property of dissolving metallic oxides, hydroxides and carbonates with the formation of phosphates.

Incidentally, a very weak solution of this phosphoric acid is sometimes used in medicine as a potent tonic, particularly when mixed with a solution of quinine sulphate.

**A MODEL MAKER'S CATALOGUE**

THIS year Messrs. Bassett-Lowke, Ltd., have been revising their various catalogues, and the range to-day consists of their Twin Train catalogue, Section TT, price 2d., which contains all the new developments in gauge "00," their gauge "0" catalogue, Section GR., price 3d., containing latest locomotives and equipment (both new editions of which will be ready during October), their ship catalogue, Section S, now current until the spring, price 6d., and last, but by no means least, an entirely new list entitled "Steam Locomotives. Stationary Engines and Everything for the Model Constructor," Section AB.

This catalogue is a combination of the A and B lists of previous years and contains many new items of interest to the model engineer. It deals in a very comprehensive manner with "live steamers" from gauge "0" up to 10 1/2 gauge, gives details of track, rolling stock, signals, station buildings and railroad accessories from gauge 1 upwards and among other articles described are stationary engines, both inexpensive and really workmanlike productions including the Stuart range, engine and boiler fittings, sheet and rod metal, castings for locomotive and stationary engines, raw materials, drawings, finished and unfinished parts for the model maker and also a fine list of useful books for the model engineer. Altogether the list is one which should be on every model maker's bookshelf as a work of reference. It contains 160 pages and has a carefully compiled index at the back and costs 6d. "over the counter" at Northampton or London and Manchester branches, or 8d. post free from Northampton.

**PRACTICAL LEATHERWORK AND OTHER ALLIED CRAFTS**

By Fred Jace

This handbook not only deals exhaustively with leatherworking, but other crafts such as Appliqué, Gesso, Raffia, Batik, stencilling and rug-making. It contains 96 pages and 179 photographs and diagrams.

From all Booksellers, 1s. or by post 1s. 2d. from the publishers, George Newnes, Ltd., (Book Dept.), Tower House, Southampton Street, Strand, W.C.2.



**You Can Have  
a BODY  
Like This!**

*Charles  
Atlas*

This actual snapshot taken at the beach shows how Charles Atlas looks to-day. If you want a body like this read below.

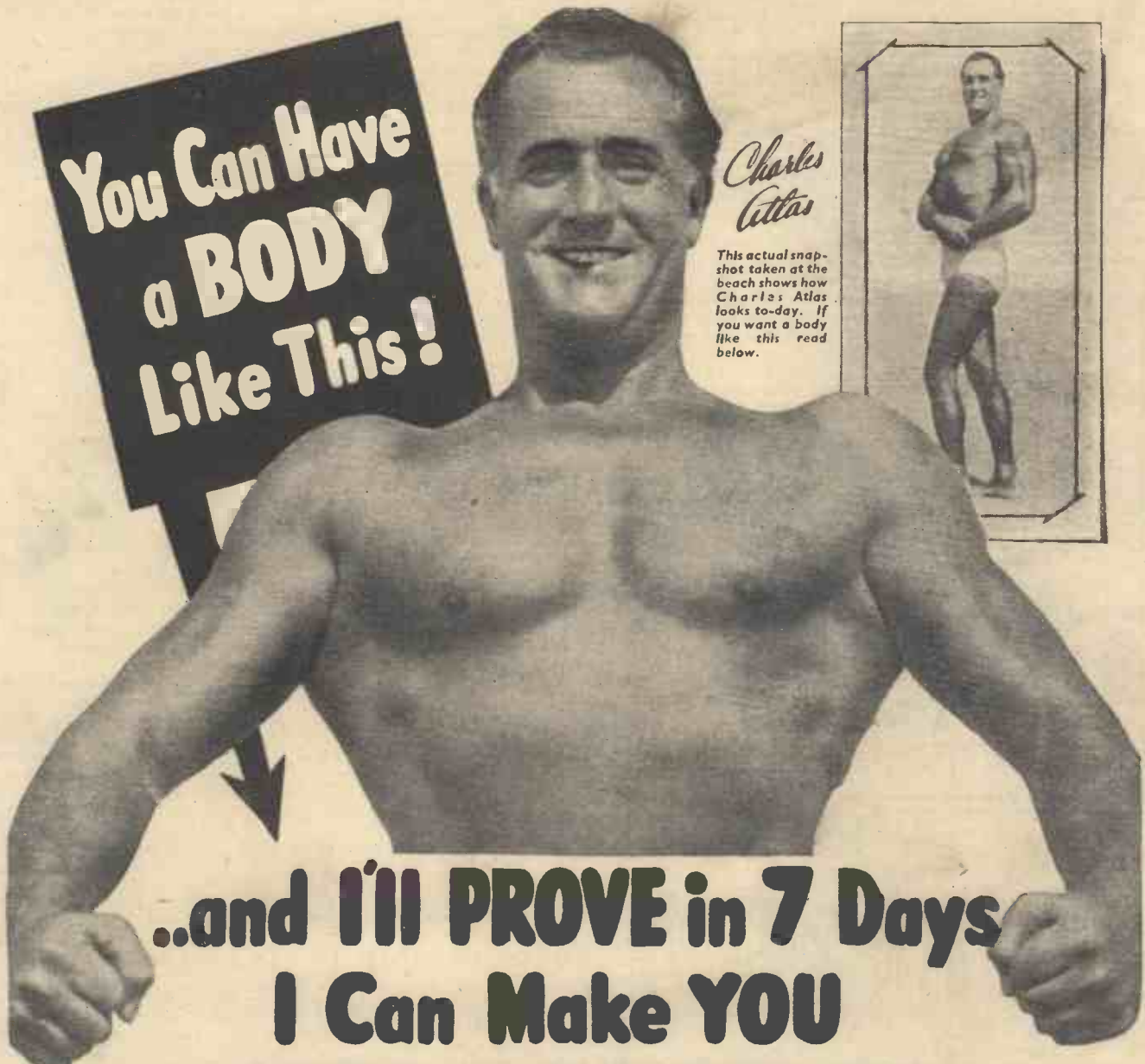

**..and I'll PROVE in 7 Days  
I Can Make YOU  
a NEW MAN!**

**YOU** want a big, strong, healthy body. And you want to get it **QUICK!** I've discovered the **SPEEDY, EASY, SURE** way to rebuild ordinary bodies. Change "pipestems" into full-rounded arms and legs covered with sinewy muscles of giant strength! Expand flat chests to big bellows of vital health! Straighten sagging shoulders; make them "wide as a door." Add firm flesh to underweight bodies, or pare down overweight men to fighting trim! Chase out pimples, sallowness, other troubles! Add the rich, red blood of lively health! Make **NEW MEN!**

I'll take you just as you are right now and **PROVE** in the first 7 **DAYS** that I **CAN** do it! You'll be able to look in the mirror and **SEE** that I've got you on the **FAST** way to develop the magnificent body that men respect and women admire!

**Here's My Secret of Body-Making**

Don't worry if you're skinny or flabby now. Or if you feel always tired and worn-out. Or if you're bothered with a lot of common ailments. I'll straighten you out in almost no time at all! Once I was a 7-stone weakling. Flat chested, nervous, half-alive. No games or sports for me. No good times—**UNTIL** I found the startling secrets of Dynamic Tension. Nature's own way for body-building! No contraptions that may cause ruptures, strain the heart, damage vital organs.

No hard grind through dreary months with little benefits. Dynamic Tension is genuine **MANLY** fun. Pleasant, easy, gets results in double-quick time! Just see what it did for me. Changed me completely from a poor, run-down no-account runt. Gave me the body that **TWICE WON CHAMPIONSHIPS** and the **TITLE** of "The World's Most Perfectly Developed Man!" And what I did for myself I've since done for thousands of others. I'll do it for you, too! And give my **GUARANTEE** to make you the **REAL** man you can and ought to be—or you pay nothing!



**WIN THIS STERLING SILVER CUP!**

I will award this foot-high solid sterling silver cup to my pupil whose measurements show greatest improvement. Your chances therefore, are as good as the next man's! So get started to-day. Post the coupon. Let me give you the champion body that wins prizes!

**FREE BOOK**

Here's the way you've always wanted to get strong **QUICK!** With results guaranteed! Get the proof in my big book. Numerous photos show exactly what I'll do for you. Dozens of letters from pupils **PROVE** Dynamic Tension gets **QUICK BENEFITS.** Take the first step now. Fill in and mail the coupon right away. Address **CHARLES ATLAS (Dept. 10/X) 2, Dean St., London, W.1.**

**CHARLES ATLAS (Dept. 10/X), 2, Dean Street, London, W.1.**

I want proof that **DYNAMIC TENSION** will make a new man of me—give me a healthy husky body and big muscle development. Send me your **FREE** book "Everlasting Health and Strength" and full details of your 7-day Trial Offer.

NAME.....  
*Please print or write clearly*

ADDRESS.....





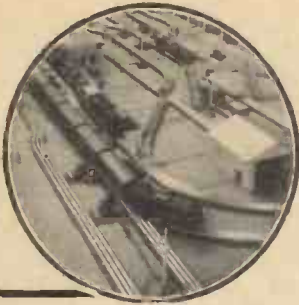

A Twin Train Railway Layout.

This year this well-known company has revised their series of Model Catalogues. For their latest productions ask for :

**GR.12** new edition gauge "0" catalogue—clockwork, electric, steam—engines, rolling stock and all accessories. Price 3d.

**TT.12** new edition gauge "00" catalogue of the Twin Train Table Railway. Wonderful new developments in this most popular of table railways. Price 2d.

**S.12** catalogue of Model Ships and Ship Fittings, current for this year. Price 6d.

**AB.12** "Steam Locomotives, Stationary Engines and Everything for the Model Engineer." 160 pages. Describes steam engines from gauge "0" to 10 1/2 ins., stationary engines, boilers, fittings, castings, etc. Price 8d. post free

Other helpful booklets "Laying Permanent Way," 2d. "How to Build a Traction Engine," 3d.; and the T.T.R. Permanent Way Manual, 1/3.



**BASSETT-LOWKE, LTD.**  
NORTHAMPTON LONDON: 112, High Holborn, W.C.2.  
MANCHESTER: 28, Corporation Street.

## MODELS to FASCINATE YOU!

Railways of all gauges . . .  
Engines of all sizes . . .  
Ships of all varieties . . .  
you will get them from  
**BASSETT-LOWKE**

## Ohlsson Petrol Engines

The Perfect Aeroplane engine or planes up to 8 lbs. weight. Bore 1/2 in. Stroke 15/16. Power 1/5 h.p. Weight complete as illustrated 13 ozs. The finish of these engines is as near perfect as it can be made. The crankshaft is hardened and ground. The piston is a perfect compression fit in the cylinder which gives these engines a far greater running life than most engines of this size. Price complete with plug, coil, condenser, carburetter and tank, ready to run.

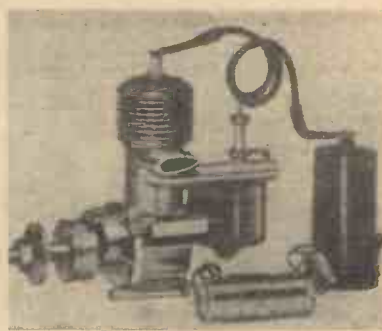

£4 12 6 Postage 6d.

## Ohlsson "23" Engine

A smaller engine, bore and stroke 5/8 in. Price complete £4 5 0 Postage 6d.

### ENGINE CASTINGS

To make up similar engines only to the above but with aluminium cylinders having steel liners. Prices:—

bore	stroke	...	...	...	11/6	Postage 6d.
bore 1/2	stroke	...	...	...	15/6	Postage 6d.

## A.C. Split-Phase Motors

220-240 volts 50 cycles.

These motors are suitable for workshop use or any other purpose where continuous full load output is required from the motor. They are practically dead silent when working and are fitted with large oil sleeve reservoir bearings.

PRICES: 1/2 h.p., 1,425 r.p.m. 55/-  
1/2 h.p., " " " 55/-  
1/2 h.p., " " " 65/-

Built-in Switch, 3/9 extra. Car. Forward.



SEND FOR BOND'S 1940 GENERAL CATALOGUE PRICE 6d.; THIS WILL INTEREST YOU AS ITS 208 PAGES CONTAIN EVERYTHING THAT THE MODEL MAKER MAY REQUIRE.

**BOND'S O' EUSTON ROAD LTD.**  
357, EUSTON ROAD, N.W.1  
'Phone EUSton 5441-2 Established 1887

## Start right with a

# DLP

## VICE-SCREWING MACHINE

£5.17.6 (complete as specified) Patent No. 418,829

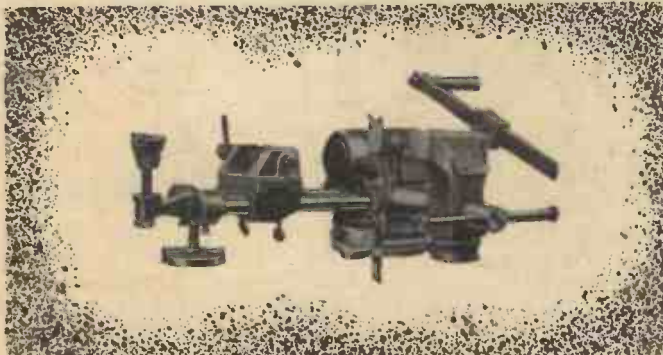

The DLP Machine is the best possible nucleus of a workshop. It comprises:—a Parallel Vice; Pipe Vice; Tube, Rod and Strip Bender; Cable, Rod and Pin Cutter; Punching Machine; Cable Stripper; Screwing Machine for threads up to 1/4-in. Whit., 1/2-in. Gas and 1-in. Conduit; Flat and Conical Anvils. The space required on your bench is only 12-in. x 18-in. Illustrated Folder on application.

Sole Distributors for the British Isles:  
**BUCK & HICKMAN LTD**  
2 WHITECHAPEL ROAD · LONDON · E · 1

Overseas Enquiries to the Manufacturers' DeLa Pro Components Ltd., Northampton

# A. R. P.

## "WHAT TO DO IN EMERGENCY"

This important new book is not a mass of dry facts and figures. The information is given in a new way—in story form! You will read how a family just like yours—the Jones family—prepared for air raids, how the raiders came, and how they dealt with the situation. It tells how, because they were prepared, they won through. Specially produced for every family, this book fulfils the most vital need in the home to-day. You must read:

**THE JONES FAMILY SEES IT THROUGH**  
*The Great New Method of Instruction Through Narrative!*

WHAT TO DO IN EMERGENCY also deals with Air-Raid Warden Service, Casualty Services, Rescue and Demolition Service, Gas Detection and Decontamination Services, First Aid, Auxiliary Fire Service, Air-Raid Shelters, Evacuation to Country Areas, etc.

For Safety's  
Sake Get a  
Copy To-day!

6<sup>d</sup>.  
ONLY

ALSO INCLUDES:  
HOW TO EQUIP A REFUGE ROOM: Specially drawn in full detail. Construction of Trenches, Garden Shelters, etc. Packed with action photographs, diagrams and sketches.

Of all Newsagents  
and Bookstalls.



# MASTERS OF MECHANICS

No. 49. A MASTER OF MECHANICAL STITCHCRAFT

*The Eventful Life of Elias Howe, Inventor of the Sewing Machine*

**S**TITCHERY is one of the world's earliest occupations. Yet, less, even, than a century ago, it constituted for many people one of the greatest forms of drudgery. To have to sew garments by hand day in and day out for a mere pittance of a wage was the lot of countless men and women the world over. We are not surprised, therefore, to learn that as machinery became more and more a practical proposition there were not lacking inventors who endeavoured to bring into being a machine which, by stitching mechanically, would rid the art of sewing of much of its drudgery and which therefore, would not only do away at one stroke with countless strained eyes and numb, weary fingers, but would, also, greatly speed up the rate at which sewn fabric could be turned out.

## First Invention

The first invention for a stitching machine was patented by an Englishman, one Thomas Saint, in 1790. But Saint's invention never came to anything, nor, for that matter did the early mechanical sewing machine brought out some thirty-five years later by a poor French tailor named Barthelemy Thimonnier.

It is to the United States that we must turn when we go in search of the origins of the practical sewing machine, and, to this end, let us betake ourselves in imagination to a small workshop situated in the American City of Boston, the year being just one hundred years ago, to wit 1839. Here we see a curly-headed young fellow of 20 quietly listening to a conversation which is being carried out by a group of individuals, among whom is his employer, the conversation being given over to the possibility of devising a machine which would stitch cloth.

"But I tell you," says one of these men, "that it is even now possible to stitch cloth mechanically. Walter Hunt, the Quaker, of New York City, has done it."

"That may be so," remarks the senior man of the group, "but nothing came of Hunt's machine. No, Sir, it is definitely not possible to sew by machinery. But anyone who could make a successful sewing machine would indeed insure for himself an independent fortune."

## A Fortune

An independent fortune! The words rang in the ears of the curly-headed youth, Elias Howe, by name, who had spent most of his life on his father's farm at Spencer, Massachusetts, having been born there in 1819. Howe was a mechanically minded fellow. Even when he was only six years old he had worked with his brothers and sisters at stitching wire teeth into leather strips to make "cards" for the combing and spinning of cotton. As he grew up, he had forsaken agriculture and had obtained a living at a factory in Lowell, Mass., making cotton machinery. And



*Elias Howe, the inventor of the sewing machine*



*Isaac M. Singer, the first mass producer of domestic sewing machines*

finally, he had found his way into the workshop of one Ari Davis, the Boston manufacturer in whose presence the above-recorded conversation took place just one hundred years ago.

Perhaps the memory of that conversation faded in the mind of young Howe, for we find that at that time he had other important business to attend to. In less than a year he married and within a few years he found himself faced with the pressing

claims of a family for food and clothing. His weekly wage, however, was a mere dole, and it very much looked as though the spectre of slow starvation was going to raise up its ghastly figure before the Howe family.

Such a necessity it was which turned Elias Howe's thoughts back to the memory of that workshop conversation concerning the possibility of inventing a sewing machine, and the rewards which would be attached to such a creation. As a result, Howe decided to give himself over seriously to the solution of the problem.

Working in a little garret, he tried for months to copy by means of a machine the action of his wife's right hand and arm in sewing a simple seam of cloth. But this proved impossible, and, as a result, Howe relinquished his task poorer than ever.

Nothing daunted, however, Howe's next plan was to act upon a notion which suddenly entered into his mind,—the idea of using two threads in his sewing machine, the one passing through the eye of a needle which is mechanically forced through the cloth so as to form a loop below, and the other which would, by being carried on a bobbin within a small shuttle, pass through this loop and thus make a perfect stitch.

## No Money

Unfortunately, Howe had no money to prosecute his trials any further. But he was acquainted with a former schoolmate of his, one George Fisher, a coal and wood dealer in a fair way of business, who, convinced of the possibility of Howe's projects, provided him with money and material (to say nothing of board and lodgings) so that he could bring his projected sewing machine into concrete existence.

In December, 1844, Howe promising Fisher a half share in his eventual patent, began work on his sewing machine and by the April of the following year, he had finished it and got it to sew a seam of cloth satisfactorily. In the July of that year, he sewed on his machine two suits, one for himself, the other for George Fisher.

An inventor's troubles, it is said, seldom cease, and, as a matter of fact, Howe's, at this stage, were only just beginning! Despite the fact that he gave a public exhibition of his sewing machine, and held "sewing trials" in which he pitted himself for speed of sewing against expert seamstresses from all over the United States, nobody seemed particularly interested in the machine. Naturally, the latter was by no means perfect. It had many drawbacks, despite the fact that its fundamental principle of the "lock-stitch" was sound enough. And even when Howe patented his machine on September 10th, 1846, little interest was shown in it.

And then, to make matters worse, George Fisher, being only human, and not having experienced that "fine frenzy" of inventive



creation, grew discouraged. He repudiated his agreement, refused to back Howe financially any further, and more or less gracefully retired from the game.

#### Finding A Market

Howe's next step was to secure a loan from his father and to send his brother, Amasa B. Howe, across to England with a model of the machine in the hope that he would be able to find a market for it there. Amasa Howe, it seems, was not a very wise man. Arrived in London, he fell in with a William Thomas, a corset-maker, of Cheap-side, who saw great possibilities in the invention and who offered to purchase the entire British rights of the invention for the sum of £250, and the Howe's undertaking to adapt the machine to Thomas's special trade requirements.

Amasa Howe returned to America in 1846 to seek his brother's approval of the London offer, an offer which was reluctantly accepted, since no one seemed at all interested in sewing machines in America. Thus it was that, on February 5th, 1847, the brothers Howe set sail for London, Elias taking, besides his essential constructional tools, his delicate wife and their three children.

The party duly arrived in London and after about eight months of hard work, the Howe's succeeded in modifying the sewing machine invention to the special requirements of Thomas's trade.

After this, Thomas began to turn traitor. He made matters intolerable for Elias Howe, and, in the end, discharged him from his employ.

#### A Final Effort

A complete stranger in London, poor, discouraged, downcast and almost starving, Elias Howe made one final bid in England for success in connection with his machine. Sending his ailing wife, his children and his brother back to America, he reduced his living expenses to a minimum, existing in great poverty and, at the same time, contriving to build another model of his sewing machine. This he managed to sell for only five pounds after a great deal of trouble, and now, thoroughly sickened, he decided to leave England for good and all and to return to the States. In order to do this, however, he had to pawn his precious U.S. patent papers and the model of the sewing machine which he originally brought over to this country with him. And then, arriving back in New York, in April, 1849, he found himself with the equivalent of half a crown in his pocket. To make matters worse, a few weeks later, after obtaining some employment in New York, he received the news that his wife was fast dying of consumption. With the help of another loan from his kindly father, Howe speeded to his wife's bedside and arrived there just in time to see her pass away.

It was much in the nature of the last blow to Howe, this loss of his devoted and ever-faithful wife, for, strangely enough, after that tragic event, his fortunes seemed gradually to turn.

During his absence in England, America had apparently wakened up to the fact that a practicable sewing machine had been invented. Some types of sewing machines were actually being marketed. They all, however, infringed Howe's master patent, and Howe found himself under the necessity of looking on whilst others climbed to success, for, it will be remembered, his

patent papers and his first model of his machine reposed in a pawnbroker's establishment in far-away London.

There was nothing for it, as Howe quickly realised, but to get back his patent papers and model machine from London as quickly as possible. As it happened, Howe had a trustworthy acquaintance who was going to London, and, borrowing—one hardly knows from what source—a hundred dollars, Howe entrusted this sum to his friend to take over to London with him for the purpose of redeeming the patent papers and the model. Howe's friend carried out his part of the business faithfully. He located the vital papers and model, redeemed them and dispatched them at once to Howe.

#### Infringement

The latter's next plan was to commence actions for infringement of his patent rights. Legal actions, however, invariably cost money, and Howe himself had no finance with which to embark upon such tactics. Here, however, his ever-obliging



*Elias Howe's first sewing machine*

father again came to his aid by advancing, as a security, a mortgage upon his farm to a group of individuals who had consented to finance Howe in his fight against the infringers.

Whilst these legal proceedings were being undertaken, Howe found the time and money to commence manufacturing his machine on his own account, and in 1850, he started, in New York, a small workshop, in which he turned out a score or more of his sewing machines, selling them to various garment-makers in that city.

The infringers of Howe's patents were by no means men of small resources. Some of them had genuinely invented sewing machines which, more or less accidentally, had incorporated one or two of the fundamentals of Howe's machines. Among these were Allen B. Wilson, and James Edward Allen Gibbs, both of whom had hit upon very excellent sewing-machine inventions.

Another sewing machine manufacturer with whom Howe crossed swords was Isaac Merrit Singer, the founder of the now famous organisation of that name. Singer was more of a manufacturer, an ingenious organiser, publicist and mass-producer than an inventor, although there is no doubt that the machine which he put on the

market was, from a practical point of view, a considerable advance upon the original Howe model.

#### Victorious

Howe, however, finding himself backed financially, fought his infringement cases at law and came off victorious in all of them. And, as time went on, he found himself, owing to a complicated set of circumstances which it is impossible to detail here, the sole owner of his original patent. Hence, he was in a position to exact a tribute from every sewing machine manufacturer in the United States, a policy which he adopted unhesitatingly and consistently.

Even the great Isaac Merrit Singer had, in the end, to bow before the Howe master patent, although he did not do so without fighting a battle royal with Howe in the courts.

And so it was that Howe, after having for years experienced almost every imaginable species of poverty and destitution, acquired patent royalties which began with three hundred dollars per annum and quickly mounted up to two hundred thousand dollars yearly. Howe's machine was exhibited in Paris in 1867, receiving a gold medal award, whilst its inventor was invested with that French honour, the Membership of the Legion of Honour.

Perhaps, however, Howe's phenomenal success came too late for him to profit by it. Returning to America after the Paris Exhibition of 1867, his health permanently enfeebled as a result of long years of struggle, disappointment, sorrow and poverty, he sickened and died at Brooklyn in the October of that year at the comparatively early age of forty-eight.

So, indeed, did pass the short-lived glory, success and triumph which eventually crowned the struggles of Elias Howe.

In many circles it is the fashion to decry the work of Howe, to represent him as a mere trifle of an inventor and, above all, to denounce him for his many patent actions which he instigated against other sewing-machine makers.

#### Legal Activities

In this latter respect, Howe is by no means above criticism. His legal activities saddled other sewing-machine inventors with some disadvantages which should not rightly have been theirs. Yet, on the other hand, Howe's sewing machine, although it was never sufficiently practicable for ordinary domestic employment, did constitute practically the first working machine which would sew satisfactorily a continuous line of stitches, and it had thus a prior right above others.

One can understand, also, how embittered Howe must have been to find other mechanics reaping, at least, a portion of the fruits of his invention, and particularly so after the terrible experiences which he had undergone during the previous years of his life.

Scientific history, therefore, and the annals of mechanical invention will inevitably devote a prominent niche to Elias Howe for his invention of the lockstitch sewing machine, for not only was this pioneer invention absolutely sound in conception, but, also, its basic principle is the one which still underlies the ordinary sewing machine of the present day.



# MODEL AERO TOPICS

Current News from the World of Model Aviation

## The Wakefield Cup Contest

THE Wakefield Contest, as briefly announced in last month's issue, was won by America. Our team made a very poor showing. Dick Korda, the American, made a first flight of over 43 minutes, which was duly recorded as a world's record. Korda's machine on the preliminary examination was found not to comply with the conditions governing the contest. He altered it, and in the very first flight of the contest put up the duration mentioned. Unfortunately, in this country, we are not well blessed with the wide open spaces and a natural supply of thermals with which America seems so adequately supplied by nature. The result of the contest means that if there is to be a Wakefield contest next year, we shall have to find the money to send a team. I suggest, therefore, that the S.M.A.E. should call a special meeting of all those who have visited America as representatives of Britain in the Wakefield Contest, so that they can discuss the methods and the conditions of training there for the advice of those who wish to enter next year's contest, if one is held.

### "Skybirds" Service for Model Aircraft Constructors

"SKYBIRDS" Service Motor is now available (by arrangement) for Flying Clubs and school exhibitions and for displays in the London and Home Counties area.

For such exhibitions, the van will

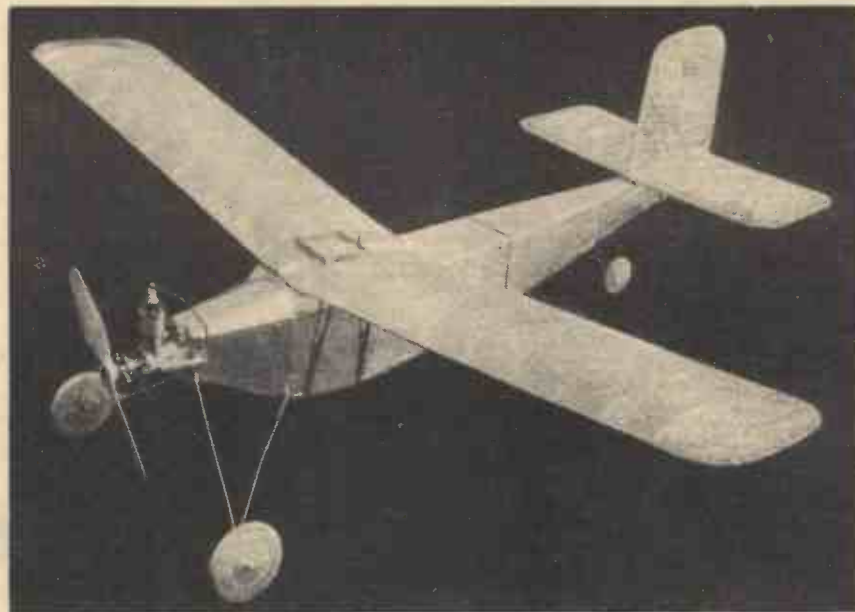

One of the Hallam Petrol Models

carry two specially designed show cases containing a complete range of "Skybirds" scale model aeroplanes. These show cases, displayed on trestle tables with the van as a background, make most attractive exhibits.

### National Cup Result

		Tot.	Av.	Secs.
1. North Kent.	590.175			
2. Hayes.	576.775	"	"	"
3. Kingston.	562.825	"	"	"
4. Nth. Heights.	520.075	"	"	"
5. Luton.	515.125	"	"	"
6. T.M.A.C.	488.675	"	"	"

### Bowden Trophy Result

1. J. Coxall.	Hayes.	200 pts.
2. E. Ross.	Nth. Hghts.	195 "

3. R. Stubbs	Essex.	181 pts.
4. F. Almond.	Nth. Kent.	135 "
5. A. Poulton.	Luton.	130 "
6. F. W. Lawrence.	Bromley.	129 "

### Frog Senior Cup Finals, 1939

		Points.				Total.
		A.	B.	C.	D.	
1. J. R. Vanderbeck.	T.M.A.C.	10 nil	25	80.15	115.15	
2. P. Montgomery.	Fife.	25	15	15	44.0	
3. E. Chasteneuf.	B'heath.	20	5	20	49.1	
4. — Guest.	Gen. Air.	45	5	10	10.075	
					70.075	

### Sir John Shelley Cup Results, 1939

1. P. Rowe.	Bournemouth	128.75
2. E. Ross.	Nth. Hths.	126.7
3. F. Almond.	Nth. Kent.	124.5
4. J. Blunt.	Brighton.	123.6
5. D. R. Byfield.	Hayes.	121.5
6. R. W. Stubbs.	Essex.	117.5

### Women's Challenge Results

		Av.
1. Mrs. Baines.	D'g'ham.	163 Secs.
2. Mrs. Weller.	Surrey.	111.16 "
3. Miss Lundy.	Nth. Hghts.	96.6 "
4. Mrs. Clifford.	Crty (B.)	87.6 "
5. Mrs. Hill.	Lancs.	78.6 "
6. Miss Offord.	W. Sussex	67.06 "

### S.M.A.E. Council Meeting

THE Royal Aeronautical Society, having settled in their new headquarters, have offered the S.M.A.E. a room for holding council meetings and the offer has been accepted.

### New S.M.A.E. Cup

DR. A. P. THURSTON the President of the S.M.A.E. has offered the Society a cup to be



The British Wakefield Cup team on board the "Aquitania." (Left to right) C. Gibson, N. Lees, R. Copland, A. F. Houlberg, E. F. H. Cosh, R. Narburn, L. Scott and R. A. Hill



awarded on the lines of the Plugge Cup but for individual championships.

#### F.A.I. Meeting

AT the last F.A.I. Meeting it was stated that Italy, Germany and Poland asked for certain alterations to be made to rules relating to the cross-sectional area of fuselages and it was also desired that the rules relating to the timing of models should be altered. Some countries wished the timekeepers to follow the models. The S.M.A.E. has, however, sent a letter to the F.A.I. expressing their disagreement with the suggested alteration.

The S.M.A.E. have sent a letter to the Royal Aero Club requesting that official S.M.A.E. timekeepers should be recognised for purpose of timing F.A.I. records.

#### Effect of the Crisis

WE feel quite certain that the S.M.A.E. faced with the same difficulties which confronted the Kite and Model Aeroplane Association at the beginning of the last war is making all arrangements to safeguard the position of the valuable trophies for which it is responsible. It will be remembered that when the last war ended the cups were spread about all over the country and extreme difficulty was experienced in getting them together again. The K.M.A.A. went out of existence during the last war and efforts to revive it after the war failed. At that time, the only really active club was the London Aero Models Association, and the present writer was responsible at a meeting held in Windmill Street, Piccadilly, for that club changing its name to the more national one of the Society of Model Aeronautical Engineers and approaching the Royal Aero Club for recognition as the lineal successor of the K.M.A.A.

The S.M.A.E. is a vastly better organised body than the K.M.A.A. and we suggest that they should take immediate steps to recall all cups held by those called to the colours. There can be no doubt that it will be almost impossible to carry on model aeroplane contests during the war, but we trust that the meetings will be held as long as possible and that the S.M.A.E. will be able to keep at least a skeleton committee together.

The position also of the younger members of clubs not of military age

will arise. It is most essential that they should be kept together so that the position of the S.M.A.E. which they have built up during the past 15 years is not destroyed. They have created a world-wide reputation as the governing body and they have established contacts all over the world. It will be a pity if arrangements were not now made for the delegation of duties if and when members of the committee are called up.

This applies also to the secretaries of local affiliated clubs. They should make efforts to pass their jobs over to someone else with strict instructions

We have on our files names and addresses of the secretaries of nearly every affiliated and non-affiliated club. We issue a special appeal to non-affiliated clubs to join the Society of Model Aeronautical Engineers so that the whole movement can be brought under the control of the central body.

This would be in the best interests of the individual clubs, for membership of the S.M.A.E. confers advantages not obtainable in any other way, and not the least of these is that club entries can be accepted for certain of the national



Members of the U.S.A. Wakefield team with the Lord Wakefield Trophy, which they retain for 1939. Over a hundred models competed in the Wakefield Contest. (Left to right, seated) James Bohash of Illinois, Dick Korda of Ohio, Ralph Baker of California. (Standing) Robert Chaille of Florida, Ted Just of Pennsylvania, and James Thames, also of Pennsylvania

that the club must be kept going.

#### Notice to Club Secretaries

IN order that we may keep our record of club secretaries and their officials accurate and up to date, we shall be glad if when changes are made the Press Secretaries will apprise us of such changes. We receive dozens of letters each week from new enthusiasts who desire to join clubs, and it is essential that we should be able to give them the correct name and address of the secretary.

In the past there have been as many as six changes in secretaryship during the year, and we feel that the time has come when any officer accepting duties in a club should hold that office for at least six months.

contests. Additionally, the advice of the various departments of the S.M.A.E. is available upon request.

#### The Baby Gnome Kit

THE Baby Gnome is a lightweight kit, supplied by the Model Aircraft Supplies Ltd., 171 New Kent Road, London S.E.1. It includes ample supplies of first-quality balsa, birch, bamboo, tissue, dope, cement, rubber lubricant, and a specially shaped propeller blank.

The span of the model is 28 ins. and the weight  $1\frac{1}{2}$  ounces. The best recorded flight made with the model constructed from one of these kits, which cost 7s. 6d. carriage paid, is 7 minutes.



# Warship Models—Past and Present

By W. J. BASSETT-LOWKE,  
M.I.Loco.E

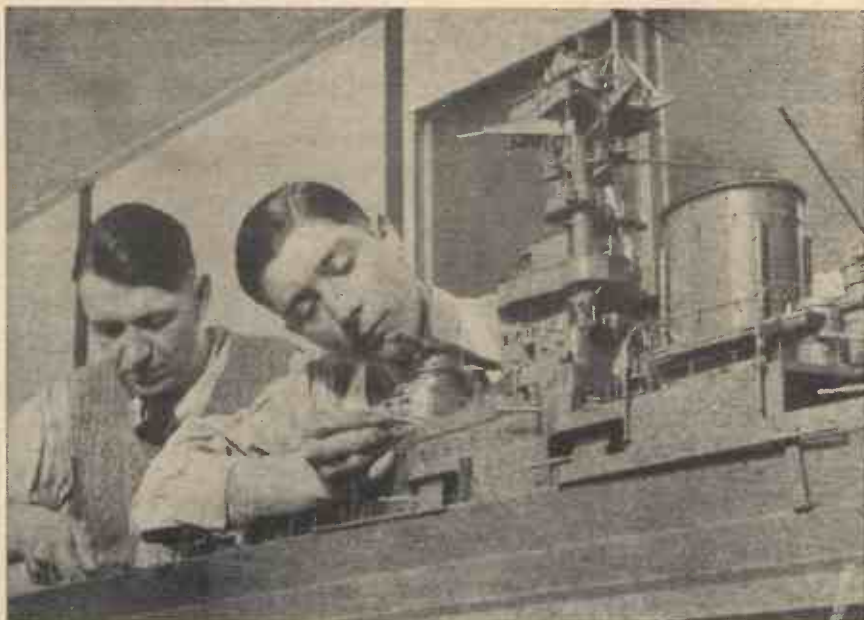

Views of the 3-16 in. to the foot model of the battle cruiser H.M.S. "Hood"

**T**HE present international situation, and the many naval reviews, have to-day centred a growing interest in our fighting fleet and those of other countries. At the moment, therefore, model fighting vessels—great and small—are in the news.

## The H.M.S. "Hood"

Two views are shown on this page of a wonderful model of H.M.S. Hood, made for the builders, John Brown & Co., Ltd., of Clydebank, and exhibited at the Glasgow Empire Exhibition. The model was built from the original drawings of the Hood—the largest battle cruiser in the world, one of the four ships in its class begun in 1916 under the emergency war programme, as an answer to the German battle cruisers *Graf Spee*, *Mackensen*, *Ersatz Freya* and *Ersatz A*. The British vessels and their contractors were *Anson*, *Armstrong*; *Howe*, *Cammell Laird*; *Rodney*, *Fairfield*, and *Hood*, *Brown*. As the enemy ceased work on all his large cruisers in 1917, the *Anson*, *Howe* and *Rodney* were stopped in March 1917. The *Hood*, however, was launched on August 22, 1918, and completed in March, 1920, and since then has received several extensive refits. It is amazing to think that the annual upkeep of one of these giant battle cruisers is £390,000.

## Large Scale

As for the model shown on this page, it is built to a scale of 3/16 of an inch to the foot and is approximately 14 ft. 2 in. long. A warship model requires much more detail than a vessel of the Mercantile Marine. There is a greater amount of small metal work. The *Hood* has four revolving gun turrets and twelve 15-in. 42 calibre guns, which must be modelled, beside all the deck gear and the various control positions.

One of the earliest and probably the largest model shipbuilding contracts ever carried out by a model firm was in 1913, when a fleet of working model battleships was produced for the Imperial Services Exhibition at Earls Court. These were designed by Mr. Edward W. Hobbs, A.I.N.A., and the driving power was provided by electric motors and accumu-

lators. The larger warships, approximately 20 ft. long, carrying two men, and the smaller ones, 14 ft. long, carried one man. They were tested at Northampton on the river Nene before being dispatched to London, and here is a picture taken in 1913 showing part of the fleet. In the foreground is the warship *King George V* with one of its operators in view!

## Small Models

But the genuine amateur, unless he has unlimited time, skill and means, does not go in for warships on such a large model scale. He would be well advised to try his hand at small 50 ft. to the inch and 100 ft. to the inch waterline miniatures. An amazing amount of fine detail can be modelled, few tools are required—a plane, razor blade, file, sandpaper, chisel, fretsaw, tweezers, cutters—and the hobby is one into which you can put whole-hearted work, with good result. I was talking to one of my expert craftsmen about this

very hobby recently. His advice to amateurs is to get as close-grained a wood as possible—American white wood is a good one. Other accessories are Bristol board, a good adhesive, florist's wire for the finer parts and stronger wire for the masts and guns. Ripolin paint—a matt

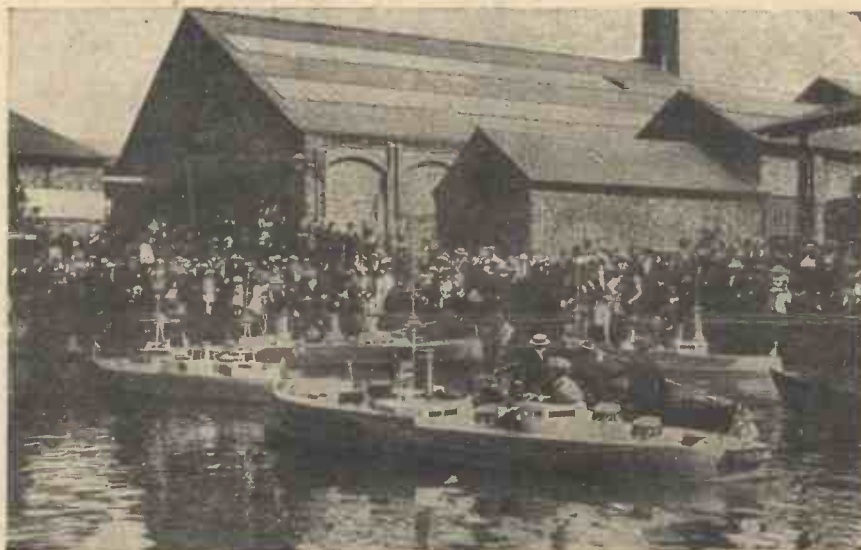

A picture taken in 1913 on the river Nene at Northampton showing part of a huge fleet of model warships made for the Imperial Services Exhibition by Bassett-Lowke, Ltd.



# INSIDE A CYC

## During Recent Years Dynamo Lighting S and many Interesting and Novel Dynamo Drawings showing the Construction of Shown B

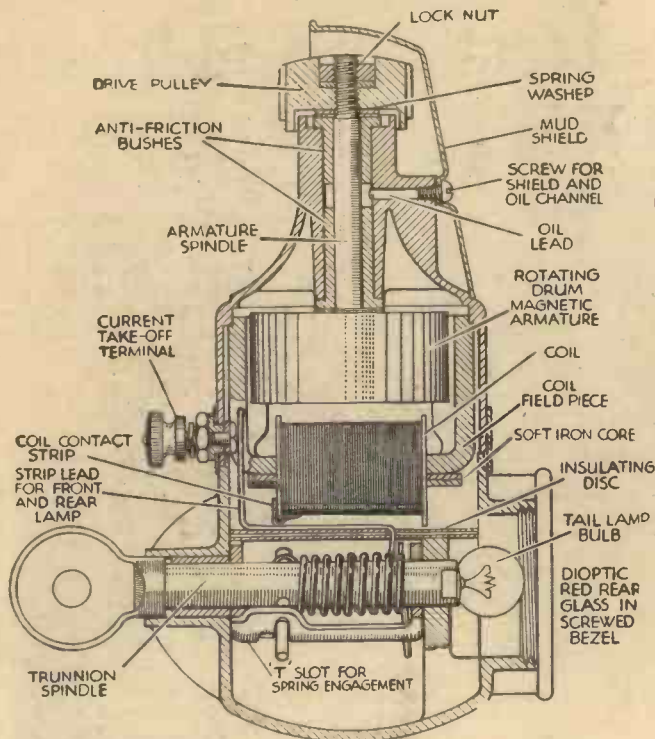

The Miller 6-watt dynamo, in which the coil is stationary and the permanent magnet rotates, energising the soft core of the coil in alternating polarity, and inducing an alternating current in the stationary coil

**M**OST of the cycle dynamos on the market differ very little in design. They are of the alternating-current type and those placed on the market in recent years have moving magnets instead of moving coils, so that there are no sliding contacts inside. Practically all now incorporate a form of voltage control to avoid burning out the bulbs through excessive speed when, for example, free-wheeling down a steep hill.

### Magnetic Poles

The number of magnetic poles in different dynamos varies from two to, in the normal

pattern of dynamo, about eight. The larger the number of poles, the more steady the output and the easier it is to rotate the dynamo.

One of the most recent developments, the Dynohub, is built into the hub of the front wheel, the rotating member of the dynamo is a 20-pole magnet, housed

in the hub, which rotates as a magnetic field around a fixed armature which consists of 20 enamel-covered wire coils. This energises

20 field pieces whose faces are traversed (with a small air gap between) by the 20 poles of the surrounding rotating magnet in the hub shell. This coil unit is fixed to the front wheel spindle, and carries an insulated disc with two terminals, from which the current can be taken off without the need

for any friction or other wiping contacts. Since the speed of rotation is the speed of the cycle wheel itself, it is evident that such a dynamo is rotating at a very considerably reduced speed as compared with the speed of a dynamo driven in the conventional manner (by a

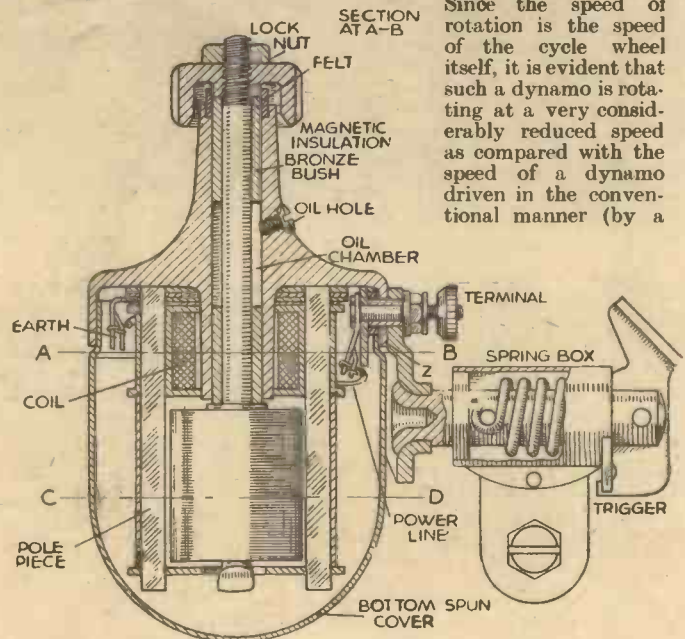

The Philidyne lightweight, which is an eight-pole dynamo. It will deliver current at a low cycle speed and is so arranged that at high speeds the voltage does not rise to any point which will endanger the filament of the lamp bulb

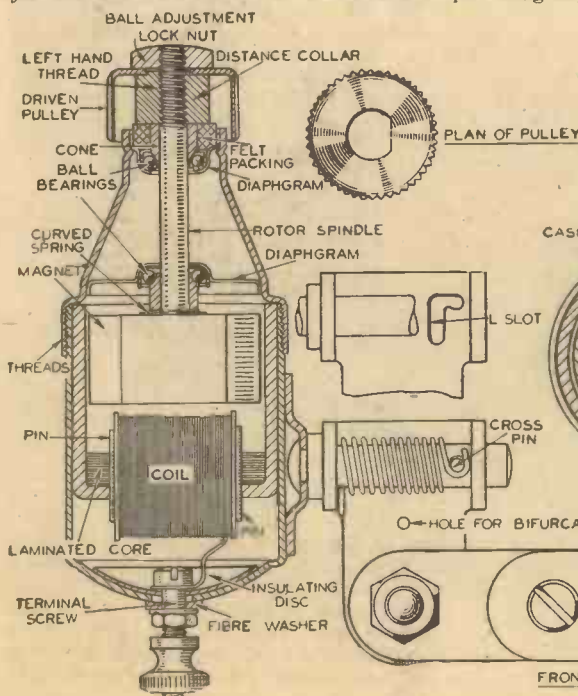

(Left) This is the Roto-Phare, a French-made set constructed largely of duralumin. As a result of its extremely light weight it is very popular with club cyclists

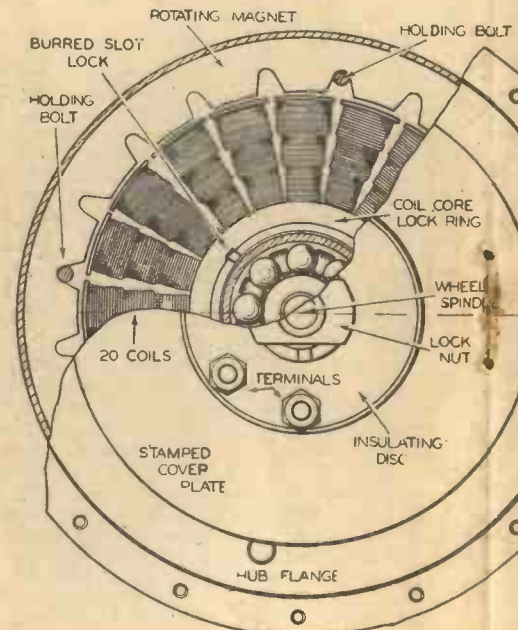

The patent Dynohub, which is now a standard item of



# THE DYNAMO

sets Have become Extremely Popular, are now on the Market. Sectional a Few of the Popular Models are Below

friction pulley or roller contacting with the tyre).

### Upkeep Nil

The modern dynamo requires an absolute minimum of attention. The cost of upkeep, of course, is nil and the only servicing it requires is an occasional spot of oil. Oil-lubricated dynamos have an oil-retaining felt washer which also serves to exclude foreign matter. The case itself is completely weather-tight and in most cases non-detachable.

The better-class dynamos have a spindle running on ball bearings arranged to take thrust as well, because if a dynamo is not completely in adjustment, the pulley will tend to ride up or down the

tyre. Plain bearings are also quite a popular arrangement and make an additional feature possible. This is the so-called oil-less dynamo. In this case the plain bearings are of soft metal in which are em-

(Right) The Impex Alfa lightweight dynamo, another popular continental model. The agents for this set in Great Britain and Northern Ireland are Cleminson's Agencies, Ltd., of 17, Duncan Terrace, City Road, London, N.1

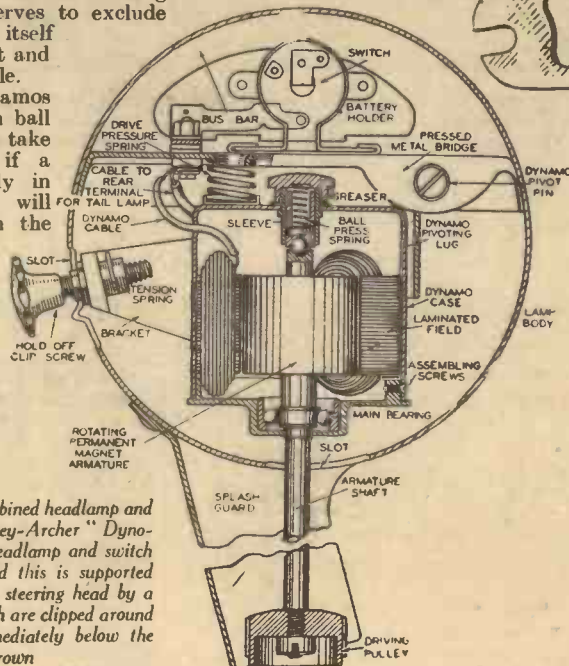

A unique type of combined headlamp and dynamo is the Sturmey-Archer "Dynamo-lamp." Dynamo, headlamp and switch are in one unit, and this is supported in front of the cycle steering head by a pair of brackets which are clipped around the front forks immediately below the fork crown

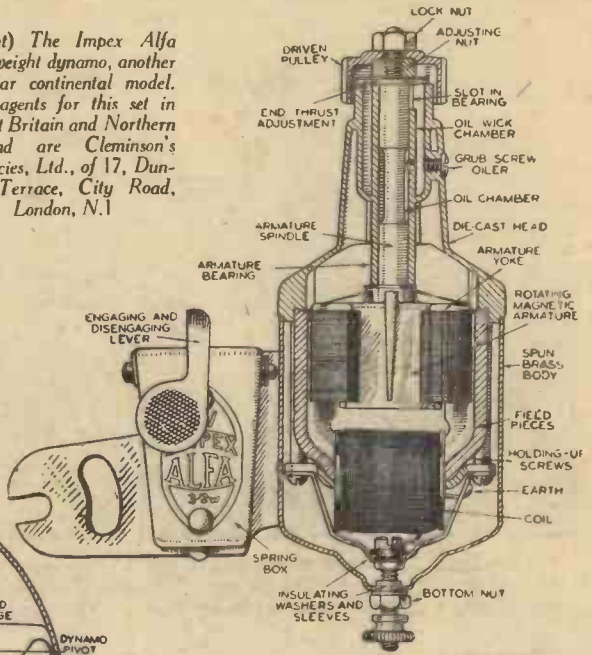
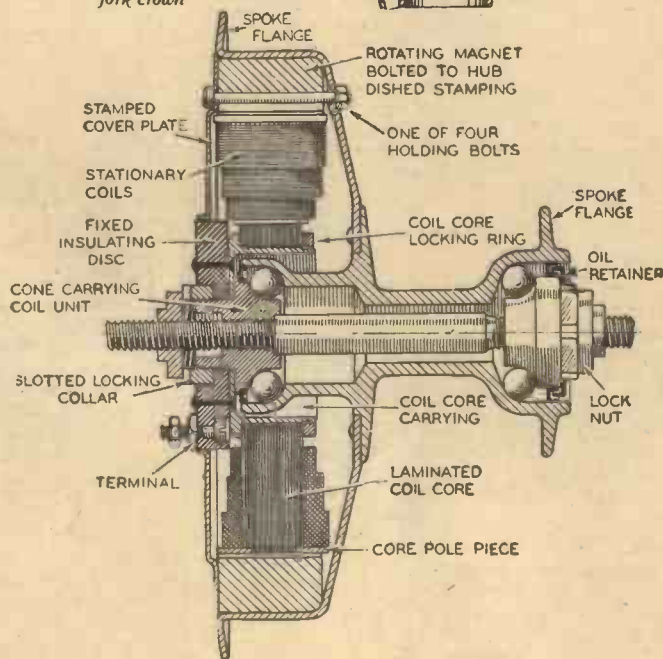

bedded minute pieces of graphite, an excellent lubricating material.

The brackets attaching dynamos to the frame of a bicycle have also received the attention of designers. In some cases they are now incorporated in the dynamo, keeping the bearings free from wet and mud. Where the dynamo is designed to be fitted to the front fork sometimes a pedal is provided so that it may be put into operation by the foot without dismounting. In one special case there is a push button in the side of the dynamo which, when pressed, brings the dynamo into contact with the tyre.

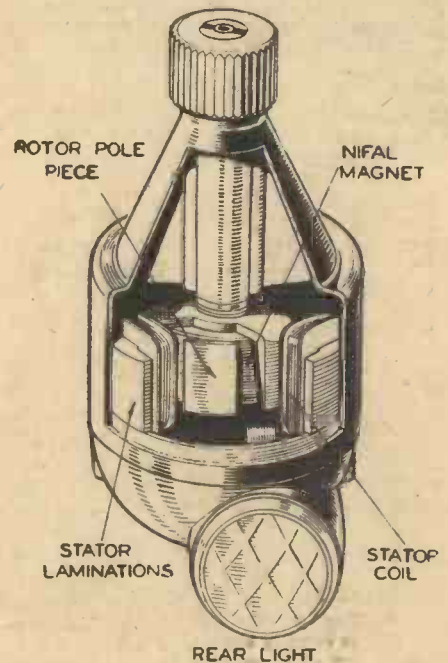

One of the best-known British dynamos on the market—the Lucas. The internal arrangements shown here are common to the types C25MU and C25MR. Other Lucas dynamos are similar in general layout but differ slightly in minor details such as the bracket mounting and the position of the rear lamp. (Makers: Joseph Lucas, Ltd., Great King Street, Birmingham, 19)

equipment on certain Raleigh and Humber models. It is not an attachment, but is built into the front wheel hub of the bicycle





Fig. 1.—(Left) A servant attached to the back edge of an ordinary dining table, ready to receive articles vanished in the course of a trick. Fig. 11.—(Centre) A tray and servant combined. The bag servant folds up under the tray and can be brought on or taken off in full view of the audience. Fig. 14.—(Right) Apparatus for producing a shower of sweets. The bag is so constructed that it remains closed until stroked down with the hand, when it permits the contents to escape

# The Tricks of Conjuring

*Some of the Hidden Devices that Make Tricks Possible*

ILLUSTRATED in Fig. 1 is a servant which can be easily attached to the back of any ordinary table. It consists of a metal frame provided with screw clamps for fastening to the table. The frame is covered with a network of wool. Articles may be secretly dropped on to the servant without a sound or they may with equal ease be secretly picked up from it.

Here is an example of its use. A tumbler is put on the table and covered with a large sheet of paper. The paper is crushed round the glass and drawn off the back of the table. The glass is allowed to fall unseen on to the servant and the paper, retaining the form of the glass is carried into the

*By Norman Hunter*  
(The Well-known Conjurer of "Maskelyne's Mysteries")

*Further Articles on the Secrets of Conjuring will appear Regularly and Exclusively in this Journal*

behind it from the servant. The hat is then covered and the box of chocolates allowed to drop inside ready for production.

Figs. 2, 3 and 4 show further ways of arranging a servant behind a table. In Fig. 2 the cloth at the back of the table is pinned up so as to form a pocket. In Fig. 3 a box or a couple of large books placed near the front of a small table and covered with a cloth, provides a small section of table at the back which does duty as a shelf. A folded handkerchief or

a shallow box padded with cotton wool placed on this shelf will deaden the sound of articles dropped on to it. Fig. 4 shows how an ordinary drawer in a table forms a natural servant. The drawer side faces away from the audience and the drawer is pulled out a few inches. The drawer is padded with a cloth to ensure silence in use.

### Adapting a Table

One advantage of this latter servant is that a borrowed table can instantly be adapted to conjuring requirements and, if the shelf is gently pushed in again after use, the table can be moved across the room and casually turned round during the performance to prove the absence of preparation.

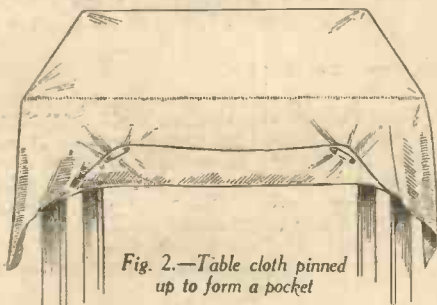

Fig. 2.—Table cloth pinned up to form a pocket

audience before being screwed into a ball. Articles which the conjurer has palmed can also be dropped on to the servant in the act of picking up some article from the table.

### The Servante

Producing articles by means of the servant is equally simple. The article, say a small box of chocolates, is placed on the servant with one end resting on the rear framework. A tray or folded newspaper is shown and laid on the table, overlapping the back edge, while a hat is shown empty. The tray or newspaper is picked up and the box of chocolates is secretly picked up

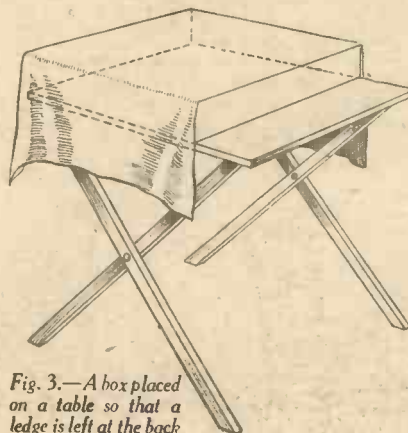

Fig. 3.—A box placed on a table so that a ledge is left at the back

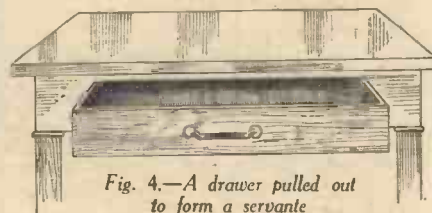

Fig. 4.—A drawer pulled out to form a servant

Fig. 5 shows a simple way of holding a long article such as a fan or a candle, ready for production behind a table. Two large cup hooks are screwed into the table and the article rests in them, ready to be picked up behind a sheet of paper by simply curling the fingers under it between the hooks. To make it suitable for use on a borrowed table the device would consist of a strip of wood with the two hooks screwed to it, and two fine points projecting from the opposite side of the strip which could be pressed into the back of the table. Needless to say when any device is to be fixed to a borrowed table by means of needle points, care should be taken to obtain a small kitchen table or other piece of



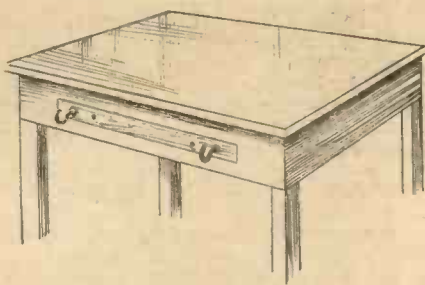

Fig. 5.—A hook servante

furniture which will not be harmed in the process.

**Special Holder**

Fig. 6 shows a holder for a ball or a tumbler. It consists of a ring of stout wire with cycle valve rubber stretched over it to prevent noise. There is a gap at one part of the circumference to enable the fingers to pass through in removing the load. The ring is attached to the table by two drawing pins or tacks passed through holes in the metal plate at the back.

Servantes may also be attached to chairs as well as to tables. Fig. 7 shows a simple type consisting of a ring with a bag sewn to it. A short cross piece attached to the ring has a tape run through by means of which the bag may be attached to the back of a chair. It is concealed from the audience either by using a solid backed chair or by throwing a fancy cloth or flag over the back of the chair.

An addition to this servante is shown in Fig. 8. This consists of a clip attached to a vertical piece of metal rising from the ring. In this clip some article may be placed and secretly secured under cover of picking up a handkerchief previously laid over the back of the chair. Exchanges of articles are also easily accomplished with this servante. Both articles are wrapped to look alike and the one to be changed is dropped into the bag, the fingers bringing into view the other article from the clip. The whole change is done in a second and can be well disguised by bending down to pick up a plate from the seat of the chair on which to put the changed article. The free hand resting on the back of the chair in a perfectly natural attitude has ample opportunity to drop one article into the bag and remove the other from the clip while the plate is being picked up.

**Vanishing Large Objects**

A useful servante for vanishing a fair-sized object consists of a bag on a wire frame attached behind the seat of a chair as shown in Fig. 9. The back of the chair may, in this case, be an open one, but the chair seat should have several sheets of newspaper lying on it and overlapping, to mask the bag from the front.

The article to be vanished, say a toy rabbit, is laid on one of the sheets of paper and the paper gathered round it. In doing this it is a simple matter to push the rabbit through the back of the chair and let it fall into the bag. The wrapping process is then continued as if the toy were still in the paper. The subsequent disappearance of the toy rabbit can be effected quite sensationally in the midst of the audience. Or some solid object such as an alarm clock may be apparently wrapped up, the parcel placed on a metal tray and set light to. The vanish of the clock in the flames of the burning paper is as effective a piece of magic as you could wish for.

**Suitable Disguise**

Sheets of newspaper laid over a board

resting on the backs of two chairs can also serve to disguise a useful servante as shown in Fig. 10. The servante consists of a frame with cloth stretched over it. It is fastened to the underside of the board so as to project at the back. Before attaching

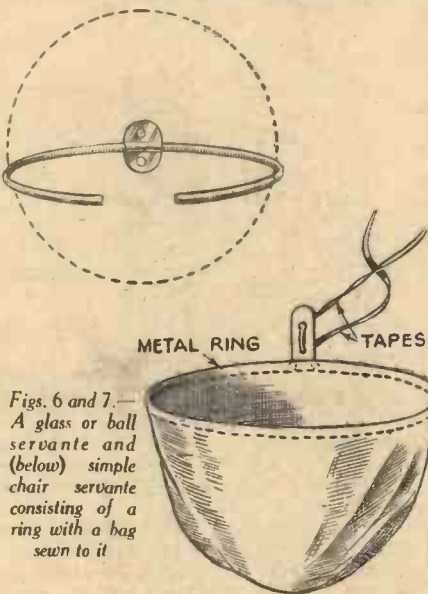

Figs. 6 and 7.—A glass or ball servante and (below) simple chair servante consisting of a ring with a bag sewn to it

it to the board some sheets of paper are laid over the board and allowed to hang down at the front and back. The servante is then clamped on and the paper at the back hides it from view. Some loose sheets of newspaper are laid on top and these are used for

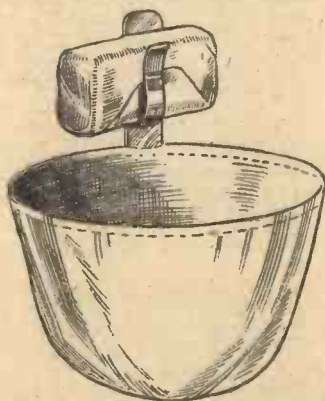
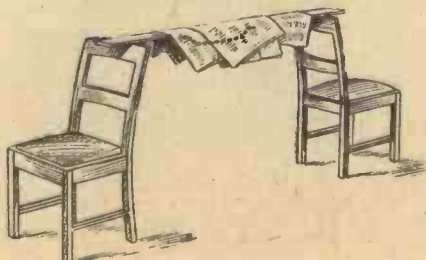

Fig. 8.—A servante fitted with a clip for making exchanges

wrapping up whatever it is desired to vanish, the said article being gently deposited in the servante during the wrapping process.

In Fig. 11 is a servante attached to a tray. This folds under the tray and in this state the tray may be brought forward in full view of the audience and put on the table. It is held with the top rather tilted towards the spectators and the servante



may be unfolded as the tray is laid down, thus preparing for the disappearance of various objects on an unprepared table.

Figs. 12 and 13 shows respectively a glass servante attached to the back of a box, and a very cunning servante contrived in a glass tumbler. The box with the bag behind may be used to hold various articles used in the performance, and the act of putting something down on the lid provides ample cover for secretly disposing of any small article concealed in the hand. The glass, a large one, is fitted with a vertical partition of mirror behind which is a wad of cotton wool. A fan may be laid on this apparently empty glass and a palmed ring or coin thereby dropped into the padded rear compartment. The apparent transparency of the tumbler misdirects any suspicion that it may be responsible for part of the mystery.

**Special Pockets**

Special pockets are not used to any great extent by the conjurer of to-day, but a large pocket in each of the tails of a dress coat is sometimes very handy for disposing of moderate sized articles. These pockets, called by conjurers "profondes," are lined with buckram to keep them open and the top openings of the pockets are cut slanting for easy access.

It is not, as a rule, practical to get articles out of these pockets during a performance, as they have to be fairly deep. They are, however, of considerable use for disposing of palmed objects without recourse to a table or chair. If the conjurer does not wish to have such pockets permanently made into his dress coat, they can be made on a wire frame, furnished with safety pins and attached when required. In that case, however, it is more practical to fasten the pockets to the backs of the trouser legs in a position where they will be easily get-at-able and yet be covered by the tails of the coat.

Now we come to separate fakes designed to enable the conjurer to produce various effects with unprepared articles.

Fig. 14 is a triangular shaped bag, the mouth of which is kept closed by pieces of whalebone sewn along each side. From the two corners of the mouth of this bag stiff wires are sewn reaching along the sides and meeting at the apex of the triangle. A small sharp hook is sewn to the bag at this point.

**Producing Sweets**

The usual purpose of the bag is to produce a shower of sweets from a borrowed scarf. The bag is first filled with sweets. It may be held by the point with complete safety as the whalebone strips keep the mouth of the bag closed. Thus loaded, it is placed upon a servante behind a chair.

The scarf having been borrowed, it is thrown for a moment over the back of the

Figs. 9 and 10.—(Right) A useful servante for vanishing large objects consisting of a wire frame attached behind the seat of a chair. (Left) Sheets of newspaper laid over a board resting on the backs of two chairs can also serve to disguise a useful servante

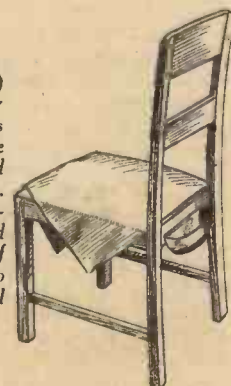



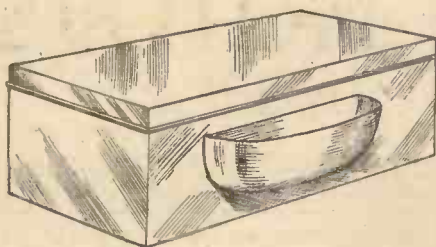

Fig. 12.—A servante behind a box

chair and, of course, over the concealed bag. A plate is handed to a member of the audience, the scarf is picked up near the centre with the bag hidden inside it. The scarf is held over the plate and stroked down with the free hand. This stroking movement enables the wires to be pressed together, thus causing the mouth of the bag to open as shown in Fig. 14 and the sweets fall in a shower on the plate.

If desired, the bag instead of being put on the servante, may be concealed inside the V opening of the jacket. The scarf being spread out is then moved towards the body and upwards, catching the sharp point on the bag and lifting it out. The scarf is then grasped from the front about the centre and with it the point of the bag.

A good comedy trick can be worked by using two of these fakes, one filled with chocolates and one with monkey nuts. A lady is asked to breathe on a scarf and a shower of sweets falls on to the plate she holds. Another scarf is taken and a gentleman is asked to blow upon it, when monkey nuts pour out.

#### A Useful Fake

Another very useful conjuring fake consists of nothing more unusual than a fine hair net. This net is spread carefully inside a bowl, the bowl being one of those coloured papier mâché articles sold for growing bulbs in. The net will be quite invisible even at a short distance. The corners of the net are

allowed to hang down outside the bowl.

The bowl is now filled with handkerchiefs, or coloured paper balls, in fact anything light in weight and not small enough to pass through the net. A cloth is drawn over the bowl and when removed the contents have vanished.

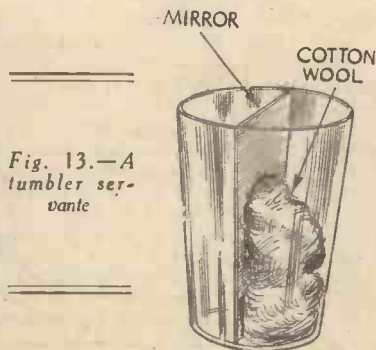

Fig. 13.—A tumbler servante

The net is removed in the act of drawing the cloth over the bowl, and dropped unseen into the servante behind the table. To make the trick easier a fine wire ring may be attached to the net. The procedure is illustrated in Fig. 15.

By substituting a lining of celluloid or talc for the net, such commodities as tea or bran may be vanished in the same way. In this case the fake need not necessarily conform to the shape of the bowl, but may simply be in the form of a cone inverted into the bowl. The bowl should be enamelled with some bright and glossy coloured enamel.

#### Vanishing Rice

A handy little fake for vanishing a handful of rice or other material consists of a small purse with elastic attached. The free end of the elastic is attached to the back of the waistcoat, and the length of the elastic adjusted so that normally the purse hangs out of sight under the coat.

Having got the purse into the right hand, it is opened and, the back of the hand being kept towards the spectators, the rice is poured into the purse. The purse is then snapped to, a throwing movement made and the elastic allowed to carry purse and rice out of sight.

Vanishing a handful of coloured beads can also be simplified by the use of a fake consisting of a number of beads threaded on two or three short strings, the string being tied together. This fake is placed in a box with a quantity of loose beads. A handful of loose beads is taken up and allowed to trickle back into the box. Another handful is apparently taken, but this time it is the fake which is picked up. This fake can now be attached by means of a hook or clip to a length of elastic and vanished under the coat as described for the purse fake, or it may be apparently tossed into the air, being actually left in the "profonde" as the hand swings downwards.



Fig. 15.—First and second fingers hold cloth leaving first fingers and thumbs free to lift wire frame net out of bowl as cloth is drawn over

## ITEMS OF INTEREST

New Locomotives; Cobb's Record; Train Arrival Indicator.

### Streamlined Monsters

L.M.S. workmen are busy at the Crewe works constructing stream-lined locomotives of the Coronation class. The first of them, which was named the City of Birmingham, was recently put into service, and the rest of the locomotives will follow at regular intervals. They weigh 165 tons.

Before the design of the engines was decided upon, a wind tunnel 4 ft. square and 30 ft. long was built, and scale model engines were used with detachable fronts, so that different shapes could be tried out and the results recorded.

### Cobb Does It

JOHN COBB was successful in his attempt on the land speed record and he has now put the figure up to 368.85 m.p.h. for the measured mile. The attempt was made on the Bonneville Salt Beds, Utah, U.S. His speed over the measured mile for the north run was 370.75 m.p.h. and in the opposite direction it was 366.97 m.p.h.

### Train Arrival Indicator

ONE of the latest devices to be installed at Waterloo Station is a new mechanical train arrival indicator. It is the first of

its kind in the country, and it not only shows the arrival platform, but also stations at which trains stop en route with branch line connections, and the number of minutes

late (if any). Announcements regarding main line arrivals are shown on twelve panels, each panel having 29 slats, coloured green with white lettering, for the station name plates. The panel in the centre contains information about boat train arrivals from Southampton. The whole frame is finished in stained teak, French polished, with gold lettering.

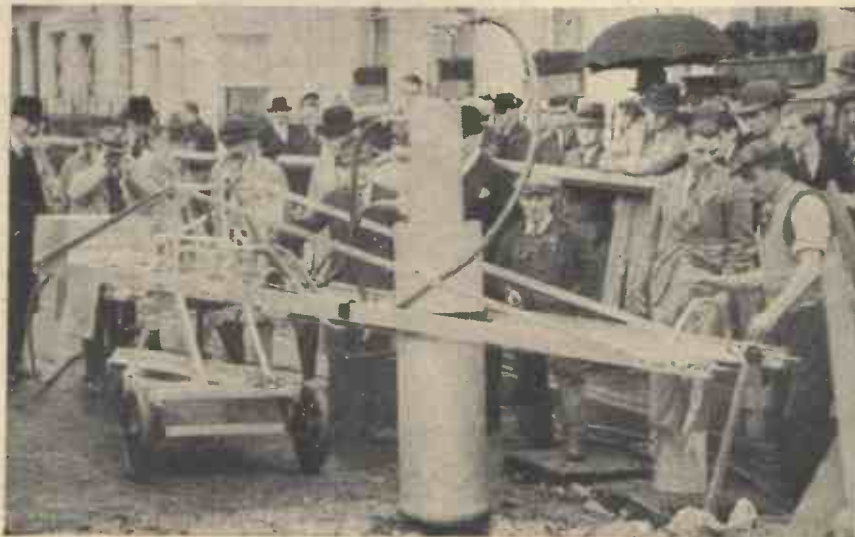

The first public test of a silent pneumatic road drill, invented by Mr. Walter Pettit, consulting engineer, was carried out recently. Members of the Noise Abatement Society watched the demonstration



# MODEL AEROPLANE MOTORS

## EFFICIENT RUBBER MOTORS AND FREE WHEEL DEVICES

**O**NE of the most important points of a flying model is the rubber motor. A perfectly designed and built model can be ruined by using the wrong power. Usually, the power required is estimated by experience obtained from other models, but the addition or subtraction of a strand may make the difference between a good flight and a bad one. There are two main types of rubber, the first being American brown, and the second, black. The American brown rubber is used by a large number of flyers in this country, especially in competitions, as it seems to contain more energy for its weight than any other type of rubber known to us at present. It is able to absorb a greater number of turns than the black rubber, and (this is

**Avoid Grit in the Motor**  
 A motor should never be allowed to drop on the ground or become gritty, as grit will often cause a breakage at less than half maximum turns.  
 Should a motor become gritty, it should always be well washed in cold water (under the tap is best) and dried with a soft cloth. It should then be re-lubricated, but make sure that the rubber is well lubricated all over, as a dry part tends to stick, and tears.  
 A new motor should never be given full turns until it has been prewound. The method used by the writer is to first well lubricate the motor, and give approximately 20 per cent. of maximum turns, increasing by 10 per cent. stages to 60 per cent. The motor should then be sufficiently run in,

quired in a model, the rubber is made into 10 strands, twice the normal length (+slack), and a number of turns, which will just leave the entwined motor slack, are wound on. Find the centre of the rubber and double back, making sure that the turns are not released. Hold the ends "A" and "B," and let go of the end "C." The rubber will then entwine itself depending on the number of turns applied. Naturally, the required number of turns differs with different motors, but the writer found that on an 18 strand of  $\frac{1}{8}$  in. rubber motor 44 in. long (normal length) the required number of turns is approximately 180.  
 The advantages of using this tensioner are that there is no addition to the weight, there are no mechanical parts which can go

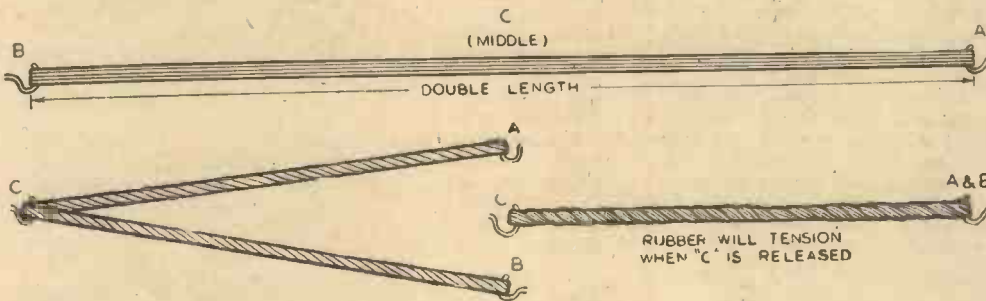

Diagram explaining how to use elastic

wrong, and if one, or even more strands, should break, there is not the tendency to fly back into the fuselage as they are held in position by the tension of the other strands.

When using this method, the rubber can be prewound when the motor is untensioned (i.e., double length) as it helps to level the strands, and the motor tensions better afterwards.

Unfortunately, turns charts cannot be relied on with any degree of certainty, as nearly every batch of rubber varies.

Also the maximum turns vary with the condition of the rubber.

a very important point) the initial burst of power is definitely not so violent.

### Sensitive Rubber

Brown rubber is more sensitive to conditions than any other rubber, and it should be kept away from heat or the sun, as a few hours of exposure will ruin it.

Black rubber is very popular with aeromodellers at the present moment, as, with reasonable care, it wears very well, and lasts longer than American brown. The initial burst, however, is very violent, and the power output does not seem to be so gradual and steady as that of American brown rubber. Generally, the care of both types of rubber varies little, although extra precautions should be taken when using brown rubber. When not being used, the rubber motors should be stored in an airtight tin in a cool place, or, better still, in a stone jar, which contains rubber lubricant.

and remember always save your full maximum turns for the last flight.

When winding a large number of turns on to a motor, stretch the rubber about five times its normal length and wind half of the required turns before "coming in." Then "come in" towards the machine so that there is always about 2 in. to 3 in. of elasticity in the rubber, and by the time you reach the machine you should have wound on the required number of turns.

### Breaking Point

One point to remember is that good rubber will always warn you before breaking, by becoming very tight, and another point is, don't "come in" too quickly, as this tends to cause the rubber to bunch.

On the majority of planes the rubber motor is considerably longer than the length of the fuselage, and in order to stop this from shifting about in the plane after the turns are exhausted, the rubber must be tensioned in some way.

There are many types of mechanical tensioners, several of which are shown here, and are self-explanatory.

Also, there is the inherent rubber tensioner, which was developed by Mr. H. White, of the N.H.M.F.C. (see sketch).

If a motor of, say, 20 strands is re-

### Maximum Turns

The best method of knowing the maximum turns of a batch of rubber is to make up a motor of the required length and number of strands, and after lubricating and prewinding in the normal manner, stretch wind the rubber in the same way as for a flight, until it breaks, naturally noting the number of turns applied.

However, if a large amount of rubber is used during a season, the cost of using this method is great. To avoid this, the writer uses the following method, which he finds very satisfactory.

### A Useful Hint

Make up a motor of the required number of strands, about 6 in. long, and lubricate and prewind in the normal manner. Then break the motor as in the first method. The breaking turns can then be divided by six, to find the breaking turns per inch, and multiply by the length of the required motor.

(E.g., motor 6 in. long breaks at 240 turns. Divide by 6=40 turns per inch. Length of required motor, 30 in.  $30 \times 40 = 1200$ .)

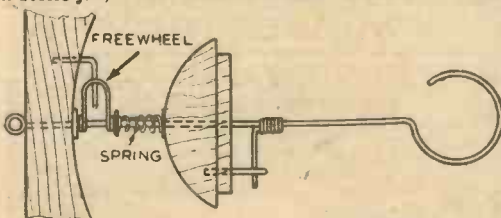

The writer has kept several motors for long periods by using the last method, and believes that it is far superior to any other. Care should be taken, however, to examine all knots which are bound with thread, as the lubricant tends to rot the thread.

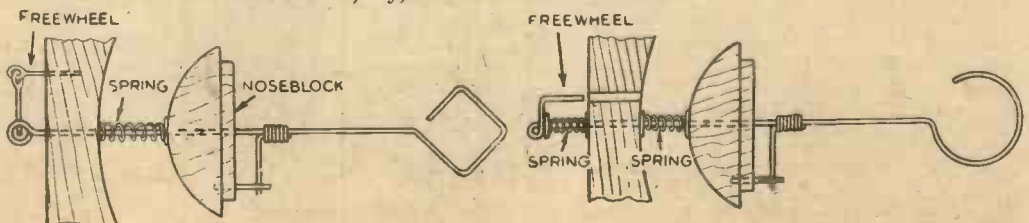

Three free wheel devices and rubber tensioners



A Wonderful New Work For All Engineers

# NEWNES' ENGINEERING PRACTICE



In 5 Vols., bound in Steel Grey Cloth, and lettered with 22-carat Gold.

WITH the publication of this valuable work you can now avail yourself of the knowledge of 47 PRACTICAL EXPERTS. These men have written down in simple language the results of their years of experience, and at a very nominal cost you can take advantage of this wonderful fund of expert information. Hundreds of special photographs, line drawings and diagrams show in detail all kinds of engineering operations, from the rolling of a locomotive tyre to the packing of a gland, and to the correct method of fitting a driving pulley on a shaft.

A MONEY-MAKING INVESTMENT  
•  
**47**  
EXPERT CONTRIBUTORS  
•

A Purchaser writes —  
"I appreciate the clear way in which the processes are described and illustrated. It is easy to see that your contributors are practical men who have been through the mill."

To the HOME LIBRARY BOOK COMPANY  
(George Newnes, Ltd.)  
TOWER HOUSE, SOUTHAMPTON ST.,  
LONDON, W.C.2.

Please send me, without any obligation to purchase, full particulars of ENGINEERING PRACTICE and details of how I may obtain this work for a small initial subscription.

Name .....

Address .....

Occupation ..... P.Mech.1039

If you do not wish to cut your copy, send post card mentioning "Practical Mechanics" to above address.

  
**POST THIS COUPON FOR FREE BOOKLET**

George Newnes, Ltd.

NEW . . . FROM COVER TO COVER . . .

# COMPLETE ELECTRICAL ENGINEERING

STUDY the information contained in this great new work and you will add considerably to your earning capacity in the electrical engineering world! COMPLETE ELECTRICAL ENGINEERING is offered to you at a price you can afford to pay. It is a complete library—a ready reference to the thousand and one applications of present-day electrical engineering. Its contents are absolutely comprehensive and deal with everything you can possibly want to know—from Electrical Power Supply to Talking Picture Equipment; from the Wiring of Modern Flats to Electrical Timing Instruments; from Emergency Storage-Battery Systems to Testing Electrical Machinery; from Lift Operation and Control to Garage Electrical Testing Equipment; from Time Switches and Time-Delay Devices to Electrical Welding Plant; from Refrigeration to Electric Meters and Cookers, etc.

It is impossible in this space to include details of the 160 Sections, but the special brochure which is yours for the asking—and without obligation to purchase—will show you that COMPLETE ELECTRICAL ENGINEERING is the very work you have been looking for. It can be yours within a few days!

Over 3,000 Pages of Exclusive, Practical, Worth-while Information  
Over 2,500 Action Photographs, Plans, Tables and Calculations  
63 EXPERT CONTRIBUTORS  
Special Chart Case with 48 Data Charts  
2 YEARS' POSTAL ADVISORY SERVICE

Complete in 8 Volumes

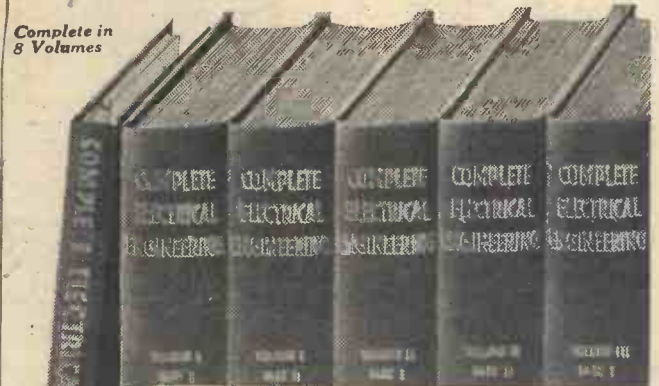

POST COUPON TO-DAY

HOME LIBRARY BOOK COMPANY

(George Newnes, Ltd.)

Tower House, Southampton Street, London, W.C.2

Please send me, without any obligation to purchase, full particulars of COMPLETE ELECTRICAL ENGINEERING and details of how I may obtain this work for a small initial subscription.

NAME .....

ADDRESS .....

Occupation ..... P.Mech.1039

If you do not wish to cut your copy, send a postcard mentioning "Practical Mechanics" to address above.

George Newnes, Ltd.



# The Shannon Hydro-Electric Scheme

By G. LONG, F.R.G.S.

*A Masterpiece of Engineering.*

*The tubes feeding the turbine*



*Tubes feeding the turbine and dam for holding back the water*

## Size Determined

This combination of rapid fall, and large volume of water determined the site of the great power station at Ardmacrusha. Headworks have been built across the Shannon at a point about five miles below Lough Derg, where a sandstone rock runs across the river bed and so gives a safe foundation for the mighty dam. As this had the effect of raising the river level by nearly thirty feet, the banks of the Shannon had also to be raised to prevent flooding, and a huge canal was dug to carry the water to the Power Station.

This canal—or head-race—is about eight miles long, with banks running up to over fifty feet high, and nine thick at the top. The maximum width is nearly three hundred feet, and the depth 35. The end of the head-race is closed by a huge dam over 80 feet high, through which pass four gigantic steel tubes each about nineteen feet in diameter, that is perhaps big enough to drive a motor lorry through. These enormous tubes each lead into a Francis Turbine, with a spiral volute chamber and vertical shaft, coupled to a three phase generator. These mighty turbines each develop 38,600 h.p. at a speed of 150 r.p.m., but so well are they balanced and so smoothly do they run that I could hear and feel nothing when standing outside the great hall in which they work. They are bedded in concrete, and are 36 feet in diameter. They are stiffened by a gigantic supporting ring of steel weighing 21 tons.

*The generating room*

**T**HERE is something rather fine about a government which plans to transform a country by scientific and mechanical achievement. Something of the kind has been done by the Russians under the Five Year Plan, and in our own country through the Electric Grid.

The Sister Island of Eire has long suffered from a lack of manufacturing industries, largely due to an absence of raw materials, and of natural resources of power. Coal has to be imported and has always been dear, so very little electricity was made.

The Shannon Electric scheme bids fair to change all this, and to carry light and power into every village in the land.

This splendid plan was born in the dismal period which followed the Civil War, so the Government of that day are to be con-

gratulated upon their courage and vision. To those who said the plan was too big, one statesman replied that they were determined to give the people "something big to think about."

Since Ireland has no mountains like the Alps, power from lofty waterfalls was unobtainable, so the engineers turned their gaze upon the mighty river Shannon, which is over two hundred miles long, and has a total fall of more than three hundred feet.

In its course the river expands to form three great lakes, Lough Allen, Lough Rea, and Lough Derg. It has been calculated that the river discharges 240 cubic metres a second into this—the lowest of the three lakes—and over a distance of about seventeen miles there is a fall of more than ninety feet.



### Egyptian Simplicity

This great power house has an almost Egyptian simplicity and solidity. The four mighty generators stand in a row along the great hall, the turbines which drive them are bedded in concrete underneath and out of sight. When I visited the place one of these huge dynamos was stripped down for repairs, and I was able to examine the huge rotor—or armature—which weighs 195 tons. This great mass, however, is far less than that of the turbine which drives it. The revolving part of the turbine, together with the contained water, weighs over five hundred tons.

There are some ingenious devices to ensure safe running, and to prevent breakdowns. There are quick-closing arrangements to shut off the water supply to the turbines in thirty seconds in case of emergency. If the normal speed of the turbines is exceeded, centrifugal governor relays on the turbines automatically control the closing mechanism.

Since breakdown might occur through the water-gratings becoming blocked with sludge or detritus, an electrically operated cleaning machine is installed. Each turbine is provided with two servo-motors for setting the guide blades. The oil for these is pumped under pressure by electrically driven gear pumps, but if there should be a failure of current, a stand-by pump automatically takes over this vital oil supply. It is directly geared to the turbines. Since a short circuit would have devastating effects on these huge generators, ample safeguards are installed.

A "short" would probably occur between the windings of a phase, or between phases. Otherwise a part of the generator might be earthed. If either of these accidents should happen the generator is automatically switched off, and rapidly de-excited. At the same time CO<sub>2</sub> gas is injected. It is claimed that this will extinguish a fire in four seconds.

### Danger

Another danger is that there might be an abnormal rise in voltage on a generator, or it might be over-loaded. There is an automatic cut-out, if either of these things happens.

When this scheme was first launched, it was planned to develop it in three stages, each of which was based on one of the three great Shannon lakes.

The first stage of development made use of the water of Lough Derg, the lowest of the chain of lakes. This was enough for three turbines. At the time of my visit further construction had been completed, and there were four turbines. There will shortly be six.

A few figures may be of interest. The cost to present date has been six million pounds, or less than has sometimes been expended on a mere chain of retail shops in England.

The present capacity of the plant is 93,500 K.W. The average cost per unit generated is 1.31 pence per unit, and the average selling price is 1.69 pence per unit, and the number of consumers in 1938 was 145,230.

When the scheme was first planned it was proposed to supply electricity to every village having a population of 500 and upwards. I am informed that this will soon have been accomplished. In an article

been issued for a peat plant at Portarlinton with a capacity of 25,000 K.W. In addition to these the steam plant at Pigeon House, at the mouth of Dublin's river, has now been increased to 79,000 K.W., but it is only used as a stand-by.

### Aid for Shipping

It should perhaps be mentioned that important constructional work was undertaken to aid shipping. The construction of the dam across the Shannon blocked the way for navigation, so provision had to be made for vessels to avoid it by passing through the canal by way of the Power



The canal carrying water to the turbines

written when the scheme was first mooted, it was stated that the plant would supply three hundred million units, at a cost first of a half-penny, and finally of a farthing a unit.

### Charge for Current

It is clear that these figures have not been reached yet, but I am officially informed that such estimates were not made by the Electricity Supply Board, but by optimistic outsiders. They say that the rates charged for current compare favourably with those in England. At present the Shannon is supplying 80 per cent. of the current used in Eire, but when its full power has been utilized further interesting developments are planned.

Work has already begun on the Liffey Hydro-electric scheme which is expected to develop 30,000 K.W., and tenders have

Station. We have mentioned that the head-race—or channel above the dam—is eight miles long, and the tail-race, or canal below it, is a mile and a half in length, to the point where it rejoins the Shannon.

To mount the dam two navigation locks are necessary, each with a lift of over fifty feet. They can carry ships up to 150 tons. Since the tail-race is filled with water flowing from the turbines, precautions had to be taken to prevent accidents to ships caused by a violent swell above or sudden drop in depth below caused by stopping several turbines at once.

When a turbine stops, a segment gate opens automatically and admits more water into the tail-race from the overflow channel. This prevents a dangerous fall in depth, which might ground ships.

## A Bread-slicing Machine and—

IT is common knowledge that the adoption of the saw edge on knives of all descriptions has been surprisingly rapid, practically every season having seen an expansion of its uses. Knives with a saw-edged blade were introduced in the first place for kitchen use, and as soon as they had proved a success, they were quickly adopted by butchers, purveyors of cooked meats, and similar establishments. We now learn that the circular knife on bread-slicing machines is also being made with a saw edge, so that it will be possible in future to cut thin slices quickly and easily from fresh soft white bread, as well as from the harder and more closely-grained brown bread; thin slices can be cut in the same way from

soft breakfast sausage with hard skin, as well as roast meat, ham, cooked meat, etc. It is also reported from trade circles that it is quite easy to sharpen the circular knife when necessary.

## —A Novel Notebook

A NOVEL type of notebook holder has now been produced for the shorthand typist. The holder itself is not screwed to the typist's desk, but is fixed to a plate which at the same time acts as the baseplate for the typewriter. Being fitted with spherical rubber shock-absorbers made on

the same principle as those used for the resilient mounting of motor car engines it is an excellent noise-reducing device and is, moreover, fitted with suction feet to prevent the machine slipping about when in use. This new notebook holder should soothe the nerves and minimise the effort required for typing; it will take any kind of notebook, even large ones which are somewhat heavy. The holder itself is a universally-jointed design with balanced compensators and will remain immovable even with fast typing and a heavy touch, though, on the other hand, it can be moved by a touch of the finger if required. It can also be used as a writing desk or for preparing sets of papers and carbons.



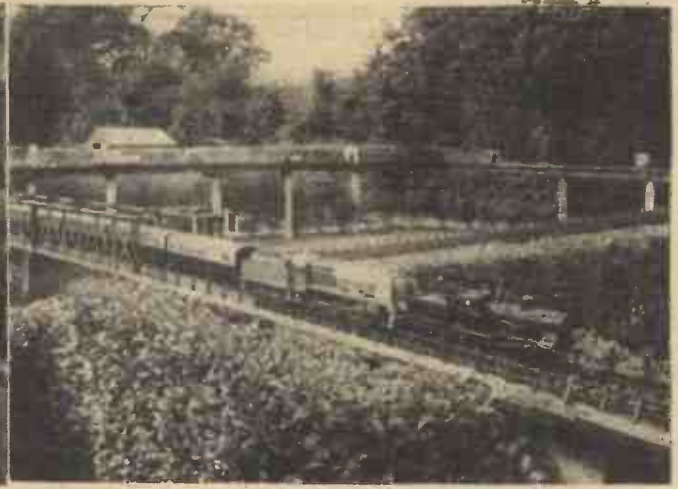

(Left) Young Mr. Harrison and the three-coach electric train passing over the new portion of the line. (Right) Ancient and modern—the "Royal Scot" headed by an inexpensive gauge 1 tinplate low-pressure L.N.E.R. model built in 1909.

# "MOTILUS" PEEPS INTO THE MODEL WORLD

Pictures and News from Far and Near

### Picturesque Railway

MANY readers, I have no doubt, are familiar with the picturesque and comprehensive railway which Mr. Victor B. Harrison has laid out in his garden at Bishops Stortford. This is one of those rare lines which does not detract in any feature from the beauty of its surroundings, and even since I saw it last, noticeable improvements have taken place. The privet hedge he set some two or three years ago on either side of the concrete supports of the railway has now grown to the required height and is trimmed to sleeper level. Also an under and over road has been added and under a portion of the track an attractive arched viaduct has been built. I was over there watching the trials of his new gauge 1 L.M.S. "Royal Scot," built for him by Bassett-Lowke, Ltd. Although using the usual five-wick methylated spirit

firing, Mr. Harrison has had a proper fire tube boiler fitted, just as in the real railway locomotive. This incidentally increases the weight of the locomotive, the fire tube boiler being twice the weight of the ordinary water tube type. One of Mr. Harrison's



The load tests at Northampton of Mr. Harrison's gauge 1 L.M.S. "Royal Scot"

smoke box in front of an eight-day timepiece. The depth of this clock from front to back is only 2½ in., but in this small space—layer upon layer—the model of the locomotive is cunningly built up in low relief, each succeeding layer depicting some outline or feature of the real locomotive—from the front buffers to the driver's cab—all in the correct colours of the L.M.S. Railway. In the clock movement you may choose Smith Synchronous, Ferranti, or Temco, and the case may be either of oak, as shown, or figured walnut. The price, carriage paid, I discovered, is £4 10s.—a most acceptable gift for the model fan.

### A Model Ship

From locomotive to ship—or, in fact, the "front" of a locomotive to the "stern" of a vessel—may strike my readers as a



Stern view of the model R.M.S. "Andes"

latest stunts is picking up the mail, the operations on his track being exactly true to the real thing. He has also added a gauge 1 electric three-coach Southern Railway train supplied to him by Bonds o' Euston Road, which carries its own batteries and is a very useful adjunct for those who have non-electric tracks and wish to give a small display with electric traction. Incidentally Mr. Harrison has all three methods of traction on his line—clockwork, electric, and steam—which makes it one of the most varied as well as picturesque railways in the country.

### "Royal Scot" Model

Rich uncles and fathers are always on the look out for a present for the railway-minded nephew or son's birthday, Christmas or holiday present, and here is something that is useful and at the same time has a railway-like atmosphere. It is an impressionistic model carried out in different woods of the "Royal Scot," mounted on a clock case of light oak, with in place of the



The railway clock



swift way of getting to the end of things, but the original of this picture, the Royal Mail liner *Andes*.

This luxury vessel will be the fastest and finest on the South American service and as, all other Royal Mail ships, she will do a number of cruises during the year. This photograph shows to good advantage the two swimming pools she possesses—one first-class and the other for second-class passengers. This will make her especially popular when she is cruising. The model is one of the three  $\frac{1}{4}$  in. to the foot waterline models of the vessel just constructed for Royal Mail Lines for publicity concerning her entry into the Merchant Service.

#### The "Green Dragon"

While on the subject of ships here is a real brain wave, which admirably fills the empty space between the toy boat and the working scale model. Clockwork and electric boats there are in plenty, but inexpensive and reliable steam boats are at a premium, and Bassett-Lowke's *Green Dragon* shows forethought on the part of the makers for the more neglected steamship enthusiast. This little ship has a hand-carved hull of nice clean lines, 29 in. long, and is fitted with a model M.E1 marine steam engine plant. The engine itself has a cast brass frame, with cylinder bored from the solid, and heavy turned brass flywheel.

#### The Boiler

The propeller shaft is brass, with polished cast brass propeller, pitched as in large speedboat practice. The complete unit can be removed from the steel base-plate (12 in. by 3 in.), and mounted separately in the boat. The boiler is of solid drawn brass tube, with domed ends, fitted with spring loaded brass safety valve, steam dome, and union. The engine casing is of smart appearance and the modern pear-shaped funnel, finished in delicate buff, adds the final touch, with decks fitted with ventilators, bollards, and fairleads, and the whole model enamelled in attractive colours. The boat is £2 10s. complete; the steam plant, 12s.

#### From Norway

When in Norway the other week I came across two interesting items, although they are not exactly of the "model world."

First, in one of the small villages a Norwegian peasant had outside her cottage an old weaving frame and was making rugs and tapestries for her own use and for sale. This method of working seemed slow



The old Norwegian weaving frame



The T.T.R. scale model Bassett-Lowke "Coronation Scott"

and strange to those, like myself, who have been so long mixed up with the modern machine age, in the so-called progressive and more mechanically minded countries.

However, Norway has gone modern in some respects, especially in a few of the hotels. In the basement of an hotel at Merok I came across a novel type of fireplace. As you know, wood is the only type of fuel used in Norway, except their famous "white coal"—the snow fields, the water from which provides all the electric power for which the country is famous. This fireplace, if you can call it so, took the form of a cylindrical corrugated column in the centre of the room, with two open arches in which burnt a crackling birchwood log fire. A large concrete mass in the centre of the room formed the heating apparatus, and the fire gave a bright and lively effect to the underground room.

#### Trix Novelties

I mentioned last month the new Trix novelties for the coming season. Here is a photograph of one of them—the presentation case set of the "Coronation Scot." This is the finest production they have yet placed on the market and is a Bassett-Lowke scale model. The locomotive is fitted with searchlight in front and dummy bell, exactly as its famous prototype, which has gone to New York for the World's Fair. The locomotive and tender are fitted with remote control uncoupling, and the three coaches fitted for uncoupling in conjunction with the T.T.R. ramp rail. The complete set, in its smart leatherette case, complete with controller, fittings and instruction book, costs six guineas. Certainly the Trix Twin Railway grows every year in scope and attraction.

## PRACTICAL MECHANICS HANDBOOK

By F. J. CANN.

An extremely valuable book, packed with facts and figures, tables and formulae for the mechanic engineer and designer.

From all booksellers 6s. net, by post 6s. 3d. from the publisher: George Newnes, Ltd. (Book Dept.), Tower House, Southampton Street, Strand, W.C.2.

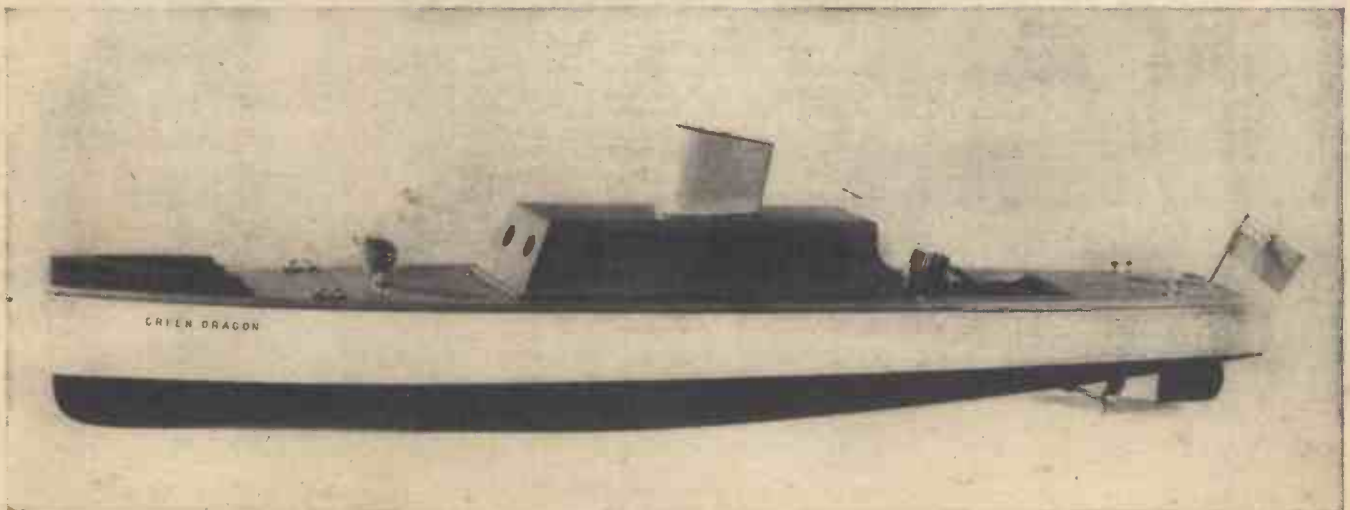

A new inexpensive steamboat "Green Dragon"



# The Puzzle of Perfumes

## Strange Facts Concerning The Little-known Science of Smells

**I**MAGINE that you have two bottles, one of them containing a quantity of chalk and the other having in it some powdered naphthalene, that white crystalline material out of which "moth balls" are usually made.

You take a sniff at the contents of both bottles. The chalk you find to be absolutely odorless, but you recognise the naphthalene immediately by its peculiar and strongly characteristic odour.

Or, again, suppose you are given two bottles, one containing water and the other containing carbon bisulphide. Here again you can instantly distinguish between the two colourless liquids, water being entirely devoid of smell, but carbon bisulphide having such a detestable odour that, once sampled, it is likely to be remembered for life!

### Why do Things Smell?

Why, you now inquire, are various substances endowed with the property of odour? How is it that some materials smell strongly, whilst others have no odour at all? And why, too, do some substances exhale a delicious perfume whilst the odour of others is so rank and vile as to be almost unbearable?

The above questions are straightforward and eminently reasonable, yet, strange as it may seem, science has, as yet, no definite and satisfactory answer to them. We do not know why one thing smells abominably whilst another not very dissimilar material has an odour calculated to titillate the most exacting and refined nostril. Nor, indeed, are we aware of the reason why substances smell at all.

All that science can say upon this fundamental question of odoriferousness is that the odorous substance must, in some way, continually shoot off almost inconceivably tiny particles of itself into the surrounding air, and that these particles—impinging upon the olfactory membrane of the human nose—thereby give rise to what we term smell or odour. Ultimately, of course, we perceive odours with our brains, just as we translate light impulses into the sense of vision with our brains. But precisely how the particles of odoriferous materials bombarding our nostrils are converted into the sense of smell is, as yet, an almost untouched problem.

### Amazingly Sensitive Nose

There is no doubt of the fact that the average human sense of smell is a very delicate one. Indeed, the trained nostril can rival the spectroscope in its power of detecting ultra-minute amounts of matter. We can, for instance, detect by the sense of smell the presence of one two-millionth of a milligram of a powerful perfume such as musk, whilst, strangely enough—as if nature were trying to give us an added protection—our power of perceiving bad smells is even more sensitive. One of the worst smells imaginable is that of a compound known as ethyl mercaptan. To this truly

*The "snooper." Ruling over every perfumery laboratory is this important individual, whose task it is to pass judgment on the perfumes of compounded products*



vile odour our nose is amazingly sensitive, it having been calculated that one two-billionth of a milligram (and, perhaps, even less) of this substance can be discerned by the average healthy nostril. When one considers that a small drop of water weighs

a firework throwing-off sparks, the odoriferous substance should be continually losing in weight, since it is constantly ejecting particles of itself around it.

Probably this inference is a perfectly correct one, but, up to the present, nobody has been able to prove it. Strongly-smelling substances have been most accurately weighed and then, after a long interval of time, reweighed, but, so far as could be ascertained, no loss in weight resulted.

### The "Smell Particles"

Perhaps, therefore, the truth of the matter is that the "smell particles," as we might term them, which are ejected from odoriferous materials are so minute as to be, even after long intervals of time, completely unweighable. Yet they must have a great potency, since it is well-known that some animals, as, for example, certain breeds of dogs, can detect smells which escape even man's ultra-sensitive olfactory organs.

Many attempts have been made to classify odours with a view to determining whether certain types of chemical compounds give rise to definite varieties of smells. Such endeavours, however, have not been very satisfactory, for who can classify odours so diverse as the following: watercress and garlic (mustard gas), musty hay (phosgene), decaying horseradish (selenium), rotten fish (hydrogen phosphide), new-mown hay (coumarin), "mice" (acetamide), musk (tri-nitro-butyl-xylene), "moth balls" (naphthalene), and roses (phenyl ethyl alcohol). Besides such strongly characteristic and almost individually indescribable smells as those of ammonia, iodine, petrol, ozone and acetylene?

We hear little, therefore, about the classi-

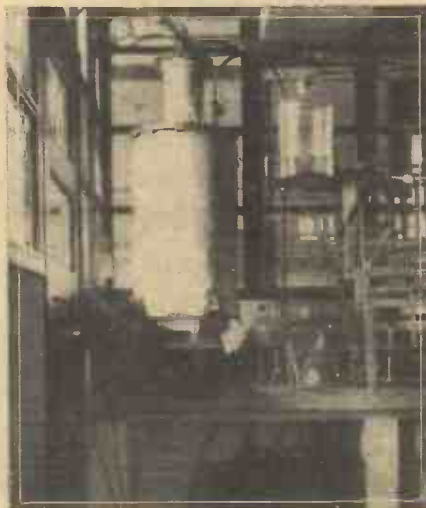

*A still for the refining of essential oils and flower essences*

approximately a milligram, the delicacy of the human sense of smell can be to some extent appreciated.

If the prevailing scientific theory of smell is correct, that is to say if it is true that the smell of a compound is due to its ceaseless throwing-off from itself of tiny particles like



fications of smells nowadays, since no satisfactory "smell-system" can be devised to contain them all.

Curiously enough, although our noses are usually very sensitive to odours of all types, there are some characteristic smells which cannot be sensed by certain people. One notable odour which comes into this category is that of prussic or hydrocyanic acid, that deadly compound which normally smells something like bitter almonds. Consequently, such people walking into an atmosphere of hydrocyanic acid would be instantly overcome without their being aware of the presence of the death-dealing gas.

Carbon monoxide, another highly poisonous gas, possesses a faint odour which cannot be detected by a large number of people, whilst some individuals are seemingly almost "smell-blind" to powerful odours such as those of iodine, musk and oil of geranium as others are "colour blind" to vivid hues.

### The Olfactory Membrane

It is well known, of course, that the olfactory membrane of the nose is very easily fatigued and even virtually paralysed for a time. After half a dozen sniffs at a bottle of a powerfully odoriferous substance, the nostril becomes almost numbed to the odour. Similarly, although the well-known chemical laboratory odour of sulphuretted hydrogen, which is like that of bad eggs, is almost intolerable at first, the nasal membrane quickly accommodates itself to it so that within a relatively short time, it no longer senses the smell. Acetylene has a similar action with many individuals.

In view of our ever-increasing knowledge of synthetic organic chemistry, it might be thought that the production of synthetic perfumery materials would oust the flower-grower from the position which he has held in this respect from time immemorial, just as the introduction of artificial dyes has almost killed the former trade in vegetable colouring matters.

As a matter of fact, however, the art of the chemist has, if anything, only more firmly established the flower grower in his position of supremacy, for the synthetic perfume cannot equal the natural product.

A natural perfume, such as attar of rose, is, in reality, like an orchestra of smells. It contains many minor smells in addition to its principle rose odour and these auxiliary odours, as they might be called, each play their own individual part in accentuating, maintaining and bringing out the characteristic odour of the attar of rose. That is why the compound known to chemists as phenyl ethyl alcohol, which is one of the most important constituents of attar of rose oil and which can nowadays be synthesised cheaply, cannot be substituted satisfactorily for the true attar of rose. True it is that, to the extremely crude and unappreciative nostril, phenyl ethyl alcohol might pass for otto of rose perfume, but, in reality, to substitute this synthetic or artificially-made compound for the real rose oil would be like replacing a well-known symphony orchestra with a quartet of amateur players.

### Natural Perfumes

It is for the fundamental reason that the natural perfumes are made up of many "minor smells" in almost undetectable proportions, that the synthetic perfumery materials will never supersede the natural ones, just as the crystal of artificially-produced "milk glass" can never hope to equal the intrinsic beauty and loveliness of the naturally-occurring fire opal.

Although many of the perfume oils, such as oil of lavender, are extracted from flowers

merely by steam distillation, the amounts of odoriferous material existing in some flowers, as, for example, the violet, is so minute as to be absolutely unextractable by ordinary methods. In such instances the principle of *enfleurage* is employed for the extraction of the perfume. This principle is based upon the well-known fact that fats tend to absorb odours, as any individual who has attempted to store butter in close proximity to fish well knows.

By the method of *enfleurage* the flowers are laid on shallow trays placed within a specially-constructed tower. Moist air is slowly sucked up the tower and, in ascend-

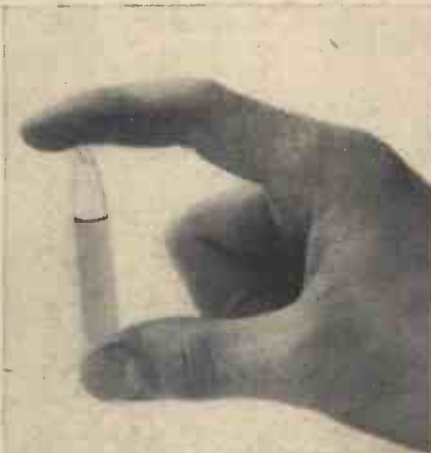

*Skatol, the quintessence of stinks. Although having a vile odour, such compounds are essential ingredients of many delicate perfumes*

ing, it passes over the trays of flowers Alternating with the flower trays are glass sheets smeared with the purest lard. After a few days of this *enfleurage* process, it is found that the lard becomes strongly charged with the active odoriferous principle of the flowers. It is then merely scraped away and the perfume dissolved out with a solvent.

### Bad Odours

A remarkable fact concerning many of the finest natural perfumes is that they contain traces of compounds which themselves have an almost intolerable bad odour. Consequently, it has been found that the very best artificially-compounded perfumes *must* contain, as an essential ingredient, a trace of this bad odour.

To take a concrete example of this astonishing fact, let us consider the case of natural oil of jasmine, which is a very much admired and expensive material. Now, natural jasmine oil contains a trace of skatol which is an abominably bad-smelling compound always present in animal excreta. Consequently, when perfumers wish to compound an artificial jasmine perfume they must always incorporate a trace of skatol into their perfume, for, although the presence of this malodorous substance is quite undetectable, its *absence* can at once be discerned by the trained nostril.

Indol, which is another compound of disgusting odour, likewise goes into many artificially-compounded perfumes, since traces of this substance are invariably present in some natural perfume oils.

Despite the fact that the natural flower perfumes cannot be imitated artificially, the compounding of artificial and synthetic perfumes has made enormous strides during the past few years in consequence of the increasing demand for such products, not only in the vast cosmetic industry, but also for manufacturing activities concerned with the making of toilet soaps, brilliantines, hair oils, shaving powders, astringent lotions and the like.

### Lasting Perfumes

To be successful, a perfume must be lasting, but not very strong. No one in his senses could endure for long the horribly powerful violet-like smell of ionone, a synthetic product. But, suitably diluted and compounded with other materials, ionone can make quite a delicate perfume.

Perfume making is still very much an empirical art rather than an exact scientific method, because fine and delicate smells prove themselves to be such strange and wanton entities. Take, for example, the fact that the minutest trace of an impurity or of a foreign odour in a compounded perfume can completely ruin it. Also, consider the well-known manufacturing fact that if a fine perfume be poured through a copper or a tin funnel it will not only itself be rendered useless for fine perfumery work, but that it will also completely ruin any other perfume liquid with which it is mixed.

Perfumes, too, sometimes "kill" each other in some mysterious way. By mixing together unsuitable perfumes, the result can be a most unholly smell, just as the sounding of two or three dissonant notes on the pianoforte can give rise to a horrible discord.

### The "Snooper"

Hence it is that the greatest care must invariably be taken in the manufacture of perfumes, no matter to what use the latter may afterwards be put. Above even the scientific chemist in the modern perfume manufactory is the all-powerful *parfumeur*, or the "snooper" as our American friends call him. This highly-paid functionary must be an individual of at least an outwardly blameless life, for he must neither smoke nor drink, nor must he partake of highly-seasoned foods. His job is to smell the finished batches of manufactured perfumes and to sanction their use or otherwise as the case may be. Sometimes the "snooper" may refer back for further treatment a batch of perfume which he considers to be deficient in one of its odoriferous constituents.

In his job, the *parfumeur* or "snooper" is omnipotent. Useless is it for the chemist or analyst to argue with him, for the delicacy of smell of a trained and experienced *parfumeur* transcends the limits of chemical analysis. Such an individual is usually infallible. His nose knows!

## THE P.M. LIST OF BLUEPRINTS

F. J. CAMM'S  
PETROL-DRIVEN MODEL MONOPLANE  
7s. 6d. per set of four sheets, full-size.

The "PRACTICAL MECHANICS" £20 CAR  
(Designed by F. J. CAMM).  
10s. 6d. per set of four sheets.

"PRACTICAL MECHANICS" MASTER  
BATTERY CLOCK  
Blueprint 1s.

The "PRACTICAL MECHANICS"  
OUTBOARD SPEEDBOAT  
7s. 6d. per set of three sheets.

A MODEL AUTOGIRO  
Full-size blueprint, 1s.

SUPER-DURATION BIPLANE  
Full-size blueprint, 1s.

The P.M. "PETREL" MODEL MONOPLANE  
Complete set, 5s.

The I-c.c. TWO-STROKE PETROL ENGINE  
Complete set, 5s.

STREAMLINED WAKEFIELD  
MONOPLANE—2s.

The above blueprints are obtainable post free from  
Messrs G. Newnes Ltd., Tower House, Strand, W.C.2



"PRACTICAL MECHANICS" WIRELESS SUPPLEMENT

# THE 1939 RADIO SHOW

## THE HIGHLIGHTS EXPLAINED



This Ekco receiver has the push-buttons above the dial for ease of operation

At a casual glance it might be said that the receivers on show this year bear an appearance very little different from those which have been seen at previous shows. A more critical examination will, however, reveal several interesting features which appear for the first time, and which mark a step forward in the design of modern radio apparatus. In general respects the styles of cabinet remain unchanged, but the earlier types of cabinet design have given way to more severe lines and styles, more in keeping with

modern furnishing schemes. Moulded bakelite cabinets are not now so common, but in this connection it is interesting to note that Philips have utilised the idea of a moulding in one or two cabinets, and have produced some models in which both wood and bakelite are employed. The front portion of the cabinet is moulded, and the chassis is attached to this. Thus, by a simple movement the whole front of the cabinet may be pulled forward, revealing the entire receiver chassis and loudspeaker fully accessible for test and servicing pur-

pleased to note that this year the G.E.C. have found at least one effective way of overcoming the trouble. They have made use of neat louvres in certain designs, and

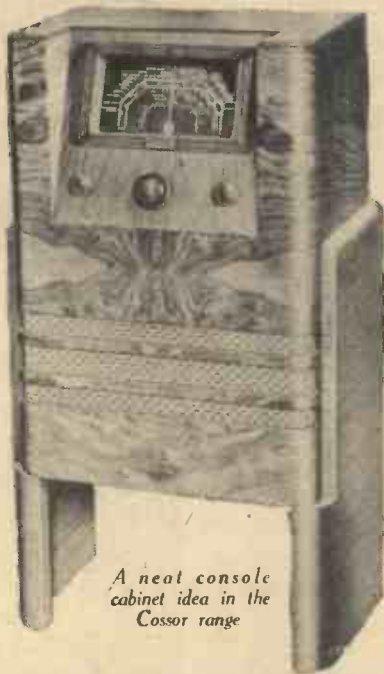

A neat console cabinet idea in the Cossor range



The Ekco "Pick-me-up" portable—an 8-stage superhet. It measures 11 1/4 in. by 11 1/2 in. by 7 3/8 in.

this has, in some of the cabinets, made a marked improvement in appearance and will no doubt appeal to many listeners on aesthetic grounds.

### Push-buttons

A further outward development seen this year is the remarkable array of designs in push-button controls. From the original small bell-push types, these have been modified until now there are all shapes, some sunk flush, some projecting, some requiring to be pushed in, and others which have to be depressed. Various fancy names have been given, such as organ key, piano key, press-button, push-button, etc. In all



This 4-valve portable by Cossor is a battery receiver with single-knob tuning and auto grid bias. Size is 12 1/2 in. by 10 1/4 in. by 7 1/2 in.

poses. This is quite a good point. Murphy probably typify the modern trend in their particular cabinets which are entirely free of embellishments and fancy work, but nevertheless are extremely pleasing in design and colour and will harmonise with any modern furnishing scheme.

### Speaker Frets

A further point in exterior design concerns the loudspeaker fret or opening. In the early days we had elaborately fretted fronts reminiscent of the early pianos, and gradually the woodwork has been removed until to-day the majority of cabinets have merely a rectangular opening backed by fancy silk or similar material. This is certainly a step in the right direction, but why must the opening be so prominent? This point in design has obviously been tackled by several firms and we were



A table model in the G.E.C. range, with the new speaker opening idea





This is the Pye Baby "Q." It measures 11 ins. high by 12½ in. wide by 8 in. deep. Price is 8½ gns.

cases, of course, the idea is the same, namely, the changing of a station merely by operating a button carrying the name of the desired station. In some receivers the buttons are sub-divided into medium and long-wave stations, whilst in others a wave-change switch has to be operated separately. In view of the fact that the stations which may be pre-tuned will vary in different parts of the country, various attempts have been made to facilitate the change in setting provided for the buttons. In the early days the cabinet had to be opened and various tricky adjustments made. In some of the modern receivers small panels are attached above the buttons and by removing the panel the stations may be changed. A most ingenious and effective scheme is seen in the new Philips receivers, however, a small key being provided and retained in a clip at the rear of the cabinet. When it is desired to change a station the button required is depressed. The key is then inserted in a slot beneath the button which is down and the key turned until the desired station is heard. The key is removed and henceforth that station will be heard until changed by the key. The three left-hand buttons on these receivers may also be adjusted for long or medium waves. To change the wave-band the button is not depressed, but the key is inserted and turned until the maximum travel is obtained in either direction (according to the change which is desired) and then the button is depressed and the station tuned in as already mentioned. It is thus a very simple matter and may be carried out by the most inexperienced person.

Motor-driven push-button operated sets are, of course, now fairly common, but

when the manual control is operated the usual trouble is that of high gearing, resulting in a tiring operation when searching through the full scale for a station which is giving a programme suitable for the mood of the moment. On some receivers this is a real wrist-aching procedure. Marconiphone and H.M.V. this year have introduced "cruiser" tuning, which was shown in addition to the Ekco device on somewhat similar lines. The idea is that the motor used for mechanical tuning is brought into circuit to rotate the condenser to avoid the normal manual process, and it may be stopped as soon as a desired station is reached.

In connection with automatic tuning we also note that several firms now have the tuning apparatus geared up to the dial indicator. On many receivers the pointer remains stationary when the automatic tuning device is in operation, but the pointer is now being operated so that it may be seen at a glance just what station is in use. Of course, automatic-frequency control and similar devices are practically standard features with mechanically operated tuners.

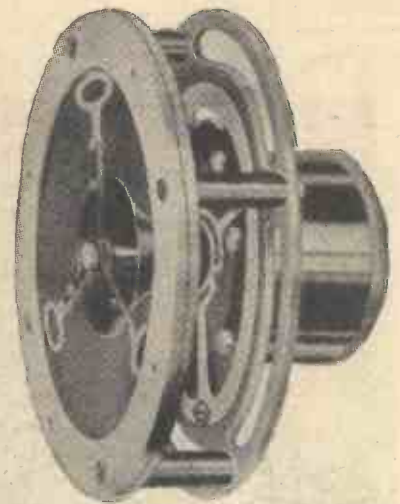

A new loudspeaker, known as the "Infinite Baffle" model has been produced by Goodmans' Industries



This is the Invicta B29 Portable. Note the speaker opening and station-name dial

#### Economy Valves

A new line to be seen this year is the economy valve, which has resulted in the introduction of special portables and bat-

teries. This particular type of valve, has a 1.4-volt filament and thus may be operated from a dry battery instead of a standard 2-volt accumulator. This means that the portable receiver may be made more compact and lighter in weight, as a small dry cell only is required for the filament. An example of the new portable was shown on the Vidor stand, whilst Ferranti also showed a superhet battery (table model) using these new valves. The new batteries are generally of a 11 all-in type incorporating both the H.T. and L.T. sections and these were seen on several stands. Various plug-in or clip connections are used for the L.T. circuit.

#### Car-radio

There remains only car-radio to be dealt with. Cossor's are new comers to this market and have produced a neat two-piece receiver with readily changed station setters. Whilst motoring it is possible to pass out of the range of one station and into the range of another, and it is a simple matter in this particular receiver to make a change on the push-button mechanism whilst driving, without taking your eyes from the road. Ferranti are also showing a car-radio receiver, whilst the Philips is also to be seen on their stand. Special aerials for cars are also being developed and were seen on several stands.

Right is a new Philips model and below is seen the method of adjusting the push-buttons for different stations

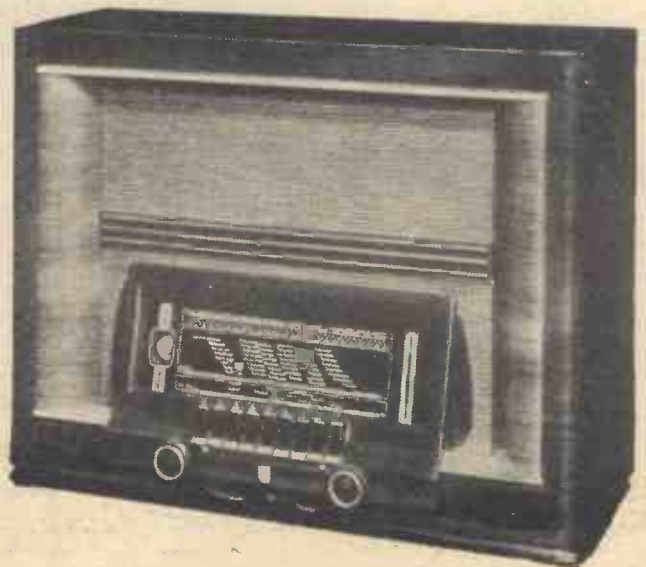



# Some Notable Miniature Railways

By "Modeller"

## The South Hampshire Railway



Fig. 1.—The locomotive depôt at Sealand Station, showing locomotive and giant crane

THE layout about to be described is by no means ambitious in its magnitude, but it includes some definitely interesting and clever gadgets which are mainly the fruit of the ingenuity of the owner, Mr. T. A. Warne-Browne, of Gosport. Mr. Warne-Browne has for many years been a close follower of the craft of railway modelling, though somewhat hampered by the necessity of occasional and sudden removals, and it was not until he had evolved a scheme of his own to meet with the exigencies of his vocation that he was really able to get down to business. From the outset, his aim has been to develop a scheme which would ensure certain conditions incidental to his repeated changes of residence and the unavoidable variation in available space in one residence and another. The conditions to be met were in the main as follows: speedy and immediate portability, a certain elasticity in the demand on space, permanence of track and wiring installation, absolute rigidity and robustness of structure, and the whole system to be capable of



Fig. 2.—South-east corner of the miniature railway

collapse into the minimum space for transport. It will be agreed that these advantages have been admirably secured.

### The Layout

Until very recently the layout included only the plans shown in the upper section of Fig. 3, which was in overall dimensions

the cross over on the east side. The buildings and surface structures are the work of Mr. Warne-Browne with one or two small exceptions. Following upon the completion of this section, a need was felt for something in the way of development. It happened at the moment that the admirable terminus layout in the lower diagram had been laid down as part of the West Midland Lines by Mr. Ian R. Frazer, and it was forthwith agreed that an additional terminus should be planned according to the same scheme, on a portable baseboard which might be located in another spare room or outhouse, a connecting line in both up and down directions being provided. It will at once be seen that this feature has enormously extended the possibilities of the entire layout. The only notable deviation in this second plan from that of the West Midland Lines is in the matter of the width of the site; and this condition was secured by eliminating the harbour and substituting a large factory.

### The Folding Baseboard

Details of the folding baseboard for the upper layout are given in Fig. 4, which depicts one of the two side sections which are joined, of course, by the short end-sections. There are thus six pieces to this collapsible baseboard. The two side sections, however, are hinged at the centre for folding (after the manner of the old-fashioned bagatelle-board), the track ends thus broken having their fish-plates first pushed along the rail to break the joints. Points are so arranged throughout as to avoid occurring at the breaks in the base, and the whole base, assembled with thumb-

Fig. 3.—The layout of the South Hampshire Railway

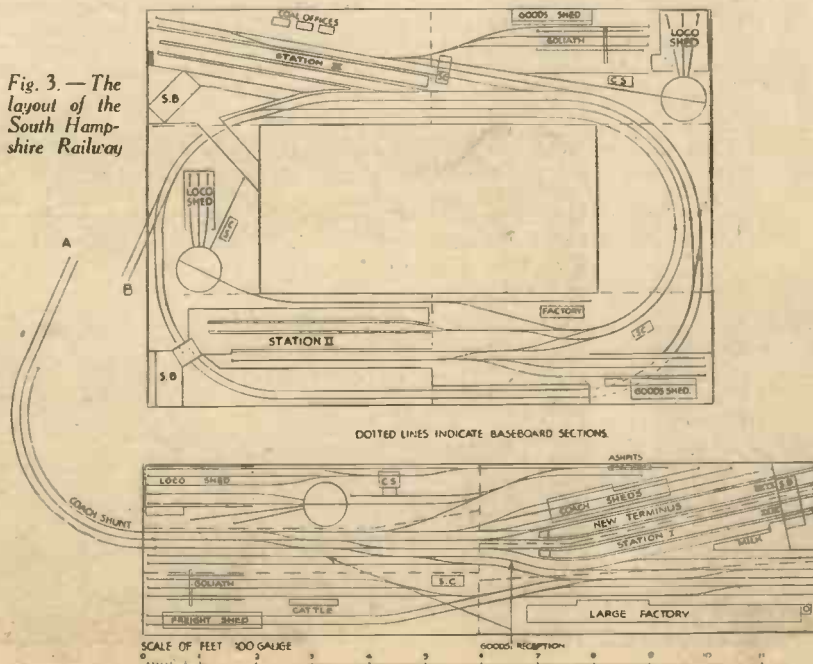



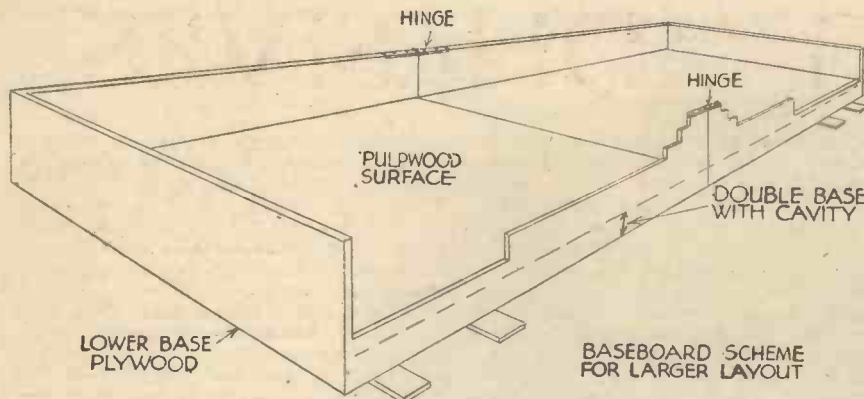

Fig. 4.—Details of the folding baseboard.

screws, rests solidly upon six trestles which also fold flat. The actual baseboard is duplex, with a cavity of an inch or two between each layer, the upper layer consisting of Sundela patent pulp-wood as used extensively in the building of yachts, the lower layer being of ordinary stained whitewood. Sundela is a magnificent material for a base, being soft, solid, light and smooth, almost like cork, and can be had in such large sections as to require no joints except at places where the breaks occur. The result of this carefully thought-out scheme is that this baseboard can be completely dismantled by two people in the space of an hour, and can be reassembled in approximately the same time.

The baseboard scheme of the second section is even more ingenious, and is shown in Fig. 5. The surface is 12 ft. long by 3 ft. in width and is arranged to fold across the centre. The break here is supported by two slide-in wooden struts which are retained in metal loops to the design given, and the trestle supports are hinged to the underside, so that when folded the table is in an integral section.

**The Terminus**

The new terminus is linked up with the earlier system by means of the double-junction on the west side, as shown, and the intervening route depends, of course, upon the particular location of the new island section. It may run across an upstairs landing, connecting two rooms; or through a french-door on to an outer porch, or into the garden; or it may simply take a circuit of the same room, if this is large enough to accommodate both the layout sections at one time. The larger, fabricated layout is furnished with a number of interesting and clever gradients, all of which are singularly lenient. The island section is, of course, at one level. A coach spur is projected in parallel with the main lines which approach this terminus, so that solid trains can be shunted in and out of the coach sidings and

by the builder. The result is admirable and completely overcomes the difficulty of lettering in very minute characters. Another interesting item in rolling stock is an L.N.E.R. Flatrol wagon with a marine boiler load. There are also a number of wagons which were the work of Sir Eric Hutchinson, Bart., and which formerly ran on his East Highland Railway before that gentleman reverted to 0-gauge. The goods shed with the G.W.R. tarpaulined wagon in front of it was a labour of love on the part of the writer.

There are a number of interesting locomotives—an 0-8-0 tank, a rebuilt Walker's 0-6-0 tender engine with a new form of cab, both examples appearing in the photograph which shows the sheds at Sealand, the latter the work of the owner. Sanded

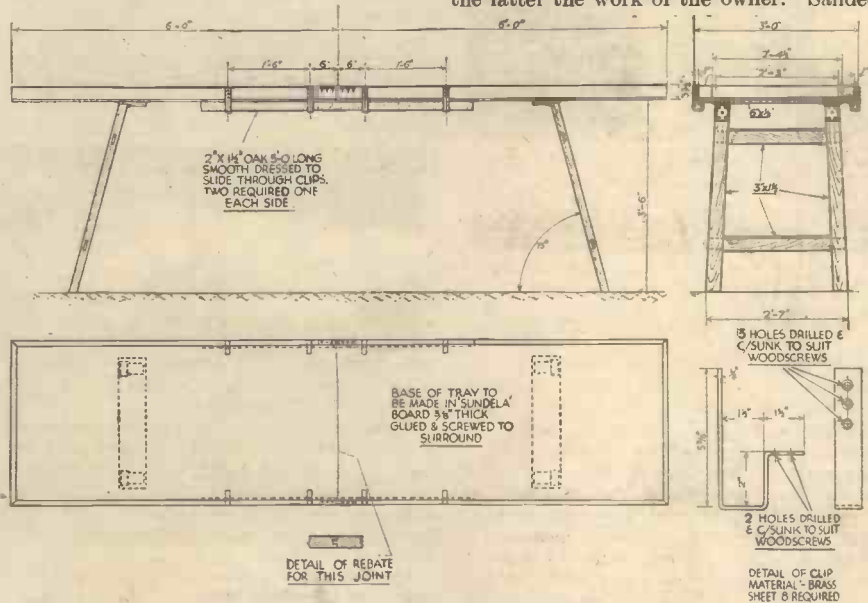

Fig. 5.—Details of the island trestle scheme.

platform tracks without any operation that unduly fouls the mains.

**Building Structures**

There are a few of the building structures which were made by the writer—the station building at Station III (Sealand), the goliath crane at the same depôt, the factory building for the island section—but the remainder are the work of the owner who is entire expert at this work, and at all manner of model construction. One of the finest pieces of 00-gauge rolling stock in existence, for example, is an L.M.S. transformer wagon built in brass by Mr. Warner-Brown, for the lettering of which an extremely original and expeditious method was evolved. The letters were first drawn out in pencil, then inscribed by a jeweller, and afterwards filled out in flat white paint

roof-felt is employed for the sub-track surfacing. In passenger rolling stock, a recent acquisition is a 5-coach train of six-wheel suburban stock specially built to the writer's design by Exley of Bradford. Coaches have the Southern Railway colours, and locomotives a livery approaching very closely the L.N.E.R. green. The layout is wired on the constant potential system, wherein two sets of batteries are used, the one for the forward and the other for the reverse direction, the tracks being in one common section throughout the layout.

One of the most significant of many excellent characteristics of the South Hampshire Railway is its invariable condition of cleanliness and immaculate perfection. After several years of usage everything always looks most orderly and operates unflinchingly.



Fig. 6.—Sealand Station.



Fig. 7.—A goods shed at Sealand.



# MAKING ADHESIVES



Don't forget to add a few drops of carbolic acid or other preservative to all gums and pastes.

**O**F recent years, the preparation of commercial adhesives has literally been transformed. Formerly, a purely rule-of-thumb business, modern adhesive manufacturing has now become a highly scientific process, demanding, in many instances, skilled scientific control.

In consequence of this fact, adhesive materials nowadays are far superior to those of even a few decades ago, besides being, in most cases, decidedly cheaper.

Ordinary glue still remains, of course, the adhesive capable of the widest application. A good glue will absorb more than double its weight in water and, indeed, the more water a glue will take up, the better it is.

## Glue Solution

In order to make a glue solution of the highest quality for woodworking, place several broken pieces of cake glue at the bottom of an old glass jam jar, and cover the glue with four times its weight of water. After standing for twelve hours, the glue will have swelled up and filled the liquid with a gelatinous mass. The jar is now stood in a saucepan of cold water which is gradually brought up to the boil and retained there for some time. On stirring, the gelatinous mass of glue will form a yellow solution having the consistency of thin varnish. To this liquid should be added two or three drops of strong carbolic acid in order to prevent the glue from going mouldy on standing. It is a good plan, also, to add three or four drops of glycerine to every pint of glue solution made, for this imparts additional flexibility to the glue film and prevents it from cracking or chipping in dry weather or under conditions of abnormal heat. Thus the addition of a trace of glycerine to the glue actually strengthens that medium by rendering it less liable to chip.

Many "liquid glues" are on the market at the present day. These consist essentially of ordinary good quality glue (generally fish glue) to which has been added a small quantity of acetic or formic acid, either of which acids prevents the glue from setting in the mass.

A good liquid glue may be made by soaking a mixture of three parts of ordinary glue and one part of gelatine in three parts of water until the maximum swelling occurs.

The gelatinous mass is then heated in the ordinary manner to dissolve it and when, eventually, a rather thick yellow solution results, a quantity of acetic acid equal to one-half of the weight of the gelatine is added to the liquid and stirred well into it.

The resultant product will not set on cooling. Neither will it go mouldy. It may, however, be used after the fashion of all tube glues, i.e., by being thinly spread on the surfaces to be united.

No cold glue can give the strength of union which is to be derived from the use of an ordinary hot glue. Nevertheless, for many purposes, a cold glue of the above nature can be extremely useful. It can, of course, be made in almost any degree of consistency.

works or laboratory suppliers) in about 6 parts of benzole and then by adding 20 parts of powdered shellac to the liquid. The benzole is then heated by being surrounded by a vessel of hot water, the liquid being well stirred at the same time. When a thick solution results, it is poured into small bottles and well stoppered.

Usually, this "marine glue" (which is waterproof) will have to be applied warm, for it solidifies on cooling, but cold marine glue solutions can be made merely by increasing the quantity of benzole in the mixture.

A highly excellent waterproof adhesive compound can readily be made by making up a strong solution of bitumen in petrol and by adding this to a solution of rubber

## Essentially Practical Hints On The Preparation Of Various Types Of Glues, Pastes And Cements

If, for any reason, a cold glue which is slightly acid in nature is objected to, a non-acid cold glue can be prepared by adding calcium chloride to an ordinary hot glue solution, the amount of calcium chloride added being one-quarter of the weight of the glue in solution.

Waterproof glues are sometimes required in constructional work. A very simple variety of waterproof glue may be made by adding a small quantity of potassium dichromate solution to ordinary glue. On exposure to light, such glue becomes quite insoluble in water.

Another type of waterproof glue may be made by allowing ordinary glue to swell up under cold water and then by melting this gelatinous material with an equal weight of raw linseed oil. This "oil glue" takes several days to set, but it makes a very effective waterproof medium.

## Marine Glue

What is usually called "marine glue" is, actually, not a true gelatine glue at all, but, rather, a compound of shellac and rubber. It may be made by dissolving 1 part of rubber powder (obtainable from any rubber

in naphtha, the two solutions being mixed in approximately equal parts. The resulting liquid should have a fairly thick consistency. It will stick all kinds of materials together with great tenacity and, as already remarked, it is waterproof. The only disadvantage of this compound is that it is not heatproof, since it softens appreciably at temperatures near the boiling-point of water.



Dissolving old cine films cleaned of their emulsion in acetone and amyl acetate.



Glue MUST be allowed to swell completely before it is finally dissolved in the water by heating

Celluloid or "peardrop" cements are much in evidence at the present day not only in view of their essential cheapness but, also, in consequence of their high efficiency for many classes of work.

## Celluloid Cement

A good celluloid cement may be made by dissolving clean scrap celluloid in a mixture of approximately equal volumes of acetone and amyl acetate, both of which liquids are now usually obtainable from paint stores and drysalters' premises. The celluloid must be immersed for several hours in the mixed liquids, and, after the elapse of that time, the liquid must be shaken vigorously in order to dissolve the celluloid. A fairly



thick solution of celluloid should be obtained. This, when stored in well stoppered containers, will keep indefinitely. The cement however, is inflammable and, therefore, care should be taken during making.

Celluloid cement is of great use in cementing glass, pottery and china together, since it is transparent and cleanly in use. For this purpose, the cement should be of a thick consistency and it should be applied to both surfaces of the material to be joined.

Incidentally, the use of a "sand box" is of great assistance in the cementing together of fragments of pottery, glassware and the like.

Such an article consists merely of a wooden box full, or partially full of clean, dry sand, and its use may be illustrated in the following way:

If, let us imagine, a valuable plate or wall plaque has been broken across and has to be cemented together, the lower half of the plate is pushed down into the sand in the box and after the celluloid or other cement has been applied to the fractured surfaces, the upper half of the plate is set in position and kept in weighted contact with the lower half by means of one or two strings which are passed over it, the strings having light weights attached to their free ends. By utilising this principle, perfect cementing of glass, china and other fragile articles can be attained.

For the sticking together of paper and thin cardboard, any of the usual pastes and gums can be employed.

For "large" work, such as wall-papering, billposting and the like, there is still no better adhesive medium than ordinary flour paste, provided, of course, that such material is correctly made.

#### Flour Paste

The best way to make flour paste is to take a quantity of ordinary flour and to grind it under cold water so that it produces a thin and lump-free cream. To this cream a little common alum may be added in order to act as a slight preservative of the resulting paste. Boiling water is then poured on to the flour cream, the latter being stirred rapidly the while, until the liquid swells up and thickens. The resulting paste may be used either hot or cold.

Most of the commercial gums comprise merely a thick solution of dextrine. As such, they can be made quite simply at home merely by boiling a quantity of dextrine in water until a clear solution results. This, on cooling, congeals to a thick yellowish liquid-gum. When making such preparations it is essential to provide for their preservation in some way, particularly if a quantity of the material is being prepared.

A few drops of any preservative added to the liquid in its hot condition will suffice to preserve it from mouldy growths and the like. Preservatives which can be employed for this purpose are carbolic acid or phenol, nitrobenzene, oil of cloves, oil of cinnamon, camphor, thymol, oil of sassafras and many other essential oils and disinfectants.

#### Adhesive Pastes

Many excellent adhesive pastes can be made from dextrine, a material which is cheap and which may be obtained from any wholesale chemist or laboratory supplier. The following is a typical paste formula containing dextrine:

Dextrine	...	...	450 parts.
Borax	...	...	50 "
Sugar	...	...	50 "
Water	...	...	400 "

The borax is first dissolved in the heated water, then the dextrine and finally the sugar. Whilst hot, add a few drops of preservative or antiseptic and strain through a coarse-mesh cloth into tins or wide-mouthed bottles. This paste dries very quickly and it keeps well over long periods.

By dissolving varying amounts of cooking gelatine in the water used for preparing the above paste, a still stronger, albeit slower setting, adhesive can be obtained.

Casein, which is a product obtained from milk, has recently been used a good deal as an adhesive agent. For amateur use, a good casein adhesive may be made by dissolving casein powder in a warm saturated solution of borax. The adhesive is fairly quick setting and is extremely tenacious.

Although apt to be looked upon as "old-fashioned," there is still a good deal to be said for ordinary gum arabic as an adhesive for paper and thin card. This material, when allowed to swell up over night in cold water, and then dissolved by heating, forms a very strong adhesive. Since, however, gum arabic solutions readily

UPPER HALF OF PLATE HELD IN POSITION BY BALANCE OF WEIGHTS TIED ON OPPOSITE ENDS OF STRINGS PASSING OVER PLATE

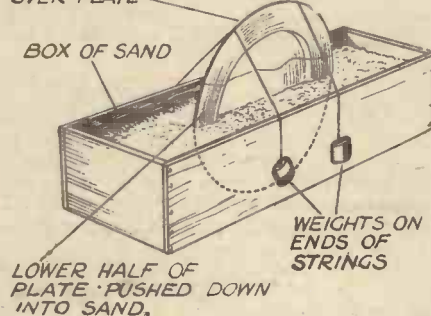

The "sand-box" method of cementing broken pottery and other delicate and fragile articles

putrify and thereby lose their adhesive properties, such solutions must be well preserved with carbolic acid or other antiseptics.

#### Gum Arabic

Gum arabic not unfrequently enters into the composition of photographic mountants. For instance, the following formula makes an excellent creamy mountant for photographic purposes:

Gum arabic	...	...	1 part.
Starch	...	...	1 "
Sugar	...	...	2 "

Dissolve the gum arabic in the minimum amount of water. Then add the sugar and afterwards the starch. Finally, very gently simmer the mixture until the "cooking" of the starch causes it to thicken. Strain through cloth, add a few drops of disinfectant, and bottle tightly in wide-mouthed bottles.

Within the last year or two a new type of adhesive has appeared in this country after having had a considerable vogue in the United States. This is rubber latex, a naturally-formed emulsion of rubber obtained from the rubber plant. This latex is mixed with various solvents, as, for example, benzene, and applied to the paper.

"Self-sealing" envelopes are prepared with this latex, also, the latex being allowed to dry and presenting thereafter a slightly tacky surface which is sufficiently adhesive for normal envelope use.

Of the various mineral cements having workshop uses, mention can be made of but one or two.

#### Luting Needs

For luting purposes, as, for example, the cementing of a glass tube inside a metal one, an excellent cement consists of magnesium oxide made into a thick paste with a strong solution of magnesium chloride. This, although it takes one or two days to harden thoroughly, will withstand the action of boiling water. What is more, the cement or luting slightly expands on setting, which, for most purposes, is a decided advantage.

Another good luting is a mixture of equal parts of rubber powder and bitumen, to which flowers of sulphur is added until the mass attains the required consistency. The resulting material, which consists of partly vulcanised rubber intimately mixed with bitumen, is an extremely tenacious medium and may be used for a variety of cementing, luting and filling purposes. It is extremely weather- and waterproof, but will not resist the action of heat.

Frequently a "non-drying" adhesive material, such as that coated upon medical plasters, is required. The preparation of such a material is not easy and is decidedly messy. Nevertheless, it may be carried out successfully in the following way:

Mix together 1 part of powdered litharge (oxide of lead), 2 parts of olive oil and 1 part of water. Boil these ingredients very gently for five hours, stirring frequently and adding water during the process to make up for that lost by evaporation.

Thus resulting material will form a non-drying and powerful adhesive, and, as such, can be employed for the grease-banding of trees, as well as for many workshop purposes.

The Handiest Book Yet Published for Draughtsmen, Fitters, Turners, Mechanics, Pattern-Makers, Erectors, Foundrymen, Millwrights and Technical Students

#### WORKSHOP CALCULATIONS, TABLES AND FORMULÆ

By F. J. CAMM  
(Editor of Practical Mechanics)

3/6 or 3/10 by post from Geo. Newnes, Ltd., Tower House, Southampton Street, Strand, London, W.C.2.

Its Comprehensive and Fully Illustrated Contents include:—The Micrometer and Vernier; Mensuration; Trigonometrical Formulæ; Extracting Square Root; Extracting Cube Root; Continued Fractions; Arithmetical Progression; Geometrical Progression; Harmonical Progression; English Weights and Measures; Horse Power; Force, Energy and Power; Heat, Time, and Velocity; Electrical Units; Comparison of Thermometers; Pulleys; Parallelogram Forces; Pendulum; Levers; Centrifugal Force; Moments of Inertia; Metric Systems; Screw Cutting; Tool Grinding Angles; Lubricants for Cutting; Spur Gearing; Tapers and Angles; Bevel Gears; Worm and Worm Wheels; Spiral or Screw Gearing; Pulley Calculations; The Dividing Head; Differential Indexing; The Slide Rule; H.P. Required to Drive Shop Tools; Table of Cutting Speeds; Proportion of Keys and Cotter; Standard Screw Threads; Drill Sizes; Circle Spacing Table; Tapers and Angles; Melting Points of Metals; Weights of Materials; Twist Drills for Wood Screws; Wood Screw Proportions; Weights of Woods; Powers and Roots of Numbers; Wire and Sheet-Metal Gauges; Natural Sines, Cosines and Tangents; Logarithms and Antilogarithms.



# AIR RAID PRECAUTIONS

## Useful Hints on Fitting Dark Curtains and Making Windows Splinter Proof

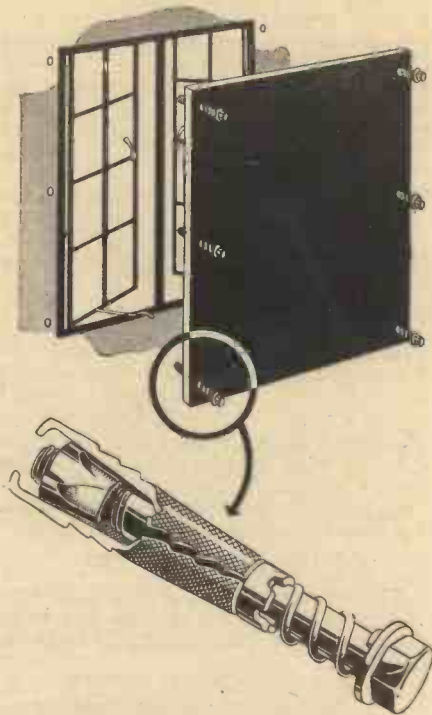

Steel shutters should be fixed in place with Rawlbolts fitted with a buffer spring as shown

THE metropolitan police, London County Council and other important bodies have effectively overcome the problem of fixing A.R.P. shutters by means of Rawlbolts, the advantage of which is since only small diameter holes are needed to take them, little damage is done to the masonry. Furthermore, in position they are barely noticeable. Rawlbolts are of two types; the projecting type where bolt and expanding member can be inserted in the hole together and the loose-bolt type where the bolt has to be inserted after the expanding member and the article to be fixed are in position. The police and L.C.C. are both using the loose-bolt type Rawlbolts, as shown in the illustration, with a buffer spring to absorb shock and lessen the danger of the metal shutter being buckled. When not in use, the shutters and bolts can be stored away and, when needed, placed in position in a few minutes.

### Darkening Windows

Where shutters are necessary for purposes of protection these also serve the purpose of darkening windows at night. Where risk of injury from blast is not so great, blinds or curtains are required for darkening windows, roof lights, skylights, etc. Naturally such blinds or curtains must be of a sufficiently heavy and opaque nature to ensure that no light penetrates them.

It will be seen that the fixing of curtain rails and blind rollers must be undertaken with extra care. It requires a little imagination to visualise the rough handling to which these may be subject in an emergency and what serious consequences might follow on the failure of these fixings during an emergency. Complete confidence can be placed in Rawlplugs for this class of fixture, for the largest Rawlplug will stand a weight of over 4 tons.

Small holes of the right size to take the

appropriate size of plug are made with a Rawldrill and a firm neat job is ensured without damage to masonry and decorations. Furthermore, should it be necessary to take down the fixture the screws can be removed or replaced quite easily.

### Air Raid Shelters

Underground shelters sufficiently large to accommodate not more than 50 persons are usually provided for employees of factories and, whilst they are necessarily only intended for use in an emergency, a number of items such as partitions, electric light fittings, clothes racks, brackets for tools and fire equipment, seats, hooks for emergency lighting, ventilation and air filtration apparatus, must be fitted.

Three factors in particular must be taken into account when considering screw fixings in underground shelters. These are, firstly, the rough usage and severe strains these fixings may be called upon to resist during times of emergency; secondly, the possibility of damp conditions, and thirdly, the type of material into which the fixings have to be made. As far as the question of rough usage is concerned all Rawlplug fixing devices are capable of standing up to stresses far exceeding those likely to be encountered.

### Dampness

Where dampness is likely to cause damage

to fixings, either Rawlplug White Bronze Plugs or Screw Anchors are specially suitable. The material into which fixings have to be made will usually be either reinforced concrete or pre-cast lining units of some kind. Consequently it may be necessary to bore a hole right through the unit. If this is the case, Rawlplug Screw Anchors are the fixing device to use since they are flanged to prevent their being pushed too far when the screw is inserted.

### Falling Glass

Most modern factories have large expanses of glass roofing in order to take full advantage of daylight. This, however, presents rather a serious problem during an emergency. The danger of glass falling on persons working below must be safeguarded against and if work has to be carried on at night in such premises, these roof lights must be suitably darkened. Some factories have found it convenient to deal with this problem by means of shutters as previously mentioned, but the disadvantages of this method are obvious.

The most common method is to suspend  $\frac{1}{2}$ -in. mesh wire netting below roof lights so as to catch falling fragments. It depends on the expanse and weight of wire netting requiring to be fixed whether Rawlplugs and screw hooks or Rawlbolts with hook bolts are employed.

## WITHDRAWAL OF EXPERIMENTAL WIRELESS LICENCES

THE Postmaster General announces that by notices issued in the *London Gazette*, all licences for the establishment of:

- (a) Wireless telegraph sending and receiving stations for experimental purposes
- (b) Wireless telegraph receiving stations for experimental purposes and the use of wireless sending apparatus in con-

junction with "artificial aerials," and (c) Wireless telegraph sending and receiving stations for Royal Naval Wireless Auxiliary Reserve purposes are withdrawn.

The above-mentioned notices have no application to the ordinary wireless receiving licences issued to the general public at Post Offices throughout the country.

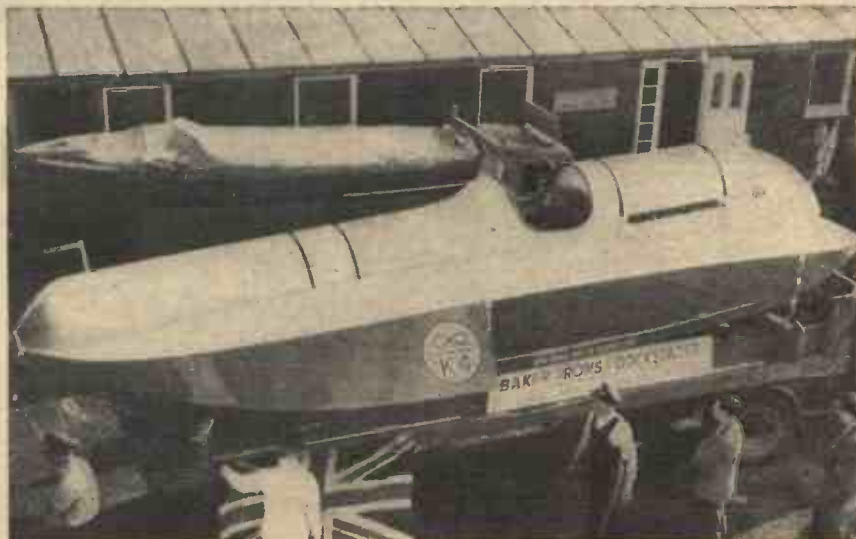

The new Bluebird II in which Sir Malcolm Campbell broke the world water speed record with a speed of 141.74 m.p.h.





## QUERIES and ENQUIRIES

A stamped addressed envelope, three penny stamps, and the query coupon from the current issue, which appears on page III cover, must be enclosed with every letter containing a query. Every query and drawing which is sent must bear the name and address of the sender. Send your queries to the Editor, PRACTICAL MECHANICS, Geo. Newnes, Ltd., Tower House, Southampton Street, Strand, London, W.C.2.

### Winding a Bell Transformer

I WISH to make a transformer for operating an electric bell off the A.C. Mains. Would you please tell me what lengths of wire I shall require for the primary and secondary coils and what gauge would be most suitable?—J. K. (Angus).

THE important thing in winding a transformer for any specified input and output is the number of turns on the primary and secondary coils, the length of wire being of secondary importance and depending upon the mean diameter of the coil which, of course, will vary with the dimensions of the iron core.

In the case of bell transformers the iron core is usually of about  $\frac{1}{2}$  in.  $\times$  1 in. section, that is half a square inch cross sectional area and of the "shell" type. The turns necessary for the windings are calculated from the following formula:—

$$\text{Turns} = \frac{\text{Volts} \times 100,000,000}{\text{Flux} \times 4.44 \times \text{cycles}}$$

the working flux density for Stalloy cores being usually in the region of 50,000 to 60,000 lines per square inch.

Assuming the primary to be connected to the standard mains supply of 230 volts 50 cycles single-phase, this flux density corresponds to about 8 turns per volt for cores of one square inch section, therefore in the case of a core of 0.5 sq. in. section 16 turns per volt must be allowed. Assuming a 230 volt primary therefore, the number of turns must be  $230 \times 16 = 3680$ , and as the secondary windings are provided with tappings at 4, 8, and 12 volts the total number of secondary turns will be  $12 \times 16 = 192$  turns, tapped at 96 turns for 8 volts and 48 turns for 4 volts.

As regards gauges of wire, the primary will be left connected on continuously, so that a fairly liberal gauge is necessary, such as No. 38 SWG enamel covered copper, while the secondary which will only be in use very intermittently will not overheat if wound with No. 26 ditto. Great care is necessary with the insulation of the primary coil, and a perusal of the handbook *Small Transformers* (P. Marshall & Co.) will enable details of design and winding calculations to be worked out for a large range of transformers.

### Electric Wiring

AS fuse wire is such a small gauge and delicate affair and yet stands the strains, etc., encountered in a lighting circuit of 50 volt and 5 to 10 amps, why can't it be used all through a house lighting circuit instead of the usual heavy stuff?

I want to run two supply wires 50 volt 5 amp to a farm 80 yards away (overhead). What gauge wire do I need so as not to cause current drop, etc.?

Are there any firms who recondition refrigerator mechanism? There are firms who re-condition suction cleaners, but I cannot trace any refrigerator reconditioners.

What is the possible result of trying to use an ordinary 6-volt car starter-motor as a

motor but driven by a 50 volt battery instead of a 6 volt?—P. L. (Sark, C.I.).

THE reason that fuse wire is not employed for the whole of the wiring in an electric circuit is twofold; first it would get sufficiently hot to endanger risk of fire before it fused, and secondly it would be extremely inconvenient to have to search over the whole of a long circuit, perhaps partly concealed under flooring or in the walls, before the fused point could be located and repaired. If any other reason were necessary it is that the resistance of so fine a wire would cause an enormous loss of voltage between the supply and the accessory in use. To run overhead cables to a distance of 80 yards, carrying 5 amperes at 50 volts requires the use of a 7/036 stranded copper conductor braided and impregnated with weather-resisting compound. A much smaller cable such as 1/044 would carry the current, but in the 480 feet of lead and return the voltage drop at full load would amount to 16 volts, leaving, of course, very little useful pressure at the far end. To employ a 50-volt battery for running a 6-volt starter motor would result in burning out the motor and rapidly discharging the battery, unless the current is limited by a series resistance of about 2 ohms 25 amperes carrying capacity. For reconditioning refrigerators you will be well advised to let the makers only deal with them.

### Gloss Paint

I UNDERSTAND that gloss paint can be made easily and cheaply. Could you tell me the materials and their quantities used? Can these be obtained locally?—E. T. (Wilts.).

THERE are literally scores of different varieties of "gloss" paints. It is, therefore, not possible for us to suggest a formula for one without knowing the type of paint you need.

If, however, you require an ordinary oil paint having a very high gloss, you can prepare such by stirring the necessary dry pigment or colour into a quantity of hard

varnish. If the paint so prepared is too thick, it can be let down with a little boiled linseed oil or turpentine. Varnish and paint pigments can be obtained from any paint, colour or decorating stores.

### Pyrophoric Metals

SOME time ago you published an article on the preparation of pyrophoric metals. You described the preparation of pyrophoric iron as the reduction of ferric oxide in a stream of hydrogen. Is the substance formed iron or ferrous oxide?—K. R. (Bridlington).

THE pyrophoric iron formed by the reduction of the oxide is pure iron in a finely-divided form. Frequently, however, it contains small amounts of ferrous oxide, FeO.

### Organic Chemistry

I HAVE a good elementary knowledge of inorganic chemistry, but I know nothing of organic chemistry, could you recommend a book on the subject?—R. C. (Ewell).

A GOOD book on theoretical and practical organic chemistry is *Organic Chemistry*, by W. H. Perkin and F. S. Kipping. This is rather an old-fashioned work, but is an excellent one for the beginner.

### Static Electricity

WHERE can I obtain a small neon tube about 2 in. long and about  $\frac{1}{4}$  in. wide, for testing for static electricity?—L. T. (Bristol).

MESSRS. PHILIP HARRIS & CO., LTD., Birmingham, will probably be able to fulfil your requirements with regard to the small neon tube.

### Flashlight Powder

WHAT is the composition of the powder used in photography for producing a white flash?—D. S. (Brixton, S.W.).

FLASHLIGHT powders vary greatly in composition. They usually contain powdered magnesium, potassium chlorate and barium perchlorate, the magnesium comprising about half the volume of the powder.

### Model Aeroplane Dope

HOW can I make a good quality dope cement, and banana oil for model aeroplane work?—T. H. (South Africa).

A GOOD quality aeroplane dope may be prepared by dissolving scrap celluloid in a mixture of approximately equal parts of amyl (or butyl) acetate and acetone. A fairly thick solution should be made. This may then be thinned down by the addition of toluene, which will not only cheapen its production but which will also considerably improve its uniformity of drying.

The amyl acetate (or butyl acetate) and acetone can be used separately for the solution of the celluloid, but the mixed liquids give a better product. Scrap films can be used provided that the gelatine surface is removed from them.

A cement of the proprietary type you mention consists merely of a strong solution of celluloid in some suitable solvent, say, in a mixture of equal parts of amyl acetate and acetone. The solution should be evaporated down until it attains a clear pasty condition.

Banana oil is a natural material. You would probably be able to obtain supplies of it from a London chemical wholesaler such as Messrs. Harrington Bros., Ltd., City Road, London, E.C.1, but we think that you will obtain it with less trouble and delay from one of your South African chemical supply depots.

## THE HOME MECHANIC ENCYCLOPÆDIA

An up-to-date and comprehensive guide to the Mechanical, Scientific and Technical Interests of the day—with expert articles on Aircraft, Television, Models, Astronomy, Electricity, Photography, Chemistry, Woodwork, Motor Cars, Wireless, Home Cinema, with over 600 illustrations.

Only 3/6 Net

4/- post free from the Publishers—Book Dept., George Newnes, Ltd., Tower House, Southampton Street, Strand, London, W.C.2.

NEWNES : LONDON



### Phenol Phthaline

WHAT is phenol phthaline and its chemical components (please give symbols)?—A. K. (Bristol).

PHENOLPHTHALEIN is a white crystalline material which possesses the chemical formula:—

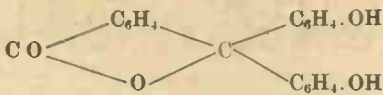

It is made by heating phthalic anhydride with carbolic acid and zinc chloride for about eight hours. It dissolves in alkaline solutions giving rise to an intense pink colour, owing to the formation of strongly coloured salts. Phenolphthalein is also used in medicine as a strong purgative.

### Hardened Glass

HAVE recently heard of a hardened glass which can be cut with a fine saw. Where can I obtain such a glass and what is its fusible point?—B. W. (Enfield).

SOME varieties of hardened glass can be cut with a fine saw, but such glasses are by no means entirely non-brittle. Write to Messrs. Pilkington Bros., Ltd., St. Helens, Lancs., for particulars of their "toughened" glasses.

There is, also, now available a glass-like synthetic resin product. This is quite non-brittle. You may obtain particulars of it from Imperial Chemical Industries, Ltd., Millbank, London, S.W.1. There are no books published on the subject of these glasses.

### Converting Dynamo to A.C. Motor

RECENTLY purchased an old Lucas Dynamotor, and would like to know whether it is possible to convert it into an A.C. motor for a voltage of 230, 50 cycles. I require it for driving a small lathe.—C. B. (Abbey Wood, S.E.)

IT would be possible to convert your dynamotor into an A.C. series wound motor, but one quarter horse power is the utmost you can expect in the way of output on a 230-volt 50-cycle circuit. Beside the heating due to the presence of a solid yoke ring there will be considerable eddy-current losses and a low efficiency limiting the power output to a degree depending on the maximum safe temperature rise, which must not exceed 40 deg. C.

It is not recommended to make the motor into a repulsion type, but to rewind as a plain series-connected motor, and in either case the same objection will be present in that the speed depends entirely upon the loading for the time being, which is not very satisfactory for lathe work. A variable hand controlled series resistance may be found necessary to limit the speed when running light.

The following is the winding specification recommended for operating on 230 volts 50 cycles, to develop  $\frac{1}{4}$  h.p. at 2,000 r.p.m.:

**Armature.**—29 coils each containing 63 turns of No. 28 SWG. d.s.c. copper, coil span from slot 1 to slot 8, wave-connected to 29-part commutator.

**Fields.**—4 coils, each containing 400 turns of No. 22 SWG. d.s.c. copper, connected in series with one another and in series with the armature

**Brushes.**—2 in number, spaced 90 deg. apart, of grade "C/4" carbon.

You must be prepared for a considerable amount of sparking at the brushes, with the relatively few commutator bars.

### High Frequency Coil

WISH to make a Tesla high-frequency coil. As I already have a  $\frac{1}{2}$  in. spark-coil, is it possible to energise a laboratory-sized high-frequency coil, from my  $\frac{1}{2}$  in. induction coil? If not, then what is the minimum size of spark used to excite a 2 ft. or 3 ft. Tesla coil?—L. C. (London, E.3.)

A HALF-INCH spark coil is much too small for producing high-frequency effects. Moderate results are to be obtained with a 4-inch coil, but for the size of Tesla coil you have in mind a 10-inch spark coil would be the minimum likely to be of service. The results are to a certain extent dependent upon the type of interruptor, and we recommend you to apply for a copy of W. Watson & Sons Ltd., high-frequency catalogue, obtainable from Sunic House, Parker Street, Kingsway, London, W.C.2.

### Constructing a Constant-Voltage Dynamo

AM anxious to construct a dynamo for charging a 12 v. car battery which will generate about 300 r.p.m., giving about 15 amps. at 1,500 or 2,000 r.p.m.

I think  $\frac{1}{2}$  amp. at 300 r.p.m. is usual for this type of dynamo, although a higher rate would suit my requirements better.

I would be obliged for necessary data: gauge of wire, no. of turns, no. and size of armature stampings and commutator, etc.—C. O'C. (Donegal).

THE winding specification recommended for the size of car-lighting and charging dynamo you mention is as follows: output capacity 15 volts 15 amperes at 1,400 r.p.m. upwards when coupled up to a 12-volt accumulator, charging to commence at 300/400 r.p.m., constant voltage type with third brush control:

**Armature.**—28 former-wound coils, each containing 8 turns per coil of No. 19 SWG. d.c.c. copper, grouped two coils per slot and connected to 28-part commutator. Span of coils from slot 1 to slot 7 inclusive.

**Fields.**—2 coils each containing 600 turns of No. 24 SWG copper, one end attached to main brush, the other to intermediate third brush, 6-mil d.c.c. covering.

**Brushes.**—All of C/M3 copper-carbon Morganite.

### Seed Germination

WISH to shorten the period of germination in certain hot house plants. I find that it will be necessary for me to sterilize the seed. Can you describe any method in which this can be carried out successfully to avoid killing the live germ?—J. W. (Boston Spa).

THERE are several methods of sterilizing seed. In the first place you may soak the seeds for a few hours in a very dilute solution (1 in 2,000) of mercuric chloride, or in a 1 in 2,000 solution of formalin.

A solution of copper sulphate of such a strength that it is of a faint blue colour will have a similar sterilising effect.

### Obtaining Mercury

WHERE can I obtain mercury, sodium and selenium and what are their approximate prices?

THE nearest supplier of the materials you name is The British Drughouses, Ltd., City Road, London, N.1. Most branches of Boots the Chemist, also, will be able to obtain supplies of these materials for you. Mercury is listed at 5s. 6d. per lb., sodium at 2s. 9d. per lb. and Selenium at 2s. per ounce, these figures being approximate.

# PELMANISM

PELMANISM is a system of training the mind on scientific lines. It has sometimes been described as "Psychology made popular and practical," but it is something more than that. The system is taught through the medium of fifteen "Little Grey Books" which are accompanied by examination papers. After studying the first of these books, the student answers the accompanying examination paper to the best of his or her ability, and this paper is sent up to an examiner, who marks it and adds appropriate comments. Then the second book is taken, and so the Course continues until the fifteen lessons are completed.

### A MODERN COURSE FOR MODERN TIMES

The world-famous Pelman Course has once again been completely revised and brought up to date with the latest scientific findings. For over 40 years the Pelman Institute has been training the minds of men and women in Britain, her Dominions, and the world over. During that period over half a million people have taken the Course, thereby enabling them to realise their ambitions and enjoy to the full the glorious possibilities of life. It is undoubtedly the finest Mind-training Course the world has ever seen.

A course of Pelmanism brings out the mind's latent powers and develops them to the highest point of efficiency. It banishes such weaknesses and defects as:

- |                   |                     |
|-------------------|---------------------|
| Depression        | Inferiority Complex |
| Shyness           | Indecision          |
| Forgetfulness     | Weakness of Will    |
| The Worry Habit   | Pessimism           |
| Unnecessary Fears | Procrastination     |
| Mind-Wandering    | Morbid Thoughts     |

which interfere with the effective working powers of the mind, and in their place it develops strong, positive, vital qualities such as:

- |                |                   |
|----------------|-------------------|
| —Optimism      | —Organising Power |
| —Concentration | —Self-Confidence  |
| —Observation   | —Self-Control     |
| —Judgment      | —Tact             |
| —Initiative    | —Reliability      |
| —Will-Power    | —Decision         |
- and a Reliable Memory

By developing these qualities Pelmanism certainly adds to your Efficiency and consequently to your Earning Power.

What is equally important, Pelmanism increases your happiness and enables you to develop a finer appreciation of the beauties of Nature, the Arts, and Life generally.

In a sentence, Pelmanism enables you to live a fuller, richer, happier, and more successful existence.

"The Science of Success"—Free

The newly revised Pelman Course is fully explained in a little book entitled "The Science of Success." The Course is simple and interesting and takes up very little time, and, as this book shows, you can enrol on the most convenient terms. This book will be sent you, gratis and post free, on application to-day to—

Pelman Institute,  
(Established over 40 years)

130, Pelman House, Bloomsbury Street,  
London, W.C.1

Write or call for this free book to-day.

PELMAN OVERSEAS INSTITUTES: PARIS, 176 Boulevard Haussmann. NEW YORK, 271 North Avenue, New Rochelle. MELBOURNE, 396 Flinders Lane. JOHANNESBURG, P.O. Box 4928. DURBAN, Natal Bank Chambers (P.O. Box 1489). DELHI, 10 Alipore Road. CALCUTTA, 102 Clive Street. AMSTERDAM, Damrak 48. JAVA, Malabarweg, Malang.



# I Show You How to Start Your Own RADIO BUSINESS *Without Capital!*



**I Train You at Home in Spare Time  
for a Radio Business of Your Own  
Or A GOOD RADIO POSITION**

Would you like to be your *own employer*—have your *own name* over a money-making Radio Shop? Then write for my free Book that tells how I help you start.

I show you how to install and service all types of receiving sets. From the very start, I give you special money-making lessons that help you get and do spare time Radio jobs *while learning*. I teach you every branch of Radio and help prepare you for a Radio service business of your own, requiring no capital—or for a good-pay position in broadcasting, loud speaker systems, talking pictures, radio operators, radio receiving or distributing, television, etc. Diploma upon graduation.

**I am as Close to You as Your Post Office**

The distance between us makes no difference as my internationally-known method of training keeps you constantly in lessons and practical experiment work. I have helped hundreds of men, in countries all over the world, make more money I can help YOU

**THIS POWERFUL RADIO  
GIVEN with your Training  
NO EXTRA COST**

10 big kits of Radio Parts for practical experiments—and to construct this 8-tube All Wave Receiver.

**Post Coupon Today**

for my free 40-page Book telling about spare time and full time opportunities in Radio



**This  
FREE  
BOOK**  
has helped  
hundreds of  
men make  
more money.

C. H. MANSFIELD, Pres., Dept. 306-S  
Hollywood Radio & Television Institute  
810 W. Sixth St., Los Angeles, Cal., U.S.A.

Send me your free book, "Your Opportunities in Radio," explaining how you can prepare me for spare time or full time work in Radio.

Name \_\_\_\_\_  
Address \_\_\_\_\_

Letter postage to United States, 1½d. Post Card, 1d.

## HAVE YOU A RED NOSE?

Send a stamp to pay postage, and you will learn how to rid yourself of such a terrible affliction free of charge.

Address in confidence—

**P. TEMPLE, Specialist**  
"Commerce House," 72 Oxford Street, W.1  
(Est. 38 years.)



Castings made from our  
castings 12/6 per set.  
Complete Engines  
ready to run from  
£3.15s.

**J. HALLAM & SON**  
Upton, Poole,  
Dorset

MEASURED PETROL ENGINES for  
Aeroplanes and Speed Boats. 1 to 15 c.c.  
Send 3d. for particulars

## PERFECT USED MODELS

Send 4½d. for our Catalogue and Save Money  
**GEORGES', 11, Friars St., Ipswich**

## In WORKSHOP and HOME keep warm with a PORTABLE TILLEY RADIATOR



The unpleasant conditions of winter are soon forgotten amidst the comforts of the home. The Tilley Radiator being PORTABLE, provides warmth in workshop, sitting-room, bedroom, bathroom, etc., as required. Burns ordinary paraffin at the low cost of 1d. for 6 hours. Requires no connections or fixing. Absolutely safe. No wick to adjust and causes neither smoke, smell nor mess. British throughout. Price 37/6.

Sold by all good Ironmongers and Stores. If any difficulty, write to:—

**TILLEY LAMP CO. (Dept. P.M.), HENDON, N.W.4**

# WORKSHOP CALCULATIONS, TABLES & FORMULÆ

by F. J. CAMM

A handbook dealing with methods of calculation, solutions to workshop problems, and the rules and formulæ necessary in various workshop processes. It contains all the information a mechanic normally requires.

From all booksellers 3/6 net, by post 3/9 from the publisher

**GEORGE NEWNES, LTD.**

(Book Dept.), Tower House,  
Southampton Street,  
London, W.C.2.



**Sealing and Paraffin Wax**

WHAT is the permittivity of ordinary sealing wax and paraffin?—D. B. (W. Hampstead).

WE are not clear as to what you mean by the expression "permittivity." If you mean the degree of permeability, this varies according to the nature of the permeating substances and is, therefore, not constant.

**Dismantling an Electric Lamp**

ARE ordinary modern electric lamps gas-filled? Can you suggest the best method of dismantling one, and would piercing a hole in the bulb cause it to shatter?—S. T. (Watford).

THE majority of electric lamps are now gas-filled, although some of the lower wattage lamps are of the older vacuum type. You will find it very difficult to dissect an electric lamp without shattering the bulb. Your best plan would be to remove the outer bayonet cap, after loosening

it, it was always apt to become "poisoned" by impurities existing with the gas. So far as we are aware, these catalytic gas-lighters are no longer manufactured, the main reason for their discontinuance being the continually increasing price of platinum.

You can, however, obtain platinum sponge or platinum black suitable for lighter construction from Messrs. Johnson, Matthey and Co., Ltd., 73-82, Hatton Garden, London, E.C.1.

**Wire Gauge**

WHAT is B. and S. gauge D.S.C. wire and does it correspond to our standard gauge?—A. K. (Dartmouth).

THE "B. and S." gauge is an American wire gauge, the initials standing for Browne and Sharpe, the introducers of the gauge. It is used throughout America for copper and brass wires and varies but slightly from our own standard wire gauge. "D.S.C." of course, stands for "double silk covered."

**An Absorbing Hobby**

BUILDING A STUART MODEL IS AN ENROSSING PASTIME, AND THE RESULT A CONTINUOUS PLEASURE



We illustrate:  
STUART NO. 10.  
High Speed Steam Engine.  
Bore 2".  
Stroke 3/4".

Each set is quite complete—drawings and instructions are included.

If you have a lathe—  
The rough castings - - - 8/6  
If not—  
Fully machined set - - - 18/6  
Ditto, with all holes drilled and tapped - - - 25/-

This and many other Stuart engines are fully described in the 72-page CATALOGUE No. 3, 6d. post free.

**STUART TURNER LTD.  
HENLEY - ON - THAMES**

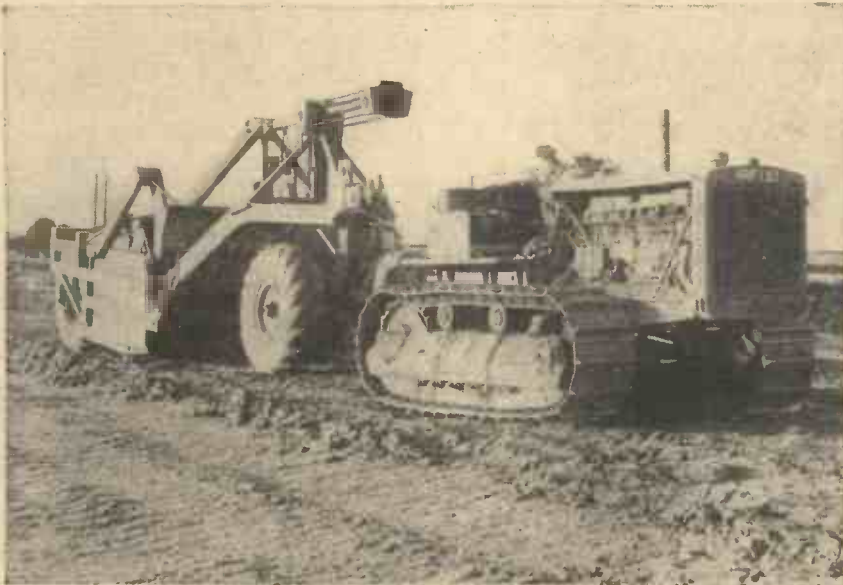

These huge scrapers are capable of scraping 15 tons of earth at one scoop from the top of a hill and depositing in a corresponding hollow. They are used for levelling ground for road construction

ing its cement by soaking it for a day in a strong solution of caustic soda. This will expose the glass nipple through which the bulb was exhausted. If this is very carefully heated until it softens, air will rush into the bulb and may not result in the shattering of the latter. When this happens the bulb may be broken cautiously without any injury being done to its internal parts.

**A Gas Lighter**

COULD you please supply me with the name and address of the maker(s) of any coal gas ignition apparatus, depending for its action upon catalysis between the hydrogen of the coal gas and atmospheric oxygen (agent fine platinum wire)?

I had such an appliance in my possession some years ago purchasing from a street vendor, but have not been able to obtain another since.—P. W. (Bath).

THE gas lighters you mention contained platinum sponge (not platinum wire), the platinum sponge glowing under the influence of the coal gas. They were uncertain in action, for, after a time, the platinum sponge lost its catalytic property and, in

**A Sticky Cape**

HOW can I remove stickiness from a cape? I have tried linseed oil, but it has no effect.—P. T. (Glasgow).

IT is very difficult to remove the stickiness which develops on some types of oiled fabrics. Rubbing with linseed oil is usually useless and only makes the trouble worse. Your best plan will be to rub the garment over with a rag charged with naphtha. This will remove a good deal of the stickiness and after several treatments on these lines, the garment should be capable of use again. We feel bound to say, however, that once an oil-skin has acquired a highly sticky condition it is doubtful whether any treatment can restore it to its original state.

**THE INSTITUTION OF MECHANICAL ENGINEERS**

THE Institution of Mechanical Engineers is carrying on the bulk of its work at a temporary address in the country, The Meadows, Betchworth, Surrey (Telephone: Betchworth 63), but the Institution building in Storey's Gate will remain open, possibly during restricted hours, for dealing with personal inquiries and for members or others wishing to make use of the Library.

**Be sure YOU have it!**

The famous All-British

**TILLEY LANTERN**

(Burns ordinary Paraffin)



Light of 300 c.p. for 6 hours for 1d. Mechanics and owners of small workshops, lathe sheds, observatories, etc., will find it invaluable for work after dark, either in or outdoors. Holds enough oil for 10 hours' use on one filling. Can be placed anywhere with absolute safety. Easy to light. Wind and rain proof. Strongly made in stout brass. No parts to rust, corrode or get out of order. For dependability you cannot do better than get the Tilley Storm Lantern, Price 36/-. Sold by all good Ironmongers and Stores.

If any difficulty, write to:—

**TILLEY LAMP CO. (Dept. P.M.), HENDON, N.W.4**

**The New "HOMRAY" PROJECTOR**

(previously under another name)



Hand Turned Model 27/6

Mains Motor Driven Model (Universal)

**£3. 17. 6**

Obtainable from leading Stores and Photographic Dealers Write to-day for illustrated list, and name of nearest stockist

**HOMRAY PROJECTOR COMPANY**  
(P.M. Dept.), 46 High Pavement, Nottingham



# BUY, EXCHANGE OR SELL

**The 'ADEPT' Bench Hand Shaper**

Price £3-3-0

Length of stroke of ram, 3 1/2 ins.; Length of cross travel of slide, 3 ins.; Size of Table, 4 1/2 ins. x 4 ins.; Rise and fall of Table, 2 ins.; Vertical feed of tool slide, 1 1/2 ins.; Maximum distance between tool and table, 3 ins.; Weight, 18 lbs. Also the 'Adept' No. 2B.H. Shaper, 6 1/2-in. stroke. Price £6-9-6. Manufactured by F. W. POEYASS, 28 ELLERS STREET, SHEFFIELD.



Machine Vice 1/1.

## TOOLS.

**GRAYSON'S** Glass-boring Outfits and Tube Cutters avoid risk.—Below.

**DRILLS, Taps, Dies, Files, Chisels and Punches.** Best quality at keenest prices.—Grayson & Company, 300 Campo Lane, Sheffield.

**MYFORD LATHE SPECIALISTS.** Cash or on deposit terms from 10/- monthly. Immediate deliveries anywhere.—Nuttalls, 20, Albert Street, Mansfield.

**120 Combined Engineers & Woodworkers Vices,** a most useful tool in any workshop, 6" Jaws, opens 4 1/2". Clearance price, 4/9 each; honestly worth double.—Below.

**500 Woodworkers Vices, 4" Jaws,** clear 2/9 each.—Below.

**85 Machine Vices for Drilling or Milling Machine.** Robust design, Width of Jaws 2 1/2", opens 3 1/2", very cheap to clear, 3/3 each, below.

2/9 any lot. Eight lots £1.—Below.

**8" Toolholder with four H.S. Tools.**

**1/2" Adj. Boring Tool with H.S. Tool.**

**1/2" Drill Chuck, taper or straight shank.**

**1/2" to 1 1/2" Silver Steel, 13 pieces.** 13" long.

**1/2" to 1 1/2" Silver Steel, 4 lb., 2" to 4" long.**

**500 Ass. Brass and Steel Screws, etc.**

**100 Steel Hex. Bolts and Nuts, 1/2" to 1 1/2".**

**16 H.S. Drills, 1/32" to 5/32".**

**Slitting Saws, five 1/32" to 1/4" thick, 1" hole.**

**Two dozen Fine and Odd Thread Taps, to 3/4".**

**Three dozen Tungsten Hack-Saws, to 12".**

**18 Grinding Wheels, 1" to 1 1/2" diam.**

**Three H.S. Tap Fluting Cutters, 1 1/2" diam.**

**One dozen Ass. Files, 4" to 12".**

**Dozen Toolmaker's Needle Files, indispensable.**

**Best Carborundum Wheel, 7" by 1 1/2" by 1" hole.**

**200 Springs to approx. 6" long.**

**Four Ass. Carborundum Wheels, to 3 1/2" diam., 1/2" hole.**

**Doz. Emery Wheels, 1 1/2" to 1 3/4" thick, 1 1/2" hole.**

**0" to 1" Adjustable Tap Wrench. Burke.—Below.**

**12 Sets Stocks and Dies, etc., 1/8", 3/16", Split Dies, cutting 3/32", 1/4", 5/32", 3/8", 7/32", 1/2", 5/8", Whit. or B.S.F. or 0, 1, 2, 3, 4, 5, 6, 8, B.A. Complete with Taper Taps, Adjustable Tap Wrench and Die-Stock, Seven Dies and Taps, usual price of these sets is 12/6, clear while stock lasts at 6/6 per set, extra sets of Taps, Seconds or Plugs, 1/9 set of seven. Burke.**

**Small Taps, 7, 8, 9, 10, 12 B.A.; 1/8" Whit. 6d. each.**

**No dies these sizes. Burke.**

**1" Round Dies, Screwing 1/8", 3/16", 1/4", 5/16", 3/8", 1/2", Whit., B.S.F.; or Brass 26 Threads; or American Fine. S.A.E. for Yankee Cars, Set of Five Dies 2/9; Four Sets 10/-; Best Quality 1" Die-Stocks, all Steel unbreakable with Hardened adjusting Screws, 1/9 each.—Below.**

**4,000 Taps, Taper. 2nd or Plug, same sizes and threads as Dies, 2/9 set, four sets 10/—Below.**

**See Blocks and Clamps, Sturret pattern, accurate, first-class finish, 4/- pair.—Below.**

**41 orders carriage paid, except abroad.**

**J. BURKE, 30 TRIPPET LANE, SHEFFIELD, 1.**

## MISCELLANEOUS

**TELESCOPES, MICROSCOPES, Scientific Instruments, etc.** Send for lists. Sale or Exchange.—C. V. Boltou, F.S.M.C., 49a Leigh Road, Leigh, Lancs.

## ELECTRADIX

**HEADPHONES.** Lightweight for Crystals. Famous makes. 2,000 ohms. 4.6. Single high res. earpieces, 2/6. Sullivan 120 ohm. W.D. model. Aluminium body and headbands. Maker's price to-day, 15/-. Our price 2/9 per pair. 3d. postage.

**CRYSTAL SETS.** Model B, Pol. Mahor. case 9in. x 10in. 2 tuning condensers, plug-in coils, Permanent Detector. 7/6. 4,000 ohms. 'Phones, 4/6.

**CRYSTALS, RECEIVING.** Super Detector, glass cover, fine adjustment, 10/-. Enclosed 2-crystal permanent Detector. 2/. Carborundum Marconi Army Detector. 2/6. Galena point Detector, mounted, 1/6. Galena and Neutron Crystals, 4d., 6d., and Perikon, 1/6. Carborundum mounted, 8d.

**CRYSTAL OR BATTERY SET BUILDERS.** Fitted Table Cabinets, polished oak 13 1/2in. x 7 1/2in. x 6in., oval aluminium black panel fitted geared, 0005-mfd., sunk dial, 3-way coil switch and a single plate vernier condenser, and 10 terminal Strip, new stock, 15/-.

**A.R.P. Three-colour light Switch Box with Morse key for code signals, 4/6. Walter's enclosed Key, all bakelite, 10/6. Super Transmitting.**

**A.R.P. PETROL ELECTRIC GENERATING SETS for Lighting and Charging.** 20 STUART TURNER DIRECT COUPLED SETS, 150 watts D.C., 1,300 r.p.m. 2-stroke water-cooled 1 h.p. 1-cyl. Engine with fuel and oil tank, magneto ignition. On bed plate with 30 volts 5 amps Dynamo, £12.

**90 Large Size 1 KW. STUART TURNER Petrol Electric Sets, 500 watts, 2-stroke water-cooled 1 h.p. 1-cyl. Engine on bed plate direct coupled to 50/70 volts 10 amps. D.C. Dynamo magneto ignition, £16, worth double.**

**MORSE PRACTICE SET.** Sound Type No. 10, with Key and Buzzer on base, 3/-. Visual type No. 2A with Key and Lamp on base. No. 3A Duplex with Key and Buzzer and Lamp for sound and visual, line plus is on base, 7/-.  

**DIX-MIPANTA VEST POCKET TESTER.** A versatile moving-iron millivoltmeter for service on A.C. or D.C. THREE ranges of volts: 0-7.5, 0-150, 0-300. Used for MILLIAMPS, reads: 121 m.a. In black bakelite case, 2 1/2in. x 2 1/2in., with pair of test leads and plugs.

**MOTORS.** All sizes from 1/40 h.p. 15/- to 1/2 h.p. 25/-.

**MOTORS, MOTORS, MOTORS.** Small and Medium. A large stock of really fractional horse-power motors have been released at bargain prices. 6 volts, 50 volts, 100 volts and 230 volts.

**A.C. MAINS MOTORS.** Enclosed, self-start on load. A.C. reulsion 180 h.p. with pulley. Type 36, 1,500 revs., 18 6. Ditto 1/16 h.p. G.E.C., 3,000 revs., 27/6. Induction 1/10 h.p., 2,500 revs., 35/-. 1 h.p., 1,425 revs., 49/-.  
**D.C. MAINS MOTORS.** 1/40 h.p., 110 v. or 230 v., K.B. series, 1,750 revs., 15/-. Ditto 1/40 h.p., G.E.C., 230 v. series, 2,000 revs., 16/-. Ditto 1/12 h.p., Croydon 110 and 230 v. shunt, 30/.

**ELECTRADIX RADIOS WONDERSFUL BARGAINS.** Home Recording with the all-gear-ed FEIGH Electric Recorder, Ball Bearing centre gear-box and traversing rod. Is the lowest priced electric home recorder that will fit any gramophone. The set with Tracking Gear, Pick-up and tone arm with diamond. Gear only 21 6. **37/6**

**ACUSTIC RECORDERS.** Great Fun. Lasting interest. Cost is low. New MIVOICE acoustical sets, complete outfits in cartons, de luxe, 16/-. No. 2 Mivoice, 10/6 Junior, 5/6.

**ELECTRIC SOLDERING IRONS.** Heavy workshop type, 125 watts, 220/230 volts, 6/6.

**VARIABLE CONDENSERS.** 0005 mfd. Tekade, 1/3; .00075 Polar Compax 1/-; S/W. Formo 2/-; J.B. Midget, .0001, 1/6; 2-gang variable, .0005, 2/6; 3-gang, 3/6.

**BELLS.** G.P.O. type trembler Circular Desk Bell, with movement in gong, 1/6. Wall Bells, trembler, 2/6. Ditto, large size, 7/6. Large metal 12-volt single stroke Bells, 10/-.  
**MAINS BELLS.** A.R.P. 220-volt ironclad Trembler Alarm Bells, with 10-in. gong, outdoor type, listed, 90/- Sale 37/6.  
 Single Bell Wire, 1/- 100 yards. Twin Bell Wire, 3/- 100 yards. Hooters, 6 and 12 volts, 4/6. Bell Transformers for A.C. 100 volts, 2/6. 230 volts, 5/6 and 15/-.  
**GREAT BARGAIN IN 5- PARCELS.** 10 lb. of resistances, tubulars, micas, variables, wire, sleeving, vol. controls, coils, magnets, chokes, switches, terminals, mouldings, etc.  
 Have you had our Bargain List "P.M.?" Free on request.

**ELECTRADIX RADIOS**  
 218, UPPER THAMES STREET, LONDON, E.C.4  
 Telephone Central 4611

*Learn*  
**RADIO**  
 AT HOME



**FREE** (NO EXTRA COST)  
 -all this fine EQUIPMENT

Train at home just as National Schools trains students in its internationally recognized resident school. During your spare time you can learn these Trades and—

**EARN BIGGER PAY**

Radio Service Communications  
 Sound Recording Broadcasting  
 Public Address Television

**EASY-TO-LEARN METHODS**

Proven American methods tested for 34 years. 30,000 graduates. Operate your own radio service business or prepare for a good-pay Government job or position in studios, theatres, shops, laboratories, plants, etc. Diploma at graduation. Shop-tested instruction.

**FREE TOOLS & EQUIPMENT**

No extra charge to students. All-Wave Superheterodyne Receiver with Cathode Ray Tuning Indicator; Modern AC-DC Multi-tester; Test Oscillator; Speaker; Headphones; also set of tools in fine metal box.

**ASK FOR FREE BOOK**

Gives full details and tells true facts about opportunities in Radio.

**NATIONAL SCHOOLS**  
 Los Angeles, California, U.S.A.

MAIL COUPON TODAY FOR FREE BOOK

Mr. J. A. Rosenkranz, President,  
 NATIONAL SCHOOLS, Dept. CGR-10  
 4000 S. Figueroa St., Los Angeles, Calif., U.S.A.

Without obligation, please send FREE BOOK and complete information

Name \_\_\_\_\_  
 Address \_\_\_\_\_  
 City \_\_\_\_\_  
 Country \_\_\_\_\_

Postage to U.S. Letter 1 1/4d.; postcard 1d.

**NEW MODELS**  
 A.C. Motors. Self Starting. Switch built in. 1/2 H.P. 53/-  
 1,440 R.P.M. 200/250V. Universal Usages.

**GRINDING AND POLISHING UNIT**

1/10th H.P., A.C.-D.C., 100 or 250 Volts, 5,000 r.p.m. Fitted with 4in. Mop, 3in. Grinding Wheel, Guard and Tool Rest, Built-in Switch and 4 feet of Flexible Cable. Price **23/9/6**

**EASCO** 18 P.M., Brixton Rd., London, S.W.9  
 Telephone: BELliance 1693



When replying to Advertisers  
 Please mention "Practical Mechanics"



# BUY, EXCHANGE OR SELL

Advertisements are accepted for these columns at 3d. per word (minimum 12 words at 3s.—advertisements of less than 12 words are charged at the minimum rate of 3s.) subject to a discount of 2½% for 6 consecutive monthly insertions or 5% for 12 consecutive monthly insertions. **TERMS** :—Cash with order. Cheques, Postal Orders, etc., should be made payable to George Newnes, Ltd. *The Proprietors reserve the right to refuse or withdraw advertisements at their discretion.* All advertisements must be received on or before the 5th of the month preceding date of publication and should be addressed to the Advertisement Manager, "Practical Mechanics," George Newnes Ltd., Tower House, Southampton Street, Strand, W.C.2.

## BOOKS

**ALL TECHNICAL BOOKS**, including Radio Engineering, Photography, Chemistry, and Mechanics, etc., can now be purchased for as little as 2/6 monthly. —Write a card or call personally for details and lists from the Technical Department, Phoenix Book Company, Chandos Place, W.C.2.

## CANOEES

**BOAT AND CANOE.** Kits from 27/6. Also completed craft. Lists stamp. Winter reductions.—Metacraft (P), Christchurch, Hants.

## CINEMATOGRAPHY

**ART CINE FILMS.** Exclusive 9.5 and 16 mm. Cine Bargains, all makes. State wants.—P. M. Dane, 64 Stanley Street, Liverpool 1.

## PHOTOGRAPHY

**PHOTOGRAPHIC MATERIALS.** Plates, films, mounts, chemicals, etc. Interesting money-saving lists and samples free. Kindly thoughts. "Kimber's," 105 Queen's Road, Brighton.

£500 worth, good, cheap Photo Materials, Films, Plates, Cards, Papers, Chemicals, Catalogue and 4 Samples free.—Hackett's Works, July Road, Liverpool, 6.

## PHOTOGRAPHY—Continued

**DON'T TAKE RISKS.** Good developers mean good results. Our reliable stock developers keep twelve months after mixing. Satisfaction certain to amateurs and professionals. Best developers ever put on the market. Make two pints strong developer. 6d. each. 6 for 2/3, 12 for 4/-. Post free.—Hackett's Works, July Road, Liverpool, 6.

## WATCHMAKING

**WATCH & CLOCK REPAIRERS.** Send 3d. for complete list of material and tools.—Blakiston & Co. Ainsdale, Southport.

## WIRELESS

**HEAR AMERICA, AUSTRALIA, JAPAN.**—Receivers 10/6. List, W. Buckle, 63 Avenue Approach, Bury St. Edmunds.

## CLOCK MOVEMENTS

**CLOCK MOVEMENTS,** Timepiece, Strike, Chimes, etc., for mantel, granny, and grandfather cases, also Electric and Recording Movements of every description.—Needham, 25 Stratton Road, Manchester, 16.

## ELECTRICAL

**A.C., D.C. MOTORS,** Grinders, Fans, Drills, Chargers. 1939 interesting lines. List free. Easco Electrical Services, 18pm, Brixton Road, S.W.9.

## ENGINEERING

**METAL FOR THE MODEL ENGINEER.** Sheet, Tube and Sections in Aluminium, Copper, Brass, etc. No quantity too small. Stamp for lists. The Universal Productions, Rigby Lane, Bromsgrove, Worcs.

## MICROSCOPY

**"THE MICROSCOPE AND ENTOMOLOGICAL MONTHLY."** The premier journal for all students of nature. 1/-, from newsgagents, or 1/1 from Microscope, 20/21 Took's Court, London, E.C.4.

## JUBILEE WORM DRIVE HOSE CLIPS



The long-life clip with the ever-tight grip.

*The Best Known*  
For Radiator Joints,  
Air, Oil, and Water  
Hose Joints.

We guarantee a Tight Joint.

Stocked by all Garages  
and Accessory Dealers

L. ROBINSON & CO.,  
25 London Chambers,  
GILLINGHAM, KENT.

## CUT THIS OUT

Practical Pen Coupon Value 3d.

Send five of these coupons with only 3/- (and 2d. stamp) direct to the Fleet Pen Co., 119, Fleet Street, E.C.4. By return you will receive a handsome lever self-filling FLEET S.F. PEN with solid gold nib (fine, medium, or broad), usually 10/6. Fleet price 4/3, or with 5 coupons only 3/-. De Luxe Model, FLEET SELF-FILLER, 2/- extra.



## METAL WORK

**MAKE METAL TOYS.** Easy, profitable with "Success" Moulds. List free. Complete trial mould 1/6.—Lee's, 1 Birkin Avenue, Nottingham.

## MODELS

**EVERYTHING FOR** electrical rewinds and repairs. Screws, nuts, and washers for model engineers. Lists free.—Lumen Electric Co., Litherland, Liverpool, 21.

## MUSICAL INSTRUMENTS

**BAND GUIDE.** Hints on the Bugle, Drum, Flute, Staff Parade formation, etc. Free, post paid.—Potter's (Manufacturers), West Street, London, W.C.2.

## PATENTS

**REGINALD W. BARKER & CO.** (Established 1886), 56 Ludgate Hill, London, E.C.4.—Patent and Trade Mark Booklets Gratis.

## PATENTS AND INVENTIONS

**WE SUCCESSFULLY SELL** inventions, patented and unpatented. Write for proof, and tell us what you have for sale.—Chartered Institute of American Inventors, Dept. 16-C., Washington, D.C., U.S.A.

## TOOLS

**BRAND NEW POWER TOOLS** of quality. 10-inch bandsaws, 54/-; Jigsaws, 22/6; Bench Drills, 11/-; Circular Saws from 25/-; 3-inch S.C. Toolroom Lathes, from £4 5s. New 1-inch chromium plated Micrometers, 12/6; Electric Drills, 37/6; Grinders.—John P. Steel, Bingley.

## CAN YOU PLAY THE PIANO ?



If you are a music lover why have you not acquired this enjoyable accomplishment and great social asset? Doubtless because the prospect of practical practice! practice! has dismayed and discouraged you. **I HAVE TAUGHT OVER 51,000 ADULT PUPILS DURING 35 YEARS** by post, in a third the time, with a quarter the work, at a tenth the expense of the ordinary methods of dull, mechanical, wearisome practice, **AND I CAN TEACH YOU.** Ordinary musical notation only used, no freakish methods, enabling you to read and play at sight any standard musical composition. Send p.c. for **FREE** Booklet, "Mind, Muscle and Keyboard," and form for free advice.

Say If Advanced, Moderate, Elementary or Beginner.

Mr. H. BECKER

(Dept. 58)

69, Fleet St., E.C.4

## MAKE MORE MONEY

£3 to £6 weekly can be earned at home in a wonderful business of your own. No matter where you live you can commence to make money in your spare or whole time. No risk, canvassing or experience required. A wonderful opportunity for anyone wishing to add pounds to their income. Particulars, stamp.

**BALLARD,** York House, 12 Hambrook Road, LONDON, S.E.25.

## WEBLEY AIR PISTOLS

Marvellously accurate for target practice.



No licence required to purchase or use at home.

Senior 45/-, Mark 1 32/6

Junior 21/-, Webley Air Rifle 95/-

Write for List. WEBLEY & SCOTT LTD., 106 WEAMAN STREET, BIRMINGHAM.

## OUR ADVICE BUREAU COUPON

This coupon is available until October 31st, 1939, and must be attached to all letters containing queries, together with 3 penny stamps. A stamped addressed envelope must also be enclosed.

PRACTICAL MECHANICS, OCT., 1939.





# GAMAGES

Send for copies of  
Gamages Tool  
Bargain Leaflets  
for Metalworkers  
and Woodworkers

## Enormous Purchase of First Quality, Heavyweight 3-in. SCREWCUTTING BACK GEARED LATHES

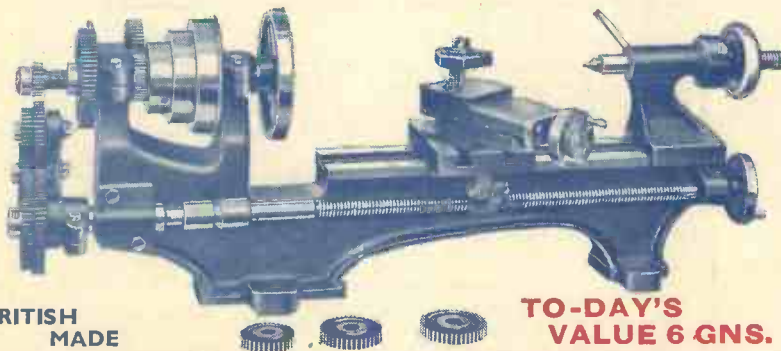

BRITISH  
MADE

TO-DAY'S  
VALUE 6 GNS.

GAP BED, SLIDING, MIL-  
LING AND SURFACING

75/-

Exceptionally strong headstock with adjustable bearings. Heavy, solid bed ensures accurate work. Machine cut change wheels for all English threads. Saddle and slide have large bearing surfaces, and the tailstock is of rigid design. Swing, over saddle 4 1/2 in., over bed 6 in., over gap 8 in. Diameter of mandrel 3/4 in., mandrel nose 1/2 in. x 12 threads. Mandrel and tailstock bored 1/2 in. clear. Centres No. 1 Morse taper, lead screw 1/2 in. x 8 T.P.1 Cone pulleys 3 1/2 in., 3 1/4 in., 2 3/4 in. x 1/2 in. Back gear ratio. 30 to 20; distance between centres 12 in., overall length 27 in., weight 52 lb. Complete with face plate and ten change wheels.

OR DELIVERED ON FIRST OF 12 MONTHLY PAYMENTS OF 6/9

Carriage (outside our extensive delivery area) 3/6 extra  
England or Wales.

## ELECTRIC MOTOR-DRIVEN JIGSAW

Big, powerful and speedy



Will cut up to 3/4 inches plywood and to the centre of a 24 inches circle. Cutting table 8 inches square. Combined belt pulley and 8 inches diameter sanding disc. Overall length 18 inches. Height to top of frame, 12 1/2 inches. Maximum width, 8 inches. Powerful Universal motor. For A.C. or D.C. mains, 200/250 volts. Carriage (outside our extensive delivery area) 1/6 England or Wales.

5/6

## DELCO-REMY ELECTRIC MOTORS

at a Substantial Reduction

As is well known, Delco-Remy Electric Motors are of extremely robust construction. Designed for heavy continuous use, they are equally satisfactory for repeated intermittent work such as in refrigeration. No special switch is needed for starting, and the motor can be operated by means of an ordinary tumbler electric light switch. All brand new.

1/5 h.p. A.C. Capacitor start, 200/250 volts. 50 cycles. Originally listed at 74/-.

Carriage (outside our extensive delivery area) 1/6 England or Wales.

55/-

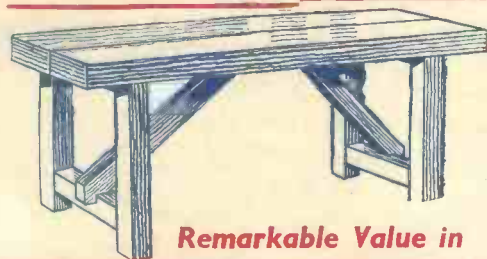
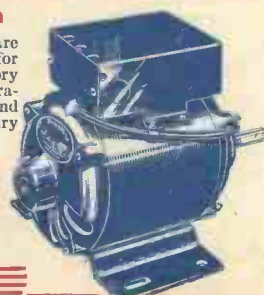

## Remarkable Value in HEAVYWEIGHT BENCHES

British made, and very solidly constructed throughout. An ideal bench for the home workshop or garage. Note the generous dimensions: Top 72 in. x 17 1/2 in. x 2 1/2 in. Legs 2 1/2 in. sq. Height 34 in.

Carriage forward outside our extensive delivery area.

21/-

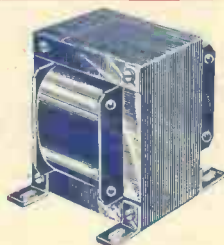

## MAINS TRANSFORMERS

at a Remarkably Low Price

Exceptionally robust construction. Operate on any 200,240 volt A.C. main, transforming to 6 volts, 3 amps. Ideal for machine tool lighting driving models, garage inspection lamps, and as a component for battery chargers, or cine projector work. Brand new and guaranteed. Post 6d.

2/6



## 2 1/2 in. Plain Gap Bed LATHES

Will stand the hardest usage by hand or power.

Constructed on sound orthodox lines, and possesses many refinements usually found on larger or more expensive lathes. Length between centres 10 in. Faceplate, 3 3/8 in. diam. Height of centres from Gap, 2 1/2 in. Slide Rest with Vee Slide, Square Thread Lead Screw. The Head-stock Hollow Mandrel is bored 1/4 in. Mandrel nose 1/2 in. by 16 threads and bored No. 0 Morse Taper. Cone Pulleys 2 1/2 in. and 1 1/2 in. inside, and 2 1/2 in. and 1 1/2 in. outside. Lead Screw 1/2 in. Square thread. Weight of Lathe, 18 lb.

Carriage 2/- England or Wales.  
Foot Motor, 18/6. Countershaft, 15/6.  
3-Jaw Dog Chuck, 6/6. Belt, 2/-.

37/6

## 6in. Enclosed 1/3 h.p. ELECTRIC DOUBLE GRINDERS

Heavily constructed they are ideal for the workshop where grinding jobs constantly arise. Totally enclosed. Ball bearings. Single-phase motor, 3,000 r.p.m. Complete with Wheel Guards, 6 in. Grinding Wheels. Weight 52 lb. For 200/220 and 230/250 volts, A.C. 50 cycles.

£5.19.6



OR DELIVERED ON FIRST OF 12 MONTHLY PAYMENTS OF

10/9

Carriage (outside our extensive delivery area) 2/6 England or Wales

## SURFACE GAUGES

Accurately made and fitted with fine adjustment device. Overall height 12 inches. Diameter of base, 3 1/2 inches.

7/6

Post 6d.

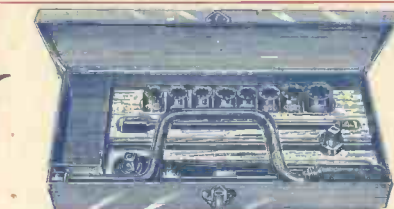

## Super-chrome Ratchet Socket Spanner Set

A first-class set comprising 14 ins. brace, 9 ins. sweep, 10 1/2 ins. heavy ratchet, 12 ins. sliding tee bar, 10 ins. extension piece and eight sockets. Sizes: 3/8, 1/2, 5/8, 3/4, 7/8, 1, 1 1/8, 1 1/4, 1 1/2, 1 3/4, 2, 2 1/4, 2 1/2, 3, 3 1/2, 4, 4 1/2, 5, 5 1/2, 6, 7, 8, 9, 10, 11, 12, 13, 14, 15, 16, 17, 18, 19, 20, 21, 22, 23, 24, 25, 26, 27, 28, 29, 30, 31, 32, 33, 34, 35, 36, 37, 38, 39, 40, 41, 42, 43, 44, 45, 46, 47, 48, 49, 50, 51, 52, 53, 54, 55, 56, 57, 58, 59, 60, 61, 62, 63, 64, 65, 66, 67, 68, 69, 70, 71, 72, 73, 74, 75, 76, 77, 78, 79, 80, 81, 82, 83, 84, 85, 86, 87, 88, 89, 90, 91, 92, 93, 94, 95, 96, 97, 98, 99, 100. Carriage (outside our extensive delivery area) 1/- England or Wales. Also available in 1/2, 3/4, 1, 1 1/2, 2, 2 1/2, 3, 3 1/2, 4, 4 1/2, 5, 5 1/2, 6, 7, 8, 9, 10, 11, 12, 13, 14, 15, 16, 17, 18, 19, 20, 21, 22, 23, 24, 25, 26, 27, 28, 29, 30, 31, 32, 33, 34, 35, 36, 37, 38, 39, 40, 41, 42, 43, 44, 45, 46, 47, 48, 49, 50, 51, 52, 53, 54, 55, 56, 57, 58, 59, 60, 61, 62, 63, 64, 65, 66, 67, 68, 69, 70, 71, 72, 73, 74, 75, 76, 77, 78, 79, 80, 81, 82, 83, 84, 85, 86, 87, 88, 89, 90, 91, 92, 93, 94, 95, 96, 97, 98, 99, 100. S.A.E. at same price.

37/6

GAMAGES, HOLBORN, LONDON, E.C.1

Phone your order: HOLborn 8484

City Branch, 107 Cheapside, E.C.2

Published about the 30th of each month by GEORGE NEWNES, LIMITED, Tower House, Southampton Street, Strand, London, W.C.2., and Printed in England by THE SUN ENGRAVING CO., LTD., London and Watford. Sole Agents for Australia and New Zealand—Gordon & Gotch, Ltd. Sole Agents for South Africa—Central News Agency, Ltd. Subscription Rates: Inland and Abroad, 7s. 6d. per annum; Canada, 7s. per annum. Registered at the G.P.O. for transmission by Canadian Magazine Post.