

# PRINTING FOR PROFIT AT HOME

NEWNES

# PRACTICAL MECHANICS

MARCH

6<sup>d</sup>

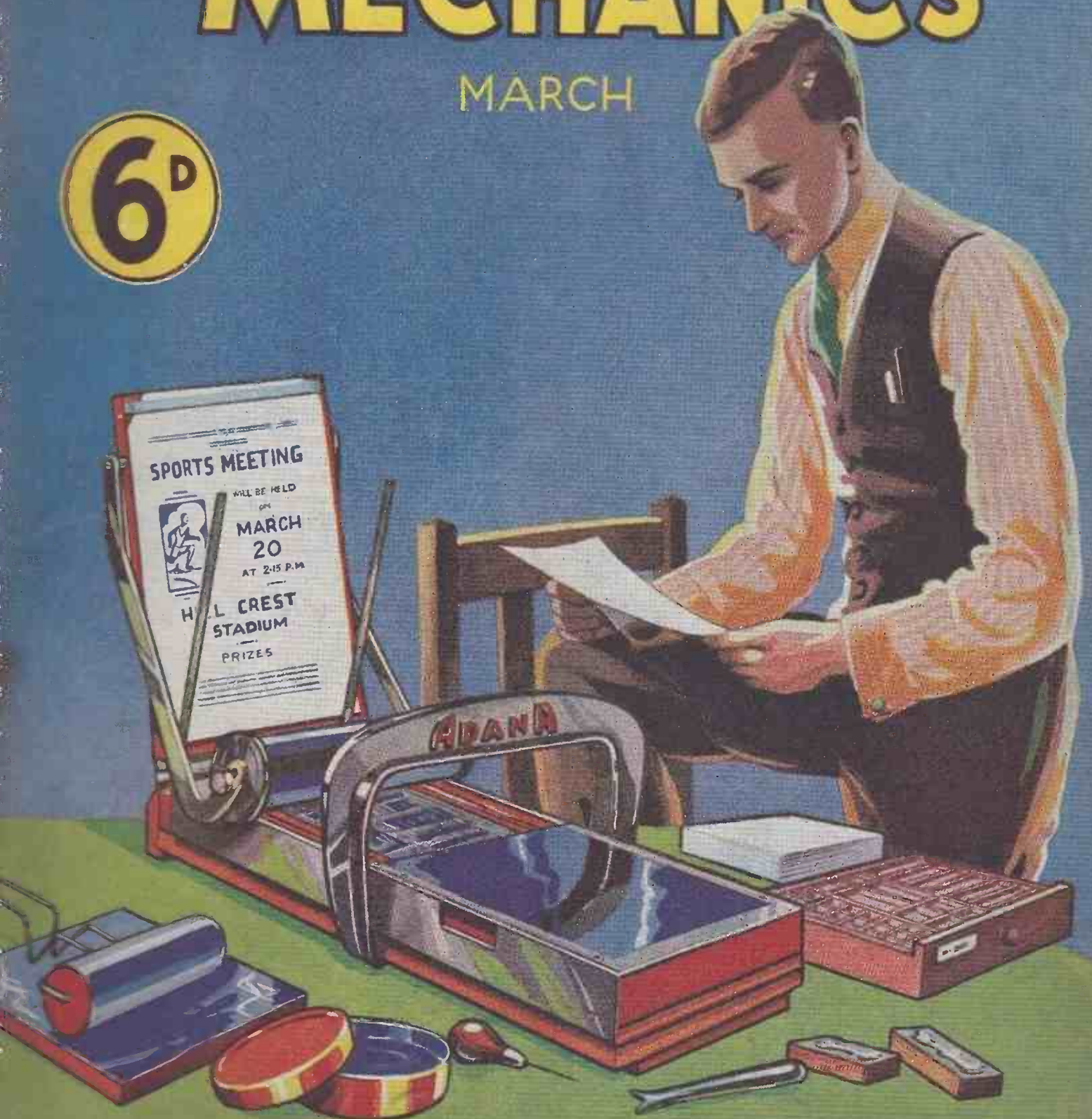



# I USE THEM AT WORK-AND AT HOME



## FOR ALL FIXING PURPOSES

"I use Rawlplugs at work for fixing anything from machinery to shelves—and they've never let me down. So it's natural that I should use them at home when there's a fixing job to be done. Things like towel-rails, hooks, pictures and dozens of other articles can be fixed in a few minutes the Rawlplug way. I find that they save money and always give a neat job. Have you a Rawlplug Outfit in your tool kit?"

### COMPLETE OUTFITS :

1/6, 3/6 or 5/6

Illustrated literature free on request.

**THE RAWLPLUG CO. LTD.**  
RAWLPLUG HOUSE, LONDON, S.W.7

## RAWLPLUG

# PLASTIC WOOD

## WOOD IN PUTTY FORM

"Here's a line that saves pounds in repair bills. Rawlplug Plastic Wood is like putty to handle, yet when it's dry it is just like ordinary wood. It's wonderful for repairing cracks in tables and floors, filling in holes, making mouldings, and repairing things like knife handles and kiddies' toys. It is a fine adhesive, in addition to its other qualities. When Rawlplug Plastic Wood is dry, it can be stained or painted, cut and planed—in fact it can be treated in exactly the same way as ordinary wood.

Available in tubes at 6d. and 1/-  
or in tins from 9d. upwards.

B 178



## A Book Guide for the Electrical Engineer

# The Electrical Educator

Revised, Enlarged and Rearranged in Convenient Form

This Famous Work Now Covers

## Electrical Development, Telegraphy, Telephony

Television, Photo-Telegraphy, Wireless Telegraphy, etc., up-to-date

EDITED BY SIR AMBROSE FLEMING, M.A., D.Sc., F.R.S., WITH CONTRIBUTIONS  
BY THE GREATEST LIVING AUTHORITIES

### SOME OF THE SUBJECTS COVERED :

The Education of Electrical Engineers—Electricity and Magnetism—Electrical Measuring Instruments—Mechanics for Electrical Students—Electric Materials—Cables—House Wiring—Electric Fittings and Switches—Electric Lamps—Wireless Telegraphy and Telephony—Direct Current Measuring—The Institute of Electrical Engineers—What We Owe to the Arc Lighting Period—Armature Winding—Electric Traction—Central Station Steam Plant—Costing for Power Station Engineers—Power Station Records—Private Generating Plant—Drawing for Electrical Engineers—Electric Salesmanship—Education and Training for the

Electrical Industry—Accumulators—Automatic Telephones—Photographing Heart Beats—The Miner and the Super Power Station—Invention in Electrical Engineering—The Law of Electric Supply—Electrical Advertising—The Ether—Photo-Telegraphy and Television—Theory of Alternating Currents—Development of the Electrical Industry (by Colonel Crompton)—Electrical Condensers—Special Steels in the Electrical Industry—History of the Electrical Industry—Electricity from Sand—Electrical Calculations—Pioneers of Electricity (Biographies)—Co-operation in the Electrical Industry—The Future of the Electrical Industry, etc.

IF IT IS ANYTHING CONNECTED WITH ELECTRICAL ENGINEERING, YOU WILL FIND IT IN THIS WORK

Our FREE Pamphlet Will Tell You About It

This up-to-date Book-Guide will never fail you. It answers every question: it solves every difficulty. It pays for itself.

Once acquired, you can study the subjects listed above, making yourself more and more efficient in the difficult knowledge belonging to your chosen work without leaving your armchair. You may have the complete work for only 5/- first payment.

The New Era Publishing Co., Ltd., 12-14 Newton Street,  
High Holborn, London, W.C.2.

Send me, free of cost or obligation to order anything, descriptive booklet on THE ELECTRICAL EDUCATOR in its new, convenient form, with particulars as to popular price and easy terms of payment.

NAME.....

ADDRESS.....

DATE.....P.M.60

### ELECTRADIX

#### HOME RECORDING Great Fun. Lasting Interest.

Cost is low. New MIVOICE acoustic sets, complete outfits on cartons de luxe; 21/-, No. 2 Mivoice, 12/6. Junior, 7/6. ELECTRIC recording Turntables, 25/-, Cutter needles, sapphire, 8/6. Diamond, 7/6. Blank discs, 4/- doz. **ARMCHAIR RADIO CONTROL.**—Modula high res.-compression, Volume Control, 12 ft., twin flex and valve adaptor, 1/6. **SPEAKERS.** 6 in., B. & A. new. Moving Coil. Half-price, 7/6. **SIEMEN'S TABLE CONE,** 4/6. **CRYSTAL SETS** for crystal-pure reception. Desk type, full B.B.O. range, 7/6. Headphones, 2,000 ohms, 4/6.



**TELEPHONES.**—120-ohm Sullivan Headphones, W.D. model, at a tenth of cost, price, 2/9 per pair. Table and Wall Phones in good order, cheap, from 17/6 per pair. **LIGHT AND RAY CELLS.**—Selenium Rayostat, 31/-; Kingston, 15/-. Rayostat outfit with relay and amplifier, 45/-. Photo-cells, for Sound-on-Film, Television and Ray Work, B.T.F., 15/-; R.O.A., 25/-; G.E.O., 25/- to 23 10s. Beck Angle Prisms, mounted in carrier, 5/6. Micrometer

adjusters for lens, 1/-. Eyepieces with prism and lenses for photo cell inspection, 12/6. Five-guinea X-ray valves, new, 10/- only. **MIRRORS.**—2 1/2 in. dia. Bell or Television, 1/6. Parabolic Concave, 10 in., 20/-; 20 in., 25/-; 24 in., 30/-. Carr. fwd. Neon Lamps, 2/6 and 3/- each, with holder. Miniature Neons, 2/6. **SHORT-WAVE 2-pin coils.** 2, 3, 4 turns, 1/- each; 5, 6 turns, 1/6 each. **MICROPHONES.**—HEAR YOUR VOICE on your radio set loudspeaker. Be your own announcer. 5/- **BUTTON MICROPHONES** for all purposes. Usually sold at 3/6. Our price has always been 1/-. We have supplied thousands.

**A NEW PRACTICAL HOME MICROPHONE** for broadcasting at home. It is a general-purpose, robust mike, with solid bakelite body, back terminals, front metal grille. No. 11. New design, finely finished, 5/6. **No. 11A.**—Special in solid brass body, unacquainted at the price on speech and music, 7/6. **FLOOR STANDS,** 26 in., 12/6; 37 in., 15/-; 48 in., 18/6. **X-RAY TUBES.**—As illus. previous issues. Brand new W.O. Surplus. 7 in. dia. bulb, big tungsten electrodes. Full emission. Cost 25. Sale, 10/-. 12 1/2 in. Spark Coil, Fluorescent Screens and Plate-holders, cheap. **MOTORS.**—Fractional H.P. for occasional workshop or model drive, 6 volts, 12/6; 60 volts, 14/-. **A.C. MAINS MOTORS.**—H.P. with pulley, enclosed type, 1,500 revs., 18/6. Ditto, H.P. G.E.O., 3,500 revs., 27/6. Induction H.P., 2,500 revs., 18/6. H.P., 1,425 revs., 49/-, etc., etc.

1,000 other Bargains in New Sale List "P.M." Post Free. **ELECTRADIX RADIOS** 218 Upper Thames Street, London, E.C.4 'Phone: Central 4611.

### THE WEBLEY SERVICE AIR RIFLE MkII

NO LICENSE REQUIRED TO PURCHASE



WRITE FOR DESCRIPTIVE FOLDER  
Rabbits, Rats, Squirrels, Sparrows and similar vermin can be destroyed by this extremely accurate and powerful Air Rifle. Ideal for Target Practice.

CALIBRE 22-177 With Lightsight and Peepsight  
WEBLEY & SCOTT Ltd. 106 WEAGMAN STREET, BIRMINGHAM, 6

FRACTION	W.C.	S.W.C.	W.C.	S.W.C.	W.C.	S.W.C.	W.C.	S.W.C.
1/2	1/4	1/8	1/16	1/32	1/64	1/128	1/256	1/512
3/4	1/2	1/4	1/8	1/16	1/32	1/64	1/128	1/256
5/8	3/4	1/2	1/4	1/8	1/16	1/32	1/64	1/128
7/8	1	3/4	1/2	1/4	1/8	1/16	1/32	1/64

The "INSTANTUS" is a small folding chart for the pocket containing 3,000 equivalents arranged in a novel manner, enabling quick reference to relative sizes of drills, gauges, taps and dies, etc., and is invaluable to Model Makers and Engineers generally. Printed on durable cloth—centred card. PRICE 6d. EACH. Obtainable from Tool Dealers or W. H. Smith & Sons, or send P.O. and 1/4d. postage to G. Best (Dept. P5), 10 Forrest Gardens, Norbury, London, S.W.18.

### MAKE MORE MONEY

£3 to £6 weekly can be earned at home in a wonderful business of your own. No matter where you live you can commence to make money in your spare or whole time. No risk, canvassing or experience required. A wonderful opportunity for anyone wishing to add pounds to their income. Particulars stamp. **BALLARD, York House, 12 Hambrook Rd., LONDON, S.E.25**

### Good Turners Command Good Wages! TIPS FOR TURNERS

The Practical Handbook that TEACHES Turning and Screw-cutting. Twenty pages of useful tables. 2s. 6d. (2d. postage). Manual Press (P.), 10 Crofton Rd., London, S.E.5

### EARN MONEY AT HOME

Become a Commercial Artist through the Paramount Simplified Method of Designing Modern Display Cards. You can genuinely make a regular £3-£5 in your spare time and quickly turn your training and connection into a full-time occupation. Iron Clad Guarantee of Success. Write at once for free details.

PARAMOUNT DESIGNING  
1 (P) Glenside, PLYMOUTH

## "Duplex Tailstock" and "Junior" Lathes

Before buying that lathe send stamp for our lists; you will see that:— There is no comparison.

**WARD & POLLARD**  
Orchard Works  
Plumstead High St., London, S.E.18



**SPECIALISTS IN TECHNICAL ILLUSTRATIONS**  
Write or phone us at  
**HIGH HOLBORN HOUSE, HIGH HOLBORN, W.C.1**  
Hol. 8638.

### JUBILEE WORM DRIVE HOSE CLIPS

The long-life clip with the ever-tight grip  
**The Best Known**  
For Radiator Joints, Air, Oil, and Water Hose Joints.  
Large sizes stop squeaking brakes.



Stocked by all Garages and Accessory Dealers  
**L. ROBINSON & CO., 25 London Chambers, GILLINGHAM, KENT.**

### TROUSERS MADE TO MEASURE

Any Waist fitted, 28 in. to 58 in. or larger.  
Inside Leg, 26 in. to 36 in. or longer.  
We cut and make from tested cloth of Blue, Grey, or Brown.  
Please state waist, inside leg, side seam and width of bottom required.



**5/11 6/6 8/6**  
Post 6d. or C.O.D.  
Satisfaction guaranteed or money instantly returned. Send for FREE Patterns.  
**C. HAROLD NURSE, 108 BORDLESLEY GREEN, BIRMINGHAM, 9**

## An Absorbing Hobby

**BUILDING A STUART MODEL IS AN ENGRASSING PASTIME, AND THE RESULT A CONTINUOUS PLEASURE**



We illustrate:  
**STUART NO. 10.**  
High Speed Steam Engine.  
Bore 3/4".  
Stroke 3/4".  
Each set is quite complete—drawings and instructions are included.

If you have a lathe—  
The rough castings - - 8/6  
If not—  
Fully machined set - - 18/6  
Ditto, with all holes drilled and tapped - - 25/-  
This and many other Stuart engines are fully described in the 72-page CATALOGUE No. 3, 6d. post free.

**STUART TURNER LTD. HENLEY-ON-THAMES**

### DON'T BE BULLIED



Learn to fear no man. The BEST self-defence ever invented, namely, **JUJITSU**. Easy to learn. Send 2 penny stamps for **SPLENDID ILLUSTRATED LESSONS**, Photo ARTICLE, Testimonials and particulars, or P.O. 1/- for **FIRST PART** of my course. You will be more than delighted. A Japanese Secret, Kill Fear Cure. Free to pupils. Dept. F., Blenheim House, Bedford Lane, Feltham, Middlesex.

### BLUSHING FREE

to all sufferers, particulars of a proved home treatment that quickly removes all embarrassment, and permanently cures blushing and flushing of the face and neck. Enclose stamp to pay postage to Mr. M. Temple (Specialist), "Palace House," 128 Shaftesbury Avenue (2nd Floor), London, W.1. (Est. 35 years.)

### BE TALL

Your Height increased in 14 days or money back. The amazing Stebbing System soon brings 3-5 inches increase and new energy. The first, original and the one **GENUINE GUARANTEED** Height Increase System. Recommended by Health and Efficiency. Complete Course 5/-. or Booklet free, privately. **STEBBING SYSTEM, Dept. M.P., 28, Dean Rd., London, W.1.**

### A REVOLUTIONARY HAIR-GROWING DISCOVERY



ENDORSED BY DOCTORS PRESS AND PUBLIC.

### BALDNESS

A Medical Discovery Re-grows New Hair. The ages of delighted Clients range from 22 to 89 1/2. Medically recommended. £1000 for denial.

Write to-day to:  
**THE LABORATORIES (P.M.), 37 New Bond Street, London, W.1.**

# IMPORTANT!

A special announcement to every air-minded and patriotic person of Great Britain is in the MARCH issue of

## The MODEL AEROPLANE CONSTRUCTOR Now on Sale Price 6d.

Constructional articles, full-size Plans, all the news, and fully illustrated—it's a good sixpennyworth. GET YOUR COPY TO-DAY!

Obtainable at all newsagents and bookstalls or direct from the Publishers, price 7d. post free. The Model Aeroplane Constructor, 85 Manor Rd., Wallington, Surrey.

### VEE-VEE INFINITE SPEED VARIERS

for British Patent No. 428027  
**ELECTRIC MOTOR DRIVES**  
**GLASGOW ELECTRICAL ENGINEERING CO., LTD.**  
 45-47 Pitt Street, Glasgow

Write for new catalogue of above, originally called the GEECO Speed Varier, but now called "Vee-Vee" in order not to confuse with the products of The General Electric Co., Ltd.

# ARE YOU INTERESTED IN FLYING?

"POPULAR FLYING," the National Aviation Magazine, tells you in non-technical language all that is new in the world of aeronautics; its articles and features are illustrated with most interesting photographs.

- Special Contents of the March number include:
- NIGHT MAIL OVER THE SOUTH ATLANTIC by Jean Mermoz.
  - TEACHING ATLANTIC PILOTS by Don Glassman.
  - MEMORIES OF 63 SQUADRON by H. Holden.
  - McCUDDEN, SCOUT PILOT by John Hook.
- Model Aircraft, Topical News and Latest Pictures.

# POPULAR FLYING 6d. MARCH

Of all Newsagents and Bookstalls, or by post 7½d. from the Publisher, C. Arthur Pearson Ltd., Tower House, Southampton Street, Strand, London, W.C.2.

### ANGLE PLATES. Fully Machined. DRILL CHUCKS.

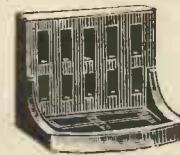

3" x 1½" x 1½"	2/3
3" x 2" x 1½"	2/6
3" x 2" x 2"	2/9
3½" x 2" x 2"	3/6
3½" x 2½" x 2"	4/3
4" x 2½" x 2½"	4/9
4" x 3" x 2½"	5/-

Post Extra.



Straight or No. 1 Morse Taper Shanks. Cap. ¼" ⅜" ½" 1/6 2/3 3/- ea.

### THE "IDEAL" POCKET MICROMETER.



¾" Capacity 4/- each. Post Free.  
 1" 7/6 " " "  
 1-in. x 1/1000 with Ratchet Stop and Locknut, Complete in case, 17/6.

### FACE PLATE CLAMPS.



Malleable Iron  
 2½", 3d.; 2 7/8", 3½d.; 3", 4d.;  
 3½", 5d.; 4½", 6d. each.

### LATHE CARRIERS.



### FACE PLATE DOGS.



Price Without Bolts.  
 Malleable Cast 2" x 1" 4d. each.  
 Stamped Steel 1½" x ¾" 5d. "

1"	¾"	1"	1½"	2"
10d.	1/-	1/2	2/-	2/9

### BORING TOOLS.



Stamped Steel 1½" x ¾" 5d. "  
 Stamped Steel 2" x 1" 6d. "  
 These Steel Clamps are superior to Castings in strength.  
 ¼", 1/-; ⅜", 1/3; ½", 1/6; 1", 1/9.

### BORING BARS.

**E. GRAY & SON LTD.**  
 18/20 CLERKENWELL ROAD, LONDON, E.C.1  
 ESTABLISHED 1822

### ECONOMIC ELECTRIC CO., TWICKENHAM, LONDON, S.W.



**MICROPHONES.** Sensitive broadcasting microphones with suspension hooks and terminals. Price 4/6d. each. Complete with table stand, 10/6d. each. Super-sensitive microphones suitable for deaf-aids, with flex, 8/6d. each. Button microphones, 1/- each.



**MICROPHONE TRANSFORMERS** suitable for above, 5/- each. Transverse microphones in chromium-plated case suitable for dance halls, etc., 50/- each.

**"CLIP-ON" READING LAMP.** Can be clipped in any position and shade adjusted to any angle. A useful present. Complete with lamp 3/6.

Larger type can also be used as Standard Lamp, 7/6.

### ELECTRIC CLOCKS.

Good-quality electric clocks for A.C. mains, fitted with alarm, flex and adaptor. Reliable and perfect time-keepers, 18/6d. each.

**"TOM THUMB" Charger.** Charges 2-volt accumulator at 5 amp. Fitted with metal rectifier and double-wound transformer. Complete with flex and plug 12/6d.

1/60th h.p. Universal A.C.-D.O. motors. Speed 2,000 r.p.m. 15/6d. each.

LIST.—Send for our Illustrated Catalogue containing 70 pages, fully illustrated, of all that you are likely to require—Meters, Motors, Telephones, Coils, Fittings, Transformers and parts, Lighting Sets, Tools and Workshop Material. It costs 6d. to print, but we send it to you for 2d. post free.

## MICROSCOPES FROM 3/9 TO £50



PENCIL POCKET MICROSCOPE 25x 3/9 Post Free.

### ADJUSTABLE STAND MICROSCOPE

With 1½" Lens, Power approx. 5x. In adjustable Ball and Socket Mount on Solid Iron Base. Ideal for Nature Study, Philatelists, Engravers, etc.

In Wooden Box, Size 4" x 3" x 2"

4/6 Post Free



List of Telescopes, Microscopes, Binoculars on request. The finest selection in London.

Note our name and address:—

**BROADHURST CLARKSON & CO.**  
 "TELESCOPE HOUSE," 63 FARRINGTON ROAD, LONDON, E.C.1  
 (3 mins. from Farringdon St. Metro. Rly. Station).

# AMBITIOUS ENGINEERS

## THIS IMPORTANT HANDBOOK ON SUCCESSFUL ENGINEERING CAREERS

# FREE ON REQUEST



After months of intensive effort and research, we are pleased to announce that the 1937 edition of our Handbook, "ENGINEERING OPPORTUNITIES," is now out of the publishers' hands and ready for *free distribution*. Containing 268 pages of practical guidance, this book is, beyond argument, the finest and most complete handbook on Successful Engineering Careers ever compiled. It is a book that should be on the bookshelf of every person interested in engineering, whatever his age, position or experience.

The Handbook contains, among other intensely interesting matter, details of B.Sc., A.M.I.C.E., A.M.I.Mech.E., A.M.I.E.E., A.M.I.A.E., A.M.I.W.T., A.M.I.R.E., CIVIL SERVICE, and other important Engineering Examinations: outlines courses in all branches of CIVIL, MECHANICAL, ELECTRICAL, AUTOMOBILE, RADIO, TELEVISION and AERONAUTICAL ENGINEERING, BUILDING, GOVERNMENT EMPLOYMENT, etc., and outlines the unique advantages of our Employment Department.

**WE DEFINITELY GUARANTEE  
"NO PASS—NO FEE"**

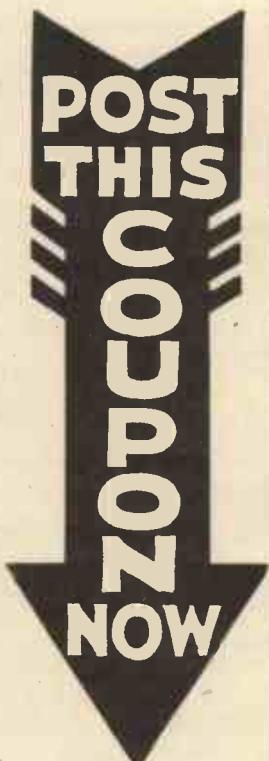

If you are earning less than £10 per week you cannot afford to miss reading "ENGINEERING OPPORTUNITIES." In your own interests, we advise you to send for your copy of this enlightening guide to well-paid posts by filling in and posting the coupon NOW. *There is no cost or obligation of any kind.*

**BRITISH INSTITUTE OF  
ENGINEERING TECHNOLOGY**

410, SHAKESPEARE HOUSE,  
17, 18, & 19, STRATFORD PLACE, LONDON, W.1

-----TEAR OFF HERE-----  
**FREE COUPON**

**BRITISH INSTITUTE OF  
ENGINEERING TECHNOLOGY,**  
410, Shakespeare House,  
17-19, Stratford Place, W.1.

Please forward, Free of cost or obligation of any kind, your 268 page Handbook.

NAME.....  
ADDRESS.....  
.....  
.....

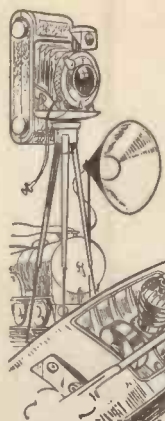

# PRACTICAL MECHANICS

EDITED BY F. J. CAMM

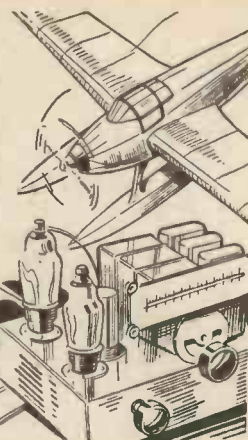

VOL. IV. No. 42  
MARCH  
1937



## "Seeing" Thought Waves

A SCIENTIST who is carrying on the work of the late Dr. Kilner, of St. Thomas's Hospital, pioneer explorer of aura, has discovered a new sensitiser which enables him to see waves of 300 millionths of a millimetre, nearly a third shorter than those visible to Kilner.

Kilner sensitised his eyes with dicyanin, which enabled him, after patient experiment, to observe with the naked eye the actual "waves" of the aura.

## A Five-mile Tunnel

ONE of the greatest engineering feats in Highland industrial development since a water tunnel was driven through Ben Nevis, is nearing completion in the Grampian Mountains. It is the construction of the five-mile tunnel which was begun about two years ago, between Loch Garry and Loch Erich, Perthshire, for the Grampian electricity scheme.

## Radio Approach Beacons

EXPERIMENTS are now being made at the London air-port, Croydon, with three different systems of ultra-short-wave radio approach beacons—the Lorenz, Plessey, and Marconi. It is explained that these radio systems are designed to give automatic navigational assistance to aircraft coming in to land in bad visibility, and that they should be a valuable complement to the normal direction-finding ground equipment, which is designed only to lead aircraft to the immediate proximity of an aerodrome.

## A Railway in a Liner

TO expedite work on the Cunard-White Star liner No. 552, at Clydebank, railway tracks have been laid inside the ship.

## Studying the North Pole

SOVIET Arctic fliers are seriously considering a proposal for landing a big scientific expedition on the ice at the North Pole, and leaving it there to study Polar conditions for an entire year. Their idea is to drop the entire expedition by means of parachutes.

## The Efficiency of Parachutes

ONE of Russia's star parachute jumpers, Shchukin, recently made a parachute jump covered all over with glass trinkets and other breakable material, including chains of electric-light bulbs, and nothing was smashed on landing.

## 340 m.p.h. on Land

AN American syndicate is building a car which is intended to beat Sir Malcolm Campbell's land record of 301 m.p.h. The car, named Yankee Doodle, is designed to

## NOTES, NEWS, AND VIEWS

reach 340 m.p.h. It will cost £20,000 to construct.

### A New Air Line

THE establishment of an air line from Teheran and Istanbul is being considered.

### Large Propeller Pumps for Moscow-Volga Canal

TWELVE giant propeller pumps, said to be the only types of their capacity and efficiency in Europe, have been produced by the Borets Engineering Works in Moscow for the Moscow-Volga Canal. Weighing 82 tons, and driven by a 3,000 Kw. electric motor, each of the pumps has a productivity of 25 cubic metres of water per second at a head of 8.5 metres. The height of the pump is 21 metres.

### A Hydrocycle

IT may be possible to take a trip on the sea by hydrocycle. Mr. B. Fry, who has invented the device, states that it can travel at 10 m.p.h., and the machine is quite seaworthy in rough weather.

### Very Attractive

FROM America comes the news that they have produced a compact magnet capable of producing the highest permanent magnetic field ever attained, with an intensity 150,000 times greater than the earth's field. It will be used for fundamental studies of the effects of intense magnetic fields on matter, especially at low temperatures in the neighbourhood of absolute zero, or 459.69 degrees below zero Fahrenheit.

### 5,000,000 Volts

AN electric sphere is now being made in Paris under the supervision of Madame Joliot-Curie and Mr. Lazard into which will circulate an electric current of 5,000,000 volts, causing huge sparks.

## Dry Gas from Petrol

MR. A. E. DODDS has invented a device, with Mr. L. C. Miller as his developing engineer, that generates dry gas from petrol. It was recently tested on an aeroplane engine, and the inventors claim that there is more complete combustion with the dry gas than petrol.

## Discovering Flaws in Railway Lines

AN "iron doctor" is being used in America for discovering flaws in train rails. A rail "stethoscope" glides along with the train and discovers signs of weakness in rails, by X-ray. A tape in the train records every flaw discovered, and the faulty rails are replaced later.

## Drying Walls of New Houses by Electricity

OWING to the length of time it takes for the plaster of new walls to dry in winter time, Moscow builders have been trying out a method of drying plaster by electricity. Rows of fine wire (1 to 1.5 mm.) are placed under the plaster at distances of 15 to 20 centimetres. With the aid of a transformer, current of 60 to 110 volts is transmitted through the wire. Water being a good conductor of electricity, the current spreads along the wall as it passes through the wire and dries the dampness in the plaster. The entire process of drying is said to take from 18 to 24 hours, depending on the thickness of the plaster.

## Tail-in-the-Air Aeroplane

A NEW type of aeroplane, with the appearance of having the tail standing upright immediately behind the pilot, has successfully been tested at Toussus le Noble, France. This new plane has a light engine of 30 h.p. and lands vertically. It is the invention of M. Charles de Rouge.

## Heat and Power Station for Kotlas

THE plans have been completed for the building of a large heat and power station about 20 miles from Kotlas, in the Northern Province of the U.S.S.R. The station will be built in virgin forest, near the site where building work is now proceeding of cellulose, chemical, and wood-working enterprises for the Soviet timber and paper industry.

## Flood-lighting at the Hong Kong Air-port

DETAILS have come to hand of the aerodrome flood-lighting recently installed at the Hong Kong air-port. The equipment consists of three banks of lights, each comprising a 3,000-watt projector mounted in front of a reflector. The beam candle-power of the whole installation is approximately 1,200,000. This flood-light is capable of illuminating objects quite clearly up to a distance of approximately one mile.

### SUBSCRIPTION RATES

Inland and Abroad, 7s. 6d. per annum  
Canada - - 7s. per annum

Editorial and Advertisement Offices: "Practical Mechanics," George Newnes Ltd.  
Tower House, Southampton Street, Strand, W.C.2.  
Phone: Temple Bar 4363.  
Telegrams: Newnes, Rand, London.  
Registered at the G.P.O. for transmission by Canadian Magazine Post



Removing a stickful of type from the stick.



Spotting up.

# PROFITABLE PRINTING AT HOME

## An Extremely Fascinating and Remunerative Hobby

EVER since primeval man learned how to express his thoughts and convey his ideas

to his fellows, first by drawings, then by hieroglyphics, and so finally by written script, mankind has sought the perfect means of reproducing the written word and drawn illustration in quantity. So printing was born.

Long before metal type such as we know to-day was possible, men experimented with wooden blocks, and wood-engraving was the true originator of modern printing.

As early as the sixth century, the Chinese—always renowned for their ingenuity in wood and ivory carving—were using engraved wooden plates for the production of books.

### Came From the East

Printing came to Europe from the East in the early centuries of the Christian era. As might be expected, it was the Church which developed the craft, the monks printing pictures of saints from wooden blocks. It was from these pictures, rudely printed and rudely carved, that the invention of movable type sprang.

In their secular field, playing cards—a Chinese invention—were also printed from wooden blocks, and at the same time a practice had been growing whereby merchants and lawyers, and state officials of all kinds,

To Gutenberg also is attributed the first crude experiments in casting separate metal types,

probably in a sand mould.

Within a few years William Caxton was setting up the first English press at Westminster and was producing books to the astonishment and delight of King Edward IV and his Court.

The early presses used by Gutenberg and Caxton are in principle the foundation of every modern printing press. In fact, printing continued in England almost without change from the time of Caxton until 1801 when Earl Stanhope invented the first iron press. Steam printing followed a few years later, and the middle of the nineteenth century saw the rapid development of the printing industry and its growth towards the perfection which it enjoys to-day—the fulfilment of what could only have been a vague, unrealisable dream to pioneer William Caxton.

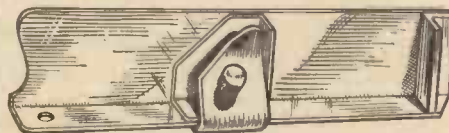

The composing stick.

used wooden stamps of their names and callings so that they could more easily sign agreements and documents.

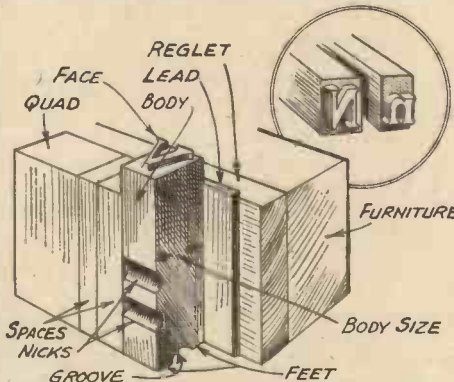

Type and spacing material. (Inset) Upper and lower case.

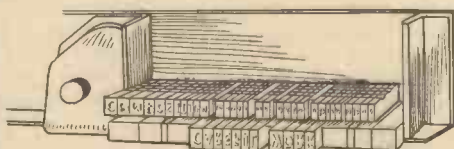

The stick with type in place

From these early beginnings it was an easy stage to the printing, from wooden blocks, of books, and so to the real beginning of modern printing by the invention of the printing press and movable type by Johann Gutenberg of Mainz about the year 1450.

### A Miniature Printing Press

The craft of printing has always exercised the greatest fascination for the layman, and many ambitious home-craftsmen have built their own

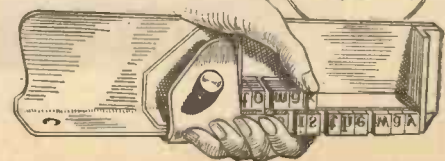

The stick in use. (Inset) Close-up of justification.



Making up the stick.



printing press and have set up as printers in their spare time.

At the great International Exhibition of 1862 a miniature printing press invented by a woman, Mrs. Daniel Jones, was shown. In the official catalogue Mrs. Jones announced that the press was designed to turn the attention of ladies to printing.

After Mrs. Jones, several individuals and firms specialised in the production of printing machines for the home user, but it was left to a young Twickenham man to bring printing within the reach of all and finally to establish the craft of printing as a practicable hobby and possible means of money-earning at a negligible capital outlay.

This young man, Donald Aspinall, was perhaps the first to realise the enormous field afforded by printing to the small man. He also saw the possibilities of business firms and societies doing their own printing on office machines, thus saving both time and money.

### His First Machine

In 1922 he built his first machine, found it satisfactory, and put it on the market. It was named the "Adana"—an anagram on the initial letters of the inventor's name.

The machine proved a success, and in the past fifteen years the firm of Adana has grown from a tiny concern to a big manufacturing business supplying machines and accessories to all parts of

the world from their factory in Church Street, Twickenham, Middlesex.

Mr. Aspinall celebrates 1937—his fifteenth year as a manufacturer of small printing machines—by putting on the market a new model with some remarkable features. It is called the Adana Automatic Flatbed Machine, Model 2B. While not entirely new in principle, being a direct descendant of early highly successful models, it is remarkable on account of its extraordinarily low price, its simplicity of operation and the big size of its type area.

The machine costs £2 18s. 6d. and prints a full quarto page, size 10 in. by 8 in. in one operation. It is worthy of note that no machine of the same size has ever before been marketed at less than double the price, not even by Adana, who have always made consideration of the customer's purse their first thought.



Making ready the platen.

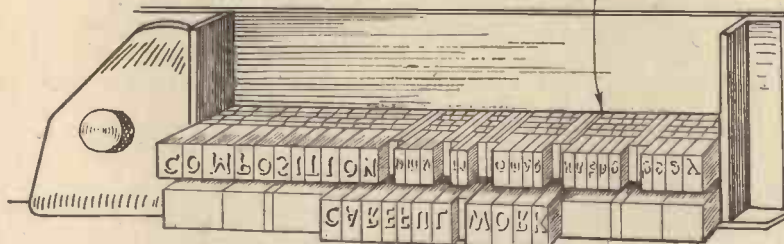
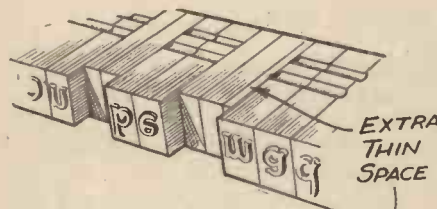

Further details of the stick and type.



A locked-up forme ready for the machine.

The secret is, of course, efficient mass-production. The Adana 2B machine is turned out in a model factory which produces one complete machine every eight minutes. (Incidentally, feeling certain that an opportunity to visit this compact and efficient factory—which even boasts its own type foundry—would be welcomed by many readers, we have therefore made arrangements with Mr. Aspinall enabling readers to "see for themselves," merely by writing to Adana and mentioning PRACTICAL MECHANICS.)

Returning to the more immediate practical considerations of a printing machine: letterpress printing may be defined as a process for multiplying copies of an original by thinly inking a prepared surface (type) and transferring the impression to paper or other material, by means of a printing machine.

The simplest form of letterpress printing is the rubber stamp—though here, of course, the type is made of rubber and not of metal. The stamp is pressed on a pad covered with ink, lifted and pressed on a sheet of paper, and thus an impression of print is made. All ordinary letterpress printing from type is an extension of this process, the difference being that the revolving ink-roller and a heavy press do more speedily and efficiently the work of the flat inking pad.

Type itself, defined in the dictionary as "rectangular block of metal having on its upper end a raised character that produces, by the process of printing, an impression on paper," is cast from an alloy of lead antimony and tin in a variety of different styles and sizes.

### Type

The arrangement of these type characters, their formation into words, is known as type-setting or composition. Once they are arranged in the necessary order they are placed in an iron frame known as the chase, the whole arrangement (type locked in a chase) being now known as the forme.

The forme is placed in the bed of the machine. The paper to be printed is laid on the flat lid or platen. The hand lever, on being pressed down, moves the inked roller over the surface of the type and at the same time brings down the platen carrying the paper to the type. Pressure is applied for a moment, released, and the platen

The forme is placed in the bed of the machine. The paper to be printed is laid on the flat lid or platen. The hand lever, on being pressed down, moves the inked roller over the surface of the type and at the same time brings down the platen carrying the paper to the type. Pressure is applied for a moment, released, and the platen

The forme is placed in the bed of the machine. The paper to be printed is laid on the flat lid or platen. The hand lever, on being pressed down, moves the inked roller over the surface of the type and at the same time brings down the platen carrying the paper to the type. Pressure is applied for a moment, released, and the platen

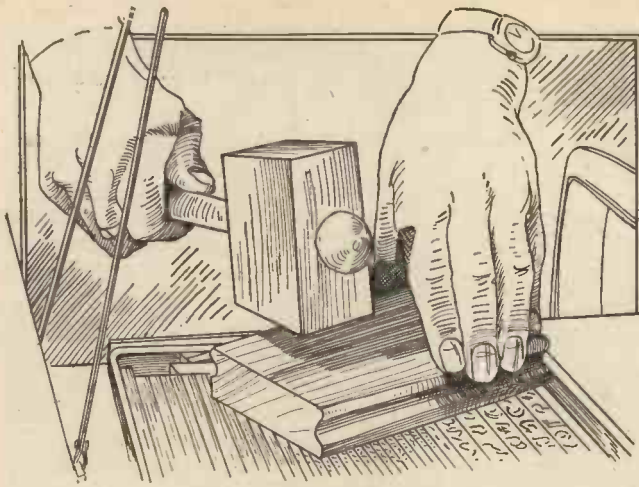

*Planing a forme on the machine bed.*

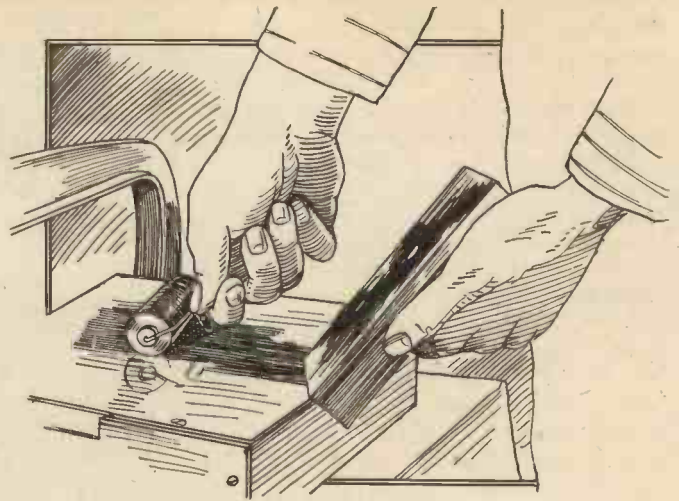

*Inking up the machine.*

lifted back into its original position and the printed sheet removed from the machine. The illustrations accompanying this article will make clear better than a multitude of words the exact process, and for those whose intention it is to take up printing seriously, the instruction book supplied with every machine and outfit will give all the help and guidance necessary.

No great capital outlay is necessary in order to start printing. As has already been shown, a first-class printing machine is obtainable for less than three pounds, and a few further shillings spent on an outfit of type and accessories will supply the beginner with everything necessary for his immediate needs. The man who intends to make a spare-time business of printing will, of course, be well advised to invest just as much money as he can possibly spare. But even from a very modest beginning a reasonable turnover can be expected, thus enabling the home printer to purchase additional plant and equip himself more fully for a

greater variety of work. In fact, following the old axiom that one must learn to crawl before one can run, the idea of starting in a small way is to be recommended. Too great a wealth of equipment may only confuse and hinder.

#### Free Advice

One man may have in mind a scheme which will eventually involve the expenditure of many pounds in plant, whilst for another the outlay of a few shillings will suffice for all his needs. The final decision must ultimately be governed by what the plant is required to do. The beginner who is in doubt can receive free advice on the matter by writing direct to the Editor of PRACTICAL MECHANICS or, alternatively, to the manufacturers of the Adana.

Don't run away with the idea that a great deal of type in many different varieties is required in order to turn out good work. It is much better to have a good quantity of one or two styles and sizes, than too wide a selection of assorted varieties. An

expert typographer, responsible for the production of many striking press advertisements and publicity booklets, once told the writer that he was perfectly happy with six good type faces of his own selection. "I very rarely go outside that number," he said. "With six good faces it is possible to ring the changes indefinitely."

People who know nothing about printing sometimes get the wrong idea about the durability of type; they imagine that type can only be used once for one job and then is of no further use. While this is true of big commercial work such as newspaper printing, where type is cast in solid lines and scrapped as soon as finished with, it is entirely wrong from the jobbing printer's point of view.

#### The Jobbing Printer

The type used by the jobbing printer is composed of a hard alloy which is a mixture of various high-grade metals accurately cast in a mould. It is very durable and, if used with reasonable care, will last a

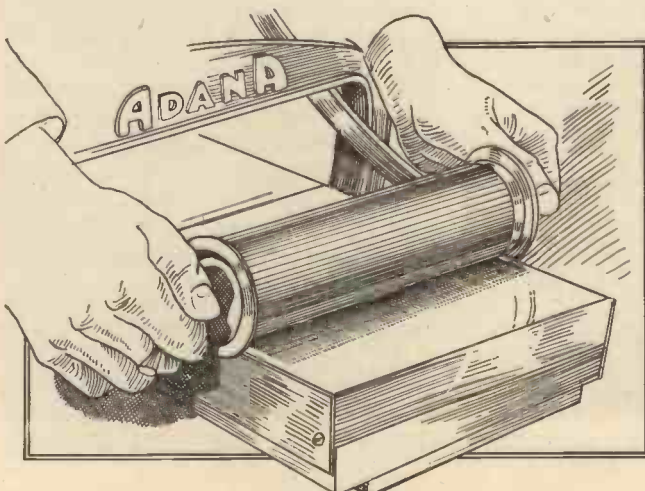

*Inking the machine roller.*

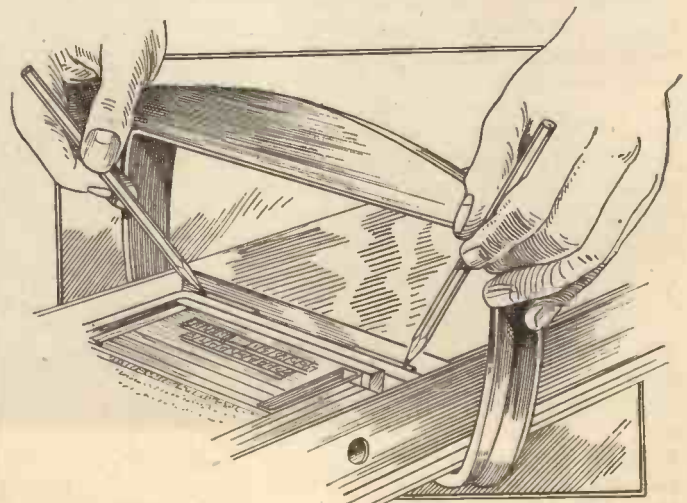

*Fixing the machine chase.*

life-time. The actual setting of type is very simple and may be likened to the building of a child's model house with toy bricks—accurate pieces of metal taking the place of wooden blocks.

It requires no great imagination to envisage the possibilities opened up for the home worker who possesses a printing machine. Within reasonable limits there is nothing that the owner of such a machine cannot do.

Everyone requires print in some form or another. Such obvious things as letterheads, leaflets, business cards, bill-headings, printed envelopes, order forms, advertising folders, labels, time-tables, menus, catalogues, hand-bills, programmes, small posters, magazines and a hundred and one other items in daily use spring to mind.

Whether as a recreational craft, occupation or as a commercial proposition, the possibilities of printing are unlimited.

In the craft sense, printing provides a fine hobby and properly

crowd of enthusiastic amateurs on their own press.

Even book printing is not out of the question. At Tunbridge Wells there lives a man who prints books, which he himself has written, on an Adana machine, identical in size and principle to their new 2B model. This particular printer is an old man of seventy and a chronic invalid, but he finds his ill-health little disability and produces his books with no thought of commercial profit.

Enthusiastic amateur cinematographers have also found in a printing machine a simple solution for one of their major difficulties—the problem of neat titling. There can be no question

that, excepting hand-lettering by a good artist, a printed title gives the neatest and most satisfactory appearance. Instead of printing with black ink on white or light-coloured paper as is usual, the cinematographer uses a white ink and prints on a black paper. While the ink is still wet the printed title-card is dusted with silver powder resulting in brilliant silver letters on a jet-black background, the silver surface refracting the light in the titling outfit and giving a perfect title.

**Its Uses**

The uses of a printing machine to a business house are too numerous and too obvious to be mentioned in detail. There is scarcely any business which could not employ with advantage its own printing plant. In fact, in many businesses where one machine has been installed

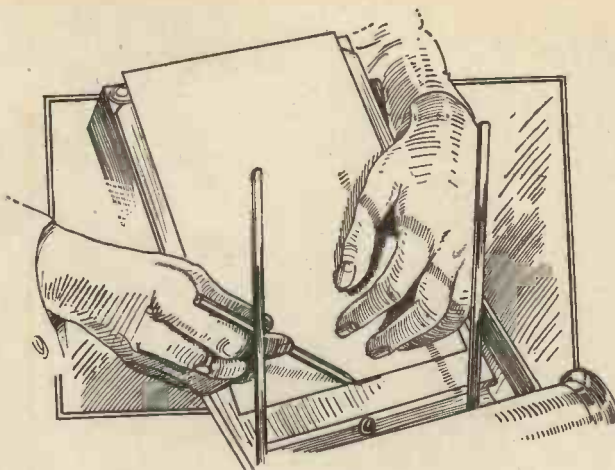

*Finding lay positions.*

to begin with, so much work has been found for it that a second has followed in due course. It would probably surprise the average reader to know just how many big business houses to-day run their own complete miniature printing establishments on their own premises. Thus in the hotel and restaurant business, to take a simple example, the production of such diverse items as tariff cards, room notices, daily menus, etc., may well be undertaken on a small printing machine. It is worth while paying attention to such things.

This article must have shown the essential requirements. You have learned what is required in order to start printing, that the necessary apparatus may be obtained from Adana, 17 Church Street, Twickenham, from whom full details will be sent on application. The fact that you are a reader of PRACTICAL MECHANICS is sufficient evidence that you have some leaning towards things mechanical, are possibly a skilled craftsman. The rest is easy; all that is required is a little concentration on your part in acquiring the technique of a new craft.

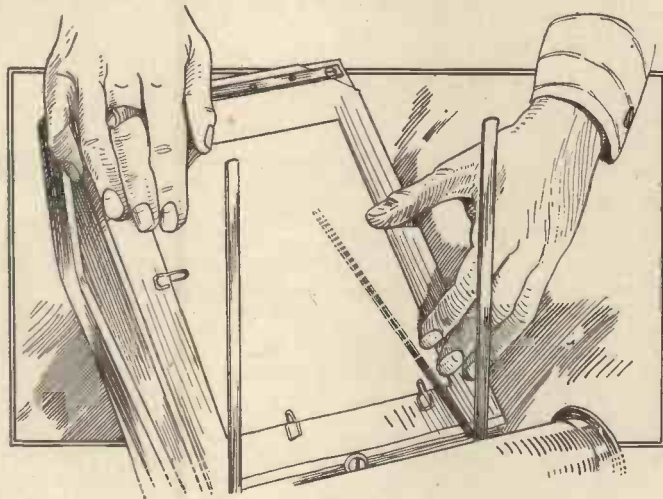

*The job held by grippers and lay gauges.*

developed with artistic ability may be reckoned as much an art as etching, painting or sculpture. This aspect is being more and more realised by scholastic authorities, and to-day many schools and colleges throughout the country include printing in their craft syllabus. The scholars learn a sensible and utilitarian handicraft and have all the fun of producing their own school and class magazines in entirety.

**For Clubs**

Similarly churches, clubs, societies, Boy Scout troops, etc., find in a printing machine the solution of many of their difficulties. There is at least one London model engineering club which prints all its own matter, and the writer has seen many excellent church and scout magazines turned out in truly professional style by a

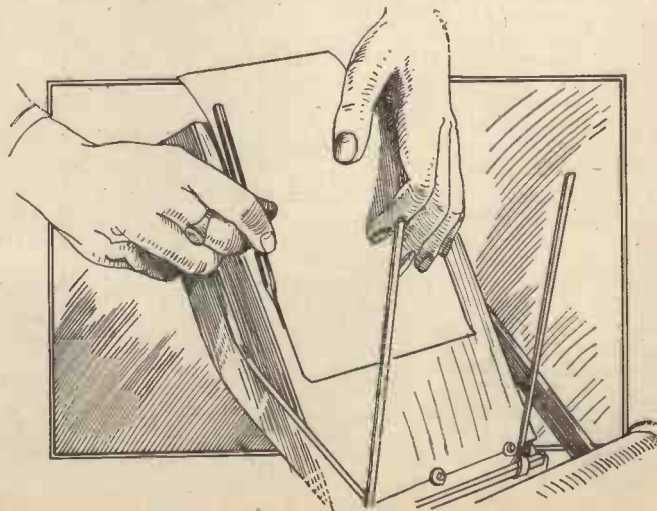

*Further details for finding lay positions.*



Fig. 1.—Two suitable magnetos for converting to dynamos.

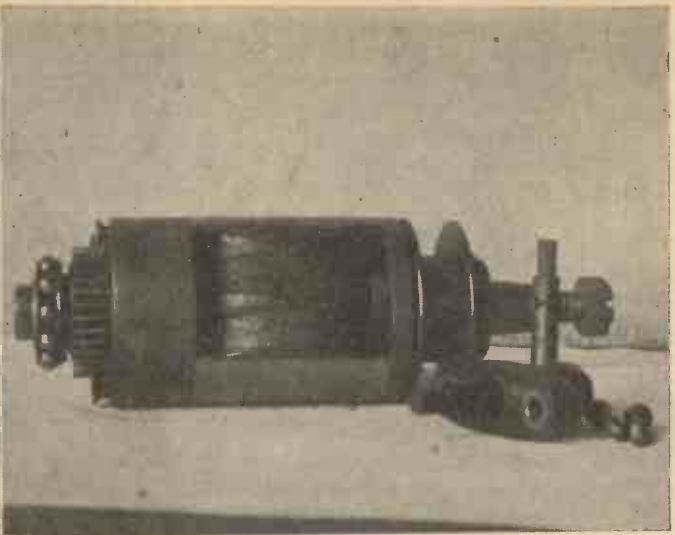

Fig. 2.—The wound and assembled armature.

# MAKING A DYNAMO FROM A MAGNETO

SOME time ago we gave details on how to convert a car dynamo or starter motor into an A.C. motor. This article proved very popular with readers, and as a result we now give details dealing with the conversion of a magneto to a dynamo. Of course, there are various sizes of magnetos; the smallest are to be found on single-cylinder motor cycle engines, while the larger ones are used on 'buses, lorries, and aeroplanes. You should have no difficulty in obtaining a magneto from the local garage and here are a few tips on the choice of one. Explain to the attendant that you want one for making into a dynamo, and make sure that the magnets and armature turns are quite good. For stationary work, the larger the machine the better, as, with some of the four-cylinder types, from 20 to 30 watts output can be expected. For a small dynamo to be driven by a steam engine, use a single-cylinder magneto. Several large firms supply magnetos, either new or reconditioned, at all prices from 4s. 6d. to 10s. These, of course, are excellent for our purpose as we know that the magnetos are in excellent condition. If you have the choice of several magnetos, pick the one that gives the largest spark (see Fig. 1), providing its price is within the reach of your pocket.

## Testing the Armature

Having obtained a magneto, examine it thoroughly. Observe that in certain positions the armature is stiff to turn, and when revolved freely, comes to rest in the same position. This is due to the pull of the magnets, since the armature lies across the poles. On the end opposite the driving spindle you will observe a cover, or perhaps two covers, depending on the type of magneto. It will be found that in a single-cylinder magneto there is one cover over the make-and-break, but in multi-cylinder ones, there is also a cover over the distributor gear. Remove them both, and as a matter of interest, turn the spindle and note how the machine functions. The

The Article on converting a Car Dynamo into an A.C. Motor appeared in "Practical Mechanics" Dated June 1934.

centre brush of the distribution gear must be pulled out and can be dispersed with. In the centre of the make-and-break there is a small hexagonal screw; undo this and pull off the complete end. The magneto will no longer spark. Now go straight forward with the dismantling of the machine, taking off each end, but before the armature is removed, slip a soft iron keeper over the magnet poles, and then and *only* then, pull it out. The keeper, in emergency, can be a pair of pliers, screw-driver, etc., but as soon as possible stand the magnets on an anvil or a domestic flat iron or other thick piece of magnetic material. Clean up all the parts and wash well in petrol. You must discard all the distribution gear except the high-tension pick-up brush. On the end of the armature

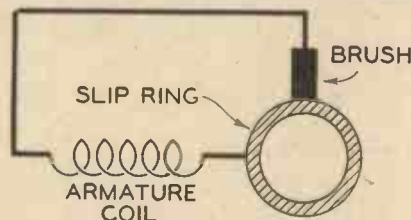

Fig. 3.—The armature circuit.

near the driving spindle you will find what looks like a large ebonite pulley with a brass centre, and this is the high-tension slip ring on which the high-tension brush bears. As our first machine is to be a very simple one, the output is A.C., the period depending on the speed of revolution.

## Rewinding Operations

The armature must, of course, be re-

wound, and to do this easily, dismantle it. You will find it to be made up of a centre section of steel to which two ends are attached by screws. Undo these screws and pull off the ends. It may be necessary to tap them slightly, but mark which end is which and in what position it is screwed before removing them. To remove the end with the high-tension ring attached, it may be necessary to remove some of the ebonite. Actually the ebonite may be removed with a saw right down to the slip ring, but at this stage it is hardly necessary. The old winding must be removed, and the easiest way is with a sharp knife. It is hardly worth while to wind off all the fine wire, but you may keep a sample for future experiments. When all the fine, or secondary wire has been removed, you will come to the primary, which is of a fairly stout gauge of silk-covered wire. This must also be removed.

## Neatness Essential

The armature is rewound with a single coil of wire, i.e. from end to end and then back again, repeating until the space is completely filled. Put the wire on as neatly and as tightly as possible, laying each turn closely up to the next, and by this means you will get an increased output over a poorly wound one. The original insulation may be left over the metal. Take the end of the coil of new wire and solder it to the armature, or if you cannot solder leave about 6 in. over so that it may be fixed to one of the securing screws. Now wind on as much wire as possible. The gauge to use will depend on the output required, and also on the strength and size of the magnets, but No. 24 S.W.G. D.C.C. will be ideal for most work. If you want a higher voltage, use No. 28, but here the current will be reduced, No. 20 can be used for low voltages and higher currents. In machines that we have converted the following windings and outputs have been used: A small single-cylinder magneto with No. 24 S.W.G. wire gave an output of 4 volts 1 amp., but the same machine

(Continued on page 355)

# BUILDING A PEDESTAL WRITING DESK

By "Handyman"

It is Quite Inexpensive to make, and the Construction has been Simplified. Details of Every Part of the Structure are Given

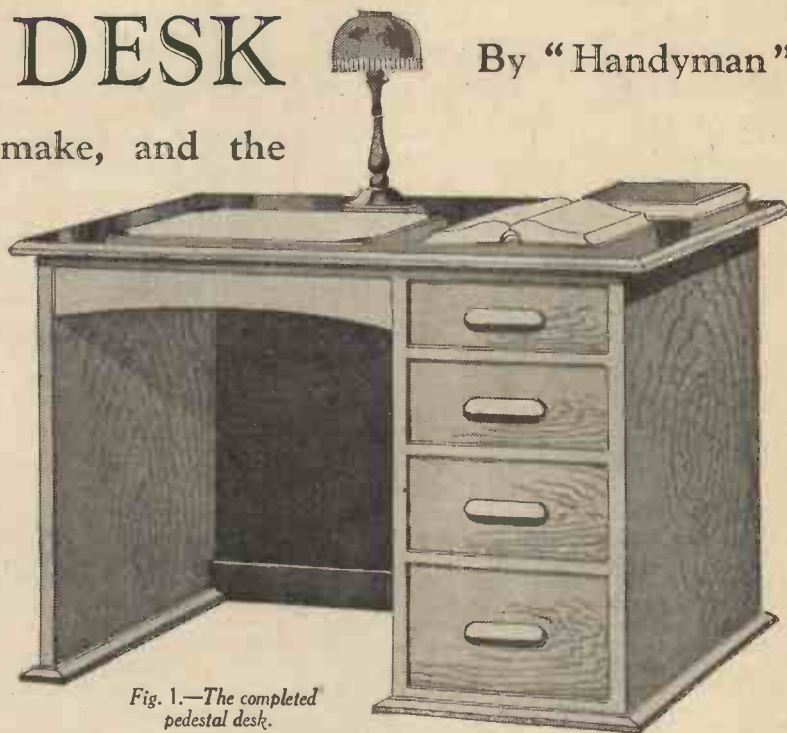

Fig. 1.—The completed pedestal desk.

ONE of the most useful things any handyman can make for himself is a writing desk. That shown at Fig. 1, as well as being useful, is an attractive piece of furniture. The cost of the material will not be exorbitant, and the work is simple enough for any fellow of average ability. In the desk shown in Figs. 1 and 3, there is a single pedestal with four drawers, the two uppermost could be used for stationery and writing material, while the two bottom ones

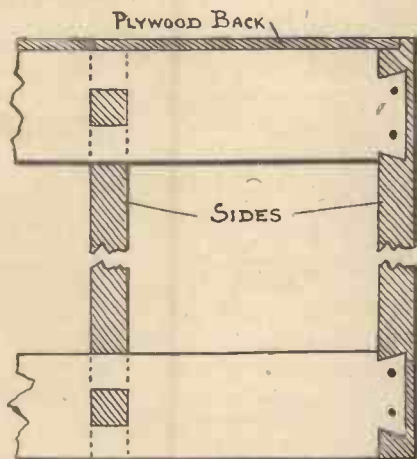

Fig. 2.—The bottom drawer rail should be dovetailed into the side as shown.

could be conveniently fitted up as index files, for letters, press-cuttings, and subjects in which one may be interested. If cost has to be considered, deal stained and varnished makes a very satisfactory job;

but for appearance oak is, of course, the most suitable wood. With the exception of the sides and top all the material is in fairly narrow pieces, and a piece of plywood could be used for the back. Those who desire a larger desk than the single pedestal could make the double one shown in Fig. 5. The construction is identical to that about to be described, with the exception that two pedestals have to be made instead of one.

### The Framework

The dimensions to which the work should be carried out are shown in the elevations Figs. 3 and 5, and the section Fig. 4, whilst constructional details of the desk are shown in the remaining sketches. Except where otherwise stated, the wood used should be  $\frac{3}{4}$  in. or  $\frac{7}{8}$  in. thick. The three sides are 2 ft.  $3\frac{1}{2}$  in. long, two being 1 ft. 8 in. wide, and the remaining one 1 ft.  $7\frac{1}{2}$  in. wide, while if wood of sufficient width cannot be obtained, two or even three pieces may be glued together to make up the required width. Rebates  $\frac{1}{2}$  in. wide by  $\frac{1}{4}$  in. deep are cut in

the back edges of the two wider sides for fitting the plywood back. The narrow side and one of the wide sides are taken first, and the pedestal is built up by fitting the four drawer rails between them. These rails are 13 in. long by 3 in. wide, the three top ones are either tenoned or dowelled into the sides as shown in Fig. 7. If tenoned in, the tenons should be of the double pattern, and if dowelled, the dowels should be  $\frac{3}{8}$  in. diameter bored 1 in. into the rails and  $\frac{3}{8}$  in. into the sides, their positions being carefully marked off with a square and gauge. The bottom drawer rail is dovetailed into the bottom edges of the sides. The three sides are then joined at the top with two top rails 2 ft.  $11\frac{1}{2}$  in. long by 3 in. wide, the narrow side is mortised through the rails, and the latter are dovetailed into the sides as shown in Fig. 2. It is desirable both for appearance and strength to frame a shaped rail, 3 in. wide at the ends and 2 in. wide in the middle, in the knee-hole portion of the desk under the top rail, the shaped rail being tenoned into the sides as shown in Fig. 8.

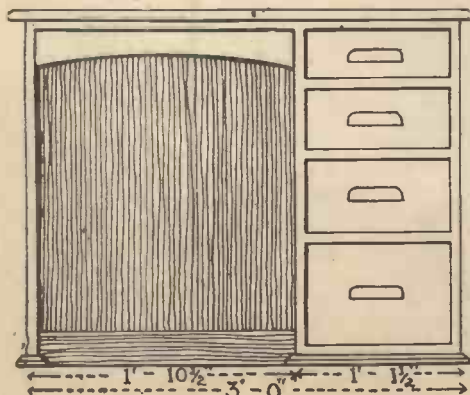

Fig. 3.—A front view of the desk.

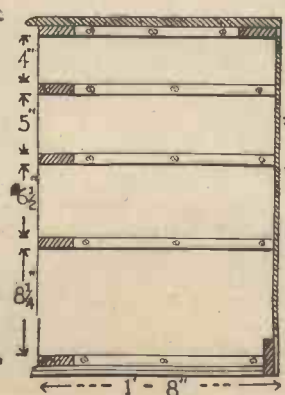

Fig. 4.—A sectional view.

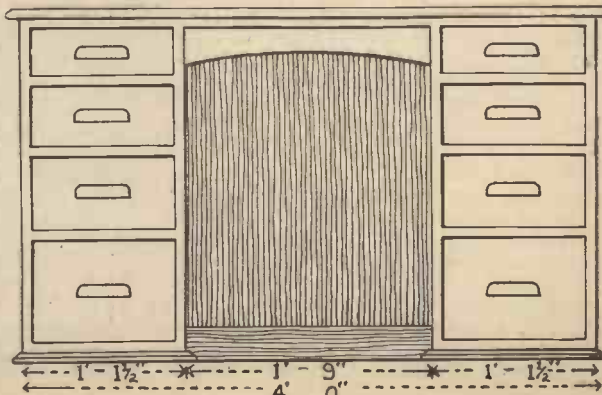

Fig. 5.—A double pedestal desk for those who require something larger.

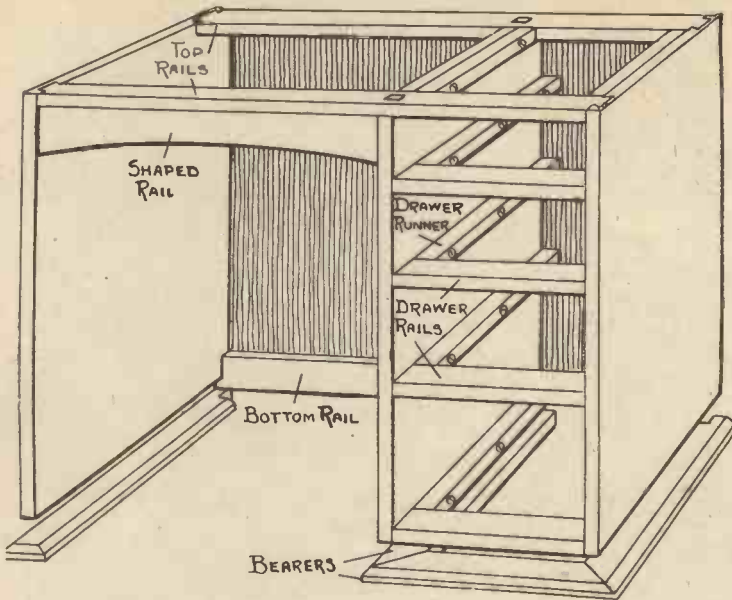

Fig. 6.—The framework of the desk, with details of the various rails.

the pedestal are chamfered  $\frac{3}{8}$  in. wide on one edge, and that under the side forming the knee-hole is chamfered on both edges. The bearers should be fitted around the back rail, those under the pedestal are mitred at the corner, and they are screwed to the ends of the sides. The top of the desk is a solid piece of wood 3 ft. 3 in. long by 1 ft. 9 in. wide, the front and the edges are rounded.

**The Drawers**

The final consideration is the drawers, and while they may be dovetailed up in a professional manner, many will, no doubt, adopt the simple construction shown in detail in Fig. 10. The drawer fronts should be of the same material as that used in constructing the desk, the sides should be of  $\frac{3}{8}$  in. deal, and the backs and bottoms of  $\frac{1}{2}$  in. deal. Grooves  $\frac{1}{4}$  in. deep are cut in the sides to receive the back and bottom, and a similar groove is also cut across the front on the inside to receive the front edge of the bottom. The sides are let in flush with the ends of the front.

**Fixing the Parts Together**

When the work has been carried to this stage the parts may be finally cleaned up and fixed together. The upper drawer rails are fixed to the sides first, after which the bottom rail is fixed, and finally the shaped rail and the two top rails, the joints being glued, and the top rails and the bottom drawer rail are also nailed. Drawer runners 1 in. wide are fixed in the pedestal behind the top rails, and all the drawer rails,

the runners being screwed to the sides, and fixed quite level so that the drawers will work properly. A bottom rail 2 ft. 11  $\frac{1}{2}$  in. long by 3 in. wide is fitted across the back of the sides, the rail being notched in level and screwed, as shown in Fig. 9, and allowed to project  $\frac{3}{8}$  in. or  $\frac{1}{2}$  in. below the bottom edges of the sides, according to the thickness of the material which is being used. The bottom edges of the sides are finished with bearers 3 in. wide, those under

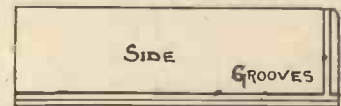
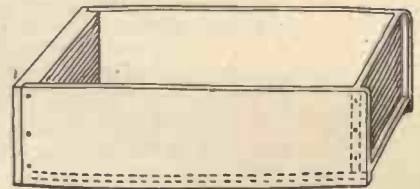

Fig. 10.—The drawer with side and drawer handle.

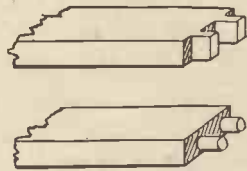

Fig. 7.—Two methods of joining the top rails.



Fig. 8.—How the shaped rail is tenoned into the side.

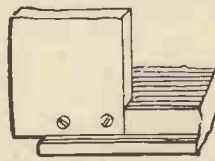

Fig. 9.—The bottom rail should be notched in and screwed as shown here.

THE "blue-print" process is extensively used for making copies of engineers' tracings, but it can be used successfully for prints from photographic negatives if the negatives are strong and contrasty, having dense high lights and clear shadows. Weak, thin negatives—although giving good results with gaslight paper—are useless for making blue prints. The process is simple, cheap, and easy to work, for after exposure the prints only need a wash in water to make them permanent, thus avoiding the usual developing, toning, and fixing. This paper is very suitable for printing rough proofs, being much cheaper than self-toning or bromide papers. It does not appear to be sold in small quantities suitable for amateurs, but can easily be made at home by following the instructions given below.

**Chemicals Required**

Obtain from a chemist or photographic dealer 1 oz. of ammonio-citrate of iron and 1 oz. of ferricyanide of potash. Dissolve each of these chemicals separately in 4 oz. of water, i.e. dissolve the ammonio-citrate in 4 oz. of water in one vessel and the ferricyanide in another 4 oz. of water in a separate vessel. When both are completely dissolved, mix the two solutions together to make 8 oz. of sensitiser. The mixed solution should be kept away from the light; a good tip for achieving this

**BLUE PRINTS**  
How to Prepare Your Own Sensitised Paper

object is to wrap thick brown paper round the outside of the bottle, binding the paper with string or rubber bands.

Ask the chemist to weigh out the exact quantity of each chemical, for it is not advisable to keep small quantities of poisonous chemicals unless you have a properly equipped dark room with a special chemical cupboard. For a similar reason you are advised to coat as much paper as you are likely to require and throw away the surplus solution, as it only costs a very few pence to prepare a fresh lot when required; in any case never put any solution whatever away without labelling the bottle clearly, describing the contents.

**Coating the Paper**

Writing paper with a smooth but not greasy surface is a suitable material for coating. Pin the paper out flat on a board with drawing-pins to stop it curling up when wet. A piece of absorbent cloth folded into two or more thicknesses is doubled over the edge of a piece of glass and held in place with a rubber band; an old negative will do for the glass. The

solution is poured out into a flat dish so that the coating appliance may be dipped in to charge it with solution; the gadget is then passed over the surface of the paper in a weak light only, leaving a wide band of sensitive solution on the surface; make other bands slightly overlapping the previous one until the surface of the paper is covered, then while still wet give a second coating with the bands at right angles to the first and put away to dry in the dark.

**The Method of Printing**

This is carried out in the ordinary way and should be continued until the deepest shadows assume a bronzed appearance. No time for printing can be given, as so much depends upon the light and the negative. A very few minutes would suffice in summer sunshine, but it might take a day or more in winter.

To finish the print it is just washed in water after being removed from the printing frame until the water runs off clear and free from yellow tinge. The colour becomes darker as the print dries and will be slightly improved if the wet print is subjected to a bath of extremely weak acid—say a teaspoonful of vinegar in a pint of water—before the final rinsing in clean water.

Titles may be written on the finished print with an ordinary pen by using a solution of ordinary washing soda in place of ink.

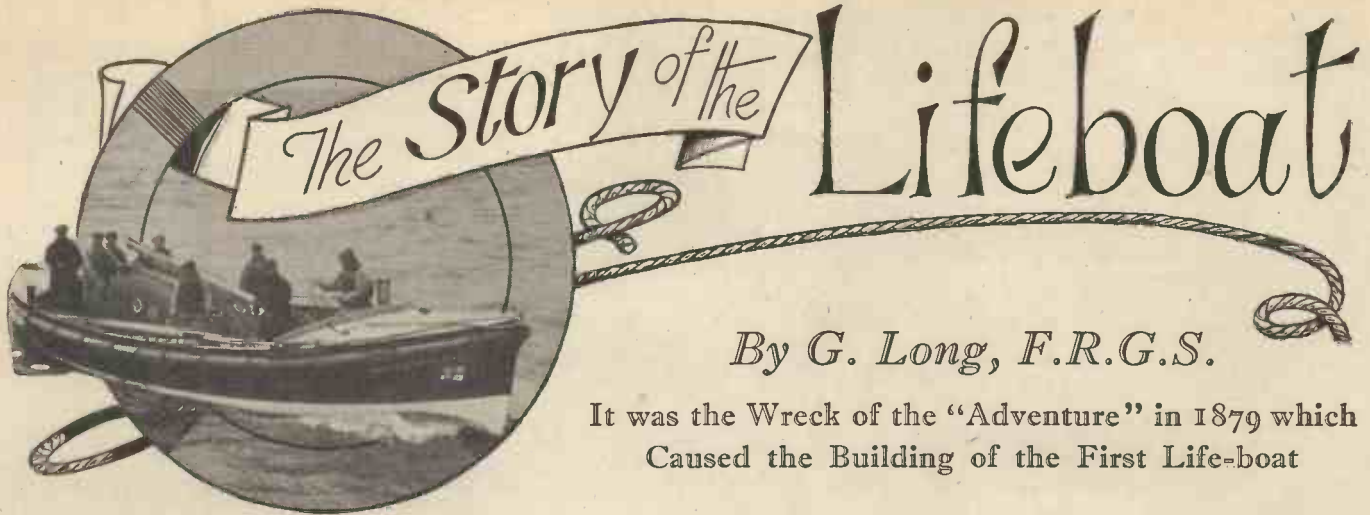

By G. Long, F.R.G.S.

It was the Wreck of the "Adventure" in 1779 which  
Caused the Building of the First Life-boat

**I**N a recent article I related the history of the lighthouse, which has saved countless lives from the perils of the sea. Useful though it is, the lighthouse is purely passive, it warns but does not rescue—that splendid enterprise is the job of the life-boat.

We have shown that the lighthouse is a very ancient idea, and warning lights shone out over the midnight sea as long ago as 660 B.C., but nearly twenty-five centuries elapsed before the first life-boat was launched. Why this delay?

The need for the life-boat was just as clear and obvious as that of the lighthouse, but no boat had yet been invented which could live in a gale. Also many people made money from wrecks, and all round the coasts there were men who would lure a ship on the rocks by means of false lights, in order to obtain the cargo when it was washed ashore. And so through long centuries nothing was done to save shipwrecked people.

#### Wreck of the "Adventure"

It was the wreck of the *Adventure* in 1779 which caused the building of the first life-boat. Some gentlemen at South Shields had a kind of social club meeting at Lawe House, overlooking the mouth of the Tyne. From here they must have witnessed many dreadful wrecks, and that of the *Adventure* was especially harrowing, because the whole ship's company were drowned one by one in full view of thousands of horrified spectators, who were powerless to help. No boat then existed which could live in such a tempest, and the rocket apparatus had not then been invented. Hardy sailors on shore wept at their impotence, while the victims were swept one by one into the sea, and before darkness fell the ship itself was broken up. But the lesson had been learned. A committee was formed at Lawe House, and a reward was offered for the best life-boat. As a result of this offer, many models were sent in. The best design was submitted by William Wouldhave; it was the world's first self-righting boat. It had high, peaked ends fitted with water-tight cases filled with cork, and a very heavy keel. Although this invention was not considered good enough to take the whole prize, he was offered—and refused—half. His design is still the basis of all self-righting boats. The next best boat was put in by Henry Greathead, and soon a special craft was designed embodying all the best features, and an actual boat was built from it by Greathead and named the *Original*.

#### World's First Life-boat

This—the world's first life-boat—served for forty years, and saved hundreds of lives without the loss of any member of her crew. She was finally smashed on the rocks in 1830, but by the end of the year 1803 Greathead had built thirty-one more.

All of these were rowing boats, and in 1807 a coach-builder named Lukin built the first sailing life-boat for service on the Suffolk coast.

National Life-boat Association was founded in 1824.

#### Amazing Feats

It would be a fascinating task to recount the amazing feats of courage and endurance performed by the heroes of the life-boat. The crews are recruited from among the fishermen and boatmen around our coasts. These men earn a scant living sailing the seas in all weathers, and have an unrivalled



The "Abdy Beauclerk" lifeboat stationed at Aldeburgh.

The next great pioneer of the life-boat was Sir William Hillary, a wealthy and patriotic baronet, who had retired to live in the Isle of Man. His sympathetic soul was deeply moved by the sight of many terrible wrecks. Though long past middle age, he took an active part personally in saving more than three hundred shipwrecked sailors, and also formed a local Life-boat Association, which soon had four life-boats stationed round the island. He also started a great campaign to form a national life-boat association, which should organise rescues all round our coasts, and as a result of this the splendid Royal

skill in handling boats, together with a most intimate knowledge of the rocks, shoals and currents. They are *volunteers*, not paid servants of the Institution, but they are rewarded for every service they perform, and their dependents are pensioned if they lose their lives. Since 1850 they have rescued more than 42,000 persons, and 250 life-boat men have perished in this unselfish work.

Space will not permit me to enlarge on this topic, we must return to the subject of the life-boat, and the scientific and mechanical marvels which it embodies.

During the last decade or so, a great

change has taken place both in the life-boats themselves, and in the method by which they are launched.

Until a decade or so ago, our life-boats were mostly small craft, propelled by oars and sails, and dragged to the beach by men or horses. They were launched by man—and woman—power, brave helpers going waist-deep into the freezing waves to shove off the boat. Very picturesque were some of these emergency launches, as for instance in 1881 when the Whitby life-boat was dragged by teams of men and women six miles through a snowstorm, went safely down that frightful hill to the beach at Robin Hood's Bay, and was successfully launched. Six men were saved from the *Victor*.

#### The Modern Life-boat

To-day the heroism remains, but much of the picturesque element has departed. The modern life-boat is really a small ship, driven by powerful motors, and launched by caterpillar tractors, whose engines are completely enclosed. The latest motor life-boats have two six-cylinder engines of 80 h.p. each, which are both water-tight themselves and are placed in a water-tight compartment. Her tremendous power makes her able to proceed in the teeth of the fiercest gale, and a clever device of automatic valves gets rid of the sea water as fast as it enters the boat. She is divided into fourteen water-tight compartments and is further fitted with seventy air cases. If all her compartments were flooded, and a score of holes were knocked through her sides, she would still float. She can take on board 130 people as well as her crew, and is furnished with an electric searchlight, a line throwing gun, a fire-extinguishing apparatus and a device for throwing water on the sea to calm down the angry waves.

The biggest modern life-boats are *not* self-righting, as it is unlikely than any sea could overturn them. Most of the smaller boats, whether sailing or motor, however, are fitted with this valuable principle; and one such, when travelling with all her crew on board,



The E.C.F. motor cabin lifeboat stationed at Rosslare Harbour.

and with all sails set, can right herself (when overturned) and empty out the water in twenty-five seconds. With the motor self-righting life-boats a very clever automatic cut-out ignition switch is fitted, which comes into action whenever the boat turns over, and stops the engine. This is necessary, because the engines are so efficiently protected that they would continue to function, and so the boat would go on at full speed, after tipping out her crew, and would leave them helplessly struggling in the water, and unable to catch up.

A very interesting recent addition to the life-boat fleet has been specially designed for saving life from aeroplanes. She is named the "Sir William Hillary" after the gallant founder of the R.N.L.I., and was built in 1929 and stationed at Dover.

She has two 375 h.p. engines, and a speed of nearly 18 knots, the fastest and most powerful life-boat in the world. Speed is of paramount importance in plane disasters

at sea, since a wrecked aeroplane is not likely to keep afloat for many minutes.

#### Can Live in Any Sea

We may say then that the modern life-boat represents every device that scientific skill can discover, in order to construct a boat which can live in any sea, and face any gale that can possibly be encountered. Our island has five thousand miles of coast line, and every mile of this is fraught with peril for ships in fog or storm.

I have made many voyages, and have conversed with many seafaring men, who have assured me what a comfort it is to them to know that the life-boat is always ready when needed, all along our rugged coasts.

So when you next encounter a "Life-boat Day," you can put your offering in the box with the full knowledge that your money will be helping one of the most splendid and unselfish services in the world.



The "Charles Cooper Henderson" lifeboat being launched at Dungeness, Kent.



# The Principles of Domestic Heating Apparatus

By S. Boocock

It is an Advantage to have a Working Knowledge of Domestic Electric Appliances

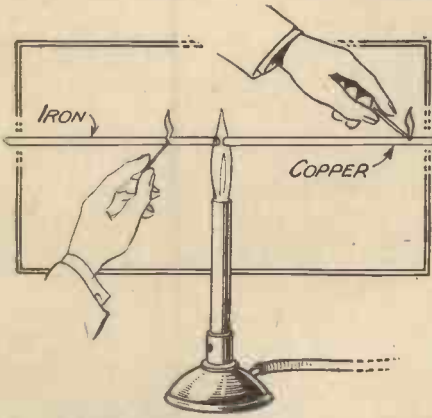

Fig. 1.—Showing how a match ignites on copper first, proving that copper is the better conductor of heat.

THE various methods of heating our homes, offices and workshops depends for their efficacy on clever yet simple applications of scientific facts and principles. An understanding of the basic principles may in some cases enable the apparatus to be used to greater advantage, and quite apart from this, it is of interest to have a working knowledge of domestic appliances.

There are three systems of heat transference known to man, namely, conduction, convection and radiation. Heat is said to travel by conduction when it is passed or conducted through a substance or when it passes from one object to another in contact with it.

### Applications of Conduction

To quote the classic example, heat passes along a poker which is placed in a fire, travelling from the fire to the handle by conduction. It is by conduction that heat passes from a boiler fire to the water inside. In the case of a gas heater or geyser, the heat is conducted from the flame to the water which flows through a copper spiral as a rule.

Certain substances are better conductors of heat than are others, that is the heat will pass through some substances more rapidly than it will pass through others. For this reason it is becoming a more common practice to put non-conducting handles of wood or bone or one of the plastic materials, such as bakelite, on metal teapots and hot-water jugs. Boilers are often enclosed in a non-conducting casing to conserve the heat and thus economise on fuel.

A simple experiment to illustrate the comparative conductivity of different materials is by means of two pieces of wire, one of copper and the other of iron, both being of the same length and gauge. Place one end of each in a Bunsen flame and, after heating for some time, run a live match head along each wire, starting at the ends remote from the flame. It will be found that the match lights first on the copper wire, the heat having travelled farther along the better conductor (Fig. 1).

### So-called Radiators

Another method of heating is by convection. The air in contact with a hot object is warmed by conduction. It expands and therefore diminishes in density so that it rises. It is common knowledge that hot gases rise, this being the reason

that flames burn upwards. As the warm air rises, cold or cooler air moves in to take its place and in turn becomes warm. Thus are created currents which carry the heat by means of the fluid itself, whether it is air or water.

The distinction between conduction and convection is that in the latter the particles of the substance carry the heat, while in the

vection with all types of heating apparatus, but the heating devices which function largely by convection are oil stoves and the so-called radiators and pipes containing either steam or hot water. A better name for the latter would be convectors.

This may be shown quite easily by holding a smouldering rag above one of these articles when they are in action (Fig. 2).

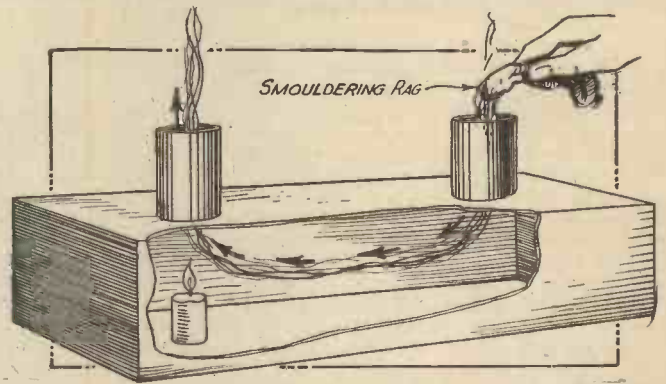

Figs. 2 and 4.—(Left) Holding a smouldering rag above an oil stove. (Right) Details of a simple experiment.

The smoke from the rag will render the currents visible, as will that from a lighted cigarette. A further rough experiment is to hold the hand about a foot from the side of one of these heating devices, then to move the hand to a position the same distance above. It will be found that more heat is felt when the hand is above the apparatus than when at the side. This clearly illustrates that the amount of heat sent out to the side by radiation is small compared with the amount which is distributed by convection currents.

The circulation of hot water in the domestic hot-water system depends on the fact that the warm water rises and the cold water falls to take its place. Thus all the water in the system is finally warmed by passing through the boiler.

### Convection Currents Illustrated

The transference of heat by convection may be illustrated by two simple experiments. Sprinkle some sawdust in a jam jar containing water (a beaker is better), and allow the heavier particles to settle. Then place the tip of a candle flame below the jar when the small particles of sawdust will begin to rise, passing across the surface and falling down the side of the jar remote from the flame (Fig. 3). A better result can usually be obtained by using two or three small crystals of permanganate of potash in place of the sawdust. The jar will crack if the flame is held in contact with it for any length of time, but a few moments should suffice to set the convection currents in motion. The second experiment requires a small

former, the heat passes from one particle to the next one.

There must be a certain amount of con-

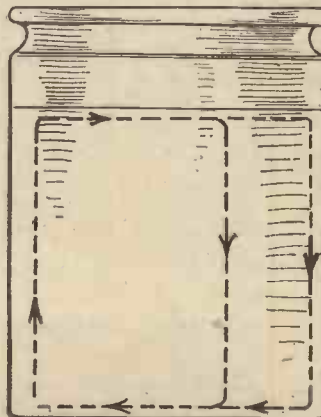

Fig. 3.—An experiment showing the transference of heat by convection.

box, a cardboard chocolate box being excellent for the purpose. Cut two holes about the size of a penny at opposite ends of the lid (Fig. 4). Put a small portion of a lighted candle below one hole and replace the lid. If a smouldering rag be held over the second hole, the smoke will be carried down that hole by the air currents and will emerge from the other hole where the candle is warming the air, causing it to rise. Two chimneys fixed over the holes will improve the experiment.

#### Heating by Radiation

The heat we get from the sun reaches us by travelling through space in the same

way as light, and it is noticed that it does not warm the air through which it passes. It is a well-known fact that the air at high altitudes is extremely cold. This method of propagation of heat through space is known as radiation, and this is the best principle to adopt for heating a room.

The old-fashioned and wasteful coal fire is an excellent radiator, probably one of the best at our disposal, while gas fires and electric radiators emit heat largely by radiation.

Radiant heat may be reflected by a polished surface just as light is reflected by a mirror. This, of course, is the reason that electric bowl fires are fitted with a shiny

reflector behind the heating element. By adjusting this reflector it is possible to throw a welcome beam in any desirable direction. This is particularly useful in the case of the heater which is made to hang on the wall of the bathroom.

The gas cooking stove employs all three methods of heat transference. A saucepan placed over a gas-ring conducts the heat from the flames to the liquid inside, which is then heated by convection currents. The oven is heated by convection, the flames being at the bottom. The grill is an iron plate which becomes red-hot and radiates the heat downwards, thus cooking by radiation.

# METEORITE AND MARTIANS

FROM time to time we read in the newspapers that a meteorite has landed somewhere or other, but beyond a mild speculation whether a meteorite is a thunder-bolt, or whether such things as the latter are non-existent, little more is thought of the matter. In the *British Encyclopaedia* we read:

"It is now generally believed that these phenomena are all of the same nature and are due to the existence of a great number of bodies, most of them extremely minute, revolving round the sun. . . . Under certain circumstances portions of these bodies reach the earth's surface. . . . They are composed of chemical elements terrestrially, and are mostly of a stony nature, but a few are almost pure iron alloyed with nickel."

This is all very well as far as it goes, but leaving aside the bulk which we learn are of a stony nature, let us turn our attention to those composed of iron and nickel. They may, of course, be odd bits of worlds that blew up more years ago than there are grains of sand in the Sahara desert; on the other hand, perhaps the origin is a far more romantic one.

#### Communicating with Mars

From time to time an epidemic of suggestions arises for communicating with Mars and other planets, or even speculation on the feasibility of calling there in person to have a look round!

It is reasonable to assume that if Mars is inhabited, the people (?) would either be simple-minded savages, or be far more advanced than the inhabitants of the earth. They may, of course, be much the same as we are, but such a coincidence would be rather remarkable.

As far as we are aware there is no immediate likelihood of any of our fellow earthmen calling personally on Mars, but if, as has often been suggested, the Martians are more clever than we are, is it not more reasonable to assume that they might call here?

Quite apart from the unpleasant possibility of their "Spaceship" arriving in the middle of St. Paul's Cathedral, which is beside the point at the moment, it would seem that if they have set out on such a journey, one of three things must happen:

A. They do not arrive, having lost their way, or possibly come off second best in an encounter with one of the meteorites above mentioned.

B. They might arrive here in good order. This has not happened so far! or

C. They might misjudge something or other and arrive here at 1,000 miles per second or so faster than they intended.

### What is a Meteorite? Will the Inhabitants of Mars Ever Communicate with Our World?

#### "Spaceships"

Jules Verne, and other more recent authorities on the design and construction of "Spaceships," suggest that the descent of such a ship would be at any sort of speed about 10,000 miles an hour, the conventional brake being a sort of rocket action from the nose of the ship, tending to shoot it back from whence it came, thus slowing down the rocket's progress until that gentle speed is reached when the ship can be brought nicely to rest in Hyde Park. If, on the other hand, this arrangement failed to work satisfactorily, the "Spaceship" would reach our atmosphere at such a speed that air would seem almost like a brick wall, in the same way that water feels extremely solid to a diver who misjudges his comparatively insignificant leap through space.

Whatever the shape of a "Spaceship" hitting our atmosphere at a speed intended for space travel, it would go flying off in any indiscriminate direction, and could be expected to melt in a matter of seconds. The lead or basic metal with a comparatively low-melting point would vaporise, while the remainder, possibly iron, nickel, and carbon, would hurl itself into somebody's back garden, half bury itself, and be referred to in the local newspaper as a "large meteorite."

#### A Possibility

Another possible happening which would bring about the same disastrous condition would be if visitors from another planet were unaware of the existence or density of our atmosphere, and arranged for their "Spaceship" to circle round the earth at some few miles' distance until their momentum was generally checked by rocket apparatus and they could alight safely. In the writer's opinion, quite a feasible manoeuvre, but if carried out through ignorance within the earth's atmosphere, yet another meteorite would be reported in possibly that old-established newspaper *The Peruvian Examiner*.

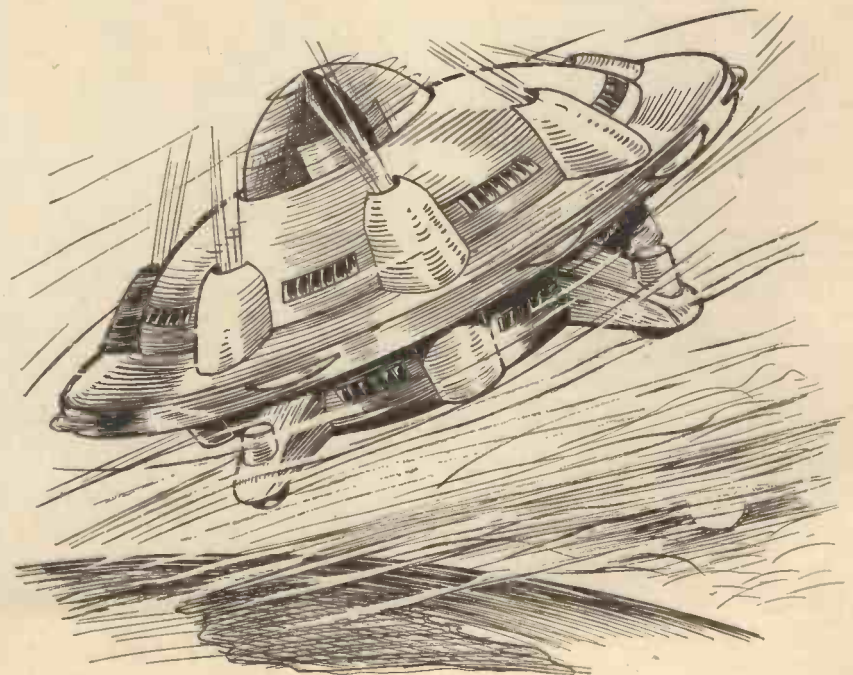

A "spaceship" of the future.

# Making a Billiards Table

“By Home Mechanic”

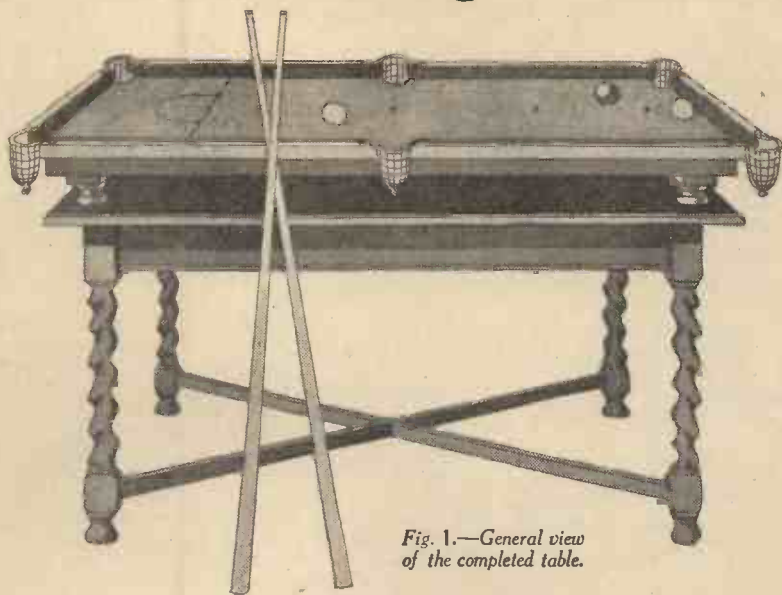

Fig. 1.—General view of the completed table.

Below we Give Full Constructional Details of a 4 ft. 4 in. × 2 ft. 4 in. Table, but it is Quite a Simple Matter to modify the construction if a Larger Sized Table is Desired.

**B**ILLIARDS hold premier place with all indoor games, but many have been prevented from frequently indulging in the game through its costliness and the large amount of room a full-size billiards table requires. The introduction of miniature billiards has brought the game within the reach of everyone, and what is more, anyone with even an elementary knowledge of wood-working can make a billiard-table on which a very good game may be played. These tables are intended to stand on the ordinary dining-table, and one is shown in the accompanying drawings and described in this article.

Standard sizes for miniature tables are :

- 4 ft. 4 in. × 2 ft. 4 in.
- 5 ft. 4 in. × 2 ft. 10 in.
- 6 ft. 4 in. × 3 ft. 4 in.
- 7 ft. 4 in. × 3 ft. 10 in.

A table of the smallest size has been chosen for description, but it will be a simple matter to make any of those mentioned above from the instructions given. Although it is possible to play a better game on a larger table, it should be remembered that a smaller one is less difficult and costly to make, and requires less room. The table is made with a thick plywood top fixed to a strong frame. The top is covered with baize, the cushions are also covered with the same material, and four feet are screwed under the frame in such a way that the table may be adjusted and set quite level. Balls 1½-in. diameter should be used.

### The Top

The plywood top measures 4 ft. 4 in. × 2 ft. 4 in., it should not be less than ¼-in.

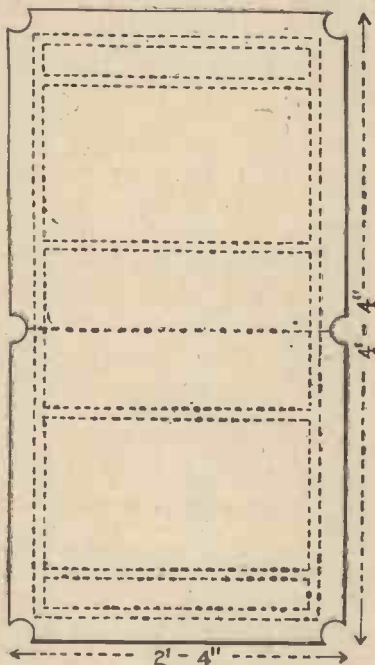

Fig. 2.—A plan view of the table.

thick, and is set out as shown at Fig. 2. It will be necessary to choose a good board, free from imperfections. The

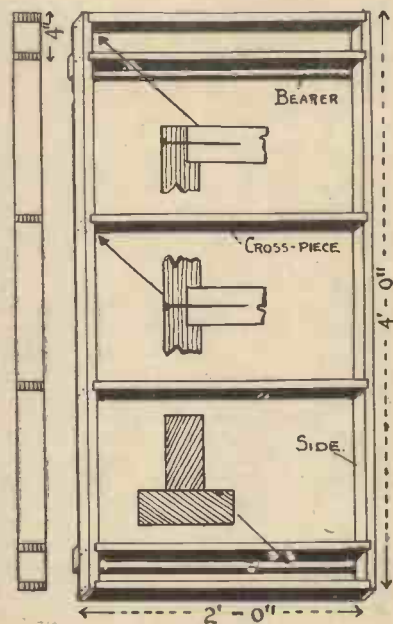
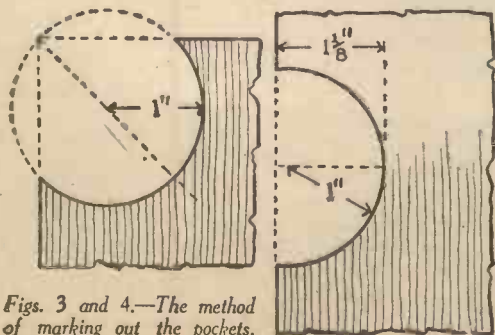

Fig. 5.—The frame.

pocket holes, one of which is cut at each corner, and the two remaining ones in the middle of the sides, are marked with a pair of compasses set to the radius of 1 in., as shown at Figs. 3 and 4. The edges should be planed quite straight and square, and the holes may be cut with a fretsaw.

### The Frame

This is shown at Fig. 5, and is made with two sides 4 ft. long by 2 in. wide by ¾ in. thick, and six cross-pieces 1 ft. 11 in. long × 2 in. wide × ¾ in. thick. The cross-pieces are framed to the sides by cutting grooves ¼ in. deep in the latter and fitting the cross-



Figs. 3 and 4.—The method of marking out the pockets.

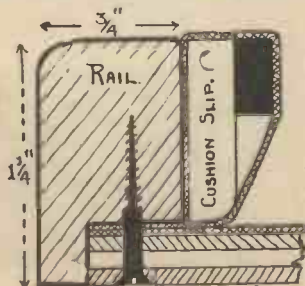

Figs. 6 and 7.—(Left) The outer top edges should be rounded off as shown. (Right) Small fillets pinned underneath to form the rebates.

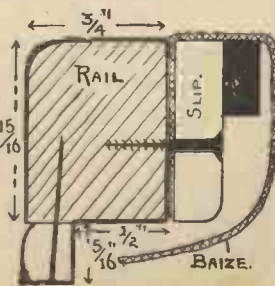

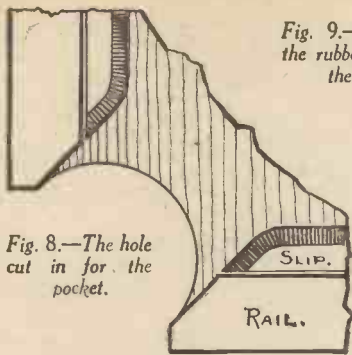

Fig. 8.—The hole cut in the pocket.

Fig. 9.—(Right) How the rubber is fitted for the cushions.

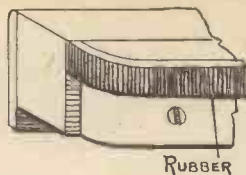

Fig. 10.—The pocket plates.

pieces in, fixing them with glue and nails. Care should be taken in setting out and cutting the joints, for the frame must provide a perfectly level bearing for the plywood top. On completion it could be tested for trueness with the eye, and a straight-edge should be used to see that the sides and cross-pieces are level, if not they must be planed. To complete the frame two bearers 2 ft. long  $\times$  2 in. wide  $\times$   $\frac{3}{4}$  in. thick are prepared and fitted under the sides and the cross-pieces next to the end ones, screws being used for fixing. The top is pinned to the frame, the latter being shown under the top by the dotted lines in Fig. 2. If the frame is first placed above the top and its position is marked in pencil, the lines will form a guide for driving the pins. Brass pins with small heads are the most suitable to use; they should be punched in and the holes stopped.

**The Rails and Cushions**

The table is surrounded with six rails, one at each end and two at each side. The end rails are roughly 2 ft. 1 in. long and the side rails 2 ft. long  $\times$  1 1/4 in. high  $\times$  3/4 in. wide. Rebates 1/2 in. wide  $\times$  1/8 in. deep are cut at the bottom edges of the rails for fitting over the plywood top, and the outer top edges are lightly rounded over, as shown at Fig. 6. If difficulty is experienced in cutting the rebates, the rails could be prepared 1/8 in. high  $\times$  3/4 in. wide, and small fillets 1/8 in. high  $\times$  1/4 in. wide glued and pinned underneath to form the rebates, as shown at Fig. 6, the outer edges of the fillets being rounded over to break the joint. The rails should be fitted in place; they finish level with the edges of the pocket holes, and the ends are cut to an angle of 45 degrees across the width of the rebates, as shown at Fig. 8. The cushions are formed with strips of fairly soft rubber 3/8 in. wide  $\times$  1/8 in. thick, and if strips of this size cannot be obtained they may be easily cut from a sheet about 2 ft.

2 in. long  $\times$  3 in. wide. The strips of rubber are cemented to cushion slips 1 3/8 in. wide  $\times$  1/4 in. thick; the slips finish 3/8 in. shorter than the rails at each end, and the ends of the slips are rounded as shown at Fig. 8. The rubber

ends of the rails and fixed with a few small tacks to provide a smooth entry for the balls into the pockets.

**Covering the Top**

The baize covering should be just large enough to cover the top, and it should be pressed with a hot iron before fixing. A few drawing-pins could be used to hold it in place at first. It is then stretched tight, and tacked around the edges, the ends are brought down over the pocket holes and fixed underneath, and the rails and cushions are fixed with screws driven through the top as shown at Fig. 6.

**Finishing the Table**

The pocket plates may be fashioned from 1/8 in. round brass, flattened at the ends, and provided with screw holes for fixing, as shown at Figs. 9 and 10, while the pocket nets could be purchased.

The plan of the finished table, Fig. 10, shows the position of the baulk line and spots, which may be marked with pipe-clay or a hard crayon.

Turned feet about 2 in. diameter  $\times$  1 in. high are fitted under the table, methods of adjustment being shown at Fig. 15. The simplest method is to drive dowel screws into the feet and screw them to the bearers of the frame so that the height may be adjusted. Another method is to drive metal-thread 1/8-in. bolts into the feet; the heads of the bolts should be removed and the nuts let in flush with the top of the bearers, while holes are bored through the bearers and a short distance into the cross-pieces of the frame. A spirit level is necessary to try the levelness of the table when setting it up, the feet being adjusted as required.

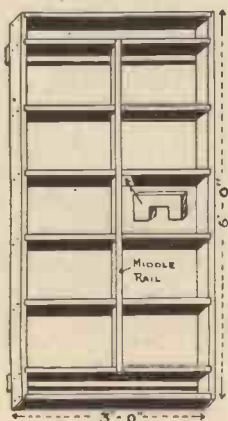

Fig. 12.—The frame for a 6 ft. 4 in. table.

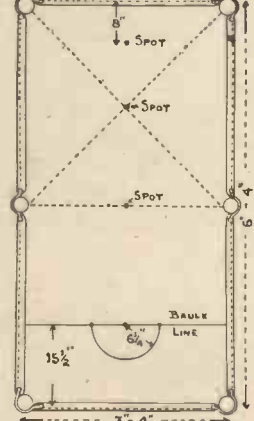

Fig. 13.—How to mark out a 6 ft. 4 in. table.

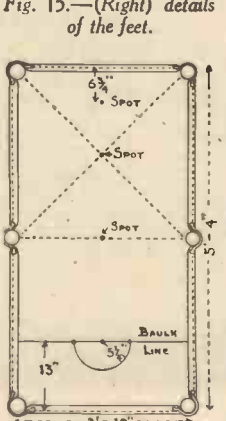

Fig. 14.—Details of a 6 ft. 4 in. table.

to the back of the cushion slip, the latter is then fixed to the rail with screws, as shown at Fig. 7, and the baize is brought over and tacked under the rail, as shown at Fig. 6. The baize must be neatly fitted over the

**Larger Tables**

If you consider making the larger sized table, shown in Fig. 12, it will require additional cross-pieces and a stouter frame. The sides and cross-pieces should not be less than 3 in.  $\times$  1 in., the two end cross-pieces should be framed in and fixed first, after which the remaining ones are fitted and fixed, and the upper edges planed perfectly straight and true.

Owing to the extra width it will be advisable to provide a middle rail 1 1/2 in.  $\times$  1 in., to support the plywood between the cross-pieces. This should be fitted after the frame has been trued up, and it is then planed level with the cross-pieces. The 5 ft. 4 in. table could be made with or without the middle rail, but the framework need only be 2 1/2 in.  $\times$  7/8 in.

The method of marking out a 6 ft. 4 in. table is shown in Fig. 13, and a 5 ft. 4 in. table in Fig. 14. Balls 1 1/2 in. diameter should be used for the larger table, the pocket holes would be 2 3/8 in. diameter, and the rails, cushion slips, and cushions of the section shown in Fig. 16. For the smaller table the balls should be 1 1/4 in. or 1 1/2 in. diameter; if the former are used, the rails will be of the section previously given, but the cushions could be 3/8 in.  $\times$  1/4 in.

Fig. 15.—(Right) details of the feet.

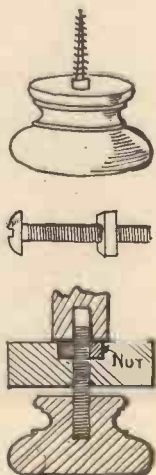
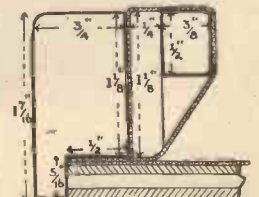

Fig. 16.—The method of making the cushions for the larger sized table.



# A SENSITIVE BAROMETER

## How to Construct a Simple, Inexpensive yet High Sensitive Mercurial Instrument

**T**HE barometer whose construction is described in this article will stand comparison, so far as actual performance goes, with many of the highest-class instruments on the market. Yet it can be made at a cost of not more than five shillings and, indeed, this total outlay can be reduced considerably if the amateur happens to have already available some of the constructional materials required.

The barometer is of the "pediment" type. It consists of a straight tube filled with mercury, the mercury tube being suitably mounted and permanently secured on a wooden board. The height of the mercury column is read off by means of a simple form of indicator against a scale, an accurate reading of the barometric pressure of the atmosphere thereby being attained.

### Very Sensitive

There can be no more sensitive form of barometer than one consisting of a column of mercury the height of which is governed directly by the prevailing pressure of the atmosphere. Such a type of barometer possesses no pivots, wheels, cranks, or levers to become dirty and to stick. Once calibrated, the barometer described and illustrated in this article will go on working almost indefinitely without requiring any attention whatsoever, its accuracy of performance being consistently of a very high order.

It is best to begin the construction of the barometer by making the board of the instrument. The dimensions for this latter are embodied in the diagram given on this page. These dimensions are to be regarded as being approximate only, and they may, within reason, be varied by the individual constructor to suit his own purpose and ideas.

The choice of the wood used for the making of the barometer board is, again, a matter for the individual. If the instrument is required merely for workroom or home laboratory use, then the cheapest wood obtainable will probably suffice so long as it is in a reasonably seasoned condition. If, however, the barometer is, as is often the

case, to become a piece of household furniture as well as a scientific instrument, then the constructor will be well advised to select a better variety and quality of wood, such as, for example, well-seasoned oak, mahogany, or walnut.

### The Protecting Box

It will be noted that the lower end of the barometer board terminates in a box-like enclosure in which the lower end of the mercury

Filling the barometer tube with mercury.



tube is enclosed. In the instrument illustrated, this protecting box is fitted with an upward-sliding front in order that the lower end of the mercury tube can be inspected

from time to time. In place of a sliding front, a hinged door can be provided or, indeed, any type of protection may be devised for the vulnerable lower portion of the mercury tube so long as it is serviceable, efficient, and not, in appearance, out of harmony with the rest of the instrument.

Having constructed the barometer board, the next thing to do is to stain and polish it in accordance with individual taste. An oak board would be best stained, lightly shellacked, and then wax polished, whilst mahogany board would usually be finished by means of some french polishing and staining process.

We now come to the matter of the barometer tube itself. If the amateur has facilities for glass-bending he can make a "plain" barometer tube for himself merely by sealing the end of a length of thick-

walled glass tubing and then by bending the other end into a "U" shape, the short limb of the "U" being about an inch and a half in length. It is better, however, to purchase a ready-made barometer tube having a mercury "cup" at its lower end. These cost about half-a-crown each and may be procured from most laboratory furnishers and scientific supply stores. The barometer tube should be approximately 34 in. in length. It must not be less than 31 in. The tube should have a 3/8 in. bore. A wider bore tube will tend to make the barometer slightly more accurate; but, on the other hand, it will necessitate the use of a greater amount of mercury.

### "Redstilled" Mercury

A 34-in. barometer tube having a 3/8-in. bore will hold about two ounces of mercury, but for ease in filling the tube with mercury, about four or six ounces of this metal should be obtained. The purest mercury available should be used and it will be found advantageous to purchase "redstilled" mercury, which, at the present time, may be obtained from chemical supply firms at the price of 5s. 6d. or 6s. per pound.

Having obtained the barometer tube and the necessary amount of mercury, we may now proceed to the filling of the tube. For this we require a small enamelled, or better still, a glass funnel and a short length of rubber tubing. A metal funnel must not be employed, since it might contaminate the mercury.

The interior of the barometer tube must be scrupulously clean and dry, as, also, must be the mercury itself. It is advisable to place both the tube and the mercury in a warm cupboard for a few days in order to make sure that all traces of dampness are driven off them.

If the mercury is "dirty" and leaves "tails" when drawn along paper it may be cleaned by forcing it through a chamois-leather bag pierced with a needle hole. Even so, however, such mercury may be contaminated with other metals, in which case it will be absolutely useless for barometer work. It is always



(Left) The finished barometer and (right) details of the glass tube.

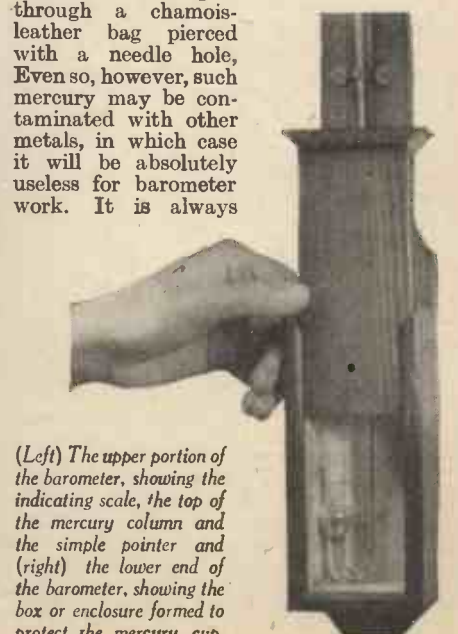

(Left) The upper portion of the barometer, showing the indicating scale, the top of the mercury column and the simple pointer and (right) the lower end of the barometer, showing the box or enclosure formed to protect the mercury cup.

best, therefore, to use for barometer filling freshly purchased "redistilled" mercury.

The method of filling the mercury tube will be made clear by a study of the photograph accompanying this article. The tube is inverted so that the short arm or cup of the tube points downwards. A short length of rubber tubing is attached to the open end of the cup and at the opposite end of the rubber tubing a glass or enamelled funnel (not a metal one) is secured. Make sure that the funnel and the tubing are perfectly clean and dry and that there is no loose rubber powder within the rubber tube. To make certain of this latter, it is best to pour a quantity of scrap mercury several times through the rubber tube in order to carry away all loose particles. This mercury, of course, must not be used for the actual barometer filling.

#### Filling the Tube

The barometer tube is filled by holding it in the left hand whilst the funnel is held in the right hand, the funnel and barometer tube being connected by the rubber tubing, as shown in the photograph. All the available clean mercury is now poured into the funnel and a tuft of clean cotton-wool is then loosely packed into the funnel in order to prevent the escape of any mercury. Holding the funnel always at a higher level than the inverted barometer tube, the latter is given a series of quick vertical movements or jerks. By this procedure, mercury will be shaken round the bend of the tube, and, falling to the bottom of the latter, it will displace the contained air. When the long tube is completely full of mercury, the rubber tube may be removed and the long tube restored to its normal upright position. The mercury within the tube will not run out. It will sink about three or four inches from the top of the tube and then remain stationary. A little more mercury is then poured into the cup at the lower end of the tube and the latter is then closed by means of a cork, through which a small hole has been driven, or else with a tuft of cotton-wool.

It is a good plan to conduct the filling of the barometer tube over a newspaper-lined household bath so that if any mercury is lost during the process it may easily be collected again.

#### The "Vacuum Hammer" Test

Before securing the filled barometer tube to the wooden board, it is advisable to apply to it the well-known "vacuum hammer" test. This is done by slightly inclining the upper end of the mercury tube so that the column of mercury rises and hits the end of the tube. At each impact of the mercury with the upper end of the tube, a peculiar metallic thud will be heard. This is the so-called "vacuum hammer," and its presence is a sign that an effective degree of vacuum has been secured above the mercury column.

The mercury tube is now fixed to its board. This is effected by means of two or three small metal bridge-pieces which hold the tube securely to the woodwork.

The barometer must now be left for a few hours in order that the mercury in the tube may attain an even temperature. Subsequently, the barometer must be calibrated.

In order to calibrate the instrument and to render it suitable for use, draw a scale similar to the one shown in the photograph. This scale is best executed in Indian ink on smooth white paper. The scale must be very accurately drawn in inches, each inch being divided accurately into tenths. The weather indications (Fair, Change, etc.),

may then be written in the scale in the approximate positions seen in the photograph.

The scale should now be pasted down on the left-hand side of the upper end of the barometer board, care being taken to see that the right-hand blank margin of the scale is slipped under the upper end of the barometer tube in order that the mercury level in the latter may be rendered clearly visible. The scale, after its adhesive has dried, is then varnished over, or covered with a strip of celluloid or glass in order to protect it from atmospheric contamination. If such a scale is carefully drawn and covered with glass, it will be almost indistinguishable from an instrument scale which has been silvered in the orthodox manner.

#### Calibrating the Barometer

Finally, the barometer must be "set" or calibrated. To do this we must know the

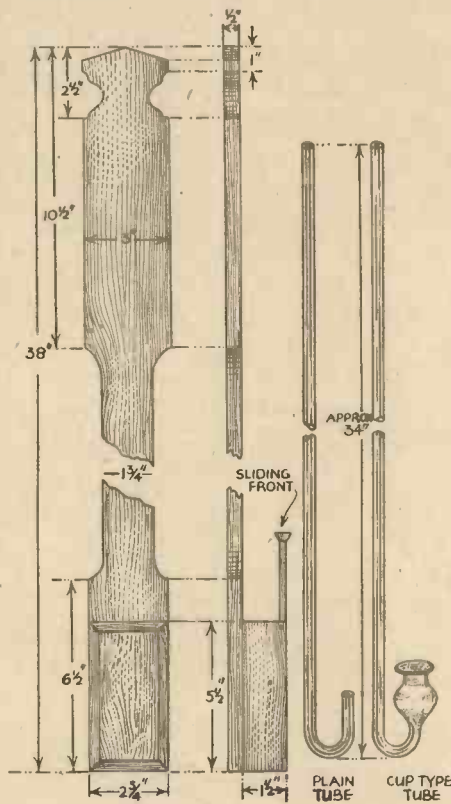

Dimensions of the barometer board.

height of the barometer at the time of calibrating the instrument. This information may usually be obtained by telephoning to any meteorological office, airport, or observatory, whilst, of course, most opticians, newspaper offices, and other interested concerns usually have a good barometer on their premises.

Suppose, therefore, that we know the height of the barometer in our district to be, say, 29.6 inches. Loosening the bridge-piece which holds the barometer tube fast to its board, we move the tube up or down until the top of the mercury column is exactly level with the reading 29.6 on the barometer scale. We then tighten up the bridge pieces which secure the tube to its board, and from then onwards the barometer readings will be accurate ones.

An indicating pointer is not an absolute necessity for the barometer, for the height of the mercury column may be read off against the scale by means of the eye alone.

At the same time, a pointer of one type or another is a very useful adjunct. A simple type of pointer may be cut out of a small strip of brass and, by means of a miniature coiled spring, be made to slide gently and firmly up and down a length of stout copper wire fastened to the barometer board opposite the scale of the instrument.

## NEAR AND FAR

#### Motor Roads in Germany

**DURING** the next six years, Germany is to construct an additional 4,500 miles of double-tracked concrete motor roads. Each road will be entirely free of level crossings or cross-roads.

#### Glass Bricks

**THE** use of hollow glass bricks as a substitute for masonry work has recently been demonstrated on a large scale by an Illinois company.

#### American Air Liners

**DETAILS** of six new Boeing Clippers to be built for Pan American Airways have just been announced. Each machine will weigh over 40 tons and will be able to carry more than 60 passengers. Sleeping accommodation will be provided for 40. The machines, which are to be of the high-wing monoplane type, will have a wing span of 152 ft. and a maximum speed of about 200 m.p.h. Like our own Short flying boats, the machines will be provided with two decks, the top one accommodating the control cabin and the crew's quarters, and the lower one containing the day and night compartments for the passengers as well as the kitchen. The wings will be provided with internal gangways to permit inspection and repairs to the engines while in flight.

#### An Automatic Fuse

**A** NOVEL type of electric fuse has been developed which makes use of the expansion of mercury when heated. If a short circuit or overload occurs, the heat generated expands the mercury and breaks the circuit. The fuse may be restored, however, by unscrewing a plug and swinging it sharply like a clinical thermometer, thereby returning the mercury to the two contact points within the fuse.

#### America's Airships

**A** FEW years ago an unfortunate succession of accidents so alarmed public opinion in America that all use of airships was suspended. Opinion seems to have changed, however, because the development and construction of airships is now to be encouraged by an amendment to the Maritime Act. As it would take at least two years to build an airship of the size of the "Hindenburg" however, negotiations are in hand to buy or rent one of the two ships now under construction in Germany.

#### A Large Pebble!

**WHAT** is believed to be the largest block of stone ever quarried has recently been broken away at Stoke Quarry, Grindlefold. It measures 30 ft. long, 26 ft. high, and 14 ft. thick, and weighs about 1,200 tons.

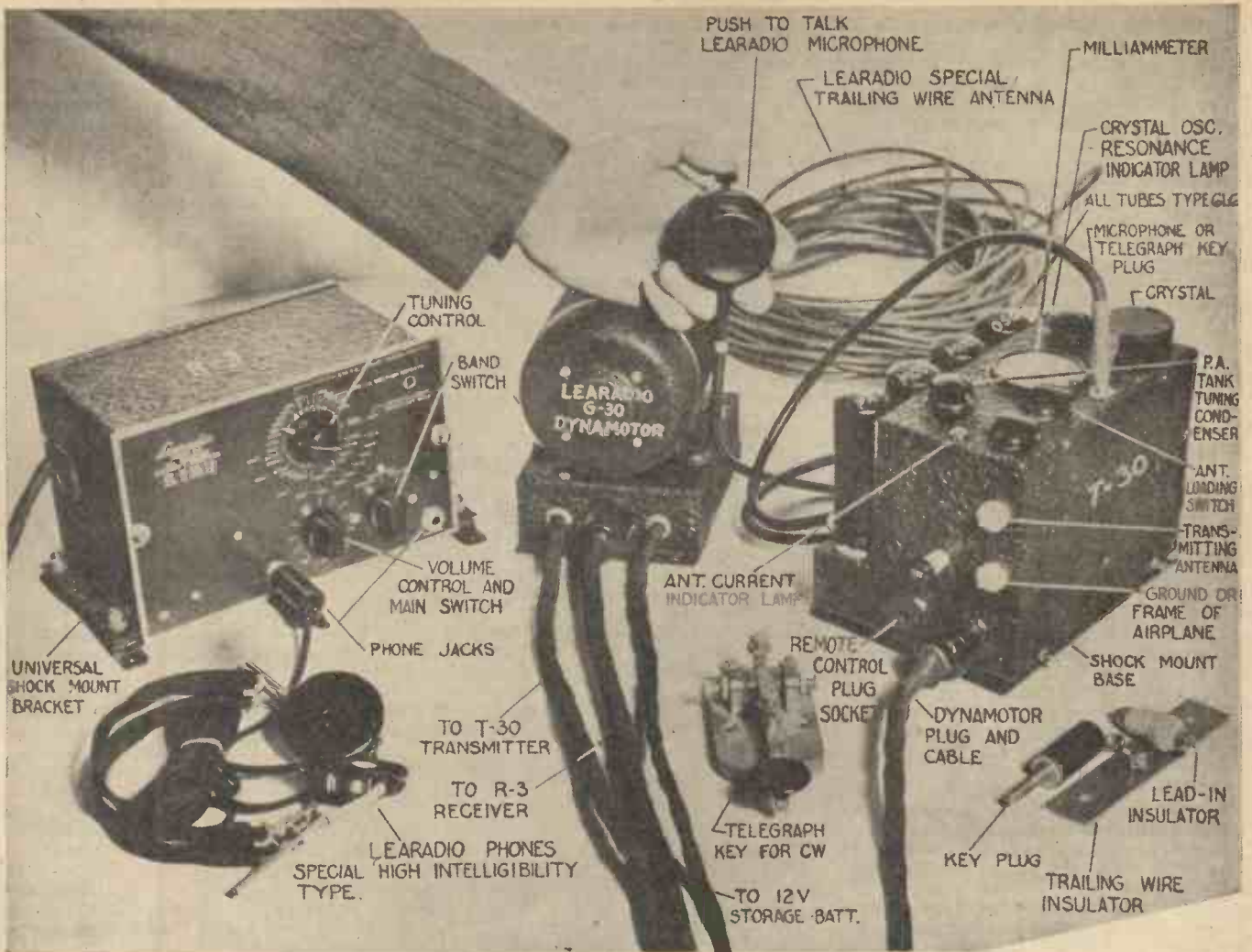

The complete radio apparatus. Showing the control unit, and compact arrangement of the transmitter.

# AIRCRAFT RADIO

**T**HE problem of fitting an efficient transmitter to an aeroplane has received considerable attention in the past, and in the U.S.A., where there are so many separate air lines in daily use there have been several interesting types of equipment which have been designed. The following details will, no doubt, interest our readers as they give the main features underlying the design of one of these American transmitters, which has been produced by Lear Developments.

The transmitter proper is a very compact unit, intended to be locally controlled from the pilot's seat. The overall requirements are: height 6½ in., depth 5¼ in., length 8½ in. The approximate weight is 6½ lb.

The dynamotor unit is supplied with 8 ft. of battery cable and 15 ft. of cable to run to the transmitter. This unit may be installed in any convenient place, such as the baggage compartment, or under the seat. The overall height is 6½ in., depth 4½ in., and length 6½ in. The approximate weight is 10 lb.

A plug is provided in the dynamotor base which will supply operating voltages for any receiver which is wired to work with this system. The dynamotor can be operated from either the transmitter or receiver and a relay in the base switches the high voltage

from one to the other as the microphone button is operated. Resistors are automatically cut into the input and output circuits of the dynamotor when it is used to supply the receiver. The current consumption while supplying the receiver is but a fraction of that used by the transmitter.

A binding post on the end of the trans-

## Details of a Transmitter which has Recently been Designed in America.

mitter provides sidetone output to be fed into the audio system of the receiver for monitoring the transmitter, and also allows the microphone to be used for interphone purposes when the transmitter is turned off. The microphone voltage is not controlled by the on-off switch, and is available whenever the microphone button is pressed.

The dynamotor and transmitter are protected against short circuits by a 20-ampere cartridge fuse placed in the positive battery lead at the battery end of

the cable. Any short beyond this point will cause the fuse to blow.

### Determining the Efficiency of a Transmitter

The real measure of a transmitter's efficiency is the power output and intelligibility of the signal it produces, but the effectiveness of any transmitter depends directly upon the efficiency of the aerial system with which it is used.

Take, for example, a transmitter using a small fixed aerial strung between two points on the plane. Under a particular set of conditions we may find the range of this transmitter with this aerial to be thirty miles. If at the same time we change to a trailing wire aerial of proper length, we find that the range may be increased to one hundred miles or more.

The Lear-O-Phone Type T-30 transmitter is purposely made compact to be convenient and serve the special purpose intended. This result is obtained by special design and because of the advantages offered by the new 6L6 valves, rather than by limiting the power or performance of the unit. The power output of the T-30 is comparable to other transmitters much larger and heavier.

Power output alone is not the chief factor to consider in determining the efficiency of a

transmitter. The effective range does not bear direct relationship with power output, but is determined largely by the actual intelligibility of the transmitted signal. The T-30 uses a push-pull modulator which modulates the plate and screen voltages of the R.F. power amplifier, and the clarity of the signal is exceptionally good. The transformers used are designed to operate only at the useful voice frequencies, while the lower and higher frequencies are not transmitted. These extreme frequencies would carry engine noise, cabin rumble and high whistling sounds which would only reduce the useful power available for voice frequencies and produce a signal of poor intelligibility.

It is impossible to state the exact range

of a transmitter because of the many variable factors involved. It may be safely stated that under normal weather conditions the T-30 transmitter employing a trailing wire aerial will have a useful range of at least 100 to 150 miles. However, it has repeatedly worked distances several times this range. Users of the T-15 (15 to 20 watts) transmitter report regular transmission range of 300 miles in daylight and 500 miles at night. The T-30, using the 6,210 kcs. transmitting frequency (which is much more suitable for daylight transmission) should far exceed this performance.

#### The Remote Control

The remote control for the T-30 trans-

mitter consists of a small panel on which there is mounted the main control switch, which has three positions—Off, Phone, and CW or telegraph—microphone jack, which also is the key jack (or in an emergency the push-to-talk button on the microphone becomes the key for CW). This panel is complete with a 20-ft. remote control cable on the end of which is an eight-point connector, which can be plugged into the socket already provided on the side of the T-30 transmitter. Although the T-30 transmitter was at first designed for local control operation, it is readily made into a remotely controlled transmitter by just the addition of the above unit.

The remote control unit weighs 4 lb., including the weight of the cable.

# In the World of Science

## Fireproof Wood

A NEW treatment by means of which ordinary timber can be rendered efficiently fireproof has been developed by Messrs. Imperial Chemical Industries Ltd. The timber is impregnated with a special compound to which the name "Faspos" has been given. The timber can absorb between 10 per cent. and 15 per cent. of its own weight of the compound and the treatment costs only about 2s. per cubic foot.

## Coloured Aluminium

A NEW process by means of which aluminium may be dyed with permanent colours has been developed and a new company, Anotints Ltd., has been formed to exploit the process at Hockley Hill, Birmingham.

Although aluminium has been coloured before, the new process, which is an electrical one, is claimed to give a protective covering to the aluminium which becomes an integral part of the metal and is not a form of deposit such as is produced by ordinary plating. The surface of the aluminium becomes an electrical insulator capable of withstanding pressures up to 500 volts and the coloured surface is said to withstand the effects of light and heat.

Another application of the process is being used in America for the treatment of motor-car pistons. It has been found that pistons treated with the process require decarbonising less frequently and it is understood that experiments in this direction will be conducted in Birmingham.

## New Air Liners for Imperial Airways

AMONG the other additions to Imperial Airways' fleet to be made next year will be twelve giant air liners each seating 42 passengers. The machines are now being built by Armstrong Whitworths and will have a top speed of nearly 200 m.p.h. Each machine will have four engines driving variable pitch air screws, and retractable undercarriages will be fitted. The machines will be of the high-wing monoplane type with a span of 123 ft., and it is understood that each machine will cost £42,000.

## Gearless Motor Cars

THE possibility that both the clutch and gear lever may be eliminated on motor-cars of the future has been carried a stage nearer fulfilment by the successful tests which have been carried out over a distance of 30,000 miles of a transmission system invented by Mr. H. F. Hobbs. The system incorporates a completely auto-

matic epicyclic gear and an automatic free wheel, the only controls being the accelerator and brake pedals. All starting and changes of speed are made merely by using the accelerator.

The mechanical efficiency of the gear is high, being only just under 100 per cent. on the direct drive and over 90 per cent. on indirect drive. The fact that the overall efficiency is excellent is shown by the petrol consumption figures of a 6-ton lorry which

achieved are very satisfactory and it appears likely that the new system will be widely applied in the near future.

## A Giant Dam

A DAM is now being built across a canyon near Los Angeles to prevent the disastrous floods which have taken place there from time to time. The new dam cannot be built of concrete or masonry on account of the nature of the underlying rock. As a result, more than 10,000,000 cubic yards of rock have got to be blasted, quarried, removed and dumped to build the dam. The total cost will be nearly two and a half million pounds.

## A High-Pressure Mercury Lamp

A HIGH-PRESSURE mercury discharge lamp in which a temperature of 8,000° C. is reached—equal to that of the sun—is being shown in public for the first time at an Exhibition of Electric Illumination now being held at the Science Museum. The lamp, which is made of quartz, is surrounded by a glass tube through which cooling water circulates continually. The lamp itself contains mercury vapour under a pressure of over 100 atmospheres. Although the source of the light is only five centimetres long, it gives a light equal approximately to 7,500 candle power, while the power consumed is 1,000 watts. The life of these lamps is at present only about 100 hours, but the colour of the light is much nearer to daylight than is the light of the mercury lamps now being widely used.



The Breguet gyroplane, fitted with a 300 h.p. Hispano-Suiza engine, which won the French Air Ministry prize for "hovering." It was stationary in the air for more than ten minutes.

has been fitted with the new gear. Before conversation, it consumed 1 gallon to every 6.65 miles, but with the new gear it does 8.76 miles per gallon, an improvement of over 30 per cent. Although the gear is still in the development stage, the results being

7,500 candle power, while the power consumed is 1,000 watts. The life of these lamps is at present only about 100 hours, but the colour of the light is much nearer to daylight than is the light of the mercury lamps now being widely used.



# YOUR WORK AND YOUR PAY



This is

## International Buildings

Kingsway, London, Head Offices of the

# I. C. S.

It is the centre from which radiates technical, commercial, and professional instruction that has been of great benefit to tens of thousands of ambitious people.

The I.C.S. is the greatest as well as the largest Institution in the Empire devoted to spare-time training. Its prestige is unequalled. The Admiralty, Royal Air Force, Royal Army Service Corps, and other State Departments have entered into working arrangements with the I.C.S. for the training of men.

More than 1,000 I.C.S. text-books, prepared at International Buildings, are marvels of clearness, accuracy, and practical helpfulness.

There are 80 Instructors at Kingsway, many of them Associates, Members, or Fellows of their respective technical or professional bodies. All are specialists, and expert in giving the student individual attention throughout his Course of Study.

Among the 400 I.C.S. Courses there is one that can qualify YOU for Promotion and Better Pay.

The size of your salary is more or less in accordance with the measure of what you know and therefore can do. The more you know, the greater your pay.

Success—progress won by merit—depends on trained ability. Unless you have studied IN YOUR SPARE TIME, you have little chance of promotion, for knowledge that comes through everyday work is not enough.

You must know the principles underlying your work and be familiar with the many processes closely related to that work. *The one and only means of obtaining such knowledge is specialized study.*

No man need be without that extra efficiency which adds so much to his income, security and happiness. He can acquire it, on easy terms, by the simple I.C.S. method of teaching by post.

If you are in the early stages of your career and have not yet had a specialized training, you should start to get one without delay. Or perhaps you feel that your knowledge is a little out of date and ought to be modernized. In either case

## The International Correspondence Schools can help you.

*Our expert advice on any matter concerning your work and your career is yours for the asking—free and without obligation. Let us send you a booklet dealing with the subject in which you are especially interested. It is packed with valuable information. All you have to do is mention your subject and, if you wish, tell us your problem or your difficulty. Write to us to-day or fill in and post the attached coupon. Your inquiry will be dealt with promptly. It may prove to be one of the most fortunate things you ever did.*

### COUPON FOR FREE BOOKLET

**INTERNATIONAL CORRESPONDENCE SCHOOLS, LTD.; (Dept. 95), International Buildings, Kingsway, London, W.C.2**

Please send me your booklet containing full particulars of the Course of Correspondence Training before which I have marked **X**. I assume no obligation.

- |   |  |   |
|---|--|---|
| <input type="checkbox"/> Accountancy              | <input type="checkbox"/> Diesel Engineering        | <input type="checkbox"/> Marine Engineering           |
| <input type="checkbox"/> Advertising              | <input type="checkbox"/> Draughtsmanship           | <input type="checkbox"/> Mechanical Drawing           |
| <input type="checkbox"/> Aeronautical Engineering | <input type="checkbox"/> Electrical Engineering    | <input type="checkbox"/> Mechanical Engineering       |
| <input type="checkbox"/> Air Conditioning         | <input type="checkbox"/> Engineering Shop Practice | <input type="checkbox"/> Mining Engineering           |
| <input type="checkbox"/> Architecture             | <input type="checkbox"/> Fire Engineering          | <input type="checkbox"/> Motor Engineering            |
| <input type="checkbox"/> Boiler Engineering       | <input type="checkbox"/> Garage Management         | <input type="checkbox"/> Pattern-making               |
| <input type="checkbox"/> Book-keeping             | <input type="checkbox"/> Gas-Power Engineering     | <input type="checkbox"/> Plumbing                     |
| <input type="checkbox"/> Building                 | <input type="checkbox"/> Heating & Ventilation     | <input type="checkbox"/> Radio Equipment & Servicing  |
| <input type="checkbox"/> Chemical Engineering     | <input type="checkbox"/> Hydro-Electric            | <input type="checkbox"/> Sanitary Engineering         |
| <input type="checkbox"/> Civil Engineering        | <input type="checkbox"/> Journalist                | <input type="checkbox"/> Scientific Management        |
|   |  | <input type="checkbox"/> Sheet-Metal Working          |
|   |  | <input type="checkbox"/> Short-Story Writing          |
|   |  | <input type="checkbox"/> Steam Engineering            |
|   |  | <input type="checkbox"/> Surveying                    |
|   |  | <input type="checkbox"/> Telephone and Telegraph Eng. |
|   |  | <input type="checkbox"/> Textiles                     |
|   |  | <input type="checkbox"/> Welding, Gas & Electric      |
|   |  | <input type="checkbox"/> Wireless Engineering         |
|   |  | <input type="checkbox"/> Woodworking                  |
|   |  | <input type="checkbox"/> Works Management             |

#### EXAMINATIONS

Technical Institutions and Civil Service (G.P.O.). State which.....

NOTE.—If your subject is not on the above list, write it here.....

NAME..... AGE.....

ADDRESS.....

# THE "BABY GNOME"



## THE NEW OUTDOOR SUPER DURATION MODEL

Span 28 ins. 2 mins. Weight  $1\frac{1}{4}$  ozs.

Duration (Average)

DESIGNED FOR 1937

### COMPLETE CONSTRUCTION KIT 6/6

Which includes: All Balsa Wood Strips, Tissue, Celluloid Wheels, Celluloid Tube, Gloss Dope, Rubber, Cement, in fact everything; not forgetting a full-size working Blueprint and all Instructions.

**MODEL AIRCRAFT SUPPLIES LTD.**  
171 NEW KENT ROAD, LONDON, S.E.1 Phone: HOP 3482

## BE "UP-TO-DATE" WITH YOUR HOBBY IT'S IN THE AIR!

BUILD MODEL PLANES THAT FLY

You cannot do without

### "THE NEW MODEL AEROPLANE MANUAL"

"The most comprehensive book on the subject" 3s. 4d. post paid

The finest Designs, Kits, and Materials, etc., for building successful flyers are described in

### "THE PREMIER GUIDE" & FULL PRICE LIST

Send at once to 4d. post paid

#### PREMIER AEROMODEL SUPPLIES

2a HORNSEY RISE, LONDON, N.19

Phone: ARC 2376

## FREE BEAUTIFUL ART PLATE OF FAMOUS AIRCRAFT with every issue

These beautiful free presentation plates will make excellent and most suitable wall decoration for the Club Room or Model Maker's Workshop.

Order your copy to-day

### AERO MODELLER

The Foremost Model Aviation Magazine 6 D.

From all Bookstalls and Newsagents

• Specimen copy gladly sent on request • Monthly

24/6 Dean St., Fetter Lane, London E.C.4.

## BUILD YOUR NEXT MODEL

IN

## SELLEY-TEX

The wonder material, lighter and stronger than Balsa. Ready-moulded parts to build realistic models 5/- to 23/-

### THE FAMOUS "BURD" AMERICAN KITS

They contain everything to build a "Flyer"—even the 1/3 kit contains a shaped saw-cut propeller.

#### A "BURD" ALWAYS FLIES!

#### FIVE SIZES OF "BURDS" TO CHOOSE FROM

16-in. span, 1/3 post free. Six models: Mr. Mulligan, Fokker D7, 1936 Scinson Reliant, Curtiss Hawk, Ryan St., and Curtiss Robin.  
25-in. span, 2/3 post free. Six models, including Consolidated P30, Waco Military "D," Monocoupe, etc.  
30-in. span, 3/3 post free. Douglas Observation, Mr. Mulligan, Boeing P26A, 1936 Scinson, Aerona C70.  
60-in. span FAIRCHILD 24, only 9/6 post free. WHAT A KIT!  
Two other models. These kits include a 12-in. PROPELLER, READY CUT-OUT RIBS, and SHAPED COWL where needed.  
60-in. "KING BURD" Gas Model, £1.1.0 post free.

Send 2d. for lavishly illustrated Catalogue, just enlarged.

#### WHOLESALE AND CLUBS SUPPLIED

## ELITE MODEL AIRPLANE SUPPLIES

45 TAMWORTH AV., PRESTWICH, MANCHESTER  
Dept. P. Prestwich 2671.

## M.S.S. VALUE KITS SCIENTIFIC, IMP AND BUNCH KITS

These are outstanding examples of value:—

**HI-FLYER, 20-in. kits, 23 Models. Each .. .. 3/3**

Four new HI-FLYERS have been added to the series. These have

MOVABLE CONTROLS, but price remains the same: namely .. 3/3

New models are Hell-Diver: Monocoupe 90A; Waco F6 and Waco Custom Cabin.

**BUNGH CADET, 20-in. span, 3/6; 30-in. span, 9/-** "MIGHTY MIDGET" set of parts, 65/- prop. extra.

**IMP KITS, 15-in. span, 5 Models, 2/-; 23-in. span, 6 Models. Each .. .. 4/-**

**HI-FLYER De Luxe, 4 Models, 25-in. span. Ea. 6/6**

"SCIENTIFIC" KITS, 25-in. span, movable controls, bridge type landing gear. Completest Kit on the market. Build "Mr. Mulligan," the flyer 9/-

The Splendid MONOCOUE 90A, 50-in. span 30/-

New 1937 "GWYN-AERO" 6 c.c. Petrol Motor 92/6

Many improvements. Now fitted piston rings, heavy duty points, etc. With special prop., 100/-

**MODEL SUPPLY STORES, (Dept. P), 46, Derby Rd., Prestwich, Manchester**



## THE BEST PETROL MODEL LIGHTWEIGHT IS THE BRITISH "COMET II"

6-foot Span Highwing Cabin Model, designed by A. E. BROOKS and W. J. FORSTER.

Complete Kit of Parts to build the Model, including "Baby Cyclone" Engine, Coil, Propeller, "B.B." Air Wheels and 2 large sheets full-size Drawings **£7-15-0**

Or with half-size Drawings **£7-10-0**

SEND 2d. STAMP FOR LISTS.

**THE MODEL AIRCRAFT STORES**  
129B HANKINSON ROAD, BOURNEMOUTH

# A Petrol-Driven Model for 2.5-c.c. and 3-c.c. Engines

(Continued from page 261 of last month's issue)



Fig. 10.—The model gliding into a landing with the propeller stopped.



Fig. 11.—This view shows the detachable engine and mounting and wiring retaining elastic bands.

## Covering the Fuselage

THE whole fuselage is now covered with  $\frac{1}{16}$  in. thick lightweight balsa sheet. This sheet has celluloid windows glued inside at the forward end to indicate the cabin type of machine. Each side of the fuselage is cut out separately. Cellulose glue is then applied to the side of the fuselage along the longerons and uprights. The balsa sheets are then placed on the sides, and model aeroplane elastic is wrapped around the fuselage to keep the sheets in position, whilst the glue is drying. When dry the top and bottom are similarly covered, except that the bottom is covered with 1 mm. 3-ply from No. 1 to No 7, former. This forms a firm base for the coil, etc. If the balsa sheet is difficult to bend around the rounded nose, soak the sheet in hot water for a few minutes, it will then be quite pliable and can be put on damp.

When the whole is firmly set, the edges can be bevelled off and the whole sandpapered down smooth. The fuselage is then covered with thin jap silk. This adds great strength. Smear the fuselage a bit at a time, but liberally, with Kodak or similar photopaste and then apply the silk, carefully stretching it taut and without wrinkles. Photopaste makes this operation very simple and when dry prevents the dope from soaking into the balsa sheet and so putting up the weight too much.

Having covered the fuselage with silk, it should be given one coat of clear glider dope. I personally use Cellon Dope. It is far better to obtain half a gallon of this full-size dope than to use model dope, as it gives greater rigidity and strength for a petrol model. A little plastic wood should be placed inside the fuselage, behind the nose-piece, and around the undercarriage tubes, where they touch the fuselage. This will add extra strength to these highly-stressed fittings.

A small incidence block is built up on top of the fuselage to form a platform for the wing. This is built of  $\frac{1}{16}$  in. thick balsa sheet. The correct incidence of the wing is as given in Fig. 4.

## Ignition Details

The coil and condenser provided with the "Elf" engine are wired up on a small

By C. E. Bowden  
The British Petrol Model Aeroplane  
Record Holder

wooden base. It will, therefore, be possible to put in longer wires on the same system. But should the constructor buy another type of engine that is not sold ready wired up, Fig. 12 will show how to do it.

The coil and condenser are strapped to the inside bottom of the fuselage, 1 mm. 3-ply floor, by merely tying down with thread and adding a little cellulose glue to keep steady. They are situated just behind No. 6 former.

A small square is cut out from the completed balsa side of the fuselage by a razor blade, so that the coil can be inserted and a

mentioned.) The battery is thus outside the fuselage, but as it is very small and at the bottom it is scarcely visible, but has the advantage that it does not require any weakening door in the light balsa fuselage. It can be easily got at and inspected and can be moved slightly for adjustment of C.G. weight.

There are two further leads taken up to two sockets that are now mounted on a small 3-ply panel, behind former No. 9.

These are wired into the circuit so that a large ground 1½-volt bell battery can be plugged in for starting up and warming up.

The plugs and sockets can be obtained from any wireless store.

The square that has been removed from the fuselage side can now be glued back into position and recovered with a small piece of silk and redoped.

An opening is made in the fuselage top in a similar manner for the insertion of the clock-timing mechanism and the ground battery sockets, which are both mounted on 3-ply panel. This panel is then glued into position, and the edges covered with silk and doped.

The panel is fitted in between Nos. 7, 8 and 9 cross pieces.

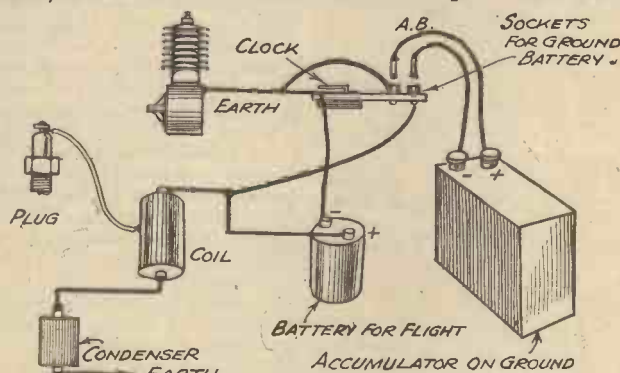

Fig. 12.—For flight, the two plugs A and B are removed after the switch on the clock mechanism has been connected. The engine is thus started by the ground battery, and the plane flies on the small pocket flash lamp battery.

large needle with thread will "sew" it down to the floor. The wiring is then threaded forwards to the engine and back to the clock-timing mechanism, and two leads are led out through a hole in the fuselage bottom just in front of former No. 7. These leads have spring wireless clips attached to their ends. The little flash lamp battery, a "Drydex, No. F. 12, Bijou pocket lamp," price 4d., is then merely slipped under the elastic bands attached to the wire hooks that look downwards from former No. 7. (These have already been

flight of the model. It is positive in action and operates by cutting off the ignition to within any desired second. It is a safety device of the greatest importance, for with a little care and thought the model can be flown in quite small fields with this device, without any danger of the model flying away. The device is also useful for the preliminary test flights as will be explained later under "Flying the Model." The extra 3½ to 4 oz. weight is well worth carrying and the wing loading of the model has been designed to carry the weight. Mr.

## The Clock-timing Mechanism

Allman, of Wakefield Cup fame, designed the clock mechanism for the writer.

A small 2s. 6d. clock should be obtained, the mechanism extracted from the case, and the latter, with the dial and hands, are discarded. Projecting shafts, except the winding shaft, are cut off as short as possible. The escapement mechanism is removed and discarded (see Fig. 13). The escapement wheel must be removed and converted into a governor.

Two strips of very thin, hard, brass foil about  $\frac{1}{1000}$  in. in thickness are cut, slotted and curved. The slotted ends of the strips are then soldered to the escapement wheel on opposite sides, so that the strips fit round the escapement wheel in the same direction as indicated by the teeth. Two blobs of solder are then put on to the ends of the strips.

Now construct a small cylinder of thin tin. It should be just large enough for the escapement wheel to revolve inside without the strips or the solder weights touching the sides of the cylinder. Replace the escapement wheel and cylinder into the clock mechanism and solder the cylinder in position.

Now construct a starting and stopping lever of heavy gauge brass, to which is fixed a small spring catch of fine steel wire. When the lever is up the fine steel wire engages in the spokes of the gear wheel next to the governor (see sketch). The time switch is now screwed to a panel of 3-ply wood, which is fitted as previously explained into the top of the fuselage.

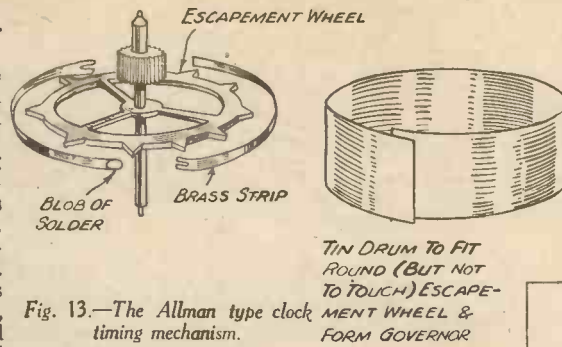

Fig. 13.—The Allman type clock escapement wheel & timing mechanism.

battery. When ready for flight the movable contact A is pushed over on to the fixed contact B, and the plugs are then removed and the engine is now running on the small battery. As the model is released the brake lever is pressed to allow the clock to start. The time switch then breaks the ignition at the time set on the dial.

It is possible to test out the new model with complete safety, starting with a short flight of five seconds, and gradually increasing the duration until perfect trim is obtained.

**The Undercarriage and Tailwheel**

A good model aeroplane glides onto the ground with its nose slightly down, whereas the full-sized aeroplane lands with the nose pulled up at the last moment by the pilot.

This is called a three-point landing and the shocks are mostly in an upward direction, whereas the model undercarriage has to take the shock in a backwards direction and then upwards. The undercarriage on this model is designed to carry out these requirements and will save the model and itself from damage. It is also detachable, so that the model can be carried in a smaller space, and it is practically unbreakable.

Fig. 14.—Details of the rear chassis.

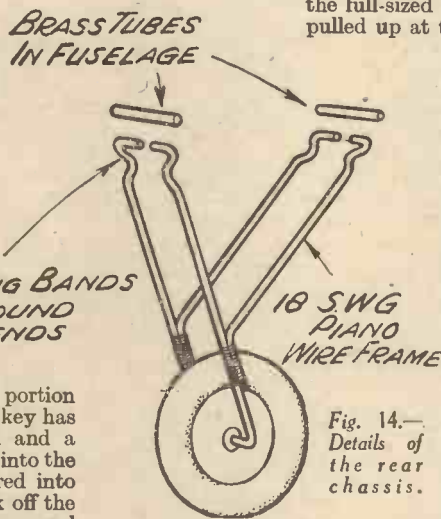

Now the top portion of the winding key has to be removed and a nail is inserted into the hole and soldered into position. Mark off the top of the 3-ply panel as a dial. This is calibrated in seconds with the aid of a second watch or stopwatch.

**Electrical Contacts**

Finally the electrical contacts are fixed on the 3-ply panel as shown in Fig. 13. The nail or "finger" operates these contacts when it approaches "zero hour." It moves the movable arm from the plate and the ignition circuit is broken.

Before fixing the set screw B into position wind the spring until the mechanism is half-wound up. To operate the time switch for controlling duration of flight the stop and start lever is raised and the pointer is wound up to the desired number of seconds. The ground battery is plugged in to the two sockets that should be fitted to the 3-ply clock panel (see Fig. 12), and the engine is started and warmed up on the ground

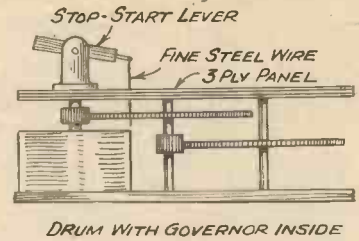

DRUM WITH GOVERNOR INSIDE

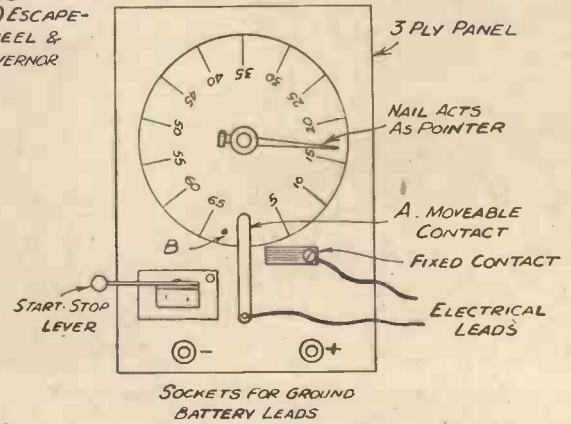

SOCKETS FOR GROUND BATTERY LEADS

These circular spring legs are duplicated and bound to each other side by side by insulating tape in the same way that racing car springs are bound. This gives an excellent shock-absorbing effect.

The main legs are then covered with  $\frac{1}{8}$ -in. thick balsa wood glued on either side of the legs. This is streamlined off with a razor blade and sandpaper, and the legs are then coated in photopaste and silk strips are bound around them. They are finally doped, one coat of full-strength glider dope and then painted any desired colour to waterproof. This final silk covered fairing makes the legs very strong and indestructible. Two light "M and M" American 3-in. diameter airwheels are fitted. They weigh 3 oz. the pair.

A tailwheel, which is also detachable, can be fitted as shown in Fig. 14.

**The Main Plane**

This is 63-in. span with a chord at the root of 9 in. and at rib No. 8 of  $6\frac{1}{2}$  in. See

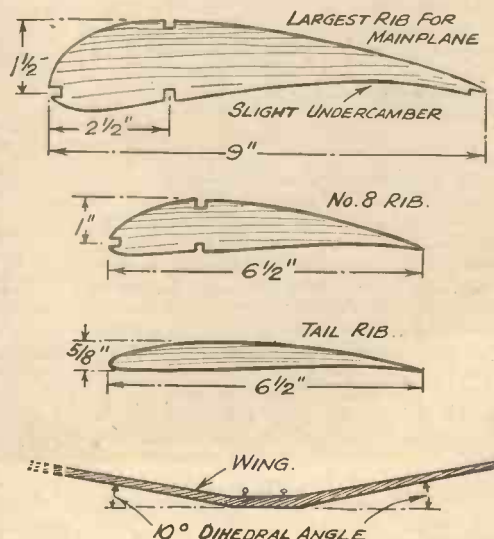

Fig. 15.—The ribs for the main plane and tail.

two piano-wire legs with the ends turned outwards at the bottom to form stub axles. The wire used is 14 s.w.g. piano wire throughout. The top ends are turned inwards for 1 in., and these ends fit into the duralumin or brass tube that has already been described as fitted to the fuselage. Two strengthening pieces of piano wire are bound and soldered—one along each leg. A crossbar situated about one-third from the top of the legs is also bound and soldered to each leg.

There are two circular spring rear legs that are bound to the main legs and soldered (see sketch). The rear ends of the circular legs are turned inwards for 1 in. and form prongs to fit into the rear fuselage tube.

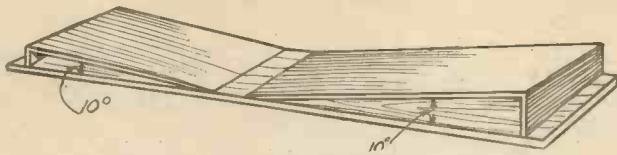

Fig. 15 for general measurements and section of ribs. Nine main ribs of  $\frac{1}{4}$ -in. thick soft balsa are fitted and five riblets (see Fig. 4). It will be observed that the wing has a tapered plan with the trailing edge coming well forward. This is important for stability purposes.

A full-sized plan drawing must be made of the wing so that it can be built over the drawing.

This drawing is then placed on a wooden bed that has the correct dihedral angle built into it. The dihedral angle is 10 degrees for each wing from the horizontal (see Fig. 15 at bottom, also Fig. 16). Now look at Fig. 16, and the method of constructing the wooden bed will be clear. This is important as it ensures that the wing does not warp from true when the dope is setting, for the wing is weighted with old kitchen irons or any other weights during this period.

The bed also ensures that the correct dihedral angle is built into the wing, and it forms a convenient place to leave the wing when not in use, and if weights are kept on it the wing will always remain true.

Above the drawing place the usual grease-proof but transparent paper to prevent the glue sticking to the drawing.

Newcomers to model work may wonder how to draw in the ribs to correct size owing to the taper of the wing. This operation is quite simple. When the plan drawing has been made of the wing and the ribs numbered. The height of the largest rib and the smallest rib are drawn on a front elevation sketch (full size) of the wing, and this maximum height is used to draw in each rib separately on the plan drawing of the wing. Afterwards these drawings of the ribs are traced on to  $\frac{1}{4}$ -in. sheet balsa

with carbon paper. The ribs are then cut by fret machine around the lines or by a

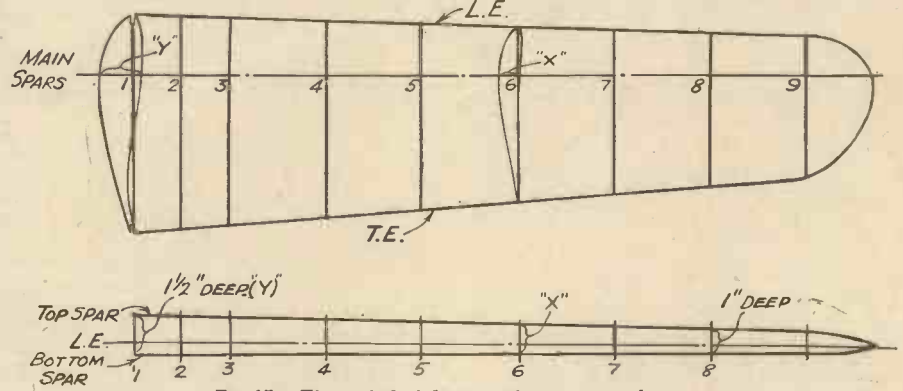

Fig. 17.—The method of drawing ribs on a tapered wing.

sharp safety razor blade. Fig. 17 will make the method clear.

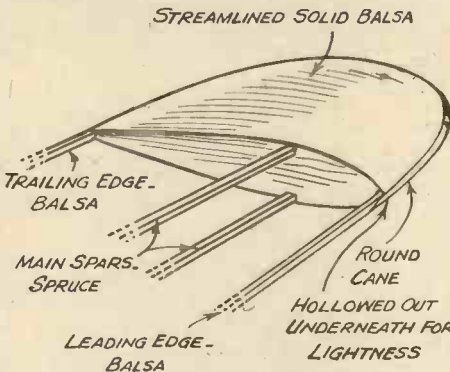

Fig. 18.—The construction of the wing tips.

**The Ribs**

When all ribs are cut and slotted as in Fig. 9, they are glued with durofix or quick-drying model aero glue, into their correct positions over the drawing on to the bottom mainspar which is  $\frac{1}{4}$ -in. by  $\frac{1}{4}$ -in. spruce. The top spar also of  $\frac{1}{4}$ -in. by  $\frac{1}{4}$ -in. spruce is then glued into its slots. Now the leading edge spar is glued into its slots. This is of

$\frac{1}{4}$ -in. by  $\frac{1}{4}$ -in. medium balsa. Now the trailing edge is added of the same sectioned balsa. Under the trailing edge a length of 1 mm. thick balsa sheet 1 in. wide is glued, and also glued to the ribs just before they meet the T.E. This has a great strengthening effect. The wing tips are made light yet damage proof, by first bending lengths of softish round cane to the shape of the tip shown on the drawing. This can be done with the fingers. The two ends are glued to the leading and trailing edge and pinned until set. The tip is now filled in with a solid piece of very soft white balsa. This is carved to a streamline shape and sand-papered smoothly off. (See Fig. 18.) The underneath can be hollowed out slightly for lightness. This type of wing tip will never become damaged although it is light.

**A Roman Kiln**

**B**ETWEEN 1,600 and 2,000 years ago on a site near which the village of Compton, Berkshire, now stands, the manufacture of pottery was carried on. After the pottery had been shaped by hand out of the crude clay, it was burned or fired in a kiln to harden it. The kiln, crudely constructed of clay in a hollow of the chalk subsoil has recently been unearthed in the middle of a ploughed field where it has lain hidden for centuries.

The discovery of the kiln was due to the acquisition of a motor tractor plough by the farmer which rendered deeper ploughing possible. The farmer noticed a patch of soil which was darker than the rest of the field and casual examination disclosed pieces of broken pottery. Closer examination suggested the presence of the kiln and careful excavation revealed the entire kiln in a perfect state of preservation. Constructed of hardened clay, the kiln consists of a lower chamber in which the fire burned beneath a "floor" which supported the pottery. The floor is perforated by a number of holes which allowed the heat to reach the pottery, and, when in use, the kiln would have been covered over by a temporary covering to maintain the temperature.

The discovery of this kiln is of considerable interest since it is the only perfect example known. This fact caused the authorities of the Science Museum to under-

**WHAT WE HEAR**

take its excavation and removal to London. Encased in a complete cradle of reinforced concrete and weighing 4 $\frac{1}{2}$  tons it was transported intact to London where it is now on exhibition in the Science Museum and where it will be preserved for future generations.

**Spraying Fireproof Cement**

**T**HE spraying of paint, distemper and other liquids has been common practice for a number of years, but now the spraying of cement is coming into use.

A particularly useful application is in connection with the refractory lining of certain types of furnaces. It is found desirable to cover the firebrick walls with a smooth lining, and by means of a high-pressure cement gun, a perfect coating can be quickly and easily applied. Not only does the cement penetrate into the interstices of the bricks far more efficiently than when applied by hand, but the cement sets harder and with a more perfect surface.

It seems not unlikely that this development will have important applications in the ordinary building industry.

**New Petter Oil Engine**

**A** NEW type of oil engine has recently been demonstrated by Petters Ltd., in

which the principle of "harmonic induction" is used to extract the exhaust gases from the cylinders. By a special design of the exhaust pipe arrangement, a wave motion is created in the exhaust gases, and a partial vacuum which occurs periodically serves to scavenge the burnt gases. In this way, more complete charging of the cylinders is possible and the power obtainable from a cylinder of given volume is increased by no less than 50 per cent.

**Petrol Tank Explosions**

**O**N several occasions in recent years, explosions of empty petrol tanks have occurred for no apparent reason. Last April, a serious one took place at Hull in which three men were killed, and the results of the investigation which followed have just been published.

It is believed that the explosion was due, indirectly, to some water which had been left in the bottom of the tank. The water, which had come from the sea, contained dissolved sulphates and also certain bacteria which are able to reduce the sulphates with the liberation of sulphuretted hydrogen gas. The evidence seems to indicate that the sulphuretted hydrogen attacked the iron of the tank, with the formation of a type of pyrophoric iron sulphide, a substance which is liable to spontaneous ignition due to the heat generated by oxidation.

# BAIRD'S MULTI-MESH TELEVISION SCREEN

By H. J. Barton Chapple, Wh.Sch., B.Sc.(Hons.)

Producing Large-Size Television Pictures



Fig. 1.—The person being televised is positioned in front of a framework accommodating the photo-electric cells.

FROM the very beginning it has been the aim of every television inventor to produce large-size pictures. This did not mean necessarily that the dimensions should be identical with cinema screens, but big enough for audiences of several hundred

first laudable attempt at big screen working was the lamp screen shown by Baird to the public in 1930 at the Coliseum, London. This screen, illustrated in Fig. 2, comprised 2,100 pocket-lamp type bulbs arranged in seventy horizontal rows with thirty lamps in each row. This was to conform to the low-definition television standards then in operation.

### Reduced Flicker

As will be seen from Fig. 3, the received signal after amplification was passed to a large commutator with 2,100 segments, each segment being connected to a lamp. A brush sweeping round the commutator bars at high speed imparted the television signal to each lamp in turn. The measure of luminosity of each lamp, therefore, was proportional to the signal strength at that instant. By fronting the screen with frosted glass the picture, as observed by the audience, was sufficiently bright and large (7 ft. x 3 ft.) to be seen in a large theatre. Another important factor with this device was that although the complete picture traverses only amounted to 12½ per second, flicker was not very prominent. This was a direct outcome of the persistence of illumination of the lamps themselves supplementing normal visual persistence. Again in 1932 a back projection television screen was exhibited at the Metropole Cinema, London, so that the finish of the Derby could be watched by the audience. Here again, however, only 30-line definition was used, although three matched zones of thirty lines each enabled a picture giving a total of 90-line dissection to be seen.

### An Original Development

The present Baird multi-mesh screen

to watch the pictures in complete comfort, without the slightest trace of eyestrain.

With pictures of the old low-definition standard, the problem was solved with varying degrees of success in several different ways.

In one case a translucent glass was backed with a very long tube filled with neon gas, the tube being bent to form a zigzag channel so that a travelling point of fluorescence could trace a picture in lines at sufficient speed to give the illusion of a moving television picture. This was not particularly successful, and it is now a matter of history that the

installed at the Dominion Theatre, London, is really a modification of the intermeshed system used by the inventor as far back as 1923. This original equipment is now in the Science Museum, South Kensington, and Fig. 4 is a photograph showing the crude apparatus, a lens disc being used in place of the mirror drum employed with the present apparatus. The system was abandoned at that time, as for low-definition work a complex system of scanning unduly complicated the apparatus at a period when television technique was not sufficiently developed to utilise its advantages. When the introduction of ultra-short waves opened up the possibility of high-definition television, work was recommenced with the multi-mesh system as far back as 1929.

It is interesting to note that an improved and enlarged version of this complex system was built in the Long Acre laboratories so that experiments could be continued. This equipment is shown in Fig. 6, and consisted of a series of lenses mounted at the extremities of radial arms, something like the spokes of a mariner's steering wheel on the bridge of a ship. This revolved in conjunction with two large slotted discs, shown in the foreground of Fig. 6, in order to give the

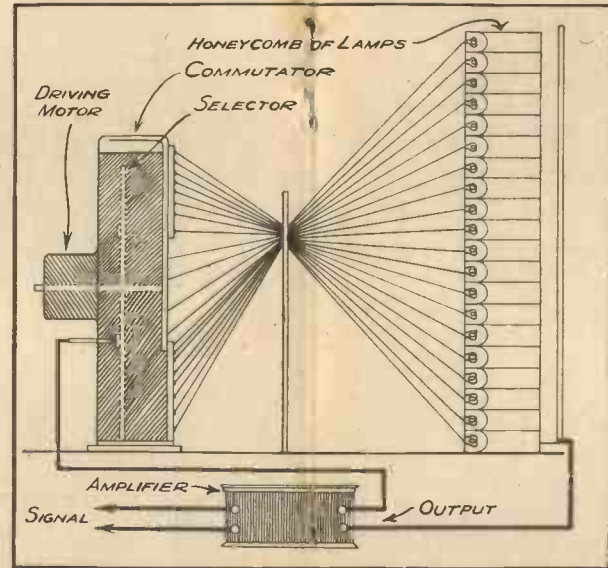

Fig. 3.—Showing how the commutator bars fit the incoming television signals to the lamps in turn.

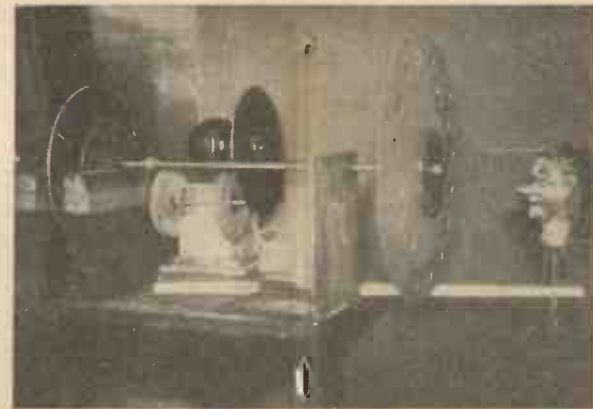

Fig. 4.—A view of the early-type multiple scanning apparatus used by Mr. Baird.

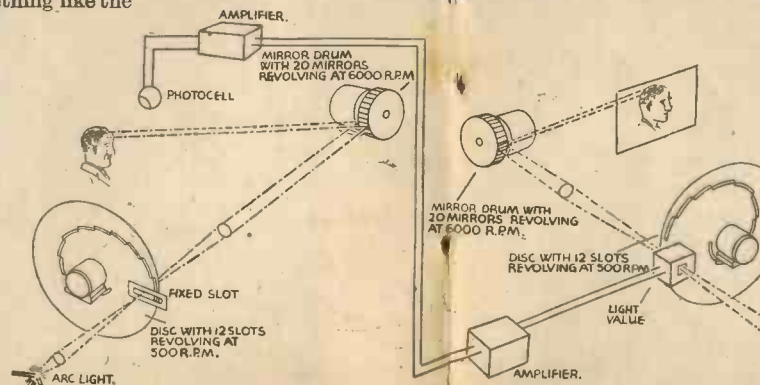

Fig. 5.—A pictorial representation of the transmitter and receiver.

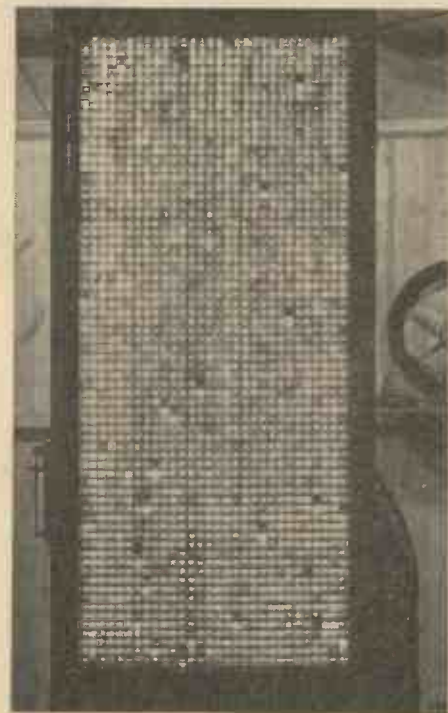

Fig. 2.—The 2,100-lamp screen in the laboratory prior to being installed at the London Coliseum.

# MESH SCREEN

), etc.

ures

required scanning action. These experiments are interesting as they have a direct bearing on the methods employed at the Dominion Theatre, which is an installation to act primarily as a "visual" loud-speaker to show a greatly enlarged television picture of an entertainer or lecturer to every member of an audience seated in a large theatre.

## Results

Demonstrations were first of all given to a company of press representatives, and later the screen was featured three times a day for a week. It is now shown each Friday evening as part of the programme seen by the cinema patrons. The results are very satisfactory, flicker being almost non-existent, synchronising almost perfect, while the brilliance is ample to enable every member of the audience to see with ease.

In making the transit from the laboratory to the theatre, considerable difficulties had to be overcome. It was found, for example, that a screen which appeared sufficiently brilliant in a laboratory was not nearly bright enough to be seen properly throughout the large theatre auditorium. Considerable changes had to be made to overcome this difficulty, and make the screen both non-directional and adequately

dispersive. Furthermore, although the programme was transmitted from a studio in one of the Dominion Theatre dressing-rooms, it is perfectly applicable to wireless, and successful radiations had been made between the Dominion Theatre and the Crystal Palace. The recent fire has, however, destroyed the radio transmitter. As the art advances the present screen will be enlarged in size and clarity, and the Dominion Theatre will be in a position to show each advance as it takes place.

## Technical Details

The success of this large screen achievement is due in no small measure to the many novel features which are included in the system. First of all, there is the multi-mesh scanning, which in effect is the simple interlaced scanning, now so familiar to readers, carried several stages forward. A secondary field is made up from two or more primary interlaced scans; this secondary scan being repeated a number of times, and displaced at each repetition. In the present Dominion apparatus, the secondary scan consists of two 20-line scans intermeshed to form a total of 40 lines. This 40-line field has a triple repetition, being in each case laterally displaced to interlace with the other fields so as to form a final field of 120 lines. The rate of scanning used gives  $16\frac{2}{3}$  complete pictures per second, or 100 partial scanings per second.

It is claimed that by this scheme several advantages materialise when compared with the more usual straight or consecutive scanning. The chief of these is that in the receiving apparatus the width of the scanning spot is not restricted to the width of the final scanning strip, but is so wide that each traversal constitutes a complete scanning of the picture. Hence by using a scanning spot so that the secondary scan completely fills the field, a great increase in light efficiency is obtained with a relatively small loss in definition.

Flicker is also reduced very considerably, a fact made very clear by the demonstrations themselves, while since

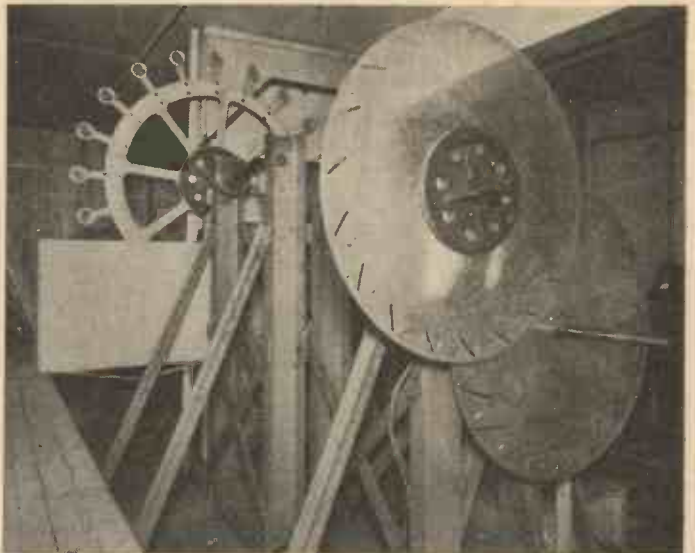

Fig. 6.—An enlarged version of the multi-mesh equipment built in the Long Acre laboratories.

the frame frequency is very much higher, being the same as the frequency of the primary 20-line scan, the communication channel may have a much higher low-frequency cut-off. The actual band width employed in the case under review is about half a megacycle. Finally, an optical system of high efficiency but great simplicity can be utilised.

## Method of Working

In Fig. 5 is shown a pictorial view of the complete system, the transmitter being illustrated on the left and the receiver on the right. Taking these in turn, at the transmitter we have first of all a 15-amp. arc-lamp crater focused on to a slot in a fixed diaphragm, behind which a disc revolves. This disc has twelve concentric slots located on a spiral trace cut into the face, being driven at a speed of 500 revolutions per minute. The slots in the discs

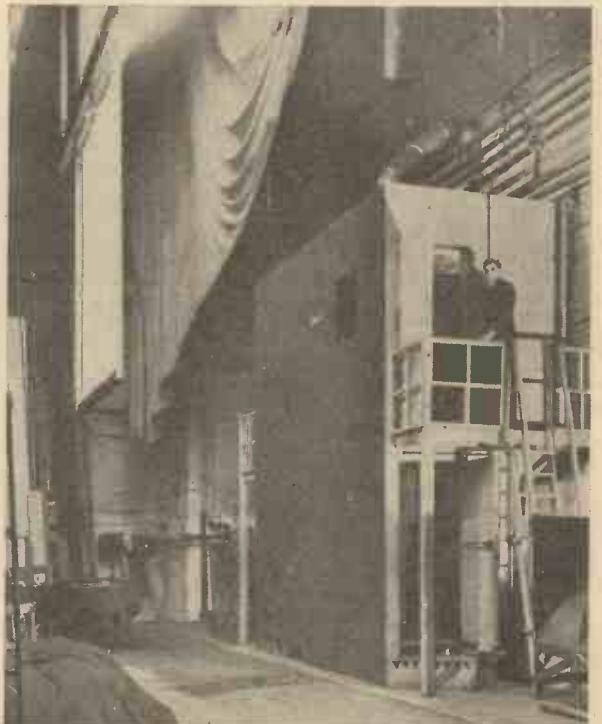

Fig. 7.—The fireproof receiver cabin located at the back of the theatre stage.

as they pass across the slot in the diaphragm, form an aperture which moves backwards and forwards as the disc revolves. The resultant beam is passed to a mirror drum having twenty facets and kept running at a constant speed of 6,000 revolutions per minute. It will be seen, therefore, that this is the primary scan of 20 lines, as each

number of lines in the picture, and by choosing a suitable combination, any desired degree of line definition can be secured.

The person being televised, as shown in Fig. 1, stands before this back screen and the light reflected from the features and clothes is picked up by a bank of six photoelectric cells let into a framework, which is

possible efficiency.

### The Receiver

In its essential features where the scanning equipment is concerned, the receiver and transmitter are identical. A 150-ampere Sperry type arc lamp is used as the light source, and the focused beam from the crater is modulated by passing the incoming television signal to a special type of Kerr cell. This cell is a light valve which has the property of passing through its combination more or less light in strict proportion to the strength of the voltage signal applied to the cell plates. By means of the disc and drum scanner, the modulated beam is back-projected on to the screen seen on the left of Fig. 7, producing a 120-line field of bright light, 8 ft. high and 6 ft. 6 in. wide. Whereas in the transmitter the light strips formed by the "flying spot" do not overlap, at the receiver, as indicated earlier in the article, the scanning spot is enlarged so that the secondary scan completely fills the available field in order to obtain a substantial increase in intrinsic field brilliancy.

Mr. Baird has pointed out that the multi-mesh system can be used for cathode-ray tube receiver work and also electronic scanners, and experimental work in this direction is already being undertaken.

It will be understood that this "Super Screen" is intended for the specific purpose of providing special entertainment and not for receiving any of the programmes broadcast by the B.B.C. Theatres will, however, be in a position to make their own arrangements to use the television screen for their own purposes by means of a private transmission so that any event which the management would like to cover could be presented to an audience. In the cinema itself, artistes can, of course, be put on the screen at a moment's notice.



Fig. 8.—The interior of the receiver cabin, showing Mr. Baird with some of the equipment.

disc slot moves across the fixed aperture slot in the time taken for one complete drum revolution.

As the drum revolves, the spot of light so formed is focused by a 14-in. diameter lens on to a back screen so that it is covered by a succession of vertical strips. Readers will see that the number of disc slots and the number of mirrors on the drum, together with their relative speeds, determine the

supported on the wall separating the transmitter mechanism from the studio. The normal spot-light type of television signal is thereby generated, and after amplification, this is fed to the receiving equipment located in a fire-proof cabin at the back of the stage, as shown quite clearly in Fig. 7. The inside of the cabin is shown in Fig. 8, being built on sound engineering lines to ensure the greatest

### The "Strand" Coronation Souvenir 2/6

AN exquisite souvenir of the Coronation of Their Majesties the King and Queen. Size 14 in. by 9½ in. 64 pages of pictures and text, finely printed in two colours, including 16 beautiful colour plates by well-known artists, designers and photographers.

This is likely to be by far the most beautiful book issued in connection with the Coronation of Their Majesties King George VI and Queen Elizabeth, and has been specially written by Edward Shanks.

In the text attention has been paid in the first place to the lives of the King and Queen. In addition, however, much space has been devoted to the Coronation ceremony in history, and to the same ceremony as it is to-day.

The admirably written text matter is adorned with many fine photographs, and the colour plates, by such artists as Gordon Nicholl, R.I., Ellis Silas, Reginald Knowles and others, are perfect examples of colour reproduction.

The colour plates include:

Coloured title-page of Royal Coat of Arms. Their Gracious Majesties King George VI and Queen Elizabeth.

The Kings of England: A Genealogical Tree.

T.R.H. The Princesses Elizabeth and Margaret Rose.

The First Oblation, King Charles.

The Coronation of Queen Elizabeth.

Proclamation of King George VI's Accession.

The King's Champion.

Westminster Abbey: The High Altar.

### HERE AND THERE

The Inauguration of Oliver Cromwell as Lord Protector.

Queen Mary.

The Coronation Banquet of King Henry VIII.

The Court of Claims: Period of Edward V.

The Coronation of William the Conqueror.

The Crown Jewels (I).

The Crown Jewels (II).

### British Cellophane, Ltd.

IN a recent article in this journal, entitled "Transparent Mysteries," we made several references to "Cellophane." We should like to draw readers' attention to the fact that the word "Cellophane" is not a general term, but that it is the registered trade mark in Great Britain and many parts of the British Empire of British Cellophane, Ltd., to denote, and denote only, the brand of transparent cellulose sheets supplied by this company.

### The Energy of Heavy Hydrogen

DISCOVERED only a year or so ago, the new element deuterium, better known as "heavy hydrogen," seemed to have little practical application, especially as it costs about £3,000 per lb. Ordinary hydrogen, from which it superficially differs very little, can be purchased for about 1s. a pound!

It is now reported, however, that means have been discovered for producing jets of deuterium gas of such high velocity that the energy available from a single pound of the gas is equivalent to that

obtainable from the combustion of 2,500 tons of coal.

When a jet of the gas is caused to impinge on certain substances, remarkable changes occur and artificially radioactive substances are produced. Common salt, for example, becomes changed to such an extent that it possesses a radioactivity half as intense as pure radium. The radioactivity, however, which is thus induced artificially is short lived and disappears completely in a few weeks, while that of radium continues almost undiminished for centuries.

The use of radioactive salt is likely to have very important medical applications, for while pure radium cannot be injected into the blood-stream on account of the impossibility of recovering it, yet a dose of radioactive salt could be given by the mouth or by injection and the short period of natural decay would eliminate the dangers of excessive exposure.

### Liquid Coal

A VALUABLE and economic outlet for large quantities of waste coal and dust has been found by the addition of pulverised coal to the oil used in oil furnaces. The dust and small coal are ground to an extremely fine state, and in this condition they mix almost perfectly with the oil, and although some difficulty was experienced at first in making the coal remain in suspension, this has now been overcome by the addition of lime-resin soap. By the addition of pulverised coal to petroleum or coal-tar oils, an important saving in the quantity of imported oil fuel will be made, especially as it is understood that the oil-coal mixture can be used with excellent results for diesel engines.



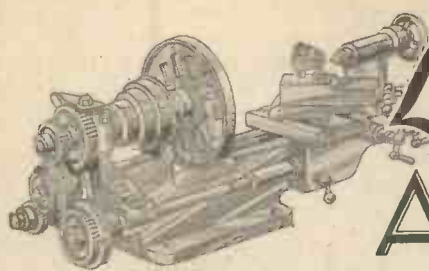

# Lathe Work FOR AMATEURS

## MAKING A SCREW DIE

**W**HERE a die is required for screwing an odd size of thread or to replace a die which has become worn, it may be easily made if the following instructions are carefully followed.

If a tap is not available this must be made first. It will be of cast steel and should be turned to the full size of the thread, and then screw-cut in the lathe and finished with a standard chaser. The latter is important. It should then be grooved, which may be done with a file or by holding it still between the lathe centres and traversing a side tool of the shape shown in Fig. 1 along by the saddle-heel screw. The position of the tool should be relative to the tap blank as shown in the section. A stop pin, A (Fig. 1), should be plugged in a hole in the top slide to prevent the tool slewing round under the cut. It should then be heated to a cherry red and plunged in water to make it dead hard. To temper: brighten the grooves with emery cloth or a carborundum slip, and hold the tap inside a piece of gas barrel, the end of which has been heated to a full yellow-red colour, till the flutes show a straw colour. Then quench in cold water. This is shown in Fig. 2.

### Cut from Cast Steel

To make the die, which will best be a round disc in shape, cut the disc off the end of a piece of round cast steel and face up and polish each side in the three jaw chuck.

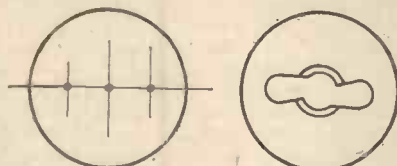

Fig. 3



Fig. 5.



Fig. 4

Figs. 3 to 5.—  
Three stages in the making of a die.

Then scribe a line across its diameter, mark the centre and mark two other centres equidistant from the centre on the diameter line as in Fig. 3.

These two centres should be at a distance equal to half the diameter of the screw plus roughly one quarter its diameter from the central centre. We thus get three circles, as in Fig. 4, the central circle being twice the diameter of the two side circles, and the holes just on the point of breaking into each other. Drill down the centre point with a drill the tapping size of the screw thread to

be cut by the die. Then tap the hole. This should be done after the piece has been annealed by heating red and cooling slowly in hot ashes.

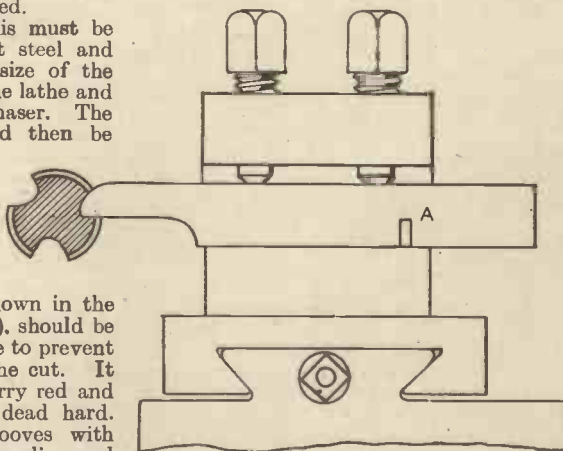

Fig. 1.—The method of grooving the tap.

Now, with the tap we have made, or a tap already available, and with plenty of oil as a lubricant, carefully tap out the screw

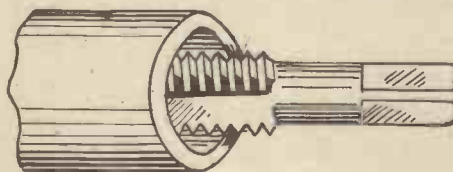

Fig. 2.—Method of tempering a tap.

thread to full size. Then with a taper reamer, reamer out the thread till there is only a full thread in the hole for nearly half its length. The other length (just over half) will have the thread cut away at a taper. This gives a start for the die, and it will now be as in Fig. 4, the central hole having threads and the side holes clear and just close to the outside diameter of the threaded hole.

### The Cutting Edge

With a small flat warding file, file a slot through from the side holes into the central hole at an angle as shown. This gives a

cutting edge to the threads in the die which act as teeth to cut the thread on the piece required to be threaded. Use a very fine file and finish with a thin emery strip or strip of very fine "Washita" stone to give a smooth surface.

The die now requires to be hardened and tempered. Heat it to a full red heat and plunge it (flat down not sideways) into the vortex of swirling salt water in a pail. It will then be dead hard.

Brighten the face at the side which has the full cutting teeth (not the side which has the taper lead-in), and lay it down with

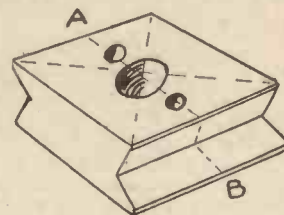

Fig. 6.—The die is divided on the dotted line A B.

the bright side uppermost on a flat piece of iron or steel heated to a slight red. Gradually the colour on the top surface will turn from pale yellow to full yellow, and then golden yellow. When just approaching the golden yellow colour quench, as before, in the vortex of the salt water, and the die is finished.

### A Split Die

If making a split die, as for a die stock, instead of using the cast steel disc, a piece is cut from a cast steel bar of a width equal to the full width of the die over the Vs, square, and of a thickness equal to the thickness of the die holder plus 1/4 in. Then cut the V-grooves each side so that it is of the shape shown in Fig. 6, and fit it in the die stock so that it easily moves up the stock and without shake. Now scribe diagonals as indicated by the dotted lines, and mark off at the centre the central screwed hole and the side holes, as shown, and proceed as in making the solid disc die up to the point at which we hardened and tempered it.

Then cut the die in half with a hacksaw along the line A B, and file up the cutting edges—A in Fig. 7—at the correct angle, which will mean filing the cutting face back a little between the two holes on the faces represented by the line A B in Fig. 6. This gives the angle of the cutting edges of the die.

To harden, heat to a full red, quench in

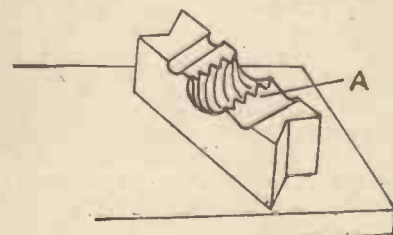

Fig. 7.—The cutting edges A should be filed to the correct angle.

salt water and polish the faces. Then lay each die (as in Fig. 7) on its flat edge on a red-hot piece of iron and watch the colour till it is golden yellow at the cutting edges. Then quench as before.

After the die is hardened it is good practice to grind or hone the front surfaces of the cutting edges which may be left rough by the saw cut. These should be honed down till the edge is quite sharp at the faces of the Vs of the thread.

## LATHE WORK FOR AMATEURS

By F. J. CAMM

96 Pages

1/- or 1/2 by post from Geo. Newnes Ltd., 8/11 Southampton Street, W.C.2.

# ELECTRIC RADIATOR

By K. C. Barnes

An Electric Radiator is an Extremely useful Asset for the Household,  
and below we give Details of their Construction

**T**HE heating element of the radiator shown is wound on a former,  $9\frac{1}{2}$  in.  $\times$   $\frac{1}{2}$  in. This is wound with No. 26 nickel-chrome wire, and with this winding, 230 volts will give a current of about 4 amps., and a consumption of about 1 kilowatt. A heater of lower consumption could be made by using 28 or 30 gauge wire, but no attempt should be made to increase the consumption above 1 kw., except by using a second heater element. The ends of the wire are secured by passing, through the small holes provided, into the bore of the tube and out through the ends, leaving a few inches for connection to the brackets.

## Fitting the Heater

The heater is held in a stainless steel reflector by two brackets made from brass strip and projecting through two holes in the reflector. The heater should be held at least two inches away from the reflector to avoid burning the polished surface, though the danger of this is much less with stainless steel than with other materials. The brass brackets are fixed to an iron bar with insulating bushes made from vulcanised fibre strip. This arrangement is shown in Figs. 2 and 3, and it can be seen that one of the bolts on each bracket is provided with a terminal fitting. Four BA brass bolts are fitted so as to project inwards through the free ends of the brackets; these are to hold the heater tube in position and to connect the ends of the nichrome wire to the brackets.

## The Reflector

The reflector is of 22 gauge stainless steel, and its size will depend upon how much the constructor can afford, a convenient size being about 16 in.  $\times$  12 in. Square holes are cut in the flat sheet with a small cold chisel, the material resting on a flat iron surface while cutting. The holes should be large enough to leave at least  $\frac{1}{4}$ -in. clearance round the brackets, so as to avoid any danger of the latter coming into electrical contact with the reflector. The sheet is then carefully worked into a roughly parabolic shape by placing it centrally along a roller and pressing on the edges. It is strengthened by two  $\frac{1}{4}$ -in.  $\times$   $\frac{1}{4}$ -in. iron strips bent to the same curve and fixed to it by four small countersunk bolts. These iron strips are fixed between the square holes and the ends of the

reflectors, and are so placed that the ends of the bar carrying the brackets can be screwed to them. But the bar must be

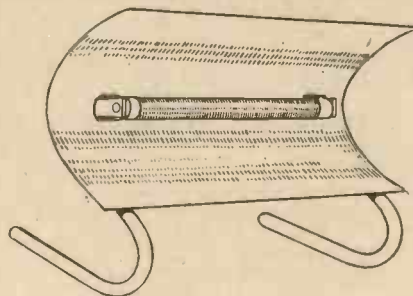

Fig. 1.—The finished radiator.

sufficiently far from the back of the reflector to avoid the latter coming into contact with any of the live parts; it should therefore be held away from the curved strips, to which it is fixed, by interposing one or more nuts on the bolts used.

The electrical connections are obviously made to the two terminals behind the

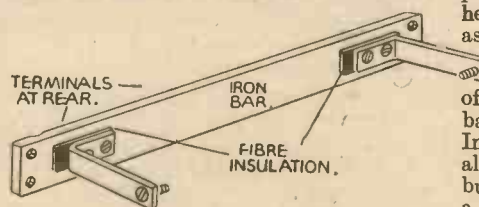

Fig. 2.—The brass brackets are fixed to an iron bar with insulating bushes.

brackets. The bar and connections are shielded by a box of galvanised iron fixed at its edges to the two curved strips on the reflector, leaving an air gap to allow passage of air up the back of the reflector. The

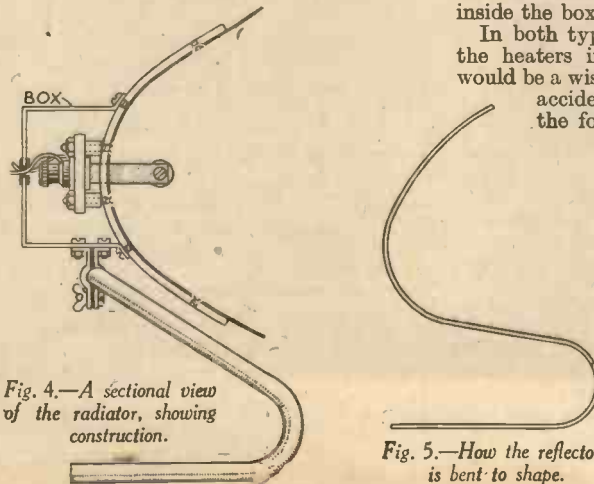

Fig. 4.—A sectional view of the radiator, showing construction.

flex from the terminals passes out through a wooden or ebonite boss, and if a three-point switch is available on the main supply, a third wire is connected to the framework and goes to the earth point of the switch.

## The Stand

The stand shown in Fig. 4 is made from plated bicycle handlebars usually costing about 4s. 6d., and the fixing arrangement allows the radiator to be tilted to any angle.

Expense can be reduced, however, by using a smaller reflector, or substituting copper or aluminium for the stainless steel (these will, of course, require frequent polishing), or by dispensing with the handlebar stand and simply continuing the curved strips behind the reflector in the shape shown in Fig. 5.

## Improvements

The need for insulating bushes can be avoided if an asbestos-composition bar is used instead of iron.

A 2-kilowatt, 2-element fire can be made by arranging for the brass brackets to project further, so as to carry another heater. The inner heater is then connected as before, but the outer heater, while connected to its bracket at one end, has its other end carried away through a piece of clay-pipe stem to a switch mounted on the back of the iron bar, as shown in Fig. 6. In this case, the nichrome wire cannot be allowed to pass into the bore of the tube, but has to be secured by tying it down with a few turns of another piece of wire. The protecting box at the back has a hole cut in it so that the lever of the switch projects through. Thus, one or both heaters can be used as desired. With the greater number of live parts at the back, it is even more important, in the two-bar radiator, to supply an earth wire to the framework. This protects anyone handling the fire from shock if any of the wires have strayed inside the box.

In both types, a wire cage or grid over the heaters in the front of the reflector would be a wise addition, protecting against accidental burns and breakage of the formers.

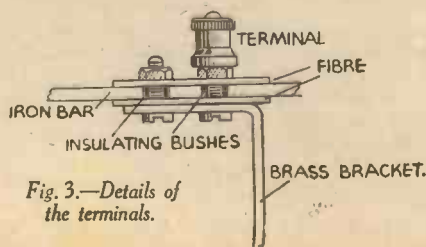

Fig. 3.—Details of the terminals.

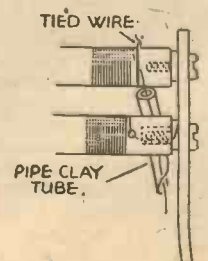
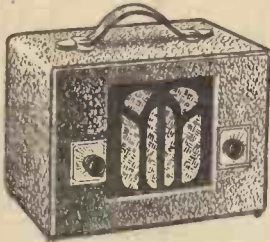

Fig. 6.—How the heaters are wired.

Fig. 5.—How the reflector is bent to shape.

**A Really Portable ALL MAINS SET!**



A.C. and D.C. 110-250 Volt.  
5 Valves—Moving Coil—No Earth  
required—Self-contained Aerial—  
Long and Medium Wave. Station  
Names logged on illuminated dial.

The latest thing from America, fine tone  
and excellent range. Attractively covered  
in washable Fabrikoid Leather in several  
colours, or in Polished Walnut Cabinet.

MEASURES 10" x 7" x 6"  
SPECIAL PRICE **£3.15**

**Special Bargain : KADETTE** 3-valve AC/DC, 100-  
250 Volts—No aerial—  
No earth required. Normally retailing  
at £3.17.6 Size 7 in. x 5 in. x 4 in. **OUR PRICE 55/-**

**DOUGLAS HOLT** (Car and Radio Accessories)  
9 Little Turnstile, Holborn, W.C.1.  
Estd. (1919) Ltd.



THE HALLAM "NIPPER" 6-c.c.,  $\frac{1}{2}$ "  
BORE,  $\frac{1}{2}$ " STROKE. ILLUSTRATION  
HALF SIZE. ENGINE COMPLETE  
WITH COIL, TANK, AND PRO-  
PELLER. WEIGHT 10 oz. PRICE  
£4.0.0. SET OF CASTINGS AND  
PRINT, 10s. 6d. WE GIVE SERVICE  
OF SPARE PARTS AND REPAIRS  
BY RETURN OF POST. BRITISH  
AND BEST.

SEND 6d. FOR CATALOGUE  
DESCRIBING 12 ENGINES AND  
CASTINGS FROM 6 to 80 c.c.

**J. HALLAM & SON**  
ENGINEERS,  
POOLE - DORSET

**engineering**

Our NEW ENGINEERING GUIDE explains clearly how  
all the best jobs are secured. It shows how to obtain  
such money-making qualifications as A.M.I.C.E.,  
A.M.I.Mech.E., A.M.I.W.T., A.F.R.Ae.S., etc. How  
to secure permanent, progressive and pensionable posts  
in the Government and Municipal Service, and describes  
numerous "Higher-pay Courses" in CIVIL,  
ELECTRICAL, MECHANICAL, AUTO and  
AERO-ENGINEERING; TELEVISION, TALKIE-  
PICTURE WORK, etc.

**SUCCESS—OR NO FEE**

We definitely guarantee success. If you fail your  
examination, or if you are not satisfied in every way with  
our service, then your full tuition fee will be returned  
without question.

Write to-day for this remarkable publication and details  
of our employment service, etc.

**NATIONAL INSTITUTE OF ENGINEERING**  
(Dept. 29), Staple Inn Bldgs., High Holborn, London, W.C.1



**Use this fine Varnish  
Stain...**

...and give your woodwork  
a first class finish

Home-made radio sets, models, cabinets,  
in fact all woodwork can be given a  
perfect finish with 'Varnene.' This  
finer oil varnish stain provides a tough,  
high-gloss surface that will not chip  
and resists scratching.



Obtainable at Grocers, Oilmen, Iron-  
mongers, &c. In Dark Oak, Walnut,  
Mahogany, Light Oak, Ebony Black  
and Olar (Colourless) Varnish.

TINS: 6" 1/2 & 1/6



**VARNENE** THE NEW AND  
OIL VARNISH STAIN MORE EFFICIENT

Makers: Chiswick Products Ltd., London, W.4.

**ENGINEERING  
WORKSHOP PRACTICE**

This entirely new book provides a complete  
practical course of instruction in every important  
branch of engineering workshop methods,  
materials and equipment. It deals with the under-  
lying principles, craftsmanship, machines, tools,  
measuring processes and machining methods of  
to-day, and it will prove indispensable to the  
engineer, draughtsman, mechanic, apprentice and  
engineering student. Its scope extends from  
simple hand tools and machines to the latest  
elaborate machines and methods employed for  
mass-production purposes.

**DATA AND RECIPES**

Apart from the mass of practical instructional and  
descriptive information given there is a wealth of data,  
formulae, workshop recipes, hints and tips which render  
this book a valuable reference work for all connected  
with engineering workshops.

**SOME OF THE SUBJECTS**

Files, Chisels, Scrapers, Shears, Punches, Burnishers,  
Hand Screw-cutting Tools, Spanners, Vices, Various  
measuring methods. Verniers, Micrometers, Gauges,  
Optical Devices, Fluted and Twist Drills. Grinding  
Angles, Drilling Data, Small and Large Drilling Machines,  
Electric Drills, Practical Lathework in all its branches,  
Machining of Metals and Synthetic Materials. Tungsten-  
carbide and Diamond Tools. Lapping, Honing, Cleaning,  
Polishing and Rust-protection of various metals. Grind-  
ing Operations and Machines, Milling Operations, Cutters  
and Machines. Planing, Shaping, Slotting and Broaching  
Operations. Special Machines for Production Purposes.  
Plate and Bar Machines. Gears and Gear Cutting  
Methods. Templates, Jigs and Fixtures. Overhauling  
and Adjusting Machines. Millwright Work. Welding,  
Brazing and Soldering Metals. Forging Work. Sheet  
Metal Work. Foundry Work. Patternmaking Practice.  
Press Work. Engineering Steel and other Metals; their  
Properties, Testing. Hardening, Tempering and An-  
nealing. Engineers' Drawings. Workshop Calculations,  
Data, Hints and Recipes.

**THE ILLUSTRATIONS**

The book is lavishly illustrated so that the explanations  
are rendered very clear with examples taken from actual  
works practice in many instances. There are 24 full-page  
plates and 877 line and photographic illustrations in the  
text.

**A FREE BOOKLET**

To the Caxton Publishing Co., Ltd.,  
119 Clun House, Surrey Street,  
London, W.C.2.

Please send me, free of charge, Illustrated Booklet  
describing "Engineering Workshop Practice."

Name .....

Send this form in unsealed envelope (½d. stamp)  
or a postcard.

Address .....

G.4. ....

# QUALITY *and* QUANTITY

**WHY NOT HAVE THE BEST?**  
It costs no more. Visit any Model Railway and you can at once pick out the **BASSETT-LOWKE** Models by their accurate proportions, their smart finish, and last but not least, their excellent working capabilities and hauling power.

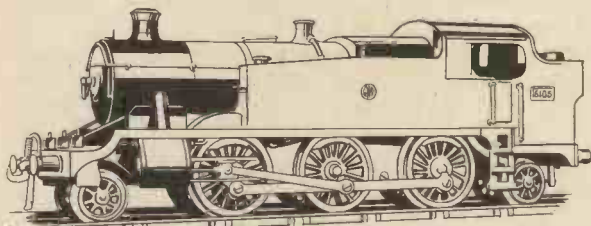
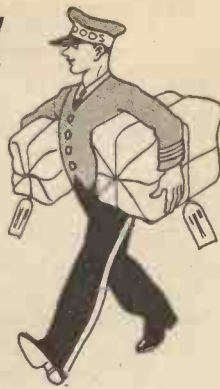

**G.W.R. 2-6-2 Tank Locomotive No. 6105.** A fine super-detail model, for the Great Western enthusiast, of the "6100" type rank. The large boiler and large diameter chimney, the sweeping taper of the boiler, the high firebox and arch of the cab, are all faithfully re-created in the model, which, in either clockwork or electric, costs **£8.0.0**. Just one of the new models described in detail in **A.12, MODEL RLWY. CATALOGUE, 6d. post free**

Other **BASSETT-LOWKE CATALOGUES** include:  
S.12, with all the new Model Ships and Parts. **6d.**  
B.12, of Stationary Engines, Castings, Etc. each  
Free Booklet of "O" gauge models. "REALISM IN MINIATURE." F.12.  
Booklet of the new Twin Trains, T.T.12, free.

**BASSETT-LOWKE LTD.**  
NORTHAMPTON  
London: 112 High Holborn, W.C.1  
Manchester: 28 Corporation Street



Actual Photograph of Bond's British Permanent Way.

## THE CHEAPEST SUPER DETAIL PERMANENT WAY . . . .

IN ALL GAUGES FROM "OO" TO  $\frac{3}{4}$ " SCALE.

We illustrate above an **ACTUAL PHOTOGRAPH** of Bond's Super Detail Permanent Way; this is not an Artist's Impression, but a Photograph of the Model Rail and Chairs which Bond's supply. The Rail Sections faithfully reproduce the outline of the Full Size Rails, also the Model Chair—that of the Latest Standard Chair as standardised by the British Railway Companies. If you want Super Detail for your Model Permanent Way, you can only get this with Bond's Super Detail Permanent Way Parts.

### PRICES STANDARD GAUGE "O" PARTS

Steel Rail, sheradised .. .. .	per yd. 2d., 1/6 doz. yds.
Brass Rail .. .. .	per yd. 4d., 3/9 doz. yds.
Cast Chairs, slide-on fit .. .. .	per 100 1/2.
Cast Chairs, for wooden keys .. .. .	per 100 1/2.
Keys .. .. .	per 100 6d.
Fishplates .. .. .	per doz. 3d.
Sleepers, stained correct colour .. .. .	per 100 2/-
Battens, $\frac{3}{4}$ " x $\frac{1}{2}$ " section .. .. .	per yd. 2d., 1/9 doz. yds.
Pins, approx. 1,000 .. .. .	6d. packet.
Track Gauge, special, with elec. chair jig .. .. .	9d. each.

All Prices Plus Postage. For Prices of Gauge "OO," "1,"  $\frac{1}{2}$ " Scale and  $\frac{3}{4}$ " Scale, see General Catalogue, Price 6d. It contains 200 pages, which illustrate all the requirements of the Model-maker, including a complete list of Tools and Materials.

**BOND'S O' EUSTON RD. LTD.**  
254 EUSTON ROAD, LONDON, N.W.1  
Telephone: Euston 3780  
Established 1887

## 2 YEARS TO PAY FOR YOUR NEW CAMERA OR HOME CINE PROJECTOR

Anything over £10 on 24 or 15 monthly payments—or under £10 on 15 monthly payments only. Choose now from the best range of apparatus in the country.

### KODASCOPE "E" FOR 26/2 A MONTH

for 24 months or 42/- a month for 15 months.

This is absolutely the latest Kodascope 16-mm. projector. It has carrying case and projection stand combined. Gives big, clear, theatre-like pictures. Cash price **£30.**

### 35-mm. "RETINA" FOR 9/5 A MONTH

for 24 months or 14/9 a month for 15 months.

This popular miniature camera takes up to 36 exposures at a loading. Fitted with F/3.5 lens. Cash price **£10 10s.**

Send for complete list of our stock and let us quote the new terms on your choice of apparatus.

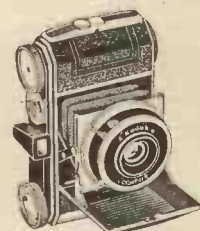

**CITY SALE & EXCHANGE (1929) LTD.**  
59/60 CHEAPSIDE, LONDON, E.C.2

## THE HOME OF SCALE "OO"

For Stations and Lineside Buildings use **Merco Building Papers**

These useful brick papers greatly add to realism on a layout. There are 20 varieties of brick, tile, and stone papers available.

Size of sheet, 17 in. by 11 in.

Price **3<sup>d</sup>** per Sheet

Ready March 1st, new 1937 Catalogue, double the size of last edition. Over 80 illustrations, price 4d.

**HAMBLINGS** 10 CECIL COURT CHARING CROSS RD. LONDON, W.C.2



## THE ROLLS-ROYCE OF LATHES

The Ideal Lathe for making perfect models

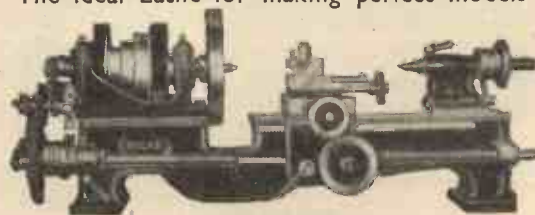

SEND FOR LISTS

**HENRY MILNES**  
(Dept. P.M.)  
INGLEBY LATHE WORKS, BRADFORD



Fig. 1.—The main station entrance at Laureceton.

# The Latest in Railway Modelling

By E. Beal

## Designing and Planning Passenger Stations

**P**ASSENGER stations on model layouts should depend for their size and style upon the two main determinants which influence the same work in actual practice: first, the amount of passenger traffic to be dealt with, and secondly the precise location of the tracks in relation to the proposed depot. The installation of large and ambitiously planned stations having several double-track platforms is very rarely advisable, though this is a common error into which beginners often fall. It is far better, and a much more realistic procedure, to be

be a high-level depot with a highway approach from below or from the same level as the railway; or it may be a low-level station with a road approach from above or from a level identical with the tracks.

it deserves. A number of sketches are given in Fig. 3 which depict four typical modern examples of highway approach. First we have a high-level station whose tracks pass over the roadway on a plate girder bridge, and whose concourse buildings are arranged on the low-level with entrances at right-angles to the tracks. The buildings on the street frontage include a small shop, for the sale of newspapers, tobacco and sweets. Next we have an example of a street entrance at either the platform level or giving upon foot-bridges behind which would lead down to the low-level tracks. Third comes a modern country station with a front stairway giving on to the booking-hall, an inclined bank for ingress of luggage barrows, etc., and, at the opposite end, a loading bank for milk-churn traffic. Lastly there is a design for a high-level station with a low-level approach arranged parallel to the tracks, a low-level yard approach for goods traffic being also provided. A detailed layout plan for this type of station will be given later in this article.

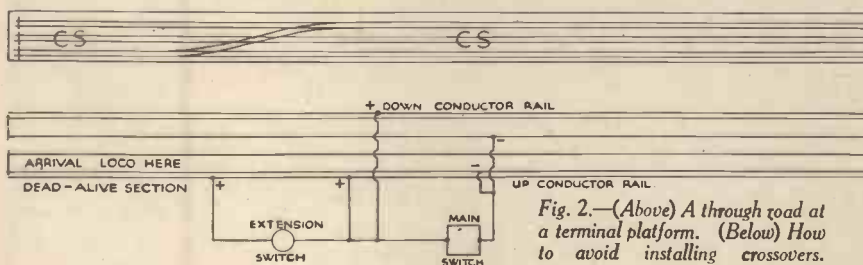

Fig. 2.—(Above) A through road at a terminal platform. (Below) How to avoid installing crossovers.

content with the minimum capacity permissible under the traffic conditions. A single island-platform passing station can be made fully as effective as regard both appearance and operation as a much larger design. Then, the question as to whether the layout will represent a high-level, low-level, single-track or double-track depot depends entirely on the position of the tracks in relation to the street approaches as the whole layout determines. It may

### Road Approach

This question of the road-approach in relation to the track-locality is a very interesting and important one indeed, and does not generally receive the attention

### Modern Types

The question of modern versus Victorian types of architecture is also an important one. Hitherto, most of the designs given for model passenger stations have been

(Left) A street entrance at street level.



A low-level parallel approach with yard entry.



Fig. 3.—Typical modern station approaches drawn by Mr. E. Beal.



A low-level approach at an angle.



Ramp and stairway approach to platform.

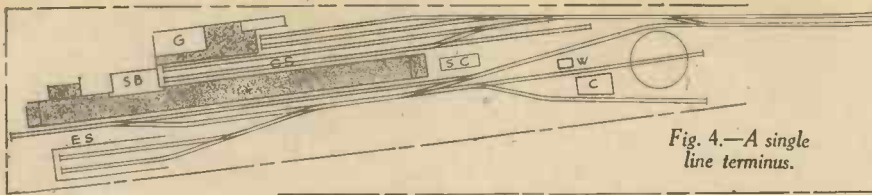

Fig. 4.—A single line terminus.

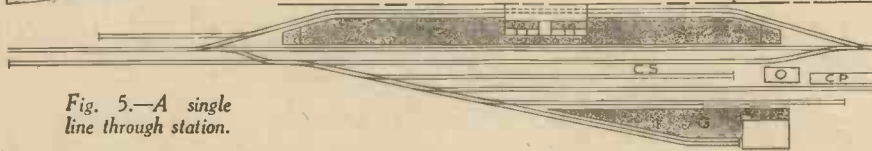

Fig. 5.—A single line through station.

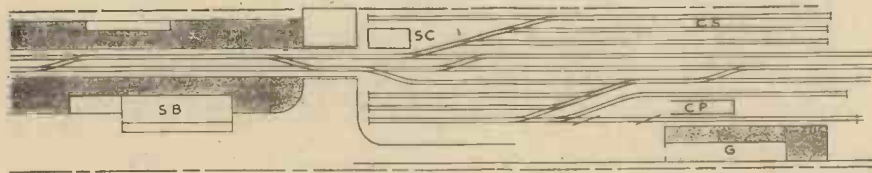

Fig. 6.—A double line station with a low-level parallel approach.

almost exclusively based upon quite ancient practice, though the simple plain concrete or brick structure of contemporary usage is much to be preferred, and, incidentally, is a great deal easier to model. A complexity of roof gables, platforms having elaborate lattice underbearers, and so forth, not only involve a waste of effort, but have little attractiveness when completed. This does not mean, of course, that all modelling of old work is excluded entirely; it is always possible to allow for this interesting feature in connection with blackened retaining walls or running sheds. A layout with "all-new" buildings presents a monotonous appearance, and tends to be "toylike."

**A Covered Platform**

Whether a passenger station is to be modelled with a covered platform concourse or not, is another vexed question. It is true that this procedure does often prove a serious impediment in the way of operation. But like many other arguments this one has its modifying factors. For one thing, it is now so thoroughly practicable a matter to operate a system in the smallest gauges without any manual contact with the rolling stock at all that this deterrent scarcely exists any longer. If track and points are properly laid, a 00-gauge train will run just as faithfully out of sight as when visible and accessible; and it must be admitted that there is something extremely fascinating about the appearance of a miniature train under a covered roof, moving along or being manoeuvred about from place to place. In designing a really large model terminus, one of which there will probably be on any ambitious layout, it is necessary often to allow for a bridge-and-incline approach for hackney vehicles. If the road and tracks are at the same level, this may be brought into the central platform

around the inner end of the platform nearest to the highway itself. The presence of a few road vehicles will always lend an arresting effect.



Fig. 7.—Station building close to a background.

**Railway Traffic**

But let us proceed to the consideration of some of the demands of the railway traffic itself at passenger stations. As has already been hinted in an earlier article, a common mistake of the novice is the omission of adequate coach-storing facilities. This is highly important—as much so, indeed, as it is to provide for proper main-line train

Railway and its subsidiary lines it is installed throughout.

**A Scissors Crossing**

In planning a passenger station provision must be made so that any train arriving can, if needs be, enter any platform, and departing can leave from any platform and immediately gain the departure main line.

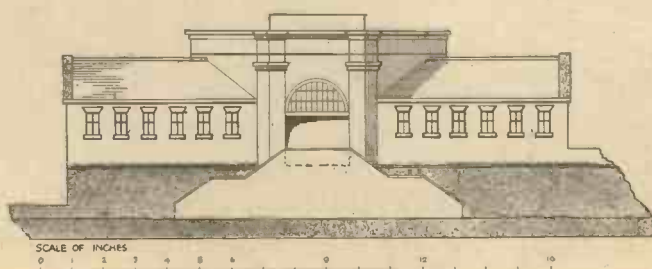

Fig. 8.—A design for a station building on a scenic background.

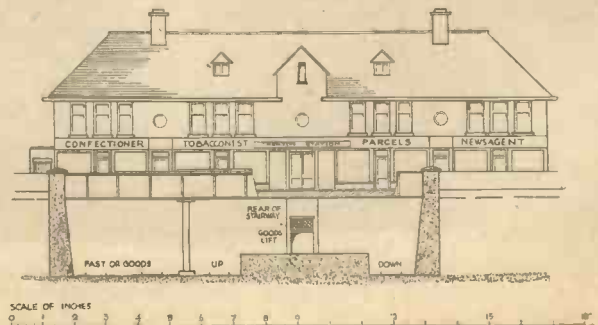

Fig. 9.—A station building for an overtrack span.

This is more or less an emergency provision, of course; and under normal working the up and down or arrival and departure tracks are rigidly kept to their function; but at the same time it must be remembered that a reversing train has to get out of its arrival track and back into the departure track before taking its passengers. The usual provision for this "universal access" arrangement is a scissors crossing at the entrance to the depot. In model work this

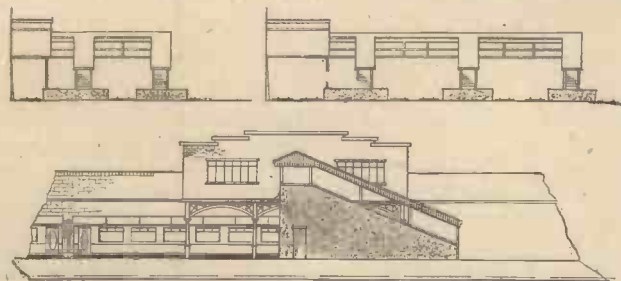

Fig. 10.—An adaptable station design.

may be substituted by two opposed cross-overs set close together. A useful track-adjunct to a terminus station is known as a "through road." This consists (Fig. 2) of an arrangement of three tracks, the outer two of which are the arrival and departures, the middle one being a coach storage track. A crossover forming a reversing loop cuts across the central track by means of a diamond crossing.

Space has been found in this article for three simple station plans in which passenger traffic receives the main attention. The first of these (Fig. 4) depicts a single line terminus, complete, for the corner of a room. The following references will elucidate the plan: SB, station buildings; G, goods shed; M, fruit and milk platform; SC, signal box or cabin; ES, engine shed; CP, cattle pen; O, oil storage tank for the supply of distributing lorries; C, coal store; W, water tank; CS, coach storage sidings. Turning, then, to Fig. 4, we have a country terminus for single line working, having a single platform with a loop track. The road approach is from the rear corner, and gives directly upon the concourse, the goods shed and the milk bank. There is a locomotive depot with all facilities, a lengthy coach siding and a good-sized yard for freight, the spur for shunting purposes passing out alongside the main line. Arriving goods trains enter from the main line, and shunt back into the spur, in which the yard engine is waiting. The main line engine then gets out and shunting can proceed. Fig. 5 shows a single line through station with one island platform. There is also a reversing loop line alongside the main track. The yard entrance is on the track level to the right; the passenger approach is on the high-level and "comes out" of the background scene, the concourse building being over the slow track. Fig. 6 shows a plan for a station suited to the sketch of the Taunton approach. The station is a through one, with one pair of tracks between two platforms on the high-level.

**A Pedestrian Approach**

The type of pedestrian approach shown in Fig. 5 will bear some very interesting elaboration. It is an extremely adaptable style, if only because of the fact that, working into the background scene as it does, it can be applied to either a low- or high-level layout. But that is not all; it may be greatly varied in style of architecture, and, as Fig. 10 suggests, its foot-bridge style of

ingress makes it suited to variable platform arrangements. The upper elevation of Fig. 10 depicts a concourse building standing out from the back wall of the room and skirted by a model stone wall in the rear. The style of foot-bridge may vary considerably also. On the other hand, it is not absolutely necessary to project the concourse building at all. Fig. 8 may be followed as an alternative. Here, the station building as a whole is produced on the back-sheet itself, the work being executed in cardboard and building papers, with a little judicious shading, the foot-bridge then spanning the tracks directly from the edge of the room wall. Fig. 10, in the lower diagrams, shows some possible adaptations of the foot-bridge to varied platform layouts.

For a high-level road-way approach to a low-level station, consult Fig. 9. Here we have a suite of building-crossing the tracks at right angles and set upon a plate-girder bridge. Within the main building are four shops, one of which is given over to parcel traffic, and towards the centre is the passenger entry to the booking office. The private entries to the houses above the shops is by the end door and up a flight of stairs, a gallery running along the upper rear of the building. The luggage lift from the platforms may be arranged to come down at the back of the platform stairway which leads to the booking office above. There is

Fig. 12 gives a suggestion for a very small passenger halt for an extremely restricted space—a situation which very often occurs on a limited layout. Here, the approach to the station is from a road foot-bridge passing across the tracks, and the station, of course, includes nothing beyond the bare double platform and island buildings. For a single line railway the space required would be even less.

**Useful Hints**

A few general principles would, perhaps, be useful as a guide to those who are at the beginning of the work. Do not make ordinary platform s(00-gauge) wider than 4½ in. unless they include a carriage-way, or narrower than 2-in. unless for a mere halt. Restrict their height to ¾ in., and the length of the ramp ends to 3 in. For a good platform surface finish; paint with flat black paint, and add an edge coping, consisting of buff gummed parcel stirp ¼-in. wide, cut with a ruler and knife. See that this is well stuck down and trim it flush with the edge. If desired, the solid platform may first be covered with a strip of cardboard projecting for a ledge over the edges for ¼ in. But in that event the wooden platform should be correspondingly lower to begin with. Line out the parcel strip with a ruler and pencil to suggest paving flags. Leave ⅛-in. clearance between platform edges and the outer edge of running rails. This will avoid all fouling by locos at crossovers. Do not cramp, the length of platforms; have nothing shorter than 3 ft. 6 in., and make them as much longer than this as you can. Try to arrange all platforms to be readily accessible to the hand, though this is not

Fig. 11.—An awning roof for station platforms showing use of O-gauge signal brackets.

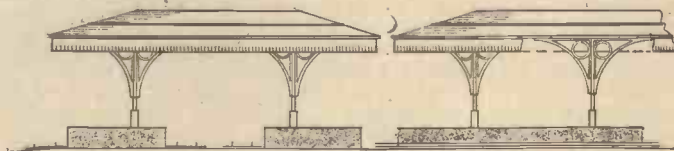

enough space for four tracks, two of which, for fast passenger or for goods traffic, may be laid on the off-side from the platforms.

**Platform Awnings**

In 00-gauge modelling, a good scheme for making the supports for platform awnings is to use O-gauge metal signal brackets, as indicated in Fig. 11. These are soldered in pairs to upright posts or pillars of wire, the bases of these pillars consisting of rolls of adhesive paper tape. The pillars themselves set right down into the platforms, for which, in 00-gauge, solid planed wood is recommended. The upper section of the roof can then be made to lift off the lower section, to afford access to the trains if necessary. Metal valance for awning edges

nearly so important as with goods and engine yards. If you must choose between the three for this arrangement, put the passenger tracks the farthest away, coach sidings next, goods next, locos nearest. In designing stairways to foot-bridges, be sure to give these an easy gradient, as shown in Fig. 10, with, if possible, a flat break in the middle. Carriage ranks are placed by the side of arrival platforms, main line, so that incoming passengers get away quickly and avoid congesting the station.

A good method of forming a roof over a platform span is that of employing 00-gauge rail in the structure, and covering this with fairly stout celluloid, in a single sheet, on which has been scribed with a sharp instrument definite fine lines

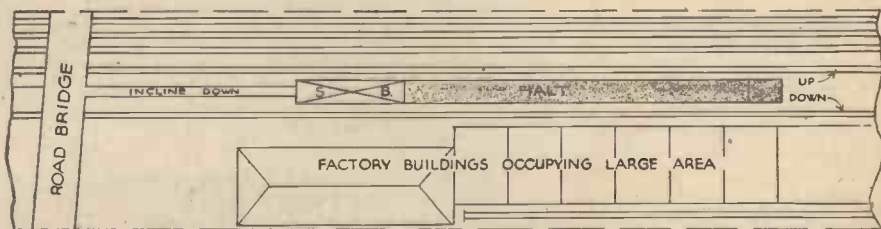

Fig. 12.—A plan of a halt for a restricted space.

is a commercial product, costing a few pence a foot. It is not necessary to have four brackets to each pillar—two only will serve the purpose, these being arranged in the longitudinal position.

to form skylights. This is best done by pinning down the celluloid over a sheet of Merco sash-paper and scribing the lines over the lines of the paper. Care should be taken to get the scratches regular and distinct.

# STARGAZING FOR AMATEURS

A NEW SERIES

**T**HE Sun will enter the Zodiacal Sign Aries (the Ram) and reach the celestial equator at 1 a.m. on the 21st. This will mark the Equinox, when the days and nights are of equal length all over the world. It also denotes the conventional commencement of Spring. The Moon will be at almost its greatest distance from the Earth in March (251,410 miles), on the 3rd; and at its greatest distance (251,910 miles), on the 31st. It will be at its nearest in the same period (225,940 miles), on the 15th. The Zodiacal Light may possibly be seen over the western horizon in the dusk on clear evenings at the beginning and end of the month. With an unrestricted outlook in districts free from artificial glare, this gigantic cone of pale luminosity should be distinctly traceable tapering slantingly upwards towards the Pleiades, from the spot where the Sun disappears. The Zodiacal Light is believed to be due to diffused sunlight reflected by a flattened ring of either myriads of minute meteoric particles or clouds of waste matter thrown off by our luminary.

## Planets

The planets Mercury and Saturn are temporarily out of sight. Towards the end of the month, Jupiter may be seen low down in the south-east morning sky at about 4 o'clock. Mars does not rise until soon after midnight, so is not conveniently placed as yet; it is, however, rapidly growing brighter. Venus is now a glorious object in the south-west after dusk. On the 12th it will attain greatest brilliancy as an "evening star" during the present "apparition." Though the phase will then be reduced to a crescent, it will be of dazzling lustre and best observed telescopically in the twilight. As the sky grows darker the intervention of a tinted glass screen, such as a pair of sun spectacles, will be helpful. On the 15th, if the weather is clear, the proximity of Venus to the young Moon will afford an impressive sight until they set together at 10 o'clock. They will then be about 2 degrees (four apparent lunar diameters) apart. It was a similar but much closer approach that, on the taking of Constantinople (now Istanbul) in 1453, caused the Turks to adopt the Crescent and Star as their national emblem.

## Neptune

The remote planet Neptune will be in opposition on the 8th. It will then be at its nearest to the Earth this year, though at the immense distance of 2,713,790,000 miles. This huge world is 33,000 miles in diameter—four times that of the Earth. It is still officially regarded as the planetary limit of the solar system, notwithstanding the discovery of the diminutive Pluto in 1930. Neptune's "annual" circuit round the Sun drags out to the equivalent of nearly 165 of our years; but the length of its days and nights are not known definitely. From the variability of its light and numerous spectroscopic observations, its axial rotation is believed to be either  $7\frac{1}{2}$  or 15 hours. Neptune is 17 times more massive and 72 times more bulky than the Earth.

By N. de Nully

## A GUIDE FOR MARCH

But, as its materials are specifically less than one-third as light, the force of gravity on its surface is practically the same as here.

### A Solitary Body

So far as is ascertainable, Neptune possesses but a single satellite, to which the name of Triton has been given. This solitary body, though twice the diameter,



Telescopic appearance of the double star, Cor Caroli. The larger star is third and the smaller fifth magnitude.

rather resembles our Moon in that it is equally dense and circulates around its primary at about the same distance, but in the reverse direction. Titan's period of revolution is, however, only 5 days 21 hours, compared with Luna's 27 days  $7\frac{1}{2}$  hours. Viewed from Neptune, all the planets are "morning" or "evening" stars; though Mercury, Venus, and the Earth would probably never stray sufficiently far out of the



A globular star cluster (M. 3) in the constellation Canes Venatici.

Sun's radiance to be visible—except in large telescopes. To us Neptune, when examined through a fairly good instrument under favourable conditions, exhibits a tiny disc; but its moon needs very large apertures to detect. The present position of the planet is approximately R.A. 11 hr. 15 min. N. Dec. 6 deg., which is just below the fourth magnitude star, Sigma Leonis, high in the south-east.

### Striking Constellations

The striking constellations described last month are all still on view on clear moonless nights, though they have of course drifted slightly westward. Those readers having a star atlas and an astronomical telescope might like to locate some interesting stellar features now conveniently placed, but requiring optical assistance to discern distinctly. In the west there is the Great Spiral Nebula in Andromeda which, even in moderate apertures, is seen as a hazy oval patch. It is considered to be a complete universe comparable with our Milky Way or Galactic System. This nebula is the farthest object perceptible to the unaided eye. Higher up is the double star cluster in Perseus, illustrated in a previous article; while almost overhead is another, but single, cluster (M. 37), in Auriga. In the south-west the constellation Taurus contains (besides the open clusters Pleiades and Hyades), the curious "Crab" Nebula (M. 1), just above Zeta Tauri. Moreover, that strange celestial fog patch known as the Great Nebula in Orion (M. 42), is certainly worthy of further examination.

### A Beautiful Cluster

In addition to the fine double star Castor, the constellation Gemini to the eastward includes a beautiful cluster (M. 35), near Eta Gemini. Though small, many of the components are of different colours. In Cancer (the Crab), to the south-east of Gemini, will be found the Praesepe, or "Beehive" (M. 44), a rather scattered cluster between Delta and Gamma Cancri. In the north-east, below the "Plough," lies a closely-packed agglomeration of stars (M. 3), in the constellation Canes Venatici (the Hunting Dogs). This remarkable globular cluster (of which a remarkable photograph is reproduced), is estimated to contain 50,000 stars; in a large telescope the scene is one of impressive splendour. There is also a bright spiral nebula (M. 51) in the same constellation. Cor Caroli (Alpha Canum Venaticorum) the only conspicuous star of the group, is a striking gold and lilac double separable in quite a small telescope.

### A Planisphere

A Philips Revolving Card-board Planisphere is a handy contrivance for indicating the situation of the principal constellations above the horizon at any hour on any date. It can be effectively employed outside in the dark with the aid of an ordinary flash lamp. It costs but a few shillings through any stationer.





# CLIX

## FUSE PLUGS AND FUSES

They safeguard your radio and domestic electrical apparatus at its source of supply. Simple to wire, give perfect contact.

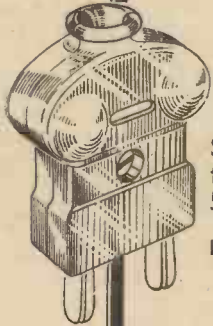

Supplied complete, fitted with pair of 5, 2, or 1 amp. fuses.

PRICE 1/8 EACH

CLIX FUSES

6d. each.

5, 2, or 1 amp. ratings.

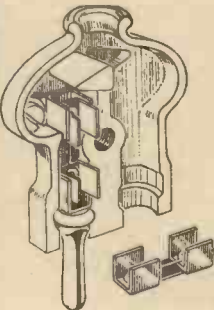

Clix Components Folder "P.M." Free.

*Yours faithfully*

LECTRO LINX LIMITED

79<sup>A</sup> ROCHESTER ROW. LONDON S.W.1

## GIVE YOUR SET NEW VALVE VITALITY

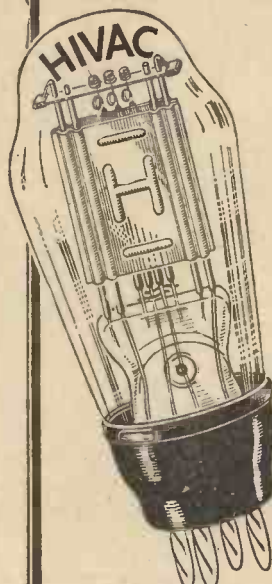

THE NEW HIVAC VALVES WILL MODERNISE YOUR SET

"Tired" valves are responsible for poor results from an otherwise perfectly good set.

For the fractional cost of a new set, you can restore its original quality, give it increased sensitivity and greater power than it originally possessed.

Just replace the "tired" valves with Hivac modern equivalents. These British-made valves which are used by the World's experts will modernise any battery or mains sets.

If in doubt as to the types you require, send us a list of those valves at present in your set, and we will advise you, free of charge, the valves you require.

Write Department "P.M."



THE HIGH VACUUM VALVE CO. LIMITED  
111-117 FARRINGTON ROAD  
LONDON, E.C.1

THE HOMEWORKER

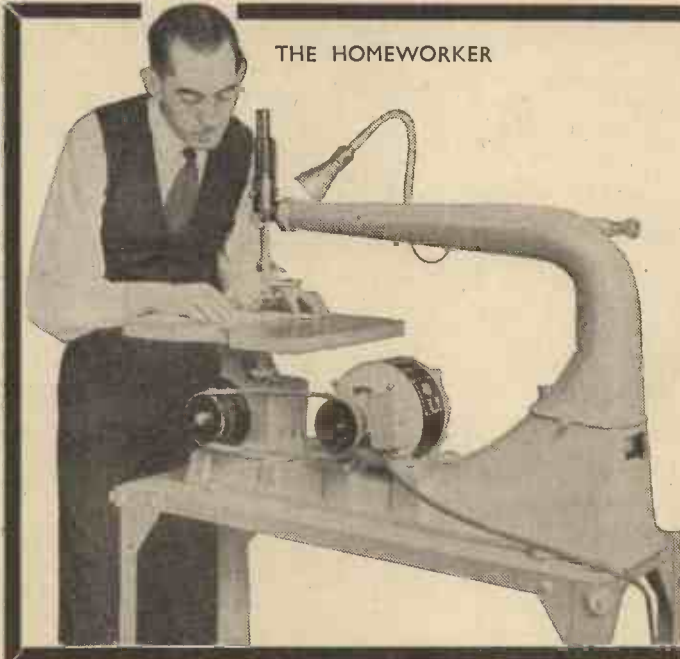

## SPECIALLY for YOU— in your home workshop

You were the person in the mind of the designer when DRIVER POWER TOOLS were planned. That is why they are such fine value. Every refinement of adjustment, with sturdy ability and convenient features of modern design, at most moderate prices.

Look at this cheap-to-run pair. Why limit yourself to hand-sawing?



SEND FOR DRIVER CATALOGUE

To E. P. BARRUS LTD.  
36 UPPER THAMES STREET  
LONDON, E.C.4

Send me DRIVER TOOLS Catalogue (P.M.)  
Mr. ....

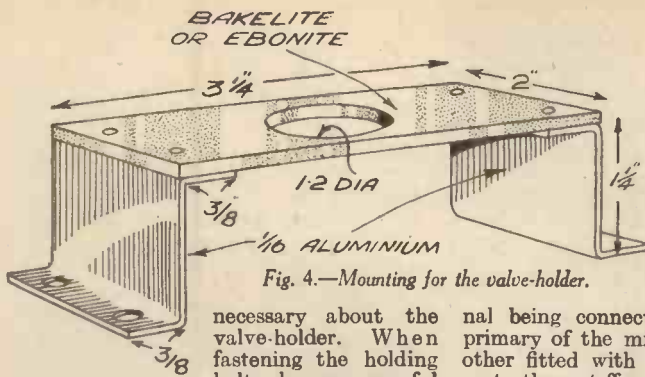

Fig. 4.—Mounting for the valve-holder.

necessary about the valve-holder. When fastening the holding bolts, be very careful not to exert too much pressure, otherwise there is a risk of cracking the ceramic material.

Bolt the aluminium brackets to the platform, but, before screwing the assembly to the baseboard, connect to each required valve pin, except one filament, a piece of tinned copper wire about 9 in. long. I would strongly advise the use, if possible, of solder to eliminate the fracture or breaking of wires by the locking screws in the valve

being connected to one side of the primary of the mike transformer, and the other fitted with a 4-in. length of flex to go to the on/off switch on rear panel. The centre tap, or the other side of the primary, according to the microphone in use, is joined to one of the flex leads from the mike battery.

The H.F. choke and .001 mfd. by-pass condenser should now be mounted, leaving the anode coil to the last.

The use of two switches and a terminal block may cause some comment. These components were purposely used, as they are more convenient, from the experimenter's point of view, than a dual-purpose switch, and a plug and jack.

**The Coil**

This is shown in Fig. 5, and is wound with 18 S.W.G. tinned copper wire on a six-ribbed, 1 1/2 in. diam. good-quality ebonite former or, better still, one of the special low-loss formers obtainable from Messrs. Peto-Scott or B.T.S. There are twenty-two turns, each turn being spaced 1/8 in. and wound on as tightly as possible, each end being anchored

through a small hole to their respective mounting strips.

The brass strips (Fig. 6) are so arranged that they fasten direct on to the terminals of the fixed and moving vanes, of the anode variable condenser, the coil being arranged just above the condenser. Before winding the coil, unwind about five yards of the wire and stretch it until all unevenness is removed. It will be noted that no tapping points, which are essential for use with a radiating aerial, are shown.

When all wiring is completed, the apparatus can be fitted into the rack, and the back panel mounted, the microphone on/off switch having been mounted just above the terminal block cut-out.

It will be found that the panels keep the perforated zinc tight against the corner pieces, and make the whole structure quite rigid and firm.

**LIST OF COMPONENTS FOR ONE-VALVE PHONE TRANSMITTER**

- One ebonite panel, 9 in. by 7 in. by 1/8 in.
- One valve—Cosor 240B.
- One variable condenser—B.T.S. -000067 type: Ceramic.
- One fixed condenser, .001 mfd.
- One H.F.C.—short wave—Eddystone.
- One L.F. choke—Varley.
- One microphone transformer—Bulgin, type L.F.35.
- One dial—Bulgin, type I.P.8.
- One knob—Bulgin, type K. 58.
- One terminal block, and two insulated-head terminals.
- One Eric resistance, 30,000.
- One Quartz Crystal and holder. Frequency 7 M.c. (Quartz Crystal Co.).
- Coil to specification (see text).
- Two push-pull switches—Bulgin, type S.33 or S.22.
- Two panel brackets—Bulgin, type P.B.3.
- One valveholder—B.T.S. U.H.7.
- Two brackets.
- One strip bakelite.
- Four 16-in. lengths 3/8-in. angle aluminium.
- Four 9-in. lengths 1/2-in. angle aluminium.
- Bolts (6BA), nuts, 2 spade ends, 2 E.T. plugs.

pins. To the one filament pin left vacant, the red-lead of a 12-in. length of red and black twin flex must be connected, the remaining black lead being taken to one side of the on/off switch on the panel.

**Connecting the Components**

The crystal holder, L.F. choke, and microphone transformer can now be mounted on the baseboard, and the connections made according to plan. Be careful with the two

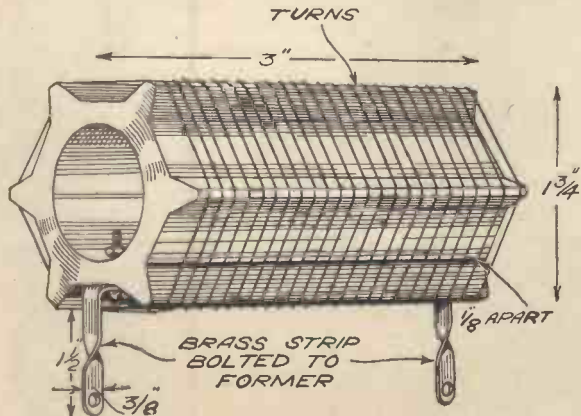

Fig. 5.—The coil is made up as shown here. 18 S.W.G. tinned copper wire is used.

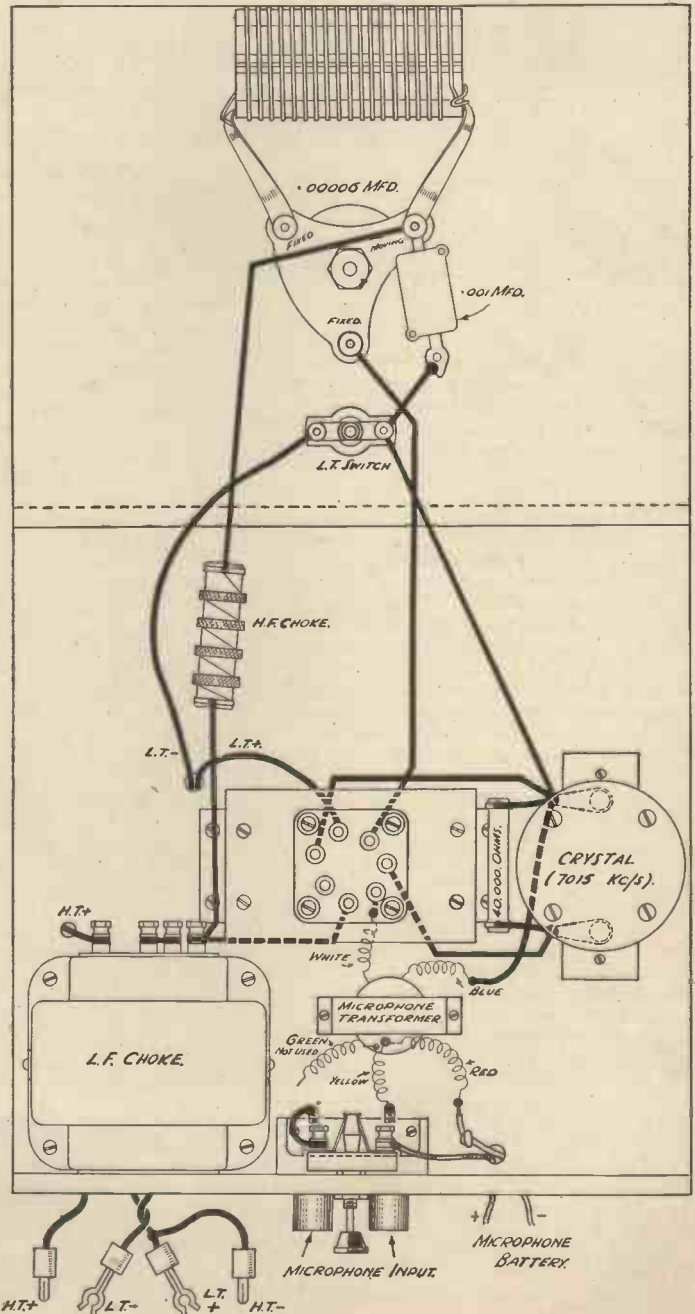

Fig. 6.—The wiring diagram for the single-valve transmitter.

# THE MODERN

A STEAM PRESSURE OF 160 LB. TO  
GAINED AS HIGH IN 1890. TO-DAY  
REACHED THE



The arrangement of a pulverised fuel fired water-tube boiler. The grid arrangement of the burners can be clearly seen, and the method of lining the furnace on every side with water tubes is shown. A bogie truck under the throat of the furnace stands ready to take delivery of the ash of the burnt fuel.

**S**TEAM is the life blood of industry. It provides both power and heat. The scientific development of the steam boiler, rapid increase of steam pressures, and high rates of steam production have been amongst the most notable engineering achievements of the twentieth century. In 1890 a steam pressure of 160 lb. to the square inch was regarded as high, and a boiler which would evaporate 1,000 gallons of water was a large unit. To-day, steam pressures have soared up over the 1,000-lb. mark. The boilers of a large power station evaporate 25,000 gallons an hour, and the very largest pulverised fuel fired boilers evaporate 100,000 gallons an hour.

## Fire-tube Boilers

Boilers in which water is contained in the shell and the flame from the fire passes through one or more tubes in the centre are called fire-tube boilers. They have this advantage, that they hold a large volume of steam and superheated water ready for conversion into steam. They thus still find use in the railway locomotive, aboard ship, and in some chemical works where large and irregular demands are made for steam, in fact anywhere a reserve of steam must be held in hand. But they are limited to low-pressure work of under 300 lb. to the square inch, because boiler drums cannot be made strong enough to stand the high pressures of steam which rule in water-tube boilers.

## Water-tube Boilers

Wherever high-pressure steam, high evaporative capacity, and speedy pick up from cold are required, water-tube boilers

are used. The economical pressure for water-tube boilers runs about 800 lb. to the square inch, although in special cases the pressure may run over 1,000 lb. The steam plant at the Ford Dagenham works runs at 1,200 lb., for instance. As to speed of pick up, a power station can heat up a boiler to full steam pressure from cold in less than ten minutes.

A water-tube boiler can be regarded as a steel, firebrick-lined box. At the bottom is the grate which carries the fire. Across the track of the flame and radiation from the fire is strung a whole series of tubes running between header drums at the top and bottom. More tubes line the walls of the box and protect the furnace lining

from the tremendous heat of the fire. These tubes take the heat from the fire and transmit it to the water inside. They generate the steam. Although they have to stand full boiler pressure they do not need to be exceptionally thick in the wall as they are only of small diameter. The header drums, on the other hand, are thick-walled solid forgings, but they are not inside the boiler and they are not exposed to the heat of the grate.

## Clean Chimney Gases

The track of the gases to the chimney stack is involved. They first pass through a nest of tubes inside which the feed water

to the boiler circulates. The feed water is pre-heated in this way. In a second nest of tubes, called the economiser tubes, the air to the fire for burning the fuel is similarly pre-heated. Then the waste gas is cleaned by passage through centrifugal dust-catchers. Finally it is washed with dilute lime water to remove the sulphur dioxide. By this time the gases have not enough heat left in them to get them up the boiler stack. They are therefore passed along ducts over the boiler top to warm them up and are then ejected to the stack by fans. In the Battersea Power Station the gas-cleaning plant occupies the whole of the end walls of the boiler house underneath the chimney stack.

## The Water-Tube System

The water-tube system, although it looks complicated, is nothing more than a series of tubes connecting top and bottom header drums. The number of drums and their arrangement differ according to the make of the boiler, but, in all, the principle is the same. Steam is drawn off at the top drum and passes thence through a subsidiary nest of super-heater tubes which dry and raise the temperature of the steam. Dry super-heated steam is in effect a perfect gas, and in this state is a far more efficient vehicle for transmission of power to a turbine.

Fresh supplies of feed water are also fed into the top drum. Rate of steam flow from the drum and rate of inflow of water are carefully balanced against one another by automatic meters. If a device of this sort were not incorporated, the boiler might get too much water, in which case the steam mains would get flooded, or if the supply ran short, the boiler would run dry and burn out. So rapid is the rate of steaming on modern boilers, that they would boil dry in less than two minutes if the water supply failed.

## Automatic Stokers

The arrangements for firing boilers have undergone many modifications. Increase in size of units has banished hand stoking. All arrangements are automatic, and a modern boiler house can be regarded as a machine for turning heat into steam entirely by automatic means. The engineer at the control panel has eliminated the man with the shovel.

The earliest method, and still a favourite for small boilers, is the chain grate. This consists of linked fire-bars in an endless band passing over driving sprockets at front and rear. Coal is fed on at the front, ignites under a fiercely hot combustion arch,

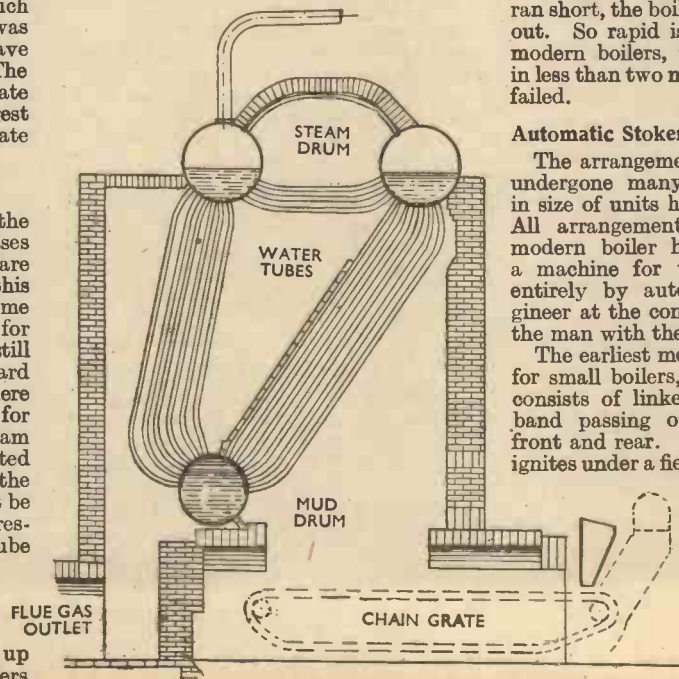

A sectional view of a water-tube boiler, showing the position of the automatic chain-grate stoker.

# STEAM BOILER

THE SQUARE INCH WAS RE-STEAM PRESSURES HAVE 1,000-LB. MARK

passes along and is finally tipped off as burnt-out clinker at the back. Air is supplied at intervals under the chain to burn the coal.

The workable width of a chain grate is limited, and for large units, like those at Battersea and Fulham, the retort plate stoker is used. This is a series of iron louvres set at a sharp angle like the tiles on a roof. The coal is fed on the top of the incline in a heap, where the heat of the furnace at once cokes it so that it cannot give off smoke. A jiggling mechanism actuates the louvres so that the coal gradually slides off the pile at the top, down the incline, and finally off at the bottom again as burnt-out clinker. The inclined set of the grate gives a tremendous vertical intensity of radiant heat on to the boiler tubes.

### Pulverised Fuel

Pulverised fuel firing is particularly useful where stocks of the fine dusty wastes from coal-cleaning plants are available. These have a high ash content and are not really suited for any other type of firing. The coal is first ground down in ball mills to two-hundredths of an inch size. It is then blown in with a primary supply of air through holes in special burner plates. Each hole in the plate from which coal dust issues is surrounded by holes from which secondary air at high temperature is admitted. In this way the coal is intimately mixed with air at so high a temperature that it immediately burns as though it were a gas. Conditions in the boiler literally approach incandescence, and pulverised fuel is coming in for the very largest plant of the highest steam-raising capacity. Yet ten years ago engineers were saying that there was no future for pulverised fuel firing.

### Water Supplies

The water supply to a modern boiler must be absolutely pure. Solids or scale of any sort would rapidly build up on the boiler tubes and reduce the rate of heat transmission through the boiler walls. Overheating of the tubes would then be quickly followed by burning out, and a serious boiler explosion would result. The problem is solved by condensing as much steam as possible when it has been used. In this way, only distilled water is returned to the plant. Any required make up is provided from a separate water distillation plant, but even then the water cannot be passed as fit for use. Oxygen which would corrode and rust the boiler tubes must be eliminated by subjecting the water to a vacuum in a deaerator plant.

### Loeffler Boiler

It is a physical fact that water can pick up more heat from a hot tube if it is passed through at a high velocity than if it passes through at a low rate. In an ordinary boiler the only force effecting circulation of water through the tubes is the ordinary convection force which makes the water rise in the tubes as it gets hotter. Forced

and ordered circulation at a high rate in the tubes has now been achieved.

An Austrian professor named Loeffler realised that water at very high temperatures and pressures required very little power to drive it through a tube, because the frictional resistance to water flow and the volume of water and steam at high pressures and temperatures are small. In fact, if he could design a pump to run at something like two thousand pounds and several hundred degrees centigrade, the pump would be compact and would require very little power to drive it. He overcame the difficulties of pump design and produced what is known as the Loeffler boiler. The boiler is really a water super-heater and not an evaporator. In this respect it is different from the ordinary boiler which combines the functions of evaporator and super-heater all inside the boiler furnace.

In the Loeffler boiler the water is fed into

an outside drum where it is evaporated by bubbling steam from the outlet of the boiler tubes. The pump then picks up this steam, compresses it to such a pressure that it again liquefies to water, and in this state forces it through the boiler tubes, where it is super-heated to a very high temperature. Steam to the main steam line passes off through a flash-off valve. The rest of the steam goes to the water drum, evaporates more water, and so once more round the boiler tubes.

### An Evaporating Machine

The boiler is really and truly an evaporating machine, for the circulating pump is coupled with the automatic feed of pulverised fuel to the boiler. The rate at which the boiler is fired can thus be adjusted to the rate at which the steam circulation removes heat. By this means a wide flexibility of steam output can be obtained. This, on a power station, is a very desirable state of affairs, as by still more remote control from the turbo-alternators, the rate of steam supply can be automatically controlled by the demand for power.

Several Loeffler installations have been built on the Continent and in Russia. One is being built for the grid system in North London, although it is not yet at work. When it is put into operation, it is confidently expected that the over-all efficiency figures for conversion of the potential heat of coal into electrical energy, will exceed the figures obtained by such stations as Battersea and Fulham. At those stations the figure is said to be nearly 30 per cent. The Loeffler system is said to give 35 per cent. As thermal efficiency of the boilers in the end means cheaper current, every one per cent. increase in efficiency is of the highest importance.

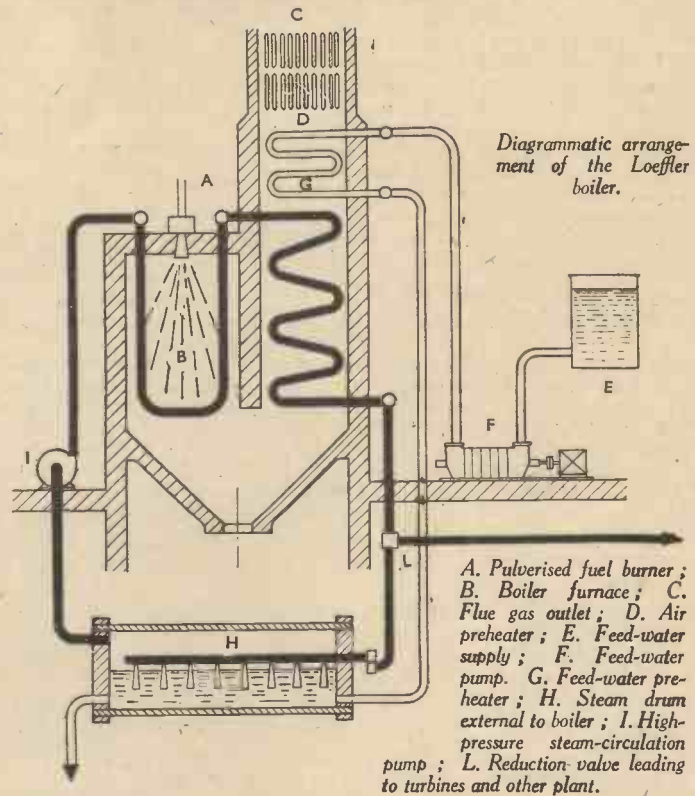

In a modern boiler water tubes line the furnace walls in every direction.

# A Taper Turning Lathe Centre

WHEN turning long tapers, which are longer than the traverse of the top slide of the compound slide rest, it is necessary to set over the back poppet or else turn the piece in two operations. In the latter case, it is often difficult to get a true straight cut across the whole length of the piece; and when the back headstock is not arranged to set over for taper turning, some other method is advisable. In such cases the tool shown in the accompanying drawings may prove useful.

## The Arrangement of the Device

Fig. 1, is a front end view, Fig. 2 is a sectional view in plan and Fig. 3, is a rear end view. The arrangement of the device is easily seen from the sectional view. *A* and *B* are the poppet headstock and barrel, respectively, and the taper turning attachment is clamped upon the latter by a clamp *C*, shown in the rear view, Fig. 3. The body of the tool *D*, is a circular block of cast iron with a screw thread around its

The Tool Described in this Article will Prove Extremely Useful when Turning Long Tapers

standard taper for the lathe centres, and is intended to hold a centre to take the place of the usual centre in the poppet headstock barrel.

It will be seen that by loosening the ring cap *G*, the disc *K*, can be rotated on the body of the tool *D*, so as to bring the centre round to be in dead line axially with the axis of the back poppet headstock barrel. Thus, the centre is in line with the lathe headstock centre, and shafts between the centres will be turned parallel if the tool is

## Machining Operations

To machine *D*, clamp it on the face plate, bore out the recess to fit the end of the headstock barrel, and face the end of the boss and bore the hole at the end of the recess. Then reverse it on the face plate, with the faced end of the boss resting against the face plate, and bolt it down eccentric by a hexagon screw into a screwed hole in the face plate (as far away from the centre as can be managed) and with the outside periphery running true, and turn and screw cut the external thread and face off the front.

Proceed in the same way with the casting for the disc *K*, facing off the boss and boring the taper hole from the centre, and then reversing it on the face plate and turning the back face to face up to *D* and of a diameter equal to the bottom thread diameter of the thread on *D*.

The ring, *G*, will be chucked in the three-jaw chuck by the inside and the outside, and the front face is turned. It will then be reversed in the three-jaw chuck with the

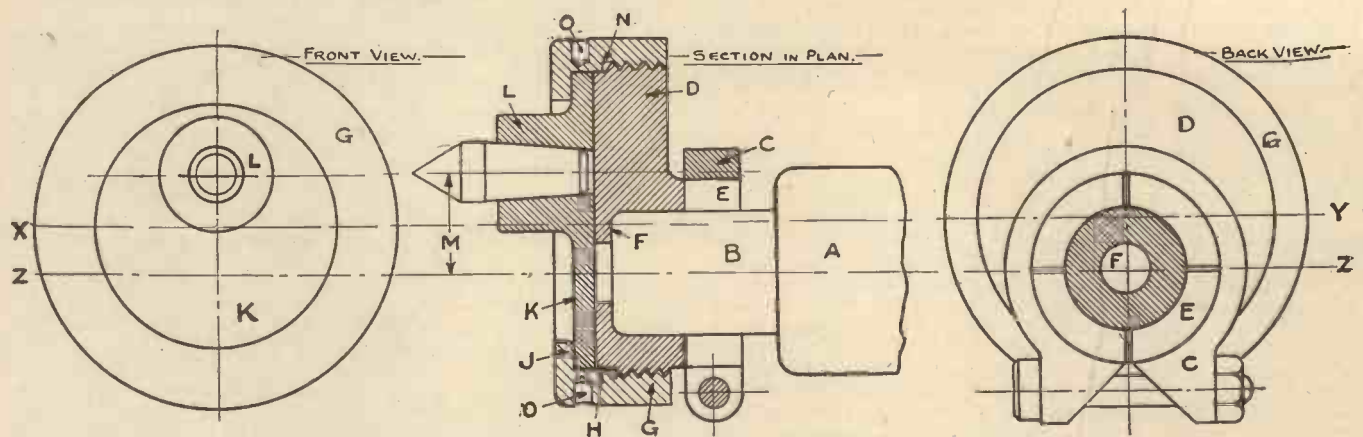

Figs. 1 to 3.—(Left to right): A front end view, a sectional view in plan, and rear end view of the tool.

periphery. The centre of this is a line *X Y*, eccentric with the axis of the headstock and back centre, marked by the line *Z Z*. In it is a boss, *E*, which, as shown in Fig. 3, is slotted across in two directions, making four slots. Its inside bore is such as to fit snugly on the end of the back headstock barrel, *B*, and the clamp *C* clamps it in any position upon the latter. Its bore is internally shouldered at *F* so as to take the pressure of holding the work between the centres. Outside this body is screwed the ring cap *G*, the inside bore of which is cleared parallel at *H* and has an internal flange at *J*, so that when screwed up on the body it will hold the disc *K*, which exactly fits the cleared parallel portion of the ring cap *G*, and is of the bottom thread diameter.

This disc *K*, which has, integral with it a boss *L*, which is eccentric to the disc by the amount *M*, which may be any amount suitable for the range of taper likely to be required. The cap *G* has a series of holes around its outside surface, two of which, *O, O*, are shown. There may be four or more of these and they may conveniently be  $\frac{3}{8}$  in. or  $\frac{1}{2}$  in. in diameter and  $\frac{1}{4}$  in. deep. They allow the ring cap, *G*, to be screwed up tight by a curved pin spanner—curved to the circumference of *G* and with a hardened pin, radial to the curve, to fit the pin holes. The boss *L*, is bored out to the

traversed by the saddle along the lathe bed.

## Out of Centre

In Fig. 2, the lathe centre is out of centre with the poppet head barrel centre, by the maximum amount of eccentricity which the tool allows—the amount *M*—and if in this position (we are looking at it in plan), the shaft between centres will be taper with the big end of the taper towards the back poppet headstock. If we loosen the clamp *C*, we can turn it half round and get the lathe centre as much eccentric in the opposite direction, in which case the shaft will be turned with the small end of its taper next to the poppet headstock.

By turning the disc *K*, in the body *D*, and the body *D* around the back poppet headstock barrel, we can get the boss *L* at any distance out of centre and still at a height above the lathe bed corresponding to the height of the headstock barrel, and by clamping the clamp *C* and screwing up the ring cap *G* (by means of the pin spanner or tommy), we get a firm and solid support for the lathe centre, and for turning taper work of any taper within the maximum allowed by the amount of eccentricity shown at *M*.

A plain wooden pattern should be made for the body *D*, and the disc *K*, and the boss *L*, should be bradded on *K*, and the boss *E* bradded on *D*. A pattern should be made for the ring *G* and for the clamp *C*.

outside face close up to the chuck-jaw faces, and the inside will be turned out to exactly fit over the disc *K*, and then the threads will be cut to fit the threads on the body *D*. A clearance at *N* will be turned to ensure that the ring grips the disc *K* before the ends of the threads meet.

## The Clamp

The clamp *C* will be turned to fit tightly the turned boss, *E*, on *D*, and faced up each side. The hole for the nut and bolt will then be drilled and then the slot cut and filed  $\frac{3}{8}$  in. wide, so that it can be clamped on to the boss, *E*, and contract the latter tightly on to the end of the back headstock barrel.

The proportions shown should be adhered to, but the size of the tool should be to suit the lathe for which it is intended, and the diameter of *D* will be such as to suit the maximum eccentricity, *M*, for which the range of the tool is intended.

The pin holes around *G* will be drilled by scribing a line around the ring, dividing it for the number required (four is enough), centre punching the divisions on the line, and drilling by holding the drill in the three jaw chuck with enough drill projecting to drill the required depth and feeding up by the back centre which is located in the centre punch hole for the opposite pin spanner hole.

# A FULL-SIZE CANVAS CANOE

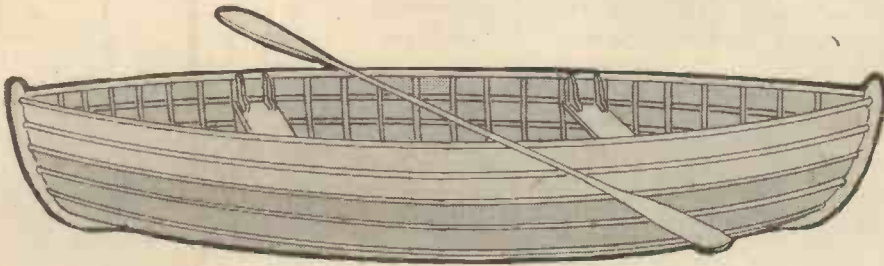

Fig. 1.—The finished canoe.

*It is Quite Within the Scope of Any Handyman to Build This Canoe at Very Small Cost and with the Aid of Only a Few Tools*

**A**LTHOUGH boat-building in the ordinary sense is a highly-skilled trade requiring much experience and many tools, it is quite within the scope of any handyman to construct a really serviceable canvas canoe at small cost, and with few tools. It is a job requiring care and patience, but beyond this the work is of a simple character, there are no difficult joints to negotiate, and for those who live near suitable waters a craft of this kind provides endless pleasure and amusement.

The canoe about to be described is 10 ft. long overall, 2 ft. 9 in. beam, and 1 ft. 1 in. deep amidships. The work has been kept on the simplest lines possible, and no technical terms have been introduced to confuse the amateur boat-builder. Before the work is really started a certain amount of "setting-out" will be necessary, and although sizes have been given they need not be strictly followed, as the same method of construction may be adopted for a larger or smaller craft. A canoe of this kind is made in the form of a framework covered with canvas. The framework is built up with a keel and stems to form the backbone, small slats or laths known as stringers are fixed lengthways between the stems, and other laths known as ribs are fixed over the keel and around the stringers to complete the frame. To give the canoe its shape, and to form a guide for fixing the stringers and ribs, temporary wood moulds are necessary, and it is in connection with these moulds, and the shape of the stems, that the setting-out has to be done.

### Preparing the Moulds

A plan and section of the canoe are shown in Fig. 2. The principal sizes are given in these illustrations, and the positions of the temporary moulds are shown. The parts requiring to be set out full-size are one end of the section Fig. 2, to show a part of the keel and the stem, and the patterns for the moulds. All the sizes required for setting out the keel and stem

are shown in Fig. 2, and sections of the moulds with sizes in Fig. 3. Care must be taken in setting out, one half of the moulds could be prepared first, and the other half marked by folding the paper or tracing. The moulds may be built up from any rough stuff from  $\frac{1}{2}$  in. to 1 in. thick in the manner shown in Figs. 4 and 5, the outer shaped pieces being held in place with two battens screwed across.

### The Keel and Stems

The keel and stems may be of oak, elm, or ash, wood of good quality free from

but to make a good job of the canoe it is advisable to prepare stocks for the keel to rest on. This could be a wide board 8 ft.

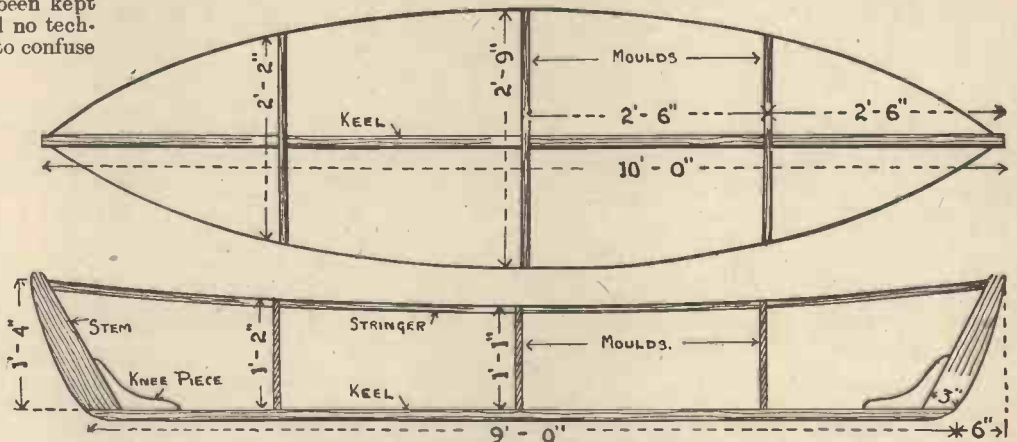

Fig. 2.—A plan and sectional view of the canoe.

knots being essential. The keel is 9 ft. long by  $1\frac{1}{2}$  in. deep by  $1\frac{1}{4}$  in. thick, and the stems are 1 ft. 8 in. long by 4 in. wide by  $1\frac{1}{4}$  in. thick, shaped as shown. Screws are used to fix the stems to the keel, the correct line of joint being obtained from the full-size pattern, and knee pieces prepared from  $1\frac{1}{4}$  in. stuff with the grain running the lengthway are fixed between the stems and keel as shown in Fig. 6. The outer edges of the stems are bevelled from a line drawn about 1 in. in to about  $\frac{1}{2}$  in. thick at the edge.

### The Stringers and Ribs

It would be possible to fix the stringers and ribs without any special preparation,

long laid on edge as shown in Fig. 7, or a light spar resting on supports stayed upright from the ground. The keel should be held on the stocks by nailing a few cleats at each side. A spar should be arranged to run above the keel at a convenient height and in line with it, and the stems are stayed to the spar. The wood moulds are now fixed to the keel in their respective positions, wood blocks screwed in place, or nails driven in slanting direction being used to hold them, while they are also stayed to the spar above as shown in Fig. 7. Oak or ash is suitable for the stringers, 12 of which should be cut 11 ft. long by 1 in. wide by  $\frac{1}{2}$  in. thick, and two 5 ft. 3 in. long. The

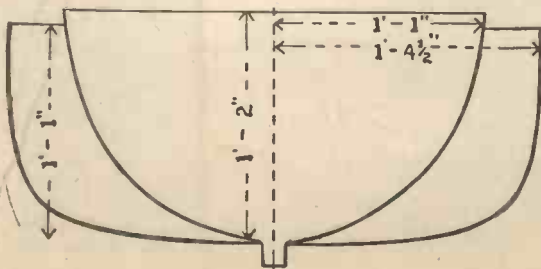

Figs. 3 and 4.—(Left) A sectional view of the moulds, with measurements. (Right) How the moulds are built up.

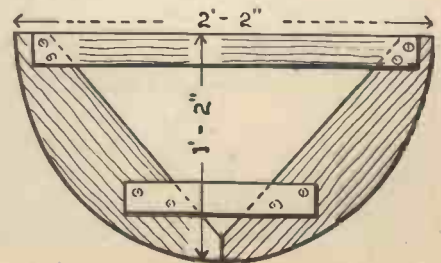

two short ones are fixed on each side of the keel, and the positions of the remaining ones, which are fixed equal distances apart, should be marked on the stems and moulds. It should be possible to bend the stringers and fix them in place without any difficulty. One end is first cut and fitted at the stem, where it is fixed with a screw; it is then brought back on each of the moulds

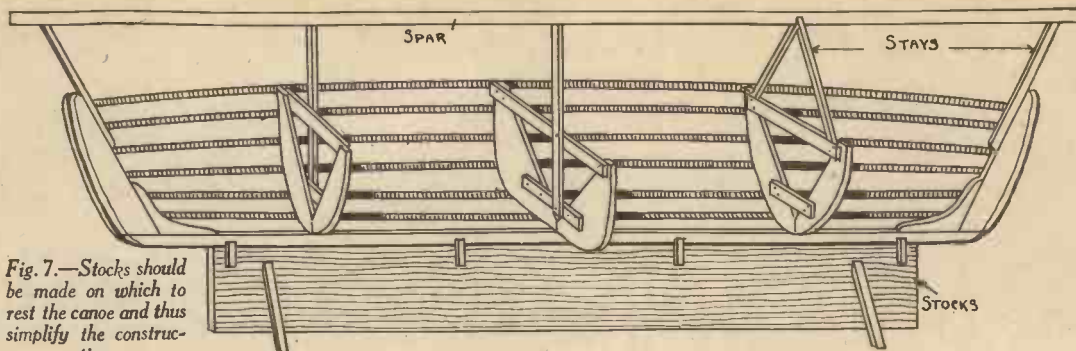
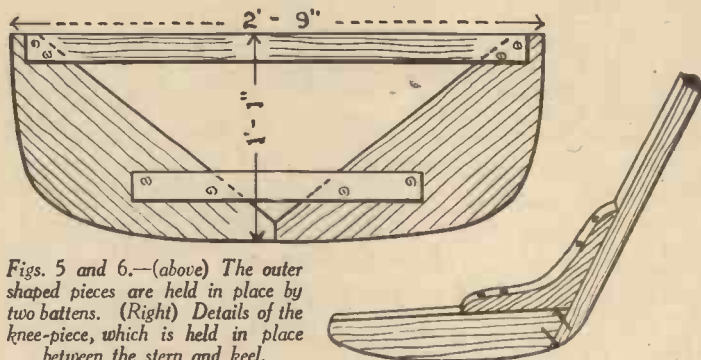

Fig. 7.—Stocks should be made on which to rest the canoe and thus simplify the construction.

and fixed with screws until the other stem is reached. Good stout screws should be used at the stems, but fine ones at the moulds because they will eventually be removed. If the craft is being built without resting it on the stocks, and staying the moulds as previously described, the two top stringers should be fixed first and

craft will resemble that sketched in Fig. 8, but before the moulds are removed the seats about 6 in. wide are preferable, and they are carried on small knee-pieces, screwed through the top stringers, while supports may be fitted between the seats and keel as shown in Figs. 8 and 9.



Figs. 5 and 6.—(above) The outer shaped pieces are held in place by two battens. (Right) Details of the knee-piece, which is held in place between the stern and keel.

together; that is, they should each be fixed at the stem, then brought back on the first mould, and so on, or else the moulds will be forced out of position by the unequal strain.

The ribs should be of oak, 1 in. wide by  $\frac{3}{8}$  in. thick. Before attempting to fit them in place they should be soaked in water for several hours as this will enable them to be bent more easily. If they will not bend to shape with this treatment they must be immersed in a pan of boiling water. Care should be taken not to break the ribs, neither should they be bent hastily. Fix with a screw at the keel first, then work away on each side, driving a short screw into each stringer. The ribs should be spaced about 6 in. apart, and those near the stems do not run right around in one piece, but are fixed against the stems and knee pieces.

**The Seats**

These details having been completed, our

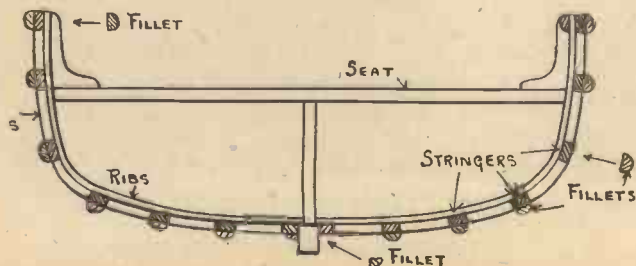

Fig. 9.—Showing small fillets fitted on the side of the keel.

**The Canvas Covering**

All the wood-work should be painted or varnished before the covering is fixed. Canvas of the kind used for tarpaulins is the most suitable; it should be about a yard wide, eight yards being required. Turn the canoe upside down and fit the

canvas to the keel, using just a few tacks, bring it up over the top stringer and roughly cut to shape. The parts over which the canvas will be fitted should be treated with a thick coat of white lead paint, after which the canvas may be finally fixed. It is closely tacked along the keel first, the edges being turned in to give a good hold for the tacks. Some care should be taken in laying the canvas over the stringers to get it to fit as neatly as possible, and it may be necessary to arrange pleats in a few places. It is nailed up the stems, and the top edge is turned over the top stringer and tacked inside. Small fillets could be fitted on each side of the keel, half-round fillets may also be fitted along the stringers to protect the canvas, and the top inner edges may also be finished with fillets as shown in Fig. 9. The canvas is made watertight by giving it a coat of boiled linseed oil, after which it should be given two or three coats of paint.

A light grating should be arranged in the bottom of the canoe, to protect the canvas from the occupants' feet. A double-bladed

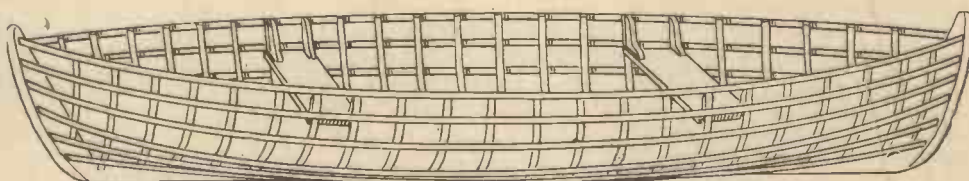

Fig. 8.—The frame ready for covering with the canvas.

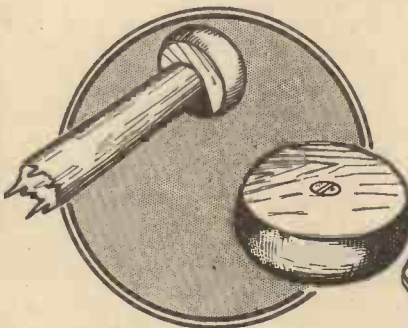

Fig. 10.—The knob grip.

or single paddle may be provided, according to individual taste.

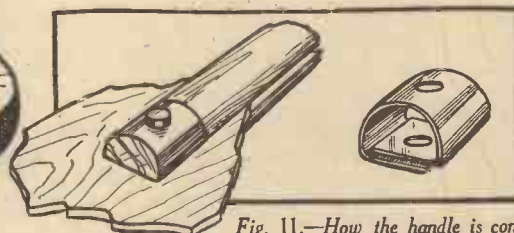

Fig. 11.—How the handle is connected to the blade.

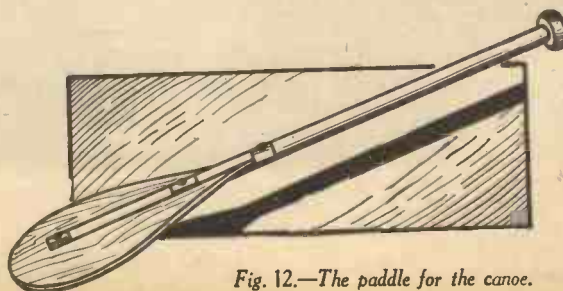
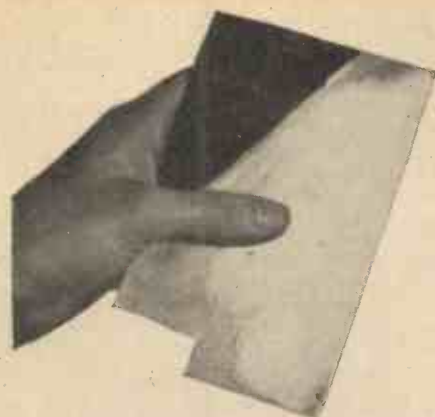

Fig. 12.—The paddle for the canoe.



# THE CHEMICAL COLOURING OF METALS

By "Chemist"



A sheet of brass, partly blackened by means of the chemical method described. Giving an antique green appearance to brass and copper articles.

THE art of metal colouring is as old as the proverbial hills. The ancient Egyptians coloured many of their metals by chemical processes, some of which are well recognised, others of which are nowadays unknown. Indeed, if a metal is left alone for a sufficient length of time it invariably tends to colour itself. Thus copper, for instance, will either turn green or brown according to the conditions under which it has been exposed. Zinc and lead will usually acquire a whitish appearance, iron, of course, will turn brick-red in hue, whilst even gold itself, will, under some conditions, acquire a deeper and mellow colouration.

The colouring of metals by chemical means is usually termed "bronzing," although, strictly speaking, such a term should only be applied to the browning of metals. If, however, we turn iron blue or copper green, we usually refer to the "bronzing" of the metal.

Not unfrequently, the home mechanic, after completing a piece of metal work, feels the desire to "bronze" or colour his metal object some definite hue and shade. Usually, in the case of the common metals and alloys, this object is not difficult to fulfil.

## Polishing and Cleaning

It is of the greatest importance that all metal objects selected for chemical colouring be perfectly clean. The object should first be polished. Then it should be "degreased" by swabbing it over with methylated spirit or some other grease solvent. Finally, it may be advisable to dip the metal object in a bath of warm dilute hydrochloric acid (spirit of salts) for a minute or two in order to scour it thoroughly. After this treatment, the object is rinsed in warm water and is then ready for "bronzing."

If a metal object is not scrupulously clean, its subsequent colouring will very frequently be patchy and uneven. Also, the colouring may not be permanent. Hence, it will be clear that a thorough cleaning of the metal object before "bronzing" or colouring is an absolute essential to the success of whatever process may be used, and in all the instructions for chemical colouring given in this article it will be assumed that the metal object undergoing the process has previously been thoroughly cleansed and, indeed, scoured.

## A Dead Black Surface

Most common metals can be given a dead black surface colouration very readily by chemical means. For instrument work, such a colouration is very useful and often indeed, a necessity. The black colour, un-

like many of the painted-on lacquers, does not flake off or chip away. Brass and cop-



Copper and brass objects moistened with vinegar and suspended in an atmosphere containing carbon dioxide gas evolved from a soda solution contained in the cup.

per articles can be blackened by immersion for a few minutes in the following liquid :

Copper nitrate . . . . .	1 oz.
Water . . . . .	3 ozs.

A small quantity of silver nitrate dissolved in the above solution is said to

## How to Obtain Various Coloured Effects upon Metal Surfaces by Chemical Means

improve the black colouration produced upon the metal, but its employment is by no means essential.

Copper (but not brass) articles may be made to acquire a slightly shiny black surface by immersion in the following solution :

Ammonium sulphite (or Liver of Sulphur) . . . . .	1 part
Water . . . . .	4 parts

Brass articles take upon themselves a steely grey colour in this solution.

By immersing iron articles in a solution of photographer's "hypo," they are given a blue-black colour, particularly if a little lead acetate or nitrate is dissolved in the hypo. Silver immersed in sodium sulphide solution turns almost black, while a black colour on zinc can be obtained by immersing it in a solution of antimony chloride.

A pleasant grey colour is produced on iron by boiling it for half an hour in a weak solution of iron phosphate. This process is akin to that of "coslettisation," a thin film of iron phosphate and oxide being formed on the surface of the metal.

In order to colour brass or copper a variety of shades ending in black, the metals should be immersed in a very dilute solution of ammonium of sodium sulphide. Brass, for instance, placed in an extremely dilute solution of either of these sulphides will acquire a golden appearance, whilst copper, in the same solution, will be reddened. By making these sulphide colouring solutions stronger or by allowing a longer time for them to act upon the metal, the individual amateur will find that he can get almost any yellow, red, brown or black colour he desires on these metals.

Steel articles, can be "blued" simply by passing them through a flame. Better still, they may be blued by boiling them for a short time in a strong solution of hypo, containing a little lead nitrate.

## Antique Effects

The production of antique effects on articles of brass and copper will be of interest to many readers, since, by careful working, beautiful effects of these metals can be obtained fairly readily. The green or brown colouration which an article of brass or copper usually acquires by age and from exposure to the elements is termed a "patina," the word signifying an encrustation. Copper, bronze and brass patinas can be divided into two varieties, to wit, green and brown. The latter are the easier to imitate by chemical means. If, for instance, an article of copper is dipped in a dilute solution of sodium sulphide, it will instantly acquire a brown patina, the exact shade and depth of the colouration being dependent upon the strength of the sulphide solution. Brass acquires a good patina of the brownish variety when it is heated in a paste made of sulphur and lime.

The green patina which is often seen on brass or copper articles of great age and which is often very beautiful in appearance consists, for the most part of a layer of copper carbonate. We may obtain such a patina on brass and copper articles by bury-

ing them in damp earth for a considerable period. Such a process, however, is a slow and an uncertain one.

**Green Patina**

An excellent green patina can be given to copper and brass objects by suspending them from some improvised wooden stand and then by placing them in an air-tight container. Within the container is placed, also, a small vessel containing some ordinary washing soda or bicarbonate of soda, together with a little water. The metal articles are brushed over with strong vinegar or, better still, with dilute acetic acid and a little of the acid is poured into the soda-containing vessel, the container then being immediately closed up. The carbon dioxide gas evolved from the soda-acid mixture will react with the acetic acid on the metal articles and, gradually, the latter will acquire a yellow-green colouration and a hard shiny surface.

The operations mentioned in the above paragraph should be repeated every alternate day until the metal articles have been sufficiently coloured, a task which will occupy about two or three weeks.

A quicker method of obtaining a green colour upon brass or copper articles consists in painting them over daily with the following solution :

Copper carbonate . . . . .	3 parts
Sal ammoniac . . . . .	1 part
Common salt . . . . .	1 "
Copper acetate . . . . .	1 "
Cream of Tartar . . . . .	1 "
Strong vinegar . . . . .	8 parts

This solution gives a blue-green colouration which takes about four complete days to develop.

Quite a good yellow-green colouration may be obtained on copper and brass (particularly the latter) articles by brushing them over daily with a mixture of vinegar, common salt and ordinary sugar.

Note that for the production of these antique green colourations, the metals must not be immersed in the solutions, but merely brushed over with them.

**Dulled Aluminium**

The silvery appearance of aluminium is not always desirable. It may, however, be permanently and uniformly dulled by dipping the metal in a hot moderately strong solution of caustic soda (sodium hydroxide) for a few seconds. The metal will thereafter have a matt appearance. If aluminium so treated is immediately rinsed in warm water and then immersed in a hot solution of an aniline dye, the aluminium surface will take up a little of the dyestuff and will become permanently tinted. This constitutes an imitation of the now well-known process of "anodising" aluminium and the subsequent "dyeing" of the metal.

By immersing zinc in a hot solution of ammonium molybdate containing a little free ammonia, a deposit of metallic molybdenum will be obtained on the surface of the zinc. This "molybdenum-plated" zinc has a very fine colour, ranging from an irridiscent golden yellow to a steely brown. Aluminium articles can be made to acquire a dusky hue by the same process.

What is known as "oxidised-silver" is

simply silver which has been immersed in a weak solution of liver of sulphur (potassium sulphide) containing a little ammonia. Very weak solutions produce the best result, for, in strong solutions, the silver is merely blackened.

Similarly, nickel-plated articles may be "oxidised" by immersion for a few seconds in the above solution, in which they acquire usually a dark golden tint.

Brass articles may be made to acquire an extraordinary series of colourations ranging from pale gold to pink and pale blue simply by immersing them in a solution containing half an ounce each of lead acetate and "hypos" (sodium hyposulphite) to the pint of water.

**Permanent Colouration**

It is difficult to get good permanent colourations on tin objects. If, however, a sheet of tin is heated to near its melting point and then suddenly plunged into the following solution :

Nitric acid . . . . .	1 part
Sulphuric acid . . . . .	10 parts
Water . . . . .	89 parts

The surface of the metal will acquire a very beautiful crystalline appearance to which the term "*moiré métallique* (watered metal) has been applied.

Metal articles which have been chemically coloured should invariably be well rinsed in warm water and then dried in warm sawdust before a fire. Afterwards their surface appearance may be heightened and improved by rubbing them over with a soft polishing cloth charged with a little light oil.

**MODERN ELECTRIC LIGHT BULBS**

To most people an electric lamp is quite a simple thing—merely a glass bulb containing a tungsten filament and a small quantity of gas. A visit to a modern

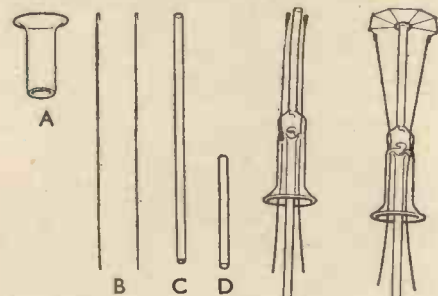

(Above) The component parts of the lamp stem. A. Flange. B. Lead-in and support wires. C. Exhaust tube. D. Support rod. (Right) The Assembled stem.

electric lamp factory, however, is a revelation to the uninitiated not only because of the robot-like machinery, but also for the large number of separate operations entailed. Throughout all stages of manufacture British Engineering Standards are rigidly adhered to.

**"Accelerated Life Test"**

To ensure the required standard of quality and uniformity, lamps are taken from each batch and put through an "accelerated life test," the purpose of which is to

*Various stages in their manufacture*

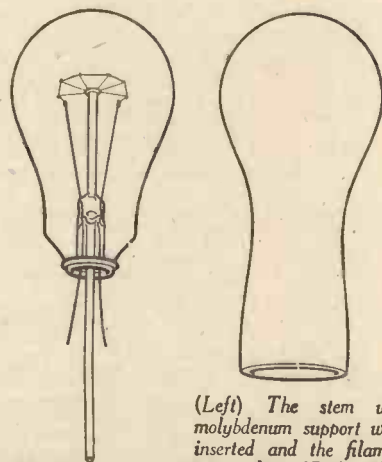

(Left) The stem with molybdenum support wires inserted and the filament mounted. (Right) The glass bulb.

**Variety of Types**

The Atlas Lamp Works produce a wide variety of types and voltages, covering the whole range of lamp requirements including such types as traction lamps, Sign lamps and motor-car lamps. Among the many large users of Atlas lamps are some of the leading British hotels, theatres, cinemas, shipping companies, factories, mines and municipal corporations. In addition, large shipments are regularly sent overseas to all parts of the British Empire. The Atlas factory employs a large number of British workpeople and only the best British materials are used.

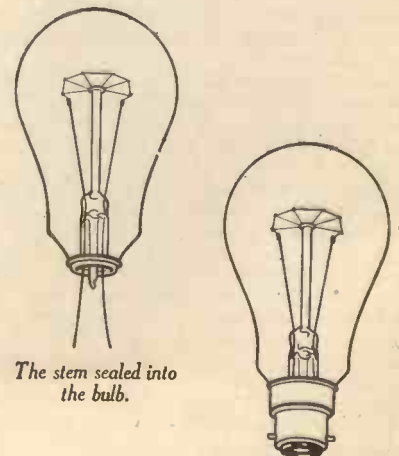

The stem sealed into the bulb.

The completed lamp.

prove that the lamps have an average life of one thousand hours, that their characteristics are as rated and that their light output in lumens per watt is up to standard throughout the life of the lamp.

# MASTERS OF MECHANICS

No. 19. *Nicolas Joseph Cugnot*

**M**OST of us have long harboured the idea that the first steam locomotive, as well as the first stationary steam engine, was invented, designed and constructed by British brains on British soil. True it is that the earliest applications of steam power were the products of English inventive minds, but, despite all ideas to the contrary, the first locomotive carriage to move under the power of steam was not a British invention, but, rather, a French one.

There is no doubt of the fact that William Murdock, Watt's right-hand man, constructed in 1784 a small steam locomotive which actually ran along the ground on its own accord. Murdock's locomotive may this day be inspected in the Birmingham Reference Library. It is, however, merely a model, but there is no doubt that if it had not been for Watt's jealous discouragement, Murdock would have developed his model locomotive on large-scale lines.

Fourteen years before Murdock created his miniature locomotive, certain individuals in Paris were busily engaged in testing a curious-looking waggon which ran on three wheels, and which carried before it an enormous copper boiler heated by means of an internal fire-grate. The trials of the vehicle were being kept as secret as possible in view of the fact that the carriage was intended solely for military purposes.

## Many Possibilities

Military engineers were, in the main, not slow to recognise the fact that the vehicle, cumbersome and strange-looking as it might be, possessed very many possibilities, and the designer of the carriage was kept busy in attending to various points of detail concerning it.

This latter individual was a military engineer attached to the French army. From all that we can now gather concerning his life story, he appears to have thought little about the fact that his carriage constituted the world's first working locomotive. His sole aim, it seems, was to ensure his vehicle's passing triumphantly through the tests which were applied to it. Like many another inventor, he found the needs of the moment more pressing than speculations concerning the future.

Nicolas Joseph Cugnot, for such was the name of the inventor of the vehicle, was born in the little market-town of Void, in Lorraine, on September 25th, 1725. His parents were middle-class people and so they were able to give him the groundings of a good education. Ultimately, Cugnot chose to seek his livelihood in the profession of a military engineer. Accordingly, he left his home at Void and, after travelling up and down, found his way into Germany, in which country he spent a considerable time in gaining first-hand knowledge of military engineering and the construction of fortifications.

## A Well-received Book

Cugnot ultimately wrote a book on the science of fortification and his work was apparently well received by the military authorities of the day.

Exactly how, when or where he first conceived the idea of constructing a carriage which would move under the influence of

*The Builder  
of the World's First  
Locomotive*



*The Cugnot memorial at Void, France.*

steam is quite unknown and, perhaps, now unknowable. Before Cugnot's time, so the records of engineering construction tell us, two very crude models of carriages impelled by steam had been built. The first was made by a Jesuit missionary in China, a certain Father Verbiest, and it seems to have been driven by the reaction of a jet of steam. The second model locomotive is supposed to have been constructed by Dr. Denis Papin, the inventor of the piston, about 1698. There exist, however, no details whatever concerning this supposed creation and, doubtless, if Papin ever did construct a crude locomotive it constituted merely an imperfectly working toy.

The steam carriage of Nicolas Cugnot, however, crude as it appears to modern minds, was anything but a toy. The second of Cugnot's locomotives, but, in reality, the first locomotive to function at all, may be seen in the Conservatory of Arts and Trades, in Paris. It was capable of sustaining a load of three or four tons, and contemporary records inform us that it was constructed in the Paris arsenal under the direction of

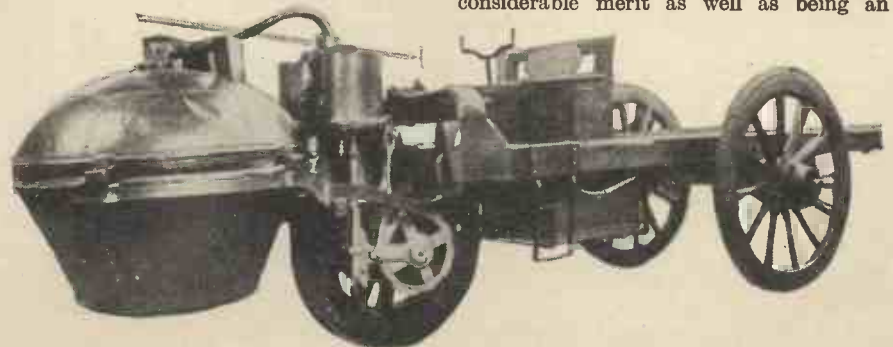

*The world's first steam-propelled vehicle. The steam carriage built by Cugnot in 1770.*

Nicolas Cugnot, by order of the Duc de Choiseul, then Minister of War for France. The Duc had had his attention drawn to Cugnot's first and wholly imperfect locomotive, and he had been so struck by the possibilities inherent in steam-propelled waggons for military purposes that he had authorised Cugnot to construct a larger and a more perfect vehicle at the cost of the State.

## The Second Locomotive

Cugnot's second road locomotive was completed about November 1770. It cost the French nation approximately £900 to build. When finished, the loco., travelling "all out," would make about 6 m.p.h. for a period of twelve to fifteen minutes. Then it would come abruptly to a standstill, its steam pressure having failed. After about a quarter of an hour's rest, the locomotive would again move of its own accord for a further twelve to fifteen minutes, when the rest interval would again have to be repeated.

There is extant a quasi-legend which has it that the end of Cugnot's pioneer steam locomotive came about when it crashed through a wall, nearly injuring a number of curious and interested spectators among which were some high French officials. The story is a doubtful one, however. What actually happened was that Cugnot, on the strength of a state pension which was granted to him, carried on for a number of years secret experimental work which aimed at improving the vehicle and making it suitable for ordinary day by day use.

## Died a Pauper

Like many another individual, however, Cugnot had to fly from Paris on the outbreak of the French Revolution. Ill and nearly dying, he took refuge at Brussels. Then, after the storm of the Revolution had passed, he returned to Paris in 1800 and obtained some sort of a position and a new pension under the aegis of Napoleon I. But Cugnot's health was, by this time, completely wrecked. His inventive faculties had departed and he sank lower and lower into obscurity. Four years subsequently, on October 10th, 1804, Cugnot died—almost a pauper and with hardly a friend in the world.

The road locomotive of Cugnot which is housed in the Conservatory of Arts and Trades in Paris demonstrates to this day the fact that Cugnot was an engineer of considerable merit as well as being an

inventor of great originality. The vehicle, as we have previously noted, is mounted on three wheels, the boiler, engine and the whole of the steam mechanism being mounted over the single front wheel by means of which, also, the vehicle is steered.

The copper boiler, containing a crude enclosed fire-box below it, is supported in front of the carriage by two projecting bars. Two single-acting inverted cylinders, each 13 in. in diameter, provide the engine of the carriage. By means of a curious arrangement of chains, lever and pawl, each descending piston turns the front driving wheel of the vehicle through a quarter of a revolution and, at the same time, returns the piston of the opposite cylinder to top dead centre. A valve is now automatically opened and the steam, being admitted to the latter cylinder, forces down the piston, thus continuing the sequence of operations.

Despite the ingenious (but cumbersome) mechanism which Cugnot employed in his locomotive, in spite, even, of the sound constructional work which was evidently put into the building of the vehicle, some important points in its design are exceptionally crude. For instance, the boiler fire could not be attended to when the carriage was in motion. Nor, for that matter, could the boiler be replenished with water without actually unscrewing the main steam pipe!

#### Difficult to Steer

The front wheel of Cugnot's locomotive is very heavy. It is iron tyred and is steered by means of a hand tiller mounted in front of the driver's seat. No wonder that those eighteenth-century French military experts found Cugnot's vehicle difficult to steer and often almost uncontrollable, for all the weight of the carriage seems to have been concentrated at its front end and over its front wheel.

Cugnot's main fault in the design of his steam carriage was that he aimed at too spectacular results. Had he been content, in the first instance, to design his engine on a small scale and to apply it to the driving of a light road vehicle, he might not only have obtained greater and more lasting

success in his work but, also, have netted a small fortune in the bargain.

#### Military Employment

The mind of Cugnot, however, was entirely a military one. He himself, so far as we can gather, could conceive no other use for a steam-driven vehicle apart from purely military employment. His vehicle, however, although it actually worked, failed and failed badly to attain a position of service. What Cugnot might have done

inventor began to crop up in technical discussion and in engineering circles. Gradually, Cugnot's inventive work attained a greater and greater degree of prominence until nowadays the name of Nicolas Joseph Cugnot stands high on the roll of French pioneers and celebrities.

During the spring of 1913—more than a century after Cugnot's death—M. Raymond Poincaré, then President of the Republic of France, unveiled a life-size bronze statue of Cugnot at Void, the inventor's birthplace. The memorial also embodies a reproduction

A close-up view of the boiler, cylinders, and piston mechanism of Cugnot's locomotive.



with his invention had not the ill-fated French Revolution come upon the country is useless to conjecture. From a mechanical and engineering standpoint, however, Cugnot's awkward and cumbersome road locomotive is, in many respects, one of the world's most interesting steam-driven vehicles, for, without any doubt whatever, it constitutes the first road vehicle which actually ran over an ordinary road by the power of steam.

The memory of Nicolas Joseph Cugnot lay buried for a generation or more in France. Eventually, however, the name of the

inventor in bronze of Cugnot's epoch-making steam carriage. Cugnot, indeed, died in the obscurity of dire poverty, but the present generation of engineers has resurrected his memory and it pays due honour to him. Despite the practical failure of Cugnot's pioneer steam locomotive, its creator's name nowadays justly occupies a prominent position on the immortal list of famous inventors and originators by means of whose labours and through whose genius of mind the modern world of mechanics and engineering, with all its enormous and ever-expanding resources, has come into being.

#### Growing Tomatoes Without Soil

**A**N account of an interesting American horticultural experiment reads like a gross deception of long-suffering Mother Nature. Tomato seeds were planted in sawdust held on wire mesh over a tank of water. The water was kept at a warm, even temperature by electric heating elements thermostatically controlled. The water was further charged with chemical fertilisers which were kept at the correct concentration for the well-being of the plants by addition of more fertiliser as analytical tests showed necessary. The seeds germinated rapidly and the plants thrived at a remarkable rate. They grew to ten feet high in less than four months, and came into full bearing of fruit long before tomatoes planted in soil. After all, soil is not really necessary for plant growth, although it will take a lot to convince old-fashioned gardeners to the contrary.

#### Earl's Court Exhibition

**T**HE new Earl's Court Exhibition buildings situated in West London present several unusual engineering features. The seven-acre site is honey-combed by the network of electric railways which converge on Earl's Court. No fewer

### OUR BUSY INVENTORS

than seven separate lines and fly-over tunnels have either been bridged with massive concrete slabs or have undergone reinforcement of their tunnel roofs. From these spring the foundations of the buildings themselves. The main hall, when finished, will be the biggest single-span building in the country. There are no supporting pillars to encumber the floor. The roof is borne on seven immense girders. Each is 250 feet in length, weighs 73 tons, and will bear a load of 300 tons. To allow for expansion and contraction with temperature the girders are not anchored on their supports but ride on phosphor bronze bearing plates. Perhaps the most unique feature of the hall is, however, the complete absence of windows or means of ingress of daylight. The reasons for this foretaste of the future are twofold. First, abolition of windows reduces heating costs in winter and prevents overheating in summer. Secondly, exhibitors will be assured of uniform lighting conditions, which is an all-important consideration in these times when so much

attention is paid to colour schemes on exhibition stands.

#### A Burglar-proof Mint

**I**T will take a super cracksmen to burgle the new mint of the State of California at San Francisco. The defences include a network of pipes which when operated by any one of numerous burglar alarms floods the building with tear gas. If anyone attempts to cut off the current operating alarms and defences, an auxiliary plant at once starts up which floods every room and wall in the place with light. The doors are all coupled together, so that if one is forced all the others are doubly locked with secondary bolts and bars. These are the defences against the lone criminal. In the case of mob attack, a guard housed in a central fortress tower is armed to repel attack with enflaming machine guns and searchlights. Our own London Mint must seem very insecure to Americans. But they have at least one sound idea. Minute quantities of gold and silver dust can be carried away in the air from a mint and in the exhaust gases from the furnaces. To guard against these "thefts" an electrical precipitation device is installed which removes the metal dust from all gases or air by the use of very high-voltage current.

## MAKING A DYNAMO FROM A MAGNETO

(Continued from page 314)

wound with No. 26 gave 8 volts at the same speed but the current fell to just under  $\frac{1}{2}$  amp. This machine was run direct-coupled to an A.C. motor at 1,450 revs., but when connected to a series machine and allowed to race, 10.5 volts were recorded, the speed being over 3,000 revs. A large four-cylinder machine gave 20 volts and 1.25 amps. and would, when run at a higher speed, light a 30 watt 12-volt headlamp bulb brilliantly. We know of a machine that gave quite good service in a workshop, lighting two 6-volt headlamp bulbs. These were placed near the machine tools and shone the light just where required; the drive was from a water motor and is very successful. Fig. 2 gives the circuit.

### The Joint

The end of the wire is passed through the bush and ebonite slip ring, and soldered to the metal. This joint must be made carefully and at the side of the ring so that it will not foul the brush. Now re-assemble the armature, but first remove the condenser from the make-and-break end, which is generally located inside the brass end-ring. Slip the armature into place, remove the keepers, and then re-assemble the machine omitting the distribution gear as mentioned earlier. It is a good plan to test the continuity of the winding by placing a lamp and battery in

series before finally assembling the machine.

Leads from the machine are taken from the frame and one from the high-tension brush. Test by connecting to a lamp of 3.5 volts—an ordinary low-voltage flash lamp bulb will do—and turn the armature over slowly, increasing the speed gradually until the lamp glows. If at quite low speeds the lamp is bright, try two or three in series or use a higher voltage or higher wattage lamp. By experimenting you can determine the output of the machine in watts. A more accurate method is to connect the dynamo, as the magneto is now called, to a variable resistance with an ammeter in series and a voltmeter across the resistance. Start up the dynamo and adjust the resistance until it is absorbing the maximum output, noting the volt- and ammeter readings. Fig. 3 shows the finished armature.

### High-Tension Brush

The original high-tension brush, which is of carbon, can be used, but better results are obtained if a special one of soft copper gauze is made. Obtain a small piece of gauze about 1 in. wide and 3 in. to 4 in. long. Anneal by heating to red heat in a clear flame, and clean by dipping immediately in a little methylated spirit. The wire is now dead soft and must be rolled into a solid rod to just fit the high-tension brush tube. Dip one end into molten solder to prevent it unwinding, and file the other flat to make a good contact with the slip ring. The output from this machine can be used for a variety of purposes and experiments, but cannot be used for battery charging or electroplating.

you. Mrs. Flack Ackley, the author, describes the simple method of making the type of marionettes she has developed so successfully. These attractive little puppets are made of cloth and stuffed with cotton. The expressive faces of the figures are easily made with a few stitches. Directions for making and costuming the puppets, manipulating and staging are given, together with suggestions for programmes. Five original short plays from the author's own repertory are included in the book, and also a series of full-size pattern sheets for making bodies, faces and costumes. Many excellent illustrations help to make each step easy for the reader.

"Copper in Chemical Plant." 69 pages. 38 half-tone illustrations. Published by the Copper Development Association, Thames House, Millbank, London, S.W.1.

This book has been prepared to indicate some of the applications of copper in the chemical industry and to review briefly the physical, mechanical, and corrosion-resisting properties upon which the use of copper depends. Copies of this book will be sent free of charge to interested readers upon application at the above address.

"Calvert's Mechanics' Year Book, 1937." Published by William Endors & Co., Progress House, 75, Wood Street, Manchester 3. 189 pages.

This is the sixty-second edition of a useful year book, incorporating Calvert's Mechanics' Almanack. No mechanic should be without this useful guide, as it deals with every possible subject likely to be met with by the practising technician. In addition to many hints in different branches of mechanical work, there are some valuable tables and an article on the subject of Patents. The work is profusely illustrated, and costs only 6d.

## A STORY WITHOUT WORDS

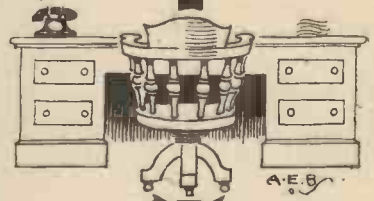
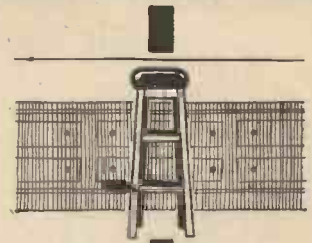

### SEND FOR THIS FREE BOOK TO-DAY

TO THE PELMAN INSTITUTE,

(Established 40 years.)

130, Pelman House, Bloomsbury St., London, W.C.1  
Please send me a free copy of "The Science of Success," with full particulars showing me how I can enrol for the Pelman Course on the most convenient terms.

NAME .....

ADDRESS.....

Occupation.....

All correspondence is confidential.



## BOOKS worth READING

"Elements of Mechanics," by Henry A. Erikson, Ph.D. Price 12/6, 269 pages. Published by McGraw-Hill Publishing Co., Ltd., Aldwych House, London, W.C.2.

THE author of this textbook is a Professor of Physics at the University of Minnesota. Explaining the purpose and scope of this book, he says in the preface that he has attempted "to crystallise out the basic relations underlying Newtonian mechanics and in the gradual leading up from the simpler concepts to the more complex." The author appears to have carried this out well, dealing first with length, time, and then mass. Force and energy, involving all these three concepts, are dealt with after length and time have been used in the study of motion in the abstract. Professor Erikson pins his faith on algebraic analysis and the supplementary problems given at the end of the book are almost exclusively algebraic. "Elements of Mechanics" is a useful book for the amateur mechanic's bookshelf even if just used as a reference to formulae. The appendix gives tables of weights and measures, logarithm tables, and other useful data.

"Marionettes," \$2.50. 115 pages, published by Frederick A. Stokes Company, New York.

Have you ever been enchanted by a marionette show, and resolved to make and learn to manipulate puppets yourself at home? If so, this is just the book to help

# Do YOU want A PHOTOGRAPHIC MEMORY

Many people—some quite brilliant—fail to achieve success because of an unreliable memory. They go through life accepting forgetfulness as inevitable. Unhappily the evil does not end there. It breeds lack of confidence, loose thinking, mental insecurity and other defects of the mind.

## MEMORY—THE BASIS OF ALL SUCCESS

In his book, 'Memory Efficiency,' J. Louis Orton, the famous psychologist, tells you how you can acquire a photographic memory which is the basis of all success. This book is the equivalent of an expensive course of mental training and practical psychology. In mastering its contents you will automatically develop every function of your mind: you will learn to observe instead of merely seeing, to think connectedly, to direct all your energies towards the goal you have chosen in life. When you can answer 'pat' every question fired at you, you will find that doubt, indecision and fear disappear. Inferiority complex is banished by an unquenchable confidence based upon the firm foundation of knowing you have a well-trained mind that can rise to every emergency.

## A COMPLETE COURSE OF MENTAL TRAINING 3/6

By Post 3/10

YOU ARE TAUGHT to observe and apprehend. To retain everything you learn. To recall your impressions whenever you desire. To think logically.

Two other books which will assist you are 'Personality,' by J. Louis Orton, and 'Mastery of Mind,' by Dr. Jas. Flower. Each Volume 5/4 post paid.

Get your copies of these important Books Now—through your bookseller or direct from the publishers.

**THORNSONS, Publishers**  
Dept. III, 91 St. Martin's Lane, W.C.2  
Complete Catalogue gladly sent on request.



"A job worth doing is worth doing well"—  
A proverb with which you'll agree,  
Then tackle it right by using  
**FLUXITE**—  
A good TIP—and given you  
**FREE!**

See that **FLUXITE** is always by you—in the house—garage—workshop—wherever speedy soldering is needed. Used for 30 years in government works and by leading engineers and manufacturers. Of Ironmongers—in tins, 4d., 8d., 1/4 and 2/8. Ask to see the **FLUXITE SMALL-SPACE SOLDERING SET**—compact but substantial—complete with full instructions, 7/6.

Write for Free Book on the ART OF "SOFT" SOLDERING and ask for Leaflet on CASE-HARDENING STEEL and TEMPERING TOOLS with **FLUXITE**.

TO CYCLISTS! Your wheels will NOT keep round and true unless the spokes are tied with fine wire at the crossings AND SOLDERED. This makes a much stronger wheel. It's simple—with **FLUXITE**—but IMPORTANT.

## THE FLUXITE GUN

Is always ready to put Fluxite on the soldering job instantly. A little pressure places the right quantity on the right spot and one charging lasts for ages. Price 1/6.



ALL MECHANICS WILL HAVE

# FLUXITE

IT SIMPLIFIES ALL SOLDERING

FLUXITE Ltd., Dept. P.M., Oregon Works Bermondsey St., E.C.1

## PRACTICAL MECHANICS



# Replies to Queries and Enquiries

If a postal reply is desired, a stamped addressed envelope must be enclosed. Every query and drawing which is sent must bear the name and address of the sender and be accompanied by the coupon appearing on page 303. Send your queries to the Editor, PRACTICAL MECHANICS, Geo. Newnes Ltd., Tower House, Southampton Street, Strand, London, W.C.2

### EXPERIMENTING IN COLOUR

"I AM experimenting in colour and require the following information.

"1. The names, and if possible, prices of dyes suitable for dyeing gelatine in the spectrum colours? Also formulae of liquids which would transmit these colours?

"2. Is it possible to use the transformer and metal rectifier from an Ekco combined unit Type K18 A.C. mains eliminator to drive a small electric motor, such as the Trix, for use with colour discs.

"3. Is it possible to use the same transformer to light 6-volt motor-car lamps, and if so, how many without overloading?

"4. Can you give me the approximate dimensions of an epidiascope for use with house lighting. I propose using a photographic lens of 2-in. aperture and approximately 9 in. focal length as a projection lens. The apparatus is for use in a large room, and is required to give an 18-ft. throw. I wish to make the apparatus as simply and as cheaply as possible at first, but in such a way that I can improve it as opportunity occurs.

Would it be possible to use such an instrument for micro-projection and for projection of polariscope colours? I was considering using aluminium sheet in the body construction and should be glad to know what gauge. What power lamps would be required for ordinary work and what is the lowest power lamps I could use for projecting ordinary photographs a distance of about 4 ft.? I have at my disposal garage tools including a lathe, an electric drill, and oxy-acetylene welding apparatus." (N. C., Birmingham.)

1. IT is not possible to obtain a range of dyes which will transmit all the spectrum colours with perfect sharpness. However, the following dyes will probably suit your purpose. They can be obtained in small quantities from The British Drughouses, Ltd., Graham Street, City Road, London, N.1.:

- Red . . . Neutral Red.
- Orange . . . Monobromfluorescein.
- . . . Orange.
- . . . Flavazine T.
- Yellow . . . Quinoline Yellow.
- . . . Chrysoidine.
- Green . . . Naphthol Green B.
- . . . Brilliant Green.
- Blue . . . Methylene Blue.

The above dyes, made up in 2½ or 5 per cent. solution will transmit the colours required.

2. It all depends upon the type of motor which you intend to employ, but we doubt whether the Ekco transformer would be of much service for this purpose.

3. The Ekco transformer could doubtless be used for lighting 6-volt bulbs. Not more than four bulbs should be lighted in this manner, however.

4. The actual dimensions of the epidiascope which you propose to make cannot

be given here because they will depend entirely upon a number of varying factors, as, for instance, the type of illuminant you propose to use. Epidiascope lamps of the projector type are expensive articles and you will require a 250-watt lamp, at least, for such a purpose. On an experimental scale, you might project ordinary photographs a distance of 4 ft. using an ordinary 100 watt gas-filled lamp. You cannot use the epidiascope principle satisfactorily for the projection of actual microscope images and polariscope colours, since the optical system of the epidiascope will interfere with that of the microscope. You can, of course, project actual photomicrographs. Sheet aluminium of any thickness may be used for the construction of the lantern body of your instrument, but you should be careful to have behind it a layer of sheet asbestos. The body of the instrument must be well ventilated since high-power projector lamps develop a good deal of waste heat. The making of a serviceable epidiascope is a difficult task, but you would doubtless obtain extra information and component parts from Messrs. C. Baker, High Holborn, London, E.C.1.

### A DEVICE FOR THE EASY EXTRACTION OF BOTTLE CORKS

"ENCLOSED you will find a rough sketch of a recent invention of mine for the easy extraction of bottle corks. This is not yet patented, and I should be pleased to know if you think it worth while covering with a patent, also if, in the event of your thinking it a really useful appliance, whether it would be possible to sell before patenting, and if so, could you possibly give me the name and address of a firm likely to be interested?" (R. W., Palestine.)

THE improved device for the easy extraction of bottle corks is probably novel and could possibly form fit subject matter for protection by patent. It is not advisable, nor yet usually possible, to sell an invention which is not first protected. The invention appears to comprise a flanged cork which is attached by its flanges to an internally screwed sleeve or cap which presumably is adapted to engage with a corresponding screw thread formed on the exterior neck of the bottle, the arrangement being such that on unscrewing the sleeve or cap, the cork is removed.

This invention is not considered to have any commercial value nor to be worth the cost of patenting. The obvious drawbacks are, the necessity of using specially shaped corks, the provision of screw threads on the necks of the bottles, the difficulty in inserting such corks with the usual bottling machines, and the additional cost. Moreover, it is more than probable that great difficulty will be experienced in rotating the sleeve or cap, and when rotated, the flange

# THE GLUE THAT GRIPS! STE-FIX

PURE VEGETABLE GLUE

\* COLOURLESS \* REQUIRES NO HEAT \* ODOURLESS

IN TUBES  
2d 6d 9d

For Joinery, Fretwork, Leather, Model-making, Repairing Pottery, Glassware, etc., and for all purposes where a really powerful adhesive is required.

Made by the Proprietors of  
**STEPHENS' INKS**  
57 ALDERSGATE STREET, E.C.1

ALWAYS READY TO USE

## 9 COMPLETE STORIES

by

W. Somerset Maugham  
Sir Philip Gibbs  
Dorothy Black  
Storm Jameson  
W. Cooper-Willson  
Dennis Wheatley  
etc.

in the March

# GRAND MAGAZINE

Of all Newsagents and Bookstalls,  
or by post 9d. from The Publisher,  
George Newnes, Ltd., Tower House,  
Southampton Street, Strand,  
London, W.C.2

7<sup>d</sup>.

is more likely to be torn away from the cork than to extract it.

### A PLANER GUARD

"I ENCLOSE a sketch of a planer guard which, I believe, will minimise the danger of cuts, and also help to keep the work up to the fence. I should like your opinion of my idea, and whether it is fit matter for protection by patent." (H. R., Lancaster.)

THE improved guard so far as can be understood from the sketches is thought to be novel and forms fit subject matter for protection by letters patent. An application for patent can be filed either with a provisional specification or a complete specification. The provisional specification must describe the nature of the invention, and when the application is accepted gives a priority date with protection. If a full patent is desired, a complete specification fully describing the invention with drawings must be filed within twelve months from the date of application. The official search for novelty of an invention is only made after the filing of the complete specification.

We would advise you to apply for a patent with a provisional specification in the first instance as being the least expensive way of obtaining protection, and protection so obtained during the twelve months allows for the invention to be tried out. It also allows time in which to try and market the invention and incidentally to ascertain its novelty before incurring any great expense.

As the drafting of patent specifications is a highly specialised business, you are advised to employ professional assistance.

### FITTING A STOPCOCK

"I SHOULD be very much obliged if you would kindly inform me on the following:

"1. I wish to fit a stopcock to a cistern, the necessary hole in the cistern being already made. There is a shoulder on the stopcock and a back nut for pulling the shoulder up to the side of the cistern. Can you tell me how to make the joint watertight using hemp and a thick paint made up of dry red lead, boiled oil, turps, and about 20 per cent. pure white lead paint? Is this mixture suitable for the job? The cistern contains cold water.

"2. Can you suggest a paint which could be applied to the inside of a cistern to prevent rust? Would paint similar to that used on the bottoms of ships be of use? If so, how long do you think it would offer efficient protection to the metal? Where could I obtain such paint?

"3. What is the capacity in gallons of a cistern 24 in. by 36 in. by 20 in." (A. T., Kent.)

1. THE safest and most permanent union of a pipe to a cistern is only to be obtained by welding, and, in many instances, a welded joint is essential. Since, however, your cistern is to be used for cold water only, we think that the jointing composition you mention will be satisfactory. Give the composition as long a time as possible in which to set. Also, if possible, use asbestos string in place of hemp, working the jointing composition well into the string before wrapping in round the union.

2. No paint will prevent rust for an indefinite period. For your purpose, however, the best (and the cheapest) paint to use is ordinary red oxide paint, used thinly. The paint must contain genuine turpentine and not "turps. substitute." Give the interior of the tank two thin coats of this paint, allowing the first coat to dry

# AMAZING INVENTION

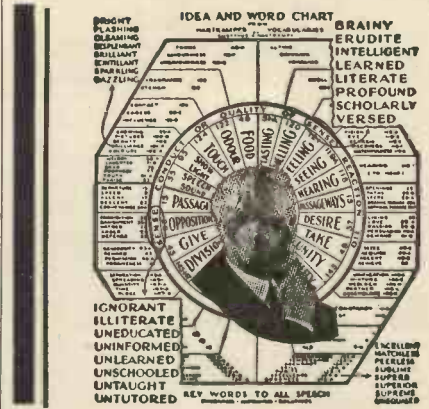

## FREE Gives the Right Word at a Glance

This wonderful Idea and Word Chart is of priceless value. Simple and easy to use, it gives the exact word you want, when you want it. It puts words and ideas at your finger-tips. It steers your thoughts into those amazing word channels that make your talks, letters or any use you make of words sparkle with brilliance, charm and power. Gilbert Frankau says: "It is a big advance on anything hitherto produced. . . . henceforth it is not going to leave my desk." Every writer and speaker of English is invited to send for a free copy of this wonderful Chart. No cost—no obligation.

**PSYCHOLOGY PUBLISHING**  
(Dept. PR/HV4), CO., LTD.  
3, 5 & 12 QUEEN ST., MANCHESTER, 2

## A GUIDING HAND

A. M. SALDO, in athletic form at 58, is willing to prove it in public contest with the heavyweight who claims superiority for his stereotyped method.



Saldo is about 15 years older and 4 stone lighter than this gentleman.

A GENTLEMAN, aged 30, wrote in April, 1936: " . . . 4 years ago, broke down in health, confined to bed with heart attacks. Doctors informed me my heart was quite sound and my complaint was entirely functional, it being the nerves. My present state is a pitiable one, unable to attend any place of amusement, or travel any distance alone, easily exhausted and lacking in will-power." He began MAXALDING at the end of April and reported on November 19th:

"I have had the feeling of A GUIDING HAND, which has been a great help to me in making the effort to regain my health."

He reported on January 23rd, 1937: "I have now completed the Curative and Strength courses with almost incredible results.—Again many thanks for LIFTING ME FROM THE DEPTHS OF NEURASTHENIA. You are at liberty to use any part of this letter as you wish."

### INVESTIGATE MAXALDING

By Postcard, Letter or Coupon. When Coupon is used, kindly delete the unnecessary items and post it, together with the following particulars, to Mr. Saldo: NAME, ADDRESS, Age and Occupation.

MR. A. M. SALDO (Dept. 77),  
14 CURSITOR STREET, LONDON, E.C.4

Send me, free of postage or liability, your 20,000-words Illustrated explanatory treatise:—  
NATURE'S WAY TO HEALTH.

- I suffer from, and desire to be cured of Constipation, Indigestion, Nervous Debility, Weak Lungs, Fatigue, Lack of Development, Rheumatism, Obesity, Susceptibility to Colds, or.....
- I desire to secure Great Speed and Endurance.
- I desire to secure Strength and Development.

## BECK'S CHEMISTRY



**SETS**  
PRICES FROM:  
**2/6 to 105/-**  
(post free)

**EQUIP YOUR OWN LABORATORY WITH APPARATUS AND CHEMICALS.**

**WRITE FOR LATEST CATALOGUE FREE!**  
(Scientific Dept. A.), 60 High Street,  
**BECK** STOKE NEWINGTON, LONDON, N.16

## Be a MAN that Women ADMIRE



Stebbing Pupil Collins

Now YOU can be the kind of **MANLY MAN** that women admire. Take up my world-famous 4-in-1 Course for building Body, Brain, Nerves and Will, practise my new advanced methods for 30 days; if by that time you have not gained Robust Health, doubled physical and mental Strength, 10-25 ins. more muscle and 12-28 lbs. in weight—I WILL REFUND YOUR MONEY IN FULL. Thousands of testimonials, seen by leading Editors. The one complete all-round **MAN-MAKING** System. Complete Course 5/-, or send 2/6 now and 2/9 when satisfied. Sent privately under plain cover.—Lionel Stebbing, Stebbing Institute, 28 (MP-5), Dean Road, London, N.W.2.

## "UNO" PEN STENCILS



for Lettering

**POSTERS · SHOWCARDS · PRICE TICKETS ENGINEERS' & ARCHITECTS' PLANS, ETC.**

DEFENDABLE FROM THE PATENTERS AND MANUFACTURERS—  
A. WEST & PARTNERS, 36 BROADWAY, LONDON, E.C.4  
AND ALL DRAWING OFFICE MATERIAL DEALERS.

## ARE YOU TIRED OF YOUR JOB?

IF you are tired of your present position and feel that you are worthy of something better, send for our booklet and learn how to quickly qualify for a higher position and better pay. Expert postal tuition in Book-keeping, Business Training, Secretaryship, Hotel Book-keeping, Salesmanship, Journalism, etc., from 2/- per lesson. Prospectus and testimonials free.

**LONDON SCHOOL OF COMMERCE (Dept. P.M.1),**  
116 HIGH HOLBORN, LONDON, W.C.1

### The 'ADEPT' Bench Hand Shaper

Price £2 - 17 - 6

Length of stroke of ram, 3 1/2 ins.; Length of cross travel of slide, 3 ins.; Size of Table, 4 1/2 ins. x 4 ins.; Rise and fall of Table, 2 ins.; Vertical feed of tool slide, 1 1/2 ins.; Maximum distance between tool and table, 3 ins.; Weight, 18 lb. Also the 'ADEPT' No. 2 B.H. Shaper, 6 1/2-in. stroke. Price £5 - 17 - 6.

Manufactured by  
**F. W. PORTASS**  
33a, Sellers' Street, SHEFFIELD.

Machine Vice 10/-

## GRAMOPHONE

ATTACHMENTS for Radio, electric motors 25/-, Pick-ups 9/6, Portable Gramophones 12/-, spring motors 4/6, dozen 36/-, 100 £12/10, 1,000 £100, walnut pedestal Anaxgram 45. Soundboxes, Tonearms, Horns, Cabinets, needles, gears, springs, accessories cheapest. Quantity Buyers obtain lower prices. Catalogues free.

**REGENT FITTINGS COMPANY,**  
289D-120, Old Street, London, E.C.1.

thoroughly before applying the second. Used as an underwater paint, the above will remain in reasonably good condition for from eighteen months to three years—always provided that the water is not excessively alkaline and does not contain iron and/or sulphur bacteria. Red oxide paint can be obtained from any paint stores.

3. 62.3 gallons.

### A GEAR-BOX FOR MOTOR VEHICLES

"DO you consider that the device outlined below has any commercial possibilities. I realise that my explanation is a little sketchy, but I am anxious to know if it is worth while trying to develop it.

"The idea, and main advantage of this device, is the production of an infinitely variable speed gear-box for motor vehicles. Briefly, it consists of two sets of pumps connected by pipe lines, and filled with oil. The system of operation is as follows: the first set of pumps are operated by the engine crankshaft and are so arranged that their centre movement may be varied by a hand-lever, fixed under the steering-wheel. The second set are mounted so that their movement works a cranked shaft which is coupled to the transmission. Thus, by varying the length of stroke of the first pumps, a greater or less quantity of fluid will be forced to the second set, thereby giving a gear reduction, but when the first pumps are brought to their central position no movement can take place.

"The device would be provided with valves for inlet and return purposes, and be submerged in oil." (M. H. T., Essex.)

THE broad idea of employing hydraulic gear as a variable speed gear for motor road vehicles is not novel. Within recent years there have been a great number of patents obtained for different constructions of such gears. Before you proceed further with your invention, you are advised to make a search amongst prior specifications in the class dealing with variable speed gears. Although the broad principle is old, it will, of course, be possible to obtain a patent for a specific construction of gear provided it be novel and more useful than existing gears.

### APPLYING FOR A PATENT

"I AM desirous of applying for patent provisional specification for a small appliance I have assisted in inventing, and I am doubtful as to what particulars are necessary in my application to the Patent's Office. I should, therefore, deem it a great favour if you would kindly assist me in this matter.

"I take this opportunity to express my appreciation for the simplicity in which the constructional details were given for the construction of the Synchronous Electric Clock which appeared in 'Practical Mechanics' a month or so back, which I have completed and which is working successfully. It was made in a few days, and I find that its time-keeping abilities is indeed remarkable." (F. T., Norwich.)

THE application for patent must be made on patents form No. 1, stamped with a £1 stamp and accompanied by a provisional specification in duplicate on patents form No. 2. The provisional specification must give a clear description of the nature of the invention, and unless this is done, post dating of the application to the date on which an adequate description is received may be necessary.

As the drafting of specifications is a highly specialised branch of the legal profession you are strongly advised to employ professional assistance.

## BE TALLER THIS SPRING

with the aid of a box of Challoner's Famous Formula—

### H.T.N. TABLETS

and easy system: well tried and safe. No strenuous exercises or old-fashioned appliances. If one box is insufficient we guarantee to supply a further box FREE. G. Y. (Watford) writes: "I have never had confidence in any system till I tried yours, now I've gained in height, weight and fitness." Act now! Full particulars 1 1/2d. Sample 7 1/2d. Book on height improvement 3d., stamps or P.O. only. Sent under plain sealed cover. Colonial Air Mail reply 1/- extra.



**THE CHALLONER CO. (late Bond Street), Dept. L31**  
Laboratory & Works, Hyde Heath, Amersham, Bucks.

## CONSIDER THESE "WILCO" FEATURES

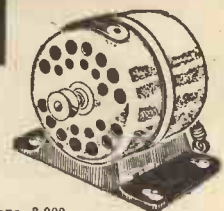

- Induction Motor.
- Bronze bearings.
- Constant lubrication.
- Silent and powerful.
- Does not interfere with radio.

**1/10th H.P.**

This powerful motor develops 3,000 R.P.M. It is totally enclosed. Perfect for driving sewing machine, small lathes, etc. Most useful power unit for any workshop. Reliable, smooth, quiet running. Many other models listed in latest catalogue, 4d. post free.

**39/-**  
Cash or C.O.D.

**L. WILKINSON, 204 Lower Addiscombe Rd., CROYDON**

### DEFERRED TERMS ARRANGED



## "IDEAL-LATHES"

3 1/2 in. S.C.B.G. from £7/18/6. LISTS, Stamp please.  
**J. WILLIMOTT & SON, Neville's Factory, Chilwell, Notts.**

## INVENTORS:

### VALUABLE GUIDE

General Advice Free. POST FREE 6d.

## CHATWIN & CO. Est. 1880

Regd., Patent, Design and Trade Mark Agents for all countries.

**253 (D) Gray's Inn Road, London, W.C.1**

### HOW TO OBTAIN A PERFECT LOOKING NOSE

MY LATEST IMPROVED MODEL 25 corrects all ill-shaped noses quickly, painlessly, permanently and comfortably at home. It is the only nose-shaping appliance of precise adjustment and a safe and guaranteed patent device that will actually give you a perfect-looking nose. Write for free booklet and testimonials.

**M. TRILETY, Specialist (D75),**  
45, Hatton Garden, London, E.C.1.

## NERVOUSNESS

Every nerve sufferer should send for my interesting book, which describes a simple, inexpensive home treatment for Self-consciousness, Blushing, Depression, Worry, Insomnia, Weak Nerves, Morbid Fears, and similar nervous disorders. This wonderful book will be sent in a plain sealed envelope to any sufferer without charge or obligation. Write NOW and learn how to conquer your nervousness before it conquers you!

**HENRY J. RIVERS (Dept. 40 Lamb's Conduit St., LONDON, W.G.1)**

### BUILD and FLY your own AEROPLANE

## The "SAFETY FIRST" Luton MINOR.

Aero Engine "Sprite," 25 h.p., 30-80 m.p.h. Art Blue-prints 65. Full set Materials, Wheels, Blue-prints, etc., £40. Semi-manufactured Set 475. Ready to fly away £200.

**LUTON AIRCRAFT, Ltd., Phoenix Works, Gerrards Cross**

When replying to Advertisements, please mention **PRACTICAL MECHANICS**



# BUY, EXCHANGE OR SELL

Advertisements are accepted for these columns at 2d. per word (minimum 12 words at 2s.—advertisements of less than 12 words are charged at the minimum rate of 2s.), subject to a discount of 2½% for 6 consecutive monthly insertions or 5% for 12 consecutive monthly insertions. **TERMS:**—Cash with order. Cheques, Postal Orders, etc., should be made payable to George Newnes Ltd. *The Proprietors reserve the right to refuse or withdraw advertisements at their discretion.* All advertisements must be received on or before the 5th of the month preceding date of publication and should be addressed to the Advertisement Manager, "Practical Mechanics," George Newnes Ltd., Tower House, Southampton Street, Strand, W.C.2.

## BUSINESS OPPORTUNITIES

**ARE YOU A METAL WORKER?** Our organisation of men experienced in fine metal work is increasing rapidly; many of them are earning more in their spare time than their normal wages. If you are interested in spare-time work, here is an opportunity to make use of your qualifications. Send 1d. stamp for full particulars to:—**ARTCRAFT ELECTRICAL PRODUCTS**, Nasec Buildings, Manchester Street, Oldham.

## CANOE

**BOAT AND CANOE.** Home constructor sets from 25/-. Completed craft from £2 2s. Special 10 per cent. discount offer. List stamp. Trade also Pouncy Products: Sawpits, Wareham.

## CHEMISTRY

**CHEMICALS** and apparatus. Elementary and advanced. Bargain prices.—**GRAY**, 40 Grange Road, Lewes.

## CINEMATOGRAPHY

**FILMS, 35 mm.** every description, from 5s.—**Baers**, 176 Wardour Street, W.1. Est. 1907.

**ARTISTIC CINE FILMS.** Exclusive 9.5-mm. and 16-mm. productions. List free. Projectors, Ciné Cameras.—**P.M. Dane**, 64 Stanley Street, Liverpool, 1.

**CINEMATOGRAPH FILMS.**—Standard size from 6d. 100 feet. Machines, Accessories. Sample Films 1/- and 2/6 post free. Catalogues free.—"Filmeries," 57 Lancaster Road, Leytonstone, E.11.

**MOVIES AT HOME.** How to make your own Cinema Projector. Particulars free. Moviescope (N), Pear Tree Green, Dodinghurst, Essex.

## CLOCKS

**CLOCK MOVEMENTS** of every description ready for cases. Lists and hints on case making post free.—**Nedham**, 25 Stratton Road, Manchester, 16.

## ELECTRICAL

**A.C. MOTORS, DRILLS**, all voltages. 1-phase, 50 cycles, H.P.s: 1/100th, 15/9; 1/10th, 35/-; ¼, 49/9; ½, 69/-; ¾, 89/6. Electric Drills—¼, 125/-; ½, 155/-; 2 grinding wheels, switch and flex. Repair specialists. Lists free.—**Esaco**, Electrical Service, 18 Brixton Road, S.W.9.

**SURPLUS ELECTRICAL** and Engineering Materials, low prices.—**The London Electric Firm**, Croydon.

**SUPER A.C. MOTORS.** Brand new, ¼ h.p., 26/-; ½ h.p., 36/6; ¾ h.p., 60/-; larger sizes. Electric Tools, Machines, Pumps, Compressors, etc.—**John P. Steel**, Clyde Street Mills, Bingley.

## ENGINEERING

**MODEL** parts machined. Boiler brazing, etc. Estimates free.—**LEWIS GATENBY**, Engineer, 17 Thornton Lodge Road, Huddersfield.

## EXPERIMENTS

**TEN ELECTRIC EXPERIMENTS RARELY SEEN.** Very simple, but amazing. Paper, poker, tray, candles, thread, sugar only necessary; harmless sparks. Booklet 9d. post free.—**WALLACE**, Salisbury Road, St. Margaret's Bay, Kent.

## Engineers' Guide To Success Free!

For a well-paid post study at home with The T.I.G.B. Write NOW for this great Guide containing world's widest choice of engineering courses—covering all branches and—which alone gives the Regulations for Qualifications such as A.M.Inst.C.E., A.M.I.Mech.E., A.M.I.E.E., etc. Training until Successful Guaranteed.

The Technological Institute of Great Britain, 98 Temple Bar House, London, E.C.4. (Founded 1917. 20,000 Successes.)



## CIVIL SERVICE VACANCIES

Age Limits 15—26; Either Sex. Commencing Pay 15/- to £7 14s. per Week. No Experience Required.

### FREE GUIDE



The 1937 Edition of our Civil Service Handbook is now ready for distribution. Those desiring details of Openings, Age Limits, Pay, Promotion, and Entrance Examinations for all branches of the Service (Taxes, Customs, Post Office, Clerical, Engineering, L.C.C., Municipal, etc.) are advised to apply for this free Handbook immediately.

**B.T.I. (Dept. 160), 358, Oxford Street, W.1.**

# Baker's SOLDERING FLUXES

Sold in 6d. and 1/- tins at all Cycle Accessory Dealers, Tool Shops, Ironmongers, etc.

Write for your free copy "Joining of Metals"

**SIR Wm BURNETT & CO. LTD** CHEMICALS  
GREAT WEST ROAD, Uxbridge  
TELEPHONE: HOUSLOW 0478

## FREE ADVICE BUREAU COUPON

This coupon is available until March 31st, 1937, and must be attached to all letters containing queries.

**PRACTICAL MECHANICS, MARCH, 1937**

## HYPNOTISM & MAGIC

"HYPNOTISM," 25 Long Lessons 2s. 6d. Learn "VENTRILLOQUISM" nine dialogues 1s. 3d. Several PROFESSIONAL ESCAPE ILLUSIONS for sale. Lists 2d. stamp.—"MAGICRAFT," 41 Longford Place, Manchester 14.

## LITERATURE

**CALVERTS MECHANICS YEAR BOOK 1937.** Over 190 pages. Illustrated Workshop Hints and Calculations. 8d. post free.—**Endors & Co.**, Progress House, 75 Wood Street, Manchester, 3.

## METALWORK

**MAKE METAL TOYS.** Easy, profitable with "Success" moulds. Lists free. Complete trial mould, 1/6.—**Lec's**, Bentinck Road, Nottingham.

## MICROSCOPY

**MICROSCOPIC OBJECTS**—unmounted prepared. Assorted packet 2/-. **MOULDED SLIDES STOCKED**.—**LENG**, 183 MANCHESTER DRIVE, LEIGH-ON-SEA.

## MISCELLANEOUS

"PHOTO-ENGRAVING." A practical handbook with complete set of materials for engraving printing blocks, 4/6.—**ARTEC**, 2 Waldegrave Park Twickenham.

**CHEAP GOVERNMENT WIRE !!!** Great for training fruit trees, peas, beans, roses, arches, greenhouses, tomatoes, raspberries; tying, fencing, etc. Strong, flexible, steel-stranded and waterproof covered. Several thicknesses from 17/6 mile (full 1,700 yards). Small lots quoted. Postcard to-day for free samples and list of 300 bargains.—**Green's Government Stores**, 723 Albert Street, Lytham.

**RAILWAY—CYCLE—ELECTRICAL.** Send for free list.—**Kirby**, 606-608 Washwood Heath, Birmingham.

**SHEFFIELD GUARANTEED SAFETY RAZOR BLADES** from 3s. 6d. gross (¼ gross—1s. 10d., ½ gross—1s.), post free. Send 1d. stamp for samples.—**J. Peat**, Bradway, Sheffield.

## MODELS

**FITTING, TURNING, and BRAZING**, Models repaired, moderate terms. Accuracy guaranteed. Estimates free.—**BARTRUP, ENGINEERS**, 5 Stafford Road, London, E.3.

**EVERYTHING FOR** electrical rewinds and repairs. Screws, nuts, and washers for model engineers. Lists free.—**Lumen Electric Co.**, Litherland, Liverpool, 21.

## MONEY-MAKING BOOKS

"3,000 MONEY-MAKING FORMULAS, PROCESSES, RECIPES AND TRADE SECRETS." Thousands of people with very little outlay are launching business ventures based upon the FORMULAS contained in this book. Many have been started on practically nothing, owing to making use of waste and by-products. This BOOK, also "DIRECTORY" where to buy CHEMICALS (wholesale) Containers, Glass Bottles, Jars, Tins, etc. BOTH sent for 4s. 9d. "150 WAYS OF MAKING A LIVING," and interesting literature, 1s. 6d. "MAKE MONEY" from drained MOTOR OIL, full instructions 1s. Interesting literature and book catalogue 4d. stamps.—"TECHNO-CRAFT," 41 Longford Place, Manchester 14.

# BUY, EXCHANGE OR SELL

## MONEY-MAKING OPPORTUNITIES

**MONEY-MAKING OPPORTUNITIES** constantly occurring; highly recommended; particulars free. Send postage.—Messrs. Green, 17 Church Lane, Hull.

## MOTORS

**MOTORS.** Small practical power. Build BUTLER'S 1/2 h.p. petrol motors. Most interesting—small power extent. Castings 9/9. Dynamo and motor catalogue 3d.—Write BUTLER'S Profit-sharing Works, Wade Street, Littleover, Derby.

**ELECTRIC MOTORS ONLY 1/-**, plus 6d. postage. With instructions. 4½ volts, 5,000 r.p.m. Will drive any model. Stock limited. Write at once to SERVAULS, Berkeley Street, Douglas, I.O.M.

## MUSICAL INSTRUMENTS

**BAND GUIDE.** Hints on the Bugle, Drum, Flute, Staff Parade formation, etc. Free, post paid.—Potter's (Manufacturers), West Street, London, W.C.2.

## PATENTS

**REGINALD W. BARKER & CO.** (Established 1886), 56 Ludgate Hill, London, E.C.4.—Patent and Trade Mark Booklets Gratis.

## PHOTOGRAPHY

**"PANTOGRAPHS"** make large accurate drawings from small photographs, printed drawings, etc., easily. 1s., post free.—Cooke, 33 Hawthorn Road, Levenshulme, Manchester.

**£500** worth good, cheap Photo Materials, Films, Plates, Cards, Papers, Chemicals, Catalogue and 4 Samples Free.—Hackett's Works, July Road, Liverpool 6.

**DON'T TAKE RISKS.** Good developers mean good results. Our reliable stock developers keep twelve months after mixing. Satisfaction certain to amateurs and professionals. Best developer ever put on the market. Makes two pints strong developer. 6d. each, 6 for 2/3, 12 for 4/-. Post free.—Hackett's Works, July Road, Liverpool 6.

**PHOTOGRAPHIC MATERIALS.** Superb quality. Keen prices, films, plates, papers, postcards, mounts, etc. Factory fresh always. Small quantities supplied. Interesting lists and samples free.—"KIMBER'S," 105 Queens Road, Brighton.

## STAMPS

**FREE!!** Twenty Unused Colonials. "Neurope," 1¼d. Fifty for 9d.—G. H. Barnett, Limington, Somerset.

**TO STAMP COLLECTORS!** I have a large quantity of unpicked variety stamps and am willing to sell at 2s. per 500.—R. D. Gardiner, Highcroft, Cholsey, Berks.

## SITUATIONS VACANT

**G.P.O. ENGINEERING DEPT.** (no experience required). Commencing £3 13s. per week. Age 18-23. Excellent prospects. Free details of Entrance Exam. from B.I.E.T. (Dept. 579), 17-19 Stratford Place, London, W.1.

**1937 EDITION—FREE. AMBITIOUS ENGINEERS.** Our new 268-page Handbook shows clearly how to secure a recognised qualification, such as A.M.I.Mech.E., A.M.I.E.E., A.M.I.A.E., A.M.I.W.T., A.M.I.R.E. We guarantee "NO PASS—NO FEE." Our book outlines over 150 Exams., and courses in all branches of Civil, Mech., Elec., Motor, Radio, Television and Aero Engineering, Building, Government employment, etc. In your own interests, we advise you to send for your copy of this enlightening Handbook to-day—FREE and without obligation.—BRITISH INSTITUTE OF ENGINEERING TECHNOLOGY, 140 Shakespeare House, 17-19 Stratford Place, London, W.1.

**DO YOU WANT A PROFITABLE BUSINESS OF YOUR OWN?**—We show you exactly how to start and run a business with little capital from your own address. No office, shop or experience is necessary. You receive working details of 201 profit-earning businesses from which to make an immediate start. No risks. No waiting. Results are sure. Just send a p.c. to-day—NOW—for fully descriptive book to Business Service Institute (Dept. 128W), 6, Carmelite Street, London, E.C.4.

## SITUATIONS VACANT (cont.)

**YOU CAN USE YOUR SPARE TIME** to start a Mail Order Business that quickly brings you a full-time income. Follow the lead of others who are averaging £12 per week net profits. Get away from a drudging routine job—join the big-money class. No previous experience necessary. Few pounds capital only needed. No samples or outfits to buy; no rent, rates or canvassing. New method makes success certain. Write to-day for FREE BOOKLET to Business Service Institute, Dept. 36D, 6 Carmelite Street, London, E.C.4.

**POST OFFICE ENGINEERING.** Good positions open to youths and men, age 18 to 30. Start £3 13s. weekly at age 18. FREE details of vacancies from N.T.O. (Dept. 307), 335 High Holborn, W.C.1.

## WIRELESS & TELEVISION

Marconi's and other Employers require hundreds of trained men next year.

We train students for ALL BRANCHES OF RADIO at our Residential Colleges in Southampton and Colwyn Bay, and GUARANTEE APPOINTMENTS.

LICENSED BY POSTMASTER GENERAL—RECOMMENDED BY MARCONI'S.

WRITE FOR FREE PROSPECTUS:

## THE WIRELESS COLLEGE, COLWYN BAY.

Or to London Office, 4 WINTON AVENUE, N.11

## TOOLS

**300 Straight Shank Twist Drills**, sizes  $\frac{1}{8}$ " to 1" dia., usual price, 1s. 9d. to 3s. each. Brand new, clearing at three assorted 2s. 6d.—Below.

**2,000 Extra Long Straight Shank Twist Drills.** Best quality, guaranteed Tungsten steel;  $\frac{3}{8}$ " to  $\frac{1}{2}$ " dia., 7" long, 1s. 3d. each; three assorted, 3s.;  $\frac{1}{2}$ " to  $\frac{3}{4}$ "  $\frac{1}{2}$ " long, 1s. each, three for 2s. 6d.—Below.

**85 Only, 2-Jaw Drill Chucks**, complete with key; capacity, 0 to  $\frac{3}{8}$ "; present-day price, 7s. 9d. each; clearing at 4s. 9d. each. "The chuck with the surest grip."—Below.

**30 Only,  $\frac{1}{8}$ " Micrometers**, guaranteed accurate, complete with friction stop; 5s. 9d. each; a neat, useful tool at a low price.—Below.

**Our Popular 1s. 9d. Bargain Parcels**, any four, 6s.—Below.

**Lot 1, approx. 1 gross each No. 4 B.A. Bolts and Nuts**, Hexagon.—Below.

**Lot 2, three gross Assorted Wood Screws.**—Below.

**Lot 3, one gross Assorted Washers**,  $\frac{1}{4}$ " to  $\frac{3}{4}$ ".—Below.

**Lot 4, one gross Whit. Screws**,  $\frac{1}{4}$ " to  $\frac{1}{2}$ ".—Below.

**Lot 5, one dozen Assorted Emery Wheels and Grinding Wheels.**—Below.

**Lot 6, one dozen Small Files**, 4" to 6".—Below.

**Lot 7, two dozen Hacksaw Blades**, any size to 12".—Below.

**2,000 Long Drills**,  $\frac{1}{8}$ " to  $\frac{1}{2}$ ", 5" to 8" long, six assorted, 2s. 6d.—Below.

**500 No. 1 Morse Taper Shank Drills**,  $\frac{1}{8}$ " to  $\frac{1}{2}$ ", six assorted, 2s. 6d.; twelve, 4s. 6d.—Below.

**200 Straight Shank Twist Drills**, best makes only,  $\frac{1}{8}$ " and  $\frac{1}{4}$ " dia. only 6d. each.—Below.

**250 High-speed Centre Drills**, small and medium, double ended, three assorted, 1s. 3d.—Below.

**500 No. 1 Morse Taper Shank Twist Drills**,  $\frac{1}{8}$ " dia., clear at 4d. each.—Below.

**300 High-speed Tap Fluting Cutters**,  $\frac{1}{4}$ " dia.,  $\frac{1}{8}$ " bore for Taps  $\frac{1}{8}$ " to  $\frac{3}{8}$ ", 1s. 3d. each, three for 3s.; Larger,  $\frac{3}{4}$ " to  $2\frac{1}{2}$ " dia.,  $\frac{1}{4}$ " bore, for Taps  $\frac{1}{4}$ " to 1", 1s. 9d. each, three for 4s. 6d.; cost more than this each.—Below.

**Best Quality Whitworth and B.S.F. Taps, Taper, Seconds or Plus**,  $\frac{1}{8}$ ",  $\frac{1}{4}$ ",  $\frac{3}{8}$ ",  $\frac{1}{2}$ ",  $\frac{5}{8}$ "  $\frac{1}{2}$ "; 2s. 9d. per set of five sizes (one tap each size).—Below.

**Special Large Purchase of Best Sheffield Files.** These have been made up into useful parcels, containing two dozen files, 4" to 10". Clearing at 5s. per parcel. Actually worth treble.—Below.

**2,000 Adjustable Tap Wrenches**, capacity 0 to  $\frac{1}{4}$ ", polished finish, usual price 1s. 6d. each, clearing at 6d. each, post 2d.; low prices for gross lots.—Below.

**1,700 Die-Stocks to take  $\frac{3}{8}$ " dia.** Round Dies, all bright finish, usual price 1s. 3d. each, clear at 6d. each; 4s. 6d. per doz. Why bother changing Dies?—Below.

**4,000 Pairs Small Pliers**, 2d. pair, 4 pairs 6d.; offers invited for gross lots, will clear cheap.—Below.

**Special Large Purchase of Tungsten Steel Hacksaw Blades**, 8", 9", 10", 12", with 14 to 32 teeth per inch; the cost of these blades in the ordinary way is from 16s. to 22s. per gross. Secure a stock now 8s. 6d. per gross, 7s. 6d. per gross in three-gross lots; sample orders, 10d. per doz. Guaranteed superior Sheffield quality.—Below.

## TOOLS (continued)

Please Note, 10s. orders and above only are post paid; small orders please allow for postage. Steel Bars, Carriage Forward.—Below.

**5 Bundles Best Quality Silver Steel**, precision ground to size, not bright drawn; sixteen assorted standard sizes,  $\frac{1}{8}$ " to  $\frac{1}{2}$ " dia., round, 4s. per bundle, for making Punches, Cutters, Drills, etc.; easily hardened.—Below.

**Power Hacksaw Blades**, 1" wide, 12", 2s. doz.; 14", 3s. doz.—Below.

**29 Only,  $\frac{1}{8}$ " Micrometers**, Lock-Nut and Ratchet-Stop; decimals stamped on frame; guaranteed accurate; complete in case; to-day's bumper value; usual shop price, 27s. 6d. each, clear at 16s. 6d. each; postage 6d.—Below.

**800 Sets 1" Circular Dies**, Screwing  $\frac{1}{8}$ ",  $\frac{1}{4}$ ",  $\frac{3}{8}$ ",  $\frac{1}{2}$ ", Whitworth and B.S.F. Clearing at 2s. 9d. per set. Both sets 5s. Die Stocks to suit, 1s. 9d. each.—Below.

**60 Only, Genuine Norton Grinding Wheels**, suitable for general shop use, 9" dia., 1" wide, 1" hole, 4s. 9d. each; also few 1½" wide, 5s. 9d. each.—Below.

**1,000 Fine Emery Wheels**, 2" to 4" dia.,  $\frac{1}{8}$ " hole,  $\frac{1}{4}$ " to  $\frac{1}{2}$ " thick, slightly used, but quite serviceable, 1s. 6d. per doz.—Below.

**250 Bundles Bright Drawn Mild Steel**, approx. 5' length each piece, sizes  $\frac{1}{8}$ ",  $\frac{1}{4}$ ",  $\frac{3}{8}$ ",  $\frac{1}{2}$ ",  $\frac{5}{8}$ ",  $\frac{3}{4}$ ",  $\frac{7}{8}$ ",  $1\frac{1}{8}$ ",  $1\frac{1}{4}$ ",  $1\frac{1}{2}$ ",  $1\frac{3}{4}$ ",  $2\frac{1}{4}$ ",  $2\frac{1}{2}$ ",  $2\frac{3}{4}$ ",  $3\frac{1}{4}$ ",  $3\frac{1}{2}$ ",  $3\frac{3}{4}$ ",  $4\frac{1}{4}$ ",  $4\frac{1}{2}$ ",  $4\frac{3}{4}$ ",  $5\frac{1}{4}$ ",  $5\frac{1}{2}$ ",  $5\frac{3}{4}$ ",  $6\frac{1}{4}$ ,  $6\frac{1}{2}$ ,  $6\frac{3}{4}$ , 7", 7½", 8", 9", 10", 11", 12", 13", 14", 15", 16", 17", 18", 19", 20", 21", 22", 23", 24", 25", 26", 27", 28", 29", 30", 31", 32", 33", 34", 35", 36", 37", 38", 39", 40", 41", 42", 43", 44", 45", 46", 47", 48", 49", 50", 51", 52", 53", 54", 55", 56", 57", 58", 59", 60", 61", 62", 63", 64", 65", 66", 67", 68", 69", 70", 71", 72", 73", 74", 75", 76", 77", 78", 79", 80", 81", 82", 83", 84", 85", 86", 87", 88", 89", 90", 91", 92", 93", 94", 95", 96", 97", 98", 99", 100", 101", 102", 103", 104", 105", 106", 107", 108", 109", 110", 111", 112", 113", 114", 115", 116", 117", 118", 119", 120", 121", 122", 123", 124", 125", 126", 127", 128", 129", 130", 131", 132", 133", 134", 135", 136", 137", 138", 139", 140", 141", 142", 143", 144", 145", 146", 147", 148", 149", 150", 151", 152", 153", 154", 155", 156", 157", 158", 159", 160", 161", 162", 163", 164", 165", 166", 167", 168", 169", 170", 171", 172", 173", 174", 175", 176", 177", 178", 179", 180", 181", 182", 183", 184", 185", 186", 187", 188", 189", 190", 191", 192", 193", 194", 195", 196", 197", 198", 199", 200".—Below.

**250 Adjustable Boring Tools**,  $\frac{1}{4}$ " square shank, fitted with  $\frac{1}{8}$ " round boring bar, complete with high-speed tool. Usual price, 8s. 6d. each; clearing at 3s. 9d. each.—Below.

**500 Small Lathe Tool Holders**,  $\frac{1}{4}$ " square shank, fitted with high-speed tool ready for use. A very useful bargain, 1s. 9d. each.—Below.

**2,000 Slitting Saws**, 21" dia., 1" hole,  $\frac{1}{8}$ " to  $\frac{1}{4}$ " thick, six assorted, 3s. 6d.—Below.

**30 Bundles Bright Mild Steel**, round,  $\frac{1}{8}$ ",  $\frac{1}{4}$ ",  $\frac{3}{8}$ ",  $\frac{1}{2}$ ",  $\frac{5}{8}$ ",  $\frac{3}{4}$ ",  $\frac{7}{8}$ ",  $1\frac{1}{8}$ ",  $1\frac{1}{4}$ ",  $1\frac{1}{2}$ ",  $1\frac{3}{4}$ ",  $2\frac{1}{4}$ ",  $2\frac{1}{2}$ ",  $2\frac{3}{4}$ ",  $3\frac{1}{4}$ ",  $3\frac{1}{2}$ ",  $3\frac{3}{4}$ ",  $4\frac{1}{4}$ ",  $4\frac{1}{2}$ ",  $4\frac{3}{4}$ ",  $5\frac{1}{4}$ ",  $5\frac{1}{2}$ ",  $5\frac{3}{4}$ ",  $6\frac{1}{4}$ ,  $6\frac{1}{2}$ ,  $6\frac{3}{4}$ , 7", 7½", 8", 9", 10", 11", 12", 13", 14", 15", 16", 17", 18", 19", 20", 21", 22", 23", 24", 25", 26", 27", 28", 29", 30", 31", 32", 33", 34", 35", 36", 37", 38", 39", 40", 41", 42", 43", 44", 45", 46", 47", 48", 49", 50", 51", 52", 53", 54", 55", 56", 57", 58", 59", 60", 61", 62", 63", 64", 65", 66", 67", 68", 69", 70", 71", 72", 73", 74", 75", 76", 77", 78", 79", 80", 81", 82", 83", 84", 85", 86", 87", 88", 89", 90", 91", 92", 93", 94", 95", 96", 97", 98", 99", 100", 101", 102", 103", 104", 105", 106", 107", 108", 109", 110", 111", 112", 113", 114", 115", 116", 117", 118", 119", 120", 121", 122", 123", 124", 125", 126", 127", 128", 129", 130", 131", 132", 133", 134", 135", 136", 137", 138", 139", 140", 141", 142", 143", 144", 145", 146", 147", 148", 149", 150", 151", 152", 153", 154", 155", 156", 157", 158", 159", 160", 161", 162", 163", 164", 165", 166", 167", 168", 169", 170", 171", 172", 173", 174", 175", 176", 177", 178", 179", 180", 181", 182", 183", 184", 185", 186", 187", 188", 189", 190", 191", 192", 193", 194", 195", 196", 197", 198", 199", 200".—Below.

**1,300 Sets Hexagon Die-Nuts**, Sheffield made, Whitworth, B.S.F., also American thread, U.S.S. and S.A.E., suitable for Ford and other American cars,  $\frac{1}{8}$ ",  $\frac{1}{4}$ ",  $\frac{3}{8}$ ",  $\frac{1}{2}$ ",  $\frac{5}{8}$ ",  $\frac{3}{4}$ ",  $\frac{7}{8}$ ",  $1\frac{1}{8}$ ",  $1\frac{1}{4}$ ",  $1\frac{1}{2}$ ",  $1\frac{3}{4}$ ",  $2\frac{1}{4}$ ",  $2\frac{1}{2}$ ",  $2\frac{3}{4}$ ",  $3\frac{1}{4}$ ",  $3\frac{1}{2}$ ",  $3\frac{3}{4}$ ",  $4\frac{1}{4}$ ",  $4\frac{1}{2}$ ",  $4\frac{3}{4}$ ",  $5\frac{1}{4}$ ",  $5\frac{1}{2}$ ",  $5\frac{3}{4}$ ",  $6\frac{1}{4}$ ,  $6\frac{1}{2}$ ,  $6\frac{3}{4}$ , 7", 7½", 8", 9", 10", 11", 12", 13", 14", 15", 16", 17", 18", 19", 20", 21", 22", 23", 24", 25", 26", 27", 28", 29", 30", 31", 32", 33", 34", 35", 36", 37", 38", 39", 40", 41", 42", 43", 44", 45", 46", 47", 48", 49", 50", 51", 52", 53", 54", 55", 56", 57", 58", 59", 60", 61", 62", 63", 64", 65", 66", 67", 68", 69", 70", 71", 72", 73", 74", 75", 76", 77", 78", 79", 80", 81", 82", 83", 84", 85", 86", 87", 88", 89", 90", 91", 92", 93", 94", 95", 96", 97", 98", 99", 100", 101", 102", 103", 104", 105", 106", 107", 108", 109", 110", 111", 112", 113", 114", 115", 116", 117", 118", 119", 120", 121", 122", 123", 124", 125", 126", 127", 128", 129", 130", 131", 132", 133", 134", 135", 136", 137", 138", 139", 140", 141", 142", 143", 144", 145", 146", 147", 148", 149", 150", 151", 152", 153", 154", 155", 156", 157", 158", 159", 160", 161", 162", 163", 164", 165", 166", 167", 168", 169", 170", 171", 172", 173", 174", 175", 176", 177", 178", 179", 180", 181", 182", 183", 184", 185", 186", 187", 188", 189", 190", 191", 192", 193", 194", 195", 196", 197", 198", 199", 200".—Below.

**300 Drill Chucks**, takes four sets, three jaws. No. 1 Morse taper shank or  $\frac{1}{4}$ " straight shank; 2s. 9d. each.—Below.

**5,000 Small Grinding Wheels** suitable for Flexible Shaft use, etc.,  $\frac{1}{8}$ " to 1" dia., assorted thicknesses, etc.; brand new, unused, 2s. per doz.—J. Burke, 30 Trippet Lane, Sheffield.

**GRAYSON'S Glass-boring Outfits and Tube Cutters** avoid risk.—Below.

**DRILLS, Taps, Dies, Files, Chisels and Punches.** Best quality at keenest prices.—Grayson & Company, 300 Campo Lane, Sheffield.

**THE MYFORD 3-in. LATHE.** Have you seen our new superior model with additional refinements? Standard model still in production. Economical in first cost. Generous in design. Proclaimed best value on the market. Write for illustrated list and instruction booklet, or ask your local tool merchant.—Myford Engineering Co., Neville Works, Beeston, Notts.

**NEW POWER TOOLS.** 10-in. Bandsaws, 50/-; Jigsaws, 21/-; Bench Drills, 22/6; Surface Grinders from 17/6; Circular Saws from 25/-; 3-in. B.G.S.S.C. Toolroom Lathes, £6 Os. 0d.; Electric Drills, Grinders, Spray Plants, Guns, Air Compressors, Woodworking Machines, etc.—John P. Steel, Clyde Street Mills, Bingley.

**LATHES, DRILLERS, CHUCKS**, workshop supplies. A.C. motor castings.—Queen's Engineering, 60 Queen's Road, Battersea, S.W.8.

## WATCHMAKING

**WATCH AND CLOCK REPAIRS.** Everything for the watch, clock and model maker. Large stock of watches, clocks, and clock movements, etc. Wholesale prices. List 3d.—Blakiston & Co., Ainsdale, Southport.

**WATCH, CLOCK AND JEWELLERY REPAIRS** a speciality. Materials, Tools, Invar Steel and Wheel-cutting. Catalogue 6d. Shockproof Watches from 2/3. List 1½d. (Overseas excluded)—Young & Son, Material Dealers, Chippenhain.

## WOODWORK

**CABINET HARDWOODS**, Oak, Mahogany, Ash, Whitewood, Plywoods, etc. Lowest Prices. Send Cutting lists. Planning free. Speciality Prime Jap Oak, all thicknesses.—Wilfred Parr & Co., March Works, Lancaster Road, Leytonstone, E.11.