

PICTURES BY WIRE & WIRELESS

NEWNES

PRACTICAL MECHANICS

AUGUST

6^D₀



MARVELS OF THE X-RAY · HOW DIAMONDS ARE CUT AND POLISHED · TELEVISION MADE EASY · A PHOTOGRAPHER'S AUTOMATIC DISH ROCKER · RUBBER-DRIVEN MODEL BOATS · LATHEWORK FOR AMATEURS · CHEMISTRY · BUILDING MODEL STEAM ENGINES · GLASS SPINNING · LATEST NOVELTIES · TOOLS · PATENT ADVICE Etc. Etc.

SIGNS of the TIMES

The Budget has restored
POLICE OPPORTUNITIES

The Air Force is to be increased
AVIATION MUST DEVELOP

Pay Cuts have been restored
CIVIL SERVICE

Suitable to both sexes. Ages 15½ to 24.
PERMANENT, PROGRESSIVE,
PENSIONABLE POSITIONS.

G.P.O. ENG. DEPT.

CUSTOMS AND EXCISE, INSPECTOR OF TAXES, ETC. NO EXPERIENCE REQUIRED. OPEN EXAMS.

MATRICULATION

There are many ways of commencing a career, but Matriculation is the jumping-off board for all the best ones.

We prepare candidates for all

INSTITUTE EXAMS.

TECHNICAL, ACCOUNTANCY, SECRETARIAL, INSURANCE, ETC.

ENGINEERS and DRAUGHTSMEN

All Branches—Employers are advertising for them.

TELEPHONY, RADIO and MOTOR ENGINEERING are expanding rapidly. There are lots of vacancies. Our postal courses will make you eligible. Advice on all careers Free.

Also ask for our New Book (Free of Charge)

THE HUMAN MACHINE

Secrets of Success



CAN YOU CHANGE MY EXPRESSION?

IF SO, YOU MAY BE THE ARTIST THAT COMMERCE IS WAITING FOR.

Just try it for yourself, trace or draw the outline and then put in the features.

Jim Duok

There are hundreds of openings in connection with Humorous Papers, Advertisement Drawing, Posters, Calendars, Catalogues, Textile Designs, Book Illustrations, etc.

60 per cent. of Commercial Art Work is done by "Free Lance Artists" who do their work at home and sell it to the highest bidders. Many Commercial Artists draw "retaining fees" from various sources, others prefer to work full-time employment or partnership arrangement. We teach you not only how to draw what is wanted, but how to make buyers want what you draw. Many of our students who originally took up Commercial Art as a hobby have since turned it into a full-time paying profession with studio and staff of assistant artists; there is no limit to the possibilities. Let us send full particulars for a **FREE TRIAL** and details of our course for your inspection. You will be under no obligation whatever.

Jim Duok

Art Dept/76.

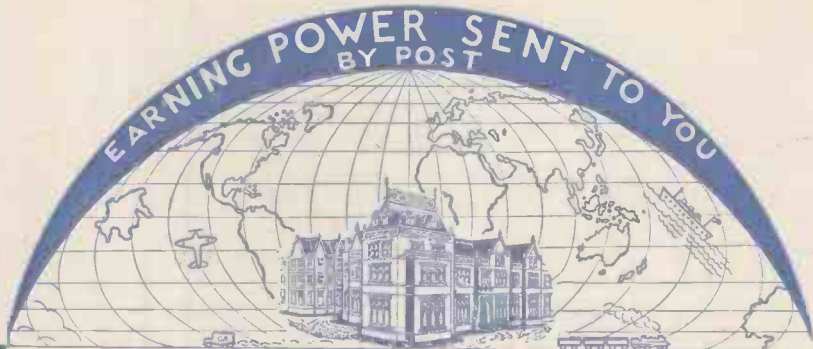

STUDY AT HOME IN YOUR SPARE TIME

OPEN LETTER TO PARENTS

Dear Sir or Madam,—When your children first arrived they brought with them a wonderful lot of sunshine. Later you became proud of the intelligence they displayed, but still later you became anxious as to what would become of them in the future. Perhaps you were anxious when you visualised them as grown men and women. Even with plenty of money it is not always easy to select the right career, and a parent is sometimes inclined to ask advice of some relative and in ninety-nine cases out of a hundred that relative knows nothing at all about the possibilities of employment. Why not let me relieve you of some of your anxieties? In fact, why not let me be their Father? We do not profess to act as an employment agency, but the nature of our business compels us to keep an eye upon the class of men and women that are wanted and who wants them. There are some people who manufacture an article and put it on the market to sell. We do not do that, we work in exactly the opposite direction. We find out what employers want and we train our students to fill those jobs. We have to be experts in the matter of employment, progress and prosperity. If you have any anxieties at all as to what your sons and daughters should be, write to me, or better still, let them write to me personally—Fatherly Advice Department—and tell me their likes and dislikes, and I will give sound, practical advice as to the possibilities of a vocation and how to succeed in it. Yours sincerely,

J. Bennett

YOU CAN HAVE A COLLEGE TRAINING IN ALMOST ANY CAREER FOR A FEW SHILLINGS MONTHLY

Accountancy Examinations
Advertising and Sales Management

A.M.I. Fire E. Exam.
Applied Mechanics
Army Certificates
Auctioneers and Estate Agents
Aviation Engineering
Banking
Boilers

Book-keeping, Accountancy and Modern Business Methods
B.Sc. (Eng.)

B.Sc. (Estate Management)
Building, Architecture and Clerk of Works
Cambridge Senior School Certificate

Civil Engineering
Civil Service
All Commercial Subjects
Commercial Art
Concrete and Structural Engineering

Draughtsmanship, All branches
Engineering, All branches, subjects and examinations

General Education
G.P.O. Engineering Dept.
Heating and Ventilating
Industrial Chemistry

Insurance

Mathematics
Matriculation
Metallurgy

Mining, all subjects
Mining, Electrical Engineering
Motor Engineering
Motor Trade

Municipal and County Engineers
Naval Architecture
Pattern Making

Police, Special Course
Preceptors, College of Pumps and Pumping Machinery
Radio Service Engineering
Road-Making and Maintenance

Salesmanship
Sanitation
Secretarial Exams.

Shipbuilding
Shorthand (Pitman's)
Structural Engineering

Surveying
Teachers of Handicrafts
Telephony and Telegraphy

Transport Inst. Exams.
Weights and Measures Inspector
Welding

Wireless Telegraphy and Telephony
Works Managers

If you do not see your own requirements above, write to us on any subject.

HOW TO STUDY

In your spare time when it suits YOU. You fix your own time, you do not GO to your studies—the postman brings THEM TO YOU. There is nothing that a class-room teacher can show on a blackboard that we cannot show on a white paper. The lesson on a blackboard will be cleaned off, but our lessons are PERMANENT. A class-room teacher cannot give you a private word of encouragement, but a Correspondence Tutor can do so whenever your work deserves it. On the other hand he can, where necessary, point out your mistakes PRIVATELY.

TO STUDENTS LIVING ABROAD

or on the high seas, a good supply of lessons is given, so that they may be done in their order, and despatched to us for examination and correction. They are then sent back with more work, and in this way a continuous stream of work is always in transit from the Student to us and from us to the Student, therefore distance makes no difference.

IT IS THE PERSONAL TOUCH WHICH COUNTS IN POSTAL TUITION

EVERY DEPARTMENT IS A COMPLETE COLLEGE EVERY STUDENT IS A CLASS TO HIMSELF



Dept. 76, THE BENNETT COLLEGE, SHEFFIELD.

Practical Mechanics

VOL. II. No. 23
AUGUST
1935

Edited by F. J. CAMM

SUBSCRIPTION RATES :
Inland and Abroad, 7s. 6d. per annum
Canada - - 7s. per annum

Editorial and Advertisement Offices : "Practical Mechanics," George Newnes Ltd., Southampton Street, Strand, W.C.2.
Registered at the G.P.O. for transmission by Canadian Magazine Post.

Steam Locomotive Adopts Car Practice

THE recently exhibited L.M.S. turbine-driven locomotive, known as the "Turbomotive," is not only the first of its kind in the history of British railways, but is also the first steam locomotive to be fitted with anti-friction bearings.

All wheels of the engine and tender are fitted with Timken tapered roller bearings, which have been familiar to the motor industry, and especially the commercial motor industry, for many years.

A New Speed Indicator

AN innovation for motor-cars is a large speed indicator which is fitted to the back of the car. By this means, police and pedestrians can tell the speed at which the car is travelling; its range is 100 yds. A vertical line shows clearly when the 30-mile limit has been passed, and another line shows a speed of 45 miles an hour.

A Gliding Record

A MOSCOW aviation instructor named Kartashev claims to have flown a distance of 125 miles in a glider. The previous record for a glider was 60 miles.

The New Hudson River Tunnel

A WORLD record in tunnel construction is claimed by engineers who are building the new tunnel under the Hudson River, leading from New York City into New Jersey State. In one week the cutting shield has moved forward under the river from the New Jersey side a distance of 250 ft. This greatly exceeds any other known distance in one week's tunnelling.

A Turbine Rail Engine

FOR the first time in the history of British Railways, the L.M.S. have constructed at their Crewe works a locomotive embodying a turbine engine as the method of traction. The drive from the turbine is direct on to the driving wheels.

The Largest Seaplane

WHAT is claimed to be the largest seaplane in Great Britain recently led a parade of seven huge seaplanes at the Hendon Air Pageant. It weighs 31 tons, and has a cruising speed of 170 miles an hour.

A £30 Car

THE United States is to have a "baby" car which will sell for £30. Its maximum yearly fuel cost is estimated at £18. The

Notes, News and Views

car is a one-seater, 32 inches wide with a wheelbase of 88 inches. It is stated that the speed of the car is 110 m.p.h.

A New Stratosphere Flight

A BALLOON which recently took off from a Moscow airport, recorded an altitude of 17,000 metres (55,775 ft.) before it reached its highest point, which is not yet known. The capacity of the gas bag is 24,000 cubic metres, and the balloon is fitted with an improved safety gondola.

THE MONTH'S SCIENCE SIFTINGS

The world's largest all-welded ship, the "Joseph Medill," was recently launched at Wallsend.

A new 24-ft. wind tunnel, the largest in Britain, for testing aeroplanes was recently opened at Farnborough, Hants.

By means of this tunnel, a jet of air may be accelerated to a speed of 115 m.p.h. by a 30-ft. fan collector driven by a 2,000-h.p. electric motor.

A "captive parachute" device consisting of a 115-ft. steel tower from which the jumper takes off, will be used to train aviators in parachute jumping.

A New Short-wave Invention

THE discovery of new short wireless waves is announced in Berlin by the German Telefunken Co. It is claimed that news of a secret nature transmitted by these waves cannot be detected by anyone not in the line of transmission. They are also declared to be immune from atmospheric and other forms of interference.

Wireless Atmospherics and Lightning

IT has now been proved to the satisfaction of British scientists, that atmospheric sometimes heard in the loudspeaker of a

wireless set are caused by lightning. Apparatus has been perfected that photographs the atmospheric, at the same time disclosing its exact place of origin.

New French Air Liner

A NEW French air liner with a speed of 250 m.p.h., which has just completed its trials, is expected to improve considerably on the 2 days 20 hours 45 minutes record recently set up for the air mail service from Paris to Buenos Aires.

The First Robot Plane

EXPERIMENTS have recently been carried out with a robot plane that can fly without any pilot on board. It is operated entirely by radio, and can fly at more than 100 m.p.h. and rise to more than 10,000 ft. This triumph is the result of ten years' research by the technical department of the Air Ministry.

A Record Non-stop Flight

WE learn that a French seaplane—the Croix du Sud—recently made a non-stop flight of 2,709 miles. This is 125 miles more than the record held by Italy.

The World of Wireless

DURING the annual congress of the International Radiophonic Union, at which twenty-two European countries and United States broadcasting companies were represented, it was estimated that there are 200,000,000 wireless receivers in the world.

A Transatlantic Air Service

THE early operation of a regular British Transatlantic air service between England and the United States, using giant flying-boats, is now being planned.

New Luxury Buses

IT is stated a fleet of 105 new luxury buses will shortly be operating in New York. The buses will be streamlined and built to carry 72 passengers, all sitting down. The engine is placed at the back, and a special concentrated lighting system is incorporated in the bus which eliminates shadows and facilitates reading.

Car and Autogiro Combined

WE learn that the Autogiro Company of America are considering the possibilities of an "Autogiro" car. With wings folded for road travel, it will occupy a space 7 ft. by 24 ft., and its weight will be 1,350 lb. Its speed in the air will be 115 m.p.h. and its road-speed will be 25 m.p.h.



Pictures by WIRE and WIRELESS



Various Types of Picture, Including Ordinary Photographs, may be Transmitted over Ordinary Telephone Systems or by Means of Standard Wireless Systems. Some of the Methods of Doing this and the Difficulties Involved are Explained in this Article.

ONE of the most important departments in a modern newspaper office is the photo-telegraphic section, and as the name implies, this is used for the transmission or reception of photographs by ordinary telegraphic means. It may not be realised at first what tremendous possibilities there are in this invention, but apart from the fact that illustrations may be received and printed in a newspaper whilst an event is still in progress, there is the valuable fact that the police force may be assisted by the transmission of the photograph of fingerprints of a criminal, a missing person, etc. As an instance of the first-mentioned feature may be cited the fact that during the

funeral of the King of the Belgians a London evening paper was on sale in the streets of London with photographs of the funeral procession whilst the ceremony was still in progress in Brussels!

The Broad Principles

At the present time there are in force in this country several systems of photo or facsimile transmission. Amongst these may be mentioned the Belin, the Siemens Schuckert, the Bartlane, the Marconi, and

the American Telephone and Telegraph Co. Taken as a group, it may be stated that the principles involved are similar in each system, with modifications and refinements as decided by each particular

inventor. Stated broadly, it may be said that the original picture—be it negative or positive—is analysed by a light spot, and a light-sensitive device is thereby affected by the reflected light. The variations in an electric circuit so produced are transmitted, and at the receiver end these variations are caused to modify the light from a powerful lamp which is directed on to photo-

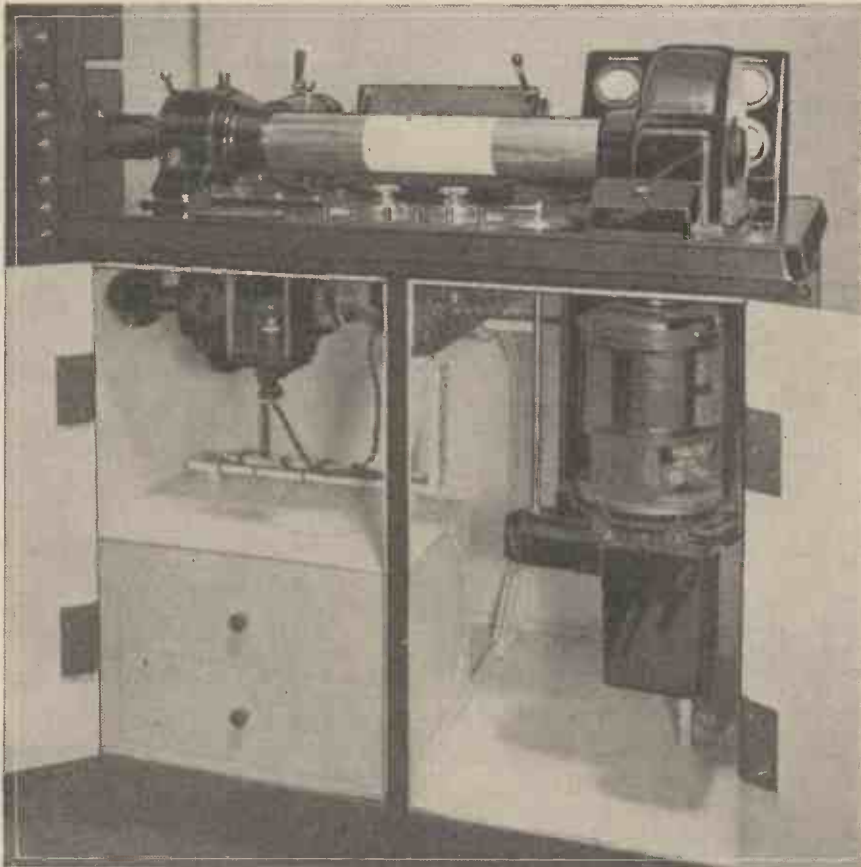

Fig. 1.—The Marconi Facsimile Transmitter.

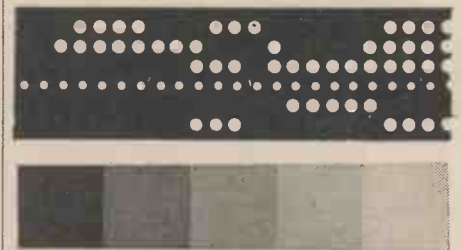

Fig. 2.—A section of paper tape as used in the Bartlane process, and the screens through which the light is passed to form the various tones.

graphic material and so reproduces the original light and shade. As will be seen from this brief description, there are many difficulties to be overcome in order to ensure that the received picture shall be as clear as the original, and many of the principles of ordinary television transmission enter into the subject. It is obvious, first of all, that the receiver must be in synchronism with the transmitter. That is to say, the relative positions of the light and paper must be the same so that the positions of the various objects in the transmitted photograph will be maintained in the received illustration. Similarly, the speed of the transmitter and receiver must be identical and they must keep in step. The reason for this will be seen in a moment. To make the arrangement clear we will describe the Belin system which is used by several pictorial daily newspapers.

The Belinographe

In this system a photograph is scanned in a similar manner to a television image and a photo-electric cell is modulated by the reflected light. To accomplish this the illustration is wrapped round a cylinder

which is rotated by a motor at a definite and regular speed. Fig. 3 shows a portable transmitter using this device and the photograph may be seen round the cylinder. As the latter rotates it is drawn along steadily through a train of gears and thus passes slowly past the photo-electric cell. In this manner a very fine helix is traced out commencing at one corner of the photo, and finishing in the opposite lower corner. The two edges of the photograph do not meet, and the small space thus left is used for synchronising purposes which, at the receiver, is effected through a powerful magnet which is brought into action with the difference in current and causes a brake to act upon the cylinder shaft. At the receiver a special stroboscopic device is fitted and is visible to the operator, and this ensures that the speed of the cylinder will be maintained correctly.

Protection from Light

As the reception is carried out on photographic material (either film or paper) it is necessary to protect it from the light, and an ingenious method is adopted for carrying out this protection. The cylinder is easily removed from the shaft and consists of a shell and an internal solid section. Along the shell is a narrow slit to which is fitted a sliding cover. When the inner portion is withdrawn a piece of photographic paper or film is held in position by two longitudinal clamps and the outer cover is slipped over and a partial turn closes the slot and the light is thus excluded. This process is, of course, carried out in an ordinary photographic dark room and the cylinder is then taken to the receiver and placed into position, a light-proof door closed, and the apparatus is then ready for the reception of a picture. As soon as the operator receives a given signal the motor is started and the various controls are operated to bring the apparatus into step with the transmitter. At the correct moment the slot in the cylinder is automatically opened and light from a powerful light source is projected through a lens in the form of a very fine spot on to the photographic material inside the cylinder. As this slowly rotates and is gradually carried along on its shaft the light spot affects the paper or film, and at the conclusion of the transmission the slot

Fig. 3.—A Portable Belin Telephoto Transmitter. A picture may be seen in position round the cylinder.

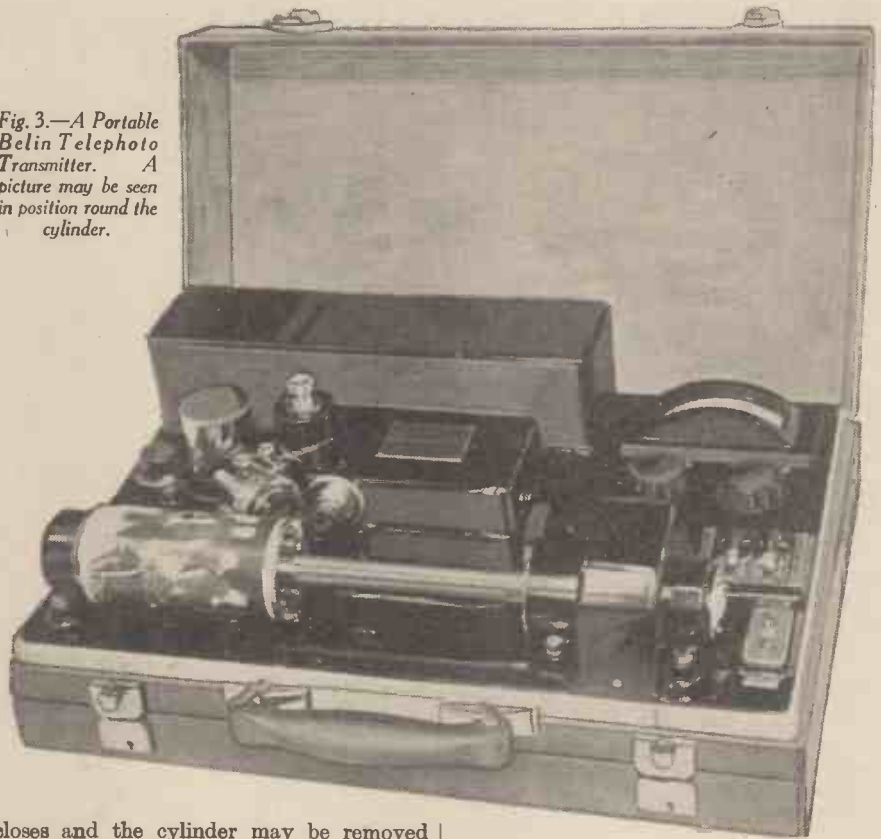

closes and the cylinder may be removed and carried to the dark room for the ordinary procedure of developing and fixing. In this system a photograph approximately 8 in. by 6 in. takes about 12 minutes to complete, although, of course, this time could be shortened by using faster emulsions for the film or paper, but detail would be liable to suffer. As a sample of the high efficiency of this system, an actual telephoto is reproduced in Fig. 5 from which it will be seen that the grain is practically non-existent.

Other Systems

The Siemens system is very similar, except that the light spot carries out the

traversing action, whilst the cylinder rotates in one plane. In the Marconi system the image is moved laterally over a transverse slot in a cylinder and a revolving optical system inside the cylinder throws a fine spot of light through the slot on to the image and thereby traces out the helical course which is reproduced on a similar arrangement at the receiver end. A Marconi Facsimile Transmitter is shown in Fig. 1.

The Bartlane Process

In view of the necessity of preserving detail and otherwise ensuring that the image will be as near perfect as possible, it is

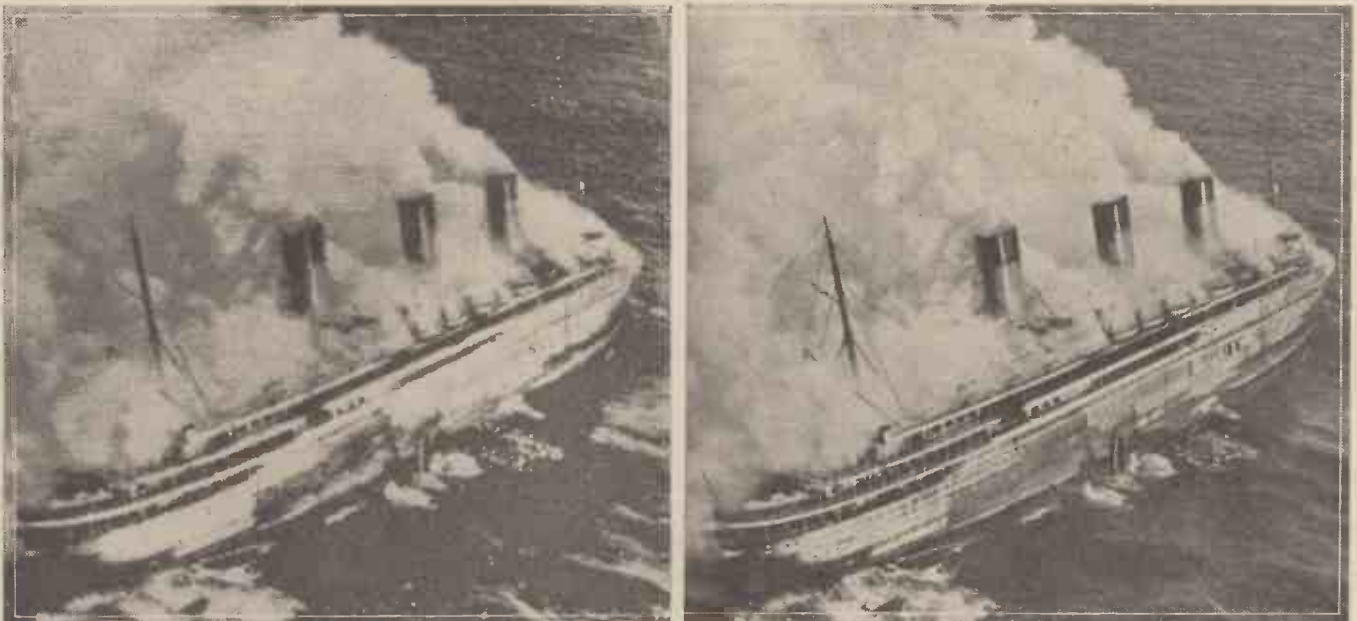

Fig. 4.—(left) A picture as sent by the Bartlane process, and (right) the original.



Fig. 5.—An actual picture received by the Belinographe. Note the perfect detail and absence of lines or grain.

obvious that amplification has to be resorted to. Over moderate distances this is not a difficult problem, but for use over the transatlantic cables a somewhat different method is adopted by means of which the picture is translated into a code. This has the advantage that the picture may be coded and retained for any length of time before transmission, and at the receiver end it may be taken off and again retained for any length of time before reproduction.

Duplicates

Similarly, any number of prints may be obtained. For this process the original picture is scanned, as previously described, but instead of the impulses from the light-sensitive device being sent away they are taken to another part of the apparatus where are situated five small electrically-operated punches. The picture is analysed through a series of apertures and is thereby divided up into 15 tones. The punches are operated according to the tone which is received and a narrow strip of black paper tape is perforated in a succession of small holes. In Fig. 2 is an actual reproduction (full size) of a piece of tape carrying a portion of a picture. The row of small holes across the centre is simply used to enable the paper to be drawn along by a toothed wheel, although they also perform the dual function of synchronising impulses. The first tone would be represented by the punch hole in the bottom row of the strip; the second tone by the next row of holes; the third tone by another row, and so on, with various combinations of the five rows of holes to produce 15 individual tones. At the receiver a powerful light is directed through a strip containing five separate tones as shown in Fig. 2. These holes are square, as distinct from the round holes of the tape, to prevent dark patches in the received picture. The tape passes across this shaded opening and the light which passes through the opening is focused by a lens on to the photographic film or paper. The five holes are brought to a common focus point by the optical system, and it is obvious that the light from the lamp will only pass through the openings which are uncovered by the perforated strip.

Light Variations

Thus the total amount of light reaching the film or paper will be varied and the picture thus formed. The tape may be passed across the light source at any speed and a

picture may be reproduced in a very small period of time, the limit being governed more by the strength of the paper tape than by the speed of the photographic emulsion, as the centre holes will tear out if the speed is too great, but the picture would be just as clear as if the speed were reduced. A sample picture in its original form, and as it appears after passing through the Bartlane apparatus is shown in Fig. 4.

The Connecting Links

The transmitter and receiver are generally connected through standard Post Office telephone lines (except where a wireless link is employed) and there are a number of difficulties to be overcome in this direction. At the newspaper offices and other places where the receiving apparatus is installed, private lines are used, and these are, of course, free from interruption. The development of the portable picture transmitter (one of which is shown in Fig. 3) has enabled the transmission of pictures to be carried out from any part of the country,

and it is obviously necessary for this transmitter to be connected with the telephone lines before a transmission can be carried out. A Post Office Engineering Officer carries out the connection, the newspaper concerned making application beforehand for his services. A list of exchanges where special linemen for the purpose are stationed is furnished to interested users of the apparatus, and the connection is generally made straight to a trunk line at the main frame. In view of the fact that ordinary overhead telephone wires are liable to interference from various electrical sources, an underground trunk line is generally employed for picture transmission, and the system known as a 4-wire repeated underground circuit is adopted. The frequency range for modern photographs is approximately from 500 to 2,400 cycles per second, and the underground circuits just mentioned are equalised up to 3,000 cycles per second so that no loss of detail should occur. It is also obvious that special steps have to be taken to prevent interruption by operators, etc., and thus special markings are adopted at the exchange.

Line Connections

The apparatus may be attached to a telephone wire at any point, and, as may be seen in the illustration on our cover, a connection may be made out in the open by the side of the road or at any similar point. Generally, the apparatus is installed in a house, to prevent damage, and connection made to a private subscriber's line, the wires being removed from the ordinary telephone and connected to the transmitter. By the use of the 4-wire system it is possible to carry on ordinary voice telephony at the same time as the picture is being transmitted, and the portable transmitter is used with a microphone and headphones for the operator.

Under modern conditions it is also possible for the picture from a transmitter to be sent to more than one station at a time, and a special forked amplifier is used for this purpose, and under experimental conditions it has been found possible to transmit six channels of voice frequency two-way working together with one channel of two-way picture transmission.

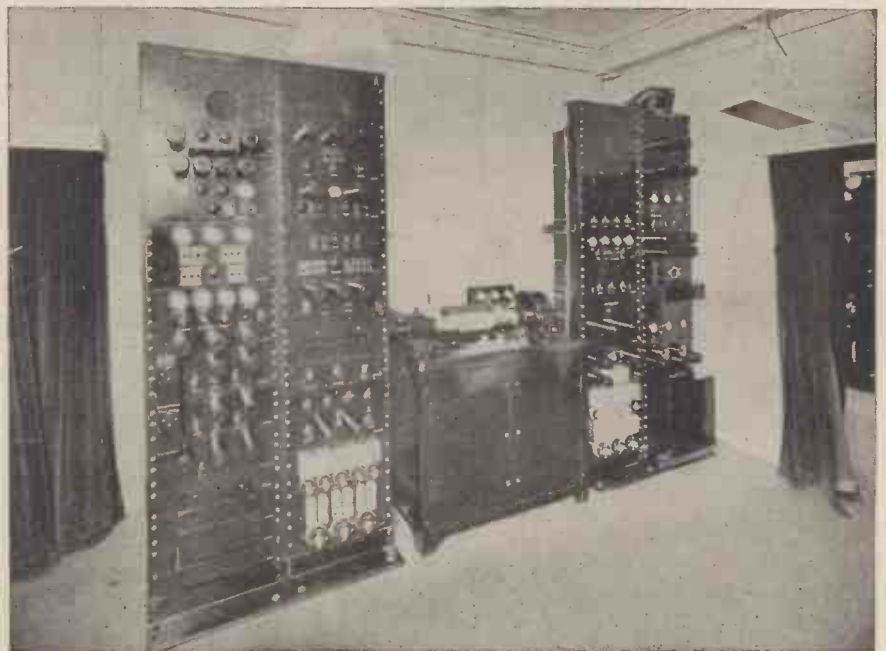

Fig. 6.—The Marconi Facsimile Transmitter and the associated equipment.

THE STORY OF THE TYPEWRITER

By G. R. M. GARRATT, M.A. (Cantab.)

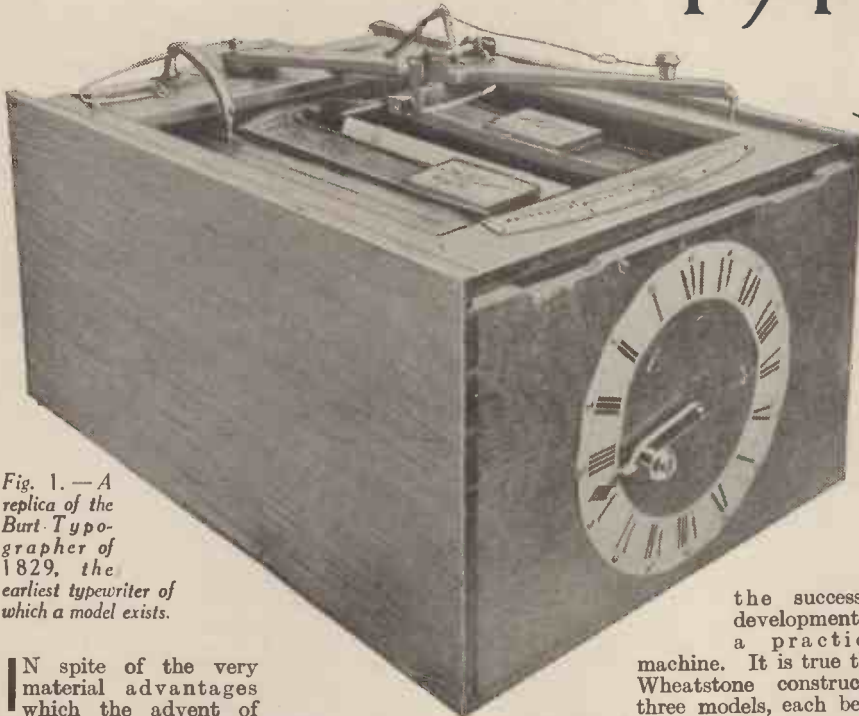

Fig. 1.—A replica of the Burt Typographer of 1829, the earliest typewriter of which a model exists.

It is True to Say that the Typewriter, more than any Other Modern Invention, has Contributed Enormously to the Modern Revolution in Commercial Life.—For it has not only Contributed to the Speeding up of Business Communications, an Honour which it shares with the Telegraph, the Telephone and the Radio, but, unlike these others, the Typewriter alone Succeeded in Paving the way for the Entry of Women into Business.

IN spite of the very material advantages which the advent of the typewriter brought about, its arrival was so gradual that the change was scarcely appreciated, and, as a result, its history has been almost forgotten. Few indeed there are who know the story of its birth and fewer still are the typists who realise the debt they owe to Charles Latham Sholes, of Wisconsin and Milwaukee, U.S.A.

We will not concern ourselves with the fairly numerous inventions of writing machines which appeared between 1830 and 1860—the Burt Typographer of 1829, the Thurber machine of 1843, the Hughes machine for the blind or the Wheatstone inventions between 1850 and 1860, for although these inventions and many other similar ones had the common aim of rapid writing, yet their designs were such as to render them of little practical utility. Generally only one machine was made, and, after being protected by patents, the inventors seem to have lost confidence in their efforts and turned their minds to less difficult problems. They lacked that foresight and solid perseverance which alone could lead to

the successful development of a practical machine. It is true that Wheatstone constructed three models, each being an improvement on the last, but it remained to C. L. Sholes to attack the problem with sufficient enthusiasm and perseverance to construct the first really practical machine.

The First Practical Machine

Sholes was a printer by trade, and for some years prior to 1866 he had been experimenting with a machine to number consecutively the pages of a book. The idea was suggested to him, "If numbers, why not letters?" but he proceeded no further until an article in a scientific journal was brought to his notice. This article described a typewriter invented by John Pratt, and it went on to prophesy that not only would the successful inventor of a practical writing machine reap a considerable fortune, but that the machine would soon become so universally used that "the weary process of learning penmanship in schools will be reduced to the acquirement of the art of writing one's own signature."

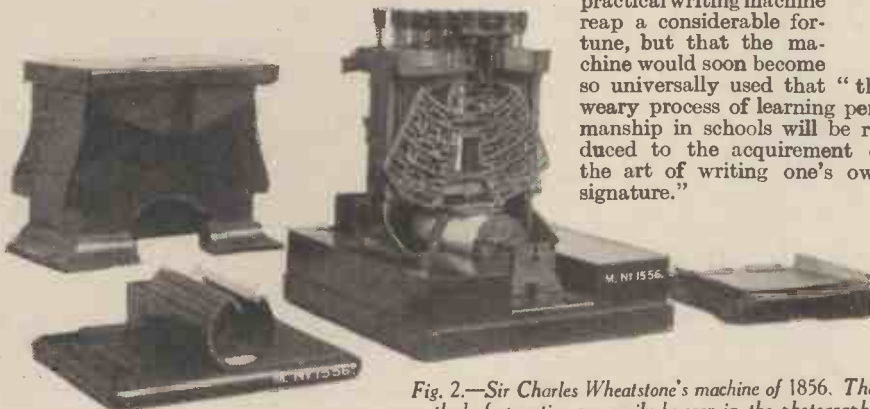

Fig. 2.—Sir Charles Wheatstone's machine of 1856. The method of operation can easily be seen in the photograph.

One of John Pratt's machines which inspired this article is still preserved at the Science Museum, South Kensington. It was only a little more practical than its predecessors, but it has the distinction of having been the inspiration which led indirectly to the invention of the typewriter of to-day. Pratt was an American citizen, and although his machine was invented and built in London, many years were destined to pass before an Englishman either invented or improved upon the machine which was developed by Sholes between 1867 and 1873.



Fig. 3.—Sholes-Glidden typewriter as produced in September 1873. It wrote capital letters only.

Sholes' enthusiasm having been aroused by the article mentioned previously, entered into partnership with two friends, Glidden and Soulé, and this trio, probably ignorant of almost all the previous efforts, set out to construct a practical typewriter. Glidden provided the money for the experimental work. Sholes invented the spacing mechanism and innumerable other details, while the idea of typebars which converge to a common printing point as the keys are struck was Soulé's suggestion.

They began work at once and by September, 1867, the first machine was ready for use. Letters were written on it and it wrote

rapidly and well, but extended trials showed that it fell a long way short of being an acceptable and practical machine.

One of the first letters which had been written on it was sent to a wealthy acquaintance, Mr. James Densmore. He was so impressed with the invention that he wrote by return mail asking to be permitted to join the enterprise. Sholes replied that two others were already interested but that they would offer Densmore a quarter interest in return for the payment of all expenses up to date. Such was Densmore's enthusiasm that, without ever having seen the machine or even knowing the price he had to pay, he wrote again by return mail saying that he would accept the terms and asking that the bill should be sent to him!

The Machine Criticised

Densmore did not see the machine until early in 1868 and, when he did, he described it as good for nothing except to show that the idea was feasible. His verdict was a just and very wise one. He pointed out defects which must be remedied before the machine became a commercial proposition and he urged Sholes to devote continuous efforts to devise improvements. Soon after this interview, Glidden and Soule dropped out of the enterprise, but, with Densmore's enthusiastic encouragement, Sholes persevered in making improvements. One device after another was conceived, tried out, and developed until between twenty and thirty experimental machines had been constructed, each one a little different and a little better than the one before. As each machine was finished it was put into the hands of a stenographer, Mr. J. O. Clephane, who tested them, and, in testing, he destroyed them one after the other until poor Sholes' patience was almost exhausted. Densmore insisted, however, that Clephane

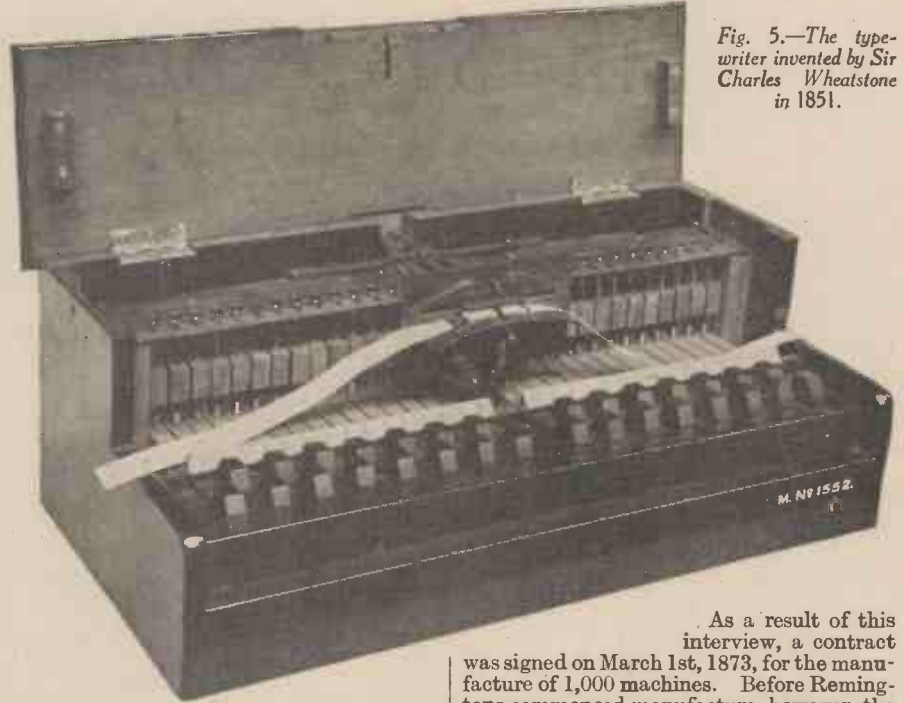

Fig. 5.—The typewriter invented by Sir Charles Wheatstone in 1851.

was their salvation, for he brought out the defects and showed where improvements must be made before a commercial venture could be risked.

Densmore's criticism and Clephane's undoubted ability to wreck almost any machine would have been more than sufficient to dishearten most men, but Densmore combined boundless enthusiasm with his criticism and, fortunately, Sholes persevered. At last, in 1873, they judged it sufficiently perfect to consider manufacture in quantities.

Of the various companies who might have been capable of undertaking its manufacture, the Remington Armoury Company of Ilion, U.S.A., seemed the most appropriate. They already made sewing machines and, accordingly, Densmore travelled to Ilion with the precious model, the culmination of six years of experiment.

A Contract for 1,000 Machines

Sholes did not go to Ilion; perhaps it is fortunate that he did not, because he was far too modest a man to plead successfully the cause of his own invention. Instead, Densmore took with him a certain George Washington



Fig. 6.—The Remington Model 2, which was produced in September, 1878. This machine could write both small and capital letters.

Yost, who, like many Americans of to-day, possessed almost unlimited for-
ensic ability. He was, in fact, a salesman par excellence, and Densmore cer-
tainly relied on Yost's fluency to persuade the Remington company to take over the manufacture of the typewriter.

tainly relied on Yost's fluency to persuade the Remington company to take over the manufacture of the typewriter.

tured in quantities, and it was not until September, 1873, that actual manufacture began.

Priced at £60

As only too many inventors have learned both before and since, it is one thing to invent a practical device of any kind; it is another matter altogether to sell one's device to a suspicious and incredulous public particularly when the price of the device is nearly £60. The typewriter was no exception, and one sales organisation after another collapsed in the effort to win popularity and success for the infant typewriter.

(Continued on page 516.)

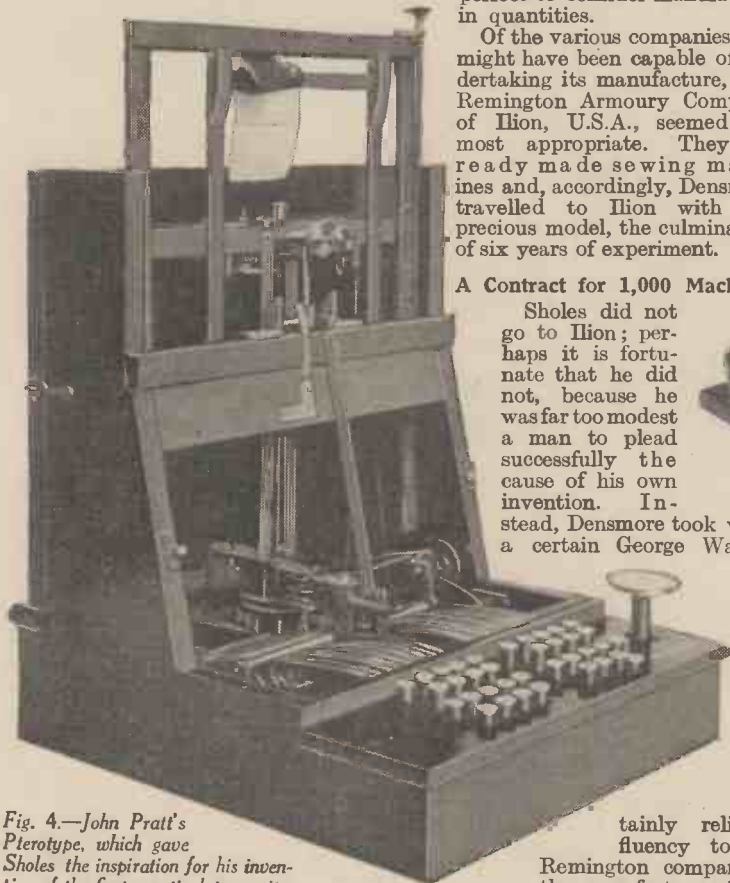
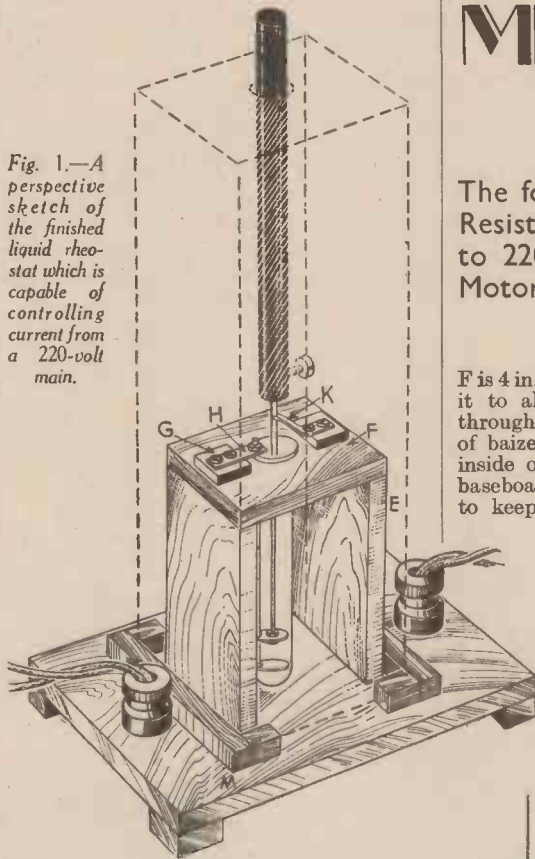

Fig. 4.—John Pratt's Pterotype, which gave Sholes the inspiration for his invention of the first practical typewriter.

MAKING A LIQUID RHEOSTAT

Fig. 1.—A perspective sketch of the finished liquid rheostat which is capable of controlling current from a 220-volt main.



THE finished rheostat is shown in perspective in Fig. 1, while Fig. 2 shows the main part of the apparatus. The plugs can be purchased for 1s. the pair at any multiple store, the glass tube can be obtained for about 4d., and the remainder of the apparatus consists of light brass, vulcanite, glass tubing and either pine or white wood.

The Construction

The glass tube is a resistance glass test tube, 8 x 1 in., having walls of from 1 to 1.5 mm. in thickness. From thin sheet brass (about .5 mm. thick), cut out two discs A and B (Fig. 2) of such a size that they will pass fairly easily up and down the tube. Next obtain a piece of 1/8-in. brass rod (C) 8 1/2 in. long, and thread the two ends to take No. 5 nuts. Fasten the disc A to one end by two nuts as shown, and push it to the bottom of the tube. Fit over the brass rod C a piece of glass tube 7 1/2 in. long to insulate C. The glass tube may be easily cut to the required length by making a small notch at the necessary point, placing the thumbs together on the opposite side from the notch and going through the action of attempting to bend the tube, when it will snap off neatly and cleanly at the notch. Next take a similar brass rod D, 8 1/2 in. long, and thread the two ends as before. With a rat-tail file cut out a circular slot in the disc B so that it can slide fairly easily over the glass tube as shown in Fig. 2. Fasten it to one end of the rod D by two nuts, and place it in the test tube.

The Wooden Support

All the woodwork shown is 1/2 in. thick. First of all, prepare a rectangular base board 10 in. x 5 in., and if small blocks are screwed to the corners, it greatly assists the stability of the apparatus, and the ease and neatness of the wiring. The uprights E are 7 1/2 in. high and 2 in. wide, and the platform

The following Article Describes the Construction of a Variable Resistance Capable of Dealing with Currents from any Mains up to 220 Volts, and can be Used for Controlling Small Electric Motors, Dimming an Electric Light, or for any Purpose Where the Mains Current Requires Regulating.

F is 4 in. x 2 in. with a circular hole bored in it to allow the test tube to easily pass through. A cosy fit is ensured if a piece of baize or other cloth is glued round the inside of the hole, and the centre of the baseboard should be countersunk slightly to keep the bottom of the tube steady. Next screw on to the platform, two rectangular pieces of vulcanite (G), 1 in. x 1/2 in. x 1/4 in., to act as insulators.

From the sheet brass cut out two strips 1/8 in. wide. One of them, H, 1 1/4 in. long, the other, K, 1 1/2 in. long. Drill two holes to take the rod C and a wood screw, with a corresponding hole in the vulcanite to also take the latter. Fasten the rod C by means of a nut, and screw the brass strip down on to the vulcanite. The rod C then becomes a fixture, and is insulated.

With a rat-tail file, cut a circular notch in the strip K to fit the rod D. Bend the strip to make contact with K as shown. Drill the strip and the vulcanite to take two wood screws and fasten them to the platform. If the curve of K is adjusted, it will be found that the rod D will slide up and down

the test tube while maintaining contact with K.

L consists of a 1/2-in. rod of vulcanite, or other insulating material, 8 1/2 in. long. Drill and tap one end so that it can be screwed on to D and about 1/2 in. up from the bottom fix a screw to act as a stop to prevent D from being entirely withdrawn from the liquid in the tube.

The Wiring

The next step is the wiring which is shown by the dotted lines in Fig. 3. Join H to one socket of one plug, and K to one socket of the other plug. The free sockets of the two plugs should be joined together.

To cover any "live" parts, construct a box having a hole in the top to allow the rod L to pass through. The outline of this box is shown by dotted lines in Fig. 1. To maintain it in position, fasten cleats M to the baseboard, but not so close to the box that it cannot be lifted easily. Finally, it is necessary to fill the tube with the electrolyte which is a 5 per cent. (approx.) solution of sodium sulphate. This can be made up by dissolving 1/2 oz. of the salt in 1/2 pint of water.

The apparatus is now ready for use. The current from the mains is plugged in at either side and the lamp or motor, etc., at the other. If B is touching A at its lowest point there is no resistance in the circuit. On raising the rod L the resistance is increased in the circuit, and the amount of current passing is reduced. The rod L must be moved up and down slowly to allow the liquid to flow past B or the liquid may be expelled from the tube. The rheostat requires no attention except to add a little water to the tube from time to time to make up for any loss from evaporation. The brass has no tendency to corrode even after a long interval of time.

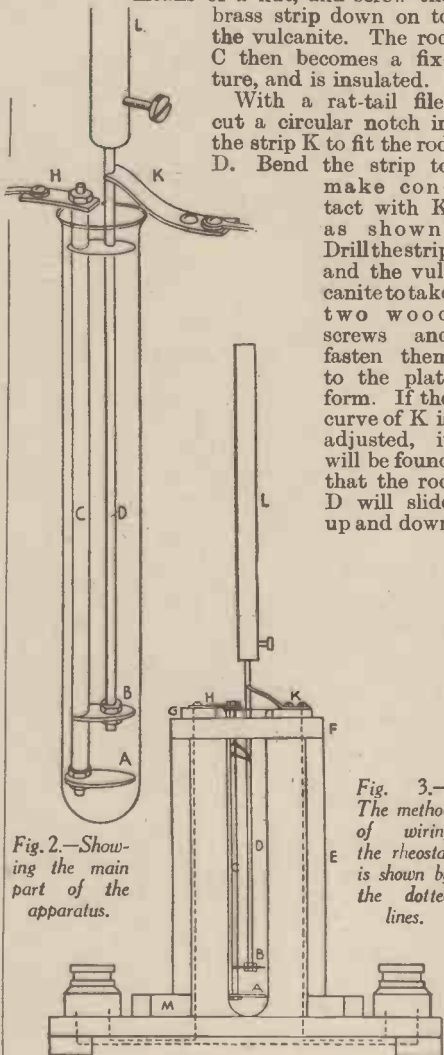

Fig. 2.—Showing the main part of the apparatus.

Fig. 3.—The method of wiring the rheostat is shown by the dotted lines.

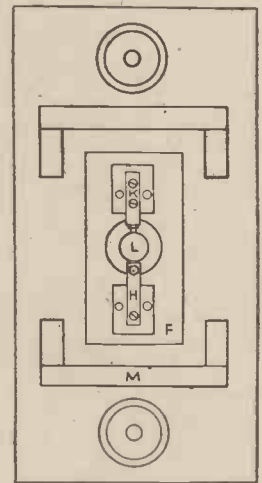

Fig. 4.—A plan view of the apparatus.

A NEW HANDBOOK!

POWER-DRIVEN MODEL AIRCRAFT
1/-, or 1/2 by post from George Newnes
Ltd., 8-11 Southampton Street, Strand,
W.C.2.

A self-contained shock-proof X-ray unit for chest and lung work, with the front and one side panel removed to show the arrangement of the interior components.



MARVELS OF

Six Years Ago a Simple Shockproof X-Ray Outfit day over 2,000 of these Outfits are in Regular X-Rays Could

parent to the X-ray than is bone. The presence of an object of greater density will, therefore, always be apparent in an X-ray inspection of something of lesser density; the reverse also applies.

Acting on the sound principle that prevention is better than cure, manufacturers in several widely different branches of industry are using X-ray equipment to satisfy themselves of the per-

fection of their products. In this way, they can determine whether any flaws exist within the fabric of a structure.

Faults in Welding

Perhaps one of the most important industrial applications of the penetrative qualities of X-rays, is the examination of welds in joints between two pieces of steel. Faults in a weld, such as cracks, blow holes, slag inclusions, etc., introduces a point of weakness. Where such defects are present in a structure which has to stand heavy stresses or pressures, a failure of the fabric

X-RAYS, light rays and wireless waves are held by physicists to be similar in that they are all wave impulses in space—the difference is merely that of the length of the wave. The extremely short wave-length of X-rays enables them to penetrate substances which are opaque to light rays, and the extent to which such substances are penetrated depends upon their density. Aluminium, for instance, is penetrated much more easily than is lead, and flesh is much more trans-

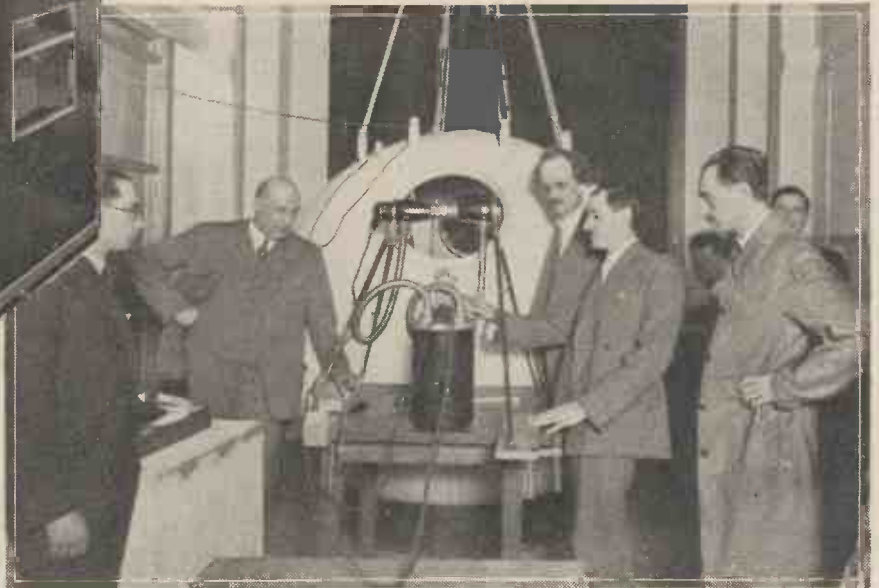

Showing Prof. Piccard's stratosphere balloon gondola being examined by means of an X-ray unit to ensure the strength of the welded parts.



Showing a patient lying prone whilst an X-ray exposure is being made of his back. The radiograph shown on the right is the result of the exposure.

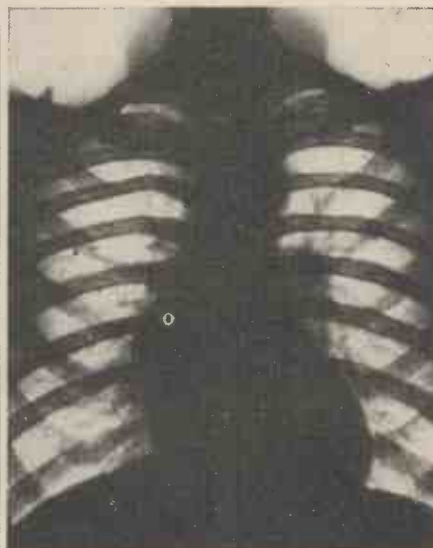

at the point of weakness is probable. By using X-rays, however, any fault will be revealed.

Metal castings or forgings are similarly liable to contain imperfections concealed in the interior of the metal, and sooner or later these parts will fail under strain. Here, again, the X-ray detects the fault. Parts for aeroplanes, railway locomotives, marine boilers, chemical plant and other equipment which will be called upon to stand high pressures or heavy strains are now tested in this way as an ordinary matter of routine procedure.

It is not possible to test all structures by X-ray methods because there is a limit to the thickness of some materials which can be penetrated by the ray. Up to the present the greatest thickness of steel which has been satisfactorily penetrated is 3-4 in. Experimentally the possibilities of penetrating greater thicknesses have been explored and plant for heavier work is now in the course of construction. Lighter metals, of course, can be penetrated in greater thicknesses.

Wooden components for aeroplanes are naturally subject to very considerable stress.

THE X-RAY

was First Used by the Medical Profession. To-Use. No Better Testimony to the Value of be Provided.

Any flaws such as worm holes, resin pockets, faulty joints and so on, would result in serious, and probably tragic consequences. The systematic testing of such parts under X-rays goes a long way towards ensuring the perfection of the structure.

When goods are manufactured by the assembly of component parts, there is a possibility that damage or displacement might take place internally during the course of later operations. The damage is not always apparent and it is only after the goods are sold and fail to act that the defect

mediately be discovered in this manner and a decision taken as to whether it is worth while unwinding the coverings to retrieve gems or ornaments for further inspection.

Examining Paintings

A great deal of valuable and interesting information concerning paintings about which some doubt existed has been elicited when they have been subjected to expert scrutiny in this way. Paintings which had previously been regarded as valuable old

masters have been exposed as forgeries, and alterations made upon a painting by another hand have been disclosed. Older pigments are, in general, more opaque when viewed under X-rays than are more modern pigments; this property provides one of the means of differentiating between the true and the false. It is also possible to determine the existence of an earlier painting which has been covered over by another picture. Artists sometimes buy an old painting for the sake of the canvas and paint over it without removing the original. On one occasion, a supposed "old master" was discovered to have been painted over a modern scene.

X-ray and the Jeweller

Jewellers are also among those who find

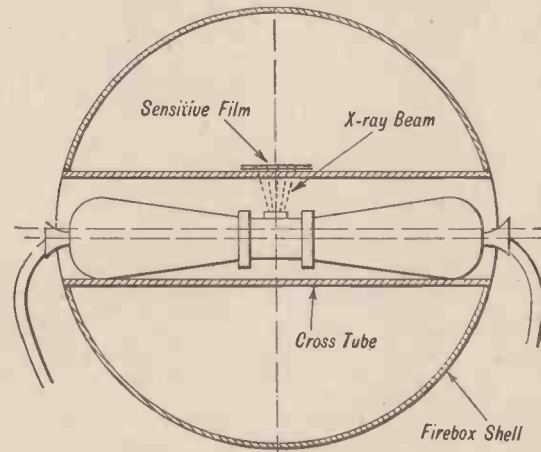

A sectional sketch of a firebox with the X-ray tube located inside the cross tube.

is discovered. A manufacturer of metal wireless valves has installed an X-ray equipment and all valves are examined in two directions before they leave the factory, in order to make certain that the grid and filament are correctly positioned.

Golf Balls

Golf balls also undergo inspection in this way. If you take the outer cover off an old ball, you will find that there is an inner elastic-wound core. In order that the flight of the ball be perfectly true, it is essential that it should be absolutely spherical and accurate in balance. Although the finished article might respond to tests for exterior sphericity, there may be a displacement of the inner core which would result in loss of balance, and inaccurate flight in play. By examining the balls as they pass beneath the X-ray screen, it is easily determined whether they are in good order.

An interesting application is in obtaining an exact knowledge of the fit of a screw thread. This was at one time a matter of some difficulty; nowadays, the adoption of X-ray technique makes the examination perfectly simple.

Outside the sphere of industry, the all-seeing eye of the X-ray finds considerable scope for its talents in the realms of art and archaeology. The examination of mummies has been greatly facilitated in this way when it has been desired to preserve specimens intact. Details casting valuable light on the finds have been discovered without unwrapping and damaging the specimens. Jewels buried with the mummy can im-



A reproduction of a radiograph (unretouched) taken with the "tunic junior" unit made by Messrs. Watson & Sons, Ltd.

the X-ray of service and the instrument can be used for determining whether a gem is false or real. Diamonds are transparent to X-rays whereas synthetic or fake stones are more opaque. Genuine pearls can be told from false because the former seem to radiate a visible light beneath the X-ray whereas the latter are "dead."

The modern smuggler finds in the X-ray an implacable enemy. Any suspected parcels or packages can be rapidly examined and the presence of contraband disclosed.

Many developments have been made in the equipment and technique in late years and new uses and applications are regularly discovered. The facility with which the invisible is revealed has rightly earned for X-rays the title of "Industry's Detective."



A further X-ray exposure being made of the patient's arm, and the radiograph on the right shows the result obtained.



THE WILLIS "WORLD CLOCK"

A Timekeeper Indicating the Correct
Time in any Part of the World

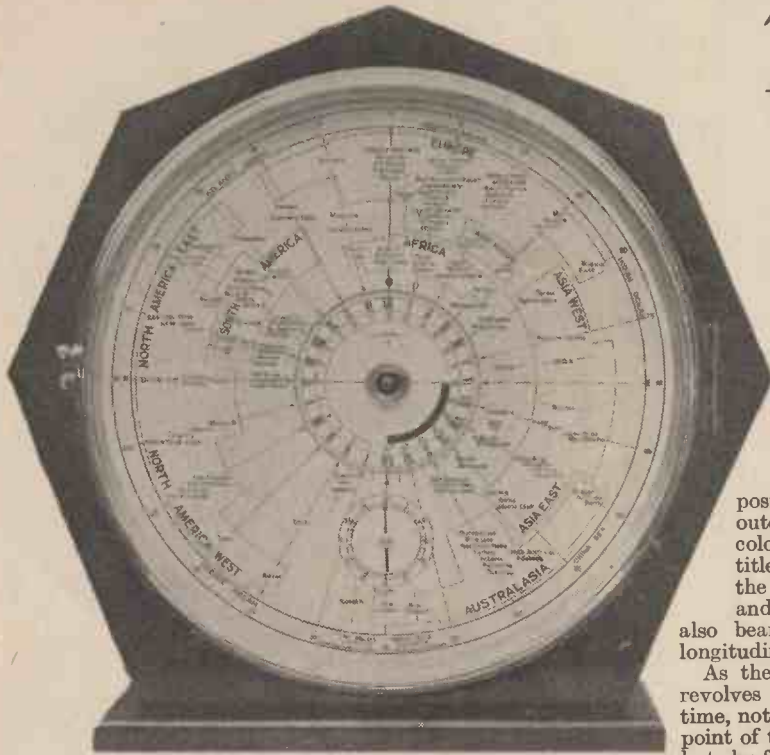

Showing the dial of the "World Clock" invented by a Norwich Scientist. The dial itself rotates once in 24 hours and gives remarkably accurate readings.

THE developments of science and invention are rapidly making the world a much smaller place than it was, even a few years ago. Now that the aeroplane has made it possible to fly to Africa and back in a day, the telephone, to talk from one's home to New York or Tokio, and wireless, to listen to radio programmes from South America, it is safe to say that the most remote places are as near as France was in the time of our grandfathers.

The difference in the local times of various parts of the world must, however, always remain, and in communicating with places having different longitudinal positions, it is becoming increasingly important to know what this local time is.

A clock which gives the time at any point on the earth has now been made by a Norwich scientist, and this clever instrument he has called the "World Clock." Its simplicity is, perhaps, its most notable feature, for there is only one dial, and this gives a remarkably accurate reading. The dial itself rotates once in 24 hours, and is located at the centre of a larger ring which is marked out with continents, oceans, seas and islands. The rotating dial has its edge divided up into hours, quarters and 5-minute spaces, and two sets of Roman figures from "I" to "XII" show the A.M. and P.M. used in this country. A second ring of figures, this time Arabic, give the 24-hour notation used abroad.

The Dial Mechanism

The dial is driven by a clock, and revolves anti-clockwise, whilst the outer ring is marked with outlined blocks representing the larger land masses or continents. Inside the outlines appear the chief countries and cities of the continents, each on a line giving its appropriate longitudinal position. The portions of the outer ring inside the outlines are shown in white, but the rest of the dial is shaded light blue, and on this appear the smaller lands and groups of islands, again on their appropriate longitudinal

positions. An outer ring, also coloured blue, is titled to indicate the chief oceans and seas, and also bears the main longitudinal divisions.

As the dial slowly revolves it gives the time, not only at the point of the observer, but also for any other, for it is only necessary to find the title of any place on the

ring, and then to read the time on the central dial which appears in line with it at the moment.

A further point is that as the minutes of standard time are the same all over the world, a second small dial, seen below the central one, can be used to enable time to be read to the nearest minute. This small dial has a hand which makes one turn per hour, and thus gives a similar reading to that of the usual minute hand. For the few places which have found it necessary to standardise on a time differing by half an hour from the nearest standard hours, the minute reading is obtained by taking the opposite end of the hand, this being coloured red for distinctness.

A Problem Solved

A still further problem is presented by those places which do not conform to any standard, and have local times of their own, but this has been surmounted by marking

them on the ring at the places which will give their times when read on the central dial. In order to give the minutes of these places also, the number by which they differ from standard is shown below the titles, together with a sign to indicate whether these minutes must be added or subtracted from the reading on the minute dial. An instance can be seen in the South America division, where British Guiana is shown with a + 20 indication, to show that 20 minutes must be added to the minute dial reading to get British Guiana time.

To give Summer Time as well as Standard, the names of the places that use it are duplicated on the meridians which they temporarily adopt, and our own country can be seen both on meridian "0" and on "15" East. These Summer Time titles are in red to prevent mistakes.

Although reading the time on the clock seems a little strange at first, one soon becomes familiar with it, and can rapidly read the time for anywhere almost at a glance.

The clock mechanism which drives the clock is interesting, for in some ways it resembles a time-switch clock. It is wound by the square to be seen in the centre of the revolving dial, and a suitable wheel in the train operates the minute hand. Both the hour dial and the small hand are set by simply twisting to the correct point with the fingers. The escapement used for the clock, which is of British construction, is a jewelled platform lever, and the timekeeping is of a high order.

Its Possibilities

In addition to the spring driven type already made, electrically wound and synchronous-motor operated types are in preparation, and so the clock will be capable of working under any conditions. Its value in determining the time of receipt of telephone and radio messages to distant points, and the ease with which it enables one to listen to radio programmes sent out at very different local times from one's own seem to indicate a wide usefulness for this timekeeper. It has already attracted considerable attention from the B.B.C., the Post Office, and several shipping companies and cable companies, but these must only represent a small part of the possibilities of this clever device.

Its inventor, Mr. J. H. Willis, of Norwich, did not design it for commercial use in the first instance. He really produced it as an aid to his own radio listening, and it was not until he had used it for some time that he realised the great possibilities possessed by it. More strange still is the fact that Mr. Willis is not a clockmaker, for the design suggests that the inventor was an expert horologist.

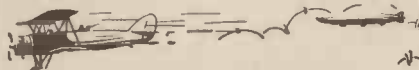

MODEL BOAT BUILDING

The "ABC" of this most fascinating hobby—practical and comprehensive.

With 131 Illustrations

From all Booksellers

Only 1/- net

Newnes
**HOME
MECHANIC**
Series

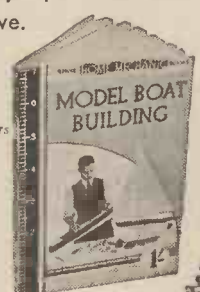

RUBBER-DRIVEN MODEL BOATS

In Comparison with Clockwork Motors the Ingenious Rubber Mechanisms Described Below will be Found much Cheaper, Considerably More Simple, and More Easily Fitted. By E. W. TWINING

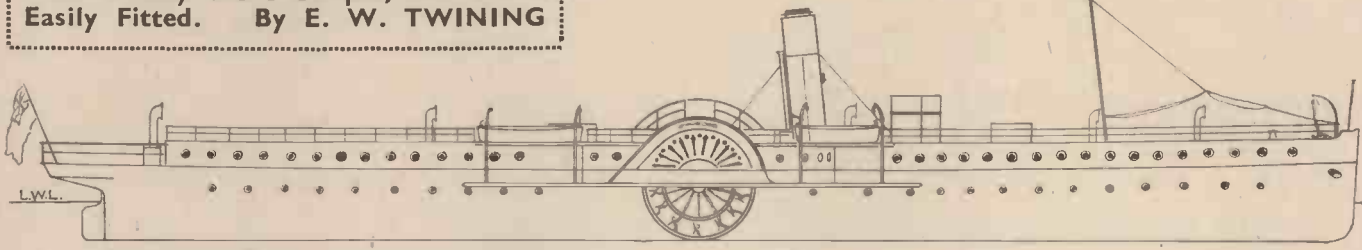
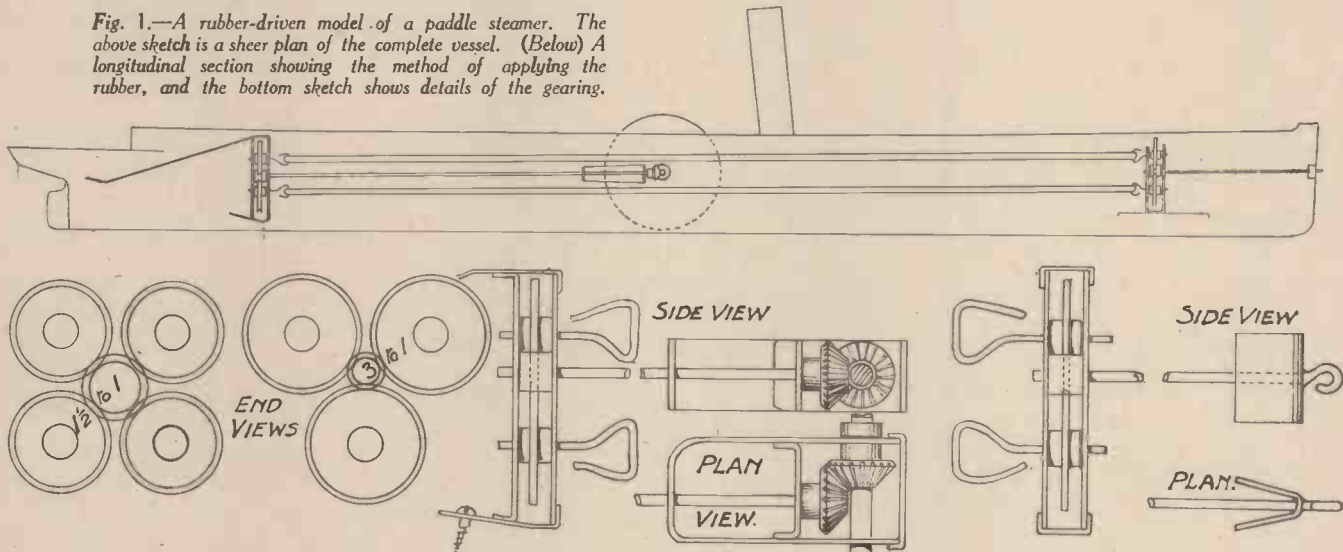

Fig. 1.—A rubber-driven model of a paddle steamer. The above sketch is a sheer plan of the complete vessel. (Below) A longitudinal section showing the method of applying the rubber, and the bottom sketch shows details of the gearing.



As everyone knows, from the very earliest days of model aeroplaning, twisted rubber has been the most popular source of power. In spite of all the ingenuity of those who have experimented with flying models, no other form of power has displaced it, for it is a well-known fact that when properly applied it gives a greater number of foot-pounds of energy, weight for weight, than any other motor, except, perhaps, the internal-combustion engine.

The thing that strikes one forcibly is the fact that in spite of its extreme simplicity, it has never been very much applied as a motor to other models. On the other hand, heavy clockwork is frequently fitted to small model boats, model locomotives and other miniature self-propelled vehicles. I think that for such toys, especially when they are home-made, rubber has much to commend it. For model boats, for instance, a light motor means much less displacement of the vessel and, consequently, greater speed, since the skin friction on the hull would be greatly reduced.

We cannot here give sketches showing the application of rubber to all the different types of water craft, but in Figs. 1 and 2 are shown two forms of prototype in which the power is differently applied. The first is a paddle steamer and the second a speed boat, or fast launch, propelled by a screw. The paddle steamer is in a class by itself, but the method of application of rubber to

the speed boat could quite well be copied for any other kind of craft—tug, tramp steamer, trawler or liner.

It may be argued that the disadvantage of rubber is that the motor has to be wound up. With this I agree, but so has clockwork, and it is not suggested for a moment that rubber should take the place of steam or electric motors with batteries, in both of which the

power exerted is uniform and may be continuous for a long time, but, as I have said, for the home-made model rubber is much cheaper, considerably more simple as regards mechanism, and more easily fitted than clockwork.

A Paddle Steamer

Turning to the drawings, Fig. 1 shows one of the well-known white funnel steamers of Messrs. P. & A. Campbell, Ltd., of Bristol; this prototype being chosen simply by way of an example. The upper sketch is a sheer plan of the complete vessel; below that is a longitudinal section showing the way in which the rubber is applied, whilst the bottom sketches show details of the gearing.

Now the gear wheels can be purchased quite cheaply and the frames which carry them are simple to make from stout tinplate and only require the use of a pair of tinman's snips, a drill and a soldering iron. On the left-hand side at the bottom of the drawing is shown end views of the gears. On the extreme left there are four wheels gearing into one. With this arrangement there would be four skeins of rubber, but alternatively another end view is shown with only three gear wheels for three skeins. This latter, I think, is the better arrangement, but the reader can please himself which he fits. With three gear wheels, the skeins will have to be a little heavier, say four strands of rubber instead of three, because the ratio, or gear reduc-

From All
Booksellers

Only 1/- net
With 147
Illustrations

25
SIMPLE
WORKING
MODELS

Ingenious, Practical and Highly
Interesting Designs for Electric,
Steam and Clockwork Models
for the "Modest" Workshop.

Newnes HOME MECHANIC Series

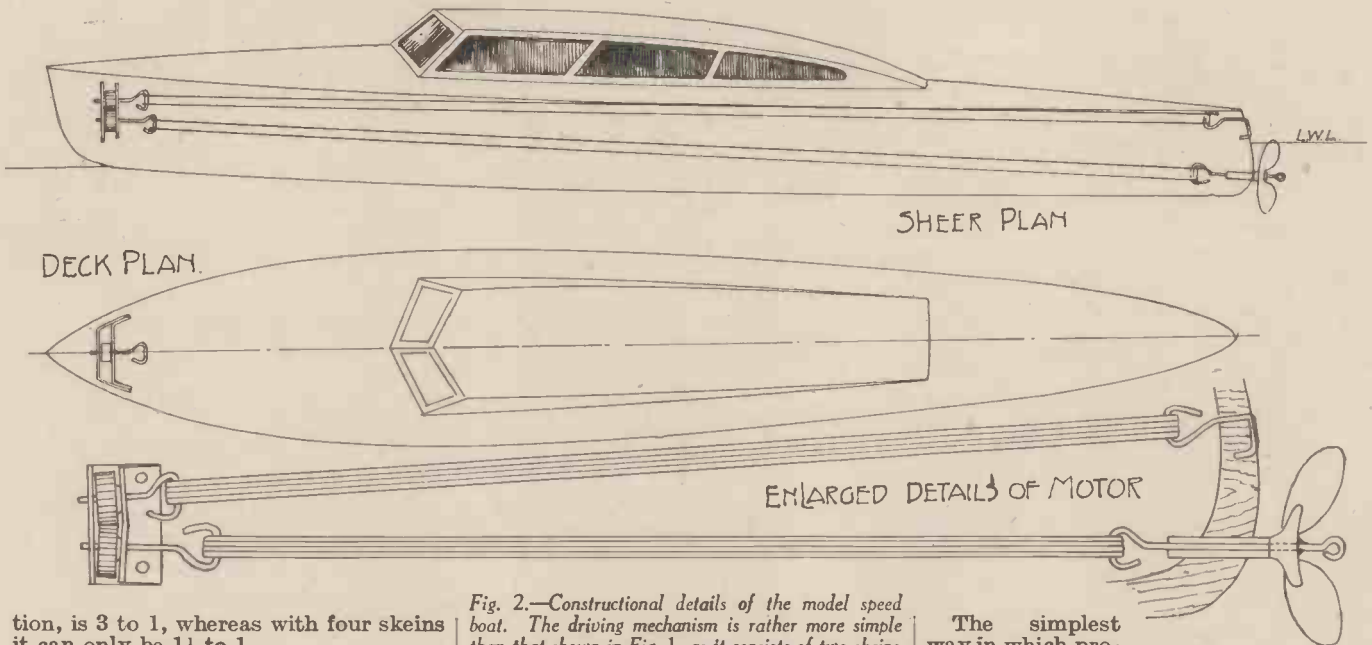

Fig. 2.—Constructional details of the model speed boat. The driving mechanism is rather more simple than that shown in Fig. 1, as it consists of two skeins of rubber and only two gear wheels.

tion, is 3 to 1, whereas with four skeins it can only be $1\frac{1}{2}$ to 1.

The Driving Mechanism

The rest of the lay-out of the motor will, I think, be understood from the middle drawing. Here it will be seen that from the gearbox at the stern of the ship a shaft is carried from the middle, or driving pinion to a mitre, or bevel gear, on the paddle shaft. At the bows of the vessel there is a similar pinion, but this only revolves when the motor is being wound up.

On the extreme right at the bottom of the drawing there is a sketch of a rod with a hook at its end and a piece of plate soldered next to the hook bent to V form. This V fits over the stem of the ship and so prevents the rubber from unwinding at the bow end. To wind up the motor a drill brace is used, having gripped in the jaws of the chuck a piece of wire with a similar hook. Whilst one person holds the vessel and prevents the paddles from revolving, the operator hooks the drill-brace winder on to the hook at the stem of the vessel, pulls it towards him, disengaging the V from the stem, and begins to turn the brace. The rubber will be capable of standing

several hundred turns, according to the size and length of the model. When fully wound, the hook on the ship is allowed to be pulled by the rubber back into position for the V to engage with the stem. The brace is unhooked and the model ready for placing in the water.

When constructing such a model as this, it is necessary that the upper deck should be made to lift off so as to render the rubber motors accessible for renewal and examination.

A Speed Boat

Fig. 2 is rather more simple in regard to the application of the rubber. There are two skeins and only one pair of gear wheels. These gear wheels render the two skeins equivalent to one long one, folded back upon itself, of double the length of those fitted, and the wheels are only the means of connecting together. In this model the motor is wound by the same form of hook in a drill brace, which hook will be passed into the eye shown on the propeller shaft just outside of the blades.

The simplest way in which propellers for craft of this kind can be made, and they are quite efficient, is by making a brass boss to sweat with solder on the shaft, and in this making two saw cuts each at right angles one to the other and 45 degrees to the centre line of the shaft. Into these saw cuts oval blades of sheet brass are soldered.

Motor Road Vehicles

The next model, which is shown in Fig. 3, is of a totally different kind. By way of an example a motor coach is shown, but a rubber motor such as is indicated can be equally well applied, of course, to models of private cars.

Here again in the upper sketch in Fig. 3 there is another form of applying the power, whilst below the coach is shown a further alternative, although this latter is almost exactly the same as that fitted to the paddle steamer. In each case three skeins are used; in the upper drawing the three coming in succession to equal one long one, whilst below the three are worked together and drive a propeller shaft coupled by bevel gearing to the back wheels of the coach.

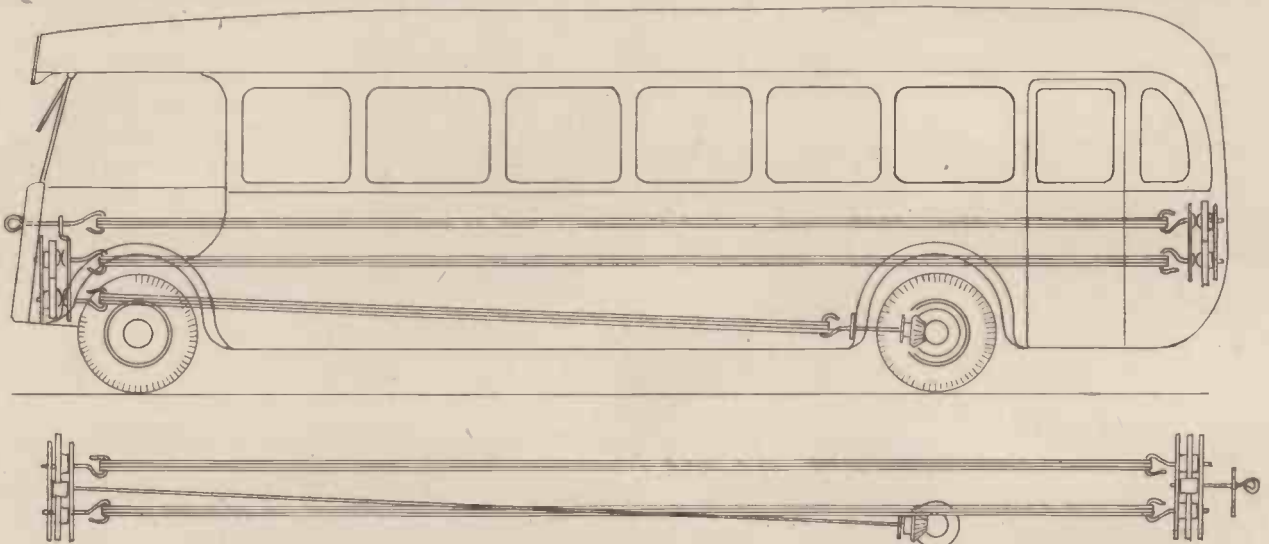

Fig. 3.—Showing the method of fitting an elastic motor to a model road coach. This type of motor can also be applied to model cars, motor buses, etc.

TELEVISION MADE EASY

THE cathode-ray tube has come so much into prominence within the last twelve or eighteen months in connection with its marked suitability for reproducing television pictures, that many people imagine that the device is quite new. This is an erroneous impression, however, for as far back as 1907 both Campbell Swinton and Boris Rosing made known, almost simultaneously, ways and means for employing these tubes both at the transmitting and receiving ends. While creditable in every way, the results were far from acceptable, and it is only of recent date that the technique in cathode-ray tube design has been developed for the special application of building up television pictures.

Simple Electrode Assembly

Modern refinements have not in effect altered the principles of operation, so it is advisable first of all to deal with the simplest type of electrode assembly. Starting first of all with the filament or cathode, the function is almost identical to that of a normal receiving valve. It is rendered incandescent or active, by the passage of a direct current through it. Due to the rise in temperature of the cathode, brought about by the flow of electrons, the agitation of the electrons becomes so intense and violent that those "free" electrons near the cathode surface, overcome the surface tension or attraction and escape to form a cloud (invisible, of course) in close proximity. This is analogous to the water vapour which collects over a pool of water by evaporation.

Since each electron is really an extremely minute particle of negative electricity, the electron cloud acts as a repulsive negative field, tending to prevent the release of further electrons from the cathode surface. The first object, therefore, is to provide a method for drawing away the electrons once they are released from the cathode. One of the simplest ways of effecting this is to include inside the neck of the cathode-ray tube a metal disc or anode, in the centre of which is a small perforation. By applying a high-positive potential to this electrode the electrons are attracted towards the anode surface, and some pass right through the aperture at high velocities, to finish their "flight" by striking the screen at the belled-out end of the tube.

Adding a Shield

The greatest proportion of the electrons strikes the anode and produces a current in the positive potential circuit, but, as far as the electron stream is concerned, however, they are wasted. A device is required which will concentrate the electron flow at the anode aperture, and the first man to accomplish this successfully and simply was Wehnelt. He surrounded the cathode with a cylindrical metal shield, and by applying a negative potential to this, with reference to the cathode, a repulsion field was produced which guided the electrons in paths terminating at the anode hole.

The intensity of the electron stream is in this way increased enormously. After leaving the anode hole, however,

This Month we Describe the Cathode-ray Tube, and How it Has Been Developed for the Special Application of Building up Television Pictures.

the stream or beam tends to diverge somewhat, with the result that the area of impact on the fluorescent screen is rather large (comparatively speaking), and the spot of light as seen by the eye, is said to be fluffy or misfocused. Just as in any lens system a combination of lenses is required to secure a most satisfactory and sharp light image or spot, so with the cathode-ray tube it is possible to include an electrical lens system which performs a similar function. This generally takes the form of two or more anodes, similar to the first one, but placed slightly nearer to the screen.

Instead of adjusting their distance apart as one would do in a normal optical system, the inter-relation between the positive voltages applied to

each anode is altered until the electron beam converges to a sharp small spot on the screen; this focus being retained irrespective of the signal modulation.

Producing a Scanning Motion

The first condition for portraying television pictures is in this way satisfied, but in these circumstances, the only evidence of operation is the appearance of a steady, sharp, bright spot of fluorescence at that point on the whole screen area where beam impact occurs. The second requirement is to impart to this beam a movement which will allow the light spot to trace out a field of given boundaries, in a series of vertical or horizontal lines at a predetermined speed so as to duplicate the scanning process, effected either mechanically or electrically at the transmitting studio end. Various methods have been proposed for this, but the most successful so far, makes use of varying electromagnetic or electrostatic fields under proper control.

If two coils are placed one on either side of the cathode-ray tube neck just

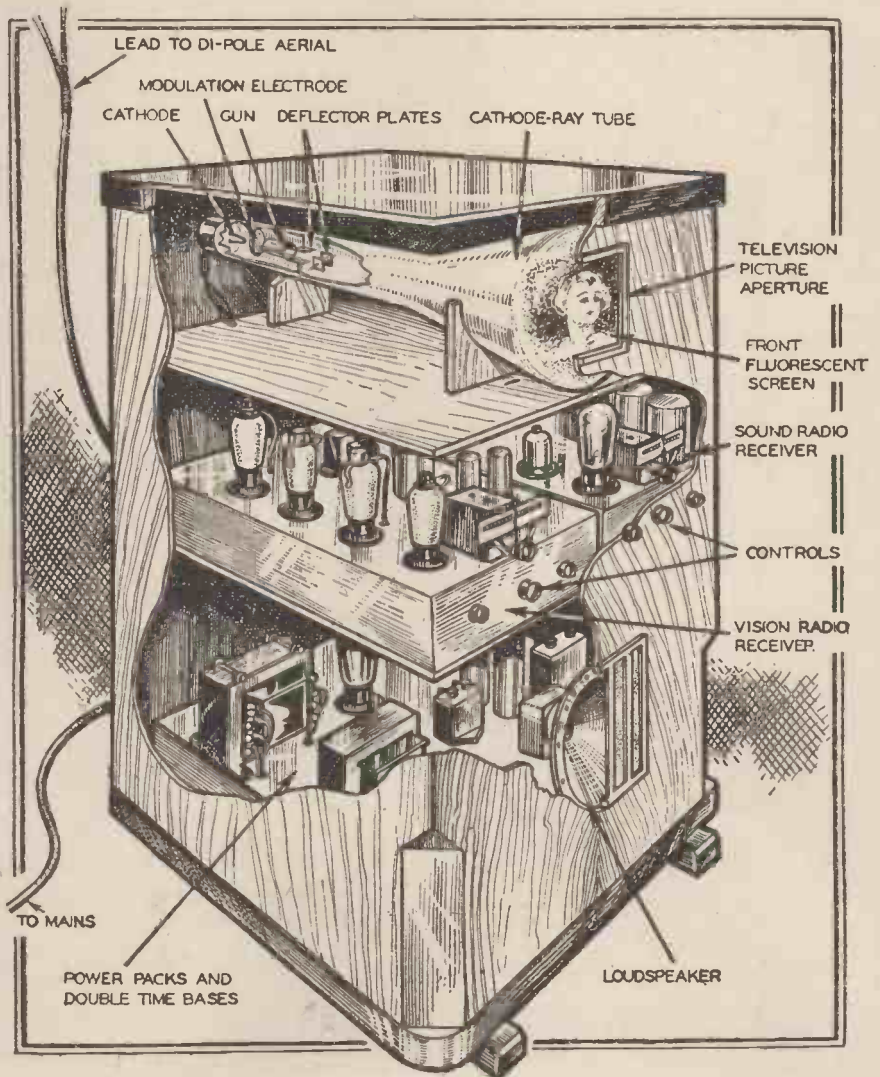

A pictorial sketch of a complete cathode-ray tube receiver, showing the internal construction.

after the last anode and a current is passed through them in series so that they give an additive field, the lines of force produced will "cut" the stream of electrons. The negative electrical character of the beam will make it responsive to any field effects, and for a steady current, the beam will be "bent" so that the screen spot shows itself at some new position as a minute area of fluorescence.

A Controversial Point

Altering the field current will cause the spot to move in sympathy and trace a line of light on the screen. An exactly similar effect is brought about, if in lieu of the externally applied electromagnetic field, a pair of parallel metal plates are inserted inside the tube neck, and a potential difference maintained between them to produce similar electrostatic field variations. Both methods are in use for television reception. Only prolonged tests over a considerable service period will decide which is the better scheme, or alternatively, a combination of the two may prove the best solution.

Reverting now to the electrical scanning effects which must be generated, the principles involved are really identical whether internal plates or external coils are used. A current or voltage variation has to be produced, which increases in magnitude at a constant rate. This steady building up of the electron beam deflecting field causes the spot to move in a straight line across the screen at uniform velocity. At the end of its traverse the field producing the motion must be made to collapse as quickly as possible, so that the spot flies back to its initial position. Repeating this double action of a uniform forward trace and a rapid flyback, if carried out fast enough, shows a straight line of light on the fluorescent screen of material.

Double Motion

To meet the television scanning conditions, however, each line must not be superimposed on its neighbour, but trace

a contiguous path, hence, to bring this about, a second scanning field is introduced at right angles to the first with the aid of a pair of coils or a pair of plates mounted at right angles to, and slightly separated from, the first pair. The field produced by this medium goes through an identical process of variation, causing the beam to move downwards at a steady rate and fly back suddenly at the end of its traverse, but the rate of working is much slower than the first field, the ratio of the two frequencies of action being, in the case of "straight" scanning, equal to the number of lines into which the television picture is dissected.

It is now quite easy to see the results brought about on the screen by this dual action. The field producing the horizontal scan of the lines makes the

spot move from left to right (or right to left depending on the standard adopted at the transmitting end) at a steady tracing speed, but owing to the existence of a downward dragging force imparted by the second field the line traced is not, strictly speaking, horizontal, but has a very slight inclination downwards in the direction of the trace. When the line is complete the flyback to the other side of the screen is so rapid that it cannot be seen, but in effect it traces a straight horizontal line. The process repeats itself continuously, so that on the fluorescent screen is seen a trace which slightly resembles a zigzag. When the last line has been traced, both scanning fields collapse together and so the spot flies back to its starting-point to commence the work all over again.

Importance of Spot Size

When observing a scanning field of, say, a 240-line traverse built up in this way on the fluorescent screen of a cathode-ray tube, it is necessary to get quite close to the screen to detect the line structure, while with an 8-in. \times 6-in. picture the distance between the line centres is only $\frac{1}{6}$ in. These figures emphasise the extreme importance of a correctly focused spot, otherwise it is likely to be so large that it overlaps two or three lines and so gives rather blurred picture detail.

To produce the scanning fields, electrical time bases have been developed. Primarily they depend on the charging action given to a fixed condenser of certain capacity from a constant current source. This causes a steady building up of voltage across the condenser plates until a value is reached which is sufficient to ionise a gas-filled relay connected in parallel with it. The ionisation of the gas causes a sudden current surge through the relay which has to be furnished by the condenser, with the result that it discharges and the voltage drops instantaneously. When this voltage falls below the ionisation value the relay ceases to function and the condenser starts once more to build up its charge. This has been termed popularly as the saw-tooth motion, because of its alleged resemblance to the teeth of a saw.

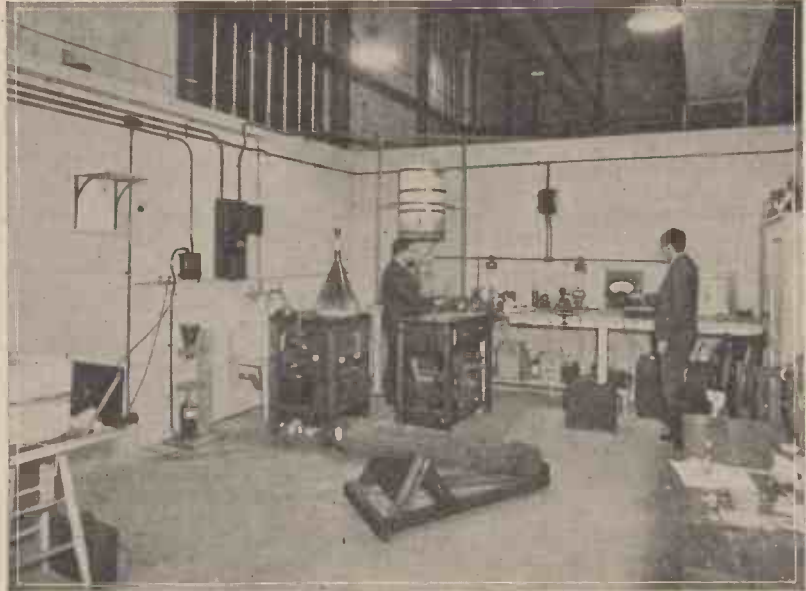

Very interesting work is being undertaken in the cathode-ray tube research laboratory shown here.

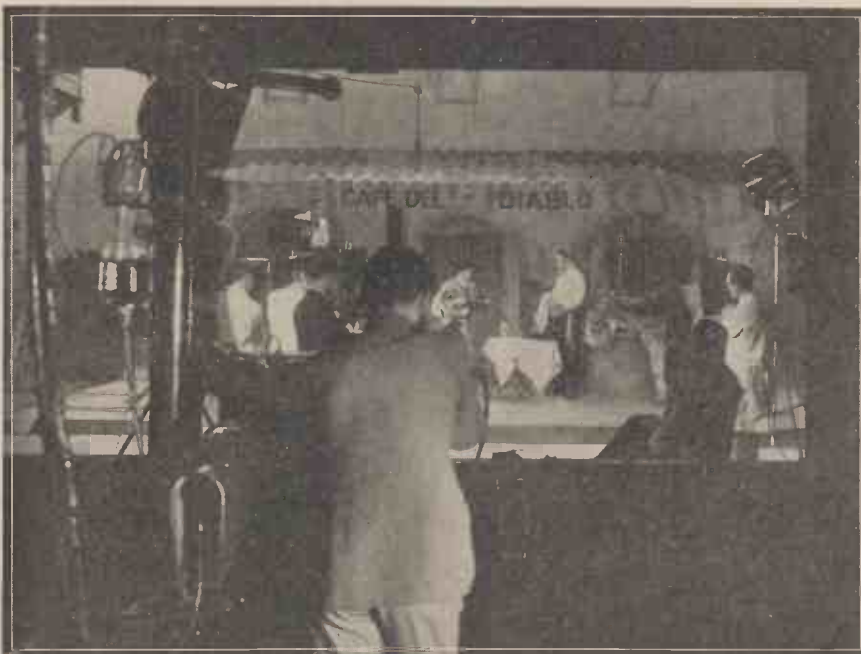

Using the intermediate film scanner for the purpose of televising an interior studio scene. The operator has his camera focused on the artists.

A Petrol-driven Model Monoplane

Completing the Fuselage of the Interesting Model Introduced Last Month.

By F. J. Camm.

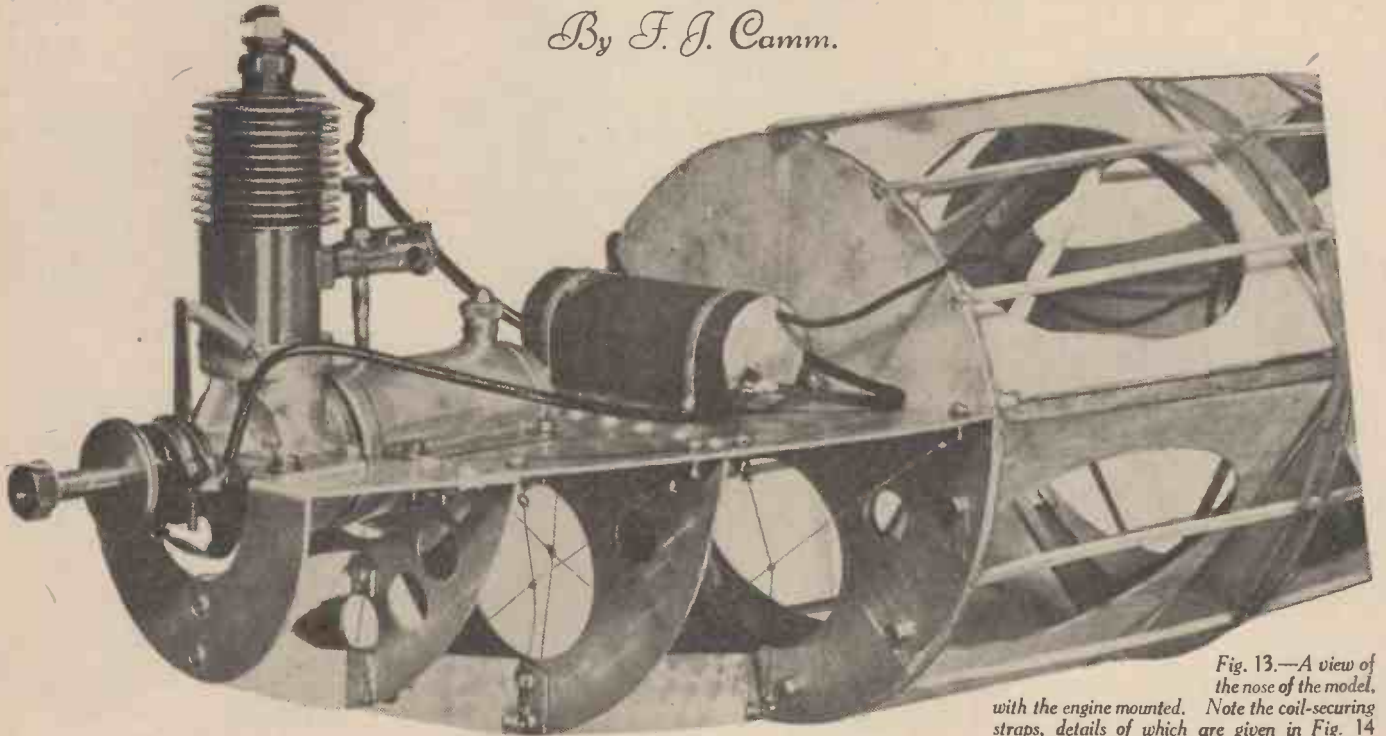

Fig. 13.—A view of the nose of the model, with the engine mounted. Note the coil-securing straps, details of which are given in Fig. 14 and also the bracing of the engine mounting.

THE next stage in the construction is to evenly space round each bulkhead the notches to receive the $\frac{1}{8}$ in. square stringers, whose purpose it is to maintain the fuselage form and to support the fabric with which the fuselage is to be covered. Should you have difficulty in obtaining $\frac{1}{8}$ in. square material, it will be in order to use the standard $\frac{3}{32}$ in. square section. The best method of marking out the notches is to space off the first bulkhead adjacent to the engine bearer to receive two stringers between each of the four longerons, and to similarly treat the rearmost bulkhead.

Fitting Stringers

Cut the notches to suit the stringers and lay the latter in place. Pencil off the position of the stringers on each bulkhead, and complete the cutting of the notches. The stringers are pinned to the foremost $\frac{3}{8}$ in. thick bulkhead, glued into the $\frac{1}{8}$ in. thick bulkheads and pinned at their rearmost extremity to a piece of $\frac{1}{2}$ in. by $\frac{1}{4}$ in. spruce glued and pinned between the top and bottom longerons. Observe from the photograph (Fig. 17) that the stringers do not continue to the sternpost, but a small $\frac{3}{8}$ in. gap is left. The reason for this is that the sternpost is to be covered by a metal socket which forms supports for the rudder and tail, the construction of which will be dealt with next month.

This sternpost socket is illustrated in Fig. 18, and it includes the bracing lugs for the rearmost cellule. Eye along the fuselage after the stringers are fixed to make quite sure that the curve is free from humps or depressions. If the curve is not pleasing, it can be corrected by cutting the slots deeper or packing the stringers higher, by means of a small piece of plastic wood.

When the curves have been corrected and the glue is dry, carefully sandpaper each bulkhead, and each longeron, so that no sharp edges or malformed curves protrude through the covering when it is applied. (Details next month.)

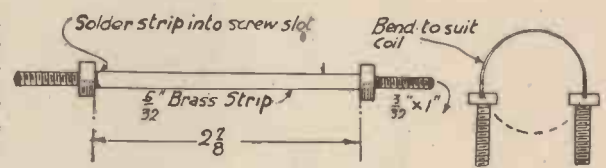

Fig. 14.—Details of the coil-securing straps. Two are required.

Parts Required for F. J. Camm's Power-driven Model Monoplane.

- 18-gauge Aluminium Bulk Heads (4).
- Aluminium Stringers (3).
- Aluminium Engine Cradle (1).
- Half-Gross $\frac{3}{32}$ -in. Aluminium Rivets.
- 4-ft. Duralumin Tube.
- 2-ft. 30-gauge Aluminium Cowling.
- 14-in. Electron Propeller.
- Petrol Engine (9 c.c., or 15 c.c.).
- One 4-volt Accumulator.
- One two-pin Ignition Plug.
- One On-Off Snap Switch.
- One Ignition Coil.
- One Delco Remy Condenser.
- One half-gill Petrol Tank.
- One 4-volt Dry Cell.
- Six pieces Millimetre 3-ply, 12 by 6 in.
- Six dozen $\frac{1}{4}$ -in. Brass Round-head Screws.
- One Reel 30-gauge Bracing Wire.
- Four lengths $\frac{3}{8}$ ths square Birch 4 ft. long.
- Twelve lengths $\frac{1}{2}$ nds in. square Spruce Stringers.
- 2 yds. Proofed Silk.
- Two tins Aluminium Dope.
- Birch Spruce and 3-ply for Main Plane, Tail and Rudder.
- One packet Brass Pins.
- One 1½-in. Diameter Rear Wheel.
- One pair 4-in. Disc Wheels.

The above components are obtainable from Messrs. E. Gray & Sons, Ltd., A. E. Jones Ltd. and Model Aircraft Supplies Ltd.

Bracing the Fuselage

The next stage is to brace each section in the manner shown in the photograph. This bracing is very necessary, for it prevents the fuselage from twisting. The lattice arrangement in a vertical and horizontal direction makes the fuselage enormously stiff in those planes, but it relies upon the bracing to resist torsional stresses. When completely braced in the manner shown in Fig. 21, the whole structure is unbelievably strong, yet light. Brace every section of the fuselage except the front two, which must be left for the moment, since certain other fittings to receive the chassis, main-planes, etc., are to be made. These two front sections are also further to be stiffened by the fitting of pieces of $\frac{1}{8}$ in. plywood between them in the manner shown in the photograph. The object of these pieces is to take the strain of landing and the lift of the wing. No drawings are given for these, since it will be necessary for you to fit them according to the position of the bulkhead. You may not have worked exactly to the drawings given last month, and hence the sizes of these pieces for individual models will vary. Elliptical shaped holes are cut in each piece (of which eight will be required) to lighten them. Each piece should fit

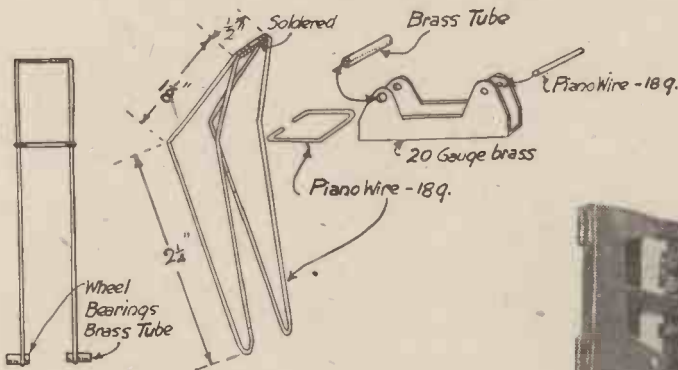

Fig. 15.—Parts of the rear chassis.

tightly against the bulkhead, and permit of no movement. They should rest on short pieces of 1/4-in. square birch pinned to the bulkheads. The method of fixing these eight pieces of ply is to glue them, and then to glue over each point of contact with the bulkheads and longerons a piece of silk about 1/2 in. wide. This makes an enormously strong, yet light, method of fixing.

The Bracing Attachment

It will be noticed from Fig. 21 that the bracing is attached to circular pieces of tinfoil. If any difficulty is experienced in cutting these, they may, of course, be cut square. Each piece of tinfoil is pinned at its centre to the longeron, and thus acts as an abutment for the wooden lattice braces. Notice that a piece of 1/8-in. brass tubing about 3/8 in. long is passed over each wire before it is threaded through the hole in the tinfoil. The end of the bracing wire is finally passed again through the piece of tube and bent back. This is a far neater method than twisting the wire round itself.

Great care is necessary in bracing the fuselage, since it is possible to pull the longerons out of truth and also to twist the fuselage. Apply just sufficient tension to each wire to make it taut, and brace each section completely before turning to the next. View along the members as the work proceeds, and correct, by releasing or increasing the tension on each wire, any tendency of the fuselage to be pulled out of truth. When the bracing is completed, final tension can be applied to each bracing wire by binding some florist's wire round each point of intersection, pulling it back by means of an end left on the florist's wire for that purpose, and applying a spot of solder whilst this tension is applied. Then apply a spot of solder to each of the pieces of brass anchoring tube and break off the projecting end of bracing wire.

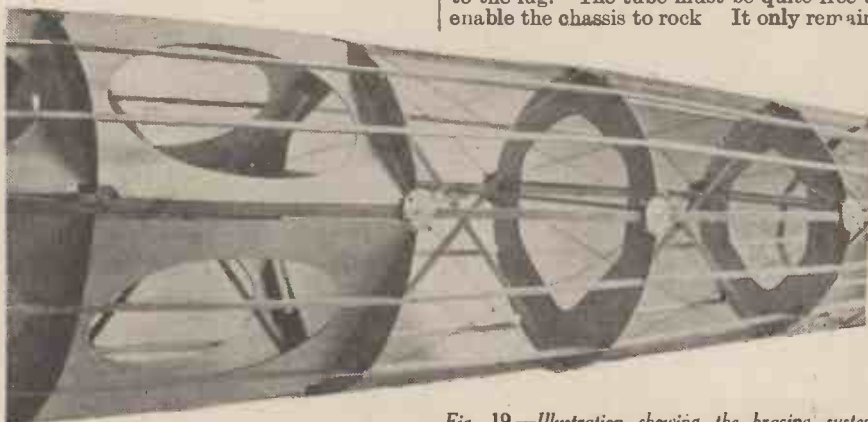

Fig. 19.—Illustration showing the bracing system adopted between the bays and cellules to resist torsion. Fig. 21 should also be consulted.

The Rear Chassis Construction

The next portion to make is the rear chassis; the construction of this is quite clearly shown

to solder a short stiff spring to the two positions shown in the photograph, when the chassis is complete except for the two wheel bearings. The best method of fixing the latter is to solder a straight length of tube between the two extremities of the chassis to ensure that when a piece is cut away to enable the wheel to pass between, each wheel bearing will be horizontal. A small washer soldered at each

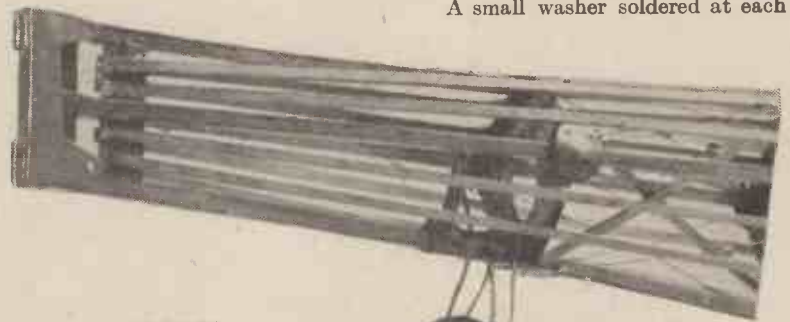

Fig. 17.—The rear chassis and sternpost socket. The latter is shown in Fig. 18.

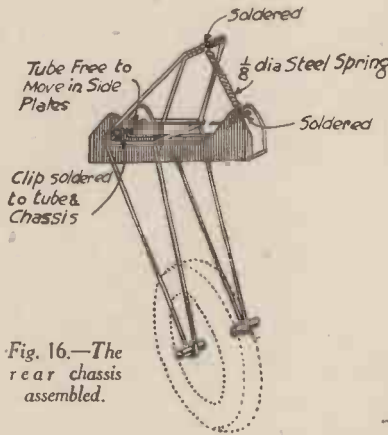
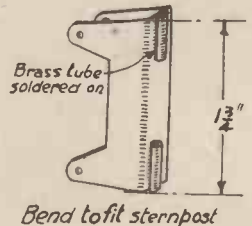

Fig. 16.—The rear chassis assembled.



Fig. 18 (Right).—Details of the sternpost socket. This is also shown in Fig. 17, above.



in the drawings and needs no special explanation except in the manner of its fitting, which is as follows: the two sides of the chassis are made from one piece of wire, using a full-size copy of Fig. 15 as a template to which to form the bends. The two ends of the piece of wire finish at the top connecting bar, and they are bound with florist's wire and soldered. Next, fit the bracket to the bottom longeron, slide the two limbs over the front lug of it, pass the brass tube pivot through the holes drilled to receive it, pass the square-shaped wire clip round the rearmost members of the chassis, and spring the two ends of the clip into the tube. Now lightly solder the clip to the chassis and the front ends of it into the tube, the latter also being soldered to the front members of the chassis. Make sure that the solder does not run and secure the pivot to the lug. The tube must be quite free to enable the chassis to rock. It only remains

end of the piano-wire wheel axle completes this assembly.

The Main Chassis

This is of the sprung type and may be made from streamline section Duralumin tube of from 3/8-in. diameter steel tube. The drawings show the length of the members. It will be seen that each limb is riveted to an anchor plate in which the divided axle can rise and fall under the shock of landing. Additional springs are provided inside the fuselage so that the shock of landing is divided between those two points instead of being taken entirely by the fuselage, as is usually the case. The pneumatic tyres, of course, further reduce the shock. The front of the chassis is hinged in the manner shown in Fig. 22 to permit the suspension system to act. The chassis itself presents no particular difficulty in making, and further drawings giving the dimensions and method of attaching the springs will be given next month. In the meantime, the engine may be attached in the manner shown in the photograph and the coil mounted by means of the two straps shown in Fig. 14.

Note that each bay of the engine mounting is cross-braced to resist torsion. These bracing wires are anchored to eyebolts, or to pieces of 18-gauge brass wire shaped like a figure eight, and passed through holes drilled at appropriate positions in the engine bearer and stiffeners. One part of the figure eight will, of course, be formed, the projecting tailpiece passed through the hole in the engine bearer, and the figure of eight then completed with a pair of round-nosed pliers. Complete the bracing in the manner already detailed for the rest of the fuselage.

I would repeat that full-size blueprints

will shortly be available, showing the construction of every part, at 7s. 6d. post free. A limited number only will be available, and it is necessary for you to reserve a set.

Review of a Review!

I am adopting the unusual practice of reviewing a review of my own book, *Power-driven Model Aircraft*, which costs only one shilling. It is not for me, of course, to comment on my own work, but there are certain statements in the review in question which are in need of amplification. I shall not name the contemporary in which the review appears.

The review favourably comments on my book, but endeavours to damn with faint praise by suggesting that I should have given space to the work of certain others, who are named, beside that of Capt. Bowden. In a book of 96 pages one must cover all aspects of the subject, and it is not possible to record everything which has been attempted. A technical book is not intended to be a history, for even while it is going through the press, models are being made rendering some of the previous ones obsolete. My book is intended to convey the results of my experience and knowledge of the subject, and not to form a pictorial souvenir for a mutual admiration society. I included details of Capt. Bowden's models because they hold the records and have proved themselves most consistent fliers over a long period. I cannot say the same of some other petrol-driven models I have seen. Theirs has been a mere succession of crashes punctuated occasionally by a short flight. One modelmaker, well known for his views on "design," and a member of a competition committee, built a petrol-driven model incorporating his "ideas"

describe were either reluctant or unable to supply me with details of them, as they had apparently made them on the hit-and-miss principle without first preparing drawings. Such models cannot be soundly designed. Any spectator who watched this year's competition for the Sir John Shelley Cup will agree with me on this point.

In another part of the review in question, which the reviewer is bold enough to sign with his initials only, he suggests that the last six chapters deal with models which are out of date. None of the designs in those chapters were made before 1933, and they are all as the reviewer admits, satisfactory designs, capable of consistent performance without crashing. The only thing, therefore, which seems to be out of date is the knowledge of the reviewer!

I do not, of course, object to sound and reasoned criticism of my work where such is justified, but I hope I have now indicated that the reviewer in question, willing to wound and yet afraid to strike, just imagines faults and hesitates dislike. It is always, as I have said, unwise to damn with faint praise and, when you are uncertain of a subject, to rush in and exhibit the fact.

My book was written for those who wish to build successful and up-to-date models, not for a few who merely claim to know all about it.

No 15 c.c. (or less) engines for models were produced before 1933, and my book is as up-to-date as its press date permitted.

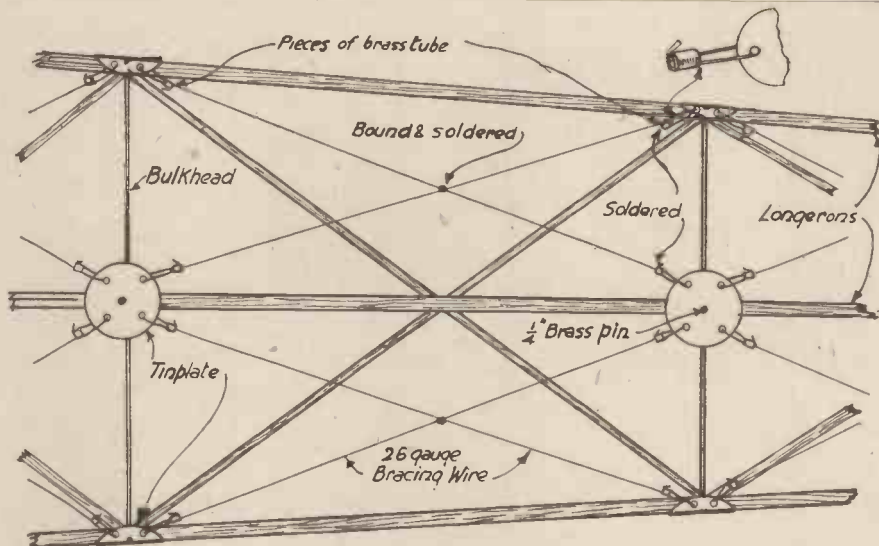

Fig. 21.—How the bays are cross braced.

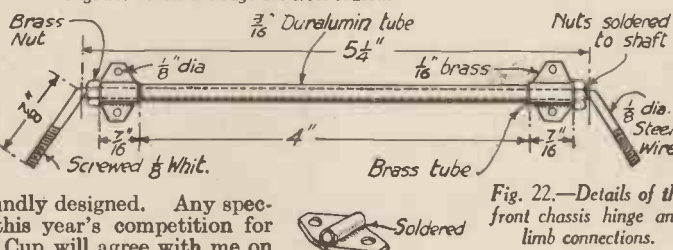

Fig. 22.—Details of the front chassis hinge and limb connections.



Fig. 20.—Various parts of the front chassis. See also Figs. 22 to 24.

which collapsed in the air! He did not know the first principle of wing bracing! In the exercise of my discretion I rigorously excluded all details of any model about which I was not satisfied. I know my subject, and authorities do not need to "collect" information!

Another reason is that other model-makers whose models I was willing to

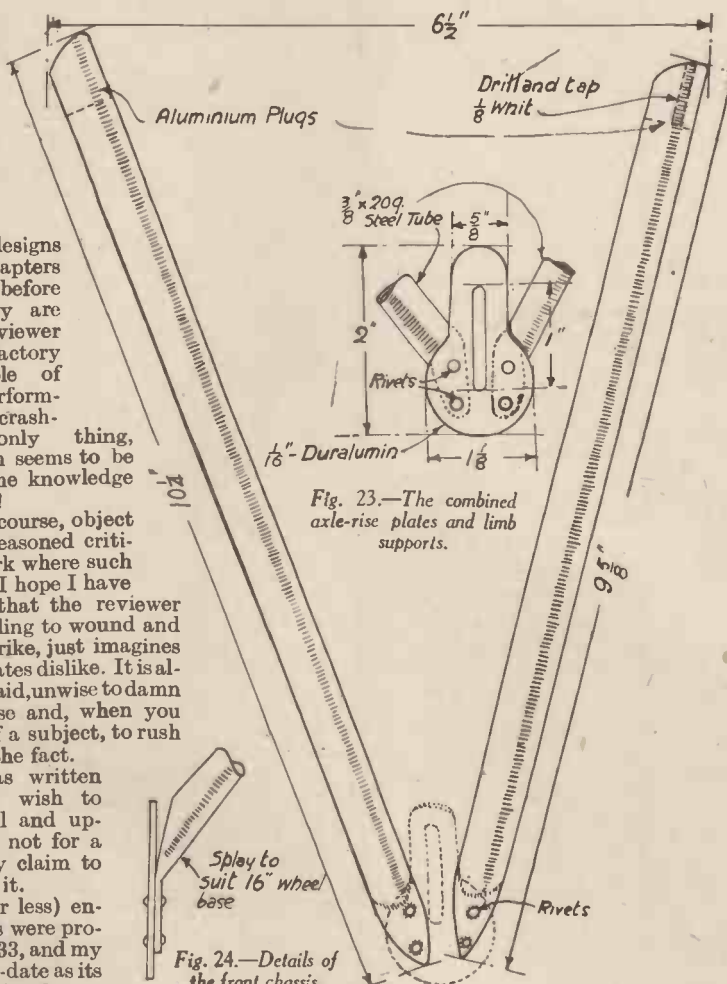

Fig. 23.—The combined axle-rise plates and limb supports.

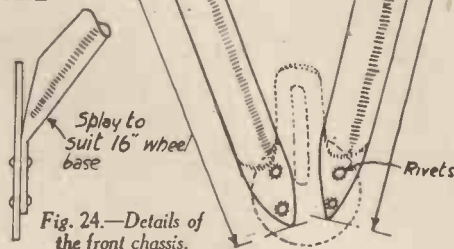

Fig. 24.—Details of the front chassis.

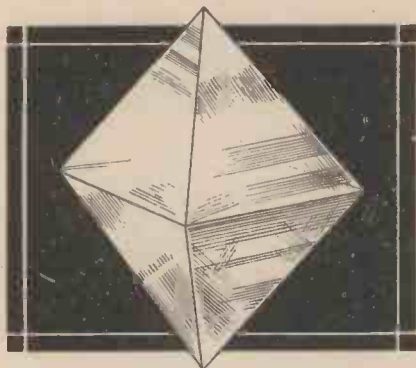

Fig. 1.—A natural diamond in the form of a perfect octahedron. Such a well-defined crystal as this is the exception rather than the rule.

It is a well-known fact that the pure crystallised form of carbon which we call diamond is the hardest substance in existence, and in order to cut it, it becomes necessary to use another diamond.

Diamond in its natural state is found chiefly as octahedral crystals, although the shape of the octahedron is not always immediately discernible owing to irregular growth, etc. Pure octahedral crystals of diamond such as that shown in Fig. 1 can easily be cut into perfect "brilliant" stones, but as it is unusual to find perfectly formed natural stones free from flaws and blemishes, it becomes necessary to use other processes than just ordinary cutting and polishing.

Cleaving or Splitting the Stone

One of the chief methods used is that of cleaving, which means that the diamond is split along its grain.

That a diamond is not perfectly homogeneous may seem strange, yet it is a definite fact, the knowledge of which is of infinite value to the cutter. A diamond can literally be split along the grain like splitting a log of wood. However, in the case of the diamond, this cleaving results in the production of two perfectly flat surfaces, not uneven as in



Fig. 4.—Showing the cleaving process in operation. A sharp blow on the back of the knife is all that is necessary to split the stone along the natural grain.

the case of wood or ivory. The plane along which a stone may be split can be determined from its outward appearance and is always parallel to one of the original faces of the octahedral crystal, hence there are four directions in which the stone may be cleaved. One of the possible cleavage surfaces is shown in Fig. 2.

The stone to be treated is embedded in cement in what is known as a cleaving stick. This has a metal cup to hold the cement, fixed to the end of a wooden handle. A piece of bort (inferior

diamond) held in a similar stick is used to make a small incision in the stone to be cleaved. A great deal of experience is necessary before the cleaver knows the best place to make an incision in the diamond, and on this depends the success of the cleaving. The incision having been made, a cleaving knife, which is a strip of metal with a thick back and a blunt edge as shown in Fig. 3, is taken and the edge is placed in the incision. A sharp blow on the back of the knife is all that is necessary to split the stone along its natural grain. The cleaving process is shown in Fig. 4.

It is interesting to note that the

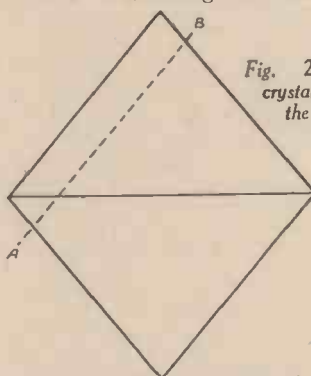

Fig. 2.—An uncut crystal, showing one of the possible lines of cleavage, AB.

presence of the cleavage grain is attributed to the peculiar atomic structure of the diamond. This has been clearly revealed by the use of X-rays, which show that the carbon atoms are arranged on a definite symmetrical plan within the crystal.

Sawing

If it is desired to part the stone along lines other than those of its natural grain it is necessary to resort to sawing. This is done by a circular saw driven by electricity. The saw, about 3 in. in diameter, is made of copper-bronze and is so thin that it can be bent with the fingers, while the cutting edge is of extremely small width. Actually, the saw has no teeth, but its cutting edge is surfaced with finely powdered diamond dust mixed with oil; thus it is actually the diamond dust which does the sawing and the disc-saw is only a means of holding the abrasive. The stone is held



Fig. 5.—A circular saw, 3 in. in diameter and made of thin copper-bronze, is used for sawing the stones along lines other than those of its natural grain. When sawing, the stone is held in an adjustable tool over the saw as shown.

Diamond Cutting

An Article Dealing with the Cutting and

in an adjustable tool over the saw, as shown in Fig. 5. It is driven at about 1,500 revolutions per minute, and its own weight combined with that of the tool is all the pressure that is applied, although the operation may go on for some days. The flat face thus produced is a base for the craftsman to proceed with the actual cutting and polishing operations.

Cutting and Polishing

The name "brilliant" has come to symbolise the diamond, and is the principal form of cutting employed to bring out the beautiful optical effects known as "fire." The true brilliant-cut consists of fifty-eight facets (faces), thirty-three above the girdle or setting edge, and twenty-five below the girdle. The girdle is cut by mounting the stones in a cup attached to a chuck on a cutting machine, where it is revolved while the cutter holds a bort stick (similar to that used in cleaving), with the long end tucked under his arm for steadiness, against the stone. The girdle is thus formed and the cutter can proceed to the faceting of the stone.

The cutting and polishing of the facets are done on a horizontal disc or lap (known as a schive), which is driven by electricity at a speed of 2,000 to 2,500 revolutions per minute. The disc must

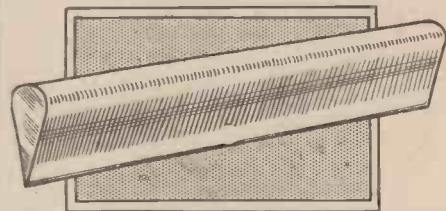

Fig. 3.—A cleaving knife such as is used for splitting a diamond.

be perfectly flat and has to be perfectly smooth-running. The bearings in which the lap runs are of wood, which, as it wears, can be adjusted up or down, and is easily renewed at small cost; if metal bearings were used wear would soon show and the cost of renewing would be much greater. It is interesting to note that the method of cutting has advanced very little since the very early ages; in the old days hard wood laps were used, whereas cast-iron laps prevail to-day.

The lap or schive, as in the case of the saw, is only the vehicle for carrying the abrasive, which is, of course, finely powdered diamond dust. This dust is made by crushing fragments of bort, the inferior diamond from the mines, and chips obtained during the earlier processes of cutting, in a metal mortar until a smooth powder is produced. This diamond powder is mixed with a fine oil, and is applied to the surface of the cast-iron lap, the surface being pitted with tiny holes to which the dust clings, and is thus prevented from flying up when the lap is revolving. The method by which the stones are held

and Polishing

Polishing of Nature's Hardest Substance

against the rotating disc is very simple : each stone to be cut is held in a dop (a bronze or brass cup on a copper stem) (see Figs. 6 and 7).

The Use of the "Dop"

The cup is filled with a special solder in which the diamond is set, so that the part to be polished is the only part projecting above the solder. Rough tongs are used to set the stone when the solder is still warm and pliable. The size of the dop varies with the size of the stone, and may weigh anything between 8 oz. and 4 lb. In recent times a mechanical dop has been perfected which is highly efficient.

It is made of iron or steel and has claw-like arrangements which grip the stones, and has adjustable parts by

crown or top part of the stone. The table facet (Fig. 8) has been produced by sawing or cleaving, and should be slightly less than a half of the total width of the stone. The crown should be one-third, and the material below the girdle two-thirds, of the total depth of the stone.

The Bezel and Pavilion Facets

The first facets cut are what are known as the Bezel facets, which slope down from the table to the girdle, and are eight in number, making the final shape of the table a perfect octagon. Having completed these, the stone is removed from the dop, and is turned over so that the corresponding facets, called the Pavilion facets, may be polished on to the base. Before these are



Fig. 7.—An operator at work cutting and polishing a stone on a horizontal disc or schive, which is driven by electricity at a speed of 2,000-2,500 revolutions per minute.

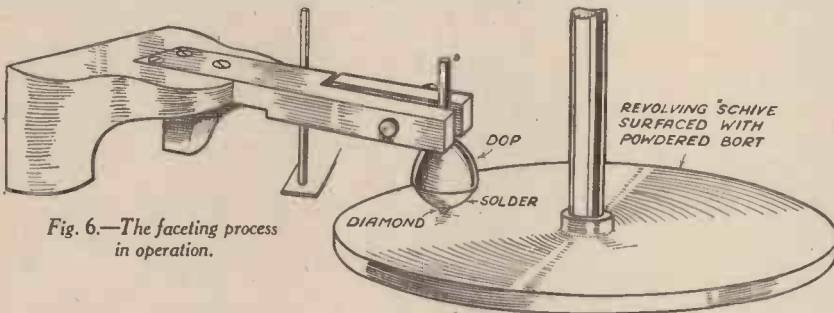

Fig. 6.—The faceting process in operation.

which means the diamonds can be adjusted according to the position required.

The dop, with the stone in position, is gripped by a metal clamp, whose jaws may be adjusted by a nut. The clamp is fixed just beside the lap-disc, so that the diamond in the dop just comes into contact with the rapidly moving surface of the disc ; as pressure is required to polish the stones, heavy lead weights are placed on top of the clamp.

To adjust the angles of the dop for fresh facets, the copper stem is bent slightly so that the desired position of the stone is obtained. The fine lines which result from the polishing must now be removed so that the stone may show the "life" and lustre for which it is noted ; this is done by moving the stone across the surface of the lap to and fro instead of allowing it to remain in a fixed position, and in this way marks are removed.

The polishing of the facets is done in stages, starting above the girdle on the

made, a small flat facet is cut parallel to the table ; this is called the Culet, and is only to take the sharp point off the stone, and to prevent it from splintering ; its size being about one-sixth of the width of the table. Figs. 9 and 10 illustrate the stone at this stage of the work.

The Pavilion facets are put on in exactly the same way, and are directly beneath the Bezel facets, and

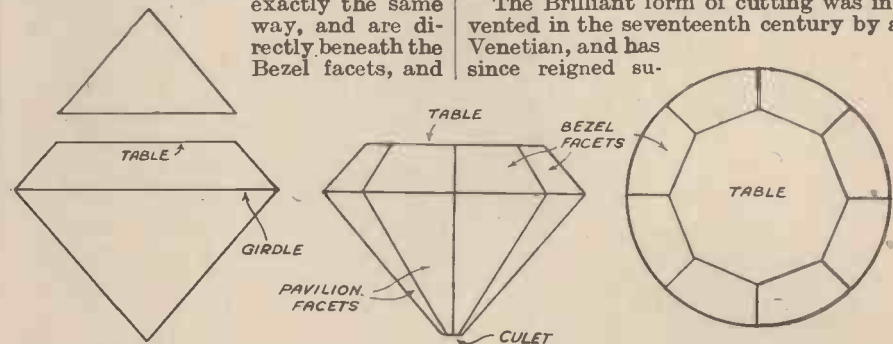

Figs. 8, 9, and 10.—Illustrating various stages in the preparation of the finished gem. (Left to right) Showing how the top of the stone is sawn off to form the table. A side view showing the arrangement of the Bezel and Pavilion facets. A plan view after the Bezels have been cut.

it is upon this that the symmetry and the final "life" of the stone depends. The stone is again reversed in the dop, and eight triangular or Star facets are added, pointing down from each side of the table. Sixteen small Split facets, also triangular in shape, having as a base-line the girdle, and cutting into the Bezel facet completes the cutting of the top part of the stone (Crown). This gives one Table, eight Bezel, eight Star,

and sixteen Split facets, a total of thirty-three facets in all, above the girdle.

The stone is once again reversed in the dop, and sixteen Split facets are applied directly beneath those of similar character made on the crown, and cutting into the Pavilion facets. This completes the cutting of the base, one Culet, eight Pavilions, and sixteen Split facets, in all a total of twenty-five facets below the girdle. Sometimes an additional set of eight Star facets are placed around the Culet, but these are not really necessary.

Obtaining the "Fire" Effect

The process of cutting the full brilliant stone, shown in Fig. 11, is one necessitating great skill, as all of the angles of the facets are made by the judgment and experience of the cutter. The Bezels make angles of approximately 45 degrees with the table, the Pavilion being parallel to the Bezels, also 45 degrees, Star facets 26 degrees with the table, and the Split facets are about 5 degrees larger than the Bezels and the Pavilion. These factors, together with the high refraction of the stone, cause the splitting up of white light into its component colours (spectrum colours), and give the effect known as "fire."

The Brilliant form of cutting was invented in the seventeenth century by a Venetian, and has since reigned su-

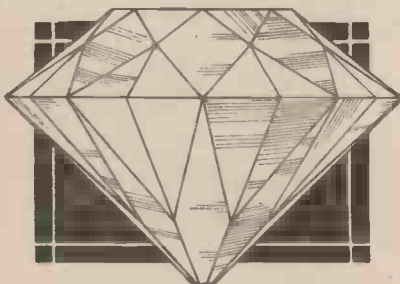

Fig. 11.—The finished fully cut brilliant.

preme amongst the varied forms of cutting. It has graduated from the poor lapidaries' cottage to the modern diamond-cutting factory, and it is interesting to note that little change has taken place in the methods of cutting the gems, apart from one or two mechanical improvements, and no devices have been invented to curtail the loss of practically 60 per cent. of the rough material which occurs when the stones are cut.

A REVERSING SWITCH

Constructional Details of a Cheap and Robust Reversing Switch Suitable for the Amateur Experimenter

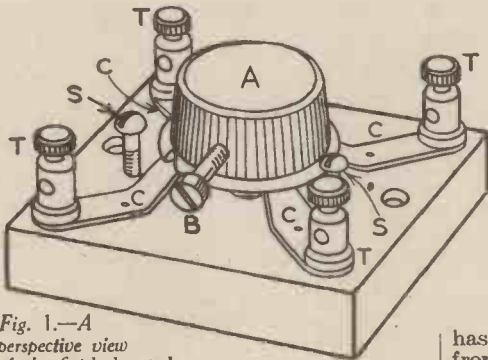

Fig. 1.—A perspective view of the finished switch.

THE usual reversing switch or commutator used in the laboratory, or by the amateur experimenter, is of the unreliable, unportable, and fragile mercury type. The switch described below is cheap, portable, robust, and easily made. It is shown in perspective in Fig. 1, and details of construction are shown in Figs. 2 to 7, while Figs. 8 and 9 show the connections and action of the switch.

The materials required are an old wireless filament rheostat knob A (a 1-in. brass metal screw B being substituted for the usual grub screw), a base, four terminals T, size 64, two 1/2-in. round-headed brass wood screws S, 1/8-in. brass sheet for the contacts C and R (Fig. 1), and a length of threaded brass rod D (Fig. 4) of suitable length and diameter for the knob, and fitted with a washer and nut N.

The Base

The base (Fig. 2) consists of a slab of wood, vulcanite, or other insulating material 3 in. square and 1/2 in. thick. Scribe the diagonals, and at the centre, drill a hole to allow D to pass through it easily. On the underside, recess it to take the washer and nut N. At a distance of 1/2 in. from each corner, drill a hole to take the terminals T. It is advantageous to drill and countersink two holes H to take wood screws, so that the switch may be screwed down if necessary.

The contacts C are cut out and filed from the 1/8-in. brass sheet, and should be tempered after being made. The dimensions are shown in Figs. 6 and 7. The hole drilled at the rounded end is to take the terminals, and the small hole to take a small brass pin to prevent the contact from rotating with the movement of the knob. The tapered end should be thinned down somewhat, and bent up as shown in Fig. 7.

Next cut a washer R from the same brass sheet, 1 1/4 in. outside, and 1/2 in. inside diameter. Fasten this to the bottom of the rheostat knob by four fine wood screws. File off the heads of the screws so that they are flush with the washer. If the knob

has a metal core, this must be insulated from the ring. Then, with a triangular

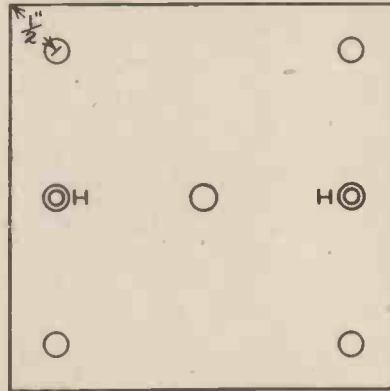

Fig. 2.—Details for marking out the base of the switch.

file, cut a groove right through the washer and into the knob, so that the

SIMPLE ELECTRICAL APPARATUS

Simple to make, clearly explained, these basic pieces of apparatus will enable every amateur electrician to perform hundreds of useful experiments.

With 138 Illustrations

From All Booksellers

Only 1/- net

Newnes HOME MECHANIC Series

washer is now in two sections, but out of electrical contact with each other. This groove must be at an angle of 45 degrees to the direction of the screw B.

Assembling the Switch

The business of assembly is a matter of a few moments. Fix the contacts in position, as shown in Fig. 3, by means of the terminals and pins. Fasten the threaded rod D into the knob by means of the washer and nut, so that the knob will turn fairly easily, but see that electrical contact is maintained between the brass strips and the ring. Finally,

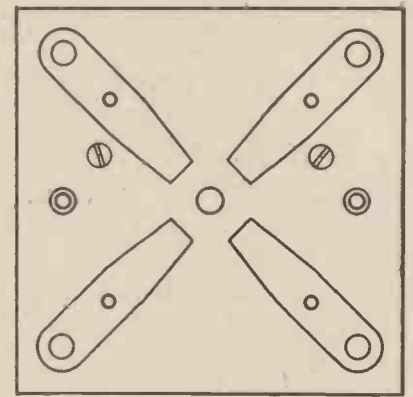

Fig. 3.—How the contacts are fixed into position on the base.

fix the screws S into the base so that they will come into contact with the screw B as the knob is rotated, and act as stops.

The connections are easily followed from Figs. 8 and 9. If a source of current is connected across the corners I and II and the split ring is in the position shown in Fig. 8, the current will flow in an external circuit from IV to III. If, with the battery still connected to I and II as before, the ring is turned to the position shown in Fig. 9, the current will flow in the external circuit from III to IV, and thus it will be reversed.

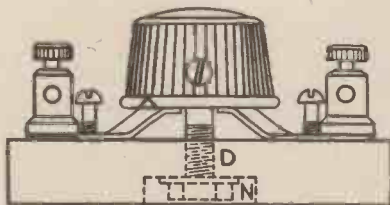
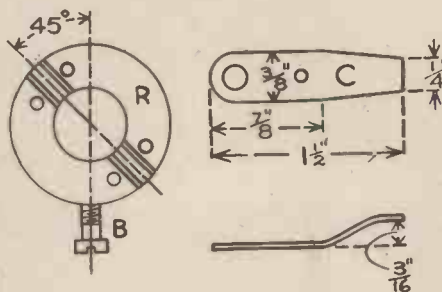
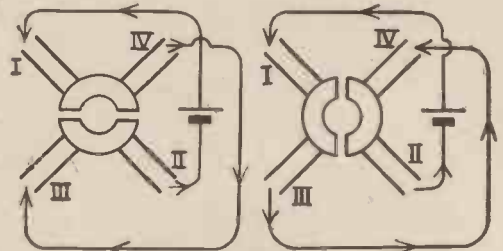

Fig. 4.—A side view of the reversing switch.



Figs. 5, 6, and 7.—Diagrams showing the underside of the switch knob, a plan of the contacts, and a side view of the contacts.



Figs. 8 and 9.—Showing the connections and action of the switch.

LATHE WORK

FOR AMATEURS

By "HOME MECHANIC"

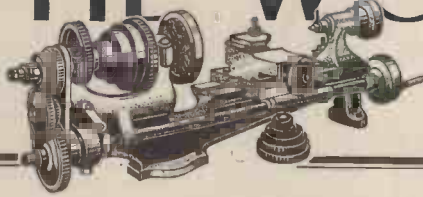

THE lathe is still the principal machine tool. In a primitive form it existed for many hundreds of years, and was composed of two tree trunks or stumps, each holding a nail to make the pointed centres on which the work spun to and fro under the compulsion of a cord and bow. The tools were held by the hands, or sometimes partly guided by the toes, and beautiful specimens of wood turning resulted from this simple device. The elements are still apparent in most lathes, the stumps being represented by the poppets or heads; but the work is rotated by a running spindle and driver. The important changes which occurred at the beginning of the industrial era were the substitution of power for hand drive, and the introduction of the slide-rest, carrying the tool positively and unyieldingly to cut any

many kinds of lathes, there are specialised designs solely for one or the other. The centre or engine lathe is often set up for long periods to turn shafts, spindles, rods, tubes, and all sorts of cylindrical forms mounted on centres. Parallel or tapered contours can be produced, the latter by a suitable motion of the slide-rest, or by setting over the loose head or tailstock. The tools are controlled by hand, but only for amateurs, and certain trades, as brass finishing and scientific instrument making. In the majority of cases the slide-rest imparts longitudinal and transverse feeds, by handle or self-acting gear, and ensures (with proper care) accuracy in the desired shape.

For chuck work the loose head does not come into action, and the piece is held either on the faceplate by clamps or dogs, or in a chuck having sliding jaws. Several types of lathes, called face or chucking lathes, operate solely in this manner, and vertical turning and boring mills also run on the same system, but with a horizontal chuck, a more convenient way of handling some work and observing the cutting processes.

Screw-cutting

This is effected by feeding the slide-rest at a specified rate in relation to the speed of the spindle, so causing the

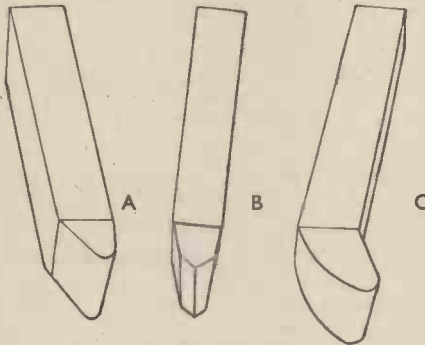

Fig. 1.—Some essential lathe tools. A. Round-nose roughing. B. For roughing, or cutting into corners. C. Bent rougher.

shape. Then screw-cutting mechanism marked another very important advance. The other vital improvements were substitution of automatic feeds for hand operation, and the multiplication of tools, both in ordinary (called engine lathes) and the turret lathes. Some of the automatic lathes and screw machines are very highly complicated, and run continuously when supplied with magazines of single pieces, or bars from which to turn and cut components.

The differences in types of lathes are concerned with the size and shape of the work-pieces, the particular operations which have to be performed, and the relative quantities of like shapes required. A very simple lathe can be made to effect the same results as a complicated one, but in much longer time, and at greater trouble in manipulating the tools and taking measurements.

Centre and Chuck Work

Primarily lathe subjects are divisible into centre work and chuck work, and although both can be dealt with on

tool to cut a spiral along the piece of the required pitch. The rest moves by means of a screw (the lead-screw), which rotates at a suitable speed through the intervention of change wheels driven from the spindle. In an ordinary lathe the turner controls the stopping of the traverse, the slight feeding in for another pass, and so on until the thread has been cut to the required depth, but automatic lathes function without attention for cutting any sort of long or short screws. Internal threads are cut with a tool projecting from the rest, the component goes in a chuck, and the procedure is similar to that of doing parts held between centres.

A lathe employed by an amateur, or instrument maker or tool maker, may be capable of accomplishing a variety of diverse operations with the help of attachments. Grinding, external and internal, accurate drilling, milling, gear-cutting, shaping, slotting, broaching, relieving, or backing off the cutting edges of mills and other cutters are all possible. Many of these processes are on a small scale, where it would be out of the question to effect them on appropriate machines, as would be done in a larger shop; but much of the fine tool, die, and cutter making may be performed by one skilled lathe man, carrying out several of the above-mentioned operations on his precision lathe. In a large tool-making department, or one devoted to the manufacture of fine parts, youths or girls will run the small lathes set up for one process only.

Special-purpose Lathes

Special-purpose lathes are numerous, in motor, textile, agricultural, engine,

carriage and wagon, locomotive, and marine-engine building shops. They take only one size or type of object, and have facilities for rapid handling, chucking, bringing the tools to position, measuring the results, if necessary, and removing the finished pieces. Shafting lathes use tools at front and back, roughing and finishing at a rapid rate to gauge. Pulleys and flywheels

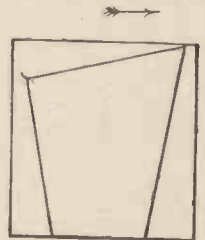

Fig. 4.—Front view of a turning tool showing the side slope or rake which gives a cutting angle towards the direction of feed.

go on face lathes, with tools cutting at front and back, and often a boring bar for the hole working simultaneously. Railway wagon, carriage, and locomotive axles are rapidly handled on axle lathes, possessing a central headstock revolving the axle, and slide-rests at each end turning the journals simultaneously. Hard steel rollers may effect a burnishing action subsequently to impart a close hard finish to these bearing surfaces.

Tyres are bored on face lathes equipped with sets of tools controlled to bore and recess to gauge, and arrangements are made for one attendant to look after two or more lathes. Mounted sets of tram, wagon, or locomotive wheels go in double-ended lathes carrying a driving chuck on each headstock. Special devices raise the sets to position, either a pneumatic hoist below, or an

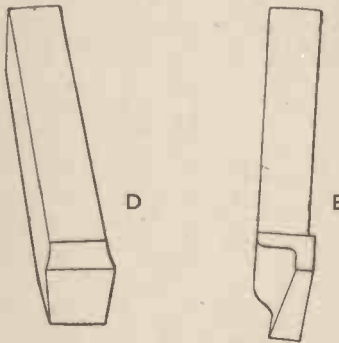

Fig. 2.—D. Square-nose finisher. E. Knife or side tool for cutting down faces.

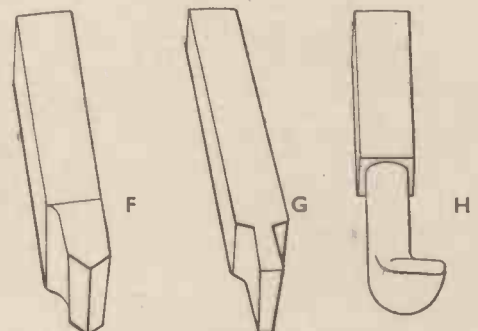

Fig. 3.—F. Screw cutting. G. Parting off or grooving. H. Boring; also made square-edged.

overhead hoist on a girder, and one headstock is moved along by power to complete the chucking. Two duplex slide-rests manipulate sets of tools at front and rear to rough and finish and complete the profiles, and overhead

the cross-slide for the respective cuts. Very complicated articles may need so many tools at them that the turret "stations" are insufficient, and one or more must be arranged to receive two or more tools, substituted by hand, and locked with a clamp handle. The dimensions cut are governed by the construction of some of the tools, made

or set to size; or diameters, lengths, depths, depend on "stops," solid blocks or strips to positively check the movements of the tool-carrying elements. In some automatics cams exercise control.

Capstan Lathes

Small capstan lathes are run by three handles: for feeding, and chucking the rod or holding single components; actuating the capstan, and the cross-slide. Stopping and starting, and possible reverse, are effected by an overhead lever, or pedals. The larger capstan and some turret lathes embody power feeds to the slides, consequently the attendant only has to exert a slight degree of control, and the feeds are automatically tripped. Several types of full automatic machines only require the component to be chucked, and the sequence of operations goes through without further attention; but if the

being sketched in Figs. 1 to 3. Some are straightforward, others must be right- and left-hand. The disadvantage of solid tools is the cost of the steel, and the trouble incurred when the end breaks. Therefore, a good many styles of holders are made to take short pieces of tool, held by a screw or wedge. The essential difference in types is whether the front rake is embodied permanently when the bit is put in the hole (Figs. 5 and 6), or whether the top rake is permanent. For general use a holder ought to take a standard section—round, square, or oblong—but many designs hold a special section, for convenience of cutting certain formations or obtaining a non-slip grip on the bit. Boring holders (Fig. 7) fit in a split block clamped on the rest. A multiplicity of tool holders is employed in the rapid production of lathes of all sorts, and automatics.

Tips of any cutting substance can be brazed or welded on to shanks, and this practice has spread so much recently, that tool holders do not find much favour in some shops for the engine lathes. The tip is fitted on a ledge or in a slot of the shank, and united with the greatest firmness by the brazing or welding action. Fig. 8 shows a typical example.

Turning

This may be accomplished by a straightforward movement, or by a traverse, the first-named method being restricted to some finishing cuts, grooving, forming, and parting. Traverse is effected with a V-edged or round-nose tool, and top slope or side rake (Fig. 9) must be ground to slope away from the

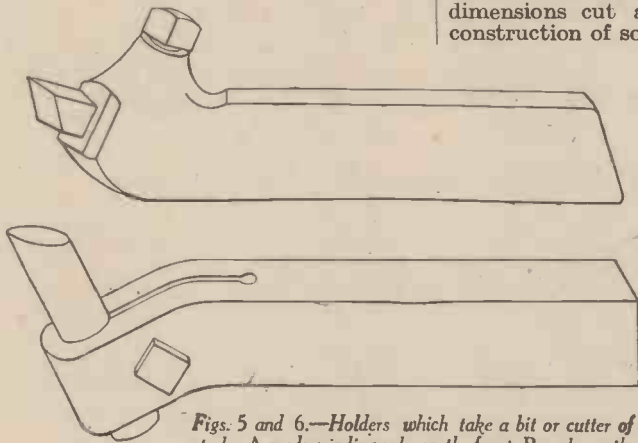

Figs. 5 and 6.—Holders which take a bit or cutter of tool steel. A needs grinding only on the front; B, only on the top.

gauge rods may be applied to ascertain whether both rims are exactly the same diameter.

Multi-cutting Lathes

These have developed extensively of late. The idea is to do away with the piecemeal treatment of shafts, spindles, pins, hubs, wheels, gear blanks, etc., that is, by taking cuts in an ordinary lathe over the different sections in turn, and instead have a lathe with elaborate tool outfits cutting on all or most of the surfaces at one pass. Production time is thus limited to the period consumed in taking the longest cut. Frequently roughing and finishing sets of tools come into action successively. Cams or hydraulic cylinders operate the feeds, and by sliding, rocking, angular, and compound movements the tools can be fed to cut complicated forms. Quick chucking facilities are essential, and coolant is flooded on from numerous pipes. Specialised designs deal with camshafts and crankshafts, the first having rocking motion according to the cam contours to be turned, the latter chucking arrangements and steadies in which to drive the shafts.

The capstan or turret principle appears in a vast number of hand, semi-automatic, and full automatic machines. A complete set of drills, counterbores, facing tools, reamers, turning, boring, threading, and other tools goes in the capstan, while a cross-slide is usually included with ordinary or turret holders. The tools operate in quick succession, being brought up by hand manipulation, or automatically under control of cams and other details. Time is saved by giving rapid motion to and from the cutting positions. The processes are subdivided according to the relative suitability of the turret and

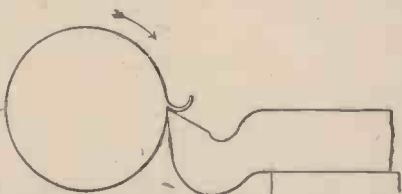

Fig. 9.—Average tool angle for turning steel.

bar is fed automatically, or a magazine discharges intermittently to the chuck, production becomes continuous.

With regard to lathe tools, the difference between those for wood and metal is one of cutting angle. The former type can be thin-edged, to penetrate the easily worked material, but the latter kind must be much stronger, hence the cutting angle (Fig. 4) ranges from about 6 degrees top rake for cast iron to 10 degrees for steel.

Front rake or clearance varies from 4 degrees to 6 degrees. Brass, gun-metal, etc., can be turned with a tool having no top rake. The materials employed for tools comprise carbon steel, high-speed steel, Stellite, and the new tungsten-carbide, which cuts at rates unprecedented until recently. Diamonds are often utilised for turning aluminium, vulcanite, bakelite, and such substances which wear any other tool too rapidly.

Standard Tools

A considerable number of shapes occur for tools, but a few standard ones are sufficient for ordinary use, these

including the latest, tungsten-carbide, will operate without injury on scale.

(To be continued.)

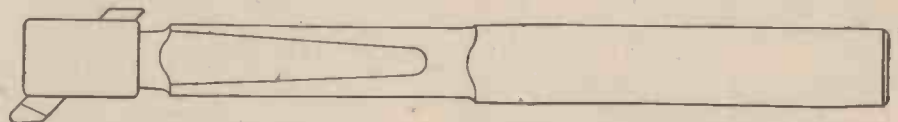

Fig. 7.—A slide-rest boring tool holder. The cutter is locked by a wedging action of the collar forcing the cutter against a flat on the shank.

direction of feed. Hence the reason for right-hand and left-hand tools. A roughing cut is generally taken of good depth in order to remove most of the metal, and leave only a slight amount for smooth and accurate finishing. Formerly it was imperative to get well under the skin of a casting or forging at the first cut, to avoid the risk of the edge being damaged by occasional scraping over the skin, but this does not matter now that new compounds,

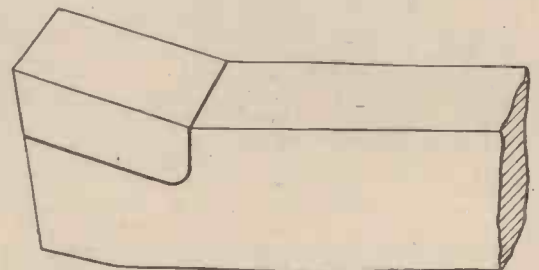
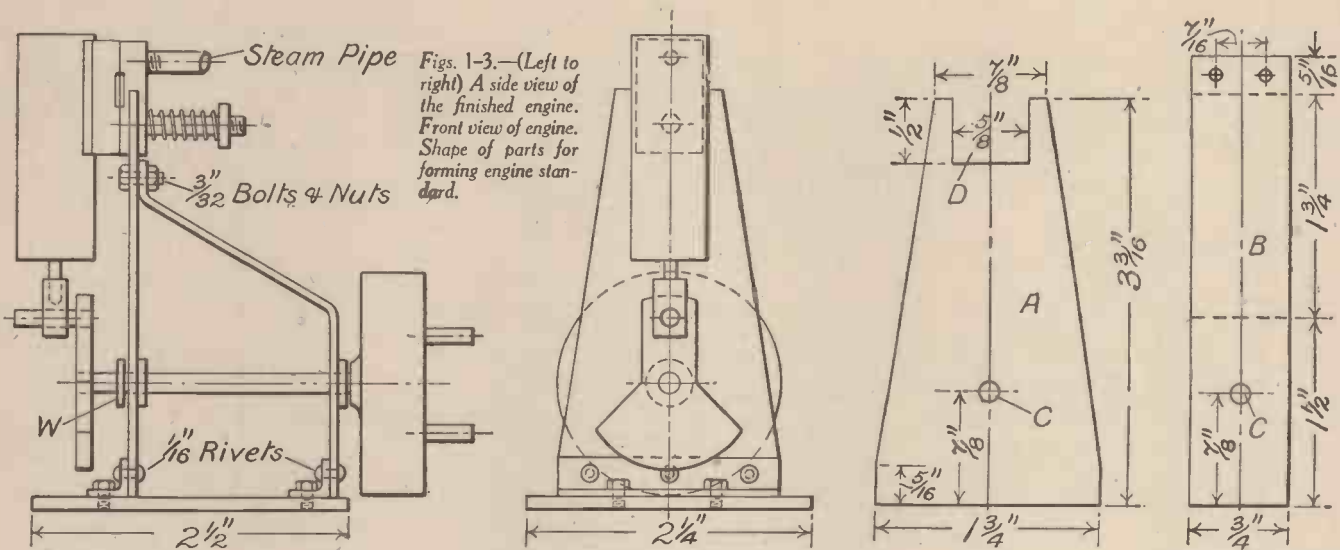

Fig. 8.—A steel-tipped tool. The tip is brazed on to a mild steel shank.



WORKING MODEL ENGINES

A Single-Cylinder Model Boat Engine

WORKING model steam engines still have a peculiar fascination for young and old alike, and although many types can be purchased ready-made, added interest is given to a working model if it is constructed by the owner. It is assumed that the reader does not possess a lathe, so that the few parts which require turning will have to be purchased at a model maker's supply stores.

A knowledge of soft soldering is necessary, and also the ability to use a few metal-working tools, such as a hammer, cold chisel, hacksaw, screw-plate, hand-drill, etc. Most of the tools required can be purchased very cheaply.

The model engine to be described first is a small boat engine having a single-acting oscillating cylinder, which is particularly adapted for the purpose owing to the fact that no stuffing box is required, and therefore friction is considerably reduced. The cylinder in oscillating automatically controls the steam admission and exhaust so that no separate valve is required, as in the case of a slide-valve cylinder. A side and end view of the complete engine are given in Figs. 1 and 2 respectively.

Details of Construction

For the engine standard a piece of sheet brass 1/8 in. thick will be required, on which the two parts A and B (Fig. 3) can be marked out, with the aid of a scriber, to the dimensions given. Centre punch the holes ready for drilling, and with a hammer and cold chisel roughly cut out the two pieces, and then hold each part in the vice and file down to the scribed lines, leaving the edges as square as possible. When using a hammer and chisel for cutting out sheet metal the latter must rest on a flat metal surface,

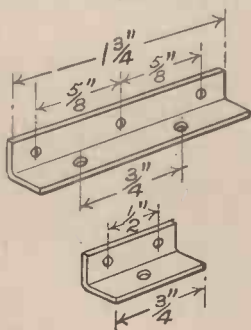

Fig. 4.—The angle pieces for the engine standards.

The First of a Series of Short Articles for the Beginner, Explaining the Construction and Working of Various Types of Small Model Steam Engines and Boilers. Lathe-work is Eliminated.

and an old domestic flat-iron answers very well for the purpose.

The holes marked C can be drilled 5/8 in. diameter for the crankshaft, and the two holes in the top of part B are drilled 3/8 in. diameter for small bolts and nuts. The square slot D can be roughly cut out to the dimensions given, but should not be filed

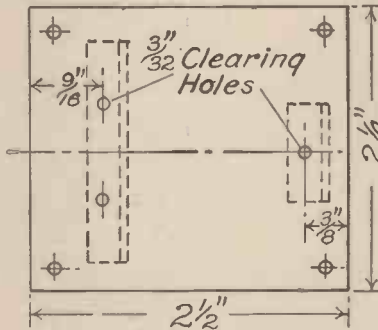

Fig. 5.—A plan of the baseplate showing the position of the holes for fixing screws.

to the exact size till the cylinder steam block is finished.

A small brass washer about 1/8 in. thick, and with a 1/8-in. hole, can now be soldered on to each plate so that the hole in each washer registers with one of the holes C, as depicted in Figs. 1 and 2. These washers are provided for the purpose of thickening the bearing surfaces for the crankshaft. The plate B can now be bent on the dotted lines to conform to the shape shown in Fig. 1, after which a piece of 1/8-in. angle brass can be lightly soldered to the bottom of each plate so that the

bottom faces of the angles are flush with the edges of the plates. The angle pieces should previously be marked out and holes drilled as indicated in Fig. 4 to take the rivets and holding-down screws. After soldering in position, the holes for the rivets can be continued through the plates and 1/8-in. copper or brass rivets can be inserted and the ends riveted over.

The Baseplate

For the baseplate a piece of 3/2-in. sheet brass measuring 2 1/2 x 2 1/4 in. will be required, in which seven holes have to be drilled as indicated in Fig. 5. The position of these holes can be carefully marked out first with the aid of a small square and scriber, and then centre punched. The four holes near the corners of the baseplate are to take screws for fixing the latter in position, while the other three holes are for the bolts which clamp the angles of the engine standards in position.

Standard A is fixed in position on the baseplate by means of 3/8-in. bolts. Test with a square to see that it stands at right angles to the baseplate, and then bolt standard B in position. This must be adjusted by bending it slightly one way or the other till the top part just touches standard B. Apply a touch of solder to prevent the top from moving and then drill the two holes through to take the fixing bolts.

Crankshaft

For the crankshaft a piece of 5/8 in. diameter mild steel rod will be required, 2 3/4 in. long, a thread being cut on one end for a distance of 1/8 in. To make the crank, which is of the balanced type, take a piece of sheet brass 1/8 in. thick, and after scribing a centre line, carefully set out the shape of

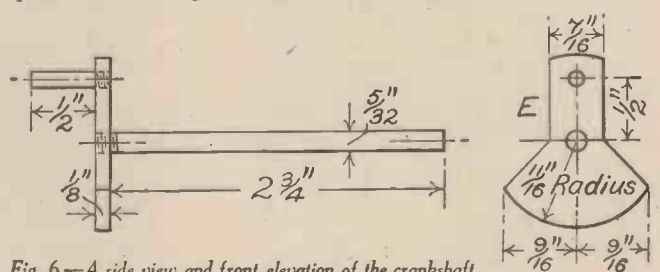
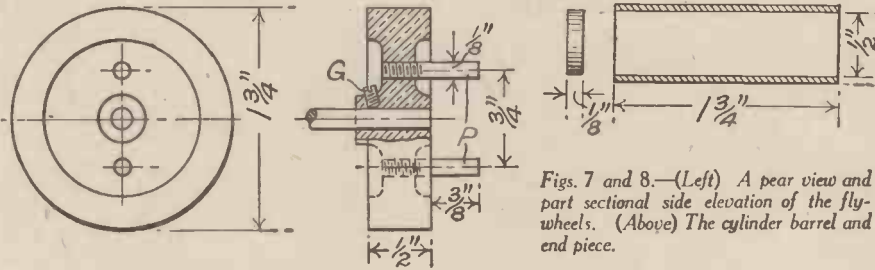

Fig. 6.—A side view and front elevation of the crankshaft.



Figs. 7 and 8.—(Left) A pear view and part sectional side elevation of the flywheels. (Above) The cylinder barrel and end piece.

the crank and the position of the two holes, as shown at E, Fig. 6. Centre punch the holes and drill and tap them to receive the screwed ends of the crankshaft and crank pin. Roughly cut out the crank with a hacksaw and then file down to the scribed outline, keeping the edge as square as possible. The crank-pin consists of a 3/8-in. length of 1/2 in. diameter steel rod, threaded at one end for a distance of 1/2 in. for screwing into the crank.

The Flywheel

This type of engine requires a fairly heavy flywheel, and this can be of brass or iron 1 1/2 in. diameter and 1/2 in. across the rim. It must have a 3/2-in. hole through the centre to fit the crankshaft, and a 1/4-in. hole should be drilled and tapped in the boss to take a small grub screw G for fixing the wheel firmly in position on the shaft. The two driving pins P can conveniently be cut from a French nail. Select one of the required diameter, which should be perfectly straight, and after cutting off two pieces 3/4 in. long, cut a thread on one end of each for a distance of 3/8 in. for screwing into the holes tapped out to receive them in the position indicated in Fig. 7.

Before fixing the flywheel on to the shaft, slip on a small washer W, pass the shaft through the bearings, and push the flywheel on. Adjust the shaft so that the back of the crank is 1/4 in. from the standard, and then neatly solder the washer W to the shaft so that it just touches the standard. See that a small clearance is left between the boss of the flywheel and the bearing on the other standard, and then tighten up the grub screw.

Engine Cylinder

The cylinder is 1/2-in. bore and 1-in. stroke, and for the cylinder barrel we shall require a piece of solid drawn brass tubing a bore 1/2 in. inside diameter, and 1 1/2 in. long. The tubing need not be more than 3/16 in. thick, and if it is sufficiently true the bore may only require cleaning out with the aid of a piece of fine emery cloth wrapped round a wooden rod of suitable diameter, using a little machine oil as a lubricant. If the bore, however, is at all out of true, a 1/2-in. parallel reamer can be passed through it. Having done this carefully, file the ends of the tube square till it is exactly 1 1/2 in. long (Fig. 8), and then well clean up the outside of the tube with fine emery paper.

The port block R, Fig. 9, which has to be soldered to the cylinder barrel, can be fashioned out of a short piece of 3/8 x 1/2 in. strip brass to the dimensions given. One side of the block must be filed concave to fit the cylinder barrel after the holes have been drilled through for the steam port and pivot pin. For this pin cut off a piece of 3/32 in. diameter mild steel rod 1 1/2 in. long and cut a thread on both ends as indicated. File the recess in the face of the block, and then slightly countersink the top of the hole into which the pivot pin screws. The

working face of the block can now be prepared by rubbing it on a piece of plate glass, using either pumice or fine emery powder as an abrasive medium. The port block can then be sweated to the cylinder barrel after tinning the surfaces which come in contact. Now take the drill that the steam port was made with and continue the hole through the cylinder wall; the burr formed on the inside can be removed by passing the reamer through the cylinder again. For the top end of the cylinder a plain brass disc 1/2 in. thick will be required, which must be a good push fit in the cylinder barrel.

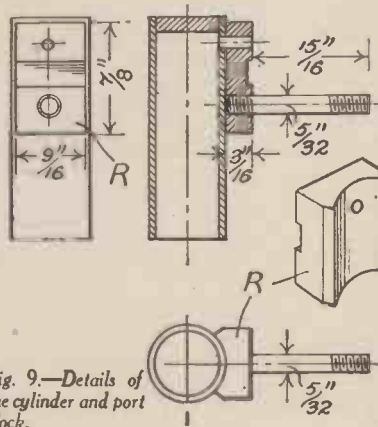
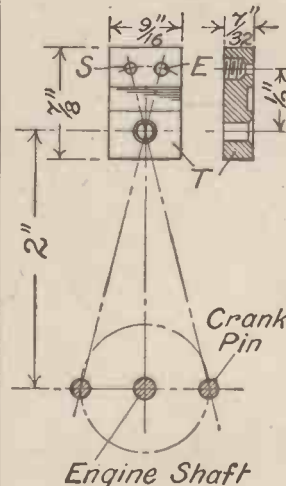

Fig. 9.—Details of the cylinder and port block.

Steam Block

The fixed steam block T can be made with a piece of stick brass, and must be carefully filed to the dimensions given in Fig. 10. Mark out the position of the three holes and drill out as indicated, the exhaust port E being made slightly larger than the steam port S. This port can be enlarged from the back face of the block, as shown, and tapped to receive the screwed end of the steam pipe. The setting out is also given in Fig. 10, which shows how the



Figs. 10-12.—(Left) Details of the steam distributing block and the method of setting out the ports. (Below) The method of making the piston. (Right) Sectional view of the finished cylinder and steam block.

exact position of the ports is determined. The distance between the two ports must be a little more than the diameter of the port in the cylinder head, otherwise there would be a leakage of steam when the cylinder is in the mid position. After centre punching and drilling the holes through carefully, slightly countersink the one for the pivot pin, and file the recess across the working face as in the case of the other block.

The Piston

The piston can be made from a 3/8-in. length of brass tubing which must be a good push fit in the cylinder barrel. Both ends of the tube should be filed square and a brass disc 1/2 in. thick, with a centre hole drilled and tapped with a 3/32-in. thread, can be soldered in one end of the tube as shown in Fig. 11. Remove all superfluous solder by filing that end of the piston quite flush.

For the piston rod cut off a 2-in. length of 3/8 in. diameter steel rod and thread both ends for a distance of 1/2 in.

The piston rod head, shown in Fig. 12, can be filed to shape from a piece of stick brass and a hole drilled in one end for a distance of 1/2 in. and tapped to receive the screwed end of the piston rod. Another hole 1/2 in. diameter can be drilled through the head near the other end to take the crank-pin, as shown. The spring for the pivot pin may preferably be of hard brass wire, and is 1/2 in. outside diameter, and 3/8 in. long unloaded.

A sectional view of the complete cylinder and steam block is given in Fig. 12, which also shows the small nut or screwed collar N which is tightened up on to the spring for the purpose of preserving contact between the two port faces of the cylinder and steam block. By carefully adjusting this nut the spring is caused to exert just sufficient pressure to prevent steam from escaping from between the port faces when the engine is working.

Mounting the Cylinder

The slot D, in the top of the engine standard, can be filed to fit the steam block. After adjusting it so that the working face is parallel to the upright part of the standard, carefully solder it in place by running a thin fillet of solder down each side of the block. Place the cylinder in position, connect up the piston rod head with the crank pin, and put the spring and nut on the pivot pin.

Apply a little lubricating oil to all the working parts, and give the flywheel several turns to run the oil well into the bearings.

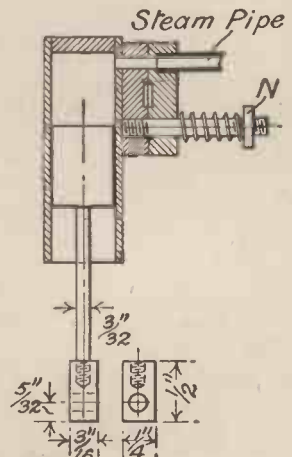

THE BEGINNER'S GUIDE TO

CHEMISTRY

An Alphabetical Explanation of the More Important Chemistry Terms and Processes

Abrasives.—Preparations which are used for cleansing by friction. Examples of these are to be found in carborundum (silicon carbide), emery, rouge, tripoli powder, soapstone, pumice, etc.

Absolute Alcohol.—Ethyl alcohol deprived of all water, by passing its vapour in the final distillation over quicklime.

Absolute Temperature.—This is reckoned on the absolute scale in which zero is 273° C. (absolute zero). To convert Centigrade readings to the Absolute Scale, add 273.

Absorption.—A swallowing or drawing in of one substance by another. A physical term.

Acetates.—Salts of acetic acid.

Acetylation.—The process of adding an acetyl group to another substance. Often accomplished by employing acetic anhydride as in the production of acetylsalicylic acid (aspirin).

Acid.—A substance containing hydrogen which is replaceable either wholly or partly by an element or a group of elements. With phosphoric acid, for instance, there are three possible phosphates of sodium, the nature of each depending on the amount of hydrogen replaced by the sodium. They are: sodium dihydrogen phosphate, disodium hydrogen phosphate, and normal sodium phosphate. Aqueous solutions of acids have a sour taste and change the colour of blue litmus (a vegetable dye) to red. When free from water they are non-conductors of electricity, but when in solution in water they become conductors.

Acidimetry.—Process for estimation of acid strength by titration to neutralisation with alkali of known strength.

Acid Radicals.—The hydrogen of an acid is referred to as the positive radical. That single element, as chlorine in hydrochloric acid, or group of elements as SO₄ in sulphuric acid, attached to the hydrogen is the negative radical which may be thus simple or compound. If compound it often reacts as one unit.

Acid Salt.—A salt which retains some hydrogen of the acid. (See also Acid.)

Actinometer.—An instrument which registers the chemical activity of light.

Additive Products.—Substances formed by the direct union of unsaturated compounds with atoms or groups of atoms.

Adsorption.—Surface condensation or concentration on a surface. Addition of a substance to a two-phase system will often create a concentration of this substance on the surface of one of the phases. Charcoal will decolourise colloid dye systems by adsorption. Soap cleans by adsorption.

Aeration.—Saturation with a gas. Aerated table waters are saturated with carbon dioxide gas.

Aerometer.—An instrument for measuring the weight of air and gases.

Affinity.—The tendency to undergo chemical change.

Albo-carbon Light.—The light emitted by a burning mixture of coal gas and naphthalene vapour.

monohydric alcohol, ethylene glycol is a dihydric alcohol, and glycerine is a trihydric alcohol. "Solid" alcohol is ordinary alcohol jellified with soap.

Alcoholometry.—The measurement of the percentage alcohol strength of aqueous spirit. Simply accomplished by reading the spirit gravity with Syke's hydrometer and referring to conversion tables.

Aliphatic.—A term applied to all organic compounds which are considered as derivatives of methane. All other organic compounds are classed as "aromatic" (benzene and its derivatives). There are thus two great groups of organic chemicals.

Alkali.—A soluble base. Alkalies usually have an acrid taste and turn red litmus solution blue.

Alkalimetry.—Process for estimation of strength of alkali by titration to neutralisation with acid of known strength.

Alkaline Earths.—Sources of barium, strontium, and calcium.

Alkaloids.—Basic nitrogenous sub-

Albumins.—Those protein bodies which are coagulated by heat. They cannot be "salted out" of aqueous solution.

Albuminoses.—Complex degradation products formed from albumins by either chemical or enzyme hydrolysis.

Alchemy.—Embryonic chemistry.

Alcohols.—Substances derived from the paraffins by substitution of a hydroxyl group(s) for atom(s) of hydrogen. They are named according to the number of hydroxyl groups they contain. Thus ordinary alcohol is a

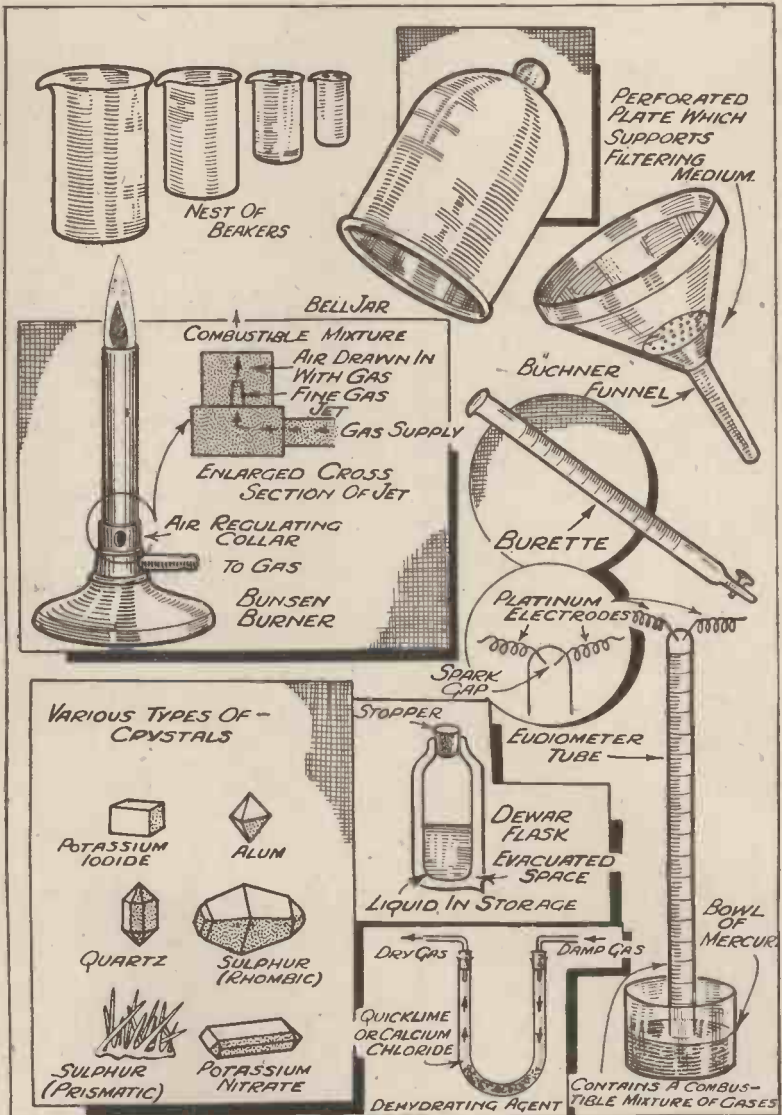

Various pieces of Chemistry apparatus.

stances of plant origin and having important physiological activity—morphine and quinine, for example.

Aldehyde.—The oxidation product of a primary alcohol.

Allotropy.—The property exhibited by certain elements of existing in different forms. Carbon, sulphur, and phosphorus are outstanding examples of this.

Alloy.—A mixture of two or more metals. Brass is an example.

Aluminothermy.—A process for obtaining metals from their oxides. Oxides which are difficult to reduce by ordinary means are powdered and mixed with aluminium dust and fired with magnesium. Aluminium oxide and the metal are formed in the ensuing reaction, the heat of which ($3,000^{\circ}\text{C}.$) is intense enough to liquefy both. This forms the basis of the "Thermite" welding process.

Alums.—A series of isomorphous double sulphates having the general formula $X_2\text{SO}_4 \cdot Y_2(\text{SO}_4)_3 \cdot 24\text{H}_2\text{O}$. The first sulphate is of a diad metal, the second a triad.

Amalgams.—Alloys of mercury.

Amides.—Organic substances derived from ammonia, by substitution of acid radicles for either one, two, or

three of its hydrogen atoms.

Amines.—Organic substances derived from ammonia by substitution of alkyl radicles or metals for either one or more of its available hydrogen atoms.

Ammonal.—A high explosive of the ammonium nitrate; zinc dust class.

Amorphous.—Devoid of crystalline structure.

Amphoteric.—Compounds having both acidic and basic properties. Aluminium hydroxide is a typical example.

Amylase.—An enzyme which converts starch into sugar (maltose).

Analysers.—The rotating prism of the polarimeter.

Analysis.—The investigation of the constituents of a compound or mixture.

Angström Unit.—The unit of wavelength of light—the ten-millionth of a millimetre or 10^{-7} millimetre.

Anhydride.—An oxide which will combine with water to form an acid. It may be regarded as an acid deprived of the elements of water.

Anhydrous.—Devoid of water.

Anion.—A charged particle which travels to the anode in electrolysis.

Anode.—The electrode at which most non-metals are liberated in electrolysis.

Annatto.—A yellow dye of vegetable origin.

Antibodies.—Substances formed in the blood to counteract injected foreign bodies.

Antichlor.—An agent applied after chlorine bleaching to inhibit further action of the chlorine which would prove destructive. Sodium thiosulphate is frequently used as an antichlor.

Anti-toxins.—Toxin neutralising substances formed in blood plasma.

Aqua Fortis.—An old name for nitric acid.

Aqua Regia.—An old name for nitrohydrochloric acid—a solvent of gold and platinum.

Aromatics.—Organic benzene derivatives—closed chain or cyclic compounds. (See also Aliphatics.)

Asbestos.—A mineral composed mainly of silicates of calcium and magnesium.

Ashing.—Also termed "incineration." A process of heating an organic substance strongly in air, thereby driving off carbonaceous matter and leaving an ash residue.

Aspirator.—A piece of apparatus which draws a current of air or gas through a chamber.

Aspirin.—A household synonym for acetylsalicylic acid.

Assay.—A quantitative estimation.

Association.—That state of a substance when its molecules are multiples of their simplest form. Water, for instance, at normal temperatures exhibits the formula $(\text{H}_2\text{O})_2$, and possibly $(\text{H}_2\text{O})_3$. Dissociation into the simpler molecular structure occurs gradually as the temperature is raised.

Asymmetry.—An unsymmetrical atomic arrangement. A substance whose molecules contain an asymmetric carbon atom has the property of rotating the plane of polarisation of polarised light.

Atmolytic.—The separation of a mixture of gases into their components by the relative rates of diffusion through a porous partition.

Atom.—May be regarded as the limit of subdivision of matter and is the smallest possible particle which may undergo chemical change.

Atomic Weight.—Taking the weight of one atom of hydrogen as the standard, the atomic weight of a substance is the weight of its atom relative to this hydrogen standard.

Atomcity.—See Valency.

Autoclave.—An apparatus by means of which substances may be maintained at a constant temperature and pressure. The heat is maintained by superheated steam automatically controlled. Complete sterilisation processes are quickly accomplished by it.

Autoxidation.—Spontaneous oxidation such as is exhibited by linseed oil or phosphorus.

Avogadro's Hypothesis.—"Equal volumes of different gases at the same pressure and temperature contain the same number of molecules."

Azo Compounds.—An important organic group, the source of many dyes. They are obtained by treating a nitro compound with an alkaline reducing agent.

Babbit's Metal.—An alloy of antimony, tin, zinc, lead, and arsenic used as an anti-friction lining in bearings.

Bakelite.—A condensation product formed by phenol and formalin in presence of a catalyst. (To be continued.)

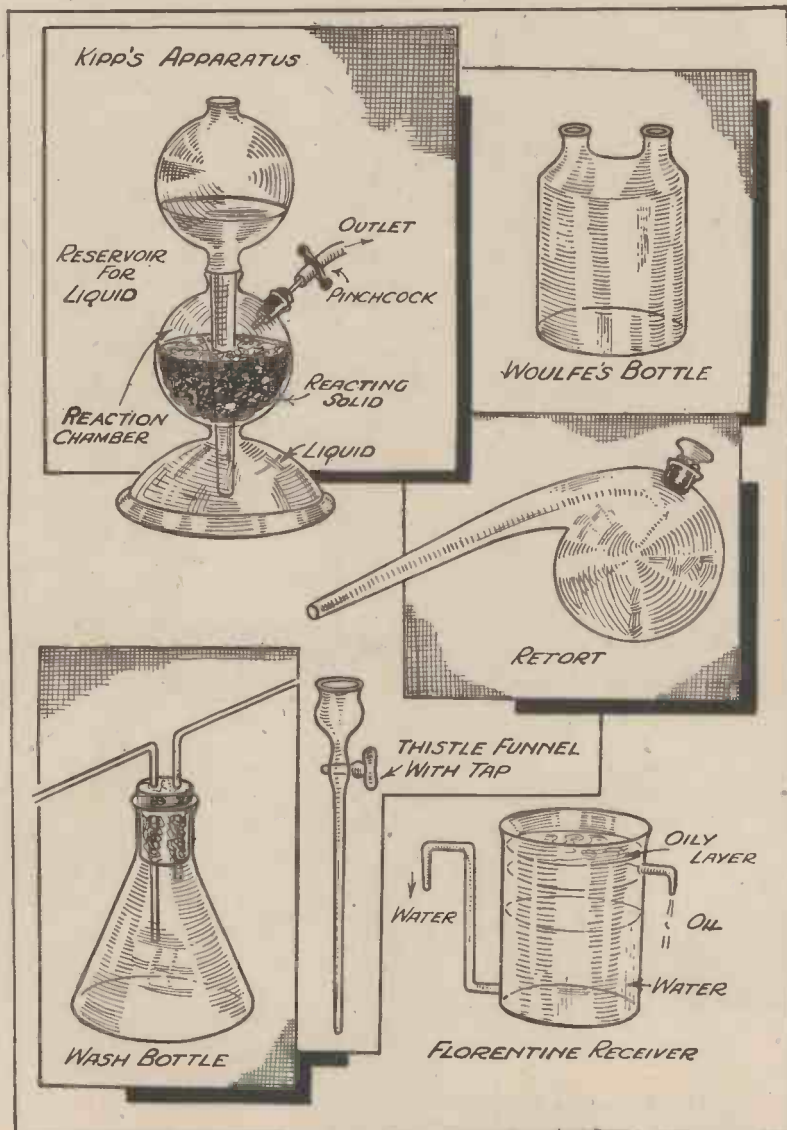

Further chemical apparatus. Showing a wash bottle, thistle funnel and florentine receiver.

AN AUTOMATIC DISH ROCKER

A USEFUL DEVICE FOR THE PHOTOGRAPHIC DARK ROOM

By "PHOTOGRAPHER"

THE number of photographers who find the manipulation of the dish containing developer and plate both tedious and tiresome must be legion, yet it is a job which has to be done. When the time required for fully developing a plate occupies anything from seven to ten minutes, it is felt that such time may very well be occupied in doing other things, such as attending to the washing of plates which have already been fixed, and examining those still in the hypo bath. When panchromatic plates are being dealt with the task is still more irksome, because one has to stand in absolute darkness just doing nothing but moving the ends of the dish up and down.

To overcome these objections and to render it possible to leave the dark room entirely, knowing that the plate will be perfectly developed, I have from time to

time that I had still to stand and attend to the rocking, giving a fresh impulse at every few seconds; so I set about devising something to overcome this difficulty, something which would provide the necessary power to give a small impulse at every oscillation of the pendulum. The result is shown in Fig. 1.

I may remark here that this very effect of the action of moving masses of fluid was utilised some years ago in cross-channel steamers to stop rolling and pitching in choppy seas, the fluid—ordinary sea water—being contained in long tanks. Although the scheme was successful, I believe the idea was abandoned, possibly for reasons of the effect on the structure of the ship. Referring to Fig. 1, *a* is the end of the dark room bench; *b* is a pair of wooden brackets screwed to the legs of the bench; *c* is the rocking panel on which the developing dish is placed; *j* is a pendulum bob made of two hemispheres of lead, which may be formed by melting the metal in an iron ladle and allowing the lead to cool; *j*¹ and *j*² are stout iron wires of, say, about No. 16 gauge, having hooks formed at their upper ends hanging in screw-eyes, *j*³, screwed into the under-side of the panel.

The Motive Power

This is provided by a falling weight, *h*, which may be made from an empty cocoa or coffee tin, holes being bored in opposite sides and a wire pushed into these holes and bent as shown. The weight is provided by lead shot or other small bits of lead placed in the tin. *d* is a toothed gear wheel, 3½ in. in diameter, and *e* another toothed wheel, ½ in. in diameter, both of these being in brass. They are standard Meccano gears, made to mesh one with the other, and may be obtained at any stores where Meccano parts are stocked. *d*¹ is a drum over which a cord is wound, having the weight, *h*, hanging at its end. *f* is an oak backboard which may be screwed to the wall of the dark room, and *g* is a connecting rod, the upper end of which is attached by a crank and crank pin to the wheel *e*. The lower end has a screw passing through it into the rocking panel *c*.

It will be seen that the apparatus is of a most simple character, and as there is no bearing needed to support the spindle on which *d* and *d*¹ revolve, the winding up of the weight is performed just by taking *h* in the left hand and turning the cord round and

round the drum with the right hand until all the

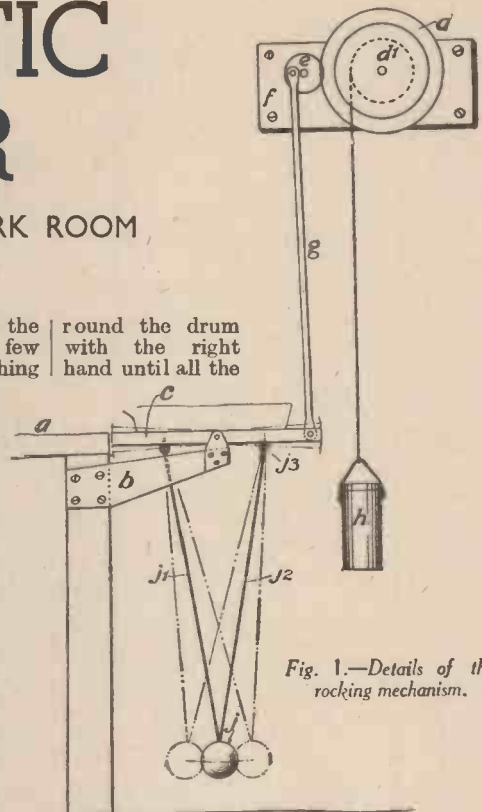

Fig. 1.—Details of the rocking mechanism.

cord is wound on, and the weight close to the drum. If the workbench top and the panel are about 3 ft. 3 in. above the floor, this will allow of a pendulum having such a length that it will make one oscillation per second; so it will be seen that the fall of the weight, if the height of the drum is made 7 ft. to 8 ft., will be sufficient to keep the dish rocking for at least five minutes.

Mounting the Panel

Fig. 2 is a sketch showing details of the mounting of the panel, *c*. *b* is one of the previously mentioned brackets; *dd* are metal plates which can be cut from thick tin-plate or steel of about No. 18 gauge. Passing freely into holes in these plates are nails driven exactly into the centres of the length of the panel, the nails having their heads removed and filed, as shown at *e*. The V-shaped ends thus form knife-edge pivots giving the minimum of friction. *j*¹ and *j*² are the wires, and *j*³ one of the screw-eyes.

Fig. 3 is a detailed sketch showing a portion of the large gear wheel, *d*, and the small wheel, *e*. *e*¹ is an ordinary wood screw of such diameter as will fit the hole in *e*.

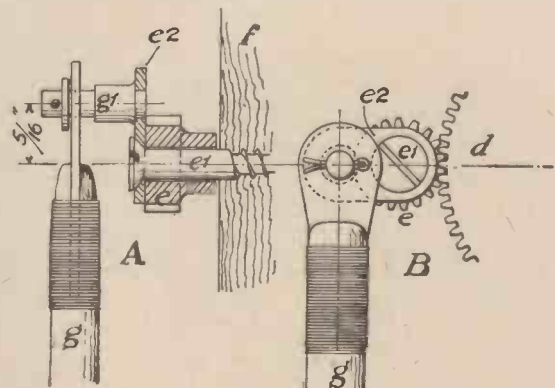

Fig. 3.—A portion of the large gear wheel.

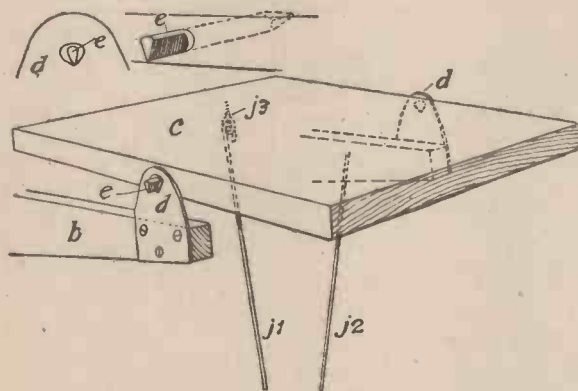

Fig. 2.—Showing the method of mounting the panel.

time devised dish-rocking apparatus. The simplest scheme of all, which I used for many years when I was working on nothing larger than quarter plates, was the pivoting of a small rectangular panel in the top of the dark room bench, with a long rod extending downwards from the centre of the panel having a heavy weight at the lower end. The pendulum thus formed was set swinging just as the developer was poured over the plate, the dish being placed on the panel. The rocking then continued automatically by the swinging of the pendulum for several minutes, a second impulse being given perhaps half-way through the development.

Large Dishes

When I came to large dishes containing whole plates, however, I found that this simple apparatus did not work, the reason being that the very much greater quantity of developer in the dish—8 oz. to 10 oz.—flowed backwards and forwards in the dish with such force that it put a very powerful braking action on the pendulum. So great was this effect that the pendulum bob, which I had made as heavy as 8 lb., was brought to absolute rest in no more than four oscillations: the length of the pendulum was nearly 3 ft. The consequence was

Soldered to *e* is a crank arm of steel or thick brass, having a throw of $\frac{1}{8}$ in. Again soldered into this crank is the crank pin *g*¹, which should be shouldered down as shown, to take one end of the connecting rod. This rod, *g*, is exactly similar at both ends. It is made of wood having a saw cut at each end, into which cuts pieces of steel plate are fitted, drilled for two pins passing through both wood and steel and bound tightly around with strong thread. *A* is a cross-section through the crank, gear wheel *e* and panel *f*, and *B* is a front elevation.

Fig. 4 is a cross-section of the large gear wheel *d*, the panel *f* and the drum *d*¹. This drum is made from two cheeks cut from brass and a piece of brass tube $1\frac{1}{4}$ in. in diameter, having a length of $1\frac{1}{2}$ in. If no lathe is available, the simplest way to proceed will be to scribe circles on the brass plate, one for the outside diameter and an inner one for the diameter of the tube. Where the centre of the compass is placed, holes $\frac{1}{8}$ in. in diameter should be drilled to fit on the steel spindle, which it will be seen passes into the backboard *f*. The tube should be cut off square, placed exactly over the inner scribed circles on the cheeks, clamped between the cheeks and well sweated around the joint with solder. One of the cheeks is then drilled with about six $\frac{3}{32}$ -in. holes and riveted to similar holes drilled in the gear wheel. The spindle will need to be threaded at one end to take a $\frac{1}{8}$ -in. model-makers' nut, and at the inner

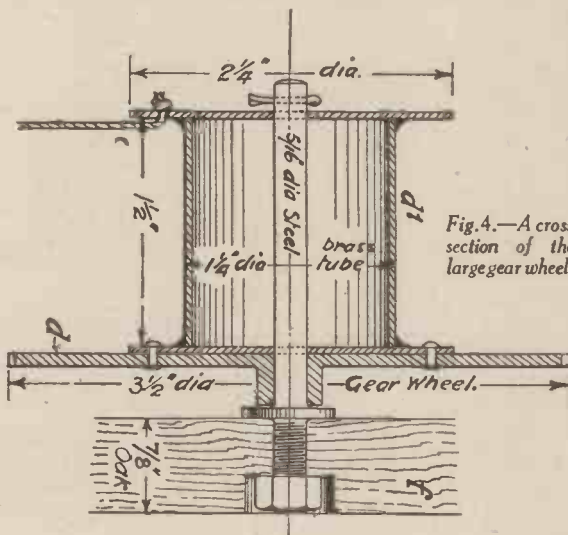

Fig. 4.—A cross section of the large gear wheel.

end of the thread, that is to say, at $\frac{7}{8}$ in. from the extreme end, a steel washer, which should be a tight fit on the spindle, is brazed. A cycle-maker or repair garage would doubtless do this little brazing job for those who have not their own workshop. At the opposite end of the spindle from the backboard a hole is drilled to receive a $\frac{1}{8}$ -in. split pin. To secure the end of the cord a hole may be drilled in the outer cheek: through this the cord is passed from the inside and a knot tied on the outside.

Re-winding the Cord over the Drum

As some objection may be raised to the necessity for reaching up to a height of 8 ft. in order to re-wind the cord over the drum, I show in Fig. 5 an alternative position for the gearing, which does away with the need for a connecting rod, but introduces a slotted arm projecting from the rocking panel. It also involves the fixing of a pulley, *g*, at a point 8 ft. or so above the floor.

This arrangement will be found very much more convenient for re-winding the cord, since it will be on a level with the developing bench. In this drawing I have shown the weight, *h*, fitted with a double purchase arrangement on the cord. A fixed point is provided, *i*, on the same level as pulley, *g*, and the weight, *h*, instead of having the cord directly attached to it, is fitted with a pulley *h*¹. This, of course, means that for every foot of fall of the weight, 2 ft. of cord will be unwound off the drum *d*¹. Consequently the whole apparatus will run at one winding for double the length of time. As a matter of fact, with a fall of 8 ft. the pendulum and dish will rock for nearly ten minutes.

THE STORY OF THE TYPEWRITER
(Continued from page 494)

On the other hand, some of the claims originally made for the machine are equally curious. The first catalogue issued by the Remington Company, after stating that "The Type-Writer in size and appearance somewhat resembles the Family Sewing Machine" (an apt description of the original model), goes on to say, with rather more questionable accuracy, "... It is graceful and ornamental—a beautiful piece of furniture for office, study or parlour..."; and the average cross-Channel traveller would certainly doubt the truth of the subsequent assertion that "Persons travelling by sea can write with it when writing by the pen is impossible."

Success at Last

More than ten years were destined to pass

Figs. 5 and 6 (left).—The slotted plate to be fixed in the rocking panel, and (right) An alternative position for the gearing.

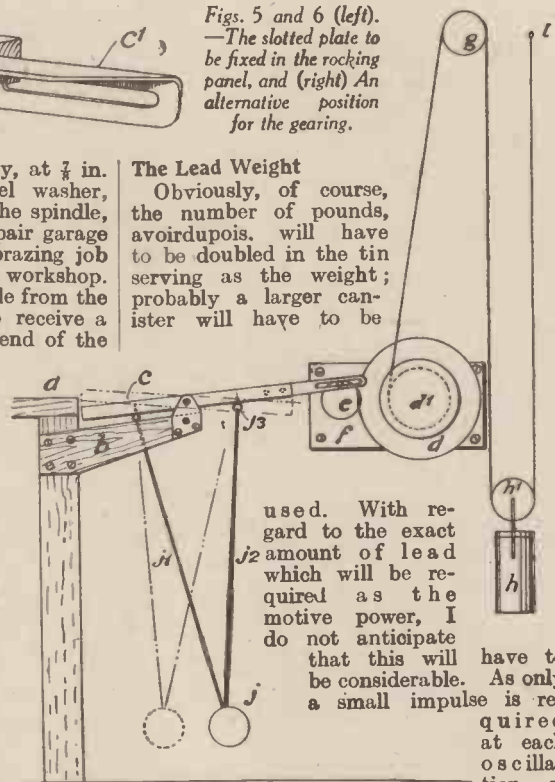

The Lead Weight

Obviously, of course, the number of pounds, avoirdupois, will have to be doubled in the tin serving as the weight; probably a larger canister will have to be

used. With regard to the exact amount of lead which will be required as the motive power, I do not anticipate that this will be considerable. As only a small impulse is required at each oscillation of

pendulum, I think probably 4 lb. or 5 lb. will do the necessary work.

The last sketch, Fig. 6, shows a suggestion for the slotted plate to be fixed in the rocking panel. *c* is the panel and *c*¹ the plate, which may be inserted into a saw-cut in the panel and secured with one or two screws passing through the wood and through holes drilled in the plate. In order to render the plate sufficiently stiff to resist accidental bending, and causing friction on the the crankpin, I suggest that it should be made in the form of an angle, as shown.

As it sometimes happens that prolonged development, with the dish moving symmetrically at every oscillation, will produce streaks or lines of unequal development in the negative, it is advisable, when using these automatic rockers, to place the dish slightly in a diagonal position on the panel. This will have the effect of breaking up the straight line movement of the liquid.

The fight to win recognition for the new machine was waged relentlessly, but public acceptance was stubborn in those early years and no fortunes were made in the typewriter business.

Many tales are told of the indignation which was felt by the recipients of their first typewritten communication. One gentleman from Kentucky returned the letter to its author with a curt note in the margin, "You don't need to print no letters for me. I kin read writing." Less blunt, but equally poignant, is the dignified reply of a District Agent to his banker which runs as follows:

"... I realise, Mr. Johns, that I do not possess the education which you have. However, until your last letter I have always been able to read the writing. I do not think it was necessary then, nor will it be in the future, to have your letters to me taken to the printers, and set up like a handbill. I will be able to read your writing, and am deeply chagrined to think that you thought such a course necessary. . . ."

before the tide began to turn and public conservatism began to appreciate the wonderful service which the writing machine alone could give. Since 1885, however, the progress and popularity of the typewriter have never looked back, and if countless other typewriters have been invented since that day only to bring ruin on their supporters, their failure must be attributed to lack of that perfection of development and to lack of well-established sales and service organisations which alone can secure and retain the confidence of a discriminating public.

There is surely a moral in this story of the invention of the first practical typewriter which should be learned by all would-be inventors of to-day. For the story shows that even an invention which is capable of bringing about a complete revolution in the business world must have years of patient development behind it. The germ of the idea is valueless without the most thorough practical development at the hands of experienced and expert designers.

TWO BASSETT-LOWKE WINNERS!

A line sketch of the fine working model Road Tractor described below.

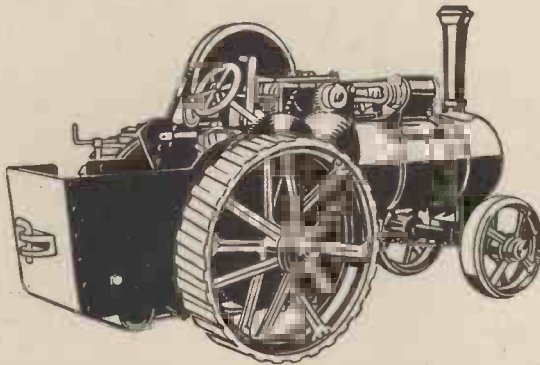

THIS Burrell type Traction Engine has the most complete set of castings, and is the most attractive model of its kind ever produced.

Complete castings and drawings cost 12 gns. A new booklet on how to build this magnificent model, written by Mr. Camm, our editor, price 3d., can now be obtained from all BASSETT-LOWKE branches. Send for it and decide to build this engineering masterpiece now!

Then comes "STREAMLINIA"—the sensation of the Motor Boat world, the smartest design yet in metre models, has done 10 knots, fast, reliable, easy to manipulate, and exquisitely finished. Complete sets of parts, or just hull and machinery supplied. Finished model costs 9 gns.

Section "B" 12, containing interesting particulars about Scale Model Engines, including the Traction, costs 6d. post free.

Section "S" 12 gives details of all manner of ships as well as "STREAMLINIA." Price 6d., post free.

BASSETT-LOWKE, LTD.
NORTHAMPTON LONDON: 112 HIGH HOLBORN, W.C.1
 MANCHESTER: 28 CORPORATION ST.

THE WORLD'S SMALLEST CAMERA



ACTUAL SIZE

Opens a new era in Amateur Photography. The Camera is so small it can be carried with ease in a Lady's hand-bag or in a Gentleman's waistcoat pocket.

Note these Details:

- Bakelite Case, measuring only 2½ in. × 1¼ in. × 1 in. Weight of Camera, 1¼ oz.
- Finished in rose, green, walnut, or black.
- Fitted with specially designed Meniscus F.10 lens. Definitely guaranteed to take perfect pictures capable of enlargement.
- Instantaneous Shutter working at 30 sec.
- Fitted with direct brilliant viewfinder.
- Roll films 6-exposure, retail price 6d. each.
- Silk-lined Morocco-grained leather Case, coloured to match Camera, 1/9 each.

A Camera—not a toy **5/6**
 From all high-class Photographers

NEW IDEAS!!!

NEW METHODS AND MATERIALS FOR EVERY HOME CRAFTSMAN



PUBLISHED 19th AUG.
250 PAGES OF VITAL INTEREST TO EVERY MAN WHO LIKES MAKING THINGS

Here is a book you simply cannot afford to miss! It contains a mass of valuable information dealing exhaustively with every branch of home handicrafts. Pages of Fittings, Materials and Ideas that mean the difference between success and failure. A colossal literary section includes three full-size designs for building models of an Elizabethan flagship, "The Conqueror," a modern luxury liner, "The Empress of Britain," and an aeroplane, the De Havilland Leopard Moth; a special feature by "Craftsman" on "Points You Should Know About Tools." The articles on "Wood Finishing" and "The Wood You Use" are of equal interest to all workers who value craftsmanship. A remarkable series on things to make and how to make them includes a Radiogram, Bench Cabinet, Bedstead, Music Stool, Record Cabinet and a Garden Workshop. In addition, there is a splendid variety of games that can be made quite easily by the amateur, including a Billiard Table and Shove Ha'penny Board.

1/-

You can get the Annual at any Newsagent, or at any Handicrafts Agent. Alternatively, we will send it direct for 1/- post free.

The Home Craftsman could not spend a shilling more profitably—
HANDICRAFTS 1936 ANNUAL

HANDICRAFTS LTD. (DEPT. P.M.), WEEDINGTON ROAD, KENTISH TOWN, LONDON, N.W.5.

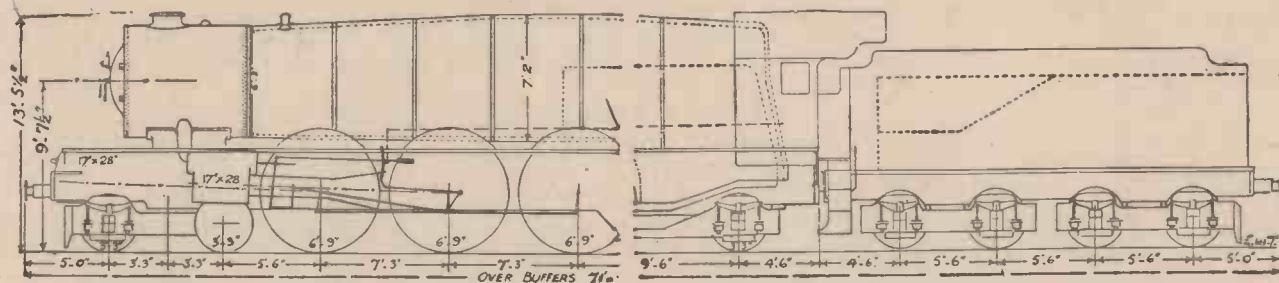

Fig. 1.—A suggested design for a locomotive, 4-6-2 type of maximum size for the British loading gauge.

MODEL RAILWAY CONSTRUCTION FOR BEGINNERS

It is not only interesting, but extremely instructive to everyone connected with either model or full-size railways to design and build a miniature engine which shall be larger by scale than any existing British locomotive: that is to say, build an engine which shall be of the maximum possible size to fit into the British loading gauge. Of course, we know that at the present time some of the largest locomotives running already nearly fill the loading gauge; nevertheless, there is still much which the model maker can do in this direction. For instance, Fig. 1 indicates such a possible design. The other direction which free-lance design may take gives even more scope for originality on the part of the builder, and unlimited freedom. He is unrestricted by gauge of track and loading figure, and the only thing which may limit its size and proportion is consideration for the curves in the track on which the engine is to run. Such untrammelled freedom is most exhilarating when one comes to set out a design on paper, for one can do just what is felt to be required to make the locomotive as efficient a machine as possible. Bearings, pins, bushes, and all working parts can be as large as they should be; fire-grate area and heating surface can be large; fuelling arrangements can be perfected, and natural draught through the fire maintained. Lubricators can be large and, therefore, efficient, and generally an engine so produced will be useful and stand up to hard work.

The Haulage Capacity

Turning to the haulage capacity of models, it may be said with truth that the results which are constantly being achieved are really wonderful. When one considers the size of boilers and cylinders, the fact that it is possible

Below are Given Useful Hints on Model Railway Design and Construction Which Will be Found Extremely Helpful to Those Readers Desirous of Taking up this Fascinating Hobby

for a 1 1/2-in. gauge engine to pull a fully grown man is remarkable. Of course,

the working parts have been given increased dimensions. A scale model, even as small as this, would soon require to go into the shop for repairs, whilst a 1/2-in. to the foot or smaller locomotive would soon knock itself to pieces. As a matter of fact, the smallest gauge which can be comfortably ridden upon is 1 in. to the foot, i.e., 4 1/2-in. gauge. An engine of this size, liberally designed as regards rods and pins, etc., will easily pull two or three people.

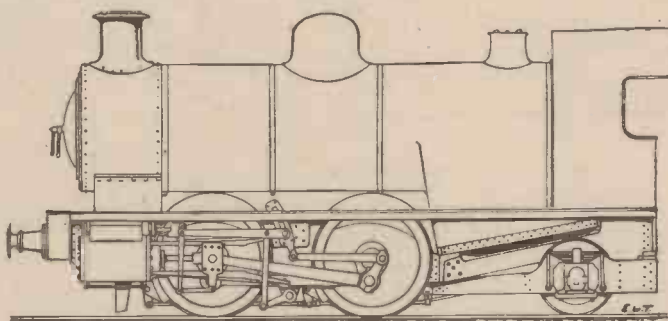

Fig. 2.—A model with a simple wheel arrangement.

Types of Locomotives

A word or two may be said about the types of locomotives, that is to say, wheel arrangement, most suitable for modelling. If it be a prototype, of course, there is nothing more to say, but in free-lance design it is not by any means necessary to build with six-, eight- or ten-coupled wheels. Consideration for axle loading in relation to the track does not apply as in full-size practice, and given a certain weight in the locomotive, just as much adhesion can be obtained by putting that weight upon four-coupled wheels as it can on eight or ten. If, therefore, an original and unrestricted design is contemplated it is best to make the wheel arrangement as simple as possible, as, for example, the heavy powerful model shown in Fig. 2. This does not, of course, mean that many carrying wheels are permissible, that is to say, it would not do to compare a 4-4-4 type, i.e., four-coupled with a bogie at each end, with a 2-10-0 (see Fig. 3, A and B), for obviously the adhesion with the latter would be greater than with the former, but if idle wheels are eliminated, as in Fig. 3, C, or reduced to a very minimum, then all the weight can be placed upon the power-driven wheels, and so the adhesion would be the same whatever the number of such wheels.

this may perhaps be described as a freak performance, even though the engine is capable of doing it repeatedly, and at any time it may be called upon, but it is obvious that the model is being overworked. For hauling a passenger nothing smaller than about 3 1/4-in. gauge should be used, roughly 1/2 in. to the foot scale, and only then if all

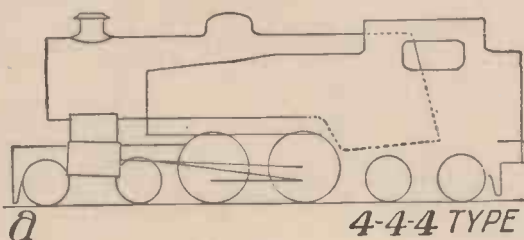
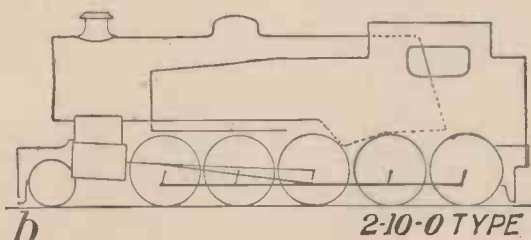
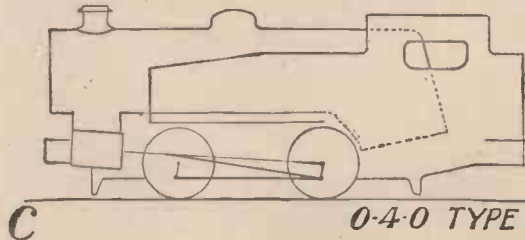

Fig. 3.—Various wheel arrangements for model locomotives.



B 2-10-0 TYPE



C 0-4-0 TYPE

Weight in a model is no disadvantage—quite the reverse—and, fortunately, it is possible to make model locomotives heavier in proportion to their size than their full-scale prototypes. Such models as the No. 1 gauge engine previously referred to, when they are called upon to haul exceptional loads, have to be specially weighted in order to secure the necessary grip of the wheels upon the rail. It will be seen, therefore, that when constructing a model one does not need to pare down the weight when designing and making all the parts.

Reducing Friction

Friction, however, should always be reduced to the least possible amount, and this, not by making all parts of the motion and gear loose fitting, but by very careful and accurate alignment and fitting. The most common source of friction with the average model is in the packing of the pistons and piston and valve rod stuffing boxes. At these points, of course, there must be some compression of the packing in order to ensure steam-tight joints, but

here again accuracy of workmanship comes in. If the pistons and rods and the cylinders and their covers are not dead true and concentric the builder frequently tries to put the trouble right by forcing in an undue amount of packing in order to secure steam tightness. The consequence is that a tremendous amount of power is lost through the friction set up. The writer once heard it argued by a model locomotive man, who should have known better, that piston and rod packing ought to be so tight that when the engine is pushed by hand along the track the wheels will not revolve. This argument was applied to engines whose cylinders were considerably under the scale in the matter of bore. Such a contention is of course, ridiculous. When the engine is cold, the regulator open, and blow-off cocks on the cylinders open, the wheels should revolve quite freely when turned by hand, and yet they should be perfectly tight when the engine is under steam. It is not, of

Fig. 6.—An ordinary loco-type boiler fired by a Primus burner.

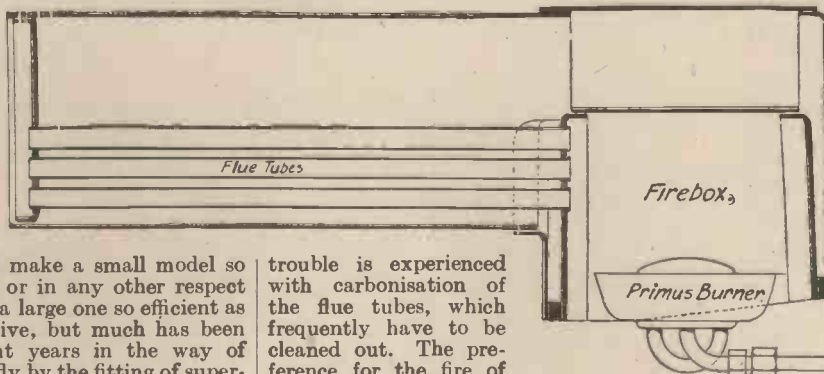

course, possible to make a small model so efficient thermally or in any other respect as a large one, nor a large one so efficient as a full-size locomotive, but much has been done during recent years in the way of improvement, chiefly by the fitting of super-

heaters in the steam pipe line to the cylinders. The writer believes that he was the first, some eighteen years ago, to advocate and show in drawings (of a nondescript "Pacific" type engine flue), tube superheaters, special large diameter flue tubes being provided to accommodate them. They have been adopted frequently since. Then again the introduction of a wide fire-box burning solid fuel has made a marked improvement also in the steaming of models.

Boiler Types and Fuelling

The old water tube type boiler, invented

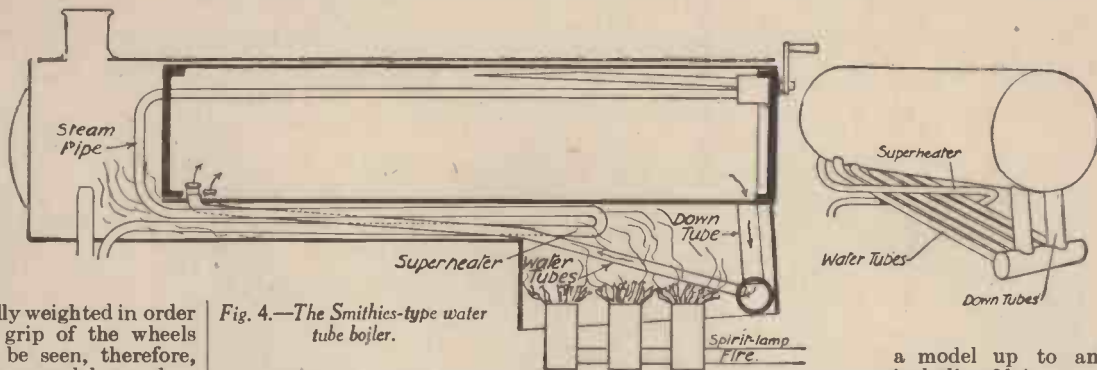

Fig. 4.—The Smithies-type water tube boiler.

is paraffin oil consumed in burners of the Primus stove type, arranged as in Fig. 6. Burners of this kind are fixed at the bottom of the fire-box in place of the usual bars, and fed with oil from the pressure tank in the tender, or, in the case of a tank engine, in what is normally the coal bunker.

A Glossary of Locomotive Terms

In connection with models, one frequently hears, or reads, expressions or terms which to the novice call for definition or explanation, and it is often not easy to turn to a book of reference which, short of being a complete glossary, will readily give the

meaning of the word sought for, so it is thought that such a glossary, even though a brief one, may be of use here. A few technical terms which are likely to crop up in conversation about locomotive models will be found as follows, the words being arranged in alphabetical order:—

Admission.—This refers to the timing and manner in which the steam enters the cylinders through the ports, which are uncovered by the slide valve. The point of admission is usually expressed as a percentage of the exhaust stroke, and is the point in the stroke at which the valve commences to open the port. The period of admission is that during which the valve, whilst it is travelling, allows the port to remain open; that is to say, the period between the initial opening and the final closing of the port. Admission is sometimes inside and sometimes outside the valve. (See Slide Valve.) (To be continued.)

Fig. 5.—A coal-fired boiler.

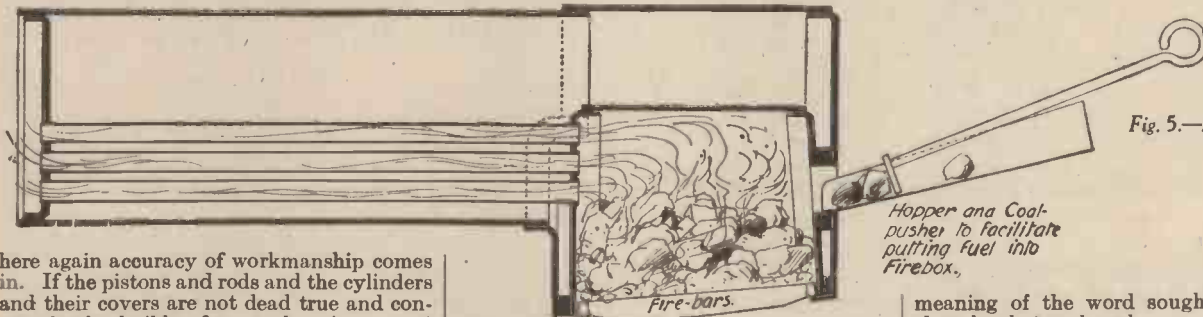

by Smithies nearly thirty years ago, is still going strong, though it is only suitable for small-scale engines. The arrangement of it is shown in Fig. 4. In this, superheating can be made extremely efficient, since the steam pipe can be made to pass through the flames of the fire if desired. The fuel burned in boilers of this type is chiefly methylated spirit, which, although it serves its purpose well enough in a way for simple models, is more messy and not nearly so efficient as vaporised oil burned in properly designed and constructed burners. For engines of 3/4-in. scale and upwards, that is to say, models which are large enough to ride behind, solid fuel burned in a correct type fire-box having a complete water jacket is by far the best (see Fig. 5), although unless a clear, hot fire is constantly maintained,

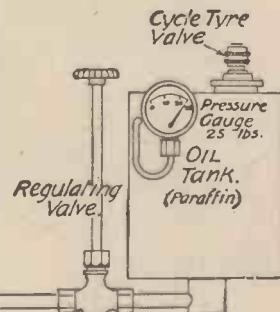

NO OPTION

"Practical Mechanics" maintains its original policy of *solus* specification to ensure successful reproduction of its designs.

Where perfect contact is essential, there is no option but to specify "Clix," and Mr. F. J. Camm in his Two-Valve Short-Wave Superhet uses "Clix" Terminal Strips, "Master" Wander Plugs, Spade Terminals and Standard Chassis Mounting Valveholders.

- Terminal Strips. A.E. and L.S., 6d. each.
- Wander Plugs. H.T. and G.B., 1½d. each.
- Spade Terminals. Large 2d., Small 1½d.
- Standard Valveholders. 4-pin 8d., 5-pin 9d., 7-pin 1/-.

Write for Illustrated Folder, "P.M."

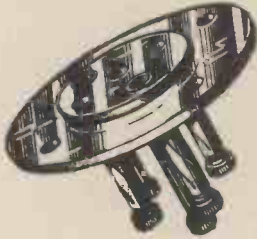

STAND
No. 115
OLYMPIA

CLIX
LECTRO LINX LTD.
79a ROCHESTER ROW
LONDON S.W.1

7-POINT ANCHORAGE

Microphonic noises can invariably be traced to an incorrect method of filament mounting. In the HIVAC Type D.210 (special Detector) the filament is anchored at seven points, and supported from above by a hairpin spring. This complete immunity from extraneous noises is one of many outstanding features responsible for their high efficiency and the preference which designers show for Hivac.

Mr. F. J. Camm chooses
HIVAC

for the
"PRACTICAL MECHANICS"
"TINY" PORTABLE THREE

Ask your Dealer for Hivac.
D.210, 3/9. L.210, 3/9. P.215, 4/9.

STAND
S.27
OLYMPIA

HIVAC
THE SCIENTIFIC
VALVE

HIGH VACUUM VALVE CO., LTD.
113-117 Farringdon Road, London, E.C.1

BRITISH
MADE

TRUSTWORTHY

All Amplion components and speakers are subjected to rigorous tests before they are distributed to the trade, thus ensuring that the public receive them in perfect condition for carrying out their functions in an entirely satisfactory manner.

CHOOSE "AMPLION"
as specified by
MR. F. J. CAMM
for the
"TINY"
PORTABLE THREE

- Amplion Fixed Condensers from 6d. each
- Amplion 1-watt Resistors. All values. 1/- each
- Amplion Cartridge Fuses. 60 m/a to 3 amp. 6d. each
- Amplion "Sonette" Speaker 5-in. Cone. Universal Transformer. 27/6

From all Dealers.

AMPLION

AMPLION (1932) LTD.

82-84, ROSOMAN ST., ROSEBERY AVE.,
LONDON, E.C.1



SPECIFIED for
"PRACTICAL
MECHANICS"
"TINY" PORTABLE
THREE

Amplion—Fixed Condensers—Wire-wound Resistances and the Amplion "Sonette" Speaker.



Television is the coming boom in wireless—it will bring even greater prosperity to the industry and create many more opportunities for a career. Men who foresaw the broadcasting boom made good—be trained and prepared for this television boom which must follow as surely as night follows day.

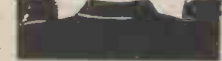

At the WIRELESS COLLEGE students receive training in all the latest developments in all branches of the Wireless profession. Marine, Aircraft, Manufacturing, Designing, Experimenting, Sales and Service, etc. College on sea front. Write for free prospectus.

STUDENTS ACCEPTED AS BOARDERS. TRAINING FEE CAN BE PAID AFTER APPOINTMENT SECURED
The WIRELESS COLLEGE COLWYN BAY N. WALES

The **STANLEY**
REG. TRADE MARK

VEST-POCKET MICROSCOPE

Three magnifications of 40, 50 and 60 instantly available.

17/6
Post Free

Soft Leather Case 1/6 extra.
Descriptive Leaflet P.255 upon application.

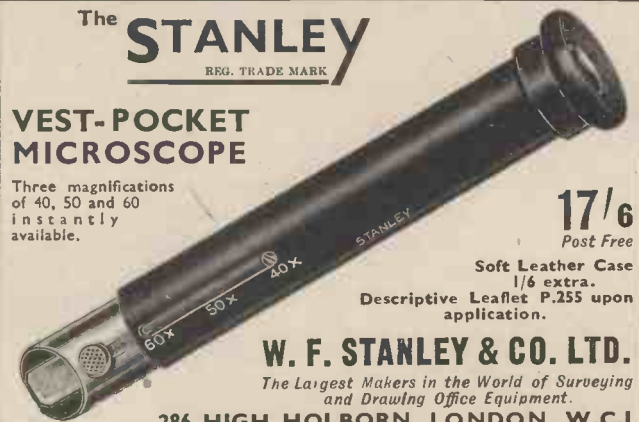

W. F. STANLEY & CO. LTD.

The Largest Makers in the World of Surveying and Drawing Office Equipment.

286 HIGH HOLBORN, LONDON, W.C.1

The PRACTICAL MECHANICS

WIRELESS EXPERIMENTER

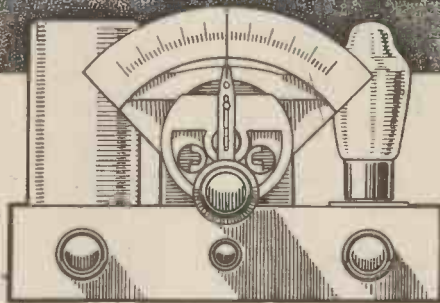

THE P.M. TINY PORTABLE THREE

An Easily Portable, Simply Constructed Three-valve Receiver of the Straight Type.

THE two-valve superhet described in the July number of PRACTICAL MECHANICS has proved to be a very popular design, but our correspondence indicates that there are hundreds of readers who favour the straight type of set. This is probably due to the simplicity of the latter; it is cheap to build and easily operated, and if used in conjunction with a moderately efficient aerial-earth system, this type of three-valve receiver can be relied upon to pick up a number of stations at good speaker strength in any part of the country. Straight receivers fall into two classes: one having a detector as first valve, followed by one or more L.F. stages, and the other employing one or more high-frequency amplifying stages preceding the detector. High-frequency amplifying stages are certainly useful when a large number of distant stations is desired, but their use tends to complicate the design, thus making the set more difficult to construct and to operate.

reaction condenser does not provide adequate control of volume, and therefore we decided to add an L.F. volume control. This control works very smoothly and obviates the possibility of overloading of the low-frequency amplifying valves. This component is of the modern type having a switch attached, and therefore a separate on-off switch is unnecessary—when it is desired

to switch off, the control knob is rotated to its off position. It will be seen that the second L.F. transformer is parallel fed. This method of connection prevents direct current from passing through the transformer primary, thus providing an improvement in bass response and also reducing the possibility of a transformer burn-out. The output valve is of the power type, and has been chosen in preference to a pentode, as the latter is likely to be overloaded when two L.F. stages are used. The maximum undistorted output of the power valve is high for this type of valve, however, and good-quality reproduction is obtained if the specified speaker is used.

The Layout

It will be seen that the components have been very neatly arranged on the baseboard, with the three valves in an easily accessible position, and the placing of the transformers at right angles to each other obviates the possibility of interaction between these two components. As the speaker is to be enclosed in the same cabinet as the set, it was not thought advisable to increase the size of the baseboard in order to accommodate loudspeaker sockets; it is only necessary to connect one of the speaker leads to the anode socket of the last valve holder, and the other lead to the HT+ socket of the battery. A flat baseboard assembly has been used in order to allow as much space as possible for the speaker and batteries. Good results may be obtained with a 60-volt H.T. battery, and if the receiver is to be used as a portable, this size of battery is recommended. When the set

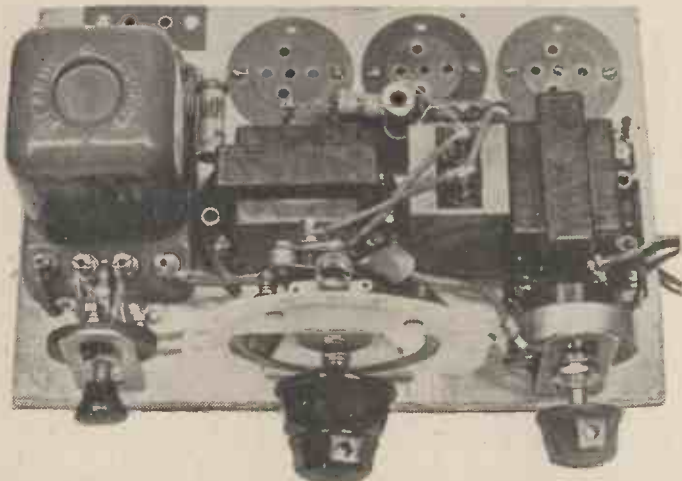

A plan view of the receiver with the valves removed. Cheap, neat, and efficient is an apt description of the P.M. Tiny Portable Three.

The Circuit Arrangement

To meet the demand for a simple, portable receiver, capable of picking up the local stations at good volume and having a sufficient margin of sensitivity for the reception of the more powerful foreign stations, we have decided, this month, to submit the design of an efficient straight three-valver, employing a detector and two transformer coupled low-frequency amplifying stages.

In the older receivers of this type, low-frequency instability was often experienced. By carefully designing the L.F. stages, however, this receiver is perfectly stable, even when fed from a run-down H.T. battery. A study of the theoretical circuit will reveal that the detector anode circuit is adequately decoupled, and as a step-up transformer couples the detector to the second valve, a high degree of amplification is attained in this stage. When tuned to the local station, it is often found that the

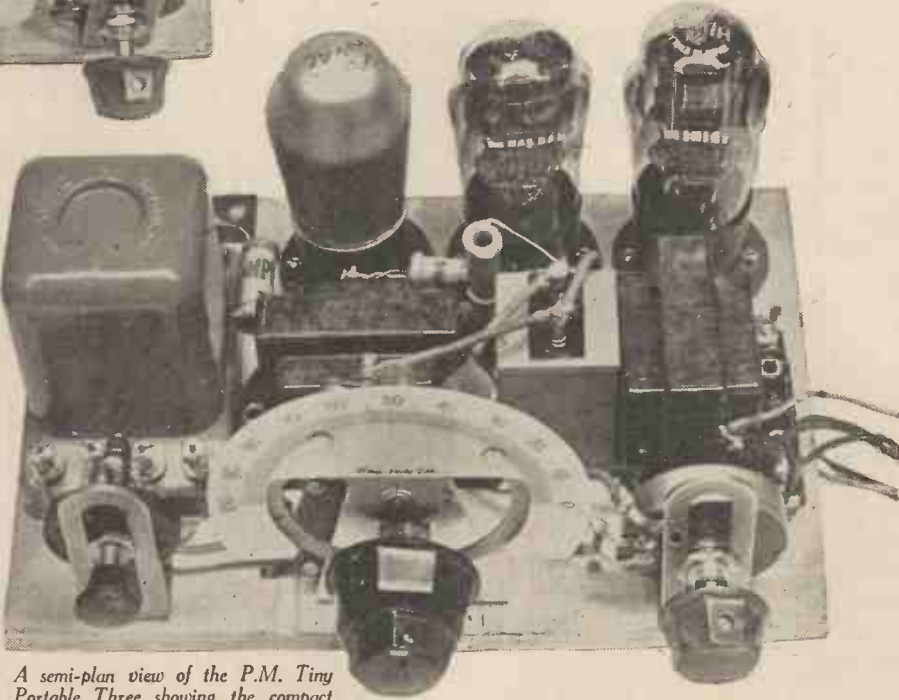

A semi-plan view of the P.M. Tiny Portable Three showing the compact layout of the components and the simplified knob arrangement which facilitates tuning.

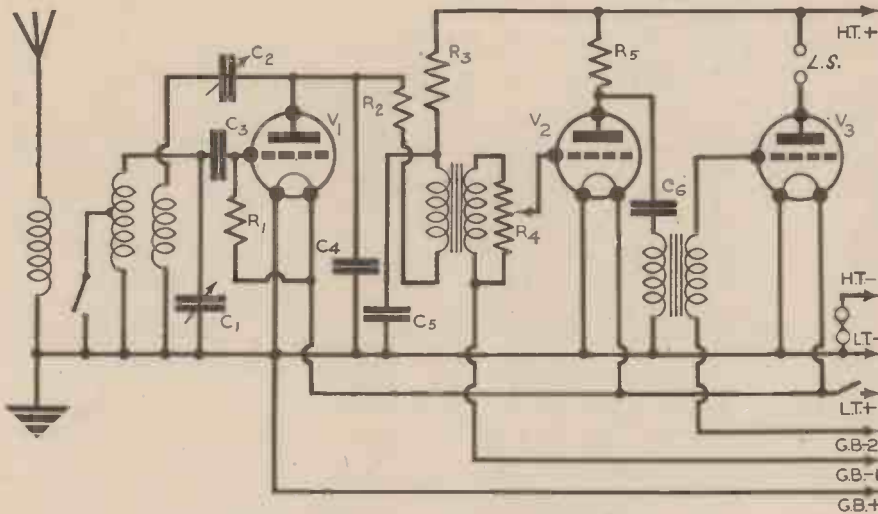

The circuit diagram of the P.M. Tiny Portable Three.

is to be used in the home, however, the voltage can be advantageously increased to 120 volts, if desired.

Construction

The constructional work is of a very simple nature, and therefore no difficulty should be experienced. It is advisable to drill the holes for the valve holders before commencing the mounting of the components, and for this purpose a 7/8-in. drill should be used. A 1/4-in. drill may be used for the A.E. strip, or a groove 1 in. long by 3/8 in. deep may be cut. As the wiring is easily accessible, the components may be mounted in any order. In some of our receivers instructions have been given to scrape the metallised coating from under component brackets, but as the moving arm of the potentiometer chosen for this set is not making contact with the spindle, the bracket may be screwed on to the metallised surface.

Wiring

It is advisable to commence the wiring at the aerial terminal, proceeding to the coil, wave-switch, tuning and reaction condensers, and thence to the L.F. transformers. Finally, the battery leads may be connected to their respective terminals and the fuse placed in position. This compon-

ent has been added in order to safeguard the valves, and although the receiver would function without it, the fuse is certainly a worthwhile addition to any receiver. It will be noted that there are a few soldered joints, but no difficulty should be experienced with these if a well-tinned iron is used and the wire is perfectly clean.

Adjusting and Operating

After the wiring has been completed and carefully checked, the battery and aerial-earth leads may be joined up and the valves placed in their respective sockets, the D210 being placed in the socket nearest to the coil, the L210 in the centre socket, and the P215 in the third socket. The H.T.+ plug should be inserted in the maximum voltage socket of the H.T. battery, and the H.T.- plug in the negative socket.

The L.T.- and L.T.+ spades should be joined to the 2-volt L.T. accumulator, and the G.B.+ lead to the - socket of the H.T. battery. The G.B.-1 and G.B.-2 plugs must be adjusted to suit the H.T. voltage used; if a voltage of 60 is employed,

(Continued on page 524)

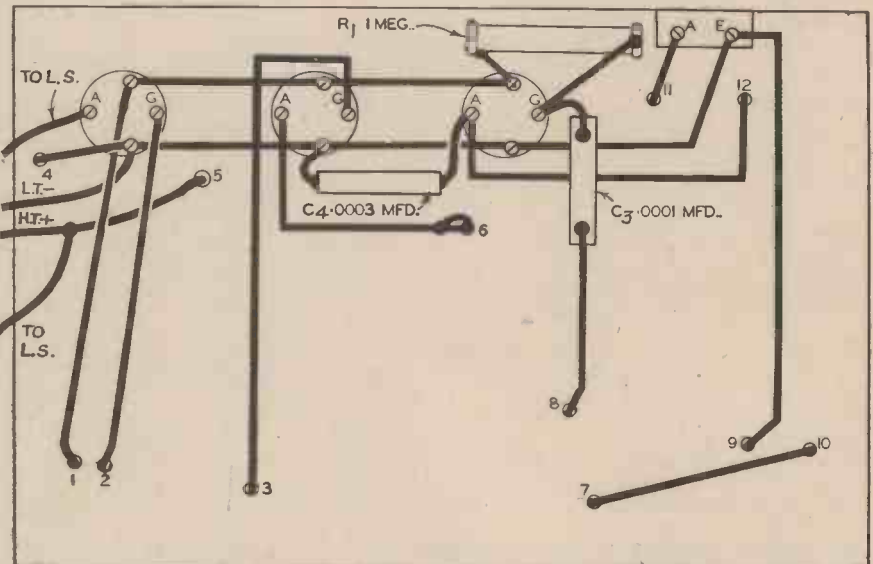
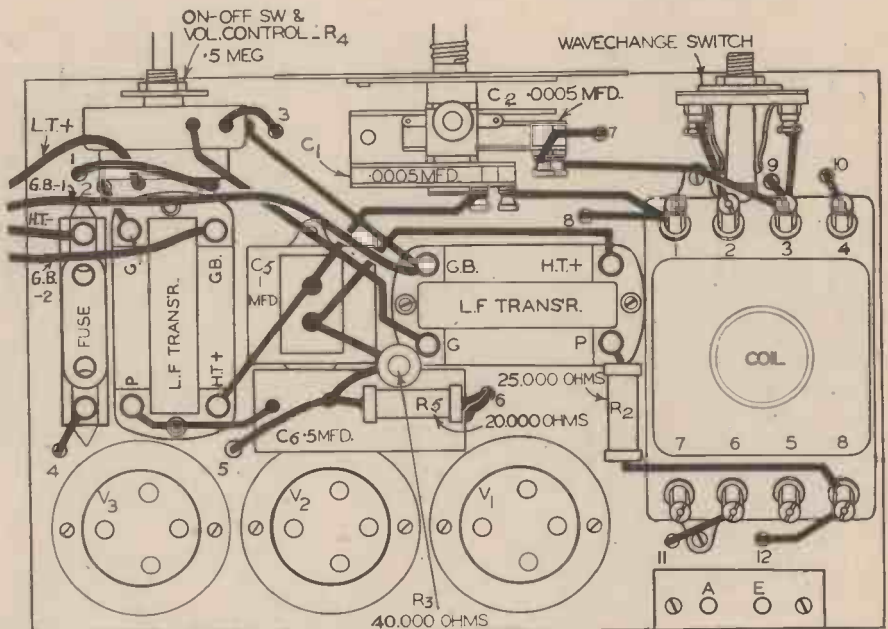

The top and underneath chassis wiring plan of the P.M. Tiny Portable Three.

The P.M. Tiny Portable Three

- One Universal Type "A" Coil (Wearite).
- One .0005 mfd. Dual Tuning and Reaction Condenser, C1, C2 (B.R.G.).
- Four Fixed Condensers: .0001 mfd., C3; .0003 mfd., C4; .5 mfd., C6; 1 mfd., C5 (Amplion).
- Four Fixed Resistances: 1 meg., R1; 40,000 ohms, R3; 25,000 ohms, R2; 20,000 ohms R5 (Amplion).
- One 500,000 ohms Potentiometer with Switch, R4 (Orion).
- Two 3/1 L.F. Transformers (B.T.S.).
- Two Component Brackets (Peto Scott).
- Three Four-pin Valve Holders (Clix).
- One Two-point Switch (Bulgin).
- One Terminal Strip, A.E. (Clix).
- Five Plugs: H.T. -, H.T. +, G.B. +, G.B. - 1, G.B. - 2. Two Spades L.T. -, L.T. + (Clix).
- One 60 m.a. Fuse (Microfuse).
- Metallised Chassis, 8 1/2 by 5 1/2 in. (Peto Scott).
- Three Valves: D210, L210, P215 (Hivac).
- Batteries.
- 120-volt H.T., 9-volt G.B., 2-volt Accumulator (Eride).
- Speaker: Amplion Sonette, 27s. 6d.
- One Portable Cabinet (Peto Scott).



STRENGTH WITHOUT STRAIN

Athletes, Tennis and Golf Enthusiasts, please note:

The Denman Thumb-Grip is the grip complete, catering for four fingers and thumb. Will increase the dimensions and strength of wrist, arms and neck to an extent that will astonish. No strain, no cumbersome apparatus. Mind concentration and nerve control improved. Ask your Dealer to supply, or from

DENMAN PRODUCTS LTD.
169 REGENT STREET, LONDON, W.1

PRICE PER PAIR
4/6

HOLIDAY & SPORTS BINOCULARS!!



Our Famous 8 x 25 Broa/Clar Binocular, complete in Case, offered at Special Bargain Price, 5/6 post free.

8 x 30 Broa/Clar De Luxe, 7/5/- post free.

8 x 25 [Prismatic Pocket Telescope, with Sling Carrying Case, 3/5/- post free.]

5 x Army Model Sports Glass, 2/5/- post free.
5 x Army & Navy " " 2/7/6 " "

Lists of Telescopes, Microscopes, Binoculars, Etc., Free on Request.



BROADHURST CLARKSON & CO. TELESCOPE HOUSE
63 FARRINGDON ROAD, LONDON, E.C.1
ALL OPTICAL REPAIRS—BY CRAFTSMEN

A Screwdriver — a gimblet



and the **Beacon** 456 **CURTAIN RAIL**

Patent No. 311518

is ready to hang your curtains



perfectly. Any handyman can erect. Fits all shapes of windows—square bays, round and oval.

Most fittings **SOLID CHUNKS OF BRASS** and whole system is a thoroughly sound job. Stands hardest wear—woodwork would have to give way first.

IN FOUR QUALITIES.
Strong (Brass) ... 1/- ft.
Light (Brass) ... 9d. ft.
Steel (Rustproofed) ... 9d. ft.

White (Aluminium Alloy) ... 9d. ft.
Complete with all fittings.

From all ironmongers. If any difficulty write for nearest stockist's name. Beware imitations.

Any length cut to order

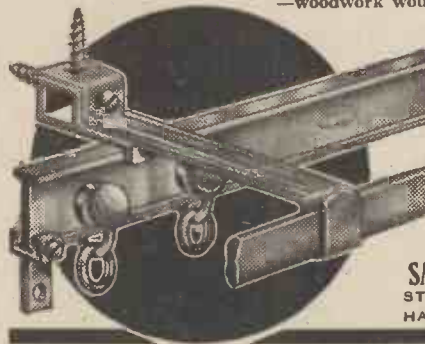

SMITH AND DAVIS LIMITED,
STAMPED BRASSFOUNDERS
HAMPTON ST. BIRMINGHAM

WHICH OF THESE IS YOUR PET SUBJECT?

CIVIL ENGINEERING GROUP

Specifications.
Road Engineering.
Hydraulics.
Municipal Engineering.
General Civil Engineering.

SURVEYING GROUP

Valuations.
Heating and Ventilating.
Clerk of Works.
Structural Design.
Structural Engineering.
Reinforced Concrete.
Sanitary Engineering.
Geology.

COMMERCIAL ENGINEERING GROUP

Salesmanship.
Advertising.
Languages.
Commercial Engineering.
Cost Accounts.

MECHANICAL ENGINEERING GROUP

Works Management.
Press Tool Work.
Maintenance Engineering.
Metallurgy.
Sheet Metal Work.
Welding.
Diesel Engines.
Refrigeration.

WIRELESS GROUP

General Wireless.
Advanced Wireless.
Television.
Talking-Picture Engineering.
Radio Servicing.

AUTOMOBILE ENGINEERING GROUP

Garage Management.
Electrical Equipment.
Claims Assessing.
High-speed Diesels.

ELECTRICAL ENGINEERING GROUP

Traction.
Electrical Supply.
Electrical Meters.
Electrical Design.
Installations.
Electrical Engineering.
Mains Engineering.
Telephony.
Alternating Currents.
Neon Lighting.
Power House Design.

AERONAUTICAL ENGINEERING GROUP

Aerial Navigation.
Aeroplane Design.
Aero Engines.

One of these examinations would multiply your earning power! **WHICH ONE?**

A.M.I.C.E.
A.M.I.Struct.E.
Sanitary Inspectors.
A.M.I.H. & V.E.
A.M.I.Mech.E.
A.M.I.P.E.
A.M.I.W.T.
A.Rad.A.
M.I.M.T.
A.F.R.Ae.S.
B.Sc.Degree.

G.P.O. Supt. of Traffic.
Patent Office Examiner.
Handicrafts Instructor.
Inspector of Factories.
Aircraft Apprentices.

Inst. Mun. & Cy. E.
M.R.San.I.
F.S.I.
A.R.I.B.A.
L.I.O.B.
F.A.I.

City & Guilds.
A.M.I.Fire.E.
A.M.I.E.E.
A.M.I.A.E.
A.M.I.Ae.E.

London Matriculation.
G.P.O. Prob. Inspector.
Air Navigators Certificate.
Ground Engineers Certificate.



May we send you full particulars of our unique tutorial organisation? Whatever your requirements, whether you desire a complete course of instruction, or tuition in some specialised subject, our Organisation is so planned that it will dovetail into your needs exactly.

As an indication of the strength of the B.I.E.T. Tutorial Organisation, it should be clearly noted that we alone guarantee to return full fees to any student who does not pass his chosen Examination successfully. In short, "If you do not pass, you do not pay."

Send to-day for a free copy of "ENGINEERING OPPORTUNITIES." This valuable 268-page Guide shows clearly and definitely the way in which you may carve out a successful career in your chosen branch of Engineering, irrespective of your age, education or experience. Among a host of other things, it gives details of all the above-mentioned Courses and shows the easiest way to prepare (in the privacy of your own home) for any of the recognised Examinations we have listed.

"ENGINEERING OPPORTUNITIES" should most certainly be in your hands. Send for your copy at once—free of cost or obligation.

BRITISH INSTITUTE of ENGINEERING TECHNOLOGY

410 SHAKESPEARE HOUSE, 29-31 OXFORD STREET, LONDON, W.1

Australasian Enquiries: P.O. Box 3597S, Sydney. South African Enquiries: P.O. Box 4701, Jo'burg. Canadian Enquiries: 219 Bay Street, Toronto. P.O. Box 1025, Bombay.

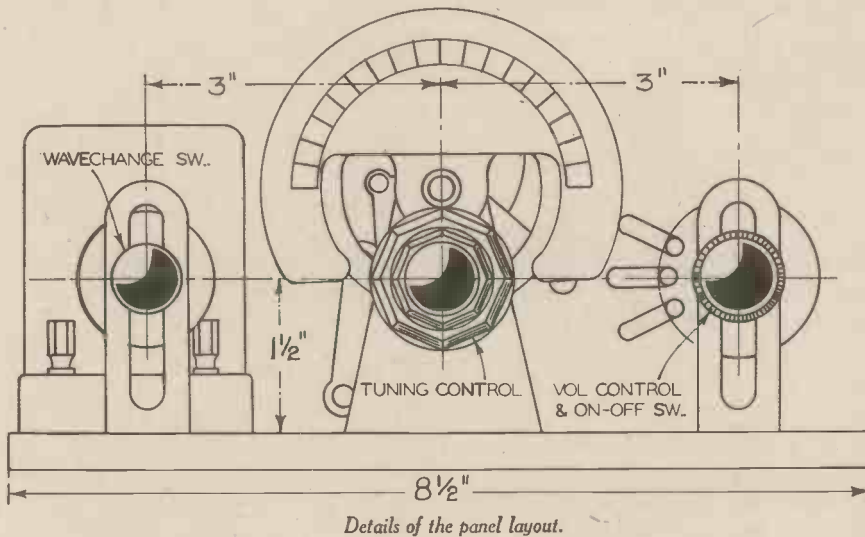

THE P.M. TINY PORTABLE THREE

(Continued from page 522)

G.B.—1 should be plugged into the $-1\frac{1}{2}$ socket and G.B.—2 into the -3 socket. As the H.T. voltage is increased, however, the G.B.—2 voltage must be increased, approximately—7½ volts being suitable for a 120-volt H.T. battery. It will be noted that a G.B. + plug has not been shown on the wiring diagram, as it is possible to obtain combined H.T.—G.B. batteries suitable for use in portable receivers. In these batteries the H.T.— socket acts as a G.B. + socket as well, and therefore a G.B. + lead is unnecessary. When separate H.T. and G.B. batteries are used with this receiver, it will therefore be necessary to connect the G.B. + socket of the G.B. battery to the $-$ socket of the H.T. battery. No trouble should be experienced in tuning the set, as only one tuning condenser is used, this being controlled by the larger of the two knobs of the centre control; the smaller knob of this control operates the reaction condenser and need only be used when distant station reception is desired. When medium-wave reception is desired, the knob on the left-hand side of the chassis (when viewed from

the front) should be pulled out, and volume is controlled by rotating the knob at the right of the chassis.

The Aerial-Earth System

If distant station reception is desired, an efficient aerial-earth system will be required for a three-valve receiver of this type, of course, but very satisfactory reception of stations situated within 100 miles of the receiver may be obtained with a short length of throw-out aerial in use. This aerial lead may be coiled inside the receiver when the latter is being carried about, and then when reception is desired, the lead

may be uncoiled and thrown across the room or over the branch of a tree. In these circumstances an earth lead is desirable, but by no means essential; if a permanent earth bolt is not easily available, the earth lead may be wound round a piece of metal, such as a large nail, and driven into the nearest earth point.

Using a Pick-up

This receiver is eminently suitable for gramophone reproduction, as a powerful L.F. amplifier is incorporated. Some pick-ups require a heavy input signal, whereas others are very sensitive and require a very low input voltage. As this set has two L.F. stages, however, it may be used in conjunction with practically any type of pick-up. If one of the very sensitive models is employed, it will only be necessary to use the last two valves, one of the pick-up leads being connected to the grid of the second valve and the other to the G.B.—1 lead. If an unsensitive pick-up is employed, however, it will be advisable to make use of the three valves. The two pick-up leads should then be connected to the grid of the first valve and the $-1\frac{1}{2}$ socket of the G.B. battery respectively.



"Building Construction," Part I, price 6/6, by Charles F. Mitchell, twelfth edition, revised by George A. Mitchell, F.R.I.B.A., M.I.Struct.E., A. E. Holbrow, A.R.I.B.A., M.I.Struct.E., and A. M. Mitchell, B.Sc. (Eng.), A.C.G.I., A.M.I.Struct.E., published by B. T. Batsford, Ltd., 15, North Audley Street, Mayfair, London. 464 pages, 1,173 figures, and 3 art plates.

THIS book, which is published in two parts, has long been recognised as a standard text-book for students of the subject, and the fact that it is widely used in technical schools and colleges is sufficient proof of the high esteem in which it is held. Part I, which we have recently received, is the Elementary Course and has just been revised and enlarged, so that it is entirely up-to-date and includes details of the newer methods of construction employed in the building industry. It is designed to meet the requirements of students entering for examinations of most of the recognised institutions, and treats the subject in a very thorough and lucid manner. The authors are all well-known authorities who have a full knowledge of their subject and who have wide experience in both the practical and theoretical sides of building work, as well as being lecturers to the well-known Regent Street Polytechnic.

The book covers the course by chapters on all subjects from Instruments and Materials to Building Quantities, and is well indexed and cross-referenced. There is also an Appendix comprising over 20 pages, in which are given 133 selected questions from various examination papers.

"Handicraft Woodwork," price 7/6, by A. L. Keeble, F.Col.H., published by Sir Isaac Pitman & Sons, Ltd., Parker Street, Kingsway, W.C.2. 224 pages, 275 illustrations.

WRITTEN particularly for the teacher of handicraft and for the student who proposes to sit for one of the many handicraft examinations, the book comprises a complete and interesting course. It is divided into four sections, which are: technical drawing, ornament, blackboard illustration, and practical work, and has a complete index which provides easy reference.

The treatment throughout is thorough, explanations are clear, and the illustrations well carried out. Each section is complete and fulfils its set objects in an excellent manner, without being too detailed. In every respect the book provides exactly the required material for the practising handicraft teacher who treats his subject in modern style, and for the student who wishes to qualify as a teacher by taking one of the examinations organised by The Board of Education, The City and Guilds of London Institute, and the College of Handicraft.

A STANDARD WORK

Newnes Encyclopædia of Popular Mechanics, by F. J. Camm. 5/- or 5/6 by post from Geo. Newnes Ltd., 8/11 Southampton Street, Strand, W.C.2.



A Review of the Latest Devices for the Amateur Mechanic. The address of the Makers of the Items mentioned can be had on application to the Editor. Please quote the number at the end of the paragraph.

A Hand Metal Punch

FOR punching clean holes in brass this strongly constructed hand punch will be found to be a useful accessory for the tool kit. It will punch brass and soft steel $\frac{3}{8}$ in. thick, and galvanised iron and other metals up to a thickness of 18 gauge. The ample throat clearance of $1\frac{1}{2}$ in. enables holes to be punched well in from the edge of the metal. The model illustrated is supplied with a $\frac{1}{4}$ -in. punch and costs 12s. post free. Extra punches

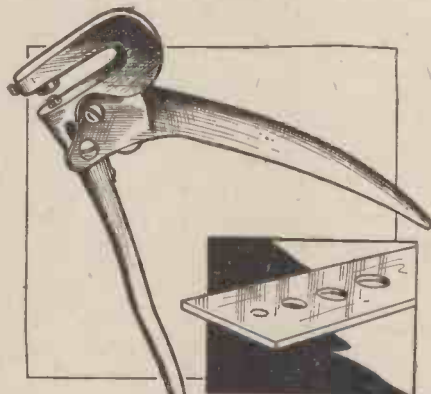

A hand metal punch for punching holes in brass, soft steel, galvanised iron and other metals up to a thickness of 18 gauge.

and dies ranging from $\frac{3}{8}$ to $\frac{1}{4}$ in. by $\frac{1}{2}$ in. are obtainable at 4s. per pair. [130.]

The "Eclipse" Direct Reading Saw Set

"ECLIPSE" hack-saw blades, due to their consistently high quality, and "Eclipse" frames owing to their distinctive designs and outstanding value have admittedly replaced to a great extent many lines which were formerly purchased from abroad. In a similar manner the latest "Eclipse" line, the No. 77 Direct Reading Saw Set compares more than favourably with the numerous foreign makes which have practically monopolised the market, and because of this, in addition to its inherent merit, it is certain to find favour with all users. This British Saw Set combines simplicity with accuracy and is ideal for either the amateur or professional woodworker. The direct reading anvil which is graduated from 4 to 12 points gives instantaneously the setting position to recommend for general work. One continuous movement of the handle grips the saw firmly and then ap-



Showing the shallow frame hack-saw which is ideal for work where limited space makes it impossible to use a standard hack-saw.

plies the setting tool to set the tooth. Springs actuating the return movement are of robust strength, being totally enclosed to ensure lasting and efficient service.

One important feature is that the tool is held in a natural position and the teeth of the saw are clearly visible during setting, whilst finger-tip adjustment is provided, entirely dispensing with the use of a screw-driver or any other tool. This "Eclipse" Saw Set, which retails at 6s. 6d. has a polished black oxidised finish—both attractive and durable. [131.]

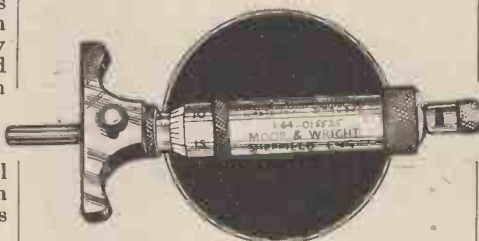

A depth gauge micrometer will prove a useful adjunct for the workshop.

A Shallow Frame Hack-Saw

NUMERABLE occasions arise in mechanical work where limited space rules out the use of a standard hack-saw, and it is at these times when the shallow framed model will be found to be the tool for the job. The sketch gives a good idea of its sturdy construction and the simple and rigid method of blade-tensioning which is employed. Two models are obtainable, one to take a 6-in. and the other an 8-in. blade, and the prices are 2s. and 3s. 2d. post free respectively. [132.]

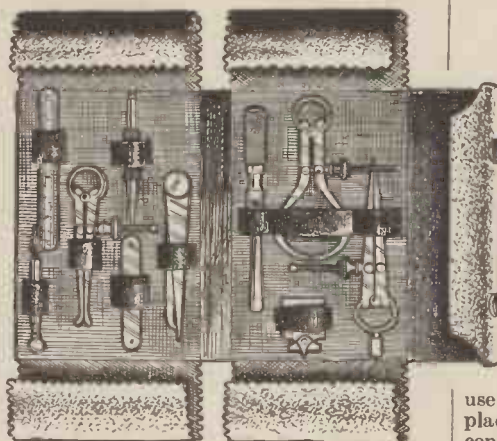

A neat and compact kit of tools which can be carried in the pocket.

A Serviceable Lathe

A LATHE which will prove ideal for the maker of small mechanical models, is now obtainable for a very moderate outlay. Known as the "Adept," it is soundly constructed, is thoroughly orthodox and there is nothing freakish about it. The mandril bearings are adjustable for wear, the mandril nose is threaded to take the catch plate, etc., and is bored taper to accommodate the centre, which is removable and renewable. The lathe is fitted with a fully compound slide rest, the slides of which are of the orthodox Vee type, having gibs and adjusting screws, and the tailstock has a sliding barrel which is clamped in position by a set screw. It will take work up to 6 in. in length between centres, is 6 lb. in weight, and has an overall length of $11\frac{1}{2}$ in. The lathe costs £1 with compound slide.

rest, and 12s. 6d. with hand rest instead of compound slide. [133.]

A Depth Gauge Micrometer

FOR really high-class precision work, this gauge will be found invaluable to the "Practical Mechanic."

It has a 1-in. movement of the screw and will measure grooves, holes and cavities with absolute accuracy.

Decimal equivalents, besides the normal readings are marked on the thimble. Of strong and rigid construction the tool is adjustable for wear and costs 30s. [134.]

A Pocket Tool Kit

ATTRACTIVE and conveniently housed in a folding leather case, this tool set should appeal to every true mechanic. It contains a 4-in. spring divider, 4-in. outside spring caliper, 4-in. inside spring, 4-in. fine joint jenny, tap-holder, centre punch, screw-cutting gauge, 8-bladed feeler gauge, 12-in. steel folding rule and a pocket scriber. The price is 25s. post free. [135.]

A Spacing Prick Punch

INCORPORATING two punches in one, this tool is extremely useful when absolute accuracy is required in marking out.

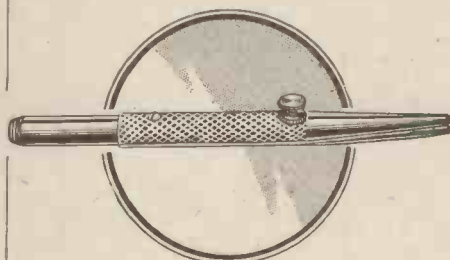

An adjustable two-in-one punch.

Having set the points at the required pitch, by means of the set screw, one blow of the hammer on the punch will make both markings on the work. This will be found especially useful where a series of equidistant centre punch marks is required. The price is 3s. 4d. post free. [136.]

A Bell Centre Punch

THIS punch enables one to mark the centre of a shaft or spindle quickly and accurately without the use of jenny calipers. The bell when placed over the end of the shaft, to be centre punched, automatically centres up the punch, which slides in the handle. They are made in three sizes: 1 in., $1\frac{1}{2}$ in., and 2 in., and are 2s., 2s. 6d., and 3s. 3d. post free respectively. [137.]

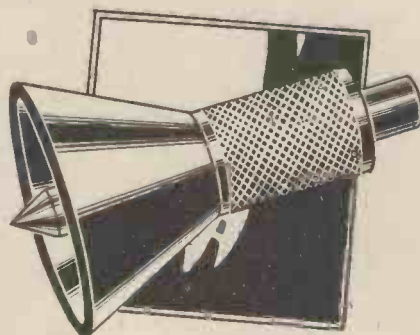

A bell centre punch.

BEST HOLIDAY READING



These special Holiday Annuals are produced to make your holiday brighter and better in every way. Hundreds of humorous drawings by the cleverest artists, and stories by the world's laughter-makers.

TIT-BITS SUMMER ANNUAL 1/-

A grand array of writers! Every one a laughter-maker, their very best work in "Tit-Bits Summer Annual"—Hylton Cleaver, K. R. G. Browne, F. Morton Howard, W. E. Richards, Peter Barton, etc., etc., and many humorous cartoons.

HAPPY HOLIDAY EXTRA 1/-

Packed from cover to cover with the best and cheeriest summer stories, the brightest holiday features—and the jolliest "illustrated-laughs." Writers include Evadne Price, Lawson Court, Lyddon Surrage, Owen Fox, Allen Hadley, etc.

NEWNES' HOLIDAY ANNUAL 1/-

Over 120 humorous drawings by Ridgewell, Bert Thomas, Wallis Mills, D. L. Chilchik, Treyer Evans, G. S. Sherwood, Bertram Prance, G. L. Stampa, A. E. Beard, Wilson Fenning, etc., and many summer stories and humorous articles.

**A HOLIDAY
REMINDER—
PACK ONE IN
YOUR BAG**

Obtainable from all news-
agents and bookstalls,
price 1/- each, or by
post 1/2 each from
George Newnes, Ltd.,
8-11, Southampton
Street, Strand,
London, W.C.2.

SMALL TOOLS AND CUTTERS—2

The First Article on this Subject Appeared in our June 1935 Issue.

BEFORE departing from the subject of Hollow-Mills, mention must be made of the more special forms for combined stripping and forming, and also a similar type of cutter that is used purely for ending or finishing.

The particular cutters now referred to are non-standard and therefore will require making to suit the job in hand. Reference to Fig. 1 will give an indication as to their sphere of application. From these shapes it will be gathered that in order to produce

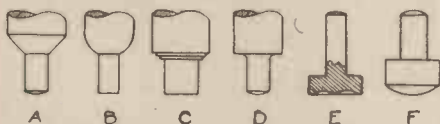

Fig. 1.—Non-standard cutters that have to be made to suit the particular job in hand.

the underhead profile as it were, it is necessary to form a corresponding female shape on the face of the cutter.

As a general rule, parts finishing with a



Fig. 2.—Hollow cutters require special treatment as regards backing off as will be seen from the sketch.

Fig. 3.—How ending cutters are treated in the matter of gashing.

square corner, as at *A*, *B*, and *C*, can be stripped down, and the underhead profile formed in one operation. Where a fillet is required, as at *D*, it is better to strip the shank down with a standard hollow-mill and then form the radius with a special one. This is necessary on account of the metal being cut, tending to "crowd" into the mouth of the cutter where the corners are radiused. Therefore an attempt to strip down the shank for any considerable distance with such a cutter would most likely result in seizure. Ending or head finishing as shown at *E* and *F* can also be carried out by means of this type of cutter.

The hollow cutters are gashed in the manner already described, but the backing off must follow the shape in the mouth of the cutter. It should be made clear that this method should not be employed for parts such as *C*, where the steps formed by the varying diameters adjacent to the shank are other than of a slight nature. These cutters require special treatment as regards backing off, and reference to Fig. 2 will make the matter clear.

Ending cutters require careful treatment in the matter of gashing, but here again, the necessary information can be better imparted by means of a sketch (see Fig. 3). When backing off such cutters, remember that it is easier to file the metal when soft, than to use a stone after hardening. Therefore, bring the cutting edges up sharp with suitable fine files, and merely use a stone after hardening to impart a high degree of finish to the edges. Careful attention to this finish is an all-important point, if subsequent polishing of the product to remove toolmarks is to be avoided.

Taps

Standard hand taps are readily obtain-

able in the general range of screw-thread systems in common use. Hand taps are put up in sets of three, taper or starting, second and finishing, or bottoming. The products of different tap manufacturers may vary as regards the style in which the taps are made. This is an important point which is not perhaps generally realised, and is therefore worthy of mention, on account of the bearing that it has on the tapping operation and also explains why size for size prices may vary.

The most familiar style is that in which the tap blanks are made identical as to diameter over the tops of the threads. The blank for the "taper" is reduced at the front to the core diameter of the thread, and a taper formed to wash out about half-way along the threaded portion. That for the

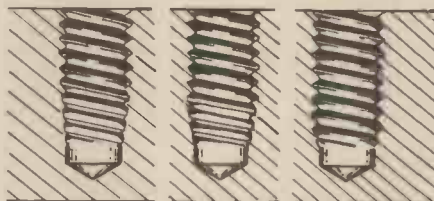

Fig. 4.—Three stages in tapping a blind hole.

"second" is treated in a similar manner, excepting that the taper is more abrupt,

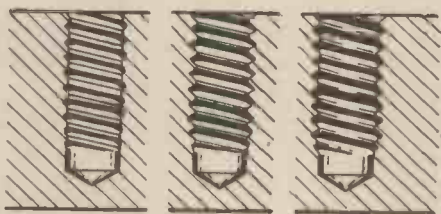

Fig. 5.—This style of tap is suitable for tapping deep holes in tough material.

washing out in three or four threads, the "plug" blank being merely chamfered. After being fluted, the taps are relieved on the tapered portions away from the direction of rotation. Fig. 4 shows the three stages in tapping a blind hole with such taps. From this, it will be seen that the thread is completed from the root diameter, outwards.

A Reversed Process

Another style of tap is that in which the process is reversed. This is accomplished by making the taps in each set with a different outside diameter, the taper being the



Fig. 6.—Certain makes of taper taps are made in the form shown.

smallest and the bottoming tap only correct to size. The successive stages of tapping are shown in Fig. 5. Such taps are, in addition, an indication as to nominal diameter and threads per inch, clearly marked by one, two, or three annular rings on the shank to denote the correct order of usage. Backing off is achieved as previously men-

tioned. While this style of tap is undoubtedly superior for tapping deep holes in tough material, it is, perhaps, not so suitable for amateurs as that first mentioned, as an ordinary taper tap will produce at once a full thread in a clear hole in steel up to a thickness equal to about $1\frac{1}{2}$ times the diameter of the tap.

Certain makes of taper taps are made in the form shown in Fig. 6. The diameter of the front portion is equal to the correct tapping size, and is unrelieved. It is obvious that the intention is to provide a pilot to maintain the axis of the tap in line with the drilled hole, and is a feature that saves considerable time in starting the tap square with the work.

The free-cutting properties of a tap are greatly enhanced by reducing the width of the land to a minimum. Unfortunately, such reduction, by increasing the width of the flutes, produces a weak tap. This objection may be overcome, to a certain extent, by relieving the taps of the threads, as shown in Fig. 7.

A satisfactory method of reducing the land without detracting from strength is to be found in the class of tap having relieved threads, that is, the threads are relieved at the root, crest, and flanks, as shown in Fig. 8. Such taps are naturally more costly than those of other types, and are not to be had in the smaller sizes.

Using Taps

More taps finish their career by breakage than by becoming "worn out." Thus it would appear, that in using taps, the main point to guard against is breakage. Most of the causes contributory to breakage are inconsistent with the practice necessary for the production of good tapped holes. Therefore, it follows that the avoidance of the causes of breakage enumerated will represent the correct method of usage in order to produce good work.

One of the most important points is to drill a tapping hole of the correct diameter,



Figs. 7 and 8.—(Left) Overcoming a weak tap by relieving the taps of the thread and (right) a tap with the threads relieved at the root, crest, and flanks.

while in softer materials and also for finer pitched threads it is necessary to have the tapping hole of such a size that a full thread will result. It is an advantage where there is a deep thread of coarse pitch, such as any of the larger sizes (above $\frac{1}{8}$ in.) in the Standard Whitworth range, to drill the tapping hole

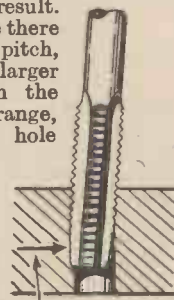

Fig. 9.—Showing the bending strain imposed on the tap when entered out of square.

bending strain

oversize. The amount permissible will naturally be dictated by the particular requirements of the work, but as a general rule can be anything that will allow at least two-thirds of a full thread being tapped.

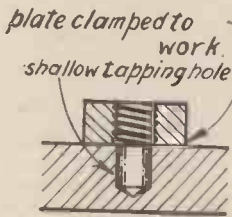

Fig. 10.—Where very shallow blind holes have to be tapped, the method shown here will prove satisfactory.

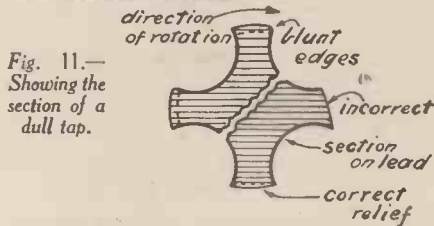

Fig. 11.—Showing the section of a dull tap.

Breakage frequently results from the failure to start the tap square with the hole. Fig. 9 shows the bending strain imposed on the tap when entered out of square. The use of a tap wrench providing unequal leverage will also tend to produce a similar result. While on the subject of wrenches, it should be mentioned that the leverage used must not be sufficient to lose the "feel" of the tap cutting.

In tapping deep blind holes, chips can cause a lot of trouble either by building up under the end of the tap, filling the flutes, or locking the tap. The latter condition is overcome by reversing the tap occasionally while feeding in. When tapping a blind hole in steel, a lot of work is left for the second and plug taps to do, unless the tapping hole can be drilled considerably deeper than the actual amount of thread required. Where this is not permissible, the thread is carried to depth by alternate use of the second and plug taps. Where very shallow blind holes have to be tapped, the method shown in Fig. 10 will be found useful.

Avoid, if possible, carrying the thread in a blind hole down until the end of the plug tap strikes the bottom, as this may chip the end, thus making the removal of the tap a difficult matter.

Although certain materials tap satisfactorily dry, always use a suitable lubricant for deep holes in all cases excepting for cast iron. This fact is most essential where steel is being employed. The use of blunt taps not only increases the physical effort required to drive the tap, but also increases the risk of breakage. Fig. 11 shows the section of a dull tap, and it is usually sufficient to grind these rounded edges of the flutes to restore the tap to an efficient working condition (see Fig. 12).

Where it is necessary to re-grind a taper or second tap on the tapered portion, see that the "backing off" is not overdone (as in Fig. 11), or the tap will merely act as a reamer or chatter badly.

Tapper Taps

A type of tap that is extremely handy where a number of small thin parts of a nut-like character have to be tapped is what is known as a machine-shank tap. Such taps are intended for use in nut-tapping machines and can be had in sizes down to No. 8 B.A.

The shanks of these taps are longer than those of the hand variety, the diameter being smaller than the core diameter of the thread. Such taps may be driven in a

lathe or drilling machine, the work being continuously fed on to the tap and passed over on to the shank. As soon as the shank is full of parts, the tap is removed from the machine and they are slid off. Ordinary hand taps may be converted by reducing the diameter of the shank.

Tap Making

It is often only by means of a special tap that a satisfactory repair job can be carried out, as, for instance, when a badly damaged thread in a part that cannot be mounted on the lathe has to be cleaned out, or, when for the purpose of a repair a thread is required in an existing odd-sized hole.

Without going into details regarding the turning of the tap blank, it is sufficient to say that the thread is carefully cut and finished to correct form with a suitable chaser. The design of the blank will depend upon the purpose for which it is intended, and also upon the means available for cutting the flutes. If the tap is required to merely clean out a thread, then the threaded portion needs only to be made very short. As regards material, in many instances mild steel, if subsequently case-hardened, is good enough. The first two or three threads are tapered down to the core diameter in the lathe. If the tap is a large one, the blank is turned with a reduced



Fig. 12.—Grinding the rounded edges of the flutes to restore the tap to an efficient working condition.

shank and the flutes roughed out by slotting in the lathe and finished off by hand with a round file to remove the burrs thrown up in the threads, the leads being backed off with a fine file, as in Fig. 13.

Reverting to the question of cutting the flutes, it is, of course, presumed that means for milling them are not available.

With smaller taps that are made from Silver Steel Rod, without prior turning, the flutes may be filed in, as in Fig. 14. It will be noticed that the flutes wash out gradually towards the shank, and while this is not an ideal form, the tap will be quite satisfactory excepting for prolonged service. In filing the flutes, emphasis is laid on the fact that the edges must be finished cleanly. A good plan is to first file a groove with a three-square file down what will be the centre of the flute to act as a guide for the round file.

An easier way of "fluting" small blanks is seen at Fig. 14, but taps made in this manner are only suitable for brass and similar material.

Although Silver Steel is suitable material for small tap-making, larger ones for work of any consequence should be made from a "non-shrink" class of tool steel. This is mentioned, as a tap made from ordinary

cast steel may shrink in hardening and cause serious pitch error.

Fig. 14.—With smaller taps, the flutes may be filed in as shown.

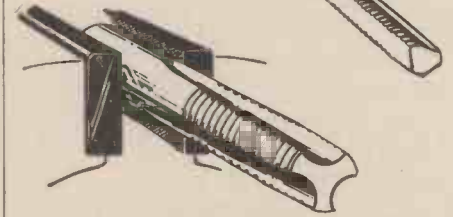

Fig. 13.—Hand taps may have the flutes filed.

Where a suitable wheel is available, the cutting edges of the flutes will be improved by grinding, but in any case they should be "stoned," together, with the relieved portion which does the actual cutting.

ITEMS OF INTEREST

Camera Bargains

A WELL-ILLUSTRATED 32-page catalogue, which will be appreciated by every home photographer, has recently been issued by the well-known firm of Messrs. Sands Hunter & Co., Ltd., 37, Bedford Street, Strand, W.C.2. They offer amazing bargains in new and second-hand roll-film and plate cameras, press cameras, ciné cameras, and photographic apparatus of every kind. Every item listed in their book has been thoroughly overhauled, and every customer is assured of a first-class piece of apparatus for his money. Any second-hand apparatus may be had on 7 days' approval, and orders may be sent through the post. Write at once to Messrs. Sands Hunter & Co., Ltd., at the above address, who will be only too pleased to send you their free catalogue by return.

The Denman Thumb-grip Developer

GRIP developers in the past have only aided in developing the four fingers, but the device shown on this page compels the user to grip not only with the four fingers, but, most important of all, the thumb as well. A glance at the illustration will show that unless the Denman Grip—as it is

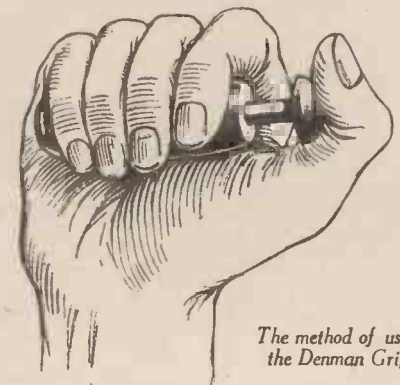

The method of using the Denman Grip.

called—is held tightly with the four fingers, the grip would be pushed out of the hand when pressure is applied to the thumb button. In this way a complete grip is assured and results are obtained in the development of the wrist, forearm, neck, and shoulder muscles. They cost 4s. 6d. a pair.

Glass Spinning

By Adapting the Rear Portion of a Bicycle as Described Below it is Quite Easy for the Amateur to make Glass Wool which can be Put to a Number of Artistic Uses

ALTHOUGH the art of glass spinning may, at first sight, appear very technical and extremely difficult, it is not so, and with a small initial outlay the amateur can equip himself with the necessary glass and apparatus, and be able to turn out glass wool, which can be put to a number of useful and artistic uses, at practically no cost whatever.

Glass can be worked easily because, when heated, it does not melt completely at a definite temperature, as ice does, but passes gradually through a viscous stage as sealing wax does, and the manipulation of the glass is carried on at that stage. Glass rod for the purpose of spinning can be obtained from any firm which supplies scientific apparatus. It is best to obtain 1 lb. of rod of about 8 mm. diameter, costing about 1s. 9d. per lb. Glass rod can also be obtained in various colours, and the resulting glass wool will be found to possess beautiful pastel shades.

The Apparatus Used

This consists of a Meker burner (16 mm. diameter, cost 4s. 6d.) and an old bicycle from the scrap heap. If the glass worker possesses a blow-pipe with a compressed air supply, this may be substituted for the Meker burner.

Only the rear wheel, a portion of the frame, and the drive of the bicycle are used. Carefully remove the nut which holds the saddle pillar, thus releasing the hind forks and top cross bar and with a hack-saw cut through the sloping member. Remove the brake, mudguard and stays, tyre but not the tape, and one pedal and crank. Cut away the treads of the other pedal and bind the centre with blind cord to form a handle C as shown. Obtain a suitable wooden baseboard—about 2 ft. 6 in. × 6 in. × 1 1/4 in.—and fasten the half-bicycle to it. Flatten the bar D at the end, bend it back for about 2 in. and drill a hole in it to take a wood screw or bolt. Bend the tops of the fork E outwards and the bolt holes, already at the end, will serve to take screws or bolts. In

the valve hole in the rim fix a cork, through which passes a piece of glass rod F. This is to affix the glass wool to at the beginning of the spinning operations which can now be commenced. Remember that glass rod requires heating gently at first or it will crack and fly back.

Spinning the Glass

Heat a piece of glass rod in the burner arranged on the bench, as shown, until it is thoroughly soft. Still keeping it in the flame, transfer it and the burner to F and heat the piece of rod which protrudes through the rim. When this is soft also,

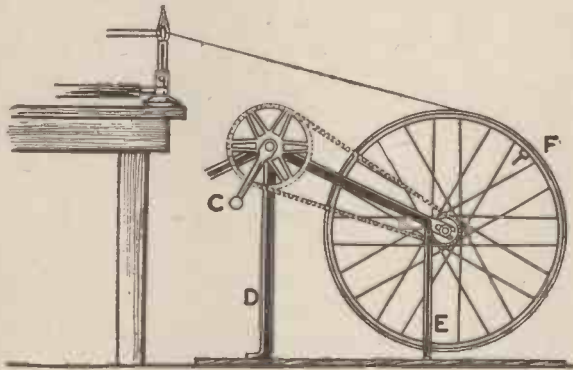

Showing how the apparatus is arranged for glass spinning.

press the first rod on to the second and withdraw the burner and first rod back to the original position, and begin to turn the wheel. The glass will be drawn off from the rod in a very fine thread and wrapped round and round the wheel. This operation can be continued until the whole of the rod has been drawn out. To remove the wool from the wheel make a cut through the whole mass of the wool with a penknife when it will come away easily.

A little practice is required to start the thread running and to find the right position to hold the rod in the flame, but once this knowledge has been acquired, it will be found that it is as easy to spin glass wool from a rod as it is to wind cotton on to a sewing machine bobbin.

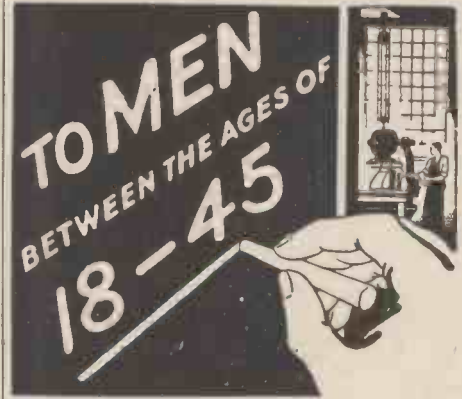

Things are happening to-day which vitally affect you!

If you are about 18, perhaps you are getting settled in your chosen work and already feeling the strain of competition for a better position. If you are in the 40's, your family responsibilities are near the peak, the necessity for money is tense—and younger men are challenging your job. And men of the ages between 18 and 45 face similar problems, in one form or another.

The most valuable employment security to-day is the security a man creates for himself—in himself! Through training, he is able to adapt himself to new conditions, to utilise experience without being handicapped by habit! He masters jobs and makes new jobs. He meets emergencies—and is not overwhelmed by them. And this is an age of emergencies.

For 44 years the International Correspondence Schools have helped thoughtful and ambitious men to acquire the training they need. To-day, with this need more urgent than ever, this world-famous institution offers greater opportunities than ever. Why not permit us to show you the way to greater security and larger earnings? Our expert advice is free. Write to-day.

...COUPON FOR FREE BOOKLET...

INTERNATIONAL CORRESPONDENCE SCHOOLS, LTD.

Dept. 95, International Buildings, Kingsway, London, W.C.2.

Please send me your booklet containing full particulars of the Course of Correspondence Training before which I have marked X. I assume no obligation.

- | | |
|---|--|
| <input type="checkbox"/> Accountancy | <input type="checkbox"/> Marine Engineering |
| <input type="checkbox"/> Advertising | <input type="checkbox"/> Mechanical Engineering |
| <input type="checkbox"/> Aeronautical Engineering | <input type="checkbox"/> Mining Engineering |
| <input type="checkbox"/> Architecture | <input type="checkbox"/> Motor Engineering |
| <input type="checkbox"/> Bookkeeping | <input type="checkbox"/> Plumbing |
| <input type="checkbox"/> Building | <input type="checkbox"/> Radio |
| <input type="checkbox"/> Chemical Engineering | <input type="checkbox"/> Railway Equipment and Running |
| <input type="checkbox"/> Civil Engineering | <input type="checkbox"/> Salesmanship |
| <input type="checkbox"/> Draughtsmanship | <input type="checkbox"/> Steam Engineering |
| <input type="checkbox"/> Electrical Engineering | <input type="checkbox"/> Textiles |
| <input type="checkbox"/> Engineering Design | <input type="checkbox"/> Woodworking |

Examinations, state which

The I.C.S. teach wherever the post reaches, and have a wide variety of courses of Study. If, therefore, your subject is not in the above list, write it here.

Name..... Age.....
Address.....

MODEL S.E.5A. COMPETITION RESULT

The judging of the above competition, announced on page 370 of our May issue, has been completed and the following readers have been awarded the prizes. Each model sent in by readers was constructed from a set of "Welcom" parts made by Messrs. Williams, Ellis & Co. The standard of workmanship was very high, and considerable difficulty was experienced in choosing the 1st, 2nd and 3rd prizewinners from the hundreds of models sent in. The probable prizewinners were finally sorted by a competent staff and they were then carefully examined by the Editor and Mr. Williams, who kindly consented to judge the competition. The following readers were successful.

- 1st Prize: £1 10s. A. W. NICHOLS, 15, Bessborough Street, Westminster, S.W.1.
2nd Prize: £1. C. F. COMPTON, Southleigh, Pilley, Lymington, Hants.

3rd Prize: 10s. W. BREWER, 18, Thompson Street, Higher Tranmere, Birkenhead.

Consolation prizes consisting of books were awarded to the following: J. S. Duthie, 64, Mortimer Street, Hospital Park, Dundee. A. J. Firth, St. Clair, Agincourt Road, Clacton-on-Sea. J. Davidson, 72, Cathedral Street, Glasgow, Scotland. B. Stringer, 24A, Charlemont Road, East Ham, E.6. H. T. Grayland, 74, Kingsley Road, Maidstone, Kent. S. Garland, 14, Manor Way, Barnehurst, Kent. Kenneth Lowe, 3, Halsey Avenue, West Derby, Liverpool, 12. C. W. Locke, 201, High Street, Acton, W.3. B. Stacke, Kidbrooke Cottage, Forest Row, Sussex. W. Hall, 2, Windsor Avenue, Lansdowne Street, Anlaby Road, Hull. Kenneth Spink, 23, Somerset Street, Hull, Yorks. H. W. Auger, 751, Lincoln Road, Peterborough.

Flying Ten-Million Miles

STATISTICS which have just been brought up-to-date show that fourteen of the veteran Air Captains of Imperial Airways have, amongst them, now spent just over 100,000 hours in the air, which represents approximately 10-million miles of flying.

Two of these aerial veterans, Captains Jones and Rogers, have each spent just over 10,000 hours in the air at the controls of aircraft of various types; while the log-books of Captains Wilcockson and Youell show that their figures are now approximately at the 10,000 hours' mark. The records of Captains Walters, Perry, Hersey, Dismore and Drew indicate each of these five airmen has now been in the air more than 8,000 hours; while the log-book of Captain Travers shows that his figures have now risen well over the 7,000 hours' mark.

Captains Alcock, Armstrong and Spafford have each spent between 6,000 and 7,000 hours in the air.

Among the remarkable flying records of some of these veteran airmen, a conspicuous place is taken by that of Captain Dismore. Gaining his certificate of proficiency as a pilot as far back as 1913 in a crude box-kite biplane, he has been flying constantly ever since. But whereas the first 'plane he flew was driven by a 50-h.p. engine, and carried only two people, to-day Captain Dismore sits at the controls of multi-engined air-liners developing more than 2,000 h.p. and carrying as many as 43 people—39 passengers and a crew of 4.

Another of these flying veterans, Captain

Youell, began work at a pioneer aviation school at the age of sixteen, and within a year was piloting one of the school aeroplanes.

Three others of these fourteen pilots, Captains Jones, Travers and Wilcockson, have all been flying aeroplanes for eighteen

years, the last-named having been one of the pilots of the official air-mail, carrying letters to our Army of Occupation on the Rhine, which preceded the establishment in 1919 of the first commercial London-Paris Air Service.

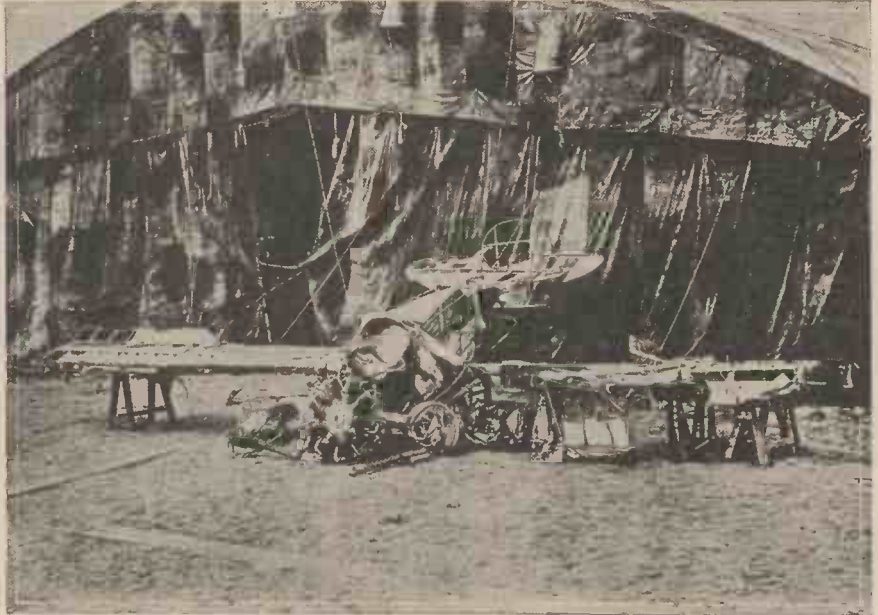

This picture, reproduced from one in the possession of Humber Ltd., shows the battered remains of the redoubtable Baron Von Richthofen's machine shot down at an air base in France during the war.

"GRAYSPEC"

THE ABSOLUTE IDEAL TWO-STROKE ENGINE FOR MINIATURE AIRCRAFT

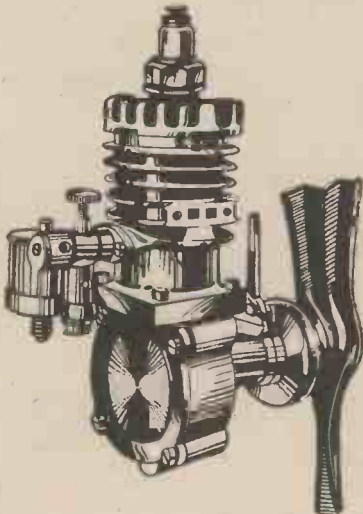

THE "GRAYSPEC" 15-c.c. ENGINE

P.E. BOOKLET POST FREE 3D.

These Engines have proved their air-worthiness on numerous flights.

15-c.c. Two Stroke.
1 1/8-in. Bore.
1-in. Stroke.
Complete as illustrated
£5 10s. 6d.

MARINE MODELS CAN ALSO BE SUPPLIED.

Sets of Castings in Aluminium Alloy, for Aero or Marine Engines, complete with full-size blue print,
12/6 post free.

Sets of Castings in Light Alloy, 18/6.

E. GRAY & SON, LTD.,

18 & 20 CLERKENWELL ROAD, LONDON, E.C.1.

Established 1822.

Telephone: Clerkenwell 0151.

'LINDBERG' FLYING SCALE MODELS

LEAD for ———
— FLYABILITY ———
— AUTHENTICITY ———
— and VALUE! ———



AND NOW you can obtain one of these kits for 1/6 post free.

Send now for any of these special 12-in. to 13-in. span kits:
S.E. 5, Fokker Triplane, U.S. Navy Racer, Boeing P-26 A, Curtiss 'Goshawk' Monocoupe, Fairchild 24.

Monocoupe Model D-145. 1/2-in. scale. Span 20 in. Length 13 1/2 in.; Weight 1 1/2 oz. Accurately reproduced in all details, with movable controls from cabin. Kit contains full-size drawing and instructions, printed out balsa wood, turned cowling and other ready-cut parts. Tissue, cement, dope, elastic and 2 propellers, etc., etc. Stability and speed give this model a fine performance.

Price (U.K.) 9/6 Post Free.

Send for your kit NOW, and enter our SPECIAL FREE SCALE MODEL CONTEST. Valuable Prizes.

NORTHERN MODEL AIRCRAFT CO., HIGH ST., MANCHESTER 4.

Designers and sole manufacturers of kits for 'CONDOR' High-Performance Duration-type Models, including 'OONQUEROR,' Wakefield International Cup Winner, 1933. Send 1/4d. stamp for list of all kits and supplies.

"PRACTICAL MECHANICS"

SCALE OF CHARGES FOR ADVERTISEMENTS

Whole Page	£20 0 0
Half Page	£10 0 0
Quarter Page	£5 0 0
Eighth Page	£2 10 0
Single Column	£6 13 4
"	15 0

For Classified Advertisements Rates—see page 536. Special Positions by arrangement

SERIES DISCOUNTS—A discount of 2 1/2% is allowed for definite orders of 6 insertions and 5% for 12 insertions completed within 12 months from the date of 1st insertion.

All communications to Advertisement Manager, GEORGE NEWNES, LTD., 8-11 Southampton Street, Strand, London, W.C.2

Phone: TEMPLE BAR 7760.

Telegrams: "ADVITOS," RAND, LONDON

HANGING CURTAINS

A Modern and Inexpensive Solution to an Old Problem.

ALTHOUGH at first sight hanging curtains may seem just one of those jobs that the average handy man about the house can do in an evening or Saturday afternoon, there is more in it than meets the eye. The hanging of curtains

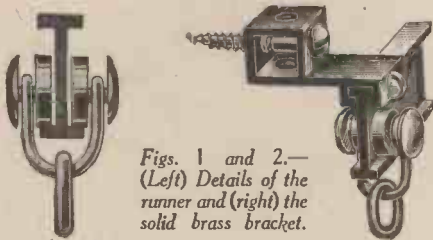

Figs. 1 and 2.—(Left) Details of the runner and (right) the solid brass bracket.

must be done right to ensure satisfactory results—proper “hang,” easy movement and freedom from sticking. There is only one correct way to hang curtains. This may seem a platitude, but at the same time there are so many methods of hanging curtains now offered readers that they are apt to become confused. The following notes will therefore prove useful. In the main, the fittings consist of an I-shaped curtain rail. The top bar of this is held by special brackets made for the purpose. The system we have under review has a heavy nickel-plated brass runner (Fig. 1) and a solid brass bracket as Fig. 2, which shows bracket, rail and runner. The runners run along the bottom track of the rail. The brackets are so made that they can be screwed either to the side of the window frame or beneath. One fitting thus serves for both purposes.

The Runners

The runners, as can be seen, consist of small wheels in solid brass, nickel plated, and shaped so as to easily thread on to the

rail—making for easy fitting in “awkward” places. Attached to these are loops to which the curtain is fitted. Fixing is simple—all that is needed is to measure the width of the window for the actual length of the rail. If an overlap of the curtains in the centre is required, from 6 in. to 9 in. should be added, and the rail then is divided in the centre so that when fitting there will be sufficient rail over to overlap. Brackets are supplied, one for every foot run of the rail, and for the overlap a double centre bracket can be had (see Fig. 4).

In the great majority of cases a valance is fixed as well as the ordinary curtain; for this a special bracket is needed which is fixed over the ordinary rail bracket, as in Fig. 3.

A stop must be fitted in every case to the ends of the runner rails to obviate the possibility of the whole curtain “running over”

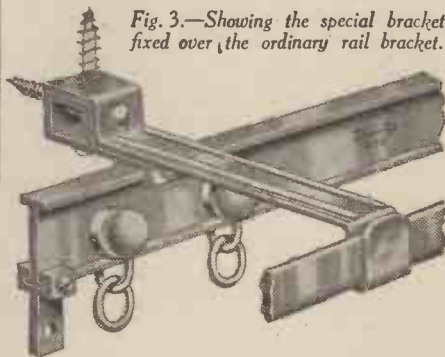

Fig. 3.—Showing the special bracket fixed over the ordinary rail bracket.

and being pulled off at the ends—these are shown in Figs. 3 and 4.

Its Advantages

The advantage of this trouble-free system to the handy man is that the curtain

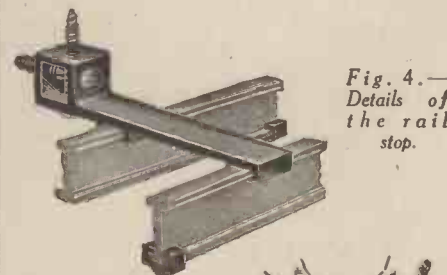

Fig. 4.—Details of the rail stop.

Fig. 5.—How the curtain rail can be bent into a bow shape to fit into a round bay window.

rail can be bent in the hands to any shape required. This gets over the trouble of peculiarly shaped windows outside the usual bow and bay shapes (see Fig. 5).

Readers who require further particulars of this excellent and efficient system should write to the Editorial Department of PRACTICAL MECHANICS.

There was a young fellow named Knight
Who believed in doing things right!
A perfect mechanic—
Who just didn't panic—
KNEW his job—and
RELIED on FLUXITE!



See that FLUXITE is always by you—in the house—garage—workshop—wherever speedy soldering is needed. Used for 30 years in government works and by leading engineers and manufacturers. Of Ironmongers—in tins, 4d., 8d., 1/4 and 2/8. Ask to see the FLUXITE SMALL-SPACE SOLDERING SET—compact but substantial—complete with full instructions, 7/6. Write for Free Book on the ART OF “SOFT” SOLDERING and ask for Leaflet on CASE-HARDENING STEEL and TEMPERING TOOLS with FLUXITE.

TO CYCLISTS! Your wheels will NOT keep round and true unless the spokes are tied with fine wire at the crossings AND SOLDERED. This makes a much stronger wheel. It's simple—with FLUXITE—but IMPORTANT.

THE FLUXITE GUN

is always ready to put Fluxite on the soldering job instantly. A little pressure places the right quantity on the right spot and one charging lasts for ages. Price 1/6.



ALL MECHANICS WILL HAVE

FLUXITE

IT SIMPLIFIES ALL SOLDERING

FLUXITE Ltd., Dept. P.M., Dragon Works, Bermondsey St., S.E.1

The New STUART CATALOGUE No. 3

describes in 72 profusely illustrated pages the full range of Stuart products—

Steam engines and boilers, pumps, petrol engines, fittings, screws, drills, materials, etc.

The Stuart centrifugal pump for fountain or waterfall.



The Pump: 20/-

Electrically driven: £4:7:6

Please send now for “Cat. No. 3.”

6d. Post Free.

STUART TURNER LTD.
HENLEY - ON - THAMES

By F. J. Camm
ACCUMULATORS
How to Get the Best Out of Your Car or Wireless Batteries—a Little Book that will Save You Pounds.

With 84 Diagrams and Sketches

Only 1/- net

From All Booksellers

A NEWNES HOME MECHANIC BOOK
Illustrated

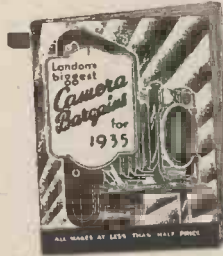

Free!

Write to-day for a copy of this 36-page catalogue of Camera Bargains for 1935. The finest selection of second-hand photographic apparatus ever offered. Cameras by all the well-known

makers at surprisingly low prices. All overhauled and in perfect working order.

SANDS HUNTER & CO. LTD.,
37 Bedford Street, Strand, London, W.C.2

BE TALL

Your Height increased in 14 days or money back. The amazing Stebbing System soon brings 3-5 inches increase and new energy. The first, original, and the one GENUINE GUARANTEED Height Increase System. Recommended by Health and Efficiency. Complete Course, 5/-, or Booklet free, privately.

STEBBING SYSTEM, Dept. M.P., 28 Dean Rd., London, N.W.1

DEFERRED TERMS ARRANGED

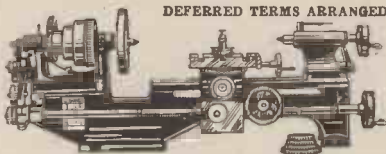

"IDEAL-LATHES" 3 in. S.C. LATHES from £4.
3½ in. S.C.B.G. from £7/18/6. LISTS, Stamp please.
J. WILLIMOTT & SON, Neville's Factory, Chilwell, Notts.

DON'T BE BULLIED



Learn to fear no man. The BEST self-defence ever invented, namely, **JUJITSU**. Easy to learn. Send 2 penny stamps for **SPLendid ILLUSTRATED LESSONS**, Photo ARTICLE, Testimonials and particulars, or P.O. 1/- for **FIRST PART** of my course. You will be more than delighted.
Dept. P., Blenheim House, Bedford Lane, Feltham, Middlesex.

MICROFU GOLD FILM FUSES

20 Stock Ratings.
Type F.2, suitable for Mains sets, 500 mA blows at 1 amp. resistance 1½ ohms 280 volts D.C. Now available 2 mA, 4/-, 1 mA, 4/6.
Type F.2, suitable for Battery sets. 150 mA blows at 300 mA resistance 7½ ohms voltage 260 volts D.C.
FUSES 6d. HOLDERS 6d.
Specified for the "TINY" PORTABLE THREE.
You need one 80 mA Type F.2 Microfuse.
MICROFUSES Ltd., 4, Charterhouse Bldgs., Goswell Rd., London, E.C.1. Phone: CLE 3040.



The DOSSETT Studio

GOOD IDEAS—
are often rejected because of unconvincing drawings!
Let us prepare attractive illustrations which will convey your idea quickly and clearly to Manufacturers, Editors, Agents, etc.
We specialise in Patent Office and Technical drawings of all descriptions.
Write or phone us at
HIGH HOLBORN HOUSE,
HIGH HOLBORN, W.C.1.
Hol. 8638.



The **LATEST** **Novelties**

The address of the makers of any device described below will be sent on application to the Editor, PRACTICAL MECHANICS 8-11, Southampton St., Strand, W.C.2. Quote number at end of paragraph.

A Combined Ciné Camera and Projector

WE show on this page the Midas Ciné camera and projector which is now obtainable at the very reasonable price of 60s. This camera combines in one compact instrument the camera for taking, and the projector for showing, the films. British made, the Midas possesses photographic and mechanical refinements found only in most expensive cameras. Fitted with a Taylor-Hobson f. 2.5 lens, it takes



A combined ciné camera and projector.

standard 9.5-mm. films. The camera is also fitted with a direct vision finder and a device for showing the length of film exposed. It is sold complete with a daylight charger and 30 ft. of film at the price mentioned above. [133.]

A Vest Pocket "Telescope"

INGENIOUS in inception and practical in use, these glasses enable one to perform the almost impossible feat of producing a telescope from the vest pocket. By holding the smaller lens to the eye and the larger one from 18 in. to arm's length away, as shown in the illustration, it is possible to obtain a magnification of from four to six times.

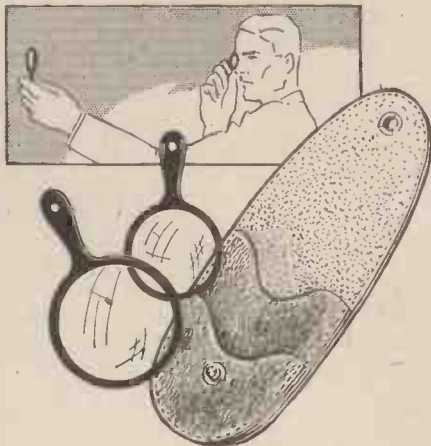

A vest pocket "telescope."

When not in use the "telescope" may be packed into the neat case, which is supplied, and slipped into the pocket. The price complete is 12s. 6d. post free. [134.]

A Flameless Cigarette Lighter

ALMOST uncanny in its action, the "Glolite" cigarette lighter, shown in the sketch on this page, has no "works" to go wrong and may be used in the strongest wind. All that is necessary is to place the lighter squarely against the end of the cigarette and draw long, slow puffs. The action of the lighter is based on the chemical phenomenon known as "catalysis," which is the process of producing a chemical reaction between two substances by means of a third, the catalyst, which itself remains unchanged. A few drops of a special



A flameless cigarette lighter.

fluid occasionally on the wick, in the base of the lighter, form the only "running cost." The cost of the lighter is 6s. 6d. post free. [135.]

Noise-free Wireless Reception

A DEVICE is now on the market which is applicable to any normal receiver and aerial and, when fitted, will reduce noise from most electrical appliances to something less than a whisper. Known as the "Goltone" Aerial Stataformer, it is used in conjunction with a shielded lead-in wire. It enables efficient reception on broadcasting wavelengths to be obtained, and in many instances, actually gives an increase of signal strength on the medium waveband as compared to a normal aerial system. It costs 4s. 6d. [136.]

Renovating Paintwork

COMPLETE and really useful is the Robbialac enamelling outfit. It contains everything required for the renovating of paintwork—tins of Robbialac gloss and transparent paints, rubbing felt, glass paper, pumice powder, cleaning soda and a special Robbialac brush. There is also included a book of full instructions on renovating and repainting. The enamels may be obtained in any colour, ranging in price from 15s. to 95s. per outfit. [137.]

AMERICA DIRECT on your PRESENT SET!



HEAR America, hear Short Wave stations in every corner of the World. Plug the B.T.S. Short Wave Adaptor into your present battery or A.C. mains Set and instantly convert it to an efficient all wave receiver . . . with no alterations to your set whatsoever. No other adaptor at the price incorporates all the B.T.S. features. Send to-day for fully descriptive booklet.

52/6 With 2 Plug-in Coils, 13-26 and 24-52 metres. Extra coils, 46-96 and 90-190 metres, 4/6 each. From all Dealers. If any difficulty send direct.

B.T.S. COMPONENTS

SPECIFIED for the

P.M. "TINY" PORTABLE 3

— Described in this Issue —

2 L.F. TRANSFORMERS 35:1 4/6 each
1-0005 REACTION CONDENSER 2/6

FROM ALL DEALERS. Or send direct. Ask for B.T.S. Short Wave and Television Lists.

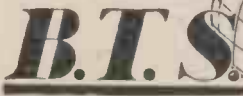

Short Wave and Television Specialists
BRITISH TELEVISION SUPPLIES, LTD.,
BUSH HOUSE, Dept. Pr. M., LONDON, W.O.2.
Telephone: Temple Bar 0134

WHY NOT!

Construct a Model Railway. Full electric control derived from 6-volt accumulator, will run a complete system. Our new list is now ready. Send 3d. for illustrated list and samples.

HAMBLING'S 26 CHARING CROSS RD., LONDON, W.C.2

Baker's SOLDERING FLUXES

Sold in 6d. and 1/- tins at all Cycle Accessory Dealers, Tool Shops, Ironmongers, etc.

Write for your free copy "Joining of Metals" to

SIR Wm BURNETT & CO (CHEMICALS) LTD
GREAT WEST ROAD, ISLEWORTH, MIDDLESEX
TELEPHONE: HOUSLOW 476

WHEN REPLYING TO ADVERTISERS PLEASE BE SURE TO MENTION "PRACTICAL MECHANICS."

A Midget Camera

NO bigger than a matchbox, this amazing little camera is capable of taking delightfully sharp photos. It is



A midget camera for the vest pocket.

fitted with a fixed focus lens giving accurate focus from 5 ft. to infinity. The shutter speed is one-thirtieth of a second and the aperture F.10. The six-exposure film is capable of being loaded or unloaded in daylight, and enlargements up to 2½ x 3½ in. may be obtained. The direct vision brilliant view-finder which is fitted makes sighting and "snapping" practically instantaneous. The price, 5s. 9d. post free, is extremely moderate, and a silk-lined leatherette case (in walnut, green, black or red) is supplied for 2s. [138.]

The "Read-eesi" Book Rest

READING at mealtime is made much more convenient and pleasurable by using the clip-on "Read-eesi" support

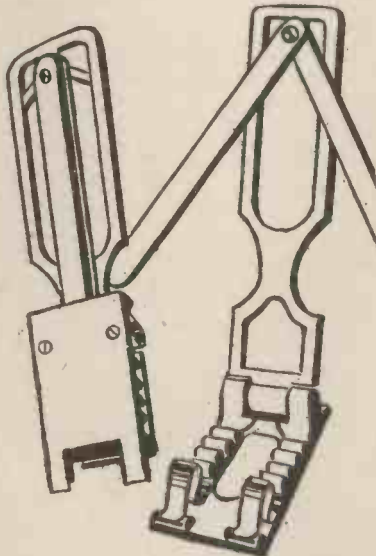

The "Read-eesi" book rest shown open on the right and closed on the left.

shown on this page. It is strongly made in well finished bakelite, is adaptable for any size paper, magazine or book, and clips on to any size of plate. The device folds up flat when not in use, and is so constructed that when fitted the paper or book cannot fall over. It costs 2s. 9d. post free. [139.]

The WEARITE UNIVERSAL COIL (Type "A") Specified for the TINY PORTABLE



Because of its ultra-efficiency this new coil is specified. Designed to cover 150-550 and 750-1,000 metres, it is equally suitable for H.F. Aerial or Band Pass Tuning. Whether you are building the TINY PORTABLE—or any other receiver—get the fully-illustrated Wearite catalogue first. Please use coupon.

Price Per Coil 5/-

If you are interested in the SHORT WAVES, Wearite have a new range of special low cost coils for the "Ultra Shorts." Ask for details.

Post this Coupon for Full Details

To Messrs. Wright and Weare, Ltd., 740 High Road, Tottenham, N.17.

Please send copy of your Booklet P.M/834 with technical data on Coils, Chokes, Transformers and Theoretical Circuit Diagrams. Please also send leaflet describing the NEW TYPE "A" UNIVERSAL and NEW WAVE TRAP COILS.

Name

Address P.M.8.35.



BE TALLER



HEIGHTEN Your Chances in Life

Short people can be made taller with the aid of a box of Challoner's Famous Formula—

H.T.N. TABLETS

and easy system: well tried: harmless and safe. No strenuous exercises or old-fashioned appliances. If one box is insufficient, we guarantee to supply a further box FREE of all charge. E.H. (Sutton) writes: "Results beyond expectations and I am as pleased as Punch." Act NOW! Send 1½d. stamp for full particulars in sealed envelope. Sample 7½d. Book on height improvement 3d. P.O. or stamps only. Overseas, Return Air Mail 1/- extra.

THE CHALLONER CO. (late of Bond St.)
Department G43, Laboratory and Works:
HYDE HEATH, AMERSHAM, BUCKS.

PATENTS, DESIGNS AND TRADE MARKS

A VALUABLE GUIDE ON INTERNATIONAL PROTECTION OF INVENTIONS.

100 Pages - Post Free, 6d.

The TECHNICAL ADVERTISING AGENCY
253 (D) Gray's Inn Road, London W.C.1

PRACTICAL HINTS ON PATENTING

and the development of Inventions.

Sent free on application.

THE IMPERIAL PATENT SERVICE

First Avenue House, High Holborn, W.C.1.

Preliminary Consultation Free.

Make More Money

£3 to £6 weekly can be earned at home in a wonderful business of your own. No matter where you live you can commence to make money in your spare or whole time. No risk, canvassing or experience required. A wonderful opportunity for anyone wishing to add pounds to their income. Particulars, stamp.

BALLARD, 71 Graces Rd., London, S.E.5

HEIGHT

I GUARANTEE to increase your height in 12 days or return your money! Amazing new discovery acts upon growth-glands, spine, joints, etc., and adds 2-5 inches to your height permanently. Guaranteed harmless. Increased my stature 4 inches in under 5 weeks. Hundreds of testimonials. Full course 5/-. Particulars free.

P. M. MORLEY,
8 BREAMS BUILDINGS, LONDON, E.C.4.

'WILCO' SPECIALTIES

Electric Motors—
Grinders-Drills-Motors—
Miniature Lighting
Accessories—
Boat Motors—Mains
Transformers—
Cycle Dynamo Sets
Etc.

40 PAGE CATALOGUE
3" POST FREE

L. WILKINSON

Dept. P.M., 8 City Road, London, E.C.1



HUMATAGRAPH

(Hygrometer)

Indicates the humidity of the air with scientific accuracy. Models for the home and industrial purposes. Matt Black, 25/-; Chromium plated, 28/-; Pocket model in case, 14/6.

C. L. BURDICK MFG. CO.
40-44 BOLBORN VIADUCT
LONDON, E.C.1

WEBLEY AIR PISTOLS

Marvellously accurate for target practice.

No license required to purchase;

Senior 45/-. Mark I 30/-;

Junior 20/-. Entirely British.

Write for List. WEBLEY & SCOTT LTD.,

106 WEAMAN STREET, BIRMINGHAM, ENG.



FROST & CO.

70 Old Compton St., London, W.1

Engineers, Tool and Model Makers.

Models of all descriptions.
Inventors, Scale and Advertising.

Patterns, Castings, or Finished Parts, Small Stampings and Press Tools.

Experimental and Repetition Work.

PRACTICAL MECHANICS



Replies to Queries and Enquiries

If a postal reply is desired, a stamped addressed envelope must be enclosed. Every query and drawing which is sent must bear the name and address of the sender and be accompanied by the coupon appearing on page 111 of cover. Send your queries to the Editor, PRACTICAL MECHANICS, Geo. Newnes Ltd., 8-11 Southampton Street, Strand, London, W.C.2.

INCREASING OUTPUT OF DYNAMO

"I HAVE a small dynamo which generates 2-4 volts at a rate of 2,000 r.p.m. How could I get the same voltage when driven at 1,000 r.p.m.? What alterations are needed? 1. Magnets weak. No coil on magnet. 2. Arm. wound with 32 S.W.G. 0 S.C. (1½ oz.). 3. Core ¾ in. long, 1 in. diam., 2-pole arm. 4. 1 brush from shaft, 1 brush from commutator (not split)." (R. B., Ipswich.)

THE only method of increasing the output of the machine, is to remagnetise the magnets. To do this wind each limb with as much No. 22 insulated wire as possible and connect the ends to an accumulator of 4 to 6 volts. Allow the current to pass until the fields are strongly magnetised, but switch it off occasionally, as this increases the magnetising effect.

MODELLING WAX

"Can you suggest a formula for making a substance having practically the properties of a pure white 'plasticine,' and which could be coloured by the addition of powdered colours if necessary? White soap is too hard and brittle, whilst paraffin wax is somewhat translucent and becomes greyish when softened by the hands. Some kind of opaque white modelling wax or clay is indicated." (K. S., Canada.)

A GOOD modelling wax can be prepared according to the following formula, the parts by weight being approximate:

White wax (not paraffin wax)	10 parts
Turpentine	2 parts

Heat the turpentine in a basin and add the wax little by little with constant stirring. When the wax has completely dissolved, allow the mixture to cool. It will set to a plastic mass. If the resultant mass is not hard enough, re-heat it and add more wax.

If the modelling wax so prepared is not opaque enough, re-melt it and, when fully molten, add a small quantity of whiting. After this addition, stir the wax continuously until it is cold. If the wax so produced is not white enough, repeat the process, this time adding a very small quantity of ultramarine or some other blue pigment. In a similar manner, by the admixture of other coloured pigments, various colours can be imparted to the wax. Such pigments, however, must be exceedingly finely ground and stirred well into the wax, otherwise the resultant modelling wax will not be homogeneous in shade.

MAKING A PHOTRONIC CELL

"COULD you please inform me as to how photronic cells are made? I have used such a cell, and found it very efficient, and

should like to try and make one for myself; as there is no vacuum in connection with these cells, I do not see why construction should be particularly difficult. Could you also supply me with references of any scientific journal in which I could obtain information as to research done on the photo-electric properties of cuprous oxide films?" (L. A. K., Midlothian.)

PHOTRONIC cells are a very recent development of the photo-cell. In these cells, light impinging upon a sensitive surface generates a relatively heavy current, and this flows through an external circuit. Some of these photronic cells contain surfaces sensitised with alkali metal hydrides. They do not work in a vacuum, as you point out, but, nevertheless, the sensitive surfaces in such cells are surrounded by an atmosphere of inert gas at low pressure.

Photronic cells have been developed by the big electrical corporations. You will not find any references to them (or to the photo-electric properties of cuprous oxide films) in journals such as you mention. A search of recent Patent Office literature will provide the best mine of information in these matters. Also the recent files of the Journal of the Institution of Electrical Engineers and other similar publications.

For any detailed information, the Wembley Research Laboratories of the General Electric Company might be consulted.

DISTILLATION OF WOOD

"I am carrying out the laboratory experiment of destructive distillation of wood and the distillation of its products. I desire information, practical and historical, on how to work up the liquid products in this distillation." (D. J., Acton.)

WHEN wood is destructively distilled, a brown pungent liquid, which separates into two layers, is obtained. The lower layer is termed "wood tar." It is insoluble in water and contains mostly tarry materials which are of little use working up on a small scale. The upper aqueous layer, known sometimes as "wood vinegar," contains acetic acid, methyl alcohol, and acetone. It is distilled roughly into two fractions, the first containing methyl alcohol and acetone. This is known as "wood spirit." The second fraction contains impure acetic acid and is known as "pyroligneous acid."

In order to obtain acetic acid, the crude pyroligneous acid is neutralised with milk of lime. Calcium acetate is

thus formed. This is recrystallised and then distilled with hydrochloric or sulphuric acid (dilute). Dilute acetic acid collects in the receiver. In order to obtain the strong or *glacial* acetic acid, the dilute acid is carefully neutralised with sodium carbonate and evaporated to dryness. The resulting sodium acetate is fused in order to drive off all traces of water. The fused sodium acetate is then powdered up and distilled from concentrated sulphuric acid. Strong acetic acid passes over and collects in the receiver. When cooled in ice, the strong acetic acid should freeze to a mass of ice-like crystals.

A liquid containing about 98 per cent. of methyl alcohol will be obtained. In order to obtain the pure alcohol, the liquid from the last distillation is mixed with powdered anhydrous calcium chloride. The methyl alcohol forms a compound with the calcium chloride. This latter substance is filtered off, pressed between cloths to remove acetone, and then mixed with a little water and gently distilled. Methyl alcohol collects in the receiver. Acetone is difficult to extract from wood distillation products. Advantage may be taken of the fact that acetone forms a definite compound with sodium bisulphite. If, therefore, strong sodium bisulphite solution be added to the 98 per cent. methyl alcohol, a crystalline compound, the "acetone-bisulphite compound," may be obtained. This is collected and distilled with a little sulphuric acid, whereupon acetone passes over into the receiver.

Pyroligneous acid was known to the alchemists of the sixteenth century. At that period, Basil Valentine showed that a fairly strong acid could be obtained from it. Pyroligneous acid was first shown to contain acetic acid by Fourcroy and Vauquelin in the year 1800. The Hon. Robert Boyle first investigated the properties of wood spirit in 1661. Lemery, in the seventeenth century, first described acetone.

WATER SOFTENING

"COULD you please help me with the following difficulty? Is there any preparation which could be added to the hard water of an ordinary household hot-water system to minimise corrosion in pipes (galvanized). It is fed from main town supply which is particularly hard. I know there are complete water-softeners on the market, but I cannot afford these at present. I am moving into a new house shortly and would like to counteract what I know can prove to be a troublesome and expensive job. (G. W., Burton-on-Trent.)

A fine model of a Wurlitzer organ made entirely from cardboard by Mr. E. A. Houlden. It is made to a 1/4th scale and took about 100 hours to make.



It is possible that you are somewhat mistaken in ascribing corrosion to the presence of hard water. Hard water is usually objectionable in consequence of the hard deposits which it causes in pipes and boilers, but it is unusual for it to set up actual corrosion.

Many materials have been proposed and tried for the softening of hard water, but, of these, only three have survived the test of time. They are: caustic soda, sodium carbonate, and lime. The first two are unsuitable, particularly for use on a small scale, since they require to be added to the water in very exact proportions, otherwise the water becomes alkaline, and, although effectively softened, acquires actual corrosive properties.

Lime is a more harmless water-softening agent. Added to the hard water either in the form of milk of lime or as lime water it will soften water fairly effectively. At the same time, the use of water over-charged with excess lime for drinking purposes would be objectionable. Hence, unless the lime were very carefully added to the feed-supply of the house, the remedy for the hard-water trouble would be worse than the trouble itself.

The small water-softening units work very successfully, and, really, they comprise the *only* solution to your difficulty. Such units contain a cylinder packed with a mineral substance known as "permutite." This has the property of combining with the hardness-producing constituents of the water and thus removing them. In time, the permutite becomes fully charged with these hardness-producing constituents and thus becomes unable to perform its function. It is, however, "revived" very simply by allowing a solution of common salt to percolate through it.

Permutite is a relatively expensive material, its retail price being about 4s. per lb. It is, however, practically indestructible. Perhaps, therefore, instead of experimenting with the cautious addition of lime to your water, you might procure some permutite (obtainable from any large firm of wholesale chemists), pack it loosely into a long cylinder and arrange for the water to flow through it.

When asking a Query, don't forget the Coupon!

INEXPENSIVE CHEMISTRY EQUIPMENT

APPARATUS & CHEMICALS FOR STUDENTS' LABORATORIES
Complete range of CHEMICALS in Bottles from 3d. each—
Extensive selection of APPARATUS, including Beakers, Flasks, Graduated Ware, Condensers, Retorts, Balances, etc.
SPECIAL PARCEL OF APPARATUS.
1 Flask, flat bottom 150 c.c., 1 Beaker, spouted 100 c.c., 3 Test Tubes 4 in. x 4 in., 1 Thistle Funnel 20 cm., 3 ft. Glass Tubing, 1 Rubber Cork 2 holes, 4 inches Rub. 2/6 Post
ber Connection Tubing, 1 Glass Stirring Rod. Free
BECK (Scientific Dept. A.), 60 HIGH STREET, STOKES NEWINGTON, LONDON, N.16
Write for Catalogue—FREE.

Price £2-17-6
Machine Vice 10/-
The 'ADEPT' Bench Hand Shaper
Length of stroke of ram, 31 ins.; Length of cross travel of slide, 3 ins.; Size of Table, 4 1/2 ins. x 4 1/2 ins.; Rise and fall of Table, 2 ins.; Vertical feed of tool slide, 14 ins.; Maximum distance between tool and table, 3 ins.; Weight, 18 lb. Also the 'Adept' No. 2 B.H. Shaper, 64-in. stroke. Price £5-17-6.
Manufactured by **F. W. PORTASS**
83a Sellers Street, SHEFFIELD.

BE STRONG
I positively GUARANTEE to give you Robust Health, Doubled Strength and 10-25" more muscle in 30 days or return your money in full. The famous STEBBING 4-in-1 Course consists of four great courses in one, yet costs only 5/- post free. It has been proved (1) The most effective HEALTH and ENERGY System ever devised; (2) It quickly builds NORMAL WEIGHT and VIRILE MANHOOD; (3) It develops a Strong Will, rigid SELF-CONTROL; and (4) It includes an amazing SUCCESS and PERSONAL MAGNETISM Course.
Complete Course 5/-
No extras, no appliances to purchase.
Further details sent privately, under plain, sealed cover.
LIONEL STEBBING, STEBBING INSTITUTE,
Dept. C.P., 28 Dean Road, London, N.W.2.

SOLELY SPECIFIED
for the
Power Driven Model Monoplane
By F. J. Camm
described in the July and August issues of "Practical Mechanics"
Square Birch Spruce Stringers
Proofed Silk Aluminium Dope, etc.
from
THE MODEL AIRCRAFT SUPPLIES Ltd.
171 NEW KENT ROAD, S.E.1
Telephone: Hop. 3482

GENUINE AND ONLY CHROMATIC MOUTH ORGAN
Sent for 1/6 Deposit, plus 6d. postage, etc. Balance 1/6 weekly for 4 weeks to approved customers. Cash price, 6/6 post free.
GUARANTEED the same type of instrument as played by **LARRY ADLER** in his Stage, Broadcast and Gramophone Performances.
This superb **HOHNER** INSTRUMENT with its beautiful deep, rich, organ tone, can be played in ANY Key (all 12 Keys) including all Sharps and Flats, exactly as your own Piano.
SUPER CHROMONICA MODEL with three complete Chromatic Scales, in beautiful Silk-lined case. 2/- only deposit, plus 6d. postage, etc. Balance 2/- weekly (for 5 weeks) to approved customers. Cash price, 10/6 post free.
MODERN MUSIC STUDIO
High Holborn House (P.M.), 62 High Holborn, London, W.C.1
SPECIAL TUTOR for these instruments, 1/- extra.

BUY, EXCHANGE OR SELL

Advertisements are accepted for these columns at 2d. per word (minimum 12 words at 2s.—advertisements of less than 12 words are charged at the minimum rate of 2s.), subject to a discount of 2½% for 6 consecutive monthly insertions or 5% for 12 consecutive monthly insertions. **TERMS:**—Cash with order. Cheques, Postal Orders, etc., should be made payable to George Newnes Ltd. *The Proprietors reserve the right to refuse or withdraw advertisements at their discretion.* All advertisements must be received on or before the 5th of the month preceding date of publication and should be addressed to the Advertisement Manager, "Practical Mechanics," George Newnes Ltd., 8-11 Southampton Street, Strand, W.C.2.

CINEMATOGRAPHY

CINEMATOGRAPH FILMS.—Standard size from 6d. 100 feet. Machines, Accessories. Sample Films, 1/- and 2/6 post free. Catalogues free.—"Filmeries," 57 Lancaster Road, Leytonstone, E.11.

MOVIES AT HOME How to make your own Cinema Projector. Particulars free. Moviescope (N), Pear Tree Green, Dodinghurst, Essex.

"**FILM-CRAFT.**"—Here is a fascinating series of authoritative textbooks for everyone interested in the Cinema as the newest of the arts. The Filmcraft series, each 3s. 6d. net, includes volumes by Pudovkin, Adrien Brunel, G. E. Kendall, D. Charles Otley, Percy W. Harris. From all Booksellers and Newsagents.—George Newnes Ltd., 8-11 Southampton Street, Strand, London, W.C.2.

CONTACTS

CONTACTS, Tungsten, Silver or Platinum; any shape or size, on screws or rivets.—**TUNGSTEN CONTACTS LTD.,** 3 Haverstock Hill, N.W.3. Primrose 6621.

ELECTRICAL

ELECTRIC DRILLS, fan-cooled powerful motor, all voltages AC/DC, chuck ¼ in. max. high-speed drilling, £2 10s. Used reconditioned fully guaranteed drills 14/9 all voltages, with new chucks. Ance! Cine Co., 8 Highbury Terrace Mews, N.5.

INSTRUMENT MAKING, Acoustic and Electrical, etc., Inventors' Models, Experimental Work, Machining, Gear Cutting, Turning, Screw Cutting, Milling, etc. Send requirements for quotation, Gaydon & Co., Scientific Engineers, 42a Sydenham Road, Croydon.

SURPLUS ELECTRICAL and Engineering Materials, low prices.—The London Electric Firm, Croydon.

A MAGAZINE of Electrical Progress. Amazing developments in Electrical Engineering are rapidly revolutionising industry and bringing new benefits to the whole community. To keep in touch with all the latest in Electrical Progress read this live Magazine. Written by experts, it is indispensable alike to the technician and the ambitious student, while the "layman" will find it full of interest and inspiration. "**THE PRACTICAL ELECTRICAL ENGINEER.**" 1s. monthly. Obtainable at all Newsagents and Book-stalls, or by post 1s. 3d. from George Newnes Ltd., 8-11 Southampton Street, Strand, London, W.C.2.

ENGINES

ENGINES. Buld Butler's ½-h.p. practical Model Petrol Engine. Set of Castings 9/9. Interesting Catalogues 3d. Write Profit-Sharing Works, Littleover, Derby.

MAGIC

RETIRED PROFESSIONAL has Valuable Manuscripts, "second-sight" Act, etc., for sale. Stamp for particulars. Deville, 41 Longford Place, Manchester.

METAL WORK

MAKE METAL TOYS. Easy, profitable with "SUCCESS" Moulds. List Free. Lee's, Bentinck Road, Nottingham.

MICROSCOPY

MICROSCOPIC OBJECTS—unmounted prepared. Assorted packet 2/-. **MOUNTED SLIDES STOCKED.** LENG, 183 MANCHESTER DRIVE, LEIGH-ON-SEA.

MISCELLANEOUS

ENLARGE YOUR DRAWINGS MECHANICALLY with a "Perfect" Pantograph. Oak, brass fittings. Boxed with instructions. Approval 3/-. Industries, 13 Gordon Avenue, Twickenham.

"**CLARK'S CREAMED BARLEY.**"—Willing to buy Yellow "Brea." King, 67 Salisbury Road, Liverpool, 19.

MODELS

SCREWS, NUTS, WASHERS (special Model Engineers' sizes). Everything for Electrical Re-winds and Repairs. Lists Free.—Lumen Electric Co., 9 Scarisbrick Avenue, Litherland, Liverpool 21.

HALF-PRICE MODEL RAILWAYS, STATIONARY ENGINES, etc. Finely reconditioned and tested models, almost indistinguishable from new. Interesting illustrated catalogue, 4½d. Model Exchange, 11 Friars Street, Ipswich.

BARGAINS: Large stock to clear. Some of the goods described are sold at 70% below their actual factory cost: mostly foreign goods. Salling, Clockwork, Electric and Steam Boats from 2/6 to 15/-. Also Steam Engines, Boilers, Locomotives, Trucks, Electric Motors by Stuart's, Marklin's, Bing's, also nails, sheds, etc. Inspection invited without obligation. F. C. Reiser, 72 Twyford Avenue, W.3. 'Phone: ACORN 1783.

"**WORKING MODELS** and How to Make Them." Edited by F. J. Camm, 3s. 6d.—This book will appeal to all who are handy with tools. Contains complete instructions for the making of every kind of working model. Each model has been actually constructed in accordance with the details given and subjected to stringent tests. The instructions and diagrams are so clear that even the most elaborate model can be built without fear of failure. Obtainable at all Booksellers and Newsagents.—Geo. Newnes, Ltd., 8-11 Southampton Street, Strand, London, W.C.2.

MONEY MAKING

"**3,000 FORMULAS,** Recipes, Trade Secrets," also "Directory" of "Where to Buy" Chemicals (wholesale). Both sent for 4/9. "Soap Making" at home (no machinery needed), 4/- . Polishes and their manufacture, 1/- . Send orders to Technocrat, 41 Longford Place, Manchester, 14.

MUSICAL INSTRUMENTS

ACCORDEONS, PIANO AND CHROMATIC. The finest, accordions ever made are obtainable from Hesty's on cash or terms. Scandall, Pancotti, Frontalini, Dallame models in prices ranging from £6 to £40 10s. Hundreds of genuine testimonials. Write for beautifully illustrated catalogue. Below.

GUITARS. Hesty's recommend Dobro Amplifying Guitars. The finest guitars money can buy. Prices, £4 19s. 6d. to 19 guineas on cash or deferred terms. Catalogues free on request to Hesty's. Below.

SAXOPHONES. The sure way to success is with a Hesty saxophone. Beautiful tone, accuracy of pitch, easy fingering. Cash or terms. Write, Hesty's Ltd., 18-20 Manchester Street, Liverpool 1.

PHOTOGRAPHY

£500 worth good, cheap Photo Material, Films, Plates, Cards, Papers, Chemicals, Catalogue, and 4 Samples Free.—Hackett's Works, July Road, Liverpool 6.

POSTCARDS FROM ANY PHOTO. Time to finish, four days. 25 1/9; 50 3/-; 100 5/-; 500 17/-; 1000 30/-. Enlargements 1/-. Samples and List Free.—Hackett's Works, July Road, Liverpool.

PRINTING

"**PHOTO-ENGRAVING.**"—A practical Handbook with complete set of materials for engraving printing blocks, 4/6. Industries, 13 Gordon Avenue, Twickenham.

PRINT YOUR OWN CARDS with "Simplex" Outfit, 17/6 complete. Particulars free, Type List, Samples of Cards, Memos, Billheads, 3d. (refunded first order). "Simplex" P.M., 6 St. James Road, Mitcham, Surrey.

TOOLS

NEW GRINDSTONE fitted to powerful (over ½ h.p.) motor all voltages AC/DC, bargain 14/9, guaranteed. Second-hand machinery carriage forward. Lathe bed takes 3-in. diameter work, with head and tail stock, 9/6. Machine stand drill chuck ¼ in. max., 8/11; motor for same, about ½ h.p., 12/6. Three jaw self-centring chuck takes 3 in. diameter, 11/6. Hobbies fret-saw machine, 8/6. Polishing heads, 5/6. Ance! Cine Co., 8 Highbury Terrace Mews, N.5.

TOOLS upon easy payments. Treadle Saw Benches £8/10/0, power £3, Constructors' Saw Bench Fittings 12/6, Lathes 25/-, Compound Reats 15/-, Foot Treadles 35/- . Lists 2d.—Brown Bros., Accrington.

WIRELESS

MICROPHONES, G.P.O.—12 in. high, with mouthpiece. Standard model, 4/6. Post 9d. No. 11A, special, in solid Brass body, unequalled at the price on speech and music, 7/6. Pedestal Mike No. 10B, 10 in. high, 12/6. No. 12B, Ring Pedestal, 18/6. Elsel famous P.A. and Band Mike (Reisz Principle), 55/- . Stand 10/- extra. Screened impeded. matched Transformer, 7/6. Highest quality. Uniform response. Can be obtained from us only. Electradix.

PARTS for Home Constructors.—Buttons, 1/- each. Microphone Carbon Granules, in glass capsule, for four buttons. Grade No. 1, 8d.; No. 2, Medium, 1/-; No. 3, Fine, 1/6; Carbon, solid back, blocks, 3d. Mouthpieces, curved or straight, 10d. Carbon diaphragms, 5s M/m, 6d. Electradix.

TELESCOPES, Navy Gun 24 in., 17/6. Hand spotting, 25/- . Stick Periscopes, 34-in. mirror, 6d. August Illustrated Sale List "P.M." Post Free. Electradix Radios, 218 Upper Thames Street, London, E.O.4. Telephone: Central 4611.

FOR THE RADIO ENTHUSIAST.—"The Wireless Constructor's Encyclopedia," by F. J. Camm (Editor of "Practical and Amateur Wireless"), third edition. Compiled by one of the most accomplished designers and writers on the practical side of Wireless, it covers the whole field. A veritable Treasury of Wireless Knowledge. Price 5s., from all Booksellers and Newsagents.—George Newnes, Ltd., 8-11 Southampton Street, Strand, London, W.C.2.

A DICTIONARY OF WIRELESS TERMS, by Ralph Stranger. A Wireless Work of Reference that should be on the bookshelf of every keen amateur. Compiled by a master of lucidity, it gives the meanings of all Technical terms in general use. Price 2s. 6d. from all Booksellers and Newsagents.—George Newnes, Ltd., 8-11 Southampton Street, Strand, London, W.C.2.

FREE SERVICE FOR READERS

READERS requiring information concerning goods or services advertised in *PRACTICAL MECHANICS* should give names of Advertisers from whom particulars are desired. Any number of names may be included and we will obtain for you catalogues, lists, and any other information you may be wanting. **THERE IS NO CHARGE FOR THIS SERVICE.**

Readers desiring particulars from a number of Advertisers will, by this method, save time and postage. Halfpenny stamp only is required if your envelope is left unsealed. If any Advertiser stipulates that stamps or postal orders are necessary before samples or catalogues are sent, please enclose the necessary amount with your instructions. You are cordially invited to make full use of this Service.

Post this to

ADVERT. SERVICE DEPT.,
PRACTICAL MECHANICS,
8-11 SOUTHAMPTON STREET,
STRAND, W.C.2

Please obtain and send to me particulars from the Advertisers in your August issue whose names I give on list attached.

Advertiser	Page No.	Information Required
------------	----------	----------------------

Attach sheet of paper, with particulars, and your name and address (written in **BLOCK** letters), with date, to this announcement.

**FREE ADVICE BUREAU
COUPON**

This coupon is available until August 31st, 1935, and must be attached to all letters containing queries.
PRACTICAL MECHANICS, AUGUST, 1935

The Books for You!

These books are written, designed and published specially for the modern handyman—they are practical and helpful, explaining everything fully but without “bookish” elaboration—the illustrations are included to assist, not merely as decoration—and they cover the widest possible range of interests.

- | | |
|-------------------------------|-------------------------------|
| THE HOME WOODWORKER | MODEL AEROPLANES AND AIRSHIPS |
| MODEL BOAT BUILDING | POWER-DRIVEN MODEL AIRCRAFT |
| THE HANDYMAN'S ENQUIRE WITHIN | SIMPLE ELECTRICAL APPARATUS |
| TOY MAKING FOR AMATEURS | LATHE WORKS FOR AMATEURS |
| 25 SIMPLE WORKING MODELS | |
| MOTOR CAR OVERHAUL AND UPKEEP | |
| ACCUMULATORS—CAR AND WIRELESS | |

Each
1/- net



**NEWNES
HOME
MECHANIC
BOOKS**

Illustrated

From Booksellers Everywhere
GEORGE NEWNES LTD.
Southampton Street, Strand,
London, W.C.2

George Newnes Ltd.

"Who Am I?"



"The clerk pointed to the hotel register"

THE amazing true story of a man who lost his memory and with it all trace of his former identity is told in this month's **WIDE WORLD MAGAZINE**. Forty years old, he awakened in a strange hotel one morning to discover that he had no idea who he was; even the name he had signed in the register meant nothing to him! Some overmastering fear prevented his seeking the aid of the police, and for *eight years* he wandered hither and thither, utterly unable to recall his past. Then Fate took a hand; he was recognized as a long-sought "missing" man and taken back to his former home—to discover, like Enoch Arden, that his wife, believing him dead, had remarried.

Read this astounding true story in the August

**13
TRUE
ADVENTURE
STORIES**

*From all Parts of
the World*

WIDE WORLD

*On sale at all Newsagents and Bookstalls, or by post 1/3
from George Newnes, Ltd., 8-11 Southampton Street,
Strand, London, W.C.2*

**A MAN'S
MAGAZINE 1/-**

George Newnes, Ltd.