

THE AUTOMATIC PILOT

NEWNES

PRACTICAL MECHANICS

JULY

6^D



**NOVEL MODEL SPEEDBOAT • STAGE EFFECTS & ILLUSIONS • WHEN IRON
BOATS • MAGIC WITH MIRRORS • WIRELESS • THE PANAMA RAILWAY • TELE-
CONTROL OF MECHANICS • AUTOMATIC TRAFFIC LIGHTS • BUILDING MODEL
PROPPLANES & RAILWAYS • LATEST NOVELTIES & TOOLS • PATENT ADVICE ETC.**

SIGNS of the TIMES

The Budget has restored
POLICE OPPORTUNITIES

The Air Force is to be increased
AVIATION MUST DEVELOP
Pay cuts have been restored.

CIVIL SERVICE

Suitable to both sexes. Ages 15½ to 24.
PERMANENT PROGRESSIVE,
PENSIONABLE POSITIONS.

G.P.O. ENG. DEPT.

CUSTOMS AND EXCISE, INSPECTOR OF
TAXES, ETC. NO EXPERIENCE REQUIRED.
OPEN EXAMS.

MATRICULATION

There are many ways of commencing a career,
but Matriculation is the jumping-off board for
all the best ones.

We prepare candidates for all

INSTITUTE EXAMS

TECHNICAL, ACCOUNTANCY,
SECRETARIAL, INSURANCE, Etc.

ENGINEERS and DRAUGHTSMEN

All Branches—Employers are
advertising for them.

**TELEPHONY, RADIO and MOTOR
ENGINEERING** are expanding rapidly.
There are lots of vacancies. Our postal
courses will make you eligible. Advice
on all careers Free.

Also ask for our New
Book (Free of Charge)

THE HUMAN MACHINE

Secrets of Success



CAN YOU
CHANGE MY
EXPRESSION ?

IF SO, YOU MAY BE
THE ARTIST THAT
COMMERCE IS
WAITING FOR.

Just try it for yourself,
trace or draw the out-
line and then put in
the features.

Jim Duck

There are hundreds of openings in connection with
Humorous Papers, Advertisement Drawing, Posters,
Calendars, Catalogues, Textile Designs, Book
Illustrations, etc.

60 per cent. of Commercial Art Work is done by
"Free Lance Artists" who do their work at home
and sell it to the highest bidders. Many Commer-
cial Artists draw "retaining fees" from various
sources, others prefer to work full-time employment
or partnership arrangement. We teach you not
only how to draw what is wanted but how to make
buyers want what you draw. Many of our students
who originally took up Commercial Art as a hobby
have since turned it into a full-time paying profes-
sion with studio and staff of assistant artists:
there is no limit to the possibilities. Let us send
full particulars for a FREE TRIAL and details of
our course for your inspection. You will be under
no obligation whatever.

Jim Duck

Art Dept. 76.

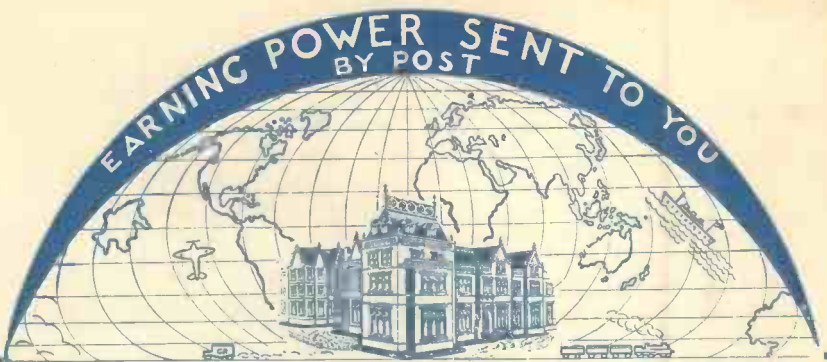

STUDY AT HOME IN YOUR SPARE TIME

OPEN LETTER TO PARENTS

Dear Sir or Madam,—When your children first arrived they brought with them a wonderful lot of sunshine. Later you became proud of the intelligence they displayed, but still later you became anxious as to what would become of them in the future. Perhaps you were anxious when you visualised them as grown men and women. Even with plenty of money it is not always easy to select the right career, and a parent is sometimes inclined to ask advice of some relative and in ninety-nine cases out of a hundred that relative knows nothing at all about the possibilities of employment. Why not let me relieve you of some of your anxieties? In fact, why not let me be their Father? We do not profess to act as an employment agency, but the nature of our business compels us to keep an eye upon the class of men and women that are wanted and who want them. There are some people who manufacture an article and put it on the market to sell. We do not do that, we work in exactly the opposite direction. We find out what employers want and we train our students to fill those jobs. We have to be experts in the matter of employment, progress and prosperity. If you have any anxieties at all as to what your sons and daughters should be, write to me, or better still, let them write to me personally—Fatherly Advice Department—and tell me their likes and dislikes, and I will give sound practical advice as to the possibilities of a vocation and how to succeed in it. Yours sincerely,

J. Bennett

YOU CAN HAVE A COLLEGE TRAINING IN ALMOST ANY CAREER FOR A FEW SHILLINGS MONTHLY

Accountancy Examinations
Advertising and Sales Manage-
ment
A.M.I. Fire E. Exam.
Applied Mechanics
Army Certificates
Auctioneers & Estate Agents
Aviation Engineering
Banking
Boilers
Book-keeping, Accountancy and
Modern Business Methods
B.Sc. (Eng.)
B.Sc (Estate Management)
Building, Architecture and
Clerk of Works
Cambridge Senior School
Certificate
Civil Engineering
Civil Service
All Commercial Subjects
Commercial Art
Concrete and Structural
Engineering
Draughtsmanship. All branches.
Engineering. All branches,
subjects and examinations
General Education
G.P.O. Engineering Dept.
Heating and Ventilating
Industrial Chemistry

Insurance
Mathematics
Matriculation
Metallurgy
Mining, all subjects
Mining, Electrical Engineering
Motor Engineering
Motor Trade
Municipal & County Engineers
Naval Architecture
Pattern Making
Police, Special Course
Preceptors, College of
Pumps and Pumping Machinery
Radio Service Engineering
Road-Making and Maintenance
Salesmanship
Sanitation
Secretarial Exams.
Shipbuilding
Shorthand (Pitman's)
Structural Engineering
Surveying
Teachers of Handicrafts
Telephony and Telegraphy
Transport Inst. Exams.
Weights and Measures Inspector
Welding
Wireless Telegraphy and
Telephony
Works Managers

If you do not see your own requirements above, write to
us on any subject.

HOW TO STUDY

In your spare time when it suits
YOU. You fix your own time, you
do not GO to your studies—the
postman brings THEM TO YOU.
There is nothing that a class-room
teacher can show on a blackboard
that we cannot show on a white
paper. The lesson on a blackboard
will be cleaned off, but our lessons
are PERMANENT. A class-room
teacher cannot give you a private
word of encouragement, but a Cor-
respondence Tutor can do so when-
ever your work deserves it. On the
other hand he can, where necessary,
point out your mistakes
PRIVATELY.

TO STUDENTS LIVING ABROAD

or on the high seas, a good supply
of lessons is given, so that they
may be done in their order, and
despatched to us for examination
and correction. They are then sent
back with more work, and in this
way a continuous stream of work is
always in transit from the Student
to us and from us to the Student,
therefore distance makes no
difference.

IT IS THE PERSONAL TOUCH
WHICH COUNTS IN POSTAL
TUITION

EVERY DEPARTMENT IS A
COMPLETE COLLEGE.
EVERY STUDENT IS A CLASS
TO HIMSELF.



Dept. 76, THE BENNETT COLLEGE, SHEFFIELD.

FOUNDED 1902



Practical Mechanics

VOL. II. No. 22
JULY
1935

Edited by F. J. CAMM

SUBSCRIPTION RATES :
Inland and Abroad, 7s. 6d. per annum
Canada - - 7s. per annum

Editorial and Advertisement Offices : "Practical Mechanics," George Newnes Ltd., Southampton Street, Strand, W.C.2.
Registered at the G.P.O. for transmission by Canadian Magazine Post.

Notes, News and Views

A New Stratosphere Flight

PROFESSOR PICCARD is now at Warsaw preparing for a flight into the stratosphere, during which he hopes to reach a height of nineteen miles.

Sound Films in a Train

THE latest practice for the entertainment of the railway travelling public is talking films in the train. A demonstration run was made recently between King's Cross and Peterborough during which films were made.

Match Strikes 24 Times

WE learn that a match that will strike twenty-four times has been patented by a Czecho-Slovakian, named Rudolph Petruska. The matches are damp-proof and will strike anywhere. The inventor has been working at this invention for thirty-five years.

A Stratosphere Scheme

M. R. C. FOLEY, an Irishman, announces that on July 21st he will attempt a stratosphere flight from New York to Dublin. He will use a machine equipped with a "robot" pilot.

Free Television

THE German Post Office has opened four theatres in Berlin where television programmes may be seen free of charge.

A "Bullet" Bus

A "BULLET" bus made entirely of steel has been constructed in Cologne. Completely streamlined, it has a running speed of 75 miles per hour.

A Wireless Set in a Hat

A WIRELESS set which can be fitted in a hat, and is operated by batteries carried in the pocket, was recently described in one of our companion journals, *Practical and Amateur Wireless*.

An Invisible Ray

IT is stated that a new and astonishing defensive weapon, which has the effect of putting aircraft out of action, has been perfected by a young scientist in Bavaria.

It is said that if a car is in the path of one of these wireless rays for more than a couple of minutes, the entire magneto melts!

A New Gliding Record

HERR HEIN DITTMAR, of Durmstadt, has set up a new gliding height record for a passenger flight, reaching 8,860 ft.—3,280 ft. higher than the previous record.

THE MONTH'S SCIENCE SIFTINGS

A new system of rocket post invented by a Belgian inventor was recently tried out at Brussels.

A new Army tank that will float in water is the latest addition to the French Army.

A miniature electric motor, weighing under $\frac{1}{8}$ of an ounce, and claimed to be the smallest working model in the world has been produced by a sixteen-year old boy.

Speaking in London recently Senor de la Cierva, inventor of the autogiro, visualised a "flying motor car."

A destroyer capable of a speed of 36 knots has recently been built by Messrs. John Samuel White & Co., of Cowes.

Experiments are being carried out with a device that will enable submarines to be traced at a range of many miles.

The present range of detecting apparatus for locating submarines under water is 400 yd.

An Amphibian Car

A YOUNG German inventor, Herr Jakob Baudig, recently crossed from Calais to Dover in an Amphibian car. The journey took six and a half hours. The length of the car is 14 ft., weight 1 ton, land speed 20 m.p.h., and the water speed 5 m.p.h. The engine is enclosed in a watertight compartment.

New Fog Signals

FOG, the greatest enemy of the railways, is being challenged by two new signals which are being tried out by the L.M.S. It is hoped that these signals will greatly minimise the effect of foggy weather on the running of trains. One signal gives a flashing light at the rate of 120 flashes a minute, and the other projects a powerful electric beam of special design.

A Train Speed Record

A GREAT effort to establish a new world's rail speed record with a British engine is to be made in August. The present record of 108 m.p.h. was set up by a British locomotive. The aim of the new attempt will be 115 m.p.h.

Largest Blast in Britain

TWENTY tons of gunpowder was recently used to dislodge nearly 1,000,000 tons of grey granite from the 500-ft. high quarry face on the mountain-side above Bonawe village.

A powder shaft and chambers, sunk nearly 100 ft. deep in the rock took over two years to construct, at a cost of £5,000.

A Pocket Television Receiver

A TELEVISION receiver that can be carried in the pocket is being developed in Birmingham. Similar in size to a pocket camera, the receiver adopts new television principles. It is fitted with a miniature cathode-ray tube with an inch square "reflector screen" which projects pictures twelve times its own size on to an external folding screen.

"Normandie" Breaks her own Record

ON her journey from New York to Plymouth, the *Normandie* beat her own record for the crossing of the Atlantic which she set up on her outward journey. Her official time from New York pier to Plymouth was 4 days 8 hours 45 minutes, her average speed being 30.35 knots. Her best day run was 711 miles and her highest speed 32.3 knots. The average speed on her outward journey was 29.68 knots. Previous best average speeds were as follows:—*Mawretania*, 27.05 knots, *Europa*, 27.4 knots, *Bremen*, 28.51 knots, *The Rex*, 28.92 knots.



ALTHOUGH experimental work on the automatic control of aircraft has been in progress for nearly 20 years in several different countries, the difficulties have been such that it is only during the last five years that substantial success has been attained. To-day, however, the Automatic Pilot has reached such a stage of development that it is invariably installed in large machines of the Royal Air Force and the time is rapidly approaching when no large passenger or freight-carrying aircraft will remain unequipped.

The navigation of an aeroplane is an easy matter in good weather and in a clear sky, but it is another matter altogether in rough weather when the ground is invisible or when visibility is reduced by darkness or by fog. Under such conditions it is impossible to keep even a large machine on an even keel, because the pilot has no stable datum upon which he can base the operation of his controls. Certain gyroscopic instruments such as the "Turn Indicator" can render very great assistance, but the strain of watching such instruments for hours on end is a serious one, and under really bad conditions there is thus the ever-present risk of loss of control and possible disaster.

The Automatic Pilot, however, renders the

By G. R. M. GARRATT,
M.A.(Cantab.)

The "Robot" or Automatic Pilot is an amazing Mechanical Device which is Capable of Keeping an Aeroplane on its Correct Course, without the Pilot's aid.

navigation of any aircraft, large or small, a simple matter in even the worst conditions, and provided that sufficient visibility exists for the pilot to take-off and land the machine he can leave the Automatic Pilot to control the movements of the machine while actually on its course.

The Automatic Pilot possesses one great advantage over the human pilot in that it can instantaneously detect any deviation of the machine from its correct course or altitude, and simultaneously apply the movements necessary to the rudder, elevators, or ailerons to correct the disturbance. In the case of a human pilot, however, he has first to observe the disturbance, which must clearly have reached a certain magnitude before he can appreciate it; he must then estimate its magnitude and decide on what control movements are required to correct it. Although this sequence becomes quite instinctive after a very little practice, yet it will be clear that some appreciable time-lag must be inevitable and when the pilot's judgment is obscured by his inability to see some fixed object such as the ground or the horizon, the delay in applying the correct controls may easily cause a disaster.

The Automatic Pilot achieves this advantage over the human pilot by the incorporation of a highly established datum in

established datum from which deviations of the aircraft can be detected.

The motive power to drive the gyroscope and to operate the controls is compressed air which is derived from a small self-contained air-compressor system. The compressor (Fig. 1) is usually placed on a wing or strut of the machine and is driven by a small windmill, but it is sometimes fitted direct to the engine. It supplies air at a pressure of 35 lb. per sq. inch which spins the gyroscope at a speed of 11,000 r.p.m.

The gyroscope is mounted in a pair of "gimbal rings" the construction and assembly of which has to be carried out with the greatest care. The gyroscope, which may be seen in Fig. 4, rotates on ball bearings in the inner gimbal ring; the inner gimbal ring is pivoted on almost frictionless pivots in the outer gimbal ring, and the whole unit is carried by vertical pivots in the main framework. It will thus be seen that the gyroscope possesses three degrees of freedom, i.e., it spins on its own axis and it is free about both the horizontal and vertical axes. Bearing in mind, therefore, that the spinning gyroscope tends to maintain fixed, the direction of its axis, it will be seen that when any deviation of the aircraft occurs on account of some atmospheric disturbance, a relative movement will occur between the

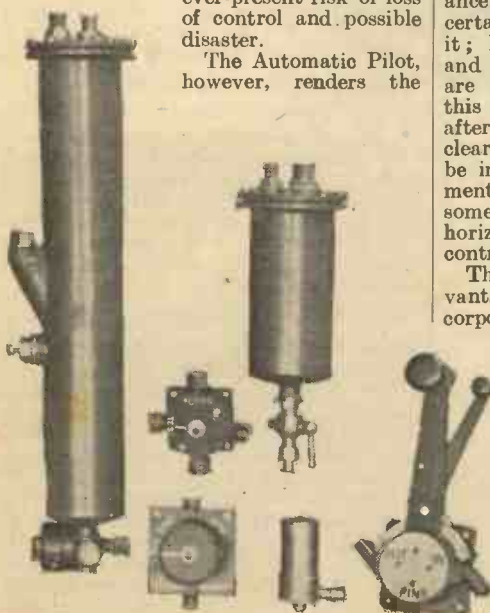
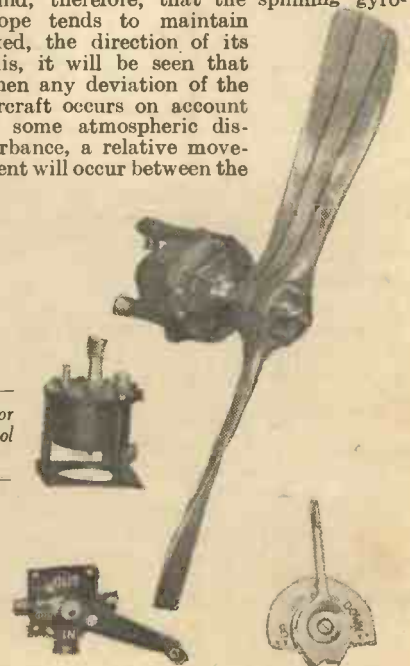

Fig. 1.—The component parts of the air compressor system, the oil and air reservoirs and the pilot's control levers.

the form of a gyroscope, not unlike those used in gyro-compasses on ships. An accurately balanced gyroscope spinning at high speed possesses the property of maintaining the direction of its axis fixed in space unless acted upon by some external force, and it thus forms a highly



gyroscope, its gimbal rings and the supporting framework. This relative movement is used to operate the respective controls.

There are three separate controls on the normal aircraft, the rudder, the elevators, and the ailerons, and although it is not always essential to control the ailerons, it is usual to control both the rudder and the elevators. These can both be automatically controlled by a single gyroscope, but the control of a third axis demands the use of a second gyroscope. To illustrate the general principles we will consider only the operation of the rudder control as this is the most simple of the three.

The gyroscope is so installed in the aircraft that its axis lies approximately

determined course. The relative motion between the main framework and the outer gimbal ring causes the rudder valve to operate, and this permits the entry of compressed air into one side or the other of the rudder servo-motor, depending on the direction in which the aircraft has deviated. The servo-motor piston then moves, and through the rudder bar, causes the rudder of the aircraft to move in the direction to return the aircraft to its true course.

It will be apparent, however, that unless special means were taken, the slightest deviation of the aircraft from its correct course would result in the application of the full amount of the rudder. This would

cause the casing of the rudder valve. This valve is very accurately constructed, and a deviation of only six minutes of angle is quite sufficient to bring it into operation and to cause the admission of compressed air to the rudder servo-motor. The follow-up mechanism consists in so arranging the mechanism that when the rudder valve is operated and compressed air thereby admitted to the rudder servo-motor as the result of a deviation of the aircraft from its course, the resulting movement of the servo-motor piston and rudder bar causes the casing of the rudder valve to follow the apparent movement of its piston, thus closing the valve and preventing the further application of rudder angle. The actual

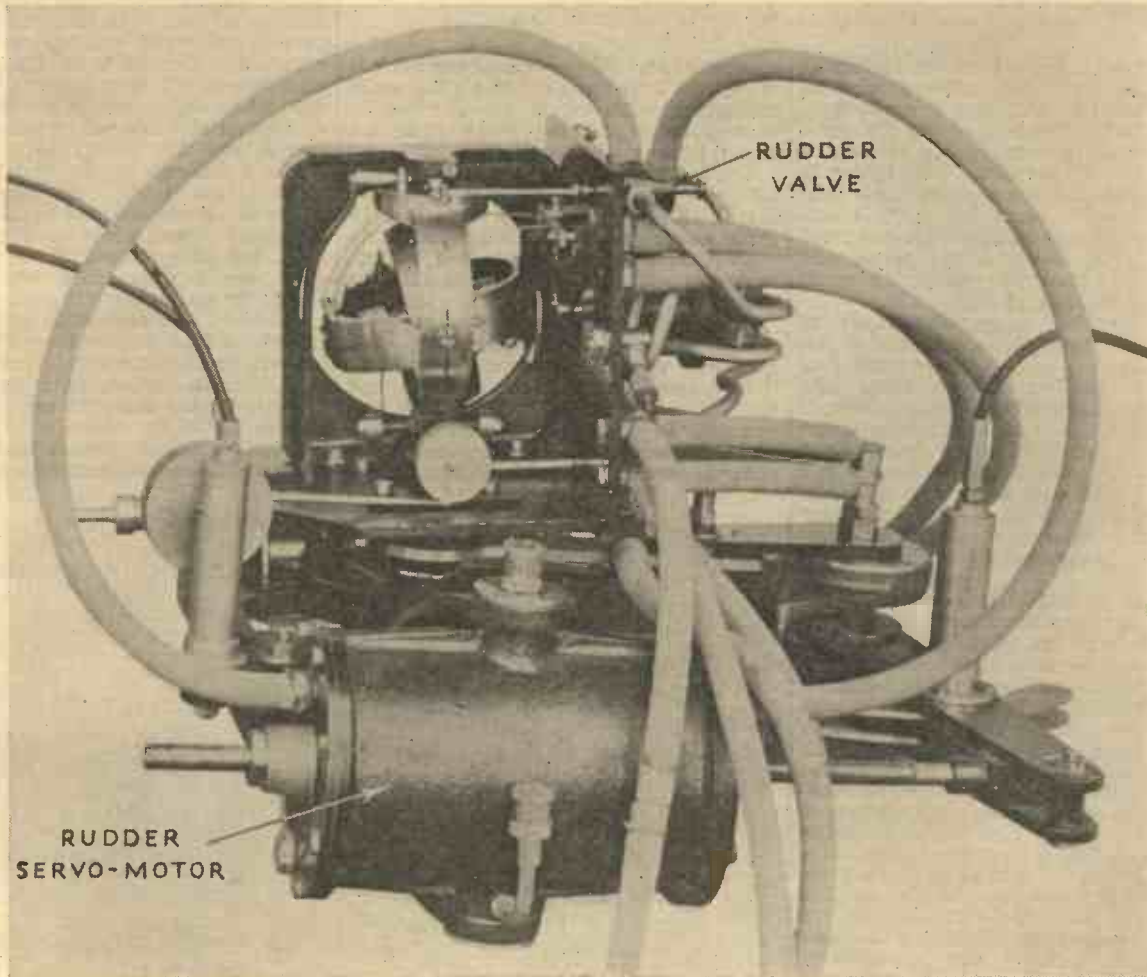

Fig. 2.—A view of the gyrosopic unit of the rudder and elevator control.

parallel to the fore and aft line of the machine. Suppose that the gyroscope is in operation and that the aircraft deviates from its true compass course. Since the gyroscope and gimbal rings are directionally stabilised, it is clear that relative movement must occur about the vertical axis of the outer gimbal ring. This relative movement operates a small air valve known as the rudder valve, the piston of which is connected by a link to a point on the outer gimbal ring, as may be seen in Fig. 2. The outlets from the rudder valve are connected to the two ends of a large cylinder which contains a double-acting piston, the rod of which is connected to the rudder bar of the aircraft. This cylinder, which is known as the rudder servo-motor, may be seen in the front of Fig. 2, and the piston rod and rudder bar may also be seen.

When the aircraft deviates from its pre-

be disastrous as it would cause violent and continual oscillations of the aircraft. What is actually required is some device which will result in the application of rudder angle in exact proportion to the angle through which the aircraft has deviated from its course. Such a control will result in the return of the aircraft to the true course without appreciable oscillation.

Fortunately, it is possible to achieve this proportional application of the controls by a fairly simple device which is known to gyro engineers as a "follow-up system." The principles of the follow-up system are rapidly finding fresh applications in engineering practice, and the particular arrangement used in the Automatic Pilot will therefore be described in detail.

As already described, a deviation of the aircraft from its correct course results in relative movement between the piston and

application of rudder angle is thus limited to an amount depending on the actual deviation of the aircraft from its course and, as the aircraft is returned to its course, the rudder angle is automatically and progressively reduced.

In order to alter the course of the aircraft while flying under automatic control, it is necessary to "precess" the axis of the gyroscope into the required direction and the aircraft automatically follows the gyroscope for the reasons which have been described. To precess the gyroscope "in azimuth," i.e., about the vertical axis, in order to turn the aircraft, it is necessary to apply a torque to the gimbal rings. It might be supposed that the torque should be applied to the outer gimbal ring about the vertical axis, but, on account of the somewhat complicated dynamics of gyroscopes, such a torque would only cause the

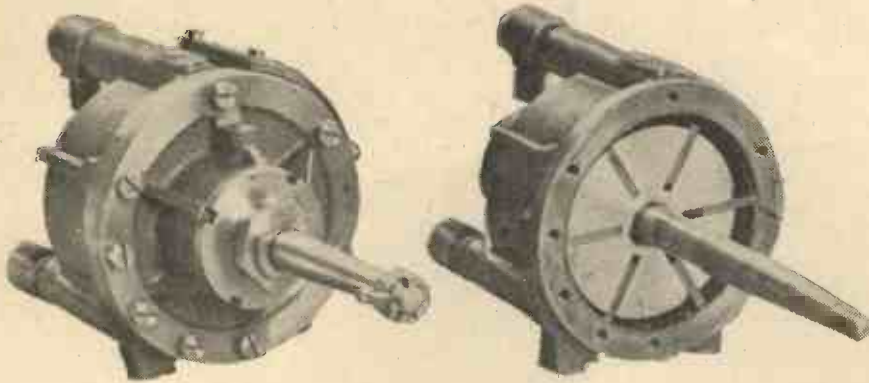

Fig. 3.—The air compressor, showing external and internal views.

gyroscope to topple about the horizontal pivots. In actual fact, a torque must be applied to the inner gimbal ring about its horizontal axis in order to cause the whole gyroscope and gimbal system to precess about the vertical axis. This torque is applied through the perforated girder link, which can be seen on the left in Fig. 4, and is caused by the admission of compressed air to a small double-acting piston and cylinder, which may be seen just beneath the rudder valve in Fig. 2.

It is impossible to construct a perfect gyroscope on account of the friction of the various pivots which introduce small precessions and so limit the accuracy. The accuracy of the gyroscope of the Automatic Pilot is such, that an aircraft flying under automatic control, will only deviate from its course between 3 and 5 degrees per hour, and while such an error is negligible in the rudder control, it would be very important in the case of the elevator control which is operated by the same gyroscope.

In order to maintain a constant pitch attitude, it is necessary so to control the gyroscope that its pitch angle remains constant. This is achieved by gravitational means by the use of the two circular weights which may be seen in Fig. 2, one of them being just beneath the gyroscope and the other on the left. These weights are attached by links and levers to the outer gimbal ring. If the gyroscope accumulates a pitch error, the pitch attitude of the aircraft will be changed by a similar angle. This would cause the vertical axis of the outer gimbal ring to be tilted either backwards or forwards. So long as this axis remains vertical, the two weights just referred to have no effect, but as soon as the axis is tilted, they introduce a gravitational torque about the axis, the effect of which is to cause the inner gimbal ring to be returned to its correct attitude.

The elevator valve, which is operated from the inner gimbal ring, cannot be seen in Fig. 2 as it is situated on the opposite side, but since its operation is very similar to that of the rudder system, it will not be described in detail.

Most modern aircraft are sufficiently stable laterally to dispense with any form of aileron control altogether. When aileron control is necessary, however, a separate gyroscope must be used. The operation of the aileron gyroscope is very complicated, although the principles are similar, and a full description would be out of place in these pages.

In actual operation the entire mechanism of the Automatic Pilot is controlled by a single air-cock in the pilot's cockpit and, once he has put the mechanism into operation, he may devote his full attention to

other matters. He may even leave his seat altogether for a time unless his numerous instruments such as oil pressure gauges, thermometers and revolution indicators require his constant attention.

The Automatic Pilot described above was developed by the Air Ministry for use in the Royal Air Force and while it may justly be claimed to be the most accurate control yet produced, it would be unfair not to mention either the Sperry or the Siemens controls.

The Sperry system employs a separate gyroscope for each axis, and while this arrangement possesses some advantages, the increased cost and complexity is not justified. The Sperry servo-motors are operated by hydraulic pressure and the additional compressor necessary is a further potential source of trouble besides adding

appreciably to the weight of the equipment. The gyroscopes of the Siemens system operate under rather different principles from those described above as they are spring-controlled. Their function is fundamentally to measure the rate of change of trim, rather than the actual amount of the change and although the eventual result is similar, it is necessary to use certain auxiliary apparatus to provide the required datum. The weight of the Siemens system is nearly 300 lb., which renders it quite unsuitable for any but the largest planes. The weight of the British Automatic Pilot is only 125 lb.

With the continual growth of long-distance air routes and the development of night mail services, which have to fly to fixed schedules, it is inevitable that the use of automatic controls will become universal. The value of the automatic pilot is certainly most appreciated by the pilot whose duties compel him to fly under all weather conditions, even when visibility is bad and the control of the aircraft rendered difficult by the violence of the disturbances. Under such conditions the safety of the aircraft and the lives of the occupants depend solely on the skill of the pilot, but with the aid of the automatic pilot, the dangers which are otherwise inevitably associated with such conditions are reduced to a negligible quantity. The Automatic Pilot controls the motions of the aircraft far more accurately than the most skilled human pilot, and taking into account the very greatly increased comfort and the increase in safety which is thereby provided, it is safe to predict that within a few years its use will become universal.

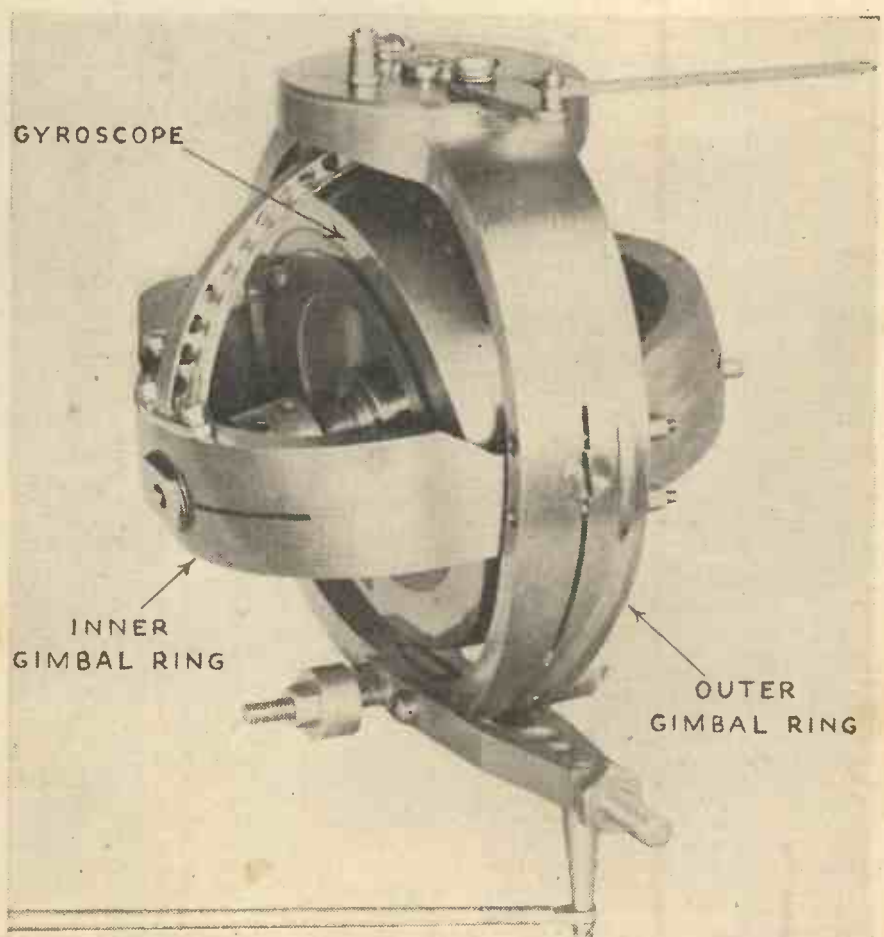

Fig. 4.—A view of the gyroscope and gimbal rings dismantled from the main unit.

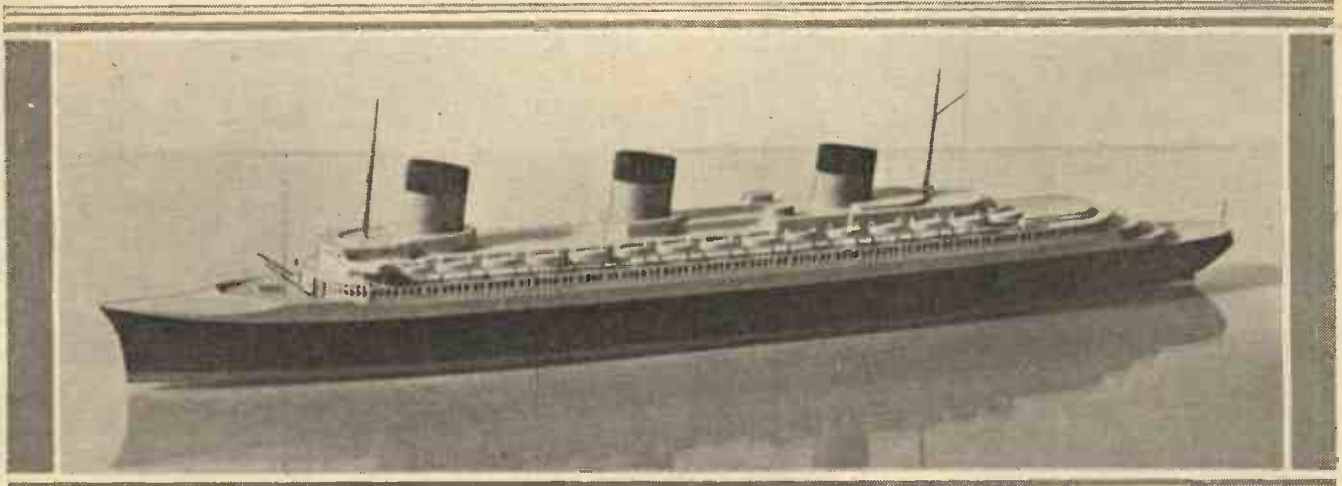

Fig. 1.—Showing the realistic appearance of the finished waterline model of the "Normandie."

MAKING A MODEL OF THE "NORMANDIE"

EVERY ship model enthusiast and connoisseur of ship miniatures will shortly be adding to his collection of "historic" ships of the Western Ocean, the giant French liner *Normandie*.

At Northampton recently the well-known model firm of Bassett-Lowke have been working on a huge order of 1,500 hand-made waterline models of this beautiful ship for her owners, and it occurred to me that there are many amateur model makers who would like to construct a simplified waterline scale model of the *Normandie*.

The cost of the materials is quite small, all those mentioned can be obtained for under 5s., and the smart little miniature, added to your ships' cabinet, will well repay your time and patience.

The scale chosen—100 ft. to the inch—produces a model just over 10 in. long, for the *Normandie* herself, from stem to stern, measures 1,029 ft. and thus can claim the proud title of the largest vessel in the world.

This ship has a number of interesting points, which come out well in a miniature—the modern lines of her hull, for instance—her clear-cut whaleback fore-castle deck and unusual yachtlike stern, built on "counter" instead of the usual "cruiser" lines. Her very large streamline funnels (three express trains would pass abreast down any one of those on the real ship) and terraced decks aft, are bold characteristics, which give plenty of scope for artistic modelling (see Fig. 1).

Fig. 3 shows the complete set of parts.

- A.1. Block of lime wood for hull.
- A.2. Forward deck.
- A.3. Terraced decks aft.
- A.4. Spacing pieces for same.
- B.1 and 2. Promenade and boat decks.
- C. Main deck house of lime.
- D. Window strip of drawing paper.
- E. Top deck house of lime.
- F.1. Bridge deck.
- F.2. Bridge house.
- F.3. Bridge front.
- G. Café terrace.
- H. Lifeboats, complete with davits.
- I. Funnels.
- J.1, 2, 3 and 4. Funnel casings.
- K. Grill room roof aft.
- L. Ventilators.
- M. Square hatch forward.
- N. Masts.

A 10-in. Waterline Miniature of the Largest Ship in the World and Which now Holds the Record for the Atlantic Crossing

The Hull

Parts A.1, A.4, C, E, F.2, J.1, 2, 3 and 4 and L are cut from the $\frac{1}{8}$ -in. lime wood, and parts A.2, A.3, B.1, B.2, F.1, G, K, and M from Bristol board, which can be thickened by sticking two pieces together.

Take part A.1, the hull block, and mark

out the shape by pricking through the drawing with a needle, or tracing with carbon paper. Cut the elevation or profile shape first, and then the plan or top shape. Mark the waterline outline on the bottom and shape the hull as shown in the cross sections (Fig. 2).

All this work can be done with the usual wood-working tools, or if these are not available, a penknife smoothed up with glass paper makes a good substitute. Cut out the small anchor spaces in the hull, three at the front and one astern, and then

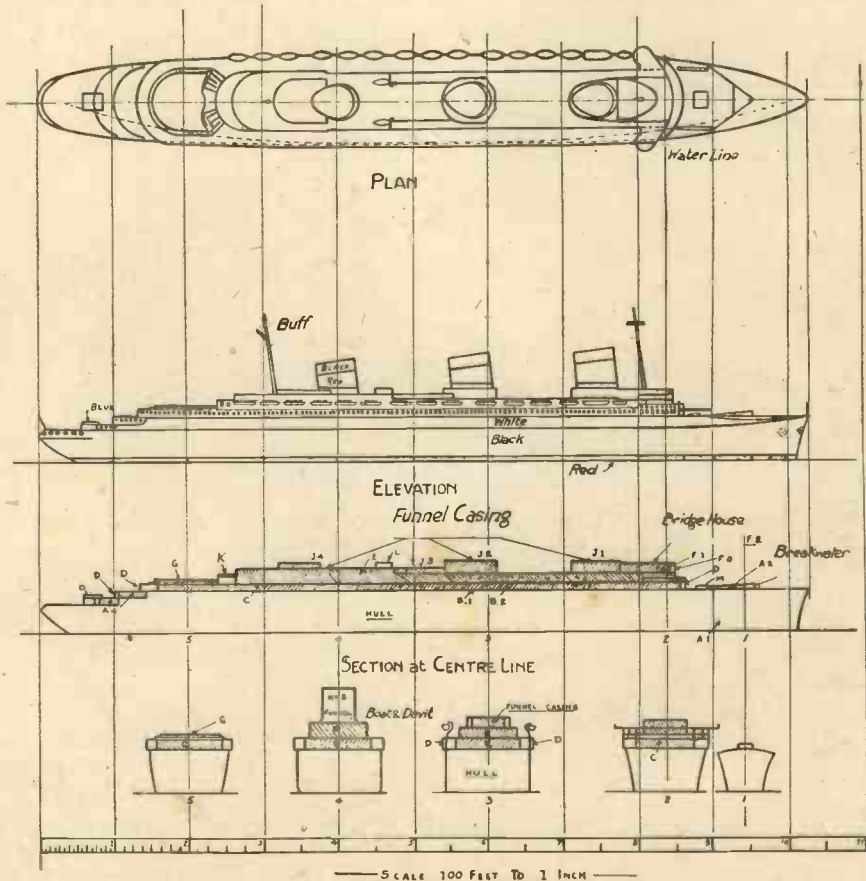

Fig. 2.—Constructional details and method of assembling the model of the "Normandie."

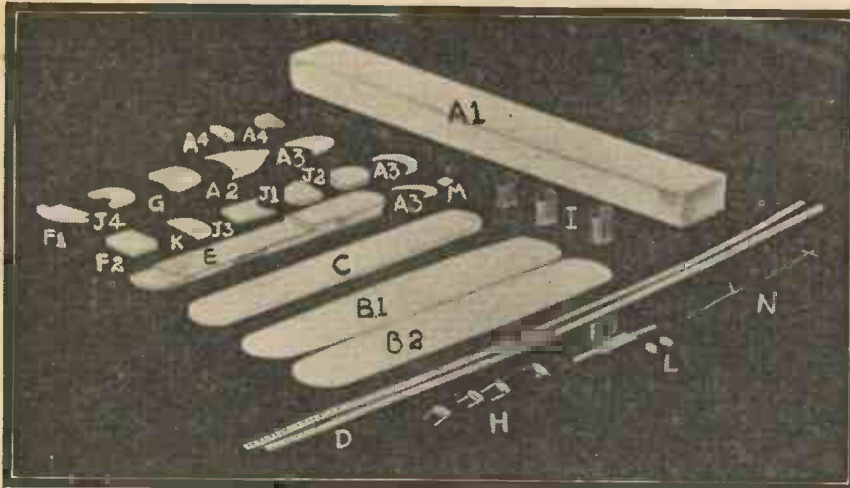

Fig. 3.—Showing the complete set of parts for the model "Normandie."

carefully shape up the shellback forecastle deck, which is an attractive feature peculiar to this ship. It should be cut on the hull, running in to the line of the breakwater, which is formed on the forward deck A.2 by bending the front edges ($\frac{1}{16}$ in.) up at right angles, on to the triangular support shown on drawing.

You will require plenty of the window strip, part D, which goes along the edges of the decks. This part is made from strips of drawing paper suitably marked out. Draw the windows in position and cut them through with your penknife or a small bradawl sharpened up like a chisel to the right size.

The Terraced Decks

Parts A.3, forming the series of terraced decks aft, should next be constructed, with spacing pieces, A.4, underneath. Fix window strips of the required length round these three decks.

The superstructure, or main decks, parts B.1, B.2 and C, should be cut out from the

of lime wood, then bridge deck, F.1, is glued on, and bridge house, F.2, fixed on the top of it. The bridge front, F.3, is now cut from drawing paper and attached around the front, and a low half-oval bulwark, $\frac{1}{32}$ in. high, will improve the appearance of the bridge house roof (see drawing).

Part G, the café terrace aft, is made from

two thicknesses of Bristol board, with steps of drawing paper cut to size and stuck together.

The Funnel Casings

The funnel casings, J.1, 2, 3 and 4, are now glued in position and the complete main top deck house added to the model.

The grill room overlooking the café terrace aft, part K, is cut from Bristol board and fitted to the deck house with a piece of special window strip round the edge.

A simple method of making the lifeboats is to shape a long strip or rod of wood to the contour of the top of the boats, then cut them off the required height with a fretsaw. The davits are made from the

THE PARTS REQUIRED

- One Block of Lime Wood, $10 \times 1\frac{1}{2} \times \frac{3}{4}$ in.
- One Sq. Ft. of Lime Wood, $\frac{3}{16}$ in. thick.
- One Sheet of Size 4 Bristol Board.
- One Sheet of Drawing Paper.
- Brown Paper.
- One Tube of Seccotine.
- One ft. of $\frac{3}{8}$ in. dia. Rod Wood.
- One Coil of Fine Florists' Wire.
- Two Large Needles, $1\frac{1}{2}$ in. long.
- One Small Tin each of Red, Black and White Ripolin.
- One 100 ft. to the inch Waterline Plan (reproduced half-size in this article).
- Tubes of Buff and Blue Poster Paint.



Figs. 4 to 6.—(Left and below) A number of models of the "Normandie" made by Messrs. Bassett Lowke Ltd., and (above) showing workmen constructing the models shown in the photographs below.

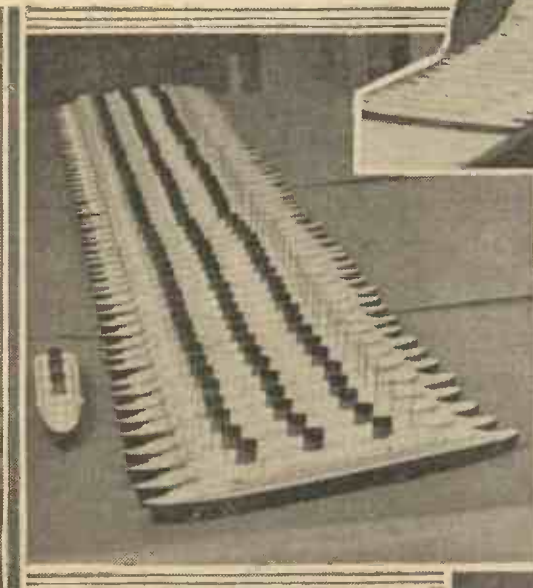

drawing, and in doing so particularly notice the main deck overhang of $\frac{1}{32}$ in. all round B.1 and B.2 are exactly the same size, and should be stuck together with spacing piece C in between. When these are quite dry you can stick the window facings in position with seccotine, and affix this complete part to the hull.

Now proceed with the main top deck house in lime, which is made up of several parts. Part E is cut from a single piece

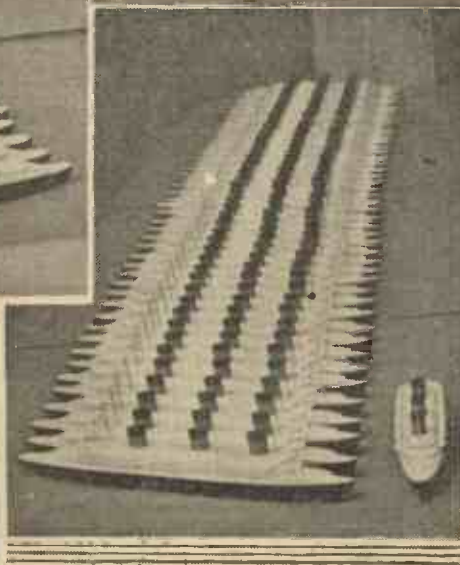

florists' wire, bent to shape as shown in Fig. 2. Mark on the deck with a needle where these are to be fitted, then fix a pair of davits to the lifeboat with a small pair of pliers and push the complete boat and davits into the deck.

The funnels, part I, can be made from solid blocks of wood.

The two ventilators, L, and the hatch forward, M, and the swimming pool complete the constructional work, and we have only to make the masts and the two derricks forward, which are of needles and wire. The yard on the main mast and the gaff on the mizzen are made respectively of thin wire and are soldered in place.

Apply four thin coats of white paint, which must be strained through muslin.

Approximately $\frac{1}{16}$ in. of the red colour below the waterline is shown on the model, and the rest of the hull is black, with white superstructure, buff masts and a spot of blue for the pool. The funnels are red with a $\frac{3}{32}$ in. band of black at the top.

SOME INTERESTING FACTS ABOUT TRAFFIC LIGHTS



Behind the Red Lights

THERE can be little doubt that the light signal system is a tremendous improvement over the average point policeman. It never makes one wonder "Does he mean me?" It gives just as good signals at midnight as at noon, and, furthermore, no one can obstruct traffic by stopping to ask it questions!

Most ingenious devices are really very simple, but the automatic signalling apparatus is hardly that. A general idea of its main principles can be easily grasped, however. The semi-automatic system, which is now almost everywhere superseded by the traffic-controlled apparatus, is simple enough. It is usually driven by a timed A.C. motor (somewhat similar to that used in an electric clock), and a camshaft operates the switches in the correct order. The deficiencies inherent in this system will be obvious to every motorist.

The Electromagnetic System

This is, of course, operated from a detector, set into the road surface. The detector consists of two steel plates sealed in a rubber envelope. When a vehicle passes over the detector the upper plate flexes and makes contact with the lower. Tramcars operate the signals by lifting a shoe which lies on the overhead trolley wire. When a vehicle operates the detector it opens a relay which switches on a current of 400 volts. This current flows through a high resistance to a condenser. Owing to the resistance, the condenser charges up slowly, so that it may take several seconds before it reaches 400 volts. The condenser passes on the current to a neon tube. A feature of the neon tube is that it will not pass a current of electricity until that current reaches a certain value which is called the Ionising Point of the neon tube. After it has reached this value the current is allowed to pass and continues to do so until it again falls below the Ionising Point.

Observe how this affects the signalling lights. The road contact opens the relay and sends current through the resistance to the condenser, which passes it on to the neon tube. At first it passes only a low voltage—the neon tube refuses it: then the voltage increases and the neon tube lets it through. The current energises a solenoid, moves a camwheel which makes contact in the lighting circuit, and lights the amber lamp a given number of seconds after the vehicle registered its presence.

The Period of Charging

Besides moving the camwheel, however, the current switches on a low resistance which discharges the condenser, the current falling below the Ionising Point of the neon tube. The components are now set for the next operation.

It will be observed that the higher the

resistance the longer is the period of charging the condenser and the longer the interval before the lights change. The lights are now set at amber. The road relay is still locked and the charging process starts again, this time through a different resistance. In due time the neon tube strikes, the camwheel is moved, the green light comes up and the components are reset again. Once again the process begins, but this time provision is made for any vehicle which might follow behind the first. Every time such a vehicle crosses the detector it places a small resistance in shunt with the condenser and partially discharges it, thus delaying the re-charging time and giving the vehicle time to cross over. But this has a snag, in that if a continual stream of vehicles crossed the detector they would so discharge the condenser that it never could charge to the Ionising Point of the neon tube and the lights would be perpetually in one direction.

To understand how this is overcome we must inquire into the working of the opposing stream of traffic. The detector on the other route has its own condenser, resistances and neon tube and proceeds in exactly the same manner, but it is interconnected with the first route and cannot start working until the first route has finished its complete cycle of operations. This works quite satisfactorily if route number one finishes quickly, but if, as we have observed, route number one holds on to the green light indefinitely the change-over is accomplished in the following manner.

Route number two is allowed to charge up its own condenser very slowly, irrespective of what number one is doing, and at the end of a maximum period of about one

minute it flashes over its neon tube and takes the right of way from number one.

A Safety Provision

All the connections are made between the two crossings by means of the camwheels, which number eleven, each having two or three cam contacts. Another safety provision which is allowed for is on behalf of the foolish driver who jumps the amber light. If a driver on route number one is waiting for amber to change to green, and a vehicle on route number two crosses the detector, an extra two seconds is allowed on number one for any following traffic. In certain cases, then, a driver may actually delay the lights on his own route by crossing the detector!

Another remarkable feature of the electro-

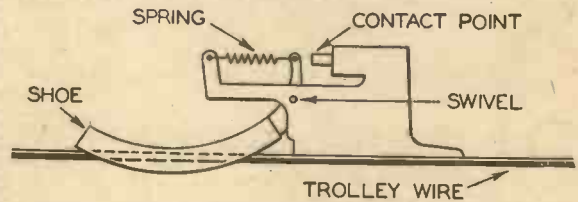

Showing how tramcars operate the signals by lifting a shoe which lies on the overhead trolley wire.

matic system is that it can distinguish between slow and fast traffic. A car passing over the contact pad at 35 m.p.h. will make contact for .01 second (the fast shutter speed of a medium-price camera), while a bicycle crossing at 10 m.p.h. will make contact for .035 second—three and a half times as long. This length of contact is sufficient to alter the discharge voltage of the condenser. Thus .01 second of contact gives a discharge voltage of 147 and a right of way of 2.8 seconds, while .035 gives a voltage of 12 and a right of way of 4.8 seconds. Thus a slow-moving vehicle is given extra time to cross the intersection. A further adjustment of the system allows for the "Go" signal to revert automatically to an arterial road, after it has been changed by a contact pad on a minor road.

The detectors cannot be operated by a vehicle proceeding in the wrong direction on its wrong side of the road—a contingency which does occasionally arise. To accomplish this the detector is specially designed. The upper of the contact plates is divided in two. The two halves fight against each other: if the correct half is touched first it operates the signals and puts a clinch on its opponent, but if the wrong half is the first to make contact it does nothing itself and prevents the other half from doing anything.

By altering the values of the various resistances the time periods can be suited to different traffic conditions and different gradients.

It is interesting to note that nearly £1,000 a year is saved by having road traffic robots in place of point-duty policemen at a crossing.

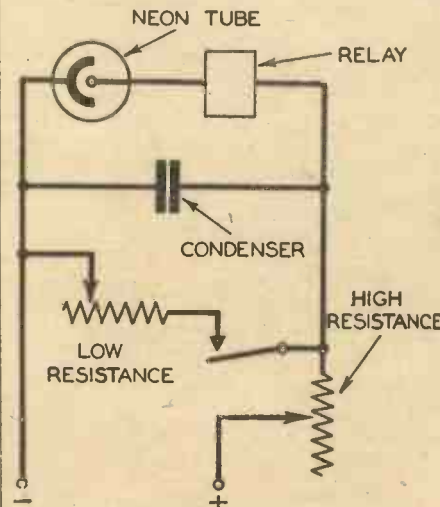

The circuit diagram of a detector operated by ordinary traffic.

25 YEARS in SCIENCE

THE past quarter of a century is the fullest, most remarkable and certainly the most interesting in the whole history of science, mechanics and invention. It has seen the creation of the aeroplane and airship, wireless and television, the industrial Robot, the gramophone, silent and talking pictures, mechanical travel, stratosphere ascents, and many other modern marvels which have now become commonplace.

Success begets success. The perfection of any one science is interdependent on the perfection of many others, and it is in the eternal search for perfection in the various sciences that new marvels and new ideas emerge. This pictorial supplement indicates some of the advances which have been made.

The Grid System

Electricity, the nature of which is still rather obscure, is now used extensively throughout the world. This has been made possible by the recent development of the grid system,

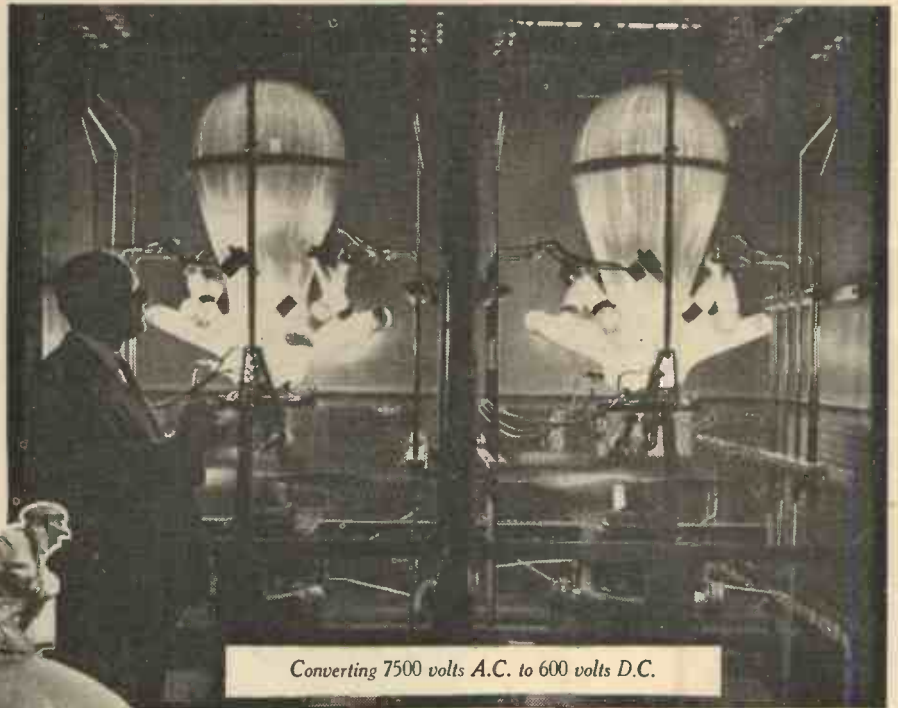

Converting 7500 volts A.C. to 600 volts D.C.

whereby cables, mounted on steel pylons hundreds of feet in height, carry millions of volts many miles across country. Huge power stations, similar to the one recently described in this paper, have also been erected all over the

world for the production of these enormous voltages. Thus we have seen the development of the electric railway, electric lighting, and many other ingenious devices that rely upon electricity as their source of power.

The extraordinary photograph seen above shows two of the Hewettic rectifying valves converting 7,500 volts A.C. to 600 volts D.C. for the Liverpool and South-

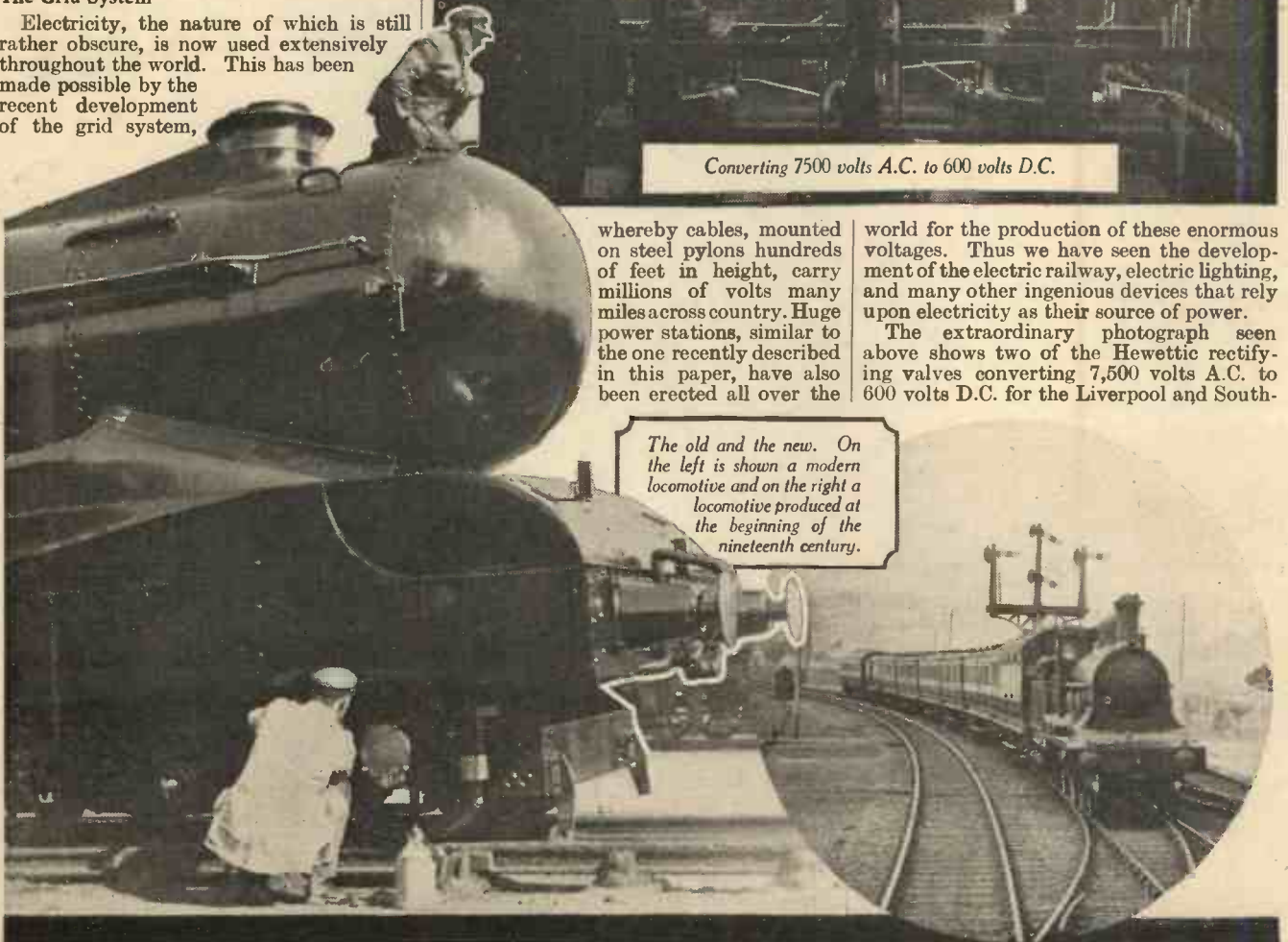

The old and the new. On the left is shown a modern locomotive and on the right a locomotive produced at the beginning of the nineteenth century.

of PROGRESS MECHANICS & INVENTION



Describing the working of the latest and most intricate of world communication apparatus at the Post Office Research Station.

port Electric Railway on the L.M.S. System. The rectifier works unattended and is controlled automatically by push buttons two miles distant.

Electricity has also made possible the invention of the telephone, and the photograph at the top of this page shows telephone workers being taught the wonders of communication, at the Post Office Research Station, Dollis Hill, N.W.2. Here, skilled workers are taught the working of the latest and most intricate of world communication apparatus.

The Railway

Development on the railway has also made rapid strides during recent years,

and it is interesting to study the photographs shown on page 448, which show

the progress of the railway engine during a period of twenty-five years. The train on the right, shown crossing the points, made its appearance in 1910, and that on the left is the G.W.R. crack express, King Henry VII. Streamlining is very much in evidence in this powerful locomotive. It has been fitted with a "bullet nose" front to reduce wind resistance, and certain modifications have been made to the boiler, cab and tender by use of light steel plates.

Thus by reducing the wind resistance of a vehicle when in motion, we have added considerably to its speed.

The Progress of the Car

Now compare the two cars on this page, one of which is a product of 1910, and the other is Sir Malcolm Campbell's famous Blue-bird, which has attained

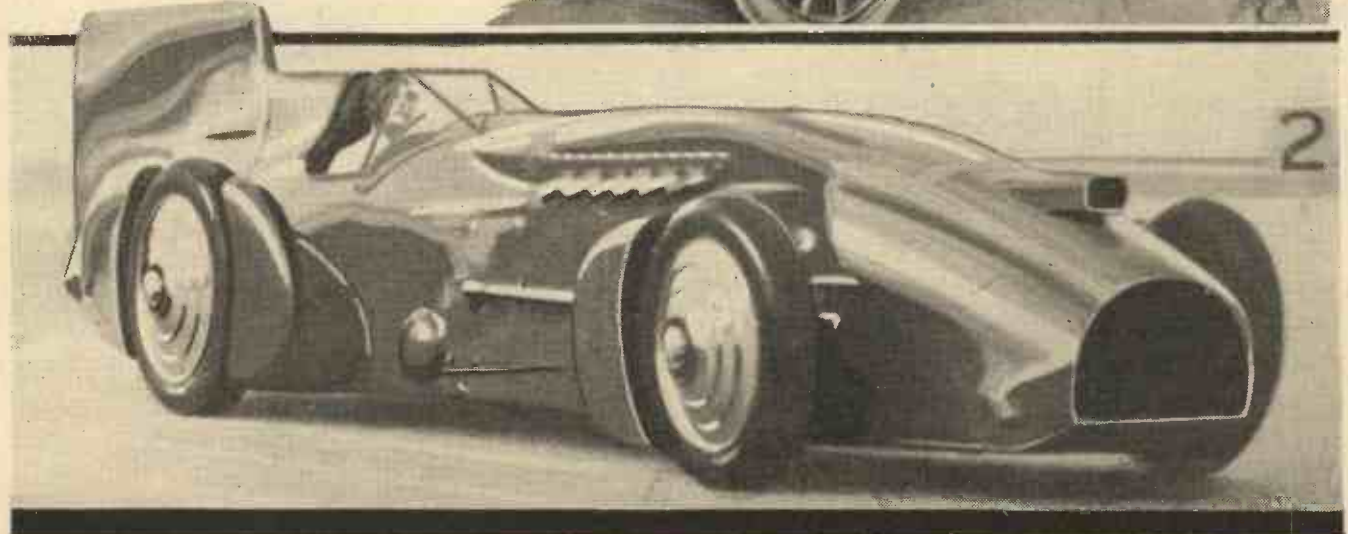

These two photographs show the progress made in the design of the motor car.

(Left) The original B.B.C. London station 2L.O. and (below) the present Droitwich Transmitting Station.

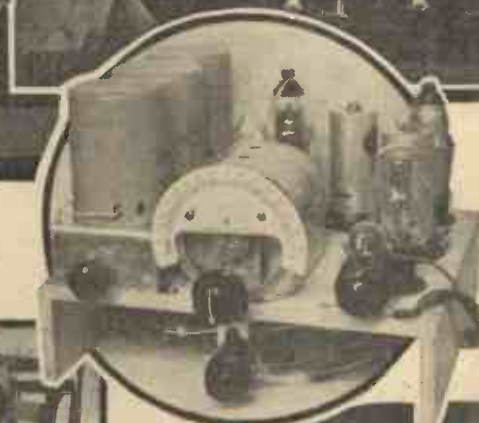
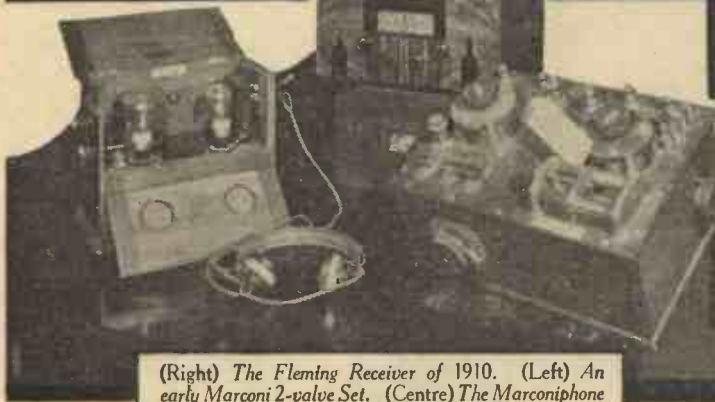
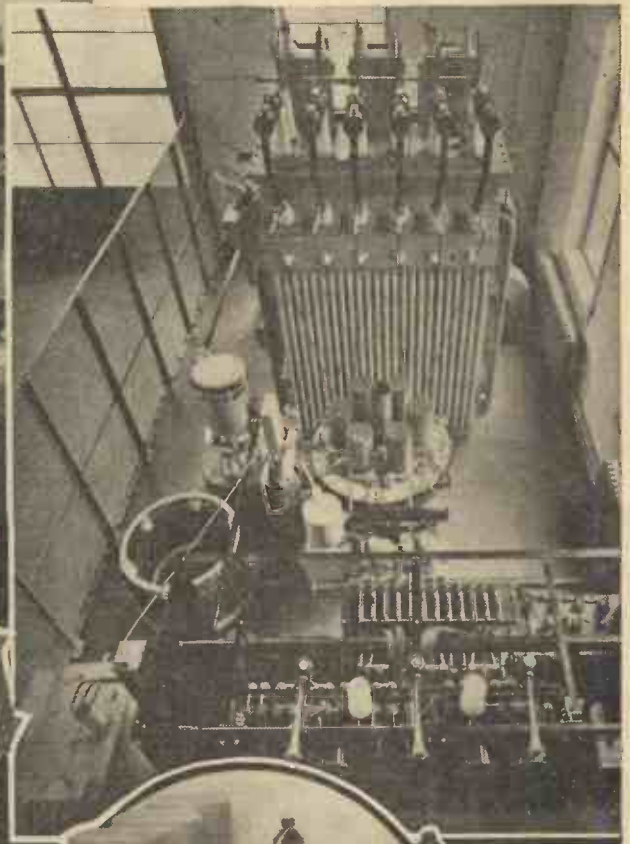
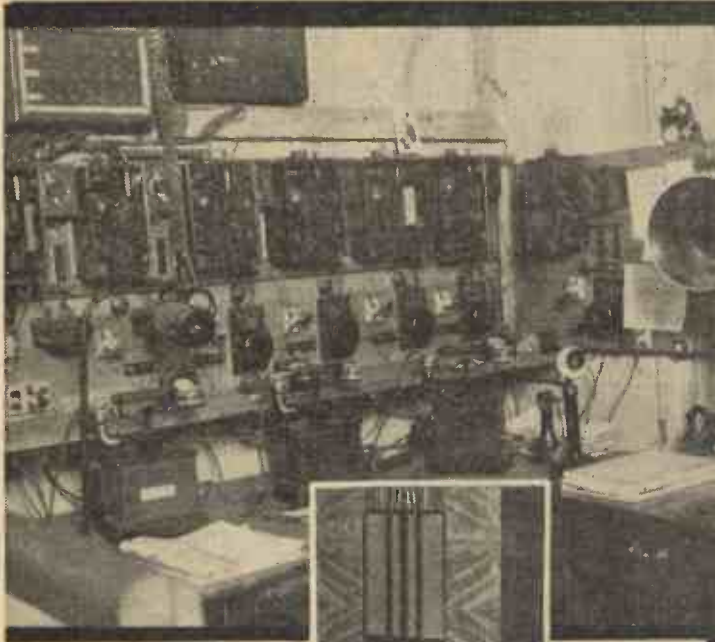

(Right) The Fleming Receiver of 1910. (Left) An early Marconi 2-valve Set. (Centre) The Marconiphone Jubilee Model "264" of 1935.

A modern home-constructed wireless receiver.

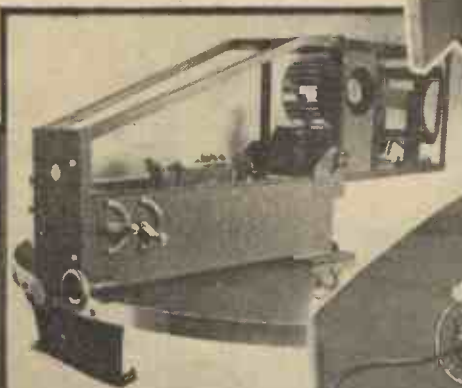

(Left) A modern television receiver. (Centre) A television transmitter with the cover removed. (Right) A remarkable musical instrument—the Electrone—music from the air!

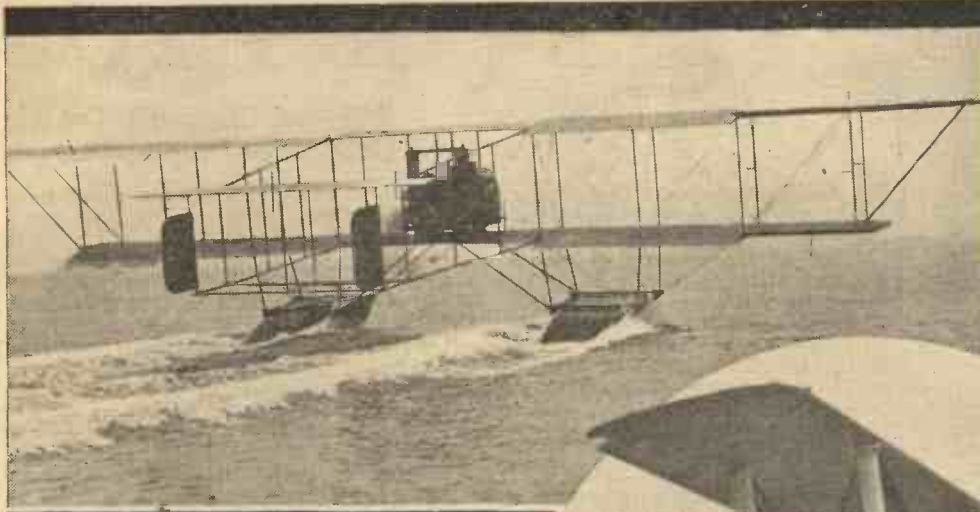

Progress in the Air

The tremendous strides made in flying is certainly remarkable when one considers that at the beginning of the nineteenth century there was no such thing as a flying machine. Thus during the last twenty-five years we have seen the birth of the heavier-than-air machine, seen it pass through its various phases, until to-day we have machines capable of flying at over 400 miles per hour. A typical example of the progress in aircraft design is afforded the reader by comparing the two seaplanes shown here.

(Above) An early type of naval seaplane and (right) its modern counterpart.

a speed of over 270 m.p.h. Here, again, complete stream-lining has helped considerably to increase the speed of the car.

Wireless, and in more recent years television, has been given to the world. Photographs in this supplement show the progress made in this particular branch of science.



The progress made in aviation is shown in the above photograph of the autogiro.

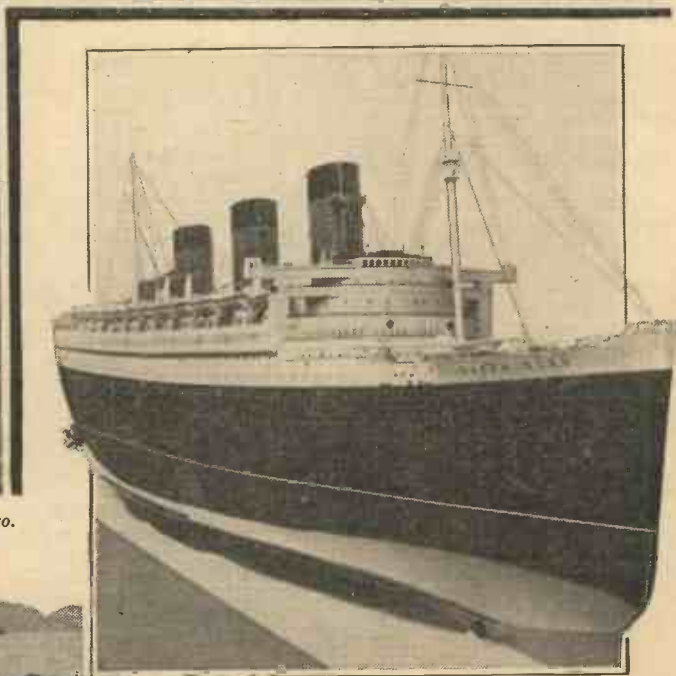

(Above.) The new Cunard White Star Liner "Queen Mary" and (left) A speed boat capable of travelling at over 100 miles per hour.

The difference is indeed startling! Again, the autogiro, for many years the dream of every aircraft designer, has made its appearance in the last year or two, and thus we have a machine capable of hovering in the air, and rising vertically off the ground. What will the next 25 years reveal?

TELE-CONTROL

A Simple, Cheap and Reliable Mechanisms from a Distance.

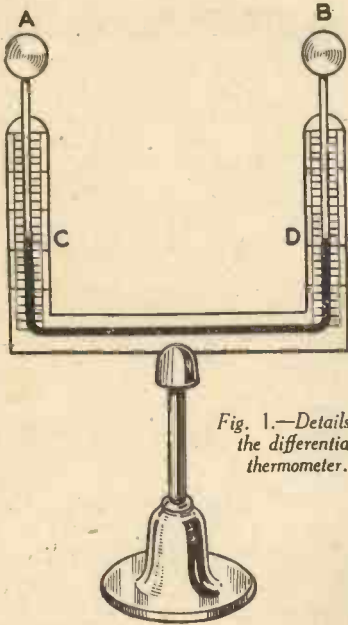

Fig. 1.—Details of the differential thermometer.

ONE of the most fascinating problems of the present century is that of operating things from a distance, such as the lighting of lamps, the starting and stopping of motors, etc., without any visible means by which this is brought about.

When distant control is mentioned, one at once thinks of "wireless control"; but wireless waves are by no means the only form of waves which may be used. Any form of radiant energy may be employed—sound, heat, light, ultra-violet, etc., as well as electric or magnetic.

I choose heat because it is by far the cheapest, as well as the simplest and most reliable. I am more especially concerned with the stopping, starting and steering of a small model motor boat on a small pond or stream, but the system can be applied to any control that the reader wishes.

In Fig. 1 is shown what is known as a differential thermometer, used for showing the difference in temperature between two neighbouring places. Two glass bulbs, A and B, filled with air, are connected by a bent glass tube of fine bore, the lower part of which is generally filled with some coloured liquid such as alcohol. Let us suppose this is replaced by mercury,

and that two pieces of platinum wire have been fused into the tube—one somewhere along the bottom and the other just above the top of the mercury column in the left-hand tube. Under ordinary circumstances A and B will be at the same temperature and C and D at the same horizontal level, but if we place the instrument so that B is in the sun and A in the shade, the air in B will expand, the mercury will fall below D and rise above C, and if the platinum wires be placed in an electric circuit a lamp in that circuit will be lighted. If the process be reversed, i.e., A in the sun and B in the shade, the lamp will go out.

Preliminary Experiment

Obtain a piece of thin tin some $2\frac{1}{2}$ in. square and turn up all the edges at right angles to a depth of about $\frac{1}{8}$ in.; drill a hole in the centre about $\frac{1}{8}$ to $\frac{3}{16}$ in. just sufficient to take any small piece of brass tubing. The length of this tubing need

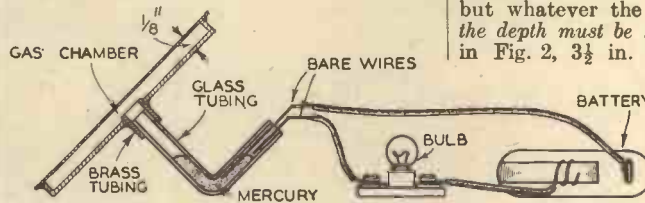

Fig. 2.—The complete circuit of the control.

not be more than $2\frac{1}{2}$ to 3 in. Solder it into the hole, allowing the tube to project on that side on which are the turned-up edges, not more than $\frac{1}{16}$ in. Fit into this brass tube a short piece of glass tubing, making an air-tight joint with secotone. This tube can be from 2 to 3 in. long; heat it and bend it at right angles in the centre before inserting it into the brass tubing.

Now solder on to the little tray a piece of very thin copper foil—cutting $\frac{1}{8}$ in. larger, i.e., $2\frac{3}{8}$ in. square. Next take a bowl or dish, nearly full of water; take a cycle pump and connect with the piece of glass tube by means of a piece of rubber tubing, bind with wire if necessary to make air-tight, immerse the apparatus in the bowl of water, having previously pulled out the pump handle, press gently but firmly down—if bubbles of air escape these parts must be resoldered—it is essential that the vessel be absolutely air-tight.

Then arrange the apparatus as in Fig. 2, with lamp and battery in circuit; two wires are pushed down the glass tube, one pushed well down into the mercury and the other just not touching it, and place the apparatus in the sun or put it in the shade and reflect the sunlight on to it from a mirror. If there is no sun hold a lighted taper an inch or so from it. The lamp will quickly light up—but it will not go out—or at least not for a considerable time. We require two such vessels connected together to form a thermostat to be of any practical use (see Fig. 4). Also our thermostat must be more sensitive; but first let me explain why the instrument is so shallow—the first one made by the writer was the size of a small cocoa tin and failed because there was too much air (too many

layers to heat), for air is not a good conductor of heat. It is the layer of air that is next to the copper foil that is heated, in other words, the distance from the copper foil to any part of the enclosed gas should be as small as possible. Referring to Fig. 1, this means that A and B or the two gas chambers should be as near one another as possible. So long as you can reflect heat rays on to one gas chamber at a time—they can be as close as you like—some 3 to 4 in. between their inner edges should be ample.

You will require two sets of gas chambers, etc. Now suppose each gas chamber to be $3\frac{1}{2}$ in. square with 4 in. between them, and also 4 in. between the two sets—the total length will be $3\frac{1}{2} + 4 + 3\frac{1}{2} + 4 + 3\frac{1}{2} + 4 + 3\frac{1}{2}$ in., or 26 in., which would necessitate a boat only 30 in. long. In a 3-ft. or a metre boat they could be larger, even up to nearly 6 in. if necessary. How far an enlargement in size would be an improvement is a matter for experiment, but whatever the back and front area—the depth must be kept to a minimum. As in Fig. 2, $3\frac{1}{2}$ in. square is a convenient size, but the depth is only $\frac{1}{8}$ in., which represents about a minimum. We proceed then to construct our starting and stopping apparatus as follows—the construction of the gas chambers being the same as in Fig. 2, save that they have a depth only of $\frac{1}{8}$ in. Before soldering on the front of the copper foil, we must coat the inside and shallow sides of the tin tray with lamp-black by holding it in the flame of a burning wax taper or some similar device. Don't coat the inside of the copper foil, because this has to radiate heat into the chamber, and we lamp-black the other to prevent radiation by conduction.

When the gas chamber is finished, the entire outside must be coated with lamp-black; one way is to mix some lamp-black and turpentine with a little varnish and paint it on with a brush. This can be handled when dry without coming off. When soldering the copper foil to the tin tray, place the tin tray on the foil and this or a layer or two of paper and the whole on a flat surface and press down fairly hard—the foil must be tightly and flatly soldered to the tin. Before coating outside with lamp-black, of course, test with cycle pump for air tightness.

Next take a strip of tin of dimensions shown in Fig. 3 and mount as shown—you may want them to be inclined at a small

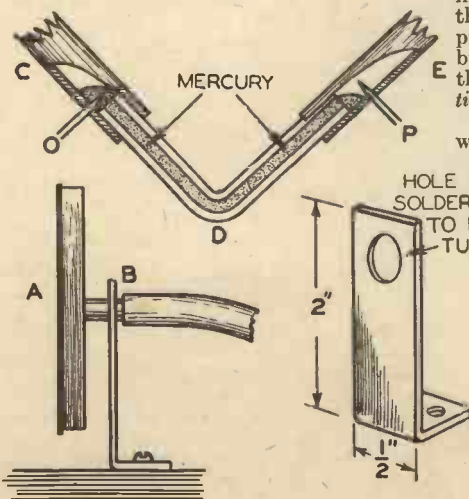

Fig. 3.—Details of the operating switch and support for the rubber tube to the gas chamber.

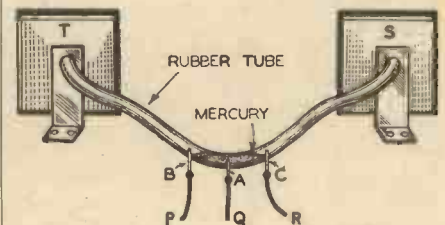

Fig. 4.—The device for steering a model boat. T and S are two gas chambers connected by a piece of rubber tubing.

OF MECHANISMS

Method of Controlling Model
By V. E. JOHNSON, M.A.

angle and not vertical, and when once required and angle found—a stay or two can be easily fixed to keep them firmly in that position. Treat the other gas chamber the same, mounting this a suitable distance from A.

D (Fig. 3) is a piece of glass tubing, curved or bent at right angles, about 2 to 3 in. long. This is fixed in a vertical plane by any convenient means centrally between the two gas chambers—this piece of glass tubing is connected to the two gas chambers by means of two pieces of rubber tubing known as Romac Windscreen Wiper Tubing—thick with a fairly fine bore and ribbed so that it bends at right angles without kinking. The tubing must be such that it fits fairly tightly, and it will be noticed that the rubber tubing governs the size of the glass tubing and the brass tubing soldered into the gas chamber (7-ft. of this rubber tubing can be purchased for 1s.). Next we have to insert the mercury into the tubing, and this must be done, of course, before the second piece of rubber tubing is pushed on to the brass tubing of the gas chamber. The glass tubing should be thoroughly cleaned with hot soda and water—dried washed out in methylated spirit, and again dried. The mercury is inserted by means of a fountain pen filler or similar instrument. It must be continuous without any break, and that is why the piece of glass tubing is inserted to see (by tilting to right and left) that it is. If it is not, it can generally be made so by pushing down a piece of very fine cotton-insulated wire and working it to and fro.

O and P are two pieces of copper wire, not too thick—just capable when their ends are sharpened of being pushed through one side of the rubber tubing, so that when the mercury touches both the desired electric circuit is completed. They must not be at the same height, i.e., not in the same horizontal level. One, say O, must be somewhat higher than P; O must always be immersed in the mercury, and P must not. Now the quickest way I find to do this is as follows. Insert the wire O first, before the mercury is put in, then put in some mercury and push a bare wire down the tube E until the circuit is complete and the lamp, etc., lights—the apparatus being, of course, horizontal. Next lay this wire along the outside of the tube, and insert wire P just in front of the end of the wire lying along the tube. The hole in the rubber must be made with the wire itself, and only a short length should be used. The end should be fixed to a terminal in the board at once and must not be moved about; squeeze a little rubber solution where the wire enters the tubing. The

little board to which the thermostat is fixed can then be slightly tilted so that the lamp just fails to light, and a very small movement of the mercury then completes the circuit.

How the Device works

Owing to the vast distance of the sun from the earth, its rays, both heat and light, are parallel for all practical purposes, and by means of a plane mirror can be reflected in parallel rays as well.

A glass mirror is not very suitable for the purpose, because we require a material reflecting the maximum amount of heat rays. Silver or zinc, when well polished, absorbs no more than 2 or 3 per cent. of the incident radiant energy, the remaining amount being reflected. A piece of zinc, $\frac{1}{8}$ in. thick and 6 in. square, costs 9d. only—it should be silver-plated (not nickel or

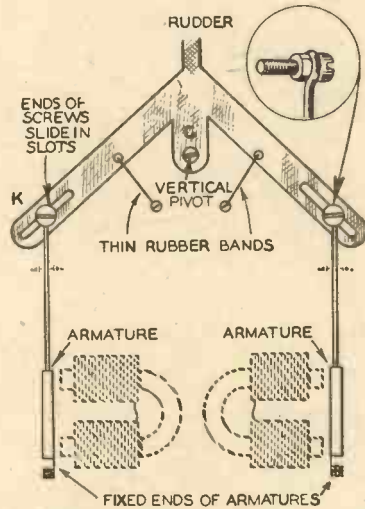

Fig. 6.—How the rudder of a boat may be operated by the heat control.

chromium) on one side, and this side should be as flat as possible; drill holes round the side and screw on to a piece of rather larger seven-ply wood, also quite flat. Plated copper appears to answer practically equally well. The metal should be painted black on the back, and a piece of thin asbestos board can be put between it and the wood. We use this, of course, to reflect the heat and light rays of the sun on to the desired gas chamber—the light rays only to see the position of the beam of heat.

Obviously, all our regulating devices must be in the shade. We therefore put over our entire boat at a suitable distance above the gas chamber a canopy, which can consist of a very thin piece of plywood, painted white on the top side and black on the underneath. The rays should be directed as near as possible perpendicular to the foil of the gas chamber for maximum effect.

Steering the Boat

Let us next consider how the boat can be steered—for this we shall require two more gas chambers mounted as before, connected by a curved piece of the rubber tubing (see Fig. 4). A is the lowest

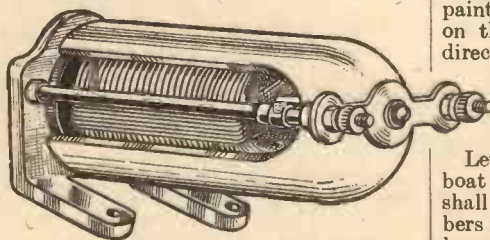

Fig. 7.—A permanent-magnet electric motor.

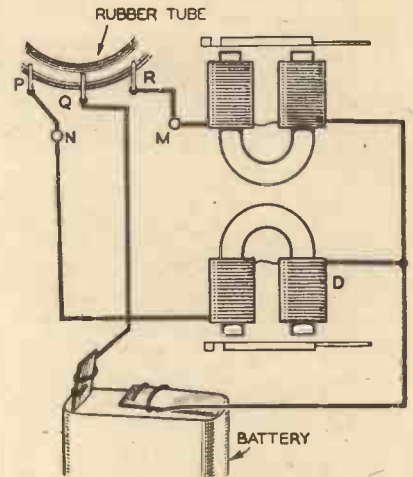

Fig. 5.—The wiring of operating magnets to control the mechanisms.

point, and B and C are two points equally distant from A and at the same horizontal level. Copper wires are inserted into the tubing at A, B and C, and are connected to the terminals P, Q, R; sufficient mercury is put into the tubing to not quite reach B and C when the board to which the apparatus is fixed is horizontal. Heat the chambers, and the mercury rises on the left-hand side, and one electric circuit is established through P and Q; heat T, and another circuit is established through Q and R. Each of these circuits energises its own electromagnet, which by the system shown in Fig. 5 is made to move the rudder to port or starboard. When both circuits are open, the rudder is straight. When the P, Q circuit is closed the electro-magnet D (see Fig. 5) is energised and its armature, mounted like the armature in an electric bell, is pulled to it, only a small distance, but if its length be increased its end K can be made to turn the V-shaped piece of centrally pivoted metal shown in Fig. 6 through an angle quite large enough to steer the boat in any desired curve.

The magnets are easiest made in the short stumpy horse-shoe type, from soft iron rod some $\frac{1}{8}$ in. thick and wound with about 24-gauge wire, not to take too much current. They should be fairly powerful and that part of the armature opposite the poles should not be less than $\frac{1}{8}$ in. thick.

Referring to Fig. 6, the rubber band or very weak spring must be just strong enough to hold the rudder in position. The whole piece of apparatus should be mounted on a piece of $\frac{1}{8}$ -in. thick ebonite or similar insulating material.

(Continued on page 480.)

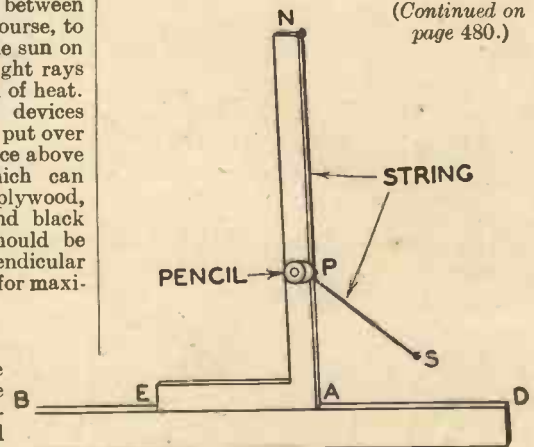

Fig. 8.—Showing the apparatus for drawing a parabola.

PLUGGING WALLS

Practical Methods of Fitting Plugs for Making Fixtures to Walls, Plaster, Tiles, etc.

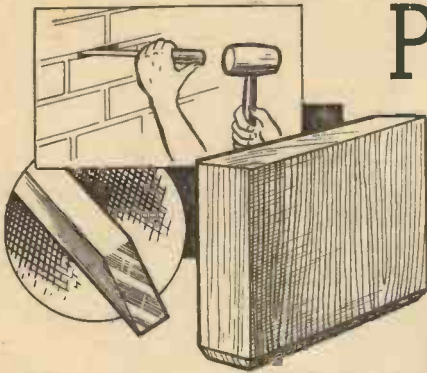

Fig. 1.—Fitting a wooden plug between the seams of two bricks.

OUTSIDE brick walls are usually the easiest to plug for fixtures, as it is possible to choose the location of the plug. There are four different ways of doing this. Fig. 2 shows a round plug inserted at the intersection of a corner in a seam. The hole should be cut with a round chisel or jumper, which can be made from a piece of gas pipe, cut across the top to form a crown, as shown in Fig. 2. The serrations are cut with a triangular file. When using the jumper do not attempt to drive it into the brickwork; obviously it will not go unless something breaks away inside. You should be able to feel the teeth cut into the material and then go no further. Then turn the jumper a few degrees and cut again. Remove the debris at frequent intervals. Cut the hole at least $\frac{1}{4}$ in. deeper than the length of the screw, or rather, the length of screw which will enter the plug. Keep the jumper straight and produce a parallel hole. The plug, which is shown in Fig. 2, should be about $\frac{1}{8}$ in. larger in diameter than the hole, so that it is compressed as it is driven into the hole, but not so large as to crush the wood and separate the grain, or cause the outer surface of the plug to shoot, as shown in Fig. 3. The sides of the plug must be parallel, the kind of plug one sees so often, and illustrated in Fig. 3, being quite useless, it being impossible to obtain a really good fixing with it, because only the front end of the plug is in contact with the brickwork, and the wood at the back end is so small that it splits as soon as the screw is driven home. Drive the plug in steadily, preferably with a mallet or a hammer and a piece of wood, to prevent smashing the top and splaying the grain. The choice of wood should receive careful consideration. Choose a piece of straight-grained resinous pine, not oak, or any other hard wood. Further, do not rely on the screw expanding the plug to fit the hole. The chances are of the wood splitting and

its solid strength lost. When the plug is inserted, drill a hole right through for the screw. This will allow of easy driving of the screw, and the egress of any material the point of the screw may push forward.

The plug shown in Fig. 1 takes advantage of the seam between two bricks. Use a thin chisel sideways, as shown, to take the mortar or cement out in the same way as you would cut a mortise in a piece of wood. Keep the sides parallel and cut the plug as shown. The width of the

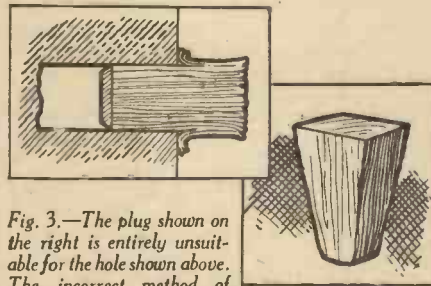

Fig. 3.—The plug shown on the right is entirely unsuitable for the hole shown above. The incorrect method of driving in the plug shown in Fig. 2 is shown on the left.

plug can be plus $\frac{1}{4}$ in., but the thickness should not be more than plus $\frac{1}{8}$ in. The plug must be parallel on all sides, although the ends may be chamfered to make entry easy.

It may be found that having broken through the cement painting there is little or nothing behind. When this happens and the plug has to stand a weight, it is advisable to fill up with cement, a mixture of sand and cement, 1-1, being suitable. Clear the seam and feed the cement well in, until no more can be inserted. Then, when the cement is still wet, insert a core made of three pieces of wood, tapered as shown in Fig. 4. These should be an easy fit between the bricks and should not be driven in. When the cement is hard, give it two or three days, withdraw the wedges and insert a plain ordinary plug. Combination plugs made on the drawing wedge

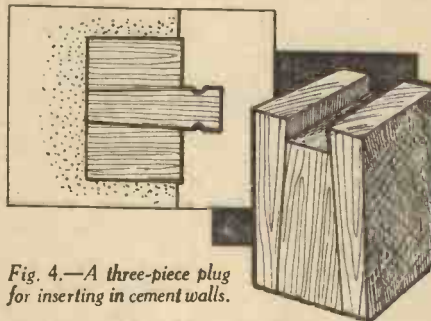

Fig. 4.—A three-piece plug for inserting in cement walls.

principle are not satisfactory for small plugs, but may be used for very large screws and where the sections are sufficiently large to carry the screws without splitting. Such a plug is shown in Fig. 4.

It sometimes may occur that a plug has to be inserted near the edge of a brick, as shown in Fig. 5. In any case the edge of the brick will break out, so first of all take out the seam and drop in a piece of steel, packed up with small wooden wedges. This helps to keep the chisel up into the

hole being cut, and prevents the corners of the brick breaking away. The hole should be cut with a chisel shaped as in Fig. 5, and not hacked out. Mark out the shape of the hole and cut across the face as shown. Then turn the chisel round and cut downwards. Keep the chisel sharp and cut well into the corners. When sufficient depth has been attained, take out the steel and fill the space with a wood plug or cement. The plug shown in Fig. 5 should be used. Note the twist, the plug being cut this way. Actually the diagram shows excessive twist for purposes of clarity, and a few degrees only are required on the actual plug.

This covers the majority of common types of plugs used in brick walls, and similar principles apply in all other materials. Plaster-faced walls sometimes cause trouble through the plaster breaking away. It is important to remember that plaster will not hold a plug itself. It is far too soft and exceptionally friable. The best method to adopt is to deliberately cut away a larger area of plaster than for the hole required, as shown in Fig. 6, and then fit a plug, preferably flush with the face of the brick as described previously, and "make good" with "Keen's" cement, leaving a nail or

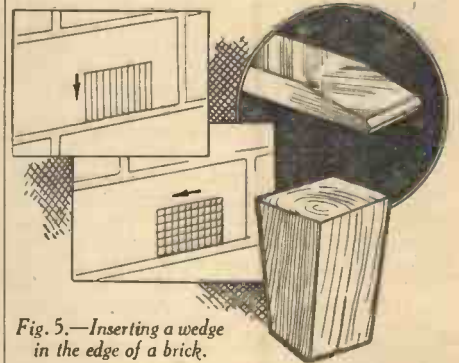

Fig. 5.—Inserting a wedge in the edge of a brick.

screw protruding from the plug to locate it later.

Tiles present a problem on their own, as a chisel cannot be used with safety for fear of cracking the tile. The writer finds the best way is with an arrow-headed drill lubricated with turps or paraffin. The drill must, of course, be kept sharp, but once the glaze has been penetrated the rest is comparatively easy. Rawlplugs are undoubtedly ideal for tiles, but the punch supplied with the kit should not be used for tiles, although perfectly satisfactory for other materials.

It may seem totally unnecessary to plug wood, but if one meets a really good piece of old oak, plug it. It is the easiest way. Drill a round hole and put in a Rawlplug or a piece of softer wood. Steel screws should not be used on oak, because they are liable to rust.

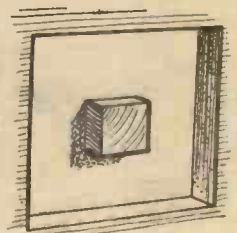

Fig. 6.—Inserting a plug into a plaster wall.

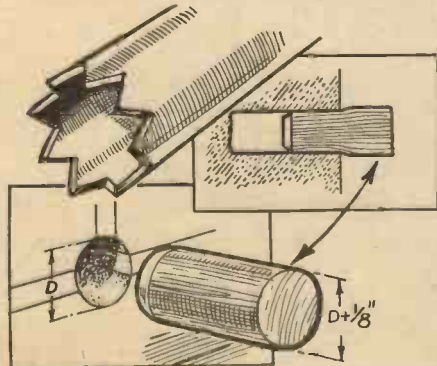

Fig. 2.—For inserting round plugs, the hole should be cut with a jumper made from a piece of tube, as shown.

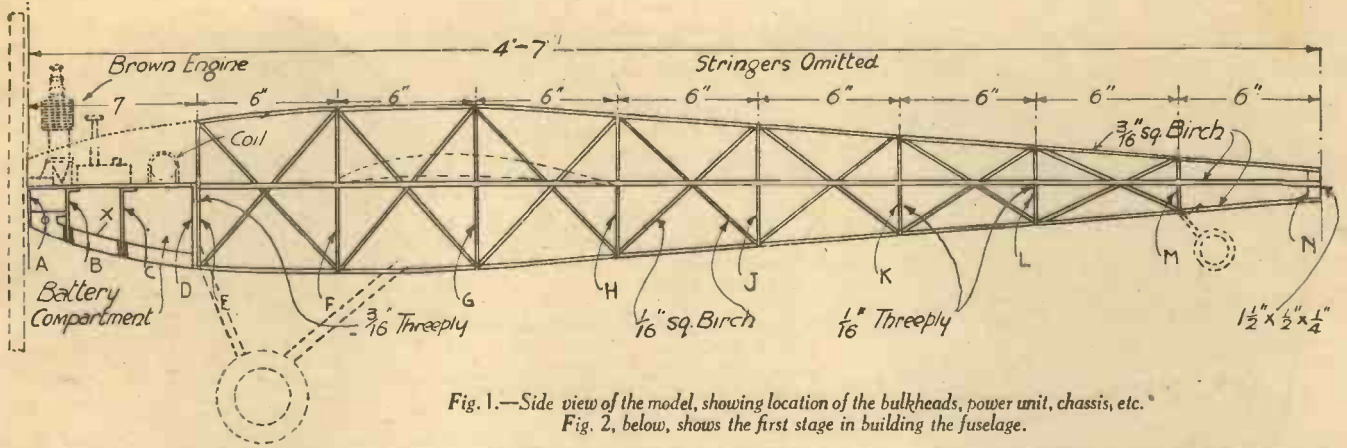
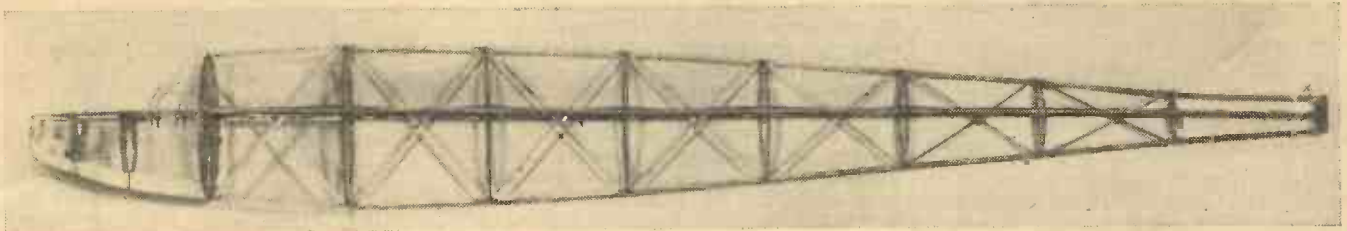

Fig. 1.—Side view of the model, showing location of the bulkheads, power unit, chassis, etc.
Fig. 2, below, shows the first stage in building the fuselage.



A PETROL-DRIVEN MODEL MONOPLANE

A Simple and Satisfactory Design Suitable for Any of the Small Petrol Engines now Available.
Full-Size Blueprints are Available

By F. J. CAMM

SINCE my announcement in the May issue that I proposed to publish a design for a pusher type of petrol-driven model aeroplane I have received many letters from interested readers requesting that I first of all publish designs for a model of the tractor type. Accordingly, I have deferred publishing the design for the pusher machine and include in this issue details and drawings for making the fuselage of a small tractor monoplane of simple, yet satisfactory, design.

I have designed the fuselage from the point of view of efficiency only, and not according to the empirical formula laid down by the Competition Committee of the S.M.A.E. If readers therefore wish to enter this model for any competition organised by the M.S.A.E. they should satisfy themselves that it accurately complies with the formulæ, which is:

$$\text{Max. cross sectional area} = \frac{(\text{overall length of model})^2}{100}$$

As the cross section of the fuselage is more or less elliptical, the cross sectional area must be calculated from the formula for the area of an ellipse which is: Multiply the diameters together and the product by 0.7854. As the dimensions of the largest bulkhead are 7 in. x 6 in. the maximum cross sectional area of this model is 7 in. x 6 in. x 0.7854 = 32.98 sq. in. The total length of the model is 4 ft. 7 in. The square of 4 ft. 7 in. is 3,025 sq. in., which divided by 10 = 302.5 sq. in. It will thus be seen that if my dimensions are adhered to the present model is within the formula. It is possible, of course, by careless shaping of the bulkhead to reduce the cross sectional area, and very careful plotting of the shape of the bulkheads as illustrated here are therefore necessary, if the formula is to be complied with.

Full-size Blueprints

For the convenience of readers who prefer to work from a full-size blueprint (and thus

save themselves the trouble of scaling up from the illustrations here given) we can supply such giving the full-size shape of every bulkhead and the engine cradle for 1s. post free. The blueprint may be stuck down on to the plywood and the bulkheads cut to their exact shapes. A series of full-size blueprints of the entire model will also be available shortly at 7s. 6d., but as these will be limited in number it is necessary, should you desire a set, to reserve them at once by writing to the Publisher, Geo. Newnes, Ltd., 8/11 Southampton Street, Strand, W.C.2.

The Power Unit

I have designed the model so that any of the petrol engines available—the A.E. Jones Improved Atom Minor, the Brown Junior, the Hallam, the Economic Electric, the Grayspec, the A.E. Jones Andrich, or my own engine—may be fitted into it. Details of all these engines appear in my handbook POWER DRIVEN MODEL AIRCRAFT,

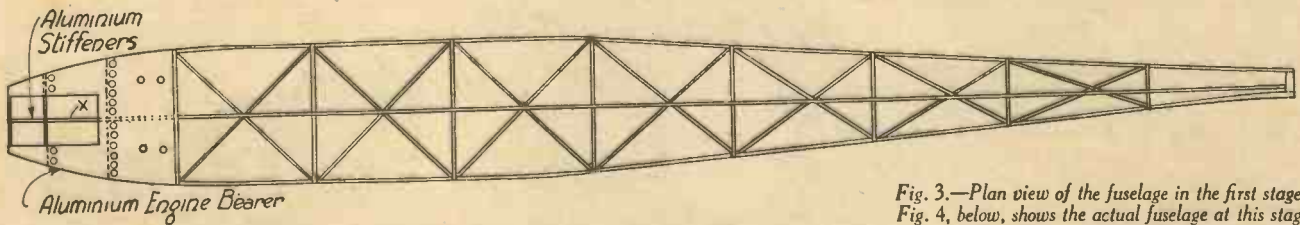
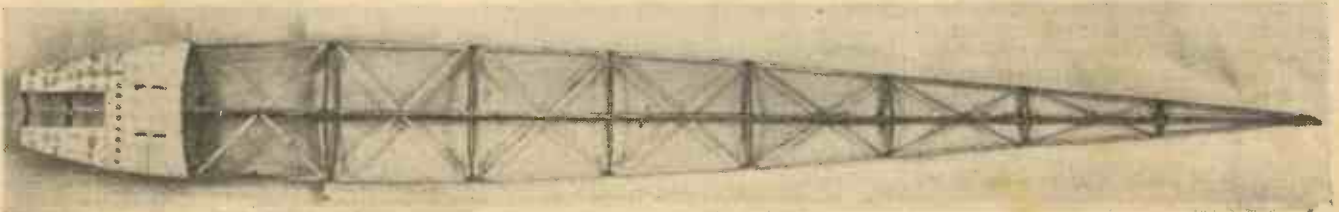
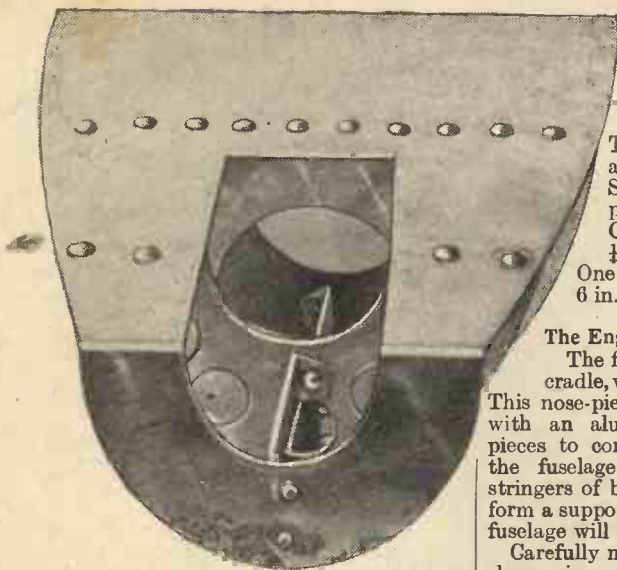

Fig. 3.—Plan view of the fuselage in the first stage.
Fig. 4, below, shows the actual fuselage at this stage.





Three ft. of $\frac{1}{8}$ in. plywood 6 in. wide (in 12 in. lengths).
 Four lengths of 4 ft. \times $\frac{3}{8}$ in. square birch for cross braces.
 One piece 18 gauge aluminium, 18 \times 7 in.
 Three dozen $\frac{3}{8}$ in. snap-head aluminium rivets.
 Small packet of $\frac{1}{16}$ in. fine brass pins.
 One piece of birch, $1\frac{1}{2}$ \times $\frac{1}{2}$ \times $\frac{1}{4}$ in. for stern post.
 One piece of $\frac{1}{8}$ in. three-ply, 7 \times 6 in. for bulkhead E.

The Engine Cradle and Fuselage Nose

The first part to make is the engine cradle, which forms also the nose-piece. This nose-piece will eventually be covered with an aluminium cowl made in two pieces to complete the fuselage line, and the fuselage itself will have additional stringers of birch let into the bulkheads to form a support for the fabric with which the fuselage will be covered.

Carefully mark out the aluminium to the shape given in Fig. 7, marking it off into $\frac{1}{2}$ in. squares, tracing off the curves, and marking off the dimensions given. It will be noticed that this aluminium nose-piece is strengthened by bulkheads B and C bulkheads A and D being, of course, cut

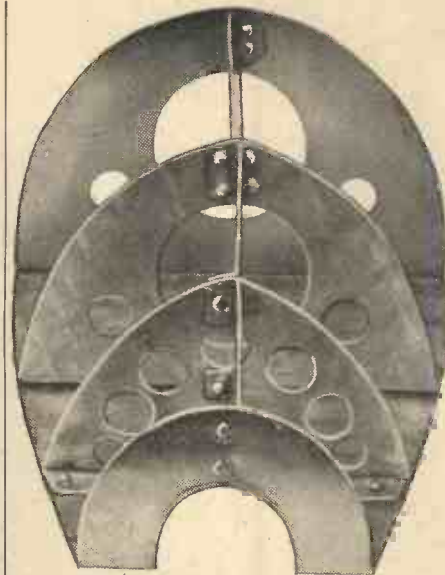

Fig. 6.—Underneath view of the combined engine cradle and fuselage nose.

Fig. 5.—The combined engine cradle and fuselage nose. This is eventually covered with an aluminium cowl.

obtainable from newsagents for 1s., or by post from us for 1s. 2d. It will be seen that the nose of the fuselage is designed to form

of the nose-piece are riveted together with the aluminium rivets and for this purpose

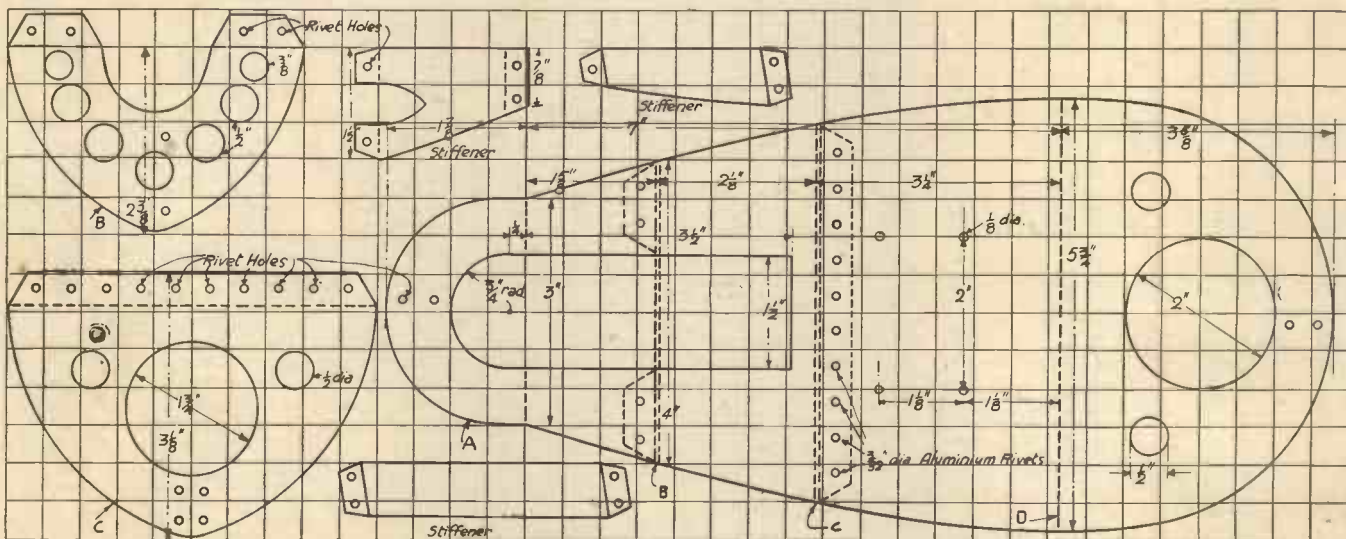

Fig. 7.—Detail drawing of the engine cradle. Copy this drawing on to the 18 gauge aluminium, making the squares of $\frac{1}{2}$ in. sides. The piece of aluminium measures 18 \times 7 in.

also the engine cradle, the design of which will merely need to be modified according to the type of engine selected. I shall be glad to hear from readers as to the style of engine they propose to fit so that I can prepare suitable designs for nose adaptors.

The engine cradle and fuselage nose are made from aluminium of sufficient strength—18 gauge—to resist torque and yet sufficiently ductile to bend in the event of a crash and thus avoid damage to the power unit.

Materials Required

In order to avoid confusing detail I have arranged the design for construction in easy stages, and I have arranged with advertisers in this issue to supply the necessary materials.

The following materials are required to proceed with the construction dealt with in this issue:—

Four lengths of birch, 4 ft. long by $\frac{3}{8}$ in. square.

solid with the top surface of the cradle and bent down at right angles to it. The parts

I recommend the use of the special rivet punch, which can be purchased for a few pence.

After assembling bulkheads C and D in this way cut out the stiffening pieces which are fitted on the centre line between the four bulkheads A, B, C, and D.

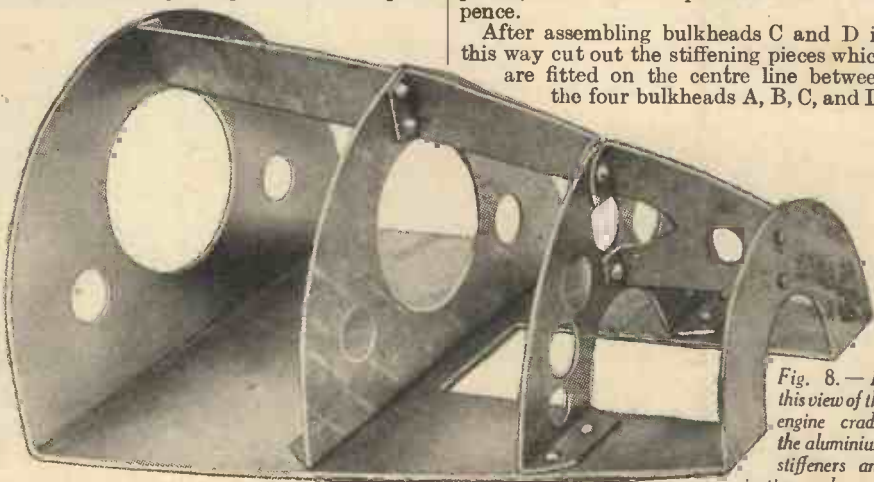
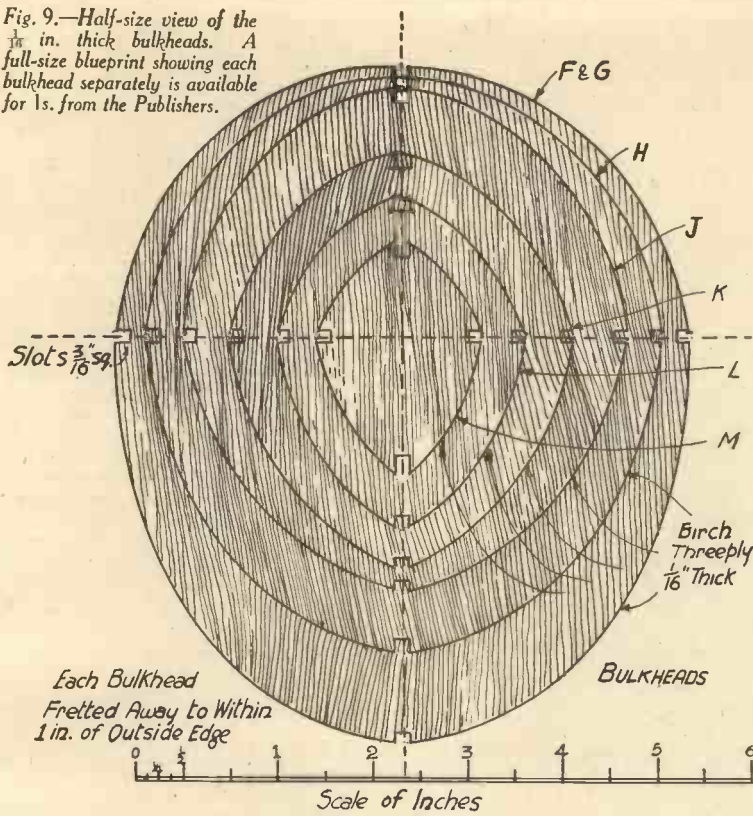

Fig. 8.—In this view of the engine cradle the aluminium stiffeners and riveting can be seen.

Fig. 9.—Half-size view of the $\frac{1}{16}$ in. thick bulkheads. A full-size blueprint showing each bulkhead separately is available for 1s. from the Publishers.



glued and pinned together at their points of intersection further to stiffen the structure. The rubber bands should be left on until the glue is dry, when the pins may be neatly clinched by hammering the projecting ends over.

The Stern Post and Main Bulkhead

The rear ends of the fuselage members are coupled to the stern post in the manner shown in Fig. 12, and fixed by pinning and gluing. It will be noted that the members are haunched into the stern post, the centre members being halved into it. The main bulkhead E is fretted out to suit the aluminium bulkhead D, but the top portion of it is left solid, so that various controls can be attached thereto. The longerons are not attached to the bulkheads in any other way than by glue, the cross-bracing keeping them in position, the only exception being with bulkhead E into which they are pinned as well as glued.

When finished the fuselage should be given one coat of goldsize and one coat of knotting, which will keep out the moisture and prevent it from warping. In the condition shown in the photographs the fuselage should weigh .6 oz., and the aluminium nose-piece 4½ oz. Readers who wish to proceed in advance of publication of details herein should reserve a set of the full-size blueprints. For details of engines refer to the handbook already mentioned.

The fuselage is enormously strong for its weight, and has the advantage that, should the nose become damaged, the remainder

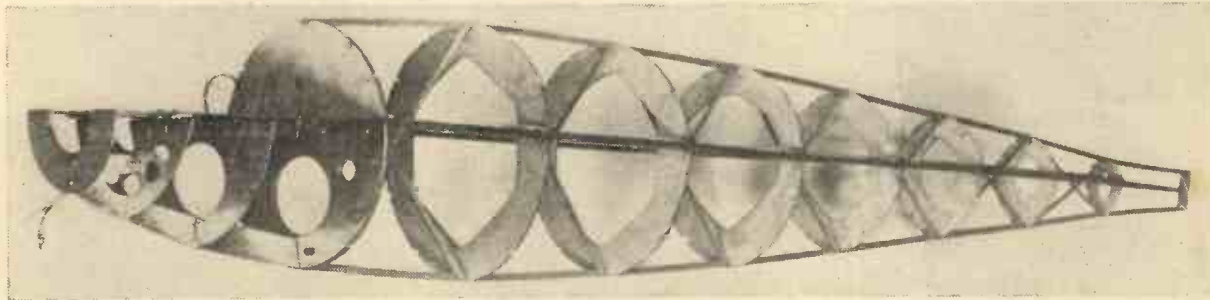

Fig. 10.—Another view of the partly finished fuselage and engine mounting.

No lengths are given for these, since it will be necessary to fit them snugly between the bulkheads; flanges are bent round at right angles on each stiffener and they are then riveted to the bulkheads C and D. They may then be riveted to the main piece of aluminium. It will also be necessary to fit torsion members to the nose-piece, but this I will deal with next month. The engine cradle at this stage is shown in Figs. 5, 6, and 8.

The Bulkheads

The bulkheads of the fuselage, which are lettered alphabetically from the nose to the tail in Fig. 1, are made of three-ply, bulkhead E being of $\frac{3}{16}$ in. three-ply, and the remainder of $\frac{1}{16}$ -in. three-ply. All of the bulkheads except E are fretted out in their centres to within 1 in. of their outside edges for lightening purposes, four $\frac{3}{16}$ in. square slots being cut at the points marked to accommodate the longerons. After cutting the bulkheads thread the longerons on to them, spacing the bulkheads at intervals of 6 in. Some large rubber bands passed over the longerons will enable you to space the members, to gauge the form taken by the longerons, and to do any final trimming necessary to preserve continuity of line. Any little humps formed by the bulkheads may be removed by cutting the slots a little deeper.

Bracing

Proceed to lattice-brace the various longerons in the manner shown in Figs. 1 to 4 by pinning and gluing $\frac{3}{16}$ in. square birch braces cross-wise between the cellules. Care is necessary during this operation, otherwise the fuselage will be pulled out of truth. The horizontal members, for example, must be kept horizontal, and it will be necessary frequently to "eye" along the fuselage during construction in order to preserve symmetry and alignment. The braces should also be

of the fuselage is kept intact, thus making for speedy repair.

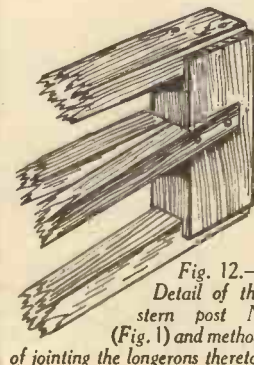

Fig. 12.—Detail of the stern post N (Fig. 1) and method of jointing the longerons thereto.

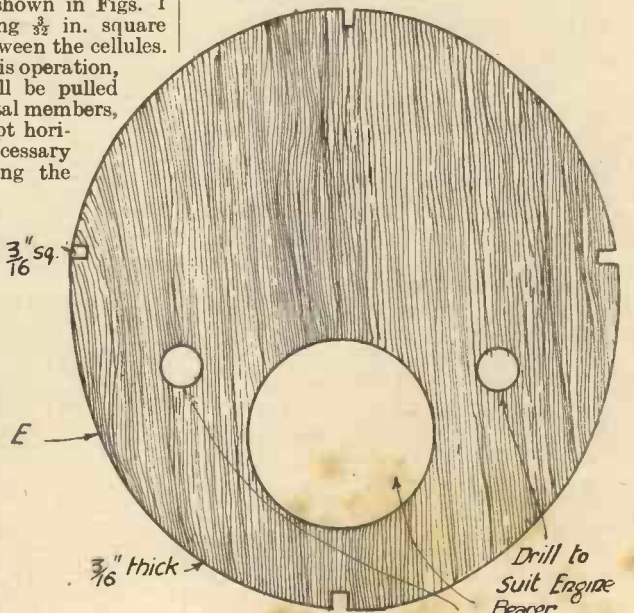
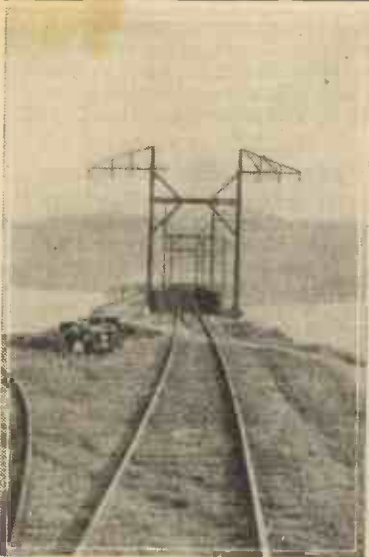

Fig. 11.—The main bulkhead E.

THE PANAMA RAILWAY

THE WORLD'S FIRST TRANS-CONTINENTAL SYSTEM



(Above) The Panama railway crossing Rio Chagres. (Right) Towing a ship through Gaton Lock. The electric loco is seen climbing to the level of the second lock (four locos are used to each vessel).



the merest tourist, for a considerable part of the old main street actually faces on the line, and its original name was Aspinwall Bay. The name Colon was adopted as a compliment to Columbus, who discovered the place in 1502, since it is the Spanish form of his surname, while Cristobal is that of his Christian name. Cristobal is the new American town alongside Colon, which has grown up during, and after the construction of the Canal.

The First Railway

This was built in five years by an American company during 1850 to 1855, and its completion antedated by fourteen years the first transcontinental railway in the United States.

The gauge was 5 ft., and the length about 48 miles. The difficulties were due to the climate and to the nature of the country traversed. No line has ever been built at a greater cost per mile in human life. Exact figures are difficult to ascertain as it is so long ago, and records have not been kept, but local gossip is to the effect that *every sleeper on the line represents a death*. This must be an exaggeration, but it is certain that before the coming of sanitation this district was a veritable "White Man's Grave." The railway was made a generation before De Lesseps commenced his canal, and although he built some splendid hospitals, his death roll was from *thirty to forty a day for months* at a stretch, until it was usual to say there were more dead men buried at Colon than living persons remained in the town!

The Dean of the Medical Faculty at Colon neatly divided the seasons as follows:

AMONG all the mighty achievements of modern engineering skill, few have had more practical value to mankind than the world's great transcontinental railways, and the Panama Line occupies a unique place among these. It was the first to link the shores of the Atlantic and Pacific Oceans, it was constructed in the face of enormous difficulties, in a deadly climate, and at a frightful cost in human lives. And then, when it had been actually completed, and had been working efficiently for sixty

This is the more remarkable since it is probable that the canal could never have been constructed without the railway, and yet, save for an obscure obelisk, the names of these pioneers would have been forgotten. It stands near the Washington Hotel at Colon, and bears the names of Aspinwall, Stephens and Chauncy, pioneers and founders of the railway.

The town has been very ungrateful to its creator, for it was Aspinwall and his railway which made Colon. This is obvious even to

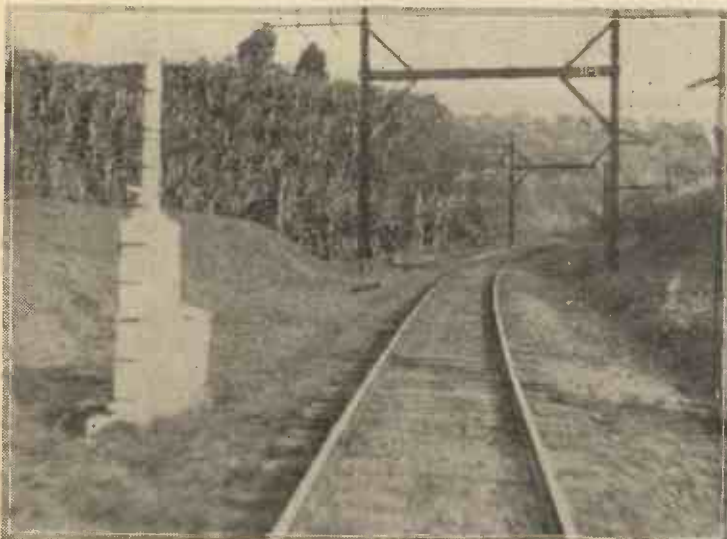

(Left) The Panama Railway passing through banana groves.

years, it was deliberately submerged under a gigantic artificial lake and had to be almost entirely rebuilt! No railway in the world traverses a more romantic route than does this midget line across the Andes.

It is a remarkable fact that, although scores of volumes old and new have been written about the Panama Canal, no book has yet been devoted to the plucky engineers who built the Panama railway, and faced the awful risks of this deadly climate long before De Lesseps made his costly failure.

(Right) The Kings Bridge, Panama, over which the incas gold was carried; relic of 1635.



"First we have a wet season, lasting from about the 15th of April to the 15th of December when people die of yellow fever in four or five days. Next you have the dry or healthy season, from December 15th to April 15th, when people die of pernicious fever in from twenty-four to thirty-six hours."

The Problem of Rains

Another tremendous problem was the rains, and the resultant floods on the Chagres River and its tributaries which traverse the route of the railway. In England about 2½ in. of rain form a normal month's fall, and if so much were recorded in a single day it would be regarded as an exceptional deluge. But on the route of the Panama Railway 2½ in. of rain have fallen in three minutes. This is not rain at all, but a blinding cataract of water that no man can face, like that which I have encountered in the Cave of the Winds at Niagara. And after the rains came the floods. The Chagres River follows the line of the railway; in the dry season it is a peaceful stream about as wide as the Thames at Chelsea, and 3 or 4 ft. deep. In the wet season it becomes a raging torrent, which has been known to rise thirty-four feet in twenty-four hours, and the resulting inundations sweep everything away. In the fall of 1879 many miles of the railway were flooded to a depth of 18 ft., and in another season the track was submerged from Tiger Hill to Emperador, a distance of about twenty-six miles.

The Swamps

But the swamps were even worse than the floods. If a man incautiously stepped in that deadly ooze he would swiftly vanish for ever, unless help were instantly available. Colonel Totton encountered a terrible

mosquitoes, which bit and tormented him, and carried the germs of malaria and yellow jack. If he brushed against a tree or lay down on the grass, he would be smothered with ticks, which buried themselves in his flesh, leaving only the breathing tubes outside the skin. If a drop of oil is placed on this part of the insect it comes out instantly,

but if the man attempted to pull it out a festering wound would result. At night, as he slept, giant cockchafers bit into the quicks of his toe-nails, or jiggers laid their eggs in the flesh which, unless removed carefully by a needle, would produce a frightful septic wound. Occasionally the vampire bat would alight on the naked foot of a sleeping man, and lull him to deeper slumber by flapping wings, while it drank greedily of his blood!

And when they had cleared the jungle and laid the track, it needed constant vigilance, or the jungle would return and swallow it up again. The trackway had to be sprayed with weed-killer, and the dense walls of jungle hacked back, or the line would have been lost within six months.

All honour to these brave pioneers, who hewed their way through these miasmatic jungles in a stifling heat like that of the steam-room of a Turkish bath, and carried the iron road through swamps, and over great rivers to the summit, and down to the Pacific Ocean. The highest point in the original line was at



Panama City Station, Panama Railway.

Barbacoas, a splendid iron structure more than 600 ft. long, which cost half a million dollars. In the great earthquake of 1882 the bridge was violently shaken, and moved slightly out of line, but undamaged! When De Lesseps started his canal, he bought the Panama Line and found it of the utmost value in constructional work. After his failure the railway was used by trans-continental passengers, who disembarked at Colon, and re-embarked at Panama, and vice versa.

When the new canal was built, the whole of the line was submerged under the artificial Gatun Lake, except the first four miles from Colon to Mindi, and a similar length on the Pacific coast from Corozal to Panama. The rest was rebuilt by the American Government at a cost of over \$9,000,000. It is single-track, rock-ballasted, with 90-lb. rails and automatic signalling. There are three ordinary trains each way with sixteen intermediate stops which do the journey in one and three-quarter hours, but the tourist specials take about seventy minutes. The trains are of the modern corridor type with oil-fired engines, and there is now a very considerable tourist traffic. The railway owns two splendid hotels, the Washington at Colon close to the sea, and the Tivoli at Balboa Heights, looking over the Pacific. To-day it is claimed that the Canal Zone has a lower death rate than that of many North American towns, and so a former "White Man's Grave" has been transformed by the practical application of modern science into a beautiful and salubrious winter playground. Bathing can be enjoyed all the year round, and the climate is quite pleasant except during the rainy season.



Widening the Culebra Cut, Panama Canal.

swamp at Mindi when building the very first stretch of line. The black foetid mud swallowed everything, and soundings finally reached bottom at 200 ft.; it was not until many thousands of tons of rock and soil had been plunged into the abyss that the metals could be laid. And after the swamp was the jungle, so dense that it was impossible to move for a yard without hacking a road with machetes. These are heavy knives like swords, which all the natives carry, and use for chopping firewood and settling differences with their neighbours. The jungle was full of perils. The dreaded tiger-cat lurked in the dense bushes, and huge alligators sunned themselves beside the streams. Snakes were everywhere, and often a despairing cry from a peon told that his naked foot had been struck by poison fangs. But the insects were even worse. Every man walked in a cloud of buzzing



(Above) The city of New Panama and (right) a view of Culebra Cut, Panama.

Culebra (or "the Serpent") which is 238½ ft. above sea-level.

The Culebra Cut

This is where the famous Culebra Cut on the Canal has since been made, and is the lowest pass in the whole length of the Andes.

The finest bridge on the line is at



FIRST SOLO!

A Story of the Most Thrilling Moment in the Life of Every Pilot.

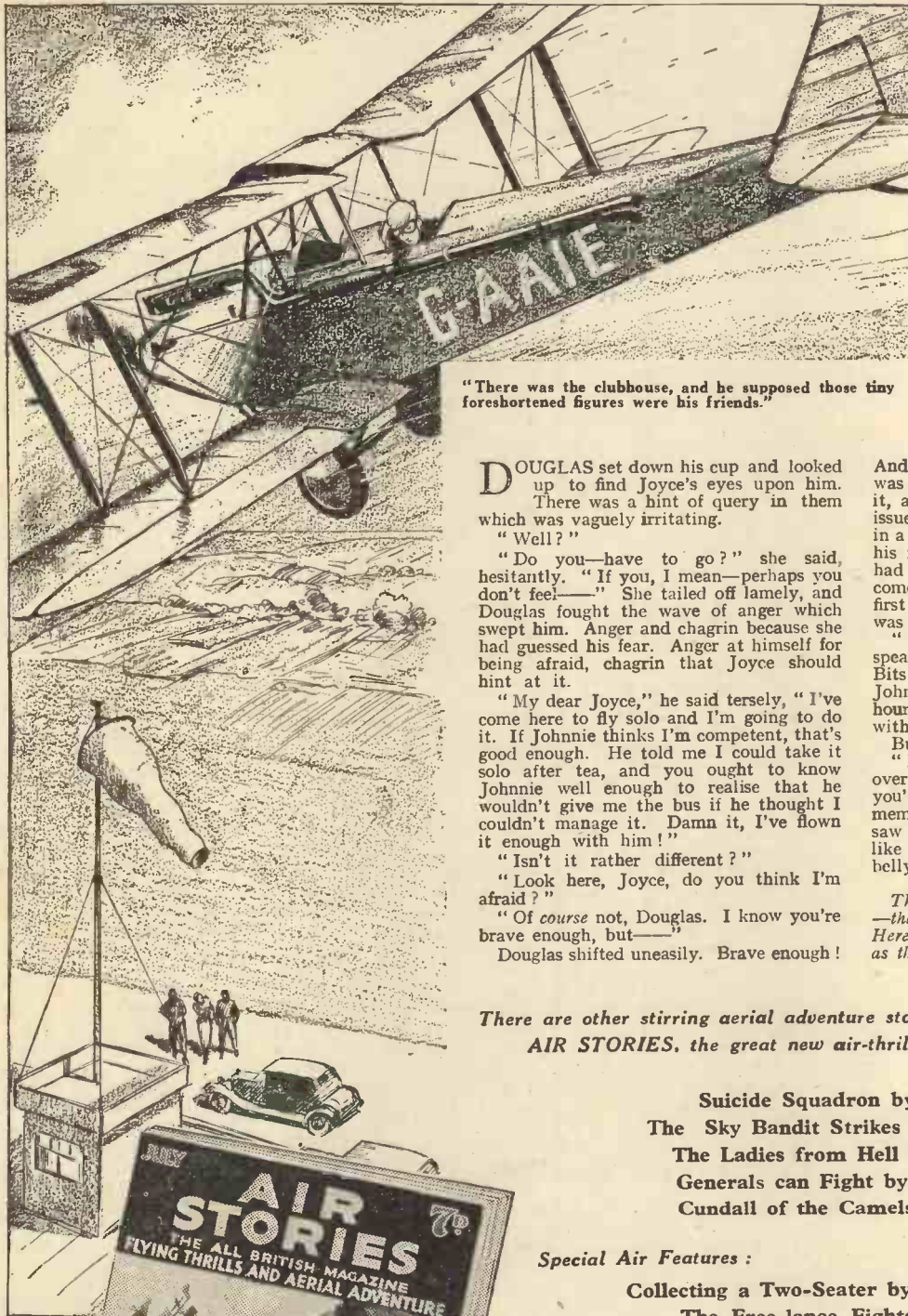

"There was the clubhouse, and he supposed those tiny foreshortened figures were his friends."

DOUGLAS set down his cup and looked up to find Joyce's eyes upon him. There was a hint of query in them which was vaguely irritating.

"Well?"

"Do you—have to go?" she said, hesitantly. "If you, I mean—perhaps you don't feel—" She tailed off lamely, and Douglas fought the wave of anger which swept him. Anger and chagrin because she had guessed his fear. Anger at himself for being afraid, chagrin that Joyce should hint at it.

"My dear Joyce," he said tersely, "I've come here to fly solo and I'm going to do it. If Johnnie thinks I'm competent, that's good enough. He told me I could take it solo after tea, and you ought to know Johnnie well enough to realise that he wouldn't give me the bus if he thought I couldn't manage it. Damn it, I've flown it enough with him!"

"Isn't it rather different?"

"Look here, Joyce, do you think I'm afraid?"

"Of course not, Douglas. I know you're brave enough, but—"

Douglas shifted uneasily. Brave enough!

And he wasn't. Damn it, he wasn't! He was a coward. All his life he had suspected it, all his life he had successfully dodged the issue. Nothing of importance had happened in a safe, ordinary existence that would put his nerve to the crucial test. Always he had felt: "If anything big crops up, I'll come up to scratch." And now for the first time in twenty-four years a real issue was before him, and—he was scared.

"It's ridiculous," he said, trying to speak firmly. "Millions of people do it. Bits of boys. Women. Look at Amy Johnson; went to Australia with only ten hours solo. I've had about twenty hours with Johnnie. Nothing to worry about."

But inside his mind was the voice of fear.

"Pretend to be ill," it whispered. "Fall over and twist your ankle. Don't go up—you'll be killed, smashed to pieces. Remember that chap from the Club? You saw him. Crushed, horribly. You'll be like that—bits of jagged metal in your belly. Blood. Hot oil. Fire. *Don't go!*"

This is the feeling which comes to many pilots—the moment before their "first solo"! Here is a story you will thoroughly enjoy, as though you yourself were in the machine.

There are other stirring aerial adventure stories in the grand July number of **AIR STORIES**, the great new air-thrills magazine. They include:

Suicide Squadron by E. C. Parsons.

The Sky Bandit Strikes by Arch Whitehouse.

The Ladies from Hell by Jack Townsend.

Generals can Fight by G. Fielding Eliot.

Cundall of the Camels by V. M. Yeates.

Special Air Features:

Collecting a Two-Seater by Major Oliver Stewart

The Free-lance Fighter: Albert Ball, V.C.

Famous Warplanes, etc., etc.

AIR STORIES

THE NEW ALL-BRITISH
AIR-THRILLS MAGAZINE

7D

July Number Now on Sale at all
Newsagents and Bookstalls

George Newnes, Ltd.

STAGE EFFECTS: How They are Produced

Mechanical Stage Effects Have Improved Considerably in Recent Years, and with the Advent of the Revolving Stage, Spectacular Stage Productions Have Been Made Possible

eventually soar aloft (supported by wires), singing out her soul, just newly restored to her.

The Coliseum Revolving Stage

In recent years, mechanical stage effects have been invested with an efficiency previously undreamt of. The London Coliseum, for instance, is equipped with a revolving stage 75 ft. in diameter, made up of three concentric rings capable of revolving in opposite directions or in the same direction as required. Wonderful use of this and similar revolving stages elsewhere is from time to time made in the mounting of spectacular productions.

Before the cinema with all its natural advantages began to compete from a spectacular point of view with the stage, stage effects were frequently crude in the extreme, but no longer is the heroine of melodrama, benighted in a storm of paper snow, a sympathetic figure. A metallic "clip-clop" sound from the "prompt" side of the stage fails to beguile a modern audience into acceptance of the suggestion that the villain, entering, it may be, from the opposite side, has just arrived there on horseback. Before the advent of the cinema such effects were, at any rate, conventionally acceptable, just as it is still conventionally acceptable for audiences to

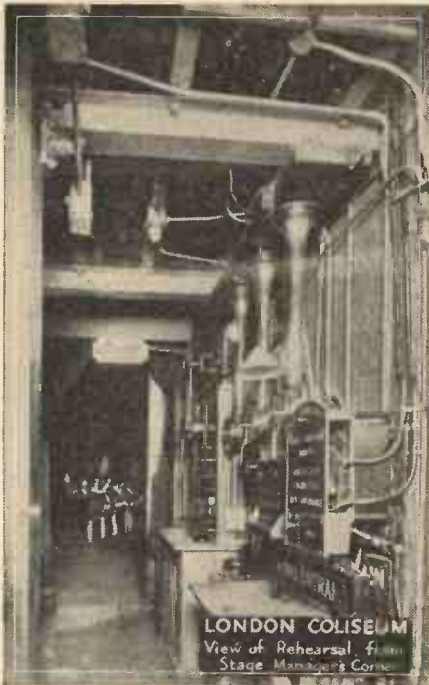

On the right of the photograph can be seen the switch for operating the dual tableau winch and various other switch arms for stage operation.

FROM earliest days the theatre has depended for effectiveness largely upon mechanical aids. In ancient Greece those playing the parts of mythological gods and goddesses made their descent from the supposed heavens upon scenes of inevitable turmoil beneath in cradle-like contrivances lowered by ropes and pulleys. Their arrivals upon the scene were surprisingly opportune, which fact spoke as well for contemporary stage management as it did for dramatic instinct. A familiar phrase persists in our language as a result: "The god out of the machine," employed to signify a timely deliverance from difficulty.

More recently, in "Faust," Mephistopheles would at one time have been considered unworthy of the name had he not traditionally appeared in a flash of burning brimstone through a mechanically-operated "trap" in the stage, and Margherita indeed a disappointing heroine who did not

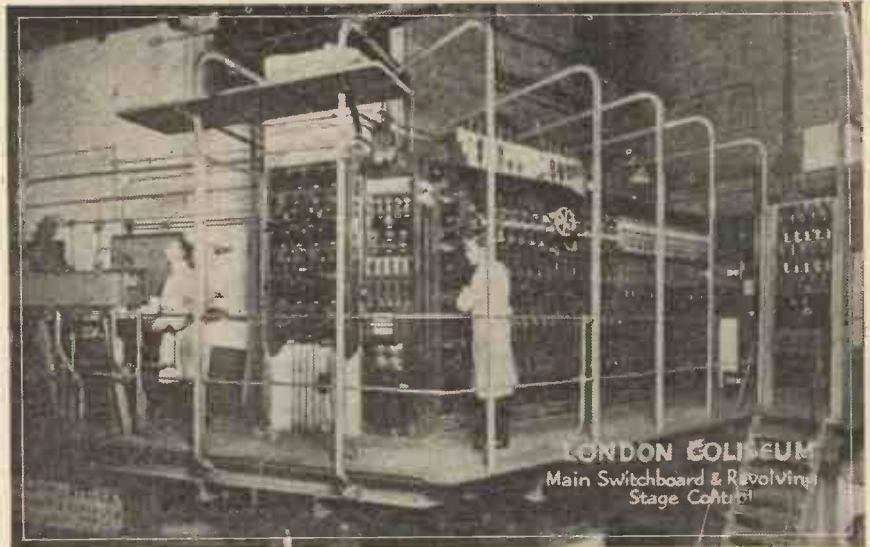

Showing the extraordinary number of switches on the main switchboard and the controls for the revolving stage.



A photograph taken below the revolving stage of the Coliseum.

see, with Hamlet, the ghost which the Queen, though present in the scene referred to (Act III., Scene IV.), is supposed not to see.

Stage Conventions

Sir W. S. Gilbert made great fun of certain stage conventions in "Pirates of Penzance," in which the pirates stamp on to the stage, dropping crowbars and jemmies meanwhile, and singing at the top of their voices:—

"No sound at all;
We never speak a word.
A fly's footfall
Could be distinctly heard."

There was to come a time when, faced with the then unequal advantage held by the cinema in presenting train accidents, earthquakes, explosions, and so on, the theatre began temporarily to leave stage effects severely alone. Not to be taken too seriously, Simplicitas, in "The Arcadians," still fell (or appeared to fall) the height of the stage from his aeroplane, and Peter Pan,

of course, still flew in at the window, but producers began to rely on pure suggestion rather than actual representation. Nevertheless, such productions as "The Whip" and "Sealed Orders" at Drury Lane owed much to spectacle, the race between a motor car and a railway train in the latter play being particularly effective. The record-breaking "Chu Chin Chow," which, without the aid of a revolving stage, ran for 2,238 performances in London, set a high standard for unforgettable scenic effect, in which skilful lighting played a large part. Having the advantages of revolving stages, the London Coliseum and the Theatre Royal, Drury Lane, have many productions to be proud of, notably "White Horse Inn" and "Casanova" at the former theatre, and "Cavalcade" and "Wild Violets" at the latter.

"Real" Rain

In Bernard Shaw's "Pygmalion" the first scene is played to the accompaniment of rain pouring in torrents from behind the arches under which the characters are sheltering, real water being used for this effect, and in the play "Rain," adapted from a short story by Somerset Maugham, practically the whole action of the play is accompanied by a similar effect. Years before the first production of either of these plays, however, real water was occasionally used to represent a rain storm on the stage, notably in the last act of "The Fortune Hunter."

When the form of stage entertainment known as "revue" was still in its infancy, a spectacular scene was introduced in which chorus girls marched into a tank containing water set in the middle of the stage and having completely submerged themselves, apparently stayed there, hidden beneath the surface! Actually, of course, they passed under a partition and bobbed up to the surface again out of sight of the audience.

Stage Fires

Realistic stage fires can be represented by "flames" made of flimsy red and orange material agitated upwards by draughts of air from electric fans, together with clouds of illuminated steam. "Kindly keep your seats, ladies and gentlemen. There is absolutely no danger," used to be printed in programmes referring to such scenes.

The waves of the sea can be extremely well suggested by light reflected from a surface of water that is kept agitated.

"Noises off" can play a tremendous part in the dramatic effectiveness of a play. Sometimes a simple effect such as the knocking at the door in "Macbeth" can work wonders. In "The Cat and the Canary" the innocent striking of a grandfather clock at a tense moment in the action of the play was positively startling, as it was really intended to be. Good play as it was in any case, the noise effects in "The Ghost Train" undoubtedly made its fortune secure.

A great deal more than the mere lighting of a scene can be accomplished by the alteration of lights. Thus in the old form of transformation scene, one stage setting could be made to merge gradually into an entirely different one, the principle employed being that if a backcloth of thin transparent material on which a scene has been represented is illuminated from the front and not from the back it will reveal the scene shown upon it, but if another scene behind it is illuminated and it itself is left in darkness it will become to all intents and purposes transparent again. Effective use of this type of transformation

scene was made in "The Blue Bird." In quite early productions of "Faust" a piece of scenery representing a solid brick wall would become transparent in the same way to reveal a vision of Margarita.

"Pepper's Ghost"

"Pepper's Ghost" was a well-known illusion of some years ago, a conjuror named Pepper having developed the principle that a piece of plate glass will reflect light under certain conditions almost as well as will a mirror. By introducing a piece of plate glass across a small stage at an angle either vertically or horizontally of 45 degrees, the ghostly reflections of people standing in the wings or reclining beneath the stage, out of sight of the audience, could be super-imposed on a scene in which persons of obvious flesh-and-blood enacted more or less hair-raising comedies.

Many readers will be familiar with a type of illusion in which an apparently decapitated head is yet obviously alive, in this case an unsuspected mirror (or mirrors), at an angle of 45 degrees screening the body and limbs of the "victim." Similarly, a mirror can make it appear that a conjuror's cabinet is empty when in

in this was truly bewildering, since not only did the scenery change in a flash but also the costumes, and even the complexions of a stage full of players! Thus you might have seen a character wearing a bowler hat become suddenly an Eastern potentate wearing a turban. Actually all that changed was the colour of the lighting. Anyone may try an interesting experiment to prove the effectiveness of this. Take into a dark room three similar objects, one coloured green, one coloured red, and the other white. Illuminate the three with green light and the green and white objects will appear practically as bright as each other, the red object appearing almost black. Change the green illumination to red illumination however, and the red and the white object will now appear almost equally bright in appearance, while now the green object appears black. A little thought will show how this interesting principle can be developed.

Shadows in Relief

A shadow pantomime that appeared to be stereoscopic had a considerable vogue in Europe some years ago. There were two sources of illumination simultaneously in



Showing a number of stage hands busily at work preparing a stage setting.

reality it may even contain the conjuror himself!

Impersonation

Many people are bewildered when apparently a conjuror vanishes from the stage and re-appears in the gallery long before he has had time to change position. In such cases some form of impersonation has taken place for a short space of time. He may, for instance, appear to walk momentarily behind a pillar and re-appear still walking from the other side of it, whereas in reality it is he who has walked into concealment and someone else, dressed like him, who has walked out again. His impersonator then has an inconspicuous part to perform (it must, of course, be inconspicuous), though he must not leave the sight of the audience until it is time for him to disappear, by which time the real conjuror has taken up his place ready to make his surprising re-appearance, a "trap" in the stage, perhaps, having allowed him to leave his position behind the pillar.

Scientific Transformation Scene

Not many years ago a form of scientific transformation scene was very popular in certain revues in this country. The effect

operation placed some distance apart. The result of the confliction of shadows on the screen was that to a member of the audience regarding it through a special pair of "spectacles," provided one eyepiece of which was green, and the other red, the shadow pantomime appeared to stand out in relief. The effect was considerably heightened by various ingenious devices and the amusing nature of the shadow pantomime, apart from its puzzling and scientific character.

POWER-DRIVEN MODEL AIRCRAFT

By F. J. CANN

96 Pages, 120 Illustrations

1/- or 1/2 by post from Geo. Newnes
Ltd., 8/11 Southampton Street,
Strand, W.C.2.

MAKING IRON FLOAT

Some Interesting Experiments that Can be Carried Out with the Simplest of Apparatus.

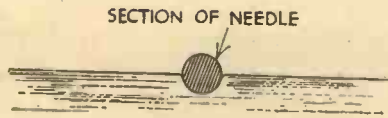

Fig. 1.—A needle floating on water.

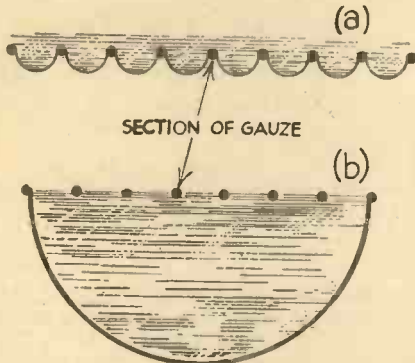

Fig. 2.—Showing water in a wire gauze vessel. Note that in (b) the lower surface film of water has a much greater weight of water to support (per sq. in.) than in (a).

THE peculiar behaviour of the outer layer of a liquid, as distinct from the main bulk, gives rise to some unexpected results to those who make acquaintance with the phenomena for the first time. This behaviour plays its part in such widely diverse spheres as in the rise of water in a lump of sugar, the soaking up of ink by blotting paper, the power of quite heavy insects to walk on water, the prevention of malaria and yellow fever, the saving of life at sea and so on. To make a complete list would be difficult, if not impossible.

In all liquids the surface, whether in contact with air, solid, or some other liquid, behaves as if it were a stretched piece of india-rubber, which can stand quite a considerable pressure without breaking. The tendency of this surface, like the stretched rubber, is to make itself as small as possible. In consequence of this, a liquid will always try to form itself into spherical drops, such as one sees when quicksilver is spilt on a table or when water is spilt on a greasy surface.

The experiments given below can all be performed with simple apparatus at home, and should provide a pleasant way of spending an interesting hour or two. It should be emphasised, however, that where water is mentioned, clean water is essential. The strength of the outer "skin" of a liquid depends very largely on the kind of liquid, its temperature, and its freedom from impurity.

The Floating Needle

Obtain an ordinary sewing needle, which should be slightly greasy (mere handling is

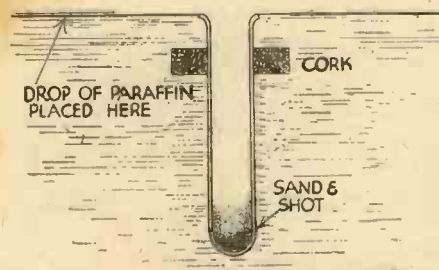
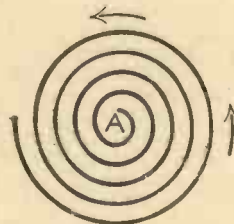

Fig. 4.—Showing how insect larvæ are killed. The floating tube imitates the larva, as when the paraffin lamer reaches the test-tube, the tube sinks.

usually sufficient to give it a thin coating of grease). Place the needle on a small piece of blotting paper and float the paper on water. When the blotting paper gets wet it will sink, leaving the needle floating on the water. It will be noticed that there is a depression in the surface of the water, but the surface tension is usually high enough to prevent the needle from breaking through (see Fig. 1). If some soap solution is carefully added (a drop or two should be sufficient) to the water in the above experiment, the needle sinks, as the surface layer is weakened by the presence of the soap solution.

Obtain a piece of wire gauze (about 20 mesh, and 3 or 4 in. square) and bend it to form a shallow dish $\frac{1}{4}$ to 1 in. deep. Melt some candle wax in a tin vessel and dip the gauze into it, afterwards shaking the surplus wax out of the holes. If water is

Fig. 3.—A revolving wire spiral. The soap solution should be inserted at A. Arrows show the direction of rotation.



now carefully poured into the gauze dish it will not go through the holes, particularly if a piece of paper is laid flat on the bottom to break the fall of the liquid as it is poured in. Alternatively, if the dish is carefully dried it can be floated on water.

This experiment illustrates how difficult it is for water to penetrate canvas—the surface layer of tiny drops of water is very difficult to break—and only when the drops get big is the weight of the liquid sufficient to do this.

Touching the canvas with the fingers or any object which has been dipped in the water causes several of the smaller drops to unite into a larger one with a greater weight of water than can be supported by the "skin" (see Fig. 2).

Further Experiments

Float two matches in water parallel and about an inch apart. If the water between the matches is touched with a rod which has been dipped in petrol, methylated spirit or soap solution, the matches immediately spring apart, because the surface layer of water between them has been weakened.

Obtain a white dish with a flat bottom—a soup plate will do—and just cover the bottom with coloured water. Touch the surface with a piece of wood dipped into petrol, oil, or methylated spirit. The water leaves that part of the dish, leaving the bottom dry.

Sprinkle a light powder such as French chalk or flowers of sulphur on the surface of water. Rub a finger through the hair, which will make the finger greasy and then touch the dusty surface with it. The part touched immediately becomes clear of powder.

A hot piece of metal produces a similar result.

Bend a piece of thin wire into the shape of a flat spiral, and float it on water. If the water in the inner part of the spiral is touched with a rod dipped in soap solution, the wire begins to rotate (see Fig. 3).

An Experiment with Paraffin

Obtain a small glass test-tube about $1\frac{1}{2}$ in. long and $\frac{1}{4}$ in. in diameter. Make a hole in a piece of cork and push the tube in. Weight the tube with lead shot and sand until it will only just float, with the open end just flush with the surface of some clean water into which it is placed. Put a drop of paraffin on the water some distance away from the test-tube. When the film of oil has spread out sufficiently over the water to reach the test-tube, the latter will sink (see Fig. 4).

This experiment illustrates the method of clearing stagnant pools of mosquito larvæ—the mosquito being the carrier of the disease germs of malaria and yellow fever. In the larval stage the insect swims to the surface of the water and puts out a tube to breathe, clinging on to the surface which is just strong enough to hold it. The

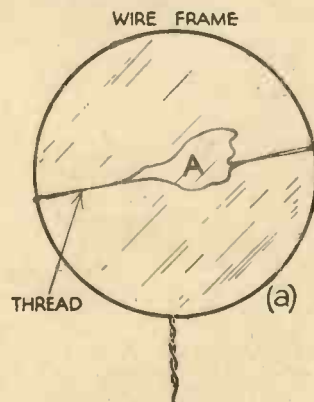
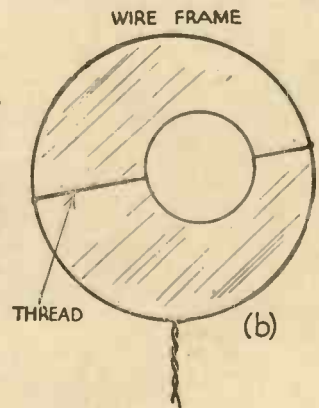

Fig. 5.—Illustrating the elasticity of a soap film. When the point (A) is touched with a hot wire the film inside the loop breaks and the thread takes up a circular form as in (b).



paraffin layer weakens the surface, the larva sinks to the bottom and is drowned. The discovery of the carrier of the malaria germ by the late Sir Ronald Ross, and the subsequent method of dealing with the insect, must by this time have saved hundreds of thousands of valuable lives. Not until the mosquito was practically exterminated from a wide belt of land was it possible to construct the Panama Canal, and it was estimated that previous attempts to make it had cost about 50,000 lives from insect-borne diseases.

A fairly strong soap solution should first be made (soft soap is best). Bend a piece of wire to form a ring about 2 in. in diameter and tie a loop of cotton across it. If a hot needle is thrust into the loop the soap film breaks inside, owing to the weakening of the surface by the heat, and the loop is pulled out by the outer layer into a circular shape (Fig. 5).

Experiments with Glass Tubing

Some narrow ("capillary") glass tubes can be made by softening the middle of a short length of narrow ($\frac{1}{4}$ in.) glass tubing

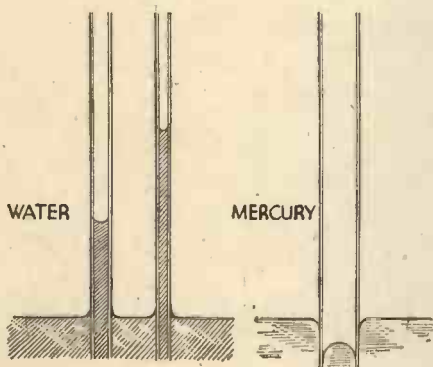

Fig. 6.—Showing the effect produced when narrow tubes are inserted in water and mercury

in a gas flame and pulling out the ends. The capillary tubing is easily broken into lengths, and if one of them is taken and dipped into coloured water the liquid immediately rises in the tube—several inches, if the tube is narrow enough. The height to which the liquid rises is inversely proportional to the diameter of the tube.

If a narrow glass tube is placed in mercury instead of in water the liquid in the tube is depressed. An ordinary mercury barometer usually reads a little low on this account (see Fig. 6).

Thoroughly clean two pieces of glass about 2 in. square and clamp them together with an elastic band. Between the glasses at one edge, place a matchstick to separate them. If the glasses are now dipped into water it will be found that the water rises between the glasses, but rises much higher where they are close together (see Fig. 7).

The Mercury Heart

Into a small saucer or a watch glass place

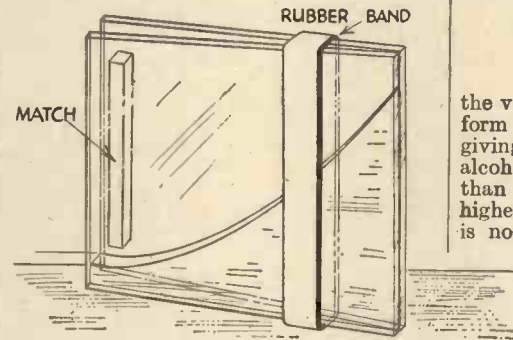

Fig. 7.—Showing a method of demonstrating the rise of liquid between glass plates.

a small quantity of mercury to make a "blob" of about $\frac{1}{2}$ in. diameter. Notice that the liquid does not spread like water—its surface tension is very much greater and more than compensates for its extra weight. Just cover the quicksilver with some dilute sulphuric acid (accumulator acid will do), in which a few crystals of permanganate of potash have been dissolved. Lay a large nail or needle in the acid so that the point just touches the mercury. The latter immediately shrinks away owing to the alteration of its surface tension by the presence of a coating of hydrogen gas which is formed. The gas is quickly removed by the permanganate and the mercury resumes its former position. The process is continually repeated and may take place sufficiently rapidly to give the impression of a beating heart (see Fig. 8).

Pour a little wine (or a mixture of methylated spirit and water) into a wine-glass. Shake the liquid so as to wet the sides of the glass and allow it to stand for a short time. It will soon be noticed that where

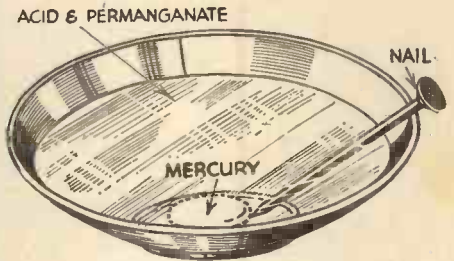

Fig. 8.—The mercury "heart."

the vessel has been wet the liquid begins to form drops which run down the sides, giving the appearance of falling tears. The alcohol on the sides evaporates more easily than the water and the liquid left has a higher surface tension, consequently there is now a greater tendency to form individual drops than there was at first.

There are many other phenomena not so easily shown with simple apparatus, but all of which are based on the strength of the surface layer (the surface tension) of a liquid.

Another example is that of the manufacture of lead shot, when molten lead is allowed to fall from a tower. Owing to the high surface tension of the liquid, the tendency is for spherical drops to form, and this shape is retained when the metal becomes solid.

In conclusion, it may be of interest to quote figures which illustrate the differences between the strengths of the surface films of a few liquids—approximately the numbers represent the pull in milligrams along each centimetre length of film.

Water (at 15° C.)	73
„ (at 100° C.)	58
Mercury	547
Molten lead	473
Alcohol	22
Paraffin	26

A Hint for Model Engine Builders

THE diagram shows how to set the slide valve. The slotted link should be placed in the neutral position as shown, with the crank on dead centre. It is unnecessary to provide lap and lead to the valve on small models. Whilst in the position shown, the valve rod must be adjusted for length so that the valve is centrally over the three ports in the valve block. To set the valve, of course, it will be necessary to remove the valve cover and guide. After adjusting the eccentric rods for length so that they appear as in the diagram, the lock-nuts on the yoke ends of each rod should be tightened. Make quite sure that the front and back edges of the slide valve just coincide with the outer edges of the ports. It is most important to get this exact, otherwise the engine will not run satisfactorily, or develop full power. The slightest error here will cause steam to enter to cylinder either before or on top dead centre. In the latter case the engine will run jerkily, if at all, and in the former it will run in the opposite direction to that

Setting the Slide Valve and Reversing Gear for Our Model Road Tractor. Described in the March and April, 1934, Issues of "Practical Mechanics."

desired. In order to ensure the correct port coverage it may be necessary to slightly file the ends of the valve with a dead smooth file. Make sure when doing this that you do not leave any burrs. Note that the two eccentrics are set at 180 degrees to one another, and locked to the crankshaft by means of the grub screws with which they are fitted. They are also set at 90 degrees to the crank. This operation completed, it

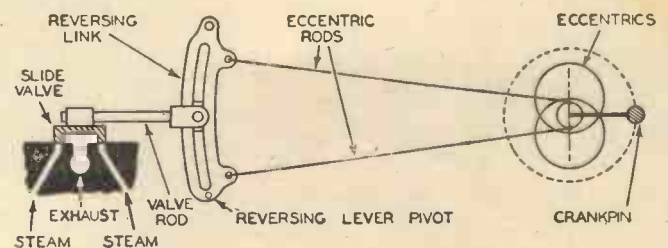

Showing the method of setting the slide valve.

is merely necessary to adjust the length of the reversing rod so that it articulates the bell crank lever, and causes the link to move up and down. It should be particularly noted that looking at the flywheel for forward motion, the flywheel revolves

in a clockwise direction, and, of course, in an anti-clockwise direction for reverse gear.

SPECIAL OFFER

A limited number of new B.T.H. Motors, 1/50 h.p. 2,000 R.P.M. Fitted with Special Bearings to allow motor to run horizontally or vertically



Universal ! 110-250v. D.C. or A.C. 50 or 100 cycles complete with resistance

30/-

Carriage Free U.K.

Send to-day for the foremost Electrical List of 1935. 105 pages. Over 1,000 illustrations. Post free 3d. The Catalogue of the Educational and Experimental World

GRAFTON ELECTRIC CO.

(Dept. P)

Tottenham Court Rd., London, W.1



THINK OF THE THINGS YOU COULD MAKE IF ONLY YOU HAD THE TOOLS!



HERE'S THE KIT YOU'VE ALWAYS WANTED

IT'S YOURS FOR ONLY 5/-

THE TOOLS, Comprising 31 items:

Beechwood Jack Plane with 2½ in. double iron, adjustable iron Smoothing Plane, 12 in. Tenon Saw, 20 in. Handsaw, Padsaw, Brace, four Bits, four Chisels (¼ in., ½ in., ¾ in., 1 in.), beechwood Spokeshave, two Turn-screws, 9 in. Square, Marking Gauge, Warrington pattern Hammer, Pincers, Pliers, Oilstone, Tin Oilit, Mallet, Bradawl, Mitre Block, Full-use Bench Vice, 2 ft. folding Rule, a box of Assorted Nails, Handbook on use and care of Tools.

CASH PRICE **59/-** Carriage Forward

EASY PAYMENT TERMS. Complete kit supplied now on receipt of deposit of 5/-. 12 additional monthly payments of 5/- complete the purchase.

HANDICRAFTS LTD. (DEPT. P.M.)
Weedington Road, Kentish Town, London, N.W.5.

A. E. JONES LTD.

97 NEW Oxford Street, London, W.C.1

(Telephone : Temple Bar 6350.)

Suppliers of RELIABLE ALL BRITISH Model Aircraft that DO FLY

Also Material and Sets of Parts for building same. AGENTS for CELLON Model Aircraft Dopes.

CALL AND SEE US

The **STANLEY**
REG. TRADE MARK

VEST-POCKET MICROSCOPE

Three magnifications of 40, 50 and 60 instantly available.



17/6
Post Free

Soft Leather Case 1/6 extra.

Descriptive Leaflet P.255 upon application.

W. F. STANLEY & CO. LTD.

The Largest Makers in the World of Surveying and Drawing Office Equipment.

286 HIGH HOLBORN, LONDON, W.C.1

The Very Latest SHORT-WAVE SET!

A very interesting 3-valve Battery-operated Short-wave Receiver has been designed by the Editor of Wireless Magazine and Modern Television, Percy W. Harris, M.I.R.E., for his own personal use. Its performance is exceptionally fine, and its highly novel and original system of construction offers many valuable advantages.

Fully described and illustrated with photos and diagrams in the July number of

WIRELESS MAGAZINE

AND MODERN TELEVISION OUT NOW 1/-

THE HAWKER HART MODEL

A Most Realistic Flying Model of a Famous Aeroplane

THE full-size Hawker Hart was designed by Mr. Sydney Camm, chief designer to the H. G. Hawker Engineering Co., Ltd., to meet the demand for a high performance 2-seater fighting bomber. Since 1929 it has formed the equipment of various bomber squadrons of the Royal Air Force, as well as of three

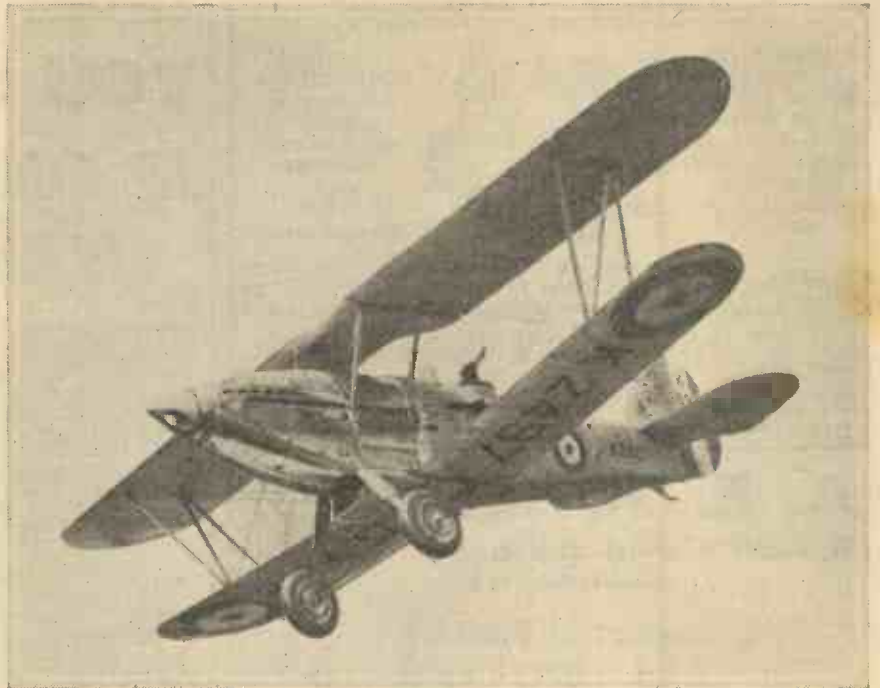

View from beneath of the Hawker Hart Model.



Three-quarter rear view of the Hawker Hart Model.

auxiliary squadrons and numerous squadrons in continental air forces.

International Model Aircraft, Ltd., have recently marketed, at the reasonable price of £2 2s., a flying scale model of it, and so exact is the reproduction of detail that it is difficult to realise that the photographs on this page are of the actual model and not of the full size machine. Yet such is the case. The model represents a manufacturing achievement, and even the instruction book is produced on the same lines as the Air Ministry Instruction Book for the full-size machine.

The model is reproduced to a scale of $\frac{1}{4}$ in. to the foot. Its span is $18\frac{1}{4}$ in., its length overall 15.36 in., the chord of the upper mainplanes is 3 in., and of the lower plane $2\frac{1}{2}$ in. The maximum gap is 2.84 in.

It is driven by a 6.35 in. airscrew, powered by 12 strands of $\frac{3}{8}$ in. elastic through a triple geared motor. Its maximum speed in level flight is 22 miles

an hour, and its minimum speed 14.3 miles an hour. Its ceiling is 65 ft., and its range 220 to 300 yd. It takes off after a run of from 8 to 9 ft. The containing box includes the winding mechanism, and the Instruction Book, beautifully produced and well illustrated, explains how to get the best from the model. It is one of the most remarkable aeroplanes we have yet examined.

Model Aircraft Accessories

Builders of light-weight model aeroplanes have found it difficult to obtain wheels the weight of which was proportionate to the rest of the model. The Balsa wheels formerly obtainable were imported from America, but we are pleased to note that Model Aircraft Supplies are now marketing a range in various diameters which are entirely British made. They have succeeded in turning Balsa wood and the specimens we examined were beautifully finished, accurately turned, and of very low weight. Interested readers should get into touch with Model Aircraft Supplies, Ltd.



The Hawker Hart Model in flight. It is difficult to distinguish it from the full-size machine.

DEVELOPERS (contd.).

Dilute with equal quantity of water. Suitable for plates, films and papers, and keeps indefinitely in well-corked bottle. Do not use when the solution has turned too dark.

Fixing Bath

HYPO

Hyposulphite of soda . 4 oz.
Water . 20 oz.

ACID HYPO

Hyposulphite of soda . 4 oz.
Potassium metabisulphite . 200 gr.
Water . 20 oz.

Both of the above baths are suitable for plates, films and papers.

Frilling

Puckering up and detachment of the emulsion at the edges of a plate, film or paper, caused by high temperature or through the employment of too much alkali in the developer.

Gas Light Paper

A printing-out paper coated with a very sensitive emulsion which may be acted upon in a few seconds by ordinary artificial light. It is sufficiently slow to enable it to be handled in a shady spot, or at a distance of several feet from an ordinary domestic lamp (electric or gas), but when exposed to the light a distance of a few inches a normal exposure may be made in six seconds or so. The resultant image is invisible, and has to be produced by development in the same manner as a plate or film. The normal colour is black and white.

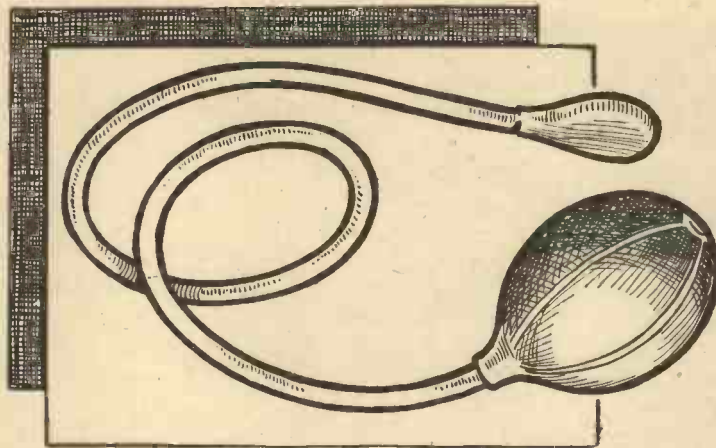

The pneumatic release. This works by means of the air contained in the tube. When the large bulb is squeezed the smaller bulb swells out and raises the shutter release.

Hypo

Clear transparent crystals which keep indefinitely in a dry place. A temperature drop is experienced when hypo is dissolved in water, and therefore warm (not hot) water should be used.

Infinity

The distance to which a lens is focussed, and beyond which all objects are well focussed or sharply defined.

Intensification

The process of strengthening an image.

Intensifier

An under-exposed or under-developed plate or film appears very thin and transparent by transmitted light, and consequently will print very dark.

A chemical may be employed to increase the density by depositing further salts upon those already left upon the plate or film. The entire picture may be inserted in a bath of intensifying chemical or it may be applied locally with a brush.

Iris Diaphragm

A device consisting of a number of curved plates pivoted so that they all operate together. An adjustment is provided so that the size of the aperture may be varied.

Lens

The glass in front of the camera. It may take various forms. The simplest lens is of the meniscus type and is only fitted in the cheapest cameras. It consists of a single piece of glass, concave on one side and convex on the other. The other form of single lens is the plano-convex, convex on one side and flat on the other. The diaphragm (or shutter) is usually mounted in front of these single lenses. A double lens is made from two pieces of glass (one flint and one crown), and may be of the meniscus or plano-convex type. A combination lens consists of two single lenses mounted, with the diaphragm arranged between the two components. The single lens is non-achromatic, and the compound lens is achromatic.

AN A.B.C. OF PHOTOGRAPHY

THE THIRD ARTICLE OF A SERIES

Gold Chloride

Usually obtainable only in sealed glass tubes. In view of the fact that it is only required in very small portions it is kept as a solution, and the strength adjusted so that even amounts may be added as required in various formulæ. Black deposits in the bottom of the tube indicate impurities and should be thrown away.

Halation

The "flare" or light patch which appears round windows, lights, or similar bright objects, and which is due to the high light being reflected by the back of the glass plate. It may be avoided by coating the back of the plate with some opaque material.

Half-Tones

All the graduations between which bright light has acted. Thus in a negative the high lights are the deepest (or darkest) portions, and in the print they are the lightest portions.

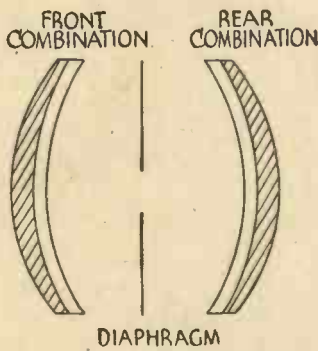

DIAPHRAGM

The single lens is arranged with the diaphragm either in front or behind. In the compound lens (which consists of two sets of single lenses) the diaphragm is arranged between the two component halves.

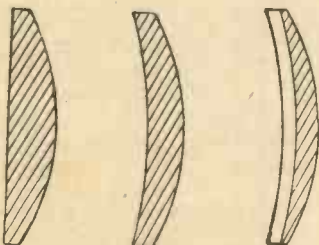

(Left) The simplest type of lens—the meniscus. This is also a plano-convex, that is, one surface is flat, whilst the other is convex. (Centre) The concavo-convex lens—one side concave, the other convex. (Right) A corrected lens. This has both chemical and visual foci coinciding, due to the fact that it is made up from two dissimilar types of glass.



Diagram explaining the fault known as spherical aberration.

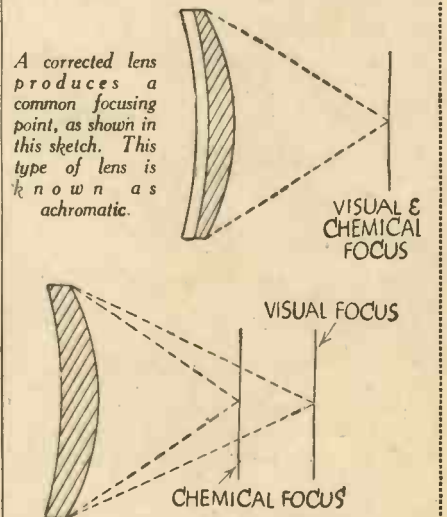

The principal fault of the "uncorrected" lens is due to the fact that visual and chemical foci do not coincide. This results in chromatic aberration.

Light Filter

A coloured glass which is fitted in front of the lens to cut off certain rays in order to obtain better colour renderings. With an ordinary cheap plate or film and no light filter it will be found that clouds cannot be

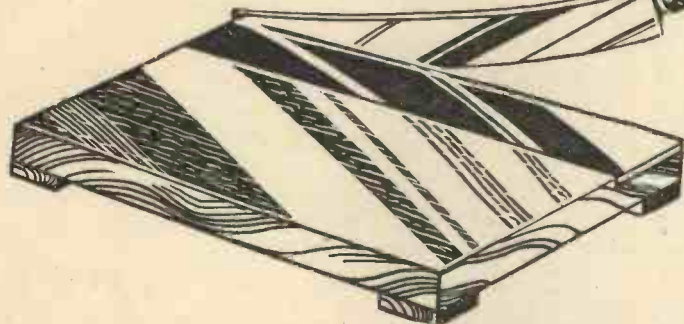

For trimming prints and enlargements this guillotine will be found useful.

recorded on an ordinary outdoor snap, and that yellow is recorded much darker in tint than red. Yellow filters cut out the blue rays and enable clouds to be recorded in a landscape, and special colour filters of varying densities, in conjunction with panchromatic plates, enable yellow to be recorded in its correct shade when compared with red.

Local Reduction

The process of reducing certain parts of a negative to enable better renderings to be obtained.—See Reducer.

Metal

Abbreviated form of monomethyl para-diphenol sulphate. White powder which keeps very well in a dry place. Dissolves readily in water and keeps well in solution.

Panchromatic

Sensitive to all the colours in the spectrum.

Orthochromatic

Sensitive to all colours other than blue and ultra-violet.

Plate

Actually a sheet of glass having a sensitive emulsion deposited upon one side. In practice it is customary to refer the film or other material upon which the picture is taken as the "plate."

Plate and Film Sizes

The standard photographic sizes are set below :

Inches.	Inches.
2 x 1½—Vest pocket.	8½ x 6½—whole Plate.
2½ x 2½	9 x 7
3½ x 2½	10 x 8
3½ x 3½—Lantern slides.	12 x 10
3½ x 3½	15 x 12
4½ x 3½—Quarter-plate.	18 x 16
5 x 4	20 x 16
5½ x 3½	22 x 18
5½ x 3½—Postcard.	24 x 18
6 x 4	24 x 20
6 x 4½	45 x 107 mm. Stereoscopic.
6½ x 3½	
6½ x 4½	4.5 x 6 cm.
6½ x 4—Half-plate.	9 x 12 "
7 x 5	10 x 15 "
7½ x 5	13 x 18 "
8 x 5	13 x 18 "

Pneumatic Release

A rubber bulb and tube connected with the shutter and releasing it when the bulb is squeezed.

Potash Alum—See Alum.

Potassium Bromide

Coarse white powder or cubical crystals which keep well in a dry place.

Potassium Carbonate

Coarse white powder which must be kept in well-stoppered bottle as it absorbs moisture from the atmosphere. As a

solution should be kept in a bottle with a rubber cork as a stopper will stick.

Potassium Metabisulphite

Small sharp white crystals which should be rinsed before use to remove the slight covering of powder. Hot water should not

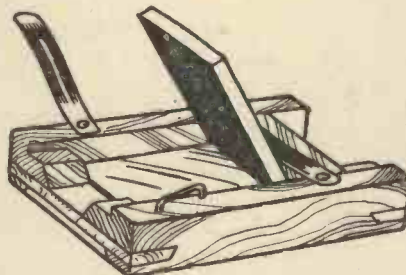

A simple printing frame for use with plates or films.

be used when dissolving this chemical. Keeps well in corked or stoppered bottle in either crystal form or in solution.

Printing Frame

A device for holding a negative and printing paper in contact whilst exposure is made.

Pyro

Fine white powder, or small crystals. Keeps indefinitely in powder form in a dry place, but when in solution turns darker. When assuming a dark reddish and thick appearance should not be used. Abbreviation of pyrogallie acid.

Quinol

Abbreviated form of hydrokinone (which see).

Rectilinear Lens

One which does not distort or show curvature of the straight lines of an image.

Reducer

An agent for removing some of the deposited silver salts and thereby permitting the passage of more light. A dense, or very dark, negative is reduced in order to enable printing to be carried out in less time. In a landscape picture sometimes the sky appears very dense, and consequently it is not possible to obtain a rendering of the clouds without over-printing the foreground. Reduction of the sky may be carried out by soaking a piece of cotton wool (or using a brush) as a reducer. This is known as local reduction.

Reflex Camera

A special type of camera in which a mirror is supported at an angle of 45 degrees inside the camera. The lens is always open, exposure being made by means of a roller-blind focal-plane shutter. The top of the camera is fitted with a ground glass screen and a light protecting hood, and the lens projects the image on to the mirror, from whence it is projected on to the ground glass screen, right way up. It is thus visible until the moment of exposure, when the action of releasing the shutter also raises the

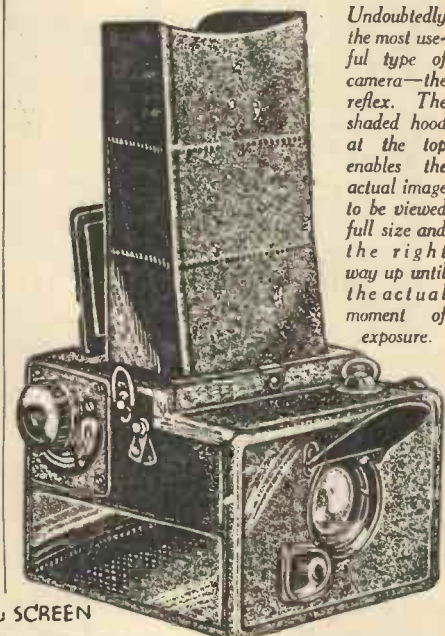

Undoubtedly the most useful type of camera—the reflex. The shaded hood at the top enables the actual image to be viewed full size and the right way up until the actual moment of exposure.

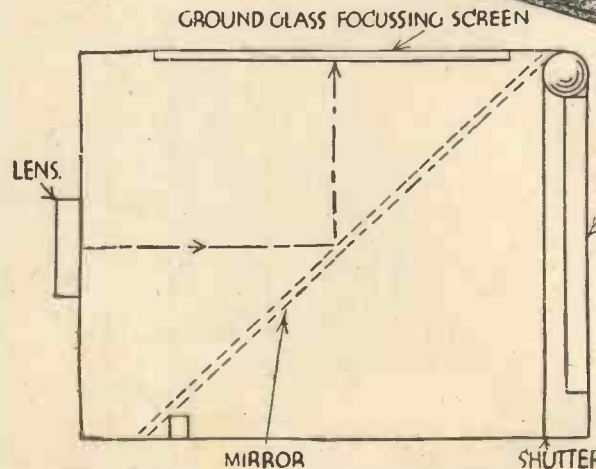

Diagram explaining the working of the reflex camera.

mirror and enables the lens to project the image direct on to the plate.

Restrainer

The agent which holds back the process of development in order to prevent uneven renderings.

Retouching

The process of altering detail in a picture by means of a pencil or brush. A portrait is invariably retouched in order to remove wrinkles, freckles, etc.

(To be continued.)

Perfection in Miniature



BASSETT-LOWKE'S exquisite miniature ships are the embodiment of the very spirit of their great prototypes. "QUEEN MARY," "NORMANDIE," "BREMEN," "REX," "ORION," "SCHARNHORST," "STRATHMORE," "PRINCE BAUDOIN," all the latest ships of the Mercantile Marine and of the Navies of the World. What more pleasing souvenir of a sea trip or tour of a ship can you have than an accurate hand-made waterline miniature?

Make waterline models yourself from BASSETT-LOWKE'S 100 ft. to the inch waterline drawings.

Special "NORMANDIE" plan available at 2s. 0d.

See full particulars of these "TINYCRAFT" models in Catalogue S.12, price 6d., post free, which also contains descriptions of their full range of power boats, yachts, scale models and fittings.

BASSETT-LOWKE LTD.
NORTHAMPTON LONDON: 112 HIGH HOLBORN, W.C.1
 MANCHESTER: 28 CORPORATION ST.

THE WORLD'S
 SMALLEST CAMERA

5/6



HOW OFTEN HAVE YOU SAID "I WISH I HAD MY CAMERA WITH ME NOW"?

THE Ideal Midget Camera you can always carry with you—taking pictures comparable in clarity and sharpness with those produced by a full-sized camera, yet it is not as long as a cigarette. (Actual size 2 1/2 in. x 1 1/8 in. x 1 in.) Fitted finest quality Meniscus F.10 Lens, Instantaneous Shutter, and Direct Brilliant Viewfinder. Finished green, rose, walnut, or black.

Sold by all High-class Photographic Dealers.
 Send for Descriptive Literature.

Coronet Camera Co., 310 Summer Lane, Birmingham, 19

ECONOMIC ELECTRIC CO. TWICKENHAM, LONDON, S.W.



There is no better Boat Motor than E.E.C. for finish, efficiency, speed and power; they are still, after 25 years, the best. Made in four sizes:—

15 oz. 15/-; 25 oz. 17/6; 40 oz. 21/-; 48 oz. 25/- For smaller sizes see our list.

SUITABLE ACCUMULATORS

4 v. 5 amp. 6/6; 6 amp. 7/6; 10 amp. 10/-.

HIGH-CLASS PROPELLERS

Clean Cast Phosphor Bronze
 2" 2/-; 2 1/2" 3/-; 3" 3/6.

VALUE FOR MONEY

Utility Electric Drill, A.C. 200/250 volts. Takes Drills up to 1/2". 40/6 Post Free.

Handy Grinder Motor for above voltages. Fitted 2 Aloxite Grinding Wheels. 21/9 Post Free.

OUR 70-PAGE ILLUSTRATED LIST

Is compiled to assist the Experimenter to obtain all his requirements from one source. It contains all you can require for workshop or amusement. Send for your copy to-day.

POST FREE 3d.

HOLIDAY & SPORTS BINOCULARS !!



Our Famous 8 x 25 Broa/Clar Binocular, complete in Case, offered at Special Bargain Price, 57/6 post free.

8 x 30 Broa/Clar De Luxe, 75/- post free.

8 x 25 Prismatic Pocket Telescope, with Sling Carrying Case 35/- post free.

5 x Army Model Sports Glass, 25/- post free.
 5 x Army & Navy " " 27/6 " "

Lists of Telescopes, Microscopes, Binoculars, Etc., Free on Request.

BROADHURST CLARKSON & CO. TELESCOPE HOUSE
 63 FARRINGTON ROAD, LONDON, E.C.1

ALL OPTICAL REPAIRS—BY CRAFTSMEN

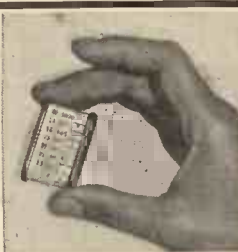

NEW!

AN INSTANT SUCCESS
 A REAL VEST-POCKET
 EXPOSURE METER
 THE "LEUDI"

Measuring only 1 1/2 x 1 x 3/8 in.—less than half the size of an ordinary pocket lighter!

—the "LEUDI" is easily the smallest, neatest, and lightest exposure meter made. As simple as it is small, and as efficient as it is simple; it is the finest value in exposure meters that you can possibly obtain, is as effective indoors as out of doors, and can be used with plates or films of any make.

Price only 5/-. PURSE CASE 1/-

Obtainable from all photographic dealers or
SANDS, HUNTER & CO. LTD.

37 BEDFORD STREET, STRAND, LONDON, W.C.2

The "UNICORN" Electric Drill

1" CAPACITY. BRITISH MADE

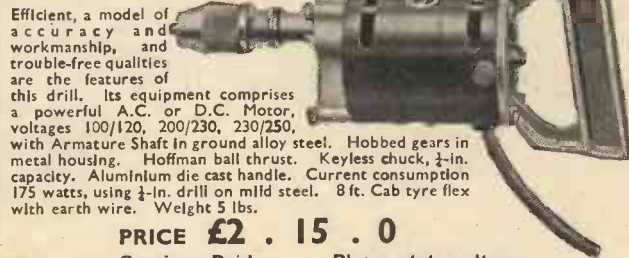

Efficient, a model of accuracy and workmanship, and trouble-free qualities are the features of this drill. Its equipment comprises a powerful A.C. or D.C. Motor, voltages 100/120, 200/230, 230/250, with Armature Shaft in ground alloy steel. Hobbed gears in metal housing. Hoffman ball thrust. Keyless chuck, 1/2-in. capacity. Aluminium die cast handle. Current consumption 175 watts, using 1/2-in. drill on mild steel. 8 ft. Cab tyre flex with earth wire. Weight 5 lbs.

PRICE £2. 15. 0

Carriage Paid.

Please state voltage.

Send for Illustrated leaflet to:—

Tele.: GULLIVER 3739.

CORONA ENGINEERING CO., Leighton Place, Kentish Town, N.W.5

A NOVEL TYPE OF SPEEDBOAT

Many Interesting Experiments can be Carried out With this Novel and Fast Speedboat, the Construction of Which is Described Below. It is Easily and Cheaply Built.



ANY ship, boat or model moving through water has constantly to be displacing a certain mass of water of the same weight as the model itself, and the water has to fill in the subsequent void. To do this with the least expenditure of energy it must do it as gently as possible. If it is not done gently, a wave is formed on either side, indicating that energy is being wasted in raising the water above its normal level. These waves cannot be eliminated entirely, but it is the business of the naval architect to reduce them to a minimum.

In addition to this displacement resistance there is the resistance due to what is known as skin friction per square foot of wetted surface, and this resistance is pro-

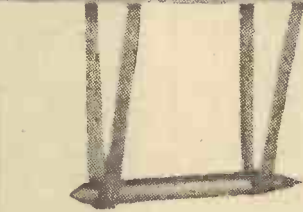

Fig. 1.—A photograph of the finished model of the steam-driven speedboat.

portional to the amount of wetted surface. Water offers very little resistance to bodies moving slowly through it, but this resistance or inertia increases very rapidly with the speed; at high speeds (above 16 knots) it behaves more like a solid than a liquid.

Obtaining the Maximum Speed from a Boat

(1) The boat must be long in proportion to its breadth.

(2) It must be as light as possible, *i.e.*, displacement must be at a minimum.

(3) Its shape must offer minimum resistance, *i.e.*, it must have a sharp cutting edge and a tapering form of stern to fill up the void without turbidity.

(4) Its centre of gravity must be as low as possible.

What type of boat best fulfils these conditions? In all probability (with the exception of No. 4) an eight-oared racing boat.

This type of boat has, of course, a high centre of gravity and is balanced by the long oars of the rowers, but there is an easy method by which this can be overcome.

The Three Models

Three types of boat are dealt with in this article. The smallest one is 3 ft. long and has a maximum width of 4 in.; a cylindrical boiler 12 in. long and 1½ in. in diameter; a special vapour lamp (to be described in detail later); and a Stuart Turner "Meteor" engine. It is carefully "lagged" to prevent steam condensation.

The torpedo-shaped body beneath is the keel, and all three models have such keels.

The long, narrow model is 5 ft. long and 3 in. maximum width. The plan, or horizontal section, is that of a racing eight.

The third model has a maximum width of 5½ in. and is 4 ft. long. It has a boiler 1 ft. long and 2 in. in diameter; a Whitney engine, ½ in. bore and ½ in. stroke double-acting; and also a Stuart Turner lubricator and steam tap.

The long, narrow model is electrically driven by means of two 4-volt accumulators and an 8-pole motor geared down about one to six.

The Torpedo Keels

The idea underlying the design of these keels is to lower the centre of gravity the

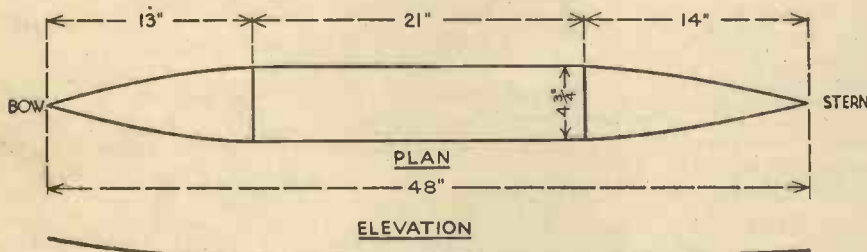

Fig. 2.—A plan and elevation of the sheer of the speedboat shown above.

portional to the amount of wetted surface. It varies with the nature of the skin, *i.e.*, the substance of which it is made or with which it is coated. This resistance in the case of destroyers has been found to be:

At 12 knots	80 per cent.
At 16 "	70 "
At 20 "	50 "
At 30 "	45 "

These figures are taken from a standard work on marine engineering.

An Experiment with a Rotating Disc

A gyroscopic disc (with a certain string pull) was rotated for five and half minutes in air. With the same pull in water it spun for ten seconds only. The disc was then coated with a film of paraffin wax; it then rotated for twenty seconds. This experiment shows in a very striking manner how great this resistance can be and how it can be lessened.

Hydroplanes

Why are hydroplanes so much faster than ordinary boats?

A hydroplane, or skimmer, is so constructed that it lifts itself out of the water when running, and actually displaces very much less water and has far less wetted surface than when at rest. To enable the boat to lift from the water, it must have a speed of about 16 knots, and unless this is the case this type of broad, flat-bottomed boat is not nearly so easy to drive through the water as the long and narrow type—say, the

The advantage of the hydroplane over the ordinary boat is greatly increased speed. In the boat the power is employed in wave-making and overcoming skin friction. The hydroplane, when travelling at speed, may have its wetted surface reduced by as much as two-thirds, leaving only one-third to produce skin friction—the displacement resistance having lessened in the same proportion. Thus, provided it registers sufficient speed, the hydroplane will always be much faster than the ordinary boat of the same power, even allowing for the power expended on dynamic support.

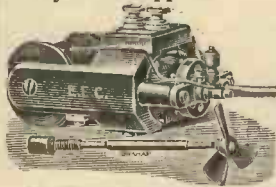

Fig. 3.—A close-up view of the engine of the steam-driven model and (inset) The Economic electric motor which is suitable as an alternative for the electrical-driven model.

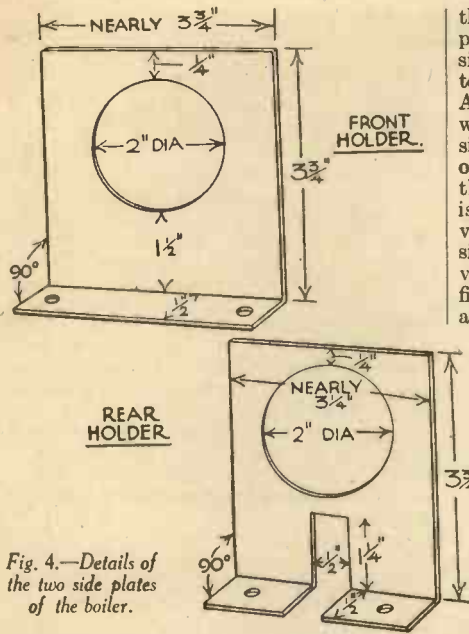

Fig. 4.—Details of the two side plates of the boiler.

necessary amount—on the principle of the lever—with the minimum of weight, a 1-lb. weight $\frac{1}{4}$ in. below boat bottom being equivalent to 4 lb. 1 in. below it. Their torpedo shapes offer minimum resistance.

Results

Let us take the electrically-driven model first. Various motors were tried and various dry cells. Finally the plant described above was installed. Unfortunately this was very heavy—each accumulator weighed 1 lb. and the motor $1\frac{1}{2}$ lb.— $3\frac{3}{4}$ lb. in all. The balancing-keel weight was $\frac{1}{2}$ lb. and had to be placed $6\frac{1}{2}$ in. below the boat. The hull weighed $\frac{1}{2}$ lb., and the result was that the boat was too deeply immersed for good results. Nevertheless, with freshly-charged accumulators, using 8 volts, and favourable conditions, a speed of between 6 and 7 miles per hour was obtained. The immersed portions of the boat were coated with paraffin wax. By far the most interesting feature, however, was the absence of wave formation, just a ripple spreading out, certainly not $\frac{1}{2}$ in. deep.

The smaller of the steam-driven models, at a steam pressure of 80 to 100 lb., was capable of a speed of 8 to 9 miles an hour. This model, although not so deeply immersed as the long electric one, obviously suffered from an insufficient flotational capacity. The larger steam-driven model was capable of practically the same speed as the smaller, at a pressure from 60 to 80 lb. per sq. in.

Its general behaviour was, moreover, far superior to the smaller one. So far as I know these speeds are in excess of anything hitherto reached with a similar type of plant and size of boat.

Constructional Details of the Hulls

In the case of the steam-driven models

the bottom is a piece of ordinary $\frac{1}{8}$ -in. three-ply, cut to the shape shown in Fig. 2. The sides are $\frac{1}{8}$ -in. three-ply, glued and fastened to the bottom with small gimps pins. At the bow and stern V-shaped pieces of wood are fitted, to which the bottom and sides are glued and pinned. Round the top of the sides, from end to end, a strip of $\frac{1}{8}$ -in. three-ply $\frac{1}{2}$ in. broad is fastened. The hull is further strengthened by one or two transverse pieces of L-shaped tin fastened to the sides. The hulls were given three coats of varnish and two of aluminium paint. Paraffin wax was run round the inside edges and V-shaped pieces at prow and stern, to make them thoroughly watertight.

The hull of the long electrical model had a backbone or keel of wood, 5 ft. long (with tapering ends), $\frac{1}{4}$ in. broad and $\frac{1}{2}$ in. deep. To this was fastened ribs cut from $\frac{1}{8}$ -in. three-ply, and the shell was of three-ply, $\frac{1}{2}$ in. thick. A piece of $\frac{1}{8}$ -in. three-ply, $\frac{1}{2}$ -in. deep, was fitted to the top, on each side, from end to end. V-shaped pieces were placed at prow and stern. In every case V-shaped pieces of tin capped the bow and stern to give a knife-edge. Boats constructed as above are much stronger than would be supposed.

The Torpedo Keels

Having decided on the weight to be used, a piece of thin brass tubing should be cut

and into these are fitted suitable turned or shaped pieces of wood to give the tapering forms at prow and stern. Screws through the holes described above fix them to the tubing.

In the case of the electrically-driven model the tube was $\frac{5}{8}$ -in. in diameter, total length 9 in., distance from bottom of boat $6\frac{1}{2}$ in., and weight $\frac{1}{2}$ lb.

In the smaller steam-driven model the tube was $\frac{5}{8}$ -in. in diameter, $8\frac{1}{2}$ in. long, distance below boat $8\frac{1}{2}$ in., length 7 in., weight $\frac{1}{2}$ lb.

For the larger model the tube diameter is $\frac{3}{4}$ in., total length 7 in., distance below boat 7 in., and the weight, 1 lb. From a minimum resistance-point of view the first has the best proportions.

The Power Plant and Lamp

After considerable experimenting, two lamps of different design were constructed, both of which gave very good results. The first lamp, however, did not give quite so low a centre of gravity for the boiler, was not so easy to start, but had the advantage of simplicity. A vertical section of the lamp is shown in Fig. 5, and is quite simple to make.

Obtain a piece of thin tin, $11\frac{1}{2}$ in. by $2\frac{1}{4}$ in., and bend a piece of thin sheet copper to the shape and dimensions shown in Fig. 6. Solder the two edges of the latter to the edges of the strip of tin (note the central rectangular portion must not quite touch

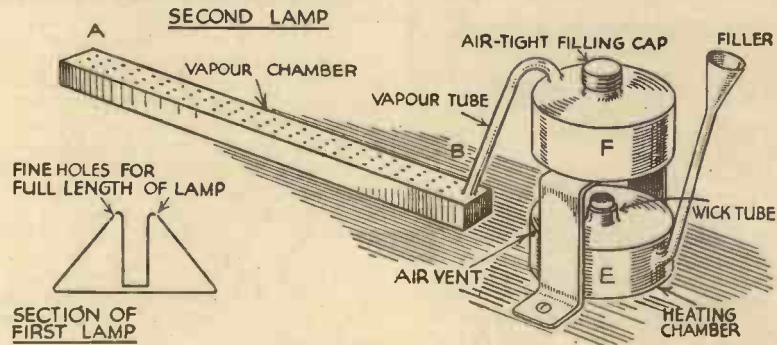

Fig. 5.—The construction of the two types of vapour lamp described in the text.

and filled with molten lead (excepting $\frac{1}{4}$ in. at either end). Three small holes are drilled very near the two ends of the tube, having equal circumferential differences,

the tin) and solder two rectangular strips of tin, one at each end, to the central rectangular portions of the copper. Make the joints fluid-tight, and then solder a piece of thicker copper over each end, having previously drilled two small holes, one at each end in the bottom of the copper. When spirit is poured into the central trough it will run through and partly fill the entire chamber. A number of small holes are drilled from end to end on the upper outside edge of the trough, and when the spirit in the trough is ignited the copper, a good conductor, is soon heated. Spirit vapour is thus formed, and, issuing from the holes, at once ignites. This lamp is to be preferred to any form of wick lamp and gives a far more intense heat. Owing to the narrowness and depth of the trough, the spirit is troublesome to ignite (especially in cold weather) unless it is poured in hot. It is heated by standing the container in boiling or very hot water.

The second lamp is shown pictorially in Fig. 5. It contains three distinct parts: an ordinary spirit lamp with wick, E; a chamber, F, in which spirit is boiled and evaporated, and from which a pipe leads to a piece of brass or copper tubing of rectangular $\frac{1}{4}$ -in. section, closed at both ends. This tubing rests on the bottom of the boat, thereby giving the lowest possible centre of gravity for the boiler. In the top of this tube is drilled a large number of holes (fifty

(Continued on p. 483.)

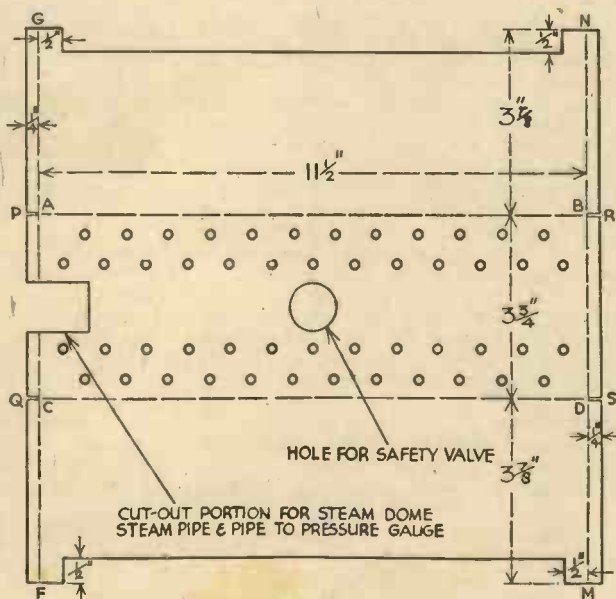

Fig. 6.—Construction details of the casing for the boiler.

NOTES CONCERNING THE USE OF

BOLTS, NUTS AND SCREWS

IN view of the diverse nature of standard types regarding thread systems, style and quality, a working knowledge of the items forming the title of this article becomes essential sooner or later. While it is true that certain non-standard bolts and screws are encountered occasionally, those used by most manufacturers conform to standard patterns, but when it is remembered that at least eight different thread systems are in common use, it must be realised that such knowledge is desirable if only on account of the ability to identify different classes of threads for replacement purposes.

The terms bolt and screw are somewhat confusing, as a bolt may be used as a screw,



Fig. 1.—A standard 1/2-in. Whitworth bolt.



Fig. 2.—A 1/2-in. British Standard Fine bolt.

and a screw (metal thread) may also be used as a bolt. In reality, the only difference lies in the manner of application: a bolt being generally understood to mean that which is secured by a nut, and a screw that which is retained by a thread tapped in the part through, or into which it passes.

Leaving for the moment the question of difference in screw-thread systems, standard bolts, screws and nuts are manufactured in a variety of types, each type having a special sphere of application, being made in a range of different sizes.

Bright Hexagon Bolts

Bright bolts of this description are commonly made from bright hexagonal mild steel bar. Such bolts are in general suitable for fixing or holding-down purposes, but even where apparently adaptable are totally unsuitable for use under conditions where they will be subjected to heavy stresses.



Fig. 3.—Showing a typical coach bolt.

The length of the threaded portion is made proportionate to the diameter of the bolt, and is usually equal to twice or three times the diameter, although extra long bolts have more thread than this. Bolts of this description, in fact all bolts, are fitted with standard nuts. Two distinct standards exist for bolt head and nut dimensions. Thus, in the British Standard Fine, British Standard small hexagon or Auto-Whitworth ranges, the widths of the bolt heads, or nuts, across the flats are, in

By W. H. DELLER.

A Practical Article in Which the Author Describes the Various Thread Systems Employed and the Method of Making and Using the Items Mentioned in the Title

comparison with standard Whitworth bolts, made equal to the next lower size in that range, that is to say, 1 1/4-in. bolt in the B.S.F. range measures 0.445 in. across the flats, whereas in the standard Whitworth range the same material is used for a 3/8-in. diameter bolt. Fig. 1 shows a standard 1/2-in. Whit. bolt, and Fig. 2 1/2-in. B.S.F. This fact is worth remembering when buying set spanners, as those normally intended to cover standard Whit. nut sizes from 1/8 to 1 1/8 in. will also fit standard B.S.F. nuts from 1/4 to 3/4 in.

High Tensile Bolts

Mild steel bolts are manufactured from steel having a medium tensile strength. As previously stated, such bolts are, under certain conditions, unsatisfactory. In use, a bolt must be regarded as a spring on account of the metal between the head and the nut, forming the shank of the bolt, being in tension. Now, in the case of a joint between two surfaces, maintained by means of a bolt or bolts, or for that matter studs and nuts, the requirements are that the intervening packing or jointing must be compressed to a certain extent before the joint will hold. Should the packing material be of an unyielding nature mild steel bolts will stretch before the jointing has compressed sufficiently to provide a tight joint.

Again, in a connection between a driving and driven member by means of flanged couplings, the friction between the faces of the couplings does much to relieve the bolts from shearing strains. Unless the bolts holding them together will tighten sufficiently without yielding, they will, in use, take the whole load. This means that wear will occur at the junction of the couplings and on the shanks of the bolts, and anything in the nature of a "snatch" may be sufficient to shear the bolts.

The instances already mentioned are typical of the duties best fulfilled by high tensile bolts, but as a measure of safety they should always be used where everything depends on the bolts. As the name implies, these bolts are made from steel of high tensile strength, that is to say, the material has great physical properties in comparison with mild steel, especially in a condition of tension. They are made in both Whitworth and B.S.F. threads and are readily distinguishable on account of appropriate markings on the heads and having been heat treated after manufacture.

Coach Bolts

The familiar shape of the coach bolt illustrated in Fig. 3 is known as a cup, square, bolt and nut, and is made in Whit-

worth sizes from 3/8 in. upwards. Their chief uses are in certain forms of body construction for anchoring body irons to wood framing, and securing the body to the chassis. In all cases the squared portion of the bolt should fit into a corresponding hole in the iron bracket to permit the nut being secured or released easily. Similar bolts are to be had with countersunk heads, and these may be found useful in carrying out body repairs where projecting cup-shaped heads might be objectionable.

Wing bolts are similar to the cup head bolts. The difference lies in the head, which is larger in diameter and shaped like a mushroom, also the domed surface is turned smooth.

Nuts

Plain hexagon nuts are made in two styles—full and lock. In both the standard Whit. and B.A. ranges the full nuts are in thickness made equal to the diameter of the bolt, and chamfered on one side only. Lock-nuts, on the other hand, are chamfered on both sides, and in thickness equal a dimension representing two-thirds of the bolt diameter. Similar nuts in the B.S.F. or Auto-Whit. ranges correspond as regards thickness to the next lower size in the standard Whit. range. Slotted hexagon and castle nuts are made deeper than standard nuts to compensate against unduly weakening the nut by the pin slots. This point should be borne in mind when making



Fig. 4.—This type of nut is known as a cap nut.



Fig. 5.—A typical wing nut.

allowances for nuts on bolts that require pinning, otherwise the chances are that there will be insufficient thread left projecting beyond the bottom of the slot to accommodate the split pin hole. As a

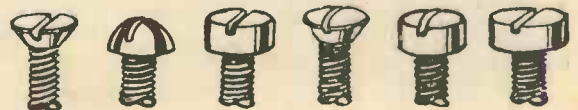

Fig. 7.—A heavier type of screw known as the coach screw.

general rule the thickness of a slotted nut is equal to the diameter of the bolt excepting Whit. and other coarsely threaded nuts, which are made thicker.

The type of nut shown in Fig. 4 is known as a Cap nut. Besides being used as wheel nuts, this type, in one of the many sizes in which they are manufactured, are suitable as a protection and finish to bolt ends, particularly those used for interior body fittings. Commonly made in brass they are to be had in self-colour or plated finishes.

Fig. 6.—Types of screw head. (Left to right) Countersunk, Round, Cheese, Instrument or Raised, Fillister and Connection.



Both brass and malleable iron-winged nuts of the shape shown in Fig. 5 are as standard tapped with Whit. thread in sizes ranging from $\frac{3}{8}$ to $\frac{1}{2}$ in. diameter.

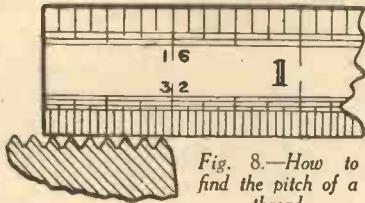

Screws

All metal thread screws are threaded right up to the head. Standard Whit. and B.S.F. screws are made in four shapes, namely, Hexagon, Countersunk, Round and Cheese-head, as shown in Fig. 6. These shapes are also repeated in the B.A. range, which includes such additional head shapes as instrument, fillister and connection.

Wood screws are to be had in three styles, countersunk, round and raised head, the latter being similar in shape to those of the instrument screws in the B.A. range. A heavier type of wood screw known as a coach screw and suitable for certain kinds of body repairs is seen in Fig. 7. It will be noticed that the screw is driven by means of a spanner. Wood screws are referred to for size, by numbers running from 00 smallest and upwards. Coach screws are referred to by the actual shank diameter.

Measurement and Identification of Screw Threads

The length of a bolt or screw is the measurement taken from under the head to the end of the thread, excepting in the case of countersunk screws, in which the length is the overall measurement.

The threads in common use are British Standard Whit., British Standard Fine, British Standard Pipe, and British Association, these being, of course, the standards of this country. Those of America are United States Standard or Sellers, Society of Automobile Engineers and American Society of Mechanical Engineers. The International System Metric Thread is the standard of most continental countries. In the order named, the threads mentioned, in an abbreviated form, are designated as follows: B.S.W. or Whit., B.S.F., B.S.P., B.A., U.S.S., S.A.E., or A.S.M.E. and S.I.

Whit. screws or studs are most likely to be used in soft metals on account of the deep thread afforded by the coarseness of the pitch. B.S.P. threads are used in connection with unions for petrol and oil piping. The nominal diameter of the thread refers to the bore of the piping for which it is suitable and this practice is followed out in the case of Union Nuts which are mostly tapped with this thread. Unions for both $\frac{1}{2}$ and $\frac{3}{8}$ in. diameter pipes are tapped $\frac{1}{2}$ B.S.P.

Although as a warning it should be mentioned that those for $\frac{3}{8}$ in. diameter are sometimes tapped $\frac{1}{2}$ in. diameter \times 19 threads per inch.

B.A. threads are used in substitution for B.S.F. in sizes below $\frac{1}{2}$ in. diameter. These run from No. 0 just under $\frac{1}{4}$ in. diameter to No. 22 about $\frac{1}{4}$ in. diameter, and are in common use on the items comprising the instruments and electrical equipment. In this class of work screws below No. 10 B.A. are seldom used, and therefore need not be considered.

As far as its application is concerned, the S.A.E. thread may be likened to B.S.F. and A.S.M.E. to B.A. As with B.A. the

diameters are denoted by numbers, No. 0, the smallest, is about $\frac{1}{16}$ in. diameter, and No. 30 just over $\frac{1}{8}$ in. diameter the largest.

Of the thread systems mentioned, two only employ the same thread formation. These are Whitworth and B.S.F. For purposes of identification thread formation may be ignored excepting in the case of the U.S.S. thread which size for size up to $1\frac{1}{2}$ in. diameter follows Whitworth as to pitch, with only one alteration, which is the $\frac{1}{2}$ in. diameter bearing 13 threads per inch. As distinct from Whitworth the shape of this thread is shallower on account of the angle being 60 degrees and is flat at the root and crest.

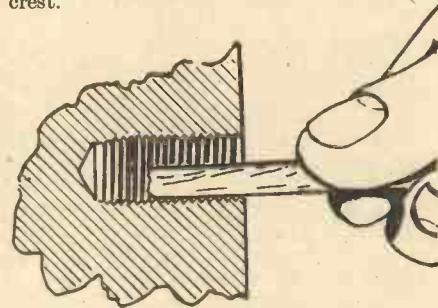

Fig. 9.—A simple method of measuring the pitch of a female thread by impressing the screw-thread on a piece of wood.

Screw Pitch Gauges

Although screw pitch gauges form the most convenient method of measuring pitch, such gauges are not absolutely necessary; in fact, a fine rule and a pair of outside callipers will give satisfactory

results as far as tools are concerned. For measuring the diameter of coarse threads, the callipers should have broad gauging faces.

After the diameter of the thread has been measured, the pitch is found as shown in Fig. 8, the end of the rule is set opposite to the root of a thread and the number of complete threads in a given distance counted. In the illustration there are seven complete threads in a $\frac{1}{2}$ in., or fourteen threads per inch. Thus, if the diameter is $\frac{3}{8}$ in. the thread would be identified as $\frac{3}{8}$ B.S.F.

It is not always possible to measure the pitch of a female thread directly with a rule, and a simple method of doing so is shown in Fig. 9. A piece of soft wood that will pass easily into the tapped hole is pressed into the thread and the pitch taken from the resultant impression. Smaller sizes can be dealt with by twisting a piece of wood, a little larger in diameter than the core diameter of the screw, into the hole and unscrewing carefully so as not to damage the shallow thread obtained.

Referring to the thread tables it should be pointed out that in certain instances approximate diameters are given in order to facilitate calliper measurements being taken. Also the method used to indicate the pitch of B.A. threads is not the normal one, but is closely approximate for rule measurement.

Both System International and French Standard pitches are given in the metric sizes. Here again the method is a departure from the normal one which is to indicate the linear pitch of each thread. Mention must be made of the fact that here, of course, all dimensions are given in millimetres.

Threads per Inch.										
Diameter	$\frac{1}{4}$	$\frac{3}{8}$	$\frac{1}{2}$	$\frac{5}{8}$	$\frac{3}{4}$	$\frac{7}{8}$	1	1 $\frac{1}{8}$	1 $\frac{1}{4}$	1 $\frac{1}{2}$
Whit.	20	18	16	14	12	12	11	10	9	8
B.S.F.	26	22	20	18	16	16	14	12	11	10
U.S.S.	20	18	16	14	13	12	11	10	9	8
S.A.E.	28	24	24	20	20	18	18	16	14	14

B.S.F. Nominal Sizes.								
	$\frac{1}{4}$	$\frac{3}{8}$	$\frac{1}{2}$	$\frac{5}{8}$	$\frac{3}{4}$	$\frac{7}{8}$	1	1 $\frac{1}{8}$
Actual diam.383	.518	.656	.825	.902	1.041	1.189	1.309
Approx. diam.	$\frac{3}{8}$ f	$\frac{3}{8}$ f	$\frac{1}{2}$	$\frac{5}{8}$ b	$\frac{3}{4}$ b	$1\frac{1}{8}$ b	$1\frac{1}{4}$ f	$1\frac{1}{8}$ b
Thds. per inch	28	19	19	14	14	14	14	11

B.A.											
Numbers	0	1	2	3	4	5	6	7	8	9	10
Actual diam.2362	.2087	.185	.1614	.1417	.126	.1102	.0984	.0866	.0748	.0669
Approx. diam.	$\frac{15}{64}$ f	$\frac{13}{64}$ f	$\frac{11}{64}$ b	$\frac{9}{64}$ f	$\frac{7}{64}$ b	$\frac{5}{64}$ b	$\frac{3}{64}$ f	$\frac{1}{64}$ f	$\frac{1}{64}$ f	$\frac{1}{64}$ b	$\frac{1}{64}$ f
Thds. (approx.) per inch	25 $\frac{1}{2}$	28 $\frac{1}{2}$	31 $\frac{1}{2}$	34 $\frac{1}{2}$	38 $\frac{1}{2}$	43	48	53	59	65	73

A.S.M.E.													
Numbers	0	1	2	3	4	5	6	7	8	9	10	12	14
Actual diam.060	.073	.086	.099	.112	.125	.138	.151	.164	.177	.190	.216	.242
Approx. diam.	$\frac{1}{16}$ b	$\frac{3}{64}$ b	$\frac{1}{8}$ f	$\frac{3}{32}$ b	$\frac{1}{4}$ f	$\frac{1}{4}$	$\frac{3}{16}$ b	$\frac{1}{4}$ b	$\frac{3}{16}$ f	$\frac{1}{4}$ f	$\frac{1}{4}$ f	$\frac{1}{2}$ b	$\frac{3}{8}$ f
Thds. per inch	80	72	64	56	48	44	40	36	36	32	30	28	24

All Dimensions in inches. f denotes full, b denotes bare.

Metric Sizes.															
Diam. mm.	4	5	6	7	8	9	10	11	12	14	16	18	20	22	24
System International. Thds. per 10 mm. (approx.)	14 $\frac{1}{2}$	11 $\frac{1}{2}$	10	10	8	8	6 $\frac{3}{4}$	6 $\frac{3}{4}$	5 $\frac{1}{2}$	5	5	4	4	4	3 $\frac{1}{2}$
Standard French. Thds. per 10 mm. (approx.)	13 $\frac{1}{2}$	13 $\frac{1}{2}$	10	10	10	10	6 $\frac{3}{4}$	—	6 $\frac{3}{4}$	5	5	4	4	4	3 $\frac{1}{2}$

CLIX



It is acknowledged that at least 90% of reception troubles are ultimately traceable to faulty connection at some point or points of contact in set, battery or accumulator. Avoid all such troubles by using only Clix perfect contact components, which are consistently chosen by leading set designers.



CLIX SPADE TERMINALS

The positive metal-to-metal wiring is fully protected from creeping acid by a specially designed collar which stops all corrosion. Large as illustrated **2d.** Small **1½d.**

CHASSIS MOUNTING STRIPS

Make for easy wiring, speedy and perfect plug and socket contact. A.E. or L.S. **6d.** each. Clix Soidd Plugs for same **2d.** each.



CHASSIS MOUNTING VALVE-HOLDERS

"Airsprung" type. 4-pin 1/2. 5-pin 1/3. 7-pin 1/4.

CLIX "MASTER" PLUGS

Non-collapsible pins. Metal-to-metal wiring device. Give perfect contact with all sockets having internal diameters from 1/8" to 3/16". Medium or short shank **1½d.** each. Specified for the "P.M." 2-valve Superhet.

LECTRO LINX LTD.
79a Rochester Row, London, S.W.1



Y 220

Where economy, both in first cost and upkeep, is of primary importance HIVAC Y 220 is the inevitable choice. For a given input and H.T. consumption this HIVAC valve provides an exceptionally high undistorted output.

HIVAC Y 220 10/6

Specified for the
"P.M." 2-VALVE SUPERHET

Have you had full details of the HIVAC MIDGET VALVES, if not, send for special Leaflet "P.M."

HIVAC
THE SCIENTIFIC
VALVE
BRITISH MADE

HIGH VACUUM VALVE CO. LTD.
113-117 Farringdon Road, London, E.C.1

AMPLION

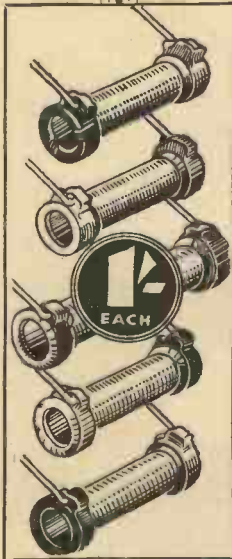

Amplion Components carry the Amplion reputation for quality and efficiency. They are often listed among those "specified" by well-known set designers.

MR. F. J. CAMM
HAS CHOSEN AMPLION
RESISTORS
FIXED CONDENSERS
AND ALSO AN AMPLION
"DRAGON" SPEAKER
for his
"P.M." 2-VALVE SUPERHET

Fixed Condensers :—
·0001, 6d. ·005, 7d. ·5 mfd., 2/-
Resistances (1-watt types) :—
100,000 and 250,000 ohms, 1/- each
"Dragon" Speaker, as specified, 29/6

AMPLION (1932) LTD.
82-84 Rosoman St., London, E.C.1

Descriptive Literature "P.M."
Free on Request.

100

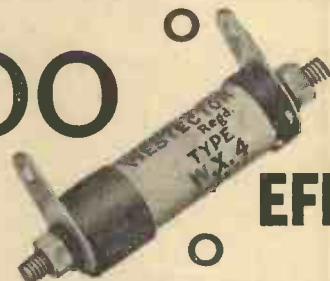

EFFICIENCY

Send 3d. to Dept. P.M. for a copy of "THE ALL METAL WAY, 1935," with full particulars and circuits of Westectors.

No detector overloading, simple circuit, no H.T. or L.T., permanent. Simplicity—efficiency—security.

WESTINGHOUSE BRAKE & SIGNAL CO. LTD.,
82 YORK ROAD, KING'S CROSS, LONDON, N.1

WESTECTORS



Television is the coming boom in wireless—it will bring even greater prosperity to the industry and create many more opportunities for a career. Men who foresaw the broadcasting boom made good—be trained and prepared for this television boom which must follow as surely as night follows day.

At the **WIRELESS COLLEGE** students receive training in all the latest developments in all branches of the Wireless profession. Marine, Aircraft, Manufacturing, Designing, Experimenting, Sales and Service, etc. *College on sea front. Write for free prospectus.*

STUDENTS ACCEPTED AS BOARDERS. TRAINING FEE CAN BE PAID AFTER APPOINTMENT SECURED
The **WIRELESS COLLEGE** COLWYN BAY N. WALES

The PRACTICAL MECHANICS

WIRELESS EXPERIMENTER

DURING recent years the superheterodyne receiver has definitely re-established itself, and it is now a generally accepted fact that the selectivity of this type of set surpasses that of the straight type. The majority of commercial superhets have four or more valves, however, and are therefore expensive to run if they are of the battery-operated type. With a view to reducing the total current consumption we have been conducting exhaustive experiments with three-valve superhets during the past twelve months, and the popularity of the £5 Superhet Three, described in *Practical Wireless*, dated October 27th, 1934, prompted us to try a further reduction in the number of valves. The two-valve receiver described in this article gives results equivalent to those obtained with a five-valve set of the 1932-33 type, as two of the valves perform a dual function, and the Westector takes the place of a valve as second detector.

Circuit Arrangement

The first valve is of the pentagrid type. This incorporates an H.F. pentode and a triode, thus enabling the frequency changing to be effected without the use of a separate oscillator valve. The output from this valve is fed to the second valve through an I.F. transformer, and thence to the Westector second detector. The rectified signal is then passed back through an L.F. transformer to the second valve, which serves the dual purpose of intermediate and low-frequency amplifier. The condenser C_3 prevents the low-frequency signal from leaking to earth through the I.F. transformer secondary, and the stopper resistance R_4 prevents the intermediate frequency signal from passing to the L.F. transformer secondary. It will be noted

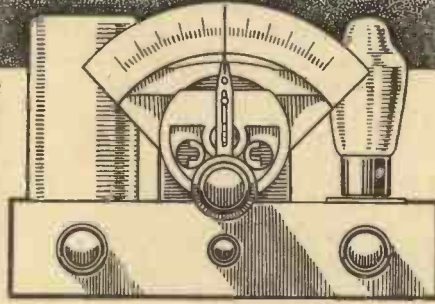

THE "P.M." TWO-VALVE SUPERHET

An Ultra-efficient Two-valve Receiver, working on the Superheterodyne Principle, is described in this Article.

that a fixed condenser is connected across the speaker terminals; this acts as a tone control, and also as a by-pass for the I.F. signal.

Intermediate Frequency

It has been found in practice that the use of a high intermediate frequency, although causing a slight loss of sensitivity, eliminates the annoying second channel whistles which are often experienced when a frequency of 110 kc. is used. When a low frequency is employed the first valve must be preceded by a band-pass filter in order to ensure adequate pre-selector selectivity, but when a frequency of approximately 465 kc. is used, the frequency of the station which might cause second channel interference differs so greatly from that of the desired station that very selective pre-selector circuits are unnecessary, and therefore the band-pass filter may be dispensed with.

Construction

The chassis is of the metallised wood type, and therefore no difficulty should be experienced in drilling the holes for the valve-holders and terminal strips. Care should be taken, however, to place the valve-holders centrally in the holes in order to avoid a short-circuit occurring from the pins to the metallised surface of the baseboard, and it is also advisable to scrape the metallising from underneath the brackets holding the wave switch and on-off switch. If a chassis, having the underside as well as the top of the baseboard metallised, is supplied, the bare ends of the resistances and the Westector must be kept clear of the metallised surface, and it should be noted that points marked MB must be in contact with the top surface of the base-

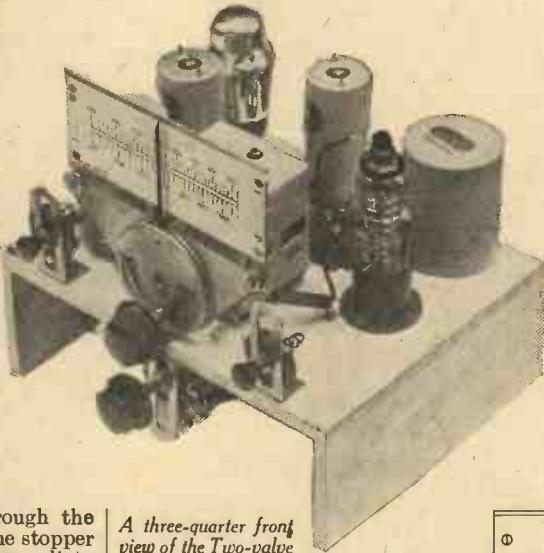

A three-quarter front view of the Two-valve Superhet.

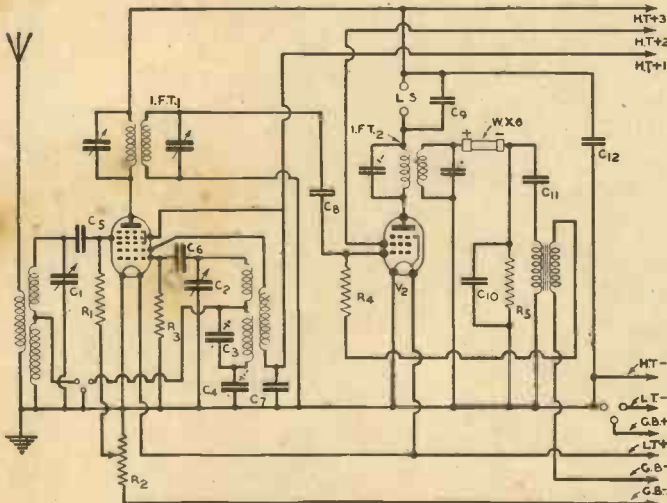

The circuit diagram of the Two-valve Superhet.

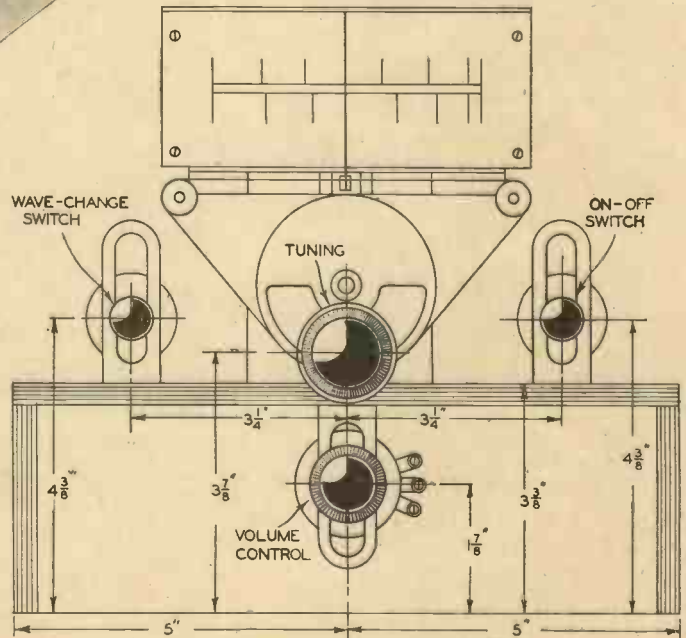

Details of the panel layout

board. In order to ensure good contact to MB it is advisable to place washers underneath the MB bolts and screws. It is not necessary to mount the components in any particular order, as all the terminals are easily accessible. It will be noted that soldering has to be resorted to in a few instances, but provided that a well-tinned iron is used no difficulty should be experienced.

Testing and Adjusting

After the wiring has been completed and carefully checked, the battery leads may be joined up. The H.T. 1, H.T. 2 and H.T. 3 plugs should be inserted in the 60, 100 to 120, and 120-volt sockets of the H.T. battery respectively, and the G.B. - 1 and G.B. - 2 plugs in the -4.5 and -9 sockets of the G.B. battery. The H.T. -, G.B. +, L.T. - and L.T. + leads should, of course, be joined to the appropriate sockets of the H.T., G.B. and L.T. batteries. After the battery leads have been connected up, the aerial and earth and speaker leads may be joined to the A.E. and L.S. terminal strips, and the receiver switched on by means of the three-point switch on the right side of the chassis. A station should then be tuned in on approximately 250 metres, and C1 trimmer adjusted until maximum volume is obtained. After this adjustment has been effected the tuning dial should be rotated until a station is tuned in at approximately 550 metres. C2 trimmer should then be adjusted whilst the tuning knob is moved slowly backwards and forwards. If the setting of C2 does not hold for stations at the top and bottom ends of the tuning range, the I.F. transformer trimmers should be slightly adjusted. These trimmers are controlled by the screw and hexagonal nut at the top of the transformers. The trimming procedure may seem rather complicated, but in practice very little difficulty should be experienced as the I.F. transformers are adjusted by the manufacturers.

THE TOP AND UNDERNEATH CHASSIS WIRING PLAN OF THE TWO-VALVE SUPERHET

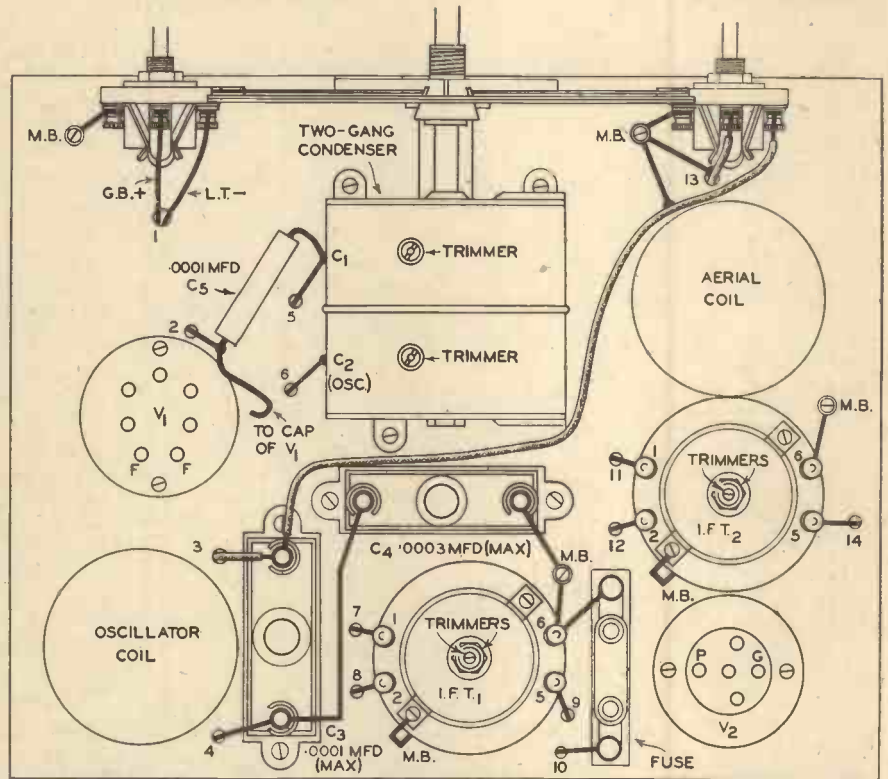

M.B.=METALLISED BASEBOARD

L.S.

A.E.

List of Components for the "P.M." TWO-VALVE SUPERHET

- Two Hall Mark Coils (B.T.S.).
- One 2-gang Superhet 465 K.C. Condenser with VP drive (Polar).
- Two 465 Kc. I.F. Transformers (Varley).
- One L.F. Transformer (B.T.S.).
- Eight Fixed Condensers (four .0001, C5, C6, C8, C10; one .005, C9; two 1 mfd., C7, C12; one .5 mfd. (Amplion)).
- Two Preset Condensers, .0001, .0003, C3, C4 (Ward and Goldstone).
- Four fixed Resistances (1 watt type), one 100,000 ohms, R3; three 250,000 ohms, R1, R4, R5 (Amplion).
- One 50,000 volume Control Potentiometer, R2 (B.T.S.).
- One WX.6 Westector (Westinghouse Brake).
- Two Air-sprung Valve Holders, one 7 pin, one 5 pin (Clix).
- Two Terminal Strips (L.S. and A.E.) (Clix).
- Two three-point Switches (B.T.S.).
- Seven Wander Plugs (Clix) (H.T. -, H.T.1, H.T.2, H.T.3, G.B.+, G.B.1, G.B.2) Clix.
- Two Spades (L.T. - and L.T.+) (Clix).
- Three Component Mounting Brackets (Peto-Scott).
- Metallised Chassis, 10 x 8 x 3 in. (Peto-Scott).
- One Fuse, 60 m/a. (Microfuse).
- One 210 P.G. Valve.
- One Y.220 Hivac Valve.
- One 120-volt H.T. Battery.
- One 9-volt G.B. Battery.
- One 2-volt L.T. Battery.
- Loudspeaker (Amplion).

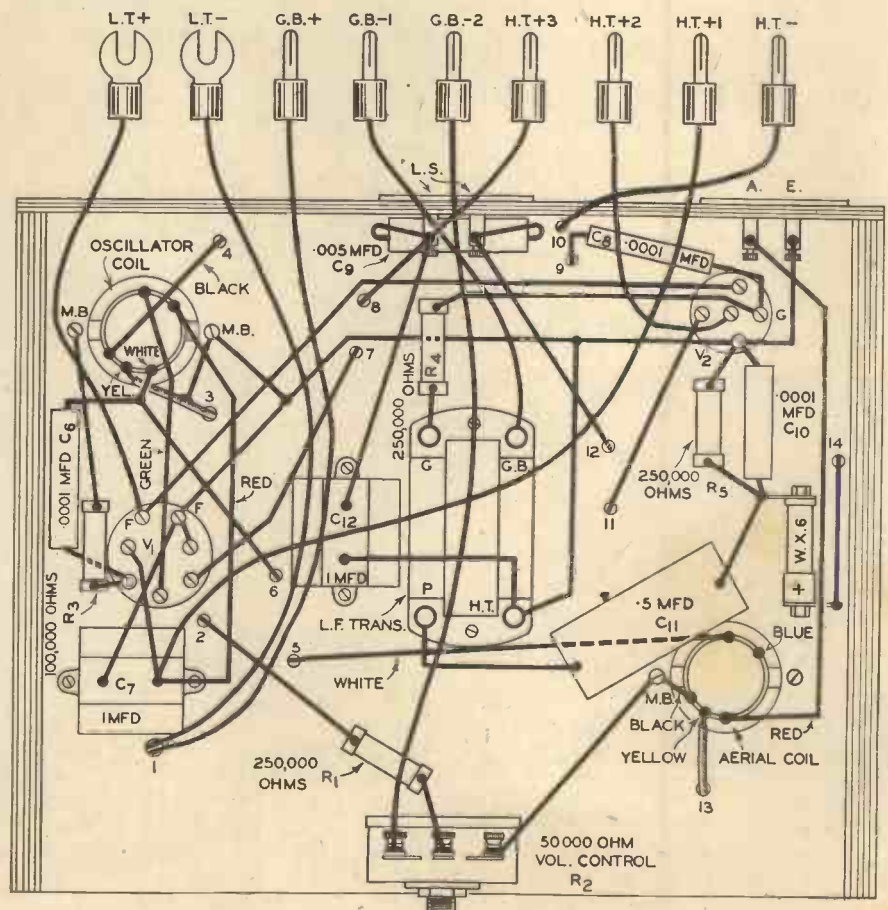

E. GRAY & SON LTD

THE "GRAYSPEC"

The Ideal 15 c.c. 2-stroke Aero Engine.

Weights only
15½ ozs.

Bore, 1⅛ ins.
Stroke, 1 in.

Set of Castings in
aluminium,

12/6

Set of Castings in
magnesium alloy,

18/6

All material for
model aero
construction
supplied from
stock. Write
to us for lists
PE and MM
(price 3d. each,
post free)
giving full
details.

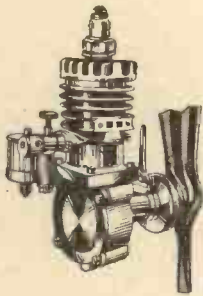

18-20
CLERKEN-
WELL
ROAD,
LONDON,
E.C.1

A Screwdriver - a gimblet



and the **Beacon** 456 CURTAIN RAIL

is ready to hang
your curtains

Patent No. 311518

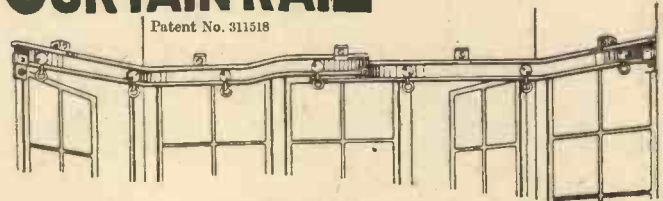

perfectly. Any handyman can erect. Fits all shapes
of windows—square bays, round and oval.

Most fittings **SOLID CHUNKS OF BRASS** and whole system is a
thoroughly sound job. Stands hardest wear
—woodwork would have to give way first.

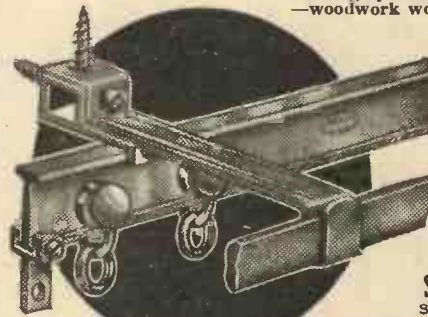

IN FOUR QUALITIES.
Strong (Brass) ... 1/- ft.
Light (Brass) ... 9d. ft.
Steel (Rustproofed) ... 9d. ft.

White (Aluminium Alloy) ... 9d. ft.
Complete with all fittings.

From all ironmongers, if
any difficulty write for
nearest stockist's name.

Beware imitations.
Any length cut to order

SMITH AND DAVIS, LIMITED
STAMPED BRASSFOUNDERS
HAMPTON ST. BIRMINGHAM

WHICH OF THESE IS YOUR PET SUBJECT ?

CIVIL ENGINEERING GROUP

Specifications.
Road Engineering.
Hydraulics.
Municipal Engineering.
General Civil Engineering.

Structural Design.
Structural Engineering.
Reinforced Concrete.
Sanitary Engineering.
Geology.

SURVEYING GROUP

Valuations.
Heating and Ventilating.
Clerk of Works.

Surveying and Levelling.
Building Construction.

COMMERCIAL ENGINEERING GROUP

Salesmanship.
Advertising.
Languages.

Commercial Engineering.
Cost Accounts.

MECHANICAL ENGINEERING GROUP

Works Management.
Press Tool Work.
Maintenance Engineering.
Metallurgy.
Sheet Metal Work.
Welding.
Diesel Engines.
Refrigeration.

WIRELESS GROUP

General Wireless.
Advanced Wireless.
Television.

TALKING-PICTURE GROUP

Talking-Picture Engineering.
Radio Servicing.

AUTOMOBILE ENGINEERING GROUP

Garage Management.
Electrical Equipment.

Claims Assessing.
High-speed Diesels.

ELECTRICAL ENGINEERING GROUP

Traction.
Electrical Supply.
Electrical Meters.
Electrical Design.
Installations.
Electrical Engineering.

Mains Engineering.
Telephony.
Alternating Currents.
Neon Lighting.
Power House Design.

AERONAUTICAL ENGINEERING GROUP

Aerial Navigation.
Aeroplane Design.

Aero Engines.

One of these examinations would multiply your earning power! **WHICH ONE?**

A.M.I.C.E.
A.M.I.Struct.E.
Sanitary Inspectors.
A.M.I.H. & V.E.
A.M.I.Mech.E.
A.M.I.P.E.

A.M.I.W.T.
A.Rad.A.
M.I.M.T.
A.F.R.Ae.S.
B.Sc. Degree.

G.P.O. Supt. of Traffic.
Patent Office Examiner.
Handicrafts Instructor.
Inspector of Factories.
Aircraft Apprentices.

Inst. Mun. & Cy. E.
M.R.San.I.
F.S.I.
A.R.I.B.A.
L.I.O.B.
F.A.I.

City & Guilds.
A.M.I.Fire.E.
A.M.I.E.E.
A.M.I.A.E.
A.M.I.Ae.E.

London Matriculation.
G.P.O. Prob. Inspector.
Air Navigators' Certificate.
Ground Engineers' Certificate.



May we send you full particulars of our unique tutorial organisation? Whatever your requirements, whether you desire a complete course of instruction, or tuition in some specialised subject, our Organisation is so planned that it will dovetail into your needs **exactly**.

As an indication of the strength of the B.I.E.T. Tutorial Organisation, it should be clearly noted that we **alone guarantee to return full fees to any student who does not pass his chosen Examination successfully**. In short, "If you do not pass, you do not pay."

Send to-day for a free copy of "ENGINEERING OPPORTUNITIES." This valuable 268-page Guide shows clearly and definitely the way in which you may carve out a successful career in your chosen branch of Engineering, irrespective of your age, education or experience. Among a host of other things, it gives details of all the above-mentioned Courses and shows the easiest way to prepare (in the privacy of your own home) for any of the recognised Examinations we have listed.

"ENGINEERING OPPORTUNITIES" should most certainly be in your hands. Send for your copy at once—free of cost or obligation.

BRITISH INSTITUTE of ENGINEERING TECHNOLOGY

410 SHAKESPEARE HOUSE, 29-31 OXFORD STREET, LONDON, W.1.

Australasian Enquiries: P.O. Box 3597S, Sydney. South African Enquiries: P.O. Box 4701, Jo'burg. Canadian Enquiries: 219 Bay Street, Toronto.

MODERN MOTOR REPAIR AND OVERHAULING

A Comprehensive and Authoritative Guide compiled by Practical Men for the Use of the Mechanic, the Garage Proprietor and the Motor Owner.



In four Volumes, strongly bound in Cloth, lettered 22 carat gold, 1,568 pages, 2,500 illustrations and 3 Charts.

Why this Work will Interest You

1. Because experienced men in the Garage Industry consider it to be the best book of its kind yet published.
2. Because it contains no frills and no padding. The language is straightforward and clear. The articles tell you exactly how to start any particular job, how to proceed and how to finish in a workman-like manner.
3. Because the information is sound and authoritative, having been supplied by men who have many years experience in motor repair work.
4. Because it places the advice of 35 experts at your service.
5. Because whether you wish to reline the clutch of an Austin 12/6, to re-wind the armature of a burnt-out starting-motor or to overhaul an A.E.C. Ignition-Compression engine, you will find in this work just the information you require to enable you to do the job in the shortest possible time consistent with good workmanship.
6. Because to the motor mechanic "MODERN MOTOR REPAIR" is worth many times its cost.

Use Coupon below for free, illustrated descriptive Brochure. It will be a revelation to you. By writing you will place yourself under no obligation.

READERS' OPINIONS

(TYPICAL OF MANY RECEIVED)

"I consider 'MODERN MOTOR REPAIR' the best text book on Modern practice for the motor user or repairer."—R. B. (Leeds).

"Congratulations on issuing 'MODERN MOTOR REPAIR.' I consider it the finest work ever published on this subject."—G. S. M. (Leyton, E.10).

"I must state that your books are very well written and just the thing that was required."—T. C. H. (London, S.W.15).

"I must say as regards your 'MODERN MOTOR REPAIR' that since I first commenced to serve my time as a motor mechanic I have never come across any books of such practical value and in which one could place such implicit confidence. Again and again I have saved time and worry over the 101 jobs which require to be done in any large public garage, and I have gained quite a reputation amongst customers. This is well worth the time spent in perusing these volumes of compressed knowledge, without taking into account the considerable amount of enjoyment obtained. I must, as the Americans put it, 'hand it to you' and your staff on the team-work which must have been necessary for such results."—N. A. J. (Glasgow).

"I have a considerable library of books on automobile engineering. Some of them are good: all of them contain something worth while, but not one of them deals with the subject in the plain and practical manner that characterises your publication. Your books are worth having and recommending."—H. P. (Birmingham).

A PRACTICAL WORK FOR THE PRACTICAL MAN

GET THIS—AND JUDGE FOR YOURSELF

(Postage ½d. if envelope is unsealed.)

To THE HOME LIBRARY BOOK CO.,
23 & 24 Tavistock St., London, W.C.2.

Please send me FREE copy of your illustrated Brochure giving full particulars of "MODERN MOTOR REPAIR." This places me under no obligation whatever.

NAME

ADDRESS

P. Mech. 735

If you do not wish to cut your copy, send a postcard, mentioning Practical Mechanics, to the address above.

MASTERS OF MECHANICS—NO. 2

THE BEGINNINGS OF STEAM POWER

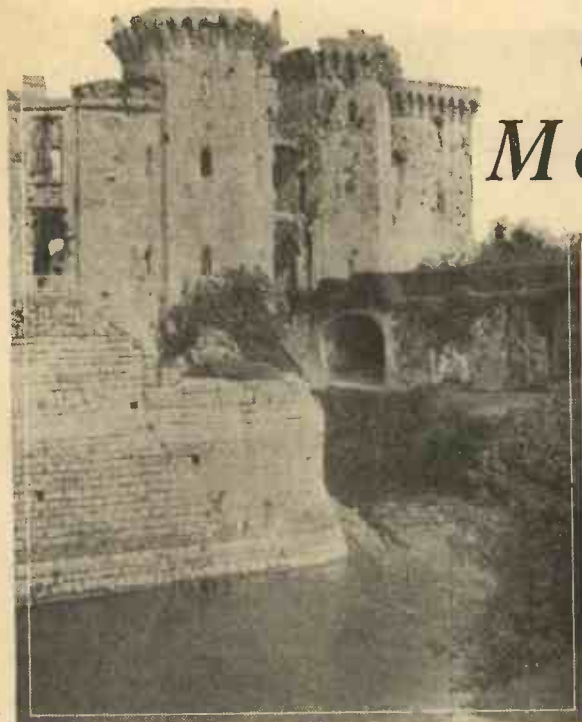

Raglan Castle, Monmouthshire, as it stands at the present day. In this now celebrated ruin, the first useful steam engine was born.

THE gradual application of the power of steam, which began at the commencement of the seventeenth century initiated and fostered an enormous extension of practical mechanics. Previous to the dawn of steam power the development of mechanical arts had been very slow indeed. In many respects mechanics had been a theoretical science more than an eminently practical one and the few books which had been published on the subject emphasised its theoretical and mathematical side alone. With the coming of steam power, however, an entirely new field was opened up for the applications of the mechanical sciences. As steam engines developed and were put more and more into working practice so did mechanics, the art and science of making and maintaining machines, extend, particularly in its practical aspect. The need for steam engines and other mechanisms having arisen, the means of making them quickly, accurately and efficiently had to be developed. A new era had arrived and the practical utilisation of steam motive power constituted one of the main causes of the new civilisation.

Solomon de Caus

Probably the first individual to employ steam for doing practical work was a certain Solomon de Caus, who was born at Dieppe in 1576. Fleeing from religious and political persecutions, De Caus, who had been architect, surveyor and chief engineer to Louis XIII. of France, settled down at Heidelberg, in Germany, having obtained a post under the patronage of the Duke of Bavaria. It was in 1615, during his residence in Heidelberg, that De Caus published his book on "Mechanical Forces," a work in which he describes his own inventions. In this volume we come across a description of a method of raising water by the power of steam. A spherical metal boiler was fitted with a long metal tube which reached almost to the bottom of the boiler. A tap for supplying water to the boiler was also provided. When De Caus lit a fire under his boiler the generation of

steam forced the water up the vertical pipe and provided a miniature fountain. Such was the earliest steam engine of modern ages. Whether De Caus actually applied his engine for any practical water-raising purposes is doubtful. Indeed, assertions have not been wanting to the effect that De Caus never actually constructed the engine which he describes in his book. It is more than probable, however, that De Caus was well acquainted with the practical working of his primitive engine, for he observes that if the vertical tube be closed at the upper end,

the water-filling tap also remaining closed and the heating of the boiler continued, "the metal sphere will burst into pieces with a noise like a petard."

The Steam Engine

The French claim De Caus as the inventor of the steam engine. Such a claim cannot, of course, be substantiated. De Caus first drew attention to the practical use of the expansive force of steam, but the idea of obtaining mechanical movement from the force of steam apparently never entered into his head.

The next description of a steam engine appeared in 1629, in which year was published at Rome a book entitled "Le Machine." Its author was Giovanni Branca, of Loretto, in Italy. Branca, who had several original mechanisms to his credit, describes and illustrates very quaintly in his book a form of steam engine working on the turbine principle. Steam issuing from a boiler impinges upon a number of vanes arranged around the circumference of a wheel and in this manner motive power is obtained. Branca suggests in his book that his steam engine might be of service in the mechanical pounding of drugs. It is doubtful, however, whether Branca, who was by profession an architect, ever constructed a working model of the engine which he describes. More probably than not, his notion was an elaboration of the steam jet principle of the ancients. Nevertheless, his description of this early steam engine is of importance as being the very first one of its kind.

Undoubtedly the inventor of the first steam engine which had the slightest practical use was Edward Somerset, Second Marquis of Worcester, who was born in London in 1601. Somerset lived in a romantic and an unsettled age and a very picturesque figure he makes. One of the greatest classics of mechanical writings is the Marquis of Worcester's "Century of Inventions," an extraordinary volume of mechanical descriptions which he published in 1663.

The Marquis of Worcester

The Marquis of Worcester set up a laboratory and workshop in his castle at Raglan, in Monmouthshire. Here he worked incessantly on the various mechanical projects and inventions which flooded through his fertile brain. He employed a clever mechanic, Caspar Kalthoff, to assist him in the constructional part of his work. In the remoteness of Raglan Castle, Edward Somerset, Marquis of Worcester, developed what was to be the very first practically-useful steam engine ever devised. It was a water-raising engine. It contained no moving parts, being, in most respects, merely an elaboration of Solomon de Caus's earlier steam engine. In the Marquis of Worcester's first engine two hollow spheres made of stout metal were provided, each with a filling tap and a vertical tube reaching down to the bottom of the sphere. Each vertical tube was provided with a tap

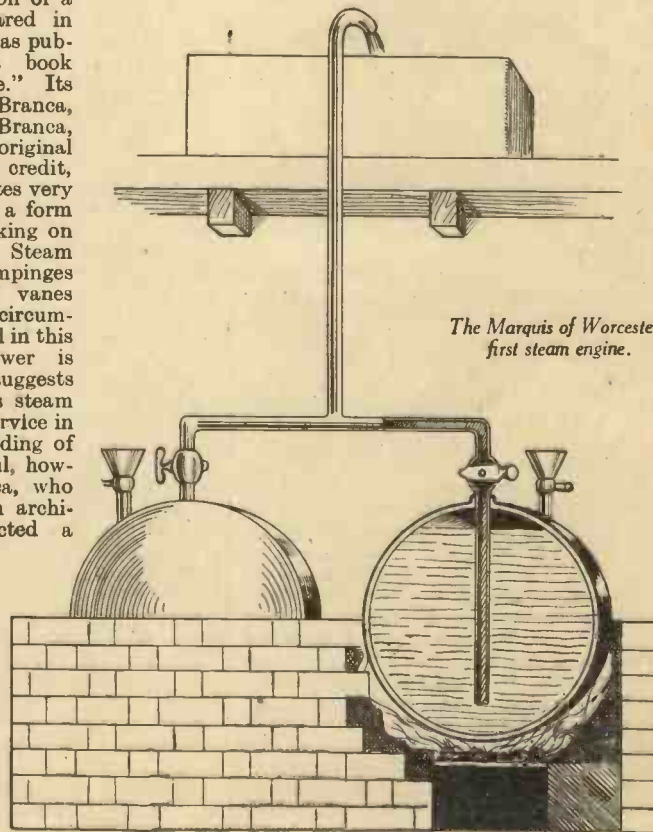

The Marquis of Worcester's first steam engine.

and it was connected by means of a T-piece to a third upright tube. The engine worked by both boilers being filled with water, the taps of the delivery tubes being closed. One boiler was heated rapidly, the other slowly. When the water in the rapidly heated boiler was judged to be sufficiently hot, the tap of the delivery tube was opened, whereupon the internal steam pressure forced the water out of the boiler and into an upper tank. The delivery tube tap of the empty boiler was now closed and its filling tap opened. The boiler was then refilled with water. During these operations the water in the second boiler had become heated enough to generate an internal steam pressure. The delivery tube tap of the second boiler was then opened and the water flowed upwards to the elevated tank by virtue of the internal steam pressure. In this way, by working both boilers alternately, a continuous flow of water (of a sort) was effected.

A Water Supply System

By means of an engine of the above nature, the inventive Marquis of Worcester fitted up a water supply system in his romantic castle at Raglan. Raglan still remains as England's most picturesque castle ruin, but the present-day visitor to its walls and apartments will look in vain for any relics of the many mechanical devices which the worthy Marquis fitted

up therein. Cromwell's soldiers subsequently destroyed the ancient castle too effectively for that.

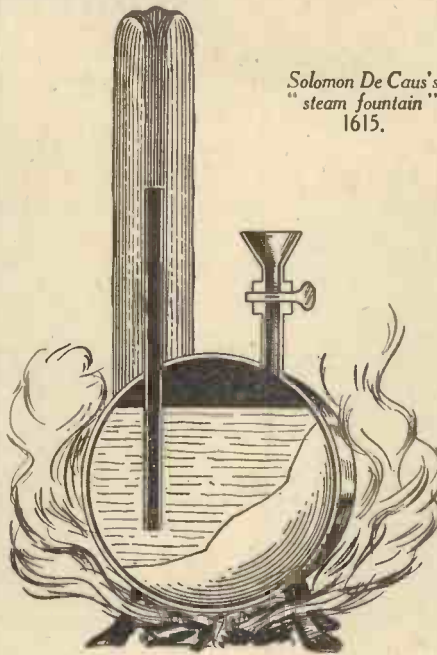

Solomon De Caus's
"steam fountain"
1615.

In a later and improved type of steam-raising device, which the Marquis termed his "Water-Commanding Engine"—an engine which, by special Act of Parliament in 1662, he secured a sort of patent for—a water-raising principle similar to that which operated his earlier engine was made use of, the steam in the "water-commanding engine" being generated in a separate boiler and being led into another vessel filled with water. The steam pressure in this vessel forced the contained water upwards through a vertical pipe. The vessel was again filled with water and the steam re-admitted to it. Further water was forced up the vertical pipe, and thus the water-raising action continued with the necessary interruptions. In 1663 the Marquis erected one of his "water-commanding engines" at Vauxhall. It raised water to a height of 40 ft.

Despite the mechanical ingenuity of the Marquis of Worcester, the production of actual motive power of a useful kind by the agency of steam was not yet forthcoming. The fundamental conception of the piston and cylinder had not yet arrived. How the earliest idea of the piston originated and the manner in which this indispensable mechanism was applied in early steam engine practice is a narration full of interest, but it is one which will have to be left for consideration in a future article of this series.

TELE-CONTROL OF MECHANISMS

(Continued from page 453)

A More Sensitive Thermostat

So far we have only considered air in the gas chamber, but the most suitable gas is one having maximum volumetric expansion and minimum specific heat, such as vapours of alcohol, ether, carbon tetrachloride, etc. Of these, ether, which boils at 34.9° C., is probably the best. If a little ether be placed in the gas chamber and the lower half be placed in hot water, plenty of ether vapour will be given off. On no account must this vapour be brought near a naked light. Vapour is given off even at ordinary temperature and due care must be exercised. This undoubtedly considerably increases its sensitiveness and quickness of action.

The finer the thread of mercury in the tube the further it will move for a given expansion of gas in the chamber. The tube, therefore, should have as fine a bore as practicable. Now the bore of the Romac tubing is sufficiently large to allow of a piece of cycle valve tubing being drawn through, only the best black tubing costing 6d. a yard should be used.

Although the rubber tubing works quite well, it is a difficulty not being able to see the mercury and points of contact, and the best method is platinum wire fused into glass tubing of fine bore. This wire is used because it has practically the same coefficient of expansion as glass, and, moreover, the mercury has no chemical action on it. Three inches can be bought for 1s. 6d., and this would be enough for the five contacts, since only a short piece is required outside, where copper wire can be joined to it by means of a spot of solder. Only short curved lengths of glass tubing need be used, and these can be joined up to the gas chamber by thick rubber tubing, which would make the apparatus far less fragile.

Since no great speed is required, the boat can be conveniently driven by the type of permanent magnet motor shown in Fig. 7, which takes only a small amount of current. The entire system can be worked with dry cells of fair size, but better still with two small accumulators of 6 volts for motor and 4 volts for the tele-control.

The gas chamber so far considered can only be worked from one side; if, however, we made our shallow tin tray also of foil, we can play our rays on either side, back or front. It would obviously quicken the action of our thermostat if our heat rays impinged both on the front and back—this can be done by arranging a zinc or copper mirror, preferably plated, at an angle of 45 degrees, so as to reflect rays passing the gas chamber on to the rear of the same. It is stated that the best foil to use is not copper but platinum; its price is, however, prohibitive. But lamp-black silver foil (which is not expensive) should be better than copper owing to its lower specific heat, 0.0557 instead of 0.0949 for copper; platinum is 0.0355; but if we consider thermal conductivity, silver stands first with 100.0, copper 74.8, and platinum only 9.4—platinum has only a very low coefficient of thermal conductivity and the best foil to use certainly appears to be silver.

One point more, instead of having the tube (glass or otherwise) curved at its lowest point we can have it straight, i.e., horizontal up to and beyond the contact wires and then turned up and have a column of alcohol or water, etc., at each end of the mercury, because mercury has a very high specific gravity, 13.598, i.e., it is very heavy and even a slight difference of level requires a certain amount of difference of pressure in the gas chambers, much more so than in the case of water, specific gravity, 1; alcohol, 0.803; ether, 0.723.

BOOKS RECEIVED

Calverts Mechanics Almanack. 6d., 190 pages. Published by W. E. Endsor & Co., 5 Bridge Street.

FOR the sixtieth year this handy little pocket encyclopaedia appears on the market, and at 6d. no mechanic (be he electrical, gas or other trade) should be without it. 190 pages, roughly 6 in. x 4 in., are devoted to the various tables, working notes, workshop hints, etc., without which no workshop is complete. Hints on setting up work in the lathe, selecting hack-saw blades, mounting various types of work for lathe or drilling operations, hints on working aluminium, electric welding, fuel consumption data, essential conditions for economical working of steam engines, oil and internal combustion engines, and dozens of other details concerning materials, tools, etc., are interestingly packed in its pages.

Telephotography. Price 3s. 6d., 117 pages. Published by Sir Isaac Pitman & Co., Parker Street, Aldwych.

THE various aspects of photography from a distance are dealt with in a new publication from the house of Pitman. Written by H. A. Carter, F.R.P.S., this deals not only with ordinary still photography but also with cinematography with the use of telephoto lenses. In addition to the more intricate details of covering power, exposure, etc., this book deals with many commercial cameras and fittings designed especially for the long-distance photographer. Copiously illustrated, with examples of the advantages of telephotography in the portraiture of wild life, etc., this hand-book, which costs 3s. 6s., should be read by all photographers.

The LATEST Novelties

The address of the makers of any device described below will be sent on application to the Editor, PRACTICAL MECHANICS 8-11, Southampton St., Strand, W.C. 2. Quote number at end of paragraph.

A Novel Fountain Pen

COMBINING several ingenious features the fountain pen, illustrated on this page, should prove unusually interesting. Unlike the normal fountain pen, it has no sac, the filling operation being carried out by an entirely new principle which also dispenses with piston pumps and valves. The absence of "mechanism" enables a much greater quantity of ink to be carried—in fact, the makers claim a 120 per cent. increase of capacity over a similar sized



A novel fountain pen combining several ingenious features.

sac-type pen. The barrel being built up of alternate rings of jet and silver pearl, forms a translucent barrel, which enables one to see at a glance the amount of ink remaining for use. On some models a specially treated nib is fitted which enables it to be used on either side, the advantage of which will be apparent from the illustration. The prices vary from 20s. to 40s. [130.]

Plastic Metal

A VERY quick-hardening iron cement, known as plastic metal, which is suitable for repairing articles of iron, brass, steel, copper, lead, aluminium, etc., is now on the market. The cement is in powder form, and for use it is necessary to mix about six parts of cement with one part of cold water. When well mixed, it will form a stiff putty that can be worked into position by hand. Plastic metal can be successfully applied to articles that are hot, cold or warm. It will withstand fire, water, steam, ammonia, oil, petrol and very high pressures, and can be used as a filling for repairing breaks in castings, making tight joints and seams, and many other home uses referred to in the directions sold with the tin. The price is 9d. per 1/2 lb. tin. [131.]

For Draughtsmen

IT is not easy nowadays to improve upon the modern draughtsman's equipment, but the drawing kit shown herewith will not only prove decidedly practical and useful, but shows definite progress in the methods employed for recording sketches, and drawings of all types. The board itself is bounded on the bottom and left-hand side by two raised straight edges, firmly fixed at an exact right angle, and divided in inches and one-sixteenths, or metric scale. The paper on which the drawing is to be made is firmly attached to the board, in the form of a pad, by two interscrews at the top. These interscrews are quickly loosened by means of the edge of a coin to allow the pad to be renewed or exchanged for one of tracing cloth or another type of paper, etc. This obviates the use of drawing pins, and avoids loss of time in fixing a new sheet of paper to the board. Only one moving implement is required for drawing both horizontal and vertical lines to the full width and length of the paper. This is accomplished by sliding the L-square along one or other of the two fixed straight edges.

A second moving implement in the form of a 45-60-75 degree triangle enables lines, by employing the three angles, to be drawn at 15-degree intervals throughout the circle with equal ease and rapidity. For intervening angles an ordinary protractor can also be used.

Attached to the board is a rigid flap cover which is provided with a series of packets securely to hold the L-square, triangle, pencils, compasses, etc. (these in turn being protected with a further waterproof cloth flap). This cover, when folded across the board, is fastened by means of press studs, so that a complete and compact

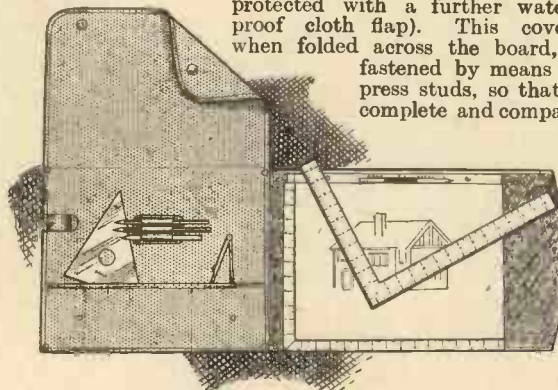

An efficient draughtsman's kit

outfit for recording all types of drawings is contained and adequately protected, in a cloth-covered case. In addition a strong waterproof satchel is provided as an extra to facilitate carrying of the block and protector against climatic conditions. It costs 15s. [132.]

Place an Order with your Newsagent for "PRACTICAL MECHANICS" to be regularly delivered!

B.T.S. AGAIN! CHOSEN by Mr. F. J. CAMM P.M. 2-valve SUPERHET

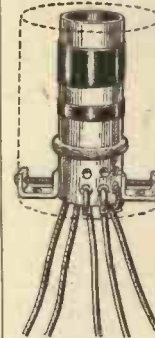

Again B.T.S. Components are the choice of the expert . . . once more Mr. F. J. Camm prefers, uses and exclusively specifies B.T.S. for the most vital components in his latest receiver.

B.T.S. COILS

As used by Mr. Camm, no other coils will take their place. . . only B.T.S. will make your version exactly as the original
TYPE No. HMO. 8/6
THE PAIR

ALSO SPECIFIED

FROM ALL DEALERS
If you cannot obtain locally, please send your order direct.

1 B.T.S. L.F. Transformer, Type No. s. d. L.T. 135 4 6
1 B.T.S. 50,000 ohms. Volume Control Potentiometer, Type No. V.R.50 3 6

REFUSE ALL SUBSTITUTES

Short Wave and Television Specialists.

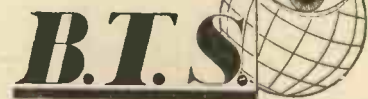

BRITISH TELEVISION SUPPLIES LTD., BUSH HOUSE, Dept. "Pr. M." LONDON, W.C.2



Without Medicine Operation or Glasses

EYESIGHT IMPROVED

OUR EYE BOOK FREE

If your eyes are affected you need our Book on "Eyes," describing a harmless method by which you can strengthen the eyes and restore the vision without operation or the aid of drugs or glasses. It is in the nature of a gentle massage which stimulates the action of the blood in the eye arteries with the result that natural sight is improved, and the eyes become painlessly and surely moulded to perfect shape. By this means Near Sight, Far Sight, Astigmatism, and other defects are corrected. You can discard your glasses and counteract headache and eyestrain by five minutes' manipulation daily in your own home.

See Nature with Naked Eyes—not through Glass Windows. A 1/- BOOK on the "Eyes" Free.

This book is published at 1/-, but its contents are of such vital importance to all sufferers from eye defects that we have decided to give away 50,000 copies at cost. Safeguard your eyes. Send no money, only your name and address, with 3d. (abroad 6 foreign) stamps for expenses to:—

NEU-VITA (Dept. JF.33), 163-252 Central Buildings, London Bridge, London, S.E.1, Eng.



CASTING MOULDS

Make your own lead soldiers, animals, Indians, etc.

Illustrated Catalogue free. J. Toymoulds, 18 Kenyon St., Birmingham

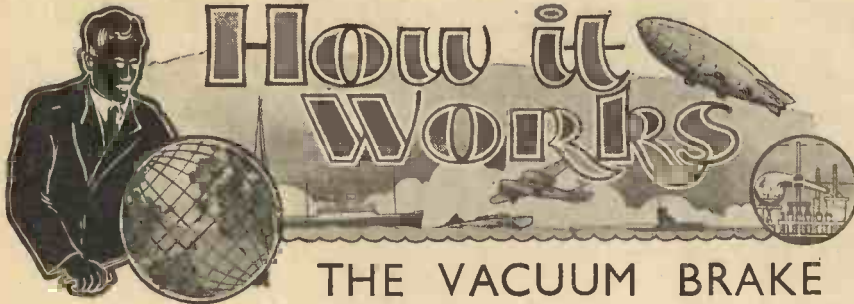

How it Works

THE VACUUM BRAKE

THIS branch of engineering in the railway world has undergone a wonderful development since the invention of a continuous brake by Lord Masham in 1843, and the introduction of the simple vacuum in this country by Mr. Smith in 1874, and of later years the "Sanders and Clayton" automatic vacuum brake. The present-day exponents can be safely credited to the Gresham family, who have done yeoman service, and E. S. Luard, Esq., and many are the ingenious ideas of the above named which have undergone patient trial and experimentation, and finally put into practice with the result that they are now fulfilling their various functions with marked success.

The Automatic Vacuum Brake is adopted by some English railways as their standard. It is also adopted by the vast railway system in India; it is largely used in the Argentine, South Africa, Australia, and to some extent in other parts of the world. All passenger carriage stock is fitted with either a "vacuum" or "pressure" brake apparatus, but the use of air brakes on wagon stock is by no means universal; much of the wagon stock is fitted with hand-power brake only. If the reader has ever travelled on a train conveying a royal personage he perhaps will have noticed how gradual and gently the whole train was brought to a stop; of course, this applies in a less marked degree to an ordinary train (in addition to the perfection of the brake

apparatus the human element of the driver plays an indispensable and considerable part); on the other hand, it is possible in the case of an emergency stop (to avert, say, an accident) to bring a heavily-loaded train travelling at a high speed to a standstill within the length of the train.

Regulating the Brake Power

It may be here mentioned that there are inventions which aim at regulating the brake-power in correct proportion to the speed and weight of the train respectively, and to apply too much brake-pressure in either of the above cases would produce skidding, thereby producing flats on the peripheries of the wheels. Thus the brake-pressure through a system of leverage is

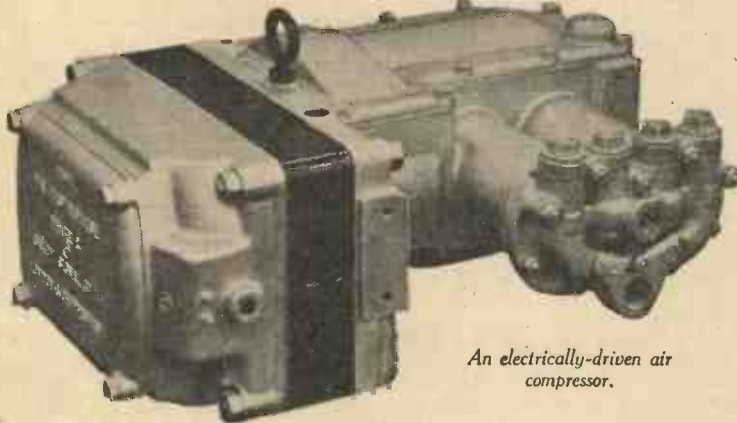

An electrically-driven air compressor.

generally designed up to and within a maximum percentage of the load. In vacuum brakes, air at atmospheric pressure is used; this we may take at approximately 15 lb. per square inch pressure. It should be noted that the pressure of the atmosphere varies at different altitudes, from the sea-level. When a vacuum or partial vacuum is produced in a vessel, the whole or part of the air contained is exhausted or drawn

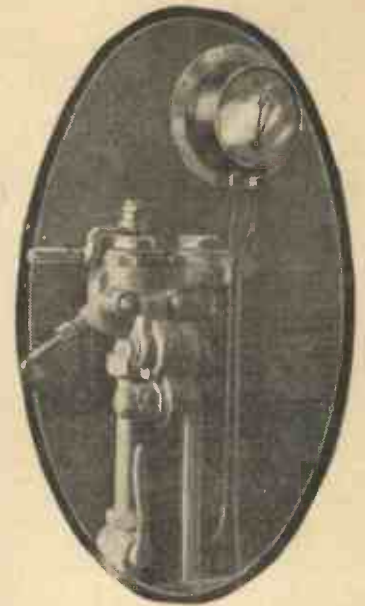

The driver's brake valve for an automatic brake.

from it, thereby reducing the pressure within the vessel. Boyle's law tells us that the pressure varies inversely as the volume, and so, if we draw half the volume of original air from a vessel and allow no more to enter it, there is a reduction or "drop in pressure" of half the original pressure.

We will now briefly trace the action of the brake cylinder and its connections right from the ejector, to which is attached the driver's valve. From the ejector there is a continuous pipe to the end of the last vehicle; between each vehicle the pipe is connected by flexible pipes technically termed hose-pipes. The hose-pipe on the end of the last vehicle is stopped up by placing it on a plug; the cylinders are connected to this continuous pipe by a small-bore hose-pipe.

Starting the Engine

Prior to starting the locomotive, the driver puts the driver's valve handle to the "brake off" position; this admits steam to the ejector and sucks out a portion of the air from the brake-pipe, thus creating a partial vacuum in the pipes and cylinders on both the top and bottom sides of the piston. The handle is then put in the "running position"; with the handle in this position the ejector maintains a constant and partial vacuum, so keeping the brake off. When the driver's valve is placed in the "brake off" position, steam

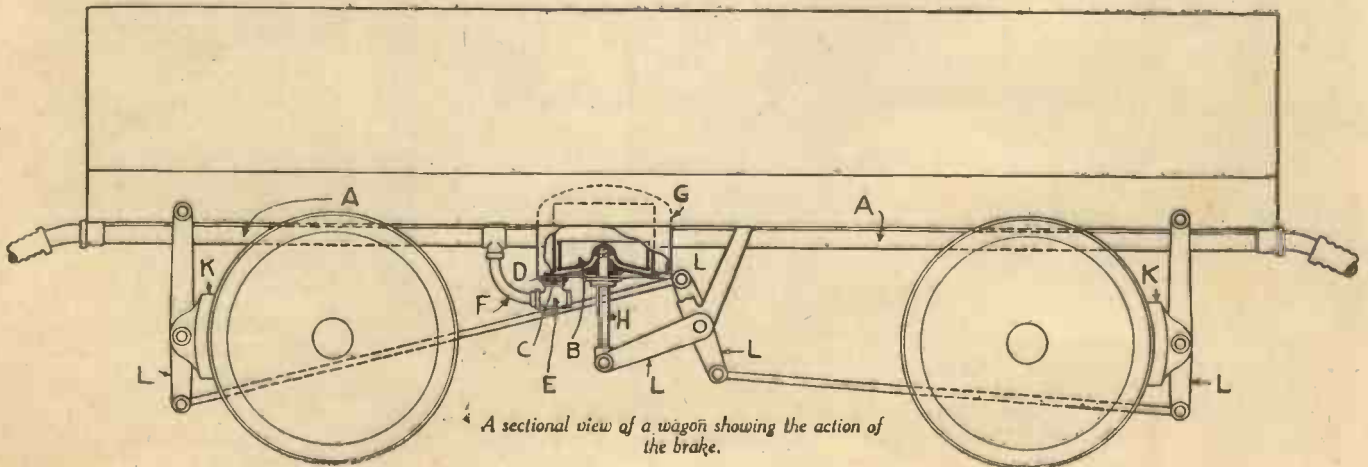

A sectional view of a wagon showing the action of the brake.

is cut off and air is admitted to the brake-pipes, these being connected to the cylinders. Air is admitted to the bottom side of the piston, but is prevented from flowing to the top side of piston by means of a ball-valve (whose action allows air to be sucked through only and not blown through). There is now a partial vacuum on the top side of piston and atmospheric pressure on the bottom side, or, in other terms, different pressures on top and bottom sides of the piston respectively, the greater pressure, of course, being on the bottom side. This forces the piston up, which through the intermediary of the piston rod, which is coupled to the brake-shaft lever, actuates a system of levers which convey the pressure to the brake-blocks; these in their turn (when in contact with the wheels) exert the necessary pressure on the wheels and retard their motion, thus slowing up or stopping the train. On the previous page is a sketch of a wagon showing a cylinder G in position, which, in conjunction with the following description, should be easily followed by the reader.

piston B through the holes C and D, through the ball-valve E, and connecting-pipe F.

When air is admitted to pipe A it passes through pipe F into ball-valve E, and thence to bottom side of piston through

The new all-steel, "Comprestall" air brake cylinder.

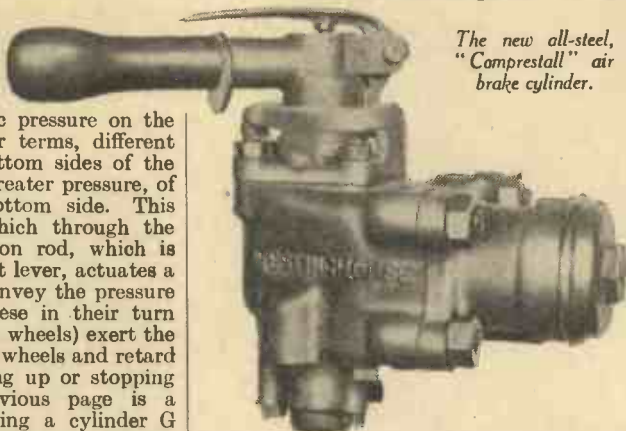

hole D; a ball lying on the periphery of a vertical hole at the bottom of ball-valve E, and in communication with hole C, prevents the passage of air to top side of piston B.

G is the brake cylinder; H is the piston-rod; K are the brake blocks; L the levers connecting the blocks to the cylinder, sometimes termed the "rigging."

The Action of the Ball-valve

When the air is exhausted or sucked from the continuous train pipe A, it is also exhausted from the top and bottom sides of

A NOVEL TYPE OF SPEEDBOAT

(Continued from page 471.)

to sixty in number), using a 69- to 75-twist drill. They commence at A and continue to B, as shown. This lamp gives a steadier flame than the previous one, and can also be regulated by the flame of the heating lamp. It has only one disadvantage, however, for if the heating lamp wick is blown out it very quickly ceases to function. With this lamp, when once started, 6 oz. of cold water has been raised to a steam pressure of 60 lb. in ninety seconds. It generates steam sufficiently fast to keep up the pressure for the "Meteor" engine and for the larger 3/8-in. bore and stroke, the pressure falling very slowly with both engines going all out, and using a 2-in. propeller in both cases. The tins used for the lamps were made out of lower parts of old fruit tins, and only soft soldering was used throughout.

The dimensions of the various parts are as follows: For the larger model (see Fig. 5) the container, E, is 3 in. in diameter, 1 in. deep; container F, 3 in. in diameter, 1 1/2 in. deep, and for the smaller model, E, 2 in. by 2 1/2 in.; F, 2 1/2 in. by 1 1/2 in.

The actual amount of spirit to put in each is best found out by a few experiments, but E needs but little, and should not go on heating F after all the spirit is evaporated. There is very little actual pressure and no safety valve is needed; soft soldering alone will answer—but silver soldering makes the best job.

The Boiler

This must be brazed. Obtain a piece of copper or brass tubing of about 18 gauge and of a suitable length. Blanks are required for the ends; a heavier gauge should be used for these, say 16, or even 14.

To provide the dry steam you must have a steam dome and a safety valve. They can be bought from 3d. up to 5s. 6d., and it

is certainly advisable to use a good one. The same hole into which this screws is, of course, used to fill the boiler, which should be filled not more than two-thirds full. A 2-in. boiler, 12 in. long, holds 16 oz. of water. A pressure gauge is essential, and if using a vertical engine it is essential to use a lubricator.

To mount the boiler cut two pieces of thin tin to the dimensions shown in Fig. 4, and bend as shown. The 2-in. hole can be cut with an ordinary 2-in. centre bit. They are then placed one at each end of the boiler, allowing about 1/4 in. to protrude. They should be a good fit, their upturned portions being screwed to the bottom of the boat.

The Casing or Cover

This is of thin tin cut to the dimensions shown in Fig. 6 and bent to shape. It is essential to line the sides with thin sheet asbestos inside. A similar sheet of asbestos is placed on the top of the boiler—slightly curved and with the necessary holes for safety valve, etc. Any additional corner or end pieces of tin that may be necessary to thoroughly shut in the flame must be fastened on with very small nuts and bolts; soldering is useless.

The safety valve (if spring is external) must be protected from the flame or its temper may be spoiled. Asbestos-lined caps should be fitted over the ends of the boiler to prevent radiation.

Lagging, etc.

To obtain the best results, careful lagging of the pipe conveying steam from the boiler to the engine and of the engine itself is essential. To do this, place pieces of asbestos in a saucepan containing a small amount of water and boil, at the same time pounding the asbestos to a pulp. Now squeeze it in a cloth and apply round the pipe, etc., afterwards binding with tape. The slide valve and cylinder of the engine should be similarly treated.

The boiler and container F, especially the bottom, soon become coated with a deposit of carbon—a powerful non-conductor of heat; therefore they must be frequently cleaned.

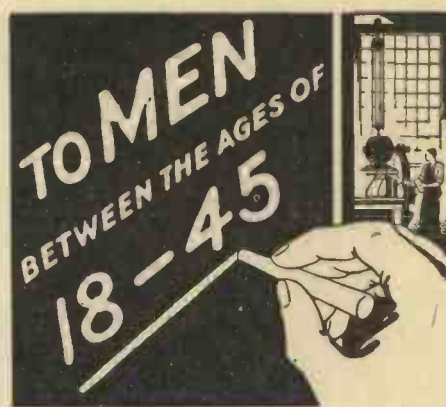

Things are happening to-day which vitally affect you!

If you are about 18, perhaps you are getting settled in your chosen work and already feeling the strain of competition for a better position. If you are in the 40's, your family responsibilities are near the peak, the necessity for money is tense—and younger men are challenging your job. And men of the ages between 18 and 45 face similar problems, in one form or another.

The most valuable employment security to-day is the security a man creates for himself—in himself! Through training, he is able to adapt himself to new conditions, to utilise experience without being handicapped by habit! He masters jobs and makes new jobs. He meets emergencies—and is not overwhelmed by them. And this is an age of emergencies.

For 44 years the International Correspondence Schools have helped thoughtful and ambitious men to acquire the training they need. To-day, with this need more urgent than ever, this world-famous institution offers greater opportunities than ever. Why not permit us to show you the way to greater security and larger earnings? Our expert advice is free. Write to-day.

...COUPON FOR FREE BOOKLET...

INTERNATIONAL CORRESPONDENCE SCHOOLS, LTD.
Dept. 95, International Buildings, Kingsway, London, W.C.2

Please send me your booklet containing full particulars of the Course of Correspondence Training before which I have marked X. I assume no obligation.

- | | |
|---|--|
| <input type="checkbox"/> Accountancy | <input type="checkbox"/> Marine Engineering |
| <input type="checkbox"/> Advertising | <input type="checkbox"/> Mechanical Engineering |
| <input type="checkbox"/> Aeronautical Engineering | <input type="checkbox"/> Mining Engineering |
| <input type="checkbox"/> Architecture | <input type="checkbox"/> Motor Engineering |
| <input type="checkbox"/> Bookkeeping | <input type="checkbox"/> Plumbing |
| <input type="checkbox"/> Building | <input type="checkbox"/> Radio |
| <input type="checkbox"/> Chemical Engineering | <input type="checkbox"/> Railway Equipment and Running |
| <input type="checkbox"/> Civil Engineering | <input type="checkbox"/> Salesmanship |
| <input type="checkbox"/> Draughtsmanship | <input type="checkbox"/> Steam Engineering |
| <input type="checkbox"/> Electrical Engineering | <input type="checkbox"/> Textiles |
| <input type="checkbox"/> Engineering Design | <input type="checkbox"/> Woodworking |

Examinations, state which.....

The I.C.S. teach wherever the post reaches, and have a wide variety of courses of study. If, therefore, your subject is not in the above list, write it here.

.....
Name..... Age.....
Address

GENUINE AND ONLY CHROMATIC MOUTH ORGAN

Sent you for
1/6 Deposit, plus 6d. postage, etc.
 Balance 1/6 weekly for 4 weeks to approved customers. Cash price, 6/6 post free.

GUARANTEED the same type of instrument as played by **LARRY ADLER** in his Stage, Broadcast and Gramophone Performances.

This superb **HOHNER** INSTRUMENT with its beautiful deep, rich, organ tone, can be played in ANY Key (all 12 Keys) including all Sharps and Flats, exactly as your own Piano.

CHROMONICA MODEL with three complete Chromatic Scales, in beautiful Silk-lined case. 2/- only deposit, plus 6d. postage, etc. Balance 2/- weekly (for 5 weeks) to approved customers. Cash Price, 10/6 post free.

MODERN MUSIC STUDIO
 High Holborn House (P.M.),
 52 High Holborn, London, W.C.1.
SPECIAL TUTOR *ments. 1/- extra.*



BE TALL

Your Height increased in 14 days or money back. The amazing Stebbing System soon brings 3-5 inches increase and new energy. The first, original, and the one **GENUINE GUARANTEED** Height Increase System. Recommended by *Health and Efficiency*. Complete Course, 5/-, or Booklet free, privately.

STEBBING SYSTEM, Dept. M.P., 28 Dean Rd., London N.W.1.

TAKE YOUR OWN PERSONAL MOVIES

We offer reconditioned Cine-cameras at 35/-, 75/- and upwards. Why not write now for our free Booklet and list? We fully guarantee every item, offer approval facilities, and most attractive part exchanges.

AMATEUR CINE SERVICE LTD.
 52 WIDMORE ROAD, BROMLEY.
 (20 minutes from Charing Cross)

MICROFU GOLD FILM FUSES
 20 Stock Ratings.

 Type F.2, suitable for Mains sets. 500m/A blows at 1 amp. Resistance 1 1/2 ohms, 260 volts D.C. Now available 2 m/A, 4/-, 1 m/A, 4/6.
 Type F.2, suitable for Battery sets. 150 m/A blows at 300 m/A. Resistance 7 1/2 ohms. Voltage 260 Volts D.C. **FUSES 6d. HOLDERS 6d.**

Specified for the "P.M." 2-VALVE SUPERHET

You require one 60 m/A MICROFU for the above Receiver

MICROFUSES LTD., 4 Charterhouse Bldgs., Goswell Rd., London, E.C.1. Phone: OLE 4049.



FOR DURATION FLYING build THE LINCOL

We quote an extract from a letter recently received:—
 "Fine flying—one flight 5 mins. 23 secs. I had ten flights, total flying time 30 minutes."—K.B.E., Yeovil.

Specification: 36 in. span, all Balsa tissue covered, weight 2 1/2 ozs. Blue Print with instructions, 2/9. Our latest. English Turned Balsawood Wheels, 2 in. diameter, 10d., 1 1/2 in. diameter, 8d.

MODEL AIRCRAFT SUPPLIES LTD.
 171 New Kent Road, LONDON, S.E.1.

The New Adana Printing Machine

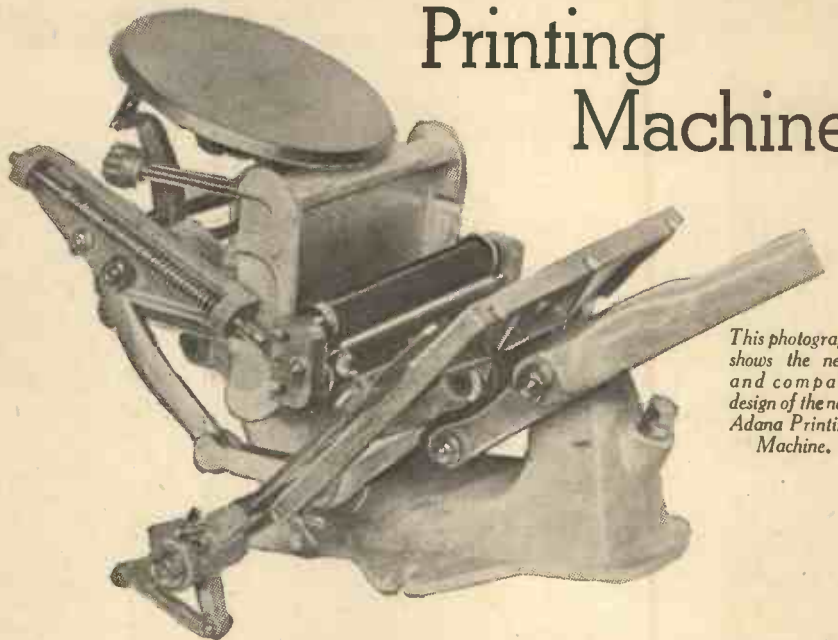

This photograph shows the neat and compact design of the new Adana Printing Machine.

A FIRST-CLASS mechanical job of modern design, the new Adana de Luxe Model No. 2, shown on this page, is capable of fine art printing and is sold with a five-year guarantee. As a spare-time occupation this machine will prove a ready cash producer, and turns out work comparable with professionally produced work—and no experience is necessary. Costing only 92s. 6d., it is the product of many years' close experiment and design. It was not until the secret of employing pressure die-castings of non-ferrous alloys in the construction was discovered, that the perfection sought for by the Adana Company was at length obtained.

High-Class Results

With the new de Luxe Adana you can tackle the production of high-class literature, fine colour work and quality printing of every sort and description with the fullest assurance that you have a machine capable for the job—a machine that will not let you down.

The operation is quite simple. Place the paper to be printed on to the rectangular flat plate, and on pressing the hand lever downwards, the plate carrying the paper is

moved to the already inked surface of the type, and is lowered again when the lever is released. The operator can then remove the printed copy and lay on a new sheet.

The Machine Described

The two principal parts of the machine are the bed (the container which holds the type) and the platen (the plate which carries the paper to be printed). These two components are attached to the main frame which is built up of pressure die-castings of a tensile strength of over 20 tons, and is strong and rigid enough to withstand all the pressure and wear and tear of printing.

The Inking Gear

The motion of the inking gear synchronises with the action of the platen. Inking rollers travel over the type matter, and thence over a prepared inked plate which revolves on the action of the machine. In the laying-on position, the rollers rest at the bottom of the type bed as can be seen in the photograph, and, as the platen is brought up to the type, the rollers move over the type and on to the circular ink plate.

At a meeting to be held on Saturday, July 6th, Mr. C. Macklin will give a talk entitled "Problems of Interplanetary Travel." D. Mayer, 20 Hollin Park Rd., Leeds 8.

S.C.M.R.C.

OUR Fourth Annual Exhibition, held at Streatham during the Whitsuntide holidays, proved a great success, and we have gained a few new members. Our club-room is closed during July and August, but numerous visits have been arranged, and full particulars can be obtained from the Secretary. Our club magazine *The Rocket* for June is now ready, and copies can be obtained from the Secretary, 4d., or 5d. post free. Order your copy now. Special Exhibition number with enlarged supplement of photographs.

Secretary: L. J. Ling, Brooke House, Rotherhill Avenue, Streatham, S.W.16.

What the Clubs are Doing

Club Reports for inclusion in this feature should not exceed 250 words in length, and should be received no later than the 12th of each month for inclusion in the subsequent month's issue.

INSTITUTE OF SCIENTIFIC RESEARCH

ON Saturday, June 1st, a meeting of the Leeds branch was held. Mr. R. Robson gave an interesting talk on "Rocketry." After passing over the history of rockets, and outlining their actions, the speaker proceeded to explain why we look to the rocket as a means of stratospheric and extraterrestrial propulsion. He next went on to discuss the problem of rocket composition and fuel, and concluded by describing how rockets have been used for propelling cars and aeroplanes. The talk was illustrated by experiments. On Thursday, June 13th, a visit was paid to the works of Henry Thorne & Co.

MODEL AEROPLANES AND AIRSHIPS

By F. J. Camm

96 Pages, 120 Illustrations

1/- or 1/2 by post from Geo. Newnes Ltd., 8/11 Southampton Street, Strand, W.C.2.

Magic with Mirrors

Interesting Experiments with a Conical Mirror

method is to make the mirror out of thin brass or copper used to fill out space, as when joints in a machine wear thin. The metal, in this case, can be easily bent and soldered, after which it should be dipped in hydrochloric acid and have mercury rubbed upon its surface until coated, thus producing quite a brilliant mirror.

Another Type of Mirror

Still another type of mirror can be made with ordinary zinc amalgam. This should be placed in a bag or small sack of chamois leather and rubbed on bristol board. This will produce a very beautiful mirror. The method of making the amalgam is to take pure zinc and add mercury thereto until there is an excess of mercury. In other words, sufficient mercury is added so that when the amalgam is pressed, a few globules of mercury will drop out of the mass. If this amalgam is then placed in the chamois sack, and pressure applied thereto while the bristol board is rubbed, an almost perfect mirror is obtained, which can be twisted, turned or bent into any conceivable or desirable shape. This idea is particularly adaptable to this experiment because of the fact that it is inexpensive, and enables the experimenter to construct the mirrors for the designs shown here.

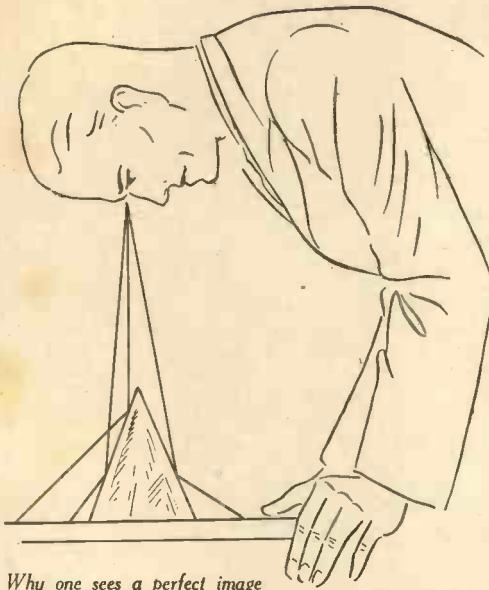

Why one sees a perfect image when looking down on a conical mirror, placed over one of the grotesque drawings shown elsewhere on this page, is made evident from the diagram above. The conical mirror acts as a concentrator or centre of focus for the freak drawing placed under it.

THE rather odd pictures shown on this page become common objects when viewed from over the apex of the mirror, placed in the circle in the centre of the object. To secure the best results we suggest that the reader should enlarge the pictures with an ordinary camera or make the enlargements by means of a pantagraph. As a matter of fact, enlargements are not absolutely necessary—the mirror could be made small enough to be mounted in the circle shown in the various diagrams.

As shown in Fig. 1, the picture is viewed from above. The principle of both the drawing, the pictures, and the solution to them, is illustrated by the tracing of the main rays of incidence and reflection.

Making the Mirror

The mirror can be made out of sheet tin which should possess a high metallic lustre. This tin should be cut in the form of a sector of a circle, and then the radial edges of the sector are soldered together, being permitted to overlap each other slightly.

Experiment will show the required height of the cone. It will be found that the diameter should in general be equal to the height of the reflector, and that the diameter will depend upon the size of the enlargement of the pictures and be equal to that of the centre circle. Another

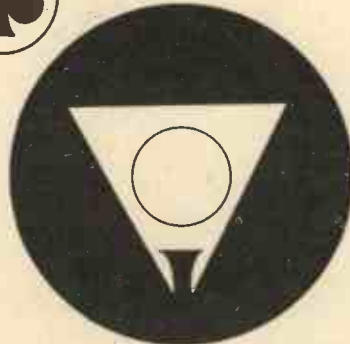

When the conical mirror is placed in the centre circle of the diagram above, and one looks down upon it from a height of a foot or so, the oddly-shaped black figure resolves itself into a shamrock.

After viewing these distorted objects the experimenter will find it quite simple to make other drawings similar in effect, yet perhaps more grotesque.

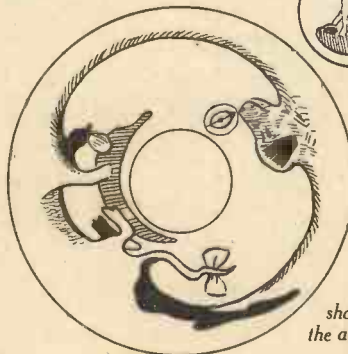

(Left) When the conical mirror is placed in the centre circle of this drawing, the confused looking dog is seen balancing a ball on his nose.

(Right) This odd shaped drawing shown, by the aid of a conical mirror changes into a pair of shears.

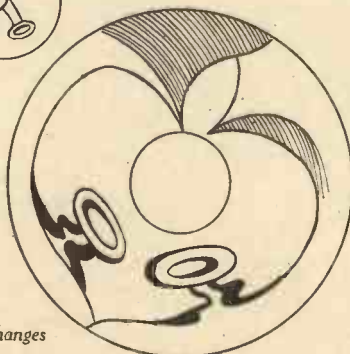

There was a young
Tinker named Phil
Worked so hard—he
never was still;
He heard of FLUXITE—
Said "this is alright—
Less effort—yet
more in the till!"



See that FLUXITE is always by you—in the house—garage—workshop—wherever speedy soldering is needed. Used for 30 years in government works and by leading engineers and manufacturers. Of Ironmongers—in tins, 4d., 8d., 1/4 and 2/8. Ask to see the FLUXITE SMALL-SPACE SOLDERING SET—compact but substantial—complete with full instructions, 7/6.

Write for Free Book on the ART OF "SOFT" SOLDERING and ask for Leaflet on CASE-HARDENING STEEL and TEMPERING TOOLS with FLUXITE—Dept. P.M.

TO CYCLISTS! If your wheels are to keep round and true the SPOKES must be TIED with fine wire and SOLDERED at the CROSSINGS. This gives a more rigid wheel. It's simple—with FLUXITE—but IMPORTANT.

THE FLUXITE GUN

is always ready to put Fluxite on the soldering job instantly. A little pressure places the right quantity on the right spot and one charging lasts for ages. Price 1/6.



ALL MECHANICS WILL HAVE

FLUXITE

IT SIMPLIFIES ALL SOLDERING

FLUXITE LTD., DRAGON WORKS, BERMONDSEY ST., S.E.1

The New STUART CATALOGUE NO. 3 JUST OUT

describes in 72 profusely illustrated pages the full range of Stuart products—

Steam engines and boilers, pumps, petrol engines, fittings, screws, drills, materials, etc.

The Stuart centrifugal pump for fountain or waterfall.

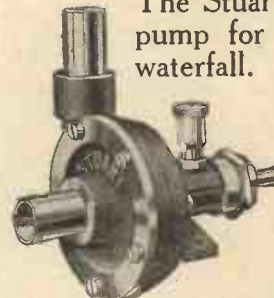

The Pump :
20/-

Electrically
driven:
£4 : 7 : 6

Please send now for "Cat. No. 3."
6d. Post Free.

STUART TURNER LTD.
HENLEY - ON - THAMES

PATENTS, DESIGNS AND TRADE MARKS

A VALUABLE GUIDE ON INTERNATIONAL PROTECTION OF INVENTIONS.

100 Pages — Post Free, 6d.

The TECHNICAL ADVERTISING AGENCY
253 (D) Gray's Inn Road, London W.C.1

PRACTICAL HINTS ON PATENTING

and the development of Inventions.

Sent free on application.

THE IMPERIAL PATENT SERVICE
First Avenue House, High Holborn, W.C.1.

Preliminary Consultation Free.

PATENTS,
TRADE MARKS
AND DESIGNS

FREE!
ADVICE, HANDBOOK
AND CONSULTATIONS

KINGS PATENT AGENCY LTD.

B. T. King, C.I.M.A., Pat. Agent G.B., U.S.A. & Can.

146a Queen Victoria St., LONDON, E.C.4.

49 Years' References. TELEGRAMS: G.E.O.L.O.G.I.C., LONDON.

PHONE: CITY 6161.



ROSS for HEIGHT!

Pupil, age 19, gains 5 ins. in 6 wks.	No Appu-
" " 21, " 5 ins. in 5 mths.	drugs—No
" " 20, " 3 1/2 ins. in 16 d'vs.	Drugs. No
" " 30, " 2 ins. in 4 wks.	Dieting.
" " 40, " 1 1/2 ins. in 6 wks.	

Increased my own height to 6' 3 1/2". Ross System
Hundreds of Testimonials from all
over the world. Never Fails

Fee £2 2s. Convincing testimony 2/6d. stamp.
Height Specialist, P.O.
L. Malcolm Ross Scarborough, Eng. Box 15.

NERVOUSNESS

Every nerve sufferer should send for my interesting book, which describes a simple, inexpensive home treatment for Self-consciousness, Blushing, Depression, Worry, Insomnia, Weak Nerves, Morbid Fears, and similar nervous disorders. This wonderful book will be sent in a plain sealed envelope to any sufferer without charge or obligation. Write NOW and learn how to conquer your nervousness before it conquers you.

HENRY J. RIVERS (Dept. K.D.4), 40 Lamb's
Conduit St., London, W.C.1

FOR WORKSHOP AND GARAGE—

The "Wilco" Electric Grinder incorporates a fan-cooled 1/50 h.p. induction motor with switch and carries fine and coarse grinding wheels.

For A.C. 200/220 or
230/250 v.

PRICE
25/-

Carriage Paid
40 page Catalogue "P.M."
3d. post free.

L. WILKINSON,
8 City Rd., London, E.C.1

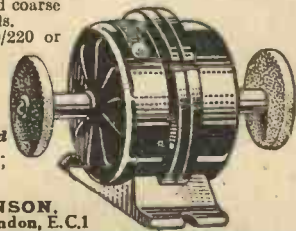

Make More Money

£3 to £6 weekly can be earned at home in a wonderful business of your own. No matter where you live you can commence to make money in your spare or whole time. No risk, canvassing or experience required. A wonderful opportunity for any one wishing to add pounds to their income. Particulars, stamp.

BALLARD, 71 Graces Rd., London, S.E.5

FROST & CO.

70 Old Compton St., London, W.1

Engineers, Tool and Model Makers.

Models of all descriptions.

Inventors, Scale and Advertising.

Patterns, Castings, or Finished Parts, Small
Stampings and Press Tools.

Experimental and Repetition Work.



By A BARRISTER-AT-LAW

The services of a professional Patent Expert are available free to every reader. He will advise you on the validity, novelty, and value of any idea you may have. No charge is made for this service, but the Query Coupon appearing in our advertisement pages must be enclosed with every query and a stamped addressed envelope enclosed if a postal reply is desired.

PROTECTING THE INVENTOR

AMONG the different kinds of property recognised by the law we find freehold land, for instance, which is classified as "real" to distinguish it from less permanent forms of "personal" property, such as a leasehold interest which only lasts for a limited number of years, or goods and money which are liable to be destroyed or consumed in various ways.

Another distinction is drawn between solid or substantial possessions, and those intangible "rights" such as the benefit of a life or other insurance, which are based on some form of contract. The protection given to the inventor who takes out a patent comes under the last-named heading.

Patent rights form part of a large group, known as intellectual property, which has been brought into existence by various Acts of Parliament. The Copyright Act, for instance, protects the writer, the composer, the sculptor, the painter, and other workers in the purely artistic field; whilst the inventor, the designer, and the trader who originates a Trade Mark and spends money in advertising it, all create industrial rights which are safeguarded by the patent system.

Taken in bulk, the artistic and industrial forms of intellectual property represent vast sums of money. Copyright in a single novel—including the theatrical and film rights—may run to over a hundred thousand pounds; the value of a well-known trade mark or name, such as Bovril, is probably nearer a million; whilst the value of some of the master patents, say, in wireless and other industries, exceeds even that figure.

Unfair to the Inventor

Strangely enough, in common law, there is no personal property in an idea. Once it has been liberated from the mind it falls into common stock and can be appropriated by all and sundry.

A little reflection will show that there is something obviously unfair in treating the artist and inventor on this footing. The common law, which protects the owner of ordinary property against theft, does nothing to safeguard the inventor of a new machine or the discoverer of a valuable commercial process from those who, in effect, steal his brains.

The patent law steps in to fill the gap so far as the industrial side of intellectual property is concerned. It gives the inventor that protection which is his due—allowing, as we must, that the man who invents a new machine, or who improves an existing one, is as much entitled to a reward for his mental labours as the man who merely works with his hands.

But to gain this protection it is necessary to fulfil certain conditions. The inventor is called upon, in fact, to enter a kind of contract, whereby in return for filing a full and detailed description of his invention at the Patent Office, and paying certain

fees, he is given an official grant of letters patent which prohibits any unauthorised person from using his protected invention.

Of course, in practice this really means that the patented apparatus can only be used *subject* to the payment of a royalty to the inventor.

It is important to remember that the issue of a patent is based upon an implied contract between the inventor and the State. On the one hand, the State recognises the value of invention in industry, and sets up the patent system to encourage it. On the other hand, the inventor must produce something that is really new and useful. He must also describe it fully and fairly in an official specification, and he must pay certain stamp fees which are necessary to finance the system as a whole.

A Patent Held Void

If the inventor fails to carry out any one of these conditions, then the patent, even if granted to him, may be held to be void by the Courts of Law should the patentee ever seek to enforce it. This explains why an action for infringement is often decided against the patentee.

In other words, although a patent may be issued by the Patent Office it does not always follow that the inventor has fulfilled his share of the bargain. It may turn out that the alleged invention was in fact known to others before the date of the patent; or the Court may discover that it has not been fully and honestly described in the patent specification. The responsibility in both cases lies upon the inventor, and if he is at fault his patent is not worth the paper it is printed on.

Obviously he is not entitled to claim as his own an improvement which has already been patented by someone else—nor one which has previously been openly used or described, because this rules it out as a new invention.

Similarly the law insists upon the inventor filing a full and honestly drawn specification, because it is part of the bargain that, at the end of the normal life of the patent the benefit of the invention must pass on to the public at large. If when this time comes the description is found to be so faulty or inaccurate that it is not possible for anyone to build the improved machine, or to repeat the process described, then the public is obviously defrauded. And a contract founded on fraud is void in the eyes of the law.

Before a patent is issued, the inventor's specification is examined by officials, who scrutinize the way in which the invention is described, and also make a search in order to ascertain, as far as possible, whether it is really new and original. The applicant will probably regard this as a troublesome ordeal, though it is actually intended to help him to secure a patent which can be enforced in the courts of law.

The DOSSALL Studio

GOOD IDEAS—

are often rejected because of unconvincing drawings! Let us prepare attractive illustrations which will convey your idea quickly and clearly to Manufacturers, Editors, Agents, etc.

We specialise in Patent Office and Technical drawings of all descriptions.

Write or phone us at

HIGH HOLBORN HOUSE, HIGH HOLBORN, W.C.1.

Hol. 8638



DON'T BE BULLIED



Learn to fear no man. The BEST self-defence ever invented, namely, **JUJITSU**. Easy to learn. Send 2 penny stamps for **SPLendid ILLUSTRATED LESSONS**, Photo **ARTICLE**, Testimonials and particulars, or P.O. 1/- for **FIRST PART** of my course. You will be more than delighted.

Dept. P., Blenheim House, Bedford Lane, Feltham, Middlesex.

DEFERRED TERMS ARRANGED

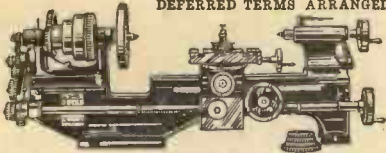

"IDEAL-LATHES" 3in. S.C. LATHES from £4.

3 1/2 in. S.C.B.G. from £7/18/6. **LISTS**, Stamp please. **J. WILLIMOTT & SON**, Nevill's Factory, Chilwell, Notts.

HAVE YOU A RED NOSE?

Send a stamp to pay postage, and you will learn how to rid yourself of such a terrible affliction free of charge.

Address in confidence—

P. TEMPLE, Specialist,

"Palace House," 128 Shaftesbury Avenue, W.1 (Est. 30 years.)

HEIGHT

I GUARANTEE to increase your height in 12 days or return you money! Amazing new discovery acts upon growth-glands, spine, joints, etc., and adds 2-3 inches to your height permanently. Guaranteed harmless. Increased my stature 4 inches in under 5 weeks. Hundreds of testimonials. Full course 5/-. Particulars free. **P. M. MORLEY,** 8 BREAMS BUILDINGS, LONDON, E.C.4.

CURE YOURSELF AS I DID. STAMMERING

After stammering terribly for 20 years and trying "teachers," schools, and advertised methods without relief, I at last discovered the real cure for Stuttering and Stammering (which is very simple) and cured myself. Now no stranger could tell that I had ever been a Stammerer. YOU (or your child) can be quickly cured in the same way. Thorough and permanent cure Guaranteed or no charge. Full particulars will be sent FREE, privately, if you mention "Practical Mechanics."—**MR. FRANK P. HUGHES, 7 Southampton Row, London, W.C.1.**

WEBLEY AIR PISTOLS

Marvellously accurate for target practice.

No license required to purchase;

Senior 45/-, Mark 1 30/-,

Junior 20/-, Entirely British.

Write for List. **WEBLEY & SCOTT LTD., 108 WEAMAN STREET, BIRMINGHAM, ENG.**



At the Applicant's Risk

But in spite of the official examination the patent is issued at the applicant's risk, so that he has only himself to blame should he try to claim more than he has actually invented, or fail to describe clearly what it is he wishes to protect. A famous lawyer once remarked that the layman who draws up his own will usually has a fool for a client. The same may be said with equal truth of the inventor who files his own patent specification.

Of course, if the invention is a simple one and is easily described, it may be possible for an inventor to get a patent through without professional assistance; but in most cases it is advisable to seek the help of a recognised patent agent, whose skill in drafting and knowledge of procedure will be found well worth the extra cost involved.

The usual procedure in applying for a patent is first to file a provisional application, which costs £1 in stamp fees, and to follow this up within twelve months by filing a complete specification which costs £4, making £5 in all. Or a complete specification may be filed in the first instance at a cost of £5.

A Year for Experimenting

The object of the Provisional application is to encourage an inventor to file a preliminary Specification at the Patent Office as soon as possible after he has conceived the original idea. He then has a year in which to make experiments and perfect the invention. In the Provisional Specification it is only necessary to describe the broad nature of the invention, though it is advisable not to be too vague about it, but to give as much detail as will definitely identify its novelty. The Complete Specification, when filed, should, of course, describe the perfected invention in full, usually with the help of drawings.

Inventors often have a mistaken idea of the real purpose of applying for provisional protection. In the first place there is no such thing as a provisional "patent." A patent can only be issued after a complete specification has been filed, accepted, and sealed. A provisional Specification gives no legal protection whatever, beyond an assurance to the inventor that when he comes to file a complete specification, the latter document will in effect "date" from the time of receipt of the provisional application.

An inventor who merely files a Provisional application and does not follow it up with a Complete Specification is held to have abandoned his original intention of taking out a patent. He is then in the same position as if he had never started.

Sealing a Patent

Assuming, however, that a Complete Specification has been filed, either in the first place, or following a Provisional application, and that it has passed the official examination and has been duly accepted, the next step is to Seal a patent on it. This costs the inventor another £1 in stamp fees, and he is then in a position to manufacture as a patentee, and to sue infringers or to grant them a licence in return for the payment of royalty fees.

The patent lasts for four years without any further payment. At the end of that time a renewal fee of £5 must be paid to keep the patent alive for the fifth year. At the end of that year another renewal fee of £8 falls due for the sixth year, and so on, until at the end of fifteen years a final payment of £16 gives the patent its last year of life. After that it becomes public property and can be used by everybody without let or hindrance.

INEXPENSIVE CHEMISTRY EQUIPMENT

APPARATUS & CHEMICALS FOR STUDENTS' LABORATORIES

Complete range of CHEMICALS in Bottles from 3d. each.—Extensive selection of APPARATUS, including Benkers, Flasks, Graduated Ware, Condensers, Retorts, Balances, etc. **SPECIAL PARCEL OF APPARATUS:** 1 Flask, flat bottom 150 c.c., 1 Beaker, spouted 100 c.c., 3 Test Tubes 4 in. x 1 in., 1 Thistle Funnel 20 cm., 3 ft. Post Glass Tubing, 1 Rubber Cork 2 holes, 4 inches Rub. 2/6 Free per Connection Tubing, 1 Glass Stirring Rod. **BECK** (Scientific Dept. A.) 60 HIGH STREET, STROKE NEWINGTON, LONDON, N.16. Write for Catalogue—FREE.

Every One a Practical Money-Maker

"3,000 FORMULAS, RECIPES,"

Processes, and Trade Secrets, also

"DIRECTORY," where to buy Chemicals wholesale.

You CAN pay more money, but you CANNOT get a better book. Thousands of ways of making money with very little outlay. 100,000 already sold.

Price 4/9 Post Paid. FREE—to the first 500 purchasers, a catalogue of other money-making books.

TECHNOGRAPH, 41 Longford Pl., MANCHESTER, 14



MAN! Read THIS!

I positively GUARANTEE to give you Robust Health, Doubled Strength and 10-25" more muscle in 30 days or return your money in full. The famous **STEBBING 4-in-1 Course** consists of four great courses in one, yet costs only 5/- post free. It has been proved (1) The most effective HEALTH and ENERGY System ever devised; (2) It quickly builds NORMAL WEIGHT and VIRILE MANHOOD; (3) It develops a Strong Will, rigid SELF-CONTROL; and (4) It includes an amazing SUCCESS and PERSONAL MAGNETISM Course. Complete Course, 5/-

No extras, no appliances to purchase.

Further details sent privately, under plain, sealed cover.

LIONEL STEBBING, STEBBING INSTITUTE, Dept. C.P., 23 Dean Road, London, N.W.2.

Baker's SOLDERING FLUXES

Sold in 6d. and 1/- tins at all Cycle Accessory Dealers, Tool Shops, Ironmongers, etc.

Write for your free copy "Joining of Metals" to

SIR W. M. BURNETT & CO. (CHEMICALS) LTD. GREAT WEST ROAD, Uxbridge, MIDDLESEX. TELEPHONE: HOUSLOW 0476



The 'ADEPT' LATHE

11 in. centres, 6 in. between centres.

With compound slide-rest, 21. or with hand-rest only, 12/6. Screw Tail Stock 5/- extra. Post 2/-

THE SUPER ADEPT 30/

F. W. PORTASS, 83a, Sellers Street, SHEFFIELD.

HEIGHT INCREASE FREE! FREE!

Original leading 5/- Course that will increase your height 2-5 inches and improve your physique 100% by Natural Methods. Numerous testimonials. Sent absolutely free, without any obligation (but 3d. postage appreciated), plus our amazing bargain catalogue of Famous American Physical Culture (etc.) Courses and Books.

ECONOMY EDUCATOR SERVICE, (Dept. 76), 1 Glenside, PLYMOUTH

BUY, EXCHANGE OR SELL

Advertisements are accepted for these columns at 2d. per word (minimum 12 words at 2s.—advertisements of less than 12 words are charged at the minimum rate of 2s.), subject to a discount of 2½% for 6 consecutive monthly insertions or 5% for 12 consecutive monthly insertions. **TERMS** :—Cash with order. Cheques, Postal Orders, etc., should be made payable to George Newnes Ltd. *The Proprietors reserve the right to refuse or withdraw advertisements at their discretion.* All advertisements must be received on or before the 5th of the month preceding date of publication and should be addressed to the Advertisement Manager, "Practical Mechanics," George Newnes Ltd., 8-11 Southampton Street, Strand, W.C.2.

CINEMATOGRAPHY

CINEMATOGRAPH FILMS.—Standard size from 6d. 100 feet. Machines, Accessories. Sample Films, 1/- and 2/6 post free. Catalogues free.—"Filmieries," 57 Lancaster Road, Leytonstone, E.11.

MOVIES AT HOME How to make your own Cinema Projector. Particulars free.—Moviescope N, Pear Tree Green, Dodinghurst, Essex.

"FILM CRAFT"—Here is a fascinating series of authoritative textbooks for everyone interested in the Cinema as the newest of the arts. The Filmcraft series, each 3s. 6d. net, includes volumes by Pudovkin, Adrien Brunel, G. E. Kendall, D. Charles Otley, Percy W. Harris. From all Booksellers and Newsagents.—George Newnes Ltd., 8-11 Southampton Street, Strand, London, W.C.2.

CONTACTS

CONTACTS, Tungsten, Silver or Platinum; any shape or size, on screws or rivets.—**TUNGSTEN CONTACTS LTD.**, 3 Haverstock Hill, N.W.3. Telephone 6621.

ELECTRICAL

ELECTRIC DRILLS, ½ in. max. chuck, high power motor, hardened nickel chrome replaceable pinion on shaft hobbled gears; cuts mild steel with ease, neatly polished, £2/10/0. A few workshop finish, unpolished, mechanically, electrically perfect, 17/6; voltages 200/250 A.C./D.C. universal. Television and other motors on application.—Ancel Cine Co., 8 Highbury Terrace Mews, N.5.

SURPLUS ELECTRICAL and Engineering Materials, low prices.—The London Electric Firm, Croydon.

A MAGAZINE of Electrical Progress. Amazing developments in Electrical Engineering are rapidly revolutionising industry and bringing new benefits to the whole community. To keep in touch with all the latest in Electrical progress read this live Magazine. Written by experts, it is indispensable alike to the technician and the ambitious student, while the "layman" will find it full of interest and inspiration. **"THE PRACTICAL ELECTRICAL ENGINEER"** 1s. monthly. Obtainable at all Newsagents and Book-stalls, or by post 1s. 3d. from George Newnes Ltd., 8-11 Southampton Street, Strand, London, W.C.2.

ENGINES

ENGINES. Build Butler's ½-h.p. practical Petrol Engine. Set of Castings 9/9. Interesting Catalogues 3d. Write Profit-Sharing Works, Littleover, Derby.

FORMULAS

FORMULAS, Secret Recipes, commodities easily made at home, and sold at enormous profits. (State wants.) Lists—Literature, 4d. stamps.—**TECHNO-CRAFT**, 41 Longford Place, Manchester, 14.

MAGIC

BE A HOUDINI. Make sensational escapes from Handcuffs, Vaults, Safes, Trunks, Ropes, Strait-jackets, Mail-bags, etc. **FULL INSTRUCTIONS** 5/- "Second-sight" Mental Telepathy Act, £1. "Needle through body" Illusion, £1. Comedy Second-sight Act, 2/6. The famous "X RAY" Eye Act, 6/- "Squeezing a girl in two" Rope Feat, 2/6. Books on Hypnotism, etc., 2/6 each. Professor DEVILLE, 41 Longford Place, Manchester, 14.

PERPLEXITIES AND TANTALISERS.—"The Strand Problems Book" is the finest collection of puzzles of all kinds ever assembled, mathematical, geographical, literary—acrostics and codes, by W. T. Williams (Tantalus) and G. H. Savage. Only 2s. 6d. net, from all Booksellers.—George Newnes Ltd., 8-11 Southampton Street, Strand, London, W.C.2.

MICROSCOPY

MICROSCOPIC OBJECTS—unmounted prepared. Assorted packet 2/-. **MOUNTED SLIDES STOCKED.** LENG, 183 MANCHESTER DRIVE, LEIGH-ON-SEA.

MISCELLANEOUS

COMMUTATORS for small motors and dynamos up to 500 volts. Ready to slip on armature shaft. 24 segments 1½" dia., ¾" long, ¼" bore, 3/-. 30 segments 1½" dia., ¾" long, ¼" bore, 3/6.—Electradix Radios, 218 Upper Thames Street, London, E.C.4. Central 4611.

TELESCOPES, Navy Gun 24", 17/6. Hand spotting, 25/-. Stick Periscopes, 3½" mirror, 6d.—Electradix Radios, 218 Upper Thames Street, London, E.C.4. Telephone: Central 4611.

MODELS

INVENTORS' IDEAS DEVELOPED. Drawings, Models, Patterns.—Bland, 105a Crawford Street, London, W.1.

MODEL YACHT BUILDING made easy. 36 in. laminated hull and blue prints 35/-. 2d. stamp full particulars.—Dickinson, 96 Westgate Road, Newcastle-on-Tyne, 1

SCREWS, NUTS, WASHERS (special Model Engineers' sizes). Everything for Electrical Re-winds and Repairs. Lists Free.—Lumen Electric Co., 9 Scarisbrick Avenue, Litherland, Liverpool 21.

HALF PRICE MODELS.—Electric, Steam, Clockwork, Hot-air. All kinds, excellent condition. July illustrated catalogue 4½d. Locomotives wanted.—Stamp.—Model Exchange, 11 Friars Street, Ipswich.

AN INVALUABLE Handbook. ACCUMULATORS. Up to date, practical, dealing with every type of accumulator, methods of charging them at home, care and maintenance. This little book also explains how to erect a charging station. This is one of Newnes' Home Mechanic Books. Ask your Newsagent to show you; other Titles in this Helpful Series. Obtainable at all Booksellers, 1s. each.—George Newnes Ltd., 8-11 Southampton Street, Strand, London, W.C.2.

ARE YOU HANDY With Your Hands?—If you like making and mending things you ought to know about the "Home Mechanic" Series of 1s. Handbooks. They cover a wide field, from model and toy-making to motor-car upkeep and radio construction. Each is complete in itself and fully illustrated. Price 1s. each from all Booksellers and Newsagents (from whom a list of subjects can also be obtained).—George Newnes Ltd., 8-11 Southampton Street, Strand, London, W.C.2.

"WORKING MODELS and How to Make Them" edited by F. J. Camm, 3s. 6d.—This book will appeal to all who are handy with tools. Contains complete instructions for the making of every kind of working model. Each model has been actually constructed in accordance with the details given and subjected to stringent tests. The instructions and diagrams are so clear that even the most elaborate model can be built without fear of failure. Obtainable at all Booksellers and Newsagents.—George Newnes Ltd., 8-11 Southampton Street, Strand, London, W.C.2.

PHOTOGRAPHY

£500 worth good, cheap Photo Material, Films, Plates, Cards, Papers, Chemicals, Catalogue, and 4 Samples Free.—Hackett's Works, July Road Liverpool 6.

POSTCARDS FROM ANY PHOTO. Time to finish, four days. 2s. 1/9; 50 3/-; 100 5/-; 500 17/- 1,000 30/-. Enlargements 1/-. Samples and List; Free.—Hackett's Works, July Road, Liverpool.

PRINTING

"PHOTO-ENGRAVING."—A practical Handbook with complete set of materials for engraving printing blocks, 4/6—Industries, 13 Gordon Avenue, Twickenham.

PRINTING PRESSES, Self-inking, 8 x 6, 5/- Agents wanted.—Johnson, 10 Otley Road, Harrogate.

PRINT YOUR OWN CARDS, etc., with a Simplex Printing Outfit, 17/6 complete. Samples of work and Type List, stamp.—Simplex (P.M.), 6 St. James Road, Mitcham, Surrey.

TOOLS

TOOLS upon easy payments. Treadle Saw Benches £8/10/0, power £3, Constructors' Saw Bench Fittings 12/6, Lathes 25/-, Compound Rests 15/-, Foot Treadles 35/-. Lists 2d.—Brown Bros., Accrington.

200-PAGE Bargain Tool Catalogue. 1/- post free. John P. Steel, Bingley.

WIRELESS

EXCHANGE your obsolete Wireless Set for new. Best allowances given. We supply Radio goods at keenest prices. Let us quote your requirements.—Servwell Wireless Supplies, 64 Prestbury Road, London, E.7.

ERICSSON PEDESTAL TRANSMITTERS, 12-in. high, with mouthpiece. Standard model, 4/6. Post 9d. No. 11A, special, in solid Brass body, unequalled at the price on speech and music, 7/6. Pedestal Mike No. 10B, 10-in. high, 12/6. No. 12B Ring Pedestal, 18/6. Eisel famous P.A. and Band Mike (Reisz Principle), 55/- Stand 10/- and band. Screened imped. matched Transformer, 7/6. Highest quality. Uniform response. Can be obtained from us only.—Electradix Radios, 218 Upper Thames Street, London, E.C.4. Central 4611.

PARTS for Home Constructors. Buttons, 1/- each. Microphone Carbon Granules, in glass capsule, for four buttons. Grade No. 1, 8d.; No. 2, Medium, 1/-; No. 3, Fine, 1/6; Carbon, solid back, blocks, 3d. Mouthpieces, curved or straight, 10d. Carbon diaphragms, 5s 5m, 6d. Panel Brackets, pivoted, 5/- Reed Receiver Unit for Amplifier making, 3/- Head-phones, 2/9.—Electradix Radios, 218 Upper Thames Street, London, E.C.4. Central 4611.

A DICTIONARY OF WIRELESS TERMS, by Ralph Stranger. A Wireless Work of Reference that should be on the bookshelf of every keen amateur. Compiled by a master of lucidity, it gives the meanings of all technical terms in general use. Price 2s. 6d. from all Booksellers and Newsagents.—George Newnes Ltd., 8-11 Southampton Street, Strand, London, W.C.2.

FOR THE RADIO ENTHUSIAST.—"The Wireless Constructor's Encyclopedia," by F. J. Camm (editor of "Practical and Amateur Wireless"), third edition. Compiled by one of the most accomplished designers and writers on the practical side of Wireless, it covers the whole field. A veritable Treasury of Wireless Knowledge. Price 5s., from all Booksellers and Newsagents.—George Newnes Ltd., 8-11 Southampton Street, Strand, London, W.C.2.

"THE MATHEMATICS OF WIRELESS," by Ralph Stranger.—This book is essential to the amateur who wants to gain a further knowledge of the subject without loss of time—or temper! Fully illustrated, 256 pages. Price 5s., from all Booksellers and Newsagents.—George Newnes Ltd., 8-11, Southampton Street, Strand, London, W.C.2.

WOODWORK

CABINET HARD WOODS, Oak, Mahogany, Ash, White Wood, Ply Woods, etc. Lowest prices. Send cutting lists. Planning free. Specialty prime Jap Oak, all thicknesses.—Wilfred Parr & Co., March Works, Lancaster Road, Leytonstone, E.11.