

AMAZING INVENTION! SEEING YOUR TELEPHONE CALLED

NEWNES

PRACTICAL MECHANICS

APRIL
6^D

EXPLORING
THE
STRATOSPHERE



ASCINATING NEW DISCOVERIES

WORKING ENGINEERS

ALL BRANCHES

Unfortunately, you are not eligible for the Institute Examinations, but we can tell you how to make progress in your trade. Our advice is free; do not decide until you have communicated with us. You will be under no obligation whatever.

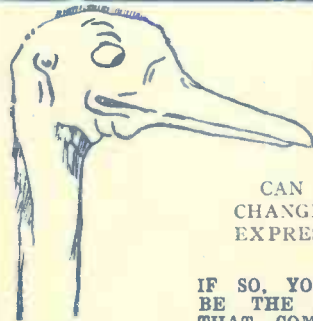

CAN YOU CHANGE MY EXPRESSION?

IF SO, YOU MAY BE THE ARTIST THAT COMMERCE IS WAITING FOR.

Jim Duck

Just try it for yourself, trace or draw the outline and then put in the features.

There are hundreds of openings in connection with Humorous Papers, Advertisement Drawing, Posters, Calendars, Catalogues, Textile Designs, Book Illustrations, etc.

60% of Commercial Art Work is done by "Free Lance Artists" who do their work at home and sell it to the highest bidders. Many Commercial Artists draw "retaining fees" from various sources, others prefer to work full-time employment or partnership arrangement. We teach you not only how to draw what is wanted, but how to make buyers want what you draw. Many of our students who originally took up Commercial Art as a hobby have since turned it into a full-time paying profession with studio and staff of assistant artists; there is no limit to the possibilities. Let us send full particulars for a **FREE TRIAL** and details of our course for your inspection. You will be under no obligation whatever.

Jim Duck Art Dept. 76

YOUNG MEN

Young men physically fit and whose careers are not definitely fixed should join the Police Force. We have Special Courses for Entrance and Promotion.

1/- per week brings success.
Full particulars free.

Address: Police Dept. 76.

TO STUDENTS LIVING ABROAD

or on the high seas, a good supply of lessons is given, so that they may be done in their order, and despatched to us for examination and correction. They are then sent back with more work, and in this way a continuous stream of work is always in transit from the Student to us and from us to the Student.

LET ME BE YOUR FATHER

Unless you are in touch with all branches of industry, you cannot see the possibilities of employment, but with our gigantic organisation we are in touch with every sphere of activity, and we know that in many trades and professions there are more vacancies than there are trained men to fill them.



J. Bennett

We do not profess to act as an employment agency, but we certainly are in a position to give fatherly advice on all careers and the possibility of employment therein.

THE MOST SUCCESSFUL AND MOST PROGRESSIVE CORRESPONDENCE COLLEGE IN THE WORLD

We teach by Post in all parts of the world and specialise in all Examinations.

Accountancy Examinations
Advertising and Sales Management
A.M.I. Fire E. Exam.
Applied Mechanics
Army Certificates
Auctioneers and Estate Agents
Aviation Engineering
Banking
Boilers
Book-keeping, Accountancy and Modern Business Methods
B.Sc. (Eng.)
B.Sc. (Estate Management)
Building, Architecture and Clerk of Works
Civil Engineering
Civil Service
All Commercial Subjects
Commercial Art
Concrete and Structural Engineering
Draughtsmanship. All branches
Engineering. All branches. subjects & examinations
General Education
G.P.O. Engineering Dept.
Heating and Ventilating
Industrial Chemistry
Insurance

Mathematics
Matriculation
Metallurgy
Mining, all subjects
Mining, Electrical Engineering
Motor Engineering
Motor Trade
Municipal and County Engineers
Naval Architecture
Pattern Making
Police, Special Course
Preceptors, College of Pumps and Pumping Machinery
Radio Reception
Road-Making and Maintenance
Salesmanship
Sanitation
Secretarial Exams.
Shipbuilding
Shorthand (Pitman's)
Structural Engineering
Surveying
Teachers of Handicrafts
Telephony and Telegraphy
Transport Inst. Exams.
Weights and Measures Inspector
Wireless Telegraphy and Telephony
Works Managers

IF YOU DO NOT SEE YOUR OWN REQUIREMENTS ABOVE, WRITE TO US ON ANY SUBJECT.

IT COSTS NOTHING TO ENQUIRE.

Also ask for our New Book (FREE OF CHARGE), **THE HUMAN MACHINE**, Secrets of Success.

STUDY AT HOME

U

IN YOUR SPARE TIME

CAN HAVE A COLLEGE TRAINING IN ALMOST ANY CAREER FOR A FEW SHILLINGS MONTHLY.

MATRICULATION

There are many ways of commencing a career, but Matriculation is the jumping-off board for all the best ones.

CIVIL SERVICE

Suitable to both sexes. Ages 15½ to 24.

G.P.O. ENG. DEPT.

CUSTOMS AND EXCISE; INSP. OF TAXES, Etc.
NO EXPERIENCE REQUIRED
OPEN EXAMS.

We prepare candidates for all

INSTITUTE EXAMS.

TECHNICAL, INSURANCE, COMMERCIAL, GENERAL, POLICE Etc., Etc.

ENGINEERS ALL BRANCHES

There are examinations which are open and suitable to you, others which are not. Get our advice before deciding.

The Commercial Side of

THE MOTOR TRADE

offers exceptional opportunities for young men of good education.

EVERY DEPARTMENT IS A COMPLETE COLLEGE. EVERY STUDENT IS A CLASS TO HIMSELF.

DO NOT DELAY

There may be chances for you to-day for which you may be too late to-morrow. Every day counts in a man's career.

NOTE ADDRESS CAREFULLY:

Dept. 76, THE BENNETT COLLEGE LTD., SHEFFIELD

6/8 GETS A CAMERA YOU'LL BE PROUD OF!

Pay the remainder by 8 similar Monthly Payments while you use your Camera. We have Cine Cameras too—from 14/9 down and lots of bargains. We pay well for your used Camera in part exchange. **WRITE US NOW!**

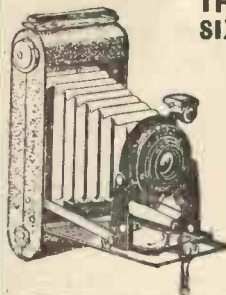

THE 'KODAK' SIX-20 JUNIOR

An excellent camera with fast F/6.3 lens and KODON shutter. Opens ready to take anything in an instant at the simple press of a button. The camera for the young enthusiast.

YOURS FOR 6/8

And 8 similar monthly payments or 55/- cash.



PATHESCOPE 'B' CINE CAMERA

You'll get hours of sport making movies with this popular model. Simple to use, With F/3.5 lens.

YOURS FOR 14/9

And 8 similar monthly payments or £8/6/0 cash.

OR PATHE LUXE (as illustrated) £10/10/0



THE 'BRILLIANT'

A modern roll-film camera of the reflex type. Takes 12 pictures on standard 3 1/2 x 2 1/2 film. Simple focusing. Supplied with leather shoulder lanyard.

YOURS FOR 6/8

and 8 similar monthly payments or 55/- cash.

100-PAGE CATALOGUE FREE AND POST FREE

CITY SALE & EXCHANGE

(1929) LTD.

59 CHEAPSIDE, LONDON, E.C.2

ECONOMIC ELECTRIC CO. TWICKENHAM, LONDON, S.W.

E.E.C. BOAT MOTORS

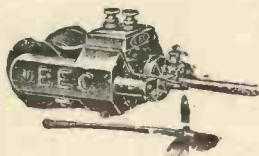

Fast. Powerful. Made in four sizes: 15 oz. 25 oz. 40 oz. 48 oz.

Consumption: 1 amp. 4-6 volts.

Prices: 15/- 17/6 21/- 25/- Propeller and Shaft 3/-.

4 VOLT BOAT ACCUMULATORS



5 amp. 6 amp. 10 amp.

6/6 7/6 10/-

Post 6d.

Special new design low consumption boat motor. Takes 3 amp. only. Runs from dry battery.

Vertical Type, Small Size. 7/-. Large. 12/6.

Horizontal Type, Small Size 6/-. " 10/6.

MIDGET IGNITION COILS, WEIGHT, 2 1/2 oz.

Non-Trembler, 9/6. Trembler, 10/6.

ACCURATE SWITCHBOARD METERS

Best quality in plated cases.

1 1/2" Dial, 0-5 up. volts, 6/6. Post 4d.

" " 0-2 up. amps., 6/6. "

3" Dials, volts or amps., 12/-. Post 6d.



TRANSFORMER STAMPING, Standard Sizes, 6/- Gross Pairs.

TANTALUM STRIP FOR RECTIFIERS, 1/8 Post Free.

Send for our 60 pp. Illustrated List containing particulars of Gas and Petrol Engines, Motors, Dynamos, Telephones and Spares, Switchboards, Meters, Fittings (Miniature and Standard), Resistance and Instrument Wires, Tantalum, Metal Sheet, Rod and Tube, in fact all you require for your Workshop or Hobby. Sent on receipt of 2d.

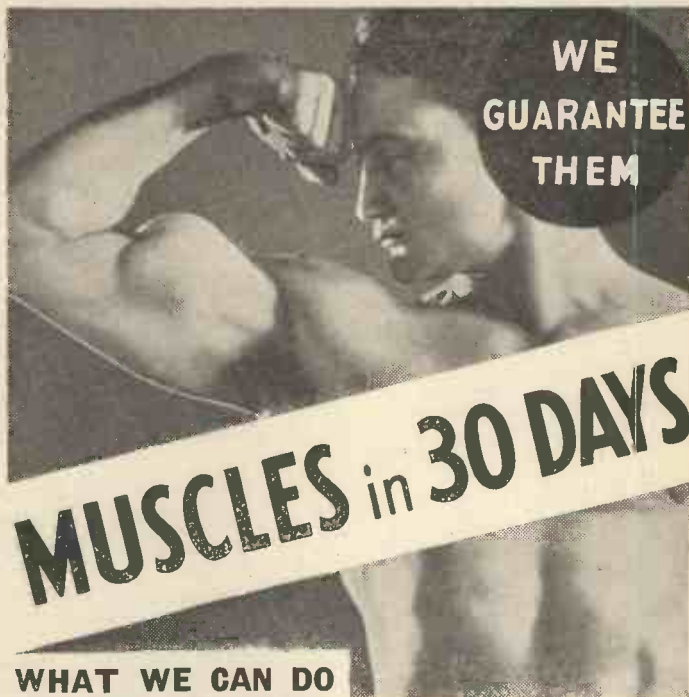

WHAT WE CAN DO FOR YOU IN 30 DAYS

We know something about muscle building! In just 30 days you are going to see such a change in your appearance that you will scarcely be able to believe your own eyes. In 30 days we GUARANTEE to add one inch of solid muscle to each of your arms—yes, ONE INCH—and two full inches to your chest measurement.

Your neck will quickly become erect and strong. We will make your shoulders broader and squarer and your back straighter. Yes, we can do it. We only ask you to put us to the test. You won't need a mirror to tell you what a difference a month's work has made in your appearance. You will know it by the way men will treat you with a new respect. Women's eyes, too, will tell you that you are a man—ALL MAN! They will look at you with an interest they never showed in you before. Your friends will be astonished at the marvellous change in you. Yes, you will indeed begin to taste the pleasures of life when we start putting your weak body into shape—when we cover it with solid layers of powerful muscle and make it throb with new energy and power.

IT TAKES JUST 90 DAYS

Great as the improvement in your appearance will be in 30 days, it is nothing to the change we will work in your body in 90 days. We want 90 days to complete the job properly. Then you will indeed marvel at the extraordinary change in your appearance—you will realise the true meaning of strength. At the end of 90 days, when you look in your mirror, you will see a NEW MAN. You will see a physically perfect form—a deep, full chest, broad square shoulders, great muscular arms, and powerfully developed legs. You will see bands of rippling muscle covering your arms, your chest, your back. You will be proud of your superb development from head to foot.

THE DYNAM INSTITUTE, 97 Greycoat Galleries, Greycoat Place, London, S.W.1.

We Work on those Internal Organs too!

We'll put NEW LIFE into your internal organs. Long before we are finished with you, you'll be glad you are alive. Your whole system will be toned up to fighting pitch. The Dynam System, does not merely give you broad shoulders, a deep chest, and big muscles on your arms, legs and back. That is only half of what we do for you. The Dynam System wakes up all those dormant inside muscles that control your inner organs. While we are building up your outer muscles we are also exercising and toning up those inner muscles—bringing them back to life and making them perform their functions in such a way that you will realise that you never knew before what abounding health and energy really meant.

You will gain new nerve-strength and every organ of your body will become alive with HEALTH and VITALITY, as never before. You get results and get them quickly when we commence building up that body of yours. Inside and out—mentally and physically—we give you real, through-and-through manly health, strength, and power. Not only do we give you muscles so fast that you wonder where they came from, but we give you ENERGY, VIGOUR, HEALTH. Remember, we do not merely promise these things—WE GUARANTEE THEM.

GET THIS BOOK FREE

"HOW TO BUILD MUSCLES" is the name of a book that will put you on the road to mighty muscular power, and the health and vitality of a trained athlete. This book will open your eyes to the marvellous changes that can be swiftly worked in your own body by the Dynam System in the privacy of your own home with only 15 to 20 minutes' work each day. This book is FREE. Thousands of men are sending for it. We can scarcely print it fast enough. Make sure of your copy by sending for it to-day. Cut out the coupon and post it NOW.

COUPON

THE DYNAM INSTITUTE, 97 Greycoat Galleries, Greycoat Place, LONDON, S.W.1.

Please send me a copy of your FREE Book, "How to Build Muscles." It is understood that this request places me under no obligation to you. I enclose 3d. in stamps for postage, etc.

NAME _____ ADDRESS _____

HERE'S A CAREER WITH A REAL FUTURE!

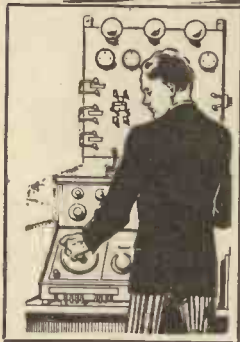

WIRELESS

The One Bright Spot in British Industry

Students trained for all branches of the Wireless Profession. Marine, Aircraft, Broadcasting, Manufacturing, Designing, Experimenting, Sales and Service.

Men who foresaw the Broadcasting boom made good—Be trained and prepared for the Television Boom which must follow as surely as day follows night.

TRAINING FEE CAN BE PAID AFTER APPOINTMENT SECURED
Students accepted as Boarders.

College on Sea Front. Officially recognised as Britain's Leading Wireless Training Centre. Write for free Prospectus.

THE WIRELESS COLLEGE COLWYN BAY, N. WALES

Readers in or near London should request an appointment with our London representative.

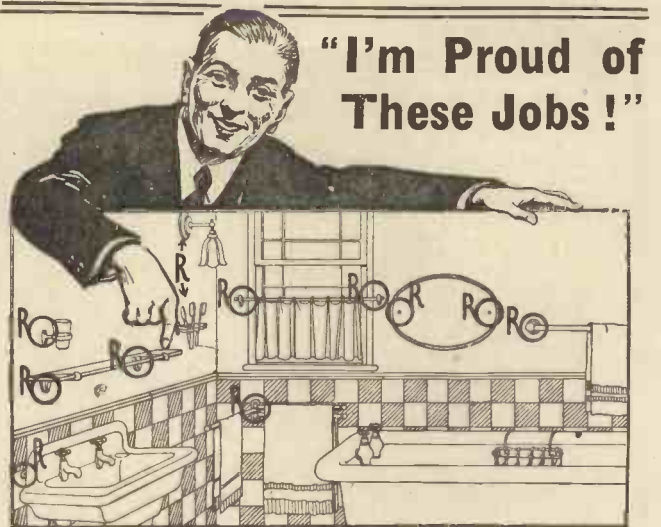

"I'm Proud of These Jobs!"

NOT a tile chipped, not a crack in the wall—every fixture neat, firm, clean and workmanlike. You don't need to be an expert to put up fixtures that will stay fixed if you use Rawlplugs. Millions of Rawlplugs are used annually by the War Office, G.P.O., Admiralty, Railways and Municipal Authorities everywhere. Complete Outfits for home use, 1/6, 3/6 and 5/6 can be obtained from all Ironmongers, Stores, etc.



THE RAWLPLUG CO. LTD., CROMWELL ROAD, LONDON, S.W.7.

Combine **HIGH QUALITY**

THE EXCELLENT CONSTRUCTION

of Hivac valves is accountable for their consistent results as well as being responsible for their efficiency and long life.

HIVAC

Again Specified

These are the valves used by the designer of the

"P.M.

SHORT-WAVE SUPER THREE"

S.G. 210	-	-	-	10/6
L 210	-	-	-	4/6
Y 220	-	-	-	12/6

Any Readers in outlying districts having difficulty in buying Hivac valves locally may send order and cash direct to us.



BRITISH MADE

with **LOW PRICES**

HIGH VACUUM VALVE CO. LTD., 113-117 FARRINGDON ROAD, E.C.1

CLIX CHASSIS MOUNTING VALVEHOLDERS

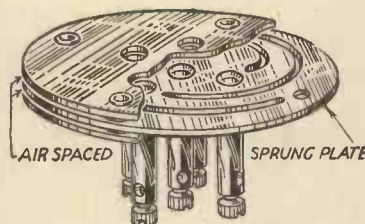

The designer of the "P.M. SHORT-WAVE SUPER THREE" has for this receiver chosen the following types of Clix Chassis Mounting Valveholders.

ONE 4-Pin (Airsprung) for the detector valve and TWO 5-Pin (standard) for the other stages. The "Airsprung" model is anti-microphonic, and the sockets are practically air-insulated, thus making it ideal for short-wave work.

AIRSPRUNG		
4-Pin	1/2
5-Pin	1/3
STANDARD		
4-Pin.	8d.
5-Pin	9d.

The designer also specifies CLIX PANEL TERMINALS

These are extremely robust and soundly made. Hexagonal shoulder, which, by being held with a spanner while the nut behind is made tight, greatly facilitates mounting. Insulated and non-removable head. Provision for secure, solderless connection. Clear and easily read markings.

Type B (Illustrated) . 4d. Type A . 2d.

Obtainable from all Dealers. Folder "M" from

LECTRO LINX LTD.

79a ROCHESTER ROW, LONDON, S.W.1





Practical Mechanics

VOL. 1 No. 7
APRIL
1934

Edited by **F.J. CAMM**

SUBSCRIPTION RATES:
Inland and Abroad, 7s. 6d. per annum
Canada - - 7s. per annum

Editorial and Advertisement Offices: "Practical Mechanics," George Newnes Ltd., Southampton Street, Strand, W.C.2.
Registered at the G.P.O. for transmission by Canadian Magazine Post.

Notes, News and Views

Oil-engined Rail Cars

THE London, Midland and Scottish Railway are shortly putting into service three oil-engined rail cars of a new type. The motive power is provided by a Leyland 9.9-litre oil engine of a new design developing 130 b.h.p. at 2,000 r.p.m. It drives through the same type of hydraulic converter that is used in the gearless buses, but the reverse gear is contained in the double-reduction axle. The car is capable of accelerating from rest to 50 miles an hour in approximately 50 seconds.

World's Largest Motor Trawler

DESIGNED for fishing off the banks of Newfoundland, the motor-driven trawler *Jutland* is stated to be the largest motor trawler in the world. She is 220 ft. long, with a beam of 37 ft., and a depth of 19 ft. 9 in., the gross tonnage being 1,200. The motor is of the four-stroke single-acting type, and its six cylinders develop 1,100 h.p.

New Petrol-driven Roller

AN interesting exhibit at the B.I.F., where it was shown for the first time, is the new Aveling-Barford petrol-engined grass roller. This new model weighs 9 cwt., and has a rolling width of 30 in. The speed is 2 m.p.h. and the petrol consumption per working day is 4½ pints. The length is 4 ft. 8 in., width 2 ft. 11 in., and height 3 ft. 6½ in. The engine is a two-stroke, and there are only two controls, the drive being by means of a roller chain.

The New Tees Bridge

THE new bridge over the Tees at Middlesbrough which was opened recently is one of the latest engineering achievements. It is of the lift-span type, and has a roadway nearly 300 ft. long. Unlike the Tower Bridge, with its bascules, the whole centre span of the Tees bridge, weighing over 5,000 tons, is raised in a horizontal position between two supporting towers to a sufficient height to allow tall-masted ships to pass under.

New Air Liners

TWO giant air liners of the "Scylla" class are now being built at Rochester aerodrome for Imperial Airways. One of the machines had to be assembled on the stocks in the open because no hangar was big enough to house it. These aeroplanes will be the largest air liners to be built for regular air route service, and each will carry thirty-nine passengers and a crew of four. The machines will be driven by four high-power engines.

A High-powered Diesel Engine

A LARGE double-acting two-cycle Diesel engine, just constructed for a power station in Shanghai by Messrs. Sulzer Brothers, is one of the most powerful engines built for this purpose. It runs at a speed of

THE MONTH'S SCIENCE SIFTINGS

A new type of anchor having only one pointed end and no cross-bar, resembling a double-bladed ploughshare, has been designed by Professor G. I. Taylor. During a recent test it was shown to have at least twice the holding power in proportion to its weight of any existing anchor.

What is claimed to be one of the largest gear wheel blanks ever cast in one piece has recently been produced at the Cammell Grimesthorpe foundry. It is no less than 13 ft. 8 in. in diameter, has a rim face of 40 in., and a width of 44 in. through the boss. There are eighteen spokes, and the casting weighs 27½ tons.

A new R.A.F. bombing plane, a Hawker Hart, has recently undergone its tests. With a specially designed air-cooled engine which permits of closer streamlining, the machine is expected to be one of the fastest of its type in the world.

A new alloy, known as Kunial, has recently been discovered in the Chemical Industries laboratories at Birmingham. It consists of a new series of copper alloys which, when subjected to simple heat treatment, become not softer, like ordinary metals, but three times as hard and twice as strong as any copper alloys now known.

The auto dial, a new automatic telephone apparatus, will shortly be introduced by the General Post Office. By means of this device a subscriber on an automatic exchange can be rung up by simply depressing a lever without rotating the dial.

Three young Cambridge scientists have just succeeded in introducing radio-activity of nitrogen into a piece of graphite, with the result that it emits rays similar to those of radium. For fifteen minutes a bombardment of atoms of hydrogen at an electrical pressure of 600,000 volts was directed against a piece of graphite. When tested the graphite remained radio-active up to half its initial intensity for ten minutes.

136 r.p.m., driving a huge alternator of 8,000 kilowatts capacity, generating fifty-period current at 5,200 volts. The engine is of the vertical marine type, and has eight cylinders. The oil fuel is injected by air pressure.

Progress in Television

CONSIDERABLE progress has recently been made in television transmission equipment, and the B.B.C. continues to conduct experiments with the various new systems at present available. One system recently demonstrated, using a cathode ray oscillograph of special design, gave particularly brilliant and steady pictures. It is thought that when the transmission system has been perfected there will be little need for the somewhat elaborate and certainly expensive synchronising gear at present fitted to television receivers, for the purpose of the latter is merely to compensate for transmitting fluctuations.

A Note to Querists

QUERISTS will greatly assist us if they would write on one side of the paper only, and put their names and addresses on any sketches accompanying their letters. We are also enabled more promptly to deal with queries when those relating to separate subjects are written on separate pieces of paper, each, of course, bearing the name and address of the sender. All envelopes containing queries must bear a 1½d. stamp, and we only reply by post when a stamped and addressed envelope is enclosed. Will those readers who submit "Hints and Tips" please bear in mind that these are only acknowledged when a stamped and addressed envelope is enclosed? If it is desired that unsuitable contributions should be returned to the sender, this rule must be complied with.

Low-powered Motor Cars

NEWS arrives from Germany that several new motor cars have appeared of the four-cylinder four-seater type, having engines of only 500 c.c. This is nearly 300 c.c. less than the lowest-powered English car. The cost of running is proportionately reduced, and it is claimed that the petrol consumption is nearly 60 miles per gallon, and over 1,000 miles to the gallon of oil. Also, these cars are only about half the weight of the lightest 7-h.p. car.

Midget Wireless Components

IT would seem that the tendency in wireless receiver design is towards the Lilliputian, for valves no larger than the thumb are already in production, moving-coil speakers (permanent magnet and field energised) are now obtainable as small as 5 in. in diameter, and many other components, such as transformers, tuning coils, variable condensers and chokes have been produced showing a similar reduction in size. In America, of course, miniature receivers have been in vogue for a number of years,

EXPLORING THE

What has been discovered in this comparatively unexplored and fascinating region, and the purpose of stratospheric ascents.



How some of the stratosphere explorations are conducted. Note the wireless transmitting apparatus.

THE recent spectacular ascents into the specially-constructed balloons into the stratosphere has brought into prominence the higher regions of the atmosphere, the existence of which seems to have been appreciated only by a few people. And yet the nature of the various layers of belts of air, nitrogen, hydrogen, helium and ionised gas, which surround the earth is no new discovery. It may appear to be so because of the new name, or comparatively new name, which has been given to it. Although Professor Piccard was actually the first human being to ascend into and examine the conditions present in that at present unexplored altitude, it may surprise many to know that in 1898 a famous French scientist, M. Teisserence de Borth constructed a special sounding and recording balloon which ascended over 12 miles in altitude, and his pioneer work made possible the recent successful ascents. Forty years ago the layer we know as the stratosphere was referred to as the Isothermal Region, and you will find it so referred to in many of the earlier atlases.

The desire of scientists to ascend into this region is not based on a mere desire to break records. Many may wonder indeed what useful purpose can possibly be served in wishing to explore a region where human life, except under artificial conditions, would be impossible, and whether the world's heritage of scientific knowledge can possibly be enriched, apart from the natural tendency of the scientist to reach out for fresh fields to conquer. Man has conquered the sea and the regions beneath the sea; he has conquered overland travel, and travel through the air. He has not yet conquered the atmosphere. What little knowledge he has of the inter-stellar regions has been gained more by observation and from the results of astronomical research rather than from actual ascents into the regions themselves.

The Value of the Experiments

Although the recent altitudes attained may seem enormous compared with the

recent altitude records of balloons and aircraft, they must not be considered as opening up the possibility of travelling to the moon, which is the nearest celestial body—250,000 miles away—but if there is any possibility at all of travelling into the Epyrean it is necessary that experiments such as those undertaken by Professor Piccard and the two Russian scientists should be continued.

A diagram next page gives various layers earth's surface regarding the recently achieved stratosphere

given on the details of above the and also data records recorded. It has been ascertained that the consists almost



The gondola of the balloon in which Professor Piccard made his memorable ascent into the stratosphere.

entirely of nitrogen, hence the need for the hermetically-sealed apparatus in which these attempts have been made. It is a tribute to previous investigations from the earth's surface that previous conjecture as to the nature of the stratosphere was, in fact, proved by Professor Piccard. The stratosphere balloon is of necessity equipped with means for providing oxygen and heat, for the air of the stratosphere is unbreathable and the temperature is such that life would be impossible in it.

The three ascents into the stratosphere recently made confirm that the outside temperature is approximately 80 degrees below zero. It was also found that, in addition to this extremely cold temperature, extreme calm and brilliant sunshine prevailed. There are no clouds or winds, and extreme changes in the weather are confined entirely to the lower regions of the atmosphere.

A curious fact has emerged from these experiments, for it has been ascertained

that the deadly cold of the stratosphere extends to about 40 miles above the surface of the earth. Yet higher up a layer of relatively warm air is encountered, with a temperature as high as 30° C. A study of the diagram given on the opposite page shows that in ascending into the stratosphere we first of all pass through a belt of comparatively dense air. Next to the stratosphere, which is, as I have said before, at a temperature of approximately 80 degrees below freezing point, comes the ozonosphere, which is a belt at a slightly higher temperature occupied by rarified oxygen; and, lastly, we come to the ionosphere, which extends to a further altitude of about 150 miles.

It has been discovered that this latter region consists chiefly of oxygen in a diffused state which, under bombardment by the ultra-violet rays emitted by the sun, is separated into free electrons and ozone, which latter is an active allotropic variety of oxygen and having a peculiarly exhilarating smell.

Effects on Radio Transmissions

It is well known among designers of wireless and transmitting apparatus to have a marked effect on radio transmission, because it reflects the impulses or wireless waves back to earth. It is also well known that this effect enhances the possibilities of long distance reception on the short waves, for reflection on short-wave transmissions is most marked and there is very little absorption due to the Heaviside Layer. A peculiarity worthy of note is that on long waves the reverse is the case—absorption is greater and reflection less.

On the medium waves the effect is about equally balanced. Another important point is that the effect is most marked at night. Long-wave transmissions are thrown sharply back, thus causing a zone of strong reception near to the transmitter, while shorter waves are reflected



The start of Professor Piccard's ascent at 5 o'clock in the morning.

STRATOSPHERE

By THE EDITOR

at a shorter angle, giving rise to the phenomenon known as skip distance and the creation of areas of poor reception on the waves concerned.

Ultra-short waves, it has been discovered, pass straight through the layer. In spite of the ascents of Professor Piccard and others, we are still without accurate knowledge of the constitution of the Heaviside Layer, for whilst the general scientific belief is that it consists of ionised gas, as previously stated, this belief can hardly be supported when it is remembered that the layer persists at night through about 90 kilometres and only 40 to 50 kilometres in the day time. A modern theory is that it consists of frozen hydrogen in minute particles, which would account for the reflection of radio waves as well as for the Aurora Borealis, for hydrogen in a frozen state has many of the characteristics of a silvery-looking metal. If this theory be correct, it would absolutely account for the Aurora, for the principle of diffraction of light rays setting up a prismatic display of colours would apply.

The Cosmic Rays

During recent ascents into the stratosphere investigation was made concerning cosmic rays, which are those rays caused by the rising and setting of the sun. Professor Piccard found that cosmic radiation became weaker as altitude increased—the exact opposite to previously accepted theory.

Another surprising fact evinced is that a container of metal having a polished outside surface reflected the sun's rays and maintained an interior temperature equal to that of the surrounding air. Yet a similar container with a black outer surface absorbed the solar rays and the interior temperature increased to 170 degrees above zero. This makes possible the construction of a simple thermo engine which would derive its power from these differences in temperature or by the differences in the

co-efficient of expansion of different metals.

The Magnetic Effects

The deductions which can be made from these stratospheric ascents are certainly fascinating; everyone knows that the earth resembles a magnet, and like a magnet it has a north and south pole. Correspondingly, there will be the usual magnetic field and the corollary magnetic lines of force extending from the north to the south. If we agree that the ionosphere and the ozonosphere



The Austrian stratosphere ascent. The special prismatic gondola is shown here.

is responsible for the ebb and flow of the tide, and to a lesser degree the sun produces the same effect. It would also account for the phenomenon in wireless reception known as fading.

Considerable colour is lent to the theory expounded when it is remembered that heat cannot travel through a vacuum, yet the sun's heat greets us in spite of the vacuum which exists in space, because the pole electro-magnetic rays from the sun are transformed into heat when they strike the atmosphere enveloping the earth, just as a current travelling a cold metal cable is transformed into heat and light in the electric lamp bulb. It is interesting to reflect that a well-known law of dynamics is that resistance of a body moving through air increases as the square of the velocity. Therefore the velocity of a body for a given power of propulsion should increase as altitude increases, provided that suitable means can be introduced for counterbalancing the decrease in efficiency due to the rarefaction of the air; presuming, of course, that an air-screw is used for propulsion. Should, however, the rocket principle be applied, it would merely be necessary to construct a device which would propel itself to such an altitude that the gravitation of the earth ceased to have effect and the gravitation of, say, the moon took effect. This reasoning is based on solid scientific fact, and there can be little doubt that one day it will be an accomplished fact.

Advanced as is our knowledge of the ether there are still vital missing links, and we are merely on the threshold of our knowledge of rays.

The electro-magnetic rays from the sun, the cosmic rays, ultra-violet rays, and X-rays, are but a few of those embraced by the spectrum from the invisible to the visible limits.

At one end we have the cosmic, gamma, X-ray, and ultra-violet, with wavelengths of .0001 millimeter and below. We then come to the violet, blue, blue-green, green, yellow-green, yellow, orange, and red, which comprise the visible colour spectrum with wavelengths of .00043 millimeters to .000644 millimeters, and finally to the infra-red and radio with wavelengths of .00077 millimeters and upwards. The effect of some of these rays was first discovered by Herschel, and the scientific world now relies upon those whose urge it is to explore the stratosphere to complete our knowledge of this fascinating subject.



Diagram illustrating the various details of the belts surrounding the earth.

are conductors, a current must be induced when any conductor passes through them. Hence, if these ionised layers pass through the magnetic field of the earth an electric current will be generated, and such might explain some of the atmospherical disturbances and other upheavals which have up to the present awaited satisfactory explanation. It is beyond all dispute that the moon



A model of the next Piccard stratosphere balloon. The proportions between the gondola and the balloon should be noted.

SEEING YOUR —

By H. J. BARTON CHAPPLE,

"Hello—are you there?" is an old telephone expression the purpose of carrying on a conversation. We have by well-established electrical methods of communication may shortly be able to see and be seen when carrying has already been successfully demonstrated.

electrical signal, which, after amplification, was transferred to the other booth by a short length of telephone cable.

Defects

While these television signals were being produced in Booth No. 1 and sent along to Booth No. 2, a similar television transmission was occurring in Booth No. 2, the signals produced being transferred to Booth No. 1 where, after amplification, they were fed to a flat plate neon lamp mounted horizontally behind the disc aperture at the top, as indicated in Fig. 1. The single spiral apertured disc therefore served a dual purpose and while the face of the individual was being scanned by the light spot passing through the holes at the bottom of the disc, by keeping his gaze fixed on the top of the same disc he saw built up with the associated neon lamp an image of the head and shoulders of the person at the other end of the wire.

The scheme was an extremely simple one, but apart from the received image being of poor quality the light spot playing on the face made it difficult to see the image at all. Another defect arose from the fact that the light beam scanned the face at a somewhat acute angle if the head was raised to look up at the formed image, with the result that the image seen at the other end was of a face sloping backwards and not a true impression as would be formed by normal sight.

A More Ambitious Experiment

Notwithstanding the relative crudity of the scheme, the demonstration gave birth to

many speculations, and less than a year afterwards, April 1930 to be exact, the Bell Telephone Laboratories, Inc. demonstrated their own system in New York between West St. and Broadway. A general idea of the scheme is given in Fig. 2, each participant in the "see and hear" experiment being seated comfortably in a booth, a scan of the head and shoulders being effected through the medium of an arc source of light and a single spiral apertured disc mounted in the top section of the booth. Three banks of photo-electric cells at each side and above the subject produced the television signal in the usual manner. The image of the person spoken to could be seen just below the "scanning aperture," being built up by a neon lamp and scanning disc.

Horizontal scanning was employed and eighteen pictures per second portrayed, while the accompanying speech was picked up by a sensitive microphone, the words from the far booth being reproduced from a concealed loud-speaker. Although the image seen was rather more natural than in the case of the German demonstration owing to the narrower "vision angle" (seen as a dotted line in Fig. 2) there was still the same objection that the participants carrying on the conversation were compelled to gaze into an intense flickering light beam and concurrently watch a somewhat dim image.

Subsequent to the original demonstration, use was made of a blue light beam for the spot light scanning of the subject, this reducing the inconvenience, and later still came the addition of a deep red component

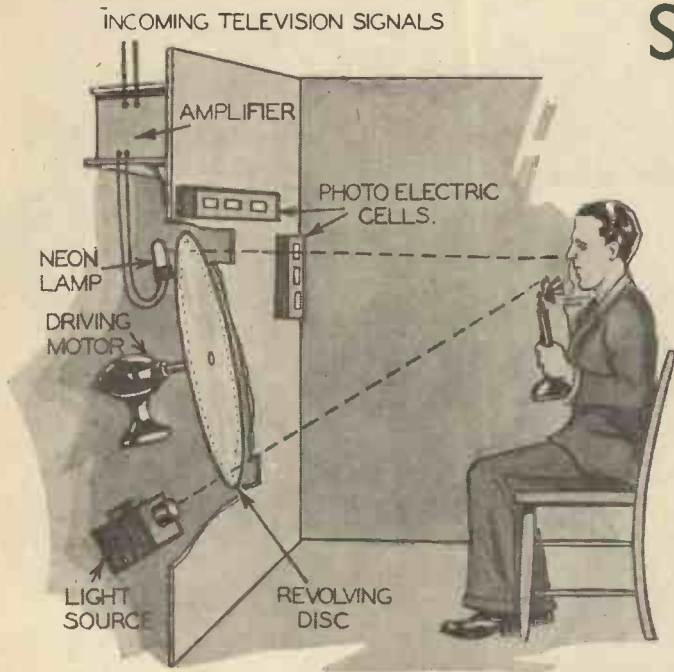

Fig. 1.—A schematic impression of the Berlin demonstration of two-way vision and telephony.

THIS is no speculative flight of imagination but a natural outcome of the developments at present taking place in television. Furthermore, the principles of the scheme on which this two-way vision and telephony link may be established have already been demonstrated, and it is largely a question of time and finance before television is harnessed definitely to the telephone in one form or another.

The First Demonstration

In suggesting how the work is likely to materialise it will be useful to deal with the attempts which have been made in the past. The first one of any importance occurred in August 1929 on the occasion of the Radio Exhibition held in Berlin, and the credit for this must be given to the German Post Office. Being in Berlin at the time I was able to see exactly how the scheme functioned and also participate in the experiment. Two booths were erected about twenty-five yards distant from one another, and members of the public were invited to enter the booths and converse by telephone as well as to see one another simultaneously by television.

Of course, as far as the sound side of the problem was concerned, normal practice was followed, but the rough sketch of Fig. 1 gives the reader an impression of how the vision side was catered for. A single spiral apertured scanning disc rotated at 750 revolutions per minute, being accommodated in a rectangular casing and positioned about two feet away from the seated "subscriber." Small rectangular apertures were cut at the top and bottom of the casing, and through the bottom one emerged a pencil of light. As the disc revolved, the concentrated beam from a powerful light source was focussed on the back of the disc and in this way spot light scanning was effected in the established manner by the spiral of small square holes passing across the light area. The rapidly moving light spot played on the seated individual's features and the varying reflections were "picked up" by three sets of photo-electric cells suitably arranged in front of the disc casing (one at the top and two at the side). This gave the light variation for translation into an

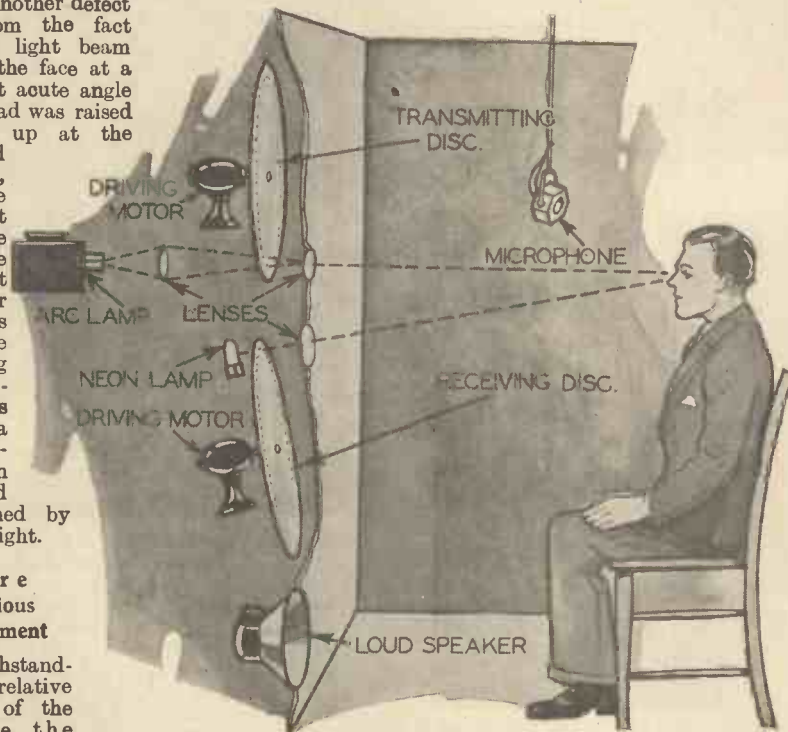

Fig. 2.—Showing the equipment arrangement in the New York experiment.

TELEPHONE CALLER

WH.SCH., B.Sc.(HONS.), A.C.G.I., D.I.C., A.M.I.E.E.

which we all use when ringing up another subscriber for become so accustomed to this "blind" speech effected that it may surprise many readers to know that they on telephone conversation in the future. Such a device

to the exploring ray, making the resultant light purple in character, photo-electric cells sensitive to these colours being used also. Although the authorities concerned hoped to commercialise the project and the apparatus was much more elaborate than that used in Berlin, the scheme unfortunately failed to materialise.

Another Effort in Europe

Nothing more was heard of two-way vision and telephony until the suggestion was put forward that the principles of Noctovision could be applied to the problem, an infra-red beam, invisible to the human eye, taking the place of the visible light spot used previously. Experimental evidence

reference to Fig. 4 and the diagrammatic sketch Fig. 5. The outstanding feature arose from the fact that the persons carrying on the conversation were not conscious of any scanning taking place, this arising from the incorporation of the principles of Noctovision. An ordinary disc type light spot transmitter (seen on the right in Fig. 4) was employed with the disc encased in a dust-proof cover. Behind the disc was the light assembly consisting of a 900-watt metal filament projection lamp and reflector.

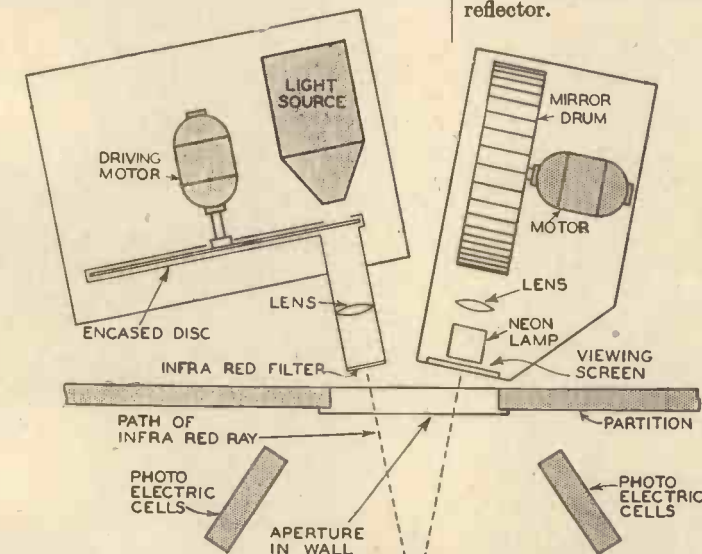

Fig. 5.—Using the principles of Noctovision for the Paris demonstration of viso-telephony.

being forthcoming in support of this idea, special apparatus was made for the purpose by Baird's in this country, but the first demonstration took place in Paris in May 1932. I flew over to that city to participate in the experiment, the official opening ceremony being performed by the Minister of Commerce and P.T.T.

A dual transmitter and receiver was erected at the offices of the French newspaper *le Matin*, while a duplicate set of the same apparatus was housed in a studio in the Galeries Lafayette. The studio itself was of a very simple character and Fig. 3 is an actual photograph of one of them. A diffused bluish-violet light gave sufficient illumination in the small room and the telephone subscriber sat at a table on which stood the telephone.

Immediately in front of the seated individual a rectangular aperture was cut in the wall dividing this studio from the transmitting and control room. Flanked on either side of the table will be noticed the banks of photo-electric cells (four in each bank) mounted on adjustable stands.

Since the two sets of apparatus were identical, a description of both the transmitter and receiver at one end will be furnished, and this will be made clear by a

and in consequence only the infra-red component of the light beam explored the head and shoulders.

This telescopic lens was positioned on the left of the wall aperture and the variations of the infra-red beam reflected from the face were "picked up" by the two banks of cells, these cells of course being chosen for their special sensitivity to the infra-red end of the spectrum. After amplification the resultant signals "translated" by the cells were sent along to the other end of the telephone line when they

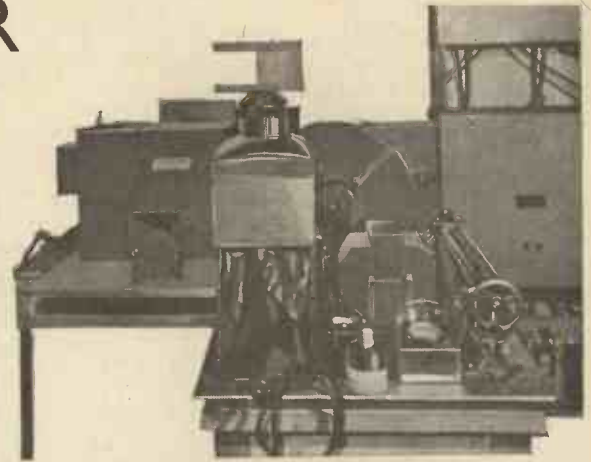

Fig. 4.—A rear view of the combined transmitting and receiving apparatus located behind the aperture in the partition. The mirror-drum receiver is housed in the metal casing on the left.

Producing the Infra-red Beam

The concentrated beam of light emerged from a short tunnel, and before this revolved the disc with its single turn spiral of twenty-four holes at a speed of 750 revolutions per minute. The resultant moving light spot produced by this combination passed into a telescopic lens which focussed the beam on to the features of the seated telephone caller. All the visible light was filtered out, however, by interposing a thin disc of ebonite,

passed through another amplifier before being handed to the television receiver.

The receiver, seen on the left of Fig. 4 and indicated diagrammatically in Fig. 5, was built up from a circular drum having twenty-four mirrors accurately positioned round its periphery, each mirror being set at a slightly different axial angle with reference to its immediate neighbour. The drum revolved at 750 revolutions per minute, and focussed on to the moving mirrors was the light from a hot cathode spot light neon lamp.

The incoming television signals made the light intensity of the lamp vary in accordance with their strength, and the resultant light beam reflected back from the tiny mirrors on to a translucent screen of frosted glass built up the image through the medium of the twenty-four light strips positioned next to one another. The light and shade of the subject transmitted was clearly visible, the screen size being ten inches high by five inches wide. Furthermore, synchronism was established by means of a cogged wheel automatic synchroniser similar to that described for use in conjunction with the Tele-Discovisor published in earlier issues of "Practical Mechanics."

At the demonstration the features of the telephonist seated in the distant studio showed clearly and distinctly on the image screen. The play of expression on the face was most impressive, and lip and head movement could be followed with absolute ease, in spite of the fact that only a twenty-four line vertical scanning was used.



Fig. 3.—A photograph of one of the studios used in Paris.

AN ELECTRIC "SLAVE" CLOCK

THE first thing to obtain is an old clock. Remove the spring and take out all the cogs except the two behind the face. Fix the frame of the clock together again and replace the fingers if these have been removed. It will be seen that when the knob, which was for adjusting the fingers, is turned, the fingers move round rapidly and easily. This constitutes the mechanical part of the clock.

A cog wheel must be made with sixty teeth. This requires some care, but it may be easily made, provided that the diameter is large enough. Mark out, on a sheet of brass or mild steel about $\frac{1}{8}$ in. thick, a circle 3 in. in diameter. With the same centre draw another circle $2\frac{1}{2}$ in. in diameter and move this radius $1\frac{1}{2}$ in. round, marking on the circumference of the smaller circle. This is divided up into six equal parts, each of which must be divided up into ten equal parts. The teeth are cut to the shape shown in Fig. 1, and are trimmed off by using a three-cornered file.

When the wheel is complete, it must be soldered on to the shaft passing through the clock.

The Electric Part of the Clock

The electric part of the clock consists of a powerful electro-magnet. Obtain two carriage bolts, $1\frac{1}{2}$ in., $\frac{1}{4}$ in., and file

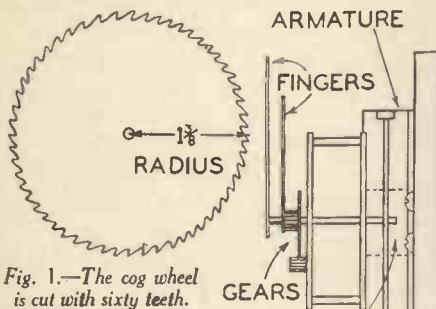

Fig. 1.—The cog wheel is cut with sixty teeth.

the heads flat. Cut a bracket of soft iron and drill it to take the carriage bolts. The holes should be $1\frac{1}{2}$ in. apart. Fix the bolts in the bracket and wrap them with insulated tape. Wind the bolts with No. 24 D.C.C. wire, packing it on as neatly and tightly as possible. Cut a strip of mild steel for an armature and leave a small lug projecting so that it may be screwed on to the back of the clock. Cut the back for the clock from $\frac{1}{2}$ -in. wood and by means of the brackets mount the clock in the centre (see Figs. 2 and 3). The end of the armature is bent at right angles and the end is then bent again at right angles to form a small hook. Mount the armature so that the small hook engages with the wheel, and mount the magnets so that they will easily attract the armature. The construction of the stops A (Fig. 2) is clearly shown in Fig. 5. They consist of 1-in. nuts and bolts, with the nuts soldered to the metal brackets, and should be mounted in the position indicated (see Fig. 5). The arm B is a strip of mild steel cut and mounted as the armature. Two terminals should be fixed on the back to which

Last month we described how to make a master pendulum clock, and the present article deals with the "Slave" clock, any number of which may be operated from the one master control clock.

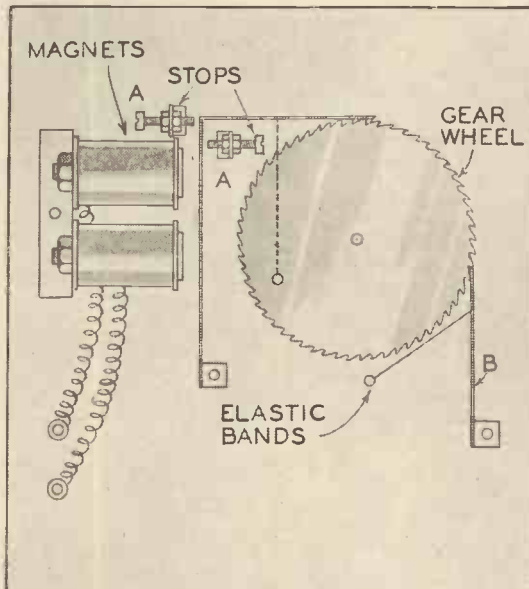

Fig. 2.—A front view of the clock showing the construction.

the magnet coils are connected. A good plan is to attach elastic bands on to the armature and spring, as this makes their action quicker.

Testing the Clock

Test the clock as follows: connect it in series with two dry cells and a Morse tapper. Press the key and adjust the stops so that the wheel advances one tooth each time the circuit is completed. The spring B acts as a ratchet and, when the current is switched off, the armature springs back and the wheel remains in its position. It will be seen that for each tooth the wheel advances, the finger moves on one minute. This should be tested for all sixty teeth.

On the spindle of the second finger of the master clock fix a contact about 1 in. long. This may be a piece of wire twisted round the shaft and secured with a blob of solder. On the back of the clock an insulated contact is fixed so that once each minute the two contacts meet. Solder a wire to the frame of the clock and another to the insulated contact and connect them in series with the clock and two dry cells (see Fig. 6). Once each minute the circuit is completed and the wheel advances one tooth and the minute finger travels on one minute. Once the clock is installed it needs no attention, except for the occasional renewing of the batteries.

To finish the clock off, build a case round

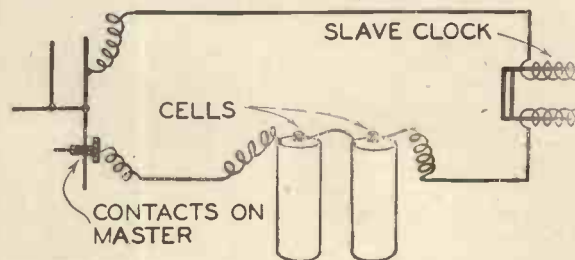

Fig. 6.—Wiring of the master contacts and slave clock magnets.

the "works" and design and out a suitable face, then stain the whole a dark brown.

Any number of these clocks may, of course, be operated from the "Master" clock which was described last month, and the only question is the carrying of the necessary wires from master to the slaves. The best arrangement will be found to include all the slaves in parallel, that is, two wires are run from the master to the furthest slave, and branches taken from the two wires to each clock as desired.

Chimes

If chimes or striking mechanism is required, this will most conveniently be arranged on the master clock, or in its vicinity, although there is no reason why the master should not be built (without the small indicating clock at the top) and installed in a cellar or attic, out of the way, and each room fitted with a slave. In this case the striking or chiming mechanism could be fitted in the required room or in the hall. It is not proposed to give any actual constructional details at this point for installing suitable chiming mechanism. There are numerous different methods of fitting such apparatus, which may be electrically driven or clockwork operated, the actual mechanism being set into operation by electrical means at the required time.

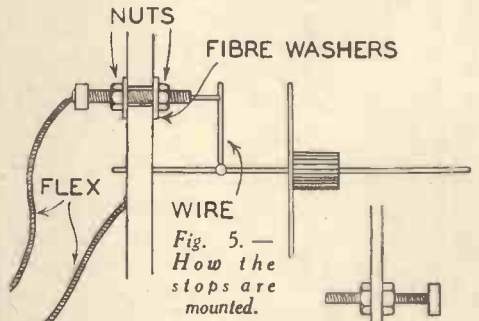

Fig. 5.—How the stops are mounted.

Westminster chimes, consisting of ordinary brass rods clamped to tune to the required notes, may be easily constructed, and the four hammers operated by a rotating drum fitted with small projecting fingers or cams. A small electric motor could be set into operation for this purpose, very little power being required. The small dry cell would operate this. Alternatively, large diameter brass tubing could be used to provide heavy church-like tones, and hammers for these could be power operated, each by a small magnet or motor, the individual motors or magnets being set into operation through the medium of a rotating contact maker, itself driven by a small motor. If sufficient interest is shown by our readers we shall give actual constructional details for this purpose.

It should not be difficult to arrange a small operated wheel on the lines shown in Fig. 2 with contacts at the four quarters. The hour-striking mechanism will, of course, have to be separately controlled, owing to the time taken when chiming the longer hours, unless some scheme can be incorporated for giving continuous action on the striking mechanism whilst the minute wheel continues to move.

How a TORPEDO WORKS

THE torpedo, that ingenious engine of destruction so much feared by seafaring men in war-time, was invented by Captain Luppis, formerly of the Austrian Navy, but it was a British engineer, Mr. Robert Whitehead who, working in conjunction with Captain Luppis in 1868, produced the first self-propelled torpedo. The torpedoes used in the British Navy today are a development of this early invention.

Known as "tin fishes" by naval men, torpedoes are really small robot submarines, as, once launched into the water, they not

In this Article the Author briefly describes the Construction and Working of this Deadly Weapon of War.

By A. J. BUDD

other high explosive. Projecting from the nose is the end of a striker rod, the other end of which is pointed. When the torpedo strikes a ship's side, or other rigid object, the sharp-pointed end of the striker rod is

Propelling and Controlling Mechanism

Next to the compartment which contains the explosive charge is an air chamber which holds the compressed air for driving the propelling engines. The air is pumped in at an extremely high pressure by air pumps on board the ship from which the torpedo is fired. Adjoining the compressed air chamber is another compartment called the "balance chamber," which contains the automatic steering apparatus, and abaft the "balance chamber" is the compartment containing the engines. These are driven by the compressed air and revolve a

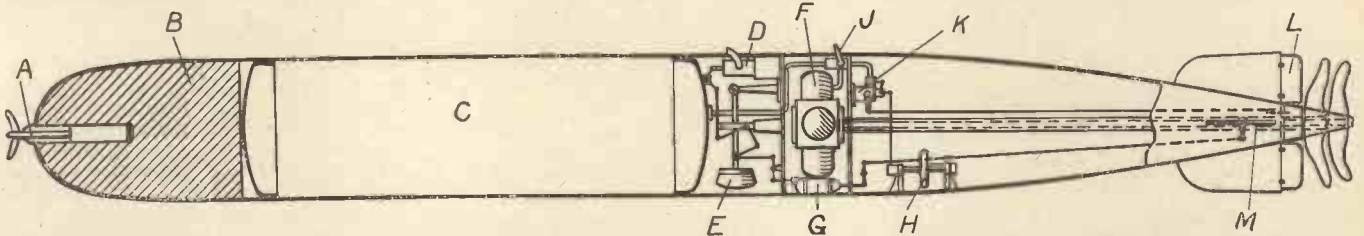

Fig. 3.—Section of a torpedo showing the various compartments and positions of controlling mechanism. A. Striking rod. B. Explosive charge. C. Compressed air chamber. D. Hydrostatic valve. E. Pendulum weight. F. Propelling engines. G. Auxiliary motor for operating vertical rudders. H. Gyroscope. J. Trip lever of starting valve. K. Small compressed-air motor for operating vertical rudders. L. Vertical rudders. M. Horizontal rudders.

only propel themselves but are under complete control by means of self-contained mechanism.

General Characteristics

The Whitehead torpedo is a cigar-shaped object, parallel for the greater part of its length, the shell being made of the finest steel. It is from 14 to 19 ft. long and from 14 to 18 in. diameter at its thickest part. In the nose or head of the torpedo is placed a large charge of T.N.T. (trinitrotoluene) or

driven against a detonator in the middle of the high explosive, and the charge is then exploded, often with devastating results.

The torpedo is fired from a vessel's side, either from a submerged tube below the water level, as in the case of a submarine, or from a tube on deck. Compressed air is usually employed for firing the torpedo, but in some cases a small impulse charge of gunpowder is used. The illustration Fig. 1 (in the heading) gives a good idea of the launching of a torpedo.

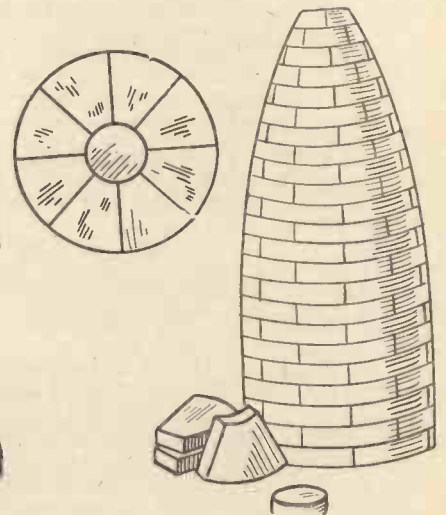

Fig. 5.—Showing how the explosive charge was formerly built up of guncotton slabs.

Fig. 4.—Training torpedo deck tubes in readiness for firing.



shaft arranged along the axis of the torpedo. To the end of the shaft are fixed two screw propellers which rotate in opposite directions and drive the torpedo through the water. To the rear of the engine compartment is a hollow chamber for the purpose of giving the requisite buoyancy to the torpedo.

Four rudders are fitted, two horizontal and two vertical ones, the former being used for keeping the torpedo at the required depth and the latter

for keeping it on a straight course. Fig. 2 shows the rear fins and propellers and gives a good idea of the size of a modern torpedo.

Depth-keeping Apparatus

For controlling the torpedo at its proper depth in the water a very ingenious apparatus is used, consisting of two separate devices. One is a swinging weight, or pendulum, delicately balanced, and the other is a spring-controlled hydrostatic valve which is operated by the pressure of the water when the torpedo goes below a certain depth. By adjusting the spring the valve can be made to operate at any required depth which is registered on an indicator outside the shell of the torpedo.

The pendulum, which moves in a fore and aft direction, controls the movement of the horizontal rudders. When the torpedo travels nose downwards the pendulum swings forward, in relation to the body of the torpedo, and the rudders are operated to steer it upwards. When the nose of the torpedo tends to rise the reverse happens, and the torpedo is thus kept on a level course through the water.

The hydrostatic valve mechanism works in conjunction with the pendulum arm and augments its action when the torpedo goes below a certain depth. The combination of the hydrostatic valve and pendulum does not actually operate the rudders direct, but acts as a kind of relay, and really controls a special type of compressed-air motor which supplies the power for operating the rudder control rods, much in the same way as a steering engine amplifies the power of the helmsman.

Steering a Straight Course

The vertical rudders, for keeping the torpedo on a straight course, are controlled by a gyroscope. This actuates a lever attached to the air valve of another small compressed-air motor which operates the control rods of the vertical rudders. When the torpedo, from any cause, becomes deflected from a straight course, the gyroscope, by virtue of its peculiar property of maintaining its original axial position, operates the air valve of a motor, as previously mentioned, thus actuating the rudders which steer the torpedo back to its original course. Fig. 3 is a sectional view of a torpedo showing the positions of the controlling mechanism.

Firing the Torpedo

The tube from which the torpedo is

launched has a hinged door at the breech end through which the torpedo is pushed into position inside the tube in readiness for

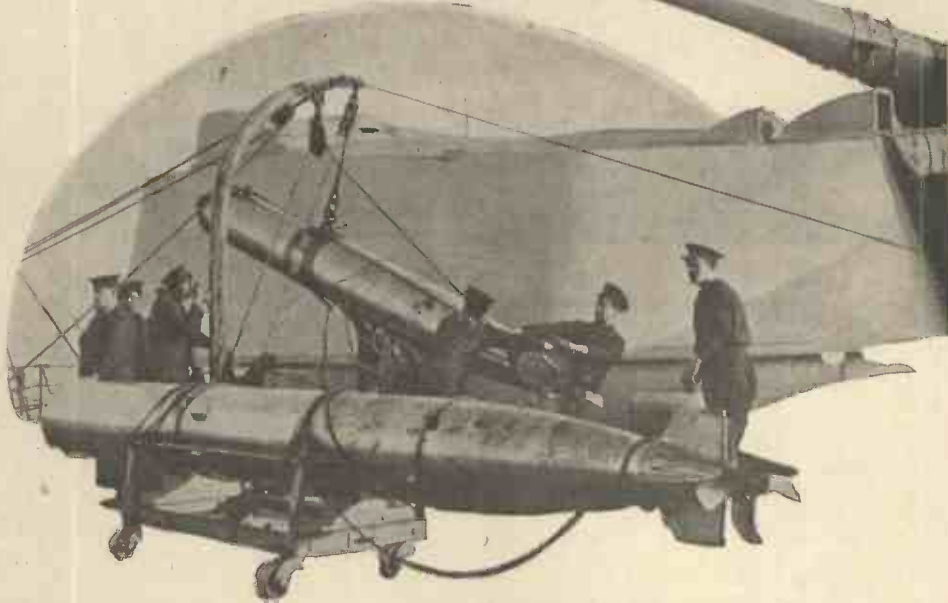

Fig. 2.—Hauling a torpedo aboard a British battleship.

discharging. The tube is mounted on a turntable, or "racer," by means of which the tube can be quickly trained in any direction. The torpedo can either be fired by a hand lever on the tube or electrically from the bridge of the ship. The torpedo rests on narrow ledges inside the tube, and at the moment of firing is "blown" out either by compressed air, which is suddenly injected into the rear end of the tube, or by an impulse charge of a few ounces of gunpowder.

As the torpedo leaves the tube a projection inside it catches against a small lever which operates the starting valve and allows the compressed air to pass to the engines. By means of a delay-action valve the propellers are prevented from racing before the torpedo becomes submerged. This valve is operated by a device called a "tripper," and when the torpedo strikes the water the "tripper" is turned and causes the air-valve ports to open fully, thus allowing the full force of the compressed air to pass to the propelling engines. Fig. 4 shows a pair of torpedo tubes being trained across the deck of a torpedo boat.

The Explosive Charge

This was formerly built up of slabs of gun-cotton, in the manner shown in the illustration (Fig. 5), but in a modern torpedo, where guncotton is used for the explosive charge, it is usually formed of one block moulded to shape from guncotton pulp. This results in a more complete detonation and, consequently, a more effective explosion for a given weight of guncotton. In modern times guncotton has largely been superseded by T.N.T. To give the reader some idea of the devastating effect of the resulting explosion when a torpedo strikes its objective, a rent 15 ft. square is known to have been torn in the steel plates in the side of a ship.

Detonating Charge

For exploding the main charge in the head of the torpedo a small detonating charge consisting of fulminate of mercury is used. Only a minute quantity of this is used, and when ignited by a blow from the pointed end of the striker rod the fulminate expands to about 2,500 times its own size, and this sudden and violent expansion causes the main charge surrounding it to explode.

Modern Watch Repairing and Adjusting

BY A SWISS EXPERT, with additional chapters by T. R. ROBINSON. Price 4s. net. Demy octavo. 118 pages. N.A.G. Press Ltd., Old Street, London.

The enormous number of watches, both pocket and wristlet, which are in use to-day, and the fact that the repairer has to deal with very little else, has brought about a demand for a really authoritative source of information on matters connected with the repair and adjustment of these watches. Up to the present this has been sadly lacking, such data as was available being very incomplete and existing in only disjointed form. This text-book begins where others end, and brings the most modern methods of working before the craftsman. The latest innovations in watch construction have their special features explained and their difficulties and pitfalls pointed out. No other text-book yet published contains the same information. Every page is practical and informative.



Planecraft (Hand Planing by Modern Methods)

Price 1s. 6d. net. Demy octavo. 135 pages. Messrs. C. & J. Hampton Ltd., Sheffield.

This text-book is a useful and complete workshop companion, and will prove of considerable interest to the amateur who finds enjoyment in his leisure by the exercise of this craft. The authors have endeavoured to outline for the benefit of the reader the results of a long and varied experience as craftsmen in making and using the various tools described in this book. It deals with the history of the plane, bench planes, grinding and whetting the iron, how to overcome difficulties in planing and their solution, rabbets and rabbeting, combina-

tion planes, multi-planes, spokeshaves and scrapers. It contains nearly 200 illustrations, a glossary and four-page index.

Printing for Amateurs

By ARNOLD SELWYN. Price 1s. 6d. net. 73 pages. Percival Marshall & Co. Ltd., 66 Farringdon Street, London, E.C.4.

The above title adds one more to the series of popular technical handbooks published by the above firm. These handbooks give exactly the information you want at a minimum cost, and are written so that anyone can understand them and follow their instructions. There is a great amount of pleasure to be got out of the art of printing, and if a handbook on such a technical subject is to be a practical help, its duty is to offer first aid at all stages. This book contains a number of helpful chapters on the actual printing plant, selecting the type, making ready and machining, the care of the plant and finishing operations, etc. It also contains an interesting chapter on colour printing.

MAKING AN ELECTRIC GAS-LIGHTER

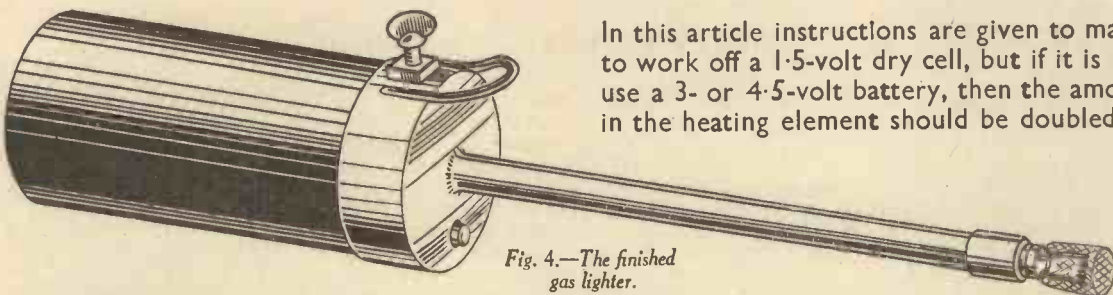

In this article instructions are given to make a lighter to work off a 1.5-volt dry cell, but if it is proposed to use a 3- or 4.5-volt battery, then the amount of wire in the heating element should be doubled or trebled.

to dry for a few hours in a hot oven. The platinum wire is wound into a spiral on a knitting needle and each end is straightened out for a distance of $\frac{1}{2}$ in. Take a

THE best type of battery to use for the lighter described below is a small bell cell or one of the specially designed cells; these, however, are rather expensive, being about twice the cost of the bell cells. The unit can be fitted with an adaptor so that it can be screwed into any standard holder. The only other article which must be bought is a $\frac{3}{4}$ -in. length of No. 40 platinum wire and this will cost only 4d.; No. 38 wire may be used. Start the construction by selecting a suitable dry cell, make a cap, to fit easily over the end of the battery, from stout sheet brass or copper; this should be about $\frac{3}{8}$ in. deep. Select a piece of brass tubing about $\frac{1}{4}$ in. outside diameter and 6 in. long and solder it in the centre of the cap; drill a hole through the cap into the tube so that a No. 20 insulated wire will easily pass through. Cut a disc of $\frac{3}{8}$ -in. plywood to fit tightly in the cap and drill a $\frac{1}{4}$ -in. diameter hole in its centre. From springy brass, or the longer contact of a 4.5-volt battery, cut a strip $\frac{1}{4}$ in. wide and about $\frac{1}{2}$ in. less in length than the diameter of the battery; this is secured to the plywood using $\frac{1}{4}$ -in. wood screws. Take care that the points do not go right through the wood and touch the cap.

The Plunger

A plunger, similar to that in a bell push,

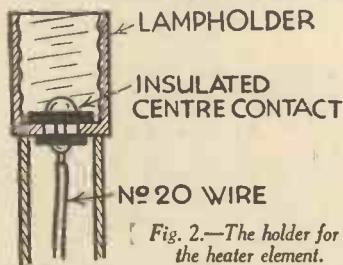

Fig. 2.—The holder for the heater element.

is cut from $\frac{1}{4}$ -in. dowelling rod and shaped with a pen knife and sandpaper; this should move freely in a small hole drilled through the cap and wood underneath the end of the brass spring.

Now cut a washer from $\frac{1}{4}$ -in. wood or fibre to fit the cap and with a centre hole almost as large as the battery. The above construction may be more easily performed before the wood is inserted. Drill a $\frac{1}{4}$ -in. hole in the side of the cap and over it solder a $\frac{3}{8}$ -in. nut, the bolt of which should be

about $\frac{1}{2}$ in. long with a strip of metal soldered into the slot to give finger adjustment. This arrangement serves to clamp the apparatus on to the battery and to make electric contact between the zinc and the battery. The construction may easily be followed from Figs. 1 and 2. When a bell cell is used the centre terminal must be removed and the brass cap filed flat so that when the plunger is depressed the brass strip makes contact with the centre terminal. It may be necessary to bend the brass strip in order to ensure perfect contact. A simple miniature brass batten holder

LOOP FOR SUPPORTING

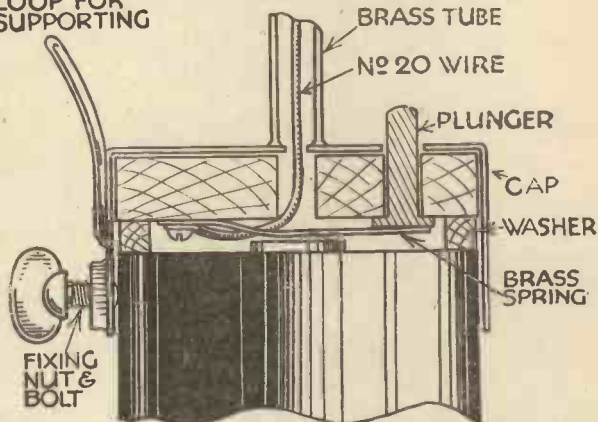

Fig. 3.—A sectional view showing the various working details.

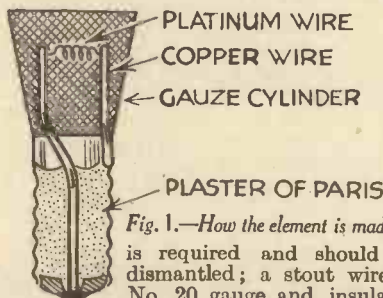

Fig. 1.—How the element is made.

is required and should be dismantled; a stout wire of No. 20 gauge and insulated is fixed to the centre terminal of the holder; thread the wire through the tube and solder the holder to the end of the tube; the end of the wire is soldered to the brass spring. The apparatus may be tested by screwing a bulb into the holder; the lamp should light on depressing the plunger (Fig. 3).

The Element

Obtain an old flash-lamp bulb and carefully remove the glass, sealing compound and the connecting wires; the hole formed by the centre wire should be enlarged to take a No. 16 bare copper wire. Solder a short length of bare copper wire of No. 16 gauge to the inside of the brass cap and another to the centre contact and bend them until the ends are about $\frac{1}{2}$ in. apart; fill the cap with plaster of Paris and allow

sharp pen knife and make a clean cut in the end of each wire deep enough to take the platinum wire; this is best done on a small anvil giving the knife a sharp blow with a light hammer. Insert one end of the wire into one cut and burr the copper over it; with tweezers pull out the spiral and secure the other end in a similar manner. These joints may be silver-soldered. A small cylinder of large mesh copper gauze is soldered round the burner to protect it from damage. To complete the instrument a hook is soldered to the cap so that the lighter may be hung in a convenient position near the gas stove (Fig. 4).

When using a bell cell this lighter will give about 10,000 lights and thus shows a considerable saving on matches and cleaning, as no more burnt sticks are left lying on the stove. The current taken is about 2.5 amps. so that it is obvious that the switch should be closed for the shortest time; in use always turn the gas on before pressing the switch and hold the lighter above the gas. Never leave the lighter on the stove or hanging above it; put it in some cool, dry place. The apparatus may be used in any existing battery-holder by soldering the copper tube to an old screw cap instead of to the brass battery cap.

VISITORS to the British Industries Fair were very interested in a remarkable process which has been introduced by Imperial Chemical Industries Ltd. This consists of an invention which enables ordinary aluminium to be dyed, exactly in the same manner as ordinary cloth and similar materials are dyed. Hitherto, metallurgists had considered metal as an

DYEING ALUMINIUM

undyable material, and although the present invention has only been used with success in conjunction with aluminium, it is stated

that it is possible that in the near future other metals may be treated in a similar way. The treatment enables the metal to absorb and retain any known direct colour, and this overcomes one of the greatest disadvantages of aluminium, namely, its readiness to oxidise. Lesser disadvantages are the difficulties of polishing and retaining a polished surface.

HELPFUL AIDS TO MECHANICAL DRAWING : By "DRAUGHTSMAN." (Concluded from the March issue.)

Drawing Curves

I THINK that the drawing of true curves is a bugbear, particularly when we have only one curve which will fit the object which we are drawing and yet we have to produce that same curve in two directions : that is to say, one curve in reverse of the other. To get over these difficulties I set about making for myself pairs of curves,

curvature required, by the hands alone. Lead was too soft. This particular solder used can be bought in strips measuring about 20 in. long \times $\frac{3}{8}$ in. wide \times about $\frac{1}{8}$ in. thick. Some of these were taken and cut off to various lengths, clamped between straight strips of steel in the vice and the edges draw-filed true and parallel. By carefully sliding a strip of this solder over the

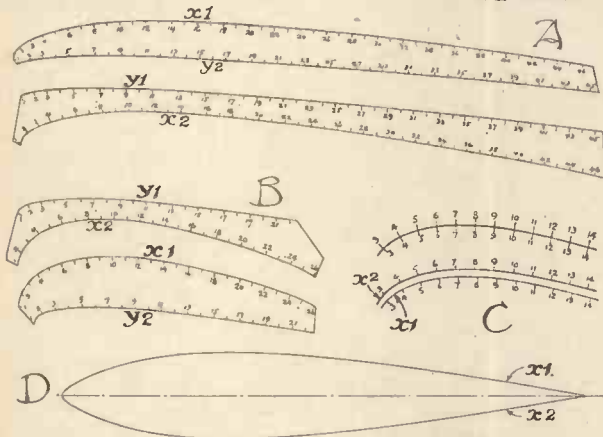

Fig. 6.—Types of calibrated curves that overcome a number of difficulties met with on the drawing board.

which would obviate the necessity of turning the board around, and calibrated at regular intervals on both edges so as to save the need for special marking as occasion arose. The particular curvatures selected for each pair were those which were most likely to occur in drawing the cambers of aerofoils and streamlined parts of aeroplanes. In Fig. 6 I show two such pairs of curves, but it will be seen that each pair consists of two different curves. At A is a pair which I have found extremely useful for drawing wing sections, whilst at B is another pair by means of which the profiles of tail planes, rudders, etc., can be drawn. On the edges of all of these, short cross lines are scribed at intervals of $\frac{1}{4}$ in. and numbered, as at C. Referring to A, I should point out that the edges x_1 and x_2 are made to fit perfectly together, and similarly the edges y_1 and y_2 . In drawing such a streamlined object as that at D, the convex edge, x_1 , is used to draw the upper curve, whilst the concaved curvature, x_2 , is used to draw the lower half of the streamline. In order to make both halves of the streamline exactly balance, numbered points are selected on both edges of the curves which will cut through the centre line of the streamline.

The making of curves such as these calls for some little skill and painstaking. The sheet of celluloid from which they are made may either be cut with a penknife or, if of considerable thickness, with a fret-saw, after which the truth and regularity of the curves must be got by fine files and fine glasspaper glued on to strips of wood.

Having found the need for curves which could be varied, I hit upon the idea of using tinman's strip solder, which is hard enough to retain its shape with a reasonable amount of care and yet is sufficiently flexible to be readily set, to any

solder strip for drawing a convex curve, whilst in the perspective sketch the strip is turned over for drawing a concaved curve. This latter drawing will explain the reason why the accessory is shaped in the form of a crescent. It will, I think, be clear from the drawing that the ends of the crescent are fitted with two very sharp points made from steel needles, which dig into the solder and enable the operator to move the curve about upon the drawing.

The last item which I have to describe is, so far as its purpose is concerned, not, I believe, original. I have heard that it is possible to obtain an implement for automatically spacing cross section lines in engineering drawing, though I have never seen one and do not know what they are like. The particular gadget which is illustrated in Fig. 8 was not actually made

for engineering drawing, but for the rendering of the different tinctures in Heraldry, but it is equally applicable to the ordinary work of the engineer's draughtsman. It consists of a straight-edge made from aluminium plate of No. 12 gauge, and screwed to this is a thick hack-saw blade, which can be purchased from an engineer's tool supply stores. A set-square having the same thickness as the aluminium is fitted with an adjustable quadrant having two points, or pawls, either of which drop into the space between the teeth on the saw blade. The underneath side of the straight-edge is fitted with needle points, to enable the straight-edge to grip upon the face of the drawing. As a matter of fact, in my own example these needle points are removable and are really fitted into the knurled knobs, as shown in Fig. 8, which screw into the aluminium. There are two knobs and three tapped holes, the object of this arrangement being to enable the implement to be used, if necessary, upon a small drawing board where a portion of the straight-edge may have to overhang the board, in which case one of the end holes would not be in use. The straight-edge may not always be required to lie parallel with the edges of the drawing board, and the moving of the needles and knobs from one point to another may depend upon both the angle at which the implement is to be used and the position on the board of the portion of the drawing which is to be cross-sectioned.

Incidentally, the quadrant is required also in order to reverse the pawls : to put one out of action, after using it as at A, and

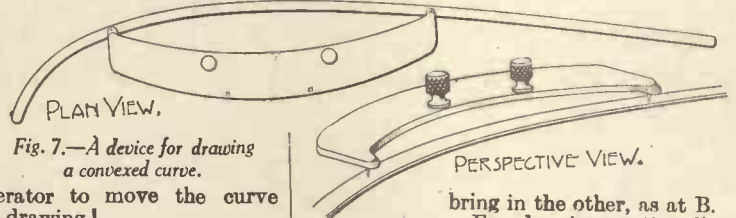

Fig. 7.—A device for drawing a convex curve.

bring in the other, as at B. For drawing section lines with the 45 degrees angle of the square, and particularly when inking in, it is more frequently necessary and convenient to have a quadrant shape, as at C, where the pawls have angles oppositely directed from those in A and B, and if only one quadrant is made I should arrange the pawls as at C. D is a cross section through the straight-edge and square.

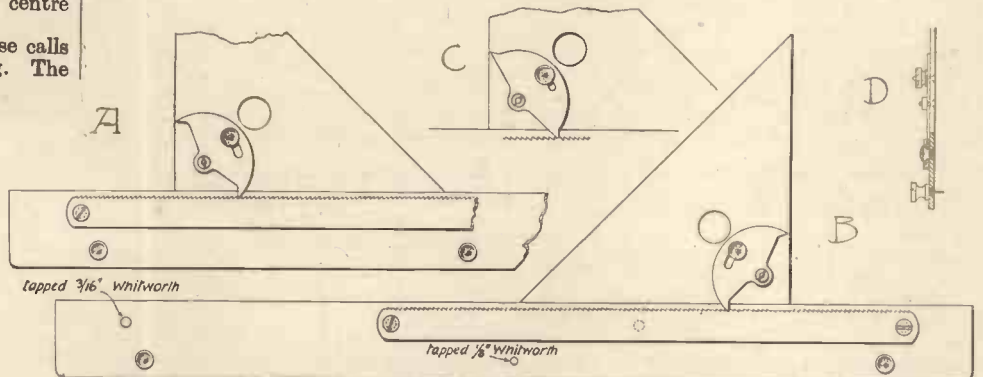

Fig. 8.—Another ingenious device which has a number of uses.

A UNIVERSAL HOLDER FOR THE LATHE

By W. H. DELLER.

SELDOM is a part finished after the lathe work proper has been completed. Usually in the case of shafts, holes have to be drilled, keyways cut or flats provided for grub or set screws. In fact, it is safe to say that a set screw is often used as a substitute for a key, owing to the trouble involved in setting up the job in the lathe for the purpose mentioned. This remark mainly applies to lathes that are not fitted with an overhead pulley for driving a milling attachment. Where such an attachment is available, however, the power obtainable at the cutter is generally such that only a comparatively minute cut can be taken, thus making the operation decidedly tedious.

The universal work-holder or fixture illustrated in Fig. 1 is simple to make and has the added advantage of the fact that in its present form it can be constructed from material that is easily obtainable. No castings are required.

You will notice that there are three main parts, namely, a pair of V-blocks and clamps, a circular base, and a narrow slotted angle plate. The base is adjustable in a vertical direction on the angle plate and may be locked in any position within the restriction of the slot. Independent of this the centre of the V's may be set to lie in a vertical or horizontal position, or for that matter, at any angle between these positions.

Before proceeding to give constructional details, a brief survey of some of the many operations which in the ordinary way entail a certain amount of laborious hand-work, or if performed on the lathe a lot of rigging and careful setting up.

The V-Block Unit

This is removable and is extremely useful in the preparation or marking out of parts. Further, it may be used on a drilling machine in the usual manner for holding bars or shafts whilst drilling pin or cotter holes. Not infrequently a hole has to be drilled in a shaft or piece of bar material at an angle other than 90° to the axis, as in the case of the cutter holes in certain types of boring bars. Such holes are easily drillable with the aid of the complete fixture clamped to the table of the machine. To overcome the difficulty of starting the drill on an inclined surface a shallow hole is drilled in the correct position, the depth being governed by the diameter of the hole before the shaft is elevated to the intended angle. This precaution will prevent the point of the drill from running down the inclined surface of the material. Spot facing or counterboring can be, where necessary, carried out with a pin drill at the same setting.

For use on a lathe the fixture is bolted in place of the toolholder. The hole in the base of the angle bracket is passed over the centre stud of the toolholder, with the clamp plate removed of course, and clamped down with a distance piece and a nut. Where the lathe is fitted with an American type tool post a stud screwed into a plate to fit the slot will be necessary.

The universal holder for the lathe described in this article is constructed from material that is easily obtainable, and no castings are required.

Cutting Keyways

With a suitable cutter mounted in the chuck any type of keyway may be cut. Fig. 1 shows a shaft after cutting a woodruff keyway. For cutting a key or featherway

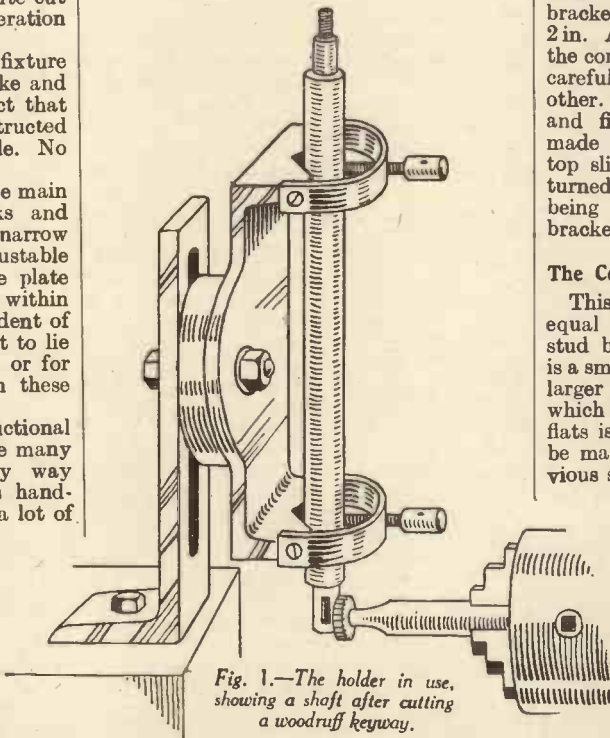

Fig. 1.—The holder in use, showing a shaft after cutting a woodruff keyway.

with an end mill the V-blocks are set to bring the shaft in a horizontal position. Slots in tube are produced in a like manner. Squares are milled by releasing the clamping screws and turning the shaft in the V's after the completion of each face. Thus it will be seen that any round material of a size within the limits of the V-blocks and that will span them can be conveniently held for this class of

machining. Bushes or bush-like objects can be mounted on a mandrel to facilitate the process. These examples should be sufficient to show the directions in which the article under discussion may be employed.

Fig. 2 shows the various parts comprising the fixture. The angle bracket is made from a narrow piece of structural angle steel and the V-blocks from channel section. No dimensions are given, as it will be realised that they must necessarily vary according to the average size of the work being handled and the size of the lathe. Where the height of the angle bracket equals 4 in. its width should equal 2 in. After removing all burrs and rounding the corners, the front and bottom should be carefully filed flat and square with each other. The long slot on the front is drilled and filed out parallel and a short slot made in the base to suit the stud on the top side of the lathe. A thick washer is turned from cast iron, the outside diameter being equal to the width of the angle bracket.

The Centre Stud

This should be machined solid, a flange equal to about twice the diameter of the stud being left in the centre, behind this is a smaller portion that must be sufficiently larger than the stud to allow for flats which fit into the slot. The object of these flats is to allow for vertical adjustment to be made without interfering with the previous setting of the V-blocks. The washer is bored to suit the centre of the stud and counter-bored to let the flange in flush with the surface. A pin should be fitted through the flange and into the washer to prevent movement. Mark out and drill the channel section steel to the shape shown. The projecting radius is equal to that of the washer and the hole a good running fit on the front portion of the stud. Before cutting the V's make certain that the largest size shaft that can be held will not foul the fixing nut which is mounted on the stud. After sawing and filing out the V's check for accuracy with a piece of bright mild steel measuring from the back of the channel steel which should have previously been filed up flat. Clamps and screws are made of mild steel and are attached to the V-blocks with cheese-head screws which pass into holes drilled and tapped at either side.

When making the clumps use material that is heavy enough to withstand the pull of the clamping screws without distortion. Failure to do so may result in the work slipping under the cut being taken.

As a refinement the edge of the circular base may be graduated to provide for easy setting. Where this is done it will be better to fit flat mild steel strips on to the back of the circular base to act as keys. These should be a good sliding fit in the angle plate-slot.

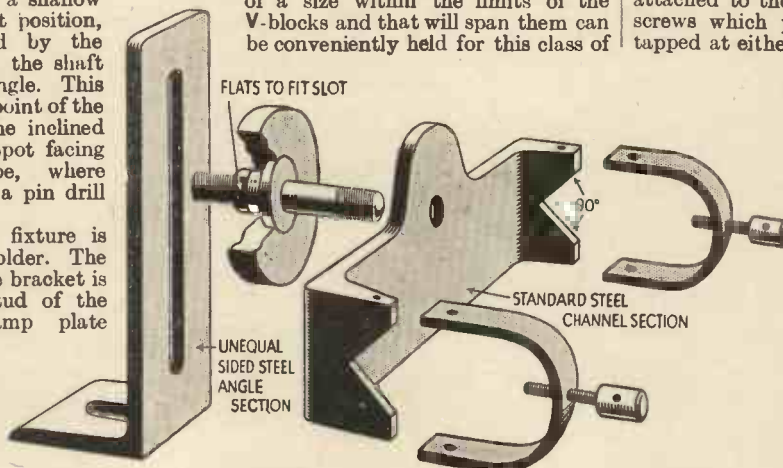

Fig. 2.—Constructional details of the holder, showing how the various parts are put together.

ELECTRICAL INFLUENCE MACHINES

By V. E. JOHNSON, M.A.

A Berlin instrument-maker constructed the first practical electrical influence machine in 1880, and as this machine is the parent of modern high-speed influence machines and contains their essential features, it is dealt with in this article.

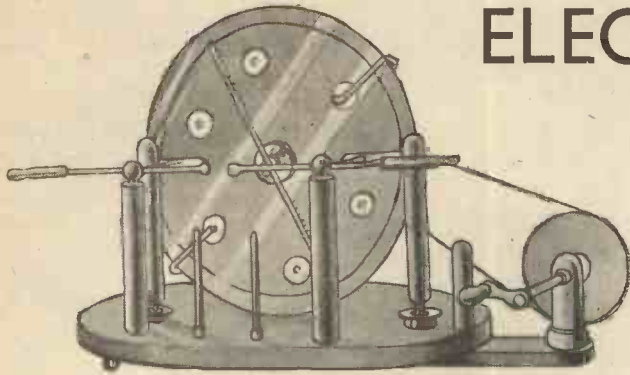

Fig. 1.—The Voss machine.

In ordinary friction machines the electrical charges are generated entirely by friction, and the actual power expended in turning the machine is mostly wasted in overcoming friction and generating heat; the modern influence machines work by influence and are far more efficient, the worst being at least eight times so. "Influence" means the electrostatic induction which gives rise to electrical charges in bodies when brought into an electric field. The machine consists of parallel flat plates of glass or ebonite, one fixed, the other capable of rotation on a spindle passing through its centre. On the back of the fixed disc or plate are cemented two discs of tinfoil (see Fig. 2). Each of these is protected by a sheet of shellac-varnished paper. The carriers are small discs of tinfoil cemented on to the front or rotating plate. The distance between the discs on the rotating and fixed plate is the same. To prevent the discs on the rotating plate being worn away by rubbing against the brushes a small metallic button is attached

of the rotating plate. These brushes "appropriate" the charges that are conveyed by the carrier discs on the rotating plate and "replenish" the charge on the armatures or field plates. The machine is provided with two further sets of brushes called neutralising brushes fitted on to the diagonal or diametrical conductor DD' (Fig. 3). In addition to the foregoing, which are sufficient to constitute a complete self-exciting machine, two collecting combs, in metallic connection with the inside coatings of two Leyden jars (whose outside coatings are also connected), are added.

In order to work the machine successfully the diametrical conducting rod carrying the neutralising brushes must be set so as to touch the carriers on the rotating plate just before they pass out of the influence of the field plates, and the replenishing brushes be set so as to touch them just after they have come under the influence of the same. The discharging knobs (Fig. 1) should be drawn much further apart than shown in the sketch. Start the moving disc rotating briskly. A few turns only will be found sufficient to excite it, a gentle hissing will be heard (visible as bluish brushes in the dark) and more resistance will be experienced in turning it. Push the knobs closer together and sparks will commence to leap across the air gap.

It should be noted that the neutralising brushes and collecting combs are considerably longer than the diameter of the tinfoil discs. If too long the ends of the collecting combs will discharge themselves on to the axis or centre knob of the machine.

The Quantity of Electricity

Now the "quantity" of electricity generated by such a machine as the above depends (1) on the number and size of the plates, (2) the speed of the rotating disc. Roughly, double the size or number of discs or double the speed and you double the quantity. But large discs give a proportionately better result than small ones.

Since ebonite can be run at a much higher speed than glass without risk of fracture, an ebonite disc can be made to generate much more than a glass one of the same size. The discs or plates should be as close together as possible without actually touching; this will not prevent the machine from working but may cause fracture.

The Wimshurst Machine

This is shown in its simplest form in Fig. 4, and consists of two circular plates of the same size, both of which rotate in opposite directions, one of the driving belts being crossed; at least twice as much power is therefore required to drive it compared with a volt machine of the same size. On the outer side of each disc is pasted an equal number of radial sectors, shaped pieces of tinfoil or light metal at equal distances

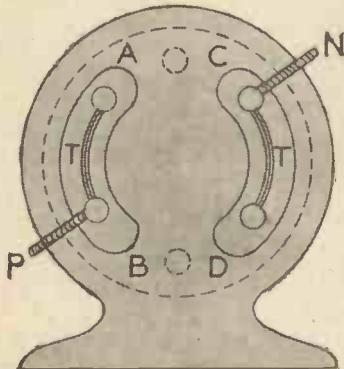

Fig. 2.—The method of arranging the conducting surfaces on the disc.

to each. The two tinfoil discs (Fig. 2) connected by the strip of tinfoil, T and T, constitute the field plates or armatures. The paper sectors AB and CD tend to prevent the escape of electricity from the field plates and the tinfoil discs are of considerable assistance in facilitating the self-excitation of the machine which is self-exciting.

Why it is Self-exciting

It is undoubtedly from the friction of the brushes on the metallic knobs. After the machine has actually started working it is no longer essential that the brushes should touch the metal knobs. Thin metal rods (highly polished) (see Figs. 2 and 3), bent in the form of a horseshoe, pass from the field plates round the edges of both plates, each carrying a metal brush (small wisps of very fine springy wire, or, better still, gilt or silver tinsel cord) which pass lightly over the metal studs fixed on the front surface

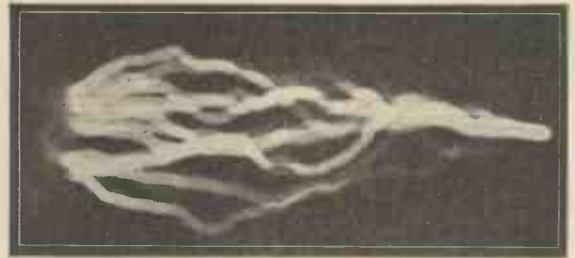

Fig. 8.—A 5-in. spark discharge from the machine shown in Fig. 7.

apart. Two brass rods, $b b'$, $c c'$, usually curved, terminating at their ends in fine wire brushes, are placed as shown in the illustration; they are capable of rotation, so that the angle at which they are placed with respect to one another can be varied. The collecting combs are four in number; originally they were horseshoe in shape, two in front of the machine, and two at the back, the two on the left-hand side being connected together and also the two on the right. These are mounted on insulating pillars of glass or ebonite; from them branch the two discharging rods, which terminate in two balls of unequal size; between them the discharge takes place. In this machine, which is self-exciting, it

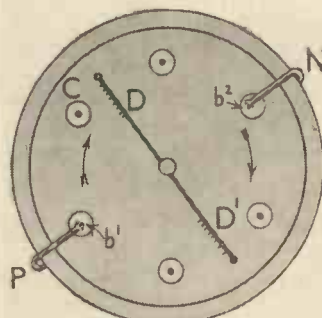

Fig. 3.—Contact surfaces, and neutralising brushes.

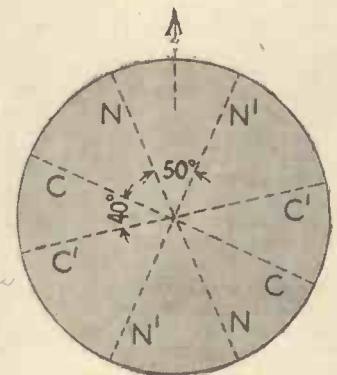

Fig. 5.—Method of marking out the disc.

will be noted that the metallic sectors act both as inductors and carriers in turn. Now these horseshoe-collecting combs are supposed to withdraw an equal amount from each plate as they revolve before them—this is in theory; in practice this is far from the case, owing to want of perfect symmetry in the make of the machine and for other reasons.

Now if we arrange the neutralising rods and collecting combs (now straight and not horseshoe-shaped) as shown in Fig. 5, where NN and N'N' are the neutralising rods and cc, c'c', the collecting combs, the angle between the neutralising rods being 50 degrees and between the collecting combs 40 degrees, and displace the back combs forwards relatively to the direction of rotation of the front disc and the front combs similarly with respect to the back discs, the output of the machine is doubled. The greater the number of sectors, the greater the output, but the less the length of spark, the question of insulation evidently sets a limit to the number of sectors we can use. Since the smaller the sectors and the greater their number the greater and more efficient the action, and therefore the greater the output, we see that in the limit we arrive practically at a sectorless machine as the most efficient. It is true that such machine is not self-exciting, but given a small charge by means of a brushed and warmed piece of brown paper or an ebonite rod or penholder and rubbed with a piece of flannel, it will at once commence to work.

at the inner end. Note from Fig. 7 that the neutralising rods cannot only be set at any angle to one another, but that the rods at the end carrying the rods in which the brushes have been inserted are also capable of rotation; the same applies to the collecting combs, which are knife-edged pieces of brass inserted lengthways into polished brass tubing with balls at their ends to avoid leakage of the enormously high-tension electricity generated by such machines. Now let us take the machine shown in Fig. 7, and compare it with a two-disc Wimshurst having the same size plates. It will be found that a modern high-speed influence triplex can give 144 times the output of an ordinary two-plate Wimshurst. Fig. 8 demonstrates this clearly; the length of the spark is 5 in., and time of exposure one second. The size of the plates was 12 in., the length of rod carrying the brushes and of the collecting combs, i.e., the diameter of the annulus or ring swept over was 3 in.

Mica Plates

I mentioned that although glass or ebonite is usually employed for the plates, other substances had been successfully used. Mica is one, but the discs have a maximum limit of 12 in. in diameter; it can be run at a very high speed, but it tends to flake and is easily split or broken; it has also a high surface leakage. In the case of glass plates, it is usual to coat them with shellac varnish unless they work in a glass case; bakelite varnish is, however, far better, and can be used for ebonite plates with advantage as well. Now let us transform down the spark from the Leyden jar of an influence machine and see what happens; connect the outer coating of a Leyden jar with one end of a bobbin of well-insulated fine wire 1,000 ft. or more in length, wound compactly on a hollow, non-conducting bobbin. In the centre of this bobbin (totally disconnected and well insulated from the outer winding) place another coil of coarse wire some 5 or 6 ft. in length, this same coarse wire being wound once around a bundle of soft iron wires. Across the ends of this inner coil of coarse wire place a 5 or 6 candle-power lamp. Let the Leyden jar have a capacity of 1 gallon, with glass $\frac{1}{8}$ in. thick, make the gap between the knob of the jar and the small knob on the coil of fine wire 2 in. in length. Each discharge will

brilliantly illuminate the lamp for an instant, a very small fraction of a second. Couple together a number of powerful influence machines, then it is obvious, provided the discharges were sufficiently frequent, we could by means of such a

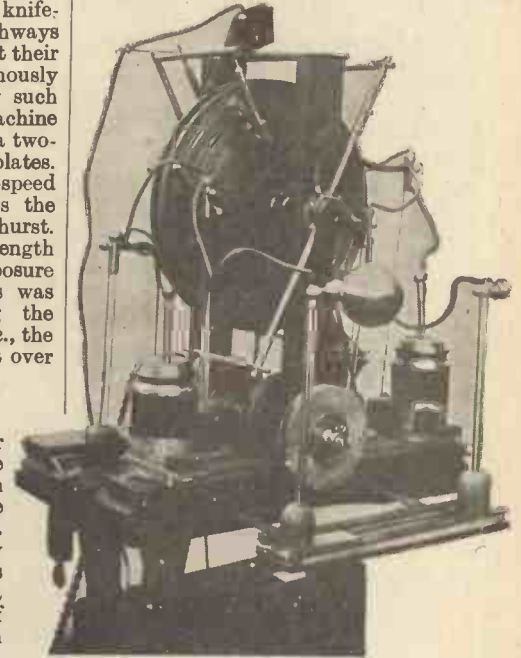

Fig. 7.—A high-speed Triplex machine with grooved discs designed and constructed by the author and fitted with Leyden jars.

transformer light our rooms by incandescent lamps or even run ordinary electric motors.

But the inverse order, the step-up transformer, is much the easier of the two at present. But don't forget it can be done.

Practical Applications

Influence machines have been successfully applied to therapeutics, more especially in the United States. To electro-culture, i.e., in assisting the growth of plants by the aid of electricity; to animal culture or growth—Professor Wentworth, of Los Gatos, California, showing how a flock of sheep, 1,000 in number, kept on ground under the electric discharge, gave a lamb crop more than double and a greatly increased yield of wool. To wireless, in its earlier days; to the separation of particles of different dielectric capacities—over 220 minerals can now be separated by this method, the voltages employed are from 20,000 to 23,000 volts; to improve the hygienic and economic condition of the atmosphere of dwelling-houses and other enclosed spaces, by (briefly) ionisation of the air. As a smoke and fog clearer, if a series of points be arranged in an enclosed vessel filled with smoke, and electric discharges are allowed to take place between the points, the smoke is very quickly precipitated.

As an igniter of gas and other inflammable vapours, as long ago as 1885 a most ingenious patent (No. 6313) was taken out for gas ignition; I still have one of these pieces of apparatus. In this device small electric discharges are produced by a little influence machine of the cylindrical type, the cylinder itself forming the handle—the inner cylinder is kept revolving by the repeated pressures of the thumb on an external knob. The machine is of the Voss type.

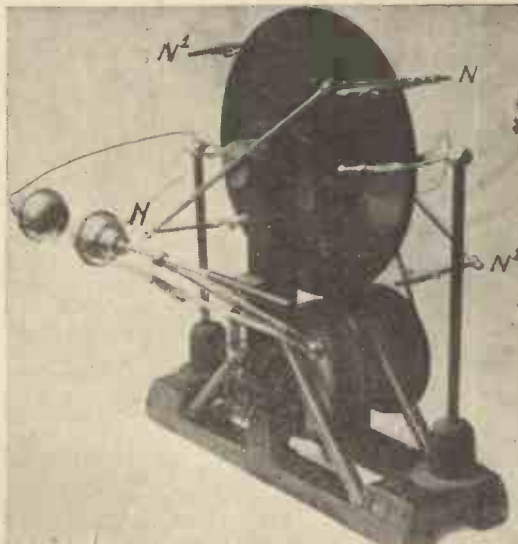

Fig. 6.—A similar machine to that shown in Fig. 7 but without Leyden jars.

From such a machine can be obtained twice the output to that from an exactly similar Wimshurst machine containing thirty-two sectors on each plate.

A Modern High-Speed Influence Machine

Fig. 6 shows a triplex machine of the sectorless type in which there are three rotating discs; note the three driving pulleys, the centre belt is crossed, the two outer discs revolve in the same direction, and the double inner disc revolves in the opposite direction.

The centre disc is really two discs separated by a considerably smaller ebonite disc about $\frac{1}{8}$ in. thick. In Fig. 6 NN is the neutralising rod for both outer discs, N'N' for the inner double disc—in the latter case a piece of fine steel wire, bent to a closed curve

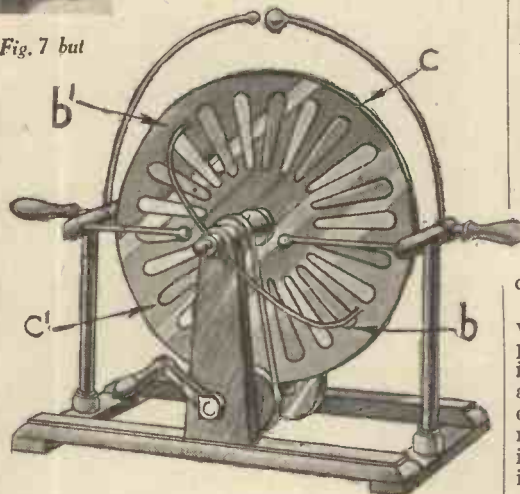

Fig. 4.—A simple form of Wimshurst machine—hand-driven.

Movie Making for the Beginner

By
PERCY W. HARRIS,
Editor of "Home Movies"

Most readers of this magazine know that it is now possible to purchase for a few pounds a home cine camera which will take excellent films of high photographic quality, but I imagine few realise how easy it is to take those trick pictures which make a cinema display so amusing.

this car the audience is always amused and mystified. A similar trick is to show just as many people getting out—in fact, this is often the more amusing of the two versions.

All you have to do in filming this is to set up your camera on a stand, so that it will be steady, and film the car from some convenient

viewpoint. As soon as each person has got into the car stop the camera and let them get out of the other door. Immediately they are out of the picture start the camera again and let the next person walk into the picture and get in, stopping once more when the moment comes for them to get out on the other side. When the picture is run through the projector it will appear to be continuous, for there will be no picture of the people getting out, and as the camera is quite steady on the stand, there will be no means of seeing how the trick is done. When arranging for people to get out of the car you will adopt a similar procedure by not filming the people getting in at the other door.

The disappearing figure is another simple trick which can be elaborated to almost any degree. Children love films in which a figure is made to appear or disappear by the wave of a fairy wand, and there is usually a great competition as to who shall be the fairy! If you want to make a figure appear in this way, get the fairy to wave her wand, and then, telling her to keep quite still, stop your camera and get the person who is to appear in the picture to walk into the scene and stand just where the wand is pointing. Now start the camera again and carry on with the scene. When projected the figure will mysteriously appear directly the wand is waved, and by adopting a similar procedure, stopping the camera at the right point and asking the person to walk out of the picture, he or she can be made to disappear in equally mysterious fashion.

Ghost pictures are a little more
(Continued on page 339.)



THE simplest of all tricks is to take some of your pictures with the camera held upside down. Imagine that you are taking a picture of a horse trotting down the street. Your cine camera takes a series of little pictures, a sixteenth of a second apart, of every movement of the horse from near by, to, let us say, the end of the street. If you film this in the ordinary way the first part of the film exposed will show the horse near to you, and the last part the horse at the time it has reached the end of the street. Now hold the camera upside down and the pictures will be taken in the same order, but, of course, they will be all upside down in relation to the previous ones. When you receive the finished and developed strip of film, in order that the pictures may come the right way up on the screen you must reverse it, so the end of the film comes now at the beginning. When this is run through the projector the whole of the motion will be seen to be reversed and the horse will trot backwards up the street till it reaches you.

I need not waste any time telling you of the numerous subjects which appear so funny when run backwards. A boy eating a plate of macaroni, swimmers jumping off a diving board into the water, ducks walking across the farmyard—all of these are extremely funny when shown in this way. All that is necessary is simply to hold the camera upside down when filming, and then, when you get the film back from the processing house, to cut out the upside-down strip and reverse it, making proper joins with your splicer.

An "Elastic" Car

Another very funny trick is to show about a dozen people getting into a baby car of the saloon type. This always raises a laugh, particularly if you can include a very fat man or woman in the party. When seen on the screen the car drives up, the door is opened by one of the members of the party, and a dozen people get into the saloon one after the other. As it is ludicrously impossible for even a quarter of the number of people to comfortably seat themselves in



A scene being taken during the filming of "The Sign of the Cross"



Maurice Chevalier being filmed during his picture "Love Me To-Night."

THE SPEAKING CLOCK OF PARIS

A CLOCK THAT TELLS THE TIME OVER THE 'PHONE IN A HUMAN VOICE

By ARNOLD SELWYN

IMPATIENTLY the telephone receiver is lifted up and an annoyed voice asks for "Odéon 8400." It is in Paris, and this is just one of the quarter million calls asking for the correct time that the Paris telephone service gets every month. Quarter of a million!

So accustomed are people to having time within easy reach, on the wrist or on the wall, that something like panic descends when it is found that their watch or clock has unaccountably

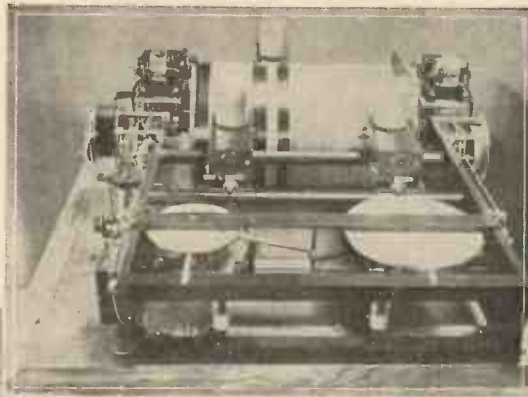

The possessor of a particularly clear voice would have been asked to recite the time statements, which were photographed on to narrow strips by the method of microphone, photo-electric cell and continuous length of sensitive film that film studios employ. The resulting strips develop with a pattern of "sound" bands, and are attached around the outside of a cylinder, which is then set revolving. As the strips pass into the view of the once more useful photo-electric cell

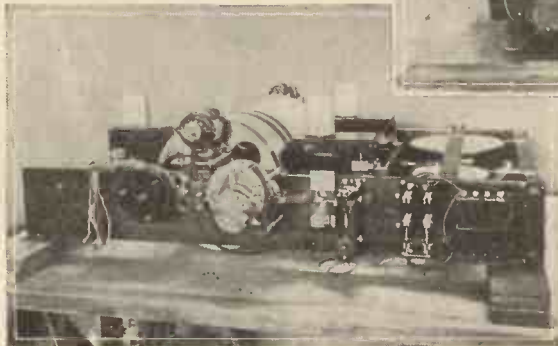

Figs. 1, 2 and 3.—(Above) The speaking Clock at the Paris Observatory. The three white bands on the cylinder are sound strips for announcing hours, seconds

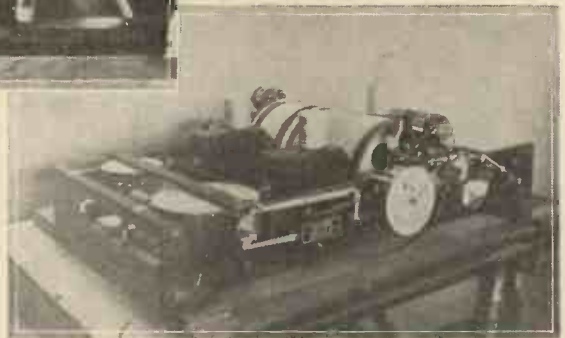

and minutes respectively. (Left) Another view of Speaking Clock. The dark rectangular chambers with white tops are the three photo-electric cells. The flat discs at side control their scanning movement. (Right) Near the small motor (on right) that drives the sound film cylinder is the speed control mechanism.

stopped. Thus arise those 8,000 anxious calls per day; from households where a clock has met with an accident or a wrist watch collided unluckily with the furniture or, more simply but just as annoying, someone forgot to wind up the family timepiece.

There are often as many as thirty simultaneous calls received in Paris from people who know that "Odéon 8400" will save the situation for them. The Speaking Clock of Paris never fails, day or night, to answer the unspoken inquiry, and to reply with exact hour, minute, and even second. Unspoken inquiry, note, because the subscriber merely asked for a particular number, and the local telephone exchange, who put the call through to Odéon Exchange, have by that act brought the time seker within earshot of the clock itself. And more than that, his call has automatically switched into activity the valves of the speaking mechanism, and almost immediately he will hear the voice of the clock delivering in human tones that announcement that it is now "six heures, trois minutes, dix secondes."

The means that render this possible are ingenious to the highest degree and employ the photo-electric cell, amplifying valves and, of course, a clock as accurate as only an astronomical observatory possesses. It was the progress being made with talking film technique that led the director of the Paris Observatory, M. Esclancon, to conceive of this way of satisfying the multitude of callers upon the Observatory's reputation as a supplier of right time.

Great Demand for "Time"

That reputation had necessitated, in past years, an official being kept permanently on duty, doing nothing but answer telephone inquiries as to the exact time. Not only was this a strain on the Observatory staff, but it blocked the telephone lines for any other business. Up to five years ago this condition of affairs went on, and then a change was made by constructing an

elaborate mechanism that could automatically indicate the time to an inquirer by a system of dot and dash sounds. The Speaking Clock, by comparison, provides a much better service. The method now so appreciated by Parisians breaks away from the code idea and substitutes sounds resembling the human voice. One thinks immediately of a gramophone record, but further thought shows that no record, nor series of records, could stand up to the wear of continuous use by day and by night. That demand is better met by the sound film strip, which with its photographed image of lines and bands offers a medium that can produce sounds of words instantaneously, continuously and perfectly audibly.

they give rise to frequencies of current that, by a long chain of connections, stir the air at the listener's end into word sounds.

It remains to regulate the rotation of the cylinder, that it turns with the precision of the hands of an extremely accurate observatory timepiece, and thus a given "sound" pattern, telling you it is such and such a number of minutes and seconds, is actually arriving opposite the photo-electric reproducing cell at that very instant. Not to do so would be unforgivable!

Such is the outline of this unique time service, possessed by no other city in the world. Technical details will now follow.

Checking "Spoken" Time

Starting with the apparatus in the Observatory, the first essential is the speed regulating device, whose unflinching accuracy is the backbone of the system. The Gerrish speed regulator installed functions by checking the speed of the motor-driven cylinder every second. The principle, as in most speed-governing devices, is to cut down the motive force the instant the

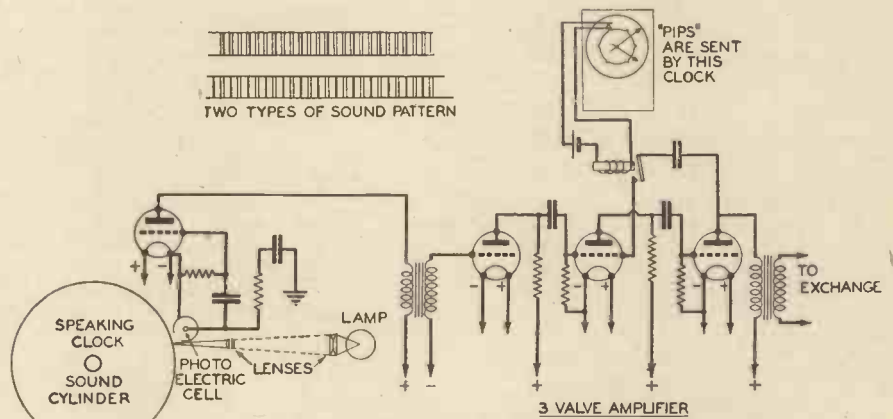

Fig. 6.—A complete schematic diagram of the phone-clock system.

drive proves too fast. The motor driving the sound cylinder gets no current until contact C is closed (see Fig. 5), by attraction of the armature. This necessitates the battery circuit being closed, which occurs for a brief instant every time the swinging pendulum makes a passing contact at A. That gives a brief supply of current to the motor every second. Whether a longer supply of current is to be given, as is needed of course for continuous work, depends on the behaviour of the sound film cylinder.

It is not convenient to use the cylinder itself as a checking mechanism, but a disc (see lower part of diagram), driven from the cylinder by suitable gearing is used in its place. This disc should make precisely one turn per second. It follows that a pin, projecting from the side of the disc, must be in a certain position every second. The speed control concentrates its serious function on the position of this pin. At correct speed the pin will be at the bottom of the circle it describes. The tip of contact D, which falls in its path later, remains undisturbed and closed. Therefore the power is still on for the motor (contact B having closed when the pendulum touched A), and remains so whilst the pin travels up half the circle. Reaching the top, it lifts

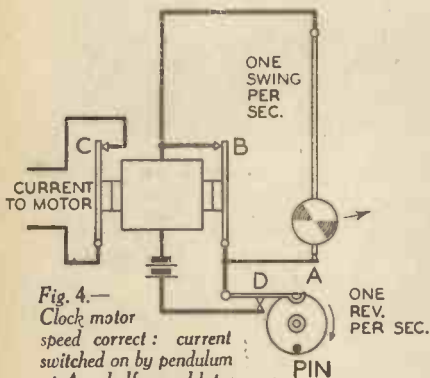

Fig. 4.—Clock motor speed correct: current switched on by pendulum at A; half second later it will be cut off by pin at D.

and breaks contact D, and the current to the motor is interrupted for half a second, whilst the pin enters the downward course of its revolution.

In effect, the motor gets current the first half of each second and none the next; switching on is done by the pendulum, supported by B; switching off by the pin.

Watch the consequences if the disc lags behind. The travelling pin has, say, three-quarters of a circle to traverse, instead of the normal half. The longer interval before D is reached procures for the motor a longer supply of current, allowing the speed of the motor to increase. If the disc is ahead of time, the travelling pin is too far round and will the sooner switch off current, giving shorter dose for the motor.

The Sound Film Cylinder and Light Cell

Let us look now at the cylinder (Fig. 2), 2 ft. long, 12 in. in diameter, and made of aluminium. Around its grooved surface are attached ninety strips, $\frac{1}{8}$ in. wide, of talking film, some strips ready to tell the hour, others the minute and second, with separate strips for the words "At the third dot" and "it will be exactly"—in French, of course—these phrases being needed every completed minute. We know already how the revolution of the cylinder will produce the right statement at the right instant.

Three photo-electric cells are wanted, one to face each group of strips. Lenses focus the light from a lamp filament on to the strip. The dark and light character of

the markings is reflected from the strip into the photo-electric cell, which, we know, passes more or less current according to the light it receives. These delicate fluctuations of current have to be amplified by a 3-electrode valve. This valve receives its anode supply through the primary winding of a low frequency transformer, the output of which passes to a 3-valve resistance-capacity coupled amplifier, and so on to the line connecting Observatory with telephone exchange. The output of the other two photo-electric cells reaches the 3-valve amplifier in the same way.

All this is done at the Observatory, and when the amplified currents reach the Odéon Exchange they require further amplification through another valve and transformer, before they will act on the diaphragm of the subscriber's earpiece and give him an audible statement.

What you Hear

What the inquirer hears is a statement that runs "Six hours, five minutes, ten seconds"—sharp dot—"Six hours, five minutes, twenty seconds"—sharp dot. In their turn the thirtieth and fortieth seconds are similarly given. The fiftieth second is not reported because the clock needs time to begin an announcement: "At the third

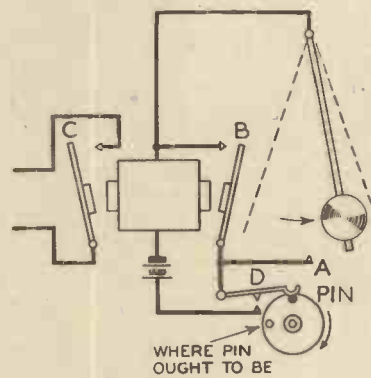

Fig. 5.—Clock motor speed too fast: only quarter of a second has elapsed since pendulum touched A (- current switched on) and already pin has lifted D cutting off current. B and C fall back. Note where pin ought to be.

dot it will be exactly six hours six minutes"—and then follow three signals representing the fifty-eighth, fifty-ninth and sixtieth second. This is the point at which most people would check their watches or clocks, and once the right minute has been identified from an earlier announcement the three dots lead up to the moment when the minute hand of your own timepiece should cover the minute mark.

These dot sounds are produced by putting to good use what is ordinarily a defect, namely, by a momentary throwing of the amplifier into oscillation at the right instant, resulting in a "pip" whenever a cam, driven by the standard clock, has closed a contact. By this action the anode of the third valve in the amplifier is joined through a condenser to the grid of the second valve, causing the oscillating note.

The Cylinder

Reconsidering the cylinder again—to have got upon it a collection of all the statements as needed throughout the twenty-four hours would have called for an extremely long cylinder. By grouping, making the minute statements serve for any hour, and the seconds statements for any minute, space was saved, as they needed putting only once around the circumference. True, this means that the photo-electric chamber for the seconds has to slid smartly back to starting point every minute; that for the minutes moves back as soon as it has announced the fifty-ninth

minute, in order to be ready for saying "one minute" when the hour has turned. The lamp chamber that scans the hours strips must return, like Cinderella, directly midnight has been indicated.

You are now aware how the time statement is picked by the photo-electric cells from three different parts of the cylinder, and reaches your ear in correct order. The sounds might have been photographed on to a disc instead of a cylinder, but the latter gives equal length revolutions and allows of more accurate timing. Ordinarily, speech films are transparent, and how to get a glass cylinder of accurate exterior was a problem. Finally, the makers, Brillé Frères, decided to give up projection through the film, and by the aid of reflected light illuminate the bands for the cell to scan.

When your call is finished all the valves and lamps of the apparatus are automatically switched off, this saving current. At some parts of the day the demands for the right time are so numerous that all of the thirty lines open to inquirers are engaged, and it is proposed to increase the service to sixty lines.

The Speaking Clock of Paris has now been functioning a year, and the day it opened 140,000 calls were made. The usual number is around 8,000 per day, and this produces a revenue for the telephone service of £2,000 a month. In London, where a good service of wireless time signals is available, there are nevertheless 3,000 calls a day, and it has been suggested that Londoners would appreciate a similar service.

PHOTOGRAPHIC FLASHLIGHT POWDER

THIS consists of a correctly proportioned mixture of chlorate and perchlorate of potassium, and magnesium powder, and the amateur must not for a moment think that this is safe and can be treated roughly. When one considers the tremendous affinity of magnesium for oxygen, it is apparent that such a mixture, upon the application of a few degrees of heat, or if subject to the slightest friction, will explode violently.

Safety First

The only safe manner in which the amateur may take instantaneous flashlight photographs is by means of metallic magnesium dust blown through a spirit-lamp flame. For the benefit of those who desire to make their own flash powder and who are prepared to exercise the greatest care in the process, I recommend the following formula:—

Potassium chlorate in powder 1½ oz.

Potassium perchlorate in powder, 1½ oz.

Magnesium powder, 1½ oz.

By the potassium salts in powder form. Do not attempt to reduce the coarse variety to powder. Mix the two thoroughly on a porcelain tile, using a bone knife. Just before the powder is intended to be used, mix with the salts the magnesium powder, again using the bone knife and very gentle treatment.

Correct Quantity to use

Fifteen grains of the powder will be sufficient for a normal exposure. Place it on a tray away from all room hangings, curtains, or anything else likely to catch fire, and ignite it with a taper tied to the end of a yard-stick. After the flash, open the windows and allow the smoke of magnesium oxide to escape. Caution! Do not look at the flash—the strain may injure the sight.

HINTS ABOUT HOBBIES

Practical Ideas— —Contributed by Readers

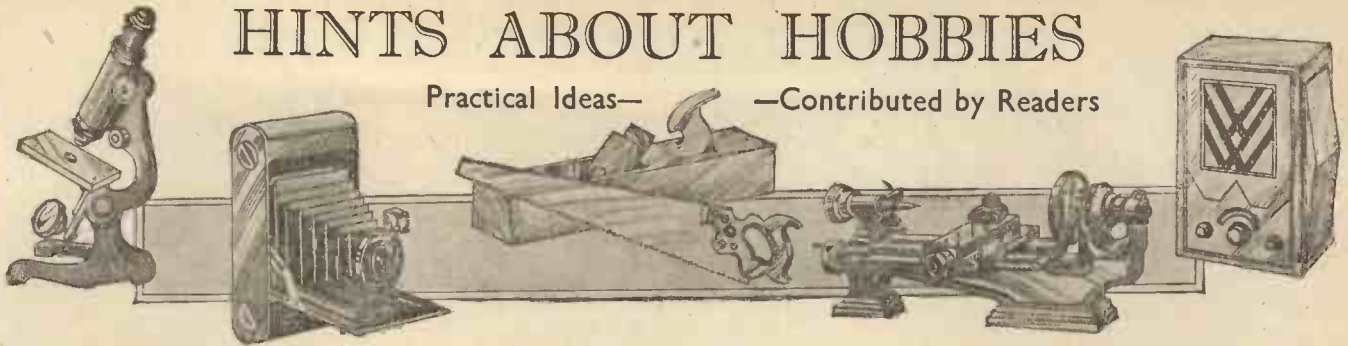

A Bracket of Two Nails

WHERE a strong bracket is wanted for suspending heavy objects, such as machine parts, from the wall or a wooden post, two nails driven in at different angles may be employed, as shown in the sketch, the lower nail acting as a strut for the upper one. Knock the two heads into close contact.

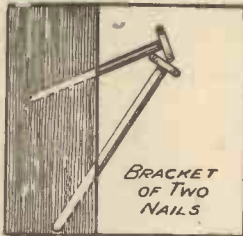

A strong wall bracket made from two nails.

THAT HINT OF YOURS

Every reader of PRACTICAL MECHANICS must have originated some little dodge which would be of interest to other readers. Why not pass it on to us? For every item published on this page we will pay \$5. Address your envelope to "Hint," PRACTICAL MECHANICS, George Newnes Ltd., 8-11 Southampton Street, W.O. Put your name and address on every item. Please note that every hint sent in must be original.

may be interested in the following little device, which ensures absolute accuracy when drawing objects seen through the microscope. A circular cover slip is fixed with a dab of secotino to a strip of springy brass, which is shaped, as in diagram, to fit over the drawtube of the microscope.

Fixing Wall Brackets

TO those people living in council or estate houses who have small brackets or light china cabinets that need fixing on the wall, the following idea will get over the difficulty of not being allowed to make holes in the wall. Obtain two picture hangers, straighten out the bottom lip, bore and countersink a hole large enough to take a No. 6 screw, and, after

cutting a slot in the bracket, fix with the largest screw that the thickness of the wood will allow. When hangers are bent to the proper angle the finished article will hang on the picture rail and lie close to the wall.



Simple wall brackets.

A Tea-pot Strainer

HERE is a tea-pot strainer that will not clog. We all know the annoyance caused by a pot that either lets all the tea-leaves through, or holds all back by clogging. A glance at the sketch will show how to make this device; it is of a fairly fine steel gauze, the depth of the tea-pot, with a gauze bottom soldered on. A piece of wire is soldered across the top for use as a lifting handle. Steel gauze will not corrode, as the tannic acid in the tea forms a protective coat.

When preparing the tea, the tea-leaves are put into this receptacle instead of being loose in the bottom of the pot. The cleaning of the pot after use is also simplified, as the grouts can all be lifted out together in the gauze.—A. F. Biddlecombe (St. Margaret's-on-Thames).



The tea-pot sieve described.

The instrument being placed in a horizontal position and the object brightly illuminated and correctly focussed, the angle of the cover slip to the eye-piece is so adjusted that, on looking down through the cover slip, the image of the object is seen on a sheet of paper placed below it.

It is now quite easy to see the image and a pencil point at the same time, and (modifying the light if necessary) to draw the outline and details, keeping both the pencil point and the image in view.—E. G. Watts (Devizes).

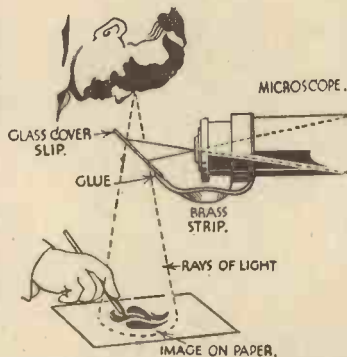

Showing how microscope pictures can be drawn.

Drawing Microscope Pictures

THOSE readers possessing a microscope and a penchant for sketching,

Since the hammer and the bells of the telephone are connected, all that is needed is some method in which the hammer can be made to strike a piece of wire when the bell is ringing. The switch is made in the following way: A paper clip connected to one of the leads of the extension wire is fixed to the top of the bells, and a piece of wood is fitted between the bells. To this is attached a piece of fuse wire, the other end being fixed to the extension wire. The fuse wire is then bent so that the hammer hits it when the bell is ringing.

A Simple Wall Plug

AN excellent wall plug may be made by cutting a round plug to fit the hole in the wall, splitting the plug and driving a wedge between it, as shown in the diagram. The wedge is inserted in the hole first, and in hammering the plugs in, the wedge opens them out so that they are immovably bedded in the hole. It is an extremely satisfactory manner of doing a difficult job.

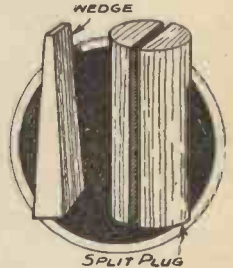

An excellent plug for walls can be made as shown.

Brackets for Kitchen Bowls

A USEFUL bracket for hanging kitchen bowls in can easily be made from two pieces of strip iron. It will prove itself to be a most convenient device, as a bowl is a rather clumsy article to stow away anywhere.

Take two strips of iron 13 in. long x 1/2 in. wide x 1/8 in. thick, and bend them on an anvil or iron block to the shape in the sketch. Two holes are drilled in each piece and are fixed to the wall.

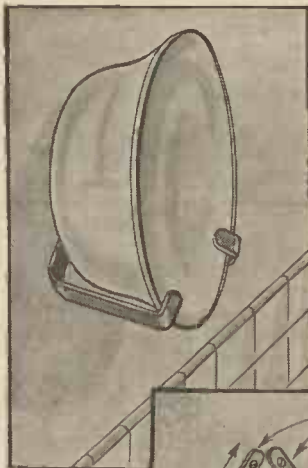

The handy bowl brackets described.

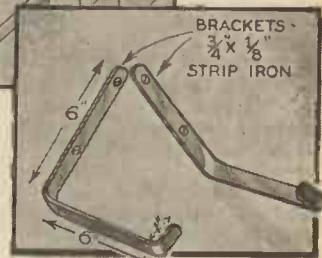

A Telephone Extension Bell

THE main part of the apparatus described on p. 192 of the Jan. issue consists of a switch in which the hammer of the telephone bell acts as a make and break contact.

A POWER SUPPLY UNIT FOR OPERATING MODELS FROM THE MAINS

By RAILROAD

IN this constructive article the unit dealt with is for the type of engine requiring 8 volts, with a current consumption up to 3 amps. The materials required are given in the component list and the total cost is under 50s., which is cheap when the cost of charging 6- to 8-volt accumulators is considered and the relative working costs are compared. Details of a case or box have not been given for the reason that the constructor may not wish to use the unit in box form, but fit it into an existing power house or other type of model building in use.

The Paxolin Panel

This is dealt with first, and is cut to the size given in Fig. 1.

All drilling should be completed before the panel is laid aside.

Drill lightly and at the highest possible speed, and it will be found that clean holes can be obtained. Having completed the drilling, clean up the under-side of the panel with a piece of coarse glass paper to allow the nuts to bed down when the panel is fitted up.

The Contact Arm

This is shown in detail in Fig. 2 and is of great importance in a unit of this type, where fairly heavy current is passing, and requires accurate workmanship, as bad contact by the studs means sparking and the possibility of short circuit across the rectifier. If, however, the constructor keeps

MATERIALS

- One Paxolin Panel, 8 1/4" x 6" x 1/4".
- One Paxolin Strip, 8 1/4" x 1/2" x 1/4".
- Strip Brass, 1/2" x 1/4".
- Spring Brass, 1/2" x 3/16".
- One and a half dozen 4 B.A. Studs.
- One dozen Counter sunk 4 B.A. Bolts and Nuts.
- Half a dozen Counter sunk 6 B.A. Bolts and Nuts.
- One 2 B.A. Bush.
- One 2 B.A. Bolt and two Lock Nuts 1 1/2".
- One Stiff Spring 2 B.A.
- Two Plugs and Sockets.
- One Rectifier type M 63, McDaniel and Co.
- One Mains Transformer type T 63, 11 volts at 4 amperes output.

to the layout and measurements given, these troubles will not arise.

The brass used for the spring contact should be such that it will bend up when subjected to continued pressure of the contact stud, also it will be seen from the drawing of the contact arm that the studs at the extreme ends of the arm are connected together and for this purpose a short length of 16 S.W.G. copper wire is used covered by systoflex. For neatness this may be connected on the under-side of the arm and the wire must not be omitted as this forms the connection between the change-over switch and the speed control, and while the unit would give the full output and change the direction of current flow, the speed would remain the same over the whole range of the studs.

The greatest difficulty experienced by the owners of electrical models is power supply, and this generally necessitates the use of accumulators with all the troubles of charging. When the electric mains are in the house, this difficulty can be overcome by the construction of the unit described below, which is particularly suitable for Model Electric Railways.

The panel and arm being in readiness, the transformer is mounted on the under-side of the panel with the rectifier close up to it, and as the transformer may not be to the same drilling position as the transformer used, the necessary holes have not been included in the drilling template, but ample room has been allowed for almost any transformer.

The transformer should be placed on the

poles are changed. Join the positive pole of the rectifier to the top left-hand plate, then to the bottom right-hand plate, and join the negative pole to the top right and bottom left. When the contact arm is moved to the right, positive current is supplied to socket No. 2, via the top contact on the arm to the bottom contact and stud. The circuit is completed by negative return which is made via the spring contact on the arm and the centre spindle and socket No. 1. It will therefore follow that when the arm is moved to the other side this position is reversed, and the studs at the bottom of the panel being connected on each side, the speed control is always in circuit.

The rectifier being plainly marked positive and negative, a glance at the wiring diagram is all that is required, with the exception of the resistances, which may be made by taking 1 yd. of nickel chrome 22 S.W.G. wire and making a spiral by bending tightly round an ordinary lead pencil. Divide this coil into four equal parts, but do not cut and pull out the loops to fit under the lock nuts on the studs.

Join the commencement to the stud on the extreme right, the

first loop to the next stud and so on, the

end of the wire being joined

to the stud next to the centre, but no connection of any kind may be made to the centre stud or a short circuit will result. The studs thus treated are now connected to the corresponding studs on the opposite side of the panel by means of 18 S.W.G. wire bringing the control into use when the arm is on the other side.

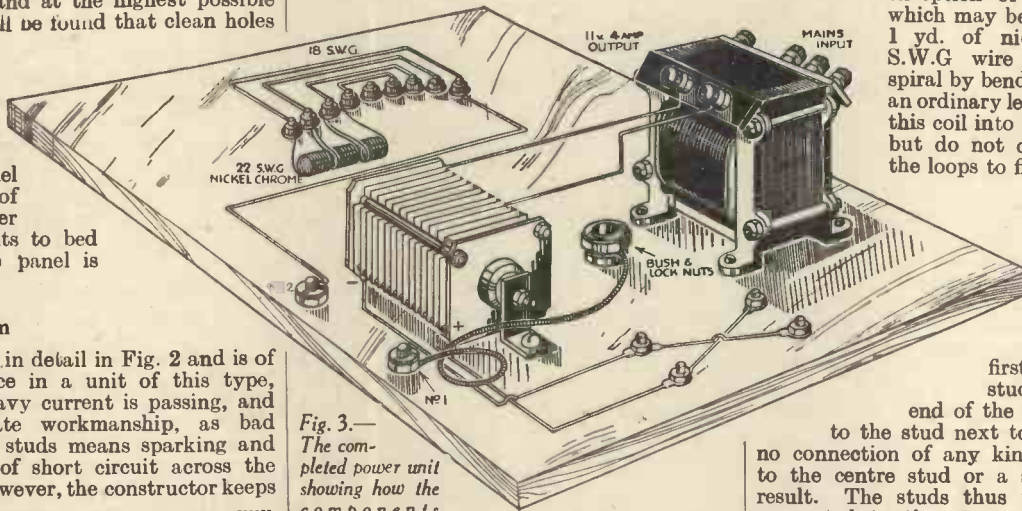
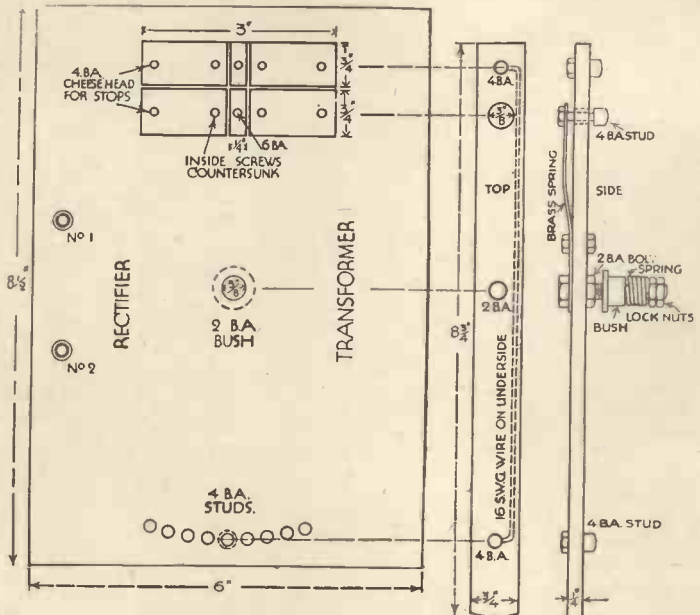

Fig. 3.—The completed power unit showing how the components should be laid out.

under-side and the hole positions marked out and drilled. Secure this to the panel while the holes for the rectifier are marked, removing again for the drilling; these positions have not been given for the same reason as above.

Wiring the Unit

It will be seen that the top left-hand plate and the bottom right-hand plates are connected together as are the two opposite side plates while the centre plate is dead in each section, as is the centre stud of the speed control, thus stopping all current flow while



Figs. 1 and 2.—(Left) How to mark out the panel, and (right) Details of the contact arm.

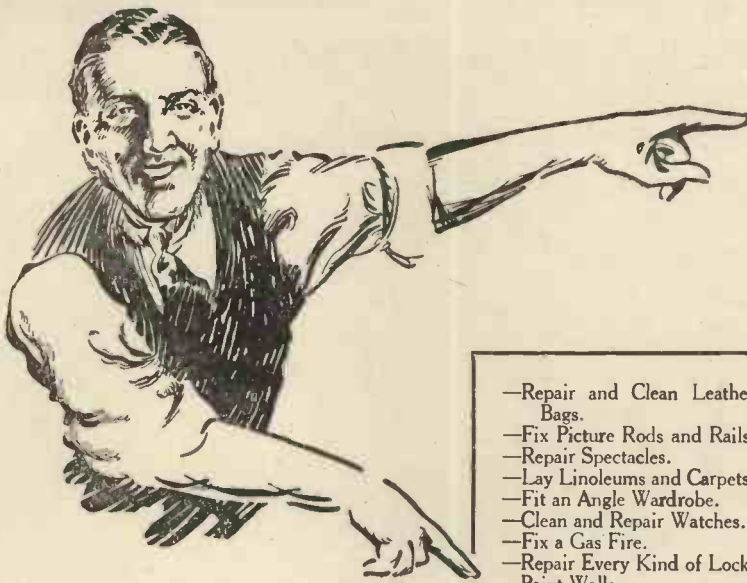

WHAT are you doing with your spare time? You can **SAVE POUNDS** by making and mending things for yourself. You can **MAKE POUNDS** by making and mending things for others. Indeed, many have started profitable spare and whole-time businesses of their own in this useful way—by using "The New Amateur Mechanic."

- Repair and Clean Leather Bags.
- Fix Picture Rods and Rails.
- Repair Spectacles.
- Lay Linoleums and Carpets.
- Fit an Angle Wardrobe.
- Clean and Repair Watches.
- Fix a Gas Fire.
- Repair Every Kind of Lock.
- Paint Walls.
- Repair Defective Floor Boards.
- Clean a Range Boiler.
- Make Varnishes.
- Clean Stone and Brickwork.
- Modernise Wood Bedsteads.
- Repair and Restore China and Oil Paintings.
- Re-Web Chair Seats.
- Do Fine Fretwork.

1,001 Ways to SAVE and EARN more MONEY

- Make Model Flying Machine.
- Make a Gramophone.
- Cut and Fit Carpets.
- Repair Knives and Forks.
- Repair Hot Water Cylinder.
- Cure Dryrot.
- Grind and Repair Scissors.
- Light House with Air Gas.
- Bind Magazines and Books.
- Repair Pianos.
- Stuff Animals and Birds.
- Repair Plastering.
- Make a Mattress.
- Erect Trelliswork.
- Repair Burst Water Pipes.
- Overhaul a Motor-Car.
- Fix Shelves.
- Lay a Tiled Hearth.
- Make a Pair of Boots.
- Re-Upholster a Couch.
- Distemper Ceilings and Walls.
- Make Frames for Pictures.

AND HUNDREDS OF OTHER MONEY-MAKING, MONEY-SAVING JOBS ARE TAUGHT IN "THE NEW AMATEUR MECHANIC."

The NEW Amateur Mechanic

Edited by BERNARD E. JONES

4 Big Volumes

6,000 Stage-by-Stage Illustrations

This is a book that will save you one hundred times its cost during the many years it will serve you. It tells how to do hundreds of useful jobs about the house or garden, from building a chicken house to doing your own brick work and concreting—from repairing water taps to laying linoleum.

The thousands of illustrations and working plans, together with the clear instructions, make you feel as though you have a skilled workman standing by you telling you what to do at every turn. You need no previous experience to be able to use this book. Why not send the coupon below to-day for our FREE booklet, and learn more about this useful and profitable book?

2/6d.

first payment brings you IMMEDIATE DELIVERY of the four big volumes of "The New Amateur Mechanic."

Send no money now.

Send for FREE Booklet.



You can do paperhanging, plastering, distemping, varnishing, painting, etc., if you follow the clear instructions in the book.

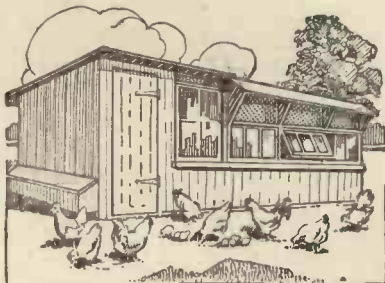

The making of greenhouses, fowlhouses, garden furniture, sheds, etc., all fully dealt with in "The New Amateur Mechanic."

FREE

On receipt of coupon at right we will send you an interesting and attractive free booklet, fully illustrated, and telling you all about "THE NEW AMATEUR MECHANIC."

SEND TO-DAY

To The **WAVERLEY BOOK CO. LTD.**,
96 & 97 FARRINGDON STREET, LONDON, E.C.4.

Please send FREE Illustrated Booklet about "THE NEW AMATEUR MECHANIC"; also information as to your offer to send the complete work for a small first payment.

NAME

(Send this form in unsealed envelope, under ½d. postage, or send p.c.)

ADDRESS

P.M.E. 1934

WHY NOT BUILD YOUR OWN FURNITURE AND RADIO CABINETS

FROM
OSBORN KITS OF PARTS?
Machined ready to assemble

SEND FOR OUR 2 ILLUSTRATED CATALOGUES

- (1) Containing 36 pages of Radio Cabinets
- (2) " 28 " " Furniture

BOTH SENT FREE ON RECEIPT OF 3d. IN STAMPS

CHAS. A. OSBORN

Offices and Mills:
THE REGENT WORKS (Dept. P.M.), ARLINGTON ST., NEW NORTH ROAD, LONDON, N.1.
Showrooms: 21 ESSEX ROAD, ISLINGTON, N.1
Telephones: CLERK 5095 & 5634

METERS

OF EVERY DESCRIPTION. Voltmeters, Ammeters, Milliameters, Microammeters, Combined Meters, Reading Millivolts, Milliamps., Volts, Amps.

MOVING IRON TYPES.

VOLTS, AMPS. AND MILLIAMPS.

From 5/6 to 45/-

SURFACE, FLUSH &

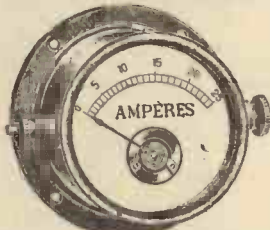

MOVING COIL TYPES.

VOLTS, AMPS. AND MILLIAMPS.

From 25/- to 70/-

PORTABLE TYPES.

For full details, descriptions and prices of meters; and Innumerable other electrical apparatus, A.C. Transformers, Bells, Miniature Fittings, Rectifiers, Tantalum for A.C. Chargers, Lighting and Power Cables, Bell Wires, Instrument Wires, Resistance and Nickel-Chrome Wires and over 50 varieties of Flexibles, etc., send for our Catalogue. 105 Pages. Fully Illustrated.

GRAFTON ELECTRIC CO., (DEPT. P.)
54 Grafton Street, Tottenham Court Rd., London, W. 1

A GREAT PRICE ACHIEVEMENT

IRON CORED TUNING, AUTO WAVE-CHANGE RADIO — FOR 27/6d.

Such are the outstanding features of our amazing 1934 "GOLD-MINE" 3-v. (det.-dr.-CL.B.) Kit, which for sheer value surpasses all previous standards. Just look at these — a few only of the items actually included in Kit A.—1 pr. CL.B. Trans (list 17/-), 1 Iron Cored Coil (list 8/6), 1 Extender fitted 360 degrees, S.M. drive (list 18/6), and a completely assembled metallized chassis, simple as A.B.O., "no soldering" instructions, ensures 20-30 stations at full Moving Coil volume, and makes success certain.

KIT A. Components, chassis, diagrams, etc., and all sundries 27/6d.	KIT B. As Kit "A" with matched set British Valves. 42/6d.	KIT C. Kit "B," with 30/- console cabinet and P.M.C.O. speaker. 67/6d.	KIT D. Kit "C" with batteries, comprising complete outfit. 79/6d.	POST FREE 27/6d. Cash or C.O.D.
--	--	---	--	---

3d. ONLY. INVEST TO-DAY IN THE RADIO GOLD-MINE FOR 3d.

It's the greatest investment you'll ever make. It will pay you many pounds dividends in hard cash saved. The "RADIO GOLD-MINE"—the biggest and most comprehensive list of surplus and liquidation stocks yet produced. April issue is illustrated—the best yet!

London East Central Trading Co.
(Dept. R.77) 23 BARTHOLOMEW CLOSE, E.C.1 (National 7473)

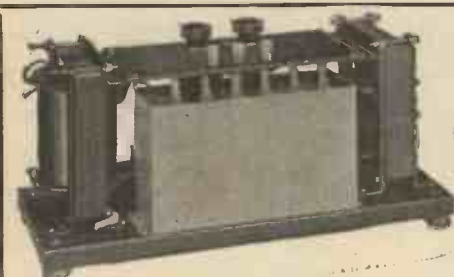

BUILD YOUR OWN MAINS UNIT

with a Heayberd Assembled Kit of Parts. This is a simple job—the components

are mounted on a metal baseboard, and all you have to do is to wire from one point to another. Blueprint supplied with every Kit. Here is the model C.150. Alternative Outputs: 150 or 120 volts at 25 m.a. H.T.1 Variable S.G. 40/110 volts. H.T.2 Variable 60/130 volts. H.T.3 Fixed 150 volts. L.T. 4 volts 4 amps. 8/- extra. PRICE 76/-

A large range of Unassembled Kits can also be supplied. Cut out this advt. and send with 3d. in stamps for 40 pp. booklet containing SPECIAL TELEVISION SUPPLEMENT

F. C. HEAYBERD & Co.
10 FINSBURY STREET, E.C.2

AMPLION
Signifies Supremacy—



Specified for the "All-wave Super Three."

There is no other speaker which has achieved and maintained a reputation as high as that of the Amplion P.M. Speaker. The outstanding merits of this new speaker are its consistent performance, its wonderful faithfulness in reproduction and its ability to handle volume without distortion. Designed to suit the characteristics of modern receivers such as the "All-wave Super." It is the practical result of our highly experienced technical staff, and, because it is fitted with an all-purpose Universal Transformer, it exactly meets the varying demands made upon it.

The M.C.22. has a magnet no less than 8 1/2 in. high, 2 in. wide, 1/2 in. thick and weighs 6 1/2 lbs. The all-purpose Universal Transformer as fitted assures perfect reproduction with the

"ALL-WAVE SUPER THREE"

- " M.C.22 " Moving-Coil Speaker, 7-in. Cone, 39/6
- " Audiola " 9-in. Cone, 49/6

Both models fitted with all-purpose Universal Transformer.

Descriptive Literature "P.M." on Amplion Speaker and Receivers, free on request.

AMPLION

Telephone: Clerkenwell 54401.

Amplion (1932) Ltd., 82/84, Rosoman Street, London, E.C.1

ALL RADIO
QUESTIONS
ANSWERED
FREE.

The PRACTICAL MECHANICS

Every Question
must be accom-
panied by the
Coupon on
page 3 of Cover.

Wireless Experimenter

In the last five issues of "Practical Mechanics" we have described a wide range of receivers of types to meet the requirements of the majority of readers. Our post-bag has shown, however, that there is an insistent demand for a really good short-waver of reasonably simple and effective design. The receiver to be des-

THE "P.M." SHORT-WAVE
THREE SUPER
An Efficient Short-Wave Receiver
with a World-Wide Range

pointer over rather more than three degrees of the 180-degree scale. Another advantage of this "Micro-dial" is that the scale is made of aluminium, and this acts as an effective screen and avoids hand-capacity troubles.

Simple Efficient Circuit

A brief examination of the circuit employed will prove interesting. As mentioned before, the aerial circuit is untuned and consists simply of a 250,000-ohm fixed resistance. This feeds into the S.G. valve, which is coupled to the detector by the tuned-grid system, a short-wave H.F. choke being included in the anode circuit. The coupling condenser from the anode of the S.G. valve can be connected to one of two tappings on the grid coil in order to obtain

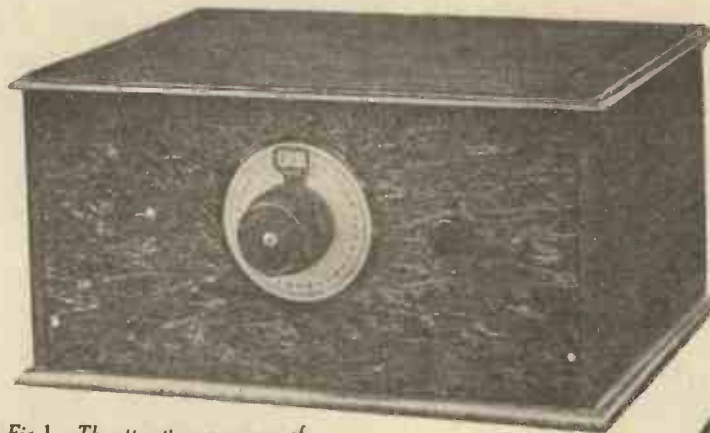

Fig. 1.—The attractive appearance of the finished set can be judged from this photograph.

cribed this month has been specially designed to meet this demand, and we are sure that it will meet with the approval of all readers.

The usual type of short-wave receiver consists of a detector valve followed by one or more low-frequency stages, and although such a set is very efficient on the wavelengths for which it is intended, it calls for a fair amount of skill in operation. Additionally, a special aerial is often required in order to secure optimum results. These difficulties can generally be overcome by fitting an S.G. amplifying stage, but if this is of the usual type a second tuning control is called for, and this introduces a further difficulty, especially since accurate setting of the tuning condensers is extremely important on short waves. Every one of the troubles referred to has been obviated in the present case by employing an S.G. amplifier of the so-called semi-periodic, or untuned type. Thus, the S.G. valve, besides giving a certain amount of useful amplification, simplifies tuning,

15-60 Metres with One Coil

A point of special interest is that a wavelength range of 15 to 60 metres can be covered with a single plug-in coil, and without the use of any switching device.

As a matter of fact, the eight-pin plug-in coil (the Elelex "Duplex") employed covers a wavelength range of 15 to 30 metres when inserted in its holder in one position, and of 28 to 60 metres when it is reversed in its holder. This ingenious tuning unit has two complete and separate windings, so that there can be no "dead-end" effects, and therefore no loss of efficiency on the lower range.

Easy and accurate tuning is secured by means of a special low-loss .0002-mfd. short-wave variable condenser used in conjunction with a micro-meter dial which is provided with a 100 to 1 reduction drive. In other words, the knob has to be rotated through a complete revolution to drive the hair-line

two different degrees of selectivity. When it is connected to terminal 3 a loose-coupled untuned winding is included between the anode and the detector grid circuit, and when it is transferred to terminal 4 a direct coupling is obtained.

The detector valve operates on the usual leaky-grid principle, but the values of grid condenser and leak are different to those employed in the usual broadcast receiver. A plain 5:1 L.F. transformer is used between the detector and pentode valves, and a "stopper" resistance of 100,000 ohms is included in the grid circuit of the latter to prevent the possibility of L.F. instability. A common H.T. positive tapping supplies the anodes of all three valves, the detector being de-coupled by means of a 50,000-ohm resistance and a 2-mfd. condenser, but a separate tapping is provided for the screening grid of the first valve.

Simple Construction

It will be seen that a metallised wooden chassis is employed in conjunction with an ebonite panel, the latter accommodating the three controls. The first step is to drill the panel to receive the condenser and dial. Three-hole mounting is employed

removes the difficulty of employing a special aerial and at the same time ensures a uniformity of efficiency over the complete range of wavelengths covered.

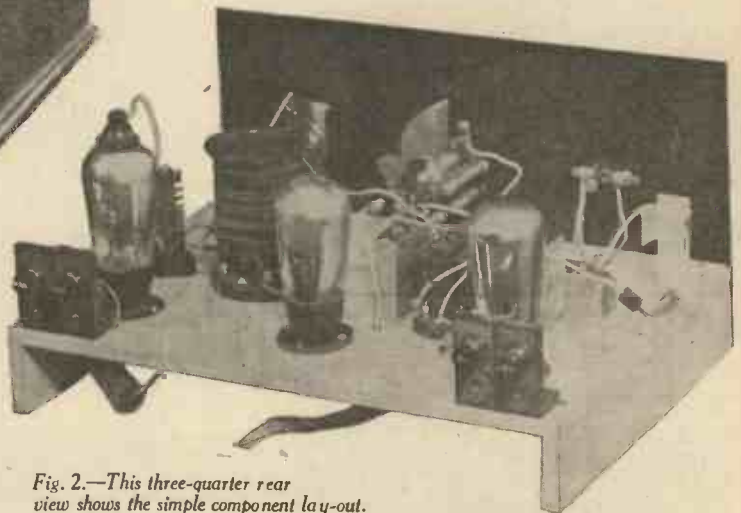

Fig. 2.—This three-quarter rear view shows the simple component lay-out.

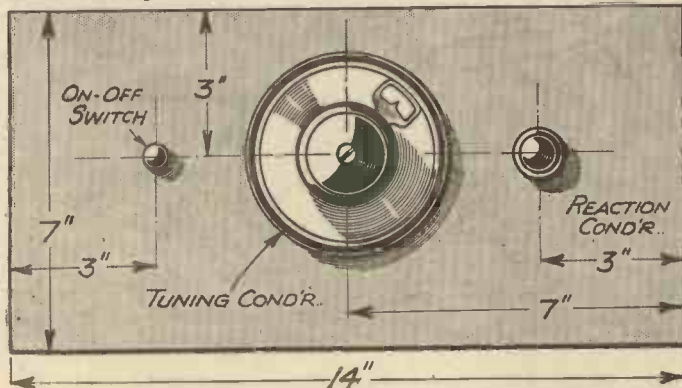

Fig. 3.—The positions of the panel holes are shown in the above diagram.

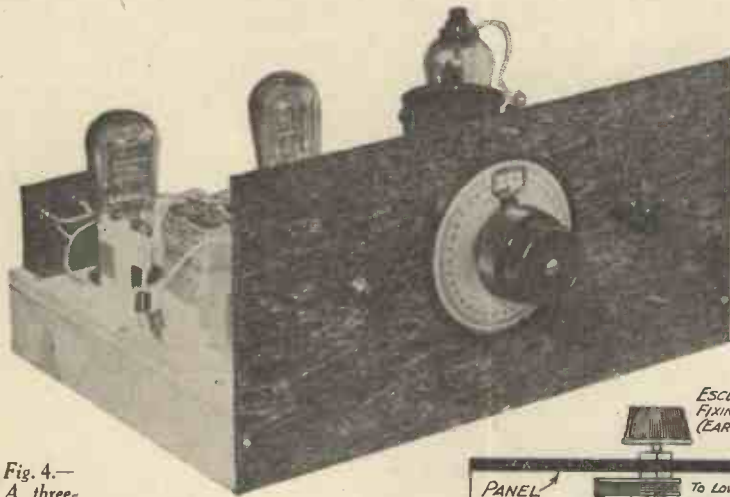

Fig. 4.— A three-quarter front view which emphasises the simplicity of the panel controls.

for the condenser in order to ensure absolute rigidity, and it is best to make a template for this by making a slip of paper to fit over the spindle and then marking with a pencil the centres of the three screw holes. This can be laid on the panel and the positions of the holes easily transferred by means of a scribe or centre punch. Take care in drilling the holes, since absolute accuracy is of great importance. After making sure that the condenser fits properly, the "Micro-dial" should be attended to. On unpacking this it will be found that there is a small envelope in the carton which contains a couple of washers, a large washer with stud, a short stud with a screwdriver-out in the end and a longer stud. The first two items are not required in the

present case (they are provided for use with condensers of the single-hole fixing variety), but the two studs are used to attach the dial to the panel. First of all lay the aluminium

scale in position so that the "0" mark is on the left and readings up to 180 follow on in a clockwise direction. Then mark off the centres of the two holes and drill holes $\frac{3}{8}$ in. diameter through the panel.

Little explanation is called for in respect to the mounting of the other components, all of which are clearly shown in the wiring plans. It might be mentioned that the tubular condensers and fixed resistances are not attached to the chassis, but are simply supported by the wiring. All wiring is carried out in the B.R.G. push-back connecting wire specified, and it might be mentioned that in using this wire there is no need to scrape off the insulation, since it can be pushed back the required distance by means of the

LIST OF PARTS FOR THE "P.M." SHORT-WAVE SUPER.

- One Ebonite Panel, 14 in. by 7 in., Ward & Goldstone.
- One Metallised Chassis, 14 in. by 10 in., with 1½ in. runners, Peto-Scott.
- One .0002 mfd. Short-wave "Special" Condenser, Jackson Bros. (C.1).
- One "Micro-dial" Wilkins & Wright.
- One .0002 mfd. Reaction Condenser, Burne-Jones "Magnum" (C.2).
- One On-Off Switch, British Radiogram (S.1.)
- Two 4-pin Chassis-mounting Valve Holders, Clix "Ahr-sprung."
- One 5-pin Chassis-mounting Valve Holder, Clix.
- One "Duplex" Short-wave Coil and 8-pin Holder, J. J. Eastlick.
- Two Short-wave H.F. Chokes, Ward & Goldstone.
- One 5 : 1 L.F. Transformer, British Radiogram.
- One .1 mfd. Tubular Condenser, T.M.C. (C.3).
- One .0002 mfd. Tubular Condenser, T.M.C. (C.4).
- One .0001 mfd. Tubular Condenser, T.M.C. (C.5).
- One 1 mfd. Fixed Condenser, 300 volts working, T.M.C., type 30 (C.6).
- One 2 mfd. Fixed Condenser, 300 volts working, T.M.C., type 30 (C.7).
- One 250,000-ohm Metallised Resistance, Dubilier (R.1).
- One 50,000-ohm Metallised Resistance, Dubilier (R.4).
- One 100,000-ohm Metallised Resistance, Dubilier (R.3).
- One 5-megohm Grid Leak, Dubilier (R.2).
- Two pairs Terminal Mounts, Ward & Goldstone.
- Four Terminals: marked "Aerial," "Earth," "L.S. +" and "L.S. -" Clix.
- One 100-m.a. Fuse, Microfuse.
- One pair Grid Bias Battery Clips, Bulgin, No. 1.
- One 5-way Battery Cord, Bulgin.
- Five Wander Plugs: marked "H.T. + 1," "H.T. + 2," "H.T. -," "G.B. +" and "G.B. -" Clix.
- Two Spade Terminals: L.T. + and L.T. -, Clix.
- British Radiogram Push-back Connecting Wire, Screws, Flex, etc.
- One 120-volt H.T. Battery, Lissen.
- One 9-volt G.B. Battery, Lissen.
- One 2-volt Accumulator, Ediswan, type ELM4.
- Three Valves: S.G.210, L210 and Y220, Hivac.
- One Loud Speaker, Amplion, type M.C. 22.
- One American-type Cabinet, 14 in. by 7 in. by 10 in., Peto-Scott.

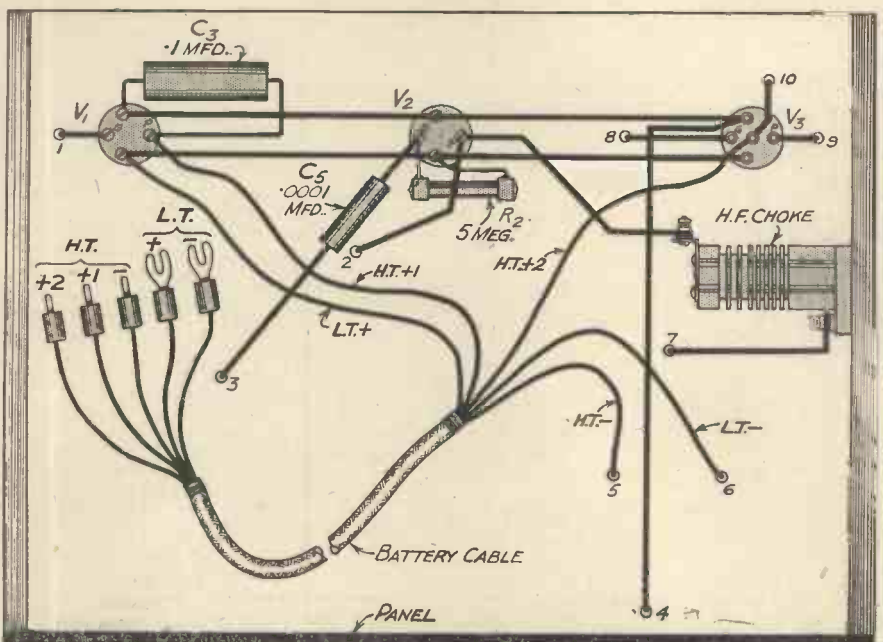
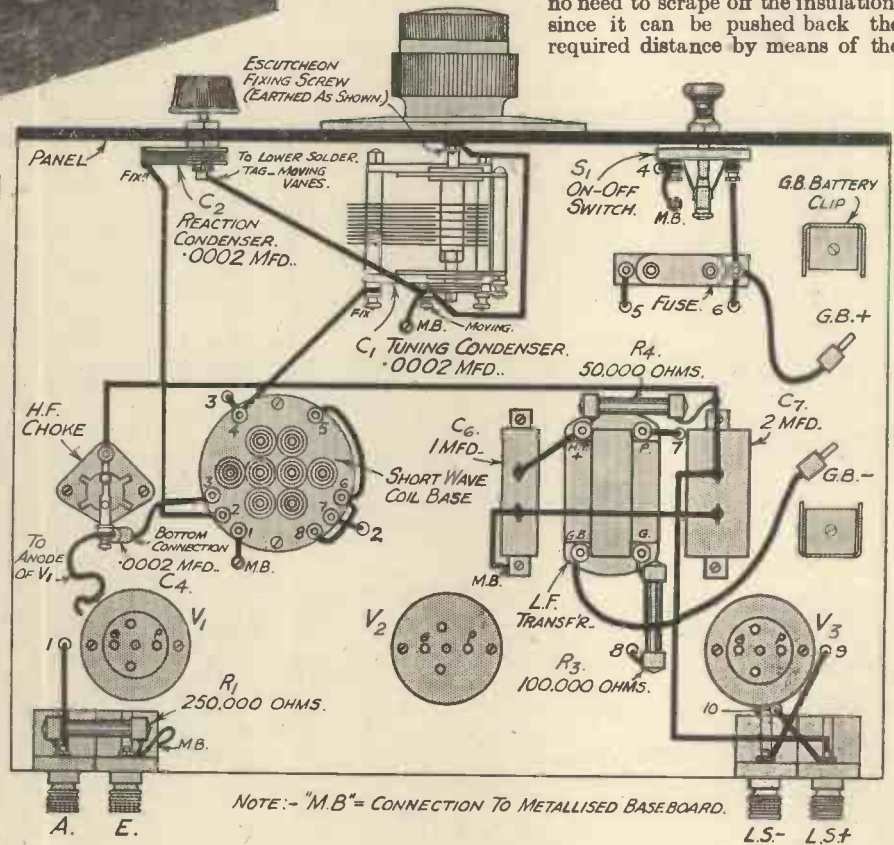

Fig. 5.—Above and below chassis wiring plans. The few and simple connections are very evident.

MAKE MONEY

WITH

The ADANA All-Steel Automatic Self Inking

PRINTING MACHINE

Machine only

45/-

Supply the big WEEKLY demand for Printed Material in your own District and make **LARGE PROFITS**. The Possibilities are enormous—the market **HUGE**. Tradesmen, Cinema Proprietors, Dance and Concert Organisers, etc., etc.—all **MUST Have** a regular supply of Printed Material from Week to Week. **YOU** could easily produce this!

If you own a Business, **SAVE MONEY** by doing your own printing! Produce your own Leaflets, Circulars, Note-headings, etc., and put the Printer's Profit into your own pocket.



EASY PAYMENT TERMS:

My Machine will print anything from a **CHEMIST'S LABEL** to an **ILLUSTRATED MAGAZINE**. Fully Illustrated Instruction Book included **FREE**. No Previous Experience is necessary. Many men, knowing nothing about printing, who started with an Adana, now own Profitable businesses. Why not **YOU**?

SEND AT ONCE for Full Free Particulars, samples of Actual Work Produced, and Easy Payment Terms.

D. A. ADANA (P.M.6.), 17 Church St., Twickenham
LONDON SHOWROOMS, Ludgate House, Fleet St., Manchester, 60 Oldham St.

PROTECT YOUR SET

AGAINST

LIGHTNING AND STORMS

with the

"GOLTONE" BAKELITE LIGHTNING ARRESTER



TO AERIAL AND TERMINAL ON SET

MADE IN ENGLAND

TO EARTH AND TERMINAL ON SET

ROBUST CONSTRUCTION, FITTED IN A FEW MINUTES, PRACTICALLY INDESTRUCTIBLE.

Complete with Galvanised Iron Bracket, massive metal parts, and strong Bakelite Cover.

R17/476 **2'6** ea.

Obtainable from all First-class Radio Stores. Refuse substitutes—if any difficulty write direct.

FREE on request. 1934—56 page **RADIO CATALOGUE**, of interest to every Radio enthusiast.



UNIFORMITY



Uniformity is the order of the day in the factory where T.M.C. Hydra Condensers are manufactured by the most up-to-date machinery. All T.M.C. Hydra Condensers conform to their rated capacities to within very narrow limits of tolerance. This accuracy, combined with absolute reliability, makes T.M.C. Hydra Condensers so essential for the good performance of your set.

Write to the Sole Sales Distributors if you have any difficulty in obtaining supplies.

Price List from Sole Sales Distributors for Great Britain:

HARWELL LTD.

The Sessions House, Clerkenwell Green, London, E.C.1
Telephone: Clerkenwell 6905



T.M.C. BRITISH MADE HYDRA CONDENSERS

Made by TELEPHONE MANUFACTURING Co. Ltd.

HOT WATER!

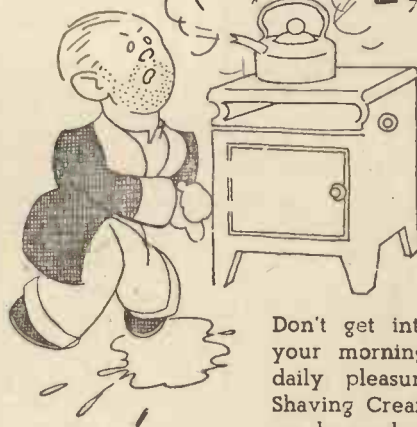

Don't get into "hot water" with your morning shave. Make it a daily pleasure with Parke-Davis Shaving Cream. Even tepid water can be used with this new perfected beard softener, and your skin will be left smooth, immaculate and wonderfully soothed.

PARKE-DAVIS Shaving Cream

EUTHYMOL, (180/24) 50, Beak Street, London, W.1
Please send **FREE** sample tube Shaving Cream

Name
Address

(Use block letters please)

A trial will prove it. Buy a 1/6d. tube from your chemist, or, if you prefer, send for a free 7-day sample. Made by the makers of Euthymol Tooth Paste

finger and thumb. A number of soldered connections are used and, as a matter of fact, it is well worth while to solder all wires in any short-wave set, since slightly loose connections can cause very serious crackling noises which are not always easy to trace.

After the wiring has been completed, the valves can be inserted into their holders, arranging them in the order:—S.G. 210, L210 and Y220 from right to left. Connect the accumulator, speaker, G.B. and H.T. batteries and aerial and earth. In regard to the G.B. negative lead, this should be given about 4½ volts bias. The H.T. +1 plug should be placed in the battery at about 60 volts, H.T. +2 being given the

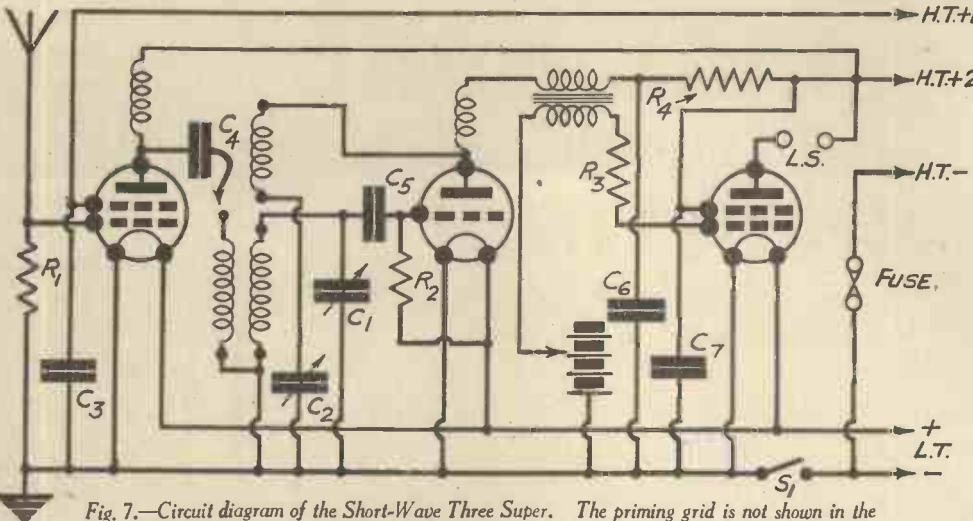

Fig. 7.—Circuit diagram of the Short-Wave Three Super. The priming grid is not shown in the pentode valve for the sake of simplicity, and because no external connection is made to it.

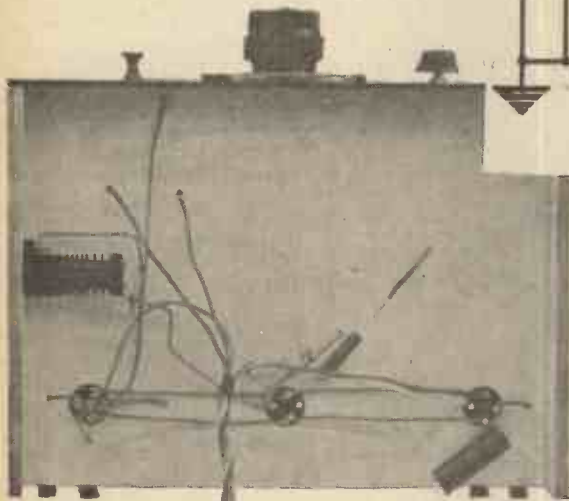

Fig. 6.—An under-chassis view showing the simple wiring.

full 120 volts. Insert the coil with the word "Long" toward the back of the chassis and switch on. The reaction condenser should then be operated until the set just begins to oscillate; this will be indicated by a faint "breathing" sound in the speaker. After that the tuning knob can be rotated until a carrier-wave whistle is heard. The reaction setting should then be reduced and tuning slightly adjusted until the station is heard clearly. Those who are new to short-wave reception might be rather confused with the different whistles which are received; some of these are heard as steady sounds and repre-

sent telephony stations, but others sound like a series of "chirps," and these are morse transmissions which will probably be of no interest and will disappear as soon as the set stops oscillating.

As conditions on short waves vary very considerably from time to time, it is often advisable to employ ear 'phones when first trying out the set. Even later, 'phones are to be preferred when long-distance reception of lower-power stations is required, although most of the European and many of the American stations can easily be received on the speaker under moderately good conditions. In most parts of the country there will be a number of amateur transmitters to be heard on Sunday mornings.

CASH, C.O.D. OR H.P.

PILOT CLASS "B" FOUR KIT

GUARANTEED MATCHED

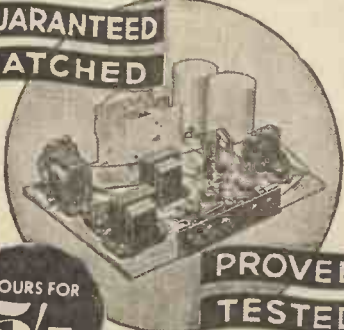

PROVED TESTED

YOURS FOR 5/-

Another Peto-Scott triumph—this latest Class "B" Battery 4 Kit at a popular price. Seven times the volume of an ordinary battery set, with outstanding performance equal to "mains" receiver. Kits supplied with detailed "Simple to build" instructions and assembly blueprint. Matched and tested components. Guaranteed for 12 months by Peto-Scott.

KIT "A." less Valves and Cabinet. Cash or C.O.D. Carriage Paid. £3/10/0. Or 5/- deposit; balance in 12 monthly payments of 6/-.

KIT "B."—As Kit "A." but including 4 matched and tested valves. Cash or C.O.D. Carriage Paid. £2/8/0. Or 12 monthly payments of 9/6.

KIT "C."—As Kit "A." but including 4 matched and tested valves and Peto-Scott Console cabinet. Cash or C.O.D. Carriage Paid. £3/15/0. Or 12 monthly payments of 10/6.

Recommended Peto-Scott SPEAKER, if required, add 22/6 to Cash Prices or 2/- to each monthly payment.

PILOT AUTHOR KIT EXACT TO SPECIFICATION

SHORT - WAVE SUPER 1934 STRAIGHT THREE

As described in February Issue.

KIT "A." Author's Kit of first specified parts including ready-drilled Panel and Metaplex Chassis, but less Valves, Cabinet and Speaker. Cash or C.O.D. (carriage paid). **£2/15/0** Or 12 monthly payments of 5/-.

KIT "B." As for Kit "A." but with set of Hivac Valves. £3/11/6. Or 12 monthly payments of 6/6.

KIT "C." As for Kit "A." but with Valves and Peto-Scott Twin de Luxe Cabinet. Less Speaker. £5/16/6. Or 12 monthly payments of 10/8.

KIT "A." Author's Kit of first specified parts including ready-drilled Panel and ready-drilled Metaplex Chassis, less Valves and Cabinet. Cash or C.O.D. (carriage paid). **£3/7/6** Or 12 monthly payments of 6/3.

KIT "B." As Kit "A." but with set of specified Valves. Cash or C.O.D. (carriage paid). **£4/15/0**. Or 12 monthly payments of 8/9.

KIT "C." As Kit "A." but with Valves and Peto-Scott American Type Table Cabinet. Cash or C.O.D. (carriage paid). **£5/10/0**. Or 12 monthly payments of 10/-.

ALL-WAVE ECONOMY 3

As described in January issue.

KIT "A." Author's Kit of specified parts as detailed, with ready-drilled Panel and Metaplex Chassis, less Valves, Cabinet and Speaker. Cash or C.O.D. (carriage paid). **£4/6/0** Or 12 monthly payments of 7/9.

KIT "B." As for Kit "A." but with specified Valves. Cash or C.O.D. (carriage paid). **£5/1/6**. Or 12 monthly payments of 9/3.

KIT "C." As for Kit "A." but with Valves, Peto-Scott Console Cabinet less Peto-Scott Moving-Coil Speaker. Cash or C.O.D. (carriage paid). **£6/6/0**. Or 12 monthly payments of 11/6.

KIT-BITS

You pay the Postman. We pay Post Charges on all orders over 10/- GREAT BRITAIN ONLY.

- 1 Peto-Scott Metaplex Chassis drilled to E. S. D. specification ... 3 9
- 1 Peto-Scott Ebonite Panel drilled to specification ... 4 0
- 1 Set of specified Hivac Valves ... 1 7 6
- 1 Peto-Scott American Type Table Cabinet, 14" x 7" x 10" ... 15 0
- 1 Eastick "Duplex" S.W. Coil and Holder ... 7 6
- 1 B.R.G. Type 66-5:1 L.F. Transformer, ... 5 6

IMPORTANT. Miscellaneous Components, Parts, Kits, Finished Receivers or Accessories for Cash, C.O.D. or H.P. on our own system of Easy Payments. Send us a list of your wants. We will quote you by return. O.O.D. orders value over 10/- sent carriage and post charges paid (GREAT BRITAIN ONLY). OVERSEAS CUSTOMERS CAN SEND TO US WITH CONFIDENCE. We carry a special export staff and save all delay. We pay half carriage—packed free. Send full value plus sufficient for half carriage. Any surplus refunded immediately. Hire Purchase Terms are NOT available to Irish or Overseas customers.

PETO-SCOTT CO. LTD. 77 City Road, London, E.C.1
Telephone: Overkennell 9406/7.
West End Showrooms: 62 High Holborn, London, W.C.2.
Telephone: Holborn 3248.

Dear Sirs,
Please send me CASH/C.O.D./H.P.
for which I enclose £.....
CASH/H.P./DEPOSIT.....
NAME.....
ADDRESS.....
P.M. 4/34

STRICT PRICE PRIVACY GUARANTEED — WE DEAL WITH YOU DIRECT

HOW LENSES ARE MADE

By DAVID CHARLES

THE making of a lens begins with mathematics, not with mechanics. Probably more arithmetic is used in the design and manufacture of lenses than in that of any other article of commerce. This is due not only to the complexity of the properties of various kinds of optical glass, and the still greater complexity of the technical requirements which a good lens has to conform with, but to a very great extent upon the fact that optical glass itself is a variable product. From the first rough notes made by a lens "computer," to the time when the first trial lens of its type is placed on the testing bench, usually occupies several months of elaborate calculations. These calculations are based on and checked by observations of selected samples of glass in a highly specialised instrument called a refractometer.

Simple Lenses

But even then the computer's work is not done, simply because successive batches of optical glass constantly vary in their properties, and the workshop specification has as constantly to be altered in accordance with these variations. If one takes, for example, one of the simplest of photographic lenses consisting of only two simple "combinations" with one air-space between them, each of the combinations will consist of at least two single glasses called "elements" cemented together with transparent "balsam." Consequently this simplest of lenses has eight curves and five thicknesses; for the "thickness" of the air separation is as important in its shape and dimensions as though it were one of the glasses. Thus there are no less than thirteen items, each of which is calculated and adjusted to the astounding accuracy of 1/500,000 of an inch. Half a millionth of an inch, probably the greatest degree of precision that is ever reached in any manufactured article of commerce.

The raw material, namely, the optical glass, comes to the lens factory in either of two forms. Slabs about an inch thick and about 5 in. square represent one form, while for mass-production of standard lenses it is very usual for the glass to be purchased in "moulds," i.e., rough mouldings corresponding approximately to the curves and dimensions of the required product. The latter naturally cost more, but they save not only the work of cutting up of the slabs, but also the very large element of

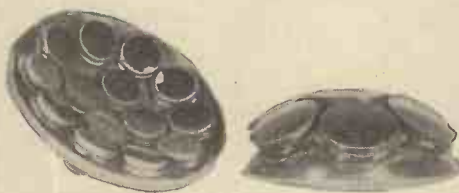

Fig. 1.—Single elements for polishing a number at a time.

waste which obviously is entailed in cutting round the squares! When it is stated that the average cost of raw optical glass is "a pound a pound," the importance of waste material looms large.

Grinding and Polishing

The actual grinding and polishing of lenses is done by means of metal tools of mushroom shape, each one naturally having



Fig. 2.—A tiny lens stuck on a "peg" to handle it for polishing.

been previously turned to the curve it is required to produce on the glass. The first rough grinding is done with water and coarse emery, in what appears at first sight a rather primitive device. Each single curve, convex or concave, is a separate operation performed by hand, and the "substance" after grinding is also continually checked by a micrometer. "Substance," in optical language, means the thickness of the lens in its centre, and bears no relation to the nature of the glass itself, of which several kinds are used. So soon as a sufficient number of each single element have been rough-ground they are assembled upon an iron tool of appropriate curvature, and are stuck upon it by means of warmed pitch. Since each curve is always an arc it is clear that a number can be finely ground and polished as though the assembly were one complete lens of a larger size. This point is made clear on reference to Fig. 1, which shows such assemblies of elements for finishing the concave and convex surfaces respectively. Finer and yet finer emery, with water as lubricant, is used for these final stages of grinding, a novel feature of which is the fact that the emery itself becomes finer during the process, and consequently is itself used over and over again in successive stages of the work.

Perfection of the grinding process is continually checked by means of a master lens called a "test plate." This is a thick cylinder of glass in a side of which is ground a curve which should fit precisely upon those being polished. Wiping off the

emery paste, and placing the master lens over one of those being polished, the accuracy of the finish is observed by means of the "Newton rings," those bands of rainbow effect which show, by their shape and disposition, any lack of accuracy to the half-millionth of an inch.

Two very interesting facts arise out of this process of lens manufacture, quite apart from the extraordinary degree of accuracy achieved. One is that so tiny are some of the recent lenses made for the popular types of cinematograph cameras, that they cannot be handled at all in the regular factory fashion, but require to be ground and polished one at a time, being cemented by the ever useful pitch to a small wooden "peg," the size of an ordinary match-stick (see Fig. 2). The other fact is that it is only of comparatively recent years that any mechanical aid to the operator's own exertions has been used for polishing to the final curves.

"Edging"

When the various single elements have reached the stage of perfect polish, and have passed all the tests for correct curvature and of "substance," under the master lens and the micrometer respectively, there is still another grinding operation to be performed, called "edging." It should be realised that if a curve has been ground, however truly, on either side of a piece of glass, there is no certainty that the optical centres of these two curves will coincide absolutely with the mechanical centre of that piece of glass. Therefore each glass is stuck, again by means of pitch, on the chuck of a sort of lathe. A lamp with a bright filament is shone on to the lens. An image of the filament is seen as a minute speck of light in both the front and the back surfaces of the glass, and when the glass is revolved these two specks of light will remain either quite steady, or will be seen to approach and then to recede from one another, this indicating that the curves are not optically central on the chuck. While the pitch is still warm and soft the operator moves the glass this way or that, until no movement of the specks is seen, showing that the curves, if not the glass itself, are perfectly central. This is clearly an operation requiring extreme deftness, especially in the case of some of the minute lenses used in cine cameras and microscopes. As soon as this adjustment has been achieved, and the pitch is set, an edging tool is brought against the circumference of the glass, which is thus trued accurately to the optical centre.

(Continued on page 337.)

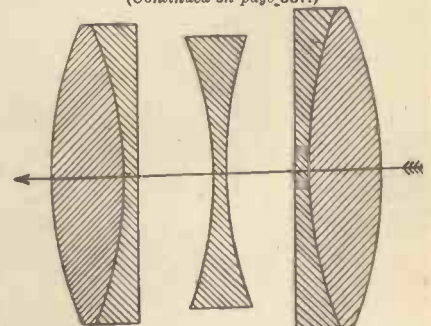

Fig. 4.—A diagrammatic section of a modern lens.

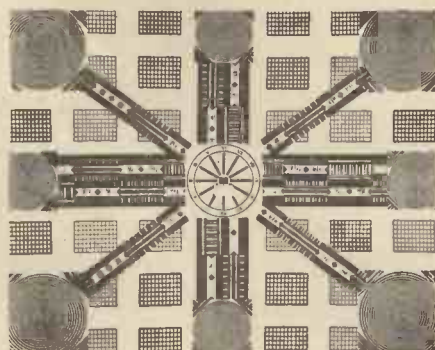
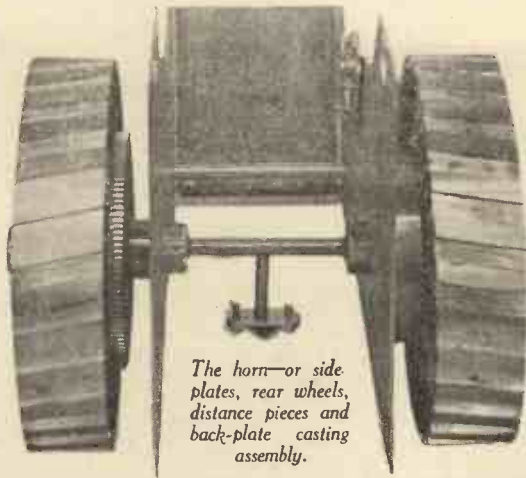

Fig. 3.—This large chart, 10 ft. by 8 ft., is photographed to discover any possible faults in the performance of a finished lens.

LATHE WORK

A WORKING MODEL

The Second Article on the Castings, of this Realistic



The horn or side plates, rear wheels, distance pieces and back-plate casting assembly.

PRESUME that the reader has prepared most of the turned parts from the instructions and drawings which I gave last month. The work of assembling can now be proceeded with. As the model is erected on the two horn plates these parts should be made first. In the drawing below it will be noted that certain holes are common to the right- and left-hand side horn plates, and for convenience both sides should be made together, drilling the holes which appear in one plate only afterwards. You will find a sheet of brass in the set of parts, and this should be cut into two pieces and lightly tacked together round the edges with solder. Next transfer the positions of the holes from the drawing given on this page, accurately centre-punch the holes, and drill through. Nearly all of the holes are clearing holes,

only one of them is tapped. Having finished off the horn plates, clamp the bunker back-plate casting into place (this merely requires to be cleaned up with a file), assemble the two sides by means of the distance pieces which are tapped and form a support for the spirit reservoir, and proceed to drill through the back series of holes for the small copper rivets which secure it into place. A small rivet set

This is to be silver soldered into the down-comer casting, and the front boiler end is similarly silver soldered in place. To those readers who have never before attempted to do silver soldering, it is necessary to say that the parts should be cleaned up bright with emery cloth and then brought to a red heat by means of a blow-lamp, borax applied as a flux, and then a stick of silver solder should be led round the joint following the solder with the flame. A steel spatula will assist in getting the solder to flow into the joints.

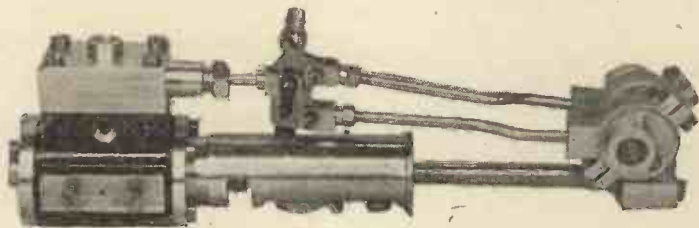

The cylinder, cross-head guide, connecting-rod and eccentrics.

should be used to close these over. The correct size of rivet is supplied. To make a more secure job of this assembly, I also recommend that it be sweated with a neat seam of solder. So far as the side-plates are concerned, proceed to assemble the brake screw and bracket, the reversing quadrant casting and lever, the back-wheel spindles, and the gear studs, when this part of the work can be placed aside whilst attention is directed to the Smithies type boiler.

course, previously have been drilled and tapped to receive the miniature pressure gauge, the water gauge, the injector plug valve, whilst the blower top should be tapped to throttle. It that these parts machined, as a safety valve, connecting rod, the eccentrics, barrel is lagged with asbestos its point of contact (that

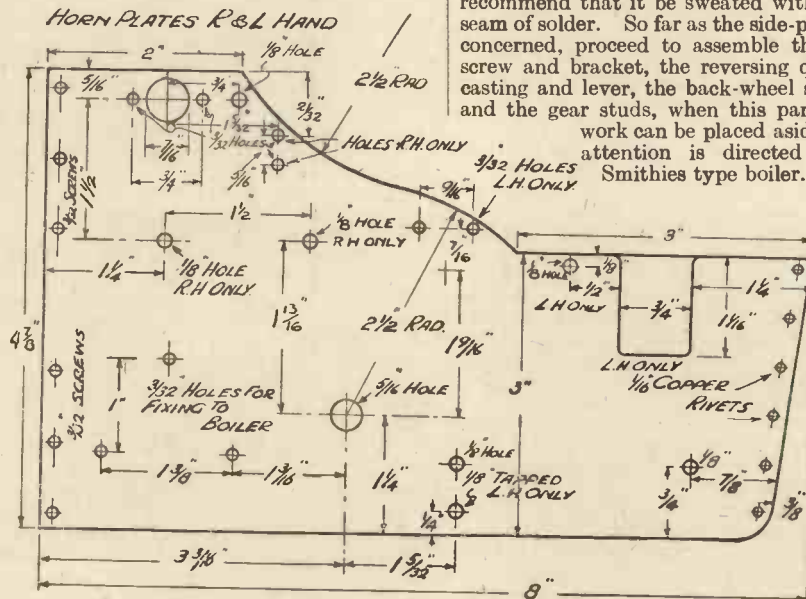

The horn or side-plates.

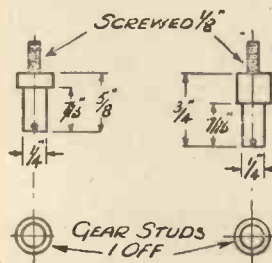

The gear studs.

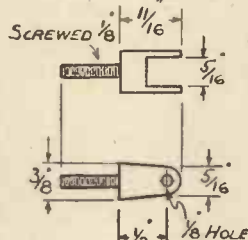

The front axle swivel.

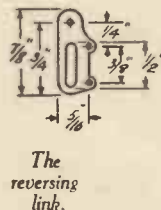

The reversing link.

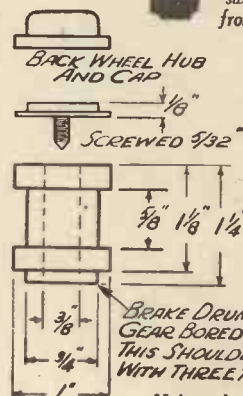

Hubs and caps.

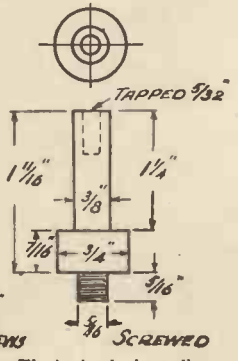

The back wheel spindles.

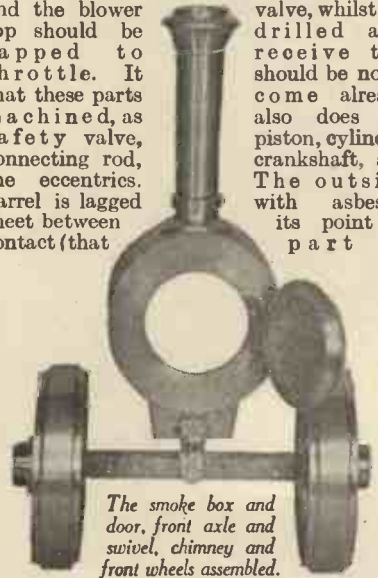

The smoke box and door, front axle and swivel, chimney and front wheels assembled.

Five tubes are soldered into the bottom of the downcomer casting, and into the front end of the boiler in the position shown in the sectional view given last month. The back of the downcomer casting will, of

also does the piston, cylinder, crankshaft, and The outside of the boiler barrel is lagged with asbestos its point of contact (that

FOR AMATEURS OF A ROAD TRACTOR

Construction, from Standard and Valuable Model

By F. J. CAMM

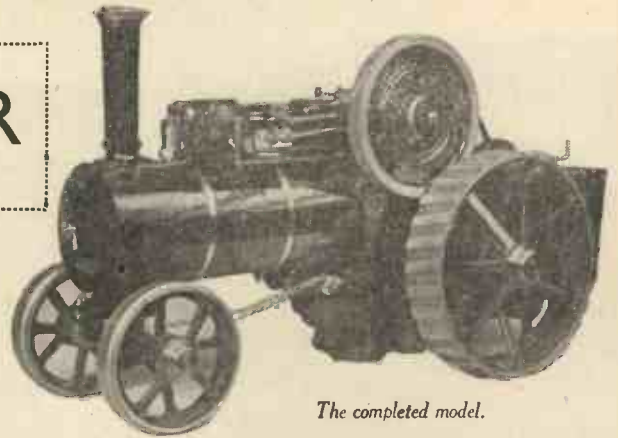

The completed model.

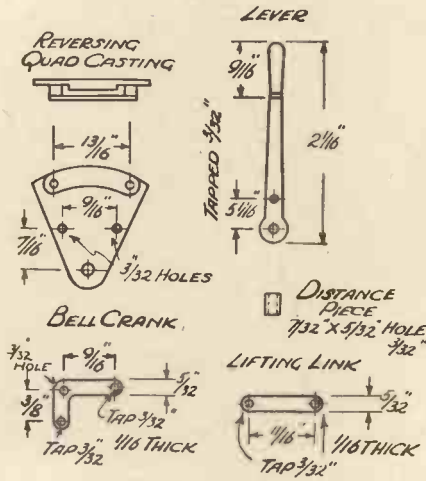

Various small parts.

the barrel which is cut and splayed at the rear) with the horn plates. At this part it is bolted to the horn plate, the front portion of the barrel being either riveted or soldered to the smoke box. It is presumed, of course, that the reader has previously fixed the cylinder saddle and drilled the hole in the barrel to receive the safety valve which is fixed to the front of the boiler, and projects



The assembly almost complete.

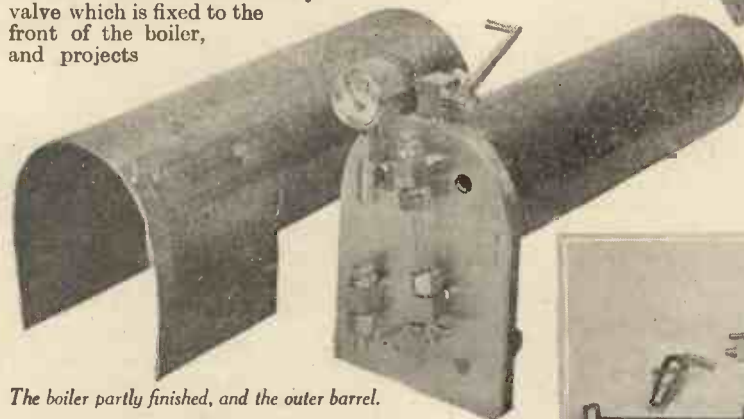

The boiler partly finished, and the outer barrel.

through the barrel. The central pivot which carries the front axle is bolted through the smoke box, and the smoke-box door, of course, is fitted with a snap spring, and the dummy clamping handle. The front-plate casting and the throat-plate casting are next bolted to the front of the horn plate, the chain-roller and steering rod is assembled, and the steering chain connected up.

At this stage assembly of the motion can be commenced. First of all, connect the big end to the crank and the eccentrics to the crankshaft on the left-hand side of the

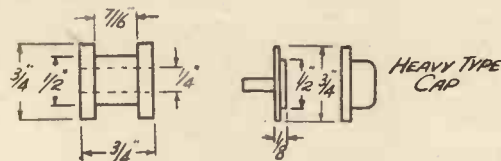

The front wheel hub cap.

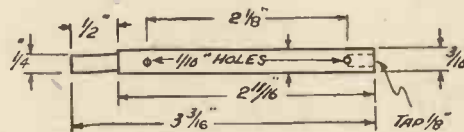

Spindle for steering chain.

bearings to each horn plate by means of two bolts. The flywheel should be connected to one side of the crankshaft, and the driving pinion to the other. This pinion, of course, is made to slide so that the engine drive can be disconnected from the reduction gears.

Now lock up the collar on the left-hand side of the crankshaft so that there is just a little side play. Proceed to mount the cylinder by means of the two screws to the cylinder saddle.

It only remains now to couple up the junction for the steam pipe, the displacement lubricator, the reversing gear rod, and the exhaust pipe, when attention can be turned to the lamp.

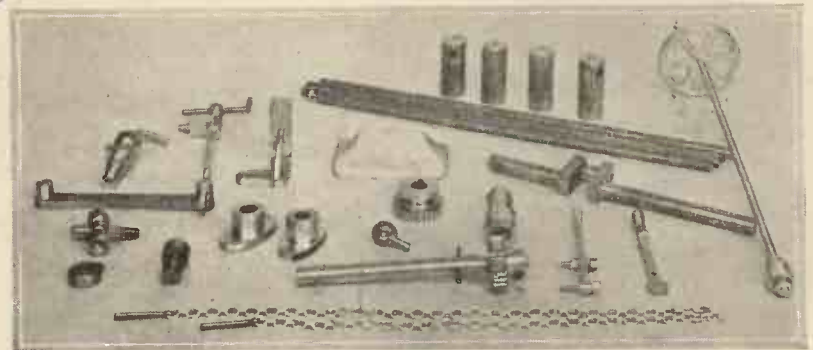
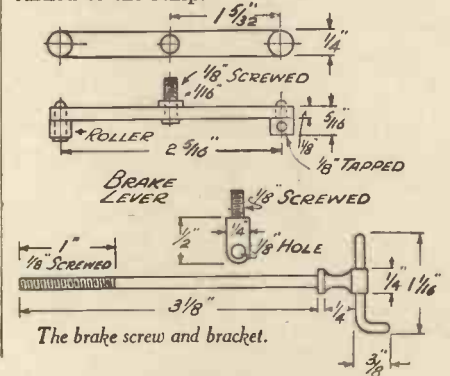

Various small turned parts and accessories for the model road tractor.

crankshaft looking towards the front. Next, pass over the small locking collar supplied, slip a bearing over each end, and then drop the whole assembly between the two slots in the horn plates, securing the

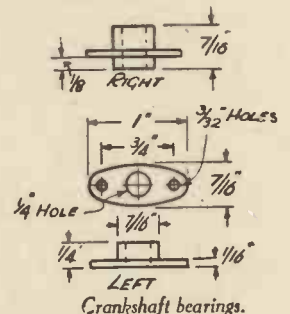

Are YOU Building This

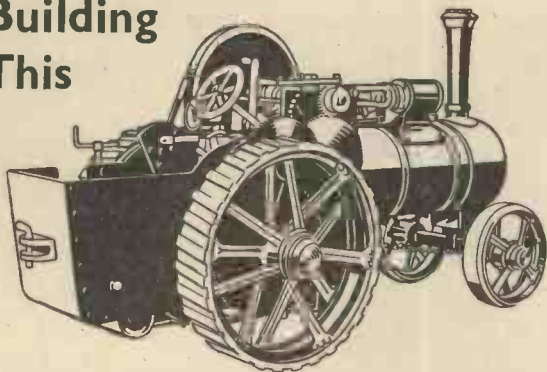

Fine TRACTION ENGINE?

IF not, start at once! Follow Mr. Camm's articles, and you will have a model to be proud of! Full set of castings and parts can be bought, or separate ones supplied as required. Send for leaflet with full details.

OUR NEW EDITION "B" LIST—ENTIRELY REVISED is NOW ready. Get your copy to-day. Ask for New B.12. Price 6d. post free.

Are you interested in Model Turbine Steamers? Bassett-Lowke Ltd. are bringing out a fine new range of speed-boats of this type. Write for particulars. Model Ships Handbook, S.12, and Handbook of Model Railways, A.12, price 6d. each, post free.

Bassett-Lowke Ltd., Northampton

London: 112 High Holborn, W.C.1. Manchester: 28 Corporation Street.

HAND BENCH SHAPER

Carriage Paid 57/6

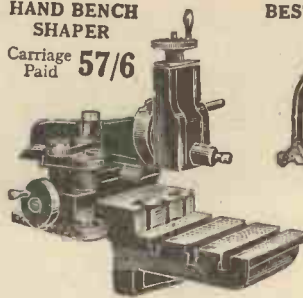

BEST QUALITY PIERCING SAW FRAME



Depth: 2 1/2" 4" 6" 12"
1/9 2/6 3/- 3/9
Piercing Saws for Metal 3 1/2 grs. 3d. doz.
Wood 2/9 grs. 3d. doz.

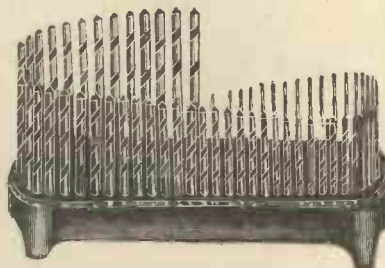

SETS TWIST DRILLS
Set of 29 Drills
From 1/8 to 1/2 in. by 1/64ths.
Complete on Iron Stand 9/6
Post 9d. extra
Cast Iron Stand only, 1/6

Cast Metal Stands
1-60 or 1/8" to 1", each 2/-

FOUR IN ONE SCREWDRIVER
Brass 10d.

Nickel-plated 1/2 each

ANGLE PLATES

Malleable Iron. Fully Machined



3 x 1 1/2 x 1 1/2, 2/3.
3 x 2 x 1 1/2, 2/6.
3 x 2 x 2, 2/9.
3 1/2 x 2 1/2 x 2, 4/3.



FACE PLATE CLAMPS

Malleable Iron
2 1/2" 3d.; 2 3/8" 3 1/2d.; 3" 4d.
3 1/2" 5d.; 4 1/2" 6d. each



E. GRAY & SON, Ltd. 18-20 Clerkenwell Rd. LONDON, E.C.1

Established 1822

Phone: Clerkenwell 0151-2

THE MODEL RAILWAY EXHIBITION



1934

LOCOMOTIVES . COACHES . WAGONS, ETC. WORKING MODELS.

● FREE RIDES. ● FREE CINEMA.

Central Hall . Westminster

TUESDAY 2 p.m. to 10 p.m. APRIL 3rd to 7th OTHER DAYS 11 a.m. to 10 p.m.

REFRESHMENTS CAN BE OBTAINED AT THE EXHIBITION.

Admission (including tax): ADULTS 1/3 CHILDREN 7d. (UNDER 12)

Hon. Sec., 85 Wood Vale, London, N.10.

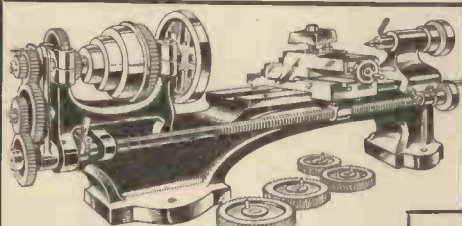

10!

GAMAGES SCREW-CUTTING, GAP-BED, SLIDING, MILLING AND SURFACING LATHE.

This Lathe is a real machine tool and can be used for serious professional work. An exceptionally heavy scientifically designed bed permits of heavy cutting without distortion.

Carriage extra.

Counter Shaft for same, 14/6, Cast-Iron Stand with Treadle, £3 7 6. Foot Motor only, 35/-.

GAMAGES, HOLBORN, LONDON, E.C.1. Telephone: HOLborn 8484

City Branch: 107 Cheapside, E.C.2

DOWN SECURES THIS FINE LATHE.

Balance in 10 further Monthly Payments of 10/-

£4.19.6



MODEL PETROL ENGINES

FOR ALL PURPOSES from £3 3 0

Our Aero Model weighs 15 ozs. and has flown Machine 5 1/2 lbs.

J. HALLAM & SONS, Engineers POOLE, DORSET, ENGLAND

ALL BRITISH !!
ASTRONOMICAL TELESCOPE
FOR THE BEGINNER OUR FAMOUS B.99. **70/-**
MICROSCOPES FOR STUDENTS AS ILLUSTRATION
FROM 17/6 (BRITISH MAKE)
ALL ACCESSORIES, EVERYTHING OPTICAL
Lists on request:
BROADHURST, CLARKSON & CO.
MANUFACTURING OPTICIANS
"TELESCOPE HOUSE"
63 FARRINGTON RD., LONDON, E.O.1.
OVER 100 YEARS' REPUTATION

SOME HINTS ON MODEL RAILWAY PLANNING

By THE PADRE

The planning of a model railway layout is generally restricted by lack of space, but the author gives here a number of useful hints that will be found very helpful.



A complicated layout at a locomotive depot on the West Midland Railway.

TO begin with, everything depends on what you are going to do with your line, or, in other words, what is your favourite approach to the hobby. If you are merely interested in—what appears to me to be—the dreary business of running a nice engine around a circle, all you will require is the circle mentioned. If you are insistent upon the glories of the open air, you will go in for an O-gauge (or larger) garden layout. A large room about 75 x 70 ft., or a barn, and plenty of time and money, will enable you to adopt a comprehensive O-gauge scheme for indoors. But if

you are interested in everything pertaining to a railway's operation—train running, shunting, signalling, artistic appeal, scenic features, permanent way, scale modelling of details, and all the endless offshoots of the hobby in its fullness, you will, without doubt, be wise and adopt one of the two smallest gauges, either OO-gauge (4 mm. to the foot), or HO-gauge (3½ mm.). There is a difference in the two standards, as Figs. 1 & 2 will reveal.

I maintain that one can build an elaborate OO-gauge layout, having about 200 ft. of track, at the same cost as an O-gauge permanent way layout one-sixth the size.

That should be enough to make most people think carefully before plunging recklessly into larger standards because these happen to be more ancient, or because "one can more easily obtain components." The latter argument is a pure fallacy.

The Room Space available

If you have decided upon OO-gauge, you will first require to measure up your room to see whether you can accommodate a single or double track system. Double track is more interesting, involves scarcely any more signalling, but demands double the amount of track. It also involves double



A fine composite view of the Laurenceton Depot.

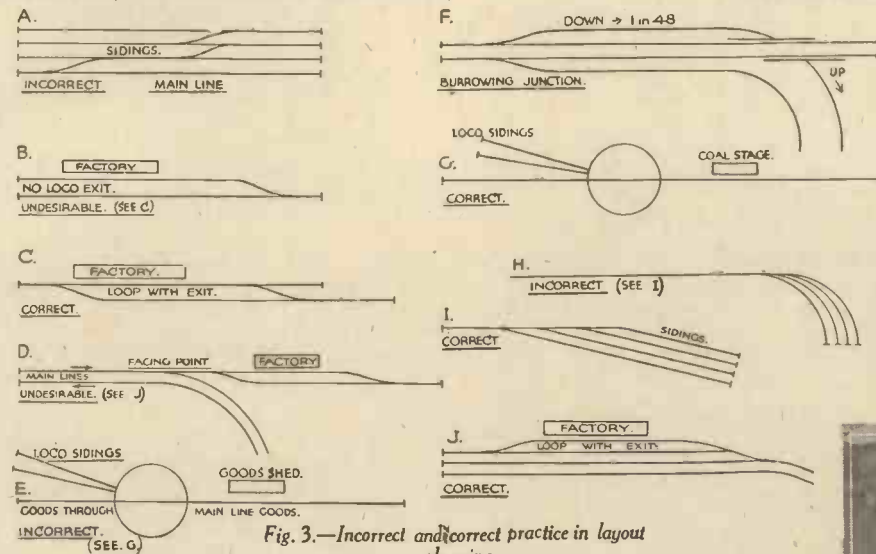

Fig. 3.—Incorrect and correct practice in layout planning.

track wiring and control, and special wiring work at all crossovers to insulate one section from the other. The latter is not such a formidable item as it sounds. My own experience has been that to run one train at once respectably, without derailments, is about as much as one operator can manage without the pleasure becoming a task. Moreover, on 8 volts or less, two locomotives will not run to full capacity at one time. One will take the life out of the other.

But to get down to actual rules for planning; here are a few. First avoid anything extreme, remembering that *trains have to be run*. The thing you have in view may look very pretty; but will it allow of this? If you make curves of less than 18-in. radius, gradients of steeper incline than 1 in about 48, points inside tunnels, lift bridges

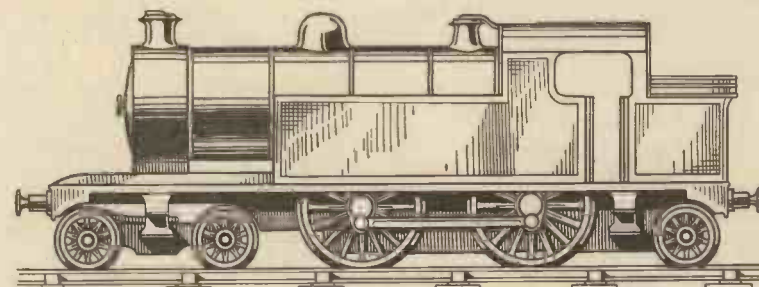

Fig. 1.—A sketch of an HO-gauge engine (approx. 3/4 actual size). Compare with Fig. 2.



A chewing-gum factory on the West Midland occupying an otherwise useless corner.

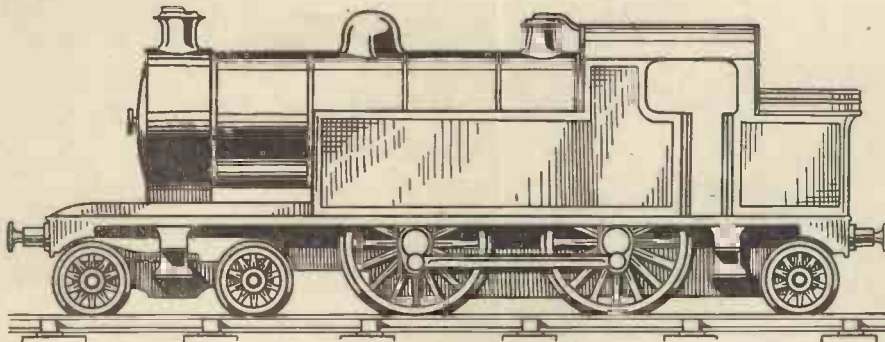

Fig. 2.—Sketch of an OO-gauge locomotive (approx. $\frac{2}{3}$ actual size). Compare with Fig. 1.

all over the place, your baseboard less than 3 ft. from the floor, certain places having track more than 18 in. from the baseboard edge, any part of your baseboard not strong enough to stand on without depressing the track, you will have more trouble than you want. Moreover, you must bear in mind that track MUST be laid absolutely level. The maximum deviation from perfect level permissible is about $\frac{1}{16}$ in., and if you greatly exceed this, you will have endless derailments. But the same is true, in proportion, of all the gauges. And the same applies to track width and the height of outer conductor rails.

Furthermore, never make a station on an incline; you will have trouble starting trains. Never make an opening bridge if the place can be stooped under; stick to your fishplate joints at rail-ends. If you install a diamond crossing, try to avoid doing so on a curve, though in case of a double junction this is unavoidable. Never make two entries to any goods yard, and try if possible to provide both an arrival track and a departure track apart from the actual shunting roads.

Points to remember

In planning your layout, remember the following: (1) Secure, if possible, both point to point running between two termini and an optional continuous run, so that in

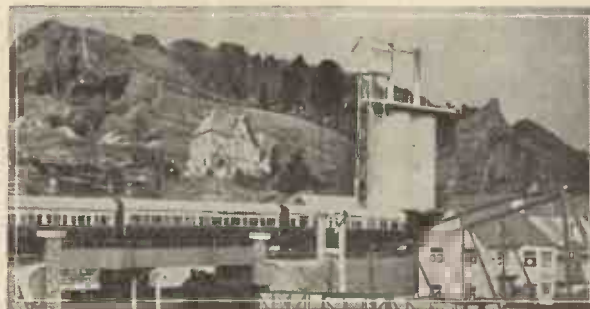

A good effect provided by a model lime works and background scenery.

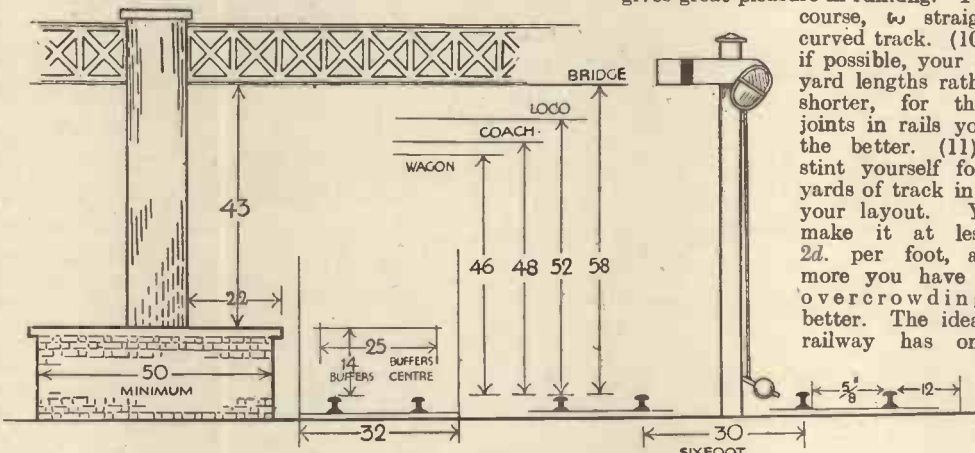

Fig. 4.—Some OO-gauge dimensions (in millimetres).

travelling from one end to another your run can be as long as you please. (2) Try to arrange the continuous section so that, in traversing it, the trains do not pass one station more than once. In other words, never have any stations on this continuous

section at all. Set them all on the branches or at termini, and lay down factory sites on little branch lines. I give in Fig. 3 some sketches of correct and incorrect, desirable and undesirable practice. (3) Under no circumstance allow for any shunting of trains off the main line. (4) Never put a turntable on any line which must be traversed by trains, or by engines on their way to any destination other than the stall of a loco shed. (5) In every passenger and goods station, leave a clear way out for an engine that has arrived on a main line train. Main line engines rarely do shunting excepting at way stations on a journey; and you must allow for a small engine to substitute the large one which has brought in the train, and for the passenger loco to get off on its journey or to the front end of its own coaches. (6) Provide some tracks purposely for the storage of coaches. (7) Make, if possible, in the front of a large loco shed, in such a way as the light falls fully on it, a "parade ground" for the engines when they have left the shed. This should consist of a foot or more of duplicate tracks according to the number of roads into the shed itself. (8) Never have a tunnel without means of ample and immediate access. Derailments always occur more in tunnels than anywhere else. (9) Install along one side of the whole layout a really long length of triple or duplicate track. It looks awfully well and gives great pleasure in running. I refer, of course, to straight, not curved track. (10) Make, if possible, your track in yard lengths rather than shorter, for the fewer joints in rails you have, the better. (11) Never stint yourself for a few yards of track in making your layout. You can make it at less than 2d. per foot, and the more you have without overcrowding, the better. The ideal model railway has only one

level; but that will also be a deprivation.

So, if you must have gradients, make them as easy as you can. Level running takes years to wear out a motor; but you can ruin a splendid machine on a gradient in ten minutes.

An Improved Oil-can

EVERY user of an oil-can has experienced the annoyance of a leaking oil-can caused by the mislaying of the nozzle protector cap. An inventor has provided a simple remedy. A threaded holder is fitted at the base of the spout to which the cap can be screwed when your oil-can is in use. The can is made in two sizes, retailing at 6d. and 1s. respectively.

An Ingenious Screwdriver

EVERY home mechanic is aware of the difficulty of inserting small screws in awkward places, where the fingers cannot easily hold the screws in place. The screw usually drops into an inaccessible corner, from which it cannot be retrieved. Many devices have been marketed to facilitate

the operation, not the least ingenious of which is the nip-it screwdriver. The blade portion of this is split and the split is opened to form a sort of leaf spring. Close the two parts of the blade, and when inserted into the slot of the screw they will spring open and grip it so that with one hand the screw may be inserted and started. The long blade enables the hand to be kept well clear of the work.

A Screwdriver for Wireless Construction

IT is an all-metal tool, the length over all being about 6 inches, the blade approximately $\frac{1}{8}$ inch wide. In use the end is held stationary in the palm of the hand and the driver turned by means of a chequered portion. Simple to use and handy in size, it has many advantages over an ordinary screwdriver for small

work, as an even pressure can be maintained upon the screw, thereby minimising the likelihood of the blade "jumping" the screw cut. These screwdrivers are sold at most popular stores at 6d. each.

A Gramophone Speed Tester

MANY gramophone enthusiasts fail to get the best out of their records because they do not run them at the speed named on the record. The result of this is that the music is reproduced in a key which differs from that in which it was recorded. To get over this drawback, a speed tester is available. By placing the tester on the turntable spindle while the record is playing, you will be able to see if the record is revolving at the speed necessary to ensure true reproduction. The device is quite cheap.

AMAZING VALUES IN TOOLS

WE HOLD THE FINEST STOCKS OF HIGH-GRADE TOOLS OF EVERY DESCRIPTION AND THE OFFERS MADE ON THIS PAGE ARE OF THE HIGHEST QUALITY AND WORKMANSHIP

FITTED CHESTS OF GUARANTEED TOOLS

47 Strongly made Standard Size Tools.

~~£6.6.0~~ 50/-



F.O.R. EVERY TOOL Fully Guaranteed. Offer cannot be repeated after present stock cleared.

Free Gift to every purchaser of the above a 6/6 Volume on "Home Wood Work" will be sent free.

HIGH SPEED GRINDERS

25/- Complete F.O.R. with all accessories as detailed.

Free wheel running Crank. Flexible Shaft is 39 in. long. Flexible shaft, chuck and accessories can be supplied separately, 16/6 complete. F.O.R.

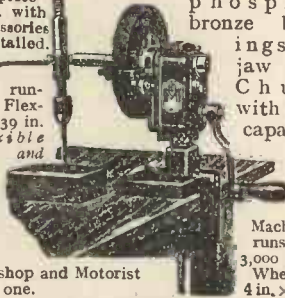

With FLEXIBLE SHAFT DRIVE. Solid Steel Gears in four stages. Machine cut teeth, phosphor bronze bearings. 3-jaw Drill Chuck with 1/2 in. capacity.

Machine runs at 3,000 r.p.m. Wheel is 4 in. x 1/2 in.

Every Workshop and Motorist should have one.

TWIST DRILL STANDS

All Metal—Holes accurate in size—upper face ground and polished. Figures being raised can be read at a glance. T.M. 230a 1/64th to 1/2 in. x 64ths... 2/6
T.M. 230b 1 to 60 all sizes... 2/9
T.M. 230c Sets of Drills 1/64th to 1/2 in. x 64ths... 9/-
M. 230d Sets of Drills 1 to 60, all sizes... 9/-



Fitted Case WHITWORTH STOCKS, DIES, TAPS and WRENCHES (taper and plug tap each size). 1/2 in., 3/4 in., 1 in., 1 1/4 in., 1 1/2 in., 1 3/4 in., and 2 in. 25/- complete. Carriage Paid.

We have a few Full Size HANDSAWS. Sheffield made but slightly soiled. Usual price 8/6. Clearing 3/6 Carr 9d. at

Ditto, 12 in. TENON SAWS 2/9 Carr. 6d.

3' Centre BACK GEARED SCREW CUTTING LATHES

Gap Bed Sliding, Milling and Fine Surfacing Hollow

Mandriladmits 1 in. bar bored No. 1 Morse Taper Height of centre 3 in. Distance between centres 12 1/2 in. Length overall 30 in. Delivered on first payment of 8/6 and 10 monthly payments of 8/6. Worth 8 Gns.



£4'19'0

Special offer Catalogue for Model Engineers' Tools. Post 2d. COMPLETE CASH SALE PRICE F.O.R.

5 SHEFFIELD MADE CHISELS, 1/2, 3/8, 1/2, 5/8 & 1 in. 4/5 Post 6d.

CRAMP HEADS

To make any length required. Takes wood bar 2 x 1 in. 3/- Pair Postage 9d.



BRITISH MADE

CUSHMAN SYSTEM 3-JAW CHUCKS

With 2 sets of Jaws. 2 1/2 in. ... 26/6
3 " ... 27/6
4 " ... 29/6
6 " ... 39/6
T.M. 207. 6 " Backplates fitted to above Chucks and screwed to fit Lathe Nose.

2 1/2 and 3 in. 8/- 4 in. 10/- 6 in. 15/-



HALF INCH BENCH DRILLS

BRITISH THROUGHOUT

Ball Bearing. Weight, 14 lbs. Height, 20 in. Automatic Adjustable Feed, Steel Spindle, Cut Gears, 3-Jaw Self-Centring Chuck 0 to 1/2 in. Including Set of 9 Twist Drills. 35/- Value 14/6 Carr. Paid

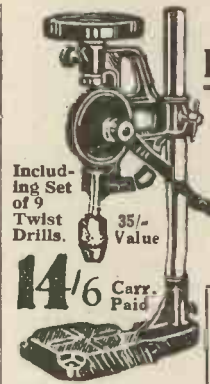

We still have a few Combined Engineers' and Woodworkers' All-metal Vices, as previously advertised, 6 1/2 in. jaws, 6/- Post Free.

POLAR CLUB ELECTRIC DRILL

Made for 110, 200-220, and 230-250 volts, A.C. or D.C. Beautifully finished in black and steel.

An indispensable tool for the workshop, garage and home. A really efficient electric drill at a popular price. It takes drills up to and including 1/2 in., and will bore through steel of any thickness. It is equipped with a cooling fan and ball bearings, and, although it works at high speed, very little vibration is felt. The switch is conveniently placed in the pistol-grip handle. (Triple flex and plug 10/- extra.) PRICE 63/-



A Real Bargain! 6in. HIGH SPEED HAND GRINDER

British made. Complete with adjustable tool rest. Useful in the workshop and the home.



Fitted with Corundum Wheel 6 ins. x 1 in. 5/9

WOODWORKERS' METAL VICE

Steel parallels slides, machine cut threads, width of jaws 6 in., open 4 1/2 in. 4/- Carriage 1/-

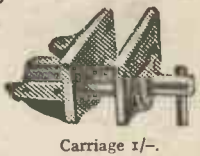

S. TYZACK & SON LTD. TOOL SPECIALISTS, DEPT. P.M., 2 341 to 345 OLD STREET LONDON, E.C.1

Please send me the following Catalogues:—
1. WOOD WORKING TOOLS (Postage 2d.)
2. METAL WORKING TOOLS (Postage 2d.)
(Postage on both Catalogues 3d.)

NAME _____
ADDRESS _____

HOW LONG DOES YOUR ACCUMULATOR LAST?

By DEREK ARCHER

A simple arrangement which allows you to check up on your charging station.

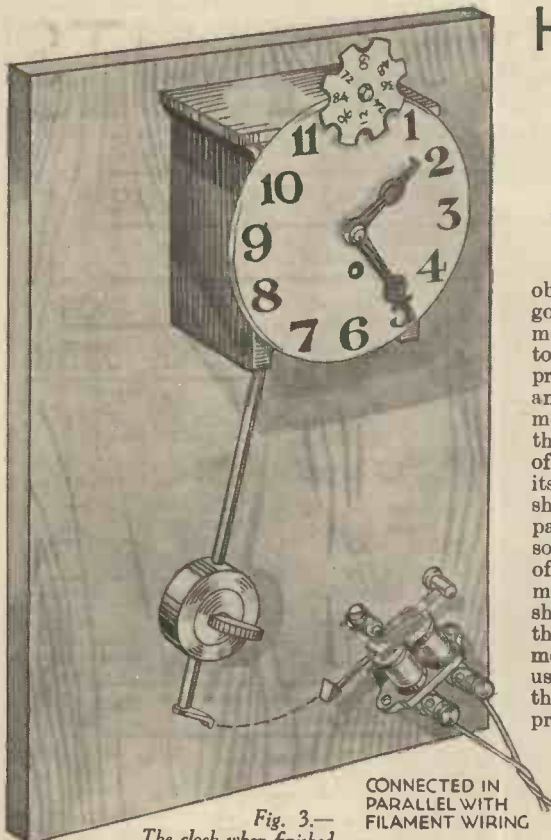

CONNECTED IN PARALLEL WITH FILAMENT WIRING

obtain an electric bell movement in good condition. Mount the clock movement on a piece of stout board towards the left-hand side. The principle of the idea is fully explained and the details can be decided as the mechanism is put together. Remove the brass ball at the end of the stem of the bell movement and solder in its place a brass pallet shaped as shown in Fig. 1. The faces of the pallet should be smooth and free of solder. Then solder to the very end of the pendulum rod another pallet made from thin brass strip. This should be made fairly light so that the timing of the clock is not affected more than can be corrected by the usual adjusting screw. Now set up the clock movement to work in its proper position and offer up the bell movement so that the pallet on the pendulum just misses the pallet on the end of the bell arm when the armature of the bell is pressed up against the pole pieces. Secure the bell movement in this position.

The movement can be secured to a piece of wood provided with slots so that adjustments can be made after it is mounted. Then adjust the usual contact screw, which will not be used electrically to push the armature towards the pole pieces so that the two pallets just engage in one another when the armature is released. Sufficient engagement should be allowed to hold the pendulum back just at the top of its swing.

The Wiring

Disconnect the two wires of the bell movement and take the two wires from the coils themselves to two conveniently placed terminals on the clock board. These two terminals are then connected up by flexible wire to the receiver. The wires are connected direct to the two filament terminals of one of the valve holders so that current is only applied to them when the receiver is switched on. The circuit and the complete arrangement is shown

in Fig. 3. It is important to note that the two wires must not be connected across the accumulator terminals or across the filament switch. Some tests should now be made to see that the idea is working correctly. Catch the pendulum up on to the bell pallet and switch on the receiver. The current should then traverse the windings of the coils and magnetise the cores. The armature should then be drawn up to the pole pieces and the pendulum released and the clock start working in the usual way. The receiver should next be switched off when the armature returns to its normal position against the adjustment screw. The pendulum on its next swing will thus catch up on the pallet and the clock will be stopped. There are one or two points which require attention. It may be found that the armature refuses to "come unstuck" when the receiver is switched off. This is due to the residual magnetism in the cores and the armature, but this may be overcome by securing a piece of paper to the ends of the cores or on the back of the armature so that the armature and the ends of the cores do not come into contact with each other. Another method is to run a small blob of solder on the top of each core—anything to prevent the armature and the pole pieces touching, and so sticking together when the current is switched off. Another point which may require attention is the fact that the armature may not release when the set is switched on owing to the weight of the pendulum pressing too hard against the pallets. The faces of the two pallets should be filed so that they slide over each other easily and if necessary be polished. Another point which requires attention is the two coils of the bell movement. Usually these coils are of a very low resistance, the pair used by the writer being 4 ohms, and therefore pass a fairly large current. In fact, the coils can use up as much juice as the valves in the receiver. This must of course be cut down considerably. The insertion of a 400-ohm resistance in one of the leads to the coils cuts the current down to about 5 m.a.'s, which is quite small compared with the current taken by the receiver. However, it may be found that the ampere turns on the coil have been cut so low that the armature will not operate with so small a current. The bobbins can be rewound with No. 40 enamelled wire and the resistance will then come up to several hundred ohms.

SOME accumulator charging stations are not exactly what they should be, and possibly due to carelessness or too many accumulators to charge on an inadequate plant, one finds that one's accumulators last for different periods each time of charging. Whereas sometimes the accumulator lasts a week, other times it lasts a fortnight. The writer has had much experience of this and much argument with the charging station, and for some time kept a log. Although this was satisfactory up to a point, one cannot expect other users of the same receiver to have the same interest, and therefore the log was not an accurate one exactly. So the writer rigged the following device up, which has given some satisfactory service, but has opened up interest from many points of view. The device counts up the actual time the receiver is in use and gives a true account of the life of the accumulator charge. It also indicates the hours the receiver is used by others than the writer, and indicates over longer periods the life of an H.T. battery—not by so many months, but by the actual hours.

Mounting the Clock Movement

Obtain an eight-day clock movement, one with a pendulum, or an ordinary one-day clock will do, providing the winding is not forgotten. A clock with a rotating flywheel is not recommended, as it is nearly impossible with simple mechanism to make it start by itself once it is stopped. Also

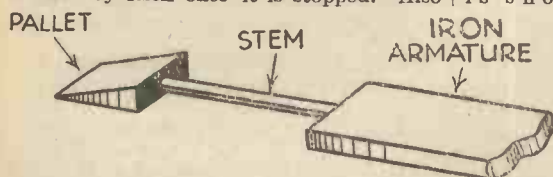

Fig. 1.—Details of the brass pallet and armature.

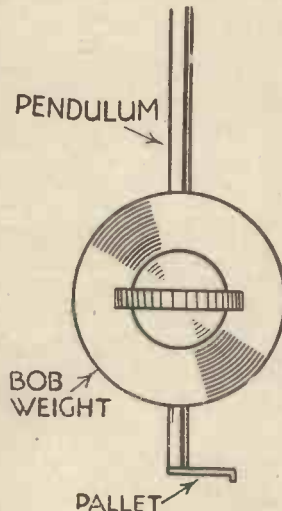

Fig. 2.—A pallet is also fitted to the end of the pendulum.

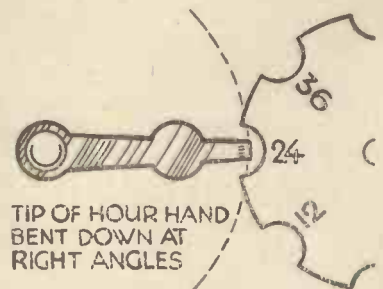

Fig. 4.—How additional hours may be recorded.

SIMPLE SPRAY EQUIPMENTS

By W. WYMER

THE object of this article is to outline the construction of two simple but efficient spray outfits that may be used by manufacturers of small articles for applying paints, varnishes and lacquers, etc.; and by others for innumerable purposes about the workshop or household. To get a wider appeal into the subject, it is intended to show how either of these sprays may be turned to account as "money makers" by those who, having apparently no use for a spray, go to the trouble of making one.

As many readers will know, the finishing of articles with a spray, whether the material used be cellulose or water stain, is a business that only experience can teach. Different jobs entail individual treatments with differing "standard named" materials. Incidentally, spray equipments are by no means of a standard pattern; being instead designed to "general" work to be done. And because of this, the subject of material application is limited—just as are the sprays to be described.

The simplest sprayer, based on the principle of the familiar perfume spray, consists of two parts, namely, the air compressor and the material reservoir. A glance at the sketches will make this clear. For the former a hand type motor pump may be used, although this is not recommended, as the average barrel of a pump has not a very big air capacity. A better plan is to use a 2-ft. length of 3 or 4 in. diameter metal tubing that has no projecting seam on the inside. Any small quirk or recess on the inside, formed by an outside seam, however, can be filled in with plastic material.

Other Parts of the Pump

The plunger (Fig. 7) consists of a 2 ft. 6 in. length of steel rod, provided with a suitably sized leather washer affixed between two metal washers by two spindle collars. Those with engineering facilities may wish to cut a thread on the rod and thus be able to employ two nuts for the fixing; but as long as the leather washer is held tightly and squarely, the method of fixing is immaterial.

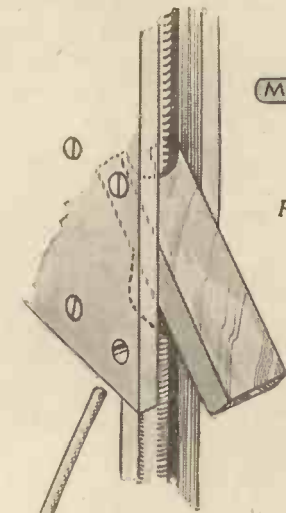

Fig. 2.—The trigger fitted into position with the locking pin removed.

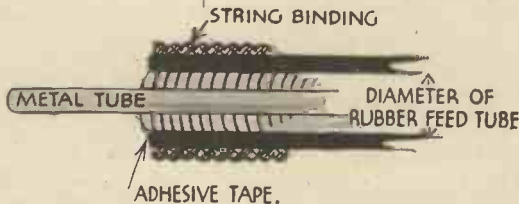

Fig. 4.—The nozzle should be bound with string as shown.

The important parts of the pump concern the two wooden ends fitted into the barrel ends. These must fit air-tightly, one being bored centrally with a brace-bit $\frac{1}{8}$ in. greater diameter than the plunger rod employed; the other, nearest

Two simple types of home-made paint sprayers that will enable readers to obtain excellent finish on all articles that require painting in the household and workshop.

the reservoir, with no more than a $\frac{1}{8}$ -in. drill or red-hot hatpin.

The Liquid Reservoir

This may be fashioned out of any screw-capped tin or jar (Fig. 6). A piece of $\frac{3}{8}$ in. internal diameter metal tube being soldered through a hole in the lid towards the side of it as depicted, its projecting end coming level with the centre of the pump hole when the whole is stapled to the wooden barrel end. The other end should

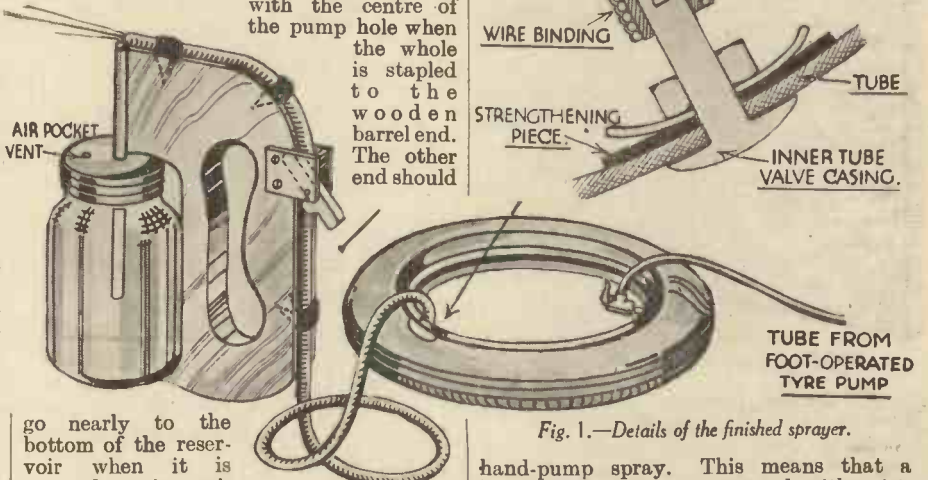

Fig. 1.—Details of the finished sprayer.

go nearly to the bottom of the reservoir when it is screwed up in position. Further to this, a small air-vent is bored in the reservoir lid; and the washer should be lubricated with fairly heavy oil.



Fig. 3.—The trigger for stopping the flow of air in the air pipe.

There is little mystery how such a spray works. By forcing the plunger inwards, a high velocity air stream is

forced across the top of the material feed tube and effects a suction effect through making a reduction of pressure in the tube, with the consequent drawing up of material. This material, being sucked up into the air stream, is atomised into a fine mist and forced on to the object under treatment.

Fig. 5 shows the finished sprayer. Fig. 1 illustrates an improved model that costs but little more, but which can be used for work impossible with the one described. Instead of using a pump adjacent to the reservoir, an air-compression tank, fashioned out of an old motor tube (complete with wheel and tyre) is used intermediately to maintain indefinitely a pressure of air for working purposes. A foot type motor inflater feeds

this tank which in turn feeds via an air line a jet, affixed to a wooden handle, over the material feed tube.

No Break in Air Pressure

It will be found that with this apparatus one of the operator's hands can be free to do the hundred and one jobs that crop up during working time. The chief advantage, however, is that there is no break of air pressure over the reservoir feed tube, as there is bound to be with a "straight"

hand-pump spray. This means that a larger surface can be sprayed with mist, instead of mist and "spray," as would be the case, because any reduction or fluctuation in air pressure changes the power of atomisation. The pipe-line is joined to this by the shell of an inlet valve taken from a spare inner-tube. This should be soundly resealed so that there is no escape of air, or weak surrounding likely to bulge and burst. Any cycle repairer will do this job for a few coppers. The tyre and wheel, by the way, are only reinforcing agents for the tube when it is fully inflated.

The "Gun" Construction

One is not bound to adhere rigidly to the plan given, although it is recommended that the metal feed tubes be of no greater bore than the figures given. The air tube, because at one end it has to fit in the rubber pipe-line, which may be too big in bore, can be built to thickness with adhesive tape. Strong string or wire should be used to bind the joint (Fig. 4). The material reservoir is the same as the one hitherto described; therefore there remains only the air-tap (Fig. 3) to consider, which, although it may be dispensed with, is worthy of inclusion on the gun. Its sole purpose is to stop at will the flow of air over the reservoir feed tube, and it does this if the finger on the tap is pressed, causing the block to tighten in the walls of the pipe-line. A sturdy wire pin is used to form a lock (Fig. 2).

When completed, it is advisable to practise spraying with water. After filling the reservoir three parts full the air-tap should be closed and pressure worked up in the "tank." Release the air-tap slowly and play the gun on the practice surface so that the mist ejected hits it at an angle of about 30 degrees. Coverage progress in

width over wide surfaces should be made by just overlapping the first line (although there is no line) of material put on. It should be remembered that the greater the distance between the gun and the object,

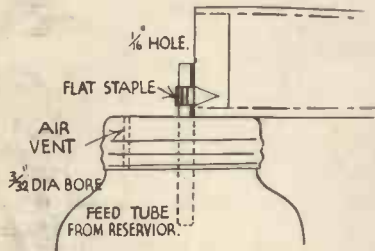

Fig. 6.—How the pump and paint compartment are fitted together.

the wider the coverage area, and the "lighter" the coating of material applied. With a "hefty" tube for the tank it will be found that short runs of spraying can be done successfully without reinforcing the pressure supply in the tank; but even so, because the gradual reduction in tank pressure will alter to some extent the size of the mist molecules—hence the surface finish—it is best to operate the pump from start to end of the work. Incidentally, an outfit of this type can be used to spray almost any liquid material, providing it is not too heavily bodied with silicates. Thick solutions have sometimes to be diluted, and two coats given to the object instead of one to make up any deficiency

that may arise. The following diluents are recommended for the most likely materials to be used.

Cellulose brushing lacquers and enamels : Amyl acetate, ethyl acetate or cellosolve.

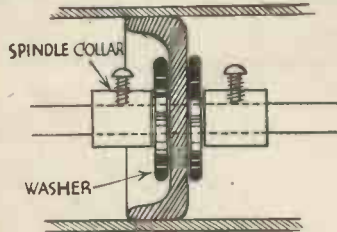

Fig. 7.—Details of the plunger.

Paint : Petrol or the usual turpentine.
Varnish paint : Turpentine.

In all cases where a second coat of material is to be applied, the first coat should be thoroughly dried and polished with pumice powder. What of the money-making possibilities of these outfits? Well—either can be used to whitewash ceilings, a call for which is endless during the spring. Where the surface to be treated is

extensive, a larger material reservoir will prove useful.

Creosoting

In residential districts there is much of this to be done, and can be done by anyone who goes to the trouble of preparing a sound circular, pointing out the economical feature of having fences, etc., treated with creosote once a year.

Tree spraying, etc. Gardeners who make a spray outfit will soon find out that the initial outlay is saved on materials sprayed.

Poster writers will find endless uses for a spray of the larger type, amongst which shadow-graph work can be cited. And



Fig. 5.—A more simple type of sprayer.

mechanically-minded money-makers may consider manufacturing an advanced design of either of these outfits, remembering when they get to the marketing stage of their business that either kind of spray may be used for air dusting, metal dusting, washing, and other purposes in the workshop and home where a constant supply of high velocity air is required.

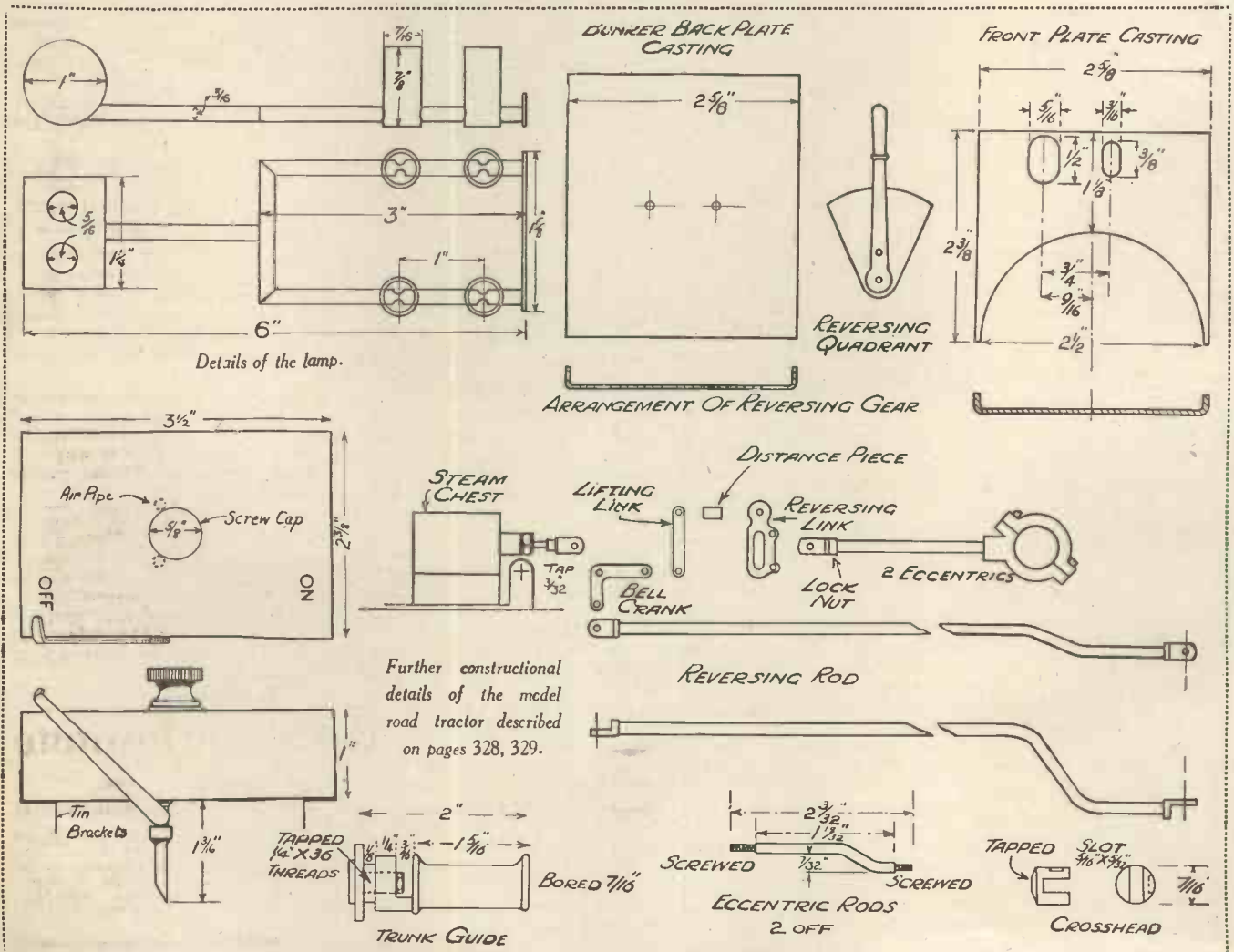

ARRANGEMENT OF REVERSING GEAR

Further constructional details of the model road tractor described on pages 328, 329.

HOW LENSES ARE MADE

(Continued from page 327.)

Even then the various precision tests are again applied, and in a dust-proof room, for a speck of dust would prevent the accurate observation of the Newton's rings formed by placing the master lens upon its appropriate curve on a glass. In fact, so perfect is the fit when correct that often a decided effort is required to separate the two glasses after the test. Having passed all these elaborate tests the various combinations of single elements are cemented together. This is done by placing a drop or two of Canada balsam, a thick treacle-like liquid, upon one glass, and bringing its counterpart upon it. A little squeezing and sliding, and the combination is laid aside for the cement to set hard. These combinations are then ready for mounting in the brass cells.

The Mounts

The mounts of a modern lens are in themselves quite elaborate pieces of mechanical production. The various dimensions of the lens mount require to be practically as accurately made as the glasses themselves, since upon the perfection of the tubes do the centring and the spacing apart of the combinations depend.

Most of the brass and aluminium tubing used for lens mounts is prepared to fairly accurate dimensions prior to turning by being "drawn." That is to say, it is pulled through steel dies in a powerful machine. This mechanical operation affords a curious contrast to the method of making specially large mounts, for which tube is not available, from sheet brass bent and seamed by brazing in a furnace.

When the glasses are finally placed in their brass cells, in some cases they are held in place by means of screwed rings. In other cases they are carefully "bezelled," by which is meant the turning, again in a lathe, of the edge of the brass cell over the glass to secure it. As soon as the whole assembly, with iris diaphragm, is put together, the lens is ready for its final tests, which, in a modern factory, are no less drastic than those which have preceded them. Each lens is placed in turn upon a special camera, and the image of a row of small lamps is observed critically upon the ground-glass screen. By this apparently simple means checks are made for the various faults to which photographic lenses are subject, and which the computer in the first place took so many months to eliminate from his calculated results. For even when a number of lenses have all been made to exactly the same specifications, and checked by the same microscopically accurate gauges, nothing is taken for granted by a reputable manufacturer. Even then actual photographs are taken with at least one lens out of each small batch. But not of an ordinary subject. The object photographed is a peculiar-looking chart, shown in Fig. 4, which covers one wall of the testing room, being 10 ft. long. A curious arrangement of lines and of curves is designed specially to show, on examination of the developed negative, exactly those faults in lenses which will show themselves, if they exist, in just those places, and just those ways, which the chart is designed to coax them to do!

A lens which passes all these complicated tests must be perfect indeed, but there is still one fault that even they will not discover, and for which a further test is made. This is a "colour" test. Although it is fairly well known that light of different colours travels on different "wavelengths," it is not so familiar a fact that a lens may

not focus such different colours upon the same plane, or even to the same dimensions. Thus a Union Jack, photographed with a faulty lens, might show either the blue or the red stripes slightly out of focus, and if carefully measured, the dimensions of the stripes in the photograph would not be proportionate to the actual stripes in the flag itself!

ABOUT PHOTOGRAPHIC PRINTING PAPER

PHOTOGRAPHIC paper may be coated with a similar emulsion to that used for plates and films, in which case it will need developing and fixing in the same way, or, on the other hand, it may be treated with a different type of emulsion—one which is much slower in action and which produces an image without being developed. As the chemistry of the former type of paper is much the same as that of a film or plate, we will not enter into a description of that here, but will pass on to a study of the latter type. There are several varieties, all of which can be used in daylight. The active element in their composition is silver chloride. The action of light on silver chloride is to produce what are known as photo-chlorides of silver. There are several of these compounds, and they vary in colour from pink, red, reddish purple, purple, and dark brown to almost black. They are a cross between silver chloride and pure silver, that is to say, they contain silver and chlorine, but less chlorine than does ordinary silver chloride. There are also produced some curious forms of metallic silver, which are quite unlike ordinary silver, being coloured like the photo-chlorides. One form is actually soluble in water!

The emulsion used for coating these printing papers is usually gelatine containing silver chloride and other substances. When the paper is exposed to bright daylight under a negative it gradually turns reddish purple in the parts which are in contact with the thin or transparent parts of the negative. Thus the light parts of the negative are reproduced as dark parts on the paper, while the dark portions of the negative are represented by white paper. In this way a true replica of the original view as "seen" by the camera is produced.

There are two main types of daylight printing paper. The older type is called printing-out paper (P.O.P.), while the more popular kind is known as self-toning paper. The image produced by P.O.P. is, as we have just said, of a red or reddish-purple colour. This is not a very pleasing tint, and it is therefore "toned" after printing by placing it in a solution of gold chloride. The action of the gold chloride on the silver image is to deposit finely divided metallic gold, which neutralises the red tone of the print and produces a rich dark shade. Self-toning paper is similar to P.O.P., but has the gold toning ingredient incorporated in the emulsion. This paper only needs fixing in hypo after printing.

Standard Work on Model Aircraft "Model Aeroplanes and Airships" by F. J. Camm.

96 pages. 120 Illustrations.

Obtainable from all newsgents, price 1/- or from Messrs. George Newnes, Ltd., 8-11 Southampton Street, Strand, W.C.2, for 1/2 post free.

The DECIDING FACTOR

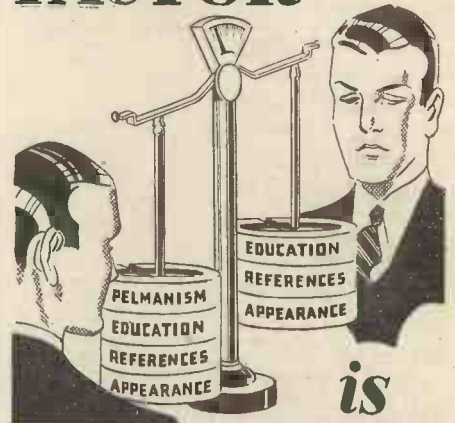

is PELMANISM

"Of two young men in business, one takes a Course of Pelmanism, the other does not. Other things being equal, the one who takes the Course will quickly pass the one who has not availed himself of this advantage in the race of life."

The late Mr. T. P. O'Connor, M.P.

Pelmanism means a big "pull" for you when you are applying for a new situation or for promotion in your present position. Employers know that the man who is a Pelmanist will bring to his work a quality of brain that is wanted in every business and profession. It means that he possesses Initiative, Judgment, Reasoning Power, Ability to Originate and Plan, and, above all, a sound and absolutely dependable Memory.

These valuable qualities are not too common, and they distinguish the Pelmanist from the man who has not troubled to train his mind and develop his faculties.

Pelmanism, in fact, is the indispensable completing touch to any kind of education—it is a system which makes all other education fruitful. That is why, whatever career a man may choose, he needs Pelmanism to enable him to attain success and earn a big income.

Pelmanism is very simple and interesting to study; it can be very quickly mastered, yet it makes 100% difference in the value of a man to his employer. That is why employers always prefer the Pelman-trained man.

We shall be glad to send you a copy of "The Science of Success," 48 pages, post free. You can make just a bare application by letter or postcard. Your inquiry will be regarded as a confidential communication. You are sure to be interested in at least one of the people who, in "The Science of Success," speak highly of Pelmanism from practical experience.

Address: The Secretary,

The Pelman Institute

130 Pelman House, Bloomsbury Street, London, W.C.1.

Pelman (Overseas) Institutes: PARIS, 80, Boulevard Haussmann. NEW YORK, 271, North Avenue, New Rochelle. MELBOURNE, 396, Flinders Lane. DURBAN, Natal Bank Chambers. DELHI, 10, Alipore Road. CALCUTTA, 102, Clive Street. AMSTERDAM, Leliogracht 30. JAVA, Kramhoutweg 8. Bandaeng.

THE ORIGIN OF THE MARINER'S COMPASS

By
HERBERT WILLIAM JONES



This illustration shows the Husan Patent Dead Beat Compass manufactured by Messrs. Hughes & Son, to whom we are indebted for permission to use this photograph.

or needles which had been magnetised by rubbing on a lodestone. These needles were then pushed into a reed and either floated freely on water, or were made free to turn on a pivot.

We can copy this very easily by rubbing a needle on the two poles of a common horseshoe magnet. Then if the needle be dry and clean and it be lowered carefully on to the surface of

water in a basin, it will float of itself without any raft, and will then point magnetically north and south. This, however, will not take us very far, because if the needle is disturbed it promptly sinks.

A Simple Experiment

We need not worry ourselves about a needle, nor a basin of water, because the horseshoe magnet itself will act as a compass. All we have to do is to hang it up by a piece of cotton at least a yard in length, and leave it overnight to allow the cotton to unwind. In the morning we shall find it pointing north and south.

Such a needle balanced on a pivot was quite good enough to take Christopher Columbus to America in 1492. He wished simply to keep on going vaguely towards the west, hoping some time to arrive somewhere. He needed a more definite sense of direction on his return journey.

More than a century later, in 1597, a certain William Barlow says: "Two East Indians were brought into London. I questioned with them. . . . They spoke of a magnetical needle six inches long upon a pin in a dish of white China earth filled with water. There were lines ruled on the bottom of the dish."

Navigation of the Seas

Ships, however, had been navigating the seas for many centuries before Christopher Columbus, but we can understand that they were chary of trusting their lives to a needle 6 inches long upon a pin in a dish.

It was probably the navigators of Genoa, Venice and the other merchant cities of the Middle Ages who took over the knowledge of the primitive compass from the Arabs and then developed it; for in the times of St. Louis, King of France, and the Crusades it was known that a magnetised needle had a "vehement desire" to point to the north.

The chief differences between a primitive compass and one of the present day are in sensitiveness and in reliability.

Sensitiveness is obtained by attaching half a dozen highly magnetised needles to the under surface of a light card or disc which is suspended by silk threads from a pivot. The upper face of the disc is marked with the points of the compass, because it does not make any difference whether the needle moves over a fixed card, or the card



It was the mariner's compass which enabled cartographers to verify the shape of the world.

moves opposite to a point fixed with regard to the ship.

Reliability is a more difficult matter, because we may compare the motion of a small ship in a rough sea and its compass to that of a small boy on the back of a buck-jumping pony. The animal moves bodily to the right, to the left, forward, backward, up in the air, down again with a bump, and at the same time rolls sideways and almost somersaults tail over head. All the time this is going on the boy must keep a perfectly steady seat.

This is exactly what the compass must do, and not only retain its seat, but must, as it were, hold out a hand and point in a fixed direction.

This is managed by a double system of suspensions of the compass-box whereby the rolling and pitching of the ship are eliminated. At the same time too violent and temporary oscillations of the disc are prevented by filling the box with liquid.

A serious complication has been introduced in modern times by the practice of building our ships of steel. The effect of this mass of magnetic material all round the compass has to be most carefully allowed for.

The Story of Floki

When all is done a modern vessel has at its service a most wonderful instrument which enables it to find its way when "neither sun nor stars" shine upon it "for many days."

We may, in conclusion, compare the certainty with which we traverse the ocean with the account we find in the Scandinavian records which tell us that "Floki, son of Vilgerd, instituted a great sacrifice and consecrated three ravens which should show him the way (to Iceland); for at that time no men sailing the high seas had lodestones upon northern lands."

This was written about A.D. 1300 and refers to an expedition in A.D. 806 for the purpose of rediscovering Iceland.

Floki probably arrived in Iceland more through his own instinctive ability of finding his way about at sea than by any help which the ravens gave him.

OUR first knowledge of magnetism was the lodestone. Probably the name lode, or lead, originally meant that it was seen to attract particles of iron or other pieces of iron ore to itself. The easiest way to view this attraction is to float the object to be attracted on a small raft. This led at once to the discovery that the lodestone if left to itself on a raft assumes a definite directive position.

The lodestone is not in the least mysterious; it is merely a piece of magnetic iron ore. It can be obtained anywhere.

A knowledge of the lodestone is credited to the Chinese, Arabs, Etruscans, Greeks, Finns and Italians. All the stories are very contradictory, but need we be too disbelieving of the account in Chinese history which says that in the sixty-fourth year of Hwang-Ti, that is, in the year 2634 B.C., he attacked Tchi-Yeon, and finding his army lost in a fog raised by the enemy, he made a chariot which indicated the south and so pursued Tchi-Yeon and made him prisoner. The story does not say in so many words that this fascinating chariot contained a lodestone, but how else could it have pointed consistently in a desired direction? Let us accept the story respectfully because of its antiquity.

Tcheon-Choung and the Chariots

Is it the same story retold when we read that about 1100 B.C. three ambassadors from the Kingdom of Annam were entrusted with the carrying of a gift of white pheasants to the Emperor of China? After setting out on the return journey they lost their way, and Tcheon-Choung gave them five travelling chariots so constructed as always to indicate the south. Mounted in these chariots they arrived safe and sound the following year in their own country. It seems that in each chariot was a wooden man balanced on a pivot whose stretched-out arm contained a magnetised bar of steel. We shut our eyes to the improbability of the said Tcheon-Choung knowing anything about magnetised bars of steel as early as 1100 B.C.

Whether we believe these stories or not, it is clear that the earliest compasses in use in navigation were made of small steel rods

USE WILCO MOTORS

THIS ONE 12/6



Sturdily built Economical to run

Made in several sizes for working off Batteries, Accumulators, or direct off the Electric Mains without a transformer.

With gearing as illustrated or just with 2 pulleys on shaft.

Trade Supplied

PRICES:

WITHOUT GEARING. WITH GEARING.

4/6 volts 89 1/100 H.P. 17/6 4/6 volts 12/6 1/100 H.P. 21/6
 1/50 H.P. 25/- 1/30 H.P. 35/6 1/50 H.P. 22/6 1/30 H.P. 38/6

MAINS MOTORS are fitted with lead and adaptor, ready for use, and terminals are enclosed in base.

Send for Electrical Catalogue of other Models suitable for SPEED BOATS, etc., Ad., Post Free.

L. WILKINSON, 8 City Road, London, E.C.

MOVIE MAKING FOR THE BEGINNER

(Continued from page 316.)

difficult to produce, but I have seen quite good ones produced on the simplest 9 1/2 mm. cameras. Pictures of this kind are made with a double exposure of the film.

Ghost Scenes

Say, for example, you are taking a scene outside an old dismal-looking castle and you wish the ghostly figure to stalk across the scene. We will imagine at the same time that there is to be a group of people staring in amazement at the ghostly visitant. First of all calculate the story you want to use, with any of the good exposure meters, and with the camera on a stand film the background and the surprised people gazing at the spot where the ghost is to appear. Use one stop smaller than the exposure meter tells you is correct. Now tell your actors to keep quite still for a few minutes (they should stand in such a position that they can retain this posture without physical inconvenience for several minutes) and then take your charger out of the camera and in either a dark room, or, as dark rooms are not usually conveniently placed in such scenes, in a changing bag used for loading plates, open the charger and carefully wind back enough film to at least equal the amount of the scene you have already shot. Close the charger again, reload the camera, being careful not to move it, and film the scene again, but this time arranging for the figure which is to be the ghost to walk in a slow and stately fashion into the picture.

When the film comes back from the processing house everything will be properly exposed except the figure of the ghost and the background behind him. You will be able to see the background right through the figure, and the whole effect will be that of the conventional ghost scene.

It is not so easy to do this trick with the ordinary 16 mm. cameras, because they have to be removed from the stand in order to do the rewinding unless the camera is specially fitted with a reverse action.

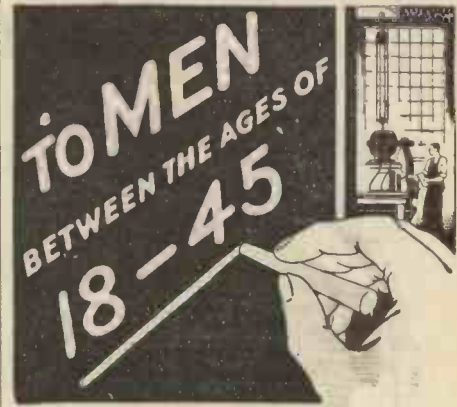

Things are happening to-day which vitally affect you!

If you are about 18, perhaps you are getting settled in your chosen work and already feeling the strain of competition for a better position. If you are in the 40's, your family responsibilities are near the peak, the necessity for money is tense—and younger men are challenging your job. And men of the ages between 18 and 45 face similar problems, in one form or another.

The most valuable employment security to-day is the security a man creates for himself—in himself! Through training, he is able to adapt himself to new conditions, to utilise experience without being handicapped by habit! He masters jobs and makes new jobs. He meets emergencies—and is not overwhelmed by them. And this is an age of emergencies.

For 42 years the International Correspondence Schools have helped thoughtful and ambitious men to acquire the training they need. To-day with this need more urgent than ever, this world-famous institution offers greater opportunities than ever. Why not permit us to show you the way to greater security and larger earnings? Our expert advice is free. Write to-day.

... COUPON FOR FREE BOOKLET ...

INTERNATIONAL CORRESPONDENCE SCHOOLS, LTD.,
 Dept. 95, International Buildings, Kingsway, London, W.C.2

Please send me your booklet containing full particulars of the Course of Correspondence Training before which I have marked X. I assume no obligation.

- | | |
|---|--|
| <input type="checkbox"/> Accountancy | <input type="checkbox"/> Marine Engineering |
| <input type="checkbox"/> Advertising | <input type="checkbox"/> Mechanical Engineering |
| <input type="checkbox"/> Aeronautical | <input type="checkbox"/> Mining Engineering |
| | <input type="checkbox"/> Motor Engineering |
| | <input type="checkbox"/> Plumbing |
| <input type="checkbox"/> Architecture | <input type="checkbox"/> Radio |
| <input type="checkbox"/> Bookkeeping | <input type="checkbox"/> Railway Equipment and Running |
| <input type="checkbox"/> Building | <input type="checkbox"/> Salesmanship |
| <input type="checkbox"/> Chemical Engineering | <input type="checkbox"/> Steam Engineering |
| <input type="checkbox"/> Civil Engineering | <input type="checkbox"/> Textiles |
| <input type="checkbox"/> Draughtsmanship | <input type="checkbox"/> Woodworking |
| <input type="checkbox"/> Electrical Engineering | |
| <input type="checkbox"/> Engineering Design | |

Examinations, state which.....

The I.C.S. teach wherever the post reaches, and have nearly 400 courses of Study. If, therefore, your subject is not in the above list, write it here.

Name..... Age.....

Address.....

The WEBLEY SERVICE AIR RIFLE, Mk. II.

No Licence required to purchase



WRITE FOR DESCRIPTIVE FOLDER

Rooks, Rabbits, Rats, Sparrows and similar vermin can be destroyed by this extremely accurate and powerful Air Rifle. Ideal for Target Practice.

Calibre 22 or 177 With Leasight and Peepsight.

WEBLEY & SCOTT, Ltd. 108 Weaman St., BIRMINGHAM 4

BUILT TO LAST A CENTURY BRITISH MADE

SHEDS

2/6 DOWN

ERECTED IN A FEW MINUTES

2-in. planed interlocking weatherboards.

Long	Wide	High	Cash Price	Down
4 ft.	4 ft.	6 1/2 ft.	£1 : 14 : 0	or 2/6
6 ft.	4 ft.	6 1/2 ft.	£2 : 1 : 0	or 3/6
8 ft.	5 ft.	6 1/2 ft.	£2 : 18 : 0	or 4/6
10 ft.	7 ft.	6 1/2 ft.	£4 : 4 : 0	or 6/6

Sent carriage paid.

Greenhouses from 53/6
 Garages from 79/6

Send for big free book No. 38.

THOMPSON, BAYLISS & CO., LTD.,
 No. 38, Walton Works, The Hyde, Hendon, N.W.9.

THE Febson TEST INDICATOR

Provisional Patent No. 2837/33. BRITISH MADE.

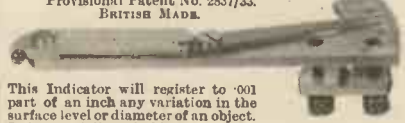

This Indicator will register to .001 part of an inch any variation in the surface level or diameter of an object. It is especially suitable for attachment to the pillar of a surface gauge, but may be fitted to any suitable form of vertical pillar for use on machines, etc.

The Tool is extremely strong in construction, reliable, sensitive and accurate. Made in nickel silver throughout, with hardened steel studs and pivots.

Price 9/- post free.
 If fitted with spring control, 10/6.

THE FEBSON MANUFACTURING CO.,
 122 Kinveachy Gardens, Charlton, London, S.E.7
 or the principal tool dealers

Health, Stamina

I positively GUARANTEE to give you Robust Health, Doubled Strength and 10-25% more muscle in 30 days or return your money in full. The famous STEBBING 4-in-1 Course consists of four great courses in one, yet costs only 5/- post free. It has been proved (1) The most effective HEALTH and ENERGY System ever devised; (2) It quickly builds NORMAL WEIGHT and VIRILE MANHOOD; (3) It develops a Strong Will, rigid SELF-CONTROL; and (4) It includes an amazing SUCCESS and PERSONAL MAGNETISM Course. Complete Course, 5/-

No extras, no appliances to Pupil S. Davey (London), purchase.

Further details sent privately, under plain, sealed cover.

LIONEL STEBBING, STEBBING INSTITUTE.
 Dept. C.P., 28 Dean Road, London, N.W.2.

The Small Printer's Handbook

By D. A. ASPINALL. Neatly bound in linen board for the pocket. Price 2s. 6d. Adana, Twickenham, London and Manchester.

THIS handbook should prove a most useful and essential book for the small printer. The chapter on costing and pricing of work is a real guide to the inexperienced. It not only contains a list of prices with each item quoted in various quantities, but complete with details of how the prices are arrived at through the costing system. The margin within which the price can be cut can be seen at a glance. The section on general information contains tables of all printer's sizes, paper and card sizes and a full description of type faces. This text-book is written carefully to give the beginner help that will save him pounds.

Handicraft Printing for the Schools

By C. A. H. ASPINALL. 112 pages, fully illustrated. Price 2s. 6d. Adana, Twickenham, London and Manchester.

THIS text-book is a companion volume to the one mentioned above and explains the marvellous scope of handicraft printing in schools. It also deals with the necessary equipment to commerce, how to obtain a good range of type cheaply, the machine voted the best by school authorities, and numerous other items dealing with school printing. A supplement is also given on printing with the "Baby" Adana Printing Machine.

The Police Force as a Career

THE steady rise in the physical and educational standards required by the Police Forces, both at home and abroad, is making the Service a more and more attractive proposition, especially for young men who prefer an out-door occupation. Those who are turning their attention to the Police Force will find all the information they require in the 17th edition of the "Handy Guide to the Police Forces at Home and Overseas" (8d.) (Police Review Publishing Co. Ltd., 5/8, Red Lion Square, London, W.C.1.) Within the 36 pages of this manual is compressed a volume of accurate detail obtained from official sources and forming a reliable guide to the conditions of service in the Police Forces throughout the Empire. Advice is given as to the best way of setting about obtaining a position and a draft letter of application is included. Specimen examination papers are given and various departments of the Service explained.

The DOSSÉLL Studio

GOOD IDEAS—

are often rejected because of unconvincing drawings!

Let us prepare attractive illustrations which will convey your idea quickly and clearly to Manufacturers, Editors, Agents, etc.

We specialise in Patent Office and Technical drawings of all descriptions.

Write or phone us at

**HIGH HOLBORN HOUSE,
HIGH HOLBORN, W.C.1.**

HOL. 8838



BANISH THE TORTURE OF

“NERVES”

Every sufferer from “nerves” should get my absorbingly interesting book describing an inexpensive home-treatment for Weak Nerves, Depression, Morbid Fears, Insomnia, Self-Consciousness, and similar nervous disorders. Sent free in sealed envelope. Write now and you will be delighted to learn how easily you can conquer your nervous fears!

HENRY J. RIVERS (Dept. K.D.2)
40 Lamb's Conduit St.,
London, W.C.1.

Genuine Testimonials:

“Such a unique and valuable course is worth its weight in gold.”

“It is really marvellous how my fears have all vanished—they were so firmly established and of such a dreadful nature.”

“Since taking this course I have never looked back. I could thrill with the sheer joy of living.”



GROW TALLER IT PAYS TO BE TALL

Short people are snubbed and overlooked. By my simple, private method you can add several inches to your height without violent exercises, without apparatus. No risk or strain. Full particulars free if you write at once and mention *Practical Mechanics* (April). Address:

P. EDISON, 39 Bond Street, Blackpool

DEEPEES 35 BEAK STREET,
LIMITED REGENT STREET, LONDON, W.1
PHONE: 2560 GERRARD. HOURS—9 to 7.
MANUFACTURERS OF AND DEALERS IN
ALL SCIENTIFIC INSTRUMENTS

APOLOGISE FOR DELAY IN REPLYING TO REQUESTS FOR LISTS

YOU MAY RELY ON GETTING
ONE WITHIN A DAY OR TWO

THE MOST USEFUL SHOP FOR SCIENTIFIC AMATEURS

L. S. DAY, C. C. SWATMAN, A. J. PULLON, Directors.

WHY BE THIN?

BUILD UP YOUR BODY AGAINST ILLNESS
AND DISEASE. DON'T HIDE YOUR BONES
UNDER AN OVERCOAT!

Thousands have put on weight and muscular tissue, with the aid of

VITAEPON (THE ENEMY OF THINNESS)

A customer writes:—“After my illness I gained 15 lb. in weight, and my nerves improved tremendously as the result of a six weeks' course of Vitaepon.”

Vitaepon is not a drug—simply take two tablets with the morning and evening meal.

Obtainable only from:—

WESTCOTT & CO. (Dept. P.),

37 Albemarle Street, Piccadilly, London, W.1.

For Week's Trial Supply send P.O. for 3/- or 15/- for full six weeks' course. Abroad by registered post, 3/6 and 16/-, post free. Sent in plain covers.

A new book, entitled “Thinness: Its Cause and Cure” sent free with every six weeks' course.

THE DISCERNING PENDULUM

By H. F. SLATTERY

We publish the following article as a basis for discussion by our readers; it must be distinctly understood that we do not admit that the device described does what is claimed for it.—Ed.

MOST readers have no doubt heard it said that it is possible to determine the sex of an egg by the simple expedient of holding over it a ring suspended by a thread of cotton: if the ring-pendulum rotates in a circular path the egg will produce a cockerel, but if it moves simply backwards and forwards in one plane we may confidently predict a hen-bird. If you harbour any doubts that such things can be, you may readily convince yourself and your friends by the following simple experiments which illustrate some of the more recondite applications of the pendulum.

Place a sheet of clean white paper on the table. Tie a ring or any convenient weight to a thread about 12 in. long to serve as the pendulum. Rest the right elbow on the table and let the ring hang suspended about

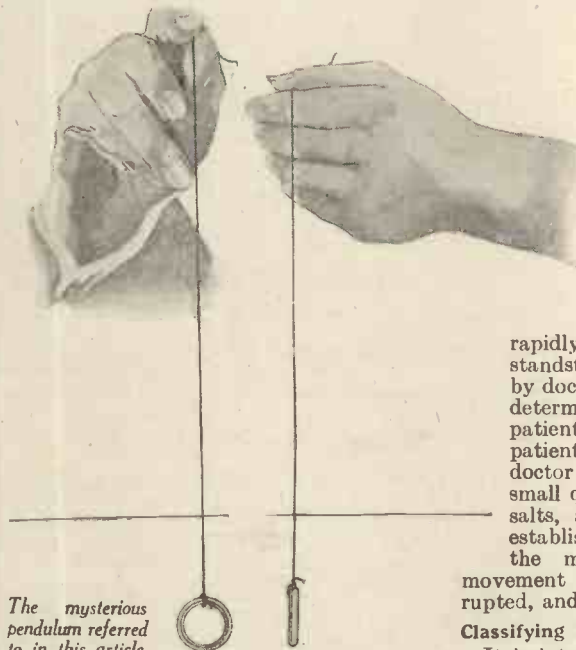

The mysterious pendulum referred to in this article.

What principle, if any, is involved in its stated sensitivity to male and female?

1 in. above the paper. The thread should be held between the first finger and the thumb as lightly as possible, and the muscles of the arm must be relaxed. When the ring is steady, place beneath it a small iron object. Now concentrate your thoughts to observe the movements of the pendulum. Do not “will it” to move. Maintain an open mind, and, above all, don't be frivolous. The reaction is dependent on the mind of the operator, and therefore no result is possible without serious application on his part. After a few moments the ring will begin to move. Record observations of the direction and nature of the movement, and then repeat the experiment, using in turn, silver, gold, red paper, blue paper and violet paper.

Here are the reactions which will be obtained:—

<i>Substance.</i>	<i>Pendulum Movement.</i>
Iron	Circular, counter-clockwise.
Silver	Oscillations, in plane extending from operator.

<i>Substance.</i>	<i>Pendulum Movement.</i>
Gold	Circular, clockwise.
Blue paper	Circular, clockwise.
Red paper	Circular, counter-clockwise.

Violet paper . Oscillations, in plane extending from operator.

If you repeat the experiments, holding the pendulum in your left hand, the reactions will also be reversed.

Even more remarkable is the facility with which sex may be distinguished by use of the pendulum. If the ring is suspended as before from the right hand of the operator over the hand of a man, or over a specimen of male hand-writing, or over a garment that has been worn by a man, it will describe a circular path. Over a lady's hand, photograph, clothing or writing it will react as it did for silver and violet paper. Again, the man's right hand will cause a clockwise, and his left hand a counter-clockwise, motion. The lady's left hand will induce a reaction as did silver, and her right hand will cause one-plane oscillations transverse to the operator.

Suspend the pendulum as before over an iron object, and when the ring is revolving vigorously, touch another iron object with your free hand. The pendulum will rapidly decelerate and come to a standstill. This fact has been utilised by doctors, especially in Germany, to determine salt-deficiencies in their patients. For instance, to test a patient for deficiency in calcium, the doctor suspends his pendulum over a small quantity of one of the calcium salts, and when the reaction is well established touches the patient. If the man is calcium deficient the movement of the pendulum is not interrupted, and *vice versa*.

Classifying Different Elements

It is interesting to carry out a series of tests and to classify different elements and colours into groups: iron, gold and silver, or, if you prefer it, into left- or right-handed males and females, and to compare your results with those of others. For it will be found that a reaction will be obtained to nearly every substance. In attempting to explain these phenomena, this much is clear. The pendulum is a mechanical device which records minute forces which would not otherwise be perceptible. It is applied in the seismograph, which records the jolt of an earthquake in the opposite quarter of the globe; in the ballistic galvanometer, and again in that most delicate instrument, the Östvos balance, which is sensitive to infinitesimal variations in the force of gravity. The crude pendulum used in our experiments is the recording instrument by which we are able to observe minute reactions of our subconscious minds. It is fairly established that the human mind is made up of a conscious element which is governed by the will and intellect, and a subconscious element which is strongly attuned to Nature. The subconscious mind has powers which cannot readily be utilised because it cannot easily express itself.

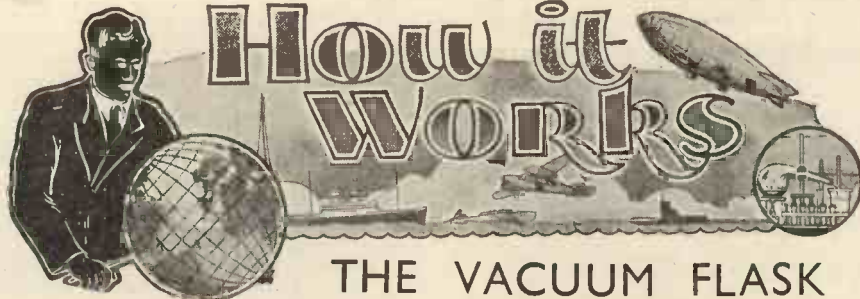

THE VACUUM FLASK

A simple account of the principles on which this useful article works.

At first an invention devised for laboratory use, the vacuum flask (or "Thermos" flask, to make use of a proprietary name) has been adapted with great success to popular requirements.

If we consider a cup of hot coffee, for instance, we know that if it is left standing for only a few minutes it will become cold, i.e., it loses its heat. We must first understand how and where this heat goes before we can understand the action of the vacuum flask.

Heat is a form of energy, and as such is indestructible; it can pass from one substance to another of lower temperature, or it can be converted into mechanical, electrical or chemical energy, but it cannot vanish altogether. In the case of the cup of coffee there are four ways in which it can dispose of its heat: conduction, radiation, convection and evaporation. These will be referred to again later.

The illustration shows a section of a vacuum flask. It consists of a kind of double glass bottle, the inner one holding the hot coffee or other liquid, while the outer one forms a sealed space all round the inner bottle. The outside surface of the inner bottle and the inside of the outer one are silvered like a mirror by introducing a silver solution into the space. After the silver is deposited, the liquid is removed and the air pumped out of this space, leaving a vacuum, which is maintained by sealing up the glass-tube connection. The connection can always be seen as a kind of nipple near the base of the outer bottle.

Coming back to the cup of coffee, a certain amount of heat gets away by being passed on from molecule to molecule through the cup and anything in contact therewith. This flow of heat is called "conduction" and is prevented in the flask by removing the surrounding air, so that by surrounding the hot coffee with a vacuum there is nothing to conduct the heat away at all, except for a very little which leaks edgewise along the glass at the neck and through the cork.

Anything that is hotter than its surroundings "radiates" heat. The sun, for example, radiates enormous quantities of heat in all directions, and our cup of coffee does the same thing on a lesser scale. Now if a vacuum could stop radiant heat we should get no warmth at all from the sun, for his heat has to traverse nearly 100,000,000 miles of space, which is a complete vacuum. Obviously, then, the vacuum space round the flask will offer no barrier at all to loss of heat by radiation. But radiant heat can be reflected in the same manner as light, therefore the silvered surface of the inner bottle reflects the radiated heat back into the bottle again. The reflecting properties of silver on glass are very nearly 100 per cent., so the clever device of silvering almost entirely prevents loss of heat by radiation. It is not used to make the article look pretty.

"Convection" has been mentioned as a cause of loss of heat. This means that as the heat is conducted to the surrounding air, the air becomes warm and rises, forming a current of air, which acts as a kind of vehicle to carry away the heat. These are termed convection currents, and in the case of the vacuum flask are effectively prevented by the simple means of putting a cork in the neck. There can, of course, be no convection currents at the walls of the bottle on account of the vacuum.

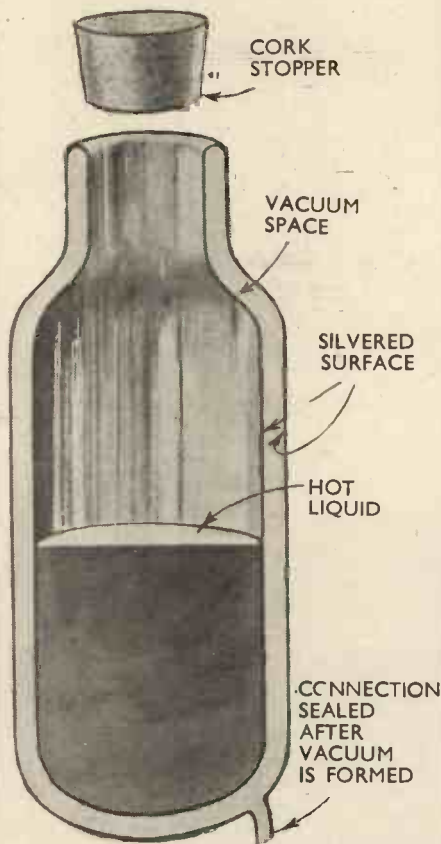

Cross section through a vacuum flask.

The fourth source of loss—evaporation—can be seen operating in the rising steam. A certain amount of the liquid becomes vaporised, and in the process of evaporation absorbs what is termed "latent heat." This is not quite so easy to explain as the other kinds of heat loss, but is very easily dealt with by the cork, which prevents evaporation and therefore stops heat loss from this cause.

The action of a vacuum flask, the reader will know from his own experience, is very effective. In fact, if the liquid is put into the flask nearly boiling in the morning, it will be found too hot to drink in the evening.

Here is YOUR WAY to Happiness and Prosperity
The THREE STAGE Plan

These 3 Cheques for YOU

£450 AT THE END OF 10 YRS

£450 AT THE END OF ANOTHER 5 YRS

£1,350 AT END OF A FURTHER 5 YRS

Three big cheques for you, the last the largest of all. What a boon will be that first cheque; what a boon will be that second cheque; what a wonderful thing for you and yours will be that third and final cheque! Picture the future to yourself, with these three cheques in prospect. Then fill in and post the Enquiry Form for full details of the plan which will bring so much additional happiness to you and to yours.

It is an extremely practical plan. It protects you at every turn. It saves you Income Tax each year—a most welcome advantage for any salaried man or woman. It handsomely protects your family should you not live. It is one of the most up-to-date and generous plans ever devised. Behind the plan is the Sun Life of Canada, with its Government-supervised assets of £125,000,000. This Company has already helped tens of thousands of men and their families to prosperity and happiness; it can do the same for you.

If you are a salaried man or woman, with or without dependents, and whatever your age, do not hesitate to send for details of this Plan. No obligation is incurred, and you owe it to yourself to learn how easily the plan adapts itself to your circumstances and requirements and how greatly it will increase your prosperity.

POST NOW OR SEND LETTER

To H. O. LEACH (General Manager)
SUN LIFE ASSURANCE COMPANY OF CANADA

(Incorporated in Canada in 1865 as a Limited Company)
118 Sun of Canada House, Cockspur Street,
Trafalgar Square, London, S.W. 1.

Assuming I can save and deposit £..... per..... please let me have—without obligation on my part—full particulars of your "Three Stage" Plan.

NAME..... (Mr., Mrs. or Miss)

ADDRESS.....

Age..... Occupation.....

P. Mechanics, April 1934.

The LATEST NOVELTIES

The address of the makers of any device described below will be sent on application to the Editor, PRACTICAL MECHANICS 8-11, Southampton St., Strand, W.C. 2. Quote number at end of paragraph.

A Camera in Miniature

THE accompanying illustration shows one of the latest novelties. It is a camera in miniature, as will be seen when compared with the box of matches shown on the right of the camera. It has a perfect shutter and lens and takes pictures in exactly the same way as the larger and more expensive cameras. We were amazed at the clearness of the pictures taken. The

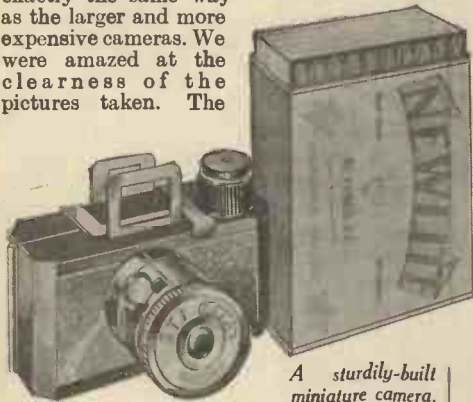

A sturdily-built miniature camera.

camera weighs only 2½ oz. The lens is a special meniscus aperture F.8 of 31 mm. focus, with a fixed focus for all distances from four feet to infinity. It has a special adjustable shutter for instantaneous or time exposures. Roll films cost 8d. each. The price of this ingenious novelty is 4s. 11d. in Ulca nickel and 3s. 11d. in Ulca black. A leather case for the camera is also obtainable for 1s. [46.]

A Non-Leak Oil Can

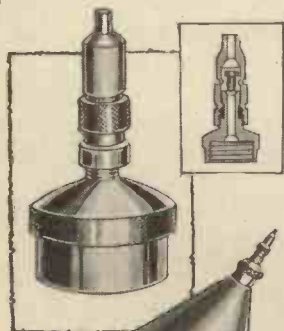

A patent non-leak oil can spout, known as the Parker-Hale "Valve-spout"

a patent spout which makes it impossible for the oil to leak out. There is no cap as is supplied with most oil cans to unscrew

THE oil can illustrated on the left is known as the Parker-Hale "Valve-spout" oil can. It is supplied with

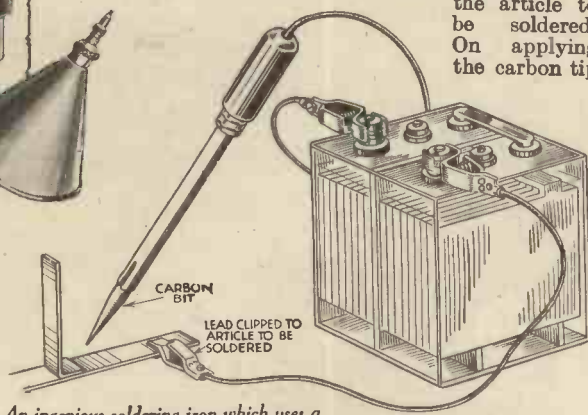

An ingenious soldering iron which uses a carbon bit in place of the ordinary copper bit. By connecting the two leads to a 6 or 12-volt accumulator, an arc is produced when the iron is brought near the work, which welds the job together.

when the oil can is in use. A glance at the small detailed sketch shows how the valve works. Its cost is quite moderate. [47.]

The Master Flexible Steel Tape Rule

THERE are a number of flexible steel rules on the market, but the one shown in the sketch has a number of advantages that make it indispensable to the handyman. It has a durable plated case so designed that it forms a natural hand-grip when the rule is in use. It has a quick and safe push and pull action, and there is no danger of the rule flying back once it has been withdrawn. This rule is made from the highest quality tape steel ½ in. wide. It is fitted with a tape lock which affords accurate lock measurements, permitting the rule to be withdrawn for closer reading. It is marketed at 10s. 6d. [48.]

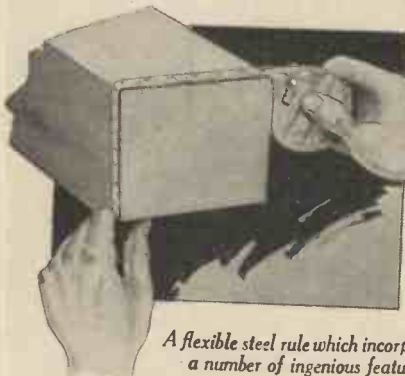

A flexible steel rule which incorporates a number of ingenious features.

Ingenious New Electric Soldering Iron

A NOVEL idea for soldering, to take the place of the ordinary soldering iron, is a device having a carbon bit in place of the usual copper bit. A flexible connection is provided by means of a clip to a 6 or 12-volt accumulator. Another clip clamps on to the article to be soldered. On applying the carbon tip

to the work a small arc is formed, the heat generated being sufficient to melt the solder. It costs 4s. 6d. [49.]

A Super Cream Machine

THE machine shown below enables the user to obtain the finest cream in a few minutes by heating butter and milk and passing it through the machine by operating the handle as shown. All parts of the machine are removable for cleaning. It is finished in either white enamel or polished aluminium and is marketed at 12s. 6d. [50.]

"Perma Lead" Outfits

AN outfit has been recently produced on the market whereby an imitation of a leaded window may be easily made. The outfit contains one coil of Perma lead (any width), one tin of cement, a brush, sponge,



A super cream machine, which makes the finest cream from butter and milk.

and full instructions for using the kit. A design for a leaded window is shown in the sketch. The outfit costs 4s. [51.]

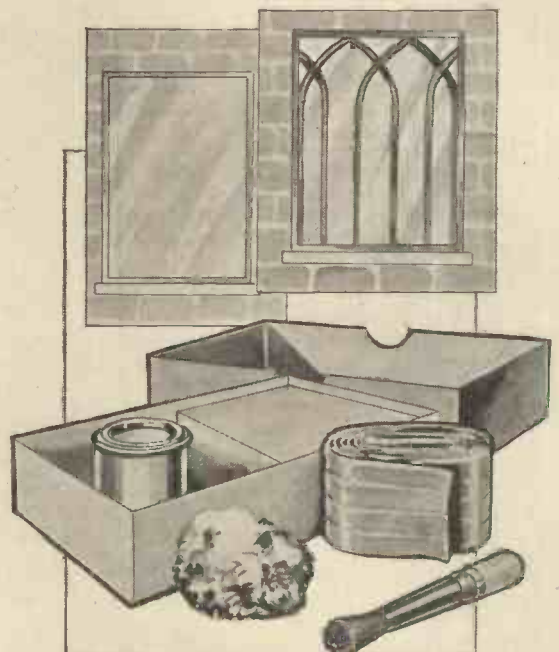

An outfit which enables the user to make imitation leaded windows at a moderate cost.



A Review of the Latest Devices for The Amateur Mechanic. The address of the Makers of the Items mentioned can be had on application to the Editor. Please quote the number at the end of the paragraph.

Handy Trepanning Cutter

It is always a problem to cut large holes or discs which come outside the range of ordinary drills, also a difficult job to drill by hand holes above half an inch in diameter and holes of odd sizes not covered by the normal drill range. The trepanning cutter illustrated, however, which is supplied with two cutters—one for metal—of holes within a well-made de-square shank for with a wood. It will also prove all wireless for cutting circular panels, etc. [41]



A handy trepanning cutter that can be adjusted to cut any size hole within its range.

A Useful Combination Tool

COMBINATION TOOLS HAVE appeared on the market from time to time and most of them incorporate a number of ingenious features. The one shown on this page is not an exception and is really seven tools in one. As will be seen it can be used as a hammer, reamer, countersink, screw-driver, etc. When the tools attached to the cap at the end of the handle are required for use



the hammer head is removed by unscrewing the small screw in the head of the shaft and pushing the required tool

up through the centre of the handle and locking it in place with the adjusting screw. It costs 5/-. [42]

The "Clico" Scraping Tool

THE device shown at the top of the next column is very novel as it can be used for scraping, planing, smoothing and cleaning wood. As will be seen, the tool has four cutting edges and is made in two or three sizes. The tool shown is No. 2 size and is marketed at 2/-. [43]

A Staircase and Shelving Saw

THIS special form of saw has a stook running its whole length forming a handle at each end. The blade is adjustable

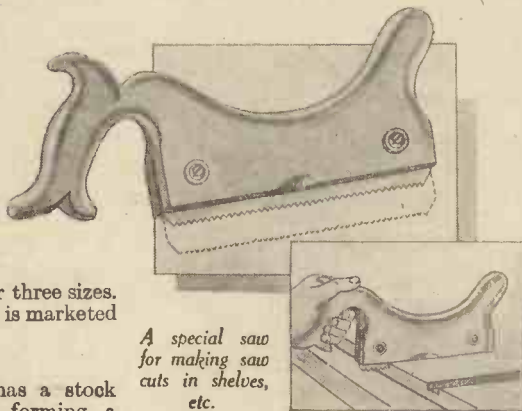

A special saw for making saw cuts in shelves, etc.

in depth so that a series of saw cuts can be made in shelving or planks to a given depth, for making housing joints. This special form of stock provides added rigidity to the saw, and also acts as a guide so that an even saw cut is made in the wood. It costs 5/-. [44]

A Wedge for Hammer Head

THERE are a number of wedges for securing hammer heads on the market at the present time and the one shown in the



An ingenious tool for scraping, planing, cleaning and smoothing.

sketch and known as "Itsawedge" is undoubtedly an

efficient wedge which will prevent the hammer head from flying off when the hammer is in use. The wedge is hammered into the handle as shown in the sketch, and range in size from 1/2 in. to 1 1/2 in. It is obtainable at the low price of one penny. [45]

A Handyman's Hand Vice

THE vice shown in the sketch will prove very useful to the handyman for holding various small jobs which are met with in the workshop. It is small in size, which is a distinct advantage, but at the same time it is efficient and sturdily made. It is made to grip the object by screwing down the wing nut, details of



A combination tool which incorporates seven tools in one.

which are shown in the sketch. It is known as the "Sa-Vu" Handyman's Hand Vice and costs 1/-. [46]



"We're Fluxite and Solder—the reliable pair; Famous for Soldering—known everywhere!"

Here's a gentle reminder —to friends on the road; To ensure speedy repairs—take US in your load!"

See that Fluxite and Solder are always by you—in the house—garage—workshop—anywhere where simple, speedy soldering is needed.

ALL MECHANICS WILL HAVE **FLUXITE** IT SIMPLIFIES ALL SOLDERING

All Ironmongers sell Fluxite in tins; 4d., 8d., 1/4 and 2/8. Ask to see the FLUXITE POCKET SOLDERING SET—complete with full instructions—7/6. Ask also for our leaflet on HARDENING STEEL with Fluxite.

FLUXITE, Ltd. (Dept. P.M.), Rotherhithe, S.E.16

FOR ALL REPAIRS!



The SCIENTIFIC MICROPHONE BUTTON has a hundred uses



A simple, efficient yet cheap gadget, which can be used by any novice in hundreds of ways to demonstrate the wonders of sound. It provides an endless source of amusing and instructive experiments in home broadcasting, relaying music, detecting and over-hearing; baby alarms,



phones, etc. The book "The Wonders of the Microphone" explains in simple language the science of sound. Over 25 diagrams and illustrations of numerous useful and interesting experiments. 6d.

A FREE GIFT of this book will be made to all purchasers of the Scientific Microphone Button until end of April.

This is the little device that does the trick. Every one tested 3/6 and guaranteed THE SCIENTIFIC MICROPHONE BUTTON, post free or O.O.D. Guaranteed.



SCIENTIFIC SUPPLY STORES (WIRELESS) LTD. (Dept. M)

126 Newington Causeway, Elephant and Castle, London, S.E.1: 'Phone: Hop: 4177.

A Fight Against Rupture

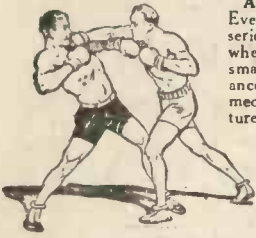

Attention vs. Neglect
Everyone should realise the seriousness of Rupture, even where the protrusion is small. The Brooks Appliance is the finest kind of mechanical support for Rupture that it is possible to build. Hard pads and stiff springs are entirely eliminated. Our Automatic Air Cushion, light, cool and absolutely sanitary, is protected by patents in the British Isles and all important foreign countries. Your name and address pinned to this advertisement will bring complete details of our free trial plan in plain sealed envelope. No need to write a letter.

BROOKS APPLIANCE CO., LTD.,
(292) 80 Chancery Lane, London, W.C.2.
(202) Hilton Chambers, Hilton Street,
Stevenson Sq., Manchester, 1.

EVERYONE A SCIENTIST!

THIS POWERFUL POCKET MICROSCOPE



having all the power and definition of the more expensive instrument can be used for a myriad purposes. Indispensable for testing cotton, wool, wholesomeness of food and water besides many interesting things such as examining crystals, animalcules in water, construction of insects showing detail hitherto impossible without a first-class instrument. Requires no skill to use. Gives hours of interesting study. Made of brass, capable of magnifying 150 areas. Count the joints in microbial cheese animalcules. Complete with object glass, spring and full instructions.

AIRCRAFT PRODUCTS
(Dept. P.M.5.)
87 New Oxford Street, W.C.1

HOME MOVIES

Wide range of new and used Projectors, Cameras, Films and Accessories in 8mm., 9.5mm. and 16mm.
Bargain Lists and Literature post free

PERMAREC HOME RECORDING

Waxed Discs 3/- each

Recording Gear Lists on Request

WHY NOT TRY THIS FASCINATING HOBBY?

SPECIAL OFFER

- Coronet all-electric projectors . . . 27/6d.
- Coronet F3.9 Cine-Cameras . . . 37/6d.
- 30-ft. Library Films, each . . . 1/-
- 60-ft. 2/6d. Super 300-ft. Films . . . 12/6d.

Part exchanges . Approval . Easy Payments

THE AMATEUR CINE SERVICES
50 WIDMORE RD., BROMLEY, KENT
(20 minutes from Charing Cross)

"HEIGHTEN"

your chances in life



Tall people get the best of it. Why not be taller? One box of Challoner's famous tablets will develop height and figure quickly and with absolute safety. "Results beyond expectation," writes E. H. (Sutton). No time-wasting exercises or appliances. If one box is insufficient we supply another FREE. Height will give you confidence—have confidence now and gain height. Send 1½d. stamp for full details in sealed envelope, Sample 7½d. Book on height improvement 3d. P.O. or stamps only.

THE CHALLONER CO. (late Bond St.), Dept. C82, Laboratory & Works, Hyde Heath, Amersham, Bucks.

Record Improved Combination Plane

THE Record Accommodation Plane shown here is a combined tool which will perform most planing operations generally required in cabinet making and joinery. It is fitted with spurs for cross grain work, adjustable depth gauge and fence,

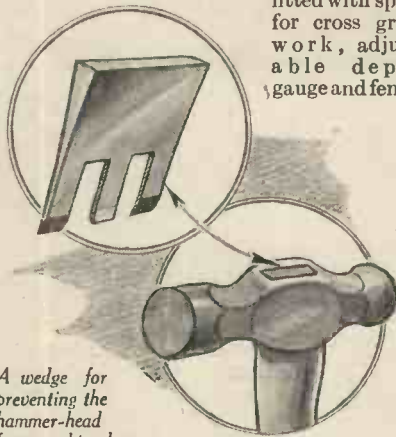

A wedge for preventing the hammer-head from working loose.

beading stock, and also shading deflector for use when tonguing. It is also fitted with a screw adjustment of the cutter which enables it to be fed into the work with an accurate and easy control. The plane is nickel plated and is contained in an attrac-

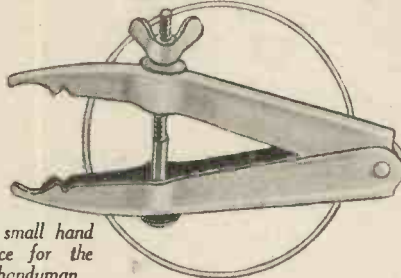

A small hand vice for the handyman.

tive and substantial box with compartments for each loose part. The plane is 9½ in. long and weighs 3½ lb. It is also fitted with a cutter clamping bracket which enables cutters narrower than ¼ in. to be used. The plane is supplied with a standard set of five cutters and in addition a power cutter, each ¼ in. and ⅛ in. wide. Should extra cutters be required they are available at an extra charge. It costs 30/- [47]

The Wedge Axe Log and Wood Splitter

THE splitting of logs and wood can be facilitated by using the wedge axe log and wood splitter which has recently appeared on the market. This wedge is made of cast steel tempered and hardened to cut wood. Place the wood upon the edge of the cutting tool and strike with a heavy hammer or mallet, and the wood splits instantly. When cutting wood transversally use the tool with the flat side of the cutting blade to your right, and the wood will not fly upwards when cut through, which generally happens when using an ordinary axe. It costs 2s. 6d. [48]



A combined tool that will perform most planing operations generally required in cabinet-making and joinery.

INEXPENSIVE CHEMISTRY EQUIPMENT

APPARATUS & CHEMICALS
FOR STUDENTS' LABORATORIES
Complete range of CHEMICALS in Bottles from 3d. each—Extensive selection of APPARATUS, including Beakers, Flasks, Graduated Ware, Condensers, Retorts, Balances, etc. **SPECIAL PARCEL OF APPARATUS.**
1 Flask flat bottom 150ccs., 1 Beaker, spotted 100ccs., 3 Test Tubes 4 in. x 3 in., 1 Thistle Funnel 20cm., 3ft. Glass Tubing, 1 Rubber Cork 2 holes, 4 inches Rubber Connection Tubing, 1 Glass Stirring Rod. **2/6 Post Free**
BECK (Scientific) 60 HIGH STREET, (Dept. A.) STOKES NEWINGTON, N.16
Write for Catalogue—FREE.

THE RELAX



CIGARETTE HOLDER

This holder is ideal for use while working at your hobby when cigarette smoking is usually a nuisance. All the ash is caught in the swinging aluminium tray, and it can be safely placed on any flat surface by means of the little stand when desired. Also made with rubber sucker in place of stand for motorists' use at same price. Mouthpiece in assorted colours.

Sole Manufacturer: **F. J. N. BRYANT** **1/9**
Perseverance Works,
2a Brighton Road, LONDON, E.6 Post Free

YOUR MIKE

The "P.M." No. 11. TABLE MIKE for use on pick-up terminals of any Radio Receiver, has no end of uses; relays music, home produced imitation variety turns, your own special news items, or make-belief "S.O.S." messages by members of your party, etc., all reproduced loudly and vividly.



Complete in fine 3" x 3" Bakelite case, fitted with transformer and switch, detachable brass base. High quality, good value, low price. Guaranteed 12 months.

No. "P.M." 11
10/6

ELECTRADIX RADIOS,
218, UPPER THAMES STREET, LONDON, E.C.4.
Telephone: CENTRAL 4611

BE A MAN!

If you are conscious of **INFERIORITY COMPLEX, SELF-CONSCIOUSNESS, UNREASONABLE FEARS, LACK OF CONCENTRATION, TIMIDITY, LACK OF SELF-CONTROL, WEAK WILL, THINNESS,** etc., it is obvious that you are suffering from **NERVOUS DISORGANISATION** arising from a depleted state of the Nerve Centres. Such a condition does not arrive naturally in a healthy individual. To trace the cause, write for my free book

"DO YOU DESIRE HEALTH?"

Sent POST FREE in plain envelope. Also, write to me fully in confidence for a Free and considered opinion of your case.

I am the only Practising Physical Culture Consultant who has specialised for over 30 years in Nerve cases and the restoration of Robust Health and Manly Self-control over Weakening Habits.

All replies and books sent in plain sealed envelopes.
T. W. STANDWELL, Physical Culture Consultant
Dept. P., 329 HIGH HOLBORN, LONDON, W.C.1.

What the Clubs are Doing

Club Reports for inclusion in this feature should not exceed 250 words in length, and should be received not later than the 10th of each month for inclusion in the subsequent month's issue.

WEST MIDDLESEX AMATEUR CINE CLUB
Headquarters: 105 Uxbridge Road, Ealing, W.5.
Hon. Secretary: Hugh P. B. Davies, 105 Uxbridge Road, Ealing, W.5

ALTHOUGH this is the first report we have made in these columns of "Practical Mechanics," it is not because we are a newly-formed society, so let us introduce ourselves forthwith.

The Club was formed in October 1929, and has since that date held regular weekly meetings, at which we have always had good attendances. The main object of our existence being the furtherance of amateur cinematography in all its branches, we cordially invite visitors to our meetings which are held every Tuesday at 8.15 p.m. at the above address. Anyone who is interested should communicate with the Hon. Secretary as we still have vacancies for new members, having set ourselves no fixed maximum membership, and our Secretary welcomes correspondence with fellow enthusiasts throughout the world. All the films the Club has so far produced have been made on 16 mm. stock, but a 9.5 mm. section of the Club has recently been formed, who are now making preparations for their first production, the shooting of which they hope to be able to embark upon in the near future.

STREATHAM COMMON MODEL RAILWAY CLUB

MEETINGS are held every night of the week at 201 Gleneldon Mews, Streatham High Road, S.W.16, from 6.30 p.m. to 10 p.m. We shall welcome any readers or friends to any one of our meetings. Meeting March 14th: "Talks and Demonstrations." Mondays, Wednesdays (except 14th) and Fridays are Track Nights; Tuesdays, Thursdays and Saturdays are Workshop Nights. The track has now been started upon, being laid with steel rail and cast chairs to replace the existing tin-plate. A portion of it is hoped to be on view at our Exhibition. The Club's Magazine, "The Rocket," for March, is now on sale: Price 5d., post free. Enlarged Number. A very interesting lecture was given at the Club Room recently by Ian Macnab, Esq., assisted by L. T. Catchpole, Esq., on "The Liverpool Overhead Railways." The lecture was illustrated by some very interesting slides.

Club Exhibition.—This year, as in previous years, the Club is holding its Annual Exhibition at 70 Conyers Road, Streatham, on April 27th (6.30 p.m. to 8.30 p.m.) and April 28th (3 p.m. to 8.30 p.m.). Admission 3d. All readers are very welcome. Attractions include a Passenger-carrying Railway, Exhibition of Members' Work, a Fun Fair, etc., etc. A special ticket competition is being arranged by the Club. Holders of tickets will notice a number on them. The lucky number, which will entitle the holder to a year's free supply of "The Rocket," will be drawn on Friday, and the holder is requested to show his half-ticket with that number on it at the Sweet Stall on either day. Tickets can be obtained from any member or through the Secretary. Will You help to make this exhibition a success?

To those who bring up models for testing. We are very pleased for you to do this, but as our track is laid to one standard, the New Alloy Wheels, some models may not be able to run upon the track.

Secretary: L. J. Ling, Brooke House, Rotherhill Avenue, Streatham, S.W.16, who will, on request, forward a copy of "Concerning Ourselves," post free.

THIRD ANNUAL EXHIBITION, at 70 Conyers Road, Streatham.

April 27th (6.30 p.m. to 8.30 p.m.) and April 28th (3 p.m. to 8.30 p.m.). Admission (both days) 3d. (inc. tax). The Exhibition includes the members' work during the last year, a ride on a 5-inch passenger-carrying railway, ticket competition for the lucky number on the ticket, various competitions, etc., etc. Tickets can be obtained now, price 3d. from any member, or through the Secretary, L. J. Ling, Brooke House, Rotherhill Avenue, Streatham, S.W.16, who will be glad to supply full particulars of the Club to anyone interested.

THE MODEL RAILWAY CLUB

OUR approaching exhibition at the Central Hall, Westminster, during Easter week, April 3rd to 7th, occupies the attention of all our members. Track night, February 8th, gave an indication of the amount of work being put in on new models, when a large array of most interesting items was on view. An electrically driven L.M.S. eight-coupled freight engine (4-mm. scale) attracted special attention amongst the many models in this smallest size. This loco. has a very low gearing of 32:1, and pulled a total weight of some 19 lb. An "Underground" station in 34-mm. scale was shown complete with concealed lighting and posters. The new L.M.S. "Pacific" is receiving the

attention of three members at least. Probably the most interesting model of the evening was, however, a 7-mm. scale motor coach of the late L.B.S.C. railway type, in which the reversal of the pantograph is effected by remote control, all the necessary electrical mechanism being secured to the underside of the roof. A very novel item was a display card showing various types of chain slings as used in the goods yards on the Southern Railway.

A most interesting evening was spent on January 25th, when a lecture on "Locomotives of the Southern Railway" was given by Mr. J. Clayton, M.B.E., M.I.M.E., from the Chief Mechanical Engineer's Department of the Southern Railway. Copious lantern slides were shown, as also films showing track details and a run to Brighton on the new electric line as additional matters of interest.

Hon. Sec. Mr. J. C. Watts, 85 Wood Vale, N. 10.

THE BRITISH INTERPLANETARY SOCIETY REPORT

MEETINGS were held on January 19th and February 2nd. At the former meeting the President, Mr. P. E. Cleator, had just returned from Berlin where he had been visiting the German rocket experts, notably Herr Willy Ley and Herr Nebel. During his stay he visited the Raketenflugplatz and was shown the experiments in progress, and given a description of the progress that is being made in the science of rocketry in Germany. Experiments, said Mr. Cleator, are being made on a very sound basis and with a view to their ultimate practicability. The results are tabulated, so that if eventually any exploit is contemplated there will be little difficulty in determining the factors involved.

A list of rocket experts throughout the world was obtained from Herr Ley, and it is anticipated that they will co-operate with the British Society.

At the meeting on February 2nd, considerable progress was reported. Various technical journals had interested themselves in the project of a rocket car, while much publicity had been given to the Berlin visit. Evidently the importance of this has been realised both from the point of view of co-operation in a common scientific object and also of international friendship.

An informal talk was given by the Secretary on "The Mysteries of Venus and Mars," and led to considerable discussion. The Society was also informed of the very great possibility of a considerably bigger and better Journal.

A notable addition to the membership of the Society is the famous French engineer, M. Esnault-Pelterie. This promises closer co-operation between the British, French and German engineers.

Meetings continue to be held at 81 Dale Street, Liverpool, 2. The office is on the Second Floor, Room 15, and the meeting starts at 6.30 p.m. Meetings are held fortnightly on Fridays, every other Friday from February 16th, 1934. Leslie J. Johnson, Hon. Secretary.

THE BIRMINGHAM MODEL RAILWAY CLUB

THE Annual General Meeting was held at Christ Church Schools, Gt. Charles Street, on January 16th, at which the progress of the Club was reviewed and its programme for the present session discussed.

The first Club Night took place on February 1st, and was well attended. The attraction of the evening was a hauling competition: clock work *versus* steam.

Other Club Nights were arranged as follows:— Tuesday, February 13th. March 1st: Track running, and also a talk by Mr. B. H. K. Wickham, entitled "What the Railways Have Done Since 1929." March 13th: Electric Loco. Haulage Competition.

THE PARK MODEL AIRCRAFT LEAGUE

A MOST interesting evening was spent on March 2nd last, when Mr. Jordan, Vice-president, read a very instructive paper on "Flying Scale Models." To many of us some quite new methods of construction were introduced, and we are expecting to see some experimental models in the near future as a result.

The next meeting will be held on April 6th.

The following is a list of P.M.A.L. open competitions for the season at which we shall be pleased to welcome any aero-modellist.

April	15	Duration	Mitcham
	29	Distance	Tooting
May	6	Seaplane	Wimbledon
"	13	Duration	Mitcham
"	27	Aerial Golf	Tooting
June	3	Scale and Semi-scale	Tooting
	17	Duration	Mitcham
July	15	Duration	Mitcham
	22	Speed	Mitcham
	29	Weight Carrying	Tooting
August	28	Duration R.O.G.	Mitcham
September	9	Climbing	Tooting
	23	Duration	Mitcham
October	7	Steering	Mitcham
	21	Duration	Mitcham

Full details may be obtained from the Hon. Secretary: Mr. F. H. Dillistone, 112 Rodenhurst Road, Clapham, S.W.4.

Place an Order with your Newsagent for "PRACTICAL MECHANICS" to be regularly delivered!

1934 EDITION of HENLEY'S BOOK of

10,000

MONEY-MAKING FORMULAS, PROCESSES and TRADE SECRETS

At this very moment there are millions of people who want to make more money, but cannot think of an idea; this book will be a wonderful help to such persons—it explains fully how to make and sell almost everything under the sun. **BIG MONEY-MAKING OPPORTUNITIES** are waiting for both men and women. With very little capital and without risk you may exploit thousands of proved ways of amassing wealth easily and quickly.

BE YOUR OWN MASTER!

Fortunes have been made through this book, and thousands of people, with very little cash, are launching small business ventures, many of them based upon these formulas. Furthermore, numerous concerns, the owners of which were facing failure, have taken on a new lease of life, simply by seizing upon an idea contained in this vast storehouse of money-making facts and formulas. In many cases the costs of materials for starting a small manufacturing business are practically nil, owing to the utilisation of waste and by-products. There are without doubt hidden sources for profit making which this book will disclose; it will show you how to break fresh ground, how to exploit avenues of money making that at present seem non-existent.

THIS BOOK IS AN INVESTMENT THAT WILL PAY YOU A THOUSANDFOLD

No licence or fee whatever is required to use any of these 10,000 Money-making Formulas, Processes and Trade Secrets—for the purpose of making things or using the methods.

THIS COUPON IS WORTH

5! TO READERS OF "PRACTICAL MECHANICS"

COUPON

For Free Descriptive Particulars and Special Offer to readers of "Practical Mechanics."

To (Dept. P.M.) The Scientific and Commercial Publishing Co., Artillery House, Artillery Row, London, S.W.1.

Please send Free Descriptive Particulars of your Book of 10,000 Money-making Formulas, Processes and Trade Secrets (complete in one volume).

Name

Address

If this coupon is sent, without any other written matter, and placed in unsealed envelope, half-penny stamp only is required.

Please use BLOCK CAPITALS. PM925

A PRACTICAL BOOK I

Television To-day and To-morrow

By Sydney A. Moseley and H. J. Barton Chapple, Wh.Sc., B.Sc., Author of "Television for the Amateur Constructor," etc.

THIS is a fascinating book for every wireless enthusiast and home mechanic. It tells you what television is, describes the principles and their application, and shows what television has achieved. If you want to experiment in this interesting field, you should read this valuable book immediately.

"This is a very good book."—*"Wireless Trader"*
"A remarkable book."—*"Sunday Referee"*
"Provides instructive reading of great interest."—*"Electrical Review"*
"One of the most fascinating of modern scientific romances."—*"The Gramophone"*

230 pp. Third Edition. Illustrated

7/6 net

Order from a Bookseller or send 8/- (to include postage) direct to:

PITMAN Parker Street, King'sway, W.C.2.

Be a Master of ENGLISH

You are judged by the way you speak and write. Learn to express yourself clearly and forcefully and avoid embarrassing errors. Send to-day for interesting booklet—FREE.—**REGENT INSTITUTE** (Dept. 32E), Regent House, Palace Gate, London, W.8.

BE TALL

Your Height increased in 14 days or money back. The amazing Stebbing System soon brings 3-5 inches

increase and new energy. The first original and the one GENUINE guaranteed Height Increase System. Complete Course, 5/-, or Booklet, Testimony and Guarantee sent free, privately, under plain sealed cover. **STEBBING SYSTEM**, Dept. M.P., 28 Dean Road, London, N.W.2.

DON'T BE BULLIED



Learn to fear no man. The BEST self-defence ever invented, namely, **JUJITSU**. Easy to learn. Send 2 penny stamps for **SPLENDID ILLUSTRATED LESSONS**. Photo ARTICLES, Testimonials and particulars, or P.O. 1/- for **BEST PART** of my course. You will be more than delighted. Dept. P., Bleasheim House, Bedford Lane, Fencham, Middlesex.

HAVE YOU A RED NOSE?

Send a stamp to pay postage, and you will learn how to rid yourself of such a terrible affliction free of charge.

Address in confidence—**P. TEMPLE, Specialist**, "Palace House," 128 Shaftesbury Avenue, W.1 (Est. over 25 years.)

REPLIES TO QUERIES & ENQUIRIES

If a postal reply is desired, a stamped addressed envelope must be enclosed. Every query and drawing which is sent must bear the name and address of the sender and be accompanied by the coupon appearing on page 311 of Cover. Send your queries to the Editor, PRACTICAL MECHANICS, Geo. Newnes Ltd., 8-11 Southampton Street, Strand, London, W.C.2.

A Design for a Petrol Engine

"I AM thinking of applying for a patent for a petrol engine design which I intend to use for model work. I should be pleased to have any information as to its originality, value, etc., for the purpose mentioned. A feature of this engine is its extreme lightness." (T. Horsman, Leeds.)

The actual constructional form of the two-stroke internal combustion engine is probably novel, but it is not thought that any very broad claim could be made in view of the many two-stroke engines which have been already patented. The inventor is advised to make, or have made, a search amongst prior Patent Specifications for two-stroke motors before incurring any great expense in Patenting his invention so as to ascertain the novelty of the idea. If the construction should prove to be novel, it being understood that a model engine has been made and apparently tested for efficiency, there should be a much wider field for its employment than for model work.

Making a Lantern

"For an experiment I am trying it is necessary for me to build a lantern with the slide horizontal and the screen vertical. I have made a temporary lantern, but have obtained no results. (1) Will you please advise me how to build a satisfactory lantern? (2) Is 60 candle-power sufficient for a screen 24 in. by 24 in.? (3) If I have a lantern behind the screen, and show through it, what material must I use for the screen?" (S. T., Sudbury.)

(1) Your sketch shows no condensing lens. You must arrange such a lens (which must be slightly larger in diameter than the slide) between the lamp and the slide. Then move the lamp nearer to or further from the condenser until best results are obtained.

(2) We think a 60 candle-power lamp of the right type would do, but the ordinary lamp for domestic use is not the best. Try to obtain a special lamp for lantern purposes. If you use an ordinary lamp, a "pearl" or "opal" glass bulb would give better results than clear glass.

(3) Use "cambric" or "lawn," the latter for preference.

Reducing Battery Plates to Metallic Lead

"I have approximately 2 or 3 tons of old motor and house lighting battery plates. Could you advise me of the best way to reduce this to make lead as cheaply as possible? I might mention I am well equipped with machines, lathes, drills, etc., also welding and cutting apparatus." (T. T., Omagh.)

Heat the scrap lead strongly in contact with charcoal. This reduces the various oxides to metallic lead, which may be then run off into moulds. The best way of tackling the job is to smash up the scrap into small pieces and mix them well with several pounds of common wood charcoal, the whole being then placed in a furnace and brought up to red heat.

A Mechanical Water Finder

"My idea is a mechanical water finder used for locating water in tanks containing light oils such as petroleum or kerosene, etc. I have tested the instrument both at home and at work, and find it satisfactory in every way. Can you tell me if there is any other mechanical water finder on the market? I, myself, have only seen the water-finding paste and papers, which are very inconvenient in wet or windy weather, especially on board oil-tankers. From my own experience I think my idea is more superior than the other mentioned. It is unaffected by rain or spray on board ship, and saves the tiresome job of manipulating the papers." (G. Pitt, Lynton.)

The Applicant has invented a means for locating water in light oil tanks which differs from the means at present employed for such purpose. As the Applicant has not given any particulars of his invention, it is not possible to advise him definitely as to whether his invention forms fit subject-matter for Letters Patent. As to the novelty of his invention, which is a necessary attribute to obtaining a valid Patent provided it also contains invention or subject-matter, the only way of ascertaining this is by making, or having made, a search amongst prior Patent Specifications relating to the subject. The address of the Patent Office is 25, Southampton Buildings, London, W.C.2. The stamp duty payable on an Application for Patent is £1, on a Complete Specification £4, and on sealing a Patent £1, which is payable after acceptance of the Complete Specification. A Patent Agent's fees are, of course, in addition to the above stamp duties, and the Applicant is advised to employ a reputable Patent Agent since his fees are well worth the additional cost.

Preventing Prints from Sticking

"Can you tell me the recipe for a solution for preventing photographic prints from sticking to ferrotype plate, glass, etc.? Is this also known as print-hardener?" (P. B., Bristol, 2).

Wash the prints after fixing and place for ten minutes or so in the following solution to harden the film:—

Formalin 1 oz.
Water 10 oz.

The glass or ferrotype plate must be scrupulously clean. Dust the surface while dry with French chalk and then polish with a soft clean rag until every trace of French chalk is removed. Lay the wet print face down on this, drain off the surplus water, cover with a sheet or two of blotting-paper and squeeze down with a roller squeegee. Do not attempt to remove the prints until they are bone dry, when they should come off very easily.

Unrolling Old Manuscripts

"As an enthusiastic and regular reader of your valuable periodical I would appreciate any advice you can give on the following:—

"(a) What liquid is used for unfolding old and fragile manuscripts where handling has become impracticable?

"(b) How can brass which has become badly tarnished be cleaned? Some method of removing the coating quickly being required." (K. R., Liverpool.)

(a) We know of no liquid which can be used for the purpose mentioned, but suggest that if the papers are very gently steamed by holding them over a pan of boiling water they may be softened enough to unfold them without damage.

(b) A mixture of vinegar and salt, scrubbed on with a stiff brush, will remove tarnish from brass. If something stronger is required, a mixture of equal parts of strong nitric acid and strong sulphuric acid can be used. This should be used with great care, as it is dangerous stuff. Don't put your fingers in it, and don't let it splash your face or clothes. It will completely dissolve a brass article if left in it too long.

The Colours of the Sky

"The generally-accepted theory as to why the sky is blue is that the rays of light which come from the sun are scattered by the dust particles in the upper atmosphere, and the blue rays, having a shorter wavelength than the red, are scattered to a greater extent, the sky therefore appearing blue. But violet and indigo rays are of shorter wavelength than blue rays. Why is it then that we do not see the sky as violet?" (A. E. W., Manchester.)

This is due to reactions between the waves of light and the molecules and particles (of various sorts and sizes) which both compose and float in the atmosphere. The particular colour produced by "scattering" depends upon the sizes of these various molecules and particles, a good blue requiring that they should be smaller than the wavelength of light. Nevertheless, even under such conditions, the light so "scattered" cannot be as blue close to the earth's surface as it is in the upper levels; for, in the latter, there are fewer particles of dust and water vapour to add longer wavelengths to the shorter waves due to the exceedingly small air molecules alone.

This is particularly the case in northern latitudes where, owing to much moisture in the air, the blue of the sky is pale and watery, compared with the almost indigo tint sometimes met with in drier regions nearer the equator. Yet it is obvious that the constitution of the atmosphere will not permit of a clarity sufficient to exhibit a hue so deep as violet.

A Chemical Query

"Please give me a list of substances whose fluorescence or phosphorescence decays very rapidly, earmarking those whose decay is considerably accelerated by infra-red rays. Is there a convenient way of coating a glass plate with the substances?" (A. P., Northumberland.)

Fluorescence is a definite property of certain substances and does not "decay." The luminosity of certain bodies like sulphides and phosphorus is however lost under certain conditions. Phosphorus ceases to emit any glow when in pure oxygen below 27 degrees.

Substances like calcium sulphide (luminous) and barium sulphide (luminous) gradually "age" and finally cease to give out any light, when they may be revived by placing in a bright light for a time. Again, the luminosity of phosphorus is destroyed by the vapour of turpentine.

The sulphides may be applied to a glass plate in a paste made by grinding a little to a fine powder and mixing it with gum arabic solution. Phosphorus is dangerous stuff, but if querist is cautious he may succeed in coating the plate by flooding it with a solution of phosphorus in carbon disulphide.

The effect of infra-red light on these phosphorescent bodies has not been investigated to my knowledge. It seems rather a pointless line of research. It is fairly safe to assume that if the rays are very powerful they will cause an almost imperceptible increase in luminosity of phosphorus due to the slight heating effect. Of their action on the sulphides it would be unwise to definitely predict—but it is almost a certainty that there would be no effect. Infra-red rays are not chemically active, the other end of the spectrum provides us with the light waves of chemical activity.

Patent Advice

By A. MILWARD

The services of a professional Patent Expert are available free to every reader. He will advise you on the validity, novelty, and value of any idea you may have. No charge is made for this service, but the Query Coupon appearing in our advertisement pages must be enclosed with every query.

SOME EARLY PATENTS FOR INVENTIONS

(continued)

A Patent for Making Glass

BEFORE 1611, Sir William Slingsby had obtained a Patent for making glass with sea-coal, and from 1615 until about 1634 Admiral Sir Robert Mansell (1573-1656) held a Patent of monopoly for glass making. Flint glass was probably first made at Newcastle-on-Tyne. The iron industry as we know it to-day was first founded in 1620 by the Dudley family. On February 22nd, 1620, Letters Patent No. 18 were granted to Edward Lord Dudley, and on May 2nd, 1638, a second Patent No. 117 was granted to Dud Dudley, son of Edward Lord Dudley, for making iron with "pit-coale or sea-coale and with the same fuell to melt and fine imperfect mettals and refine perfect mettals."

In 1665 Dud Dudley published his celebrated "Metallum Martis," which deals *inter alia* with previous inventions relating to the use of "pit-coale or sea-coale," and the trials and difficulties he encountered in overcoming the vested interests of charcoal iron masters, which one can well understand since their price for charcoal pig iron was £6 to £7 per ton, and for bar iron £15 to £18 per ton, against Dudley's price of £4 per ton for pig iron, and £12 per ton for bar iron.

Military Engines

The next interesting Patent to be dealt with is interesting, not only by reason of its subject matter, but also in respect of the personality of a very remarkable man, the Patentee, William Drummond.

William Drummond was born in 1585, and was related to the Royal Family of Scotland through Annabella Drummond, Queen of Robert III. of Scotland. He was a poet, historian and scientist, and a friend of "Rare" Ben Jonson. He was an M.A. of Edinburgh in 1605 and the laird of Hawthornden in 1610. His death in 1649 was ascribed to grief at the execution of Charles I. This monarch, on September 29th, 1626, granted to Master William Drummond, Letters Patent for twenty-one years for his invention concerning the manufacture of military engines. This Patent is noteworthy, in that it was only granted in respect of Scotland and was subject to the proviso that it was to cease if one or more of the machines were not reduced to practice within three years from the date of grant. The Patent was granted in respect of sixteen different inventions, and included (1) a "box-pistoll" or "muskett-box" by which a "single man can be of no less avail in battle than five or six with the ordinary weapons," (2) a new sort of spear or "pick-arquebus," (3) a machine made of musket barrels fastened together by the aid of which any single soldier may be considered able to fill the place of a hundred musqueteers. (4) An engine by which five balls can be fired in the same time as one

is. (Note these two latter inventions appear to be an apt description of a modern machine gun.) (5) and (6) Mortars or tube guns for defending walls and ships and destroying masts and rigging of ships. (7) An improved helepolis suitable both for attacking forts and repulsing attacks upon them. The eighth invention is omitted. (9) A new sort of ship called the "Leviathan" which can enter any kind of barricaded port and destroy whole ships by fire. (10) An instrument for measuring the proportionate increase and decrease of the winds. (11) A light boat which can be moved by oars and sails at any time against the strongest wind. (12) An instrument for calculating the different longitudes of places, either at sea or on shore. (13) An instrument by which salt water may be made sweet and drinkable at small expense. (14) Burning glasses by which combustible matters at any distance may be set on fire. (15) Spy glasses, and (16) a machine producing perpetual motion from a natural cause and one incapable of fatigue by the employment of whose aid a variety of mechanical operations may obtain motive power.

Longitude of Ships at Sea

From the above, it will be seen that many inventions regarded as modern are foreshadowed, and perhaps the most important is that suggesting a means for discovering the longitude of ships at sea. This apparently is the first known means of any attempt having been made to determine the longitude of a ship while at sea. It was not until 1674 that a Frenchman (St. Pierre) proposed to Charles II. a method of doing this, and out of this in passing, arose the foundation of the Greenwich Observatory in the following way. On the proposal of St. Pierre being submitted to a committee of astronomers, John Flamsteed, who was one of the committee, drew attention to the incorrectness of the lunar tables, by which the position of the moon among the fixed stars was to be calculated. Charles II. was struck by the deficiency and immediately founded the Observatory at Greenwich (1675), giving Flamsteed the title of Astronomer Royal with a salary of £100 per year.

From the practice of the Sovereign granting monopolies, arose the present system of granting Patents for inventions.

Sir Edward Coke (1552-1634) in 1620 vigorously attacked the granting of monopolies and laid down that by ancient common law the King could grant to an inventor or an importer of an invention from abroad a temporary monopoly for his invention, but that grants in restraint of trade were illegal. This was the law laid down previously in the first recorded case, *Daroy v. Allin* (1602), and was never over-ruled in any subsequent case, but the law was frequently evaded.

(To be continued.)

REAL SUPERMEN INSTEAD OF WEAKLINGS



MR. GERARD NISIVOCIA whose picture shows the embodiment of health and physical fitness.

says the President of The Newark P.C. Club. Here are his exact words:—

"Dec. 1st, 1933. . . . having been a follower of THE MAXALDING PRINCIPLES for some time, I believe that your courses are conducive to the appreciation of the body of strength, mentally and physically. KEEP THEM UP AND THE WORLD WILL BE BLESSED WITH REAL SUPERMEN INSTEAD OF WEAKLINGS, which are a burden to humanity. Once more please accept my appreciative thanks for the great consideration that has been rendered me.

Gratefully yours,
(Signed) GERARD NISIVOCIA, L.L.B."

MAXALDING IS FULLY DESCRIBED in a 20,000-words illustrated treatise. It is published at 1/- nett, but one copy will be sent free to any applicant, from any part of the world, who sends name, address, age and occupation together with postage for 3 oz. sealed cover. No Cost or Obligation involved.

MAXALDING (Dept. 787) 14 CURSITOR ST., LONDON, E.C.4.

PATENTS, TRADE MARKS AND DESIGNS	"ADVICE HANDBOOK" AND CONSULTATIONS FREE!
KINGS PATENT AGENCY LTD Director: B. T. King, O.B.E., Reg. Pat. Agent G.B., U.S.A. & Can. 146a Queen Victoria St., LONDON, E.C.4 and 87 Chancery Lane (near Patent Office), W.C.2. 49 Years' Experience. TELEPHONE: CITY 6161.	

PRACTICAL HINTS ON PATENTING
and the development of inventions.
Sent free on application.

THE IMPERIAL PATENT SERVICE
First Avenue House, High Holborn, W.C.1.
Principal: M. E. J. GHEURY DE BRAY, F.P.S.
Preliminary Consultation Free. Telephone: Holborn 9191.
Telegrams: Imperatrix, London.

PATENTS, DESIGNS AND TRADE MARKS
A VALUABLE GUIDE ON INTERNATIONAL PROTECTION OF INVENTIONS. 100 Pages - Post Free, 6d.
The TECHNICAL ADVERTISING AGENCY 253(D) Gray's Inn Road, London, W.C.1

Send to FOYLES FOR BOOKS!
New and second-hand books on every subject. Over two million volumes in stock. Catalogues free on mentioning your interests.
119-125 Charing Cross Road, London, W.C.2 Telephone—Gerrard 5660 (seven lines).



18 CT. PLATED DEMI HUNTER 59 POST 3d.

This genuine 18 ct. surfaced Engine Turned Geneva Lever Watch is renowned for lifelong reliability and time-keeping accuracy. Handsome case is fitted with interior damp and dustproof dome. 10-year guarantee given. As sold for £2.2.0. Full Hunter same price.

FREE to all purchasers: 18 ct. plated Curb Dress chain with real gilt coin. Send P.O. today to **Direct Mail Co. (London)** (Dept. P.M.H.1), 87 New Oxford Street, London. W.O.1. Opposite Glauco, 2nd Floor.

7/6 A.C. Battery Charger 7/6

Kit "A," 1/2 amp. Charger; Mains Transformer 4/6, Tantalum 1/6, other parts 1/3. Complete, 7/6 post free. Kit "B," as "A," but charging at 1 amp., 12/6 post free. Kit "C," with Westinghouse Rectifier, 1/2 amp., 12/6, post 6d. Model "D," complete in metal Case, charges 2, 4 or 6 volt cells at 1 amp., ready to plug-in, 17/6 post free. Model "E," a real charger. As "D," but charging at 2 amps., 21/-.

ALL ABOVE SUITABLE FOR 100-250 VOLT A.C. MAINS. Please state Mains Voltages when ordering.

Variety A.C.H.T. Unit, 150v., 25 M/A, four tappings, complete in attractive metal case, 30/-.

Variety Mains Transformer 250-0-250v., 60 M/A, 4v. 1a., 4v. 3a., C.T., massive job, 8/6.

Mains Chokes, 30 henries, 3/6, 20 henries, 2/6. Etesca Dual Coils, new, boxed, 1/6, post, 3d.

Brandes' All-brass 0005 Variable Condensers, 2/-, 2 mfd. Condensers, 750v. test, 1/3, 1 mid., 1/-. Brownie Wireless L.F. Transformers, 5-1, 2/6. Send 1/2d. stamp for complete list of surplus Radio Components.

FROST RADIO CO., 21 Red Lion St., E.C.1

KEEP IN TOUCH

with the growth of air communications at home and abroad by collecting Air Mail Stamps. Our

AIR MAIL LIST

contains hundreds of offers of these interesting stamps as well as flown covers and will be sent free on request

WHITFIELD KING & CO., (P.M.) IPSWICH SUFFOLK. Established 1869.

EVERY HOUSEHOLDER'S IDEAL UTILITY TOOL.

SPLITS AND CUTS LOGS, GARDEN STICKS, BONES, Etc.



The MIGHTY WEDGE

Its unique steel cutting blade eliminates all danger of the wood flying upwards. Easy to sharpen. Cast Steel. British Manufacture. Awarded Only Bronze Medal Inventions Exhib. 1933. Hair Post 3d.

Also the **MIGHTY WEDGE AXE** with handle 6d. extra. As supplied to the L.C.C. Discard that dangerous chopper—Your sight is more precious. Order Now. Satisfaction or money refunded.

LOG & WOOD SPLITTER

J. G. BROWN, (P), 4 Palgrave Road, LONDON, W.12.

MICROFU GOLD FILM FUSES

20 Stock Ratings. Type F.2, suitable for Battery sets, 150 M/A blown at 300 M/A Resistance 71 ohms. Voltage 280 Volts D.C.

Type F.2, suitable for Mains sets, 500 M/A FUSES 6d. blows at 1 amp. resistance 14 ohms. 280 Volts HOLDERS 6d. D.C. Now available, 2 M.A. 4/-, 1 M.A. 4/6.

MICROFUSES LTD., 36, Clerkenwell Rd. LONDON, E.C.1. 'Phone: CLE 4049.

ART MAKE MONEY IF YOU SKETCH or wish to write showcards in your own time. Write for our free booklet. It will interest you. All kinds of drawings bought. **Secretary, ART STUDIOS, 12 & 13 HENRIETTA STREET, STRAND, W.C.2.** Est. 1900

AROUND THE TRADE

BRIEF ITEMS AND TOPICAL THOUGHTS CONCERNING MANUFACTURERS AND THEIR PRODUCTS.

The Householders' Vade-mecum

HOW do you repair a leaky roof? How can you make an Aquarium? Many other similar problems occur every day in our lives, and the answers to them all are contained in the "New Amateur Mechanic," a Four-volume work that costs only 2s. a day for twelve months. The Waverley Book Co. Ltd., of 96 and 97 Farringdon Street, London, E.C.4 will forward details and a most interesting Free Illustrated Booklet to all who ask for it.

Make Your Hobby Pay

THOUSANDS of men who started radio as a hobby are now in well paid regular employment. Research and laboratory work, designing, testing, servicing, installing, demonstrating and selling, technical correspondence, and many other interesting jobs at good pay are available for trained men, whilst many other industries outside radio also require men with radio knowledge. The Technical and Commercial Radio College, Cromwell House, High Holborn, London, W.C.1, can train you and give you the sort of training that employers demand. Every student is guaranteed introductions to leading employers, and is given valuable assistance in obtaining the type of work he requires.

Radio Mains Equipment

HEYBERD mains units have now been on the market so many years that they have proved their superb quality and their reputation is unassailable. By doing away with batteries and fitting a Heyberd mains unit to your receiver, you save literally pounds on the year's running, and you are assured of a constant, ever-available voltage. A catalogue of their various types of mains units, also containing circuit diagrams for installing them in your set, is obtainable free upon application. The book also gives helpful hints which may prove of assistance when dealing with mains radio.

Do Your Own Printing

EVERYONE likes to have a visiting card, and there are also many occasions when some small printing would be found very useful. The Adana Printing Machine, which costs 45s. from the D. A. Adana Co. (P.M.1), 17 Church Street, Twickenham, will print visiting cards, leaflets, price lists, dance programmes, concert programmes, note headings, and sundry other items. As a spare-time occupation this machine will prove a ready cash producer and turns out work comparable with professionally produced work—and no experience is necessary.

Model Railways and Model Boats

THE name of Bassett-Lowke Ltd., of Northampton, is well known in connection with model railways, and some of the scale models manufactured by this firm may be seen at all the great exhibitions. A splendid free booklet obtainable from this firm will give some idea of the remarkable models which are obtainable.

Apparatus for the Hobbyist

RECENTLY had occasion to visit the well known firm of Messrs. Griffin and Tatlock Ltd., Kemble Street, Kingsway, London, W.C.1, and inspected a small portion of their enormous stock which is displayed in their showroom. Laboratory apparatus, machinery and equipment for all branches of educational research and industrial chemistry, chemicals and reagents, scientific and technical books, are stocked by this firm ready for your inspection. Their staff are extremely willing to help and answer questions relating to any particular apparatus you may require. You should certainly pay them a visit without delay.

HOW LONG DOES YOUR ACCUMULATOR LAST?

(Continued from page 334.)

Such a clock will of course only register up to twelve hours, but another device can be added so that multiples of this can be registered. This consists of a disc of metal or any other fairly hard material mounted through its centre on the spindle near the edge of the face of the clock, and of sufficient diameter to come well underneath the hour hand. The edge of the disc is carefully filed out into half circular niches at necessary intervals which must be determined by experiment on the particular clock movement which is being used. The tip of the hour hand is turned down so that it engages with one of the niches as it comes round and so turns the disc. The disc should be mounted sufficiently tightly on the spindle to prevent it rotating on its own, but at the same time not so tight that the hour hand is stopped. The niches can then be marked off in 12—24—36 and so on.

Use **"Baker's" SOLDERING FLUID**

Sold in 6d and 1/- tins at all Cycle Accessory Dealers Tool Shops, Ironmongers, etc.

For the Free Book "Money of Money" to Sir WILLIAM BURNETT & CO. (Chemists) LTD., 114 Wall, London E.C.4

"For a quick clean job"

BAND GUIDE

giving hints on the Bugle, Drums and Flute, also Parade Formations, use of Parade Cane, Staff etc., Post Free.

Makers: **H. POTTER & Co.,** 36/8, West St., Charing Cross Road, LONDON, W.C.2

YOU CAN USE YOUR SPARE TIME TO START A MAIL ORDER BUSINESS

that quickly brings you a full-time income. Few pounds' capital only needed; no samples or outfits to buy. No rent, rates, or canvassing. New method makes success certain. Send to-day for free booklet.

BUSINESS SERVICE INSTITUTE (Dept. 366A) 6 Carmelite Street, London, E.C.4.

LEARN TO MAKE PICTURE FRAMES

Picture Framing, Tray-making, Craft Work, etc. Wonderful Wholesale Bargains in Mouldings, B. adings, Frets, Plys, Jacobean Legs, Table Tops, Corner and Tray Mouldings, Fine Art Pictures, Transfers, Silhouettes.

Fully Illustrated Gui'e, post free, 3d.

WATKINS PROVIDER NEWPORT, Mon.

CURE YOURSELF AS I DID. STAMMERING

After stammering terribly for 21 years and trying "teachers," schools, and advertised methods without relief, I at last discovered the real cure for Stuttering and Stammering (which is very simple, and cured myself. Now no stranger could tell that I had ever been a stammerer. **YOU** (or your child) can be quickly cured in the same way. Thorough and permanent cure Guaranteed or no charge. Full particulars will be sent FREE, privately, if you mention **PRACTICAL MECHANICS—M.F. & N.K.M. HUGHES,** 7 Southampton Row, London, W.C.1.

BE TALLER!!

RESULTS SPEAK FOR THEMSELVES

Pupil, age 19 1/2,	gains 5 ins. in 6 wks.
" " 21,	" 5 ins. in 5 mths
" " 30,	" 3 1/2 ins. in 16 d'ys
" " 40,	" 2 ins. in 4 wks
" " 40,	" 1 1/2 ins in 6 "

Increased my own height to 6' 3 1/2" **ROSS SYSTEM** Testimonials from all over the world **NEVER FAILS** Fee: £2.2s. complete. Convincing Testimony 2/6. stamp. Mailed privately.

L. MALCOLM ROSS, Height Specialist Scarborough, England. (P.O. Box 151)

MAKE YOUR OWN LEAD SOLDIERS

Cowboys, Indians, Animals, Zulus, Model Army Sets, Rodeo, etc. Our **CASTING MOLDS** make thousands from any scrap lead WITHOUT PREVIOUS EXPERIENCE. Send stamp to-day for NEW Illustrated Catalogue. **J. TOYMOLDS,** 7 Jamaica Row, Birmingham. Mention "Practical Mechanics."

BLUSHING FREE

to all sufferers, particulars of a proved home treatment that quickly removes all embarrassment, and permanently cures blushing and flushing of the face and neck. Enclose stamp to pay postage to Mr. M. Temple (Specialist), "Palace House," 128 Shaftesbury Avenue (2nd Floor), London, W.1. (Est. over 25 years.)