

Practical Electronics

JUNE 1966

PRICE 2/6

THYRISTOR CONTROL UNIT



ADCOLA

PRODUCTS LIMITED
(Regd. Trade Mark)

SOLDERING EQUIPMENT

for the
*Discriminating
Enthusiast*



ILLUSTRATED:
L64 $\frac{3}{16}$ " BIT INSTRUMENT IN
L700 PROTECTIVE SHIELD

APPLY DIRECT TO:
SALES & SERVICE DEPT.
ADCOLA PRODUCTS LTD.
ADCOLA HOUSE
GAUDEN ROAD
LONDON, S.W.4
TELEPHONE: MACAULAY 0291/3

Great Repair Aid

HELPS YOU EARN MORE

Time-saving Repair Data for
nearly **900** Radios & TV's.

Now you can have at your fingertips Circuits and Data for repairing all the popular TVs, Radios, Grams, Record players and Tape recorders—right back to 1964. A guaranteed money spinner . . . saves your time, increases your earning power! Compiled by a team of research engineers Newnes RADIO & TV SERVICING not only gives repair information for nearly 60 principal makes but also includes section of latest developments in the industry. Thousands upon thousands of copies of previous editions sold—it's the most sought-after publication in the trade. Seize this opportunity to see it on free trial. Send now!



NEWNES Radio & TV Servicing

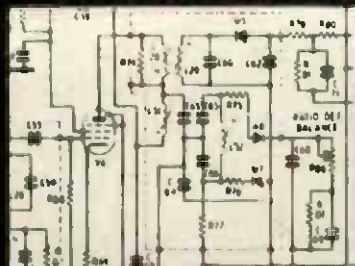

CIRCUITS-DATA

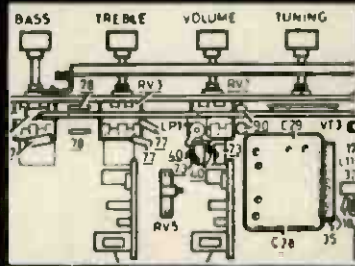

REPAIR HINTS

TELEVISION • RADIO
RADIOGRAMS • CAR RADIOS
RECORD REPRODUCERS
TAPE RECORDERS

All these makes covered—
Alba, Baird, Bush, Carousel, Corsor,
Dansette, Decca, Defiant, Dynatron,
E.A.R., E.M.I., Ekco, Elizabethan,
Ever Ready, Ferguson, Ferranti,
Fidelity, G.E.C., Grundig, H.M.V.,
Hitachi, Invicta, Kolster-Brandes,
McMichael, Magnavox, Marconi-
phone, Masteradio, Motorola, Murphy,
National, Newmatic, Pam, Perdio, Peto-
Scott, Philips, Playcraft, Portadyne,
Pye, Radiomobile, Regentone, Revela-
tion, R.G.D., Roberts' Radio, S.T.C.,
Sanyo, Sharp, Sinclair, Smiths' Radio-
mobile, Sobell, Sound, Standard, Stella,
Stereosound, Teletron, Thorn, Trans
Arena, Ultra, Zenith.

2 VOLUMES • OVER 1,000 PAGES
NEARLY 1,400 CIRCUITS, COM-
PONENT LAYOUT DIAGRAMS &
DRAWINGS.

Plus section of latest developments
in Radio and Television

Yours for a week

FREE

EASY NO-INTEREST TERMS IF KEPT AFTER FREE TRIAL

Buckingham Press Ltd *If under 21 your father must fill up coupon*
15-17 Long Acre
London, W.C.2

Please send Newnes
RADIO & TV SER-
VICING (2 volumes,
1964-66 models) with-
out obligation to buy.

If you accept this applica-
tion I will post 15/-
deposit 8 days after recei-
pt of books, then 15/-
monthly for 10
months, paying £8.5s.
in all—or return the
books. Cash in 8 days
£8.5s.

Full Name
(BLOCK LETTERS) (Mr./Mrs./Miss)

Address

Occupation

Signature.....

100/2225

Tick where applicable

The address on left is—

My Property	<input type="checkbox"/>
Rented unfurnished	<input type="checkbox"/>
Parents' Home	<input type="checkbox"/>
Furnished Accom.	<input type="checkbox"/>
Temporary Address	<input type="checkbox"/>



LAFAYETTE HA-63 COMMUNICATION RECEIVER

7 valves plus Rectifier. 4 Bands. 530 kc/s-31 Mc/s. "S" Meter-BFO-ANI-Bandspread Tuning. 200/250 v. A.C. Brand New 24 Gns. Carr. Paid.

LAFAYETTE HA-230 AMATEUR COMMUNICATIONS RECEIVER

Supersedes model HE-30. 8 valves + rectifier. Continuous coverage on 4 bands. 550 Kc/s-30 Mc/s. Incorporates 1 RF & 2 IF stages, Q Multiplier, B.F.O., ANL, "S" meter, Electrical bandspread, Aerial trimmer, etc. Supplied brand new and guaranteed. £33. S.A.E. for full details. Also available in semi Kit Form. 25 gns.

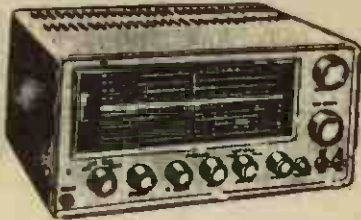

LAFAYETTE HA-55 AIRCRAFT RECEIVER

108-136 Mc/s. High selectivity and sensitivity. Incorporates 2 RF stages including 6CW4 Nuvistor, 8 tubes for 11 tube performance, solid state power supply, adjustable squelch control, slide rule dial, built in 4in. speaker and front panel phone jack. 220/240V. A.C. Supplied brand new and guaranteed. £19.7.8. Carr. 10/-.

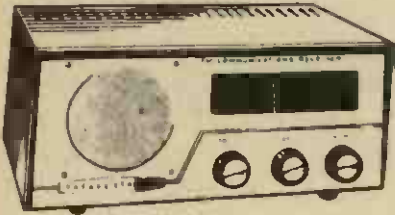

HAM-1 COMMUNICATION RECEIVER

5 valve superhet receiver covering 550 Kc/s-30 Mc/s on 4 bands. Special features include slide rule dial. Bandspread tuning. "S" meter. B.F.O. Built in 4" speaker. Operation 220/240 v. A.C. Brand New with handbook. 16 GNS. Carr. 10/- S.A.E. for details.



MAIN LONDON AGENTS FOR CODAR EQUIPMENT

All items available as advertised

SINCLAIR TRANSISTOR AMPLIFIERS

Z12 Amplifier 89/8; Power Pack 54/-; X10 Amplifier Built £8.19.8, Kit £5.19.8; X10 Power Pack 54/-; X20 Amplifier Built £9.19.8, Kit £7.19.8. X20 Power Pack £4.19.8. Micro FM Radio Kit £5.19.8. Micro 6, 59/8; TR750 amp Kit 39/8; Micro amp 28/8; Micro Injection 27/8. Post Paid.

TRANSISTORISED TWO-WAY TELEPHONE INTERCOM.

Operative over amazingly long distances. Separate call and press to talk buttons. 2-wire connection. 1000's of applications. Beautifully finished in ebony. Supplied complete with batteries and wall brackets. £8.10.0. pair. P. & P. 3/6.



MAGNAVOX 363 TAPE DECKS

New 3-speed tape deck, supersedes old Collaro studio deck. 2-track £10.10.0. 4-track £13.10.0. Carr. Paid.

PCR3 RECEIVERS

Absolutely brand new 3 wave bands 190-550 metres and 2.2-23 mc/s with circuit £8.19.8. Carriage 10/6. Plug-in power supply 12 volt d.c. 19/8. 230 volt a.c. 35/-.

AMERICAN TAPE

First grade quality American tapes. Brand new. Discounts for quantities.

3in., 225ft. L.P. acetate	4/-
3 1/2in., 600ft. T.P. mylar	10/-
5in., 600ft. std. plastic	8/6
5in., 900ft. L.P. acetate	10/-
5in., 1,200ft. D.P. mylar	15/-
5in., 1,800ft. T.P. mylar	35/-
5 1/2in., 1,200ft. L.P. acetate	12/6
5 1/2in., 1,800ft. D.P. mylar	22/6
5 1/2in., 2,400ft. T.P. mylar	45/-
7in., 1,200ft. std. mylar	12/6
7in., 1,800ft. L.P. acetate	15/-
7in., 1,800ft. L.P. mylar	20/-
7in., 2,400ft. D.P. mylar	25/-
7in., 3,600ft. T.P. mylar	58/6

Postage 2/- Over £3 post paid.

CALLERS WELCOME!

Open 9 a.m. to 6 p.m. every day Monday to Saturday. Trade supplied.



2-WAY RADIOS

Superb quality. Complete with all accessories and fully guaranteed. 3 Transistor £7.19.8 pr. 4 Transistor 11 gns. pr. 5 Transistor £8.5.0 pr. 9 Transistor £22.10.0 pr. 10 Transistor 28 gns. pr. Post extra. (S.A.E. for full details). These cannot be operated in U.K.

VOLTAGE STABILIZER TRANSFORMERS

Input 80-120v. and 160-240v. Constant output 110v. or 240v., 250 watts. Brand New Guaranteed. £10.10.0. Carr. 7/6.



VARIABLE VOLTAGE TRANSFORMERS

Brand New—Fully Shrouded. Input 230v. 50/60 c/s. Output 0-260 Volts. 1 Amp £4.10.0 2.5 Amp £5.17.8 5 Amp £9.0.0 8 Amp £13.10.0 10 Amp £17.0.0 12 Amp £19.10.0 20 Amp £32.10.0 2.5 Amp Portable—Metal Case with Meter—Fuses, etc. £9/17/6.



SILICON RECTIFIERS

200 v. P.I.V. 200mA	2/8
400 v. P.I.V. 3 amp	7/8
1,000 v. P.I.V. 650 mA	6/8
800 v. P.I.V. 500mA	5/8
800 v. P.I.V. 5 amp	7/8
400 v. P.I.V. 500mA	3/8
70 v. P.I.V. 1 amp	3/8
150 v. P.I.V. 165mA	1/-

Discounts for quantities. Post extra.

TEST EQUIPMENT

PORTABLE OSCILLOSCOPE CT.52

A compact (9" X 8" X 16 1/2") general purpose scope. T/B 10 c/s-40 kc/s. Band width 1 Mc/s. Mullard DG 7/5 2 1/2" CRT. For operation on 200/250 v. A.C. Supplied complete with metal transit case, strap, test leads, and visor hood. Brand new. £22.10.0. Carr. 10/- Supplied complete with instructions.

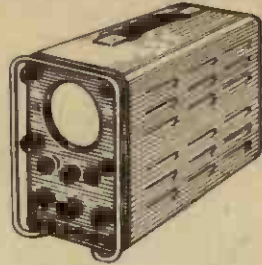

OS/8B/U OSCILLOSCOPES

High quality Portable American Oscilloscope. 3" c.r.t. T/B 3 c/s-50 kc/s X Amp: 0-500 kc/s Y Amp: 0-2 Mc/s. Power requirements 105-125v. A.C. Supplied in brand new condition, fully tested. £25. Carr. 10/- Suitable 230/115v. Transformer 15/6.

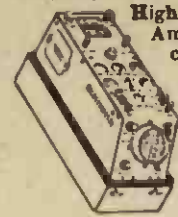

ERSKINE TYPE 13 DOUBLE BEAM OSCILLOSCOPE

Time base 2 c/s-750 kc/s. Callibrators at 100 kc/s and 1 Mc/s. Separate Y1 and Y2 amplifiers up to 5.5 Mc/s. Operation 110/230 volt A.C. Supplied in perfect working order. £27/10/-. Carriage 20/-.

TE-20 RF SIGNAL GENERATOR



Accurate wide range signal generator covering 120 kc/s-260 Mc/s on 6 bands. Directly calibrated. Variable R.F. attenuator. Operation 200/240 v. A.C. Brand new with instructions, £12.10.0. P. & P. 7/6. S.A.E. for details.

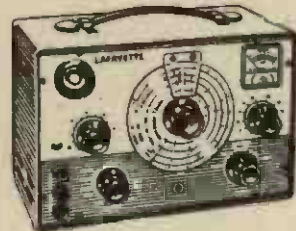

LAFAYETTE TE-46 RESISTANCE CAPACITY ANALYZER

2 PF—2,000 MFD. 2 ohms—200 Megohms. Also checks impedance, turns ratio, insulation 200/250v. A.C. Brand New £15. Carr. 7/6.

LAFAYETTE NUVISTOR GRID DIP METER

Compact true one hand operation. Frequency range 1.7-180 Mc/s. 230v. AC operation. Supplied complete with all coils and instructions. £12.10.0. Carr. 5/-.



TE22 SINE SQUARE WAVE AUDIO GENERATORS

Sine 20 cps to 200 kc/s. on 4 bands. Square: 20 cps to 20 kc/s. Output impedance 5,000 ohms. 200/240 v. A.C. operation. Supplied Brand New and Guaranteed with instruction manual and leads. £15. Carr. 7/6.



NOMBREX EQUIPMENT

Transistorised Audio Generator 10-100,000 c/s. Sine or square wave. £18.15.0. Transistorised Signal Generator 150 kc/s. 350 Mc/s. £10.0.0. Transistorised resistance capacity bridge 1Ω. 100 MegΩ, 1 pf-100μF. £9.10.0. Transistorised Induction bridge 1μN-100H. £18. Mains operated Transistor power supply unit, output 1-15v. up to 100 mA. £8.10.0. All above post paid with battery.

CLEAR PLASTIC PANEL METERS

First grade quality, Moving Coil panel meters, available ex-stock. S.A.E. for illustrated leaflet. Discounts for quantity. Available as follows: Type MR. 38P. 1 21/32in. square fronts.

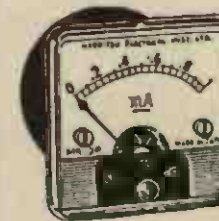

100-0-100μA	27/6	200mA	22/6	100V D.C.	22/6
500-0-500μA	22/6	300mA	22/6	150V D.C.	22/6
1-0-1mA	22/6	500mA	22/6	300V D.C.	22/6
1mA	22/6	750mA	22/6	500V D.C.	22/6
2mA	22/6	1A D.C.	22/6	750V D.C.	22/6
5mA	22/6	2A D.C.	22/6	15V A.C.	22/6
10mA	22/6	5A D.C.	22/6	50V A.C.	22/6
20mA	22/6	3V D.C.	22/6	150V A.C.	22/6
50mA	22/6	10V D.C.	22/6	300V A.C.	22/6
100mA	22/6	20V D.C.	22/6	600V A.C.	22/6
150mA	22/6	50V D.C.	22/6	"S" Meter 1mA 28/6	

POST EXTRA. Larger sizes available—send for lists.

TE-51 NEW 20,000Ω/VOLT MULTIMETER

0 / 6 / 60 / 120 1,200V. A.C. 0 / 3 / 30 / 60 / 300 / 600 / 3,000V. D.C. 0 / 60μA / 12 / 300 MA. D.C. 0 / 60K / 6 Meg. Ω 85/- P. & P. 2/6.



MODEL PV-58 VALVE VOLTMETER

11 meg. input. 7 D.C. volt ranges. 1.5-1,500 v. 7 A.C. volt ranges 1.5-1,500 v. 4,000 Peak to Peak. Resistance .2 ohm to 1,000 megohm. Decibels -10db to +65db. Supplied brand new with instructions, leads and probe. £12/10/- P. & P. 3/6.



TS-76 20,000 O.P.V. PUSH BUTTON MULTI-TESTER

Simple operation. D.C. volts up to 1,000 v. A.C. volts up to 1,000 v. Resistance up to 10 megohm. Current up to 250 mA. Decibels -20 to +36 db. £5.5.0. P. & P. 2/-.



MODEL 500. 30,000 o.p.v. 0/.5/1/2.5/10/25 / 100 / 250 / 500 / 1,000v. D.C. 0 / 2.5 / 10 / 25 / 100 / 250 / 500 / 1,000v. A.C. 0 / 50μA / 5 / 50 / 500mA. 12 amp. D.C. 0 / 60K / 6 Meg. / 60. Meg Ω. £8/17/6 Post Paid.

G.W. SMITH & CO (RADIO) LIMITED

Phone: GERRARD 8204/9155
Cables: SMITHEX LESQUARE
3-34 LISLE STREET, LONDON, W.C.2

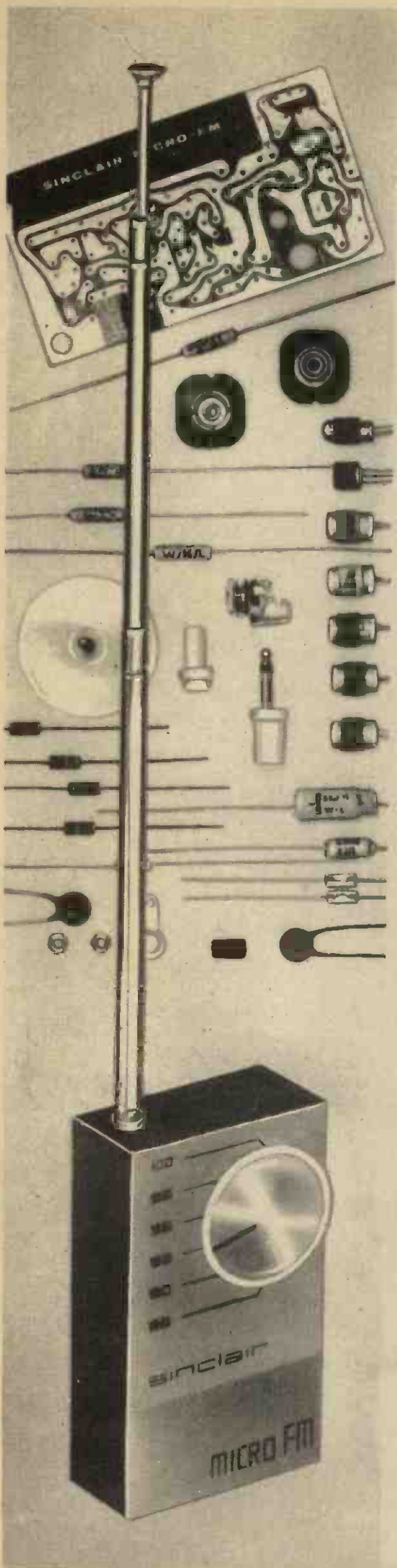

Build the World's most amazing FM tuner-receiver

The Sinclair Micro F.M. is *more* than an F.M. Tuner; *more* than an F.M. Receiver, for it combines the advantages of both with many other unique features to make it the most advanced set of its kind in the world. Anyone can construct it for, unlike other F.M. constructional kits, the Micro F.M. needs no aligning and is ready to work as soon as it is finished. Pulse-counting detection gives better audio quality than any other discriminator system. Excellent sensitivity assures good reception using no more than the set's own small telescopic aerial in all but the worst reception areas. When built, the Sinclair Micro F.M. has all the appearance of a professionally engineered set both inside and out. Its distinctive, elegant exterior makes it particularly pleasing to own and to operate whether as a tuner for amplifier or tape recorder or independently as a self-contained pocket F.M. portable.

- **SUPPLY VOLTAGE**—9V from self-contained standard battery
- **CONSUMPTION**—5mA
- **SENSITIVITY**—Typically 3 microvolts
- **SIGNAL TO NOISE RATIO**—30dB at 30 microvolts
- **AUDIO FREQUENCY RESPONSE**—10-20,000 c/s \pm 1 dB
- **A.F.C.**—for automatically locking on to each station tuned in
- *Inserting plug of earpiece or tuner lead switches set ON*

TECHNICAL DESCRIPTION

THE SINCLAIR MICRO F.M. is a completely self-contained double-purpose F.M. superhet housed within a case less than 3" high \times 1½" wide with a depth of ¼". It uses 7 transistors and 2 diodes. The R.F. amplifier is followed by a self-oscillating mixer and three stages of I.F. amplification which dispense with I.F. transformer and all problems of alignment. The final I.F. amplifier produces a square wave of constant amplitude which is eventually converted into uniform pulses so arranged that the original modulation is reproduced exactly. A pulse-counting detector ensures absolute linearity and therefore better audio quality at the output stages. After equalisation the signal is channelled to one output for feeding to amplifier or recorder and to another in which the receiver's own audio amplifying stage enables the Micro F.M. to be used as an independent self-contained pocket portable. A.F.C. is used to lock the programme tuned in. The telescopic aerial included with the kit will be found sufficient in all but the worst signal areas.

SINCLAIR MICRO FM

**7 TRANSISTOR—2 DIODE SUPERHET
F.M. TUNER-RECEIVER WITH A.F.C.
PULSE-COUNTING DETECTION AND
TWO OUTPUTS**

Complete kit of parts including telescopic aerial, case assembly, transistors, lightweight earpiece and instructions

£5.19.6



FULL SERVICE FACILITIES AVAILABLE TO ALL SINCLAIR CUSTOMERS

SINCLAIR

sinclair radionics Ltd.
22 newmarket road, cambridge

Telephone 52731

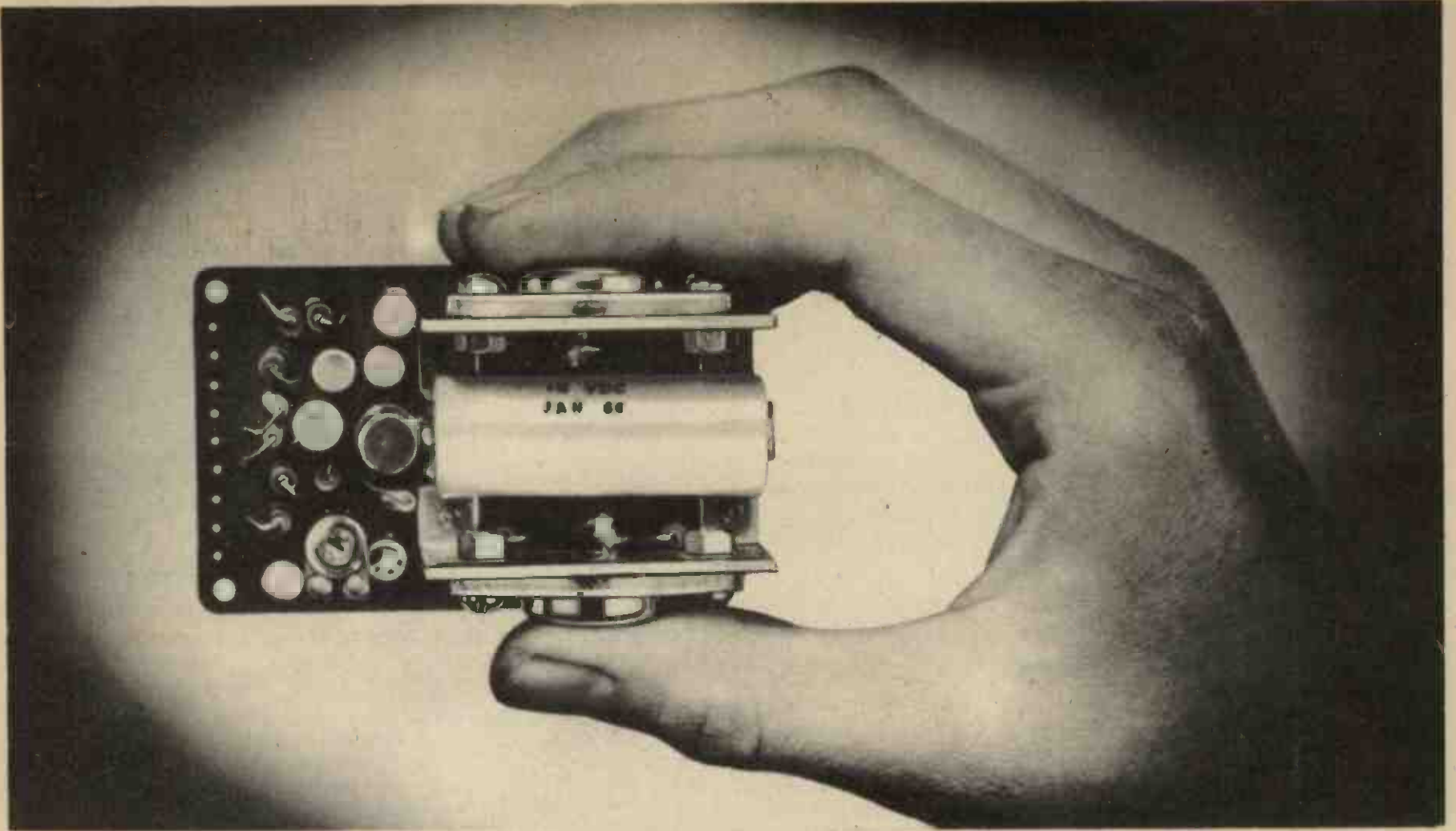

More power per square inch than any other amplifier in the world!

THE SINCLAIR Z.12 is a powerful, high fidelity amplifier of exceptional compactness complete with its own high gain pre-amplifier and ready to connect to any input. Its great power gives you an output equal to SIX WATTS PER SQUARE INCH of its total size—a standard of performance unsurpassed by anything in its class. And because of its size and unique circuitry you can now use quality amplification in applications never before possible. 8 special H.F. transistors are used in a circuit in which generous negative feedback and ultralinear class B push-pull

output achieve the highest possible standards of quality. ● The unit will operate from 6 to 20 V. d.c., and when not using a battery, the new PZ.3 will be found ideal. ● Response—15 to 50,000 c/s \pm 1dB. ● Input sensitivity 2mV into 2 K ohms. ● Signal to noise ratio is better than 60dB, and the output may be fed directly into any load from 3 to 15 ohms, or two 3 ohm speakers may be used in parallel. ● The manual included with the Z.12 gives full details of matching tone and volume control circuits for mono and stereo, together with multi-input switching facilities.

SINCLAIR
Z.12 combined 12 watt
hi-fi amplifier
and pre-amp

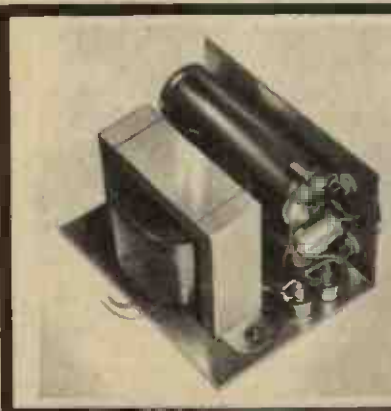

NEW POWER SUPPLY UNIT SINCLAIR PZ.3

This is an entirely new design using original circuitry based on advanced transistorised techniques to achieve phenomenally good smoothing, thus assuring ideal operating conditions for the Z.12 for which it was designed. Ripple is a barely measurable 0.05V, and the PZ.3 will power two Z.12s with ease. Output—20V.d.c. for A.C. mains operation, 200/250V., 50-60 c/s. **79/6**

Ready-built, tested and guaranteed, with Z.12 manual

89/6

Guarantee

Should you not be completely satisfied with your purchase when you receive it from us, your money will be refunded in full and at once without question.

- 12 WATTS R.M.S. OUTPUT
CONTINUOUS SINE WAVE (24 W. PEAK)
15 WATTS R.M.S. MUSIC POWER (30 W. PEAK)
- SIZE—3" × 1 $\frac{3}{4}$ " × 1 $\frac{1}{3}$ "
- IDEAL FOR 12V. OPERATION
- FOR HI-FI, RADIO TUNER, GUITAR, INTERCOM, ETC.

If you prefer not to cut coupon from page, please mention P.E.6 when writing your order.

ORDER FORM

To SINCLAIR RADIONICS LTD.
22 NEWMARKET ROAD, CAMBRIDGE

Please send.....

for which I enclose

CASH/CHEQUE/MONEY ORDER

for £ s. d.

NAME.....

ADDRESS.....

PE.6

SINCLAIR MICRO-6—The smallest radio in the world—TURN TO PAGE 396

SINCLAIR

SURPLUS TO REQUIREMENTS ...

Gramdeck offers you an amazing clearance bargain!

The chance of a lifetime for 'do-it-yourselfers'

You enjoy making things . . . experimenting . . . adapting? Then here's a truly fantastic offer—an opportunity you can't afford to miss. Limited quantities of the famous Gramdeck Pre-Amplifier/Control Unit original list price £6 6s. are available at the "give-away" price of only 26s. each. Guaranteed brand new and perfect.

A Really Versatile Unit

Ideal for adding a tape-deck to an existing Hi-Fi system, or a monitor-head to your tape recorder—can be used for super-imposing sound on pre-recorded tape, making pilot commentaries or for constructing a transfer mechanism from tape to stripe, adapting a record-player for public address, etc., etc. Contains a host of useful components for the experimenter (see below) or is ready for use as supplied.



The Gramdeck Pre-Amplifier 6" x 4" x 3½", comes in a compact metal case, with simulation-wood front panel. 3 Ediswan XB 102 Transistors, printed circuit board, 6-pole 4-way switch, 8 resistors, 11 capacitors, compensating coil, bias oscillator coil, sockets, wander plugs, leads, battery clips, etc., etc. Connects directly to tape-head. 600 hours working with PP9 battery (supplied). Rotary selector switch gives "Play", "Off", "Record Radio", "Record Microphone" positions.

. . . and A Matching Microphone

A superb matching moving-coil Lustraphone microphone, medium impedance (nominal 600 ohms at 1 kc/s) in cream plastic casing with a fabric blast guard, 9 ft. co-axial lead, fitted Belling-Lee co-axial plug—list price £3 7s. 6d., yours for only 26s. This high-quality mike is omni-directional in the horizontal and approaches cardioid characteristics in the vertical position. Frequency response approx. 70-12,000 cycles/sec.



This Offer may not be repeated—act NOW!

ONLY
50/-
FOR BOTH
ITEMS!
(or 26/- each)

Post Paid

All orders in strict rotation. Rush your order now, while stocks last. This is a genuine surplus - to - requirements offer.

Money Orders, Postal Orders or Cheques should be crossed and made payable to "Andrew Merryfield Ltd."

ANDREW MERRYFIELD LTD.

Dept. PL/802, 29 Wrights Lane, London, W.8

Keep those Contacts CLEAN

by using a

DIACROM SPATULA

The "Diacrom" is a metal spatula upon which diamond powder has been deposited by a special process. No deep scratches are possible because density is controlled and the polishing of the contacts is achieved by a gentle brushing motion. With coloured nylon handle for complete insulation and easy size identification.



Manufactured in France
British Patents applied for

- Grain size 200, thickness 55/100 mm., both faces diamonded. For quick cleaning of industrial relays and switching equipment, etc.
- Grain size 300, thickness 55/100 mm., both faces diamonded. For smaller equipments, like telephone relays, computer relays, etc.
- Grain size 400, thickness 25/100 mm., one face diamonded. For sensitive relays and tiny contacts. Two close contacts facing each other can be individually cleaned, because only one face of the spatula is abrasive.

Sole Distributors for the United Kingdom

SPECIAL PRODUCTS (DISTRIBUTORS) LTD.

81 Piccadilly, London, W.1. Phone: GROsvenor 6482

As supplied to the War Office, U.K.A.E.A., Electricity Generating Boards, British Railways and other public authorities; also to leading electronic and industrial users throughout the United Kingdom.

Build the smallest set in the world

—it's the inimitable

SINCLAIR MICRO 6

SIX STAGE POCKET RECEIVER

Anyone can build it in an evening

- ONLY 1½" x 1⅝" x ½"
- WEIGHS 1 oz.
- FANTASTIC RANGE AND POWER
- PLAYS ANYWHERE

MALLORY MERCURY CELL ZM.312 (2 required) each 1/11. Pack of Six 10/6.

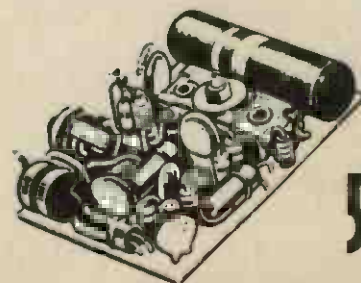

59/6

The wonderful Micro-6 brings in stations all round the medium waveband and has bandspread to bring in Luxembourg like a local station, yet it is actually smaller than a matchbox. Batteries and ferrite-rod aerial are contained within the minute white, gold and black case, and the set will play virtually anywhere. Building the Micro-6 is easy. When completed, it will delight and enthrall you with its fantastic performance which brings an intriguing new approach to radio listening.

This wonderful set has two stages of R.F. amplification, double diode detector and 3 stages of audio amplification with powerful A.G.C. to counteract fading from distant stations. Slow motion tuning makes station separation easy. Kit complete with transistors, case, dial, lightweight earpiece and instructions manual.

FULL SERVICE FACILITIES AVAILABLE • ORDER FORM PAGE 395

sinclair

SINCLAIR RADIONICS
22 Newmarket Road
Cambridge 52731

Eddystone



DIE CAST INSTRUMENT BOXES

The largest of the range—Cat. No. 903—is illustrated above. Made of aluminium alloy, it has internal dimensions of 7½ in. x 4½ in. x 3 in. and weighs 21 oz. Details of the other boxes are as follows:

Catalogue Number	dimensions	weight
896	4½ in. x 2½ in. x 1 in.	11½ oz.
650	4½ in. x 3½ in. x 2 in.	18 oz.
6908P	4½ in. x 3½ in. x 2 in.	9½ oz.
845	7½ in. x 4½ in. x 2 in.	32 oz.
6827P	7½ in. x 4½ in. x 2 in.	16 oz.

Cat. No. 6908P and Cat. No. 6827P are of aluminium alloy, the others of Mazak alloy. All are complete with close-fitting flange lids and are supplied in natural metal. Data sheets on request.

Eddystone Radio Limited

Eddystone Works, Alvechurch Road, Birmingham 31
 Telephone: Priory 2231. Cables: Eddystone Birmingham.
 Telex: 33708

LTD/ED9

take your pick!



from IR semiconductor centers

Over 100 IR semiconductor devices are available from your dealer, many with free instruction manuals and project and experiment details.

Look for the floor-standing 'Semiconductor Center,' or the counter-top 'Minicenter.'

- EXPERIMENTER SEMICONDUCTOR KITS
- MOUNTING KITS AND HEAT SINKS
- SILICON BRIDGE RECTIFIERS
- UNIUNCTION TRANSISTORS
- SELENIUM PHOTO CELLS
- INSTRUMENT RECTIFIERS
- AUTOMOTIVE RECTIFIERS
- SILICON SOLAR CELLS
- SILICON RECTIFIERS
- GERMANIUM DIODES
- THYRISTORS (S.C.R.)
- ZENER DIODES
- TRANSISTORS
- SELENIUM STACKS

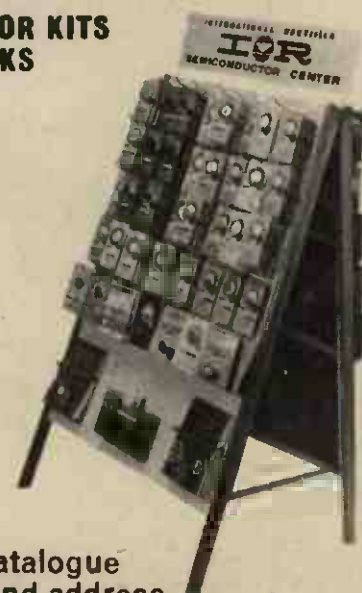

Write for the free illustrated catalogue and price-list, also the name and address of your nearest IR SEMICONDUCTOR CENTER

INTERNATIONAL RECTIFIER
 HURST GREEN • OXTED • SURREY • Tel.: OXTED 3215

Dealers—write for details of how you can start your own IR SEMICONDUCTOR CENTER.

IR semiconductor centers



D.I.Y. with GOODMAN'S HIGH FIDELITY MANUAL

A new, larger and more colourful edition—revised and completely up-to-date. It contains articles of particular interest to the D.I.Y. enthusiast—including special beginners page, advice on stereo, stage-built systems and full cabinet drawings. Whether building or improving your own audio set-up or choosing a complete speaker system, you'll find it useful and interesting as well as informative. Ask your Goodmans dealer or send coupon for your FREE copy.

Please send me a free copy of the Goodman's High Fidelity Manual

Name

Address

P.E.6

GOODMANS

GOODMANS INDUSTRIES
 Axiom Works, Wembley, Middlesex
 Telephone: WEMbley 1200
 A Division of Radio Rentaset Products Ltd.

SNIPERSCOPE

Famous war-time "cats eye" used for seeing in the dark. This is an infra-red image converter cell with a silver caesium screen which lights up (like a cathode ray tube) when the electrons released by the infra-red strike it. A golden opportunity for some interesting experiments. 5/- each, post 2/-. Date will be supplied with cells if requested.



MAINS POWER PACK

MAINS POWER PACK designed to operate transistor sets and amplifiers. Adjustable output 6 v. - 9 to 12 volts for up to 500 mA (class B working). Takes the place of any of the following batteries. PR1, PP3, PP4, PP6, PP7, PP9, and others. Kit comprises: mains transformer-rectifier, smoothing and load resistor, 5,000 and 500 mfd. condensers, zener diode and instructions. Real snip at only 14/6, plus 2/6 post.

SPEAKER BARGAIN

12in High fidelity loudspeaker. High flux permanent magnet type with either 3 or 15 ohm speech coil. Will handle up to 10 watts. Brand new, by famous maker. Price 29/6, plus 3/6 post and insurance.



ARMCHAIR CONTROL UNIT



Remote Controller for Philips, Stella and Cosor T.V. sets but adaptable to most others, and to model control. Comprises three rock switches, two variable resistances and components including Mullard OA81-Knobs-10 way plug, 11 ft. 7 way cable, etc., etc. List price £3/3/-, yours for only 12/6, plus 2/- post and insurance.

STUPENDOUS OFFER—£11 for £2

The Princess superhet described below is a very fine little set that has been carefully designed for high performance. Only recently (under another name of course) this was on offer in many radio shops, for £10. 19. 6, but we have been fortunate in obtaining the parts at a very low price and now pass this saving on to you. If you act quickly you can purchase this for only 39/6 plus 3/6 post and insurance. Note these features:

- Long and Medium Wave.
- Long clear dial with travelling pointer and slow motion drive.
- Push pull output approximately 350 m.w.
- A.V.C. and feed back.
- Dust cored H.Q. I.F. transformers.
- High selectivity ferrite aerial.
- Six tested and guaranteed transistors.
- Printed circuit board for fool-proof assembly.
- Economy output circuit gives long life from PP3 battery.
- Permanent magnet moving coil speaker.
- Cabinet size 4 1/2 in. x 3 in. x 1 1/2 in. (with carrying strap). Data included or separately 2/6.



TRANSISTOR BARGAIN

With carrying handle size 10in. x 8in. x 3in. Strongly made from best ply-wood and covered two-tone fabric—looks very smart, suitable for receiver — amplifier — extension speaker, etc. —

Originally listed at 29/6 — but offered this month at only 15/- plus 5/- post and insurance; also given free with it is a printed circuit board to suit it and building instructions for fine two-wave radios. Don't miss this grand offer.

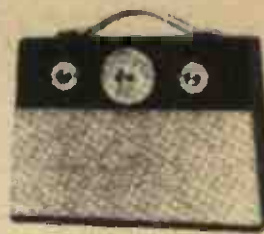

FOUR-STATION INTERCOM

Will save time and improve efficiency. Ideal in home—office—shop—

surgery, etc. Complete outfit comprises Master unit and three substations each of which can call the master and have full two-way working. No wiring problems as subs fitted with 60ft. twin flex and they plug into sockets. Also included is packet of staples—and battery. Nothing else to buy—£7/15/-, plus 4/6 post and insurance.



THIS MONTH'S SNIP

GARRARD AUTO RECORD PLAYER Model 2000



This is one of the latest products of the world's most experienced maker of fine record reproducers. Its superior features include: automatic playing of up to 8 mixed size records, stopping and starting without rejecting, manual playing, pick-up pivots to give low stylus pressure, large diameter turntable for max. stability, adjustments include pick-up height, pick-up dropping position and stylus pressure. Size is 13 1/2 in. x 11 1/2 in. clearances 4 1/2 in. above, 2 1/2 in. below. fitted with latest hi-compliance cartridge for stereo, and mono, L.P. and 78. Supplied complete with mounting template and service sheet. Offered this month at the Special Snip price of £6/9/6d. plus 7/6 carriage and insurance.

750 mW TRANSISTOR AMPLIFIER

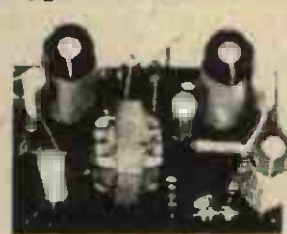

4 transistors including two in push-pull input for crystal or magnetic microphone or pick-up—feed back loops—sensitivity 5 m/v. Price 19/6. Post and ins. 2/6. Speakers 3in. 12/6; 5 in. 13/6; 6in. x 4in. 14/6.

ELECTRONICS (CROYDON) LIMITED

102/3 TAMWORTH ROAD, CROYDON, SURREY (Opp. West Croydon Station)
266 LONDON ROAD, CROYDON, SURREY (Opp. ABC Cinema, West Croydon)

Post orders to: Dept. PE, SPRINGFIELD ROAD, EASTBOURNE, SUSSEX

Z & I AERO SERVICES LTD.

Head Office and Warehouse: 44A WESTBOURNE GROVE, LONDON, W.2.

Retail Shop: 85 TOTTENHAM COURT ROAD, LONDON, W.1
Tel.: LANGHAM 8403 Open all day Saturday
Tel.: PARK 5641/2/3

OA2 8/-	GAG7 6/-	6BZ6 6/-	6Y6G 10/-	128F5GT 9/-	EBF89 7/-	EF95 5/8	GZ30 8/-	PL36 10/-	UBF69 7/-
OB2 6/-	6AJ5 9/-	6C4 2/8	7B5 10/-	128Q7GT8/6	EBL1 14/-	EF98 12/8	GZ32 10/-	PL38 16/-	UBF84 7/8
OB3 8/-	6AK5 5/8	6C5 8/-	7B6 11/-	128Y7 8/-	EBL31 20/-	EF183 8/-	GZ34 10/-	PL81 8/-	UBF89 7/8
OC3 6/-	6AK6 7/-	6CB6 5/-	7B7 7/-	1487 18/-	ECC84 7/-	EF184 8/-	KT66 16/-	PL82 7/8	UBL21 11/-
OD3 5/-	6AL5 3/-	6CD6GA17/-	7C6 7/-	19AQ5 5/-	ECC85 6/8	EF804 21/-	KT88 22/-	PL83 7/8	UCC84 10/-
IA7GT 8/-	6AM6 4/-	6CH6 8/-	7C7 5/-	20L1 14/-	ECC86 7/-	EFP60 10/-	N78 15/-	PL84 7/-	UCC85 7/-
IB3GT 7/-	6AN4 15/-	6CL6 9/-	787 18/-	20P1 14/-	ECC88 10/-	EL34 11/-	N8P1 25/-	PL302 14/-	UCF80 10/-
IC5GT 8/-	6AN5 15/-	6CW4 12/-	7Y4 8/-	20P3 13/-	ECC89 12/-	EL37 17/8	N8P2 22/-	PL500 15/-	UCH21 9/8
ID5 7/8	6AN8 10/-	6CY6 10/-	7Z4 8/-	20P4 14/-	ECC89 12/-	EL38 17/8	PABC80 7/8	PL801 10/-	UCH42 9/8
IG6GT 7/-	6AN9 5/-	6DK6 6/-	10C2 13/-	20P5 12/-	ECC89 12/-	EL41 9/8	PC86 12/-	PP5/400	UCH43 8/-
IL4 2/8	6AQ5 6/-	6EAS 11/-	10D1 7/-	25AGG 5/-	ECC89 12/-	EL42 9/-	PC88 12/-	PC97 9/8	UCH81 7/-
IN6GT 8/-	6AR5 6/-	6F1 14/-	10F1 14/-	25C5 10/-	ECC89 12/-	EL50 6/-	PC97 9/8	PC990 12/-	UCL82 8/8
IR4 6/-	6AR6 6/-	6F6 8/-	10F3 8/-	25L6GT 8/-	ECC89 12/-	EL81 9/8	PC990 12/-	PCC84 6/8	UCL83 10/-
IR5 5/-	6AR8 17/8	6F8G 5/-	10F18 9/-	25ZAG 8/-	ECC89 12/-	EL83 8/-	PCC84 6/8	PCC85 8/-	UF1 9/-
IR4 5/-	6A85 5/-	6F13 6/8	10L1 7/8	25Z5 10/-	ECC89 12/-	EL84 5/-	PCC85 8/-	PCC88 12/-	UF2 9/-
IR5 4/8	6A86 5/-	6F14 15/-	10P13 12/8	25Z6GT 11/-	ECC89 12/-	EL85 8/-	PCC88 12/-	PCC89 12/8	UF3 8/-
IT4 3/-	6A87 20/-	6F15 11/-	10P14 13/-	27M1 60/-	ECC89 12/-	EL86 8/-	PCC89 12/8	PCC189 12/-	UF80 8/-
IT6GT 8/-	6AT6 4/8	6F17 6/-	12AC6 8/-	28D7 7/-	ECC89 12/-	EL90 6/-	PCC189 12/-	PCC805 12/8	UF85 8/-
IU4 5/-	6AU4GT 9/-	6F23 11/8	12ADG 8/-	30A5 7/-	ECC89 12/-	EL91 2/8	PCC805 12/8	PCC806 14/-	UF86 11/-
IU5 6/-	6AU6 6/-	6F28 10/8	12AL5 7/-	30C1 7/8	ECC89 12/-	EL95 6/-	PCC806 14/-	PCF80 7/8	UF89 7/8
IX2B 7/-	6AV6 6/-	6F32 3/-	12AQ5 7/-	30C15 11/-	ECC89 12/-	EL360 22/-	PCF80 7/8	PCF82 8/-	UL1 9/-
2A3 5/-	6AW8A 14/-	6G6G 2/8	12AT6 5/-	30C17 13/-	ECC89 12/-	EL821 6/-	PCF82 8/-	PCF86 9/-	UL84 6/8
2D21 6/-	6AX5GT 12/8	6J4 9/-	12AT7 4/-	30C18 11/-	ECC89 12/-	EM34 12/-	PCF86 9/-	PCF87 13/-	UM4 10/-
3A4 4/-		6J54 4/-	12A7 4/-	30C18 11/-	ECC89 12/-	EM35 8/-	PCF87 13/-	PCF800 11/-	UM80 7/-
3A5 8/-	6B7 5/-	6J6 3/8	12A7 4/-	30F5 11/-	ECC89 12/-	EM71 12/8	PCF800 11/-	PCF801 11/-	UU7 8/-
3AR6GT 8/-	6B8 9/-	6J7 9/-	12A7 4/-	30FL1 12/8	ECC89 12/-	EM80 7/-	PCF801 11/-	PCF802 11/-	UU9 7/-
3Q4 6/8	6BA6 5/-	6K6G 8/-	12A7 4/-	30FL12 12/-	ECC89 12/-	EM81 7/8	PCF802 11/-	PCF805 11/-	UY1N 9/-
3Q5GT/68/8	6BE6 5/8	6K7GT 5/-	12A7 4/-	30FL14 12/-	ECC89 12/-	EM84 8/-	PCF805 11/-	PCF806 13/-	UY21 9/-
384 5/-	6BG6G 15/-	6K8 8/-	12A7 4/-	30L1 6/8	ECC89 12/-	EM87 7/-	PCF806 13/-	PCF808 12/-	UY41 6/8
3V4 8/-	6BH6 7/8	6L6GA 8/-	12A7 4/-	30L15 12/8	ECC89 12/-	EN91 6/-	PCF808 12/-	PCL80 12/8	UY82 9/8
5R4GY 9/-	6BJ6 8/-	6P25 12/8	12A7 4/-	30L17 14/-	ECC89 12/-	EN92 6/-	PCF808 12/-	PCL81 9/-	UY85 6/8
5U4G 5/-	6BK4 25/-	6Q7G 6/-	12A7 4/-	30P12 10/-	ECC89 12/-	EF51 8/-	PCF808 12/-	PCL82 8/-	W21 5/-
5U4GB 6/8	6BL7GT 9/-	687 7/-	12A7 4/-	30P19 14/-	ECC89 12/-	EF55 8/-	PCF808 12/-	PCL83 8/8	W81M 6/-
5V4G 9/-	6BN6 7/8	68J7 8/-	12A7 4/-	30PL1 12/-	ECC89 12/-	EF80 5/8	PCF808 12/-	PCL84 8/8	X65 5/8
5Y3GT 5/-	6BQ6 11/-	68K7 5/-	12A7 4/-	30PL13 12/-	ECC89 12/-	EF86 8/8	PCF808 12/-	PCL85 9/8	X66 8/-
5Z3 7/8	6BQ7 8/-	68Q7 7/-	12A7 4/-	30PL14 12/8	ECC89 12/-	EF89 5/8	PCF808 12/-	PCL86 9/8	X78 20/-
5Z4G 8/-	6BR7 12/-	6T8 7/-	12A7 4/-	35A3 12/-	ECC89 12/-	EF91 4/-	PCF808 12/-	PCL88 12/8	X81M 18/-
6/30L2 11/-	6BR8 5/-	6U4GT 10/8	12A7 4/-	35A5 11/-	ECC89 12/-	EF92 2/-	PCF808 12/-	PCL801 12/-	Z729 7/-
6AB4 6/8	6BS7 17/8	6V6 8/-	12A7 4/-	35C5 6/8	ECC89 12/-	EF93 5/-	PCF808 12/-	PFL200 17/8	Z759 23/-
6AF4 10/-	6BW6 9/8	6V6GT 7/8	12A7 4/-	35D5 12/-	ECC89 12/-	EF94 6/-	PCF808 12/-		
6AF6G 11/-	6BW7 10/-	6X4 4/-	12A7 4/-	128C7 4/-	ECC89 12/-				

COMPLEMENTARY TRANSISTORS—2N697 (NPN) and 2N1132 (PNP), 50 mc/s cut-off; 600 m/W dissipation; gain 80. 50/- per pair.
CATHODE RAY TUBES 3GP1—as recommended in the Practical Electronics Oscilloscope in March and April issues. £2.10.0. P.P. 5/-. Base 6/8. DG7-5; 2" screen; 6.3V heaters; EHT required 800V; Deflection Sensitivity .125 mm/V for X and .200 mm/V for Y; Green phosphor medium persistence. £2.15.0. P.P. 5/-. Base 1/9.

FOR P.E. SCALER AND TIMER
6810M DEKATONS. 40/-. Base 3/8. Indicator shield 1/9. P.P. 1/6 per set.

SILICON POWER RECTIFIERS
8L800, equivalent to, and identical with Mullard BYZ10. 7/6

POCKET MULTIMETERS TYPE U-I
Sensitivity 1,000 Ω/V. D.C. and A.C. voltage ranges 0-10-50-200-500-1,000 V. D.C. current ranges 0-100-500 mA. Resistance ranges 2,000 Ω-200,000 Ω. Brand new. £2.2.0. P.P. 7/6.

HEADPHONES
DLR5, Low Impedance, balanced armature. Earpieces can be used as sound powered Microphones. 10/-.
CLR, High Impedance (2000Ω per insert). 15/-.
No. 10 Assembly:
Moving Coil Headphones with moving coil Hand Microphone fitted with press-to-talk switch. Rubber earpads. Cord terminated with army type 6-point moulded connector. Low impedance. Brand new. 20/- ea.
Small quantity available of second hand assemblies, checked, in perfect order. 8/6 ea. P. & P. 3/6 per set.

PLEASE SEND SAE (FOOLSCAP) FOR FULL PRICE LIST

Please add 2/6 in £ for postage. Minimum charge 2/-. No C.O.D. Orders Accepted. Please address all correspondence to the Head Office.

SEMICONDUCTOR PACKS AT SUPER-SAVE PRICES

**TRANSISTORS FOR EXPERIMENTER,
KIT BUILDER, HOBBYIST**
50 MIXED UNTESTED TRANSISTORS. . . 10/-

**"FREE" ONE 10/- PACK OF YOUR OWN "FREE"
CHOICE WITH ORDERS VALUED
£4 (FOUR POUNDS) OR OVER**

- 2 SIL. PLANAR 200 M/Cs TRANS. BSY 26/27 STC . . . 10/-
- 15 AF RED SPOT TRANS. ALL FACTORY TESTED. PNP . . . 10/-
- 15 RF WHITE SPOT TRANS. ALL FACTORY TESTED. PNP . . . 10/-
- 3 HIGH CURRENT SWITCHING TRANS. OC42 MULLARD . . . 10/-
- 1 GERM. EPITAXIAL MESA. PNP. 500 M/Cs 2N700
MOTOROLA . . . 10/-
- 1 AF139 GERM. TRANS. 1500 M/Cs V.H.F. 4 LEAD . . . 10/-
- 10 GOLD BONDED COMPUTER DIODES ASSORTED . . . 10/-
- 4 SUBMINIATURE SIL. RECT. 400 PIV 400 mA . . . 10/-
- 6 MATCHED MULLARD TRANS. 10C44 20C45 10C81D 20C81 . . . 10/-
- 1 60 WATT SIL. POWER TRANS. 5 M/Cs NPN . . . 10/-
- 4 0A5 GERM. GOLD BONDED DIODES MULLARD . . . 10/-
- 4 ASSORTED NPN TRANS. OC139 2N1304 Etc. . . . 10/-
- 2 10 AMP. SIL. RECT. 50 & 100 PIV. STUD . . . 10/-
- 2 POWER TRANS. 1 OC26 1 OC35 . . . 10/-
- 10 GERM. DIODES GD10 STC EQVT. 0A81 150 PIV . . . 10/-
- 8 GLASS GERM. DIODES. 4 0A70 4 0A79 MULLARD . . . 10/-
- 5 SIL. RECT. 400 PIV 200 mA I.R. WIRE ENDS . . . 10/-
- 4 GERM. 1 AMP RECT. PIV. 200/300 AEI STUD . . . 10/-
- 1 POWER TRANS. OC20 45 WATTS 100 VLTS. MULLARD . . . 10/-
- 4 ZENER DIODES 5.1 VLTS 1/2 WATT 5% MULLARD . . . 10/-
- 3 OC71 TRANS. MULLARD . . . 10/-
- 2 ZENER DIODES 10 VLTS 1/2 WATT. WIRE ENDS AEI . . . 10/-
- 3 SIL. RECT. BY101 400 PIV. 400 mA THORN. AEI . . . 10/-
- 1 SIL. CONTROLLED RECT. (SCR) 100 PIV 12 AMP . . . 10/-
- 6 SIL. RECT. 120 PIV 100 mA FERRANTI . . . 10/-
- 1 POWER TRANS. 90 WATT 40 VLTS. GERM. CLEVITE . . . 10/-

6 SIL. RECT. TYPE BY100 800 PIV. 550 mA . . . 20/-
50 MIXED ALL MARKED TRANS.
AF/RF SIL. & NPN TESTED 35/-

LOW COST SILICON CONTROLLED RECTIFIERS TESTED-NEW

PIV	7 AMP		PIV	16 AMP
100	10/6		100	16/8
200	15/-	STUD	200	25/-
300	25/-		300	30/-
400	30/-	TYPE	400	40/-
500	40/-		500	50/-
600	45/-		600	55/-

**FREE CIRCUIT DIAGRAMS
WITH ALL SCR ORDERS**

**FIRST EVER EDUCATIONAL "LOGIC KITS"
£5.5.0 — DETAILS FREE**

HUNDREDS OF OTHER SEMICONDUCTOR BARGAINS INCL. S.C.R.s., UNIUNCTION TRANSISTORS, LIGHT SENSORS, DUAL TRANSISTORS, RELAYS, TANTALUM CAPACITORS, Etc. FOR COMPLETE LISTS AND TRANSISTOR SUBSTITUTION CHART SEND 9d. IN STAMPS
MINIMUM ORDER 10/-, CASH WITH ORDER PLEASE
ADD 1/- POSTAGE & PACKING PER ORDER

**POSITIVELY NO WAITING,
BY RETURN POSTAL SERVICE**

DAVIS & WHITWORTH LIMITED
SEMICONDUCTOR SPECIALISTS
220-224 WEST ROAD
WESTCLIFF-ON-SEA, ESSEX
Tel.: SOUTHEND 46344

EXCEL

in

ELECTRONICS

Through this ICS 3-way Training Method:

1

MASTER THE THEORETICAL SIDE

From basic principles to advanced applications, you'll learn the theory of electronic engineering, quickly and easily through ICS. That's because each course is set out in easy-to-understand terms.

2

MASTER THE PRACTICAL SIDE

ICS show you how to develop your practical abilities in electronic engineering—*alongside* your theoretical studies. It's the only sure way to success. All training manuals are packed with easy-to-follow illustrations.

3

MASTER THE MATHEMATICAL SIDE

To many this aspect is a bitter problem. Even more so because no electronic engineer is complete without a sound working knowledge of maths. But new ICS teaching makes mathematics easier to learn.

Wide range of courses available include:

Radio/T.V. Engineering and Servicing, Closed Circuit T.V., Electronics, Electronics Maintenance, Instrumentation and Servomechanisms, Telemetry, Computers, etc.

NEW! Programmed Course on Electronic Fundamentals

EXPERT COACHING FOR:

- INSTITUTION OF ELECTRONIC AND RADIO ENGINEERS
- CITY AND GUILDS TELECOMMUNICATION TECHNICIANS
- CITY AND GUILDS SUPPLEMENTARY STUDIES
- R.T.E.B. RADIO/T.V. SERVICING CERTIFICATE
- RADIO AMATEURS' EXAMINATION
- P.M.G. CERTIFICATES IN RADIOTELEGRAPHY

And there are practical "learn as you build" radio courses as well.

Member of the Association of British Correspondence Colleges

FOR **FREE** HANDBOOK POST THIS COUPON TODAY

I.C.S., Dept. 151, INTERTEXT HOUSE,
PARKGATE ROAD, LONDON, S.W.11

NAME

ADDRESS

OCCUPATION.....AGE..... 6.66

INTERNATIONAL CORRESPONDENCE SCHOOLS

LASKY'S RADIO

For the Finest Value and Service to the HOME CONSTRUCTOR AND THE ELECTRONICS ENTHUSIAST

SPECIAL INTEREST ITEMS!

TEST METER ADAPTOR

Type P.E. 220—this is a fully transistorised device which enables any 50 microamp D.C. Multimeter to be used in place of a valve volt meter. On the 1V. range an impedance of 1 megohm is offered which increases on the 1000 V. range to 100 megohms. 7 ranges: 1 to 1000 volts. Designed for immediate connection to Avo 8 and similar size meters but quite suitable for use with any other 50 microamp meter. Size 6x6x5 in. New and boxed. List Price 7 Gns.

LASKY'S PRICE 39/6

Post 2/6. Set of batteries 7/5 extra.



GORLER UT 340 FM/VHF TUNING HEART

Permeability tuned — covering 87 to 108 Mc/s. For use with one ECC85 valve. In metal case, size 3x2 1/4 x 1 1/2 in. Circuit supplied

LASKY'S PRICE 15/11 Post 2/-
ECC85 valve 9/- extra

U.H.F. TUNERS

Only a few available. Complete with PC86 and PC88 valves. We regret no circuit or data is available. Knobs included.

LASKY'S PRICE 59/6 Post 2/6.



CONSTRUCTORS BARGAINS

The "Sixteen" Multirange METER KIT

This outstanding meter was featured by *Practical Wireless* in the Jan. '64 issue. Lasky's are able to offer the complete kit of parts as specified by the designer.

RANGE SPECIFICATION: D.C. volts: 0-2.5-25-50-250-500 at 20,000 Ω/V. A.C. volts: 0-25-50-250-500 at 1,000 Ω/V. D.C. current: 0-50 μA, 0-2.5-50-250 mA. Resistance: 0-2,000 Ω, 0-200k Ω, 0-20 MΩ. Basic movement: 40 μA i.s.d. moving coil. With universal shunt full scale deflection current is 50 μA. Black plastic case—3 1/2 x 6 1/2 x 1 1/2 in. Controls: 12 position range switch; separate slide switch for A.C. volts—D.C. ohms; ohms zero adjustment pot, meter, meter zero. Power requirements: One 15v. and one 1.5v. batts. Complete with all parts and full construction details. H.P. Terms available.



Data and circuit available separately, 2/6; refunded if all parts bought. Pair of batteries 2/- extra.

LASKY'S PRICE £5.19.6. P. & P. 5/-

VEROBOARD — High grade laminated board with copper strips bonded to it and pierced with holes.

Boards	Accessories
42/1503 2 1/2 x 5 in.	Terminal pins — pkt. of 50
43/1504 2 1/2 x 3 1/2 in.	Spot face cutter tool
45/1507 3 1/2 x 5 in.	Pin inserting tool
46/1508 3 1/2 x 3 1/2 in.	Post 6d. per item extra.
44/1505 3 1/2 x 17 in.	Orders of 10/- and over post free.

TRANSFILTERS By BRUSH CRYSTAL CO. Available from stock.

TO-01B 465 kc/s. ± 2 kc/s.	TO-02D 470 kc/s. ± 1 kc/s.	7/6 EACH
TO-01D 470 kc/s. ± 2 kc/s.	TF-01B 465 kc/s. ± 2 kc/s.	
TO-02B 465 kc/s. ± 1 kc/s.	TF-01D 470 kc/s. ± 2 kc/s.	Post 6d.

TRANSISTORS ALL BRAND NEW AND GUARANTEED

GET 81, GET 85, GET 86 2/6; 873A, 874P 3/6; OC45, OC71, OC81D 4/6; OC 44. OC 70, OC 76, OC 81 5/6; (pair 10/6); AF 117, OC 75, OC 200 6/6; OC 42. OC 43, OC 73, OC 82D 7/6; OC 201, OC 204 15/-; OC 203, OC 206 19/6; OC 28 24/6.

207 EDGWARE ROAD, LONDON, W.2 Tel: PAD 3271
33 TOTTENHAM CT. RD., LONDON, W.1 Tel: MUS 2605
Both open all day Saturday. Early closing Thursday.
Please address all Mail Orders and Correspondence to 3-15 Cavell St., Tower Hamlets, London, E.1.

42 TOTTENHAM CT. RD., LONDON, W.1 Tel: LAN 2573
152/3 FLEET STREET, LONDON, E.C.4 Tel: FLE 2833
Both open all day Thursday. Early closing Saturday.
Tel.: STE 4821/2

LASKY'S FOR SPEEDY MAIL ORDER SERVICE

FULLY GUARANTEED INDIVIDUALLY PACKED VALVES

KT66 22/-	Q81202 8/-	UY21 7/6	2C34 2/6	6AL5W 7/-	6J7M 6/-	12AH7 5/-	75 5/6	5704 9/-
KTW61 4/6	QV04/7 8/-	UY85 5/-	2C45 22/6	6AM5 2/6	6K6GT 5/6	12AT7 4/-	76 5/-	6064 7/-
KTW63 2/-	R10 9/-	VMP4G 12/-	2C46 30/-	6AM6 4/-	6K7G 2/-	12AU7 5/-	77 5/6	6065 6/-
KTZ41 8/-	RM 8/-	VP23 3/-	2C51 12/-	6AQ5 7/-	6K7GT 4/9	12AX7 6/-	78 5/-	6080 23/-
KTZ63 5/-	RK72 6/-	VP133 9/-	2D21 5/-	6AQ5W 9/-	6K8G 3/-	12AY7 10/-	80 5/6	7193 1/9
MH4 5/-	811E12 10/-	VR99 5/-	2X2 3/-	6A86 4/-	6K8GT 9/3	12BA6 5/6	81 9/-	7475 2/-
ML6 6/-	8130P 15/-	VR105/30 5/-	3A4 4/-	6A86W 9/-	6K8M 8/6	12BE6 7/-	82 3/-	8013A 25/-
N78 15/-	8130 12/8	VR150/30 5/-	3B7 5/-	6A87G 20/-	6L6G 6/-	12BH7 7/-	84 8/-	8020 8/-
NE17 7/-	8P2 8/8	VR150/30 5/-	3B24 5/-	6AT6 4/-	6L6GA 7/6	12C8 8/-	85A2 8/-	9001 3/-
OA2 6/-	8P41 1/6	VR150/30 5/-	3D6 4/-	6AU6 7/-	6L7G 4/-	12H6 2/-	2158G 6/-	9002 4/6
OB2 6/-	8P61 1/8	VU33A 4/-	3E29 50/-	6AX4 8/-	6L34 4/6	12J5GT 2/6	225DU 9/-	9003 6/-
OB3 7/-	8P210 3/6	VU39 6/-	3Q4 6/-	6B7 8/-	6LD20 5/9	12J7GT 6/6	307A 5/6	9004 2/6
OC3 5/-	T41 10/-	W21 5/-	3Q6GT 7/6	6B8G 2/6	6N7 6/-	12K7GT 2/-	313C 25/-	9006 2/6
OD3 5/-	TP22 5/-	W118 8/-	3S4 4/-	6BA6 5/6	6N7G 5/9	12K8M 10/-	350B 8/-	C.B. Tubes
OD3 5/-	TP25 15/-	W119 8/-	3V4 5/9	6BA7 5/-	6P25 12/6	12Q7GT 3/3	357A 70/-	CV1596
OZ4A 5/-	TT11 5/-	X66 7/8	4C27 35/-	6BE6 4/3	6Q7G 7/-	12SA7 7/-	368A 5/-	(09J) 55/-
PC86 9/-	TT15 35/-	X118 8/-	4D1 4/-	6B7 7/-	6R7 5/6	12SC7 4/-	393A 15/-	VCR97 28/-
PC88 9/-	TT15 35/-	X145 8/-	5A173G 5/-	6BR7 9/-	6RA7 7/-	12SG7 3/-	446A 8/-	VCR138 30/-
PC900 12/-	TTM1 45/-	Y63 5/-	5A174G 5/-	6BW6 9/-	6SA7GT 6/6	12SH7 3/-	703A 30/-	VCR517 25/-
PC88 9/-	TZ20 16/-	Y65 4/-	5B/251M 25/-	6C4 2/-	6SK7GT 4/-	12SJ7 5/-	705A 10/-	VCR517B 40/-
PCF80 7/-	U81 8/-	Y66 8/-	5B/253M 15/-	6C5G 2/6	6RC7 7/-	12SK7 5/-	715B 60/-	VCR517C 40/-
PCF82 6/6	U12/1 8/-	Z800U 20/-	5B/254M 40/-	6C6 4/-	6RC7GT 5/-	12SN7GT 5/9	717A 3/-	
PCF84 8/-	U17 5/-	Z801U 10/-	5B/255M 35/-	6C6G 3/-	6RF3GT 5/6	12SR7 5/-	724A 15/-	3FP7 45/-
PCF86 9/-	U18 6/-	IC54T 6/-	5R4GY 9/-	6C8G 3/-	6RH7 3/-	12Y4 2/-	801 6/-	3EG1 40/-
PCF802 11/-	U25 11/-	1A3 3/-	5R4G 7/-	6C8G 3/-	6R7 5/-	14L7 7/-	803 22/6	5CP1 30/-
PCL81 9/-	U26 11/-	1A5GT 5/-	5C4G 4/6	6C8G 3/-	6S7 7/-	15D2 6/-	807 8/-	5FP7 12/6
PCL83 8/6	U27 8/-	1B22 30/-	5C4G 4/6	6C8G 3/-	6S7Y 6/6	12P4 13/-	808 8/-	88D 40/-
PCL84 7/-	U80 4/6	1D8GT 6/-	5C4G 4/6	6C8G 3/-	6SK7 4/6	21B6 9/-	811 22/6	Photo Tubes
PCL85 8/6	U82 4/6	1E7G 7/6	5C4G 4/6	6C8G 3/-	6S7Y 6/6	25AGT 5/8	813 65/-	CMG8 5/-
PCL86 9/-	U80 18/-	1F2 3/-	5C4G 4/6	6C8G 3/-	6S7GT 6/6	25Y5 6/-	815 35/-	GM16 12/6
PEN25 4/6	U80 18/-	1G6GT 2/-	5C4G 4/6	6C8G 3/-	6S7GT 6/6	25Z4G 6/6	829B 50/-	931A 55/-
PEN46 3/-	U80 18/-	1LA 2/6	5C4G 4/6	6C8G 3/-	6S7GT 6/6	25Z5 7/6	830B 4/-	6097C 350/-
PFL200 17/6	U80 18/-	1LA6 6/-	5C4G 4/6	6C8G 3/-	6S7GT 6/6	25Z6GT 8/6	832A 45/-	
PL36 9/-	U80 18/-	1LC8 7/-	5C4G 4/6	6C8G 3/-	6S7GT 6/6	25Z7 6/-	832B 45/-	Transistors
PL38 18/-	U80 18/-	1LH4 4/-	5C4G 4/6	6C8G 3/-	6S7GT 6/6	25Z8 6/-	833 15/-	OC16 20/-
PL81 7/-	U80 18/-	1N21B 5/-	5Z4G 6/6	6C8G 3/-	6S7GT 6/6	25Z9 6/-	833 15/-	OC22 23/-
PL82 5/-	U80 18/-	1N43 4/-	5Z4GT 8/-	6C8G 3/-	6S7GT 6/6	25Z10 6/-	833 15/-	OC25 12/-
PL83 6/-	U80 18/-	1N70 4/-	5Z4GT 8/-	6C8G 3/-	6S7GT 6/6	25Z11 6/-	833 15/-	OC44 6/-
PL84 6/6	U80 18/-	1R4 5/-	5Z4GT 8/-	6C8G 3/-	6S7GT 6/6	25Z12 6/-	833 15/-	OC45 6/-
PL500 15/-	U80 18/-	1R5 3/6	5Z4GT 8/-	6C8G 3/-	6S7GT 6/6	25Z13 6/-	833 15/-	OC71 4/6
PM24A 5/-	U80 18/-	1R4 5/-	5Z4GT 8/-	6C8G 3/-	6S7GT 6/6	25Z14 6/-	833 15/-	OC72 6/-
PT15 10/-	U80 18/-	1R5 3/6	5Z4GT 8/-	6C8G 3/-	6S7GT 6/6	25Z15 6/-	833 15/-	OC73 10/-
PT25H 7/6	U80 18/-	1R4 5/-	5Z4GT 8/-	6C8G 3/-	6S7GT 6/6	25Z16 6/-	833 15/-	OC81M 7/-
PT25M 7/6	U80 18/-	1R5 3/6	5Z4GT 8/-	6C8G 3/-	6S7GT 6/6	25Z17 6/-	833 15/-	OC82 10/-
PX4 14/-	U80 18/-	1R4 5/-	5Z4GT 8/-	6C8G 3/-	6S7GT 6/6	25Z18 6/-	833 15/-	OC122 16/-
PX25 9/-	U80 18/-	1R5 3/6	5Z4GT 8/-	6C8G 3/-	6S7GT 6/6	25Z19 6/-	833 15/-	OC200 10/6
PY33 9/6	U80 18/-	1R4 5/-	5Z4GT 8/-	6C8G 3/-	6S7GT 6/6	25Z20 6/-	833 15/-	XC141 10/-
PY80 5/6	U80 18/-	1R5 3/6	5Z4GT 8/-	6C8G 3/-	6S7GT 6/6	25Z21 6/-	833 15/-	XC142 15/-
PY81 5/6	U80 18/-	1R4 5/-	5Z4GT 8/-	6C8G 3/-	6S7GT 6/6	25Z22 6/-	833 15/-	XC155 20/-
PY82 6/-	U80 18/-	1R5 3/6	5Z4GT 8/-	6C8G 3/-	6S7GT 6/6	25Z23 6/-	833 15/-	XC156 22/6
PY83 6/-	U80 18/-	1R4 5/-	5Z4GT 8/-	6C8G 3/-	6S7GT 6/6	25Z24 6/-	833 15/-	2N247 9/6
PY800 8/-	U80 18/-	1R5 3/6	5Z4GT 8/-	6C8G 3/-	6S7GT 6/6	25Z25 6/-	833 15/-	2N502 47/-
PZ1-35 9/-	U80 18/-	1R4 5/-	5Z4GT 8/-	6C8G 3/-	6S7GT 6/6	25Z26 6/-	833 15/-	2N585 10/6
PZ1-75 12/-	U80 18/-	1R5 3/6	5Z4GT 8/-	6C8G 3/-	6S7GT 6/6	25Z27 6/-	833 15/-	2N1090 20/-
QP21 6/-	U80 18/-	1R4 5/-	5Z4GT 8/-	6C8G 3/-	6S7GT 6/6	25Z28 6/-	833 15/-	2N1091 29/6
QP25 5/-	U80 18/-	1R5 3/6	5Z4GT 8/-	6C8G 3/-	6S7GT 6/6	25Z29 6/-	833 15/-	
QP230 5/-	U80 18/-	1R4 5/-	5Z4GT 8/-	6C8G 3/-	6S7GT 6/6	25Z30 6/-	833 15/-	
Q895/10 8/6	U80 18/-	1R5 3/6	5Z4GT 8/-	6C8G 3/-	6S7GT 6/6	25Z31 6/-	833 15/-	

P.C. RADIO LTD

170 GOLDHAWK ROAD, W.12
Shepherd's Bush 4946
Open 9-5.30 p.m. Thursday 9-1 p.m.

MANY OTHERS IN STOCK include Cathode Ray Tubes and Special Valves. U.K. Orders below £1 P. & P. 1/-; over £1, 2/-; over £3, P. & P. free. C.O.D. 2/6 extra. Overseas Postage extra at cost.

Why

NOT BUILD ONE OF OUR PORTABLE TRANSISTOR RADIOS...

All components may be purchased separately if desired. Parts price lists and easy build plans available separately at prices stated. Overseas post 10/-.

BACKED BY OUR SUPER AFTER SALES SERVICE

NEW ROAMER SEVEN Mk IV

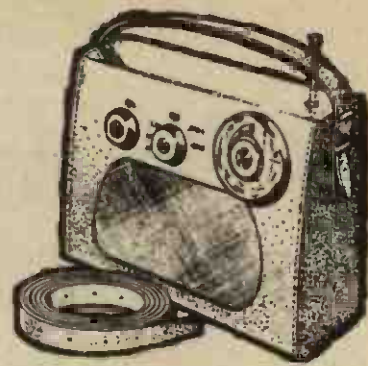

7 WAVEBAND PORTABLE OR CAR RADIO
 Amazing performance and specification ★ Now with PHILCO MICRO-ALLOY R.F. TRANSISTORS
FULLY TUNABLE ON ALL WAVEBANDS ● 9 stages—7 transistors and 2 diodes
 Covers Medium and Long Waves, Trawler Band and three Short Waves to approx. 15 metres.
 Push-pull output for room filling volume from rich toned 7" x 4" speaker. Air spaced ganged tuning condenser. Ferrite rod aerial for M & L Waves and telescopic aerial for S Waves. Real leather-look case with gilt trim and shoulder and hand straps. Size 9" x 7" x 4" approx.
 The perfect portable and the ideal car radio. (Uses PP7 batteries available anywhere.)
 ★ EXTRA BAND FOR EASIER TUNING OF PIRATE STATIONS, etc. Total cost of parts now only **£5.19.6** P. & P. 5/6

Parts Price List and easy build plans 3/- (Free with kit)

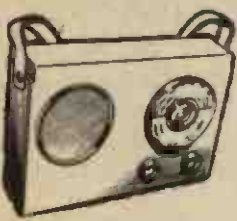

NEW ROAMER SIX

NOW, WITH PHILCO MICRO-ALLOY R.F. TRANSISTORS
 ● 6 WAVEBAND!!
 ● 8 stages—6 transistors and 2 diodes
 Listen to stations half a world away with this 6 waveband portable. Tunable on Medium and Long Waves, Trawler Band and two Short Waves. Sensitive Ferrite rod aerial and telescopic aerial for short waves. Top grade transistors. 3-inch speaker, handsome case with gilt fittings. Size 7½ x 5½ x 1½ in. (Carrying Strap 1/6 extra.)
 ★ EXTRA BAND FOR EASIER TUNING OF LUX, ETC.
 Total cost of all parts now only **£3.19.6** P. & P. 3/6 Parts Price List and easy build plans 2/- (Free with kit)



NEW TRANSONA FIVE

"Home, Light, A.F.N. Lux. all at good volume"
 G.P., Durham
 ● 7 stages—5 transistors and 2 diodes
 Fully tunable over Medium and Long Waves and Trawler Band. Incorporates Ferrite rod aerial, tuning condenser, volume control, new type fine tone super dynamic 2½ in. speaker, etc. Attractive case. Size 6½ x 4½ x 1½ in. with red speaker grille. (Uses 1289 battery available anywhere.)
 Total cost of all parts now only **42/6** P. & P. 3/6 Parts Price List and easy build plans 2/- (Free with kit)

TRANSONA SIX

● 8 stages—6 transistors and 2 diodes
 This is a top performance receiver covering full Medium and Long Waves and Trawler Band. High-grade approx. 3in. speaker makes listening a pleasure. Push-pull output. Ferrite rod aerial. Many stations listed in one evening including Luxembourg loud and clear. Attractive case in grey with red grille. Size 6½ x 4½ x 1½ in. (Uses PP4 battery available anywhere.) Carrying Strap 1/- extra.
 Total cost of all parts now only **59/6** P. & P. 3/6 Parts Price List and easy build plans 1/6 (Free with kit)



POCKET FIVE

● 7 stages—5 transistors and 2 diodes
 Covers Medium and Long Waves and Trawler Band, a feature usually found in only the most expensive radios. On test Home, Light, Luxembourg and many Continental stations were received loud and clear. Designed round supersensitive Ferrite Rod Aerial and fine tone 2½ in. moving coil speaker, built into attractive black case with red speaker grille. Size 5½ x 1½ x 3½ in. (Uses 1289 battery, available anywhere.)
 Total cost of all parts now only **42/6** P. & P. 3/6 Parts Price List and easy build plans 2/- (Free with kit)



NOW READY!
 "Pocket Five"
 medium and long wave version with miniature speaker.
29/6 P. & P. 3/-

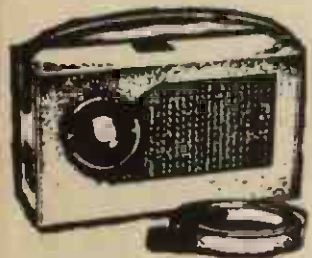

MELODY SIX

● 8 stages—6 transistors and 2 diodes
 Our latest completely portable transistor radio covering Medium and Long Waves. Incorporates pre-tagged circuit board, 3in. heavy duty speaker, top grade transistors, volume control, tuning condenser, wave change slide switch, sensitive 6in. Ferrite rod aerial. Push-pull output. Wonderful reception of B.B.C. Home and Light, 208 and many Continental stations. Handsome leather-look pocket size case, only 6½ x 3½ x 1½ in. approx. with gilt speaker grille and supplied with hand and shoulder straps.
 Total cost of all parts now only **£3.9.6** P. & P. 3/6 Parts Price List and easy build plans 2/- (Free with kit)

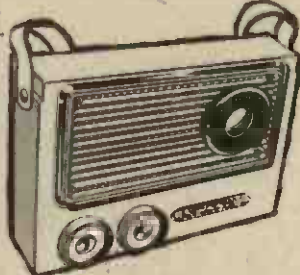

SUPER SEVEN

● 9 stages—7 transistors and 2 diodes
 Covers Medium and Long Waves and Trawler Band. The ideal radio for home, car, or can be fitted with carrying strap for outdoor use. Completely portable—has built-in Ferrite rod aerial for wonderful reception. Special circuit incorporating 2 RF Stages, push-pull output, 3in. speaker (will drive large speaker). Size 7½ x 5½ x 1½ in. (Uses 9v battery, available anywhere.)
 Total cost of all parts now only **£3.19.6** P. & P. 3/6 Parts Price List and easy build plans 2/- (Free with kit)

BARGAIN CORNER!

HEAVY DUTY CELESTION SPEAKERS. 3 ohm. Slightly soiled but in perfect working order. 7" x 4". Only 9/6. P. & P. 2/6.
TUNING CONDENSERS. Air spaced, fine quality German manufacture with slow motion drive. 0.0005. With oscillator section. Only 5/- P. & P. 1/6.
CYLDON PERMEABILITY TUNERS. By famous manufacturer. Full M.W. coverage. Fitted coupling coil, oscillator coil, ferrite slugs and slow motion tuning with cursor, etc. In original sealed cartons. GIVE AWAY PRICE 10/- P. & P. 1/6.

THE SIG-GEN. A versatile Signal Injector. Something no constructor should be without. This ingenious device generates an audible signal through the Audio and R.F. ranges. With variable output. Telescopic Probe. Pocket size slim-line case measures 4½" x 3½" x ¾". Complete set of parts with full instructions. 19/6. P. & P. 1/6.



QUICK CHECK TRANSISTOR TESTER. Checks gain of R.F. and Audio Transistors. Also checks for noise level and duds. All parts ready to be assembled in attractive grey case with red grille, complete with Dial, Knobs, and 2½" Speaker. Simple assembly instructions free with set of parts. 39/6. P. & P. 3/6.



Callers side entrance
 Barratts Shoe Shop.

RADIO EXCHANGE Ltd

Open 9—5 p.m.
 Saturdays 9—12.30 p.m.

61a HIGH STREET, BEDFORD. Phone: 52367

8 tips for practical soldering

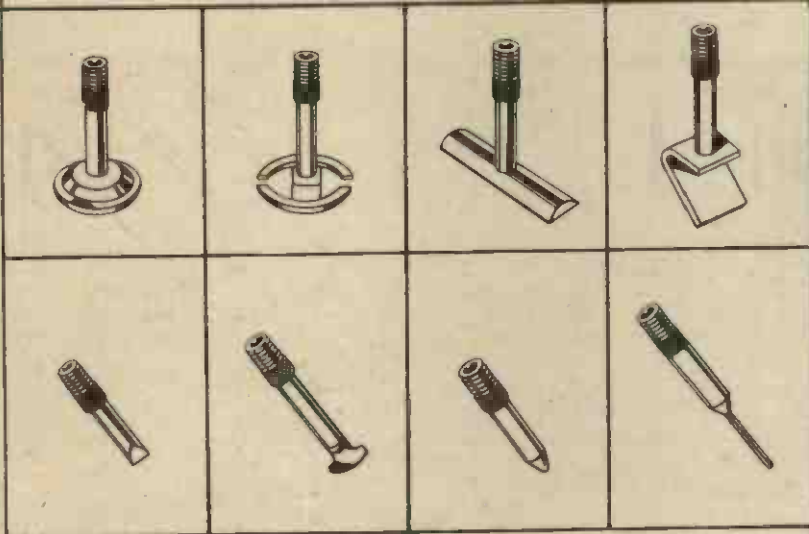

NEW!

The Instant Heat Soldering Kit complete with 2 tips, extension barrel, probe and solder. Complete £3 19 6
Ask for a demonstration from your local dealer or fill in the coupon below for full details.



SG 1225 KIT

Name PE/6/66
Address

BURGESS PRODUCTS CO. LTD.
SAPCOTE, LEICESTER.
Tel: Sapcote 292 Telex: 34549



FIRST QUALITY PVC TAPE

5 1/2" Std. 850 ft. 9/-	5" L.P. 850 ft. 10/6
7" Std. 1200 ft. 11/6	3" T.P. 600 ft. 10/6
3" L.P. 240 ft. 4/-	5" T.P. 1800 ft. 25/6
5 1/2" L.P. 1200 ft. 11/6	5 1/2" T.P. 2400 ft. 32/6
7" L.P. 1800 ft. 18/6	7" T.P. 3600 ft. 42/6

P. & P. on each 1/6, 4 or more post free.

CYLDON U.H.F. TUNER

complete with PC.88 and PC.86 Valves. Full variable tuning. New and unused. Size 4 1/4" x 5 1/2" x 1 1/2". Complete with circuit diagram. 35/- plus 2/6 P. & P.



3 to 4 WATT AMPLIFIER KIT

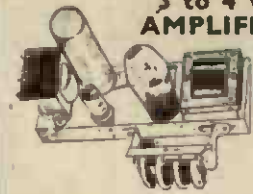

comprising chassis 8 1/2" x 2 1/2" x 1". Double wound mains transformer, output transformer, volume and tone controls, resistors, condensers, etc. 6V6, ECC81 and metal rectifier. Circuit 1/6 free with kit. 29/6 plus 4/6 P. & P.

8-watt 5-valve PUSH-PULL AMPLIFIER & METAL RECTIFIER

Size: 9 x 6 x 1 1/2" A.C. Mains 200-250v. 5 valves. For use with Std. or L.P. records, musical instruments, all makes of pick-ups and mikes. Output 8 watts at 5 per cent total distortion. Separate bass and treble lift controls. Two inputs, with controls, for gram. and mike. Output Transformer tapped for 3 and 15 ohms speech coils. Built and tested. £3.19.6. P. & P. 10/-

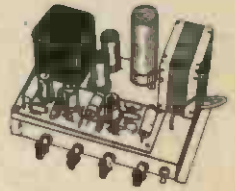

"MUSETTE" 6-TRANSISTOR SUPERHET PORTABLE RADIO

- ★ 2 1/2" Speaker.
- ★ 6 Transistors Superhet Output 200 mw.
- ★ Plastic Cabinet in red, size 4 1/2" x 3" x 1 1/2" and gold speaker louvre.
- ★ Horizontal Tuning Scale.
- ★ Ferrite Rod Internal Aerial.
- ★ IF 460 Kc/s.
- ★ All components Ferrite Rod and Tuning Assembly mounted off printed board.
- ★ Operated from PP3 Battery.
- ★ Fully comprehensive instructions and point-to-point wiring diagram.

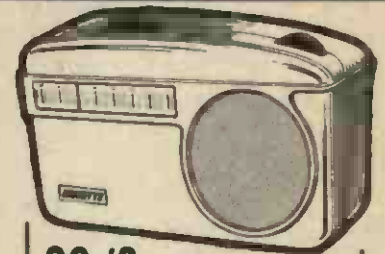

39/6 Inc. carrying strap. Circuit Diagram 2/6—
P. & P. 3/6 free with parts

- ★ Printed Circuit Board.
- ★ Tunable over medium and long waveband.
- ★ Car aerial and earpiece socket.

TRANSISTORISED SIGNAL GENERATOR



Size 5 1/2" x 3 1/2" x 1 1/2". For IF and RF alignment and AF output, 700 c/s frequency coverage 460 Kc/s to 2 Mc/s in switched frequencies. Ideal for alignment to our Elegant Seven and Musette. Built and tested. 39/6. P. & P. 3/6.

ELEGANT SEVEN Mk. II

Combined Portable and Car Radio
The Radio with the "Star" Features

- ★ 7-transistor superhot. Output 350 mW.
- ★ Wooden cabinet, fitted handle with silver-coloured fittings, size 12 1/2 in. x 8 1/2 in. x 3 1/2 in.
- ★ Horizontal tuning scale, size 11 1/2 in. x 2 1/2 in. in silver with black lettering.
- ★ All stations clearly marked.
- ★ Ferrite-rod internal aerial.
- ★ Operated from PP9 battery.
- ★ I.F. neutralisation on each stage 460 kc/s.
- ★ D.C. coupled output stage with separate A.C. negative feed back.
- ★ All components, ferrite rod and tuning assembly mounted on printed board.
- ★ Fully comprehensive instructions and point-to-point wiring diagram.
- ★ Printed circuit board, back-printed with all component values.
- ★ Fully tunable over medium and long waveband.
- ★ Car aerial socket.

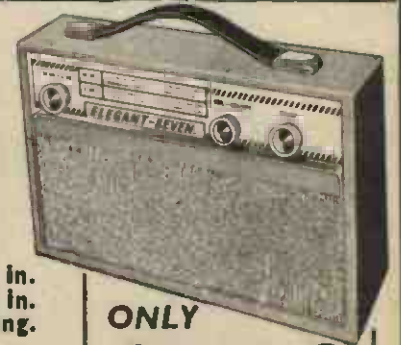

ONLY £4.4.0
Plus 6/6 Post & Packing

POWER SUPPLY KIT
to purchasers of Elegant Seven parts, incorporating mains transformer, etc. A.C. mains 200-250v. Output 9v. 50mA, 7/6d. extra.

4 in. SPEAKER. Parts list and circuit diagram 2/6. FREE with parts.
Shop Hours 9 a.m. — 6 p.m. Early Closing Wednesday
All enquiries stamped addressed envelope

RADIO & T.V. COMPONENTS (ACTON) LTD.
21D, HIGH STREET, ACTON, LONDON, W.3

4 *Easy-to-build* IMPROVEMENTS FOR YOUR GARDEN

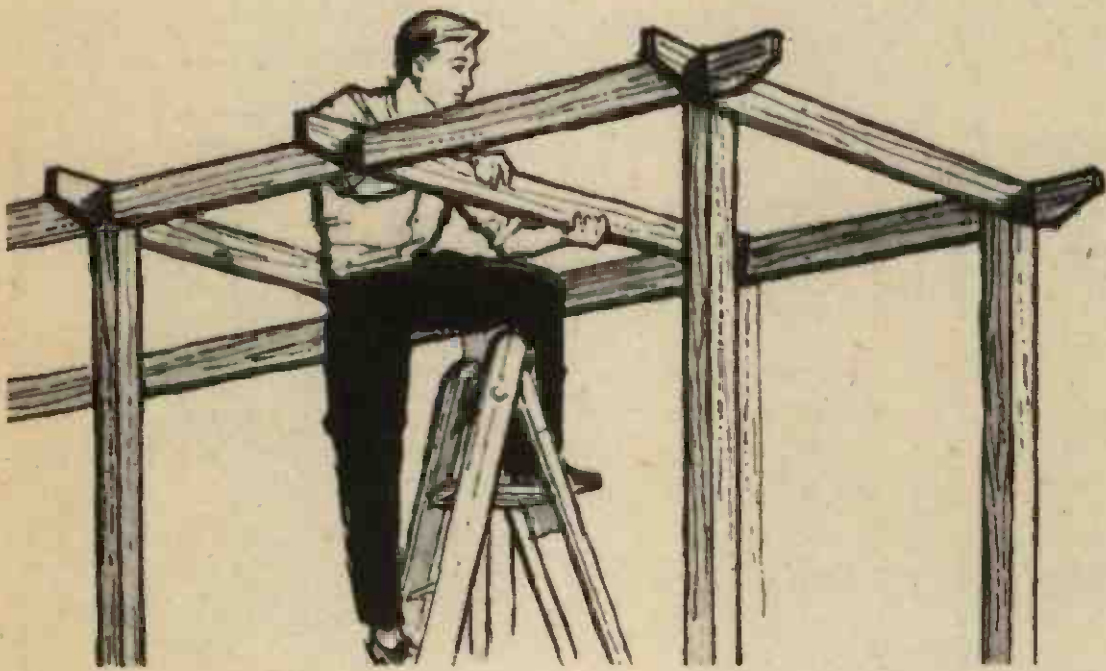

Get to work on these worthwhile garden improvements . . . and save pounds on each job. You can tackle them all—easily, efficiently—with the step-by-step instructions in the June PRACTICAL WOODWORKING. And you'll find plenty more in this great new magazine . . . page after page of new ideas and expert know-how.

Plus 4 OUTSTANDING EXTRAS:-

2 *Fold-out Sheets to build*
HOUSEHOLD STEPS
FOLDING PASTING BOARD

2 *Data Sheets for*
GATE HINGES AND FITTINGS
GATE CATCHES AND LATCHES

- PERGOLA
- GARDEN TABLE
- COLD FRAME
- MAKE-IT-YOURSELF FENCING

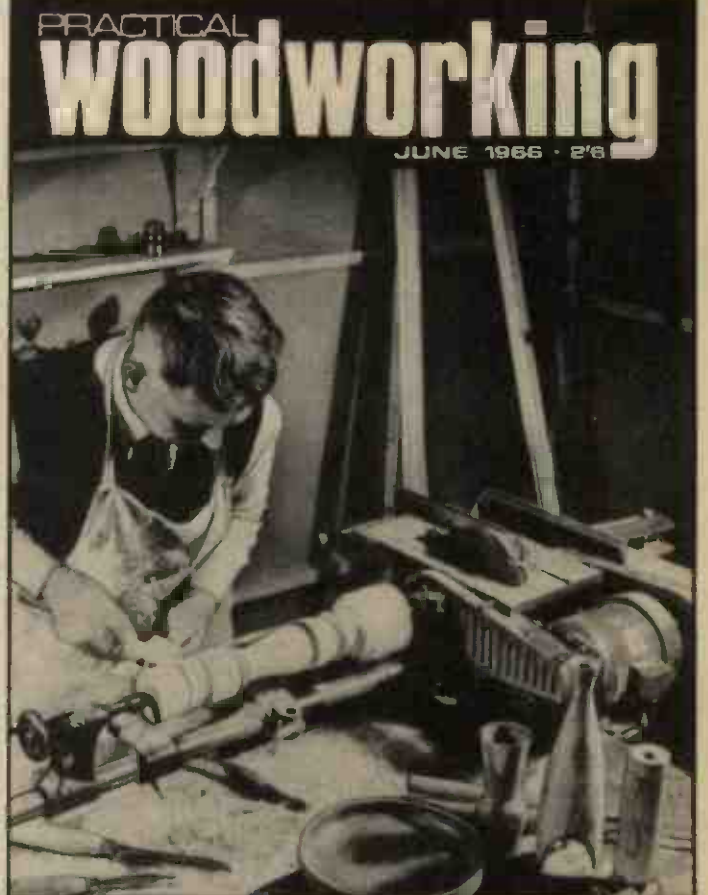
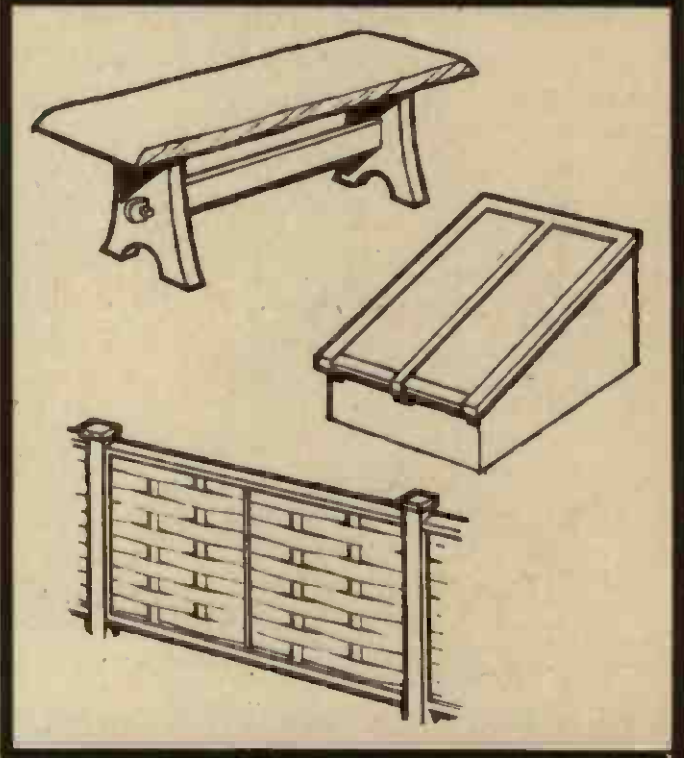

PRACTICAL
WOODWORKING

JUNE ISSUE
OUT NOW
2/6



Sub-miniature Electrolytics for Transistor Circuits

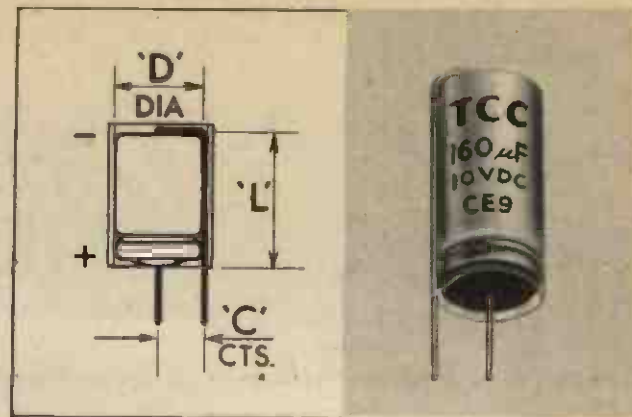

T.C.C. TYPE No.	Case Size in inches			Maximum D.C. Wkg. Voltages and Cap. (µF)					
	D	L	C	3V.	6V.	9V.	12V.	15V.	25V.
CE.2 'V' or 'H'	1/8	1/4	0.07	8	6	4	3	3	—
CE.3 ..	1/8	3/16	0.1	25	20	15	10	6	4
CE.4 ..	1/8	1/4	0.1	40	30	20	15	8	6
CE.5 ..	1/8	3/16	0.14	50	40	25	20	10	8
CE.6 ..	1/8	1/4	0.14	80	60	40	30	15	12
CE.7 ..	1/8	1/4	0.18	100	75	50	40	20	15
	D	L	C	3V.	6V.	10V.	15V.	25V.	50V.
CE.8 ..	1/8	1/4	0.14	100	80	60	40	25	8
CE.9 ..	1/8	1/4	0.2	250	200	160	100	60	20

Operating Temperature Range. —20°C. to +60°C.

Connection wires are welded for low resistance contact, and solder-coated for ease of assembly, the standard length being 1 1/2" for the horizontal range, cropped to 3/8" long for the vertical range.

The capacitors are in insulated seamless aluminium cases, and sealed with a synthetic rubber bung.

Cap. Tolerance. The standard tolerance of all capacitors is —20% + 100% of the rated capacitance.

Leakage Current. CE.2-7 may be determined from the following: 1 (µA) = .01 C.V. + 10 at applied working voltage and at 20°C. CE.8-9 may be determined from: .02 C.V. + 20 at applied working voltage and at 20°C.

V=Vertical Mounting H=Horizontal Mounting

THE TELEGRAPH CONDENSER CO. LTD.

Electronics Division · NORTH ACTON · LONDON · W.3 · Tel. ACOrn 0061 · Telex: 261383
also at CHESSINGTON, SURREY and BATHGATE, SCOTLAND

HOME RADIO (Mitcham) LTD., 187 London Road, Mitcham, Surrey. Phone: MIT 3282

One of the most interesting sections of our Components Catalogue is the KITS SECTION, which runs to 14 pages listing 169 different items. Here is an extract from the page dealing with RADIONIC KITS . . .

"Designed for both the beginner (aged 10 and upwards) and the expert in electronics. The only tools required are the spanner and the pair of scissors. Build and rebuild as often as you wish and check circuit at a glance through the transparent panel. Extra components can be purchased to expand sets as required. Adopted by Universities, Technical Colleges, Schools and the Armed Forces for electronics training."

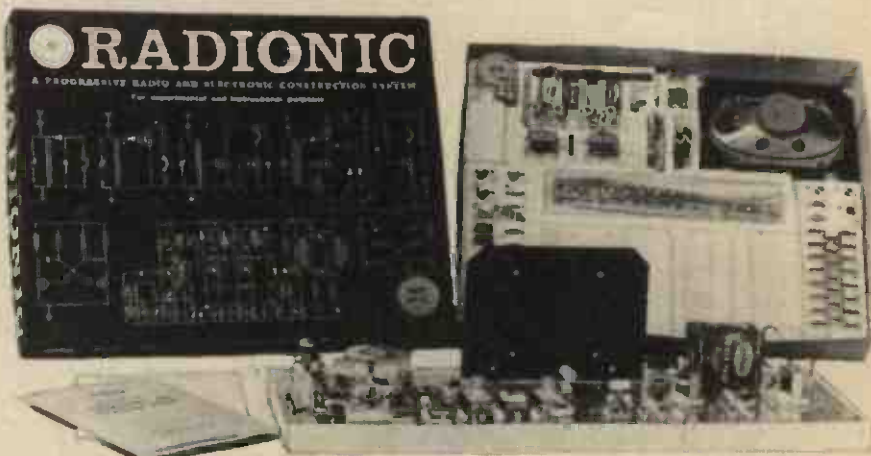

- KT 46 Set No. 1. Fourteen different circuits can be made, including regenerative receivers for earphone operation £5.18.6
- KT 48 Set No. 2. Twenty different circuits. T.R.F. and Reflex receivers £6.19.6
- KT 50 Set No. 3. Twenty-two different circuits, including microphone and pick-up amps. and receivers for loud speaker operation £10.19.6
- KT 52 Set No. 4. Twenty-six different circuits, including a 6-transistor super-heterodyne receiver £14.19.6

Would you like to see the other 209 pages, listing 5,800 items. 900 of them illustrated, plus a 21-page supplement and a Semi-Conductor Centre brochure? Then post the coupon now with your cheque or P.O. for 9/- (7/6 plus 1/6 P. & P.). Remember, every catalogue contains five coupons, each worth one shilling when used as directed.

Please write your name and address in block capitals

NAME

ADDRESS

.....

HOME RADIO LTD., Dept. PE, 187 LONDON RD., MITCHAM

AUTOMATED COMMUTERS

AUTOMATION is no mere gimmick: its adoption in some degree or another is essential if certain industries are to survive under modern conditions. Although one usually thinks of manufacturing industries in this connection, it is in service industries such as railways that some of the greatest opportunities exist for development and application of new automated methods.

London Transport, faced with the apparently insolvable problem of obtaining sufficient manpower, has already decided that automation will be the answer in the future. They are fortunate of course in that the electrified underground railway system is ideally suited for conversion to fully automatic operation; and, indeed, work has been proceeding towards this end for some considerable time now. Realisation of the ultimate goal is now likely in the foreseeable future thanks very largely to new developments in electronic technology.

Possible facilities for an automated railway were described recently by R. Dell, Chief Signal Engineer, London Transport, in his Presidential address to the Institution of Railway Signal Engineers. Some of these facilities already exist and are in operational use on various sections of the London Underground System: automatic routing of trains is performed by programme machines which read off a prepared programme and operate signals and points without the intervention of a signaller; and automatic driving of trains has been proved under normal service conditions, the motors and brakes responding to coded signals picked up from the running rail.

To achieve the fully automated railway system as envisaged for the future by Mr. Dell, the above-mentioned facilities would have to be co-ordinated by a central supervision office; while the operation of each station would be supervised by one official seated in an office in the ticket hall where all suitable visual and audible aids would be employed in order to monitor the platforms and to communicate with passengers.

The platform entrances and exits would be guarded by automatic barriers. Tickets obtained from vending machines would be magnetically marked with information such as issuing station, fare paid, and date. At the barrier the ticket would be scrutinised by a small computer and if in order a signal initiated to release the gate—the whole action, from the insertion of the ticket by the passenger, taking a mere second or so.

Perhaps significantly, it is here at this point of human participation that most difficulty is being experienced. A number of different style gates are currently being tried out at stations under normal working conditions, but none as yet has proved entirely satisfactory for passenger operation.

Perhaps there is a moral here. All the best laid plans of technologists can come to nought unless we, the general public, have been properly disciplined or conditioned always to react in a predictable manner just like an electronic circuit. Some may shudder at the thought, but if we are to enjoy the advantages promised by the new technological age, we will just have to "automate" ourselves on occasions.

THIS MONTH

CONSTRUCTIONAL PROJECTS

PHOTOGRAPHIC PROCESS TIMER	410
COMPUTER FOR NIM	413
ELECTRONIC MANDOLIN	420
THYRISTOR CONTROL UNIT	442
MODIFYING THE P.E. GUITAR AMPLIFIER	452

SPECIAL SERIES

NEON NOVELTIES—10	419
BEGINNERS START HERE—20	436

GENERAL FEATURES

ELECTRON MICROSCOPES	406
SEEING THROUGH FOG	425
EXPERIMENTS IN LOGIC DESIGN—I	427
INTRODUCTION TO THYRISTORS	438
RADIO CONTROL OF MODELS	446

NEWS AND COMMENT

EDITORIAL	405
THE 73 PAGE	426
DETACHED PARTICLES	433
ELECTRONORAMA	434
READOUT	456

*Our July issue will be published on
Thursday, June 16*

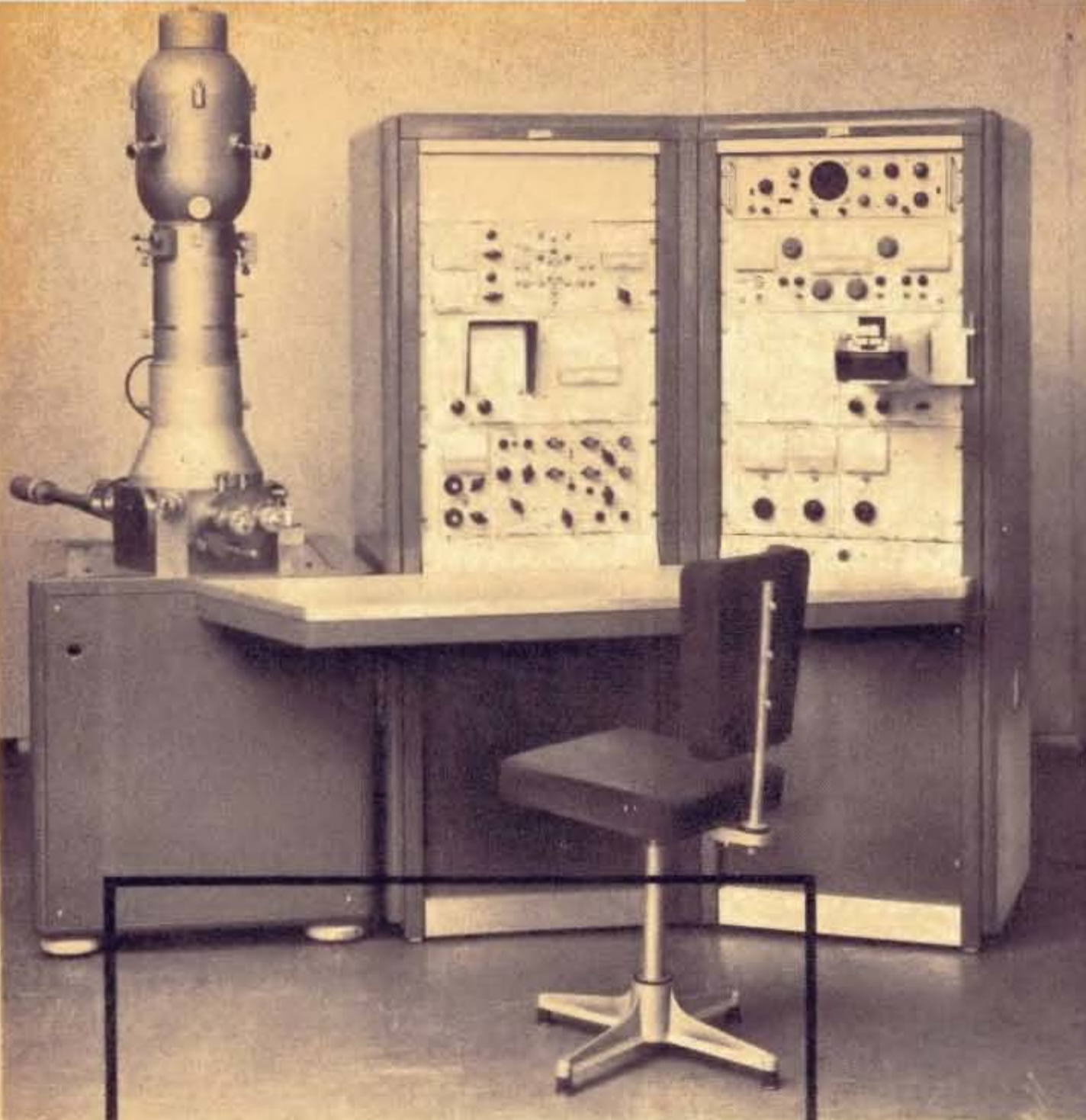

"Stereoscan" scanning electron microscope

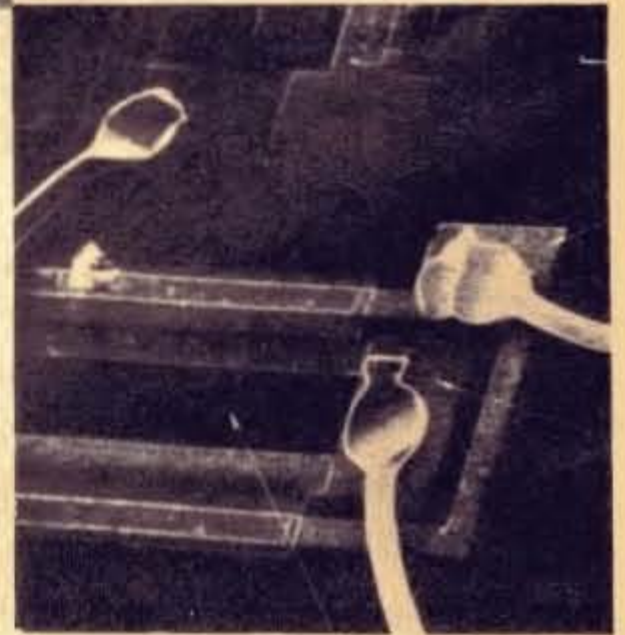

ELECTRON MICROSCOPES

by ADRIAN MORRIS

WE ARE all familiar with optical microscopes such as those in school science laboratories and research departments in industry. Although this article is aimed at explaining the function and applications of the electron microscope, it is probably a good idea to touch briefly on the optical microscope first, so that the intricacies of electron types may be better understood. However, there are some differences in principle which will be explained later.

OPTICAL MAGNIFICATION

Optical microscopes depend on the use of lenses to magnify the image of the specimen under scrutiny. To show up the minute contours of the specimen, one usually places a light in such a position that it is

reflected onto the specimen, usually shining on the underside.

Considerable development work has been carried out on optical microscopes so that they will show up objects which cannot normally be seen with the naked eye. For this kind of investigation it is necessary that we should be able to measure the size of these objects; obviously, it is impracticable to use inches or millimetres.

Two basic units of microscopic measurement are used: the micron and the angstrom. The micron is the largest of the two and is equal to one millionth part of a metre. The symbol used is the Greek letter μ (μ). The angstrom unit is equal to 10^{-8} centimetre, or one thousand-millionth part of a metre. The symbol for the angstrom unit is \AA .

The optical microscope has been developed to "see" objects as small as 5,000 angstrom units. This is very close to the limit of human perception because the wavelength of "white" light is of the same order of magnitude. You may wonder, then, how can we see finer details? Although higher magnifications are possible the essential point is that the visible detail tends to deteriorate. In order to be able to see this minute detail more clearly, we must use a means of illumination of shorter wavelength than visible light. For example, a light beam in the ultra-violet wavelength can be used.

Ultra-violet microscopes can show details as small as $2,000\text{\AA}$ but, because this kind of light is invisible, a special kind of conversion system is used to display the image.

ELECTRON ACCELERATION

During the mid-1920s experiments were carried out by German scientists to study the properties and potential uses of electrons, which were then solely regarded as mysterious minute particles of negatively charged electricity. When these particles were forced to move at a very high velocity by applying many thousands of volts, they behaved as though they had a wavelength which is considerably less than one angstrom unit, thus providing a means of illumination nearly one-hundred-thousand times brighter than ordinary light.

Metal oxide silicon transistors. Basically these devices, photographed by staff members of the School of Engineering Science, University College of North Wales, are field effect transistors using surface barriers instead of pn junctions. Notice the tonal gradation for different applied voltages. On the left (magnification approximately X367) the "drain" connection is the right-hand lead, the gate connection is the lower lead. Below are pictures (X1140) giving drain voltage V_D and gate voltage V_G :

left (a) $V_D = -15V$, $V_G = -6V$

below (b) $V_D = 0$, $V_G = -6V$;

(c) $V_D = -15V$, $V_G = -6V$;

(d) $V_D = -15V$, $V_G = 0$

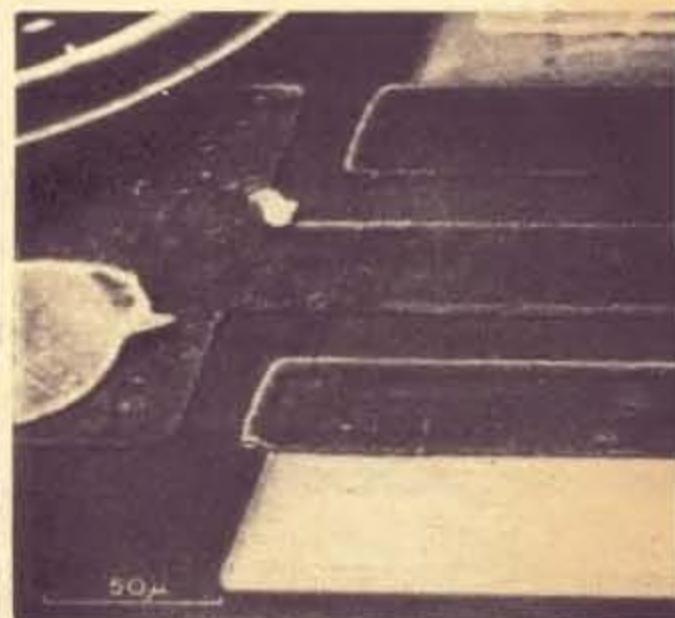
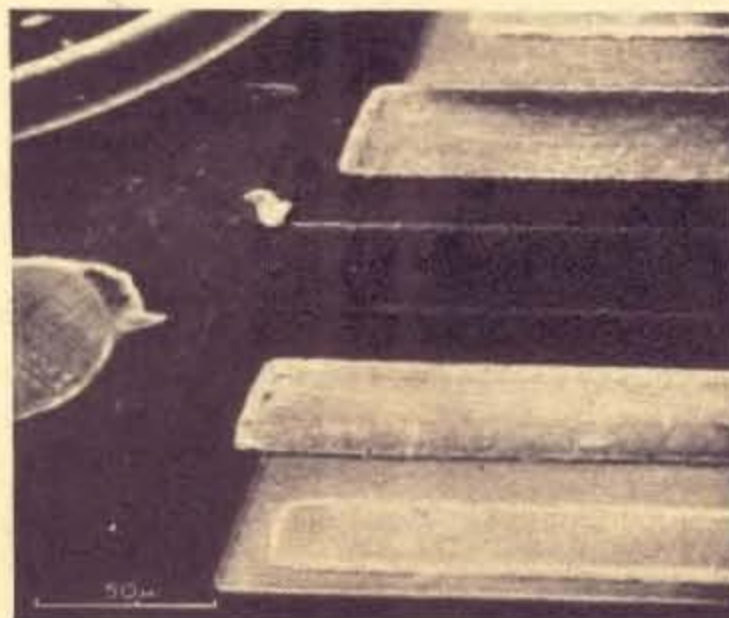
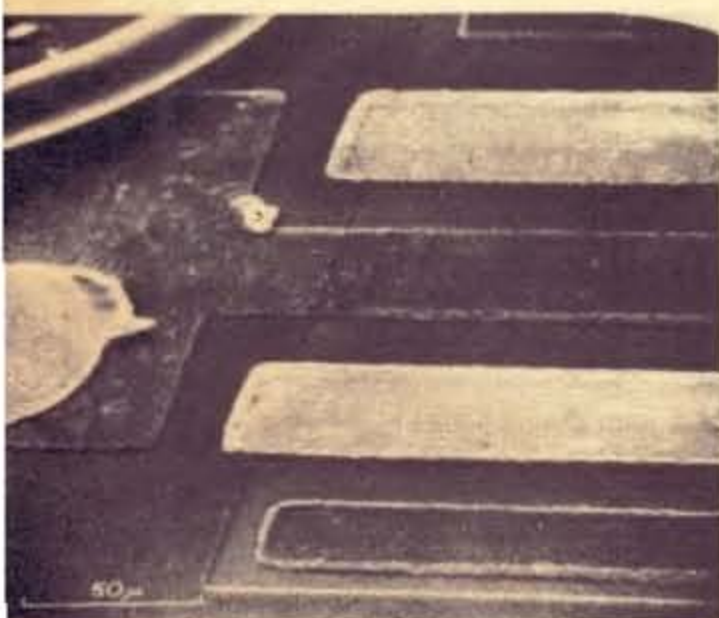

Here we can see the analogy with the cathode ray tube as used in television receivers and oscilloscopes today.

The electron stream is "fired" from the cathode by applying a very high voltage. This electron stream can be influenced in its path by the application of a magnetic field in close proximity. The electrons can be "squeezed" into a narrow stream, or deflected off course by attraction or repulsion to an electromagnetic field. Therefore, the electron stream can be made to bombard any pre-arranged part of some object.

This bombardment is useless unless it can be made to show up the affected part of the object. In the cathode ray tube the screen is coated with a phosphorescent substance so that the invisible electrons striking it are converted to visible light.

TRANSMISSION MICROSCOPE

In the conventional electron microscope, known as the "transmission microscope", the electrons pass through the object to be examined before a magnified image can be formed. The tonal qualities of this image are made up according to the *density* of the bombarded particles. If the transmitted electrons, after passing through the specimen, are projected on to a fluorescent screen the resulting image will consist of a proportional tonal picture of the specimen.

This is all very well in theory, but there are practical limitations involved. The electrons must be magnified and focused after passing through the specimen to offset the scattering and absorption during penetration. Hence objects of very low density are usually the most suitable for specimens.

Many different techniques have been tried to overcome these difficulties. Probably the best was that known as "replication" which was subsequently adopted. A thin layer of plastic substance or resin was deposited on the surface of the specimen, then carefully removed for inspection under the electron microscope. Here again, it is essential to provide absolute perfection in this coating so that the electron image is not falsified by uneven thicknesses.

Other methods of producing perfect thin sections of metal samples are etching and fine electro-polishing. These have the advantage of exposing detail below the

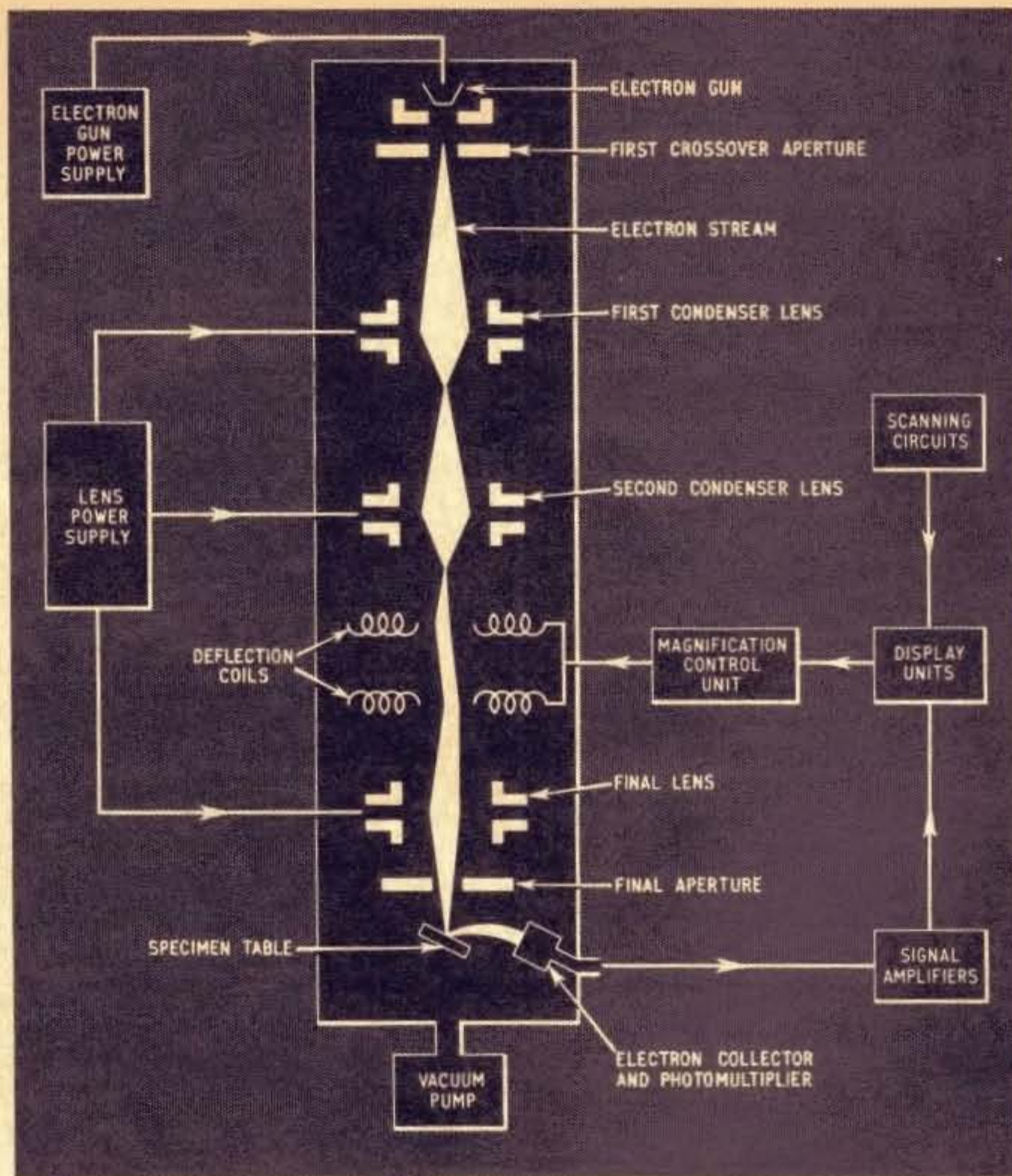

Block diagram of the "Stereoscan" electron microscope

surface but the original finish or topography of the surface is destroyed.

SCANNING ELECTRON MICROSCOPE

In 1935 the first experimental scanning electron microscope was constructed in Germany but, after some further development in Germany and in the U.S.A., it was not until 1948 that Professor Oatley began a research programme at Cambridge University into the possibilities of perfecting it.

This type of microscope overcomes many of the disadvantages of previous types because the electron beam used for illumination is not required to pass through the specimen. The image obtained gives a much clearer picture of the specimen without any apparent blurring.

A high velocity stream of electrons is focused to a fine point on the specimen and is made to sweep across the surface in a raster-like pattern. When they hit or slightly penetrate the surface of the specimen, secondary electrons are emitted from the surface and collected and amplified for display on a cathode ray tube. The specimen is placed in a vacuum chamber so that there is no undesirable influence on the electrons

apart from that governed by the nature of the specimen surface.

The electron gun is mounted in the top of the tall cylindrical column as shown in Fig. 1. The accelerating voltage is continuously variable between 1 and 20 kilovolts. The condenser lenses (there are three) are situated between the gun and the specimen chamber. These lenses are not glass optical lenses, although they serve the same purpose as those in an optical system.

They are, in fact, electromagnetic lenses, the upper two being mechanically interchangeable. The third is fitted with three interchangeable apertures. The working distance between the lower surface of the lens and the specimen is adjustable to anything between 0 and 15 millimetres. The scanning coil which deflects the electron beam over the specimen in the raster pattern, is mounted within the bore of the final lens, so that low minimum magnifications can be obtained. It consists of a double deflection system, an 8-pole magnetic stigmator, and electrical "fine shift" coils.

Magnification is determined by the ratio between the length of the line scanned on the display screen to that on the specimen. The signal strength to the scanning coils can be adjusted to provide a wide

range of magnification for a number of preset accelerating voltages. Magnification values obtainable vary between $\times 50$ and $\times 100,000$ at a working distance of 14mm and between $\times 110$ and $\times 220,000$ at a working distance of 0mm.

The useful magnification, however, lies between $\times 20,000$ and $\times 30,000$, enabling details as small as 200 Å to be resolved.

SIGNALS FROM THE SPECIMEN

The specimen is usually fixed to a small table, which is at the foot of the column, and can be rotated by means of a vernier drive mechanism. The table is set at an angle to the horizontal so that the secondary electrons are directed towards the electron collector. The collection system consists basically of an electrostatic focusing electrode, and a positively biased scintillator, optically coupled to a photo-multiplier. By adjusting the potential of the focusing electrode, the proportion of secondary to reflected electrons collected can be varied. The electrons are attracted to the scintillator by a 12kV charge, then liberate sufficient light to make the electron detection process virtually noise-free.

Signals from the photo-multiplier pass through a head amplifier mounted near the specimen chamber then are injected into a video amplifier for display.

In the "Stereoscan" electron microscope, built by Cambridge Instruments Limited, there are two display screens: one is coated with a long persistence phosphor to give a pictorial image from a slow moving trace; the other is normally fitted with a camera for taking photographs, like those of certain specimens shown in this article.

Magnified view of a wasp's head using the "Stereoscan". This picture, although the correct view of the face, has been inverted. The specimen was lying on its back and coated with 800Å layer of gold. The gun potential was 2 kilovolts. Magnification here is approximately $\times 17.5$. Notice one antenna is retracted



The power supplies for the gun, lenses, scintillator, and display units are housed in a large cabinet, which is kept far enough away from the microscope column to prevent the electromagnetic fields (from transformers, etc.) upsetting the normal functions of the deflector coils and lenses.

A comprehensive interlocking safety system protects the whole instrument against damage, which might be caused by accidental misuse, water failure, mains failure, or vacuum leaks.

SCANNING CONTROL

The picture displayed on the screen is synchronised to the scanning coils in the column by using a scan generator. The voltage waveforms provided by this generator can be monitored on a small oscilloscope screen. Each display unit has a useful screen area of 10.5 centimetres square, but the size of the scanned raster can be reduced and positioned anywhere on the screen.

Images can be formed by using mainly secondary electrons or mainly reflected electrons. Secondary electrons are the most useful because they can be made to follow a curved path to the electron collector. It is possible to see details in deep re-entrant holes, or other areas screened from the direct line of sight of the collector, which would otherwise be almost impossible to achieve with the much higher energy reflected electrons.

Due to the vast variation in the nature of adjacent areas of a specimen, the secondary electrons are emitted at different angles to each other. A distinct contrast of tone is made apparent because of this.

Close-up of a wasp's antenna protruding from its socket. The area (bottom right) is part of its eye. The specimen was coated with an 800Å layer of gold. The gun potential was 20 kilovolts. Magnification approximately $\times 61$

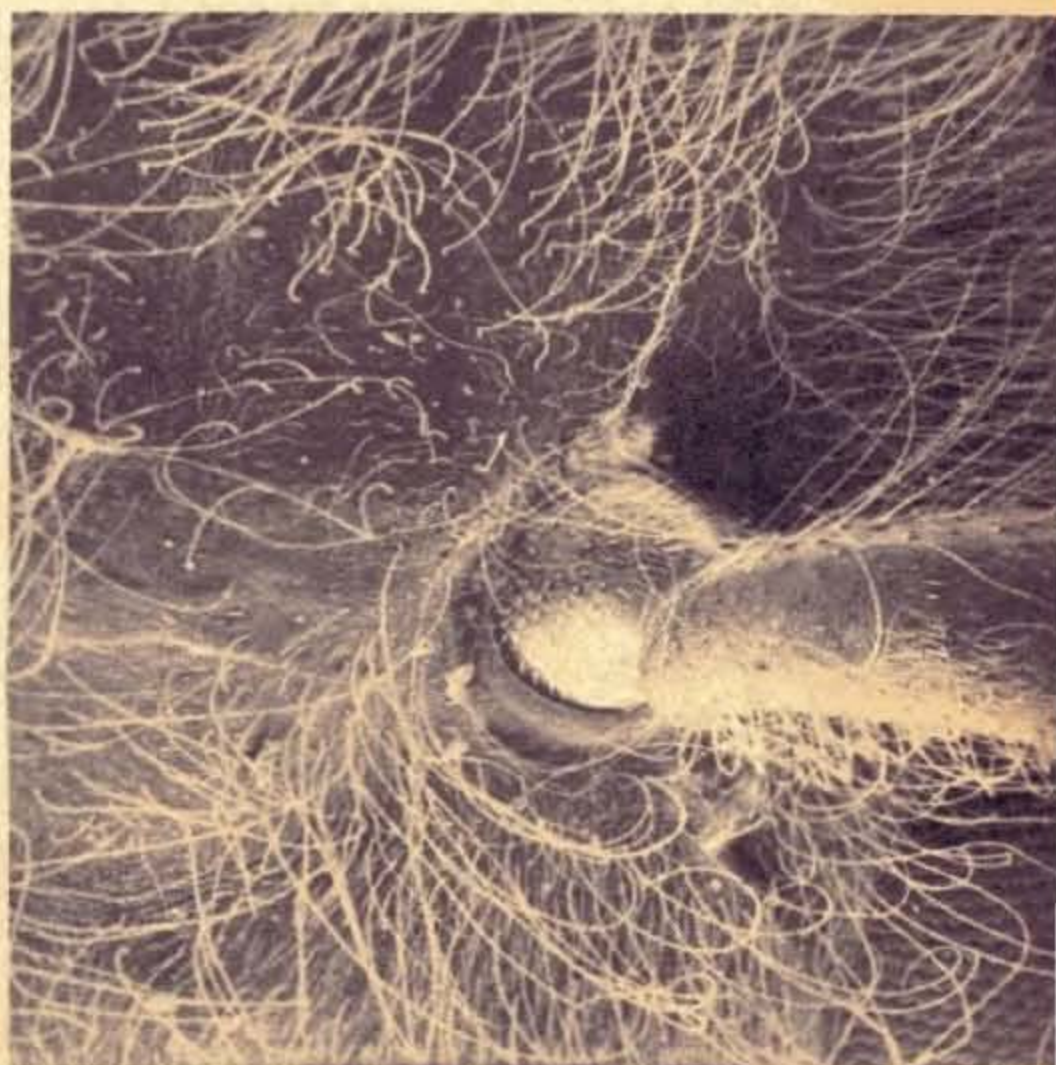

PHOTOGRAPHIC



Part of the head of a common house fly. The "pebble" appearance of the two eyes show remarkable uniformity of size and shape. The nearest eye has specks of dirt on them. The area between the eyes shows the hairs protruding from pores in the skin

and so gives a three-dimensional appearance of the image. Specimens such as semiconductor devices and integrated micro-miniature circuitry can be examined without the risk of upsetting their dynamic properties.

Work is being carried out by Dr. P. R. Thornton at the University College of North Wales, Bangor, to show how applied currents behave in semiconductor circuits. So far it has been possible to "see" the current flowing through a transistor junction in the form of varying densities of grey on the image; see the photographs of the metal oxide silicon transistor. If there is a small defect in the semiconductor material, this shows as a dark irregular area, rather like an ink blot. The path of the current through the material is diverted and shows up as remarkable crescent shaped patterns leading away from the defected area.

Because of the high efficiency of the electron collection system the probe current in the "Stereoscan" microscope is very small. The dissipation of energy in the specimen is much lower than in the transmission microscope, for similar accelerating voltages.

It is possible to see fragile specimens, such as biological tissues with little risk of damage to them. However, it is often necessary to provide a microscopic coating to non-conductive specimens; gold was used on the specimens of insects shown in the photographs. Under certain conditions, the specimen can be examined uncoated, but some loss of resolution will be noticed.

Its application to injection laser technology, to the "physics of failure" in devices, and to the study of morphology of epitaxial layers and whisker crystals, was illustrated recently at the Physics Exhibition in London.

The scope of applications is obviously enormous; the photographs show just a few of the fascinating examples of electron microscopy that have been studied so far. Probably one of the most important uses lies in studying metallurgy, for example, detecting defects in aircraft structures. ★

THIS timer is designed for use in a dark room where panchromatic film or plates are developed, the development time being four minutes after which a bell, connected to the timer, will ring. It may easily be adjusted to provide timing periods from less than one minute to over five minutes with the components shown, or for longer periods if extra capacitance is added in parallel with the timing capacitor.

As a secondary function the timer emits a loud ticking sound at one second intervals during the timing period. This ticking sound serves two purposes: it assures the operator that the timing period is in operation and proceeding; it may be used to count seconds of exposure time during enlarging or printing.

In conditions of complete darkness, necessary for the dish-development of panchromatic plates, it is important that the act of starting the timer should be very simple and come to hand immediately. Accordingly the timer (which has the appearance of a small extension speaker) was mounted fairly high up on the wall, with a cord dangling from its middle. All that is required to start the timer in the dark, is to feel along the wall for the cord and give it a short tug.

The timer is driven from the mains. Its supply is coupled with that of the warning light outside the dark room, so that no one would forget to switch this warning light on during the development process, or switch the timer supply off after use.

The bell, which rings for a period of about six seconds at the end of the timing period, is separately powered from a 6 volt battery, and is mounted remote from the timer in a position where it may be heard at some distance from the dark room.

CIRCUIT

The circuit of the timer is made up of three parts, namely the delay, the ticking, and the bell. The sequence of the three parts is controlled by the three sets of contacts of the relay shown RLA in Fig. 1 (relay contacts are shown in the normal or de-energised condition).

The delay period is started by a short pull on a cord attached to the lever of the microswitch S1. The lever contact of this switch is connected to the positive line and it is shown at rest in the NC (normally closed) position. Also at rest is the changeover contact RLA1, which connects R2 in series with C1.

As the negative side of this capacitor is connected via the coil of relay RLA to the negative supply, then the capacitor will quickly become fully charged.

The starting tug on the cord momentarily moves the microswitch contact to the lower NO (normally open) position, which isolates C1 and applies the positive supply line to RLA coil. The relay is thus energised and its changeover contact RLA1 breaks C1 from R2 and applies the fully charged capacitor to VR1 and R3. The transistor TR1 is completely cut off, thus causing almost all the current passing through R4 to flow through the base of TR2. The emitter and collector of TR2 passes sufficient current through the coil of RLA for it to remain in the energised state after the microswitch has been released from the NO position, back to NC.

Capacitor C1 now starts to discharge through VR1 and eventually a point is reached when the voltage at the base of TR1 is such that it commences to pass

PROCESS TIMER

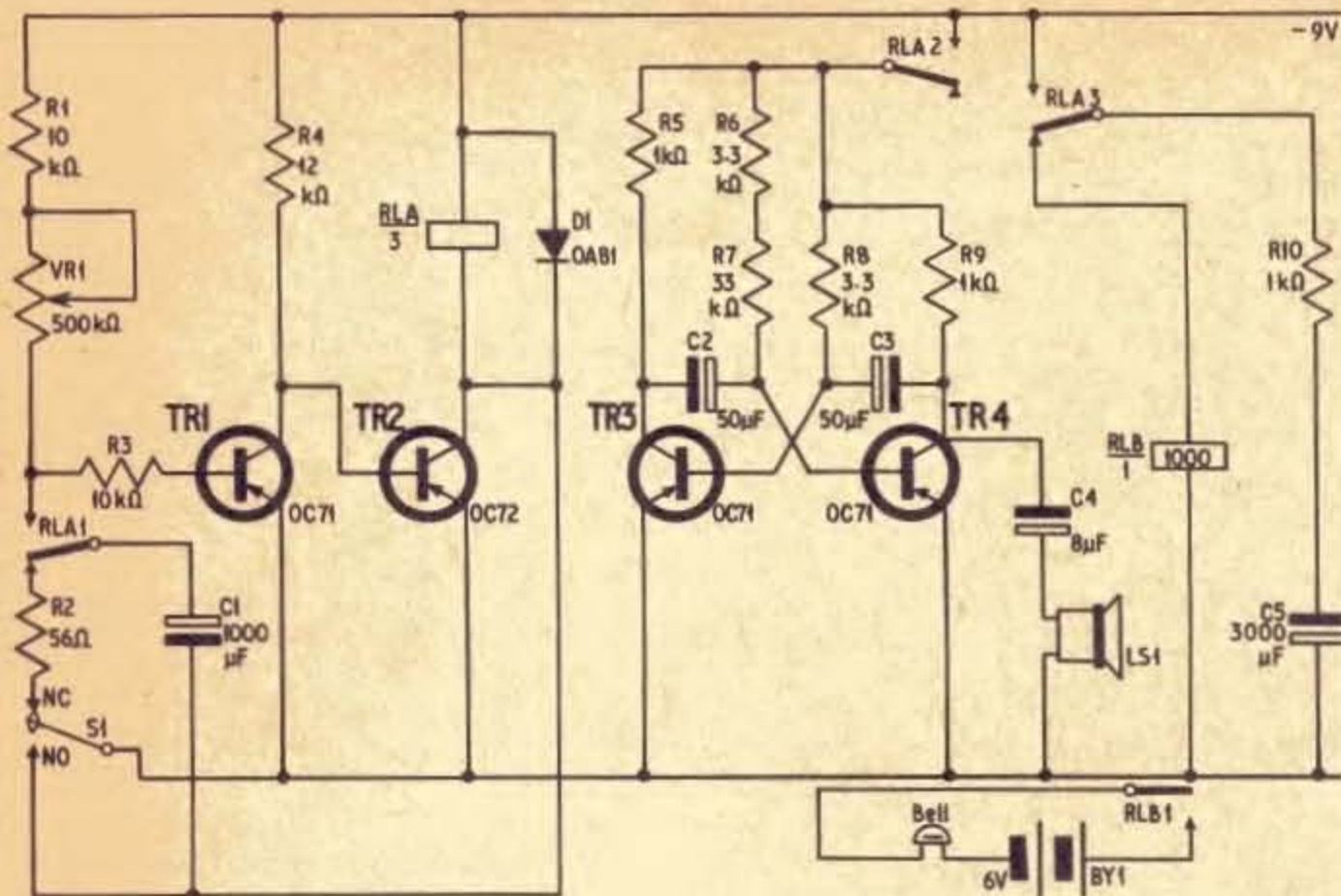

By
G. E. DUNNING

Fig. 1. Complete circuit diagram of the process timer and alarm bell

Fig. 2. Suggested circuit for a mains power supply unit

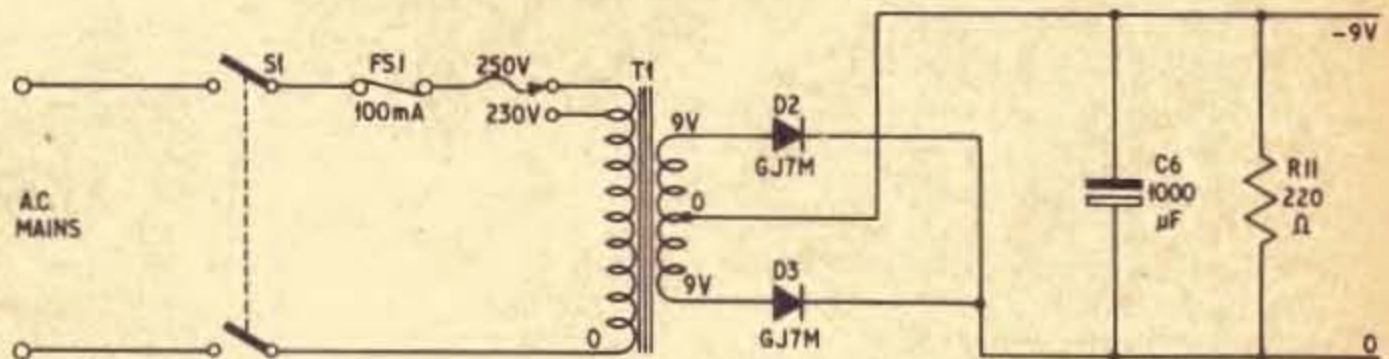

COMPONENTS . . .

TIMER UNIT

Resistors

R1 10kΩ	R 6 3.3kΩ
R2 56Ω	R 7 33kΩ
R3 10kΩ	R 8 3.3kΩ
R4 12kΩ	R 9 1kΩ
R5 1kΩ	R10 1kΩ

All 10%, ½ watt carbon

Potentiometer

VR1 500kΩ log. carbon

Capacitors

C1 1,000µF elect. 12V (see Text)
C2 50µF elect. 12V
C3 50µF elect. 12V
C4 8µF elect. 15V
C5 3,200µF elect. 16V (Mullard) (or made up from 2,000µF + 1,000µF 25V in parallel)

Transistors

TR1, TR3, TR4	OC71 (Mullard) (3 off)
TR2	OC72 (Mullard) (1 off)

Diode

DI OAB1 (Mullard)

Relays

RLA 90Ω with 4 sets of changeover contacts Omron type MH4P (Keyswitch Relays)
RLB 1,000Ω with at least one set of changeover contacts (G.P.O. type 600)

Microswitch

S1 Single pole miniature changeover with lever arm

Loudspeaker

LS1 3Ω 2½in diameter

Battery

BY1 6V dry battery, heavy duty (for bell)
BY2 9V dry battery, heavy duty (if required for main supply to circuit)

Miscellaneous

Chassis 7½in × 5½in × 2½in
Veroboard laminated wiring board, 5in × 2½in

POWER UNIT

(if required to replace BY2)

Resistor

R11 220Ω 10%, 1 watt carbon

Capacitor

C6 1,000µF elect. 15V

Transformer

T1 Pri. 230/250V a.c.
Sec. 9V-0-9V 80mA
Type MT98 (Henry's Radio)

Diodes

D1 & D2 GJ7M (2 off)

Switch

S1 Double pole on-off toggle switch

Fuse

FS1 100mA Cartridge

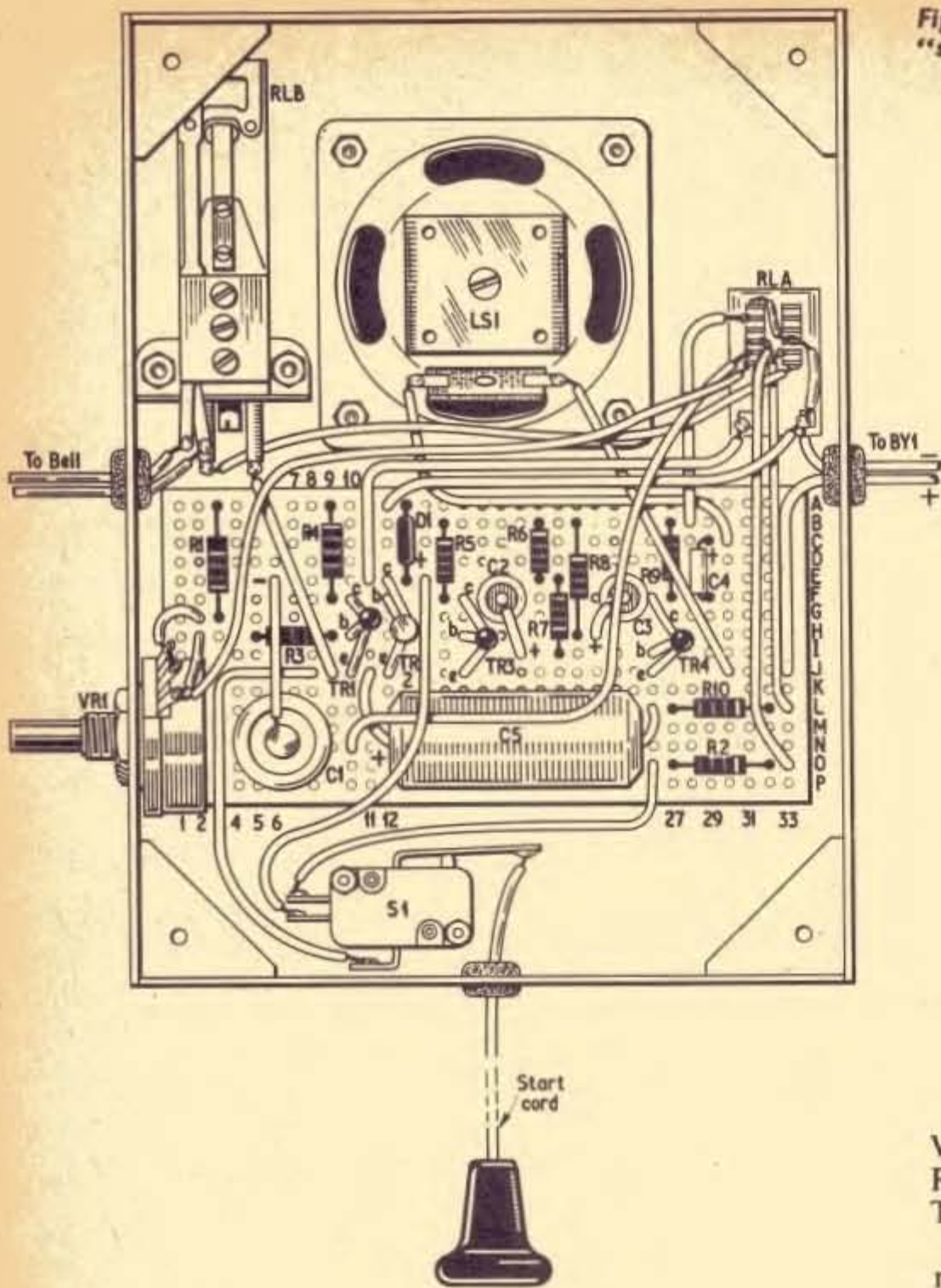

Fig. 3 (left). Complete wiring details of the unit. The "start" cord is soldered to the microswitch lever

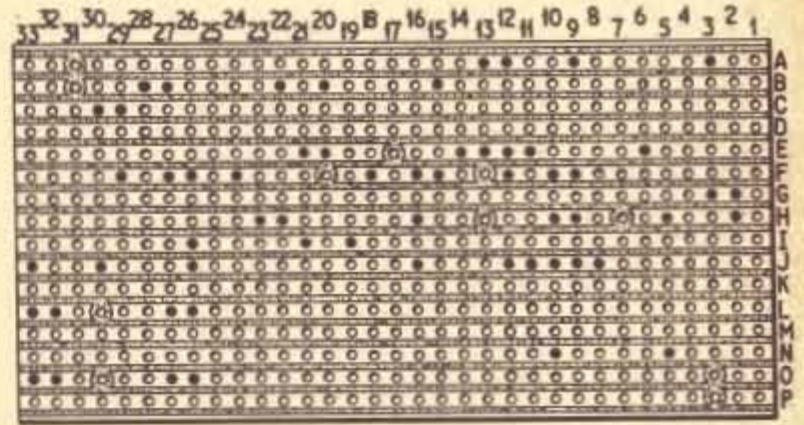

Fig. 4. Underside view of the component board

more and more current, thus reducing the current flowing to the base of TR2. Consequently, the current through the coil of RLA is reduced until it is no longer able to hold RLA on. Any increase in the reluctance of the magnetic circuit causes a corresponding reduction of flux passing through the coil, which in turn causes a back e.m.f. to be developed across it. The diode D1 is connected in parallel with the coil of RLA to ensure that this back e.m.f. does not damage the transistor TR2. The timing period is made to end smartly and precisely thus returning the circuit to normal.

The ticking sounds are produced by an astable multivibrator comprising transistors TR3 and TR4 and their associated components. Its action is unbalanced so that TR4 is on for a much shorter period than TR3. The pulse from TR4 is transmitted to a small 3 ohm loudspeaker via the capacitor C4 to give an audible tick, whilst the longer pulse from TR3 is not heard and forms the interval between the ticks. R7 is adjusted until this interval is of one second duration. This circuit becomes energised when RLA2 is closed and so the ticking occurs only during the timing period.

The bell circuit (shown separately below the main circuit) is closed only when relay RLB is energised.

When RLA is energised the changeover contacts RLA3 connect R10 and C5 across the supply voltage. Thus capacitor C5 charges during the timing period.

On completion of the timing period contact RLA3 returns to normal in the position shown and C5 discharges through R10 and the 1,000 ohm coil of RLB. Relay RLB operates causing contacts RLB1 to close. The bell now rings during the decay period of the charge held by capacitor C5, the decay time being equal to

$$\frac{C_5 \times (R_{10} + R_{RLB}) \text{ seconds}}{10^6}$$

where C is in microfarads and R is in ohms.

CONSTRUCTION

The small components may conveniently be built up on Veroboard laminated wiring board; the relays and loudspeakers are bolted to the metal chassis (see Fig. 3).

The microswitch should be of the type which has a spring lever to actuate the button; this should be mounted firmly inside the case with a cord or wire attached to the lever. The potentiometer VRI should also be mounted so that its spindle passes through the chassis. A scale can be calibrated for this and marked in fractions of seconds.

The power pack can be made up from the circuit shown in Fig. 2 or a heavy duty battery can be used.

As regards the connection to the mains. In the original model connection was made at the rose of the warning lamp, after the mains had been turned off of course, but if this is considered inadvisable the warning lamp could be a neon wired separate from the mains and the whole unit connected by a plug in the normal way.



COMPUTER FOR NIM

by F. MOORE

THIS article describes a simple circuit, based mainly on multipole Yaxley-type wafer switches, of an infallible machine for playing the game of "Nim". The game is played entirely on these switches, and four lamps are used to indicate the correct moves to the machine operator.

First, it is necessary to say a little about the game itself and about the tactics of winning. The game now known as "Nim" is in fact a very ancient one and is believed to be of Chinese origin. It is for two players who play alternately. At the beginning of the game a number of objects (for example, matches) are divided into several heaps, either in a pre-determined manner or in a manner decided by one of the players.

At each turn a player takes away one or more matches from one of the heaps. He must take at least one match and he may take the whole heap if he wishes, but he is not permitted to take from two different heaps in one turn. The player who eventually takes away the last match is, in one version of the game, the winner and, in another version, the loser. Naturally it is necessary for the players to agree beforehand which version they are playing.

TACTICS OF "NIM"

In this section an account is given of the tactics of the game. It is not necessary for the constructor to master this section, since all the tactical devices are incorporated in the circuit to be described.

A complete understanding of the mathematical background of "Nim" has been known for many years, but the application of the remarkably simple rules resulting from it rarely fails to baffle the uninitiated.

Basically the tactics for winning depend on the fact that all possible combinations of numbers are either "winning combinations" or "losing combinations". Every possible play made from a winning combination results, for the player, in a losing combination, whereas from a losing combination it is always possible to make at least one play that results in a winning combination. In other words, if player "A" contrives to leave a winning combination early in the game, any move player "B" can make necessarily results in what is for him a losing combination, whereupon "A" can once more play to leave a winning combination and hence eventually win the game.



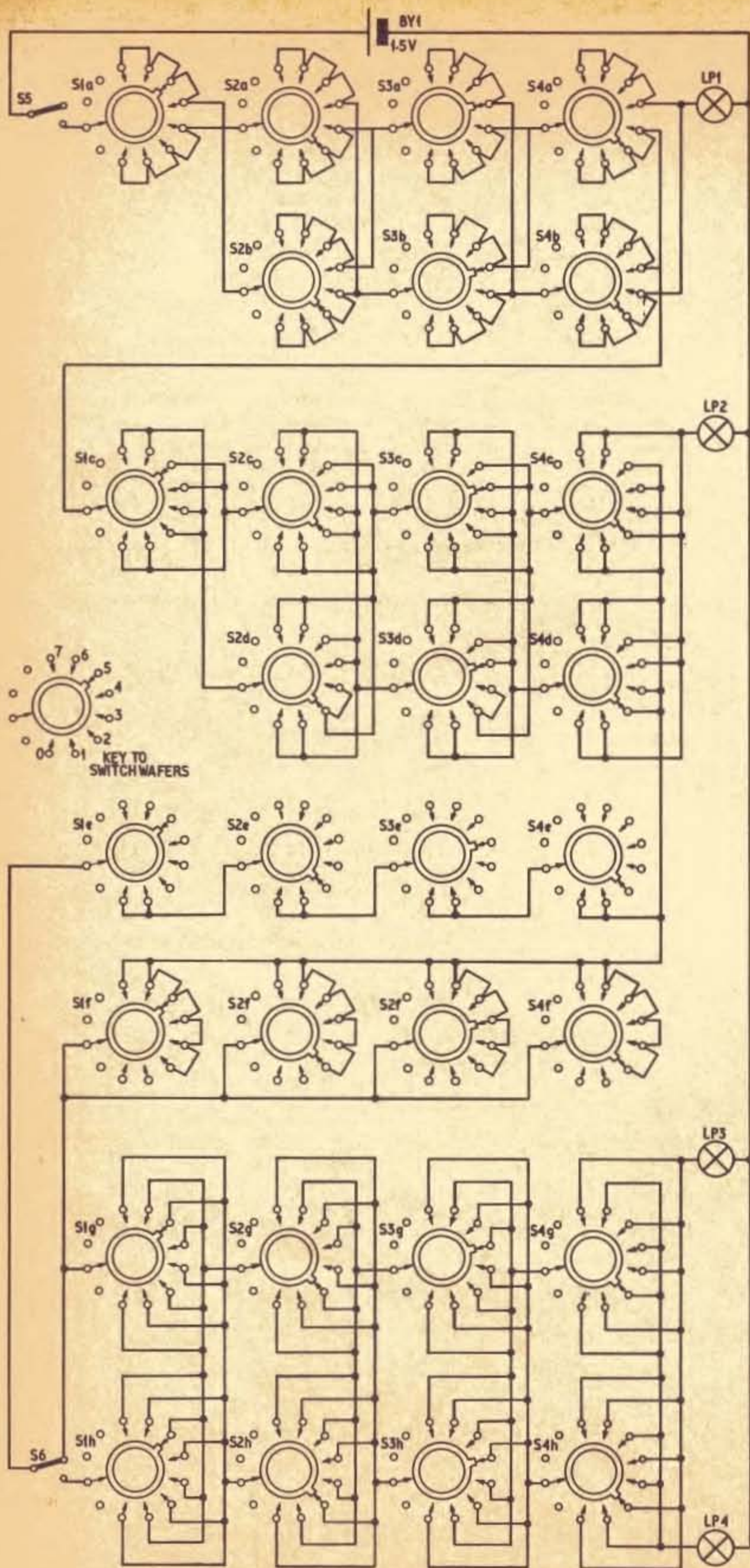

To determine whether a given combination is a winning or a losing one, the numbers of matches in the various heaps are expressed as the sum of one or more numbers of the series 1, 2, 4, 8, 16, 32, etc., that is, in terms of the powers of 2. Then, if each power of 2 (including unity) is present an even number of times (or absent altogether), the combination is a winning one.

If any power of 2 is present an odd number of times, the combination is a losing one. For example, suppose we have four heaps containing respectively 11, 10, 3 and 2 matches, we express these heaps as having $8 + 2 + 1$, $8 + 2$, $2 + 1$, and 2 matches respectively. Since there are two 8's, no 4's, four 2's, and two 1's, this is a winning combination. However the combination 7, 6 and 3, which may be written $4 + 2 + 1$, $4 + 2$, $2 + 1$, is a losing one because the number 2 is present an odd number of times.

This rule applies throughout the game in the version in which the player taking the last match is the winner. It requires a slight modification for the version in which the last to play is the loser. The extra rule here is that, when no heap contains more than one match, an odd number of heaps (i.e. an odd number of 1's) is a winning combination and an even number is a losing combination.

The only other information necessary for winning at "Nim" is on how to turn the opponent's losing combination into a winning one for oneself. The rule is to take from the heap containing the highest power of 2 that is present an odd number of times, and to leave behind sufficient to pair off all the unpaired powers of 2 in the other heaps.

For the 7, 6 and 3 losing combination noted above; since 2 occurs in each heap, three alternative plays are possible, leaving one of the winning combinations 5, 6, 3; 7, 4, 3; or 7, 6, 1. However, with the losing combi-

Fig. 1. Circuit for Nim Computer showing the "losing combination" 5, 2, 4, 2. The wafers are shown as seen from below and the numbering is shown in the key diagram alongside. The wafers "a" to "h" are ganged for each switch

nation 10, 8 and 5, only one winning play is possible—that which leaves the combination 10, 8, 2.

CIRCUIT DESCRIPTION

The circuit illustrated in Fig. 1 represents a game of "Nim" in which there may be up to four heaps of matches and up to seven matches in each heap. The numbers of matches are represented by the seven settings of the switches S1 to S4. It should be noted that S1 is a 6-pole, 8-way switch and S2, S3 and S4 are 8-pole, 8-way switches. The numbering of the positions of all switches is represented in the key. The position illustrated shows the combination 5, 2, 4 and 2 for S1 to S4. All S1 wafers are ganged; all S2 wafers as well; the same with S3 and S4.

The indicator bulbs LP1 to LP4 may conveniently be 1.5V flashlight bulbs and, since not more than one can be lit at once, the circuit may be powered adequately by any small 1.5V battery.

The single pole 2-way switch S6 is used to select the version of the game being played. If the last to play is to be the winner the switch should be in the upper position as illustrated, i.e. S1e connected to S1g and S1f wipers. The lower position is used when the last to play is to be the loser, i.e. S1e wiper connected to S1h wiper.

The operation of the circuit is as follows. The positive terminal of the battery is connected via the main on/off switch S5 to the wiper of S1a. If any one or three of the switches S1 to S4 are set at positions 4, 5, 6, or 7, it will be seen that the supply voltage reaches LP1, which consequently lights up, while the remainder of the circuit is dead. If however none, two, or four of the switches are set at 4, 5, 6, or 7, the supply voltage is transferred from LP1 to the wiper of S1c.

Now if any one or three of the switches S1 to S4 are set at positions 2, 3, 6, or 7, it will be seen that LP2 will be lit and the remainder of the circuit will be dead. If however none, two, or four switches are set at 2, 3, 6, or 7, LP2 is not lit and the voltage is applied to wafers S1e-S4e and S1f-S4f.

The function of these "e" and "f" wafers is to distinguish combinations, in which numbers greater than 1 are present, from those made up solely of 1's and 0's. It will be seen that if one or more of S1 to S4 are set at a number higher than 1, the supply voltage reaches the wiper of S1g via the "f" wafers, which are wired in parallel. If, however, S1 to S4 are all set at the 1 or 0 positions, the supply reaches the wiper of S6 via the "e" wafer switches which are wired in series. Nevertheless, if S6 is set in the upper position (last player the winner) the supply again reaches the wiper of S1g.

Now if any one or three of S1 to S4 are set at positions 1, 3, 5, or 7, lamp LP3 will be lit, whereas if none, two, or four switches are set at 1, 3, 5, or 7, lamp LP4 will be lit.

When S6 is switched to the lower position (last player the loser) the supply from S1e reaches the wiper of S1h instead of S1g. Now with one or three switches set at position 1, LP4 is lit, whereas with none, two, or four switches set at 1, LP3 is lit.

COMPONENTS . . .

Switches

S1	6-pole, 8-way wafer switch (1 off)
S2-4	8-pole, 8-way wafer switches (3 off)
S5	Single pole, on-off toggle switch (1 off)
S6	Single pole, two-way toggle switch (1 off)
LP1-4	1.5V flashlight bulbs (4 off)

Battery

BY1	1.5V dry battery
-----	------------------

Miscellaneous

Four pointer knobs, four lampholders, box 10½in × 5½in × 4in, p.v.c. covered wire.

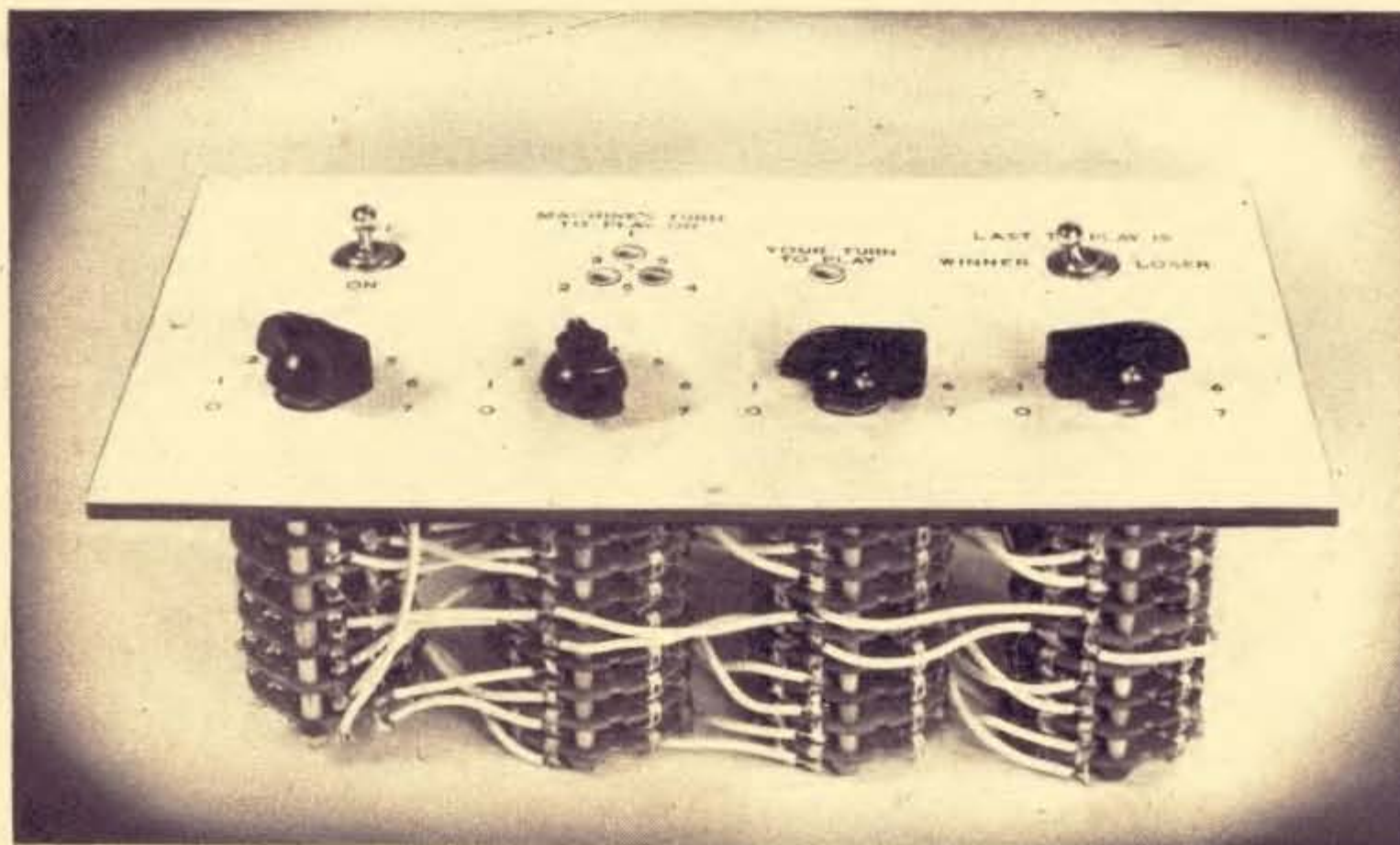

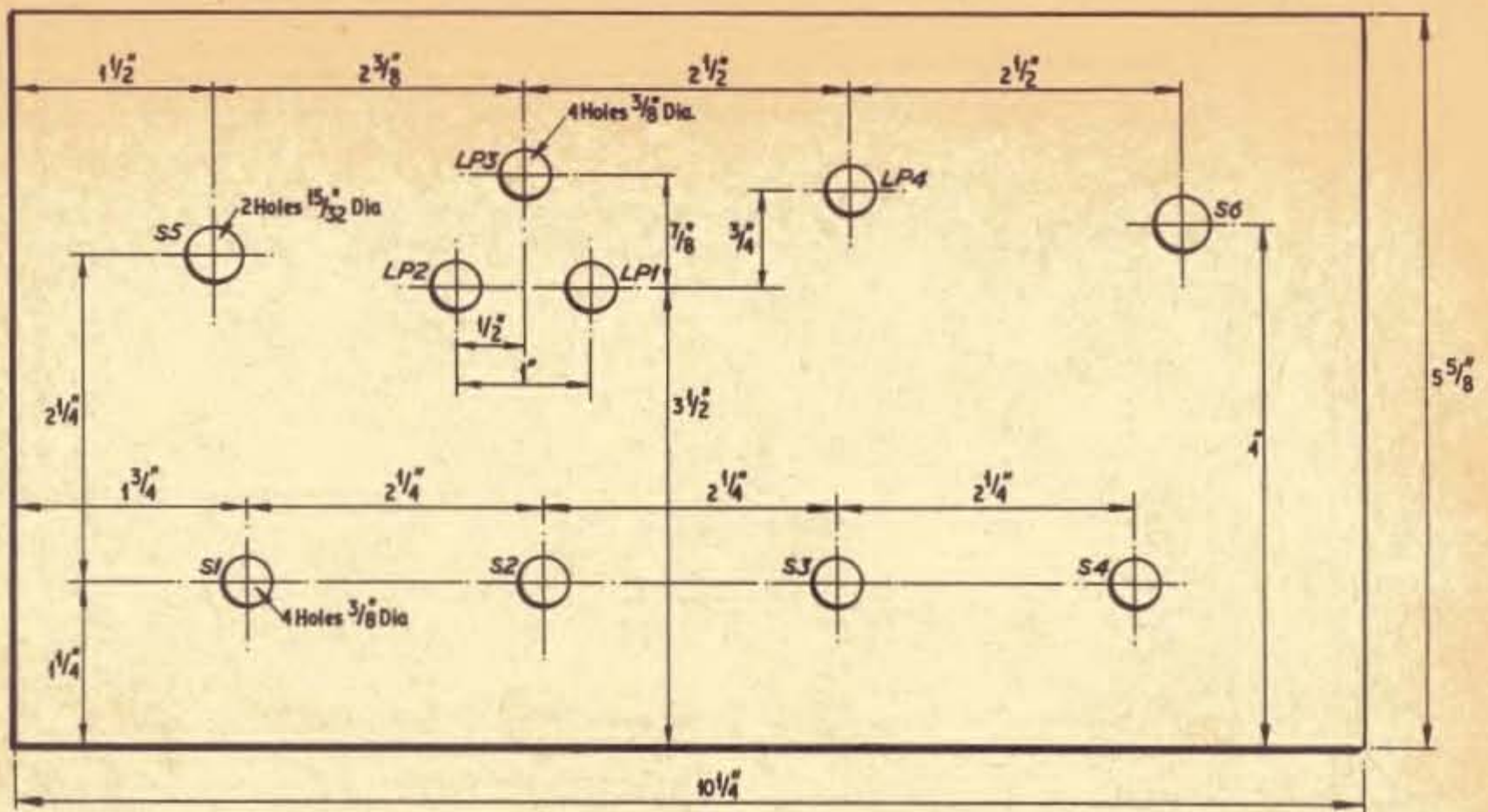

Fig. 2. Suggested layout and drilling details of the panel looking at the top face

To summarise: if LP4 is lit, the switches are set at a winning combination; if LP1, LP2, or LP3 is lit, the switches are set at a losing combination and the highest unpaired power of 2 is respectively 4, 2, or 1.

Although the circuit shown in Fig. 1 is not incorrect, it is not necessary to make the connections to positions 2 to 7 inclusive on S1h, since S1h is only live when S1 is set at 0 or 1.

LAYOUT AND CONSTRUCTION

The photographs and Fig. 2 show a suggested layout. All the components are panel mounted in what might conveniently be the lid of a box measuring approximately $10\frac{1}{4}$ in \times $5\frac{5}{8}$ in \times 4 in. Pointer knobs are used on the switches S1 to S4, and the positions are numbered from 0 to 7.

The positioning and labelling of the lamps LP1 to LP4 is at the discretion of the constructor and depends to what extent he wants to give away the secrets of operating the computer. If he is prepared to commit to memory the functions of the various lamps then little or no labelling is necessary. In the suggested layout, LP4 (which indicates a winning combination) is labelled "Your Turn to Play" and is coloured green. Lamps LP1 to LP3, which indicate losing combinations are coloured red and are arranged within a triangular pattern of numbers (see Fig. 2). The significance of this is that the correct move for the machine involves turning a switch set at any of the four numbers immediately surrounding the illuminated lamp.

Little need be said about the wiring of the computer. It is recommended that the connections between the wafers and contact tags should be made on each of the switches S1 to S4 before the interconnections between these switches are made. It will be noted that for the a- and b-wafers, the 0, 1, 2, and 3 positions on one wafer are connected to the 4, 5, 6, and 7 positions on the other wafer. For the c- and d-wafers, the 0, 1, 4, and 5 positions on one wafer are connected to the 2, 3, 6, and 7 positions on the other, while for the g- and h-wafers, the odd numbered positions on one wafer are wired to the even numbered positions on the other.

PLAYING "NIM" ON THE COMPUTER

The contestant who wishes to challenge the computer is invited to set any combination of numbers he pleases on S1 to S4 and also to set S6 at the position of his choice. The game consists in the machine operator and the contestant turning back the switches to zero according to the rules of "Nim" (i.e. for each move any one switch may be turned back as far as desired), and the winner is as indicated by S6.

All the machine operator has to do is to observe which bulb is lit, note the numbers around this bulb, find a pointer that is set at one of these numbers and then turn this back until the green bulb L4 lights. If the contestant allows the machine to decide who plays first, then the machine will inevitably win if operated as described above. If a particularly "difficult" contestant disputes the machine's initial indication of who is to play first, the operator should switch off S5 before each turn of the contestant. Any mistake by the latter will then allow the machine to take control and win.

ALTERNATIVE SWITCH COMBINATIONS

The machine described above can be built for about £4. Similar design principles can however be used to build either larger or smaller machines for various outlays. Suitable switch combinations are listed below.

Table 1

Number of switch positions (ways)	Switches required	
	One with	Two or more with
3 or 4	4 poles	6 poles
5 to 8	6 poles	8 poles
9 to 16	8 poles	10 poles
17 to 32	10 poles	12 poles

If the winner/loser changeover facility represented by S6 is not required, each switch may have two poles less. The game is trivial with only two switches. ★

LEARN ELECTRONICS — AS YOU BUILD



over **25** **CIRCUITS**
EXPERIMENTS
TEST GEAR

including . . .

● CATHODE RAY OSCILLOSCOPE

- | | |
|--------------------------------|--------------------------|
| ● Valve Experiments | ● Square Wave generator |
| ● Transistor Experiments | ● Morse Code Oscillator |
| ● Electro-magnetic Experiments | ● Simple Transmitter |
| ● Basic Amplifier | ● Electronic Switch |
| ● Basic Oscillator | ● Photo-electric circuit |
| ● Basic Rectifier | ● Basic Computer Circuit |
| ● Signal Tracer | ● Basic radio receiver |
| ● Simple Counter | ● A.C. Experiments |
| ● Time Delay Circuits | ● D.C. Experiments |

The full equipment supplied comprises: valves, transistors, photo-tube, modern type chassis board; printed circuit board; full range resistors, capacitors and inductors; transformers; potentiometers; switches; transistors; valves; all hardware, wiring and every detail required for all practical work *plus* CATHODE RAY OSCILLOSCOPE for demonstrating results of all experiments carried out. All practical work fully described in comprehensive PRACTICAL MANUALS. Tutor service and advice if needed.

This complete practical course will teach you all the basic principles of electronics by carrying out experiments and building operational apparatus. You will learn how to recognise and handle all types of modern components; their symbols and how to read a completed circuit or schematic diagram. The course then shows how all the basic electronic circuits are constructed and used, and HOW THEY ACTUALLY WORK BY USING THE OSCILLOSCOPE PROVIDED. An application is given in all the main fields of electronics, i.e. Radio; control circuits; computers and automation; photoelectrics; counters, etc., and rules and procedure for fault finding and servicing of all types of electronic equipment.

- | | | |
|--------------------------------|---------------------------|--|
| ● NO PREVIOUS KNOWLEDGE NEEDED | ● NO MATHS USED OR NEEDED | ● REASONABLE FEE—NO EXTRAS REQUIRED |
| ● SENT IN ATTRACTIVE BOX | ● COMPLETE ADVICE SERVICE | ● EVERYTHING REMAINS YOUR OWN PROPERTY |

A completely **NEW** up-to-date home study experimental course by
BRITISH NATIONAL RADIO SCHOOL —
Britain's Leading Electronic Training Organisation.

POST NOW FOR FREE BROCHURE

To: BRITISH NATIONAL RADIO SCHOOL, READING, BERKSHIRE. Please send free Brochure, without obligation, to:

NAME

ADDRESS

.....
Block Capitals Please

OR WRITE IF YOU PREFER NOT TO CUT COUPON

PE 4.65.

**FOR THE
FIRST TIME**



Plug-in ELECTROLYTIC CAPACITORS

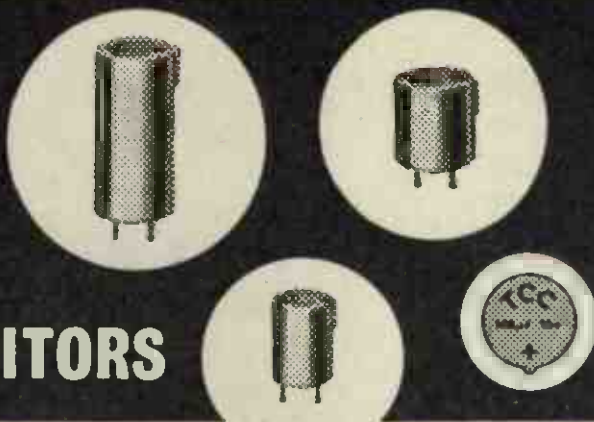

SMALL • FULLY ENCAPSULATED • PLASTIC CASED

These new T.C.C. small plastic-cased electrolytic capacitors have been specially developed for vertical mounting on printed circuit boards, and are designed for operation at temperatures from -20°C to $+70^{\circ}\text{C}$ and for intermittent operation up to 85°C . Three case sizes are available in rated voltages up to 50V. The standard tolerance of the range is -20% $+100\%$ of rated capacitance. The anodes are of super-purity aluminium, with all-welded internal connections. A special electrolyte ensures low impedance at all frequencies in the audio range.

LOW LEAKAGE CURRENT & LONG LIFE—
leakage in $\mu\text{A} = 0.02\text{CV} + 20$.

**TERMINATIONS OF STEEL CORE
COPPER WIRE—**

specially solder coated for fast, ripple soldering technique.

QUICKER ASSEMBLY

Steel cored wire gives precision acceptance of capacitors when inserting into punched printed boards.

QUICKER IDENTIFICATION

Colour coding and embossed values enable instant selection of the right capacitance and voltage.

HIGHLY COMPETITIVE PRICES

For full details please write for Technical Bulletin No. 102

THE TELEGRAPH CONDENSER CO. LTD.

NORTH ACTON, LONDON W.3 • Telephone: ACO rn 0061 (16 lines) Telegrams: Telefarad, Wesphone, London. Telex: 261383
(also at) CHESSINGTON, SURREY • BATHGATE, SCOTLAND

**HOUSING
HI-FI?**

See the Longfellow hi-fi cabinet in Room 447, Audio Fair, Russell Hotel, W.C.1 (April 22-25).

See how this superb cabinet will take your records, turntable, tape-recorder, amplifier and tuner—all within its 77 inches length.



Walnut or Mahogany 39 gns.
Teak 42 gns.

RECORD HOUSING

Write now for catalogue of full range and nearest stockist (UK only):
(Dept. PE4) Brook Road, London, N.22
Telephone: Bowes Park 7487

**GUITAR AMPLIFIERS
WITH TREMOLO**

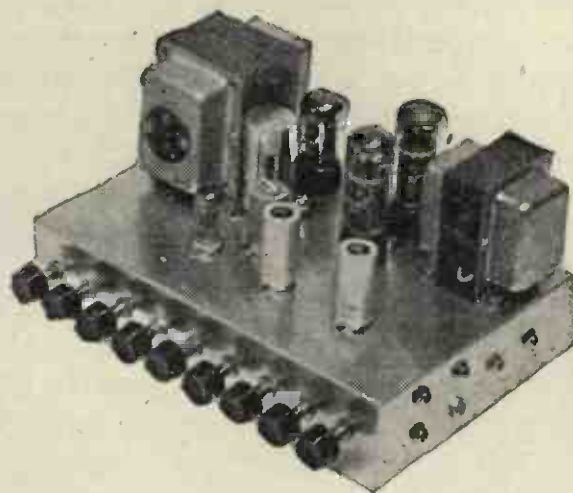

Five jack socket inputs, four with separate mixing volume controls, and one input "straight through". All inputs are of very high sensitivity only 10 millivolts input is required for full output, making them suitable for all types of guitars and microphones. Separate Bass and Treble controls, giving a wide range of lift and cut. Separate master gain control. Tremolo speed and depth controls. Jack socket for remote tremolo switching.

Outputs for 3 and 15 ohms speakers. Valves used in the 30 watt and 50 watt amplifier ECC83, ECC83, EL34, EL34, GZ34. In the 15 watt amplifier ECC83, ECC83, EL84, EL84, EZ81. An extra valve ECC83 is used in the tremolo circuit. The chassis is complete with baseplate and is solidly made of 18 gauge steel, finished silver grey hammer. Size $12 \times 8 \times 6\frac{1}{2}$ inches high.

PRICES—

50 watt with tremolo	£20.10.0
50 watt less tremolo	£19.10.0
30 watt with tremolo	£15.10.0
30 watt less tremolo	£14.10.0
15 watt with tremolo	£12.10.0
15 watt less tremolo	£11.10.0

Add carriage 10/- any amplifier. Send for free descriptive leaflet.

CREDIT TERMS ARRANGED

STROUD AUDIO

PAGANHILL LANE, STROUD, GLOS.

Stroud 783



NEON NOVELTIES

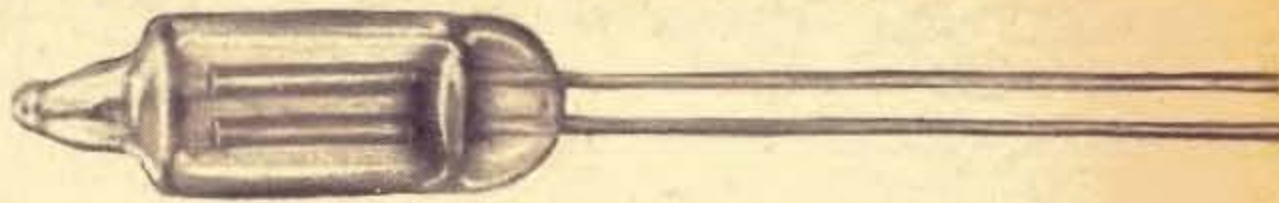

THIS article completes the series illustrating some of the many uses of neon lamps. The neons employed are all miniature wire-ended types as shown above.

Two examples which are ideally suited to these applications are those supplied by Radiospares (striking voltage 65 volts), and the Hivac type 3L general purpose neons. The latter type requires a striking voltage of 80 volts and maintaining voltage of 60 volts.

Some neon indicators have a resistor wired in series with one of the neon wires to make them suitable for mains voltages. These would normally be unsuitable for the circuits described unless the resistor is removed or short-circuited.

TEN VOLUME LEVEL INDICATORS

by R. Bebbington GRAD.I.E.R.E.

JUDGING by the wide differences in volume level settings, adopted by members of the family when adjusting the radio or television, the ear is not necessarily the best device for deciding optimum volume. Neons have already been used for peak and overload recording level indicators on tape recorders and the circuit shown here is quite suitable for this application. However, its use may be extended to indicate volume level on mains operated domestic receivers.

There are only three connections to be made to incorporate this refinement. The potential divider chain across the h.t. supply AB is symmetrical; one end connects to h.t. positive, the other end connects to the common line or chassis. Connection C, the junction of the two series resistors of the neons, is taken to the anode of the output valve. The preset controls should be adjusted so that one neon glows on the accepted peak output and the other glows if the volume level is excessive.

The neon indicators can be mounted to protrude through the front panel of the set. As the h.t. voltage may be between 200 and 300 volts, care must be taken to ensure that none of the wiring is exposed. The two

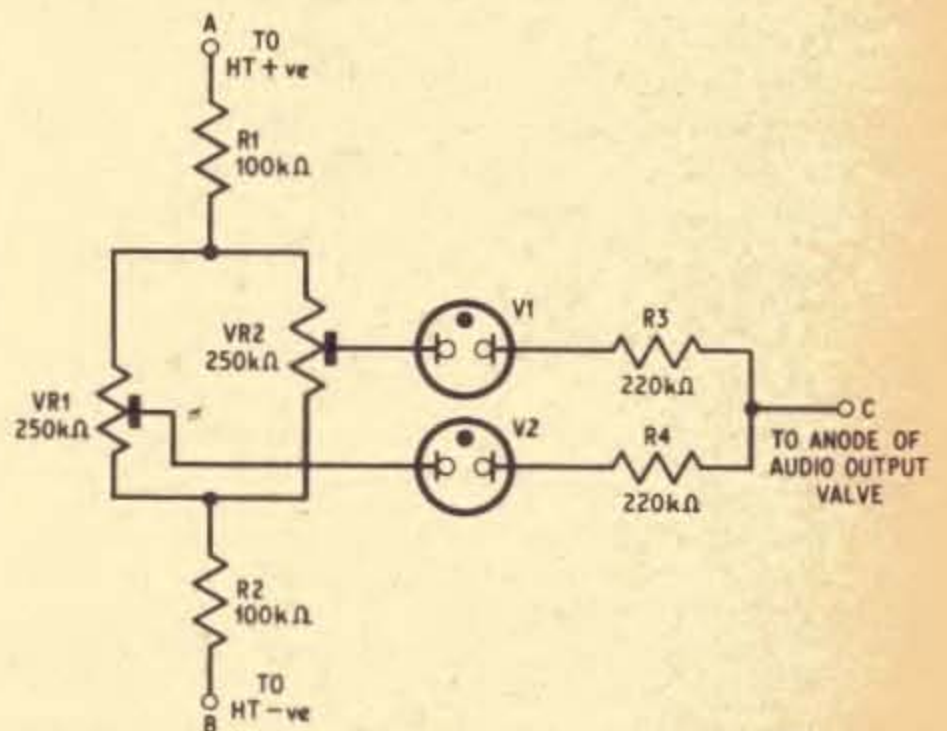

preset potentiometers VR1 and VR2 may either be fitted to the chassis of the set or may be mounted on a small paxolin panel together with the two fixed resistors R1 and R2. ★

PRACTICAL WIRELESS

JUNE

- ★ Sub-miniature 300 mW Amplifier
- ★ "Imperial" 3 Band Transmitter
- ★ The Radio Collector
- ★ Transistor Set Booster

On sale NOW

2s 6d

PRACTICAL TELEVISION

JUNE

- ★ Ideas for Amateur TV
- ★ Add-on Sync cancelled Auto-Gain Unit
- ★ Servicing Without a Manual
- ★ Pinpointing the Trouble Area

On sale MAY 19th

2s

ELECTRONIC Mandolin

By S. Chisholm



THE mandolin, which has for some time been popular with folk-song singers, is now beginning to appear in conjunction with the electronic guitar in "pop" groups. Although in itself adequate for solos, it requires amplification to compete in harmony with other instruments.

Fortunately, it is a fairly easy and inexpensive task to modify an existing mandolin provided it meets certain requirements. The modification described herein will add an electronic pick-up, a volume control, vibrato control and a bass lift control. Two jack plugs and one 4-way cable (or two 2-way cables) connect the mandolin to the amplifier. The electronic *Guitar Amplifier* (described in the February and March 1965 issues of *PRACTICAL ELECTRONICS*) should be modified for low impedance input as shown elsewhere in this issue. The mandolin provides a low impedance input.

Although designed for this particular amplifier, the mandolin can be used with a high impedance input amplifier, provided that a matching transformer of about 50 : 1 step-up ratio is connected between the output of the mandolin and the input of the amplifier.

At current prices the overall cost of the modification is reasonably small—approximately £2. Allowance should, of course, be made for the cost of the amplifier which, if a commercial item, would be fairly expensive.

The prototype is a twelve-stringed instrument, but the standard eight-string mandolin adapted as described can be very effective. The aperture under the strings must be large enough (or enlarged) to allow access for small fingers to fit the electronic components, including the pick-up, which spans the aperture. The photograph in Fig. 1 shows the prototype, which is a left-hand instrument; right-handed players should follow the component location instructions but keep in mind that their instrument will be a "mirror image". The switches, jacks and volume control for a right-hand instrument would be on the opposite side. The pick-up and all wiring connections will suit both types.

PICK-UP

A little information on pick-ups may be of interest before actually going into the constructional details. The fundamental item in any electro-magnetic pick-up is a permanent magnet with two "poles", one north, one south. These are not always easily recognised in the shape of some magnets, but the type of "button" magnet used in this modification (see components list) has two very prominent "poles" or stubs. If a yard or two of insulated wire is wound round one pole and a sensitive milliammeter is connected to the ends of the wire, the meter pointer or "needle" will remain motionless at zero. But if a steel or iron nail, screwdriver, or other steel object is touched on to the pole, the needle will "kick" one way or the other, showing that an electric current has passed momentarily through the wire around the pole. Remove the nail, and again the meter will kick, but in the opposite direction.

Now move the nail swiftly across the pole, very close but *not* touching; the meter needle will move in sympathy, showing that, as long as the magnetic field around the pole is interrupted, there will be an electric current induced in the wire.

Now we can see the basic guitar pick-up action. Instead of moving a nail across the pole, let us set a steel guitar string in vibration above the pole. Current will be generated in the wire, this current being related to the speed, or "frequency" at which the string passes to and fro over the pole. Since "frequency" is another name for a "musical note", the frequency of the pick-up signal current represents the note which is produced when the string is plucked. This current is fed into a powerful amplifier to obtain a larger "output" current, truly representative of the input or pick-up signal frequency, to drive a loudspeaker. The sound we hear from the loudspeaker is the same musical note produced by the string, but very much more powerful.

The pick-up used in this instrument follows the foregoing principles but the sensitivity is enhanced by having both poles of the magnet under the strings. In this way, the magnetic field is increased so that the vibration of the strings will generate a larger current in the pick-up winding. Magnets used are the button type (manufactured by James Neill & Co. (Sheffield) Ltd.), and are obtainable from ironmongers.

PICK-UP CONSTRUCTION

Obtain a piece of brass plate about 4in by 2in by $\frac{3}{32}$ in. The length will depend on the width of aperture in the mandolin and should be long enough to be bolted on either side of the aperture. Shape the plate as in Fig. 2 then draw a centre-line along its length to mark the positions of holes "a" and "b". Slip the plate under the mandolin aperture and mark on to the plate the position of each group of strings, while the plate is centrally positioned. In some mandolins it may be necessary to slacken the strings to insert the plate in the aperture. See that the strings are in their correct positions on the bridge before marking the string positions on the plate. Now mark the edge of the aperture on the left and on the right, and the foot of the aperture (i.e. side nearest the bridge); this should be very close to the edge of the plate.

Remove the plate. Place an "Eclipse" $\frac{1}{2}$ in diameter button magnet in turn above each pair of lines representing each group of strings. Stagger the magnet positions as shown in Fig. 2 to obtain clearance between magnets, and mark through the centre hole in the magnet. Remove the magnet. Halfway between the edge of the plate and the outline indicating the left-hand edge of the aperture, mark the position of securing hole "a". Treat the right-hand edge in the same way. Drill all of these marks, using a No. 32 drill, then tap the holes for 4B.A. screws.

Obtain four $\frac{1}{2}$ in by 4B.A. countersunk head screws to secure the magnets to the plate, and temporarily assemble the magnets. Mark and drill two holes $\frac{1}{16}$ in diameter, alongside the two outer magnets at positions "c" and "d" to carry connecting wire. (See Fig. 2.) Place the magnet assembly in position *above* the aperture and mark through the securing holes "a" and "b" on to the mandolin. Remove the assembly and drill the mandolin for 4B.A. clearance (No. 26 drill) where the plate is to be attached.

MAGNET HEIGHT

Tighten the two outermost strings until just taut. Slip the magnet assembly under the wires and into the

aperture, holding it firmly against the inside of the body and in its intended position. (Assistance may be required during the next step.) With the magnet assembly firmly held, press the nearest outer string on to the fret wire nearest the magnets and note the gap between string and magnet. If the gap exceeds $\frac{1}{16}$ in packing will be required between magnet and plate. Check the magnet gap at the other outer string, whilst pressed on to the fret wire, and again determine whether packing is wanted. Remove the magnet assembly, dismantle the magnets, and by adding washer(s) between magnet and plate raise the magnets as required. When finally assembling the magnets, note that one side of a magnet tends to pull towards its neighbour but the other side will not "stay put" and turns away. Fit the magnets so that the repelling sides (like poles) are adjacent; this prevents a magnetic "short-circuit".

WINDING

Pass a turn of self-adhesive tape round one limb of each magnet to prevent the wire being damaged on the corners of the magnet. Using 30 s.w.g. enamelled copper wire, pass about eight inches of the wire through hole "d" alongside the right-hand magnet. Small grommets or sleeving should be used on the end to prevent chafing on the plate. Wind 50 turns on one limb of each magnet, observing the winding direction shown in Fig. 2. Add a touch of glue to each winding and around the sleeving to prevent them coming adrift, then leave the assembly to set. While the glue is setting, a cover for the magnets can be formed from 24 s.w.g. sheet brass bent into a U-shape. The top of the

Fig. 1. Left-handed mandolin modified for use with the P.E. Guitar Amplifier

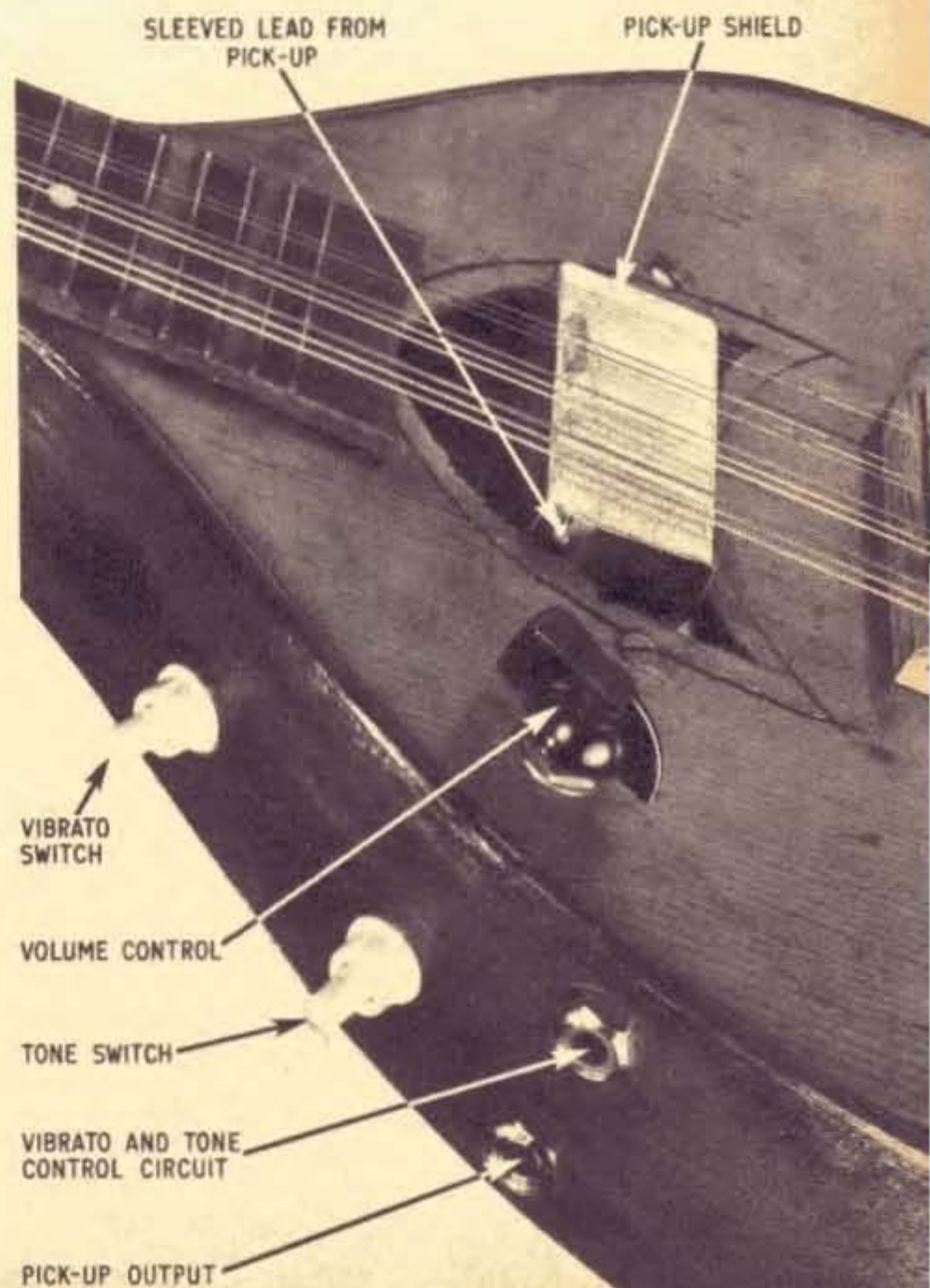

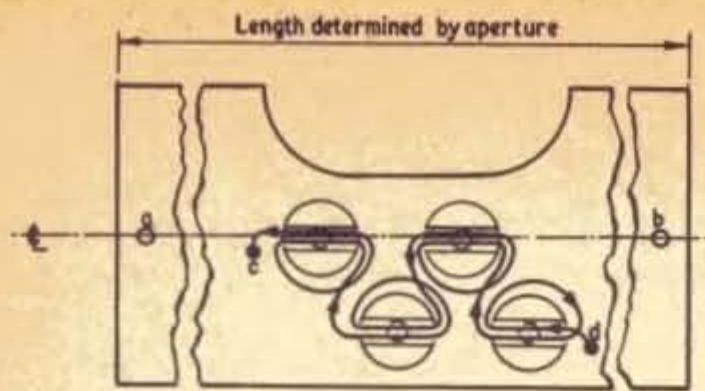

Holes 'a' and 'b' tapped 4BA also holes for magnet fixing screws
Holes 'c' and 'd' to take sleeving protecting ends of winding

Fig. 2. Brass plate with the magnets mounted and winding direction shown

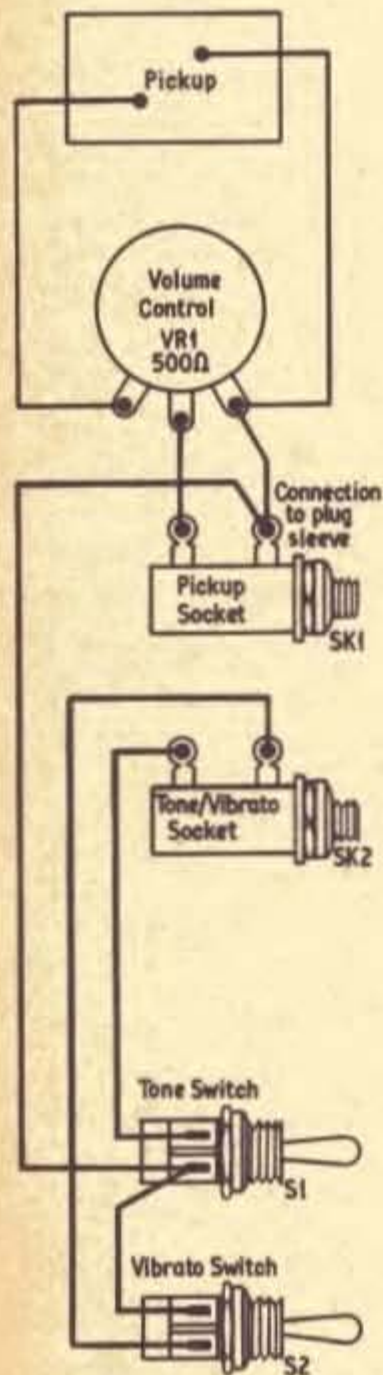

Fig. 3. Wiring diagram of the components inside the mandolin body. If not used with the P.E. Guitar Amplifier, omit SK2, S1, and S2

NOTE: S1 is a bass boost control; no treble boost is provided because the mandolin is naturally high in treble content

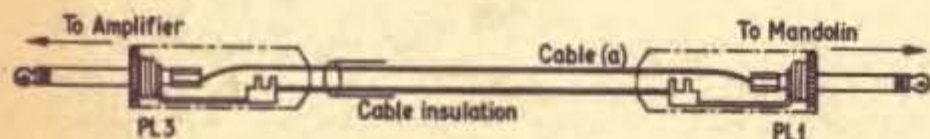

Fig. 4a. Cable connections from PL1 (pick-up) to PL3 (amplifier input)

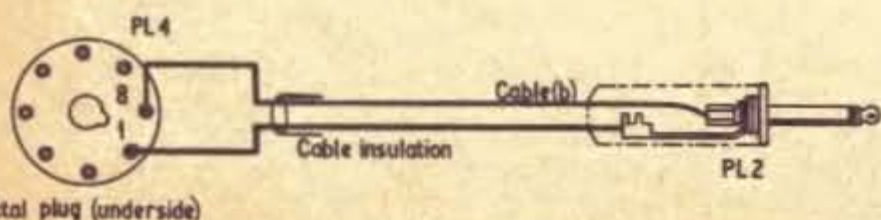

Fig. 4b. Cable connections from PL2 (tone/vibrato) to PL4 (amplifier circuit)

U can be allowed to rest on the magnets, and the limbs of the U held to the assembly plate by soldering at four points. Polish the surface of the cover and apply a clear lacquer (or "banana oil" from a model shop).

WIRING

If the mandolin is to be used with the guitar amplifier described in the February 1965 issue, you will need in addition, two jacks with plugs, two toggle or push-switches, and one volume control. If the mandolin is to be used with a different amplifier, you will need only one jack with plug and the volume control.

The prototype shows the controls on the left for a left-handed player; for a right-handed player, the sockets and switches will be on the right-hand side of the mandolin body, and the volume control on the right of the strings, i.e. the mirror image of the layout shown in Fig. 1.

When cutting holes for the controls, use a twist-drill, not a "wood-cutting" bit, as the latter may splinter the veneer or split the top surface; loosen all strings so that the top surface is free from strain. Position the volume control so that the knob can be readily turned by a finger when the hand is in a playing position. The switches should also be easily operated without noticeable delay when playing. Hole dimensions are not given since they depend on the actual components used.

Connect the components as shown diagrammatically in Fig. 3, leaving sufficient wire between them to allow fitting in their allotted positions. Check each connection by tugging fairly firmly. If the wire comes away easily, a "dry" joint is evident; the wire will have to be reconnected and soldered properly. When assured that all joints are sound, fit the components into the mandolin, leaving the wires from the volume control, for connection to the pick-up, emerging from the aperture. Now fit the pick-up in position; chrome finish countersink head screws are quite effective on a polished surface. Slip a 1 in piece of sleeving on to one wire from the volume control, about 1/4 in of the end of this wire and about 1/2 in of one of the pick-up wires. Twist these wires together along their lengths, solder the connection, then slip the sleeve over the connection. If the sleeve is loose, a spot of glue will keep it in place. Treat the other pick-up and volume control wires similarly, then tuck them back inside the mandolin body. This completes the mandolin, apart from tightening and tuning the strings.

Two unscreened twin-wire cables taped together at intervals (or one 4-wire cable), carry the pick-up output and the vibrato and tone control circuits. These should be connected as shown in Fig. 4. The drawings are based on the use of the PRACTICAL ELECTRONICS guitar amplifier with the modification described elsewhere in this issue. Only one cable is required (cable (a) in Fig. 4a) if the mandolin is used on other amplifiers, but a 50:1 matching transformer is necessary if the amplifier has no low impedance input socket. Fig. 5 illustrates a matching transformer with a jack plug to connect it to a commercial amplifier.

continued on page 451

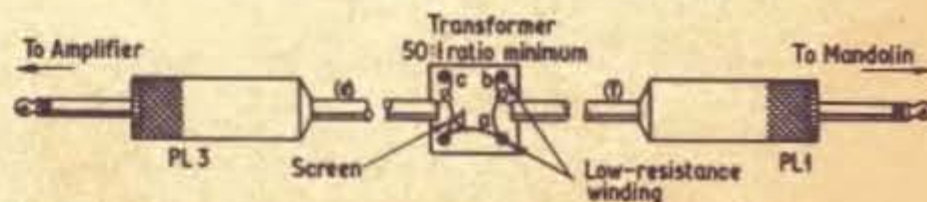

Fig. 5. Alternative wiring of PL1 and PL3 using a 50:1 matching transformer for a high impedance amplifier

WHY NOT VISIT THE NEW KEDECO SHOWROOM at 76 VICTORIA ROAD, SWINDON?

KEDOCO CLASSIC 20 WATT TRANSISTORISED AMPLIFIERS NOW AVAILABLE IN THREE ALTERNATIVE DESIGNS



SS20/7 £9.19.6

The now well proven model as illustrated comprising pre-amplifier measuring 4.7" x 2.3" and main amplifier measuring 4.5" x 4" both mounted on base plate and supplied complete with bass, treble and volume on/off controls.



SS20/8 11 GNS

A de luxe version complete in itself and ready to mount into your cabinet. Supplied with three controls mounted on the front of the stove enamelled chassis and has moulded plastic and spun aluminium control knobs fitted as standard. A tag strip mounted on the back of the chassis in addition to facilitating the L/S and H.T. connections provides separate inputs for crystal, ceramic cartridge, magnetic pick-up, radio and tape recorder. The max. dimensions of the whole unit are 6 1/4" x 9 1/4" x 2".

SS20/9 19 GNS

A beautiful table model version with its own power supply and in keeping with the modern trend to build hi-fi systems from self contained separate and compact units. Ready to operate and to connect to tape, gram and radio via coax sockets at the back of the cabinet. The amplifier and power supply are housed in an attractive pressed steel case finished in a subdued grey stoved enamel and embellished with a gilt brushed aluminium front panel engraved and displaying the four controls. Treble, bass, volume on/off and three position input selector. Cabinet measurements 12" x 6.5" x 2.1".

TECHNICAL SPECIFICATION

All three models employ similar circuits, have the same electrical specification and are fully transistorised. Six silicon planar transistors and two germanium power. Two diodes. All have benefits of negligible noise and distortion, high efficiency, low power consumption, compact design and no warm up time when switching on. The amplifiers are D.C. coupled throughout (no distortion) and there is a transformerless coupled output having a very low output impedance. Power output, 20 watts peak into 3 ohm speaker. Input impedance, selected to suit input. Output impedance, 0.25 ohms. Bass boost, 12 dB at 100 c/s max. Treble boost, 12 dB at 16 Kc/s max. Distortion 0.1% typical. Frequency response, 16 c/s to 20 Kc/s. Noise, 80 dB down on max output. Power requirements, SS20/7 and SS20/8 only. 20 mA quiescent. 3 amps peak. 30 volts.

UNDOUBTEDLY

THE FINEST RANGE OF TAPE RECORDER EQUIPMENT ON THE MARKET TODAY

THE COMPLETE 12 VOLT SYSTEM

TAPE PRE-AMP SSTR/7

All silicon transistor. Zero hum. High gain and equalised at 7 1/2" per sec. to give flat response output. Simple mod. described in accompanying instructions allows equalisation at all speeds. Suitable for all medium impedance heads. Dimensions 40 x 50 x 15 mm. **ASSEMBLED 29/6**

Record pre-amp SR/8 couples SSH/9 to ribbon and dynamic mic. High gain all silicon transistor. **29/6**

MINICLASSIC PRE-AMP SSPA/50

Tone controlled high gain preamplifier designed specially for application with the SS3/10. All silicon transistor. Zero hum, requires 12 volt + H.T. Dimensions 70 x 40 x 35 mm. Separate inputs for crystal 70 x 40 x 35 mm. ceramic cartridge and radio. **ASSEMBLED 42/-**

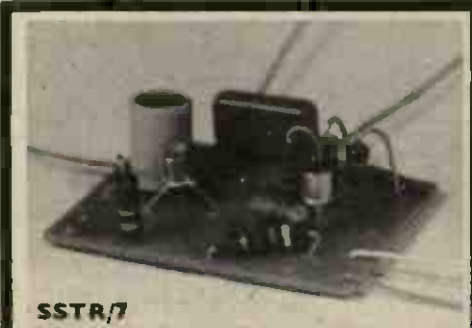

SSTR/7

MINICLASSIC SS3/9 AND SS3/10

Two high fidelity amplifiers providing adequate power for normal domestic listening or portable equipment. The SS3/9 is the more powerful and provides a maximum of 6 watts into a 3 ohm speaker. The SS3/9 provides 4 watts into 3 ohms and has the advantage of working from a 12 volt rail. Specification: Frequency response, 16 c/s to 30 Kc/s. Input Sensitivity 1 volt. Both will operate directly from crystal pickup and make complete tape amplifier with SSTR/7. 6 transistor 2 diode. HT+ SS3/9 18 volt. SS3/10 12 volt. Dimensions 50 x 105 x 22 mm. **ASSEMBLED 69/-** Both models

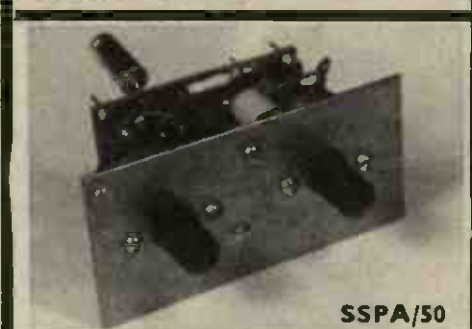

SSPA/50

TAPE OSCILLATOR SS013

Complete unit incorporating push pull silicon transistor oscillator giving adequate erase power and recording bias. The only unit on the market at such an economical price. Ferrite pot core oscillator. Frequency 50-60 Kc/s. Unit also provides high voltage D.C. rail for the record amplifier. A high efficiency oscillator operating from 12 volt supply at approx. 250 mA. **COMPLETE 69/6**
Dimensions 90 x 54 x 35 mm.

RECORD AMPLIFIER SSH9/3

Fully transistorised. High voltage H.T. rail derived from oscillator. Provides substantially constant current record signal. 1 volt input sensitivity. Input impedance 5 k. Power requirements 1 mA 75 V. derived from SS013 and 1 mA 12 V. This is a gain stabilised low distortion circuit. Dimensions 45 x 40 x 20 mm. **ASSEMBLED 45/-**

KEDOCO COMPONENTS

A COMPLETE RANGE TO SATISFY ALL YOUR NEEDS

ZENER DIODE

Silicon planar diffused units featuring very sharp knee. Type No. specifies voltage. KZ5.1
Types KZ7.5, KZ5.6
KZ8.2, KZ6.2
KZ9.1. KZ6.8
10% tolerance.
Slope resistance nominally 10 ohm at 5mA, I_Z.
Dissipation 250 mW
Temperature coefficient 0.01% per degree C.

3/11 each

POWER SUPPLIES

30 volt, 3 amp. Ready built and ideal for your Kedoco Classic and will power 2 of them. **69/6**

18 volt 1 amp 59/-
12 volt 1 amp 59/-

PLANAR EPITAXIAL SILICON TRANSISTOR GOLD PLATED, ALL WELDED

Double diffused npn. Suitable from audio to RF power applications. I_{CO} less than 100 nA. B_{VCEO} greater than 20 volts. Power output at 28mc/s typically 300mW. Emitter/base breakdown voltage greater than 5 volts. Typical F_T 300 mc/s. h_{FE} KPS 24 min. h_{FE} 20 KPS 25 min. 50. KPS 26 and 27 are two special low level transistors specially designed for front end amplification. h_{FE} at I_C = 200µA, 25 and 40 min. respectively.

KPS 24
7/11
KPS 25
9/11
KPS 26
12/-
KPS 27
16/6

RADIO MICROPHONE

80-100 mc/s. F.M. Proven performance. A quality product. Professionally engineered. All silicon transistor. Dimensions 20 mm. x 55 mm. x 45 mm. Ideal for stage work, intercom, broadcast clarity and remarkable sensitivity.

SS007 (standard power) £9.9.0
SS008 (increased power) £13

TV/FM BOOSTER

WHY PUT UP WITH A WEAK PICTURE. Suitable for Bands 1 and 2. Battery operated.

Dimensions 80 x 50 x 20 mm. **32/3**
COMPLETE

Mains operated model housed in steel case and covering Band III in addition. Dimensions 60 x 20 x 45 mm. 45/-

BOOK

Theory and applications of planar epitaxial transistors. Explains significance of these new transistors and gives many interesting circuits. **3/11**

RESISTORS 1/2 watt HYSTAB
4.7Ω, 10, 27, 100, 150, 270, 470, 1K, 1.5K, 2.2K, 3.3K, 4.7K, 10K, 15K, 18K, 24K, 33K, 56K, 100K, 330K, 560K, 1M. **5d. each**

ELECTROLYTIC CAPACITORS
8µF, 10µF, 30µF, 50µF, 100µF. 15V. **all at 1/3 each**

MYLAR CAPACITORS
1,000 pF, 2,000 pF, 6d. 5,000 pF and 0.1 µF
7d. 0.02 µF, 9d. .05 µF, 10d. 0.1 µF, 1/-.

ORDER FORM: To KEDOCO ELECTRONICS, Sales and Mail Order Dept.: 76 VICTORIA RD., SWINDON, WILTS.

PLEASE SUPPLY _____

ADDRESS _____

Enclose Cheque/P.O. for Postage 2/6 extra for all orders under £1

All KEDOCO products are fully guaranteed and should you not be completely satisfied with your purchase we will gladly refund your money if your purchase is returned within seven days of receipt.

BARGAIN XTAL PICK-UP ARM Complete with ACOS LP-78 Turnover Head and Stylus 20/-; Stereo 30/-
SPEAKER FRET Tygan various colours, 52in. wide, from 10/- ft.; 26in. wide from 5/- ft. **SAMPLES S.A.E.**
EXPANDED METAL Gold or Silver 12 x 12 in. 6/-

FULL WAVE BRIDGE SELENIUM RECTIFIERS:
 2, 6 or 12 v. outputs, 1 $\frac{1}{2}$ amp., 8/9; 2 a. 11/3; 4 a., 17/6.
CHARGER TRANSFORMERS. Tapped input 200/250 v. for charging at 2, 6 or 12 v., 1 $\frac{1}{2}$ amps., 15/6; 2 amps., 17/8; 4 amps., 25/-. Circuit included. Amp meter 5 amp., 10/6.

MOVING COIL MULTIMETER TK 25.	47/6
0-1,000v. A.C./D.C., ohms 0 to 100k. etc.	
MOVING COIL MULTIMETER EP10K.	79/6
0-1,000v. A.C./D.C., ohms 0 to 3 meg. etc.	
MOVING COIL MULTIMETER EP20K.	99/6
0-2,500v. D.C. 20,000 ohms per volt, 0-1,000v. A.C. Ohms 0 to 6 meg. 50 Microamps full scale.	

NEW MULLARD TRANSISTORS
 OC71 6/-; OC72 7/6; OC81D 7/8; OC81 7/6; AF115 10/6;
 AF114 11/-; OC44 8/-; OC45 8/-; OC171 9/-; OC170 8/6;
 AF117 9/6. OC26 12/6; Transistor Holders 1/3.

VALVE HOLDERS. EA50 6d. MOULDED Int. Oct. 6d. Mazda Oct. 6d.; B7G, B8A, B8G, B9A, 9d.; B7G with can 1/8. B9A with can 1/9. Ceramic OCTAL, EF50, B7G, B9A, 1/- Valve base plugs B7G, B9A, Int. Oct., 2/3.

TRANSISTOR MAINS ELIMINATORS 29 6
 PP1-8 volt, PP9-9 volt (All same sizes as batteries) 80 mA.
DOUBLES 42/6. PP1+PP1, PP9+PP9, PP11-4 $\frac{1}{2}$ +4 $\frac{1}{2}$.
POWER PACK 9v. 300 mA. Full wave. Fully smoothed. Tapped mains input. Chassis size 5 x 4 x 2 in. 45/-.

WEYRAD P50 — Transistor Coils
 RA2W 6 in. Ferrite Aerial Spare Cores..... 6d.
 with car aerial coil..... 12/6 Driver Trans. LFDT4..... 9/6
 Osc. P50/1AC..... 5/4 Printed Circuit, PCA1. Ready
 1st and 2nd I.F. P50/2CC drilled and printed..... 9/8
 470 kc's..... each 5/7 J.B. Tuning Gang..... 10/8
 3rd I.F. P50/3CC..... 6/- Booklet..... 2/-

Volume Controls 80 Ohm Coax 6d yd.
 Long spindles. Midget Size Semi-air spaced Cable
 5 K. ohms to 2 Meg. LOG or 40 yd. 17/8. 60 yd. 25/-
 LIN. L/S 3/-. D.P. 5/- Low loss 5dB. per 100ft.
 Stereo L/S 10/8. D.P. 14/8. at 500 mc/s.
 Linear or Log Tracks. Ideal 625 lines 1/6 yd.

COAXIAL PLUG 1/-. PANEL SOCKETS 1/-. LINE SOCKETS 2/-.
OUTLET BOXES, SURFACE OR FLUSH 4/6.
BALANCED TWIN FEEDERS 6d. yd., 80 or 300 ohms.
TELESCOPIC CHROME AERIALS. 12in. extends to 33in. 6/8 each. **CAR AERIAL PLUGS 1/8.** Sockets 1/3.

RETURN OF POST DESPATCH Minimum P.P. Charge 1/6 per order unless otherwise stated. Full List 1/-, C.O.D. 2/6 extra. **CALLERS WELCOME**

RADIO COMPONENT SPECIALISTS

337 WHITEHORSE ROAD,
WEST CROYDON Telephone
 THO 1665

Written guarantee with every purchase. (Export. Send remittance and extra postage, no C.O.D.) Buses 133, 68 pass door. S.R. Stn. Selhurst.

1966 GRAM CHASSIS



Three Wavebands: Long., Med., Short. Five Valves: ECH81, EF89, EBC81, EL84, EZ80.
 12-month guarantee. A.C. 200-250 v. Ferrite Aerial A.V.C. Negative Feedback. 5 watts 3 ohm. Chassis 13 $\frac{1}{2}$ in. x 7in. high x 5in. deep. Glass dial size 13in. x 4in. horizontal wording. Two Pilot Lamps. Four Knobs. Aligned calibrated. Chassis isolated from mains.

BRAND NEW £10.10.0 Post Free
 With SPECIAL 12in. BAKER loudspeaker £15.10.0

STEREO RADIOGRAM CHASSIS £14.19.6 Post 5/6
 With Long, Med. and Short Wavebands, 15in. x 7in. x 9in.

HIGH GAIN TV. PRE-AMPLIFIER BAND I B.B.C.
 Tunable channels 1 to 5. Gain 18 dB. ECC84 valve. Kit price 32/8 or 55/- with power pack. Details 6d. (PCC84 valves if preferred for 0.3a heater chains).
BAND III I.T.A.—same prices. Tunable channels 7 to 13. Band I or III. Coils and circuit only, 9/6. Chassis 4/9. B.B.C. 2 Super Booster transistor model. Ready built 75/-.

BLANK ALUMINIUM CHASSIS. 18 s.w.k. 2 $\frac{1}{2}$ in. sides. 7 x 4in. 5/6; 9 x 7in. 6/8; 11 x 3in. 6/8; 11 x 7in. 7/6; 13 x 9in. 9/8; 14 x 11in. 12/6; 15 x 14in. 15/-.

ALUMINIUM PANELS 18 s.w.k. 12 x 12in. 5/6; 14 x 9in. 4/6; 12 x 8in. 3/8; 10 x 7in. 2/9; 8 x 6in. 2/-; 6 x 4in. 1/6.

NEW GARRARD GRAM MOTORS

also suitable for models, tape decks, fans, etc.
 100-130 v. A.C. 15/- pair for 200/250 v. (in series)

B.S.R. TAPE DECK AMPLIFIER T.D.2

With Pre-Amplifier, Oscillator, all valves, "magic eye" tuning indicator, matching 7" x 4" loudspeaker and crystal microphone. 4 watt. 3 stage amplifier especially built for B.S.R. T.D.2. Tape Deck. Bolts directly to tape deck chassis. Only six connections to solder. Inputs for mike and radio/gram. Output 3-5 ohms. A.C. 200/250v. Ready built. PRICE £8.15.0.

B.S.R. T.D.2. TAPE DECK £8.15.0. CABINET £3.10.0.

★ RADIO BOOKS ★ (Postage 9d.)

At a glance Radio Valves and T.V. Tube equivalents ... 8/-
 Radio, T.V. Valves, Diodes, Transistor equivalents ... 10/6
 Mullard Maintenance Manual ... 16/-
 High Fidelity Speaker Enclosures and Plans ... 5/-
 Transistor Superhet Commercial Receivers ... 7/8
 Mullard Audio Amplifier Manual ... 8/6
 Radio Valve Guide, Books 1, 2, 3, 4, or 5 ... each 5/-
 Practical Radio Inside Out ... 4/8
 TV Fault-Finding, fully illustrated ... 6/-
 Transistor Audio Amplifier Manual ... 6/-
 Shortwave Transistor Receivers ... 5/-
 Transistor Communication Sets ... 6/-
 International Radio Stations List ... 2/8
 Modern Transistor Circuits for Beginners ... 7/8
 Sub-Miniature Transistor Receivers ... 5/-

JACK SOCKETS Std. open-circuit 2/6, closed-circuit 4/6. Lead Socket 6/-, Grundig 3-pin 1/3; Lead 3/6.

Phono Plugs 1/-. Socket 1/-. Banana Plugs 1/-. Sockets 1/-.
JACK PLUGS STANDARD. Screened 3/-. Grundig 3-pin 3/6.
BULGIN NON-REV PLUGS and SOCKETS. P74 2-pin 4/3; P73 3-pin 4/6; P194 6-pin 6/6; P468 6-pin 12/6; P360 4/-.

RESISTORS. Preferred values, 10 ohms to 10 meg. 1 w., 1 w., 20%, 4d.; 1 w., 8d.; 2 w., 1/-; 1 w., 10% 6d.

HIGH STABILITY. 1 w., 1%; 2/- Preferred values. 10 ohms to 10 meg. Ditto 5%, 10 ohms to 22 meg., 9d.

5 watt { 0.5 to 8.2 ohm 3 w. 1/8
 10 watt { WIRE-WOUND RESISTORS 1/9
 15 watt { 10 ohms to 6,800 ohms 2/-

10K, 15K, 20K, 25K, 10W. 3/-

MAINS DROPPERS. Midget. With sliders. 0.3 a., 1K. 0.2 a., 1.2 K., 0.15 a., 1.5 K., 0.1 a., 2 K., 6/- each.

LINE CORD 100 ohms ft. twin plus resistance. 1/- ft.

WIRE-WOUND 3-WATT WIRE-WOUND 4-WATT
 POTS. Miniature T.V. STANDARD SIZE POTS

Type. All values 10 ohms LONG SPINDLE VALUES
 to 25 K., 3/- ea.; 30 K. 4/-; 50 OHMS to 50 K., 8/6;
 Carbon 30 K. to 2 meg., 3/-; 100 K. 7/8.

ARDENTE TRANSISTOR TRANSFORMERS

D3035, 7.3 CT : 1 Push Pull to 3 ohms for OC72, OC81 ... 11/-

D3034, 1.75 : 1 CT. Push Pull Driver for OC72, OC81 ... 11/-

D3058, 1.75 : 1 Output to 3 ohms for OC72, OC81 ... 11/-

D239, 4.5 : 1 Driver 11/6; D240, 8.5 : 1 Driver ... 11/6

ARDENTE TRANSISTOR POT. 5 K. switched VC1545 5/8

Anti-Parasitic beads (ferrite) ... doz. 3/8

PRINTED CIRCUIT ETCHING KIT & 20 Circuits ... 7/8

C.R.T. BOOSTER TRANSFORMERS

for heater cathode short circuit or tubes with failing emission. Full instructions supplied, mains input. Optional 25% and 50% boost 2v. or 6.3v. or 12.6v. State voltage required. PRICE 15/6

'SERCEL' DIOTESTOR



The DIOTESTOR detects faulty diodes and transistors when still in circuit without need for unsoldering.

BRITEC LIMITED

17 Charing Cross Road, London, W.C.2
 WHitehall 3070

Stand N312A, I.E.A.
 OLYMPIA 23-28 MAY

ABC's of SILICON CONTROLLED RECTIFIERS

by Lytel. 17/-

THE RADIO AMATEUR'S HANDBOOK 1966, by A.R.R.L. 43/-

PROXIMITY DETECTORS AND METAL LOCATORS, how to build, by Shields. 21/-

KNOW YOUR SIGNAL GENERATORS, by Middleton. 21/-

KNOW YOUR TEST METERS (VOM-VTVM), by Risse. 22/-

TRANSISTORS IN LOGICAL CIRCUITS, by Altes. 17/-

UNDERSTANDING DIGITAL COMPUTERS, by Benrey. 17/-

PRACTICAL TRANSISTOR SERVICING, new ed. by Caldwell. 25/-

SERVICING ELECTRONIC ORGANS, by Pittman. 31/-

SOLID STATE POWER SUPPLIES AND CONVERTERS, by Lytel. 21/-

TRANSISTOR CIRCUITS FOR RADIO CONTROLLED MODELS, by Boys. 8/3

All prices include U.K. postage

Where possible 24-hour service guaranteed

UNIVERSAL BOOK CO.

12 LITTLE NEWPORT ST., LONDON, W.C.2
 (Leicester Square Tube Station)

MINIY TRANSCEIVER



Push-button operation; crystal control. Fully transistorised (3-transistor circuit) for perfect reception. Tremendous commercial scope. Complete with carrying strap, battery and 8-section antenna. Uses 9v PP3 battery and operates up to half mile in open country. Measures 5 $\frac{1}{2}$ in. x 2 $\frac{1}{2}$ in. x 1 $\frac{1}{2}$ in. Frequency 27-125 Mc/s.

ONLY £6.19.6 pair

(Post & Insurance 4/6)

These sets cannot be operated in the U.K.

NICKEL CADMIUM Rechargeable Cells

No corrosion, no gassing, no maintenance. Why keep buying batteries when you can purchase one of the new rechargeable nickel cadmium cells which pay for themselves over and over again? Charging units available.



Equiv. PP3 37/-, U7 12/6, PP9 £6.5.0, U2 £1.12.6, U11 £1.1.6 (P & I 2/3 on each)

TELEVISION AERIAL

for fringe-area B.B.C.-2
 More and more areas are able to receive BBC-2, and here's your chance to purchase a famous-make 11 reflectors fringe aerial at Trade price. For loft or roof fixing. Limited stocks so hurry! State channel required and nearest transmitter. Only 45/- (P. & I. 5/-). Co-axial cable 1/6 yard. Set of sockets 2/6.

All Post orders to: **ELECTRAMA** Dept. PE11
 Dormers · Windmill Hill · Hailsham · Sussex
 Tel.: Herstmonceux 3276

SEEING THROUGH FOG

By L. M. COZMAN B.Sc.

THAT electronic science, in its present stage of development, can find a perfect solution for the apparently insoluble problem of fog will be seen in the device described in this article, by means of which objects at distances of miles away can be clearly seen through fog. It is a fog-vision-penetrator representing a radical departure from used methods of obtaining optical images of remote objects through fog.

Not only is the device characterised by very wide range, but it has also the following advantages:

(a) Very light weight, to be measured in ounces, and this makes it suitable even for pedestrian use in the form of a pair of spectacles, not heavier than those employed at present for hearing aid purposes.

(b) It dispenses completely with vacuum tubes or transistors, with their amplifying noise concomitant and, instead, makes use of a new, very efficient system of amplification by feedback based on what is called the *suspensoid cell*, which is composed of a very thin layer of colloidal graphite situated between two layers of conductive glass in an electrostatic field.

(c) Though the device is so very tiny, it is actually a television transmitter and receiver in which the scanning procedure is eliminated, all the picture elements being reproduced simultaneously on a mosaic consisting of a very large number of very small suspensoid cells.

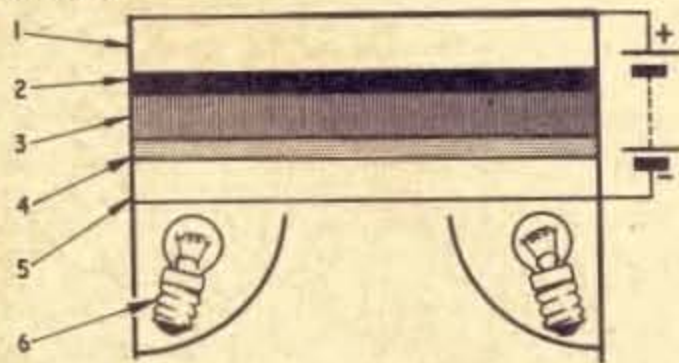

Fig. 1 (above). This cross-sectional view shows the build-up of the fog penetrator device

Fig. 2 (right). The device in use. The scene would be "illuminated" by a lamp having a high output in the infra-red region

DESCRIPTION OF THE DEVICE

The essential features of this device are clearly shown in Fig. 1 and Fig. 2.

A conductive glass disc 1, which in addition to being transparent to the infra-red rays and thereby passing them on to the photo-conductive semiconductor layer 2 on its back surface, puts the semiconductor layer 2 in electrical connection with the positive side of a d.c. source of suitable voltage. The layer 2 is in touch with a mosaic 3 of a very large number of very small pieces of conductive glass, bound together and separated electrically from each other by an insulating adhesive. A disc 5 of conductive glass is transparent to visible light rays falling on it from two lamp bulbs 6, and also serves as the h.t. path.

Between the mosaic 3 and disc 5 is a very thin layer 4 of colloidal graphite crystals suspended in an insulating liquid, for example, thin mineral oil. An infra-red image is projected on to the disc 1 by any suitable means, illustrated as a lens L in Fig. 2. The mosaic 3, layer 4 and disc 5 together form the *suspensoid cell*.

METHOD OF OPERATION

The apparatus functions as follows: An image of the scene, by infra-red rays, is projected on the layer 2 through the transparent glass 1. Each element of the semiconductor layer will have its electrical resistance decreased by an amount that is proportional to the intensity of the impinging rays, and thus the surface of the semiconductor layer 2 in touch with the pieces of conductive glass in the mosaic 3 will be nearer to or further from the full h.t. voltage of the source according as the intensity of the rays is high or low. In this way, an electrical image is built up on the undersurface of the layer 2 that corresponds to the infra-red image.

The mosaic 3 is made up of small pieces of conductive glass that are insulated from each other, so that there will be no mixing-up of electrical charges in the elements of the semiconductor layer 2 which they touch. The graphite, though in minute particles, retains its characteristic plate-like crystalline form. An electric charge acting on a graphite crystal will be accompanied by lines of force, and the graphite crystals will tend to set themselves along these lines of force, just as small pieces of paper tend to stand on end when dropped on to a charged metal plate.

The rotation of the graphite crystals, from their haphazard arrangement to "end-on" positions, will depend upon the voltage on the corresponding element of the semiconductor layer 2, which is transmitted

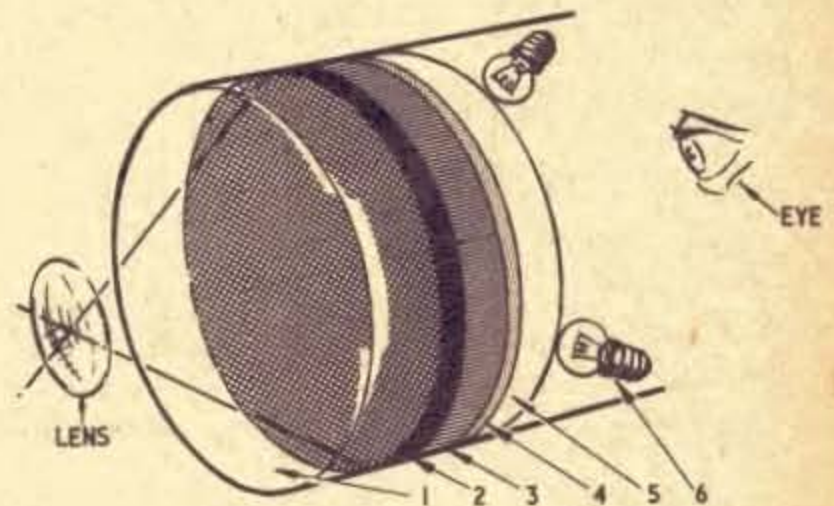

to the layer 4 through the touching pieces of conductive glass in the mosaic 3. The rotation will be most complete where the voltage is greatest, that is, for the most intense parts of original scene; and will effect almost complete parallel orientation of the crystals to transform parts of the liquid suspensions from opacity to transparency. Intermediate voltages will give rise to intermediate orientations of the crystals and correspondingly intermediate transparencies. Thus the suspensoid cell converts the electrical image into corresponding degrees of transparency.

When the electric lamp bulbs 6, are switched on, a light-reversed image of the original scene can be viewed by looking into the glass disc 5. The light is reversed, i.e. the dark parts in the scene appear bright through the disc 5 because the highest transparency in the suspensoid cell is attained for those parts of the scene that are brightest.

This device is specified in British Patent No. 996,414.

the 73 page

by Jack Hum
G5UM

"Seventy" is Special

On this page last time we began a review of the peculiarities—and qualities—of the various v.h.f. and u.h.f. bands which are allocated to the

communication sub-band, planned geographically exactly as "Two" is, with the Home Counties in the middle, the North at the top and the West Country operators at the bottom.

Another practical advantage of regarding 432 to 434Mc/s as the communication "sub-band" is that two metre transmitters, by dropping their third harmonics within it, can be used as drivers for 70 centimetre stages.

Next up from "Seventy" is "Twenty Three". Here again convenience decrees that 432Mc/s output stages shall be used as drivers for this u.h.f. area, which in consequence discloses much activity centred around 1,296Mc/s.

Although the 23 centimetre band is "very line of sight", communication well over the hundred mile range and indeed into the continent of Europe has been recorded on many occasions. Truly, the challenges offered by this quite "difficult" band have been met and overcome by the ingenuity and enthusiasm of the British transmitting amateur.

Still more formidable challenges are offered by the "ultra highs" beyond "Twenty Three", but as yet occupancy there is only minimal.

persons able to show that they have passed both the Radio Amateurs' Examination and the morse code examination (the latter at 12 words a minute).

For "Sound Licence B" a pass in the Radio Amateurs' Examination alone is required. Morse is not. In fact, its use is forbidden! But Sound Licence B permits operation only in the 427-450Mc/s band and in the bands higher in frequency still, and its holders are allocated the special "G8-plus-three letter" call-signs that identify them as u.h.f. men.

Advanced Technology

To date, over three hundred call-signs in this sequence have been allotted to three hundred persons who, with their eyes open and their wits about them, know that if they are to go on the air at all they need to master the fairly formidable difficulties of engineering a transmitting station capable of receiving and sending on the "ultra highs" to which they are confined.

It is jejune to argue that in half the time it takes to organise such a station the experimenter could have mastered the morse code and qualified himself for a full licence. Many don't want to! The sheer satisfaction of taming the recalcitrant "ultra highs" is to them its own reward.

The impact of the G8-plus-threes on the u.h.f. scene in Britain has been remarkable. For many years before their advent in 1964, Seventy Centimetres was a barren waste unattractive by reason of the technical problems which it posed except to the few persistent enough to try to break them down. Now, with "Sound Licence B" men much in evidence, it is possible to work in one day as many stations as once could be worked in a week—or even in a month.

And on the still higher "ultra highs" quite difficult development work goes on in the confident knowledge that the lone-wolf days are over and that there really will be someone—probably a G8-plus-three—at the other end ready to share the fruits of the labours.

You don't need morse to get a Sound Licence B, but you *do* need a great deal of know-how!



Examples of QSL Cards sent out by holders of Sound Licence B to confirm communication in the ultra high frequency spectrum

Amateur Service. Here indeed is a subject of vast extent, and it was not surprising that space ran out by the time we had dealt with the four metre and two metre bands—and long before we had begun consideration of the next band up, 70 centimetres ("up" in terms of frequency!).

It may truly be said that "Seventy" is a rather special band, but before we go on to saying why, it is as well to remind readers that, as was shown in last month's diagram, the 70 centimetre band extends from 427 to 450Mc/s, and that a segment from 432 to 434Mc/s has been voluntarily adopted by amateurs as a communi-

The "G8" Plus Threes

We said above that "Seventy" is special. This goes also for all the frequency bands above it; for it is to these allocations that the new "G8-plus-threes" are confined. Who are the "G8-plus-threes"? They are the holders of what the G.P.O. calls quite simply "Sound Licence B", but which is fancifully dubbed "Technicians Licence", the "Morseless Licence" and one or two things besides which bear little relationship to the true situation.

"Sound Licence A" is the licence which the Post Office will grant to

the 73 page



EXPERIMENTS in LOGIC DESIGN

by S. T. ANDREWS

The purpose of this series is to demonstrate the use of switching and logic circuits for arithmetical calculation.

A brief description of some of the basic circuits will be given, both in theory and practice. Various ways of using these circuits will be discussed, leading up to the design of a binary adding unit.

Then will follow the development of additional circuitry needed to extend the facilities of the simple adder in order to perform the further operations of subtraction, multiplication and division.

To begin with, it is convenient to discuss certain basic switching and logic circuits individually, keeping each type as simple as possible. As far as possible each circuit should be compatible with all the others, both in respect of power requirements and input and output impedances and signal amplitudes; then one unit can feed directly into another and so large-scale networks can be built up.

The first two circuits to be mentioned are the so-called "AND" and "OR" gates or circuits. These can be represented by a "black box" as in Fig. 1.1a. In the case of an OR circuit, a signal is generated at the output when there is a signal present at either input 1 or input 2, hence the name of the circuit. With the AND circuit, a signal is generated at the output only when there is a signal present at input 1 and a signal at input 2, simultaneously. Again the derivation of the name is obvious.

A signal, in this general description, can mean a voltage pulse across the input, or a sudden pulse of current, or both. A convenient way of representing these circuits on paper (but by no means the only way) is to draw a circle and write inside it the minimum number of input signals required for an output to be produced. Thus Fig. 1.1b needs only one input signal to produce an output, so this is the symbol for an OR. Similarly the symbol for a simple AND is shown in Fig. 1.1c.

When designing the electronics to go inside the black box it is necessary to decide what type of signal is to be used. In the circuits to be discussed in this series, a signal is taken as meaning a negative-going voltage pulse of about 5-6 volts amplitude. The duration of the pulse is not yet important.

It is quite possible to have gates with more than two inputs and these may be OR's or AND's. Fig. 1.2a shows a three input OR: if any one of the inputs carries a signal then a signal appears at the output. Fig. 1.2b shows a four input AND, in this case there will be an output when signals are simultaneously present at any

two inputs, all inputs being equivalent. Another version of this would be an arrangement where all four input signals had to be present at once in order to generate an output signal, and the symbol for this is given in Fig. 1.2c.

Both these gates belong to the group known as "logical circuits" since they are capable of making some simple distinction between various input conditions. Other arrangements of gates are possible but these are the only two with which we are immediately concerned.

OR GATE CIRCUITS

So much for theory. There are numerous ways of building such gates in practice, the actual circuit depending on the type of signal which is being used. In our case, where voltage pulses are used as signals, one very convenient type of arrangement uses only diodes and resistors to produce the desired logical

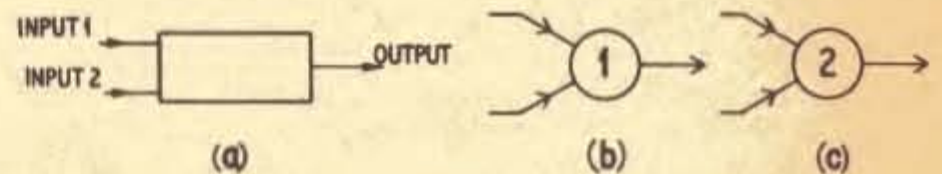

Fig 1.1. Symbolic representation of gate circuits. (a) Simple "black box" symbol. (b) and (c) The conventional way of indicating an OR and an AND gate, respectively

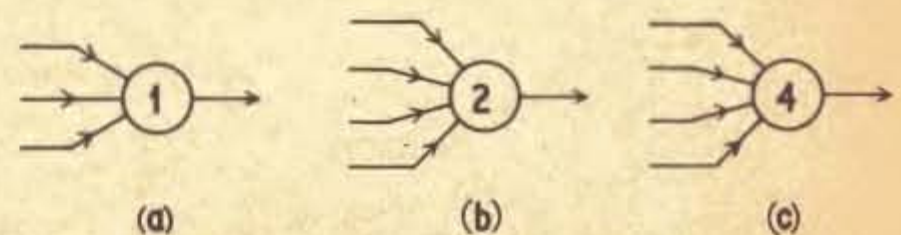

Fig. 1.2. Symbols for gates having more than two inputs. (a) Three-input OR gate. (b) and (c) Four-input AND gates

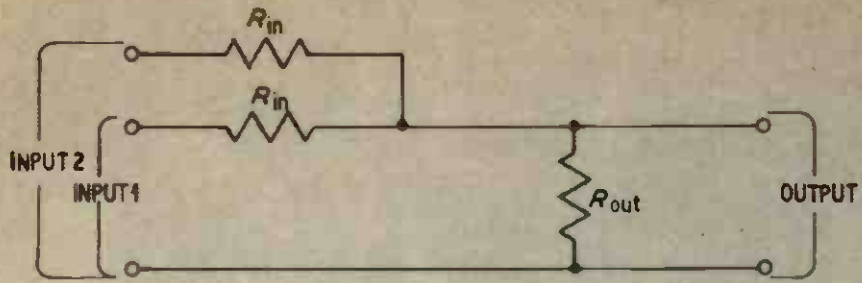

Fig. 1.3. Basic gate circuit for voltage operation

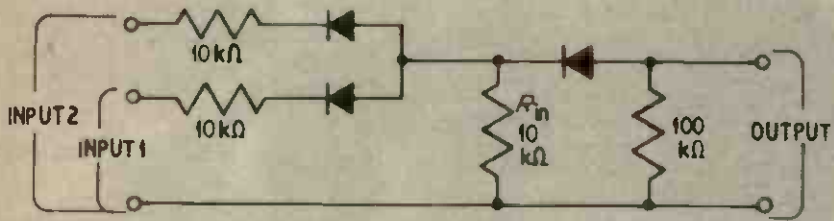

Fig. 1.4. An OR gate circuit developed from Fig. 1.3. This circuit operates on negative-going signals

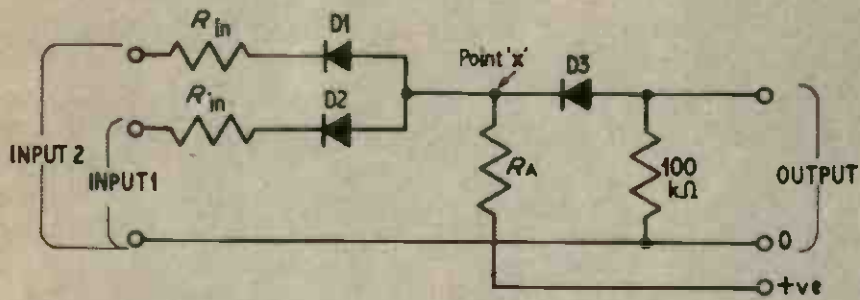

Fig. 1.5. An AND gate derived from Fig. 1.3

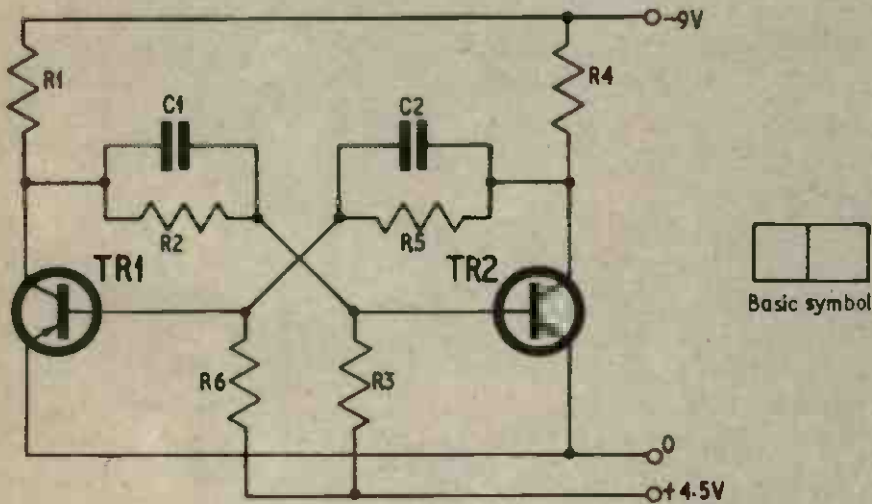

Fig. 1.6a. A bistable switch circuit. This circuit has two stable conditions, with either transistor conducting and the other cut-off

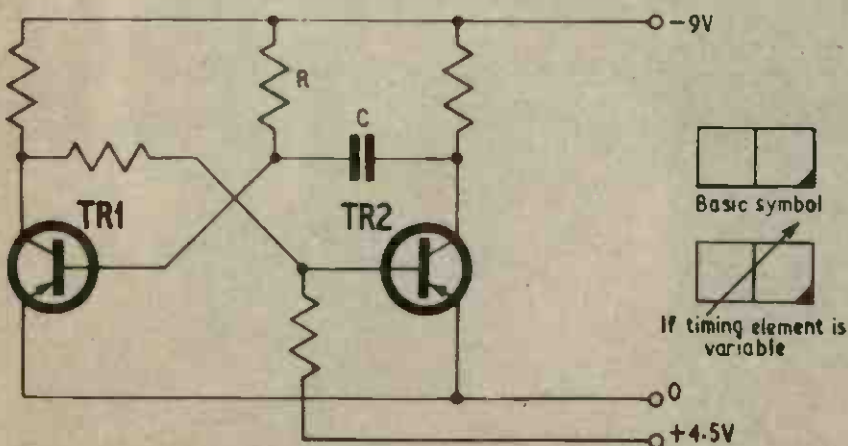

Fig. 1.6b. A monostable switch, or "flip-flop"

functions, this method being known as diode-resistor logic and being applicable only to voltage pulses as signals. The arrangement is built around a very simple network, the basis of which is given in Fig. 1.3.

Considering the OR gate first, it is fairly clear that the circuit given in Fig. 1.3 is an OR gate by itself. A positive-going or negative-going pulse applied to either input will produce a similar pulse across the output—although this will be at a reduced amplitude. In order to decouple the inputs from each other it is usual to connect a diode in series with each input, and it is important to note that the polarity of these diodes determines the polarity of the signals which the gate will accept. A further diode in the common input lead prevents any signals of wrong polarity from reaching the subsequent circuitry, although this component can be omitted.

The complete OR gate, excluding the amplifier needed to make up for the attenuation, and using typical component values, is given in Fig. 1.4. This circuit will operate on negative-going signals of any amplitude, within the tolerance limits of the diodes, and gives a negative output when a negative voltage is applied to either input. Reversing the polarity of the diodes would cause the circuit to operate on positive-going signals. Any number of inputs can be connected to this sort of circuit, all being applied to the common input resistor R_{in} .

AND GATE CIRCUITS

There are several ways of producing the AND gate from the basic circuit of Fig. 1.3. One method uses the circuit for an OR and returns the input resistor to a positive bias as in Fig. 1.5. When no input is applied the cathode of diode D3 is positive with respect to its anode, the diode behaves as an open circuit, and no voltage is developed across the output. R_A is adjusted so that when one negative input is applied the potential at point "X" in Fig. 1.5 rises to exactly zero. When a second input is simultaneously applied the potential at point "X" becomes negative with respect to the zero line, diode D3 conducts and a negative voltage appears at the output. Diodes D1 and D2 serve to decouple the circuit as before. In effect the positive bias is used to cancel out one of the inputs.

The AND circuit of Fig. 1.5 resembles that of the OR in Fig. 1.4 in several ways. Both circuits have a high output resistance and so can only be fed into other circuits which have a high input resistance. Both give a low output level, due to inevitable attenuation by the circuit. Typical numerical results for these circuits are given in Table 1.1. Apart from the obvious logical difference between them, there is one other point. The OR gate can handle signals of any amplitude, but this is not true of the AND. If, in Fig. 1.5, $R_{in} = R_A$ then the positive bias must be equal in amplitude to the signal voltage, though opposite in polarity. Once this bias has been set the circuit can handle only signals of the set amplitude,

TABLE 1.1

	OR	AND
1 input	3.0V	<0.1V
2 inputs	4.1V	2.8V

$R_{in} = R_A = 10$ kilohms
Diodes = OA81
6V input signals

if a single excessive signal is applied it will over-ride the bias and give an output even though only one input is being used. If signals of too low an amplitude are applied they will be unable to overcome the positive bias and no output at all will result. So it is seen that this form of AND, unlike the OR, can operate only on signals of a certain polarity and a definite amplitude.

Figs. 1.4 and 1.5 represent two passive networks, containing diodes and resistors only, and the reason for calling them "diode-resistor logical elements" is obvious. Despite their simplicity both these circuits perform their logical operations well and they will be discussed again later when dealing with the applications of logical circuits. The amplifiers needed to make up for the attenuation will be mentioned then so we can leave AND's and OR's for a time and consider something else.

BISTABLE SWITCH

The bistable switch and the flip-flop are two units which have a wide use in pulse circuitry. Their respective circuits are given in Figs. 1.6a and 1.6b together with the symbols used to represent them.

The bistable switch of Fig. 1.6a is a symmetrical circuit, being the transistor equivalent of the Eccles-Jordan circuit, and its action is also symmetrical, there being two stable conditions in which the circuit can remain. With TR1 conducting, a heavy positive bias is applied to TR2 base keeping this transistor cut off. Its collector remains at about the potential of the -9 volt line and, via R5, this keeps TR1 base negative so the transistor continues to conduct. The circuit will remain in this state as long as it is undisturbed. Alternatively TR2 could conduct and by a similar argument TR1 would be maintained in the cut-off state, this is the other stable condition and is a "mirror image" of the first. This type of bistable switch, then, has two sets of conditions in which it will remain stable: in each state one transistor is conducting and the other is not.

In order to make a bistable switch change from one stable state to the other, either *A*, a positive-going pulse must be applied to the base of the conducting transistor, or *B*, a negative-going pulse must be applied to the base of the non-conducting transistor. Either of these triggering modes will cause the switch to change from the stated initial state to the other stable state, but a further similar pulse will not cause it to change back again. A negative-going pulse applied to the base of the non-conducting transistor will cause the

circuit to switch over, but further pulses will have no effect. In order to make the switch change back again it is necessary to either apply a positive-going pulse to the same place, or apply a negative-going pulse to the other transistor.

It is possible to devise a triggering circuit which will make a bistable switch change either way when triggered by the same sort of pulse at the same point in the circuit. This can be done by applying a positive-going pulse to both collectors, and a suitable circuit is given in Fig. 1.7. The length of the pulse needed to do this is fairly critical and is proportional to the collector-to-base time constant of the bistable.

MONOSTABLE SWITCH

A similar circuit to the bistable switch is the flip-flop, or monostable switch, already seen in Fig. 1.6b. It has one stable state which is characterised by TR1 conducting and TR2 cut off. A positive-going pulse applied to TR1 base causes TR1 to cut off and TR2 to take over the conducting state. After a certain time, however, the circuit spontaneously flops back to its initial state without any further external action. The length of time it takes to flop back after being triggered is proportional to the time-constant CR. The usefulness of the flip-flop lies in its action as a single-pulse generator and in its ability to act as a "delaying unit"; it will be used in both these ways later in this series.

This discussion of the flip-flop completes the descriptions of the individual circuit elements and it is now possible to consider some of their uses.

USES OF LOGIC CIRCUITS: THE BINARY TWO-INPUT ADDER

Logical circuits can be put to a wide range of uses, but in this particular series we are especially interested in their use in calculating devices. By careful design these circuits can be built up into networks which can perform simple arithmetical operations, and it is the construction of such networks which we will consider now.

It is assumed that the reader has some knowledge of binary arithmetic, so only a brief synopsis is given here.

Binary arithmetic has only two digits which, by convention, are usually called 0 and 1. Any number can be expressed in binary by using these two digits and conversion from this numerical system to decimal can be done quite easily. A few binary numbers and their decimal equivalents are given in Table 1.2.

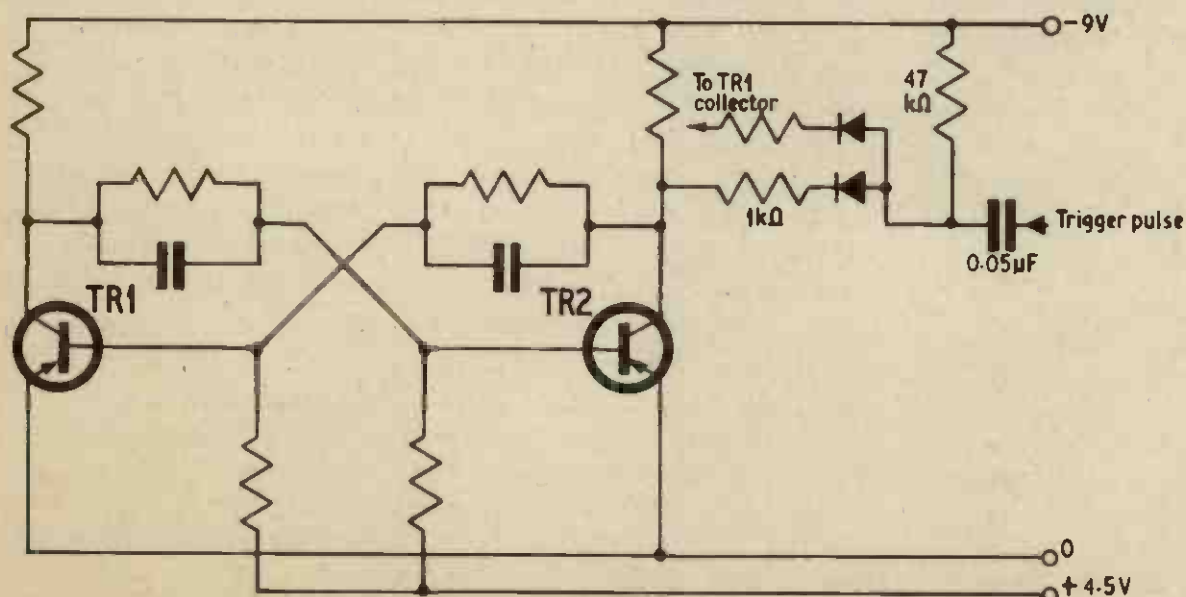

Fig. 1.7. A circuit arrangement which permits a bistable switch to be operated successively by one kind of trigger pulse

TABLE 1.2

Decimal	Binary
0	0
1	1
2	10
3	11
4	100
5	101
6	110
7	111
8	1000
9	1001
10	1010
16	10000
32	100000
43	101011
51	110011

Addition, subtraction, multiplication and division in binary are performed in the same way as in decimal, thus the addition of two numbers 10110 and 00101 is carried out:

$$\begin{array}{r} 10110 + \\ 00101 = \\ \hline 11011 \end{array}$$

and the multiplication of 1101 by 111 is done:

$$\begin{array}{r} 1101 \times 111 = (1101 \times 1) + (1101 \times 10) + (1101 \times 100) \\ = 1101 + 11010 + 110100 \\ = 1011011 \end{array}$$

so $1101 \times 111 = 1011011$

and this can be checked by conversion to decimal,

1101 = 13 in decimal

111 = 7 " " "

1011011 = 91 in decimal

and, since $13 \times 7 = 91$ the sum is seen to be correct.

The great usefulness of binary arithmetic lies in the fact that anything capable of existing in two stable states can be used to store a binary digit. We have already come across one such circuit in the bistable switch and by assigning an arbitrary convention to such a switch we can say that in one stable state it represents a 0 and in the other state it represents a 1. The former state is also referred to as the "unset" state, and the latter as the "set" state.

Other two-way systems capable of holding a binary digit include the presence, or absence, of a voltage at a particular point, the presence or absence of a magnetic field in a material, and the direction of a field if one exists.

The storage of binary numbers in bistables is uneconomical in large-scale equipment since other, more compact, methods are available (ferrite core storage, magnetic tapes and drums, etc.) but in experimental equipment it is very convenient since it is easy to tell how each bistable is set, simply by applying a voltmeter.

In binary arithmetic the entire addition table consists of just four sums, thus:

$$\begin{array}{r} \text{SUM} \\ 0 + 0 = 0 \\ 0 + 1 = 1 \\ 1 + 0 = 1 \\ 1 + 1 = 0 \text{ carry } 1 \end{array}$$

the "carry" digit being added into any subsequent calculations.

A CRUDE ADDING UNIT

It would be instructive to attempt the construction of an electronic adder capable of performing these addition functions, using a voltage signal to represent a 1 and the absence of such a signal to represent a 0.

In the circuits which follow a signal is taken as meaning a voltage pulse, measured with respect to the common zero line, of six volts amplitude, negative polarity.

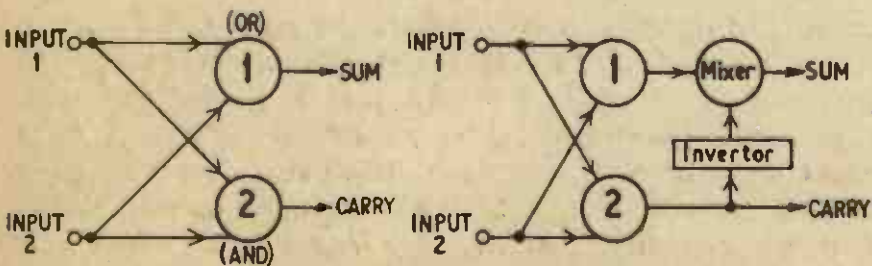

Fig. 1.8 (left). Logical diagram of an embryo adding unit

Fig. 1.9 (right). Logical diagram of simple two-input binary adder

From the binary addition table we see that a CARRY signal is produced only when both inputs occur together, so to get the CARRY output it is only necessary to connect an AND between the two inputs. Connecting an OR between the inputs gives the beginnings of a SUM output and although there is a flaw in this, we now have the start of a crude adding unit, shown diagrammatically in Fig. 1.8.

With no input voltage applied there is no output, corresponding to $0 + 0 = 0$. A single input, connected to either input 1 or input 2, will pass through the OR and give an output on the SUM; this is the representation of the $0 + 1 = 1$ and $1 + 0 = 1$ functions. Finally, both inputs applied together operate the AND giving an output on the CARRY, which is correct, but incorrectly an output through the OR giving a SUM signal as well. In order to make the adder add correctly this erroneous SUM output must be cancelled out. In principle this can be done by using the CARRY output, inverting the polarity of it, and mixing it with the SUM output as in Fig. 1.9.

In this case the first three addition functions remain the same as before and the SUM output passes through the mixer unchanged. When both inputs are applied the CARRY signal is produced as before but some of it is inverted in polarity and mixed with the unwanted SUM output. If the mixer is correctly set the two signals, now of opposite polarity, cancel each other out leaving no SUM output. Thus Fig. 1.9. represents the block diagram of a simple two-input binary adder. Since the symbols used represent logical elements, Fig. 1.9 is also known as the logical diagram of the adder.

A PRACTICAL CIRCUIT

Converting the logical diagram of Fig. 1.9 into a practical working circuit is not at all difficult. As we have seen already the outputs from the AND and OR gates are of a low signal level and must be amplified. Since the initial version of the adder is to be used on d.c. signals, and since a negative input must give a negative output, it follows that both gates must be followed by two-stage amplifiers capable of operating on d.c. signals. As it happens, if a standard type of amplifier is used, it is only necessary to add one extra resistor to include the cancelling of the SUM output when two inputs are applied.

The circuit of the two-input adder is given in Fig. 1.10. The input circuits, comprising an AND/OR combination in parallel, use diodes D1-D6, resistors R1-R8 and VR1. VR1 is set to tap off 6 volts so making D3, D4, D6, R3, R4, R6, R8 into an AND element which feeds TR2. D1, D2, D5, R1, R2, R5, R7 form an OR which feeds TR1.

Ignoring R_x , we see that TR1 and TR4 make up a d.c. amplifier for the OR and TR2 and TR3 act similarly for the AND. With no inputs connected TR1 and TR2 are cut off, TR3 and TR4 are conducting so the two outputs are almost at zero potential. A negative signal applied to either input will pass through the OR, cause TR1 to conduct and TR4 to cut off. This results in the SUM output going sharply negative which is equivalent to an output signal and is exactly what we want. If two inputs are applied simultaneously the same thing happens but in addition the AND gate opens, allowing TR2 to conduct, cutting off TR3 and so giving a negative-going signal at the CARRY output.

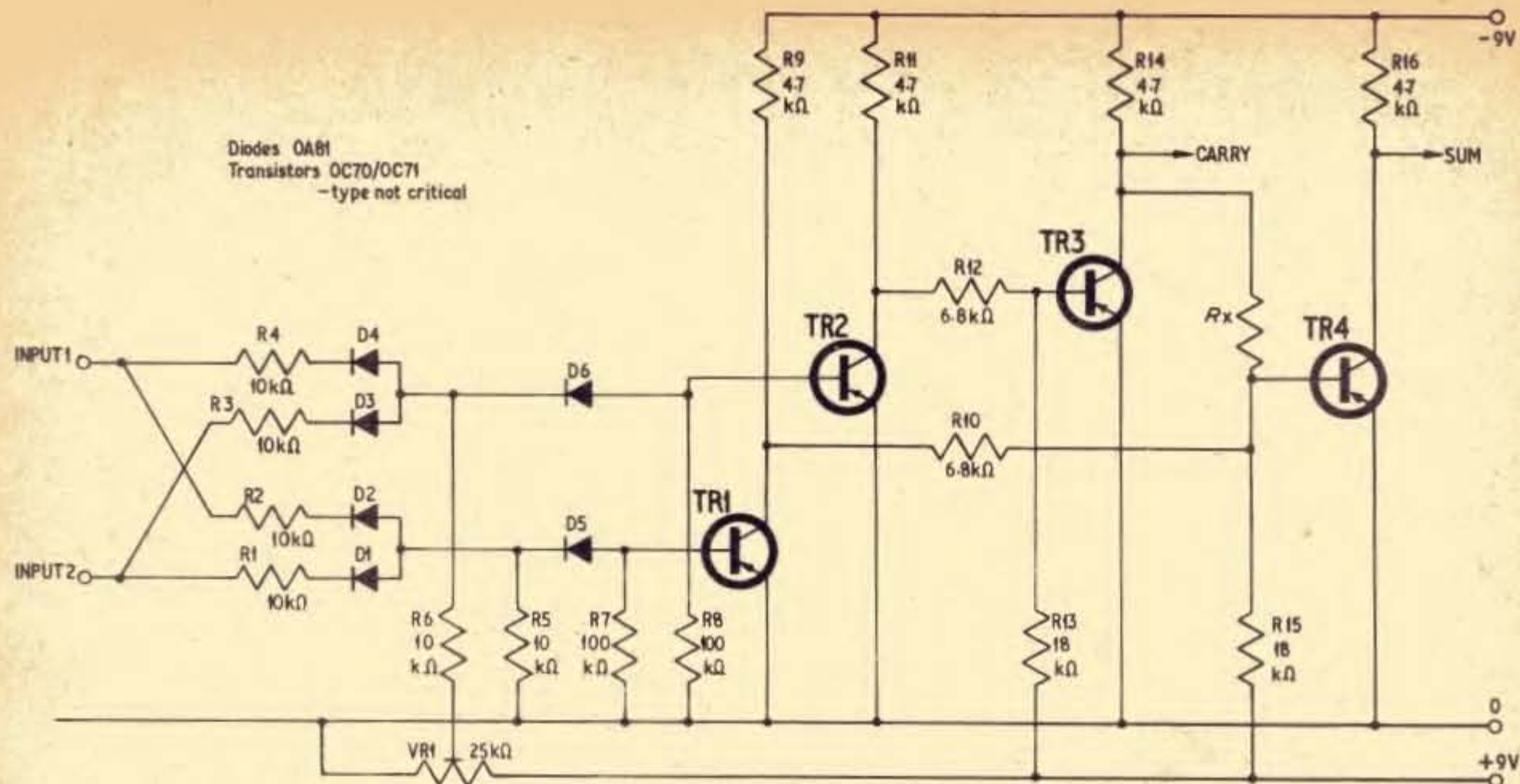

Fig. 1.10. Detailed circuit diagram of a two-input adder such as represented by Fig. 1.9

SUM CANCELLING

In the absence of R_x , the circuit is merely a parallel AND/OR combination feeding two amplifiers and is the same as Fig. 1.8. It is R_x which causes the SUM cancelling to occur and the method of operation is as follows. When one input only is applied to the adder the base of TR4 is pushed down towards the zero line as TR1 begins to conduct. R_x has little effect on this since the collector of TR3 is at a low potential anyway, consequently the SUM output occurs as before. However, when both inputs are applied simultaneously and the CARRY signal is produced, TR3 collector rises towards the -9 volt line and, via R_x , maintains the base of TR4 negative. TR1 still conducts, of course, and still has an effect on TR4 through R10, but this effect is now at least partially cancelled out by TR3. In effect the base of TR4 is pulled down to the zero line by TR1, and up to the negative line by TR3. The net result is that TR4 continues to conduct and does not give any erroneous SUM output.

The value of R_x is rather critical and it is necessary to use a variable resistor of 10-25 kilohms in this position and adjust it accordingly. If R_x is too large then the SUM output will not be cancelled when a CARRY signal is generated. If R_x is too small the base of TR4 will be kept too positive and will be unable to give a proper SUM output even when it is supposed to do so.

The two-input adder shown in Fig. 1.10 is not a purely hypothetical circuit, but a working practical one. The most convenient way of testing it is to use 6 volt batteries as signals and measure the voltage developed across TR3 and TR4 collector loads.

It is possible to economise on components by making TR2 generate the cancelling signal and using this to inhibit the input to TR1. The circuit of an "abbreviated" adder using this technique is given in Fig. 1.11, but it has the disadvantage that the output signals are positive-going and so non-standard as far as our conventions are concerned.

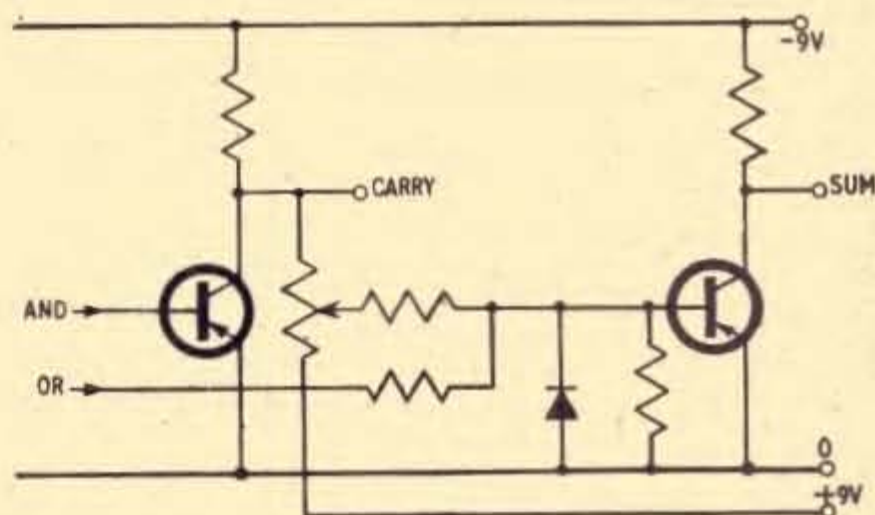

Fig. 1.11. Circuit arrangement for an "abbreviated" adder

NEED FOR THREE-INPUTS

The circuit of Fig. 1.10 is our first example of a complete arithmetical element, that is, one which is capable of performing a complete sum, even if only a very simple one. This circuit can do all four of the basic numerical operations of binary arithmetic and is a very good starting-point for a more complex adding system.

By itself, the two-input adder can form the sum of any two binary digits, but in adding complete numbers this is not always enough. Consider the following addition:

DCBA
1110
1101
11011

when adding these two numbers the right-hand column (A) is added first, then the next column to the left (B), then column C and finally D, just as in decimal addition. The two-input adder would add columns A, B, and C satisfactorily but it would get stuck on column D. In this last case there are three digits to be added, not two, the two digits of the numbers being added, plus a CARRY digit from the previous stage. This possibility of having to add three digits could arise in any column of the addition except the extreme right-hand one, so in a binary adder which is to be able to add

numbers larger than 1 each adding unit must be able to add three digits. The need arises, then, for a three-input binary adder instead of the two-input version, the complete addition table now reading:

	SUM	CARRY
0 + 0 + 0 =	0	0
1 + 0 + 0 =	1	0
0 + 1 + 0 =	1	0
1 + 1 + 0 =	0	1
0 + 0 + 1 =	1	0
1 + 0 + 1 =	0	1
0 + 1 + 1 =	0	1
1 + 1 + 1 =	1	1

The two left-hand columns are digits from numbers being added, the next column the CARRY digit from the previous stage.

THREE-INPUT ADDER

A binary three-input adder can be constructed from two two-input adders by linking them as shown in Fig. 1.12. One additional logical element is required, an OR to feed the carry output.

Although it might not at first sight appear so, all three inputs are equivalent and a little consideration will show that this arrangement will give the desired combination of outputs.

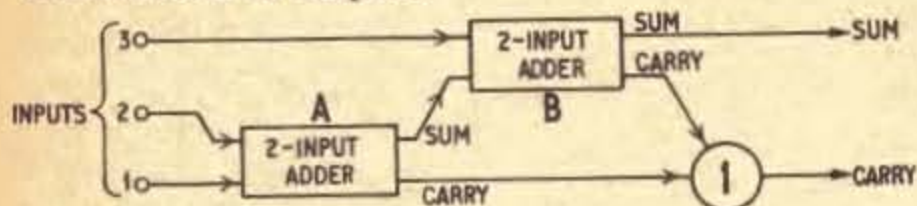

Fig. 1.12. Logical diagram of a three-input adder

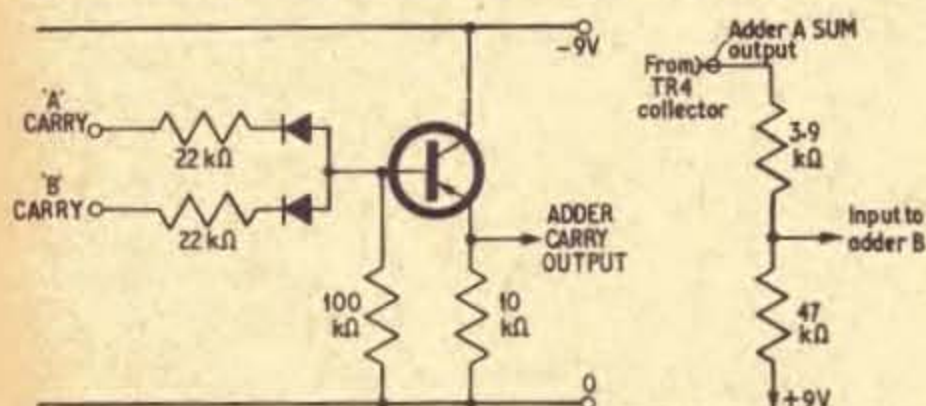

Fig. 1.13 (left). Circuit of an OR gate suitable for use in the adder shown in Fig. 1.12

Fig. 1.14 (right). Suitable coupling arrangement for use between SUM output of A and input of B (Fig. 1.12)

A single input at either input 1 or 2 will pass through adder A, leave on its SUM wire, pass through adder B, and leave on the SUM output. A single input at input 3 will go directly through B and also leave on the SUM output. A single input at 1 or 2, together with a signal at 3 will generate a CARRY in B which will go via the OR gate to the CARRY output. Two inputs at 1 and 2 generate a CARRY signal in A and this also leaves via the OR gate. If this happens simultaneously with an input at 3 then the CARRY is still produced in A and a SUM output is generated in B at the same time.

It is not felt necessary to give the full circuit of the three-input adder since this is merely two two-input adders joined up. A suitable OR gate for the CARRY output is given in Fig. 1.13. The SUM output of adder A is coupled to the input of adder B as shown in Fig. 1.14. This ensures that the input is at zero potential in the absence of a signal from A. (The collector of TR4 in A is not quite at zero when the transistor is conducting.)

NEXT MONTH

in

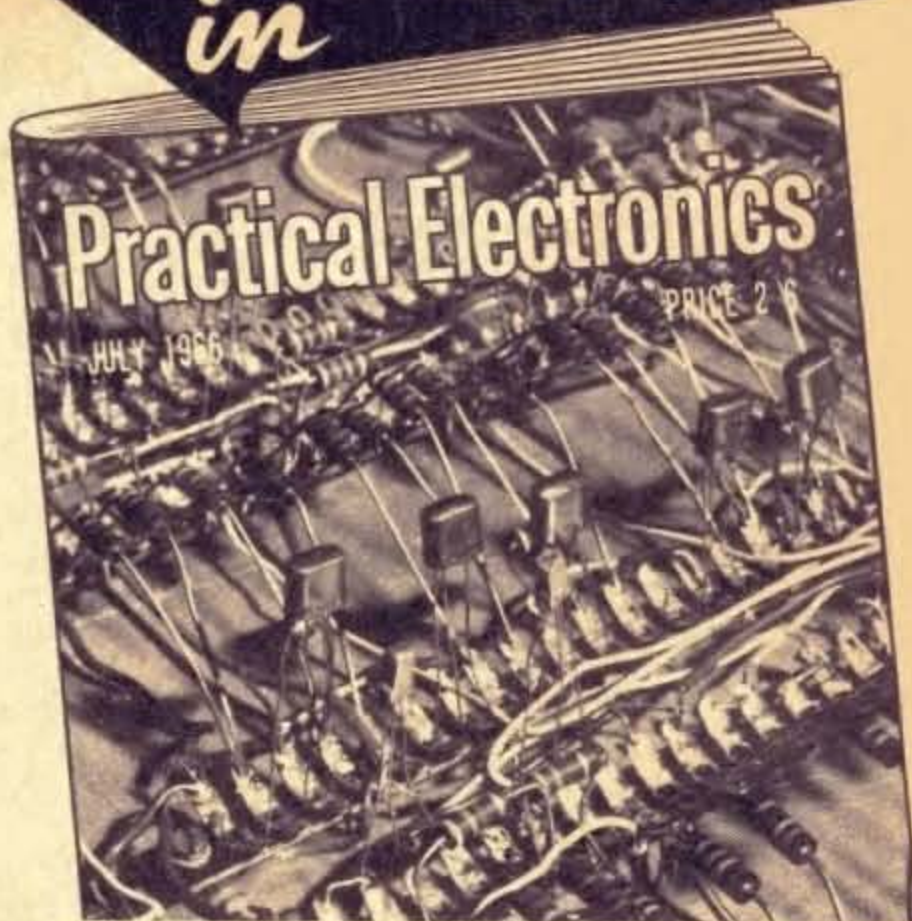

GUITARIST'S FUZZ BOX

An effects unit widely used by professional and amateur pop groups. Also known as a "Tone Bender"

MICROBUG LOCATOR

This useful instrument will detect and locate an eavesdropping device. It will also trace sources of troublesome electrical interference.

FOUR CHANNEL MICROPHONE MIXER

An inexpensive transistorised unit of particular interest to recording enthusiasts.

STABILISED POWER SUPPLY

Providing d.c. outputs of 13V at 500 mA and 9V at 50mA this compact mains-operated unit is the ideal power source for experimental transistor circuits.

PLUS SPECIAL FEATURE :

EXPERIMENTS IN LOGIC DESIGN-2.

ORDER YOUR COPY ON THE FORM BELOW

To..... (Name of Newsagent)

Please reserve/deliver the July issue of PRACTICAL ELECTRONICS (2/6), on sale June 16, and continue until further notice.

NAME.....

ADDRESS

detached particles

JOHN VALENCE

THE VALVE LINGERS ON

A few weeks ago I joined a crowded meeting at the IEE here in London listening to a discussion on the problems facing the television receiver designer when going "solid state".

Some of the particular problems which were described seemed formidable enough, certainly to someone on the side lines such as myself. On the other hand the general competence of the speakers and their complete familiarity with the subject made one suspect that technical problems are not the sole reason for the somewhat tardy progress towards transistorisation. It seems more likely that set manufacturers are not too enthusiastic about changing from well tried valve designs for economic reasons.

The ensuing question and answer period ended fittingly enough with a somewhat challenging probing enquiry concerning the nearness of the solid state successor to the cathode ray tube. Alas, no confident predictions on this subject.

THINGS TO COME . . .

Talking of solid state devices, I am reminded of this year's Physics Exhibition. This show provided ample evidence that research into solid materials is one of the most important and rewarding activities today.

Certainly at least one came away with the knowledge that significant developments are in the pipe-line and that electronic technology is bound to feel the impact of many of these ideas soon. (We will get that solid state television screen before many more Exhibitions have passed, I am sure!)

. . . AND OF YESTERYEAR

After looking around at exhibits likely to influence our future, it was relaxing to turn attention for a while to a collection of scientific instruments of bygone days.

In recognition of the fact that this was the 50th Exhibition of its kind, the organisers had set one corner of the hall aside for the display

of historical instruments and apparatus. Most of these items were developed in the period just before or immediately after the first exhibition held by the Physical Society in 1905. This was the brass, ebonite, and mahogany period as represented by sturdy, well engineered examples of the instrument maker's art, as well as the inventive genius of the designer. Like, for example, the first ohmmeter made by Sidney Evershed (1889); Siemen's Dynameter for measuring current, resistance, and power; Fleming's Cymometer which enabled wavelength, inductance and capacity to be directly measured; and the first production model of Fleming's diode valve.

artiste will be seen as well as heard. Frightening thought.

I can't really believe there is much of a future for this idea. Now, a cheap video tape recorder—that's something different.

CAPTIVE AUDIENCE

I had the temerity to attack pirate broadcasters last month. No doubt I will be unpopular with some other people when I mention that there are also "pirates" at the receiving end. These are the characters who bilk the BBC of licence money, and are probably at the same time severe critics of the programme material they receive for free.

It will be recalled that the sugges-



Finally, although strictly non-electronic, I must not overlook that fine vintage model gramophone: the very same model that together with "Nipper" formed the subject of the painting which was destined to become the most famous trade mark of all.

VISUAL ACCOMPANIMENT

It is a far cry from the "dog and trumpet" to the "TV discs" now being planned in America. By plugging the record player into the television receiver, the latest pop

tion was made a while ago that radio and television retailers should pass on to the authorities names of set purchasers.

By way of retaliation, the Radio and Television Retailers' Association puts forward the interesting proposition that receiving licences are out-of-date anyhow, and that the BBC should be financed out of public funds.

Meanwhile, an interesting sidelight on the amenities allowed in H.M. Prisons is the Home Office instruction to all prison governors that detainees must have individual licences for their radios. No great problem here for the G.P.O. sleuths, one suspects.

ELECTRONORAMA

HIGHLIGHTS FROM THE CONTEMPORARY SCENE

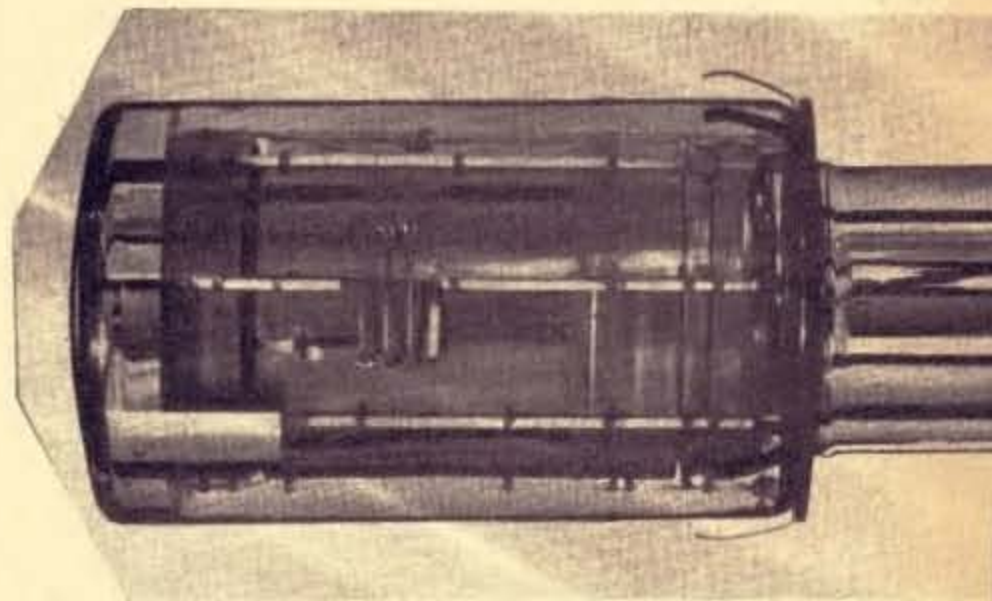
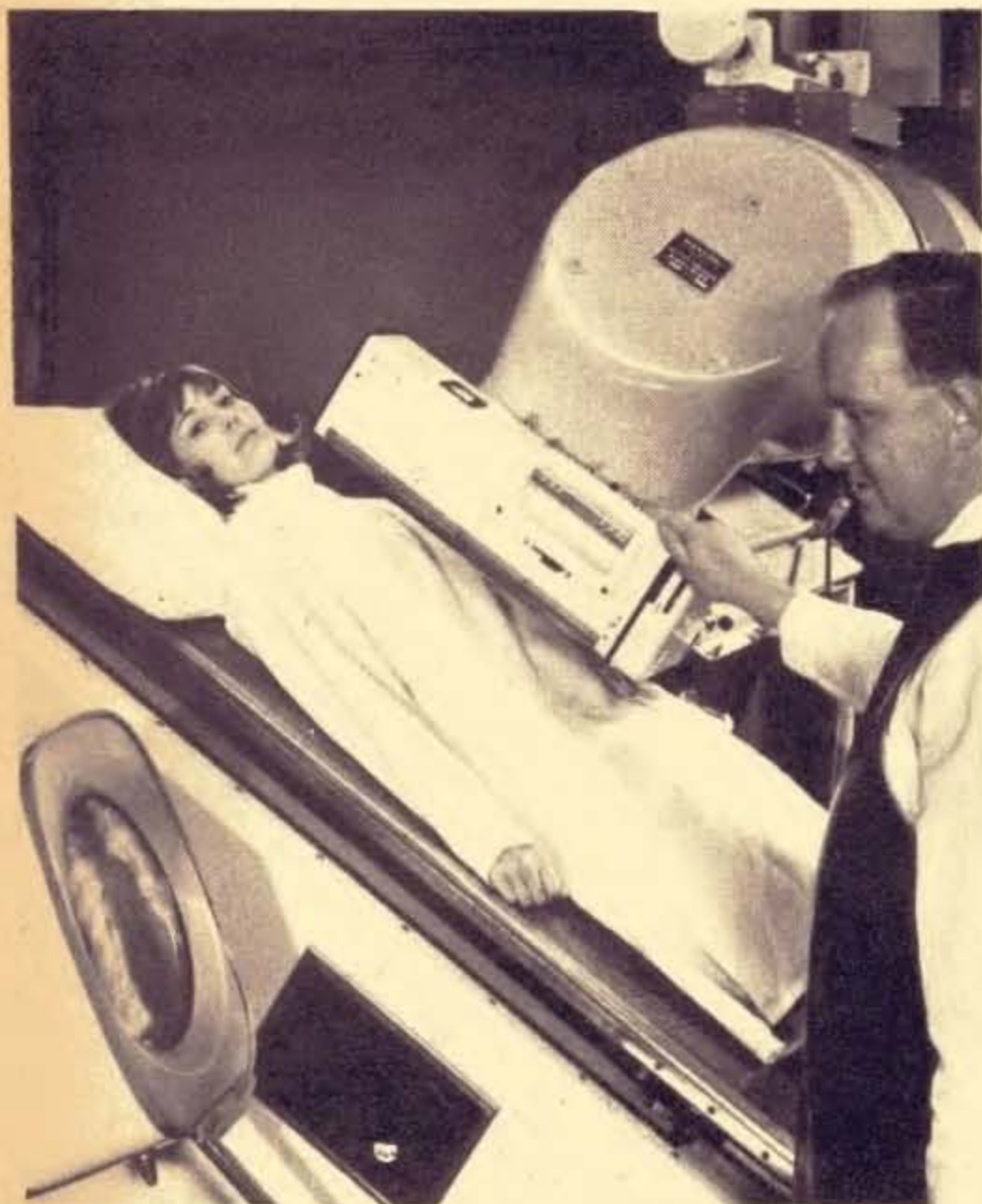

X-ray Image Intensifiers

PRODUCTION of new transistorised equipment to assist X-ray photography have been developed by Marconi Instruments Limited and the English Electric Valve Company. Two diagnostic X-ray image intensifiers, using a direct television image orthicon camera tube (above), produces a picture on a flat fluorescent screen. A lens system focuses the X-ray image on to the photocathode of the camera tube. The picture quality is controlled automatically irrespective of the strength of the X-ray image. The two models—10in Marionette (left) and 12in type OA1700—will become available in August this year.

Global Satellite Defence Link

THE world's first global satellite communications network is being set up for the U.S. Department of Defence for military use.

Instant world-wide voice and teletype communications, relatively unaffected by atmospheric or solar disturbances, will be made possible by the satellites and pin-pointed ground-link terminals. The first satellites are to be launched later this year.

The ground-link terminals, built by the Hughes Aircraft Company for the U.S. Army's Satellite Communications (SATCOM) Agency, are transportable and can be assembled and put into operation in 48 hours.

Each terminal, known as Mark 1B, has a 40ft diameter parabolic antenna housed for protection against weather in a dual-wall inflatable radome 58ft high (right). The terminals are able to transmit and receive four voice and four teletype messages at the same time, and can also send and receive facsimile photographs.

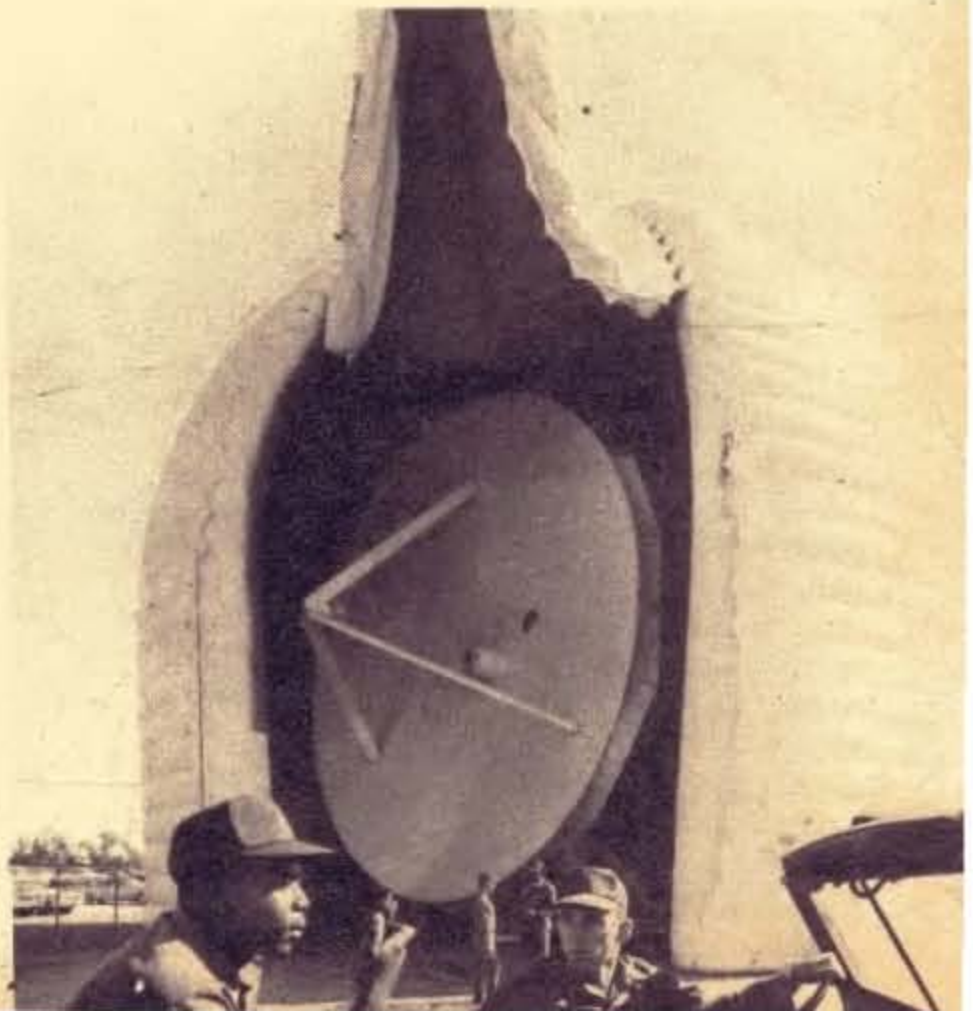

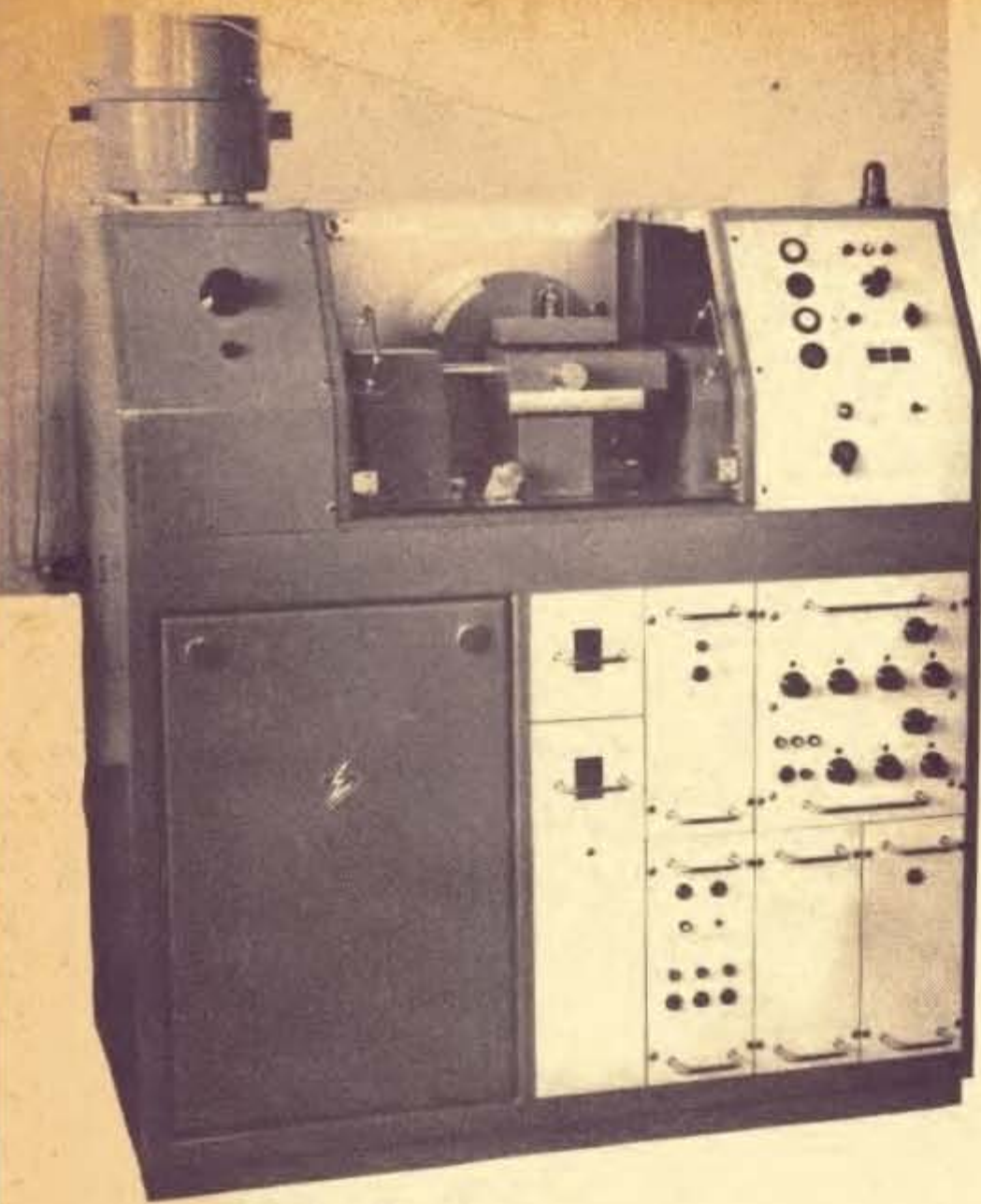

Automatic Resistor Grinding Machine

THIS machine (above) represents the latest developments in the resistor grinding field and is designed to automatically grind metallised or carbo-film resistors from 1.8 to 6mm in diameter and 6 to 20mm in length. Components are brought to pre-set final values between 10 ohms and 10 megohms by grinding a spiral in the metal or carbon.

The machine (shown at the A.S.E.E. Exhibition) has been developed by Veb Elektromat of West Germany and is being supplied to British manufacturers by Techna (Gt. Britain) Ltd.

High Power Thermoelectric Generators

TWO new thermoelectric generators, with greatly increased power ratings, have been developed by the 3M Company. Both models, rated at 100 watts and 200 watts operate on propane, butane or natural gas, as do the four earlier models.

Accessories for them include voltage limiters, to regulate the voltage output of the units, as well as gas pressure regulators and automatic gas shut-off valves. The generators are capable of producing either 6, 12 or 24 volts d.c. Applications include providing cathodic protection for underground pipelines, powering remote radio transmitting and relay stations, and for powering marine buoys.

Wafer Probing Machine

AT THE Instruments Automation and Electronics Exhibition (23-28 May at Olympia, London) one of many new items on show will be this wafer prober (right) developed by the Transistor Automation Corporation in U.S.A. and imported by Livingstone Group. The machine rapidly tests integrated circuits, transistors and diodes in the wafer form prior to "scribing" or dicing operations. It can deal with 10,000 units per hour.



Micamodules

INTEGRATED resistance capacitance circuit systems are being produced in modular form by Johnson, Mathey & Company. Known as "Silver Star Micamodules" these circuit systems have screen-printed noble metal films fired on to mica substrates. Screen-printed silver films are used for capacitors and conductors, the mica acting as the dielectric. Transistors and diodes can be soldered, then the complete circuit is encapsulated in an epoxy resin. The picture above shows one of these modules being tested.

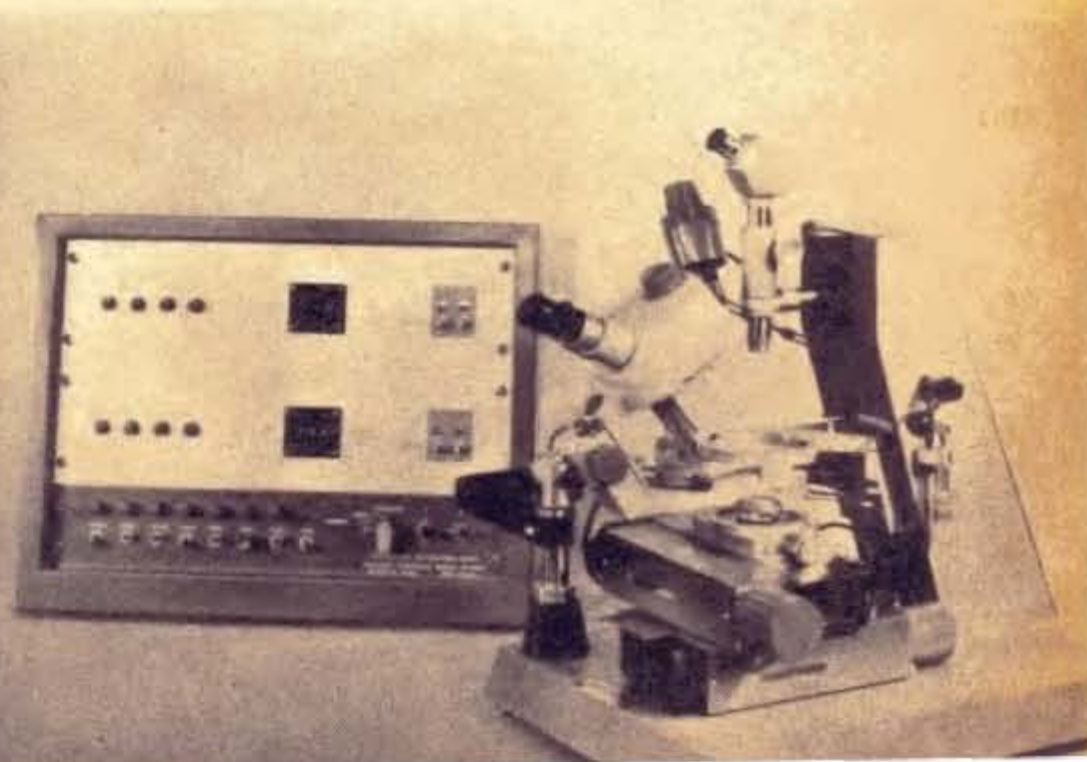
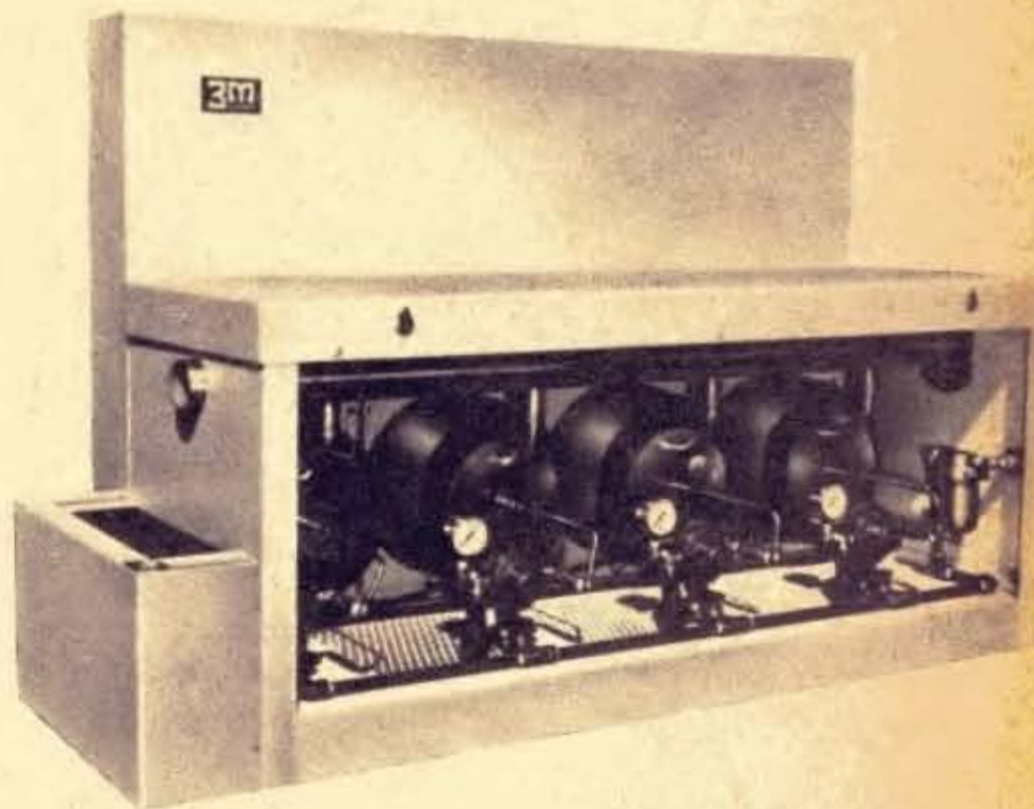

BEGINNERS start here... 20

An Instructional Series for the Newcomer to Electronics

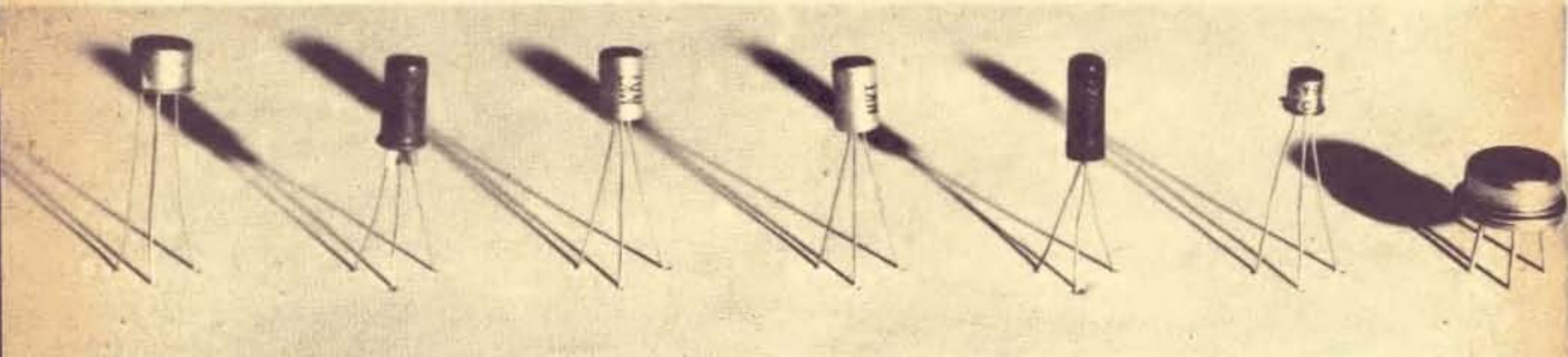

THIS month we move on to consider the modern counterpart of the thermionic valve. Instead of glass enclosed vacuums, we find ourselves dealing with certain kinds of solid materials. These materials fall into a special class: they are neither good electrical conductors, nor perfect insulators; for this very good reason these materials are referred to as *semiconductors*.

SEMICONDUCTORS

In some respects, the flow of electrons through the spaces between the orderly "rows" and "columns" of some crystalline materials produces a situation analogous to the electrons moving in the vacuum of a valve envelope. The crystalline substances we refer to are the semiconductor materials which have become very important nowadays, such as *germanium* and *silicon*.

Normally, few electrons are available for current conduction in a *pure* specimen of semiconductor. The outer or *valency* electrons of the various atoms

link up, forming the crystalline structure of the material as indicated in Fig. 20.1a. However, by adding a controlled amount of an *impurity* substance to the pure semiconductor material, the conductive properties can be considerably affected. If the added impurity material has more electrons in its atoms than the basic material, these electrons become "spare" or "free" and can act as current carriers. See Fig. 20.1b.

It is also possible to add an impurity material which has one less valency electron in each of its atoms than the basic material. This results in a deficiency of electrons in the crystalline structure bonds. This deficiency, or vacancy, is called a positive *hole*. See Fig. 20.1c. The drifting free electrons pop into the

Fig. 20.1a (left). This is a two-dimensional representation of the crystalline structure of elements which have four valency electrons, such as germanium (Ge) and silicon (Si). The outer or valency electrons of the atoms determine the conductive nature of the material. Each valency electron pairs off with another in an adjacent atom, thus there are no "free" electrons to act as current carriers

Fig. 20.1b (below left). Here two "impurity" atoms such as arsenic (As) or antimony (Sb) have been added to the pure germanium or silicon. The added "impurity" atoms have five valency electrons each, and so there is one electron per atom spare after the co-valent bonds have been made. These spare electrons are available as current carriers. The doped material is known as *n* type

Fig. 20.1c (below). Here the pure semiconductor material has been "doped" with two atoms such as gallium (Ga) or indium (In) to produce *p* type material. The impurity atoms have only three valency electrons and so vacancies occur in the crystal bonds. The vacancies are called "holes" and can be considered to act as positive current carriers

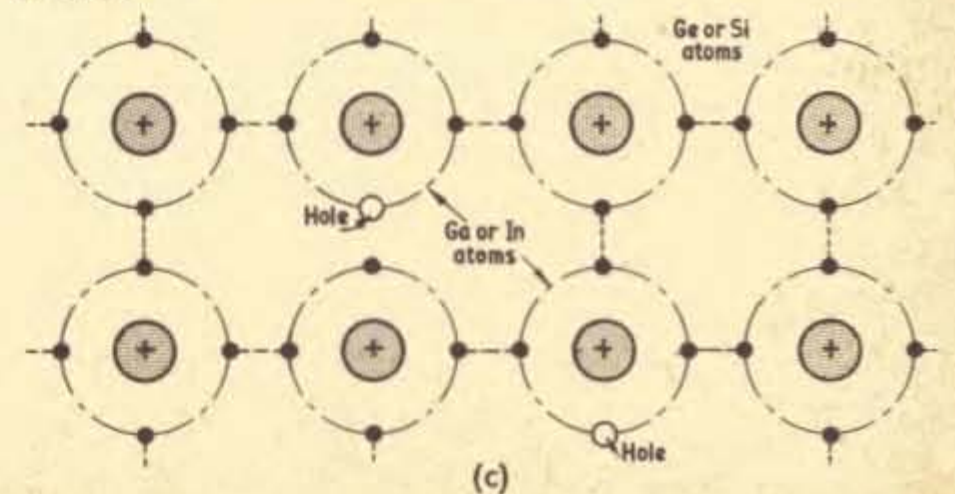
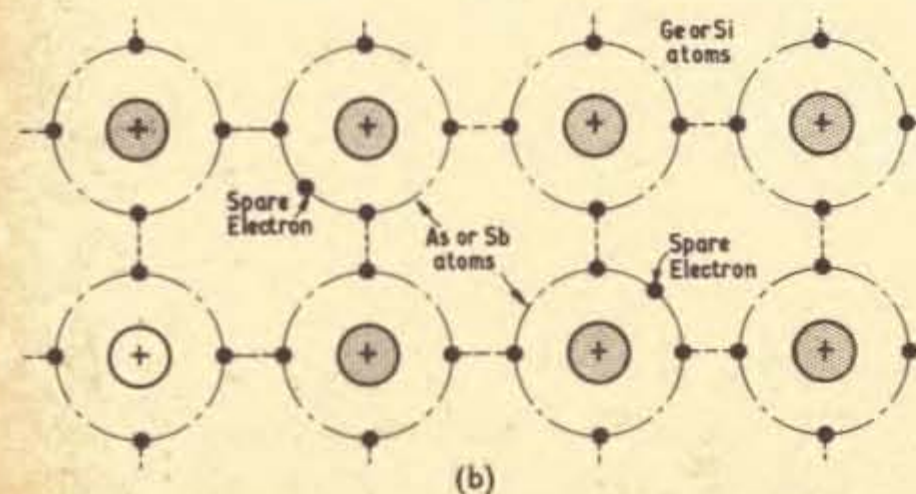
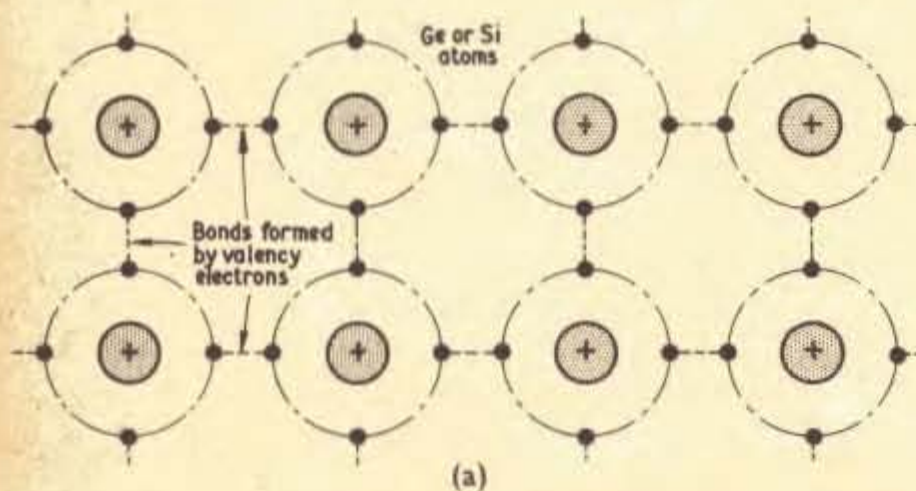

holes, and in so doing can be considered to create other holes—whose movement is in the opposite direction to that of the electrons.

Thus in semiconductors we might find current flowing by electrons wandering one way, or by positive holes flowing the other way. Notice that this situation shows that two different methods of current flow are possible.

Now for a few technical terms you will come across in this subject. The process of adding an impurity material is called *doping* the semiconductor. If the impurity tends to produce a cloud of free electrons, the semiconductor is called "*n* type". If it is a cloud of positive holes, then the material is called "*p* type".

The semiconductor crystals are grown from the very purely refined elements germanium or silicon, although for a number of purposes compound semiconductors are used, such as cadmium sulphide or lead sulphide. The doping materials are often antimony for *n* type and indium for *p* type materials.

RECTIFICATION IS POSSIBLE

Semiconductor crystals can be arranged to conduct electricity in one direction only—or to rectify alternating currents. This makes them of great value in electronics.

Two types of semiconductor crystal rectifier or diode are possible, one is the *point contact* diode, coming down as a development of the crystal and "cat's whisker" of the early days of radio. Galena (lead sulphide) was often used then, but germanium is the common material now.

The other type of rectifier is called the *junction* diode, and is a result of modern finely controlled industrial production methods. This last type is very interesting and important and we shall attempt an elementary explanation of how it operates.

JUNCTION DIODE

First consider a small block of semiconductor crystal as illustrated in Fig. 20.2. We have arranged the left-hand half to be doped *n* type, and the right half is *p* type. The sharp dividing line between the two halves produces the *junction*, although in fact the crystal structure passes uninterrupted physically from one end of the block to the other.

There will be a cloud of electrons milling around in the left-hand half, while a corresponding cloud of holes exists in the right-hand part. If a battery is now connected across the crystal block as shown in Fig. 20.2a, the left-hand half of the crystal is made positive and the right-hand side negative. Therefore the electrons will all tend to move down towards the left, and the holes will move towards the right. (Unlike charges attract.) No charges cross the junction, which in fact is now a region depleted of charge carriers (holes or electrons). This region is technically called the *depletion layer*. A very high resistance is offered by the block of semiconductor crystal under these conditions.

Reversing the battery connections as shown in Fig. 20.2b drives the appropriate carriers *towards* the junction, and they stream across it and on to the electrodes. This happens continuously, and a very low resistance is offered.

The first condition (Fig. 20.2a) is termed the *reverse direction*, the second (Fig. 20.2b), the *forward direction*. Thus we have a rectifier, very efficient, without a vacuum and requiring no heater.

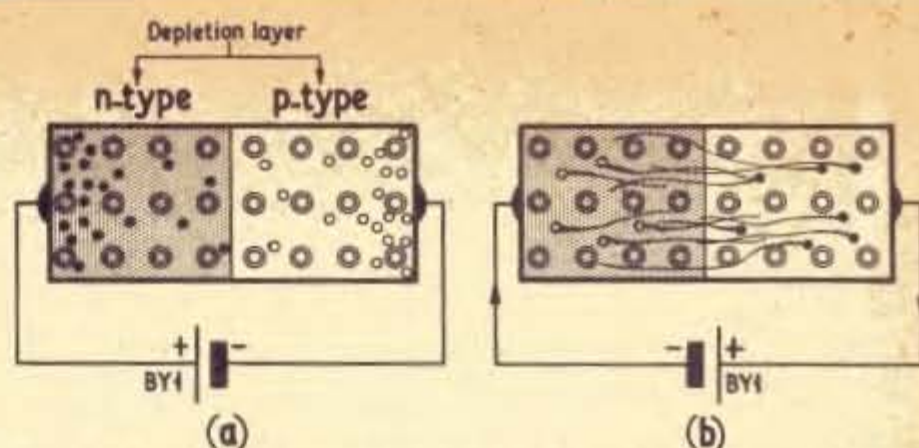

Fig. 20.2. When a *p-n* junction is formed, current will only flow through the crystal if the voltage is applied as in (b). If the battery is connected as in (a) the electrons and the holes move towards the ends of their respective sections and there is no current flow through the junction (apart from a very small leakage current)

MAKING THE SEMICONDUCTOR AMPLIFY

Just as it was thought that the electrons flowing in a vacuum valve lent themselves to external control by a third electrode, so it must have occurred to many early investigators that semiconductors might also be subjected to some external control. This did not materialise in a practical form until about 1948: the thermionic valve had won and attracted all the attention, and the crystal detector fell into disuse. (It is interesting to speculate what would have happened if the crystal amplifier had developed first!)

When the transistor did arrive on the scene, it certainly created a sensation—*electronics has never been the same since!*

The *transistor* (the name comes from "transfer resistance") consists really of two semiconductor diodes back-to-back. Both point contact and junction types are known, but the use of point contact types has diminished.

In Fig. 20.3 we show various symbols used to depict transistors in circuit diagrams.

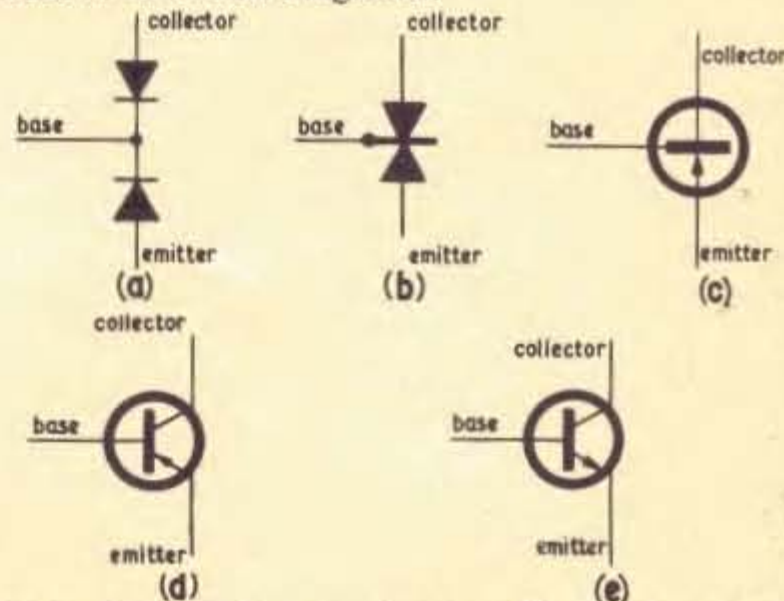
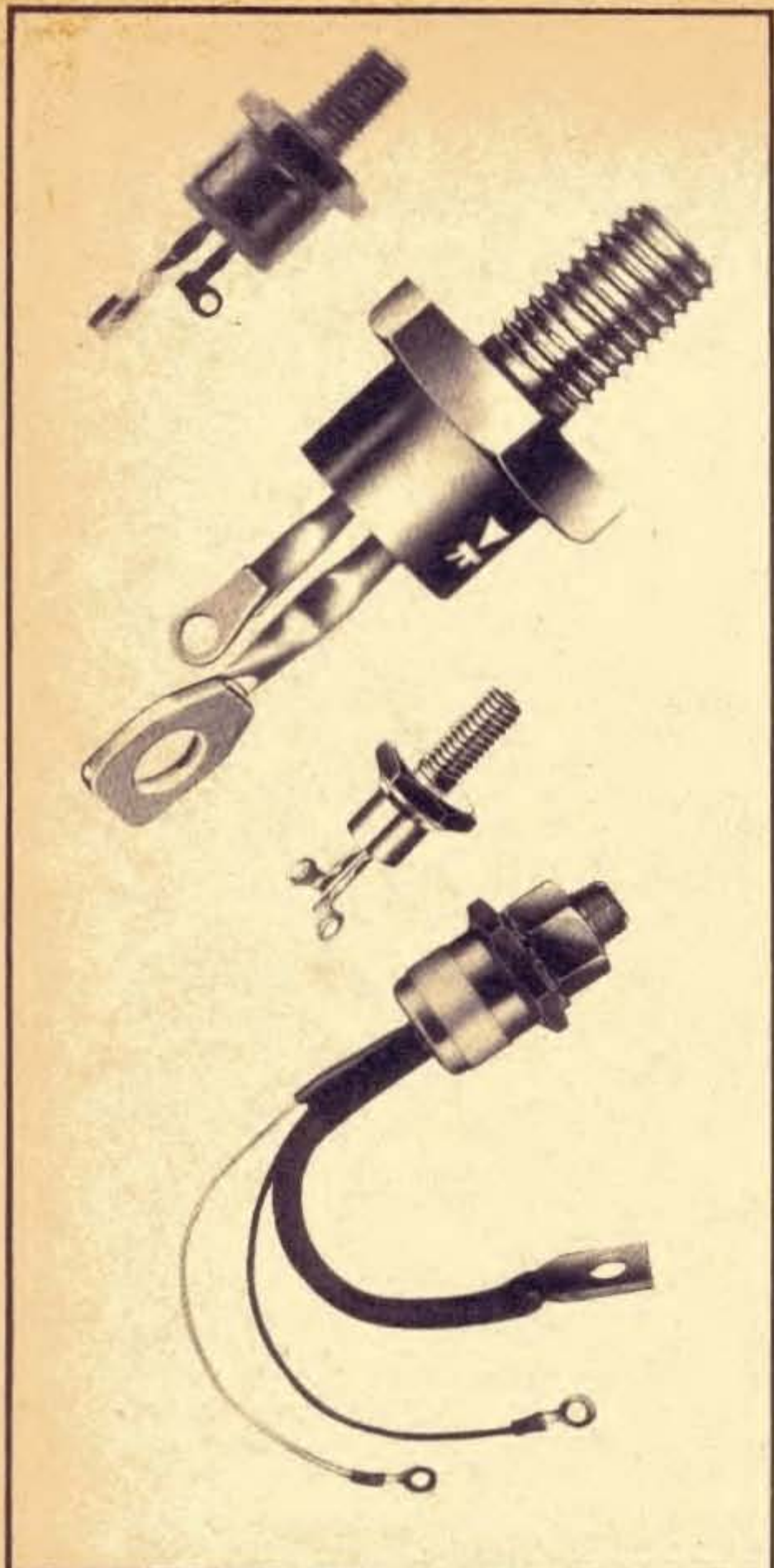

Fig. 20.3. Symbols for transistors. The last two are the symbols we are most concerned with: (d) *pnp* transistor, (e) *npn* transistor

Although a transistor can be represented by the two diodes drawn symbolically as in (a), the common electrode is really one and the same thing, and (b) would be a more accurate representation. (This symbol has been proposed for junction transistors.) The standard symbol now widely adopted is shown in (d). This particular symbol has in fact been derived from the point contact type. Some journals use the symbol shown in (c), this being a much closer resemblance to the actual construction of a junction type. We in PRACTICAL ELECTRONICS adhere to the British Standards Institution recommendation, i.e. as in (d) and (e).

Next month we will have a look at the way a transistor operates.



**INTRODUCTION
to
THYRISTORS**
by **B. F. PAMPLIN**

IN the U.K. most of the present applications of thyristors are in industrial control equipments such as those found in steel, paper, textile mills, etc. In the U.S.A., where they have been available longer, they are found in portable drills, vacuum cleaners, washing machines, fan heaters, bedside lamps, sewing machines and a hundred and one other domestic appliances, although these applications are now gradually being accepted in the U.K. Acquiring knowledge about a new component is usually built up in three separate stages. They are:

1. Learning about the fundamental behaviour of the device.
2. Experimenting with some proven circuits.
3. Using ingenuity in applying the basic circuits to specific requirements.

This article will help you with stages 1 and 2. Stage 3 is for you to follow up. Learning fundamentals is never very light work but in this case the time spent will be richly rewarded.

BASIC THEORY

Unlike a transistor which has three layers, either *npn* or *pn*, the thyristor (or silicon controlled rectifier) has four—*pnpn*. This is illustrated in Fig. 1, where it will be seen that the structure can be considered to consist of an *npn* and a *pn* transistor with a common collector junction. This, of course, must not be taken to mean that a thyristor can be made up from a pair of transistors by joining together the collector leads. It is not quite as simple as that!

The thyristor has three leads (tags or studs in the case of the big ones) and these are connected inside the can to three distinct parts of the structure. These are shown in Fig. 1.

Let us now look at the circuit symbol for the thyristor as shown in Fig. 2a. You will see that it uses the basic diode symbol with the gate lead "tagged" onto the cathode. Although this symbol has been used generally for some time, it does not truly represent the relative connections, since the gate is, in fact, *between* anode and cathode. Fig. 2b shows the British Standard preferred symbol which indicates, in addition, the direction of flow of the gate current for a *pn* device. It is reversed for *npn*.

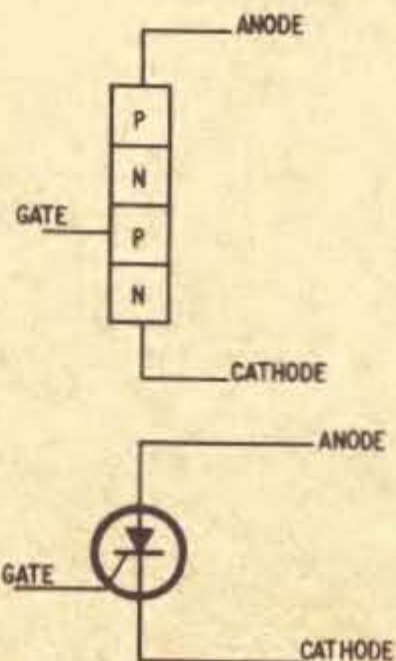

Fig. 1. Diagram of the make-up of *p* and *n* layers with relative connections

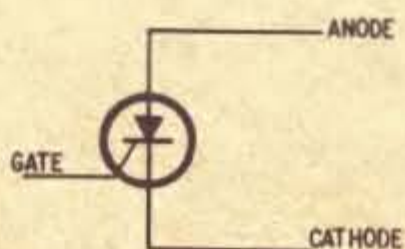

Fig. 2a. Conventional symbol for a thyristor

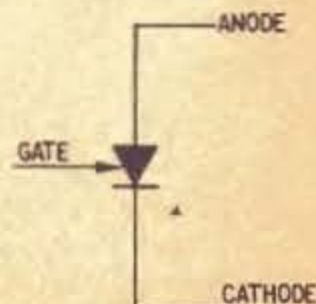

Fig. 2b. British Standard symbol for a thyristor

A proper understanding of thyristor depends on the appreciation of five basic facts:

1. It can be in one of two possible states. It can be on (allowing a current to flow from cathode to anode) or off (allowing only a very small leakage current to flow from cathode to anode).

2. When it is on it acts exactly like an ordinary diode, i.e. it will only pass current in one direction.

3. It can be switched from the off to the on state by a positive signal on the gate, but once it is on the gate cannot exert any further control, i.e. only a pulse on the gate is necessary to turn it on. Once on, the cessation of the gate signal cannot turn it off.

4. Once the thyristor is on the only way to switch it off is to reduce the current flowing through it to zero (actually slightly above zero as explained later) for a short period of time, typically 50 microseconds.

5. The thyristor needs a positive potential on the anode to enable it to conduct in the same way as an ordinary diode.

Like other semiconductors, thyristors come in different sizes with different specifications. When building up equipment the first, and most important, problem is selecting the right unit for the job.

Manufacturers of these devices issue comprehensive data sheets on their products. These are usually freely available and the importance of having full data on a device before using it cannot be too strongly stressed. In the data sheet you will find upwards of 20 different parameters mentioned. Of these, seven are of real importance in all applications and the rest relate to the use of the device under specified circuit conditions. These seven characteristics are the forward current, the peak reverse voltage, the holding current, the maximum gate current, the minimum gate current, the maximum reverse gate voltage and the maximum forward voltage. We will examine each of these in turn and see how they are related to actual circuits. One very important point to bear in mind is that temperature variations affect the characteristics in the same way that they affect transistors. In each case the way in which temperature affects the performance will be given.

FORWARD CURRENT

This is the maximum current which the thyristor will carry and switch. It is sometimes given as an average value and sometimes as an r.m.s. value. The peak current for a specified short time interval is also usually given; this would apply where the thyristor feeds a reservoir capacitor. Units currently available are in the range 100mA, up to hundreds, even thousands, of amperes. To determine the current rating you require for a particular circuit a simple calculation is necessary.

$$\text{Minimum current rating} = \frac{\text{Supply voltage}}{\text{Resistance of load}}$$

Or, if you know the power rating of the load,

$$\text{Minimum current rating} = \frac{\text{Power of load}}{\text{Supply voltage}}$$

For example, if you want to control two electric fire bars each rated at 1 kilowatt on a 230 volt a.c. supply, you would require a thyristor with an r.m.s. current rating of at least

$$\frac{2 \times 1000}{230} = 8.7\text{A}$$

Thus a 10A thyristor would be required.



Size of a 200mA thyristor (left) and a 10A thyristor (right) compared with a matchbox

PEAK REVERSE VOLTAGE

For a particular current rating the cost of devices rises steeply as peak reverse voltage ratings increase. Ratings range from 25 volts up to several kilovolts. This particular parameter is only applicable to thyristors working in a.c. circuits and it is a measure of the maximum voltage which can be applied to the device in the reverse direction, i.e. negative to anode, without causing a breakdown.

When determining the p.r.v. rating required in a particular application, bear in mind that it is a *peak* rating, whereas most supply voltages are expressed as an *r.m.s.* rating. The peak of an a.c. voltage is approximately 1.4 times its r.m.s. value. For example, a thyristor required to operate from a 230 volt a.c. supply must have a p.r.v. rating of at least $1.4 \times 230 = 322$ volts. In practice a 400 or 800 volt device would be used depending upon the margin of safety required. Incidentally p.i.v. (peak inverse voltage) is the same as p.r.v.

HOLDING CURRENT

If the current through a relay coil is gradually reduced from its full value the relay will drop out before the current reaches zero. The same is true of a thyristor and the minimum current, below which it may not remain on, is the holding current.

Holding current values lie between about 1 and 50mA depending upon the size of the s.c.r. The practical effect of the holding current value is to limit the amount of resistance which the load may possess. If you find a condition where the current passed by the load is below the holding current value, a suitable shunt resistor can be wired across the load to bring the current up to the correct level. Holding current decreases as the temperature increases.

MAXIMUM GATE CURRENT

To switch the thyristor on, a positive voltage is applied to the gate. This voltage must be applied through a resistor so that the maximum gate current rating is not exceeded. Typical ratings lie between 100mA and 5A. The minimum value of resistor is found by calculating

$$\text{Minimum resistance} = \frac{\text{Volts applied to gate}}{\text{Maximum gate current}}$$

In this connection it should be appreciated that the relationship between the gate and the cathode is that of a forward biased diode and as such the resistance between the two is very low.

MINIMUM GATE CURRENT

This is simply the minimum value of gate current which will cause the thyristor to switch on. Because it is very temperature dependent (its value drops as the temperature increases) most manufacturers give a graph of current against temperature instead of a single value. The two factors affecting the gate current are the voltage applied to the gate circuit and the value of the series resistor. To ensure that the thyristor will fire at all times, check that the resistor value will allow sufficient gate current to flow at the lowest temperature envisaged, with the gate circuit voltage at its lowest possible level.

For example, assume the equipment has to operate down to -20 degrees C and the gate circuit voltage is from a 12 volt battery which can drop down to 10 volts. To determine the maximum value of gate resistor, check the data sheet to find the minimum gate current at -20 degrees C, say 8mA and divide the 10 volts by this figure

$$\text{Maximum resistance} = \frac{10}{0.008} = 1,250 \text{ ohms}$$

Typical values for minimum gate current lie between 1 and 50mA at room temperatures.

MAXIMUM REVERSE GATE VOLTAGE

Because the gate and cathode form a diode it is apparent that the reverse voltage which can be applied to the gate is limited. When feeding the gate from an a.c. supply, this point has to be watched closely. If there is any doubt whether the gate can go negative with respect to the cathode, it is wise to connect a diode between the gate and cathode, with the anode of the diode connected to the cathode of the thyristor. This will then clamp any negative voltage which appears on the gate.

MAXIMUM FORWARD VOLTAGE

This is the value of voltage which, when applied to the thyristor with positive to the anode, will not cause the device to switch on spuriously, i.e. without a gate signal. If it is switched on without a gate signal it is a good sign that the forward voltage rating is being exceeded. There are two very important points to remember about forward voltage rating:

1. It is very temperature conscious in that as the temperature rises its value goes down;
2. Its actual value depends upon how quickly it is applied to the thyristor.

The first one is due to the fact that, as the temperature increases, the leakage current between the various layers gets larger and this has the same effect as partially triggering the unit on its gate. This effect can be overcome to some extent by connecting a resistor of about 1,000 ohms between gate and cathode and allowing the leakage current to flow out of the junctions.

The second effect is more complex but in practice any measures which can be taken to apply the anode voltage slowly, rather than quickly, will allow a greater margin of safety on the forward voltage rating. In practical terms this means avoiding the use of fast action switches, such as microswitches, to apply the voltage to the thyristor. If difficulty is experienced, try connecting a small ($0.1-1\mu\text{F}$) capacitor between the anode and cathode as this, in conjunction with the load, will form a small time constant and will stop the anode voltage rising too quickly.

BASIC GATE CIRCUITS

When designing gate circuits it must be borne in mind that three basic requirements have to be met:

1. Gate current must not exceed maximum;
2. Gate current must always exceed minimum;
3. Negative voltage must be kept off gate.

Manual switching on d.c. supplies. This is the simplest case and the circuit is shown in Fig. 3. The switch could equally well be a relay contact or a reed switch.

Manual switching with a.c. supplies. This is shown in Fig. 4. The only difference between this and the previous arrangement is the inclusion of diode D1 to prevent the gate going negative.

Delayed switching with d.c. supplies. If you want a time interval between applying power to the gate circuit and the thyristor firing, this can be achieved as shown in Fig. 5. When the switch is closed, C1 starts to charge. When it reaches the Zener voltage of the Zener diode D1 the diode conducts and fires the thyristor. If necessary a resistor is wired in series with the diode to ensure that the maximum gate current is not exceeded.

Delayed switching with a.c. supplies. If the principle described above is applied to an a.c. circuit the result is a phase control and it is this which forms the basis of all thyristor a.c. power control circuits. With an

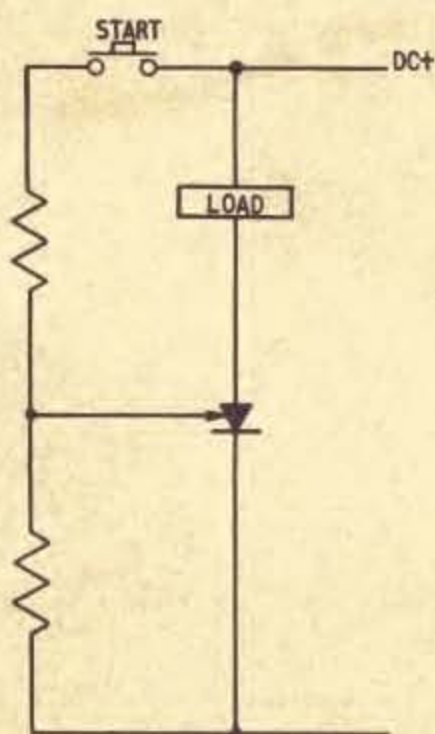

Fig. 3 Simple gate circuit for a d.c. supply

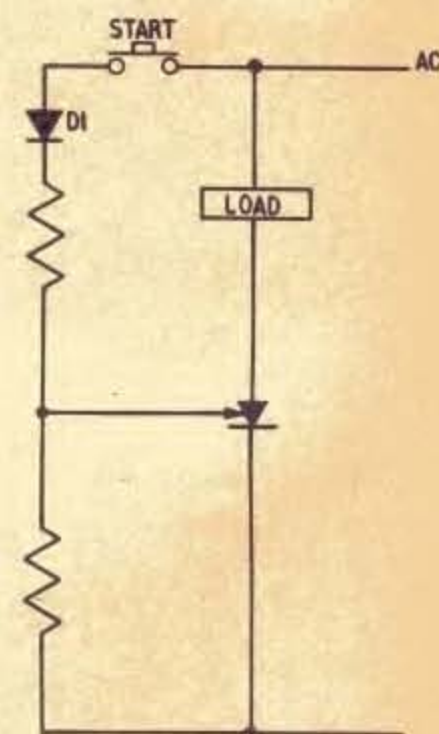

Fig. 4. Simple gate circuit for an a.c. supply

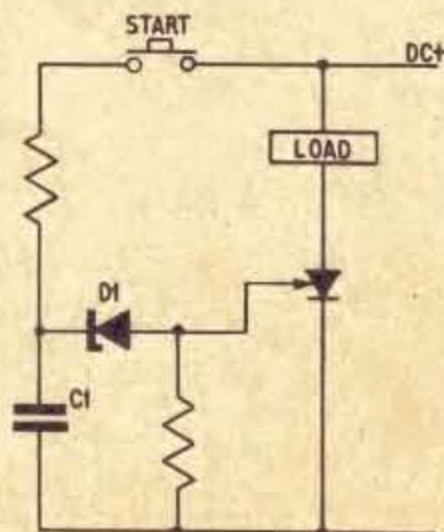

Fig. 5. Delayed firing for d.c. supply

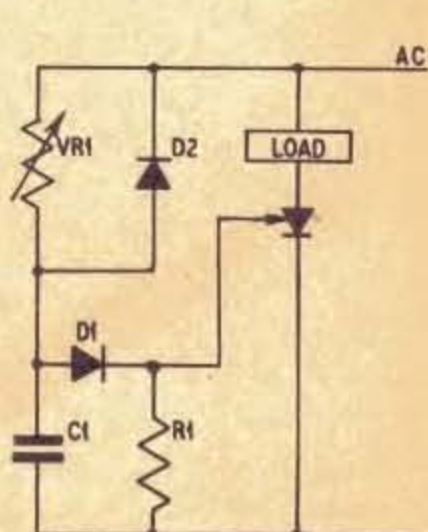

Fig. 6. Basic phase control circuit for a.c. supply

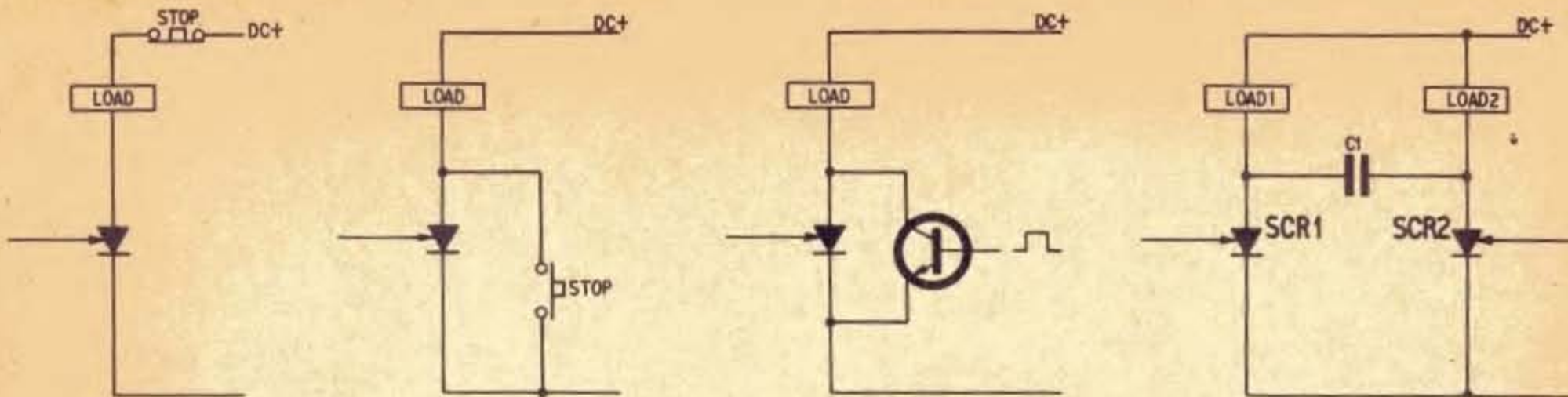

Fig. 7. Methods of switching thyristors off when fed from d.c.

a.c. supply on the anode, the anode voltage falls to zero at regular intervals. The gate can exert a constant control over the current in the anode load (in d.c. circuits once the thyristor fires it remains on and the gate cannot exert any further control). Consider the circuit in Fig. 6, which is not intended as a practical circuit but is simplified to show the operation.

When the anode voltage starts to rise the capacitor commences to charge. After a delay, which depends upon the setting of VR1, the thyristor turns on and supplies power to the load until the end of the cycle, when the anode voltage falls to zero and the thyristor turns off. When the anode goes negative the thyristor cannot switch on, but the capacitor is discharged via D2. On the next positive half-cycle the thyristor fires again after a delay and so on.

From this it will be seen that the point on the positive half-cycle at which the load is connected depends upon the setting of VR1. Since VR1 is only controlling the capacitor current it can be a small carbon type variable resistor, but it can vary the current in a load rated at several thousand watts. The practical disadvantage of this circuit is that only every other half-cycle is applied to the load, but this difficulty can be overcome as described a little later.

TURNING OFF THE THYRISTOR

We have already seen that in a.c. circuits the thyristor is automatically turned off every half-cycle. In d.c. circuits some method has to be found to interrupt the current flowing through the device momentarily. Fig. 7 shows four possible ways of doing this. In Fig. 7a a "normal-closed" switch in series with the anode is opened to switch the device off. In Fig. 7b a "normal-open" switch across the thyristor diverts the load current when it is closed and the load is de-energised when the switch re-opens. In Fig. 7c an

npn transistor is used in the same way as the switch in Fig. 7b. By switching the transistor on the current will be diverted from the thyristor and the load will de-energise when the transistor is switched off.

Fig. 7d shows how one thyristor can switch another one off. Assume SCR1 is on and load 1 is energised. The "left-hand" side of C1 will be virtually at earth potential and the "right-hand" side will charge up to the supply voltage via load 2. If SCR2 is now fired its anode and the right-hand side of C1 will fall. Since the charge on a capacitor cannot change instantaneously, the left-hand side of the capacitor, and hence the anode of SCR1 will also fall. This will cause SCR1 to be momentarily reverse biased and it will switch off. If SCR1 is now fired it will switch SCR2 off, and so on. C1 is called the commutating capacitor and the basic circuit can be adapted to form several types of oscillators and flashers.

EXPERIMENTAL CIRCUITS

Having now considered the various facets of thyristor behaviour we will finish off this article by describing a few practical circuits which can easily be made up on the bench and which illustrate the various basic arrangements described above. The actual types of thyristor used will depend on the current drawn by the load; hence no types are quoted on the diagrams. The same applies to the diodes. Use lamps for the loads.

Experiment 1. This is shown in Fig. 8. Closure of the "start" switch will turn the lamp on, and opening of the stop switch will turn it off. In each case only a momentary action is required.

Experiment 2. This is basically the same as the previous one except that a "normal open" stop switch is used in parallel with the thyristor. See Fig. 9.

Experiment 3. This circuit (shown in Fig. 10) is a

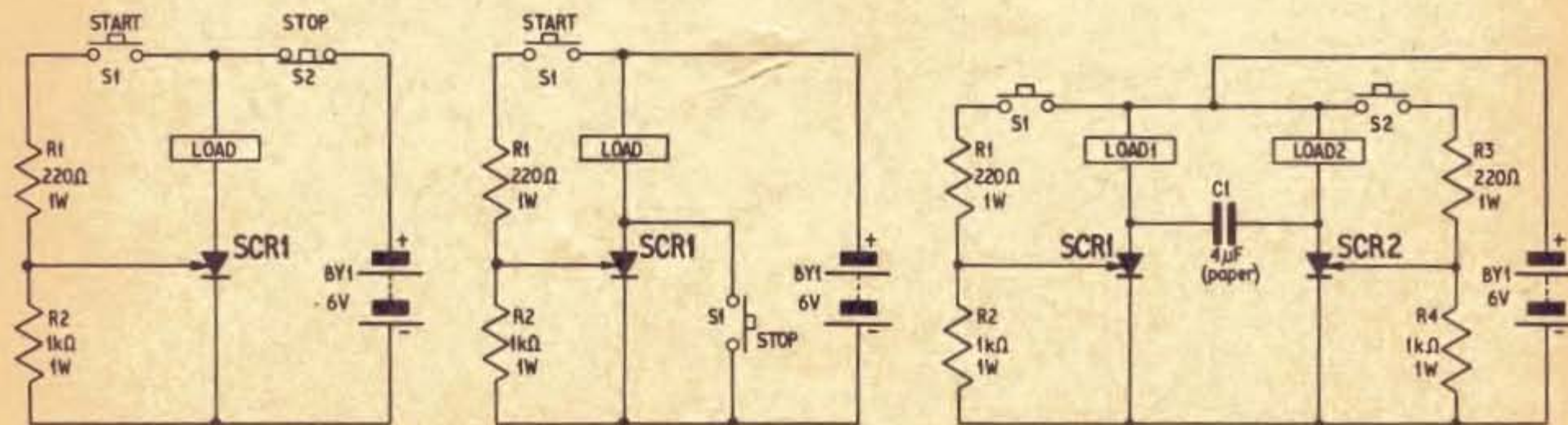

Fig. 8. Simple on-off control with a "normal open" stop switch in parallel with the thyristor (experiment 1) Fig. 9. Another on-off control with a "normal open" stop switch in parallel with the thyristor (experiment 2) Fig. 10. Basic thyristor flip-flop (experiment 3)

practical arrangement designed to illustrate the flip-flop action of two thyristors having their anodes coupled by a commutating capacitor. Initially neither lamp is alight. Operating either of the start switches will cause the appropriate lamp to light and further operation of the second switch will cause the second lamp to light and the first lamp to go out.

Experiment 4. This is the same arrangement as experiment 1 but with an a.c. supply. In this case the lamp only lights to half brilliance, because the thyristor only conducts on the positive half-cycles. It

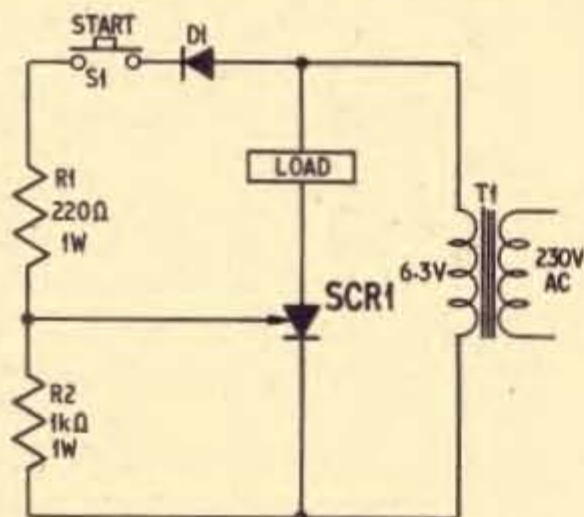

Fig. 11. Simple on-off control with a.c. supply (experiment 4)

only remains alight as long as the start switch is kept closed, because the a.c. supply falls periodically to zero; on the next "zero" after the switch is opened it turns off and stays off. See Fig. 11.

Experiment 5. We saw in experiment 4 that on a.c. supplies the thyristor only conducts every other half-cycle. One way to overcome this problem would be to use two thyristors connected back to front. This arrangement is entirely practical but it requires two lots of gate circuits and two thyristors, which can be expensive items. A novel alternative circuit is shown in Fig. 12.

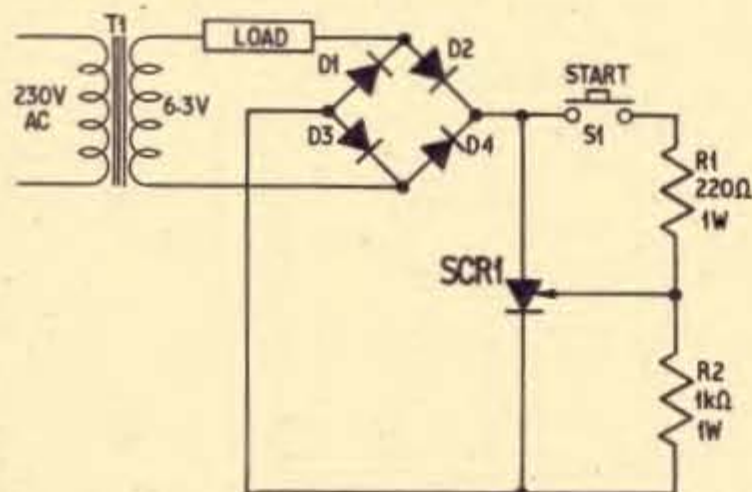

Fig. 12. Use of a bridge rectifier to obtain full wave control of the load (experiment 5)

Notice that the load is connected in series with the input to a bridge rectifier and the thyristor is arranged so that, when it turns on, it shorts the output of the bridge. A little thought will show that when the output of the bridge is shorted the full a.c. supply will be applied to the load, since both halves of the sine wave can pass through the bridge network. The beauty of this arrangement is that the thyristor is effectively switching d.c., whilst the load is fed from a.c. By replacing the resistor divider in the gate circuit by a resistor-capacitor combination you have the basis of all thyristor a.c. power control circuits. ★

THYRISTOR CONTROL

ONE of the most useful electronic additions to the workshop bench is a means of controlling the speed of an electric drill, especially when drilling brickwork. The circuit described here may be used to control the mean power fed to a number of other devices such as, flood lighting, photographic lighting or an a.c. electric motor (not a synchronous type).

The main element is a monostable trigger which generates a pulse to fire a thyristor (otherwise known as a silicon controlled rectifier) at a predetermined point on the positive excursion of the mains sine wave.

TRIGGER CONTROL

Referring to Fig. 1, the 240 volts a.c. mains supply is rectified by D1 such that only the positive going half of the sine wave appears across the Zener diode D2. The two resistors, R1a and R1b in series, limit the current flowing in the Zener diode, and the Zener diode clamps the supply to the trigger circuit to 15 volts. The output from across the Zener diode consists of a positive going square wave as shown in Fig. 2b.

This positive going square wave is used as the power supply for the remainder of the circuit. It is also fed via C1 to a monostable trigger formed by TR1 and TR2; the waveforms are shown in Fig. 2. The positive going edge of this waveform (at C1) coincides with the supply being applied to the circuit and TR1 turns on and TR2 turns off. As C2 charges towards the supply voltage via VR1 and R6, a point is reached where TR2 turns on and in turn TR1 switches off. The output from TR2 collector consists of a positive going square wave, where the leading edge is controlled by the phase of the mains and the lagging edge by the setting of VR1 control.

The output from the monostable trigger is amplified and inverted by TR3 and differentiated by C4 and R9 at TR4 base. TR4 is an emitter follower normally held non-conducting by R9. The negative going pulse at the base of TR4 does not appear at the emitter due to the stage being non-conducting, and the positive going pulse turns the stage on and a positive pulse appears at TR4 emitter. This is fed via C5 and the limiting resistor R11 to the gate of the thyristor, SCR. Diode D3 prevents the gate from going negative.

The thyristor in the quiescent condition is non-conducting on either half-cycle of the mains. A positive going pulse appears at its gate coincident with the positive half-cycle of the mains at the anode. The thyristor then fires and remains conducting until the mains waveform passes through zero; it then cuts off.

The thyristor therefore conducts for a portion of the positive excursion of the mains sine wave. The time that it is conducting is determined by the setting of VR1 control, and the mean current in the anode is used to drive the load.

Improved smoothness of operation and a wider range of control can be obtained if a conventional power supply is used as shown in Fig. 3. The disadvantage of using this is that the size and weight of the unit is increased considerably.

UNIT



by A. THOMAS

COMPONENTS

The unit is constructed in an Eddystone type 650 aluminium box, with the following mounted on the lid: outlet socket 13 amp rating type MK734 or MK732 with the front plate removed; two on-off switches, one which isolates the unit from the mains and the other which switches from full power to half power, where fine control is exercised by the potentiometer.

The thyristor is mounted in the unit by fixing the stud into the neutral terminal of the outlet socket SK1. The remainder of the electronics are contained on a piece of Veroboard mounted by two insulated pillars using the same fixing screws as for the outlet socket.

The components as specified in the parts list, should be used to enable the unit to fit together without trouble. The Radiospares and MK plug and socket

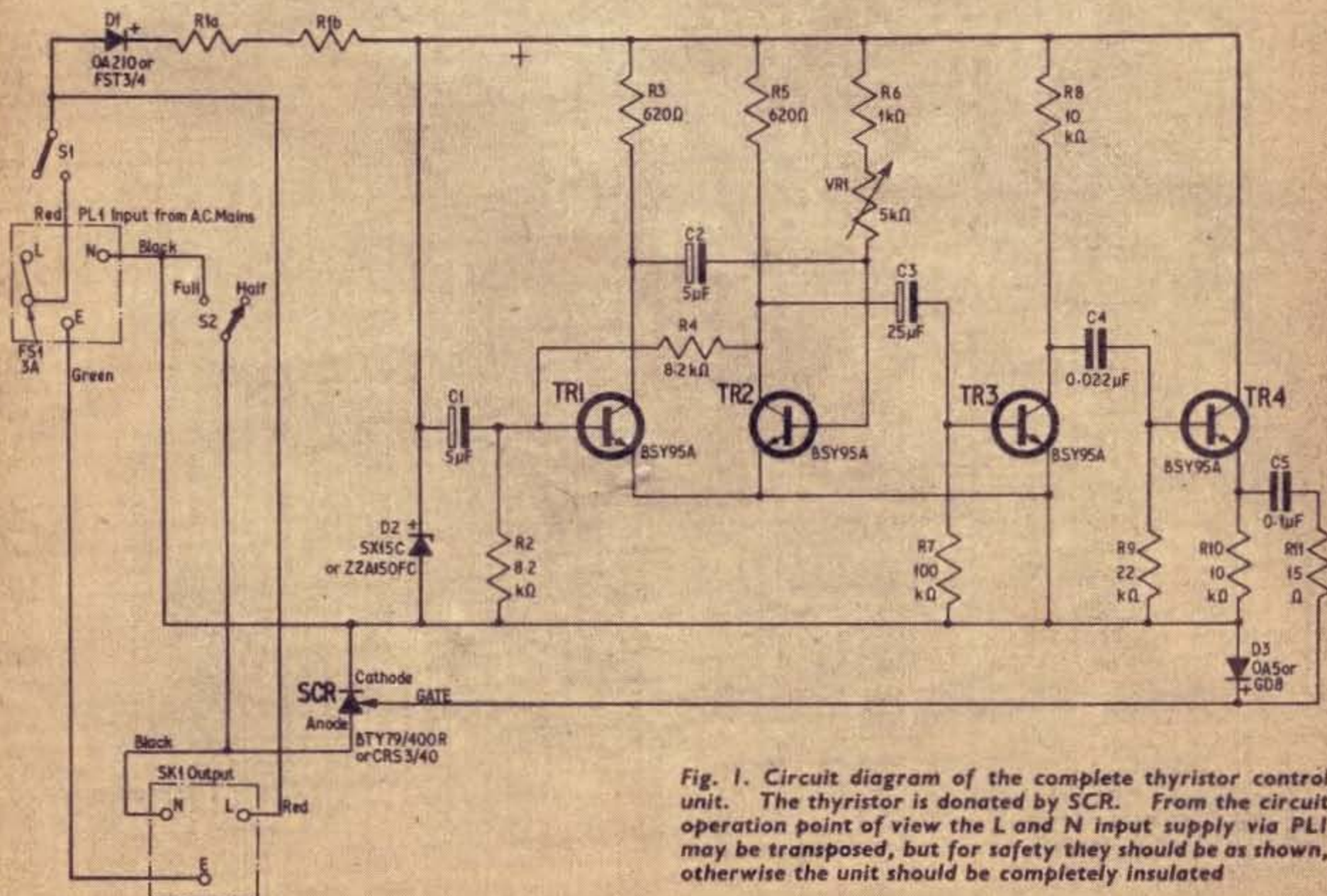

Fig. 1. Circuit diagram of the complete thyristor control unit. The thyristor is denoted by SCR. From the circuit operation point of view the L and N input supply via PL1 may be transposed, but for safety they should be as shown, otherwise the unit should be completely insulated

may be ordered through any radio and electrical retailer. The semiconductors (transistors are all *npn* types) may be ordered from one of the many advertisers in this publication. Resistors R1a and R1b can be replaced by a single resistor 5,000 ohms 10 watts if preferred.

The thyristor connections are identified as follows: stud is the anode; short tag is the gate; long tag is the cathode. The CRS3-40 has a peak inverse voltage of 400V and a mean current rating of 3.75A with a peak repetitive current of 20A. The unit as described will safely handle 750 watts. To obtain a higher rating a different thyristor type would be required, but it is likely to be approximately three times the price of the low current types. Typical high power types suggested are S.T.C. CRS25-40 or Mullard BTY87-400R. The unit will drive these types satisfactorily but a different mounting arrangement would be necessary using a heat sink.

MAKING UP

The drilling and cutting details of the box panel is shown in Fig. 4. There are a number of ways of

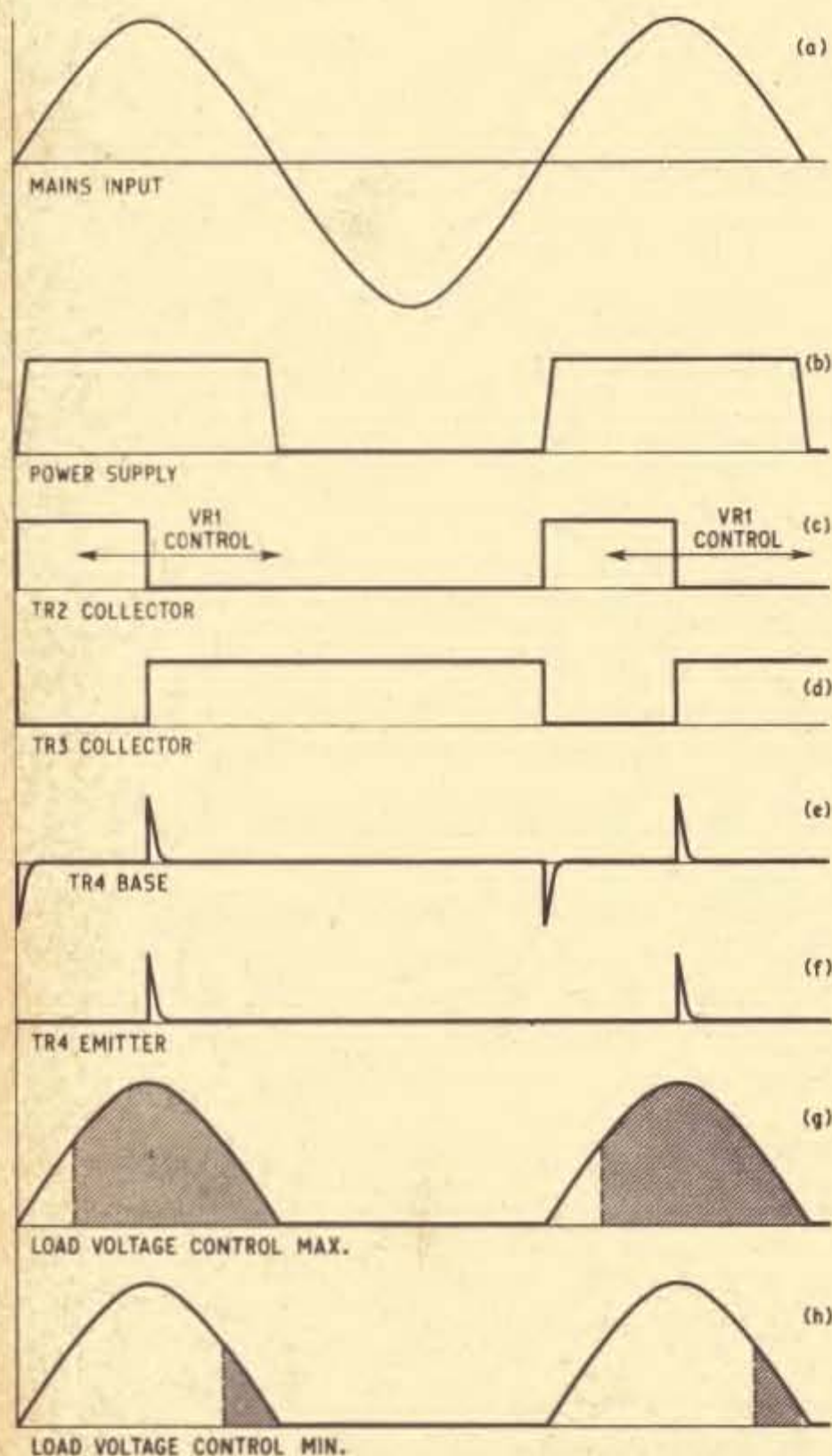

Fig. 2. Synchronized waveforms at different parts of the circuit

cutting out the 'T'-shaped hole for SK1. Probably the best way is to mark out the shape with a scribe, drill holes all round the inside of this line, break out the waste piece, then file to the required shape and size. Two 4 B.A. clearance (No. 26 drill) holes are drilled to fix the socket and pillars for mounting the Veroboard panel. A drawing is also shown at the bottom of Fig. 4 giving the details of the pillars. Holes should be drilled in each end, then tapped very carefully to avoid damage to the material and the tap.

The photographs show how the pillars are fitted. Notice from Fig. 4 that one end of each pillar is 4 B.A. (No. 32 drill), which is attached to the fixing screws through the metal plate of the box and the socket. The other end is 6 B.A. (No. 43 drill) to fix the component board.

Full wiring details are shown in Fig. 5. The Veroboard has some link wires and the breaks are shown in Fig. 6. Observe the interconnections between the control panel and the component board. The wires are colour coded for easy reference to wiring connections. Care must be exercised when mounting transistors, diodes, thyristor, and capacitors; make sure the connections and polarities are correct.

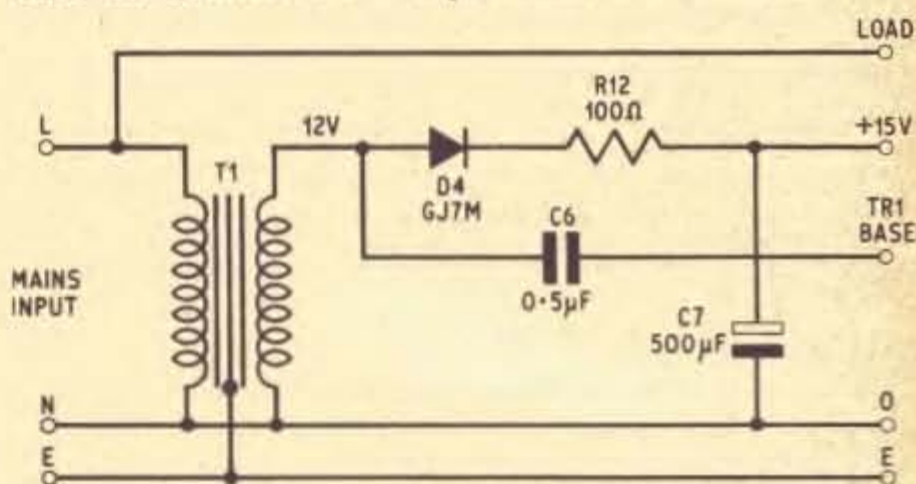

Fig. 3. Suggested circuit for an auxiliary power unit to give smoother operation of the control unit

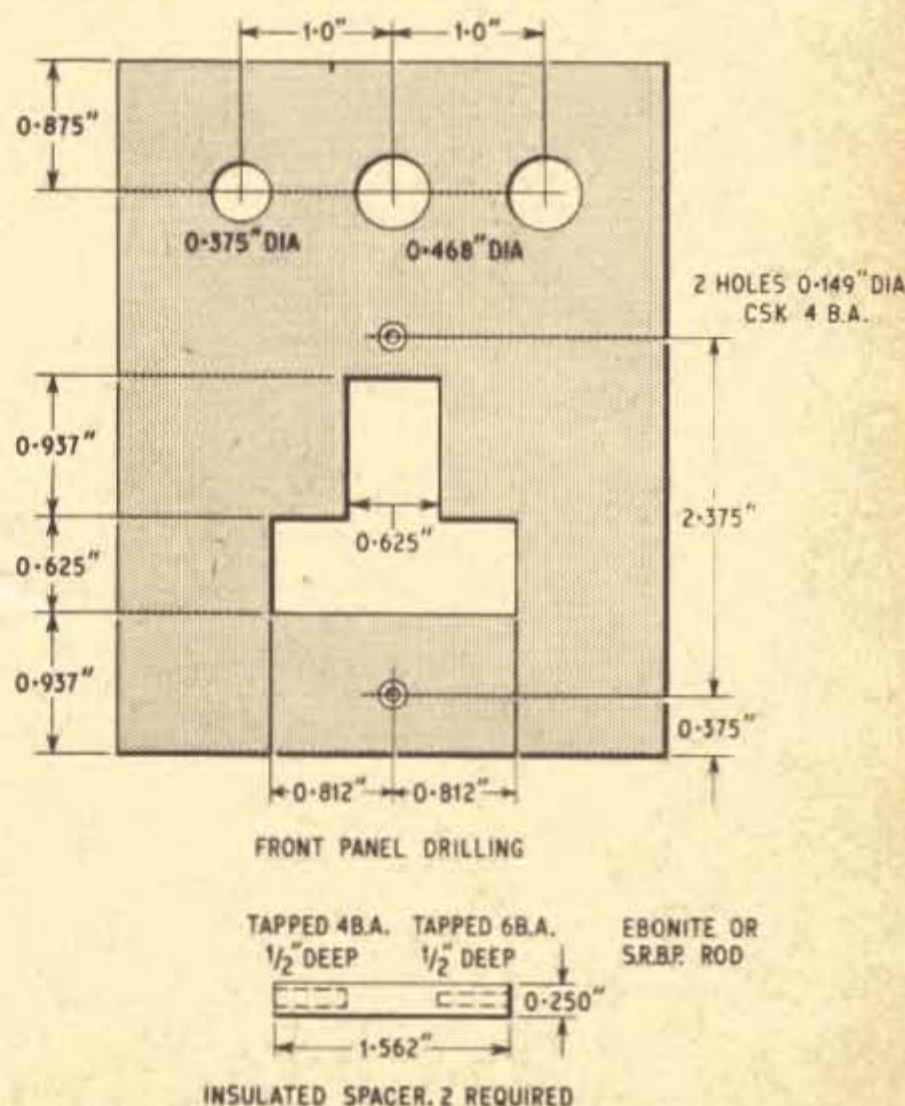

Fig. 4. Drilling details of the control panel and spacers

COMPONENTS . . .

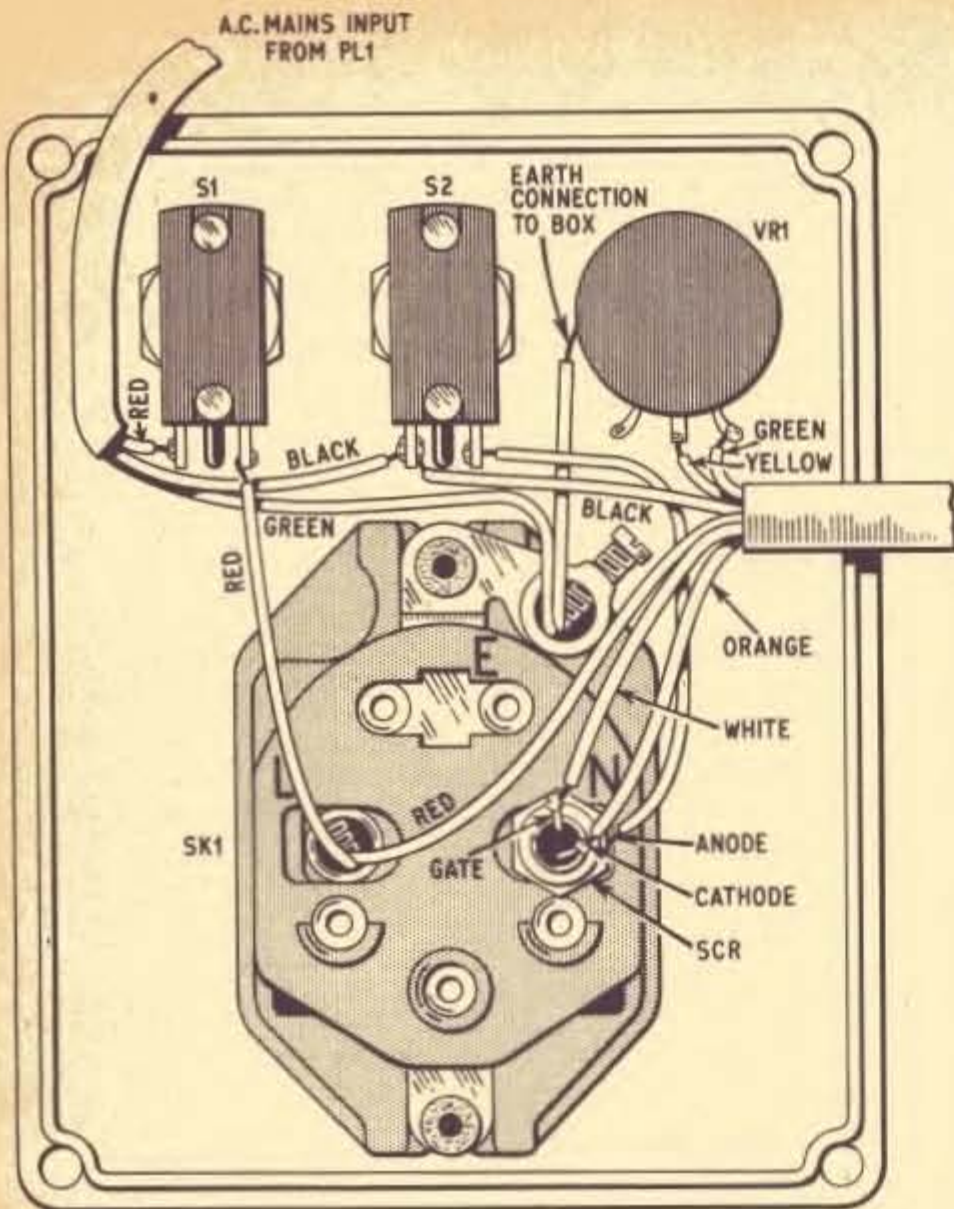

Fig. 5a (above). Wiring details of the control panel with multi-cored cable to component assembly board

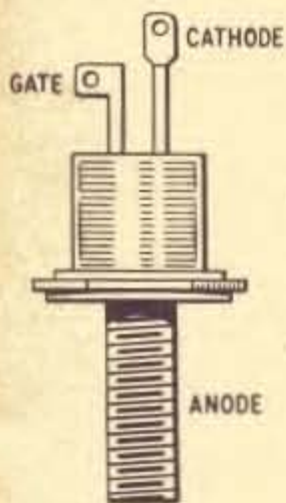

Fig. 5b. (left). Connections for the thyristor

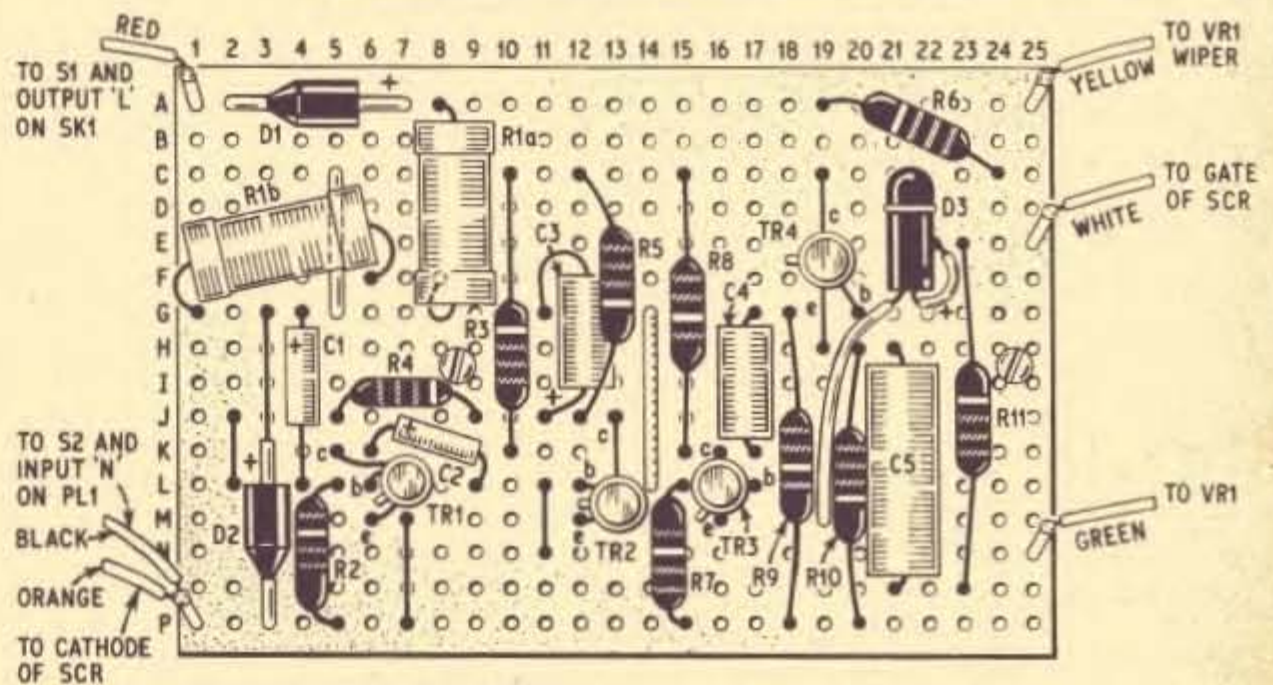
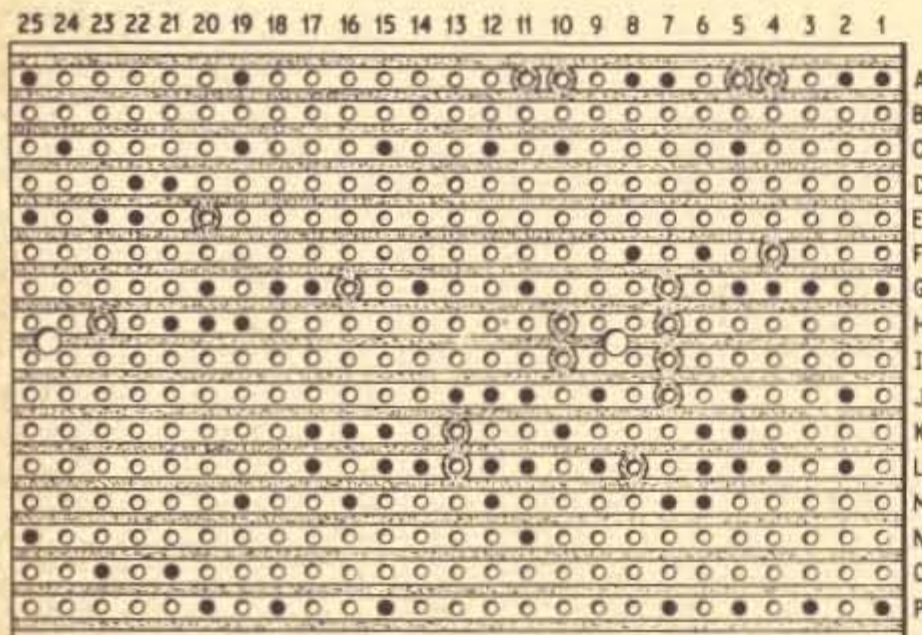

Fig. 5c (above). Wiring details of the component assembly board

Fig. 6 (left). Underside view of the component assembly board



DRILL TWO HOLES .120" DIA

Resistors

R1a	2.5k Ω 10W	} or R1 5k Ω 10W					
R1b	2.5k Ω 10W						
R2	8.2k Ω	R5	620 Ω	R8	10k Ω	R11	15 Ω
R3	620 Ω	R6	1k Ω	R9	22k Ω		
R4	8.2k Ω	R7	100k Ω	R10	10k Ω		

R2 to R11 are all 5% high stability carbon types

Potentiometer

VR1 5k Ω linear carbon

Capacitors

C1	5 μ F elect. 15V	C3	25 μ F elect. 15V
C2	5 μ F elect. 15V	C4	0.022 μ F polyester
		C5	0.1 μ F polyester

Transistors

TR1, 2, 3, 4 BSY95A (S.T.C.) (4 off)

Thyristor

SCR BTY-79-400R (Mullard) or CRS3-40 (S.T.C.)

Diode

D1 OA210 (Mullard) or FST3/4 (S.T.C.)
 D2 Zener SX15C (Mullard) or Z2A150FC (S.T.C.)
 D3 OA5 (Mullard) or GDB (S.T.C.)

Switches

S1 Single pole, on-off, toggle switch
 S2 Single pole, on-off, toggle switch

Plug and Socket

PL1 13 amp 3 pin with 3A fuse (FS1 in Fig. 1) or to suit mains supply socket on wall with additional 3A fuse if required

SK1 13 amp 3 pin mains type

Miscellaneous

Diecast box (Eddystone type 650), 3-core mains cable. Pointer knob and p.v.c covered wire. Veroboard 43/1504

TRY IT OUT

When the unit is complete and the wiring is correct, it can be tried out. Insert PL1 into the mains supply; S1 should be off and S2 should be on at first (i.e. set for full power). A domestic lamp (about 40W) is probably best to start with. Connect the load to SK1 and switch on S1. Having ascertained that the full mains is supplying the lamp, you can now set VR1 to minimum and switch S2 to "half" power. Adjust VR1; the lamp brilliance should alter correspondingly. The unit can be tried out on other appliances provided they are within the range of power previously mentioned.



Part Five

SINGLE CHANNEL PROPORTIONAL SYSTEMS

By R. H. WARRING

Radio Control of Models

SINGLE channel radio control presents a challenge to ingenuity to extend the service offered beyond simple sequential movements. There are definite limits to what can be attempted in order to provide practical methods of sequence selection; there are equally definite limits to the number of individual sequence positions which can be utilised without rendering the whole control system unmanageable. Thus, as far as model control systems are concerned, straightforward single channel operation can only provide incomplete coverage of requirements, the real attraction being that it is by far the cheapest form of radio control available. For that reason alone it remains the most popular type of radio control, in this country at least.

About the only way in which single channel signalling can be improved in performance as a basic "control" method is to adapt it to proportional signalling rather than simple on-off switching and related "bang-bang" movement of the associated actuator. This demands some modification of the transmitter signal to provide a variable signal and a modified form of actuator capable of interpreting that intelligence.

Electronically (at the transmitter end) and electromagnetically (at the actuator end) this is relatively simple to arrange; but although this may produce a "proportional" system it will still have distinct limitations as a practical control method, typically a lack of a positive or "safe" neutral position, for example. Also such servo circuits are almost invariably of open-loop type and thus not truly proportional, as the actual position assumed by the actuator output will be influenced by the load on it.

Single channel proportional systems do, however, provide an interesting field for experiment; a number of commercial systems operating on this principle are now also available. The cost is appreciably lower than conventional "multi-channel" systems and very much lower than the multi-channel proportional systems. This is because all the "intelligence" required can be superimposed on the output of a conventional single channel transmitter.

PULSE SIGNALLING

The basic method of achieving "proportional" signalling is to transmit the master (single channel) signal in a series of pulses rather than as a continuous signal. At the receiver end the actuator (which can be a simple electric motor) is wired to the receiver relay as shown in Fig. 5.1.

Assuming that the transmitter signal is pulsed at a steady rate with equal periods of "on" and "off" (i.e. a mark/space ratio of 1 : 1), the receiver relay armature will follow at the same rate, alternately completing the battery circuits to drive the motor first one way and then the other. In other words, the motor will oscillate about a mean or "neutral" position.

If the pulse rate is increased, there will come a point at which the motor is virtually stationary since it will not have time to start moving in one direction before it is switched with opposite battery polarity to move in the opposite direction. In practice, it is only necessary to increase the pulse rate to the point where the oscillation of the actuator (motor) is rapid enough

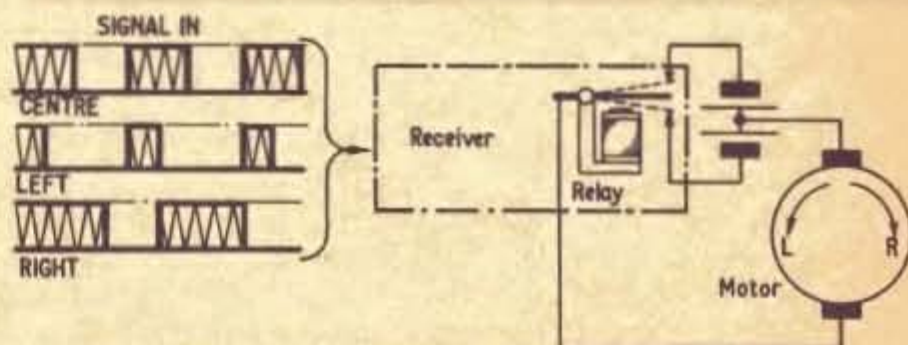

Fig. 5.1. Pulse proportional signal operates the relay according to its mark/space ratio



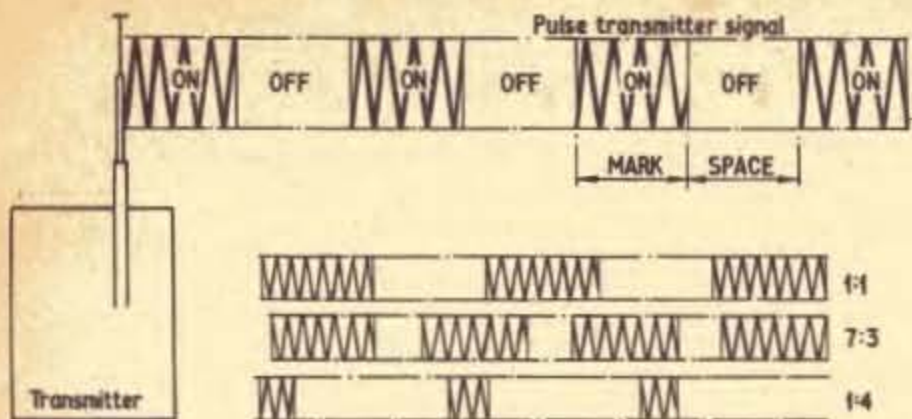

Fig. 5.2. Comparison of different mark/space ratios of the transmitter signal

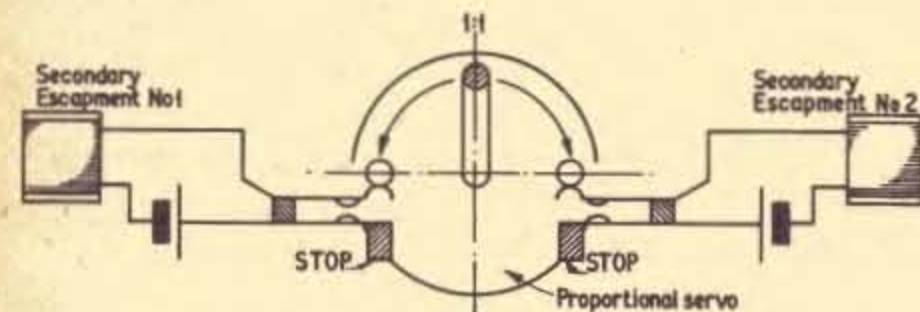

Fig. 5.3. The movement of the crank to left (mark/space $1 : > 1$), through centre (mark/space $1 : 1$), to right (mark/space $> 1 : 1$)

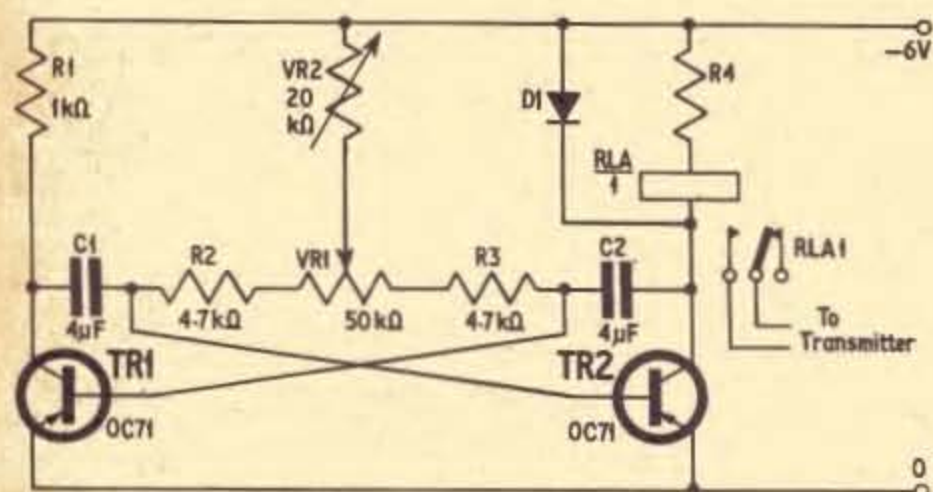

Fig. 5.4. Multivibrator circuit for providing variable mark/space ratio pulse signals

not to have any appreciable effect on the performance of the model being controlled. This corresponds to a minimum of four pulses per second in the case of model aircraft.

Having established a satisfactory pulse rate, if the mark/space ratio is now altered the relay armature will tend to dwell for longer on one contact than the other. Therefore, the effective "neutral" position of the motor will be biased to one side in proportion to the mark/space ratio. Thus a complete range of "proportional" movement is made available, from continuous rotation in one direction (all "mark") back to the true neutral position ($1 : 1$ mark/space) to continuous rotation in the other direction (all "space")—see Fig. 5.2.

In practice, rotation of only 90 degrees from the true neutral is necessary to obtain a full control movement as far as mechanical output is concerned. Hence a mechanical stop would normally be used at this position (allowing the motor to continue to run against a slipping clutch) whilst holding a "full on" control position.

Alternatively the "full" control position could be used for triggering a separate switching circuit to operate a secondary actuator, thus giving proportional movement of the main control, plus one or two separate and additional services switched by selecting an extreme control position (all "mark" or all "space")—see Fig. 5.3. Normally these auxiliary circuits would have to operate on a "trigger" basis, because if either were selected, it would mean momentarily selecting a full-on position for the main control.

ELECTRONIC PULSING

The necessary pulsed output from the transmitter can be achieved either mechanically or electronically. The latter is the preferred method, although quite excellent mechanical systems have been produced by individual modellers. Electronically all that is required is a simple multivibrator circuit driving a relay. The transmitter output signal is then taken through the relay contacts and is "pulsed" at the rate corresponding to the multivibrator frequency.

A typical circuit is shown in Fig. 5.4 together with component values. Resistor R_4 in series with the relay is selected to make the combined value of R_4 plus relay coil resistance equal to R_1 . The mark/space ratio is controlled by VR_1 . As far as mechanical control is concerned, an arm attached to the potentiometer spindle forms the "control stick". Rotation in one direction increases the mark/space ratio; rotation in the other direction decreases the mark/space ratio. The central position of the control stick (i.e. central position of the potentiometer) corresponds to $1 : 1$ mark/space and thus the "neutral" position. VR_1 would have a linear track.

It is necessary that some resistance be left in the circuit at either end of the potentiometer. This can be done either by limiting the mechanical movement of the control stick so that some resistance remains at either end of the movement, or by adding fixed resistors of about 4.7 kilohms each, in series with each outer terminal of VR_1 and each base.

A refinement is to include a diode across R_4 and the relay coil, as shown in Fig. 5.4. This will protect the second transistor against transient currents induced by the relay.

The addition of a 20 kilohm potentiometer VR_2 between battery negative and VR_1 wiper will provide a further method of control in this circuit by permitting adjustment of the pulse rate. Once a suitable pulse rate has been established this potentiometer can be replaced by a fixed resistor of equivalent value to the setting established.

The pulser circuit is quite independent of the main transmitter circuit. Thus it can be built as a separate unit, powered by its own battery, and simply attached to the transmitter case as an extra fitting. It can thus be used with any size and type of single channel transmitter to adapt it for "pulse proportional" operation. In the case of a modulation (c.w.) transmitter, the pulser relay contacts would be connected in series with the h.t. lead. With a tone transmitter the pulser relay contacts would be used to switch the tone circuit.

The single-channel relay receiver needs no modification at all for pulse operation, other than the utilisation of both relay contacts for completing the actuator circuit, and the necessity of having a suitable relay for following the pulsed signal.

There is, however, some advantage in employing a simple transistor switch (such as in Fig. 5.5) for greater

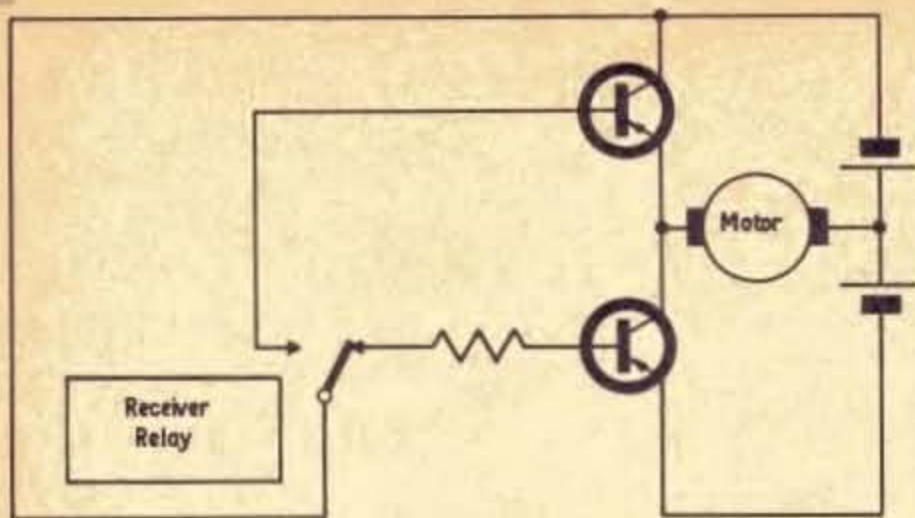

Fig. 5.5. Using a pair of transistors to operate the motor

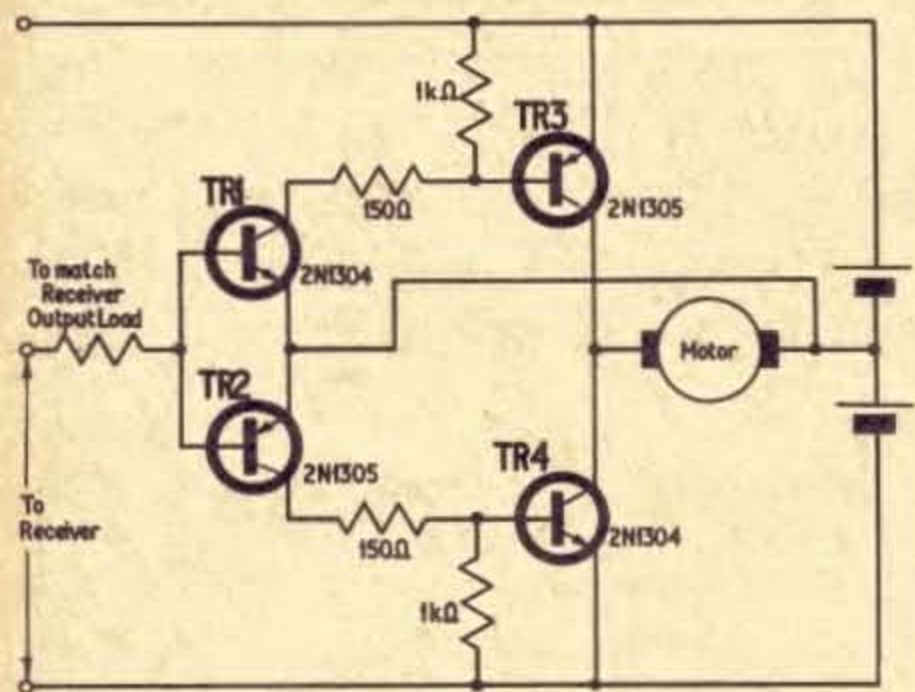

Fig. 5.6. Transistors can be used in place of the relay

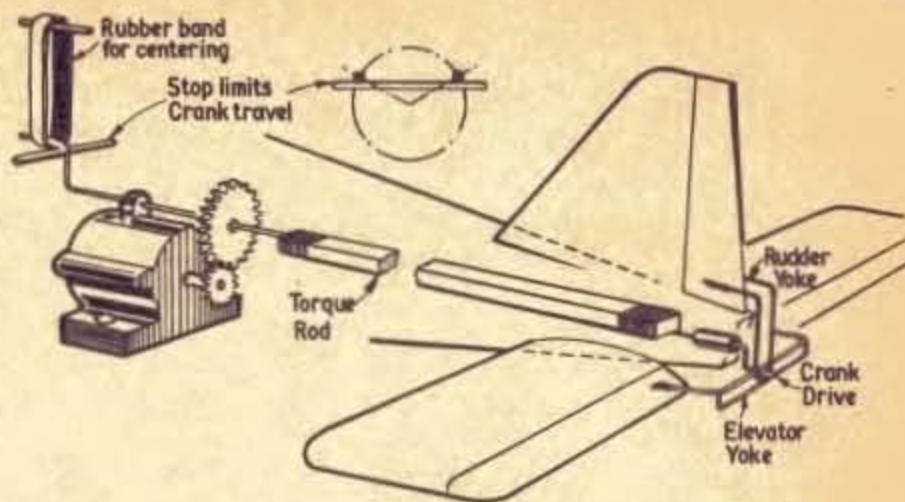

Fig. 5.7. Schematic diagram of how the motor would be coupled to the rudder and elevator flaps

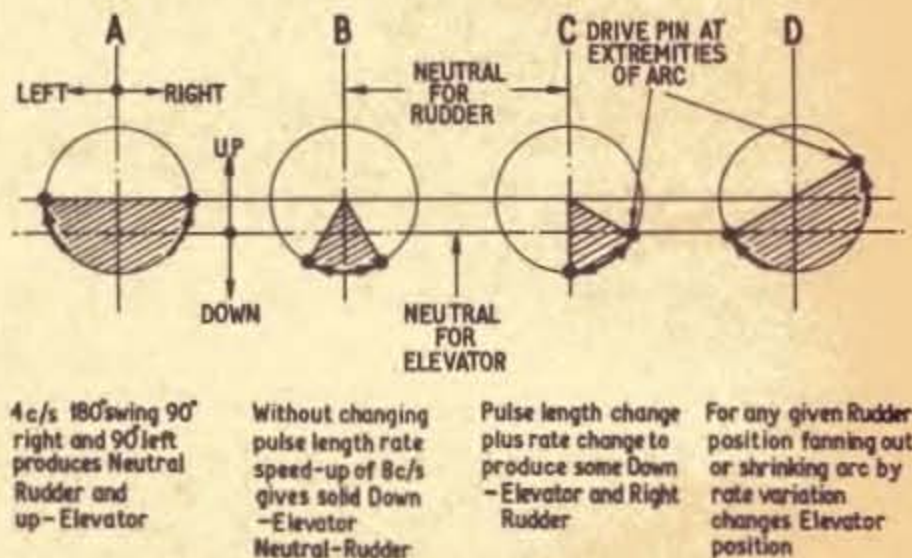

Fig. 5.8. Positions of the crank drive in relation to rudder and elevator flaps

reliability of operation. The transistors must be chosen with regard to the operating voltage and current passed to meet the requirements of the actuator (motor) without overloading. Type 2N1305 are generally satisfactory for small motors operating on not more than 3 volts if they are never allowed to assume a stalled position.

With a relayless receiver the adaptation is rather different. However, it is a simple matter to connect the receiver output to a relay of suitable coil resistance, when it will operate just like a relay receiver with the relay contacts wired to the actuator (motor). Alternatively, a transistor switching circuit can be employed instead of a relay (see Fig. 5.6).

Both types of receiver (and relayless receivers in particular) are susceptible to interference from the actuator motor. An obvious precaution is to position the actuator as remote from the receiver as possible, but suppression may also be necessary. Alternative methods were shown in Fig. 4.11 last month.

Very sensitive receivers may only work satisfactorily with pulsed systems employing magnetic actuators instead of motors. These use only coil circuits (with no make and break contacts) with spring self-centring.

They are attractive in principle but not very satisfactory, or useful, in practice due to the very low mechanical output possible. Motors are generally far more satisfactory provided they have light armatures and very good brushes. In practice the mechanical output would be extracted via reduction gearing rather than direct from the motor spindle, thus providing torque multiplication.

IN PRACTICE

In general, the simple pulsed proportional system described works quite well when applied to aircraft models and other systems where control loads are light, but can be difficult to master as a flying control because of the lack of a positive self-centring neutral. It is not so satisfactory for boat rudder control because of the much higher loads on the control surface; although in this application the type of response provided is easy to master as a working control system.

For aircraft control systems a more satisfactory arrangement is "simple-simultaneous" or the "galloping ghost" system which is essentially a dual proportional system, although worked off a single-channel signal. It should be emphasised that it is essentially

BUILD OVER 40 CIRCUIT/EXPERIMENTS

and master electronics the LERNAKIT way

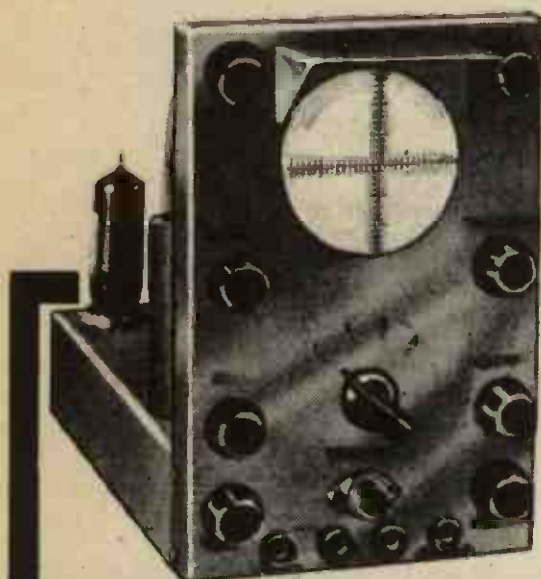

- No maths — No unnecessary theory
- NO PREVIOUS KNOWLEDGE NEEDED
- BUILD A PROFESSIONAL
CATHODE RAY OSCILLOSCOPE

Learn how to

- READ AND DRAW CIRCUIT DIAGRAMS
- RECOGNISE, HANDLE AND UNDERSTAND
every type of modern **ELECTRONIC COMPONENT**

OVER 40 EXPERIMENTS — including:-

- Valve Experiments
- Transistor Experiments
- Electro-magnetic Experiments
- Basic Amplifier
- Basic Oscillator
- Basic Rectifier
- Signal Tracer
- Simple Counter
- Time Delay Circuits
- Square Wave Generator
- Morse Code Oscillator
- Simple Transmitter
- Electronic Switch
- Photo-electric Circuit
- Basic Computer Circuit
- Basic Radio Receiver
- A.C. Experiments
- D.C. Experiments

This complete practical course will teach you all the basic principles of electronics by carrying out experiments and building operational apparatus. You will learn how to recognise and handle all types of modern components, their symbols and how to read a complete circuit or schematic diagram. The course then shows how all the basic electronic circuits are constructed and used and **HOW THEY ACTUALLY WORK BY USING THE OSCILLOSCOPE PROVIDED**. An application is given in all the main fields of electronics, i.e. Radio; control circuits; computers and automation; photoelectrics; counters, etc., together with rules and procedure for fault finding and servicing of all types of electronic equipment. For a new and exciting approach which gives a real understanding of electronics in an entirely practical way—this course has no equal anywhere to-day.

POST NOW FOR FREE COLOUR BROCHURE

To: **BRITISH NATIONAL RADIO SCHOOL, READING, BERKSHIRE**

Please send free Brochure, describing your LERNAKIT Oscilloscope Course without obligation, to:

NAME.....

ADDRESS.....

BLOCK CAPITALS PLEASE

OR WRITE IF YOU PREFER NOT TO CUT COUPON

(No representatives employed)

P.E.6.66

British National Radio School

VARIABLE VOLTAGE TRANSFORMERS

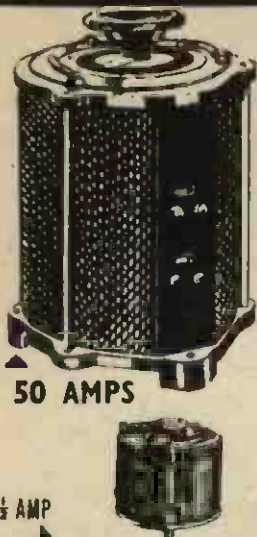

50 AMPS

1/2 AMP

INPUT 230/240v. A.C. 50/60—
OUTPUT VARIABLE 0-260v.
BRAND NEW Carriage Paid.
Buy direct from the importer,
keenest prices in the country.
All Types (and Spares) from
1/2 to 50 amp. from stock.
OPEN TYPE (Panel Mounting)
1/2 amp, £3. 3. 0. 1 amp, £4. 17. 6.
2 1/2 amps, £5. 12. 6.
SHROUDED TYPE
1 amp, £4. 10. 0. 2.5 amps,
£5. 17. 0. 4 amps, £8. 7. 6.
5 amps, £9. 0. 0. 8 amps,
£13. 10. 0. 10 amps, £17. 0. 0.
12 amps, £19. 10. 0. 15 amps,
£22. 0. 0. 20 amps, £32. 10. 0.
37.5 amps, £65. 0. 0. 50 amps,
£85. 0. 0.
PORTABLE TYPE
2.5 amps, Portable £9. 17. 6.

LIGHT SENSITIVE SWITCH

Kit of parts, including ORP12 Cadmium Sulphide Photocell, Relay, Transistor and Circuit, etc., price 25/- plus 2/6 P. & P. ORP 12 including circuit, 10/6 each, plus 1/- P. & P.



A.C. MAINS MODEL

Incorporates Mains Transformer, Rectifier and special relay with 3, 5 amp mains c/o contacts. Price inc. circuit 47/6 plus 2/6 P. & P.

NEW! PHOTO ELECTRONIC COUNTER

Can be set for counts of up to 500 per minute. 210-250 v. A.C. powered. Kit of Components including photo cell. High speed non-resettable counter. Transformer, relay, etc., together with clear circuit diagram. £3.2.6, plus 2/6 P. & P.

100 WATT POWER RHEOSTATS (NEW)

AVAILABLE IN THE FOLLOWING 9 VALUES

10 ohm, 3 a.; 25 ohm, 2 a.; 50 ohm, 1.4 a.; 100 ohm, 1 a.; 250 ohm, .7 a.; 500 ohm, .45 a.; 1,000 ohm, 280 mA; 1,500 ohm, 230 mA; 2,500 ohm, .2 a. Diameter 3 1/2 in. Shaft length 3 in., dia. 1/2 in. All at 27/6 each. P. & P. 1/6.

NOW ALSO AVAILABLE IN 25 WATT

10 ohm, 1.5 a.; 25 ohm, 1 a.; 50 ohm, .75 a.; 100 ohm, .5 a.; 250 ohm, .3 a.; 500 ohm, .2 a.; 1,000 ohm, .15 a.; 1,500 ohm, .12 a.; 2,500 ohm, .1 a.; all at 14/6. P. & P. 1/6.

"GABY" MULTI-RANGE TEST METER

Model B40. D.C. volt, 0.5 v., 2.5 v. at 10,000 ohm per volt. Ideal for transistor circuit testing. A.C. and D.C. volt, 10 v., 50 v., 250 v., 500 v., 1,000 v. at 4,000 ohm per volt. Resistance, 2K ohm, 200 K ohm, 2 megohm, 20 megohm.

Price includes Test Leads, Battery, Instruction book, Packing and Post (U.K.). £6.2.6. 3 additional models available from 54/- to £14.14.0. Leaflet gladly sent on request.

34R SILICON SOLAR CELL

4 x .5 Volt unit series connected output up to 2V at 16-20 mA in sunlight. 30 times the efficiency of selenium. As used to power Earth Satellites. 37/6. P. & P. 1/-.

230 VOLT A.C. GEARED MOTORS

5 r.p.m. 1.7lb. inch £2.9.6. P. & P. 2/6
80 r.p.m. .26lb. inch £2.2.0. P. & P. 2/6

LATEST HIGH SPEED MAGNETIC COUNTERS

4 figure 10 impulses per second. Type 100D, 4.1 ohm coil, 3-6 v. D.C. operation. Type 100A, 500 ohm coil, 18-24 v. D.C. operation. Type 100B, 2,300 ohm coil, 36-48 v. D.C. operation. Any type, 15/- each, plus 1/6 P. & P.

L.T. TRANSFORMERS All primaries 220-240 volts.

Type No.	Sec. Taps	Price Carr.
1	30, 32, 34, 36 v. at 5 amps.	£3.5.0 6/-
2	30, 40, 50 v. at 5 amps.	£5.5.0 6/6
3	10, 17, 18 v. at 10 amps.	£3.10.0 4/6
4	6, 12 v. at 20 amps.	£4.17.6 6/6
5	17, 18, 20 v. at 20 amps.	£5.12.6 6/6
6	6, 12, 20 v. at 20 amps.	£5.5.0 7/6
7	24 v. at 10 amps.	£3.15.0 5/6
8	28, 29, 30, 31 v. at 21 amps.	£7.10.0 10/-



SANGAMO WESTON

Type S32 2 1/2 Edgewise Meter
250 Micro-amp., scaled in dB's. New 29/6. P. & P. 1/-.

230 V. A.C. MOTOR and REDUCTION GEAR BOX

Reversible 1/2 h.p. 1,450 r.p.m. 3/4" dia. 1" long shaft. Mounted in anti-vibration cradle. Supplied complete with precision 20-1 reduction gear box and pulleys.

Made to highest standard for computer work. Ex equip. First-class condition. Price £3.5.0. P. & P. 7/6.

SOUND POWER OPERATED

EX-ADMIRALTY HEAD AND BREAST SETS

Two such sets connected up will provide perfect intercom. No batteries required. Will operate up to 1/2 mile. Price 17/6 each plus P. & P. 3/- or 32/6 per pair. P. & P. 5/6.



METERS

2 1/2" Flush Round
A.C. AMMETERS
0-1, 0-5, 0-10, 0-15, 0-20 Amp. All 21/- each, p. & p. extra.
A.C. VOLTMETERS
0-25, 0-50, 0-150 V. All 21/- each, p. & p. extra. 0-300 V. A.C. m/c Rectifier £19.0.

UNIVERSAL DEMONSTRATION TRANSFORMER

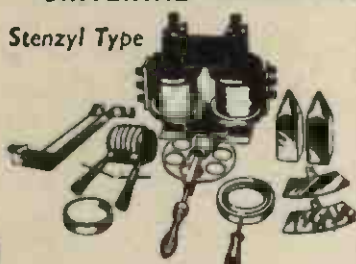

A complete composite apparatus, comprising a Transformer and electro-magnet with removable coils and pole pieces. Coil tapped for 230 v, 220 v, 110 v, 115v; 6, 12, 36, 110 v. A.C. These coils are also used for D.C. experiments. Complete with all accessories as shown. £17 10/- carriage. Leaflet on request.

WIMSHURST ELECTROSTATIC GENERATORS

RS300 Series. All types 1.5 amp. wire ended. RS310, 100 v. P.I.V. 4/-, RS330, 300 v. P.I.V. 6/-, RS340, 400 v. P.I.V. 7/-, RS350, 500 v. P.I.V. 8/-, RS360, 600 v. P.I.V. 9/-, RS380, 800 v. P.I.V. 10/- 4 can be used to make 3 amp. bridge. Not Seconds. Brand New Stock. Post paid.

S.T.C. SILICON POWER RECTIFIERS

RS300 Series. All types 1.5 amp. wire ended. RS310, 100 v. P.I.V. 4/-, RS330, 300 v. P.I.V. 6/-, RS340, 400 v. P.I.V. 7/-, RS350, 500 v. P.I.V. 8/-, RS360, 600 v. P.I.V. 9/-, RS380, 800 v. P.I.V. 10/- 4 can be used to make 3 amp. bridge. Not Seconds. Brand New Stock. Post paid.

SOLENOID. Overall length 3 1/2", stroke 1/2" to 3/4". Maximum push 8 oz. 12-24 v. D.C. operation. D.C. resistance 35 ohm. Price 8/6. P. & P. 1/6.

ULTRA VIOLET BULBS

Easy to use source of U.V. for dozens of practical and experimental uses.
12 volt 36 watt A.C./D.C. SBC 6/6.
12 volt 60 watt A.C./D.C. SBC 8/6.
P. & P. 1/- on above items.
Transformer to suit the above. Input 200-240 v. A.C., 12 volt 36 watts, 16/6; P. & P. 2/6. Input 200-240 v. A.C. 12 volt 60 watt, 22/6. P. & P. 3/6.

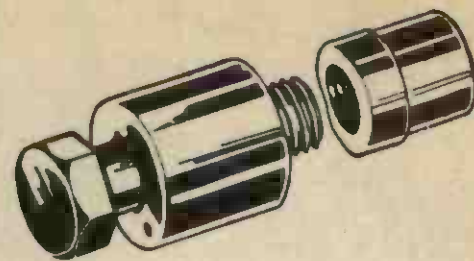

The PUNCH you need!

HOLE PUNCHES

Instant Type

3/8" diameter	6/10 ea.
Screw-up Type	
1 1/2" diameter Toggle switch	8/6 ..
1 1/2" .. B7G	8/6 ..
1 1/2" .. B8A, B9A	9/- ..
1 1/2" ..	10/2 ..
1 1/2" ..	10/8 ..
1 1/2" ..	11/8 ..
1 1/2" diameter Int. Octal	13/4 ..
1 1/2" ..	16/2 ..
1 1/2" ..	18/10 ..
1 1/2" .. B9G	21/8 ..
1 1/2" ..	24/4 ..
2 1/2" .. Meter	33/2 ..

Complete Set £9.3.6.

No extra charge for postage and packing in the U.K.

Now supplied by:

TOMPKINS & LONGMAN LTD.

237 GIPSY ROAD
WEST NORWOOD, S.E.27
Tel.: Gipsy Hill 5000

4-STATION INTERCOM



£7/15/0

Solve your communication problems with this latest 4-Station Transistor Intercom system (1 master and 3 Subs), in de-luxe plastic cabinets for desk or wall mounting. Call/talk/listen from Master to Subs and Subs to Master. Operates on one 9V battery. On/off switch. Volume control. Ideally suitable for Office, Factory, Workshop, Warehouse, Hospital, Shop, etc. Complete with 3 connecting wires, each 66ft. & other accessories. Nothing else to buy. P. & P. 4/6 in U.K.

INTERCOM/BABY ALARM



Usually ~~£10.00~~
Our Price ONLY ..

57/6

Modernize business and home with this latest two-way Transistor Intercom, consisting of two units, Master and Sub, in strong plastic cabinets with chromium stands. Elegantly designed to use as two-way instant communication system—Call/talk/listen—between two persons. Operate on one 9V battery. Complete with 60 ft. wire. Battery 2/6. P. & P. 2/6 in U.K.

TELEPHONE AMPLIFIER

75/-



Why not increase business efficiency with this De-luxe Telephone Amplifier with Rotary Calendar and Pen-Holder which enables you to take down long telephone messages or converse without holding the handset. A status symbol? Yes, but very useful one. On/off switch. Volume Control. Operates on one 9V. battery (supplied) which lasts for months. P. & P. 3/6 in U.K. Full money refunded if not satisfied in 7 days.

WEST LONDON DIRECT SUPPLIES (PE/8)
169 KENSINGTON HIGH STREET, LONDON, W.8

SERVICE TRADING CO

All Mail Orders—Also callers:
47/49 HIGH STREET, KINGSTON on THAMES
Telephone: KINGston 9450

Personal callers only
9 LITTLE NEWPORT STREET
LONDON, W.C.2 Tel.: GERrard 0576

an aircraft system and is specific to a two-dimensional control system.

Basically, one channel of proportional intelligence is extracted from a variable mark/space ratio, as with straightforward pulse proportional. In addition the pulse rate is also altered, the control stick being mechanically connected to "mark/space" potentiometer and pulse rate potentiometer in a typical "pulser" circuit. It will be appreciated that this involves exactly the same electronic circuitry as for straightforward pulse proportional operation, utilisation of the additional channel of intelligence (variable pulse rate) being afforded mechanically.

Rudder and elevator linkage for aircraft is provided as shown in Fig. 5.7. The actuator motor is spring self-centred and movement of the output arm in either direction is limited by mechanical stops. Rudder control is given by varying the mark/space ratio, causing the motor to oscillate about a "neutral" position in proportion to the mark/space ratio. Variation in pulse rate varies the swing of the torque rod, which in terms of mechanical response causes the elevators to flap up and down.

In fact, both rudder and elevator are operated at the same time and control is obtained by causing the motor to "dwell" in a pre-determined position remote from the true neutral. Thus with a 1 : 1 mark/space ratio the rudder position will be true neutral. If the pulse rate is slow then the degree of rotary movement of the torque rod will be a maximum in one direction, causing the elevator to "dwell" in the "up" position—Fig. 5.8. Increasing the pulse rate, whilst still holding the same 1 : 1 mark/space ratio, will then progressively reduce the elevator bias until eventually it will assume a full "down" position. Any intermediate position can be selected by selecting an intermediate pulse rate.

If the pulse rate is held constant and the mark/space ratio varied, then the bias achieved corresponds to rudder movement to one side or to the other proportional to the mark/space ratio. Equally, both pulse rate and mark/space ratio can be varied simultaneously to give both rudder and elevator bias at the same time. Thus if the two control potentiometers are connected to a single stick, mechanical movement can be arranged so that a true "joystick" response is obtained, i.e. movement of the stick from side to side produces proportional rudder movement (bias); fore and aft movement produces elevator movement.

The fact that the control surfaces are, in fact, oscillating all the time has no appreciable effect, provided the pulse rate is 4c/s or greater. A pulse rate range of from 4c/s to 8 or 10c/s is then quite adequate for a full range of elevator control. The system is eminently workable, although it does have some inherent disadvantages. For example, there is nearly always some interaction destroying true proportionality of response; loss of true proportionality is also aggravated by blowback (i.e. aerodynamic loads on the control surfaces when displaced from the neutral position).

Further variations on this scheme have included methods of providing an additional signal intelligence by "pulse omission"—i.e. either a full "on" (all "mark") or full "off" (all "space") signal for selecting and holding extreme positions of the main control (the rudder). Basically, however, this is just a further extension of the utilisation of "limit" movements previously described with the simple pulse proportional system, with the possibility of operating one or more ancillary services. ★

ELECTRONIC MANDOLIN

continued from page 422

The octal plug (Fig. 4b) is the equivalent to the "guitar plug" shown in *Modifying the P.E. Guitar Amplifier* elsewhere in this issue. Other connections to this plug (as shown for the guitar) are not needed.

Connect the plugs into their relevant sockets. Turn the volume control to mid-position. Switch on the amplifier and allow warming-up time. Play each set of strings individually and note that the volume from each is fairly equal. Turn the volume control clockwise and note that the sound output increases. If it decreases interchange the outer connections on the volume control. Check whether "vibrato" is in operation; if not, switch on the vibrato switch S2 and check that vibrato begins. Check whether bass tone control is in operation; if not, switch on the tone control switch S1 and check that the tone alters.

COMPONENTS . . .

Potentiometer

VRI 500 Ω log. carbon

Switches

S1 and S2 Single pole, on-off, toggle or push button types (2 off)

Sockets

SK1 and *SK2 2-way jacks (2 off)

Plugs

PL1 and *PL2 2-way jack plugs to fit SK1 and SK2 (2 off)

PL3 2-way jack plug to fit pick-up input socket on amplifier

*PL4 International octal type 8-way plug to fit I.O. valveholder on P.E. Guitar Amplifier

Pick-up

"Eclipse" button magnets, $\frac{1}{2}$ in dia (4 off)

Enamelled copper wire 30 s.w.g.

Self-adhesive tape

Miscellaneous

Brass sheet 4in \times 2in \times $\frac{1}{8}$ in (must be non-ferrous metal) for pick-up plate

Brass sheet 4in \times 2in \times 24 s.w.g. (for pick-up cover)

Screws 4 B.A. \times $\frac{1}{2}$ in csk. head (6 off)

P.V.C. covered connecting wire

4-core cable* or twin-core cable

Matching transformer 50 : 1 may be required (see text) if used with a high impedance amplifier.

*Items marked with an asterisk are not needed if this mandolin is used with a commercial amplifier or any amplifier other than the P.E. Guitar Amplifier.

FAULT FINDING

If due care is taken, no trouble should be experienced, but accidents and mistakes *can* happen on any job. If one set of strings gives very small output, that magnet winding is faulty, and rewinding is the only cure. If volume decreases when turning the control clockwise, reverse the outer connections on the control. If a loud hum is caused by touching the metalwork of the pick-up, one coil is shorting to the magnet. The pick-up must be rewound with new and better insulation applied to the magnets. ★



by S. Chisholm

Conversion of the "Guitar Amplifier" described in the February 1965 issue to accept a low impedance input

SINCE the description of an electronic guitar amplifier was published in this journal in February and March 1965, the author has received many requests for information on a simple method of converting the vibrato controlled input circuit from high impedance to low impedance.

There are several good reasons for the conversion, among them being the difficulty of finding a transformer small enough to fit into the interior of a "solid-body" guitar; also the noticeable increase in the weight of a modified, hollow instrument if the transformer is not a modern small component.

MODIFICATION PROCEDURE

For the purposes of this article, it will be assumed the reader possesses the amplifier referred to above; in any case, relevant diagrams are repeated here, together with a diagram which appeared in the January 1965 article describing the guitar.

On examining the layout behind the control panel of the amplifier, room for a transformer will be found between the vibrato control switch, S1 and the vibrato indicator lamp LPI. The transformer can be that used in the guitar. However, this entails some modification to the wiring within the instrument, but this

should not prove difficult because the design allows fairly easy access to the electronics. Let us assume that the guitar transformer will be used. The guitar wiring diagram is reproduced here in Fig. 1.

Begin by opening up the control panel on the guitar (see Fig. 5 on blueprint, January 1965); save the woodscrews for re-use. Proceed step-by-step as detailed below.

- (1) Disconnect the pick-up leads from the transformer (Fig. 1).
- (2) Disconnect the volume control lead and screen from the transformer. Remove the transformer.
- (3) The existing volume control has rather a high resistance for a low impedance input arrangement and it will probably be fairly critical in operation. If this is likely to be a nuisance to the reader, the control should be changed now for one of 500 ohms.
- (4) Connect the pick-up leads to the new volume control (one lead to one outer tag, the other lead to the remaining outer tag). The central connection has coaxial cable (B) as before.
- (5) The pick-up connections to the volume control should now be as shown in Fig. 2. Replace the control panel to complete the work on the guitar.

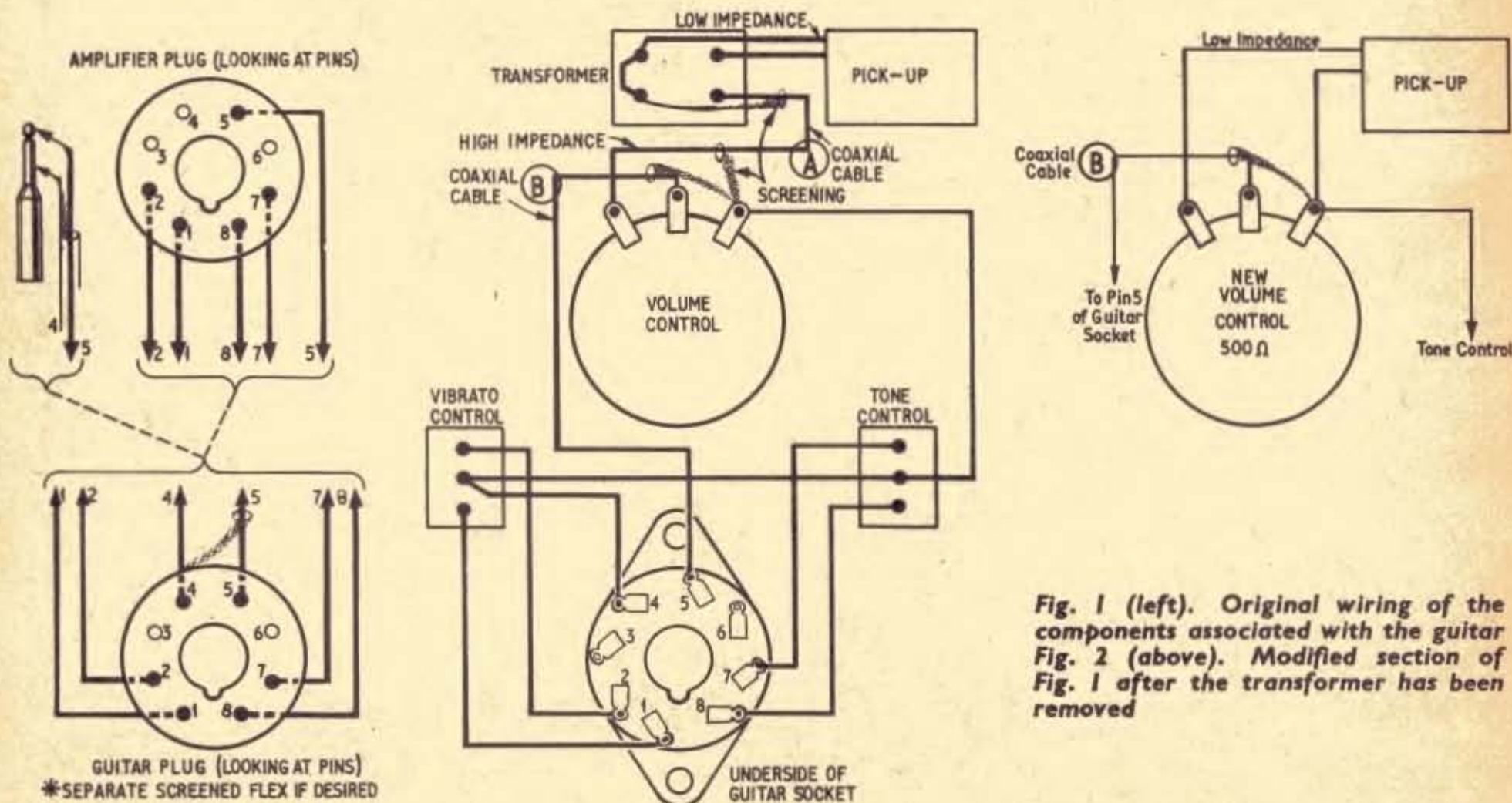
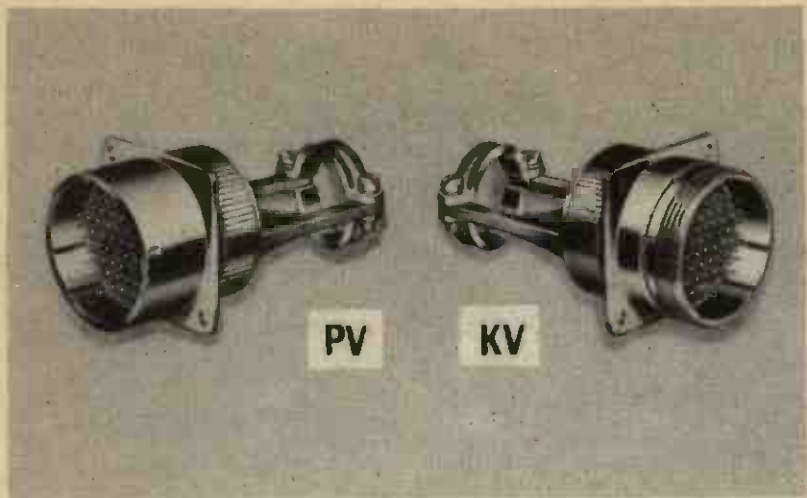

Fig. 1 (left). Original wiring of the components associated with the guitar Fig. 2 (above). Modified section of Fig. 1 after the transformer has been removed



HIGH TEMPERATURE MINIATURE PLUGS

The PV is intermateable with MIL-C-26482 Plugs and the KV with MIL-C-26500 Plugs.

Cannon Electric
(Great Britain) Ltd.,
Lister Road,
Basingstoke, Hants.
Tel: Basingstoke 3171



Registered Trademark

CANNON

The SUPER 6 LONG AND MEDIUM WAVE TRANSISTOR RADIO



★ 6 transistors and diode. ★ 350mW. ★ Superhet, Ferrite rod aerial.
★ Component positions and references printed on back of board. ★ Wooden cabinet, 11 x 7 1/2 x 3 1/2 in. ★ Vinyl covered. ★ 6 x 4 in. speaker. ★ Booklet 2/-, Free with kit. ★ Lining up service. ★ All parts supplied separately. Write for list. S.A.E. please. VT9 or P.P.9. (3/9 with kit).

COMPLETE SET OF PARTS ONLY £4.0.0.

PLUS 5/- POST

OR FULLY BUILT \$6.7.6 Tax & Carr. Paid

AM/FM (V.H.F.) RADIO GRAM CHASSIS £15.15.0

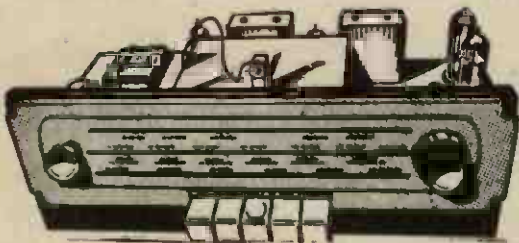

Chassis size 15 x 6 1/2 x 5 1/2 in. high. New manufacture. Dial 14 1/2 x 4 in. in cream and red. 200-250v. A.C. only.

Pick-up. Ext. Speaker. Ac., E., and Dipole Sockets. Five pushbuttons—L.W., M.W., S.W., F.M. and Gram. Aligned and tested. Tone control. 1000-1900 M.: 200-550 M.; 88-100 Mc/s; 6-17 Mc/s. EZ.80 rect., ECH81, EF89, EABC80, EL84, ECC85. 3-ohm speaker required. 9 x 6 in. Elliptical Speaker 25/-.

TERMS: £4.0.0 down and 5 monthly payments of £2.10.0. Total H.P. price £16.10.0. Circuit diagram 2/6. V.H.F. Dipole 12/6. Feeder 6d. yd. Carr. to N. Ireland 20/- extra.

NEW 6 PUSHBUTTON STEREOGRAM CHASSIS

M.W.; S.W.1; S.W.2; VHF; Gram; Stereo Gram. Two separate channels for Stereo Gram with balance control. Also operates with two speakers on Radio. Chassis size 15" x 7" x 6 1/2" high. Dial cream and red 15" x 3". ECC85; ECH81; EF89; 2 x ECL86; EM84 and Silicon Rect. Cream moulded escutcheon for dial 7/6 extra.

Price \$19.19.0 carr. paid or \$5.0.0 deposit and 5 monthly payments of \$3.3.0. Total H.P. price \$20.15.0.

GLADSTONE RADIO

66 ELMS ROAD, ALDERSHOT, Hants.

(2 mins. from Station and Buses.)

CLOSED WEDNESDAY AFTERNOON

Aldershot 22240

CATALOGUE 6d.

**YOU CAN
NOW BUY THE
WORLD'S FINEST
SPEAKER VALUE
DIRECT FROM**

R&A

The 700 Mark V Range

Specially designed to provide outstanding range, smoothness and uniformity of frequency response with freedom from self generated forms of distortion up to levels more than adequate for domestic listening. The speakers in this range all have a highly developed dual radiating system with optimum termination of both cones — voice coil impedance 15 ohms.



Power handling capacity in appropriate enclosures:—

780 Mk. V Price £3 . 18 . 6
8 in. 6 watts r.m.s. 12 watts peak. (inc. 10/6 P.T. and P. & P.)

7100 Mk. V Price £4 . 13 . 0
10 in. 8 watts r.m.s. 15 watts peak. (inc. 12/6 P.T. and P. & P.)

7120 Mk. V Price £4 . 18 . 6
12 in. 10 watts r.m.s. 18 watts peak. (No P.T. but inc. P. & P.)



Send for full technical data sheet with suggestions for enclosures to:

REPRODUCERS AND AMPLIFIERS LTD.
Frederick Street, Wolverhampton England

LOUD SPEAKER MANUFACTURERS TO THE
RADIO INDUSTRY SINCE 1930

ELECTRICAL ENGINEER'S REFERENCE BOOK

"A comprehensive
survey of the most
recent information
in all branches of
electrical engineering"
Industrial Equipment News

Consulting Editor: M. G. Say, Ph.D., M.Sc.,
A.C.G.I., D.I.C., M.I.E.E., F.R.S.E., M.Brit.I.R.E.

The ELECTRICAL ENGINEER'S REFERENCE BOOK has established itself over the years as a standard work of reference. In this new Edition, the book has undergone an extensive revision. Among sections which have been expanded or completely rewritten are: 2. Energy Conversion; 3. Electrical Materials; 4. Transformers; 5. Cables and Wires; 8. Electric Motors; 9. Electric Motor Control; 10. Rectifiers and Convertors; 11. Wiring and Installation; 12. Illumination and Lamps; 13. Instruments and Measurements; 17. Batteries and Electrochemistry; 18. Electric Traction; 19. Marine Applications of Electricity; 20. Applied Electronics; 23. Automatic Control; 24. Electricity in Mines; 25. Electricity in Agriculture and Horticulture; 27. Industrial Heating; 31. Education and Training and 32. Periodicals and Standards. Section 30 is a completely new classified review of current equipment and techniques in all branches of the industry.

Among the more important new articles, each by a recognised authority, are those on Germanium and Silicon, Printed Circuits and Potting Materials, Transformer Windings and Design, Variable-Speed Induction Motors, Electronic Motor Control, Silicon Controlled Rectifiers, Cold-Cathode Lighting, Automatic Warning System of Train Control, Automatic Signalling, Supervisory Remote Control Equipment, Tele-communications in Mines, Electricity in Agriculture and Private Telephone Systems.

From your bookseller or post free from **GEORGE NEWNES LTD.**
Tower House, Southampton Street, W.C.2

7½" x 5"
—
2,200
pages
—
over
2,000
diagrams
and
photographs
—
33
sections
—
11th Edition
—
120 shillings

2 YEARS' GUARANTEE
now on all Slim-Line TV's

EX-RENTAL TELEVISIONS

14 in.
£7.10.0
17 in.
£11.10.0

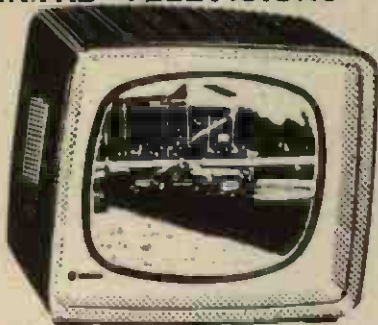

12 months' 3 Star Guarantee

★ Tube ★ Valves ★ Components
COLOURED FREE LIST
Channels for all areas
Demonstrations daily from Large Selection
Personal collection or Insured Carriage 14in.
20/-; 17in. 30/-.

RECORD PLAYER CABINETS 49/6. Latest design covered cabinet takes any modern autochanger.
SINGLE PLAYER CABINETS 19/6. P. & P. 5/6.
RADIOGRAM CABINETS FROM £3 0 0.
Long Low Design. Personal Shoppers.
RESISTORS 5/- per 100. New. Mostly High Stabs. Assorted. P. & P. 2/-. Overseas 3/6.

DUKE & CO. (LONDON) LTD.
621/3 Romford Road · Manor Park · E.12
Liverpool Street — Manor Park — 10 mins.
Phone: ILFord 6001/2/3 Stamp for Free List

BATTERY ELIMINATORS

The ideal way of running your TRANSISTOR RADIO, RECORD PLAYER, TAPE RECORDER, AMPLIFIER, etc. Types available: 9v; 6v; 4½v (single output) 39/6 each. P. & P. 2/9. 9v + 9v; 6v + 6v; or 4½v + 4½v (two separate outputs) 42/6 each. P. & P. 2/9. Please state output required. All the above units are completely isolated from mains by double wound transformer ensuring 100% safety.

R.C.S. PRODUCTS (RADIO) LTD.
(Dept. P.E.), 11 Oliver Road, London, E.17

I.F. TRANSFORMERS—This month's snip! Brand new, small size, 2 different types Television I. F.'s and only 5/- PER PAIR! Limited quantities available.

CAPACITORS—
100 x 300 x 100 x 16 MFD, 275v. } 7/6 each
100 x 400 x 16 } 275v. } + 1/- P. & P.
100U, 25v., 2/- each + P. & P. 3d.

AERIAL WIRE—Still some of this wonderful insulated wire left at old prices—25ft. coil, 1/5; 50ft. coil, 2/8. P. & P. 6d.

BATTERY ELIMINATORS—For value for money you can't beat our "QUANTA" 9v. power supply. Complete and ready to use in place of a PP3 etc., it costs only 16/3 + P. & P. 1/-. For the connoisseur, the slightly more sophisticated Eagle Model LA-6P with a self-contained pilot lamp is still cheap at 23/6 + 1/- P. & P.

TEST METERS—1. Model 200H—A wonderful buy for the discerning engineer with a limited budget. 20 K. ohms per volt makes this an extremely accurate instrument that measures voltages, current, resistance, capacitance and decibels. At 24.9.6, it is second to none!

2. Model Test 7—At last, an inexpensive multi-meter with a mirror included in the scale. Why pay over £20 when this will often do the trick for only 22.5.0.

3. Avo-Minor Mk. IV—Still one of the best and all British, 29.10.0.

4. Taylor 127A—Excellent value, 21.10.0. Full range of panel and multi-meters always in stock.

LOUDSPEAKERS—At really keen prices—all 8 ohm, brand new. 2in. and 2½in., 7/6 each. 3in. and 3½in., 9/- each; 4in., 10/6; 5in., 12/-. All plus 1/- P. & P.

AMPLIFIERS—Veritone 60W, 226.19.6 complete; 30W, 219.15.0 complete; 4½W, 6 gas complete but less cover; 3/4W, Record Player amplifier—ready to plug in and use. Manufacturers surplus. Brand new, 22.19.6.

Mullard OA81 Diodes, brand new, 2/3 post free.
Mullard OA91 Diodes, brand new, 2/6 post free.
Mullard OA95 Diodes, brand new, 2/6 post free.

REMEMBER:



**BOTHWELL ELECTRIC
SUPPLIES (Glasgow) LTD.**
54 EGLINGTON STREET,
GLASGOW, C.5.

Member of the Lauder Group

is at your disposal whether you are a personal or mail order customer. Use our FREE ADVISORY SERVICE by writing, or 'phoning SOUTH 2904—Trade enquiries welcomed.

SUBMINIATURE SKELETON POTS

Egen Type 467. Only ¼ inch diameter. Preset. P.C. mounting or support in wiring. 100 mW dissipation. Linear law. Values available: 500 ohms, 1.5K, 5K, 15K, 50K, 150K, 500K, 1M, 1.5M. Any 3 for 5/-. Larger quantities 1/6 each.

TRANSISTORS

2N2926 High-gain silicon planar. 200 mW. 18V. 200 Mc/s cut-off. General purpose, low noise a.f. and r.f. New first grade. Data supplied. NPN.

Red Dot	β = 55-110	4/6 post paid
Orange	β = 90-180	4/9 post paid
Yellow	β = 150-300	5/- post paid
Green	β = 235-470	6/- post paid

GET693. Ge. 50 Mc/s cut-off. β = 40 (min). 3 for 5/-.

GET873 equiv. Ge. 7 Mc/s cut-off. β = 30 (min). OK for audio and low r.f. 5 for 5/-.

Post free. Cash with order. Mail order only. Quantity discounts.

AMATRONIX LTD.

396 Selsdon Road, Croydon, Surrey

"PRACTICAL ELECTRONICS" CONSTRUCTIONAL DESIGNS

All specified 1st grade Components, complete Metalwork, full range of Materials, engraved Panel Plates, Ancillary Equipment and Assembled Units. Comprehensive lists available for each "P.E." Constructional Article.

Please send 6d. in stamps for each design
MALVYN ENGINEERING WORKS
Engineers to the Radio and Electronic Industries
7 CURRIE STREET, HERTFORD, HERTS
TELEPHONE: HERTFORD 2264

MODIFYING THE AMPLIFIER

Ensure that the amplifier mains plug is completely withdrawn from the mains supply socket, open up the amplifier and proceed as follows. Fig. 3 shows the panel after modification.

(1) Mark, drill and countersink two holes in the control panel to accept fixing screws for the matching transformer, which has just been withdrawn from the guitar. If the guitar is to remain intact, a new component of about 50 : 1 step-up ratio will be required, of suitable dimensions to suit the intended location, and preferably completely screened is required.

(2) At socket SK1 (Fig. 3), disconnect the two leads which come from volume control VR1.

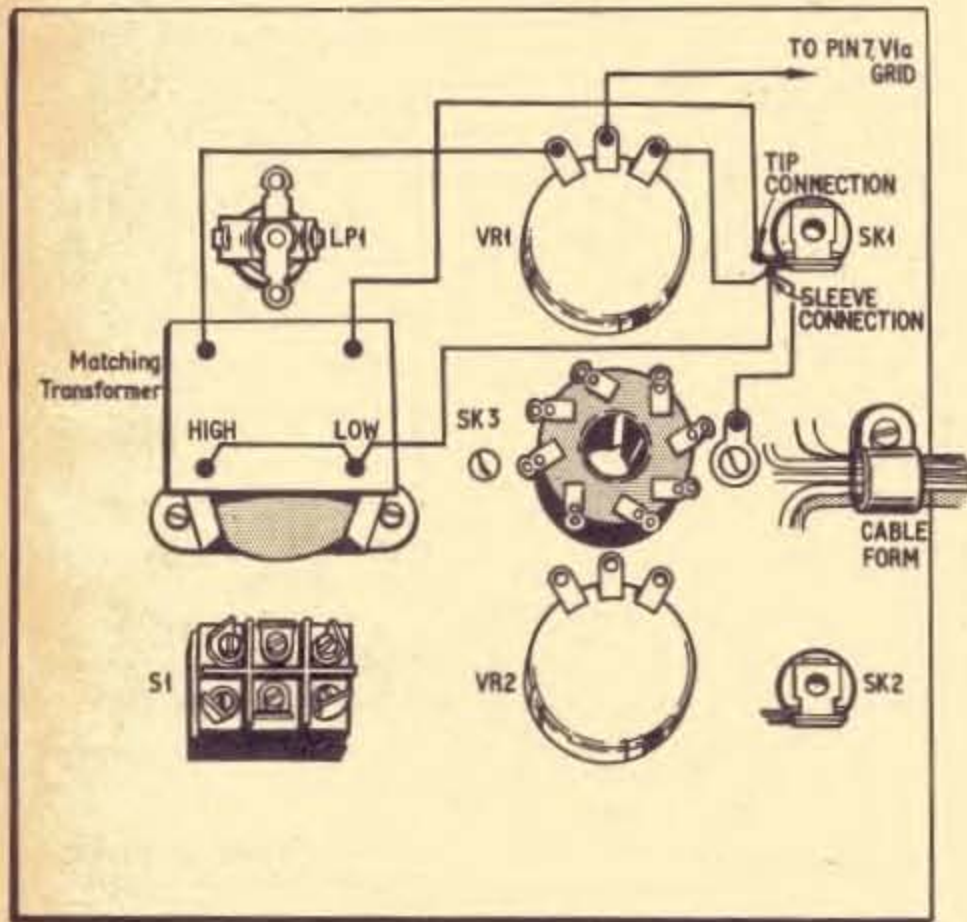

Fig. 3 (above). Modified control panel layout and extra wiring for the guitar amplifier

Fig. 4 (right). Modified part of the amplifier circuit showing the connection of the matching transformer

(3) Connect the volume control leads to the matching transformer. The central connection on the volume control is not disturbed.

(4) Socket SK1 has now to be connected to the low impedance connections on the matching transformer.

It is as well to check whether one of the pick-up leads is connected to "chassis"; this can happen when winding the pick-up, although it should not. Earthing connection should be made at one point only, preferably remote from the grid of the first stage. The best place is from the sleeve connection of SK1 to a tag under one of the fixing screws.

Make a final check that the connections are now as shown in Figs. 2 and 3. This completes the modification and the amplifier now has one low impedance input and one high impedance input.

The modified version of the circuitry around V1 is shown in Fig. 4.

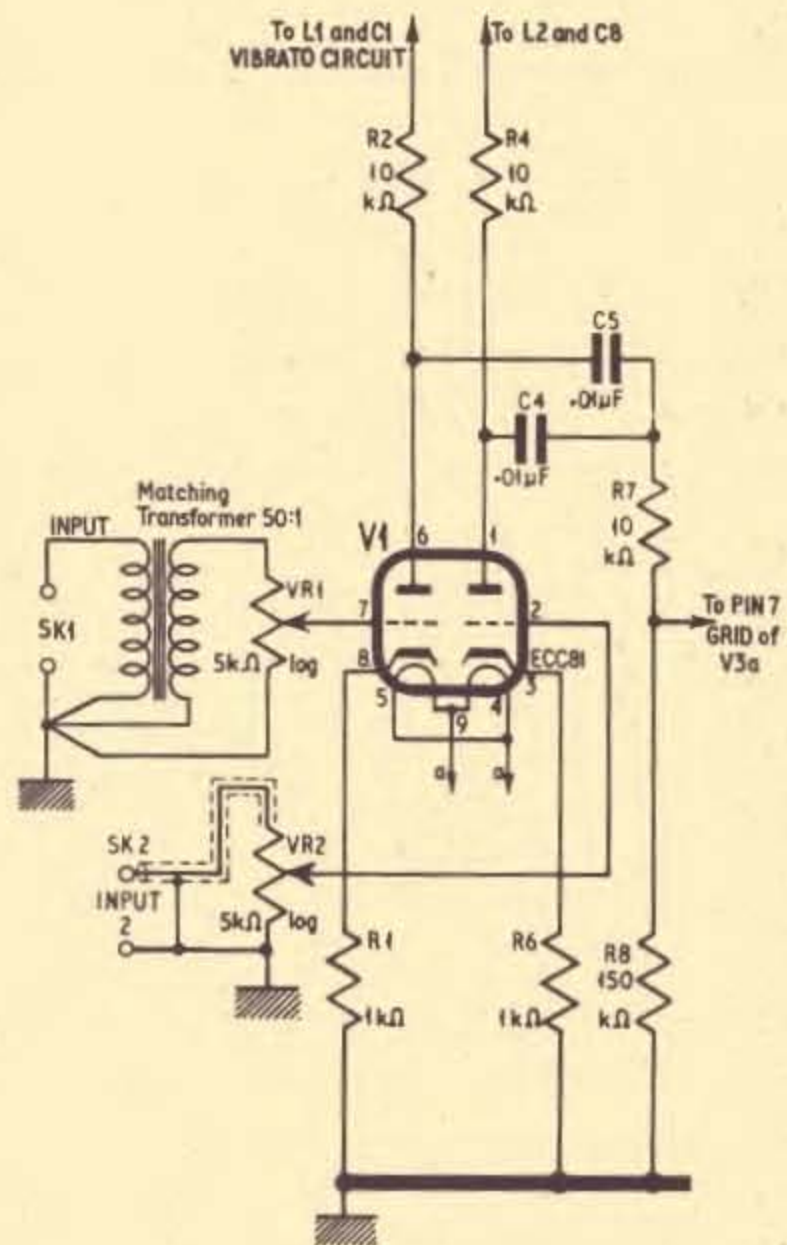

MATCHING TRANSFORMER

Many low to high impedance matching transformers are now marked to show which are the input (low impedance) terminals; if the transformer in question is not so marked, an ohmmeter check will show a lower resistance between one pair of terminals than the other pair. This low resistance pair are the pins to which the pick-up has to be connected. If the transformer case is painted, and no earth tag is provided, ensure that a clean metal-to-metal contact exists between the transformer case and the control panel, which is (or should be) "earthed" to the amplifier. ★

Readout—

A SELECTION FROM OUR POSTBAG

Need for tolerance

Sir—Would it be possible for mention to be made in the text of your magazine of the meaning of the word "tolerance" in relation to components? A circuit may call for a $4\mu\text{F}$ capacitor. If we have not got this value and send say a $5\mu\text{F}$ capacitor, this will often be returned as "unsuitable". What some of your readers fail to realise is that the tolerance of most electrolytics is -20 per cent to $+80$ per cent, i.e. a $5\mu\text{F}$ nominal rating may be anywhere between $4\mu\text{F}$ and $9\mu\text{F}$ in actual capacitance. This of course would also apply to the nominal $4\mu\text{F}$!

In the same way resistors of say 100 kilohms; 20 per cent could be between 80 kilohm and 120 kilohm, yet an 82 kilohm close tolerance resistor would again, by some people, be regarded as unusable—despite the fact that it is within the tolerance range of the nominal value!

Much wasted time could be saved if this were explained with care for the benefit of the less initiated readers!

G. F. Milward,
Drayton Bassett,
Staffs.

Electronic organ constructors society

Sir—In view of the growing interest in the amateur building of electronic organs, I would be grateful if you could mention the existence of our Society.

Regular meetings are held in London, at which home built instruments are demonstrated. Technical information and news is available, by post, to all members at home and overseas.

New members are most welcome and should write to the Secretary: E. Kirk, 66, Arnold Crescent, Isleworth, Middlesex.

R. S. Purdy,
Billericay,
Essex.

An electronic organ is one of the items on our list for publication at a future date.
—Ed.

Cheap fuzz

Sir—After reading the letter from Mr. C. J. Gatton in *Readout* March 1966 issue, I have thought of one way to make a distortion booster or "fuzz box" quite cheaply.

It consists of one red spot transistor (OC71) and a $50\mu\text{F}$ capacitor connected as shown in the circuit diagram below.

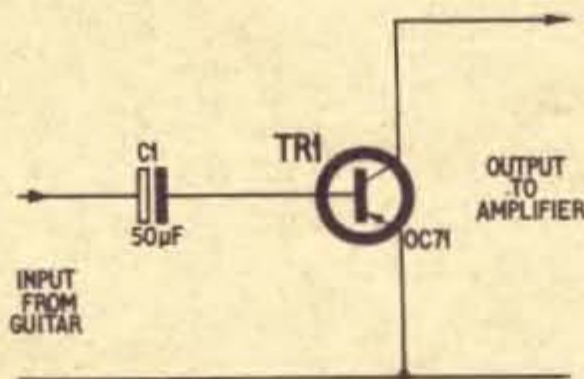

This produces quite good "fuzz" at minimum cost.

G. K. Mitchell,
Orpington,
Kent.

Copyright in scientific information

Sir—Two views may be taken of the publication without their permission of the pictures of the Moon's surface obtained by Russian probes.

One is that no scientific discoveries—as distinct from purely commercial inventions and "secrets"—have any ethical right to be owned and protected; they are the property and the products of the human species as a whole, without whose prior achievements and social facilities they would never have been made.

The other is that the pictures partook of the nature of publications and trademarks. That they were "shrunk" in the original versions is tantamount to no more than saying that some piece of printed matter is printed in, say, condensed Gill Sans and can therefore be "pirated" in Times Roman!

For my own part, I regard with dismay and anger the greedy, dog-in-the-mangerish behaviour of nationalistic and commercial interests towards scientific and technological discoveries and inventions. They resemble, it seems to me, the selfish, visionless adventurers of the 16th and 17th centuries who, in their sordid hunt for easy gold, land and slaves, savagely stole from their inhabitants the lands and natural resources of newly discovered parts of the globe—with a great deal of sanctimonious humbug about service to their kings and churches!

W. H. Cazaly,
Ilford, Essex.

Would W. K. Mace of Sheffield, who also wrote on this topic, please forward his full address?—Ed.

CAN YOU HELP?

Letters for inclusion under this heading should be as brief as possible. Replies should be made direct to the readers concerned

Sir—I am willing to pay a good price for the November 1964 and January 1965 issues complete with blueprints, if any?

D. Westcott, 10, Leighton Road, Southville, Bristol, 3.

Sir—I wish to obtain back copies of the whole of Volume 1 and also Nos. 1 and 2 of Volume 2 of PRACTICAL ELECTRONICS. These are intended for use in my sixth-form electronics course, and I would be glad if any of your readers who have any of the above copies for disposal would get in touch with me by postcard as soon as possible.

G. Whitaker, Head of Science Department, Eastwood Hall Park Technical Grammar School, Mansfield Road, Eastwood, Nottinghamshire.

Sir—Can any reader supply me with the first sixteen articles of the instructional series for newcomers to electronics *Beginners Start Here* . . .

A. Bowman, 2/2 Cardinal Street, Vittoriosa, Malta.

Sir—There seems to be an almost total lack of information on the "Theremin" and "White Noise Generator", two instruments with which my friend and I would like to experiment. If any readers could forward any information on these I would be very pleased.

J. S. Robinson, 129, Beverley Road, Hessle, East Yorkshire.

Back numbers are usually very quickly exhausted. We strongly advise all our readers that a standing order be placed with their newsagent to avoid any future disappointment.



BUILD A HI-FI SYSTEM WITH WHARFEDALE LOUDSPEAKERS

These Loudspeakers are the actual speakers that Wharfedale use in their world famous cabinet models. Each is fitted with roll surround for low resonance and double diaphragm assembly for extended H.F. response.

Send today for further details of these units plus free cabinet construction sheets to enable you to build a top quality Hi-Fi loudspeaker system.

SUPER 8/RS/DD

Frequency range 40 c/s — 20,000 c/s. Impedance 10/15 ohms. Power handling capacity 6 watts (12 watts peak) £7.0.0. (tax paid)

SUPER 10/RS/DD

Frequency range 30 c/s — 20,000 c/s. Impedance 10/15 ohms. Power handling capacity 10 watts (20 watts peak) £11.13.4. (tax paid)

SUPER 12/RS/DD

Frequency range 25 c/s — 20,000 c/s. Impedance 12/15 ohms. Power handling capacity 20 watts (40 watts peak) £17.10.0. (no tax)

FREE CONSTRUCTION SHEETS

Complete this coupon for 8 page booklet on Wharfedale Speaker Units plus FREE CABINET CONSTRUCTION SHEETS for your own Hi-Fi system. (Dept. PE6)

NAME

ADDRESS

TOWN.....COUNTY.....

RANK WHARFEDALE LIMITED
 IDLE, BRADFORD, YORKSHIRE
 Telephone Bradford 612552/3 · Telegrams 'Wharfdel' Bradford

YOURS FREE FOR 7 DAYS



The New 'Picture-Book' way of learning **BASIC ELECTRICITY (5 VOLS.)** **BASIC ELECTRONICS (6 VOLS.)**

You'll find it easy to learn with this outstandingly successful new pictorial method—the essential facts are explained in the simplest language, one at a time; and each is illustrated by an accurate, cartoon-type drawing.

The books are based on the latest research into simplified learning techniques. This has proved that the Pictorial Approach to learning is the quickest and soundest way of gaining mastery over these subjects.

The series will be of exceptional value in training mechanics and technicians in Electricity, Radio and Electronics.

WHAT THIS MONTH'S ENTHUSIASTIC READERS SAY

"... Having gone through the volumes I must say how much I enjoyed reading them and I am sure they will be of great value to me in my job as Electrical Instructor for the N.C.B. ..."
 H. S., HUDDERSFIELD

"... Now that I have had time to read BASIC ELECTRONICS received last month, may I congratulate you on honest advertising—a real find these days ..."

H. E., DERBY
 A TECH-PRESS PUBLICATION

To Selray Book Co.
 60 Hayes Hill, Hayes, Bromley, Kent

Please send me Without Obligation to Purchase, Basic Electricity/Basic Electronics on 7 Days' Free Trial. I will either return set, carriage paid, in good condition within 8 days or send down payment of 15/- (Basic Electricity) followed by 6 fortnightly payments of 10/-. Down payment of 15/- (Basic Electronics) followed by 6 fortnightly payments of 12/6. Alternatively, I will send 68/- (Basic Electricity—5 parts). 81/- (Basic Electronics—6 parts) post free. This offer applies to United Kingdom only.

Tick against set required (only one set allowed on free trial).

BASIC ELECTRICITY BASIC ELECTRONICS

Signature.....
 (If under 21, signature of parent or guardian)

Name

FULL POSTAL Address

P.E.6

POST NOW FOR THIS OFFER!!

Practical Electronics Classified Advertisements

The pre-paid rate for classified advertisements is 1/- per word (minimum order 12/-), box number 1/6 extra. Semi-displayed setting £3.5.0 per single column inch. All cheques, postal orders, etc., to be made payable to PRACTICAL ELECTRONICS and crossed "Lloyds Bank Ltd." Treasury notes should always be sent *registered post*. Advertisements, together with remittance, should be sent to the Advertisement Manager, PRACTICAL ELECTRONICS, George Newnes Ltd., Tower House, Southampton Street, London, WC2, for insertion in the next available issue.

BOOKS AND PUBLICATIONS

SURPLUS HANDBOOKS

19 set Circuit and Notes ...	3/6 P.P. 6d
1155 Instruction Handbook ...	4/6 P.P. 6d
H.R.O. Instruction Handbook ...	3/6 P.P. 6d
38 set Instruction Handbook ...	3/6 P.P. 6d
46 set Walkie-talkie circuit & notes	3/6 P.P. 6d
88 set Walkie-talkie Instruction Handbook	5/- P.P. 6d
Frequency Meter BC221 Instruction Handbook	3/6 P.P. 6d
Wavemeter Class D Handbook Mk. I, II, III	3/6 P.P. 6d
18 set Circuit Details & Notes ...	3/6 P.P. 6d
A.R.88D Instruction Manual	15/- P.P. 1/6d
R.107 Instruction Handbook ...	5/- P.P. 6d
CR.100/B.28 Receiver Handbook	8/6 P.P. 9d
R1116/A Circuit Diagram & Details	1/9 P.P. 6d
R1224/A Circuit Diagram & Details	1/6 P.P. 6d
R1353 Circuit Diagram & Details...	1/6 P.P. 6d
RF, 24, 25, 26 Circuit Diagrams and Details	1/6 each P.P. 6d
Amplifier A1134 Circuit Diagram & Details	1/9 P.P. 6d
Transmitter T1154 Circuit Diagram & Details (all models)	2/- P.P. 6d
Resistor Colour Code Indicators. Indicates the value of a resistor at a glance	1/6 P.P. 6d

All mail orders to:
Instructional Handbook Supplies
Dept. P.E. Talbot House, 28 Talbot Gardens
Roundhay, Leeds, 8

MISCELLANEOUS

"P.E." Bonanza Board Projects. Electronic Vibrato Unit. Burglar Alarm. Portable Rate-meter. Compact Power Unit. A.F. and R.F. Signal Tracer. Pipe and Cable Locator. Electronic Candle. Servo System. Miniprobe Signal Generator. Simple Digital Computer. Fire Alarm System. Neon Novelties. Doorphone. Audio Oscillator and Valve Voltmeter. Water Level Alarm. New Look Tape Recorder. General Purpose Scaler. Echo Unit. Noughts and Crosses Machine. Transistor and Diode Tester. Simple Analogue Computer. Stereo Record Player. Integrated Transistor Amplifier. Two Band Radio Tuner. Intercomm Unit. V.H.F. Broadcast Receiver. R/C Bridge. Inexpensive Oscilloscope. Mullard Miniature Electrolytics and Hi-stab Resistors. Dark Room Timer. Light Dimmer. S.A.E. for itemised price lists. AJAX ELECTRONICS, 18a, Rumbold Road, Fulham, London, S.W.6.

ELECTRONIC KITS. All types expertly constructed. Tested and calibrated. Economic charges. VIRMANI, 41 Holland Park, London, W.11.

TRANSFORMERS Rewound. Output or mains. Specials made to order. Reasonable prices. S.A.E. enquiries. RATCLIFFE, 27 Station Road, Holmfirth, Yorks.

PRINTED CIRCUITS. Made photographically to your specification. S.A.E. (large) for full details and prices. FORREST STUDIOS, Market Street, Carnforth, Lancs.

BERNIESOUND (AUDIO ENGINEERS). Consulting Film/TV. Sound Engineers. Details of services available. From:—Mr. BROWN, 1 Effie Place, London, S.W.6.

MISCELLANEOUS

(continued)

CONVERT ANY TV SET into an Oscilloscope. Diagrams and Instructions, 12/6. REDMOND, 42 Dean Close, Portslade, Sussex.

FOR SALE

RELAYS. 8 assorted 12-24 volt Ex-Equipment, 20/-, p. & p. 4/-. We can supply most relays as recommended in this journal.

GOVERNMENT SURPLUS. Electrical and Radio Equipment. Our new catalogue No. 16 now ready, 2/6 Post Free, cost refunded on purchase of goods over £2. ARTHUR SALLIS, Radio Control Ltd., 93, North Road, Brighton.

TRANSISTORS UNMARKED UNTESTED. 40 for 10/-, P. & P. 1/-. 4 packets post free. Relays, thousands of types, special catalogue free. General Catalogue of Mechanical & Electrical Gear, Tools, etc., 5,000 items, free. K. R. WHISTON (Dept. PET), New Mills, Stockport.

A.C. STANDARD. Mains Motors Fractional H.P. 3 1/2 in dia x 4 in long with 1/2 in spindle. Many uses. Brand new, 25/- each. P. & P. 2/6d. Small Battery Motors 1 1/2 in dia x 2 in long—4 1/2 to 9 volts. Heavy construction; only 7/6d. each. P. & P. 1/-. WALTONS WIRELESS STORES, 15 Church Street, Wolverhampton.

HAMMERITE

HAMMER PATTERN BRUSH PAINT FOR PANELS AND BOXES

★ THE PATTERN IS IN THE TIN ★
ALL YOU DO IS BRUSH IT ON!

2 1/2 oz. tins	3/6	1 gallon	35/-*
1 pint	7/6	1 gallon	58/-*
1 pint	15/-		(* sent by road)

Carriage: Orders up to 5/-, 9d; up to 10/-, 1/9; over 10/-, 2/9. Colours: Blue, Silver, Black or Bronze. Return of post service, Monday to Friday. From your component shop or direct from the manufacturer:
FINNIGAN SPECIALITY PAINTS (PE)
Mickley Square, Stocksfield, Northumberland
Tel. Stocksfield 2280

FOR SALE. Oscilloscopes — Galvanometers — Evershed & Vignolles Meggers. Also other items and components. Free list. Stamp please. R. & E. MART, Box 9, G.P.O., Tunbridge Wells, Kent.

VALVES & SERVICE SHEETS

T.V. & RADIO, MOST MAKES
PRICE 4/6 each & 6d. postage
Valve price list sent on receipt of stamped envelope. Valves guaranteed new & boxed.

T.V. ELECTRONICS
MARKETING HOUSE
361 EDGWARE ROAD
LONDON, W.2
Mail Order Only

VENNER TIME SWITCHES. Reconditioned, 14 day clock, once on once off every 24 hours. Jewelled movement, fully guaranteed, 15 amp. 37/6. P. & P. 2/6. A. R. BATCHELOR, (E.M. Dept.) 4 Park Road, Bromley, Kent.

FOR SALE

(continued)

CRACKLE PAINT. Black or Grey, 1/2 pint tins 4/-, post 6d. from the component specialists. SERVIO RADIO, 156-8 Merton Road, Wimbledon, London, S.W.19.

ADHESIVE STRIP LABELS. 3/4" embossed Glossy, P.V.C. various colours. 1 1/2d. letter. C.W.O. and S.A.E. to:—Mr. BROWN, 1 Effie Place, London, S.W.6.

RECEIVERS AND COMPONENTS

ELECTROVALUE

New high performance economy transistors
Ultra High Gain NPN U.H.F. NPN
2N2926, 8235 to 470 @ 7/- 2N3663 FT 1200
2N3390, 8400 to 800 @ 10/6 Mc/s @ 17/-
High Voltage NPN
C407, 120v, 200mW @ 9/-
High Gain, Medium Power NPN
2N3403, 25v, 500mA, 8180 to 540, 560mW @ 8/6
Germanium High Gain, Amplifier/Switching
2N1304, NPN, 840 to 200 @ 5/6
2N1305, PNP, 840 to 200 @ 5/6
6 Mansfield Place, Ascot, Berkshire

SPECIAL OFFER

1 Watt S.T.C. 300 MC/S N.P.N.
Silicon Planer. 100% Transistors.
Limited Stocks. £1 for 6.

3/- each. OC44, OC45, OC70,
OC71, OC81, OC81D, OC200,
Get 16, Get 20.

4/- each. AF114, AF115, AF116,
AF117, OC170, OC171.

5/- each. OC139, OC140, Get
7, Get 8, Get 9, XC141, BY100,
OA211.

SUN SOLAR CELL KITS

24 Page Booklet on Experiments
inc. 4 Solar Cells 11/- Set.

G.P.O. DIAL TELEPHONES

20/- each. 35/- pair.

Send 6d. for full lists: inc. S.C.R.
Zeners.

Cursons

78 Broad Street
Canterbury
Kent

RECEIVERS AND COMPONENTS

(continued)

R. & R. RADIO & TV SERVICE

Dept. P.E.

44 Market Street, BACUP. Tel. 465

NEW VALVES!

6K8, 6V6, 6R7 4/6d. 6K7, 6F6, 6BBG 3/-.

SALVAGE VALVES

6F13	4/6	PCF80	4/-
6F15	5/-	PCL83	5/-
6L18	4/6	PL81	5/-
6K25	10/-	PL82	4/-
6U4GT	5/-	PL83	4/-
6BV6	5/-	PY81	3/6
6/30L2	5/-	PZ30	5/-
EB91	1/-	U801	7/6
6F1	2/6	U301	6/-
EBF80	5/-	U329	5/-
EF80	1/6	10F1	1/-
EF91	2/6	10LD11	5/-
EF85	5/-	10P13	5/6
ECC82	4/-	10P14	5/-
EY86	4/-	PY800	5/-
ECL80	4/-	20F2	5/6
20P3	5/-	20D1	2/-
20P4	7/6	20P1	6/6
30F5	5/-	20P5	6/6
30PL1	5/-	30FL1	6/6
EF37A	7/6	30P12	5/-
PL36	7/6	30P4	7/6
PY33	7/6	PY32	6/-
PCC84	4/-	PY82	5/-

Postage on valves 6d.—3 or more post free.

1 Pole 8-way switch, complete with 8 resistors 2 @ 1K, 2 @ 15K, one each of 22K, 15K, 18K, 6.8K. 3/6 incl. post.

Fireball Tuners as removed 14/9. Selected Tuners 18/9. Speakers ex T.V. 6 x 4 inch 3/6. 8 inch rnd 6/- Resistors New: 1/2 watt 3 1/2d., 1 watt 5d., 2 watt 9d. all 10%.

Postage on Tuners and Speakers 2/6.

S.A.E. with all enquiries. All goods subject to satisfaction or money refunded.

"EXPERIMENTAL" PRINTED CIRCUIT KIT

Contents

(1) 2 Copper Laminate Boards 4 1/2" x 2 1/2".
(2) 1 Board for Matchbox Radio. (3) 1 Board for Postage Stamp Radio. (4) Resist.
(5) Etchant. (6) Resist Solvent. (7) Cleanser/Degreaser. (8) 16-page illustrated booklet.

"PRINTED CIRCUITS FOR AMATEURS"

containing full etching instructions.
Also free with every kit (9); Essential Design Data and Constructional Details of

30 SUGGESTED PROJECTS which you can build on a P.C. chassis made from this kit using your own components. Circuit Diagrams. P.C. Chassis Plans. Assembly Drawings. Photographs. Many recently developed very efficient designs you probably haven't heard of yet, including ...
4 Crystal Sets. Carrier Power Conversion Receiver. Matchbox Photocell Radio. Solar Battery L/S Radio. Pocket L/S Double Reflex. Triple Reflex with self-adjusting regeneration. Bacteria-powered Radio.
3 micro-miniature radios just released. Postage-Stamp Radio 1.62" x .95" x .25". Wrist-Watch Radio 1.15" x .80" x .55". Ring Radio .70" x .70" x .55". 2 Intercoms. 4 Amplifiers. Photoelectric Alarms. Light-controlled Robot. Human Body Radiation Detector. "Perpetual Motion" Machine. Amateur Transceiver for 10 metres. Man/Woman discriminator. Amateur Transmitter Licence required.
Transistor Tester and many more ...

(10) Miniature Radio Dial SW/MW/LW
Price 7/6 Post and Packing 1/-

"YORK ELECTRICS"

181a, York Road, London, S.W.11
Send S.A.E. for full details

RECEIVERS AND COMPONENTS

(continued)

TRANSISTORS AND COMPONENTS

OC71, OC72, OC44, OC45, OC81, OC81D—3/- each. OC83 6/- each p.p. 4d. Any quantity. AF116, AF117, OC170, OC171—3/6 each. OC75 2/- each. AF118 3/- each. OC172 3/- each. Mullard Branded BY100 Silicon Rectifiers 250 volt @ 550 M/A 5/- each.

MATCHED SETS TO CLEAR

1 OC82D + 2 OC82,
Set of 3—7/6 set

1 OC44 + 2 OC45—8/- per set
Mullard GET Transistors

1 GET874=OC44 } 8/- per set
2 GET873=OC45 }

AC126 8/- each. ASY28 8/6 each.
AF186 cut of freq. 800 Mc/s—27/6.
Texas GM290 cut of freq. 700 Mc/s 19/6 each.

TEXAS TRANSISTORS

2N1302=ASY28—6/6 each.
2G302=GET872—7/6 each.
2G301=GET873—6/6 each.
2S301 Similar to OC72—3/- each.

MAT TRANSISTORS

MAT 100 7/9. MAT 101 8/6. MAT 120 7/9. MAT 121 8/6.

Acos Record Player Cartridge Replacements for Collaro, Garrard, B.S.R. etc.—12/6 each.

SILICON RECTIFIERS

100 P.I.V. @ 10 amps (same size as BYZ13) 5/- each post paid.

100 P.I.V. @ 3 amps 3/- each post paid.

50 P.I.V. @ 20 amps 12/6 each post paid.

Mullard BYZ15 200 P.I.V. @ 40 amps £2.17.0 each.

OC26 transistors 7/6 each. AF119 3/- each. AC127 2/6 each. OC169 3/- each. OC172 3/- each.

MIN TRANSISTOR CONDENSERS

.1 100v. 9d. each 4d. postage any quantity

.05 " 8d. " " " " "

.02 " 7d. " " " " "

.01 " 7d. " " " " "

.005 " 7d. " " " " "

.001 " 7d. " " " " "

.04 " 8d. " " " " "

SUB MIN ELECTROLYTICS

1 to 100 Mfd from 1/3 each. Please forward component list for pricing.

MINIFLUX LF/60 ERASE HEAD

£2.0.0 plus P.P. 3/-.

DENCO TECHNICAL BULLETIN

2/4 post paid.

J. ROBINSON

(Radio & T.V.)

4 HIGHCLIFFE ROAD, BLACKLEY
MANCHESTER 9

RECEIVERS AND COMPONENTS

(continued)

COMPONENTS, VALVES, TRANSISTORS, etc. Call or send 6d. for list. ROGERS, 31 Nelson Street, Southport.

40 Semiconductors commonly used in Electronic and Radio Circuits consisting of 20 Transistors OC42-45-71-81, etc.

10 Silicon Rectifiers 50-800 PIV 200-800 mA. Inc. BY100's plus 10 Diodes OA70-79-81 Zener and Gold Bonded.

All brand new. Valued over £5. For only 40/-, plus post and packing 1/-, to:

BI-PAK SEMICONDUCTORS

8 Radnor House, 93/97 Regent Street, London, W.1

COMPONENTS BONANZA! Parts to suit many projects! Build an Electronic Didgeridoo! Workshop clearance, many bargains; also new stocks available. List 1/-. A. J. BASSETT 28 Park Road, Chorley, Lancs.

EDUCATIONAL

B.Sc.(ENG.), A.M.I.Mech.E., A.M.I.E.R.E. City & Guilds, etc., on "Satisfaction or Refund of Fee" terms. Wide range of expert Home Study Courses in Electronics, Computers, Radio, T.V., etc. 156-page Guide—FREE. Please state subject of interest. BRITISH INSTITUTE OF ENGINEERING TECHNOLOGY, 124k College House, Wright's Lane, London, W.8.

Full-time courses in RADAR and RADIO-TELEGRAPHY for prospective marine Radio Officers. Govt. approved exam. centre.

Also courses in basic ELECTRONICS, RADIO, TELEVISION and COMPUTERS.

Apply:—Director, British School of Telegraphy, 20 Penywern Road, Earls Court, London, S.W.5

STUDY RADIO, TELEVISION AND ELECTRONICS with the world's largest home study organisation. I.E.R.E., City & Guilds, R.T.E.B., etc. Also Practical Courses with equipment. All books supplied. Write for FREE Prospectus stating subject to I.C.S. (Dept. 577), Intertext House, Parkgate Road, London, S.W.11.

HOME STUDY COURSES in Practical Electronics. Free Brochure without obligation from: BRITISH NATIONAL RADIO SCHOOL, Reading, Berks.

A.M.I.Mech.E., A.M.I.E.R.E. City & Guilds, G.C.E., etc. Become a Technician or Technologist for high pay and security. Thousands of passes. For details of Exams. and Courses in all branches of Engineering, Building, Electronics, etc., write for 156-page handbook—FREE. B.I.E.T. (Dept. 125k), London, W.8.

PROGRAMMED TRANSISTOR experiments teach Conventional and Computer Circuits. Details S.A.E. BOX No. 4.

PUBLIC APPOINTMENTS

MINISTRY OF DEFENCE (Army Department) Chertsey, Surrey, requires Technician to work as a member of a team engaged in designing and developing all types of electrical and electronic equipment for Military Vehicles. To organise vehicle electrical trials. Quals.: Recognised engineering apprenticeship. Practical experience in design/development, manufacture or inspection of electrical equipment for the Marine, Aircraft or Heavy Automotive field. RE ME or similar experience an advantage. ONC (Electrical), C. & G. Finals or equivalent. Salary: £945 (age 26)—£1,120 (National) p.a. Application: Form from THE MANAGER (P.E. 2389), Ministry of Labour, Professional and Executive Register, Atlantic House, Farringdon Street, London, E.C.4.

TAPE RECORDERS, TAPES, ETC.

TAPES TO DISC—using finest professional equipment—45 r.p.m. 18/-. S.A.E. leaflet. DEROY, 52 Hest Bank Lane, Lancaster.

SITUATIONS VACANT

RADIO TECHNICIANS

A number of suitably qualified candidates will be required for training, leading to permanent and pensionable employment. (Normally at Cheltenham but with opportunities for service abroad or appointment to other U.K. establishments including London).

Applicants must be 19 or over and be familiar with the use of Test Gear and have had Radio/Electronic workshop experience. They must offer at least "O" level GCE passes in English Language, Maths and/or Physics, or hold the City and Guilds Telecommunications Technician Intermediate Certificate or equivalent technical qualifications.

Pay according to age, e.g. at 19 £747, at 25, £962 (highest age pay on entry) rising by four annual increments to £1,104.

Prospects of promotion to grades in salary range £1,032 - £1,691.

Annual Leave allowance of 3 weeks 3 days, rising to 4 weeks 2 days.

Normal Civil Service sick leave regulations apply.

Apply

Recruitment Officer (RT/54)
Government Communications Headquarters
Oakley
Priors Road
CHELTENHAM, Glos.

A FULL TIME TECHNICAL EXPERIENCED SALESMAN required for Retail sales. Write giving full details of age, previous experience, and salary required to: The Manager, HENRY'S RADIO LTD., 303 Edgware Road, London, W.2.

ROYAL COUNTY OF BERKSHIRE

Appointment of Assistant Visual Aids Technician

Applications are invited from suitably experienced persons for the post of ASSISTANT VISUAL AIDS TECHNICIAN at the County Education Office. The duties will be mainly concerned with the installation, maintenance and repair of visual and aural aids in schools throughout the County of Berkshire.

The salary scale is £780 rising to £890 per annum. A travelling allowance or a County Council car will be provided.

Further details and an application form may be obtained from the Director of Education, Shire Hall, Reading, Berks.

RADIO & RADAR ENGINEERS required to service and operate various equipments (including airborne radio and radar) at an airfield on the coast near Barmouth, North Wales. Ex R.A.F. or Naval Personnel ideally suited for these vacancies. Apply SHORT BROTHERS & HARLAND, Llanbedr, Merioneth.

SITUATIONS VACANT (continued)

Eastern Electricity

CHILTERN SUB-AREA

MEASUREMENTS and COMMUNICATIONS SECTION

A vacancy exists in the Measurements and Communications Section of the Sub-Area Engineer's Department for a craftsman who has a sound knowledge of basic Electronics and preferably experience in V.H.F./U.H.F. radio-telephone installation and maintenance. The successful applicant will be based at Leighton Buzzard, Bedfordshire.

Salary is in accordance with the National Joint Industrial Council Agreement, Group 'G', and a stagger pattern of working is in operation for which an additional payment will be made.

Basic rate of pay = £16 11s. 9d. per week including incidental overtime allowance.

Plus 10s. 6d. per week productivity bonus.

Plus £1 10s. 0d. per week stagger payment

Total pay £18 12s. 3d.

Also an additional 7/8d. per week will be paid after two years' service and a further 7/8d. per week after three years' service.

Applications should be made, in writing, stating age, experience and present position to the Manager, Chilterns Sub-Area, Eastern Electricity, Prebend Street, Bedford, as soon as possible.

TECHNICAL TRAINING by ICS IN RADIO, TELEVISION AND ELECTRONIC ENGINEERING

First-class opportunities in Radio and Electronics await the ICS trained man. Let ICS train YOU for a well-paid post in this expanding field.

ICS courses offer the keen, ambitious man the opportunity to acquire, quickly and easily, the specialized-training so essential to success. Diploma courses in Radio/TV Engineering and Servicing, Electronics, Computers, etc. Expert coaching for:

- * INSTITUTION OF ELECTRONIC AND RADIO ENGINEERS
- * C. & G. TELECOMMUNICATION TECHNICIANS' CERTS.
- * C. & G. SUPPLEMENTARY STUDIES.
- * R.T.E.B. RADIO AND TV SERVICING CERTIFICATE.
- * RADIO AMATEURS' EXAMINATION.
- * P.M.G. CERTIFICATES IN RADIOTELEGRAPHY.

Examination Students Coached until Successful.

NEW SELF-BUILD RADIO COURSES.

Build your own 5-valve receiver, transistor portable, signal generator and multi-test meter—all under expert tuition.

POST THIS COUPON TODAY and find out how ICS can help YOU in your career. Full details of ICS courses in Radio, Television and Electronics will be sent to you by return mail.

MEMBER OF THE ASSOCIATION OF BRITISH CORRESPONDENCE COLLEGES.

INTERNATIONAL CORRESPONDENCE SCHOOLS

A WHOLE WORLD OF KNOWLEDGE AWAITS YOU!

International Correspondence Schools
(Dept. 152), Intertext House, Parkgate Road,
London, S.W.11.

NAME
Block Capitals Please

ADDRESS

6.66

SERVICE SHEETS

SERVICE SHEETS for all makes of Radio and TV 1925-1966. Prices from 1/- with free fault-finding guide. S.A.E. inquiries. Catalogue of 6,000 models, 1/6. Valves, modern and obsolete. Radio/TV Books. S.A.E. lists, HAMILTON RADIO, Western Road, St. Leonards, Sussex.

CIRCUIT, COMP., VALUES, Avo model 7. 2/6 plus S.A.E. TELRAY, Maudland Bank, Preston.

STATE MODEL NO. Radio 1/6. TV 3/-. S.A.E. DARWIN, 10 George Street, St. Helens, Lancs.

SERVICE SHEETS

4/- each, plus postage.

We have the largest supply of Service Sheets for all makes and types of Radios and Televisions, etc. in the country. Speedy Service.

To obtain the Service Sheet you require, please complete the attached coupon:

From:
Name:

Address:

To: **S.P. DISTRIBUTORS**
44 Old Bond St., London, W.1
Please supply Service Sheets for the following:

Make:
Model No.: Radio/TV
Make:
Model No.: Radio/TV
Make:
Model No.: Radio/TV

I also require the new 1966 list of Service Sheets at 1/6 plus postage. (please delete items not applicable)

I enclose remittance of which includes postage

MAIL ORDERS ONLY June PE



Masterbox

kits afford the quickest, easiest method of assembling control boxes, indicator panels, small switchboards, etc., using a screwdriver only and in a matter of minutes.

The modular principle of construction of Masterbox is unique—units can be bolted together in any combination to build larger assemblies—can be altered, extended and adapted indefinitely to meet altered requirements.

Masterboxes are ideal for all kinds of experimental work, combining convenience with smartness, strength and adaptability.

Send to Cockrobin for details of Masterbox—or write for all lists. A 3d. stamp would oblige.

COCKROBIN CONTROLS
36 Villiers Avenue, Surbiton, Surrey

SENSATIONAL HALF PRICE OFFER!

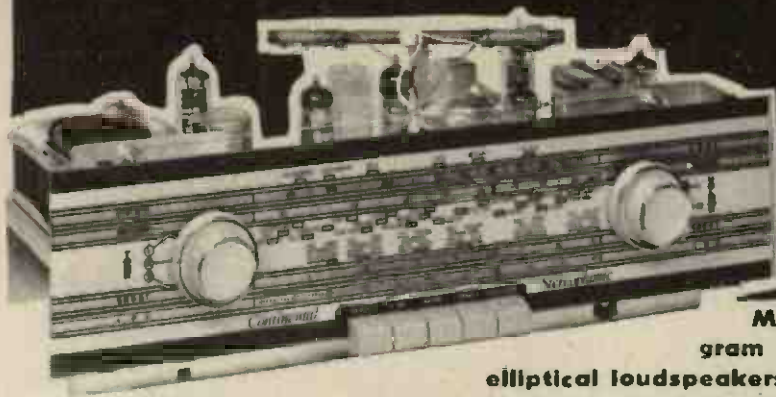

THE FAMOUS
'Continental'
RADIOGRAM
AT
HALF PRICE!

Magnificent Stereophonic Radiogram Chassis complete with two 10" elliptical loudspeakers, plus a Mono/Stereo 4-speed automatic record changer.

Only £29-19-6

- Easily fitted
- No soldering or Technical knowledge necessary
- Fits almost any cabinet with minimum trouble
- Modernises your old radiogram
- Built-in ferrite rod aerial
- Piano key switching
- Luxembourg and Caroline received at full strength
- Listen to U.S.A., Russia, Africa, Canada and even Australia
- Unique Lewis Radio 365 day guarantee, even on all the valves
- All British make

SPECIAL terms available of £7.10.0 deposit followed by 18 monthly payments of £1.9.1 (total H.P. £33.13.6) + postage & packing 15/- extra.

INDIVIDUAL CABINETS SUPPLIED ON REQUEST

Send your cheque or P.O. today for £8.5.0 while stocks last to Dept. PE66

LEWIS radio

LEWIS RADIO, 100, CHASE SIDE, SOUTHGATE LONDON, N.14. Telephone: PAL 3733/9666

BBC2 (625 LINE) TV AERIALS

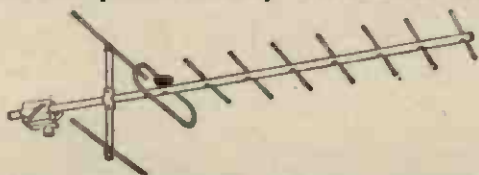

MAST MOUNTING ARRAYS, 9 element 45/-; wide spaced high gain, 11 element 55/-; 14 element 62/6. **WALL MOUNTING WITH CRANKED ARM**, 9 element 60/-; wide spaced high gain, 11 element 67/6; 14 element 75/-. **CHIMNEY ARRAYS COMPLETE**, 9 element 72/-; wide spaced high gain, 11 element 80/-; 14 element 87/6. **LOFT ARRAYS**, 7 element 32/6; wide spaced high gain, 11 element, **WITH TILTING ARM** 62/6; 14 element 70/-. **ALL HIGH GAIN UNITS HAVE SPECIAL MULTI-ROD REFLECTOR.** **LOW LOSS CO-AXIAL CABLE** 1/6 yd. **UHF transistor pre-amps** from 75/-.

BBC ♦ ITV ♦ F.M. AERIALS



B.B.C. (BAND 1), Telescopic loft 21/-. External S/D 30/-.

I.T.V. (BAND 3), 3 Element loft array 25/-; 5 element 35/-. Wall mounting, 3 element 35/-; 5 element 45/-.

COMBINED B.B.C./I.T.V. Loft 1+3, 41/3; 1+5, 48/9. Wall mounting 1+3, 56/3; 1+5, 63/9. Chimney 1+3, 63/9; 1+5, 71/3.

VHF transistor pre-amps from 75/-.

F.M. (BAND 2), Loft S/D 12/6. "H" 30/-, 3 element 52/6. External units available. Co-ax. cable 8d. yd. Co-ax. plugs 1/3. Outlet boxes 4/6. Diplexer Crossover Boxes 12/6. C.W.O. or C.O.D. P. & P. 4/6. Send 6d. stamps for illustrated lists.

QUOTATIONS FOR SPECIAL ARRAYS AVAILABLE ON REQUEST

K.V.A. ELECTRONICS (Dept. P.E.)
27 Central Parade, New Addington, Surrey
LOD 2266

HEADPHONES German made with cushioned ear-pads 29/-.
RECORDING TAPE German made long play acetate. 7" 1800' 18/9. 5 1/2" 1200' 15/9. 5" 900' 12/9.

PHOTOMULTIPLIERS 10/- each.

TERMINAL STRIPS (choc blocks) 12-way 5 amp PVC flexible 1/3.

LIGHT DEPENDENT RESISTORS LDR03 7/6 each.

LOUDSPEAKERS 5" 12/9. 7" x 4" 12/9. 8" 22/6. All 3 ohms.

POTENTIOMETERS 1K lin, 100K lin, 250K lin, 500K log, 500K lin, 1M log, 1M lin, 2M log. 1/- each. With double pole switch 500K log, 1 1/2M log. 2/- each.

Pre-set potentiometers 1K lin, 5K lin, 250K lin, 300K lin, 1M lin, 1 1/2M lin, 2M lin. 1/- each.

AMATEUR RADIO CALL BOOK (1966 Ed.) Directory of amateur radio stations in UK and Ireland. 6/6.

RSGB AMATEUR RADIO HANDBOOK (3rd Ed.), 544 pp. 36/6.

Post and Packing: orders under 10/-, 2/6 P.P. 10/- to £1, 3/- P.P. Over £1, post free.

COMMUNICATIONS EQUIPMENT

A large selection of communications receivers, test equipment, etc. always in stock.

BRIAN J. AYRES & CO.

Dept. DY, 8 Hartfield Road
Wimbledon, London, S.W.19

Telephone: Wimbledon 6063

HIGH GAIN 4 TRANSISTOR PRINTED CIRCUIT AMPLIFIER KIT Type TAI

● Peak output in excess of 1 1/2 watts.

- All standard British components.
- Built on printed circuit panel, size 6 x 3in.
- Generous size Driver and Output Transformers.
- Output transformer tapped for 3 ohm and 15 ohm speakers.
- Transistors (GET 114 or 51 Mullard OC81D and matched pair of OC81 o/p).
- 9 volt operation.
- Everything supplied, wire, battery clips, solder, etc.
- Comprehensive easy to follow instructions and circuit diagram 1/6 (Free with Kit). All parts sold separately.
- SPECIAL PRICE 45/-**. P. & P. 3/-. Also ready built and tested, 52/6. P. & P. 3/-. A pair of TAs are ideal for stereo.

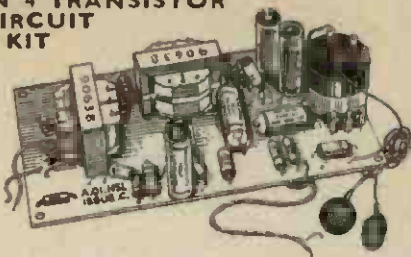

STEREO AMPLIFIER

Incorporating 2 ECL82s and 1 EZ80, heavy duty, double wound mains transformer. Output 4 watts per channel. Full tone and volume controls. Absolutely complete.

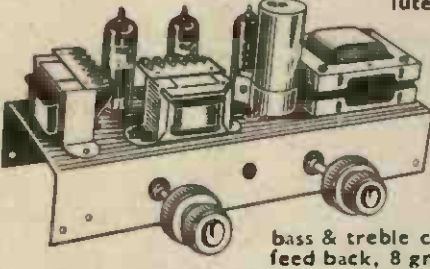

ONLY £4.19.6

P. & P. 6/6

Super Deluxe version with ECL86 valves, sep. bass & treble controls, full feedback, 8 gns. P. & P. 6/6

HARVERSON'S F.M. TUNER Mk. I

● F.M. tuning head by famous maker.

- Guaranteed non-drift.
- Permeability tuning
- Frequency coverage 88-100Mc/s
- Balanced diode output
- Two I.F. stages and discriminator.
- Attractive maroon and gold dial (7 x 3in. glass).
- Self powered, using a good quality mains transformer and valve rectifier.
- Valves used ECC85, two EF80s, and EZ80 (rectifier)
- Fully drilled chassis.
- Size of completed tuner 8 x 6 x 5 1/2 in.
- All parts sold separately.
- Set of parts if purchased at one time £5/19/6, plus 8/6 P.P. and ins. Circuit diagram and instructions 1/6 post free.
- Mark II Version as above but complete with magic eye, front panel and brackets, £6/12/6. P. & P. 8/6.
- Mark III Version as Mark I but with output stage (ECL82) and tone control, £7/7/-. P. & P. 8/6.

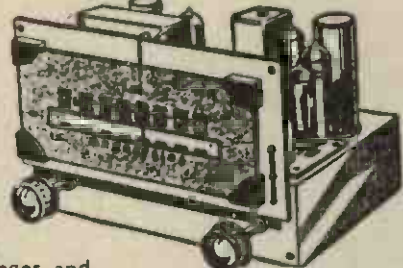

TAPE DECKS

B.S.R. MONARDECK (Single speed) 3 1/2 in. per sec., simple control, uses 5 1/2 in. spools, £6/15/-.

LATEST COLLARO MAGNAVOX 363 TAPE DECK DE LUXE. Three speeds, 2 track, takes up to 7 in. spools. 10 gns. Plus 7/6 carr. and ins. on each. (Tapes extra on both.)

ACOS CRYSTAL MIKES. High imp. For desk or hand use. High sensitivity, 18/6. P. & P. 1/6.

TSL CRYSTAL STICK MIKE. Listed at 45/- Our price, 18/6. P. & P. 1/6.

VYNAIR AND REXINE SPEAKER AND CABINET FABRICS app. 54 in. wide. Usually 35/- yd., our price 13/6 per yd. length (min. 1yd.). P. & P. 2/6. S.A.E. for samples.

QUALITY RECORD PLAYER AMPLIFIER

A top-quality record player amplifier. This amplifier (which is used in a 29 gn. record player) employs heavy duty double wound mains transformer, ECC83, EL84, EZ80 valves. Separate Bass, Treble and Volume controls. Complete with output transformer matched for 3 ohm speaker. Size 7in. w. x 2 1/2 in. d. x 5 1/2 in. h. Ready built and tested. **PRICE 69/6.** P. & P. 4/9.

ALSO AVAILABLE mounted on board with output transformer and 6in. speaker ready to fit into cabinet below. **PRICE 89/6.** P. & P. 5/9.

QUALITY PORTABLE R/P CABINET

Uncut motor board. Will take above amplifier and B.S.R. or GARRARD Autochanger or Single Record Player Unit. Size 18 x 14 x 8 1/2 in. **PRICE £39/6.** Carr. 7/6.

4-SPEED PLAYER UNIT BARGAINS

All brand new in maker's original packing.

- SINGLE PLAYERS**
- B.S.R. TU/12 £39/6. Carr. 5/6.
 - GARRARD SP25 De Luxe... £12/10/6. Carr. 5/6.
 - B.S.R. GU7 with unit mounted pickup arm. £4/18/8. Carr. 5/6.

AUTO. CHANGERS

- Latest B.S.R. UA25 Super slim £6 2 6
 - GARRARD Auto-Slim (4 pole) P/in. head £5 10 0
 - GARRARD AT6 £9.10.0. Carr. 6/6 on each.
- All the above units are complete with t/o mono head and sapphire styli or can be supplied with compatible stereo head for 12/6 extra.

BRAND NEW CARTRIDGE BARGAIN!

ACOS GP67-1. Mono complete. List price 21/- Our price 13/6. P. & P. 1/-.

BRAND NEW. 12" 15w. H/D Speakers, 3 or 15 ohm. Current production by well-known British maker. Offered below list price at 89/6. P. & P. 5/- (25w. guitar model £5.5.0). (35w. guitar model £8.8.0).

BRAND NEW 3 OHM LOUDSPEAKERS

5 in., 12/6; 6 1/2 in., 15/-; 8 in., 21/-; 10 in., 25/-; 12 in., 27/6; (12 in. 15 ohm, 30/-). 10 in. x 6 in., 26/-, E.M.I. 13 1/2 x 8 in. with high flux ceramic magnet, 42/- (15 ohm, 45/-). P. & P. 4" & 5" 2/-, 6 1/2" & 8" 2/6, 10" & 12" 3/6 per speaker.

7-10 watt OUTPUT TRANSFORMERS to match pair of ECL 86's in push-pull to 3 ohm output. **ONLY 11/-**. P. & P. 2/6.

7-10 watt ULTRA LINEAR OUTPUT TRANSFORMERS to match pair of ECL 82's in push-pull to 3 ohm output. **ONLY 15/-**. P. & P. 2/6.

MAINS TRANSFORMER for transistor power supplies. Tapped pri 200-250v. Sec. 40-0-40 at 1 amp (with electrostatic screen) and 6.3v. at 5 amp for dial lamps etc. Drop thro mounting. Stack size 1 1/2" x 3 1/2" x 3 1/2" 27/6. P. & P. 4/6.

SMOOTHING CONDENSER suitable for use with above 4000 mfd. 40v. size 1 1/2" dia. x 3 1/2" high. 3/6 each. P. & P. 1/6. And 2800 mfd. 25v. 1 1/2" dia. x 3" high 3/-. P. & P. 1/-.

MATCHED PAIR OF 2 1/2 WATT TRANSISTOR DRIVER AND OUTPUT TRANSFORMERS. Stack size 1 1/2" x 1 1/2" x 1 1/2" in. Output trans. tapped for 3 ohm and 15 ohm output. 10/- pair plus 2/- P. & P.

ANOTHER SCOOP!

FM/AM TUNER HEAD

Beautifully designed and precision engineered by Dormer and Wadsworth Ltd. Supplied ready fitted with twin .0005 tuning condenser for AM connection. Prealigned FM section covers 86—102 Mc/s. I.F. output 10.7 Mc/s. Complete with ECC85 (6L12) valve and full circuit diagram of tuner head. Another special bulk purchase enables us to offer these at 27/6 each. P. & P. 3/-. Order quickly!

Limited number also available with precision geared 3:1 reduction drive. 30/- P. & P. 3/-.

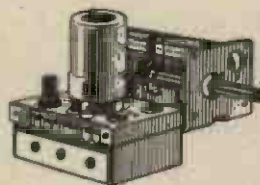

3-VALVE AUDIO AMPLIFIER MODEL HA34

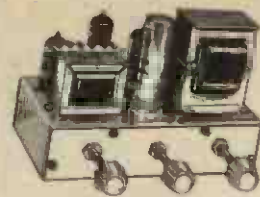

Designed for Hi-Fi reproduction of records. A.C. Mains operation. Ready built on plated heavy gauge metal chassis, size 7 1/2 in. w. x 4 in. d. x 4 1/2 in. h. Incorporates ECC83, EL84, EZ80 valves. Heavy duty, double wound mains transformer and output transformer matched for 3 ohm speaker, separate Bass, Treble and volume controls. Negative feedback line. Output 4 1/2 watts. Front panel can be detached and leads extended for remote mounting of controls.

The HA34 has been specially designed for us and our quantity order enables us to offer them complete with knobs, valves, etc., wired and tested for only **£4.5.0** P. & P. 6/-.

HSL 'FOUR' AMPLIFIER KIT.

A.C. Mains 200/250v., 4 watt, using ECC83, EL84, EZ80 valves.

- ★ Heavy duty double-wound mains transformer with electrostatic screen.
- ★ Separate Bass, Treble and Volume controls, giving fully variable boost and cut with minimum insertion loss.
- ★ Heavy negative feedback loop over 2 stages ensures high output at excellent quality with very low distortion factor.

★ Suitable for use with guitar, microphone or record player

- ★ Provision for remote mounting of controls or direct on chassis.
- ★ Chassis size only 7 1/2 in. wide x 4 in. deep. Overall height 4 1/2 in.
- ★ All components and valves are brand new.
- ★ Very clear and concise instructions enable even the inexperienced amateur to construct with 100% success.
- ★ Supplied complete with valves, output transformer (3 ohms only), screened lead, wire, nuts, bolts, solder, etc. (No extras to buy.) **PRICE 79/6.** P. & P. 6/-.

Comprehensive circuit diagram, practical layout and parts list 2/6 (free with kit). This kit although similar in appearance to HA34 employs entirely different and advanced circuitry.

10/14 WATT HI-FI AMPLIFIER KIT

A stylishly finished monaural amplifier with an output of 14 watts from 2 EL84s in push-pull. Super reproduction of both music and speech, with negligible hum. Separate inputs for mike and gram allow records and announcements to follow each other. Fully shrouded section wound output transformer to match 3-15Ω speaker and 2 independent volume controls, and separate bass and treble controls are provided giving good lift and cut. Valve line-up 2 EL84s, ECC83, EF86, and EZ80 rectifier. Simple instruction booklet 1/6. (Free with parts.) All parts sold separately. **ONLY £7/9/6.** P. & P. 8/6. Also available ready built and tested complete with std. input sockets, £9/5/- P. & P. 8/6. Carrying Case for above 28/6. P. & P. 7/6.

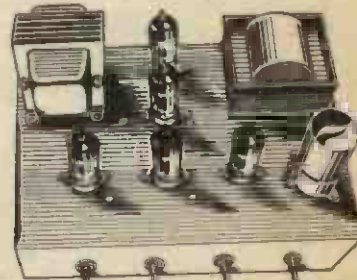

HARVERSON SURPLUS CO. LTD.

170 HIGH ST., MERTON, S.W.19. CHerrywood 3985

Open all day Saturday Early closing Wed., 1 p.m.

A few minutes from South Wimbledon Tube Station. (Please write clearly) OVERSEAS P. & P. CHARGED EXTRA. S.A.E. with all enquiries.

WENTWORTH RADIO

ANNOUNCE MORE COMPONENTS AT PRICES YOU CAN AFFORD

- OC77 3/6
- AF117 2/6
- AF115 3/6
- OC44 2/6
- OC170 3/-
- OC200 3/-
- OC76 2/6
- OC45 2/6

S. MICA 10PF-1000PF 6d.
CERAMICS 4d. MINIATURE
TRS. ELECTROLYTICS 1/2
32-32MFD 450VWG 4/6

POTENTIOMETERS 1st QUALITY MINIATURE LIN. TYPE. 5K, 10K, 25K, 50K, 100K, 250K, 500K, 1MΩ, 2MΩ. 2/- EACH, 20/- DOZ. PRINTED CIRCUIT BOARD KITS, INCL. BOARDS, CHEMICALS, ETC. 15/-.

We welcome enquiries for all types of components. Lists. S.A.E. Terms, cash with order, P/P. add 9d. for orders under £2

WENTWORTH RADIO, 1a, Wentworth Court, Alston Rd., Barnet. Tel.: BAR 3087

BARGAIN OF THE MONTH

Printed Circuit Board packed with over 90 Transistor Components, inc. 9 Transistors, 7 Diodes, 2 Zeners, 21 Electrolytics, 4 P.C. Plugs and much more.

Fantastic Value at 15/11

- WHITE SPOT 9d.
- OC72 2/6
- OC81 2/6
- OC26 10/-
- ADI40 10/-
- OAB1 1/-
- OC71 2/6
- OC81D 2/6
- OC35 10/-
- OC28 10/-
- BY100 6/-
- OA95 1/-

1/4 - 1/2 W RESISTORS
10Ω - 22M 2d.
1/10W 10% 10Ω - 1MΩ 5d.

Why not go in for RADIO CONTROL of boats, aircraft, etc.?

Send 1/- for list of TELE-RADIO Kits of transmitters and receivers. Or send 2/- for full illustrated literature to:

RECORDER

325/327 Fore St., Edmonton, N.9

Packed with concise servicing data
 the "gen" at your fingertips in one
 authoritative volume for day-to-day use!

TAPE RECORDER SERVICING MANUAL

by **H. W. HELLYER**
 A.M.T.S., A.I.P.R.E., A.M.I.S.M.

Tape recorders present special problems to the service engineer. Many decks are quite complex mechanically, whilst high performance is required of the associated electronic circuitry. The best aid the service engineer can have in dealing with recorders is adequate information. This book provides concise

**A book to save
 you time and
 make you profit**

tape recorders and decks that have been released in this country. The notes are compiled partly from manufacturers' official data, from trade sources, and also from bench notes and observations made by the author in the course of a number of years' practical servicing. Also contains an authoritative introductory section on the principles and practice of tape recording, practical repair procedures, and microphones and matching.

service data, including circuit diagrams and numerous layout diagrams and views of mechanisms and adjustments, for the majority of



**Covers 282 models
 in 344 pages
 supported by over
 345 drawings,
 exploded views and
 circuit diagrams
 63s.**

**Published by
 NEWNES**

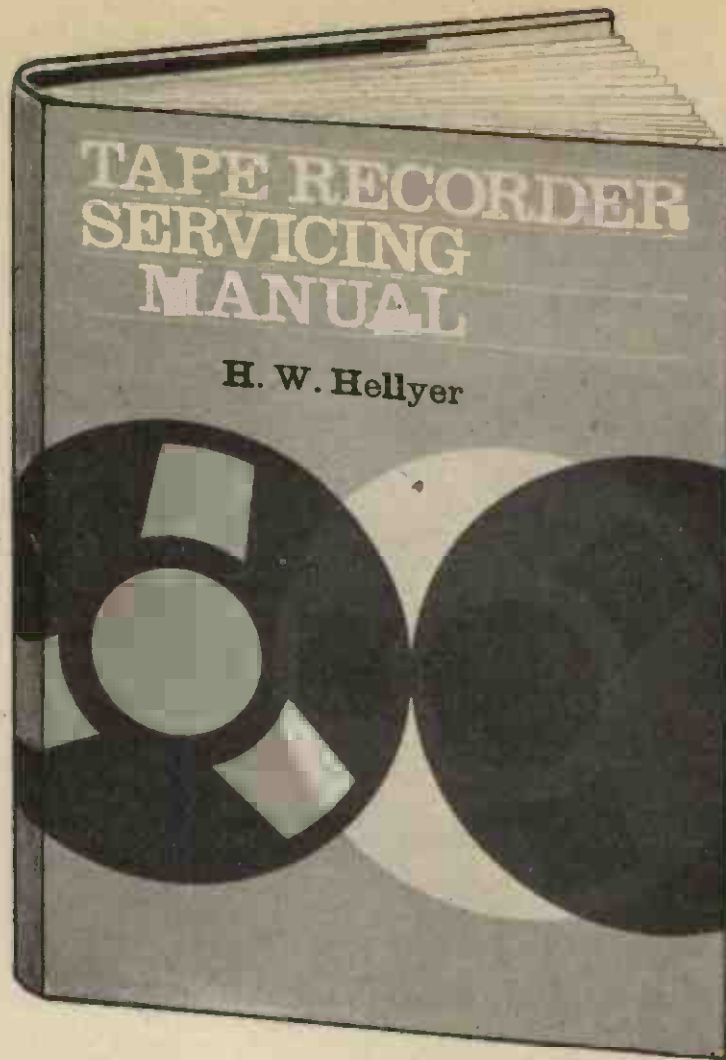

Alba, Allegro, Amplion, B.S.R., Baird, Brenell, Bush, Butoba, Collaro, Cossor, Dansette, Defiant, Dynatron, E.M.I., Editor, Ekco, Elizabethan, Elpico, Elpico-Makes covered from 63 Manufacturers include . . . Geloso, Ferguson, Ferranti, Ferrograph, Ficord, Fidelity, G.B.C., G.E.C., Garrard, Geloso, Gramdeck, Grundig, H.M.V., Hagen, Kolster-Brandes, Korting, Magnavox, Motek, Murphy, Peto-Scott, Philco, Philips, Playtime, Portogram, R.G.D., Recording Devices, Regentone, Robuck, Simon, Sobell, Sonomag, Sony, Sound, Soundmirror, Steelman, Stuzzi, Telefunken, Thorn, Truvox, Ultra, Verdik, Volmar, Walter, Winston and Wyndsor.

from your bookseller, or:—

Complete this form and post today

To George Newnes Ltd., Tower House, Southampton Street, London, W.C.2.

Please send me TAPE RECORDER SERVICING MANUAL for which I enclose remittance of 63s.

Name.....

Address.....

P.E.6

ASTONISHING LOW PRICED RADIO KITS FROM CONCORD

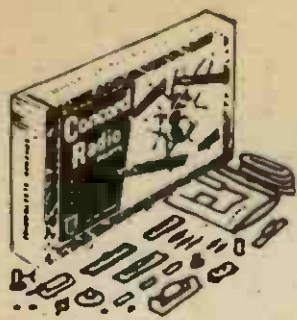

MAKE 5 DIFFERENT TRANSISTOR RADIOS for 35/-

Amazing Radio Construction Set! Become a radio expert for 35/-. A complete Home Radio Course. No experience needed. Parts include instructions for each design, Step-by-Step plan, all Transistors, loudspeaker, personal phone, knobs, screws, etc., all you need. Box size 14" x 10" x 2" (parts available separate). Originally £6. NOW 35/- plus 3/6 p. & p.

New RADIO Anyone CAN BUILD in 2-3 hours! Only 18/6 EVEN THE OLDEST CHILDREN BUILD THEM! ... no soldering — only 16 connections! Then hear it reach out bringing in station after station. 4 1/2" x 2 1/2" x 1 1/2". Many Testimonials:—M.H. of Bradford, writes: "... I have just completed one of your sets successfully, it is the first time I have ever tackled anything like a radio and I must state here and now, I am amazed how easy it is to a layman like me. Your instructions and plan have obviously been very carefully thought out so that even the most dim can follow them..." 18/6 plus 2/6 post, etc.



UNIQUE NEW PORTABLE RADIO NOW A FRACTION OF THE NORMAL PRICE. ONLY 35/-

FULLY TRANSISTORISED READY BUILT
WHY PAY MORE. All the latest refinements are packed into this new MULTI STATION ALL transistor radio — the internal aerial picks up even remote stations and the powerful built-in speaker gives room filling volume. Individual tuning, first-class reception. Purchase with confidence—packed in original manufacturers' cartons.



(Personal earpiece and battery, 4/6)
Send 35/- plus 4/6 P. & P.
(Mail Order Only)

ASTONISHING CIGARETTE RADIO! ONLY 18/6



Yes a perfectly ordinary packet of cigarettes!—but it fetches in station after station, loud and clear! Holds 10 Cigarettes — yet cleverly conceals highly sensitive, fully transistorised circuit (incl. tiny battery). Even a young boy can assemble it in under 2 hours. No soldering. No experience necessary. Only 16 Connections. From our bulging testimonial file, Mr. D. B. of Huddersfield writes:—"... I have fitted the parts in and it is working wonderfully..." ALL PARTS including Semi-Conductors, A.B.C. Plans, etc. ONLY 18/6 plus 2/6 post, etc.

CONCORD ELECTRONICS LTD · (Dept. PE26) · 77 NEW BOND STREET · W.1

CONDENSER BARGAINS!

ELECTROLYTIC			
32uf ... 1.5volt	2uf ... 6volt	64uf ... 9volt	3.2uf ... 64volt
25uf ... 3volt	10uf ... 6volt	250uf ... 9volt	5uf ... 70volt
2uf ... 3volt	25uf ... 6volt	10uf ... 10volt	4uf ... 100volt
8uf ... 3volt	30uf ... 6volt	100uf ... 10volt	2uf ... 150volt
20uf ... 3volt	2uf ... 9volt	1uf ... 50volt	8uf ... 275volt
100uf ... 3volt	2uf ... 9volt	5uf ... 50volt	
200uf ... 3volt	20uf ... 9volt	8uf ... 50volt	
	all at 1/- each or 9/- per doz.		
3uf ... 12volt	200uf ... 12volt	100uf ... 15volt	32uf ... 25volt
4uf ... 12volt	6uf ... 15volt	750uf ... 15volt	64uf ... 25volt
6uf ... 12volt	8uf ... 15volt	2.5uf ... 25volt	150uf ... 25volt
10uf ... 12volt	10uf ... 15volt	3uf ... 25volt	16uf ... 30volt
25uf ... 12volt	30uf ... 15volt	4uf ... 25volt	6.4uf ... 40volt
100uf ... 12volt	50uf ... 15volt	25uf ... 25volt	12.5uf ... 40volt
	all at 1/3 each or 11/3 per dozen		
5,000uf ... 12volt	4/- each.	500uf ... 25volt	3/- each.
PAPER CONDENSERS each doz.			
001uf ... 500volt	7d. 5/3	29/-	£7/5/-
001uf ... 1,000volt	9d. 6/9	37/6	£9/7/6
002uf ... 500volt	7d. 5/3	29/-	£7/5/-
015uf ... 300 A.C.	9d. 6/9	37/6	£9/7/6
005uf ... 750volt	7d. 5/3	29/-	£7/5/-
02uf ... 350volt	6d. 4/6	25/-	£6/5/-
02uf ... 600 A.C.	1/3 11/3	62/6	£15/12/6
1uf ... 350volt	7d. 5/8	31/3	£7/16/3
1uf ... 750volt	9d. 6/9	37/6	£9/7/6
25uf ... 350volt	10d. 7/6	41/8	£10/8/-
5uf ... 150volt	1/- 9/-	50/-	£12/10/-
5uf ... 350volt	1/3 11/3	62/6	£15/12/6
5uf ... 500volt	1/6 13/6	75/-	£18/15/-
			7/6 per 100.
			£3 per 1,000.
SILVER MICA, CERAMIC, POLYSTYRENE, Mixed types, values, 10/- per 100.			
RESISTORS. 1/4 watt to 3 watt. Close Tolerance. Mixed values. Polythene wrapped on cards of 10. Fantastic value! Only 50/- per 1,000 plus 5/- post and packing.			
RESISTORS FOR TRANSISTOR WORK. Low values. 1/4 watt. 5% tolerance. Long leads. Excellent quality. 50 for 10/-. Our selection only.			
TRANSISTORS. Untested, unmarked. Excellent Value at 12/6 for 50, £1 for 100. I.B.M. Computer Switching Transistors. Very small. NPN or PNP. 6 for 10/-. NKT 124/5 Switching Transistors. 6 for 10/-. Diodes 1/- each, 9/- dozen, 50/- 100, £12/10/- per 1,000.			
SIGNAL INJECTOR. Transistors, components, circuit, to make, 10/- only.			
REV. COUNTER. Transistors, components (excluding meter), 10/- only.			
LOUDSPEAKERS. 3in., 4in., or 5in., 10/- each.			
MICROPHONES. Magnetic, Lapel, 10/- each. With plug and lead.			
EARPIECES. Magnetic, 5/- each. With plug and lead.			
PICK-UP HEADS. MONO 14/-, STEREO 21/-, DIAMOND STEREO 28/9 ACOS MAKE.			

G. F. MILWARD

17 Peel Close, Drayton Bassett, Nr. Tamworth, Staffs.

Phone: Tamworth 2321

ORDERS UNDER 10/- PLEASE INCLUDE 1/- POST AND PACKING

YUKAN SELF-SPRAY AEROSOL WAY!

GET THIS AIR DRYING HAMMER FINISH NOW!

YUKAN Aerosol spraykit contains 16 ozs. fine quality durable easy instant spray. No stove baking required. Available in Grey, Blue, Gold, Bronze at 14/11 at our counter or 15/11, carriage paid, per pushbutton self-spray can. SPECIAL OFFER: 1 can plus optional transferable snap-on trigger handle (value 5/-) for 18/11 carriage paid.



Choice of 13 self-spray plain colours and primer (motor car quality) also available

Please enclose cheque or P.O. for total amount to:

YUKAN · DEPT. PE/6 · 307a EDGWARE ROAD · LONDON · W.2

A book for every electronics engineer...

TRANSISTOR POCKET BOOK

by R. G. Hibberd, B.Sc., M.I.E.E., Sen.M.I.E.E.E.

A comprehensive guide to the characteristics and use of the various types of transistor now available. The manufacture of the various types of transistor, up to and including the latest epitaxial planar, field of effect and metal-oxide silicon transistors, is described in detail in order to make clear the different characteristics of each. Includes notes on the use and handling of transistors, and chapters on solid state circuit techniques and recent developments.

304 pages 250 illustrations 25s

From your Bookseller, or in case of difficulty, 27s. from GEORGE NEWNES LTD., SOUTHAMPTON ST., W.C.2

NEWNES

Build the 'SOLETTE' in 20 hours

Construct this organ easily with our factory made units

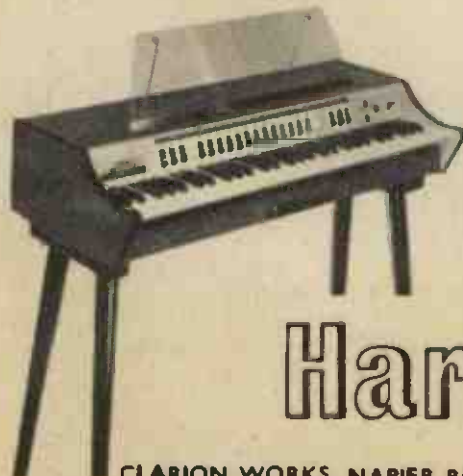

Suitable for music of all kinds. Self contained amplifier and loudspeakers. Excellent tone and volume. Five pitches + solo and melodic bass. Fully transistorised and portable. Price £118 complete. Other models from £82 (terms available).

Harmonics

(Bromley) Ltd

CLARION WORKS, NAPIER ROAD, BROMLEY, KENT. RA9 2JZ

TECHNICAL TRADING Co.

All items previously advertised available, also see items advertised in Practical Wireless. Huge Hi-Fi and Components stocks at all branches.

STEREO AM/FM CHASSIS

Large de-luxe A/C radiogram chassis. Mullard valves normal valve 17 Gns. approx. 24gns. Ditto AM Stereo Chassis £10. 15. 0. AM/FM Mono Chassis £11. 10. 0.

BARGAIN 7lb. PARCELS

Including variable condensers, i.f. coils, loudspeaker plugs/sockets, knobs, pots, condensers, resistors, nuts, bolts, cabinet fittings, switches, transformer choke, rectifier, transistors. List value 17/6 over £6. Carr. 5/-. Try one!

TRANSISTOR PLAYERS

UA2588 Autochanger, 2 external inputs (mike etc.). External speaker socket, with hi-flux speaker, mixer, base, treble controls, really de-luxe portable, large satin chrome control panel. 17 Gns. Normal price 25 gns.

Old and New Customers welcomed at our New London Branch, Telephone No. MUS 2639. 10 TOTTENHAM COURT RD., LONDON, W.1
350/352 FRATTON RD., PORTSMOUTH. Tel: 22034
72 EAST STREET, SOUTHAMPTON. Tel: 25851
ALL MAIL ORDER AND RETAIL SHOP
PARK CRESCENT PLACE, BRIGHTON

VALUABLE NEW HANDBOOK FREE TO AMBITIOUS ENGINEERS

Have you had your copy of "Engineering Opportunities"?

The new edition of "ENGINEERING OPPORTUNITIES" is now available—without charge—to all who are anxious for a worthwhile post in Engineering. Frank, informative and completely up to date, the new "ENGINEERING OPPORTUNITIES" should be in the hands of every person engaged in any branch of the Engineering industry, irrespective of age, experience or training.

On 'SATISFACTION OR REFUND OF FEE' terms

This remarkable book gives details of examinations and courses in every branch of Engineering, Building, etc., outlines the openings available and describes our Special Appointments Department.

WHICH OF THESE IS YOUR PET SUBJECT?

MECH. ENGINEERING
Gen. Mech. Eng. — Maintenance Eng. — Diesel Eng. — Press Tool Design — Sheet Metal Work — Welding — Eng. Pattern Making — Inspection — Draughtsmanship — Metallurgy — Production Eng.

RADIO ENGINEERING
General Radio — Radio & TV Servicing — TV Eng. — Telecommunications — Electronics — Sound Recording — Automation — Practical Radio — Radio Amateurs' Exam.

CIVIL ENGINEERING
General Civil Eng. — Municipal Eng. — Structural Eng. — Sanitary Eng. — Road Eng. — Hydraulics — Mining — Water Supply — Petrol Tech.

ELFC. ENGINEERING
General Electrical Eng. — Installations — Draughtsmanship — Illuminating Eng. — Refrigeration — Elem. Elec. Science — Elec. Supply — Mining Elec. Eng.

AUTO ENGINEERING
General Auto Eng. — Auto. Maintenance — Repair — Auto. Diesel Maintenance — Auto. Electrical Equipment — Garage Management.

BUILDING
General Building — Heating & Ventilation — Plumbing — Architecture — Carpentry — Painting — Decorating — Specifications & Quantities — Surveying — Architectural Draughtsmanship.

WE HAVE A WIDE RANGE OF COURSES IN OTHER SUBJECTS INCLUDING CHEMICAL ENG., AERO ENG., MANAGEMENT, INSTRUMENT TECHNOLOGY, WORKS STUDY, MATHEMATICS, ETC.

Which qualification would increase your earning power?
A.M.I.Mech.E., A.M.S.E., A.M.I.C.E., A.M.I.E.R.E., B.Sc.,
A.M.I.P.E., A.M.I.M.I., A.R.I.B.A., A.I.O.B., A.M.I.Chem.E., A.R.I.C.S.,
M.R.S.H., A.M.I.E.D., A.M.I.Mun.E., CITY & GUILDS, GEN. CERT. OF EDUCATION, ETC.

BRITISH INSTITUTE OF ENGINEERING TECHNOLOGY
316A COLLEGE HOUSE, 29-31 WRIGHT'S LANE, W.8

THIS BOOK TELLS YOU

- ★ HOW to get a better paid, more interesting job.
- ★ HOW to qualify for rapid promotion.
- ★ HOW to put some letters after your name and become a key man . . . quickly and easily.
- ★ HOW to benefit from our free Advisory and Appointments Depts.
- ★ HOW you can take advantage of the chances you are now missing.
- ★ HOW, irrespective of your age, education or experience, YOU can succeed in any branch of Engineering.

156 PAGES OF EXPERT CAREER - GUIDANCE

PRACTICAL EQUIPMENT

Basic Practical and Theoretic Courses for beginners in Radio, T.V., Electronics, Etc., A.M.I.E.R.E. City & Guilds Radio Amateurs' Exam. R.T.E.B. Certificate P.M.G. Certificate Practical Radio Radio & Television Servicing Practical Electronics Electronics Engineering Automation

INCLUDING TOOLS

The specialist Electronic Division of B.I.E.T. NOW offers you a real laboratory training at home with practical equipment. Ask for details.

B.I.E.T.

You are bound to benefit from reading "ENGINEERING OPPORTUNITIES", and if you are earning less than £30 a week you should send for your copy *now*—FREE and without obligation.



POST NOW!

TO B.I.E.T., 316A COLLEGE HOUSE,
29-31 WRIGHT'S LANE, W.8.

3d. stamp if posted in an unsealed envelope.

Please send me a FREE copy of "ENGINEERING OPPORTUNITIES." I am interested in (state subject, exam., or career).

NAME

ADDRESS

WRITE IF YOU PREFER NOT TO CUT THIS PAGE

THE B.I.E.T. IS THE LEADING INSTITUTE OF ITS KIND IN THE WORLD

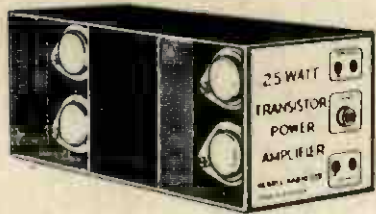

(6)

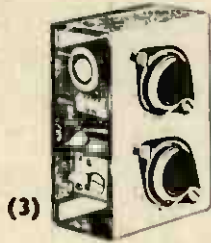

(3)

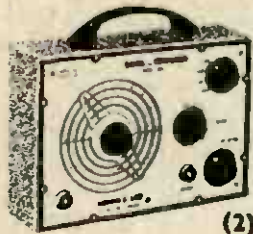

(2)

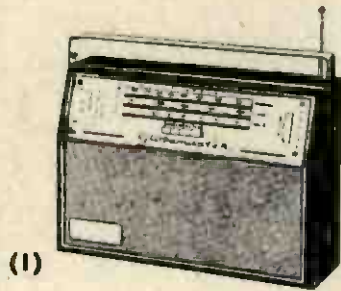

(1)

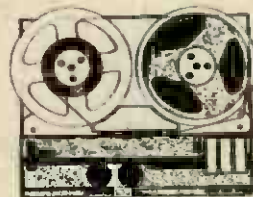

(8)



(16)

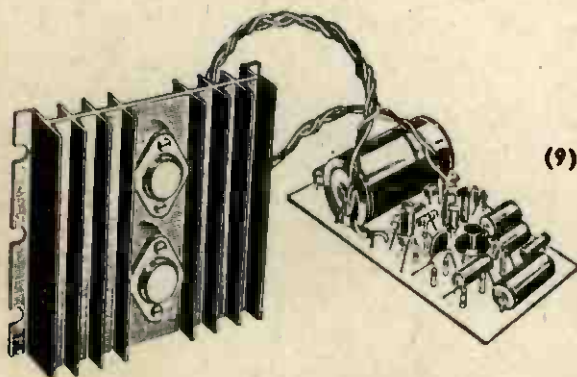

(9)



(10)

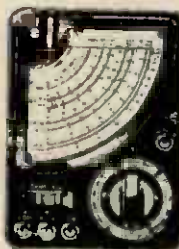

(12)



(7)



(11)



(14)

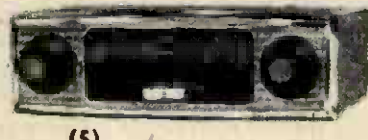

(5)



(13)



(15)

1966 150 PAGE CATALOGUE

Fully detailed and illustrated components, equipment and Hi-Fi. All types and makes. 5000 Stock lines. 500 Transistors and Devices. 1000 Quartz Frequencies. 800 Valves and Tubes. The Finest and Largest Range available. A mine of information.

Price 6/- post paid

FREE with Catalogue, 6/- Value Discount vouchers gives 2/- in pound discount on purchases.

CATALOGUE COSTS NOTHING AFTER USING VOUCHERS

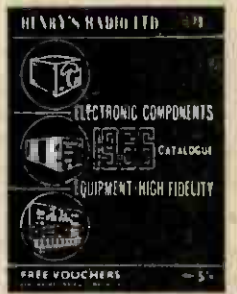

(1) GLOBEMASTER MW/LW/SW PORTABLE RADIO TO BUILD

Special purchase reduces prices Full 3-waveband tuning. Pushbutton wavechange. Superhet printed circuit. Black-chromed cabinet 11 x 7 1/2 x 3 1/2 in. (SW 17-50 metres). Ear/Record sockets. **TOTAL COST TO BUILD £7.19.6** P.P. 3/6.

(16) VHF FM TUNER TO BUILD

87/105 Mc/s Transistor Superhet. Geared tuning. Terrific quality and sensitivity. For valve or transistor amplifiers. 4 x 3 1/2 x 2 1/2 in. **TOTAL COST TO BUILD £6.19.6** P.P. 2/6. (Cabinet Assembly 20/- extra)

10 AND 20 WATT MONO AND STEREO TRANSISTOR AMPLIFIERS

(9) POWER AMPLIFIERS. 10 watts RMS output. 100mV input. 30 c/s to 20kc/s ± 1dB. 6-Transistor Push-pull. Panel size 4 x 2 1/2 x 1 in. H/S 4 x 4 in. TPA10/3 3-5 ohm spkr. £5.10.0, p.p. 2/6 TPA10/15 12-16 ohm spkr. £5.19.6, p.p. 2/6 (Mains unit for 1 or 2 amplifiers, 59/6, p.p. 2/6)

(10) PREAMPLIFIERS. 8 input selector. Treble, bass, volume, filter controls. 1 1/2 mV to 300mV inputs. Battery operated or from Mains Unit. Output up to 150mV RMS.

MP2 Mono 9 1/2 x 2 1/2 x 2 in. £5.10.0, p.p. 2/6 (brown and gold front panel 8/6)

SP4 Mono/Stereo, 9 x 3 1/2 x 1 1/2 in. £10.19.6, p.p. 3/6 (front panel plate 12/6)

● ALL UNITS BUILT AND TESTED

(8) BUILD A QUALITY TAPE RECORDER

Three speeds—3 watts. Complete kits with new "363" decks. Supplied as preassembled sections. Complete with portable cabinets and Speaker—excellent quality. 7" 1,200ft. tape and spool and Acos 45 microphone. "363" decks with tape and Acos mic. (2 track 10 gns. 4 track £13.10.0. P.P. 5/-)

★ TWO TRACK ★ FOUR TRACK

£26 P.P. 8/6 £30 P.P. 8/6

(3) 5 WATT AMPLIFIER

6-Transistor Push-pull, 3 ohms. 6mV into 1K. 12/18V supply. 2 1/2 x 2 x 1 1/2 in. **BUILT AND TESTED 79/6** P.P. (optional mains units 54/-) 2/- 1 1/2 watt version 59/6. New matching Preamplifier, 6 inputs, treble/bass/selector/volume controls. 6-10mV/put. 9-18V supply. 79/6, p.p. 2/- For use with any Transistor Amplifier

DEAC CHARGER

To charge 3.6 volt and 9.6 volt packs. Fully mains isolated **45/-** P.P. 2/- In moulded case.

(13) REGENT-6 MW/LW POCKET RADIO TO BUILD

6-Transistor superhet. Geared tuning. Push-pull output. Moulded cabinet 5 x 3 x 1 1/2 in. Phone socket. **TOTAL COST TO BUILD 69/6** P.P. 2/- Special purchase reduces price

(15) HI-FI EQUIPMENT

Special parcel prices. Let us have your enquiries for equipment.

(4) DEAC CELLS

RECHARGEABLE BATTERIES ● 3.6 volt 500 mA/H. Size: 1 1/2" x 1 1/2" dia. 12/6, p.p. 1/6 ● 9.6 volt 225 mA/H. Size: 2 1/8" x 1" dia. 20/-, p.p. 1/6 **BRAND NEW** — Offered at a fraction of normal retail price.

(6) 25 WATT AMPLIFIER

New 8-Transistor design. Push-pull output for 7 1/2 to 16ohm speaker. 150mV input. 30c/s to 20kc/s ± 1dB. For use with valve or transistor preamplifiers as item (10) above. Size 2 1/2 x 2 1/2 x 6 1/2 in. **PRICE BUILT AND TESTED £8.19.6** P.P. 3/- (Mains unit 79/6, p.p. 2/6)

(5) ROADSTER MW/LW CAR RADIO TO ASSEMBLE

Supplied as Preassembled Panels. Permeability tuned superhet. Push-button wave-changer. Push-pull output. Fits any car. 7 x 4 x 2 in. 12 volt (+) earth. **ASSEMBLY TOTAL COST £8.19.6** P.P. 3/6 (Speaker/Baffle/Car Fixing Kit, 20/-)

(11) GARRARD DECKS

(p.p. 5/- any type) 1000 mono £5.19.6. stereo £6. 6.0 2000 mono £6. 6.0. stereo £6. 6.0 *SP25 mono £10.10.0. stereo £10.19.6 Autoslim mono £5. 9.6. stereo £5. 9.6 *AT6 mono £8.19.6. stereo £9.10.0 *AT60 mono £10.10.0. stereo £10.19.6 3000LM stereo £8.19.6

(*Deram cartridge add 60/- to mono price). All autochange (except SP25), complete with cartridge. Brand new.

(7) VHF FM TUNER

Supplied as 2 Preassembled Panels, plus metal work Superhet design, 88-108 Mc/s, 9 volt operated. Total cost to assemble £12.17.6, p.p. 2/6.

(12) MULTI-METERS

PT34 1kv 39/6 TP55 20kv £5.19.6 M1 2kv 49/6 EP30k 30kv £6.10.0 TP10 2kv 75/- EP50k 50kv £8.15.0 EP10k 10kv 79/6 500 30kv £8.17.6 IT1-2 20kv 69/6 EP100k 100kv £10.10.0 EP20k 10kv 99/6

(14) MW/LW QUALITY TRANSISTOR RADIO TUNER

Fully tunable superhet with excellent sensitivity and selectivity. Output up to 1/2 volt peak. Complete with front panel, etc. 9 volt operated. For use with any amplifier or tape recorder. **TOTAL COST TO BUILD £3.19.6** P.P. 2/6

HENRY'S RADIO LTD.

303 EDGWARE RD., LONDON, W.2
PADdington 1008/9
Open Mon. to Sat. 9-6. Thurs. 1 p.m.
Open all day Saturday.

(2) NOMBREX TEST UNITS

*150 kc/s—350 m/c/s RF Generator All Transistor £9.10.0 *10 c/s—100 kc/s Transistor Audio Generator £16.15.0

LET US QUOTE FOR COMPONENTS AND EQUIPMENT FOR YOUR CIRCUIT