

Practical Electronics

DECEMBER 1965

PRICE 2/6

FIRE ALARM

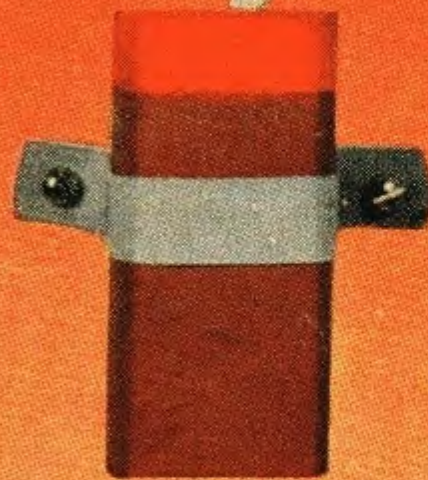

Free! **2** **BLUEPRINTS** and **DATA CHARTS**

POWER FOR TOMORROW

It seems certain that significant and perhaps spectacular developments in the field of electrical power generation will occur in the next few years. The idea of obtaining electrical power by direct conversion of heat—without the use of moving machinery—has occupied the minds of scientists and engineers for many years. Various methods of direct conversion have been demonstrated in the laboratory, but the development of practical models has only in recent times become a distinct possibility.

The space programmes of the U.S.A. and U.S.S.R. have provided the main stimulus for the current drive to develop new kinds of portable power generators. But research on this subject is certainly not confined to these two countries. All advanced industrialised countries are faced with the problem of satisfying an ever increasing demand for power, while future progress in under-developed countries depends much on the availability of small portable generators.

★ ★ ★

There are three conversion schemes that seem suitable for small portable generators. They are based on thermoelectric, photoelectric and thermionic effects.

The thermionic converter seems the most promising for immediate use. It is considered most likely that this type of generator—which is basically a diode—will be first exploited in space vehicles. The cathode would be heated either by exposure to the sun, or to a radioactive source on board the vehicle. In due course, it is expected that the thermionic generator will become a practical proposition for more conventional applications. Ultimately this device may be used to power motor cars.

★ ★ ★

The schemes mentioned so far are essentially for low power generators, with maximum outputs of the order of a few hundred watts. At the other end of the power scale, the magnetohydrodynamic (MHD) system is expected to boost the output of conventional electrical generating stations. This system produces power by ionisation of high temperature gas and is particularly favourable for use in conjunction with nuclear reactors.

★ ★ ★

In considering future sources of electrical power, one cannot overlook the fuel cell—although this is not electronic in the usual sense of the word. The fuel cell produces electrical energy by chemical reaction, rather like the Leclanche type primary cell. This device uses hydrogen as fuel but could possibly operate from petrol. The opinion has been expressed by one authority, that the fuel cell may well provide the main motive power for all road transport before the next 30 years have passed.

THIS MONTH

CONSTRUCTIONAL PROJECTS

S.C.R. LIGHT DIMMER	987
AUDIO OSCILLATOR AND VALVE VOLTMETER	991
FIRE ALARM SYSTEM	1004
MULTI-RANGE TEST METER	1014
GENERAL PURPOSE SCALER	1016

SPECIAL SERIES

BUILDING BLOCKS—9	997
BEGINNERS START HERE—14	1012
NEON NOVELTIES—4	1028

GENERAL FEATURES

COMMUNICATIONS BY SATELLITE	982
INSTANT MORSE	1003

NEWS AND COMMENT

EDITORIAL	981
THE 73 PAGE	996
ELECTRONORAMA	1010
NEWS BRIEFS	1024
DETACHED PARTICLES	1027
NEW PRODUCTS	1031
READOUT	1032

*Our January issue will be published on
Thursday, December 16*



COMMUNICATIONS BY SATELLITE

by PATRICK HALLIDAY

THE far-reaching implications of communications satellites first attracted public attention with the transatlantic television relays via *Telstar* in June 1962. Since then *Telstar II*, *Relay*, *Syncom II* and *III*, and, more recently, the continuous transmission capabilities of *Early Bird* have all confirmed that a new and most effective means of transmitting broadband signals has been developed. From a communications viewpoint this can well be compared with such decisive breakthroughs as the first trans-oceanic cables, the first long-distance radiotelegraphy, the opening up of the short-waves in the mid-twenties or, in the post-war period, the development of broadband microwave links and trans-oceanic telephone cables.

In fact *Telstar* was not the first communications satellite; for a number of years before there had been, at first, speculation and then practical work on "sat-com" systems. The idea of using artificial Earth satellites as microwave relay stations—and even of placing them into the *Early Bird* type of synchronous orbit—was first advanced by the British scientist Arthur Clarke in 1945, although at the time, no rockets capable of putting an object into orbit had been developed. By this time the large German V2 rockets had shown that, with further development, this might not be so far distant.

Later, but still some time before the launching of the first Russian sputnik, J. R. Pierce of Bell Telephones of America published detailed articles on communications via satellites. Various investigations into the subject were started by several companies.

MICROWAVE PROPAGATION

Why, it may be asked, are satellite relay stations needed? Radio transmissions which are reflected by the ionosphere—the ionized layers surrounding the earth—are limited to frequencies very much below about 30Mc/s. All high frequency (3–30Mc/s) radio

transmissions are subject to daily, seasonal and 11-year propagation cycles, to fade-outs and severe interference from other stations.

Even more important, the bandwidth of these transmissions has to be severely limited on practical grounds. It would be impossible, say, to use the entire band 15–18Mc/s for one fairly low-grade television transmission without attracting protests from all other users of these frequencies. By using independent side-band modulation systems, it is possible to transmit four telephone channels on a single h.f. transmission with a bandwidth of about 12kc/s, but this is about the limit.

To transmit broadband signals, such as television or a large group of telephone circuits, we need a bandwidth measured in megacycles per second. Over land this is possible using co-axial cables or line-of-sight microwave systems with relay stations placed 30 to 50 miles apart. By such means, up to about 1,800 two-way telephone circuits can be carried on a single microwave transmission. Another method of transmission, high power troposcatter system, can carry a number of channels—though nothing like as many—over distances of about 400 miles, by relying on the small amount of radio energy scattered by the various layers in the atmosphere. The U.S. Army does, in fact, have a number of continuous telephone circuits between the U.S.A. and the U.K. by this system, routed via Greenland and Iceland. But this technique is not really suitable for busy long distance civilian systems or for television relays.

If a powerful microwave transmission could be beamed to a satellite, this could either reflect the signals from a reflective surface (*passive satellite*) or preferably receive, amplify and retransmit the signals (*active satellite*) to a sensitive receiver at the distant end of the link.

How far apart the ground stations could be placed would depend upon the height of the satellite, the power of the transmitters and the sensitivity of the receivers.

POWER SIGNALS

When the use of satellite relay stations was first suggested, microwave equipment was still at a relatively early stage of development. Transmitter powers were low, no really large parabolic aerials capable of being steered in any desired direction had been constructed, and microwave receivers, with a crystal diode mixer as the first stage, were noisy. Furthermore, transistors had not been invented.

By the time large rockets had been developed (primarily for inter-continental ballistic missiles), a great change had taken place in the microwave field. Low-noise devices such as the maser (microwave amplification by stimulated emission) and parametric amplifiers were under development; travelling wave tubes and klystrons, originally low-power receiving devices, had grown to the stage where kilowatts of microwave power could be generated; all sorts of ferrite and semiconductor devices had shown that really compact equipment was feasible. Radio astronomers had pioneered the large steerable radio telescopes capable of concentrating signals into very narrow beams, so providing enormous power gain.

For some years there were still severe limitations. At first only small objects could be orbited. These would not reflect signals sufficiently well to provide practical passive satellites.

For active satellites there were serious problems of generating enough electricity in the satellite, and of developing electronic circuits of great complexity, but sufficiently reliable to ensure that they would work unattended for months or years.

Potentially the passive satellite, needing no power and containing no electronics to go faulty, seemed to have much in its favour. In 1960, *Echo I*, the first of two large "balloons" of over 100ft diameter with a surface of plastic film coated with aluminium, was successfully inflated in orbit.

While both *Echo I* and later *Echo II* have been successfully used for communications experiments—including the relay of television across the United States—both encountered difficulties which have tended to turn attention towards active satellites. *Echo I* suffered from gas leakage, causing the surface to become wrinkled and thus to lose a good deal of its reflectivity. *Echo II* was designed to be more rigid but unfortunately it was punctured by its own container during the very first orbit. With the limited surface area and with no amplifications, only very weak signals can be expected with passive satellites, but

An artist's impression of Bell System's Earth Satellite Station near Andover, Maine, showing some of its functional uses with Telstar

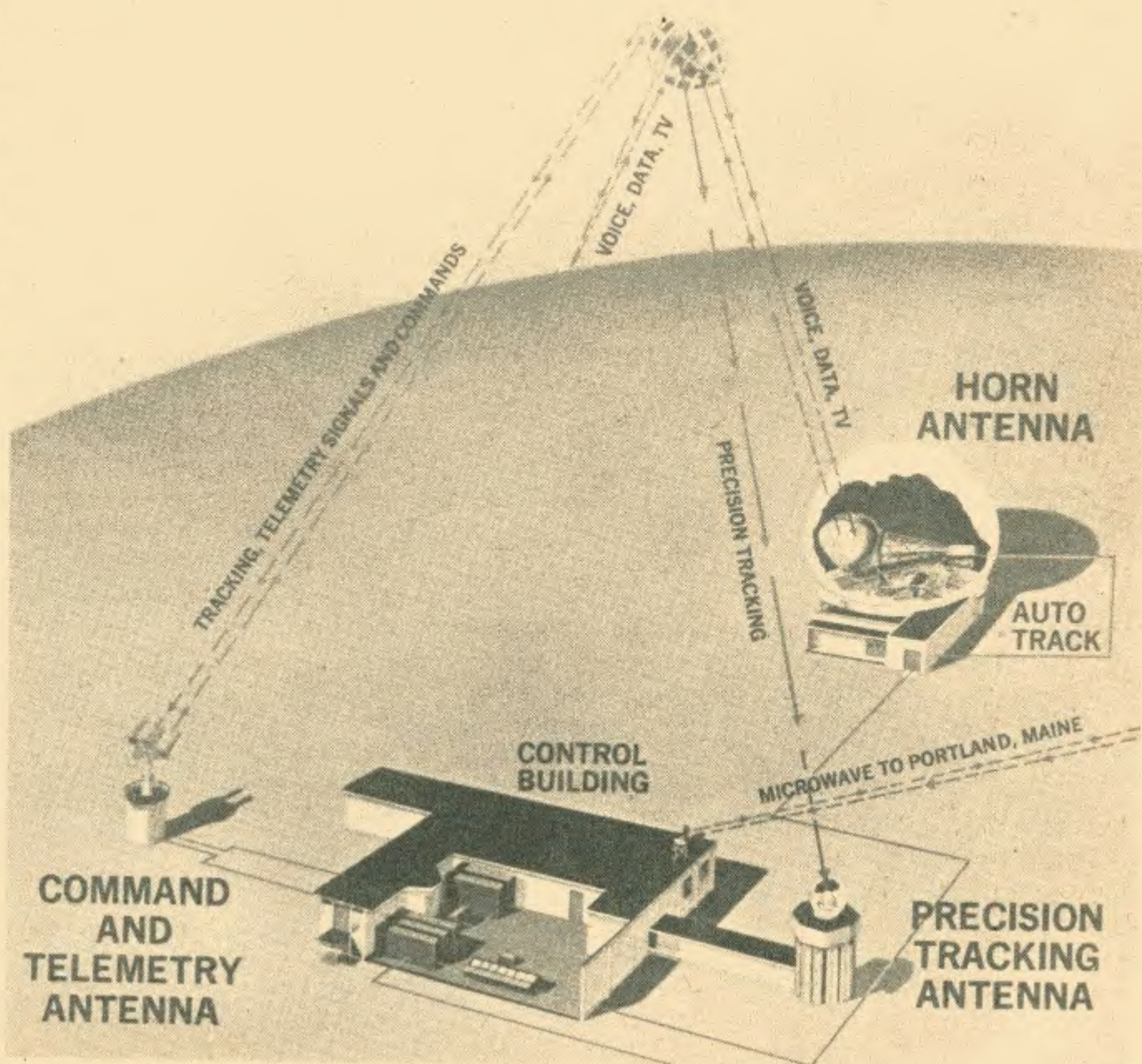

they remain a feasible system. Similarly, millions of tiny fibre-like copper "dipoles" were used in the West Ford experiment to establish a reflective ring around the globe.

SOLAR POWER

For active satellites, a major problem is still the generation of sufficient electricity. So far most satellites have relied on solar semiconductor cells which convert radiation from the sun into electricity. Each *pn* junction cell produces up to about 30 milliwatts of power at about 400 millivolts. To generate any substantial amount of power, large numbers of cells are needed, mounted either on the external surfaces of the satellite or on special solar panels. *Early Bird*, for example, has 6,000 cells providing 45 watts.

It was soon found that solar cells could be seriously damaged by the high energy radiation in the Van Allen belts or—particularly in the case of *Telstar I*—in radiation belts caused by the explosion of nuclear weapons in outer space. However *n* on *p* cells, protected by fused silica quartz windows have proved much less susceptible than the earlier *p* on *n* cells.

Other methods of developing power in space have been intensively studied and recently a nuclear reactor (Snap 10A) producing over 500 watts has been successfully placed in orbit. But these high power generators have proved very expensive to develop, and for some time to come the solar cell seems likely to remain the main source of power for communications satellites.

Thus the amount of transmitter power in the satellite is limited. The *Telstar* and *Syncom* satellites had transmitters providing just over two watts of microwave power. *Relay*, with over 8,000 solar cells, had a transmitter power of almost 10 watts. The communications transmitters on *Early Bird* each provide



Reproduction of the first television picture to be transmitted from England via Telstar to U.S.A.

some 4.3 watts. This has to suffice to transmit broadband signals well over 20,000 miles. The development of higher power satellites, or alternatively arranging for additional aerial gain, is still a major task. But much higher power systems including 100 watt transmitters are already at the drawing board stage of development.

SYNCHRONOUS ORBIT

Of vital concern to the planning engineer is the type of orbit into which the satellite relay station is placed. The lower the orbit, the shorter will be the time in each passage, when it is above the horizon, from any given ground station. At an altitude of 200 miles, a satellite would make 16 passes a day but would be "visible" for only 0.15 hour on each pass. At 1000 miles, there would be 12 passes and 0.4 hour visibility. At exactly 22,300 miles altitude the satellite would be moving with exactly the same "period" as the Earth's rotation; it would thus hover over the same spot on the Earth's surface and would be continuously visible from roughly one-third of the Earth's surface.

Very low orbits are useful only if information is stored in the satellite (by means of a tape recorder) and then retransmitted when over the distant ground

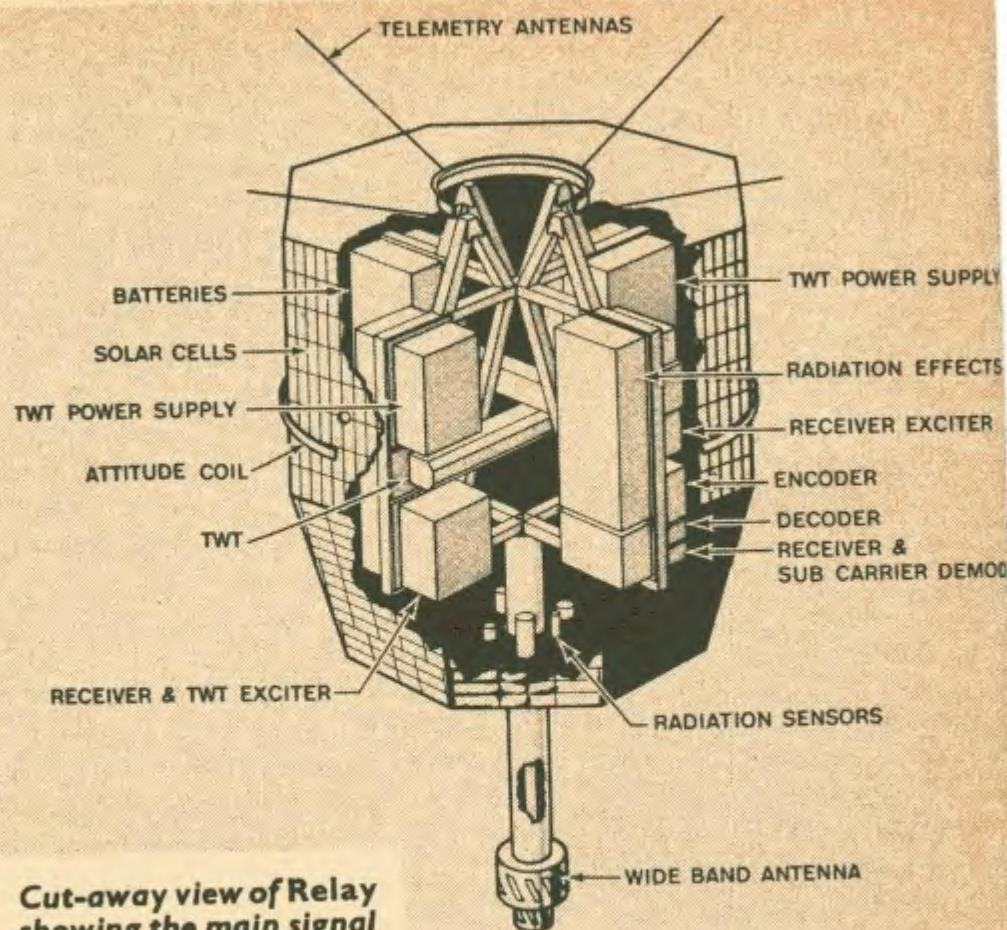

Cut-away view of Relay showing the main signal transfer equipment

station—this was the system used with the earlier active communications satellite *Courier* which operated for three weeks in October 1960.

For "real-time" communications—as needed for two-way telephony—a medium or high altitude system is needed. This also reduces the number of orbiting satellites required to maintain a continuous link.

A U.S. military system due to begin operation in 1966 is planned to have 20 satellites in a near synchronous orbit, for world-wide links. British military ground stations are to co-operate in this scheme.

If a satellite is to hover continuously over one spot, it must be in a circular orbit in the same plane as the Equator. Such a satellite is termed "synchronous" or "geo-stationary". So far this has not been achieved, and the orbits of *Syncom* and *Early Bird* have been inclined to the Equatorial plane, resulting in the satellites appearing to trace out a slender figure of eight, north and south of the Equator.

Table I. Main Communications Satellites Data

	Telstar	Relay	Syncom	Early Bird
Transmitting power (watts)*	2½	10	2	4.5†
Transmitting frequency (Mc/s)	4,170	4,170	1,815	4,100
Receiving frequency (Mc/s)	6,390	1,725	7,360	6,350
Shape	Spherical	Eight-sided prism	Cylindrical	Cylindrical
Weight (lb)	170	172	150 (90lb motor)	85 (in orbit)
Solar cells	3,600	8,215	3,840	6,000
Power generation (watts)	14	45	25	45
Manufacturer	Bell Telephones	R.C.A.	Hughes	Hughes
Design capacity	TV signal or 60 two-way telephone circuits	TV signal or 12 two-way telephone circuits	1 telephone circuit (but used for TV signals)	TV signal or 240 two-way telephone circuits

* Transmitting aerial gain 9dB.

† All have used one or more travelling-wave tubes in the final output stage and are otherwise solid state. On *Early Bird* two separate 25Mc/s transponders (frequency-translators) drive a common t.w.t. amplifier, with a stand-by t.w.t. amplifier which can be commanded to replace the working unit.

With a true geo-stationary satellite, hovering exactly over the same point on the Earth's surface, its direction from any given ground station would remain constant. This would mean that the ground station aerial could be more or less fixed, thus dispensing with all the complex aerial tracking and switching arrangements for changing over from one satellite to the next, as required with medium altitude systems. Only three synchronous satellites (syncsats) would be needed to give virtually world-wide coverage (except for example near the Poles where there are very few people requiring such facilities), provided that these were accurately placed over the Equator and spaced 120 degrees apart.

To place a "syncsat" in orbit, the satellite is first placed into an elliptical orbit, and then in a second stage is put into circular orbit.

So far this final positioning has been done by means of small gas jets controlled from the ground. Control systems of this type have a limited lifetime owing to chemical changes, but an alternative system based on the electrolysis of water has now been developed, but not yet tried out. There is also the possibility of using for this purpose small ion engines in which a stream of ions are ejected, rather like a valve without an envelope.

It is necessary not only to place a "syncsat" in its correct station keeping position, but also to maintain its position relative to Earth to allow the use of directional aerials and so increase the effective radiated power.

RELAY STATION

The "syncsat" thus provides a reasonably stable platform in space on which can be built a microwave relay station. The problems from then onwards are those of any broadband communications system—but involving distances vastly greater than any encountered with terrestrial networks.

The slant range from a ground station to a "syncsat" will always be more than 22,300 miles, often up to about 25,000 miles. Because of the "inverse square law" affecting all radio transmission, every time we double the distance of transmission we reduce the power available at the receiver by four times. The requirements for a microwave link of 25,000 miles will therefore be much more stringent than for say 50 miles.

To transmit the strongest possible signal towards the satellite we need a high-power microwave transmitter. At Goonhilly a travelling wave tube—the most powerful of its type in the world—provides some 8kW output at 6,300Mc/s. This power can be increased by concentrating it along a narrow beam by means of the large 85ft paraboloid reflector. The gain of this aerial is of the order of 60dB at the frequencies involved, resulting in an effective radiated power almost one million times greater than the actual transmitter power.

Even so, by the time the signal has travelled 25,000 miles it is fairly weak, and we need the best possible

Early Bird—the world's first communications satellite—seen here having a final check of its electronic equipment, in preparation for vacuum chamber tests at the Hughes Aircraft Company, California

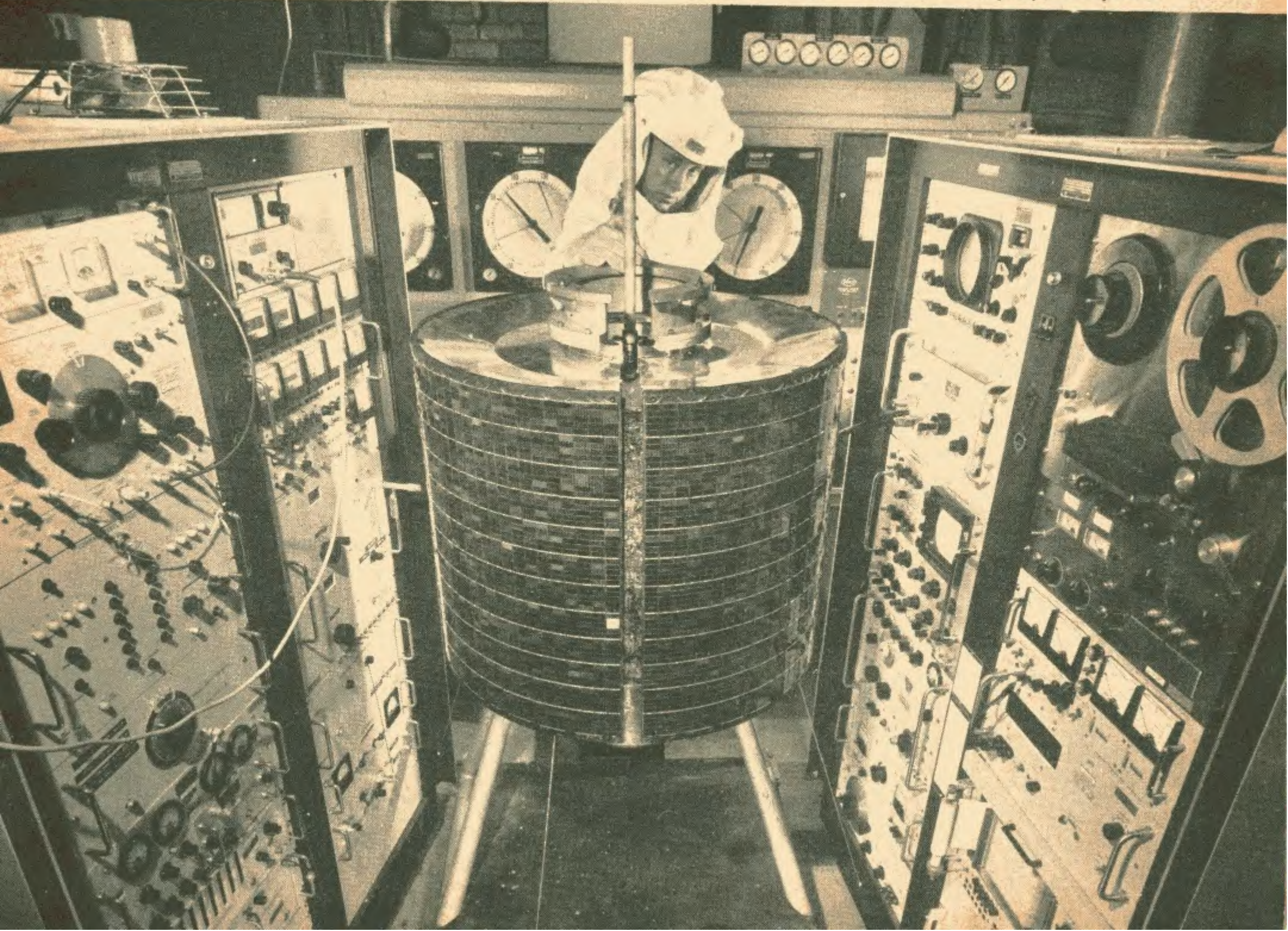

receiver in the satellite. This is particularly necessary since it is impossible at present to mount a high-gain aerial on the satellite, and we cannot obtain the very low noise available with cooled masers or parametric amplifiers.

OPERATING SIGNALS

In future satellite receivers, use will probably be made of tunnel diode pre-amplifiers which will significantly improve sensitivity and reduce noise. The incoming signals are converted down to an intermediate frequency, amplified and used to frequency modulate the satellite transmitter. Because of the lower power of this transmitter and the modest gain of the satellite aerial, the signals start their journey back to the earth very much weaker than when they first left from the ground station—but still very much stronger than if they had been merely “bounced” off the satellite.

With an effective radiated power of just a few watts, the only means of obtaining a workable broadband signal at the distant ground station is to use a high-gain aerial and an extremely sensitive receiver. The Goonhilly receiver can deal with signals of only one-tenth of a picowatt delivered to the maser pre-amplifier.

Signals with a baseband of about 2.5Mc/s (and total frequency modulated bandwidth of about 25Mc/s) can be handled by “syncsats” of the *Early Bird* type. This is sufficient for one television signal (accepting some degradation), or for about 240 two-way telephone channels. More advanced “syncsats” have been designed capable of handling 1,200 telephone channels or even possibly 20,000 telephone circuits, when used with ground stations like those at Andover in the U.S.A. or Goonhilly in Cornwall.

There are some situations where huge ground stations are unnecessary. In these circumstances we can, in effect, trade bandwidth against aerial size and receiver sensitivity. The Americans have been using *Syncom III* to provide a few telephone circuits to South Vietnam, using transportable ground stations with an aerial diameter of only 15ft. It has been shown that such small terminal stations can be mounted on ships, and experiments have also been carried out in operating a radio teleprinter circuit from an aircraft flying over the Pacific to the United States via *Syncom III*.

The advantages of a synchronous orbit can thus be summarised as operational simplicity, with only three satellites required for near global coverage; the ground stations need track only over a limited range, and later possibly not at all; all the problems of “pass-on” switching from one satellite to another are avoided; there are no significant Doppler frequency shifts as found with fast-moving satellites; and since the transmissions are always beamed along similar paths, interference between different microwave services can be minimised.

TIME DELAY

Time delay is inevitable with the synchronous orbit. To receive an answer to a spoken question, the outgoing signal has to travel from ground to satellite and back to ground, and the answer has to follow the reverse path. This means a transmission approaching 100,000 miles for the round circuit. And fast though radio signals travel (186,000 miles per second) such a journey must take about 0.6 second.

There has been much discussion on just how important such delays would be in practice, and this is one reason why the practical experiments with *Early Bird*

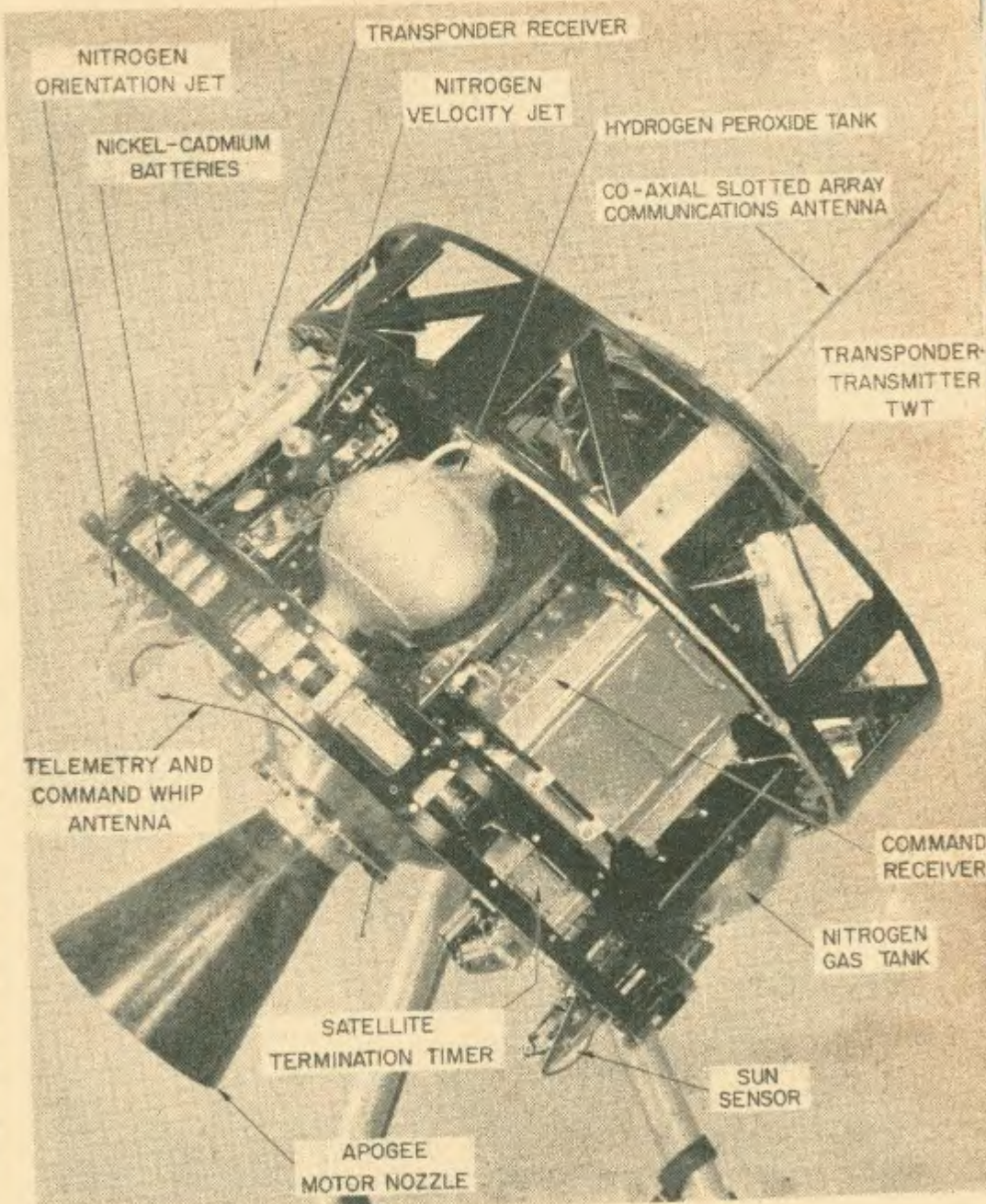

Open view of *Syncom III* showing the interior units

(which is the first satellite to handle normal commercial telephone circuits) are so important.

It is generally agreed that time delay is most disturbing when one hears the “echo” of one’s own voice coming back. For this reason it is most important that extremely good echo suppressors are always used in terminals for “syncsat” circuits. When this is done, most engineers believe that a two-way delay of 0.6 sec will prove to have little effect on conversations, except just possibly with “nervous” speakers who tend to overlap the sentences with his communicant.

A more serious time-lag arises when we attempt to work through two “syncsats” in tandem. This has been tried out experimentally via *Syncoms II* and *III* in circuits from the United States to Asmara, Eritrea. Here we have an all-round path of some 200,000 miles and a time lag of appreciably over one second. Such tandem working would be needed for circuits from the United Kingdom to the eastern cities of Australia and to New Zealand, though it is theoretically possible to reach Western Australia from the U.K. in a single hop.

Since the grade of telephone service possible with satellites has been shown in all other respects to be as good as that with short terrestrial cross-country microwave links, there are still some engineers who consider that it would be wrong to accept the inevitable time lag of “syncsats”. They would prefer to use medium altitude systems despite all the added complexities.





SCR LIGHT DIMMER

By **E. BARNETT**

THE invention of the silicon controlled rectifier (s.c.r.) has given engineers a new power control device which has many of the advantages of other semi-conductors.

The present maximum voltage and current ratings of individual units to date are around 1,000 volts and 300 amperes, although with series and parallel configurations they can be operated in systems above the maximum ratings. For a very wide range of low to medium power applications the s.c.r. is replacing many old established control devices such as thyratrons, saturable reactors, and rheostats.

The construction of the unit described in this article would not have been feasible before the invention of the s.c.r., hence a new useful device, a light dimmer, can be introduced to house lighting systems. The s.c.r. used is type BTZ19 (obtainable from G. W. Smith & Co., Lisle Street, London, W.C.2).

S.C.R. OPERATION

The s.c.r. is an *npn* four-layer, solid state semiconductor device which normally blocks voltage in either direction. But when a voltage or current pulse, of correct polarity and amplitude, is applied to the gate electrode, current will flow in the forward direction from anode to cathode. When the applied voltage across the anode and cathode is reversed the s.c.r. will block again but cannot re-conduct in the forward direction until application of another gate pulse.

Hence the s.c.r. can be likened to an ordinary rectifier except that the start of conduction can be controlled by the gate input at a pre-determined time. Once conduction has started, the gate has no further control until the load current drops below a relatively low "holding" value, when the s.c.r. turns off and the cycle is repeated. Hence the s.c.r. can be regarded as the solid state equivalent of the thyatron.

WARNING

Extra care should be taken with this unit. All the time the light dimmer is operational there are mains voltages around the circuit, hence extra caution when working on the unit is required.

LIGHT DIMMER

Fig. 1 is a block diagram of the light dimmer showing the two basic parts of the whole circuit.

The trigger circuit consists of a *pnp-npn* complementary pair, which provides trigger pulses to a power control circuit consisting of an s.c.r. and four silicon diodes connected in bridge form. When the trigger pulses are applied to the s.c.r. it "fires" and the current through it rises to a value determined by the load and amplitude of the applied mains voltage at the time of firing.

The phase of the trigger pulses with respect to the mains supply can be varied by adjustment of a potentiometer, which causes the trigger pulses to occur either late or early in each half cycle of the mains supply, hence altering the mean level of power developed in the load (see Fig. 2).

POWER CONTROL CIRCUIT

The power control circuit is a full wave device which allows the use of a single s.c.r. for a.c. control.

By using a four-diode bridge arrangement the s.c.r. is protected from high reverse voltages; any failure of the s.c.r. or diodes results only in a loss of control. The circuit used is shown in Fig. 3.

The a.c. path during alternate half-cycles of the supply voltage is via the mains supply, D1, SCR, D4, through the load (light bulb), and returning to the mains. During the inverse alternate half-cycles, the current flows through D2, SCR, D3, and the load. Full wave rectified d.c. pulses, which are applied to the trigger circuit, appear across points "X" and "Y".

TRIGGER CIRCUIT

The trigger circuit effectively buffers the timing network of R1 and C1 from the s.c.r. gate input impedance, which is relatively low. It also provides a gate pulse with the necessary fast rise time to turn on the s.c.r. quickly and so help to minimise s.c.r. power dissipation.

The full wave rectified d.c. pulses that appear between points X and Y in the circuit charge up capacitor C1 through VR1, R1, and R5. Since the voltage across a capacitor lags the current through it by almost 90 degrees, the phase lag of the voltage across capacitor C1 can be varied with respect to the voltage at X and Y by varying the resistance VR1 in series with C1.

When the voltage across C1 rises to a value sufficient to cause forward current through the emitter-base junction of TR1, the transistor conducts and injects a current from the charge on C1, via its emitter and collector, into TR2 base. This causes TR2 to conduct hard, the resultant voltage drop at its collector assisting TR1 to conduct more. Hence the regenerative action causes both transistors to turn on rapidly and conduct hard; the current pulse through TR2 causes the s.c.r. to "fire".

When the s.c.r. fires, the voltage across X and Y falls to zero and resets the trigger circuit ready for the next half-cycle pulse of a.c. input voltage; then the whole procedure is repeated.

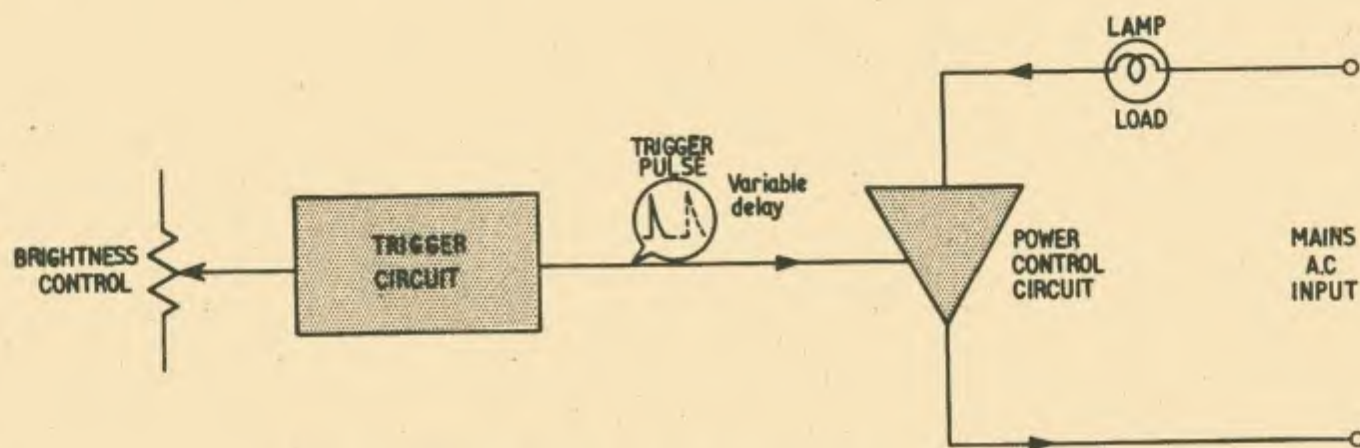

Fig. 1. Block diagram of the complete dimmer circuit

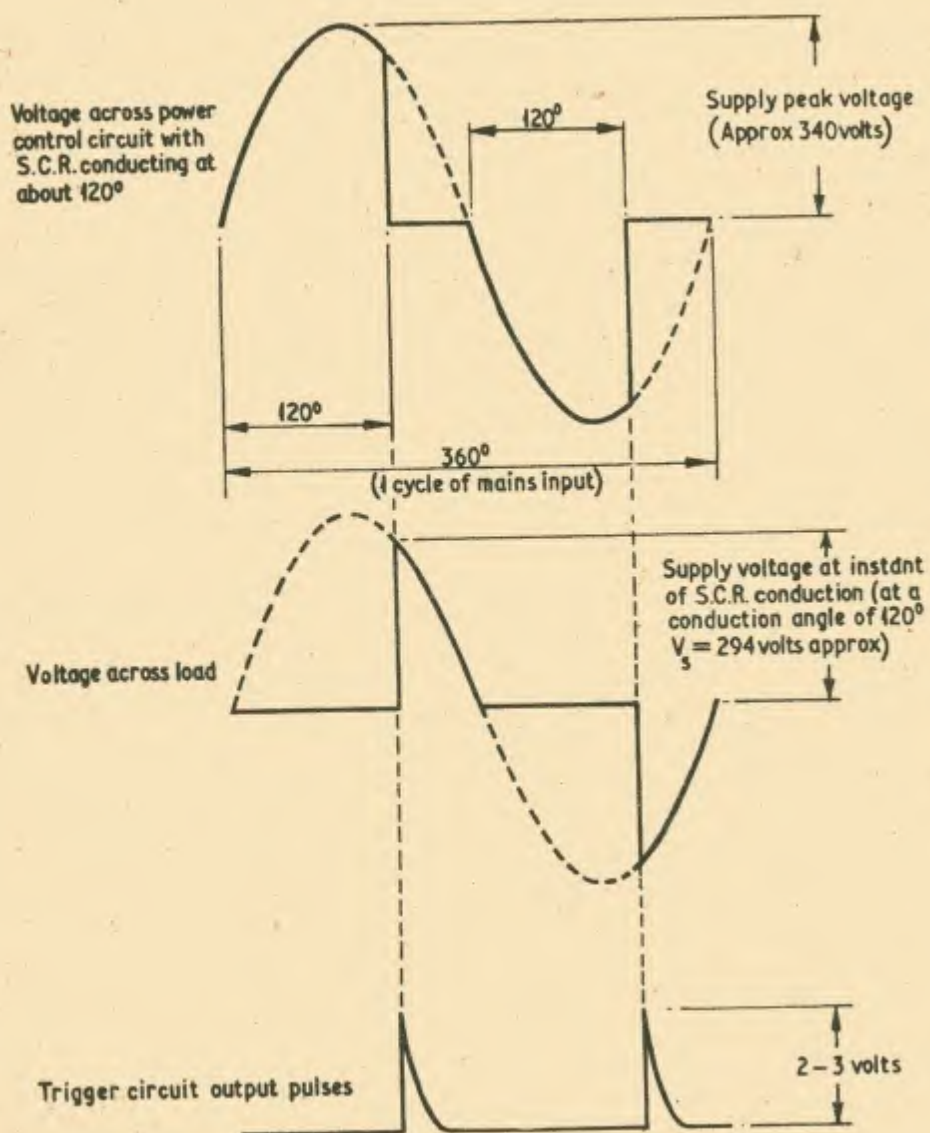
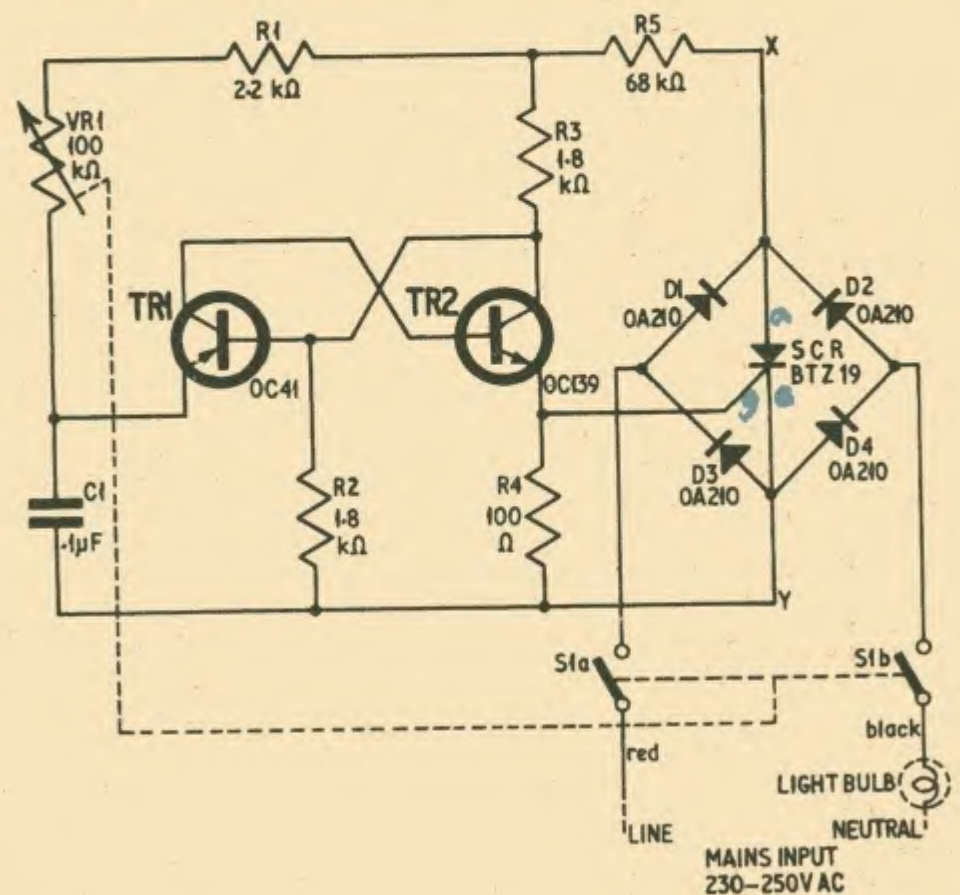

Fig. 2 (left). Typical circuit voltage waveforms

Fig. 3 (below). Complete circuit of the light dimmer



CONSTRUCTIONAL DETAILS

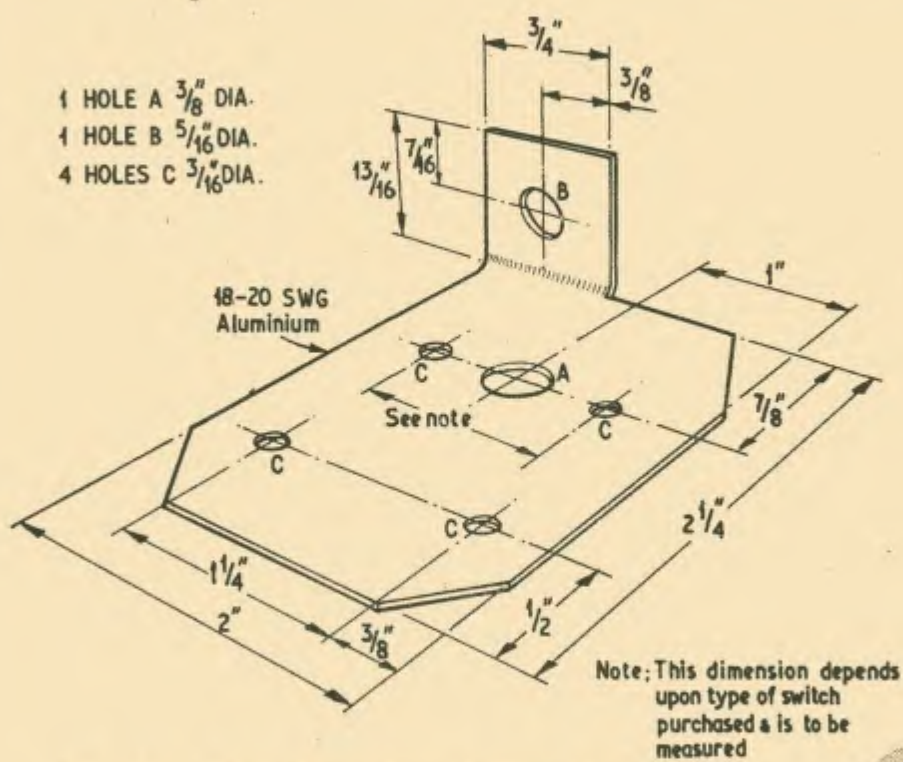

Fig. 4a. Main baseplate drilling details

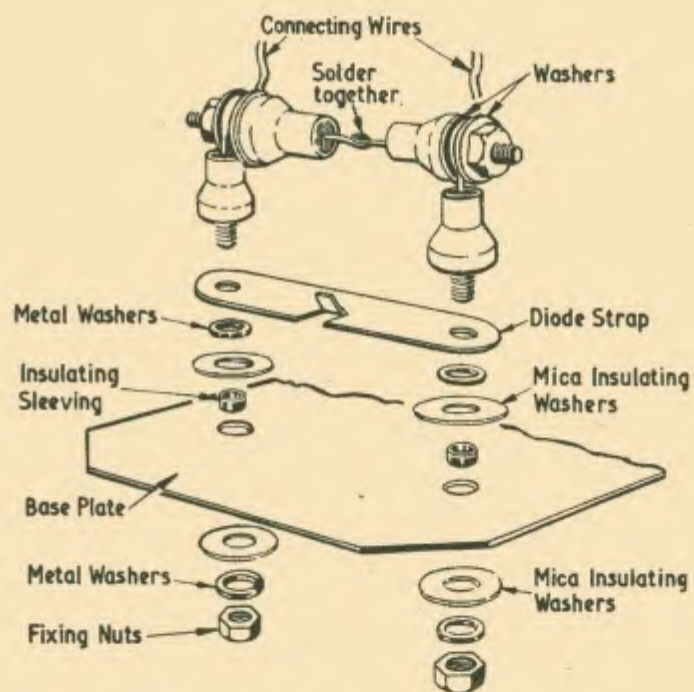

Fig. 4c. Exploded view of diode assembly

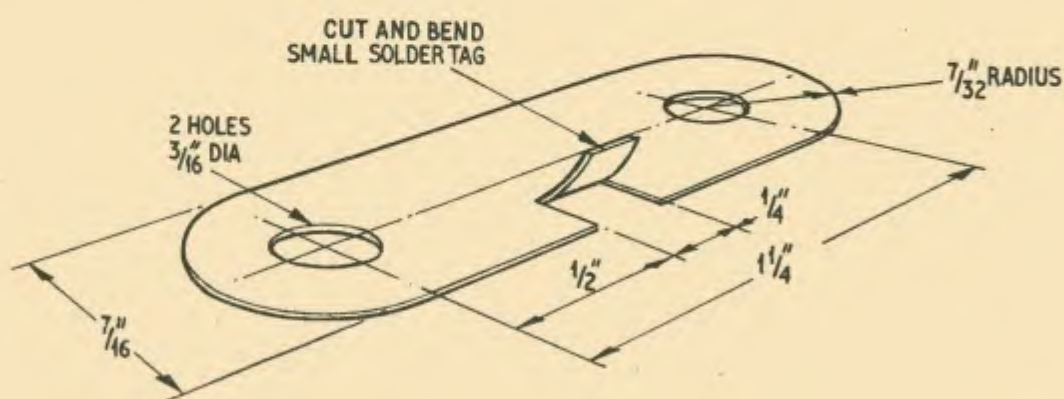

Fig. 4d. Drilling details of the diode strap used in the assembly shown in Fig. 4c

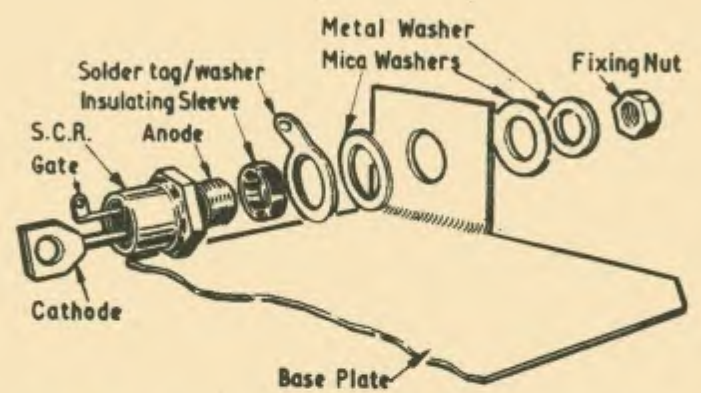
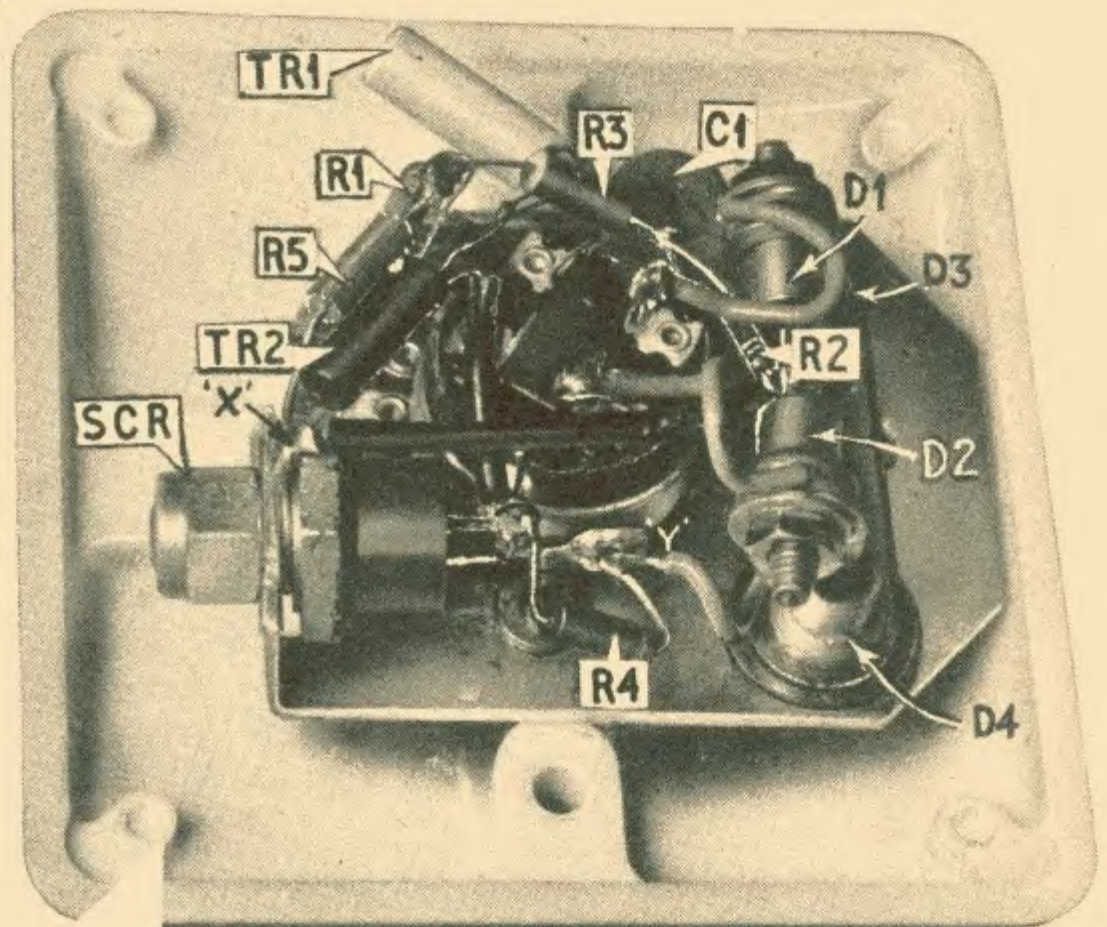

Fig. 4b. Exploded view of s.c.r. assembly



Completed dimmer unit attached to the switch plate

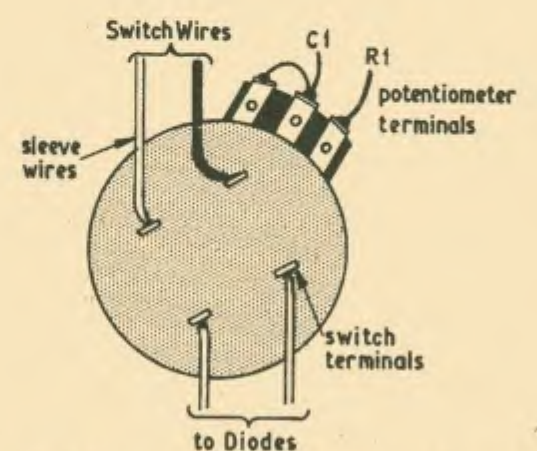

Fig. 5. Connections to VRI and the ganged mains switch

CONSTRUCTION

The main advantage of the light dimmer is that it can be made small enough to fit into an average size, domestic wall-mounted light switch box about $2\frac{1}{2}$ in \times $2\frac{1}{2}$ in and $\frac{3}{4}$ in to 1in deep.

First of all it is necessary to purchase a wall switch, which has a switch block containing the switch mechanism fixed to the front plate by screws, since the screws are required. Some types of wall switch have their switch blocks riveted to their front plate and so are unsuitable.

After the switch block has been removed and discarded, measure the distance between the holes fixing the switch block. On the author's unit this dimension was $1\frac{1}{8}$ in.

Apply the dimensions to the small aluminium base plate, the construction of which is shown in Fig. 4a.

To reduce the depth of the light dimmer to a minimum, discard the inner lock nut of the potentiometer VR1, remove the small orientation lug found on most potentiometers, mount the potentiometer flush against the base plate and retain it by a single lock nut and shakeproof washer. Make sure that the soldering tags of the potentiometer are not touching the base plate and are not positioned such that they will short on any part of the assembly.

Next mount the s.c.r. in hole B and diodes on to the base plate as shown in Figs. 4b and 4c. Once the s.c.r., potentiometer and diodes have been mounted, the base plate assembly can then be offered up to the switch front plate and secured with the screws previously used for the switch block.

Complete the wiring of the assembly by soldering on the components and taking the usual precautions necessary with transistors by using pliers as heat shunts while soldering. All wires should have ample sleeving, particularly those soldered to the switch tags:

COMPONENTS . . .

Resistors

R1	2.2k Ω	R4	100 Ω
R2	1.8k Ω	R5	68k Ω
R3	1.8k Ω		

All resistors 10% $\frac{1}{2}$ watt carbon

Potentiometer

VR1 100k Ω linear carbon with ganged double pole, on/off mains switch S1

Capacitor

C1 0.1 μ F paper 150V

Transistors

TR1 OC41
TR2 OC139

Diodes

DI-4 OA210 (4 off)

Silicon Controlled Rectifier

SCR BTZ19 (Mullard)

Miscellaneous

Flush mounting wall light switch
Small pieces of aluminium sheet (18 s.w.g.)
PVC covered connecting wire and p.v.c. sleeving
Push-fit type of knob

here the sleeving should be large enough to fit over the tags and wired as shown in Fig. 5.

When wiring the s.c.r., note that the gate is the shortest of the two pins (see Fig. 4b) and is connected to the emitter of TR2. The long pin is the cathode which is point Y shown in Fig. 3. The anode (to point X) is connected to the case which is fitted with a soldering tag.

Observe the polarity of the diodes. The two connecting wires shown in Fig. 4c should be connected to the mains switch. The diode strap is the junction of D3 and D4 and is wired to the junction of R4 and the cathode of the s.c.r. at point "Y".

The cathode wires of D1 and D2 are joined and soldered together as shown in Fig. 4c. A wire is soldered to this joint and connected, at the other end, to the case of the s.c.r. and R5 at point "X". The photograph shows points "X" and "Y".

The knob used on the potentiometer spindle should be of the "push on" type. Do not use the type which uses a grub screw for securing to the spindle for safety reasons. A number of attractive knobs made for a variety of domestic purposes can be obtained from any electrical showrooms.

After final assembly check the insulation between diodes and s.c.r. cases, base plate and potentiometer spindle; preferably with a 250 volt to 400 volt insulation tester. Insulation can be checked with a multimeter on the highest resistance range (for example, Avo Model 8 on "ohms \times 100" range is suitable).

INSTALLATION

Before any installation work at all is to be carried out, the current must be switched off at the mains. The mains switch is usually located under the stairs or in some cupboard along with the fuses and electricity "lighting" meter.

After switching off the main supply, remove the light bulb (or bulbs) from the socket which is controlled by the light switch to be replaced. Next remove the old light switch and slacken the grub screws retaining the two wires to the switch block. Loop the bare ends of the mains wires through the switch tags of S1a and S1b on the back of the potentiometer switch as shown in Fig. 5 and solder them in place. It is best and safest to use a gas-heated soldering iron but, if the only soldering iron available is electrically heated, ensure the mains supply is turned off again immediately prior to soldering the wires to the switch lugs. Before finally mounting the whole assembly into the light box, wrap a sheet of reasonably thick polythene (0.010in to 0.020in) around the exposed circuitry and secure with adhesive tape to provide insulation.

TEST

After mounting the light dimmer unit into the wall box, check that the potentiometer control is fully anti-clockwise so that the switch is off. Fit a low power light bulb (40W or less) into the light socket and switch on the mains supply at the main switch.

Rotate the light dimmer control slowly clockwise; the light emitted by the bulb should increase from zero to maximum as the control is rotated. If the light comes on immediately after switching on and gets progressively dim then reverse the outer connections on the potentiometer.

If the tests are satisfactory replace the test bulb with one of the required rating up to 120 watts.





PART TWO AUDIO OSCILLATOR AND VALVE VOLTMETER by H.T. KITCHEN

ASSEMBLY and wiring can commence when all the metal work is complete and all the components to be used are at hand. A start can be made by fixing the mains transformer, choke, smoothing capacitors, and valveholders to the chassis, but the meter and tuning capacitor, being relatively delicate, are best left until the unit as a whole is nearing completion. The front panel is attached to the chassis by the fixing nuts and bolts of the input and output sockets, and the fixing nuts of S1, S2, S3, and VR1.

The heater wiring should be carried out with tightly twisted stranded wire to minimise hum pickup. Then the other components can be added. The wiring to each valveholder should be completed before starting the next one, then the coupling components can be connected. It would be advisable to leave the thermistor until the last and then solder it into circuit using a pair of pliers as a heat shunt, for it is a fragile and expensive component and should be treated with care.

A definite colour code should be adopted for the different wires carrying h.t., heater current and signals, for it does minimise chances of incorrect wiring and makes checking easier. Where there is any prospect of component leads touching, appropriately coloured sleeving should be used.

The centre spigot of the valveholders should be connected to the chassis. The negative side of C16, C17 (usually the can) should be insulated from the chassis and connected to the centre taps of the mains transformer secondary windings, to which is also connected the mains earth. These simple precautions do minimise 100c/s hum flowing through the chassis, thereby reducing the possibility of hum being induced into either circuit.

When the wiring has been completed and double checked it is advisable, before the mains are connected, to check with a sensitive ohmmeter that there are no direct shorts to chassis from either h.t. line and all points connected thereto. The mains can now be connected and switched on.

PRELIMINARY TESTS

If the fuses remain intact and there is no sign of overheating, a number of preliminary checks can be carried out, commencing with a voltage test using if

possible a meter of 20,000 ohms per volt sensitivity. A less sensitive meter such as one of 1,000 ohms per volt will load the circuits more, indicating a voltage somewhat less than is actually present, this effect being more pronounced when measuring anode voltages. The voltages obtained should be within 10 per cent of those shown on the circuit diagrams (see last month's article).

A pair of headphones or an audio amplifier connected to the output of the oscillator will show whether the oscillator is functioning. There is very little to go wrong with this circuit; any lack of oscillation will almost certainly be due to faulty components or wrong wiring. It must be remembered that the response of most headphones and many loudspeakers falls off towards the extreme ends of the audio frequency range and more so towards the low frequency end. Any attempt to compensate for this by increasing the oscillator output can result in irreparable damage to the phones or loudspeaker.

The meter needle should momentarily flick upwards as the range switch S1 is operated and fall back to zero. Should it fail to do so or should it show a steady reading appreciably greater than zero, one of several faults are likely, and these can be checked systematically.

First remove V1. If the needle drops to zero, the valve or its associated wiring is faulty; possibly heater-to-cathode or heater-to-grid short, or hum may be picked up in the range switch and resistors. Wiring and components should be rechecked. Should removal of V1 fail to effect a temporary cure, V2 should be removed to check whether the second stage is faulty. Failing this C6 is almost certain to be "leaky" and substitution is the best check. An electrolytic capacitor passes too much leakage current and should not be used for C6; only a good quality paper capacitor should be used. Whatever the cause it must be found and rectified before any attempt is made at calibration.

FREQUENCY CALIBRATION

Having established that both the oscillator and the meter circuit function satisfactorily, it will now be necessary to calibrate them and for this purpose, an accurate a.c. voltmeter, reading 10 or 25 volts full scale deflection, and an oscilloscope having a stable timebase

should be used if possible. If another accurate audio oscillator is available, calibration will be much easier for the familiar Lissajous figure can be used, simplifying and speeding up calibration. However, the author is aware that many constructors will not have access to another audio oscillator, and so proposes to describe a method whereby the oscillator can be calibrated from 25c/s right up to about 200kc/s, if care is exercised in using the 50c/s mains supply.

For the purposes of calibration the units and test equipment must be allowed to settle down for at least half an hour after switching on. Trimmer VC1 across VC2 is used to set the 25c/s point of range 1 so that it occurs with VC2 and VC3 completely closed, i.e. fully interleaved. The "Y" amplifier of the oscilloscope is then connected to a source of 50c/s, usually the mains. The 6.3 volt secondary of T1 is a convenient source of supply for this. The timebase is adjusted until one full cycle precisely is displayed and remains stationary. This connection is then removed and the output of the audio oscillator connected in its place.

Set the switch S2 to range 1, the dial should be rotated until the oscilloscope again displays one full cycle, the dial reading being noted. The audio oscillator is now oscillating at 50c/s. Further calibration points can be noted at 25c/s, 100c/s, 150c/s, 200c/s and 250c/s; these being obtained by adjusting the dial so that first one half-cycle, then two, three, four and five are displayed on the screen. Only the oscillator dial is adjusted, the timebase controls on the oscilloscope should be left alone.

When the "Y" input frequency is twice the timebase frequency, two full cycles are displayed on the screen; three times, three cycles are displayed; five times, five cycles, and so on. When the "Y" input frequency is half the timebase frequency, only half a cycle is

displayed. Provided the timebase frequency is known the "Y" input frequency can be accurately measured, and vice versa.

When the last full cycle on range 1 at maximum frequency is displayed, leave the timebase alone and switch S2 to range 2. Decrease the oscillator frequency until the same number of cycles are displayed as at the end of range 1, namely 250c/s. Now readjust the 'scope timebase so that one full cycle is again displayed. Both the oscillator and the 'scope timebase are now running at 250c/s.

If the previous method of obtaining 2, 3, 4, 5 cycles and so on up to 10 full cycles is repeated, range 2 will be calibrated from 250c/s up to 2,500c/s. If the 'scope cannot display up to 10 cycles so that they can be identified and counted, the oscillator can be calibrated to show up to 5 cycles and repeated by readjusting the timebase to display one cycle and so on. When 2,500c/s on range 2 is calibrated, the oscillator is readjusted to show the same frequency on range 3 at the low end. Calibration of ranges 3 and 4 are made in a similar manner.

It is suggested that a number of practice runs should be made first to familiarise oneself with the procedure, before final calibration is attempted. Throughout calibration the very minimum of sync should be used to prevent the trace moving and causing waveform distortion, both of which can result in errors. When range 4 has been calibrated, it is worthwhile checking its accuracy by comparing its output on 200kc/s, and if strong enough on 100kc/s, against the carrier frequency of the BBC Light Programme on 1,500 meters. Unless mistakes have been made or the 'scope timebase or 50c/s mains have drifted the calibration should be reasonably accurate. A practical point

Underside view of the chassis. The screen around S2 has been removed to show the range resistors

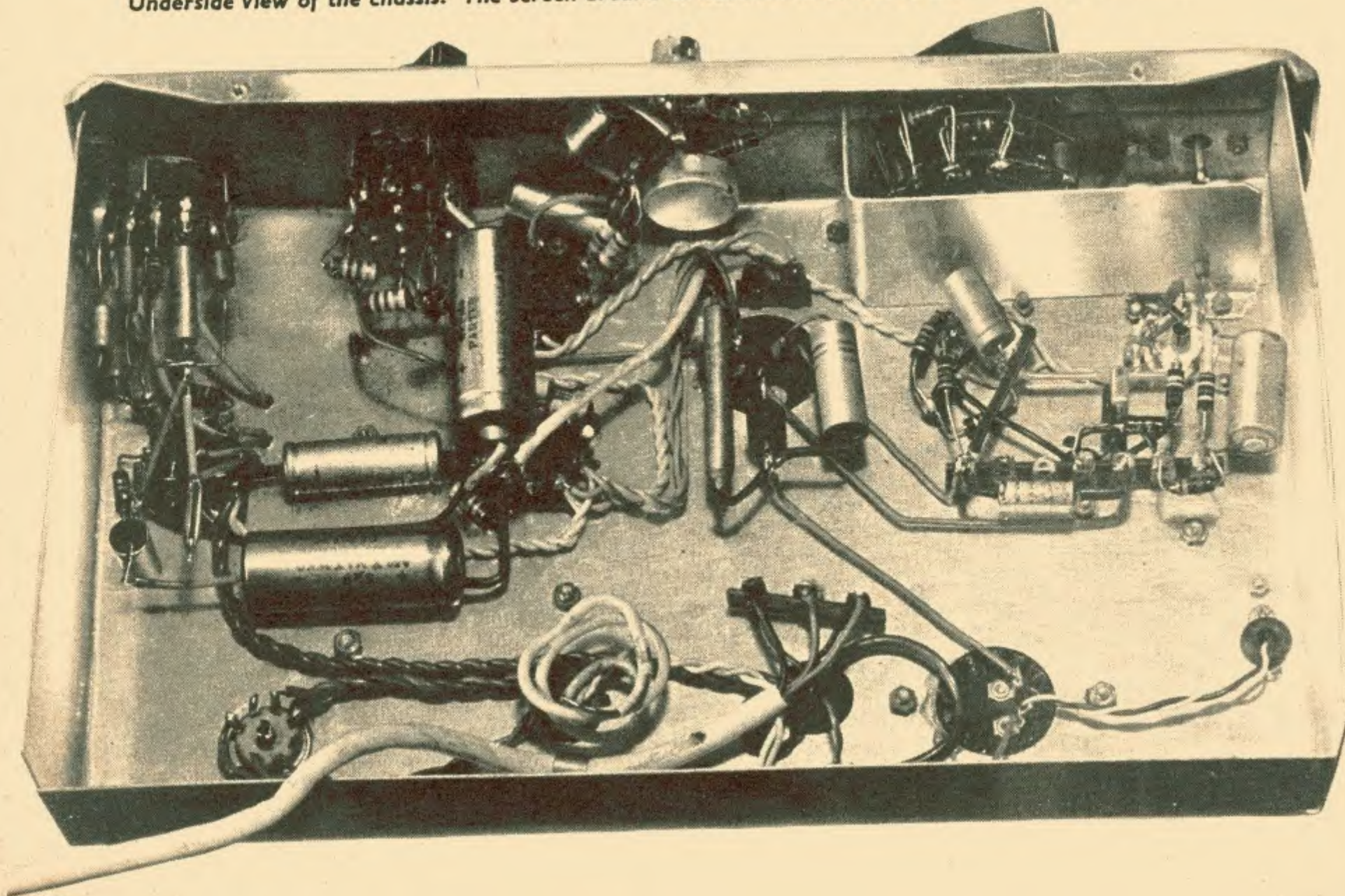

worth remembering is that on range 4 even the thickness of the cursor line can represent several kilocycles, but for practical purposes of the instrument it is not sufficiently inaccurate to worry about at 200kc/s.

Unless the oscillator is calibrated by more accurate methods, the four ranges will not coincide exactly, necessitating one of three alternatives. One can either use a graph for each range; calibrate the four ranges on a piece of paper and stick it on the dial; or adjust the range resistors to bring about frequency coincidence. In the author's opinion there isn't much between the three alternatives but, in practice, adjustment of the range resistors will be found to be much the best. To do this range 1 is calibrated fully; then a large collection of 2M Ω , 200k Ω and 20k Ω resistors is obtained. These are then tried one at a time until the beginning of range 2, then 3 and 4, coincide with that of range 1.

Alternatively a number of pre-set potentiometers could be inserted in series with one of the appropriate range resistors. For instance, one of the 2M Ω resistors required for range 2 could consist of a 1.8M Ω fixed resistor in series with a 500k Ω preset potentiometer. Similarly, ranges 3 and 4 could have fixed resistors and preset potentiometers of 180k Ω and 50k Ω , and 18k Ω and 5k Ω respectively. It will be appreciated that these are only suggestions based on the author's personal experience and preferences; it is up to the individual to decide which method suits him best.

OUTPUT VOLTAGE

With the frequency calibration completed, attention can be turned to calibrating the output controls; to do this an accurate a.c. voltmeter will be required. This is connected across the output. With the coarse and fine output controls at maximum, R32 is adjusted until precisely 10 volts is indicated. S3 will then give up to 10V, 1V, 100mV, 10mV. If the fine output control (VR1) is provided with a scale divided into 10 equal parts, outputs as low as 1mV will be obtained with reasonable accuracy.

VALVE VOLTMETER

The calibration of the valve voltmeter is carried out as follows. The a.c. meter is connected to the audio oscillator and the controls adjusted until 5 volts is indicated at a frequency of less than 2kc/s. A low frequency is used because the response of the selenium rectifiers usually used in test meters falls off at frequencies above a few kilocycles per second and could give misleading results at higher frequencies.

With the controls set to give an output of 5 volts the a.c. meter is disconnected and the valve voltmeter reconnected, set to the 5 volt range. R12 is then adjusted until the meter also reads 5 volts or full scale. It may be necessary to adjust R11 as well. If resistors R1 to R5 are of 1 per cent tolerance, it should be sufficient to calibrate one range only, though it is advisable to check the other ranges by feeding in appropriate voltages.

FREQUENCY RESPONSE

With both sections of the unit calibrated, one further check remains; that is the frequency response of the unit as a whole. To do this the output of the oscillator is connected to the input of the valve voltmeter and a convenient reference level selected at 1,000c/s. The oscillator is then swept from 25c/s up to 250kc/s and readings noted every octave (i.e. 25c/s, 50c/s, 100c/s,

200c/s, 400c/s, and so on). A graph can then be plotted showing the combined frequency response and will allow any corrections found necessary to be made on measurements taken when the instrument is used on other equipment. If the combined frequency response showed a dip or rise of say 2dB at 25kc/s relative to the reference level at 1kc/s, 2dB would have to be added or subtracted at 25kc/s when measuring the response of another amplifier at these frequencies.

It may be appropriate at this stage to enlarge on a number of points which were only briefly mentioned previously. The most important of these is the frequency calibration of the audio oscillator. A method was discussed whereby, on range 1, calibration points could be plotted as 25, 50, 100, up to 250c/s at 50c/s intervals and for many applications this will be all that is needed. However it is possible that the need may arise to use 33.3 or 59.7 c/s or any other odd figure. Interpolation at such frequencies may be achieved by using graph paper with a logarithmic scale corresponding to the frequencies on the "X" axis. To do this the 50c/s points are marked on the dial which is then rolled along one side of a sheet of graph paper. As each mark comes opposite the graph paper, a corresponding mark is made on the paper. A frequency scale is drawn along the other side of the graph paper and a line drawn connecting this scale with the marked frequencies.

This graph can then be used to find the required scale marks which are then transferred to the dial by rolling it along the line.

CONCLUSION

It may be of interest to explain why this particular oscillator circuit was chosen. There are two basic types of oscillators, resistance-capacitance and inductance-capacitance. The LC circuit or, as is more generally known, the beat frequency oscillator, possesses the ability of covering the entire audio frequency band in one range, but due to a number of disadvantages is little used nowadays. Its place has been taken by the RC oscillator which can take the form of, among others, the Wien bridge which in the author's experience has proved to be very reliable. The Wien bridge, in common with other RC oscillators, possesses the disadvantage of requiring a number of ranges in order to cover a sufficiently wide band, as shown in the equipment described here.

The Wien bridge can consist of fixed capacitors and variable resistors or fixed resistors and variable capacitors. The fixed capacitance, variable resistance type possesses one disadvantage making it unsuitable for applications where the frequency has to be slowly swept from low to high or vice versa, for example when the resonant frequency of a loudspeaker is being sought. This is because the output voltage tends to vary in small steps as the variable resistors are adjusted, however carefully or slowly this is done.

The present design which uses fixed resistors and variable capacitors is entirely free from this defect, but due to the high value resistors employed in the low frequency range, hum pick-up has to be very carefully isolated, hence the screen round S2.

To conclude, a word about components: the audio oscillator and valve voltmeter were intended to be precision measuring instruments and as such deserve the best components. Components of unknown condition or origin should definitely not be used, otherwise there is a risk of the instrument being unreliable. ★

the 73 page

by Jack Hum
G5UM

Anniversary

With the present instalment *The 73 Page* reaches its first anniversary, carrying us to an appropriate stage from which to look back on what has been done so far, and at the same time to discuss some of its followers' reactions to it during its first twelvemonth of activity.

For the benefit of new readers it may be no bad thing to recapitulate the purpose of this feature and especially how it came to get its title. This page is about amateur radio communication in all its aspects—and when one states that the world total of licensed amateur transmitting stations is well over a quarter-of-a-million, far outnumbering all the "professional" stations put together; the size, influence and potential market offered by the movement are at once apparent.

From its inception PRACTICAL ELECTRONICS has aimed to meet the needs of this gigantic "clientele" in various ways, and particularly by the periodical appearance of *The 73 Page*, its title deriving from the abbreviation most often used by the transmitting amateur—"73" meaning "best wishes", with which every contact concludes.

And how has *The 73 Page* been getting on during its first year of publication? There is only one way to tell—and that is by the volume of comment which it has generated. No comment would mean no interest.

This has not been the case at all. Over the air and via the mails a steady stream of reader-reaction has made itself felt—without exception couched in the friendliest of terms, inspiration indeed for the continuance of the feature in its present form.

Thirst for Knowledge

It does not do, however, to sit back and feel that all's well. For what has also become quite evident from the correspondence received is the

existence of a great thirst for more knowledge of what the amateur radio movement is and does, and how the inquiring reader may best break into it. Requests for information on a variety of subjects related to amateur radio have been received in great number over the past twelvemonth—almost all of them, incidentally, accompanied by stamped addressed envelopes. (Considerate readers!)

Many of those who have written seem to have landed themselves with pieces of equipment upon which information is required. Unhappily, it is not generally possible to give satisfactory replies to such inquiries for the simple reason that to do so would call for the resources of a vast library itemising every piece of (usually war-surplus) equipment on the market. "The best thing you can do is to throw it away" is cold comfort to an enthusiast who may have spent several pounds on an apparently promising item of equipment, yet often this proves to be the kindest advice to give, though perhaps not quite so brutally.

The practical electronics technician is advised to buy a piece of equipment for the return it is likely to give him in terms of pleasurable experimenting, rather than "because it is likely to come in useful". And always ask the seller exactly what it is and does, and is there an instruction sheet with it?

Receivers

More specific have been the inquiries received in respect of suitable receivers to buy for use on the amateur bands. Clearly, there are hundreds of readers anxious to make a start in the "73 world" but dubious about how to do so.

Here once again copious literature would be required to answer every would-be short-wave listener's queries about the receiving facilities that would be best for him; it is hoped in some part to meet this need in the new series of articles describing a number of classic communication receivers which are available at reasonable prices. We started with the BC348 last month—remember?

From receiving to transmitting... the romance of communication has prompted more than one young reader to imagine that he can go on the air simply because he wants to, without observing any of the formalities society demands for the proper control of potentially anarchic devices (yes, we are talking about

radio transmitters, not motor-cars!)

Always, one's reply to enthusiasts who wish to transmit is a dual one. First, write to the G.P.O. for a copy of the leaflet "How to Become a Radio Amateur". Secondly, do not invite the ire of the licensed transmitting members of your district by "going pirate". Branded as one of those who couldn't wait, you will have a long hard row ahead of you to hoe before your sins are forgiven.

Listening

A few ask how to transmit. Many ask how to receive, as has been said—but in particular how best to achieve a satisfactory return from the operation of a newly acquired communication set.

This question, more than any other, has arisen most persistently during the past year, and it must be the first to which we bend our attention in 1966.

Meanwhile, at the end of this first twelve months may one wish all members of the amateur radio move-



"The 73 Page" concludes its first year of life as it began: with a picture of a motor car carrying the coveted figures on its number plate (a handpicked index mark indeed!). Appropriately, the vehicle has been halted next to a roadside sign bearing the same magic number.

ment who chance to see these words the greeting they would themselves give to their fellows: "73 for 1966!"

the 73 page

ELECTRONIC BUILDING BLOCKS

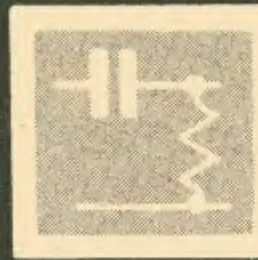

PART NINE

by R. A. DARLEY

IN THE instrumentation and computer fields of electronics, the most widely used circuits are those belonging to the multivibrator family. These are basically two-transistor (or valve) circuits in which one transistor is switched on and the other off, i.e. the circuit has two distinct "states". The multivibrator may be regarded as an electronic two-pole two-way switch.

MULTIVIBRATOR TYPES

Three distinct types of multivibrator circuit are in common use:

(1) *Astable Multivibrator*. Two sets of time constants are introduced to the circuit. Initially, TR1 is on and TR2 is off. After a pre-determined time, the circuit suddenly changes its state: TR1 switches off and TR2 on. The circuit remains in this new state for a period dictated by the second time constant, and then reverts to its initial state, with TR1 on and TR2 off. The cycle of events repeats itself *ad infinitum*. The circuit is free running and acts as a pulse or square wave generator.

(2) *Bistable Multivibrator*. No external time constants are introduced to this circuit, which has two "stable" states. Once a particular state has been attained, it is held permanently until a special switching pulse is applied, in which case the circuit switches to its other stable state. Two switching pulses are required to complete a full cycle of events; the circuit can thus be used to divide by two.

(3) *Monostable Multivibrator*. This circuit is a cross between the other two. It has one stable and one unstable state. Normally in the stable state, a trigger pulse may be applied to switch the circuit to the unstable state. After a pre-determined time, it reverts to its initial stable state.

ASTABLE MULTIVIBRATOR

Fig. 9.1a shows the best known version of this circuit. Transistors TR1 and TR2 have collector loads R1 and R4 respectively, while R2-C1 and R3-C2 form the two time constant circuits. Outputs may be taken from either collector.

The operation of the circuit can be understood with the aid of the relevant waveforms shown in Fig. 9.1b. Assume initially that C1 and C2 are discharged and the negative supply is not connected to the transistor circuit since S1 is open.

When S1 is closed base current flows in each transistor as shown in Fig. 9.1a. The base current of TR1 flows from the emitter, through the base, and then splits into two paths, one to the negative rail via R3 and the other to the negative rail via C2 and R4.

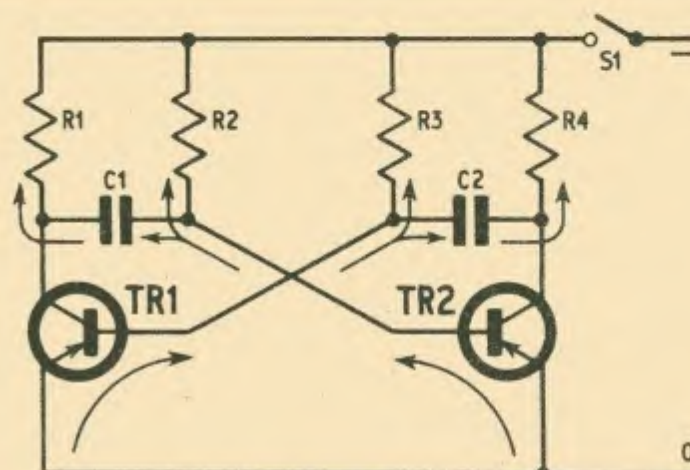

Fig. 9.1a. Basic astable multivibrator

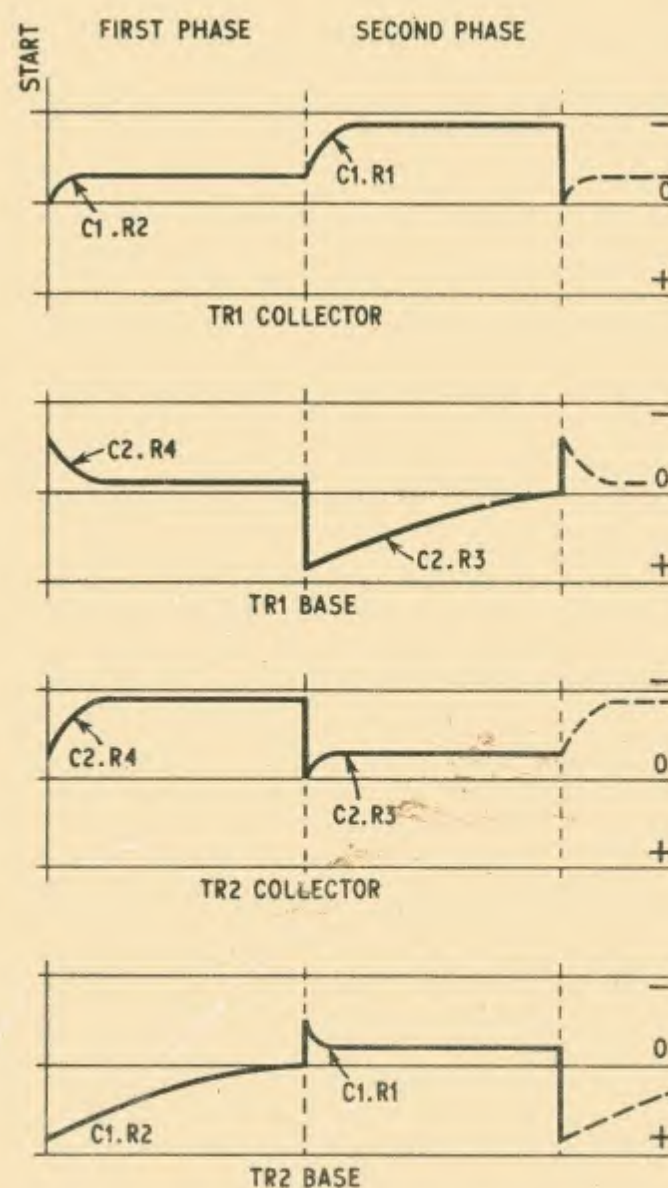

Fig. 9.1b. Astable multivibrator waveforms

The value of R4 is small, relative to R3 so it can be considered that the capacitor charges up in a negligible time, and that any varying voltage is seen equally on both sides of the capacitor. The total base current is equal to the sum of the two individual currents.

The flow of base current in TR1 causes a flow of collector current in TR1, which causes a voltage drop across R1, making the collector go less negative. This fall in voltage is reflected via C1 to the base of TR2, causing its base and collector current to fall; less voltage is thus dropped across R4 and TR2 collector becomes more negative. The change in potential at TR2 collector is reflected via C2 to the base of TR1, causing its base current to increase even more. Cumulative action takes place.

This action tends to occur similarly to both halves of the circuit, but due to the natural unbalance of component values the action is more pronounced on one side of the circuit than on the other. Assume that in the present case the result of this unbalance is that TR1 switches on and TR2 switches off. Fig. 9.1b shows the voltages in the circuit at this instant, which we shall refer to as the "starting" state. TR1 collector is at near zero potential, and its base is considerably negative. TR2 base is considerably positive. In the period between "switch-on" and "start", C1 is charged up to almost the full negative supply potential in a time determined by R1 and C1. At the end of this period, TR1 collector falls to near zero volts and, since C1 is still charged, causes the complete capacitor charge to move down with it, making TR2 base go positive.

TR2 collector is by no means fully negative, in spite of the fact that TR2 is biased beyond cut-off; base current is flowing in TR1 via C2 and R4, hence the voltage loss at TR2 collector. C2 is not fully charged.

Consider now the action of the circuit after the START point, starting with what shall be referred to as the "first phase".

In the early part of this phase, two things happen. C2 charges via R4 and the emitter-base junction of TR1. A short time constant is involved, and the base of TR1 drops rapidly towards zero, reducing TR1 base and collector currents, and causing the collector voltage to become more negative; only small changes in potential are involved. Since C2 charges via R4, the charging action is seen at the collector of TR2, which rises rapidly almost to the full negative rail potential.

The main part of the action in this first phase takes place via C1. The capacitor discharges via R2, which has a comparatively high value; the time constant involved is long. As C1 discharges, TR2 base voltage rises towards zero, but since TR2 is initially biased beyond cut-off there is no effect on the circuit.

As soon as the base voltage reaches a value where TR2 is taken out of cut-off, rapid action takes place: TR2 begins to conduct; a volt drop occurs across R4 and is reflected to the base of TR1, reducing the base current of that transistor. The voltage drop across R1 is reduced, making TR1 collector go more negative; this negative move is reflected to TR2 base via C1, making TR2 conduct even more. Cumulative action takes place. This can be considered as the end of the first phase. Waveforms are as shown in Fig. 9.1b

The second phase of operations is basically the same as the first phase; C1 charges via R1, with a short time constant, affecting the voltages at the base and collector of TR2 and the collector of TR1 by a small amount. The main action takes place via C2, which initially takes TR1 base sharply positive, after which it discharges via R3 with a long time constant. As C2

discharges to the point where it brings TR2 out of cut-off, a regenerative action again takes place and the two transistors "flip" or switch over, reverting to the state they were in at "start" and repeating *ad infinitum*.

If the two main time constants R2-C1 and R3-C2 are equal, the output of the circuit, taken from either collector, will approximate to a square wave, i.e. the output will have a 1 : 1 mark-space ratio. By suitably altering the relative time constants, a wide range of mark-space ratios can be obtained.

An important point to note with this circuit is that the negative supply rail must be connected very rapidly to the circuit, otherwise the unbalance in component values may be "masked" and the circuit may not "start".

DESIGN PROCEDURE

Quite simple empirical rules may be applied to the design of the circuit; the design is a matter of compromise and there are limitations in the scope of performance that can be expected.

When choosing transistors, remember that a large positive voltage will be applied to the base during parts of the operation. The transistor must be designed to work with a base-collector voltage of at least twice that of the negative supply line. Make sure that the current ratings of the transistor are adequate with regard to the collector load resistor when the transistor is switched hard on.

FREQUENCY OF OPERATION

The *period* of operation $t \approx (1/f)$ in seconds and is given by the formula:

$$t = 0.7(C_1R_3 + C_2R_4)$$

If the circuit is to be used as a square wave generator, the formula simplifies to

$$t = 1.4CR$$

the frequency being

$$f = 1/(1.4CR)$$

CHOOSING COMPONENT VALUES

There is a limiting relationship between the value of the main timing resistors and the collector loads that must be adhered to if the circuit is to work at all. Although the circuit is not used as an amplifier, amplification is essential for its operation. For the circuit to work, the current gain of each transistor must be numerically greater than the numerical ratio of the relevant timing resistor to collector load resistor. For example, if the transistor current gain is 50 and the collector load is 1 kilohm, the timing resistor must not be greater than 50 kilohms. Thus, when designing for a particular frequency of operation with a given transistor, the designer is restricted mainly to selecting a suitable timing capacitor.

It is the above limitation that makes the circuit design such a matter of compromise. Referring to Fig. 9.1a, it is the relative time constant of C1-R1 and of C2-R4 that results in the "rounding" of the otherwise rectangular waveform whose period is determined mainly by C1-R2 and C2-R3. The greater the ratio between the relative charge and discharge times of each timing capacitor, the more nearly square will the leading edges of the waveform be, but the limit of these ratios is restricted by the gain of the transistors.

FREQUENCY LIMITATIONS

Practical limitations are set on the upper and lower usable frequencies by the transistors themselves. The main attraction of the circuit is that it can generate a

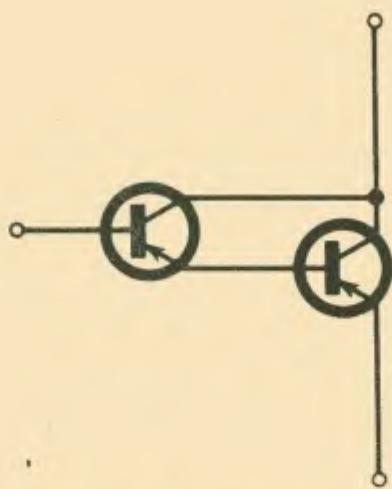

Fig. 9.2a. Darlington pair, three-terminal two-transistor stage

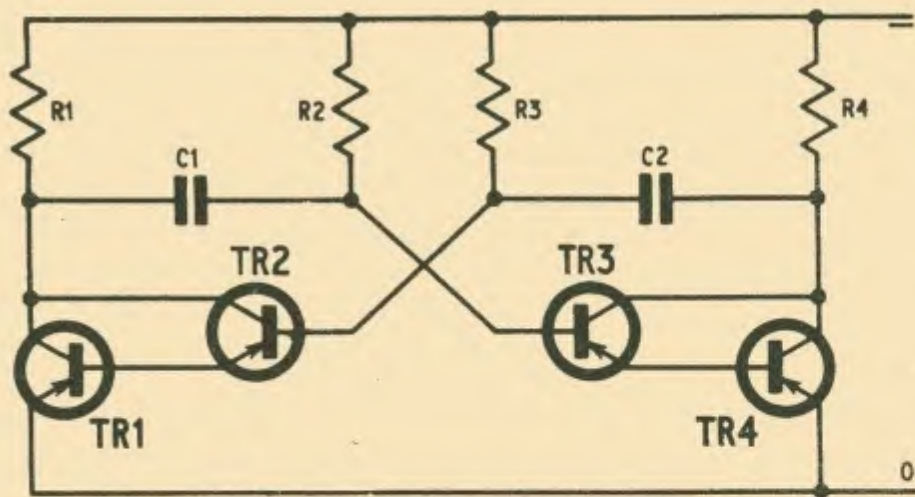

Fig. 9.2b. Darlington pair astable multivibrator

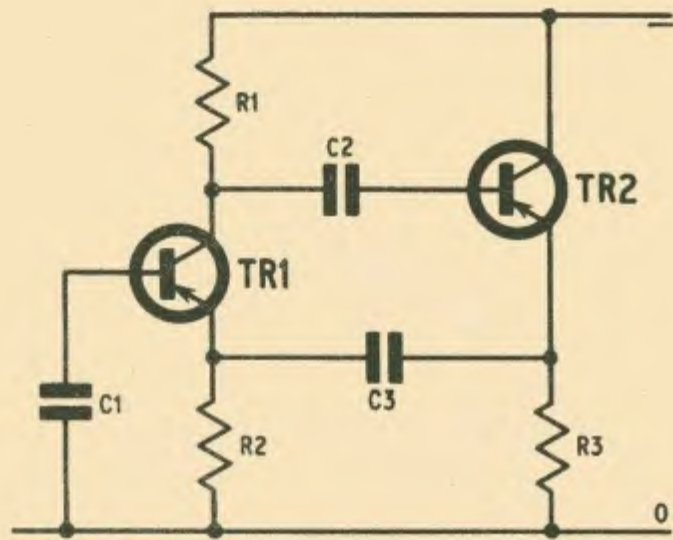

Fig. 9.3a. Basic emitter coupled multivibrator

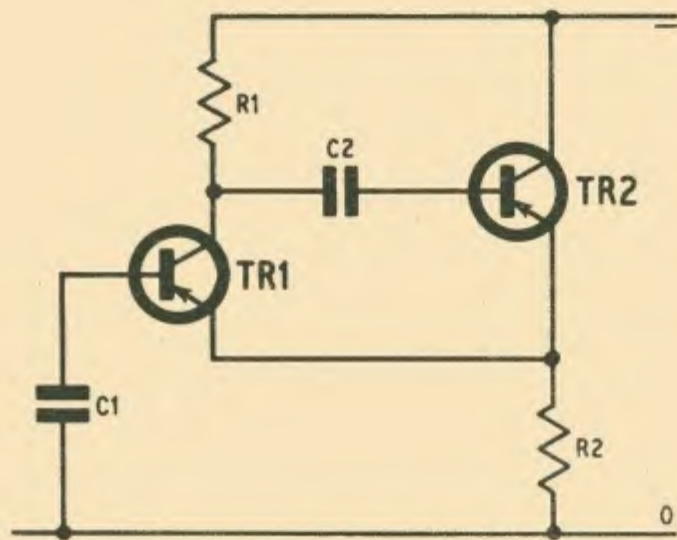

Fig. 9.3b. Simplified version of Fig. 9.3a by connecting the two transistors as a long-tailed pair

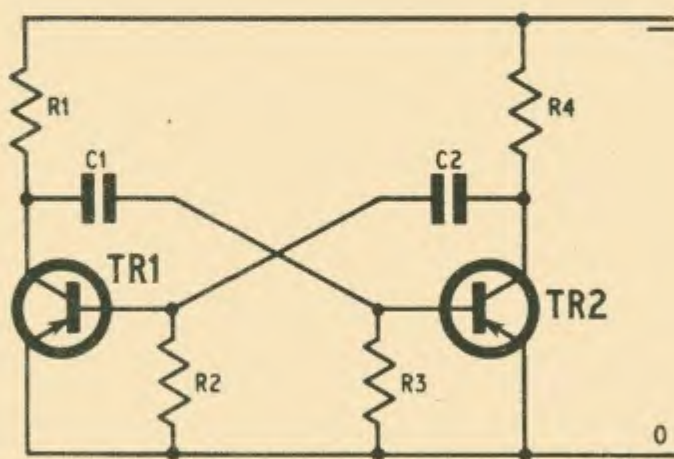

Fig. 9.4. Conventional multivibrator with the timing resistors connected to the common line

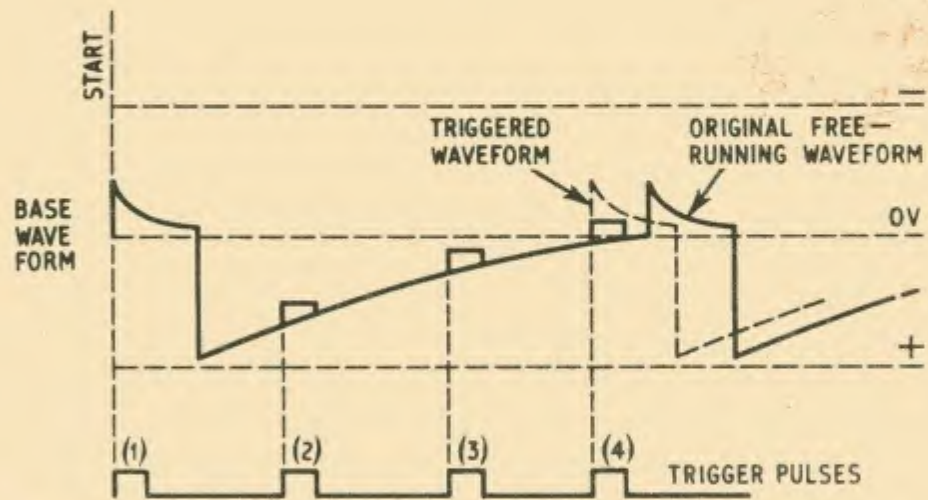

Fig. 9.5. Relative waveforms of a triggered and a free running multivibrator

waveform that is very rich in harmonics. If one had a square wave and passed it through an amplifier that could not operate beyond, say, the fourth harmonic, the resultant output would not be a square wave at all, but more like a distorted sine wave.

Thus, to give a reasonable square wave, the transistors used in the astable multivibrator must be able to work up to at least the tenth harmonic of the fundamental in the common emitter mode. Audio transistors are adequate up to a few kilocycles, while at tens of kilocycles per second, r.f. types should be used. In the range of hundreds of kilocycles per second, v.h.f. types are almost essential.

At the low frequency end of the spectrum, the limitations are somewhat different. The available range of resistors in the timing circuits are limited, so the best way to lower the frequency of operation with a given transistor is to increase the value of the timing capacitor. At very low frequencies, very large values are used; these are often electrolytic types. These have very high leakage currents, and a point is reached at which their leakage currents will exceed those of the transistors themselves. Beyond this point, the frequency of operation can not be decreased.

FREQUENCY STABILITY

The astable multivibrator, in its basic form, gives rather poor frequency stability. Variations in supply voltage will cause appreciable changes in frequency, so the first step towards improving frequency stability is to stabilise the supply voltage.

A far more difficult problem is created by the transistors themselves; the timing cycle is largely controlled by the base currents of the transistors. A factor that has not been taken into account is the base leakage or collector leakage currents of the transistor, which are by no means constant and are subject to variations with temperature. If these leakage currents are of appreciable value compared with the normal currents in the timing circuits, very poor stability will result, particularly under changing temperature conditions. Thus, for good frequency stability, leakage currents must be kept relatively small.

DARLINGTON ASTABLE MULTIVIBRATOR

In an earlier part of this series it was shown that if two transistors were connected as shown in Fig. 9.2a, to form a three terminal network, the circuit could be regarded as a single transistor that has a current gain that is the product of the two individual gains, the configuration being known as the "Darlington" or "super-alpha" pair. By using this configuration in the astable multivibrator circuit, many of the limitations of the more conventional astable can be overcome. Such a connection is shown in Fig. 9.2b.

The circuit is most widely used to allow very low frequency operation to be carried out; as has been pointed out, low frequency limits are normally set by the availability of low leakage, high value timing capacitors. By using the Darlington connection, the transistor gains are effectively squared, thus permitting the use of very much larger timing resistors than is normally possible, thus reducing the need for large timing capacitors.

Although it is not widely used in circuits working at "normal" speeds, because of its increased cost, the Darlington circuit has many advantages to offer. The high gain enables exceptionally low base current to be

used, compared with the currents of the normal timing circuits; very good temperature stability can therefore be obtained.

Because of the very high effective current gain, very wide ratios between collector and timing resistors may be used, resulting in vastly improved "squaring up" of the output waveforms.

VARIANTS OF THE ASTABLE CIRCUIT

So far we have considered only astable circuits that use cross-coupling between base and collector for operation. Since the astable circuit is simply a two-stage positive feedback oscillator, it is evident that other forms of feedback connection can be used without changing the basic ideas of the circuit. A number of versions thus exist, as would be expected.

One of these is the emitter-coupled multivibrator, shown in basic form in Fig. 9.3a. TR1 collector is capacitively coupled to TR2 base, and TR2 emitter is capacitively coupled back to the TR1 emitter, so providing the overall positive feedback required for oscillation. The emitter coupling circuit can be simplified by using the "long-tailed pair" principle (outlined in an earlier part of this series) without effectively altering the operation of the circuit, and this is the system that is generally preferred. Such a circuit is shown in Fig. 9.3b. The method of operation is basically the same as that of the normal astable circuit.

Another variant, far more commonly used in valve than transistor circuits, is shown in Fig. 9.4, where the timing resistors are taken from base to ground instead of the more normal base to negative rail. The circuit differs in detail of operation from the normal, but results in the same type of output waveform. Because of the shunting effect of the base-emitter circuit on the timing resistor, the circuit is most suitable for applications where short time constants are involved.

TRIGGERED ASTABLE MULTIVIBRATOR

In spite of its normally poor frequency stability, the astable multivibrator can be "locked" very easily to an external triggering circuit and used as the source of very stable square waves. It is not essential that the triggering circuit be working at the same frequency as the multivibrator circuit; it may be at a higher harmonic frequency. In this case the multivibrator is used as a frequency divider.

The method of operation in this case is shown in Fig. 9.5, which calls for very little explanation; the base waveform of an astable multivibrator with an "on" time that is very short compared to its "off" period is shown, so that for most of the total period the transistor is biased beyond cut-off.

Also shown are the sync or trigger pulses; by applying these to the base, they can be used to bring the transistor out of cut-off prematurely, causing the circuit to switch. In the diagram, pulses are shown as the triggering medium, but in practice almost any waveform, including sine or square, may be used. It is essential that the triggering "pulses" be of stabilised amplitude if consistent triggering is to be obtained. Using this principle, frequency division down to one tenth can be obtained with little difficulty.

If a triggered square wave, as opposed to a rectangular waveform output is required, the trigger pulses can be fed to both of the transistor bases at once.

Next month: Bistable and monostable multivibrators

INSTANT MORSE

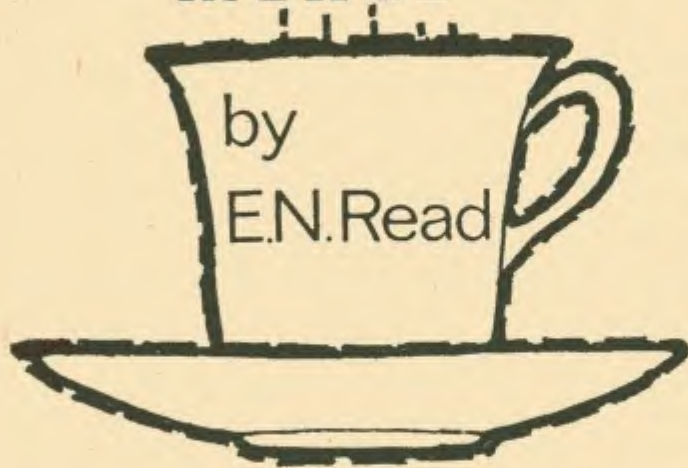

To become a proficient radio operator takes time and practice. The first step towards it is to learn the morse code. While this may seem obvious you would be surprised at the number of people who think it is one and the same thing. They are two distinct operations and should be approached as such.

As time is precious do not waste days and even weeks learning the symbols. Do it in an evening. Or even better, two hours flat!

This is all the time you need if you are prepared to concentrate on this one subject. That is, to learn the code thoroughly. Once mastered it is a simple matter gradually to increase your speed until you are able to send and receive simple messages. But at this stage do not attempt to make the symbols on a morse key. Learn the code first. And, in this article, that is the last time we shall actually consider becoming an operator. Now to learn the code.

GROUPS EASY TO MEMORISE

When, as a child, you first mastered the alphabet, had someone stopped you in the middle it would have been necessary to go back and start again at A. We must avoid this trap in learning the code. Do not learn it in a consecutive, alphabetical sequence or you will find that starting back 25 letters to remember X will become tedious. Obviously sequences are necessary but we will break them down into groups of three and four letters, groups easy to memorise and easy to recall.

But first let us decide how we are going to speak of the symbols. To keep saying *long long short, long long long* is tiresome and unhelpful. We want something that will further assist the learning. Some people like to hiss the symbols. After half an hour this becomes unhygienic and

tiring. You will find it more convenient to refer to *dit and dah*. When they come together leave out the "t", thus: *didah*, or *dididahdit*. This will quickly become a habit even if at first you find yourself mouthing them as though you were taking an elocution exam.

Now for the groupings we mentioned.

A · - (didah)
U · · - (dididah)
V · · · - (dididah)

You will notice that these are in ascending numbers of *dits* ending in one *dah*.

LISTEN TO THE SOUND

When you actually say them it is very important not to say *dit* (pause) *dit* (pause) *dah*. But *dididah*. This is the *sound* you will want to hear when you are familiar with the code. Reading this article you are not seeing each letter and word of print and working out what it means. You are looking at a group of letters making a word and a group of words making a sentence. It is second nature. You do not think about it. In morse you are going to listen to a group of *sounds* (*dididah*) making a letter and it is this *sound* that will mean something. Better start to use it from the beginning.

Back to A, U, V. Learn them till you know them backwards and forwards. Then on to,

N - · (dahdit)
D - · · (dahdidit)
B - · · · (dahdididit)

An ascending number of *dits* preceded by a *dah*. Learn these just as thoroughly. Master them completely. Back to A, U, V. Now A, U, V, N, D, B. Keep at these till you can recall any one at will. If you have really mastered them get comfort from the fact that you have already learnt, never to be forgotten, nearly a quarter of the alphabet!

Next group,
T - (dah)
M - - (dahdah)
O - - - (dahdahdah)

Follow the same procedure, memorise the group completely. Now go back to the previous six letters and work in this new group. Memorise the whole nine thoroughly. This is very important.

Now for some *dits*.

E · (dit)
I · · (didit)
S · · · (dididit)
H · · · · (didididit)

Learn the group first, then mix them in with the previous groups. You have now learnt exactly half the alphabet. Enough letters to try out a few short words. Test yourself on these. HOUSE, AID, SAVE, OMIT. How did you make out? If you had much difficulty go back and study the groups again. At this stage speed is quite unimportant. But remember that the pauses

are to be between letters and not symbols of a letter. Try and keep each letter going at a good steady speed. It will help enormously.

OPPOSITES AND SIMILARS

The rest of the alphabet we split down into opposites and similars.

G - - · (dahdahdit)
W · - - (didahdah)
and
F · · · · (dididahdit)
L · · · · (didahdidit)
K - · - (dahdidah)
R · · · (didahdit)
Q - - · · (dahdahdidah)
Y - · · · (dahdidahdah)
P · - - · (didahdahdit)
X - · · · (dahdididah)

Which leaves only three letters in the odd group out which have no connection at all,

C - · · · (dahdidahdit)
J · - - - (didahdahdah)
Z - - · · (dahdahdidit)

Another useful but repetitive group is,

A · - (didah)
W · - - (didahdah)
J · - - - (didahdahdah)

Go over these groups again and again till they are thoroughly committed to memory. You will already have realised how effective this is by the degree with which you are now so easily able to remember the first two groups. Write them down, look at them, memorise them. Now, for the first time run through the alphabet. Get a friend to check you. Four or five of the letters will be more difficult than the others. They always are. Pay particular attention to them and they will soon be as easy as the rest.

FIGURES

The numerals next. These almost provide their own reminders.

1 · - - - -	6 - · · · ·
2 · · - - -	7 - - · · ·
3 · · · - -	8 - - - · ·
4 · · · · -	9 - - - - ·
5 · · · · ·	0 - - - - -

Study the whole of the alphabet, at least, in one sitting. At the end of this time your head may be reeling but you will have broken the back of the job. Each time you refer back to it you will be astonished how much of it you remember.

From here on it is practice. You can do this wherever you are and quite inconspicuously. Advertisements in buses, motor car numbers, signs in windows, names of shops. Do this in every spare second and you will have mastered the morse code.

Then, and then only you will need to know one or two special signs. At this stage these will be learnt as easily as you might learn a new word, without confusion to the rest of your vocabulary. You are now ready to start on stage two—becoming an operator. ★

FIRE ALARM SYSTEM

by M.L. Michaelis M.A.



A multi-point area control system using a self-contained battery-operated circuit with "infinite" battery life and built-in functional test facilities.

A RELIABLE fire-alarm system is desirable for any premises which are too large for the owner to keep his eye on all parts thereof directly. This may apply, for example, to a large single building with numerous rooms on several floors, or to a farm with several separate buildings.

Fire alarms are also a valuable protection for any places of storage of inflammable materials, such as book and paper supplies, hay and straw lofts, timberyards, public or private libraries, offices, and numerous other examples.

Sometimes fire insurance companies may demand the incorporation of a fire alarm in any such remote places in addition to fire extinguishing equipment, particularly if normally left unattended for long periods.

It is evident that a fire alarm must therefore most frequently consist of a suitable fire detector which is connected by cable to the alarm sounding unit which may be several hundred yards distant from the detector—at the nearest position where there is normally some person present at all times.

REQUIREMENTS

All requirements for a fire alarm system may be summed-up in the stipulation of *maximum reliability*. Above all, this means that any likely fault of the alarm system itself which could render it insensitive to fire

should either set-off the alarm right away, or draw attention to itself in some other manner. The owner of the premises, or other responsible person, can then rectify the fault in the system before incurring possible damage due to any fire which may arise subsequently and not be announced by an alarm.

This is not hedging the point that an alarm system should ideally be built such that it cannot go wrong, because the latter condition is impossible to satisfy in practice.

Although one should strive to use the best circuit and most reliable components, so as to minimise the likelihood of a breakdown, it is necessary to remember that the equipment will be in operation day and night, year in year out, and sooner or later a fault is virtually bound to occur. Expensive commercial fire alarms are available, which automatically set-off an alarm for all manner of likely and unlikely faults within the equipment itself, possibly even indicating the nature of the fault on the panel of the alarm control unit quite automatically.

The simple design published in this article does not go quite to these lengths. Despite this it is possible that the design presented here will meet with the approval of fire insurance companies under many circumstances, provided it is built with first-class components and strictly according to the details given.

CIRCUIT DESCRIPTION

We will now describe the functioning of the circuit (see Fig. 1 on blueprint), discussing the reasons why the particular arrangement was adopted in relation to the requirements of reliability.

The circuit of the alarm unit is based on a three-stage d.c. amplifier using a total of five silicon *npn* transistors. The first stage, TR1 to TR3, is a threefold fan-in gate for three separate lines from three fire detectors at different remote locations. We will discuss the input relationships with respect to TR1 base circuit and the detector line connected at SK1; they apply quite analogously to TR2/SK2 and to TR3/SK3.

As long as the detector line at SK1 through the fire detector presents a closed circuit of about 1 kilohm resistance, it forms a high-ratio voltage divider in conjunction with R5, so that a negligibly small voltage appears at the base of TR1. This voltage is definitely below the cut-on threshold of a silicon transistor (about 0.2V is the threshold level of most silicon transistors), so that TR1 draws no emitter or collector current. Since it draws no emitter current, the second stage, TR4, can obtain no base current and in turn draws no emitter current, wherewith the third stage TR5 also obtains no base current and thus draws no emitter current. The entire amplifier is thus cut off completely, and relay RLA is de-energised and its contacts break the bell circuit.

SILICON TRANSISTORS ESSENTIAL

This circuit will not work reliably, if at all, with normal germanium transistors, because the latter have no definite cut-on threshold, and because they generally have high and temperature dependent leakage current. This means that even with no or negligible base bias and base current, appreciable emitter-collector residual current can flow, which would be amplified fully by TR4 and TR5. At the best this would lead to an unnecessarily high standing battery drain, usually also to unnecessary false alarms on warm days, when the temperature-dependent rise of leakage current of germanium transistors would be amplified sufficiently to energise RLA.

Silicon transistors have very much smaller, for most purposes quite negligible, leakage current. The specified types BSY53 or 2N1613 are particularly good transistors in this respect.

It is seen that with an intact fire detector connected to SK1, R5 imposes a load of 2.2 megohms across the 9V battery, thus drawing about $4.1\mu\text{A}$ of current. All three input line circuits together thus draw nominally $12.3\mu\text{A}$ through the respective resistors R3, R4, and R5. A measurement actually made on the prototype showed that the total battery drain under these conditions (electronic microammeter connected across the switched-off on/off switch S5) was $13\mu\text{A}$. The difference may be due to the tolerance of the resistors R3 to R5; at any rate the leakage current of the resting amplifier circuit is negligible in comparison with the deliberate load resistors R3 to R5.

ALARM CONDITIONS

An alarm is set off when any one of the input lines SK1 to SK3 goes *open* circuit or increases to such a high resistance that the input-stage transistors are cut-on by a rise of base voltage. The normal event is an open circuit, due to fire or excess temperature at the detector having melted the fusible alloy. The total current gain of the affected input stage transistor with TR4 and TR5 is about a hundred thousand and the output current in

the relay RLA energising circuit is 135mA, so that about $1.35\mu\text{A}$ are drawn by the base of the affected input stage transistor.

This input current must come through the appropriate input resistor R3, R4 or R5, causing a voltage drop of about 3 volts across that resistor, so that the base of the relevant input transistor rests at 3V below the battery terminal voltage, i.e. at 6V positive to chassis. Now the three current amplifier stages are simply cascaded emitter followers, so that the voltage at the input base is roughly repeated at the output emitter, i.e. across RLA energising circuit.

When, say, Line 1 is open circuit, the base of TR1 rises to +6V in the manner just described, and thus the emitter of TR1 is also at about +6V. Consequently the emitters of TR2 and TR3 are also lifted to +6V with respect to chassis. But the bases of TR2 and TR3 are still just above zero volts, assuming their input lines are still intact. Thus when the alarm is released via TR1, the other two input transistors are all the more heavily cut off and cannot interfere with the action. The same applies to the "intact line" transistors when the alarm is set off by any other line going open circuit.

CURRENT LIMITING

Assuming that the transistors have a mean current gain of about 40 to 60 each in the circuit used, giving a total current gain in the region of a hundred thousand, it is clear that the chosen value for the base input resistors R3 to R5 already limits the output current at TR5 emitter due to voltage drop across the input resistors as already described. However, this measure alone is not sufficient, for the actual current gains of some samples of the specified transistor type may diverge. Thus the resistor R12 and the Zener diode D2 have been added as safety measures.

If the current gain of the particular transistor specimens should happen to be unusually high, or if a substitute relay of lower current rating is used, then the input base current at TR1 to TR3 will be much smaller and the voltage drop across R3 to R5 much less, so that in the absence of R12, D2 the output emitter of TR5 would tend to be driven to virtually the full battery voltage. However, D2 limits the rise to 6 volts, the excess then being dropped at a safe current level through the relatively high value resistor R12. In the prototype D2 was actually a 7V Zener diode, which nevertheless limited at 6V output at TR5 emitter, on account of the small Zener current and the threshold difference of TR5.

THE RELAY CIRCUIT

Although frequently shown in circuits, it is undesirable to connect a relay coil directly in the emitter or collector circuit of a switch transistor if optimum reliability is being aimed at. This is because a sudden interruption of collector or emitter current can then cause very high induced back e.m.f.'s across the relay coil, which could exceed the voltage ratings of the transistor. This alone is generally no danger to a transistor, as long as the breakdown current resulting therefrom is limited in magnitude and duration, i.e. as long as it results from only slight energy of the relay magnetic field which has to be dissipated. However, this condition may not be satisfied.

Many relays store considerable energy in their magnetic field, which has to be dissipated when the relay is de-energised. The best way to achieve this with negligible resulting induced back e.m.f. is to connect a

large electrolytic capacitor across the relay coil, as here represented by C1. Then the parallel connection of C1 and RLA is harmless from the point of view of induced voltages at switch-off, but the *current* surge into C1 upon switch-on would now be excessive without the limiting resistor R13. The combination R13, C1, RLA thus represents the correct and fully safe method of connecting a relay in the emitter or collector circuit of a transistor. The value of R13 must be small compared with the resistance of the relay coil, to prevent loss of available energising voltage, unless a substitute relay with much lower energising voltage is used.

For example, if a relay with nominal ratings 3V 50mA (i.e. 60 ohms coil) is substituted for the specified one, then R13 must be increased to 60 ohms (use a 56 ohm preferred value resistor) to drop the other three volts. The reduced current of 50mA in this example relative to the specified 100/135mA relay is unimportant, because R12, D2 assure correct current limiting in the manner already described.

The resistor R10 also requires correct choice with reference to a half-exhausted battery. We may take a new battery to have a terminal voltage of 9V on load, an exhausted one a terminal voltage of 6V on load and thus the half-exhausted terminal voltage is 7.5V. We must choose R10 such that the collector to emitter voltage of TR5 in the cut-on state under alarm conditions is less than 1V, for 7.5V battery voltage. Thus some 0.5 to 1.0V must be dropped across R10 at the rated relay current of RLA, which is satisfied with the value 4.7 ohms for the specified relay.

If relays of lower current rating are used, R10 must be proportionately increased, in addition to the already mentioned need to increase R13 if the voltage rating of the relay is less than 6V. In general, the correct value for R10 is some 10–15 per cent of the relay coil resistance.

These measures limit the power dissipation in TR5 to well below 800mW even with a very new battery, so that no special cooling arrangements are required even when using the specified relay which requires a relatively high energising current.

This relay has been selected for its reliability even after years of "waiting". It is encapsulated in a transparent plastic case, and is suitable for mounting on a printed circuit card. A wide selection of alternative relays is usable, bearing in mind the corresponding adjustments described above, but the reader is warned not to use inferior quality components, since these could impair the reliability of such an important device as a fire alarm.

ALARM LATCHING

The principle of the fire detector is that a fusible alloy link in the detector at the far end of the input line is melted by fire or excess temperature, so opening the input line circuit and cutting-on the amplifier and causing RLA to energise. One contact of RLA then completes the circuit of the bell X1, which thereupon rings.

Now it is conceivable that further advance of the fire will also burn the cable insulation near the detector, causing a renewed short, which would silence the alarm again just at the time when the bell should carry on ringing until somebody hears it, before the fire advances still further.

To prevent such unwanted silencing of the alarm, the bell circuit is latched on via the second relay contact RLA2 which provides RLA1 with an alternative

path via R11 for energising current once it is energised via TR5—even if TR5 should subsequently be cut off again by burning of the detector line insulation. The bell then definitely continues to ring until either the battery is exhausted (after a few hours) or the on/off switch S5 is actuated manually.

LINE FAULT SAFEGUARDS

The most probable faults on the detector lines are *interruptions* somewhere on the long runs from the alarm unit to the respective fusible detectors. Such breakages could occur after months or years due to chafing, wind, rodents, interior decoration or furnishing operations, or numerous other causes, including wilful damage by children, or intruders mistaking the installation for a burglar alarm. Any such line breakage immediately sets off an alarm, so that it is announced without delay and appropriate repairs can be undertaken.

This is the reason why a system with *resting current* was chosen. In other words, the detector circuit carries a continuous current in the resting state, which is broken by a fire or defect, rather than using a normally open circuit which is closed by the fire. The latter would announce only short circuit faults directly, which are less likely than open circuit faults, i.e. line breakages.

Nevertheless, short-circuit faults are also conceivable and some means of showing these up prior to failure of the unit in the face of an outbreak of fire is essential. The simple method adopted here is to give each line a definite external resistance of 1 kilohm by inserting a resistor of that value at the far end of the line beside the fusible link. A rudimentary ohmmeter is included on the panel of the alarm unit, in the form of the meter M1 and associated components.

If S4 is depressed, D1 and R2 supply the meter circuit with a *stabilised* test voltage of about 4V, irrespective of the state of exhaustion of the battery.

If one of the switches S1, S2 or S3 is now depressed simultaneously to S4, the meter shows a deflection in accordance with the line resistance and the setting of the appropriate potentiometer VR1, VR2 or VR3.

The latter are preset individually (to compensate tolerances of the 1 kilohm resistors at the three detectors) for exactly half-scale deflection of the meter on any intact line. This point on the meter scale is marked "line".

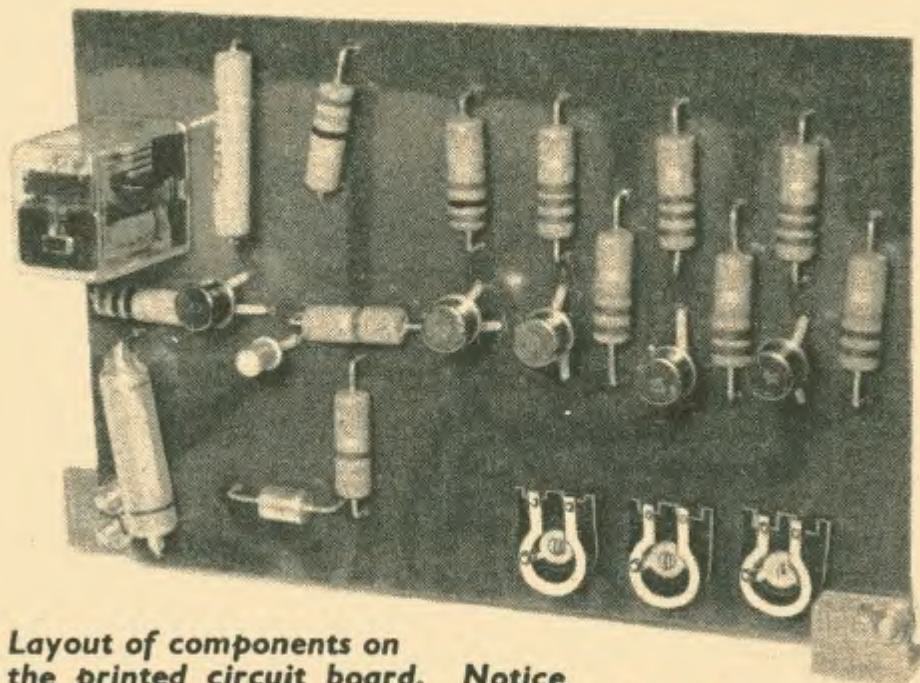

Layout of components on the printed circuit board. Notice potentiometers VR1, VR2, and VR3 fitted on the bottom right-hand corner. TR5 is nearest the relay and three input stages, TR1, TR2, and TR3, are on the right

A check should be made once or twice a week, depressing S4 and, simultaneously in turn, the three line switches. A short on any line will be revealed as a meter deflection at or near full scale, instead of at the correct "line" mark at half-scale. A poor contact, i.e. a line about to go open circuit, may be indicated by too low a meter deflection. In either case, the line in question should be checked and repaired immediately. The bell will ring as soon as any one of the line buttons is pressed, because the other contact of each switch simulates a line break, i.e. an alarm condition. This tests the respective input transistor TR1 to TR3 and the remainder of the circuit as a whole. After testing each line for correct resistance and alarm readiness, release S4 and momentarily flip the on/off switch S5 off and on again to unlatch the bell before pressing the next line button.

When all three lines show correct meter readings and correct alarm release whilst simultaneously holding S4 depressed, finally depress any one of the line buttons again *without* depressing the S4 button. The meter now receives the full battery voltage via a circuit resistance which is known to be nominally correct, so that the indication is a measure of the battery condition.

Note that this procedure again releases the alarm, so that the battery voltage is measured *on load* as required. The circuit conditions as shown give approximately full-scale deflection for 9V, and the battery is considered serviceable down to 6V terminal voltage on load. Thus mark the last third of the meter scale with a thick-line sector labelled "good", and the lower extremity thereof "replace battery".

BATTERY VOLTAGE

A considerable safety margin is essential i.e. the circuit should function on a supply voltage well below 6V at which the battery would normally be discarded. This is because battery deterioration is usually rather rapid at this stage, and the consequent danger of a "just still o.k." reading at one weekly test, yet complete ineffectiveness before the next weekly test, has to be

avoided. If the battery reads only *just* within the good sector at any one check time, it may then nevertheless safely be left in the unit until the next time—"premature" replacement is not essential.

The circuit should be adjusted once and for all to meet these requirements as follows. First of all, connect S5 to only *one* new 4.5V flat battery, instead of the normally employed two in series. RLA will be found to energise quite securely when an alarm is released in the normal manner under these conditions, by unplugging one of the lines at SK1 to SK3 or by pressing one of the line switches. Now choose the *largest* possible value for R14 which still definitely allows the bell to ring under these conditions. The resulting value for R14 will depend on the particular bell used—the value of 6.8 ohms applies in the prototype but may well be different for other bells.

The alarm readiness of the circuit, therefore, is assured down to one half of the nominal battery voltage, so that the alarm will still ring for a reasonable time even with a meter reading for battery voltage near the "replace battery" position, yet the bell current will be no greater than really necessary, so that the duration of an alarm is the maximum possible under all conditions of the battery at the time of release of an alarm.

Check that an alarm can definitely be set off on one battery alone whenever the two have to be replaced. The meter should read half-scale, i.e. again about at the "line" point, when intact lines are connected and a line button is depressed, with S4 open, when only one 4.5V flat battery (new) is connected. Provided that the specified meter characteristics are used (other meters shunted appropriately), slightly adjust R1 if necessary to give about half-scale reading (at any rate a reading well below the "replace battery" mark at two-thirds scale) with a single battery.

WHY NOT MAINS OPERATION?

The adoption of battery operation for this unit is by no means a mere novelty or whim of fancy. Some definite reasons make battery operation preferable to

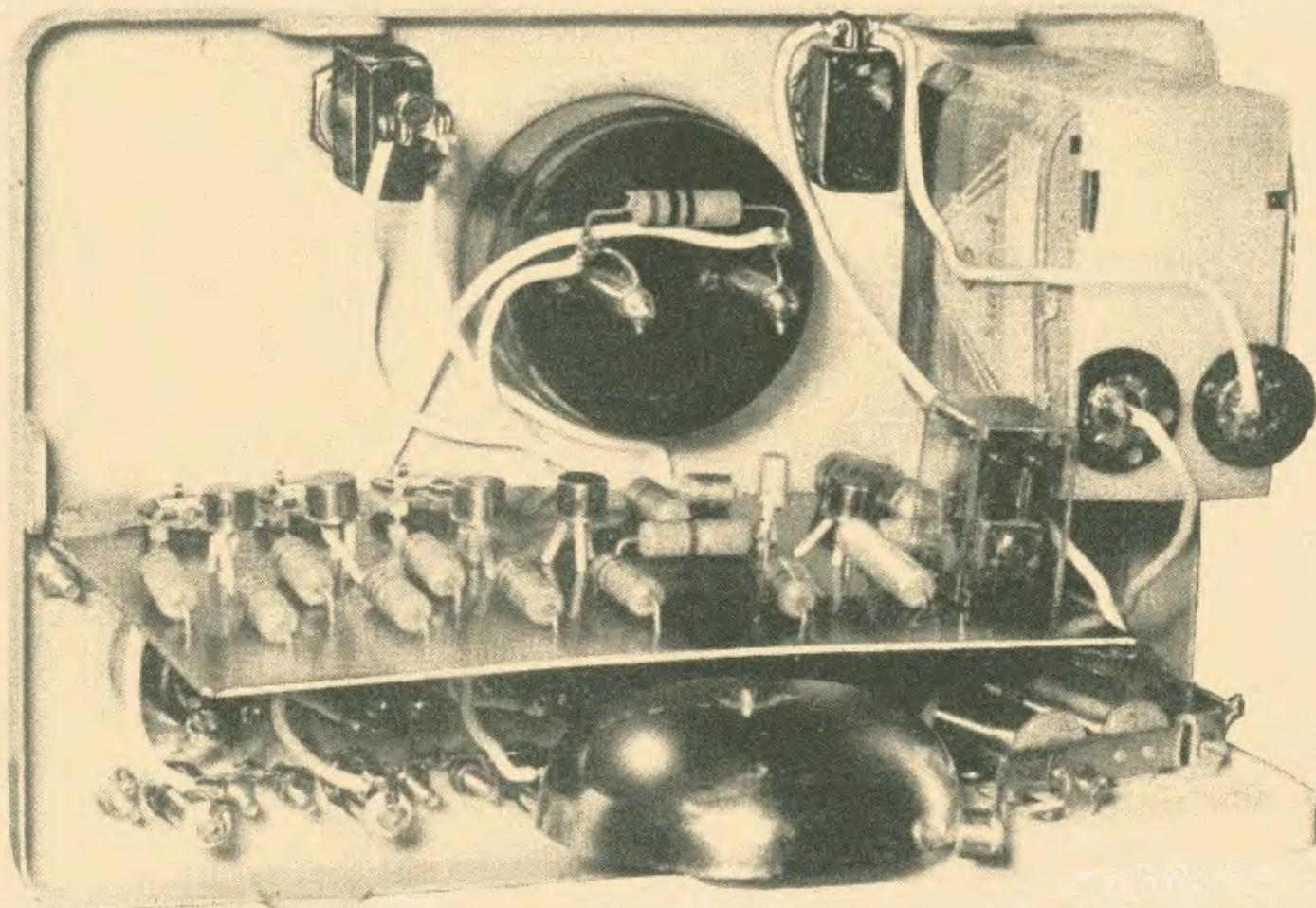

Rear view of the alarm unit front panel showing all the components

mains operation. First of all, the conditions under which fires may arise frequently also lead to a failure of the mains supply—for example, during severe thunderstorms in rural areas. Secondly, equipment which is interconnected with the mains involves a certain (though usually very slight) risk of fire of its own, due to possible equipment faults. Thirdly, the present circuit does not require the expense of a mains power pack, since battery consumption is so low that many years of operation would be needed before the price of batteries has equalled the probable outlay for a mains power pack. Fourthly, a mains power pack would be a source of possible failures quite out of proportion to the risk of breakdown of the rest of the circuit as here published, since a transformer, rectifier and *smoothing electrolytics* would be operating continuously for years.

CONSTRUCTION

The diagrams given on the blueprint should make clear the form of construction followed for the alarm unit. The smaller components are mounted on a printed wiring board, which can be prepared from the full size diagram in Fig. 2.

All switches, line sockets and the meter are mounted on the front panel of an instrument case. The printed wiring board is attached to this panel by means of a pair of brackets.

A standard type electric door bell is secured to the front panel with another bracket. This bracket must be fashioned to suit the particular bell used. Finally, a strip of aluminium or tin is bent around the two flat batteries and secured by a couple of small brackets to the front panel.

The completed assembly should be wired up as indicated in Fig. 3, and then installed in the metal case.

FIRE DETECTORS

Commercial systems use a number of detection principles, each with their particular advantages and disadvantages. So-called smoke detectors may employ an e.h.t. voltage between two plates, leading to a discharge current when smoke enters the space separating the plates. Such a system can be quite sensitive, but it entails a number of inherent dangers on account of the high voltage which is a risk to persons and a risk of fire, as well as being subject to breakdown. An amateur design on this principle is hardly to be recommended.

Other smoke detectors may use a lamp and photocell method. Such arrangements are quite sensitive, safe and amenable to amateur construction. However, they are subject to interference from stray light and prohibitively expensive when *many* sites are to be monitored by the envisaged system. Moreover, the continuous operation reliability over years is rather poor, which is true of the e.h.t. system as well.

Another common principle employs bimetal contacts which bend as a result of temperature changes and thereby open or close an electric circuit. Unless special commercial bimetal contacts are used, such devices tend to be insensitive and often unreliable.

Apart from numerous more refined principles which may be appropriate in special cases, this leaves the simplest method of detection of all, namely the "destruction" of an electrical connection by the heat or fire. It is possible to achieve excellent sensitivity in this manner, by using electric circuits with a link made of an alloy melting at a sufficiently low temperature.

The melting point should be as little as possible above the maximum temperature ever likely to be encountered

under normal climatic conditions at the proposed detector site. Solder is usable at a pinch, but normally unnecessarily insensitive.

Two alloys are well-known which melt below the boiling point of water, i.e. at temperatures much less than the charring point of wood or paper. These are *Rose's Alloy* (melting point $94^{\circ}\text{C} = 201^{\circ}\text{F}$) and *Wood's Metal* (melting point $71^{\circ}\text{C} = 160^{\circ}\text{F}$). They are normally readily available through good chemical suppliers, and in case of any difficulty, at least the ingredient metals according to Table 1 should be obtainable.

Table 1. Fusible Alloys

Name	Composition	Melts at
Solder	Tin and Lead	200–300°C 392–572°F
Rose's Alloy	2 parts Bismuth 1 part Lead 1 part Tin	94°C 201°F
Wood's Metal	4 parts Bismuth 2 parts Lead 1 part Tin 1 part Cadmium	71°C 160°F

First melt the lead in an old tin lid on a gas flame or primus stove and then add the bismuth. Finally add the tin, and the cadmium if used. When all is melted, stir thoroughly and cool to about 100°C by heating on a boiling water bath. Project two copper wires (preferably tinned) well spaced into a depression in a block of wood and quickly pour the just molten metal into the depression.

After solidification, remove the blob of alloy with its two wire connections and solder to the tagstrip of the detector as shown in Fig. 7. Do not make the alloy blob unnecessarily large, nor the copper wires unnecessarily long, so that the wires definitely can not touch when the alloy has subsequently been melted off. The blob of alloy should hang vertically downwards from the tagstrip, so that it drops clear and breaks the circuit when it melts.

Rose's Alloy is probably best as far as sensitivity is concerned, and it avoids the need to procure cadmium metal if made up from ingredients. Wood's Metal is best if somewhat greater sensitivity is desired for monitoring mere temperature rise in electric or

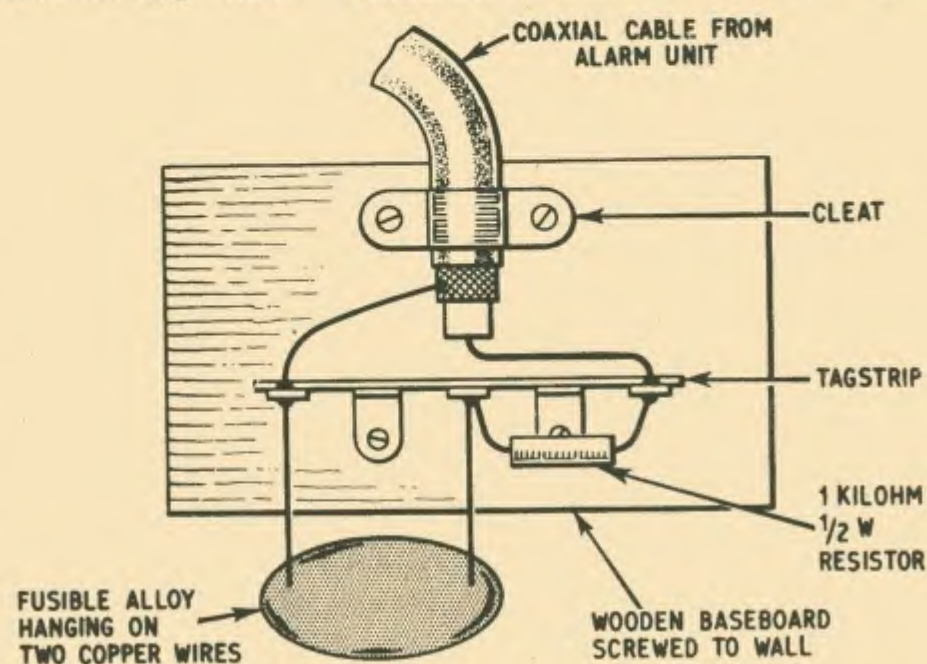

Fig. 7. Fusible alloy lump fitted to detector tag strip

electronic equipment, since it melts at just about the maximum temperature which modern equipment will normally tolerate.

DAMP AREAS

Adequate spacing is essential on the tagboards of any detectors in damp locations, to avoid creep resistance of moisture closing the line. If a fire did occur in such locations, it would dry out such moisture anyway, so that the alarm would most likely still operate, as long as dirt deposits have not accumulated within the moisture. If an installation is made involving some detector sites where these conditions could conceivably arise, a practical test must be carried out at frequent intervals.

Melt the fusible alloy with a match or candle at each suspected site and make sure that the alarm is always definitely set off thereby. If there is any unreliability in this respect, then the values of the appropriate base resistors R3 to R5 must be reduced to not more than a quarter of the lowest leakage resistance encountered on the respective lines. If such measures should ever have to be taken to extremes (which should be rare with good materials), battery life will suffer correspondingly. There is of course no need to reduce all base resistors if only one line should require this, i.e. the various input stage transistors may be operated with appropriately different base resistors. R12 and D2 will take care of current stabilisation for any value of base resistors between 56 kilohms and the specified values of 2.2 megohms, so that other circuit adjustments will not be necessary.

ENCLOSING THE DETECTOR

It may be considered advisable, in some circumstances, to shroud the fire detector in order to protect it from mechanical destruction or corrosion, or from moisture and dirt deposits, etc., which would impair the desired function.

A satisfactory hood would be one of the small transparent plastics boxes of rectangular shape and dimensions of two or three inches, which are sold for safe keeping of small quantities of small items such as bolts, transistors, washers, etc., in the workshop. There are numerous such items on the market, and all those which are *immediately* pierced by the bit of a hot soldering iron are satisfactory for our purpose. Those which resist the bit of a hot soldering iron for more than a second or two are not satisfactory.

The price paid for this protection is somewhat reduced sensitivity, since the hood fuses at a higher temperature than the detector alloy and consequently gives a certain degree of thermal screening. It is thus advisable to use the more sensitive Wood's Alloy when encapsulating the fire detectors, whereas this is unduly sensitive for open detectors for which Rose's Alloy is better.

LOCATION OF FIRE OR FAULT

The first thing to do when an alarm is set off is to go to the control unit (unless the location of the fire can be seen by flame or smoke) and quickly press each line switch successively. The fire or fault is on that line whose line switch *fails* to give a meter deflection. Nevertheless press all, to make sure that several lines are not open.

If just one line is found to be open circuit, i.e. to give no meter reading, immediately go to the site of the detector at its far end and check whether there is an outbreak of fire or a detector fault there. On the way, if possible glance at the run of the line, since a fire

anywhere along its length could also release an alarm by severing the cable, even if this is momentary before further advance of the fire shorts the cable.

If there is no fire and no detector fault present, check the line, the plug connections at the control unit and the associated input components (including the line switch) more thoroughly.

If, on the other hand, a brief actuation of any line switch always gives a meter deflection in each case when the alarm has gone off, repeat pressing S4 simultaneously. If any line then gives an anomalous reading, i.e. different from half-scale on the meter, go at once to the detector at the far end of that line, and if there is no fire there, trace and clear the fault on the line.

If none of the lines show any anomaly, then the alarm was probably set off by a brief contact fluctuation of sufficient duration to latch-on the relay. In this case, and this case only, the alarm ceases and does not reappear when S5 is momentarily flicked on and off again. Whilst nevertheless striving to check all detector sites at the earliest opportunity even in this case, chiefly suspect a contact fault in the control unit. Switch S5 off and rapidly actuate every line switch many times. Unplug each plug, check security of connections, clean and resolder if necessary. Then leave one or more plugs disconnected, so that the alarm is always set off, and flick S5 on and off many times. This will make RLA and the bell energise and de-energise in sympathy. There should be no hesitations. After completing these measures, reconnect all lines and switch S5 on again, whereupon the bell should remain silent and a false alarm should not reappear. ★

SEND PRACTICAL ELECTRONICS FOR CHRISTMAS

What better Christmas present could you give an electronics enthusiast than a year's subscription to PRACTICAL ELECTRONICS? Your friends will thank you every month in the coming year for the help and interest this absorbing "practical" magazine brings them.

Simply send your friends' names and addresses, together with your own, and remittance* to cover each subscription to: The Subscription Manager (G.2), PRACTICAL ELECTRONICS, Tower House, Southampton Street, London, W.C.2. Your friends will receive a Christmas Greetings Card announcing each gift.

* RATES (INCLUDING POSTAGE) FOR ONE YEAR (12 ISSUES): U.K. AND OVERSEAS £1 16s 0d. U.S.A. \$5.00.

To make sure of your own copy why not place a regular order with your own newsagent.

ELECTRONORAMA

HIGHLIGHTS FROM THE CONTEMPORARY SCENE

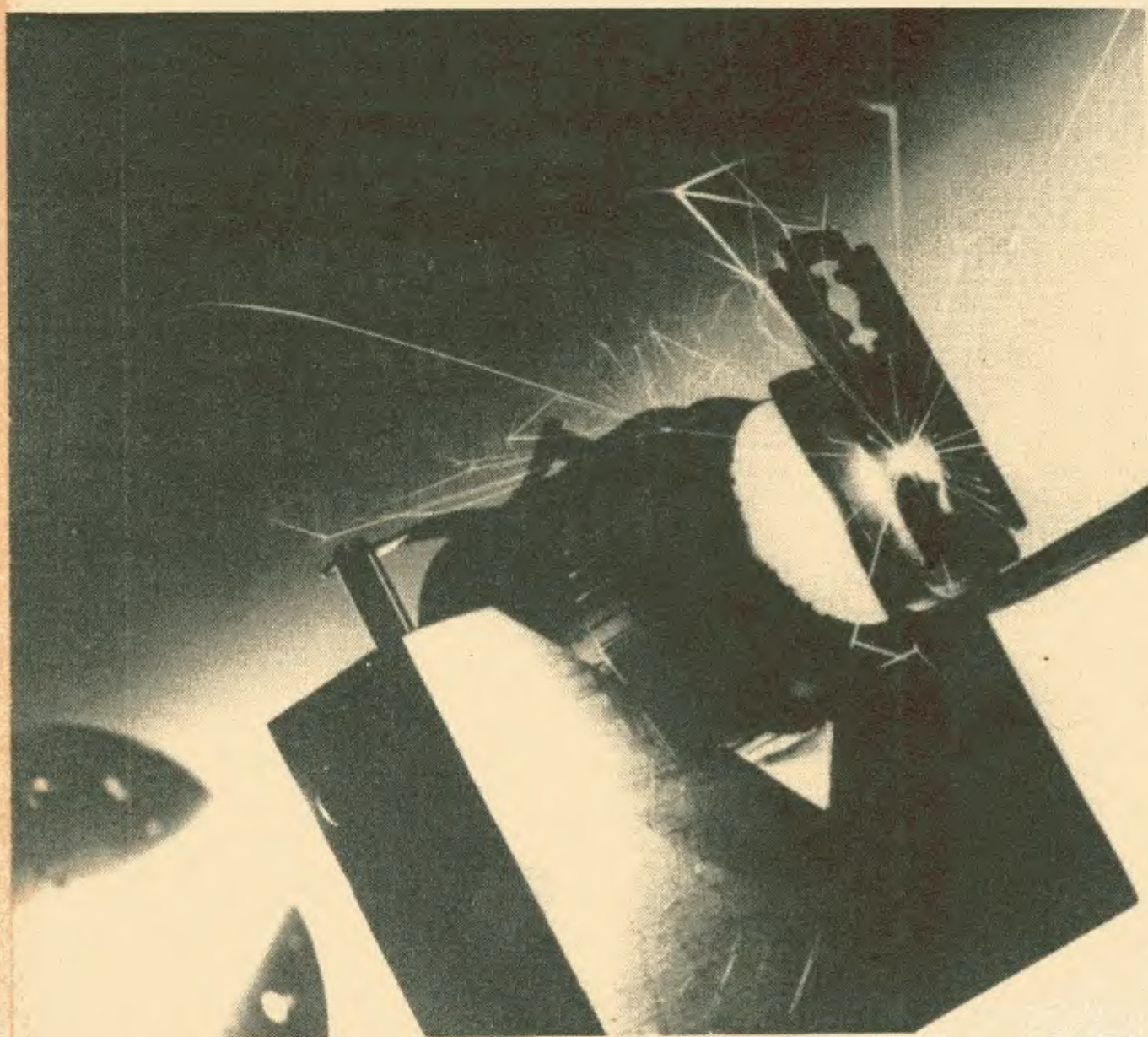

Light Amplification by Stimulated Emission of Radiation

THE LASER is now accepted as a potentially useful tool with many applications. One of these is in eye surgery. However, by the same process, the laser can either repair or permanently damage the retina by coagulation. The patient feels no pain, but the protection of the eyes from incidental or accidental damage, which may occur while the laser is used for other purposes, is vital because the damage can be done before he has had a chance to blink.

The photograph on the left shows how a laser beam can penetrate and burn a hole in a steel razor blade. Minute particles of white hot metal are scattered in all directions.

Scaler Measures Grain Velocity

NUCLEONIC instruments supplied by EMI electronics Limited are being used in the Mechanical Engineering Department of the University of Bristol to assist in the study of the pneumatic transport of granular materials.

The long term aim of the experiments is to improve the efficiency and design of pneumatic conveyors, such as are used in the extraction of grain from ships' holds.

A test rig has been constructed in the University in which grain is conveyed by an air stream up a 50ft vertical pipe of 2in diameter (shown in the centre of the picture). One of the grains has been "tagged" by the insertion of a small piece of radioactive Co_{60} wire of strength 200 microcuries. The forces acting on individual grains at various heights up the pipe are determined by measuring such quantities as the velocity of the radioactive grain.

To do this two shielded scintillation detectors are located close to the pipe and can be placed anywhere along its entire length.

As the radioactive grain passes the lower detector it "switches" the 100kc/s oscillator to a "Wells" scaler, and disconnects it when the grain passes the upper detector. The number of pulses recorded by the scaler is a measure of the time taken for the grain to pass between the detectors, and thus the velocity of the grain can easily be calculated.

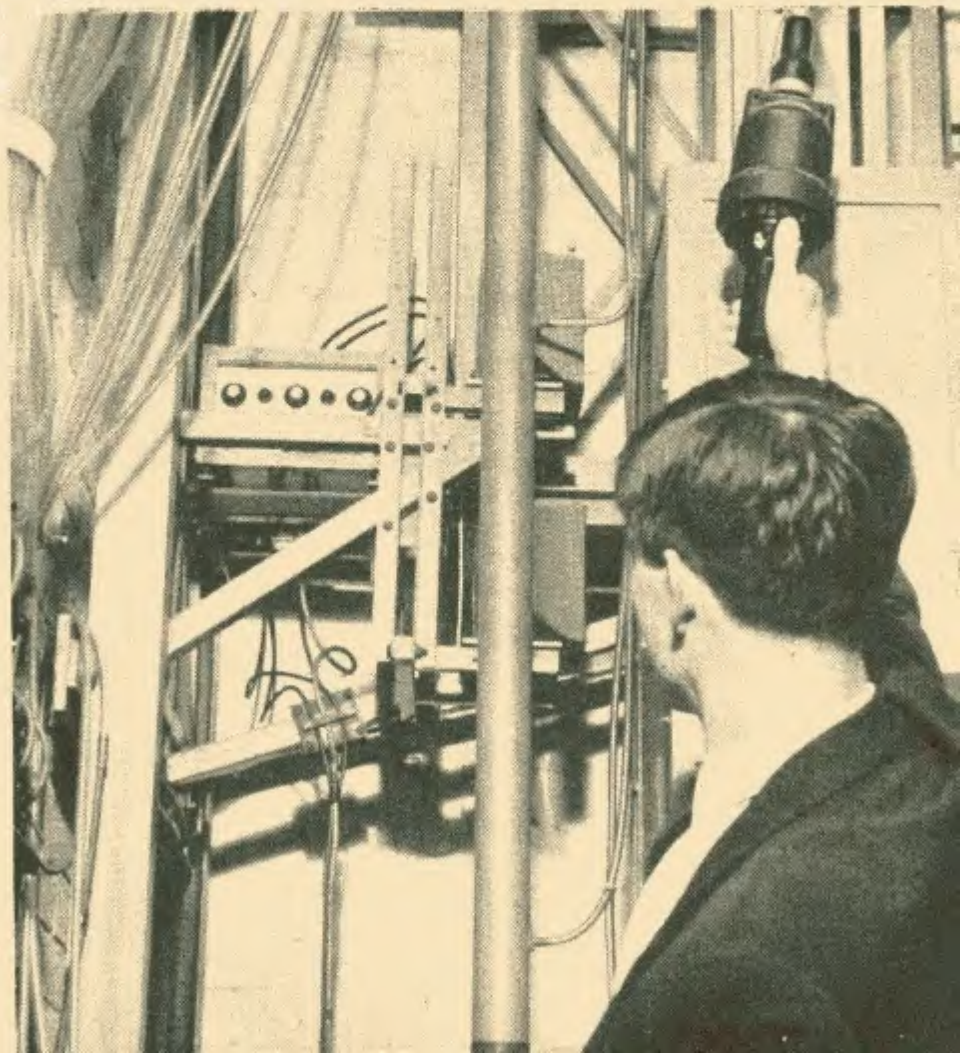

Colour Visual Simulator ▶

THE TRAINING of airline pilots has been made much easier over recent years by using "aircraft simulators", which give the trainee pilots realistic flying conditions. So far their usefulness has been limited to "blind" flying using instruments only.

Redifon have now developed and installed VC10 flight simulators, at the BOAC training centre adjacent to London Airport, which operate with a new three-dimension colour television system. Pilots can practise take-off, approach, and landing under any desired weather conditions by day or night without leaving the ground.

The visual system enables the pilot to see a "moving landscape", including the "runway", in full colour. A television camera is mounted on a gantry, that travels on a railway track, scanning a huge model representing an area 9 miles by 2½ miles.

The colour picture is transmitted to a colour projector, mounted on the roof of the cockpit (far right) which projects the picture on to a large screen in front of the cockpit windscreen. The flight deck and screen move in accordance with the pilots' control actions.

Additional features, including completely realistic sound effects can be introduced to the system.



Mechanised Mail

AT A recent exhibition in London, the Post Office showed the public what will be done in the future to help speed the growing volume of mail. The photographs below (reproduced by courtesy of H.M. Postmaster-General) show, on the left, a letter sorting machine, controlled by a pattern of phosphorescent dots printed on the envelopes by a coding desk operator, according to their destinations. These dots are translated by electronic equipment (right) into electrical impulses which open the sorter's trap doors.

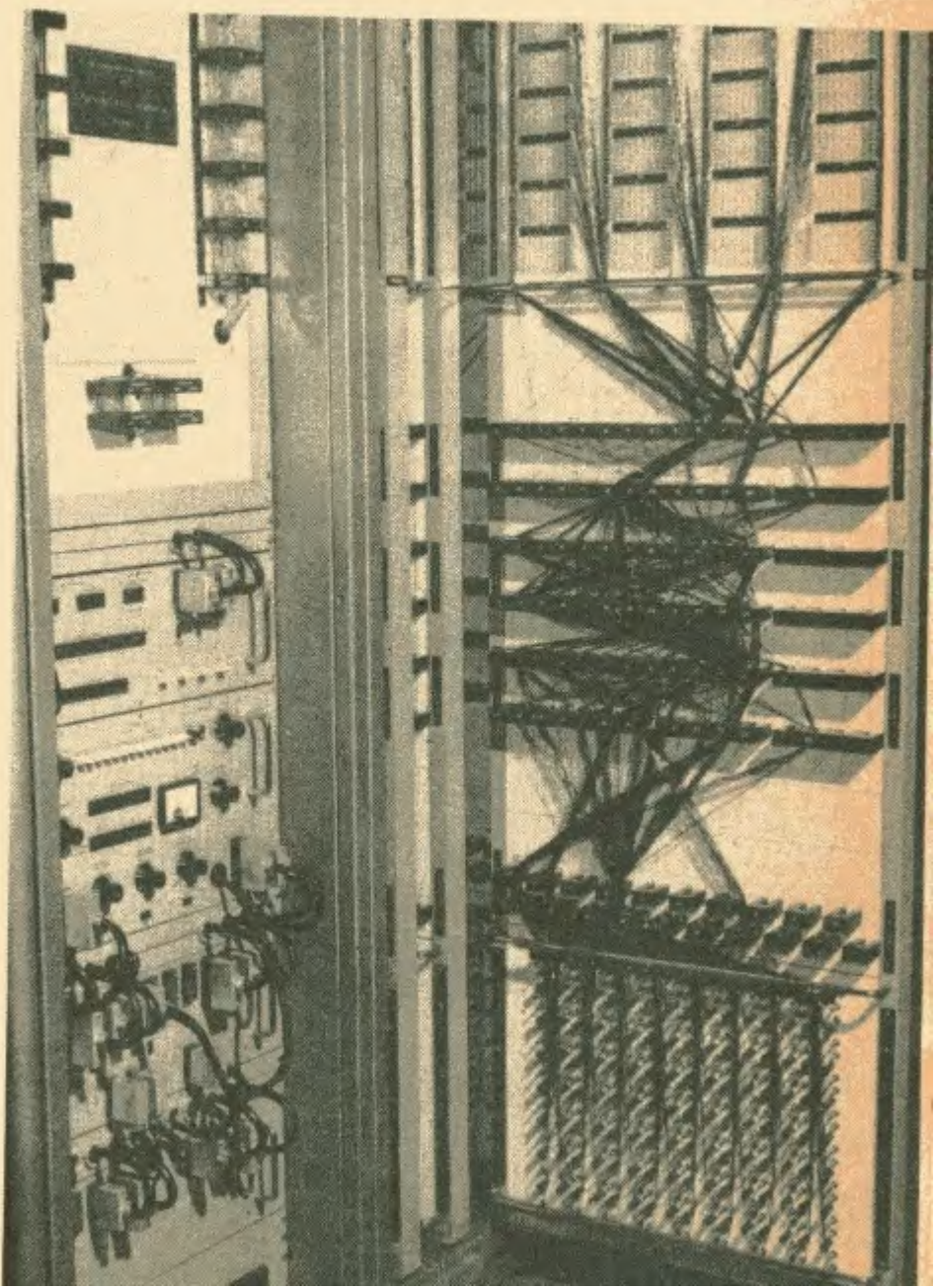

BEGINNERS start here... 14

An Instructional Series for the Newcomer to Electronics

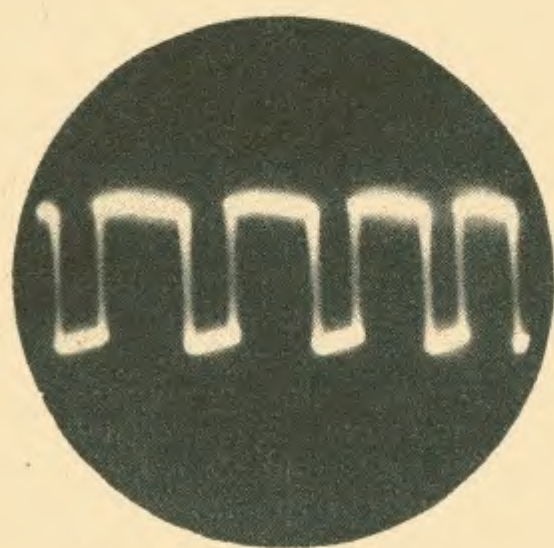

Square waves,
odd harmonics

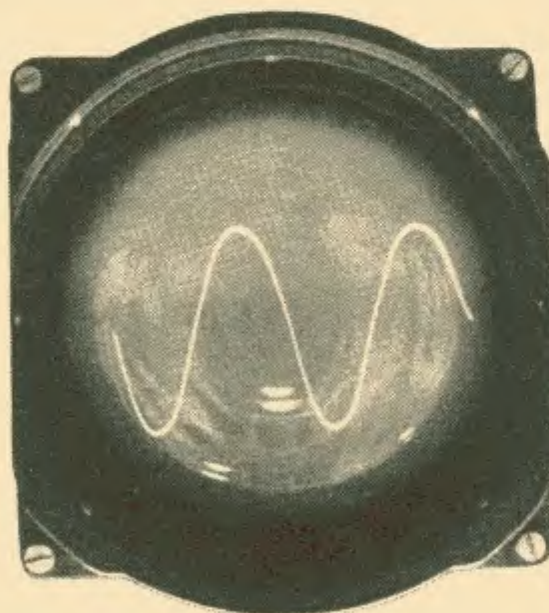

Sine wave

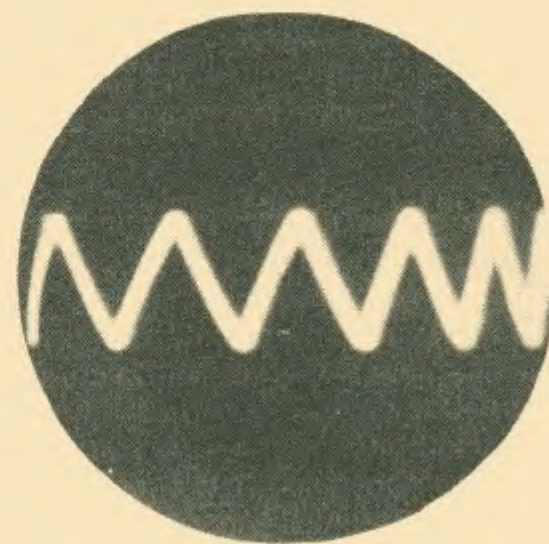

Saw tooth waves,
even harmonics

ALTERNATING CURRENT

Alternating currents (a.c.) have been mentioned several times already in this series, and most people are aware that in nearly every case a.c. is the form in which power is supplied by the Electricity Authorities.

Alternating current is particularly convenient for long distance power systems such as the National Grid; just consider the ease with which the voltage can be transformed up and down. By passing the output of the generators at the power station through a winding on a vast iron core, the powerful changing magnetic fields are made to induce a current at a greatly increased voltage in a separate (or secondary) coil of many more turns wound on the same core. This current at high voltage is then sent on the overhead cable systems to the centres of industry and population, where step-down transformers reduce the voltage ultimately down to the 200–240 volts usually provided for domestic users.

By transmitting the power at high voltage, the *current* is correspondingly reduced for a given power loading. This means that the losses in the cables are greatly reduced, and to carry the comparatively small current, cables of a smaller cross section can be employed. It is important to note that although a transformer can step up voltage, the power does not increase, for the current goes down in proportion. At both the input or *primary* coil $V \times I = \text{watts}$ and at the output or *secondary* $V \times I = \text{the same number of watts}$, that is ignoring the small loss incurred in the transformer itself.

A.C. WAVEFORMS

Now, how about the electronic applications where it does seem that we are for ever attempting to change the mains a.c. into d.c. in our equipment, and taking great pains to "smooth" out any ripples. All this is necessary because the a.c. in the circuitry we use in television, radar, computers, etc. is very seldom the 50 cycles per second sine wave type that comes in via the mains. Perhaps we ought, at this stage, take a closer look at the facts of a.c. waveforms. Of course, the first picture we can visualise is that the current flows one way, then reverses, and moves off in the other direction. The number of reversals in one second is called the *frequency*. A graph of the current variations is the usual picture used to illustrate a.c. A cathode ray tube will draw this graph directly on its face—hence the usefulness of an oscilloscope.

Fig. 14.1 shows the growth of current up to the *peak value* in the positive direction, then the fall to zero and reversal to the maximum in the opposite, or negative direction. The peak value is also called the *amplitude*. One complete rise and fall is called a *cycle* and frequency is measured in *cycles per second* (c/s). The time for one cycle is called the *period* of the waveform.

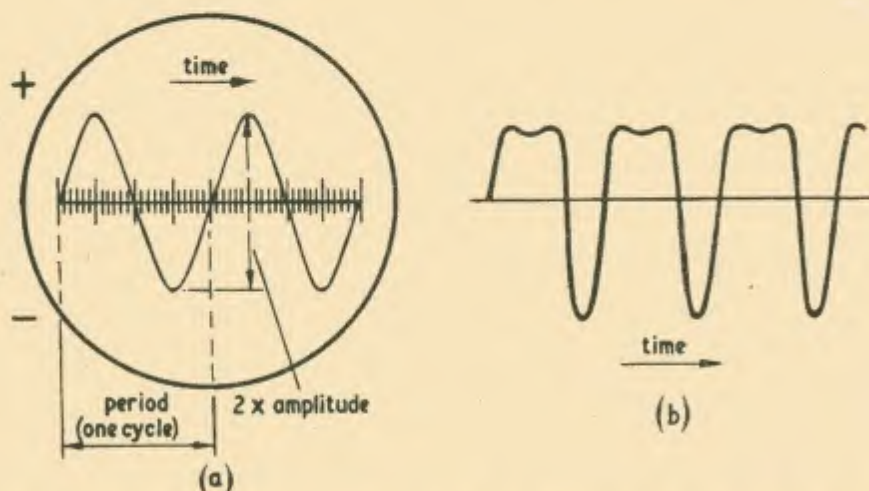

Fig. 14.1. (a) A sine wave as it could be seen on the oscilloscope screen. (b) An "odd" waveshape, which could be split up into its component sine waves

The shape of the curve can be made to take many forms, the most common is the smooth rise and fall called the *sine wave*. This is the shape of the a.c. mains waveform, or it is the waveform that could be drawn if a pen was fixed to a swinging pendulum bob, and a piece of paper pulled steadily along underneath. It is a very common waveform in natural occurrences and is the most important in electronics.

POWER IN A.C. CIRCUIT

Suppose we think of direct current for a moment, the power is steadily drawn from the supply all the time. But, in the case of alternating current, the energy is used in bursts corresponding to the starting and stopping of the current. In the d.c. case the power is given by:

$$P \text{ (watts)} = V \times I$$

What is the corresponding power in a circuit using a.c.? The answer cannot be the product of V and I at the beginning of the cycle; they are both zero at this point. It cannot be the peak values either, because that would produce an answer far too large. This is because although the power is at its peak, it is less at all other times and the average value must therefore be less. It is the *average* power we are interested in.

We do not notice the electric fire, or even the light, going on and off 100 times every second! It is interesting to notice that the energy is "positive" (that is, we get it supplied from the source) on both half cycles, because $V \times I = +$ power on the positive half-cycle, also $-V \times -I = +$ power on the negative half-cycle. When two negative quantities are multiplied the answer is always positive. We can see this clearly using the formula $I^2R = \text{power}$ (see Part 2). I^2 is always positive, whether I is positive or negative.

ROOT-MEAN-SQUARE VALUE

Now to decide how we can talk of power in an a.c. circuit. The easiest way to visualise this is to operate, say, two electric fires, one from a d.c. supply and one from an a.c. supply. We know what power is being

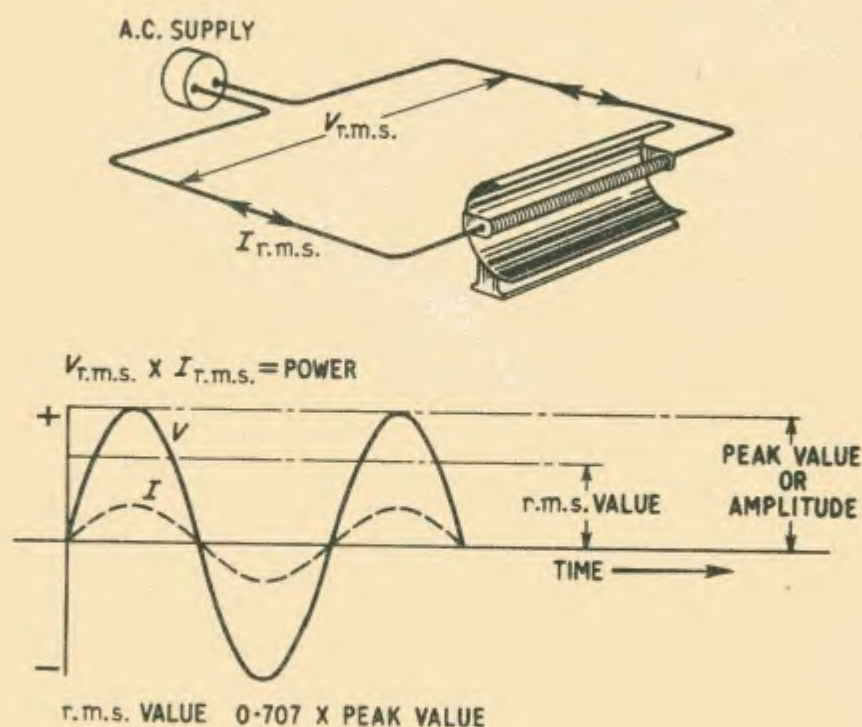

Fig. 14.2. The current flowing through the fire is changing direction 50 times per second. That is it alternates from a peak positive value to a peak negative value and back to peak positive again. An ammeter inserted in this circuit would indicate a current (I) equal to the root-mean-square (r.m.s.) value as indicated in the above graph

consumed in the d.c. case (power = $V \times I$) and we adjust the a.c. supply to operate the other fire so that it gives *exactly the same heat output*. The effective values of a.c. voltage and current operating are then known in terms of the equivalent d.c. values, and the power is again given by $V \times I$.

These power values are known as the root-mean-square (r.m.s.) levels for the particular a.c. supply considered.

It is the r.m.s. value which is always quoted when the mains is being discussed. This means that a 230 volt mains supply has a peak value somewhat higher than this. For a sine wave supply, the r.m.s. value is 0.707 times the peak value. As an example, consider the mains again. If $0.707 \times \text{peak value} = 230$, then the peak value is $\frac{230}{0.707} = 325.3$ volts. The importance of taking great care when dealing with a.c. is thus apparent.

We end this section with a note that the r.m.s. values of a.c. with waveshapes other than pure sine waves are not necessarily 0.707 times the peak value.

HARMONICS

You probably will think that the statement "all other wave shapes can be built up with sine waves added with the right amplitudes and frequencies" is rather odd, but it is perfectly true and shows why sine wave shapes are the most important, since others don't really exist!

A closer look into this reveals that all wave shapes can be made by adding to the basic frequency, or *fundamental* as it is often called, a whole series of what are known as *harmonics*.

The second harmonic is exactly twice the fundamental: so the second harmonic of the 50 cycles per second mains is 100 cycles per second, the third is three times, and so on. In radio and audio amplifier techniques we go to great lengths to preserve the wave shape; that is, not to distort or introduce harmonics that were not there to start with. Hence the hi fi cult! But, in other branches of electronics this distorting, or formation of wave shapes is used a great deal. It is deliberately introduced.

If all the *odd* harmonics are added (theoretically an infinite number, but in practice this can't be achieved), then a *square wave* is obtained (Fig. 14.3a). All the even harmonics produce a *triangular wave* (Fig. 14.3b). Other wave shapes have various mixtures of odds and evens.

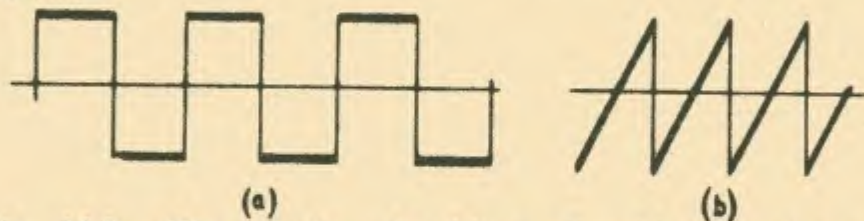

Fig. 14.3. The results of adding all odd and all even harmonics of a wave (a) square waves and (b) triangular waves

Whatever the wave shape, a.c. is changing all the time, so that the capacitors are charging and discharging, magnetic fields are moving, and automatic switches are going on and off all the time in sympathy. Soon we shall discuss these happenings in more detail, and you should begin to see the operation of electronic circuits unfold, thus realising afresh the fascination of our subject.

Next month we will commence a discussion on the different effects of resistors, capacitors, and inductors in d.c. and a.c. circuits.

MULTI-RANGE TEST METER



SPECIFICATION

A.C. Ranges

Volts 0-1; 0-10;
0-100; 0-500

D.C. Ranges

Volts 0-1; 0-10; 0-100; 0-500
Current 0-1mA; 0-100mA; 0-500mA; 0-3A; 0-5A
Resistance calibrated in "preferred value" steps to 22kΩ

A MULTI-RANGE meter is the subject of one of our blueprints provided with this month's issue. Although the meter has some obvious limitations (for example, it should *not* be used to measure *a.c. current*), it will serve as a useful basic test instrument.

The actual meter used here is a 1mA moving coil type with a coil resistance of 76 ohms, providing a measurement sensitivity of 1,000 ohms per volt. The ranges covered are shown in the specification above. The rectifier is a Westinghouse 1mA type MR44, although any low current bridge rectifier will do, such as a matched set of four OA81 diodes.

RESISTANCE

The scaling of the resistance range is arbitrary between zero and about 22 kilohms, with higher values obtainable at the "cramped" left-hand end of the scale.

On this instrument, preferred value "standard" resistors were used to calibrate the resistance range at the values indicated above. This avoids having a congested scale and intermediate values can be reasonably interpolated.

Alternatively, one could construct a graph of resistance against current for accurate interpolation.

For example, if the f.s.d. of the meter is 1mA and the battery supplies 1.5 volts, then the total resistance (R_T) of the meter plus the set value of VR1, is 1.5 kilohms, when the test leads are shorted. The unknown resistance (R) is then calculated from

$$R = \frac{V_{\text{batt}}}{I} - R_T$$

$$R = \frac{1.5}{I} - 1,500 \text{ ohms}$$

where R is in ohms, I is in amps and V_{batt} is in volts.

Since all the gradations of I up to 1mA are known all the values of R concurring with these points can be calculated. Hence a very accurate graph can be drawn so that all future readings can be taken from it.

When using the instrument to measure resistance, set S1 to "D.C." and S2 to "OHMS".

MULTIPLIERS

The calculation of multipliers used for the voltage ranges can be demonstrated by considering the meter of internal resistance 76 ohms set to read d.c. volts with the

100 volt range selected. When a current of 1mA is flowing the voltage drop across the multiplier and meter will be $0.001 \times (76 + 100,000) \approx 100V$. The low resistance multiplier swamps the effect of the meter resistance. If this representative calculation is pursued on other ranges it will be seen that the meter resistance can be ignored. The percentage mean error at full scale deflection over the d.c. voltage ranges was found to be better than three per cent.

Since the meter on a.c. voltage ranges varies proportionally to the average rectified current, it follows that to interpret these readings as volts r.m.s. the reading should be multiplied by 1.11, since $V_{\text{rms}} = V_{\text{av}} \times 1.11$.

If all a.c. voltage readings are multiplied by this factor, it will improve the percentage f.s.d. mean error of six per cent, resulting from direct meter readings.

SHUNTS

The resistance wire for the d.c. current shunts was selected from lengths of electric fire elements readily obtainable from electrical retailers. The low current shunts can be arranged in a suitable helix for compactness. Shunt resistance values can be obtained from

$$R_s = \frac{\text{meter resistance} \times \text{meter f.s.d. rating (mA)}}{\text{required f.s.d. (mA)} - \text{meter f.s.d. rating (mA)}}$$

For example, to calculate the shunt value for an f.s.d.

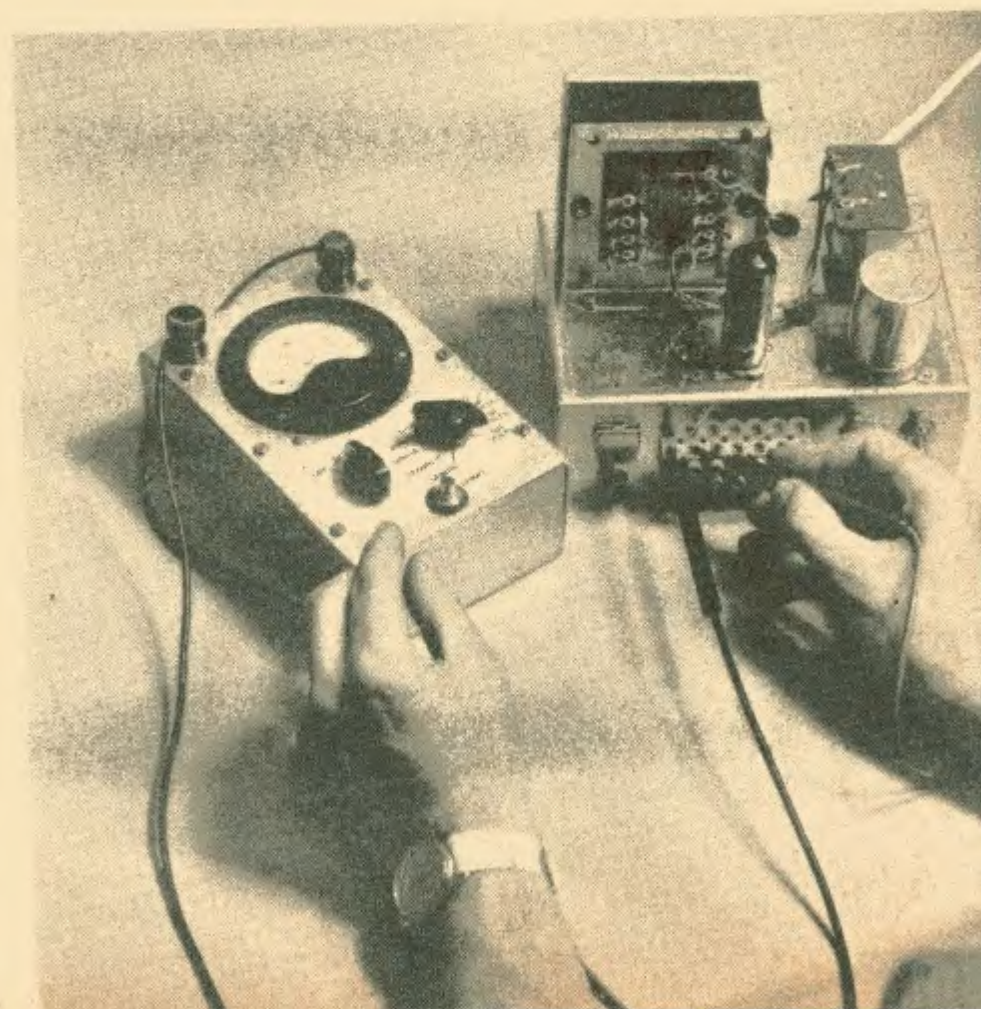

by W. Mason

of 100mA on this instrument:

$$R_s = \frac{76 \times 1}{100 - 1} = \frac{76}{99} \approx 0.75 \text{ ohm}$$

As indicated, this is the value of R4 (see Fig. 1 on the blueprint). The resistance values of the shunts given facilitate the selection of suitable resistance wire lengths by using a Wheatstone bridge for measuring. If such a bridge is not available a known accurate multi-range or ohmmeter can be used, but make sure that it is set at zero with the test leads shorted first.

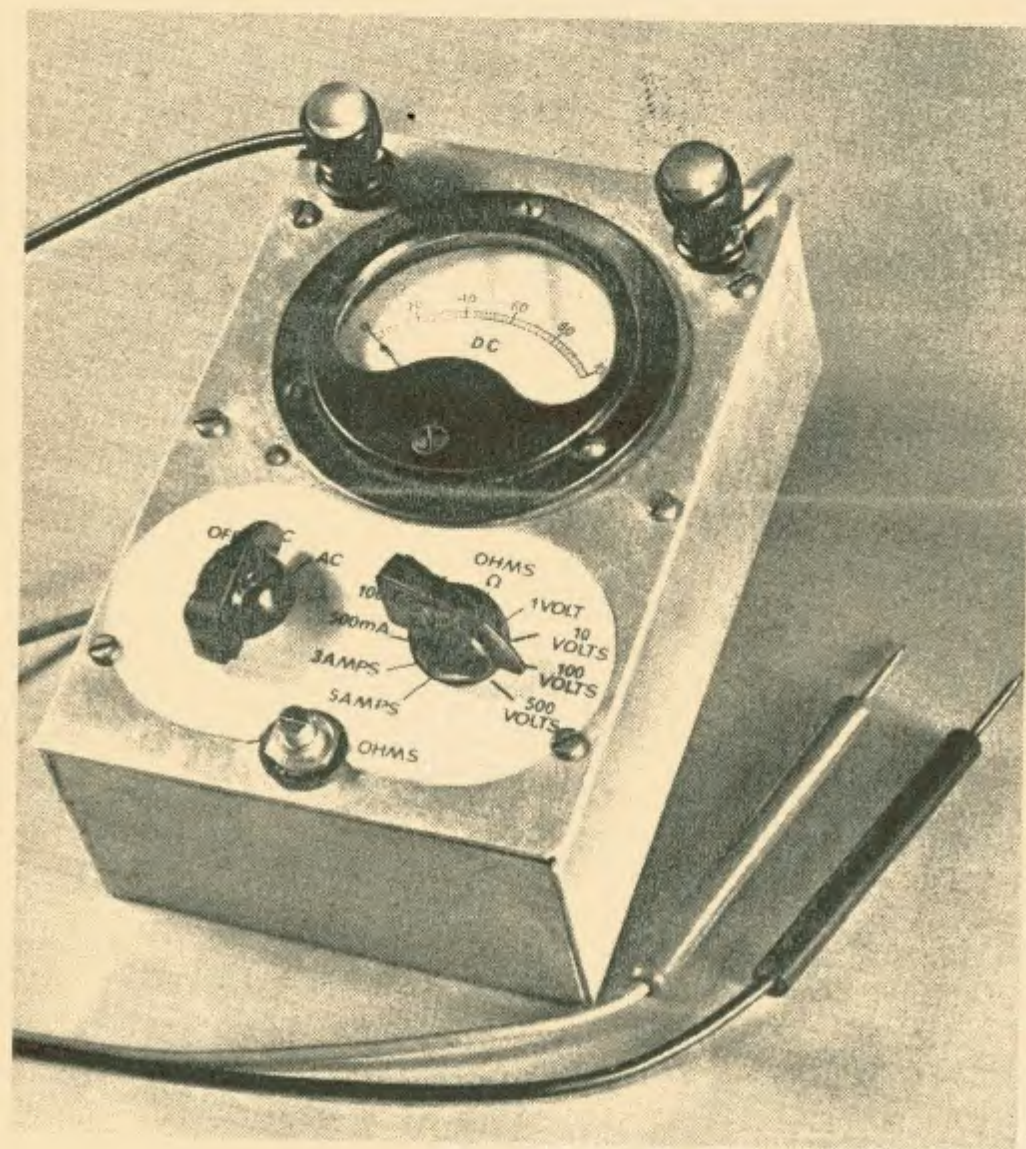

Finished model of the multi-range test meter

For a.c. measurements the function switch S1 is switched to "A.C." and the required voltage range selected on S2. Note that this meter should not be used to measure a.c. current. For d.c. measurements S1 is set to "D.C."; S2 is switched to the appropriate current or voltage range.

CONSTRUCTION

The wiring diagram should present no difficulties, but it would facilitate later wiring if the shunts are connected first to the tags of the lower wafer of the banked switch S2.

Full details of drilling the holes in the front panel are given in Fig. 2 on the blueprint. The dimensions of the meter hole are not given since these will depend on the shape and size of the meter used. An aluminium case at least 2in deep is used to house the instrument; all components are mounted on the front panel. The wiring of these components can be seen in Fig. 3 on the blueprint.

Case construction is simplified if the universal chassis is used (see the components list on the blueprint), but if metalwork is preferred, a case can be constructed from 16 s.w.g. sheet aluminium. ★

NEXT MONTH IN Practical Electronics

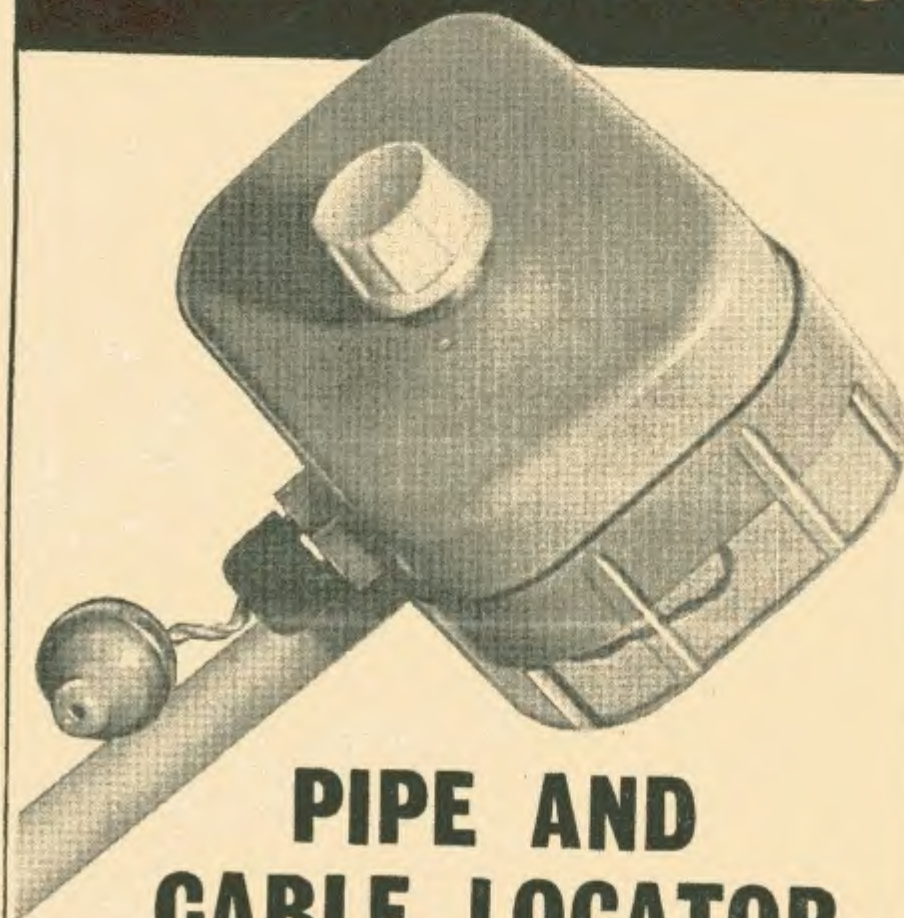

PIPE AND CABLE LOCATOR

A simple device to track down the location of concealed house wiring and piping.

SIMPLE DIGITAL COMPUTER

The beginner's introduction to binary arithmetic, with instructions for making a simple basic computer unit.

SERVO SYSTEM

Practical details of a closed loop feedback system for accurately controlling the position of a remote shaft.

**JANUARY ISSUE
ON SALE DECEMBER 16th**

ORDER YOUR COPY NOW!

THIS third and final article illustrates some of the uses to which this instrument may be applied.

THE SCALER AT WORK

In the physics laboratory the scaler is fast becoming a general purpose tool as essential as an oscilloscope or a multimeter. The teaching of modern physics in schools calls for its use, while it has many accurate and sophisticated uses in various other fields.

The following are a few simple examples of its use. It is hoped that these will show the capabilities of a scaler and provide an inspiration for the development of further experiments. Actual experimental results are given for the experiments described.

FINDING "g". THE ACCELERATION OF GRAVITY

Many ingenious experiments have been devised by schoolmasters and others to demonstrate the acceleration of gravity and to measure its value. With the scaler a direct determination can be made by measuring the time of fall of a ball bearing from small convenient heights.

The following ancilliary equipment is required and easily produced.

Impact switch; electro-magnet; ball bearings; and double-pole switch.

The impact switch. The design of this is only limited by the ingenuity of the constructor. The author has found that a common P.O. type of "press to test" switch can be easily adapted to make an excellent impact switch, which will either make or break when actuated.

The switch is first modified by removing the spring and filing two flats on the sides of the plunger. Thus modified the switch remains stable in either position. It is mounted with a hinged platform above it whose travel is just sufficient to operate the switch before being brought to rest by the side arms of the mounting. See Fig. 18.

Electro-magnet. A magnet taken from a 12 volt relay was used, but almost any type will serve with the appropriate voltage supply.

Ball bearings. A selection of these may be obtained from the local garage. Unless the impact switch is very robust, a small sized ball is desirable for longer falls.

Should any doubts be raised by the observers of the experiment over the equal times of fall of different balls, a subsidiary experiment may be conducted to clear the point. Even a ping pong ball, with a steel drawing pin in it for attachment to the magnet, will show the same rate of fall over small distances.

Double-pole switch. Any quick acting toggle switch will serve.

EXPERIMENTAL DETAILS

The scaler has its own internal counting pulse derived from the mains frequency. This gives an accuracy well within the limits of our experiment. If the scaler is set to "time" it can be stopped quite safely by shorting the a.c. socket to earth. This is the method of control used. The circuit is arranged as in Fig. 19.

A ball bearing is suspended from the magnet above the impact switch. The control switch is arranged to release the ball by breaking the current through the magnet and simultaneously starting the scaler by removing the short across the "A.C." and "E." sockets. The impact switch when hit by the ball again



GENERAL PURPOSE SCALER

By R.W.SAWYER, B.Sc.

shorts the "A.C." socket to earth and so stops the scaler. The time of fall can then be read to the nearest hundredth part of a second. The average of several timings is taken.

For convenience a series of drops are made from heights which are perfect squares, the distance being measured from the bottom of the ball to the platform.

The well known formula $h = \frac{1}{2}gt^2$, where h = height, g = acceleration of gravity and t = time may be rearranged as

$$\frac{\sqrt{h}}{t} = \sqrt{\left(\frac{g}{2}\right)}$$

If we plot \sqrt{h} (remember we made h a perfect square!) against " t " we shall obtain a straight line graph whose slope is equal to $\sqrt{(g/2)}$. This graph may not pass exactly through the origin due to "personal errors" in the switch—a point of interest in high speed timing. However, by making a straight line graph and finding its slope we can eliminate the "personal error" and average out other experimental errors and so obtain a good value for $\sqrt{(g/2)}$ and hence for " g ".

TABLE I. ACCELERATION OF GRAVITY: EXPERIMENTAL RESULTS (average values)

h (cm)	\sqrt{h}	time (sec.)
4	2	0.01
9	3	0.14
16	4	0.19
25	5	0.24
36	6	0.28
49	7	0.33
64	8	0.37
81	9	0.42
100	10	0.46

From graph

$$\frac{\sqrt{h}}{t} = \text{slope} = \frac{11.1}{0.5} = 22.2 = \sqrt{\left(\frac{g}{2}\right)}$$

$$\therefore \frac{g}{2} = (22.2)^2$$

$$\therefore g = 986 \text{ cm/sec}^2$$

CALIBRATION OF AN AUDIO OSCILLATOR

An audio oscillator can be directly calibrated with the scaler, as constructed, up to about 3,800c/s.

The audio oscillator, which must have some form of graduated control dial, is switched on and allowed a suitable warming up period. The output at the lower end of the scale is then fed into the a.c. sockets of the scaler and a count made over at least 100 seconds. Thus the cycles are directly counted and, by dividing by the time in seconds, their frequency in c/s is found. Counts are then made throughout the required range. The scale readings are plotted against the frequency to give a calibration curve for the oscillator. This graph may be used for subsequent frequency determinations or a new dial made for the audio oscillator calibrated in cycles per second.

Fig. 18 (top). The impact switch is mounted in a wooden box by means of a metal plate. The hinged platform is made from thin plastics sheet

Fig. 19 (centre). Circuit for the gravity experiment

Fig. 20 (bottom). Circuit for timing a camera shutter

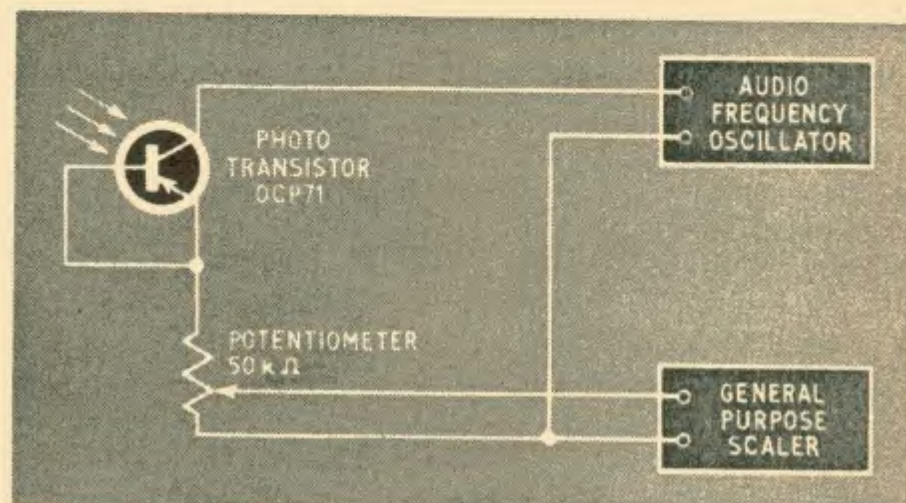
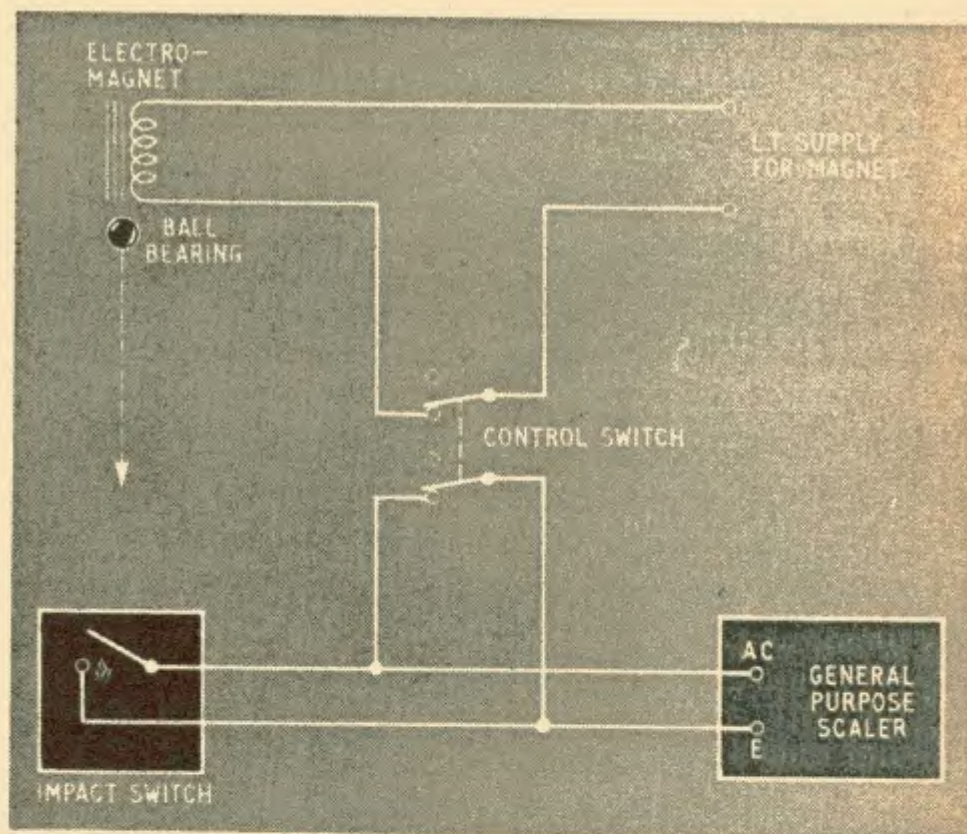
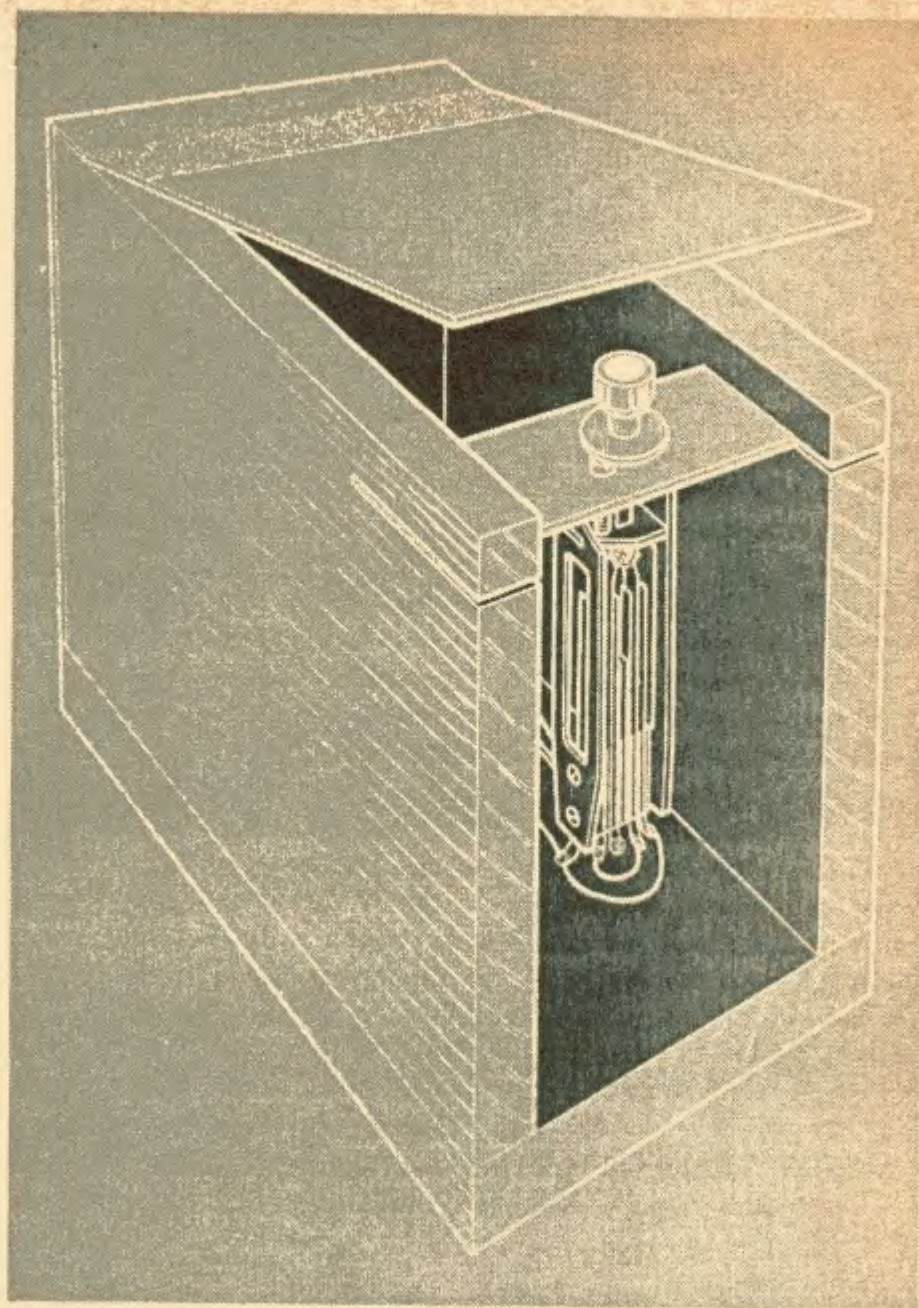

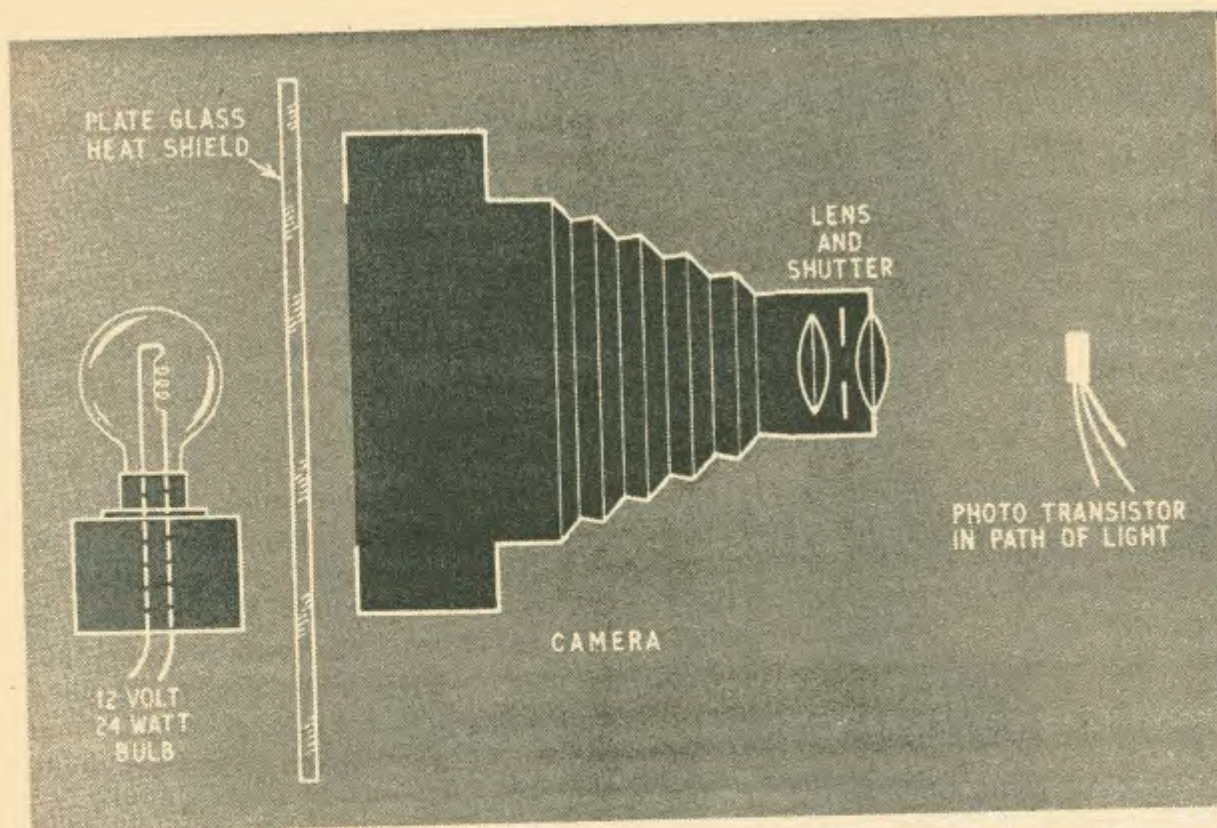

Fig. 21. Measurement of the true speeds of a multispeed camera can be carried out to a high degree of accuracy with the scaler, used in conjunction with a phototransistor and an a.f. oscillator. This picture shows the positioning of the lamp, camera shutter and transistor. See also Fig. 20

MEASUREMENT OF TUNING FORK

To measure the frequency of a tuning fork or other sounding source, to within about one per cent error, the loudspeaker of the scaler is switched on while an audio oscillator, which need not be calibrated, is connected to the input of the scaler. The note from the loudspeaker is compared with and adjusted to that of the source being measured. The scaler is then switched on to count and the cycles counted over, say, 100 seconds. Dividing this count by 100 gives the frequency of the source.

For a more accurate frequency determination of a tuning fork the principle of beat notes is employed. This is really the familiar heterodyne method used in radio receivers. If two audio notes, differing slightly in frequency, are sounded together, a slow beat will be heard whose frequency is that of the difference between the two notes.

The audio oscillator is adjusted to give a slow beat note with the sounding of the fork. This gives a more definite result than attempting to maintain zero beat. The frequency of the oscillator is then counted, using a stop watch, over at least 100 seconds. It is possible to count the beat note over 10 seconds. Its frequency is the difference between that of the fork and the oscillator.

To find out if the fork is oscillating at a frequency below or above that of the oscillator the fork is loaded with a small piece of *Plasticine* and again sounded.

TABLE 2. TUNING FORK CALIBRATION: EXPERIMENTAL RESULTS

Audio oscillator count over 100 secs. 31781, 31909, 31772. Average 31784
 \therefore Mean oscillator frequency = 317.84c/s

Beat note in 10 seconds (four observers) 22, 24, 20, 24. Average 22.5
 \therefore Mean beat note frequency = 2.25c/s

Beat note lowered by loading fork therefore beat frequency to be added
 \therefore Fork frequency $317.84 + 2.25 = 320.09\text{c/s}$ or 320 to nearest cycle

(fork used marked E.320)

The loading decreases the frequency of the fork, therefore an increase in beat note will indicate that the normal frequency of the fork is below that of the oscillator and vice versa. The original beat note is therefore added or subtracted from the oscillator frequency to obtain the exact frequency of the fork.

TIMING A CAMERA SHUTTER

The serious photographer using a multispeed shutter needs to know the true speeds at which his camera is working. These can be measured quite easily using the scaler with a phototransistor and an a.f. oscillator. A suitable light source and a potentiometer of about 50 kilohms are also needed.

Since the phototransistor becomes conductive when light falls upon it, a very simple circuit may be used. The principle is that the oscillations from the a.f. oscillator are fed to the scaler through the phototransistor, but when the circuit is suitably adjusted the oscillations only pass when the transistor is illuminated. The illumination comes through the camera shutter. So for the time the shutter is open oscillations pass and are counted by the scaler.

The number of oscillations counted gives a measure of the time. Figs. 20 and 21 show the arrangement of the apparatus. A piece of plate glass was interposed between the light and the camera to prevent heating the shutter.

TABLE 3. SHUTTER TIMING: EXPERIMENTAL RESULTS

Using a Compur shutter in a 1935 model Retina I camera.
 Frequency of a.f. oscillator 2,899c/s (counted by scaler)
 Results (averages of several counts)

Nominal shutter speed (secs)	Cycles counted	Time in milliseconds.	Nearest fraction of sec
1	2963	1015	1
1/2	1203	424	3/7
1/5	558	192	1/5
1/10	260	89	1/11
1/25	102	36	1/28
1/50	41	14	1/70
1/100	15	5	1/200
1/300	10.8	3.7	1/270

Fig. 22. Apparatus for determining the half-life of a radioactive substance. A 4oz size plastics squeeze bottle is recommended, and a piece of wash leather should be fitted under the cap as a final filter. A suitable quantity ($\frac{1}{2}$ to 1 oz) of thorium nitrate can be obtained from any chemical laboratory supplier

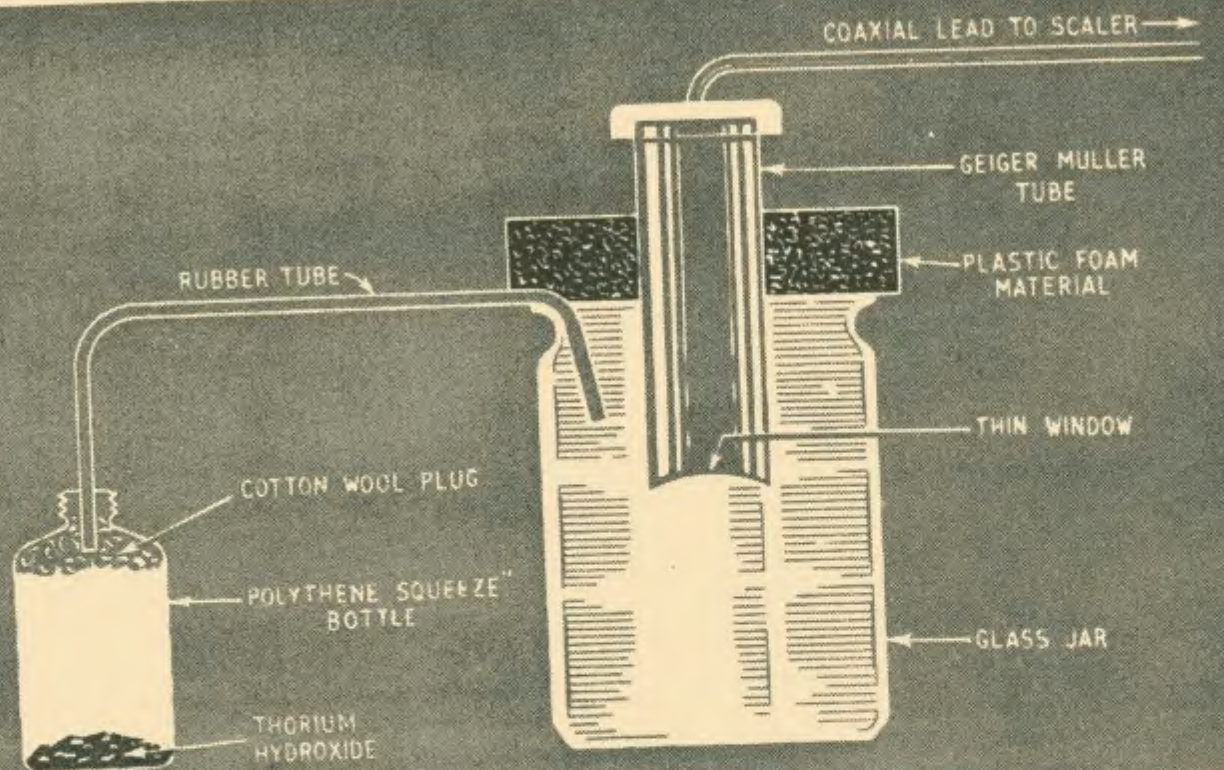

RADIOACTIVE DECAY CURVES

The direct determination of the half-life of a radioactive substance is an important and striking experiment. The dangers of radiation and the consequent necessity to use a very low power source limit the accuracy of the following experiment, but it does give a convincing demonstration of the principles.

Thorium compounds are freely obtainable and safe to handle since their radioactivity is low. Thorium has a half-life of 1.39×10^{10} years. As it decays a series of radioactive products are produced, each in turn decaying at its own particular rate. One of these products is a gas: radon 220 with a half-life of 54 seconds. However, it is being constantly produced

and will form a minute fraction of the air in the neighbourhood of a thorium compound. Since a cubic inch of air contains some 10^{21} atoms it can be seen that only one part in millions of millions still represents a large number. Each atom of radon as it decays releases an alpha particle and each of these can be counted if it enters a Geiger Muller tube.

EXPERIMENTAL DETAILS

Some thorium hydroxide is placed in a polythene "squeeze" bottle fitted with a cotton wool plug and rubber tube. If the bottle is squeezed some air containing radon 220 can be blown out and so separated from the thorium and other solid products.

Fig. 23. Plot of radioactivity/time for radon 220. This shows that the "half-life" is approximately 54 seconds

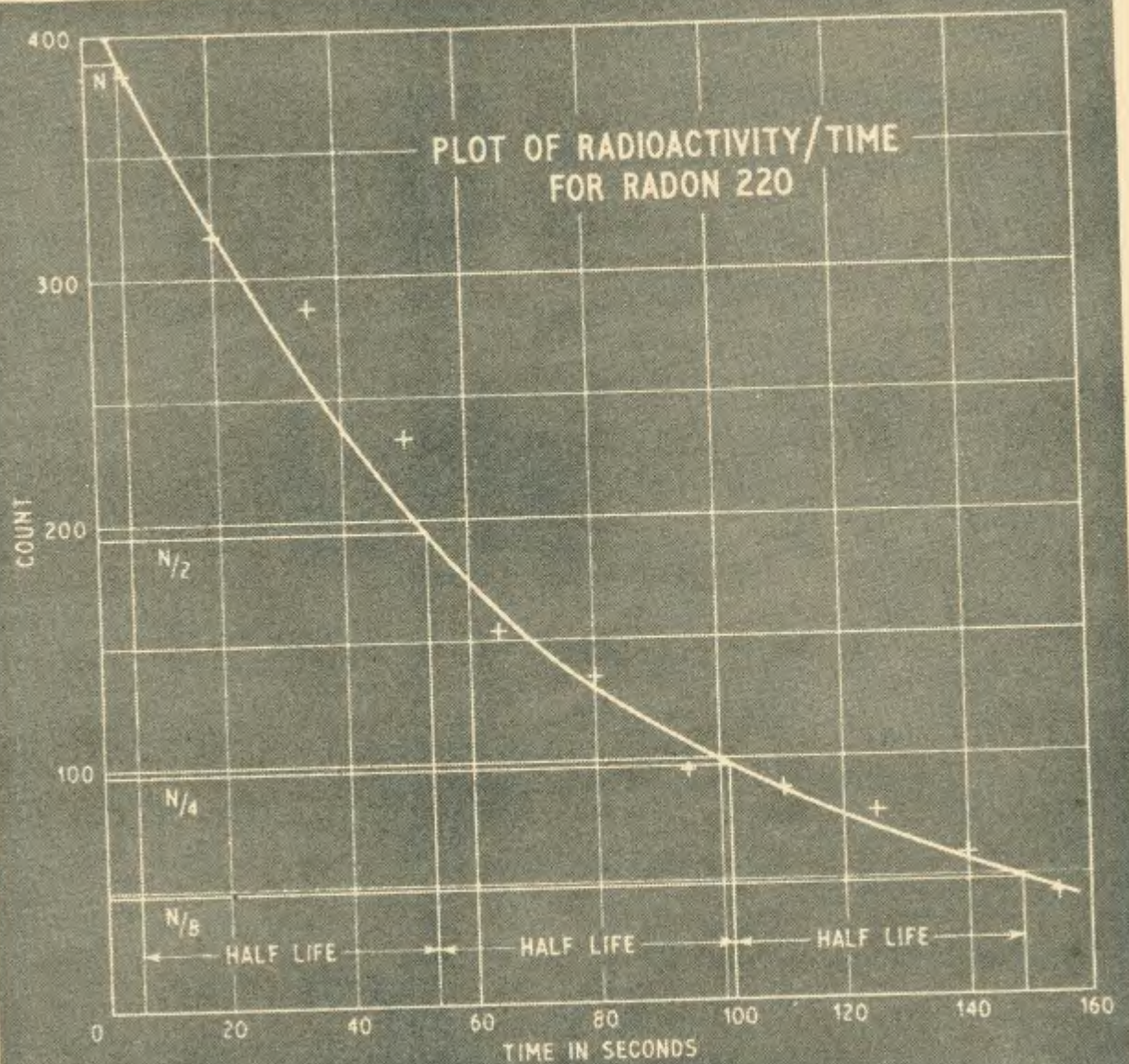

A Geiger Muller tube, having a thin window suitable for the detection of alpha particles, is connected to the scaler. The e.h.t. voltage should be set correctly as described in the previous article. Unless a lead castle is available for surrounding the tube, a count of the background radiation must be made. Background radiation is a measure of the constant random radiation falling upon the tube from cosmic rays and other sources; it must later be subtracted from the readings.

The Geiger Muller tube is then arranged with its window end in a small jar (Fig. 22). The sponge packing in which these tubes are supplied may be conveniently used as a cover for the jar through which the tube projects. The end of the rubber tube from the thorium squeeze bottle is placed in the jar and a few puffs of air containing radon are introduced. A radiation count is immediately made over 10 seconds; five seconds allowed for reading and resetting and another 10 second count made. This is continued for about three minutes.

Owing to the small quantity of radon 220 present the count will be small as shown in the figures below.

TABLE 4. RADIOACTIVITY DECAY: EXPERIMENTAL RESULTS

Background count 713 in 10 min, i.e. 12 in 10 sec (average)

Time in secs	mean time	count	count less background	\log_e count
0-5	5	398	386	5.9559
15-25	20	329	317	5.7589
30-40	35	301	289	5.6665
45-55	50	243	231	5.4424
60-70	65	166	154	5.0370
75-85	80	147	135	4.9053
90-100	95	109	97	4.5747
105-115	110	99	87	4.4659
120-130	125	88	76	4.3307
135-145	140	68	56	4.0254
150-160	155	54	42	3.7377

Radiation being of a random nature the statistical error is given as $\pm \sqrt{\text{count}}$. This is the limitation imposed by using a safe source. However, plotting the result will reduce the error by a factor of $\pm \sqrt{\text{number of counts}}$. We may therefore hope for a final result with an error of the order of ± 5 per cent.

The simplest presentation of the results is to plot radioactivity, as represented by the count over 10 seconds, against time. See Fig. 23. From this we see the activity falling to half its value in about 54 seconds, this is the half-life. It then falls to half that in another 54 seconds, and so the exponential decay continues.

A more sophisticated analysis of the results is by employing the decay formula.

$$N_t = N_0 e^{-at}$$

where

N_0 = number of radioactive atoms present at start when $t = 0$.

N_t = number of radioactive atoms present at time t .

a = decay constant, i.e. fraction of atoms present which decay in unit time.

taking logs (to the base e) throughout:

$$\log N_t = \log N_0 + (-at)$$

$$\log N_t = \text{constant} - at$$

which is of the form $y = c - ax$

i.e. a straight line whose slope is a .

Fig. 24 shows $\log_e N_t$ plotted against time t .

From this we find $a = 0.0143$ (slope of graph).

$$\text{Half-life} = \frac{\log_e 2}{a} = \frac{0.693}{0.0143} = 49 \text{ seconds.}$$

THE USE OF THORIUM COMPOUNDS

Mildly active substances such as thorium compounds are no more dangerous than the usual chemicals handled in schools science laboratories. "... the usual precautions relating to the use of toxic chemicals in educational establishments should therefore provide adequate protection for pupils or students using chemically prepared uranium or thorium compounds..."—extract from paragraph 16.4 *Administration memorandum 1/65. Department of Education and Science 8/1/1965.*



Fig. 24. This graph shows $\log_e N_t$ plotted against time for radon 220

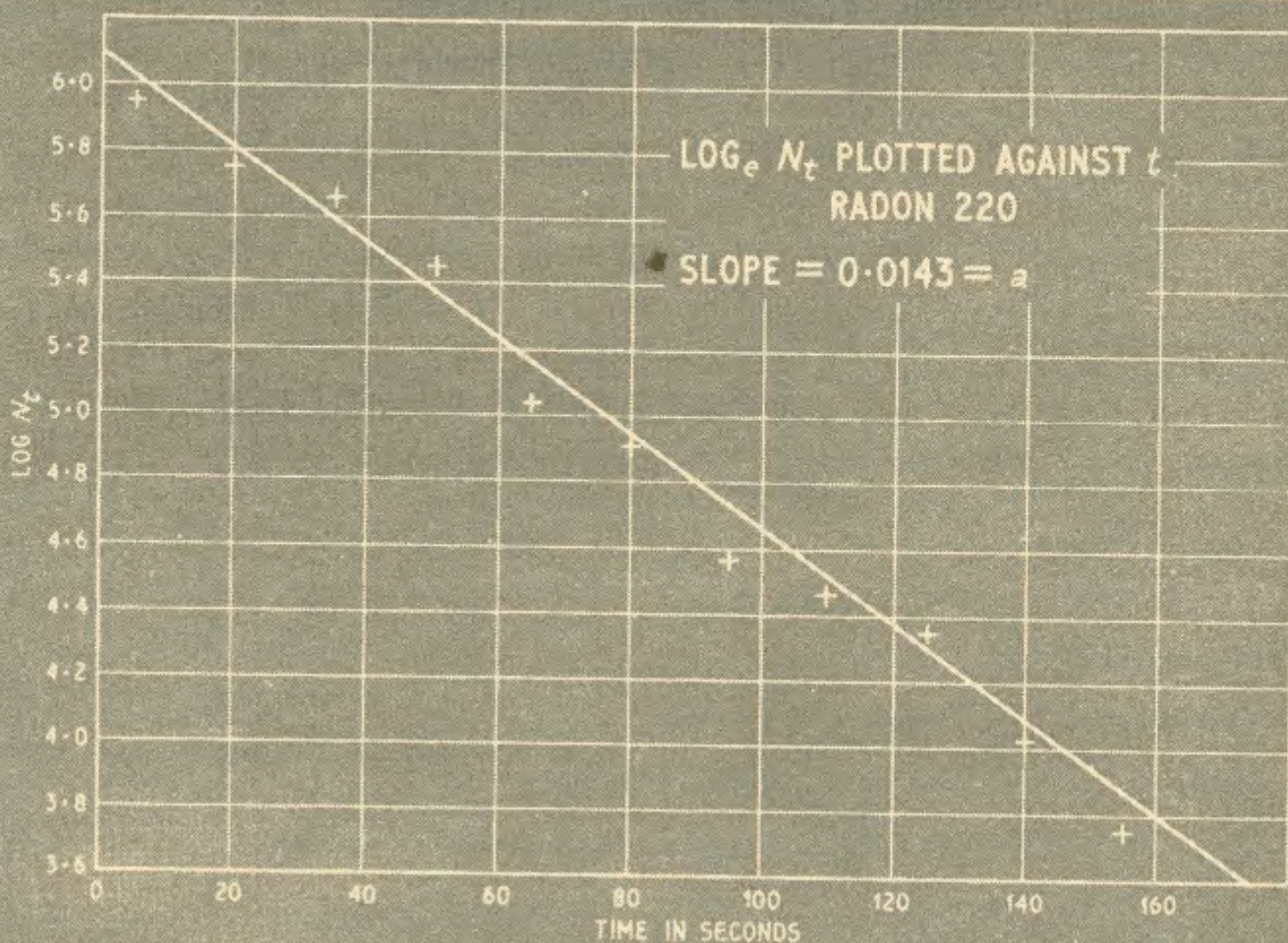

NEWS BRIEFS

Medical Electronics and Instrumentation Exhibition

THE MEDICAL profession is one of the foremost beneficiaries of modern electronic techniques. This was evident from the large selection of equipment on show at the Medical Electronics and Instrumentation Exhibition held in Brighton from 28 September to 1 October. The products displayed ranged from lightweight portable instruments for the general practitioner to comprehensive monitoring installations for hospitals. Some idea of the scope of electronics in medicine may be obtained from the following brief mentions of a few exhibits.

An electronic stethoscope shown by Cybernetics Laboratories Ltd. uses a moving coil pick-up, a resistance coupled amplifier and a dynamic ear receiver. The direct heartbeat is thus transmitted without extraneous noise, while adjustable high and low frequency filters permit concentration upon any particular range of sounds.

The Honeywell "Cardioview" is a compact portable transistorised instrument of special interest to the general practitioner. It provides four hours of continuous electrocardiograph traces (about 40-50 investigations) before battery recharging is necessary.

A portable electro-encephalograph made by Elther N.V. of Holland uses valve pre-amplifiers and transistor power amplifiers. It is claimed to have the same wide range of possibilities as desk models. Immediate accessibility of all components is a feature.

Several Intensive Care Monitoring Systems were on show—an indication that continuous monitoring of critical patients by electronic means is being introduced into many hospitals. In general, these systems allow important patient variables such as ECG, heart rate, temperature, respiration and blood pressure to be indicated and recorded at the bedside; or alternatively at a remote monitoring station where one nurse can watch the signals derived from perhaps eight or more patients. These signals are simultaneously displayed on c.r.t.'s or meters, or recorded on charts. If a signal should fluctuate beyond the limits preset by the physician, an alarm system is set in operation.

Monitoring systems based on a central station were shown by manufacturers from France, Italy, Japan and the U.K.

Rather more flexibility is offered by monitoring systems built up from modules. Both Philips Electrical and Sanborn (U.S.A.) showed small compact modules which can be used in various combinations to provide bedside monitoring facilities, or which may be incorporated in a remote monitoring system.

Laser Beam Television

AN experimental installation for transmitting television images and sound over a laser light beam has been devised by Soviet engineers. The source of light is a five-million watt gas laser.

The tests showed that the quality of image and sound is very good with the definition in the centre of the frame reaching 550 lines. Laser beams can carry information undistorted not only through clear air but also through a thin "smoke screen."

Improved Stability on 1500 Metres

IN 1945 the BBC inaugurated high precision frequency control of its 200 kc/s transmission of the Light Programme from Droitwich. The long-term frequency stability, which was then within one part in 10^7 , was considerably improved in January 1963 and since then has been maintained within 5 parts in 10^9 .

A further improvement has now been made in the frequency control of the Droitwich 200 kc/s transmission resulting in a long-term stability which is now within ± 5 parts in 10^{10} . Due to the use of automatic frequency correction the excursion from nominal does not usually exceed 1 part in 10^{10} .

"Electronic Offices" at Olympia

ELECTRONIC equipment flooded the Olympia scene in October, when the Business Efficiency Exhibition illustrated the rapidly increasing trend towards automation in office administration work.

Exhibits included desk top calculators, dictating machines, copiers, computers, intercom systems, electronic guillotines and so on. It would be a gigantic task to describe all that was seen but the following merit particular mention.

The Farrington Optical character reader, shown by Adrema Ltd., is a machine which reads batches of typewritten information and converts the data to media (for example, punched paper tape) acceptable by a computer. The machine is based on a system of electromechanical scanning of character shapes and distinguishing between black and white by using ultra violet rays. A sans serif alpha numeric type-face is used to standardise the recognition procedure.

The Shipton Automation Group claim a world first with their electronic "touch-dial" telephone, using 10 numbered keys, each internally connected to its own counting circuit.

Another "world first" is claimed by Systemation with an automatic self-programming computer designed for bookmaking accountancy offices. Known as "Dottie", this computer will deal with bet settling, taking into account the amount staked, odds, placings, singles, doubles, or trebles, etc.

Since our report last year (December 1964 issue) desk calculators have been very busy. A wide range of machines has now been developed by many companies, using digital display on digitron tubes and cathode ray tubes.

Farrington optical character reader



DETACHED PARTICLES

By John Valence

TOO MANY SHOWS?

I BELIEVE it true to say that London has a surfeit of exhibitions. In these public expositions, as in many other things, the metropolis seems to have a near monopoly. I am glad therefore to note that so far as our particular field of interest is concerned, this "drift to the south" has been partly checked by the Institution of Electronics.

Although I would not for a moment suggest this organisation is parochial or provincial in character, it is fair to say that the Institution's roots (and possibly its major strength of members, also) are located in Lancashire. When one considers Manchester's great contribution to scientific and technological knowledge, and thinks as well of the electronic firms of international repute established in and around the "Capital of The North", this strong regional concentration of interest in matters electronic is not surprising.

UP TO THE NORTH

IT was the occasion of the Twentieth Annual Exhibition and Convention of the Institution of Electronics that took me for a brief spell to Manchester a few weeks ago. After the cavernous spaciousness of Olympia and Earl's Court, the more modest sized Lancaster Hall at Belle Vue Gardens did seem at first a trifle restrictive. If movement around the stands was at times difficult due to the narrow aisles there was however a compensatory factor in the friendly and intimate atmosphere induced by this "close packing".

Here was as fine a concentration of electronic components and instruments as one could wish to see under the one roof. Many famous household names of the industry were in evidence. Although quite a number of the exhibits were not new to my eyes (as I have already suggested we are somewhat spoilt in the south) I did find much of fresh interest—particularly in the large varieties of electro-mechanical devices such as used either at the input or the output end of an electronic measuring or control system.

HARD ON THE EARS

A FULL programme of lectures and film shows was included during the exhibition period. I managed to attend two lectures—both given by members of leading component manufacturers. These were valuable and informative discourses by experts. Unfortunately, the theatre, located at the end of the exhibition hall, was not acoustically sealed. I must confess that it was a considerable strain trying to concentrate on the lecturer, since there was a continuous background noise to contend with.

Having seen all the aforementioned transducers on show, I was taken aback to discover that the lecture theatre was not equipped with that now commonplace sound transducer the "mic". An unforgivable omission in the case of an electronics convention, surely!

And just to think that the Association of Public Address Engineers held their symposium and exhibition in Manchester only the week before. Something wrong with local communications eh?

Having got this single grouse off my chest, I would say in conclusion that the I of E organisers are to be congratulated, on a lively show that well demonstrated the wide range of activities that are included in the term electronics. I should not be surprised if they have to move into a larger hall next year.



"There's always a good laugh on this channel"

TIME BASE

WHEN looking at some fascinating waveform on the oscilloscope, it is worthwhile pausing and contemplating on the link between that most versatile electronic "tool" and the tube used by J. J. Thomson for his investigations into the nature of cathode rays. As is generally well known, this famous scientist established the fact that cathode rays are comprised of a large number of separate, discrete particles. J. J. Thomson called them "corpuscles". A little later the name electron was given to these particles.

The highly sophisticated oscilloscope of today (and you can spend upwards of £1,000 on one if you care to) is descended from the embryo c.r.t. which revealed the existence of the electron. Yes, despite all the additional trimmings of the modern instrument, its heart is fundamentally the same as the tube used in those *m/e* experiments 60 odd years ago.

The oscilloscope has of course long ceased to be exclusively a tool for workers in, or closely associated with, electronics. More and more use is being made of visual presentation of data. When it comes to the display of high speed transient phenomena there is no rival to the electron beam. Thus we find the c.r.t. appearing in many widely different locations. For example, it may be found in some garages as part of a comprehensive car testing set-up. The ignition waveforms can be expanded to display every individual cylinder pattern.

The oscilloscope is extensively used in medical electronics for biological investigations. Sometimes large screens (17 or 19in) with perhaps eight traces are used for the simultaneous monitoring of different waveforms.

A quite recent innovation is the special tube fitted in some electronic calculators. This c.r.t. provides a direct numerical readout and has four "registers" which extend, one above the other, across the width of the tube. Incidentally, square roots are no problem at all with this calculator. The only problem is the price!

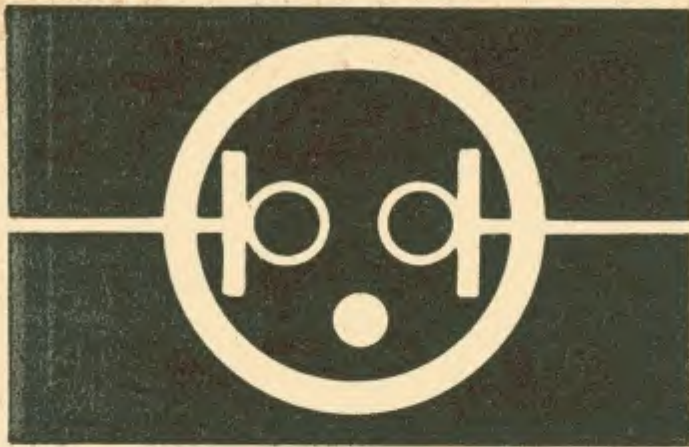

NEON NOVELTIES

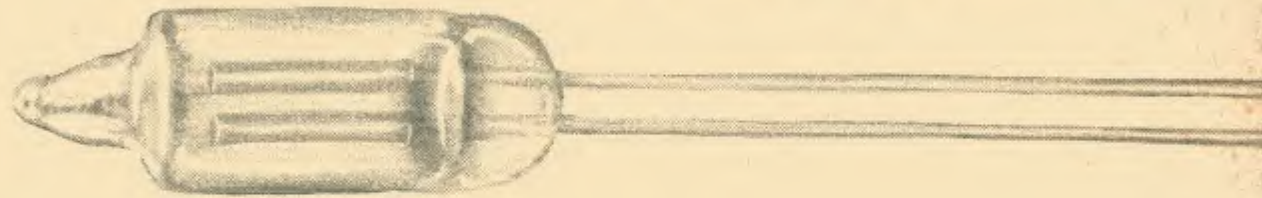

THIS is the fourth of a series of short articles illustrating some of the many uses of neon lamps. The neons employed are all miniature wire-ended types as shown above.

Two examples which are ideally suited to these applications are those supplied by Radiospares (striking voltage 65 volts), and the Hivac type 3L general purpose neons. The latter type requires a striking voltage of 80 volts and maintaining voltage of 60 volts.

Some neon indicators have a resistor wired in series with one of the neon wires to make them suitable for mains voltages. These would normally be unsuitable for the circuits described unless the resistor is removed or short-circuited.

FOUR MUSIC GENERATOR by R. Bebbington GRAD.I.E.R.E.

TAKE a 70 volt neon, add a resistance-capitance network and we have a relaxation oscillator that can form the basis of a simple but effective music generator. Fig. 1 shows a practical circuit for one oscillator of this type which may be repeated for at least the 12 notes of a musical scale if a polyphonic (chord-playing) instrument is envisaged. Additional neon circuits may be used to extend the range up or down respectively by employing a smaller or larger capacitor across the neon.

On pressing the key the capacitor C1 charges exponentially through the series resistors R1 and VR1 until the striking potential of the neon is reached. As this fires, the capacitor discharges through it until the potential has fallen to the extinguishing voltage of the neon, whereupon the capacitor again starts to charge. This cycle of events keeps repeating as long as the key is depressed and at a frequency which is dependent upon the values of R1, VR1, C1, and the battery voltage.

If a simple monophonic or melody organ is all that is required then one oscillator circuit will suffice. The variable 1 megohm resistor (VR1) is replaced by either a series chain of selected fixed resistors, one for each note of the scale, or a similar series of variable resistors. Whilst the latter arrangement is the more expensive, it does greatly facilitate the task of tuning.

Capacitor C2 and resistor R2 serve not only to couple the oscillator to the input of an amplifier, but

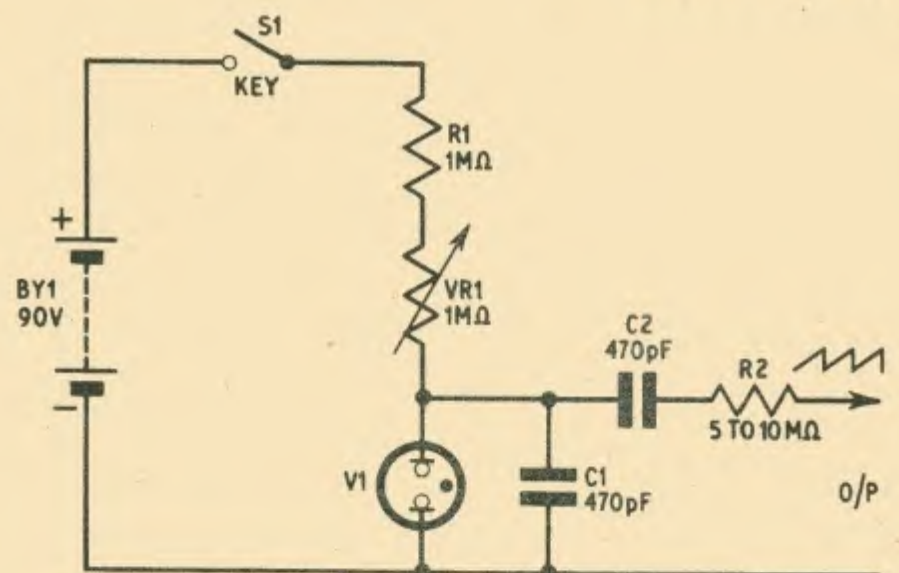

Fig. 1. Circuit of a relaxation oscillator

also to isolate individual oscillators in the case of the polyphonic version, to prevent unwanted back coupling. There is more than enough output for most amplifiers and the value of R2 may be selected to cope with the problems of balance and input matching. The "gram" sockets of an a.c. domestic radio set will provide adequate volume for these music generators, and the saw-tooth waveforms produced are musically satisfying.

PRACTICAL WIRELESS

**FREE! 24-page pocket guide to
AERIAL DATA**

WITH
DECEMBER ISSUE—ON SALE NOW

PRACTICAL TELEVISION

- ★ Circular TV Aerial for BBC-2.
- ★ Single-Gun Colour TV Tubes.
- ★ The Nev-Icon CCTV Camera.
- ★ The Short Circuit.

December issue on sale November 18th

Soldering Gun Kit

Weller Electric Corporation, Blatchford Close, Horsham, Sussex.

A very good and useful soldering gun, the Model 8100D rated at 120 watts, 240 volts a.c., is now being produced by the new English branch of Weller Electric Corporation.

Ideal for the electrician and general handyman, this gun can also be used for cutting and welding thermoplastic materials, leather and wood burning, besides numerous soldering jobs both large and small, by fitting one of three different soldering tips supplied.

For transistor work it is essential to use a heat shunt to dissipate some of the heat away from the transistor.

The heating time of the gun is claimed to be 3 to 4 seconds. During testing we found the pre-focused spotlight a great advantage when tackling awkwardly positioned joints. The soldering gun is fitted with a moulded Continental plug, which can be cut off and replaced with a standard British 13amp plug.

The kit consisting of the Model 8100D gun, resin cored solder, two spare soldering bits, brush, spanner and soldering aid is packed in a handy plastic carrying case and costs £3 12s 6d complete. The price of the basic gun is £2 17s 6d. A 275 watt version is also available at £4 9s 0d

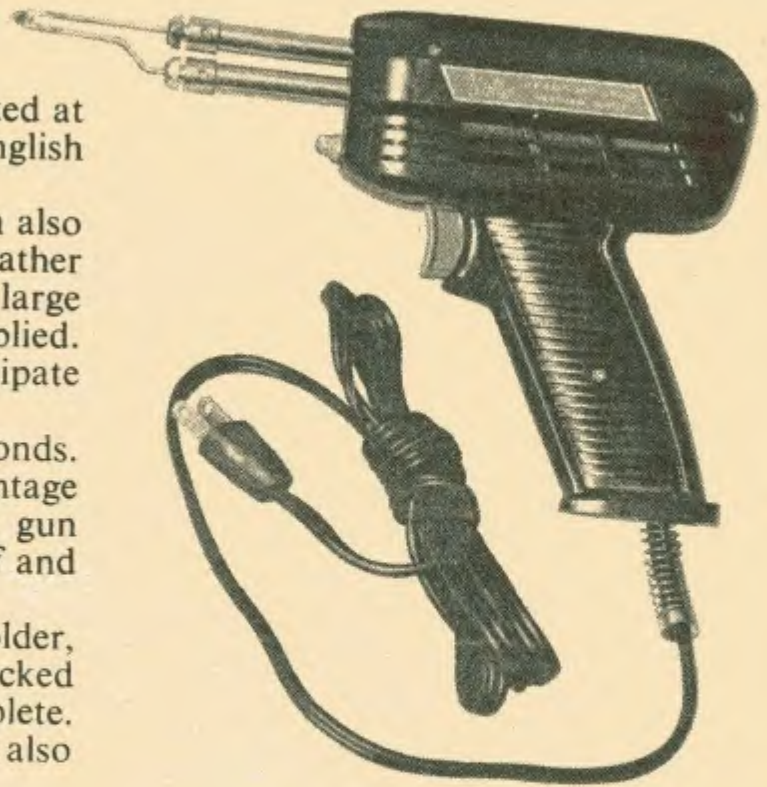

NEW PRODUCTS

Miniature Wire Strippers

Light Soldering Developments Ltd., 28 Sydenham Road, Croydon, Surrey.

Two miniature thermal wire strippers have just been added to the "Adamin" range of soldering equipment. Both strippers use a simple tweezer action for stripping covering up to about $\frac{3}{32}$ in diameter without damaging the conductors.

The 2B24 model shown in our photograph is for use on p.t.f.e. coverings only. It is powered from any 24 volt a.c. or d.c. source at 2 amps; the power consumption is approximately 50 watts.

The other stripper, model 2B6, is basically similar in design, but is for stripping p.v.c., polythene, nylon, and similar low melting-point insulating materials. The 2B6 model is available for either 12 or 24 volts a.c. or d.c. operation at 1 amp or 0.5 amp. The power consumption is approximately 14 watts, which provides just sufficient heat to melt the covering.

An isolating transformer is available for both strippers, enabling them to be used from any mains power point. These transformers have three heat output tappings and provide some degree of control over the temperature output.

The 2B24 model is available at £3 15s and the 2B6 at £3 10s.

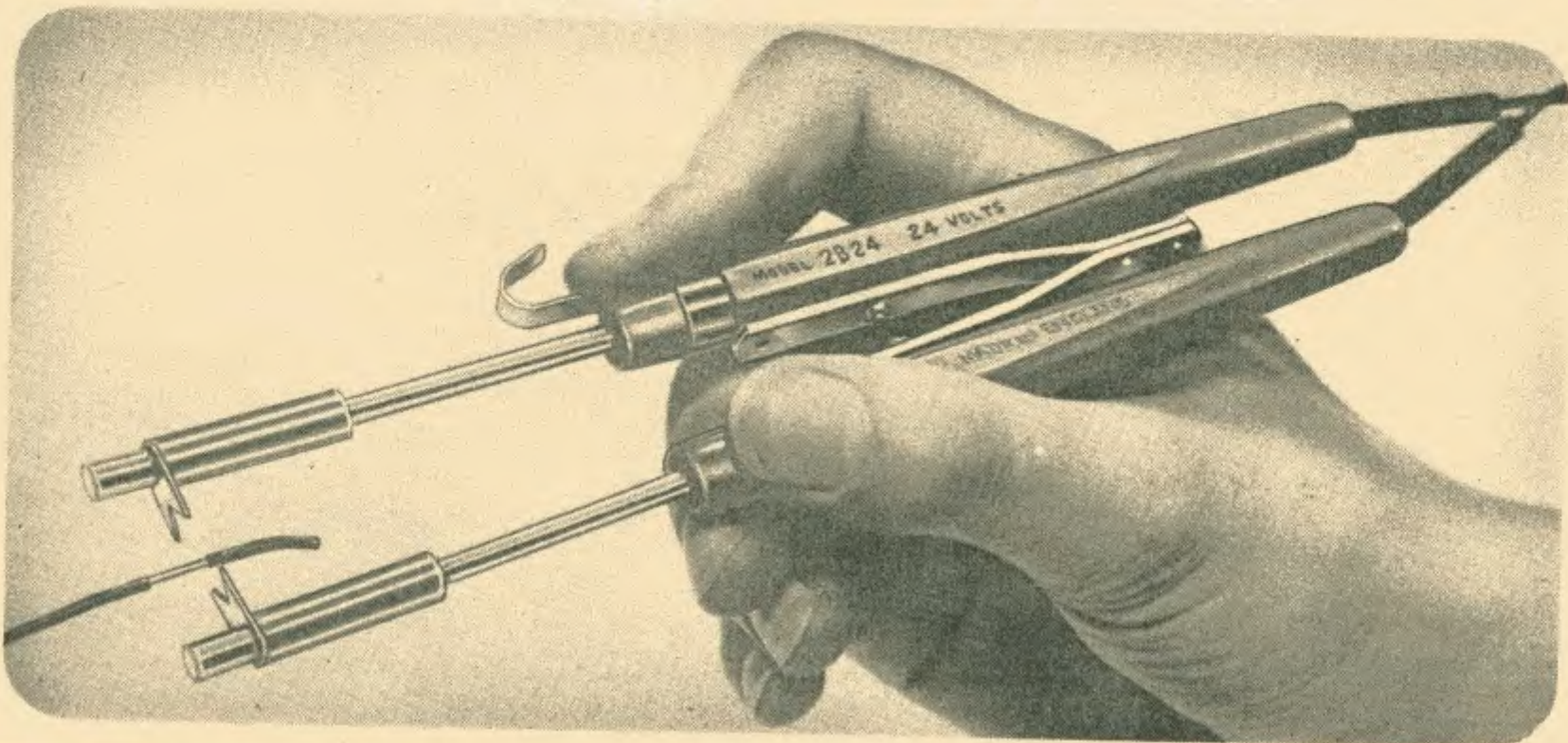

Readout—

A SELECTION FROM OUR POSTBAG

By definition

Sir—I was interested in R. McCarson's comment in the September issue. Most of us have some vague idea as to the root of the words -phonic and -aural. Those of us who take the trouble to consult a dictionary find that -aural is from the Latin "audio"—to hear, and -phonic is from the Greek "phone"—sound.

Therefore it would appear that Mr. McCarson is correct. The sound would be monophonic, but we would hear it binaurally. But I ask myself, is this distinction really necessary? The answer is: not in this case.

Language is a means to an end, not an end in itself. If everyone understands what we mean when we say "monaural" instead of "monophonic", what is the point of arguing that "monophonic" is the only word which should be used?

J. Bean,
Billingham,
Co. Durham.

Relaxation oscillator?

Sir—Here is one solution to Mr. Howells' "Valveless Oscillator Puzzle" (see *Readout*, October issue). The old battery eliminator possibly featured un-formed smoothing electrolytics and a "soft" rectifier valve—so the capacitors had a capacitance/leakage-resistance time-constant of around a millisecond and the valve constituted a gas tube. Together, these produced a relaxation oscillator powered by the raw a.c. from the mains transformer.

If the headphones were connected between the anode and cathode of the "oscillator" triode via a coupling capacitor, then the signal would still be heard through the h.t. line with this valve removed. With it in place, turning the filament rheostat changed the h.t. drain and so altered the frequency.

J. B. Cole,
Clacton-on-Sea,
Essex.

Help!

Sir—I would be grateful if any reader could sell or loan me the circuit diagram and/or any other information about the radio receiver unit type R5019 or BC-624-A.

P. Zolnienwicz,
Swindon,
Wilts.

Ergonomics

Sir—After reading the editorial of your magazine *PRACTICAL ELECTRONICS* dated September 1965, it struck me as being rather peculiar that *you* have been guilty of an error in mechanical design, unless I am mistaken. Isn't the Oscilloscope, featured in an earlier issue, designed for left-handed people only? For a right-handed person who wishes to adjust the top controls his arm will be in front of the tube, hence making adjustment difficult.

Dale Harvey,
Solihull,
Warwickshire.

Despite your apprehension the oscilloscope was designed with right-handed people in mind. The controls are normally adjusted by means of the left hand, the right hand then being free for noting the measurements and details of the waveform under examination. This being in accordance with general oscilloscope practice.

It may also be noted that controls which are infrequently used are at the top of the panel and those requiring most frequent adjustment are at the bottom.



Back numbers

Sir—I am a beginner to the field of electronics and recently began buying *PRACTICAL ELECTRONICS*. As a beginner I find that the series "Beginners Start Here", "Semiconductors", and "Building Blocks" are very useful but unfortunately I do not have all the copies from the beginning. I wonder if any of your readers would sell the copies from number one to number five inclusive. I will pay the full charges and of course, postal rates.

If such readers would send the required information (their address etc.) on a postcard or "aerogram" I would be very grateful.

G. Cleary,
46 Maona Avenue,
Onehunga,
Auckland, S.E.5,
New Zealand.

We regret that the first five, November 1964 to March 1965, issues are now out of print.

Transmitting contests

Sir—I have read with interest the article by Jack Hum (G5UM) "The 73 Page", and noted his comments about radio transmitting contests.

I would like to endorse all he has said about the enjoyment one can get from these events and the need to keep the equipment 100 per cent efficient.

Speaking as one who enters the Receiving Section of the various v.h.f. and u.h.f. events, organised by the R.S.G.B., namely, those on 4 metres, 2 metres and 70 centimetres, I can from experience agree with what he has said. Many stations from all parts of the country take part and one gets the chance to test out all the experiments one has made, under active conditions.

I would like to thank, through the medium of your magazine, the radio amateurs who go out portable to rare counties, sometimes under bad weather conditions, and give other contestants the chance both to secure points and confirmation of reception from seldom-heard places.

Those who think that contests clutter up the bands for the weekend should sit down during a contest, and log each different station they hear and see if they can remember a time when the band has been so active and full of interest.

R. A. Ham, BRS 15744,
Storrington,
Sussex.