

# Practical Electronics

JANUARY 1965

PRICE 2/6

**FREE INSIDE!**  
**2 BLUEPRINTS TO BUILD**

**PLUS**  
MORE  
PAGES  
FOR YOUR  
ELECTRONIC  
DATA  
BOOKLET

- HIGH IMPEDANCE VOLTMETER
- DARKROOM TIMER
- ELECTRONIC GUITAR

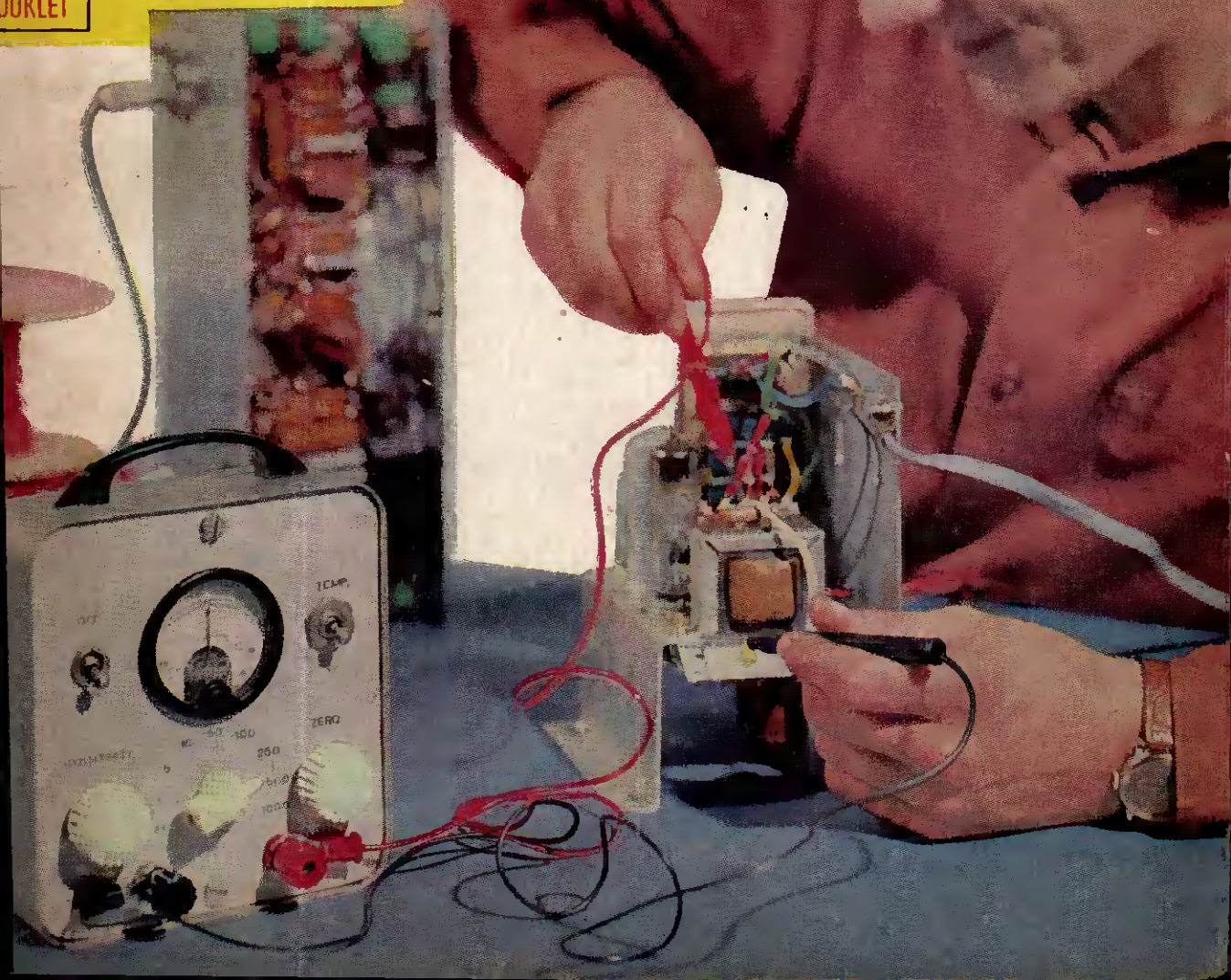



**GROUP-MASTER 30 WATT  
GUITAR AMPLIFIER**

**Goldenaire**

"THIRTY" HI-FI AMPLIFIER

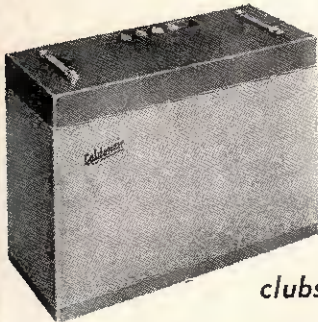

**A VERSATILE  
UNIT FOR  
INSTRUMENTALISTS  
AND  
VOCAL GROUPS**

*being suitable for  
clubs and public address*

Ideal for bass, lead or rhythm guitar, and all other musical instruments.

- ★ The two 12-inch 25-watt heavy duty loudspeakers are specially designed for this type of amplifier, and give outstanding reproduction.
- ★ Robust attractive two-tone finished cabinet of compact size, 28" x 20" x 10½" fitted with carrying handles.
- ★ For standard A.C. mains 50c/s operation.
- ★ Four inputs provided can be used simultaneously with instrument pickups or mikes.
- ★ Separate Bass and Treble controls are incorporated.



or deposit of £4.12.0 and twelve monthly payments of £3.12.5. Carriage and insurance 25/- to be sent with deposit.

A high quality 30-watt amplifier developed for use in large halls and clubs, etc. Ideal for bass, lead or rhythm guitars, schools, dance halls, theatres and public address. Suitable for any type of mike or pickup. Valve line-up: two EF86; one ECC83; one GZ34; two EL34.

Four separate inputs are provided with two volume controls. Bass and Treble controls are incorporated. Amplifier operates on standard 50c/s mains. 3 ohm and 15 ohm speakers may be used. Full 12 month guarantee. Factory built and tested. Perforated cover with carrying handles can be provided if required, price 21/- or deposit of £1.16.0 and twelve monthly payments of £1.9.2. Carriage 15/- to be sent with deposit.



**THE Goldenaire 5 WATT AMPLIFIER**

**IDEAL FOR HOME USE.** Suitable for guitars, record decks and microphones. Cabinet size approx. 13 x 18 x 7 in. The cabinet is well made and attractively finished. Volume bass and treble controls incorporated. Price 9 gns. post paid. Send S.A.E. for leaflet.



**THE Goldenaire GRAMETTE**

A compact 3-4 watt gram. amplifier that can be used with all types of record players. Fitted with volume and tone controls. Incorporating mains isolating transformer, thus making the unit completely safe. A triode pentode valve and modern silicon rectifier are utilised. Price 3 gns. P. & P. 5/-. Ready built and tested £3.19.6. P. & P. 5/-.



**THE Goldenaire THREE**

A uniquely designed 2 valve 3 watt gram. amplifier, fully enclosed in a compact well ventilated metal case, size 7 x 5½ x 2½ in. Three controls provided. Volume, Treble and Bass. A completely safe unit incorporating mains isolating transformer. Price 4 gns. P. & P. 5/-.

**TRANS. RADIO TUBULAR SPEAKER**



Booster Speaker. Plugs into earpiece socket of most radios and tape recorders. Gives double the volume and a hi fi stereo effect that will amaze you, size approx. P. & P. 1.9.

9 x 2½ in. Price 25/-.

**GOLDENAIRE  
50 WATT MODEL  
NOW AVAILABLE  
PRICE 49 GUINEAS  
OR TERMS. SEND  
FOR DETAILS**

**TRANS/RECEIVER No. 46**

Compactly carried by one man. This has a range of approx. 10 miles, and being crystal controlled tuning is avoided, and operation is as accurate as a telephone. Frequency 3.6-9.1 Mc/s. Complete stations comprising receiver transmitter rod aerial, one set of headphones and mike in canvas carrying bag. The crystal coil units can be supplied for 35/- per set, post free. Brand new in maker's sealed cartons.



Price per station £4.10.0. P. & P. 10/- each. Two stations for £9.10.0. Post Free.



**TYPE 19 SHORT  
WAVE RECEIVING SET**

Works straight off the mains. An excellent short wave receiver, requires only phones for immediate operation. Price £5.19.6. P. & P. 10/-. Suitable phones 15/- per pair. P. & P. 2/6. During an evening's testing of this excellent receiver, we obtained clear reception from scores of stations, many of them thousands of miles distant, including ship stations, government transmissions, maritime broadcasts, etc. and also the short wave Radio Luxembourg broadcasts.

**H.R.O. INSTRUCTION HANDBOOK**  
3/6 each. P. & P. 6d.

**No. 19 SET INSTRUCTION HANDBOOK**  
3/6 each. P. & P. 6d.

**1155 INSTRUCTION HANDBOOK**  
3/6 each. P. & P. 6d.

**MICRO ALLOY TRANSISTORS**

Mat 100 . . . 7/9	Mat 120 . . . 7/9
Mat 101 . . . 8/6	Mat 121 . . . 8/6
VHF Transistor ADT140 . . . . .	15/-

Above MATs postage paid  
Ferrite Slab Aerials suitable for transistor sets 3/-, P. & P. 6d.

**NEW WALK-ROUND ELECTRONIC EQUIPMENT STORE AT NO. 4 LAMBERTS ARCADE, LOWER BRIGGATE, LEEDS 1 (NEXT TO HALFORDS CYCLE SHOP). OPEN ALL DAY WEEKDAYS AND ALL DAY SATURDAY.**

C.O.D. 5/- EXTRA  
NO C.O.D. UNDER 30/-  
48hr. DESPATCH SERVICE  
POSTAGE RATES APPLY IN  
U.K. ONLY



**FOREIGN & TRADE ORDERS  
WELCOMED. S.A.E. WITH  
ALL ENQUIRIES  
PLEASE  
PHONE LEEDS 34703**

ALL MAIL ORDERS TO:-

**SONA ELECTRONIC CO. (DEPT. P.E. 3) BRIGGATE HSE., 13 ALBION PLACE, LEEDS 1**

# SURBITON PARK RADIO LTD.

ALL ORDERS DESPATCHED SAME DAY

WE PAY POSTAGE AND INSURANCE

SATISFACTION OR MONEY REFUND GUARANTEE ● DEPENDABLE SERVICE

## LEADING STOCKISTS OF MARTIN RECORDAKITS AND AUDIOKITS

### MARTIN RECORDAKITS

	Dep.	&	Mchly. pmts. of
<b>HALF TRACK</b>			
<b>TAPE AMPLIFIER FOR STUDIO DECK</b> , with ready wired printed circuit, control and input panels, mains and output transformers, knobs, plans, screws etc.; EF86, EC83, E280, EN85 and 2 EL84, 3 watts output. Magic eye, Radio & Mic. inputs, ext. speaker socket, tone and monitor controls. Can be used as an amplifier £11.11.0			
3224S, 3 motors, 7in. spools	47/-	8	25/6
CASE for above with 8 x 5in. speaker, two tone grey	44/-	8	24/6
<b>COMPLETE KIT</b> with tape and microphone	120/-	12	44/-
<b>QUARTER TRACK</b>			
<b>TAPE AMPLIFIER FOR STUDIO DECK</b> , as above. £12.12.0			
Collaro Studio Deck, fitted Marriot "X" Series heads	52/-	8	27/6
CASE as above, two tone grey	56/-	12	20/6
<b>COMPLETE KIT</b> with tape and microphone	136/-	12	49/10
<b>TAPE PRE-AMPLIFIERS</b>			
HALF TRACK for STUDIO deck, 400mV out. £8.8.0	34/-	6	25/8
QUARTER TRACK, as above SELF POWERED	39/-	6	28/4
<b>TAPE HEADS</b> , Bradmatic Half-Track Record/Replay and Erase on plate £1.19.6			

### MARTIN AUDIOKITS

The new Martin All Transistor Ten Watt Amplifier kits represent excellent value for money. Each unit is complete, requiring only to be connected to the next. We show only the popular units here. Others available including stereo. The following would make up a **TRANSISTORISED AMPLIFIER 15 ohms MODEL UNIT 1-FIVE INPUT SELECTOR**, Size 3½ x 3in. Mag. PU, Crystal PU, Radio, Mic. Tape Head £2.7.6

**UNIT 4-PRE-AMPLIFIER AND CONTROL**, Size 6½ x 2½in. Volume on/off, bass and treble control. £3.2.6

**UNIT 7-MAIN AMPLIFIER**, 10 watts 6 transistor, transformerless Push Pull output. Mounted on heat sink. L.S. imp. 15 ohms £6.12.6

**UNIT 8-POWER SUPPLY**, Gives 18 & 40 volts. Heavy duty transformer, rectifier and smoothing £2.15.0

**CONTROL PANEL** for Units 1 and 4 10.6

**ALL ABOVE FOUR UNITS WITH PANEL**, 15ohms £15.8.0

**TRANSISTORISED AMPLIFIER 3 ohms MODEL UNIT 5 MAIN AMPLIFIER**, as Unit 7 but 3 ohms £5.12.6

**UNIT 6 POWER SUPPLY**, as Unit 8 but 18-24 Volts £2.12.6

**ALL FOUR UNITS WITH PANEL 3 ohms** £14.5.0

**SEND FOR LEAFLET OF COMPLETE RANGE**

	Dep.	&	Mchly. pmts. of
62/-	12	22/6	
57/-	12	20/10	

## ARMSTRONG AMPLIFIERS AND TUNERS



	Dep.	&	Mchly. pmts. of
<b>MODEL 222</b>			
STEREO AMP, 222, 10 + 10 w.	£27.10.0	110/-	12 40/4
TUNERS SELF-POWERED			
224 F.M.	£22.10.0	90/-	12 32/2
223 AM/FM	£28.15.0	115/-	12 42/2
<b>MODEL 223</b>			
TUNER/AMPLIFIER, MONO			
127/M AM/FM with 5 watt amp	£26.10.0	106/-	12 38/10
227/M AM/FM with 10 w. amp	£36.15.0	147/-	12 53/10
<b>TUNER/AMPLIFIERS, STEREO</b>			
127/S AM/FM with 5 + 5 w. amp	£37.10.0	150/-	12 55/-
227/S AM/FM with 10 + 10 w. amp	£52.15.0	211/-	12 77/4
226/S as 227/S with Mag. P.U.	£61.0.0	260/-	12 88/-
Shelf mounting Teak Case for any of above	£3.10.0		

### MONO AMPLIFIERS

Linear L 45/A, 3 valve, 3 watt.	£6.6.0		
Dulci GAS, integrated, 5 watts ECL86	£13.2.6	52/6	12 19/3
Tripletone Hi Fi Major, 10 watts 2 EL84	£15.18.9	64/9	12 23/3
Leak TL12, 10 watts Main Amplifier only	£20.0.0	80/-	12 29/4
Leak Variolope Mono, Pre-amplifier	£15.15.0	63/-	12 23/1
Dulci DPA15, 15 watt with 2 valve pre-amplifier	£26.5.0	105/-	12 38/6

### STEREO AMPLIFIERS

Leak Stereo 20, Pre-amplifier and Main amplifier complete	£55.9.0	229/-	12 80/8
Rogers Cadex MK2 with Pre-amplifier 4 ECL86 valves	£26.15.0	107/-	12 39/2
Leak Transistor Stereo 30, Pre-amplifier and main amplifier	£49.10.0	198/-	12 72/7

### F.M. TUNERS

Tripletone, F.M. Tuner Less power	£13.19.6	56/-	12 20/6
Tripletone, F.M. Tuner With power	£15.14.6	63/-	12 23/1
Jason 3TV/2, F.M. and T.V. sound, Switched, self powered	£21.5.0	89/-	12 32/7

## SURBITON PARK RADIO LTD.

48A SURBITON ROAD, KINGSTON-UPON-THAMES SURREY

Phone: KIN 5549

ORDERS FOR CASH, C O D OR TERMS

HOURS 9 a.m. to 6 p.m. (1 p.m. Wednesday)

Easily reached by frequent trains Waterloo to Surbiton

## GRAMOPHONE UNITS

B.S.R. UA25, Very latest model with cart.	£6.6.0		
Garrard SRP10 Single player, Mono cartridge	£5.10.0		
Garrard Autoslim, 4 Speed changer Mono	£7.17.0	33/-	6 24/-
Garrard AT/5/P Improved Autoslim, Stereo	£9.0.0	36/-	6 27/4
Garrard A.T.6 Autoslim de Luxe, mono	£11.9.0	47/-	8 23/3
Garrard AT/5/3000LM as AT.6, but with slim arm, stereo	£11.12.0	46/6	8 25/9
Garrard 4H/F, Transcription unit Mono	£17.0.0	68/-	12 24/11
Garrard "Deccadek" Single Player with Decca "Deram" cartridge	£15.15.0	63/-	12 23/1
Garrard LAB. "A", Transcription changer Mono	£19.14.9	79/-	12 28/11
Garrard 301 Strobe, Transcription unit	£22.0.0	88/-	12 33/3
Philips AG1016, Stereo cartridge, will change 7in. records with adaptor 10/- extra	£12.12.0	50/6	12 18/6
Goldring GL58, with arm but less cartridge	£17.1.0	69/-	12 24/11
Goldring GL70, with arm but less cartridge	£27.9.4	111/4	12 40/1
Goldring "88", Transcription less arm	£18.18.5	76/5	12 27/6

LEAFLETS ON REQUEST

## Hi Fi LOUDSPEAKERS

Goodmans Axiote, 8 in.	£5.5.7		
Goodmans Axiom, 10 in.	£6.5.11		
Goodmans 5K/20/XL, Tweeter and Crossover	£7.7.0		
Goodmans 201, 12in. unit Full range 15 watt	£10.17.6	43/6	8 24/3
Goodmans 301, 12in. unit Full range 20 watt	£19.4.6	61/-	12 22/4
Goodmans X05000, £20.11. X0950	£5.10.11		
W.B. HF812, 8in., 3.75, 7.5 and 15 ohms	£3.16.6		
W.B. HF1012, 12in., 3.75, 7.5 and 15 ohms	£4.12.0		
Wharfedale Super 3, Tweeter	£5.16.8		
Wharfedale Super 5, Tweeter	£5.19.7		
Wharfedale Super 8 RS/DD, Full range 10 unit	£6.14.2		
Wharfedale Super 10 RS/DD, Full range 10 unit	£10.18.0	44/-	8 24/3
Wharfedale Super 12 RS/DD	£17.10.0	70/-	12 25/8
Wharfedale RS/12/DD, 12in. unit Full range	£11.10.0	46/-	8 25/6

LEAFLETS AVAILABLE ON REQUEST

## GUITAR SPEAKERS

Fane, 12in. Heavy duty unit 20 watt	£5.5.0		
Goodmans Audiom 51, 12in. 15 watt Bass	£9.2.8	36/8	6 27/8
Goodmans Audiom 61, 12in. 20 watt Bass or Lead	£14.7.8	57/8	12 21/1
Goodmans Audiom 81, 15in.	£25.0.0	100/-	12 36/8
Goodmans Audiom 91, 18in. 50 watt Bass	£27.10.0	110/-	12 40/4
Wharfedale W 12/EG, 12in. 15 watt Lead	£10.10.0	42/-	8 23/6
Wharfedale W 15/EG, 15in. 15 watt Bass	£17.10.0	70/-	12 25/8

WRITE FOR GOODMANS ELECTRIC GUITAR LEAFLET

## GUITAR AMPLIFIERS

Linear Diatonic 12 watt 2 inputs	£13.2.6	52/6	12 19/3
Linear Conchord 30 watt 2 inputs with Cover	£19.4.6	77/-	12 28/2
Leak TL 25 25 watts amp and pre-amp	£42.5.0	169/-	12 61/11
Leak TL 50 50 watts amp and pre-amp	£51.5.0	205/-	12 75/2

## MICROPHONES AND FLOOR STANDS

Reslo BBH/T, Ribbon High Impedance	£11.2.6	44/6	8 24/9
Reslo RBH/TS, Ribbon with on/off switch	£13.10.0	54/-	12 19/9
Reslo Heavy Duty Floor Stand	£7.0.0		
Teisco DM304, Dual Impedance with switch	£4.10.0		
Piezo BM3, Crystal with switch, desk stand	£2.10.0		
Jap. Floor Stand	£3.3.0		



# SINCLAIR X

## The only amplifier of its kind in the world

### USES PULSE-WIDTH MODULATION AND UNIQUE OUTPUT STAGE IN A CIRCUIT OF GREAT ORIGINALITY

10 WATT OUTPUT

### FANTASTIC STANDARDS OF PERFORMANCE

NO HEAT SINK

1mV INPUT SENSITIVITY

**X-10 NEWS FLASHES**

This high fidelity integrated power amplifier and pre-amp uses 11 transistors and has a transformerless output of up to 10 watts for feeding into a 15 ohm loudspeaker system. It requires only the addition of tone and volume controls and a 12 volt D.C. power supply to make it a complete mono high fidelity assembly of exceptional quality. Stereo is achieved by using two X-10 amplifiers and ganged or separate controls. Input sensitivity is sufficient for all crystal ceramic or magnetic pick-ups. The manual supplied with the X-10 gives detailed instructions for connecting the controls and for using the amplifier in a wide variety of applications.

This radically new transistor amplifier (patents applied for) is the first to be marketed anywhere in the world using the pulse width modulation principle (P.W.M.), a technique which permits an enormous reduction in the power dissipation in the output transistors. In the case of the Sinclair X-10, the output efficiency is about 95% as compared with about 60% for conventional class B output stages. Thus the dissipation is only 1/4th or less of that occurring in all other amplifiers.

That is why no heat sink is required for the output stage, why small high frequency transistors can be used in place of the conventional low frequency power transistors and why the X-10 will operate from two 4/- batteries with normal use for about three months. A mains operated power supply unit design specially for the X-10 is available which can be used to operate one or two amplifiers as required.

As well as the countless private constructors sending for the X-10, it has also been ordered by well over fifty large industrial organisations, by national utilities, by universities and by museums in Britain alone. Next month we look forward to letting you know what constructors tell us about this amplifier.

Philatelists might well envy our mail, for constructors are sending to us from all parts of the world for the X-10 and we are thinking of buying a larger stamp album.

Already 3 nationally famous audio equipment manufacturers in this country have expressed interest in the X-10 and it is most likely that the X-10 will radically influence all future amplifier design.

Others who have ordered the X-10 include public address specialists, professional guitarists, musicians, government departments, factories and laboratories—and, if we may say it, we hope you, too.



BLOCK DIAGRAM shows in simplified form the stages of function of this remarkable amplifier. Such design with its very much better standards of performance is made possible by use of the very latest in transistors and high quality components.

### Easiest of all to assemble

Not least among the many important features of the X-10 is the elegant component layout. This together with the X-10 Manual and assembly instructions make building exceptionally easy. When assembled the amplifier, which measures only 6" x 3" x 3/4", can be placed in any convenient position with leads brought out to controls, input, output and power supply.

### GUARANTEE

If you are not completely satisfied with your purchase immediately on arrival (we are confident you will be delighted) your full purchase price will be refunded instantly without question if you return the goods as received. FULL SERVICE FACILITIES ALWAYS AVAILABLE TO ALL SINCLAIR CUSTOMERS.

All parts including 11 transistors and X-10 Manual come to

**£5.19.6**

Ready built and tested, with X-10 Manual

**£6.19.6**

X-10 Power Supply Unit (ready built) for A.C. Mains 200-240V. Will power up to two X-10's

**£2.14.0**

The most revolutionary design yet from SINCLAIR

# X-10 COMBINED 10 WATT HI-FI AMPLIFIER AND PRE-AMP

entire world!

ELEVEN TRANSISTORS

100% BRITISH DESIGN

FOR 12 VOLT OPERATION

TRANSFORMER-LESS 15-OHM OUTPUT

CHOOSE YOUR TONE CONTROL SYSTEM

WILL RUN FROM TWO 4/- BATTERIES

BUILT-IN PRE-AMPLIFIER

SIZE 6" x 3"

## P.W.M. THE ANSWER

With P.W.M. the audio signal modulates a high frequency square wave "carrier" by varying the mark-space ratio. These variations are converted to energy in the output stage. Being independent of the transfer characteristics of the output transistors, the output is an exact replica of the input signal. The improvement in the quality of reproduction from the loudspeaker is instantly apparent. Transient response is greatly improved, there is no falling off in the higher audio frequencies, no intermodulation distortion and the response curve is so flat that you could draw it with a ruler! A new type of output stage and P.W.M. plus many other refinements result in an amplifier which is compact, rugged, stable, requires no heat sink—and costs so little. The X-10 may be used with low-pot pick ups such as Decca Deram, Ortofon, etc., as well as with microphones, tape play-back heads, etc. Used in pairs the X-10 brings new depths to stereo listening.

- ★ Number of transistors—11
- ★ Overall size—6" x 3" x 3/4"
- ★ Input sensitivity—1mV into 1K.ohms
- ★ Total harmonic distortion—less than 0.1%
- ★ Frequency response—5-20,000 c/s — ±0.5dB
- ★ Speaker impedance—15 ohms
- ★ Damping factor—greater than 100
- ★ Quiescent consumption—75mA
- ★ Supply voltage—12Volts D.C.

### SINCLAIR X-10 MANUAL

Explains how the amplifier functions, how to add volume and tone controls to suit your precise requirements, and how to use the X-10 for stereo. A variety of systems are shown, none of which will add more than a few shillings to the original cost of your X-10. The Manual which is included with every X-10 is available separately for 1/-.

**ORDER FORM AND MORE SINCLAIR DESIGNS ON PAGES FOLLOWING**



# The smallest, most exciting

## NOW IS THE TIME TO BUILD IT

With the days so short, the performance from this amazing 6-stage radio is proving sensational. Stations simply pour in from the Continent with outstanding quality and again and again the Micro-6 is reported to be giving excellent results where other sets cannot be used at all. As the illustration shows, the set is smaller than a matchbox, yet everything including batteries and ferrite rod aerial is contained in the tiny white, black and gold case. The Micro-6 has vernier-type tuning and is switched on by inserting the micro-plug of the earpiece into the socket at the side. This remarkable British receiver cannot be too highly recommended both as an intriguing design to build and a most practical radio to use. It's a set you will be delighted to build and use. IT PLAYS ANYWHERE.

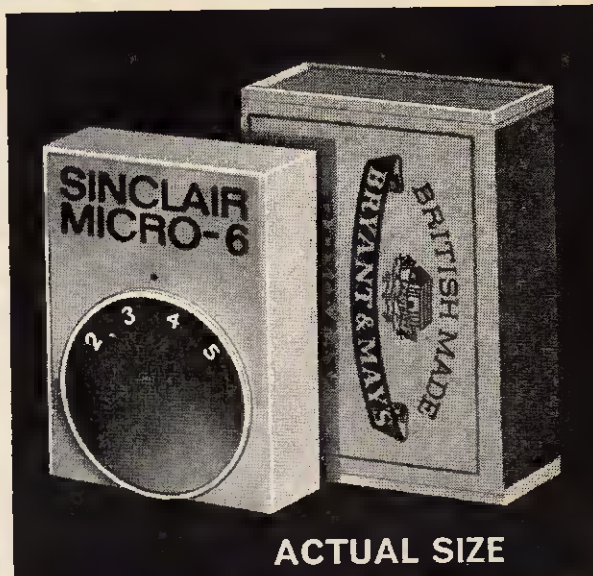

ACTUAL SIZE

## SINCLAIR MICRO-6

### BRITISH-DESIGNED 6-STAGE RECEIVER

- Size— $1\frac{1}{5}'' \times 1\frac{3}{16}'' \times \frac{1}{2}''$
- Weight—Under 1 oz.
- Tunes over medium wave band
- Bandsread for easy reception of Luxembourg

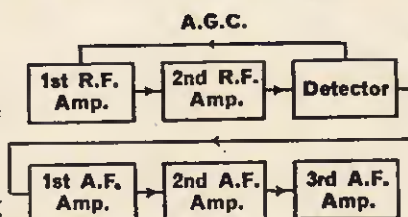

The Micro-6 uses three special Micro-Alloy transistors in a new and original circuit. Two stages of R.F. amplification are followed by an efficient double diode detector which drives a high-gain 3-stage A.F. amplifier. Powerful A.G.C. applied to the first R.F. stage ensures fade-free reception from the most distant stations tuned in.

## SINCLAIR TR750 AMPLIFIER

Designed specially for Micro-6 and Slimline users

This amplifier makes a powerful car, portable or domestic radio used with the Micro-6 or Slimline receivers and a plug is included for connecting to these sets. With its own built-in volume control and on-off switch, the TR750 has a full 750 milliwatt transformerless output for 10mV into 10K ohms and a frequency response from 30 to 20,000 c/s  $\pm$  1dB. It will also make an efficient hi-fi record reproducer used singly or paired for stereo and there are many other uses for the TR750 which is available for building or ready built.

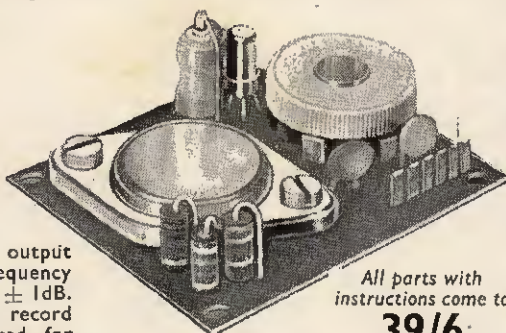

All parts with instructions come to

**39/6**

Ready built and tested **45/-**

## Trace that fault with a SINCLAIR MICRO-INJECTOR

This ingeniously designed device generates and injects a test signal into any part of audio or radio equipment at any frequency from 1kc/s to 30 Mc/s by means of which it becomes easy to locate faults rapidly and accurately. Measures  $1\frac{1}{2} \times 1\frac{1}{2} \times 1\frac{1}{2}$  in, excluding probe. With full instructions. No constructor should be without a Micro-Injector—it's a wonderful aid at all times.

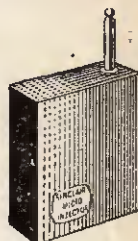

Parts and instructions come to

**27/6**

Ready built **32/6**



SINCLAIR RADIONICS LTD., COMBERTON, CAMBRIDGE  
Telephone: COMBERTON 682

# radio set in the world

OVER 10,000 BUILT  
AND IN USE  
THROUGHOUT THE WORLD

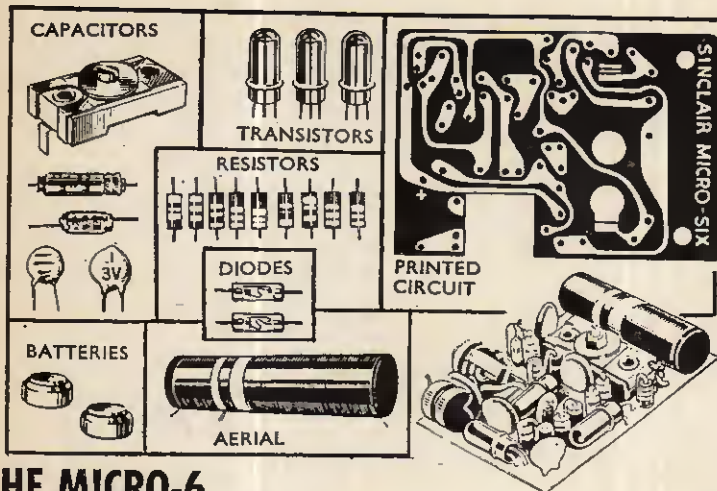

## THE MICRO-6 INCLUDES THE SMALLEST COMPONENTS EVER

We show here some of the components (apart from case dial and earpiece) required for building the Micro-6, drawn to actual size. They include the smallest components ever to be made available to domestic set constructors. Being of the kind used in space and computer electronics, they have to be reliable. The tuning system has ingenious vernier control for easy station separation. The batteries (obtainable anywhere) are each smaller than an aspirin tablet and give upwards of 70 hours working life. The 8-page fully illustrated instruction manual shows very clearly how to assemble the Micro-6 step by step, making it easy for anyone to build.

All parts required to build the Micro-6 including lightweight earpiece, case and instructions come to

### 59/6

"Transista" nylon strap for wearing the Micro-6 like a wrist watch 7/6  
MALLORY MERCURY CELL TYPE ZM312 (2 required) each 1/11  
Pack of 6 10/6

#### What they say about the Micro-6

A.F.N., Munich; Holland; France; Germany and many more stations came in without any trouble at all (on Micro-6). At 7.30 a.m. I tuned in Caroline. Kendal is not an ideal reception area.

(Signed) J.A.M., Kendal.

May I congratulate you on a truly splendid design. Keep up the good work.

(4780) (Signed) B.T., Bath.

I am highly satisfied with results. Receives most stations on medium wave band with remarkable volume in a bad signal area.

(5495) (Signed) M.A., Sheffield 6.

## SINCLAIR MICRO-AMPLIFIER



Makes an F.M. Transmitter

Makes an Audio or Broad Band R.F. Amplifier

Smaller than a 3d. piece! Frequency response 30 to 50,000c/s  $\pm$  1dB. Power gain 60dB (1,000,000 times). Instructions show you how to make a broadband R.F. amplifier, F.M. transmitter or a sub-miniature hi-fi amplifier with an output suitable for any earpiece or even loudspeaker. A fascinating design for experimenters, modellers, etc.

Parts and instructions come to **28/6**

## SINCLAIR X-10 10 WATT AMPLIFIER

See preceding pages

## This is what the unique Sinclair Guarantee means

Every purchase you make from Sinclair Radionics Ltd. is covered by the following guarantee:

If you are not completely satisfied with your purchase (we are confident you will be delighted) your purchase price will be refunded in full instantly and without question. **FULL SERVICE FACILITIES ARE ALWAYS AVAILABLE TO SINCLAIR CUSTOMERS.**

## SINCLAIR SLIMLINE

The extra-easy-to-build  
4-stage pocket receiver



- Wide range
- Smart appearance
- Easily built in 2, or 3 hours
- Excellent tone and volume

#### IDEAL FOR NEWCOMERS TO TRANSISTOR SET BUILDING

Here's a fine performing set which is ideal for newcomers to transistor building. It has self-contained aerial and takes standard PPS batteries. Measures only 2 1/2" x 1 1/8" x 1 1/4". Tunes over medium waveband by means of vernier type control. The Slimline has great power and quality and will bring in B.B.C. and European programmes. All parts including royal blue and gold case, earpiece and easy to follow instructions come to

### 49/6

If you do not wish to cut coupon from page, please mention Practical Electronics, January, when writing.

To SINCLAIR RADIONICS LTD., COMBERTON, CAMBRIDGE

Please send items detailed below:— £ s. d.

NAME.....

ADDRESS.....

TOTAL £

For which I enclose CASH/CHEQUE/MONEY ORDER

Pre. 12



# EVERYTHING YOU NEED...

The DTV Group hold the largest stocks of the widest range of rectifiers, valves, test equipment, transformers, components and accessories of all kinds. Send **LARGE** s.a.e. for free lists. Terms of Business: C.W.O. or C.O.D.

**direct TV** from **Replacements LTD**

Dept. P.E., 126 Hamilton Road, West Norwood, London, S.E.27  
Telephone: GIPsy Hill 6166 (PBX)

## TRANSDUCERS

As specified for use in the Ultrasonic Control System featured in this issue.

Gulton Transducers can be used for simple remote control without cables or electronic links, two units only being required. The Transducers are suitable for both transmitting and receiving. Ideally suited for the experimenter and designer for remote control systems

**55/-** or two of all kinds. Free TX/RX circuit with each order.

each Components for use with the Transducers:  
 GHF9 Transformer ... .. 4/- each  
 Set of 7 transistors ... .. at 3/- each  
 Low current reed relay and coil ... 25/6 each  
 2 Plugs ... .. at 1/6 each



## MICRO-MOTORS

This new Sleyride Motor is precision made and prototype tested by RAE Farnborough. Only 1 in. dia., 2 in. long and weighs only 1.3 oz. Rated 1/1,000 h.p., normal running speed 5,000 r.p.m. Spindle dia. 3/32 in., length 1 1/2 in. For 1 1/2, 6 or 12 v. Reversible.

**25/-** each  
plus 1/6 p. & p.

## TRANSISTOR TESTER

The Unique **D.909**



Tests Alpha Gain (A.C. Gain) and Beta Gain (D.C. Gain) with transistors in place. Facilities also provided for testing leakage between Collector and Emitter and Collector and Collector. Base. Exclusive Variable Voltage Smoothed D.C. Power Supply, continuously variable from 0/25 v. up to 25mA. Output voltage can be used as centre-tapped voltage supply enabling modern transistorised receivers **£10** each to be tested.

Send large S.A.E. for detailed leaflet



## EAGLE PRODUCTS AT NEW PRICES

### EAGLE STOCKISTS

The following are available:—  
 TP703 Transistor Tape Recorder  
 TI206 Transistor Intercom  
 TA790 Telephone Amplifier  
 730 Zephyr 7 Transistor Radio  
 SA80 8 watt Stereo Amplifier  
 100C Microphone  
 DM175 Microphone  
 MC70 Microphone  
 DM17HL Microphone  
 DM16HL Microphone  
 D52 Microphone Desk Stand]

F53	Microphone Floor Stand	£3.24	BM36R	Label Microphone, Magnetic	9.3
GT50	Radio Jack	£1.70	MCI	Microphone Crystal Cartridge	4.9
TD79	Tape Head Demagnetizer	£1.12.0	TF26G	2 1/2" Speaker	9.3
MM4	Microphone Mixer	£2.13.6	CM16	Guitar Pick-up	13.6
PS35	3.5 mm Plug and Socket	2.8	GM35	Guitar Microphone	£3.4.6
PS25	2.5 mm Plug and Socket	2.8	EP50K	50,000 O.P.V. Multimeter	£10.16.0
PS1	Standard Jack Plug	2.8	EP30K	30,000 O.P.V. Multimeter	£7.11.0
SP31	Standard Shielded Jack Plug	3.9	EP20K	20,000 O.P.V. Multimeter	£5.7.6
OC34	Standard Socket	2.3	EP10K	10,000 O.P.V. Multimeter	£4.6.0
SS3271	Sub-min. Slide Switch DPDT	2.23	TK20A	1,000 O.P.V. Multimeter	£2.13.6
SS219	Miniature Slide Switch DPDT	2.3	L20	Leather Case for EP30K	£1.1.0
MR4	Earphone, low res.	3.1	MR2P	50 microamp Panel Meter	£2.3.0
MR50	Earphone, with ear hanger	4.4	MR2P	500 microamp Panel Meter	£1.12.0
CR5	Earphone, crystal	4.4	MR2P	1 m/a Panel Meter	£1.12.0
TS01	Vernier Dial	13.8	MR2P	5 m/a Panel Meter	£1.12.0
TS02	Vernier Dial	15.0	MR2P	300 volt Panel Meter	£1.12.0
TS03	Vernier Dial	17.3	SR2P	"S" Panel Meter	£1.18.0
TC801	Turnover Cartridge	11.0	MR3P	1 m/a Panel Meter	£2.13.6
K4116	Volume Control	3.3	ITV1	Signal Injector	£1.18.0
PVC105	Variable Condenser	3.3	RF40	Field Indicator	£3.15.6
LT44/700	Transistor Transformers	(pair) 8.9	ARI3	Test Lead Kit	10.3
TP100	Telephone Pick-up Coil	10.3			
SF20	High Resistance Headphone	13.0			

Trade Enquiries Invited.

TRANSISTORS			
AC113	5/6	OA79	3/-
AC115	4/-	OA81	2/-
AC158	4/-	OA85	3/-
AC156	5/6	OA86	4/-
AC154	5/6	OA90	3/-
AC137	7/-	OA91	3/-
AD140	25/-	OA95	3/6
AF102	27/6	OC16W	35/-
AF114	11/-	OC19	25/-
AF110	10/6	OC26	25/-
AF116	8/-	OC35	12/-
AF117	9/6	OC36	21/6
AF118	20/-	OC41	8/-
AF124	11/-	OC42	8/-
AF125	10/6	OC43	12/6
AF128	10/-	OC44	5/-
AF127	9/6	OC45	5/-
BY100	7/6	OC70	6/6
BY114	8/-	OC71	4/3
GE113	8/6	OC72	5/6
GE114	9/6	OC73	3/-
GE116	9/6	OC74	3/-
OA70	3/-	OC75	18/-
OA73	3/-	OC76	18/-

### SETS OF TRANSISTORS

Set No. 1: comprising OC44, 2 x OC45, OC81, matched pair OC81 20V.  
 Set No. 2: comprising OC81, matched pair OC81 12V.

### RECORD PLAYER AND TAPE DECK UNITS

BSR Monarch UA14	£6.6.0
BSR Monarch UA15	£6.19.6
The new BSR Monarch UA16SS fitted with CI cassette stereo cartridge	£10.18.11
TD2 Tape Deck, half track	£8.18.0
TD10 Tape Deck half track	£10.5.0
BSR Monarch TU12	£3.10.0
BSR Monarch GU7	£3.17.6
Garrard Autostim	£7.15.0
Garrard AT6	£11.5.0
Garrard SRP10	£6.0.11

All the above are also available with stereo cartridges at slight extra cost.

### SINCLAIR KITS

Sinclair Micro 6	£2.19.6
TR750 Power Amplifier	39.8
Sinclair Micro Injector	27.6
Sinclair Micro Amplifier	28.8
Sinclair X10 Kit	£5.19.6
Sinclair X10 Ready Built	£6.19.6
Mains Unit for above	£2.14.8

### MAINS TRANSFORMERS

Primary	200/230/250V	2A	2 1/2A	3A	4A	5A	6A	8A	10A
250-0-250V	80mA 0-4-6.3v	4A	0-4-5v	2A	21/9				
300-0-300V	60mA 0-6.3v	4A	0-6.3v	1A	22/6				
350-0-350V	60mA 0-4-6.3	4A	0-4-5v	2A	21/9				
250-0-250V	100mA 0-6.3v	4A	0-5v	2A	27/6				
350-0-350V	100mA 0-6.3v	4A	0-5v	2A	27/6				
350-0-350V	200mA 0-6.3v	4A	0-5v	3A	55/-				

### CATALOGUE

Our latest 1964/65 CATALOGUE is now available. Copies have been sent to many of our regular customers. If you have not received your copy please drop us a line. Please send 1/- in stamps.

**TERMS:** Cash with Order or C.O.D. Postage and Packing Charges extra. Single valves 9d. Minimum Parcel Post charges 2/-. Please include sufficient postage with your order. Minimum C.O.D. fees and postage 3/6. These Postal Rates apply to U.K. only. For full terms of business see inside cover of catalogue. Personal shoppers 9 a.m. to 5 p.m. Mon. to Friday, Saturday 10 a.m. to 1 p.m.

**ALPHA RADIO SUPPLY CO., 103 Leeds Terrace, Wintoun Street, LEEDS 7**



# THE WHARFEDALE Super Range

Each loudspeaker in this range is fitted with roll surround for low resonance and double diaphragm assembly for extended HF response.

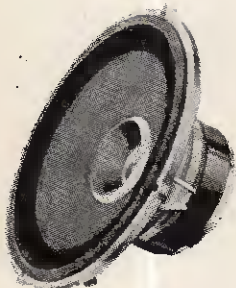

## SUPER 8/RS/DD

Impedance 10/15 ohms.  
Ceramic Magnet.  
Flux density 14,500 oersteds.  
Total flux 60,000 maxwells.  
Aluminium Voice Coil.  
Max. input 6 watts rms  
or 12 watts peak.  
Frequency range 40-20,000 c/s.  
Bass resonance 50/60 c/s.  
Price: 134/2 inc. P.T.

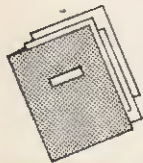

Write for informative and fully illustrated 12 page booklet

## SUPER 10/RS/DD

Impedance 10/15 ohms.  
Flux density 16,000 oersteds.  
Max. input 10 watts rms  
or 20 watts peak.  
Frequency range 30-20,000 c/s.  
Aluminium Voice Coil.  
Bass resonance 38/43 c/s.  
Price: 218/8 inc. P.T.

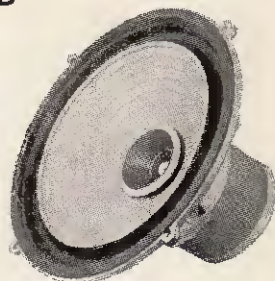

## SUPER 12/RS/DD

Impedance 12/15 ohms.  
Flux density 17,000 oersteds.  
Total flux 190,000 maxwells.  
Aluminium Voice Coil.  
Max. input 20 watts rms  
or 40 watts peak.  
Frequency range 25-20,000 c/s.  
Bass resonance 26/32 c/s.  
Price: 350/- (no tax).

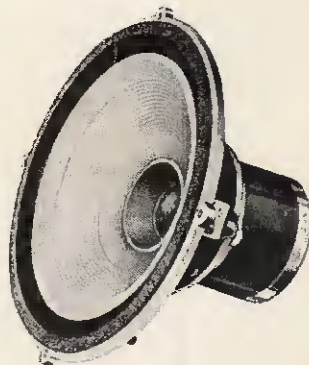

# Wharfedale

**WHARFEDALE WIRELESS WORKS LTD  
IDLE BRADFORD YORKSHIRE**

Telephone: Idle 1235/6

Telegrams: 'Wharfdel', Bradford.

# RST

*Cordially invite*

## Practical Electronics

*readers*

*To try our unsurpassed*

### VALVE MAIL ORDER SERVICE

Vast quantities of modern and obsolete fully guaranteed valves available from stock at very moderate prices. Send S.A.E. for Full lists

**SPECIAL 24 HOUR EXPRESS MAIL ORDER SERVICE**

Callers welcome

AN EXAMPLE OF THE VALUE YOU GET from **RST**

BRAND NEW TRANSISTORS			
OC35	10/-	OC72	8/-
OC42	6/-	OC74	8/-
OC44	5/-	OC75	8/-
OC45	5/-	OC77	8/-
OC71	5/-	OC81	5/-
		OC81D	5/-
		OC81m/pr	12/6
		OC82	8/-
		OC82D	4/-
		OC170	6/-

400 volts 350 mA SILICON RECTIFIERS ... 7/6 each

METAL RECTIFIERS			
RM1	7/6	14A86	23/-
RM2	8/-	14A97	26/-
RM3	10/-	14A100	28/-
RM4	17/6	14RA 1-2-3-2	21/- (FC301)
RM5	19/6	14RA 1-2-8-3	25/- (FC31)
		16RD 2-2-8-1	12/- (FC142)
		16RE 2-1-8-1	10/- (FC150)
		18RA 1-1-8-1	5/- (FC118)
		18RA 1-1-16-1	7/- (FC116)
		18RD 2-2-8-1	16/- (FC124)

SETS OF VALVES			
IR5, IS5, IT4, 354, 3V4	...	...	Set of 4, 17/-
DAF91, DF91, DK91, D[92, DL94	...	...	Set of 4, 17/-
DAF96, DF96, DK96, DL96	...	...	Set of 4, 25/-

**TERMS OF BUSINESS C.W.O. or C.O.D.  
4/2 PACKING CHARGE ON ALL C.O.D.  
ORDERS. POSTAGE 6d. per VALVE**

**RST VALVE MAIL ORDER CO.**

211a, STREATHAM ROAD, MITCHAM, SURREY

Telephone: MITcham 6202 & 6771

Mon. - Sat. 9 a.m. - 5.45 p.m.

Wednesday 9 a.m. - 1 p.m.

Lunch 1.30 - 2.30

# FRANCIS OF STREATHAM

include among their customers many who call personally from all over the country, because of the stocks and service in **TAPE AND HI-FI EQUIPMENT** to be found there. With so many shops to choose from, there must be excellent reasons why people prefer to buy from Francis. Perhaps you would care to find out by calling or writing to us about your requirements.

- ★ VERY LARGE STOCKS OF TAPE AND HI-FI EQUIPMENT
- ★ NO EXTRA FOR CREDIT UP TO 18 MONTHS
- ★ OWN SERVICE DEPARTMENT
- ★ FREE SERVICE DURING GUARANTEE PERIOD

**FRANCIS OF STREATHAM**  
169-173 STREATHAM HIGH ROAD, LONDON, S.W.16

Between St. Leonards  
Church and Streatham Stn.

Open all day  
Saturday

Phone STR  
0192'0466



The world-famous copper loaded alloy containing 5 cores of non-corrosive flux, that saves the soldering iron bit, Ersin Multicore Solder is also available in high tin quality alloys. 60/40 in 22 s.w.g. for printed circuits, transistors, etc.

#### THE HANDY DISPENSER



Easy to find in the tool box—simple to use. Virtually a third hand for tricky soldering jobs. 12 feet 5 core 18 s.w.g. ERSIN MULTICORE SAVBIT alloy in a continuous coil used direct from free-standing dispenser. 2/6 each

**SAVBIT ALLOY**  
*saves wear on soldering iron bits*

#### SAVBIT SIZE 1 CARTON

Contains approximately 30 feet of 18 s.w.g. SAVBIT. It is also supplied in 14 s.w.g. and 16 s.w.g. Obtainable from radio and electrical stores.



5/- each

#### BIB WIRE STRIPPER AND CUTTER

Strips insulation without nicking wire, cuts wire cleanly, adjustable to most thicknesses. Splits extruded plastic twin flex. 3/6 each



**MULTICORE SOLDERS LTD.**

MULTICORE WORKS • HEMEL HEMPSTEAD • HERTS. (BOXMOOR 3656)



THE WORLD-FAMOUS KIT—SETS ANYONE CAN BUILD WITHOUT PREVIOUS EXPERIENCE



## Better Performance and Value . . . with Heathkit Equipment

A WIDE RANGE OF WELL DESIGNED KIT-SETS TO CHOOSE FROM  
YOU CAN SAVE £££s BY BUILDING ANY HEATHKIT MODEL



MALVERN



COTSWOLD

"MALVERN" HI-FI EQUIPMENT CABINET. Will house all your Hi-fi equipment. Left "in the white." Size: 39½ x 32 x 21½ in. Kit £18.10. A wide range of other cabinets.

"COTSWOLD" HI-FI SPEAKER SYSTEMS. Acoustically designed enclosures, complete with 12 in. bass speaker, elliptical mid-range speaker, and tweeter to cover full frequency range of 30-20,000 c/s. Cross-over unit, level control, etc. Left "in the white." Standard "Cotswold", Size: 26 x 23 x 14 in. Kit £23.40

MFS "Cotswold" for the smaller room. Size: 36 x 16½ x 14 in. Kit £23.40

SSU-1 SPEAKER SYSTEM. A practical solution to the problem of a low-price speaker system. Two speakers. Without legs £10.17.6 Kit With legs £11.12.0 Kit

A wide range of speakers available. Send for details.



FM TUNER



S-99

5 in. FLAT-FACE GENERAL PURPOSE OSCILLOSCOPE. Model IO-12U. An outstanding 'scope. "Y" sensitivity, 10 mV rms per cm at 1 kc/s; Bandwidth 3 c/s to 4.5 Mc/s. T/B 10 c/s to 500 kc/s in 5 steps. Kit £32.12.6. Assembled £41.10.0.

2½ SERVICE 'SCOPE, Model OS-1 Light (wt. 10½ lb.), compact, 5" x 8" x 14½". The ideal portable for servicemen. Kit £22.18.0. Assembled £30.8.0.

ELECTRONIC SWITCH, Model S-3U. Convert your 'scope to dual trace. Kit £12.18.0. Assembled £18.10.0.



IO-12-U



S-3U

HI-FI FM TUNER. Range 88-108 Mc/s. Available in two units, sold separately. TUNER (FMT-4U) 10.7 Mc/s IF £2.15.0 (inc. P.T.). IF AMPLIFIER (FMA-4U) power supply and valves £13.3.0. Total Kit £15.18.0.

9 + 9W HI-FI STEREO AMPLIFIER, Model S-99. Ganged controls. Stereo/Mono Gram., Radio, Tape inputs. P.C. board construction. Attractive presentation. Kit £27.19.6. Assembled £37.19.6.

"OXFORD" LUXURY TRANSISTOR PORTABLE, Model UXR-2. Beautiful solid leather case. Kit £14.18.0

GENERAL COVERAGE RECEIVER, Model RG-1. Freq. coverage 600 kc/s-1.5 Mc/s. 1.7-32 Mc/s in 6 switched bands. Many features incl. ½ lattice crystal filter. Kit £39.16.0 Assembled £53.0.0.



IM-13U



HFV-1

6 in. DE LUXE VALVE VOLTMETER, Model IM-13U. Measures ac and dc volts 0-1.5 to 1,500V in 7 ranges. Res. to 1,000 MΩ in 7 ranges. Modern styling, with gimbal mount. Kit £18.18.0. Assembled £26.18.0.

VALVE VOLTMETER, Model V-7A. DC volts to 1,500, AC to 1,500 rms and 4,000 V pk. to pk. Res. 0.1-1,000 MΩ. Kit £13.18.6. Assembled £19.18.6. RF Probe 309-CU £11.3.6 kit. HT Probe HV-336 £2.19.6 kit. Will extend range of models V-7A or IM-13U.

TV ALIGNMENT GENERATOR, Model HFV-1. 3.6 to 220 Mc/s on fundamentals. Unique electronic sweep oscillator. Built-in fixed and variable marker generators (5 Mc/s crystal). Kit £34.18.0. Assembled £44.10.0.



UXR-2



RG-1

Send for FREE British Catalogue of Heathkit Range of Models

Deferred Terms over £10 in U.K.

Prices quoted include postage U.K.

AM/FM TUNER Covers FM 88-108 Mc/s, AM 16-50, 200-550, 900-2,000 M. Tuning heart (£4.13.6 inc. P.T.) and IF Amp. Case. Total £26.10.0 Kit

6W STEREO AMPLIFIER, Model S-33H. An inexpensive stereo/mono amplifier. Ideal for use with the Decca Deram lightweight pickup. Modern attractive styling. Kit £15.17.6 Assembled £21.7.6

"GARRARD" AUTO RECORD PLAYER. Model AT.6. A four-speed stereo/mono unit with auto, record selection. Fitted with R.105 crystal pickup £13.12.1. With Decca Deram pickup £14.6.1.

5W MONO AMPLIFIER, Model MA-5. A general purpose amplifier based on model S-33. Separate bass and treble controls, gram and radio inputs. Printed circuit. Kit £10.19.6. Assembled £15.10.0.

JUNIOR ELECTRONIC WORKSHOP, Model EW-1. 20 exciting experiments can be made. Special solderless connections. Kit only £7.13.6.

MULTIMETER, Model MM-1U. Ranges 0-1.5v to 1,500V A.C. and D.C. 150 μA to 15A D.C.; 0.2 to 20 MΩ. 4½ 50 μA meter. Kit £12.18.0. Assembled £18.11.6.



PA-1



AT-6

R.F. SIGNAL GENERATOR, Model RF-1U. Freq. coverage from 100 kc/s-100 Mc/s or six bands, on fundamentals and up to 200 Mc/s on calibrated harmonics. Kit £13.8.0. Assembled £19.18.0.

DECADE RESISTANCE, Model DR-1U. Range 1-99,999Ω in 1Ω steps. Kit £10.8.0. Assembled £14.8.0.

DECADE CAPACITOR, Model DC-1U range. 100 μF to 0.111 μF in 100 μF steps. Kit £7.5.0. Assembled £10.8.0.

INTERNATIONAL MAIL ORDER SCHEME covering the American Heathkit range of 250 models. Illustrated American catalogue and full details can be obtained from us for 1/- post paid.

50W PUBLIC ADDRESS AMPLIFIER, Model PA-1. A multi-purpose unit, suitable for vocal and instrumental groups. 4 inputs for guitars, mics, etc. 2 heavy duty speakers, vol. indicator, variable tremolo, modern cabinet. Kit £54.15.0. Assembled £74.0.0.

50W POWER AMPLIFIER, Model MA-50. Ideal for sound reinforcing systems, etc. Kit £19.18.0. Assembled £27.18.0.

"MOHICAN" TRANSISTOR GENERAL COVERAGE RECEIVER, Model GC-1U. Freq. coverage 580 kc/s to 30 Mc/s in 5 bands. Electrical band spread on 5 additional bands covers "amateur" freq. from 80-10 M. B.F.O. Tuning and Zener diode. Send for details, Kit £37.17.6. Assembled £45.17.6.

80-10m AMATEUR TRANSMITTER, Model DX-40U. Crystal controlled. Power input 75w. c.w. 60w. peak controlled carrier power. Output 40w. Kit £33.19.0. Assembled £45.17.6.

TRANSISTOR INTERCOM, Models XI-1U and XIR-1U. Ideal for home or business. Each master (XI-1U) will operate up to 5 remote stations. 9v. battery operation. XI-1U (Master) kit £10.19.6. Assembled £16.19.6. XIR-1U (Remote) kit £4.7.6. Assembled £5.16.0.

# DAYSTROM LTD.

Dept. P.M. 1, GLOUCESTER, ENGLAND

WORLD'S LARGEST SELLING ELECTRONIC KITSSETS

Please send me FREE BRITISH CATALOGUE (Yes/No)  
Full details of model(s).....

NAME  
(BLOCK CAPITALS)  
ADDRESS

PM-1

# Why

## NOT BUILD ONE OF OUR PORTABLE TRANSISTOR RADIOS...

BACKED BY OUR SUPER AFTER SALES SERVICE

### ROAMER SEVEN Mk III

5 WAVEBAND PORTABLE OR CAR RADIO  
Now with PHILCO MICRO-ALLOY R.F. TRANSISTORS  
● 9 stages—7 transistors and 2 diodes

Covers Medium and Long Waves, Trawler Band and two Short Waves to approx. 15 metres. Push-pull output for room filling volume from rich toned heavy duty 5in. speaker. Air spaced ganged tuning condenser. Ferrite rod aerial for M & L Waves and telescopic aerial for S Waves. Real leather-look case with gilt trim and shoulder and hand straps. Size 9 x 7 x 4in. approx. The perfect portable and the ideal car radio. (Uses PP7 battery available anywhere). Total cost of parts now only **£5.19.6** P. & P.

Parts Price List and easy build plans 3/-

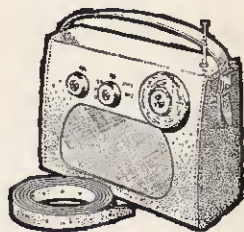

### TRANSONA FIVE

Home, Light, A.F.N., Lux. all at good volume.

G.P. Durham

● 7 stages—5 transistors and 2 diodes  
Fully tunable over Medium and Long Waves and Trawler Band. Incorporates Ferrite rod aerial, tuning condenser, volume control, new type fine tone super dynamic 2½in. speaker, etc. Attractive case. Size 6½ x 4½ x 1½in. (Uses 1289 battery available anywhere).

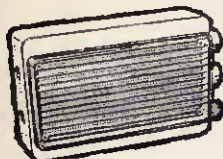

with red speaker grille. (Uses 1289 battery available anywhere). Total cost of all parts now only **42/6** P. & P. Parts Price List and easy build plans 2/-

### MELODY SIX

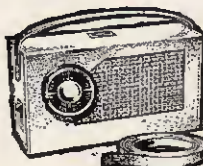

"... amazed at volume and performance. has really come up to my expectations". S.G., Stockton-on-Tees.

● 8 stages—6 transistors and 2 diodes

Our latest completely portable transistor radio covering Medium and Long Waves. Incorporates pre-tagged circuit board, 3in. heavy duty speaker, top grade transistors, volume control, tuning condenser, wave change slide switch, sensitive 6in. Ferrite rod aerial. Push-pull output. Wonderful reception of B.B.C. Home and Light, 208 and many Continental stations. Handsome leather-look pocket size case, only 6½ x 3½ x 1½in. approx. with gilt

speaker grille and supplied with hand and shoulder straps. Total cost of all parts now only **£3.9.6** P. & P. Parts Price List and easy build plans 2/-

#### COMPONENT BARGAINS ALL POST FREE

**TRANSISTORS**  
PHILCO MADT Type 2N1727  
Maximum frequency of oscillation 150 Mc/s ... 8/6.  
PHILCO MADT Type 2N1728  
Maximum frequency of oscillation 150 Mc/s ... 9/6.  
PHILCO MADT (Micro Alloy Diffused) Type 2N503  
Maximum frequency of oscillation over 500 Mc/s ... 15/-  
Diodes ... 1/6  
Standard interleaved output transformers for valve output stages ... 3/6

#### SWITCHES

Slide, single pole, heavy springs 2/3  
Yaxley 6-way, 2 pole ... 4/9

#### TUNING CONDENSERS

Air spaced fine quality German manufacture with slow motion drive. 0-0005 with oscillator section ... 9/6  
Subminiature similar 00 with tuning and oscillator sections 7/6  
Subminiature mica dielectric with trimmers. Tuning 200 pf. Oscillator 50 pf ... 5/6  
Mica dielectric 0-0003 mfd. 3/10

#### BELLPHONES

Ex-G.P.O. Suitable as sound powered telephones. Resistance of coil 60 ohms approx. 3in. U-shaped magnet ... 5/9

#### HEADPHONES

High fidelity miniature magnetic earpieces (2) on slim band with lead and plug. Easily converted to stereo. American manufacture ... 13/6  
Miniature crystal earpiece with lead plug and socket ... 6/6

#### DIALS AND KNOBS

3in. dial with polished brass insert and M/L calibrated disc ... 6/6

1in. cream knobs with polished brass insert and rim 1/3 each

#### CASES

Real leather-look cases in chestnut shade with holes punched for tuning, volume control and switch. Also holes punched for car aerial socket and tone control. 9½ x 3½ x 7½in. approx. Complete with carrying straps ... 35/-

Plastic cases in grey polystyrene with red ornamental grille, 6½ x 4½ x 1½in. approx. 6/9  
Telescopic aerials with fixing socket ... 6/6

### SUPER SEVEN

● 9 stages—7 transistors and 2 diodes

Covers Medium and Long Waves and Trawler Band. The ideal radio for home, car, or can be fitted with carrying strap for outdoor use. Completely portable—has built-in Ferrite rod aerial for wonderful reception. Special circuit incorporating 2 R.F. Stages, push-pull output, 3in. speaker. Size 7½ x 5½ x 1½in. (Uses 9v battery, (will drive large speaker). available anywhere.)

Total cost of all parts now only **£3.19.6** P. & P. Parts Price List and easy build plans 2/-

Parts Price List and easy build plans 2/-

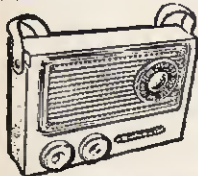

### TRANSONA SIX

● 8 stages—6 transistors and 2 diodes

This is a top performance receiver covering full Medium and Long Waves and Trawler Band. High-grade approx. 3in. speaker makes listening a pleasure. Ferrite rod aerial. Many stations listed in one evening including Luxembourg loud and clear. Attractive case in grey with red grille. Size 6½ x 4½ x 1½in. (Uses PP4 battery available anywhere.)

Total cost of all parts now only **59/6** P. & P. Parts Price List and easy build plans 2/-

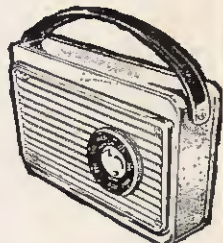

### ROAMER SIX NEW!!

NOW WITH PHILCO MICRO-ALLOY R.F. TRANSISTORS

● 6 WAVEBAND!!

● 8 stages—6 transistors and 2 diodes

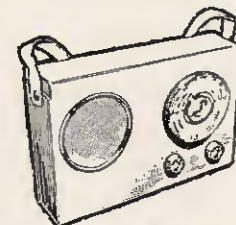

Listen to stations half a world away with this 6 waveband portable. Tunable on Medium and Long Waves. Trawler band and three Short Waves. Sensitive Ferrite rod aerial and telescopic aerial for short waves. Top grade transistors, 3-inch speaker, handsome case with gilt fittings. Size 7½ x 5½ x 1½in.

★ Extra band for easier tuning of LUX., etc.

Parts Price List and easy build plans 2/- Total cost of all parts now only **£3.19.6** P. & P. (Carrying Strap 2/6 extra.)

All components used in our receivers may be purchased separately if desired. Parts price lists and easy build plans supplied free with sets of parts or available separately at fixed prices stated.

**RADIO EXCHANGE Ltd.**  
61a, HIGH STREET, BEDFORD. Phone: 2367

Callers side entrance  
Barratts Shoe Shop  
Open 9—5 p.m.  
Sats. 10—12.30 p.m.



# L. K. ELECTRONICS

## The Cheapest—The Best—Quickest Service

● **Famous Autochanger or Single Player Units** supplied with brand new, two-tone, de-luxe portable cabinets, 17 x 15 x 8 1/2 in. Strong carrying handle, gilt finish clips and hinges are used by famous make for 22 gn. model. Ready cut out motor board, 14 x 13 in. Front baffle 7 x 4 in. High flux loudspeaker and 3 watt amplifier. Amplifier ready built on metal chassis with output transformer, volume and tone controls. All items fit together perfectly. Assembly in 30 minutes. Only 5 wires to join. 12 months' written guarantee. Available separately or package deals as below.

Our NEW MK II Superb Kits are now being dispatched.

### L K PRICES FOR COMPLETE KITS:

#### Autochanger Kits as above

B.S.R. U.A. 14, T.C. 8 Mono..... £10.17.6 P.P. 5/6  
Garrard Autoslim, Mono..... £11.7.6 P.P. 5/6

#### Single Player Kits as above

Garrard S.R.P. 10, Mono..... £10.12.6 P.P. 5/6  
E.M.I. Autostop, Mono..... £10.17.6 P.P. 5/6

Individual Prices for those who wish to purchase separately.

Record Player Cabinet with Cut-out Board..... £2.15.0 P.P. 3/6  
Amplifier with 7 x 4 in. speaker..... £3.10.0 P.P. 2/6

● **SCOOP! B.S.R. U.A. 25 Autochangers.** T.C. 8 Mono P.U. Brand new and boxed. Wired for stereo. Note OUR price £5.7.6. P.P. 5/-. The very, very latest model.

● **SCOOP! B.S.R. U.A. 14 Autochangers.** T.C. 8 Mono P.U. Brand new and boxed. Wired for stereo. Note OUR price £5.7.6. P.P. 5/-. Latest model.

● **SCOOP! Garrard Autoslim, Mono P.U.** Brand new and boxed. Wired for stereo. Latest model. Note OUR price £6.0.0 only. P.P. 5/-.

● **SCOOP! Garrard A.T.5.** Wired for stereo, inclusive of head and mono cartridge (A.T.5 is an auto transcriber). The finest changer of them all. OUR price, brand new and boxed, £7.10.0 only. P.P. 5/-.

### AUTOCHANGERS

#### Single Players

E.M.I. Autostop, Mono..... £5.7.6 P.P. 4/6  
Garrard S.R.P. 10, Mono..... £5.5.0 P.P. 4/6  
E.M.I. Separate Pick-up..... £3.0.0 P.P. 3/6

#### Transcription Units—Stereo Head—Mono

Garrard 4 H.F. Stereo..... £14.10.0 P.P. 5/-  
Phillips A.G. 10/16, Stereo..... £12.0.0 P.P. 5/-  
Garrard A.T.6, Stereo..... £9.19.6 P.P. 5/-  
Garrard 301..... £16.10.0 P.P. 5/-

● **SCOOP! Record Player Cabinets.** Two-tone, de-luxe finish with cut-out board. These are brand new and product of very famous national manufacturer. OUR price £2.15.0 only. P.P. 3/6.

● **SCOOP! 3-watt Gramophone Amplifier.** Complete with 5in. Speaker, 49/6. P.P. 5/-.

The amplifier is complete, on a fabric-covered baffle board. Output transformer included. Tone and volume controls and on/off switch. Ready to switch on and play. Terrific volume. Size 12 1/2 in. x 6 in. x 3 1/2 in. back to front. For 200-250 v. A.C. Output 3 watts.

● **SCOOP! Diodes—over 1,000,000 in stock—ideal substitute O.A.B.I. vision detector.** Note OUR price £1.0.0 per 500. P.P. 2/-. (In 500 lots only).

● **SCOOP! Transistor Tape Recorder.** The best obtainable by very famous manufacturer. Brand new, boxed, guaranteed. Reduced from 12 gns. OUR price £7.10.0. P.P. 3/6. Complete with microphone, tape, batteries and operational booklet. Features push-pull amplifier, two motors, single switch operation, pause, speed, wind, rewind, record, play back. Can be used in any position, indoor or outdoor.

● **SCOOP! Hi-Fidelity Speakers, 15-watt.** Very famous national manufacturer—we cannot mention name. 45-13,000 c.p.s., 3 or 15 ohm voice coils, response 45-13,000 c.p.s. Magnet 15,000 lines. In carton—unopened and unused. OUR price £4.4.0 only.

● **SCOOP! A Stereophonic Amplifier** with the following features. A twin gauged tone control in a special negative feedback circuit, giving a wide range of tone correction. A balance control enabling the amplifiers to be equalized in output to compensate for pick-up, lead, speakers, recording differences. A speaker switch, M1, single amplifier, M2, dual amplifiers for increased Monaural output. S.3, two speakers at 5 watts per channel. Twin gauged volume controls and all four controls placed equidistant along the front of the chassis. Designed, made and guaranteed by Brittamer Ltd. Brand new and at a fraction of original cost. OUR price £7.10.0 only.

### THE SIOUX 60 WATT GUITAR AMPLIFIER

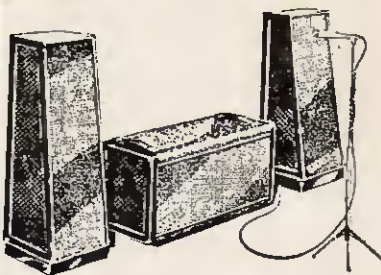

Incorporating Ten High Duty Speakers in two columns of five designed to handle efficiently the full output of Amplifier at frequencies down to 25 c.p.s. Heavily made Cabinet in two-tone Vynair. For 200-250 v. to 50 c.p.s. A.C. Mains operation. Four jack socket inputs and two independent volume controls for simultaneous connection of up to four instrument pick-ups or microphones. Level frequency response throughout the Audible Range. **OUR INCLUSIVE PRICE FOR AMPLIFIER, MIKE, STAND, SPEAKERS, LEADS, ETC., ONLY 35 GNS.**

● **SCOOP! Cartridges — Ceramic Diamond Stylus — Stereo — By Acos.** Limited Number only at one 1/2 of original price—10/- only + P.P. 1/-. White stocks last.

Speakers ex Equipment. 5in. 3/-, 7in. x 4in. 6/-, 6in. 6/6, 8in. 7/-. P.P. 1/6 each.

● **SCOOP! Microphones.** Complete Lead Coax. Plug, Brand New. OUR price 5/- only. P.P. 1/6.

● **SCOOP! A Limited Number Only. —Tape Decks by B.S.R.** Latest model. A.C./200/240 v. Brand new and boxed. OUR price £6.10.0 only. P.P. 4/6.

● **SCOOP! 1964 Radiogram Chassis.** Stereo 3-wave bands, long, medium, short. 5 watts per channel. 6 valves. Latest Mullard A.C. 200/250 v. Ferrite aerial. Glass dial. Horizontal wording. Size 13in. x 4in. Aligned and calibrated. Concentric controls. Isolated chassis. Size 13 1/2 in. x 9 in. high x 5 in. deep. Product of famous national manufacturer. Brand new and boxed. Maker's guarantee.

OUR price £13.10.0. List price £19.8.0. P.P. 5/6. Our Chassis List quotes prices—the keenest in the Trade. We are Main Agents for the complete range of Brittamer Chassis and Amplifiers. "Brittamer"—makers of Radiogram Chassis to the Top Names in Radio.

● **SCOOP! For £25.0.0 only.** A fabulous offer, Garrard A.T.5 Transcriber, plus 2 12in. 15 watt Hi-Fidelity speakers, plus the very latest Continental push-button chassis by Brittamer. Stereo, 3-wave band, 6 valves, 5 watts per channel. The finest chassis of its type in the world. You will be amazed at performance and quality. We unhesitatingly recommend this chassis.

### TRANSISTOR SECTION

● **SCOOP! A first-class 2 wave-band 3 transistor superhet chassis** by world famous manufacturer. Fully built, aligned, tested, guaranteed. Full coverage long and medium waves. Note OUR price £5.4.0 only. Suitable speaker 10/6. A few cabinets can be supplied at 22/6 each. OUR price for the package deal £6.10.0 only. Ideal for Caroline.

S.A.E. enquiries please. Our Complete Lists 1/- only—credited against your order

● IF NOT ADVERTISED IT IS STILL IN STOCK

# L.K. ELECTRONICS (Victoria) LTD.



17 GILLINGHAM ROW, WILTON ROAD, LONDON, S.W.1.



# The NEW Stern-Clyne ELECTRONIC CONCERT ORGAN TO BUILD YOURSELF

## DESIGNED —

- For the Electronic amateur seeking the most fascinating project.
- For the discriminating organist seeking an instrument which DOES sound like a pipe organ.

## NEW —

- Constructional methods introducing "sectional complete instrument" building.
- Extended range of tone colours. Without unrealistic "Gimmick" effects.

**THE MOST COMPREHENSIVE KIT OF PARTS AVAILABLE IN THIS COUNTRY**

**START BUILDING FOR AS LITTLE AS £68.10.0 approx. (H.P. Terms Available)**

Write today for brochure (enclosing 6d. stamp) to: **Electronic Organ Dept., 18 TOTTENHAM COURT ROAD, LONDON, W.C.1**, or call at your nearest branch.

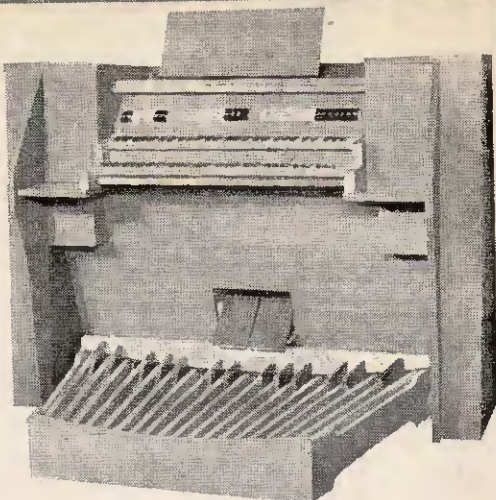

VISIT OUR SHOWROOM AT  
18 TOTTENHAM COURT RD., LONDON, W.1  
and hear this fabulous new Electronic Concert  
Organ demonstrated.

# STERN-CLYNE

GREAT BRITAIN'S GREATEST ELECTRONIC HOBBIES ORGANISATION

HERE'S WHY THOUSANDS OF ELECTRONICS ENTHUSIASTS BUY WITH CONFIDENCE FROM STERN-CLYNE —

- A wide range of exclusive equipment available including our own speciality — MULLARD DESIGNS — for the home constructor or ready assembled.
- The finest selection of Hi-Fi and Audio equipment by all leading manufacturers.
- A comprehensive range of electronic components for the build it yourself enthusiast available at all branches.
- Retail shops, showrooms and demonstration rooms throughout London and the provinces all carry extensive stocks.
- Finest Mail Order Service-g geared to give prompt and efficient attention.
- Hire Purchase facilities available on orders of £11 10. 0 and over.
- Hi-Fi advisory service to help you in choosing the right equipment.
- After sales service — complete satisfaction guaranteed.

VISIT YOUR NEAREST  
STERN-CLYNE ELECTRONICS CENTRE

### LONDON

18 Tottenham Court Rd., W.1. MUSEum 5929-0095. *Half Day Sat.*  
23 Tottenham Court Rd., W.1. MUSEum 3451-2. *Half Day Thurs.*  
309 Edgware Rd., W.2. PADDington 6963. *Half Day Thurs.*  
109 Fleet St., E.C.4. FLEEt St. 5812-3. *Half Day Sat.*  
162 Holloway Road, N.7. NORth 7941. *Half Day Thurs.*  
9 Camberwell Church St., S.E.5. RODney 2875. *Half Day Thurs.*

### BRISTOL

26 Merchant Street, Bristol 1. Bristol 20261.  
*Now open 6 days a week.*

### CROYDON

12 Suffolk House, George St. MUNICIPAL 3250. *Half Day Wed.*

### LIVERPOOL

52 Lord Street, Liverpool. Royal 7450.

### MANCHESTER

20-22 Withy Grove, Manchester 4. BLACKfriars 5379-5246.  
*Open 6 days a week.*

### SHEFFIELD

125 The Moor, Sheffield. Sheffield 29993.

### MAIL ORDERS AND ENQUIRIES TO:

Dept. P.E., 3-5 Eden Grove, Holloway, London, N.7. NORth 8161-5.



FOR - IMMEDIATE - DESPATCH - PHONE - US - TODAY

**BUILD YOUR OWN RECORD PLAYER**

4 Speed Autochange 2-tone Cabinets 17 x 15 x 8 1/2 in. High. Bass loudspeaker and 3 watt valve amplifier ready built. Quality output. Volume and Tone controls. All items fit together perfectly. Special instructions enable assembly in 30 minutes, only 5 wires to join, 12 months' written guarantee.



**AUTOCHANGE KITS** Complete - as above.

B.S.R. Monarch ..... £10-19-6 P.P. 5/-  
Garrard Antoshm ..... £11-19-6 P.P. 5/-

**QMAX CHASSIS CUTTER**

The cutter consists of four parts: a die, a punch, an Allen screw and key.

1/2 in.	14/6	1 1/2 in.	18/-	2 in.	34/3
3/4 in.	14/6	1 3/4 in.	18/6	2 1/2 in.	37/9
1 in.	15/6	1 7/8 in.	20/-	2 3/4 in.	44/9
1 1/8 in.	15/9	1 7/8 in.	20/-	1 in. sq.	31/6
1 1/4 in.	18/-	1 7/8 in.	20/6	1 1/4 in. sq.	28/-
1 1/2 in.	18/-	1 7/8 in.	22/6		

- CRYSTAL MIKE INSERTS. High output.**  
Miniature size, 1 1/2 in. dia. x 1 1/2 in. .... 6/6  
ACOS MIKE INSERT 1 1/2 x 1 1/2 in. .... 3/6  
ACOS STICK MIKE 39-1 ..... 3/6  
T.S.L. DE LUXE STICK MIKE ..... 10/6  
TELEPHONE CONTACT MIKE ..... 10/6  
GUITAR XTAL MIKE ..... 15/6  
PROFESSIONAL MAGNETIC GUITAR MIKE with Vol. & Tone Controls ..... 59/6  
Moving Coil Mike 90/-, Floor Stand 57/-  
TANNOY CARBON MIKE ..... 5/6

**FULL WAVE BRIDGE SELENIUM RECTIFIER:** 2.5 or 12 v., 1 amp., 8/9; 2 a. 11/3; 4 a., 17/6.  
**CHARGER TRANSFORMERS.** Tapped input 200/250 v. for charging at 2, 8 or 12 v., 12 amps., 15/6; 2 amps., 17/6; 4 amps., 22/6. Circuit included.  
**4 AMP CAR BATTERY CHARGER** with ammeter, Leads, Fuse Case, etc., for 6 v. or 12 v., 59/6.

**MINIATURE PANEL METERS**

Size 1 1/2 in. sq. Precision jewelled bearings, 2% accuracy, silvered dials, fine pointers, 0-1 mA. 27/6; 0-5 mA. 27/6; 0-300 V. 27/6; 0-50  $\mu$ A 39/6; 0-500  $\mu$ A 32/6. "S" meter 35/-

**MOVING COIL MULTIMETER TK20A.** 0-1000 v. A.C./D.C. ohms, 0-100k, etc., 0-150 mA Pocket size Sin. scale, 49/6.  
**VALVE HOLDERS.** EA50 6d. B12A, CRT, 1.3. Eng. and Amer. 4, 5, 6 and 7-pin 1/-. Printed circuit B9A, B7G, Int. Oct. 1/-. MORSE KEY 4/6; BUZZER 4/6.  
**MULDED Int. Oct.** or Mazda Oct. 6d.: B7G, B8A, B8G, B9A 9d. B7G with can 1/8. B9A with can 1/3. Ceramic EP30, B7G, B9A Int. Oct. 1/-. B7G, B9A caus, 1/- each. Valve base plugs B7G, B9A, Int. Oct. 2/6.

**1965 RADIOGRAM CHASSIS**

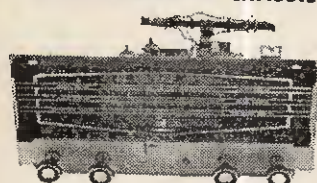

Three Wavebands S.W. 15 m.-50 m. M.W. 200 m.-500 m. L.W. 800 m.-2,000 m. 12-month guarantee. A.C. 200-250 v. 4-way switch. Short-Medium-Long-Gram, Ferrite Aerial. A.V.C. and Negative Feedback. 5 watts 3 ohm. Chassis 13 1/2 in. x 7 1/2 in. high x 5 in. deep. Glass dial size 1 1/2 in. x 4 1/2 in. horizontal winding. Two Pilot Lamps. Four Knobs. Aligned and calibrated. Chassis isolated from mains.

**BRAND NEW £9.15.6** Carr. 4/6. Matched Speakers Sin. 17/6; 10in. 25/-; 12in. 30/-

**Famous Manufacturers' Surplus Bargain Ferguson Quality Amplifier 4 Watts**

Size 6 1/2 x 5 x 4 in. 200-250 AC double wound mains transformer. Volume and tone controls. Sensitivity 200 mv. Response 25 to 20,000 cps. Price 49/6 each. Complete with valves, etc. 49/6 Brand new. 2 units matched for stereo etc., 89/6.

**BLANK ALUMINIUM CHASSIS.** 18 s.w.g. 4 sides, riveted corners, lattice fixing holes. 2 1/2 in. sides, 7 x 4 in., 5/6; 9 x 7 in., 6/8; 11 x 9 in., 6/6; 11 x 7 in., 7/6; 18 x 9 in., 8/6; 14 x 11 in., 12/6; 15 x 14 in., 15/-  
**ALUMINIUM PANELS.** 18 s.w.g. 12 x 12 in., 4/6; 14 x 9 in., 4/-; 12 x 8 in., 3/-; 10 x 7 in., 2/-; 8 x 6 in., 2/-; 6 x 4 in., 1/8.

**MAINS TRANSFORMERS 200/250 AC Post 2/- each**

**STANDARD 250-0-250, 60 mA.** 6.3 v. 3.5 a., tapped 4 v. 4 a. Rectifier 6.3 v. 1 a. tapped 5 v. or 4 v. 2 a. 22/8  
Ditto 250-0-350 ..... 29/8  
**MINIATURE 200 v. 20 mA.** 6.3 v. 1 a. .... 10/6  
MIDGET 220 v. 45 mA., 6.3 v. 2 a. .... 18/6  
**SMALL 250-0-250 v. 45 mA.** 6.3 v. 2 a. .... 17/6  
**STANDARD 250-0-250 65 mA.** 6.3 v. 3.5 a. .... 17/6  
**HEATER TRANS. 6.3 v. 1 a.** ..... 7/6  
Ditto tapped sec. 1.4 v. 2, 3, 4, 5, 6.3 v. 1 amp. 8/6  
**HEATER PURPOSE LOW VOLTAGE.** Outputs 3, 4, 5, 6, 8, 9, 10, 12, 15, 18, 24 and 30 v. at 2 a. 22/8  
**AUTO TRANS. 150 w. 0.115 v. 200, 230, 250 v. 22/8**  
**AUTO TRANS. 500 w. 0.115, 200, 230, 250 v. 22/8**  
**MULLARD "510" MAINS TRANS. TO SPEC. 3/3**  
900-0-900 120 mA., 6.3 v. CT 4a., 0.5, 6.3 v. 2 a.

**MAINS POWER PACKS.** Ready built with Mains Transformers, Rectifiers and Condensers etc., providing H.T. and L.T. 200 v. 20 mA. D.C. 3 wave 6.3 v. 1 a. A.C. 25/6  
220 v. 50 mA. D.C. 3 wave 6.3 v. 2 a. A.C. 35/6  
250 v. 80 mA. D.C. Full wave 6.3 v. 4 a. A.C. 45/6

**"THE POWER MITE" 45/-**

PM9 Mains Unit 9 volt for Transistor Radios. Same size as P.P.9 (200-250V) also Miniature PP3 model. .... 19/6

**4 TRANSISTOR PUSH-PULL AUDIO AMPLIFIER**

Size 3 x 1 1/2 x 1 in.  
A ready built miniature push-pull amplifier with Driver and output transformers, 4 transistors. Ideal for use with record players, intercoms, BABY ALARMS, etc. Complete with full instructions and circuit.  
Price 47/6 9 v. Batt. 2/3, 2 1/2 in. Speaker 15/-

**NEW MULLARD TRANSISTORS**

OC71 8/-, OC72 7/6, OC81D 7/6, OC81 7/6, AF115 10/6, AF114 11/-, OC94 8/-, OC95 8/-, OC719 9/-, OC719 9/6, OC928 Transistor Holders 1/3. Sub Miniature Condensers, 0.1 mFd., 30 v., 1/3, 1/2, 4, 5, 8, 16, 25, 30, 50, 100 mFd., 15 volt 2/6 each.

**TRANSISTOR 4 CHANNEL MIXER with 4 separate input-output controls, 59/6**

**Volume Controls**

Long spindles, Midget Size 5K ohms to 2 meg. LOG or L/S 3/-. D.P. 4/6. LIN. Stereo L/S 10/8, D.P. 14/6. Linear or Log Tracks.

**80 Ohm CABLE COAX**

Semi-air spaced 6d. yd. 40 yd. 17/6, 80 yd. 25/- Low loss 5dB per 100ft. at 600 mc/s. Ideal 625 lines 1/8 yd.

**THE "INSTANT" BULK TAPE ERASER AND RECORDING HEAD DEMAGNETIZER**

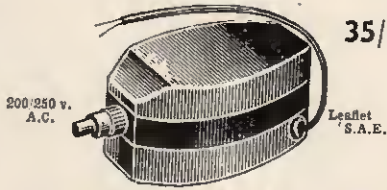

200/250 v. A.C. Leaflet S.A.E. 35/-

**B.T.H. TAPE MOTORS 115 v. A.C. 28 w. 12/6 pair, for 200 250 v. (in series)**

**BAKERS 'Selhurst'**

25 WATT 5 GNS 12" GUITAR HEAVY DUTY

15 OHM VOICE COIL RESPONSE 20-10,000 cps  
BASS RESONANCE 80 cps  
GENUINE MUSICAL INSTRUMENT LOUDSPEAKER

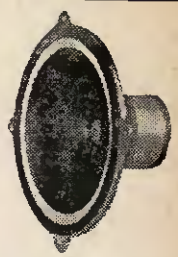

12in. STALWART HEAVY DUTY 15w. 3 or 15 ohm voice coils. Unlimited Applications. Response 45-12,000 cps. Magnet 12,000 lines. 5 gns.

12in. STANDARD HEAVY DUTY 20w. More powerful magnet 14,000 lines special suspension. 40-14,500 cps. Recommended wherever a high standard of reproduction is desired. 7 gns.

12in. BASS HEAVY DUTY 25w. New 1964 high power model. Aluminium coil former with magnetic damping 25-15,000 cps. Ideal for all electric guitars. 12 gns.

15in. AUDITORIUM MODEL 35w. Improved magnet alcomax with heavy plated assembly, weight 18lbs., 17,000 lines, 20-12,000 cps. Heat-proofed Coil Former. Ideal for all Electric Guitars. 18 gns.

Bakers offer a full repair service. Specials made to order. Older types updated. Recovered, Re-energized.

**WAVE-CHANGE SWITCHES**

2 p. 2-way, or 2 p. 6-way, long spindle ..... 3/6  
3 p. 4-way, or 1 p. 12-way, long spindle ..... 3/6  
4 p. 2-way, or 4 p. 3-way, long spindle ..... 3/6  
8 p. 2-way, 2 water, long spindle ..... 6/6  
Wavechange "MAKETS" Waters available; 1 p. 12-way, 2 p. 6-way, 3 p. 4-way, 4 p. 3-way, 8 p. 2-way. Prices include click spindles, adjustable stops, 1 water, 8/6; 2 water, 12/6; 3 water, 16/-. Extra waters up to 12, 3/6 each.  
TOGGLE SWITCHES, s.p., 2/-; d.p., 3/6; d.p.d., 4/-  
Rotary Toggles, s.p., 3/6; d.p., 4/6. Min. Slide d.p. 3/6.

**BOOKS (List S.A.E.)**

"W.W." Radio Valve Data ..... 7/6  
High Fidelity Speaker Enclosures ..... 5/-  
Valves Transistors, CRT Equivalents ..... 9/6  
At a Glance Valves, CRT Equivalents ..... 3/6  
TV Fault Finding ..... 5/-  
Mullard Audio Amplifier Manual ..... 8/6  
Radio Valve Guide, Books 1, 2, 3 or 4 ea. 5/-  
Practical Radio Inside Out ..... 3/6  
Master Colour Code ..... 1/6  
Coil Design and Construction Manual ..... 5/-  
Radio, TV and Electronics Data Book ..... 3/6  
International Radio Stations List ..... 2/6  
Boys' Book of Crystal Sets ..... 2/6  
Stroboscopic Disc 33, 45, 78 r.p.m. .... 1/-  
How to Receive Foreign T.V. .... 5/-

JACKS. Standard open-circuit 2/6, closed-circuit 4/6, Grundig type 3-pin 1/3; Grundig Lead Type 3/6. Phone Plugs 1/-, Sockets 1/-. Banana Plugs 1/-. Sockets 1/-. JACK PLUGS STANDARD SCREENED 3/-, Grundig 3-pin 3/6. JALGIN NON-REVERSIBLE PLUGS and SOCKETS. P73 2-pin 4/3; P73 3-pin 4/8; P194 6-pin 6/6; P466 6-pin 12/6; P580 3-pin 4/-; Mains selector panel with plug 1/-. 1/-

**TRIPLETONE HI-FI MAJOR £15.18.9**

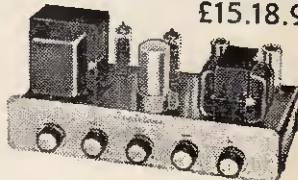

12 watts 15 to 20,000 c.p.s. 5 valves A.C. mains isolated. 12in. x 5 1/2 in. x 6 in. high. Built-in pre-amp. and mixer. Two inputs and volume controls. Sensitivity mic. 10 mV.; Gram 250 mV. 3 tone controls, Bass, Treble and Middle. Auxiliary power supply. Ideal for all Electric Guitars. Cabinet with handle, 30/- extra.

RETURN OF POST DESPATCH

\* A HAPPY CHRISTMAS TO ALL READERS \*

NO ORDER TOO SMALL

**RADIO COMPONENT SPECIALISTS**

337 WHITEHORSE ROAD, WEST CROYDON Telephone THO 1665

Written guarantee with every purchase.

Buses 133, 68 pass door.

S.R. Stn. Selhurst.

(Export welcome. Send remittance and extra postage, no C.O.D.)

Post 1/-, Full List 1/-, C.O.D. 2/- extra.

# HOME RADIO Ltd.

187 LONDON ROAD, MITCHAM, SURREY (MIT. 3282)

Shop hours:  
9-5.30; Including Sat.  
Friday, 9-6.30.  
Closed all Wednesday

*There's a hole in your baggage  
Dear Santa!  
Dear Santa!*

We trust that your HOME RADIO CATALOGUE is not among those giving Santa the slip! But just in case you haven't yet ordered one (dreadful thought) here is a gentle reminder. Fill in the Coupon and send it off today with cheque or P.O. for 6/-.

HOME RADIO LTD. WISHES  
EVERYONE A MERRY XMAS  
AND A HAPPY NEW YEAR!

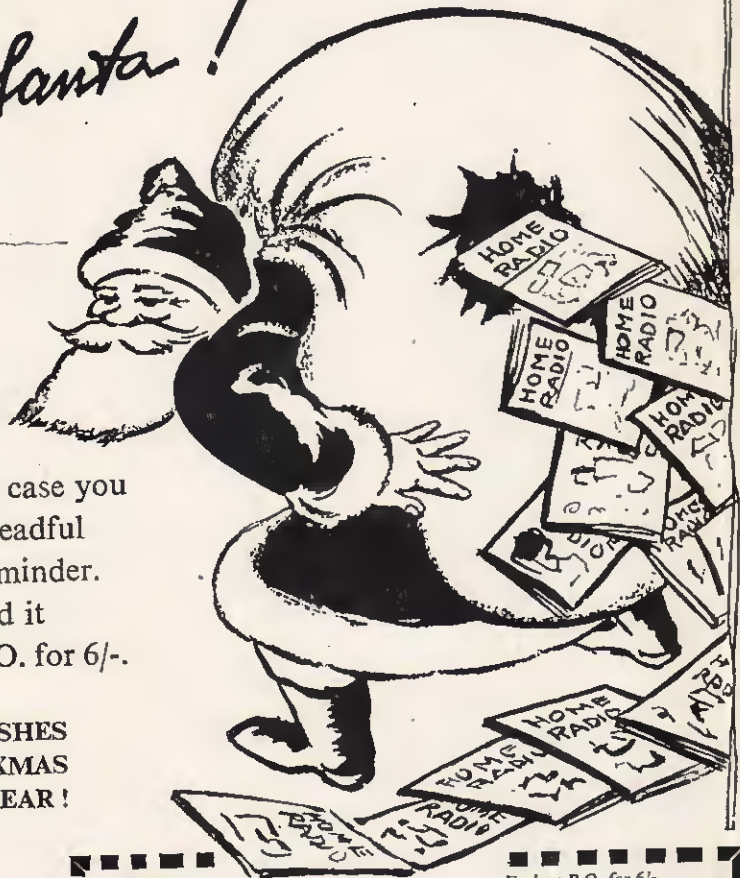

BLOCK  
CAPITALS please

Enclose P.O. for 6/-

*Remember...*

*For every complete £1's worth of Components you order from us you can enclose one of the Coupons from our Catalogue and deduct a shilling from your remittance.*

NAME .....

ADDRESS .....

HOME RADIO LTD., Dept. PE, 187 London Rd., Mitcham, Surrey



# Practical Electronics

## The Thermionic Valve

SIXTY years ago occurred an event that laid the foundation for the future electronics industry. In November 1904, Sir John Ambrose Fleming took out a patent for his oscillation valve—a device making use of the Edison Effect for the rectification of radio and audio frequencies. Thus was born the diode, the first of what was to become a large family of thermionic devices utilising the phenomenon of electron emission.

★ ★ ★

From the earliest days the radio industry adopted the thermionic valve as its own, but there were also other applications such as electrical measuring instruments where this device soon proved its worth. With these increasing and diversified uses for the valve, a new industry began to evolve—Electronics was coming into being.

New knowledge and techniques acquired particularly during the war years 1939–45 led to the development of computers and other electronically operated devices quite outside the conventional radio communications field. Ironically, these developments also resulted in research into the properties of semiconductor materials and led in turn to the discovery that would end the reign of the thermionic valve in many fields—but this is another story.

★ ★ ★

All of this is, of course, history. What of the position today, and in particular how important is the thermionic valve to the amateur constructor of electronic equipment?

Those who have taken up electronics as a hobby in the last few years and those just starting will probably have little interest in working with valves. But we imagine the valve will continue for some time yet to have its devotees among the older hands who became involved with electronics in the pre-transistor era. A spares box well stocked with "bottles" accumulated over the years is one possible assurance against sudden and total loss of interest in the valve; the plentiful supply of replacements at low prices is another.

Bearing all this in mind, it will be our policy to include a number of valve operated devices amongst our constructional projects, although current trends demand that the major emphasis be given to designs based on semiconductors.

★ ★ ★

So, sixty years after its discovery we find the thermionic valve superseded in many fields, but by no means completely eclipsed. What of the future? At least so far as high power work is concerned, it seems likely that modern versions of Fleming's diode and other valves using the cathodic emission principle will continue to play a vital role in electronic engineering for many more years to come.

## THIS MONTH

### CONSTRUCTIONAL PROJECTS

HIGH IMPEDANCE VOLTMETER	176
5 WATT INTEGRATED AMPLIFIER	178
COMPACT LOUDSPEAKER ENCLOSURE	183
DARKROOM TIMER	187
PRINT RECORDER	204
PRECISION DECIMAL STEP PRE-AMPLIFIER	208
ELECTRONIC GUITAR	217

### SPECIAL SERIES

BEGINNERS START HERE—3	200
SOUND ON TAPE—3	202

### GENERAL FEATURES

ELECTRONIC POWER	172
FLEMING AND THE DIODE	186
VALVE ON/OFF CIRCUITS	193

### NEWS AND COMMENT

EDITORIAL	171
LORD BOWDEN OPENS EXHIBITION	180
READOUT	191
NEWS BRIEFS	197
ELECTRONORAMA	198
DETACHED PARTICLES	210
P. E. DATA BOOKLETS	211
NEW PRODUCTS	212

*Our February issue will be published on  
Thursday, January 14*

# ELECTRONIC POWER

Methods of conversion from non-mechanical energy to electricity

By I. J. Kampel

**E**NERGY FROM NOTHING—perhaps a scientist's dream! All the laws of science are against it. Scientists are looking for new, efficient and cheaper ways of converting heat energy to electricity.

Thermionic, thermoelectric, magnetohydrodynamic and thermo-photovoltaic principles, the four most significant heat to electricity conversion methods, are reviewed and compared in this article.

Fig. 1 summarises a number of possible electricity producing energy conversion methods. It is a fundamental principle that, although it may be changed from one form to another, energy is indestructible. One common example is the conversion of energy from heated petrol to motion in a motor car.

In a closed thermodynamic system, energy is neither created nor destroyed. There is a limiting factor in the conversion of heat to other forms of energy, known as the Carnot efficiency factor. The greater the temperature change of a heat to electricity converter, the higher will be its conversion efficiency.

## THERMIONIC CONVERSION

One of the most common forms of thermionic converter is Edison's "double-life" incandescent lamp. Instead of enclosing a single filament in one envelope he used two filaments. Filament 1 was connected directly to the power source, and filament 2 was connected to the source via an open switch (see Fig. 2). When filament 1 broke down, the switch automatically closed bringing filament 2 into use. Edison's idea amounted to little more than a domestic gimmick,

but as it turned out this principle was the first step toward the development of the thermionic valve.

During his experiments Edison connected ammeters in the two separate circuits, as will be seen from the diagram. When filament 1 was energised a small current was registered on ammeter A2 while the switch was still open. Some electrons had moved from the hot filament to the cold one. This phenomenon became known as the "Edison Effect", the principle of thermionic emission.

Later developments of Edison's discovery led to the diode valve. In the simplest type of valve the filament acts as the cathode. Other types have separate cathodes which are heated by the filaments. Fig. 3a shows a simple diode valve circuit.

When the cathode is heated the disturbance of ions due to the high temperature produces a "cloud" of electrons in the vicinity of the cathode. This is known as a space charge.

So far, battery B2 is isolated from the valve by S1. In this condition a state of random activity exists around the cathode with no control over the electrons.

Now, if S1 is closed, battery B2 supplies a potential to the anode, positive with respect to the cathode. Here we have a new condition whereby the negatively charged electrons are attracted to the positively charged anode, causing an *electron* flow in the direction shown in Fig. 3b. If the supply voltage from B2 is increased the anode, having now a greater positive potential, will attract more electrons towards it and so increase the current

this rise in current is *not* directly proportional to the rise in anode voltage due to the retarding effect of the space charge, and therefore does not follow Ohm's Law (Fig. 3c). When the anode voltage is increased to a state whereby the maximum possible current is obtained, the diode is said to be saturated.

One other method of increasing the current is to raise the temperature of the cathode by increasing the filament voltage but this can only be done within the limits of the current carrying capacity of the filament. The effect of this method is shown in Fig. 3c.

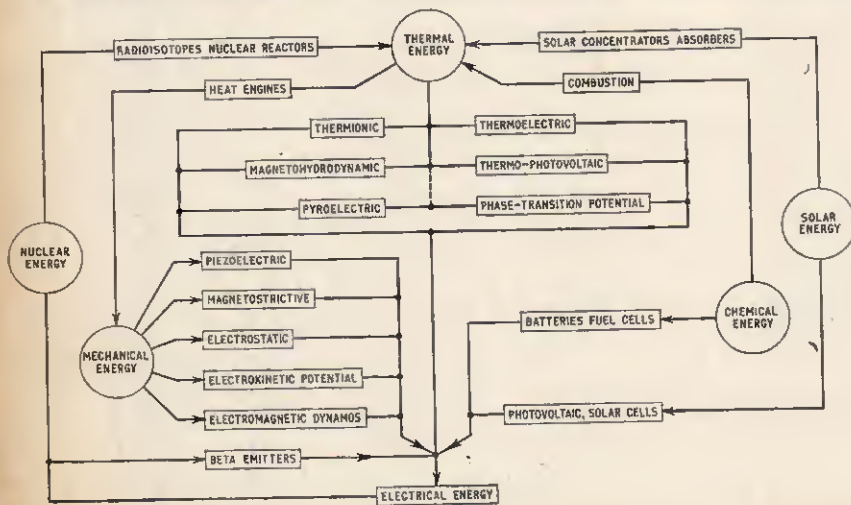
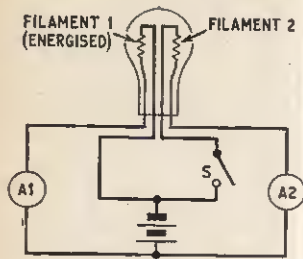

Fig. 1. Chart of energy conversion methods



**FIG 2**



*Fig. 2. Edison's "double-life" lamp*

**REDUCING THE SPACE CHARGE**

The retarding effect of the space charge can be considerably reduced by filling the valve tube with an ionised gas. Let us consider the path of a single electron passing through a certain amount of rarified gas or vapour (Fig. 4). During motion the electron will eventually collide with a gas atom (Fig. 4a), producing a new electron and positively charged ion (Figs. 4b and c). These two electrons are attracted towards the anode but on the way they collide with neutral atoms. If collision is great enough to cause ionisation there will be four electrons and three ions (Fig. 4c). This increase of electrons is called an electron avalanche.

The three main classes of thermionic energy converter are illustrated in Fig. 5. The typical diode shown in Fig. 5a is filled with caesium plasma, in which the positive ions neutralise to a great extent the negative electron space charge and permit a free flow of electrons to the anode.

To operate gas filled diodes efficiently the operating temperature should exceed 2,000°C. When filled with caesium vapour, ionisation is achieved more readily, but the high temperature necessary to provide this condition may impair the life of the cathode.

Fig. 5b shows a section of a vacuum close-spaced diode. In this type of energy converter the cathode and anode are very close together—for effective operation they should be about 0.01mm apart.

The third method of reducing the space charge effect is by using crossed electric and magnetic fields (Fig. 5c). Here the heated cathode and the cold anode are in the same plane, and separated by a space less than one-eighth of the width of the electrodes. An auxiliary anode, called the accelerator, is placed parallel to the cathode and anode a short distance away. A magnetic field is placed in such a position that the electrons, after being attracted towards the positively charged accelerator, will be diverted to the true anode. Theoretically, the magnetic triode would seem to be much more efficient than the close-spaced diode—22 per cent compared with 12 per cent under similar operating conditions.

A number of factors determine the efficiency of the system: the scattering of electrons by gas molecules; the reflection of electrons at the anode surface; general electron scattering; non-uniformity of electric and magnetic fields.

**THERMOELECTRIC CONVERSION**

The principle of thermoelectric conversion is that an electric current is produced by a change of temperature in a solid substance. Conversely, as in a thermo-

**FIG 3A**

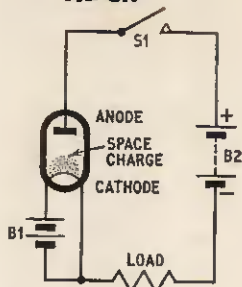

**FIG 3B**

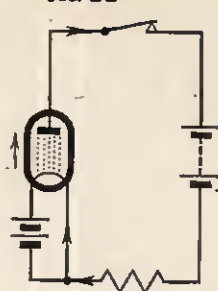

**FIG 3C**

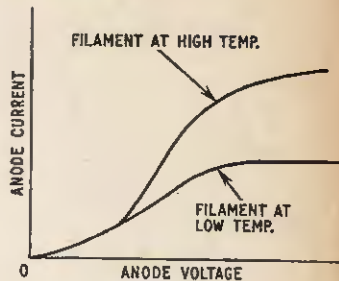

*Fig. 3. Simple diode valve circuit and characteristics*

electric refrigerator, if an electric current is passed through a solid the temperature of the solid will change. Thermoelectric effects are reversible physical phenomena.

In 1822, Thomas Seebeck discovered that when the junction of two different metals was heated an electric current was produced. He verified this theory by observing the deflection of a magnetic needle when held close to the junction.

Twelve years later, a Frenchman, John Peltier, discovered that if an electric current was passed through the junction of two different metals, the temperature of the junction increased or decreased depending on the direction of current flow.

Later, in 1857, Thomson (who later became Lord Kelvin) observed that if an electric current is passed through a single solid of homogeneous material, the temperature gradient was in fact matched by a new reversible temperature gradient created and dependent on the direction of current flow.

*Fig. 4. Electron bombardment in ionised gas*

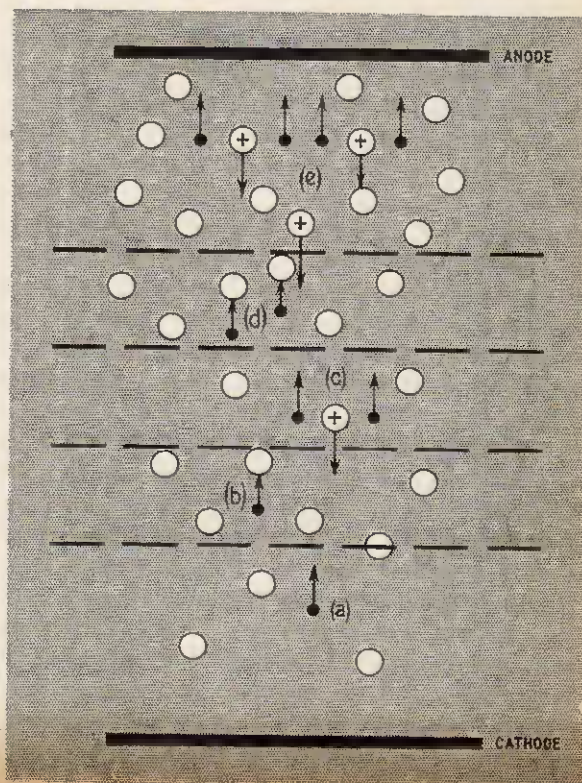

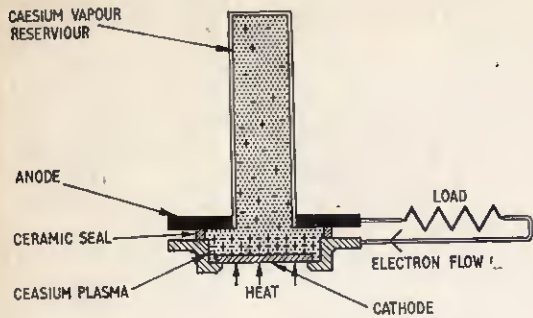

Fig. 5a. Diode filled caesium plasma

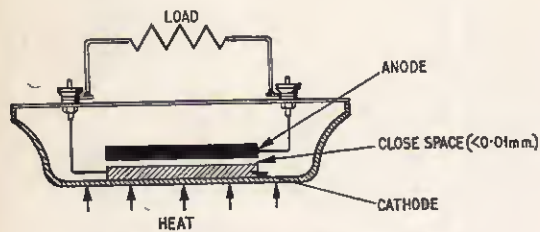

Fig. 5b. Vacuum close-spaced diode

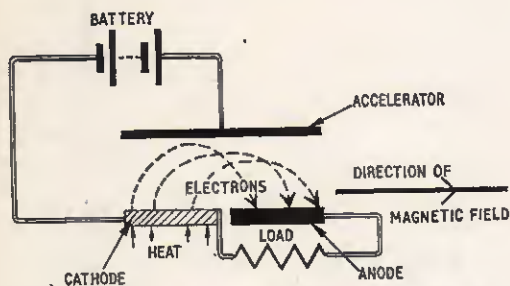
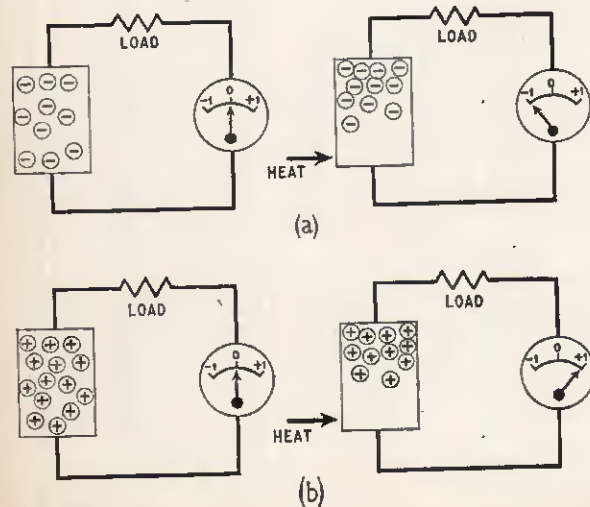

Fig. 5c. Electron flow influenced by crossed electric and magnetic fields



All these discoveries led to the development of the semiconductor device. Fig. 6 illustrates the theoretical principles of the *n*-type (6a) and *p*-type (6b) semiconductor material. In Fig. 6a the *n*-type material is negatively charged at ambient temperature with electrons moving at random. The circuit is completed by an ammeter and load resistance. If heat is applied to one end of the material the electrons move towards the cooler part charging it more negatively. The meter would show a deflection indicating the direction of current flow. Similarly the *p*-type material shown in Fig. 6b is positively charged. When heat is applied positively charged particles (holes) are attracted towards the cooler end of the material, but the direction of current flow is reversed.

The effects of combining *p*- and *n*-type semiconductor materials are shown in Fig. 6c, where the combined current produced is theoretically doubled for the same amount of heat applied.

Whilst thermoelectric conversion is very reliable the efficiency is relatively low, from 3 to 16 per cent depending on the material.

### MAGNETOHYDRODYNAMIC CONVERSION

Faraday's principle of electric induction is illustrated in Fig. 7. If an electric conductor is moved in a magnetic field an electric current is induced in the conductor. A practical example can be set up by connecting a coil directly to an ammeter. A bar magnet, capable of being inserted in the coil, is held above and in the same plane (see Fig. 7a). While the magnet is held stationary there will be no deflection of the meter needle. If the magnet is now rapidly inserted in the coil as shown in Fig. 7b the meter will register a current in one direction. While the magnet is held inside the coil, no current will flow (Fig. 7c), if the magnet is moved in the reverse direction a current will flow in the reverse direction as shown in Fig. 7d.

A new concept of this principle is used in magnetohydrodynamic conversion, but instead of a wire conductor, ionised gas is used. In the conventional power generator, a gas-driven turbine engine causes the armature to rotate cutting the magnetic lines of force and inducing a current in the armature wire (see Fig. 8a). In the m.h.d. generator ionised gas flows directly through the magnetic field inducing a current through the probe wires (see Fig. 8b).

In the practical m.h.d. converter the gas is heated to a very high temperature and pressure in the super-heater. The gas molecules partly ionise forming a plasma of negative electrons and positive ions. This ionised gas then passes through a nozzle into the conversion chamber (see Fig. 9). The gas is at a very high pressure in the chamber so cutting the lines of

Fig. 6. Thermoelectric conversion using semiconductor materials

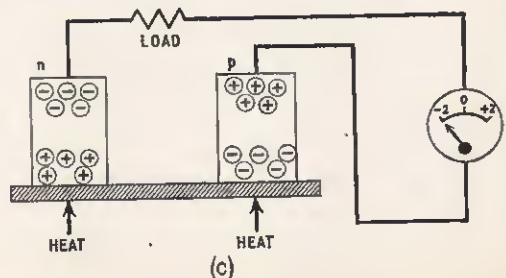



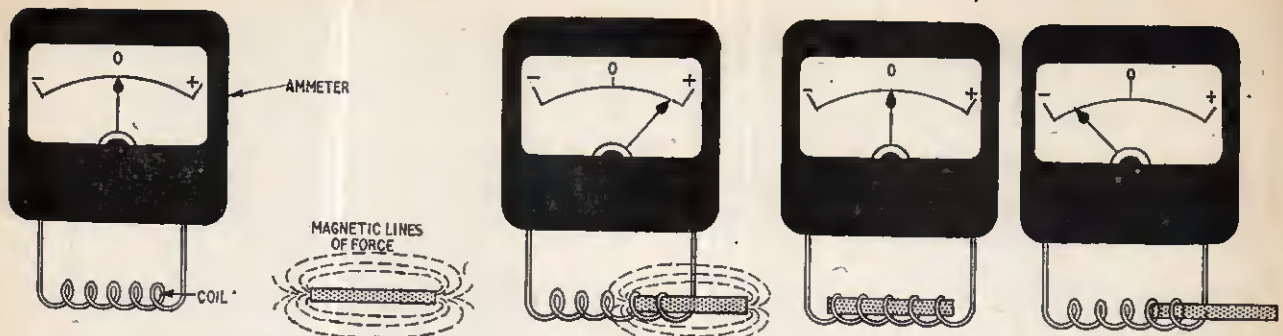

Fig. 7. Faraday's principle of electric induction

force at a very rapid rate. Two electrodes are placed one on each side of the gas stream so that the anode picks up electrons deflected by the magnetic field.

The voltage developed between the anode and cathode is dependant on the magnetic field strength, gas velocity, and electrode spacing. The conductivity of the plasma greatly influences the characteristics of the converter. Many gases do not ionise appreciably at temperatures between 2,000 and 3,000 degrees centigrade unless the gas is charged with caesium vapour or potassium.

Magnetohydrodynamic converters have one great advantage over other types described in this article: they can be constructed to produce large quantities of electrical energy for mains distribution. Efficiencies of about 60 per cent are envisaged while the conventional turbogenerator rarely exceeds 40 per cent.

### THERMO-PHOTOVOLTAIC CONVERSION

In 1961, Pierre Aigrain delivered a lecture proposing an interesting concept for heat to electricity conversion using an incandescent heat source to excite electrons in a *pn* structure. This system is particularly suitable in environments where there is little sunshine. Fig. 10 shows the theoretical circuit. The photons from an incandescent source are heated to a temperature of more than 1,800°C and are directed towards the converter surface by a parabolic reflector.

Its theoretical efficiency is about 70 per cent, but in practice this may be reduced to about 35 per cent. These figures are based on a system using monochromatic light.

The author is grateful to the American Raytheon Company, the Thermo Electron Engineering Corporation, Avco-Everett Research Laboratory, and Professor H. H. Woodson of the Massachusetts Institute of Technology for their co-operation in the preparation of this article.

Fig. 9. Complete system for m.h.d. conversion

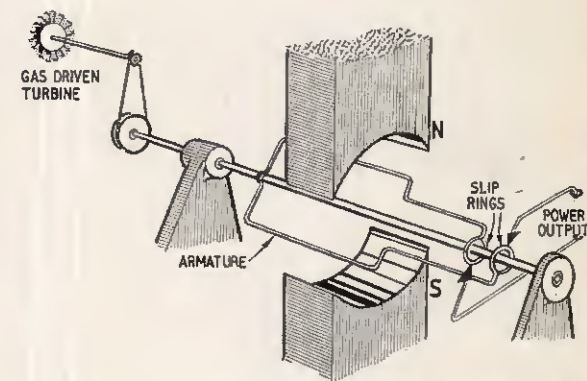

Fig. 8a. Electromagnetic generator principle

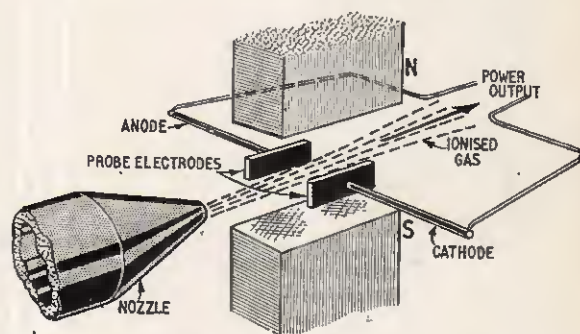
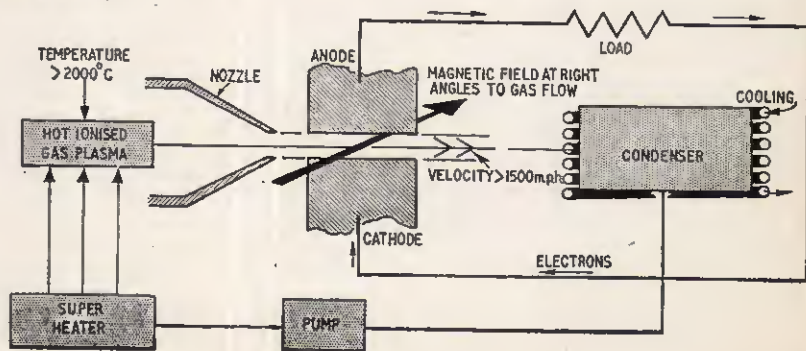
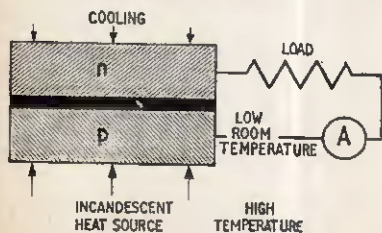

Fig. 8b. Magnetohydrodynamic conversion using ionised gas

Fig. 10. Theory of thermo-photovoltaic conversion





# HIGH IMPEDANCE VOLTMETER

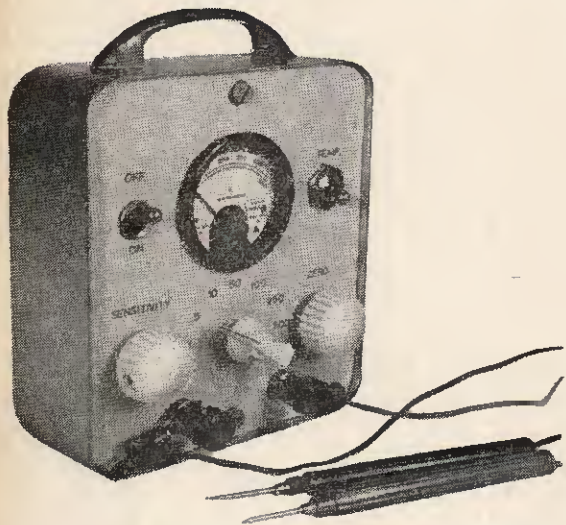

By R. E. F. STREET

Most readers will probably be aware of the danger of obtaining misleading results when using most ordinary multimeters to measure potentials in high resistance circuits. For example, if one measured the anode potential of the triode a.f. amplifier in a commercial a.m. superhet, the meter might read 20V instead of the 60V to 80V which one might expect.

The reason for this occurrence is that the meter draws sufficient current through the anode load (which may perhaps be 220 kilohms) that the anode voltage is reduced by the voltage drop across the load. Thus, if the meter took a current of  $500\mu\text{A}$ , the extra voltage drop would be 50 with a 100 kilohm load. Therefore, if the anode potential were 60V, connecting the meter would reduce it to about 10V which would be the reading obtained.

## CURRENT TAKEN

If the meter concerned were fully deflected when taking  $500\mu\text{A}$ , it would have a sensitivity of 2 kilohms per volt; the meter described here has a sensitivity of some 50 times this figure—100 kilohms per volt. The current taken (on any range) from the circuit under test in order to secure f.s.d. is thus only  $10\mu\text{A}$  and, of course, if readings are taken below the half-way point on the scale of the meter, then the current from the circuit under test will be  $5\mu\text{A}$  or less.

This design can therefore be used to take readings in circuits where very high resistances are involved without unduly reducing the potentials concerned.

There are available moving-coil multimeters with sensitivities of 100 kilohms/V, and while they give more accurate results than the unit described here, they are considerably more expensive.

In designing this meter, the aim was to produce a unit of high sensitivity which would be comparatively cheap to construct and it was decided that a high order of accuracy was not needed, or practicable, if the cost were to be kept down to a reasonable figure. Generally, where a high impedance meter is required, high accuracy in readings is secondary to the need for the meter to disturb the circuit under test as little as possible.

## CIRCUIT

The circuit of the instrument is given in Fig. 1a on the blueprint. Some readers may recognise a degree of similarity to a Mullard circuit which was in fact used as a basis for this design. One transistor is used—an OC75—in a current amplifying circuit.

The indicator is a  $500\mu\text{A}$  meter (M1) which is used in a bridge circuit. When S2 is operated, current flows through TR1 and also through R11 and VR2. VR2 is adjusted so that the potentials at A and B become equal and thus M reads zero. If now a potential is applied to the test terminals, a current flows in the base circuit of TR1 and the collector current increases, unbalancing the bridge and giving a reading on the meter M1.

## ACCURACY

The reading on M1 does not increase by equal increments for equal increases in the potential applied to the test terminals, as will be obvious if the circuit is studied. However, the non-linearity is not thought to be serious since the instrument is intended to act as an indicator rather than to give readings of high accuracy.

## METER MOVEMENT

The suggested movement is a 2in  $500\mu\text{A}$  type. There is no real point in obtaining an expensive larger meter since the accuracy of the circuit does not really justify the use of such a meter. If a physically larger meter is used, then the layout, and perhaps the mounting box, may have to be changed.

Meters of higher sensitivity can be used, but will be more expensive, though increasing the sensitivity of the complete instrument. Naturally, the values of R1 to R9 will need modifying by experiment if a more sensitive movement is employed.

## INTERNAL STANDARD

The "Calibrate" position of S1 needs some explanation. Before using the instrument, it is necessary to calibrate it; R9 and the dry cell BY1 provide a suitable internal reference potential to enable this to be done.



## RANGE SWITCHING

A single switch S1 is used for range selection. It should have very good insulation and a ceramic type may be used if available. In the prototype, a Radiospares "Maka-Switch" was employed. A one-pole, 12-way wafer was arranged, by means of the movable "stop", to give a choice of nine ways, as shown in Fig. 3 on the blueprint.

Eight ranges are shown in Fig. 1: 1V, 5V, 10V, 50V, 100V, 250V, 500V, and 1kV. Securing a range of a given f.s.d. (xV, for example) is merely a matter of interposing a resistor of (100,000x) ohms in the negative test lead, between the base of TR1 and the negative test terminal. Thus, if the constructor wished to add more ranges, or to use ranges with differing f.s.d.'s, the modification would be easy to carry out.

*Note that the Key to S1 Positions on the blueprint shows position 7 as 150V; this should, of course, read 250V.*

There are also two ways of wiring up the switch S1. In the first, shown in Fig. 1a, and used in the prototype, the multiplier resistors are arranged in a chain around the "ways" of S1. In the second method, shown in Fig. 1b, the resistors are arranged one for each way of S1, and one end of each is joined to the negative test terminal.

The first method has the advantage that the maximum value of resistor required is lower and, consequently, the resistors will, in many areas, be easier to obtain. The second method is perhaps really to be preferred since the multiplier of each range can easily be adjusted to give optimum accuracy, without affecting the values of the other multipliers. However, more will be said of this in the section on the wiring of S1.

## CONSTRUCTION

The prototype was built to fit inside a metal box intended for flush-mounting of a control unit for an electric cooker. This box is made by MK Electric

Ltd., and the list number is 5120; it can be obtained from electrical suppliers either "off the shelf" or to order. The use of the box gives a professional finish to the meter, as can be seen from the photographs.

The drilling diagram for the panel of the meter is given in Fig. 4 on the blueprint.

## BATTERIES

So that the instrument can be entirely self-contained, the batteries are housed in the case and can be seen in Fig. 3, the wiring diagram, and in the illustration on this page. Five 1.5V cells will be required and the type suggested is the Ever Ready D23 or equivalent. The Ever Ready U16 cells are also sufficiently small.

Four of the cells are wired in series as shown in Fig. 2. The method is to place the four cells side by side, alternate cells being inverted as shown, and bind them together with transparent sticky tape. Short pieces of stiff insulated wire are then soldered to the cells to connect them in series. The brass caps must first be cleaned and so must a small area of the zinc at the base of each cell so that the solder will "take" well. A hot iron is essential so that joints may be made very quickly to avoid damage to the cells.

No clips are used to keep the cells in position on the rear of the front panel. Instead, stiff insulated wire is used for all the connections to the cells (except the one to M1 and VR1) and provides enough support, particularly if the wires are kept as short as possible.

## WIRING

Wiring of the unit is not at all difficult and plastics-covered wire should be used for all leads. All the wiring shown in Fig. 3 should be carried out except that associated with the multiplier resistors.

*continued on page 211*

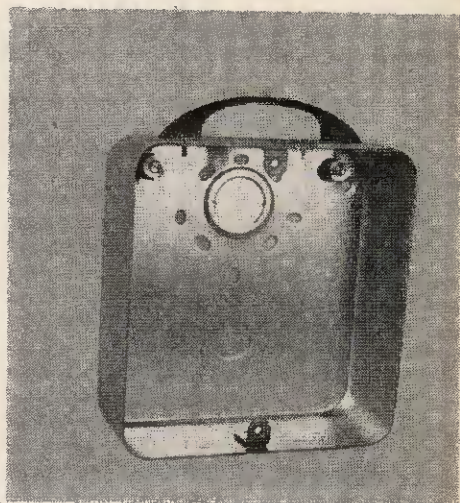
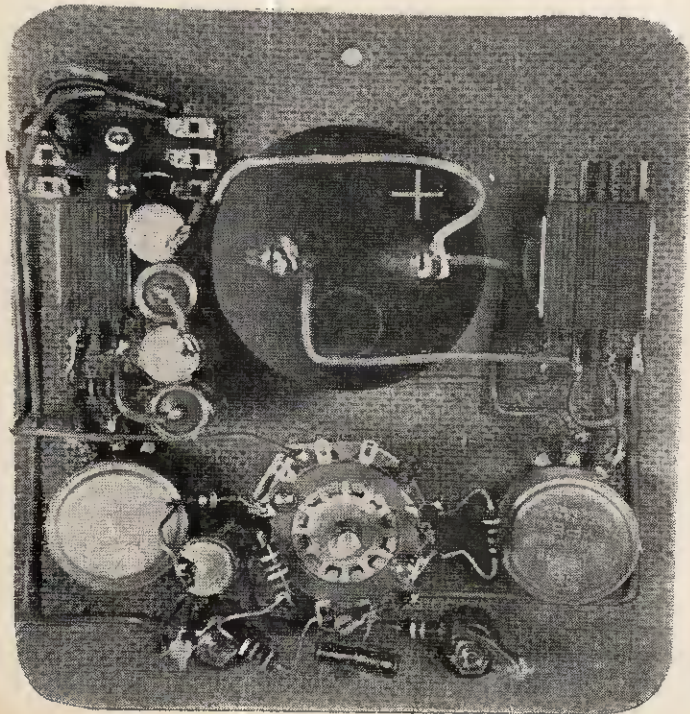

Photograph (left) shows details of wiring and component layout. Photograph (above) shows the cabinet with the front panel and components removed. A piece of felt measuring  $5\frac{1}{2}$  in  $\times$   $4\frac{3}{4}$  in is stuck to the back of this box. This felt serves two purposes: it seals the unwanted holes and it prevents any marking of surfaces on which the voltmeter may be placed



# W

# INTEGRATED TRANSISTOR AMPLIFIER

THIS FINAL ARTICLE DESCRIBES THE POWER SUPPLY AND GIVES DETAILS OF STEREO ARRANGEMENTS

THE d.c. low voltage power supply for the 5 watt integrated amplifier can be obtained from a single type PP9 battery if a low power, high quality output of some 250-300 milliwatts coupled with complete portability is the main consideration as already explained.

However, where high power quality reproduction is required, the d.c. low voltage source of power is obtained with the aid of silicon rectifiers and a suitable step down transformer, the primary of which is connected to the normal 200-240V domestic 50c/s mains supply.

Before describing in detail the power supply unit designed for this amplifier, it will be useful to explain the reasons which lead to the choice of a full wave bridge rectification circuit.

## VOLTAGE REGULATION

It is essential that the regulation of the available d.c. voltage should be very stable if distortionless reproduction is to be achieved when using a class B amplifier. With zero signal input the quiescent current is only some 50mA for the combined pre-amplifier and power amplifier; but when the input signal reaches a level of full drive the power output requirements may reach 500mA (or 1 amp if two amplifiers are used for stereo). The load current is drawn through the internal resistance of the power supply. This internal resistance is partly due to the resistance of the silicon rectifiers in the forward direction of current flow (which is fortunately very small) and to a greater extent due to the resistance of the copper wire used in secondary winding of the mains transformer.

Dealing first with the case of the bi-phase full wave

circuit, this necessitates a centre-tapped secondary winding. The secondary voltage is chosen so that for an r.m.s. voltage of 20V in each half of the secondary with respect to the centre tap, the rectified output will equal the peak voltage which is obtained by multiplying the r.m.s. value by  $\sqrt{2}$ . In this instance this equals 28 volts.

It is extremely difficult to centre-tap accurately this winding, and any imperfection of centre tap reflects an unbalance of the current distribution either side of the required neutral point or zero.

It must be clear that there will thus be a small floating potential that is never returned at any instant to true zero. This unbalance is therefore reflected upon the silicon diodes which are effectively in series across the secondary with respect to a.c. and in parallel with respect to the d.c. line. This voltage never is tied exactly to a finite neutral point and varies continuously according to the power load requirements.

## ADVANTAGE OF BRIDGE CIRCUIT

The full wave bridge on the other hand consists of four silicon rectifiers used in a self-balancing circuit and supplied by a simple untapped winding of heavier gauge copper wire (with a correspondingly lower d.c. copper resistance) and the difficulties associated with a centre tap are entirely eliminated.

This system is therefore totally adequate in its ability to provide the instantaneous varying demand of the class B output amplifier. Its regulation is inherently good and it is self-balancing with respect to earth. The ripple after rectification is very low and there is, therefore, less chance of electrolytic capacitor failure.

The complete circuit of the power supply unit is shown in Fig. 10. The 20V secondary winding of T1 supplies the bridge circuit composed of four silicon

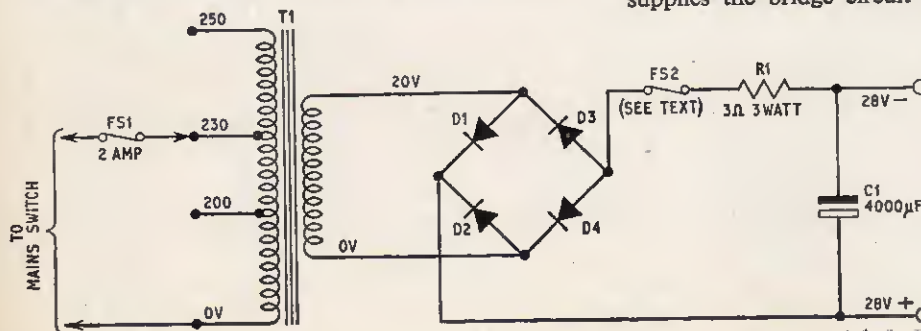

Fig. 10. Circuit diagram of the power supply unit



rectifiers D1-D4, and the pulsatory d.c. output is filtered by C1 and R1. Protection against over-load is provided by FS1 in the primary side of the mains transformer, and by FS2 in the negative d.c. line. FS2 should be 1 amp for monaural and 2 amp for stereo applications.

The mains transformer may appear to be of somewhat generous proportions, but it should be explained that this has been selected with the object of meeting the requirements of a pair of 5W integrated amplifier units—such as would be used in a stereo set-up. Furthermore this is a standard type of component and is readily available.

## CONSTRUCTION DETAILS

All components are assembled on a piece of  $\frac{3}{8}$  in plywood measuring  $7\frac{1}{2}$  in  $\times$  4 in. Output connections are made via a pair of sockets on a panel situated at one end of the unit. At the opposite end is another panel carrying the two fuses and the mains transformer voltage adjustment.

Each pair of silicon rectifiers is mounted on an angle bracket fashioned from 16 s.w.g. aluminium, see Fig. 11. The rectifiers have threaded bushes and are secured by means of the washers and nuts provided.

## STEREO REPRODUCTION

The integrated quality amplifier has not been designed *solely* for stereophonic reproduction as it is felt that a great number of music lovers have decided views regarding the restriction imposed by the positioning of loudspeakers in relation to the listener and the difficulty in obtaining good stereophonic reproduction in the average lounge or living room.

There is also the sad medical fact that a large number of music lovers do not possess identical hearing in both ears, and it was the latter fact that influenced the choice of the single-ended monaural amplifier. This presents two entirely separate amplifiers to the stereophonic user, each channel being individually adjustable for tone and volume and so enabling the most satisfactory balance to be obtained.

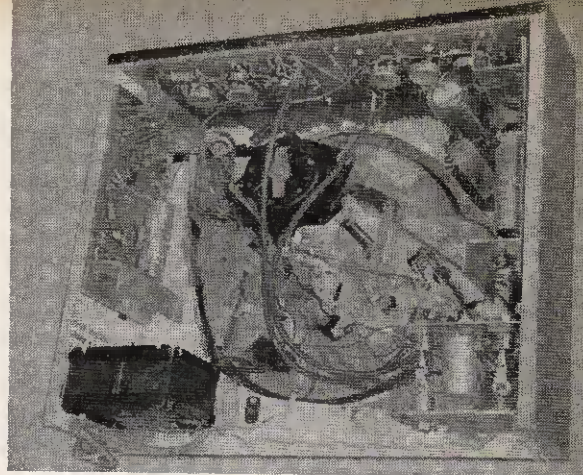

Photograph of the author's stereo arrangement. The two pre-amplifiers and power amplifiers are mounted on the front and two sides of the cabinet respectively

## COMPONENTS . . .

### Resistor

R1 3 $\Omega$  3W wire-wound

### Capacitor

C1 4,000 $\mu$ F elect. 40V (Mullard C431 series)

### Rectifiers

D1-4 BYZ13 silicon (Mullard) 4 off

### Transformer

T1 Mains transformer. Secondary 0-20V (Douglas)

### Fuses

FS1 Mains fuse 2 amp

FS2 H.T. fuse 1 amp (2 amp for stereo)

### Miscellaneous

Paxolin mains panel incorporating fuse holders; pair PK8A red and black plugs and sockets; capacitor clip; piece of paxolin  $4\text{in} \times 1\frac{1}{2}\text{in}$ ; baseboard  $7\frac{1}{2}\text{in} \times 4\text{in}$  plywood; connecting wire and sleeving; brass wood screws

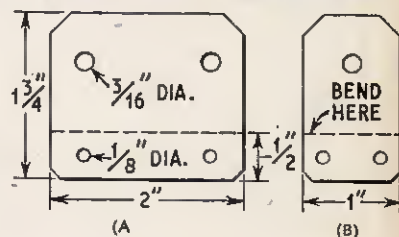
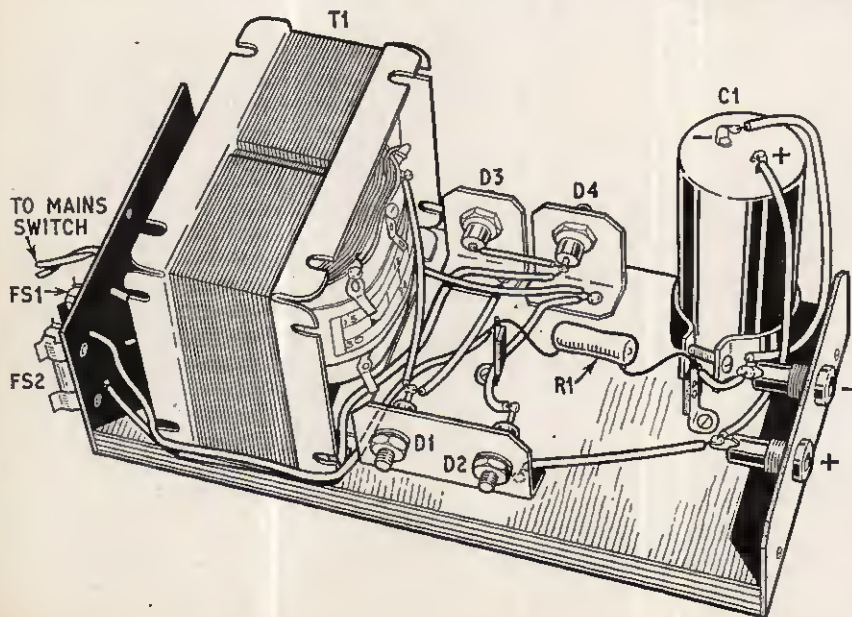

Fig. 11 (above). Drilling details of the 16 s.w.g. aluminium angle brackets for mounting the silicon rectifiers. D1 and D2 are mounted on bracket A and D3 and D4 are mounted on two brackets to the dimensions of B

Fig. 12 (left). Layout of components and wiring on plywood baseboard



To obtain stereophonic reproduction, assign one amplifier unit to the right-hand channel, and another to the left-hand channel. The output from each power amplifier is then fed to the correctly positioned right-hand and left-hand loudspeakers. The two outputs from the stereo pick-up head are fed to the correct right-hand and left-hand pre-amplifier inputs.

The volume from each loudspeaker can be individually adjusted to suit the listener's comfort and the desired tonal balance obtained by varying the setting of the bass and treble controls.

### A COMPACT INSTALLATION

It is not proposed to discuss in detail arrangements for housing these units. No real problem exists here, for the very compactness of the equipment simplifies this matter, and readers will have their own ideas concerning the type of installation they prefer.

It does, however, seem of general interest to include an illustration of one particular stereo set-up which has proved highly satisfactory. As can be seen (on page 179), all the electronic equipment is installed inside the table top cabinet which houses the record player.

TABLE I

#### 5W OUTPUT

TR1	Ve	1.5V	TR6	Ve	1V
TR2	Vc	4V	TR7	Ve	14V
TR3	Vc	1.5V	TR8	Vc	0.5V
TR4	Vc	3V	TR9	Vc	-28V
TR5	Ve	1.5V	TR10	Vc	-14V

D.C. Supply 28V

Total current—quiescent 50mA; max. drive 500mA  
Measured on 20,000 $\Omega$ /V meter. Volume control at minimum

The two pre-amplifier sub-assemblies are separately mounted on the front side of this cabinet, and the power amplifiers one on either side of the cabinet. A modified form of construction has been employed for the power supply unit. The mains transformer is mounted in the left-hand rear corner, while the remaining parts are grouped in the opposite corner.

TABLE 2

#### 300mW OUTPUT

TR1	Ve	0.5V	TR6	Ve	0.3V
TR2	Vc	1.3V	TR7	Ve	9V
TR3	Vc	0.5V	TR8	Vc	0.2V
TR4	Vc	0.8V	TR9	Vc	-9V
TR5	Ve	0.5V	TR10	Vc	-4.5V

D.C. Supply 9V

Total current—quiescent 4mA; max. drive 50mA  
Measured on 20,000 $\Omega$ /V meter. Volume control at minimum

### SCREENED LEAD

From the above account, it will be apparent that it is not essential to fix the pre-amplifier and the power amplifier assemblies together to form a single unit. But if they are separated, it is most important to use a screened lead between the pre-amplifier output terminal and the power amplifier input.

One final point concerning the combined assembly: check carefully that components or connection points on the facing surfaces of the two plastics panels do not come into contact with one another. There should be no risk of this happening if the specified types of components are used. If larger components are employed, it may be necessary to increase the separation between the two panels. ★

## Lord Bowden Opens Mullard Exhibition

ALL the current plans for a new technological revolution will come to nought without an accompanying revolution in the field of education. For this to be brought about automation must not be confined to industry and the factory floor, but must be applied in the classroom, with teaching machines, tape recorders, closed circuit television and other visual aids replacing more and more the teacher.

At least there is no doubt that this is the trend of education in the future as seen by the new minister for Education and Science, Lord Bowden.

Performing his first public function since his appointment as a minister in the new government, Lord Bowden opened the Mullard Educational Service 10th Anniversary Exhibition in London on 11 November 1964. The minister stressed the vital importance of increasing the efficiency of education—in terms one would apply to industry—by obtaining a higher output of students per teacher. For this to be achieved, "programmed learning" must be employed far more extensively than before.

Lord Bowden speaks as an authority on technological and electronic matters. Prior to entering Parliament he was Principal of Manchester College of Science and Technology; Dean of the Faculty of Technology Manchester University; Chairman of the Electronics Research Council of the Ministry of Aviation; and President of the Science Masters Association.

The exhibition set out to show how the Mullard Educational Service assists the school, the technical college, the university and the industrial training school to teach physics and electronic engineering. One section of the exhibition featured more than seventy demonstrations and experiments.

Each piece of equipment has been specifically designed for use in schools and technical colleges. Some idea of the extent of the subjects covered may be gained from the following short selection of working models:

*Determination of e/m*, using magnetron effect;  
*Light controlled oscillator*, energy conversion;  
*Velocity of sound*, echo technique method;  
*Van de Graaf generator*, a source of very high voltage;  
*Hysteresis loop displays*, using an oscilloscope and coils;  
*Slow running multivibrator* operating down to 1/c/s;  
*Geiger-Muller probe*, detection of  $\beta$  and  $\gamma$  radiation;  
*Binary adder/subtractor*—adds or subtracts digits and numbers up to a maximum of 127.

Lord Bowden (left) talking to Mr. S. R. Mullard at the Mullard Educational Service Exhibition





## SOLDER WITH PRIMAX and PRIMAXA SUPER EFFICIENT SPOTLIGHT SOLDERING GUNS



**PRIMAX**  
60 W SPOTLIGHT  
86/8 ea.

**PRIMAXA**  
100 W SPOTLIGHT  
112/8 ea.

Distributors: **S. KEMPNER LTD., LONDON, W.1**  
29 PADDINGTON STREET, Tel.: HUNter 0755

# FREE! COLOUR BROCHURE

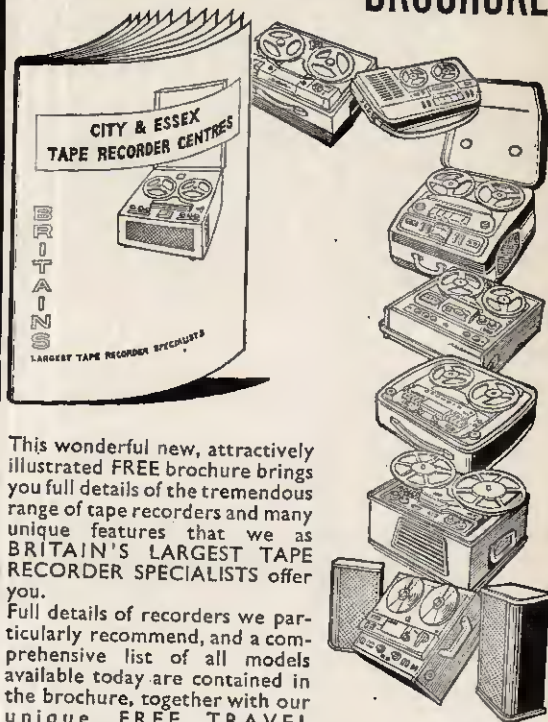

This wonderful new, attractively illustrated FREE brochure brings you full details of the tremendous range of tape recorders and many unique features that we as **BRITAIN'S LARGEST TAPE RECORDER SPECIALISTS** offer you.

Full details of recorders we particularly recommend, and a comprehensive list of all models available today are contained in the brochure, together with our unique **FREE TRAVEL VOUCHER** entitling you as a customer to full refund of your travelling expenses to and from any of our showrooms. Send for your FREE copy today, or call into any of our showrooms to see, hear and compare our fantastic selection of recorders.

## 5 STAR FEATURES

- ★ FREE TRAVEL TO AND FROM OUR SHOWROOMS
- ★ FREE DEMONSTRATIONS IN YOUR OWN HOME
- ★ OVER 300 MODELS FROM 15-243 GNS.
- ★ FREE ONE-YEAR SERVICING
- ★ FREE TECHNICAL ADVICE

Please send me your **FREE BROCHURE (P.E.3)**

Name.....

Address.....

**CITY & ESSEX TAPE RECORDER CENTRES LTD.**  
Head Office: Citax House, 191 Plashet Rd., London, E.13

## CITY & ESSEX TAPE RECORDER CENTRES

242/4 Pentonville Rd., N.1 (150 yds. from Kings Cross Station)	TER 8200
228 Bishopsgate, E.C.2 (Opposite Liverpool St. Station)	BIS 2609
2 Maryland Point Station, Stratford, E.15 (Adj. Station)	MAR 5879
205 High St. North, E.6 (Opposite East Ham Station)	GRA 6543
232 E. India Dock Rd., Poplar, E.14 (Adj. Blackwall Tunnel)	EAS 5978

NOTE: Bishopsgate Showrooms open Mon.-Fri. 9 a.m.—6 p.m. Sunday 9.30 a.m.—2 p.m. Closed Sat. Other Showrooms open Mon.-Sat. 9 a.m.—6 p.m. Thursday to 1 p.m.



## D.I.Y. with GOODMANS HIGH FIDELITY MANUAL

A Practical Guide to  
full listening enjoyment.

The Manual is much more than a catalogue of Goodmans High Fidelity Loudspeakers—it contains practical and informative articles. Those of particular interest to the D.I.Y. enthusiast include special beginners page, advice on stereo, stage-built systems and full cabinet drawings. Whether building or improving your own audio set-up or choosing a complete speaker system, you'll find it useful and interesting as well as informative. Ask or Write for your FREE copy.

Please send me a free copy of the Goodmans High Fidelity Manual

Name.....

Address.....

P.E.2

**GOODMANS**

**GOODMANS INDUSTRIES LIMITED**  
Axiom Works, Wembley, Middlesex  
Telephone: WEMbley 1200  
A Member of the Rentaset Group



# THINKING TAPE? THINK Brenell

If you're thinking in terms of tape recording, then the Brenell deck and complete recorders should be uppermost in your mind. The reliability, the versatility and the quality of manufacture are seldom equalled in other tape recorders (even in those costing much more).

How many can equal or better this specification?

4 record/playback speeds  $1\frac{7}{8}$ ,  $3\frac{3}{8}$ ,  $7\frac{1}{2}$  and 15 ips • 3 motors (capstan motor-hysteresis synchronous) • low 'wow and flutter' content (0.05% at 15 ips, 0.1% at  $7\frac{1}{2}$  ips, 0.15% at  $3\frac{3}{8}$  ips and 0.25% at  $1\frac{7}{8}$  ips) • double-gapped ferrite erase head to minimise erase noise • narrow-gapped record/playback head to give extended frequency response • pause control • superimpose control •  $8\frac{1}{2}$ " dia. reels (to take  $10\frac{1}{2}$ " dia. N.A.B. reels at extra cost) • fast rewind • digital rev. counter.

Mark 5  
Series 2  
Deck

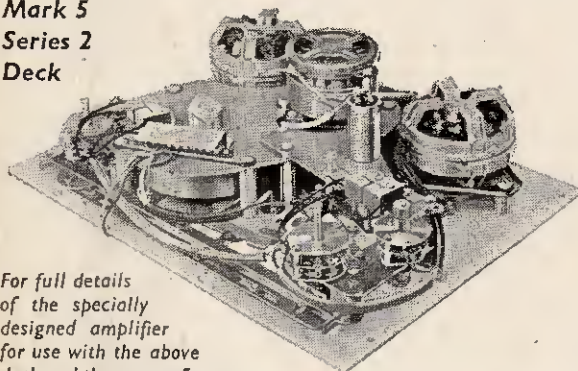

For full details of the specially designed amplifier for use with the above deck and the range of mono and stereo recorders, write or telephone the sole manufacturers:

## Brenell

PLEASE NOTE  
OUR NEW  
ADDRESS:

BRENELL ENGINEERING CO. LTD.  
231-5 LIVERPOOL ROAD, LONDON, N.1  
Telephone: NORth 8271 (5 lines)

GD840

# OXLEY

TYPE 062

## SUB-MINIATURE 'BARB' INSULATORS

A new OXLEY Patented sub miniature insulator which is speedy to assemble and with outstanding physical characteristics:

The P.T.F.E. bush, which is supplied with the heavily silver plated brass "barb" partly inserted, is located in an ordinary .062" dia. hole and the barbed spill is pressed firmly through the assembly, thus expanding the P.T.F.E. bush on the far side of the chassis and locking the complete assembly firmly in the chassis.

Working voltage 500 V.D.C.; Capacity less than .5 pF; Temperature range -55°C to +200°C; Resistance to pull in either direction 3 lbs; Chassis thickness = 22 GA; SWG = .022 / .028" = 0.56 / 0.72 mm; Mounting hole dia. .062" = 1/16" = 1.58 mm.

100 of these insulators mounted, occupy only one square inch of chassis space.

OXLEY  
DEVELOPMENTS CO., LTD.

ULVERSTON - LANCASHIRE.  
Telephone: ULVERSTON 2587

# HOUSING HI-FI?

The *Lowflex* is the world's most flexible hi-fi unit. Its three compartments are fully adjustable to take a complete hi-fi set up including tape recorder and records. For full details of this and other cabinets in the Record Housing range write for free catalogue and name of local stockist (U.K. only).

Walnut or  
Mahogany  
27 gns.  
Teak  
30 gns.

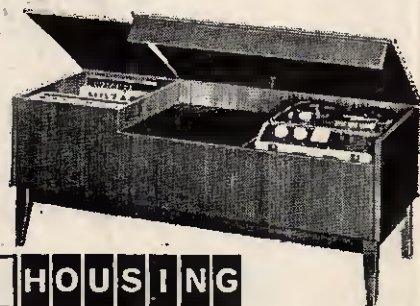

RECORD HOUSING

(Dept PE1), Brook Road, London, N.22  
Telephone: BOWes Park 7487/8



# COMPACT LOUDSPEAKER

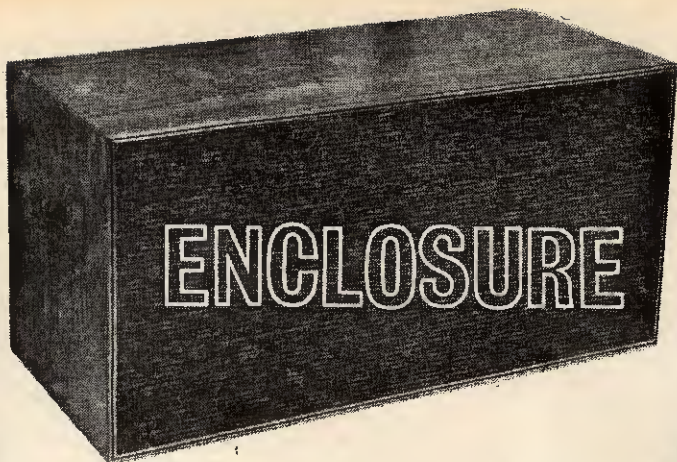

By K. F. RUSSELL  
A.M.I.E.E.

## PART ONE THE DESIGN

THOSE of us who have enjoyed high quality sound reproduction over the last decade or so have sometimes been embarrassed by the size of the enclosures housing our loudspeakers. In addition to the understandable reaction of the ladies to large and sometimes ungainly pieces of furniture, we have also been subjected to a number of entertaining articles, with references to "concrete ovens" and "Beethoven stalking you in the linen cupboard". There are, of course, very good reasons for using concrete and for building enclosures of large volume, but most of us have to live in small rooms where two large loudspeaker enclosures could not be accommodated, and we have to make sure that we are getting the best possible results from the size of cabinet we choose.

### IMPORTANCE OF ENCLOSURE SIZE

Generally speaking, the volume of the enclosure affects only the low frequency performance of the loudspeaker. This can be seen quite clearly from Fig. 1, which shows the response curves of an 8in loudspeaker in cabinets of  $1\frac{1}{2}$  cu ft and 9 cu ft respectively, at A and B. In both cases the performance remains substantially constant at the treble end up to 20kc/s, but at the bass end the 9 cu ft cabinet adds a whole octave to the performance of the loudspeaker compared with the  $1\frac{1}{2}$  cu ft cabinet. The main object of enclosure design is to maintain the frequency response of the system as flat as possible from the centre of the spectrum (say 1kc/s) down to the lowest audible frequency, and from the response curve it will be obvious that the size of enclosure is of great importance.

If we use a full-range cone loudspeaker without a cabinet, the lowest note it will produce is dependent on the size of the baffle on which it is

mounted. The positive and negative pressure waves produced instantaneously at the front and rear of the cone will cancel one another if the path length from front to rear is appreciably less than half the wave length at the frequency being produced. Frequencies in the 50c/s region would require a path length of the order of 11ft, and baffles with dimensions less than this will produce partial cancellation at low frequencies. Because of the large size of baffle required to obtain efficient bass performance, it is more usual to enclose the rear of the loudspeaker to prevent the front radiation from interfering with the radiation from the back of the cone, and to improve the efficiency of coupling the loudspeaker to the air load at low frequencies. There are three basic methods of treating the enclosure, all of which have their advantages and disadvantages, and these will be briefly considered.

### TOTAL ENCLOSURE

If the enclosure is completely sealed apart from the loudspeaker opening, there is no air path between the front and rear of the loudspeaker, and by suitably treating the interior of the cabinet with absorbent material, it is possible to eliminate substantially all the rear radiation. With this type of enclosure, the volume enclosed determines the lowest frequency produced by the system. This is because the smaller

Fig. 1. Response curves of a full range 8in loudspeaker in a  $1\frac{1}{2}$  cu ft enclosure and a 9 cu ft enclosure

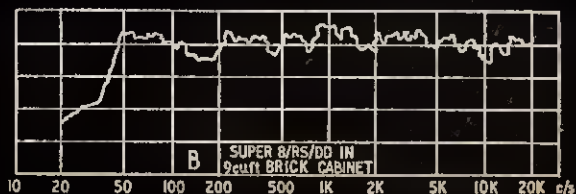
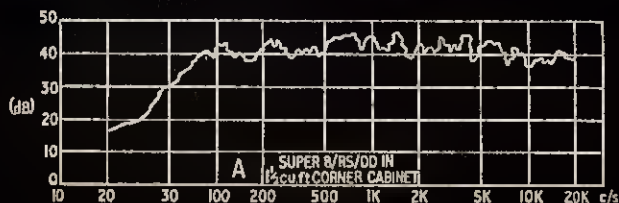

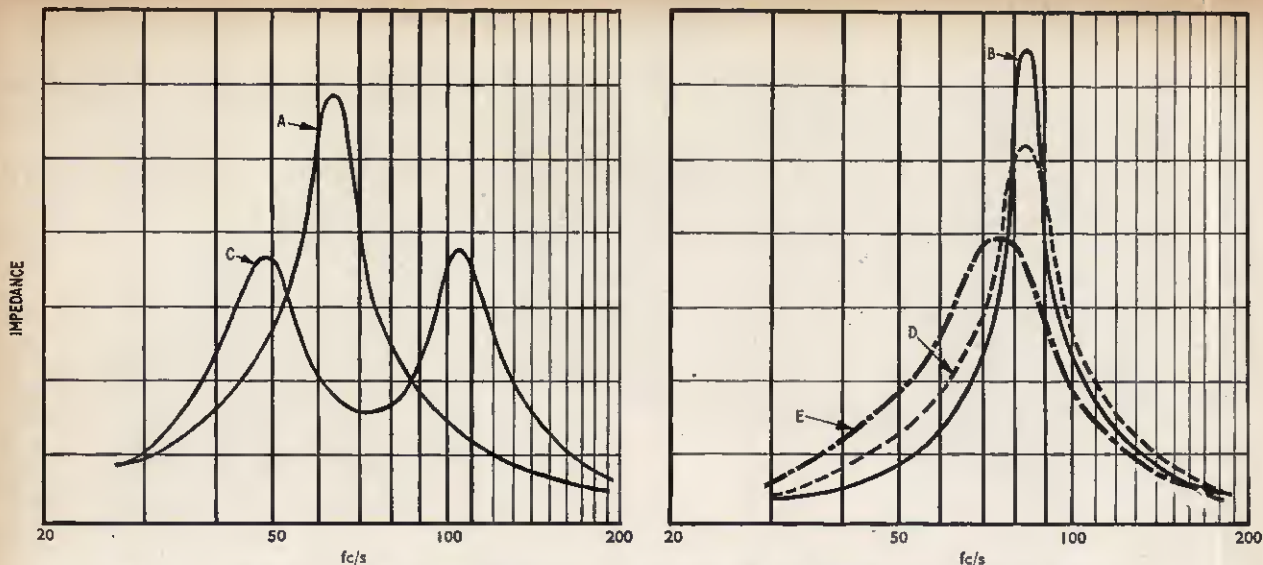

Fig. 2. Impedance curves of a full range unit in a 1 cu ft enclosure. A—open back; B—total enclosure; C—reflex tuning; D—acoustic resistance small area; and E—acoustic resistance optimum area

the volume of the enclosure, the harder it is for the cone to move against the pressure built up inside it. Total enclosures of 12 cu ft or more are very good indeed, and the bass performance remains quite acceptable in total enclosures down to about 4 cu ft. Below this, the low frequency roll-off point rapidly rises from around the 50c/s mark to 100c/s, and with enclosures of  $\frac{1}{2}$  cu ft or less the efficiency is very poor below 150c/s or so.

The effect of the enclosure on the low frequency performance can be seen from Fig. 2, which shows impedance/frequency curves of an 8in loudspeaker in enclosures of 1 cu ft capacity. Curve A shows the rise in impedance at the resonance point of the loudspeaker mounted in such a cabinet, without a back panel fitted. This is therefore equivalent to the open baffle resonant frequency of the unit, and is in the region of 63c/s. Putting the rear panel in position and sealing the enclosure immediately raises the resonant frequency of the system to 84c/s, as seen from curve B, and the Q of the system is also increased slightly. The new resonant frequency of 84c/s represents the point at which the low frequency output of the system begins to disappear. Because of the steepness of the resonance peak, the system sounds objectionable unless a considerable amount of sound absorbent material is inserted in the enclosure. This has the effect of lowering the impedance of the loudspeaker at the resonance point, and it also spreads the hump in the impedance curve over a wider range of frequencies. The result is more pleasant to listen to, but the efficiency of the system is reduced.

### REFLEX ENCLOSURES

Apart from horn loading, reflex cabinets tuned correctly give the best reinforcement to the low frequency output of loudspeakers. Any sized loudspeaker enclosure can be tuned to resonate after the manner of a Helmholtz resonator by providing an opening, sometimes in the form of a tunnel or pipe, of the appropriate dimensions, and the result is called a "reflex" or "bass reflex" enclosure.

The elastic nature of the air inside the enclosure produces a resonating system with the mass of the air in the vent, and the frequency of resonance is entirely determined by the dimensions. If the resonant

frequency of the enclosure is matched to that of the loudspeaker, the system becomes very efficient at that frequency. This is beneficial when the resonant frequency is low because it is always difficult to generate enough power at the lowest frequencies of audibility. At the resonant frequency, the output from the vent and the front of the cone are in phase, which further adds to the efficiency at this frequency, even though at other frequencies the two are out of phase and some cancellation can take place.

The disadvantage of the tuned reflex cabinet is that, like the untreated total enclosure, the resonance point is rather pronounced, and is often audible. Again, internal treatment of the cabinet can largely overcome this defect. It will be seen by referring to curve C of Fig. 2 that, by appropriate design of the vent in the reflex version of the enclosure, the resonance of the system has been lowered from 63c/s to less than 50c/s. Audibly this means that lower frequencies can be reproduced and that there is less distortion in the low frequency range. Fig. 3 shows the waveform of the vent output from a 1 cu ft tuned reflex enclosure fitted with an 8in unit, and it can be seen that even at 30c/s, the waveform is reasonably clean.

There is a second resonance peak in the impedance curve of a reflex system, which is clearly shown in curve C of Fig. 2. In this case the secondary peak appears at a little over 100c/s, and causes a slight rise in output from the system at that frequency. A second peak can be rather annoying audibly, and sometimes is quite difficult to remove.

### ACOUSTIC RESISTANCE

The use of an acoustic resistance in a resonant enclosure is analogous to the use of electrical resistance in an electrically resonant circuit. The resistance usually takes the form of a piece of cloth which covers an opening in the enclosure—in some cases the tuning vent itself. One effect is to lower the Q of the tuned system. The resistance also controls the phase shift at the vent, spreading the vent output over a wider range of frequencies and at the same time suppressing the upper resonance peak which appears on curve C in Fig. 2.

With a small area of acoustic resistance, the tuned frequency of the system is similar to that of a total



enclosure, but the  $Q$  is rather lower. This is seen at curve D in Fig. 2. With a larger resistance area, it is possible to reduce the tuned frequency of the system until it approaches the resonant frequency of the loudspeaker itself, and at the same time to maintain a reasonably sized hump in the impedance curve. The optimum acoustic resistance treatment for the 1 cu ft cabinet fitted with the 8in unit under test is shown as curve E in Fig. 2. The peak of the curve is in the region of 75c/s, but the curve itself is comparatively shallow, resulting in a useful reinforcement of output over a fairly wide band of frequencies. The upper resonance peak of the reflex enclosure has been eliminated.

The acoustic resistance in this case was provided by a number of fairly narrow slots cut in the back of the cabinet, and covered on the inside with a soft woollen cloth. In the case of curve D, four slots were used, and in the case of curve E, 12 slots. The low frequency output of this cabinet is satisfactorily clean, and efficiency is maintained below 50c/s. Low frequency waveforms are shown in Fig. 4, and show little distortion even at 30c/s with an input of 1 watt.

The 1 cu ft design using the acoustic resistance type of loading has been chosen as the subject of the remainder of the article, being the most suitable compromise providing adequate low frequency performance, good sensitivity and compact dimensions, in keeping with the 5 watt integrated transistor amplifier described in this and the two previous issues of PRACTICAL ELECTRONICS.

Having ensured that the enclosure is capable of a smooth and efficient performance at the low frequency end of the spectrum, the next important thing is to choose a loudspeaker unit with suitable characteristics.

### CHOICE OF LOUDSPEAKER

To maintain a good output at low frequencies, it is necessary to move a large amount of air, and this requirement can be most easily met by a unit with a fairly large cone area. In the case of the 1 cu ft enclosure mentioned above, a speaker unit of not less than 8in in diameter is desirable. It is important to choose a unit with a free suspension, so that the fundamental mechanical resonance is reasonably low in frequency. The free suspension is, however, more important in that it will allow a large excursion of the cone at low frequencies, enabling the unit to move a good volume of air and so maintain its efficiency in the low frequency range.

Most well designed units with free cone suspensions also employ long speech coils, which are designed to maintain a constant number of turns in the magnetic gap, even with the longest cone movement. This makes sure that the drive to the cone is in linear relationship with the applied signal. It is also important that the loudspeaker is fitted with a rigid chassis, which will not vibrate on its own account, nor easily distort to throw the speech coil and cone out of alignment. Usually die-cast chassis are better in this respect, but if a pressed steel chassis is employed, it must be of adequate gauge.

The efficiency and overall performance of a loudspeaker are decided to a very large extent by the magnet. A magnet providing high flux density in the speech coil gap is essential to good high frequency response and clean transients. Similarly, a high flux density controls the movement of the coil more efficiently at low frequencies, with the result that the low frequency performance tends to be cleaner.



Fig. 3. Waveform of vent output in a 1 cu ft reflex enclosure fitted with an 8in unit and an input of 1 watt

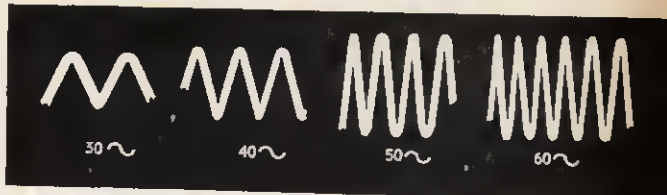

Fig. 4. Waveform of the output of an 8in unit in a 1 cu ft enclosure with slotted back and an input of 1 watt

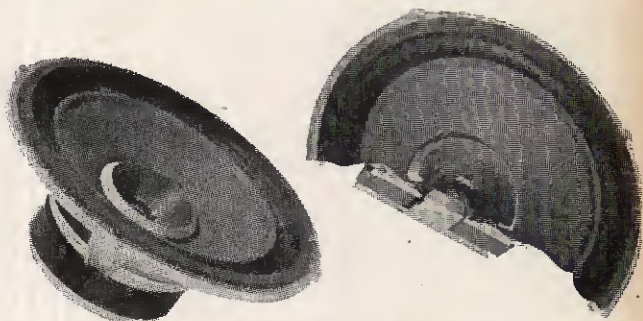

Fig. 5. A full range 8in loudspeaker showing (A) usual appearance and (B) cut away view of the edge suspension and ceramic magnet

Efficiency, too, is related to flux density, so that all in all, a large magnet is of the greatest importance in a high performance unit. This does not mean a slug magnet with a large decorative cover over it. Slug magnets represent a fairly cheap way of providing flux densities up to about 10,000 gauss with high efficiency, but flux densities in excess of this usually demand ring magnets of considerable size and weight. The best units with a diameter of 8in or so are fitted with either Alcomax or ceramic ring magnets providing flux densities in the gap of 14,000 to 16,000 gauss.

A typical high performance 8in unit is shown in Fig. 5. The magnet is of the ceramic type, which is very shallow in depth, and produces a flux density of 14,500 gauss in the gap. The cone is suspended at the edge by an annulus of flexible material with a U-shaped cross section. The main cone generates frequencies up to 10,000c/s, where the small cone takes over. The small cone is directly coupled to the speech coil and carries the response of the unit to above 20kc/s, which is generally regarded as the limit of audibility. The speech coil is wound with aluminium wire in the interests of lightness in the moving parts. The performance of this loudspeaker, as seen from the response curves of Fig. 1, shows quite clearly the effectiveness of the free suspension and the powerful magnet at the two ends of the audible frequency scale.

Next month's article will deal with the construction of a 1 cu ft design using acoustic resistance loading



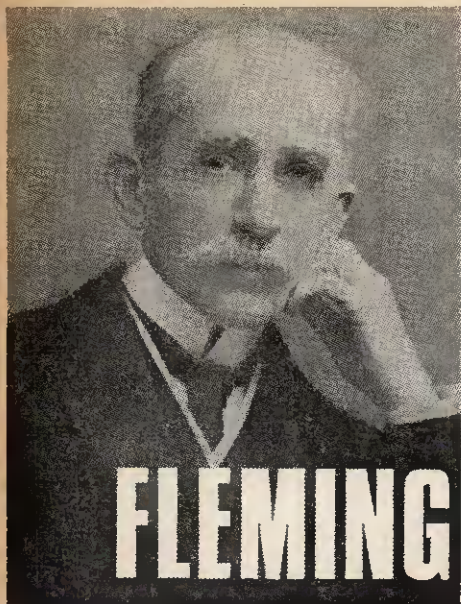

# FLEMING ... AND THE DIODE

## 60th Anniversary of the Invention of the Thermionic Valve by Sir Ambrose Fleming, F.R.S.

**T**HE "Fleming Oscillation Valve", the forerunner of today's vast range of specialised valves, was discovered by Sir Ambrose Fleming just 60 years ago, in November 1904. Perhaps one of the most important electronic discoveries of the century, this invention heralded the birth of the electronics industry.

At the time of his discovery, Sir Ambrose was Professor of Electrical Engineering at University College, London, and since 1899 had been Scientific Adviser to The Marconi Company. He was very closely associated with Marconi himself and had played a leading part in the design of the powerful transmitting equipment at Poldhu in Cornwall, with which Marconi made his first successful wireless transmission across the Atlantic in 1901.

In his search for better methods of detecting electromagnetic or wireless waves, Sir Ambrose, recalling the results of earlier research involving the passage of electric currents through rarefied gases, conducted a series of experiments utilising some of his original apparatus. This new work led him to the discovery of the "Fleming Oscillation Valve", the first thermionic valve produced in the world. This was quickly recog-

...nised by the Marconi Company and the "valve" was soon put into full production.

*Electrical Oscillations  
had in making the flow  
of electricity all in the same  
direction, so that I can  
detect them with an  
ordinary mirror galvanometer.  
I have been receiving signals  
in an aerial with nothing  
but a mirror galvanometer  
and my device, but at  
present only in a laboratory*

*Scale This opens up a  
wide field for work -  
I can now measure exactly  
the effect of the transmitter.  
I have not mentioned this  
to any one yet as it may  
become very useful*

*Yours very sincerely  
J.A. Fleming*

nised by the Marconi Company and the "valve" was soon put into full production.

The immediate effect of Fleming's diode was to improve the sensitivity of the early wireless telegraphy receiving apparatus which previously had been dependent upon coherers or crystal detectors. But the subsequent developments were even more momentous.

One man's discovery frequently inspires other workers in a similar field. This was so in the case of the thermionic valve. Following on the success of Fleming's invention, three years later Lee de Forest of America patented a thermionic valve with a third electrode. The invention of the triode (Lee de Forest originally called it the "audion") made possible both the generation and the amplification of alternating currents; it brought to an end the era of the spark transmitter, and ushered in the wireless telephone. Soon many further potentialities of the valve were perceived . . .

Sir Ambrose died in his 96th year on 18 April, 1945, at Sidmouth, where he had spent the last few years of his intensely active life in retirement.

**(Left) Three early Fleming diodes  
(Right) Two early Marconi production models of the Fleming diode**

**At the top of the page appears a reproduction of the end of a letter from Fleming to Marconi informing him of this discovery which "may become very useful"**

*(Photographs kindly supplied by the Marconi Co. Ltd.)*

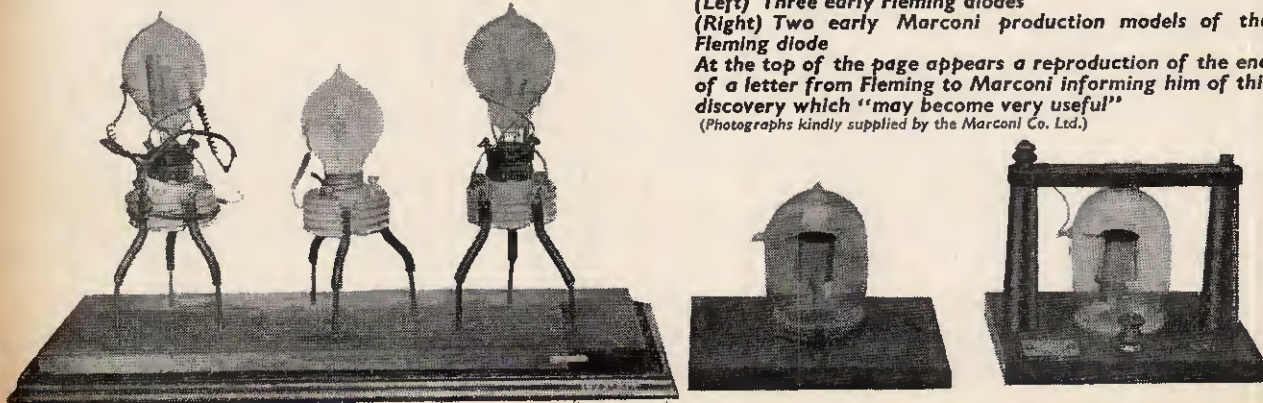





By G. J. FLANAGAN

In photographic enlarging it is necessary to switch the mains powered enlarger on for a known length of time and to do this reasonably accurately.

The timer unit described has been tested during long periods of photographic work and has the advantages of being completely self-contained and, as usual with transistor apparatus, quite small.

The design of the time circuit gives time delays of up to 45 seconds, which is longer than normal exposure times usually required during enlarging.

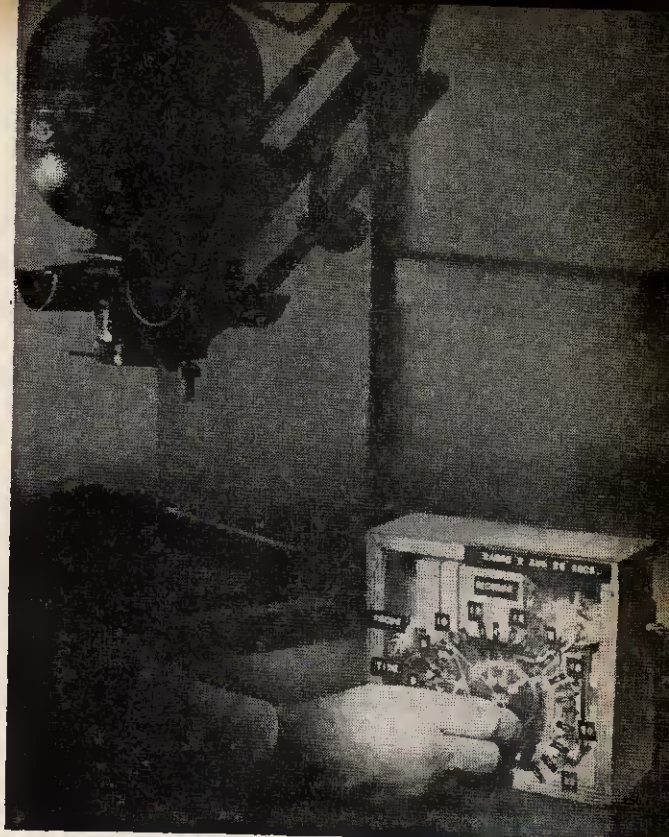

# darkroom timer

PERHAPS the easiest way of considering the working of this circuit is to split it into three distinct parts, the CR time constant circuit, the transistor amplifier which operates the relay, and the actual switching of the mains to the apparatus required.

## THE CR TIMING CIRCUIT

If a capacitor is charged from a battery, and then connected to a resistor, the time taken for the charge to decay is a simple function of the original charge stored in the capacitor and the value of the associated resistor. As may be expected, the larger the charge stored in the capacitor the longer the time it will take to decay; and also the larger the value of the resistor, the less current that can flow, and the longer the time taken for the charge to decay. The amount of charge stored in a capacitor is proportional to the value of the capacitance and the voltage to which it is charged.

The timing circuit uses a constant charging potential, that of the battery supply, applied across a large capacitor C using a variable resistor VR to obtain the variable delays. The time constant of the circuit can be obtained by the product of  $C \times R$  where C is expressed in farads and R in ohms. This gives the approximate delay in seconds. For transistor circuitry, or circuits using large time constants, it is more convenient to think in terms of  $1\mu\text{F} \times 1 \text{ megohm} = 1 \text{ sec}$ .

Referring now to the circuit diagram of the complete unit—see Fig. 1 on blueprint—with the variable resistor VR1 at minimum and the switch S2 in position 1, we have

$1,000\mu\text{F} \times 1/1,000 \text{ megohm (1 kilohm)} = 1 \text{ sec}$   
and, with the variable resistor at maximum

$1,000\mu\text{F} \times 26/1,000 \text{ megohm (26 kilohm)} = 26 \text{ sec}$

In position 2 by similar multiplication, the times are 27 sec and 53 sec. In practice these values are very slightly reduced because of the current taken by the circuit.

## TRANSISTOR RELAY DRIVE

One essential consideration in designing the relay drive is that the time constant obtained from the CR network should be changed as little as possible, that is to say that the current drawn by the base of the first transistor should be much smaller than that passing in the CR circuit. Now the input impedance of the d.c. amplifier circuit (TR1 and TR2) is:

$$Z_{in} = R_b + \beta_1 R_e$$

Where  $R_b$  is the physical resistance of the base-emitter diode of the transistor,  $R_e$  is the emitter resistance ( $= 25/I_e$  ohms,  $I_e$  in milliamps),  $\beta_1$  being the current gain of the first transistor.



Thus, for high input impedance we must use a large emitter resistance between the silicon emitter follower transistor TR1 and the germanium output transistor TR2. In the latter stage the transistor is used in the grounded emitter configuration so that voltage gain is obtained.

A silicon transistor is used for TR1 because of the low leakage current characteristic of this type. The variable 5 kilohm resistor VR2 across the base emitter junction of TR2 enables adjustment to be made to compensate for the differences in the current gains of transistors used in the circuit. VR2 is set to maximum and then reduced till the maximum time on range 1 is 25 seconds.

The diode D1 across the relay RLA prevents the reverse voltages, developed when the output stage is switched off, from damaging TR2.

### SWITCHING CIRCUITS

This section deals with the circuit required to switch a photographic enlarger but, as stated previously, the timer could be used with almost any apparatus requiring to be timed, by suitable changes to this section to suit individual requirements.

In enlarging, the basic course of events are:

- (1) Switch on and focus the enlarger, adjust iris for exposure.
- (2) Switch off enlarger.
- (3) Insert photographic paper and expose.

This cycle is then repeated for each enlargement. The timer in this circuit is only capable of a maximum time of 45 seconds, so that it is clear that for the focusing of the enlarger we must be able to switch on the enlarger independently of the timer. This is most simply done by putting a second switch S3 in parallel with the timer switch. If this is a double-pole double-throw switch it can also be used to switch off the timer supplies when focusing or when the unit is not in use. The arrangement of the relay switching contacts to do this and to charge the capacitor are shown in Fig. 1.

### CONSTRUCTION DETAILS

As can be seen from the photographs, the original unit was constructed on a plywood baseboard and this was fitted with a perspex top. The mounting of the resistors and transistors on the miniature tagstrip is shown in Fig. 5. A 2-pin socket was attached to the original, and also a mains lead, so that the unit when needed could be simply inserted between the mains supply and the enlarger, as would be a piece of extension flex.

The reason for fixing the time range switch and variable resistor to the top of the box, was to enable a long pointer to be used so as to obtain more accurate positioning of the variable resistor, and hence of the chosen time. The second range was expected, from the values chosen, to be 25 seconds greater than the first range which was timed with a stop watch. Spot checks showed this to be correct at the lower end of the scale, but to be about 2 seconds less than this at the longest time. All wiring was cableformed to make a much neater finished unit.

The timer may be powered by a 9V battery, or the mains operated supply unit depicted in Fig. 2 could be employed.

### SAFETY PRECAUTIONS

Any switch controlling the mains supply to apparatus should be fitted in the line side of the mains, so that when the switch is in the off position, the appliance in question is not live. This should be adhered to with this circuit. Since this means that the switch contacts on the timer will always be live while the timer is plugged in, some form of complete cover for the unit is essential. That is to say the circuit should not be built up and left on an open chassis. A cover like the original is ideal but a metal box could also be used, though this should be adequately earthed. This is important as the equipment will be used in near darkness with damp hands.

The timer should give long trouble free service, and save hours of clock watching.

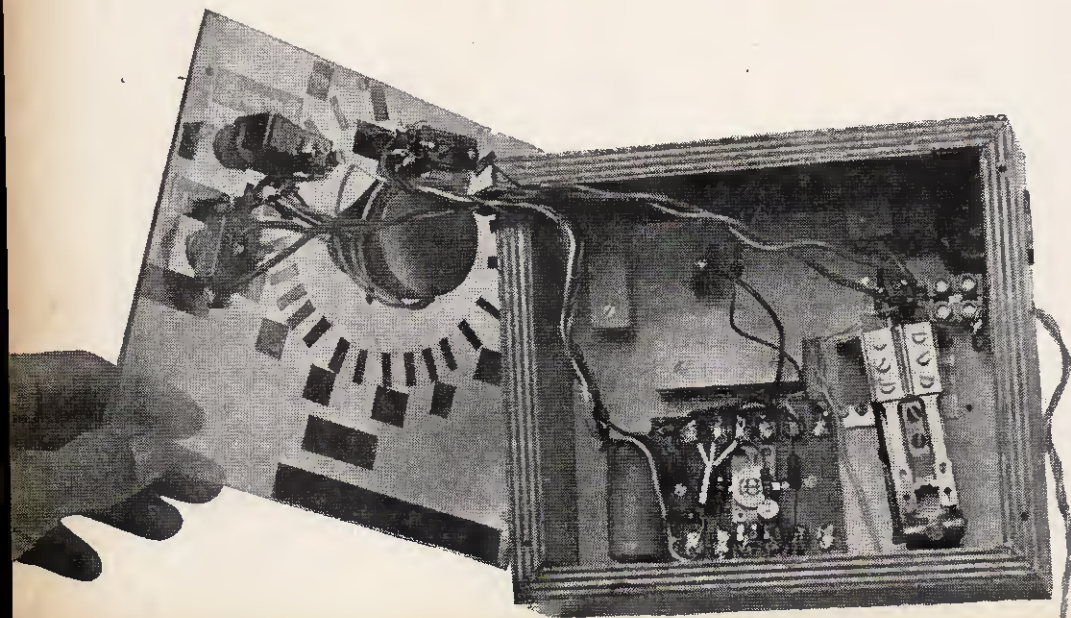

Photograph of the timer showing components mounted on the perspex front panel and layout inside the cabinet.



# LEARN ELECTRONICS — AS YOU BUILD

over **25** CIRCUITS—

**EXPERIMENTS — MODELS and  
TEST EQUIPMENT — including :**



- Valve Experiments
- Transistor Experiments
- Electro-magnetic Experiments
- Basic Amplifier
- Basic Oscillator
- Basic Rectifier
- Signal Tracer
- Simple Counter
- Time Delay Circuits
- **CATHODE RAY OSCILLOSCOPE**
- Square Wave generator
- Morse Code Oscillator
- Simple Transmitter
- Electronic Switch
- Photo-electric circuit
- Basic Computer Circuit
- Basic transistorised radio receiver using *printed circuit*
- A.C. Experiments
- D.C. Experiments

The full equipment supplied comprises: valves, transistors, photo-tube, modern type chassis board; printed circuit board; full range resistors, capacitors and inductors; transformers; potentiometers; switches; transistors; valves; all hardware, wiring and every detail required for all practical work *plus* CATHODE RAY OSCILLOSCOPE for demonstrating results of all experiments carried out. All practical work fully described in comprehensive PRACTICAL MANUALS. Tutor service and advice if needed.

*This complete practical course will teach you all the basic principles of electronics by carrying out experiments and building operational apparatus. You will learn how to recognise and handle all types of modern components; their symbols and how to read a completed circuit or schematic diagram. The course then shows how all the basic electronic circuits are constructed and used, and HOW THEY ACTUALLY WORK BY USING THE OSCILLOSCOPE PROVIDED. An application is given in all the main fields of electronics, i.e. Radio; control circuits; computers and automation; photoelectrics; counters, etc., and rules and procedure for fault finding and servicing of all types of electronic equipment.*

- NO PREVIOUS KNOWLEDGE NEEDED
- NO MATHS USED OR NEEDED
- REASONABLE FEE—NO EXTRAS REQUIRED
- SENT IN ATTRACTIVE BOX
- COMPLETE ADVICE SERVICE
- EVERYTHING REMAINS YOUR OWN PROPERTY

A completely **NEW** up-to-date home study experimental course by **BRITISH NATIONAL RADIO SCHOOL —** Britain's Leading Electronic Training Organisation.

## POST NOW FOR FREE BROCHURE

To: BRITISH NATIONAL RADIO SCHOOL, READING, BERKSHIRE. Please send free Brochure, without obligation, to:

NAME .....

ADDRESS .....

*Block Capitals Please*

PE 1.65.

# THE MOST SUCCESSFUL HI-FI PLAN EVER OFFERED TO CONSTRUCTORS

The new, easy way to build

MARTIN AUDIOKITS comprise a cleverly designed range of prefabricated transistorised units from which you can build from a single pre-amp stage to an integrated 20 watt series hi-fi assembly suitable for use with today's finest accessories. Assembling these tested and guaranteed units could hardly be simpler, but the final results appear thoroughly professional. Quality is superb; attractive knobs and escutcheons are available. As new units come along, they can be added to your assembly stage by stage so that Audiokits are never outdated.

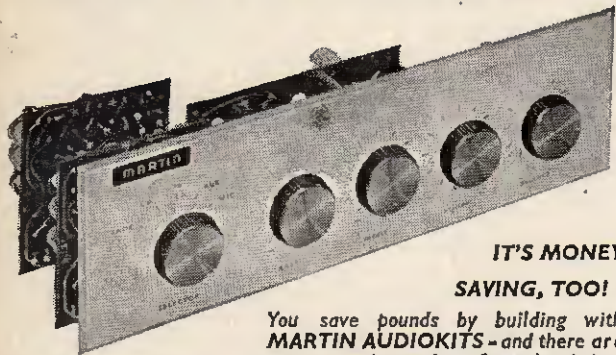

IT'S MONEY SAVING, TOO!

You save pounds by building with MARTIN AUDIOKITS - and there are so many units to choose from that it is a simple matter to select just the units to suit you best.

Coupon brings brochure by return

F.M. TUNER  
Advance Notice

A quality VHF/FM Tuner designed specifically for use with Audiokit and other Hi-Fi assemblies will be ready for release very soon. Details will gladly be sent on request.

## MARTIN Audiokits

MARTIN ELECTRONICS LTD., 154/5 HIGH ST., BRENTFORD, MIDDLESEX  
Phone: ISLeworth 1161/2

MARTIN ELECTRONICS, 154 HIGH ST., BRENTFORD, MIDDLESEX

Leaflet showing Details of all Martin Audiokits, please to

NAME.....

ADDRESS.....

P.E.1.....

**TYGAN FRET** (Contem. pal.), 12 x 12in. 2/4-12 x 18in. 3/4-12 x 24in. 4/4-etc.  
**EXPANDED ANODISED METAL** - Attractive gilt finish 1/2 in. x 1/2 in. diamond mesh 4/8 sq. ft. Multiples of 6 in. cut. Max. size 4ft. x 24ft., 47/8, plus carr.  
**BONDAGOUT** Speaker Cabinet Acoustic Wadding (1in. thick approx.) 12in. wide, any length cut, 1/8 ft., 4/4-yd.

**Volume Controls** - BK-2 Meg. ohms, 3in. Spindles. Morganite Midget Type 3in. diam. Quar. 1 year. LOG or LIN ratios less Sw. 3/- DP. Sw. 4/6. Twin Stereo less Sw. 6/6. DP. Sw. 8/- Specials to order.

**WAVECHANGE SWITCHES.** 1 p. 12-way, 2 p. 2-way, 2 p. 6-way, 3 p. 4-way, 4 p. 2-way, 4 p. 3-way, long spindle, 3/8 ea.

**ENAMELED COPPER WIRE** - 1lb. reels 14g-20g, 2/6; 22g-26g, 3/-; 28g-34g, 3/8; 36g-38g, 4/3; 39g-40g, 4/6, etc.  
**TINNED COPPER WIRE** 16-22g, 2/6 1lb.  
**ERSIN MULTIGORE SOLDER.** 60/40 4d. per yard. Containers 2/6, etc.

New Boxed VALVES	Reduced Bargain Prices	
1T4 3/8	EF86 9/8	PCL83 10/6
1R5, 185 6/-	EL33 12/8	PCL84 10/-
354, 3V4 7/-	EL34 12/8	PCL85 11/6
6CC81 7/-	EL84 7/-	PL36 10/6
6CC82 7/-	EY81 9/-	PL81 9/8
6CC83 7/-	EY85 9/-	PL85 8/-
ECL80 6/-	EZ81 7/-	PY33 10/6
ECL82 10/-	GZ32 9/8	PY82 7/-
ECL85 10/6	PC884 3/-	U28 10/6
EF80 7/8	PCF80 3/-	UL84 9/-

**CO-AX 80 ohm CABLE**  
High grade low loss Cellular Air Spaced Polythene - 1/4in. diam. Stranded Cond.  
Now only 6d. yard  
**BARGAIN PRICES - SPECIAL LENGTHS**  
20 yds. 9/-; P. & P. 1/6. Coax. Plugs 1/-; 40 yds. 17/8; P. & P. 2/6. Sockets 1/-; 60 yds. 25/-; P. & P. 3/6. Couplers 1/8.

## DE-LUXE RECORD PLAYER KIT

Incorporating 4 Sp. Garrard Auto-Slim unit and Mullard latest 3 watt printed circuit amplifier (ECL86 and EZ80), vol., bass and treble controls, with 8 x 5in. 10,000 line speaker. Contemporary styled two-tone cabinet, charcoal grey and off-white with matching blue relief. Size 17 1/2 in. x 16 in. x 8 in. A stylish unit capable of quality reproduction. Circuit and const. details 2/6 (free with kit).



**COMPLETE KIT**  
Carr. and ins. 10/- £13.19.6

Illuminated Perspex control panel escutcheon 7/6 extra. Ready wired 30/- extra. 4 contemporary mounting legs (6 or 13in.), 12/6 per set.

## RECORDING TAPE

Famous American Columbia (CBS) Premier quality tape at NEW REDUCED PRICES. A genuine recommended Quality Tape - TRY IT. Brand new, boxed and fully guaranteed. Fitted with leader and stop coils.

Standard	Double Play	Long Play	SPECIAL OFFER 3" Message
5' 600'	13/- 1,200'	31/8 900'	17/8
5 1/2' 900'	18/- 1,800'	27/8 1,200'	19/8
7' 1,200'	21/- 2,400'	47/8 1,800'	28/8

Post & Package per reel, 1/- plus 6d. each for additional reels.

Speakers P.M. - 3 ohms 2 1/2" E.M.I. 15/6. Goodmans 2 1/2" 16/6. 5" P.M. 15/6. 6" Elac 16/6. 7" x 4" Goodmans 15/6. 8" Rola 15/6. 10" R. x A. 25/-.  
9" x 6" Goodmans 22/6. E.M.I. Ceramic Magnet 37/8. Tweeter 22/6. Jack Plugs. Standard 2 1/2" Irganite Type, 2/6. Screened ditto, 3/8. Miniature scr. 1 1/2", 2/8. Sub-min. 1/8.

**TRS RADIO COMPONENT SPECIALISTS**  
76 Brigstow Rd., Thornton Heath, Surrey.  
THO 2188. Terms C.W.O. or C.O.D. Post and Packing up to 1 lb. 9d.; 1 lb. 1/8; 3 lb. 2/8; 5 lb. 2/8; 8 lb. 3/6.

## TRANSISTOR COMPONENTS

Midget I.F.'s - 465 Kc/s 3/4 in. diam. .... 5/3  
Osc. Coll M. & L.W. .... 6/8  
Midget Driver Trans. 8.5:1 .... 6/8  
Midget Output Trans. Push-Pull - 3 ohms ..... 6/9  
Elect. Condensers - Midget Type 1 mid.-60 mfd. ca. 1/8, 100 mid. 2/-, 12V.  
Condensers 150 v. working: .01 mfd., .02 mfd., .03 mfd., .04 mfd. 9d.; .05 mfd., .1 mfd., 1/-; .25 mfd., 1/8; .5 mfd., 1/6, etc.  
Midget Tuning Condensers. J.B. 100' 208 pF and 175pF, 2/6; ditto with trimmers, 3/8. J.B. 220pF and 105pF conc. slow motion 10/8. 305pF single 7/8.

Condensers - Silver Mica. All values 2pF to 1,000pF 6d. each. Ditch Ceramics 9d. Tub. 450V T.C.C. etc. 0.001 mfd to 0.01 and 0.1/350V. 8d. 0.02-0.1/500V. 1/- 0.25 Hunt, 1/8. 0.5 T.C.C. 1/8, etc., etc. Close Tol. 2/Minas - 10% 6pF-600pF, 8d. 600-5,000pF, 1/-, 1% 2pF-100pF, 8d. 100pF-500pF, 11d. 570pF-5,000pF, 1/8. Resistors - Full Range 10 ohms-10 meg. ohms 20% 4d and 1/4V, 3d., 1/4W, 5d. (Midget type modern rating) 1W, 6d., 2W, 9d. Hi-Stab. 5% 1W, 1/3W, 6d. (100 ohms-1 meg). Other values 9d. 1% 1W, 1/8, etc., etc.

**TRIMMERS, Ceramic (Compression Type) -** 30pF 50pF, 70pF, 8d.; 100pF, 150pF, 1/8; 250pF, 1/8; 600pF, 1/8.  
**PHILIPS.** See HIVE Type (conc. air spaced) - 2-8pF, 1/-; 3-30pF, 1/-.  
**KNORR** - Modern Continental types. Brown or Ivory with Gold Ring; 1" dia., 8d. each; 1 1/2", 1/- each; Brown or Ivory with Gold Centre, 1" dia., 10d. each; 1 1/2", 1/8 each. LARGE SELECTION AVAILABLE.

**METAL RECTIFIERS.** 5TC Types - RMI, 4/8; RM2, 5/8; RM3, 7/8; RM4, 16/-; RMs, 21/-; RM4B, 17/6; Mullard B100, 10/6.

**TUB-ELECTROLYTICS-CAN**  
25/25v. 50/12v. 1/8; 8 + 5/450v. 4/8; 60/50v. 100/125v. 2/-; 32 + 32/275v. 4/8; 8/450v. 4/350v. 2/8; 60/50/350v. 6/8; 16 - 16/450v. 5/8; 60/250/275v. 12/8; 32 + 32/450v. 6/8. 100 + 200/275v. 12/8.



# Readout—

## A SELECTION FROM OUR POSTBAG

### "Just what I have been seeking"

Sir—I feel certain that you will receive many letters praising your excellent new magazine, and wonder whether mine will be noticed among them, but I would like to say, all the same, how much I appreciate it.

I am thinking of taking up electronics as a career, and this publication is just what I have been seeking, from which to find general information, practical projects and the like. I am sure that it will be widely read and appreciated by electronics enthusiasts everywhere.

Thank you again for a fine magazine.—Yours faithfully,

DAVID JONES,  
Pwllheli, Caerns.

### Aid to homework

Sir—I wish to congratulate you on your new publication and wish it well for the future. I found the subject matter worthwhile and the booklet and resistance colour card worth the money. Even the Greek alphabet helped me with my son's homework. I hope you will continue along transistor lines, since the field is wide open to you relative to other publications.

I would privately welcome an attempt to list transistor equivalents—even if only approximate—and to give relative characteristics, i.e. type with type. Even if you don't get down to this I shall continue to take your publication. I wish you well.—Yours sincerely,

G. T. C. MORRIS,  
Carshalton.

### Roding Boys' Society

Sir—May we be so bold as to offer our congratulations regarding your new Journal. It should be just the thing for modern youth, and for that matter anyone with an up-to-the-minute mind.

Our own Society is dedicated to spreading science, electronics and similar activities for boys, as we think such things are sadly neglected in the Youth Programme of this country. However, many other things of great interest to lads are pursued . . . camping, expeditions, visits, etc.

There may be many of your new readership who would be very interested in the work of our Society, either as keen lads who might like to join in, or as patrons who feel like helping to spread this movement. We hope you think our activities worth mentioning in the pages of "P.E."—Yours sincerely, (signed)

D. MOERE, R. PHIPPS,  
R. MARCHANT, A. JONES  
(members) and  
K. L. SMITH, B.Sc.,  
G3JIX, Leader R.B.S.

### Beginners . . .

Sir—I have just read the first issue of your magazine and I must say I am impressed by your approach to beginners in radio and electronics—this I may say has been long awaited by many youngsters I know.—Yours faithfully,

H. S. YORKE, A.I.P.R.E.,  
Dunfermline, Fife.

### . . . Start here

Sir—First of all may I congratulate you on a first rate magazine. However, may I plead as a technical man myself that the magazine (or a portion of it) will not "talk" to us as though we were about fourteen years old.

I would appreciate the inclusion of articles dealing with radio control.—Yours faithfully,

R. F. POTTER,  
Middleton, Kings Lynn.

*Conflicting points of view! Maybe some newcomers to electronics would like to express their opinions of the manner in which this series is presented?*

### Mains stabiliser

Sir—Congratulations on a publication which seems very likely to be the much needed bridge between the other "Practicals". I am much impressed by the start, and hope that the continuation will be as good or better.

May I make a suggestion for early inclusion in "Constructional Projects"? Many readers would, I know, be glad to be able to build a mains voltage stabiliser suitable for use with electronic equipment, using components in relatively cheap supply. The following is the probable spec: Input 200–250V, 50c/s; Output 230–240V, 50c/s; Loading 0–25W. This type of unit would be of such great use with very many types of electronic gear that it may be worth an early priority in the series.—Yours faithfully,

C. A. HARLING,  
Cheltenham.

*We can almost certainly promise you a mains voltage stabiliser of this kind before long.*

### Electronic ignition

Sir—I should like to congratulate you on your new magazine. What a boon it will be to enthusiasts who are interested in electronics other than radio and television, subjects which are already well catered for by your sister magazines.

I was very interested in your article "Semiconductor Devices for Automobiles" especially the section dealing with transistor assisted ignition. If it is possible could you please let me know the value of the individual components in this circuit as I should like to attempt constructing one. Thank you very much for some very interesting reading.—Yours truly,

J. R. FENN,  
Stratford, London, E.15.

*This was essentially an introductory article. It is our intention to publish more detailed design information on transistor ignition systems in the future.*

### Garage door control

Sir—With reference to your remarks about garage door control you may be interested to hear that I have constructed a mechanism operated by simple low frequency magnetic induction. A ferrite rod is mounted behind the wall and has its coil connected to a two stage d.c. transistor amplifier. This operates a relay when a signal is received.

# Readout—

A SELECTION FROM OUR POSTBAG

continued

A simple oscillator comprising another ferrite rod, power transistor, capacitor, and battery is housed in a plastics torch case and this is carried in the glove box of the car. To operate, the "torch" is pointed through the windscreen at the brick wall.

I wish to take this opportunity of wishing you and PRACTICAL ELECTRONICS every success.—Yours faithfully,

T. J. KELLY,  
Worcester Park, Surrey.

*Magnetic induction systems are often used for control and communications purposes, but it must be noted that such systems are subject to the Wireless Telegraphy Act, and require a G.P.O. licence.—J. Valence.*

## Future projects

Sir—Congratulations! PRACTICAL ELECTRONICS is a really fine magazine, well presented, well illustrated and readable!

Can I dare hope for a readers' letters page, in the near future, and please, plenty of articles on inexpensive electronic apparatus for the constructor, test-gear, receivers, amplifiers, etc., both valve and transistor, in each issue.

Yes, a grand magazine, worthy of every enthusiast's support—my regular order has already been placed.—Yours sincerely,

H. E. CHAMBERLAIN,  
Newark-on-Trent, Notts.

Sir—Congratulations on your very forward-looking journal. I am very pleased that you will be concentrating on the solid-state physics of tomorrow.

I would like you to consider giving us constructional articles on the following: Electronic Flash-gun (transistorised circuit) and a battery portable tape recorder based on the Garrard battery-operated tape deck. Other articles which I would personally find very interesting would be a continuation of your "Electronic Didjeridoo" to include a square wave tone generator, attack and decay control, and a vibrator or tremolo

oscillator and amplifier. All these must be circuits using transistors of course.

Perhaps a more ambitious series of articles on making an oscilloscope using transistors could be considered, as also an electronic organ. A photo-electric light meter using light sensitive transistors would not come amiss either.

Enough for the moment on suggestions for future subjects. I am sure this magazine will be a great success.—Yours faithfully,

H. R. DUBASH,  
London, S.E.4.

*Our thanks to all those readers who have offered suggestions for future constructional articles. We have a busy and exciting time ahead!*

## Simple geiger-muller ratemeter

Sir—I like the first copy of PRACTICAL ELECTRONICS and have placed a regular order. Will you kindly ask Mr. Rowles whether an equivalent to the HC4 may be used for his ratemeter? May the MX168 be used instead. Perhaps Mr. Rowles would compare these two tubes for me.—Yours faithfully,

H. S. KING,  
Head of Science Dept.,  
Saint Ivo School,  
St. Ives, Huntingdon.

*The ratemeter described was designed for use with halogen quenched type Geiger tubes. As the MX168 is of this type it is quite in order to use this tube. The working voltage of this and other Mullard MX tubes is 420V, hence no alteration to the circuit as published is required. (But please note the correction to the values of R1 and R2 given on page 129 of last month's issue). The author has tried the MX168, MX115, MX108 and a surplus type tube PET 40 in the ratemeter, all giving satisfactory results.—J. F. Rowles.*

## School's report

Sir—Having had a chance to look over the first issue of PRACTICAL ELECTRONICS since yesterday, I am sure that you will be pleased to know that I approve very much its content and general layout and will have no hesitation in bringing it to the attention of pupils and colleagues.

I am especially pleased with the article on the simple Geiger-Muller ratemeter (possibly because we have just made one ourselves which might stand a little modification) and I was surprised and delighted to find the promise of a

follow-up with some basic experiments. I am also rather surprised, but very pleased to find the inclusion of such articles as "Beginners Start Here" and "New look at the Electron". These and the comments of "Detached Particles" and the other news and comment articles give, in my view, an excellent balance to the constructional projects.

For the future, I would like to see a series dealing with binary counters and simple computing elements.

In this type of magazine I think the adverts are an essential part of the reading material. You are probably as well aware of this as I am, but I think it does bear repeating that the adverts form an important consumer service—particularly in the electronics field which is ever expanding and where we often require components that we, in the provinces, cannot expect to obtain locally and which could be extremely expensive if we were not able to obtain surplus or second-hand items.—Yours faithfully,

R. MITCHELL, B.Sc.,  
Science Dept.,  
Buckhaven High School,  
Buckhaven, Fife.

## "Mathematical snobbery"

Sir—I have just read through the first number of PRACTICAL ELECTRONICS and must write to congratulate you on this production. There are only one or two small points I would criticise:

- (1) The unnecessary introduction of somewhat advanced mathematical formulae into the midst of an otherwise useful practical article by J. F. Rowles. There is a kind of mathematical snobbery which demands a mathematical appendix to scientific articles in more theoretical papers but it is out of place in the present context.

- (2) I do not follow the transistor biasing arrangements in the same article—However I was brought up on valves.—

Yours faithfully,  
R. W. SAWYER, B.Sc.,  
Head of Science Dept.,  
The Grammar School,  
Ilminster, Somerset.



# VALVE ON-OFF CIRCUITS

By G. D. Howat

THERE are three electronic circuits, all based on a common symmetrical configuration, which can be applied to a very wide range of problems. They form, in effect, three variations on a theme, and comprise the multivibrator, the monostable switch or flip-flop, and the bistable switch. It is the purpose of this article to discuss briefly the properties of the first and last of these circuits, and to investigate the flip-flop in more detail. Also it will be explained how these principles were applied to a particular design problem.

The theme and variations are set out in Fig. 1. It is seen that the first and last variations are symmetrical but the flip-flop is not.

## MULTIVIBRATOR

The multivibrator, probably the best known of the three, is a free-running oscillator which produces a square wave output at each anode. It is very useful as a signal generator and signal tracer because of the high harmonic content of the square wave output. It also finds uses in timebases, audio frequency equipment (tone generators, organs) and in various specialised applications including pulse radar techniques.

The multivibrator action consists of the alternation of two complementary astable states. In case there is any confusion about the meaning of the term "astable state", a mechanical model may help to clarify the problem. A sphere resting anywhere on a sloping surface as in Fig. 2a is an astable system since it will not remain in this condition but will roll down the slope. If two such systems are arranged as in Fig. 2b we have the mechanical analogy of a multivibrator with the sphere continually changing over from one astable state to the other.

At any instant one of the valves (V1 in multivibrator) conducts and its anode is at a potential below the h.t. The grid of V2 is negative, making the valve non-conducting. C2 charges up via R2 and R3 to almost the full h.t. voltage. At the same time C1 is slowly discharging and the voltage on its lower end is rising towards earth. At a certain point on this rise V2 starts to conduct and the potential on the top end of C2 falls. Since this capacitor has most of the h.t. voltage across it the falling potential at the anode end of C2 pushes the voltage on the grid of V1 below earth. This results in an "avalanche process": the anode end of C1 rises in potential as V1 cuts off and the grid of V2 becomes even more positive. More voltage appears across R3 and, via C2, the grid of V1 is pushed more negative still until finally the valve is cut off. The second half-cycle is now in progress and is a mirror image of the first, i.e. V2 is now conducting and will continue, via C2, to hold V1 cut off until a sufficient amount of the charge on C2 has leaked away through R2. When this has happened another change-over occurs, identical with the first, and returns the circuit to its original state. Since each anode alternates between being cut off and conducting at constant current, the output waveform at the anodes will be the familiar square shape.

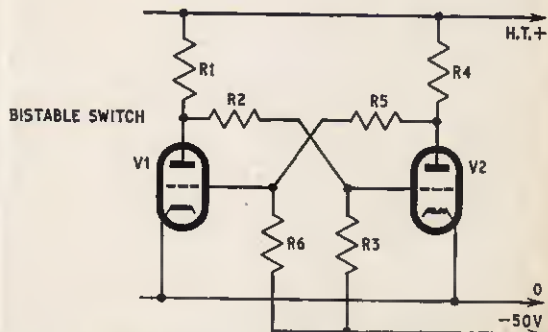
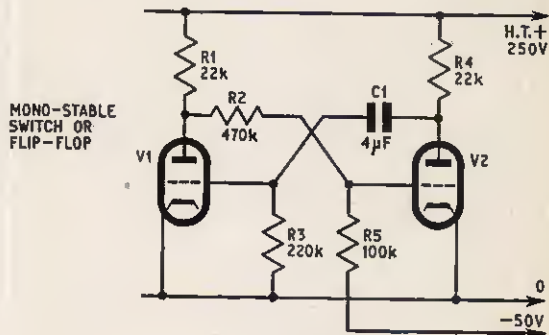
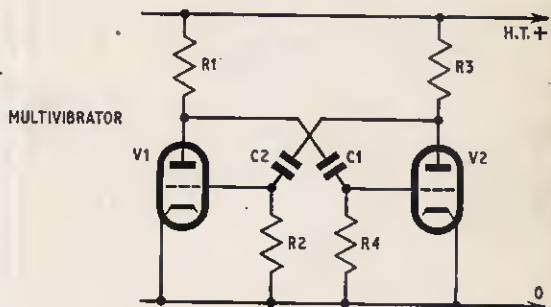
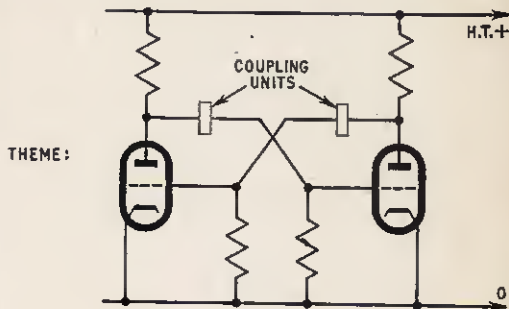

Fig. 1. Basic configuration and practical on-off circuits

## MECHANICAL ANALOGY

Before going on to discuss the remaining two circuits, it is necessary to explain the meaning of some more of the terms used, especially monostable, bistable, and quasi-stable states. These are demonstrated by the models drawn in Fig. 3. Fig. 3a shows a cone resting on a sloping surface—this being an example of a monostable system: if the cone is pushed it will always roll back to the same position. That is, it only has one position where it will remain stationary although, unlike the astable system, it will remain on the slope. If this model is modified as in Fig. 3b then the result is rather different. There are now two independent stable positions which the cone can take up—one on each side of the model. If the cone is pushed uphill it will change over from one stable state to the other, by simply rolling over the top. A second push will cause it to move back again. This is then a system with two stable states and is thus called a bistable system as distinct from a monostable one.

conducting, then a voltage exists across R1. The potential divider action of R2, R3 results in a negative voltage being applied to the grid of V2 keeping it cut off. Because of this there is no equivalent voltage across R4 and the other potential divider, formed by R5 R6, cannot bias V1 to cut off as the top of R5 is nearly at h.t. voltage. V1, therefore, continues to pass current. This represents one stable state—one valve conducting and the other one held cut off by it. Unlike the similar situation in the multivibrator, however, it will remain in this state indefinitely. The other stable configuration is the mirror image of the above one with V2 conducting and the voltage across its anode load keeping V1 cut off. In order to make the switch change over a suitable triggering pulse must be applied to the grid of the conducting valve. A negative pulse is required and it momentarily cuts the valve off, allowing the other one to take over the conducting state.

Since the bistable switch will remain in either of its stable states indefinitely it has the property of being

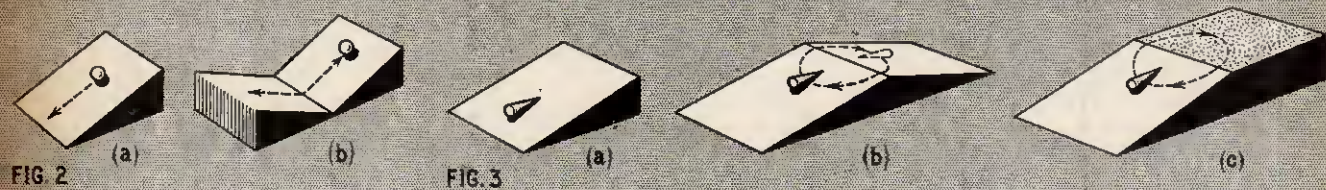

Figs. 2 and 3. Mechanical analogy of the circuit principles

If the top of the wedge in Fig. 3a is almost, but not quite, flattened as in Fig. 3c then we have a situation part way between the above two. If the cone is pushed it will roll up the plain area of 3c onto the dotted area. It will remain here for a short time, moving very slowly, but since the dotted area is slightly tilted it will ultimately roll back down to its initial position on the front (unmarked) section. This shows the action of a system with one stable and one quasi-stable state. When the cone is pushed it moves from the stable condition (blank front region) to the quasi-stable condition (on the dotted area) and stays here for a short time. Unlike the bistable system, however, it then reverts to the initial condition without the action of any external agent.

### BISTABLE SWITCH

The bistable model described above has an analogy in electronics in the form of the bistable switch. The basic circuit of this is shown in Fig. 1. The mode of operation of a bistable switch is quite simple and in some ways resembles that of a multivibrator. At any time one of the valves in Fig. 1 is conducting so there is a voltage across its anode load. Suppose V1 is

able to "remember" one single bit of information. As such it is used sometimes in the memory units of computers. Digital computers work on binary arithmetical methods, that is mathematics based on only two numbers. One bistable switch can therefore remember the entire numerical system of binary arithmetic, by letting one stable condition represent one digit and the other stable state the other one. In binary then one switch can remember 0 and 1, two switches can remember 0, 1, 2 and 3, three can remember 0 to 5 and so on. Any number can thus be stored in a sufficient number of bistable switches in binary arithmetic.

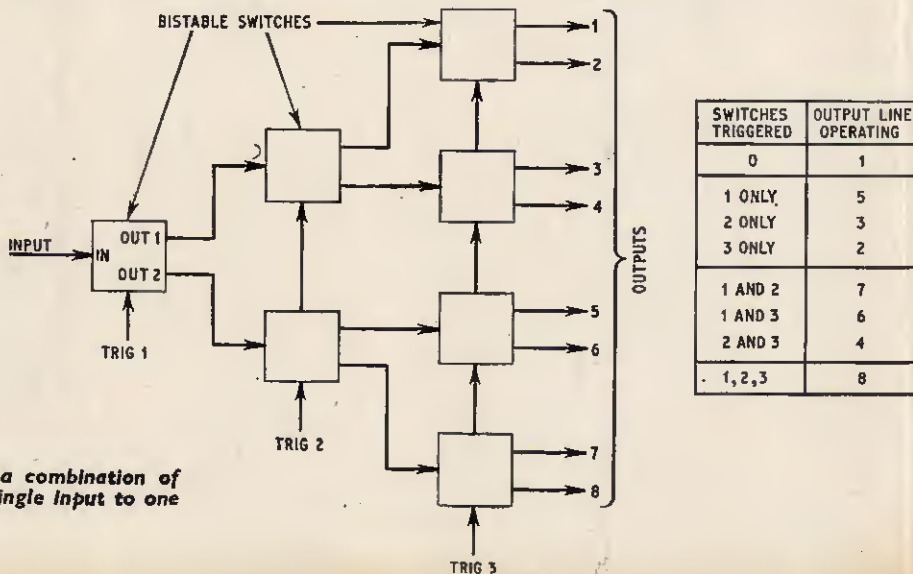

Fig. 4. An example of how a combination of switch settings connects the single input to one of eight different outputs



Now if a certain computation or calculation is required these signals can be combined in a pre-determined manner by using gates. There are five principle kinds of gate operations: AND, OR, NAND, NOR, NOT. The circuits of two of these are shown in Fig. 11. The AND circuit combines the input signals (corresponding to noughts and ones by multiplying them together. The OR circuit combines them by addition. NOT denotes a negative quantity. The NOR circuit combines the functions of both NOT and OR, while NAND combines NOT and AND functions.

#### Binary code

Suppose we want to add two numbers. For simplicity we will take 27 and 14. 27 is broken down to values of the power of 2:

$$\left. \begin{array}{r} 2 \times 2 \times 2 \times 2 \times 2 = 2^4 = 16 \\ 2 \times 2 \times 2 \times 2 = 2^3 = 8 \\ 0 = 0 = 0 \\ 2 = 2^1 = 2 \\ 1 = 2^0 = 1 \end{array} \right\} \text{added together} = 27$$

The binary coded values would then be

$$\begin{array}{r} 2^4 + 2^3 + 0 + 2^1 + 2^0 \\ 1 \quad 1 \quad 0 \quad 1 \quad 1 \end{array}$$

All positions from the highest power of 2 down to  $2^0$  must be filled. In this case  $2^2$  is not used so must be entered as 0. Now let us break down 14 as follows:

$$\left. \begin{array}{r} 0 = 0 = 0 \\ 2 \times 2 \times 2 = 2^3 = 8 \\ 2 \times 2 = 2^2 = 4 \\ 2 = 2^1 = 2 \\ 0 = 0 = 0 \end{array} \right\} \text{added together} = 14$$

Here  $2^4$  and  $2^0$  are not used and must be represented by 0. The binary values would be

$$\begin{array}{r} 0 + 2^3 + 2^2 + 2^1 + 0 \\ 0 \quad 1 \quad 1 \quad 1 \quad 0 \end{array}$$

By adding the two series of digits the same rules apply as in ordinary arithmetic except that when the answer is a 2 or more the remainder is written down and the quotient carried to the next column on the left. For instance if the answer is 2, divide by 2, carry this answer to the next column on the left and write down the remainder (0).

$$\begin{array}{r} 11011 \text{ (representing 27)} \\ 01110 \text{ (representing 14)} \\ \hline \end{array}$$

101001

It will be seen that all even numbers are represented by 0 and odd numbers by 1. Now converting back to a decimal number

$$\begin{array}{r} 1 \quad 0 \quad 1 \quad 0 \quad 0 \quad 1 \\ 2^5 + 0 + 2^3 + 0 + 0 + 2^0 = 41 \\ 32 + 0 + 8 + 0 + 0 + 1 = 41 = 27 + 14 \end{array}$$

★

## VALVE CHARACTERISTICS

### A.C. Resistance

The a.c. resistance of a thermionic valve is equal to a *small change* in anode voltage divided by a *small change* in anode current.

$$r_a = dV_a/dI_a$$

where  $d$  denotes the small part in the  $V_a/I_a$  characteristic which is almost linear—see Fig. 9 on page 3 (last month's issue).

### Mutual Conductance

The mutual conductance of a valve is an expression of the effect of changes in anode current due to changes in grid voltage.

$$g_m = \frac{dI_a}{dV_g}$$

where  $d$  denotes the small part of the  $I_a/V_g$  characteristic which is almost linear—see Fig. 9 on page 3 (last month's issue).

### Amplification Factor

The ratio of  $V_a$  to  $V_g$  is called the amplification factor ( $\mu$ ).

$$\mu = \frac{dV_a}{dV_g}$$

where  $d$  denotes the small parts of the characteristics which are used.

### Stage or Amplifier Gain

Stage gain is given as the ratio of a.c. signal voltage at the output to that at the input.

$$\begin{aligned} \text{Voltage gain} &= \frac{\text{output signal voltage}}{\text{input signal voltage}} \\ &= \frac{\mu v_{in} R_L}{R_L + r_a} \end{aligned}$$

where  $v_{in}$  is the input signal voltage and  $R_L$  is the anode load. This is often converted to decibels by using the following expressions:

$$\begin{aligned} \text{Voltage gain} &= 20 \log_{10} \left( \frac{\text{output voltage}}{\text{input voltage}} \right) \text{ dB} \\ \text{Power gain} &= 10 \log_{10} \left( \frac{\text{output watts}}{\text{input watts}} \right) \text{ dB} \end{aligned}$$

### Corrections to Data Booklet—2 (last month's issue)

page 2, Theory

Expression in the second line should read:  $I_a \propto V_a^{3/2}$

page 4, Applications

The last line in the first paragraph should read:

“... between anode and grid, known as the Miller Effect.”

## MICROPHONES

Microphones can be divided into four basic types according to their polar sensitivity patterns. The correct use of directional characteristics in microphone placement reduces the effects of extraneous noises and reverberation.

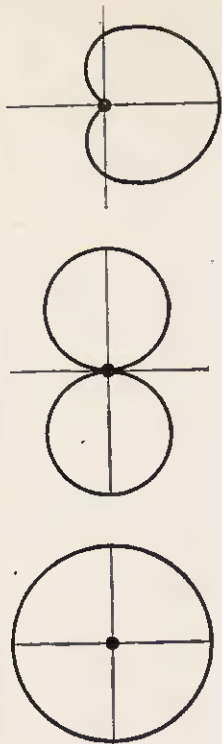

Fig. 1. Cardioid

Fig. 2. Bidirectional

Fig. 3. Omnidirectional

### Unidirectional

The most popular type of unidirectional microphone is the cardioid, the polar characteristic of which is shown in Fig. 1. This characteristic is achieved by combining the principles of a velocity and a pressure microphone. Typical front to back sensitivity ratios are of the order of 15dB but a single-element ribbon type has been developed with a ratio of 20dB. Unidirectional microphones are particularly useful for public address work where the risk of acoustic feedback has to be minimised.

### Bidirectional

The polar characteristic shown in Fig. 2 is typical for a bidirectional velocity ribbon microphone. Sound is picked up from the front and rear of the microphone at approximately equal intensities.

### Omnidirectional

The sensitivity of an omnidirectional microphone, as can be seen in Fig. 3, embraces a circular area around it. Crystal and dynamic microphones can be made omnidirectional and are particularly suitable for recording large orchestral concerts and stage productions.

### Poloidal

This type of microphone can provide a choice of two or three directional characteristics or a continuously variable characteristic.

### Impedance Matching

Carbon, ribbon and dynamic (electromagnetic) microphones usually have low impedance and require a matching transformer for linking to a high impedance amplifier input. It should be remembered that the ratio usually quoted on a transformer is the voltage ratio. The impedance ratio is the square of the voltage ratio.

Erase is effected by passing a high frequency current through the coil of a similar head, which has a gap about 20 times the size of the recording head gap. The magnetised particles of oxide on the tape are saturated by the field produced by the erase current. Due to the very high frequency used the resulting signal is inaudible.

## COMPUTER PRINCIPLES

The most common kind of computer makes use of a binary code, i.e. numbers are identified whether they are odd or even and how many times two can be divided into them. In order to be able to store such information or perform mathematical calculations, the computer has to recognise the information or number fed into it by noughts and ones. Calculation takes place by combining a series of noughts and ones in accordance with the binary code. These noughts and ones are usually stored in the computer in a logical manner by using bistable circuits (flip-flops). (These circuits are explained elsewhere in the January issue of PRACTICAL ELECTRONICS.) From this it can be seen that a circuit can be conditioned to pass one of two signals or, in the case of the computer, a nought or one.

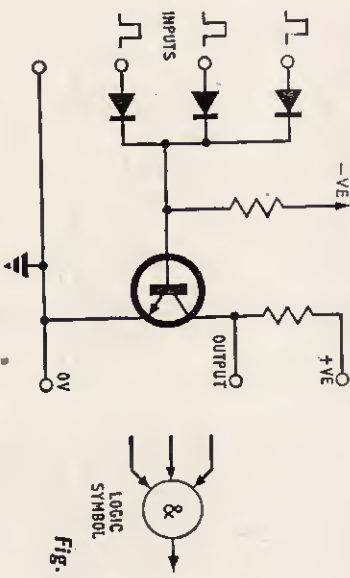

Fig. 11a. AND gate

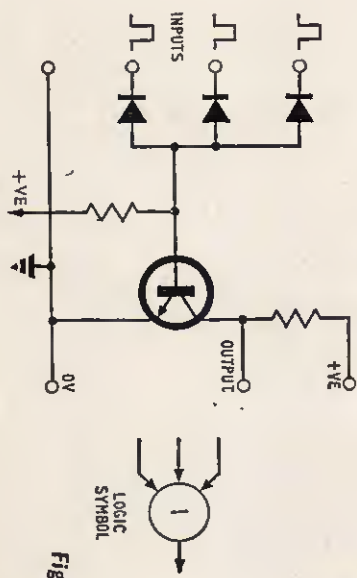

Fig. 11b. OR gate



A flexible arrangement of controlling treble and bass by using only two controls is shown in Fig. 9. A more severe degree of correction can be achieved by using the negative feedback principle. There are a number of books available which give more details of tone correcting circuits.

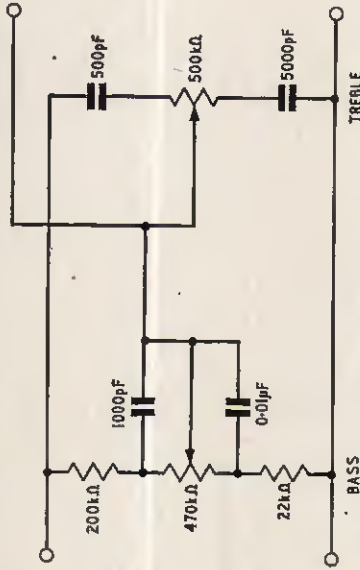

Fig. 9. Combined variable bass and treble, cut and boost circuit

#### MAGNETIC TAPE RECORDING

Current, in the form of a.c. signals, is fed through a coil wrapped round a soft iron or ferrite core (see Fig. 10). The core is so arranged that the gap between the pole faces is only about 0.0001 in maintained by the insertion of a non-ferrous shim. Each minute particle of magnetic oxide on the tape which passes the gap is magnetised when current flows through the coil. The direction and magnitude of flux in selected particles is shown in Fig. 10 when a sine wave is recorded.

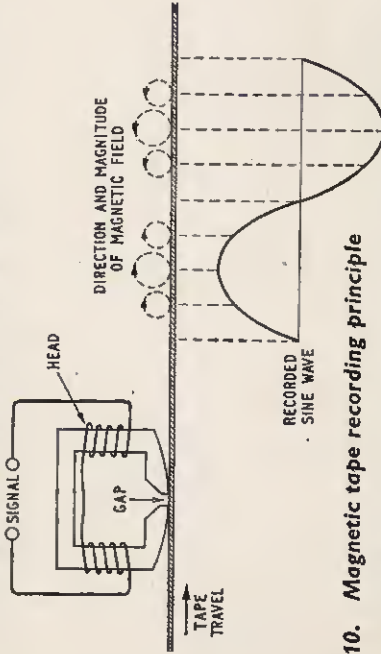

Fig. 10. Magnetic tape recording principle

Due to the partial non-linearity of the magnetic characteristic of the core a high frequency bias current is applied at the same time as the signal current to magnetise the head on the linear portion of the characteristic.

The nominal impedance of a microphone is usually quoted as being the electrical impedance at 1,000c/s since the impedance of such a non-linear device increases with frequency. For example, the range of impedance of a microphone may be from 19 to 75 ohms; the rated impedance would be 38 ohms at 1,000c/s.

Crystal microphones are high impedance devices and can be connected direct to the high impedance input of an amplifier. The crystal is effectively a capacitor which may be considered to be in series with the generated voltage and following grid resistor (see Fig. 4) which should be from  $\frac{1}{2}$  to 5 megohms. Too low a resistance may have the effect of attenuating low frequencies.

Fig. 4. Crystal microphone input

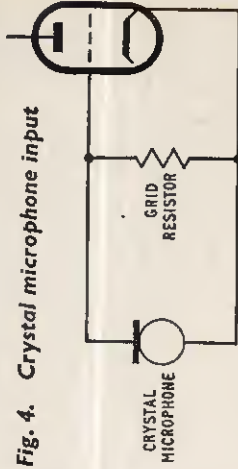

#### LOUDSPEAKERS

The most common loudspeaker in use today is the dynamic (moving-coil) type (see Fig. 5) which has to a large extent superseded the old mains energised type. The electrostatic loudspeaker is becoming more widely used but is relatively expensive. Public address systems sometimes use horn type loudspeakers where high efficiency is more important than quality of reproduction.

In the moving-coil loudspeaker the greater proportion of high frequencies are reproduced by the centre area of the cone. As a result small loudspeakers (up to about 5 in diameter) will reproduce high frequencies better than low frequencies.

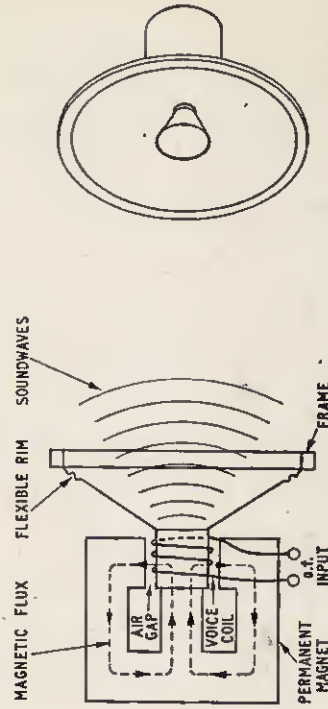

Fig. 5. Diagrammatic section of a dynamic moving-coil loudspeaker

Fig. 6. Typical dual concentric loudspeaker

Medium size loudspeakers (6 to 10in diameter) will produce a better low frequency response but may still be restricted below about 100c/s. Large loudspeakers (12 to 15in diameter) will reproduce these lower frequencies but because of the mass of the cone, free vibration at high frequencies is restricted and does not give the best results.

#### Crossover Networks

It follows from the previous paragraphs, therefore, that the ideal set-up is to have three loudspeakers of different sizes to cope adequately with the entire audio frequency range. However, many people compromise by using one large loudspeaker (woofer) and one small loudspeaker (tweeter) which give very satisfactory results. These two units should be close to each other to avoid undesirable pseudo-stereophonic effects. This is catered for by some manufacturers who make dual concentric loudspeakers (see Fig. 6). Here the small horn shaped tweeter is mounted concentric with the cone of the woofer.

Fig. 7. Simple crossover network

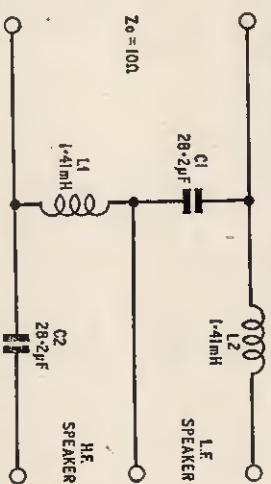

If a two or three loudspeaker system is used it is desirable that each should be fed mainly with the range of frequencies which it will handle. To achieve this a crossover network is employed. Fig. 7 shows a simple circuit for series connected loudspeakers at a crossover frequency of 800c/s and giving 10dB per octave drops. Values for components at other impedances can be determined by:

$$L = Z_0^2 / 2\pi f \sqrt{2} \quad \text{and} \quad C = 1 / 2\pi f Z_0 \sqrt{2},$$

where

$L$  = inductance of  $L_1$  and  $L_2$   $Z_0$  = speech coil impedance

$C$  = capacitance of  $C_1$  and  $C_2$   $f$  = crossover frequency

#### PICK-UPS

Much of what has already been said under microphones applies also to pick-ups and their connections to amplifiers.

#### Electromagnetic pick-ups

They are usually low impedance devices requiring matching transformers. These can be sub-divided into three types:

- (a) A moving iron pick-up has a steady field supplied by a permanent magnet with an iron armature in the gap.

- (b) A moving coil pick-up has a stylus attached to the coil which is allowed to move in the magnetic field.

- (c) Magnetostriction pick-ups make use of the principle of tension and compression of certain ferromagnetic metals (such as nickel, iron, cobalt and manganese alloys) when placed in a magnetic field. If subjected to this treatment the magnetic reluctance changes. The stylus is attached to a wire or rod of this material.

#### Piezo-electric pick-ups

This is the technical term for the more familiar crystal pick-up. The crystal is subjected to twisting or bending which produces electrical charges on some of its surfaces. The voltage produced is higher than that from most magnetic pick-ups. The characteristic impedance is also high enabling it to be connected directly to a high impedance valve amplifier. The frequency response is not as good at high frequencies above about 9kc/s or low frequencies below about 100c/s, compared with that of electromagnetic pick-ups.

#### Capacitance pick-ups

This type is self explanatory in that the stylus causes a mechanical variation of the distance between two plates so varying the capacitance in an oscillator circuit. The output is usually very low, hence it needs a very high gain amplifier. However, the frequency response is very good up to about 30kc/s.

#### Other types

Ribbon pick-ups operate on the same principle as ribbon microphones. In eddy-current pick-ups the stylus moves a high resistance vane close to the inductor of a resonant circuit in an oscillator. Strain gauge pick-ups are based on the principle that the resistance of a conductor changes when the conductor is strained.

#### TONE CONTROLS

For a number of very good reasons some audio reproducing devices give signals which haven't level (or flat) frequency response characteristics. In order to correct for this an equaliser has to be used. The simplest kinds of fixed equaliser are shown in Fig. 8. These circuits, known as passive equalisers, give only a limited amount of boost or cut, usually about 6dB per octave.

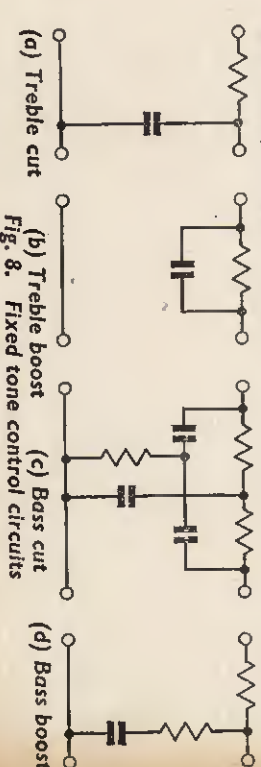

Fig. 8. Fixed tone control circuits



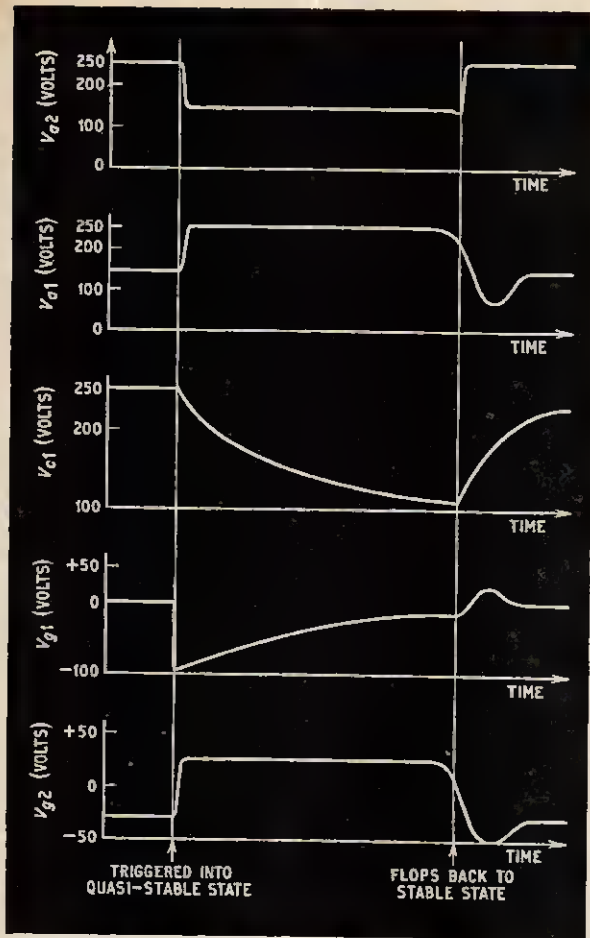
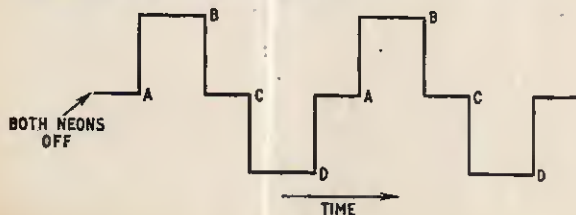

Fig. 5. Graphs of a flip-flop which took 30 seconds to revert to the stable state after being triggered

It is possible to "gate" two amplifiers with a bistable switch, i.e. arrange for two amplifiers to operate alternately, one in each stable condition of the switch. By connecting the inputs of the two gated amplifiers together, we have a two-way electronic switch where an input to the system will be passed to one of the two outputs when the switch is set one way, but will appear at the other output when the switch changes over. In this respect it operates just like an ordinary mechanical change-over switch, but differs in being able to switch over in a millionth of a second or less. As the output

Fig. 6. Two complete cycles required for a flashing display  
 A—Unit switched on, V1a conducting. Neon 1 switched on  
 B—V1a cut off. Flip-flop triggered into quasi-stable state. Both neons off  
 C—Flip-flop changes over. Neon 2 switched on  
 D—Multivibrator changes back to original state. Flip-flop triggered again. Both neons off



of one switch can be connected to the input of another, very complex switching networks can be produced. Fig. 4 is an example, each combination of switch settings connects the single input to a different one of the eight outputs.

Clearly, the bistable switch is a very useful circuit element. Unfortunately, in order to build a computer very large numbers of them are required and for this reason it is usually impractical for amateurs to attempt the construction of a digital computer. Even if the units are transistorised the cost of building several hundred or even thousand switches makes the idea impracticable. Modern digital computers are transistorised and at the present time a considerable amount of research is going on to try to build bistable units capable of operating in the shortest possible time; certain solid state circuits now switch over in much less than  $10^{-8}$  second.

## FLIP-FLOP

The final variation on the theme is the flip-flop, the circuit diagram of which is shown in Fig. 1. The circuit is seen to be "half-way" between a multivibrator and a bistable switch, with one grid-anode coupling via an RC network and the other via a resistor to a negative bias line.

In the stable condition V1 is conducting and a voltage exists across the anode load R1; the potential divider action of R2, R5 maintains the grid of V2 negative, keeping the valve cut off. Its anode is then at h.t. potential and, since V1 grid is at earth potential, C1 charges up to the full h.t. voltage. Suppose a negative-going pulse is now applied to the grid of V1. Its anode will rise towards h.t. as the valve cuts off, and the voltages at all points on the resistor chain (R1, R2, R5) rise. Because of this V2 grid now goes positive, the valve passes a heavy current and the anode potential falls sharply. Since C1 is charged to h.t. voltage, the sudden fall in potential of its upper plate causes the other plate to fall the same amount below earth. This results in V2 remaining cut off although the original triggering pulse has passed.

The flip-flop is now in the quasi-stable state: V1 is cut off and V2 is conducting. Unlike the bistable switch, however, this is not a second stable state because something is happening—C1 is discharging. The upper end of C1 is held at the anode potential of V2, which is more or less constant, but at the lower end the potential is rising towards earth. At a certain point, when V1 grid is about 12 volts negative, the valve begins to conduct and an "avalanche process" takes place, as in the multivibrator. As V1 conducts to an increasing extent the voltage across R1 increases due to anode current, so all the points on the R1, R2, R5 chain fall in potential, causing V2 to pass less current. The voltage at the upper end of C1, connected to V2 anode, rises pulling up with it the potential at its lower end, causing V1 grid to go even less negative. The whole system is now in effect an amplifier with positive feedback. The end result of all this is that V2 cuts off completely, its grid being driven very negative. V1 grid, on the other hand, is now positive, C1 having "dragged" the voltage up. It is the heavy anode current passing through R1 which keeps V2 cut off via R2. Finally, as C1 recharges to h.t., V1 grid returns to earth potential.

This shows how a flip-flop, when triggered, temporarily changes from a stable to a quasi-stable state, but always reverts to the stable state of its own accord

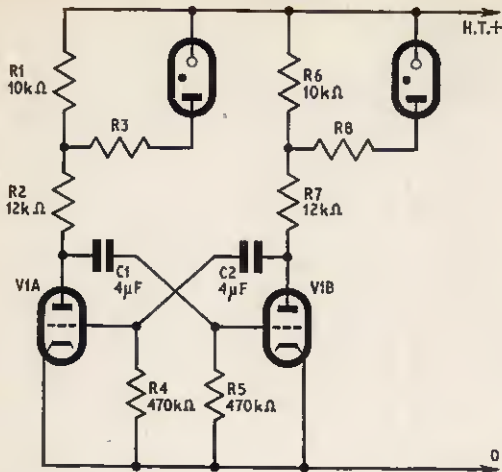

Fig. 7. A multivibrator with two alternately flashing neons connected in the anode circuits

after a definite time. This time is determined mainly by C1 and R3, and to a certain extent by R2 and R5.

In order to test the validity of this explanation, the author constructed a flip-flop which took 30 seconds to revert to the stable state after being triggered. By connecting a voltmeter to various points on this prototype,

Fig. 8b. Complete triggering circuit for switching a flip-flop

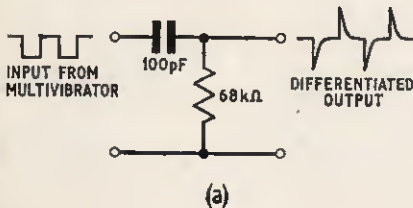

Fig. 8a. Basic differentiating circuit

the graphs shown in Fig. 5 were obtained. An examination of these shows that the expected waveforms are actually observed in practice.

For some reason flip-flops are unpopular but the author believes that they can provide the answer to a number of problems. Possibly their main use lies in their property of possessing a time delay factor which can be anything from microseconds to minutes. They find uses in the production of very short pulses, in simple timing machines, for example photographic timers or even egg timers! It is possible to obtain from one flip-flop a pulse capable of triggering a chain of subsequent flip-flops, each unit being triggered as the previous one flops back from the quasi-stable state. In this way a sequence of events can be controlled, each separate step being independently controllable from one flip-flop. This circuit can be used to switch in a number of operations during the manufacture of a particular product. Like the bistable switch the flip-flop can store one "bit" of information, but only for a limited time. It can therefore be used as a short-term

self-resetting memory unit. Where a production line is in operation, such a circuit can stop one article from following another too closely by holding back the second for a pre-determined time after the first has passed.

### PRACTICAL CIRCUIT

So far, mainly theoretical aspects of these three circuits have been discussed. To conclude this article it will be explained how a particular design problem was solved by the use of the principles outlined above. What was required was a display unit illuminated at each end by a lamp. The two lamps were required to flash on and off alternately with a time delay between one extinguishing and the other one lighting. This is easily seen by looking at Fig. 6. Both the overall cycle time and the delay time had to be infinitely and independently variable. The lamps used were neon bulbs since these can be worked directly from the circuits. As high speeds were required relays could not be used.

The basic circuit used was a multivibrator with the neons connected in the anode circuits (see Fig. 7). Each neon struck at 80 volts which was present across R1 and R6 in the anode loads. R3 and R6 are ballast or safety resistors. Using this arrangement the lights just flashed alternately and further circuitry was needed to interrupt the neon voltage supply briefly each time the multivibrator changed over.

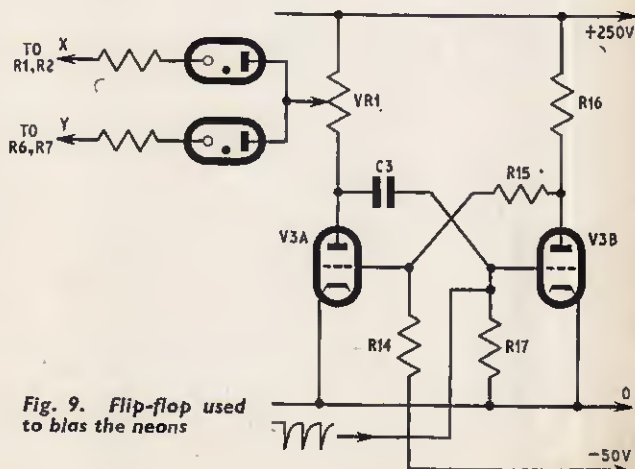
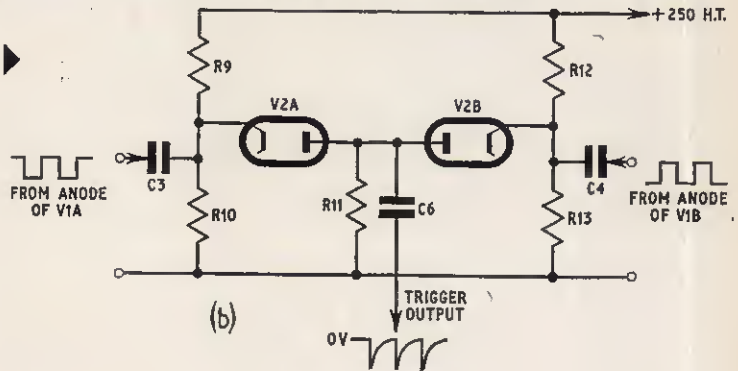

Fig. 9. Flip-flop used to bias the neons



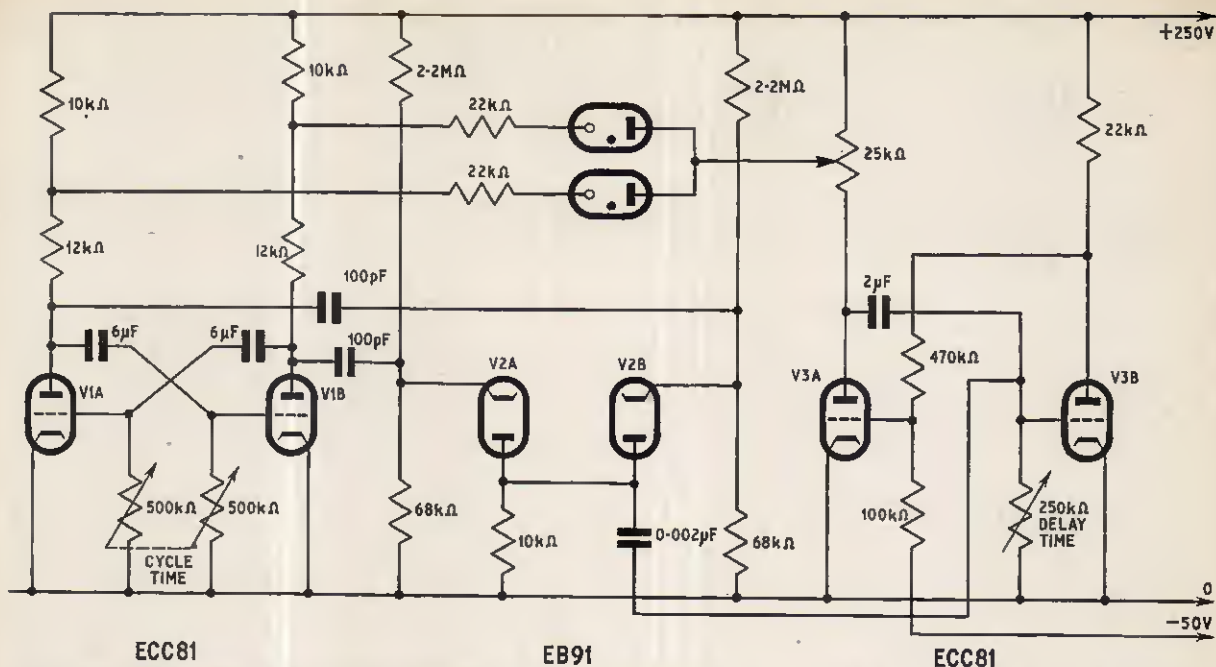

Fig. 10. The complete circuit for the display unit with added refinements to control the cycle time and delay time

A triggered flip-flop is suitable to control the flashing, the triggering device being fed by two square waves, 180 degrees out of phase, from the anodes of the multivibrator (see Fig. 8b). In order to provide a sharp pulse to trigger the flip-flop the square wave has to be differentiated by a simple RC circuit such as that shown in Fig. 8a. C3, R10 and C4, R13 are the differentiating components in Fig. 8b, their outputs being fed to the diodes which are arranged to pass only negative pulses. The pulses trigger the valve which is conducting in the stable condition of the flip-flop.

Referring now to Fig. 9, the anode of V3a is held at h.t.; the valve is not conducting. A negative pulse fed into the grid of V3b causes the voltage on the anode to rise and biases V3a to conduct. V3a anode voltage falls producing a current through the anode load, VR1, which can be adjusted to provide a common voltage

on the anodes of the neons of, say, h.t. minus 40 volts (i.e. 210 volts).

In this condition one anode of the multivibrator is not conducting and is held at h.t. The voltage across the relevant neon will be only 40 volts which is insufficient to cause it to strike.

However, the anode voltage of the other multivibrator valve will be at h.t. minus 80 volts (i.e. 170 volts). The other neon, therefore, will also have only 40 volts across it, and will fail to strike. Only when the flip-flop returns to the stable condition will the second neon strike, when the relevant multivibrator valve and V3a are not conducting. The entire cycle of operation is depicted in Fig. 6.

The final circuit used is shown in Fig. 10 with some added refinements to control the cycle time and delay time.



## NEWS BRIEFS

### P.E. Amplifier at Tape and Hi Fi Club

A MEETING of the North London Tape and Hi Fi Club took place at Bush Hill Park School on 21 October 1964, with some 30 members in attendance. The Chairman, Mr. J. Wilson, extended a warm welcome to the guest speakers, Mr. Denis Horner and Mr. Alan Nash of Cosmocord Ltd., who gave a most interesting and enlightening lecture on the growth of Rochelle salt crystals from seeds, describing the technological process involved up to the completed crystal wafer as used in the manufacture of the Acos crystal cartridge pick-up and the crystal microphone.

In the limited time available after the lecture a demonstration of hi fi reproduction was given. The equipment consisted of a Garrard transcription 301 player unit with a Warden articulated tone arm and Acos S1/1 ceramic cartridge, the amplifier chosen being the 5W integrated amplifier recently featured in PRACTICAL ELECTRONICS. The system was completed by two Tannoy Chatsworth 15 ohm loudspeakers.

### Transistorised Hi Fi

A MEETING of the newly formed Society of Electronic and Radio Technicians will be held on Thursday 14 January 1965 at 7.15 p.m. when Mr. D. M. Chave of the Lowther Manufacturing Company will talk about "Transistorised Hi Fi". The meeting will be held at the London School of Hygiene and Tropical Medicine, Keppel Street, Gower Street, London, W.C.1.

Further details may be obtained from the Society at 9 Bedford Square, London, W.C.1.

# ELECTRONORAMA

## HIGHLIGHTS FROM THE CONTEMPORARY SCENE

### Time Without Ticks

THE long admired ingenuity and skill of the watchmaker in working with minute parts appears to have been equalled by the electronic engineer, at any rate the expertise of these previously unassociated technologies have been successfully combined by a Swiss company to produce the world's first electronic wristwatch. This is the Bulova Accutron—an instrument which has been described as the first significant advance in time keeping in 300 years.

Instead of the traditional balance wheel, hairspring and escapement mechanism, the Accutron incorporates a precision tuning fork as its basis of time measurement. An accuracy of within 2 seconds a day (99.9977 per cent) is guaranteed.

The electronic heart of the watch is a transistor oscillator which converts the d.c. energy from a tiny power cell into pulses of current. These pulses energise coils which actuate the tuning fork 360 times per second. One tine of the fork is linked by a ratchet-and-pawl indexing mechanism to a conventional gear train, which drives the hands.

The transistor, resistor and capacitor can be seen in their plastics compartment in the right hand part of the watch case; the drive and phase sensing coils are visible at the top of the case. These coils are wound from copper wire 0.0006 in diameter (one-fifth the diameter of an average human hair). Each watch uses 700 feet of this wire.

Current consumption is  $6\mu\text{A}$ . The miniature cell will power the watch for a minimum period of one year, and is easy to replace.

In addition to its appeal as a personal timepiece, Accutron mechanisms have found a role in a variety of special applications. In a special case and with extra gears and switches added this watch has been used as a signal cut-off timer or "satellite-silencer" within four families of satellites—*Explorer*, *Tiros*, *Telstar* and *Syncom*.

It is currently being evaluated for use on *Nimbus*, the meteorological satellite, the Orbiting Astronomical Observatory scientific satellite, and several others.

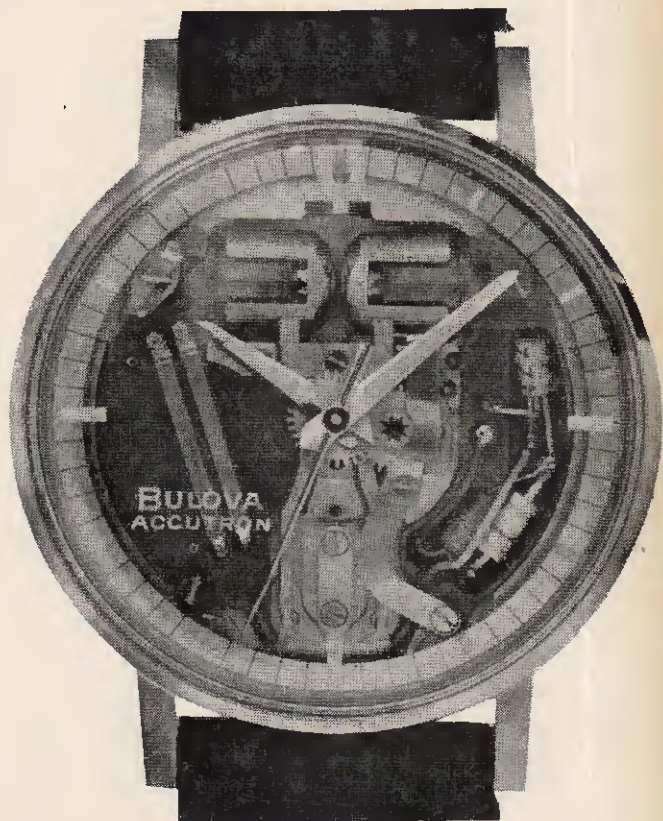

### Stable Pictures

A NEW material known as ELCON has been developed which gives prolonged life to image orthicon camera tubes. The ELCON target introduces electronic conduction in transferring the charge pattern from the image side to the beam side. Ion migration is therefore virtually eliminated. This means that sensitivity and stability of contrast reproduction remains constant and there is complete freedom from "sticking".

This picture shows the new English Electric ELCON target beside a 3 in image orthicon television camera tube.

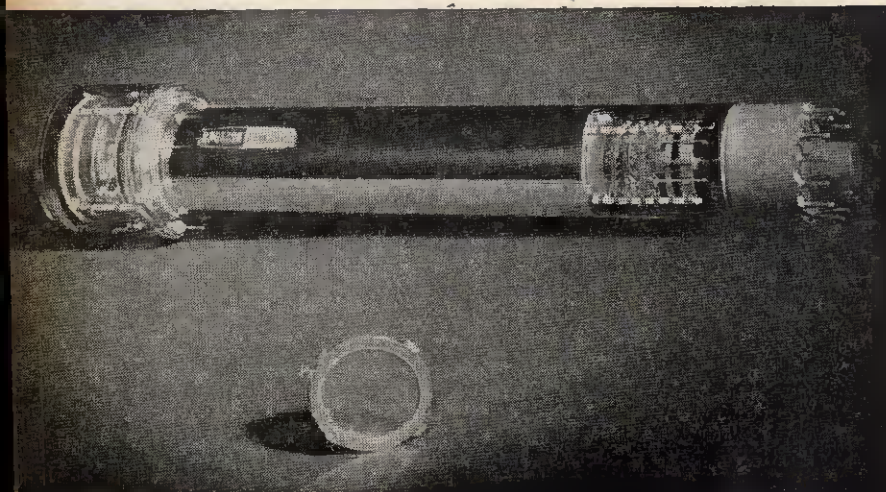



## Remote Power

HERE is one example of electronic energy conversion which is being developed in the Raytheon Spencer Laboratory, America. Microwave energy, similar to that used in radar, is beamed from a parabolic antenna on the ground upward to a small helicopter. The rectifying antenna, mounted under the helicopter, is actually an array of thousands of tiny diodes, each less than half an inch long. When the microwave energy strikes the diodes, an immediate flow of direct current takes place to drive the motor for the rotor blades.

The "helicopter" hovers within the guy ropes, keeping it positioned over the microwave beam.

## Keeping in Touch

SCIENTISTS in Russia have been working on an artificial hand which imitates the principle of the human hand and can "feel" with the fingers. The human sense of touch is detected in the brain by impulses from the nerves and sensory cells.

Transducers made of electro-conductive rubber or thin wire and sensitive to pressure are fixed on the tips of the fingers. Under influence of the pressure on the transducers, based on the grasping effort of the fingers, signals from them modulate the output from a vibrator fitted on the hand near a nerve going direct to the brain.

The new hand overcomes a shortcoming of prosthetic appliances controlled by electric signals from the muscles when the hand carries out grasping motions, but so far it cannot be used freely without the user looking at what his fingers are doing.

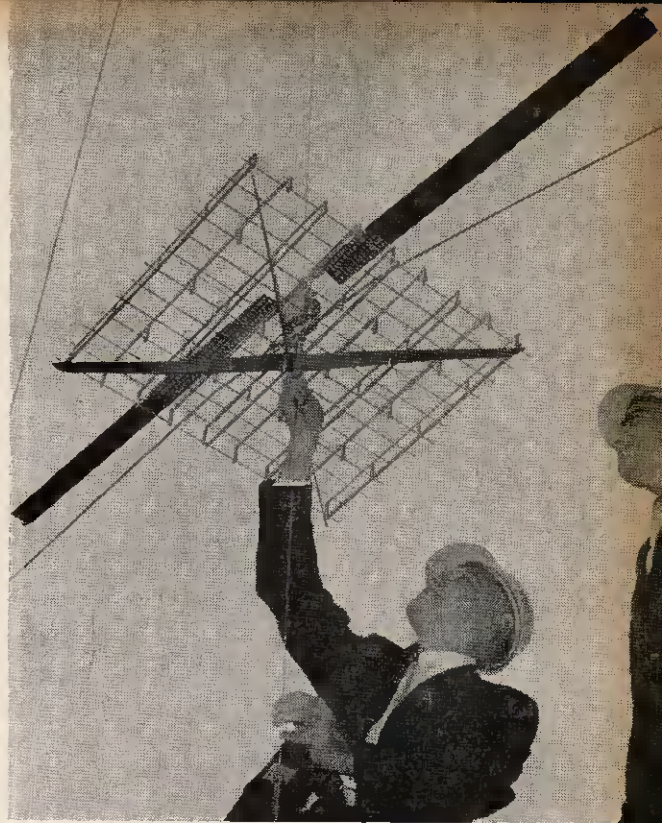

## Automatic Tyre Tread Control

THE tread on a rubber road tyre is designed to withstand a multitude of driving conditions. It is essential, therefore, that the manufacturing process should be controlled to fine limits. To prevent distortion of the tread Lancashire Dynamo Electronic Products has installed thyristor controlled plant at the Pirelli factory to control the calendar and conveyor systems. Silicon controlled rectifier units are used to supply the calendar and conveyor drive motors. Here the rubber tread strip is seen travelling from the extruder through the calendar shaping process.

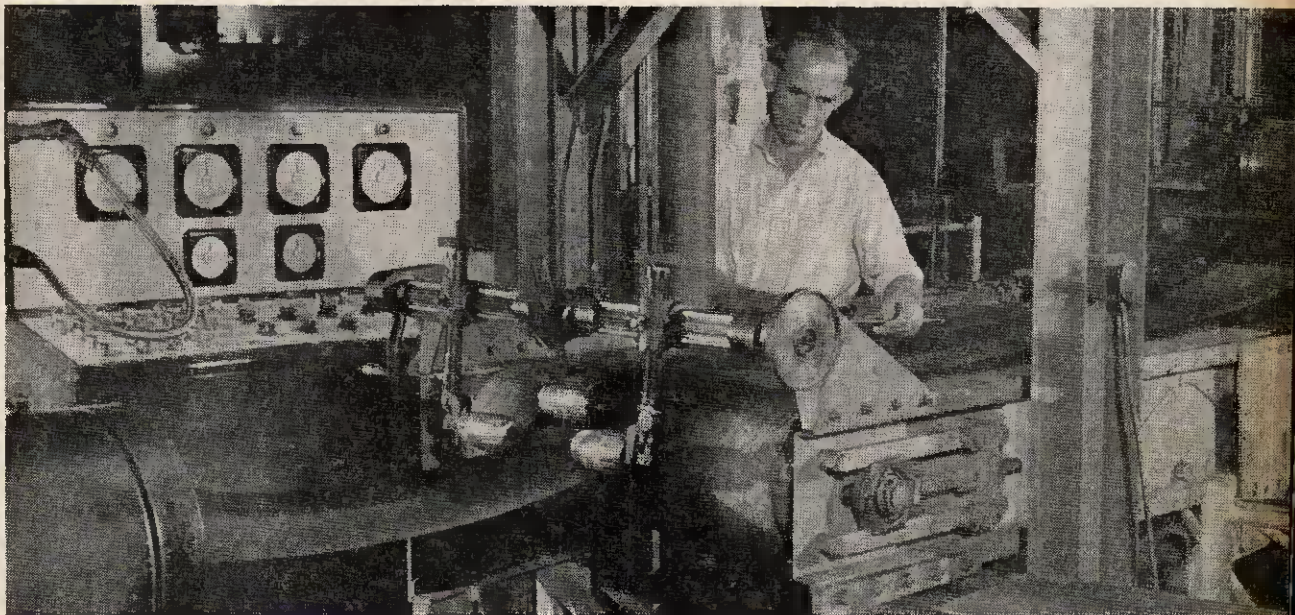



# BEGINNERS start here...

# 3

## An Instructional Series for the Newcomer to Electronics

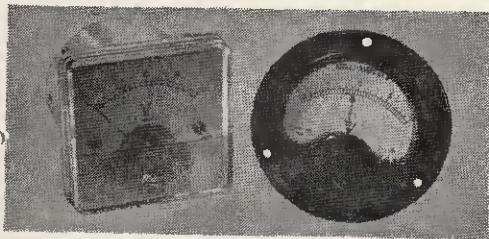
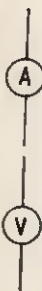

### MOVING COIL METERS

Shown here are typical examples of a left-to-right reading meter, and a centre-zero meter

### CIRCUIT SYMBOLS

This is the general symbol for a meter or galvanometer. Sometimes the function of a meter is indicated as in the two symbols given above:

A = ammeter (current)

V = voltmeter (voltage, potential difference)

OUR experimental section this month deals with the construction of a very simple device which will give an indication of current flowing in a circuit. Meters are usually delicate and expensive items of equipment, their prices ranging from £1 to £3 or even more. There are a number of retailers who stock a wide selection of meters with various ranges and different degrees of accuracy; it will be instructive to look at the advertisements on other pages. One should certainly not rush into purchasing an instrument of this nature without having first acquired some basic knowledge of the subject.

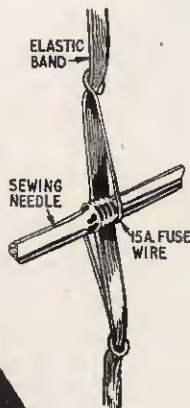
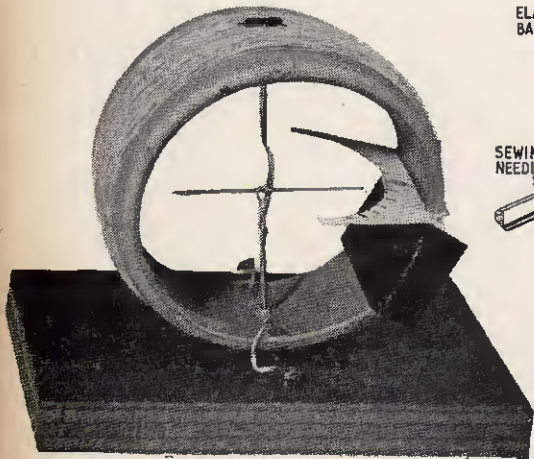

### A GALVANOMETER

Our simple meter, which is in fact more accurately described as a *galvanometer*, is illustrated in Fig. 3.1. It is very easy to make and costs very little for the component parts. The items you will need are a sewing needle, an elastic band, a wooden baseboard measuring approximately 4in  $\times$  2½in  $\times$  ½in, some sealing wax or glue, four ½in brass wood screws and a short length of 15 amp fuse wire.

The cylindrical former on which the coil is wound can be made of cardboard, and it should be about 2½in in diameter and 1½in wide. This former can be made by winding a piece of cardboard round a milk bottle, gluing it and tying until the glue is set. Alternatively, you could cut a piece from a postal tube, cut up an empty plastics liquid container, or an Ajax or Vim carton.

The pointer is an ordinary sewing needle around which is tightly wrapped a short piece of 15 amp fuse wire. If you have a soldering iron (and the necessary skill!) you can improve the pointer by soldering the needle and wire together—but this is by no means essential. The ends of the wire are then twisted around the centre of a piece of elastic so that the needle does not slip down. The ends of the elastic are pushed through holes in the cardboard former and fastened to it with sealing wax or glue. It may be necessary to experiment a little so as to get the position of the needle and the tension of the elastic just right.

Insert a pair of the wood screws through the former (from the inside), one on either side of the elastic anchor point. These two screws should be 1in apart.

### WINDING THE COIL

The only item which it is likely you will need to buy is a quantity of 36 gauge double silk covered wire. A 2oz reel will be more than adequate for the present purpose. Make a note that such wire is generally referred to in the following abbreviated form: 36 s.w.g. (standard wire gauge) d.s.c.

If any difficulty is experienced in obtaining double silk covered wire, enamelled wire will suit equally well, although it is a rather tricky operation to remove the enamel covering.

Bare the end of the wire by removing the silk covering or scraping off the enamel coating until the copper is exposed. Wrap the end of the wire tightly around one woodscrew.

Wind on a single layer of wire to cover about 1in width of the former. Bring the wire back to the start and wind a second layer immediately over the first winding. Continue in this manner with consecutive layers until the required number of turns is reached. Terminate the wire by wrapping tightly around the second screw, having first bared the wire of insulating material as before.

Fig. 3.1. The simple home-made galvanometer

Fig. 3.2 (right). An enlarged view of the galvanometer "movement". This shows how the needle is attached to the elastic band



If a soldering iron is available, you can make secure and permanent terminations by soldering the wire to these screws. The iron should be of the small instrument type, with a  $\frac{1}{8}$ in or  $\frac{1}{4}$ in bit. Use Multicore solder—this contains flux which assists the soldering operation. Ensure that the iron is fully heated and the bit well tinned, then place this on the joint and apply the solder. Remove the iron immediately the solder has flowed into the joint. Avoid an excess of solder, a thin coating is all that is necessary.

Now to return to the meter. The wood screws serve a double purpose by acting as terminals and as a means of fixing the coil former to the baseboard. If small holes are first pierced in the baseboard, the two screws can then be gently tapped into the board. Do not, of course, attempt to turn these screws for this will result in broken connections.

In the photograph you will see that we have mounted a second pair of screws on the baseboard and soldered two short wires between these and the first pair. This arrangement is not absolutely essential, but it finishes off the instrument neatly, and makes for ease of use afterwards.

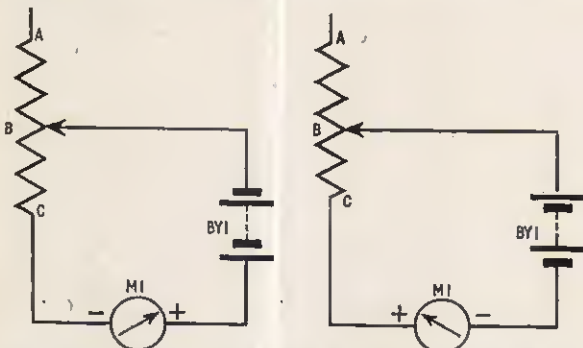

Fig. 3.3. Simple experiments can be performed using the galvanometer in conjunction with the resistance element and a small battery

## THE SCALE

Next cut out a small piece of cardboard and from this fashion the scale. If you look closely at Fig. 3.1 the required shape will be clear. Attach the scale temporarily to the coil former by means of a piece of thread.

You can calibrate the scale by connecting a number of batteries of different value to the terminals and making a mark in line with the pointer setting obtained. You will notice probably that the resulting scale is not linear. This means, if you mark the point indicated for a  $4\frac{1}{2}$ V battery then add another  $4\frac{1}{2}$ V battery in series to give 9V, the position indicated by the needle is not twice the distance from the zero position.

You will also see that by changing round the battery connections, the needle will deflect in the opposite direction. Thus the meter can be used to indicate positive or negative values. When calibration is completed the scale can be glued to the inside of the former, or may remain simply tied to it with a piece of thread.

The amount of needle deflection obtained is decided by the voltage applied to the meter. An increase in voltage causes more electrons to flow round the circuit, more current in the coil produces an increase in the magnetic field due to the coil, and this field in turn causes a corresponding increase in deflection of the

needle. As a magnetic field is produced regardless of the direction in which the current flows, the needle deflection can be in either direction—depending upon which way round the battery is connected.

## USING THE METER

Those of you who have constructed the simple resistance apparatus described in the first article of this series can use it in conjunction with the meter to show the change in current as the slider is moved along the wire. Initially, you will recall, we used a bulb to indicate a change in current; now you can repeat those experiments, replacing the bulb by the meter. This is shown diagrammatically in Fig. 3.3 which you should compare with Fig. 2.1 in last month's article.

We realise that this meter is limited in the number of uses to which it can be put and for the beginner, who hopes no doubt to make electronics his hobby for many years to come, it will be simply an *indicating* device and not a *measuring* device. We are sure that those of you who are really keen will eventually invest in a good meter which, with careful use, will last many years.

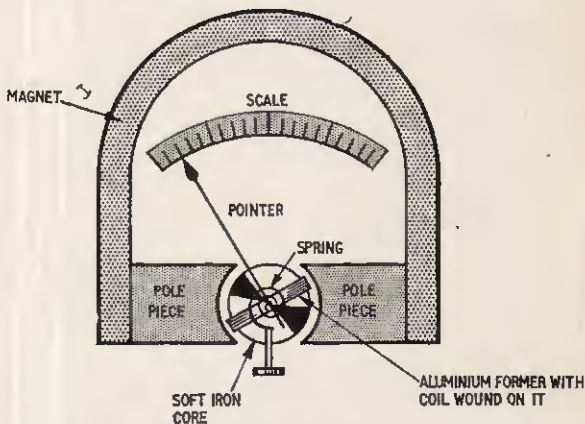

Fig. 3.4. The essential parts of a moving-coil type of current measuring instrument

## THE MOVING COIL METER

It may be useful at this point to mention briefly the basic types of meter available on the market. By far the most common meter is of the "moving coil" type. As its name suggests, this is basically a coil of wire (wound on a former) which is free to rotate in a magnetic field, see Fig. 3.4. A current flows through the coil and sets up a magnetic field of its own. This field reacts with the magnetic field produced by the horseshoe permanent magnet and causes the coil to move. Attached to the coil is a pointer, the amount of movement of the pointer being governed by the current flowing in the coil.

Notice that the pointer normally rests at the left-hand end of the scale—this is the zero position. It is held in this position by a pair of hair springs which have a dual function, for they also provide the electrical connection between the meter terminals and the coil winding.

When current flows the coil rotates in opposition to the action of the springs, and the needle is thus deflected towards the right-hand end of the scale. This type of meter is very widely used. There are also centre-zero meters which respond to either negative- or positive-going currents, as in fact does our simple home-made device.



## PART THREE

It is now proposed to discuss recording level indicators. Most tape recorders incorporate some device for indicating the signal level during recording. Where there is no such device, the reason may be twofold: first, automatic recording control may be applied, and second, the simplicity of the machine may not warrant an indicator.

We need not consider the second case here, and as for the first, this is a special subject which the author hopes to return to later. Recording level indicators fitted to most machines are intended both as warning devices, to prevent overloading, and adjustment aids, to enable us to obtain the best signal-to-noise ratio under varying conditions. Two methods are used: the magic (electronic) eye, and the meter.

The magic eye, as shown in Fig. 3.1, may take a number of forms, and the display portion can be of almost any shape, provided it gives a clear indication of the peak condition, i.e. the highest modulation level, or loudest sound. For this reason, the magic eye may be referred to as a "peak-reading device". Its one great advantage is the speed of reaction: an electron beam has no inertia, whereas a meter movement must have some damping, and, however quickly it reaches the peak indication, it must take an appreciable time to fall away again.

In practice, the meter measures a varying d.c., which is the amplified and rectified signal. This charges a capacitor, the circuit constants being chosen in such a way that the meter indicates the peak slightly after it occurs, as the discharge of the capacitor begins. Successive peaks then restore the charge and the meter indicates an average level.

Without going too deeply into a.c. theory, it is necessary to explain this business of "average values". If it was only needed to measure pure sine waves, a form of meter could be used quite safely. This is because the average value of a sinusoidal waveform is always the same, being 0.707 of the peak value, and known as the root-mean-square, or r.m.s. value.

But the audio signals with which we are concerned in tape recording are far from being pure sine waves. A meter which responded to average values would give little indication of true peaks. A meter which was incorporated in a circuit that allowed it to respond to peaks of short duration would not give a true indication of the average signal level. A compromise must be found.

### METER RISE-TIME

The validity of this compromise will depend on the rise-time of the meter, that is, how fast it can respond to peaks. The meters used by broadcasting stations

can respond to peaks which are as short as 5 msec, the circuit being arranged so that the needle falls away at a rate of 8dB per second, which still allows adequate measurement of the average modulation level. A fall-rate of about 1½dB per second is about the limit to a useful indicating device, and a figure of about 3dB per second should be obtainable with meters of modern "constructors" quality.

### FITTING A METER

Adding a meter to the normal tape recorder is not a difficult job, and may interest some readers as a useful experiment.

First, it is necessary to consider what voltages and currents are available to drive the meter, how they may be obtained, and from which points in the circuit.

One obvious source is the *high level* output or *monitor* socket of the tape recorder. But as the moving coil meter we may expect to use is a current consuming device, any attempt to use it directly will load the signal circuits of the tape recorder. A valve voltmeter is the answer to the problem.

Fortunately, we do not need to dip deeply into the purse for a convenient source of signal and a means of making a valve voltmeter based on our moving coil unit is already available. A meter of 0-1 mA f.s.d., or even 0-5 mA, should be readily procurable from several of the advertisers in PRACTICAL ELECTRONICS. But before we decide how to utilise the meter, let us take a look at the existing circuits of the magic eye.

### MAGIC EYE CIRCUIT

Referring to Fig. 3.2, V1 is a magic eye of a type widely used in modern tape recorders. The audio signal is derived from the same point which feeds recording current to the recording head, the anode of the head amplifier, and applied via a blocking capacitor C1 to the magic eye circuit.

In series with this capacitor is a limiting resistor R1, whose function is to prevent the heavy loading of the signal circuits that would otherwise be offered by the rectifier D1. This resistor is also used to regulate the signal voltage, in conjunction with C2, which acts as a high frequency bypass capacitor.

The audio signal is then rectified by D1 and a varying d.c. appears across the load R2, the capacitor C3 charging up to the r.m.s. level, and thus maintaining a changing bias in proportion to the signal level, which is applied to the control grid of V1.

The construction of the magic eye includes an amplifier triode so that a negative voltage of between 15 and 25 volts at the grid produces the zero shadow angle, or maximum indication, as when the columns meet on a display such as the EM84.



## DIODE TRIODE

We can use the existing valve base and dispense with the rectifier by fitting a diode triode, or, more conveniently, a double triode, with grid and anode of one half strapped to operate as diode. Our signal is then applied as shown in Fig. 3.3. Again, C1 feeds the signal, via R1 to the diode. But now the diode is a strapped triode, and the feed to its cathode is via a variable resistor, VR1, to enable us to set the recording level. Note the difference in the values of the load components C3, R2. This is to increase the time constant and allow for the meter inertia discussed above.

The rectified signal is now applied to the grid of the second half of the valve V2 and the amplified anode current produces a measurable voltage across the cathode bias resistor. This is made variable to allow meter "zero-ing." An alternative method would have been to insert the meter in the anode of the valve and feed the cathode from a potentiometer across the h.t.

## SCREENED LEADS

When experimenting in this way, remember to keep the leads from the existing circuit to the new circuit as short as possible, or unwanted audio feedback can occur. If any wiring is altered, it is important to avoid hum loops by keeping the screening commoned to a single point. For example, if the meter unit is more conveniently situated outside the meter, use twin-screened wire for the signal leads, and earth the screening at the tape recorder end. Take a separate lead for the h.t. negative line, and join it directly to the negative line of the head amplifier stage—not to some other, more physically convenient place.

For further experiments, it may be possible to progress at a later date to the more accurate Peak Programme Meter, which gives a better indication of peaks, while still retaining average modulation indication, as described in the earlier discussion of this subject.

The volume unit meter circuit described here measures loudness rather than peaks, and if any professional work is to be done, it is the rapid peaks that are most needful of watching. They are the signals that do the damage, overloading the tape and causing distortion.

A further refinement would be a transistorised meter circuit, allowing modification to some of the portable recorders which have no indicating devices. As a matter of interest, the reason that a meter is used on a portable rather than the popular magic eye, is simply the power demands of the latter which would quickly overtax the battery.

## PRACTICAL ELECTRONICS BINDERS

EASI-BINDERS specially designed to hold 12 issues of PRACTICAL ELECTRONICS are now available.

These binders are finished in maroon waterproof and greaseproof cloth and are embossed with gold lettering on the spine.

Order your binder from:

Binding Department,  
George Newnes Ltd.,  
Tower House,  
Southampton Street,  
London, W.C.2.

The price, per binder, is 13s. 6d., inclusive of postage.

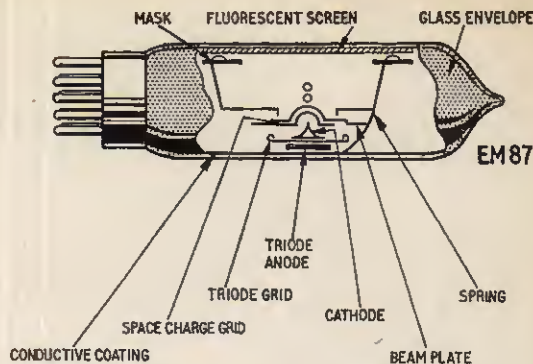

Fig. 3.1. Cross-section of Mullard EM87 magic-eye valve. The column-type beam closes with a peak input voltage of 10 volts and a  $1\frac{1}{2}$ mm overlap; a clear bright line is produced with a 15 volt peak input

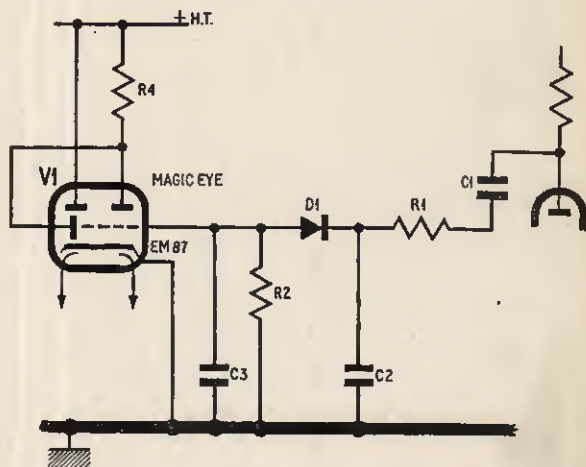

Fig. 3.2. Circuit for magic-eye recording level indicator

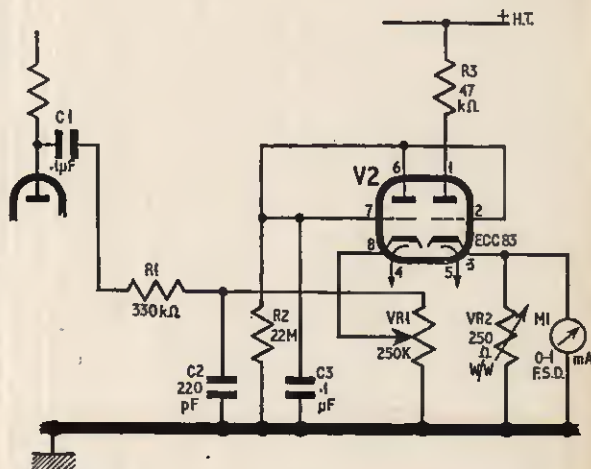
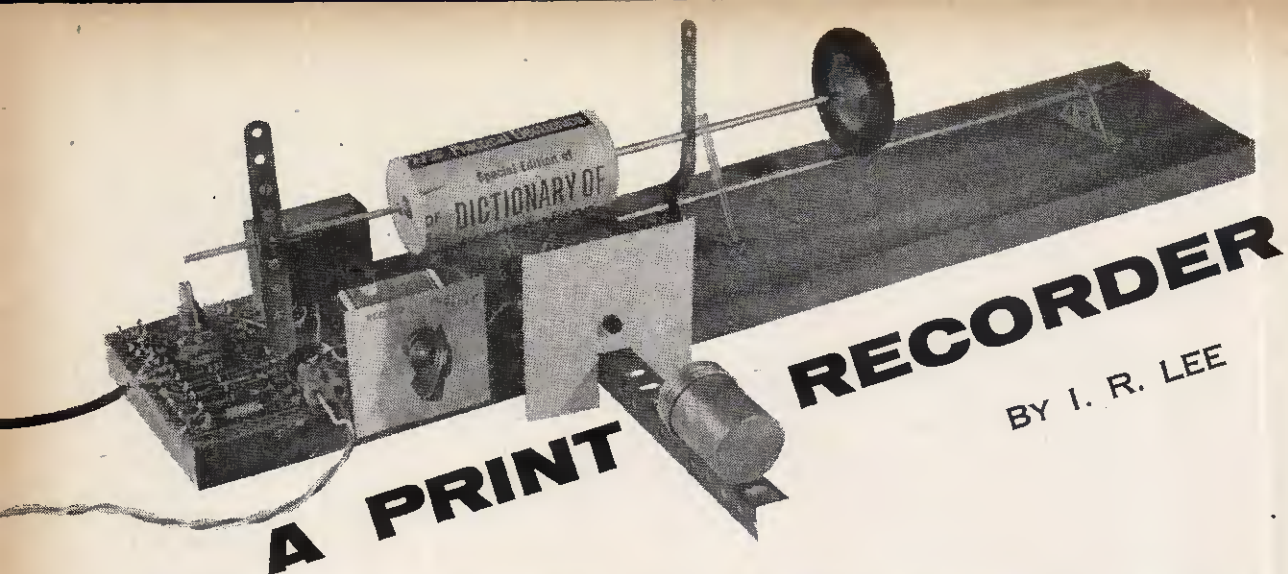

Fig. 3.3. Meter-type recording level indicator, using valve detector and amplifier



THE machine may be called, in simple terms, a print recorder but can reproduce drawings. The drum, on which the printed matter is placed, is rotated and moved along so tracing a helical path.

A minute spot of light is focused on to the print and reflected from the print on to a photosensitive device. The output from the photo device is used to modulate a.c. for recording on magnetic tape.

When a copy of the recording is required a piece of photosensitive paper is placed on the drum, the drum is again revolved, and the recorded signal is applied to the light beam which is focused on to the paper. The picture is built up on the paper, line by line, and the paper is then developed in the normal way. The finished print is a negative copy of the original.

### CIRCUIT

The photoelectric pick-up, which is placed by the drum, is an OC71 transistor with the black paint coating scraped off. This provides an adequate pick-up which is sensitive to light. The emitter and collector only of the transistor are used, the base being left unconnected.

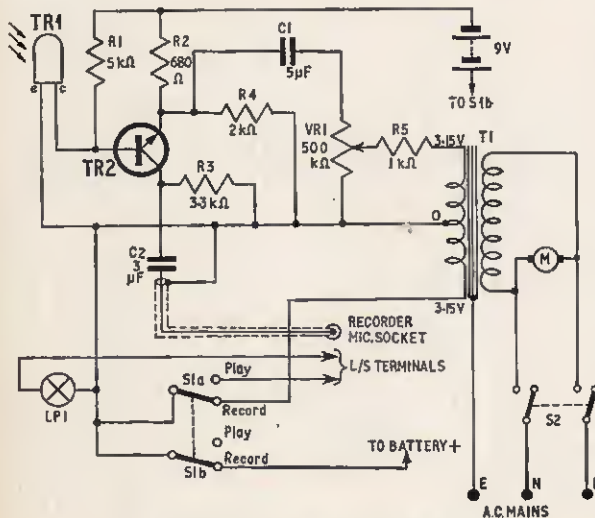

Fig. 1. Modulator circuit

The signal produced when the transistor is illuminated is used to modulate an a.c. signal from half the secondary winding of transformer T1.

The circuit shown in Fig. 1 uses any a.f. *npn* transistor. The signal from TR1 is applied to the base of the transistor TR2. The a.c. signal to be modulated is taken from half of the centre-tapped 6.3V secondary of T1 via VR1 and C1, and is applied to the emitter of the transistor TR2. The modulated signal appears across R3 and is fed to the MIC input of a tape recorder via C2.

VR1 controls the a.c. being applied to the circuit. Too much a.c. will saturate the signal and too little a.c. will cause shallow modulation so causing a very contrasting image. It may take time to obtain a reasonable setting for this control as it is very critical. R5 was put into the circuit to provide a load across T1 when the wiper of VR1 is set electrically close to the centre-tap end of T1.

The switch S1 is used to control the beam and modulation circuits. In the "record" position the beam lamp LPI is lit continuously by half of the secondary winding of T1. Modulation takes place in the record position. In the "play" position the modulation circuit is not used and the signal from the recorder is applied direct to the beam lamp.

When the tag board is wired as shown in Fig. 2, it can be screwed to the wooden base. T1 is also screwed to the baseboard. The battery can be held in position on the baseboard by adhesive tape. S1 can be mounted on a piece of aluminium sheet 2½ in square, which is screwed to the baseboard (see photograph).

Before actually fitting the pick-up to the angled strip its most sensitive surface must be found. This can be done by switching on the modulation network and monitoring the signal on a tape recorder. The pick-up is rotated in a beam of light (from a torch) until the output from the modulation network reaches its highest level. The side of the pick-up facing the beam source when the signal output is at its greatest is the most sensitive area. This surface should face the drum.

### MECHANICAL CONSTRUCTION

The recorder is built on a wooden base about 2ft long, 4in wide and ½ in thick. The mechanical system is mainly built up from Meccano parts.

The picture drum can be made to individual requirements. The model shown in the photograph employs



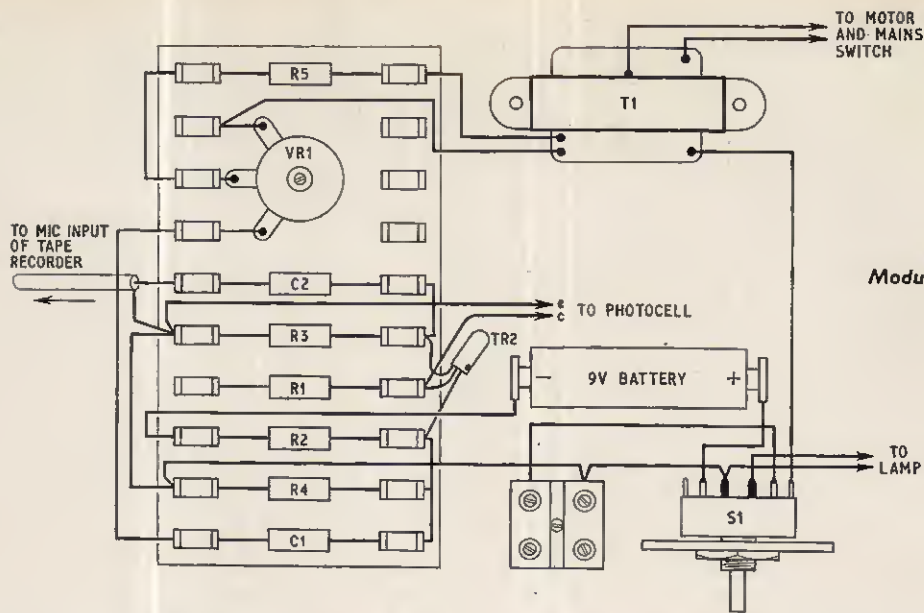

Fig. 2.  
Modulator layout

a drum made from a thick cardboard tube, but a lever top can will serve just as well. A reasonable size would be about  $2\frac{1}{2}$  to  $3\frac{1}{2}$  in long and  $1\frac{1}{2}$  to 2 in diameter. An eight-hole Meccano bush is fitted centrally on one end so that the tin will revolve truly concentric (see Fig. 3).

A hole is made in the centre of the opposite end of the drum and a long screw or a piece of studding about 4 in long is threaded through the hole and fixed on both sides of the end disc (or lid of the can) with two locking nuts (see Fig. 4). This can now be fitted on to the drum. A nut, which will fit the long screw, is clamped firmly between two Meccano perforated strips bolted together. One strip is slightly longer than the other and bent at right angles so that two holes can be used to screw it down to the baseboard (see Figs. 4 and 5).

This clamp is then placed centrally on the wooden base about 6 in from one end and screwed down through the holes in the bent up section of the perforated strip. (See Fig. 5.)

An angled trunnion (Meccano) is then placed centrally at the opposite end of the base from this clamp and screwed firmly home with two screws. Another angled trunnion is placed about 9 in away from the one at the end and aligned parallel to it and in the centre of the baseboard, then screwed down (Fig. 3).

Next, a 3 in perforated strip is bent to the shape shown in Fig. 3, part C. This strip is then bolted to the bottom hole of the second trunnion and the vacant holes aligned to take axle B.

The screw on the picture drum must now be threaded into the scanning nut which is mounted in its clamp.

Fig. 3. Drive details

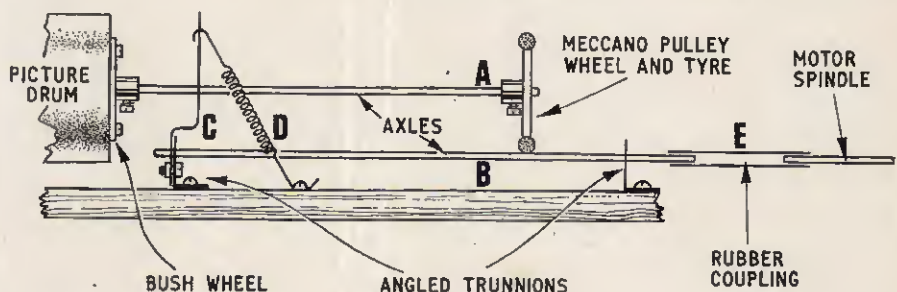

Figs. 4 and 5.  
Lead screw construction

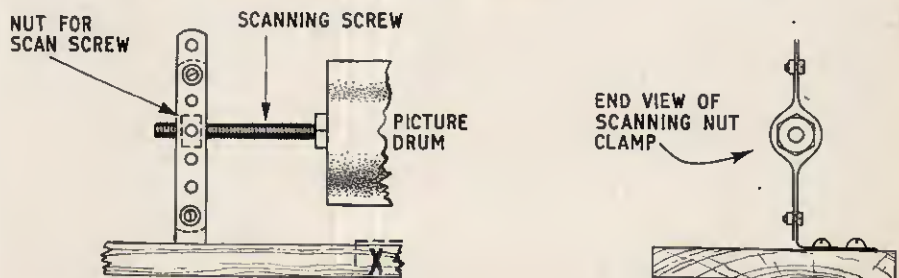

# A PRINT RECORDER continued

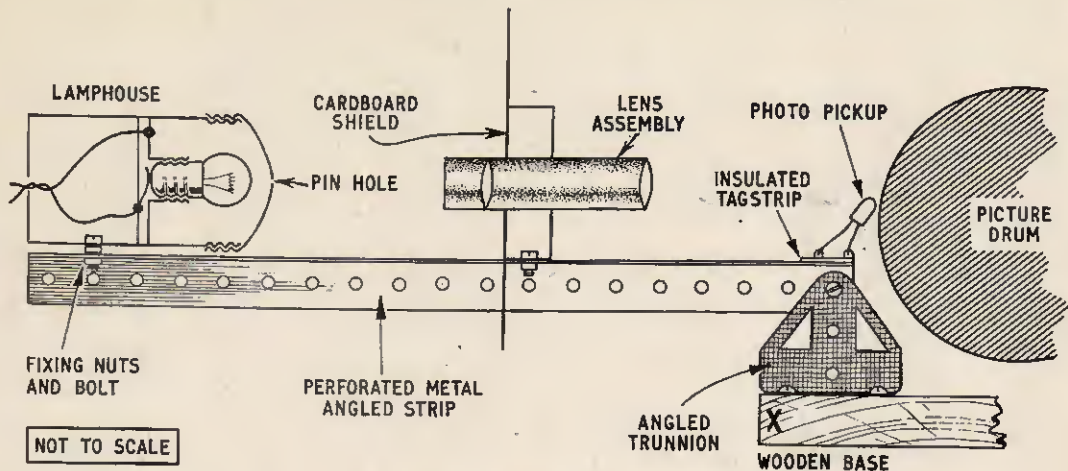

Fig. 6. Optical assembly

While holding the drum horizontally thread a  $6\frac{1}{2}$ in Meccano axle A through the fourth hole from the bottom of strip C. Next, thread it into the bush wheel on the closed end of the picture drum and clamp it with the fixing screw provided.

Now attach a Meccano pulley with rubber tyre to the end of axle A. Loosen the clamp at the other end of the base and move the bolt up and down in the clamp until axles A and B are parallel. Tighten the clamp again. An  $11\frac{1}{2}$ in Meccano axle B is threaded through the top holes of the two angled trunnions.

On the prototype a small spring D (removed from a gramophone brake system) was hooked into an upper hole of perforated strip C (Fig. 3) and the other end was screwed to the base. This assisted to provide good frictional contact between the wheel and axle B.

The electric motor used to drive the prototype was an old Collaro AC34 with a working speed of 78 r.p.m. (Reduction gears inside case.) The motor was attached to drive axle B by means of a small piece of rubber sleeving E. This was slipped over the end of axle B and the motor spindle providing an efficient flexible coupling.

## OPTICAL ASSEMBLY

The beam lamp, spot lens and pick-up are all mounted on a  $12\frac{1}{2}$ in Meccano angled perforated strip. The beam lamp LPI is mounted in a tin (such as that used for storing 35mm film, see Fig. 6).

One hole, as small as possible, is drilled in the centre of the screw-on lid. Another hole, big enough to accommodate a Meccano screw, is drilled in the side and a third hole in the bottom of the tin is made adequately large, say  $\frac{1}{4}$ in, to accommodate two thin wires. The bulb is mounted in a standard round paxolin lampholder, which is then wired and fitted inside the tin and firmly fixed with adhesive. The lead wires are taken through the hole in the bottom of the tin.

The lamp housing is attached to the angled strip with a Meccano nut and bolt threaded through the

second hole from the end of the angled strip as in Fig. 6.

In the author's model the lens was removed from an old film-strip projector and was the twin type with two lenses mounted in a small cylinder  $1\frac{1}{2}$ in long and  $\frac{1}{2}$ in diameter. The whole lens assembly is mounted in the lid of another film can. A large hole made in the centre of the lid accommodates the lens barrel and a smaller hole made in the threaded side takes the fixing nut and bolt. The lens should fit tightly in the holder. The whole lens unit was fixed with a Meccano nut and bolt half way between the lamp and the drum.

The distance of the lens from the lamp housing depends on its focal length and has to be found by experiment. Fine focusing may be achieved by sliding the lens back and forth in its mount. A cardboard shield was fitted to the lens mounting on the side nearest the lamp to prevent unwanted light by-passing the lens and upsetting the light image reflected from the drum. The shield is about 3in square with a hole cut in the middle to take the lens barrel. A slot should be cut in the bottom of the shield to accommodate the angled strip.

The angled strip containing the optical assembly was attached to the top hole of the trunnion using a Meccano nut and bolt (Fig. 6). One bolt was used so that the arm could be hinged up and down to obtain the best results from the pick-up. An angled trunnion is screwed to the baseboard attached in position X on the base (Fig. 6) so that it is in line with one end of the drum when the drum is at the end of its travel.

A piece of tagstrip with two tags should be bolted to the angled strip close to the drum so that the tags are insulated from the metal strip.

TR1 is soldered to the two tags with the sensitive side facing the drum. The wires of TR1 should be held with a pair of pliers to act as a heat shunt while soldering. Two wires are connected between the tags and the modulation unit.

TR1 should be repainted matt black on the surface which is *not* facing the drum, so that it will pick up light reflected from the drum and not from the optical



assembly. The light beam from the optical system should strike the drum just above TR1. On no account should the beam fall directly on TR1 or the performance will be severely upset.

## RECORDING A PRINT

A piece of printed paper such as newspaper can be wrapped round the drum and fixed with adhesive tape. Plug the output of the modulation network into the MIC socket of the tape recorder. Turn S1 to the "record" position, likewise the tape recorder should be switched on and set to "record". Now adjust VR1 so that when the pick-up is darkened no signal reaches the recording indicator, and when it is lit a good signal appears at the indicator. The room should be dark so that spurious light does not interfere with the instrument.

Cut a strip of bromide enlarging paper (hard) the same size as the original printed matter. Wrap it tightly round the drum and fix with adhesive tape. Switch the recorder and S1 to the "play" position and attach the appropriate wires from the machine to the external loudspeaker terminals of the recorder.

Start the machine first, then start the tape recorder and turn up the volume control until a reasonable degree of light is obtained from the lamp when the recorded signal is applied. Leave the machine until it has scanned the whole paper and then stop the recorder before stopping the machine.

Remove the bromide paper from the drum and immerse it in a developer solution specified for the paper. After the desired image has been obtained wash the paper in water and immerse it in a fixing solution (sodium thiosulphate) for 10 minutes. After "fixing" the print it may be examined in the light.

# COMPONENTS . . .

## MODULATOR COMPONENTS

### Resistors

R1	5k	R4	2k	
R2	680	R5	1k	$\frac{1}{2}W$
		R3	3.3k	

All 10%,  $\frac{1}{2}W$  carbon unless otherwise stated

### Potentiometer

VR1 500k log or linear

### Capacitors

C1 5 $\mu$ F 50V elect. } Henry's Radio  
 C2 3 $\mu$ F 50V elect. }

### Transistors

TR1 OC71 (see text)  
 TR2 Any npn transistor for working voltage above 9V

### Miscellaneous

T1 6.3V centre-tapped heater transformer  
 LPI 3.5V m.e.s. bulb  
 S1 2-pole, 2-way rotary switch  
 10-way tagboard  
 Plugs to suit tape recorder microphone and loudspeaker sockets  
 9V battery; connecting wire; knob; solder  
 Batten lampholder (m.e.s.)

## MACHINE PARTS

### Meccano List

No. 2a	4 $\frac{1}{2}$ in perforated strips (2)
4	3in perforated strip
8	12 $\frac{1}{2}$ in angle girder
13	11 $\frac{1}{2}$ in axle rod
14	6 $\frac{1}{2}$ in axle rod
20a	2in diam pulley with boss
24	1 $\frac{3}{8}$ in diam bush wheel
126	Angled trunnions (4)
142a	Motor tyre (for 2in pulley)
37	Nuts and bolts $\frac{3}{8}$ in (pkt of 24)

### Miscellaneous

4in of 4 BA studding and 4 BA nuts  
 Wooden baseboard (see text)  
 35mm film can and two screw lids  
 Lever or screw top can (see text)  
 78 r.p.m. motor (e.g. Collaro AC34)  
 $\frac{3}{8}$ in round head wood screws  
 Rubber tubing to fit axle and motor spindle  
 Small spring

A switch, connected in the mains *line* to the motor and T1, should be used to control the motor and electronics. Start the tape recorder and then start the print recorder drive motor. When the scan is completed stop the tape recorder and switch off the drive motor.

## REPRINT THE RECORDED COPY

Wind the tape back to where the signal started and return the drum to its starting position. This may be done by disengaging the coupling (E in Fig. 3), and spinning the drum by hand. If a reversible motor is used it can be arranged to be switched to a reversing condition to return the drum.

The next process must be done in RED light as it involves the use of photosensitive paper.

Wash the print well in running water for about 5 minutes. The finished print will be a negative reproduction of the original.

## VARIATIONS

Many readers who intend constructing this simple device will probably wish to improve its performance or modify it to their own requirements. Obviously, the finer the thread of the scanning screw, the more detailed will be the final reproduction. A larger drum may also be used provided allowance is made for adequate clearance between the drum and other nearby parts. If the drum is made larger in diameter a larger driving wheel is required. If the drum is made longer, the axles and screw should be longer. ★





impedance for TR2 must be greater by three factors of 1.8 compared to the former value (3 kilohms), i.e. it must now be about 17 kilohms. The new value required for R8 must thus be such as to give 17 kilohms when taken in parallel with the reflected virtual 30 kilohms. The nearest preferred value is 33 kilohms, for satisfying this condition. Accordingly, replace R8 by a 33 kilohm resistor.

The resulting 17 kilohm net impedance at TR2 emitter reflects some 20 times as large, i.e. about 340 kilohms, in parallel with R6. These reflected 340 kilohms, in parallel with the required new value for R6, must now lead to 10 times the former emitter impedance for TR1, because all four changes have therewith been completed. The former impedance at TR1 emitter was 20 kilohms, so that R6 must now be chosen to make it 200 kilohms. In other words, R6 in parallel with 340 kilohms is to be equal to 200 kilohms, making the nearest preferred value for R6 equal to 470 kilohms. The 200 kilohm net impedance at TR1 emitter now reflects as usual some 20 times as large (current gain factor of TR1) to the base of TR1, in parallel with R3.

If R3 is now replaced by a 3.3 megohm resistor, R4 by a 1.5 megohm resistor and VR1 by a 1 megohm linear preset potentiometer, the combined parallel impedance will be just about the required 1 megohm. Any slight final correction can be made subsequently by altering the value of R6 alone, after adjusting VR1 for correct d.c. operating point (350mV d.c. voltage drop across R10 in this case).

### SETTING UP CIRCUIT CARD VBI

The first step is to set the d.c. operating point. Connect across R10 a high impedance multimeter or valve voltmeter (sensitivity at least 20 kilohms per volt) set to a range of about 1 or 2 volts d.c. f.s.d. Adjust VR1 until the meter reading is 600mV (for the given case with component values as in Fig. 1 (of last month's blueprint) and 135 kilohm input impedance at PL1; otherwise reading to be *less* by the same factor as used in each of the four steps to change to a different input impedance as described).

Now connect ten 10 ohm resistors and nine 100 ohm resistors all in series across a 4 volt heater winding on a mains transformer (Fig. 11), earthing the end of the winding at which the 10 ohm resistors are situated. Connect the voltage across all ten 10 ohm resistors straight to the Y-amplifier input of the oscilloscope

with which the pre-amplifier is to be used and adjust the height of the c.r.t. display to a convenient size.

Having previously adjusted the input impedance of VB1 to near the required value (equal to the oscilloscope input impedance) as described above, connect the input of VB1 across *only one* of the 10 ohm calibration resistors. Connect the output from PL2, with the pre-amplifier set to gain 10, to the oscilloscope Y-amplifier input, having disconnected the latter from the ten 10 ohm calibration resistors without disturbing the settings of the oscilloscope controls. Now adjust VR2 with a screwdriver until exactly the same height of trace as previously is obtained. The gain of VB1 between connections 16 and 8 is then exactly 10.

Now connect the probe of the particular oscilloscope (so far not used in these adjustments) to the Y-amplifier input, and the prod of the probe to the full 4 volts applied to the calibration resistor chain. Again adjust the trace to a convenient height. Then move the probe connection to the input PL1 of the pre-amplifier set to gain 10, taking the output from PL2 to the oscilloscope Y-input directly. Connect the prod of the probe and the earth clip across all ten 10 ohm calibration resistors. Adjust the value of R6 until the display on the c.r.t. is of the same height as previously.

Now return right back to the beginning of this sequence of adjustments, re-adjusting VR1 to obtain the stipulated d.c. reading across R10, followed by repeating all subsequent adjustments in the same order.

Repeat the entire sequence until mutually correct settings are observed to have been achieved, i.e. until nothing needs altering any more on an entire run-through. VB1 is therefore properly adjusted to have a gain of exactly 10 between connections 16 and 8, and its input impedance exactly matches that of the oscilloscope Y-amplifier input.

### ADJUSTMENTS TO CIRCUIT CARD VB2

It is absolutely essential to have completed adjustments to VB1 before proceeding to adjust VB2.

The actual adjustment of VB2 is very much simpler than that of VB1, because this can be built with the component values as shown in Fig. 1 under all circumstances, whatever the input impedance actually required at PL1. The exact values of input and output impedance of VB2 are relatively unimportant.

*continued on page 214*

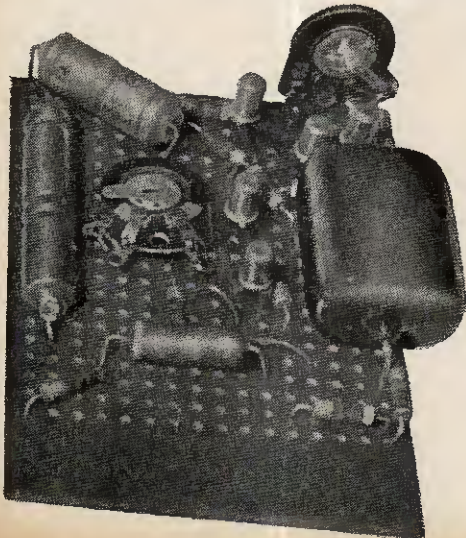

Photograph of VBI showing component layout and positioning of VR1 and VR2

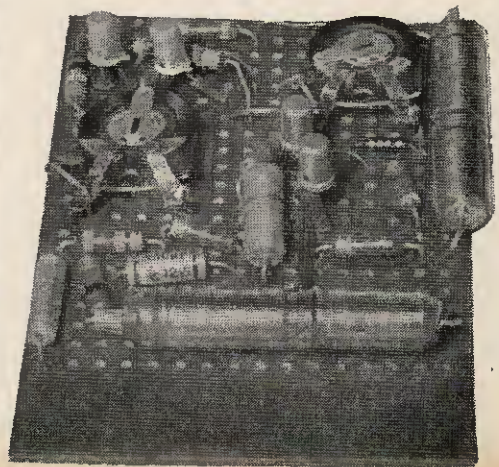

Photograph of VB2 showing component layout and positioning of VR3 and VR4



# DETACHED PARTICLES

By John Valence

## POWER WITHOUT WIRES

THE other day I was enjoying a quiet interlude strolling around the National Gallery in central London. Coming face to face again with the works of those great landscape artists Constable and Turner, I was reminded of the fierce controversy that arises whenever the Electricity Board proposes to build a generating station or wishes to run a new high voltage grid line over some part of the countryside.

Why should modern structures such as these be considered an intolerable intrusion upon the natural scene, when Constable was happy to paint man-made structures such as mills and lock-gates. Indeed, buildings like these are prominent features of some of his most admired landscapes. Why does an old broken-down mill have charm to our eyes, and why does a contemporary engineering work offend?

Consider the nuclear power stations. Each of these shows thought and consideration for the local amenities. Well designed outlines and the use of local stone wherever possible for cladding the outer surfaces have produced quite aesthetically pleasing results.

But it is mainly the transmission system that offends. It is a question of scale. In the vast mountainous regions of North Wales or Scotland

even the super grid cannot predominate over nature. However, when these networks reach the flatter (and more heavily populated) parts of the country the gargantuan towers and the aerial fence strung between them overwhelm the surrounding scene for miles.

The national grid system is the country's life-line and demands for electrical power are ever increasing. But is there no real alternative? We are told that the cost per mile of an underground cable is very nearly 15 times that of an overhead system. It is apparent that overhead cables there must be—at any rate until the transmission of power by radio or light waves becomes a practical proposition.

Power by "wireless" has been talked about for years past. I believe many of the early pioneers considered this the next logical development following successful attempts to communicate over long distances by radio waves.

Will this remain just a pipe dream for another 50 years or more? Or will visitors to the National Gallery in 2064 stand enthralled in front of landscapes painted by their contemporaries that owe much of their "old world" charm to the long disused pylons standing sentinel on the distant hill tops?

## NON-CONDUCTOR

IS the familiar cry "all fares please" soon to become extinct—soon to be numbered among the street cries of bygone days?

I started musing on this subject after reading reports of electronic ticket reading machines now being brought into service on conductorless buses in Manchester.

The scheme operates apparently like this. The intending passenger buys a special ticket with a metallic inset from a vending machine at the bus stop. When boarding the vehicle the ticket is pushed into a slot and is examined by the ticket reading machine which then cuts off the metal portion, thus preventing its further use. If a phoney ticket is offered to the machine a bell rings

and the culprit stands exposed (blushing furiously, I hope) and the driver is thus alerted to repel this particular boarder.

Electronic means for ejecting passengers who try to stay on beyond their proper fare stage have yet to be invented. In the meanwhile, this part of the operation remains exclusively in human hands (well, let's be quite fair about this—inspectors are human you know).

In case Mancunians think this is one more example of what Manchester Does Today etc., may I mention that in the greatest conurbation of all, London Transport has been trying out a number of electronic devices all with the intent of speeding the flow of its million per day commuters.

## CONTROLLED ENTRY

IN fact, an electronic ticket inspector has been on duty at one of London's Underground Railway Stations for several months now—but he is still only on probation.

The passenger places his ticket into a slot by the entrance gate, the ticket is scanned by an electronic device and, if in order, the gate is released and the passenger picks up his ticket as it emerges from another slot adjacent to a second gate which admits him to the platform.

What exactly happens should one attempt to pass off an out-of-date or phoney ticket, I have not had the courage to find out! The thought of being trapped between locked gates to the possible accompaniment of ringing bells and flashing lights is a sufficient deterrent to yours truly!

This ticket barrier heralds the arrival of automation on the London Underground Railway System. Let us hope no fuses are blown during rush hour.

Incidentally, further applications of this kind of device intrigue me. How about an electronically operated letter box for the home? This could be programmed so that bills, soap powder vouchers and other undesirable communications are promptly rejected from the front door. Well, it's a thought anyhow.

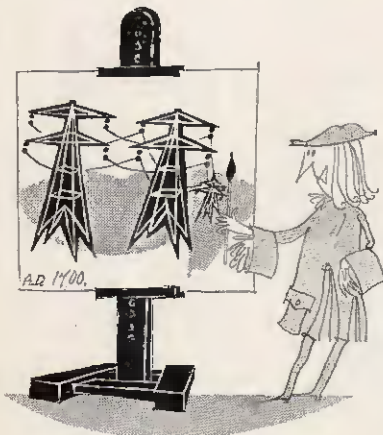

Actually . . . it's an abstract



## HIGH IMPEDANCE VOLTMETER

continued from page 177

### SI AND THE MULTIPLIERS

First wire into circuit R9 and BY1. The latter should preferably be a slightly used D23 battery (use one to feed a torch bulb for a minute or two) so that the open-circuit voltage is near to 1.5—a new cell will have an open-circuit voltage greater than 1.5. R9 should be quite accurate, say 5 per cent or closer, and can be a 10 per cent type with a suitable series or parallel resistor to bring the value closer to 15 kilohms.

Resistor R1 can be wired into circuit and should be a 5 per cent or 10 per cent type suitably adjusted with other resistors. The meter is then switched on with S2, brought to zero with VR2 (S3 may need opening or closing), and then switched with S1 to "Cal.". VR1 should then be adjusted to obtain f.s.d. on the meter.

If the scheme in Fig. 1a is being used, S1 is turned to position 2 (1V) and the resistor to be used for R2 is then temporarily connected in series with the negative test lead. The test leads are then connected to a source of which the potential is known (a used, but not exhausted, dry battery, for example) and the value of R2 adjusted, with the aid of series or parallel resistors, to give the correct deflection on the meter M. This procedure is then used to determine the other multipliers, each being soldered into position when the correct value has to be obtained. Note that the resistors must be determined in the order R2 to R8.

## P.E. DATA BOOKLETS

THE pull-out supplement in the centre of this issue forms the middle section of Data Booklet 2, pages 5 to 12 inclusive. The outer section was included in last month's PRACTICAL ELECTRONICS.

Remove these supplements by pulling smartly from the magazine. Fold each supplement in half and cut along the top edges of the pages.

### Data Booklet 1

Attention is drawn to certain amendments that should be made to Data Booklet 1 presented with our first issue.

This booklet contains formulae of fundamental importance and it is much regretted that a few inaccuracies crept in during its compilation and printing. In order to avoid any confusion arising from its use at a later date, it is suggested that the following points be recorded immediately on the appropriate pages of your copy of Data Booklet 1.

page 2

Resistance is inversely proportional to area  $\frac{1}{a}$

$$\text{thus } R \propto \frac{1}{a} \times l \text{ and } R = \rho \frac{l}{a}$$

Note:  $\frac{1}{a}$  (figure 1 not 1 in first two cases)

page 3

Multi-plate Capacitor formula should read:

$$C = \frac{EoEr(n-1)a}{d} \text{ Farads}$$

n = number of plates

pages 4 and 5

w should read  $\omega$

If the scheme in Fig. 1b is being used, each multiplier is adjusted individually and it is not essential to proceed from position 2 of S1 to position 9 in that order.

Reference potentials for ranges over, say, 50V can normally be found in the h.t. circuits of amplifiers and radio receivers. Calibration should be carried out by measuring the potentials with an ordinary multimeter connected in parallel with this instrument.

### USING THE INSTRUMENT

First, the unit is switched on with S2 and set to one of its eight ranges. The meter will probably not read zero, so VR2 should be adjusted until zero reading is obtained (it may be necessary to open or close S3 which is used to compensate for the variations in standing current through TR1 due to alterations in the ambient temperature). Having obtained a zero reading, S1 is now switched to "Cal." and VR1 turned to obtain f.s.d. on the meter. The instrument is now set up ready for use, but the adjustments may need to be repeated if it is used for long periods, particularly if the ambient temperature changes.

The meter will be found particularly useful for measuring a.g.c. potentials, limiter-grid potentials in f.m. receivers, and anode voltages where anode loads are high in value. If instability results from connection of the unit to the circuit under test, a 4.7 kilohm or 10 kilohm resistor can be used in series with the "live" test lead, right at the end, and will give rise in most cases to negligible error. ★

page 5

Second formula should read:

or using j notation  $Z \text{ ohms} = R - j\omega C$

Third formula should read:

$$= \cos^{-1} \frac{R}{Z} = \cos^{-1} \frac{R}{\sqrt{R^2 + \left(\frac{1}{2\pi fC}\right)^2}}$$

page 6

Basic Magnetic Formula. Equation (1) should read:

$$\therefore \frac{\phi}{a} = \mu_0 \mu_r \frac{IN}{l}$$

Note: l not figure 1  
and  $\mu_0$  should read  $\mu_0$

page 10

First formula should read:

$$\text{power factor } \phi = \cos^{-1} \frac{R}{Z} = \cos^{-1} \frac{R}{\sqrt{R^2 + (2\pi fL)^2}}$$

page 11

Geometrical Progression. Add under formula: for  $r < 1$  multiply top and bottom of right-hand side of equation only by  $-1$ .

Also add note:  $r = \text{common ratio}$

page 12

Trigonometrical Identities. Last line but one should read:

$$\cos 2A = \cos^2 A - \sin^2 A$$

Sine and Cosine Laws (for any triangle). Second line should read:

$$a^2 = b^2 + c^2 - 2bc \cos A \text{ Cosine Law}$$

# NEW PRODUCTS

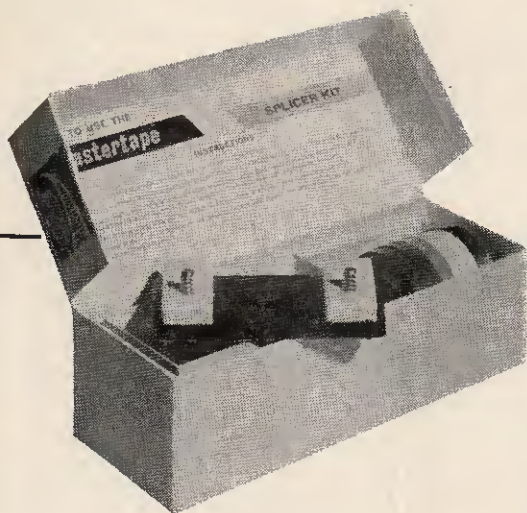

## Good Recording

Vidor Ltd., West Street, Erith, Kent.

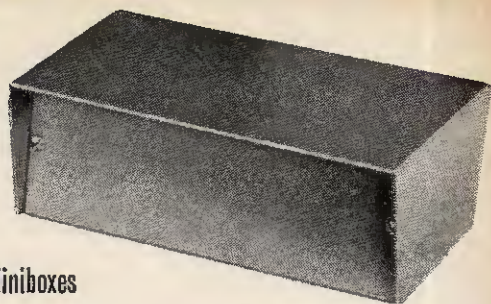

## Visor Miniboxes

Alfred Imhof Ltd., Ashley Works, Cowley Mill Road, Uxbridge, Middx.

One of the blueprints in last month's issue contains details of a home or office intercom.

Readers desirous of obtaining a truly professional finish will be glad to learn that a suitable cabinet finished in stove enamel either blue, silver or dark grey hammer tone on all internal and external surfaces is available from Imhofs.

The cabinet is made from 20 s.w.g. aluminium and is of two-piece design allowing maximum space for installing components. Our photograph shows type VM 4060 which costs £1 2s 6d.

Ideal for tape enthusiasts are two recently announced products by Vidor Ltd., and manufactured by M.S.S. Recording Ltd. These are a "Mastertape Splicer Kit" and a low cost triple play tape called "Mastertape."

The kit contains five different coloured rolls of leader tape and one roll of metallic strip and jointing tape—as well as a newly designed splicer. The complete kit which retails at 21s is shown on the left.

The new tape is available on standard spools containing 600ft to 3,600ft, price ranging from £1 1s 0d to £4 19s 0d. A polyester film 0.0005in thick is used for the base material and is covered by a new oxide with low friction finish which reduces recording head wear.

## Contact Cleaner

Electrolube Ltd., Oxford Avenue, Slough, Bucks.

The efficient functioning of electrical and electronic equipment is often impaired by the effects of corrosion and tarnish on contacts.

Electrolube Ltd. produce a range of solvents especially to deal with the above mentioned problems. The most commonly used is Electrolube Nos. 1 and 2, which are available in handy 2oz "snorkel" bottles or pen dispensers.

Electrolube No. 1 is recommended for dirty or worn contacts on potentiometers (wire or carbon track), valve or plug pins and sockets, and push-button or wafer switches. Since the solvent does not evaporate quickly it may carbonise if used on contacts where sparking can occur. For treating and lubricating all clean arcing and non-arcing contacts, surfaces and mechanisms free from mineral or other lubricants and grease, No. 2 is recommended.

Our photograph shows the solvent being applied to valve pins to improve sensitivity and signal to noise ratio.

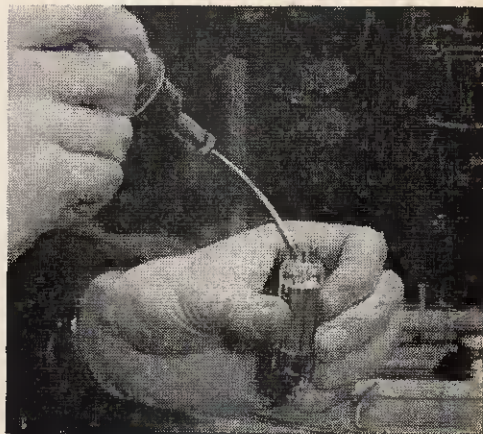



# NOW ANYONE CAN AFFORD TO TRAIN TO BE AN EXPERT IN RADIO, TV, AND ELECTRONICS

Anyone can afford these amazing courses—anyone can understand this practical training—No complicated mathematics to hold you back—No old fashioned, obscure explanations to frustrate you!

The lessons are **CRYSTAL CLEAR, PRACTICAL, EASY TO MASTER AND USE**—Early lessons make fundamentals clear even to the beginner, while other lessons will give you the practical "know-how" of an expert!

Compare favourably with some courses costing very much more! By creating a mass market through large volume sales and eliminating individual letter writing we are able to pass on these savings directly to you!

Each course is printed on extra large quarto size sheets and bound into one manual to simplify handling and distribution.

Please select the course most suitable for your requirements from the following:

**No. 1. RADIO COURSE.** Fundamental facts—Electrons—Conductors and Insulators—Radio Batteries—Circuits—Magnetism—Ohm's Law—Resistor Colour Code—Chart—What resistor to use—Electro-Magnetism—Electromagnetic Induction—Self Induction—Radio Frequency Inductances—Capacity Coupling—I.F. Transformers—Radio Coils—Radio Capacitors—The Farad—Dielectric—Capacitor Colour Code—Alternating Current Theory & Filters—Resistance and Resistance—Charts to calculate Capacity Frequency and Inductance—Handy Radio Formulae—Practical Aspects of Radio Servicing—Radio Valves—Transistor Theory—N Type Germanium—P Type Germanium—Diode Action—Transistor Action—D.C. Stabilization—Transistor Bias Adjustment—R.F. Amplification—Superheterodyne Principles—A.V.C. Power Supplies—Meters—Multimeters and Valve Testers—Point to Point Servicing—Signal Generators and Signal Tracers—Using an Oscilloscope for Servicing—Alignment—Amplifiers and P.A. Equipment—High Fidelity—Advantages of Inverse Feedback—Speakers—Frequency Modulation—How to Obtain Radio Jobs. Price for the complete course. **ONLY 36/-**. Plus postage 1/6.

**No. 2. ELECTRONICS COURSE.** Includes most of the above lessons plus L.G. and R. Combined Circuits—Resonance Phenomenon—Behaviour at Resonance—How Meters Work—Making a Voltmeter—Ohm meter Connections—Valves—Electron Behaviour—Triodes—Characteristic Curves—Power Supplies—Audio Amplifiers—Microphones—Resistance Coupling—Obtaining Grid Bias—Push Pull and Parallel—Phase Inverter Circuit—Radio Frequency Voltage Amplifiers—I.F. and Multiband Coils—Detection—Receiver Circuits—Results of Frequency Mixing—A.V.C.—Electronic Oscillators—Quartz Crystals—Radio Transmitter Circuits—Modulation and Tuning—Lines, Antennas and Radiation—Test Equipment Using Meters—Electronic Test Equipment—Thyratrons—Photo-Cell Equipment—Radio Compass—H.F. Heating—Electronic Shaping Circuits—Electric Microscope—Electric Strain Gauges—Inter-Communicators—Radio Servicing Techniques—Servicing Printed Circuits.

Price for the complete course. **ONLY 39/6**. Plus postage 1/6.

Graduates of the Electronics Course can qualify for a certificate—Details sent with each order.

**No. 3. TELEVISION COURSE.** Effect of mis-adjusted controls—Pictures of various faults—Service adjustments—Circuit Faults Indicated by a Poor Picture—Finding Bad Valves by observing Picture Faults—Separate Channel I.F. System—Inter-carrier I.F. System—Negative Picture—Interference—Antenna Principles and Practices—U.H.F. Transmission Lines—Facts About the T.V. Signal to Help you in Service Work—Synchronizing Separators—T.V. Interference Aids—All about Cathode Ray Tubes—Explanation of T.V. Circuits—Video Detector—Video Amplifier—D.C. Restorer Circuit—Automatic Gain Control Circuits—Oscillators—Deflection Coils—Automatic Frequency Control Circuits—Analysis of Stagger Tuned I.F. Receiver—Analysis of Three-Inter-Carrier Type Receivers—The Vertical Deflection Circuit—The Horizontal Deflection Circuit—Waveforms—Schematics of various sections of a T.V.—U.H.F. Converters and Tuners—T.V. Test Equipment and Alignment—Analysis of Various Problems.

Price for the complete course. **ONLY 38/-**. Plus postage 1/6.

**UNCONDITIONALLY GUARANTEED TO GIVE COMPLETE SATISFACTION**

You must be convinced that this is the best value you have ever seen in Electronics, Radio or T.V. Training, otherwise you can return the course for have your money refunded if sent with order) after you have examined it in your own home for a full seven days.

**IF YOU SEND CASH WITH ORDER WE WILL INCLUDE A FREE 70-PAGE BOOK.** Tick on the coupon one book for each course ordered with full cash.

**RADIO SERVICING FAULT FINDING BOOK. TELEVISION FAULT BOOK. OSCILLOSCOPE BOOK.**

These free books are authoritative, and loaded with information. Would cost at least 5/- each if bought separately—by sending cash you reduce book-keeping and other costs, which savings we pass back to you!



## MULTIMINOR Mk 4

The newly improved model of this famous AVO pocket size multi-range instrument has been enthusiastically acclaimed in all parts of the world for its high standards of accuracy and dependability as well as for its modern styling, its highly efficient internal assemblies and its resistance to extremes of climatic conditions.

It is simple to use, one rotary switch for instant range selection, only one pair of sockets for all measurements, and a 2 1/2-inch clearly marked scale-plate. It is supplied in an attractive black carrying case complete with interchangeable test prods and clips, and a multi-lingual instruction booklet.



RESISTANCE: 0-2MΩ in 2 ranges, using 1.5V cell  
SENSITIVITY: 10,000Ω/V on d.c. voltage ranges  
1,000Ω/V on a.c. voltage ranges

to send you a full specification of this great little instrument. It measures only 7 1/2 x 4 x 1 1/2 ins. and weighs only 24 ozs.

**AVO LTD**

AVOCET HOUSE • 92-96 VAUXHALL BRIDGE ROAD • LONDON S.W.1

Telephone: VICTORIA 3404 (12 lines)



### FREE TRIAL OFFER

Try only 5/- per week if you wish. Clip coupon right now for this special offer  
To: Sim-Tech Book Company, Dept. EL3, Gater's Mill, West End, Southampton, Hants.

Please send the following courses for a full seven days' trial.

- No. 1. RADIO COURSE.  No. 2. ELECTRONICS COURSE.  
37/6, incl. postage. 41/-, incl. postage.  
 No. 3. TELEVISION COURSE.  
37/6, incl. postage.

(Free trial customers tick one only please).

If not delighted, I may return the course post-paid without further obligation on my part. Otherwise I will pay cash price OR 5/- weekly until purchase price plus 2/6 service charge has been paid.

- Tick here if enclosing fully purchase price.  
Please send me  FREE RADIO FAULT FINDING BOOK.  
 FREE T.V. FAULT FINDING BOOK.  FREE OSCILLOSCOPE BOOK.  
Amount enclosed £.....

I understand that you will refund this money in full if I am not 100% satisfied. Overseas customers please send full amount (including Ireland).

NAME .....

ADDRESS .....

City..... County.....

MM19



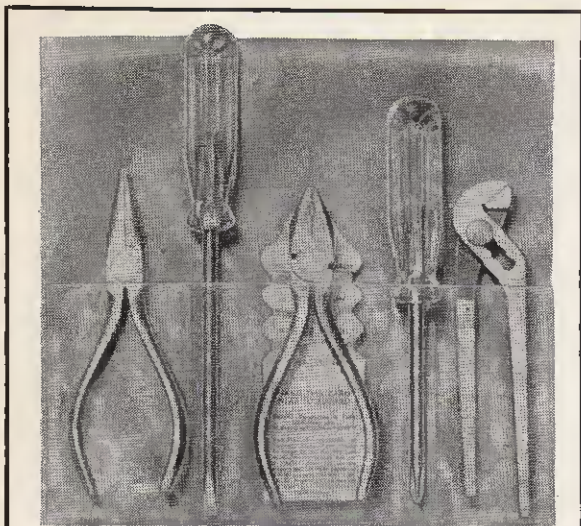

Tool Pack

W. K. & C. Peace Ltd., Templeborough Works, Sheffield 9.

A new kit of small hand tools, suitable for electronic enthusiasts, model makers, radio repairers etc., is now being marketed by the above firm.

The kit consists of three of the most commonly used pliers (combination, radio and multi-grip), two screwdrivers (one conventional and one Phillips recessed head type), and a card of 5, 10 and 15 amp fuse wire completes the pack. The kit is housed in a roll-pack wallet and retails at 28s 6d.

This new kit should prove to be a handy addition to the tool box, but we feel we must point out that the pliers do not have insulated handles and should never be used in "live" circuits.

The factors governing internal impedance relationships within VB2 are the same as for VB1.

Having completed adjustments to VB1, switch the pre-amplifier to "gain 100" with S1. Connect the oscilloscope probe directly to the oscilloscope and the prod and earth clip thereof across the entire chain of calibration resistors in the same arrangement as previously. Adjust for convenient height of display on the c.r.t. (Y-amplifier gain). Disconnect probe from the oscilloscope and connect to input PL1 of the pre-amplifier, having first adjusted VR3 for 600mV reading on a high impedance voltmeter across R20. Connect prod and earth clip of probe across one single 10 ohm calibration resistor at the extreme earth end of the chain. Adjust VR4 to bring the height of the trace on the c.r.t. to the same value as previously.

Adjustment of VB2 is now complete, as is that of the entire pre-amplifier.

### SIGNAL-TO-NOISE RELATIONSHIP

With the oscilloscope probe connected to the input of the pre-amplifier, conditions are virtually those of an open circuit. In the author's set-up about 25 microvolts of noise were observed to be developed at the base of TR1, leading to 2.5 millivolts of noise at the output terminal PL2. The resulting "grass" on the trace of the c.r.t. when everything is set to full gain is well under one millimetre wide.

If the pre-amplifier is connected to the Y-input, again with Y-gain full up and pre-amplifier gain set to 100, and input signals to the pre-amplifier are fed in directly without a probe, then the noise level will be less than the normal trace width on the c.r.t. as long as the input signal source impedance is less than 10 kilohms. In other words, noise will be quite unnoticeable on the c.r.t. under these conditions.

If the signal source impedance is even less still, as will mostly be the case for electroacoustic applications where the effects of residual hiss would be most serious, it is advisable to remove R1, connecting PL1 straight through to C1. The impedance presented to the base of TR1 by most gramophone pick-ups or microphone arrangements, with or without transformers, is then so small that the hiss level is hardly audible in the final loudspeakers following a subsequent main amplifier of any normal design. It is, however, essential to retain R1 if there is any danger of d.c. surges being applied to PL1 under any working conditions, though the value of R1 may be reduced to 10 kilohms to strike a compromise.

If the pre-amplifier is intended to be used equally frequently for electroacoustic and for metric purposes, with great importance attached to optimum signal-to-noise ratio in the former case, it is advisable to build VB1 without R1, taking PL1 straight to C1. R1 must then be built into the coaxial connecting cable reserved for metric applications, always taking care to use this cable and no other one when making quantitative measurements and/or when high d.c. components may be present in the signal source. R1, of course, has some influence on the effective gain of VB1, so that the exact adjustments should then be made including the metric cable with built-in R1.

The gain without the metric cable, for low-noise electroacoustic work, will then be very slightly higher, but this is unimportant in such cases. ★

### Transformer Design Kits

The Belclere Co. Ltd., 385-387, Cowley Road, Oxford.

Readers who find it necessary to wind their own transformers for prototype electronic circuits should find the transformer kits of the above firm helpful. They now supply 51 different kits which offer a wide selection of bobbins and clamps, if needed, together with the required amount of laminations in a choice of materials.

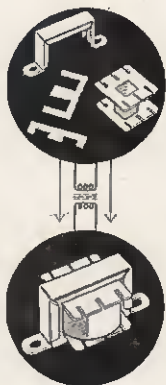



# LASKY'S RADIO

# For the Finest Value and Service to the HOME CONSTRUCTOR AND THE ELECTRONICS ENTHUSIAST

We consider our construction parcels to be the finest value on the home constructor market. If on receipt you feel not content to build the set, you may return it as received within 7 days, when the sum paid will be refunded less postage.

## TRANSISTOR PORTABLES

### THE SKYROVER RANGE

**GENERAL SPECIFICATION**  
7 transistor plus 2 diode superhet, 6 waveband portable receiver.

The SKYROVER and SKYROVER DE LUXE cover the full Medium Waveband and Short Waveband 31-94M, and also 4 separate switched band-spread ranges, 13M, 16M, 19M and 26M, with Band Spread Tuning for accurate Station Selection. The coil pack and tuning heart is completely factory assembled, wired and tested. The remaining assembly can be completed in under three hours from our easy to follow, stage by stage instructions. Superhet, 470 Kc/s. All Mullard Transistors and Diode. Uses 4-U2 batteries. 5in. Ceramic Magnet P.M. Output. Telescopic Aerial and Ferrite Rod Aerial.

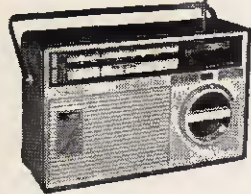

Speaker. Easy to read Dial Scale. 800 MW Output.

### The SKYROVER Mk II. The SKYROVER De Luxe

(Illustrated). Now supplied with redesigned cabinet, edgewise controls. New colour tuning scale and cabinet in Sierra Tan.

Controls: Waveband Selector, Volume Control with on/off Switch, Tuning Control. In plastic cabinet size 10 x 6 1/2 x 3 1/2 in. with metal trim and carrying handle. Can now be built for **£8.19.6** P. & P. 5/- extra.

H.P. Terms: 21/- deposit and 11 monthly payments of 16.6/-

Data for each receiver: 2/6 extra. Refunded if you purchase the parcel. Four U2 batteries 3/4 extra. All components available separately.

Tone Circuit is incorporated, with separate Tone Control in addition to Volume Control. Tuning Control and Waveband Selector. In a wood cabinet, size 11 1/2 x 6 1/2 x 3 1/2 in. covered with a washable material, with plastic trim and carrying handle. Also car aerial socket fitted.

Can now be built for **£10.19.6** P. & P. 5/- extra.

H.P. Terms: 25/- deposit and 11 monthly payments of 20/-

Data for each receiver: 2/6 extra. Refunded if you purchase the parcel. Four U2 batteries 3/4 extra.

**★ LONG WAVEBAND COVERAGE IS NOW AVAILABLE FOR THE SKYROVER and SKYROVER DE LUXE.** A simple additional circuit provides coverage of the 2100/1800m band (including 1500 M. Light programme). This is in addition to all existing Medium and Short wavebands. All necessary components with construction data. Only 10/- extra Post Free. This conversion is suitable for Skyrover and Skyrover De Luxe receivers that have already been constructed.

### REALISTIC SEVEN

Fully tunable long and medium bands. Uses 7 Mullard Transistors; plus Diode OA70.

**STAR features:**

- 7 Transistor Superhet. ● 250 Milliwatt output 5in. high flux speaker. ● All components mounted on a single printed circuit board, size 8 1/2 in. x 6 1/2 in. in one complete assembly. ● Plastic cabinet, with carrying handle, size 7 1/2 x 10 1/2 x 3 1/2 in., in blue/grey. ● Easy to read dial. ● External socket for car aerial. ● I.F. frequency 470 Kc/s. ● Ferrite rod internal aerial. ● Operates from P.P. or similar batt. ● Full comprehensive data supplied with each Receiver. ● All coils and I.F. etc., fully wound ready for immediate assembly. An outstanding Receiver.



Can be built for

**£5.19.6**

P. & P. 4/6.

### REALISTIC SEVEN De Luxe

By popular request a De Luxe version of the well-known Realistic Seven now available. With the same electrical specification as standard model—PLUS A SUPERIOR WOOD CABINET IN CONTEMPORARY STYLING covered in attractive washable material, with easy-to-use trim and carrying handle. Also a full vision circular dial, externally mounted to further enhance the pleasant styling. **ONLY £1 EXTRA**

Both models: Battery 3/6 extra. (All components available separately.) Data and instructions separately 2/6, refunded if you purchase parcel.

### TWO SINCLAIR SUPER MINIATURES



**THE MICRO-6** Self-contained pocket radio. Size only 1 4/5 x 1 3/10 x 3/4 in. A marvel of modern miniaturisation—truly amazing performance. Without a doubt the most advanced transistor circuit ever offered to home constructors—yet may be built in an evening. Complete with earphone and detailed construction data. Can be built for only **59/6** separately. Mercury cell 1/11 extra (2 required).

**THE SLIMLINE** The new amazing performance 2+transistor pocket radio size only 2 1/2 in. x 1 1/2 in. Micro alloy transistorised and printed circuit. Easy to assemble. **CAN BE BUILT FOR 49/6** available separately.

### NEW! ANOTHER SINCLAIR SUPER MINIATURE

**THE X10** 10 watt power amplifier fitted with integrated pre-amplifier. Requires only 1 mV. for an output of 10 watts undistorted. Frequency response is flat 1 dB from 5 c/s. to 20 kc/s. Size only 6 x 3 x 3 1/2 in. Weight 5 oz. Built on printed circuit. Operates from 12 v. D.C. at 75 mA. quiescent. Circuit KIT **£5.19.6** Free AVAILABLE READY BUILT, TESTED AND GUARANTEED, **£8.19.6** Post Free. 3 pots. for volume, Bass and Treble, 7/8 the 3 extra. Mains power pack if required, 54/-.

207 EDGWARE ROAD, LONDON, W.2.  
Near Praed St. PADDINGTON 3271/2

33 TOTTENHAM COURT ROAD, W.1.  
Nearest Stn., Goadge St. MUSEUM 2605

152/3 FLEET STREET, LONDON, E.C.4.  
Telephone: Fleet Street 2833

BOTH OPEN ALL DAY SAT. Early Closing Thurs.

Mail Orders to Dept. P.W., 207 Edgware Rd., W.2.

OPEN ALL DAY THURSDAY. Early Closing Sat.

# LASKY'S FOR SPEEDY MAIL ORDER SERVICE

## CONSTRUCTORS BARGAINS

### The "Sixteen" Multirange METER KIT

This outstanding meter was featured by *Practical Wireless*, in the Jan. '64 issue. Lasky's are now able to offer the complete kit of parts as specified by the designer.

**RANGE SPECIFICATION:**  
D.C. volts: 0-2.5-5-10-250-500 at 20,000 Ω/V.  
A.C. volts: 0-25-50-250-500 at 1,000 Ω/V.  
D.C. current: 0-50 μA, 0-2.5-50-250 mA.  
Resistance: 0-2000 Ω, 0-200k Ω, 0-20 MΩ.  
Basic movement: 40 μA f.s.d. moving coil. With universal shunt full scale deflection current is 50 μA.  
Size: 4 1/2 x 3 1/2 x 1 1/2 in.  
Controls: 12 position range switch; separate slide switch for A.C. volts—D.C. ohms; ohms zero adjustment pot. meter; meter zero. External connections: Two 4 mm. sockets for test lead plugs.  
Power requirements: One 1.5v. and one 1.5v. batta. Complete with all parts and full construction details.



H.P. Terms: 21/- deposit and 5 monthly payments of 21/-.  
Data and circuit available separately, 2/6; refunded if all parts bought. Pair of batteries 2/- extra.

**LASKY'S PRICE £5.19.6** P. & P. 5/-.

### BUILD A HIGH QUALITY TAPE RECORDER

Using the famous Collaro "STUDIO" deck and MARTIN pre-assembled amplifiers 2- or 4-track models.

#### COLLARO STUDIO TAPE DECK.

Latest model 3 speed, 3 motors. Take 7in. reels. Fitted with half-track heads. LASKY'S PRICE £10/10/-. New and Unused. Carr. & Pack 7/6.

**COLLARO STUDIO TAPE DECK.** As above but fitted with the latest quarter-track heads. LASKY'S PRICE £13/19/6. Carr. & Pack 7/6.

**MARTIN TAPE RECORDER AMPS.** Designed for use with Collaro Studio Tape Deck. In sub-assemblies for immediate installation. 6-valve circuit. Comprehensive instructions make final assembly as simple as possible. Everything supplied including valves, etc. Monitoring facilities. 3-ohm output, speed equalising, etc. For 200-250 v. A.C. mains.

**PRICES** 1-track Model £11/11/-. 1-track Model £12/12/-. P. & P. 2/6. Portable carrying case designed to take the Collaro Studio Tape Deck and the Martin Tape Amplifier. Fitted with 8 x 6in. speaker. Price complete with speaker £5/6/-. P. & P. 5/-.

### TRANSISTORS ALL BRAND NEW AND GUARANTEED

GET 81, GET 85, GET 86 2/8; 873A, 874P 3/6; OC45, OC71, OC81D 4/6; OC 44, OC 70, OC 78, OC 81 5/8; (match pair 10/8); AF 117, OC 75, OC 170, OC 200 8/8; OC 23, OC 12, OC 43, OC 73, OC 82D 7/8; OC 201, OC 204 15/-; OC 205, OC 206 19/8; OC 28 24/8.

### TRANSFILTERS BY BRUSH CRYSTAL CO. Available from stock.

TO-01B 465 kc/s. ± 2 kc/s.	TO-02D 470 kc/s. ± 1 kc/s.	<b>6/6 EACH</b>
TO-01D 470 kc/s. ± 2 kc/s.	TF-01B 465 kc/s. ± 2 kc/s.	
TO-02B 465 kc/s. ± 1 kc/s.	TF-01D 470 kc/s. ± 2 kc/s.	

P. & P. 6d.

### FROM PRE-AMP TO 20 WATT HI-FI STEREO ASSEMBLY AVAILABLE FROM STOCK

Using specially developed circuits, the very latest transistors and printed circuits—these kits are all fully checked and tested before leaving the factory. Although the kits are basically designed for use together the pre-amplifier and mixer stages may be used to great advantage with existing valve or transistor equipment.

- KIT 1. 6-stage Matching Input Selector Unit..... LASKY'S PRICE 47/6.
- KIT 2. Pre-amplifier with volume control..... LASKY'S PRICE 37/6.
- KIT 3. 3-Channel Mixer with plug-in adaptors for individually matching each circuit. Adaptors 8/6 each..... LASKY'S PRICE 79/6.
- KIT 4. Pre-amplifier with tone/volume control stages..... LASKY'S PRICE 62/6.
- KIT 5. 10 and 3 watt Main Amplifier..... LASKY'S PRICE 55/12/6.
- KIT 6. Power supply converter unit..... LASKY'S PRICE 52/6.
- KIT 7. 15 ohm version of Kit 5..... LASKY'S PRICE 52/12/6.
- KIT 8. Power supply for Kit 7..... LASKY'S PRICE 52/15/6.

## SPECIAL INTEREST ITEMS I

### READY BUILT TEST METERS All brand new—complete with test leads and batts.

HAIKI 20,000 O.P.V.	LASKY'S PRICE	£5 19 6
TE-13 1,000 O.P.V.	LASKY'S PRICE	£1 19 6
TMK-500 50,000 O.P.V.	LASKY'S PRICE	£8 17 6
200-H 20,000 O.P.V.	LASKY'S PRICE	£5 0 6
P-1 2,000 O.P.V.	LASKY'S PRICE	£2 12 6
P-3 4,000 O.P.V.	LASKY'S PRICE	£4 2 6
MT-955 50,000 O.P.V.	LASKY'S PRICE	£10 19 6

Also complete range of Avo and Taylor Meters and Test Equipment in stock.

### THE HARROW POWER PACK

Battery simulator for portable radios, etc. Converts your battery radio to A.C. mains. Replaces 41 v., 6 v. and 9 v. batts. Size only 3 1/2 x 2 1/2 in. x 2 1/2 in. State voltage required when ordering. LASKY'S PRICE 29/6 P. & P.



# Sub-miniature Electrolytics for Transistor Circuits

This range of shorter capacitors has been introduced to meet the ever increasing demand for smaller electrolytics to be used in miniaturised transistor circuits in both industrial and

T.C.C. TYPE NO.	Case Size in inches			Maximum D.C. Wkg. Voltages and Cap. ( $\mu$ F)							
	D	L	C	3V	6V	9V	10V	12V	15V	25V	50V
CE.2VorH	$\frac{1}{8}$	$\frac{1}{2}$	0.07	8	6	4	-	3	2	-	-
CE.3VorH	$\frac{3}{16}$	$\frac{7}{16}$	0.1	25	20	15	-	10	6	4	-
CE.4VorH	$\frac{3}{16}$	$\frac{1}{2}$	0.1	40	30	20	-	15	8	6	-
CE.5VorH	$\frac{1}{4}$	$\frac{7}{16}$	0.14	50	40	25	-	20	10	8	-
CE.6VorH	$\frac{1}{4}$	$\frac{1}{2}$	0.14	80	60	40	-	30	15	12	-
CE.7VorH	$\frac{5}{16}$	$\frac{1}{2}$	0.18	100	75	50	-	40	20	15	-
CE.8VorH	$\frac{1}{4}$	$\frac{3}{4}$	0.14	100	80	-	60	-	40	25	8
CE.9VorH	$\frac{3}{8}$	$\frac{3}{4}$	0.2	250	200	-	160	-	100	60	20

V = Vertical mounting H = Horizontal mounting

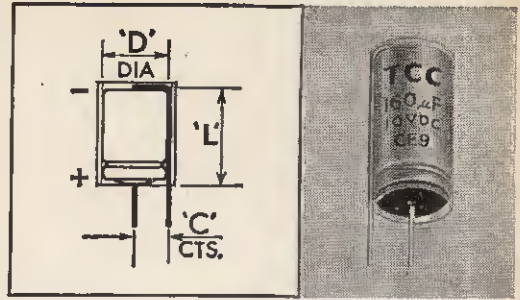

commercial electronic applications. Each type is available for either horizontal or vertical mounting and preference should be indicated when ordering by inserting V or H after the T.C.C. type number.

- ★  $-20^{\circ}\text{C}$  to  $+60^{\circ}\text{C}$  operating temperature range.
- ★ **WELDED CONNECTION WIRES** for low resistance contact, with solder-coating for ease of assembly. Standard wire length is  $1\frac{1}{2}$ " ; but for vertical mounting the wire is cropped to  $\frac{3}{16}$ " .
- ★ **INSULATED SEAMLESS ALUMINIUM CASES** sealed with a synthetic rubber bung.
- ★ **CAP. TOLERANCE OF  $-20\%$  to  $+100\%$**  of the rated capacitance.
- LEAKAGE CURRENT:** for CE.2-7 may be determined from the following:  $I (\mu\text{A}) = .01 \text{ C.V.} + 10$  at applied working voltage and at  $20^{\circ}\text{C}$ . For CE.8-9 it is determined from:  $I (\mu\text{A}) = .02 \text{ C.V.} + 20$  at applied working voltage and at  $20^{\circ}\text{C}$ .

## THE TELEGRAPH CONDENSER CO. LTD.

Electronics Division . NORTH ACTON . LONDON . W.3. Tel. ACOrn 0061 Telex: 261383  
also at CHESSINGTON, SURREY and BATHGATE, SCOTLAND

### AMERICAN TRANSISTORS

200 TYPES, ALL NEW AND GUARANTEED

#### HIGH POWER HIGH FREQUENCY:

2N1907	PNP	55/-
2N1046	PNP	50/-

#### HIGH POWER AUDIO FREQUENCY:

2N443	PNP	17/6
-------	-----	------

#### MEDIUM POWER AUDIO FREQUENCY:

2N1022	PNP	18/6
2N1294	NPN	17/6
2N342	NPN	9/6
2N343	NPN	14/-

#### LOW POWER HIGH FREQUENCY:

2N2048	PNP	19/6
2N1109	PNP	7/6

Plus many, many others

### MODULES

(All solid state)

P.A. Amplifier	35/-
Record Player Amplifier	42/-
Code Oscillator	19/6

Data and circuits with all items. Send 1/- for complete reference catalogue

**J. & J. ELECTRONICS**  
15 Kensington High Street  
London, W.8

**BASIC ELECTRONIC CIRCUITS,** Pt. 2. Compiled "Tech. Press". 18/- Postage 1/-.

**ELECTRONICS POCKET BOOK,** by J. P. Hawker and J. A. Reddihough. 21/- Postage 9d.

**UNDERSTANDING ELECTRONICS,** by J. Bendick. 13/6 Postage 9d.

**101 WAYS TO USE YOUR SIGNAL GENERATOR,** by R. G. Middleton. 18/- Postage 9d.

**THE TRANSISTOR RADIO HANDBOOK,** by D. L. Stoner and L. A. Earnshaw. 44/- Postage 1/-.

**ELECTRONIC FUNDAMENTALS AND APPLICATIONS,** by J. D. Ryder. 55/- Postage 2/-.

**INTRODUCTION TO SEMICONDUCTOR DEVICES,** by M. J. Morant. 18/- Postage 9d.

**AN INTRODUCTION TO COUNTING TECHNIQUES AND TRANSISTOR CIRCUIT LOGIC,** by K. J. Dean. 25/- Postage 9d.

**ELECTRONIC AND RADIO ENGINEERING,** by F. E. Terman. 60/- Postage 2/-.

**ELECTRONIC TEST INSTRUMENTS HANDBOOK,** by J. A. Risse. 35/- Postage 1/-.

**COMPLETE CATALOGUE,** 1/-.

### THE MODERN BOOK CO.

BRITAIN'S LARGEST STOCKISTS of British and American Technical Books

19-21 PRAED STREET  
LONDON, W.2

Phone: PADdington 4185  
Open 6 days 9-6 p.m..

### PADGETTS RADIO STORES

OLD TOWN HALL, KNOWLER HILL, LIVERSEDGE, YORKS.  
Telephones: Cleckheaton 2866

Single Phase 230 V, 1400 r.p.m.  $\frac{1}{2}$  h.p. motor with pulley, 28/- Less pulley, 24/- Fully guaranteed ex-washing machine. Carr. 8/6.  
One Sixth H.P. Motor 15/- Post 6/6.  
New Indicator Unit. C.B.T. 100. Complete with two tubes, type VCRX393 and VCRX298 plus 21 small valves. Relays removed, 67/- or less valves 32/- carr. 10/- Sorry no details on the unit.  
New Boxed Test Set. 100 only. Type 380, complete with 3 $\frac{1}{2}$  meter 1000 ohms per volt, complete with case. No details. 37/6 Post 6/6.  
New Condenser Parcel. Mixed. Send 6/- Post paid.  
New 12in. Speaker with built in tweeter. 15 or 8 ohms. 28/6 Post paid.  
P.M. Speakers, all 3 ohm, ex-TV Sets. 6in. round, 6 x 4in. and 6in. 3/- Post 2/-, 6 for 20/- Post paid, 8in. round, 6/- Post 2/-, 7 x 4in. 5/- Post 2/-.

#### VALVE LIST

Ex equipment. 3 months guarantee.			
All Post Paid			
EL91	1/8	20PW	4/- PL32 3/-
ECL50	2/-	20P4	5/6 PL33 3/-
ECC82	3/6	20P1	4/- PL33 3/-
EY51	2/6	30P4	6/- PY81 3/-
EY86	6/-	U801	3/6 PV82 3/-
EBF90	4/6	U231	5/- PCF80 4/-
6B91	6/-	V232	5/- FCC84 4/-
EL38	5/-	U320	5/- PCL82 6/6
EF91	6/-	KT36	5/- PCL85 6/6
6F1	1/-	KT60	8/- VR150/30 3/-
6F14	5/-	6V6GT	4/- IT4 1/9
6F15	5/-	6B8	2/6 IT4 3/-
6LW20	6/-	6X5	5/- 12AT7 3/-
10C2	5/-	6U25	3/6 6CH6 1/6
10P1	1/-	6U4	6/- 6X4 4/-
10P13	5/-	PY33	6/8 R18 3/6
10P14	5/-	PL31	4/- AR12 1/6
20D1	2/-	PL33	5/- 807 5/6
20L1	5/-	PY80	3/- 807 5/6
EF90 1/-, doz. 6/-; 6K7 1/3, doz. 10/-; 6V6 1/3, doz. 18/-; 6K8 1/3, doz. 18/-.			
Send S.A.E. for rare valve enquiry.			
Breaking up Mack III Type 19 Sets. Meter, 500 micro-amp., 5/- Post 1/9. Jack Socket 1/- Post 6d.			
Dox. 10/- Post paid. Jack 1/5. Post 6d. Toggle Switch Metal 6d. Post 6d. Dox. 10/- Post paid.			
Relay Type 3000 1/9. Post 1/9. Dox. 25/- Post paid.			
Any other spare send 2/- plus post to cover.			
TV Sets. 12 channels. Untested but complete, 14in. 20/- 17in. 50/- Carr. 10/- Well packed but sent at owner's risk.			
Reclaimed Tubes. Six months guarantee. 14in. Mullard and Mazda 17/- Carr. 7/6. 17in. 30/- Carr. 7/6.			



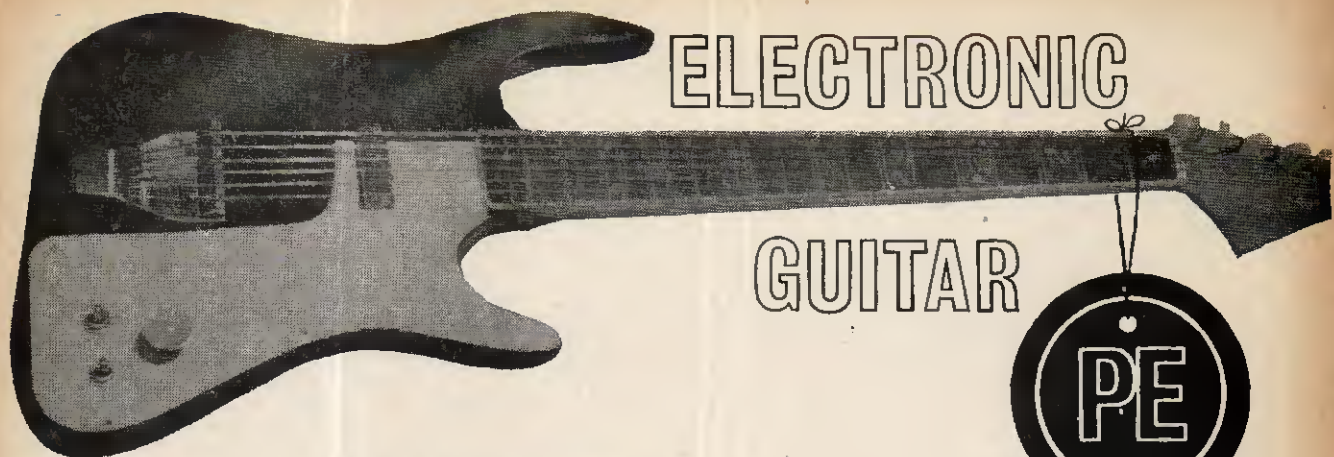

# ELECTRONIC

# GUITAR



By S. Chisholm

**T**HE tenor guitar described in this article is intended for use with the electronic guitar amplifier, details of which will be published in the February issue of PRACTICAL ELECTRONICS. The guitar includes the following controls:

- (1) Continuously variable volume control.
- (2) Preset tone control giving bass boost, normal response or treble boost, all conditions being volume compensated.
- (3) Optional preset two-speed vibrato selection.

Tremolo is not provided but can be included by a changed design of bridge assembly and the addition of a lever mechanism.

## GENERAL CONSTRUCTION

The body of the guitar (see Fig. 1 on blueprint for overall view) is formed of two close-grained hardwood plates, channelled to hold the pick-up, controls, sockets and internal wiring. The stem is also of a sound close-grained hardwood (preferably oak) with no grain curvature in any direction and well seasoned so that the stem will not bend under string tension. The fretboard on the stem is of softer material (fine mahogany) and screwed firmly to the stem. The frets are made from standard commercial fret wire.

The head is also of oak, dowelled and glued to the stem. A steel plate holds the head at the correct angle for string tensioning and prevents the head from rising under tension. The string winders are commercial items. The bridge is made from hardwood and set on the tailplate (of heavy gauge brass) secured to the face of the body. Two pressure screws provide adjustment at the tailplate to set the strings at the optimum height above the pick-up.

The pick-up cover is of thin sheet brass, clamped into position when the pick-up adjustment has been carried out. The pick-up uses Eclipse button magnets and is designed for easy construction, simple adjustment, and for ample sensitivity. If correctly made it cannot burn out, or go open-circuit. The low impedance output is passed to a transformer housed within the guitar body, then through a volume control to the output socket for connection to the amplifier.

The controls are mounted on a removable fingerboard cut from a sheet of Formica, under which the transformer is housed, making it easily accessible.

## BODY

The body should be tackled first. Obtain two pieces of hardwood approximately 18in  $\times$  13in  $\times$   $\frac{3}{4}$ in thick. Mark out the surface of one piece (A) in accordance with Fig. 1 to take the matching transformer (e), the recess for the pick-up (b), and the recess for the volume control and two switches (c). (Note that dimensions for the transformer recess are not given as these will depend on the size of the component used.) Cut out these areas completely, then cut shallow channels on the underside to link (b), (e) and (c) as shown.

Place the second piece (B) under A. Mark B through the apertures in A. Remove A, then chisel out sufficient of B to provide the required depth of recess to take the toggle switches, volume control, and transformer (the measurement will, of course, allow for the thickness of A). Note that the switches must be of shallow construction in order to clear the control socket beneath them.

Drill a  $\frac{1}{8}$ in diameter pilot hole in the centre of circle (d) within the volume control recess in B. Turn B over and, using this pilot hole, cut out the 1in diameter hole (d) to accommodate the control socket.

The shape of the body may now be marked out on A, then clamp A and B together, ensuring that the holes in A align with the recesses in B. Using a fine padsaw or similar tool, cut around the body outline. Round off the edges of the two pieces to provide a pleasing contour and smooth off with fine garnet paper any roughness on the front and back of the body which might spoil the enamelling process. The finished job should be rounded off smoothly to meet the outline of the pattern for the fingerboard.

The two pieces may now be glued together taking great care to secure accurate alignment. After glueing, hold the parts in position with clamps. It is worthwhile to cover the jaws of the clamps with scrap wood or thick rag to protect the workpiece.

## PICK-UP

The materials required are three  $\frac{1}{2}$ in diameter Eclipse button magnets, three  $\frac{1}{2}$ in 8 BA countersunk head screws with nuts and washers, an aluminium strip approximately 3 $\frac{1}{2}$ in  $\times$   $\frac{3}{4}$ in  $\times$   $\frac{1}{8}$ in thick, about 30ft of 30 s.w.g. enamelled wire, a piece of sponge

rubber approximately  $2\text{in} \times \frac{3}{4}\text{in} \times \frac{1}{4}\text{in}$ , two brass woodscrews 2in No. 4, some adhesive tape (see later), and about 12in thin plastics coated flexible wire.

Bend the aluminium strip to the shape shown in Fig. 2, then drill as shown. Check that the pick-up mount is a nice sliding fit in the pick-up aperture on the body, then fit all three magnets to the pick-up mount so that the channel in each magnet will be along the length of the body when the mount is fitted.

Around each magnet limb wind one turn of the adhesive tape making sure the ends overlap. Polyester thermosetting or electrical tapes (Sellotape Products Ltd.) should be used. Ordinary packaging tapes are not recommended as the adhesive may remove the enamel from the wire and impair insulation. The pick-up is now ready for winding.

Cut the plastics coated flex into two lengths (6in each); bare one end of each length for about  $\frac{3}{4}\text{in}$ . Bare the end of the enamelled wire for about  $\frac{3}{4}\text{in}$ . Twist these bared ends together as shown in Fig. 2, then neatly solder the connection. Carefully pass the free end of the flex through the mount as shown, then lay the connection on the outer limb of the first magnet. It is worthwhile insulating the soldered joint with tape or sleeving. Wind on 30 turns of 30 s.w.g. enamelled wire as neatly as possible so that the coils will not slip off the magnet limb; take care not to scrape the wire on the tips of the limb.

Having reached the 30th turn, carry the wire diagonally across the channel as shown in Fig. 2, then wind 30 turns on the remaining limb. Note that the direction of winding is S-shaped round the two limbs.

When 30 turns have been wound on the second limb, carry the wire, without a break and without tension, diagonally across the space between the first and second magnet, then wind 30 turns on the nearest limb. The winding direction is now the same as that on the first limb of the first magnet. Proceed as with the first magnet, then wind the third magnet similarly. When 30 turns have been wound on the last limb, cut off the surplus and bare the ends of the wire and the plastics coated flex, as described earlier, and make a connection which will lie on the outside of the last limb wound. Insulate this soldered joint with another piece of tape or sleeving. Pass the free end of flex, together with the original flex, through a larger piece of sleeving and feed the wires and sleeve through the mounting for external connections later.

Bare the free ends of the lead-in wires and if an ohmmeter is available, check continuity to ensure the connections are still quite sound. The pick-up can be tested audibly if an amplifier is available. To do so, connect the pick-up leads to the low impedance terminals of the matching transformer and the high impedance terminals of the transformer to the input of the amplifier. Switch on the amplifier, turn up the volume control (the amplifier will probably hum because the pick-up is being handled) and gently tap the pick-up limbs with a steel object. A definite click should be heard from the amplifier as each pick-up limb is tapped. Judgement may be difficult, but if one limb sounds *much* weaker than another, the turns on that limb may be short-circuited; it is advisable to rewind, using new wire.

When satisfied that the pick-up is in good order, carefully smear each limb with Scotch glue to secure the winding; it may then be fitted into the pick-up housing as follows. File around the edge of the countersunk heads of both brass screws to be used to

secure the pick-up, until the head diameter is little more than that of the holes through which they will pass. The heads will then clear the windings on the pick-up. Insert the sponge rubber into the pick-up housing to provide a resilient seat for the pick-up, then fit the pick-up mount to straddle the rubber seat, first guiding the pick-up wires into the channel provided.

Drill through the mount, and the sponge rubber, until the drill bites into the wooden body to provide a starting hole for the fixing screw. Screw down the pick-up but do not over compress the sponge rubber, as adjustment of pick-up height has to be made later. Solder the two pick-up leads to the low impedance terminals of the microphone transformer. Fit the transformer into its housing, leaving the free terminals accessible. Pieces of sponge rubber should be packed into the receptacle to absorb any vibration that may occur, as some transformers themselves act as microphones and will transmit the sound of mechanical shock. The fingerboard will eventually hold the transformer and rubber protection in place.

## STEM

The stem is cut from a length of fine grained oak  $19\text{in} \times 2\frac{1}{2}\text{in} \times \frac{3}{4}\text{in}$ . Dimensions of the finished piece are given in Fig. 3. Rounding off the back of the stem should be carefully done to give a pleasing final appearance and comfortable handling while playing. The finish must be very smooth. If correctly done, the polyurethane coating will present an appearance indistinguishable from french polish.

## FRETBOARD

This is a piece of mahogany of dimensions as shown in Fig. 3. It may now be prepared up to the point where the frets are required, fitted for size on the stem, then removed for the present.

## HEAD

Dimensions and drilling marks for the head appear in Fig. 4. The material must be very sound hardwood as there is a considerable and continuous strain exerted on the winders attached to it. Thus the material must not yield under the tension of the strings.

Having cut out the piece and drilled for the winders, drill the butt as shown, to accept two  $\frac{1}{4}\text{in}$  dowels with at least  $\frac{1}{4}\text{in}$  insertion. Note the shallow angle at the butt of the head where it will meet the stem; the dowels are fitted at right angles to the butt, and not parallel to the face of the material as one might expect. Groove the dowels along their length to allow surplus glue to escape, then glue them in position. Allow ample time for the glue to set firmly, then cut the dowels so that they protrude by  $\frac{1}{4}\text{in}$ .

## HEAD STIFFENER

The stiffener is preferably a piece of mild steel of the dimensions shown in Fig. 5. Cut a recess in the head at the area shown in Fig. 4 so that the stiffener fits firmly into it. Drill the stiffener (this is best done *after* bending the stiffener, otherwise the metal tends to bend slightly near the holes) and assemble it to the head. Mark the head through the holes in the stiffener, then drill the head to accept  $\frac{3}{16}\text{in}$  No. 8 countersunk head wood screws. The winders should now be fitted; one will have to be shaped slightly to allow room for the stiffener plate.



Jason tuners and test equipment offer a wide choice of models designed to meet present-day requirements and are a delight to build.

# JASON KITS

FMT1 F.M. Tuner, less valves £5. 19s. 0d.

MERCURY II Switched tuner less valves £9. 15s. 4d.

ARGUS Transistor m.w. tuner, complete £7. 10s. 0d.

OG10 Oscilloscope, less c.r.t. £18. 10s. 0d.

W11 Webbulator, complete £14. 19s. 0d.

EM10 Valve voltmeter, complete £23. 0s. 0d.

SB26 Tape deck (built only)  $\frac{1}{2}$  track mono 31 gns.  
4 track stereo 39 gns.



**JTV2 SWITCHED TUNER.** All BBC f.m. transmissions and BBC-I and ITV television sound channels at the turn of a switch. All components including turret and coil plate but less four valves—£14. 0s. 4d.



**JTL TAPE PREAMPLIFIER** designed to suit any tape deck or head. Will simultaneously record and playback stereo or mono using two or four track heads. All components including valves £23. 1s. 0d. Ready built and tested £30. 9s. 0d.



**FMT2 F.M. TUNER** covering 88-108 Mc's. Built-in power supply. All components, less four valves £9. 9s. 0d. (less power supply £7. 15s. 0d.).

**FMT3 TUNER** similar to above, but for fringe areas. All components, less valves £10. 9s. 0d. (less power supply £8. 15s. 0d.).



**AG10 AUDIO GENERATOR.** Excellent stability with constant output over entire range. Tunes from 10 c/s to 100 c/s in four switched ranges. All components, including valves £15. 19s. 0d.

Write for descriptive leaflets and name of nearest stockist.

# JASON KITS

VISIT OUR NEW  
WEST END SHOWROOM

18 TUDOR PLACE, TOTTENHAM COURT ROAD, LONDON, W.1 MUSeum 4666.8



## THE COMMON



## CORE SERIES

**BASIC ELECTRICITY (5 parts)    BASIC ELECTRONICS (6 parts)**  
**BASIC SYNCHROS & SERVOMECHANISMS (2 parts)**  
**BASIC ELECTRONIC CIRCUITS (2 parts)**

**WHAT READERS HAVE SAID ABOUT THEM—**

“... Thank you for sending **BASIC ELECTRONICS**. I read the first part last night and was more amazed as I read further. After reading the section on Filter Circuits once, I understood more about them than I have been able to find out in a whole year from the obscurities of other text books and manuals. Thank you for a really first class work ...”

“... I think the Basic Books are the best I have ever read, and I've read a hell of a lot ...”

“... A truly excellent publication, not in the least complicated by endless mathematics ...”

“... The books are excellent and contain the information I have been seeking for years ...”

“... Your books seem to explain things much more easily. I wish they were on sale when I had to learn radio ...”

**COUPON - SEND NOW!**

OR ASK YOUR BOOKSELLER

To **THE TECHNICAL PRESS LTD.**  
112 Westbourne Grove, London, W.2.

Name.....

Address .....

Please send me your **FREE** prospectus describing  
**THE COMMON-CORE SERIES**

PE

## RETURN-OF-POST SERVICE

We offer a really efficient Mail Order Service on all items stocked. All cash orders are dealt with on the day of receipt.  
 ● Hire purchase orders are subject to slight delay but this is kept to the absolute minimum.

● **SPECIAL OFFER!! STEREO CARTRIDGES**  
**RONNETTE 105 Stereo/Mono Cartridge.** Complete with fixing bracket and stylus. List 59/4. OUR PRICE 23/6. Post free.

### ● ILLUSTRATED LISTS

Illustrated lists are available on LOUDSPEAKERS, TAPE DECKS, TEST GEAR, GRAMOPHONE EQUIPMENT, AMPLIFIERS. Any will be sent free upon request.

### ● AMPLIFIER KITS

We have full stocks of all components for the Mullard 510, Mullard 3-3, Mullard 2 and 3 Valve Pre-amp, Mullard Stereo, Mullard Mixer. Fully detailed list on any of these sent upon request. Instruction Manual: All Mullard Audio Circuits in "Circuits for Audio Amplifiers", 9/5. Post free.

### ● LATEST TEST METERS

	Cash Price	Deposit	Hire Purchase Monthly/Pmts.
AVO Model 8 Mark III .. .. .	£24. 0 0	£4.16. 0	12 of £1.15. 2
AVO Model 7 Mark II .. .. .	£22. 5 0	£4. 8. 0	12 of £1.12. 9
AVO Multimeter Mark 4 .. .. .	£9.10. 0	£1.18. 8	12 of 14/4
T.M.K. TP10 .. .. .	£3.19. 6	£1. 3. 6	3 of £12. 0
T.M.K. TP55 .. .. .	£8.19. 6	£1.15. 6	3 of £11. 4
T.M.K. Model 500 .. .. .	£8.19. 6	£1.15. 6	12 of 13/8
TAYLOR MODEL 137A .. .. .	£10.10. 0	£2. 2. 0	12 of 15/8

Full details of any of the above supplied free on request. The AVO models 7 and 8 are both latest models from current production—not to be confused with Government Surplus.

### ● TAPE RECORDING EQUIPMENT

	Cash Price	Deposit	Hire Purchase Monthly/Pmts.
ALL CARRIAGE FREE			
COLLARO STUDIO, latest model, Two track, Bradmatic Heads .. .. .	£10.19. 6	£2. 3. 6	12 of 16/4
Four Track, Marriot Heads .. .. .	£17.17. 0	£3.12. 0	12 of 26/2

#### MARTIN TAPE AMPLIFIER KITS

Tape Amplifiers  
 For Collaro 8311-V 2-Track £11.10. 8311-4-V 4-Track £12.12. 0.  
 Tape Pre-amplifiers  
 For Collaro 8319-CP 2-Track £8.8. 0. 8319-4-CP 4-Track £9.9. 0.  
 Drop through assembly for mounting 8319 Pre-Amp under Collaro Deck, £11.1. 6.  
 Carrying Cases with speaker. For Collaro Deck and 8311 Amplifier, £5.3. 0.  
**H.P. TERMS available on decks, amp. and cases. Ask for quote.**

#### MULLARD TAPE PRE-AMPLIFIER KIT

We stock complete kits and all separate components for the Mullard Tape Pre-Amplifier. Fully detailed list available.

### ● MARTIN AUDIO KITS

High quality, easy to assemble Hi-Fi Units. Fully Transistorised for mono and stereo working. All units are assembled and tested and the constructor has only to link together the units chosen for any particular installation. The following mono units are available.

- Unit 1 Input selector 47/6.
  - Unit 2 Pre-amplifier with volume control 37/6.
  - Unit 3 Mixer Unit 79/6.
  - Unit 4 Pre-amplifier with tone and volume controls 62/6.
  - Unit 5 Main Amplifier 10 watt, 3 ohm output £5.12. 6.
  - Unit 7 Main Amplifier 10 watt, 15 ohm output £6.12. 6.
  - Unit 6 Power Unit for Unit 5 52/6.
  - Unit 8 Power Unit for Unit 7 55/6.
  - Unit 9A Special pre-amplifier for low output Pick-ups 55/6.
- Units 1, 2, 3 and 4 are available for stereo working at twice the prices shown. Smart plastic enclosures are available for all combinations of units. Full details in the Martin Illustrated Leaflet, available free.

### ● JASON F.M. TUNERS

We stock all parts needed for the construction of these excellent tuners. All parts can be supplied separately but we can offer attractive reductions in price if all items are purchased at same time as follows:

- FMT2 (less power), £7.15. 0; FMT2 (with power), £9.12. 6.
  - FMT3 (less power), £9.9. 6; FMT3 (with power), £11.7. 6.
  - FMT1, £6.12. 6; Mercury 2, £10.14. 6; JTV/2, £14.12. 6.
- Hire Purchase Terms available. Ask for list.

### ● HI-FI LOUDSPEAKERS

**GOODMANS:** Axiette Bin., £5.5. 7; Axiom 10in., £6.5. 11; 12in. Axiom 201, £10.17. 4; 12in. Axiom 301, £15.4. 6; 12in. Axiom 51 Bass, £9.2. 8; 12in. Axiom 61 Bass, £14.7. 8; Trebax Tweeter, £6.10. 2; XC5000 Crossover unit, £2.0. 11.  
**WHITELEY:** HF1016 10in., £7.7. 0; HF1012 10in., £4.12. 0; HP816 Bin., £6.6. 0;  
**T816 Bin.,** £5.19. 6; T10 Tweeter, £4.12. 0; T359 Tweeter, £1.12. 3; CX3000 Crossover unit, £1.13. 3; CX1500 Crossover unit, £2.2. 0. H.P. Terms available on all speakers.

### ● OUTPUT TRANSFORMERS

**GILSON:** W0696A, W0696B, 60/6, post 2/6. W0892, 75/-, post 2/9. W0767, 32/6, post 1/6. W01796, 66/-, post 2/6. W1796A, 66/-, post 2/6. W01932, 92/6, post 2/6.  
**PARTRIDGE:** P3667, 75/-, post 2/9. P4131, 75/-, post 2/9.  
**PARMEKO:** P2629, 49/9; P2642, 47/3; P2643, 49/9. All plus post 2/9. P2641, 30/9, post 2/-; P2928, 16/9, post 2/-; P2932, 43/-, post 2/6.

### ● MAINS TRANSFORMERS

**GILSON:** W0741A, 75/-, post 4/-; W0839, 58/6, post 2/9; W01328, 69/6, post 3/6; W0128B, 69/6, post 3/6; W01566, 96/-, post 4/6; W01341, Choke, 43/-, post 2/-.  
**PARMEKO:** P2631, 37/-, post 2/9; P2630, 57/3, post 3/3; P2644, 80/-, post 4/-; P2930, 43/-, post 3/-; P2931, 59/6, post 3/3.

## WATTS RADIO (Mail Order) LTD

54 CHURCH STREET, WEYBRIDGE, SURREY

Telephone Weybridge 47556

Please note: Postal business only. Callers welcome by appointment.

#### ★ TERMS OF BUSINESS

Cash with order or C.O.D. We charge C.O.D. orders as follows: Up to £5 minimum of 4/2. Over £5 and under £10, 2/8. Over £10, no charge. Postage extra on CASH order under £5 except where stated. Postage extra on overseas orders irrespective of price.

★ HIRE PURCHASE TERMS AVAILABLE

## PROTECT YOUR TAPE RECORDER

## WITH A STRONG, SMART COVER

Smart waterproof cover to give complete protection to your tape recorder. Made from rubberized canvas in navy, wine, tan, grey and bottle green with white contrasting pipings, reinforced base, handy zip microphone pocket and name panel.

Grundig TK.1 .. 49/6	Telefunken 75/15 & 76K .. 55/-	Stella ST458 .. 79/-
" TK.5 .. 55/-	" TK.6 .. 67/6	" ST459 .. 84/-
" TK.8 .. 63/-	Philips 8108 .. 57/6	Saba .. 63/-
" TK.14 & 23 & 18 .. 59/6	" 3548 .. 87/-	Elizabethan FT.1 .. 66/-
" TK.20 .. 52/6	" 3534 .. 79/6	" FT.3 .. 75/-
" TK.24 .. 55/-	" 3459 .. 79/6	" L229 .. 75/-
" TK.25 .. 55/-	" EL353B .. 63/-	Fi-Cord 1A .. 52/6
" TK.30 .. 60/-	" EL3542 .. 63/-	Fidelity Argyle .. 55/-
" TK.35 .. 63/-	" EL3536 .. 70/-	Clarion (with strap) .. 52/6
" TK.40 & 41 .. 66/-	" EL3515 .. 57/6	Brenell Mk.5 .. 77/-
" TK.46 .. 82/-	" EL3541/15 .. 57/6	" 3 star .. 69/-
" TK.55 .. 63/-	" 3541H .. 72/-	Truvox R92 & 94 .. 99/-
" TK.60 .. 75/-	" Starmaker .. 57/6	Robuk RK.3 .. 67/6
" TK830/3D .. 63/-	Cosior 1602 .. 57/6	Ferroglyph .. 88/-
" Cub .. 35/-	" 1601 .. 63/-	Sony 521 .. 90/-
Telefunken 85 .. 65/-	" 1604 .. 79/-	Revox .. 84/-
" 95 .. 69/6	" 1605 .. 84/-	Optecord 414 + 412 .. 63/-
	Stella ST455 .. 63/-	
	" ST454 .. 57/6	

## A. BROWN & SONS LTD.

(Dept. P.E.) 24-28, GEORGE STREET, HULL TEL: 25413, 25412

## 'SUPER SIX'

LONG & MED. WAVE TRANSISTOR RADIO KIT  
 NOW ONLY £4.17.6 (post 5/-)

When you have assembled this set, you will have value equivalent to a £12.12.0 commercial model.

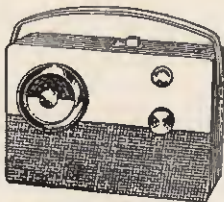

- All new parts.
- 6 transistors and diode.
- 350mW output.
- Superhet circuit, Ferrite rod aerial.
- Weymouth Radio printed circuit board.
- Component positions and references printed on back of board.
- Nicely styled wooden cabinet, 11 x 7 1/2 x 3 1/2 in.
- Vinyl covered in various colours.
- 6 x 4in. speaker giving good bass and treble response.
- Full instruction booklet 2/-. Free with kit.
- I.F. frequency 470 kc/s.

- Lining up service if required.
- All parts supplied separately. Write for list. S.A.E. please.
- Set can be supplied fully built for £6.17.6 tax and carriage paid.
- 9v. battery required. VT9 or P.P.9 (3/9 with kit).

"MINOR" RECORD PLAYER WITH "MAJOR" PERFORMANCE fully built, rexine covered, 10 x 7 x 5 1/2 in. 4 transistor amplifier. Good volume. 7 in. records 45 & 33 r.p.m. £6.7.6 (Post 5/-). Battery 3/9.

#### TRANSISTORS

Packet of 3 coded RF transistors (equivalent of OC44/5) 7/6 post paid. Set of 6 transistors and diode with circuit diagram. Neatly packed in foam-lined box; useful for presentation. 15/- post paid.

Trade Supplied.

## ELECTRONICS (Camberley) Ltd.

15 Victoria Avenue, Camberley, Surrey.  
 (Closed Saturday)



## FITTING THE HEAD TO THE STEM

Offer up the head to the stem and mark the position where the dowels will fit into the stem. Drill the stem and ensure that the dowels fit snugly. While the head is still in position, turn over the stem and head, fit the stiffener into the head as far as it will go, then mark the outline of the stiffener and fixing holes where it lies on the stem. Remove the stiffener and the head, then cut out a recess in the stem to take the stiffener. This *must* be an accurate and flush fit, otherwise the stiffener will be a permanent nuisance when playing. Drill the stiffener holes for  $\frac{3}{8}$ in No. 8 countersunk head screws.

As the string separator will be part of the stem assembly when glueing, it should be prepared now from the details shown in Fig. 3.

Warm the mating surfaces of the head and stem, apply glue to the dowels and mating surfaces, then fit the head to the stem.

Carefully fit the stiffener plate before the glue has set, then drive home the wood screws in the head and stem. The string separator is also glued into position at the head of the stem.

## FITTING THE STEM TO THE BODY

On most guitars, there is a critical angle between the upper surface of the fretboard, and that of the body. This angle determines the sensitivity of the electromagnetic pick-up and the clearance between the pick-up and strings when pressing the strings on frets low down on the stem. In this particular instrument three adjustments are provided in order to minimise the need for high accuracy. These are:

- (a) adjustable pick-up assembly,
- (b) adjustable tailplate,
- (c) adjustable angle of stem.

This adjustable stem, once set, is left as a permanent fixture. It is fitted as follows.

On the face of the body (Fig. 1) cut away the area (a)  $\frac{3}{8}$ in deep. Drill three holes in the stem for  $1\frac{1}{2}$ in No. 6 countersunk head wood screws. Provide one or two pieces of  $\frac{1}{8}$ in plywood or similar material shaped to the recess, for use later. Lay the stem snugly into the recess and mark through for entry of the wood screws. Drill on these marks and assemble the stem to the body, but *do not tighten fully* yet. The fretboard is fitted later.

## BRIDGE

The bridge tailplate is formed from  $\frac{1}{8}$ in sheet brass. Bending may require the assistance of a tinsmith with the necessary equipment.

Mark out the material as shown in Fig. 5. Shape and drill accordingly, remembering to cut keyholes to catch the beads on the strings. Prepare the bridge block from hardwood; the shape is shown in Fig. 5. Slotting of the block will be done later.

On the underside of the tailplate solder a 4 BA nut at both pressure screw holes. (Hold the nuts with a pair of pliers; brass gets *very* hot, *very* quickly.) Allow the tailplate to cool, then position it on the guitar body below the pick-up (see Fig. 1). Lay the bridge block on the tailplate so that one long side lies flush with the edge of the tailplate nearest the pick-up.

The next step is critical and assistance should be obtained. Lay a tape measure with its zero end lying exactly on the junction of the head and stem, then mark the body exactly 25in from this junction. Set the assembled plate and bridge so that the hump of the bridge lies over the 25in mark. If this is not accurately

done, the instrument cannot produce the correct notes at the frets. Mark the guitar body around the edge of the tailplate below the bridge block and a little way down both sides. Remove the tape measure and the bridge block.

At the tailplate, mark through the holes for the securing screws and pressure screws, then remove the tailplate. At the pressure screw marks, channel out an area  $2\frac{1}{2}$ in  $\times$   $\frac{3}{8}$ in to a depth to accommodate a similarly dimensioned slip of  $\frac{1}{8}$ in brass. The depth is not critical. Fit the tailplate in its marked position, and fit the securing screws so that the plate is just held without free movement. Fit a 4 BA round head screw in each of the pressure holes and check that, when they bear on the pressure plate, the front of the tailplate tilts upward, with the assembly pivoting on the securing screws. The bridge block is fitted later. If upward movement is difficult, the securing screw holes should be elongated on the pick-up side.

## FRETWIRES

The fret wires may now be fitted to the fretboard. Mark off the positions of the frets as shown in Fig. 3, then make a fine sawcut at each one, using a fretsaw blade or a junior hacksaw to accept the fretwire. When marking off, measure down *both* edges of the fretboard to ensure accuracy, otherwise the tuning of the instrument will not be correct. Use Araldite to glue the frets into position, then place a weighted board on top of the assembly and leave overnight in a warm atmosphere to harden. When set, fit the fretboard to the stem and tighten firmly. Use  $\frac{1}{2}$ in *not*  $\frac{3}{8}$ in screws.

## SLOTING THE BRIDGE BLOCK

This task is combined with positioning of the wires above the limbs of the pick-up. To do both, fit the two outer strings by passing the wires through the tailplate and over the bridge block (placed on the extremity of the tailplate), then into the outer grooves of the string separator at the head of the stem. Attach the wires to the relevant winders and tighten until just taut. Set the bridge block accurately in position, hold it firmly, then move one wire outward until it lies along the centre of the outer limb of the outer magnet. It is advisable to seek assistance to mark on the bridge the point where the wire crosses. Ease off the wire, move it into the next inner groove of the separator, tighten the wire and position it over the inner limb of the same magnet, ensuring the bridge does not drift. Mark the block bar where the wire crosses. Proceed in this way for the remaining four positions, remembering to change to a more convenient wire as necessary. When all six positions have been marked on the bar, slacken the wires, remove the bridge, and cut notches to accept the wires. The depth of cut for wrapped strings should be slightly less than for the others.

## SETTING THE PICK-UP

The horizontal balance of the pick-up is made at its securing screws, as follows. Tighten the two outer strings to approximately their correct notes. Note that the bridge block should remain in the correct position if the strings are each tightened a little at a time. Adjust the tailplate pressure screws to lift the bridge block about  $\frac{3}{8}$ in. Depress the No. 1 string halfway down the fretboard and check the string lies approximately parallel to the pick-up. If the angle between string and pick-up is excessive, unscrew the brass screw on the affected side of the pick-up assembly and tighten the other. Check the No. 6 string similarly, and re-

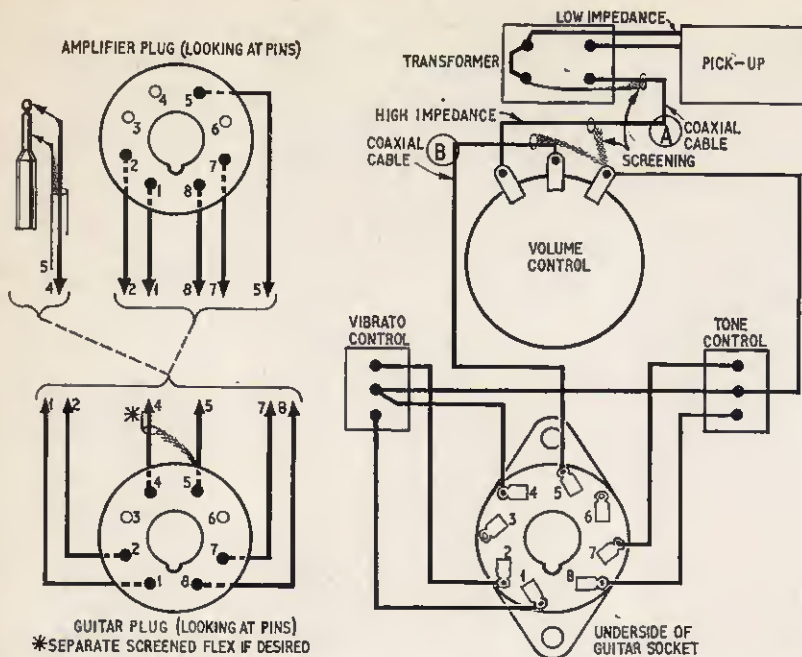

Fig. 6. Wiring details of the guitar components and connecting cable for the amplifier. Note the pin connections of the plugs and socket from underneath

adjust the pick-up as necessary. If clearance is unobtainable, see "String assembly and stem adjustment" later. When the pick-up angle is satisfactory, check that the bridge pressure screws provide adjustment to decrease and increase the gap.

### PICK-UP COVER

The pick-up cover is made up from thin sheet brass cut as shown in Fig. 2, and with the inside of all four corners held by solder. When assembled, remove the strings from the guitar and fit the cover in position securing it by small countersunk head brass screws. (Complete measurements of the cover cannot be quoted here as the height of the cover will depend on the projection of the pick-up above the body.)

### FINGERBOARD

The fingerboard plate may now be prepared to the pattern shown in Fig. 5, and the components assembled. The switches must be quite shallow in order to clear wiring to the connection socket.

Temporarily fit the plate, noting that the top edge slides under the end of the fretboard and that the cut-away surrounds the pick-up cover. When assured that the plate fits neatly, remove it and connect the volume control and both switches as shown in Fig. 6: connect wires about 4in long on the switches and control for connection to the socket. The screened lead to the transformer should be long enough to follow the channel to the transformer. Connect the pick-up and transformer as shown (the choice of pick-up lead and transformer terminal is immaterial so long as the low impedance terminals are used). If one transformer terminal is connected to the case, this must also be the terminal connected to the screen of the lead from the volume control.

Connect the remaining leads from the volume control and switches to the connector socket, ensuring that the wiring will coil down when the fingerboard plate is fitted.

Fit the plate and check that the wiring lays in the channels. When satisfactory, the plate may be screwed down using  $\frac{1}{8}$ in No. 2 plated screws.

### STRING ASSEMBLY AND STEM ADJUSTMENT

Stringing may now be completed as described earlier. Check that the strings just clear the pick-up when depressed at the highest fret and plucked. If this is not so, slacken all strings and stem securing screws. Insert a shim of single plywood into the junction of stem and body, and on the body side of the two securing screws at the extremity of the stem; tighten up and check again for string clearance. Alternatively, if the clearance was found to be excessive, the shim should be positioned on the head side of the single securing screw. The shim will set up an angle to correct the string height, whereupon the securing screws are finally tightened. Any error consequent on final tightening is taken up by the tailplate pressure screws.

The guitar may now be tuned and will then be ready for use as an acoustic instrument.

### FINISH

The prototype was finished in black gloss enamel on an undercoat of matt black. The stem was stained to deepen the natural colour of the oak, then treated with polyurethane varnish. The fretboard was stained, but not treated further. White Formica was used for the fingerboard, this providing a pleasing contrast to the glossy black body. The tailpiece is of polished brass, treated with polyurethane to provide a lacquered finish. The pick-up cover was similarly treated, but the bridge was simply polished after smoothing with the finest silicon abrasive paper obtainable. A leather support strap is attached to the body by domed mirror screws. Users will possibly have other ideas on finish.

### CABLE ASSEMBLY

The connector plug is of the type which will fit an international octal valveholder (see Fig. 6). The required leads are bared to the full length of the pin, lightly tinned, then inserted and soldered at the tip. Excess wire is snipped off. Do not allow surplus solder to set round the outside of the pins.

Grip the plug between two pieces of thick rag set in the jaws of a vice. Suspend the cables so that they are in a straight line with the plug. Melt some beeswax in a tin and fill the interior of the plug. Leave the assembly to harden and similarly treat the other end of the cable. If using a completely enclosed cable, remember to separate the signal input leads for connection to the input plug.

**Next month: a description of a guitar amplifier with special tone and vibrato controls.**



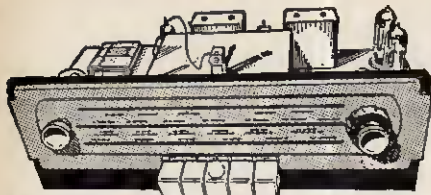

**BRAND NEW**  
**AM/FM**  
**(V.H.F.)**  
**RADIO**  
**GRAM**  
**CHASSIS AT**  
**£13.13.0**  
**(Carriage Paid)**

Chassis size 15 x 6½ x 5½in. high. New manufacture. Dial 14½ x 4in. in 2 colours, predominantly gold. 200-250v. A.C. only.  
 Pick-up, Ext. Speaker, Ac., E. and Dipole Sockets. Five push buttons—OFF, I.W., M.W., P.M. and Gram. Aligned and tested. O.P. Transformer. Tone Control. 1000-1900 M.; 200-500 M.; 88-98 Mc/s. Valves E250 rect.; ECH81, EF89, 2AB6C9, EL84, ECC83, Speaker 8 x 5in. and Cabinet to fit chassis (table model), 47/8 (post 5/-). 10 x 6in. ELLIPTICAL SPEAKER 25/- to purchasers of this chassis. **TERMS:** (Chassis) £3.10.0 down and 5 monthly payments of £2.4.0. Cheap Room Dipole for V.H.F., 12/8. Feeder 6d. per yard. **ALTERNATIVE DESIGN.** I.W. 1000-1900 M.; S.W. (9-15 Mc/s); M.W. 190-475 M.; V.H.F. 87-109 Mc/s; Gram position. Otherwise similar to above chassis. Price £15.15.0 (curr. paid). **TERMS:** £3.10.0 down and 6 monthly payments of £2.4.0. Circuit diagram 2/6.

**PUSH-PULL O.P. AMPLIFIER**  
**£5.5.0 (6/- Carr.)**

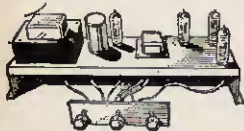

Brand new 200-240 A.C. mains Bass, treble and vol. controls, with valves E250, ECC83 and 2-EL84 giving full 8 w. Chassis 12 x 3½ x 6½in. With o.p. trans for 2-3 ohm speaker. Front panel (normally screwed to chassis) may be removed and used as "flying panel".

**LAFAYETTE BRAND TAPE**

**FULLY GUARANTEED AT RECORD LOW PRICES**

MYLAR BASE	ACETATE BASE
5in. Double play, 1,200ft. .... 15/-	5in. Stand. play, 600ft. .... 8/-
5½in. Double play, 1,800ft. .... 22/8	5in. Long play, 900ft. .... 10/-
7in. Stand. play, 1,200ft. .... 12/8	5½in. Long play, 1,200ft. .... 12/8
7in. Long play, 1,800ft. .... 19/8	7in. Long play, 1,800ft. .... 15/-
7in. Double play, 2,400ft. .... 25/-	
TRIPLE PLAY	MESSAGE TAPES
3in. 450ft. .... 12/8	3in. Stand. play, 150ft. .... 3/6
4in. 900ft. .... 22/8	3in. Long play, 225ft. .... 4/11
5in. 1,800ft. .... 42/8	3in. Double play, 300ft. .... 7/6
5½in. 2,400ft. .... 55/-	3in. Triple play, 600ft. .... 14/-
7in. 3,600ft. (unboxed) .... 75/-	

P. & P. 1/- extra per reel; 4 reels and over Post Free.

**"REALISTIC" 'SEVEN'**

Transformer Superhet. 350 Milliwatt output, 4-inch speaker. All components mounted on a single printed circuit board size 5½ x 3½in. in one complete assembly. Plastic cabinet with carrying handle, size 7 x 4 x 2½in. External socket for car aerial. Ferrite rod aerial. Price for the complete parcel including Transistors, Cabinet, Speaker, etc. and full Construction Data: £5.19.8. P. & P. 4/6. PP3 Battery 2/9. Data and instructions separately 2/6. Refunded if you purchase the parcel. Any parts supplied separately.

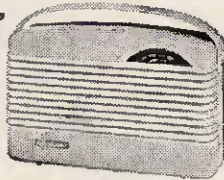

**SINGLE RECORD PLAYER USING EMI DECK AND PICK-UP**

4 speed, 200/240 v A.C. Valves, rectifier and ECL82. Cab. size 13 x 11½ x 5½in. atinic, coloured imitation leather finish. Takes 10in. records £7.19.8 curr. paid. **ALTERNATIVE TYPE OF SINGLE RECORD PLAYER** available, using BSR GU7 motor and pick-up on one plate. Valves UY85 and UCL82. Cab. size 13½ x 13 x 5½in. red or blue rexine. Takes 12in. records. Price £9.9.8 curr. paid.

**4-TRANSISTOR MINIATURE PUSH-PULL AUDIO AMPLIFIER HIGH IMPEDANCE**

PRINTED CIRCUIT. 4in. x 2½in. 1½in. over transformers. Output for 3-ohm speaker. Suitable for microphone, record player, guitar and Intercom. 9 volt battery required. Frequency range 100 cps. to 25 Kcps. Push-pull output class B. Instruction sheet provided. Fully wired ready for use. Two types. 200 mw. 29/8; 1 watt, 41/- P. & P. 2/6.



**4-SPEED AUTOCHANGERS**

	Carr. 5/- each
BSR-UA14	£5.19.8
GARRARD AUTOSLIM	£6.10.0
STEREO	£7.5.0
AUTOSLIM DE LUXE AT6	£10.19.8
STEREO	£11.10.0

**2½-WATT AMPLIFIER**

Our price ONLY 39/8 (post 5/-); a few only; valves EF91 and ECL82 with metal rectifier; 6 x 4 x 1½in. high (5in. over ECL82). Mains trans. and o.p. with vol. and tone controls; on-off; co-ax. input.

**TAPE RECORDER AMPLIFIER**

Fully built. Front panel 12½ x 3in. Chassis size 10½ x 5 x 4in. Valves EF86, ECC83 and 2EL84. Controls (1) MIC. Vol. (2) Tuner/P.U. Vol. (3) Play back or monitor. (4) Tone. 2 Jack sockets for Tuner/P.U. and MIC-switch for superimpose. Separate power pack containing trans. & rectifier. For Collozaro studio deck only. Price £8.14.0 (6/- P. & P.).

ALL ITEMS ARE NEW AND FULLY BUILT UNLESS OTHERWISE STATED. TESTED BEFORE DESPATCH. Delivery by return.  
 Terms available on items over £5. Send 6d. (stamps will do) for 20-page illustrated catalogue. C.O.D. 2/- extra  
**ALL ITEMS GUARANTEED 12 MONTHS.** VALVES 3 MONTHS  
 Regret overseas orders cannot be executed.

**GLADSTONE RADIO**

66 ELMS ROAD, ALDERSHOT, Hants.  
 (2 mls. from Station and Buses).

(CLOSED WED.)  
 Aldershot 22240

# EXCEL

in

# ELECTRONICS

## Through this ICS 3-way Training Method:

**MASTER THE THEORETICAL SIDE**

From basic principles to advanced applications, you'll learn the theory of electronic engineering, quickly and easily through ICS. That's because each course is set out in easy-to-understand terms.

1

**MASTER THE PRACTICAL SIDE**

ICS show you how to develop your practical abilities in electronic engineering—alongside your theoretical studies. It's the only sure way to success. All training manuals are packed with easy-to-follow illustrations.

2

**MASTER THE MATHEMATICAL SIDE**

To many this aspect is a bitter problem. Even more so because no electronic engineer is complete without a sound working knowledge of maths. But new ICS teaching makes mathematics easier to learn.

3

Wide range of courses available include:

Radio/T.V. Engineering and Servicing, Colour Television, Electronics, Electronics Maintenance, Instrumentation and Servomechanisms, Telemetry, Computers, etc.  
**NEW!** Programmed Course on Electronic Fundamentals.

**EXPERT COACHING FOR:**

INSTITUTION OF ELECTRONIC AND RADIO ENGINEERS  
 CITY AND GUILDS TELECOMMUNICATION TECHNICIANS  
 CITY AND GUILDS SUPPLEMENTARY STUDIES  
 R.T.E.B. RADIO/T.V. SERVICING CERTIFICATE  
 RADIO AMATEURS' EXAMINATION  
 P.M.G. CERTIFICATES IN RADIOTELEGRAPHY

And there are practical "learn as you build" radio courses as well.

Member of the Association of British Correspondence Colleges.

FOR FREE HANDBOOK POST THIS COUPON TODAY

I.C.S., Dept. 151, INTERTEXT HOUSE,  
 PARKGATE ROAD, LONDON, S.W.11

NAME .....

ADDRESS .....

OCCUPATION..... AGE..... 1.65

**INTERNATIONAL CORRESPONDENCE SCHOOLS**

# Practical Electronics Classified Advertisements

The pre-paid rate for classified advertisements is 1/- per word (minimum order 12/-), box number 1/6 extra. Semi-displayed setting £3.5.0 per single column inch. All cheques, postal orders, etc., to be made payable to PRACTICAL ELECTRONICS and crossed "Lloyds Bank Ltd." Treasury notes should always be sent *registered post*. Advertisements, together with remittance, should be sent to the Advertisement Manager, PRACTICAL ELECTRONICS, George Newnes Ltd., Tower House, Southampton Street, London, WC2, for insertion in the next available issue.

## TAPE RECORDERS, TAPES, ETC.

**FOR QUALITY** consult our sixty-page (photographically illustrated) latest Hi-Fi equipment catalogue (4/6d.). Unbiased advice, preferential terms to members, LP's from your precious tapes. **AUDIO SUPPLY**, 10 Clifford Street, London W.1.

**OPEN UP YOUR OWN TAPE STATION** and speak to the world. "WORLDWIDE TAPE-TALK," Harrow, Middlesex.

**TAPE TO DISC RECORDING.** 10in LP, 42/-; 12in LP, 48/-; 7in EP, 21/-. S.A.E., Leaflet, **DEROY SOUND SERVICE**, 52 Hest Bank Lane, Hest Bank, Lancaster. Tel.: HB.2444.

## SITUATIONS VACANT

### RADIO TECHNICIAN

A number of suitably qualified candidates will be required for training, leading to permanent and pensionable employment. (Normally at Cheltenham but with opportunities for service abroad or appointment to other U.K. stations).

**Applicants** must be 19 or over and be familiar with the use of Test Gear and have had Radio/Electronic workshop experience. They must offer at least "O" level GCE passes in English Language, Maths and/or Physics, or hold the City and Guilds Telecommunications Technician Intermediate Certificate or equivalent technical qualifications.

**Pay** according to age, e.g. at 19 £722, at 25 £929 (highest pay on entry) rising by four increments to £1,067.

**Prospects** of promotion to grades in salary range £997 - £1,634.

**Annual Leave** allowance of 3 weeks 3 days, rising to 4 weeks 2 days.

Normal Civil Service sick leave regulations apply.

Apply  
Recruitment Officer (RT/54)  
Government Communication Headquarters  
Oakley  
Priors Road  
Cheltenham

## MISCELLANEOUS

**CONVERT ANY TV SET** into an Oscilloscope. Diagrams and Instructions, 12/6. **REDMOND**, 42 Dean Close, Portslade, Sussex.

**HAMMER FINISH PAINT.** The modern finish for electronics. Can be brushed or sprayed. Blue or silver, 2½oz tins 3/6, ½ pint 7/6, 1 pint 15/-. Post 6d. on any order. Trade supplied. **PINNIGAN SPECIALITY PAINTS**, (PE), Mickley Square, Stocksfield, Northumberland.

## METAL WORK

### CABINETS • CASES CHASSIS

Anything in metal. "One-offs" a pleasure  
Send your drawing for quote

Stove enamelled in any professional finish

### MOSS, WATSON

40 Mount Pleasant Street, Oldham  
Lancs. MAIN 9400

## EDUCATIONAL

**HOME STUDY COURSES** in Practical Electronics. Free Brochure without obligation from: **BRITISH NATIONAL RADIO SCHOOL**, Reading, Berks.

**STUDY RADIO, TELEVISION AND ELECTRONICS** with the world's largest home study organisation. I.E.R.E., City & Guilds, R.T.E.B., etc. Also Practical Courses with equipment. All books supplied. Write for **FREE** Prospectus stating subject to I.C.S. (Dept. 577), Intertext House, Parkgate Road, London, S.W.11.

**A.M.I.MECH.E., A.M.I.E.R.E.**, City & Guilds, G.C.E., etc., bring high pay and security. "NO PASS—NO FEE" terms. Over 95% successes. For details of Exams and courses in all branches of Engineering, Building, Electronics, etc., write for 156-page Handbook—**FREE**. B.I.E.T., (Dept. 152), London, W.8.

## TRAINING

Full-time courses in **RADAR** and **RADIO-TELEGRAPHY** for prospective marine Radio Officers. Govt. approved exam. centre.

Also courses in basic **ELECTRONICS, RADIO, TELEVISION** and **PRACTICAL SERVICING**.

Apply:—Director, **British School of Telegraphy**, 20 Penywern Road, Earls Court, London, S.W.5

## EDUCATIONAL

(continued)

**B.Sc.(ENG.), A.M.I.MECH.E., A.M.I.E.R.E.**, City & Guilds, etc., on "NO PASS—NO FEE" terms. Wide range of guaranteed Home Study Courses in Electronics, Computers, Radio, T.V., etc. 156-page Guide—**FREE**. Please state subject of interest. **BRITISH INSTITUTE OF ENGINEERING TECHNOLOGY**, 151 College House, Wright's Lane, London, W.8.

## SERVICE SHEETS

**SERVICE SHEETS** for all makes of Radio and TV 1925-1964. Prices from 1/- with free fault-finding guide. S.A.E. inquiries. Catalogue of 6,000 models, 1/6. Valves, modern and obsolete. Radio/TV Books. S.A.E. lists. **HAMILTON RADIO**, Western Road, St. Leonards, Sussex.

## SERVICE SHEETS

4/- each, plus postage.

We have the largest display of Service Sheets for all makes and types of Radios, Televisions, Tape Recorders, etc. in the country, and can supply by return of post.

To obtain the Service Sheet you require, please complete the attached coupon:

From:

Name: .....

Address: .....

.....

To: **S.P. DISTRIBUTORS**  
44 Old Bond St., London, W.1

Please supply Service Sheets for the following:

Make: .....

Model No.: ..... Radio/TV

Make: .....

Model No.: ..... Radio/TV

Make: .....

Model No.: .....

I also require list of Service Sheets at 1/6.

I also require list of Manuals at 1/-

(please delete items not applicable)

I enclose remittance of .....

**MAIL ORDERS ONLY**



# Practical Electronics Classified Advertisements

CONTINUED

## SERVICE SHEETS

(continued)

**GENUINE SERVICE SHEETS**, Radio/TV/TV Recorders. S.A.E. with enquiries: **RED-WATT ELECTRICAL**, 41 Denmark Street, Wakefield, Yorks.

**SERVICE SHEETS**, Radio, TV, etc.; List 1/- S.A.E. Enquiries: **TELRAY**, Maudland Bank, Preston.

**STATE MODEL NO.** Radio 2/-. TV 2/6. S.A.E. **DARWIN**, 10 George Street, St. Helens, Lancs.

## WANTED

### NEW VALVES WANTED

Any type, or quantity

### CASH PAID

**R.S.T. Valve Mail Order Co.**

211A Streatham Road

Mitcham, Surrey

Telephone: **MITCHAM 6202**

## FOR SALE

**TRANSISTORS UNMARKED UNTESTED.** 40 for 10/-. P. & P. 1/- 4 packets post free. Relays, thousands of types, special catalogue free. General Catalogue of Mechanical & Electrical Gear, Tools, etc., 5,000 items, free. **K. R. WHISTON** (Dept. PET), New Mills, Stockport.

**RELAYS, EX-GOVERNMENT.** £3 for 12, our selection, post paid. **WALTONS WIRELESS STORES**, 15 Church Street, Wolverhampton.

**VENNER TIME SWITCHES** reconditioned, 14-day clock, once on, once off every 24 hours, jewelled movement, fully guaranteed, 5 amp., 32/8; 1 amp, 25/-. P. & P. 2/6. **A. R. BATCHELOR** (P.E. Dept.), 4 Park Road, Bromley, Kent.

### U.S.A. RELAYS

24 volt totally enclosed and hermetically sealed relays removed from unused U.S.A. computers. These relays are a fine example of modern electronic design. 240 ohm coil rated at 26.5 volts they will operate cleanly down to 12 volts. 4 pole change-over contacts rated at 5 amp D.C. or 4 pole rated at 1 amp.

5/- each, P.P. 1/-. Four for £1 post paid.

**HAXTED MILL, EDENBRIDGE, KENT**

**5-TON FACTORY CLEARANCE**, Radio, TV Electrical Components, in mixed parcels. Example: 281b. mixed parcel £1, pp 7/6d. Speakers, grilles, valves, bases, i.f.s. covers condensers, etc. Hundred other items. S.A.E. List and Postal Orders to **P. NEWTON**, 16 Shalcross Crescent, Hatfield, Herts.

**CONDENSER BARGAIN!** Miniature paper condensers, 1in x 1in. Ideal for transistor sets. .0001, .001, .002, .005, .02, .04µf. Your choice, 7/6d. per 100 or £3 per 1,000. **G. F. MILWARD**, 17 Peel Close, Drayton Bassett, Staffs.

## TRANSFORMERS

### ROTARY TRANSFORMERS £6,000 BULK PURCHASE BRINGS PRICE REDUCTION

TV from your OWN Car Battery

Famous **DELCO** transforms 12 or 24v. supply to mains Power for TV, 1/2" drills, etc. **NOW ONLY 65/-** C.O.D. 2/6 extra. Carr. Paid.  
**SMALLER MODEL.** 12/24v. 22/6 input, 110/250v. output. ....  
**HOOVER ROTARY TRANSFORMERS.** 6v. input, 250v. output. 12v. input, 25/- 490v. output. 32 watts. Brand new **NEW, but Store soiled** ..... 21/-  
**VIBRATOR POWER-PAK.** Step 12v. up to MAINS output. For Universal AC/DC razors, small fluorescent fittings, 32/6 radios, etc. .... Only  
**LARGE ROTARY TRANSFORMER.** 12v. input, over 1,200v. output. New. £5 For experimental purposes ....



Send NOW—Delivery by return

**JAMES WALKER, ELECTRONICS DIVISION**

36 Alexandra Street, Thurmaston, Leicester

## RECEIVERS AND COMPONENTS

(continued)

**TRANSISTORS!** Give-away price. **NKT124/5** Power Type. 6 for 10/-. **2S017 4W**, up to 60mc/s, 5/- each. Post free. **G. F. MILWARD**, 17 Peel Close, Drayton Bassett, Staffs.

**RESISTORS!** You can't resist this! 3W, 1W, 2W Polythene wrapped on cards of 10. Mixed values and wattages. **£2/10/-** per 1,000. **G. F. MILWARD**, 17 Peel Close, Drayton Bassett, Staffs.

**A.1 POST FREE BARGAINS.** Guaranteed reclaimed valves. Send for full list to: Dept. MO/E, **A.1 RADIO COMPONENTS**, 14 The Borough, Canterbury, Kent.

**COMPLETE RANGE** of Mullard Miniature Polyester and Electrolytic Capacitors in stock. S.A.E. for itemised price list of these and other Mullard Amplifier Components. **AJAX ELECTRONICS**, 18a Rumbold Road, Fulham, London, S.W.6.

**MULTIMETERS HALF PRICE!** High grade. Send S.A.E. for details. **COOPER**, 10 Fowler Street, Nchells, Birmingham 7.

## RECEIVERS AND COMPONENTS

### TESTED TRANSISTORS

All new, few equivalent.

OA202

1/- each, Red or White Spots.

2/- each, XA101, XA102, XB103, OA90, OC430, XA112, XA111.

3/- each, OC44, OC45, OC70, OC71, OC81, OC81D, OC200, GET16.

4/- each, AF114, AF115, AF117, OC170, OC171, SX658, XU611.

5/- each, OC72, OC139, OC140, OC204, ORP60, BY100, GET8.

10/- each, OC35, OC26, OC28, GET57, 2S013. All new, few equivalent.

**ZENER DIODES** 4.7 v. to 33 volt 1/2 watt, 3/6 each. 1.5 watt, 5/- each, 7 watt, 6/- each.

Send 3d. stamp for Full Price List and Free Equivalent Chart.

### B. W. CURSONS

78 BROAD STREET

CANTERBURY, KENT

## TELEVISION TUBE SHOP

FOR

Unused, Guaranteed Tubes

OVER 2,000 IN STOCK

All prices from 50% to 75% of List Price

All tubes tested before despatch and Guaranteed for 12 months

**CARRIAGE 10/- via B.R.S. or 15/- via passenger train**

**TERMS £2 down (plus carriage) and £1 per month**

See our advertisement in **PRACTICAL TELEVISION** for exact prices, or write for details

## TELEVISION TUBE SHOP

48 BATTERSEA BRIDGE ROAD

LONDON, S.W.11. BAT 6859

OPEN ALL WEEK AND SATS. UNTIL 4 p.m.

CONTINUED OVERLEAF

## RECEIVERS AND COMPONENTS

(continued)

**PRINTED CIRCUITS** Practical Electronics Designs. Didjerido. V.H.F. Receiver, Practical Wireless, Wireless World and Radio Constructor Designs. S.A.E. Details. J.E.S. ELECTRONICS, 32 Pencraig, Llangefni, Anglesey.

## R. & R. RADIO & TV SERVICE

44 Market Street, BACUP. Tel. 465

### SALVAGE VALVES

6F13 4/6 10P14 5/- PL82 3/6 20P4 6/6  
6L18 4/6 20P5 6/6 U801 7/6 30P16 5/-  
EF80 1/6 30P4 7/- 10F1 1/6 PCC84 4/-  
ECG82 6F15 5/- 20F2 5/6 PCL83 5/-  
3/-  
ECL80 EB91 1/- 30FL1 5/- PY81 3/6  
3/-  
30F5 5/- EF85 5/- PY32 6/- U301 6/-  
PL38 6/- EF37 6/- 6U4GT 10P13 5/6  
5/-  
PCF80 20P3 6/- 6F1 1/6 20D1 1/6  
4/-  
PL31 5/- 30PL1 6/- ECC81 3/- 30P12 6/-  
PZ30 5/- PL36 6/- BY86 4/- PY82 4/-  
U329 5/- PCL32 5/-

Post 6d. per valve, 3 or more post free.  
Speakers ex T.V. 5 inch round 3/6, 6 by 4 inch 3/6, 8 inch round 6/-, post 2/-.  
Ex T.V. printed circuit panels, containing valve holders, resistors, condensers, etc., 5/6, post 2/-.

Assorted mains droppers ex T.V. 2/6 each, 10 £1.  
Pre-set controls £1 per doz. assorted values, post 1/-.  
Resistors, New; ½ watt 3½d., 1 watt 5d., 2 watt 9d., all 10%. Silver mica, paper and electrolytics in stock. New Mullard transistors and condensers also in stock. S.A.E. with all enquiries. All goods subject to satisfaction or money refunded.

**TRANSISTORISED SIGNAL INJECTOR.** Complete kit of components and circuit of injector for testing and amplifier or radio, 7/6 only. Post free. G. F. MILWARD, 17 Peel Close, Drayton Bassett, Staffs.

### RCA AR88D. RECEIVER (Brand New)

Freq. 540 Kc/s—32 Mc/s, 6 waveband. Mechanical Band spread with Logging scale, Auto & Man. Vol. control, ditto Noise Limiter, BFO, Pitch & Var. HF Tone controls, RF & AF Gain, Var. selectivity with Crystal Filter. Complete with Instructions/Service Manual, Spare Valves, H/Set, Aerial, etc. £75. Carr. £2.

### RCA CANADIAN No. 29

Transmitter/Receiver 2-8 Mc/s, separate Manual tuning R.F. and Osc., also preset motor operated ditto, 25 miniature valves including 2/815's. 12/24 v. d.c. operation. Unused condition. Outside case store soiled, £12/10/-, Carr. £2. English version. Manual tuning only. Complete station, £8/10/-, Carr. £2.

**TELESCOPIC AERIAL MASTS.** Tubular steel copperised, spray finish, ring cam locking on each section provides for full or any height required. Suitable all fixings and base locations. Bottom section 18in. diameter, 20ft. (4 section) Closed 5ft. 9in. Weight 16lb. 55/-, Carr. 5/-. 34ft. (6 section) Closed 6ft. 6in. Weight 20lb. 75/-, Carr. 5/-. Further height by adding 3-4 Whipsections, 13/6, Carr. 1/6. Special price for quantities.

**CRED TELEPRINTERS.** 7B Used condition, £12/10/-. Carr. 30/-.  
B44 Mk. II & III. Dipole and rod aeriels 30/- per set, P. & P. 5/-. Microphone with connecting plug, 15/6, P. & P. 2/-. Battery input and phono plugs, 5/- each, P. & P. 1/5.

**POWER UNIT 110/230v A.C. input.** 'C' type drop through Parmeko Transformer. 315-0-315v, 6.3v output. Double choke and paper type smoothing. Combined 4 valve including 574 rectifier, 6V6 o.p. A.F. Amplifier. Self contained rack or table mounting. Fully fused. Indicator light. Mains switch. Brand new in makers cartons. 59/6 Carr. 5/-. (Quantity enquiries invited.)

**TRANSMITTER.** 175-16 Mc/s. 3 waveband tuneable, grid modulation using 813. Used complete with all valves, circuit, £7/10/-. Carriage 10/-. (Many other bargains.)

A. J. THOMPSON,  
"Eiling Lodge" Codicote, Hitchin, Herts.  
Phone: Codicote 242

## RECEIVERS AND COMPONENTS

(continued)

Key Switch, 3 position, centre off, 3 c/o + 4 c/o, 6/-

Ferox Cubes LA12, wound, 5/-

Panel Lamps, Min. Liliput screw, White Bezel, 3/-

DIR5 Headphones, with plug and socket, 12/6  
Min. Liliput screw bulbs, 12 volt, 1/6

High Speed Relay, c/o 1,000 + 1,000 ohm, 6/6  
400 ohm P.O. Relay, 1B, 5/-; 1B 1M, 6/-

2,000 ohm P.O. Relay, 1M, 5/-; 1M 1B, 6/-  
G.P.O. Hand Sets, with Press to Talk in handle, 15/-

G.P.O. Jack Plug, with load, 3/-  
Isolated Jack Socket, 2/6

Breast Set Mike, with fittings, 6/-  
500 Micro Amp Meter and Meter Switch, 15/-

Toggle Switch, SP on/off, 2/6  
Push Button Switch, DP on/off, on when press only, 2/6

Power Supply and LF Amplifier, N/O 1, 15/-  
for N/O 38 set

6 core min. Cable, 3 amp screened PVC outer, 3/- yard; 12 core ditto, both fitted with Plessey plugs and sockets, in 10 yard lengths only

New range of High Stability Resistors, 5% to 1%, ¼ to 5 watt, send for full lists.

Telescopic Drawer Slides, 17½in. to 29in., 12/6 pair

Copper Laminate Board, single or double sided, 5/- sq. ft., or 3ft. by 4ft. panels, 33/-

Jones Plugs and Sockets, 4-12-18-24-32 way, 5/- pair

Plessey Plugs and Sockets, 2-4-6-12-25 way, 5/- pair

31 way P.O. Cable, 2/- yard. Minimum 5 yards.

Ever Ready Batteries, 90V + 7½V, 4/6 or 12 for 30/-

Mallory Mercury Cells, 6-75V, 3/6

8 Tag Panels, with 150 Resistors, Condensers, Diodes, 10/-

2ft. 9in. Mobile Aerials, 6/6

30 meg. Oscillator Unit, 3 valve tuneable to 27 meg., 12/6

Parcel of ex-Government valves, 20 for 10/-

Small Component Boxes, 7 divisions, 60 for 12/6

Printed Circuit Preset Pots, 10K, 2/-

115 volt Western Electric Magslips, 50/- each

230 volt BTH Magslips, 90/- each

Electro Magnetic Counters, P.O. 4 digit, 4/6

Mu Metal Screen for 5UP7 tubes, 6/6

30 + 30 pF Variable Condensers, 4/-

½ amp Fuses, 5/- per 100, 1½in. x ½in.

Mic. Jacks, 3 for 3/-

Small Instrument Cases, 5in. x 5in. front, 4½in. deep, with grey plastic front, 6/- each. Rack to house two of these, slide by side, 7/6

Transformer PL1101, output 7 volt at 4 amp, three times plus 7 volt at 125 mA, 18/-

H.T. Transformers, 1,800 volt plus 1,800 volt at 500 mA, and 600 volt plus 600 volt at 500 mA, 60/-

## RECEIVERS AND COMPONENTS

(continued)

### PARMEKO NEPTUNE TRANSFORMERS

115 volt or mains input. Output 450-0-450 at 260 mA; 275-0-275 at 45 mA; 132 volt at 20 mA; 30 volt at 30 mA; 6.4 volt at 16 amp; 6.4 volt at 4.5 amp; 6.3 volt at 1.2 amp; 5 volt at 6 amp. These are oil filled, packed in own drum, 70/- each

### PARMEKO NEPTUNE CHOKES OIL FILLED

10 henry at 260 mA, 22/-; 15 henry at 45 mA, 12/6; 5 henry at 20 mA, 6/6

### PAPER BLOCK CONDENSERS

MFD	Volts	Price
	wkg	
1	350	1/3
1	500	1/6
1	600	2/-
1	800	2/6
1	1,200	4/-
1	3,400	5/-
2	350	1/9
2	700	3/-
2	1,000	4/-
4	400	4/-
4	600	4/6
4	800	5/-
4	1,200	7/6
4	2,000	8/-
8	400	5/6
8	600	6/-
10	250	4/-
10	700	7/-
0.5	5,000	9/-
2	2,000	14/6

ON ALL ORDERS UNDER 20/- PLEASE ADD 2/- POST AND PACKING

## SUPER BREAKDOWN UNIT

Remote Control Unit Type F. New in sealed cartons, containing P.O. Relay 2,000 ohms Resistance, 100 volt Plessey Hand Generator, Telephone Ringing Bell A.C. 8 amp Morse Key on base, 2 D.P. D.T. Key Switches, Double Phone Jack, moulded, 5 position 6 pole Yaxley Switch, Induction Coil tapped 1-17-33 ohms, 7 Brass Screw Terminals on panels, plus Resistors, Condensers, Pointer Knobs. All in a handy metal box with hinged lid and side fasteners. Also web carry strap. Size 10½in. x 10in. x 7in., 25/-, post free. Or items may be purchased separately. Relay 5/-, Hand Generator 7/6, Bell 5/-, Morse Key 4/6, Key Switches 5/- pair, Double Phone Jack 2/6, Yaxley Switch 2/-, Ind Coil 2/-, Terminals 7 for 2/-, all post free.

Also available Key Switches. 4 pole 2 throw 3/6 each or 3 position D.P. plus D.P. centre off 5/- or rotary switch 6 pole 3 way 3/-.

Speakers, 3 ohm P.M. 5in. 5/-, 6in. 6/-, 7 x 4in. 7/-, 8in. 8/-, 10in. 12/6.

U.K. ONLY

# E. R. NICHOLLS

Mail Order and Retail Shop:

46 LOWFIELD ROAD off SHAW HEATH  
STOCKPORT, CHESHIRE



# R.S.C. (Manchester) Ltd.

**MAIL ORDERS TO:**  
54 WELLINGTON STREET, LEEDS 1.  
Terms C.W.O. or C.O.D. No C.O.D. under £1. Postage 2/9 extra under £2. 4/6 extra under £5. Trade Supplied, S.A.E. with all enquiries please. Personal shoppers welcomed at any of the branches below. Open all day Saturday.

**BRADFORD** 54 Morley Street. Nr. Alhambra Theatre (Half-day Wednesday)

**BRISTOL** 14 Lower Castle Street (Half-day Wednesday)

**BIRMINGHAM** 30-31 Gt. Western Arcade, opp. Snow Hill Station (No half day)

**DERBY** 26 Osaston Rd., The Spot (Half-day Wednesday)

**DARLINGTON** 13 Post House Wynd (Half-day Wednesday)

**EDINBURGH** 133 Leith Street (Half-day Wed.)

**GLASGOW** 326 Argyle Street (Half-day Tuesday)

**HULL** 51 Savile Street (Half-day Thursday)

**LEICESTER** 32 High Street (Half-day Thursday)

**LEEDS** 5-7 County (Mecca) Arcade (No half-day closing)

**LIVERPOOL** 73 Dale Street (No half-day closing)

**LONDON** 238 Edgware Road (Half-day Thursday)

## MANCHESTER

Large new store now open at 60A/60B Oldham Street

**MIDDLESBROUGH** 106 New Rd. (Half-day Wednesday)

**SHEFFIELD** 13 Exchange Street, Castle Market Bldgs. (Half-day Thursday)

**EX. GOV. 2 V. ACCUMULATORS.** 16 A.H. Size 7 x 4 x 2in. Brand new, 4/9 each. Three for 12/6, carr. 5/-.

**Jason FMTI V.H.F./M.F. Radio Tuner design.** Total cost of parts including valves, Tuning dial, Resonance, etc., £6.19.6.

**R.S.C. G5 GUITAR AMPLIFIER**  
5-watt high quality output. Incorporating high flux 12in. 10 watt 12,000 line loudspeaker. Sensitivity 60 mv. High impedance jack input. Handsome strongly made cabinet (size 14 x 14 x 7in. approx.) finished in complementary shades of Rexine/Tygan. 200-250 A.C. mains. Or DEPOSIT £2.3 and 9 monthly payments of 22/3. Carr. 7/6.

## R.S.C. SENIOR 15 WATT LEAD or RHYTHM GUITAR AMPLIFIER

High-fidelity push-pull output. Separate bass and treble "cut" and "boost" controls. Twin separately controlled inputs so that two instruments or "mike" and pick-ups can be used at the same time. Loudspeaker is a heavy duty high flux 12in. 20 watt model with cast chassis. Cabinet is well made and finished as Junior Model. Size approx. 18 x 18 x 8in.



Only **19 Gns.** Carr. 10/-  
Send S.A.E. for leaflet. Or DEPOSIT 39/11 and twelve monthly payments of 33/4.

## ARMSTRONG RADIOGRAM CHASSIS.

All models available, Cash or Terms.



## BASS-MAJOR 30 WATT GUITAR AMPLIFIER

A MULTI-PURPOSE HIGH FIDELITY, HIGH OUTPUT UNIT FOR VOCAL AND INSTRUMENTALIST GROUPS  
Eminently suitable for bass, lead or rhythm guitar and all other musical instruments

- \* Incorporating two 12in. heavy duty 25-watt high flux (17,000 lines) loudspeakers with 2in. diameter speech coils. Designed for efficiently handling full output of amplifier at frequencies down to 25 c.p.s.
- \* Dual Cons in second speaker reproduces frequencies up to 17,000 c.p.s.
- \* Heavily made cabinet of convenient size 24 x 21 x 14in. has an exceptionally attractive covering in two contrasting tones of Vynair.
- \* For 200-250 v., 50 c.p.s., A.C. mains operation.
- \* Four jack socket inputs and two independent volume controls for simultaneous connection of up to four instrument pick-ups or microphones.
- \* Separate bass and treble controls providing more than adequate "Boost" or "Cut".
- \* LEVEL frequency response throughout the audible range.
- \* SUPERIOR TO UNITS AT TWICE THE COST.

**39 1/2 Gns.** Send S.A.E. for leaflet OR DEPOSIT OF £4.30 and 12 monthly payments of £3.9.11. Carr. 17/6.

## HIGH FIDELITY 12-14 WATT AMPLIFIER TYPE A II

PUSH-PULL ULTRA LINEAR OUTPUT "BUILT-IN" TONE CONTROL PRE-AMP STAGES

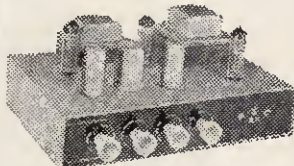

Two input sockets with associated controls allow mixing of "mike" and gram., as in A10. High sensitivity. Includes 5 valves, ECC83, ECC83, ELN4, ELN4, E281. High Quality sectionally wound output transformer specially designed for Ultra Linear operation and reliable small condensers of current manufacture. INDIVIDUAL CONTROLS FOR BASS AND TREBLE "Lift" and "Cut". Frequency response—3 dB 30-30,000 c/s. Six negative feedback loops. Hum level 60 dB down. ONLY 23 millivolts INPUT required for FULL OUTPUT. Suitable for use with all makes and types of pick-ups and microphones. Compatible with the very best designs for STANDARD or LONG PLAYING RECORDS. For MUSICAL INSTRUMENTS such as STRING BASS, LEAD OR RHYTHM GUITARS, etc.

**OUTPUT SOCKET** with plug provides 300 v., 30 mA. and 6.3 v. 1.5 a. for supply of a RADIO FEEDER UNIT. Size approx. 12 x 9 x 7in. For A.C. mains 200-250 v., 50 c.p.s. Output for 3 and 15 ohm speaker. Kit is complete to last out. Chassis is fully punched. Full instructions and point-to-point wiring diagrams supplied. If required hinged metal cover with 2 carrying handles can be supplied for 18/9. TERMS ON ASSEMBLED UNITS. DEPOSIT 24/9 and 9 monthly payments of 24/9. Send S.A.E. for illustrated leaflet detailing Cabinets, Speakers, Microphones, etc., with cash and credit terms.

**LINEAR 1.45 MINATURE 4.5 WATT QUALITY AMPLIFIER.** Suitable for any record playing unit and most microphones. Negative feedback 12dB. Separate Bass and Treble Controls. For Mains 200-250v. 50c/s. Output for 2-3 ohm speaker. Mullard valves E280, ECC83, ELN4. Size only 7 x 5 x 5 1/2 in high. Guaranteed 12 months. Send S.A.E. for leaflet. Terms: Deposit 24/9 and 5 monthly payments of 24/9. **ONLY 6 Gns.**

**LINEAR TREMOLO-PREAMP. UNIT.** Designed for introducing the Tremolo effect to any amplifier which is fitted with a reserve power supply point for smoothed H.T. and G.5 v. A.C. L.T. This applies to practically all amplifiers of our manufacture, and to those of several other manufacturers. The unit plugs into power supply point and any input socket or amplifier. Controls are Speed (frequency of interruptions), Depth (for heavy or light effect), Volume and Switch. Three sockets are for two inputs. **ONLY 4 Gns.**

## R.S.C. CORNER CONSOLE CABINETS



Polished walnut veneer finish. Pleasing design.  
**JUNIOR MODEL.** Size 20 x 11 x 8in. for 15 x 5in. or 10 x 6in. speakers. £22.9.9.  
**STANDARD MODEL.** Size 27 x 18 x 12in. for 8 or 10in. speakers. £41.1.9.  
**SENIOR MODEL.** Size 30 x 20 x 15in. for 12in. Speaker. Suitable Speaker systems below. Only 7 gns.

**R.S.C. BASS REFLEX CABINETS.**  
**JUNIOR MODEL.** Specially designed for W.B. HF1012 Speaker, but suitable for any good quality 10in. speaker. Acoustically lined and ported. Polished walnut veneer finish. Size 18 x 12 x 10in. Handsome appearance. Excellent reproduction for only £3.19.6.

**STANDARD MODEL.** As above but for 12in. speakers. Size 20 x 15 x 13in. For vertical or horizontal use £5.19.6. Set of legs with brass ferrules, 19/6.

**AUDIOTRINE HI-FI SPEAKER SYSTEMS.** Consisting of matched 12in. 12,000 line, 15 ohm high quality speaker, crossover unit (consisting of choke, condenser, etc.) and Tweeter. The smooth response and extended frequency range ensure surprisingly realistic reproduction. Standard 10 watt rating £4.19.6. Carr. 5/-. Or Senior 15 watt, £6.19.6. Carr. 7/6.

**HEAVY DUTY LOUDSPEAKERS IN SUBSTANTIAL REXINE COVERED CABINETS.** Type BGL Suitable for Bass Guitar. Speaker Unit 15in., High Flux, 15 ohms, 30 watts. Cabinet size approx. 24 x 21 x 13in. Only 19j gns. Or Deposit 42/- and 12 monthly payments of 34/-.

## R.S.C. B20 BASS GUITAR AMPLIFIER

A highly efficient unit incorporating a massive 15in. high flux loudspeaker specially constructed to withstand heaviest load conditions. Rating 25 watts. Individual bass and treble controls give ample "boost" and "cut". Two high impedance jack socket inputs are separately controlled. All controls are conveniently positioned in a recess on top of the cabinet. Cabinet is of substantial construction and attractively finished in two contrasting tones of Rexine and Vynair. Size approx. 24 x 21 x 13in. Operation from 200-250 v., 50 c.p.s. A.C. mains.

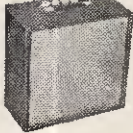

Send S.A.E. for leaflet. Or Deposit £3.2.0 and 12 monthly payments of 51/8. Carr. 17/6.

## FANE HEAVY DUTY HI-FI SPEAKERS

All with Cast Chassis and exceptionally robust 2in. diam. voice coil assemblies. 12in. 35 ohms

122/10 20 watt, 5 gns.	122/10A 20 watt, 6 gns.	152/12 30 watt, 12 gns.
122/12 20 watt, 7 gns.	122/12A 20 watt, 8 gns.	152/12 27 watt, 14 gns.
122/14 22 watt, 9 gns.	122/14A 22 watt, 10 gns.	152/17 35 watt, 16 gns.
122/17 26 watt, £11.17.8	122/17A 25 watt, £12.17.8	

"A" indicates dual cone type. 30-17,000 c.p.s. Send S.A.E. for leaflets. Terms available.

## R.S.C. 30-WATT ULTRA LINEAR HIGH FIDELITY AMPLIFIER A10

A highly sensitive Push-Pull high output unit with self-contained Pre-amp, Tone Control Stages. Certified performance figures compare equally with most expensive amplifiers available. Hum level 70 dB down. Frequency response—3 dB 30-30,000 c/s. A specially designed sectionally wound ultra linear output transformer is used with 807 output valves. All components are chosen for reliability. Six valves are used EF86, EF84, ECC83, 807, 6X4, 6X4. Separate Bass and Treble Controls are provided. Minimum input required for full output is only 12 millivolts on the ANY KIND OF MICROPHONE OR PICK-UP IS SUITABLE. The unit is designed for CLUBS, SCHOOLS, THEATRES, DANCE HALLS or OUTDOOR FUNCTIONS, etc. For use with Electronic ORGAN, GUITAR, STRING BASS, etc. For standard or long-playing records OUTPUT SOCKET PROVIDES L.T. and H.T. for RADIO FEEDER UNIT. An extra input with associated vol. control is provided so that two separate inputs such as Gram and "Mike" can be mixed. Amplifier operates on 200-250 v., 50 c/s. A.C. mains and has output for 3 and 15 ohm speakers. Complete Kit of parts with fully punched chassis and point-to-point wiring diagrams and instructions. If required perforated cover with carrying handles can be supplied for 19/9.

**11 Gns.** Carr. 10/-  
The amplifier can be supplied, factory built with ELN4 output valves and 12 months' guarantee, for 14 gns. Send S.A.E. for leaflet.  
**TERMS: DEPOSIT 33/8 and 9 monthly payments of 33/9.** Suitable mikes & spkrs. available at competitive prices.

## 12in. 10-WATT HIGH QUALITY LOUDSPEAKER. In

walnut veneered cabinet (Gans) 2.00 lines. Speech coil 3 ohms or 15 ohms. Only £4.19.6. Carr. 5/-. Terms: Deposit 13/3 and 9 monthly payments of 11/8. **12in. 20 WATT HI-FI LOUDSPEAKERS IN CABINETS.** Size 18 x 15 x 10in. Finish as above. Terms: Deposit 17/8 and 9 monthly payments of 17/8. Only £7.19.6. Carr. 8/6.

**FANE EXTRA HEAVY DUTY LOUDSPEAKER 15in. TYPE 153.** 40 watts. Total Flux 875,000 lines. Voice Coil 3in. Dia. Impedance 15 ohms. Extremely high sensitivity. Only 18 gns. or Deposit 37/6 and 12 monthly payments of 31/6. 18in. Type 183. 60 watts, 24 gns. Deposit £2.11.0 and 12 monthly payments £2.1.6.

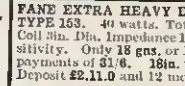









### LAFAYETTE HA-63 COMMUNICATION RECEIVER

7 valves plus Rectifier. 4 Bands. 550 kc/s-31 Mc/s. "S" Meter-BFO-ANL-Bandspread Tuning. 200/250v. A.C. Brand New \$57/10/0. Carr. 10/-.

### LAFAYETTE HE-40 COMMUNICATION RECEIVER

4 Bands, 550 kc/s-30 Mc/s. "S" Meter-BFO-ANL-Bandspread Tuning-Built-in speaker 200/250v. A.C. Brand New 19 Gns. Carr. 10/-.

### LAFAYETTE HE-30 RECEIVERS

9 valves. 550 kc/s-30 Mc/s. Semi Kit Form. \$27.10.0. Carr. 10/-.



### MODEL DA-1 AUTOMATIC ELECTRONIC KEYS

Fully transistorized. 230v. A.C. or 5 or 12 volt D.C. operation. \$18/10/0. Carr. 4/6. Semi-Automatic Bug keys, \$4/10/0. P. & P. 2/6.

### RCA AR.88 RECEIVERS

LF. Model 75-550 kc/s and 1.5-30.5 Mc/s. Guaranteed Perfect Order. \$35. Carr. 30/-. D. Model 550 kc/s-32 Mc/s. Guaranteed "As New Condition". \$65. Carr. 30/-.  
MULLARD OC81-TWO FOR 5/-



### LAFAYETTE TE-20A R.F. SIGNAL GENERATOR

120 kc/s-300 Mc/s on 6 ranges. Variable B.F. and A.F. outputs. Large clear scale. Size 7 1/2" x 10 1/2" x 4 1/2". 220/250v. A.C. Operation. Brand New \$12/15/0. Carr. 5/-.  
LAFAYETTE TE-18 GRID DIP METER

### LAFAYETTE TE-18 GRID DIP METER

Covers 300 kc/s-220 Mc/s. True one hand operation. All coils supplied, operates from 200/250v. A.C. Brand New Guaranteed. \$12/10/-. Carr. 5/-.

### COLLARO STUDIO Tape Transcribers.

2-track \$18.10.0. 4-track \$13.10.0. Post Paid.



### CLEAR PLASTIC PANEL METERS

First grade quality. Moving Coil panel meters, available ex-stock. S.A.E. for illustrated leaflet. Discounts for quantity. Available as follows: Type MR. 36P. 1 3/16" dia. square fronts.

2mA.....	22/6	750mA.....	22/6	200V D.C.....	22/6
5mA.....	22/6	1A D.C.....	22/6	500V D.C.....	22/6
10mA.....	22/6	5A D.C.....	22/6	750V D.C.....	22/6
50mA.....	22/6	3V D.C.....	22/6	15V A.C.....	22/6
100mA.....	22/6	10V D.C.....	22/6	50V A.C.....	22/6
150mA.....	22/6	20V D.C.....	22/6	100V A.C.....	22/6
200mA.....	22/6	50V D.C.....	22/6	300V A.C.....	22/6
300mA.....	22/6	100V D.C.....	22/6	500V A.C.....	22/6
500mA.....	22/6	150V D.C.....	22/6	"S" Meter/1A 22/6	

POST EXTRA Larger sizes available—send for lists.

ILLUMINATED "S" METER. 1 1/2" dia. square front. Cal. in S units. 6V. lamp. 22/6. P. & P. 1/-. Ditto 2 1/2" dia. square 39/6. P. & P. 1/-.  
LAFAYETTE TE-46 RESISTANCE CAPACITY ANALYZER 2 PF-2,000 MFD. 2 ohms-200 Megohms. Also checks impedance, turns ratio, insulation 200/230v. A.C. Brand New \$15. Carr. 5/-.

### V.H.F. RECEIVERS

#### R.1949

Aircraft version of S.27. 3 bands covering 27-145 Mc/s. FM or AM fitted "S" meter-BFO-ANL, etc. Power requirements 250v. H.T. and 6-3v. L.T. Supplied fully tested and checked. \$17.10.0. Carr. 10/-.

### RECORDING HEADS

Reuter: 3 track Set of 2.....19/6  
Min flux: 3 track. Set of 3.....29/6  
Braumatic: 4 track. Set of 2.....99/6  
Post Extra.

### HEADSETS

DLR3 Low Imp. .... 10/8  
RCA Low Imp. .... 15/6  
Chamois padded Moving Coil with Jack Plug. 22/8. Ditto with Mic. 25/-  
ALL NEW - POST EXTRA



### MULTI-METERS

Brand New—Fully Guaranteed—Lowest ever prices  
Supplied with leads, batteries, instructions

MODEL PT-34. 1,000 O.P.V. 0/10/50/250/500/1,000 v. A.C. and D.C. 0/1/100/500 MA. D.C. 0/100k/5 Meg. 100 Meg. \$27/10/0. P. & P. 1/6.

MODEL 500. 30,000 o.p.v. 0.5/1/2.5/10/25/100/250/500/1,000V D.C. 0/2.5/10/25/100/250/500/1,000V. A.C. 0/50uA/5/50/500uA 12 amp. D.C. 0/100k/5 Meg. 100 Meg. \$27/10/0. Post Paid.

MODEL NH-400 10,000 O.P.V. 0/3/3/30/120/300/600/1,200 v. D.C. 0/12/60/120/300/1,200 v. A.C. 0/120 uA/30/300 MA. D.O. 0/2K/200K/2 Meg. \$2. 100 PF-2 MFD. 79/6. P. & P. 2/6.

MODEL AR-320 20,000 O.P.V. 0/10/50/250/500/1,000 v. A.C. and D.C. 0/500uA/10/250 MA. 0/10K/100K/1 Meg. \$2. 250 PF-02 MFD. 0.500 Henrys 92/8. P. & P. 2/6.

MODEL NH-201 30,000 O.P.V. 0/25/1/10/50/250/500/1,000 v. D.C. 0/10/50/250/500 v. A.C. 0/50uA/125/10/250 MA. 0/5K/500K/5 Meg. \$2. 89/6. P. & P. 2/6.

MODEL ITL-2. 20,000 O.P.V. 0/5/25/250/500/2,500 v. D.C. 0/10/50/500/2,500 v. A.C. 0/50uA/125/250 MA. D.C. 0/50K/5 Meg. \$2. 0/1.5 MFD. 82/8. P. & P. 2/6.

MODEL TE-12 20,000 O.P.V. 0/5/5/5/50/120/600/1,200/3,000/6,000 v. D.C. 0/6/30/120/600/1,200 v. A.C. 0/60uA/6/60/600 MA. 0/6K/600K/6 Meg. \$2. 15/19/6. P. & P. 2/6.

MODEL 250T 2,000 O.P.V. 0/10/50/500/2,500 V.D.C. 0/10/50/500/2,500 V.A.C. 0/2 Meg. \$2. 0/250 mA. -30 to 35 db. \$4.8. P.P. 2/0.

### SILICON RECTIFIERS

250 v. P.I.V. 750mA.....	3/-
400 v. P.I.V. 3 amp.....	7/6
200 v. P.I.V. 6 amp.....	5/6
1,000 v. P.I.V. 650 mA.....	7/6
800 v. P.I.V. 600mA.....	5/6
400 v. P.I.V. 600mA.....	3/6
200 v. P.I.V. 200 mA.....	3/-
80 v. P.I.V. 3 amp.....	3/6
70 v. P.I.V. 1 amp.....	5/6
180 v. P.I.V. 150mA.....	3/6

Discounts for quantities. Post extra.

### 2 WAY RADIOS

New Improved Lafayette Model 9 Transistor—Range up to 5 miles. \$21 pair. P. & P. 3/6.

### MINE DETECTOR NO. 4A

Will detect all types of metals. Fully portable. Complete with instructions. 39/6. Carr. 10/-. Battery 8/6 extra.

### BEST BUY!

Send 1/- P.O. for full Catalogue and Lists. Open 9 a.m. to 6 p.m. every day Monday to Saturday. Trade supplied.

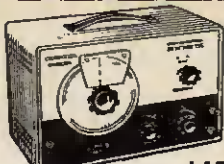

### TE22 SINE SQUARE WAVE AUDIO GENERATORS

Sine: 20 cps to 200 kc/s. Square: 20 cps to 20 kc/s. 200/240v. A.C. Brand New Guaranteed. \$15. Carr. 3/-.



### LAFAYETTE 'PRECON' AMATEUR PRESELECTION CONVERTER

Converter-20-15-10 metres. Preselector-80-40-20-15-10 metres. Crystal controlled-2 R.F. Stages. 200/250v. A.C. operation. Brand New, 19 Gns. Carr. 7/6.



### LONDON AGENTS FOR CODAR EQUIPMENT

#### VOLTAGE STABILIZER TRANSFORMERS

Input 80-120v. and 160-240v. Constant output 110v. or 220v. 250 watts. Brand New Guaranteed. \$10.10.0. Carr. 7/6.  
RK40 STEREO TAPE DECK WITH BUILT-IF PREAMPLIFIER

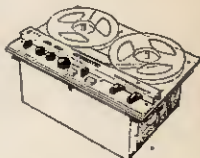

4 Transistors-4 Valves. Will record or playback 1 Track Stereo or Mono at 7 1/2 or 3 1/2 IPS. 7" spool size. Twin meter level indicators. 4 inputs. Output 500 MW. 40-18,000 CFS. response. Size 15" x 10" x 6 1/2". 200/250v. A.C. Operation. Brand New 42 Gns. P. & P. 13/-.

### 12v. D.C. D/P AERIAL C/O RELAYS-CERAMIC INS.-10/6. P. & P. 1/8



### VARIABLE VOLTAGE TRANSFORMERS

Brand New Guaranteed—Fully Shrouded. Input 230v. 50/60 c/s. Output 0-280 Volts.  
1 Amp-£4.10.0. 10 Amp-£18.10.0  
2.5 Amp-£5.17.6. 12 Amp-£18.15.0  
5 Amp-£9.10.0. 20 Amp-£32.10.0  
2.5 Amp Portable—Metal Case with Meter-Fuses, etc. £9/17/6.



ARMY FIELD TELEPHONES TYPE F Generator Bell Ringing, 2 Line Connection. With Wood Carrying Case, Fitted Batteries. Supplied Fully Tested. \$4/19/6 pair. Carr. 5/-.



### LAFAYETTE HI-FI STEREO HEADPHONES

16(2)-25-15,000 Cycles. Air Cushioned Headband with cables and overload Junction Box. Brand New Guaranteed. \$2/6. P. & P. 2/6.



### TS-76 20,000 O.P.V. PUSH BUTTON MULTI-TESTER

Large clear plastic scale, simple operation. D.C. volts up to 1,000v. A.C. volts up to 1,000v. Resistance up to 10 megohms. Current up to 250 mA. Decibels 20 to +36 db. Size 6in. x 4 1/2in. x 2 1/2in. Complete with leads, batteries and instructions. Only \$5/5/-. P. & P. 2/-.



LAFAYETTE TE-46 RESISTANCE CAPACITY ANALYZER 2 PF-2,000 MFD. 2 ohms-200 Megohms. Also checks impedance, turns ratio, insulation 200/230v. A.C. Brand New \$15. Carr. 5/-.

# G.W. SMITH & CO (RADIO) LIMITED

Phone: GERRARD 8204/9155  
Cables: SMITHEX LESQUARE  
3-34 LISLE STREET, LONDON, W.C.2



## MAINS POWER PACK

Designed to operate transistor sets and amplifiers. Adjustable output 6 v.—9 to 12 volts for up to 500 mA. (class B working). Takes the place of any of the following batteries. FP1-PP3-PP4-PP6-PP7-PP9 and others. Kit comprises: mains transformer-rectifier, smoothing and load resistor 5,000 and 500 mfd. condensers, zener diode and instructions. Real snip at only 14/6, plus 2/6 post.

## OUR BARGAIN OF THE YEAR

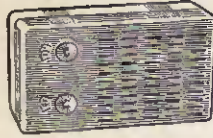

Complete kit of parts to build this 6-transistor 2 watt superbet receiver at only **39/6** plus 2/6 post and ins.

### "CORONET" Mk. III

It fully covers the medium-wave band and that part of the long-wave band to bring in B.B.C. Light. The circuit includes a highly efficient slab aerial and 2 1/2" P.M. speaker. Overall size approximately 4 1/2 x 2 1/2 x 1 1/2 in. Supplied complete with carrying case.

## MOTOR BARGAIN

Silent running mains motor by very famous maker. Ideal for gramophones, tape recorder, fan, etc. etc. 200-250 volts. A.C. shaded pole start. Size approximately 2 1/2 x 2 1/2 x 1 1/2 in. 2,750 r.p.m. Spindle diameter 5/82 in. Spindle length 1 in. Brand new guarantee. Price 12/6 plus 1/6 post.

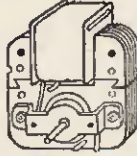

## YAXLEY SWITCHES

POLES	2 WAY	3 WAY	4 WAY	6 WAY	8 WAY	10 WAY	11 WAY	12 WAY
1	2/8	2/10	3/1	3/6	4/-	4/6	4/6	4/8
2	3/3	3/8	4/1	4/11	6/-	7/-	7/-	7/6
3	3/11	4/6	5/2	6/9	8/-	9/6	9/6	10/3
4	4/6	5/4	6/2	7/10	10/-	12/-	12/-	13/6
6	5/9	7/-	8/3	10/9	15/-	17/-	17/-	18/6
8	6/-	8/8	10/4	13/8	18/-	22/-	22/-	25/-
10	10/-	10/6	12/5	15/9	22/6	27/-	27/-	30/-
12	12/-	12/6	14/6	19/8	27/6	32/-	32/-	36/-
14	14/-	14/6	17/-	22/6				
16	16/-	16/6	19/6	25/6				

5 WAY 1 pole 3/6    2 pole 4/9    24 WAY 1 pole 15/-    2 pole 22/6

## Speaker Bargain



12in. High fidelity loudspeaker. High flux permanent magnet type with 3 ohm or 15 ohm speech coil. Will handle up to 10 watts. Brand new, by famous maker. Price 27/6, plus 3/6 post and insurance.

## Adjustable Thermostat



Suitable for industrial or domestic purposes such as controlling furnace oven, immersion heater, etc. Can also be used as a thermostat or fire alarm. Made by Sunvic these are approximately 1 1/2 in. long and adjustable over a range 0 to 550°F. The contacts are rated at 15 amps. 230 volts, and the adjustment spindle, which comes to the top, can be fitted with a flexible drive for remote control or just a pointer knob for local control. Listed at 23 or 24 each, these are offered at only 8/6, plus 2/6 postage and insurance.

## Timer Kit

Special offer of all components except metal box to make mains operated interval timer for photography, etc., 12/6 plus 2/6 post.

## BARGAINS

**Air Spaced Trimmers**, good length 1/2 in. spindle 0-20pf, but easily converted down to 0-5 pf. 2/6 ea., post 1/6. 3 in. but 2 gang for F.M. Tuners etc., 4/8 ea. Post 1/6.

**500 MW Amplifier**. Uses 3 transistors, 2 of which are in Class B push-pull for battery economy. Ideal little unit for baby alarm, record player, intercom, etc., etc., 19/6. Speaker 12/6 extra.

**Trimmer Assortment**, 3 doz. various sizes and types including doubles and ceramic air spaced. Retail list value over 24, all new and unused 10/- for 36. Post 2/6.

**Motor Generator**, 6 v. input gives 12 v. output, suitable to run 12 v. car battery radio off 6 v. battery 17/6, post and insurance 3/6.

**Midget 6in. P.M. Loudspeaker** 3 ohm, 12/6, 8 ohm, 13/6. Midget 208 pf+170 pf 1 wogang Tuning Condenser with trimmers for transistor set. Price 9/-.

## Waterproof Heater Wire

16 yd. length. 70 watts. Self regulating temperature control, 10/- post free.

## Building a Scope?



3in. oscilloscope tube. American made type No. 31P7, base 6.3 v. 6 amp. heater electrostatic deflection, brand new and guaranteed, with circuit diagram of scope, 15/- each plus 2/6 post and insurance.

## Ice-Stat

This is a small thermostat which cuts on and off at round freezing point. Has many uses, one of which could be an ice warning device to be fitted under your motor car. Price 7/6. Post 1/6.

## Simmerstat Heater Regulator

Suitable to control elements, heaters, soldering irons and boiling rings up to 2,500 watts. Complete adjustable, normal price 55/- each, special snip price 12/6, plus 1/6 postage and insurance.



## Siemens High Speed Relay

Twin 250 ohm coils adjustable tension change over contacts—platinum points 7/6. Post 1/6.

## GUITAR AMPLIFIERS WITH TREMOLO

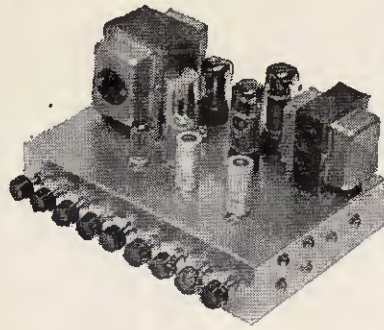

Five jack socket inputs, four with separate mixing volume controls, and one input "straight through". All inputs are of very high sensitivity only 10 millivolts input is required for full output, making them suitable for all types of guitars and microphones. Separate Bass and Treble controls, giving a wide range of lift and cut. Separate master gain control. Tremolo speed and depth controls. Jack socket for remote tremolo switching.

Outputs for 3 and 15 ohm speakers. Valves used in the 30 watt and 50 watt amplifier ECC83, ECC83, EL34, EL34, GZ34. In the 15 watt amplifier ECC83, ECC83, EL84, EL84, EZ81. An extra valve ECC83 is used in the tremolo circuit. The chassis is complete with baseplate and is solidly made of 18 gauge steel, finished silver grey hammer. Size 12 x 8 x 6 1/2 inches high.

### PRICES—

50 watt with tremolo	£20.10.0
50 watt less tremolo	£19.10.0
30 watt with tremolo	£15.10.0
30 watt less tremolo	£14.10.0
15 watt with tremolo	£12.10.0
15 watt less tremolo	£11.10.0

Add carriage 10/- any amplifier. Send for free descriptive leaflet.

## STROUD AUDIO

PAGANHILL LANE, STROUD, GLOS.

Stroud 783

## HEAVY DUTY SHROUDED AUTO TRANSFORMERS, 240-

110 v. Fitted with 2 pin American sockets or terminal blocks. State which type. Brand new and Guaranteed, 1,000 watts, £4.15.0, carr. 5/-; 500 watts, £3.10.0, carr. 4/-; 300 watts, £2.7.6, carr. 3/6; 150 watts, £1.17.6, carr. 3/6.

2 KV. In metal case, with handle, 2 American socket outputs, £9.10.0. Carr. 7/6.

## EX-MINISTRY INDUSTRIAL TYPES.

Tapped 250, 240, 230, 220, 120, 115, 110, 105 volts 10 KVA, £29.10.0; 5 KVA £19.10.0. Exchangeable. Both types enclosed in heavy metal case.

## L.T. TRANSFORMERS

Pri. tapped 200-260 v. Sec. tapped 28, 29, 30, 31 v. 25 amps. conservatively rated, £6.19.6, carr. 10/-; Pri. 200-250 v. Sec. 25-0-25 v. 7 amps, pri. earth shielded, £5.17.6, carr. 7/6; Pri. tapped 200, 225, 240 v. Sec. tapped 12, 18, 24, 30, 36 v. 10 amps, £5.15.0, carr. 7/6; Pri. 240 v. Sec. tapped 4, 6, 11 v. 200 amps, £10.19.6, carr. 10/-; Pri. 240 v. Sec. tapped 53.5, 55.2 v. 6 amps, £3.17.6, carr. 7/6; Pri. 220-240 v. Sec. tapped 6-12 v. 20 amps, £3.12.6, carr. 6/-; Pri. 230 v. Sec. 70 v. 5 amp. "C" core sealed, £4.5.0, c. 7/6. Hundreds more available. Send for list now.

## SAMSON'S ELECTRONICS LTD.

9-10 CHAPEL STREET LONDON, N.W.1.

Tel. PAD 7851

Tel. AMB 5125

## HIGH QUALITY TAPE AMPLIFIER KIT

Suitable for use with tape decks having a high impedance record head and a low impedance erase head. Magic eye recording level. 3 ohm 4 watt output. 2 inputs with tone control. Provision for monitoring. Simple point to point wiring instructions. This tape amplifier is also available completely built and tested. Ideal for use with Collaro and B.S.R. decks.

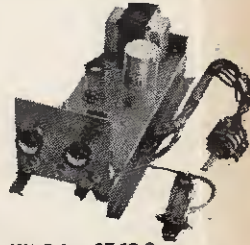

Kit Price £7.10.0  
Ready Built £9.17.6

p & p 3/6

## ELECTRONICS (CROYDON) LTD.

266 LONDON ROAD, WEST CROYDON, SURREY

Post orders to:

43 SILVERDALE ROAD, EASTBOURNE, SUSSEX

## ELECTROSURE LTD., Fore Street, Exeter



# FANE HIGH FIDELITY LOUDSPEAKERS

## Full Range of Heavy Duty Types for All Purposes

CAST ALUMINIUM CHASSIS. EXTREMELY ROBUST 2in. DIAMETER VOICE COIL ASSEMBLIES

Model	Cone	Frequency response c.p.s.	Impedance ohms	Main resonance c.p.s.	Power handling watts R.M.S.	Flux density gauss	Total flux Maxwells	Voice coil winding	Diam. of Chassis	Baffle Hole	Net weight lbs.	Retail Price
122/10	Single	25-5000	15	32 or 75	20	10,000	100,000	Copper	12in.	11in.	6lbs.	5 gns.
122/10A	Dual	10-15000	15	32 or 75	20	10,000	100,000	Aluminium	12in.	11in.	6lbs.	6 gns.
122/12	Single	25-5000	15	32 or 75	20	12,000	160,000	Copper	12in.	11in.	6lbs.	7 gns.
122/12A	Dual	30-15000	15	32 or 75	20	12,000	160,000	Aluminium	12in.	11in.	6lbs.	8 gns.
122/14	Single	25-5000	15	32 or 75	22	14,000	186,000	Copper	12in.	11in.	7lbs.	9 gns.
122/14A	Dual	30-15000	15	32 or 75	22	14,000	186,000	Aluminium	12in.	11in.	7lbs.	10 gns.
122/17	Single	25-6000	15	32 or 75	25	17,000	226,000	Copper	12in.	11in.	10½lbs.	£11/7/6
122/17A	Dual	30-17000	15	32 or 75	25	17,000	226,000	Aluminium	12in.	11in.	10½lbs.	£12/17/6
122/12	Single	25-8600	15	30 or 75	20	12,000	160,000	Copper	15in.	13½in.	8lbs.	12 gns.
122/12A	Dual	30-15000	15	30 or 75	20	12,000	160,000	Aluminium	15in.	13½in.	8lbs.	13 gns.
122/14	Single	25-3500	15	30 or 75	22	14,000	186,000	Copper	15in.	13½in.	9lbs.	14 gns.
122/14A	Dual	30-15000	15	30 or 75	22	14,000	186,000	Aluminium	15in.	13½in.	9lbs.	15 gns.
122/17	Single	25-4000	15	30 or 75	25	17,000	226,000	Copper	15in.	13½in.	12½lbs.	16 gns.
122/17A	Dual	30-17000	15	30 or 75	25	17,000	226,000	Aluminium	15in.	13½in.	12½lbs.	17 gns.

EXTRA HEAVY DUTY TYPES WITH 3in. DIAMETER POLE PIECES

153	Single	30-3500	15	40 or 75	40	14,000	375,000	Copper	15in.	13½in.	20lbs.	18 gns.
183	Single	20-8000	15	30 or 75	60	14,000	375,000	Copper	18in.	16½in.	22½lbs.	25 gns.

AVAILABLE THROUGH ALL SOUND EQUIPMENT STOCKISTS

Manufacturers' enquiries to:

**FANE ACOUSTICS LTD.**  
HICK LANE • BATLEY • YORKS

See distributors to Wholesale and Retail Trade:  
**LINEAR PRODUCTS LTD.**  
ELECTRON WORKS • ARMLEY • LEEDS

## For Discerning Enthusiasts

### Quality Transistors and Components

**UHF Amplifier Transistors** (BBC2, etc.): AF139, 36/9; T2028 (2N2398), 53/9; GMO290, 31/6. **Tunnel Diodes**: IN3712 (TD-1) 1mA, 1pk 2,300 Mc/s, 50/3; IN3720 (TD-5) 22mA, 1pk 1,600 Mc/s, 25/-. **VHF Power Transistors**: 2N3053 60V, 5W,  $f_T=100$  Mc/s, silicon planar, 15/-; AU10 70V, 4.5W,  $f_T=120$  Mc/s, germanium alloy-diffused, 53/-; BUY10, silicon npn epitaxial planar, 40V, 10W,  $f_T=90$  Mc/s (typ.), 45/-.

**Audio Transistors, matched pairs**: OC81Z, 16/- pr.; AD140, 50/- pr.; OC35, 36/- pr.

**Other Devices**: 2G102, 36/-; OC171, 9/-; MAT101, 8/6; OC71, 6/6; OC72, 8/-; OC81, 8/-; OC202, 24/6.

PROMPT SERVICE. C.W.O. PLEASE. POSTAGE 6d.  
PLEASE SEND 1/- (STAMPS) FOR REFERENCE CATALOGUE

**J. WILLIAMS & CO.** 208 HAGLEY ROAD  
BIRMINGHAM 16

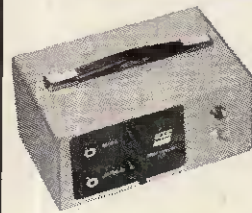

**T615 PORTABLE  
12v. TRANSISTOR  
AMPLIFIER**

**15wt. OUTPUT  
INBUILT MICROPHONE  
PRE-AMPLIFIER**

Details and Nearest Stockist from:

**Messrs. E. K. ELECTRONICS (I.A.) LTD.**  
BROTHERTON HALL, BROTHERTON  
KNOTTINGLEY, YORKSHIRE

## RES/CAP. BRIDGE 39/6

p. & p. 2/6

Checks all types of resistors, condensers  
6 RANGES

Built in 1 hour. Direct reading

**READY CALIBRATED**

Stamp for details of this and other kits

**RADIO MAIL (Dept. CC)**

Raleigh Mews, Raleigh St., Nottingham

## BATTERY ELIMINATORS

The ideal way of running your TRANSISTOR RADIO, RECORD PLAYER, TAPE RECORDER, AMPLIFIER, etc. Types available: 9v; 6v; 4½v (single output) 39/6 each. P. & P. 2/9. 9v + 9v; 6v + 6v; or 4½v + 4½v (two separate outputs) 42/6 each. P. & P. 2/9. Please state output required. All the above units are completely isolated from mains by double wound transformer ensuring 100% safety.

**R.C.S. PRODUCTS (RADIO) LTD.**  
11 Oliver Road, London, E.17

## KEY BOOK paperbacks

### HI-FI AND AUDIO

by A. T. Collins

Modern Designs for the Amateur Constructor. High Sensitivity Amplifier, Two-valve Pre-amp and Equaliser, Mains Gramophone Amplifier, Output Transformers and Loudspeakers, Cross-over Networks for Loudspeakers, Seven-valve Quality Amplifier, Five-valve Stereo Amplifier, Design for a Bass Reflex Cabinet, Radiogram Cabinet Design, etc.

### SIMPLE RADIO CIRCUITS

by A. T. Collins

A Complete 'Build Your Own Radio' Guide. Simple Mains Short Wave Receiver, Medium Wave Transistor Receiver, Dual Wave One-valve, Broadcast Bands Receiver, Two-valve Short Wave, Amateur Bands Hybrid, Transistor Superhet Tuner, Battery-operated Short Wave Converter, Five-transistor T.R.F. Receiver, Four-valve Superhet Portable.

8s. 6d. FROM ALL BOOKSELLERS . . . or, in case of difficulty, 4s. by post from George Newnes Ltd., Tower House, Southampton Street, London, W.C.2. **NEWNES**

## "PRACTICAL ELECTRONICS" CONSTRUCTIONAL DESIGNS

All specified 1st grade Components, complete Metalwork, full range of Materials, engraved Panel Plates, Ancillary Equipment and Assembled Units. Comprehensive lists available for each "P.E." Constructional Article.

Please send 6d in stamps for each design

**MALVYN ENGINEERING WORKS**

Engineers to the Radio and Electronic Industries

7 CURRIE STREET, HERTFORD, HERTS

TELEPHONE: HERTFORD 2264

**DUKE & CO. (LONDON) LTD.**  
621/3 Romford Road, Manor Park, E.12  
ILFord 6001-2-3

## T.V. TUBES

17in. — 35/-

14in. — 15/-

Most makes and types available. Set Tested. Guaranteed good picture. Ex Rental Service Depts. Stock. Carriage 5/- extra STAMP FOR LATEST FREE LIST

# Z & I AERO SERVICES LTD.

Head Office and Warehouse: 44A WESTBOURNE GROVE, LONDON, W.2.

Retail Shop:  
35 TOTTEHAM COURT ROAD, LONDON, W.1.  
Tel.: LANgham 8403  
Tel.: PARK 5641/2/3

0A2	6/-	5Y3GT	5/-	804	2/8	89J7	8/-	12B4A	9/-	90PL1	11/8	OB11	15/-	RABC80	6/-	EPF4	6/-	EY01	7/-	PCL34	7/-	U191	11/-
0B8	6/-	5X4Q	5/-	8C5G	5/-	88K7G	4/8	12B4S	8/-	90PL2	11/8	OB13	16/-	EA742	8/8	EPF5	2/-	EY70	12/8	PCL35	8/-	U261	12/8
0B3	6/-	5Z3	6/-	60C91	7/-	68L7GT	5/-	12B5E	5/-	90LGT	7/-	CL42	9/-	EB41	8/8	EPF6	2/-	EY81	12/8	PCL36	9/-	U261	13/8
0C3	6/-	5Z4GT	8/-	60C91	12/-	68N7GT	4/8	12RH7	8/-	30W4	5/-	CY21	6/6	EBC33	7/-	EPF8	10/-	EY83	8/8	PL36	8/8	U282	14/-
0D3	5/-	6/30L2	10/-	60B6	5/-	60U4GT	10/8	12BY7	10/-	3Z23	10/-	DAC32	7/-	EBC41	7/-	EPF6	6/-	EY86	6/-	PL38	16/-	U301	12/-
1A5GT	5/-	6A3	3/-	60D6G	17/-	60U8	7/8	12E1	20/-	3Z24G	4/-	DAP91	4/8	EBC81	6/8	EPF6	6/-	EZ35	5/8	PL41	7/-	U403	7/-
1A7GT	5/-	6A5	4/-	60L6	9/-	60U8A	9/-	12F5GT	8/-	3Z24GT	6/8	DAP92	6/8	EBC86	6/8	EPF9	4/8	EZ40	5/8	PL42	5/8	U401	18/-
1AD4	7/-	6A8	8/-	60W	12/-	60U8	8/-	12G6GT	8/-	3Z25GT	6/-	DAP93	6/-	EBC87	7/8	EPF1	4/-	EZ41	6/8	PL43	6/8	U402	7/8
1B3GT	7/-	6B4	6/8	60Y5	10/-	60U8	5/-	12J7GT	7/8	43	5/-	DC70	8/-	EBC88	6/8	EPF3	4/8	EZ20	6/8	PL44	6/8	U403	6/8
1G6GT	7/-	6AB7	4/-	6D3	7/8	60V6GT	7/8	12K7GT	7/8	50B5	7/-	DC80	7/-	EBC11	14/-	EPF4	6/-	EZ21	4/8	PL500	15/-	U404	8/8
1H4GT	7/-	6AC7	3/-	6D4	15/-	6X4	4/-	12K8	10/-	50C5	6/8	DET12	4/8	EBC12	11/-	EPF5	5/8	EZ20	8/8	PY33	9/-	U404	6/8
1HGT	7/-	6AF4	11/-	6DK6	6/-	6X5GT	5/8	12Q7GT	5/-	50D6GT	5/8	DF33	8/-	EBC90	8/-	EPF6	10/-	EZ22	10/-	PY81	5/8	U403	7/-
1B4	2/8	6AG7	6/-	6D84	15/-	6Y6G	5/-	12S4T	7/-	50E1GT	6/8	DF66	6/-	EBC88	12/-	EPF18	8/-	EZ24	10/-	PY82	5/8	U403	6/8
1L6	17/8	6AH6	10/-	6E5	7/-	7D8	7/-	12S7GT	4/-	60	8/8	DF72	7/-	EBC90	2/8	EPF14	8/-	EZ27	9/-	PY83	6/-	U403	7/-
1N3GT	2/-	6AK5	5/8	6E6	12/-	7K7	10/-	12S7	4/-	85A1	8/8	DF73	7/-	EBC1	5/-	EPF60	10/-	KT68	15/-	PY88	8/8	U403	11/-
1Q5GT	2/-	6AK6	7/8	6F5	8/-	7R7	12/-	12K7	4/-	85A2	8/8	DF91	3/-	EBC2	6/8	EPF6	12/8	KT68	20/-	PY80	8/8	U403	8/8
1R4	6/-	6AM6	2/8	6F7	5/-	787	16/-	12S7	6/-	85A3	5/8	DF92	2/8	EBC31	6/-	EPF6	10/-	LP2	7/8	PX25	10/-	U403	6/8
1B3	5/-	6AM6	4/-	6F8G	5/-	9B9W6	7/-	12D3	6/-	150B2	12/-	DF95	6/-	EBC32	4/-	EPF6	10/-	MU12/14	8/-	QV062-645	10/-	U403	6/8
1B4	5/-	6AN3	10/-	6F11	6/-	10C1	10/-	19A5	5/-	150B3	9/-	DF63	6/-	EBC40	9/-	EPF6	10/-	N78	15/-	QV03/10	10/-	U403	8/8
1B5	4/8	6AQ6	9/-	6F13	6/-	10C2	12/-	19G1	25/-	807	9/-	DK92	8/-	EBC41	4/-	EPF7	17/8	NSP1	28/-	R2	35/-	U403	7/8
1T4	3/-	6AQ6	8/-	6F23	9/8	10D1	7/-	19G6	15/-	829B	60/-	DK40	11/-	EBC22	5/-	EPF6	10/-	NSP2	22/-	R2	35/-	U403	8/8
1T5GT	5/-	6AR5	6/-	6F24	11/-	10F1	14/-	20F2	15/-	892	20/-	DK81	5/-	EBC23	6/-	EPF6	10/-	OOP71	24/-	R10	15/-	U403	8/8
1U4	5/-	6AR6	6/-	6F28	10/-	10F3	8/-	20L1	14/-	954	5/-	DK92	9/-	EBC24	6/8	EPF6	10/-	ORP12	12/-	R17	8/-	U403	10/-
1U5	5/-	6AR6	5/-	6F33	9/-	10F9	10/-	20P1	14/-	955	3/-	DK96	7/8	EBC25	6/8	EPF6	10/-	ORP6	10/-	R10	7/-	U403	7/8
1X3A	7/-	6AT6	22/8	6F4	9/-	10F18	9/-	20P3	12/-	956	2/-	DL96	12/-	EBC26	10/-	EPF6	10/-	PC86	12/-	RL18	12/8	U403	7/8
1X3B	7/-	6AT6	4/-	6J5G	4/-	10L1	7/8	19G1	25/-	807	9/-	DL98	10/-	EBC27	7/8	EPF6	10/-	PC88	12/-	RL30	12/8	U403	6/8
2C4	12/-	6AU6	0/-	6J6	3/8	10LD11	10/-	20P5	12/-	958	4/-	DL98	12/8	EBC28	7/8	EPF6	10/-	PC87	9/-	SU2150A	10/-	U403	7/-
2D21	6/-	6AV6	0/-	6J7G	5/-	10P13	12/8	20P6	5/-	959A	8/-	DL70	7/-	EBC28	11/-	EPF6	10/-	PC84	5/8	TH41	10/-	U403	7/8
3A4	4/-	6B7	5/-	6J7GT	7/8	10P14	12/-	25C5	10/-	2050	12/8	DL73	12/-	EBC21	10/-	EPF6	10/-	PC85	7/-	TH233	6/-	U403	6/8
3A5	7/-	6B8	3/-	6K7	5/-	11D3	7/-	25LGT	8/-	2051	6/-	DL75	10/-	EBC25	12/8	EPF6	10/-	PC88	10/8	TH321	7/-	U403	7/8
3B4	5/-	6BAG	5/8	6K7GT	8/-	11D5	7/-	25Z4G	7/-	5093	6/-	DL82	6/-	EBC22	8/-	EPF6	10/-	PC89	10/-	TP22	5/-	U403	6/8
3D6	4/-	6BEG	5/-	6K8	8/-	12C6	8/-	25Z5	7/8	5783	13/-	DL83	4/-	EBC21	6/-	EPF6	10/-	PC89	10/-	TP25	5/-	U403	10/-
3Q4	6/8	6BF6	6/-	6K8GT	8/8	12A8T	5/-	25Z6GT	8/8	6080	8/-	DL94	5/8	EBC28	7/8	EPF6	10/-	PC87	9/-	TP2626	7/8	U403	7/-
3Q5GT	6/8	6BHG	7/-	6L1	8/-	12A8H	11/-	27M1	60/-	6080	25/-	DL95	6/8	EBC28	6/8	EPF6	10/-	PC85	7/-	TT15	35/-	U403	8/-
3B4	5/-	6BJ6	8/-	6L6G	8/-	12A9G	5/-	27D7	7/-	6146	27/8	DL96	5/-	EBC22	7/8	EPF6	10/-	PC84	3/-	TT21	32/-	U403	8/-
3Y4	5/8	6BKA	7/-	6L7	8/-	12A7E	5/-	29C1	20/-	9023	5/8	DM70	5/-	EBC23	6/8	EPF6	10/-	PC86	8/-	TT22	32/-	U403	8/8
4D1	4/-	6BNC	7/-	6L8	8/-	12A7T	4/-	30C15	10/-	9029	9/-	DY86	6/-	EBC24	7/8	EPF6	10/-	PC81	10/-	TT24	40/-	U403	6/8
4TEA	14/8	6BQ7A	8/-	6N7	8/-	12AUG	6/-	30C17	12/-	A2293	15/8	EBC20	14/-	EPF6	4/8	EPF6	10/-	PC82	10/-	U12/14	8/-	U403	5/-
5R4G	9/-	6BR7	11/8	6P1	11/-	12A7	5/-	30F5	9/-	ACRLD93	6/-	E900C	12/-	EPF7A	3/-	EPF6	10/-	PCF85	10/8	U22	6/-	U403	8/8
5T4	8/-	6BR8	5/8	6Q7G	6/-	12A7E	6/-	30FL1	11/-	AZ1	9/-	E91H	12/-	EPF8	5/-	EPF7	9/-	PCF86	13/-	U25	11/-	X65	5/8
5U4G	3/-	6BR7	16/8	6R7A	8/-	12A7V	8/-	30L17	13/-	AZ12	9/-	E920C	7/-	EPF9	9/-	EN31	10/-	PCL81	9/-	U36	11/-	X66	8/8
5U3GB	6/8	6B96	8/-	6R7G	8/-	12A7K	6/-	30P12	10/-	AZ41	6/8	E180C	8/-	EPF1	7/8	EN32	10/-	PCL82	6/8	U50	5/-	X79	18/-
5Y4G	8/-	6B97	8/-	6S7	6/-	12A7V	10/-	30P19	14/-	O10	5/-	E180F	15/-	EPF2	6/-	EN32	10/-	PCL83	8/8	U76	4/-	Z60	10/-

### Mullard Transistors

OC28	8/-	OC44	6/-	OC72	8/-
OC28	17/8	OC45	6/-	OC75	6/-
OC35	15/-	OC70	5/-	OC76	6/-
OC42	8/-	OC71	5/-	OC77	8/-

OC139	12/-	Set of 2
OC170	8/-	matched
OC171	9/-	OC81 and 1
OC204	10/8	OC81D 12/6

**R.C.A. TRANSISTORS:** 2N410 (OC45), 3/6; 2N412 (OC44), 3/8.  
**G.E.C. TRANSISTORS:** GET115, 7/-; GET573, 20/-, 85/- matched pair.  
**MICRO-ALLOY TRANSISTORS:** MAT101 (60 Mc/s) 8/6; MAT121 (120 Mc/s) 8/8.  
**DIODES:** OA81, 2/-; EY210, 7/8; GJ3M, GJ3M, GJ7M, 3/6; BY800, 7/-.

All our valves carry three months' guarantee. Any faulty item replaced free of charge.

Write for full Catalogue of Valves and Tubes.

Please add 2/6 in £ for postage. Minimum charge 1/6. No C.O.D. Orders Accepted. Please address all correspondence to the Head Office.

## JOYFUL NEWS No. 3

"CQ", the Radio Amateur's Journal, reviewed the "JOYSTICK" V.F.A. in their July, 1964 issue. The following extracts are quoted:—

I tried the JOYSTICK out with HB9ACN's help and found that it performed remarkably well. FOUR DIFFERENT RECEIVERS SHOWED IMPROVED PERFORMANCE OVER A DIPOLE when the JOYSTICK was mounted high on the outside of an apartment house. A little drop-off in signal was noted when the antenna was laid against the wall on the inside. For transmitting, the antenna will take a KW.

When you write to the manufacturer for full information he will send you testimonials from many hams who have nothing but praise for the JOYSTICK, among these will be a number from U.S. hams especially W6CJW and K5GDH.

I recommend that if you buy a JOYSTICK you also buy a tuner. Actually the antenna could be used for mobile work\* too without much trouble.

**COMPLETE SYSTEM FOR RECEIVING,** comprising Standard JOYSTICK and Type J JOYMATCH for complete coverage of the Short Wave bands—will suit ANY Short Wave Receiver—£5.11.0d. including carriage and packing.

**DITTO, WITH DE-LUXE "JOYSTICK"** (all copper R.F. elements), £6.11.0d. including carriage and packing.

**COMPLETE SYSTEM FOR TRANSMITTING,** comprising Standard JOYSTICK and Type S JOYMATCH for 6 amateur bands, £42.0d. including carriage and packing. Add £1.0.0d. for DE-LUXE JOYSTICK.

**MOBILE HARNESS\*** for use with STANDARD JOYSTICK only 25/- post free.

FULL INSTRUCTIONS INCLUDED

FULL MONEY-BACK GUARANTEE

TESTIMONIALS GALORE !!!

**PARTRIDGE ELECTRONICS LTD.**

(Dept. PE)

7 SOWELL STREET, BROADSTAIRS, KENT

## CLEARANCE SALE MAKE 5 DIFFERENT TRANSISTOR RADIOS for 35/-



Amazing Radio Construction Set! Become a radio expert for 35/-. A complete Home Radio Course. No experience needed. Parts include instructions for each design, Step-by-Step plan, all Transistors, loudspeaker, personal phone, knobs, screws, etc., all you need. Box size 14" x 10" x 2" (parts avail. sep.). Originally £6. NOW 35/- + 3/- P.&P. (C.O.D.)

## ASTONISHING CIGARETTE RADIO 18/6 only

Yes, a perfectly ordinary packet of cigarettes!—but watch your friends' astonishment on hearing it fetch in station after station, loud and clear! Still holds 10 Cigarettes—yet cleverly conceals highly sensitive, fully transistorised circuit (including tiny battery). Even a young boy can assemble it in under 2 hours. No soldering. No experience necessary. Only 16 connections to make. Ideal for taking to work with you. From our bulging testimonial file, Mr. D.B. of Huddersfield writes:— "... I have fitted the parts in and it is working wonderfully..." ALL PARTS including Semi-Conductors, A.B.C. Plans, etc. ONLY 18/6d. plus 1/6d. post, etc. (C.O.D. 1/6d. ex.)

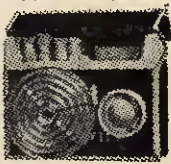

## BBC2 (625 LINE) TV AERIALS

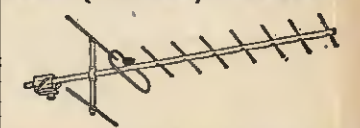

**MAST MOUNTING ARRAYS,** 9 element 45/-; wide spaced high gain, 11 element 55/-; 14 element 62/-; **WALL MOUNTING WITH CRANKED ARM,** 9 element 60/-; wide spaced high gain, 11 element 67/6; 14 element 75/-; **CHIMNEY ARRAYS COMPLETE,** 9 element 72/-; wide spaced high gain, 11 element 80/-; 14 element 87/6. **LOFT ARRAYS,** 7 element 32/6; wide spaced high gain, 11 element, with TILTING ARM 62/6; 14 element 70/-; **ALL HIGH GAIN UNITS HAVE SPECIAL MULTI-ROD REFLECTOR, LOW LOSS CO-AXIAL CABLE 1/6 yd.**

## BBC + ITV + F.M. AERIALS

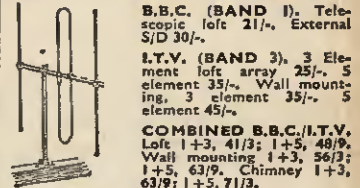

**B.B.C. (BAND 1),** Telescopic, loft 21/-. External S/D 30/-.  
**I.T.V. (BAND 3),** 3 Element loft array 25/-; 5 element 35/-. Wall mounting, 3 element 35/-. 5 element 45/-.  
**COMBINED B.B.C./I.T.V.,** Loft 1+3, 41/3; 1+2+5, 48/9. Wall mounting 1+3, 56/3; 1+2+5, 63/9. Chimney 1+3, 63/9; 1+2+5, 71/3.

**F.M. (BAND 2),** Loft S/D 12/6. "H", 30/-, 3 element, 22/6. External units available. Co-ax cable, 8d. yd. Co-ax. plugs, 1/3. Outlet boxes, 4/6. Diplexer Crossover Boxes 12/6. C.W.O. or C.O.D. P.P. 3/-. Send 6d. stamps for illustrated lists.

**K.V.A. ELECTRONICS (Dept. 2)**

3b, Godstone Road, Kenley, Surrey.  
**CRO 2527**