

THE No.1 MAGAZINE FOR ELECTRONICS TECHNOLOGY & COMPUTER PROJECTS

EVERYDAY

AUGUST 2000

**PRACTICAL**

# ELECTRONICS

INCORPORATING ELECTRONICS TODAY INTERNATIONAL

£2.65

## MOODLOOP

Surround yourself with 'mood waves'

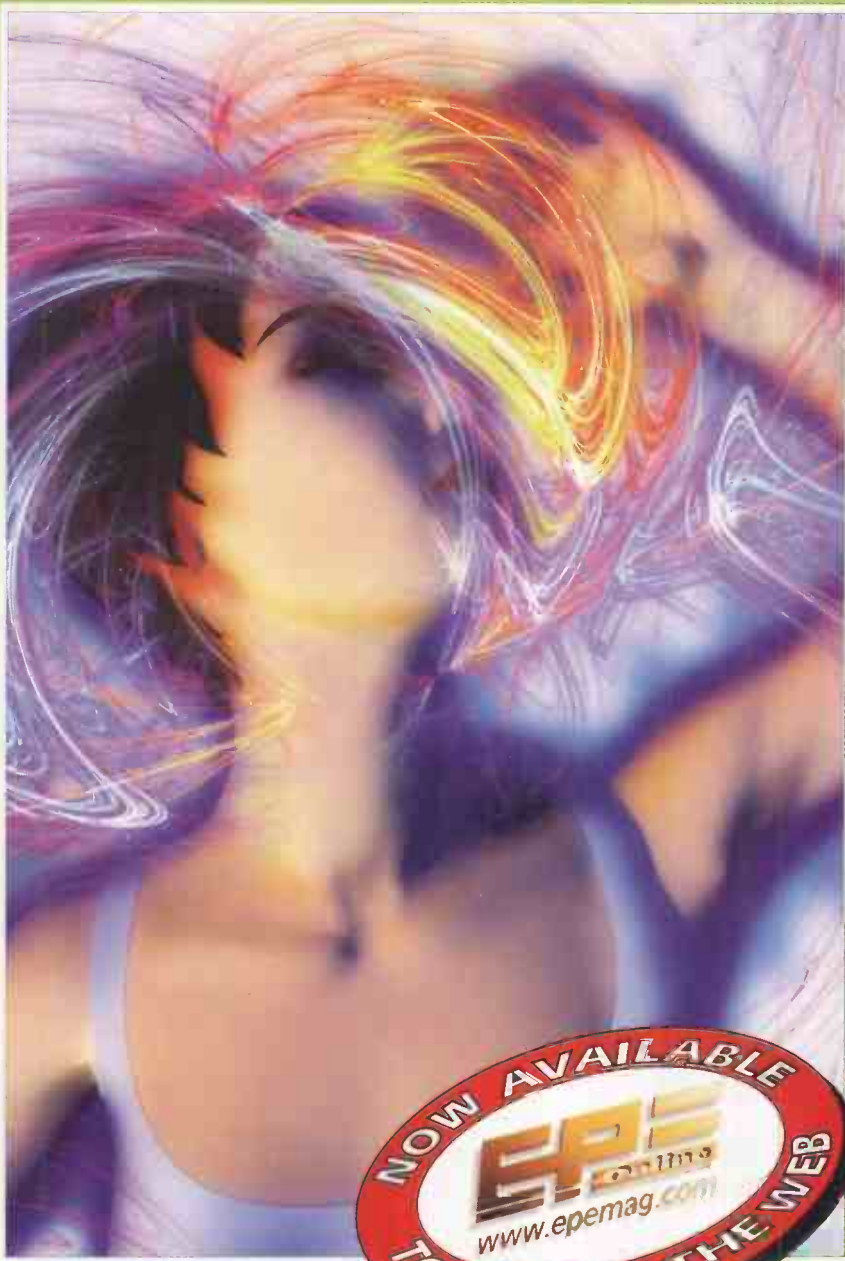

## HANDY-AMP

A multipurpose amplifier

Starter Project

## QUIZ GAME

Who pressed first?

PLUS

Ingenuity Unlimited • Interface  
Circuit Surgery • News  
New Technology Update



<http://www.epemag.wimborne.co.uk>

**12v 18Ah SEALED LEAD ACID BATTERIES, new and boxed, unused pack of 4 £39.95 ref CYC7 or £15 each ref CYC6**

**AUTOMATIC CHARGER** For the above batteries, charges 2 at once, charge level indicator circuitry, 6 hour charge. £10 ref CYC8

**A new range of 12v to 240v INVERTERS**  
**IV400S (400 watt) £89**  
**IV800S (800 watt) £159**  
**IV1200S (1200 watt) £219**

**ECG MACHINES 7/6v 10AH BATT/24V 8A TX** Ex government ECG machines! Measures 390x320x120mm, on the front are controls for scan speed, scan delay, scan mode, loads of connections on the rear including video out etc. On the front panel are two DIN sockets for connecting the body sensors to. Sensors not included, inside 2 x 6v 10Ah lead acid batts (1 in good condition), pcb's and a 8A/24v toroidal transformer (main in), sold as seen, may have one or two broken knobs etc due to poor storage. £15.99 ref VP2

**SODIUM LAMP SYSTEMS £75.70** Complete system with 250w or 400 watt SON-T Agro bulb, reflector with bulb holder and remote ballast and starter (uncased) all you need is wire. 250W system ref SLS1, 400W system SLS2.

**PC SUPPORT HANDBOOK** The ultimate technical guide to building and maintaining PC's. Over 460 A4 pages packed with technical data and diagrams just £10 ref PCBK. If you want 4 copies for £33 ref PCBK2. Also available is a CD packed with diagnostic programmes to use with the book £5 ref PCBK1

**D SIZE NICADS** Tagged, 1200mA, 1.2v pack of 4 for £6 ref CYC9 or as a pack of 24 for £22 ref CYC10

**D SIZE SEALED LEAD ACID BATTERIES**

2v 2.5Ah rechargeable sealed lead acid battery made by Cyclon. 60x45mm (standard D size) supplied as a pack of 12 or 20 giving you options for battery configurations eg 12v at 5ah, 24v at 2.5ah, 6v at 10ah. These batteries are particularly useful in that you can arrange them in your project to optimise space etc (eg boat ballast etc) Pack of 12 £10 ref CYC4, pack of 20 £16 ref CYC5

**HYDROPONICS DO YOU GROW YOUR OWN?** We have a full colour hydroponics catalogue available containing nutrients, pumps, fittings, environmental control, light fittings, plants, test equipment etc Ring for your free copy.

**PC COMBINED UPS AND PSU** The unit has a total power of 292 watts, standard mother board connectors and 12 peripheral power leads for drives etc. Inside is 3 12v 7.2Ah sealed lead acid batteries. Backup time is 8 mins at full load or 30 mins at half load. Made in the UK by Magnum, 110 or 240vac input, +5v at 35A, -5v at 5A, +12v at 9A, -12v at 5A outputs. 170x260x220mm, new and boxed. £29.95 Ref PCUPS2

**ALTERNATIVE ENERGY CD, PACKED WITH HUNDREDS OF ALTERNATIVE ENERGY RELATED ARTICLES, PLANS AND INFORMATION ETC £14.50 REF CD56**

**AERIAL PHOTOGRAPHY KIT** This rocket comes with a built in camera! It flies up to 500 feet (150 m) turns over, and takes an aerial photograph of the ground below. The rocket then returns with its film via its parachute. Takes 110 film. Supplied complete with everything including a launch pad and 3 motors (no film) £29.98 ref astro

**PROJECT BOXES** Another bargain for you are these smart ABS project boxes, smart two piece screw together case measuring approx 6"x5"x2" complete with panel mounted LED. Inside you will find loads of free bits, tape heads, motors, chips resistors, transistors etc. Pack of 20 £19.95 ref MD2

**TELEPHONES** Just in this week a huge delivery of telephones, all brand new and boxed. Two piece construction - illuminated keypad, tone or pulse (switchable), recall, redial and pause, high/low and off ringer switch and quality construction. Off white colour and is supplied with a standard international lead (same as US or modern) if you wish to have a BT lead supplied to convert the phones these are £1.55 each ref BTLX Phones £4.99 each ref PH210 off £30 ref SS2

**3HP MAINS MOTORS** Single phase 240v, brand new, 2 pole, 340x180mm, 2850 rpm, builtin automatic reset overload protector, keyed shaft (40x16mm) Made by Leeson. £99 each ref LEE1

**BUILD YOUR OWN WINDFARM FROM SCRAP** New publication gives step by step guide to building wind generators and propellers. Armed with this publication and a good local scrap yard could make you self sufficient in electricity! £12 ref LOTB1

**CHIEFTAN TANK DOUBLE LASERS 9 WATT + 3 WATT + LASER OPTICS** Could be adapted for laser listener, long range comms etc Double beam units designed to fit in the barrel of a tank, each unit has 2 semi conductor lasers and motor drive units for alignment, 7 mile range, no circuit diagrams due to MOD, new price £50,000? us? £199. Each unit has two gallium Arsenide injection lasers, 1 x 9 watt, 1 x 3 watt, 900nm wavelength, 28vdc, 600hz pulse freq. The units also contain a receiver to detect reflected signals from targets. £99 Ref LOT4.

**MAGNETIC CREDIT CARD READERS AND ENCODING MANUAL £9.95** Cased with flyleads, designed to read standard credit cards! complete with control electronics PCB and manual covering everything you could want to know about what's hidden in that magnetic strip on your card! just £9.95 ref BAR31

**SOLAR POWER LAB SPECIAL** 2x 6"x6" 6v 130mA cells, 4 LED's, wire, buzzer, switch + relay or motor. £7.99 REF SA27

**SOLAR NICAD CHARGERS** 4x AA size £9.99 ref 6P476, 2x C size £9.99 ref 6P477

**BRAND NEW MILITARY ISSUE DOSE METERS** Current NATO Issue Standard emergency services unit Used by most of the worlds Military personnel New and boxed Normal retail price £400, BULLS bargain price just £99 The PDRM B2 M is a portable, lightweight, water resistant gamma radiation survey meter to measure radiological dose rate in the range 0.1 to 300 centigrays per hour in air. The Geiger Muller (G.M.) tube detecting unit is energy and polar response corrected. The radiation level is displayed on a Liquid Crystal Display. The microcomputer corrects for the non-linearity of the G.M. tube response. The instrument is powered by three international C size batteries giving typically 400 hours operation in normal conditions. The dose rate meter PDRM B2M, designed and selected for the United Kingdom Government, has been fully evaluated to satisfy a wide range of environmental conditions and is nuclear hard. The construction enables the instrument to be easily decontaminated. The instrument is designed for radiation surveys for post incident monitoring. Used in a mobile role, either carried by troops or in military vehicles for rapid deployment enabling radiation hot spots to be quickly located. Range: 0 - 300 cGy/h in 0.1 cGy/h increments. Over-range to 1500 cGy/h - indicates flashing 300. Accuracy 20% of true dose rate +0.1 cGy/h, 0 - 100 cGy/h. 100% of true dose rate, 100 - 300 cGy/h. Energy Response 0.3 MeV to 3 MeV - within 20% (Ra 226). 80 KeV to 300 KeV - within 140% (Ra 226). Detector Energy compensated Halogen quenched Geiger Muller Tube. Controls Combined battery access and ON/OFF switch. Batteries 3 international standard C cells. Weight 560/65 gms. Operating Temperature Range -30deg C to +60 deg C. Indications High contrast 4 digit LCD. Battery low indication Dose rate Rising/Falling £99 ref PDRM.

**Hydrogen fuel cells** Our new Hydrogen fuel cells are 1v at up to 1A output, Hydrogen input, easily driven from a small electrolysis assembly or from a hydrogen source, our demo model uses a solar panel with the output leads in a glass of salt water to produce the hydrogen! Each cell is designed to be completely taken apart, put back together and expanded to what ever capacity you like, (up to 10 watts and 12v per assembly. Cells cost £49 ref HFC11

**PHILIPS VP406 LASER DISC PLAYERS, SCART OUTPUT, JUST PUT YOUR VIDEO DISK IN AND PRESS PLAY, STANDARD AUDIO AND VIDEO OUTPUTS, £14.95 REF VP406**

**SMOKE ALARMS** Mains powered, made by the famous Gent company, easy fit next to light fittings, power point. Pack of 5 £15 ref SS23, pack of 12 £24 ref SS24

**4AH D SIZE NICADS pack of 4 £10 ref 4AHPK**

**SENDER KIT** Contains all components to build a AVV transmitter complete with case £35 ref VSX02

**10 WATT SOLAR PANEL** Amorphous silicon panel fitted in a anodized aluminium frame. Panel measures 3' by 1' with screw terminals for easy connection. 3' x 1' solar panel £55 ref MAG45

**12V SOLAR POWERED WATER PUMP** Perfect for many 12v DC uses, from solar fountains to hydroponics! Small and compact yet powerful, works direct from our 10 watt solar panel in bright sun. Max hd: 17 ft Max flow = 8 Lpm, 1.5A Ref ACB £18.99

**SOLAR ENERGY BANK KIT 50x6"x12" 6v solar panels (amorphous)+50 diodes £99 ref EF112**

**PINHOLE CAMERA MODULE WITH AUDIO!** Superb board camera with on board sound! extra small just 28mm square (including microphone) ideal for covert surveillance. Can be hidden inside anything, even a matchbox! Complete with 15 metre cable, psu and tv/cv connectors. £49.95 ref CC6J

**SOLAR MOTORS** Tiny motors which run quite happily on voltages from 3-12vdc. Works on our 6v amorphous 6" panels and you can run them from the sun! 32mm dia 20mm thick £1.50 each

**WALKIE TALKIES 1 MILE RANGE £37 PAIR REF MAG30**

**LIQUID CRYSTAL DISPLAY Bargain prices, 40 character 1 line 154x16mm £6.00 ref SMC4011A**

**YOUR HOME COULD BE SELF SUFFICIENT IN ELECTRICITY** Comprehensive plans with loads of info on designing systems, panels, control electronics etc £7 ref PV1

**AUTO SUNCHARGER** 155x300mm solar panel with diode and 3 metre lead and cigar plug. 12v 2w. £12.99 REF AUG10P3.

**SOLAR POWER LAB SPECIAL** 2x 6"x6" 6v 130mA cells, 4 LED's, wire, buzzer, switch + relay or motor. £7.99 REF SA27

**SOLAR NICAD CHARGERS** 4 x AA size £9.99 ref 6P476, 2 x C size £9.99 ref 6P477

**MINATURE TOGGLE SWITCHES** These top quality Japanese panel mount toggle switches measure 35x13x12mm, are 2 pole changeover and will switch 1A at 250vac, or 3 A at 125vac. Complete with mounting washers and nuts. Supplied as a box of 100 switches for £29.95 ref. SWT35 or a bag of 15 for £4.99 ref SWT34

**VOICE CHANGERS** Hold one of these units over your phone mouth piece an you can adjust your voice using the controls on the unit! Battery operated £15 ref CC3

**BULL ELECTRICAL**

250 PORTLAND ROAD, HOVE, SUSSEX.  
BN3 5QT. (ESTABLISHED 50 YEARS).

MAIL ORDER TERMS: CASH, PO OR CHEQUE  
WITH ORDER PLUS £4.00 P&P PLUS VAT.

24 HOUR SERVICE £6.50 PLUS VAT.

OVERSEAS ORDERS AT COST PLUS £3.50  
(ACCESS, VISA, SWITCH, AMERICAN EXPRESS)

'phone orders : 01273 203500

FAX 01273 323077  
Sales@bull-electrical.com

**30 WATTS OF SOLAR POWER for just £69, 4 panels each one 3'x1' and producing 8w, 13v. PACK OF FOUR £69 ref SOLX**

**200 WATT INVERTERS** plugs straight into your car cigarette lighter socket and is fitted with a 13A socket so you can run your mains operated devices from your car battery. £49.95 ref S56

**THE TRUTH MACHINE** Tells if someone is lying by micro tremors in their voice, battery operated, works in general conversation and on the phone and TV as well! £42.49 ref TD3

**INFRARED FILM** 6" square piece of flexible infra red film that will only allow IR light through. Perfect for converting ordinary torches, lights, headlights etc to infra red output only using standard light bulbs. Easily cut to shape. 6" square £15 ref IRF2

**33 KILO LIFT MAGNET** Neodymium, 32mm diameter with a fixing bolt on the back for easy mounting. Each magnet will lift 33 kilos, 4 magnets bolted to a plate will lift an incredible 132 kilos! £15 ref MAG33 Pack of 4 just £39 ref MAG33AA

**HYDROGEN FUEL CELL PLANS** Loads of information on hydrogen storage and production. Practical plans to build a Hydrogen fuel cell (good workshop facilities required) £8 ref FCP1

**STIRLING ENGINE PLANS** Interesting information pack covering all aspects of Stirling engines, pictures of home made engines made from an aerosol can running on a candle! £12 ref STIR2

**ENERGY SAVER PLUGS** Saves up to 15% electricity when used with fridges, motors up to 2A, light bulbs, soldering irons etc. £9 ea ref LOT71, 10 pack £69 ref LOT72.

**12V OPERATED SMOKE BOMBS** Type 3 is a 12v trigger and 3 smoke cannisters, each cannister will fill a room in a very short space of time! £14.99 ref SB3. Type 2 is 20 smaller cannisters (suitable for mock equipment fires etc) and 1 trigger module for £29 ref SB2 Type 1 is a 12v trigger and 20 large cannisters £49 ref SB1

**HI POWER ZENON VARIABLE STROBES** Useful 12v PCB fitted with hi power strobe tube and control electronics and speed control potentiometer. Perfect for interesting projects etc 70x55mm 12vdc operation £6 ea ref FLS1, pack of 10 £49 ref FLS2

**NEW LASER POINTERS** 4.5mw, 75 metre range, hand held unit runs on two AA batteries (supplied) 670nm. £29 ref DECA9J

**HOW TO PRODUCE 35 BOTTLES OF WHISKY FROM A SACK OF POTATOES** Comprehensive 270 page book covers all aspects of spirit production from everyday materials. Includes construction details of simple stills. £12 ref MS3

**NEW HIGH POWER MINI BUG** With a range of up to 800 metres and a 3 days use from a PP3, this is our top selling bug! less than 1" square and a 10m voice pickup range. £28 Ref LOT102.

**IR LAMP KIT** Suitable for CCTV cameras, enables the camera to be used in total darkness! £6 ref EF138

**INFRA RED POWER BEAM** Handheld battery powered lamp, 4 inch reflector, gives out powerful pure infrared light! perfect for CCTV use, night sights etc. £29 ref PB1.

**SUPER WIDEBAND RADAR DETECTOR** Detects both radar and laser, X K and KA bands, speed cameras, and all known speed detection systems. 360 degree coverage, front & rear waveguides, 1.1"x2.7"x4.6" fits on visor or dash £149

**LOPTX** Made by Samsung for colour TV £3 each ref SS52

**LAPTOP LCD SCREENS** 240x175mm, £12 ref SS51

**WANT TO MAKE SOME MONEY? STUCK FOR AN IDEA?** We have collated 140 business manuals that give you information on setting up different businesses, you peruse these at your leisure using the text editor on your PC. Also included is the certificate enabling you to reproduce (and sell) the manuals as much as you like! £14 ref EP74

**ELECTRONIC SPEED CONTROLLER KIT** For the above motor is £19 ref MAG17. Save £5 if you buy them both together, 1 motor plus speed controller rrp is £24, offer price £36 ref MOT5A

**INFRARED REMOTE CONTROLS** made for TV's but may have other uses pack of 100 £39 ref IREM

**RCB UNITS** Inline IEC lead with fitted RC breaker. Installed in seconds. Pack of 3 £9.98 ref LOT5A

**On our web sites you can**

1. Order online.
2. Check your premium bonds.
3. Enter our auction or build your own.
4. Add E-commerce to your own site.
5. Discover our software site, optical site, hydroponics site, holiday home exchange site, inkjet site, hotels site.
6. View our web camera.
7. Invest in our future.

<http://www.bullnet.co.uk>

**YOUR HOME COULD BE SELF SUFFICIENT IN ELECTRICITY** Comprehensive plans with loads of info on designing systems, panels, control electronics etc £7 ref PV1

**AUTO SUNCHARGER** 155x300mm solar panel with diode and 3 metre lead and cigar plug. 12v 2w £12.99 REF AUG10P3

**STEPPER MOTORS** Brand new stepper motors, 4mm fixing holes with 47.14mm fixing centres, 20mm shaft, 6.35mm diameter, 5v/phase, 0.7A/phase, 1.8 deg step (200 step) Body 56x36mm. £14.99 ea ref STEP6, pack of 4 for £49.95. PIC based variable speed controller kit £15 ref STEP7

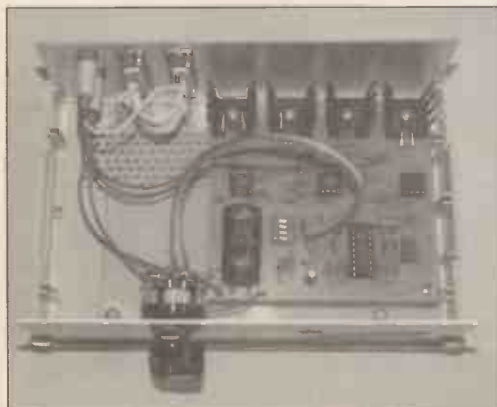
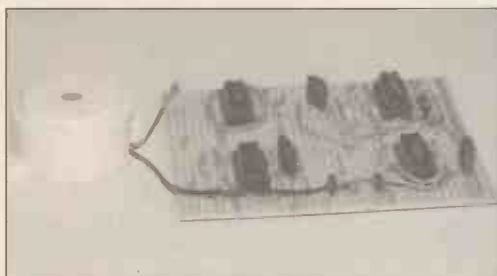

© Wimborne Publishing Ltd 2000. Copyright in all drawings, photographs and articles published in EVERYDAY PRACTICAL ELECTRONICS is fully protected, and reproduction or imitations in whole or in part are expressly forbidden.

## Projects and Circuits

- HANDY-AMP** by Terry de Vaux-Balbirnie **572**  
 A simple multi-purpose amp with built-in speaker and headphone output
- INGENUITY UNLIMITED** hosted by Alan Winstanley **582**  
 Cool Controller; VOM Continuity Buzzer; Square Wave Circuit
- QUIZ GAME INDICATOR** by Max Horsey and Tom Webb **598**  
 A low-cost fun project that cannot be questioned
- EPE MOODLOOP** by Andy Flind **602**  
 Have a relaxing "field-day" (or night) with Andy's latest mood modifier!
- DOOR PROTECTOR** by Owen Bishop **624**  
 The first in a series of "Top-Tenner" projects, featuring simple designs that can be built for around £10

## Series and Features

- NEW TECHNOLOGY UPDATE** by Ian Poole **580**  
 Atom-sized electronic devices are being developed
- TEACH-IN 2000 - 10. Transformers and Rectifiers** by John Becker **584**  
 Essential info for the electronics novice, with breadboard experiments and interactive computer simulations.
- NET WORK - THE INTERNET PAGE** surfed by Alan Winstanley **592**  
 BT's *Surftime*, Unix Permissions
- CAVE ELECTRONICS** by Mike Bedford **610**  
 How electronics assists (and electro-lights) explorers of the troglodyte underworld!
- CIRCUIT SURGERY** by Alan Winstanley and Ian Bell **617**  
 Get wise about Piecewise and Lambda
- INTERFACE** by Robert Penfold **630**  
 Four-Range Resistance Meter PC Interface

## Regulars and Services

- EDITORIAL** **571**
- NEWS** - Barry Fox highlights technology's leading edge **578**  
 Plus everyday news from the world of electronics
- ELECTRONICS VIDEOS** Our range of educational videos **594**
- BACK ISSUES** Did you miss these? Now available on CD-ROM **595**
- CD-ROMS FOR ELECTRONICS** **620**  
 Filters; Digital Works 3.0; Parts Gallery + Electronic Circuits and Components; Digital Electronics; Analogue Electronics; PICTutor; Modular Circuit Design; Electronic Components Photos.
- READOUT** John Becker addresses general points arising **622**
- SHOPTALK** with David Barrington **627**  
 The *essential* guide to component buying for *EPE* projects
- ELECTRONICS MANUALS** **628**  
 Essential reference works for hobbyists, students and service engineers.
- DIRECT BOOK SERVICE** **634**  
 A wide range of technical books available by mail order, plus more CD-ROMs
- PRINTED CIRCUIT BOARD AND SOFTWARE SERVICE** **637**  
 PCBs for *EPE* projects. Plus *EPE* software
- ADVERTISERS INDEX** **640**

Visit our website  
www.distel.co.uk

# THE ORIGINAL SURPLUS WONDERLAND!

THIS MONTH'S SELECTION FROM OUR VAST EVER CHANGING STOCKS

Surplus always  
wanted for cash!

## THE AMAZING TELEBOX

Converts your colour monitor into a QUALITY COLOUR TV!!



TV SOUND &  
VIDEO TUNER  
CABLE COMPATIBLE\*

The TELEBOX is an attractive fully cased mains powered unit, containing all electronics ready to plug into a host of video monitors or AV equipment which are fitted with a composite video or SCART input. The composite video output will also plug directly into most video recorders, allowing reception of TV channels not normally receivable on most television receivers (TELEBOX MB). Push button controls on the front panel allow reception of 8 fully tuneable 'off air' UHF colour television channels. TELEBOX MB covers virtually all television frequencies VHF and UHF including the HYPERBAND as used by most cable TV operators. Ideal for desktop computer video systems & PIP (picture in picture) setups. For complete compatibility - even for monitors without sound - an integral 4 watt audio amplifier and low level Hi Fi audio output are provided as standard. Brand new - fully guaranteed.

TELEBOX ST for composite video input type monitors £36.95  
TELEBOX STL as ST but fitted with integral speaker £39.50  
TELEBOX MB Multiband VHF/UHF/Cable/Hyperband tuner £69.95  
For overseas PAL versions state 5.5 or 6 mHz band specification.  
\*For cable/hyperband signal reception Telebox MB should be connected to a cable type service. Shipping on all Telebox's, code (B)

**NEW** State of the art PAL (UK spec) UHF TV tuner module with composite TV pp video and NICAM hi fi stereo sound outputs. Micro electronics all on one small PCB only 73 x 160 x 52 mm enable full tuning control via a simple 3 wire link to an IBM pc type computer. Supplied complete with simple working program and documentation. Requires +12V & +5V DC to operate. **BRAND NEW - Order as MY00. Only £49.95 code (B)**  
See [www.distel.co.uk/data\\_my00.htm](http://www.distel.co.uk/data_my00.htm) for picture & full details

## FLOPPY DISK DRIVES 2 1/2" - 8"

All units (unless stated) are **BRAND NEW** or removed from often brand new equipment and are fully tested, aligned and shipped to you with a full 90 day guarantee. Call or see our web site [www.distel.co.uk](http://www.distel.co.uk) for over 2000 unlisted drives for spares or repair.

- 3 1/2" Mitsubishi MF355C-L 1.4 Meg. Laptops only £25.95(B)
- 3 1/2" Mitsubishi MF355C-D 1.4 Meg. Non laptop £18.95(B)
- 5 1/4" Teac FD-55FR 1.2 Meg (for IBM pc's) RFE £18.95(B)
- 5 1/4" Teac FD-55F-03-U 720K 40/80 (for BBC's etc) RFE £29.95(B)
- 5 1/4" BRAND NEW Mitsubishi MF501B 360K £22.95(B)
- Table top case with integral PSU for HH 5 1/4" Floppy / HD £29.95(B)
- 8" Shugart 800/801 8" SS refurbished & tested £210.00(E)
- 8" Shugart 810 8" SS HH Brand New £195.00(E)
- 8" Shugart 851 8" double sided refurbished & tested £260.00(E)
- 8" Mitsubishi M2894-63 double sided NEW £295.00(E)
- 8" Mitsubishi M2896-63-02U DS slimline NEW £295.00(E)
- Dual 8" casad drives with integral power supply 2 Mb £499.00(E)

## HARD DISK DRIVES 2 1/2" - 14"

- 2 1/2" TOSHIBA MK1002MAV 1.1Gb laptop(12.5 mm H) New £79.95
  - 2 1/2" TOSHIBA MK2101MAN 2.16 Gb laptop (19 mm H) New £89.50
  - 2 1/2" TOSHIBA MK4309MAT 4.3Gb laptop (8.2 mm H) New £105.00
  - 2 1/2" TOSHIBA MK6409MAV 6.1Gb laptop (12.7 mm H) New £190.00
  - 2 1/2" to 3 1/2" conversion kit for PC's, complete with connectors £14.95
  - 3 1/2" FUJI FK-309-26 20mb MFM I/F RFE £59.95
  - 3 1/2" CONNER CP3024 20 mb IDE I/F (or equiv.) RFE £59.95
  - 3 1/2" CONNER CP3044 40 mb IDE I/F (or equiv.) RFE £69.00
  - 3 1/2" QUANTUM 40S Prodril ve 42mb SCSI I/F, New RFE £49.00
  - 5 1/4" MINISCRIBE 3425 20mb MFM I/F (or equiv.) RFE £49.95
  - 5 1/4" SEAGATE ST-238R 30 mb RLL I/F Refurb £69.95
  - 5 1/4" CDC 94205-51 40mb HH MFM I/F RFE tested £69.95
  - 5 1/4" HP 97548 850 Mb SCSI RFE tested £99.00
  - 5 1/4" HP C3010 2 Gbyte SCSI differential RFE tested £195.00
  - 8" NEC D2246 85 Mb SMD interface, New £199.00
  - 8" FUJITSU M2322K 160Mb SMD I/F RFE tested £195.00
  - 8" FUJITSU M2392K 2 Gb SMD I/F RFE tested £345.00
- Many other drives in stock - Shipping on all drives is code (C1)

## IC's - TRANSISTORS - DIODES

OBSELETE - SHORT SUPPLY - BULK  
10,000,000 items EX STOCK  
For MAJOR SAVINGS  
CALL OR SEE OUR WEB SITE [www.distel.co.uk](http://www.distel.co.uk)  
VIDEO MONITOR SPECIALS

One of the highest specification  
monitors you will ever see -  
At this price - Don't miss it!!

Mitsubishi FA3415ETKL 14" SVGA Multisync colour monitor with fine 0.28 dot pitch tube and resolution of 1024 x 768. A variety of inputs allows connection to a host of computers including IBM PC's in CGA, EGA, VGA & SVGA modes, BBC, COMMODORE (including Amiga 1200), ARCHIMEDES and APPLE. Main features: Etched faceplate, text switching and LOW RADIATION MPF specification. Fully guaranteed, in EXCELLENT condition.

used condition, £119 (E) Order as MITS-SVGA  
Tilt & Swivel Base £4.75  
VGA cable for IBM PC included.  
External cables for other types of computers available - CALL

Ex demo 17" 0.28 SVGA Mitsubishi Diamond Pro monitors, Full multisync etc.  
Full 90 day guarantee. Only £199.00 (E)

Just in - Microvitec 20" VGA (800 x 600 res.) colour monitors.  
Good SH condition - from £299 - CALL for info

PHILIPS HCS35 (same style as CM8833) attractively styled 14" colour monitor with both RGB and standard composite 15.625 KHz video inputs via SCART socket and separate phono jacks. Integral audio power amp and speaker for all audio visual uses. Will connect direct to Amiga and Atari BBC computers. Ideal for all video monitoring / security applications with direct connection to most colour cameras. High quality with many features such as front concealed flap controls, VCR correction button etc. Good used condition - fully tested - guaranteed  
Dimensions: W14" x H12 1/4" x 15 1/2" D. Only £99.00 (E)

PHILIPS HCS31 Ultra compact 9" colour video monitor with standard composite 15.625 KHz video input via SCART socket. Ideal for all monitoring / security applications. High quality, ex-equipment fully tested & guaranteed (possible minor screen bums). In attractive square black plastic case measuring W10" x H10" x 1 3/4" D. 240 V AC mains powered. Only £79.00 (D)

KME 10" 15M10009 high definition colour monitors with 0.28" dot pitch. Superb clarity and modern styling. Operates from any 15.625 kHz sync RGB video source, with RGB analog and composite sync such as Atari, Commodore Amiga, Acorn Archimedes & BBC. Measures only 13 1/2" x 12" x 1 1/2". Good used condition. Only £125 (E)

## 20" 22" and 26" AV SPECIALS

Superbly made UK manufacture. PIL all solid state colour monitors, complete with composite video & optional sound input. Attractive teak style case. Perfect for Schools, Shops, Disco, Clubs, etc. In EXCELLENT little used condition with full 90 day guarantee.

20"....£135 22"....£155 26"....£185 (F)

We probably have the largest range of video monitors in Europe. All sizes and types from 4" to 42" call for info.

## DC POWER SUPPLIES

Virtually every type of power supply you can imagine. Over 10,000 Power Supplies Ex Stock  
Call or see our web site.

## TEST EQUIPMENT & SPECIAL INTEREST ITEMS

- MITS. FA3445ETKL 14" Industrial spec SVGA monitors £245
- FARNELL 0-50V DC @ 50 Amps, bench Power Supplies £995
- FARNELL AP3080 0-30V DC @ 80 Amps, bench Supply £1850
- 1kW to 400 kW - 400 Hz 3 phase power sources - ax stock EPOA
- IBM 8230 Type 1, Token ring base unit driver £760
- Wayne Kerr RA200 Audio frequency response analyser £2500
- IBM 53F5501 Token Ring ICS 20 port lobe modules £750
- IBM MAU Token ring distribution panel B228-23-5050N £95
- AIM 501 Low distortion Oscillator 9Hz to 330KHz, IEEE £550
- ALLGON 8360, 11805-1880 MHz hybrid power combiners £250
- Trend DSA 274 Data Analyser with G703(2M) 64 vo EPOA
- Marconi 6310 Programmable 2 to 22 GHz sweep generator £6500
- Marconi 2022C 10KHz-1GHz RF signal generator £1550
- Marconi 2030 opt 03 10KHz-1.3 GHz signal generator, New £4995
- HP1650B Logic Analyser £3750
- HP3781A Pattern generator & HP3782A Error Detector EPOA
- HP6621A Dual Programmable GPIB PSU 0-7 V 160 watts £1800
- HP6264 Rack mount variable 0-20V @ 20A metered PSU EPOA
- HP54121A DC to 22 GHz four channel test set EPOA
- HP8130A opt 020 300 MHz pulse generator, GPIB etc £7900
- HP A1, A0 8 pen HPGL high speed drum plotters - from HP DRAFTMASTER 1 8 pen high speed plotter £550
- EG+G Brookdeal 95035C Precision lock in amp £750
- Veng Eng. Mod 1200 computerised inspection system EPOA
- Sony DXC-3000A High quality CCD colour TV camera £900
- Kaithley 590 CV capacitor / voltage analyser EPOA
- Rental ICR40 dual 4 channel video recorder system £3750
- Fiskers 45KVA 3 ph On Line UPS - New Batteries £9500
- Emerson AP130 2.5KVA industrial spec, UPS £2100
- Mann Tally MT645 High speed line printer £2200
- Intel SBC 486/133SE Multibus 486 system, 8Mb Ram £945
- Siemens K4400 64Kb to 140Mb demux analyser £2950

- HP6030A 0-200V DC @ 17 Amps bench power supply £1950
- Intel SBC 486/125C08 Enhanced Multibus (MSA) New £1150
- Nikon HF-X-11 (Ephiphot) exposure control unit £1450
- PHILIPS PM5518 pro. TV signal generator £1250
- Motorola VME Bus Boards & Components List. SAE / CALL EPOA
- Trio D-18 vdc linear, metered 30 amp bench PSU, New £550
- Fujitsu M3041R 600 LPM high speed band printer £1950
- Fujitsu M3041D 600 LPM printer with network interface £1250
- Perkin Elmer 299B Infrared spectrophotometer £500
- Perkin Elmer 597 Infrared spectrophotometer £3500
- VG Electronics 1035 TELETEXT Decoding Margin Meter £3250
- LightBand 60 output high spec 2u rack mount Video VDA's £495
- Sekonic SD 150H 18 channel digital Hybrid chart recorder £1995
- B&K 2633 Microphone pre amp £300
- Taylor Hobson Tallysur amplifier / recorder £750
- ADC S5200 Carbon dioxide gas detector / monitor £1450
- BBC AM203 PPM Meter (Ernest Turner) + drive electronics £1750
- ANRITSU 9654A Optical DC-2.5Gb/waveform monitor EPOA
- ANRITSU MS9001B1 0.6-1.7 uM optical spectrum analyser £5650
- ANRITSU ML93A optical power meter £990
- ANRITSU Fibre optic characteristic test set EPOA
- R&S FTD2 Dual sound unit £650
- R&S SBUF-E1 Vision modulator £775
- WILTRON 6630B 12.4 / 20GHz RF sweep generator £2750
- TEK 2445 150 MHz 4 trace oscilloscope £1550
- TEK 2465 300 MHz 300 MHz oscilloscope rack mount £1995
- TEK TD5380 400MHz digital realtime + disk drive, FFT etc £2900
- TEK TD5524A 500MHz digital realtime + colour display etc £5100
- HP3585A Opt 907 20Hz to 40 MHz spectrum analyser £3950
- PHILIPS PW1730 10 60KV XRAY generator & accessories EPOA
- CLAUDE LYONS 12A 240V single phase auto. volt. regs £325
- CLAUDE LYONS 100A 240/415V 3 phase auto. volt. regs £2900

## 19" RACK CABINETS

Superb quality 6 foot 40U  
Virtually New, Ultra Smart  
Less than Half Price!



Top quality 19" rack cabinets made in UK by Optima Enclosures Ltd. Units feature designer, smoked acrylic lockable front door, full height lockable half louvered back door and louvered removable side panels. Fully adjustable internal fixing struts, ready punched for any configuration of equipment mounting, plus ready mounted integral 12 way 13 amp socket switched mains distribution strip make these racks some of the most versatile we have ever sold. Racks may be stacked side by side and therefore require only two side panels to stand singly or in multiple bays. Overall dimensions are: 77 1/2" H x 32 1/2" D x 22" W. Order as:

OPT Rack 1 Complete with removable side panels. £345.00 (G)  
OPT Rack 2 Rack, Less side panels £245.00 (G)

Over 1000 racks, shelves, accessories  
19" 22" & 24" wide 3 to 46 U high.  
Available from stock !!

## 32U - High Quality - All steel RakCab

Made by Eurocraft Enclosures Ltd to the highest possible spec, rack features all steel construction with removable side, front and back doors. Front and back doors are hinged for easy access and all are lockable with five secure 5 lever barrel locks. The front door is constructed of double walled steel with a 'designer style' smoked acrylic front panel to enable status indicators to be seen through the panel, yet remain unobtrusive. Internally the rack features fully slotted reinforced vertical fixing members to take the heaviest of 19" rack equipment. The two movable vertical fixing struts (extras available) are pre-punched for standard 'cage nuts'. A mains distribution panel internally mounted to the bottom rear, provides 8 x IEC 3 pin Euro sockets and 1 x 13 amp 3 pin switched utility socket. Overall ventilation is provided by fully louvered back door and double skinned top section with top and side louvers. The top panel may be removed for fitting of integral fans to the sub plate etc. Other features include: fitted castors and floor levelers, pre-punched utility panel at lower rear for cable / connector access etc. Supplied in excellent, slightly used condition with keys. Colour Royal blue. External dimensions mm=1625H x 635D x 603 W. (64" H x 25" D x 23 3/4" W)



Sold at LESS than a third of makers price !!

A superb buy at only £245.00 (G)

42U version of the above only £345 - CALL

## 12V BATTERY SCOOP - 60% off !!

A special bulk purchase from a cancelled export order brings you the most amazing savings on these ultra high spec 12v DC 14 Ah rechargeable batteries. Made by Hawker Energy Ltd, type SB515 featuring pure lead plates which offer a far superior shelf & guaranteed 15 year service life. Fully BT & BS6290 approved. Supplied BRAND NEW and boxed. Dimensions 200 mm wide, 137 mm high, 77 deep. M6 bolt terminals. Fully guaranteed. Current makers price over £70 each. **Our Price £35 each (C) or 4 for £99 (E)**

## RELAYS - 200,000 FROM STOCK

Save £££'s by choosing your next relay from our Massive Stocks covering types such as Military, Actrol, Cradle, Hermetically Sealed, Continental, Contactors, Time Delay, Reed, Mercury Wetted, Solid State, Printed Circuit Mounting etc. CALL or see our web site [www.distel.co.uk](http://www.distel.co.uk) for more information. Many obsolete types from stock. Save £££'s

## COLOUR CCD CAMERAS

BIG £ SAVER

Undoubtedly a miracle of modern technology & our special buying power! A quality product featuring a fully cased COLOUR CCD camera at a give away price! Unit features full autolight sensing for use in low light & high light applications. A 10 mm fixed focus wide angle lens gives excellent focus and resolution from close up to long range. The composite video output will connect to any composite monitor or TV (via SCART socket) and most video recorders. Unit runs from 12V DC so ideal for security & portable applications where mains power not available.

Overall dimensions 66 mm wide x 117 deep x 43 high. Supplied BRAND NEW & fully guaranteed with user data, 100's of applications including Security, Home Video, Web TV, Web Cams etc, etc.

Web ref = LK33

ONLY £99.00 or 2 for £180.00 (E)

## SOFTWARE SPECIALS

NT4 WorkStation, complete with service pack 3 and licence - OEM packaged. ONLY £89.00 (E)  
ENCARTA 95 - CDROM, Not the latest - but at this price! £7.95  
DOS 5.0 on 3 1/2" disks with concise books c/w OBasic £14.95  
Windows for Workgroups 3.11 + Dos 6.22 on 3 1/2" disks £55.00  
Wordperfect 6 for DOS supplied on 3 1/2" disks with manual £24.95  
shipping charges for software is code B

**DISTEL on the web !! - Over 16,000,000 items from stock - [www.distel.co.uk](http://www.distel.co.uk)**

Display  
ELECTRONICS

ALL MAIL TO  
Dept PE, 29/35 Osborne Rd  
Thornton Heath  
Surrey CR7 8PD  
Open Mon - Fri 9.00 - 5.30

LONDON SHOP  
Open Mon - Sat 9.00 - 5.30  
215 Whitehorse Lane  
South Norwood  
On 6A Bus Route  
N: Thornton Heath &  
S: Selhurst Park SR Rail Stations

DISTEL ©  
Visit our web site  
[www.distel.co.uk](http://www.distel.co.uk)  
email = admin@distel.co.uk

ALL ENQUIRIES  
0208 653 3333  
FAX 0208 653 8888

All prices for UK Mainland. UK customers add 17.5% VAT to TOTAL order amount. Minimum order £10. Bona Fide account orders accepted from Government, Schools, Universities and Local Authorities - minimum account order £50. Cheques over £100 are subject to 10 working days clearance. Carriage charges (A)=£3.00, (A1)=£4.00, (B)=£5.50, (C)=£8.50, (C1)=£12.50, (D)=£15.00, (E)=£18.00, (F)=£20.00, (G)=CALL. Allow approx 6 days for shipping - faster CALL. All goods supplied to our Standard Conditions of Sale and unless stated guaranteed for 90 days. All guarantees on a return to base basis. All rights reserved to change prices / specifications without prior notice. Orders subject to stock. Discounts for volume. Top CASH prices paid for surplus goods. All trademarks, tradenames etc acknowledged © Display Electronics 1999. E & O E. 0799.

# NEXT MONTH

## ACTIVE FERRITE LOOP AERIAL

Whether you're a serious medium wave listener or just an inveterate band browser, this compact loop will be an aid to better reception.

The need to rotate the aerial in a horizontal plane to optimise reception is evident to every owner of a transistor portable radio. What is not so widely appreciated is the need to tilt it in the vertical if the deepest possible nulls are to be obtained.

Medium frequency radio waves reach the receiver by line-of-sight (direct waves), travel to it around the curvature of the earth (surface waves), and, at night, are reflected down from the ionosphere (sky waves). The loop must, therefore, tilt as well as turn in order to point its axis precisely at the advancing wave front.

This design provides the necessary mechanical orientation, a varicap tuning stage plus MOSFET Q multiplication and impedance matching.

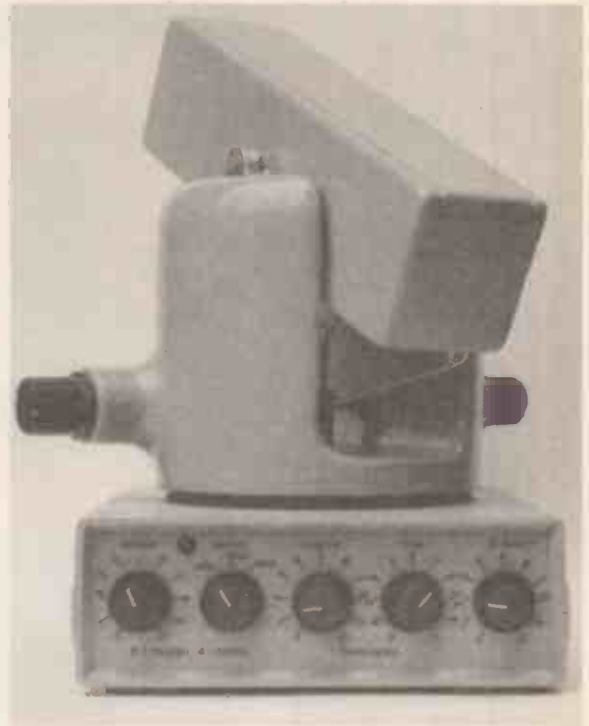

Top  
Tanner

## STEEPLECHASE GAME

This game can be played by one person just for fun, but also makes a great game for two or more opponents.

At first glance, this is a very simple game. There is a row of seven l.e.d.s, all of them red except for the one on the right, which is green. A timer drives a counter that turns on the l.e.d.s one at a time, starting from the left, in order.

The travelling display represents a horse approaching a jump, which is the green l.e.d. If the player presses a button at the exact moment when the green l.e.d. is lit, this counts as perfect timing and a "clear jump" is scored. There is an eighth l.e.d. close to the button to indicate when this happens. However, there is no time to gloat over a successful jump because the horse is already pounding toward the next fence.

Now comes the catch! There is an element of uncertainty that taxes the skill of the player. Like most horses, the steeplechaser may accelerate or hang back as it approaches and takes the jump.

## MOODLOOP POWER SUPPLY

Basically designed to power the EPE Moodloop published in August 2000, this mains operated power supply delivers 13.2V d.c. at up to 1A. Its simplicity of design and construction also make it suitable for use as a general purpose workshop unit. It can be readily modified to alternatively supply 12V d.c. at 1A. In the text there is an informative discussion of the problems which face designers of higher current power supplies and how this particular author overcame them, with particular attention to minimising excessive heat generation.

**PLUS: ALL THE REGULAR FEATURES**

**NO ONE DOES IT BETTER**

EVERYDAY  
**PRACTICAL**  
**ELECTRONICS**  
INCORPORATING ELECTRONICS TODAY INTERNATIONAL

**DON'T MISS AN  
ISSUE - PLACE YOUR  
ORDER NOW!**  
Demand is bound to be high

**SEPTEMBER ISSUE ON SALE FRIDAY, AUGUST 4**

# QUASAR ELECTRONICS

Established 1990

Unit 14 Sunningdale, BISHOPS STORTFORD, Herts, CM23 2PA

TEL: 01279 306504 FAX: 0870 7064222



ADD £2.00 P&P to all orders (or 1st Class Recorded £4, Next day (Insured £250) £7, Europe £4.00, Rest of World £6.00). We accept all major credit cards. Make cheques/PO's payable to Quasar Electronics. Prices include 17.5% VAT. MAIL ORDER ONLY. FREE CATALOGUE with order or send 2 x 1st class stamps (refundable) for details of over 150 kits & publications

## PROJECT KITS

OUR PROJECT KITS COME COMPLETE WITH ALL COMPONENTS, HIGH QUALITY PCBs, DETAILED ASSEMBLY/OPERATING INSTRUCTIONS

- **2 x 25W CAR BOOSTER AMPLIFIER** Connects to the output of an existing car stereo cassette player, CD player or radio. Heatsinks provided. PCB 76x75mm. 1046KT £24.95
- **3-CHANNEL WIRELESS LIGHT MODULATOR** No electrical connection with amplifier. Light modulation achieved via a sensitive electrical microphone. Separate sensitivity control per channel. Power handling 400W/channel. PCB 54x112mm. Mains powered. Box provided. 6014KT £24.90
- **12 RUNNING LIGHT EFFECT** Exciting 12 LED light effect ideal for parties, discos, shop-windows & eye-catching signs. PCB design allows replacement of LEDs with 220V bulbs by inserting 3 TRIACS. Adjustable rotation speed & direction. PCB 54x112mm. 1026KT £16.95; BOX (for mains operation) 2026KT £8.50
- **DISCO STROBE LIGHT** Probably the most exciting of all light effects. Very bright strobe tube. Adjustable strobe frequency: 1-60Hz. Mains powered. PCB: 60x68mm. Box provided. 6037KT £29.90
- **ANIMAL SOUNDS** Cat, dog, chicken & cow. Ideal for kids farmyard toys & schools. SG10M £5.50
- **3 1/2 DIGIT LED PANEL METER** Use for basic voltage/current displays or customise to measure temperature, light, weight, movement, sound levels, etc. with appropriate sensors (not supplied). Various input circuit designs provided. 3061KT £12.95
- **IR REMOTE TOGGLE SWITCH** Use any TV/VCR remote control unit to switch onboard 12V/1A relay on/off. 3058KT £9.95
- **SPEED CONTROLLER** for any common DC motor up to 100W/5A. Pulse width modulation gives maximum torque at all speeds. 5-15VDC. Box provided. 3067KT £14.95
- **3 x 8 CHANNEL IR RELAY BOARD** Control eight 12V/1A relays by Infra Red (IR) remote control over a 20m range in sunlight. 6 relays turn on only, the other 2 toggle on/off. 3 operation ranges determined by jumpers. Transmitter case & all components provided. Receiver PCB 76x89mm. 3072KT £44.95

## PRODUCT FEATURE

### P16PRO PIC PROGRAMMER

Our best selling PIC programmer for all 8, 18, 28 & 40-pin serial programmed PICs. Connects to PC parallel port. Will program, verify, read and erase. Designed to work with P16PRO DOS or Windows software that is supplied on a shareware basis. Power supply 16-30V DC/12-20V AC. ORDERING INFO: Kit 3096KT - £14.95; Assembled AS3096 - £24.95; Assembled with ZIF socket £39.95. OPTIONAL EXTRAS: DOS software registration £14.95; Windows software registration £21.95; 40-pin wide ZIF socket £15.95; Power supply £5.95; lead £4.95.

- **SOUND EFFECTS GENERATOR** Easy to build. Create an almost infinite variety of interesting/unusual sound effects from birds chirping to sirens. 9VDC. PCB 54x85mm. 1045KT £8.95
- **ROBOT VOICE EFFECT** Make your voice sound similar to a robot or Darlek. Great fun for discos, school plays, theatre productions, radio stations & playing jokes on your friends when answering the phone! PCB 42x71mm. 1131KT £8.95
- **AUDIO TO LIGHT MODULATOR** Controls intensity of one or more lights in response to an audio input. Safe, modern opto-coupler design. Mains voltage experience required. 3012KT £7.95
- **MUSIC BOX** Activated by light. Plays 8 Christmas songs and 5 other tunes. 3104KT £6.95
- **20 SECOND VOICE RECORDER** Uses non-volatile memory - no battery backup needed. Record/replay messages over & over. Playback as required to greet customers etc. Volume control & built-in mic. 6VDC. PCB 50x73mm. 3131KT £11.95
- **TRAIN SOUNDS** 4 selectable sounds & whistle blowing. Level crossing bell, 'clackety-clack' & 4 in sequence. SG01M £5.95
- **PC CONTROLLED RELAY BOARD** Convert any 286 upward PC into a dedicated automatic controller to independently turn on/off up to eight lights, motors & other devices around the home, office, laboratory or factory using 8 240VAC/10A onboard relays. DOS utilities, sample test program, full-featured Windows utility & all components (except cable) provided. 12VDC. PCB 70x200mm. 3074KT £29.95
- **2 CHANNEL UHF RELAY SWITCH** Contains the same transmitter/receiver pair as 30A15 plus the components and PCB to control two 240VAC/10A relays (also supplied). Ultra bright LEDs used to indicate relay status. 3082KT £27.95
- **TRANSMITTER RECEIVER PAIR** 2-button keyfob style 300-375MHz Tx with 30m range. Receiver encoder module with matched decoder IC. Components must be built into a circuit like kit 3092 above. 30A15 £13.95
- **PC DATA ACQUISITION/CONTROL UNIT** Use your PC to monitor physical variables (e.g. pressure, temperature, light, weight, switch state, movement, relays, etc.), process the information & use results to control physical devices like motors, sirens, relays, servo & stepper motors. Inputs: 16 digital & 11 analogue. Outputs: 8 digital & 1 analogue. Plastic case with printed front/rear panels, software utilities, programming examples & all components (except sensors & cable) provided. 12VDC. 3093KT £89.95
- **PIC 16C71 FOUR SERVO MOTOR DRIVER** Simultaneously control up to 4 servo motors. Software & all components (except servo/control pots) supplied. 5VDC. PCB 56x70mm. 3102KT £14.95
- **PC SERIAL PORT ISOLATED I/O BOARD** Provides eight 240VAC/10A relay outputs & 4 optically isolated inputs. Designed for use in various control & sensing applications (e.g. load switching, external switch input sensing, contact closure & external voltage sensing). Controlled via serial port & a terminal emulator program (built into Windows). Can be used with ANY computer/operating system. Plastic case with printed front/rear panels & all components (except cable) provided. 3108KT £49.95
- **UNIPOLAR STEPPER MOTOR DRIVER** for any 5/6/8 lead motor. Fast/slow & single step rates. Direction control & on/off switch. Wave, 2-phase & half-wave step modes. 4 LED indicators. PCB 50x65mm. 3109KT £14.95
- **PC CONTROLLED STEPPER MOTOR DRIVER** Control two unipolar stepper motors (3A max. each) via PC printer port. Wave, 2-phase & half-wave step modes. Software accepts 4 digital inputs from external switches & 4 single step motors. PCB fits in D-shell case provided. 3113KT £17.95
- **12-BIT PC DATA ACQUISITION/CONTROL UNIT** Similar to kit 3093 above but uses a 12 bit Analogue-to-Digital Converter (ADC) with internal analogue multiplexer. Reads 8 single ended channels or 4 differential inputs or a mixture of both. Analogue inputs read 0-4V. Four TTL/CMOS compatible digital input/outputs. ADC conversion time <10µs. Software (C, C++ & Win), extended D shell case & all components (except sensors & cable) provided. 3118KT £49.95

## X-FACTOR PUBLICATIONS

THE EXPERTS IN RARE & UNUSUAL INFORMATION!

Full details of all X-FACTOR PUBLICATIONS can be found in our catalogue. N.B. Minimum order charge for reports and plans is £5.00 PLUS normal P&P

- **SUPER-EAR LISTENING DEVICE** Complete plans to build your own parabolic dish microphone. Listen to distant voices and sounds through open windows and even walls! Made from readily available parts. R002 £3.50
- **TELEPHONE BUG PLANS** Build your own micro-bell telephone bug. Suitable for any phone. Transmits over 250 metres - more with good receiver. Made from easy to obtain, cheap components. R006 £2.50
- **LOCKS** - How they work and how to pick them. This fact filled report will teach you more about locks and the art of lock picking than many books we have seen at 4 times the price. Packed with information and illustrations. R008 £3.50
- **RADIO & TV JOKER PLANS** We show you how to build three different circuits for disrupting TV picture and sound plus FM radio! May upset your neighbours & the authorities! DISCRETION REQUIRED! R017 £3.50
- **INFINITY TRANSMITTER PLANS** Complete plans for building the famous Infinity Transmitter. Once installed on the target phone, device acts like a room bug. Just call the target phone & activate the unit to hear all room sounds. Great for home/office security! R019 £3.50
- **THE ETHER BOX CALL INTERCEPTOR PLANS** Grab telephone calls out of thin air! No need to wire-in a phone bug. Simply place this device near the phone lines to hear the conversations taking place! R025 £3.00
- **CASH COUNTER BUSINESS REPORTS** Need ideas for making more cash? Well this could be just what you need! You get 40 reports (approx. 600 pages) on floppy disk that give you information on setting up different businesses. You also get valuable reproduction and duplication rights so that you can sell the manuals as you like. R030 £7.50

# SURVEILLANCE

High performance surveillance bugs. Room transmitters supplied with sensitive electrical microphone & battery holder/cip. All transmitters can be received on an ordinary VHF/FM radio between 88-108MHz. Available in Kit Form (KT) or Assembled & Tested (AS).

## ROOM SURVEILLANCE

● **MTX - MINIATURE 3V TRANSMITTER**  
Easy to build & guaranteed to transmit 300m @ 3V. Long battery life. 3-5V operation. Only 45x18mm. ● 3007KT £5.95 AS3007 £10.95

● **MRTX - MINIATURE 9V TRANSMITTER**  
Our best selling bug. Super sensitive, high power - 500m range @ 9V (over 10m with 18V supply and better aerial). 45x19mm. 3018KT £6.95 AS3018 £11.95

● **HPTX - HIGH POWER TRANSMITTER**  
High performance, 2 stage transmitter gives greater stability & higher quality reception. 1000m range. 6-12V DC operation. Size 70x15mm. 3032KT £8.95 AS3032 £17.95

● **MMTX - MICRO-MINIATURE 9V TRANSMITTER**  
The ultimate bug for its size, performance and price. Just 15x25mm. 500m range @ 9V. Good stability. 6-18V operation. 3051KT £7.95 AS3051 £13.95

● **VTX - VOICE ACTIVATED TRANSMITTER**  
Operates only when sounds detected. Low standby current. Variable trigger sensitivity. 500m range. Peaking circuit. Used to maximum RF output. On/off switch. 6V operation. Only 63x38mm. 3028KT £9.95 AS3028 £22.95

● **HARD-WIRED BUG/TWO STATION INTERCOM**  
Each station has its own amplifier, speaker and mic. Can be set up as either a hard-wired bug or two-station intercom. 10m x 2-core cable supplied. 9V operation. 3021KT £13.95 (kit form only)

● **TRVS - TAPE RECORDER VOX SWITCH**  
Used to automatically operate a tape recorder (not supplied) via its REMOTE socket when sounds are detected. All conversations recorded. Adjustable sensitivity & turn-off delay. 115x19mm. 3013KT £7.95 AS3013 £19.95

● **LIQUID LEVEL SENSOR/RAIN ALARM** Will indicate fluid levels or simply the presence of fluid. Relay output to control a pump to add/remove water when it reaches a certain level. 1080KT £6.95

● **STEREO VU METER** Shows peak music power using 2 rows of 10 LEDs (mixed green & red) moving bar display. 0-30db. 3089KT £10.95

● **AM RADIO KIT 1** Tuned Radio Frequency front-end, single chip AM radio IC & 2 stages of audio amplification. All components inc. speaker provided. PCB 32x102mm. 3063KT £9.95

● **DRILL SPEED CONTROLLER** Adjust the speed of your electric drill according to the job at hand. Suitable for 240V AC mains powered drills up to 700W power. PCB: 48mm x 65mm. Box provided. 6074KT £17.90

● **3 INPUT MONO MIXER** Independent level control for each input and separate bass/treble controls. Input sensitivity: 240mV, 18V DC. PCB: 60mm x 185mm 1052KT £16.95

● **NEGATIVE/POSITIVE ION GENERATOR** Standard Cockcroft-Walton multiplier circuit. Mains voltage experience required. 3057KT £9.95

● **LED VICE** Classic intro to electronics & circuit analysis. 7 LEDs simulate dice roll, slow down & land on a number at random. 555 IC circuit. 3003KT £8.95

● **STAIRWAY TO HEAVEN** Tests hand-eye co-ordination. Press switch when green segment of LED lights to climb the stairway - miss & start again! Good intro to several basic circuits. 3005KT £8.95

● **ROULETTE LED 'Ball'** spins round the wheel, slows down & drops into a slot. 10 LEDs. Good intro to CMOS decade counters & Op-Amps. 3006KT £10.95

● **9V XENON TUBE FLASHER** Transformer circuit steps up 9V battery to flash a 25mm Xenon tube. Adjustable flash rate (0.25-2 Sec's). 3022KT £10.95

● **LED FLASHER 1** 5 ultra bright red LEDs flash in 7 selectable patterns. 3037MKT £4.95

● **LED FLASHER 2** Similar to above but flash in sequence or randomly. Ideal for model railways. 3052MKT £4.95

● **INTRODUCTION TO PIC PROGRAMMING.** Learn programming from scratch. Programming hardware, a 16F84 chip and a two-part, practical, hands-on tutorial series are provided. 3081KT £21.95

● **SERIAL PIC PROGRAMMER** for all 818/28/40 pin DIP serial programmed PICs. Shareware software supplied limited to programming 256 bytes (registration costs £14.95). 3096KT £14.95

● **'PICALL' SERIAL & PARALLEL PIC PROGRAMMER** for all 818/28/40 pin DIP parallel AND serial PICs. Includes fully functional & registered software (DOS, W3.1, W95/8). 3117KT £59.95

● **ATMEL 89C051 PROGRAMMER** Simple-to-use yet powerful programmer for the Atmel 89C1051, 89C2051 & 89C4051 uC's. Programmer does NOT require special software other than a terminal emulator program (built into Windows). Can be used with ANY computer/operating system. 3121KT £34.95

● **3V/1.5V TO 9V BATTERY CONVERTER** Replace expensive 9V batteries with economic 1.5V batteries. IC based circuit steps up 1 or 2 'AA' batteries to give 9V/18mA. 3035KT £4.95

## TELEPHONE SURVEILLANCE

● **MTX - MINIATURE TELEPHONE TRANSMITTER**  
Attaches anywhere to phone line. Transmits only when phone is used. Tune-in your radio and hear both parties. 300m range. Uses line as aerial & power source. 20x45mm. 3016KT £7.95 AS3016 £13.95

● **TRT - TELEPHONE RECORDING INTERFACE**  
Automatically records all conversations. Connects between phone line & tape recorder (not supplied). Operates through phone line & tape recorder at an extremely reasonable price with 1.5-12V battery systems. Powered from line. 50x33mm. 3033KT £7.95 AS3033 £16.95

● **TPA - TELEPHONE PICK-UP AMPLIFIER/WIRELESS PHONE BUG**  
Place pick-up coil on the phone line or near phone earpiece and hear both sides of the conversation. 3055KT £10.95 AS3055 £19.95

● **1 WATT FM TRANSMITTER** Easy to construct. Delivers a crisp, clear signal. Kit-stage circuit. Kit includes microphone and requires a simple open dipole aerial. 8-30VDC. PCB 42x45mm. 1009KT £14.95

● **4 WATT FM TRANSMITTER** Comprises three RF stages and an audio preamplifier stage. Piezoelectric microphone supplied or you can use a separate preamplifier circuit. Antenna can be an open dipole or Ground Plane. Ideal project for those who wish to get started in the fascinating world of FM broadcasting and want a good basic circuit to experiment with. 12-18VDC. PCB 44x146mm. 1028KT £23.95

● **15 WATT FM TRANSMITTER (PRE-ASSEMBLED & TESTED)** Four transistor based stages with Philips BL788 in final stage. 15 Watts RF power on the air. 88-108MHz. Accepts open dipole, Ground Plane, 5/8, J, or YAGI configuration antennas. 12-18VDC. PCB 70x220mm. SWR meter needed for alignment. 1021KT £35.95

● **SIMILAR TO ABOVE BUT 25W Output.** 1031KT £79.95

● **STABILISED POWER SUPPLY 3-30V/2.5A** Ideal for hobbyist & professional laboratory. Very stable & versatile design at an extremely reasonable price. Short circuit protection. Variable DC voltages (3-30V). Rated output 2.5 Amps. Large heatsink supplied. You just supply a 24VAC/5A transformer. PCB 55x112mm. Mains operation. 1007KT £17.50. Custom Designed Box 2007 £34.95

● **STABILISED POWER SUPPLY 2-30V/5A** As kit 1007 above but rated at 5 Amp. Requires a 24VAC/5A transformer. 1096KT £29.95. Custom Designed Box 2096 £34.95

● **MOTORBIKE ALARM** Uses a reliable vibration sensor (adjustable sensitivity) to detect movement of the bike to trigger the alarm & switch the output relay to which a siren, bikes horn, indicators or other warning device can be attached. Auto-reset. 6-12VDC. PCB 57x64mm. 1011KT £11.95 Box £5.95

● **CAR ALARM SYSTEM** Protect your car from theft. Features vibration sensor, courtesy/boot light voltage drop sensor and bonnet/booth earth switch sensor. Entry/exit delays, auto-reset and adjustable alarm duration. 6-12V DC. PCB: 47mm x 55mm 1019KT £11.95 Box £6.50

● **PIEZO SCREAMER** 110db of ear piercing noise. Fits in box with 2 x 35mm piezo elements built into their own resonant cavity. Use as an alarm siren or just for fun! 6-9VDC. 3015KT £9.95

● **COMBINATION LOCK** Versatile electronic lock comprising main circuit & separate keypad for remote opening of lock. Relay supplied. 3029KT £9.95

● **ULTRASONIC MOVEMENT DETECTOR** Crystal locked detector frequency for stability & reliability. PCB 75x40mm houses all components. 4-7m range. Adjustable sensitivity. Output will drive external relay/circuits. 9VDC. 3049KT £12.95

● **PIR DETECTOR MODULE** 3-lead assembled unit just 25x35mm as used in commercial burglar alarm systems. 3076KT £8.95

● **INFRARED SECURITY BEAM** When the invisible IR beam is broken a relay is tripped that can be used to sound a bell or alarm. 25 metre range. Mains rated relays provided. 12VDC operation. 3130KT £11.95

● **SQUARE WAVE OSCILLATOR** Generates square waves at 6 preset frequencies in factors of 10 from 1Hz-100kHz. Visual output indicator. 5-18VDC. Box provided. 3111KT £8.95

● **PC DRIVEN POCKET SAMPLER/DATA LOGGER** Analogue voltage sampler records voltages up to 2V or 20V over periods from milli-seconds to months. Can also be used as a simple digital scope to examine audio & other signals up to about 5kHz. Software & D-shell case provided. 3112KT £19.95

● **20 MHz FUNCTION GENERATOR** Square, triangular and sine waveform up to 20MHz over 3 ranges using 'coarse' and 'fine' frequency adjustment controls. Adjustable output from 0-2V p.p. A TTL output is also provided for connection to a frequency meter. Uses MAX038 IC. Plastic case with printed front/rear panels & all components provided. 7-12VAC. 3101KT £54.95

**BARGAIN BUY!**

**30-in-ONE**  
Electronic Projects Lab

Great introduction to electronics. Ideal for the budding electronics expert! Build a radio, burglar alarm, water detector, Morse code practice circuit, simple computer circuits, and much more! NO soldering, tools or previous electronics knowledge required. Circuits can be built and unassembled repeatedly. Comprehensive 68-page manual with explanations, schematics and assembly diagrams. Suitable for age 10+. Excellent for schools. Requires 2 x AA batteries. ONLY £17.95 (phone for bulk discounts).

WEB: <http://www.QuasarElectronics.com>  
email: [epesales@QuasarElectronics.com](mailto:epesales@QuasarElectronics.com)

Secure Online Ordering Facilities  
Full Kit Listing, Descriptions & Photos  
Kit Documentation & Software Downloads

# The science lab in a PC



**Experiments Ideas for DrDAQ**

If you are interested in performing and writing up one of these experiments, please get in touch, follow this [link] for more information

- Flickering Lights: Use a light sensor to look at tube lights, computer monitors and TV Screens
- Dawn Chorus: Use light and sound level sensors to measure the dawn chorus
- Sound waveforms: Use PicoScope oscilloscope whilst listening or singing. Switch on the website that has the highest frequency, who can't
- Sound Decay: Use a sound source with a
- Sound Insulation: Use a sound source with materials
- Sound waveforms of musical instruments
- Light decay (inverse square law), How d
- Light Insulation: Experiment with different bits of insulation have twice the effect?
- Acid Base Titration: Monitor the pH and Ti
- Acid Rain: Measure the pH of collected rain
- Exothermic Reactions: Measure the temp
- Endothermic Reactions: Measure the temp
- Day and Night: Plot temperature, light and
- Fermentation of Grass Cuttings: Measure
- Fruit Power: Make a fruit battery. Experiment
- Capacitor charge/discharge: Experiment
- Infrared remote controls: Use a photo di
- Output of a solar cell: What factors affect
- Heat Insulation: Wrap test tubes in differ
- Global Warming: Show how CO2 can affect
- Heat Loss Through Windows: Compare

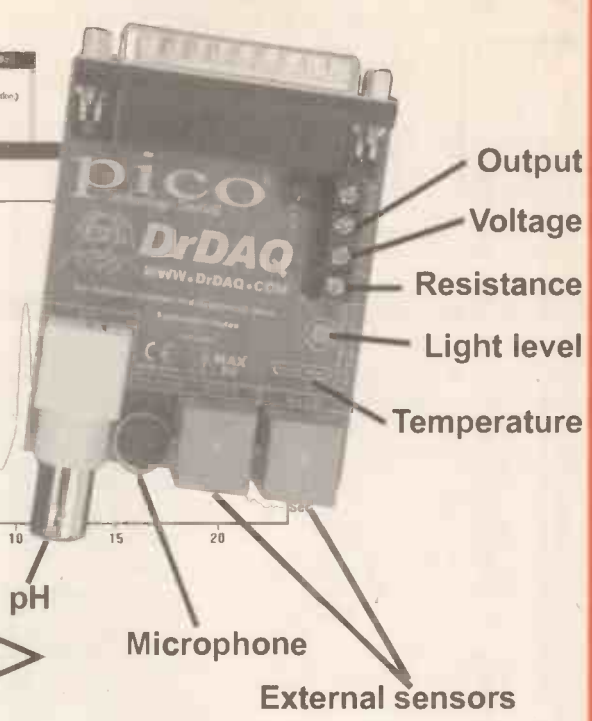
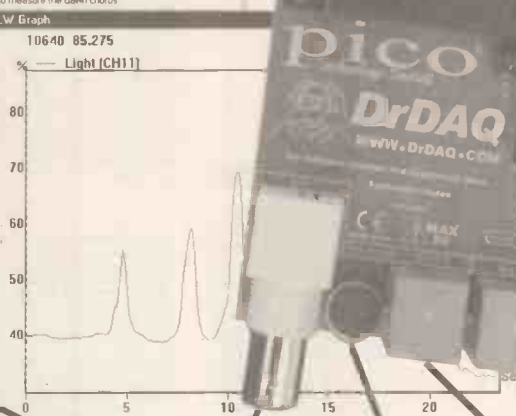

**Only £59!**  
+VAT

The DrDAQ is a low cost data logger from Pico Technology. It is supplied ready to use with all cables, software and example science experiments.

DrDAQ represents a breakthrough in data logging. Simply plug DrDAQ into any Windows PC, run the supplied software and you are ready to collect and display data. DrDAQ draws its power from the parallel port, so no batteries or power supplies are required.

- ✓ Very low cost
- ✓ Built in sensors for light, sound (level and waveforms) and temperature
- ✓ Use DrDAQ to capture fast signals (eg sound waveforms)
- ✓ Outputs for control experiments
- ✓ Supplied with both PicoScope (oscilloscope) and PicoLog (data logging) software

## Transform your PC... Into an oscilloscope, spectrum analyser and multimeter...

The Pico Technology range of PC based oscilloscopes offer performance only previously available on the most expensive 'benchtop' scopes. By intergrating several instruments into one unit, they are both flexible and cost effective.

Connection to a PC gives these virtual instruments the edge over traditional oscilloscopes: the ability to print and save waveforms is just one example. Units are supplied with PicoScope for Windows which is powerful, yet simple to use, with comprehensive on line help.

### Features

- ▼ A fraction of the cost of comparable benchtop scopes
- ▼ Oscilloscope and data logging software supplied
- ▼ Prices from £69 (excl VAT)
- ▼ Up to 100 MS/s sampling, 50 MHz spectrum analyser

### Applications

- ▼ Video
- ▼ Automotive
- ▼ Audio
- ▼ Electronics design
- ▼ Fault finding
- ▼ Education

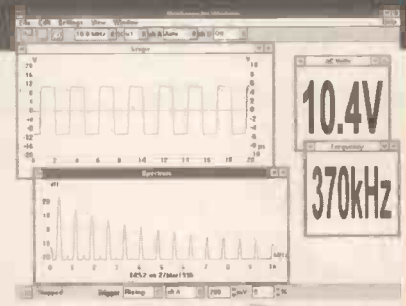

**PICO**  
Technology Limited

**8 CAVANS WAY,  
BINLEY INDUSTRIAL  
ESTATE,  
COVENTRY CV3 2SF  
Tel: 01203 650702  
Fax: 01203 650773  
Mobile: 0860 400683**



(Premises situated close to Eastern-by-pass in Coventry with easy access to M1, M6, M40, M45 and M69)

**OSCILLOSCOPES**

Beckman 9020 - 20MHz - Dual Channel.....	£150
Gould OS 245A/250/255/300/3000/3351/4000.....	from £125
Hewlett Packard 190A/180C/181A/182C.....	from £150
Hewlett Packard 1740A, 1741A, 1742A - 100MHz Dual Channel.....	£225
Hewlett Packard 54100D - 1 GHz Digitizing.....	£1250
Hewlett Packard 54200A - 50 MHz Digitizing.....	£500
Hewlett Packard 54201A - 300MHz Digitizing.....	£1450
Hewlett Packard 54512B - 300MHz - 1GS/s 4-Channel.....	£2250
Hewlett Packard 54501A - 100MHz - 100MS/s 4-Channel.....	£1250
Hitachi V152Z/V302B/V302F/V335F/V550B/V650F.....	from £105
Hitachi V650F - 60MHz Dual Channel.....	£200
Hitachi V1100A - 100MHz 4-Channel.....	£900
Intron 2020 - 20MHz Digital Storage (NEW).....	£450
Iwatsu S85710/S85702 - 20MHz.....	from £125
Meguro - MSO 1270A - 20 MHz Digital Storage (NEW).....	£450
Lecroy 9304 AM - 200MHz - 100 MS/s 4-Channel.....	£3000
Lecroy 9450A - 300MHz/400 MS/s D.S.O. 2-Channel.....	£2250
Philips PM 3055 - 50MHz Dual Timebase.....	£450
Philips PM 3211/PM 3212/PM 3214/PM 3217/PM 3234/PM33240/PM 3243/PM 3244/PM 3261/PM 3262/PM 3263/PM 3540.....	from £125
Philips PM 3295A - 400MHz Dual Channel.....	£1800
Philips PM 3335 - 50MHz/20 MS/s D.S.O. 2-Channel.....	£950
Tektronix 455 - 50MHz Dual Channel.....	£200
Tektronix 464/466 - 100MHz Analogue Storage.....	from £300
Tektronix 466/468B - 100MHz Dual Channel.....	£300
Tektronix 468 - 100MHz D.S.O.....	£500
Tektronix TAS 475 - 100MHz - 4-Channel.....	£950
Tektronix 476/475A - 200MHz/250MHz Dual Channel.....	from £400
Tektronix 485 - 350MHz - 2-Channel.....	£750
Tektronix 2211 - Digital Storage - 50MHz.....	£800
Tektronix 2213 - 60MHz Dual Channel.....	£350
Tektronix 2214 - 60MHz Dual Trace.....	£275
Tektronix 2220 - 60MHz Dual Channel D.S.O.....	£950
Tektronix 2221 - 60MHz Digital Storage 2-Channel.....	£950
Tektronix 2225 - 50MHz Dual Channel.....	£350
Tektronix 2235 - 100MHz Dual trace.....	£600
Tektronix 2235 - Dual Trace 100MHz (portable).....	£800
Tektronix 2440 - 300MHz/500 MS/s D.S.O. 2-Channel.....	£2500
Tektronix 2445 - 150MHz - 4-Channel+DMM.....	£900
Tektronix 2445A - 100MHz - 4-Channel.....	£900
Tektronix 2476B - 400MHz - 4-Channel.....	£6500
Tektronix 5403 - 60MHz - 2 or 4-Channel.....	from £180
Tektronix 7313, 7603, 7623, 7633 - 100MHz 4-Channel.....	from £300
Tektronix 7700 - 250MHz 4-Channel.....	from £350
Tektronix 7904 - 500MHz.....	from £400
Trio CS-1022 - 20MHz - Dual Channel.....	£125

Other scopes available too

<b>SPECIAL OFFER</b>	
HITACHI V212 - 20MHz DUAL TRACE.....	£160
HITACHI V222 - 20MHz DUAL TRACE+ALTERNATE MAGNIFY.....	£180

**SPECTRUM ANALYSERS**

Ando AC8211 - Spectrum Analyser 1-7GHz.....	£1995
Anritsu MS62B - 10kHz-1700MHz.....	£1995
Anritsu MS3401A+MS3401B - (10Hz-30MHz).....	£3500+£3995
Anritsu MS510B - 10kHz-2GHz (Mim).....	£4500
Anritsu MS710F - 100kHz-2GHz Spectrum Analyser.....	£5500
Avcom PSA85S - 1000MHz - portable.....	£850
Hameg 8028/8038 - Spectrum Analyser/Tracking Gen+100MHz Oscilloscope.....	£1000
Hewlett Packard 182R with 8559A (10MHz-21GHz).....	£2750
Hewlett Packard 182T+8558B - 0.1 to 1500MHz.....	£1250
Hewlett Packard 182T+8558B - 0.1 to 1500MHz.....	£2250
Hewlett Packard 3562A - Dual Channel Dynamic Sig. Analyser.....	£2500
Hewlett Packard 3580A - 5Hz-50kHz.....	£800
Hewlett Packard 3582A - 0.02Hz-25.6kHz (Dual Channel).....	£2000
Hewlett Packard 3585A - 20Hz-40MHz.....	£4000
Hewlett Packard 8569B - (0.01 to 22GHz).....	£4250
Hewlett Packard 8590A - S' Parametric Test Set.....	£2500
Hewlett Packard 8753A - Network Analyser.....	from £3000
Hewlett Packard 8753B - Network Analyser.....	from £4500
IFR 7750 - 10kHz-1GHz.....	£2000
Meguro MSA 4901 - 1-300GHz (AS NEW).....	£750
Meguro MSA 4912 - 1-1GHz (AS NEW).....	£1000
Rohde & Schwarz - SWOB 5 Polyscop 0.1-1300MHz.....	£1800
Takeda Riken 4132 - 1.0GHz Spectrum Analyser.....	£2100
Tektronix 7L18 with mainframe (1.5-60GHz with external mixers).....	£2000
Tektronix 485P - 100Hz-1.8GHz programmable.....	£4500
Tektronix 496P - 1kHz-1.8GHz Spectrum Analyser.....	£4250

**MISCELLANEOUS**

Adret 740A - 100kHz-1120MHz Synthesised Signal Generator.....	£800
Anritsu MG 3801A Signal Generator 0.1-1040MHz.....	£1250
Anritsu ME 482B 3 Transmission Analyser.....	£2500
Anritsu MG 645B Signal Generator 0.05-1050MHz.....	£750
Boonton 92C R/F Millivoltmeter.....	£195
Boonton 93A True RMS Voltmeter.....	£195
Dranetz 626 - AC/DC - Multifunction Analyser.....	£500
EIP 331 - Frequency Counter 18GHz.....	£450
EIP 545 - Frequency Counter 18GHz.....	£150
EIP 575 - Frequency Counter 18GHz.....	£450
Etek SMPS - Power Supply 60V-30V.....	£350
Farnell TSV-70 MKII Power Supply (70V - 5A or 35V - 10A).....	£200
Farnell DS6-1 Synthesised Signal Generator.....	£125
Farnell AP 3055A Power Supply 3V - 250A.....	£1750
Feedback PEG 505 Power Function Generator.....	£180
Fluke 5100A - Calibrator.....	£1950
GN ELMI EPR31 PCM Signalling Recorder.....	£2000
Guidline 9152 - T12 Battery Standard Cell.....	£550
Hewlett Packard 1630D - Logic Analyser (43 Channels).....	£500
Hewlett Packard 16500A/B and C - Fitted with 16510A/1651A/161530A/16531A - Logic Analyser.....	from £2000
Hewlett Packard 331A - Distortion Analyser.....	£300
Hewlett Packard 333A - Distortion Analyser.....	£300
Hewlett Packard 334A - Distortion Analyser.....	£300
Hewlett Packard 3325A - 21MHz Synthesiser/Function Generator.....	£900
Hewlett Packard 3335A - Synthesised Signal Generator (200Hz-81MHz).....	£2750
Hewlett Packard 3338C - Synthesised Signal Generator (10Hz-21MHz).....	£290
Hewlett Packard 3455A - 6 1/2 Digit Multimeter (Autocal).....	£500
Hewlett Packard 3456A - Digital Voltmeter.....	£600
Hewlett Packard 3488A - HP - 1B Switch Control Unit (various Plug-Ins available).....	£550
Hewlett Packard 35600A - Dual Channel Dynamic Signal Analyser.....	£3750
Hewlett Packard 358A - Selective Level Meter.....	£800
Hewlett Packard 3711A/3712A/3718/3738 - Microwave Link Analyser.....	£1500
Hewlett Packard 3746A - Selective Measuring Set.....	£500
Hewlett Packard 3776A - PCM Terminal Test Set.....	£1000
Hewlett Packard 3779A/3779C - Primary Mux Analyser.....	from £400

Hewlett Packard 3784A - Digital Transmission Analyser.....	£5000
Hewlett Packard 3785A - Jitter Generator+Receiver.....	£1250
Hewlett Packard 37900D - Signalling Test Set (No. 7 and ISDN).....	£4250
Hewlett Packard 4182A - Variable Attenuation Attenuator.....	£250
Hewlett Packard 4192A - LF Impedance Analyser.....	£5500
Hewlett Packard 4282A - Digital LCR Meter.....	£950
Hewlett Packard 4342A - 'O' Meter.....	£600
Hewlett Packard 435A or B Power Meter (with 8481A/8484A).....	from £400
Hewlett Packard 436A and 437B - Power Meter and Sensor.....	from £900
Hewlett Packard 492A - (TMS) Transmission Impairment M/Set.....	£1000
Hewlett Packard 4972A - Lan Protocol Analyser.....	£1250
Hewlett Packard 5183 - Waveform Recorder.....	£1250
Hewlett Packard 5238A - Frequency Counter 100MHz.....	£250
Hewlett Packard 5314A - (NEW) 100MHz Universal Counter.....	£250
Hewlett Packard 5316A - Universal Counter (IEEE).....	£400
Hewlett Packard 5335 - 200MHz High Performance Systems Counter.....	£600
Hewlett Packard 5324A - Microwave Frequency Counter (500MHz-18GHz) Opts 1+3.....	£800
Hewlett Packard 5359A - High Resolution Time Synthesiser.....	£2950
Hewlett Packard 5370B - Universal Timer/Counter.....	£2000
Hewlett Packard 5384A - 225MHz Frequency Counter.....	£500
Hewlett Packard 5385A - Frequency Counter - 1GHz - (HP1B) with OPTS 001/003/004/005.....	£750
Hewlett Packard 6033A - Power Supply Autorangeing (20V - 30A).....	£750
Hewlett Packard 6253A - Power Supply 20V - 3A Twin.....	£200
Hewlett Packard 6255A - Power Supply 40V - 1.5A Twin.....	£200

HEWLETT PACKARD 6261B  
Power Supply 20V - 50A £350 Discount for Quantities

Hewlett Packard 6264B - Power Supply (0-20V, 0-25A).....	£300
Hewlett Packard 6266B - Power Supply 40V - 5A.....	£220
Hewlett Packard 6271B - Power Supply 60V - 3A.....	£225
Hewlett Packard 6282A - Power Supply (20V - 5A).....	£800
Hewlett Packard 6652A - 20V - 25A System P.S.U.....	£750
Hewlett Packard 7475A - 6 Pen Plotter.....	£250
Hewlett Packard 7580A - 8 Pen Plotter.....	£350
Hewlett Packard 7810A - Chx Dual Directional Coupler.....	£600
Hewlett Packard 8015A - 50MHz Pulse Generator.....	£500
Hewlett Packard 8165A - 50MHz Programmable Signal Source.....	£1250
Hewlett Packard 8180A - Data Generator.....	£1500
Hewlett Packard 8182A - Data Analyser.....	£1500
Hewlett Packard 8350B - Sweep Oscillator Mainframe (various plug-in options available).....	£2500
Hewlett Packard 8355A - Wave Source Module 25.5 to 40GHz.....	£2250
Hewlett Packard 8355A - Millimeter - Wave Source Module 3S-50GHz.....	£4250
Hewlett Packard 8405A - Vector Voltmeter.....	£350
Hewlett Packard 8620C - Sweep Oscillator Mainframe.....	from £250
Hewlett Packard 8640B - Signal Generator (512MHz+1024MHz).....	from £850
Hewlett Packard 8652A - Signal Generator (0.01 to 1050MHz) High Performance Synthesiser.....	£6500
Hewlett Packard 8655A - Signal Generator (990MHz).....	£200
Hewlett Packard 8858B - Synthesised Signal Generator.....	£1450
Hewlett Packard 8857A - Signal Generator (100kHz-1040MHz).....	£1900
Hewlett Packard 8860D - Synthesised Signal Generator (10kHz-2600MHz).....	£3250
Hewlett Packard 8750A - Storage Normaliser.....	£295
Hewlett Packard 875A - Scalar Network Analyser.....	£1500
Hewlett Packard 8757A - Scalar Network Analyser.....	£2250
Hewlett Packard 8901A - Modulation Analyser.....	£1000
Hewlett Packard 8903E - Distortion Analyser.....	£2000
Hewlett Packard 8903E - Distortion Analyser (Min).....	£1600
Hewlett Packard 8903B - Distortion Analyser (Min).....	£1500
Hewlett Packard 8920A - R/F Comms Test Set.....	£2500
Hewlett Packard 8922B/G/H - Radio Comms Test Sets (G.S.M.).....	from £800
Hewlett Packard 8958A - Cellular Radio Interface.....	£1700
Keytek MZ-15/EC - Minizap 15kV Hand-Held ESD Simulator.....	£1050
Krohn-Hite 2200 - Lin/Log Sweep Generator.....	£995
Krohn-Hite 4024A - Oscillator.....	£295
Krohn-Hite 5200 - Sweep Function Generator.....	£335
Krohn-Hite 6500 - Phase Meter.....	£2000
Leader LDM-170 - Distortion Meter.....	£350
Leader 3216 - Signal Generator (100kHz-140kHz) AM/FM/CW with built-in FM stereo modulator (min).....	£995
Marconi 1066B - Multiplexer and Frame Alignment Monitor (new).....	£90A
Marconi 2019 - 80kHz-1040MHz Synthesised Signal Generator.....	£750
Marconi 2019A - 80kHz-1040MHz Synthesised Signal Generator.....	£1000
Marconi 2111 - UHF Synthesiser (new).....	£90A
Marconi 2185 - 1.5GHz Programmable Attenuator (new).....	£90A
Marconi 2305 - Modulation Meter.....	£1750
Marconi 2337A - Automatic Distortion Meter.....	£150
Marconi 2610 - True RMS Voltmeter.....	£2000
Marconi 2671 - Data Comms Analyser.....	£500
Marconi 2955 - Radio Comms Test Set.....	£2000
Marconi 6310 - Sweep Generator - Programmable - new (2-20GHz).....	£3500
Marconi 6950/6960 - Power Meter & Sensor.....	from £500
Marconi 6950 - Power Meter & Sensor.....	from £250
Marconi 893 - A/F Power Meter.....	£250
Philips PM5167 MHz Function Generator.....	£400
Philips 5190 - L.F. Synthesiser (G.P.I.B.).....	£800
Philips 5518 - Synthesised Function Generator.....	£1500
Philips 5519 - TV Peltier Generator.....	£350
Philips PM5716 - 50MHz Pulse Generator.....	£225
Prema 4000 - 6 Digit Multimeter (NEW).....	£350
Quartzlock 2A - Off-Air Frequency Standard.....	£200
Racal 1992 - 1.3GHz Frequency Counter.....	£700
Racal 6111/6151 - GBM Radio Comms Test Set.....	£90A
Racal 9081 - 9082 - Synthesised Signal Generator 520MHz.....	from £400
Racal Dana 9084 - Synthesised Signal Generator 104MHz.....	£300
Racal 9301A - True RMS R/F Multivoltmeter.....	£300
Racal Dana 9302A - R/F Multivoltmeter (new version).....	£375
Racal Dana 9303 - R/F Level Meter & Head.....	£650
Racal Dana 9917 - UHF Frequency Meter 50MHz.....	£175
Rohde & Schwarz LFM2 - 50MHz Pulse Generator.....	£2000
Rohde & Schwarz CMTA 94 - GSM Radio Comms Analyser.....	£6995
Schaffner NSG 203A - Line Voltage Variation Simulator.....	£750
Schaffner NSG 222A - Interference Simulator.....	£700
Schaffner NSG 223 - Interference Generator.....	£700
Schlumberger 4031 - 1GHz Radio Comms Test Set.....	£4995
Schlumberger Stalblock 4040 - Radio Comms Test Set.....	£1995
Schlumberger 7060/7065/7075 - Multimeters.....	from £350
Stanford Research DS 340 - 15MHz Synthesised Function (NEW) and Arbitrary Waveform Generator.....	£1200
Syston Donner 6030 - Microwave Frequency Counter (26-5GHz).....	£1995
Tektronix AM603+TM501+P6302 - Current Probe Amplifier.....	£995
Tektronix PG506+TG501+SG503+TM503 - Oscilloscope Calibrator.....	£1995
Tektronix 577 - Curve Tracer.....	£1150
Tektronix 1240 - Logic Analyser.....	£500
Tektronix 1241A - PAL Test Signal Generator.....	£250
Tektronix AA5001 & TMS006 M/F - Programmable Distortion Analyser.....	£1995
Tektronix TMS003+AFG 5101 - Arbitrary Function Generator.....	£1500
Tektronix - Plug-Ins - many available such as SC504, SW503, SG502, PG508, FG504, FG503, TG501, TR503+ many more.....	£90A
Time 9811 - Programmable Resistance.....	£400
Time 9814 - Voltage Calibrator.....	£400
Vaihalla Scientific - 2724 Programmable Resistance Standard.....	£1600
Wandel & Goertmann PFJ-8 - Error/Jitter Test Set.....	£11600
Wandel & Goertmann PCM4 (+options).....	£9950
Wandel & Goertmann MU30 - Test Point Scanner.....	£1500
Wavetek 171 - Synthesised Function Generator.....	£800
Wavetek 172B - Programmable Signal Source (0.0001Hz-13MHz).....	£90A
Wavetek 184 - Sweep Generator - 5MHz.....	£250
Wavetek 3010 - 1-1GHz Signal Generator.....	£1250
Wiltron 6405 - RF Analyser (1MHz-2GHz).....	£90A
Wiltron 6520 - Programmable Resistance Generator (3-5GHz-5-5GHz).....	£650
Wiltron 6747-20 - Sweep Frequency Synthesiser (10MHz-20GHz).....	£2950
Yokogawa 3555 - Analysing Recorder.....	£90A

MANY MORE ITEMS AVAILABLE -  
SEND LARGE SAE FOR LIST OF EQUIPMENT  
ALL EQUIPMENT IS USED -  
WITH 30 DAYS GUARANTEE.  
PLEASE CHECK FOR AVAILABILITY BEFORE ORDERING -  
CARRIAGE & VAT TO BE ADDED TO ALL GOODS



# SQUIRES MODEL & CRAFT TOOLS

Fluorescent Bench Magnifier.

- With 22W circular daylight simulation tube.
- 5" dia. glass lens, x1.75 magnification.
- Spring balanced arms for universal positioning.
- Multi-angle table clamp.
- Robust metal construction.

Code LA100 - Price £49.95 Post Free to UK addresses.



Post, Telephone or Fax your orders to:-  
Squires, 100 London Road, Bognor Regis,  
West Sussex, PO21 1DD  
Tel 01243 842424  
Fax 01243 842525



## Shop Now Open

## FRUSTRATED!

### Looking for ICs TRANSISTORS?

A phone call to us could get a result. We offer an extensive range and with a world-wide database at our fingertips, we are able to source even more. We specialise in devices with the following prefix (to name but a few).



2N 2SA 2SB 2SC 2SD 2P 2SJ 2SK 3N 3SK 4N 6N 17 40 AD  
ADC AN AM AY BA BC BD BDT BDV BDW BDX BF  
BFR BFS BFT BFX BFY BLX BLY BS BR BRX BRY BS  
BSS BSV BSW BSX BT BTA BTB BRW BU BUK BUT BUY  
BUW BUX BUY BUZ CA CD CX CXA DAC DG DM DS  
DTA DTC GL GM HA HCF HD HEF ICL ICM IRF J KA  
KIA L LA LB LC LD LF LM M M5M MA MAB MAX MB  
MC MDAJ MJE MJF MM MN MPS MPSA MPSH MPSU  
MRF NJM NE OM OP PA PAL PIC PN RC S SAA SAB  
SAD SAJ SAS SDA SG SI SL SN SO STA STK STR STRD  
STRM STRS SVI T TA TAA TAG TBA TC TCA TDA TDB  
TEA TIC TIP TIPL TEA TL TLC TMP TMS TPU U UA  
UAA UC UDN ULN UM UP A UPC UPD VN X XR Z ZN  
ZTS + many others

We can also offer equivalents (at customers' risk)  
We also stock a full range of other electronic components  
Mail, phone, Fax Credit Card orders and callers welcome



Connect

## Cricklewood Electronics Ltd

40-42 Cricklewood Broadway London NW2 3ET  
Tel: 0181 452 0161 Fax: 0181 208 1441

## KITMASTER EDUCATIONAL KITS

RADIO CLUBS - NOVICES - COLLEGES - SCHOOLS

TELEPHONE (07941) 252679

ALL KITS BUILT ON TRIPAD PCB  
BUILD AS YOU SEE SYSTEM

X1	2-IC MK484 M.W. RADIO	£10.00
X3	1-IC + TRAN M.W. RADIO	£10.00
X5	MK484 + 2030 M.W. RADIO	18.00
X7	MK484 TUNER M.W. NO AMP	£6.00
B2	BASIC CRYSTAL SET AMPLIFIED	0.00
B4	WORKSHOP AMPLIFIER	10.00
X11	S. METER	10.50
B44	SIMPLE H.F. M.W. ATU	£7.50
B8	S.W. TUNER GENERAL	10.00
C1	BASIC CRYSTAL SET M.W.	£5.50
B61	MW SIGNAL BOOSTER	12.50
B9	FAKE CAR ALARM FLASHER	£5.00
B10	2 L.E.D. FLASHER	£4.80
B11	LOW VOLTS L.E.D. ALARM 9V-12V	£5.00
B12	LIE DETECTOR WITH METER	£10.00
B13	TOY ORGAN	£6.50
B14	METRONOME I.C. CONTROL	£5.00
B15	TOUCH SWITCH	£5.00
B16	HEADS OR TAILS GAME	£5.00
B17	SIREN	£4.80
B18	RAIN DETECTOR	£4.80
B19	CONTINUITY TESTER	£4.50
B20	MORSE CODE OSCILLATOR	£4.80
B21	BURGLAR ALARM L.E.D. & SPEAKER	£5.00
B22	LOOP SECURITY ALARM	£5.00
B23	VIBRATION ALARM	£4.80
B24	METAL DETECTOR + METER	£14.00
B25	HAND TREMOR GAME	£4.80
B26	RAIN SYNTHESISER - NOISE	£10.50
B27	AUTO LIGHT DARK INDICATOR	£4.80
B28	ADJ. LOW LIGHT INDICATOR	£4.80
B29	DARK ACTIVATED L.E.D. FLASHER	£4.80
B30	LIGHT ACTIVATED TONE ALARM	£4.80
B31	CAR ELECTRIC PROBE	£4.50
B32	SIGNAL INJECTOR	£4.50
B33	MOISTURE METER - L.E.D.	£4.80
B34	L.E.D. TRANSISTOR TESTER NPN	£4.50
B35	DIODE TESTER - L.E.D.	£4.50
B36	L.E.D. TRANSISTOR TESTER PNP	£4.50
B37	IC 555 TESTER - L.E.D.	£5.50
B38	0-18 MIN. TIMER L.E.D. & SPEAKER	£5.50
B39	TOY THERAMIN MUSIC	£6.80
B40	AMPLIFIED R.F. PROBE + METER	£10.50

FULL KIT &  
INSTRUCTIONS

PERFECT FOR NOVICE FIRST TIME  
BUILDERS IN ELECTRONICS

B41	TRANSMITTER R.F. INDICATOR	£4.80
B43	AUDIO NOISE GENERATOR	£10.00
B45	GENERAL 3-TRANSISTOR AMP	£5.50
B46	LM386 AMPLIFIER GENERAL	£5.50
B48	COMMON PRE-AMP RADIO	£5.50
B49	PEST SCARER HIGH PITCH	£12.00
B50	VARIABLE FREQ. OSCILLATOR	£5.50
B51	AUTOMATIC NIGHT LIGHT	£5.50
B52	FROST ALARM	£5.80
B53	PRESSURE MAT & ALARM	£13.50
B54	GUITAR TUNER	£9.50
B55	TOUCH ALARM	£5.80
B56	SIMPLE LIGHT METER	£13.50
B57	L.E.D. CONTINUITY METER	£4.50
B58	SOUND-OPERATED SWITCH	£6.50
B58A	8 FLASHING L.E.D.s	£6.80
B59	TBA 820M AUDIO AMP	£10.50
B60	TD A 2030 AUDIO AMP	£9.50
B62	ELECTRONIC DICE GAME	£9.50
B63	ADVANCED THERAMIN-MUSIC	£10.50
B64	TOUCH DELAY LAMP	£5.50
B65	FISHERMAN'S ROD BITE ALARM	£5.00
B66	BEAM BREAK DETECTOR ALARM	£8.00
B67	LATCHING BURGLAR ALARM	£7.50
B68	LIGHT-OPERATED RELAY	£7.50
B69	MICROPHONE PRE-AMP	£7.50
B70	MAGNETIC ALARM - MODELS	£7.50
B72	BATH OR WATER BUTT ALARM	£6.80
B73	0-18 VOLT POWER SUPPLY UNIT	£6.80
B74	F.M. BUG POWER SUPPLY 0V-9V	£6.50
B75	1 TRANSISTOR F.M. BUG	£6.50
B76	2 TRANSISTOR F.M. BUG	£7.50
B77	CHIRP GENERATOR	£6.80
B78	TONE BURST GENERATOR	£6.80
B79	SOUND EFFECTS GENERATOR	£10.50
B80	LIGHT METER - PHOTOGRAPHY	£10.50
B81	LIGHT OSCILLATOR - PHOTOGRAPHY	£9.50
B82	LIGHT-ACTIVATED RELAY	£9.50
B83	DARK-ACTIVATED RELAY	£9.50
B84	SOUND SIREN + LOUD AMPLIFIER	£11.50
X12	AUDIO PROBE	£10.50
X14	CHILD SPEAK LAMP	£6.50
Z1	SW GEN RECEIVER	£13.50

SOLID STATE KITS P&P £3 UK  
WORDWIDE P&P £10.  
PAYMENT CHEQUES STERLING

★ SEND FOR FREE CATALOGUE ★  
READY BUILT KITS £5 EXTRA

## KITMASTER RADIO VALVE KITS

K1	VALVE RADIO POWER SUPPLY UNIT	£20.00
IDEAL PSU FOR MOST OF OUR VALVE KITS		
K2	VALVE RADIO POWER SUPPLY UNIT	£22.00
SIMILAR TO K1 BUT OFFERS HIGHER VOLTAGE OUTPUT ON H.T. SIDE		
K3	TWO VALVER REGEN RADIO	£25.00
WORKS ON MW OR SW INTERCHANGEABLE COILS. KIT COMES WITH SPEAKER. GOOD VOLUME		
K4	ONE VALVE AMPLIFIER. USES THE EL84 VALVE STILL MADE TODAY. IDEAL SHACK AMPLIFIER. GOOD STARTER KIT	£12.00
K5	BATTERY ONE VALVER NOVICE KIT	£15.00
RUNS ON 36 VOLTS. IDEAL EXPERIMENTAL VALVE PROJECT. ALSO SOLID STATE UNIT INCORPORATED TO GIVE SPEAKER VOLUME		
K6	ONE VALVE REGEN RADIO. COMES WITH CRYSTAL EARPIECE. MW/SW	£15.00
K7	TWO VALVE AMPLIFIER. GOOD VOLUME	£17.50
K8	CRYSTAL SET ONE VALVER	£18.00
EXPERIMENTAL VALVE + SOLID STATE WITH SPEAKER		
K9	ONE VALVE MW RADIO, NOT REGEN	£22.50
SOLID STATE INCORPORATED. GOOD VOLUME WITH SPEAKER SUPPLIED. WORKS VERY WELL		
K10	MODERN TWO VALVE RADIO WITH SOLID STATE	£28.50
THIS RADIO USES TWO VALVES STILL PRODUCED TODAY AND THERE ARE NO COILS TO WIND. IT OPERATES ON MEDIUM WAVE AND HAS NO REGENERATION PROBLEMS		
K11	TWO VALVE SW GENERAL RECEIVER 6MHz TO 14MHz	£27.50
USING MODERN SOLID STATE COMBINED WITH VALVE TECHNOLOGY THIS RADIO HAS VERY GOOD VOLUME, BY USING THE ECC83 AND EL54 VALVES		
K12	TWO VALVE AMPLIFIED CRYSTAL SET RADIO	£26.50
SIMILAR TO THE K8 PROJECT BUT WITH MORE AMPLIFICATION. THIS IS IDEAL IF YOU ARE INTO EXPERIMENTING WITH CRYSTAL SETS AND YOU REQUIRE LOTS OF VOLUME		
K13	TWO VALVER REGEN RADIO, MW & SW	£24.00
USES THE EF91 VALVE AS A DETECTOR AND THE ECL80 FOR AUDIO AMPLIFICATION CIRCUITRY SIMILAR TO ITS SISTER, THE K3 REGEN RADIO KIT, AS THESE VALVES ARE VERY COMMON. THIS KIT IS SLIGHTLY CHEAPER		
K14	3-VALVE RADIO MW & SW AND WITH RF STAGE ADDED WHICH GIVES MORE SELECTIVITY. ALSO COMES WITH INTERCHANGEABLE COIL FORMER, ALSO RADIO GIVES GOOD VOLUME. EASY TO ASSEMBLE - THIS SET USES TWO EF91 VALVES AND THE ECL80 FOR AUDIO	£30.00
K15	3-VALVE RADIO MW & SW. ANOTHER DIFFERENT TYPE OF REGENERATION RADIO, ALSO WITH ADDED R.F. STAGE THIS CIRCUIT USES THE MODEL EL84 FOR AUDIO WITH THE POPULAR EF80 VALVE FOR THE DETECTOR AND THE EF91 FOR THE R.F. STAGE. THIS MAKES FOR A SUPERIOR REGEN RADIO	£32.00

★ ALL RADIO CHASSIS PRE-DRILLED AND VALVE BASES FITTED READY FOR QUICK ASSEMBLY ★

Visit our new Website Address:  
<http://www.kit-master.co.uk>

For your Catalogue E-mail: [david@kit-master.co.uk](mailto:david@kit-master.co.uk)

VALVE KITS P&P £6 UK  
WORDWIDE P&P £12  
PAYMENT - CHEQUES  
STERLING

MAIL ORDER ONLY  
PLEASE ALLOW UP TO  
28 DAYS FOR DELIVERY

MAKE POSTAL ORDERS/CHEQUES PAYABLE TO DAVID JOHNS AND SEND TO:  
37 GOSBECKS ROAD, COLCHESTER, ESSEX CO2 9JR  
TEL. 07941 252679 FAX 01206 369226.

## MAIL ORDER ONLY • CALLERS BY APPOINTMENT

### EPE MICROCONTROLLER P.I. TREASURE HUNTER

The latest MAGENTA DESIGN – highly stable & sensitive – with I.C. control of all timing functions and advanced pulse separation techniques.

- High stability drift cancelling
- Easy to build & use
- No ground effect, works in seawater



- Detects gold, silver, ferrous & non-ferrous metals

- Efficient quartz controlled microcontroller pulse generation.
- Full kit with headphones & all hardware

**KIT 847 ..... £63.95**

### PORTABLE ULTRASONIC PESt SCARER

A powerful 23kHz ultrasound generator in a compact hand-held case. MOSFET output drives a special sealed transducer with intense pulses via a special tuned transformer. Sweeping frequency output is designed to give maximum output without any special setting up.

**KIT 842.....£22.56**

### ICEBREAKER

### PIC REAL TIME IN-CIRCUIT EMULATOR – SEE PAGE 531

### DC Motor/Gearboxes

Our Popular and Versatile DC motor/Gearbox sets.

Ideal for Models, Robots, Buggies etc. 1-5V to 4-5V

Multi ratio gearbox gives wide range of speeds.

**LARGE TYPE – MGL £6.95**

**SMALL – MGS – £4.77**



### Stepping Motors

MD38...Mini 48 step...£8.65

MD35...Std 48 step...£9.99

MD200...200 step...£12.99

MD24...Large 200 step...£22.95



### MOSFET MKII VARIABLE BENCH POWER SUPPLY 0-25V 2.5A

Based on our Mk1 design and preserving all the features, but now with switching pre-regulator for much higher efficiency. Panel meters indicate Volts and Amps. Fully variable down to zero. Toroidal mains transformer. Kit includes punched and printed case and all parts. As featured in April 1994 EPE. An essential piece of equipment.



Kit No. 845 .....£64.95

### PIC PIPE DESCALER

- SIMPLE TO BUILD
- HIGH POWER OUTPUT
- AUDIO & VISUAL MONITORING
- SWEPT FREQUENCY

An affordable circuit which sweeps the incoming water supply with variable frequency electromagnetic signals. May reduce scale formation, dissolve existing scale and improve lathering ability by altering the way salts in the water behave. Kit includes case, P.C.B., coupling coil and all components. High coil current ensures maximum effect. L.E.D. monitor.



**KIT 868 ..... £22.95 POWER UNIT.....£3.99**

### MICRO PESt SCARER

Our latest design – The ultimate scarer for the garden. Uses special microchip to give random delay and pulse time. Easy to build reliable circuit. Keeps pets/pests away from newly sown areas, play areas, etc. uses power source from 9 to 24 volts.

- RANDOM PULSES
- HIGH POWER
- DUAL OPTION



Plug-in power supply £4.99

**KIT 867.....£19.99**

**KIT + SLAVE UNIT.....£32.50**

### WINDICATOR

A novel wind speed indicator with LED readout. Kit comes complete with sensor cups, and weatherproof sensing head. Mains power unit £5.99 extra.

**KIT 856.....£28.00**

## ★ TENS UNIT ★

### DUAL OUTPUT TENS UNIT

As featured in March '97 issue.

Magenta have prepared a FULL KIT for this excellent new project. All components, PCB, hardware and electrodes are included. Designed for simple assembly and testing and providing high level dual output drive.

**KIT 866. . Full kit Including four electrodes £32.90**

Set of 4 spare electrodes £6.50

### 1000V & 500V INSULATION TESTER



Superb new design. Regulated output, efficient circuit. Dual-scale meter, compact case. Reads up to 200 Megohms.

Kit includes wound coil, cut-out case, meter scale, PCB & ALL components.

**KIT 848..... £32.95**

## EPE TEACH-IN 2000

Full set of top quality NEW components for this educational series. All parts as specified by EPE. Kit includes breadboard, wire, croc clips, pins and all components for experiments, as listed in introduction to Part 1.

\*Batteries and tools not included.

**TEACH-IN 2000 -**

**KIT 879 £44.95**

**MULTIMETER £14.45**

### SPACEWRITER

An Innovative and exciting project. Wave the wand through the air and your message appears. Programmable to hold any message up to 16 digits long. Comes pre-loaded with "MERRY XMAS". Kit includes PCB, all components & tube plus instructions for message loading.

**KIT 849 .....£16.99**

### 12V EPROM ERASER

A safe low cost eraser for up to 4 EPROMS at a time in less than 20 minutes. Operates from a 12V supply (400mA). Used extensively for mobile work - updating equipment in the field etc. Also in educational situations where mains supplies are not allowed. Safety interlock prevents contact with UV.

**KIT 790 ..... £29.90**

### SUPER BAT DETECTOR

1 WATT O/P, BUILT IN  
SPEAKER, COMPACT CASE  
20kHz-140kHz  
NEW DESIGN WITH 40kHz MIC.

A new circuit using a 'full-bridge' audio amplifier i.c., internal speaker, and headphone/tape socket. The latest sensitive transducer, and 'double balanced mixer' give a stable, high performance superheterodyne design.



**KIT 861 .....£24.99**

ALSO AVAILABLE Built & Tested. . . £39.99

### ULTRASONIC PESt SCARER

### EPE PROJECT PICS

Programmed PICs for all\* EPE Projects  
16C84/18F84/16C71  
All **£5.90** each  
PIC16F877 now in stock  
**£10** inc. VAT & postage

(\*some projects are copyright)

Keep pets/pests away from newly sown areas, fruit, vegetable and flower beds, children's play areas, patios etc. This project produces intense pulses of ultrasound which deter visiting animals.

- KIT INCLUDES ALL COMPONENTS, PCB & CASE
- EFFICIENT 100V TRANSDUCER OUTPUT
- COMPLETELY INAUDIBLE TO HUMANS



- UP TO 4 METRES RANGE
- LOW CURRENT DRAIN

**KIT 812..... £15.00**

## SIMPLE PIC PROGRAMMER

INCREDIBLE LOW PRICE! Kit 857 **£12.99**

INCLUDES 1-PIC16F84 CHIP  
SOFTWARE DISK, LEAD  
CONNECTOR, PROFESSIONAL  
PC BOARD & INSTRUCTIONS

Power Supply £3.99

EXTRA CHIPS:  
PIC 16F84 £4.84

Based on February '96 EPE. Magenta designed PCB and kit. PCB with 'Reset' switch, Program switch, 5V regulator and test L.E.D.s, and connection points for access to all A and B port pins.

## PIC 16C84 DISPLAY DRIVER

INCLUDES 1-PIC16F84 WITH  
DEMO PROGRAM SOFTWARE  
DISK, PCB, INSTRUCTIONS  
AND 16-CHARACTER 2-LINE  
LCD DISPLAY

Kit 860 **£19.99**

Power Supply £3.99

FULL PROGRAM SOURCE  
CODE SUPPLIED - DEVELOP  
YOUR OWN APPLICATION!

Another super PIC project from Magenta. Supplied with PCB, industry standard 2-LINE x 16-character display, data, all components, and software to include in your own programs. Ideal development base for meters, terminals, calculators, counters, timers - Just waiting for your application!

## PIC 16F84 MAINS POWER 4-CHANNEL CONTROLLER & LIGHT CHASER

- WITH PROGRAMMED 16F84 AND DISK WITH SOURCE CODE IN MPASM
- ZERO VOLT SWITCHING MULTIPLE CHASE PATTERNS
- OPTO ISOLATED 5 AMP OUTPUTS
- 12 KEYPAD CONTROL
- SPEED/DIMMING POT.
- HARD-FIRED TRIACS

Kit 855 **£39.95**

LOTS OF OTHER APPLICATIONS

Now features full 4-channel chaser software on DISK and pre-programmed PIC16F84 chip. Easily re-programmed for your own applications. Software source code is fully 'commented' so that it can be followed easily.

## PIC TOOLKIT V1

- PROGRAMS PIC16C84 and 16F84 • ACCEPTS TASM AND MPASM CODE
- Full kit includes PIC16F84 chip, top quality p.c.b. printed with component layout, turned-pin PIC socket, all components and software\*  
\*Needs QBASIC or QUICKBASIC

Kit 871 . . . **£13.99** Built and tested **£21.99**

## PhizzyB

ALL PARTS FOR SERIES INCLUDING PCBs,  
PROGRAMMED CHIP, CD-ROM AND DISPLAYS

MAIN BOARD - FULL KIT	<b>£131.95</b>	BUILT.....	<b>£149.95</b>
I/O PORT KIT.....	<b>£16.99</b>	BUILT.....	<b>£24.99</b>
L.C.D.....	<b>£12.49</b>	POWER SUPPLY	<b>£3.99</b>
8-BIT SWITCH/LATCH.....	<b>£7.95</b>	INT. MODULE.	<b>£10.45</b>

## 68000 DEVELOPMENT AND TRAINING KIT

- NEW PCB DESIGN
- 8MHz 68000 16-BIT BUS
- MANUAL AND SOFTWARE
- 2 SERIAL PORTS
- PIT AND I/O PORT OPTIONS
- 12C PORT OPTIONS



Kit 621

**£99.95**

- ON BOARD 5V REGULATOR
- PSU £6.99
- SERIAL LEAD £3.99

## Mini-Lab & Micro Lab Electronics Teach-In 7

As featured in EPE and now published as Teach-In 7. All parts are supplied by Magenta.

Teach-In 7 is £3.95 from us or EPE  
Full Mini Lab Kit - £119.95 - Power supply extra - £22.55  
Full Micro Lab Kit - £155.95  
Built Micro Lab - £189.95



## EPE PIC Tutorial

At last! A Real, Practical, Hands-On Series

- Learn Programming from scratch using PIC16F84
- Start by lighting I.e.d.s and do 30 tutorials to Sound Generation, Data Display, and a Security System.
- PIC TUTOR Board with Switches, I.e.d.s, and on board programmer

## PIC TUTOR BOARD KIT

Includes: PIC16F84 Chip, TOP Quality PCB printed with Component Layout and all components\* (\*not ZIF Socket or Displays). Included with the Magenta Kit is a disk with Test and Demonstration routines.

Kit 870 .... **£27.95, Built & Tested .... £42.95**

Optional: Power Supply - £3.99, ZIF Socket - £9.99

LCD Display ..... **£7.99** LED Display ..... **£6.99**

Reprints Mar/Apr/May 98 - **£3.00** set 3

## PIC TOOLKIT V2

- SUPER UPGRADE FROM V1 • 18, 28 AND 40-PIN CHIPS
- READ, WRITE, ASSEMBLE & DISASSEMBLE PICS
- SIMPLE POWER SUPPLY OPTIONS 5V-20V
- ALL SWITCHING UNDER SOFTWARE CONTROL
- MAGENTA DESIGNED PCB HAS TERMINAL PINS AND OSCILLATOR CONNECTIONS FOR ALL CHIPS
- INCLUDES SOFTWARE AND PIC CHIP

Kit 878 . . . **£22.99** with 16F84 . . . **£29.99** with 16F877

## SUPER PIC PROGRAMMER

- READS, PROGRAMS, AND VERIFIES
- WINDOWS™ SOFTWARE
- PIC16C6X, 7X, AND 8X
- USES ANY PC PARALLEL PORT
- USES STANDARD MICROCHIP • HEX FILES
- OPTIONAL DISASSEMBLER SOFTWARE (EXTRA)
- PCB, LEAD, ALL COMPONENTS, TURNED-PIN SOCKETS FOR 18, 28, AND 40 PIN ICs

- SEND FOR DETAILED INFORMATION - A SUPERB PRODUCT AT AN UNBEATABLE LOW PRICE.

Kit 862 **£29.99**

Power Supply £3.99

DISASSEMBLER SOFTWARE **£11.75**

## PIC STEPPING MOTOR DRIVER

INCLUDES PCB,  
PIC16F84 WITH  
DEMO PROGRAM,  
SOFTWARE DISC,  
INSTRUCTIONS  
AND MOTOR.

Kit 863 **£18.99**

FULL SOURCE CODE SUPPLIED  
ALSO USE FOR DRIVING OTHER  
POWER DEVICES e.g. SOLENOIDS

Another NEW Magenta PIC project. Drives any 4-phase unipolar motor - up to 24V and 1A. Kit includes all components and 48 step motor. Chip is pre-programmed with demo software, then write your own, and re-program the same chip! Circuit accepts inputs from switches etc and drives motor in response. Also runs standard demo sequence from memory.

## 8-CHANNEL DATA LOGGER

As featured in Aug./Sept. '99 EPE. Full kit with Magenta redesigned PCB - LCD fits directly on board. Use as Data Logger or as a test bed for many other 16F877 projects. Kit includes programmed chip, 8 EEPROMs, PCB, case and all components.

Kit 877 **£49.95** inc. 8 x 256K EEPROMS

# MAGENTA

All prices include VAT. Add **£3.00** p&p. Next day **£6.99**

Tel: 01283 565435 Fax: 01283 546932 E-mail: sales@magenta2000.co.uk



Station Road, Cullercoats, Tyne & Wear, NE30 4PQ



All Major Credit cards Accepted... Prices Exclude Vat @17.5%. Add £1.25 (UK) carriage & Vat to all orders.

See Next / Last Months Ad. for COMPONENT ACCESSORIES

Table listing electronic components such as 4000 Series, 74HC Series, and 74LS Series with their respective prices.

Table listing electronic components including RAM, Voltage Regulators, Diodes, and Linear ICs with their respective prices.

Table listing electronic components including Bridge Rectifiers, Thyristors, Triacs, and Transistors with their respective prices.

Table listing electronic components including Electrolytic Radial, Electrolytic Axial, Resistors, and Prot Resistors with their respective prices.

Table listing electronic components including Potentiometers and Teach-in 2000 & EPE Projects with their respective prices.

Advertisement for 'New Opto Electronics Catalogue' featuring 'Quality Components' and 'Quantity Discounts Available'.

# EVERYDAY PRACTICAL ELECTRONICS

INCORPORATING ELECTRONICS TODAY INTERNATIONAL £2.65

THE No.1 MAGAZINE FOR ELECTRONICS TECHNOLOGY & COMPUTER PROJECTS

## VOL. 29 No. 8 AUGUST 2000

### IT'S ALL RELATIVE

Just when you think everything is going along smoothly and all is well, along comes something to upset everything. Not only can we look forward to atomic level semiconductors with chips so small we won't even be able to see them or to connect them with conventional connecting wires (see *New Technology Update*), but now we have light travelling at 300 times the speed of light – if you see what I mean. This, of course, means that something can be in two places at once or, to put it another way, in another place before it has left the first place (see *News*) – tends to upset the mind doesn't it. If Einstein's theory of relativity is about to be disproved, what is there left of the old ways?

I guess the world will go on, it's just that we will all have to start thinking about time in a totally different way. And what will happen to our hobby when we can't solder components together any more? It's not the first time it has seemed like the future of d.i.y. electronics is doomed, and I guess conventional components will continue to be available for a decade or so more, otherwise how will anyone ever be able to repair anything (as if they would!)?

### SOLID FUTURE

Presumably at some time soon all electronic equipment will be designed and tested in a virtual world, then the chip will be automatically produced embedded as part of the case, together with all the controls/interfaces etc – just one lump of solid plastic forming everything including the battery. Maybe you'll just pop it in the microwave oven for a few seconds to charge it up.

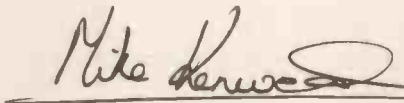

### AVAILABILITY

Copies of *EPE* are available on subscription anywhere in the world (see right), from all UK newsagents (distributed by COMAG and from the following electronic component retailers: Omni Electronics and Maplin in S. Africa. *EPE* can also be purchased from retail magazine outlets around the world. An Internet on-line version can be purchased from [www.epemag.com](http://www.epemag.com)

### SUBSCRIPTIONS

Annual subscriptions for delivery direct to any address in the UK: £26.50. Overseas: £32.50 standard air service, £50 express airmail. Cheques or bank drafts (in £ sterling only) payable to Everyday Practical Electronics and sent to EPE Sub. Dept., Allen House, East Borough, Wimborne, Dorset BH21 1PF. Tel: 01202 881749. Fax: 01202 841692. E-mail: [subs@epemag.wimborne.co.uk](mailto:subs@epemag.wimborne.co.uk). Also via the Web at: <http://www.epemag.wimborne.co.uk>. Subscriptions start with the next available issue. We accept MasterCard or Visa. (For past issues see the *Back Issues* page.)

### BINDERS

Binders to hold one volume (12 issues) are available from the above address. These are finished in blue p.v.c., printed with the magazine logo in gold on the spine. Price £5.95 plus £3.50 p&p (for overseas readers the postage is £6.00 to everywhere except Australia and Papua New Guinea which cost £10.50). Normally sent within seven days but please allow 28 days for delivery – more for overseas.

Payment in £ sterling only please. Visa and MasterCard accepted, minimum credit card order £5. Send, fax or phone your card number and card expiry date with your name, address etc. Or order on our secure server via our web site. Overseas customers – your credit card will be charged by the card provider in your local currency at the existing exchange rate.



### Editorial Offices:

EVERYDAY PRACTICAL ELECTRONICS EDITORIAL  
ALLEN HOUSE, EAST BOROUGH, WIMBORNE  
DORSET BH21 1PF

Phone: Wimborne (01202) 881749

Fax: (01202) 841692.

E-mail: [editorial@epemag.wimborne.co.uk](mailto:editorial@epemag.wimborne.co.uk)

Web Site: <http://www.epemag.wimborne.co.uk>

Online Edition [www.epemag.com](http://www.epemag.com)

See notes on Readers' Enquiries below – we regret lengthy technical enquiries cannot be answered over the telephone.

### Advertisement Offices:

EVERYDAY PRACTICAL ELECTRONICS ADVERTISEMENTS

MILL LODGE, MILL LANE

THORPE-LE-SOKEN, ESSEX CO16 0ED

Phone/Fax: (01255) 861161

Editor: MIKE KENWARD

Deputy Editor: DAVID BARRINGTON

Technical Editor: JOHN BECKER

On-Line Editor: ALAN WINSTANLEY

Business Manager: DAVID J. LEAVER

Subscriptions: MARILYN GOLDBERG

Editorial: Wimborne (01202) 881749

Advertisement Manager:

PETER J. MEW, Frinton (01255) 861161

Advertisement Copy Controller:

PETER SHERIDAN, Wimborne (01202) 882299

### READERS' ENQUIRIES

E-mail: [techdept@epemag.wimborne.co.uk](mailto:techdept@epemag.wimborne.co.uk)

We are unable to offer any advice on the use, purchase, repair or modification of commercial equipment or the incorporation or modification of designs published in the magazine. We regret that we cannot provide data or answer queries on articles or projects that are more than five years old. Letters requiring a personal reply *must* be accompanied by a stamped self-addressed envelope or a self-addressed envelope and international reply coupons. All reasonable precautions are taken to ensure that the advice and data given to readers is reliable. We cannot, however, guarantee it and we cannot accept legal responsibility for it.

### COMPONENT SUPPLIES

We do not supply electronic components or kits for building the projects featured, these can be supplied by advertisers (see *Shoptalk*). We advise readers to check that all parts are still available before commencing any project in a back-dated issue.

### ADVERTISEMENTS

E-mail: [adverts@epemag.wimborne.co.uk](mailto:adverts@epemag.wimborne.co.uk)

Although the proprietors and staff of EVERYDAY PRACTICAL ELECTRONICS take reasonable precautions to protect the interests of readers by ensuring as far as practicable that advertisements are *bona fide*, the magazine and its Publishers cannot give any undertakings in respect of statements or claims made by advertisers, whether these advertisements are printed as part of the magazine, or in inserts.

The Publishers regret that under no circumstances will the magazine accept liability for non-receipt of goods ordered, or for late delivery, or for faults in manufacture. Legal remedies are available in respect of some of these circumstances, and readers who have complaints should first address them to the advertiser.

### TRANSMITTERS/BUGS/TELEPHONE EQUIPMENT

We advise readers that certain items of radio transmitting and telephone equipment which may be advertised in our pages cannot be legally used in the UK. Readers should check the law before buying any transmitting or telephone equipment as a fine, confiscation of equipment and/or imprisonment can result from illegal use or ownership. The laws vary from country to country; readers should check local laws.

## HANDY-AMP

**TERRY DE VAUX-BALBIRNIE**

*A useful multi-purpose amplifier.*

UNTIL recently, the author's household hi-fi system had a piece of screened cable hanging down the back. This was left connected to the amplifier's high-level (auxiliary) input. When some piece of experimental audio equipment needed to be tested, the cable could be retrieved and connected to the circuit. It was then possible to listen to the result.

### NOT GOOD

This method was far from satisfactory, so a small battery-operated "bench" amplifier was designed for such purposes. As well as having an in-built loudspeaker, it has the facility for connecting personal stereo type headphones or an external loudspeaker. Also, it will accept both high-level and low-level input devices.

Magnetic record player cartridges and dynamic microphones provide a low-level output while the "line output" socket fitted to many pieces of consumer equipment (such as CD players and video recorders) provide a high level.

Many readers will, no doubt, wish to construct the amplifier for experimental purposes. However, it could have a variety of other applications. Examples include a small practice amplifier for electronic musical instruments and as the basis for an intercom, or toys and games.

Being battery-operated it may be set up outdoors and, with just a microphone (possibly with an extension lead) and a pair of headphones connected, it could be used to listen to wildlife.

Readers should note that the amplifier has been designed to be small and relatively inexpensive to construct. Although the maximum output power (one watt approximately) and sound quality are perfectly adequate for the applications suggested earlier, it is not suitable for critical applications such as serious music listening.

### WATT'S ENOUGH?

The stated power rating of 1W is applicable when the amplifier is connected to an 8-ohm load. If a 4-ohm loudspeaker were to be used, the rating would be some 1.5W. In fact, the subjective difference between the two is not great and battery life is reduced at the higher power. It is therefore recommended that an 8-ohm loudspeaker is used. A 4-ohm unit had to be used in the prototype for availability reasons.

The low-level input has its own gain control while the overall gain is set using the master volume control. This allows just about any input source to be connected, including microphones, musical instruments and consumer audio equipment.

Although not ideal, the headphone socket fitted to many pieces of electronic equipment provides a signal which will drive the high-level amplifier input. When doing this, the volume control on the equipment would need to be adjusted to obtain the correct input level. When this was tried with a small TV, the sound was better than from the TV itself.

Most of the time, the amplifier will probably be used in conjunction with the

internal loudspeaker. However, better sound quality is obtained when using either headphones or a good-quality external loudspeaker. Although the amplifier is monophonic (that is, not stereo), when used with headphones, the output is applied equally to each one. This gives a more comfortable effect than with only one headphone operating.

### ON THE PANEL

The completed Handy-Amp is shown in the photograph. For convenience, the rotary controls and all sockets and switches are mounted on the front panel. These are a jack and phono-type socket for the Low-level and High-level inputs respectively, together with the input selector switch, low-level Gain and master Volume controls, light emitting diode (l.e.d.) indicator and on-off switch, headphone jack socket, external loudspeaker sockets and output selector switch. On top, there is a matrix of holes to allow the sound to pass out from the internal loudspeaker.

There are several possible battery arrangements and the one chosen will be determined largely by the space available inside the case. This, in turn, will depend to a great extent on the dimensions of the internal loudspeaker. Whatever battery is used, it must have a nominal voltage of 9V (say, six 1.5V cells connected in series).

Cells should not have a capacity less than alkaline "AA" size. Note that a PP3 type battery would be totally unsuitable. The prototype unit was powered using two 4.5V alkaline "3LR12" batteries taped together and connected in series. These have around twice the capacity of alkaline "AA" cells.

The standby current requirement of the circuit depends on the load. In the prototype, it is 100mA. However, there will be peaks of several hundred milliamps and, depending on how the amplifier is used (operating time, load and volume), a life of some 15 hours may be expected from a pack of "AA" alkaline cells. This would be sufficient for occasional use.

With headphones connected, the standby current requirement of the prototype unit was only 50mA giving a longer battery life. The l.e.d. indicator reminds the user to switch off the unit after use.

Although battery operation is convenient and safe, for long periods of operation the use of a plug-in power supply unit might be more appropriate. More will be said about this later.



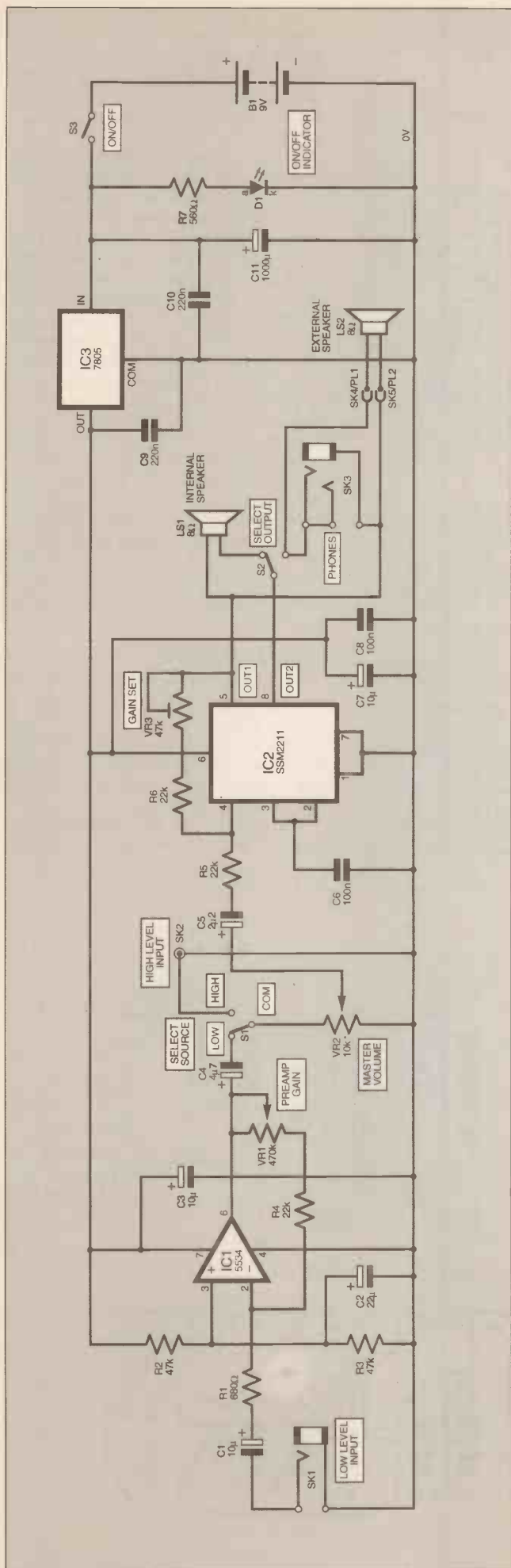

Fig. 1. Complete circuit diagram for the Handy-Amp.

## CIRCUIT DESCRIPTION

The full circuit diagram for the Handy-Amp is shown in Fig. 1. The design uses two main integrated circuits (i.c.s), IC1 and IC2, together with voltage regulator IC3.

Battery B1 provides a nominal 9V supply to the regulator which then gives a 5V supply for the main circuit. This will be maintained until the battery voltage falls to some 7V, whereupon the regulated output will fail. Thus, as the battery ages, the supply will remain constant throughout its useful life.

Note that the l.e.d. on-off indicator, D1, is connected in series with current-limiting resistor R7 directly across the battery supply – that is, it is not subject to the effect of the regulator. It will be obvious when the batteries need to be replaced because the amplifier output will become weak and distorted and the l.e.d. will become dimmer.

Capacitors C9 and C10 promote stability of the regulator. Capacitor C11 charges up from the battery and can then maintain the supply on the output current peaks when the amplifier is delivering maximum power. This helps to provide a distortion-free output.

If using a plug-in power supply unit, C11 will provide additional smoothing if a poorly-smoothed supply is used. This should not be necessary with a good-quality unit but will be useful with inexpensive ones.

## FIRST BOOSTER

When a low-level device such a microphone is connected, via socket SK1, its output voltage is first boosted using a low-noise pre-amplifier, based on operational amplifier (op.amp), IC1. High-level (line) signals are input via socket SK2, thus bypassing IC1.

## COMPONENTS

### Resistors

R1	680Ω
R2, R3	47k (2 off)
R4 to R6	22k (3 off)
R7	560Ω

All 0.25W 5% carbon film

### Potentiometers

VR1	470k min. panel mounting, lin or log rotary carbon
VR2	10k min. panel mounting, log rotary carbon
VR3	47k min. preset, vertical carbon

### Capacitors

C1, C3, C7	10μ radial elect. 63V (3 off)
C2	22μ radial elect. 63V
C4	4μ7 radial elect. 63V
C5	2μ2 radial elect. 63V
C6, C8	100n polyester, 5mm pin spacing (2 off)
C9, C10	220n polyester, 5mm pin spacing (2 off)
C11	1000μ radial elect. 16V

### Semiconductors

D1	red l.e.d., 3mm
IC1	NE5534AN op.amp
IC2	SSM2211 power amplifier
IC3	7805 5V 1A voltage regulator

### Miscellaneous

SK1	6.35mm plastic body mono jack socket
SK2	phono jack socket, single-hole fixing (see text)
SK3	6.35mm stereo jack socket, plastic body
SK4, SK5	2mm socket or as required (see text) (2 off)
S1, S2	s.p.d.t. toggle switch (2 off)
S3	s.p.s.t. toggle switch
LS1	small 8-ohm loudspeaker, 2W rating minimum (see text)

Printed circuit board, available from the EPE PCB Service, code 273; aluminium case, 203mm x 127mm x 51mm; 8-pin d.i.l. socket (2 off); 3mm l.e.d. panel clip; control knob (2 off); alkaline AA-size cells (6 off – see text); holder and connector for cells (or as required).

Approx. Cost  
Guidance Only

**£18.50**  
excluding batts. and case

The signal source is selected by switch S1 and, via volume control VR2, passed on to the power amplifier section centred on IC2.

Op.amp IC1 is configured as a voltage amplifier used in inverting mode. Pins 7 and 4 are the positive and 0V supply inputs respectively. Blocking capacitor C1 allows the alternating current signal from a source connected to socket SK1 to pass via resistor R1 to the inverting input, at pin 2.

The input impedance is set by the value of R1 and this will provide a good match for dynamic microphones. The op-amp non-inverting input, pin 3, receives a d.c. voltage equal to one-half that of the supply (nominally 2.5V) due to equal-value resistors, R2 and R3, which form a potential divider connected across the supply.

### NO PAIN, NO GAIN

The pre-amp gain is set by the ratio of feedback resistance (R4 plus VR1) to input resistance, R1. With VR1 set to minimum, this provides a gain of about 32 and at maximum, rather more than 700 (the fact that this is an inverting amplifier and the gain has a negative sign is of no real consequence here and may be disregarded).

This range of gain will suit microphones and other low-level input devices. VR1 is the low-level gain control (labelled simply "Gain" on the front panel). In use, this will be adjusted to take account of the sensitivity of individual input devices.

### MAKING THE SWITCH

The output from IC1 appears at pin 6. This passes via blocking capacitor C4 to the "Low level" (Low) contact of two-way "Select Source" switch, S1. With this set as shown, any low-level signal passes to the common contact and hence through the track of potentiometer VR2 to the 0V line.

The sliding contact (wiper) of VR2 draws off the required fraction of the signal voltage and passes it, via capacitor C5 and resistor R5, to the input of the power amplifier (IC2 pin 4). If switch S1 is set to the alternative position (High), the output from IC1 is disconnected from VR2 but now any signal applied to the high-level input socket, SK2, is directed through VR2 instead. VR2 is the master volume control (labelled "Vol" on the front panel).

### INTERNAL STRUCTURE

Power amplifier IC2 is an interesting device and a block diagram showing its simplified details is given in Fig.2. Basically, it consists of two operational amplifiers, A and B. The output of op.amp A (pin 5) provides one of the outputs (Out 1). However, it also feeds the inverting input of op.amp B (via the 50kΩ input resistor) whose output (pin 8) becomes Out 2. The loudspeaker is connected directly between Out 1 and Out 2.

Op.amp A is configured as an inverting amplifier. Thus, the signal appearing at Out 1 is an amplified and inverted version of that at the input, pin 4. Referring back to Fig.1, its gain is set by the value of external fixed resistor R6 and preset VR3 connected between Out 1 and input pin 4.

The non-inverting input (pin 3) is connected externally to pin 2 which sets it at a

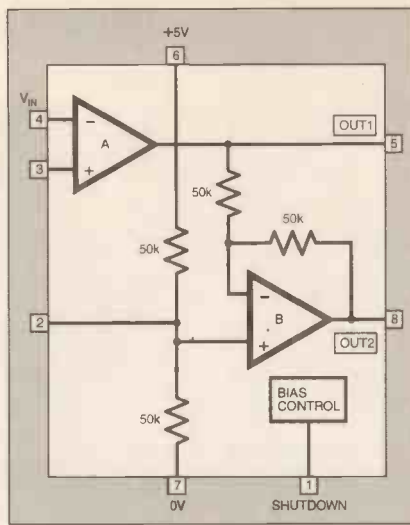

Fig.2. Block diagram of the SSM2211 power amplifier.

d.c. voltage equal to one-half that of the supply. This is due to the potential divider consisting of two internal 50kΩ resistors connected between supply positive (pin 6) and 0V (pin 7). Pins 2 and 3 are then connected to one end of the external bypass capacitor, C6, with the other end connected to the 0V line. This may be compared with the biasing arrangement used for IC1.

Op.amp B is also configured as an inverting amplifier and because the internal input and feedback resistors have equal values (50kΩ), the gain is set at minus one. Thus, any signal appearing at Out 2 is an inverted copy of that at Out 1. In this way, the input signal at pin 4 has an amplified but inverted copy of itself at pin

5 and a "straight" copy of itself at pin 8 amplified by the same amount. This is known as a bridge output configuration. Correct working depends on the two op.amp sections being exactly balanced but, of course, this is not easy to achieve precisely.

In theory, when no input signal is present, Out 1 and Out 2 will be at the same voltage. No current will then flow in a loudspeaker connected between them. When a signal is present, either Out 1 will drive current through the loudspeaker winding, which then sinks into Out 2, or Out 2 will drive current through the loudspeaker in the opposite direction and sink into Out 1. This will then reproduce the positive and negative excursions of the a.c. waveform presented to the input.

In practice, there will be a small voltage difference between the outputs in the absence of an input signal. A small standing current will then flow through the loudspeaker coil and the lower its impedance, the greater this current will be. This is added to the small current needed by the i.c. itself (for the working of op.amps A and B, and for the current drain through the internal potential divider). The overall current requirement is therefore somewhat load dependent.

### SHUTDOWN

The SSM2211 amplifier used as IC2 has a shutdown feature. Thus, if pin 1 is made high, the i.c. is put into "sleep" mode and requires very little current. However, this feature is not used here and is disabled by connecting pin 1 to the 0V line along with pin 7.

The gain of IC2 is calculated by the ratio of feedback resistance (VR3 plus

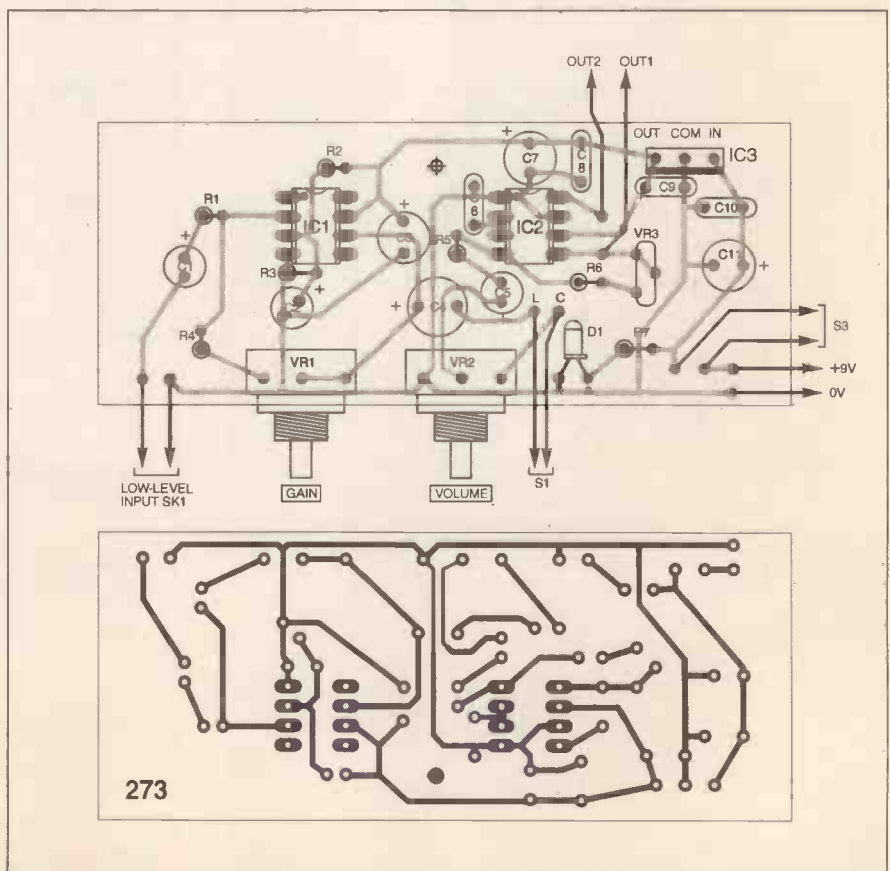

Fig.3. Handy-Amp component layout and full size copper foil track master pattern.



R6) to input resistance (R5) multiplied by two. This "multiplied by two" aspect comes about because of the bridged output configuration giving twice the voltage swing to the loudspeaker compared with a single op.amp.

With VR3 set to minimum resistance the gain is therefore two, and at maximum resistance is just over six. VR3 is a preset potentiometer which allows adjustment for the desired gain.

## OUTPUT ARRANGEMENTS

With switch S2 ("Select Output") in the position shown in Fig.1, the internal loudspeaker is connected between Out 1 and Out 2. With the switch in the alternative position, the output is directed to both the "Phones" socket, SK3, and the external loudspeaker sockets (SK4 and SK5).

It is thought unlikely that anyone would wish to connect an external speaker and a pair of headphones to the amplifier at the same time. However, even if they did, the load would not fall below the minimum impedance providing an 8-ohm loudspeaker was used.

When using headphones, a greatly reduced power is available to them compared with a loudspeaker. This is because the (usually) higher impedance allows less current to flow. The impedance of typical personal stereo type headphones is about 30 ohms for each unit.

In this design, the left and right units are connected in parallel giving a combined impedance of some 15 ohms. However, because headphones provide acoustic energy direct to the ears, only a very small amount of power is needed for them to sound with acceptable loudness.

## CONSTRUCTION

A metal case should be used as an enclosure for the Handy-Amp. A vinyl-effect aluminium box was used for the prototype unit because it gave a good appearance. Do not use a plastic box since this will not provide any screening and hum pick-up might be a problem.

Construction is based on a single-sided printed circuit board (p.c.b.). The topside component layout and full size underside copper track foil master are shown in Fig.3. This board is available from the *EPE PCB Service*, code 273.

Most of the components are mounted on the p.c.b. although there are quite a few off-board parts which will be hard-wired

to one another and to various points on the p.c.b. later.

Begin by drilling the fixing hole in the p.c.b. then solder the sockets for IC1 and IC2 in position (but do not insert the i.c.s themselves at this stage). Follow with all fixed resistors and capacitors. Note that the resistors are mounted vertically.

There are seven electrolytic capacitors and it is important to solder all of these with the correct polarity. The negative (-) end is clearly marked on the body and the corresponding lead is slightly shorter than the positive (+) one. Solder preset VR3 in place but not panel potentiometers VR1 and VR2 yet.

Fit the control knobs to VR1 and VR2. Measure how much of each spindle needs to be cut off then remove the knobs again. Hold the end of the spindle (not the potentiometer body or it could be damaged) in a vice and cut off the required length using a small hacksaw. Smooth the cut edges using a file and check that the knobs fit correctly.

Cut off the panel-location tags fitted to most potentiometers. If these are left in place, the bodies will not seat flat against the front panel when the p.c.b. is in position. The potentiometers should now be soldered to the p.c.b.

## RIGHT LEADS

Identify the l.e.d. end leads. The cathode (k) is usually shorter than the anode (a) lead. Also the body has a small "flat" to denote the cathode end. Solder the leads to the "D1" pads on the p.c.b. observing the correct polarity. Bend them through right-angles, as shown in the photograph, so that the body ends up in line with the centre of the potentiometer spindles and standing out to about the centre of the bushes.

Solder pieces of light-duty stranded connecting wire to the following points on the p.c.b.: "Low-Level Input", "S1" (L and C), "Out 1" and "Out 2". Using different colours of wire will help to prevent errors when connecting them up.

Solder the red and black battery connector wires to the "+9V" and "0V" points respectively on the p.c.b. (or use pieces of similarly-coloured stranded wire if soldered connections are needed to the batteries). Adjust the wiper of preset VR3 to approximately mid-track position.

Solder regulator IC3 in position noting that the back is towards the centre of the p.c.b. (the part that protrudes is towards the edge).



Close-up detail of heatsink mounted on IC3.

Note that the specified regulator has a current rating of 1A. Although the average requirement of the circuit is much smaller than this, in use there are peaks of several hundred milliamps and this regulator will cope well.

Due to the low average current, only a small heat sink is needed. In the prototype, this consisted of a piece of sheet aluminium size 50mm x 15mm bent through right angles as shown in the photograph. It was drilled with a small hole and attached securely to the back of IC3.

When choosing the internal loudspeaker also take into account the size of the battery pack to be used. The loudspeaker used in the prototype was a 90mm x 50mm elliptical type as used in small radios and TV receivers. Make sure that the power rating is sufficient because many small loudspeakers are inadequate in this respect. Do not use one having a rating of less than 2W.

Decide on a position for the p.c.b. and battery pack by arranging them on the bottom of the box. Consider also the loudspeaker which will be mounted on the lid section and the various off-board sockets and switches.

When the p.c.b. is finally attached, there must be several millimetres of clearance between the copper tracks and the bottom of the box. This will avoid any possibility of short-circuits. Take care that the heat sink does not touch wiring or other electrical connections.

## BORING BUSINESS

Mark the positions of the holes for the mounting bushes of potentiometers VR1 and VR2, also for the l.e.d. mounting clip. Drill these through and, gently bending the l.e.d. leads out of the way for the moment, secure the p.c.b. to the case using the potentiometer fixing nuts. Place washers (or spare fixing nuts) on the bushes on the inside of the case so that only a small amount of each bush protrudes through its hole. Mark through the p.c.b. fixing hole then remove the board again.

Mark the positions of the switches, the low-level input jack socket (mono 6.35mm type), the phono socket, the headphones



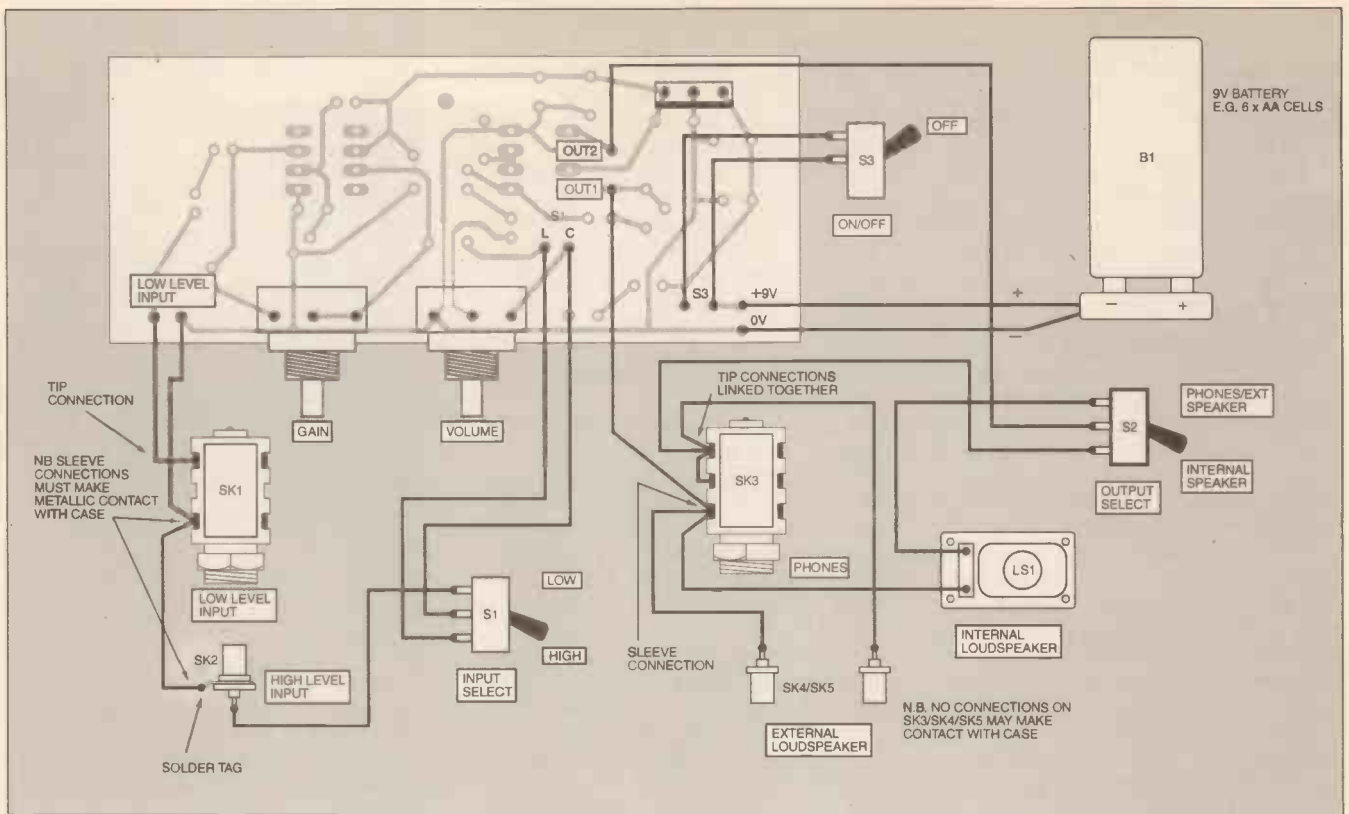

Fig.4. Off-board component connection details.

output jack socket (stereo 6.35mm – see Important Note) and external loudspeaker sockets. In the prototype, 2mm sockets were used for the loudspeaker, but the type used will depend on personal requirements. Drill the holes and mount the sockets, switches and l.e.d. clip.

### IMPORTANT NOTE

The case itself is connected to 0V (earth). It is not acceptable for the headphone stereo output socket, SK3, to be of a type where any of its contacts touch the case. If they were to, a short-circuit would be formed and this could damage IC2. This precludes using the ordinary metal sleeved type of 3.5mm jack socket because, when mounted in position, its outer (sleeve) connection would make contact with the metalwork.

There are various ways to avoid this. One method would be to use an insulating sleeve and insulating washers on a standard 3.5mm unit. However, the method used in the prototype was to use a 6.35mm plastic body stereo jack socket. This had all its connections isolated from the case. Headphones are then connected to it via a 6.35mm to 3.5mm converter.

Mount the socket and check, using a meter, which tag is which and that none of its tags make contact with the case.

The mono jack socket, SK1, used for the low-level input, unlike the headphone output socket *must* have its sleeve connected to 0V (earth). Since this socket will probably have a plastic body, it will not be done automatically and the sleeve connection will need to be hard-wired to a solder tag attached to the case.

The phono socket (SK2 – high-level input) must also have its sleeve connected to 0V. If using the specified single-hole fixing type, this will be done automatically. Note that this socket usually has a solder

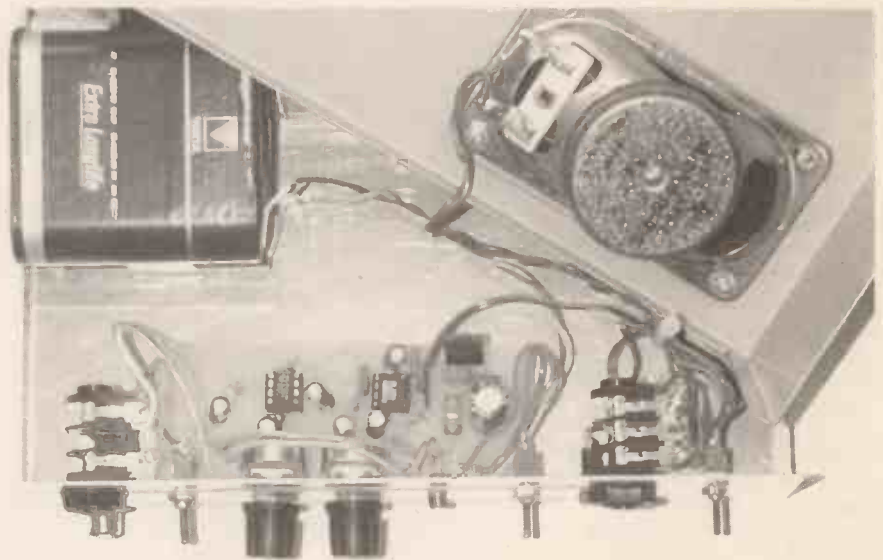

tag on its bush and this may be used for the SK1 earth connection. If the phono socket is of a fully-insulated type, you will need to make a connection between the sleeve tag and the case using a solder tag (which will also be used for SK1).

### HARD WIRING

Referring to Fig.4, carry out all the internal wiring using light-duty stranded connecting wire. By using different colours, you will avoid errors (rainbow ribbon cable is ideal). Note that the two non-sleeve (tip) tags of the headphone socket are joined together so that both headphone units are connected in parallel.

Remember to leave all wires interconnecting the various points on the p.c.b. with off-board components long enough to enable the p.c.b. to be removed without straining them, should this ever become necessary. Also, the loudspeaker wires

should be sufficiently long to allow the lid of the box to be removed without straining them.

Place the loudspeaker in position and mark the fixing holes on the lid of the case. Take care to avoid the p.c.b. (especially the heat sink on IC3) and battery pack positions.

Mark out the holes which are needed to allow the sound to pass through. Drill these using a small (say, 1.5mm) drill then increase the diameter to 5mm approximately. Work carefully because the appearance of the finished project will be spoiled if the holes are drilled carelessly.

Carefully clean away any metal particles then attach the loudspeaker. Solder the wires to its tags and apply some strain relief so that they cannot pull free when removing the lid of the case. In the prototype, this was done using a solder tag



having a long "tail". This was attached to one of the loudspeaker fixings.

The wires were protected using a short piece of sleeving and the tail of the solder tag was gripped gently around them. Take care that the wires are not so tightly held that a short-circuit is produced.

Attach the p.c.b., making sure that it is parallel with the base of the box. Measure the clearance between the copper track side and the bottom of the case. Cut a plastic stand-off insulator to the same length. Slide it into position and secure the p.c.b. using a thin nylon nut and bolt.

Gently bending the leads as necessary, push the l.e.d. into its clip. Attach the control knobs to the potentiometer spindles. If the knobs have a white line or spot, this should be arranged to be vertically upwards when the control is at its half-way position.

## FINAL ASSEMBLY

Fit self-adhesive plastic feet to the bottom of the case to protect the work surface. Attach the battery pack using a small bracket or adhesive fixing pads (sticky Velcro pads were used in the prototype). Do not connect the battery yet.

Immediately before unpacking and handling IC1 and IC2, touch a metal object which is earthed (such as a water tap). This will remove any static charge which might exist on the body. This is a wise precaution because the i.c.s are static-sensitive and could be damaged by such charge. Insert them into their sockets with the correct orientation.

Place the lid of the case in position but do not actually attach it. Make a final check that nothing is obstructed and, especially, that the heat sink on IC3 is completely free of all wiring and internal components.

Make sure switch S3 is off. Before connecting the battery, make certain the polarity is correct. The circuit will be damaged if the polarity is incorrect. Make certain the positive battery connection cannot make contact with the case or the battery will be short-circuited. This could result in damage to p.c.b. tracks. Switch on S3 and check that the l.e.d. indicator lights up.

## TESTING

Begin testing by using the amplifier with a high-level input source, such as the line output of a CD player, cassette deck or the audio output from a video recorder; if this is stereo, use only one channel. Connect it to the phono socket using a piece of mono screened lead with suitable connectors at each end. Set switch S1 to "High" and S2 to "Internal Speaker". Turn both VR1 and VR2 fully anti-clockwise.

Switch on the input device and slowly increase VR2. The sound should be heard clearly. Adjust preset potentiometer VR3 so that the sound is undistorted when VR2 is at maximum. You will find that the setting is not particularly critical. Almost maximum resistance was correct for the prototype (that is, the sliding contact almost fully clockwise when viewed from the right-hand edge of the p.c.b.).

Leave the system operating for about ten minutes then switch off and check that the regulator heat sink is not excessively

hot. If it is uncomfortable to touch, increase its area. When satisfied on this point, attach the lid section.

Turn VR2 to minimum again. Switch S1 to "Low" and connect a dynamic microphone to the low-level input jack. Increase VR2 to approximately one-third of its total clockwise rotation then increase VR1 slowly while speaking into the microphone. The sound should be clearly heard.

If the controls are turned up too far, or the microphone is placed too close to the unit, acoustic feedback will become evident. This usually manifests itself as a loud squealing noise from the loudspeaker.

Acoustic feedback is a potential problem with any loudspeaker/microphone system. It comes about because sound from the loudspeaker re-enters the microphone and builds up in a positive feedback loop. To prevent it, turn down the controls, move the microphone away and/or point it in the opposite direction to the loudspeaker. Acoustic feedback may be largely eliminated by using headphones instead of a loudspeaker.

It is unlikely that the low-level gain will need to be increased. If it is found to be necessary, decrease the value of resistor R1 to 560 ohms or even 470 ohms. Note that excessive gain leads to instability.

When connecting an external loudspeaker, always remember to switch off the amplifier first. This will avoid any possibility of loudspeaker connections touching the case and possibly damaging IC2.

## POWER ADAPTOR

If you wish to use a plug-in power supply instead of a battery, use a 9V d.c. type having a current rating of 800mA minimum. A fuse and polarity-protection diode need to be included (see later) if damage to the unit itself or to the circuit are to be avoided.

Attach a power-in type socket to the rear of the box to suit the output plug on the power supply unit. If its sleeve connection does not make contact with the metalwork automatically, you will need to hard-wire this to a solder tag attached to the case.

Preferably, the power supply unit should have a fixed polarity with the centre (pin) on the output plug being the positive and the sleeve the negative. If the polarity can be reversed, make sure that the pin is made positive. If the polarity is incorrect, the circuit will be damaged. This is why a diode should be connected in the positive feed wire. If the polarity is incorrect, the diode will not conduct and nothing will happen. The fuse protects against possible short-circuits.

Referring to Fig.5, sleeve both end wires of a type 1N4001 diode. Solder the anode (non-stripped end) to the centre (pin) connection of the socket. Attach a 20mm chassis fuse holder to the bottom of the box in such a position that the cathode of the diode can reach one of its tags. Solder this in position. A wire from the other fuse tag should then be taken to the "+9V" point on the p.c.b.

Insert a 20mm 1A quick-blow fuse in the fuse holder. Make sure none of the connections to the diode or fuse can touch the case. Use insulation if necessary. □

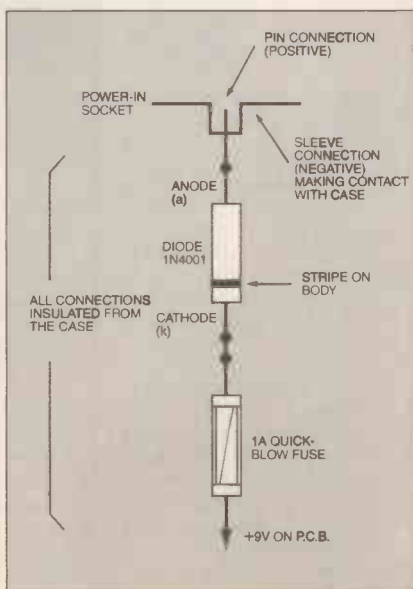

Fig.5. Using a fuse and diode as protection devices when a power supply adaptor is used.

## TAMING THE WORM

Barry Fox views the latest in holographic data storage techniques.

IMATION and parent 3M have been selling optical disk recorders for 25 years and are now promising a holographic CD-ROM recorder for £3000 by 2002. After working with Bell Labs and Lucent Technologies, Imation is confident it can achieve what others have only talked about by modifying technologies that are already being mass-produced for other applications.

Says Imation's European Technical Manager, George Purrio, "We know that others, such as Bayer, are working on holographic storage but we believe our experience in optical disk technology puts us at least two years ahead with a commercial product".

### Terabyte Storage

First generation holodisks costing \$10 will store 125 gigabytes, compared to under 20GB for a DVD. Storage will later increase to a terabyte, with data transfer rates up to a gigabit per second and at least 25 times faster than for DVD.

To cut costs Imation will use WORM (write once, read many times) blanks made from light sensitive polymer made by Lucent. With so much storage space per disk there is no need to use expensive and unstable erasable technology, such as lithium niobate. WORM users automatically build a permanent audit trail of all their data before and after any modification, without the risk of accidental erasure.

### Data Beams

A 200mW gas laser, already available for \$2000 and likely soon to cost \$300, shines through a half-silvered mirror to create a reference beam and data beam. The reference beam obliquely hits a polymer disk which spins on a modified CD-ROM drive. The data beam goes to a digital micromirror developed by Texas Instruments for video projectors. A million or more tiny mirrors on the surface of a chip flip-flop between on-off positions to let light pass through or reflect away.

The bitmap displayed on the micromirror is created either by buffering a stream of raw data from a PC, digital video or audio system, or by scanning an image or page of text.

The data beam, which now images whatever digital bitmap is displayed on the micromirror, falls on the polymer disk at the same spot as the reference beam, but at a different angle. This creates an optical interference pattern which permanently changes the chemistry of the polymer. So the disk records a sequence of bitmaps along a spiral track like a CD recording. Further series of bitmaps can be recorded

deeper into the polymer by altering the angle of the beams so that they cross at lower depths.

The disk is read by removing the micromirror and shining pure beams through the polymer and onto a megapixel CCD image sensor of the type now routinely built into digital still picture cameras that cost \$500 or less.

Data transfer is rapid because the recorder is capturing whole pages or blocks of data at a time.

### Designer Challenge

The challenge, which defeats designers without know-how in the field of disk

recording, is to servo-control recording and playback of tightly spaced data tracks at different depths.

Dr Peter Fryer is Director of Research at B&W, a world leader in high quality loudspeakers. In the 1980s, while working for another speaker company, Wharfedale, Fryer pioneered the use of lasers to analyse cone motion. He laboriously stored a pair of images on a high resolution photo plate which then interfered to create a hologram. Fryer says he would jump at the chance of storing whole series of images in real time on a disk. "People have been talking about this for 20 years. Now let's see if they can really deliver".

## ADAPTING TO THE FUTURE

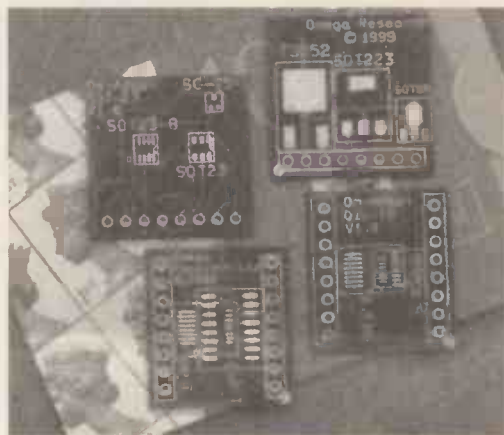

FOR some time, whilst chip manufacturers forge ahead with packing more functionality into yet smaller devices, development engineers have struggled with the problem of prototyping with these devices. The usual solution of using the leaded version of the chosen device is becoming increasingly difficult with more and more chip makers not producing these variants.

To address this situation, Omega Research has created the Om-Adapt family of miniature SMD adaptors, each tailored to suit a variety of package sizes. The adaptors have an outer array of 1mm pin holes tracked back to the SM device. The holes allow the adaptor to be more readily connected to several successive developments of a prototype design without the need for tricky SMD soldering for each stage.

Whilst the soldering of many SMD packages to the adaptors is probably beyond the capability of hobbyists, the pitch between the tracks being far too minute to allow success without sophisticated equipment, the technique obviously provides a viable solution for industrial designers.

It does hammer home that increasingly many of the newer chips can never be used by hobbyists for their designs. However, even more than a decade ago, we recognised that this would increasingly become the case. It is reassuring, though, to know that many common devices so vital to our hobby are still readily available as standard packages, which we can conveniently use with our stripboards and p.c.b.s., and seem likely to be so for many years yet to come.

Nonetheless, it is interesting to note that even industry is finding the newer SMDs problematic at the circuit design stage, justifying the use of adaptors such as Om-Adapt.

For more information on Om-Adapt, contact Omega Research Ltd., Dept EPE, 44 Coles Road, Milton, Cambridge CB4 6BW. Tel/Fax: 01223 519458.

E-mail: adm@omega-research.co.uk

Web: www.omega-research.co.uk

# LIGHT BARRIER BROKEN!

A fundamental concept has been challenged.

John Becker reports.

**A**STONISHING – the finite speed of light appears to have been exceeded! A report in the *Sunday Times* of 4 June 2000, authored by their Science Editor Jonathan Leake, states quite categorically that “scientists claim they have broken the ultimate speed barrier: the speed of light”.

Apparently, at the NEC Research Institute in Princeton, USA, Dr Lijun Wang “transmitted a pulse of light towards a chamber filled with a specially treated caesium gas. Before the pulse had fully entered the chamber it had gone right through it and travelled a further 60ft across the laboratory”.

Dr Wang’s interpretation of this phenomenon is that the pulse exceeded the speed of light by 300 times. The conventional definition of the speed of light (in free space) is  $2.997925 \times 10^8 \text{ms}^{-1}$ , or 186,000 miles per second in rounder terms.

## Profound Significance

If indeed the light barrier has been broken, this has the most profound effect upon Einstein’s assertion that the velocity of light is constant and cannot be exceeded. His famous formula of  $e = mc^2$  is based upon this assertion.

Further, it raises serious questions about our interpretation of the nature and size of the universe. It is understood that the latter is already in question based upon observations of far distant galaxies by the Hubble Space Telescope. They are far better formed than theory would predict, their estimated distances and evolution being based on how far they and their light would have travelled since the Big Bang.

The *ST* also suggests that Dr Wang’s light pulse travelled forward in time and that this “would breach one of the basic principles in physics – causality, which says that a cause must come before an effect”.

## Cautious Response

We contacted NEC Research and asked for more details of Dr Wang’s experiment. NEC spokesperson Carla Tomko replied by E-mail that “Dr Wang is not at liberty to discuss his research until such time as his article is published in *Nature*. Please watch for the article in an upcoming issue”.

Browsing through NEC’s web site ([www.neci.nj.nec.com/neci-website/bios/wang.html](http://www.neci.nj.nec.com/neci-website/bios/wang.html)) revealed a thumbnail biography of Dr Wang, which states that his “research was in quantum optics and laser physics during his Ph.D years, and light interaction with matter and the manipulation of atoms during his postdoctoral work at Duke University”.

Of himself, Dr Wang says “part of my research interest in quantum optics is to identify various aspects of such limitations”. He would appear to be exceeding his expectations!

It must be stressed, of course, that before the light barrier can be accepted scientifically as having been exceeded,

Dr Wang’s findings must be corroborated by independent researchers, a matter which may take many years of experiment and controversy. However, the *ST* also reported that physicists at the Italian National Research Council have propagated microwaves at 25 per cent above normal light speed.

We await seeing Dr Wang’s report in *Nature* with great interest. The *ST* story can be accessed at [www.sunday-times.co.uk/news/pages/Sunday-Times/stifgnusa01007.html](http://www.sunday-times.co.uk/news/pages/Sunday-Times/stifgnusa01007.html).

## ON-LINE TIMER

By Barry Fox

**P**ARENTS who fear huge phone bills when their children get hooked on the Internet or on-line Dreamcast games can try paying £40 for a Timed Internet Connection from Pulse Design of Bognor Regis.

TIC plugs between the PC or games console and phone line and limits both the connection time allowed during each 24 hour period that follows the setup time, and the waiting time between connections. Bleeps warn when automatic disconnection is imminent.

Parents choose a 4-digit PIN which prevents unauthorised reset, and the unit sounds if unplugged. Savvy parents may also want to secure the plugs with glue.

For more details contact Pulse Design, Dept EPE, PO Box 81, Bognor Regis, Sussex PO22 8YP. Tel: 01243 827179.

## LONG LIFE LAMPS

By Barry Fox

**M**ATSUSHITA, the Japanese company which makes Panasonic electronics, promises long life lamps that use microwave energy to make artificial daylight. Existing lamps use a white hot filament or electrodes that create plasma, and burn out after a few thousand hours. Matsushita’s lamp uses microwaves, at the same  $2 \times 45 \text{GHz}$  frequency as microwave ovens.

The waves resonate and amplify as they pass through a series of 10mm compartments and hit a 3mm plate coated with a mix of indium and bromide compounds that radiate light with a colour temperature similar to daylight. Microwave power is 50 watts. Because there are no filaments or electrodes to fail the lamp lasts 60,000 hours. Matsushita says product will be ready to sell by 2002.

## Smart Home Security

**BRITISH** Telecom has announced a new technology, Smart-Electrics, which is set to revolutionise the protection of people and property in home and business settings.

It will make stolen TVs, videos and hi-fi equipment useless to burglars and provide an economical platform to monitor homes or workplaces for break-ins, fire, smoke and environmental factors.

The technology is based on a simple intelligent “home control centre” to which electrical appliances are registered through a low bit rate communications protocol. Subsequently, any Smart-Electrics equipped electrical item which is stolen will refuse to operate when plugged into the mains in an unauthorised location.

More information can be obtained via BT’s news release centre accessible through [www.bt.com](http://www.bt.com).

## NIMROD GAS IRON



**INTRODUCED** by Shesto, the Nimrod range of three stylish cordless butane soldering kits are described as “go-anywhere tools that can be instantly converted from soldering iron to blow torch, hot knife or heat blower”. They are said to be ideal for occasional hobby, electrical and DIY tasks as well as for professional use.

Supplied with a range of interchangeable heads, these 4-in-1 tools can perform soft soldering, silver soldering, heat shrinking, and cutting and modelling of waxes, thermoplastics and foams. All three kits in the Nimrod range are powered by standard butane lighter fuel.

For more information contact Shesto Ltd., Dept EPE, Unit 2, Sapcote Trading Centre, 374 High Road, Willesden, London NW10 2DH. Tel: 020 8451 6188. Fax: 020 8451 5450. E-mail: [sales@shesto.co.uk](mailto:sales@shesto.co.uk). Web: [www.shesto.com](http://www.shesto.com).

# New Technology Update

*Are we looking at the beginning of the age of atom-sized electronics, asks Ian Poole*

FOR SOME time now integrated circuit developers have been saying that the concepts currently used for semiconductor devices will not be able to meet the requirements for higher speed, greater levels of integration and higher levels of functionality that will be needed by equipment manufacturers in the years to come. Researchers have been warning that the limits of the current technology will be reached very soon.

In fact, it has been a tribute to the semiconductor industry that they have been able to take the technology as far as it has come. With sub-micron feature sizes now common place, it is believed that the end of the road for the current technology might at last be in sight, and totally new technologies will be needed.

With the requirement for a new technology established and a number of ideas on the horizon, it is likely that we will see a new revolution in the world of electronics. This could be more far reaching than that caused by the introduction of semiconductors and the subsequent introduction of the integrated circuit.

## Electron Electronics

In recent years a number of organisations have been investigating the possibilities of using single electrons to act as the stimulus in circuits, rather than the very large number currently required. This could, it is said, bring about a complete change in the way that circuits operate, and in the sizes that are achievable. It is also claimed that this will result in a completely new technology being introduced and semiconductor devices as we know them today being confined to the archive box.

The possibilities that the new technologies could offer are tremendous. Not only would the size reductions enable data to be stored in a far more compact way, vastly increasing storage capacity, but also they would enable much greater speeds to be attained. With the enormous requirement for faster and smaller devices, with greatly increased functionality, such a new technology would enable electronics to take a quantum leap forward.

Although the idea of being able to develop atom-sized devices has been demonstrated, this type of technology is in its infancy and there are still many obstacles to overcome before atomic electronic devices become available for use. Currently an atom-sized memory device has been demonstrated, where a single electron is stored to give a single bit of data. However, other devices are also required if the technology is to become a reality.

As part of the development of this new area of technology scientists at the IBM Almaden Research Centre in California have developed a new method of using the wave nature of electrons to transport information on an atomic scale.

## It's No Mirage

The effect is known as the "quantum mirage effect", and it should enable data to be manipulated on an atomic scale within true micro-circuits. These will be so small that any form of conventional technology within the circuit will not be possible, and this even applies to the interconnections.

This quantum mirage effect can best be described as a way of guiding information through a solid material and can be used within a number of devices for handling data.

The discovery of the mirage effect was made by three IBM scientists: Manoharan; Lutz; and Eigler. They used a low temperature scanning tunnelling microscope (STM) to arrange several dozen cobalt atoms into an ellipse on a copper surface. This acted as what is known as a quantum corral, reflecting the surface electrons of the copper into a wave formation.

By placing a cobalt atom at one focus of the ellipse it is found that a smaller "mirage" atom appears at the other focus. The actual intensity of the mirage depends upon the quantum state of the ellipse and in turn this is dependent upon its shape.

The research has set up a number of experiments with these devices. Corrals with a variety of shapes have been built and tested. Lengths up to 20nm and widths less than 10nm have been tried to assess the differing properties that can be obtained.

Using the new technology the research scientists have commented that devices using this technology could be made exceedingly small. The basic concepts also permit many interesting experiments into topics like investigating magnetism at an atomic level, and possibly manipulating individual electron spins.

These experiments are not directed towards any particular devices at the moment, but rather at gaining a greater understanding of these effects. This will undoubtedly be useful in developing this technology and could ultimately lead to the development of further new devices.

## Current State of Affairs

It is understood that the manufacture of a device for commercial applications is still many years away. Developing the concept for use in a realisable form for widespread use still requires very significant amounts of development. For example, the process

of making the ellipse is very much a laboratory technique and not practicable for widespread use.

Moreover, there are no techniques for connecting individual devices together and this will need to be resolved before any real use can be made of the technology, even on a laboratory scale. Also a rapid and power efficient way of modulating the available quantum states must be found.

Although this technology may seem rather futuristic, pressure will soon start to build as the feature sizes on integrated circuits fabricated using traditional circuits reach the final limits.

## Looking Ahead

The ability to manipulate atoms and molecules on an individual basis has opened a new experimental frontier that makes feasible the quest for single molecular-scale devices as successors to the transistor. Not only will digital circuits be available, but if the technology is to become truly universal then analogue circuits must be fabricated as well.

Further developments that are under way include the construction of an amplifier. Work on this is already in progress using a single molecule less than 1nm in diameter. Again this device works by using a quantum mechanical effect, and to date a gain of 5 has been verified.

The implications of these developments show that scientists are very seriously looking toward the development of devices on atomic scales using totally new techniques and ideas but based around quantum mechanical effects. It is claimed that this is likely to bring a completely new way of thinking to electronics, ultimately making discrete components a thing of the past.

How and when this will happen, and the time-scales involved still remain to be seen, but it most certainly is a development that is clearly in view, even if it is right on the horizon. The big question is how long these circuits will take to become reality.

A tremendous amount of investment is required to be able to realise devices that could be used, and then it will take a considerable amount of time before they would be commercially viable. It took over ten years from the first discovery of the transistor before they were widely used.

Initially they were far too expensive for universal use. Now transistors and integrated circuits can be obtained for a few pence. As this technology is likely to require considerably more development and investment in plant, it could take much longer before devices appear in the equivalent of transistor portable radios.

from  
**£60 (inc)**  
Shareware Version  
Download & Order Online!

# PROTEUS

## VSM

Virtual System Modelling

Build It In Cyberspace

[www.labcenter.co.uk](http://www.labcenter.co.uk)

*Develop and test complete micro-controller designs without building a physical prototype. PROTEUS VSM simulates the CPU and any additional electronics used in your designs. And it does so in real time. \**

- CPU models for PIC and 8051 and series micro-controllers available now. 68HC11 coming soon. More CPU models under development. See website for latest info.
- Interactive device models include LCD displays, RS232 terminal, universal keypad plus a range of switches, buttons, pots, LEDs, 7 segment displays and much more.
- Extensive debugging facilities including register and memory contents, breakpoints and single step modes.
- Source level debugging supported for selected development tools.
- Integrated 'make' utility - compile and simulate with one keystroke.
- Over 4000 standard SPICE models included. Fully compatible with manufacturers' SPICE models.
- DLL interfaces provided for application specific models.
- Based on SPICE3F5 mixed mode circuit simulator.
- CPU and interactive device models are sold separately - build up your VSM system in affordable stages.
- ARES Lite PCB Layout also available.

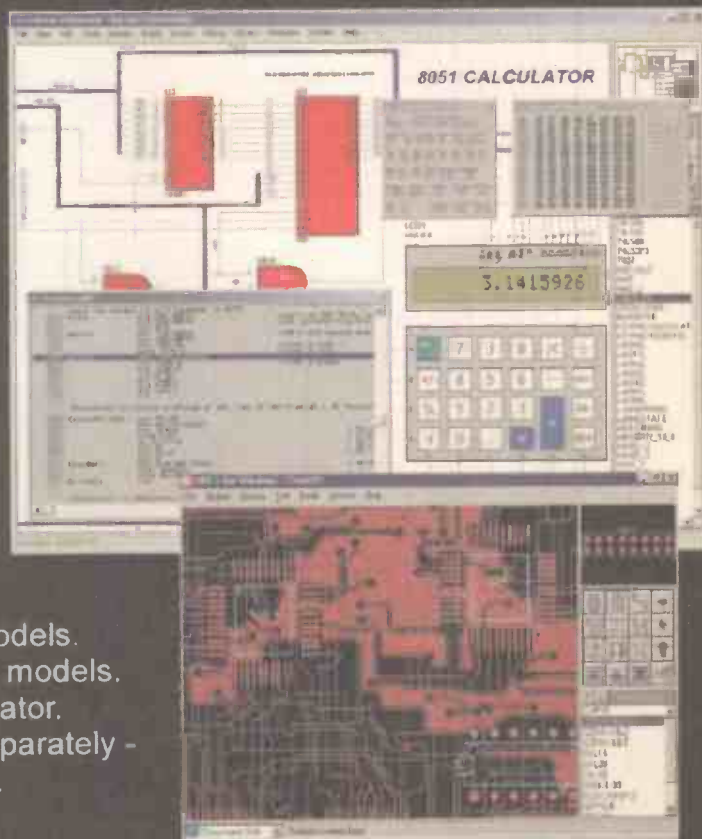

**labcenter**  
Electronics

\*E.g. PROTEUS VSM can simulate an 8051 clocked at 12MHz on a 300MHz Pentium II

Write, phone or fax for your free demo CD - or email [Info@labcenter.co.uk](mailto:Info@labcenter.co.uk).  
Tel: 01756 753440. Fax: 01756 752857. 53-55 Main St, Grassington, BD23 5AA.

# INGENUITY UNLIMITED

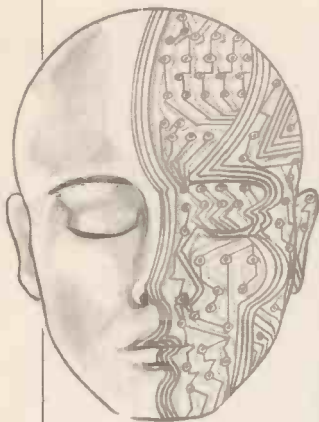

Our regular round-up of readers' own circuits. We pay between £10 and £50 for all material published, depending on length and technical merit. We're looking for novel applications and circuit tips, not simply mechanical or electrical ideas. Ideas *must be the reader's own work* and **not have been submitted for publication elsewhere.**

The circuits shown have NOT been proven by us. *Ingenuity Unlimited* is open to ALL abilities, but items for consideration in this column should preferably be typed or word-processed, with a brief circuit description (between 100 and 500 words maximum) and full circuit diagram showing all relevant component values. **Please draw all circuit schematics as clearly as possible.**

Send your circuit ideas to: Alan Winstanley, *Ingenuity Unlimited*, Wimborne Publishing Ltd., Allen House, East Borough, Wimborne, Dorset BS21 1PF. They could earn you some real cash and a prize!



## WIN A PICO PC BASED OSCILLOSCOPE

- 50MSPS Dual Channel Storage Oscilloscope
- 25MHz Spectrum Analyser
- Multimeter • Frequency Meter
- Signal Generator

If you have a novel circuit idea which would be of use to other readers then a Pico Technology PC based oscilloscope could be yours. Every six months, Pico Technology will be awarding an ADC200-50 digital storage oscilloscope for the best IU submission. In addition, two single channel ADC-40s will be presented to the runners-up.

## Cool Controller – A Cool Number

A NOVEL thermostatic controller for a small d.c. operated fan, perhaps for computer cooling or similar, is shown in Fig.1. The LM3914 bargraph driver IC2 contains 10 comparators which are referenced at 1.2V and set at pin 8. Pin 5 of the device provides the comparator network with an input. The sensor circuit stage, which provides the temperature-sensitive signal to the LM3914, comprises of a voltage divider made up of resistor R2 and n.t.c. thermistor R3, potentiometer VR1 and transistor TR3.

Changes in temperature are amplified by the transistor TR3 and applied to pin 5. A bargraph output is obtained from pins 10 through to 18 and also pin 1. These outputs are connected to ten current limiting resistors and

l.e.d.s. The motor driver circuit takes an input signal from any of the ten available points between the resistors and l.e.d.s. This drives a *pnp* transistor switch TR1 which in turn activates the Darlington power switch TR2 and drives the fan motor.

The temperature level selected is reflected by the corresponding l.e.d. being brighter than the rest of the display, which allows the user to monitor what level has been selected. The motor turns on once the predetermined temperature has been reached and switches off when the temperature falls below the selected level.

M. N. Beg,  
Johannesburg,  
South Africa.

**WHY NOT  
SEND US YOUR  
CIRCUIT IDEA**  
Earn some extra  
cash and possibly  
a prize!

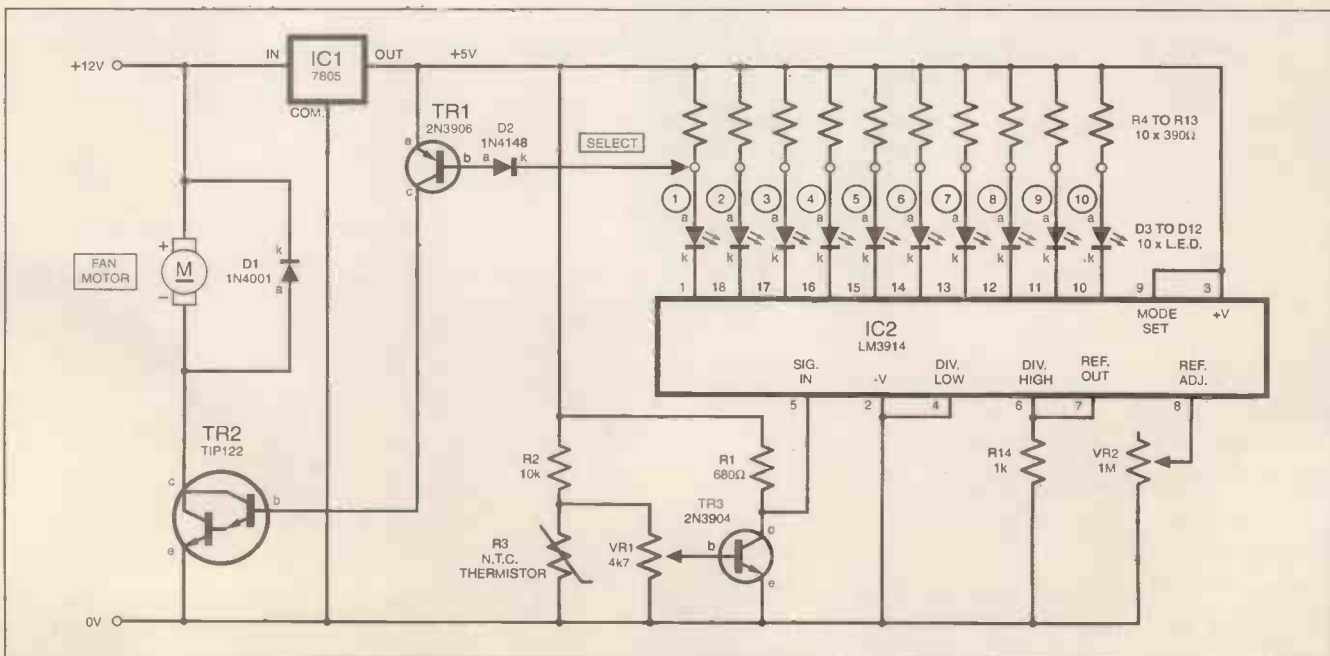

Fig.1. Circuit diagram for a thermostatic controller for small d.c. operated fans.



# VOM Continuity Buzzer -

## Making a Buzz

LIKE many electronic enthusiasts, I own both analogue and digital multimeters plus a home-made continuity buzzer. The continuity tester function on the digital voltmeter (DVM) is handy but I find that for most of the time I prefer my conventional analogue volt/ohmmeter (VOM) for troubleshooting purposes.

For many experimenters, it would be ideal to have a similar continuity buzzing function on an analogue VOM. The idea came about whilst testing the current sensitivity of a miniature reed switch. It struck me that as little as 100mA was required to operate it with a coil of 200 turns. The coil resistance was only a few ohms.

Referring to the schematic of my VOM resistance range, see Fig.2a, it was noticed that a large current of 150mA passes through one 19 ohm resistor during the Rx measurement. By wiring the reed switch operating coil in series with resistor R4 and putting a shunt resistor (R5) in parallel across it (see Fig.2b), the total resistance value between point A and B remains unchanged.

In my case, the added resistor is 180 ohms but its value depends on the resistance of the series reed operating coil. This does not affect normal Rx measurement but whenever the external resistance Rx falls below 33 ohms, the reed contact closes which sounds a 3V piezo buzzer WD1.

The circuit wiring as shown was inserted into my VOM but actually failed to work properly when the case was closed up. Eventually, I realised that the strong magnetic field of the meter had been biasing the reed's own closing magnetic field. The solution is simply to reverse the coil leads and everything worked happily ever after.

Mr. Lim Chung,  
Haywards Heath, W. Sussex.

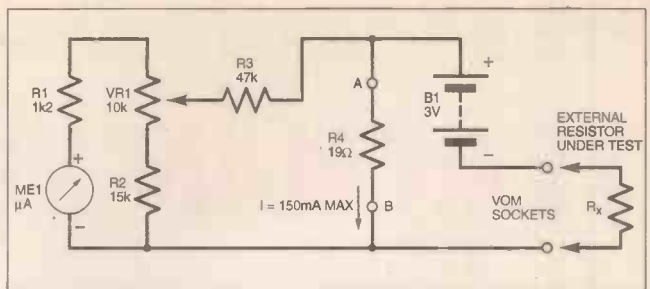

Fig.2a. VOM Rx measurement range circuit.

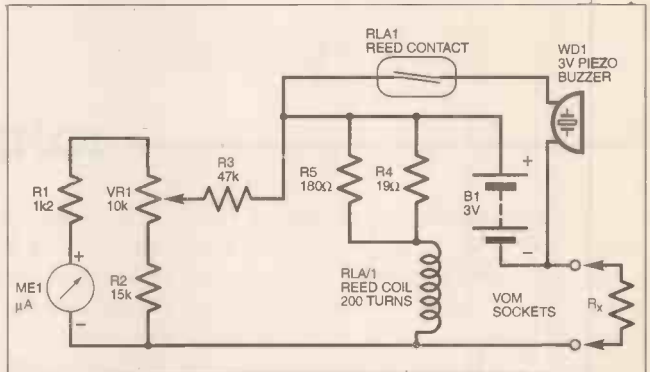

Fig.2b. Circuit showing VOM Rx measurement with buzzer added.

# Square Wave Circuit - Safe and Simple

THE circuit diagram of Fig.3 supplies a square wave at 100Hz derived from the mains but is isolated from it for safety by an opto-isolator. The mains voltage is reduced to around 9V using a small transformer (e.g. a scrap or surplus one) and full-wave rectified by bridge diodes D1 to D4 to give a waveform pulsating at 100Hz.

This is applied via resistor R1 to the l.e.d. emitter of an opto-isolator. The signal is then transmitted optically to the photo Darlington transistor (TR1/TR2) in the same package as the l.e.d. This isolates the mains by using the light rather than a direct connection to carry the signal.

A separate 9V d.c.-operated circuit is used in which the square wave is generated. The unusual part of the circuit is that the Darlington pair is used not only as part of the opto-isolator, but also as the input of a discrete Schmitt trigger which is used to "square" the output of the opto-isolator. The diode D6 in the emitter circuit of TR1/TR2 produces an almost constant emitter voltage which assists the Schmitt switching action.

## Opto-Isolator

The original circuit used a TIL119 isolator but it should be possible to use other types, even those using a single phototransistor instead of the Darlington, provided that resistor R1 is adjusted in value to give a reasonable l.e.d. current. With a 9V transformer a value for R1 of 4.7 kilohms (4k7) is a good starting point.

None of the part types is critical. Transistor TR3 is a BC149B which can be substituted with any silicon npn small signal high gain transistor (e.g. 2N3903 - ARW). The values given result in a 1:1 mark-space ratio at the output, which is

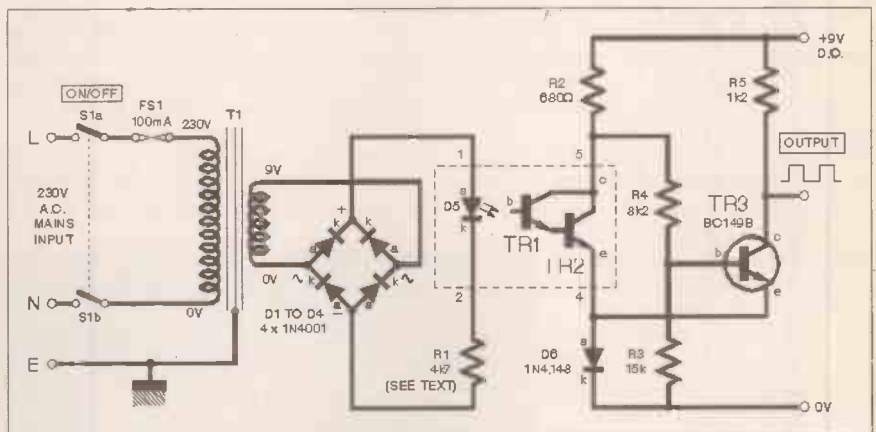

Fig.3. Square wave generator circuit. L.E.D. D5 and TR1/TR2 are contained within an opto-isolator. The circuit requires a separate 9V d.c. power supply.

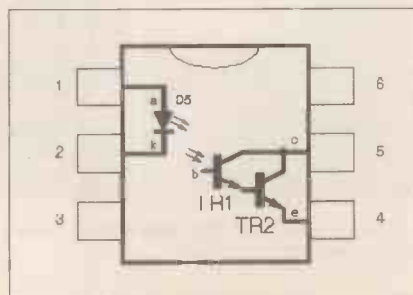

Fig.4. Pinout information for the TIL 119 opto-isolator.

taken from the collector of TR3. (Overseas readers using a 60Hz supply will see a 120Hz signal. - ARW)

J. C. Stephens (G7WJK),  
Accrington, Lancs.

## INGENUITY UNLIMITED

BE INTERACTIVE

IU is *your* forum where you can offer others readers the benefit of your Ingenuity. Share those ideas, earn some cash and possibly a prize!





# TEACH-IN 2000

## Part Ten – Transformers and Rectifiers

JOHN BECKER

Originally we had intended that the *Teach-In 2000* series should run to 10 parts. A somewhat restricted intent as it turns out! There has been far more information that we felt we should impart to you than could have reasonably fitted into just 10 parts. The Op.amps discussion, for example, had to be split into two sections, in Parts 7 and 8. Now Power Supplies have to be split into two sections as well.

In this part we examine how the mains a.c. supply can be converted to a much lower d.c. supply that can be used to power your electronic circuits. Thus it is Transformers and Rectifiers which are discussed this time. In Part 11 we shall look at how d.c. voltages can be regulated and how CR ratios affect their stability. The series will end with Part 12, in which we shall discuss displays and digital-to-analogue converters.

**P**OWER, without which *nothing!* Well, a rather grand and all-embracing statement, perhaps, but it certainly sums up the situation as far as running electronic devices is concerned – you can't use them without electrical power, as you discover each time you disconnect your battery . . .

We shall now discuss power transformation and control, partly using your computer to help demonstrate some of the fundamental facts. In the Experimental section we'll then get you trying out some of the concepts and see how they work. Most will be done with your breadboard and 6V battery, with the option to use a mains adaptor (battery eliminator) next month.

Before we start, run your computer and from the *Teach-In 2000* program's main menu select Power Supplies – Menu. From that sub-menu select Transformers – Principle (see Photo 10.1). We'll discuss the screen display presently.

### TRANSFORMERS

In the second paragraph above we used the phrase "power transformation". In the electrical sense that we discuss here, this means "transforming" the mains power supply that comes into your home at "officially" 230V a.c. (110V a.c. in some countries) to a lower and safer level more suited to conversion to a d.c. level that can power electronic circuits.

It is devices that do the transforming that we shall discuss first. Not unreasonably, they are called *transformers*.

A transformer is a device that can not only convert one a.c. supply voltage to

another, but it is usually designed so that it provides isolation (total separation) between the two.

That a transformer can do both of these things is due to another of those remarkable Laws of Nature, of which we have already met a few, this time related to magnetic fields and current flow.

One effect of this is that if an alternating current flows through a coil of wire that is wound around a magnetic material, a rod of

Furthermore, it is a hard-and-fast fact of life that if an electrical current flows, then a voltage differential exists between the current source and its destination.

Note that in a real transformer the wires are insulated to prevent electrical short circuits between each turn.

### TAKING A TURN

There is an interesting relationship that also exists when one coil induces current/voltage in the other. The voltage that is induced from the first coil into the second depends on the number of turns of wire that make up each coil.

For example, if an alternating current of 10V a.c. flows through the first coil (helpfully known as the *primary coil*) consisting of 100 turns of wire, then if the second coil (not surprising called the *secondary coil*) also has 100 turns of wire, the resulting "transformed" voltage will also have a value of 10V a.c.

However, if the secondary has only 50 turns of wire while the primary has 100, then the secondary voltage will be  $10V \times (50 / 100) = 5V$  a.c. Conversely, if the secondary has 200 turns when the primary has 100, the resulting output voltage will be

$10V \times (200 / 100) = 20V$  a.c.

(Our ancestors earlier than the 19th century would have loved to know such simple facts! Many eminent minds puzzled over magnetic fields and current flow before being able to define the principles, notably such researchers as Andre Ampere, Michael Faraday and Joseph Henry, for example.)

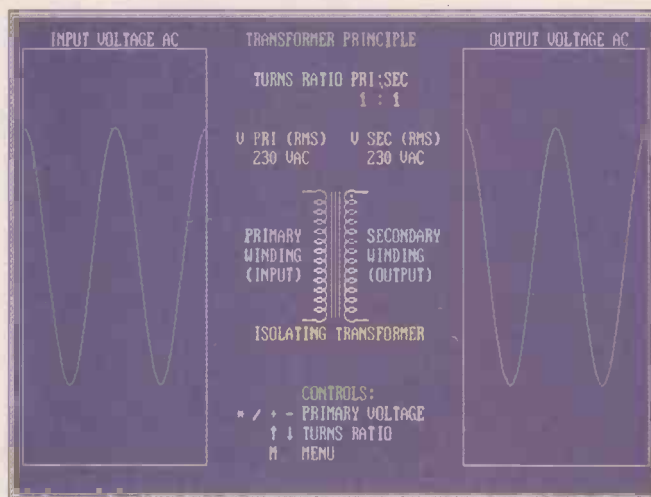

Photo 10.1 Screen dump of the interactive demo illustrating the transformer principle.

iron for example, an alternating magnetic field is set up around and within it. If another, separate, coil is also wound around that same rod, the alternating magnetic field caused by the first coil is *induced* into the second coil. This induction causes a current to flow through the second coil when its ends are connected together, usually via the circuit to be powered.

We can now summarise the voltage transformation according to:

$$V_{sec} = V_{pri} \times (T_{sec} / T_{pri})$$

where:

$V_{pri}$  = voltage across primary winding

$V_{sec}$  = voltage across secondary winding

$T_{pri}$  = number of turns in primary coil

$T_{sec}$  = number of turns in secondary coil

You should be aware, however, that the above formula represents the state of affairs in an ideal world – which seldom exists! There are conditions attached to voltage transformation, as we shall discuss presently.

## TRANSFORMER SYMBOLS

Have a look at the Transformers – Principle screen (and Photo 10.1). In the centre is shown the basic symbol for a transformer, comprising two coils representing the primary and secondary windings, with the vertical lines between them representing the magnetic material around which the coils are formed.

As shown, the coils have the same size, indicating that the primary and secondary voltages are equal. This is confirmed by the stated Turns Ratio of 1:1, and the voltages input and output are also given.

Because the two coils are not physically connected to each other, there is complete electrical isolation between them. The fact that current and voltage are present on the second coil is entirely due to magnetic coupling between it and the first coil.

Indeed, a transformer in which the primary and secondary coils are physically separate is actually known as an *isolating transformer*, although conventionally the term is generally taken to apply to a transformer connected to the mains power supply and having a turns ratio of 1:1 (same voltage out as in).

A transformer in which the secondary has fewer turns than the primary (voltage out is less than voltage in), is known as a *step-down transformer*. Where the secondary has more turns than the primary (voltage out is greater than voltage in), the term *step-up transformer* is used.

The circuit diagram symbols often associated with the three above transformer types are shown in Fig.10.1a to Fig.10.1c.

## PRIMARY DIRECTION

It is worth noting that the primary coil is that *into which* the power flows. The secondary coil is always that *from which* the transformed power is output. Even if you use the second winding as the power input (as it can be in some special situations), it then becomes called the primary, and the original primary becomes known as the secondary.

Via the screen display you now have running, you can change the primary voltage and the turns ratio, observing the way in which the gently scrolling sine wave (the normal waveform shape for which most transformers are designed) changes in amplitude, within the limits of the display. The control keys are stated on-screen.

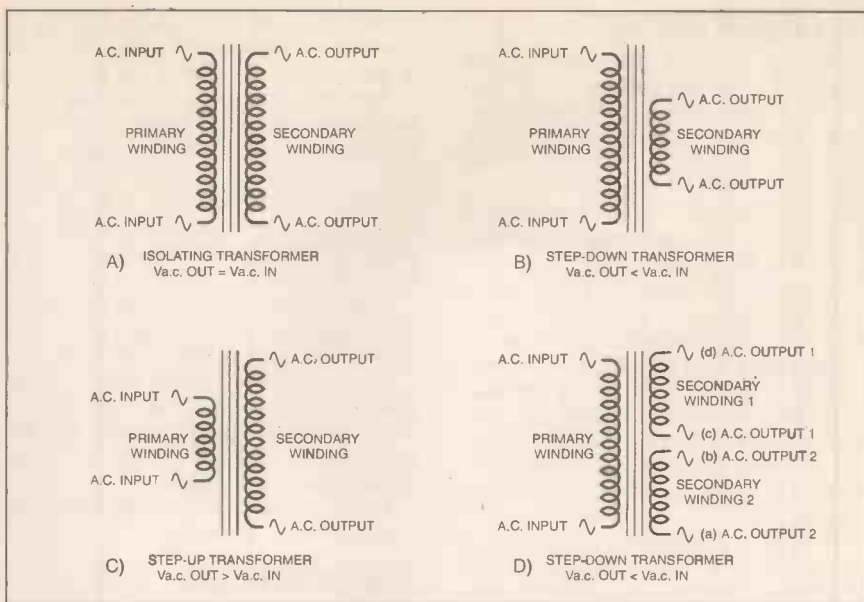

Fig.10.1. A selection of transformer symbols. Many variants exist.

Note how the transformer symbol changes between the symbols in Fig.10.1a to Fig.10.1c, depending on the turns ratio selected.

## MULTIPLE SECONDARIES

Which brings us to another interesting fact, as symbolised in Fig.10.1d.

As this illustration implies, it is permissible to have more than one secondary coil on a transformer. You could have dozens if the space is available. Note, though, that each of the additional coils is still referred to as a “secondary”.

Each of the secondaries can have its own number of turns of wire in its coil, so that each produces a different output voltage. These secondaries can either be used as separate voltage sources (also isolated from each other), or they can be connected in series so that the output voltage is the total of the two secondary voltages.

In this last situation, it is important to connect the coil terminations in the correct order. In Fig.10.1d, it is the terminations that are shown closest to each other (terminations b and c) that are joined when series connection is required.

This ensures that the phases of the sine wave do not oppose each other and cancel out the voltage transfer, while greatly increasing the current flow, possibly to the detriment of the transformer (windings could overheat and burn-out).

Note that some transformers have a *centre tap* terminal which is the equivalent junction of two separate windings having been joined.

Transformers usually have their terminals notated. For example, one having twin secondaries of 15V a.c. would typically have them marked as “0V-15V, 0V-15V”. In Fig.10.1d, the respective terminations would be a-b, c-d.

As separate windings it would not usually matter which of each winding’s terminals were connected to a subsequent circuit. For series connection, though, the two central terminals would be connected together, the two outer terminals then connected to the next circuit, in this case as a 30V a.c. supply.

Some mains transformers have two primary windings. They might typically both be 115V a.c. For 230V a.c. use they would be connected in series, again ensuring that the correct terminations are used.

## POWER RATIOS

There is a crucial fact to remember about the power available from a transformer. The total power available from the secondary windings can never be greater than that which passes through the primary winding. You don’t get free gifts in this context!

Suppose, for instance, that the primary has 100V a.c. alternating across it at a current of 1A. Suppose also that the secondary is a step-up winding having twice the number of turns of the primary, resulting in a secondary voltage of 200V a.c.

The power flowing through the primary (remember Ohm’s Law, watts = volts × amps) is 100V × 1A = 100 watts. Now, the secondary has 200 volts alternating across it, but because it can only supply the same power as passes through the primary, the current available from this winding is thus 100W / 200V = 0.5A.

Conversely, for a step-down transformer producing a 50V output for a 100V input at 1A, the output current available is actually greater, at 2A: 100W / 50V = 2A.

The rule that you can never take out more power than you put in applies irrespective of the number of secondaries. Each secondary can be capable of supplying different voltages and currents, but the total power available from them at any instant can never exceed that available from the primary.

In fact, because the power transfer between the primary and secondary windings is not perfect, the secondary power available is always somewhat less than that passing through the primary.

This fact, however, will not normally trouble you – it is the manufacturer who has to be concerned about transformer efficiencies. He then tells you how much power can be output from the secondaries, he might even tell you how much power the primary consumes in order to meet that maximum obligation (but don’t bank on it).

## VA POWER FACTOR

The way in which transformer power capabilities are expressed is as a "VA" factor. This is really just another way of stating the power in watts, since VA simply stands for Volts × Amps, which you already know equals Watts.

Thus, for example, a transformer that is said to have a 20VA rating might have been designed to supply 20V at 1A, or 10V at 2A, or even 100V at 0.2A. These values would only apply, though, if the transformer had a *single* secondary winding.

Where more than one secondary is provided, and each possibly having different voltage and current characteristics, the situation can become less clear. However, helpful transformer suppliers should clarify the capabilities of their products through their literature.

For instance, a catalogue statement about a 50VA mains transformer having two 15V secondary windings might also clarify it by stating "2 × 0.15V, 1.67A". This means that with the total power available being 50VA, each secondary can supply (50VA / 15V) / 2 = 1.6666A, i.e. 1.67A. With a bit of luck, the catalogue might actually tell you that each secondary winding is rated at 25VA.

Assuming that the primary is being powered at 230V a.c., the current though that winding must be (at least) 50VA / 230V = 217mA.

Note that transformers having twin secondaries of the same voltage can usually have their windings connected in parallel to increase the current available (total current available is the total of the currents available from each winding). They must be correctly connected, though, e.g. 0V to 0V, and 15V to 15V, (a to c and b to d, referring to Fig.10.1d).

## INTOLERANCE

We have commented before that all electronic component values are subject to various tolerances. Transformers are especially intolerant!

A secondary winding's voltage rating is normally only said to hold true when the current it supplies is at the maximum rating, known as "full load". For currents less than this, the output voltage will be greater than nominal. For currents greater than ideally permitted, the voltage will drop below nominal.

The amount of output voltage change relative to the current drawn will vary between transformer types and quality of manufacture. In the case of the 50VA transformer just referred to (as used by the author in one of his workshop power supplies), this is quoted as having a typical regulation rating of 10 per cent, calculated as:

$$\frac{(V_o - V_f) / V_o}{100\%}$$

where:

$V_o$  = off load voltage  
 $V_f$  = full load voltage

However, a 6VA transformer from the same manufacturing range is quoted as having a typical regulation of only 25 per cent.

Also note the use of the word "typical": this is the manufacturer's statement about

the regulation, but it is not necessarily qualified in the literature. The actual difference in practice is likely to be small, though.

What is of far greater significance is the fact that the UK mains supply is not held at a constant voltage level. To comply with EU regulations, the "official" UK voltage level is 230V a.c., although more typically it is likely to be around 240V a.c. It is permitted to vary within about six per cent of the nominal value.

Naturally, such deviant behaviour affects the voltages supplied by transformer secondary windings, by similar percentages.

Next month this is going to lead us into discussion about how you "regulate" or "stabilise" a d.c. power supply that has been derived from a somewhat unpredictable mains a.c. supply.

But, first things first – a discussion on "conversion"!

## RECTIFICATION

Although we can regard the changing of an a.c. supply to d.c. as a process of conversion, the correct term in this context is *rectification*. From your Power Supply program's sub-menu select Rectifier – Half-Wave, see Photo 10.2.

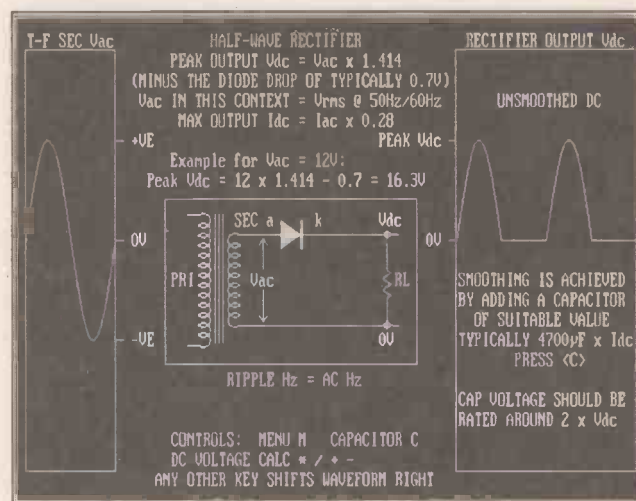

Photo 10.2. Screen dump of the interactive demo illustrating half-wave rectification.

We used the word "rectify" in passing while discussing diodes in Part 4. You will recall that a diode conducts in one direction only, from its anode to its cathode.

A mains a.c. supply is a sine wave (as discussed in Part 5) and as such alternates symmetrically above and below a mid range value, usually taken as 0V with respect to mains a.c. voltages.

This is the situation we assume in Photo 10.2 and on the Half-Wave Rectifier screen display. The circuit diagram shows a transformer secondary winding with one end of the coil regarded as the 0V termination. The other end is connected to a diode, on the other side of which is shown a resistor (RL), whose other end is also connected to the 0V line.

The sinusoidal a.c. waveform from the secondary winding (Vac) repeatedly sweeps above and below 0V at whatever the maximum a.c. secondary voltage is provided by the transformer. Let's call it 12V a.c.

You will recall that in Part 5 we discussed waveform voltages in terms of

r.m.s., peak, peak-to-peak, etc. Because we are now dealing with a sine wave, its a.c. voltage value can be taken as identical to its r.m.s. value, which Part 5 stated has a peak value 1.414 times greater.

In other words, the 12V a.c. value of the example circuit in Photo 10.2 has an actual peak value of 12V r.m.s. × 1.414 = 16.968V peak, call it 17V. That is, the waveform is evenly and repeatedly swinging between +17V, though 0V and down to -17V, and then back up again.

While the voltage is positive, current is conducted through the diode and resistor, back to the 0V line. The resistor, of course, simply represents any other circuit (the "load") to which the voltage can be sent.

A *negative* voltage, however, will not be conducted through the diode or the load.

In this circuit, the positive half of the sinusoidal waveform across the secondary winding thus appears at the junction of the diode and resistor (Vdc), as the waveform shown at the right of Photo 10.2. It has lost the lower half of its waveform (the negative half), hence the name of this circuit, *half-wave rectifier*.

There is also the matter of the voltage drop across the diode itself to be taken into account. As discussed in Part 4, for a typical silicon diode, a voltage drop of about 0.7V occurs.

As a result, it is only when the secondary voltage rises above that 0.7V threshold that current and voltage will be conducted through it and into the load. The load thus only "sees" a maximum voltage of about 0.7V below the secondary's positive peak value.

We can thus define the peak voltage seen across the load as being:

$$\text{Peak } V_{dc} = (V_{ac} \times 1.414) - 0.7V_{dc}$$

which in our example produces:

$$(12V_{ac} \times 1.414) - 0.7V_{dc} = 16.3V_{dc}$$

## WAVEFORM SMOOTHING

So far the rectified waveform is unsuited to powering a normal electronic circuit. It is still varying between two levels, 0V and 16.3V d.c. Electronic circuits, though, usually require a d.c. voltage that is considerably more stable than a repeating series of peaks and troughs, known as the *ripple* voltage. We need a way of smoothing out the ripple.

Such a smoothing component is readily available, and you've already been using it – the capacitor. Press <C> on your keyboard. In the resulting screen display a capacitor has now appeared in parallel with the load resistance, and the output Vdc waveform has become a straight line – the ideal rectified and smoothed d.c. supply voltage waveform!

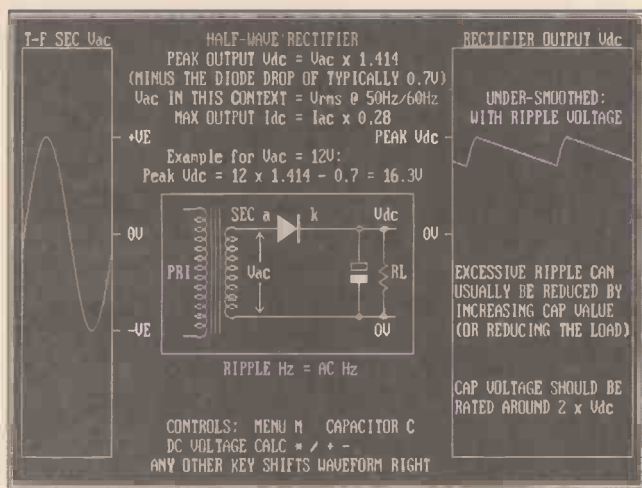

Photo 10.3. Screen dump of the demo showing a capacitor in parallel with the load (RL), and an exaggerated example of ripple voltage.

In Part 2, you proved for yourself how a capacitor can be charged up at one rate and discharged at another. This characteristic makes a capacitor ideal for smoothing rectified waveforms suitable for powering an electronic circuit.

The principle is that the capacitor in parallel with the load resistance charges up at the fastest possible rate while the rectified waveform is positive and above 0.7V d.c. When the a.c. waveform applied to the diode falls below the peak d.c. voltage now held by the capacitor, the capacitor discharges at the rate determined by the resistance of the load connected to it, not through the diode.

The knack is to choose a capacitor whose value is sufficiently great such that it does not significantly discharge through the resistance before the next cycle of the rectified waveform rises positively again, thereby "topping-up" to replace any charge lost.

Press <C> again to display an exaggerated waveform that illustrates the capacitor's ripple voltage as the resistive discharge and top-up cycle repeats, see Photo 10.3 as well.

## SMOOTHING CAPACITOR VALUE

To find out what capacitance value (C) is best suited to a particular load resistance to minimise the ripple, you need to know the maximum current (Idc) that the load is ever expected to draw.

Typically, the ideal minimum capacitance value that will reduce the ripple until it effectively no longer exists is calculated by the simple formula of:

$$C = 4700\mu\text{F} \times \text{Idc}$$

Be aware, however, that a very small amount of ripple voltage will *always* exist, even when using exceptionally high value capacitors and drawing a very small load current. In a lot of cases, though, a minor amount of ripple may not matter.

Whilst the above formula offers guidance, the final choice of capacitor value could be lower or higher than calculated, depending on just how smooth the load circuit requires its power source to be (but there are ways to avoid making an alterna-

tive choice, as we shall show next month when we examine voltage regulation).

The initial problem, though, is how to establish the value of the maximum current that will be required.

There are three basic solutions:

1. Calculate and total-up the current required by each component in the load circuit (a tedious matter that is fraught with mathematics).

2. To assume a worst case condition, that the maximum load will require the maximum current that the transformer can supply.

3. Or (as we've suggested before in another context) to cheat! Guess the likely maximum current and select a capacitance value based on that. Then, if your guess turns out to be too low, to increase the capacitance value. (Your increased experience will eventually tell you what range of capacitance value the guess should fall into.)

With a mains power supply, option 2 is the one that should be selected. There are, though, power control sub-circuits, driven from the principal power supply, for which the guesstimate technique can be satisfactory. Within certain limits, the test for power smoothing can be done using a meter, an oscilloscope, or even your ear.

The meter test will show if a significant lack of smoothing exists by the magnitude of the changing display numbers. An oscilloscope will show very fine detail of power line voltage smoothness. In the case of an audio circuit, the sound coming from the loudspeaker will sometimes tell whether or not mains "hum" exists in its power supply.

Whilst hum can come from other sources, it is always worth checking that the power supply is suitably smoothed, the hum being the residual multiple of 50Hz (or 60Hz in the USA and some other countries) ripple that the smoothing capacitor has not "mopped-up".

## OTHER FACTORS

Note that the smoothing capacitor's working voltage should ideally be at least twice the peak rectified voltage, and preferably more. For example, if the peak rectified d.c. voltage is 17V, choose a capacitor whose working voltage is at least 34V.

The diode type must be able to handle the current expected to pass through it. It

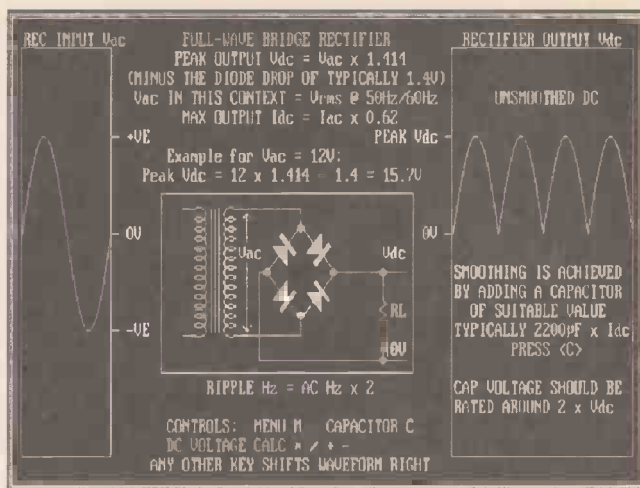

Photo 10.4. Full-wave bridge rectifier circuit as illustrated in the screen demo. Using a capacitor in parallel with RL would normally be used to smooth the ripple voltage.

must also have a voltage rating suited to the difference between the lowest voltage produced by the sine wave from the secondary winding and the peak d.c. voltage on the smoothing capacitor, otherwise known as the *peak reverse voltage*, or the *peak inverse voltage (PIV)*, in this context.

As discussed in Part 4, diodes can only stop voltages flowing back through them within certain limits, as specified for the diode type. Again, allow a good margin for extreme circumstances.

In most normal power supply instances, a type 1N4001 rectifier diode will probably suffice. This can handle a current of 1A and a peak reverse voltage of 50V.

## POWER EFFICIENCY

In the half-wave rectifier circuit, only one diode is used, and so only one side of the waveform provides power. Instinct will tell you that the efficiency of a power supply rectified in this manner can at best only be half of what might be expected if both sides (phases) of the a.c. waveform could be used.

In fact, because we are dealing with a sine wave, the situation is worse than this and the maximum d.c. output current available is typically only 0.28 times the a.c. current consumed by the secondary winding. This is formally expressed as:

$$\text{Max Idc} = \text{Iac} \times 0.28$$

The screen display allows you to calculate the d.c. output voltage typically available using different a.c. input voltages.

## BRIDGE RECTIFICATION

There is a simple circuit configuration, known as a *full-wave bridge rectifier* circuit (or commonly just *bridge rectifier*), in which the current conversion efficiency is about twice as great as in the previous half-wave circuit.

From your Power Supply sub-menu, select Rectifier - Full-Wave Bridge, and also see Photo 10.4. In the screen display press <C> to bring the capacitor into circuit.

The equation for power conversion is now seen to be:

$$\text{Max output Idc} = \text{Iac} \times 0.62$$

Because the circuit effectively sees two diodes in series the formula becomes:

$$\text{Peak } V_{dc} = V_{ac} \times 1.414 - 1.4V$$

Note that the software incorrectly states a voltage drop of  $-0.7V$  instead of  $-1.4V$ .

There are four diodes involved in the bridge rectification process. They may either be individual diodes, or combined as a single purpose-designed component (actually known as a *bridge rectifier*) in which the four diodes are arranged in the same configuration.

The pin order for bridge rectifiers can differ with various types, but pin identities are invariably printed on the body. See Panel 10.1.

Note from the bridge rectifier symbol in Fig.10.2 how the diodes are arranged. As an exercise, work out which diodes are in use at which stages of the sinusoidal waveform. You've had sine waves and diodes explained previously, you should not find the task too hard.

Apart from increased output current availability, bridge rectifier circuits offer another benefit – the d.c. output is charged at twice the rate of the half-wave circuit, because both sides of the waveform are being used. This means that the UK 50Hz mains frequency is rectified at 100Hz, allowing a smoothing capacitor of about half the previous value to be used. A suitable capacitance value (C) is thus typically calculated as:

$$C = 2200\mu F \times I_{dc}$$

The working voltage of the capacitor should still be rated at around  $V_{dc} \times 2$ , or greater.

In all but the least demanding applications, the bridge rectifier circuit is the one that finds greatest favour.

Again the screen display allows you to calculate the d.c. output typically available using different a.c. input voltages.

### BI-PHASE RECTIFIER

A third type of rectification circuit also exists, using only two diodes. Select sub-menu option Rectifier – Full-Wave Bi-Phase, and also see Photo 10.5. With the screen display press <C> to put the capacitor into circuit.

In the circuit diagram displayed, the peak rectified voltage is less than in the previous circuits and is defined as:

## PANEL 10.1. BRIDGE RECTIFIER STYLES

Bridge rectifiers come in several package shapes, circular, square and oblong (two examples are shown in Photo 10.7). Most have four connections, usually wires, but tags and screw terminals are not uncommon, and printed circuit board mounting types are also available. The circuit diagram symbol for a bridge rectifier is shown in Fig.10.2.

The identification of the wires is marked on the package, usually two squiggles (~) for the a.c. connections, and plus (+) and minus (-) for the d.c. outputs. Rectifiers with more than four terminals are available for specialist applications.

With four-terminal bridge rectifiers, it does not matter which of the two a.c. terminals are connected to the a.c. power source. The correct connection of the rectifier's d.c. pins to the circuit being powered *must always* be observed. They are labelled in the same way as the battery you are using is marked.

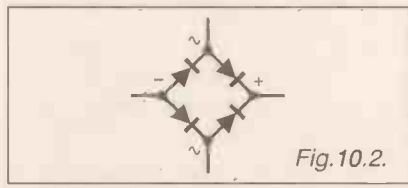

Fig.10.2.

$$\text{Peak } V_{dc} = V_{ac} \times 0.71 - 0.7V$$

The maximum output current is greater, though, at:

$$I_{dc} = I_{ac}$$

In other words, the input and output currents are the same (ignoring normal circuit losses).

As with the bridge rectifier, the rectified ripple frequency is twice that of the input frequency, while capacitor values and ratings are the same.

Once more the screen display allows you to calculate the d.c. output typically available using different a.c. input voltages.

### NEGATIVE AND DUAL-RAIL

Now select Negative and Dual-Rail Supplies from the sub-menu. Four circuits

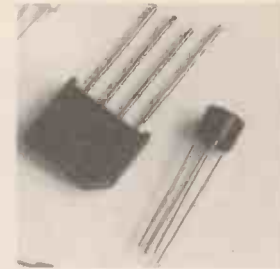

Photo 10.7.

However, an apparent contradiction can exist in circuits which have split power supply lines, i.e. +12V, 0V, -12V. In such a situation, where two bridge rectifiers are being used, one for the positive voltage and one for the negative, it is the *relative* polarity of the voltages output from each rectifier which is important.

Thus, for one of the rectifiers, its positively marked output (+) would feed to the circuit's positive power rail (+12V) and its negatively marked (-) output would feed the circuit's 0V power rail. With the other rectifier, though, the circuit requirement might be for its positive output (+) to be connected to the circuit's 0V rail, while its negatively marked output (-) would feed the circuit's -12V power rail.

are given which illustrate how negative voltages can be generated from an a.c. waveform, see Photo 10.6. Note the diode position changes in the half-wave and bi-phase circuits, compared to the positive voltage equivalents.

The bridge rectifier circuit (dual-rail supply) allows simultaneous generation of both positive and negative supply voltages.

Note that for the bi-phase and dual-rail circuits a transformer having two secondaries is used. These windings are assumed to be identical; a more complex situation exists if they are not identical (beyond the scope of this discussion).

### AUTOTRANSFORMERS

You will not normally require to use a special type of transformer called an *auto-transformer*, but we'll just say what they are for curiosity's sake!

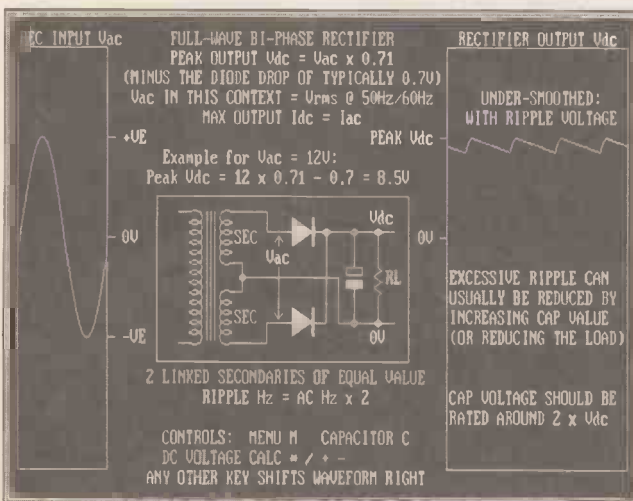

Photo 10.5. Full-wave bi-phase rectifier as illustrated via the interactive screen demo.

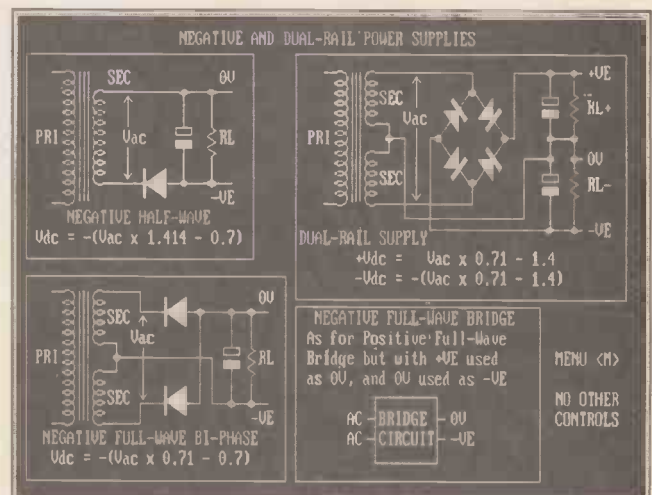

Photo 10.6. Examples of negative and dual-rail power supplies as shown via the demo screen.

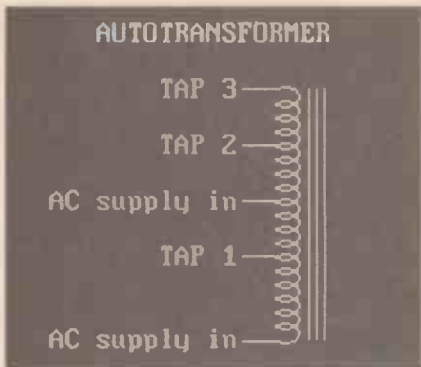

Photo 10.8. An auto transformer example as illustrated in the Miscellany demo.

They are transformers in which the primary and secondary windings are formed from a single coil wound around a magnetic material with access terminals available at various points in the winding. As such, they do not provide isolation from the mains voltages.

## PANEL 10.2. BRIDGE SPECIFICATIONS

In most situations commonly encountered in hobbyist electronics, the two principal specifications which are important for bridge rectifier choice are the current it can pass, and the maximum reverse voltage it is designed to handle.

Many of the constructional power supply circuits that you will encounter are likely to specify a 50V/1A (maximum working specification 50 volts, one amp) device. Although many such circuits operate at much lower voltages and currents, this particular bridge rectifier

specification is a minimum common-or-garden standard that is readily available.

It may often be specified by a type number of W005 (the circular device in Photo 10.7), but in reality any type number having the same two V and A specifications can quite happily be used instead, as long as the pinouts are the same. Bridge rectifiers which can handle voltages well in excess of 1000V and currents of up to 60A are available through some suppliers.

The mains a.c. supply is connected across two designated tappings on the coil. The secondary tappings can be made at selected points so that voltages both greater and smaller than the input voltage can be obtained, although the same rules about current availability still apply. The principle is illustrated at the right of the screen display accessed by

selecting sub-menu option Power Supply Miscellany (see Photo 10.8).

### NEXT MONTH

In Part 11 we examine power supply regulation and discuss capacitor integration and differentiation, showing how RC values change waveforms.

# TEACH-IN 2000 – Experimental 10

WITHOUT asking you to experiment with mains power supplies, we would like you to experiment with waveform rectification on your breadboard, enabling you to see what happens via your meter and computer display screen.

## HALF-WAVE RECTIFICATION

For a start we'll take a look at half-wave rectification, making use of the waveform being generated by the oscillator you've been using since Part 4. Even though the waveform is triangular (nearly), whereas in a mains power supply it will be sinusoidal, the principle can still be displayed.

Assemble the breadboard layout in Fig.10.3, referring to Fig.10.4 for the circuit diagram and component values.

In Fig.10.4, IC3a is an op.amp (see Parts 7 and 8) into whose non-inverting input (pin 3) is fed the triangular waveform from the oscillator (IC1 pin 1). The op.amp's gain is set at about times 3 ( $R4 / R3 + 1$ ). Resistors R1 and R2 set the required mid-way bias voltage of about 3V (half the battery level of nominally 6V). Capacitor C1 adds a bit of smoothing to the bias.

At the output of IC3a (pin 1) accessible via terminal pin TP1, the amplified waveform swings above and below the midway voltage level, probably between about 0.5V and 5.5V (see Part 7), a total swing of about 5V. We can also express this swing as being 2.5V above the midway level (3V) and 2.5V below the midway level.

What we need though, is for the waveform to actually swing 2.5V above and below 0V rather than 3V, i.e. a swing of +2.5V to -2.5V, so more closely approximately the positive and negative aspect of

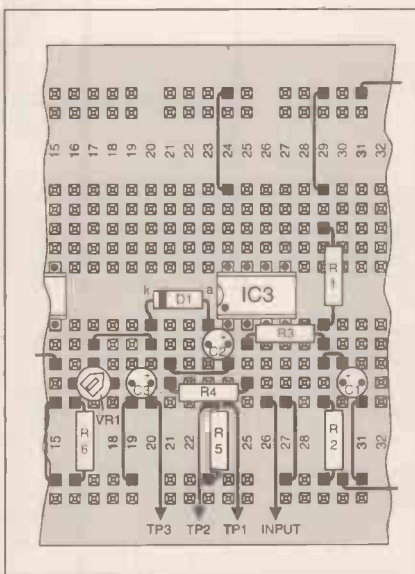

Fig.10.3. Breadboard layout for the half-wave rectifier circuit in Fig.10.4.

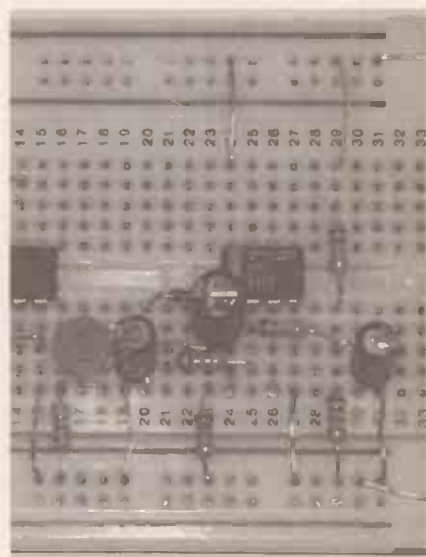

Photo 10.9. Details of the half-wave rectifier breadboard.

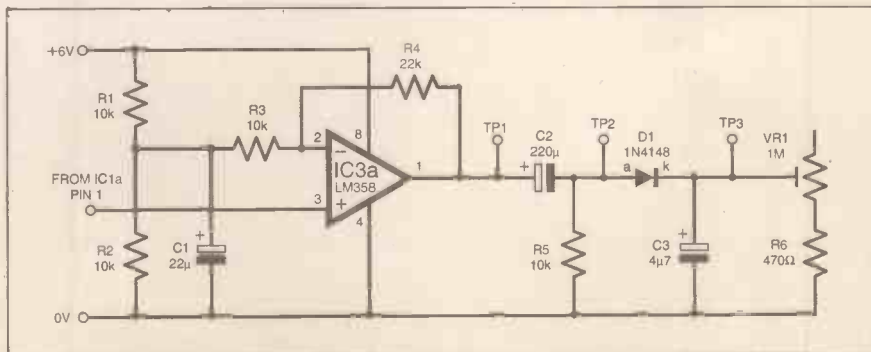

Fig. 10.4. Circuit diagram for the half-wave rectifier experiment. Do not monitor test point TP2 via the ADC (IC2) or your computer – see text.

the sinusoidal waveform discussed in the Tutorial.

We have previously discussed how a capacitor can isolate one d.c. voltage from another. We can use this principle to "shift" the 0.5V/5.5V waveform so that it alternates between -2.5V and +2.5V.

In Fig.10.6 this is done by including capacitor C2 and resistor R5, with the latter setting the midway voltage of 0V. At the junction of C2 and R5 (TP2), the waveform swings above and below 0V as required.

DO NOT try to monitor this junction via the ADC device and your computer. The ADC could be damaged by negative voltages being connected to its input. So could the computer if a negative voltage is applied to its parallel printer port.

To monitor the C2/R5 junction, your multimeter should be used, with the oscillator frequency rate set slow enough so that the meter has time to display the negative and positive voltages.

Diode D1 is used as the rectifier, allowing waveform voltages above about 0.7V to pass through to charge capacitor C3. The capacitor is discharged at a rate dependent on the capacitance value, and the resistance of the path to the 0V line via preset VR1 and R6, in other words, on the CR value (see Part 2).

The voltage across capacitor C3 can be monitored at terminal pin TP3 via the ADC and computer, and by your meter. Remember that the meter has its own resistance value which may reduce the CR value when VR1 is preset at higher resistance values.

Resistor R6 prevents the output of diode D1 being connected directly to 0V.

## VARIABLE FREQUENCY

Experiment with observing the rectified and smoothed waveform at TP2 for different values of C3, settings of VR1 and at different oscillator frequencies (initially start off with a value of 22µF for oscillator capacitor C1).

Also monitor the complete waveform output from IC3a at TP1, and confirm that half-wave rectification is taking place as described in the Tutorial, with the ripple frequency being the same as the oscillator frequency. Photo 10.10 shows a composite

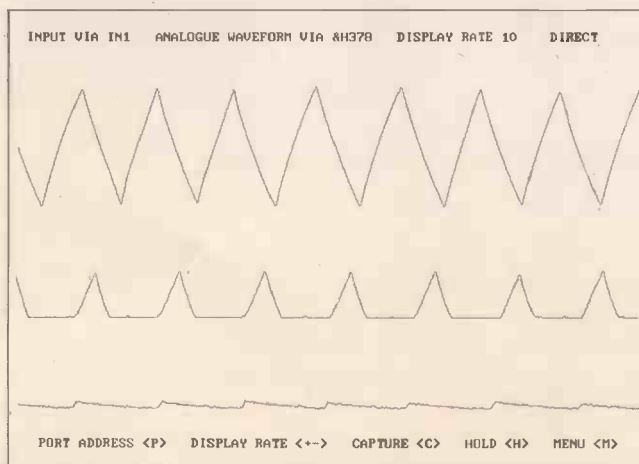

Photo 10.10. Composite screen dump created using the circuit in Fig.10.4 showing the unrectified waveform (top), the output from diode D1 (TP3) with capacitor C3 removed (middle) and with C3 in circuit showing a small amount of ripple voltage. The waveforms are not mutually aligned.

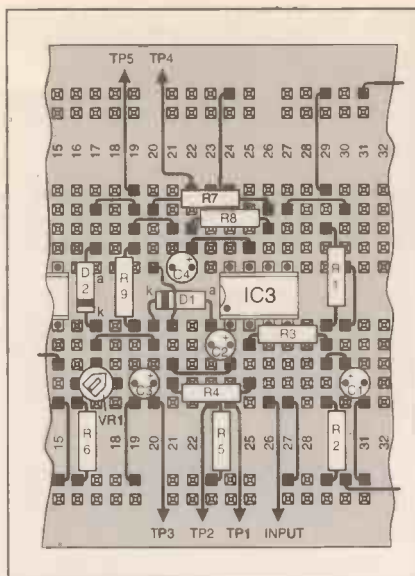

Fig.10.5. Breadboard layout for the bi-phase full-wave rectifier circuit in Fig.10.6.

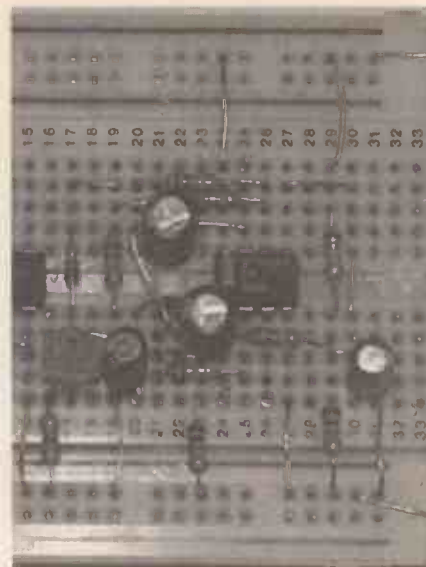

Photo 10.11. Details of the breadboard layout in Fig.10.5.

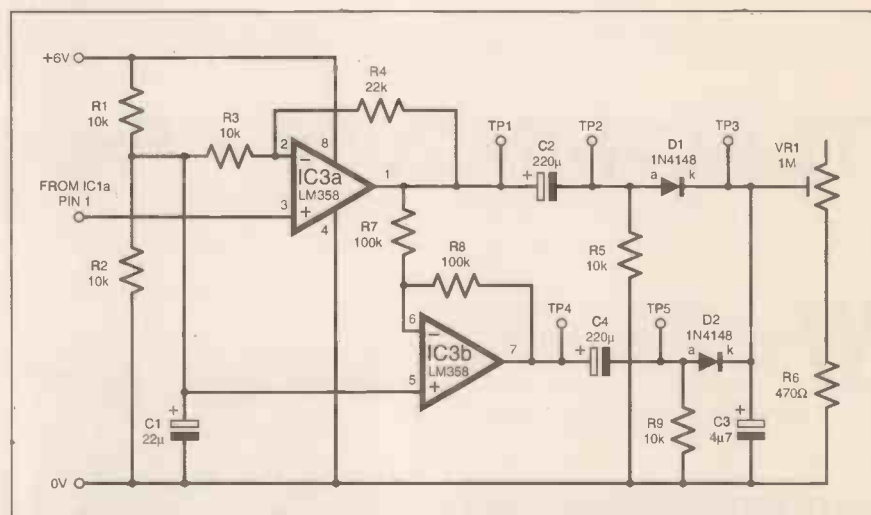

Fig.10.6. Circuit diagram for the bi-phase full-wave experiment. Do not monitor TP2 or TP5 via the ADC or computer (see text).

of three screen dumps created using the author's breadboard setup.

Recalling that the total resistance between C3 and 0V, via VR1 and R6, is the "load" discussed in the Tutorial, try to verify that the best waveform smoothing occurs when capacitor C3 is equal to or greater than the formula we quoted ( $C = 4700\mu\text{F} \times I_{dc}$ ) - use other values for C3 if you wish.

To find out  $I_{dc}$  (the peak current), measure the peak voltage at TP3 and divide this by the value of VR1 plus R6 (Ohm's Law:  $I = V / R$ ).

Also remember that the value of C3, as stated on its body, is subject to a wide tolerance factor (see Part 2).

A further experiment is to see what

happens if the d.c. decoupling capacitor C2 is removed and replaced by a wire link. How does this affect the peak voltage across C3 and the appearance of the ripple voltage on your computer display?

## BI-PHASE FULL-WAVE RECTIFICATION

It is somewhat too complicated to set up your breadboard to demonstrate full-wave bridge rectification, but we can demonstrate the principle of bi-phase full-wave rectification, using the breadboard layout and circuit shown in Fig.10.5 and Fig.10.6.

When assembling the extra components onto your breadboard take especial care to use the correct positions as some components are very close together. Note that there is a link wire that crosses above diode D1 (without touching it).

The amplified waveform from IC3a is a.c. coupled by C2/R5, rectified through D1 and smoothed by capacitor C3 as it was for the half-wave rectifier, only the positive phase of the waveform being used.

We also invert the output from IC3a by taking it through the unity-gain op.amp IC3b. This is then a.c. coupled and rectified identically, using capacitor C4, resistor R9



and diode D2, and also fed into smoothing capacitor C3.

If you compare the waveform at TP3 with that at TP1 or TP4, you will see that the ripple frequency is double that from the oscillator. Experiment as before with different values for C3, the VR1/R6 resistance and with different frequencies.

Test the full-wave formula for smoothing capacitor C3, which effectively says that C3's value can now be about half that required for the half-wave circuit.

You will have spotted, we assume, that we are not actually using both sides of the waveform as it originated from the oscillator. We have had to use op.amp IC3b as an intermediate inverter because we do not have a negative power supply available, which could allow a waveform to be generated that would evenly swing above and below 0V.

DO NOT attempt ingenuity and try to improvise a negative supply for the breadboard (or use that described in the next section) – you could kill integrated circuits and your computer.

As before, see what happens when the a.c. coupling capacitors (C2 and C4) are replaced by link wires.

## NEGATIVE VOLTAGE GENERATION

We shall now show you how to turn a positive voltage into a negative one. It's a matter of relativity (where have we heard that one before?).

Referring back to Fig.10.4, the waveform entering capacitor C2 is alternating above and below a midway voltage of about 3V, with a peak to peak magnitude of 5V. The waveform exiting C2, however, has the same magnitude, but is now alternating above and below 0V, between -2.5V and +2.5V, entirely due to the 0V reference voltage to which resistor R5 is connected.

If resistor R5 were to be connected to another voltage level, say 10V, the output waveform would then swing above and below this level instead, between +7.5V and +12.5V in this case, still with the same relative magnitude of 5V. In other words, the output midway voltage level is the same as the voltage to which the resistor is connected (biased).

We can take this level shifting characteristic a stage further by following the capacitor with a diode (D3) instead of resistor R5, see Fig.10.9.

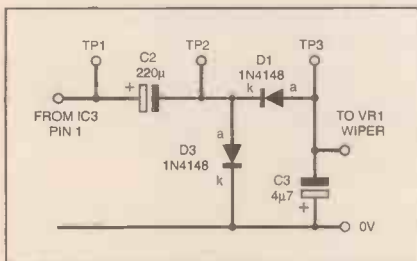

Fig.10.7. Amendment for a negative voltage half-wave rectifier.

Assuming the same 5V magnitude, when the voltage input to capacitor C2 rises, the output voltage tries to rise as well, by the same relative amount, as it did with the resistor. Now, though, the diode drains the positive voltage away through its

## PANEL 10.3. POWERFULLY LETHAL

The vast majority of you will know that a.c. mains electricity can be lethal. We wonder, though, if you realise how even a *small* a.c. mains electrical shock can kill you?

The severity of the shock will depend on a number of factors, including the magnitude of the current, whether it is alternating (a.c. – as in the vast majority of domestic mains supplies around the world) or direct (d.c.), and the route that the power takes through the body. The general health of the victim can also affect his or her reaction to electrical shock.

The magnitude of the current depends on the voltage which is applied and the resistance of the body (yes, even humans have electrical resistance). The electrical energy developed in the body depends on the time for which the current flows.

Table 10.1 illustrates just how even small mains power currents can be highly dangerous. It is reproduced from our sister publication, the *Electronic Service Manual (ESM)* and is in relation to the UK mains a.c. supply that comes into the home (nominally 230V a.c. at 50Hz).

The figures in Table 10.1 are quoted as a guide only. Note that there have been cases of lethal shocks resulting from contact with much lower voltages and at quite small values of current.

*In general, any voltage in excess of 50V should be considered dangerous.*

Remember that 1mA (one milliamp) is only one-thousandth of an amp. Thirteen thousand milliamps can flow through the standard UK domestic power plug when a 13 amp fuse is fitted. Even with a 3 amp fuse fitted, 3000 milliamps can flow before the fuse breaks the current flow.

Never tamper with mains electrical power unless you are qualified to do so. Seek help from those who are suitably qualified if a mains electrical connection needs to be made to non-standard electrical equipment (i.e. equipment that is not already correctly and fully wired by an approved equipment manufacturer).

Never run an electronic circuit at a voltage greater than specified. Never attempt to run a d.c. electronic circuit from an a.c. supply. There are specially designed power supply units that transform a.c. mains electrical power at high voltage to safe d.c. supplies at a low voltage.

We could go on for pages on this matter if we had the space. For more information contact your local medical practitioner (e.g. doctor) or electrical retailer.

Table 10.1. EFFECTS OF ELECTRICAL SHOCK

Current	Physiological effect
Less than 1mA	Not usually noticeable
1mA to 2mA	Threshold of perception (a slight tingle may be felt)
2mA to 4mA	Mild shock (effects of current flow are felt)
4mA to 10mA	Serious shock (shock is felt as pain)
10mA to 20mA	Motor nerve paralysis may occur (unable to let go)
20mA to 50mA	Respiratory control inhibited (breathing may stop)
More than 50mA	Ventricular fibrillation of heart muscle (heart failure)

Referenced to the UK mains a.c. supply (nominally 230V a.c. at 50Hz).

anode-cathode path. In this instance, the cathode is connected to the 0V line and so the output voltage can never rise above about 0.7V, the "diode drop" voltage we have referred to previously.

When the voltage input to C2 has reached its peak (5V above its starting value) and begins to fall, again the output voltage tries to change by the same relative magnitude. However, the fall in output voltage now commences at 0.7V, but the same 5V magnitude of change still occurs. The output swing thus becomes +0.7V to -4.3V. So already we have a negative aspect to the waveform.

### SIMPLY INVERTED

We now need to rectify the waveform so that only the negative voltage is retained as a d.c. level, the opposite of achieving a positive rectified d.c. voltage. The way in which this is done is simply to turn the rectifying diode round the other way, which as you will see has been done with D1 in Fig.10.7. Smoothing capacitor C3 also needs to be "turned upside-down" (positive lead on the 0V line).

With this configuration, the voltage stored across C3 is the minimum waveform voltage (-4.3V) less the 0.7V drop across D1, resulting in a stored voltage of -3.6V.

Obviously the conversion is not very efficient – about 1.4 volts have been "lost" because of the two diodes. The current which can be drawn from C3 is also very limited. Trying to draw too much current will increase the negative ripple voltage.

The current available can be increased, however, by increasing the value of C2. The ripple voltage can be decreased by increasing C3. The situation becomes a bit complicated since the values of both C2 and C3 also depend on the frequency and shape of the waveform entering C2.

In Part 11 next month we shall describe how capacitor values affect the way in which waveform shape (and hence power) can be retained or minimised.

In the meantime, modify the breadboard layout of Fig.10.5 to replace R5 by diode D1, and change the polarity connections of C3. Only monitor this circuit using your meter – DO NOT connect it to the ADC device or your computer.

Remove diode D2 from the second part of the bi-phase circuit. There is no need to remove its other components.

As a further experiment, modify this second half of the circuit to provide full-wave negative voltage rectification.

On that negative note, we positively look forward to you joining us again next month.

# SURFING THE INTERNET

# NET WORK

## ALAN WINSTANLEY

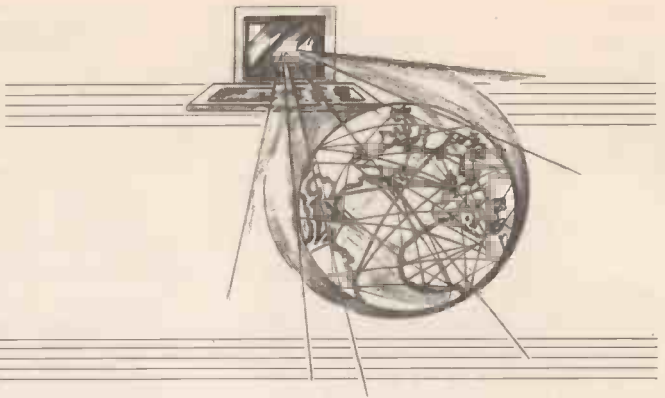

### BT SURFTIME

ON June 1 British Telecom (BT) duly sent an E-mail to those interested in signing up for BT's new Surfetime packages. These tariffs are BT's answer to the demands for unmetered Internet access, and they offer flat rate access in return for a fixed monthly fee. As always, things are not quite what they seem and BT seems determined to maintain its stranglehold on the UK Internet access. Many users simply want to pay a flat-rate figure to enjoy unmetered access through their preferred ISP, but there is a snag with BT Surfetime: you have to use a Surfetime ISP.

"Surf the net without worrying about the cost" says the BT E-mail, which offers *Surfetime Evening And Weekend* for just £5.99 (\$9.88) a month for unlimited Internet calls every evening and all weekend. The *Surfetime Anytime* costs £19.99 (\$32.98) a month for unlimited 24 x 7 Internet calls. There are several "gotchas" involved, starting with the fact that apart from the Surfetime tariffs, there may also be subscription costs charged by the ISP. There may be an option to have this bundled into your BT phone bill.

"You can choose an ISP from a number of participating companies which may include your current ISP" says BT. Checking the BT web site at [www2.btwebworld.com/netgeneration/surft/html/isps.html](http://www2.btwebworld.com/netgeneration/surft/html/isps.html) shows a list of over 40 ISPs, none of whom I've heard of apart from Freeserve and BT Internet.

Nearly all the remaining ISPs had "AIH" after their name - or Affinity Internet Holdings, which is a front end for Virtual Internet Providers Ltd. ([www.vip.uk.com](http://www.vip.uk.com)). They supply a number of branded Virtual Internet Service Providers (VISPs). VIP Ltd. is the "wholesaler" behind branded ISPs including Egg, PowerGen and Tiny Computers.

The BT list of 40-odd mostly obscure Surfetime ISPs currently boils down to BT Click for Business, BT Internet, Freeserve, PlusNet and about 20 Affinity suppliers. This may hopefully have improved by the time you read this, and bear in mind that many ISPs will still charge a monthly subscription. For example the "tenner-a-month" ISP Demon Internet hasn't bought into BT's Surfetime package yet but are expected to launch tariffs "soon"; until then you (and I) will be stuck with the same old metered tariffs.

Affinity end-users can buy all-inclusive (phone and subscription) Surfetime 24 x 7 access for £25.99 (\$42.88) a month. Services offered by BT Internet (BT's ISP arm) aren't straightforward either, with confusion reigning between the Pay As You Go and Surfetime tariffs, if complaints in the newsgroups are anything to go by. NTL ([www.askntl.com](http://www.askntl.com)) is a cable operator which has already launched free Internet access but they cannot cope with the demand for signing-up. Customers complain of serious delays in shipping the CD ROM, though NTL blames the delays on a postcode-based shipping system and an overwhelming demand for its disk.

### OTHER OPTIONS

It is worth reminding readers of other Internet access options, some of which may have been launched by the time you read this. Alta Vista UK is running late with its 0800 access (announced back in March), and others will launch through the summer.

Alternatives include ISDN2e (Home Highway etc.), which provides a speed increase (64Kbps or 128Kbps compared with typically 46Kbps for a V.90 modem). ISDN uses a TA (terminal adaptor) instead of a modem, and provides two analogue or two 64K ISDN lines (or one of each) at any one time. As an added benefit it usually accesses the Internet in a second or two instead of the minute taken to dial in with a modem. Make sure your preferred ISP provides ISDN access numbers, and note that many will not permit channel bonding - making two parallel 64K connections using the same log-in.

More demanding users should keep an eye on ADSL (Asymmetric Digital Subscriber Line), specifically BT Openworld ([www.btopenworld.com](http://www.btopenworld.com)) which uses a dedicated USB Openworld modem to provide "up to 512K" for £39.99 a month, always-on. It is early days yet for ADSL and some users may be better signing for a year's unmetered access now, then re-examine ADSL later: how well it works will depend on how far away you are from your digital exchange.

The UK Internet marketplace is a masterpiece of confusion marketing, and my advice would be to wait and see what develops before signing up. Also, check the small print very carefully before signing to any long term deal, and try to obtain a personal recommendation from someone in your locality who uses the same ISP, to see what access speeds and reliability are like.

At this point I would like to invite overseas readers, especially those in the USA and Canada, to E-mail me with details of the kind of tariffs they pay for their own Internet access, and I will publish a comparison in the future, perhaps on the web. Please E-mail a summary to [alan@epemag.demon.co.uk](mailto:alan@epemag.demon.co.uk). Every message will receive a reply. The more data I receive, the better!

### Unix Permissions

At the time of writing, the domain name of [unix.com](http://www.unix.com) is up for auction at [Afternic.com](http://Afternic.com) auctions, and bidding starts at a mere \$750,000. Whenever you access an FTP site using a web browser or an FTP client (such as the excellent WS-FTP Pro software by Ipswitch) you will undoubtedly come across the Unix operating system, even if you use Windows or Linux on your local system. The chances are you will see a directory structure containing a series of letters, but do you know what these mean? I'll round off this month's column with some general Unix pointers.

Unix file structures differ from DOS in several ways. Unix files are allocated to an "owner" who can change its user rights. The permissions for each Unix file or directory are described by a series of letters, perhaps looking like this on-screen:

```
- r w x r w x - - - 1 guest guests 4752 Jul 2 11:50 mywebpage.html
```

The first character is either "d" for directory or it will be a dash (implying it's an ordinary file, as in this example). The nine letters that follow identify the permissions for the three possible groups of user. These are the owner, the group and "others" (everyone else).

You can set the permissions of files so that only its owner can execute (x) a file and others can only read (r) or write (w). A file with permissions of - rwx rwx - - - can be written, read and executed by its owner and others in the same group, but no-one else has any rights to read, write or execute (run) it.

Sometimes permissions are described using a number code instead, such as 755 or 555. By using the Unix CHMOD (change mode) command, permissions can be set by the owner using a simple code for the owner, group and other users. Simply remember that a Read is 4, a Write is 2 and eXecute is 1.

7	r w x	(= 4 + 2 + 1)	3	- w x
6	r w -	(= 4 + 2)	2	- w -
5	r - x	(= 4 + 1 etc.)	1	- - x
4	r - -			

A program such as WS-FTP will allow user codes to be set by right-clicking and selecting CHMOD. Other programs talk about "CHMOD 555" (r-x r-x r-x) and so on. Now when you see those strange letters before Unix file names, you'll know what they mean. See you next month! My home page is at:

<http://homepages.tcp.co.uk/~alanwin> and my E-mail is [alan@epemag.demon.co.uk](mailto:alan@epemag.demon.co.uk).

**£60**  
fully inclusive\*



Shown Actual size  
103 x 70 x 20 mm

**Better than anything before!**

A world of detailed component data has never been so accessible. Now the Peak Atlas brings you fantastic features in one beautifully designed unit that is a pleasure to use.

Just connect your component any way round. The Atlas presents you with detailed component information in concise, easy to read, scrollable pages. The displayed information will include: the component type, special component features, component pinout, and measured parameters (such

as gain etc...). No more searching through data books and catalogues in order to identify components and pinouts, the Atlas does it all.

**So what can it analyse?**

More components than ever before! Here's a summary: Bipolar transistors, Darlingtons, diode protected transistors, enhancement mode MOSFETs, low power thyristors and triacs, diodes, multiple diode networks, LEDs, bi-colour and tri-colour LEDs. The Atlas intelligently displays information about the part under test, it knows the difference between LEDs and diodes and it knows if a transistor has diode protection or resistors on the base.

**The Atlas Package**

The Peak Atlas is supplied complete with a long life battery, new universal test probes and a comprehensive illustrated user guide. Furthermore, free and unlimited technical support for the Atlas is available to all users by telephone, fax, email or our web site.

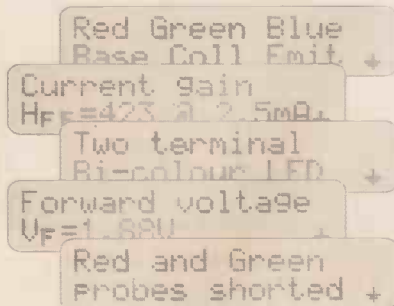

**Ordering**

The price you see is the price you pay. You can pay using major credit cards, cheques or postal orders. Feel free to contact us by phone, fax, email or our secure *e-sales* web site if you require free data sheets or you wish to place an order.

\* Please add £5 for overseas orders.

**peak electronic design limited**

West Road House, West Road, Buxton, Derbyshire, SK17 6HF. Tel.+44 (0)1298 70012, Fax. +44 (0)1298 22044  
Secure Web: [www.peakelec.co.uk](http://www.peakelec.co.uk) Email: [sales@peakelec.co.uk](mailto:sales@peakelec.co.uk)

# VIDEOS ON ELECTRONICS

A range of videos selected by *EPE* and designed to provide instruction on electronics theory. Each video gives a sound introduction and grounding in a specialised area of the subject. The tapes make learning both easier and more enjoyable than pure textbook or magazine study. They have proved particularly useful in schools, colleges, training departments and electronics clubs as well as to general hobbyists and those following distance learning courses etc



## BASICS

VT201 to VT206 is a basic electronics course and is designed to be used as a complete series, if required.

**VT201** 54 minutes. Part One; D.C. Circuits. This video is an absolute must for the beginner. Series circuits, parallel circuits, Ohms law, how to use the digital multimeter and much more.

Order Code VT201

**VT202** 62 minutes. Part Two; A.C. Circuits. This is your next step in understanding the basics of electronics. You will learn about how coils, transformers, capacitors, etc are used in common circuits.

Order Code VT202

**VT203** 57 minutes. Part Three; Semiconductors. Gives you an exciting look into the world of semiconductors. With basic semiconductor theory. Plus 15 different semiconductor devices explained.

Order Code VT203

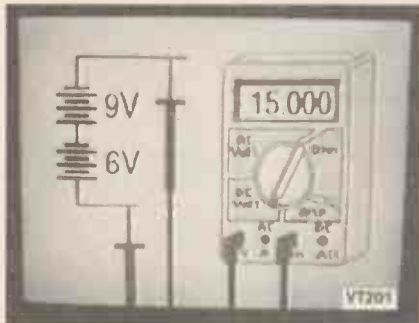

**VT204** 56 minutes. Part Four; Power Supplies. Guides you step-by-step through different sections of a power supply.

Order Code VT204

**VT205** 57 minutes. Part Five; Amplifiers. Shows you how amplifiers work as you have never seen them before. Class A, class B, class C, op.amps. etc.

Order Code VT205

**VT206** 54 minutes. Part Six; Oscillators. Oscillators are found in both linear and digital circuits. Gives a good basic background in oscillator circuits.

Order Code VT206

**£34.95** each  
inc. VAT & postage

Order 8 or more get one extra FREE  
Order 16 get two extra FREE

## VCR MAINTENANCE

**VT102** 84 minutes: Introduction to VCR Repair. Warning, not for the beginner. Through the use of block diagrams this video will take you through the various circuits found in the NTSC VHS system. You will follow the signal from the input to the audio/video heads then from the heads back to the output.

Order Code VT102

**VT103** 35 minutes: A step-by-step easy to follow procedure for professionally cleaning the tape path and replacing many of the belts in most VHS VCR's. The viewer will also become familiar with the various parts found in the tape path.

Order Code VT103

## DIGITAL

Now for the digital series of six videos. This series is designed to provide a good grounding in digital and computer technology.

**VT301** 54 minutes. Digital One; Gates begins with the basics as you learn about seven of the most common gates which are used in almost every digital circuit, plus Binary notation.

Order Code VT301

**VT302** 55 minutes. Digital Two; Flip Flops will further enhance your knowledge of digital basics. You will learn about Octal and Hexadecimal notation groups, flip-flops, counters, etc.

Order Code VT302

**VT303** 54 minutes. Digital Three; Registers and Displays is your next step in obtaining a solid understanding of the basic circuits found in today's digital designs. Gets into multiplexers, registers, display devices, etc.

Order Code VT303

**VT304** 59 minutes. Digital Four; DAC and ADC shows you how the computer is able to communicate with the real world. You will learn about digital-to-analogue and analogue-to-digital converter circuits.

Order Code VT304

**VT305** 56 minutes. Digital Five; Memory Devices introduces you to the technology used in many of today's memory devices. You will learn all about ROM devices and then proceed into PROM, EPROM, EEPROM, SRAM, DRAM, and MBM devices.

Order Code VT305

**VT306** 56 minutes. Digital Six; The CPU gives you a thorough understanding in the basics of the central processing unit and the input/output circuits used to make the system work.

Order Code VT306

## RADIO

**VT401** 61 minutes. A.M. Radio Theory. The most complete video ever produced on a.m. radio. Begins with the basics of a.m. transmission and proceeds to the five major stages of a.m. reception. Learn how the signal is detected, converted and reproduced. Also covers the Motorola C-QUAM a.m. stereo system.

Order Code VT401

**VT402** 58 minutes. F.M. Radio Part 1. F.M. basics including the functional blocks of a receiver. Plus r.f. amplifier, mixer oscillator, i.f. amplifier, limiter and f.m. decoder stages of a typical f.m. receiver.

Order Code VT402

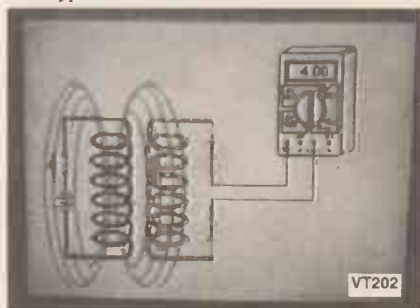

**VT403** 58 minutes. F.M. Radio Part 2. A continuation of f.m. technology from Part 1. Begins with the detector stage output, proceeds to the 19kHz amplifier, frequency doubler, stereo demultiplexer and audio amplifier stages. Also covers RDS digital data encoding and decoding.

Order Code VT403

## MISCELLANEOUS

**VT501** 58 minutes. Fibre Optics. From the fundamentals of fibre optic technology through cable manufacture to connectors, transmitters and receivers.

Order Code VT501

**VT502** 57 minutes. Laser Technology A basic introduction covering some of the common uses of laser devices, plus the operation of the Ruby Rod laser, HeNe laser, CO<sub>2</sub> gas laser and semiconductor laser devices. Also covers the basics of CD and bar code scanning.

Order Code VT502

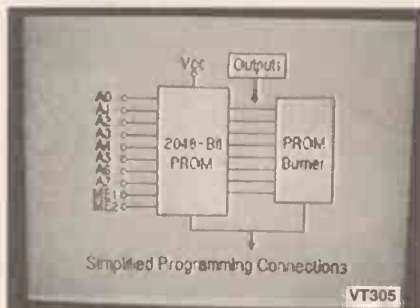

Each video uses a mixture of animated current flow in circuits plus text, plus cartoon instruction etc., and a very full commentary to get the points across. The tapes are imported by us and originate from VCR Educational Products Co, an American supplier. We are the worldwide distributors of the PAL and SECAM versions of these tapes. (All videos are to the UK PAL standard on VHS tapes unless you specifically request SECAM versions.)

**ORDERING:** Price includes postage to anywhere in the world.

**OVERSEAS ORDERS:** We use the VAT portion of the price to pay for airmail postage and packing, wherever you live in the world. Just send £34.95 per tape. All payments in £ sterling only (send cheque or money order drawn on a UK bank). Make cheques payable to Direct Book Service.

Visa and Mastercard orders accepted - please give card number, card expiry date and cardholder's address if different from the delivery address.

Orders are normally sent within seven days but please allow a maximum of 28 days, longer for overseas orders.

Send your order to: Direct Book Service, Allen House, East Borough, Wimborne, Dorset BH21 1PF

Direct Book Service is a division of Wimborne Publishing Ltd., Publishers of *EPE*  
Tel: 01202 881749. Fax: 01202 841692

Due to the cost we cannot reply to overseas orders or queries by Fax.

E-mail: [dbs@epemag.wimborne.co.uk](mailto:dbs@epemag.wimborne.co.uk)

INCORPORATING ELECTRONICS TODAY INTERNATIONAL £2.65

THE No.1 MAGAZINE FOR ELECTRONICS TECHNOLOGY & COMPUTER PROJECTS

We can supply back issues of *EPE* by post, most issues from the past five years are available. An *EPE* index for the last five years is also available – see order form. Alternatively, indexes are published in the December issue for that year. Where we are unable to provide a back issue a photostat of any one article (or one part of a series) can be purchased for the same price.

## DID YOU MISS THESE?

### MAR '99

**PROJECTS** • Smoke Absorber • Auto Cupboard Light • PhizzyB Computers-5 • Time and Date Generator • Wireless Monitoring System-2.  
**FEATURES** • Ingenuity Unlimited • I/TSEC Show Report • PhizzyB Computers-5 • Practically Speaking • Circuit Surgery • Net Work.

### APRIL '99

**PROJECTS** • Mechanical Radio • Voice Record/Playback Module • Versatile Event Counter • PhizzyB Computers-6 • Ironing Board Saver.  
**FEATURES** • Microcontrollers • PhizzyB Computers-6 • MAX761 D.C. to D.C. Converter • Interface • Circuit Surgery • Net Work • **FREE** 48-page Basic Soldering Guide booklet.

### MAY '99

**PROJECTS** • MIDI Handbells • A.M./F.M. Radio Remote Control • PhizzyB Computers-7 • PIC Toolkit Mk2-1.  
**FEATURES** • PC Engines – From 4004 to Pentium III • Ingenuity Unlimited • Practically Speaking • PhizzyB Computers-7 • Circuit Surgery • New Technology Update • Net Work • **FREE** pull-out 7400 series Pinout Data Chart.

### JUNE '99

**PROJECTS** • Clipping Video Fader (Starter Project) • PC Audio Frequency Meter • Musical Sundial • PIC Toolkit Mk2-2.  
**FEATURES** • Alan Dower Blumlein • Circuit Surgery • Interface • PhizzyB Computers-8 • Ingenuity Unlimited • Edison 3 Review • Net Work – The Internet.

### JULY '99

**PROJECTS** • 12V Lead-acid Battery Tester • L.E.D. Stroboscope • EPE Mood Picker • Intruder Deterrent.  
**FEATURES** • Practical Oscillator Designs-1 • Practically Speaking • Circuit Surgery • Ingenuity Unlimited • New Technology Update • Net Work – The Internet.



### AUG '99

**PROJECTS** • Ultrasonic Puncture Finder • Magnetic Field Detective • Freezer Alarm • 8-Channel Analogue Data Logger-1 • Sound Activated Switch.  
**FEATURES** • Practical Oscillator Designs-2 • Power Generation from Pipelines to Pylons-1 • Ingenuity Unlimited • Circuit Surgery • Interface • Net Work – The Internet.

### SEPT '99

**PROJECTS** • Loop Aerial SW Receiver • Child Guard • 8-Channel Analogue Data Logger-2 • Variable Dual Power Supply.  
**FEATURES** • Practical Oscillator Designs-3 • Power Generation from Pipelines to Pylons-2 • Practically Speaking • Circuit Surgery • Ingenuity Unlimited • New Technology Update • Net Work.

### OCT '99

**PROJECTS** • Interior Lamp Delay • Mains Cable Detector • QWL Loudspeaker System • Micro Power Supply.  
**FEATURES** • PIC16F87x Mini Tutorial • Practical Oscillator Designs-4 • Circuit Surgery • Interface • Ingenuity Unlimited • Net Work – The Internet.

### NOV '99

**PROJECTS** • Acoustic Probe • Vibratarm • Ginormous Stopwatch-1 • Demister One-Shot.  
**FEATURES** • Teach-In 2000-Part 1 • Ingenuity Unlimited • Practically Speaking • Practical Oscillator Designs-5 • Circuit Surgery • New Technology Update • Net Work – The Internet **FREE** Identifying Electronic Components booklet.



### DEC '99

**PROJECTS** • PIC Micro-Probe • Magnetic Field Detector • Loft Guard • Ginormous Stopwatch – Giant Display-2.  
**FEATURES** • Teach-In 2000-Part 2 • Practical Oscillator Designs-6 • Interface • Ingenuity Unlimited (Special) • Circuit Surgery • Network-The Internet • 1999 Annual Index.

### JAN '00

**PROJECTS** • Scratch Blanker • Versatile Burglar Alarm • Flashing Snowman • Vehicle Frost Box.  
**FEATURES** • Ingenuity Unlimited • Teach-In 2000-Part 3 • Circuit Surgery • Practically Speaking • Tina Pro Review • Net Work – The Internet.

### FEB '00 Photostats Only

**PROJECTS** • PIC Video Cleaner • Voltage Monitor • Easy-Typist Tape Controller • Find It – Don't Lose It!  
**FEATURES** • Technology Timelines-1 • Circuit Surgery • Teach-In 2000-Part 4 • Ingenuity Unlimited • Interface • Net Work – The Internet.

### MAR '00

**PROJECTS** • EPE ICEbreaker • High Performance Regenerative Receiver-1 • Parking Warning System • Automatic Train Signal.  
**FEATURES** • Teach-In 2000 – Part 5 • Practically Speaking • Technology Timelines-2 • Ingenuity Unlimited • Circuit Surgery • New Technology Update • Net Work – The Internet.

### APRIL '00

**PROJECTS** • Flash Slave • Garage Link • Micro-PICscope • High Performance Regenerative Receiver-2.  
**FEATURES** • Teach-In 2000-Part 6 • Ingenuity Unlimited • Technology Timelines-3 • Circuit Surgery • Interface • Telcan Home Video • Net Work – The Internet.

### MAY '00

**PROJECTS** • Versatile Mic/Audio Preamplifier • PIR Light Checker • Low-Cost Capacitance Meter • Multi-Channel Transmission System-1.  
**FEATURES** • Teach-In 2000-Part 7 • Technology Timelines-4 • Circuit Surgery • Practically Speaking • Ingenuity Unlimited • Net Work – The Internet • **FREE** Giant Technology Timelines Chart.

### JUNE '00

**PROJECTS** • Atmospheric Electricity Detector-1 • Canute Tide Predictor • Multi-Channel Transmission System-2 • Automatic Nightlight.  
**FEATURES** • Teach-In 2000 – Part 8 • Technology Timelines-5 • Circuit Surgery • Interface • New Technology Update • Ingenuity Unlimited • Net Work – The Internet.



### JULY '00

**PROJECTS** • g-Meter • Camera Shutter Timer • PIC-Gen Frequency Generator/Counter • Atmospheric Electricity Detector-2.  
**FEATURES** • Teach-In 2000-Part 9 • Practically Speaking • Ingenuity Unlimited • Circuit Surgery • PICO DrDAQ Reviewed • Net Work – The Internet.

## BACK ISSUES ONLY £2.75 each inc. UK p&p.

Overseas prices £3.35 each surface mail, £4.35 each airmail.

We can also supply issues from earlier years: 1992 (except March, April, June to Sept. and Dec.), 1993 (except Jan. to March, May, Aug., Dec.), 1994 (except April to June, Aug., Oct. to Dec.), 1995 (No Issues), 1996 (except Jan. to May, July, Aug., Nov.), 1997 (except March), 1998 (except Jan., March to May, July, Nov., Dec.), 1999.  
We can also supply back issues of *ETI* (prior to the merger of the two magazines) for 1998/9 – Vol. 27 Nos 1 to 13 and Vol. 28 No. 1. We are not able to supply any material from *ETI* prior to 1998. Please put *ETI* clearly on your order form if you require *ETI* issues.  
Where we do not have an issue a photostat of any one article or one part of a series can be provided at the same price.

### ORDER FORM – BACK ISSUES – PHOTOSTATS – INDEXES

- Send back issues dates
- Send photostats of (article title and issues date)
- Send copies of last five years indexes (£2.75 for five inc. p&p – Overseas £3.35 surface, £4.35 airmail)

Name .....

Address .....

I enclose cheque/P.O./bank draft to the value of £ .....

Please charge my Visa/Mastercard £ .....

Card No. .... Card Expiry Date .....

Note: Minimum order for credit cards £5. Please supply name and address of cardholder if different from that shown above.  
SEND TO: Everyday Practical Electronics, Allen House, East Borough, Wimborne, Dorset BH21 1PF.  
Tel: 01202 881749. Fax: 01202 841692. (Due to the cost we cannot reply to overseas queries or orders by Fax.)

E-mail: orders@epemag.wimborne.co.uk  
Payments must be in £ sterling – cheque or bank draft drawn on a UK bank. Normally supplied within seven days of receipt of order.  
Send a copy of this form, or order by letter if you do not wish to cut your issue.

M8/00

# STORE YOUR BACK ISSUES IN YOUR WALLET!



**NEW**  
on CD-ROM

**ONLY**  
**£12.45**  
including VAT  
and p&p

A new way to buy *EPE* Back Issues – our first wallet-sized CD-ROM is now available containing eight back issues from our *EPE Online* website plus bonus articles, all the relevant PIC software and web links.

All this for just £12.45 including postage and packing.

NOTE: This mini CD-ROM is suitable for use on any PC with a CD-ROM drive. It requires Adobe Acrobat Reader (available free from the Internet – [www.adobe.com/acrobat](http://www.adobe.com/acrobat))



## VOL 1 CONTENTS

**BACK ISSUES** – November 1998 to June 1999 (all the projects, features, news, IUs etc. from all eight issues). Note: No advertisements or Free Gifts are included.

**PIC PROJECT CODES** – All the available codes for the PIC based projects published in issues from November 1998 to June 1999.

**EPE ONLINE STORE** – Books, PCBs, Subscriptions, etc.

### EXTRA ARTICLES

**THE LIFE & WORKS OF KONRAD ZUSE** – a brilliant pioneer in the evolution of computers. A bonus article on his life and work written by his eldest son, including many previously unpublished photographs.

**BASIC SOLDERING GUIDE** – Alan Winstanley's internationally acclaimed fully illustrated guide.

**UNDERSTANDING PASSIVE COMPONENTS** – Introduction to the basic principles of passive components.

**HOW TO USE INTELLIGENT L.C.D.s**, By Julyan Ilett – An utterly practical guide to interfacing and programming intelligent liquid crystal display modules.

**PhyzyB COMPUTERS BONUS ARTICLE 1** – Signed and Unsigned Binary Numbers. By Clive "Max" Maxfield and Alvin Brown.

**PhyzyB COMPUTERS BONUS ARTICLE 2** – Creating an Event Counter. By Clive "Max" Maxfield and Alvin Brown.

**INTERGRAPH COMPUTER SYSTEMS 3D GRAPHICS** – A chapter from Intergraph's book that explains computer graphics technology in an interesting and understandable way with full colour graphics.

Order on-line from [www.epemag.com](http://www.epemag.com) or by Phone, Fax, E-mail or Post

### BACK ISSUES CD-ROM ORDER FORM

Please send me ..... (quantity) BACK ISSUES VOL 1 CD-ROM, NOV '98 to JUNE '99  
Price £12.45 (approx \$20) each – includes postage to anywhere in the world.

Name .....

Address .....

..... Post Code .....

I enclose cheque/P.O./bank draft to the value of £ .....

Please charge my Visa/Mastercard £ .....

Card No. .... Expiry Date .....

**Note: Minimum order for credit cards £5.** Please supply name and address of cardholder if different from that shown above.

**SEND TO: Everyday Practical Electronics, Allen House, East Borough, Wimborne, Dorset BH21 1PF.**

Tel: 01202 881749. Fax: 01202 841692. (Due to the cost we cannot reply to overseas queries or orders by Fax.)

**E-mail: [orders@epemag.wimborne.co.uk](mailto:orders@epemag.wimborne.co.uk)**

Payments must be by credit card or in £ Sterling – cheque or bank draft drawn on a UK bank.

Normally supplied within seven days of receipt of order. Send a copy of this form, or order by letter if you do not wish to cut your issue.



# PIC Real Time In-Circuit Emulator

20MHz full speed operation  
 PC Serial port connection  
 Use With Microchip MPLAB  
 Standard MPASM Language  
 PCB with solder mask & component ID  
 Kit with all components, PIC16F877  
 Solderless Breadboard, lcd,  
 Serial Lead, and Software  
 Kit 900 ..... £34.99

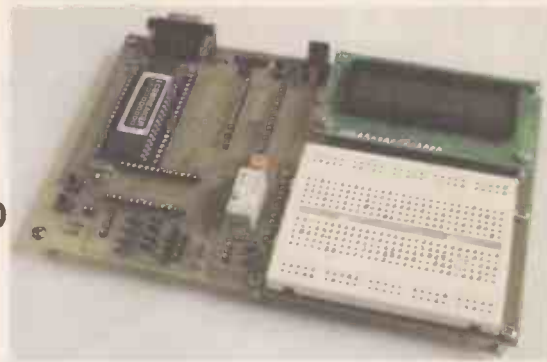

Stepping Motor & Power Supply Extra

# MAGENTA

ELECTRONICS LTD

135 Hunter Street, Burton-on-Trent, Staffs. DE14 2ST  
 Tel: 01283 565435 Fax: 546932  
<http://www.magenta2000.co.uk>  
 E-mail: [sales@magenta2000.co.uk](mailto:sales@magenta2000.co.uk)  
 All Prices include VAT. Add £3.00 p&p. £6.99 next day

# MAPLIN ELECTRONICS

Maplin Electronics' NEW catalogue offers many products including electrical and electronic components, data and computer parts - enabling you to rustle up whatever you like, whenever you like!

Includes £50 worth of FREE vouchers



**NEW AND IMPROVED!**

Catalogue for only **£3.99**  
 CD Rom for only **£1.99**



**To order call 0870 264 6000**  
 quoting reference AD003 or visit your local store. [www.maplin.co.uk](http://www.maplin.co.uk)

No postage or package will be charged for catalogues purchased via mail order. The catalogue is ONLY available through Maplin stores, mail order or the Internet.

We accept the following cards for telephone orders

E & OE. All Trademarks acknowledged. All prices inc. VAT. All prices correct at time of going to press. All prices are subject to change without notice, all offers are subject to availability.





## OUTPUT DRIVERS

The output from pin 11 of IC1d is applied, via current limiting resistor R4, to the base (b) of transistor TR2, which then turns on l.e.d. D2. Similarly, output pin 4 of IC1b is connected to TR1 via resistor R3.

The buzzer, WD1, operates when either transistor is turned on, with diodes D3 and D4 used to prevent both the l.e.d.s turning on at the same moment. The single buzzer shown in Fig 2 will sound when either button is pressed.

However, provision has been made for two buzzers with different tones, in which case each of the buzzers is connected between the positive buzzer terminal (+V) and the points labelled P1 and P2 respectively. This will be explained fully later.

Power is provided by a 9V battery or a 9V to 12V mains power supply, and capacitor C3 is used for general decoupling. The circuit can be reset by switching off the power supply switch S3. In practice it may be helpful to wire a push-to-break switch (S4) in series with S3 to enable easy resetting. Diode D5 is included in the circuit to protect against wrong supply polarity connections.

## CONSTRUCTION

To ease construction and to cut down on the chances of any wiring errors, the main circuit of the Quiz Game Indicator is built on a small printed circuit board (p.c.b.).

Only the contestant switches and two l.e.d.s are not mounted on the p.c.b.

The printed circuit board topside component layout and the full size underside copper foil master are shown in Fig.3. The board is available from the *EPE PCB Service*, code 272.

Begin construction of the p.c.b. by inserting a 14-pin d.i.l. socket for IC1, followed by the smallest components such as resistors and diodes. Ensure that the diodes are inserted the correct way round; the band on the diode indicates the cathode (k) end.

The two transistors should also be inserted with care, noting that a BC184L is specified for TR1 and TR2 (a BC184, without the "L" has its leads in a different order). In practice, virtually any small npn transistor can be used but take care to insert the leads in the correct order.

The small capacitors C1 and C2 can be fitted either way round, but C3 must be fitted with its positive side as shown in Fig.3. Positive is generally indicated by the longer lead.

## SATELLITE LINK

The l.e.d.s and push-to-make switches in the prototype have been fitted into separate satellite or "contestant" cases as shown in Fig.4 and the photographs. Four-core cable is employed to link the master unit with the satellites, and the master (on/off) switch has a Reset push-to-break pushbutton switch (S4) wired in series with it to enable easy resetting of the circuit, ready for the "next question and answer".

When connecting the l.e.d.s observe the correct polarity - the shorter lead normally indicates the cathode (k) and a "flat" usually appears on the body next to this lead. The p.c.b. contains connecting points for

## COMPONENTS

### Resistors

R1, R2	100k (2 off)
R3, R4	4k7 (2 off)
R5	470Ω (see text)

All 0.25W 5% carbon film

### Capacitors

C1, C2	100n ceramic (2 off)
C3	100μ radial elec. 25V

### Semiconductors

D1	5mm red l.e.d., plus optional one (see text)
D2	5mm green l.e.d., plus optional one (see text)
D3, D4, D5	1N4001 50V 1A rect. diode (3 off)
TR1, TR2	BC184L npn gen. purpose transistor (2 off)
IC1	4001B CMOS quad 2-input NOR gate

### Miscellaneous

S1, S2	pushbutton switch, push-to-make (2 off)
S3	min. single-pole toggle switch
S4	pushbutton switch, push-to-break (optional - see text)
WD1	3V to 20V piezo electric buzzer, p.c.b. mounting (see text)
B1	9V battery (PP3), with connector clip/leads

Printed circuit board available from the *EPE PCB Service*, code 272; plastic case, size 100mm x 76mm x 40mm; handheld plastic, snap together case, size 80mm x 55mm x 25mm (2 off); 14-pin d.i.l. socket; 4-core cable, length to choice; multistrand connecting wire; self-adhesive stand-off pillar, for p.c.b. mounting (4 off); solder pins; solder, etc.

Approx. Cost  
Guidance Only  
excluding cases & batts.

**£14**

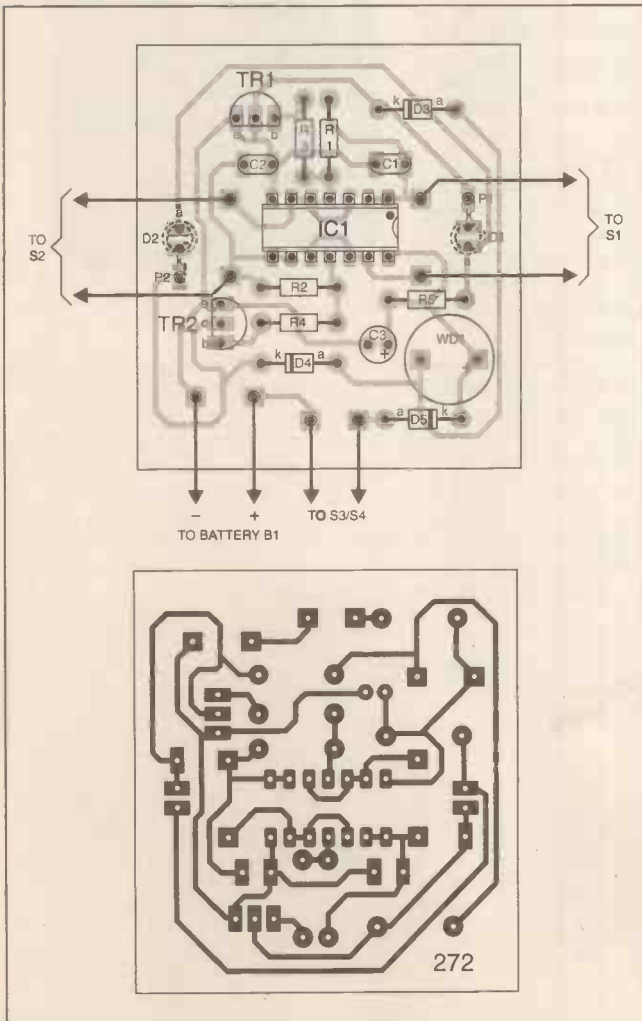

Fig.3. Printed circuit board component layout and full size copper foil master.



a single buzzer. If two buzzers are required, the positive side of each should be connected as shown in Fig.5, and the negative side of each buzzer connected to pins P1 and P2 respectively. If buzzers with different tones are obtained, the tone will indicate who pressed the button first.

When the circuit board has been completed IC1 should be inserted into its socket. Take care when handling any CMOS i.c. since it is static sensitive and may be damaged if handled without first earthing yourself by touching an earthed metal object. Note that pin 1 of the i.c. is indicated by a dot or notch; check that the i.c. is fitted the correct way round, see Fig.3.

### CASING-UP

The prototype Quiz Game Indicator is housed in three enclosures, a main case and two satellites as shown in the photographs. Begin preparation of the cases by drilling all the holes required for the l.e.d.s and interconnecting leads.

The satellite cases house the pushbutton switches S1 and S2 and can also house the l.e.d.s if desired, in which case four-core cable is used to link the main box with the satellites. If l.e.d.s are also required in the main box, they can be wired in parallel

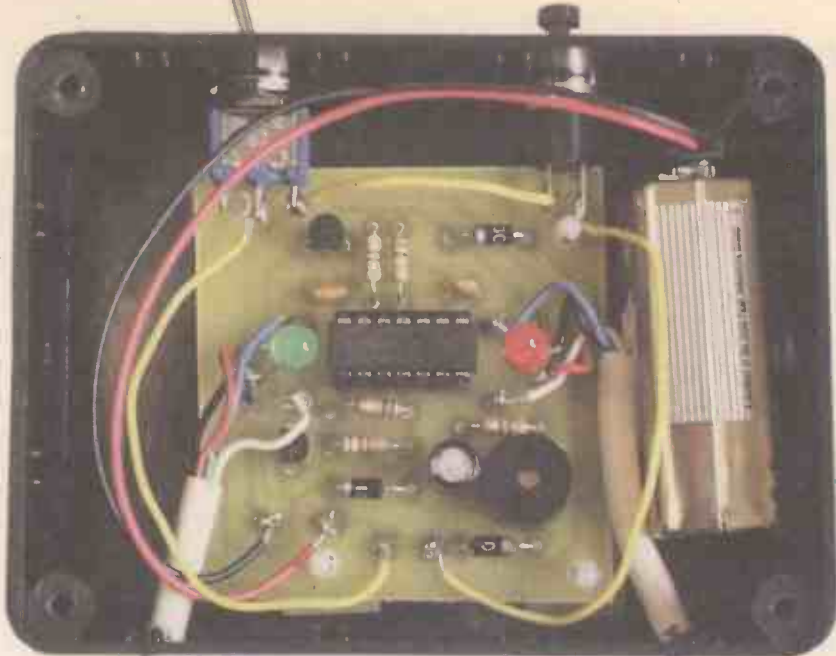

Layout of components inside the prototype master unit.

with l.e.d.s D1 and D2. In this case the value of resistor R5 should be reduced to say 220 ohms.

### TESTING

When power is first applied and on/off switch S3 closed, the circuit should start up in its reset state. Try pressing one of the contestant pushswitches. The appropriate l.e.d. and buzzer should activate. It should not be possible to activate the other l.e.d. once the first is lit.

Good test points are the output pins of each gate. Begin by connecting the negative lead of a voltmeter to 0V in the circuit, and use the positive lead as a probe.

Each output should be close to 0V or close to the positive rail depending upon its state. Pin 3 should always be at the opposite state to pin 4, and likewise pins 10 and 11 should be in opposite states.

If pin 4 is positive, enough current should flow through resistor R3 to activate transistor TR1. The same applies to pin 11, R4 and TR2. If the base of either transistor is above 0.6V then it should turn on.

This project should finally settle any arguments about "who pressed first" since the chances of the buttons being pressed at exactly the same moment, and hence lighting both l.e.d.s, are very remote. Although, human nature being what it is, it's no guarantee!



Wiring to the handset pushswitch and l.e.d.

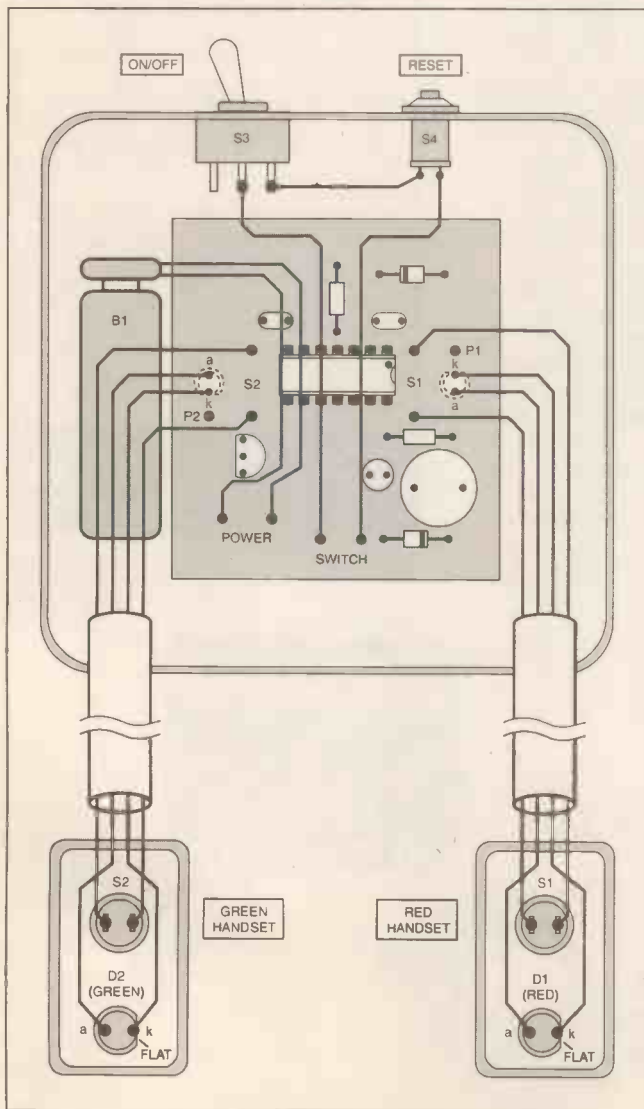

Fig.4. Interwiring between p.c.b. and the two "team" boxes. The main unit l.e.d.s are connected in parallel with l.e.d.s D1 and D2.

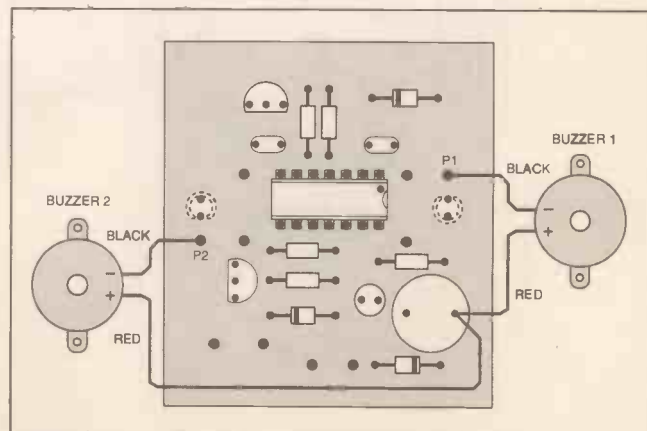

Fig.5. Wiring arrangement for the inclusion of two buzzers.

# PIC BASIC

- Quicker and easier than "C" or assembler
- Expanded BASIC Stamp II compatible instruction set
- True compiler provides faster program execution and longer programs than BASIC interpreters
- I2CIN and I2COUT instructions to access external serial EEPROMs
- More user variables
- Peek and Poke instructions to access any PICmicro register from BASIC
- Serial speeds to 9600 baud
- In-line assembler and Call support
- Supports PIC12C67x, PIC14Cxxx, PIC16C55x, 6xx, 7xx, 84, 92x and PIC16F8xx microcontrollers
- Use in DOS or Windows
- Compatible with most PICmicro programmers (we recommend the EPIC PICmicro Programmer)

The low-cost PicBasic Compiler (PBC) makes it easy to write programs for the Microchip PICmicros. PBC converts your basic language these programs into hex or binary files that can be programmed directly into a PICmicro microcontroller. The easy-to-use BASIC language makes PICmicro programming available to everyone with its English-like instruction set. No more scary assembly language!

The PicBasic Compiler instruction set is compatible with the Parallax BASIC Stamp I. Stamp I programs can be compiled into PICmicro code and programmed directly into a PICmicro, eliminating the need for a BASIC Stamp module. These programs execute much faster and may be longer than their Stamp equivalents. They may also be protected so no one can copy your code. Other benefits include substantial cost savings over a BASIC Stamp.

The PicBasic Compiler has many features beyond the BS1. Peek and Poke instructions let you use additional PICmicro features not available on the BASIC Stamp I. These include access to PORTA, B, C, D and E (if the particular PICmicro has them), A/D converters, hardware serial ports and other on-chip features in BASIC, foregoing the need to use assembly language.

If you really want to use assembly language instructions, they may be mixed with BASIC instructions through the use of the PicBasic Compiler's in-line assembler and Call instruction. Our PICmicro macro assembler is included and automatically invoked by the PicBasic Compiler.

The I2C commands let the PICmicro talk to external I2C devices, such as serial EEPROMs, using only a 2-wire interface. Two PORTA pins have been dedicated to the task (the particular pins assigned may be easily changed if desired) so there is no need to tie up any of the special purpose PORTB pins.

PIC has more user variables. The BS1 only provides variables from B0 - B13 and W0 - W6. The PicBasic Compiler allows variables from B0 - B79 and W0 - W39 when used with PICmicros having 96 RAM registers in Bank 0 like the PIC16C622 and 16C74.

The PicBasic Compiler is a DOS command line application (it also works in Windows) and runs on PC compatibles. It can create programs for the PIC12C67x, PIC14Cxxx, PIC16C55x, 6xx, 7xx, 84, 92x and PIC16F8xx microcontrollers and works with most PICmicro programmers, including our EPIC PICmicro Programmer. A printed manual and sample programs are included to get you started.

## Get your PICmicro projects running quicker and easier!

High-quality blank prototyping boards for PICmicro microcontrollers holds PICmicro, 5-volt regulator, oscillator, capacitors, DB9-25 connector. Large prototyping area. Double-sided board with plated-through holes. Solder mask on both sides makes soldering easy. Silkscreen legend on the top side to ease parts placement and wiring. Includes documentation sheet with diagram. PICProto prototyping boards are designed to help you get your PICmicro projects up and running faster and easier.

The PICmicro I/O pins are brought to the edge of the prototyping area and labeled for quick identification. Proto boards are pre-wired to hold your PICmicro, 5-volt regulator, capacitors and the oscillator crystal, RC or ceramic resonator. At the bottom edge of each board is a place for a DB9-25 RS232 style connector. From £4.95 to £8.95

## PIC16x84 programmer Kit

**WINDOWS Driver - £15.00 inc P&P and VAT**  
Programs the popular PIC1684 and 24 series serial memory devices. Connects to the serial port of PC upto pentium (not P2 or P3) and requires NO External power supply. The KIT includes Diagram, layout, High Quality PCB and all components, software on 3.5" FD

## 2 x PIC Micro CD-ROMs

over 1.2Gb of info £10 inc P&P and VAT

## Oscillators and Resonators

4Mhz and 20Mhz from 45p

## LCD DISPLAYS

£7.50 each!



## NEW 16x2 line super twist displays

SERIAL 16x2 & 20x4 displays IN STOCK NOW!

16x2 serial 1200,2400 or 9600baud & i2c £15.00

20x4 serial 1200,2400 or 9600baud & i2c £35.00

data sheets, circuit diagrams and free example code is supplied - we wont leave you in the dark!

Unless otherwise stated, all prices are exclusive of VAT postage and packing \*  
Visit the NEW web page [www.picbasic.co.uk](http://www.picbasic.co.uk)

The new PicBasic Pro Compiler makes it even easier for you to program the fast and powerful Microchip Technology PICmicro microcontrollers. PicBasic Pro converts your BASIC programs into files that can be programmed directly into a PICmicro.

The PicBasic Pro Compiler features: BASIC Stamp II commands, direct and library routine access to pins on PORTA, C, D, E, as well as PORTB, arrays, real IF...THEN...ELSE and interrupt processing in BASIC.

The PicBasic Pro Compiler gives you direct access to all of the PICmicro registers - I/O ports, A/D converters, hardware serial ports, etc. - easily and in BASIC. It automatically takes care of the page boundaries and RAM banks. It even includes built-in commands to control intelligent LCD modules.

The PicBasic Pro Compiler instruction set is upward compatible with the BASIC Stamp II and Pro uses BS2 syntax. Programs can be compiled and programmed directly into a PICmicro, eliminating the need for a BASIC Stamp module. These programs execute much faster and may be longer than their Stamp equivalents. They may also be protected so no one can copy your code.

The PicBasic Pro Compiler is a DOS command line application (it also works in Windows) and runs on PC compatibles. It can create programs for the PIC12C67x, PIC12CE67x, PIC14C000, PIC14C55x, 6xx, 7xx, 84, 92x, PIC16CE62x, PIC16F62x, 8x, 87x, PIC17Cxxx and PIC18Cxxx microcontrollers and works with most PICmicro programmers, including our EPIC Plus Pocket PICmicro Programmer. A printed manual and sample programs are included to get you started.

The PicBasic Pro Compiler can also be used inside Microships MPLAB IDE. This allows programs to be edited and simulated within Windows. It can also be used with our professional 16F877 in circuit emulator / programmer £149.95 see our web page for more info.

Version 2.3 of the PicBasic Pro Compiler adds support for the 16-bit PIC18Cxxx microcontrollers. If you are a current PicBasic Pro owner and would like the latest version, please contact us for an upgrade.

- BASIC Stamp I and II library
- True compiler provides faster program execution and longer programs than BASIC Interpreters
- Direct and library routine access to any pin or register
- Automatic page boundary handling, past 2K bit, byte and word arrays
- Real If...Then...Else...Endif
- Hierarchical expression handling
- Interrupts in BASIC and assembler
- Built-in LCD support
- Oscillator support from 3.58MHz to 20MHz
- I2C instructions to access more external devices including serial EEPROMs
- More variable space (processor dependent)
- In-line assembler and Call support
- MIPASM / ICE compatibility
- Use in DOS or Windows
- Supports PIC12C67x, 12CE67x, 14C000, 16C55x, 6xx, 7xx, 84, 92x, 16CE62x, 16F62x, 8x, 87x, 17Cxxx and 18Cxxx microcontrollers

**The Professionals choice!**

## EPIC 2000 In Circuit Programmer

- IN CIRCUIT PROGRAMMING of 16F84 and 16F877- connects directly to your circuit board, no more plugging / unplugging while testing code. I, WORKS with ANY Circuit. Full 20Mhz operation, no loss of code space, Program, download and test in circuit in one keystroke. I ideal for use with our Project Boards.
- Low cost programmer for PIC12Cxxx, PIC12CExxx, PIC14Cxxx, PIC16C505, 55x, 6xx, 7xx, 84, 9xx, PIC16CE62x, PIC16F62x, 8x, 87x and PIC17C7xx microcontrollers
- ZIF adaptors available for 8/18/20- and 40/28-pin DIP, 8-, 18- and 28-pin SOIC, 44-pin MQFP and 44-, 68- and 84-pin PLCC PICmicro microcontrollers(not ICP)
- Connects to PC parallel printer port
- Software upgradeable for future PICmicro microcontrollers
- Includes "8051" style PICmicro macro assembler

**Forms a Low Cost Professional Development System when used with our project boards**

**Epic £49.95 or £35 when purchased with PIC BASIC or PRO**  
**Epic ICP £79.95**



## PIC BASIC Programming Books and Tutorials

now in stock, call or visit our web page  
[WWW.CROWNHILL.CO.UK](http://WWW.CROWNHILL.CO.UK)  
[WWW.PICBASIC.CO.UK](http://WWW.PICBASIC.CO.UK)



PIC12c508A - £0.63	PIC12C509A - £0.63	
PIC16F84 /04p - £1.90	PIC16F84/so - £2.00	PIC16F84 /10p - £3.95
PIC16C622 /04p - £2.50	PIC16C671 - £1.60	PIC16C674 - £1.90
PIC16F877 /04p - £5.50	PIC16F877 / 20p - £6.00	
PIC16I876/04P - £4.50	PIC16I874/04p - £4.50	16F873 - £4.50
24LC16 - £0.75	24LC16/so - £0.95	24LC32 - £0.95
24LC64 - £0.95	24LC65 - £1.95	

## Crownhill Associates Limited

32 Broad Street Ely Cambridge Cb7 4PW  
Tel: 01353 666709 Fax: 01353 666710



ORDER ON-LINE [www.crownhill.co.uk](http://www.crownhill.co.uk)

# Constructional Project

# EPE

# MOODLOOP

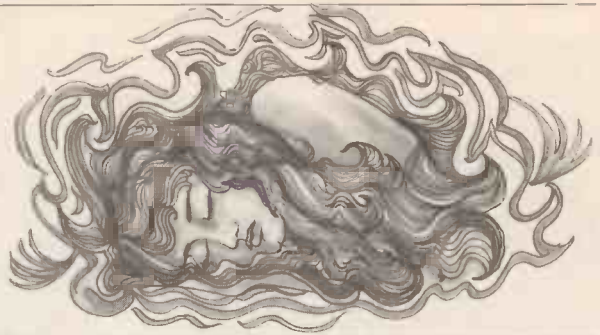

ANDY FLIND

Relax in your own personal "space".  
A NEW PIC design generating  
selectable Alpha, Beta, Delta and  
Theta fields.

**P**UBLISHED in July '99, the *EPE Mood PICKer* and its predecessor the *EPE Mood Changer* (June '98) both proved to be extremely popular with constructors.

These devices generated weak magnetic fields at "brainwave" frequencies, which are thought to encourage mental states of relaxation, creative mental imaging and even sleep. In fact, much of the feedback received from constructors concerned the ability to induce sleep since it has frequently proved very helpful in cases of insomnia.

## BRAINWAVES

To begin with some theory for readers not acquainted with this field, the human brain exhibits electrical activity in the form of tiny alternating currents. Using extremely sensitive equipment it is possible to monitor these currents from voltages present at the skin surface of the head and it has been established that different frequencies correspond to some extent with the subject's mood or mental state.

Of the frequencies established to date, the most important from our point of view fall into four broad categories which have been named by researchers. The lowest band is called *Delta* and covers the range from 0.5Hz to about 4Hz, and is found during deep sleep and in very young babies. The second is *Theta*, which spans 5Hz to 7Hz and is associated with creative mental imagery or mental picturing. Researchers have shown much interest in this area in recent years.

## WARNING NOTICE

It is known that photic stimulation at Alpha frequencies can cause seizures in persons suffering from Epilepsy. We would therefore also suggest that it is not wise for such people to try this project.

A user who is not a known epileptic, but when using the *EPE Moodloop* begins to experience an odd smell, sound or other unexplained effects, should TURN IT OFF IMMEDIATELY and seek professional medical advice.

The next frequency band on the scale runs from 8Hz to about 12Hz and is known as *Alpha*. This is the range that first came to the attention of people outside the medical profession when it was observed in Zen practitioners during a session of deep meditation.

This led to the notion that learning to generate high levels of Alpha activity might allow access to these deep meditative states without the years of rigorous training normally required. Needless to say this proved less than strictly true but many experimenters would agree that it is at least a step in the right direction and meditators sometimes refer to the "Alpha" state, which usually implies deep relaxation.

The highest brainwave frequencies commonly found are between 18Hz and 30Hz, and are called *Beta* waves. They appear during the normal alert, wakeful state. Other brainwave frequencies exist but are not as well defined and are rarely encountered outside medical EEG research.

## FORCE FIELD

Various ways of encouraging the brain to generate specific electrical frequencies exist, one of which is exposure to a suitable alternating magnetic field. Opinions on how this works vary but one likely method seems quite simple. An alternating magnetic field induces electrical currents in conductive material within range and brain tissue is such a conductor.

It seems likely that the production of weak currents of suitable frequency within the brain will either tend to produce the desired mental state directly, or it may do so by encouraging the brain to "synchronise"

to the frequency. Either way, the effect is one many people find worthwhile as shown by the interest in the two projects published so far in *EPE*.

Both of these produce tiny localised magnetic fields. This new project represents an attempt to increase the effect by delivering a much larger current into an inductive loop system which may be placed right around a small room (or around a bed in the case of insomnia!) to permeate a whole area with the desired field.

Roughly speaking, it can saturate an

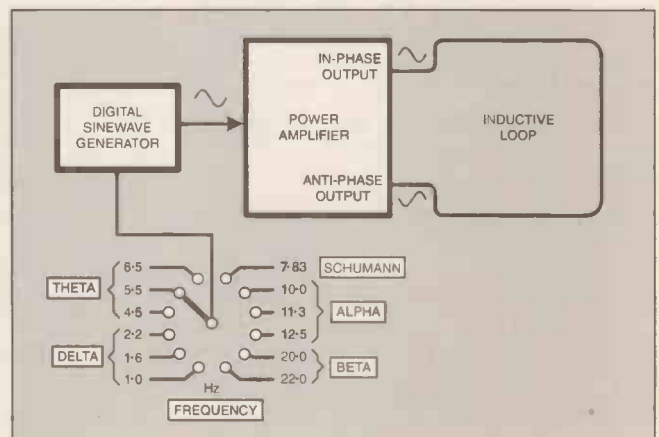

Fig.1. Block diagram for the EPE Moodloop.

area of up to four metres square with a field of intensity equal to that of one of the previous designs at a range of about three centimetres. This should be sufficient for the most ardent enthusiast of the system.

## HOW IT WORKS

The circuit consists of a low-frequency sinewave generator followed by a power amplifier designed for optimum performance at frequencies right down to d.c., see Fig.1. Low-frequency sinewaves are most easily produced using digital synthesis techniques, for which the PIC16F84 microcontroller is well suited.

A bunch of resistors with suitable values are connected to the eight outputs of Port B of the PIC, which are turned on and off in sequence at suitable intervals to give the desired frequency. The resulting output waveform is "stepped", but adequately sinusoidal when viewed on an oscilloscope, certainly sufficiently so for this project.

Each cycle takes a total of sixteen steps and the outline of the program flow is shown in Fig.2. It operates as follows.

Switches connected to the lowest four bits of Port A are used to select the desired output frequency. During initialisation Port A is configured as all input (only the lower five bits are available anyway), Port B is set to all output and both are cleared.

Next, the state of port A is copied into a register called "PTR" (for "pointer" as it is used to select the timing delay for each step). Then the main output program commences its run.

It begins by checking the current state of the four bits of Port A against the value held in "PTR". If they differ the program returns to the start where the new value is read into the register. Otherwise the first bit of Port B is set high and the appropriate delay selected by means of a "tabled go-to" and executed.

This process is repeated a further sixteen times until all eight bits of Port B are high and the output is at the maximum value. The next eight steps then sequentially set them all low again and this process is repeated continuously to generate a steady sinewave output at the selected frequency.



Points to note by anyone examining the software are firstly that the input states are read using the command "COMF" instead of the more usual "MOVF" since they are "active low", as this command inverts them so they arrive the right way up. All the delays are composed of two nested loops which take a fixed number of clock cycles to execute and hence occupy a finite time.

As the whole program is time-dependent, it is liberally sprinkled with "NOP"s to improve accuracy. The calculated output frequencies are all within a tiny fraction of a percent of the intended ones and some are theoretically spot-on.

### TIME CHANGE

The software differs in a number of ways from that of the *EPE Mood PICker*.

The timings are different since it uses a 4MHz crystal in place of the Mood PICker's 32kHz watch crystal, and the output frequencies have been changed slightly. Using a 4MHz crystal also means that the PIC is operated in XT mode instead of LP.

Different resistor values are used to generate the sinewave which no longer uses two steps at the top and bottom of each cycle, so these now execute in sixteen steps each instead of eighteen.

The outputs are turned on in sequence from 0 to 7, then turned off again from 7 to 0, rather than 0 to 7 as in the previous design. This makes little practical difference of course, but does provide a change for the programmer!

Details on obtaining the software are given in *Shoptalk*.

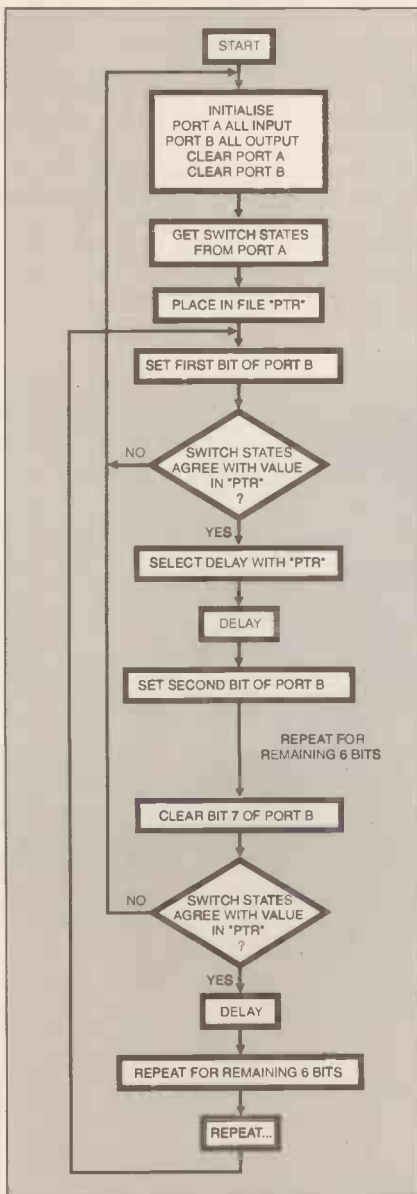

Fig.2. EPE Moodloop software flow diagram.

## COMPONENTS

Approx. Cost  
Guidance Only

£34

excl. case & power supply

### Resistors

R1, R2, R3, R17, R18 1k (5 off)  
R4 to R7, R19 to R24, R27, R28 10k (12 off)  
R8 4k7  
R9, R16 120k (2 off)  
R10, R15 47k (2 off)  
R11, R14 33k (2 off)  
R12, R13 27k (2 off)  
R25, R30 22k (2 off)  
R26, R31 68Ω (2 off)  
R29, R32 10Ω (2 off)  
All 0.6W 1% metal film type

### Potentiometer

VR1 10k 22-turn cermet preset, vertical

### Capacitors

C1 to C4, C8, C11, C14 to C16 100n resin-dipped ceramic (9 off)  
C5 10μ radial elect. 50V  
C6, C7 22p ceramic plate (2 off)  
C9, C10 10n resin-dipped ceramic (2 off)  
C12, C13 1n resin-dipped ceramic (2 off)  
C17 4700μ radial elect. 16V

See  
SHOP  
TALK  
page

### Semiconductors

D1 5V6 400mW Zener  
D2 to D17 1N4148 signal diode (16 off)  
TR1, TR3 BD135 npn transistor (2 off)  
TR2, TR4 BD136 pnp transistor (2 off)  
IC1, IC4 OP279 dual op.amp (2 off)  
IC2 PIC16F84 pre-programmed microcontroller  
IC3 TL061 single op.amp  
X1 4MHz crystal

### Miscellaneous

S1 to S4 4-way d.i.l. switch  
S5 12-way single-pole rotary switch (see text)  
SK1, SK2 15-way D-type socket, chassis mounting (2 off)  
PL1/PL2 15-way IDC plug (2 off)  
SK3, SK4 4mm socket (2 off)  
SK5 d.c. power socket

Printed circuit board available from the *EPE PCB Service*, code 271; plastic case, size 180mm x 120mm x 65mm (see text); 8-pin d.i.l. socket (4 off); 18-pin d.i.l. socket; TO126 twisted-vane heatsink, 19mm x 22mm (4 off); 15-way ribbon cable, grey IDC 0.5in. pitch, 14 metres; multistrand connecting wire; solder etc.

## CIRCUIT DETAILS

The full circuit diagram for the *EPE Moodloop* is shown in Fig.3. The main supply was chosen to be about 12V so the first task is to reduce this to a suitable operating voltage for the PIC.

Normally this would be done by a regulator referenced to the negative (ground) supply rail, with a.c. coupling between the signal and the output amplifier. This proved unsatisfactory for this design because the very low frequencies necessitate large coupling capacitors and their charging times result in long settling times when the unit is switched on.

The solution employed was to split the supply voltage with resistors R1 to R3 to obtain two voltages with a difference of about 4V, symmetrically about half the supply, which are buffered by op.amps IC1a and IC1b to become positive and negative supplies for the PIC, IC2. These have their own local decoupling capacitors C4 and C5 whilst Zener diode D1 protects IC2 in the event of brief excursions beyond its safe supply range.

A further local decoupling capacitor C8 is provided in close proximity to IC2. The OP279 dual op.amp features rail-to-rail outputs capable of currents of up to 80mA, making it particularly suitable for this application.

A further advantage of supplying the signal generating part of the circuit in this manner is that since the output is directly proportional to the supply, the drive to the output amplifier varies in direct proportion to the main supply. This means that the circuit works with optimum drive level for supplies from below 9V up to about 15V with no further adjustment after the initial setting up. A conventional regulated supply would not offer this feature.

## ACTIVE INPUTS

The four inputs RA0 to RA3 of IC2 have "pull-up" resistors R4 to R7 from the positive supply to IC2 so that the frequency selection switches are "active low", pulling them to negative when "on". A quad d.i.l. switch S1 to S4 is fitted to the p.c.b. for testing but a panel mounted rotary switch S5 may also be used, more concerning this later.

Resistors R9 to R16 convert the output sequence from IC2 to a sinewave, and the final level is trimmed to the optimum value with preset potentiometer VR1. This preset is arranged with supply splitting resistors R17 and R18 so that the output signal stays symmetrical about the midpoint of the main supply, allowing d.c. coupling to the output stages.

Capacitors C9 and C10 remove high frequency components of the "stepped" waveform to eliminate r.f. interference radiation, important in a circuit which is going to be connected to what, in effect, is a large aerial!

## OUTPUT DRIVE

For maximum drive with the 12V supply a "bridge-tied" output is used, where the load is connected to two amplifier outputs (IC4a and IC4b), one of which is in-phase with the input whilst the other is anti-phase. This effectively doubles the output voltage to the load. An anti-phase signal is needed to drive the second amplifier so this is obtained using the op.amp inverter IC3.

Two identical output stages are used. They have to be capable of a maximum current of about 1A, with a mean of about 650mA. Op.amps capable of this level of output current are available but

tend to be expensive so a design using power transistors to boost op.amp output power was decided upon instead.

The dual OP279 device was again chosen as the op.amp for its excellent output stage characteristics. Each amp drives the output directly through a 68 ohm resistor (R26, R31), but when the voltage across this resistor rises above about 0.6V in either direction the associated transistor will begin to conduct to provide the necessary load driving power.

The voltage gain of each output stage is about 5.5 so the total gain of the two stages in bridge mode is about 11. To prevent instability occurring with some types of load, resistor/capacitor "snubber" networks (R29/C14 and R32/C16), between each output and ground (0V) are used. Finally, capacitors C12 and C13 reduce the gain at high frequencies, also to improve stability and reduce high frequency components in the output.

Little mention of the frequency selection switch has been made so far. Although the unit can be operated with d.i.l. switches (one is provided on the p.c.b. for testing), it was decided to provide a rotary switch in preference to the fiddly binary d.i.l. switches.

A binary coded rotary switch can be used but most available types appear to be expensive, intended for p.c.b. mounting, fitted with non-standard shaft sizes or otherwise unsuitable for this project. So, a cheap 12-way rotary switch S5 was fitted with sixteen diodes D2 to D17 to provide a binary weighted output on four wires connected to pull-up resistors at the opposite end. The circuit arrangement for the switch and diodes is also shown in Fig.3 and their physical layout in Fig.5.

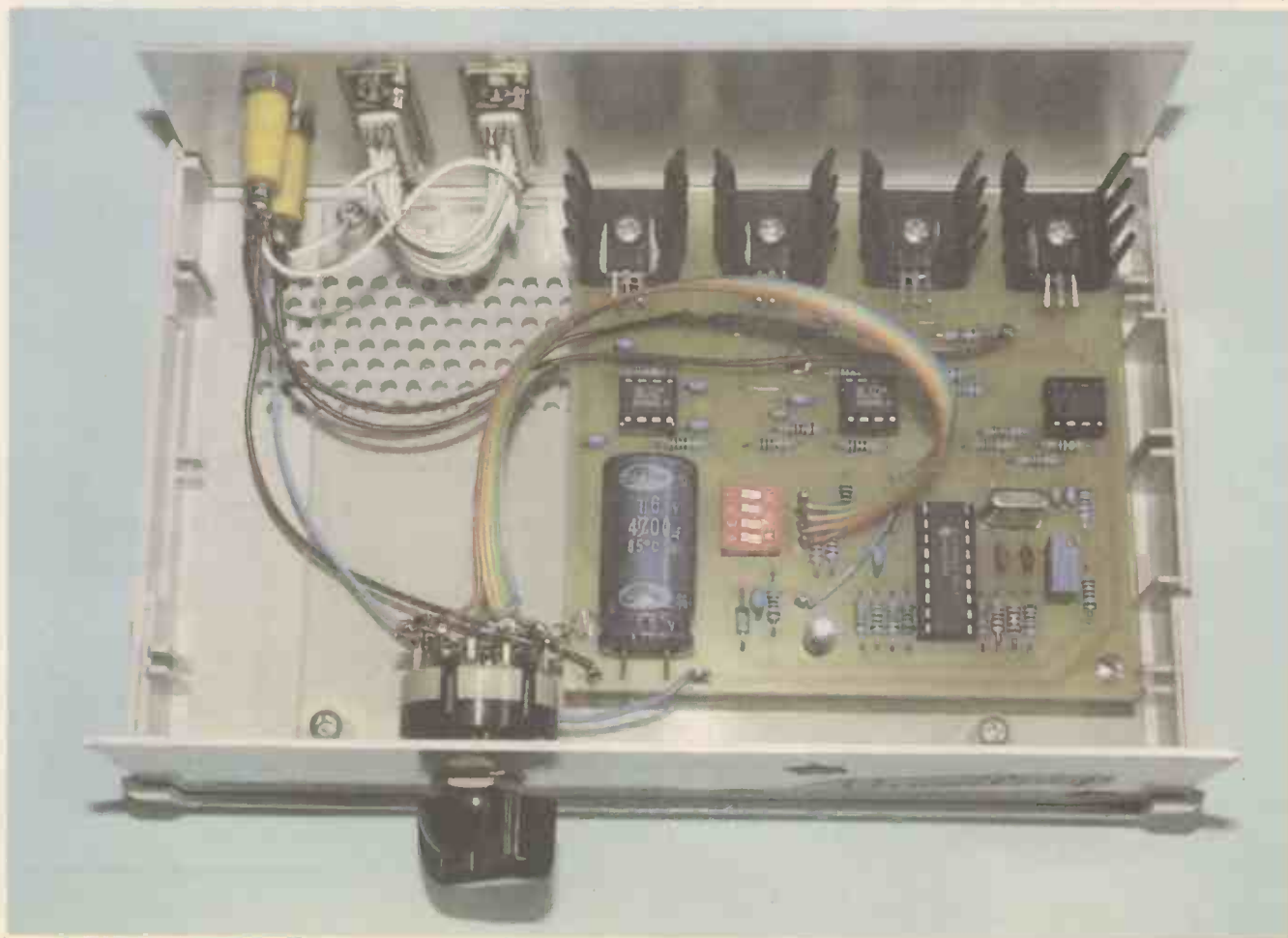

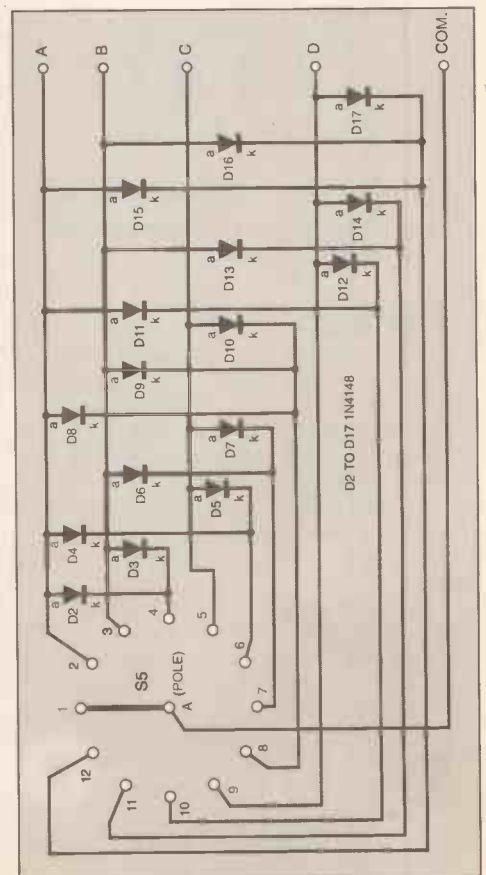
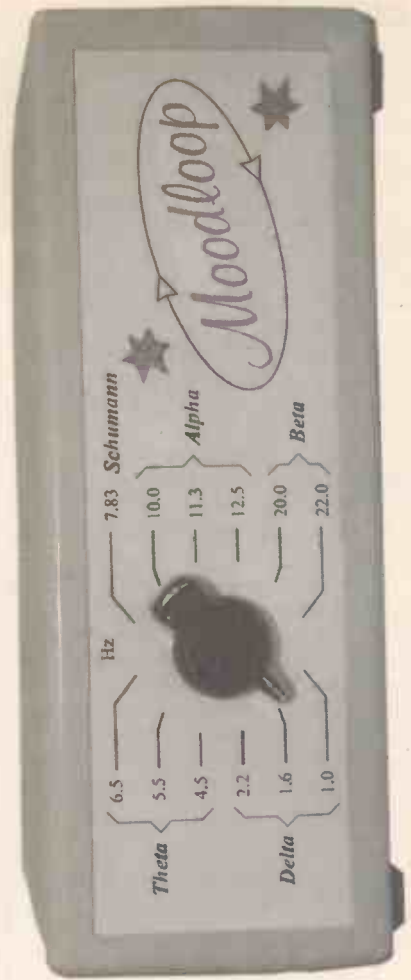
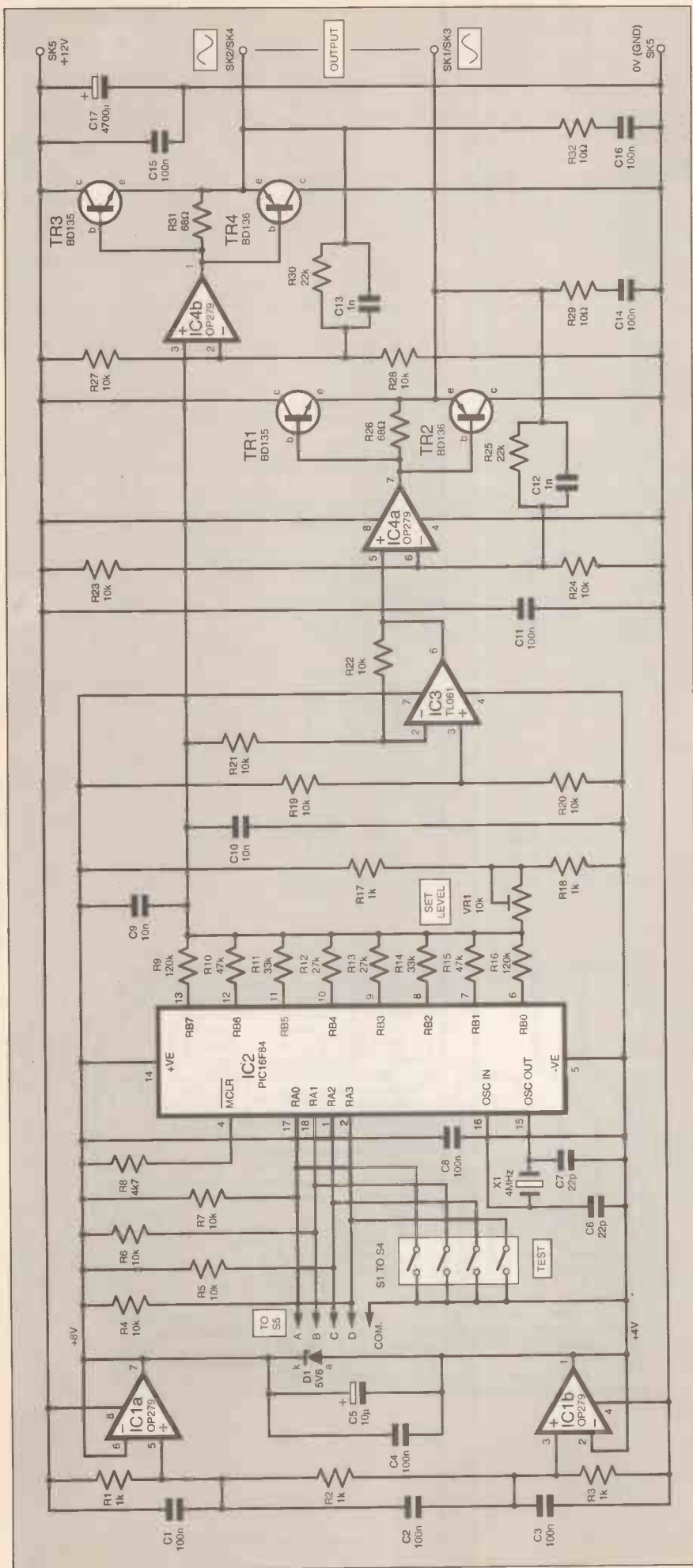

Fig.3. Complete circuit diagram, together with the frequency range switching, for the EPE Moodloop.

## CONSTRUCTION

The *EPE Moodloop* is built up on a medium size single-sided printed circuit board (p.c.b.) and the component layout and full size copper foil master pattern are shown in Fig.4. This board is available from the *EPE PCB Service*, code 271.

Construction should not present too many problems. There are six links which should be inserted first, followed by the resistors and the small capacitors. D.I.L. sockets are recommended for the four i.c.s as these simplify testing.

The large electrolytic capacitor C17 should not be fitted until testing is complete as until the load is connected it takes a long time to discharge when the power is disconnected. If a current-limited bench supply is used for testing it can cause a slow voltage rise at switch-on which in turn can lead to the PIC failing to start up correctly.

The four output transistors are mounted on small heatsinks. In the prototype they do not have insulated mounting washers and were just screwed on using dabs of heat transfer compound. Since the transistor mounting tabs are not isolated, they and the heatsinks must not come into contact with each other or with any parts of the circuit and surrounding metalwork.

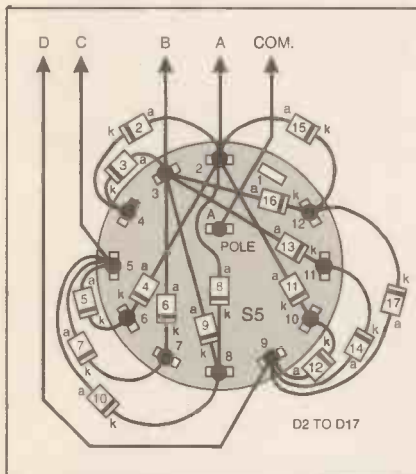

Fig.5. Frequency selection switch S5 construction and wiring.

## TESTING

For testing, the completed circuit should first be powered with a supply of 12V without any i.c.s fitted, preferably from a current-limited bench power supply. Until the load is connected, it will draw only a small current. Without the i.c.s it should draw about 6mA. The aim of this test is to check for any drastic problems before putting any of the i.c.s at risk, so it is worth doing.

If all appears well, IC1 can be inserted, the circuit powered again and the PIC supply tested. This will be found across the leads of Zener diode D1 (positive on the cathode, negative at the anode) and with a 12V supply it should be about 4V. If this checks out IC2 can now be inserted, following which things become more interesting.

Although the final intention is to fit a 12-way rotary switch for frequency selection, for testing purposes an inexpensive 4-way d.i.l. switch S1 to S4 is provided on

the board. Readers will be aware that this gives access to sixteen possible combinations, four more than the rotary switch. These have been programmed as special test frequencies.

The switches are binary weighted with S1 (top) as the lowest or least significant bit. A frequency of 0.5Hz is selected by the 13th setting, binary 12, given by S3 and S4 on, S1 and S2 off (8 + 4). Binary 13 (S1 + S3 + S4) gives 50Hz; 14 (S2, S3 and S4) sets all IC2 outputs high and 15 (all four on) sets all low.

With IC2 inserted the suggested testing procedure is as follows. The supply should be adjusted to exactly 12V for these checks. A voltmeter should be connected with the negative lead to the bottom (anode) lead of Zener diode D1 or the "common" connection point for switch S5, these being the negative supply for IC2, and pin 3 of the socket for IC4, which is the output resistor network from IC2.

With d.i.l. switches S1 to S4 all "on", preset VR1 should be adjusted for an

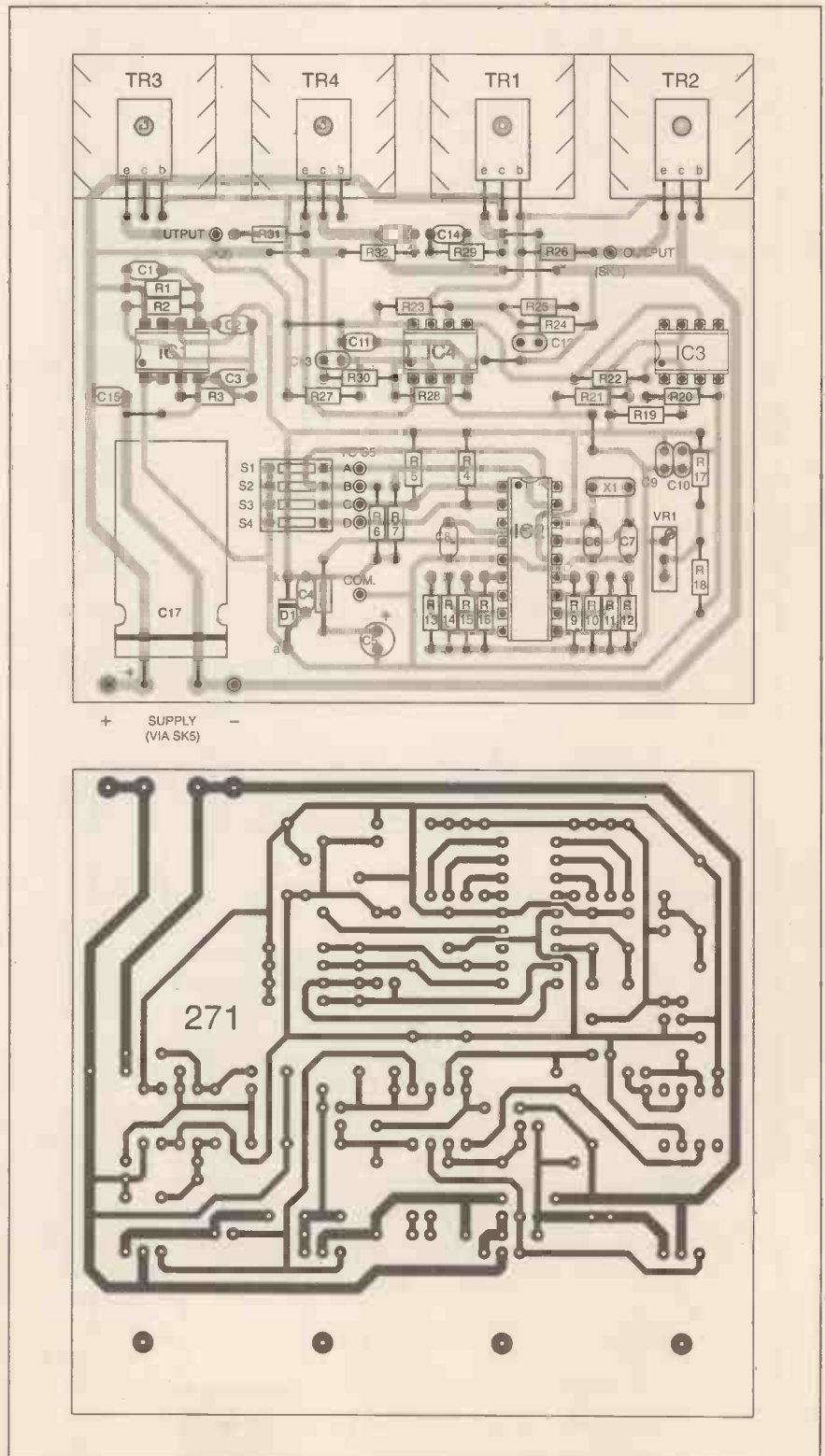

Fig.4. Printed circuit board component layout and full size underside copper foil master pattern.



indication of 1.0V. Switch S1 should then be set to "off", which should cause the reading to rise to about 3.0V.

IC3 should now be inserted on the p.c.b. This loads the output network slightly so it should reduce the above readings to about 1.2V and 2.8V. Their inverse should appear at the output of IC3, pin 6.

An analogue meter may now be used to check the action if the constructor prefers. With switches S3 and S4 "on", others "off", it can be observed following the 0.5Hz signal. With S2 "off" and the rest

## FREQUENCY SWITCH

The Frequency Selector S5 switch will probably have an end-stop behind its mounting nut to limit the number of selectable positions so this should be adjusted to give all 12 positions. In the type used in the prototype it was necessary to remove this device altogether.

Although some care is needed to ensure the diode leads do not short together, the assembly is not as difficult as it looks. It is best to solder the diodes directly to the

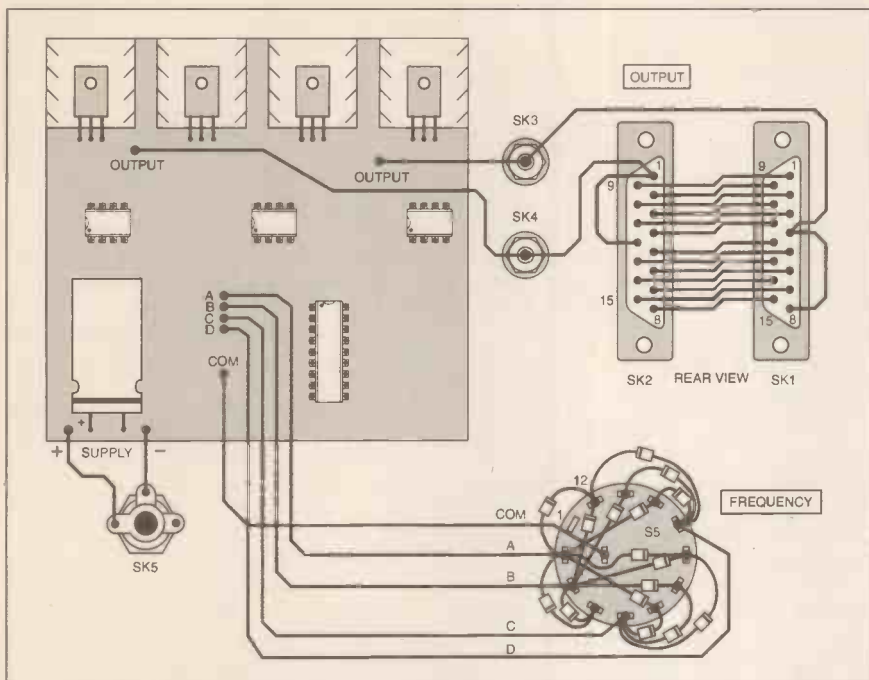

Fig. 6. Interwiring from the p.c.b. to off-board components.

"on", the 50Hz output should give an average d.c. reading of about 2.0V. A digital voltmeter (DVM) on an A.C. range should read about 550mV r.m.s. for this output.

Next, IC4 can be fitted on the p.c.b. and a DVM connected across the output terminals, at SK3 and SK4. It should read about 6.0V r.m.s. on 50Hz, or  $\pm 8.6V$  d.c. for the "all high" and "all low" switch settings.

If these tests are all OK the large electrolytic C17 can be fitted. This is mounted horizontally as shown to reduce the overall height of the completed board. The prototype has a spot of "Blu-tack" to hold it securely but glue or double-sided adhesive foam would serve as well.

The p.c.b. should now be ready for use but if a suitable load is available, such as a resistor of about 8 ohms to 10 ohms with a rating of 5W or more, it can be tested at full power with this. It should draw about 600mA to 700mA and the resistor will warm up quite quickly. The r.m.s. reading for the 50Hz output should remain about the same, but it can be adjusted to an absolute maximum of 6.5V r.m.s. with preset VR1.

Note that the power supply used for making this adjustment should be capable of at least 1A, and that continuous operation into a load in the "all high" or "all low" test settings is not recommended as this puts the maximum output current continuously through just two of the output transistors which may cause overheating.

switch tags before mounting S5 in its case.

When switch S5 is connected to the p.c.b. the d.i.l. switches (S1 to S4) should all be "off" to enable it to operate correctly and, conversely, it should be at position 1, where all the outputs are open-circuit, if the d.i.l. switches are to be used for further testing. Out of interest though, if the d.i.l. switches are set up for binary 12 (S4, S3 on) the first four positions of the rotary switch will correspond to the four "test" settings, which may prove useful.

## FINAL ASSEMBLY

The prototype model is fitted into a Vero "Patina" box with dimensions of 180mm x 120mm x 65mm, though a cheaper case can be used if preferred. The wiring between the p.c.b. and the switch, power and output sockets is shown in Fig.6. The prototype has no on-off switch as this is provided on the power supply, but one can easily be added if required.

The only points to note are that the metalwork of the transistors such as mounting bolts, heatsinks and so on *must not* come into contact with any other metalwork, and provision for airflow around the heatsinks must also be made. In the prototype this consisted of drilling plenty of holes in the top and bottom of the case, which can be seen in the photographs, and attaching stick-on rubber feet so that air can enter from below the case and leave by convection through the top. This has proved adequate in practice.



Mount the frequency switch diodes directly on the switch tags before the switch is fitted in the case.

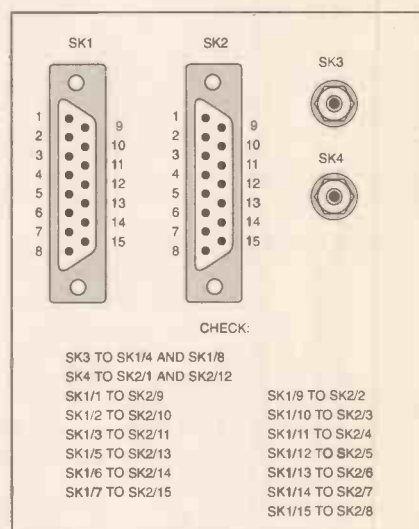

Fig. 7. Output socket wiring check.

## INDUCTIVE LOOP

The output can be connected to just about any load with a resistance greater than 8 ohms, the ideal being around 10 ohms. It is intended to drive an "inductive loop" system consisting of multiple turns of wire running around the area to be subjected to the magnetic field.

One way to do this is to use ribbon cable with the cores connected end-to-end to form several turns in series. If the overall resistance is significantly higher than 10 ohms groups of series-connected turns can be connected in parallel to achieve the target resistance.

The prototype uses about 14 metres of ribbon cable connected to give one loop of 7 turns in parallel with another of 8 turns. Two 15-way D-type chassis sockets are fitted to the case and wired as shown in Fig.6 to achieve the necessary arrangement of the cable which is fitted with 15-way IDC D-type plugs.

Polarity of these is arranged so that pin 1 of one plug connects to pin 1 of the other, and so on. They allow loops to be installed and left in place, so that the EPE Moodloop unit can be taken to any desired location and just plugged in.

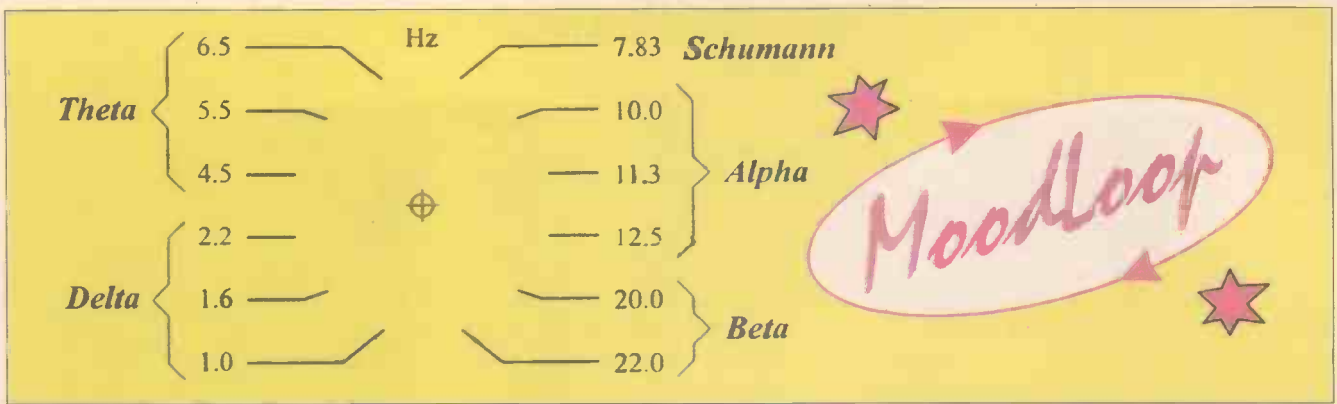

Full-size front panel legend master for the EPE Moodloop project.

For future experiments with other types of coil or loop the unit is also fitted with 4mm sockets (SK3, SK4). It would be quite simple to make a small adapter to connect these to multiway sockets of other types for different types of loop.

If the 15-way sockets are fitted and wired as shown, this should be done with extreme care as there will be little indication of errors. It is suggested that after wiring, continuity testing should be carried out from the front of the sockets as shown in Fig.7 to ensure that it is correct. The "loop" can then be plugged in and the overall resistance measured to ensure it has about the right value of 10 ohms.

### COMFORT ZONE

Positioning of the loop is up to the user. The obvious position is around the area to be covered, at floor level or possibly higher, though if it were placed vertically, perhaps against a wall, anyone in front of or behind it would be exposed to the field. The suggested length of loop may allow more than one turn around a small area for even greater field strength!

It seems likely that the user's position relative to the field is not particularly important, so long as the strength is sufficient. Experiments with a sensitive magnetic field detector show that the field actually extends for quite a distance outside the loop.

It might also be interesting to try using a solenoid of suitable resistance, although this has not been attempted with the prototype yet. A point to watch here, though, is that a few watts of heat are dissipated by the load so it should have the ability to dissipate this, which may not be the case with a solenoid.

### POWER SUPPLIES

Power for the unit is nominally 12V, but the prototype has been tested with supplies ranging from just below 9V to a maximum of 15V, at which setting the four heatsinks become rather warm, but not beyond acceptable limits.

The average current taken will normally be around 600mA to 700mA depending on supply voltage, but the peak current will be over 1A so the supply should be capable of this in view of the low frequencies involved. The voltage must be regulated, as fluctuations with load will cause corresponding distortion of the output so this rules out most "plug-top" supplies as most of these have no internal regulation.

Many constructors will already have suitable power supplies of some kind and

it is also possible to operate the unit directly from a car battery, where the use of "Alpha" frequencies may help to reduce "road rage", or "Beta" might combat fatigue on long trips. However, next month we will be giving details of a simple mains operated low-voltage regulated supply which can be used to supply this project and many others

### SCHUMANN RESONANCE

Before ending, an explanation of the front panel setting labelled "7.83 Schumann" must be given. This refers to the "Schumann Resonance", an intriguing phenomenon amongst the naturally occurring magnetic fields that have always surrounded us. It appears that the space between the earth's surface and the ionosphere forms a gigantic resonant cavity having physical dimensions which give it a frequency somewhere between 7Hz and 8Hz. Events such as lightning excite oscillations in this cavity and very low attenuation at these frequencies allows them to keep going more or less continually.

Enthusiasts of the effects of fields at this frequency say that modern man is missing out on its supposed beneficial effects

because it tends to be masked by more powerful fields from the electrical equipment and wiring which nowadays surrounds us all. It has even been claimed that NASA installed Schumann frequency magnetic field generators in spacecraft after finding that space sickness was in part due to the astronauts travelling beyond the range of this field, although the author has been unable to confirm whether this is true.

However, constructors may now create the Schumann field in their own homes and judge for themselves whether it's effects are beneficial. □

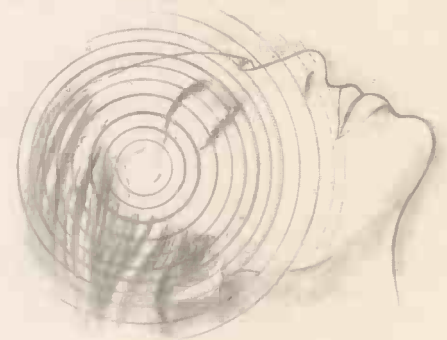

Completed EPE Moodloop (right) together with Moodloop Power Supply (next month) and a Field Strength Checker (October issue).

Prices fully inclusive

# The FED PIC C Compiler - Rapid, Efficient, High level development

## FED PIC C Compiler – Version 3.0 now available

- Designed to ANSI C Standards
- Complete development environment includes Editor, assembler, simulator, waveform analyser and terminal emulator (see screenshot below)
- Libraries include serial interfaces, 12C, LCD, keypads, delays, string handling, hardware etc.
- Simulator runs up to 10 times faster than MPLAB, allows inputs to be defined, multiple breakpoint types, single stepping, step over etc.
- Supports all 14-bit core PIC's – 12C67x, 16C55x, 16C6x, 16C7x, 16C8x, 16C87x, etc.
- Will produce code for MPLAB

### LEARN to Program PIC's in C with FED!

With the FED introductory manual:  
"Learn to program PIC's with FED PIC C"

- Suitable for complete beginners to PIC's or to the C programming language
- Leads through example
- Introduces simple C programs, then covers variables and casting, pointers, structures and unions, functions, etc.
- All examples will run fully within the simulator, or on the FED 16F84 and 16F877 development boards
- Covers use of interrupts and programming for real time applications
- Hints and tips on good programming practice with the PIC
- Full examples of debugging using FED PIC C are included
- Included FREE on our PIC C Compiler CD ROM, or available in paper copy
- Available only to existing or new customers for our C Compiler.

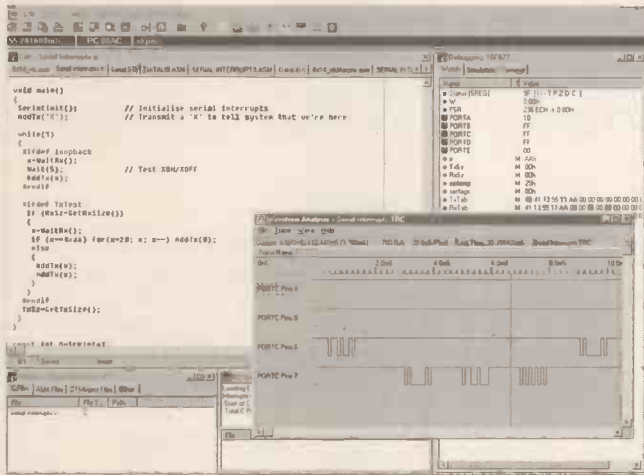

**Prices (reductions for PICDESIM/WIZPIC users)**  
**C Compiler with all manuals on CD ROM £60. CD ROM with printed manuals £75.**  
**Upgrade – PICDESIM/WIZPIC users £45.00 CD ROM.**  
 "Learn to program PIC's with FED PIC C" – £7.50.

## Programmers for PIC & AVR

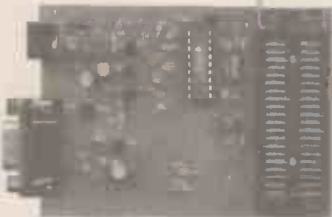

### PIC Serial Programmer (Left)

Handles serially programmed PIC devices in a 40-pin multi-width ZIF socket. 16C55X, 16C6X, 16C7X, 16C8x, 16F8X, 12C508, 12C509, 16C72XPIC 14000, 16F87X, etc.

Also In-Circuit programming. Operates on PC serial port

Price : £45/kit  
 £50/built & tested

**PIC Introductory** – Programs 8 & 18 pin devices : 16C505, 16C55X, 16C61, 16C62X, 16C71, 16C71X, 16C8X, 16F8X, 12C508/9, 12C671/2 etc. **£25/kit.**

**AVR – AVR** – 1200,2313,4144,8515, 8535, 4434 etc. in ZIF. 4.5V battery powered. **Price : £40 for the kit or £45 built & tested.**

All our Programmers operate on PC serial interface. No hard to handle parallel cable swapping! Programmers supplied with instructions, + Windows 3.1/95/98/NT software.  
**Upgrade programmers from our web site !**

## WIZPIC

### PIC Visual Development



- Rapid Application Development for the PIC microcontroller
- Drag and drop your software component selections on to your design

- Included components support timers, serial interfaces, I2C, LCD, 7-Seg displays, keypads, switches, port controls, and many more.
- Connect software components to PIC pins by point & click using the mouse
- Set parameters for each component from drop down list boxes, check boxes, or text entry
- Links your code automatically into library events (e.g. Button Pressed, Byte Received etc)
- Up to 10 times faster than MPLAB
- Supports all 14-bit core PIC's -12C67x, 16C55x, 16C6x, 16C7x, 16C8x, 16C87x etc.

**Cost – CD-ROM with Data sheets and application notes – £35.00, Floppy version £30.00.**

## Forest Electronic Developments

60 Walkford Road, Christchurch, Dorset, BH23 5QG.

E-mail – info@fored.co.uk, or sales@fored.co.uk

Web Site – <http://www.fored.co.uk>

**01425-274068 (Voice/Fax)**

Prices are fully inclusive. Add £3.00 for P&P and handling to each order. Cheques/POs payable to Forest Electronic Developments, or phone with credit card details.



## 16F877

**Fully supported by WIZPIC, PICDESIM, the serial programmer and our C Compiler.**

16F877-04 £5.50  
 16F877-20 £6.00

http://www.fored.co.uk

# CAVE ELECTRONICS



**MIKE BEDFORD**

*There are some absolutely amazing sights in the world beneath our feet, and electronics is increasingly helping us to explore them.*

**H**ELMET, lamp, rope, ladders, carabiners, abseiling gear, boots, waterproof oversuit, soldering iron – which is the odd one out?

Not the most difficult of brain teasers, you might think, and it probably took you all of five hundred milliseconds to figure out that the first eight items – but not the soldering iron – are pieces of kit used by potholers.

So you'd be a little surprised, no doubt, to hear that within my sphere of caving acquaintances there is no odd one out – all these items are used regularly in the pursuit of caving. However, before you try to conjure up some spurious caving use of the soldering iron, let me come clean and point out that I know some pretty unusual cavers.

## CAVING GROUPS

As members of the Cave Radio & Electronics Group (CREG) of the British Cave Research Association (BCRA), these particular cavers have a specialist interest in applying their expertise in electronics and computing to the sport of potholing.

This article is an investigation of cave electronics. As with any specialised area, we expect that only a minority of readers will have a first-hand need for many of the techniques or equipment which we'll discuss. However, even if you don't feel inclined, in the slightest, to venture underground, we trust that you'll find this article to be an interesting eye-opener to a most unusual field of research.

We also believe that although caving has been the motivation behind all the developments described here, some of the material will be relevant to above-ground use too.

From CREG's name, you might reasonably assume that a major emphasis of the Cave Radio & Electronics Group is cave radio. This would be a correct assumption – the development of underground communication equipment, and specifically of low

frequency induction radios for through-rock transmission, is a priority for the majority of cave electronics enthusiasts.

There's a good reason for this – effective communication is essential to the UK's cave rescue organisations. Cave radios are used on a regular basis for controlling rescues and it's probably true to say that some individuals owe their life to this technology.

Nevertheless, apart from this brief mention, this article will stay well clear of communications. The subject has been well aired in the amateur radio press, so our

emphasis here will be on some of the less known applications of electronics and computing to potholing.

If you are interested in the radio side, though, a few references to further reading on cave radio (and cave electronics) are provided at the end of this article.

## LIGHTING

As a tourist on a trip down a well-lit show cave, lighting is something you soon forget about until the guide does his usual trick of turning the lights out – caves are totally and absolutely dark. Arguably, therefore, the single most important piece of caving equipment is a lamp, something which, traditionally, isn't a particularly high tech device.

In the UK, the most popular form of caving lamp consists of a lead-acid or NiCad (nickel-cadmium) battery pack mounted on a belt and connected to a cap-lamp containing a krypton bulb which clips onto the helmet.

Some cavers, especially in Europe, swear by an even more basic solution – the carbide lamp. Here, water drips onto calcium carbide in a belt-mounted reservoir and a plastic tube carries the acetylene gas which is produced to a burner on the helmet.

Whereas many cavers take the "if it ain't broke, don't fix it" view of lighting, many of those who take an interest in electronics feel that there's got to be a better way. So, despite its rather mundane image, cave lighting is one of the main areas to exercise the minds of technically-minded cavers.

Ideally, a caving lamp should last for at least eight hours to enable people to complete most common trips without having to carry spare batteries. It needs to be body-mounted so that the caver has both hands free – essential for negotiating climbs – and it needs to be sufficiently robust that it will be reliable, even when subjected to knocks or to immersion in water. Surprisingly, a caving lamp doesn't actually need to



*Has anyone ever seen that before?*

be particularly bright since our eyes soon become accustomed to low levels of light.

## BRIGHTNESS

Although the current generation of lights do, admittedly, provide most of this, there's undoubtedly scope for improvement. For example, although krypton bulbs are remarkably efficient (given their low power rating) at turning electricity into light, the price you pay is a short lifetime.

Whereas household tungsten bulbs last for a thousand hours or more, small krypton bulbs have a lifetime measured in tens of hours. It's essential, therefore, to carry some sort of reserve lighting, indeed traditional caving lamps have a pilot bulb and it's advisable to also carry a completely independent backup lamp.

Secondly, although today's caving lamps are acceptably bright, if you want to be able to see your surroundings in some detail, as opposed to just having sufficient light to ensure your personal safety, a brighter light would be preferable.

Thirdly, it would be nice to be able to get rid of the battery pack or carbide generator on the belt, which always seems to work its way into the most uncomfortable position when you're attempting to negotiate a tight squeeze. It's not uncommon to get stuck purely because you're wearing a battery pack.

Certainly you can buy caving lamps in which the battery fits onto the helmet but, in order to keep the weight down, these only provide two or three hours of light and tend to be used by school parties and novices on short trips, as opposed to serious cavers on more protracted outings.

## LIGHT EMITTING DIODES

Given these problems with the currently available caving lamps, many electronically-minded cavers have thought intuitively in terms of light emitting diodes (l.e.d.s). They're robust, they consume a very small current and, unlike high efficiency technologies such as discharge lamps and metal halide bulbs, they are cheap, available in low power ratings, and are easy to drive using low voltage circuitry.

What many people fail to take into account, however, is that although l.e.d.s don't consume much power, they don't



Conventional Oldham lamp with large lead-acid belt battery.

## SO WHAT'S THE FASCINATION?

To understand this article, you don't need to be a caver, but a little bit of background knowledge will help you to appreciate it. Perhaps the most obvious question to try to answer is why people go potholing. This is a very valid question given the look of horror which appears on many people's faces when I mention that I'm a caver, especially if I then suggest that they might like to join me on an easy trip to find out what it's all about.

Public perception of potholing is of a dangerous and uncomfortable activity, so what is it about the underworld which potholers find so attractive? How can people get enjoyment from crawling through a passage half full of gelatinous mud, of abseiling down a three hundred foot pitch or of attempting to breath in the three inch air space in the roof of a flooded passage?

There's no single answer to these questions – ask half a dozen cavers why they do it and you'll probably get half a dozen different answers. For some people, caving is, first and foremost, a sport. So the appeal is similar to that of many other sports.

It provides physical exercise and a sense of competition although, unlike football or cricket, the competitive element is a matter of pitting yourself against nature rather than against other players. The challenge of potholing as a purely physical pursuit shouldn't be underestimated. Some of the world's more demanding caves require a very

actually generate a lot of light. Nor are conventional l.e.d.s particularly efficient at turning electricity into light, achieving a figure of, perhaps, 0.01 to 0.1 lumens per watt. A 2W krypton bulb, on the other hand, clocks up about 15 lumens per watt.

You'll notice, however, that we are referring above to conventional l.e.d.s, and as new high brightness, high efficiency l.e.d.s start to appear, there is a lot of talk about caving lamps based on l.e.d.s. New high efficiency l.e.d.s are more efficient than krypton bulbs in addition to being more robust and having a much longer lifetime.

Furthermore, filament bulbs are a mature technology, but in the realm of l.e.d.s we can expect further significant improvements. However, to use l.e.d.s as caving lamps, as opposed to as indicators, a new way of thinking is required.

Traditionally, digital equipment has been driven from a 5V supply; l.e.d.s, on the other hand, operate off a lower voltage – typically two to three volts – indeed most l.e.d.s will be destroyed if you simply put 5V

high degree of skill and stamina over a protracted period of time.

Other cavers spend a major proportion of their time in trying to find new caves, or extending caves by discovering new passages. The appeal of finding a cave which no human being has ever seen before isn't hard to imagine, especially in view of the fact that there must now be so few places on the surface of the earth which nobody has seen before.

Then we have those people for whom a caving trip is a voyage of personal discovery. Even if countless other people have been there before, there are few people, for example, who haven't been awestruck on first seeing the huge main chamber of Gaping Gill. These are the people for whom caving is primarily about seeing the wonders of nature and caves are much more than just muddy holes in the ground – there are some absolutely amazing sights in the world beneath our feet.

We also have those individuals who have some specialist interest in caving. This article concentrates on one such specialist interest – cave electronics, but this is one of many. Cave photography is another popular interest within caving and despite the extra challenges which cave photographers face, the results can be absolutely stunning.

And last, but by no means least, we have hydrologists who study the formation of caves, cave biologists, cave archaeologists, cave surveyors and even cave artists.



Experimental l.e.d. based lamp.

across them. So, a series resistor is used to limit the forward voltage at the 20mA operating current.

Note, however, that the dropper resistor will frequently end up dissipating at least as much power as the l.e.d. itself. For a 2V l.e.d. driven from a 5V supply via a 150Ω resistor, the resistor dissipates 60 per cent of the total power so the efficiency of a 20 lumens per watt l.e.d. would be effectively reduced to eight lumens per watt.

Of course, there's no reason to use a 5V battery or even the 6V battery packs which are conventionally used for caving lamps. Nevertheless it frequently won't be possible to juggle 1.2V NiCad or NiMH (nickel metal-hydride) cells to produce a battery with exactly the right voltage for a chosen l.e.d.

## MULTIPLE L.E.D.S

However, since a single l.e.d. doesn't produce enough light for a caving lamp, multiple l.e.d.s will be needed, and this offers an alternative driving method. With a 6V battery pack, for example, strings of three 2V l.e.d.s connected in series can be used. But even this isn't a particularly effective way of getting the most out of the l.e.d.s, especially if you're using a battery chemistry such as NiCad, which has a noticeably sloping discharge curve.

The current drawn by an l.e.d. has an exponential relationship to the voltage, which means that as the voltage drops there will be an increasingly large reduction in the current and hence in the light output. A modest degree of over-voltage, on the other hand, will severely reduce the efficiency of the l.e.d.

The ideal arrangement, therefore, especially if you want the flexibility to use the l.e.d. lamp with a wide range of battery types, is to incorporate a switching regulator to provide a constant voltage supply.

But, whereas the common high brightness red or green l.e.d.s might seem an ideal solution in many respects – especially if the efficiency continues to increase – monochromatic light certainly is not ideal. Quite apart from the fact that most cavers would prefer not to see everything swathed in red, green or amber light, our eyes are

optimised for white light and our perception of depth can be impaired by monochromatic illumination.

So, the recently-introduced white l.e.d.s – actually high performance blue l.e.d.s with red and green phosphors deposited onto the dies – are of particular interest.

## PROTOTYPE L.E.D. LAMPS

CREG's David Gibson has been experimenting with a prototype caving lamp using no less than 48 of these l.e.d.s. Although it consumes as much power as a conventional caving lamp, the quality and spread of that light is reported as being better.

David's long term aim is to incorporate a PIC microcontroller which will provide a range of operating modes (e.g. normal, pilot lamp, ultra-bright, emergency low power) as well as monitoring battery charge and giving advanced warning of battery failure.

Other experimenters, though, are spurning these white l.e.d.s in favour of a mixture of red, green and blue l.e.d.s to achieve a higher level of efficiency – at the moment white l.e.d.s are not as efficient as krypton filament bulbs.

A lamp designed by Chris Vernon, for example, uses just a handful of l.e.d.s in a mix of colours and is powered by a

switching regulator and a small NiMH battery pack on the back of the helmet. It is more efficient than a lamp based on krypton bulbs, lasts for eight hours, and is much more reliable than lamps based on filament bulbs.

The ratio of the red, green, blue and amber l.e.d.s was a result of balancing a couple of factors – the resultant colour of the light and ensuring that the devices could be used without loss-inducing dropper resistors.

## PRACTICAL CIRCUIT

The circuit diagram for Chris Vernon's lamp is shown in Fig.1.

The power supply for the l.e.d.s is obtained via a SEPIC (single-ended primary inductance converter) integrated circuit (IC3), actually intended for battery charger applications, which allows operation over a wide range of input voltages.

The MC33465 (IC1) is an under-voltage reset device which produces a timed shut-down if the battery voltage falls below the SEPIC's minimum input voltage of 2.7V. This causes the lamp to flash with increasing urgency as the battery's charge level becomes critical.

The lamp also has an integrated battery charger (the top half of the schematic) which operates from a 9V to 15V d.c. supply. This uses another SEPIC voltage

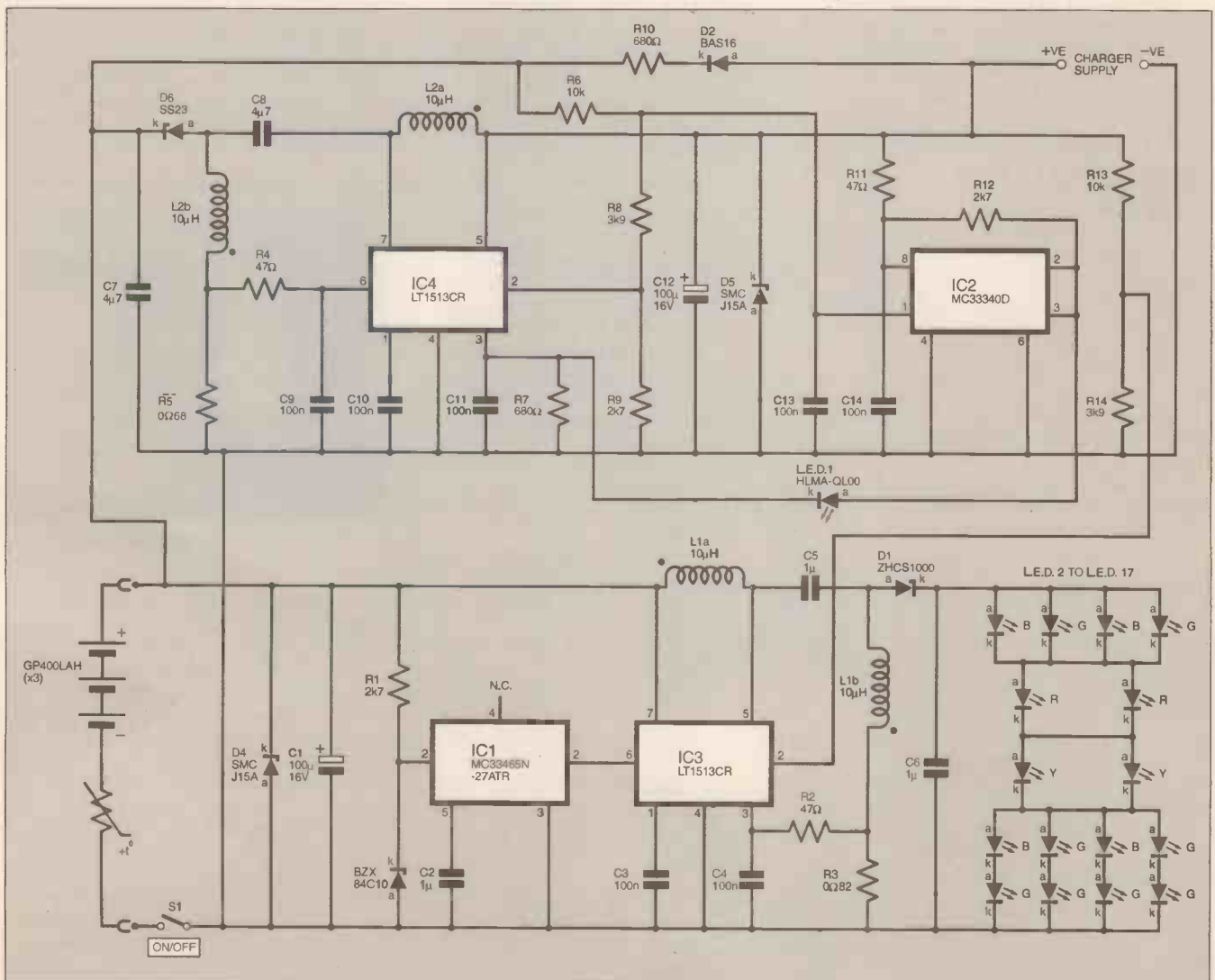

Fig.1. Circuit diagram of Chris Vernon's multiple l.e.d. lamp. Constructional advice is not offered to readers but Shoptalk provides some information on unusual components.

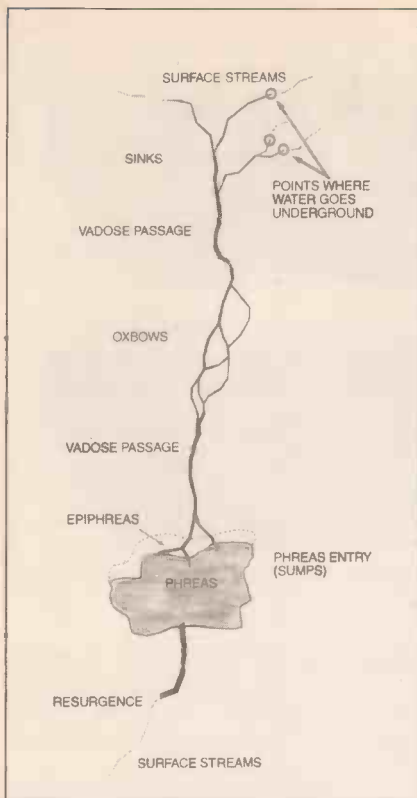

Fig.2. Representation of a typical cave system.

converter (IC4) plus an MC33340D charge controller chip (IC2) which terminates charge by the minus delta V method with time and abnormal voltage as safety measures.

So despite the fact that the component cost of a lamp like this escalates its cost beyond that of a conventional lamp, the fact that a full-blown charger is not needed reduces the overall system cost. A small d.c. power supply is all that's needed, or alternatively the lamp can be charged directly from a car's cigar lighter socket – useful if you've forgotten to put your lamp on charge before leaving for a weekend's caving.

Although the theme of this article is the application of electronics to caving, a high performance lamp like this has obvious above ground applications too.

## FINDING NEW CAVES

Given that a major ambition for many cavers is to discover a brand new cave, it's appropriate to raise the question "how do you go about finding a new cave?"

Quite a number of the caves in the UK were discovered purely by luck, but such is the interest in caving in this country that your chances of just stumbling across a new cave are now very remote indeed.

Instead, finding a new cave is nearly always the result of many days, weeks, months or even years of dedicated effort. Increasingly, even this sort of determined effort is only likely to yield results if you understand the earth sciences such as hydrology and geology sufficiently to know where unknown caves are likely to be located. This is becoming an increasingly high tech activity as electronics and computer science are coming to the fore alongside the earth sciences.

## PIONEERING

Take, for example, the pioneering work which is being carried out by John Wilcock

of Staffordshire University. Fig.2 shows a representation of a typical cave system. Various streams on a hill-side flow into one or more vertical shafts, normally called potholes. Hydrologists – scientists who study the flow of water through caves – tend to call these potholes the sinks, that is, the points at which the water enters the system.

The various sinks meet up underground and the water then flows through a network of vadose canyons – tall narrow passages with a stream flowing along the bottom. These vadose canyons then enter the phreases – an area of phreatic or flooded passages – to emerge some time later, from a horizontal cave in the valley bottom. This cave is what hydrologists call the resurgence – the point where the water leaves the cave system.

Now, let's think about what happens following a heavy rainstorm. In a very short period of time, the water level in the surface streams will rise. During a particularly wet period, that increased water level may last for quite some time, but after a quick heavy storm, especially if the ground is waterlogged, a graph of level against time will show a pronounced peak – this is called a flood pulse.

Clearly, a flood pulse in a stream feeding a cave system will enter the cave as an increased volume of water, and will reappear at the resurgence as a flood pulse some time later. Exactly how long it takes, however, is a function of the cave system and timings will differ depending on the length and types of the passages.

In fact, except in the simplest of caves, the flood pulse won't remain as a single pulse after its passage through the cave. For example, if there are two parallel routes of different lengths through the cave, then a pulse showing two distinct peaks will be seen at the resurgence.

Normally, the flood pulse at the resurgence is much more complicated than this and since there's so much variety between different caves, the shape of the pulse could almost be thought of as the cave system's fingerprint.

## FLOOD SIMULATION

John Wilcock's work involves simulating the passage of a flood pulse through a cave system using Microsoft Excel. This interesting use of a spreadsheet shows that these ubiquitous business tools are also very useful for scientific use.

John's spreadsheet has columns for each of the variables in the simulation – specifically flows and storages – and time is represented vertically. In other words, each horizontal row represents the variables one time interval later than the previous row.

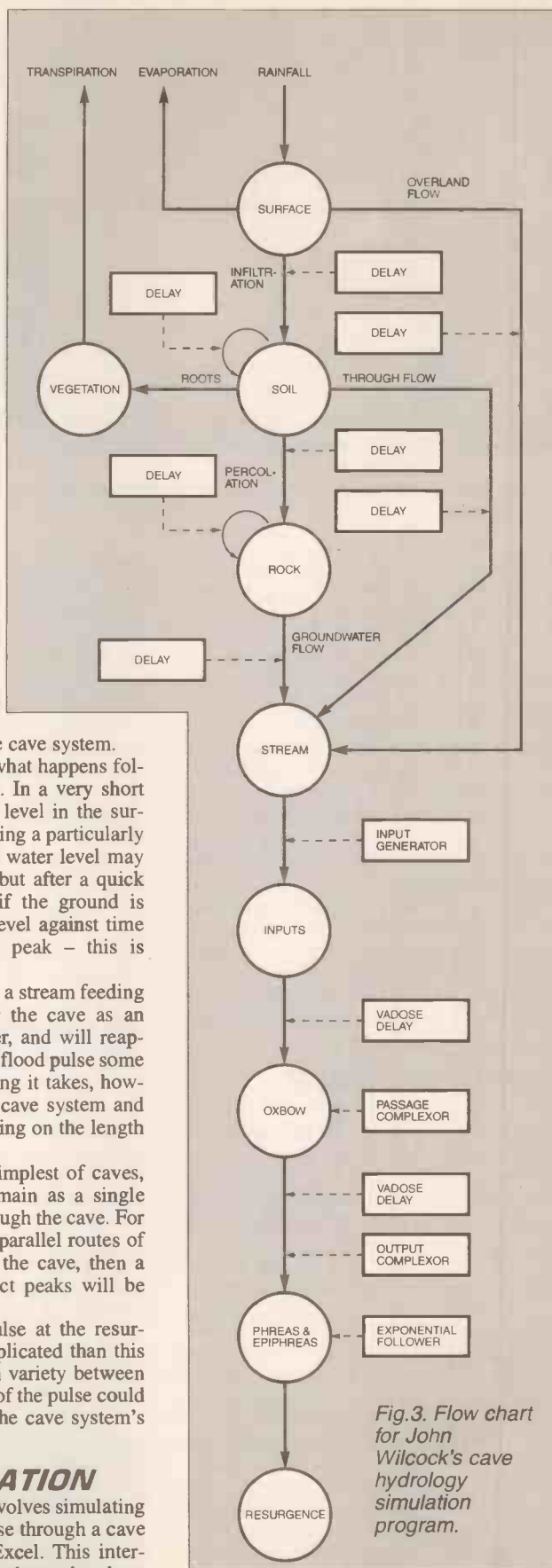

Fig.3. Flow chart for John Wilcock's cave hydrology simulation program.

The actual expressions in the cells are remarkably simple. For example, when stream passages join at a junction, the output flow is simply the sum of the input flows arriving at the junction, and conversely, when stream passages diverge at a junction the flows along each output passage are proportions of the input flow in the ratio of the cross-sectional areas of each passage.

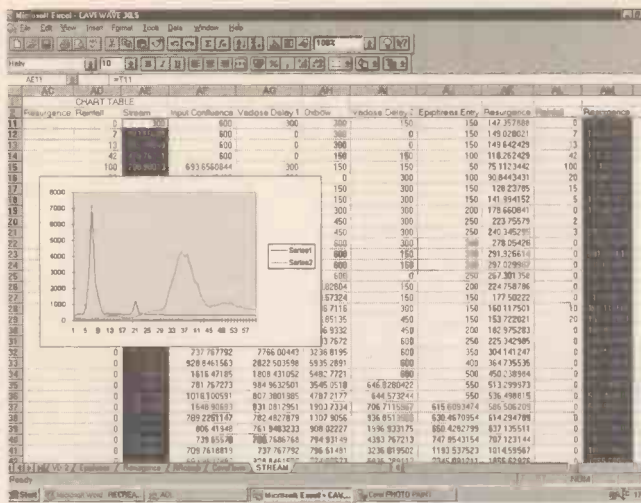

Fig.4. Typical output of John Wilcock's hydrology simulation spreadsheet.

Simulation of a straight passage is even simpler. Flow at the end of the passage is simply the flow at the start of the passage delayed by a few time intervals, that is a few rows in the spreadsheet. Obviously the length of the delay depends on the characteristics of the passage – most notably its length.

Only the phreas (the flooded area) is slightly more complicated. Here, increased flow cannot be transmitted immediately to the resurgence, so the phreas backs up into the previously non-flooded passages, until the pressure is sufficient for the increased volume of water to be forced through the restricted passages.

This is simulated by a simple exponential function. Fig.3 shows the flow diagram on which the simulation is based, and Fig.4 shows a typical screen output. You can download (free) the software from <http://www.sat.dundee.ac.uk/~arb/creg/download/cavewave.html>.

## PUSHING CAVES

Interesting, if you happen to be a cave hydrologist, you might wonder what has this to do with finding new caves. Actually it has very little to do with finding new caves, but it could just help to find new passages in existing caves, or "pushing" caves as potholers tend to call this.

Let's see how this might work. Experimentally, you collect data on rainfall in the vicinity of the cave you're studying and also measure the characteristics of the flood pulse at the resurgence. Now, you use the data on the rainfall near the sinks as input for the simulation and observe the simulated shape of the output flood pulse.

If there is a good match between the experimental and the simulated results, then you can be reasonably sure that the simulation is a good representation of reality. If the two are notably different, however, this would suggest that the simulation is flawed and this could mean, of course, that there are passages which have not been included in the simulation – presumably because nobody knew about them. And this is something which could make cave explorers very excited.

## PASSAGE LOCATION

Of course, just knowing that there are more cave passages in the system than have

already been discovered is only of limited value. Far more valuable is a knowledge of where those passages might be located, and even here John Wilcock is thinking of a possible solution.

Using techniques such as genetic algorithms, for example, it should be possible to modify the description of the passage network automatically until the simulated results match those obtained experimentally. Armed with the resulting information, finding that new passage may just be a bit easier.

Not that this is ever going to be a simple job – needles and haystacks come to mind – but the years of squeezing through impenetrable slots in the ground, of diving through flooded passages and of digging out tonnes of silt may just get reduced to months.

## GEOPHYSICAL CAVE DETECTION

In our discussion of cave hydrology we've wandered slightly off the subject of finding new caves to that of finding new passages in known caves. But what of the big one? How might electronics and computers be used to find a brand new cave?

Whenever cave detection is discussed by technically minded cavers, geophysics always seems to crop up. Various characteristics of the earth – its resistance,

permittivity and gravitational pull, for example – can be measured, and the argument goes that these characteristics will be influenced by the presence of underground voids such as caves.

Techniques such as earth resistance tomography, microgravity and ground penetrating radar are used on a regular basis by mining engineers and civil engineers. But the equipment for most forms of geophysical void detection is expensive and the data processing requirements needed to extract useful information from the background noise can be very significant.

Cavers, of course, tend to have a limited budget so attempts to find caves using geophysical methods have been comparatively rare. One notable exception is earth resistance surveying – sometimes described as the poor man's geophysical method – which the South Wales Caving Club (SWCC) have been experimenting with for some years as part of their *Greensites* project.

## RESISTIVITY METER

The use of earth resistance measurements for detecting the presence of underground artefacts has already been described at some length in *EPE*. Specifically, an instrument for carrying out resistivity surveys for archaeological purposes was described by Robert Beck (*Earth Resistivity Meter*, *EPE* Jan-Feb '97).

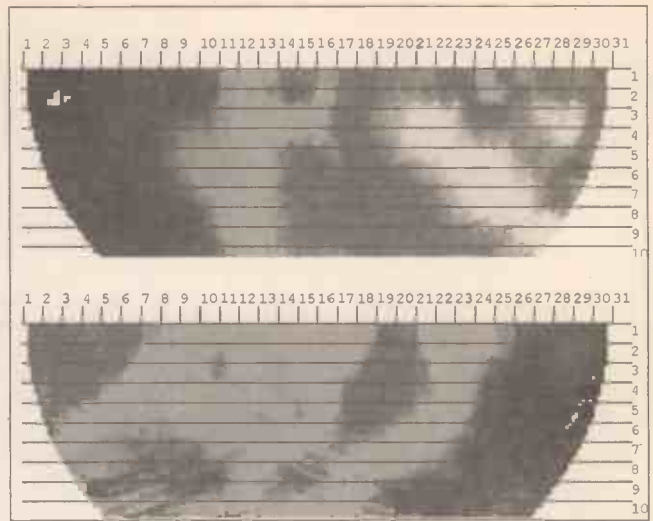
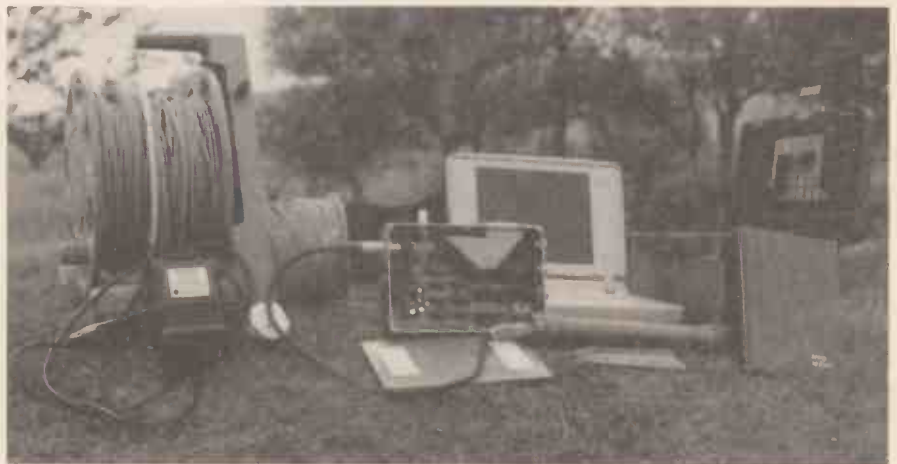

Fig.5. Resistivity techniques confirm the locations of known underground features.



SWCC's *Greensites* Project equipment used to generate resistance maps of vertical slices through the earth, such as those in Fig.5.



In general terms, this type of design works by injecting an electrical current into the ground through one pair of electrodes and measuring the potential difference between a separate pair of sense electrodes. The apparent resistance is calculated by Ohm's Law and depends on the geometry and separation of the various electrodes and the resistance of the earth.

Exactly which portion of the earth you are looking at depends on the electrode separation and the geometry. Normally, the geometry remains constant and different electrode positions and separations are used to select the portion of earth which is being sampled, either horizontally or vertically.

Robert Beck's equipment was designed to generate a 2D map of resistance at a fixed depth. Measurements were made manually in the field and subsequently processed by software to generate the map. The SWCC Greensites design, on the other hand, is used to generate a resistance map of a vertical slice through the earth.

To make the measurement less time consuming, the hundreds of measurements are made under the control of a laptop PC and a graphical representation is generated in the field. The only labour intensive part of the procedure is laying out the 32 electrodes – and this must be repeated for every vertical slice.

## INTERPRETING RESULTS

Interpreting the results requires some care, though. Large cavities at depth can be swamped out by much smaller cavities closer to the surface and the horizontal dimensions of cavities are exaggerated at depth.

Nevertheless, to a first approximation, what you see in a resistance map of a vertical section of earth and a high resistance anomaly – a cave chamber, for example – should be clearly visible. Fig.5 shows a couple of slices through a known cave – Ogof Ffynnon Ddu in South Wales and each scan reveals known features.

The first scan is near the entrance and the large entrance chamber plus a sloping passage to the surface are clearly visible. The second scan is over Gnome Passage and known underground features are, once again, recognisable.

But even with this technological advantage, finding new caves still hasn't proved to be easy. Despite SWCC's initial success



Using GPR probes to survey the terrain at Poole's Cavern.

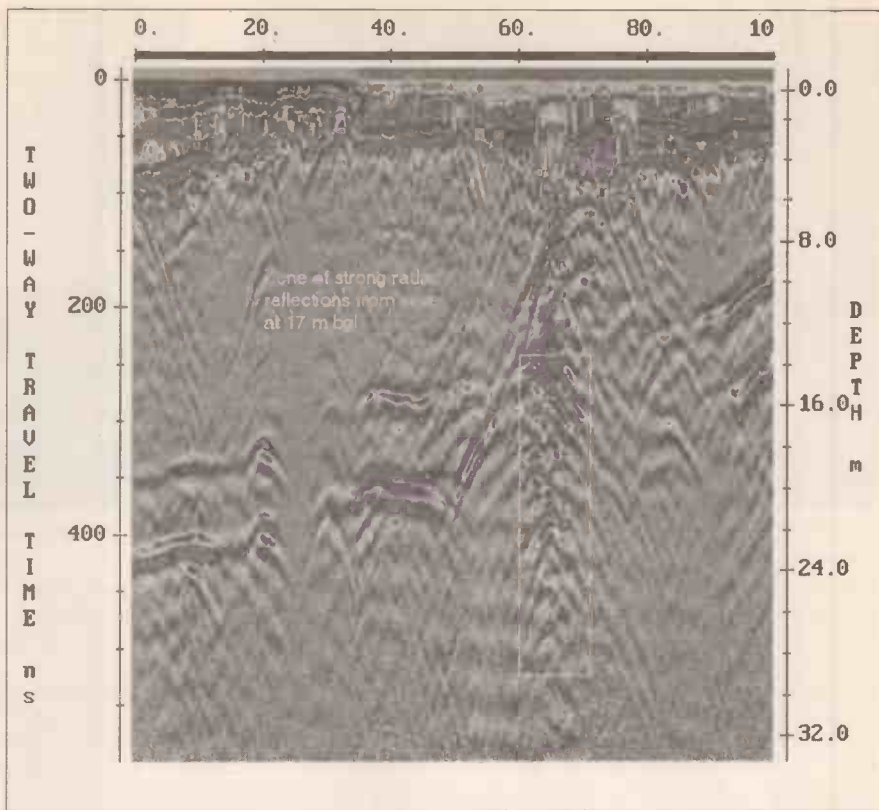

Fig.6. GPR survey beyond known extremities of Poole's Cavern shows unknown passages.

in confirming known features in known caves, the equipment has, so far, failed to find any significant new caves at all.

So how can we explain this, especially in view of the fact that this sort of technique reaps benefits commercially? Part of the difference between commercial and caving use lies in the fact that commercial users, such as mining companies, know fairly accurately what they're looking for.

For example, if you're looking for old mine passages, you'll know approximately where they're located and their approximate dimensions. So, if you find a high resistance feature of the wrong size or shape or in the wrong place, you discount it.

Cavers, on the other hand, don't know what they're looking for since cave passages and chambers come in all shapes and sizes. Unfortunately, many geological features other than cave passages will also show as areas of high resistance using this technique.

So South Wales cavers have found unknown areas of high resistivity, certainly, but in many cases, these will have been areas of shattered rock rather than voids. Commercial organisations with lots of money to spend attempt to overcome this sort of ambiguity by using a combination of geophysical methods rather than relying on any single method.

## WHERE'S THE ENTRANCE?

But there's another interesting question which is unique to finding caves. Even if geophysical methods succeed in finding a genuine void, how does this help the cave explorer? With conventional cave exploration techniques, the first thing you find is the entrance. With geophysical techniques, the first thing you find is a void, perhaps fifty metres below your feet. This isn't a great deal of help if you don't know where the entrance is.



Borehole drilling at Poole's Cavern.



Stills of video footage taken down the Poole's Cavern borehole show a cave passage in which nobody has ever set foot.

This is exactly the problem facing cavers at Poole's Cavern, a show cave in Buxton, Derbyshire. The cave currently comes to an end in a boulder choke, but cavers have long suspected that there may be further cave passages beyond or above this obstacle. But finding a way through a boulder choke, basically a huge unstable pile of massive rocks precariously balanced one on another, is both time consuming and risky.

So after years of futile work in the boulder choke, a high tech solution in the form of a ground-penetrating radar (GPR) was brought in by Rod Eddies. Fig.6 shows a portion of the survey made above an area beyond the boulder choke where no cave passages were known. It reveals features which geologists interpreted as cave passage.

Undeterred by the difficulty of finding a way into that passage, a couple of boreholes were drilled from the surface, the second of which broke into a sizeable void 16.5 metres down. To investigate this further, video recording equipment consisting of a monochrome CCD camera and 50W dichroic lamps was lowered down the borehole.

The equipment was built by Phil Gregson and is similar to equipment which is used commercially for investigating large voids within restricted locations – mainly for civil engineering applications. The results were pretty impressive, as the accompanying video stills show.

The passage was estimated to be 2.5 metres high and was lavishly decorated with flowstone, gour pools, straws, stalactites, stalagmites and curtains. The amazing thing on watching the video footage, however, is that this is a cave in which nobody has ever set foot. If efforts at finding a way into that passage continue to concentrate on the boulder choke, it could still be many years before man does set foot there.

Of course, there is an alternative method, namely to drop a shaft into the cave, indeed the merits of this approach are currently being discussed. Whether this is really in the true spirit of cave exploration, though, is open to debate.

## OTHER APPLICATIONS

We've seen some of the main areas in which electronics and computing are being applied to caving but these aren't the only

applications by any means. Cave hydrologists are using rugged microprocessor-controlled data loggers to record trends in water level, pH and temperature.

To avoid having to make frequent trips into the cave to download the results, researchers have experimented with telemetry to send the data to the surface using low frequency induction.

Cave conservationists, intent on ensuring that caves aren't destroyed by over-use, are installing caver counters in some of the more popular caves. These are small PIC-based devices, hidden from the prying eyes of cavers, which detect cavers' cap-lamps.

Cave biologists are using electronics to translate the inaudible high frequency bat calls to a frequency which we can hear. There's even talk of using a digital signal processor (DSP) to analyse the sound and thereby record which species of bats were present at particular times and dates.

We must not forget cave photography. Electronics comes to the fore here in the area of slave units to trigger one flashgun

from another, and in the flashguns themselves. Although most cave photographers currently use standard flashguns off the shelf, there's a growing interest in providing specialised flashguns with features designed specifically for caving use.

One such feature is a long burn time so that moving water actually looks blurred as if it's moving, as opposed to looking frozen – something which happens which ordinary flashguns which provide illumination for as little as a millisecond.

## ELECTRIC STOP

To give you an idea for some of the more bizarre ideas which cave electronics enthusiasts dream up, let's describe the concept of the Electric Stop. But before I start, let it be made perfectly clear that this is most *definitely not* something to be attempted as a DIY project. Certainly I wouldn't want to be around to pick up the pieces if you did try it out.

With that disclaimer, let me introduce you to SRT, otherwise known as Single Rope Techniques, the methods by which cavers descend and ascend vertical pitches using a rope. With space running out I'm not going to tell you how we get back up the rope but the downward trip is made by abseiling.

But, rather than using the figure-of-eight device which you may have seen used on outdoor pursuit courses, cavers favour the "rack" or the "stop", most commonly the Petzl Stop named after the French company which manufactures it.

All abseiling devices work by friction, but the stop has the added advantage of being virtually fail-safe. So long as the stop is attached to your harness, once you've correctly threaded the rope through its pulleys, you're only able to descend by squeezing the handle on the stop – as soon as you let go of the handle, a brake is applied.

At the bottom of a long dry pitch it's common to find that your stop is pretty hot. After all, you had a lot of potential energy at the top of the pitch which has now been dissipated as heat. So some bright sparks have figured that it must be possible to conserve this energy, converting it to electricity and using it, perhaps, to recharge your lamp battery.

This, of course, is the principle of regenerative braking which is used to increase



"Petzl Stop" which some cavers think might be modified to generate electrical power.

the efficiency of electric vehicles. In principle, you arrange for the rope to pass through a series of pulleys which are connected to a generator. So long as the generator is connected to some electrical load, a battery charger for example, then a degree of braking is applied and you make a controlled descent.

I don't think I'd be rushing out to buy one, however, even if they were on the market – one broken wire and it's the hospital if you're lucky. It's not the sort of thing you'd want to be protected by a fuse, either. If the fuse blows, the electrical load is removed and all braking is lost. And it doesn't give you too long to change the fuse when you're plummeting to the bottom of a pitch at an ever increasing velocity!

## DON'T TRY THIS AT HOME

Many of the articles which appear in this magazine are constructional projects so the whole idea is that you try it out yourself at home. By way of contrast, I'm concluding this article with that well known phrase "don't try this at home" and this doesn't apply only to the Electric Stop.

Of course, the purely electronic side of building the kit described here isn't dangerous. What you shouldn't do, howev-

er, is pack your creations up in a backpack and wander down your nearest cave or pothole. If it's not already obvious to you, let me point out that caves are dangerous environments in which you could fall to your death, drown, get lost, get stuck or simply suffer from exhaustion and hypothermia and find that you're unable to make your own way out.

That's the bad news, but the good news is that most people, so long as they're reasonably fit, could become cavers. Despite public perception to the contrary, you don't even need to be particularly thin to get down most caves and potholes.

## TAKING UP POTHOLING

If you do fancy taking up potholing, it's vitally important that you make contact with experienced cavers who can show you the ropes – literally – this is one area in which self-tuition just isn't a sensible option.

Unless you already know some cavers, your best bet is to join a club – a list of the UK's caving clubs can be found at <http://web.ukonline.co.uk/nca/clubs.htm>.

If your main interest is the electronic side, you should consider joining CREG who arrange regular field meetings, in addition to publishing a quarterly journal.

## FURTHER READING

If you want to read about the communications aspects of cave electronics, and particularly about low frequency induction or "cave radio", the following two-part article is introductory in nature:

*Introducing Cave Radio*, Mike Bedford, *Radio Active*, Jan-Feb '99.

If you want to delve more deeply (pun intended) into all aspects of cave radio and electronics, the world's premier publication on this subject is the *Journal of the Cave Radio & Electronics Group*. This 32-page magazine is published quarterly and covers the subject from both a theoretical and a practical viewpoint.

For further information on CREG and the CREG Journal, please send a self-addressed stamped envelope to Rob Gill, 61 Cross Deep Gardens, Twickenham, Middx TW1 4QZ.

<http://www.bcr.org.uk/creg/>.

## ACKNOWLEDGEMENTS

We express our thanks to the following for supplying illustrative material used in this article: Rod Eddies, Phil Gregson, Clive Jones, Alan Walker, South Wales Caving Club. □

## Regular Clinic

# CIRCUIT SURGERY

ALAN WINSTANLEY  
and IAN BELL

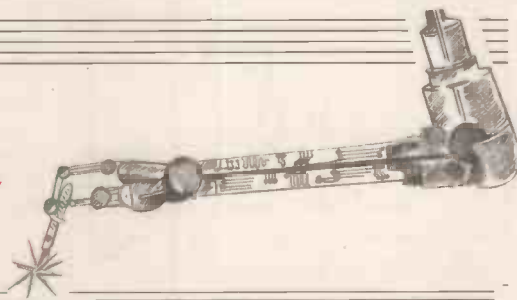

*Our in-house circuit surgeons investigate piecewise linear (PWL) approximation and explain the meaning of the lambda parameter associated with FETs.*

## Get wise about Piecewise

Our thanks to Mr P. T. Hall of Mansfield, Notts, who writes with questions relating to circuit simulation computer software. Mr. Hall asks:

*Please could you explain the meaning of piecewise linear component definitions? Also, the software that I use has a facility for creating components from data sheet information. In order to create a model of a JFET transistor a parameter called lambda is called for. On the data sheets that I use lambda is not mentioned, could you explain what lambda is and how to calculate this parameter?*

Circuit simulation software had until recent years only been used by professional electronics engineers, but now, as a look through the adverts in *EPE*, or a web search will indicate, some of these tools are being marketed to schools and hobbyists where they are proving invaluable for helping with circuit development. Of

course, if you start using a simulator there are a whole load of new concepts and jargon to learn, as Mr. Hall discovered. We would be interested to hear from readers who have used simulators and will be happy to try to answer general questions, although we probably cannot help with the use, features and (whisper) bugs of specific products.

The term **piecewise linear** has two obvious parts: **piecewise** and **linear**! The meaning of **piecewise** is straightforward, that is in "parts" or "sections" (we'll come back to this in a moment). The term **linear** has a specific mathematical meaning which is also related to the way in which circuits can be modelled mathematically (e.g. for simulation or other calculations).

Mathematically speaking, the term **linear** has a precise meaning, usually defined with respect to particular situations, perhaps the most basic being "linear functions", so it helps to know what a **function** is in order to define "linear". Functions are of interest to us because when we model a

circuit (run a simulation or perform a calculation) we are in effect saying that the behaviour of the circuit can be expressed as a mathematical function.

## Functional meaning

A function is simply a relationship between the values of two or more variables. For example,  $y=2x$  means that the value of  $y$  is twice that of  $x$ , so if  $x$  is 4 then  $y$  will be 8. Just as  $x$  stands for "any" value then we can write  $f(x)$  to mean "any function of  $x$ ". In our example  $f(x)$  is  $2x$ . Now functions relate to circuits as we have already hinted, so for example if  $x$  represents the input to a circuit (e.g. in volts) and  $y$  represents the output voltage, then if the circuit function  $y = f(x)$  is  $y = 2x$ , then the output voltage is twice the input voltage. This could represent a voltage amplifier with a gain of 2.

So what is a **linear** function of  $x$ ? It is one of the form  $f(x) = ax + b$ , in which  $a$  and  $b$  are constants. For example, the function  $f(x) = 60x + 100$  is linear. The exponential function,  $f(x) = \exp(x)$  ( $e$  to the power of  $x$ , or  $e^x$ ) is an example of a non-linear function. The use of the term "linear" for the property we are discussing should make sense if you plot graphs of functions – for a linear function you'll see a straight line; this is illustrated in Fig.1 which shows a graph of the two functions just mentioned.

You may know that a diode has an exponential relationship between forward voltage and current and therefore the diode is a **non-linear** device. You have probably also heard terms such as "linear amplifier". Returning to our earlier example of  $y = 2x$ , you should be to see that this is a linear function. In fact real amplifiers and other real linear circuits are only linear over a limited range (an amplifier has a maximum input voltage

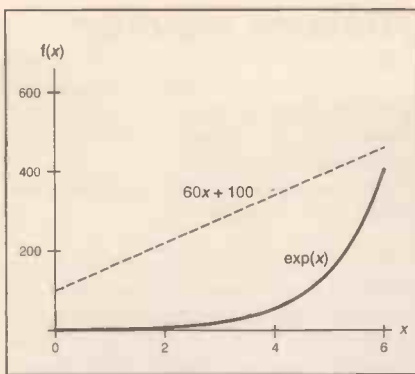

Fig.1. Two functions of  $x$ , one is linear, the other non-linear.

above which the output is no longer equal to the gain times the input).

Conversely some devices, with transistors being particularly relevant, have some non-linear characteristics, but behave with a good approximation to linearity over very small ranges of input variation. This allows linear circuits to be built using these devices as long as the input signals are small, and allows us to use what are known as "small signal models" for calculation and simulation. A good example of this is the differential amplifier which forms the input stage of op.amps (see *Circuit Surgery* April and May 2000).

## Calculating

Performing calculations with linear functions is easier (and in computing terms, often faster) than using non-linear functions, so in some situations non-linear functions can be modelled by a set of linear functions which are applied for different values. Graphically we replace a curve with a set of straight lines. This is known as a **piecewise linear approximation (PWL)**. It may be used to model components or input waveforms to a simulator. For example, we could represent the forward bias characteristics of a diode (Fig. 2a) with a PWL approximation using two straight lines (Fig. 2b).

Simulators such as SPICE generally use more sophisticated models for standard components such as basic diodes and transistors which are built into the simulator. Some of these built-in models are based on the device physics and fundamental parameters (such as the lambda value discussed below), however, you can only use them if the simulator has the

model and you know the various parameter values.

The PWL technique allows users to describe special components and those for which the basic parameters are not known. The PWL model can be thought of as a set of "data points" from a graph: for instance you could describe Fig. 2b using co-ordinates of the ends of each line segment (0,0) (0.7,0) (0.8,1.5). You will need to refer to your simulator's documentation to find out the format for entering PWL model data. Obviously, using many short lines in the PWL model provides a higher-resolution which gives greater accuracy than a small number of long lines. Some simulators "smooth" the corners to the PWL model to give more realistic results.

## FET Lambda

Moving on to the next part of Mr. Hall's question, lambda ( $\lambda$ ) is described as the "channel length modulation parameter". This models the effect of varying the drain-source voltage ( $V_{DS}$ ) on drain current ( $I_D$ ) when the device is in saturation (i.e. when the gate voltage above pinch-off ( $V_p$ ) is less than  $V_{DS}$ ). Ideally when a JFET is in saturation,  $I_D$  is set by the gate-source voltage ( $V_{GS}$ ) and does not vary as  $V_{DS}$  is varied; however for real devices, increasing  $V_{DS}$  with a fixed  $V_{GS}$  results in a change in  $I_D$ .

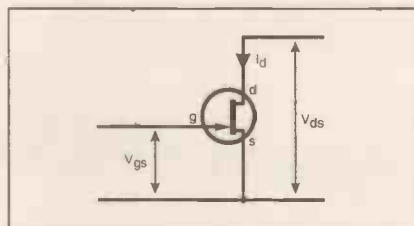

Fig.3. JFET voltages and currents.

The channel length modulation effect can be modelled by multiplying the ideal drain current in saturation by the factor  $(1 + \lambda V_{DS})$ . Ideal devices with  $\lambda = 0$  have an infinite output resistance (behave like an ideal current source), for non-zero lambda the device has a finite output resistance. Fig. 3 shows the JFET symbol, voltages and currents, and Fig. 4 shows typical output ( $I_D - V_{DS}$ ) characteristics.

If you do not specify the value of lambda in SPICE (we assume you are using a

SPICE style simulator), it may use a default value of zero (the ideal case). You could try entering zero if your software insists on a value and see what happens. Of course, a value of zero will not give you a very accurate simulation but it may be sufficient. A typical value for real devices is  $\pm 0.01 \text{ V}^{-1}$  (positive for  $n$ -channel, negative for  $p$ -channel), which may be a better guess. You could also try measuring lambda for an actual device (if you have one handy) by measuring and plotting the output characteristics (i.e.  $I_D$  against  $V_{DS}$  for various fixed  $V_{GS}$ ) and using these to obtain a value for lambda. Alternatively you can use the output characteristics given on the data sheet.

To calculate the value of lambda from the output characteristics, take two points on the same  $V_{GS}$  curve in the saturation part of the characteristic (i.e. on one of the dotted lines in Fig. 4). The values at these points are  $V_{DS1}, I_{D1}$  for the first point (lower values) and  $V_{DS2}, I_{D2}$  for the second point (higher values). Lambda is then given by

$$\lambda = \frac{I_{DS2} - I_{DS1}}{V_{DS2} I_{DS1} - V_{DS1} I_{DS2}}$$

For example, if using the  $V_{GS} = 0$  curve, we get  $I_{DS} = 14.7 \text{ mA}$  when  $V_{DS} = 10 \text{ V}$  and  $I_{DS} = 15.0 \text{ mA}$  when  $V_{DS} = 12 \text{ V}$ , then  $\lambda = (0.015 - 0.0147) / (12 \times 0.0147 - 10 \times 0.015) = 0.0114$ . These values are for illustration only and do not relate to any specific real device.

Lambda is a pretty basic device parameter so it is unlikely that you will be able to calculate it from other data sheet values (apart from the output characteristic curves) if it is not specified. In general, if you are using SPICE remember it is orientated towards integrated circuit simulation. The parameters on data sheets for discrete components do not always match up very well with SPICE model parameters. For example, SPICE models do not use the  $h$  parameters (e.g.  $h_{fe}$  often quoted for bipolar transistors). The information may be there under a different name, or you may have to read it off of one of the curves on the datasheet.

If any other readers have any general queries on the principles of using circuit simulators we will try to help, so write to us or E-mail to the usual address.

IMB.

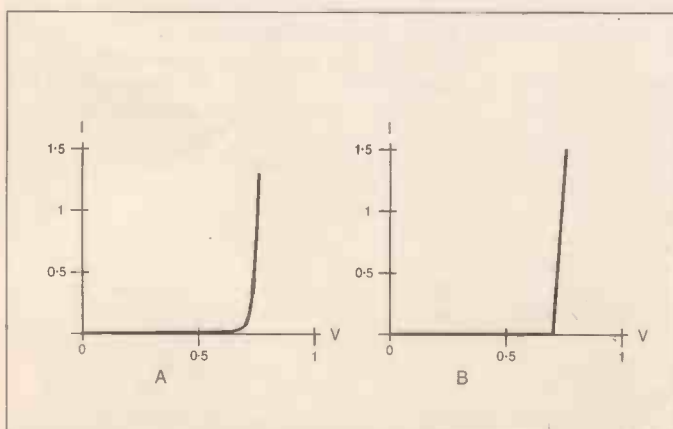

Fig.2. Diode characteristics graph (a) and piecewise approximation graph (b).

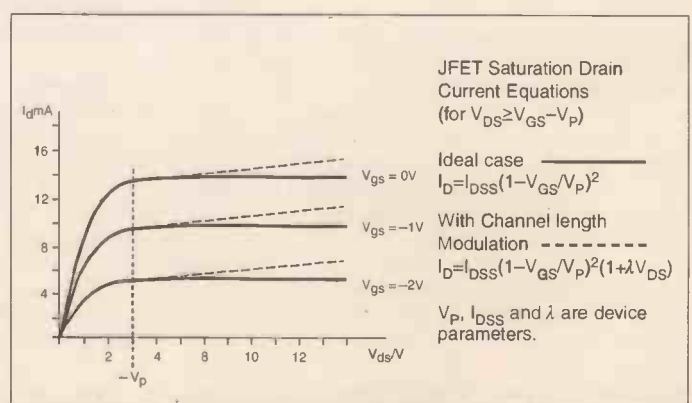

Fig.4. FET output characteristics (the values in this figure do not relate to a real device. For a real device you should be able to find these characteristics on the data sheet).

## ELECTRONICS SURPLUS CLEARANCE SALE

**SCOOP PURCHASE: FLUKE HAND HELD DIGITAL MULTIMETER, MODEL 8024B.**  
Cancelled export order 750V AC/DC 2 amp AC/DC Resistance 20Megohm plus Siemens range. Also measures temperature -20°C to +1265°C. Temp. probe not included. Calibrated for K-type thermocouple. Peak hold facility. Supplied brand new and boxed but with original purchasing organisation's small identifying mark on case. Test leads and handbook included.

Offered at a fraction of original price: £47.50, p&p £6.50

**MAGNETIC CREDIT CARD READER:** Keyboard and lap top display system, part of point-of-sale unit. Cost over £150, our price £7.50, carriage £6.50; two units £25 incl. carriage.

To be used for experimental purposes only. No info.

**SECURITY ALARM SYSTEM:** Consisting of wire loop, pressure pad, piezo alarm, sounder, key switch, plastic case. £4.50, p&p £2.50

**THE ELECTRONICS SURPLUS TRADER** - This is a listing of new first class components and electronic items at below trade prices. Includes manufacturers' surplus and overstocks. Also obsolete semiconductors, valves and high voltage caps and components. Send two first class stamps for large catalogue.

### (Dept E) CHEVET SUPPLIES LTD

157 Dickson Road, BLACKPOOL FY1 2EU

Tel: (01253) 751858. Fax: (01253) 302979

E-mail: chevett@globalnet.co.uk Telephone Orders Accepted

Callers welcome Tues, Thurs, Fri and Sat.



## DISTANCE LEARNING COURSES in:

Analogue and Digital Electronics, Fibre Optics, Fault Diagnosis, Mechanics, Mathematics and Programmable Logic Controllers leading to a

## BTEC PROFESSIONAL DEVELOPMENT CERTIFICATE

- Suitable for beginners and those wishing to update their knowledge and practical skills
- Courses are very practical and delivered as self contained kits
- No travelling or college attendance
- Learning is at your own pace
- Each course can stand alone or be part of a modular study programme
- Tutor supported and BTEC certified

For information contact:

NCT Ltd., P.O. Box 11

Wendover, Bucks HP22 6XA

Telephone 01296 624270; Fax 01296 625299

Web: <http://www.nct.ltd.uk>



Get your magazine "instantly" anywhere in the world - buy from the web.

TAKE A LOOK, A FREE ISSUUE IS AVAILABLE

A one year subscription (12 Issues) costs just \$9.99(US)

## SPECIAL OFFERS

### TEKTRONIX 244SA

4-channel, 150MHz, delay sweep, cursors/readout

£750

### TEKTRONIX 475

Dual trace, 200MHz, delay sweep

£400

### AVO 8 MK. 6 MULTI-METER

In Ever-Ready Case with Leads and Batteries

£80

Other AVOs from

£50

### RACAL TRUE RMS VOLTMETERS



9300 5Hz-20MHz usable to 60MHz, 10V-316V £95  
9300B Version £150  
9301/9302 RF Version to 1.5GHz, from £200-£300

RACAL/AM 9343M LCR Databridge, Digital Auto measurements of R, C, L, Q, D £200  
HUNTRON TRACKER Model 1000 £125  
H.P. 5315A Universal Counter, 1GHz, 2-ch £80  
FLUKE 8050A DMM 4 1/2 digit 2A True RMS £75  
FLUKE 8010A DMM 3 1/2 digit 10A £50

GOODWILL GFC 8010G FREQUENCY COUNTER, Range 1Hz-120MHz, 8 Digit Display, 15mV RMS Sensitivity Unused £75

GOODWILL GVT427 DUAL CHANNEL A.C. MILLIVOLT/METER 10mV 300V in 12 ranges Frequency 10Hz-1MHz

### SINAD MEASUREMENTS for only

£60

### MARCONI 893C AF POWER METER

300W Watts-30 Watts; 20Hz-35kHz 2.5 ohm-20 kilohms  
MARCONI 893C unused, boxed £100  
MARCONI 893B - to 10 Watts max. NO SINAD £30

### GOULD J3B SINE/SQ. OSCILLATOR

10Hz-100kHz Low distortion Balanced metered output, Attenuator

£75-

£125

### SOLARTRON 7150

DMM 6 1/2-digit, TRUE R.M.S. High Accuracy IEEE

£95-

£150

### HIGH QUALITY RACAL COUNTERS



9904 Universal Timer Counter, 50MHz £50  
9916 Counter, 10Hz-520MHz £75  
9918 Counter, 10Hz-560MHz, 9-digit £50

### MARCONI 2810 TRUE RMS VOLTMETER

Digital LCO + Analogue Meter £195  
5Hz to 25MHz + D.C. Autoranging

MARCONI TP2015 AM/FM sig gen, 10-520MHz £175  
RACAL 9008 Auto Mod Meter, 1-5MHz-2GHz £200  
LEVELL TG200DMP RC Oscillator, 1Hz-1MHz £50  
Sine/Sq. Meter, battery operated (batts. not supplied)  
FARNELL LFI Sine/Sq. Oscillator, 10Hz-1MHz £75

FARNELL L30/2 Bench Power Supply 0-30 Volts, 0-2 Amps. Constant D.C. outputs/ ONLY £80  
Constant current

MANY OTHER POWER SUPPLIES AVAILABLE



MARCONI 2022E Syn AM/FM SIG GEN, 10kHz-1.01GHz  
Up to +10dBm output, phase mod, l.c.d. display, keyboard entry, etc., small, lightweight.

£525-£600-£750

### RADIO COMMUNICATIONS TEST SETS

MARCONI 295529558 £2000

MARCONI 2955A/2960 £2500

MARCONI 2019 Synth AM/FM sig gen, 80kHz-1040MHz £475  
H.P. 8657A Synth sig gen, 100kHz-1040MHz £2500  
H.P. 8656B Synth sig gen, 100kHz-990MHz £1350  
H.P. 8656A Synth sig gen, 100kHz-990MHz £995  
GIGATRONIC 7100 Synth sig gen, 10MHz-200GHz £5000  
MARCONI 2017 AM/FM phase-locked sig gen, 10kHz-1024MHz, good signal purity £1200  
H.P. 8640A AM/FM sig gen, 500kHz-1024MHz £3400  
H.P. 8640A AM/FM sig gen, 500kHz-512MHz £250  
PHILIPS PM5328 sig gen, 100kHz-160MHz with 200MHz, freq. counter, IEEE £650  
RACAL 9081 Synth AM/FM sig gen, 5-520MHz £350  
H.P. 3325A Synth function gen, 21MHz £600  
MARCONI 6500 Amplitude Analyser £1500  
H.P. 4275A LCR Meter, 10kHz-10MHz £2750  
H.P. 8903C Distortion Analyser £750  
WAYNE KERR 3245 Inductance Analyser £2000  
H.P. 8112A Pulse Generator, 50MHz £1250  
DATRON AutoCal Multimeter, 5 1/2-7 1/2-digit, 106S/1061A/1071 from £300-£600  
MARCONI 2400 Frequency Counter, 20GHz £1000  
H.P. 5350B Frequency Counter, 20GHz £2000  
H.P. 5342A 10Hz-18GHz Frequency Counter £900  
FARNELL LP10030 Power Supply £1000  
FARNELL LP7030 Power Supply £800  
PHILIPS PM5418T1 Colour TV Pattern Generator £1750  
PHILIPS PM5418TX1 Colour TV Pattern Generator £2000  
B&K Accelerometer, type 4356 £300  
H.P. 11692D Dual Directional Coupler, 2MHz-18GHz £1500  
H.P. 11691D Dual Directional Coupler, 2MHz-18GHz £1250  
TEKTRONIX P6105B Probe, 100MHz readout, unused £80  
TEKTRONIX P6106A Probe, 250MHz readout, unused £85

### WELLER EC3100A

Temperature controlled Soldering Station 200°C-450°C, Unused £125

FARNELL AMM255 Automatic Mod Meter, AM/FM, 1.5MHz-2GHz, 3.5-digit Lcd, display, Unused £400

Also available:  
FARNELL AMM2000 Auto Mod Meter, 10Hz-24GHz, Unused £950  
MARCONI 2305 Mod Meter, 500kHz-2GHz, from £750

### SPECTRUM ANALYSERS

H.P. 8662A 1Hz-2GHz £3900  
TEKTRONIX 492 50kHz-18GHz £3500  
EATON/ALTECH 757 0.001-22GHz £2500  
ADVANTEST R3261A 9kHz-2.6GHz, synthesised £4000  
H.P. 853A (Dig. Frame) with 8559A 100kHz-2.1GHz £2750  
H.P. 8558B with main frame, 100kHz-1500MHz £1250  
MARCONI 2382 100kHz-400MHz, high resolution £2900  
B&K 2033R Signal Analyser £1500  
ADVANTEST TR4131 10kHz-3.5GHz £2750  
MARCONI 2370 30Hz-110MHz from £550  
H.P. 141 SYSTEMS from £500  
8553 1kHz-110MHz from £750  
8554 500kHz-1250MHz from £750  
8555 10MHz-18GHz from £1000

### UNUSED OSCILLOSCOPES

TEKTRONIX TD3350 dual trace, 200MHz, 1GS/s £1500  
TEKTRONIX TAS485 4-channel, 200MHz etc. £1100  
H.P. 54600B dual trace, 100MHz, 20MS/s £1000

### OSCILLOSCOPES

PHILIPS PM3092 2+2-ch., 200MHz, delay, TB etc. £950  
PHILIPS PM3082 2+2-ch., 100MHz, delay etc. £800  
TEKTRONIX TAS465 dual trace, 100MHz, delay etc. £900  
TEKTRONIX 2645 4-ch., 300MHz, delay sweep cursors £1250  
TEKTRONIX 2430 dual trace, 150MHz, 100MS/s, cursors etc. £600  
TEKTRONIX 2232 dual trace, 100MHz, 100MS/s, cursors etc. £800  
TEKTRONIX 2212 dual trace, 60MHz, 20MS/s, cursors etc. £650  
TEKTRONIX 2210 dual trace, 50MHz, 20MS/s £450  
H.P. 54200A Digitising, 50MHz, 200MS/s £600

PHILIPS PM3217 - Dual Trace 50MHz Delay VERY GOOD OSCILLOSCOPE Incl. 2 probes, pouch & front cover

FROM £250-£300

### THIS IS THE BEST CHEAP SCOPE YOU WILL EVER BUY!

GOULD DS1100 - Dual Trace, 30MHz Delay, Very bright. Supplied with manual and two probes

£200



TEKTRONIX 400 SERIES  
468 Digital Storage Dual Trace 100MHz Delay £550  
466 Analogue Storage Dual Trace 100MHz Delay £250  
485 Dual Trace 350MHz Delay Sweep £750  
475 Dual Trace 200MHz Delay Sweep £400  
465 Dual Trace 100MHz Delay Sweep £400

## STEWART of READING

110 WYKEHAM ROAD, READING, BERKS. RG6 1PL

Telephone: (0118) 9268041, Fax: (0118) 9351696

Callers welcome 9am-5.30pm Monday to Friday (other times by arrangement)

### Used Equipment - GUARANTEED. Manuals supplied

This is a VERY SMALL SAMPLE OF STOCK. SAE or Telephone for lists.

Please check availability before ordering.

CARRIAGE all units £16. VAT to be added to Total of Goods and Carriage

# Everyday Practical Electronics are pleased to be able to offer all readers these **ELECTRONICS CD-ROMS**

## ANALOGUE ELECTRONICS

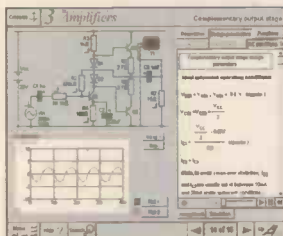

Complimentary output stage

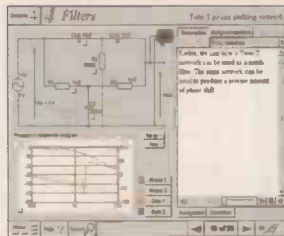

Twin-T phase shifting network

*Analogue Electronics* is a complete learning resource for this most difficult branch of electronics. The CD-ROM includes a host of virtual laboratories, animations, diagrams, photographs and text as well as a SPICE electronic circuit simulator with over 50 pre-designed circuits.

Sections on the CD-ROM include: **Fundamentals** – Analogue Signals (5 sections), Transistors (4 sections), **Waveshaping Circuits** (6 sections), **Op.Amps** – 17 sections covering everything from Symbols and Signal Connections to Differentiators. **Amplifiers** – Single Stage Amplifiers (8 sections), Multi-stage Amplifiers (3 sections). **Filters** – Passive Filters (10 sections), Phase Shifting Networks (4 sections), Active Filters (6 sections). **Oscillators** – 6 sections from Positive Feedback to Crystal Oscillators. **Systems** – 12 sections from Audio Pre-Amplifiers to 8-Bit ADC plus a gallery showing representative p.c.b. photos.

## DIGITAL ELECTRONICS

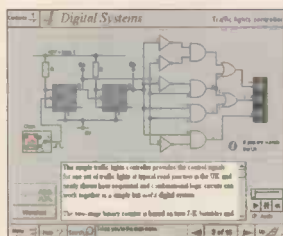

Virtual laboratory – Traffic Lights

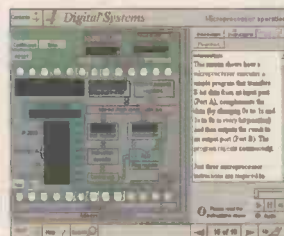

Microprocessor

*Digital Electronics* builds on the knowledge of logic gates covered in *Electronic Circuits & Components* (opposite), and takes users through the subject of digital electronics up to the operation and architecture of microprocessors. The virtual laboratories allow users to operate many circuits on screen.

Covers binary and hexadecimal numbering systems, ASCII, basic logic gates and their operation, monostable action and circuits, and bistables – including JK and D-type flip-flops. Multiple gate circuits, equivalent logic functions and specialised logic functions. Introduces sequential logic including clocks and clock circuitry, counters, binary coded decimal and shift registers. A/D and D/A converters and their parameters, traffic light controllers, memories and microprocessors – architecture, bus systems and their arithmetic logic units.

## FILTERS

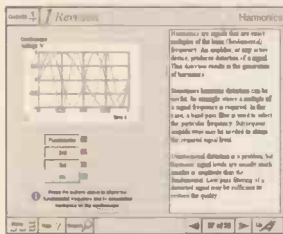

Filter Theory

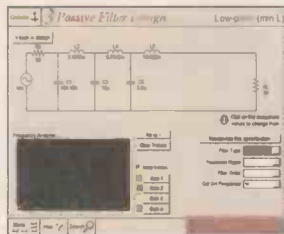

Active filter synthesis

*Filters* is a complete course in designing active and passive filters that makes use of highly interactive virtual laboratories and simulations to explain how filters are designed.

It is split into five chapters: **Revision** which provides underpinning knowledge required for those who need to design filters. **Filter Basics** which is a course in terminology and filter characterization, important classes of filter, filter order, filter impedance and impedance matching, and effects of different filter types. **Advanced Theory** which covers the use of filter tables, mathematics behind filter design, and an explanation of the design of active filters. **Passive Filter Design** which includes an expert system and filter synthesis tool for the design of low-pass, high-pass, band-pass, and band-stop Bessel, Butterworth and Chebyshev ladder filters. **Active Filter Design** which includes an expert system and filter synthesis tool for the design of low-pass, high-pass, band-pass, and band-stop Bessel, Butterworth and Chebyshev filters based on the use of op.amps.

## DIGITAL WORKS 3.0

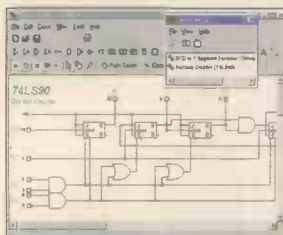

Macro screen

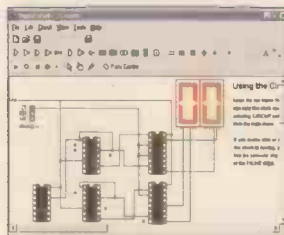

Counter project

*Digital Works Version 3.0* is a graphical design tool that enables you to construct digital logic circuits and analyze their behaviour. It is so simple to use that it will take you less than 10 minutes to make your first digital design. It is so powerful that you will never outgrow its capability.

- Software for simulating digital logic circuits
- Create your own macros – highly scalable
- Create your own circuits, components, and i.c.s
- Easy-to-use digital interface
- Animation brings circuits to life
- Vast library of logic macros and 74 series i.c.s with data sheets
- Powerful tool for designing and learning

### PRICES

Prices for each of the CD-ROMs above are:

Hobbyist/Student .....	£45 inc VAT
Institutional (Schools/HE/FE/Industry).....	£99 plus VAT
Institutional 10 user (Network Licence) .....	£199 plus VAT

(UK and EU customers add VAT at 17.5% to "plus VAT" prices)

# Interested in programming PIC microcontrollers? Learn with **PICtutor** by John Becker



The Virtual PIC

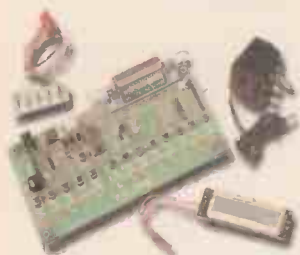

Deluxe PICtutor Hardware

This highly acclaimed CD-ROM, together with the PICtutor experimental and development board, will teach you how to use PIC microcontrollers with special emphasis on the PIC16x84 devices. The board will also act as a development test bed and programmer for future projects as your programming skills develop. This interactive presentation uses the specially developed **Virtual PIC Simulator** to show exactly what is happening as you run, or step through, a program. In this way the CD provides the easiest and best ever introduction to the subject.

Nearly 40 Tutorials cover virtually every aspect of PIC programming in an easy to follow logical sequence.

## HARDWARE

Whilst the CD-ROM can be used on its own, the physical demonstration provided by the **PICtutor Development Kit**, plus the ability to program and test your own PIC16x84s, really reinforces the lessons learned. The hardware will also be an invaluable development and programming tool for future work. Two levels of PICtutor hardware are available – Standard and Deluxe. The **Standard** unit comes with a battery holder, a reduced number of switches and no displays. This version will allow users to complete 25 of the 39 Tutorials. The **Deluxe** Development Kit is supplied with a plug-top power supply (the **Export** Version has a battery holder), all switches for both PIC ports plus I.c.d. and 4-digit 7-segment I.e.d. displays. It allows users to program and control all functions and both ports of the PIC. All hardware is supplied **fully built and tested** and includes a PIC16F84.

## PICtutor CD-ROM

Hobbyist/Student .....£45 inc. VAT  
 Institutional (Schools/HE/FE Industry) .. £99 plus VAT  
 Institutional 10 user (Network Licence) ..£199 plus VAT

## HARDWARE

Standard PICtutor Development Kit .....£47 inc. VAT  
 Deluxe PICtutor Development Kit ..... £99 plus VAT  
 Deluxe Export Version .....£96 plus VAT

(UK and EU customers add VAT at 17.5% to "plus VAT" prices)

## ELECTRONIC COMPONENTS PHOTOS

A high quality selection of over 200 JPG images of electronic components. This selection of high resolution photos can be used to enhance projects and presentations or to help with training and educational material. They are royalty free for use in commercial or personal printed projects, and can also be used royalty free in books, catalogues, magazine articles as well as worldwide web pages (subject to restrictions – see licence for full details). Also contains a **FREE** 30-day evaluation of Paint Shop Pro 6 – Paint Shop Pro Image editing tips and on-line help included!

Price **£19.95** inc. VAT

**NEW**

## ELECTRONIC CIRCUITS & COMPONENTS + THE PARTS GALLERY

Provides an introduction to the principles and application of the most common types of electronic components and shows how they are used to form complete circuits. The virtual laboratories, worked examples and pre-designed circuits allow students to learn, experiment and check their understanding. Sections include: **Fundamentals:** units & multiples, electricity, electric circuits, alternating circuits. **Passive Components:** resistors, capacitors, inductors, transformers. **Semiconductors:** diodes, transistors, op.amps, logic gates. **Passive Circuits . Active Circuits**

**The Parts Gallery** will help students to recognise common electronic components and their corresponding symbols in circuit diagrams. Selections include: **Components, Components Quiz, Symbols, Symbols Quiz, Circuit Technology**

Hobbyist/Student.....£34 inc VAT  
 Institutional (Schools/HE/FE/Industry).....£89 plus VAT  
 Institutional 10 user (Network Licence).....£169 plus VAT

(UK and EU customers add VAT at 17.5% to "plus VAT" prices)

## MODULAR CIRCUIT DESIGN

This CD-ROM contains a range of tried and tested analogue and digital circuit modules, together with the knowledge to use and interface them. Thus allowing anyone with a basic understanding of circuit symbols to design and build their own projects.

Essential information for anyone undertaking GCSE or "A" level electronics or technology and for hobbyists who want to get to grips with project design. Over seventy different Input, Processor and Output modules are illustrated and fully described, together with detailed information on construction, fault finding and components, including circuit symbols, pinouts, power supplies, decoupling etc.

Single User Version **£19.95** inc. VAT  
 Multiple User Version **£34** plus VAT

(UK and EU customers add VAT at 17.5% to "plus VAT" prices)

Minimum system requirements for these CD-ROMs: PC with 486/166MHz, VGA+256 colours, CD-ROM drive, 32MB RAM, 10MB hard disk space. Windows 95/98, mouse, sound card, web browser.

Please send me: **CD-ROM ORDER FORM**

<input type="checkbox"/> Analogue Electronics	<input type="checkbox"/> Version required:	
<input type="checkbox"/> Digital Electronics	<input type="checkbox"/> Hobbyist/Student	Note: The software on each version is the same, only the licence for use varies.
<input type="checkbox"/> Filters	<input type="checkbox"/> Institutional	
<input type="checkbox"/> Digital Works 3.0	<input type="checkbox"/> Institutional 10 user	
<input type="checkbox"/> PICtutor		
<input type="checkbox"/> Electronic Circuits & Components +The Parts Gallery		

---

<input type="checkbox"/> PICtutor Development Kit – Standard	<input type="checkbox"/> Deluxe Export	Note: The PICtutor CD-ROM is not included in the Kit prices.
<input type="checkbox"/> PICtutor Development Kit – Deluxe		

---

<input type="checkbox"/> Electronic Components Photos	Note: The software on each version is the same, only the licence for use varies.
<input type="checkbox"/> Modular Circuit Design – Single User	
<input type="checkbox"/> Modular Circuit Design – Multiple User	

Full name: .....

Address: .....

.....Post code: .....Tel. No: .....

Signature: .....

I enclose cheque/PO in £ sterling payable to WIMBORNE PUBLISHING LTD for £ .....

Please charge my Visa/Mastercard: £ ..... Card expiry date: .....

Card No: .....

Please supply name and address of cardholder if different to the delivery address.

**ORDERING**  
 ALL PRICES INCLUDE UK POSTAGE

Student/Single User/Standard Version price includes postage to most countries in the world  
 EU residents outside the UK add £5 for airmail postage per order

Institutional, Multiple User and Deluxe Versions – overseas readers add £5 to the basic price of each order for airmail postage (do not add VAT unless you live in an EU country, then add 17½% VAT or provide your official VAT registration number).

Send your order to:  
**Direct Book Service**  
 Allen House, East Borough, Wimborne Dorset BH21 1PF

Direct Book Service is a division of Wimborne Publishing Ltd. To order by phone ring  
**01202 881749. Fax: 01202 841692**  
 We cannot reply to overseas orders by Fax  
 Goods are normally sent within seven days  
 E-mail: orders@epemag.wimborne.co.uk

# READOUT

John Becker addresses some of the general points readers have raised. Have you anything interesting to say? Drop us a line!

## WIN A DIGITAL MULTIMETER

A 3 $\frac{1}{2}$  digit pocket-sized l.c.d. multimeter which measures a.c. and d.c. voltage, d.c. current and resistance. It can also test diodes and bipolar transistors.

Every month we will give a Digital Multimeter to the author of the best *Readout* letter.



## ★ LETTER OF THE MONTH ★

### TIDAL DYNAMICS

Dear EPE,

In his very interesting *Canute Tide Predictor* (June '00), John Becker enquired as to the reason the tides do not move up the English Channel at 330mph, and requested replies to *Readout*.

His assertions would be true for the case of the mythical "ideal" flooded planet, where the entire surface is ocean. In that case, the two tidal bulges he shows in Figs.1 and 2 (June '00) would indeed track the rotation of the Earth, there being nothing to impede them.

In reality, the Earth is divided into a number of oceanic basins and other bodies of water, and the effect that this has can be imagined if you consider a single large ocean occupying less than half of one hemisphere (e.g. the Atlantic or the Pacific).

As the Earth rotates, the tidal forces will tend to drag the water towards the western edge of this ocean, but then it must return to the eastern edge for the next cycle, so a circulation is set up with the effect that the high tide progresses around the coastline of the ocean, arriving at any point according to the dynamics of the system rather than the time of maximum tidal force exerted.

The world's oceans are only loosely coupled through relatively narrow straights, so act more-or-less independently of each other. The

North Sea, for instance, provides its own tidal circulation, but is strongly influenced by the Atlantic. Meanwhile, the English Channel connects the two through what an electrical engineer would consider a transmission line, so the tide "signal" propagates along it at the velocity appropriate to its "inductance" and "capacitance".

Thus, the dynamics of the tides are way more complex than the schoolbook explanation most people are familiar with. Circulations in ocean basins can have null points (where there is no rise and fall at all), double tides (four maxima and four minima per day), and produce resonances where inlets act like organ pipes and amplify the tidal oscillation to extreme proportions (e.g. the Severn Estuary and the Bay of Fundy). As John points out, the tidal profile in the Solent has a kink in it, and this is due to the circulation of tidal streams either side of the Isle of Wight.

Ken Wood,  
Blackwood, Gwent, via the Net

*Ah, I believed the land masses might be the cause, but had not thought to equate tidal flow with electronic transmission lines. Nor had I appreciated that the great ocean currents, such as the Gulf Stream, were caused by tidal movements. How extremely interesting, thank you.*

### DOUBLY TIDE UP

Dear EPE,

Your most interesting constructional project *Canute Tide Predictor* of June '00 asks for explanations about the confusing flow of tides in the English channel. Perhaps the tides around the south coast of England vie with John Becker's analysis and program for their complexity.

I cannot claim to give him a full explanation, but a few years ago I read an excellent book (regrettably I cannot recall its name) which discussed the problem and presented many diagrams. The following is based on my memory of its detailed contents.

The high tides at Dover and at Lands End/Penzance arrive from different directions. The high tide at Lands End comes from the Atlantic Ocean whilst that at Dover surges down the North Sea. They meet between Portsmouth and Weymouth, resulting in a confused tidal pattern in that region. The Isle of Wight adds its own complications and the Cherbourg peninsula is blamed for disturbed tidal patterns on the French coast.

At Poole Harbour entrance there are two high tides and one low tide in the normal twelve and a half hours. About three hours after the first high tide there is a second high, rather less than the first and then the water goes right out to low tide. The pattern changes along the coast, being quite different at Weymouth.

Ken Beard,  
Cornwall, via the Net

*Thank you Ken. In fact, not even the excellent WXTide program I referred to in the article attempts to predict tides for Poole Harbour. It does, though, simulate for various locations around the Isle of Wight.*

*Interestingly, while in Jersey recently I saw Tidal Clocks on sale. Seemingly they use the familiar electronically controlled type of clockwork mechanism, but in which the rate has been changed from the standard 12-hour rotation to probably 12 hours 25 minutes during manufacture. A single hand rotates around the clockface indicating the expected state of the tide, but without any correction for different states and positions of the Sun and Moon.*

*I was amused to read the number of disclaimers about the accuracy of this clock. However, as I pointed out in Canute, many people only need to know an approximation of tide conditions and I feel that the clock probably adequately fulfils that need.*

### TELL US A STORY

Dear EPE,

Thank you so much for my lovely surprise. Not only do I get a smashing magazine monthly but am surprised to find that ordinary people with stories are welcome to write in and even better, see themselves in print.

Dave Bishop,  
Tatsfield, Westerham, Kent, via the Net

*Dave's letter about Sputnik was chosen as Letter of the Month in June '00, for which we sent him a digital multimeter.*

*Thanks Dave, we are as much interested in the history of technology as in its applications.*

### PICTUTOR CD-ROM ODDITY

Dear EPE,

When using the Virtual PIC programs on the *PICtutor CD-ROM*, which I think is very good, I have found that instructions BCF, BSF, BTFSC and BTFSS cannot be programmed correctly if bit 7 is selected. The program listing just shows "BCF REG" and not "BCF REG,7" which, of course, is a syntax error, something the Virtual PIC should be incapable of. The running program just seems to treat the instruction as an NOP.

Also, from time to time, and I can't detect any consistency, except that it usually, but not always, occurs when the INDF register is used, is the presentation of the error message "There is no object named FSRRegister".

The "error" does not seem to affect program execution, except that it pauses until the error window is closed.

I thought your Tutorials were excellent, both from the point of view of the Virtual PIC and the hardware itself. I had coded 8080, 8085, 8088 and 8051 back in the 1980s but was rusty on machine language. Your Tutorials brought me back up to speed very quickly. My colleague had taken assembler language at the under-graduate level and hated it, but she took to the PIC quite happily.

I first tried to use the *PICtutor* hardware with Windows (shudder) NT, but could not get it to work, then found out it can't work with NT. Then I had trouble with Windows 95, until I discovered that software for a (non-existent) scanner was accessing the printer port!

If the Virtual PIC software is to be upgraded, may I suggest some additional features:

- The display should show the current .PSF file in use.
- A warning dialogue should be shown if the user tries to quit with a file not saved.
- The behaviour of GOTO statements, where lines are inserted, could be improved. I believe the label following the GOTO should be preserved wherever possible, and not replaced by the hex address of the label's former position (where this occurs).

John Waller, via the Net

*Whilst I had the pleasure of authoring the PICtutor text and PIC programming listings etc, we collaborated with Matrix Multimedia in the production of the CD-ROM and its Virtual PIC screen demos. They replied to John with the following:*

There is a workaround to the bit-7 bug: click on the far right of the number "7" when entering the bit. Most of the "7" is "underneath" another textbox, so clicking on that "hidden" part of the "7" produces the error. The far-right of the "7" is not "hidden" and produces the correct result.

We could not replicate the "There is no object named FSRRegister" error, so it is difficult to solve. If someone could supply a program that reproduces this error, then I could look into it and maybe produce a fix (send to support@matrixmultimedia.co.uk).

We have placed a new software version on our website with a fully clickable "7"! Your helpful suggestions have been noted.

Matrix Multimedia



## QBASIC AVAILABILITY

We have had numerous queries, over many months, from readers on how they could obtain QBASIC or QuickBASIC. Having been told by reader Alan S. Raistrick that it was included on Windows 95 and 98 CD-ROMS (see Readout July '00), I found that QBASIC was indeed on my CD and I asked readers to check if their CDs included it too. Here's a selection of the replies:

I've checked my CD-ROMs with the following results:

Early, upgrade version(?), `Windows95\other\oldmsdos\Qbasic`, 11 July 1995 09:50:00. Later, full version - Windows 95 version 4.00.950 B. Here QBASIC is filed as - `Windows95\other\oldmsdos\qbasic`. In the same directory is another executable - `HELP.COM`. Both these and their associated `.HLP` files are date and time stamped 24 August 1996 11:11:11.

Arthur Dyas, via the Net

My Win98 CD-Rom does include QBASIC in `<Drive>:\Tools\oldmsdos`, both application and helpfile. Searching for QuickBASIC does not find anything.

Keith Tunstall, via the Net

I checked my Win 98 (second edition) and QBASIC is there all right - under the `x:\tools\oldmsdos` directory. But hey, why are some so intent on hanging onto this? I found Visual Basic extremely easy to understand (more so than QBASIC), and produces better user interfaces in next to no time.

Admittedly some of the I/O functions have been left out but there are a number of third party (public domain) add-ons to remedy this. With Windows 98 soon to amalgamate with the Windows 2000 generation with almost no support for MS-DOS, wouldn't it be wise to wean everyone to something else more appropriate?

David Reid,

Bardsley, Oldham, via the Net

I've checked my Windows 95 and 98 CDs. Both contain only QBASIC. QuickBASIC is, as you say, readily available on the Internet. Download sites seem to change almost daily. Try <http://members.tripod.com/~qbds/qb45.htm>.

Various petitions exist to try and persuade Microsoft to release QuickBASIC as freeware (see <http://netpower.8m.com/computers/programming/qb/>) which suggests that downloading at present is not legal. A possible alternative is a compileable version of Basic called Asic, which is a shareware program. My copy was included on a disk of Basic and QBASIC programs which I purchased for £1 from the PC Information Centre on 01543 415 816 (very helpful). ([www.pcinfocentre.com](http://www.pcinfocentre.com)).

Dave Squibb, via the Net

Thank you to all of you who replied. We hope the rest of you now know where to find QB - on your Windows CD!

Regarding VB as highlighted by David Reid, I've tried to get into it, but have so far failed. David kindly says he'll send me some example programs. Would anyone else care to E-mail me some shortish examples as source code (i.e. code I can read via a text editor)?

## ARCHAEOLOGICAL LOGGING

Dear EPE,

Three years ago at the Bridgwater & District Archaeological Society, we constructed Robert Beck's *Earth Resistivity Meter* (EPE Jan/Feb '97). Working with the concurrence of the County Archaeology Officer, the Society has made important discoveries which have been recorded in the national Sites and Monuments Record (Somerset). We intend to continue with this voluntary work.

Now we have seen your remarkable 8-Channel Data Logger (Aug/Sep '99) which would appear to us to be suitable, with minor adjustments, to replace our existing laborious

and error-prone methods of on-site recording. (In each session covering 30 square metres of ground we manually record 900 3-digit readings.)

Your logger in many aspects is ideally matched to our input and output requirements. The main concern is that it is far too sophisticated for us, in that we only need a single channel (and no prospects of ever needing more). Our input would be at an indeterminate rate by hand triggering via socket SK10 (RATE=EXT), and we are warned that transfer of data to a CP/M operating system such as ours (this is shoe-string stuff!) should not exceed 2400 baud: we could not happily tolerate an 8-channel system where only every eighth word carried meaningful data.

All these factors suggest that we need to build a smaller system. We wonder whether there is available on the market a single-channel (or even a twin-channel) EEPROM? Or, better still, an i.c. that does not need programming: programming EEPROMs and Internet access are further hurdles for us backward boys. We also thought that there was a chance that you had already built a smaller development model, the circuit details of which you would be prepared to divulge in a good cause!

Peter Ellson,

Ashcott, Bridgwater, Somerset

*Although my logger can run eight channels it is perfectly happy with just the first one (see the original text). The data is output to the computer one channel at a time and if a channel does not exist it is ignored. You do not need to intercept every eighth word as you think.*

*I regret I cannot directly advise on converting to 2400 baud but if you study the PIC and Basic programs you should be able to see where the codes can be changed. I have not designed another version.*

*The follow-up article PIC16F87x Mini Tutorial of Oct '99 discusses serial output/input control and baud rate setting, with reference to the PIC and the Basic program on the PC.*

*The listings should be read in conjunction with the PIC source code (.ASM) and Basic (.BAS) software files.*

*Incidentally, you will be interested to know that we have another type of Earth Resistivity Monitor scheduled for a few months time.*

## ICEBREAKER QUERY

Dear EPE,

Referring to Mark Stuart's brilliant EPE ICEbreaker project (Mar '00), I think there are a couple of bugs in the control software which limit its usefulness a bit.

The article says "Sometimes the highlight does not track the source code exactly and is one line above or below the current line". What I see is that the l.c.d. doesn't stop accurately at breakpoints and it can be more than one instruction out, often two or three.

In practice what it means is that NOPs have to be scattered around the code in areas being investigated until one giving the desired stop point is found. This means additional unnecessary assemblies and PIC code reprograms, and a certain amount of klunky trial and error, which can be less than straightforward if you've got a program that isn't working correctly anyway.

The other problem is one which appears to corrupt the communications between the PIC monitor program and the host PC. This happens when any of pins RB0 to RB5 are written to. There is nothing in the article description nor the on-line help that implies any restriction in the use of these lines, and indeed this is precisely what the demo program `icecld1.asm` does.

Once the comms link has been corrupted in this way, breakpoints do not work, and the STOP button on the ICEbreaker main window, although it does stop the PIC program, causes a dialogue box with the error message: "Communications error: unexpected character received: A5 expected xx received" to be

displayed. Once it is in this state, registers etc cannot be displayed, and it is usually necessary to reload `icebreaker.exe` on the PC or power cycle the PIC board to get out of it, although sometimes the Reset button on the ICEbreaker window will work. However, single stepping past a write to PORTB works OK.

One other minor point: "Program" programs the data EEPROM as well as the program memory. I can't find anything that documents this, and I think there should be because it is different behaviour from other EPE PIC programmers (e.g. *Toolkit V2*) in which code and data programming are separate functions, and reprogramming the code memory leaves the data EEPROM intact.

Although MPASM allows you to embed EEPROM data in the source code, so this behaviour once understood isn't a problem, I'd actually prefer an option to turn EEPROM programming off. I use EEPROM for tables such as decimal conversion, 7-segment l.e.d. driving, stepper motor driving etc, and once these things are set up they don't need to change.

Malcolm Wiles, via the Net

Mark Stuart replied to Malcolm:

I'm glad you're finding ICEbreaker useful. The fact that the l.c.d. does not stop accurately at breakpoints is a "feature" of the PIC16F87x chips which operate in three modes: normal run, single step and run until breakpoint.

If you set a breakpoint then the Windows program sends the breakpoint address to the PIC. The PIC will run until it hits the breakpoint then saves the program counter (PC) and starts executing the debugger code. The debugger code communicates with the Windows program and tells it the stored value of the PC.

Unfortunately, the PIC doesn't always stop where it's meant to. That's especially true near to instructions that cause a skip, instructions that are skipped, jumps, calls, and destinations of jumps and calls. The breakpoint is implemented in hardware inside the PIC and there's nothing we can do to alter its behaviour.

With the other problem which appears to corrupt the communications between the PIC and PC, I don't understand what's going wrong. As you say, `icecld.asm` writes to these pins without any problems.

That's a good point about EEPROM and data programming. Should an upgrade version of the ICEbreaker software ever be produced (but no current plans for this), separate commands for writing to each could be added.

Mark Stuart

## BRIDGE THAT GAP

Dear EPE,

Thank you for an excellent magazine. I subscribed on-line just as the *Teach-In 2000* series began and have found it to be the perfect bridge between "here buy these parts, build this project" and "on a sub-atomic level the valance electrons fill the blah blah blah..."

Keep the usable and accurate hobby electronic information coming.

A correction to your February *Teach-In 2000* lesson that will help to keep your Yank readers from tearing their hair out is that on a US SPP, ECP or EPP port the ERROR line that you have as pin 23 is pin 15 on a DB-25 and pins 18-25 are ground (earth).

Stephen Skibbe,

Minneapolis, MN, USA, via the Net

Thank you Stephen, *Teach-In's* been fun to write (about two years off and on) and its gratifying to know that so many of you appreciate the series.

Connector-wise, you will by now have seen Panel 9.5 of Part 9 (July '00) which sorts out a matter we did not know about. Thanks for your suggestions for using a wire-wrap socket instead of doing soldering. Regretably we are too far down the line now for it to be usable by our TI followers.

# DOOR PROTECTOR

OWEN BISHOP

Project 1

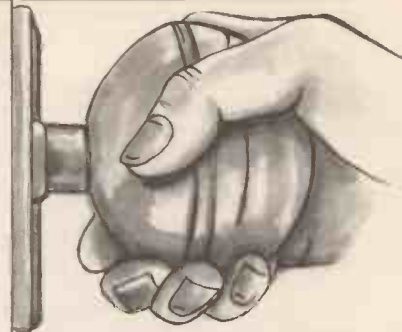

This short collection of projects, some useful, some instructive and some amusing, can be made for around the ten pounds mark. The estimated cost does not include an enclosure, for many of them work just as well as an open board.

All of the projects are built on stripboard, and have been designed to fit on to boards of standard dimensions. All of the projects are battery-powered, so are safe to build. In a few cases in which, by its nature, the project is to be run for long periods, power may be provided by an inexpensive mains adaptor. Again, the cost of such a unit is not included because most spares boxes contain a few of these, possibly pensioned off from powering now obsolete electronic gadgets.

**E**VEN if you already have an electronic security system installed in your home or workplace, there is likely to be a use for this Door Protector. With any security system, or even with none, it is important that all doors and windows should be protected by bolts, bars, grids or other physical means. It costs relatively little to fix strong bolts or locks to windows and doors, to make it virtually impossible for anyone to gain access without employing drastic measures.

Unfortunately, there is nearly always one weak point. This is the Exit Door, the door by which you normally leave the house when you are going out. This is also the door by which you enter the house when you come back home.

Other doors (and the windows) are bolted or locked from the *inside*. Once secured, they can only be opened by someone who is already inside the house. Only physical protection is needed.

On the other hand, the Exit/Entry Door has to be openable from *outside* the house as well. There is a limit to the number of locks that can be fitted, and usually it is not practicable to fit any bolts.

## DOOR GUARD

This is where electronics, in the form of this month's project, can be of help. The Door Protector system described here can be set to one of two states:

- **Disarmed:** After pressing the Disarm button, you may open and close the Exit/Entry Door as often as you like and this has no effect on the siren.
- **Armed:** You arm the system by pressing the Arm button and then have 20 seconds to leave the house via the Exit Door without making the siren sound. On re-entering the house through the same door, nothing happens for the first 20 seconds but your entry has triggered the system and the siren will start to sound after 20 seconds unless you press the Disarm button.

The timings can be altered to suit individual locations. Of course, the function buttons are hidden away so that an intruder cannot quickly find them.

## HOW IT WORKS

The circuit is triggered by a switch mounted on the door, and accessible only from the inside. This may be a microswitch or more conveniently a reed switch that closes when a permanent magnet is near it. Usually the switch is mounted on (or in) the frame of the door and the magnet is mounted on (or in) the door.

When the door is open, the magnet no longer has an effect on the switch, which springs open. When the door is closed the magnet comes very close to the switch, causing it to close.

As shown in the full circuit diagram for the Door Protector in Fig.1, the door switch S1 is closed whenever the door (with magnet insert) is closed, so pin 9 of IC1a is held at logic low. If the door is opened, even by only a few centimetres and for only a fraction of a second, the input at pin 9 is pulled to logic high, via resistor R1, for long enough to trigger the circuit.

If the circuit is in the "disarmed" state the other input (pin 8 of IC1a) is at logic low, so the output of the gate at pin 10 remains at logic high, whatever the input to pin 9. Opening and closing the door has no effect on the system.

If the system is in the "armed state", the input at IC1a pin 8 is high. Then any high level at pin 9 caused by opening the door

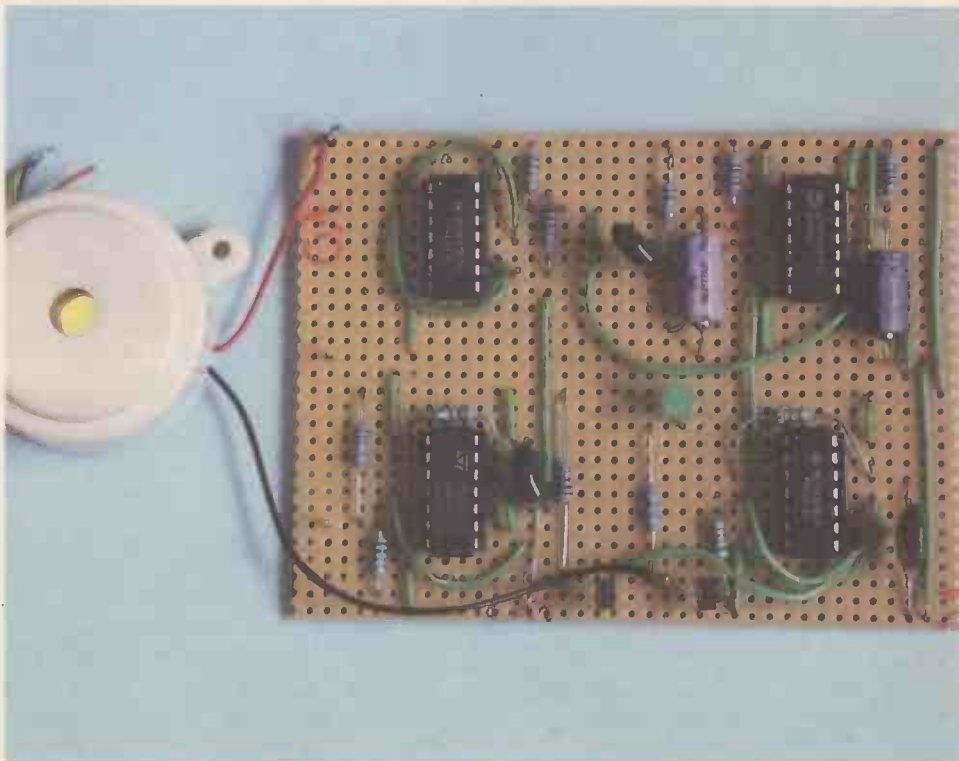

causes the output at pin 10 to become low. This output goes to a set-reset flip-flop consisting of two NAND gates, IC1b and IC1c.

In the reset state, pin 11 of IC1c is high but this goes low (and stays low) when the flip-flop is triggered. The low-going level passes across capacitor C1 and produces a short low pulse that triggers the timer IC2a. The timer output at pin 5 is normally low but now goes high for 20 seconds.

The next stage is a pulse generator, formed by IC4a/IC4b which normally has a low output at IC4b pin 11, but produces a short high pulse when the input from the timer goes low, that is, after 20s. The output from the pulse generator goes to another flip-flop, formed this time from a pair of NOR gates IC4c/IC4d.

When this receives a high pulse its output at pin 10 goes high and stays high. It turns on transistor TR1, which in turn switches on the siren (WD1). The siren sounds until the system is disarmed or the power is switched off.

The remainder of the circuit is concerned with arming and disarming. Pressing the Arm button of switch S2 has two effects. It resets the flip-flop IC1b/IC1c, making its output at pin 11 go high. It is now ready to trigger the timer (IC2a) as already described.

The second effect is to trigger another timer, IC2b. The output of this goes high for 20s and, at the end of this period, another pulse generator (IC3a/IC3b) produces a short high pulse. This sets flip-flop IC3c/IC3d, making its output at pin 10 go high.

This output is fed back to pin 8 of the input gate IC1a that also received input from the door switch S1. With pin 8 high, pulses from the door switch are passed through to the flip-flop of IC1, so triggering IC2a. The system is now armed, but not until 20s after pressing the Arm button.

The Disarm button of pushswitch S3 also has two actions. One function is to produce a low pulse to reset the arm/disarm flip-flop at pin 6 of IC3. The low pulse is also inverted by transistor TR2 and then used to reset the siren flip-flop (IC4c/IC4d) and turn the siren off.

If you want to make one or both delay times longer, recalculate the values of the timing capacitor and resistor (R3, C2 or R5, C4), using the formula,  $t = 1.1RC$ . The delay time is  $t$  seconds,  $R$  is in ohms and  $C$  is in farads.

## POWER NEEDS

Although Fig.1 shows the circuit operating at 12V, it will operate at any voltage suitable for powering CMOS i.c.s and the siren. The minimum for a reasonably loud siren is 6V, and the maximum for CMOS is 15V. We chose 12V to suit the 3-tone piezo buzzer that we had decided on. It operates between 6V and 12V but is louder at 12V, with an output of 107dB.

Its power leads are red (positive) and black (0V) and there are two additional leads for determining the kind of sound it makes. With the yellow and green leads connected, it makes a 2-tone warble. Orange and green connected give a single-tone pulsed sound. If these leads are left unconnected, the tone is continuous.

The circuit requires only a small current when the siren is not sounding, so a power

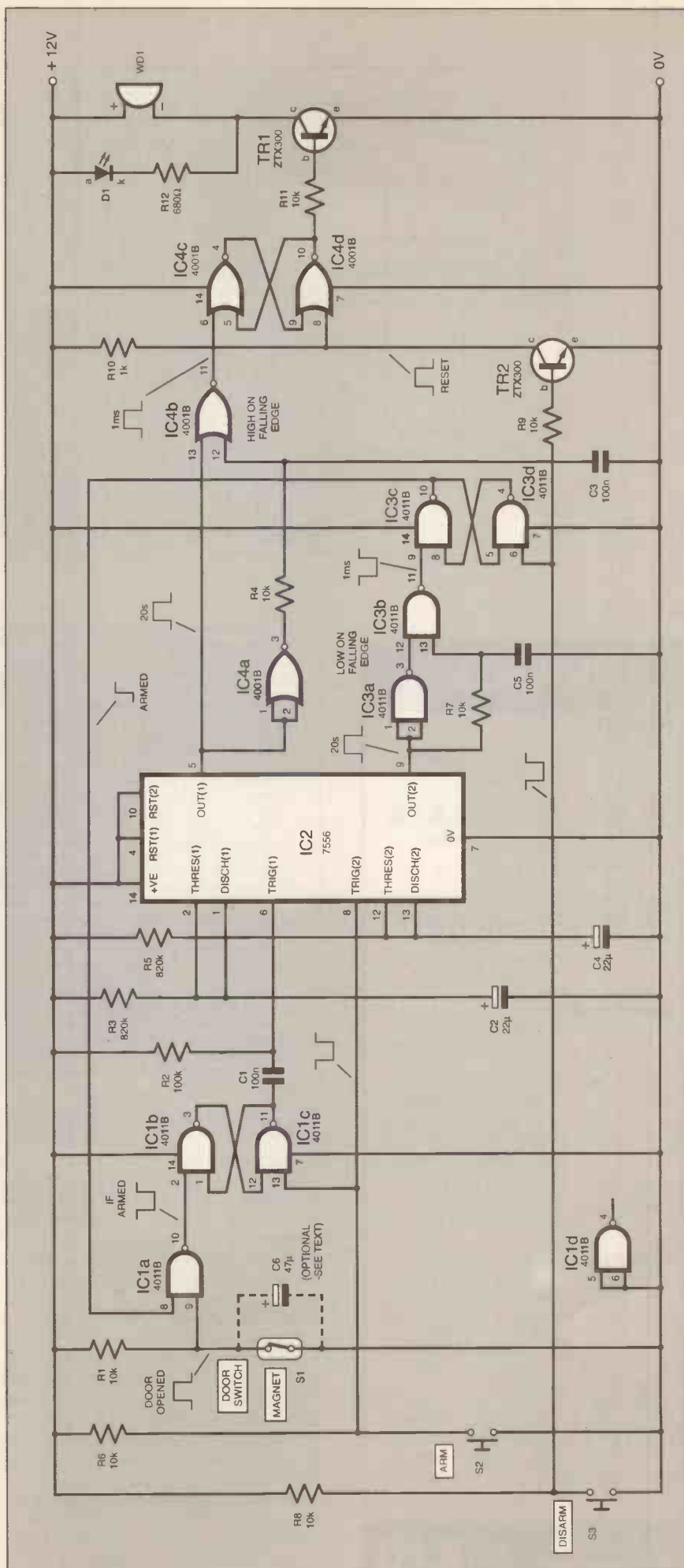
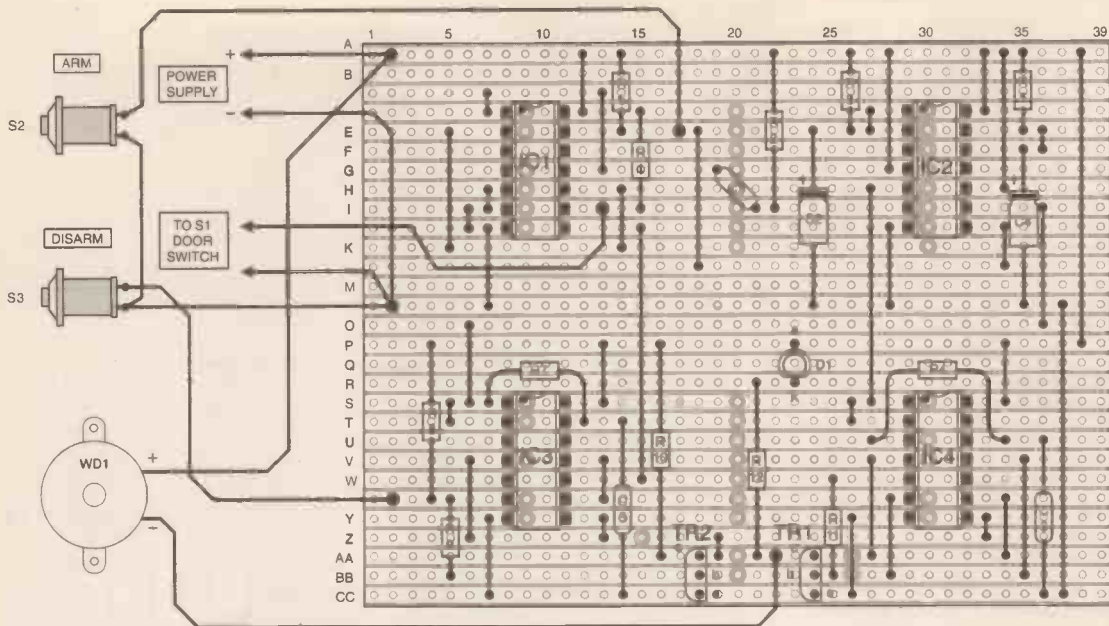

Fig.1. Complete circuit diagram for the Door Protector.



## COMPONENTS

### Resistors

R1, R4, R6  
to R9,

R11 10k (7 off)  
R2 100k  
R3, R5 820k (2 off)  
R10 1k  
R12 680Ω

All 0.25W 5% carbon film

See  
**SHOP**  
**TALK**  
page

### Capacitors

C1, C3, C5 100n polyester (3 off)  
C2, C4 22μ radial elect. 16V  
C6 47μ radial elect. 16V (optional)

### Semiconductors

D1 3mm or 5mm light-emitting diode (l.e.d.), red  
TR1, TR2 ZTX300 npn low-power transistor or similar (2N3704) (2 off)  
IC1, IC3 4011 CMOS quad 2-input NAND gate (2 off)  
IC2 7556 dual timer  
IC4 4001 CMOS quad 2-input NOR gate

### Miscellaneous

S1 magnetic reed switch, with magnet  
S2, S3 pushbutton switch, push-to-make (2 off)  
WD1 audible warning device (triple tone piezo buzzer)

Stripboard 0.1 inch matrix, size 29 copper strips by 39 holes; 14-pin i.c. socket (4 off); D-type alkaline cells or unregulated mains adaptor – see text; 1mm solder terminal pins (6 off); solder, etc.

Approx. Cost  
Guidance Only  
**£10**  
excluding batts or mains adpt.

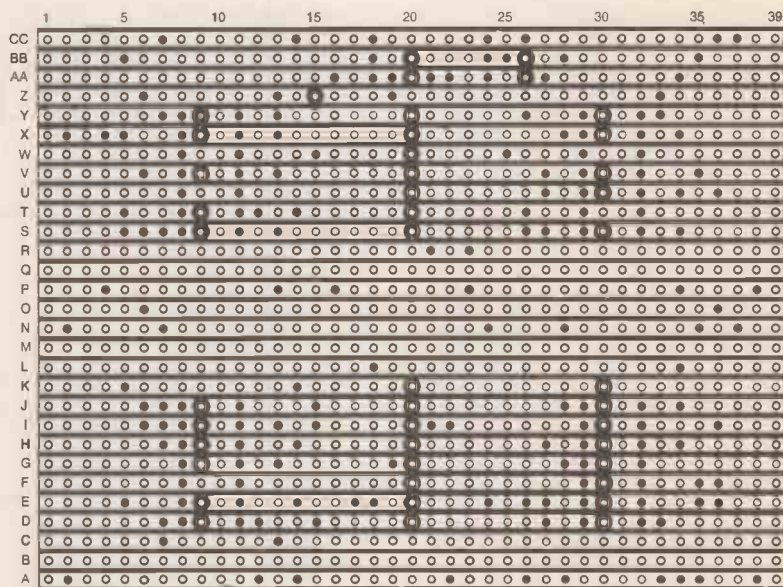

Fig.2. Stripboard topside component layout, interwiring to off-board components and details of breaks required in the underside copper tracks.

supply from four (or eight) D-type alkaline cells could be used. Using a battery makes the system immune to power cuts. However, in the long run it is more economical to use a 6V, 9V, or 12V unregulated mains adaptor rated at 300mA or more.

## CONSTRUCTION

The Door Protector circuit is built up on a piece of 0.1in. matrix stripboard, containing 29 copper strips by 39 holes. The board topside component layout and details of breaks required in the underside copper tracks are shown in Fig.2. It is recommended that d.i.l. sockets are used for all the i.c.s.

As there is plenty of room on the circuit board, there should be no problems in making the connections. Note that the copper strips are cut at certain places but that some of the strips beneath the i.c.s are NOT cut.

If you are intending to construct several of the projects in this series, it may be worthwhile investing an extra “fiver” in purchasing a special spot-face cutter for cutting the copper tracks neatly. Alternatively, a handheld twist drill bit of around 5mm dia. will do the job just as well. Whichever method you use to make the breaks you should always double-check for any slivers of copper bridging any surrounding tracks or cuts before moving on to the next break.

You can assemble the whole circuit before testing it, working from the smallest (link wires) up to the largest components, but you may prefer to check each stage as you go. If so, begin with the main triggering circuit, starting at switch S1 and working stage by stage through IC1, IC2a and IC4 to the siren.

You will need to enable the circuit by temporarily wiring pin 8 of IC1 to the

positive rail. Also, temporarily connect pin 8 of IC4 to 0V through a 10 kilohm resistor. Provide a flying lead for briefly bringing pin 8 to logic high when you need to reset the flip-flop to silence the siren.

After this, assemble and test the arming and disarming sections of the circuit, based on the second half of timer IC2 and IC3.

## INSTALLING THE SYSTEM

The entire Door Protector system, including the siren, can be located at a convenient point and housed in a single enclosure. However, it makes more sense to mount the siren in a remote and relatively inaccessible place where it can easily be heard and cannot be interfered with.

Wiring between the board and siren must be concealed as far as possible. Power leads should likewise be hidden as much as possible.

Similarly, you should hide the pushbutton switches, particularly the Disarm one, in a place where they are difficult for an intruder to find but are quick and easy for

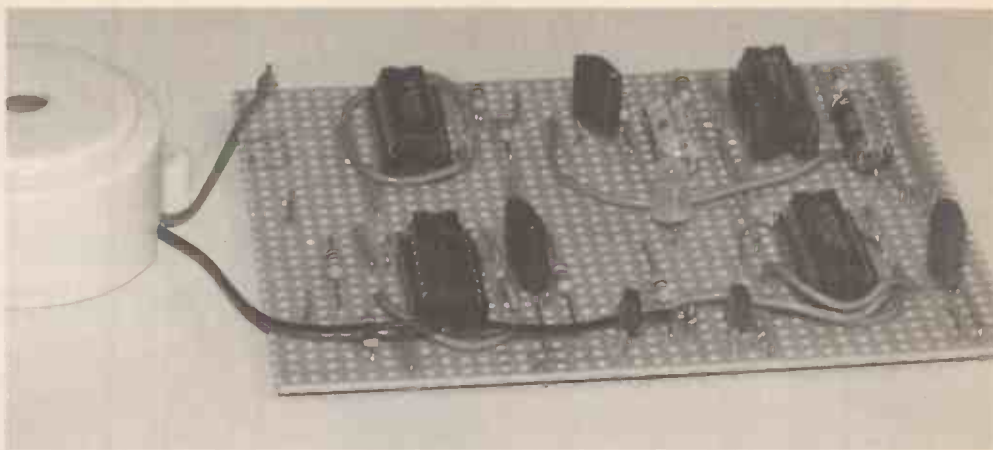

Component layout on the prototype Door Protector circuit board. No case details are given as it is left to individual choice – you may wish to hide the switches remote from the main unit.

you to reach. It is not so important to hide the leads to the door switch because, if the intruder finds and cuts these leads, it has the same effect as opening the door; the siren sounds 20 seconds later!

In some situations there may be false

triggering due to electromagnetic interference picked up in the leads joining the circuit board to the door switch. If this occurs, it can usually be cured by wiring a capacitor between IC1 pin 9 and the 0V rail (C6 in Fig.1). □

## SHOP TALK

with David Barrington

### EPE Moodloop

No real trouble should be encountered when searching for components for the *EPE Moodloop* project. The OP279 rail-to-rail, high current, dual op.amp is an Analog Devices chip and was originally ordered from Maplin, code NP18U. The BD135 and BD136 power transistors should be widely stocked, try Cricklewood (☎ 020 8452 0161, Fax 020 8208 1441).

The 15-way D-type chassis socket and 15-way IDC plug connectors should now be widely available, check out **ESR Components** (☎ 0191 2514363 or [www.esr.co.uk](http://www.esr.co.uk)) and **Magenta** (☎ 01283 565435 or [www.magenta2000.co.uk](http://www.magenta2000.co.uk)).

The Frequency 12-way rotary switch used in the model is a Lorlin type, with a limit end-stop behind its mounting bolt to set the required number of "ways". This was removed completely when mounting the switch in the unit. Most of our component advertisers should be able to offer a suitable 12-way single-pole switch as well as the 4-way d.l.l. switch (if required).

If you intend to invest in the same case, this is from the Vero Patina range which succeeds the popular 200 series. The top and bottom sections clip together, without screws, and we understand that the Vero part number is 75-265742E (series 215 box code 75-3008J). The Maplin code for the Patina case is: NC91Y.

Turning now to the software. For those readers unable to program their own PICs, the author is able to supply ready-programmed PIC16F84 microcontrollers for the sum of £6 each, inclusive of postage (overseas add £1 per order). Orders should be sent to: **Andy Flind, 22 Holway Hill, Taunton, Somerset, TA1 2HB**. Payments should be made out to *A. Flind*. For those who wish to program their own PICs, the software is available from the Editorial offices on a 3.5-in. PC-compatible disk, see *PCB Service* page 637. It is also available free via the *EPE* web site: [ftp://lepemag.wimborne.co.uk/pubs/PICS/moodloop](http://ftp://lepemag.wimborne.co.uk/pubs/PICS/moodloop).

Finally, the printed circuit board is available from the *EPE PCB Service*, code 271 (see page 637).

### Door Protector

For the first of our "Top Tenner" projects, the author has chosen a simple *Door Protector* alarm circuit. The components for this project seem to be fairly straightforward and should not cause any sourcing problems as most of our component advertisers should be able to provide suitable items.

Several of our current advertisers such as **Suma Design, Quasar Electronics, Bull Electrical** and **Maplin** may be able to offer a suitable reed switch and magnet combination. Maplin list a surface mounting type (YW47B) and a self-adhesive UPVC type (MM11M). The triple-tone buzzer, used in the prototype, also came from the last mentioned company, code KU60Q.

One last point, we understand that some overseas readers may have difficulty in obtaining the ZTX300 transistor. We suggest that they try a general purpose, low power, type such as the 2N3704.

### Quiz Game Indicator

Although the formats may differ slightly, most of the components required for the *Quiz Game Indicator*, this month's Starter Project, should be "off-the-shelf" items. However, some readers may prefer to use the identical parts as listed and shown in the article.

This may apply particularly to the neat-looking contestant boxes and the accompanying pushbutton switches. These were both purchased from **Rapid Electronics** (☎ 01206 751166 or E-mail [sales@rapidelec.co.uk](mailto:sales@rapidelec.co.uk)). The snap-together ABS mini-box carries the code 30-1905, and the miniature pushbutton switch is coded 78-1520.

The transistor used in this circuit is the BC184L, and the suffix L after its type number indicates a different pinout line-up to other BC184s. In practice, virtually any low power, small signal, *npn* general purpose transistor can be used here, but take care to check the leadouts and place them in the correct order on the p.c.b.

The small printed circuit board is available from the *EPE PCB Service*, code 272 (see page 637).

### Handy Amp

The most likely component to cause concern when ordering parts for the *Handy Amp* project is the Analog Devices SSM2211 power amplifier i.c. For those readers who do have trouble finding this chip, the one in the model came from **Maplin** ([www.maplin.co.uk](http://www.maplin.co.uk)), code OA20W. The 5534 low-noise op.amp should be generally available and is an improved version of the standard 741 type.

When ordering the headphone 6.35mm stereo jack socket you **must** specify that you need a plastic bodied (*insulated*) chassis mounting type; this should have all its connections, including the mounting bezel, isolated from the metal case. Most headphones now seem to terminate with a 3.5mm jack plug, so you will probably need a 6.35mm to 3.5mm adaptor. Both these forms of socket/plug should be available from your usual component supplier or one of our component advertisers.

Selecting an internal 8 ohm loudspeaker is left to the constructor, you do not have to use an elliptical type, just make sure it will fit inside the metal case. However, do not use one having a rating *less* than 2W.

The choice of a "vinyl-effect" aluminium case for this project is one that has proved popular in past constructionals and many of our component stockists now carry them. This is sometimes referenced as a WB3 type. Do not use a plastic box, as this will not provide any screening and hum pick-up could be a problem.

The printed circuit board is available from the *EPE PCB Service*, code 273 (see page 637).

### Cave Electronics

Some readers may be intrigued to experiment with the L.E.D.-based Caving Lamp circuit (Fig.1) contained in the *Cave Electronics* feature. We can offer the following assistance with components for this circuit.

We are informed that the 10μH inductors L1 and L2 are made up from Philips 432202097180 toroid formers (**Farnell** – ☎ 0113 263 6311 or [www.farnell.com](http://www.farnell.com)) – code 180-008) wound with four twisted strands (two parallel pairs) for the primary and secondary windings. The cores are wound with the four strands of 0.315mm wire until a single layer is completed. This gives approximately 28 turns. The ends are sorted out and soldered to the terminal pins.

Also, checkout the Linear Technology web site ([www.linear-tech.com](http://www.linear-tech.com)) where a circuit using their LT1513 switching regulator (IC1/IC3) shows the use of a twin-winding Coiltronics CTX10-1 10μH common core inductor. All we can tell you about IC2 and IC4 is that they are Motorola devices. It seems that the Schottky diodes also came from Farnell (see above).

We are told that the main "lighting" i.e.d.s are of Hewlett Packard manufacture and made up as follows: green (8 off) HLMP-BM01; blue (4 off) HLMP-BB01; red (2 off) HLMP-BD06 and yellow (amber) (2 off) HLMP-BL06. Once again, the above mentioned component supplier is a possible source.

**WHETHER ELECTRONICS IS YOUR HOBBY  
OR YOUR LIVELIHOOD . . .  
YOU NEED THE MODERN ELECTRONICS MANUAL  
and the ELECTRONICS SERVICE MANUAL**

## THE MODERN ELECTRONICS MANUAL

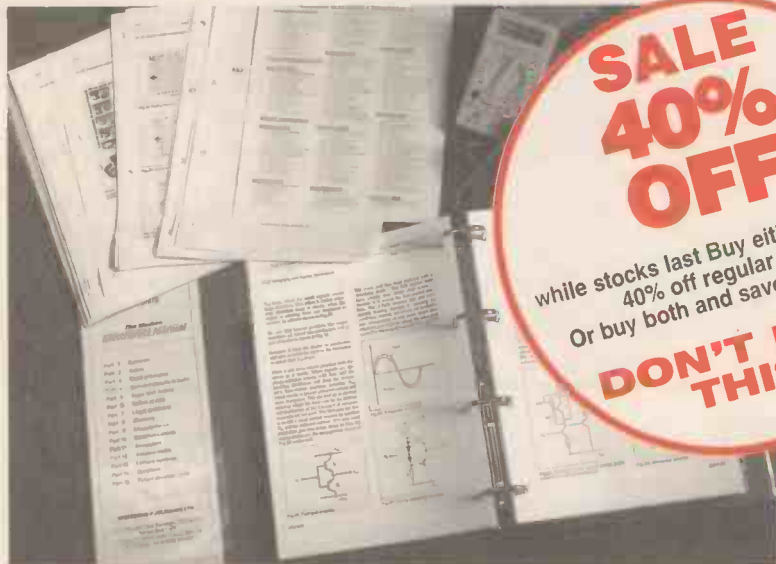

**SALE  
40%  
OFF**

while stocks last Buy either Manual at  
40% off regular price.  
Or buy both and save even more.

**DON'T MISS  
THIS!**

*The essential reference  
work for everyone  
studying electronics*

- Over 900 pages
- In-depth theory
- Projects to build
- Detailed assembly instructions
- Full components checklists
- Extensive data tables
- Detailed supply information
- Easy-to-use format
- Clear and simple layout
- Comprehensive subject range
- Professionally written
- Regular Supplements
- Sturdy gold blocked ring-binder

## EVERYTHING YOU NEED TO GET STARTED AND GO FURTHER IN ELECTRONICS!

The revised edition of the Modern Electronics Base Manual contains practical, easy-to-follow information on the following subjects:

**BASIC PRINCIPLES:** Electronic Components and their Characteristics (16 sections from Resistors and Potentiometers to Crystals, Crystal Modules and Resonators), Circuits Using Passive Components (9 sections), Power Supplies, The Amateur Electronics Workshop, The Uses of Semiconductors, Digital Electronics (6 sections), Operational Amplifiers, Introduction to Physics, Semiconductors (6 sections) and Digital Instruments (5 sections).

**CIRCUITS TO BUILD:** There's nothing to beat the satisfaction of creating your own project. From basic principles, like soldering and making printed circuit boards, to circuit-building, the Modern Electronics Manual and its Supplements describe clearly, with appropriate diagrams, how to assemble radios, loudspeakers,

amplifiers, car projects, computer interfaces, measuring instruments, workshop equipment, security systems, etc. The Base Manual describes 13 projects including a Theremin and a Simple TENS Unit.

**ESSENTIAL DATA:** Extensive tables on diodes, transistors, thyristors and triacs, digital and linear i.c.s.

**EXTENSIVE GLOSSARY:** Should you come across a technical word, phrase or abbreviation you're not familiar with, simply turn to the glossary included in the Manual and you'll find a comprehensive definition in plain English.

The Manual also covers **Safety** and **Suppliers**. The most comprehensive reference work ever produced at a price you can afford, the revised edition of **THE MODERN ELECTRONICS MANUAL** provides you with all the *essential* information you need.

## THE MODERN ELECTRONICS MANUAL

**Revised Edition of Basic Work:** Contains over 900 pages of information. Edited by John Becker.

**Regular Supplements:** Approximately 160-page Supplements of additional information which, if requested, are forwarded to you immediately on publication (four times a year). These are billed separately and can be discontinued at any time.

**Presentation:** Durable looseleaf system in large A4 format

**Price of the Basic Work:** ~~£39.95~~ **SALE PRICE £23.97** (to include a recent Supplement **FREE**)

### Guarantee

Our 30 day money back guarantee gives you **complete peace of mind**. If you are not entirely happy with either Manual, for whatever reason, simply return it to us in good condition within 30 days and we will make a **full refund of your payment** – no small print and no questions asked.  
(Overseas buyers do have to pay the overseas postage charge)

# ELECTRONICS SERVICE MANUAL

## EVERYTHING YOU NEED TO KNOW TO GET STARTED IN REPAIRING AND SERVICING ELECTRONIC EQUIPMENT

**SAFETY:** Be knowledgeable about Safety Regulations, Electrical Safety and First Aid.

**UNDERPINNING KNOWLEDGE:** Specific sections enable you to Understand Electrical and Electronic Principles, Active and Passive Components, Circuit Diagrams, Circuit Measurements, Radio, Computers, Valves and manufacturers' Data, etc.

**PRACTICAL SKILLS:** Learn how to identify Electronic Components, Avoid Static Hazards, Carry Out Soldering and Wiring, Remove and Replace Components.

**TEST EQUIPMENT:** How to Choose and Use Test Equipment, Assemble a Toolkit, Set Up a Workshop, and Get the Most from Your Multimeter and Oscilloscope, etc.

**SERVICING TECHNIQUES:** The regular Supplements include vital guidelines on how to Service Audio Amplifiers, Radio Receivers, TV Receivers, Cassette Recorders, Video Recorders, Personal Computers, etc.

**TECHNICAL NOTES:** Commencing with the IBM PC, this section and the regular Supplements deal with a very wide range of specific types of equipment – radios, TVs, cassette recorders, amplifiers, video recorders etc..

**REFERENCE DATA:** Detailing vital parameters for Diodes, Small-Signal Transistors, Power Transistors, Thyristors, Triacs and Field Effect Transistors. Supplements include Operational Amplifiers, Logic Circuits, Optoelectronic Devices, etc.

## ELECTRONICS SERVICE MANUAL

**Basic Work:** Contains around 900 pages of information. Edited by Mike Tooley BA

**Regular Supplements:** Approximately 160-page Supplements of additional information which, if requested, are forwarded to you immediately on publication (four times a year). These are billed separately and can be discontinued at any time.

**Presentation:** Durable looseleaf system in large A4 format

**Price of the Basic Work:** ~~£39.95~~ **SALE PRICE £23.97** (to include a recent Supplement **FREE**)

## The essential work for servicing and repairing electronic equipment

- Around 900 pages
- Fundamental principles
- Troubleshooting techniques
- Servicing techniques
- Choosing and using test equipment
- Reference data
- Easy-to-use format
- Clear and simple layout
- Vital safety precautions
- Professionally written
- Regular Supplements
- Sturdy gold blocked ring-binder

## ORDER BOTH MANUALS TOGETHER AND SAVE ANOTHER £8

*A mass of well-organised and clearly explained information is brought to you by expert editorial teams whose combined experience ensures the widest coverage*  
*Regular Supplements to these unique publications, each around 160 pages, keep you abreast of the latest technology and techniques if required*

### REGULAR SUPPLEMENTS

Unlike a book or encyclopedia, these Manuals are living works – continuously extended with new material. If requested, Supplements are sent to you approximately every three months. Each Supplement contains around 160 pages – all for only £23.50+£2.50 p&p. You can, of course, return any Supplement (within ten days) which

you feel is superfluous to your needs. You can also purchase a range of past Supplements to extend your Base Manual on subjects of particular interest to you.

### RESPONDING TO YOUR NEEDS

We are able to provide you with the most important and popular, up to date, features in our

Supplements. Our unique system is augmented by readers' requests for new information. Through this service you are able to let us know exactly what information you require in your Manuals.

You can also contact the editors directly in writing if you have a specific technical request or query relating to the Manuals.

**PLEASE** send me

THE MODERN ELECTRONICS MANUAL plus a **FREE SUPPLEMENT**

ELECTRONICS SERVICE MANUAL plus a **FREE SUPPLEMENT**

I enclose payment of £23.97 (for one Manual) or £39.94 for both Manuals (saving another £8 by ordering both together) plus postage if applicable.

I also require the appropriate Supplements four times a year. These are billed separately and can be discontinued at any time. (Please delete if not required.)

Should I decide not to keep the Manual/s I will return it/them to you within 30 days for a full refund.

FULL NAME .....  
(PLEASE PRINT)

ADDRESS .....

.....POSTCODE .....

SIGNATURE .....

I enclose cheque/PO payable to Wimborne Publishing Ltd.

Please charge my Visa/Mastercard

Card No. .... Card Exp. Date .....

### ORDER FORM

Simply complete and return the order form with your payment to the following address:

Wimborne Publishing Ltd, Dept. Y8, Allen House,  
East Borough, Wimborne, Dorset BH21 1PF

We offer a 30 day **MONEY BACK GUARANTEE**

– if you are not happy with either Manual simply return it to us in good condition within 30 days for a full refund.

Overseas buyers do have to pay the overseas postage – see below.

### POSTAGE CHARGES

Postal Region	Price PER MANUAL	
	Surface	Air
Mainland UK	FREE	–
Scottish Highlands, UK Islands & Eire	£5.50 each	–
Europe (EU)	–	£20 each
Europe (Non-EU)	£20 each	£26 each
USA & Canada	£25 each	£33 each
Far East & Australasia	£31 each	£35 each
Rest of World	£25 each	£45 each

Please allow four working days for UK delivery.

NOTE: Surface mail can take over 10 weeks to some parts of the world. Each Manual weighs about 4kg when packed.

# INTERFACE

Robert Penfold



## FOUR-RANGE RESISTANCE METER PC INTERFACE

**T**HE *Interface* article in *EPE* February 2000 featured a 12-bit serial analogue-to-digital converter (ADC) for use with a PC printer port. This circuit is useful as the basis of various PC-based measuring devices, such as the four-range resistance meter featured here. The four ranges covered are 0 to 4.094k, 40.94k, 409.4k and 4.094M.

In normal test meter terms a resolution of 12-bits is quite respectable at something between 3.5 and 4-digit operation. On-screen buttons are used to select the desired range, and the resistance meter interface is controlled from the printer port via electronic switches. It would presumably be possible to implement automatic ranging in the software, but the current software does not include this feature. This would be an interesting line for experimenters to pursue.

### A/D Circuit

The circuit for the analogue-to-digital converter appears in Fig.1, and this is much the same as the original design. One important change is that the supply potential for the converter is reduced from 5V to a little under 4V by IC1, which operates as a simple voltage follower driven from a potential divider (R1 and R2).

The full-scale input voltage of the converter is equal to the supply potential, which makes it awkward to realise the full resolution of the converter. Either the circuit driving the converter must be powered from a supply potential of more than 5V or the supply to the converter must be reduced slightly. Reducing the converter's supply voltage is the easier option. The supply potential is still well above the 2.7V minimum requirement of the AD7896AN converter IC2, and is also high enough to give reliable interfacing to the printer port.

### Resistance to Voltage

For the converter to operate as a resistance meter it must be preceded by a suitable resistance-to-voltage converter. This form of conversion is easily achieved, and it is just a matter of feeding the test resistance from a constant current generator. The higher the resistance, the greater the voltage needed to force the current through the test resistor.

In order to cover a wide resistance range this interface uses four measuring ranges, and it therefore has four constant current generators, see Fig.2. These are conventional in design and are based on TR1 to TR4, which are respectively used to provide the 4.094k, 40.94k, 409.4k, and 4.094M ranges.

Preset resistors VR1 to VR4 enable their respective ranges to be calibrated against precision (1 per cent or better) resistors. Ideally these should be multi-turn trimpots. The calibration components should have values approaching the full-scale values. Suitable values are 3k9, 39k, 390k and 3M9.

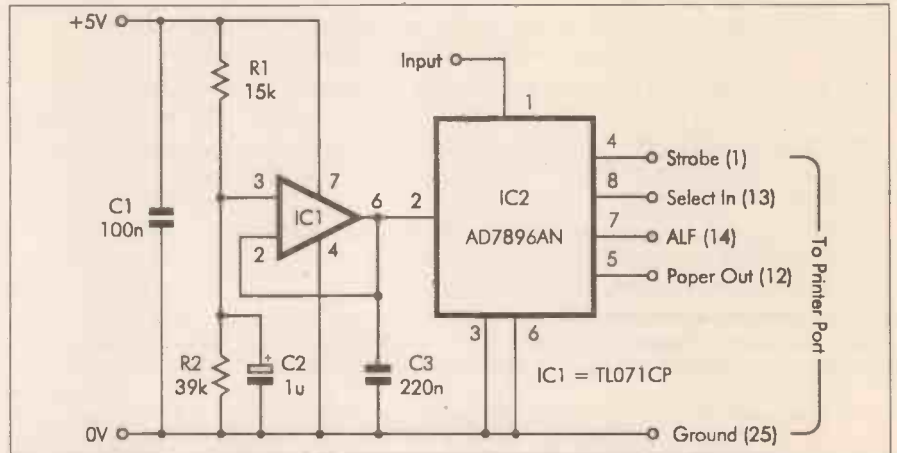

Fig.1. The circuit diagram for the A/D converter. IC1 supplies a reduced supply potential to IC2.

Resistor R4 is common to all four current generators, but in normal operation it is only connected to one of them at a time. IC3 is a CMOS quad s.p.s.t. analogue switch, but in this circuit it is connected to act as a 4-way single pole switch. R4 can be connected to any one of the current generators by taking the appropriate control input high.

The transistors in the other three generators are cut off and provide no significant output current. For example, taking pin 6 of IC3 high switches on TR3 and sets the unit to the 409.4k range. The analogue to digital converter is interfaced via some of the printer port's handshake lines, leaving the data lines free. Lines D0 to D3 are used to control the range switching.

The test component is connected across sockets SK1 and SK2. The drive current on the highest range is only about one microamp, but the high input resistance of the converter ensures that minimal loading occurs.

With 12-bit resolution noise can be something of a problem, so try to keep the circuit reasonably well away from the computer and monitor, both of which will inevitably generate a fair amount of electrical noise. Try to avoid touching the test component's leadout wires when making measurements, especially when using the highest range.

The 5V supply must be reasonably stable and noise-free. The current consumption of the circuit depends on the range in use, but it is never more than a few milliamps.

### Software

The program for the resistance interface (Listing 1) is written in Delphi 1.0 and will run under Windows 3.1, 95 or 98. It requires a form containing six command buttons, a panel and a label. The layout used for the prototype software can be seen from Fig.3, which shows the program in action, but you

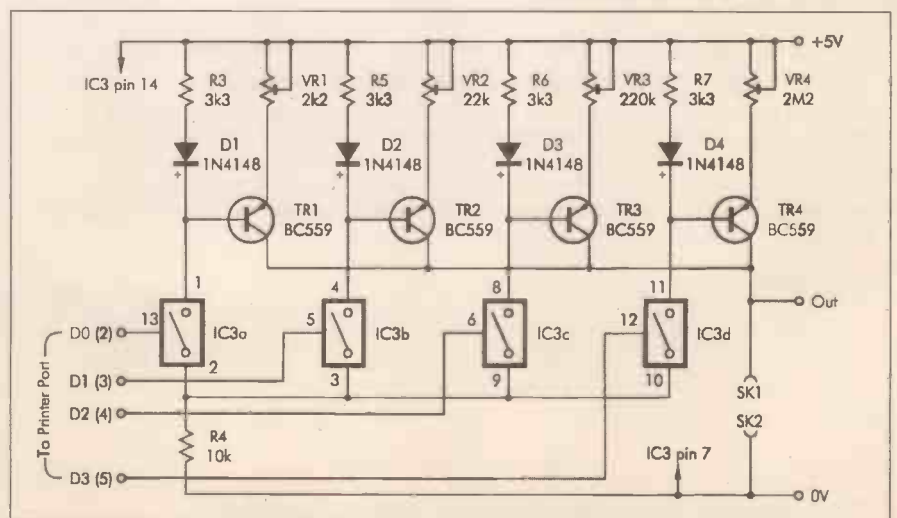

Fig.2. The resistance-to-voltage converter. There are four current generators, one for each range.



## LISTING 1

```

unit Rmet;

interface

uses
  SysUtils, WinTypes, WinProcs, Messages, Classes, Graphics,
  Controls,
  Forms, Dialogs, ExtCtrls, StdCtrls;

type
  TResMeter = class(TForm)
    Panel1: TPanel;
    Timer1: TTimer;
    Button1: TButton;
    Button2: TButton;
    Button3: TButton;
    Button4: TButton;
    Button5: TButton;
    Button6: TButton;
    Label1: TLabel;
    procedure Timer1Timer(Sender: TObject);
    procedure Button1Click(Sender: TObject);
    procedure Button2Click(Sender: TObject);
    procedure Button3Click(Sender: TObject);
    procedure Button4Click(Sender: TObject);
    procedure Button5Click(Sender: TObject);
    procedure Button6Click(Sender: TObject);
  private
    { Private declarations }
  public
    { Public declarations }
  end;

var
  ResMeter: TResMeter;
  Prn1: Word;
  Prn2: Word;
  Prn3: Word;
  Reading: Word;
  Dta: Byte;
  Busy: Byte;
  Digits: Byte;
  DecPos: Byte;
  Rding: String;
  Padding: String;

implementation

{$R *.DFM}

procedure TResMeter.Timer1Timer(Sender: TObject);
begin
  Prn1 := 888;
  Prn2 := 889;
  Prn3 := 890;
  Port[Prn3] := 1;
  Port[Prn3] := 3;
  Port[Prn3] := 1;
  Repeat
    Busy := Port[Prn2] AND 16;
  application.processmessages;
  Until Busy = 0;
  Port[Prn3] := 0;
  Port[Prn3] := 1;
  Port[Prn3] := 0;
  Port[Prn3] := 1;
  Port[Prn3] := 0;
  Port[Prn3] := 1;
  Port[Prn3] := 0;
  Port[Prn3] := 1;
  Port[Prn3] := 0;
  Port[Prn3] := 1;
  Reading := 0;
  Dta := Port[Prn2] AND 32;
  If Dta = 32 Then Reading := 2048;
  Port[Prn3] := 0;
  Port[Prn3] := 1;
  Dta := Port[Prn2] AND 32;
  If Dta = 32 Then Reading := (Reading + 1024);
  Port[Prn3] := 0;
  Port[Prn3] := 1;
  Dta := Port[Prn2] AND 32;
  If Dta = 32 Then Reading := (Reading + 512);
  Port[Prn3] := 0;
  Port[Prn3] := 1;
  Dta := Port[Prn2] AND 32;
  If Dta = 32 Then Reading := (Reading + 256);
  Port[Prn3] := 0;
  Port[Prn3] := 1;
  Dta := Port[Prn2] AND 32;
  If Dta = 32 Then Reading := (Reading + 128);
  Port[Prn3] := 0;
  Port[Prn3] := 1;
  Dta := Port[Prn2] AND 32;
  If Dta = 32 Then Reading := (Reading + 64);
  Port[Prn3] := 0;
  Port[Prn3] := 1;
  Dta := Port[Prn2] AND 32;
  If Dta = 32 Then Reading := (Reading + 32);
  Port[Prn3] := 0;
  Port[Prn3] := 1;
  Dta := Port[Prn2] AND 32;
  If Dta = 32 Then Reading := (Reading + 16);
  Port[Prn3] := 0;
  Port[Prn3] := 1;
  Dta := Port[Prn2] AND 32;
  If Dta = 32 Then Reading := (Reading + 8);
  Port[Prn3] := 0;
  Port[Prn3] := 1;
  Dta := Port[Prn2] AND 32;
  If Dta = 32 Then Reading := (Reading + 4);
  Port[Prn3] := 0;
  Port[Prn3] := 1;
  Dta := Port[Prn2] AND 32;
  If Dta = 32 Then Reading := (Reading + 2);
  Port[Prn3] := 0;
  Port[Prn3] := 1;
  Dta := Port[Prn2] AND 32;
  If Dta = 32 Then Reading := (Reading + 1);
  Str(Reading, Rding);
  Digits := Length(Rding);
  If Digits = 1 Then Padding := '000';
  If Digits = 2 Then Padding := '00';
  If Digits = 3 Then Padding := '0';
  If Digits = 4 Then Padding := '';
  Insert(Padding, Rding, 1);
  Insert('.', Rding, DecPos);
  Panel1.Caption := Rding;
  If Reading = 4095 Then Panel1.Caption := 'OVER';
end;
procedure TResMeter.Button1Click(Sender: TObject);
begin
  Timer1.Enabled := False;
end;
procedure TResMeter.Button2Click(Sender: TObject);
begin
  Timer1.Enabled := True;
end;
procedure TResMeter.Button3Click(Sender: TObject);
begin
  Port[Prn1] := 1;
  DecPos := 2;
  Label1.Caption := 'KILOHMS';
end;
procedure TResMeter.Button4Click(Sender: TObject);
begin
  Port[Prn1] := 2;
  DecPos := 3;
  Label1.Caption := 'KILOHMS';
end;
procedure TResMeter.Button5Click(Sender: TObject);
begin
  Port[Prn1] := 4;
  DecPos := 4;
  Label1.Caption := 'KILOHMS';
end;
procedure TResMeter.Button6Click(Sender: TObject);
begin
  Port[Prn1] := 8;
  DecPos := 2;
  Label1.Caption := 'MEGOHMS';
end;
end.

```



# SURVEILLANCE

## Electronic Surveillance Equipment Kits from the UK's No.1 Supplier

SUMA DESIGNS has been supplying professional quality electronic surveillance equipment kits for over 20 years. Whether your requirement is hobbyist, amateur or professional you can be sure that you are buying from a company that knows the business. We ONLY sell surveillance products, no alarms, disco lights or computer bits. All of our kits are designed for self assembly and are well tried, tested and proven. All kits are supplied complete with top grade components, fibreglass PCB, full instructions, circuit diagrams and assembly details. Unless otherwise stated all transmitter kits are tuneable and can be received using an ordinary VHF FM radio.

### UTX Ultra-miniature Room Transmitter

At less than 1/2 the size of a postage stamp the UTX is the smallest room transmitter kit in the world! Incredible 10mm x 20mm including microphone, 3-12V operation. Range up to 500m. . . . . **£13.95**

### MTX Micro-miniature Room Transmitter

Our best selling room transmitter kit. Just 17mm x 17mm including mic. Extremely sensitive. 3-12V operation. Range up to 1000m. . . . . **£14.95**

### STX High-performance Room Transmitter

High performance transmitter with buffered output for greater stability and range. Measures just 22mm x 22mm including mic. 6-12V operation. Range up to 1500m. . . . . **£16.95**

### VT500 High-power Room Transmitter

Our most powerful room transmitter with around 250mW of output power. Excellent range and penetration. Size 20mm x 40mm, 6-12V operation. Range up to 3000m. . . . . **£17.95**

### VXT Voice-activated Room Transmitter

Triggers only when sounds are detected by on-board mic. Variable trigger sensitivity and on-time with LED trigger indicator. Very low standby current. Size 20mm x 67mm, 9V operation, range up to 1000m. . . . . **£21.95**

### HVX400 Mains Powered Room Transmitter

Connects directly to 240V AC supply. Ideal for long-term monitoring. Size 30mm x 35mm, range up to 500m. . . . . **£21.95**

### SCRX Subcarrier Scrambled Room Transmitter

To increase the security of the transmission the audio is subcarrier modulated. Receiver now requires the decoder module (SCDM) connected to allow monitoring. Size 20mm x 67mm, 9V operation, up to 1000m range. . . . . **£24.95**

### SCDM Subcarrier Decoder for SCR X

Connects to earphone socket on receiver and provides decoded audio output to headphones. Size 32mm x 70mm, 9-12V operation. . . . . **£27.95**

### UTLX Ultra-miniature Telephone Transmitter

Smallest kit available. Connects onto telephone line, switches on and off automatically as phone is used. All conversations transmitted. Size 10mm x 20mm, powered from line, up to 500m range. . . . . **£13.95**

### TLX700 Micro-miniature Telephone Transmitter

Best selling kit. Performance as UTLX but easier to assemble as PCB is 20mm x 20mm. . . . . **£14.95**

### STLX High-performance Telephone Transmitter

High-performance transmitter with buffered output for greater stability and range. Connects onto telephone line and switches on and off automatically as phone is used. Both sides of conversation transmitted up to 1000m. Powered from line. Size 22mm x 22mm. . . . . **£16.95**

### PTS7 Automatic Telephone Recording Interface

Connects between telephone line (anywhere) and normal cassette recorder. Automatically switches recorder on and off as phone is used. Both sides of any conversation recorded. 9V operation, size 20mm x 67mm. . . . . **£21.95**

### CD400 Pocket Size Bug Detector/Locator

LED and piezo bleeper pulse slowly. Pulse rate and tone pitch increase as signal source is approached. Variable sensitivity allows pinpointing of signal source. 9V operation, size 45mm x 54mm. . . . . **£34.95**

### CD600 Professional Bug Detector/Locator

Multicolour bargraph LED readout of signal strength with variable rate bleeper and variable sensitivity allows pinpointing of any signal source. When found, unit is switched into AUDIO CONFIRM mode to distinguish between bugging devices and legitimate signals such as pagers, cellphones etc. Size 70mm x 100mm. 9V operation. . . . . **£59.95**

### QTX180 Crystal Controlled Room Transmitter

Narrow band FM crystal transmitter for ultimate in privacy. Output frequency 173.225 MHz. Designed for use with QRX180 receiver unit. Size 20mm x 67mm, 9V operation, range up to 1000m. . . . . **£44.95**

### QLX180 Crystal Controlled Telephone Transmitter

Specifications as per QTX180 but connects onto telephone line to allow monitoring of both sides of conversations. . . . . **£44.95**

### QSX180 Line Powered Crystal Telephone Transmitter

Connects onto telephone line, switches on and off as phone is used. Power is drawn from line. Output frequency 173.225 MHz. Designed for use with QRX180 receiver. Size 32mm x 37mm. Range up to 500m. . . . . **£39.95**

### QRX180 Crystal Controlled FM Receiver

Specifically designed for use with any of the SUMA 'O' range kits. High sensitivity design. Complex RF front end section supplied as pre-built and aligned sub-assembly so no difficult setting up. Headphone output. PCB size 60mm x 75mm, 9V operation. . . . . **£69.95**

### TKX900 Signalling/Tracking Transmitter

Transmits a continuous stream of audio beeps. Variable pitch and bleep rate. Ideal for signalling, alarm or basic tracking uses. High power output. Size 25mm x 63mm, 9-12V operation, up to 2000m range. . . . . **£23.95**

### MBX-1 Hi-Fi Micro Broadcaster

Connects to headphone socket of CD player, Walkman or Hi-Fi and broadcasts your favourite music around house and garden up to 250m. Size 27mm x 60mm, 9V operation. . . . . **£22.95**

### DLTX/RX Radio Remote Switch System

Two kits, transmitter sends a coded signal (256 selectable codes) when button pressed. Receiver detects signal, checks code and activates relay. Can be set to be momentary or toggle (on/off) operation. Range up to 100m, 9V operation on both units. TX 45mm x 45mm, RX 35mm x 90mm. . . . . **£44.95**

#### TO ORDER:

Post, fax or telephone your order direct to our sales office. Payment can be Credit card (Visa or Mastercard), Postal Order, cash (please send registered) or cheques. Kits despatched same day (cheques need clearing). All orders sent by recorded or registered post. Please add postage as follows:

ORDER UP TO £30.00: To UK £2.50 To EUROPE £5.50 All other £7.50

ORDERS OVER £30.00: To UK £3.65 To EUROPE £7.50 All others call

Overseas customers please use credit cards or send sterling cheque or bank draft.



#### SEND 2 x 1st CLASS STAMPS FOR OUR 2000 KIT CATALOGUE CONTAINING FULL DETAILS OF THESE AND OTHER KITS.

A BUILD-UP SERVICE IS AVAILABLE ON ALL OF OUR KITS, DETAILS IN CATALOGUE. VISIT OUR WEBSITE: [www.suma-designs.co.uk](http://www.suma-designs.co.uk)

Please note: Some of our part numbers are being unscrupulously used by other companies selling kits eg. MTX, VXT. DO NOT BE MISLEAD! These are NOT GENUINE SUMA KITS which are only available direct from us or our appointed distributors.

If you wish to collect kits direct from our office  
PLEASE TELEPHONE

# SUMA DESIGNS

Dept. EE, The Workshops, 95 Main Road,  
Baxterley, Warwickshire, CV9 2LE, U.K.  
Website: [www.suma-designs.co.uk](http://www.suma-designs.co.uk)

TEL/FAX: 01827 714476  
(24 HOUR ORDERLINE)  
email: [sales@suma-designs.co.uk](mailto:sales@suma-designs.co.uk)

# DIRECT BOOK SERVICE

## NEW SOFTBACK EDITION

Only **£14.99**

### THE INVENTOR OF STEREO - THE LIFE AND WORKS OF ALAN DOWER BLUMLEIN

Robert Charles Alexander

This book is the definitive study of the life and works of one of Britain's most important inventors who, due to a cruel set of circumstances, has all but been overlooked by history.

Alan Dower Blumlein led an extraordinary life in which his inventive output rate easily surpassed that of Edison, but whose early death during the darkest days of World War Two led to a shroud of secrecy which has covered his life and achievements ever since.

His 1931 Patent for a Binaural Recording System was so revolutionary that most of his contemporaries regarded it as more than 20 years ahead of its time. Even years after his death, the full magnitude of its detail had not been fully utilized. Among his 128 patents are the principal electronic circuits critical to the development of the world's first electronic television system. During his short working life, Blumlein produced patent after patent breaking entirely new ground in electronic and audio engineering.

During the Second World War, Alan Blumlein was deeply engaged in the very secret work of radar development and contributed enormously to the system eventually to become 'H2S' - blind-bombing radar. Tragically, during an experimental H2S flight in June 1942, the Halifax bomber in which Blumlein and several colleagues were flying, crashed and all aboard were killed. He was just days short of his thirty-ninth birthday.

420 pages

Order code **NE32**

**£14.99**

## EPE BOOKS



### TEACH-IN No. 7, plus FREE SOFTWARE ANALOGUE AND DIGITAL ELECTRONICS COURSE (published by *Everyday Practical Electronics*)

Alan Winstanley and Keith Dye B.Eng(Tech)AMIEE

This highly acclaimed *EPE Teach-In series*, which included the construction and use of the *Mini Lab* and *Micro Lab* test and development units, has been put together in book form. Additionally, EPT Educational Software have developed a GCSE Electronics software program to compliment the course and a **FREE DISK** covering the first two parts of the course is included with the book.

An interesting and thorough tutorial series aimed specifically at the novice or complete beginner in electronics. The series is designed to support those undertaking either GCSE Electronics or GCE Advanced Levels, and starts with fundamental principles.

If you are taking electronics or technology at school or college, this book is for you. If you just want to learn the basics of electronics or technology you must make sure you see it. *Teach-In No. 7* will be invaluable if you are considering a career in electronics or even if you are already training in one. The *Mini Lab* and software enable the construction and testing of both demonstration and development circuits. These learning aids bring electronics to life in an enjoyable and interesting way: you will both see and hear the electron in action! The *Micro Lab* microprocessor add-on system will appeal to higher level students and those developing microprocessor projects.

152 pages

Order code **TI7**

**£3.95**

The books listed have been selected by *Everyday Practical Electronics* editorial staff as being of special interest to everyone involved in electronics and computing. They are supplied by mail order to your door. Full ordering details are given on the last book page.

FOR A FURTHER SELECTION OF BOOKS SEE THE NEXT TWO ISSUES OF EPE.

Note our UK postage costs just **£1.50** no matter how many books you order!

## RADIO / TV VIDEO

### ELECTRONIC PROJECTS FOR VIDEO ENTHUSIASTS

R. A. Penfold

This book provides a number of practical designs for video accessories that will help you get the best results from your camcorder and VCR. All the projects use inexpensive components that are readily available, and they are easy to construct. Full construction details are provided, including stripboard layouts and wiring diagrams. Where appropriate, simple setting up procedures are described in detail; no test equipment is needed.

The projects covered in this book include: Four channel audio mixer, Four channel stereo mixer, Dynamic noise limiter (DNL), Automatic audio fader, Video faders, Video wipers, Video crispener, Mains power supply unit.

109 pages

Order code **BP356**

**£4.95**

### SETTING UP AN AMATEUR RADIO STATION

I. D. Poole

The aim of this book is to give guidance on the decisions which have to be made when setting up any amateur radio or short wave listening station. Often the experience which is needed is learned by one's mistakes, however, this can be expensive. To help overcome this, guidance is given on many aspects of setting up and running an efficient station. It then proceeds to the steps that need to be taken in gaining a full transmitting licence.

Topics covered include: The equipment that is needed; Setting up the shack; Which aereals to use; Methods of construction; Preparing for the licence.

An essential addition to the library of all those taking their first steps in amateur radio.

86 pages

Order code **BP300**

**£3.95**

### EXPERIMENTAL ANTENNA TOPICS

H. C. Wright

Although nearly a century has passed since Marconi's first demonstration of radio communication, there is still research and experiment to be carried out in the field of antenna design and behaviour.

The aim of the experimenter will be to make a measurement or confirm a principle, and this can be done with relatively fragile, short-life apparatus. Because of this, devices described in this book make liberal use of cardboard, cooking foil, plastic bottles, cat food tins, etc. These materials are, in general, cheap to obtain and easy worked with simple tools, encouraging the trial-and-error philosophy which leads to innovation and discovery.

Although primarily a practical book with text closely supported by diagrams, some formulae which can be used by straightforward substitution and some simple graphs have also been included.

72 pages

Order code **BP278**

**£3.50**

### 25 SIMPLE INDOOR AND WINDOW AERIALS

E. M. Noll

Many people live in flats and apartments or other types of accommodation where outdoor aereals are prohibited, or a lack of garden space etc. prevents aereals from being erected. This does not mean you have to forgo shortwave-listening, for even a 20-foot length of wire stretched out along the skirting board of a room can produce acceptable results. However, with some additional effort and experimentation one may well be able to improve performance further.

This concise book tells the story, and shows the reader how to construct and use 25 indoor and window aereals that the author has proven to be sure performers. Much information is also given on shortwave bands, aerial directivity, time zones, dimensions etc.

50 pages

Order code **BP136**

**£1.75**

## PROJECT CONSTRUCTION

### PRACTICAL REMOTE CONTROL PROJECTS

Owen Bishop

Provides a wealth of circuits and circuit modules for use in remote control systems of all kinds; ultrasonic, infra-red, optical fibre, cable and radio. There are instructions for building fourteen novel and practical remote control projects. But this is not all, as each of these projects provides a model for building dozens of other related circuits by simply modifying parts of the design slightly to suit your own requirements. This book tells you how.

Also included are techniques for connecting a PC to a remote control system, the use of a microcontroller in remote control, as exemplified by the BASIC Stamp, and the application of ready-made type-approved 418MHz radio transmitter and receiver modules to remote control systems.

160 pages

Order code **BP413**

**£5.99**

### PRACTICAL ELECTRONIC MODEL RAILWAY PROJECTS

R. A. Penfold

The aim of this book is to provide the model railway enthusiast with a number of useful but reasonably simple projects that are easily constructed from readily available components. Stripboard layouts and wiring diagrams are provided for each project. The projects covered include: constant voltage controller; pulsed controller; pushbutton pulsed controller; pulsed controller with simulated inertia, momentum and braking; automatic signals; steam whistle sound effect; two-tone horn sound effect; automatic two-tone horn effect; automatic chuffer.

The final chapter covers the increasingly popular subject of using a computer to control a model railway layout, including circuits for computer-based controllers and signalling systems.

151 pages

Order code **BP384**

**£4.99**

### A PRACTICAL INTRODUCTION TO SURFACE MOUNT DEVICES

Bill Mooney

This book takes you from the simplest possible starting point to a high level of competence in handworking with surface mount devices (SMD's). The wider subject of SM technology is also introduced, so giving a feeling for its depth and fascination.

Subjects such as p.c.b. design, chip control, soldering techniques and specialist tools for SM are fully explained and developed as the book progresses. Some useful constructional projects are also included.

Whilst the book is mainly intended as an introduction it is also an invaluable reference book, and the browser should find it engrossing.

120 pages

Order code **BP411**

**£4.99**

### FAULT-FINDING ELECTRONIC PROJECTS

R. A. Penfold

Starting with mechanical faults such as dry joints, short-circuits etc, coverage includes linear circuits, using a meter to make voltage checks, signal tracing techniques and fault finding on logic circuits. The final chapter covers ways of testing a wide range of electronic components, such as resistors, capacitors, operational amplifiers, diodes, transistors, SCRs and triacs, with the aid of only a limited amount of test equipment.

The construction and use of a Tristate Continuity Tester, a Signal Tracer, a Logic Probe and a CMOS Tester are also included.

136 pages

Order code **BP391**

**£4.99**

### TEST EQUIPMENT CONSTRUCTION

R. A. Penfold

This book describes in detail how to construct some simple and inexpensive but extremely useful, pieces of test equipment. Stripboard layouts are provided for all designs, together with wiring diagrams where appropriate, plus notes on construction and use.

The following designs are included:-

AF Generator, Capacitance Meter, Test Bench Amplifier, AF Frequency Meter, Audio Multivoltmeter, Analogue Probe, High Resistance Voltmeter, CMOS Probe, Transistor Tester, TTL Probe. The designs are suitable for both newcomers and more experienced hobbyists.

104 pages

Order code **BP248**

**£3.99**

### HOW TO DESIGN AND MAKE YOUR OWN P.C.B.s

R. A. Penfold

Deals with the simple methods of copying printed circuit board designs from magazines and books, and covers all aspects of simple p.c.b. construction including photographic methods and designing your own p.c.b.s.

66 pages

Order code **BP121**

**£3.99**

### ELECTRONIC PROJECT BUILDING FOR BEGINNERS

R. A. Penfold

This book is for complete beginners to electronic project building. It provides a complete introduction to the practical side of this fascinating hobby, including the following topics:

Component identification, and buying the right parts; Resistor colour codes, capacitor value markings, etc; Advice on buying the right tools for the job; Soldering, with advice on how to produce good joints and avoid "dry" joints; Making easy work of the hard wiring; Construction methods, including stripboard, custom printed circuit boards, plain matrix board, surface mount boards and wire-wrapping; Finishing off, and adding panel labels; Getting "problem" projects to work, including simple methods of fault-finding; In fact everything you need to know in order to get started in this absorbing and creative hobby.

135 pages

Order code **BP392**

**£4.95**

# TWO EXCITING BOOKS

Specially imported by *EPE*

## Bebop To The Boolean Boogie

By Clive (call me Max) Maxfield  
ORDER CODE BEB1 £24.95

An Unconventional Guide to Electronics Fundamentals, Components and Processes

The Foreword by Pete Waddell, Editor, *Printed Circuit Design* reads:

"Personally, I think that the title of this tome alone (hmmm, a movie?) should provide some input as to what you can expect. But, for those who require a bit more: be forewarned, dear reader, you will probably learn far more than you could hope to expect from *Bebop to the Boolean Boogie*, just because of the unique approach Max has to technical material. The author will guide you from the basics through a minefield of potentially boring theoretical mish-mash, to a Nirvana of understanding. You will not suffer that fate familiar to every reader: re-reading paragraphs over and over wondering what in the world the author was trying to say. For a limey, Max shoots amazingly well and from the hip, but in a way that will keep you interested and amused. If you are not vigilant, you may not only learn something, but you may even enjoy the process. The only further advice I can give is to 'expect the unexpected.'"

This book gives the "big picture" of digital electronics. This indepth, highly readable, up-to-the-minute guide shows you how electronic devices work and how they're made. You'll discover how transistors operate, how printed circuit boards are fabricated, and what the innards of memory ICs look

like. You'll also gain a working knowledge of Boolean Algebra and Karnaugh Maps, and understand what Reed-Muller logic is and how it's used. And there's much, MUCH more (including a recipe for a truly great seafood gumbo!).

Hundreds of carefully drawn illustrations clearly show the important points of each topic. The author's tongue-in-cheek British humor makes it a delight to read, but this is a REAL technical book, extremely detailed and accurate. A great reference for your own shelf, and also an ideal gift for a friend or family member who wants to understand what it is you do all day. . . .

**By importing these books ourselves we have managed to make them available in the UK at an exceptional price.**

## Bebop Bytes Back

By Clive "Max" Maxfield and Alvin Brown

ORDER CODE BEB2 £29.95

An Unconventional Guide To Computers Plus FREE CD-ROM which includes: Fully Functional Internet-Ready Virtual Computer with Interactive Labs The Foreword by Lee Felsenstein reads:

"1. The more time you spend with this book and its accompanying CD-ROM, the more you'll get out of it. Skimming through it won't take you where you want to go. Paying serious attention, on the other hand, will teach you more about computers than you can imagine. (You might also see a few beautiful sunrises.)

2. The labs work on two levels: on and under the surface. When you're performing the labs you'll need to look for patterns that build up from individual events.

3. When you're done, you won't look any different. You won't get a trophy or a certificate to hang on your wall. You'll have some knowledge, and some skill, and you'll be ready to find more knowledge and develop more skill. Much of this will be recognisable only to someone who has the same knowledge and skill."

This follow-on to *Bebop to the Boolean Boogie* is a multimedia extravaganza of information about how computers work. It picks up where "Bebop 1" left off, guiding you through the fascinating world of computer design . . . and you'll have a few chuckles, if not belly laughs, along the way. In addition to over 200 megabytes of mega-cool multimedia, the accompanying CD-ROM (for Windows 95 machines only) contains a virtual microcomputer, simulating the motherboard and standard computer peripherals in an extremely realistic manner. In addition to a wealth of technical information, myriad nuggets of trivia, and hundreds of carefully drawn illustrations, the book contains a set of lab experiments for the virtual microcomputer that let you recreate the experiences of early computer pioneers.

**If you're the slightest bit interested in the inner workings of computers, then don't dare to miss this one!**

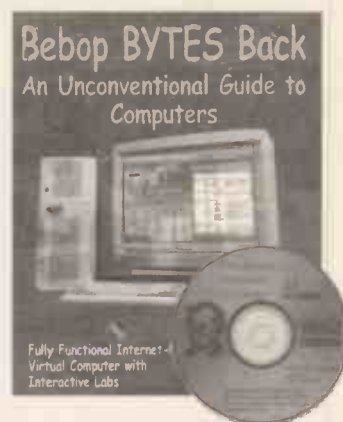
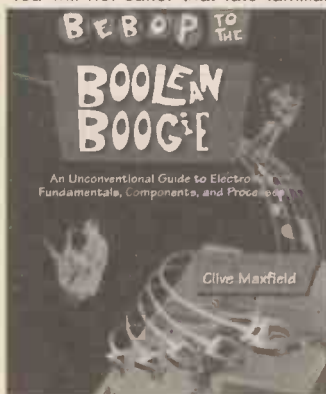

## Audio and Music

### VALVE & TRANSISTOR AUDIO AMPLIFIERS

John Linsley Hood

This is John Linsley Hood's greatest work yet, describing the milestones that have marked the development of audio amplifiers since the earliest days to the latest systems. Including classic amps with valves at their heart and exciting new designs using the latest components, this book is the complete world guide to audio amp design.

Contents: Active components; Valves or vacuum tubes; Solid-state devices; Passive components; Inductors and transformers; Capacitors, Resistors, Switches and electrical contacts; Voltage amplifier stages using valves; Valve audio amplifier layouts; Negative feedback; Valve operated power amplifiers; Solid state voltage amplifiers; Early solid-state audio amplifiers; Contemporary power amplifier designs; Preamplifiers; Power supplies (PSUs); Index.

250 pages Order code NE24 £19.99

### AUDIO AMPLIFIER PROJECTS

R. A. Penfold

A wide range of useful audio amplifier projects, each project features a circuit diagram, an explanation of the circuit operation and a stripboard layout diagram. All constructional details are provided along with a shopping list of components, and none of the designs requires the use of any test equipment in order to set up properly. All the projects are designed for straightforward assembly on simple circuit boards.

Circuits include: High Impedance mic preamp, Low impedance mic preamp, Crystal mic preamp, Guitar and GP preamplifier, Scratch and rumble filter, RIAA

preamplifier, Tape preamplifier, Audio limiter, Bass and treble tone controls, Loudness filter, Loudness control, Simple graphic equaliser, Basic audio mixer, Small (300mW) audio power amp, 6 watt audio power amp, 20/32 watt power amp and power supply, Dynamic noise limiter.

A must for audio enthusiasts with more sense than money!

116 pages Order code PC113 £9.95

### MAKING MUSIC WITH DIGITAL AUDIO

Ian Waugh

In this practical and clearly written book, Ian Waugh explains all aspects of the subject from digital audio basics to putting together a system to suit your own music requirements. Using the minimum of technical language, the book explains exactly what you need to know about: Sound and digital audio, Basic digital recording principles, Sample rates and resolutions, Consumer sound cards and dedicated digital audio cards.

On a practical level you will learn about: sample editing, digital multi-tracking, digital FX processing, Integrating MIDI and digital audio, using sample CDs, mastering to DAT and direct to CD, digital audio and Multimedia.

This book is for every musician who wants to be a part of the most important development in music since the invention of the gramophone. It's affordable, it's flexible, it's powerful and it's here now! It's digital and it's the future of music making.

256 pages Order code PC114 £14.95

## POSTAGE

You only pay

**£1.50**

per order

(UK postage)

NO MATTER HOW

MANY BOOKS

YOU ORDER

Overseas Readers see ORDERING DETAILS on the next page for overseas postage prices

# CIRCUITS AND DESIGN

## AN INTRODUCTION TO PIC MICROCONTROLLERS

Robert Penfold

Designing your own PIC based projects may seem a daunting task, but it is really not too difficult providing you have some previous experience of electronics.

The PIC processors have plenty of useful features, but they are still reasonably simple and straightforward to use. This book should contain everything you need to know.

Topics covered include: the PIC register set; numbering systems; bitwise operations and rotation; the PIC instruction set; using interrupts; using the analogue to digital converter; clock circuits; using the real time clock counter (RTCC); using subroutines; driving seven segment displays.

166 pages Order code BP394 £5.99

## PRACTICAL OSCILLATOR CIRCUITS

A. Filnd

Extensive coverage is given to circuits using capacitors and resistors to control frequency. Designs using CMOS, timer i.c.s and op.amps are all described in detail, with a special chapter on "waveform generator" i.c.s. Reliable "white" and "pink" noise generator circuits are also included.

Various circuits using inductors and capacitors are covered, with emphasis on stable low frequency generation. Some of these are amazingly simple, but are still very useful signal sources.

Crystal oscillators have their own chapter. Many of the circuits shown are readily available special i.c.s for simplicity and reliability, and offer several output frequencies. Finally, complete constructional details are given for an audio sinewave generator.

133 pages Order code BP393 £4.99

## PRACTICAL ELECTRONIC CONTROL PROJECTS

Owen Bishop

Explains electronic control theory in simple, non-mathematical terms and is illustrated by 30 practical designs suitable for the student or hobbyist to build. Shows how to use sensors as input to the control system, and how to provide output to lamps, heaters, solenoids, relays and motors.

Computer based control is explained by practical examples that can be run on a PC. For stand-alone systems, the projects use microcontrollers, such as the inexpensive and easy-to-use Stamp BASIC microcontroller.

198 pages Order code BP377 £5.99

## PRACTICAL ELECTRONICS HANDBOOK –

Fifth Edition. Ian Sinclair

Contains all of the everyday information that anyone working in electronics will need.

It provides a practical and comprehensive collection of circuits, rules of thumb and design data for professional engineers, students and enthusiasts, and therefore enough background to allow the understanding and development of a range of basic circuits.

Contents: Passive components, Active discrete components, Circuits, Linear I.C.s, Energy conversion components, Digital I.C.s, Microprocessors and microprocessor

systems, Transferring digital data, Digital-analogue conversions, Computer aids in electronics, Hardware components and practical work, Microcontrollers and PLCs, Digital broadcasting, Electronic security.

440 pages Order code NE21 £14.99

## COIL DESIGN AND CONSTRUCTIONAL MANUAL

B. B. Babani

A complete book for the home constructor on "how to make" RF, IF, audio and power coils, chokes and transformers. Practically every possible type is discussed and calculations necessary are given and explained in detail. Although this book is now twenty years old, with the exception of toroids and pulse transformers little has changed in coil design since it was written.

96 pages Order code 160 £3.99

## OPTOELECTRONICS CIRCUITS MANUAL

R. M. Marston

A useful single-volume guide to the optoelectronics device user, specifically aimed at the practical design engineer, technician, and the experimenter, as well as the electronics student and amateur. It deals with the subject in an easy-to-read, down-to-earth, and non-mathematical yet comprehensive manner, explaining the basic principles and characteristics of the best known devices, and presenting the reader with many practical applications and over 200 circuits. Most of the i.c.s and other devices used are inexpensive and readily available types, with universally recognised type numbers.

182 pages Order code NE14 £14.99

# AUDIO AND MUSIC

## INTRODUCTION TO DIGITAL AUDIO

(Second Edition)

Ian Sinclair

The compact disc (CD) was the first device to bring digital audio methods into the home.

This development has involved methods and circuits that are totally alien to the technician or keen amateur who has previously worked with audio circuits. The principles and practices of digital audio owe little or nothing to the traditional linear circuits of the past, and are much more comprehensive to today's computer engineer than the older generation of audio engineers.

This book is intended to bridge the gap of understanding for the technician and enthusiast. The principles and methods are explained, but the mathematical background and theory is avoided, other than to state the end product.

128 pages Order code PC102 £7.95

## PROJECTS FOR THE ELECTRIC GUITAR

J. Chatwin

This book is for anyone interested in the electric guitar. It explains how the electronic functions of the instrument work together, and includes information on the

## OPERATIONAL AMPLIFIER USER'S HANDBOOK

R. A. Penfold

The first part of this book covers standard operational amplifier based "building blocks" (integrator, precision rectifier, function generator, amplifiers, etc), and considers the ways in which modern devices can be used to give superior performance in each one. The second part describes a number of practical circuits that exploit modern operational amplifiers, such as high slew-rate, ultra low noise, and low input offset devices. The projects include: Low noise tape preamplifier, low noise RIAA preamplifier, audio power amplifiers, d.c. power controllers, opto-isolator audio link, audio millivolt meter, temperature monitor, low distortion audio signal generator, simple video fader, and many more.

120 pages Order code BP335 £4.95

## A BEGINNERS GUIDE TO CMOS DIGITAL ICs

R. A. Penfold

Getting started with logic circuits can be difficult, since many of the fundamental concepts of digital design tend to seem rather abstract, and remote from obviously useful applications. This book covers the basic theory of digital electronics and the use of CMOS integrated circuits, but does not lose sight of the fact that digital electronics has numerous "real world" applications.

The topics covered in this book include: the basic concepts of logic circuits; the functions of gates, inverters and other logic "building blocks"; CMOS logic i.c. characteristics, and their advantages in practical circuit design; oscillators and monostables (timers); flip/flops, binary dividers and binary counters; decade counters and display drivers.

119 pages Order code BP333 £4.95

various pickups and transducers that can be fitted. There are complete circuit diagrams for the major types of instrument, as well as a selection of wiring modifications and pickup switching circuits. These can be used to help you create your own custom wiring.

Along with the electric guitar, sections are also included relating to acoustic instruments. The function of specialised piezoelectric pickups is explained and there are detailed instructions on how to make your own contact and bridge transducers. The projects range from simple preamps and tone boosters, to complete active controls and equaliser units.

92 pages Order code BP358 £4.95

## VALVE AMPLIFIERS

Second Edition. Morgan Jones

This book allows those with a limited knowledge of the field to understand both the theory and practice of valve audio amplifier design, such that they can analyse and modify circuits, and build or restore an amplifier. Design principles and construction techniques are provided so readers can devise and build from scratch, designs that actually work.

The second edition of this popular book builds on its main strength – exploring and illustrating theory with practical applications. Numerous new sections include: output transformer problems; heater regulators; phase splitter analysis; and component technology. In addition to the numerous amplifier and preamplifier circuits, three major new designs are included: a low-noise single-ended LP stage, and a pair of high voltage amplifiers for driving electrostatic transducers directly – one for headphones, one for loudspeakers.

102 pages Order code NE33 £24.99

## PRACTICAL ELECTRONIC MUSICAL EFFECTS UNITS

R. A. Penfold

This book provides practical circuits for a number of electronic musical effects units. All can be built at relatively low cost, and use standard, readily available components. The projects covered include: Waa-Waa Units; Distortion Units; Phaser; Guitar Envelope Shaper; Compressor; Tremolo Unit; Metal Effects Unit; Bass and Treble Boosters; Graphic Equaliser; Parametric Equaliser. The projects cover a range of complexities, but most are well within the capabilities of the average electronics hobbyist. None of them require the use of test equipment and several are suitable for near beginners.

102 pages Order code BP368 £4.95

## LOUDSPEAKERS FOR MUSICIANS

Vivan Capel

This book contains all that a working musician needs to know about loudspeakers; the different types, how they work, the most suitable for different instruments, for cabaret work, and for vocals. It gives tips on constructing cabinets, wiring up, when and where to use wadding, and when not to, what fittings are available, finishing, how to ensure they travel well, how to connect multi-speaker arrays and much more.

Ten practical enclosure designs with plans and comments are given in the last chapter, but by the time you've read that far you should be able to design your own!

164 pages Order code BP297 £4.99

## BOOK ORDERING DETAILS

Our postage price is the same no matter how many books you order, just add £1.50 to your total order for postage and packing (overseas readers add £3 for countries in the EEC, or add £6 for all countries outside the EEC, surface mail postage) and send a PO, cheque, international money order (£ sterling only) made payable to Direct Book Service or credit card details, Visa or Mastercard – minimum credit card order is £5 – to:

**DIRECT BOOK SERVICE, ALLEN HOUSE, EAST BOROUGH, WIMBORNE, DORSET BH21 1PF**

Books are normally sent within seven days of receipt of order, but please allow 28 days for delivery (more for overseas orders). Please check price and availability (see latest issue of *Everyday Practical Electronics*) before ordering from old lists.

For a further selection of books see the next two issues of *EPE*.

**DIRECT BOOK SERVICE IS A DIVISION OF WIMBORNE PUBLISHING LTD. Tel 01202 881749**

**Fax 01202 841692. Due to the cost we cannot reply to overseas orders or queries by Fax.**

**E-mail: [dbs@epemag.wimborne.co.uk](mailto:dbs@epemag.wimborne.co.uk)**

## BOOK ORDER FORM

Full name: .....

Address: .....

.....

.....

..... Post code: ..... Telephone No: .....

Signature: .....

I enclose cheque/PO payable to DIRECT BOOK SERVICE for £ .....

Please charge my Visa/Mastercard £ ..... Card expiry date .....

Card Number .....

Please send book order codes: .....

Please continue on separate sheet of paper if necessary

# PCB SERVICE

Printed circuit boards for certain EPE constructional projects are available from the PCB Service, see list. These are fabricated in glass fibre, and are fully drilled and roller tinned. All prices include VAT and postage and packing. Add £1 per board for airmail outside of Europe. Remittances should be sent to The PCB Service, *Everyday Practical Electronics*, Allen House, East Borough, Wimborne, Dorset BH21 1PF. Tel: 01202 881749; Fax 01202 841692 (NOTE, we cannot reply to overseas orders or queries by Fax); E-mail: orders@epemag.wimborne.co.uk. Cheques should be crossed and made payable to *Everyday Practical Electronics* (Payment in £ sterling only).

NOTE: While 95% of our boards are held in stock and are dispatched within seven days of receipt of order, please allow a maximum of 28 days for delivery – overseas readers allow extra if ordered by surface mail.

Back numbers or photostats of articles are available if required – see the *Back Issues* page for details.

**Please check price and availability in the latest issue.**

Boards can only be supplied on a payment with order basis.

PROJECT TITLE	Order Code	Cost
★ EPE Time Machine	NOV'97 171	£8.34
Auto-Dim Bedlight	172	£6.63
Portable 12V PSU/Charger	173	£6.61
Safe and Sound (Security Bleeper)	DEC'97 179	£7.32
Surface Thermometer	JAN'98 174	£7.64
Disco Lights Flasher	178	£8.30
Waa-Waa Pedal (Multi-project PCB)	FEB'98 932	£3.00
★ Virtual Scope – Digital Board	176	£14.49
Analogue Board (per board)	177	£7.34
★ Water Wizard	180	£7.69
Kissometer	181	£7.67
★ EPE PIC Tutorial	MAR'98 182	£7.99
The Handy Thing (Double-Sided)	183	£6.58
Lighting-Up Reminder	184	£5.90
★ Audio System Remote Controller – PSU Main Board	185	£7.05
	186	£8.29
Simple Metal Detector (Multi-project PCB)	APR'98 932	£3.00
★ RC-Meter	188	£7.66
Security Auto-Light	MAY'98 189	£8.10
Stereo Tone Control plus 20W Stereo Amplifier		
Tone Control	190	£7.78
20W Amplifier	191	£8.58
★ Dice Lott	192	£8.05
EPE Mood Changer	JUNE'98 193	£7.75
★ AT89C2051/1051 Programmer		
Main Board	194	£8.50
Test Board	195	£8.69
★ Reaction Timer Software only		
★ PIC16x84 Toolkit	JULY'98 196	£6.96
★ Greenhouse Computer		
Control Board	197	£9.08
PSU Board	198	£8.10
Float Charger	AUG'98 199	£6.59
Lightbulb Saver	202	£3.00
Personal Stereo Amplifier (Multi-project PCB)	SEPT'98 932	£3.00
★ Greenhouse Radio Link	200	£8.32
★ PIC Altimeter	201	£8.15
Voice Processor	OCT'98 203	£7.18
★ Digiserv R/C Expander	204	£7.69
IR Remote Control – Transmitter	205	£3.00
– Receiver	206	£3.50
★ PIC Tape Measure	NOV'98 207	£6.82
Electronic Thermostat – T-Stat	208	£4.00
PhizzyB		£14.95 each
A – PCB B – CD-ROM C – Prog. Microcontroller	Bee (A)(B)(C)	
15-Way IR Remote Control		
Switch Matrix	211	£3.00
15-Way Rec/Decoder	212	£4.00
Damp Stat	DEC'98 209	£4.50
Handheld Function Generator	213	£4.00
★ Fading Christmas Lights	215	£5.16
PhizzyB I/O Board (4-section)	216	£3.95
Twinkle Twinkle Reaction Game	JAN'99 210	£7.55
★ EPE Mind PICKler	214	£6.30
PhizzyB I/O Board (4-section)	216	£3.95
Alternative Courtesy Light Controller	217	£6.72
Light Alarm	FEB'99 218	£6.78
★ Wireless Monitoring System Transmitter	219+a	£9.92
Receiver	220+a	£8.56
★ PIC MIDI Sustain Pedal Software only		
★ Wireless Monitoring System-2	MAR'99 219a/220a	See Feb'99
F.M. Trans/Rec Adaptors	221	£7.37
★ Time and Date Generator	222	£6.36
Auto Cupboard Light	223	£5.94
Smoke Absorber		
Ironing Board Saver	APR'99 224	£5.15
Voice Record/Playback Module	225	£5.12
Mechanical Radio (pair)	226A&B	£7.40
★ Versatile Event Counter	207	£6.82
PIC Toolkit Mk2	MAY'99 227	£8.95
A.M./F.M. Radio Remote Control		
Transmitter	228	£3.00
Receiver	229	£3.20
★ Musical Sundial	JUNE'99 231	£9.51
PC Audio Frequency Meter	232	£8.79
★ EPE Mood PICKler	JULY'98 233	£6.78
12V Battery Tester	234	£6.72
Intruder Deterrent	235	£7.10
L.E.D. Stroboscope (Multi-project PCB)	932	£3.00

PROJECT TITLE	Order Code	Cost
Ultrasonic Puncture Finder	AUG'99 236	£5.00
★ 8-Channel Analogue Data Logger	237	£8.88
Buffer Amplifier (Oscillators Pt 2)	238	£6.96
Magnetic Field Detective	239	£6.77
Sound Activated Switch	240	£6.53
Freezer Alarm (Multi-project PCB)	932	£3.00
Child Guard	SEPT'99 241	£7.51
Variable Dual Power Supply	242	£7.64
Micro Power Supply	OCT'99 243	£3.50
★ Interior Lamp Delay	244	£7.88
Mains Cable Locator (Multi-project PCB)	932	£3.00
Vibralarm	NOV'99 230	£6.93
Demister One-Shot	245	£6.78
★ Ginormous Stopwatch – Part 1	246	£7.82
★ Ginormous Stopwatch – Part 2	DEC'99 247	£7.85
Giant Display	248	£3.96
Serial Port Converter	249	£4.44
Loft Guard		
Scratch Blanker	JAN'00 250	£4.83
Flashing Snowman (Multi-project PCB)	932	£3.00
★ Video Cleaner	FEB'00 251	£5.63
Find It	252	£4.20
★ Teach-In 2000 – Part 4	253	£4.52
High Performance Regenerative Receiver	MAR'00 254, 255	} £5.49
★ EPE Icebreaker – PCB257, programmed PIC16F877 and floppy disc	256 Set	
Parking Warning System	Set Only	£22.99
★ Micro-PICscope	258	£5.08
Garage Link	APR'00 259	£4.99
Transmitter	261	} Set £5.87
Receiver	262	
Versatile Mic/Audio Pre-amplifier	MAY'00 260	£3.33
PIR Light Checker	263	£3.17
★ Multi-Channel Transmission System		
Transmitter	264	} Set £6.34
Receiver	265	
Interface	266	
★ Canute Tide Predictor	JUNE'00 267	£3.05
PIC-Gen Frequency Generator/Counter	JULY'00 268	£5.07
★ g-Meter	269	£4.36
★ EPE Moodloop	AUG'00 271	£5.47
Quiz Game Indicator	272	£4.52
Handy-Amp	273	£4.52

## EPE SOFTWARE

Software programs for EPE projects marked with an asterisk \* are available on 3.5 inch PC-compatible disks or free from our Internet site. Six disks are available: PIC Tutorial (Mar-May '98 issues); PIC Toolkit Mk2 (May-Jun '99 issues); EPE Disk 1 (Apr '95-Dec '98 issues); EPE Disk 2 (Jan-Dec '99). EPE Disk 3 (Jan '00 issue to current cover date); EPE Teach-In 2000. The disks are obtainable from the *EPE PCB Service* at £2.75 each (UK) to cover our admin costs (the software itself is free). Overseas (each): £3.35 surface mail, £4.35 each airmail. All files can be downloaded free from our Internet FTP site: <http://ftp.epemag.wimborne.co.uk>.

## EPE PRINTED CIRCUIT BOARD SERVICE

Order Code	Project	Quantity	Price
.....			
Name .....			
Address .....			
.....			
I enclose payment of £..... (cheque/PO in £ sterling only) to:			
<b>Everyday</b>		<b>Practical Electronics</b>	
<b>MasterCard or Visa No.</b>			
<b>Minimum order for credit cards £5</b>			
<input type="checkbox"/> <input type="checkbox"/> <input type="checkbox"/> <input type="checkbox"/> <input type="checkbox"/> <input type="checkbox"/> <input type="checkbox"/> <input type="checkbox"/> <input type="checkbox"/> <input type="checkbox"/> <input type="checkbox"/> <input type="checkbox"/> <input type="checkbox"/> <input type="checkbox"/> <input type="checkbox"/> <input type="checkbox"/>			
Signature.....		Card Exp. Date.....	
Please supply name and address of cardholder if different from the address shown			
NOTE: You can order p.c.b.s via our Internet site on a secure server: <a href="http://www.epemag.wimborne.co.uk">http://www.epemag.wimborne.co.uk</a>			

Everyday Practical Electronics reaches twice as many UK readers as any other UK monthly hobby electronics magazine, our audited sales figures prove it. We have been the leading independent monthly magazine in this market for the last fifteen years.

If you want your advertisements to be seen by the largest readership at the most economical price our classified and semi-display pages offer the best value. The prepaid rate for semi-display space is £8 (+VAT) per single column centimetre (minimum 2.5cm). The prepaid rate for classified adverts is 30p (+VAT) per word (minimum 12 words).

All cheques, postal orders, etc., to be made payable to Everyday Practical Electronics. **VAT must be added.** Advertisements, together with remittance, should be sent to Everyday Practical Electronics Advertisements, Mill Lodge, Mill Lane, Thorpe-le-Soken, Essex CO16 0ED. Phone/Fax (01255) 861161.

For rates and information on display and classified advertising please contact our Advertisement Manager, Peter Mew as above.

Valve Output Transformers: Single ended 50mA, £4.50; push/pull 15W, £27; 30W, £32; 50W, £38; 100W, £53. Main Transformers: Sec 220V 30mA 6V 1A, £3; 250V 60mA 6V 2A, £5; 250V 80mA 6V 2A, £6. High Voltage Caps: 50µF 350V, 68µF 500V, 150µF 385V, 330µF 400V, 470µF 385V, all £3 ea., 32+32µF 450V £5. Postage extra.  
Record Decks and Spares: BSR, Garrard, Goldring, motors, arms, wheels, headshells, spindles, etc. Send or phone your want list for quote.

**RADIO COMPONENT SPECIALISTS**

337 WHITEHORSE ROAD, CROYDON  
SURREY, CR0 2HS. Tel: (020) 8684 1665

Lots of transformers, high volt caps, valves, output transformers, speakers, in stock. Phone or send your wants list for quote.

**BEAM > ROBOTS**  
View them Online  
Also: Robot Arms  
Mobile Arms  
Micromice  
Covers  
Cybugs  
Robot Books  
www.techologydirect.com



**TIS - Midlinbank Farm  
Ryeland, Strathaven ML10 6RD**  
Manuals on anything electronic

Circuits - VCR £8, CTV £6  
Service Manuals from £10  
Repair Manuals from £5  
P&P any order £2.50

Write, or ring 01357 440280 for full details  
of our lending service and FREE quote for  
any data

**BTEC ELECTRONICS  
TECHNICIAN TRAINING**

GNVQ ADVANCED ENGINEERING  
(ELECTRONIC) - PART-TIME  
HND ELECTRONICS - FULL-TIME  
B.Eng FOUNDATION - FULL-TIME  
Next course commences  
Monday 18th September 2000  
FULL PROSPECTUS FROM

**LONDON ELECTRONICS COLLEGE**  
(Dept EPE) 20 PENYVERN ROAD  
EARLS COURT, LONDON SW5 9SU  
TEL: (020) 7373 8721

**THE BRITISH AMATEUR  
ELECTRONICS CLUB**

exists to help electronics enthusiasts by  
personal contact and through a quarterly  
Newsletter.

For membership details, write to the  
Secretary:

Mr. M. P. Moses,  
5 Park View, Cwmaman,  
Aberdare CF44 6PP

Space donated by  
Everyday Practical Electronics

**PIC On Screen Display project board**

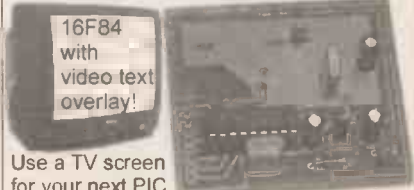

Use a TV screen  
for your next PIC  
project. Display text on any TV or monitor  
with a video input, with or without a camera.

Board no connectors £25 + £3  
Boxed with connectors £32 P&P  
**www.STV5730A.co.uk**  
The BlackBoxCamera™ Company Ltd.  
Unit U7, Lenton Boulevard,  
Nottingham NG7 2BY. 0700-2522526

**X-10® Home Automation**  
We put you in control™

**Why tolerate when you can automate?**

An extensive range of 230V X-10 products  
and starter kits available. Uses proven Power  
Line Carrier technology, no wires required.  
Products Catalogue available Online.  
Worldwide delivery.

Philips Pronto Intelligent Remote now available!

**Laser Business Systems Ltd.**

E-Mail: info@laser.com  
http://www.laser.com  
Tel: (020) 8441 9788  
Fax: (020) 8449 0430

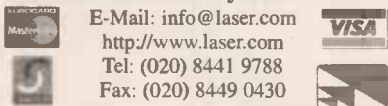

**Z88** NOW AVAILABLE WITH  
128K AND 512K - OZ4

**ALSO SPECTRUM  
AND QL PARTS**

**W. N. RICHARDSON & CO.**  
PHONE/FAX 01494 8713196  
RAVENSMEAD, CHALFONT ST PETER,  
BUCKS, SL9 0NB

**EPE NET ADDRESSES**

EPE FTP site: <ftp://ftp.epemag.wimborne.co.uk>

Access the FTP site by typing the above into your web browser, or by setting up an FTP session using appropriate FTP software, then go into quoted sub-directories:

PIC-project source code files: /pub/PICS

PIC projects each have their own folder; navigate to the correct folder and open it, then fetch all the files contained within. Do not try to download the folder itself!

EPE text files: /pub/docs

Basic Soldering Guide: solder.txt

EPE TENS Unit user advice: tens.doc and tens.txt

Ingenuity Unlimited submission guidance: ing\_unit.txt

New readers and subscribers info: epe\_info.txt

Newsletters or Usenet users advice: usenet.txt

Ni-Cad discussion: nicadfaq.zip and nicad2.zip

Writing for EPE advice: write4us.txt

On-line readers! Try the EPE Chat Zone - a virtually real-time  
Internet "discussion board" in a simple to use web-based forum!

<http://www.epemag.wimborne.co.uk/wwwboard>  
Or buy EPE Online: [www.epemag.com](http://www.epemag.com)

**Miscellaneous**

**PRINTED CIRCUIT BOARDS - QUICK SERVICE.**

Prototype and production artwork raised from magazines or draft designs at low cost. PCBs designed from schematics. Production assembly, wiring and software programming. For details contact Patrick at Agar Circuits, Unit 5, East Belfast Enterprise Park, 308 Albertbridge Road, Belfast, BT5 4GX. Phone 028 9073 8897, Fax 028 9073 1802, E-mail [agar@argonet.co.uk](mailto:agar@argonet.co.uk).

**HEAR TWEAKS' PINGS-WHISTLES.**  
Unique Receiver Design; Self-A Envelope. PO Box 694, St Helier, JE4 9PZ, Jersey CI.

**PROTOTYPE PRINTED CIRCUIT BOARDS** one offs and quantities, for details send s.a.e. to B. M. Anbro, 38 Poyning Drive, Hove, Sussex BN3 8GR, or phone Brighton 883871, fax 01273 706670.

**G.C.S.E. ELECTRONIC KITS**, at pocket money prices. S.A.E. for FREE catalogue. SIR-KIT Electronics, 52 Severn Road, Clacton, CO15 3RB.

**VALVE ENTHUSIASTS:** Capacitors and other parts in stock. For free advice/lists please ring, Geoff Davies (Radio), Tel. 01788 574774.

**FREE PROTOTYPE PRINTED CIRCUIT BOARDS!** Free prototype p.c.b. with quantity orders. Call Patrick on 028 9073 8897 for details. Agar Circuits, Unit 5, East Belfast Enterprise Park, 308 Albertbridge Road, Belfast BT5 4GX.

**FM TRANSMITTER**, very high quality, f/glass p.c.b., 2 transistor, 9V d.c. long range FET microphone, ready built and tested, £7.50; kit form, £4.50. Over 30 circuit diagrams of surveillance devices, with complete parts lists, £5. All prices inclusive. P.A.E., 65 Roseland Road, Waunarlwydd, Swansea, SA5 4ST.

**BOOK OF SURVEILLANCE CIRCUITS**, bugs, telephone, tracking etc., 30 complete circuits, with detailed component lists, some with p.c.b. foil patterns, £8.50 inclusive. 2 transistor, FM bug, f/glass p.c.b., FET mic., built and tested, £7.50 inclusive, as above in kit form, £4.50 inclusive. Payment to P.A.E., 65 Roseland Road, Waunarlwydd, Swansea, SA5 4ST. 01792 874246.

**LET'S DO IT.** Practical electronic book on CD-ROM. Ideal for hobbyist, student, apprentice and technician. A chatty book that will show you the fun and easy way to learn electronics, £10 plus £1 p&p, (£1.95 Europe, £2.95 outside). Eric Edwards, 11 Old Village Road, Barry, Vale of Glamorgan, CF62 6RA.

Ensure you set your FTP software to ASCII transfer when fetching text files, or they may be unreadable.

Note that any file which ends in .zip needs unzipping before use. Unzip utilities can be downloaded from:

<http://www.winzip.com> or  
<http://www.pkware.com>



## TRAIN TODAY FOR A BETTER FUTURE

Now you can get the skills and qualifications you need for career success with an ICS Home Study Course. Learn in the comfort of your own home at the pace and times that suit you. ICS is the world's largest, most experienced home study school. Over the past 100 years ICS have helped nearly 10 million people to improve their job prospects. Find out how we can help YOU. Post or phone today for FREE INFORMATION on the course of your choice

Electrical Contracting & Installation  
Electrical Engineering  
C&G/ICS Basic Electronic Engineering  
C&G/ICS Basic Mechanical Engineering  
TV and Video Servicing  
Radio and Hi-Fi Servicing  
Refrigeration Heating & Air Conditioning  
Motorcycle Maintenance

**FREEPHONE 0500 581 557**

Or write to: International Correspondence Schools, FREEPOST 882, 8 Elliot Place, Clydeside Skypark, Glasgow, G3 8BR. Tel: 0500 581 557 or Tel/Fax: Dublin 285 2533.

Please send me my Free Information on your Electronics Courses.

Mr/Ms/Ms/Miss  
(BLOCK CAPITALS PLEASE)

Date of Birth / /

Address

Postcode

Occupation

Tel. No.

From time to time, we permit other carefully screened organisations to write to you about products and services. If you would prefer not to hear from such organisations please tick box  Dept. ZEEE 070700

## Professional 88-108MHz FM Broadcasting Kits

### All Our Kits Include

Detailed Instructions with Schematics  
High Quality Screen Printed PCBs  
High Quality Components

### Our Product Range Includes

Transmitters from 0.05W to 35W  
FM Stereo Coders  
Audio Compressor Limiters  
Antennas  
RF Power Amps

Our Kits Are Also Available  
Fully Assembled And Tested

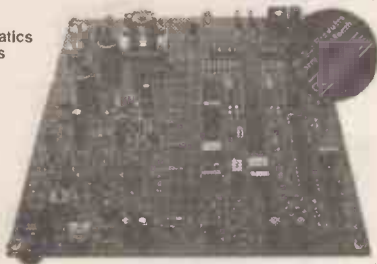

Visit our Website at <http://www.veronica.co.uk>

WE DELIVER WORLD-WIDE AND  
ACCEPT MAJOR CREDIT CARDS

Contact Us Now For A Free Brochure

Tel 01274 883434 Fax 01274 428665  
email info@veronica.co.uk

Unit 5/6 1A Sandbeds/Albert Rd Queensbury BRADFORD BD13 1AA



## VARIABLE VOLTAGE TRANSFORMERS

INPUT 220V/240V AC 50/60Hz OUTPUT 0V-260V  
PANEL MOUNTING

PANEL MOUNTING	Price	P&P
0.5KVA 2.5 amp max	£33.00	£6.00
1KVA 5 amp max	£45.25	(£45.84 inc VAT) £7.00 (£61.39 inc VAT)

SHROUDED

0.5KVA 2.5 amp max	£34.00	£6.00 (£47.00 inc VAT)
1KVA 5 amp max	£46.25	£7.00 (£62.57 inc VAT)
2KVA 10 amp max	£65.00	£8.50 (£86.36 inc VAT)
3KVA 15 amp max	£86.50	£8.50 (£111.63 inc VAT)
5KVA 25 amp max	£150.00	(+ Carriage & VAT)

Buy direct from the Importers. Keenest prices in the country.

### 500VA ISOLATION TRANSFORMER

Input lead 240V AC. Output via 3-pin 13A socket. 240V AC continuously rated. mounted in fibreglass case with handle. Internally fused. Price £35.00 carriage paid + VAT (£41.13)

### TOROIDAL L.T. TRANSFORMER

Primary 0-240V AC. Secondary 0-30V + 0-30V 600VA. Fixing bolt supplied. Price £25.00 carriage paid + VAT (£29.38)

### COMPREHENSIVE RANGE OF TRANSFORMERS-LT-ISOLATION & AUTO

110V-240V Auto transfer either cased with American socket and mains lead or open frame type. Available for immediate delivery.

### ULTRA VIOLET BLACK LIGHT BLUE FLUORESCENT TUBES

4ft. 40 watt £14.00 (callers only)	(£16.45 inc VAT)
2ft 20 watt £9.00 (callers only)	(£10.58 inc VAT)
12in 8 watt £4.80 + 75p p&p	(£5.52 inc VAT)
9in 6 watt £3.96 + 50p p&p	(£5.24 inc VAT)
6in 4 watt £3.96 + 50p p&p	(£5.24 inc VAT)

### 230V AC BALLAST KIT

For either 6in, 9in or 12in tubes £6.05+£1.40 p&p (£8.75 inc VAT)  
The above Tubes are 3500/4000 angst. (350-400nm) ideal for detecting security markings, effects lighting & Chemical applications.  
Other Wavelengths of UV TUBE available for Germicidal & Photo Sensitive applications. Please telephone your enquiries.

### 400 WATT BLACK LIGHT BLUE UV LAMP

GES Mercury Vapour lamp suitable for use with a 400W P.F. Ballast. Only £39.95 incl. p&p & VAT



### 5 KVA ISOLATION TRANSFORMER

As New, Ex-Equipment, fully shrouded, Line Noise Suppression, Ultra Isolation Transformer with terminal covers and knock-out cable entries. Primary 120V/240V, Secondary 120V/240V, 50/60Hz, 0.005PF Capacitance. Size, L 37cm x W 19cm x H 16cm, Weight 42 kilos. Price £120 + VAT. Ex-warehouse. Carriage on request.

### 24V DC SIEMENS CONTACTOR

Type 3TH8022-0B 2 x NO and 2 x NC 230V AC 10A. Contacts. Screw or Din Rail fixing. Size H 120mm x W 45mm x D 75mm. Brand New Price £7.83 incl. p&p and VAT.

### 240V AC WESTOOL SOLENOIDS

Model TT2 Max. stroke 16mm, 5lb. pull. Base mounting. Rating 1. Model TT6 Max. stroke 25mm, 15lb. pull. Base mounting. Rating 1. Series 400 Max. stroke 28mm, 15lb. pull. Front mounting. Rating 2. Prices inc. p&p & VAT: TT2 £5.88, TT6 £8.81, Series 400 £8.64.

### AXIAL COOLING FAN

230V AC 120mm square x 38mm 3 blade 10 watt Low Noise fan. Price £7.29 incl. p&p and VAT. Other voltages and sizes available from stock. Please telephone your enquiries.

### INSTRUMENT CASE

Brand new. Manufactured by Imhof. L 31cm x H 18cm x 19cm Deep. Removable front and rear panel for easy assembly of your components. Grey textured finish, complete with case feet. Price £16.45 incl. p&p and VAT 2 off £28.20 inclusive.

### DIECAST ALUMINIUM BOX

with internal PCB guides. Internal size 265mm x 165mm x 50mm deep. Price £9.93 incl. p&p & VAT. 2 off £17.80 incl.

### 230V AC SYNCHRONOUS GEARED MOTORS

Brand new Ovoid Gearbox Couzret type motors. H 65mm x W 55mm x D 35mm, 4mm dia shaft x 10mm long. 6 RPM anti cw. £9.99 incl. p&p & VAT. 20 RPM anti cw. Depth 40mm. £11.16 incl. p&p & VAT.

### 16 RPM REVERSIBLE Couzret 220V/230V

50Hz geared motor with ovoid geared box. 4mm dia. shaft. New manuf. surplus. Soid complete with reversing capacitor, connecting block and circ. Overall size: h 68mm x w 52mm x 43mm deep  
PRICE incl. P&P & VAT £9.99

### EPROM ERASURE KIT

Build your own EPROM ERASURE for a fraction of the price of a made-up unit. Kit of parts less case includes 12in, 8watt 2537, Angstrom Tube Ballast unit, pair of bi-pin leads, neon indicator, on/off switch, safety microswitch and circuit £15.00+£2.00 p&p. (£19.98 inc VAT)

### WASHING MACHINE WATER PUMP

Brand new 240V AC fan cooled. Can be used for a variety of purposes. inlet 1 1/2in outlet 1 1/2in. dia. Price includes p&p & VAT. £11.20 each or 2 for £20.50 inclusive.



## SERVICE TRADING CO

57 BRIDGMAN ROAD, CHISWICK, LONDON W4 5BB

Open Monday/Friday

Tel: 0181-995 1560

FAX: 0181-995 0549



Ample Parking Space

## COVERT VIDEO CAMERAS

Black and White Pin Hole Board Cameras with Audio. Cameras in P.I.R., Radios, Clocks, Briefcases etc. Transmitting Cameras with Receiver (Wireless). Cameras as above with colour. Audio Surveillance Kits and Ready Built Units, Bug Detector etc.

## A.L. ELECTRONICS

Please phone 0181 203 6008 for free catalogue.

Fax 0181 201 5359

E-mail: [surveillance@btclick.com](mailto:surveillance@btclick.com) [www.uspy.com](http://www.uspy.com)

New DTI approved Video Transmitters and Receivers (Wireless)

Major credit cards now taken

## N. R. BARDWELL LTD (EPE)

100	Signal Diodes 1N4148	£1.00
75	Rectifier Diodes 1N4001	£1.00
50	Rectifier Diodes 1N4007	£1.00
10	W01 Bridge Rectifiers	£1.00
10	555 Timer I.C.s	£1.00
4	741 Op Amps	£1.00
5	Assorted Zener Diodes 400mW	£1.00
12	Assorted 7-segment Displays	£1.00
25	5mm I.e.d.s, red, green or yellow	£1.00
25	3mm I.e.d.s, red, green or yellow	£1.00
50	Axial I.e.d.s, 2mcd red Diode Package	£1.00
25	Ass'dt. High Brightness I.e.d.s, var cols	£1.00
20	BC182L Transistors	£1.00
25	BC212L Transistors	£1.00
30	BC237 Transistors	£1.00
20	BC327 Transistors	£1.00
30	BC328 Transistors	£1.00
30	BC547 Transistors	£1.00
30	BC548 Transistors	£1.00
30	BC549 Transistors	£1.00
25	BC557 Transistors	£1.00
30	BC558 Transistors	£1.00
30	BC559 Transistors	£1.00
20	2N3904 Transistors	£1.00
100	1nf 50V wkg Axial Capacitors	£1.00
100	4n7 50V wkg Axial Capacitors	£1.00
12	1uf 250V encapsulated radial plastic cased capacitors	£1.00
80	Ass'dt capacitors electrolytic	£1.00
80	Ass'dt capacitors 1nF to 1µF	£1.00

200	Ass'dt. disc ceramic capacitors	£1.00
50	Ass'dt. Skel Presets (sm, stand, cermet)	£1.00
50	Ass'dt. RF chokes (inductors)	£1.00
50	Ass'dt. grommets	£1.00
80	Ass'dt. solder tags, p/conn's, terminals	£1.00
10	Ass'dt. crystals - plug in	£1.00
24	Ass'dt. coil formers	£1.00
8	Ass'dt. diode switches	£1.00
20	Miniature slide switches sp/co	£1.00
10	Standard slide switches dput	£1.00
100	Ass'dt. beads (ceramic, teflon, fish spine)	£1.00
80	Ass'dt. small stand offs, l/throughs etc	£1.00
30	Ass'dt. diode sockets up to 40 way	£1.00
10	TV coax plugs, plastic	£1.00
20	Small spring loaded terminals	£1.00
40	metres very thin connecting wire, red	£1.00
20	1in. glass reed switches	£1.00
20	Magnetic ear clips with lead and plug	£1.00
100	Any one value 1/4W 5% of resistors range 1R to 10M	£0.45
10	7812 Voltage Regulators	£1.00

Prices include VAT. Postage £1.45. 44p stamp for Lists  
288 Abbeydale Road, Sheffield S7 1FL  
Phone (0114) 2552886 Fax (0114) 2500689

E-mail sales@Bardwells.co.uk  
Web site: <http://www.bardwells.co.uk>

Get your magazine "instantly" anywhere in the world - buy from the web.

TAKE A LOOK, A FREE ISSUE IS AVAILABLE

A one year subscription (12 issues) costs just \$9.99(US)

## DIGITAL TEST METER

Built-in transistor test socket and diode test position. DC volts 200mV to 1000V. AC volts 200V to 750V. DC current 200mA to 10A. Resistance 200 ohms to 2000K ohms.

Special offer to EPE readers

**£6.99** incl. VAT

### Watch Slides on TV.

Make videos of your slides. Digitise your slides (using a video capture card) "Liesgang diatv" automatic slide viewer with built in high quality colour TV camera. It has a composite video output to a phono plug (SCART & BNC adaptors are available). They are in very good condition with few signs of use.  
£91.91 + VAT = £108.00



Board cameras all with 512 x 582 pixels 8.5mm 1/3 inch sensor and composite video out. All need to be housed in your own enclosure and have fragile exposed surface mount parts. They all require a power supply of between 10V and 12V DC 150mA.  
47MIR size 60 x 36 x 27mm with 6 infra red LEDs (gives the same illumination as a small torch but is not visible to the human eye) £37.00 + VAT = £43.48  
30MP size 32 x 32 x 14mm spy camera with a fixed focus pin hole lens for hiding behind a very small hole £35.00 + VAT = £41.13  
40MC size 39 x 38 x 27mm camera for 'C' mount lens these give a much sharper image than with the smaller lenses £32.00 + VAT = £37.60  
Economy C mount lenses all fixed focus & fixed iris  
VSL1220F 12mm F1.6 12 x 15 degrees viewing angle £15.97 + VAT £18.76  
VSL4022F 4mm F1.22 63 x 47 degrees viewing angle £17.65 + VAT £20.74  
VSL6022F 6mm F1.22 42 x 32 degrees viewing angle £19.05 + VAT £22.38  
VSL8020F 8mm F1.22 32 x 24 degrees viewing angle £19.90 + VAT £23.38

### Better quality C Mount lenses

VSL1614F 16mm F1.6 30 x 24 degrees viewing angle £26.43 + VAT £31.06  
VWL813M 8mm F1.3 with iris 56 x 42 degrees viewing angle £77.45 + VAT = £91.00  
1206 surface mount resistors E12 values 10 ohm to 1M ohm  
100 of 1 value £1.00 + VAT 1000 of 1 value £5.00 + VAT

866 battery pack originally intended to be used with an orbitel mobile telephone it contains 10 1.6Ah sub C batteries (42 x 22 dia. the size usually used in cordless screwdrivers etc.) the pack is new and unused and can be broken open quite easily  
£7.46 + VAT = £8.77



Please add £1.66 + vat = £1.95 postage & packing per order

## JPG Electronics

276-278 Chatsworth Road, Chesterfield, S40 2BH.

Tel 01246 211202 Fax 01246 550959

Mastercard/Visa/Switch

Callers welcome 9.30 a.m. to 5.30 p.m. Monday to Saturday

## SHERWOOD ELECTRONICS

### FREE COMPONENTS

Buy 10 x £1 Special Packs and choose another one FREE

SP1	15 x 5mm Red LEDs	SP131	2 x TL071 Op.Amps
SP2	12 x 5mm Green LEDs	SP133	20 x 1N4004 diodes
SP3	12 x 5mm Yellow LEDs	SP134	15 x 1N4007 diodes
SP6	15 x 3mm Red LEDs	SP135	6 x Min. slide switches
SP7	12 x 3mm Green LEDs	SP136	3 x BFY50 transistors
SP10	100 x 1N4148 diodes	SP137	4 x W005 1.5A bridge rectifiers
SP11	30 x 1N4001 diodes	SP138	20 x 2-2/63V radial elect. caps.
SP12	30 x 1N4002 diodes	SP140	3 x W04 1.5A bridge rectifiers
SP18	20 x BC182 transistors	SP142	2 x CMOS 4017
SP20	20 x BC184 transistors	SP143	5 Pairs min. crocodile clips (Red & Black)
SP21	20 x BC212 transistors	SP145	6 x ZTX300 transistors
SP23	20 x BC549 transistors	SP146	10 x 2N3704 transistors
SP24	4 x CMOS 4001	SP147	5 x Stripboard 9 strips x 25 holes
SP25	4 x 555 timers	SP151	4 x 8mm Red LEDs
SP26	4 x 741 Op.Amps	SP152	4 x 8mm Green LEDs
SP28	4 x CMOS 4011	SP153	4 x 8mm Yellow LEDs
SP29	3 x CMOS 4013	SP154	15 x BC548 transistors
SP31	4 x CMOS 4071	SP156	3 x Stripboard, 14 strips x 27 holes
SP34	20 x 1N914 diodes	SP160	10 x 2N3904 transistors
SP36	25 x 10/25V radial elect. caps.	SP161	10 x 2N3906 transistors
SP37	15 x 100/35V radial elect. caps.	SP165	2 x LF351 Op.Amps
SP39	10 x 470/16V radial elect. caps.	SP167	6 x BC107 transistors
SP40	15 x BC237 transistors	SP168	6 x BC108 transistors
SP41	20 x Mixed transistors	SP175	20 x 1/63V radial elect. caps.
SP42	200 x Mixed 0.25W C.F. resistors	SP177	10 x 1A 20mm quick blow fuses
SP47	5 x Min. PB switches	SP182	20 x 4-7/63V radial elect. caps.
SP102	20 x 8-pin DIL sockets	SP183	20 x BC547 transistors
SP103	15 x 14-pin DIL sockets	SP187	15 x BC239 transistors
SP104	15 x 16-pin DIL sockets	SP191	3 x CMOS 4023
SP105	4 x 74LS00	SP192	3 x CMOS 4066
SP109	15 x BC557 transistors	SP193	20 x BC213 transistors
SP112	4 x CMOS 4093	SP194	8 x OA90 diodes
SP114	5 x ZTX500 transistors	SP195	3 x 10mm Yellow LEDs
SP115	3 x 10mm Red LEDs	SP197	6 x 20 pin DIL sockets
SP116	3 x 10mm Green LEDs	SP198	5 x 24 pin DIL sockets
SP118	2 x CMOS 4047		
SP120	3 x 74LS93		
SP124	20 x Assorted ceramic disc caps		
SP130	100 x Mixed 0.5W C.F. resistors		

### RESISTOR PACKS - C.Film

RP3	5 each value - total 365 0.25W	£2.85
RP7	10 each value - total 730 0.25W	£4.10
RP10	1000 popular values 0.25W	£5.85
RP4	5 each value-total 365 0.5W	£3.80
RP8	10 each value-total 730 0.5W	£6.45
RP11	1000 popular values 0.5W	£8.15

2000 Catalogue now available £1 inc. P&P or FREE with first order.  
P&P £1.25 per order. NO VAT

Orders to:

**Sherwood Electronics,**  
7 Williamson St., Mansfield,  
Notts. NG19 6TD.

## Millions of quality components at lowest ever prices!

Plus anything from bankruptcy - theft recovery - frustrated orders - over productions etc.  
Send 54p stamped self-addressed label or envelope for clearance lists.

**Brian J Reed**

**6 Queensmead Avenue, East Ewell, Epsom, Surrey KT17 3EQ**

**Tel: 07775 945386 or 0208 393 9055**

**Mall Order UK only.**

Lists are updated and only 40 are sent out every 2 weeks. This normally ensures that orders can be fulfilled where only a few thousands of an item is available. (Payment is returned if sold out. I do not deal in credit notes).

## ADVERTISERS INDEX

A.L. ELECTRONICS	639
N. R. BARDWELL	639
B.K. ELECTRONICS	Cover (iii)
BRIAN J. REED	640
BULL ELECTRICAL	Cover (ii)
CHEVET SUPPLIES	619
CRICKLEWOOD ELECTRONICS	567
CROWNHILL ASSOCIATES	601
DAVID JOHNS	567
DISPLAY ELECTRONICS	562
EPT EDUCATIONAL SOFTWARE	Cover (iv)
ESR ELECTRONIC COMPONENTS	570
FOREST ELECTRONIC DEVELOPMENTS	609
ICS	639
JPG ELECTRONICS	640
LABCENTER ELECTRONICS	581
MAGENTA ELECTRONICS	568/569/597
MAPLIN ELECTRONICS	597
NATIONAL COLLEGE OF TECHNOLOGY	619
PEAK ELECTRONIC DESIGN	593
PICO TECHNOLOGY	565
QUASAR ELECTRONICS	564
SERVICE TRADING CO	639
SHERWOOD ELECTRONICS	640
SQUIRES	567
STEWART OF READING	619
SUMA DESIGNS	633
TELNET	566
VERONICA KITS	639

**ADVERTISEMENT MANAGER:** PETER J. MEW  
**ADVERTISEMENT OFFICES:**

EVERYDAY PRACTICAL ELECTRONICS, ADVERTISEMENTS,  
MILL LODGE, MILL LANE, THORPE-LE-SOKEN,  
ESSEX CO16 0ED.  
Phone/Fax: (01255) 861161

For Editorial address and phone numbers see page 571

**OMP MOS-FET POWER AMPLIFIERS**  
**HIGH POWER, TWO CHANNEL 19 INCH RACK**

1000's  
 SOLD  
 TO PRO  
 USERS

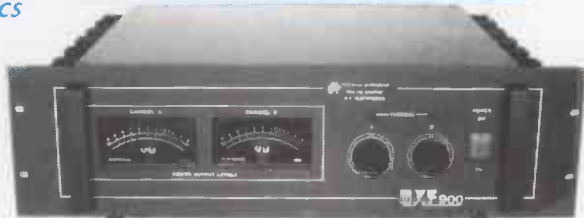

**THE RENOWNED MXF SERIES OF POWER AMPLIFIERS**

FOUR MODELS:- MXF200 ( 100W + 100W ) MXF400 (200W + 200W)  
 MXF600 (300W + 300W) MXF900 (450W + 450W)

ALL POWER RATINGS ARE R.M.S. INTO 4 OHMS, WITH BOTH CHANNELS DRIVEN  
 FEATURES: ★ Independent power supplies with two toroidal transformers ★ Twin L.E.D. Vu Meters  
 ★ Level controls ★ Illuminated on/off switch ★ Jack/XLR inputs ★ Speakon outputs ★ Standard 775mV  
 inputs ★ Open and short circuit proof ★ Latest Mos-Fets for stress free power delivery into virtually any  
 load ★ High slew rate ★ Very low distortion ★ Aluminium cases ★ MXF600 & MXF900 fan cooled with D.C.  
 loudspeaker and thermal protection.

USED THE WORLD OVER IN CLUBS, PUBS, CINEMAS, DISCOS ETC

SIZES:-  
 MXF200 W19" D11" H3½" (2U)  
 MXF400 W19" D12" H5½" (3U)  
 MXF600 W19" D13" H5½" (3U)  
 MXF900 W19" D14½" H5½" (3U)

PRICES:- MXF200 £175.00 MXF400 £233.85  
 MXF600 £329.00 MXF900 £449.15

SPECIALIST CARRIER DEL. £12.50 EACH

**OMP X03-S STEREO 3-WAY ACTIVE CROSS-OVER SWITCHABLE 2-WAY**



BASS MID TOP CONFIGURED 3 WAY  
 BASS/MID TOP 2 WAY BASS/MID COMBINED  
 BASS MID/TOP 2 WAY MID/TOP COMBINED

**FEATURES:**

Advanced 3-Way Stereo Active Cross-Over (switchable two way), housed in a 19" x 1U case. Each channel has three level controls: Bass, Mid & Top. The removable front fascia allows access to the programmable DIL switches to adjust the cross-over frequency: Bass-Mid 125/250/500Hz, Mid-Top 1.8/3.5/7Hz, all at 24dB per octave. The 2/3 way selector switches are also accessed by removing the front fascia. Each stereo channel can be configured separately. Bass Invert Switches are incorporated on each channel. Nominal 775mV input/output. Fully compatible with OMP Rack Amplifier and Modules.

PRICE:- £117.44 + £5.00 P&P

**SoundLAB SPM 12 AND 16 CH.MIXERS**

The 12 and 16 Channel SPM Series Of Studio Quality Mixers Are Ideal For Fixed Installation Stage And Mobile Use.

- ★ 48v PHANTOM POWER
- ★ BUILT IN POWER SUPPLY
- ★ 230V AC/50Hz
- ★ PEAK INPUT LEVEL LEDS
- ★ PRE FADE LISTEN (PFL)
- ★ SUB MASTER OUTPUT
- ★ COMBINED XLR/¼ JACK
- ★ 60mm FADERS ★ CH.MUTE
- ★ 2 STEREO AUX.SEND/RETURNS
- ★ CONSTANT PAN CONTROL
- ★ 3 BAND EQ WITH MID SWEEP
- ★ HEADPHONE/CONTROL ROOM O/P
- ★ CD/TAPE INPUTS & OUTPUTS
- ★ BALANCED INPUTS & OUTPUTS
- ★ BUS ASSIGN SWITCH
- ★ MONITOR SEND

PRICES:- SPM1202 4MONO MIC/LINE.4STEREO INPUTS £299.00 FREE  
 SPM1602 8MONO MIC/LINE.4STEREO INPUTS £399.00 UK P&P



**STEREO DISCO MIXER MPX-7700**

**ECHO & SOUND EFFECTS**

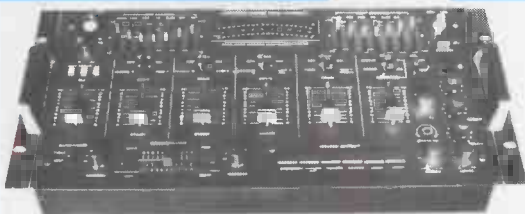

- ★ 4 STEREO INPUT CHANNELS
- ★ 2 DJ MIC INPUT CHANNELS
- ★ 2X7 BAND GRAPHIC EQUALISERS
- ★ HEADPHONE MONITOR WITH PFL
- ★ ASSIGNABLE CROSSFADE
- ★ DIGITAL ECHO

STEREO DISCO MIXER WITH:- ★2X7 GRAPHIC EQUALISERS ★2 MONO MIC INPUTS ★DJ MIC WITH FADER, TALKOVER AND VOICE CHANGER ★4 STEREO CHANNELS WITH INDIVIDUAL FADERS AND ASSIGNABLE CROSSFADE ★CHANNELS SWITCHABLE, TURNTABLE (MAG CARTRIDGE), CD, LINE, TAPE, ETC. ★ECHO WITH BALANCE, REPEAT AND DELAY ★HEADPHONE MONITOR WITH PREFADE LISTEN ★CHOICE OF 6 SOUND EFFECTS ★STEREO MONO SWITCH ★2 X LED VU METERS ★MASTER FADER ★OUTPUT 775mV  
 ★SIZE:- 482X240X115mm ★POWER:- 230V AC 50/60Hz. PRICE:- £169.00 + £5.00 P&P

**RADIO MICROPHONE CYBERWAVE FMM 1000**

- ★ IDEAL FOR:- LIVE BANDS, PUBLIC ADDRESS & KARAOKE ETC.
- ★ ON/STANDBY/OFF SWITCH MOUNTED ON MIC BARREL FOR EASE OF USE
- ★ 100 HOURS BATTERY RUNNING TIME. 1PP3 (NOT SUPPLIED)
- ★ SINGLE CHANNEL RF MICROPHONE 174.23 OR 174.56MHz
- ★ MAINS ADAPTOR FOR RECEIVER SUPPLIED ★ FM LOCK INDICATOR & VOL CONTROL ON RECEIVER. PRICE:- £119.99 FREE UK P&P



**FLIGHTCASED LOUDSPEAKERS**

A new range of quality loudspeakers, designed to take advantage of the latest loudspeaker technology and enclosure designs. All models utilize high quality studio

cast aluminium loudspeakers with factory fitted grilles, wide dispersion constant directivity horns, extruded aluminium corner protection and steel ball corners, complimented with heavy duty black covering. The enclosures are fitted as standard with top hats for optional loudspeaker stands. The FC15-300 incorporates a large 16 X 6 inch horn. All cabinets are fitted with the latest Speakon connectors for your convenience and safety. Five models to choose from.

WEDGE MONITOR



PLEASE NOTE:- POWER RATINGS QUOTED ARE IN WATTS R.M.S. FOR EACH INDIVIDUAL CABINET. ALL ENCLOSURES ARE 8 OHM.

15-15 inch speaker  
 12-12 inch speaker

- ibl FC15-300 WATTS Freq Range 35Hz-20KHz, Sens 101dB, Size H695 W502 D415mm  
 PRICE:- £299.00 per pair
- ibl FC12-300 WATTS Freq Range 45Hz-20KHz, Sens 96dB, Size H600 W405 D300mm  
 PRICE:- £249.00 per pair
- ibl FC12-200 WATTS Freq Range 40Hz-20KHz, Sens 97dB, Size H600 W405 D300mm  
 PRICE:- £199.00 per pair
- ibl FC12-100 WATTS Freq Range 45Hz-20KHz, Sens 100dB, Size H546 W380 D300mm  
 PRICE:- £179.00 per pair
- ibl WM12-200 WATTS Freq Range 40Hz-20KHz, Sens 97dB, Size H418 W600 D385mm  
 PRICE:- £125.00 EACH

SPECIALIST CARRIER DEL:- £12.50 per pair, Wedge Monitor £7.00 each  
 Optional Metal Stands PRICE:- £49.00 per pair Delivery:- £6.00

**FANE COLOSSUS POWER**  
 VERY HIGH POWER LOUDSPEAKERS

THE COLOSSUS RANGE OF LOUDSPEAKERS ARE DESIGNED FOR USE IN SUPERIOR HIGH POWER OUTPUT SYSTEMS. ALL MODELS ARE 8 OHM  
 COLOSSUS 12MB: ★ 12 INCH ★ 450WATT R.M.S.  
 ★ 900 WATTS PEAK ★ Sens 98 dB ★ Res Freq.55 Hz.  
 ★ Frequency Range 40 Hz-3.5KHz PRICE £129.00  
 COLOSSUS 15XB: ★ 15 INCH ★ 600WATTS R.M.S.  
 ★ 1200 WATTS PEAK ★ Sens 99 dB ★ Res Freq.35 Hz.  
 ★ Frequency Range 30 Hz-1.0KHz PRICE £159.00  
 COLOSSUS 18XB: ★ 18 INCH ★ 600WATTS R.M.S.  
 ★ 1200 WATTS PEAK ★ Sens 100dB ★ Res Freq.30 Hz.  
 ★ Frequency Range 27 Hz-1.0Kz PRICE £183.00  
 ALL MODELS ARE DELIVERED CARRIAGE FREE(UK ONLY)



**OMP MOS-FET POWER AMPLIFIER MODULES SUPPLIED READY BUILT AND TESTED**

These modules now enjoy a world-wide reputation for quality, reliability and performance at a realistic price. Four models are available to suit the needs of the professional and hobby market i.e. industry, leisure, instrumental and Hi-Fi etc. When comparing prices, NOTE that all models include toroidal power supply, integral heat sink, glass fibre P.C.B. and drive circuits to power a compatible VU meter. All models are open and short circuit proof.

**THOUSANDS OF MODULES PURCHASED BY PROFESSIONAL USERS**

- OMP/MF 100 Mos-Fet Output power 110 watts R.M.S. into 4 ohms, frequency response 1Hz - 100KHz -3dB, Damping Factor >300, Slew Rate 45V/uS, T.H.D. typical 0.002%, Input Sensitivity 500mV, S.N.R. -110dB. Size 300 x 123 x 60mm.  
 PRICE:- £42.85 + £4.00 P&P
- OMP/MF 200 Mos-Fet Output power 200 watts R.M.S. into 4 ohms, frequency response 1Hz - 100KHz -3dB, Damping Factor >300, Slew Rate 50V/uS, T.H.D. typical 0.001%, Input Sensitivity 500mV, S.N.R. -110dB. Size 300 x 155 x 100mm.  
 PRICE:- £66.35 + £4.00 P&P
- OMP/MF 300 Mos-Fet Output power 300 watts R.M.S. into 4 ohms, frequency response 1Hz - 100KHz -3dB, Damping Factor >300, Slew Rate 60V/uS, T.H.D. typical 0.001%, Input Sensitivity 500mV, S.N.R. -110dB. Size 330 x 175 x 100mm.  
 PRICE:- £83.75 + £5.00 P&P
- OMP/MF 450 Mos-Fet Output power 450 watts R.M.S. into 4 ohms, frequency response 1Hz - 100KHz -3dB, Damping Factor >300, Slew Rate 75V/uS, T.H.D. typical 0.001%, Input Sensitivity 500mV, S.N.R. -110dB, Fan Cooled, D.C. Loudspeaker Protection, 2 Second Anti-Thump Delay. Size 385 x 210 x 105mm.  
 PRICE:- £135.85 + £6.00 P&P
- OMP/MF 1000 Mos-Fet Output power 1000 watts R.M.S. into 2 ohms, 725 watts R.M.S. into 4 ohms, frequency response 1Hz - 100KHz -3dB, Damping Factor >300, Slew Rate 75V/uS, T.H.D. typical 0.002%, Input Sensitivity 500mV, S.N.R. -110dB, Fan Cooled, D.C. Loudspeaker Protection, 2 Second Anti-Thump Delay. Size 422 x 300 x 125mm.  
 PRICE:- £261.00 + £12.00 P&P

NOTE: MOS-FET MODULES ARE AVAILABLE IN TWO VERSIONS STANDARD - INPUT SENS 500mV, BAND WIDTH 100KHz. OR PEC (PROFESSIONAL EQUIPMENT COMPATIBLE) - INPUT SENS 775mV, BAND WIDTH 50KHz. ORDER STANDARD OR PEC

**B.K. ELECTRONICS**

UNIT 1 COMET WAY, SOUTHDOWN-SEA,  
 ESSEX, SS2 6TR.

TEL.: 01702 527572 FAX.: 01702-420243

Web:- <http://www.bkelec.com> E-mail:- [Sales@bkelec.com](mailto:Sales@bkelec.com)

# 'Electronics, Electrical and Mathematics Principles

If you are looking for an easy and enjoyable way of studying or improving your knowledge of electronics and maths then this is the software for you.

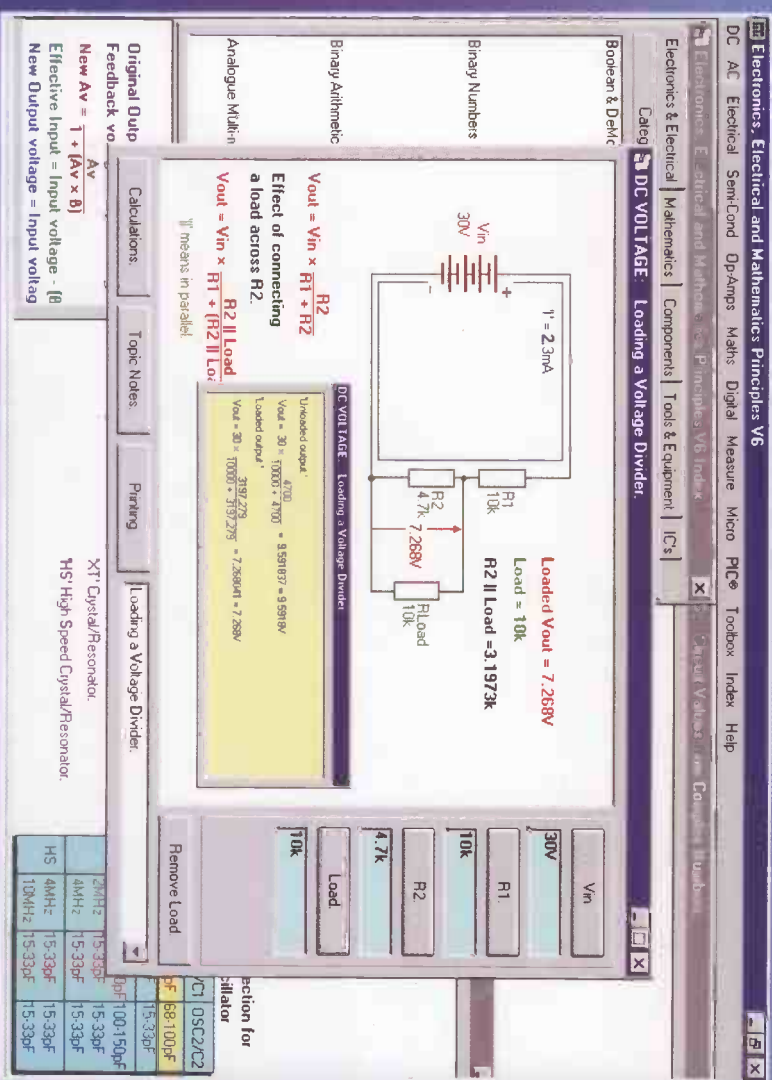

## Features.

- Analogue.
- Digital.
- Electrical.
- Microprocessors.
- PIC Microcontrollers.
- Mathematics.
- Electronics Toolbox.
- Components and Equipment Dictionary.
- Fully interactive graphics, graphs and calculations.
- Single page colour printing.
- Full Windows integration.
- Explanatory text.

**CD-ROM**  
 Students and Hobbyists the complete package for £49.95\* (\$82.17) normally £99.95\*  
 Colleges and universities including unlimited user site licence.  
 £299.95\* normally £595.95\*  
 \* +VAT if applicable  
**Postage FREE**

Hundreds of Electronics & Maths formulae with worked examples using your inputs. All calculations are shown. Default values on startup. Easy to use, no prior knowledge assumed. Comprehensive menu and indexing. Covers college courses from GCSE to university level.

Please telephone or visit our website for a list of over 900 main menu selections.

"Electronics Principles is a well thought out and comprehensive program that is also easy to install and stable in operation. It can be wholeheartedly recommended."

Robert Penfold. Everyday Practical Electronics magazine.

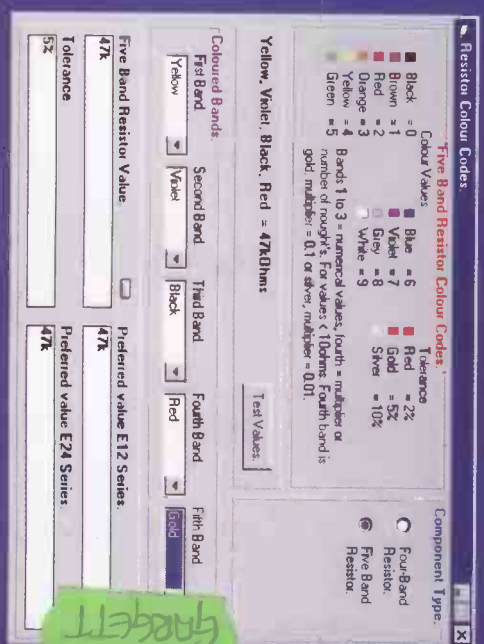

John Williams  
 GARRETT

epitsoft limited. Pump House, Lockram Lane,

Witham, Essex. UK. CM8 2BJ.

Tel: 01376 514008. Fax: 0870 0509660

info@epitsoft.com www.epitsoft.com

Switch, Delta, Visa and MasterCard payments

accepted - please give card number and expiry date.