

To be Completed in about 32 weekly parts.

NEWNES PRACTICAL ELECTRICAL ENGINEERING

IN THIS PART

ELECTRIC
GRAMOPHONE
MOTORS

HOW TO MAKE A
SMALL MOTOR OF
 $\frac{1}{8}$ H.P. OUTPUT

ELECTRICITY
SUPPLY METERS

THE DESIGN OF
APPARATUS FOR H.T.
SUPPLY UNITS

1/-

PART
22

A PRACTICAL WORK WRITTEN BY EXPERTS

STUDY
AT
HOME

YOU CAN HAVE A COLLEGE
TRAINING IN ALMOST ANY
CAREER FOR A FEW
SHILLINGS MONTHLY

IN
YOUR
SPARE
TIME

FOUNDED 1900.

32 YEARS OF SUCCESS.



THIS IS THE BENNETT COLLEGE - - ALL OF IT

The Bennett College is not a Rented Room in a well-known street—it is a College. Over 31 years ago the Founder took as his motto what has now become a household slogan:

LET ME BE YOUR FATHER

In many trades and professions there are more vacancies than trained men to fill them. We do not profess to act as an employment agency, but our gigantic organisation certainly does tell us where the demand exists, thus enabling us to give FATHERLY ADVICE ON ALL CAREERS AND THE POSSIBILITY OF EMPLOYMENT, FREE.



J.H. Bennett

WE TEACH ALL BRANCHES OF THE FOLLOWING VOCATIONS AND SPECIALISE IN ALL EXAMINATIONS CONNECTED THEREWITH.

**THE MOST SUCCESSFUL AND MOST PROGRESSIVE
CORRESPONDENCE COLLEGE IN THE WORLD**

Aviation Engineering.
Boiler Engineering.
Boiler Making.
B.Sc. (Engineering).
Civil Engineering :
A.M.I.C.E.
Quantities—Specifications.
Commercial Art

Concrete and Steel.
Draughtsmanship :
Electrical or
Mechanical.
Electrical Engineering :
A.M.I.E.E.
City and Guilds.
Engineering Mathematic.
Foundry Work.
Heat Engines.

Heating, Ventilating and
Lighting.
Internal Combustion Engines.
Machine Designs :
Theory of Machines.
Marine Engineering :
Motor.
Steam.
Mechanical Engineering :
A.M.Inst.B.E.
A.M.J.Mech.E.
City and Guilds.
Pattern Making.

Mechanics.
Metallurgy of Steel.
Mine Electrician :
A.M.E.E.
Mining (all examinations).
Motor Engineering :
A.M.I.A.E.
Municipal and County
Engineers :
M. and C.E.
Naval Architecture.
Pumps and Pumping
Machinery.
Radio Reception.
Ship Building.
Structural Engineering.
Telegraphy and Telephony.

Also ask for Our New Book
(FREE OF CHARGE)

IF YOU DO NOT SEE YOUR OWN REQUIREMENTS ABOVE, WRITE TO US ON ANY SUBJECT.
IT COSTS NOTHING TO ENQUIRE.

THE HUMAN MACHINE SECRETS OF SUCCESS

WE TEACH BY POST IN ALL PARTS OF THE WORLD

Note Address Carefully:

The BENNETT COLLEGE, Ltd., Dept. 119, Sheffield



placing the rubber washers under the motor plate to act as buffers between the plate and the wood motor board.

Fit and adjust automatic stop in accordance with instruction for Type E.D.

It is desirable to "earth" the motor by connecting a wire from the earthing tag fitted under one of the bearing cover screws.

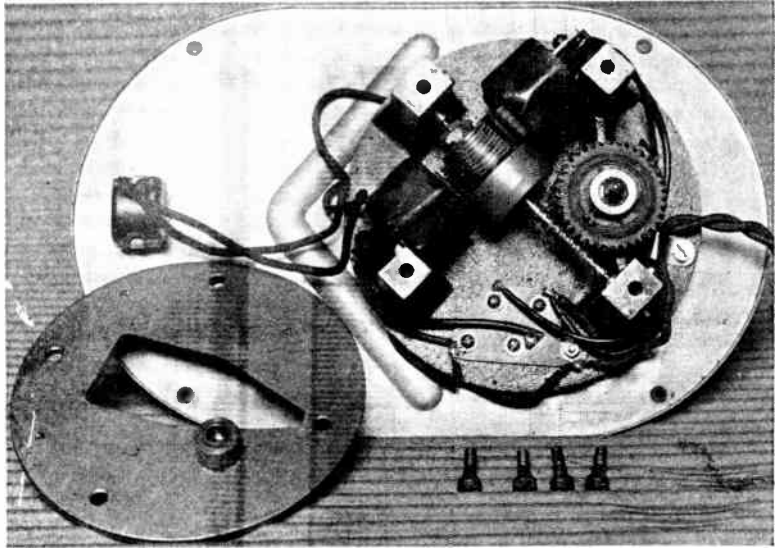

Fig. 13.—B.T.-H. SIMPLE INDUCTION MOTOR WITHOUT GOVERNOR. This motor is designed to run at one speed, namely, 78 r.p.m.

Maintenance.

Maintenance has been reduced to a minimum, the rotor bearings being lubricated by two grease cups immediately accessible on removal of turntable. With normal use the grease cups should be given a turn about once a month. The top and bottom main spindle bearings each contain a felt ring saturated in oil which keeps these important bearings lubricated. To relubricate it is only necessary to saturate the top bearing lubricating ring with oil about once a month, and the excess oil

will find its way down to replenish the bottom bearing felt ring.

The felt pads in the governor regulating brake should also be kept oiled and not allowed to become dry.

The governor is accessible by removing the name plate on the side of motor.

Taking Motor Apart for Cleaning, etc.

(1) Loosen screw A, Fig. 11.

(2) Remove the three screws B holding motor to top plate.

(3) Take out the four screws C.

(4) Very carefully remove end plate D (Fig. 12) which holds the starter windings.

(5) Carefully remove the rotor and governor, slowly rotating to unscrew the worm, taking great care not to damage or bend the spindle.

(6) Clean off any grease from the rotor E

A

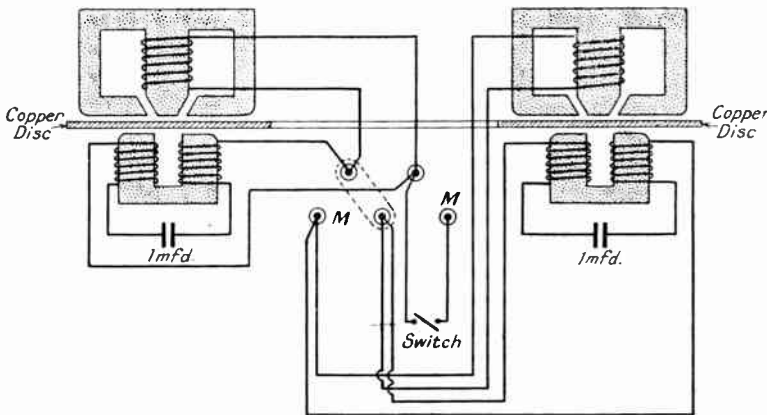

Fig. 14.—THE MAGNET SYSTEM OF THE B.T.-H. GOLDEN DISC MOTOR. Showing wiring and connections of coils. The mains are connected to the terminals M.

in Fig. 12, for the air gap is small between the rotor and stator, so that grease on the rotor may cause the motor to run slow.

(7) Remove the name plate so that when returning the rotor, the pads of the governor may be set in the correct position, in this motor double pads are used.

(8) Reassemble: taking care that the pivot F, in Fig. 12, is correctly in its bearing before fitting end plate.

The mains are connected to the centre and right legs of the auto switch, which have the screw terminal ends.

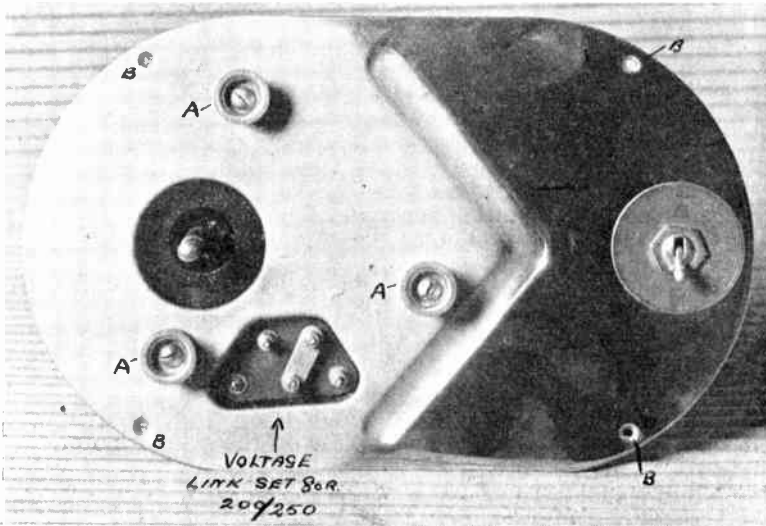

Fig. 15.—THE VOLTAGE CHANGING PLATE OF THE B.T.-H. SIMPLE INDUCTION MOTOR.

THE "B.T.H." ELECTRIC GRAMOPHONE MOTOR—TYPE "Y.G."

This gramophone motor is an induction motor for operation on 100/125 volts or 200/250 volts at 50 cycles, single phase, alternating current only.

This is the most simple electric gramophone motor produced. The armature consists of a four-pole laminated block running between two opposite pole pieces. The windings on the pole pieces are connected in parallel for 100/125 volts, and in series for 200/250 volts.

The Armature Drive.

The armature drives direct through a worm gear to the table spindle, there being no governor other than the weight

of the armature; therefore, there is no method of adjusting the speed, and the motor is designed to drive the turntable at 78 r.p.m., this being the speed at which records are now standardised.

On reference to Fig. 13, the construction of this simple system will be at once apparent. There is no automatic switch, only an "on" and "off" switch which is operated by hand; and the method of starting this motor is important.

To Start the Motor.

Place the record on the turntable with the switch in the "off" position. Spin the turntable round in a clockwise direction by placing one finger of the left hand on the middle of the non-playing part of the record. The turntable runs very easily and will quickly spin up to the playing speed.

Then turn on the switch with the right hand. Should the motor run only at half speed, the turntable has not been rotated quickly enough by hand. Switch off and start again. The motor will not start if switched on before the turntable is rotated by hand.

Instructions for Fixing the Motor.

To ensure quiet running, the motor-board should be at least $\frac{1}{2}$ in. thick and the pick-up should be fitted as far away from the motor windings as possible. Cut a hole in the motor-board sufficiently large to clear the motor, and it is important that the motor should hang freely from the metal base plate, the motor being suspended on springs.

Do not mistake the method of fixing the motor to the board, for these three

screws with the springs underneath should not be altered or used in any way; but the motor screwed down to the base board by the four small counter-sunk holes.

Lubrication.

Occasionally grease the worm wheel with vaseline, and oil the bearings of the motor and the turntable spindle with light machine oil. The laminated pole pieces are fixed to the frame by two screws.

THE "B.T.H." GOLDEN DISC ELECTRIC GRAMOPHONE MOTOR.

This motor is of the induction disc type and depends for its action upon the eddy current set up in a plain copper disc so arranged that it will rotate between the poles of two electromagnets. One of the windings is highly reactive and those of the other is as non-reactive as possible. The combination of fluxes produced by these magnets produces a travelling magnetic field. Interaction between this

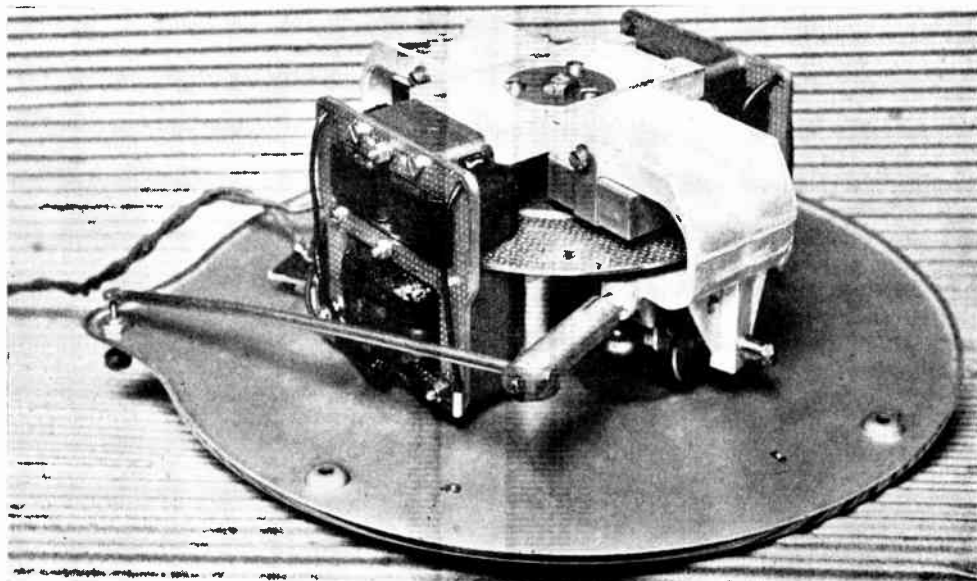

Fig. 16.—THE B.T.-H. GOLDEN DISC MOTOR.
Note the induction disc and two sets of field magnets.

If it should be necessary to remove the field coils at any time, the pole pieces are removed from the frame and the coils rewound. No trouble, however, should be experienced by a breakdown of the windings. These are well insulated and carefully wound.

The motors are despatched from the works set for 200/250 volts. Should it be necessary to alter these to 100/125 volts, simply undo the nuts holding the linking bar into position and place the two across the terminals, so that the coils are parallel (as in Fig. 15 linked for 200/250 volts).

field and the eddy current introduced produces a torque which gives the rotary motion to the disc. These magnetic pole pieces are shown in Fig. 16, and there is a similar set of coils and pole pieces on the opposite side of the motor, set at 180°. The electrical circuit on this type of motor is somewhat different from that of the ordinary motor, in so much that in series with the two lower coils is a condenser, as shown in Fig. 14. For the high voltages the coils are connected in series, but for low voltages, each set of coils is connected in parallel.

The design of the pole pieces is also

slightly different from those of an ordinary motor, as will be seen from the sketch.

The Speed Regulator.

The copper disc is attached direct to the main spindle, therefore the torque introduced into this disc is transmitted direct to the turntable. The speed regulator governor is geared by worm gearing from the main spindle, while a small rubber band drives the automatic sprocket.

How the Automatic Switch Works.

The automatic switch and stop on this motor is unique and probably one of the best designed as it operates at the end of any record, whether the record has a run-off groove or not. Immediately the tone

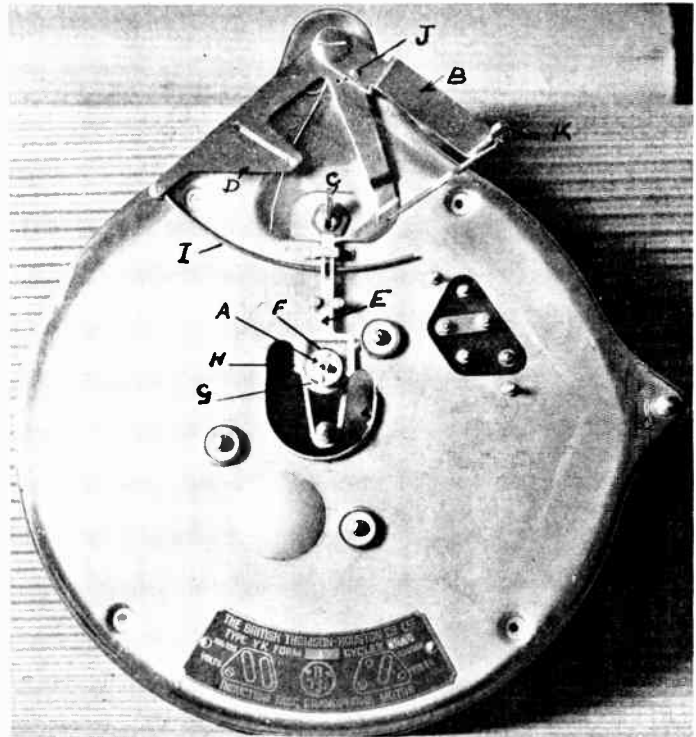

Fig. 17.—THIS SHOWS THE AUTO BREAK AND THE CAM G WHICH IS DRIVEN BY THE BELT FROM THE SPINDLE. (B.T.-H. Golden Disc Motor.)

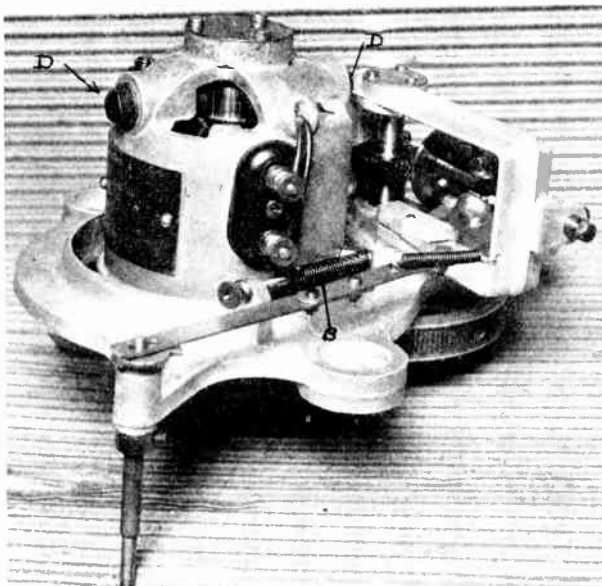

Fig. 18.—THE B.T.-H. UNIVERSAL GRAMOPHONE MOTOR. Note the spring for adjusting belt tension.

arm ceases to travel, the switch automatically knocks off. This is achieved in the following manner (see Fig. 17):—

When the lever B is swung to the right, the switch lever C is forced home by the cam D, which in turn causes the double cam slide E to travel to the bottom of its stroke. On this slide E are two cam projections, the one on the right being operated by the cam A. This cam is rotating and also carries another cam on the top, G. As this cam rotates, it knocks the lever to the right, this causes the cam G to strike the lever on the cam projection H and so knock off the switch, causing the cam E to travel upward. But this does

not happen as the tone arm is travelling, for owing to the rod l slowly travelling against the lever it is held in a left-hand position so that the cam does not hit the projection on the lever, but immediately the tone arm ceases to travel there being nothing to hold the lever in a left-hand position, the cam strikes and, therefore, knocks off the switch. Although this may appear, from the photograph, to be complicated, it is really very simple and immediately it is watched in action the principle will be readily understood.

Adjusting the Automatic Switch.

The design of this automatic switch is such that no adjustments are necessary other than setting the arm B in such a position that the pick-up carrier arm will carry the arm over the full playing space of the record. The setting of this arm is adjusted by the screw J, and the height of the arm A is adjusted by the two screws K, as it is important that the lower projection of the U-shaped arm clears the tone arm while playing. When oiling the motor, take particular care that oil does not get on to the rubber belt which drives the automatic cam. When oiling the automatic stop only a slight trace of oil is placed upon the various pivots, and all surplus oil should be wiped away.

Lubrication.

The main bearing, governor pivots and spring pads should be oiled occasionally with light machine oil, the gears smeared with vaseline, and a few drops of light

oil placed in the hole on the top of the auto-switch cam. This is best applied with a match-stick and only a few drops are required.

The voltage is changed by removing the fibre protected plate under the turntable, and the terminal links placed in a position according to the voltage required. The indication of these positions is on the name plate of the motor.

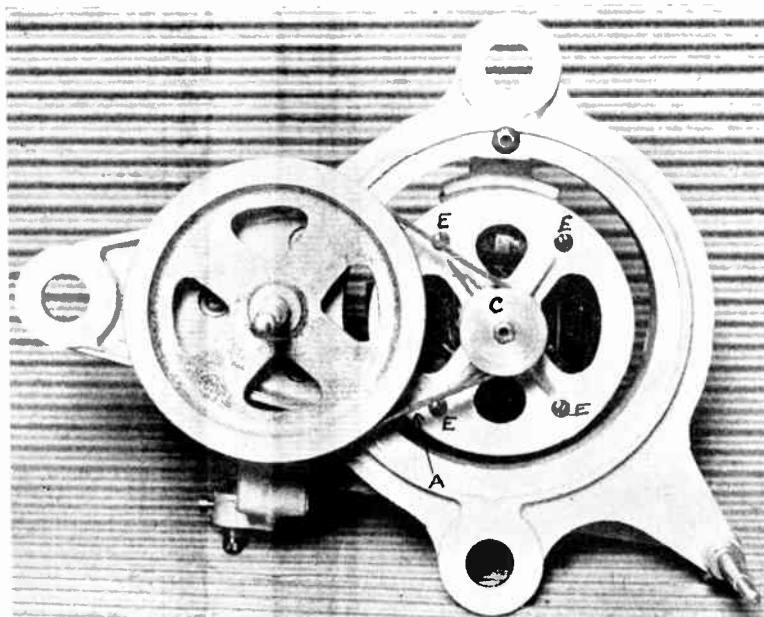

Fig. 10.— THIS SHOWS THE HEAVY CAST FRAME OF THE B.T.-H. UNIVERSAL MOTOR.

Fixing Instructions.

In fixing this motor to the baseboard, care must be taken that the position of the motor is correctly decided on as the hole necessary to clear the various parts of the motor is of peculiar shape, as will be seen from the diagram, and should a mistake be made it will be difficult to rectify the position. After having fixed the motor in position, fix the pick-up carrier arm, arranging the fork and the lever so that it is in the correct position when the pick-up is correctly tracking. It is important to remember that the pick-up arm must be in contact with the left-hand side of the lever all the time the record is playing, for, if there is any

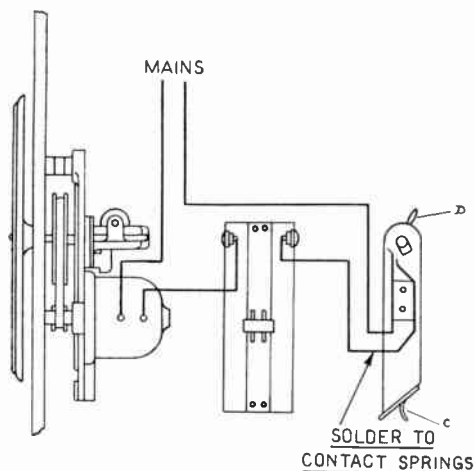

Fig. 20.—WIRING CONNECTIONS FOR B.T.H. UNIVERSAL MOTOR TYPE Y1.

space between the arm, the motor will switch off, due to the arm not travelling and preventing the automatic stop coming into action. No difficulty, however, will be found when fixing the pick-up, as there is plenty of adjustment on the arm.

THE "B.T.H." UNIVERSAL GRAMOPHONE MOTOR—TYPE Y1—FORM B.

This motor is of the commutator type and can be arranged to operate from either D.C. or A.C. current, from 25/100 cycles. A special resistance is supplied for adjusting the motor to any of the voltages, and the resistance should be fitted inside the cabinet where it cannot be tampered with or shifted. As will be seen from the photograph, this resistance has two resistance elements, and is connected in series with the motor between the top terminals, the slider short-circuiting the two resistance elements, so that the lower the slider, the more resistance in the circuit of the motor.

Resistance Settings.

On the front plate are stamped the various settings. The first column is for 50 cycles, the middle column for 100 cycles, and the third column for D.C. current. The voltages marked are appropriate, and a slight variation in the setting of the resistance will not do any harm.

In certain instances, it may be advisable, but the resistance should be adjusted so that the motor is just sufficient to carry the load imposed upon it. If, when the main spindle is held with the finger, the motor just creeps round, the setting will be correct.

Construction of the Framework.

The motor unit and framework is constructed of heavy-cast aluminium, and the reason for this robust construction is to absorb any vibration and maintain a quietly running motor, for it must be remembered that should any vibration be transmitted to the table of an electric gramophone, it will be amplified in the system, for unlike the ordinary soundbox, an electric amplifier will amplify the lowest vibration.

SERVICE TABLE FOR D.C. AND UNIVERSAL MOTORS.

SYMPTOM.	POSSIBLE CAUSE.
Motor will not revolve	Resistor unit is burnt out or sliders making bad contact. Mains supply not switched on. Switch operated by the pick-up not functioning correctly. Mechanical jam or undue friction. Insufficient or too much brush pressure on armature commutator. Dirty brushes or armature segments (clean with fine glass paper by placing a strip under brush and rotating armature. Do not forget to remove fragments of glass after cleaning).
With signs of over heating of resistor.	Break down to earth of either field or armature. Short circuit of fixed condenser. NOTE.—The purpose of this condenser is to reduce interference due to sparking between brushes and commutator.
Motor will not revolve after re-assembly.	Check up connections. Lack of lubrication.
Motor noisy mechanically.	Armature touching field coils. Loose governor spring screws or tight bearing. Bottom bearing of motor not correctly adjusted. Governor and fibre gear not "fairly" engaged.
Motor noisy electrically (i.e., causing interference on electrical reproducer).	Sparking between brushes and commutator. Intermittent disconnection, possibly in field coils or between commutator segments and armature section.
(Hum or splutter) ..	Motor frame not correctly earthed. Intermittent leak between armature windings or field windings and earth.
Motor weak	Dirty brushes. Incorrect voltage adjustment. Insufficient brush pressure. Short circuit in field coil. Lack of lubrication. Undue mechanical friction.

The main driving spindle is driven by a flat cotton belt (A) (Fig. 19), the motor being pivoted to the frame and the tension maintained on the belt by a spring (B) (Fig. 18). Do not adjust this spring other than to allow just sufficient grip, for should the tension on the belt be too great it may cause erratic running, and a slip on the belt due to voltage variation is an advantage, as it allows for the motor to slip without altering the speed of the turntable.

Lubrication.

The lower motor bearings can be oiled through the small oiler at the side of the bearing housing, but the upper bearing at the pulley end is a little more difficult. To oil this, the pulley C must be removed and the felt pad saturated with oil. The brushes are removed by unscrewing

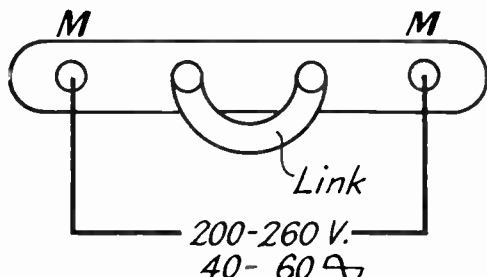

Fig. 22.—THIS SHOWS THE CONNECTIONS FOR 200-260-VOLT SUPPLY.

the insulated brush holders D, which have a hexagon head of insulated material. Should it be necessary at any time to remove the armature, the four screws E on the drive-end plate are removed, and the armature withdrawn, first removing the brushes. As in other motors, the main bearings, governor pivots and speed regulator pads should be occasionally oiled and the worm gear smeared with vaseline.

Fitting the Motor.

This motor, not being supplied with a base plate, is directly fitted to the motor board, which should be at least $\frac{3}{8}$ in. thick, as this being a heavy motor, vibration is likely to occur. Heavy plywood is to be advised. Make a template and cut a hole sufficiently large to clear the main driving

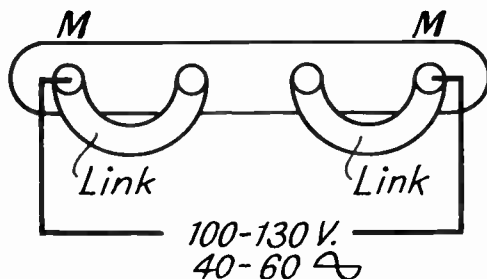

Fig. 21.—CONNECTIONS FOR SUPPLY MAINS OF MARCONIPHONE TYPE 24 D.C. MOTOR. Showing connections for 100-130 volts.

pulley and the motor pulley. This is better than cutting a hole sufficiently large for the spindle as it allows for adjusting the height of the turntable from the motor board.

Mark out and drill a hole for the speed regulator and suspend the motor by means of the rubber bushes supplied. One rubber bush is placed above the top of the motor board, three underneath, one through the casting and one under the washer and nut, as in Fig. 20. Should the turntable not be high enough from the motor board, one of the washers underneath the board may be removed, and by having a hole large enough in the board, the driving pulley will clear.

Setting the Automatic Stop and Switch.

The automatic stop and switch on this motor has to be pre-set for the switch-off at the end of the record and is not fully automatic as in the preceding motor, the lever being adjusted to suit each record. The lever C starts the motor and the lever D switches off the motor in the event

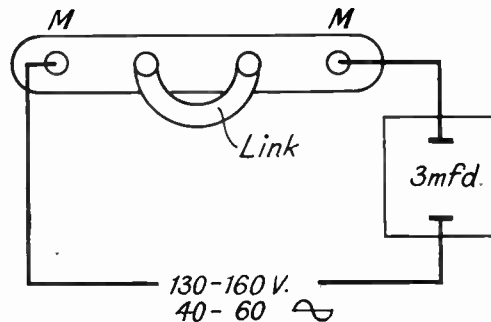

Fig. 23.—CONNECTIONS FOR 130-160 VOLTS WITH CONDENSER OF 3 MFD. PLACED IN SERIES WITH THE MAINS LEAD TO THE MOTOR ON THE MOTOR SIDE OF THE SWITCH.

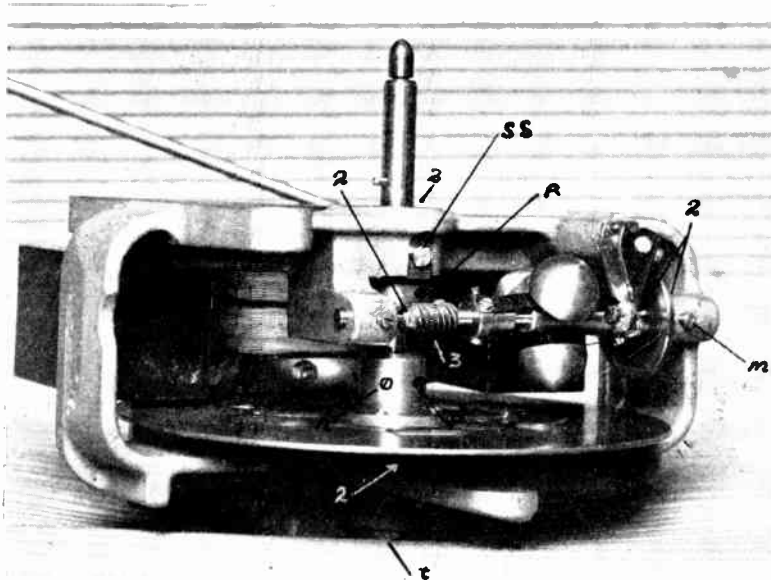

Fig. 24.—THE MARCONIPHONE INDUCTION DISC MOTOR.
Note the points which require oiling.

of the tone arm not striking the cam on the lever and releasing the switch. The automatic stop is fitted underneath the turntable, so that the levers and the rod project outside, and the position of this automatic stop is determined by the position of the pick-up carrier arm, and can only be found out when fitted to the motor.

MARCONIPHONE MOTOR, TYPE 24 FOR ALTERNATING CURRENT.

Mains Supply.

Voltage Range.—100, 130 volts, 200, 260 volts: link change-over (Fig. 23). 130/160 volts with (600-volt test) condenser of 3 microfarads placed in series with the mains lead to the motor on the motor side of the switch. Figs. 21, 22 and 23.

Frequency Range.—40, 60 cycles (periodicity).

Other Frequencies.—A special motor may be fitted for periodicities of from 75/100 cycles.

Consumption from Mains.—Approximately 25 watts.

Principles of Operation.

The induction disc type of motor depends for its action upon the eddy

currents set up in a plain copper disc, so arranged that it will rotate between the poles of two electromagnets, the windings of one being highly reactive and those of the other being as non-reactive as possible. The combination of fluxes produced by these magnets produces a travelling magnetic field. Interaction between this field and eddy currents induced in disc produces a torque which gives

rotary motion to disc spindle and turntable.

The governor is driven through worm gearing from turntable spindle.

The Magnet Unit (See Fig. 25).—Consists of:—

(A) A laminated steel core held in position by a brass clamping plate and screws *a*, *b*, *c* and *d*.

NOTE.—Screws *e* and *f*, *g* and *h* serve only to keep the core clamped together, *g* and *h* also securing the voltage change block in position.

(B) One reactive coil LR. Two non-reactive coils LN1 and LN2.

NOTE.—In all cases the inner end of the coil windings terminate in red wire, the outer windings terminating in yellow wires.

Electrical Data of Coils. (Fig. 25.)

Coil LR.—D.C. resistance (top section), 35 ohms; (bottom section) 35 ohms.

NOTE.—These values are measured as from lug 1 on C2 to voltage adjustment screw 3, and lug 1 on C1 to voltage adjustment screw 2.

Coils LN1 and LN2.—D.C. resistance, 1,100 ohms each (measured from lug 2

—C1 and screw 3 and lug 2— C2 and screw 3). To remove condensers C1 and C2 unsolder leads to lugs, slack away screws *a* and *g*, or *d* and *h*, for C1 and C2 respectively. (Fig. 25.)

Warning.—

Screws *g* and *h* must be slacked away from the back of the motor; in the case of *g*, by passing a screwdriver below the governor to the back of the magnetic unit, and in the case of *h*, by passing a screwdriver to the left of the main motor bearings from the back of the unit.

Electrical Value of Condensers. 2 mfd. each.

NOTE.—In the event of a condenser

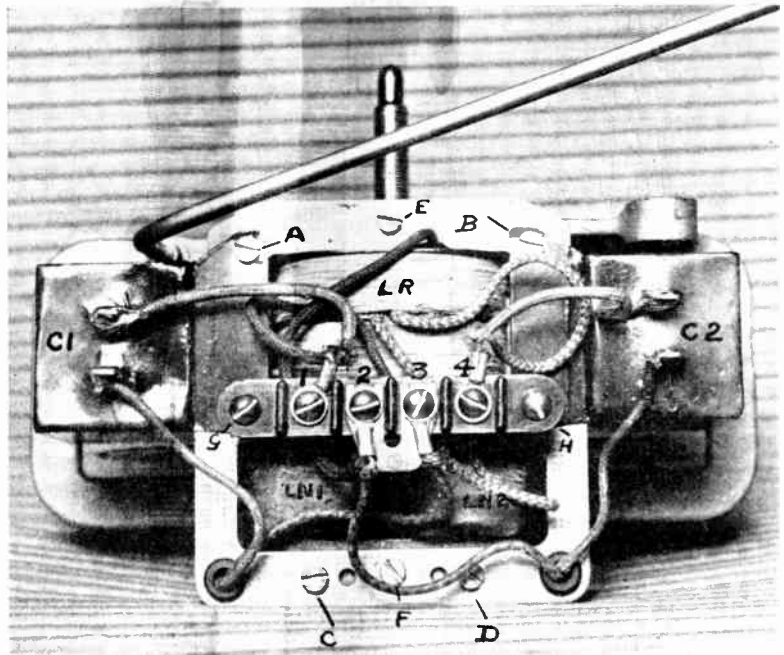

Fig. 25.—THE MARCONIPHONE INDUCTION DISC MOTOR. Note the field magnets and condensers.

breaking down, any good make of condenser, Mansbridge type, capacity 2 mfd., may be installed by screwing on the motor-board or other convenient place temporarily, while replacement condensers are being secured.

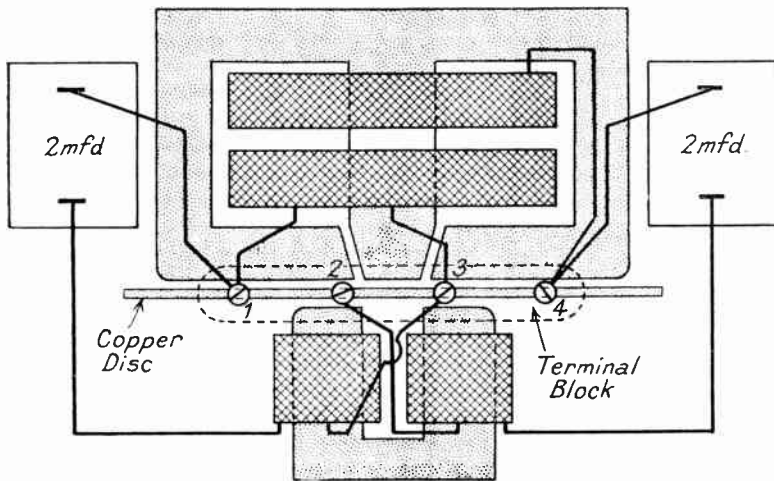

Fig. 26.—MAGNET AND COIL SYSTEM OF MARCONIPHONE TYPE 24 A.C. MOTOR. Terminal 2 is connected to the other end of the upper coil on the large magnet.

Removal of Magnet Units.

Withdraw screws *a*, *d*, *b* and *c*. Do not lose conical spacer washer between unit and motor frame. The entire magnetic and electrical units may now be withdrawn.

NOTE.—It is inadvisable to attempt to re-wind coils on this unit.

TROUBLE TRACING CHART*

SYMPTOM.	POSSIBLE CAUSES.	SUGGESTED REMEDY.
Motor will not revolve when main switch on and motor switch on.	Mechanical interference between parts of motors.	Test turntable gently by hand. If free, trouble in electrical circuit. If turntable or spindle very stiff, remove turntable, check automatic brake. If this O.K., remove motor and motor-board from instrument. Check position of driving disc in airgap between magnets; if necessary, adjust height by means of screw beneath lower bearing. Ensure that governor spindle bearings are correctly adjusted by slackening bearing set screws and adjusting pivots. Examine worm drive. Remove governor completely to test if main spindle is free in bearings.
Motor starts satisfactorily, but slows down when needle lowered on record.	<p>Motor revolves when turned by hand. Suggests failure of electricity supply.</p> <p>If supply is O.K. to motor suspect motor circuit.</p> <p>Feeble motor with increased hum.</p> <p>Voltage of supply incorrect for motor connection.</p> <p>If connections correct suspect faulty magnet coils. Check resistance.</p>	<p>Test electrical circuit to motor by voltmeter or test lamp.</p> <p>Remove motor and motor-board from instrument. Check all magnet coil circuits for continuity and for <i>insulation from frame of the motor</i>. Suspect burnt-out coil, or disconnected condenser.</p>
	<p>(85 motor only.) Break-down of one or more condensers.</p> <p>Mechanical stiffness ..</p>	<p>Check position of "series-parallel" links on motor terminal block.</p> <p>Allow motor to turn, feel coils. Shunt coils should be at the same temperature, both series coils should be at same temperature. <i>A coil hotter than others usually indicates that it is faulty. Resistance may be low.</i></p> <p>Check resistances of all coils.</p> <p>Short-circuit terminals of each condenser in turn with piece of wire, if condenser can be short-circuited without affecting motor torque, condenser may be faulty.</p> <p>If torque still further reduced, condenser probably O.K.</p> <p>Oil all bearings.</p> <p>Make sure automatic brake is completely disengaged from turntable rim when in playing position and that brake-lever collar O.K.</p> <p>Check adjustment of governor spindle and worm drive.</p> <p>Remove governor and spin turntable spindle between thumb and finger. If spindle stiff in bearings and oiling has no effect, try new spindle to determine whether original spindle or motor frame at fault. <i>See that brake lever has not slipped off speed control screw on motor platform.</i></p>
Hum	<p>Loose coil winding ..</p> <p>Loose magnet unit ..</p> <p>Loose laminations ..</p>	<p>Insert wooden wedge between outside of coil and iron laminations.</p> <p>Tighten screws securing units to frame.</p> <p>Tighten screws securing laminations to unit frames.</p>
	Insecurely fastened motor	<p>Adjust tension of these screws.</p> <p>Tighten motor securing bolts between motor and motor-board. <i>If necessary</i> insert felt washers between motor and motor-board to adjust for correct turntable height.</p>
Mechanical noise ..	Driving disc fouling magnet laminations.	Adjust height of disc by screw beneath lower main spindle bearing. <i>Ensure</i> that coil units are clamped up <i>squarely</i> to motor frame.

SYMPTOM.	POSSIBLE CAUSES.	SUGGESTED REMEDY.
Noisy motor ..	Governor springs ..	If necessary, tighten all securing screws, loose springs cause rattle. Ensure that each spring screwed up in correct relative position. This may be found by slackening all spring-securing screws slightly, then giving motor a few turns by hand. Then retighten screws.
	Excessive end play in governor spindle.	Governor spindle should have no perceptible end play. Adjust bearing pivots to quietest running position.
	Governor worm wheel ..	Worm wheel sometimes gives noisy drive; should be replaced. <i>Centre line of worm wheel should be level with the axis of worm.</i>
Variation in speed	Slack top main spindle bearing.	If upper main bearing becomes worn through turning for long periods without lubricant, motor will generally be noisy, although units already mentioned are correctly adjusted. <i>In this case the motor should be returned to the makers, giving full details of trouble experienced.</i> See "Crazy governors" below.
	Tight main spindle .. Tight governor bearings. Crazy governors. Disc rubbing pole laminations.	
Crazy governors (whirring sound)	Friction leather too hard. Lack of lubrication on leather.	Lubricate well and massage with pliers to encourage softness.
Sluggishness ..	Springs distorted .. Tight governor bearings	Adjust.
	Tight governor bearings Congealed or unsuitable lubricant in bearings. Grease on disc.	Adjust. Clean and re-lubricate.

* This chart has particular reference to the Marconiphone A.C. Motor, but most of the data applies equally well to motors of similar type.

Removal of Governor.

(Fig. 25.) Slack off governor bearing screw *k*, and governor bearing screw *m*. Slide governor gently towards these bearings so that the bearing slips sufficiently far to allow the governor to be slipped out of the bearing; then withdraw governor.

Replacing the k bearing.—This bearing is fitted with a slot which engages with the bearing screw into which this screw must locate.

Removal of Main Bearing and Induction Disc.

(1) Slack away screws *n* and *p* (Fig. 24).

(2) Slack away grub screw *r* in worm wheel hub.

(3) Withdraw spindle, worm wheel and inductor disc.

IMPORTANT NOTE.—Grub screw *r* in worm wheel and one grub screw in inductor

disc should engage in the locating dimples in the main spindle when reassembling.

Warning.—Do not lose steel ball in lower main bearing (*l*).

Use of Safety Stop.

The screen SS in Fig. 24 which secures metal collar on underside of top bearing is to prevent inexperienced persons from lifting the whole motor spindle and disc assembly when replacing or removing turntable and bringing disc in contact with magnet units.

NOTE.—The position of the screw and collar (SS) is shown clearly in Fig. 24.

LUBRICANTS.

It is essential that correct lubricants should be used for this and all other motors.

"His Master's Voice" greases and oils

are chosen and carefully tested for freedom from harmful ingredients.

It is especially important that the oil on the governor friction pad should be free from acids.

correct position in magnet jaws, i.e., does not touch either upper or lower poles.

(4) When lower bearing has been adjusted, adjust safety screw and collar so that it is impossible to raise spindle

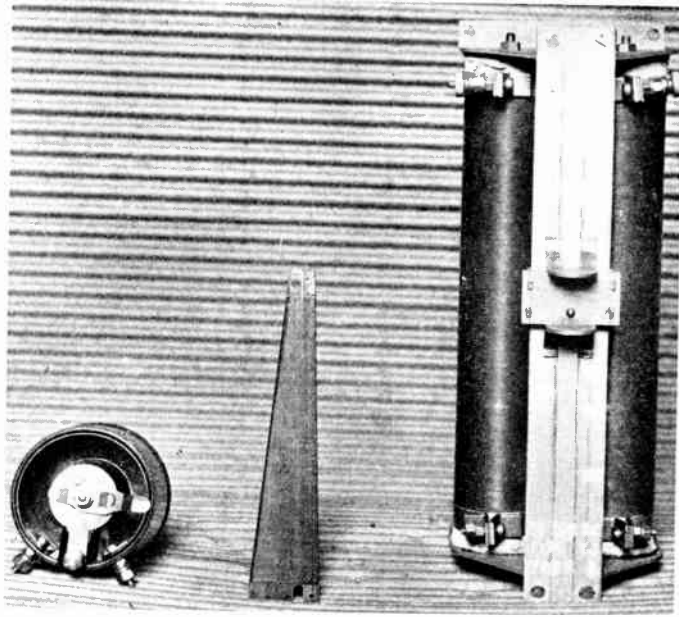

Fig. 27.—TYPICAL EXAMPLES OF A VOLUME CONTROL AND ADJUSTABLE RESISTANCE.

On the left is a Watmel wire-wound volume control. Note (centre) the tape winding of the resistance to give a square-law adjustment of volume. On the right is a B.T.-H. adjustable resistance for Universal motor.

Renewal of Governor Friction Pad.

The clip holding this pad is bifurcated. The pad may be removed by opening the jaws of the clip with a screwdriver, thus loosening the grip on the pad, and enabling the new pad to be inserted; when the new pad has been inserted, close up jaws with suitable tool.

NOTE ON RE-ASSEMBLING MOTOR.

(1) See that steel ball in lower bearing is present.

(2) See that one grub screw in inductor disc and in main spindle gear wheel are locating in special dimples on spindle.

(3) Adjust lower bearing screw so that when motor is *right way up*, disc is in

and inductor disc assembly so high that inductor disc strikes upper magnet pole. Adjust collar (SS, Fig. 24) to stop this, but see that collar is not exercising friction on top of main spindle gear wheel.

It is probable that this safety stop screw and collar will not require re-adjusting.

(5) When replacing worm wheel the grub screw should be on top. (Fig. 24.)

The greatest possible care must be taken to see that the inductor disc is not damaged or bent in any way. The disc should be carefully put on one side, after inspection, in a safe place.

A later article deals with the adjustment and maintenance of Automatic Record-changing Gramophone Motors.

HOW TO MAKE A SMALL MOTOR

By H. E. J. BUTLER

THE motor described in the article is chosen as being suitable for driving a small fan, grinding wheel, sewing machine or for working a number of models. The maximum output is $\frac{1}{16}$ h.p. The various parts can be constructed by anyone possessing a 3-in. lathe, which is essential for making the commutator, turning the end-frames and the armature shaft. The making of the commutator requires more patience and care than the other parts, but presents no particular difficulty if the processes described and illustrated are closely followed. The finished machine is shown in Fig. 1.

The motor is designed so that it may, with suitable windings, be driven from any voltage, either A.C. or D.C.

Components and Materials.

The list of components and materials from which they are made are given herewith.

The Armature Spindle.

The main part of the work of making a motor is in the construction of the armature. The first stage of making the armature is turning the spindle. This is made from $\frac{3}{8}$ -in. diameter bright mild steel.

Cut off a length of this size steel $5\frac{7}{8}$ in. long, face the ends and centre each truly with a Slocomb centring drill so that when finished the rod is then $5\frac{1}{8}$ in. long as shown in the working drawing, Fig. 2. The exact dimension of the overall length may, of course, be varied to suit different methods of drive. The lengths given allow for a wide pulley or worm at one end and for a narrow V-pulley at the commutator end.

After centring the bar, it is mounted between centres in a lathe and the short $\frac{1}{4}$ -in. shoulder is turned first. The diameter of this part should be made so that the ball race is a good push fit on it. The same applies to the other end of the shaft. The $\frac{3}{8}$ -in. long shoulder $\frac{5}{16}$ -in. diameter is the next operation. This part of the shaft takes the commutator.

When these two shoulders have been turned the shaft is reversed and the two long shoulders turned. It will be necessary to use a travelling steady for this. Set up the steady before starting to turn, because once the shaft becomes tapered it will be found difficult to correct it. The long $\frac{5}{16}$ -in. diameter shoulder should be turned

COMPONENTS REQUIRED.

Component.	Material.	Quantity.
Armature spindle ..	$\frac{3}{8}$ -in. diameter bright mild steel.	1
Armature stampings	$1\frac{1}{2}$ -in. diameter Stalloy stampings with 11 semi-closed slots, $\frac{1}{16}$ -in. hole for spindle.	100
Armature clamping nut.	$\frac{3}{8}$ in. \times 26 tpi. steel lock-nut.	1
Bearings	$\frac{3}{8}$ in. diameter by $\frac{1}{4}$ in. \times $\frac{1}{4}$ in. ball races.	2
Commutator bars ..	Drawn copper segments $\frac{5}{8}$ in. long by $\frac{1}{12}$ in., .1364 in. to .0389 in. taper.	22
Commutator mica ..	Ruby mica .030-in. thick cut $\frac{5}{8}$ in. \times $\frac{1}{12}$ in. full.	22
Micanite washers ..	Moulding or flexible micanite $\frac{1}{16}$ in. thick, 1-in. diameter by $\frac{1}{16}$ in. hole.	2
Micanite sleeve ..	Flexible micanite $\frac{1}{16}$ in. thick or micanite tube with $\frac{1}{16}$ -in. hole, $\frac{1}{16}$ -in. wall.	1
Commutator bush ..	$\frac{3}{8}$ -in. diameter brass ..	1
Clamp ring	$\frac{3}{8}$ -in. diameter brass ..	1
Commutator nut ..	$\frac{3}{8}$ in. \times 26 tpi. brass lock-nut.	1
Armature wire ..	Double-silk covered copper wire.	3 oz.
Armature insulation	Presspahn $\frac{1}{16}$ -in. thick for end insulation.	2, 12-in. circles.
	Presspahn .2 mm. for slots	12 in. \times 1 $\frac{1}{8}$ in.
	Cotton tape and Armacel varnish.	
Field magnet ..	2 pole stampings in Stalloy .018 thick.	90
Field coils	Enamel covered wire ..	4 oz.
Field coil insulation	Empire tape $\frac{1}{8}$ -in. wide ..	3 yds.
End frames	Cast aluminium ..	2
Field frame	Metal tube or casting ..	1
Brushes	Carbon, $\frac{1}{16}$ -in. square, $\frac{1}{4}$ -in. long.	2

so that the armature stampings slide on easily but without shake. Finally, screw cut the 26 per inch thread for the nut which is to clamp the stampings together.

Assembling the Stampings.

Before mounting the stampings on the shaft a special clamping nut is prepared. This may be turned from a standard $\frac{5}{16}$ -in. 26 nut, which is a cycle size. In order that it shall not unduly enlarge the winding at this end of the armature the nut is turned $\frac{1}{8}$ -in. thick and filed down to fit a $\frac{1}{4}$ -in. spanner. Chamfer the nut well. The stampings are now threaded on to the spindle; 96 should be sufficient to make $1\frac{1}{2}$ -in. It will be noticed that the armature stampings are covered with very thin paper on one side. Keep all the papered faces the same way round so as to insulate each stamping from its neighbour. Discard any rusty or bent stampings, also

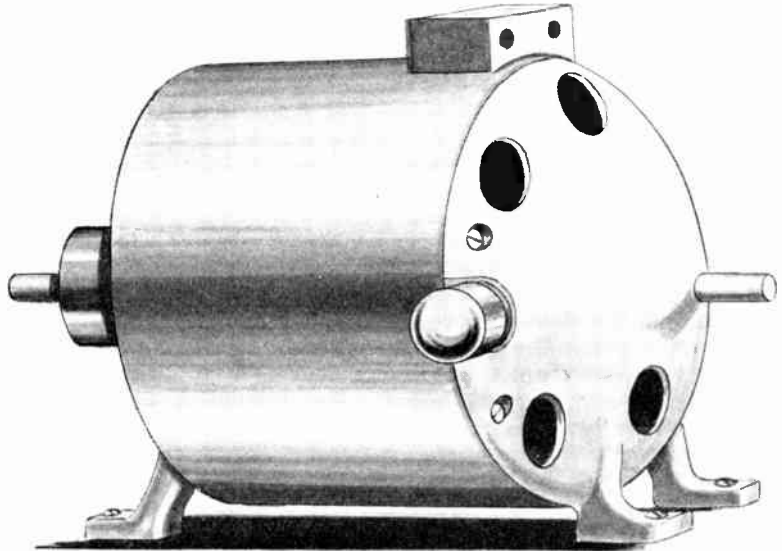

Fig. 1.—THE FINISHED $\frac{1}{16}$ H.P. MOTOR, THE MAKING OF WHICH IS DESCRIBED IN THIS ARTICLE.

any which which may have an extra thickness of paper.

When the required number of stampings have been threaded on the spindle, the nut is put on and the stampings lightly clamped. A piece of iron strip is then used to line up the stampings and hold them in alignment while the nut is done up as tightly as possible. For this purpose the commutator end of the spindle is held in the vice, taking care not to bruise or bend the shaft. Larger stampings have a key-

way punched in the hole so that the stampings may be keyed to the shaft. For a small motor, however, a clamping nut is sufficient to prevent the rotation of the stampings on the shaft.

The shape and dimensions of the stampings are shown in Fig. 4.

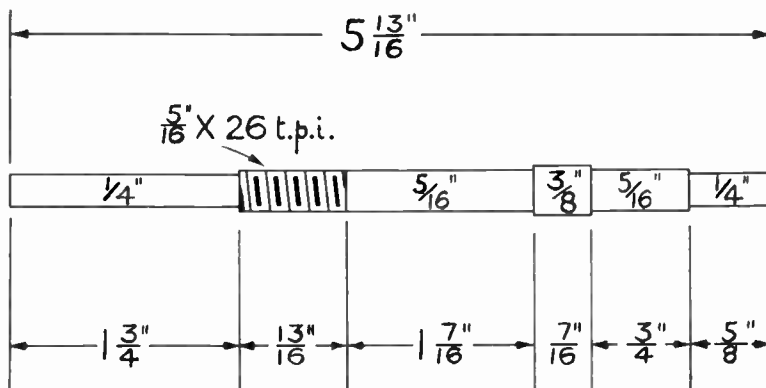

Fig. 2.—WORKING DRAWING OF THE ARMATURE SPINDLE WHICH IS TURNED FROM $\frac{5}{16}$ -IN. DIAMETER BRIGHT MILD STEEL.

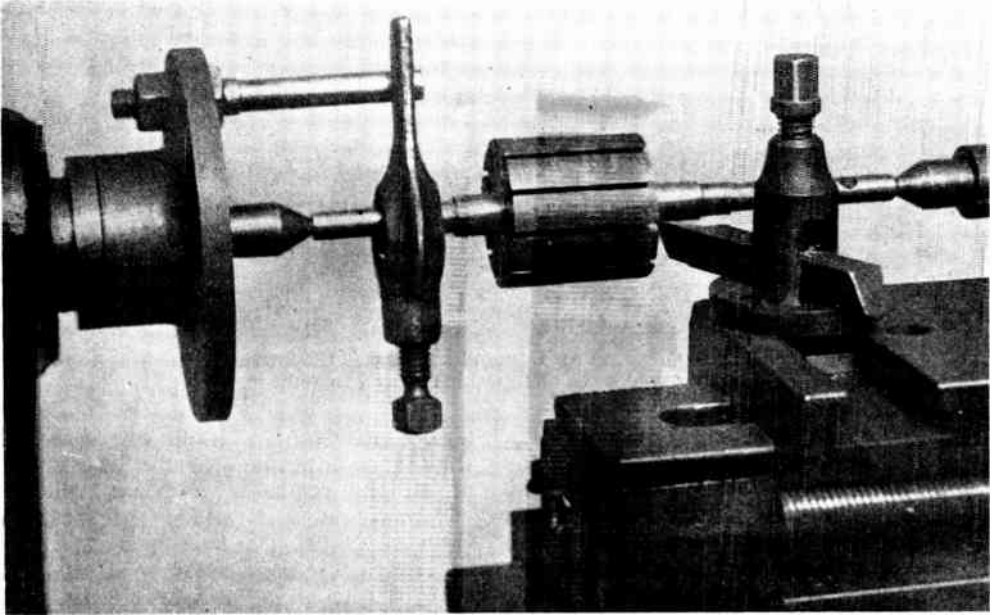

Fig. 3.—HOW THE STAMPINGS ARE TRUED-UP BETWEEN CENTRES IN A LATHE. This is done after the stampings have been assembled on the armature spindle.

Truing-up the Armature.

It often happens that the clamping up of the stampings distorts the slender shaft, or, if the shaft is not bent the stampings do not run truly when the armature is spun on the lathe centres. If the shaft is bent it may be straightened by resting the two $\frac{1}{4}$ -in. sections of the armature on a pair of V-blocks and tapping with a mallet or hammer and a piece of wood. It is not advisable to straighten the armature whilst it is mounted between centres, or the centres of the spindle may be damaged. These must be taken care of because they will be required for finishing the commutator and its subsequent returning from time to time. When the spindle runs true again the stampings are carefully skimmed up with a keen tool as shown in Fig. 3.

HOW TO MAKE THE COMMUTATOR.

The various parts of the commutator together with the clamp which is used to make it are shown in Fig. 5.

The Clamp.

Before the commutator can be started

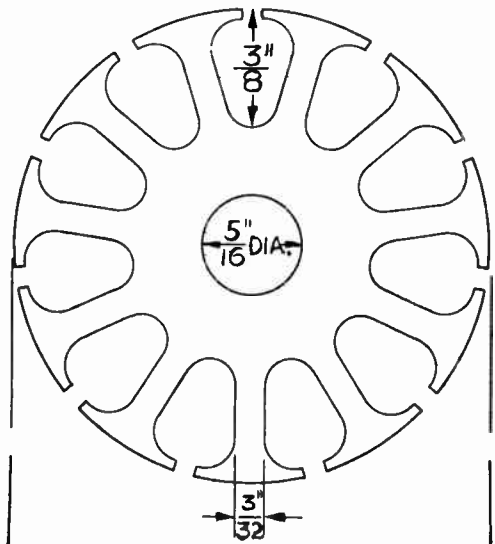

Fig. 4.—DIMENSIONS OF ARMATURE STAMPINGS.

The armature core is composed of about 96 of these stampings ($1\frac{1}{2}$ in. diameter) clamped together on the armature spindle. Some makes of stampings have a nick at the base of one slot. The nicks are lined up when the stampings are assembled to ensure perfect alignment of the stampings.

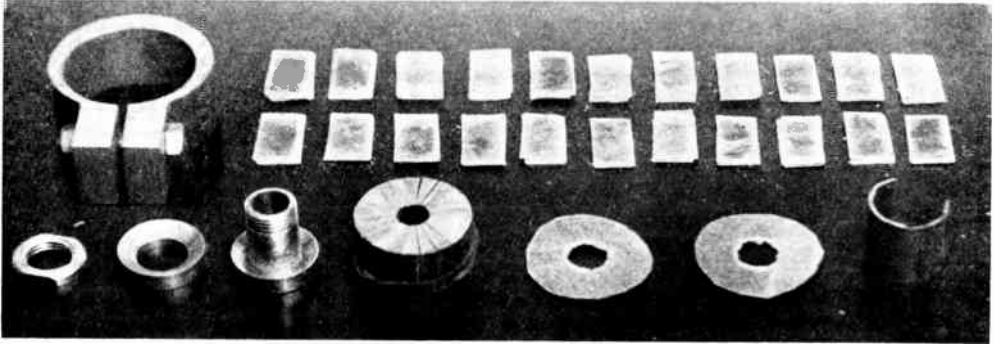

Fig. 5.—THE VARIOUS COMPONENTS OF THE COMMUTATOR. Showing also the clamp which is used to make it.

it is necessary to make a special clamp ring to hold the segments and their micas while the turning is done. The finished clamp is shown in Fig. 6. It is made from $\frac{3}{8}$ -in. of brass tube about $\frac{3}{16}$ -in. to $\frac{1}{4}$ -in. wall. Unless a piece of tube is obtainable $1\frac{1}{4}$ -in. inside diameter, the tube is first bored out to this size as shown in Fig. 7. The ring thus bored to size is then mounted on an eccentric mandrel held in an independent chuck as shown in Fig. 8. This produces

an eccentric ring. The object of making the ring eccentric is to ensure the clamping of all the segments properly, which a concentric ring does not do. After turning the eccentric ring a brass block is brazed or silver-soldered central with the thin side of the ring. Before splitting the ring a hole is drilled for a 2 B.A. steel screw. One half of the block may be tapped instead of using the nut, which gives more room for holding the ring in the chuck for subsequent operations. The slot is then cut out about $\frac{5}{16}$ in. wide. Two hacksaw blades put together will do this operation.

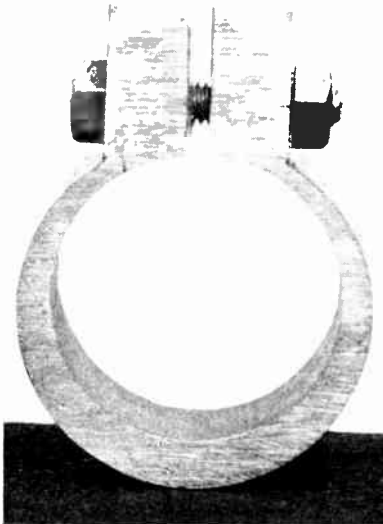

Fig. 6.—CLAMP RING FOR HOLDING THE SEGMENTS AND THE MICA TOGETHER. This is used while the coned recesses are turned at each end of the commutator.

The Commutator Bush.

Four stages in making the foundation bush of the commutator are shown in Figs. 9 to 12. A piece of $\frac{3}{4}$ -in. brass rod is held in a self-centring chuck and a shoulder turned 1 in. long and $\frac{7}{16}$ -in. diameter. Next centre the faced end of the rod carefully and drill out with a spear drill, to a depth of $1\frac{1}{16}$ in. A spear drill as shown in Fig. 9 should be used for the first drilling because this type of drill is less liable to run out of centre than a twist drill. The hole is finished to size with a $\frac{5}{16}$ -in. reamer or a carefully ground drill of the same size, so that the bush will push on the armature spindle without shake. Fig. 10 shows the next operation. This is recessing the shoulder at an angle of 60° to the turn of the bush. The exact angle is not important, provided that the angle of the commutator cones is made the same.

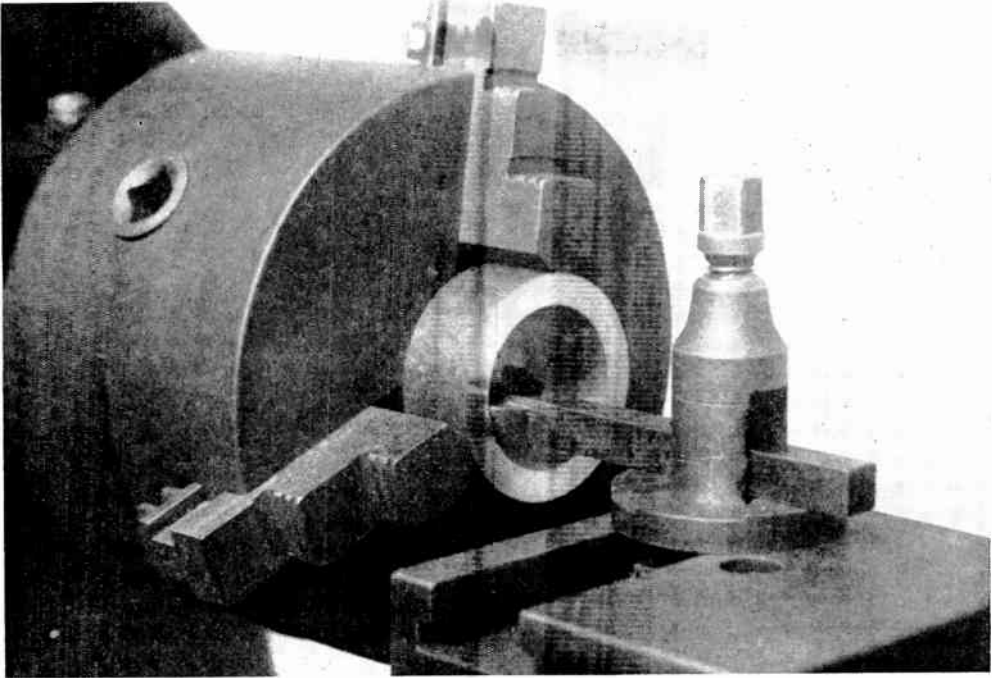

Fig. 7.—THE FIRST STAGE IN MAKING THE CLAMP RING.
This is to bore out the brass tube to $1\frac{3}{16}$ inch diameter.

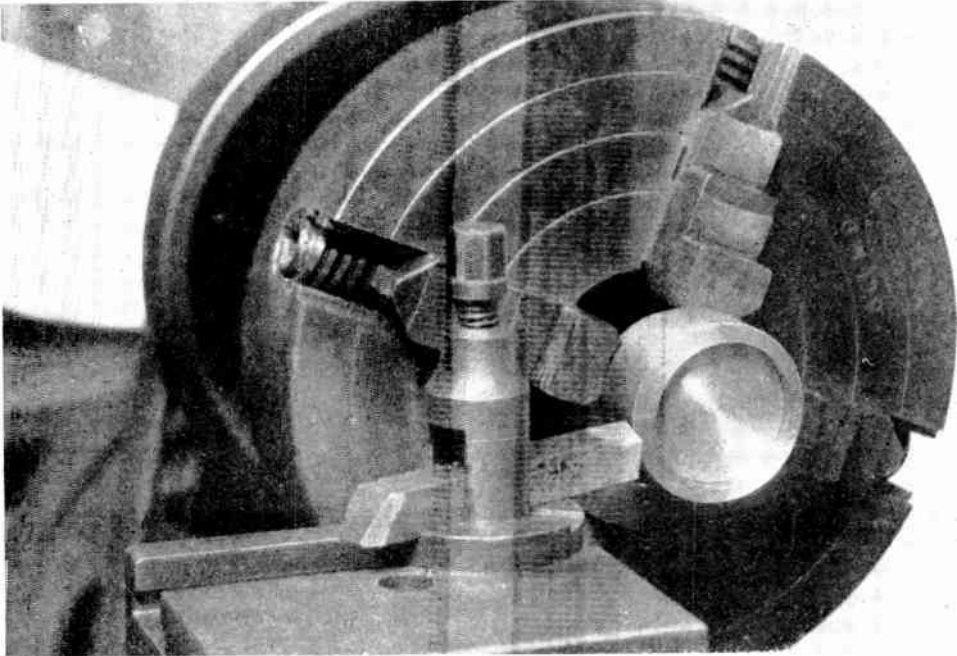

Fig. 8.—THE SECOND OPERATION IN MAKING THE CLAMP RING.
Showing how to turn the outside eccentric with the bore.

B

After turning the coned recess, the thread is cut as shown in Fig. 11. The pitch of the thread is the same as for the armature spindle; that is, 26 per inch. The thread is cut longer than necessary for which purpose will be seen when finally assembling the commutator. Lastly, the bush is parted off to leave $\frac{3}{8}$ -in. long head, as shown in Fig. 12.

The Clamping Ring.

The clamping ring is made next because it is turned from the same size of metal

up a thicker piece. The mica is easily split up with a knife into uniform leaves within a thousandth part of an inch. When the required thickness has been made up in sufficient quantity to cut 22 pieces $\frac{3}{8}$ -in. \times $\frac{1}{4}$ -in. full, the mica is laid on a flat board and the rectangles marked out with a penknife as shown in Fig. 13. The pieces are then cut up with a pair of sharp scissors or metal snips. See Fig. 14. Owing to the in-cohesion of the lamina structure of the mica, these small pieces will flake into

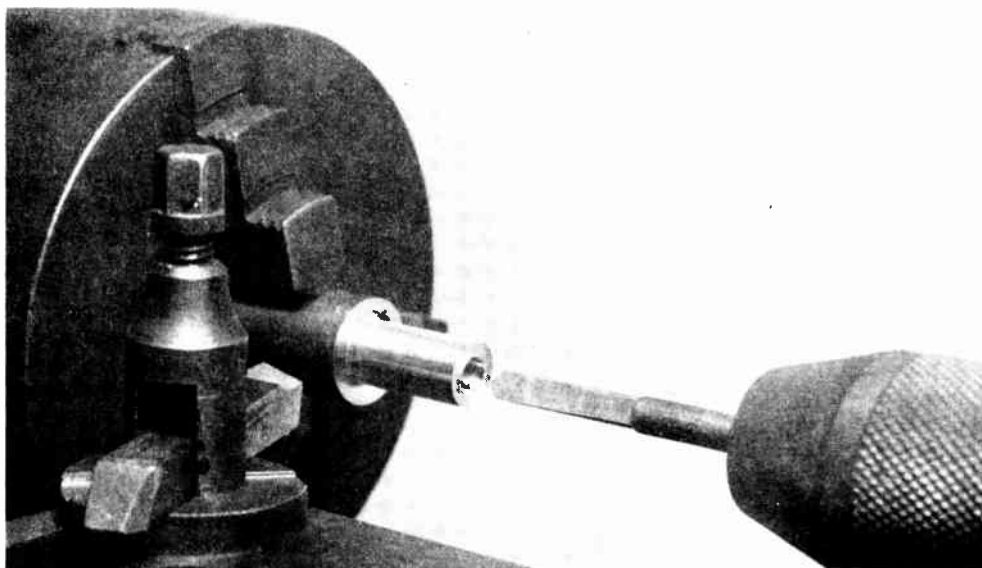

Fig. 9.—MAKING THE COMMUTATOR BUSH (1).
Showing the use of the spear drill to bore the hole.

as the bush. Its shape is similar to the head of the commutator bush. A $\frac{7}{16}$ -in. hole is drilled in the $\frac{3}{4}$ -in. bar $\frac{1}{4}$ -in. deep, and a coned recess turned as for the head of the bush. The ring is then parted off $\frac{3}{8}$ -in. overall thickness.

A nut is then made $\frac{1}{8}$ -in. thick from $\frac{5}{8}$ -in. brass bar to fit the thread of the bush. Two flats filed on this are sufficient.

The Commutator Micas.

The mica material is supplied in irregularly shaped pieces which are shown in Fig. 13. The correct thickness is .030 in. The thickness may be made up of any number of pieces or by splitting

thinner leaves when cut. This does not matter so long as each portion is preserved separately so as to give a uniform thickness of .030 in. to each piece. There is no harm in, say, cutting up twice the number of pieces .015-in. thickness and making up the thickness in this way.

The Copper Segments.

Although the copper segments can be made by one skilled with a file, it is better to purchase the copper section drawn to the size shown in the preceding table. Each section is cut $\frac{3}{8}$ -in. long. Preparatory to assembling the copper and mica for turning, the burrs are taken off the

Fig. 10 (Right).—
MAKING THE COM-
MUTATOR BUSH (2).

This shows the second operation, which consists of recessing the shoulder at an angle of 60° to the turn of the bush. The exact angle is not important provided that the angle of the commutator cones is made the same. The motor described in this article can be constructed by anyone possessing a 3-in. lathe which is essential for making the commutator, turning the end-frames and the armature shaft. The making of the commutator requires more patience and care than the other parts.

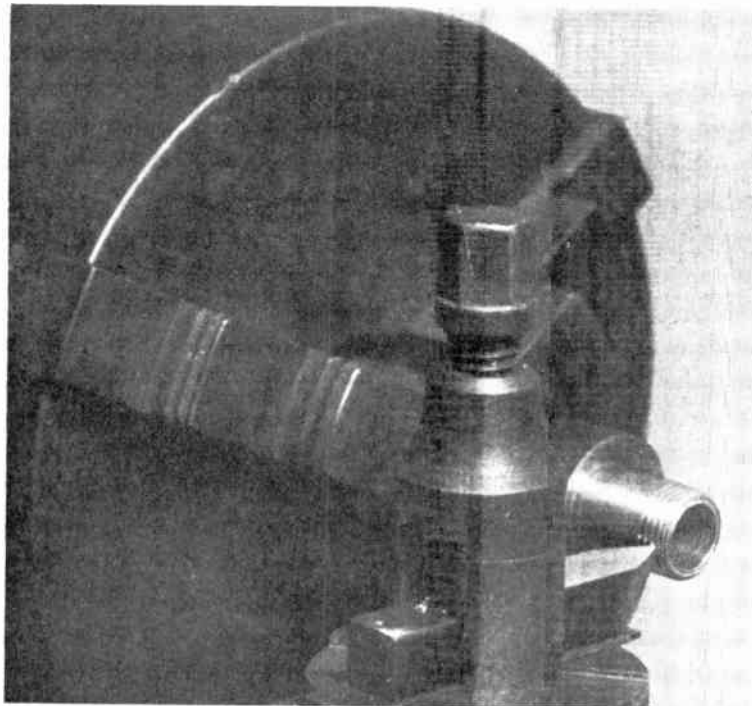
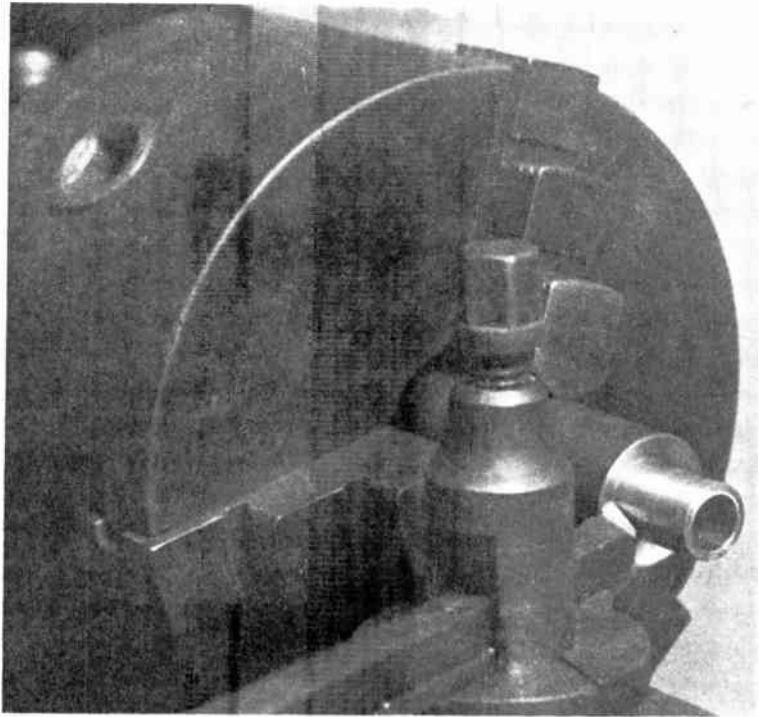

Fig. 11 (Left).—
MAKING THE COM-
MUTATOR BUSH (3).

Showing how to cut the thread on the commutator bush.

Reference should also be made to Fig. 18 which shows the completed commutator in section. The commutator bush will be clearly seen with the threaded portion on the right. A brass nut is screwed on to this end of the bush when the assembly is complete.

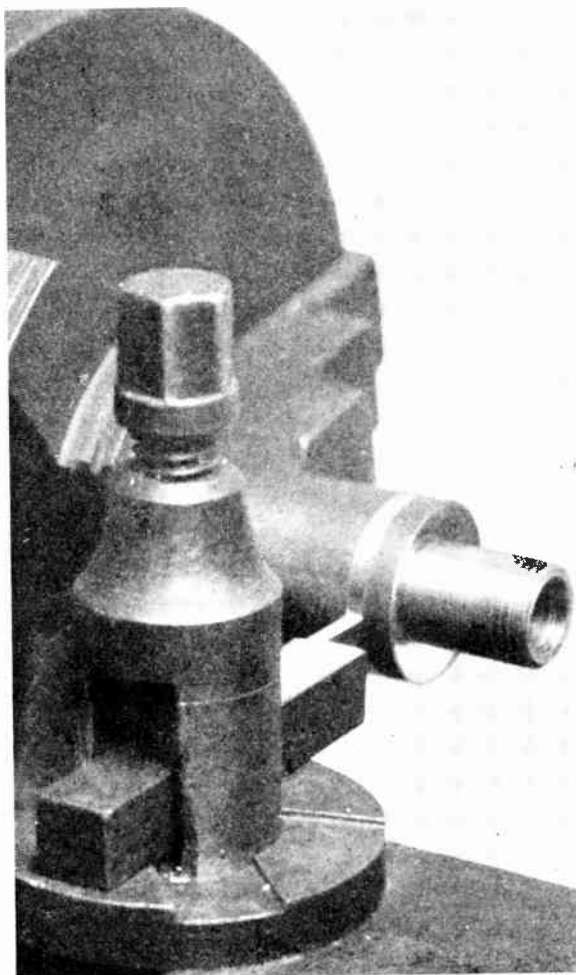

Fig. 12.—MAKING THE COMMUTATOR BUSH (4).
The final operation in making the commutator bush, showing the use of a parting tool.

faces of the copper bars by rubbing on a sheet of fine sandpaper as shown in Fig. 16. The burrs are also removed from the large end of the taper. This ensures that the segments bed closely. Keep the faces of the copper flat for if the edges are rounded a gap may be formed in the finished commutator which assists the formation of a dangerous burr when turning.

Assembling the Segments and Mica.

The 22 copper segments are now conveniently held together with elastic bands so that the coppers are easily parted with

a pointer in order to insert the micas. This operation is shown in Fig. 15. Before inserting the micas check the thicknesses with a micrometer to ensure their uniformity. With the 22 pairs of micas and copper segments thus assembled the clamp is pushed on.

The copper segments are now pushed level with a thin rod as shown in Fig. 17. The micas should now project into the bore and at each end of the commutator. See that each segment is covered properly with mica and then tighten the clamping screw of the ring. The assembly is now ready for turning.

Turning the Commutator.

For the purpose of turning the commutator, it is held in an independent chuck as shown in Fig. 19. The work is centred so that the bore of the clamping ring runs truly. The first step is to face one end of the segments and bore out the hole to $\frac{1}{2}$ -in. diameter. Fig. 19 shows a boring bar in use for this operation. The turning tools must be kept sharp and the metal and mica must be removed in light cuts or the copper will tend to bridge over the surface of the mica edges. It will be found necessary to touch up the tool every two or three cuts to produce the best result, because mica soon takes the keenness

from the tools, whether they are high-speed or ordinary carbon steel.

The next step is to turn the coned recess at one end of the commutator. This is shown in Fig. 20. Care must be taken when working into the corner that the tool does not chatter or dig. Before the coned part is turned the commutator end is recessed $\frac{1}{8}$ -in. with a square shoulder. The diameter of the recess is $\frac{1}{8}$ -in., that is $\frac{3}{8}$ -in. for the head of the bush, plus $\frac{1}{2}$ -in. each side for the micanite insulation. When this part has been turned the commutator is reversed

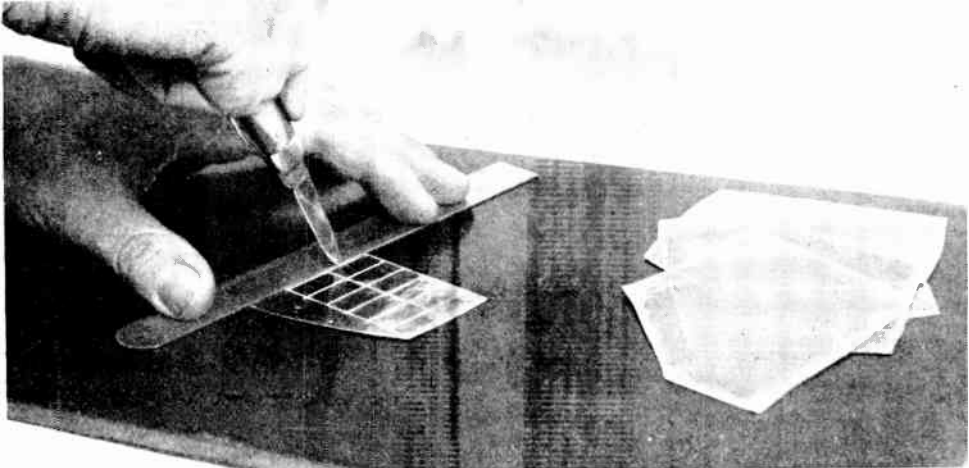

Fig. 13.—MARKING OUT THE COMMUTATOR MICAS.
This is done on a flat board with the aid of a sharp penknife and a steel rule.

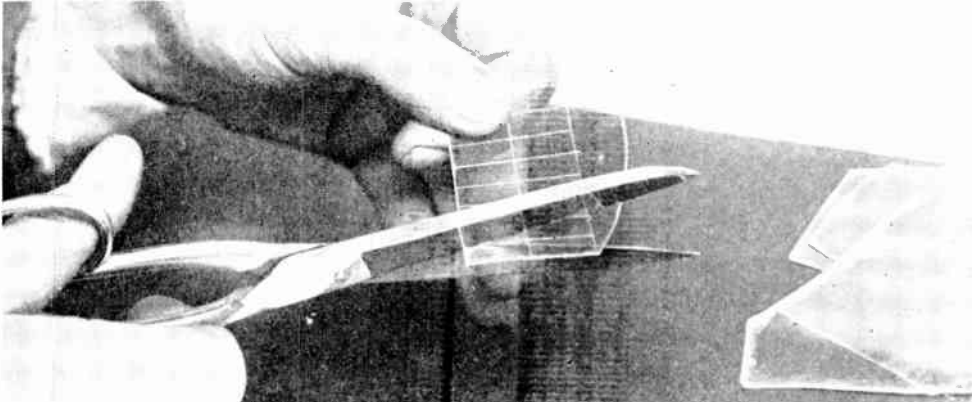

Fig. 14.—CUTTING UP THE COMMUTATOR MICAS WITH A PAIR OF SCISSORS.
† If any of the small pieces should flake up, keep each rectangle separate so that the uniform thickness is preserved.

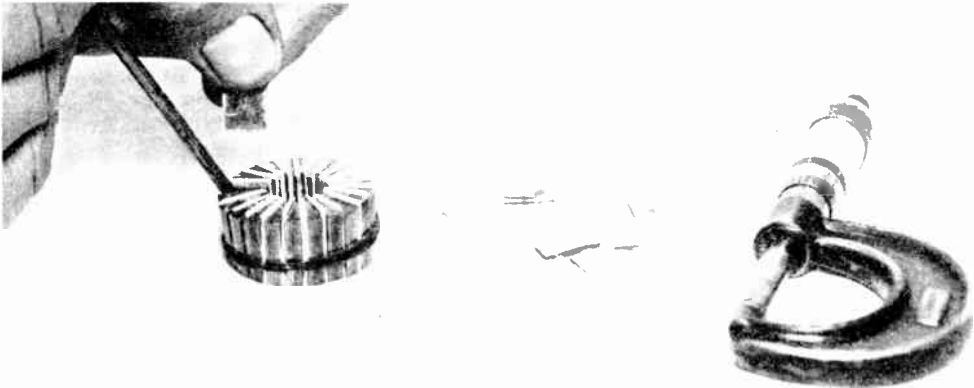

Fig. 15.—ASSEMBLING THE COPPER SEGMENTS IN THE MICA PREPARATORY TO TURNING.
Elastic bands are used to hold the assembly together while the micas are being inserted. Check the thicknesses of the micas carefully with a micrometer in order to ensure their uniformity.



Fig. 16.—REMOVING THE BURRS FROM THE COPPER SEGMENTS BEFORE THEY ARE ASSEMBLED FOR TURNING.

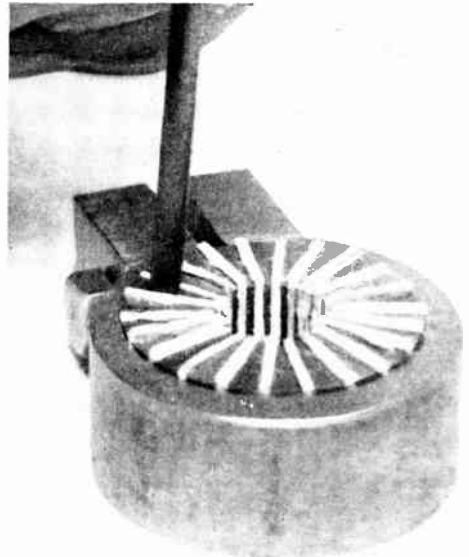

Fig. 17.—LEVELLING UP THE MICAS IN THE COPPER SEGMENTS.

This is done after the clamp has been pushed over them and the elastic bands removed.

in the chuck and carefully centred so that the bore runs truly on its entire length, when a similar recess is turned at the other end of the commutator. The angle of the coned recesses must fit that of the bush and the clamping ring. The dimensions of the commutator are given in Fig. 18, which shows a section

of the finished commutator drawn to scale. When the second end of the commutator has been recessed and faced, examine the edges of the micas to see whether any of them are partly or wholly bridged with copper. If the mica edges are quite clean the work is then removed from the chuck, but the clamp must not be released yet on any account.

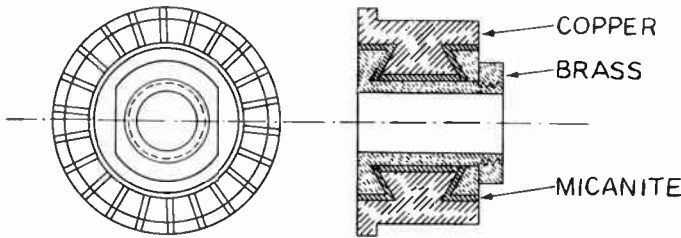

Fig. 18.—END ELEVATION AND SECTION OF THE FINISHED COMMUTATOR.

This is drawn to scale to show the finished sizes of the various parts.

The Micanite Bush.

The micanite bush serves to insulate the commutator from the brass foundation bush. It may be cut from a piece of tube $\frac{1}{2}$ -in. outside diameter and $\frac{7}{16}$ -in. bore. The length of the bush is $\frac{7}{16}$ -in. Alternatively, the bush may be bent up from a piece of flexible micanite. To do this a piece of $\frac{1}{32}$ -in. flexible micanite is cut $1\frac{9}{16}$ in. \times $\frac{7}{16}$ in., and bent while hot round

a warmed rod of $\frac{3}{16}$ -in. diameter, so that the edges just meet when the split sleeve is closed firmly round the forming rod.

Assembling the Commutator.

The final assembly of the commutator is shown in Fig. 21. After lining the commutator hole with the micanite sleeve, one of the micanite washers is threaded on the bush which is then inserted into the bore of the commutator as shown. The

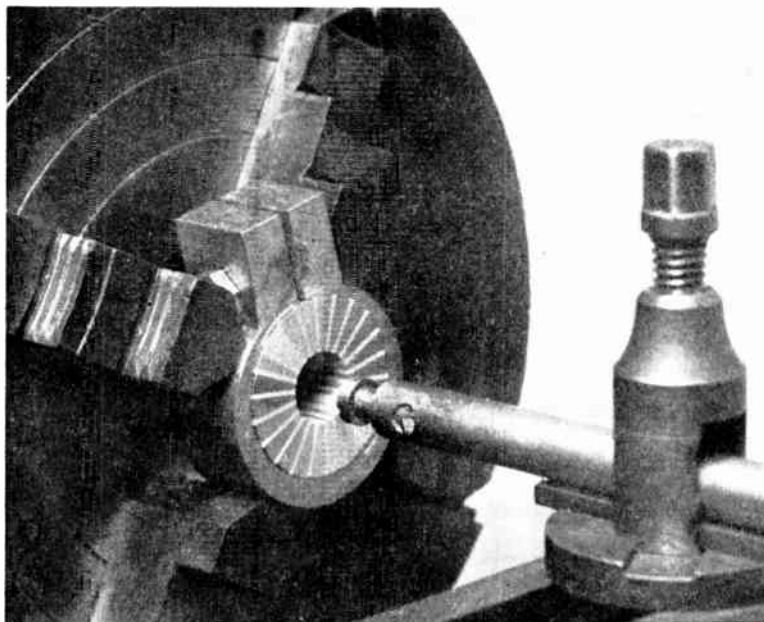

Fig. 19.—THE COMMUTATOR SET UP IN AN INDEPENDENT CHUCK FOR BORING AND FACING.

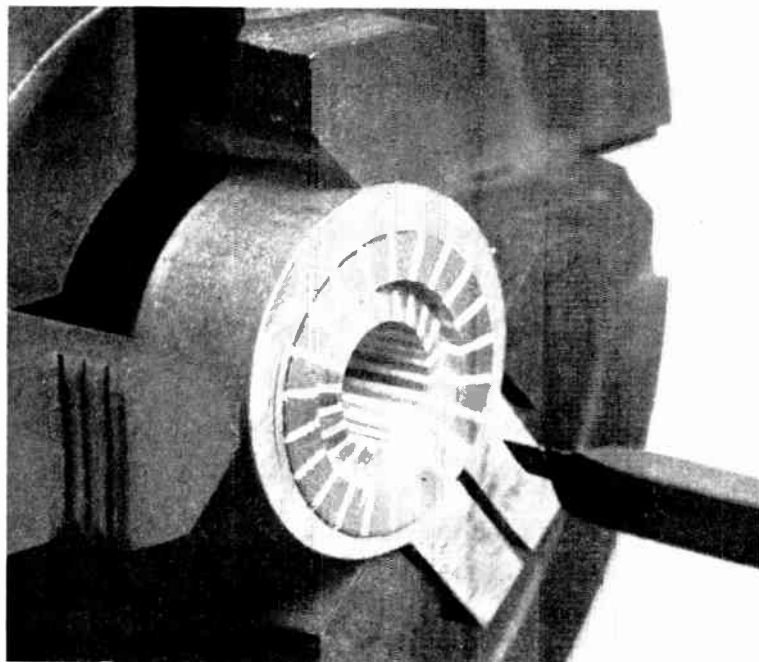

Fig. 20.—TURNING THE CONED RECESS AT ONE END OF THE COMMUTATOR. When this end is finished the clamp is reversed in the chuck and the other end treated in a similar way.

other micanite washer is then pushed on the projecting thread and the clamping ring put on with its coned side facing the segments. The nut is then screwed on and done up finger tight.

The whole assembly is now held in a pair of pliers over a flame to soften the micanite. This is shown in Fig. 22. As soon as the micanite becomes pliable, the nut is tightened with a spanner. The job is then reheated and the nut further tightened

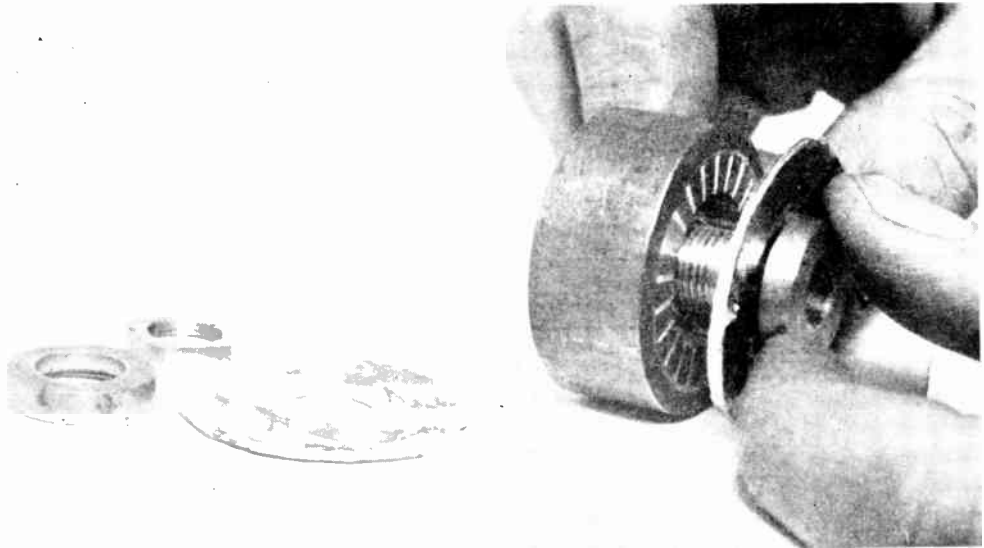

Fig. 21. —THE FINAL ASSEMBLY OF THE COMMUTATOR, FIRST STAGE.

until the micanite washers are completely formed into the cones, and the nut is clamped as tightly as the thread will permit. The final tightening of the nut must be done while the job is hot or the micanite will not bed firmly on the cones and the commutator bars will not be securely held. The superfluous micanite is then cut off both sides and the commutator removed from the clamp.

Testing the Commutator.

The insulation between the segments is tested by means of a lamp bulb and the light mains as shown in Fig. 23. The full pressure of the mains is applied to each pair of adjacent segments, with a bulb in series. The bulb will light up if any two segments are bridged anywhere. Also test between each segment and the bush. The most likely cause of failure is the imperfect forming of the micanite

Table showing armature and field windings for different voltages, both A.C. & D.C.

VOLTS	A.C. SERIES 40, 60 CYCLES.				D.C. SERIES.				D.C. SHUNT.			
	ARMATURE.		FIELD.		ARMATURE.		FIELD.		ARMATURE.		FIELD.	
	S.W.G.	Turns per Coil.	S.W.G.	Turns per Coil.	S.W.G.	Turns per Coil.	S.W.G.	Turns per Coil.	S.W.G.	Turns per Coil.	S.W.G.	Turns per Coil.
	D.S.C.		Enam.		D.S.C.		Enam.		D.S.C.		Enam.	
100	35	35	29	197	35	35	29	214	35	39	38	2860
110	35	37	27	185	35	37	27	237	39	47	39	3960
120	35	40	27	200	39	49	27	200	39	47	39	3960
200	38	97	30	330	38	97	30	430	39	74	41	5275
210	38	70	30	350	38	70	30	450	39	74	41	5275
220	38	73	30	370	38	73	30	475	40	95	42	6200
230	38	75	31	384	38	75	31	495	40	95	42	6200
240	38	75	31	400	38	75	31	515	41	107	43	7400
250	38	75	32	415	38	75	32	535	41	107	43	7400

Fig. 22 (Right). — FINAL ASSEMBLY OF THE COMMUTATOR. SECOND STAGE.

When the bush and micanite washers have been lightly clamped up, the whole assembly is heated over a gas flame until the micanite is soft enough to be formed into the coned recesses.



Fig. 23 (Left). TESTING THE INSULATION OF THE COMMUTATOR AFTER REMOVING IT FROM THE CLAMP.

The full voltage of the electric light mains is applied to each pair of adjacent segments. A bulb is wired in series to serve as an indicator of a short circuit.

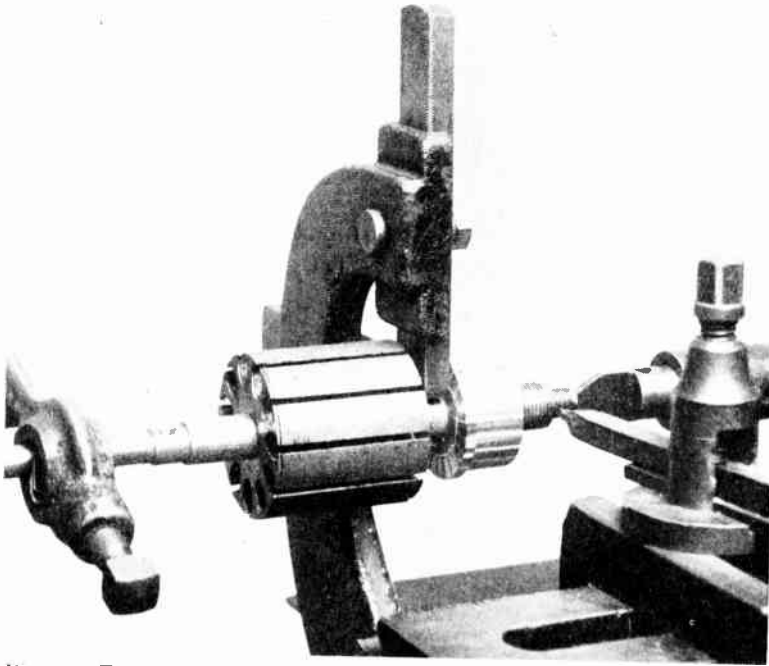

Fig. 24.—THE ARMATURE SET UP IN A LATHE FOR FINISHING THE COMMUTATOR. A steady must be used to prevent chattering when turning the outside diameter. The superfluous thread at the end of the commutator is turned off while the armature is thus set up.

cones, which may not have covered the metal cones properly in the assembling process.

Mounting the Commutator.

There are two methods of securing the commutator to the armature shaft. First, the bore of the commutator bush may be made a force fit on the shaft, but unless the sizes are just right the commutator may be damaged while being pressed on, or the commutator may work

too cool when pushed on, the extra heat may be supplied by the shaft.

loose and damage the connections. A simpler and equally effective way of mounting a small commutator is to solder it to the armature shaft. This is done by tinning the short $\frac{5}{16}$ -in. section of the shaft and the inside of the commutator bush, and, while both are still hot the commutator is pushed right up to the shoulder on the shaft. Take care not to overheat the commutator, but make the shaft rather hotter than is necessary to melt the solder so that should the bush be

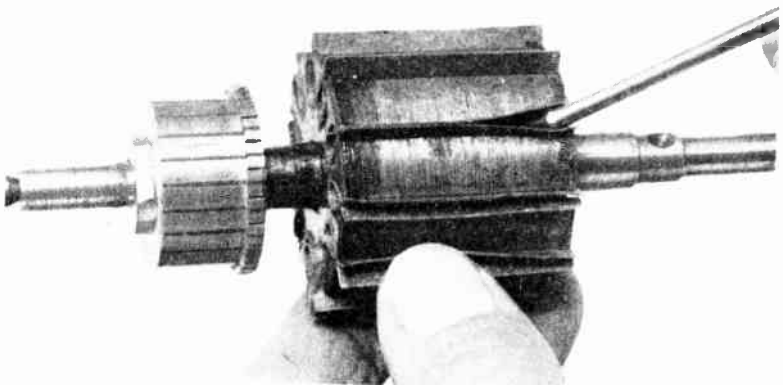

Fig. 25.—TURNING BACK THE EDGES OF THE PRESSPAHN SLOT INSULATION. This is done so as to form a guide-in for the wire during winding.

Finishing the Commutator.

By mounting the commutator on the shaft before turning up the outside diameter the need for making a special mandrel for this purpose is obviated. The first operation in truing-up the outside is to face the back and turn off any superfluous solder on the part of the shaft between the commutator and the stampings. The front face is then trued if necessary and then the outside diameter is turned parallel, so as to leave it as large as possible. This is now the diameter of the risers or the narrow extensions of the segments which house the armature connections. After this the commutator is turned down so as to leave the risers $\frac{1}{16}$ -in. higher and $\frac{3}{32}$ -in. long. The diameter of the working part of the commutator is now $1\frac{1}{16}$ in.

Fig. 24 shows the armature set up between centres in a lathe for the finishing of the commutator. In order to prevent chattering due to the slender nature of the shaft it is necessary to use a steady as shown. The illustration shows the

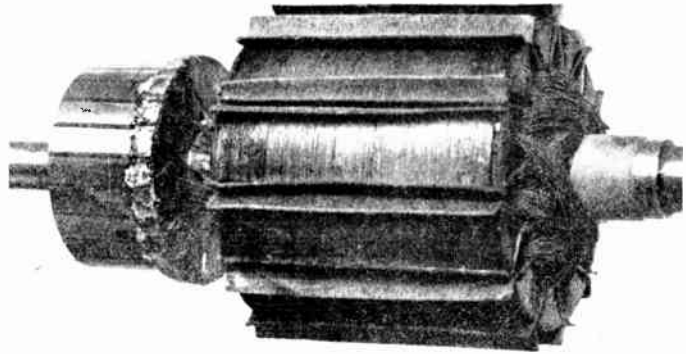

Fig. 26.—THE ARMATURE WITH HALF THE COILS WOUND AND CONNECTED TO THE COMMUTATOR.

At this stage the leads from the coils are insulated with cotton tape so that they do not come in contact with the second half of the winding.

superfluous thread of the bush being turned off after the commutator has been finished. The thread is faced off flush with the clamping nut as shown in the sectional drawing. See Fig. 18.

Although the initial turning of the commutator may have been done accurately do not be mystified if the commutator is found to run out of true with the bore after it has been assembled. This is due to the unequal flow of the micanite when forming up the cones.

Riser Slits.

Each riser must now be slotted to receive the armature wires. This may be done with a circular saw about $\frac{3}{4}$ -in. diameter mounted on a mandrel in the lathe. The armature is clamped at the correct height on the saddle and turned round for each of the 22 cuts. The slits are cut almost the full depth of the risers, taking care not to injure the commutating surface. The thickness of the saw should be the nearest available size larger than the gauge of

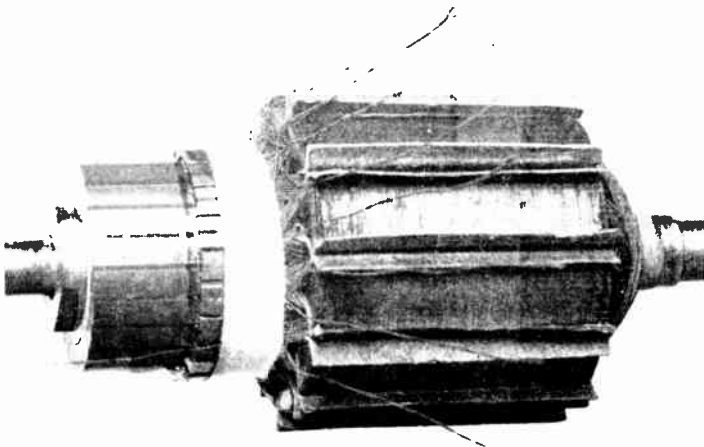

Fig. 27.—THE ARMATURE WINDING FINISHED WITH THE SECOND HALF OF THE CONNECTIONS READY FOR SOLDERING TO THE COMMUTATOR.

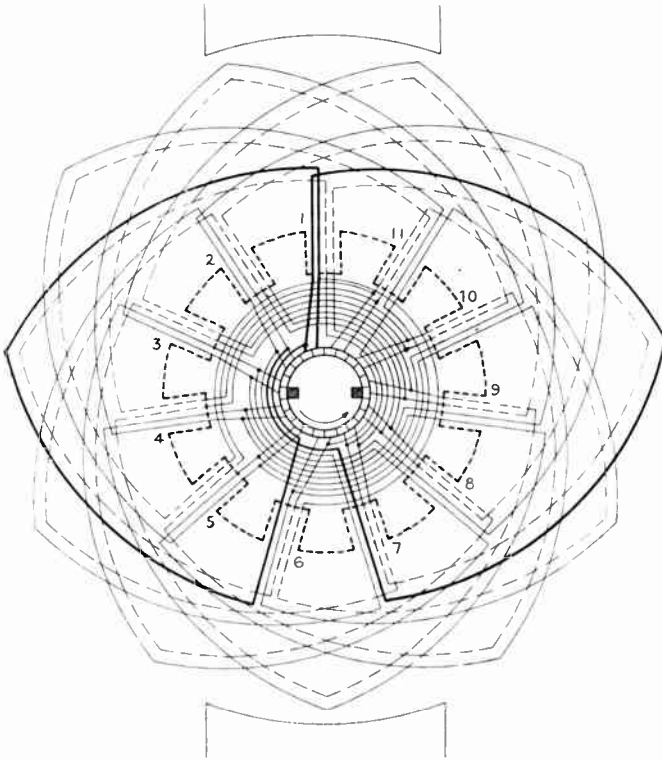

Fig. 28. THE COMPLETE ARMATURE WINDING DIAGRAM FOR THE 11-SLOT ARMATURE WITH 22 COMMUTATOR SEGMENTS.

One pair of coils is shown by heavy lines. The whole winding consists of 11 such pairs of coils wound from each of the 11 slots in order. The position of the brushes is indicated by two shaded squares inside the commutator. The second half of the winding, which starts from No. 6 slot, is indicated by dotted lines. The inter-connections of the coils are indicated by circular dots. The connections to the commutator have a lead to suit the direction of rotation shown.

wire to be used for winding the armature. If the commutator is turned on a mandrel before mounting it on the armature shaft, the slits may be cut with a fine hand saw or metal fret saw.

WINDING THE ARMATURE.

Shaft Insulation.

The end-windings of a hand-wound armature must necessarily be in close proximity to a short section of the shaft beyond each end of the stampings. It is thus essential to insulate that portion of the shaft between the back of the commutator and the armature and about $\frac{1}{2}$ -in. of the shaft at the back of the

armature. The material used is empire tape which is stuck with insulating varnish or a dab of Chatterton's compound. Two turns of tape are ample.

Armature Cheek Insulation.

Two presspahn washers $1\frac{1}{2}$ -in. diameter and $\frac{1}{32}$ -in. thick are now cut and clamped between two spare stampings. The presspahn is then cut round the slots so that two cheeks are produced exactly the same size and shape as the armature stampings. These are used to insulate the ends of the armature. The insulating cheek which goes at the commutator end must be split in order to get it in place. The presspahn cheeks are then stuck to the armature so that they register perfectly with the slots. A plain presspahn washer is made 1-in. diameter to insulate the back face of the commutator from the end windings.

Slot Insulation.

Each slot is insulated with .2 mm. thick presspahn. Eleven strips $1\frac{9}{16}$ -in. \times

$\frac{7}{8}$ -in. are cut and formed into channels on a piece of $\frac{1}{8}$ -in. rod. A presspahn channel is then pushed into each slot taking care not to damage the points of the cheek insulation. The over all length of the

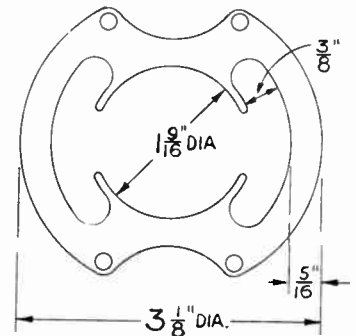

Fig. 29. THE DIMENSIONS OF THE FIELD MAGNET STAMPINGS.

Some makes of stampings have two flats instead of the circular recesses on the outer diameter. Both types are suitable.

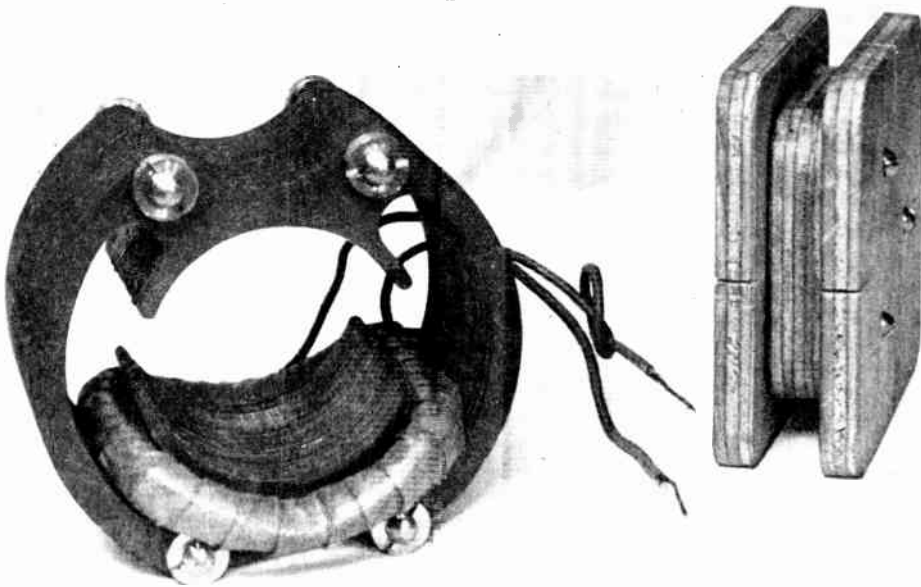

Fig. 30—THE ASSEMBLED FIELD MAGNET WITH ONE OF THE FIELD COILS IN POSITION. The wooden former on which the coils are wound is also shown.

slot insulation is the length of the armature plus the double thickness of cheek insulation. The projecting portions of the presspahn channels are then bent over with a rod, rounded at the end, as shown in Fig. 25. This gives a guide in for the conductors as they are wound on.

The Windings.

The table on page 1040 gives the armature and field windings for different voltages both A.C. and D.C. The data given for A.C. series windings may be used for D.C. of the same voltage, thereby making the motor a universal one. By using the D.C. series windings a somewhat lower speed is obtained. The D.C. series and A.C. series armatures are the same for the same voltage, but the D.C. field has more wire. The stronger field is unsuitable for A.C. operation. The shunt motor, which is used when a more constant speed machine is required, can be used on direct current only. The number of turns shown gives the data for each coil, thus for the armature there are 22 such coils, and for the field there are two.

The armature is wound with double

silk-covered wire, but the field coils are composed of enamel-insulated wire. This arrangement gives the highest possible efficiency consistent with good insulation. The windings are designed to give a speed of about 3,500 r.p.m. at full load output of $\frac{1}{16}$ h.p.

Fig. 28 shows a fully developed winding diagram of the armature as applied to this particular motor where the brushes are at right angles to the axis of the field magnets.

Full particulars relating to the order of winding the armature coils, and the scheme of connections to the commutator for an eleven-slot armature, are given on Pages 36—46. The method of winding field coils is also given in this section.

THE FIELD MAGNET.

The field magnet is composed of Stalloy stampings. The bore of the armature tunnel is $\frac{1}{16}$ -in. larger than the armature stampings so as to give an air gap of $\frac{1}{32}$ in. The stampings are clamped together by means of four 2 B.A. studs, with round nuts $\frac{1}{8}$ -in. thick at each end. The overall length of the assembled

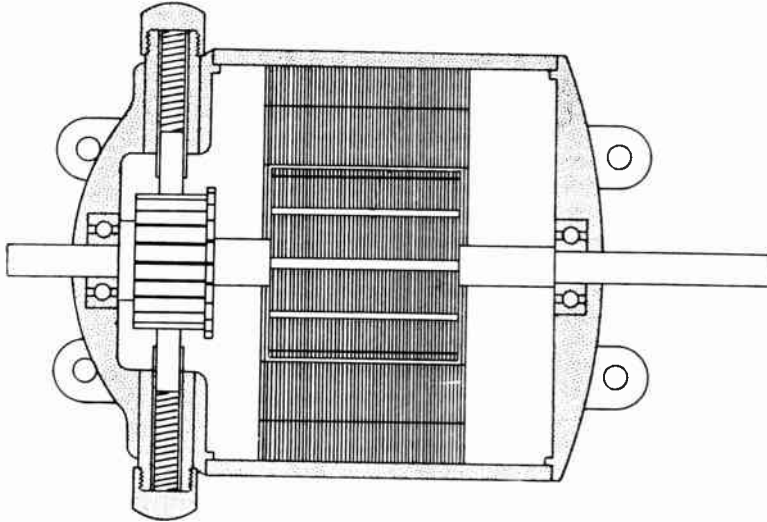

Fig. 31.—HORIZONTAL SECTION OF THE MOTOR SHOWING THE CONSTRUCTION OF THE BRUSH GEAR AND THE MOTOR CASING.

magnet is $1\frac{5}{8}$ in., which will take 85—90 stampings. The clamping studs must be a free fit in the holes of the stampings, or great difficulty will be experienced in threading them on. The yoke portion of the field magnet, which is the circular section connecting the two poles, has a total flux area of 1 sq. in., which gives a total flux in the air gap between the armature and pole faces of 55,000 lines. The dimensions of the field magnet stampings are shown in Fig. 29.

Field Coils.

The two field coils are wound on a wooden former, which is shown in Fig. 30. The centre piece of the coil former is made from $\frac{3}{8}$ -in. wood, and 2 in. square, with the corners rounded to about $\frac{1}{8}$ -in. radius. The cheeks of the former are made from $\frac{3}{16}$ -in. or $\frac{1}{4}$ -in. plywood, and four saw cuts are made to take the thread for tying up the coils. The centre piece of the former must be well tapered to facilitate removing the wound coil. This is more especially important for the fine wire coils of the shunt-wound motor. When the coils have been wound two flexible leads are soldered to the ends of each coil. The flexible lead which is connected to the start of

the coils is knotted so that the direction of the winding is easily identified after the windings have been insulated with empire tape. The two field coils are then placed in position on the field magnet, and the coils bedded well down on the pole pieces. The ends of the coils are bent outwards as far as they will go, so as to draw the coils up tightly. The field

coils are held in position by means of two soft iron strips. These are first bent a U-shape, so that the inside measurement of the U-pieces is $1\frac{3}{8}$ in. The limbs of the U-pieces are then passed between the ends of a coil and the pole piece.

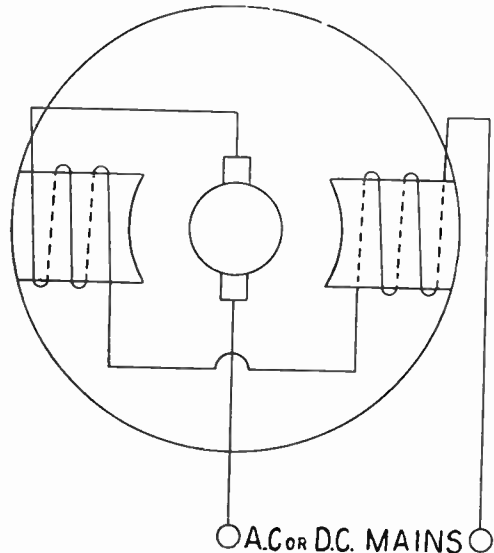

Fig. 32.—THE INTERNAL CONNECTIONS OF THE SERIES MOTOR.

The armature and the two field coils are connected all in series.

Finally the projecting ends of the strip are bent over the ends of the field coil, thus firmly retaining it in position. A piece of .2 mm. presspahn is inserted between the strip and the coil to prevent the sharp edges of the iron strip from cutting the insulation of the field winding. Fig. 30 shows one field coil in position.

The Motor Casing and Magnet.

The motor case, or frame, which houses the laminated field magnet, the brush gear and the armature, consists of three castings. The casting which houses the field magnet is a plain cylindrical tube $2\frac{3}{4}$ in. long and $\frac{1}{8}$ -in. thick. The inside diameter of the tube is made to fit the outside diameter of the field stampings, as shown in Fig. 31. The end-frames are turned with spigots which fit the inside of the cylindrical shell of the motor. When turning the motor end-frames, the spigots and the ball-race housings are turned at the same setting so as to ensure the concentricity of the armature with the field poles. The end-frames are secured to the body casting by means of small blocks screwed to the cylinder which are located so as to avoid the end-windings of the field coils.

The commutator end-frame is differently designed from the pulley end of the motor. It has two bosses which carry the brush gear. These are drilled out $\frac{7}{16}$ -in. diameter as indicated in the sectional drawing, Fig. 31.

The field magnet assembly is located $\frac{3}{8}$ -in. from the commutator end of the cylindrical housing. The stampings are fixed in position by four 4 B.A. screws, which pass through the casing into the yoke of the magnet. The holes are drilled in the casing first with a No. 27 drill, and then with the stampings in position the location of the tapped holes is marked through with the same drill. The magnet is then removed, and the four holes drilled $\frac{1}{4}$ -in. deep with a No. 32 drill, and tapped out 4 B.A.

Brush-Gear.

The brush-gear consists of two $\frac{3}{16}$ -in. sq. carbon brushes which run in square brass tubes, each $2\frac{1}{8}$ in. long. The metal brush holders are insulated from the frame of the motor by ebonite tubes, $\frac{7}{16}$ -in.

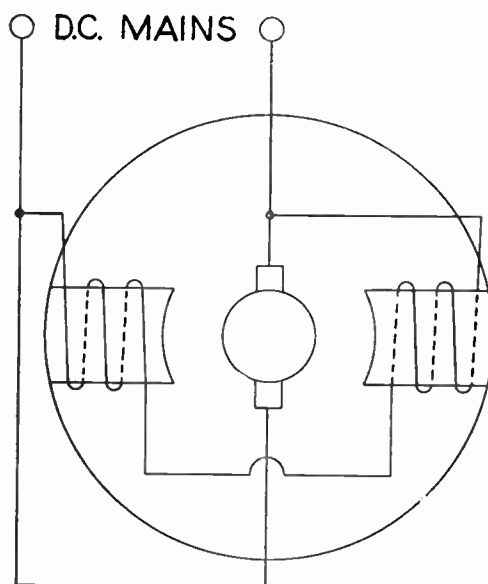

Fig. 33.—THE INTERNAL CONNECTIONS OF THE SHUNT WOUND MOTOR.

This type of machine is only suitable for D.C. supplies. The two field coils are connected in series and the ends of the field are in parallel with the armature, or brushes.

outside. The metal portion of the brush holders is made to project $\frac{3}{16}$ -in. beyond the ebonite, so that the connections to the brushes can be made inside the motor. The part of the brush holder which projects beyond the motor casing is threaded to receive an ebonite cap, which serves to retain the brush tension spring. The grade of the brushes is Link EG4.

Connecting the Field Coils.

The internal connections of the series wound motor are shown in Fig. 32. The two field coils are connected in series so that the two poles of the magnet are of opposite polarity. This means that when the coils are viewed from one side, the current must flow in the same direction round each pole piece. The field windings are connected in series with the brushes.

The connections between the brushes and the field coils for the shunt motor are shown in Fig. 33. The interconnection of the two field coils is the same as for the series motor, but the ends of the mains winding are directly across the mains in shunt, or parallel, with the brushes.

ELECTRICITY SUPPLY METERS

By KENELM EDGCUMBE, M.Inst.C.E., M.I.E.E.

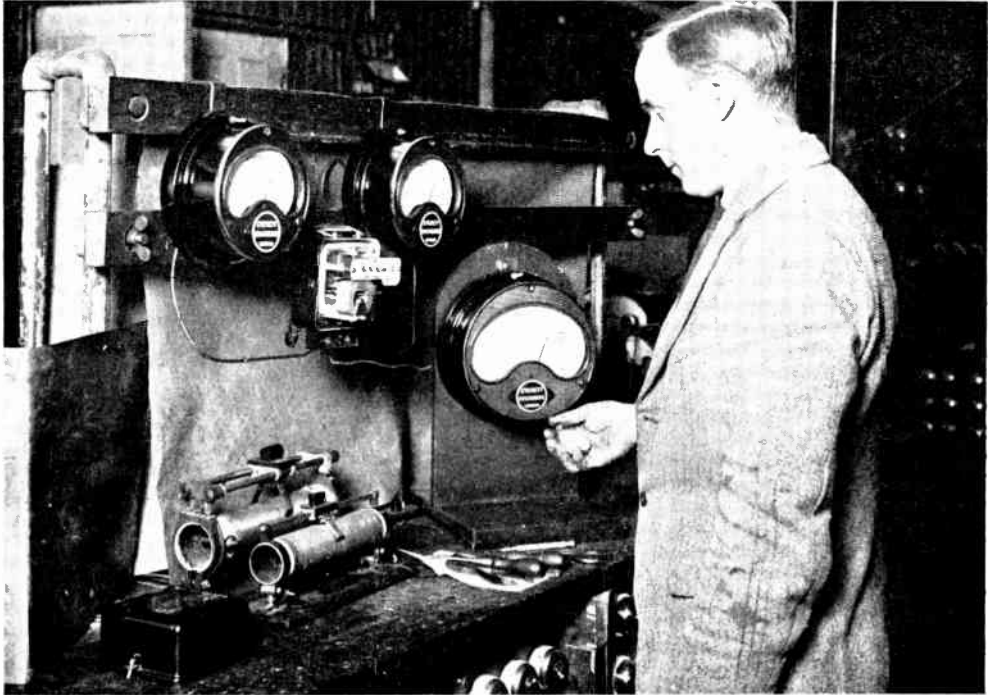

Fig. 1.—CHECKING THE PERFORMANCE OF A METER BY MEANS OF A STOP WATCH.
The connections for this test are those shown in Fig. 6.

OF the large number of supply meters available, only a very few types can be described. Those most used in this country are the mercury meter for D.C. and the induction meter for A.C.

For D.C. house service use, ampere-hour meters are used, the consumption in kilo-watt hours being calculated on the assumption of normal voltage. A.C. meters are invariably of the watt-hour pattern, since not only do such meters take into account any variations in the voltage, but in the power factor also. With A.C. loads it is never safe to calculate the power by multiplying the current and the voltage.

A.C. Induction Meters.

Fig. 2 shows a typical A.C. induction watt-hour meter without its case and with the counting train removed so as to show the working parts. An aluminium disc carried by a vertical spindle is caused to rotate by means of a compound wound electro-magnet having both volt and current windings and inducing eddy currents in the disc. The parts are so proportioned that the driving force is exactly proportional to the power flowing in the circuit to which the meter is connected. The motion is opposed by further eddy currents induced in the same rotating disc by a powerful permanent magnet which is seen to the left of Fig. 2. The

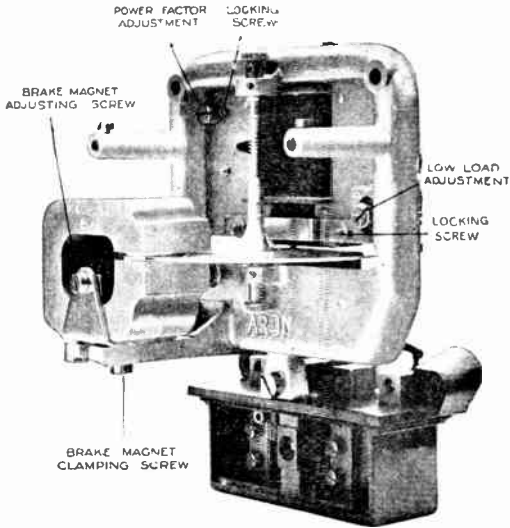

Fig. 2.—A.C. INDUCTION METER REMOVED FROM ITS CASE.

Showing how various running adjustments are made.

result of this combined action is that, when properly adjusted, the speed of rotation of the disc is exactly proportional to the power flowing, so that a counting train geared to the meter spindle by means of a worm can be made to read in units (kilo-watt hours) direct.

The Spindle.

Fig. 3 gives a sectional view of the spindle of the same meter. It will be noticed that both the bottom jewel and the top pivot are spring mounted, which protects them from damage, either in transit or when subjected to excessive vibration. The bottom pivot and jewel take all the weight; the upper one, which is much lighter, acts merely as a guide.

Curve of Modern A.C. Meter.

A modern A.C. meter should give a "characteristic curve" connecting watts with speed, which is almost a horizontal straight line, as will be seen from Fig. 4 (Ferranti A.C. meter). It will be noticed that a 10 per cent. rise or fall of voltage has but a small effect on the readings, as also a departure from the normal frequency. This latter effect is seen from Fig. 5,

which shows that whilst at normal frequency (50 cycles) the meter reads almost the same at unity power factor as at a power factor of 0.5, yet if the frequency differs from 50 cycles the error is appreciable. In modern power stations the frequency is kept so constant (see later article) that this is of small consequence.

Checking the Performance.

The curves shown in Figs. 4 and 5 refer to a new meter as delivered by the maker. After being in service for a long time many things may happen to a meter. The damping magnet may weaken, causing the meter to run fast; the pivots or jewels may be damaged, causing it to run slow; dust may accumulate in the counting train with the same effect, and so forth. It is necessary, therefore, to check such meters from time to time. If a standard integrating meter is available, the simplest method is to connect it up with the meter to be tested so that the current windings of the two instruments are in series and their volt windings in parallel. A comparison of the dial readings after the two have been run in this way for a given time enables the error in the meter under test to be determined. In order to reduce the

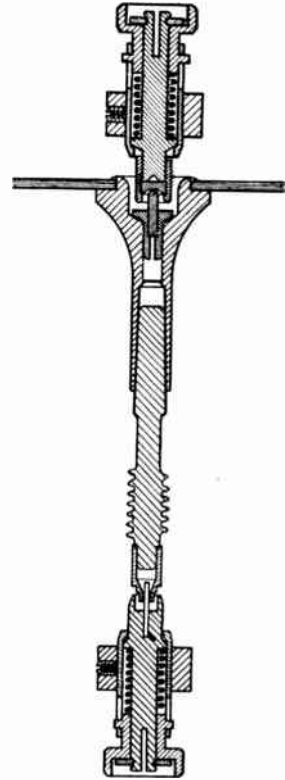

Fig. 3.—THE SPINDLE WHICH CARRIES THE ALUMINIUM DISC OF AN ARON METER.

Note the spring cushioning of the jewels to prevent damage. The top and bottom bearings are removable by slacking the grub screws seen on the right.

VOLTAGE VARIATION CURVE

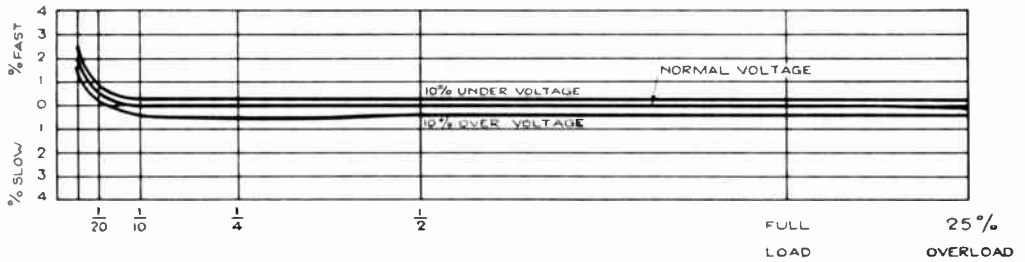

Fig. 4.—CHARACTERISTIC CURVE OF AN A.C. METER. Showing how the performance depends upon the load and the voltage.

time taken to carry out this measurement, it is usually sufficient to compare the number of revolutions made by the discs themselves in a given time. If the meter constant (that is, the number of revolutions of the disc which corresponds to 1 kilo-watt hour) is the same for the standard meter (S) and the meter under test (T) we have :—

$$\text{Percentage error of meter T} = \frac{(\text{Revs. of meter T} - \text{revs. of meter S})}{\text{Revs. of meter S}} \times 100$$

When a Standard Meter is not Available.

If a standard meter is not available, an ammeter, voltmeter and wattmeter can be connected up as shown in Fig. 6. In this case the load, as measured by the wattmeter, should be kept constant for a given time, say half an hour, by means of a variable loading resistance and the advance of the meter dials during that time noted. If the watts as shown by

the wattmeter were, for example, 1,500, the total watt-hours would then be $1,500 \times \frac{1}{2} = 750$. If the meter registered, say, 770 watt-hours, then :—

$$\text{Percentage error of meter under test} = \frac{(770 - 750)}{750} \times 100 = 2.7\%$$

Here, again, matters may be accelerated by noting the time taken by the disc to make 10 revolutions and comparing this with the time which the 10 revolutions should have taken, as calculated from the meter constant shown on the name plate, then :—

$$\text{Percentage error of meter under test} = \frac{(\text{Calculated time} - \text{measured time})}{\text{Calculated time}} \times 100.$$

Since the time taken for 10 revolutions would probably be less than one minute, it adds greatly to the accuracy if a stop watch is used to measure the time, as is being done in Fig. 1.

FREQUENCY VARIATION

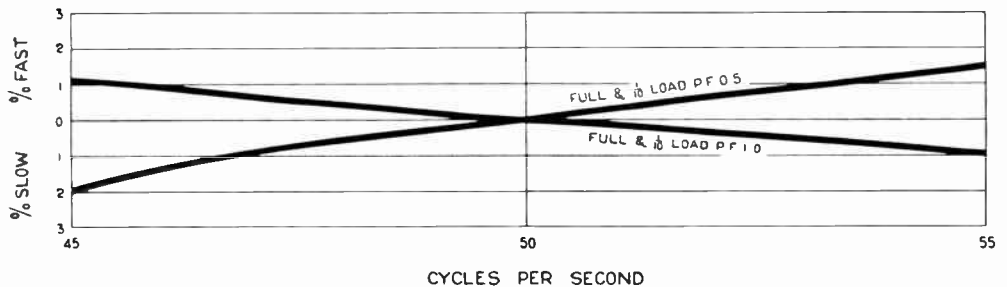

Fig. 5.—CHARACTERISTIC CURVE OF AN A.C. METER. Showing how the performance depends upon the frequency, load and power factor.

Tests at Various Loads.

As will be seen from Fig. 6, it is not necessary, when making these tests, to apply the full load to the meters and instruments; in fact, it is usually more convenient to employ a "phantom load." It is usual to make tests at various loads, such as full load, half load, quarter load and one-tenth load, and preferably at a power factor of approximately unity and 0.5. A power factor of almost unity will usually be obtained if the loading resistance is non-inductive, and a lower power factor if it is somewhat inductive.

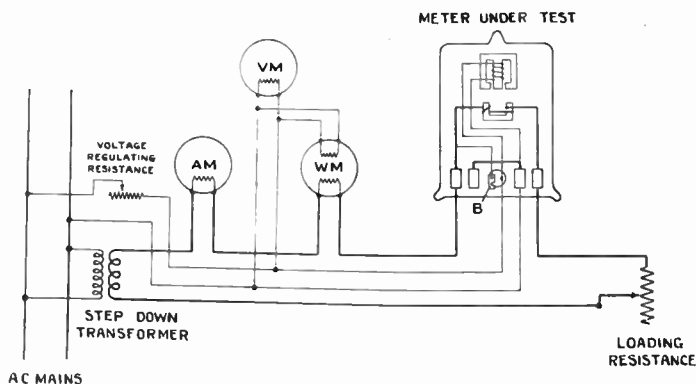

Fig. 6.—CONNECTION DIAGRAM FOR CHECKING THE PERFORMANCE OF A SINGLE-PHASE WATT-HOUR METER BY MEANS OF AN AMMETER, VOLTMETER AND WATTMETER.

If the loading resistance is made somewhat inductive by including an iron-cored choking coil, the test can be carried out at any desired lagging power factor.

N.B.—
$$\text{Power factor} = \frac{\text{watts}}{\text{amps.} \times \text{volts}}$$

The power factor can be determined from the ammeter, voltmeter and wattmeter readings, and it is for this reason that three instruments, as shown in Figs. 1 and 6, are necessary for A.C. meter testing.

Other Tests for Meters.

Besides accuracy measurements at the loads mentioned, it is usual to test a meter for (a) minimum starting current, that is, the lowest current at which the disc commences to rotate; (b) for absence of any tendency for the disc to rotate when no current is flowing through the current winding; (c) insulation resistance (see later article). If, in order to separate the volt and current windings for a test, a

link has been removed in the terminal box (see B in Fig. 6) care must be taken to replace it before installing the meter.

Correcting the Adjustment of a Meter.

Having determined the error of the meter in one of the ways described, it may be sufficient to apply a correction to the meter readings, but apart from the inconvenience of so doing it is very likely that the error will differ according to the load and power factor, so that except in the rare case of a meter which is to be used all the time at a given steady load no such constant correction can be applied. It is usually essential, therefore, to be able to correct the adjustment of the meter and for this reason meters often embody easily accessible adjustments for (1) speed at normal load; (2) speed at low load; and (3) power factor. The means of making these adjustments, as shown in Fig. 2, are typical of many induction meters. The normal load adjustment is made by moving the poles of the permanent magnet nearer to, or farther from, the centre of the disc, according to whether the speed is to be increased or decreased. The low load adjustment is made by moving a small piece of magnetic material across the poles of the volt magnet.

How Power Factor Adjustment is Effected.

The power factor adjustment is effected by varying the position of a copper ring which encircles one limb of the volt magnet and by means of which the phase relationship of the magnetic flux to the applied voltage can be changed. In Fig. 7 the operator is seen adjusting the position of the brake magnet until the speed of the meter at normal load is correct. Care must be taken that after any such adjustment the various parts



Fig. 7.—ADJUSTING THE MAGNET POSITION OF AN ARON METER AFTER CHECKING ITS PERFORMANCE WITH A PORTABLE WATTMETER AND STOP WATCH.

are again securely locked in place. When checking the speed of a meter it is important that its cover should be in place, as it may have a considerable effect upon its working.

D.C. Meters.

In the mercury ampere-hour meter, which, as has been said, is the one commonly used for D.C. metering, a copper disc or cup is carried by the meter spindle, and is free to rotate with but small clearance in a chamber filled with mercury.

The current to be measured flows in the cup or disc, connection being made by means of the mercury in which it is immersed, and a permanent magnet is so placed that a strong magnetic flux passes through it. The copper member is thus caused to rotate, such rotation being retarded by eddy currents generated in it, as well as to a much smaller extent by fluid friction. As a result of this combination the speed of rotation can be made almost proportional to the current passing.

Special precautions are taken to prevent

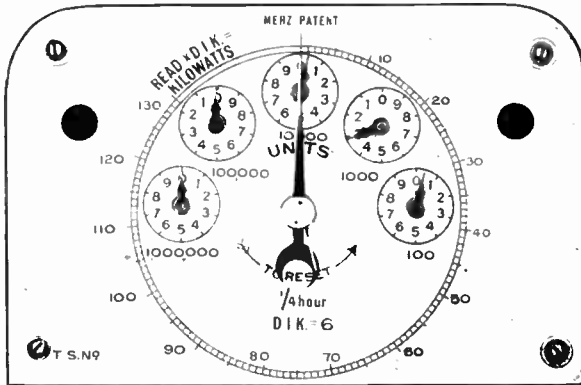

Fig. 8.—DIAL OF A METROPOLITAN VICKERS MAXIMUM DEMAND METER (MERZ SYSTEM).

The pointer is geared to the meter spindle for a quarter of an hour at a time and is left standing at the highest point reached. This position, therefore, indicates the largest number of kilowatt hours which have been registered during any quarter-hour period. This number, multiplied by four, is equal to the maximum value of the average load in kilowatts.

the spilling of the mercury during transit and care is necessary to close the mouth of the mercury chamber by the means provided before moving such a meter, since if the mercury finds its way on to the working parts much damage will be done.

Double-tariff or Two-rate Meters.

It is always the object of the supply authorities to level off the load at the power station as much as possible, since peak loads of short duration are costly to supply. In order to encourage individual consumers to assist in this direction a higher rate per unit is often charged during those hours at which the highest demand is expected, for example, in winter between 5 and 9 p.m. This is accomplished by providing the meter with two sets of dials, the one being connected to the meter spindle during "peak hours" and the other during the remainder of the day. The change is effected by means of a time switch and this may be most conveniently driven, in the case of A.C. meters, on controlled systems (see later article), by a synchronous motor so as to obviate the necessity for winding or regulating.

Maximum Demand Metering.

With the same object in view, namely, the levelling of the load, many tariffs include a fixed charge based upon the consumer's maximum demand, together with a low charge per unit consumed. The maximum demand indicator may be either a separate instrument (often of the thermal pattern, the maximum demand being then measured in amperes) or may form part of the meter itself (the maximum demand being then measured in kilowatt hours). The dial of such a meter is shown in Fig. 8 (Metropolitan Vickers). Alternatively, the maximum demand may be measured in k.V.A. (as, for example, by the Hill-Shotter maximum demand meter).



Fig. 9.—PREPAYMENT METER (FERRANTI) WITH EXTERNAL PREPAYMENT ATTACHMENT AND COIN BOX.

Prepayment Meters.

These consist of a more or less normal meter element which, after making a predetermined number of revolutions, causes the consumer's circuit to be opened, thus cutting off his supply. The insertion of a coin (usually a shilling or a penny) allows the switch to be closed once more and to remain closed until a given quantity of electricity has again passed through the meter or until a further coin has been inserted in advance. Fig. 9 shows such a meter from which the meter reader is in the act of removing the coin box preparatory to emptying it.

The meter indicates (1) the total number of units consumed; (2) the total number of coins which have been inserted; and (3) the number of coins still remaining unused, that is, standing to the credit of the consumer.

Points to be Attended to When Erecting a Supply Meter (*see also later article*).

Choose a dry situation, preferably free from dust.

Fix the meter against a flat vertical

surface with the meter spindle as nearly upright as possible.

After fixing in position, *and not before*, unclamp the rotor.

Study the maker's diagram and connect up carefully in accordance with it.

In a D.C. meter the current must enter at the + terminal and leave at the — terminal.

In an A.C. meter the terminal which is to be connected to the incoming mains is often marked "M" and that for connection to the consumer's load "L."

Do not attempt to reset the dials to zero as this can only be done by carefully drawing the pinion out of engagement with the worm—a somewhat delicate operation.

Care is necessary in reading meters provided with clock dials (Fig. 1), since neighbouring dials are numbered in opposite directions. For example, in Fig. 8 the reading is 000304 units.

Measuring Instruments.

Where reference is made to a later article, this refers to the article entitled "Electrical Measuring Instruments."

QUESTIONS AND ANSWERS

What type of meter is generally used for

(1) D.C. supply, and (2) A.C. supply?

(1) For D.C. house service use, ampere-hour mercury meters are used, the consumption in kilo-watt hours being calculated on the assumption of normal voltage.

(2) A.C. meters are usually of the induction watt-hour type, as these not only take into account any variations in the voltage, but in the power factor as well.

What faults are likely to develop in an A.C. induction meter after long use?

(1) The damping magnet may weaken, causing the meter to run fast.

(2) The pivots or jewels may be damaged, causing it to run slow.

(3) Dust may accumulate in the counting train, also causing it to run slow.

What is the simplest method of checking a meter?

By using a standard integrating meter which is connected up with the meter to be tested so that the current windings of the two instruments are in series and their volt windings in parallel.

What method must be adopted if a standard meter is not available?

An ammeter, voltmeter and wattmeter must be used.

What other tests besides accuracy tests are usually made?

(1) Minimum starting current, that is, the lowest current at which the disc commences to rotate.

(2) For absence of any tendency for the disc to rotate when no current is flowing through the current winding.

(3) Insulation resistance.

THE DESIGN OF APPARATUS FOR H.T. SUPPLY UNITS

By A. E. WATKINS

THIS article deals mainly with the design and construction of apparatus used in H.T. supply units. For additional particulars regarding the use of H.T. eliminators and the various circuits that can be employed, readers

use. It is essential that they are used on the supply circuit for which they are designed, and whether the supply is direct or alternating current.

Units for D.C. mains supply do not require a rectifier.

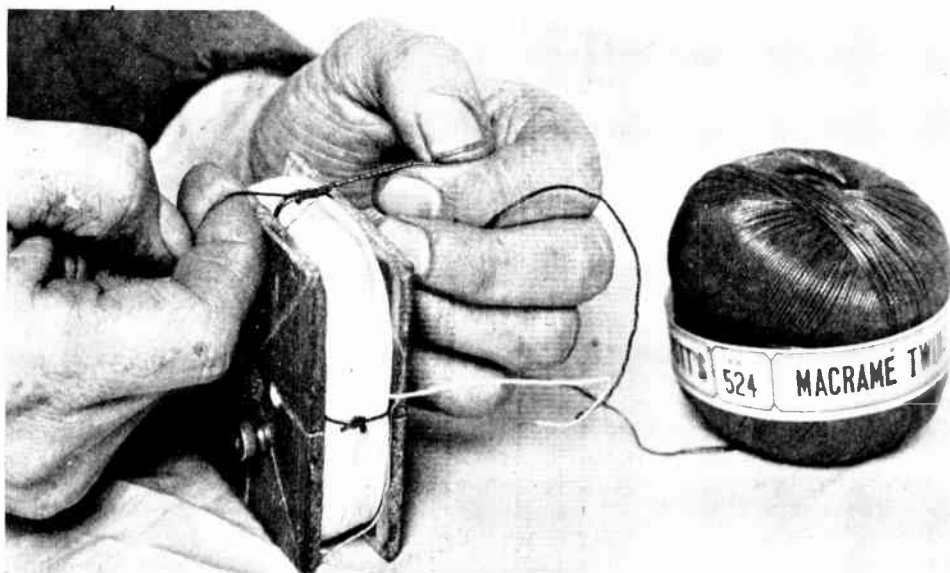

Fig. 1.—A STAGE IN THE CONSTRUCTION OF THE COILS FOR A TRANSFORMER FOR VALVE RECTIFIERS. The winding is bound together by passing a piece of fine string or strong thread through each of the slots and tying tightly. See Figs. 14 and 15 for the following stages.

are referred to the article on page 506.

High Tension Supply Unit.

An H.T. supply unit, commonly called an H.T. battery eliminator, is an apparatus to enable high tension voltage to be obtained from the electric supply main. There are two distinct types commonly used for radio work. They are those which use a metal rectifier and those which use a valve rectifier. Either type requires certain precautions in its construction and

Precautions to Take When Installing.

Before installing an H.T. unit, if the nature of the supply is unknown, write to the electric supply authorities informing them of your intentions and asking for the required information. Very serious consequences may arise if an H.T. supply unit is connected to a supply for which it is not suitable. Certain regulations of the Institute of Electrical Engineers have been framed for the introduction of H.T. supply units and these requirements are insisted.

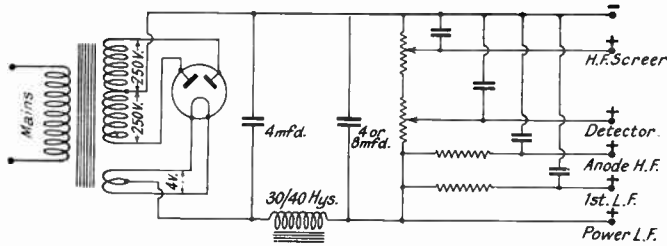

Fig. 2.—A TYPICAL VALVE RECTIFIER CIRCUIT. This has an output of 200 volts at 50/60 milliamps.

upon by the electricity supply authorities. To comply with these requirements the unit must be housed in a fire-proof metal safety box equipped with a double pole switch, the metal case of which must be earthed. In addition, the speaker must not be connected direct to the receiver output terminal, but must have a filter choke output or a separate transformer. That is to say, the speaker must be so connected that there is no high tension on the leads or terminals of the speaker.

Special Precautions with D.C. Supply.

On D.C. supplies the following precautions are required. A great many of the D.C. mains in this country are connected on what is known as the three-wire system. In some cases the negative wire entering a house may be earthed and the positive wire may be from 200 to 250 volts above earth. In this case, one additional and very important precaution must be taken. The earth terminal of the set should be disconnected from the ordinary earth connection and should be connected to one terminal of a condenser of 2 mfd. capacity of the high voltage type. The earth wire which was normally intended for the set must be connected to the other terminal of the condenser. Also, the aerial must be disconnected and connected to a small condenser of approximately .0002 mfd. The other terminal of this should be connected to the receiver terminal which was originally connected to the aerial.

Failure to carry out these latter precautions may result in very serious

consequences, for the shorting of one of the mains to earth may cause fire and even loss of life.

Other houses in the same neighbourhood may be connected to the other side of the main, in which case the positive main will be earthed and the negative will remain from 200 to 250 volts below earth. In addition to

these precautions, others are necessary. It must be remembered that the whole set and low tension batteries have now a voltage of minus or plus 200 to 250 volts relative to earth, and therefore any contact may give an unpleasant shock. The low tension battery must stand on insulated material—a piece of glass or ebonite is a satisfactory insulator.

Connecting Up L.T. Batteries.

The low tension batteries should be connected to the receiver with well-insulated cable, and should never be connected or disconnected when the eliminator is switched on. On no account disregard these precautions.

H.T. SUPPLY UNITS FOR A.C. MAINS.

The first unit in a battery eliminator for A.C. mains is the transformer. Figs. 2 and 3 show typical circuits for valve and metal rectifiers. The design of the transformer depends upon the type of rectifier. If it is a metal rectifier it only requires the primary winding which is connected to the A.C. main and one secondary winding to the rectifier as in Fig. 5. If connected to a valve rectifier it requires the primary winding, one centre tap winding for the H.T. supply to the valve plates and one

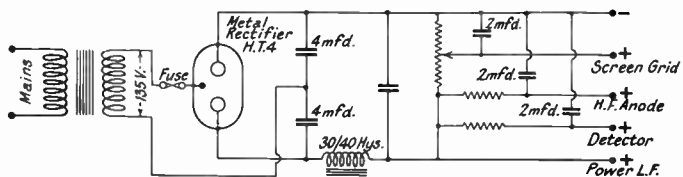

Fig. 3.—A VOLTAGE DOUBLER METAL RECTIFIER CIRCUIT. This has an output of 180 volts at 30 milliamps.

smaller winding for the filament, which is also centre tapped (see Fig. 4). This filament winding must be extremely well insulated, for this also carries the rectifier high tension current, and a short circuit between this winding and the other windings of the transformer would be serious. The primary of either transformer must be wound suitable to the supply mains and whether this is correct or not can only be gathered from the maker's markings, for the resistance of the winding bears no relation to the supply voltage for which it is designed. It is the number of turns of wire which count relative to the size of the iron core. This will be dealt with more fully in the construction of transformers, towards the end of this article.

The Rectifier.

The second unit, which is the centre of the H.T. rectifying unit, is either the metal rectifier or the valve rectifier. These are the instruments upon which the whole operation of the unit depends, for they rectify the alternating current to direct current or give a pulsating supply which can be smoothed to a steady D.C. supply.

Valve and Metal Rectifiers Compared.

The following are the relative characteristics of both types, and each is equally efficient in the long run, for, where with one the transformer is cheaper to make, the metal rectifier costs more than the valve, so that the advantages and disadvantages are balanced.

Westinghouse Metal Rectifier.

1. More efficient than the valve rectifier.
2. Has no valve or filaments.
3. It requires a simple main transformer.
4. For a given D.C. output voltage the input voltage need not be much greater.

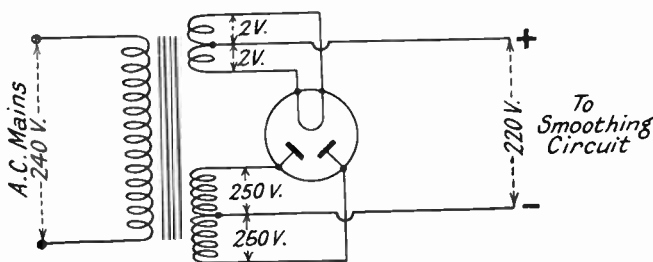

Fig. 4.—TRANSFORMER CONNECTIONS FOR FULL-WAVE VALVE RECTIFIER.

The transformer requires the primary winding, one centre tap winding for the H.T. supply to the valve plates and one smaller winding for the filament, which is also centre tapped.

5. For a given output it is more effective than a valve.
6. Its life is practically unlimited.

Valve Rectifier.

1. It is cheaper than a metal rectifier.
2. It requires a more expensive transformer because there are more windings.
3. The voltage across the secondary of the mains transformer should be double that required for the same output of a metal rectifier (full wave).
4. Replacements at rare intervals are required, but many workers prefer the valve as it is considered to have a better voltage regulation, particularly when required for very heavy loads.

Smoothing Systems.

The smoothing systems (Figs. 9 and 10) for both metal and valve rectifiers, also D.C. mains, is much the same and consists of iron core chokes, condensers and resistances, and the connections and circuits of the smoothing system are the same whether used for any of these three types. The more elaborate the smoothing system, the quieter the operation of the receiver, par-

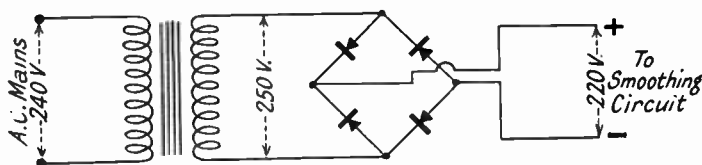

Fig. 5.—TRANSFORMER CONNECTIONS FOR METAL RECTIFIER. This needs the primary winding which is connected to the A.C. main and one secondary winding to the rectifier.

ticularly when screened grid valves are used. While a simple eliminator need only have one smoothing choke, for more elaborate receivers it is better to have two or even three, particularly three in the case of D.C. mains, as with D.C. mains we have more component ripples to smooth out than in rectified A.C. current. Reference to the graph of unsmoothed circuits in Fig. 11 will explain these difficulties.

Having now briefly described the various component parts, we will consider the construction of each separate unit, together with the design of transformers and smoothing chokes.

THE DESIGN FOR MAKING A TRANSFORMER FOR 50 CYCLES, TO USE WITH WESTINGHOUSE METAL RECTIFIERS.

If the transformer is only required for use with H.T. supply it only requires two separate windings. But if it is required for the filament supply, then an extra winding is needed; also it may be advisable to add a further winding for grid bias supply, and this can very conveniently be obtained from special small metal rectifiers.

Data for Transformer for All-mains Set.

Data has therefore been included for these two windings, since there is ample space on the core and will very materially widen the scope of unit so it can be adapted for an all-mains operated receiver. These extra windings add so little to the cost of the construction that their inclusion is well worth while. The winding for the grid bias is a voltage of 45 volts and is to provide grid bias by employing the Westinghouse G.B. rectifier unit. The others give 4 volts and a maximum current of 4 amps. This enables indirectly heated valves to be

used, thereby entirely dispensing with batteries.

Data for Various Supply Voltages.

The design of this transformer is suitable for use on either the Westinghouse H.T.1, H.T.3 or H.T.4 units. The first mentioned requires 230 volts input, whereas the H.T.3 and H.T.4 operate on 135 to 140 volts, as this is the maximum potential they will stand. It is therefore decided to tap the winding of the 230 volts secondary output for the lower voltage, but, of course, this is not necessary if the secondary winding is designed for a particular unit, as there would be no object in adding extra wire unless the higher voltage were required. The stampings for the core are Sankey's No. 4. There are other manufacturers of stampings of a similar size. Sufficient stampings are required to build up $1\frac{1}{2}$ inches. It is only necessary to construct a simple bobbin for the winding as in Fig. 13.

Constructing a Simple Bobbin.

This may be constructed of heavy gauge cardboard, after which it is well dried and soaked in shellac. A better material is bakelite, but this is difficult to cement unless a special cement is used. The class of cardboard which is recommended is that which is termed "leather board." This is a hard brown cardboard and, when well dried, forms a good insulator, particularly if the bobbin is allowed to soak in hot shellac for some time and then thoroughly baked in a warm oven. The sizes for this bobbin are set out in Fig. 13.

Size of the Core.

The size of the core of this transformer has been calculated so that the windings



Fig. 6.—THE CONSTRUCTION OF A "MULLARD" FULL-WAVE RECTIFIER VALVE.

Note that there are two plates and two filaments.

are allowed for at six turns per volt, so that it is extremely easy to work out the number of turns required for any particular voltage by simply multiplying the supply voltage by six. For instance, if the supply voltage is 100, 600 turns are required. If the voltage is 200, 1,200 turns are required, but different gauges of wire will be necessary, because on the lower voltages a higher current will have to be carried. For voltages up to 130 volts, No. 24 gauge wire is required. For 200 volts and upwards, No. 28 wire is required. These wires should be enamelled and single cotton covered, but if we should so wish on the 100, 110 and the 200 volts, double silk-covered wire can be used as there is sufficient winding space.

Winding on the Primary Wire.

The primary winding, which is wound on first, must be chosen with regard to the main voltage.

After the primary has been evenly wound on it should be covered with three layers of empire cloth. It may be mentioned here that the winding can be carried out on the winding machine described for the repair of loud-speakers (see page 298), it only being necessary to make a wooden core to take the bobbin. This machine will be found more convenient than a

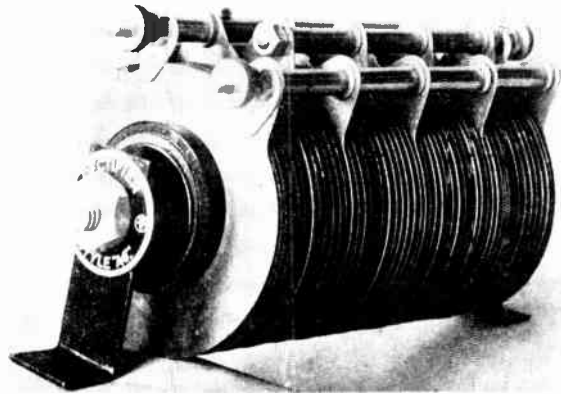

Fig. 7.—THE "WESTINGHOUSE" METAL RECTIFIER. Note the three terminal connecting bars.

lathe or other machine for rotating the bobbin while winding, because the bobbin must be rotated evenly and steadily.

Winding the Secondary.

After having insulated the primary, the secondary is wound. The secondary consists of 1,380 turns of No. 32 enamelled single cotton-covered wire, and if it is required for the lowest voltages for the other types of Westinghouse units a tapping is taken at 820 turns. If, of course, it is decided that the transformer is only going to be used for the lower voltage units, it is only necessary to wind on 820 turns of wire. The full winding is for the full voltage of 230 volts and 135 volts is a tapping at the 820th turn.

The secondary is again insulated with three layers of empire cloth and then the 45-volt winding can be wound. For this 270 turns of 36 enamelled wire will be required. When completed, again cover with three layers of empire cloth. If the 4-volt winding is also required, we then wind 26 turns of No. 16 double cotton-covered wire and a tapping is taken at the 13th turn for the centre tap. These two latter windings may be omitted, if they are not required, without affecting the performance of the transformer in any way.

Building Up the Core.

Certain points require watching during

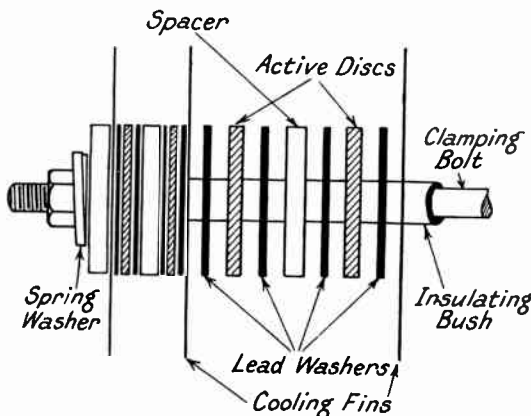

Fig. 8.—THIS SHOWS THE ASSEMBLY OF A "WESTINGHOUSE" METAL RECTIFIER.

the process of building the core, and the stampings must be placed alternately through the core or tunnel of the body. That is to say, the single leg stamping must be placed in one direction and then reversed so that when the whole core is built together it is interlaced. They must be packed as tightly as possible into the core or tunnel of the body for any looseness in the core is likely to lead to an unpleasant buzzing when the transformer is in use. The whole stamping should be clamped firmly together and it is advisable to use two castings for this purpose. A simple wooden pattern can be made and a casting made of aluminium or even cast iron. These end plates are then bolted together to clamp the whole of the stamping tightly together.

Construction of the Terminal Block.

The terminal block is also carried along the end plate. This terminal block can be constructed from ebonite or any other high-grade insulated material. After the transformer is finished it is advisable to test the insulation between the winding and the core. For this purpose a 500 volts megger will give the desired test. This can be loaned from the

majority of large electricians should the constructor not have one of his own available.

Also the insulation between each winding should be tested as it may so happen that if care is not taken in the insulation between each winding, a wire from one winding may slip between the insulation and cause trouble between the windings. Therefore every care should be taken that the empire cloth is the full width of the bobbin so that there is no chance whatsoever of the winding above slipping to the lower winding.

THE DESIGN OF TRANSFORMERS FOR VALVE RECTIFIERS.

As mentioned earlier in this article, it

is necessary for the transformers of a valve rectifier unit to have extra winding. Therefore we must proceed in a somewhat different manner in forming the winding for this transformer, for it is not practical to wind so many different windings on one bobbin. It is better to make each winding in the form of a slab coil, and independently insulated.

Making the Former for Winding the Coils.

The simplest way is to make a wooden former the size of the coil required after making due allowance for the necessary

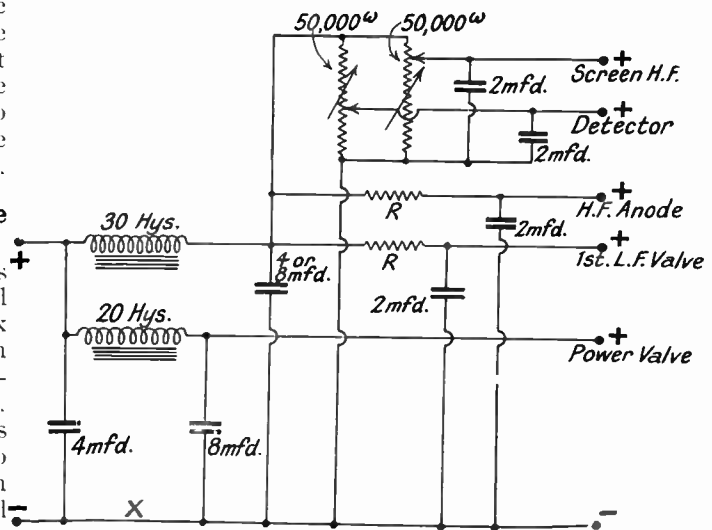

Fig. 9. —SMOOTHING CIRCUIT SUITABLE FOR MULTI-VALVE RECEIVER. If used on D.C. mains an extra smoothing choke may be required in the negative lead at X if the mains are noisy.

taping and for a centre former. Winding the coils in this manner, taking each one independently, is very simple and satisfactory, for we are certain that each coil will be perfectly insulated from the others, and it will be realised how necessary this is when we consider that between the ends of the secondary winding is a voltage of 500. The former, for winding the coils, is made of wood. First of all decide upon the size of the core. Presuming it to be 1 inch by 1½ inches and allowing for ¼ inch cardboard former, which should be made so as to fit the stamping tightly into the tunnel, the wooden centre of the former must be plus ⅛ inch; also another ¼ inch should be allowed for the tape, for,

after the coils are taped up, this will reduce the size of the inside core.

The Cardboard Centre Core.

This is to prevent any damage when the stampings are pressed in hard, for otherwise the metal of the stampings will cut through the taping. Therefore the centre wooden core would be $1\frac{3}{16}$ in. by $1\frac{1}{16}$ in., but it would not matter if this was slightly exceeded, as we could always pack in a few extra stampings. The width of the former for the primary and high voltage secondary windings should be $\frac{1}{2}$ inch and that for the filament windings $\frac{3}{8}$ inch. These sizes will suit the No. 4 stampings, and the transformers will be sufficiently large for the average set.

The side pieces of the former are screwed to the centre and a sawcut is made each side, well down into the centre of the core. The former is mounted on the winding machine and the required turns of wire wound on. It is best to use enamelled wire with single cotton covering or double silk-covered wire, as these wires can be wound on more tightly.

How the Winding is Bound Together.

After having wound on the required number of turns, the winding is bound together by passing a piece of fine string or strong thread through each of the slots and tightly tying. This is the reason for the slots being cut well into the core so that the threads can be threaded through

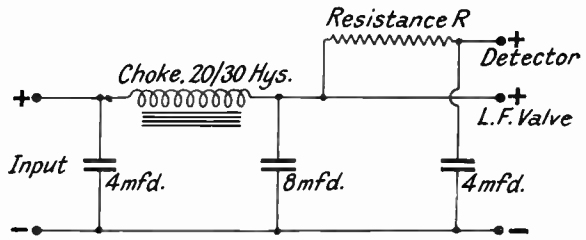

Fig. 10. A SIMPLE SMOOTHING CIRCUIT.

The value of the resistance R is calculated in the following manner. Suppose the approximate voltage required on valve is, say, 120 volts; the plate current (from the maker's curve) is, say, 3 milliamps.; and the output voltage of the unit is, say, 200 volts, subtract the approximate voltage required from the output voltage. The value of the resistance is then :

$$\frac{80 \times 1,000}{3} = \text{approximately } 27,000 \text{ ohms. (A } 25,000\text{-ohm resistance would be suitable.)}$$

under the core. Having tightly tied the core in four places, the side pieces of the former are removed and the coil taken off. It is now taped up with thin Egyptian tape. This is a special tape sold by suppliers of material for armature winding, and is usually from $\frac{1}{2}$ inch to $\frac{3}{4}$ inch wide. Two layers are carefully bound round the coil as shown in Fig. 15, after which the whole coil is soaked in insulating varnish and well baked. This will then produce a satisfactory winding which will never give any trouble, for, being tight, it will not vibrate, which would be likely if ordinary plain enamelled wire were used, as it is impossible to wind this wire tightly with satisfaction.

Mounting Coils on the Core.

The coils are now mounted on the cardboard core and the stampings assembled in the usual manner. It will be worth while to tie a small tag on the start of each coil with the gauge of wire marked, as in some cases the gauges of wire are so close that identification by this means alone is possible. Needless to say, the same direction of the winding should be maintained throughout and the coils assembled with the inside ends all coming out to the left. The reason for this is obvious as the high voltage secondaries are in two parts and are connected in series. Consequently, the direction of the winding must be the same in both halves of the coil; that is to say the end of one

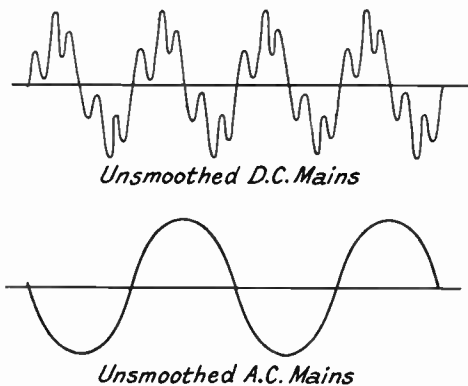

Fig. 11.—UNSMOOTHED D.C. AND A.C. CIRCUITS.

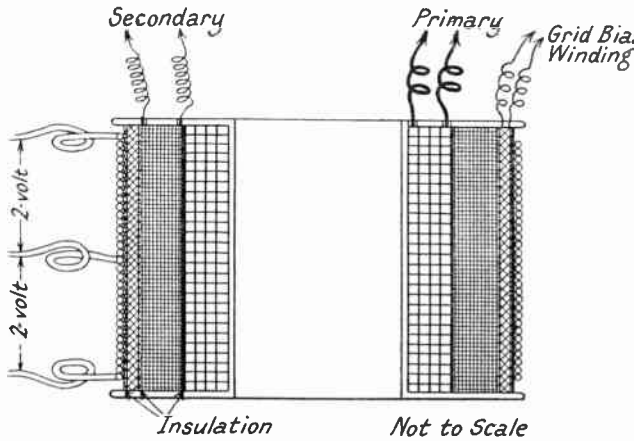

Fig. 12.—THE WINDINGS OF A TRANSFORMER FOR A METAL RECTIFIER.

These may be wound on a single bobbin. Extra windings can be included to provide filament supply and grid bias supply.

secondary winding is connected to the start of the second secondary winding, which is connected to a terminal and is the centre tap.

The Filament Windings.

These are wound in one coil and the centre tap taken at the 13th turn. We do not fear any trouble with the connection of the coils in series, for, as there are only 26 turns of wire, it is unnecessary to make two coils.

Holding the Coils in Position.

After the core is assembled and the coils placed in position, a wedge of cardboard should be pushed between the centre cores so as to hold the coils tightly in position. It is also an advantage if at each end of the coils is placed an insulated disc of bakelite so as effectively to insulate the winding from the sides of the stampings. If required, an extra filament winding can be added for heating the valve filaments of the receiver, providing, of course, that the valves are of the indirectly heated type. It is usual with a pentode to have a separate winding.

For the valve filaments the gauge of the wire should be 16 g. and that for

the pentode should be 18 g. double cotton covered.

A larger transformer can be constructed on similar lines with the necessary allowance made for the higher gauges of wire to withstand the higher loading, but this, of course, would only be necessary in the case of extremely large receivers or amplifiers.

Windings for 50 cycles transformers, section of core 1 inch by 1½ inches:—

- Mains Voltage. Primary.
- 100 - 600 turns No. 24 D.C.C.
- 200 - 1,200 turns No. 30 D.C.C.
- 220 - 1,320 turns No. 32 D.C.C.
- 240 - 1,440 turns No. 32 D.C.C.
- Two secondary high voltage windings, each coil 1,550 turns, 36 D.C.C.

Filament winding 4 volts 26 turns 18 D.C.C. Tapped at the 13th turn.

For further information regarding the construction of transformers readers are referred to the article beginning on page 204

CONDENSERS FOR SMOOTHING THE RECTIFIER CIRCUIT.

The various values of the condensers used for smoothing the circuit are stated on the diagrams, and these are the usual size employed in most commercial H.T. units for the smoothing circuits of mains receivers.

It will not be necessary to enter into the construction of these condensers as they are always made by specialised manufacturers.

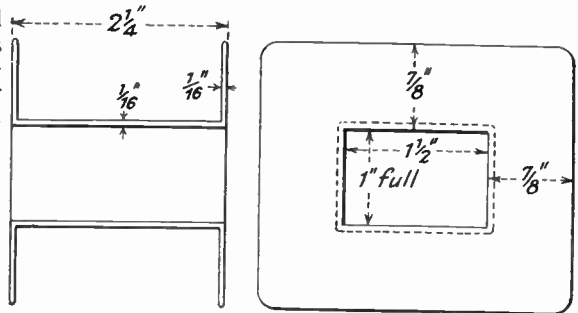

Fig. 13.—THE CONSTRUCTION OF A SIMPLE BOBBIN.

They are made up of tin foil and special insulating paper, and rated at certain test voltages. It is advisable to use the highest test voltage possible. That is to say, the test voltage is to be twice the working current. For instance, if the voltage across the condenser is 250 volts, they should have a test voltage of 500.

Troubles Caused by Faulty Condensers.

A faulty condenser in the smoothing circuit can cause considerable trouble, for it may not always break down and directly short-circuit the supply, but may cause cracking and noises of a similar nature to atmospherics. Therefore, if a condenser is suspected of being faulty, it must be replaced, and if each condenser is taken in turn, the bad one will be detected, for without special instruments it is not possible to test a condenser for this fault, and it must therefore be found by the "trial and error" principle.

RESISTANCE FOR VOLTAGE DROPPING.

The next important component in the unit is the resistance used for the voltage dropping. Having obtained a D.C. supply which has been smoothed free from ripple, it now remains only to provide the means of obtaining the various voltages required for the different valves in the set, and here the constructor has the advantage which the purchaser of a ready-made eliminator has not. It is that he can regulate these voltages to suit the valve in his receiver. The maximum voltage required on the power tapping depends upon the type of valve used in the last stage of the receiver, and care should be taken to avoid exceeding the valve manufacturer's rating, and it is as well to see that the correct grid bias is used. To obtain voltages lower than the maximum, there are two methods in common use. The first is known as the potential

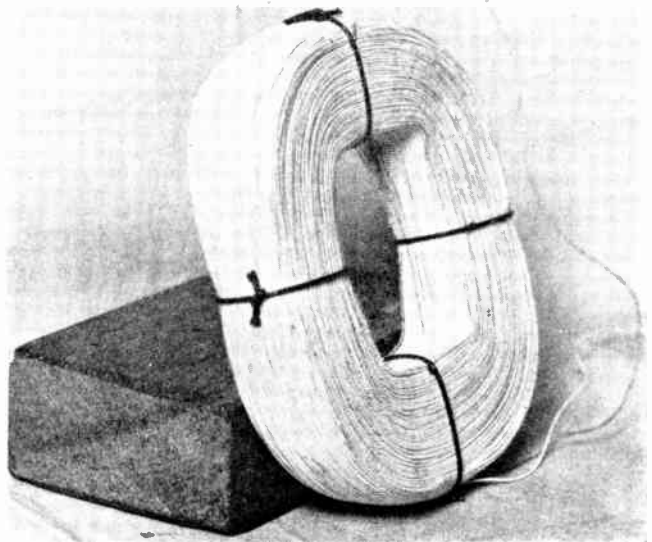

Fig. 14.—THE WINDING OF A FORMER-WOUND COIL READY FOR TAPING.
See also Fig. 1.

divider in which a resistance is placed directly across the negative and positive supplies and a tapping taken at a certain point. This circuit should only be used for obtaining suitable voltages for a screened grid valve.

Disadvantages of Potential Divider Method.

At one time it was a common practice to use a potential divider to give the supplies for all the various voltages required to the receiver, but with modern valves the back coupling introduced by this common resistance is sufficient to cause L.F. oscillation of the type usually known as motor-boating.

The Anode Feed Method.

The other method used is that of the anode feed type, in which an arrangement of wire-wound resistances reduces the voltage to the requirements for the purpose. To determine the value of the resistances used it is necessary to know the characteristics of the valves being fed by each resistance. Having referred to the valve maker's table and decided upon the plate voltage to be used, we can arrive at the anode current. The resistance must be of such a value as to absorb the difference

between the maximum available voltage and that actually required, and this voltage is obtained by dividing the difference in voltages by the plate current of the valve in milliamps, and multiplying the quotient by 1,000. For example, approximate voltage required on the H.F. valve equals 120 volts. From the maker's table the plate current is, say, 3 milliamps. The voltage to be absorbed by the resistance equals 200 minus 120, which equals 80 volts. $\frac{80 \times 1,000}{3} = 25,000$ approximately.

Wire-wound Resistances Should be Used.

All the resistances in an eliminator should be wire-wound, as resistances constructed with wire are far more reliable than those constructed of any composition, and are certainly made more accurately. Also, if the gauges of the wire with which the resistances are wound are of correct size to carry the current without undue heating, they will give indefinitely long service. Suitable wire for winding these resistances is enamelled Constantan. This may be obtained from most wire supply houses, and is wound on sub-divided bobbins. Of course, there are plenty of commercially made resistances which can

be used with every satisfaction. The manufacturers usually state their carrying capacity, and providing these resistances are rated to carry a few more milliamps. than required, no trouble will be experienced. If required, a variable resistance may be used for either the detector, or for the screened grid control, but usually the screened grid control is accommodated in the receiver itself.

The various circuits shown are for those types of eliminators which have been proved to give the best service under modern requirements, and it will be noticed that the smoothing system in each eliminator is almost identical.

THE SMOOTHING CHOKE— CONSTRUCTIONAL DETAILS.

The L.F. choke of the type commonly used in output filter circuits of battery eliminators is probably one of the most simple pieces of apparatus to construct, and involves little more than winding an appropriate quantity of wire on a bobbin and fitting this on a core made up of iron stampings similar to those employed for the transformers.

Size of Choke.

The size of the choke depends upon the amount of current which the eliminator is called upon to supply. In a small eliminator for operating a simple radio set, a choke with an inductance of approximately 20 hys. is sufficiently large, but when an eliminator has to supply screened grid valves and pentode output, it is necessary that the smoothing should be more liberal and chokes with an inductance of not less than 30/40 hys. should be used.

Size of Stamping.

We must, therefore, first decide upon the type of stamping which we are going to use. For a 20 hys. choke, a stamping the size of that illustrated in Fig. 18 will be quite suitable, and this being a standard stock size stamping, it will be easily procurable. For a 30 hys. choke we shall require a larger

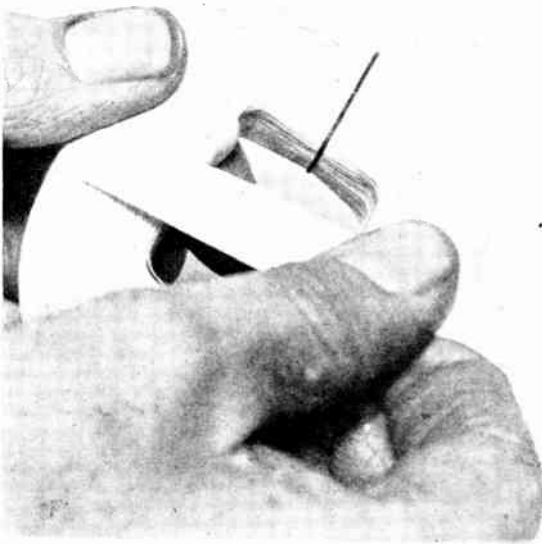

Fig. 15.—TAPING THE COIL WITH THIN EGYPTIAN TAPE.

Two layers are carefully bound round the coil, after which the whole coil is soaked in insulating varnish and well baked.

Indispensable to every Electrical Engineer, Designer and Manufacturer

THE
**ELECTRICAL ENGINEER'S
DATA BOOKS**

General Editor: E. B. WEDMORE, M.I.E.E.

(The Director of the British Electrical and Allied Industries Research Association.)

This important reference work contains much valuable new data that has hitherto been concealed in the journals of foreign institutions, in the unadvertised publications of research associations and the technical publications of manufacturers.

"The Electrical Engineer's Data Books" provide, in two handy volumes, a collection of all the most recent specialised knowledge, thus forging the necessary link between the scientist, the research worker and the practical engineer.

The detailed nature of the text and the wealth of original illustrations, tables and formulæ make this work indispensable to every Electrical Engineer, Designer and Manufacturer.

VOLUME I.—Lighting ; Switch-gear ; Power Transmission and Distribution ; Distribution by Underground Cable ; Transmission by Overhead Lines ; Traction ; Electrical Machinery.

VOLUME II.—Insulation ; Magnetic Materials and Testing ; Properties of Metals and Alloys ; Measurement of Resistance, Inductance and Capacity ; Corona Discharge.

APPENDICES.—Mathematical and Miscellaneous Tables, List of Integrals, Electrical, Mechanical and Physical Tables, etc. ; Electricity and Magnetism ; Wiring Rules ; Home Office and Board of Trade Regulations, etc.

**EXAMINE THE WORK IN YOUR
OWN HOME FREE!**

In order to give you an opportunity of examining this invaluable work at your leisure, the Publishers are prepared to supply the two volumes on Five Days' Free Approval. Send p.c. to-day for full particulars and details of the generous deferred payment system, to : Dept. E.E.22, The Home Library Book Co., 23-24, Tavistock Street, London, W.C.2

Geo. Newnes, Ltd.

This article on Design of Apparatus for H.T. Supply Units™ is continued in Part 23. Ready March 18th. Order your copy to-day.

THE BEST PRACTICAL ADVICE ON—

CARPENTRY AND CABINET-MAKING

An Illustrated Handbook for the Amateur,
with numerous Drawings and Designs.
By W. M. OAKWOOD.

Cloth. Price 1s. 6d., post free 1s. 9d.

This handbook contains a description
of the tools most generally used, with
instructions how to use them—The choice
of woods for various purposes—A chapter
as applied to cabinet-making—A chapter
on french polishing, staining and varnish-
ing.

WOOD CARVING

A Practical Guide for the Home Student.
By J. H. GARNETT.

With numerous Illustrations and Designs.
Cloth. Price 1s. 6d., post free 1s. 9d.

Contains—in addition to full instruction
on the practice of the Art of Wood-
Carving—Chapters on Choice of Wood-
Tools, Designs, Appliances, etc., Chip or
Notch Carving, Staining, Polishing, Gild-
ing, Painting, etc.

METAL WORK

By GEORGE DAY, F.R.M.S.

Cloth. Price 1s. 6d. post free 1s. 9d.

A Practical Handbook for the Amateur Worker in
Iron, Brass, Zinc, Copper, etc. With numerous
Illustrations and Designs.

Some of the 16 Chapters are—Tools required
for Metal-work—General Methods of Copying the
Pattern, drawing and transferring—General Meth-
ods of Working—To Etch on Metals—Fretworking
in Metals—Useful Recipes for Metals and Metal
Workers, etc., etc.

BASKET MAKING AT HOME

By MARY WHITE.

With many Diagrams.
Paper Wrapper.
Price 1s. 6d. net; post free
1s. 9d.

The Contents include:—
Raffia and some of its uses
—Weaving a Small Basket—
Covered Basket—Basket with
Handles—Some Work Bas-
kets—Sweet Baskets—Waste
Paper Baskets—Dolls' Fur-
niture—Caning in a Frame or
on a Chair, etc., etc.

PHOTOGRAPHY FOR BEGINNERS

By GEORGE BELL.

Illustrated.

Cloth. Price 2s. net, post
free 2s. 4d.

CONTENTS.—How a Photo-
graph is made—How a
Camera works—Exposure—
Dark Room—Developing—
Printing out—Indoor Photo-
graphy—Outdoor Photo-
graphy—Home Portraiture—
Enlargements, etc., etc.

THE STARS NIGHT

BY NIGHT

A Popular Guide to the Constel-
lations

By JOSEPH H. ELGIE,
M.B.A.S.

With over 100 Diagrams by
Author.

Limp Cloth. Price 1s. 6d.,
post free 1s. 9d.

On sale at all booksellers,
or may be had for post
free prices direct from
The Book Publisher,
PEARSON'S Book Dept.,
18, Henrietta Street,
London, W.C. 2.

HALF-HOURS WITH THE MICROSCOPE

A Popular Guide to
the use of the Micro-
scope.

By Edwin Lankester, M.D.
Cloth. Price 2s., post free
2s. 3d.

CONTENTS.—
The Structure of
the Microscope—In
the Garden—At the
Road Side—At the
Sea Side—Indoors—
etc.

ASTROLOGY

How to Read your
Fortune in the Stars

By "Sagittarian,"
Cloth. Price 1s. 6d.,
post free 1s. 9d.

The Contents in-
clude:—The Zodiac
and Nature of Planet-
ary Aspects—The
Houses, their charac-
ter and purpose—
Nature of the Signs—
The Horoscope and
how to read it—
Popular Examples—
etc., etc.