

# Practical Computing

50p

April 1980

Volume 3 Issue 4

**Memories are  
made of this**

**How to finance  
a micro business**

**Eight, yes eight  
Basics for Nascom**

**Reviews: Nascom 2,  
Commodore Database,  
Superbrain**

**More on  
assembly language**



# The computer with growth potential

The System Three is Cromemco's best selling small business computer. It's easy to see why.

Not only is it ideal for the first time computer user. But perhaps more important, it can be expanded into a comprehensive business facility servicing many varied company requirements.

## Single-user system

You can start small. A 64K computer with a megabyte of floppy disc storage costs under £4,000.\*

Perhaps your initial reason for choosing Cromemco was its flexible database management system—ideal for client records, order processing, sales analysis, inventory control, and many more business uses; or you might have required the full screen word processing system, capable of printing up to 20 original letters an hour; possibly you needed Cobol, Basic or Fortran, to develop your own customised packages.

## Easy to use

Whatever the reason, you were highly impressed with the ease with which your very first computer application got off the ground. So you added another. And another. And pretty soon quite a lot of company business was running on your Cromemco.



Single-user System Three, with 64K memory, 2 discs, terminal and printer. Ideal for small businesses.

## Will it expand?

It was then you discovered that the terminal is the limiting factor, because of the time taken to input data. If only you could connect a second terminal you could double your system's workload. . .

## Multi-user system

Fortunately, we can readily expand your Cromemco. Unlike other makers' systems, all we need to do is add some memory and a ® TU-ART interface, and the multi-user system is ready to run . . . with a printer and up to 7 terminals, each with up to 48K.

## New operating system

Moreover, your terminals can function quite independently of each other. Under Cromemco's new operating system they can be used to update and interrogate the company's database; for correspondence, with the word processing system; for data entry, using the full screen editor; or indeed for running any combination of CP/M software, *simultaneously*.

## Up to 72 megabytes

We can increase your floppy disc storage to 2 megabytes if necessary. And if that's not enough, we can also add Cromemco's hard discs to provide you with up to an amazing 72 megabytes on-line.

## Rely on MicroCentre

Remember—at MicroCentre we fully understand Cromemco systems. That's why we're Cromemco's top UK distributors. So trust your initial Cromemco investment to MicroCentre. And call us any time to discuss your hardware enhancements or software needs.

Your company's future growth may depend on it.



Multi-user System Three, with 320K memory, 4 discs, 7 terminals and fast line printer. Each terminal has its own operating system, and can run any software package independently.

\*Price excludes VAT and delivery. Terminals and printers to be added according to user requirements. ® TU-ART is a Cromemco trademark.

For  **Cromemco... call the experts**

Tel. 031-556 7354

**Micro Centre**

Complete Micro Systems Ltd., 30 Dundas Street, Edinburgh EH3 6JN

• Circle No. 101

# CONTENTS

## Practical Computing



Remember Marlene Dietrich in the Blue Angel? Seen our cover? Well, that's all she's got to do with 'Memories are made of this' on page 72. Painting by Mark Wilkinson.

### Editor

**Peter Laurie**

Technical editor

**Nick Hampshire**

Staff writer

**Duncan Scot**

Rewrite

**Martin Hayman**

Art

**Margaret Smith**

Editorial secretary

**Susie Manning**

Advertisement manager

**Tom Moloney**

Advertisement executives

**Tina Roberts**

**David Lake**

Secretary

**Stephanie Hill**

Publisher

**Chris Hipwell**

Editorial: 01-261 8752

Advertisements:

01-261 8000

Published by IPC Electrical Electronic Press Ltd, Dorset House, Stamford Street, London SE1 9LU, tel 01-261 8000, telex/grams 25137 BISPRSG

Typesetting and artwork by Bow-Towning Ltd, London EC1

Printed by Eden Fisher Ltd, Southend-on-Sea

Distributed by IPC Sales and Distribution Ltd, 40 Bowling Green Lane, London EC1R 0NE

Subscriptions: UK, £6 per annum; Europe (ex UK), £12; rest of the world, £18 (including airmail postage). Enquire Subscription Manager, IPC Business Press (S & D) Ltd, Oakfield House, Perrymount Road, Haywards Heath, Sussex RH16 3DH, tel 0444 59188

©IPC Business Press Ltd 1980

ISSN 0141-5433

Would-be authors are welcome to send articles to the Editor but PC cannot undertake to return them. Payment is at £30 per published page. Programs intended for publication should ideally be justified to 22 or 44 or 66 characters per line.

Every effort is made to check articles and listings but PC cannot guarantee that programs will run and can accept no responsibility for any errors.

- 51 Editorial/** Mike the boredom killer
- 52 Printout/** Human factor in computer crime; new maths chips from Intel
- 54 Feedback/** Foxing the PET; UK variables; language debate continued
- 60 A challenge to build – a delight to use/** Vincent Tseng tests Nascom's latest single-board machine
- 64 Easy-to-fix Superbrain looks like good value for money/** D.B. Watt examines a promising new integral machine
- 67 Commodore database is tailored for business/** As the emphasis in micros leans towards software and away from hardware, Mike McDonald assesses Commodore's first thrust into the business software market.
- 72 Memories are made of this/** Cover story: state of the art reviewed in depth by M.G. Ayres
- 77 The Turing Test/** Fancy being unable to tell a mere machine from a real person! Fiction by David Langford
- 80 Fly high or plummet/** Duncan Scot explains how to go about raising cash for your own micro business
- 86 Robots: sense and sensibility/** Part 3 of Mark Witkowski's primer on robotics techniques
- 95 Write games for fun, cash and fanmail/** Games-playing pastor George Blank's at it again!
- 100 Caught in a trap – no turning back/** M.K. Cook demonstrates Maze Runner, a game of hand-eye co-ordination for the TRS-80
- 106 Eight, yes eight, Basics for Nascom/** Nick Laurie helps the newcomer find the most suitable version for his needs
- 111 LA video link for London?/** Singing in the rain, jogging in the sunshine...
- 113 Round Two of the wrestling match with assembly language/** Part 2 of David Peckett's series for the committed computerer
- 118 Pet & Apple & Tandy/** Handy hints and tips from all over the world
- 125 Serious sorting for business/** Mike Lake on a cost-saving application
- 131 Software Buyers' Guide/** Competition hots up in the business market by Mike McDonald
- 160 Diary/** Where to learn, what it costs
- 163 Glossary/** Continuing the terminology gamut with S

# Are you someone who knows an awful lot about 380Z Hardware & Software?

If you are, Research Machines is looking for a young person who would like to join a lively young group who provide technical back-up over the telephone to 380Z users.

We are a fast growing microcomputer company based in Oxford, and this job offers an attractive salary and exciting prospects. If you are interested, please write giving full details about yourself.

D. L. Fischer,  
Research Machines Ltd,  
P.O. Box 75, Oxford.

## RESEARCH MACHINES

SUPPORT MEMBERS OF THE  
COMPUTER RETAILERS  
ASSOCIATION . . .



**THEY WILL SUPPORT YOU.**

For further details on the associations aims, membership, code of conduct etc.

Please contact: Ms Helen Gibbons,  
Owles Hall, Buntingford, Hertfordshire SG9 9PL.  
Tel: Royston (0763) 71209

• Circle No. 103

# POWERFUL MICROS AT THE RIGHT PRICE

- Multi-User • Multi-Tasking
- Multi-Language • Hard Disc Storage • Word Processing
- Priced from under £5000

Languages supported include –  
Basic, Cobol, Fortran.  
OEM, Educational and Dealer  
enquiries invited

## EQUINOX

COMPUTER SYSTEMS LIMITED  
Kleeman House, 16 Anning Street  
New Inn Yard, London EC2A 3HB  
Tel: 01-739 2387 & 01-729 4460

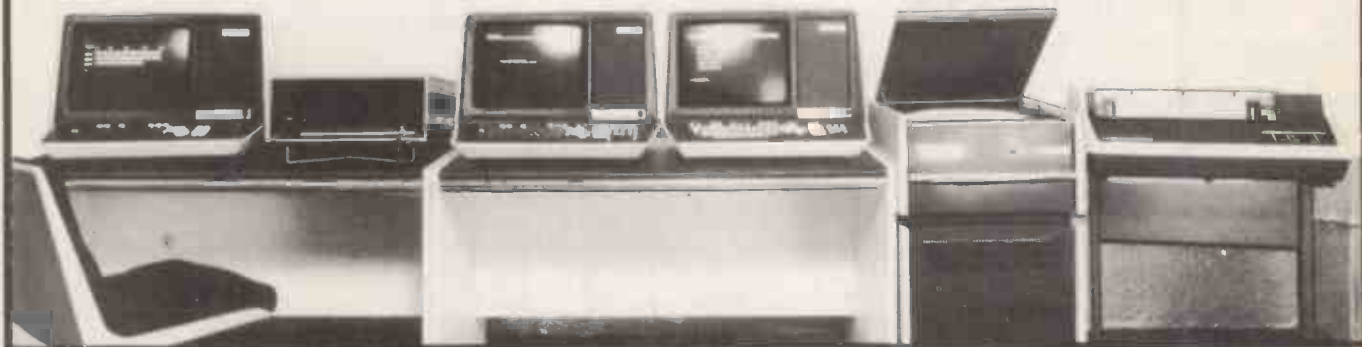

• Circle No. 104

# The Cromemco

# Z-2H



**11 Megabytes of hard disc storage in a fast, new, table-top computer.**

- Fast Z80A 4MHz processor
- 11-megabyte hard disc drive
- Two floppy disc drives
- 64K RAM memory
- RS-232 serial interface
- Printer interface
- Extensive software available

CAMBRIDGE  
CAMBERLEY  
ILFORD

LEEDS  
LONDON  
LUTON  
MANCHESTER

NEWBURY  
NEWPORT  
NOTTINGHAM

SHEFFIELD  
SOUTHAMPTON

CAMBRIDGE COMPUTER STORE, Cambridge (0223) 68155  
MICROBITS, Camberley, Surrey (0276) 34044

THE BYTE SHOP, Ilford, Essex 01-554 2177  
also at Tottenham Court Road, London 01-636 0647

HOLDENE LIMITED, Leeds (0532) 459459  
also at Wilmslow, Cheshire (0625) 529486

DIGITUS LIMITED, London W1 01-636 0105  
ISHERWOODS, Luton, Bedfordshire (0582) 424851

MICROCOMPUTERMART, Manchester (061-832) 2269  
also at West Park, Leeds (0532) 788466

NEWBEAR COMPUTING STORE, Newbury, Berks (0635) 30505  
also at Stockport, Cheshire (061-491) 2290

MICROMEDIA SYSTEMS, Newport, Gwent (0633) 50528  
COMPUTERLAND LIMITED, Nottingham (0602) 40576

also at Birmingham (021-622) 7149  
Manchester 061-236 4737  
Glasgow (041-332) 2468

HALLAM COMPUTER SYSTEMS, Sheffield (0742) 663125  
XITAN SYSTEMS LIMITED, Southampton (0703) 38740



## comart specialists in microcomputers

Comart Ltd., P.O. Box 2, St. Neots, Huntingdon, Cambs, PE19 4NY. Tel: (0480) 215005 Telex: 32514

• Circle No. 105

Widely used in UK and USA , tested and proven  
**POWER AT YOUR FINGERTIPS**  
 Just compare this list!

- Robust set of programs with error traps covering PET dos rename malfunctions, casual user error, disk failures, PET dos mismanagement block allocations, disk failures, fast single key stroke entries, controlled input with visible line length, and date verifications preventing erroneous date entry.
- Comprehensive database management system includes
  - file create/delete/search
  - record create/delete/amend/print 4 ways
  - record sort by any field both alpha or numeric
  - index search or general scan by any field (eg town or credit limit)
  - four arithmetic functions to use as calculator on last four fields
  - auto check to prevent double entry with file management system dynamically allocating information for minimum disk space consumption.
- Auto invoice numbering (with override option), plus auto print-out integrated with stock and address files for payment term discount, agent allocation, price index retrieval and auto stock update; nominal codes retrieved from address files may be optionally overridden.
- Powerful alternative double entry system providing a bureau type facility for tracking monthly trading figures and tax accruals.
- Currently using 16 sale and 66 purchase commodity codes which are automatically written into ledgers from address files (includes override option)
- Automatic triple posting of sales / purchase to invoice and general and open item ledgers with complete audit trail to include account verifications on payments in/out, so that discrepancies are re-allocated to outstanding accounts. This facilitates part payments.
- Final liquidity strikes a complete audit trail balance with creditors and debtors o/s amounts, bank balances, stock movements, and remaining stock value to give profitability of company.
- Powerful account tracking facilities include auto statement production for all accounts excluding nil balances, with date comparison \* current \* 30 days \* 60 days \* 90 days \* and appropriate messages when a date block has an inclusion.
- Complete search/create/amend/delete facilities on any significant ledger heading against either open or general ledger in date/invoice/account/agent/nominal code/headings, for full information retrieval such as a shortlist of overdue account for a specified month.
- No special printed stationery needed so your 50-100 invoices cost you a fraction of a penny each, and they are formatted precisely to fit in a standard 'Ryman' window envelope for convenient posting. Tracking program enabling printing of past invoices — recall on screen. Plus monitor of specified sales — purchases of commodities by code.
- Monthly quarterly tax calculations plus standard mailing ticket print facilities.
- Add-on option of auto stock movement report and update quantity on hand as result of purchases and sales.
- Add-on option of auto bank update from receivables and payables against ledgers.
- Stores up to 2200 addresses or up to 4000 simple ledger records on one diskette with 160K of user menu callable programs from other disk. Only one program disk — and the hard core programs can't be busted.
- Job cost centre build-up on purchase ledger for engineer/contractors.
- Substantial user group in UK and abroad with all positive feedback implemented every 3/4 weeks and re-distributed free of charge (except cost of disk and mailing 50-70 pounds p.a.) so you become part of a commonwealth of users working with an identity of interests.
- This must be surely the most comprehensive, compact, proven, and cost-effective ongoing package on the marketplace at this point in time.
- Total price version 3 £475 ... add-on stock option £100 ... add-on bank option £100 ... remaining programs 19,20,22,23 jointly £100.
- Think of just keying in 100 invoices, 50 cheques and going for a walk? (provided you left your printer on with paper in) you could leave our programs to do all the secretarial posting automatically, and when you return to set in motion the auto statement run, you can simply post out all paperwork with statements which have done the date comparison comments for you...

— SALES INVOICE —

FROM:  
 GRAMA (WINTER) LTD  
 89 BEDFORD CT MANS  
 BEDFORD AVE

TO: 1  
 G.W. COMPUTERS LTD  
 89 BEDFORD CT MANS  
 BEDFORD AVE

INVOICE	ORDER	DEPT	AGENT	DATE
3	1	1	1	25 01 80
QUANTITY	DESCR	PRICE	TOTAL TAX RATE %	
10	COMPUTER (TAKEN FROM STOCKLIST)	1000	1000	15
10	(WHATEVER DESCRIPTION YOU WISH)	10	100	15
1	SPECIAL DISCOUNT 50	50	15	
TOTAL GOODS VALUE				10050
TAX AT 2.5% OFF TOTAL				1469.82
TOTAL INCLUDING TAX				11519.82

= POUNDS STERLING E & EO  
 2.5% DISCOUNT MONTHLY

DIRECTORS AH & MC WINTER REG.NO 1264137 VAT NO 234.8094.58  
 END OF SALES INVOICE PRINT

DEBTORS OLD BAL	1146.25	TAX 146.25	TOTAL	1292.5
DEBTORS THIS RUN	10050	TAX 1469.82	TOTAL	11519.82
DISCREPENCY	1046.25	CUSTOMER 1		
DEBTORS AMT REC.	100	DIS 0	TOTAL	100
DEBTORS NEW BAL	11242.5	TAX 1469.82	TOTAL	12712.32
CREDTRS OLD BAL	10	TAX 1.46	TOTAL	11.46
CREDTRS THIS RUN	2000	TAX 292.5	TOTAL	2292.5
CREDTRS NEW BAL	2010	TAX 293.96	TOTAL	2303.96

ERROR 1046.25

LIQUIDITY1	1048.36
BANK1	0
BANK2	0
BANK3	0
BANK4	0
LIQUIDITY2	10408.36

STOCK MOVEMENTS.....\*\*\*OUT\*\*\*  
 CODE.....QUANTITY..ACCOUNT.INVOICE  
 1 10

STOCK MOVEMENTS.....***OUT***	CODE.....	QUANTITY..	ACCOUNT...	INVOICE
	1/310	1	3	
	2	10	1	3
	2	1	1	3

STOCK VALUE FOR FILE DATA = 21600  
 LIQUIDITY 32008.36

STOCK MOVEMENTS.....***IN***	CODE.....	QUANTITY..	ACCOUNT...	INVOICE
	1	20	1	74123568
	2	1	1	3
	2	10	1	3

STOCK VALUE FOR FILE DATA = 39600  
 LIQUIDITY 50008.36

Contact Tony Winter 01-636 8210  
 89 Bedford Court Mansions  
 Bedford Avenue  
 London W.C.1.

# NEW Produced and widely used in England and U.S.A. COMPLETE BUSINESS PACKAGE

INCLUDES EVERYTHING FROM INVENTORY TO SALES SUMMARY  
PROMPTS USER, VALIDATES EACH ENTRY, MENU DRIVEN

Approximately 60-100 entries/inputs require only 2-4 hours weekly and your entire business is under control.

**\* PROGRAMS ARE INTEGRATED-**

- 01 = ENTER NAMES/ADDRESS, ETC
- 02 = \*ENTER/PRINT INVOICES
- 03 = \*ENTER PURCHASES
- 04 = \*ENTER A/C RECEIVABLES
- 05 = \*ENTER A/C PAYABLES
- 06 = ENTER/UPDATE INVENTORY
- 07 = ENTER/UPDATE ORDERS
- 08 = ENTER/UPDATE BANKS
- 09 = EXAMINE/MONITOR SALES LEDGER
- 10 = EXAMINE/MONITOR PURCHASE LEDGER
- 11 = EXAMINE/MONITOR (INCOMPLETE RECORDS)
- 12 = EXAMINE PRODUCT SALES

**SELECTION FUNCTION BY NUMBER-**

- 13 = PRINT CUSTOMER STATEMENTS
- 14 = PRINT SUPPLIER STATEMENTS
- 15 = PRINT AGENT STATEMENTS
- 16 = PRINT TAX STATEMENTS
- 17 = PRINT WEEK/MONTH SALES
- 18 = PRINT WEEK/MONTH PURCHASES
- 19 = PRINT YEAR AUDIT
- 20 = PRINT PROFIT/LOSS ACCOUNT
- 21 = UPDATE END MONTH FILES. MAINTENANCE
- 22 = PRINT CASH FLOW FORECAST
- 23 = ENTER/UPDATE PAYROLL (NOT YET AVAILABLE)
- 24 = RETURN TO BASIC

**WHICH ONE? (ENTER 1-24)**

01 SUB. MENU EXAMPLE: 01 = EXAMINE: 02 = INSERT: 03 = AMEND: 04 = DELETE  
05 = PRINT (1,2,3): 06 = NUMERIC COMBINATIONS: 07 = SORT  
VERY FLEXIBLE. ADD YOUR OWN FUNCTIONS. EASY TO INTEGRATE.

All programs in BASIC for CP/M

G. W. COMPUTERS LTD, the producers of this beautiful package.

WE EXPORT TO ALL COUNTRIES:  
BARCLAYCARD ACCEPTED  
CBM APPROVED

CALLERS BY APPOINTMENT  
89 Bedford Court Mansions  
Bedford Avenue  
London WC1, U.K.

OR CONTACT TONY WINTER 01-636 8210  
BARCLAYCARD ACCEPTED  
CBM APPROVED

PRICES: Programs 1-23 EXC (19,20,22,23) £475: Inclusive £575: Stock Integrated Option + £100: Bank integrated Option + £100.  
5 - SUPERBRAIN 65K + TEXAS 810 £3445: 6 - SUPERBRAIN 64K + NEC AS W/PROCESSOR £3900.

**IMPORTANT!** We also sell the Hardware to do the above tasks  
so you can do the complete purchase at one source.

**• PET • PET • PET • PET • PET • PET •**

- PET COMPUTER 32K £795.00
- PET Floppy Disk £795.00
- PET Printer T/Feed £645.00
- PET Cables £45.00
- PAPER £28.00
- 10 Diskettes £28.00
- 1 year's software support £50.00

**• SUPERBRAIN • SUPERBRAIN • SUPERBRAIN •**

- Twin Floppy D/Density 5 1/4": Twin 280 Processor £1950.00
- 64K RAM: Just add any printer £250.00
- Optional S100 bus adapter £P.O.A.
- ADD ON 1 MEGABYTE DISC UNITS OR UP TO 10 MEGABYTE HARD DISC

**• PRINTER OPTIONS • PRINTER OPTIONS •**

- a) Paper Tiger 195 cps £585
- b) Texas 810 150 cps £1495
- c) Teletype 43 30 cps £895
- d) DEC LA34 30 cps £895
- e) QUME Daisywheel 45 cps £2450
- f) NEC Spinwriter 55 cps £1650

**• SPECIALS • SPECIALS • SPECIALS •**

- 48K Industrial Microsystems and Twin D/Drives 5 1/4" (LAST ONE) £1750
- Intertube Video Terminals £495
- COMPUTHINK 800K £895

**• SOFTWARE • SOFTWARE • SOFTWARE •**

- CPM - MBASIC - 80 £150
- CPM FORTRAN - 80 £200
- CPM COBOL - 80 £320
- CPM WORD STAR £250
- CPM PASCAL - M £200
- CPM BSTAM £75
- CPM SUPERSORT £120
- PET Comaccounts £650
- PET Compay £150
- PET Combis/Comstock £150
- PET Wordpro £75
- PET Super Comword £150
- PET 32K - FLOPPY 2040 - PRINTER 3022 £2235
- PET 32K - COMPUTHINK 800K - PRINTER 3022 £2335
- PET 32K - FLOPPY 2040 DECLA34 + INTERFACE £2635
- PET 32K - COMPUTHINK 800K - DECLA 34 + INTERFACE £2735
- SUPERBRAIN 64K + TEXAS 810 £3445
- SUPERBRAIN 64K + NEC AS W/PROCESSOR £3900

Walkie Talkie Telephone (Freedom Phone)  
Connects to normal telephone make, or take calls  
300ft from home. £195 (not P.O. Approved)

Telephone Answering Machine. Recall Message  
anywhere in World. £195 (not P.O. Approved)

Warranty includes free replacement of equipment,  
within 90 days if found defective.

WE EXPORT TO ALL COUNTRIES: CALLERS BY APPOINTMENT OR CONTACT TONY WINTER 01-636 8210

89 Bedford Court Mansions  
Bedford Avenue  
London WC1, U.K.

PLEASE CALL ONLY BY APPOINTMENT

# "The trade are going over the moon about it..."

## TRADER MICRO PACK

RECOMMENDED BY  
 **commodore**

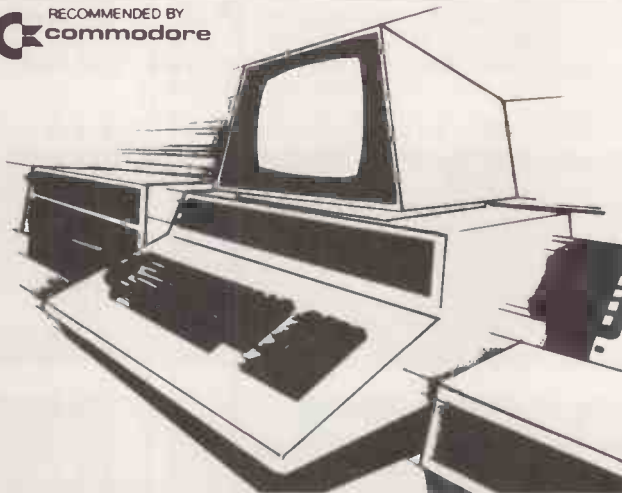

### Integrated Stock-Control, Invoicing and Sales Accounts.

### Up to 4,400 items and accounts handled simultaneously.

#### TRADER:

A powerful, real-time stock-control, invoicing and sales-accounts package with full management-information, comprehensive reports and flexible analysis.

Simple to use, TRADER can be operated by any member of staff without previous computer experience.

#### FUNCTIONS:

TRADER is totally interactive. Stock levels, account balances, sales totals, etc. are instantly and automatically updated with each transaction. VAT, discounts, gross-profit, etc. are accurately calculated as each Invoice, credit-note or other document is produced. Sales analysis and sales reports may be produced on demand showing sales volume and

gross-profits against each stock item. Stock reports are available showing stock valuation, low stock, outstanding orders, etc.

Reports showing the current status of all sales-accounts may also be produced on demand.

Full details of any stock-item or sales-account may be looked-up instantly, by any name or code designated by the user.

#### CAPACITY:

The total capacity of stock-items and sales-accounts is 2,200 (dual-drive version) or 4,400 (quad-drive version). Distribution of records is dynamic so that it is possible to enter as many stock-items or sales-accounts as required up to a combined total shown above. No significant delay in operating time is evident with large data-base.

#### MICRO PACK:

TRADER is a micro-pack product produced by the Bristol Software Factory specifically for the latest range of Commodore Professional Computer Systems. The aim of Micro-Pack products is to provide truly reliable, powerful and flexible micro-computer software. To that end all systems are fully tested for reliability and suitability in a range of business environments and are fully guaranteed and supported by the Bristol Software Factory.

#### BRISTOL SOFTWARE FACTORY

MICRO HOUSE,  
ST. MICHAEL'S HILL BRISTOL  
TEL: 0272 23430



# ...because they know!"

## TRADER Dealers:-

### LONDON

**Adda Computers Ltd.,**  
17-19 The Broadway,  
Ealing, London W5  
01 579-5845

**Da Vinci Computers Ltd.,**  
Classic Offices,  
Classic Cinema,  
Hendon Central,  
London NW4  
01 202 9630

**Capital Computer Systems,**  
29-30 Windmill Street,  
London, W1P 1HG.  
01 637-5551

**TLC World Trading,**  
32/34 Craven Street,  
Charing Cross,  
London WC2.  
01 839 3894

### SURREY & MIDDLESEX

**Micro-Facilities Ltd.,**  
127 High Street,  
Hampton Hill,  
Middx. TW12 1NJ.  
01 979 4546

**Petalect Electronic Services Ltd.,**  
33/35 Portugal Road,  
Woking,  
Surrey.  
048 62 69032

**Wego Computers Ltd.,**  
22a High Street,  
Caterham, Surrey.  
0883 49235

### ESSEX

**Dataview Ltd.,**  
Church Street,  
Colchester, Essex.  
0206 78811

**Stuart R. Dean Ltd.,**  
373 Southchurch Road,  
Southend-on-Sea.  
62707

**D. D. M. Direct Data Marketing Ltd.,**  
44 High Street,  
Brentwood, Essex.  
0277 229379

### BERKSHIRE & OXFORDSHIRE

**C.S.E. (Computers)**  
12 Wokingham Road,  
Reading, Berks.  
0734 61492

**Oxford Computer Systems,**  
3 & 5 Oxford Street,  
Woodstock, Oxford.  
0993 811976

### HERTFORDSHIRE & BEDFORDSHIRE

**Alpha Business Systems,**  
89 Railway Street,  
Hertford, Herts.  
0992 57423

**Isher-Woods Computer Systems,**  
110/112 Leagrave Road,  
Luton, Beds.  
0582 416202

**MMS Ltd.,**  
26 Mill Street,  
Bedford.  
0234 40601/2

**Buss Stop Computers,**  
255a St. Albans Road,  
Watford, Herts.  
0923 40698

### MIDLANDS

**Betos Systemms Ltd.,**  
Bennetts House,  
155 Mansfield Road,  
Nottingham.  
0602 48108

**Davidson-Richards Ltd.,**  
14 Duffield Road,  
Derby. DE1 3BB.  
0332 366803

### EAST ANGLIA, LINCOLNSHIRE & NORTHANTS

**H.B. Computers Ltd.,**  
22 Newland Street,  
Kettering, Northants.  
0536 83922

### WEST MIDLANDS, BIRMINGHAM, STAFFORDSHIRE & WARWICKSHIRE

**Cliffstock Ltd.,**  
10/12 Princess Street,  
Wolverhampton.  
24221

**Computer Services Midlands Ltd.,**  
Refuge Assurance House,  
Sutton New Road,  
Erdington,  
Birmingham.  
021 382 4171

**Camden Electronics,**  
1st Floor,  
462 Coventry Road,  
Small Heath,  
Birmingham.  
021773 8240

**System Micros Ltd.,**  
Lloyds Bank Chambers,  
7 Park Street,  
Shifnal,  
Shropshire.  
0952 460214

**Business & Leisure Microcomputers**  
16 The Square,  
Kenilworth,  
Warwickshire.  
0926 512127

### NORTH WEST & NORTH WALES

**O.B.E. (Chester) Ltd.,**  
Executive House,  
Pierce Street,  
Queensferry,  
Deeside, Clwyd.  
0244 817277

**Rockliff Bros. Ltd.,**  
2 Rumford Street,  
Liverpool.  
051 521 5830

### MANCHESTER

**Cytek (UK) Ltd.,**  
12 Exchange Hall,  
Corn Exchange Buildings,  
Manchester.  
061 832 7604

**Sumlock Electronic  
Services (M/c) Ltd.,**  
198 Deansgate,  
Manchester.  
061 834 4233

### LANCASHIRE & CHESHIRE

**Catland Computers,**  
Green Lane,  
Wilmslow,  
Cheshire,  
0625 527166

**Fylde Business Machines Ltd.,**  
28/30 Watery Lane,  
Preston, Lancs.  
0772 731901

### CUMBRIA

**Microcomputers Ltd.,**  
Borwick Fold House,  
Crook,  
Kendal.  
09662 4107

### YORKSHIRE & NORTH HUMBERSIDE

**Ackroyd Typewriter & Adding  
Machine Co.,**  
59 Leeds Road,  
Bradford, 1, W. Yorks.  
0274 31835

**Micro Processor Services,**  
139 Beverley Road,  
Hull, Humberside.  
0482 23146

**Sheffield Computer Centre,**  
225 Abbeydale Road,  
Sheffield.  
0742 53519

### NORTHEAST

**R. Ward & Sons,**  
Halifax Road,  
Dunston Ind. Estate,  
Gateshead, Tyne & Wear.  
0632 605915

### SOMERSET & DORSET

**Stage One Computers,**  
6 Criterion Arcade,  
Old Christchurch Road,  
Bournemouth, Dorset.  
0202 23570

### GLOUCESTERSHIRE

**Beam Business Centres,**  
27 Pitville Street,  
Cheltenham, Glos.  
0242 45414

### AVON

**The Bristol Computer Centre,**  
Micro House,  
139 St. Michael's Hill,  
Bristol.  
0272 23430

**Radan Computational Ltd.,**  
19 Belmont,  
Lansdown,  
Bath, Avon.  
0225 318483

### DEVON & CORNWALL

**A. C. Systems,**  
53 Magdalen Road,  
Exeter, Devon.  
0392 71718

**J. A. D. Integrated Services,**  
21 Market Avenue,  
Plymouth.  
0752 62616

**Jeffrey Martin Computer  
Services Ltd.,**  
76/78 Fore Street,  
Newquay, Cornwall.  
063 73 2863

**Devon Computers,**  
81 Upper Manor Road,  
Paignton, Devon.  
0803 526303

### SCOTLAND

**Pilgrim Business Machines Ltd.,**  
10 Albert Street,  
Aberdeen.  
0224 55104/5

**Thistle Computers,**  
39 Albert Street,  
Kirkwall,  
Orkney.  
0856 3140

### IRELAND

**Medical Scientific Computer  
Services Ltd.,**  
Altona Road,  
Lisburn,  
Co. Antrim, N. Ireland.  
084 62 77533

### ISLE OF MAN

**Resource Planning Ltd.,**  
Goldie House,  
Upper Church Street,  
Douglas, Isle of Man.  
0624 424778

# THE BRISTOL SOFTWARE FACTORY

• Circle No. 107



# MICROCOM

For Hardware, Software, Peripherals

## PET 2001



from  
**£475**

**commodore**  
authorised dealers

## TRS 80



from  
**£365**

From Radio Shack Corp.

## APPLE II

from  
**£750**

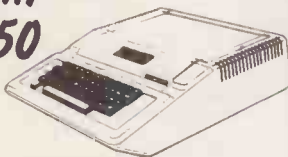

**apple & ITT 2020**  
authorised dealers

## SORCEROR

from **£740**



**err**  
authorised dealers

## COMPUCOLOR

from  
only  
**£999**



**10**  
for computer with colour monitor, keyboard and  
integral disk drive. Second disk drive **£316.00**

PET 3016 (16K RAM and large keyboard)\*  
£675.00  
PET 3032 (32K RAM and large keyboard)\*  
£795.00

IEEE/RS232 Serial Interface 'A' Output only £106.00  
IEEE/RS232 Serial Interface 'B' Input/Output £186.00  
Programmers Toolkit - 10 powerful new commands for your Pet - plug in ROM chip 8K and 16/32K resp £75/£55

TRS 80, 4K Level I consisting of Keyboard with 4K memory, Video Unit, Cassette Drive and 240v power supply unit £365.00  
TRS 80, 4K Level II (as above with Level II Basic) £425.00

TVJ 232C serial Interface £35.00  
Centronics Parallel Printer Interface (direct to keyboard) £40.00  
TRS 80, Voice Synthesizer £345.00  
TRS Voxbox - speech recognition system £135.00  
TRS 80, Numeric Key Pad supplied and fitted £49.00

Apple II Plus computer - APPLESOFT extended basic in ROM - (16K RAM) - video output £695  
Apple black and white modulator for domestic TV £20.00  
Eurocolor card - provides colour on domestic TV £79.00  
Parallel Printer Interface Card £110.00  
High Speed Serial (RS232C) Interface Card £113.00  
Communications Card £130.00  
Centronics Card £130.00  
Integer Basic Firmware Card £116.00  
PASCAL language system - includes language card to provide user with PASCAL, PALSOFT & INTEGER BASIC £299.00

Sorcerer 16K RAM (inc. UHF Modulator) £740.00

Exidy Video Monitor (High Resolution) £240.00  
Exidy Video Disk Unit £1,800.00

**ADVANCED SYSTEMS**  
Altair, Equinox, Billings, Heath, Rair, Horizon. Installations include hard disk and multi tasking. Prices on Application.

**SPECIAL OFFERS**  
(limited period)

**PET BUSINESS SYSTEM.** For only **£1999.00**  
Comprising CBM 3032 Microcomputer, CBM 3040 Dual Disk Drive, CBM 3022 Tractor Feed Printer and all cables - Total cost if items purchased separately **£2158.00**  
(Comprehensive business software available including: Sales, Purchase, Nominal Accounts; Stock Control; Word Processing etc.)  
ITT 2020 - 48K RAM Colour Output to UK Colour TV only **£595.00**

### BASIC SYSTEMS

PET 2001-8 (PET with 8K memory + integral cassette) £475.00  
**PET 3008 (8K)** with large keyboard £475.00  
PET C2N External Cassette Deck £53.00

### ACCESSORIES

IEEE-448/Centronics type parallel Interface £45.00  
IEEE to Pet Cable £19.00  
IEEE to IEEE cable £24.00  
**PETSET 1** 16 Channel AD Converter c.w. all interfacing requirements **£166.00**

### BASIC SYSTEMS

TRS 80, 16K Level II (as above with 16K memory) £499.00  
TRS 80, Expansion Interface with 16K RAM £275.00  
TRS 80, Expansion Interface with 32K RAM £360.00

### ACCESSORIES

Radio Shack Phone Modem £160.00  
UHF Modulators (encased with leads for 625 lines) £20.00  
RAM upgrade (4-16K, 16-32K, 32-48K) supplied and fitted at our premises (Kit £80.00) £85.00  
S100 interface for TRS 80 (6 slots) £375.00  
**TRS80 CPU 3** speed mod. £26.00

### BASIC SYSTEM

extended basic in ROM - (16K RAM) - video output £695

### ACCESSORIES

Real time clock/calendar card - 1/1000 sec to 388 days with interrupt, software controllable £128.00  
Speechlab - provides voice control for the Apple £127.00  
Supertalker - adds human speech output! £205.00  
ALF Music Synthesizer Card £180.00  
A1-02 Data Acquisition Card £180.00  
Graphics Tablet £462.00  
AC Line Controller £270.00  
RAM Upgrade (16-32K, 32-48K) £69.00  
Hobby Prototype Card £20.00  
Romplus - u, l/c, mixed text/graphics £105.00

### BASIC SYSTEMS

Sorcerer 32K RAM (inc. UHF Modulator) £840.00

### ACCESSORIES

Exidy S100 Bus with Interface + motherboard PSU £200.00  
CP/M for Sorcerer on Disk £145.00

**CORVUS** 11mb Hard Disk for TRS 80 & Apple. Complete with interface & D.O.S. £3500.00

**TANDY** Model II now available for demonstration at our Camberley Office. (by appointment only) P.O.A.

# PUTERS ETC

Consultancy and Competitive Prices.

Registered business name



## DISKS

<b>PET</b>	
CBM 3040 (dual drive) 343K User storage*	£795.00
Computhink (dual drive) 400K storage	£895.00
Computhink (dual drive) 800K storage	£1145.00
<b>TRS80</b>	
Shugart drive	£315.00
Micropolis drive	£315.00
Percom FD200 drive 110v	£299.00
Micropolis Dual Drive (394K storage)	£995.00
Corvus Hard Disk (11mb)	£3500.00
<b>APPLE</b>	
Apple Drive - 116K storage 1st drive	£349.00
Apple Drive - 116K storage 2nd drive	£299.00
Corvus Hard Disk (11mb)	£3500.00
<b>SORCEROR</b>	
Exidy - 143K storage	£495.00
Exidy Dual drive (630K storage)	£1195.00
Corvus Hard Disk (11mb)	£3500.00

## PRINTERS

<b>PET</b>	
CBM 3022 (80 col with PET graphics - tractor feed)*	£525.00
<b>TRS80</b>	
TRS 80 Screen Printer (text + graphics) (110v)	£445.00
New Radio Shack Micro Printer	£245.00
<b>GENERAL</b>	
Teletype 43 KSR Serial (pin or pinch feed, 132 cols)	£825.00
Teletype 33 KSR Serial (110 Baud) Reconditioned	£450.00
OKI - parallel/serial (pin or pinch feed, 40, 80, 132 cols selectable)	£499.00
Centronics 779 parallel (tractor feed, 132 cols)	£825.00
Anadex DP 8000 serial/parallel (112 cps bi-directional tractor feed, 40, 80 cols selectable)	£560.00
Centronics Micro Printer (20, 40, 80 cols selectable)	£395.00
Heath WH 14 serial (80, 96, 132 cols selectable)	£475.00
QUME daisy wheel printers	P.O.A.
TCM100/MICROHUSH Thermal Printer (40 cols) inc. interface for PET/APPLE/TRS80	£266.00

## ETC.

Diskettes 5 1/4" (blank) boxed (min order 10) each	from £3
C12 Cassettes (min order 10) each	£0.35p
Ansaback 'phonemate' telephone answering machine voice operated twin cassette	£190.00
Pace EZ-PHONE - Cordless Telephone	£225.00
Computalker Speech Synthesis for S100	£350.00
<b>BOOKS</b> - Large range of microcomputer related books and magazines	

<b>TERMINALS</b>	
Pentland V1, 80 char./24 lines 2 page memory	£580.00
<b>PROGRAMMABLE CALCULATORS. TEXAS INSTRUMENTS.</b> Business Programmable Calculators - complete range. Send for list + prices. (We are authorised TI dealers).	

IF YOU DON'T SEE IT - ASK IF WE HAVE IT

## SOFTWARE

<b>PET</b>	
PETSOFT authorised dealers - over 160 programmes on cassette and disk. Send for catalogue.	
<b>STAGE ONE COMPUTERS S/W</b> dealers - PETAID, Stock Control, etc. Send for list.	
74 Common BASIC Programs on one tape	£15.00
PETACT Business Software - Sales and Purchase Ledger	P.O.A.
<b>CBM DISK-BASED BUSINESS SOFTWARE</b> :-	
Commodore Word Processor powerful word processor package	£75.00
CSTOCK - STOCK CONTROL - gives complete stock report	£150.00
CBIS - BUSINESS INFORMATION SYSTEM - Storage & Retrieval of all types of company records	£150.00
<b>COM ACCOUNTS</b> - Full Financial Business Accounting System incl: Sales, Purchase, Nominal Ledgers (integrates with C Stock and C INV)	£610.00
<b>PAYROLL</b> - Handles hourly, weekly or monthly paid employees (Tape)	£50.00
(We are authorised CBM Business Software Dealers) Send for List.	
<b>GD 1001</b> - Assembler Development System	£50.00
<b>GD 010</b> - Lisp Interpretive Language (Artificial intelligence)	£75.00
<b>JOYSTICK PACKAGE</b> - complete with connector software	£25.00
<b>CAR INSURANCE QUOTATIONS</b> - computerised car insurance quotation suitable for insurance brokers (TVJ S/W)	£25.00
<b>MORTGAGE QUOTATIONS</b> - suitable for agents/mortgage brokers (TVJ S/W)	£25.00
<b>TRS 80</b>	
COMAC III SUITE - computerised accounting for TRS 80 (TVJ SOFTWARE)	£75.00
STOCK CONTROL - complete inventory control - recorder level - P/O's etc. CP/M	£115.00
CBASIC	£95.00
£75.00	
<b>FORTRAN</b> includes compiler, relocatable assembler text editor and linking loader	£95.00
<b>PASCAL</b> - tomorrow's programming language today	£195.00
<b>ELECTRIC PENCIL</b> - powerful word processor allows full cursor movement, insert/delete, string search block movement, adjustable line length, justification on cassette	£65.00
<b>ELECTRIC PENCIL</b> as above - disk version	£115.00
<b>LOWER CASE MOD KIT</b> for Electric Pencil	£28.00
<b>DATA MANAGEMENT/REPORT GENERATOR</b> - easily formats disk files, allows entry, edit, delete and list of records and retrieves data for display or calculation on screen or printer	£200.00
<b>RSM-2D DISK MONITOR</b> - powerful system manipulates disk data, has Z-80 break routine	£25.00
<b>ISAM</b> - INDEX SEQUENTIAL ACCESS METHOD - sub routines to facilitate control of random data files	£45.00
<b>ST80D</b> communications software	£60.00
<b>NEWDOS</b> - TRSDOS with corrections and enhancements	£25.00
<b>NEWDOS+</b> - as above but with further facilities:-	£45.00
KBFIX, Renum, Screen to printer in one step, DOS commands from BASIC, Level I in II, Superzap, Disassemble, load and save faster, list variables	£49.00
<b>LIBRARY 100</b> - an assortment of 100 programs	£39.00
<b>SARGON CHESS</b> - 16K Level II, - the 1979 Champ Version I	£14.00
<b>SARGON CHESS</b> - 16K Level II - the 1979 Champ Version II	£24.00

<b>APPLE</b>	
<b>A2FP FUNCTION PLOTTER</b> - Comprehensive graph plotting	£18.00
<b>U-DRAW II</b> - High Resolution graphics editor. Create a figure then intake, expand, contract etc and store on disk	£27.00
<b>LISP</b> - programming language suitable for research in artificial intelligence	£30.00
<b>3-MILE ISLAND</b> - Complex disk based game simulating nuclear reactor	£27.50
<b>VISICALC</b> - Instant Visual Calculation - provides a powerful planning and forecasting tool	£95.00
<b>APPLE WORD PROCESSOR</b> - Complete text editing, storage and retrieval of text (disk based)	£42.00
<b>LITTLE GENIUS</b> - Comprehensive disk based Apple Soft Tutorial	£35.00

MUSE authorised dealers. Many programs on cassette and disk. Send for list.

**SORCEROR** many programs available - send for list.

\* 5% DISCOUNT ALLOWED FOR EDUCATIONAL ESTABLISHMENTS



# T&V JOHNSON (MICROCOMPUTERS ETC) LTD

Member of the TV Johnson Group of Companies

**Camberley (Head Office)**  
165 London Road, Camberley  
Surrey, GU15 3JS.  
Telephone (0276) 62506

**Oxford**  
148 Cowley Road, Oxford  
OX4 1JJ.  
Telephone (0865) 721461

**Bristol**  
48 Gloucester Road, Bristol  
BS7 8BH  
Telephone (0272) 422061

Hours of business  
Mon-Fri. 9.30 - 5.30  
Sat. 9.30 - 1.00

+ Ansaback eves  
and w/ends.  
Telex 858893

PRICES EXCLUDE VAT, FREIGHT & HANDLING SEND OR  
PHONE FOR PRICE LIST & BROCHURES  
(All prices correct at time of compilation)

Directors: Dr. R.V. King BA, MIEE  
S.G. Johnson, BSc. (Hons.)  
T.S. Johnson, ABIBA, ACMB, FBSC, MBIM  
A.S. Barton ACII, ABIBA, CdiPAF.

Branches at:  
Birmingham, Bristol, Edinburgh, Leeds, London, Louth,  
Newmarket, Nottingham, Oxford, Byfleet, Wokingham.

# Shopping List

Super software from the world's leading microsoftware supplier.

	Software with Manual	Manual Alone
<b>DIGITAL RESEARCH</b>		
CP/M* FDOS — Diskette Operating System complete with M Text Editor, Assembler, Debugger, File Manager and system utilities. Available for wide variety of disk systems including North Star, Helios II, Micropolis, ICOM (all systems) and Altair. Supports computers such as Sorcerer, Horizon, Cromemco, Ohio Scientific, RAIR Black Box, Research Machines, Dynabyte, etc. ....	£75	£15
CP/M version 2 (not all formats available immediately)	£95	£15
MP/M	£195	£25
MAC — 8080 Macro Assembler. Full Intel macro definitions. Pseudo Ops include RPC, IRP, REPT, TITLE, PAGE, and MACLIB. Z-80 library included. Produces Intel absolute hex output plus symbols file for use by SID (see below) ....	£55	£10
SID — 8080 symbolic debugger. Full trace, pass count and break-point program testing system with back-trace and histogram utilities. When used with MAC, provides full symbolic display of memory labels and equated values ....	£45	£10
ZSID Includes Z80 memm. NEW Z80 CPU	£50	£10
TEX — Text formatter to create paginated, page-numbered and justified copy from source text files, directable to disk or printer .....	£45	£10
DESPOOL — Program to permit simultaneous printing of data from disk while user executes another program from the console .....	£30	£1
<b>MICROSOFT</b>		
BASIC-80 — Disk Extended BASIC Interpreter Version 5, ANSI compatible with long variable names, WHILE/WFND, chaining, variable length file records ....	£155	£15
BASIC Compiler — Language compatible with Version 5 Microsoft interpreter and 3-10 times faster execution. Produces standard Microsoft relocatable binary output. Includes Macro-80. Also linkable to FORTRAN-80 or COBOL-80 code modules ....	£195	£15
FORTRAN-80 — ANSI '66 (except for COMPLEX) plus many extensions. Includes relocatable object compiler, linking loader, library with manager. Also includes MACRO-80 (see below) .....	£205	£15
COBOL-80 — ANSI '74 Relocatable object output. Format same as FORTRAN-80 and MACRO-80 modules. Complete ISAM. Interactive ACCEPT DISPLAY, COPY, EXTEND .....	£325	£15
MACRO-80 — 8080/Z80 Macro Assembler. Intel and Zilog mnemonics supported. Relocatable linkable output. Loader, Library Manager and Cross Reference List utilities included .....	£75	£10
XMACRO-86 — 8086 cross assembler. All Macro and utility features of MACRO-80 plus more. Mnemonics slightly modified from Intel ASM86. Comp. utility data sheet available ....	£155	£15
EDIT-80 — Very fast random access text editor for text with or without line numbers. Global and intra-line commands supported. File compare utility included	£45	£10
<b>EIDOS SYSTEMS</b>		
KISS — Keyed Index Sequential Search. Offers complete Multi- Keyed Index Sequential and Direct Access file management. Includes built-in utility functions for 16 or 32 bit arithmetic, string/integer conversion and string compare. Delivered as a relocatable linkable module in Microsoft format for use with FORTRAN-80 or COBOL-80 etc	£190	£15
KBASIC — Microsoft Disk Extended BASIC with all KISS facilities, integrated by implementation of nine additional commands in language. Package includes KISS REL as described above, and a sample mail list program. ....	£295	£25
To licensed users of Microsoft BASIC-80 (M BASIC) .	£215	£25
<b>MICROPRO</b>		
Super-Sort 1 — Sort, merge, extract utility as absolute executable program or linkable module in Microsoft format. Sorts fixed or variable records with data in binary, BCD, Packed Decimal, EBCDIC, ASCII, floating, fixed point, exponential, field justified, etc. etc. Even variable number of fields per record! .....	£125	£15
Super-Sort II — Above available as absolute program only	£105	£15
Super-Sort III — As II without SELECT/EXCLUDE	£75	£15
Word-Master Text Editor — In one mode has super-set of CP/M's ED commands including global searching and replacing, forward and backwards in file. In video-mode, provides full screen editor for users with serial addressable- cursor terminal	£75	£15
Word-Star — Menu driven visual word processing system for use with standard terminals. Text formatting performed on screen. Facilities for text paginate, page number, justify, center, underscore and PRINT. Edit facilities include global search and replace, read/write to other text files, block move, etc. Requires CRT terminal with addressable cursor positioning	£255	£15
<b>GRAFFCOM</b>		
PAYROLL — Designed in conjunction with the spec for PAYE routines by HMI Taxes. Processes up to 250 employees on weekly or monthly basis. Can handle cash, cheque or bank transfer payments plus total tracking of all year to date figures. Prints emp master, payroll log, payslips and bank giros. Requires CBASIC-2	£475	£15
COMPANY SALES — Performs sales accounting function. Controls payments of invoices and prints sales ledger and aged debtors report. Suitable for any accounting period. Comprehensive VAT control and analysis of all sales invoices. Requires CBASIC-2	£425	£15
COMPANY PURCHASES — Performs purchase accounting function. Controls invoices, credit & debit notes. Prints purchase ledger, aged creditors report and payment advices. Comprehensive VAT control and analysis of all purchases, Interfaces with the NAD system. Requires CBASIC-2	£425	£15
GENERAL ACCOUNTING — Produces Nominal Ledger, Trial Balance, P/L and Balance Sheet. Define your own coding system. Interactive data entry plus optional data capture from Company Sales and Company Purchases. Requires CBASIC-2	£375	£15
STOCK CONTROL Maintains stock records, monitors stock levels to ensure optimum stock holding. Details include stock desc., product code, unit, unit price, quantity on hand on order/minimum. Stock analysis reports can be weekly, monthly, quarterly etc. Interfaces with Order Entry & Invoicing system. Requires CBASIC-2	£325	£15
ORDER ENTRY & INVOICING Performs order entry and invoicing function. Handles invoices for services and consumable items, part orders and part quantities. Sales Analysis report shows sales movements and trends for user-defined period Interfaces with Stock Control. NAD and Company Sales systems. Requires CBASIC-2	£325	£15
NAD — Complete control of all your names & addresses including suppliers, clients, enquiries etc. Assign your own coding system and select all output via the report generator. Will print anything from mailing labels to directories. Requires CBASIC-2	£225	£12
COMPLETE ACCOUNTING PACKAGE — Combined Company Sales, Company Purchases, General Accounting, and NAD systems	£950	£45
SALES ORDER PROCESSING PACKAGE — Combined Stock Control, Order Entry and Invoicing and NAD systems	£550	£30
<b>STRUCTURED SYSTEMS GROUP</b>		
ANALYST — Customised data entry and reporting system. User specifies up to 75 data items per record. Interactive data entry, retrieval and update facility makes information management easy. Sophisticated report generator provides customised reports using selected records with multiple level breakpoints for summarisation. Requires CBASIC-2, 24 x 80 CRT, printer and 48K system	£125	£10
LETTERRIGHT — Program to create edit and type letters or other documents. Has facilities to print, display, delete and move text, with good video screen presentation. Designed to integrate with NAD for form letter mailings. Requires CBASIC-2	£105	£15
NAD Name and Address selection system — interactive mail list creation and maintenance program with output as full reports with reference data or restricted information for mail labels. Transfer system for extraction and transfer of selected records to create new files. Requires CBASIC-2	£45	£12
QSORT — Fast sort/merge program for files with fixed record length, variable field length information. Up to five ascending or descending keys. Full back-up of input files created. Parameter file created optionally with interactive program which requires CBASIC-2. Parameter file may be generated with CP/M assembler utility	£50	£12
<b>SOFTWARE SYSTEMS</b>		
CBASIC-2 Disk Extended BASIC — Non-interactive BASIC with pseudo-code compiler and runtime interpreter. Supports full file control, chaining, integer and extended precision variables etc.	£75	£10
<b>GRAHAM-DORIAN SOFTWARE SYSTEMS</b>		
APARTMENT MANAGEMENT SYSTEM — Financial management system for receipts and security deposits of apartment projects. Captures data on vacancies, revenues, etc. for annual trend analysis. Daily report shows late rents, vacancy notices, vacancies, income lost through vacancies, etc. Requires CBASIC-2. Supplied in source code.	£300	£25
INVENTORY SYSTEM — Captures stock levels, costs, sources, sales, ages, turnover, markup, etc. Transaction information may be entered for reporting by salesman, type of sale, date of sale, etc. Reports available both for accounting and decision making. Requires CBASIC-2. Supplied in source code	£300	£25

Software for most popular 8080/Z80 computer disk systems including  
**NORTH STAR HORIZON, VECTOR MZ, OHIO SCIENTIFIC,  
 CROMEMCO, PROCESSOR TECHNOLOGY, RAI, BLACK BOX,  
 DYNABYTE, SD SYSTEMS, RESEARCH MACHINES, ALTAIR,  
 EXIDY SORCERER, IMSAI, HEATH, and 8" IBM formats**

- Software with Manual / Manual with Alone
- ☐ **CASH REGISTER** — Maintains files on daily sales. Files data by sales person and item. Tracks sales. Overings, refunds, payouts and total net deposits. Requires CBASIC. Supplied in source code. £300/£25
  - ☐ **MICRO FOCUS**
  - ☐ **STANDARD CIS COBOL** — ANSI '74 COBOL standard compiler fully validated by U.S. Navy tests to ANSI level 1. Supports many features to level 2 including dynamic loading of COBOL modules and a full ISAM file facility. Also, program segmentation, interactive debug and powerful interactive extensions to support protected and unprotected CRT screen formatting from COBOL programs used with any dumb terminal. £400/£25
  - ☐ **FORMS 2** — CRT screen editor. Automatically creates a query and update program of indexed files using CRT protected and unprotected screen formats. Output is COBOL data descriptions for copying into CIS COBOL programs. No programming experience needed. Output program directly compiled by CIS COBOL (standard). £100/£12
  - ☐ **OTHER**
  - ☐ **PASCAL/Z** — Z80 native code PASCAL compiler. Produces optimised portable reentrant code. All interfacing to CP/M is through the support library. The package includes compiler companion macro assembler and source for the library. Requires 56K and Z80 CPU. Version 2 includes all of Jensen/Wirth except variant records. £155/£15
  - ☐ **Version 3 Upgrade** with variant records and strings expected 2/80. £205/£15
  - ☐ **PASCAL/MT** — Subset of standard PASCAL. Generates portable 8080 machine code. Symbolic debugger included. Supports interrupt procedure and BCD arithmetic for real variables. CP/M file I/O and assembly language interface supported. Lacks sets, Enumeration and Record data types. Manual explains BASIC to PASCAL conversion. Requires 32K. £65/£17
  - ☐ **Source for PASCAL/MT run time package.** Requires MAC (See under Digital Research). £30
  - ☐ **tiny C** — interactive interpretive system for teaching structured programming techniques. Manual includes full source listings. £45/£30
  - ☐ **BDS C COMPILER** — Supports most major features of language, including Structures, Arrays, Pointers, recursive function evaluation, linkable with library to 8080 binary output. Lacks data initialization, long & float type and static & register class specifiers. Documentation includes "C" Programming Language book by Kernighan & Ritchie. £60/£10
  - ☐ **WHITESMITHS' C COMPILER** — The ultimate in systems software tools. Produces faster code than Pascal with more extensive facilities. Conforms to the full UNIX Version 7 C language, described by Kernighan and Ritchie, and makes available over 75 functions for performing I/O, string manipulation and storage allocation. Compiler output in A-Natural source. Supplied with A-Natural. Requires 60K CP/M. £325/£20
  - ☐ **POLYVUE/80** — Full screen editor for any CRT with XY cursor positioning. Includes vertical & horizontal scrolling, interactive search and replace, automatic text wrap around for word processing, operations for manipulating blocks of text, and comprehensive 70 page manual. £70/£12
  - ☐ **POLYTEXT/80** — Text formatter for word processing applications. Justifies and paginates source text files. Will generate form letters and custom fields and conditional processing. Support for Wheel printers includes variable pitch justification and motion optimization. £45/£10
  - ☐ **ALGOL 60 Compiler** — Powerful block-structured language featuring economical run time dynamic allocation of memory. Very compact (24K total RAM) system implementing almost all Algol 60 report features plus many powerful extensions including string handling, direct disk address I/O etc. Requires Z80 CPU. £110/£12
  - ☐ **Z80 Development Package** — Consists of (1) disk file line editor, with global inter and intra-line facilities; (2) Z80 relocating assembler, Zilog Mostek mnemonics, conditional assembly and cross reference table capabilities; (3) linking loader producing absolute Intel hex disk file for CP/M LOAD, DDT or SID facilities. £50/£12
  - ☐ **ZDT** — Z80 Debugger to trace, break and examine registers with standard Zilog/Mostek mnemonic disassembly displays. Facilities similar to DDT £20 when ordered with Z80 Development Package. £30/£7
  - ☐ **DISTEL** — Disk based disassembler to Intel 8080 or TDL/Xitan Z80 source code, listing and cross reference files. Intel or TDL Xitan pseudo ops optional. Runs on 8080. £35/£7
  - ☐ **DISILOG** — As Distel to Zilog Mostek mnemonic files. Runs on Z80 only. £35/£7
  - ☐ **TEXTWRITER III** — Text formatter to justify and paginate letters and other documents. Special features include insertion of text during execution from other disk files or console, permitting recipe documents to be created from linked fragments on other files. Has facilities for sorted index, table of contents and footnote insertion. Ideal for contracts manuals. etc. £75/£3

- Software with Manual / Manual with Alone
- ☐ **POSTMASTER** — A comprehensive package for mail list maintenance. Features include source record extraction and label production. A form letter program is included which provides neat letters on single sheet or continuous forms. Requires CBASIC. £75/15
  - ☐ **WHATSIT?** — Interactive data-base system using associative tags to retrieve information by subject. Hashing and random access used for fast response. Requires CBASIC. £70/£15
  - ☐ **XYBASIC Interactive Process Control BASIC** — Full disk BASIC features plus unique commands to handle bytes, rotate and shift, and to test and set bits. Available in integer, Extended and ROMable versions. Integer Disk or Integer ROMable. £165/£15  
Extended Disk or Extended ROMable. £215/£15
  - ☐ **SMAL/80 Structured Macro Assembly Language** — Package of powerful general purpose text macro processor and SMAL structured language compiler. SMAL is an assembler language with IF-THEN-ELSE, LOOP-REPEAT-WHILE, DO-END, BEGIN-END constructs. £40/£10
  - ☐ **SELECTOR III-C2** — Data Base Processor to create and maintain multi Key data bases. Prints formatted, sorted reports with numerical summaries or mailing labels. Comes with sample applications including Sales Activity, Inventory, Payables, Receivables, Check Register, and Client/Patient Appointments, etc. Requires CBASIC Version 2. Supplied in source code. £185/£12
  - ☐ **CPM/374X Utility Package** — has full range of functions to create or re-name an IBM 3741 volume, display directory information and edit the data set contents. Provides full file transfer facilities between 3741 volume data sets and CP/M files. £125/£7
  - ☐ **BASIC UTILITY DISK** — Consists of (1) CRUNCH-14 Compacting utility to reduce the size and increase the speed of programs in Microsoft Basic. (2) TRS-80 Basic. (2) DPFUN — Double precision subroutines for computing nineteen transcendental functions including square root, natural log, log base 10, sin, arc sin, hyperbolic sin, hyperbolic arc sin, etc. Furnished in source on diskette and documentation. £30/£10
  - ☐ **THE STRING BIT** — Fortran character string handling. Routines to find, fill, pack, reverse, separate, concatenate and compare character strings. Package completely eliminates the problems associated with character string handling in FORTRAN. Supplied with source. £30/£10
  - ☐ **BSTAM** — Utility to link one computer to another also equipped with BSTAM. Allows file transfers at full data speed (no conversion to hex), with CRC block control check for very reliable error detection and automatic retry. We use it! It's great! Full wildcard expansions and \*.COM, etc. 9600 baud with wire, 300 baud with phone connection. Both ends need one. Standard and M versions can talk to one another. £75/£5
  - ☐ **Flippy Disk Kit** — Template and instructions to modify single sided 5 1/4" diskettes for use of second side in singled sided drives. £6



Orders must specify disk type and format, e.g. North Star-Horizon single density.

Add VAT to orders for software (not manuals alone) Add 50p per item postage and packing (minimum £1)

All orders must be prepaid (except COD or credit card) Make cheques POs etc payable to Lifeboat Associates.

Manual costs are deductible from subsequent software purchase

Lifeboat Associates  
 32 Neal Street  
 London WC2H 9PS  
 01-379 7931

☐ Modified version available for use with CP/M as implemented on Heath and TRS-80 Model 1 computers.

☐ User license agreement for this product must be signed and returned to Lifeboat Associates before shipment may be made.

\*CP M is a trademark of Digital Research  
 \*\*Z80 is a trademark of Zilog Inc.

The Software Supermarket is a trademark of Lifeboat Associates.

EFFECTIVE JANUARY 1980

# Britain's first comp

**A complete personal computer for a third of the price of a bare board.**

**Also available ready assembled for £99<sup>95</sup>**

## The Sinclair ZX80.

Until now, building your own computer could easily cost around £300 – and still leave you with only a bare board for your trouble.

The Sinclair ZX80 changes all that. For just £79.95 you get *everything* you need to build a personal computer at home... PCB, with IC sockets for all ICs; case; leads for direct connection to your own cassette recorder and television; everything!

And yet the ZX80 really is a complete, powerful, full-facility computer, matching or surpassing other personal computers on the market at several times the price. The ZX80 is programmed in BASIC, and you could use it to do quite literally anything from playing chess to running a power station.

The ZX80 is pleasantly straightforward to assemble, using a fine-tipped soldering iron. Once assembled, it immediately proves what a good job you've done. Connect it to your TV set... link it to an appropriate power source\*... and you're ready to go.

### Your ZX80 kit contains...

- Printed circuit board, with IC sockets for all ICs.
- Complete components set, including all ICs – all manufactured by selected world-leading suppliers.
- New rugged Sinclair keyboard, touch-sensitive, wipe-clean.
- Ready-moulded case.
- Leads and plugs for connection to any portable cassette recorder (to store programs) and domestic TV (to act as VDU).
- FREE course in BASIC programming and user manual.

### Optional extras

- Mains adaptor of 600 mA at 9 V DC nominal unregulated (available separately – see coupon).
- Additional memory expansion board plugs in to take up to 3K bytes extra RAM chips. (Chips also available – see coupon.)

\*Use a 600 mA at 9 V DC nominal unregulated mains adaptor. Available from Sinclair if desired (see coupon).

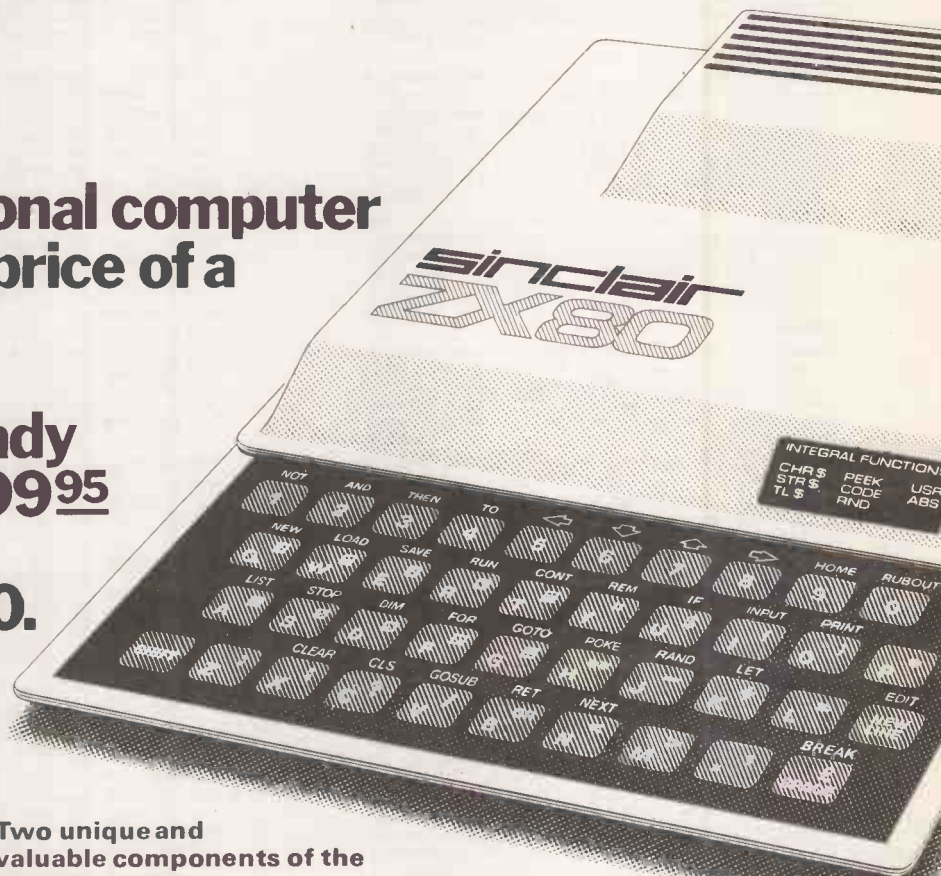

### Two unique and valuable components of the Sinclair ZX80.

The Sinclair ZX80 is not just another personal computer. Quite apart from its exceptionally low price, the ZX80 has two uniquely advanced components: the Sinclair BASIC interpreter; and the Sinclair teach-yourself BASIC manual.

**The unique Sinclair BASIC interpreter...** offers remarkable programming advantages:

- Unique 'one-touch' key word entry: the ZX80 eliminates a great deal of tiresome typing. Key words (RUN, PRINT, LIST, etc.) have their own single-key entry.
- Unique syntax check. Only lines with correct syntax are accepted into programs. A cursor identifies errors immediately. This prevents entry of long and complicated programs with faults only discovered when you run them.
- Excellent string-handling capability – takes up to 26 string variables of any length. All strings can undergo all relational tests (e.g. comparison). The ZX80 also has string input-to request a line of text when necessary. Strings do *not* need to be dimensioned.
- Up to 26 single dimension arrays.
- FOR/NEXT loops nested up to 26.
- Variable names of any length.
- BASIC language also handles full Boolean arithmetic, conditional expressions, etc.
- Exceptionally powerful edit facilities, allows modification of existing program lines.
- Randomise function, useful for games and secret codes, as well as more serious applications.
- Timer under program control.
- PEEK and POKE enable entry of machine code instructions, USR causes jump to a user's machine language sub-routine.

- High-resolution graphics with 22 standard graphic symbols.
- All characters printable in reverse under program control.

### ... and the Sinclair teach-yourself BASIC manual.

If the features of the Sinclair interpreter listed alongside mean little to you – don't worry. They're all explained in the specially-written 96-page book *free* with every kit! The book makes learning easy, exciting and enjoyable, and represents a complete course in BASIC programming – from first principles to complex programs. (Available separately – purchase price refunded if you buy a ZX80 later.)

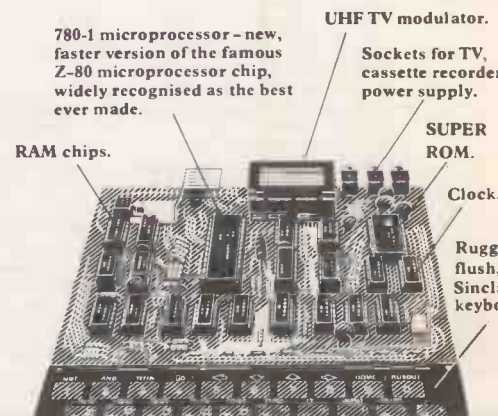

# Complete computer kit.

**£79<sup>95</sup>**

**Including VAT.  
Including post and  
packing.  
Including all leads  
and components**

**Fewer chips,  
compact design,  
volume production –  
more power per pound!**

The ZX80 owes its remarkable low price to its remarkable design: the whole system is packed onto fewer, newer, more powerful and advanced LSI chips. A single SUPER ROM, for instance, contains the BASIC interpreter, the character set, operating system, and monitor. And the ZX80's 1K byte RAM is roughly equivalent to 4K bytes in a conventional computer, because the ZX80's brilliant design packs the RAM so much more tightly. (Key words, for instance, occupy just a single byte.)

To all that, add volume production – and you've that rare thing: a price breakthrough that really is a breakthrough.

**The Sinclair ZX80. Kit: £79.95.  
Assembled: £99.95. Complete!**

The ZX80 kit costs a mere £79.95. Can't wait to have a ZX80 up and running? No problem! It's also available, ready assembled, for only £99.95.

Whether you choose the kit or the ready-made, you can be sure of world-famous Sinclair technology – and years of satisfying use. (Science of Cambridge Ltd is one of the Sinclair companies owned and run by Clive Sinclair.)

To order, complete the coupon, and post to Science of Cambridge for delivery within 28 days. Return as received within 14 days for full money refund if not completely satisfied.

**sinclair  
ZX80**

**Science of Cambridge Ltd**

6 Kings Parade, Cambridge, Cambs., CB2 1SN.  
Tel: 0223 311488.

## Order Form

To: Science of Cambridge Ltd, 6 Kings Parade, Cambridge, Cambs., CB2 1SN.  
Remember: all prices shown include VAT, postage and packing. No hidden extras.

Please send me:

Quantity	Item	Item price	Total
	Sinclair ZX80 Personal Computer kit(s). Price includes ZX80 BASIC manual, excludes mains adaptor.	79.95	
	Ready-assembled Sinclair ZX80 Personal Computer(s). Price includes ZX80 BASIC manual, excludes mains adaptor.	99.95	
	Mains Adaptor(s) (600 mA at 9 V DC nominal unregulated).	8.95	
	Memory Expansion Board(s) (takes up to 3K bytes).	12.00	
	RAM Memory chips – standard 1K bytes capacity.	16.00	
	Sinclair ZX80 Manual(s) (manual free with every ZX80 kit or ready-made computer).	5.00	
		<b>TOTAL</b>	£

NB. Your Sinclair ZX80 may qualify as a business expense.

I enclose a cheque/postal order payable to Science of Cambridge Ltd for £

Please print

Name: Mr/Mrs/Miss \_\_\_\_\_

Address \_\_\_\_\_

PC 3/80

• Circle No. 110

# aculab Ltd

## HIGH-QUALITY PRINTOUT FOR YOUR WORD-PROCESSING SYSTEM

The ACULAB 735P, a fully self-contained interface for IBM golfball output typewriters and printers.

Parallel model accepts 7-bit ASCII data via a Centronics compatible connector.

Serial model accepts RS232C/V24, selectable Baud rates. Parallel model may be retro-fitted with serial board.

Programmed for 7 different typehead layouts, covers all common golfballs and an ASCII ball, switch selectable from the front panel.

STOP/GO switch, ONLINE/OFFLINE switch, also online/offline under software control.

Parallel..... £155.00 + VAT

Accessories and cables available for use with PET/SORCERER/TRS-80 (with or without expansion interface) APPLE/ITT/RML380Z etc., etc.

Wiring and testing service for typewriters and printers.

Typewriters and printers available wired and tested and ready to go.



24 Heath Road,  
Leighton Buzzard, Beds.  
LU7 8AB

For further information  
Telephone. 0525-371393.

• Circle No. 111

## COMPUTERS FOR HOME BUSINESS EDUCATION

WIDE RANGE OF ELECTRONIC GAMES

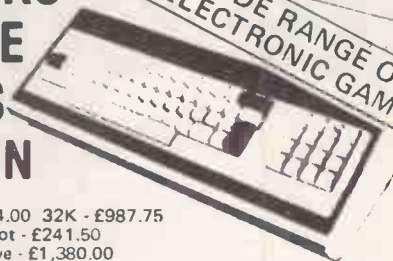

Exidy Sorcerer  
8K - £747.50 16K - £874.00 32K - £987.75  
S100 Expansion Box 6-slot - £241.50  
Micropolis Dual Disc Drive - £1,380.00  
Centronics 779 Printer - £920.00

### Z-89 ALL-IN-ONE COMPUTER

The new all-in-one computer from Zenith is the most versatile micro-computer available today.  
• 'Intelligent' video terminal • two Z80 microprocessors • floppy disc storage system • expandable to 48K RAM  
Easy to programme. Simple to operate. It is capable of a multitude of high-speed functions and speaks the language of today's most popular software. Price from £1805



### The most advanced microcomputer yet.

WH 14 SERIAL PRINTER  
With a compact table top configuration, the WH-14 is designed for a broad variety of uses in any computing environment.

Microprocessor based, it is compatible with any computer providing standard RS-232C or 20mA current loop interface connections. Price £586.50



video 100  
12" BLACK & WHITE LOW COST VIDEO MONITOR  
£90.00



RADAT 5" 10 MHz Scores only £169.00  
SELECTION OF SOFTWARE GAMES & BUSINESS

5 1/4 FLOPPY DISK for TRS 80  
Track F d I d A  
Single Drive £287.50  
Dual Drive £505.00  
Integral Power Supply



TRS80 LEVEL 2 16K  
OILY £440.00 ONLY  
EXPANSION BOX 32K £340.00

Large range of computer etc. books. Send for List  
SAE with all enquiries - All prices inclusive.

SUPPLIERS TO BUSINESS, EDUCATION & HEALTH AUTHORITIES



# N.I.C



61 Broad Lane, Tottenham, London N15.  
01-808 0377

• Circle No. 112

# How do you combine a typewriter with an output printer for a micro computer?

Simple — with a Kode Model 43 friction and tractor feed teleprinter! This reliable 10 or 30 c.p.s. machine has a 9 wire matrix printhead for exceptional print quality with true descenders on lower case. When used with single sheets of paper, the Model 43 provides an excellent keyboard or computer controlled typewriter for special reports, invoices or letters. The useful range of interfaces ensures easy compatibility with your microcomputer, and when supplied with tractor-fed fanfold paper, the Model 43 becomes a superb output printer. Two machines in one proven package — at a real value-for-money price. Contact Kode for more information now.

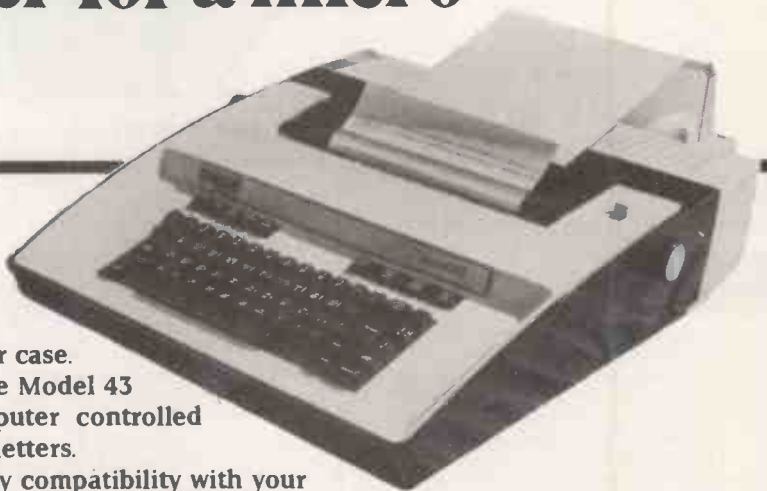

WITH A TELETYPE 43 FROM

# KODE

Station Road, Calne, Wiltshire SN11 0JR.  
Telephone Calne (0249) 813771. Telex 449335

• Circle No. 113



# STACK COMPUTERS ANNOUNCE . . .



## THE AFFORDABLE APPLE

Stack Computer Services can now offer the full range of computers and accessories for the discerning Apple owner. Our aim is to provide a "one stop" source of Apple equipment and Apple compatible peripherals. To this end we are currently expanding our existing premises to accommodate a new department dedicated to the sale and support of Apple products.

Our particular expertise is centred around industrial research and educational applications, with each system being individually tailored to meet the customers specific needs.

**Telephone (Paul Fulwood) on  
051-933 5511 (ext. 10) for further details.**



Apple II ++ 16K RAM	<b>£695.00</b>	Apple logo ties	<b>£5.50</b>
Disk drive(no controller)	<b>£299.00</b>	A.C. line controller	<b>£270.00</b>
Disk drive(+ controller)	<b>£349.00</b>	Slave for above	<b>£130.00</b>
16K memory upgrade	<b>£69.00</b>	Rom plus board	<b>£105.00</b>
Prototype/hobby board	<b>£15.00</b>	10 Apple diskettes	<b>£30.00</b>
Parallel printer card	<b>£104.00</b>	Vinyl carrying case	<b>£16.00</b>
Communications card	<b>£130.00</b>	Speechlab	<b>£127.00</b>
High speed serial card	<b>£113.00</b>	Programmers aid1	<b>£27.00</b>
Pascal language system	<b>£299.00</b>	Autostart ROM pack	<b>£38.00</b>
Centronics card	<b>£130.00</b>	Graphics tablet	<b>£462.00</b>
Applesoft BASIC card	<b>£116.00</b>	Appletel system	<b>£595.00</b>
Integer BASIC card	<b>£116.00</b>	B&W UHF Modulator	<b>£14.00</b>
Clock/calender card	<b>£128.00</b>	Supertalker	<b>£136.00</b>
Eurocolour card	<b>£79.00</b>	Microhush printer	<b>£266.00</b>
ALF music synthesizer	<b>£180.00</b>	Thermal paper for above	<b>£2.00</b>
Heuristics controller	<b>£53.00</b>	10" B&W monitor	<b>£100.00</b>
Heuristics speechlink	<b>£173.00</b>	Lower case adaptor	<b>£40.00</b>
IEEE interface	<b>£212.00</b>	Synertec light pen	<b>£165.00</b>

### COLOUR

Supercolour system for the Apple gives superb colour on a modified (But still usable) Sony 14" T.V.

Supercolour card **£90.00**  
Supercolour T.V. **£300.00**

**Stack Computer Services Ltd**  
290-298 Derby Road, Bootle  
Liverpool 20

# 051-933 5511

• Circle No. 114

## UNRIVALED PRICE/ PERFORMANCE



**£1950.00**  
+ VAT

### INTERTEC DATA SYSTEMS SUPERBRAIN

#### SPECIFICATIONS

- DUAL Z80 4MHZ PROCESSORS
- 64 KB RAM
- DUAL 5 1/4" MINI FLOPPIES 250 KB, 1.6 MB VERSION AVAILABLE SHORTLY
- CP/M OPERATING SYSTEM

#### SOFTWARE

- BASIC/COBOL/FORTRAN/PASCAL
- WORD PROCESSING/MAIL SHOT/REPORT WRITING
- SMALL BUSINESS SOFTWARE
- MAINFRAME TYPE DATA-BASE SYSTEM
- EXPANDABLE USING OPTIONAL S100 BUS ADAPTOR



**£549.00**  
+ VAT

### ESL-A65 DESK TOP CALCULATOR

#### SPECIFICATIONS

- PROGRAMMABLE IN BASIC
- BUILT IN 20 COLUMN PRINTER
- 4 KB PROGRAM MEMORY
- BUILT IN CASSETTE FOR PERMANENT PROGRAM STORAGE
- FULL SIZE STANDARD TYPEWRITER KEYBOARD

#### APPLICATIONS

- ROUTINE DATA ANALYSIS
- SCIENTIFIC & ENGINEERING CALCULATIONS
- ESTIMATING & COSTING
- SALES ANALYSIS



**£375.00**  
+ VAT

4 WEEKS DELIVERY

COMPATIBLE WITH PET, TRS-80, APPLE ETC.

### ESL MATRIX IMPACT PRINTER

#### FEATURES

- 72, 80, 96, 120 OR 132 CHARACTERS PER LINE
- UP TO 132 CHARACTERS PER SECOND
- TRACTOR/FRICTION FEED
- PAPER UP TO 9 1/2" WIDE
- RS-232, 20MA, IEEE & CENTRONICS INTERFACES AS STANDARD

- FULL 96 ASCII CHARACTER SET PLUS FULL APL
- DOUBLE WIDTH CHARACTERS AND BOLD TYPE
- USER DEFINED CHARACTER SET CAN BE DOWN LOADED
- SOFTWARE CONTROL OF TAB, AUTO LINE FEED, TOP OF FORM, ETC.

#### OPTIONS

- FOREIGN LANGUAGES OR SPECIAL CUSTOM CHARACTER SETS
- 2K BUFFER

RUGGED ALUMINIUM CASE AND SMALL PHYSICAL SIZE MAKE THIS PRINTER IDEALLY SUITED FOR INDUSTRIAL AS WELL AS HOME OR OFFICE USE

**ENCOTEL SYSTEMS LTD**  
PHONE UPPER WARLINGHAM (820) 5701  
TELEX 896 559

• Circle No. 115

## CASIO FX 502P

### PROGRAMMABLE CALCULATOR



• Amazing operating speed

- LINKS UP WITH AN ADAPTOR FOR PROGRAMME — DATA STORAGE ON STANDARD CASSETTES, PLUS MUSIC SYNTHESISING AND PLAY BACK
- 256 functional-step programme memory and 22 data registers are both protected (non-volatile)
- Up to 10 levels of parenthesis nesting
- True algebraic logic — easy key operations same as written formulae
- Battery service life is 1,300 hours. Auto power-off feature is provided
- Thin and lightweight, easy to carry around
- Up to 10 programmes available, programme keys otherwise usable as user's functions
- 51 built-in functions all usable in programmes
- A variety of "jump" commands, unconditional jumps, conditional jumps and indirect jumps
- Up to 9 subroutines Incorporable, nesting possible up to 9 levels
- Easy to edit and debug programmes. PAUSE key, random number key, back step/rapid run key

Optional FA-1 Programme Adaptor permits programme/data storage on standard cassette tape recorders for re-entry. Typical storage/re-entry time 9-16 seconds, with a three digit code for programme reference and identification.

Dimensions of both are 9.6 mm H x 71 mm W x 141.2 mm D (1 1/4" H x 2 3/4" W x 5 1/2" D). A comprehensive Programme Manual Instruction Booklet and leatherette wallet are supplied. FA-1 comes complete with a demonstration cassette with pre-recorded programmes, including games and music.

AVAILABLE BY MAIL ORDER AT LOWEST DISCOUNT PRICES

**£54.95**

FX-501P (RRP £64.95)

**£74.95**

FX-502P (RRP £84.95)

**£19.95**

FA-1 (RRP £24.95)

**MASTER PACKAGE DEAL.** Premier publications Master Pack software kit only £5 when you buy the FX-501P and FA-1 or FX-502P and FA-1. Usual price £17.95.

Master Pack comprises USER MANUAL with Basic and advanced programming etc. PLUS cassette with over 150 ready-to-run programmes, full Casio library, personal computer programs. Powerful subroutines, Data-packing and programming tips and tricks.

Prices include VAT at 15% and post and packing. Send your Company order, cheque or Postal Orders, or phone your ACCESS or BARCLAYCARD number to:

# TEMPUS

DEPT PC4  
THE BEAUMONT CENTRE  
164-167 EAST ROAD  
CAMBRIDGE CB1 1DB  
Tel: (0223) 312866

• Circle No. 116

## COMPUT-A-CROP

01-499 6987/01-771 0867 (24 hours)  
COMPUTER BUYERS

Our aim is to supply an accurate, reliable, fast, up to date and flexible system with room for expansion and diversification, to match the growth of YOUR business.

Contact us for an appointment to investigate the potential for automation of accounts, correspondence, management records and inventory maintenance and control.

Office accounting systems from £3350.00 + VAT. Professional Word processing from £4475.00 with Daisywheel printer.

### COMPUTER USERS AND VENDORS

We are distributors for DIGITAL MICRO-SYSTEMS computers and SELVEN SYSTEMS business software and suppliers of \*TANDY TRS80 MODELS I AND II, WORD-STAR and ELECTRIC PENCIL word-processing programs for CP/M and TRS80 systems.

We supply SHUGART SA400 mini-disk drives, DIABLO, TELETYPE and PAPER TIGER printers and PERIPHERAL ELECTRONICS mains interference filter units.

Telephone or circle enquiry card for details and price list.

\*Trade mark of RADIO SHACK.

• Circle No. 117

# Research Resources Ltd

Micro-computers for Education, Science and Technology.

## SWTP — New 16 Bit, Multi-user 384K RAM Computer

- 6809 16/8 Bit CPU replacement card for Level 1/2
- Two new 6809 computers — up to 384K RAM
- New DMAF-2 8" Dual Floppy disks — 2.5 Megabyte
- 64 Megabyte Hard Disks
- Memory available in 4,8,16,32,128k Boards
- New Graphics VDU — CT82B — Improved 50Hz UK Standard
- New TSC BASIC — very fast + Multi-user/Multi-tasking
- Plus LAB-BASIC, SAM, PASCAL, PILOT, FLEX, etc.
- A-D, D-A converters
- Upgrade to a GIMIX chassis — robust, more slots, more power

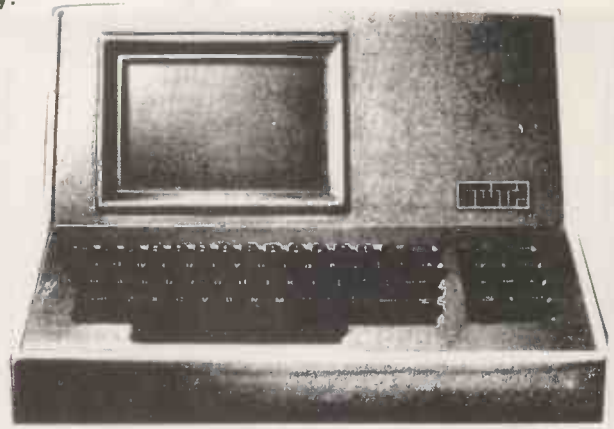

## SINTROM PERIFLEX and VECTOR MZ

- Z80A CPU, S100 Bus, CP/M
- 48k or 64k enhanced version
- Over 1/2 Megabyte of integral disk storage
- Improved Micropolis disk drives
- MDSO or CP/M operating system
- Hardware floating point board and software
- Fast fourier transform and digital filtering package
- Plus LAB-BASIC, PASCAL, FORTRAN, BASIC Compilers and SAM (Statistical Analysis for Micros)



## PET — New Models, Disc drives, Printers

- Up to 32k of user RAM
- 360k intelligent disk drives (CBM)
- 40 Column printer — only £245
- 80 Column Graphics printer
- LAB-BASIC for Control
- Full range of interfaces
- Milli-second Timer
- Exclusive Statistics Software

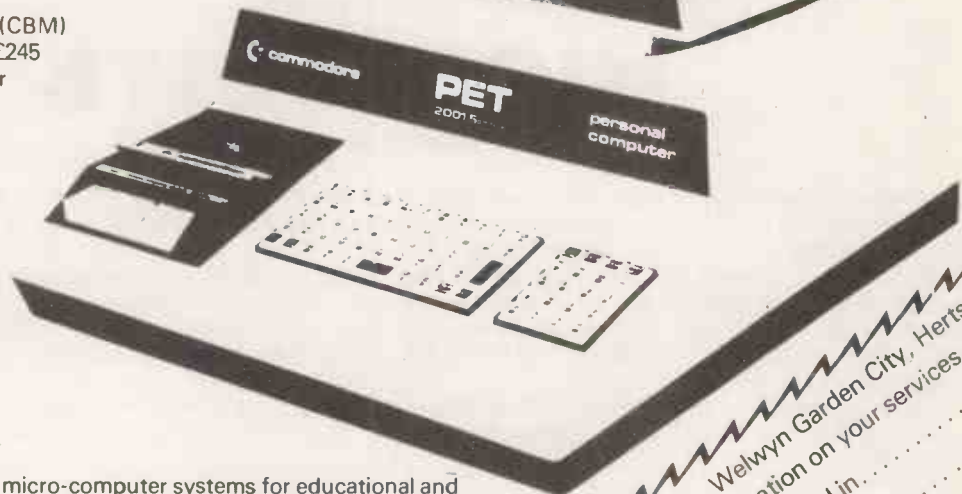

RRL specialises in designing micro-computer systems for educational and scientific use. We will supply the complete system — processor, VDU, printer, special interfaces, software etc. — to solve your problem.

For further information:

Tel: Welwyn Garden (07073) 26633

RESEARCH RESOURCES LTD, 40 Stonehills,  
Welwyn Garden City, HERTS. AL8 6PD.

To: RRL, 40 Stonehills, Welwyn Garden City, Herts  
Please supply full information on your services.  
We are particularly interested in.....  
Address .....  
Tel .....  
PCF

• Circle No. 118

## MICROCOMPUTER SHOPPING MADE SIMPLE

The Slough Microshop is the Thames Valley Specialist in microcomputer systems — for business, professional or personal use. Our services include:

- \* TAILORMADE OR PACKAGED SOFTWARE
- \* COMPLETE HARDWARE MAINTENANCE SERVICE

- \* FULL DEMONSTRATION EQUIPMENT

We are the officially approved stockist for  
**COMMODORE PET**  
**EXIDY SORCERER**  
**NORTH STAR HORIZON**  
**APPLE II**  
**IMS 5000/8000**  
**EQUINOX 300**

Ask for a demonstration. Phone or call into the Slough Microshop showroom — where microcomputer shopping is made simple.

## THE SLOUGH MICROSHOP

120 High Street Slough Berkshire  
 Telephone: Slough 72470 or 22855

• Circle No. 119



### APPLE HARDWARE

Apple 16K	£695	<input type="checkbox"/>
Disc with controller	£349	<input type="checkbox"/>
Disc drive only	£299	<input type="checkbox"/>
16K add on memory	£69	<input type="checkbox"/>

### APPLE SOFTWARE

Pay roll	£500	<input type="checkbox"/>
Stock control	£500	<input type="checkbox"/>
Purchase Ledger	£500	<input type="checkbox"/>
Sales Ledger	£500	<input type="checkbox"/>

### APPLE SERVICES

Hardware maintenance 12.5%  
 BPspoke Software  
 Hardware prototyping  
 Interfacing to Specialist equipment  
 Add VAT at 15%

Name .....

Address .....

Tel. No. ....

ADD V.A.T. AT 15%

Please enclose cheque and send to  
 Business Computer Services  
 Pollards Farmhouse, Clanville,  
 Nr. Andover, Hampshire.  
 Telephone 0264 70 300

Allow 10 days for delivery

All systems delivered by SECURICOR  
 to Mainland U.K. — carriage free



• Circle No. 120

**IF . . .** you want the best service  
 you need professional advice  
 years of experience impress you  
 you are trying to find the best computer equipment  
 as well as the finest software . . .

## MICROSOLVE

is the Company to contact

We cover a full range of equipment including the **APPLE II** (from £695/16K); the **MICROSTAR** multi-user system (from £4,950) and the powerful **ALPHA MICRO** which will run 1 to 22 terminals — the most cost effective system available today.

WE OFFER A COMPLETE SERVICE which encompasses advice, systems design, sale and installation of computer and peripherals, as well as tailor-made software, where necessary. There are fully documented **ACCOUNTING** and **WORD PROCESSING PACKAGES** etc., for **ACCOUNTANTS, SOLICITORS, MANUFACTURERS, RETAILERS, MEDICAL PRACTITIONERS** in fact all business applications.

ALSO in stock are **PRINTERS, VDUs, CONTINUOUS STATIONERY, DISKETTES, DISK BOXES**, all from the best names in the computer world — **TEXAS, LEAR SEIGLER, TALLY, QUME, PAPER TIGER** etc.

So if you either wish to buy a computer to program yourself or take advantages of our service — **TELEPHONE NOW FOR AN APPOINTMENT.**

**MICROSOLVE COMPUTER SERVICES LTD.**  
 3rd Flor (rear), **MIDDLESEX HOUSE**,  
 29-45 High Street, **EDGWARE**, Middlesex.  
 01-951 0218/9/0

(exit 4 M1/20 mins. West End). prices ex. VAT.

• Circle No. 121

# OUR SYSTEMS CAN GROW ON YOU

When you buy one of our low price microcomputer development systems you not only get a fully burnt-in and tested system designed and manufactured to industrial standards. You also get access to an ever-increasing range of software tools. And if you require a VDU or printer now or later, there is a selection of these and other peripherals from which to choose. So your system can grow and grow.

Our systems start to grow on you at £1450. This buys you a 32KB system with dual 5¼ inch double density floppy drives. At £1675 you can have a 48KB system or for £2495 one with the extra memory storage provided by dual 8 inch double density floppy drives. All the systems are based on the powerful Z80 microprocessor and S100 bus structure and can provide memory management. Cartridge disc drives are available providing up to 40MB of storage.

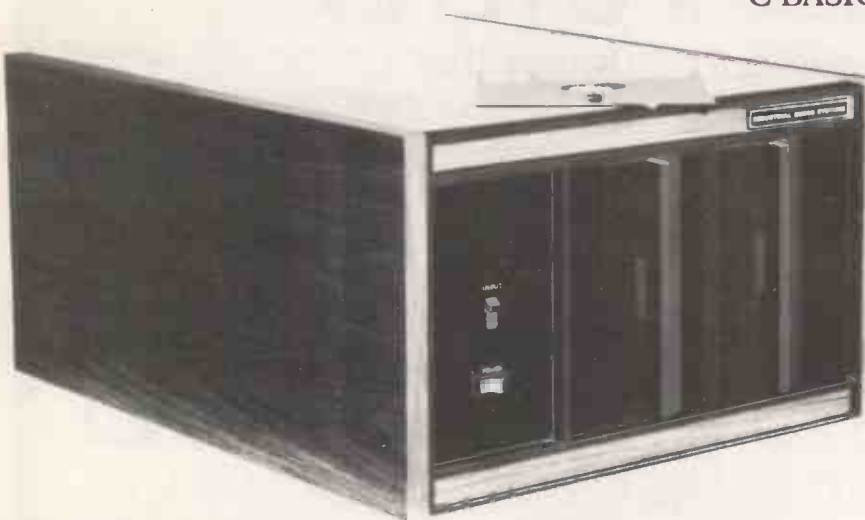

SYSTEMS  
WITH CP/M AND  
C-BASIC:

32KB + Dual 5¼ inch Floppies: **£1450**

48KB + Dual 5¼ inch Floppies: **£1675**

48KB + Dual 8 inch Floppies: **£2495**

Prices exclude VAT.  
Nationwide maintenance facilities available.

## EQUINOX

**COMPUTER SYSTEMS LTD.**

Kleeman House, 16 Anning Street,  
New Inn Yard, London EC2A 3HB  
Tel: 01-739 2387/9 & 01-729 4460

The prices include an operating system and language, in this case CP/M and C-BASIC, to

give a typical system cost. But with slight cost adjustment the software options are:

### Operating Systems

- CP/M • PASCAL • CAP MICROCOBOL BOS
- Multi-User, Multi-Tasking Operating Systems

### Languages

- C-BASIC COMPILER • M-BASIC • FORTRAN-80
- COBOL-80 • PASCAL • CIS-COBOL

There is also a word and text processing system available that is ideal for report writing.

You simply take your pick from the software options. Or visit our London showroom and see the systems demonstrated.

• Circle No. 122

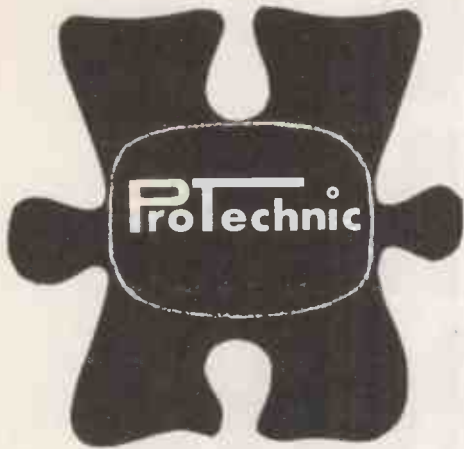

## WE HAVE ALL THE PIECES!

COME TO CAMBRIDGE AND SEE THE SOLUTION

We can demonstrate practical business systems,  
with proven software, for many applications.  
Leasing, installation and training available.

PROTECHNIC COMPUTERS LTD.

264 Newmarket Road, Cambridge.

0223 - 314855

• Circle No. 123

# MONITORS MONITORS MONITORS

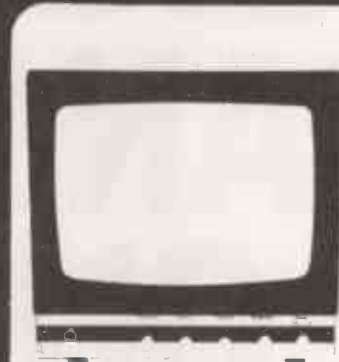

UNCASED 9"

UNCASED 12"

CASED 9"

CASED 10"

CASED 12"

MONITOR TUBES

SELF CONTAINED MONITOR PCB's

## CROFTON ELECTRONICS

Crofton Electronics Limited

35 Grosvenor Road, Twickenham, Middlesex.

Tel: 01 891 1513

• Circle No. 124



Buy  
with confidence  
from the specialists

# HB COMPUTERS



A personal computer that opens the world  
of programming to your own fresh ideas!

#### CRT Display

This unit is equipped with a 25 cm (10") monochrome CRT for up to 1,000 letters (40 letters x 25 lines). Processing results can be displayed on the CRT, and it is possible to program and edit (addition, deletion, etc.) while watching the operation for confirmation.

#### Built-In Clock and Sound Circuits

Clock circuit: time is displayed according to program.  
Sound circuit: 3-octave sound signals for aural confirmation according to program.

#### 78 Keys

ASCII standard Graphic symbols  
Alphabet (capital and small letters)

# HB COMPUTERS LTD

22 NEWLAND STREET, KETTERING, NORTHANTS.

Tel. (0536) 83922 & 520910 Telex 341297

# TAKE CONTROL



**Advanced interfacing for micro-mainframe connection, control instrumentation and communications for the microcomputer user.**

We have interfacing experience with

#### **Mainframes**

IBM, ICL, Univac, Honeywell, DEC, Harris, Etc.

#### **Instrumentation**

Strain Gauges, Gas Chromatographs, Chart Recorders, Auto Analysers, Digital Oscilloscopes, Thermocouples, Accelerometers, Etc.

#### **Peripherals**

Punches, Readers, Discs, Tapes, Plotters, Bar Codes, Etc.

For further information please contact **Graham Knott** or **Jeff Orr** on **051-933 5511**

**Stack Computer Services**  
290/298 Derby Road, Bootle,  
Liverpool 20.



Isaac Newton's

easy solution!

# Apple prices are tumbling at Microdigital!

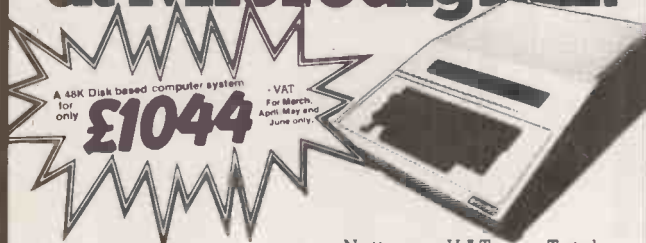

A 48K Disk based computer system  
for only **£1044**

-VAT  
For March,  
April, May and  
June only.

	Nett	VAT	Total
16K byte Apple Computer .....	£695.00	£104.25	£799.25
Disk System .....	£349.00	£52.35	£401.35
<b>Total with 32K free extra memory</b>	<b>£1044.00</b>	<b>£156.00</b>	<b>£1200.60</b>

Latest Apple II plus model with floating point basic and auto-start ROM.

Buy a 16K Apple with Disk drive and get 32K of memory Free.

Extras			
Second Disk Drive .....	£299.00	£44.85	£343.85
Pascal Language System .....	£299.00	£44.85	£343.85
Graphics Tablet .....	£462.00	£69.30	£531.30
Appletel System .....	£595.00	£89.25	£684.25
Black & White Modulator .....	£14.00	£2.10	£16.10
Eurocolour Card .....	£79.00	£11.85	£90.85
Joystick .....	£25.00	£3.75	£28.75

All Prices include courier delivery within U.K.

## Apple Business Systems -ring Graham Jones 051-227 2535

Software Packages .....	£	Word Processor/Letter Writer .....	£
Stock Control .....	£225.00	Book keeper Package .....	£295.00
General Ledger .....	£295.00	Credit Control Package .....	£150.00
Purchase Ledger .....	£295.00	Payroll .....	£385.00
Sales Ledger .....	£295.00		+ VAT at 15%

### OFFICIAL ORDERS

We Welcome official orders from bona-fide commercial and government organisations. We require payment 14 days after invoice date.

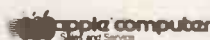

# MICRODIGITAL

25 Brunswick Street, Liverpool L2 0BJ  
Tel 051-236 0707 (24 hour Mail Order)  
051-227 2535 (All other Depts)

Mail orders to: MICRODIGITAL LIMITED,  
FREEPOST (No Stamp Required)  
Liverpool L2 2AB.

Please send systems as above at £1200.60 in addition please send:

Total Remittance \_\_\_\_\_

Name \_\_\_\_\_

Address \_\_\_\_\_

Access and Barclaycard welcome.



• Circle No. 127

# data tablet digitizer

## Summagraphics ID

The latest advancement in the sphere of data input through a tablet digitizer has a flexibility that gives it a wide application in technical, industrial and scientific projects. The 'ID' (intelligent digitizer) has a built-in microprocessor which implements important features such as a relocatable origin, incremental mode, output data formatting and many other valuable advantages inherent in the Summagraphics 'ID'.

Write, phone or complete coupon for full information.



### Terminal Display Systems Ltd

Hillside, Whitebirk Estate,  
Blackburn, Lancs. BB1 5BR  
Telephone (0254) 662244  
Telex 63162 TDS G

More information please on the data tablet digitizer.  
Send to Terminal Display Systems Ltd, Hillside, Whitebirk Estate, Blackburn, Lancs. BB1 5BR.

Name \_\_\_\_\_ Address \_\_\_\_\_



• Circle No. 128

# Happy Memories

21L02 450ns	83p	16K Memory Upgrade Kits for TRS-80, Apple and 21L02 250ns	1.00	Sorcercor all at £64.00	
2114 450ns	4.95				
2114 250ns	5.45	Vero S100 Products:			
4116 300ns	7.25	6 Slot Card Frame with Power Supply	241.36		
4116 150ns	7.25	Prototyping Cards (3 types) each	13.66		
2708 450ns	7.26	Extender Card	21.70		
2716 5V	23.50	Motherboard with 6 connectors	67.65		
IC Sockets:		Ithaca Intersystems Products:			
Pins	Solder	W/W S100 280 CPU Card 4MHz A&T	176.81		
8	10p	24p " " " " 2MHz "	150.94		
14	11p	36p " " " " 2MHz "	30.19		
16	12p	39p S100 Video Display Board A&T	125.06		
18	16p	46p " " " " Bare Board	21.56		
20	17p	58p S100 16 x 2708/2716 A&T	73.31		
22	19p	61p " " " " Bare Board	21.56		
24	21p	63p S100 Proto Board (Plated Through)	21.56		
28	27p	70p See Ithaca's own advertisement for full range			
40	37p	109p VERBATIM Mini-discs (Pet, TRS-80) etc)	21.50		
SAA5050	17.75	Cannon MIN-D 25 way connectors: Female	1.65		
SAA5020	7.99	Male 1.45 Hoods 57p Other sizes available			
81LS95	1.50	DIN 41612 Euroconnectors 64 way: Female	3.17		
81LS97	1.54	Right-angled Male 1.93 Other sizes available			
74LS series:					
Lots of them		POA DIP Switches: 4, 7 & 8 way all at	85p		

We stock a full range of Wire-Wrapping equipment and supplies for you to choose from; we have shelves of books — give us a ring with your requirements and avoid crippling postage charges. Our stocks are too numerous to list here — free price lists sent upon request.

The shop is open from 10 until 6 Monday to Saturday and is worth a visit to catch a surplus bargain — Keyboards at 39.50 today, we may have some left when this gets to print ? 18 slot S100 Mother Boards at 22.50 ? Double Eurocard prototyping boards for a pound.

ALL PRICES INCLUDE VAT. POSTAGE FREE ON ORDERS OVER 10 POUNDS IN VALUE, OTHERWISE ADD 25p. ACCESS AND BARCLAYCARD WELCOME. YOU MAY TELEPHONE WITH YOUR CARD NUMBER AND REQUIREMENTS. TRADE ACCOUNTS ON APPLICATION. GOVERNMENT & EDUCATIONAL ORDERS WELCOME £10 MIN.

19 Bevois Valley Road, Southampton,  
Hants. SO2 0JP Tel: (0703) 39267 DEPT PC

• Circle No. 129



# INNOVATIVE

# TRS-80 SOFTWARE

## FROM THE PROFESSIONALS

### VISION LOAD

VLOAD your Basic tapes rather than CLOAD them and SEE the program on the screen, byte for byte as it loads in from the recorder! After a VLOAD, the program may be executed in the normal way so having seen a good load you are then able to use it. No more having to load in a whole program before you are sure of the load. If the recorder volume is too high the display will be increasingly made up of large graphic characters. If the volume is too low there will be no data appearing on the screen. The distinction between both extremes is very pronounced, so uncertain loads are a thing of the past! As the program loads you will be able to see the ASCII characters, so identification of the program is immediate if you are not sure which program is on the tape. VLOAD only occupies three hundred bytes and resides at the top of memory. Once loaded under the System command it may be used as often as you wish. Another advantage is that as the capacity of the screen is 1K bytes, it is easy to see how long a program is by counting the number of times the screen is filled. VLOAD is supplied with two copies of the 16K, 32K and 48K versions on cassette.

Vision Load on cassette .....£11.50 + VAT = £13.23 75p P & P

### ENHANCED BASIC

EBAS is an important addition to Level II Basic. It contains about 25 new commands including: software control of the cassette motor, automatic entry to the Edit mode when typing a line, instantaneous recall of the last entry, the ability to place a block at the end of a Basic program so that you can add another to it, Hex constants and conversions, insert breakpoints in a Basic program without losing variables, single step through a program, unlimited USR calls, instring function, line input function, define function and a special command for loading cassettes which is almost independent of the volume control setting. These are powerful commands but the primary importance of EBAS is that it provides a bridge between Basic and machine code programs. If you are familiar with Basic and want to branch out into machine code, this is the program for you. Machine code may be entered as part of the Basic program with register contents returned to Basic variables! Also a Monitor is on board so that you can inspect, change and search memory, all with a return to Basic. System tapes may be created and loaded to tape. Until now there have been Basic programs and there have been machine code programs; at last you can now combine them and manipulate machine code from Basic.

Enhanced Basic on cassette ..... £24.00 + VAT = £27.60 75p P & P

### EMPEROR

Occasionally a game comes along which is of such immensity that it is almost impossible to describe. Such a game is "Emperor". It is entirely a game of strategy, played on a graphic map of the Roman Empire as it was in the first four centuries A.D. The player takes the part of the Emperor and he must pit his wits and forces against invading barbarians, rebellious provincials and treacherous Roman Generals. Even the Plebs of Rome will have to be placated with bread and circuses if the Emperor is to keep his head and his throne. If he can last out for the first eight years of the game, he is judged on the state of the Empire at the end of that time. There are three levels of play. Depending upon his choice, the Emperor has to guide the Empire through the first, third and fourth centuries. To win in the first-century he must expand the Empire by two provinces, in the third he must maintain his Empire intact and in the fourth he must lose not more than two Provinces. For each Province the player is given three items of information, the number of loyal Legions, the number of revolting legions and the number of Barbarian Invaders or Local Rebels. During play Legions must be raised, taxes inflicted and troops moved. The choice of Generals can be very critical - some are loyal and good fighters, some are neither. Battles must be fought and invasions repelled. All the while the citizens in Rome must be kept happy and - you must keep an eye on those Barbarians in Britannia!

Emperor on cassette ..... £13.50 + VAT = £15.53 75p P & P

Send large SAE (27p) for our current catalogue of TRS-80 software. Add £1.85 for a binder



**A.J.HARDING (MOLIMERX)**

28 COLLINGTON AVENUE, BEXHILL-ON-SEA, E.SUSSEX. TEL: (0424) 220391

TELEX 86736 SOTEX G FOR A. J. HARDING



• Circle No. 130

**Introducing  
MAIL ORDER  
from Intex**

**A NEW  
SERVICE  
FOR YOU!**

**MAIL ORDER DEPARTMENT  
CASH WITH ORDER ONLY**

All Goods Despatched by Return of Post  
or you will be notified of any delay and  
offered an alternative or the return of your money

<b>PET</b>		<b>DEMAGNETISERS</b>	
2001-8	495.00	Curved Head (Mains)	4.00
3016	675.00	Cassette (Battery)	12.00
3032	795.00		
C2N Cassette Deck	55.00	<b>WORKBOOKS</b>	
IEEE to IEEE Lead	25.00	TIS Workbooks (No VAT)	
PET to IEEE Lead	20.00	Set of 6	18.00
3040 Disk	795.00		
Computhink 400K for		<b>CONNECTORS</b>	
8K via Exp/PET	825.00	PET User/IEEE Port	1.25
For 16/32K	895.00	PET 2nd Cass Port	.95
800K Unit	1145.00	Covers for User/IEEE Port	
24K Expandapet	320.00	Connector	2.50
Interfaces		D25 RS232 Connectors	
Small Sys. Serial C	120.00	Male/Female	3.25
Serial B BI-DIR	175.00	Covers	2.50
TNW2000 BI-DIR	165.00		

<b>All IEEE/RS232</b>		<b>KIM</b>	
Petset 1 A/D	166.00	KIM 1	99.95
Stockists of Petsoft &		KIM 3B	99.95
Commodore Software		KIM 4	69.95

<b>PAPER</b>		<b>NASCOM</b>	
TCM100 Roll	2.50	NASCOM 1 (Kit)	125.00
Anadex/PET 80COL	15.00	NASCOM 1 (Built)	140.00
Teletype 132 COL	25.00	NASCOM 2 (Kit)	29.50
PR-40 Roll	1.00		

<b>CASSETTES</b>		Send for our full Software &	
C12 Cass Highgrade per 10 in		Mail Order Price List -	
Library Cases	4.00		

<b>DISKETTES</b>		<b>DUST COVERS</b>	
PET 3040 Per 10	25.00	PET (All Models)	£5.75
APPLE Per 10	25.00	PET 3040	£3.50
C/Think D/D Per 10	35.00	Computhink Disk	£3.00
		T/T 43 Printer	£5.75
		Anadex DP8000 Printer	£3.50

ALL PRICES ARE EX. VAT.  
PLEASE ADD 50P P&P ON SMALL ITEMS  
£2.50 P&P ON LARGE ITEMS

Don't delay  
SEND  
NOW!

Name .....

Address ..... Phone .....

Item No. ....

INTEX DATALOG LIMITED EAGLESCLIFFE INDUSTRIAL ESTATE, EAGLESCLIFFE, STOCKTON ON  
TEES, CLEVELAND TS16 6PN, ENGLAND. TELEPHONE EAGLESCLIFFE 781193 (STD Code 0642)  
CABLES INTEXRAD, STOCKTON ON TEES, TELEX 58252

**Intex**

• Circle No. 131

**LET  
US MIND YOUR  
OWN BUSINESS**

We offer systems for the smaller business user based on microprocessors by Apple and Microstar and supported by extensive software for a wide variety of applications. We also supply daisywheel printers by Qume, matrix printers by Texas, and a variety of video screens. We sell or lease equipment and guarantee our installations in the field. AND we offer in situ service support via our own engineers.

If you have specific requirements for individual items of hardware, come and discuss it with us.

We're Access Data Communications... your flexible friends.

Access Data Communications Ltd.,  
228 High Street,  
Uxbridge, Middx.  
Tel: 0895 30831/59205

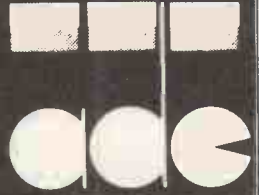

• Circle No. 132

**JPS** FOR ELECTRONICS T.T.L. standard and L.S., C.M.O.S., linear, micro-processor I.C.s, consumer circuits, semi-conductors, resistors, capacitors, Vero products, Eagle products, etc.

**thandar INSTRUMENTS**  
By Sinclair Electronics  
SC110 Scope 10MHZ  
10MV/DIV £159.85



**PFM200 FO  
METER**  
20HZ-200MHZ  
£57.27

**DIGITAL METERS**  
DM235 3 1/2 Digit 21 range £57.27  
DM350 3 1/2 Digit 34 range £79.35  
DM450 4 1/2 Digit 34 range £113.85  
PDM35 3 1/2 Digit 16 range £34.44  
Full range of accessories available  
Large S.A.E. for more details

**na/com-2**

Micro-Computer  
Kit 20K on board  
memory 8K Micro soft  
basic Z80A CPU 4MHZ  
£339.25 inclusive



**SPECIAL OFFER**  
+16K RAM BUT  
LESS 8K  
ONBOARD RAM

Imp Plain  
Paper Printer  
£373.75

**na/com-1 4K** Kit £143.75  
Assembled £161.00  
3 amp power supply £33.93  
Full range of expansion accessories  
available. Large S.A.E. for more details

A selection from our range of surplus new or ex-equipment electronics.  
Untested except where stated.

**TEN TURN POTS** 50K £2.00  
Counter Dial for above £1.50  
**15W AUDIO AMP** P.C.B.s with circuit  
2 for £1.50  
**MINI WAFER SWITCHES**  
2 pole 6 way 40p. 6 pole 2 way shorting  
30p. 1 pole 3 way 30p  
**3 POLE C/O TOGGLE SWITCHES**  
250V 10A 50p  
**SELECTIVE CALL UNITS ENCODER  
AND CONTROL HEAD.** 12V Operation  
5 thumb wheel switches 3TTL  
74 series. I.C.s 32 8KHZ XTAL Reed Relay  
13 transistors 2 min relay 8 edge  
connectors + components and 2 nice  
cases. £9.80  
**MULTI-POLE CONNECTORS**  
Sub min plug and socket 15 way £1.00  
20 way £1.00  
**STANDARD CONNECTORS** plug and  
socket 18 way £1.00, 12 way £1.00  
4 way 70p, 2 way 60p

**EDGE CONNECTORS** 18 way .15 40p  
**PANEL METERS** Scale 0-25 MA  
Basic FSD 10 MA 2 1/4" x 2 1/4" £2.50  
**L.E.D. WATCH MODULES** 4 for £2.00  
**CALCULATOR PCBs** complete  
untested most work 3 for £3.20  
**METER CASES** AVO Style  
9 3/4 H x 6 3/4 W x 3 1/2 D black £3.00  
**RELAYS** 12V 4 pole c/o about 5 amp  
including base 80p  
**MIN FANS** 3" x 3" x 1 1/2" 115 VAC £2.00  
**KNOBS** 1/2 black 4 for 25p  
**HEAT SINK** with 3 new power  
transistors 8" x 2 1/2" x 3/4"  
40251 SIM to 2N3055 x 2  
40318 NPN 300V 35W £1.50  
**NEONS** Red Lens 12p  
**PROJECT BOARD** 4 I.C. 60p, 2 I.C. 30p  
Transistor 22 strips x 5" 50p  
**13 ASSORTED PANELS** mainly for  
components but some can be repaired £5

Lists 20p + large S.A.E. VAT inclusive prices. Add 50p p.p. on orders under £10  
Cat. Available shortly 75p

**JPS** Dept., P.C., 9 East Street, Colne, Huntingdon, Cambs. 0487 840710

• Circle No. 133

# What will you do with a 12-year old programmer when he reaches 16?

Any microcomputer is a major investment for an educational establishment. Many potential users feel that a BASIC only computer is ample for their needs. That may be fine today, but with computer education starting so early you may in a surprisingly short time find you want more than current implementations of BASIC.

The 380Z is a computer that can grow to match your needs.

In the design of the 380Z our target user is the graduate research scientist. This ensures that the expandability and versatility needed tomorrow has been provided for in the computer you buy now.

approach will allow your students to advance.

380Z BASIC is not frozen in ROM. An enhanced BASIC could be loaded in mid 1980 and a BASIC with structured features sometime later.

On the 380Z the memory used by a BASIC interpreter can also be used for other software.

**Does our research-oriented design pay off in classroom hardware?**

Our scientific graphics was produced for the professional user. Interest in it for classroom use has been surprising.

The 380Z has the best graphics now available on a microcomputer,



freely mix upper and lower case text and diagrams.

Mains noise can cause system crashes which result in loss of programs and data. All current 380Zs include a mains filter which significantly reduces the chances of this happening.

**Don't buy a 380Z on patriotic grounds.**

Please only buy it if you would have bought it anyway. But remember, because it is designed and manufactured here you are bound to have better access to us for influence and help than if we were on the other side of an ocean.

Prices range from a 16K cassette 380Z @ £897 to a 56K Dual Full Floppy Disk 380Z @ £3322.



**Might you want to add disc storage in the next few years?**

*If you do:*

Given good hardware, software availability completely determines the flexibility and usefulness of your system. There is absolutely no question that a Z80 based micro-computer which uses the industry-standard CP/M\* disk operating system has several times more software on the market available to it than non CP/M computers.

Today you can purchase a mature CP/M BASIC, FORTRAN, COBOL or Text Processor for the 380Z. Soon there will be CP/M Pascal and Database Management systems.

CP/M software is several years ahead of software available for non CP/M family machines.

*If you don't:*

Remember that professionals writing packages for your cassette system will themselves often use a disk 380Z, and the power of their tools will influence what they produce.

For many people a disk machine is too expensive—but at least the 380Z

allowing multiple resolutions, multiple paging, fading and accurate control over colour. All these features help bring excitement to efforts in computer assisted learning.

Our standard machine comes with low resolution graphics and support for this from BASIC allows you to plot a point directly with a plot command—useful for training and teaching.

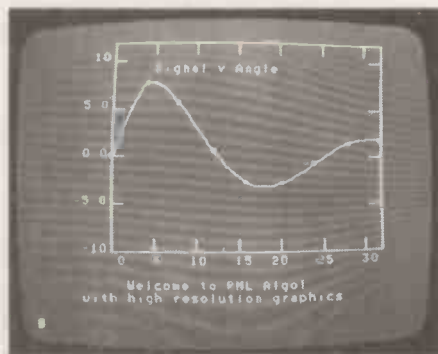

It is worth remembering too that neither our low resolution graphics nor our optional scientific (high resolution) graphics has any limiting effect on your memory usage, and in both you can

## LOWER COSTS

Three things have happened which make it easier to buy a 380Z.

- ONE: From 1st November 1979 most prices have been reduced.
- TWO: Schools and some colleges can now get a 5% discount on computer orders.
- THREE: A new Local Authority quantity discount scheme has been introduced to make it easier for more users to benefit from quantity purchasing.
- Please contact the Sales Office for details.

## RESEARCH MACHINES

RESEARCH MACHINES Ltd,  
PO. Box 75, Mill Street, Oxford, England.  
Telephone: Oxford (0865) 49791/2/3.  
Please send for full sales information.  
Prices do not include shipping costs or VAT @ 15%.

\* Trademark, Digital Research.  
• Circle No. 134

Personal demonstrations available at all times in our new showrooms at 30 Lake Street. Also a large range of personal computers, books and magazines. Barclaycard and leasing facilities available.



# Computopia LIMITED

30 Lake Street, Leighton Buzzard, Bedfordshire  
Tel: (0525) 376600 24 hour Answering Service

## EPSON

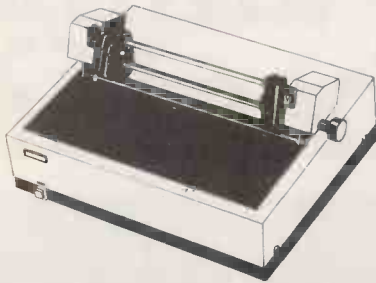

The TX-80 offers

- 96 Ascii char. set and Pet graphics
- 80 col., 150/125 char/sec
- Condensed line, Enhanced print
- 5 x 7 dot matric, 6 x 7 dot matrix for graphics

Our prices are incredibly low, starting at £445 + VAT but including postage and packing.

The TX-80 is supplied with a parallel interface as standard, but interface boards and cables for Pet, Apple, TRS 80, IEEE 488, and Serial are available at £45 each.

**£445**  
(+ VAT)

## ATARI Video Computer System

Give your T.V. a 4th channel —

We'll start you off with an ATARI console and **FREE 27 game Combat Programme Cassette** AND for a limited period at **½ PRICE** One other standard programme cassette, could be . . .

Video Olympics  
or Space War  
or any other of 14 different standard cassettes to choose from — *phone or write NOW for a list of ATARI games*

All for  
**£130**  
(+ VAT)

**£6.75**  
½ PRICE  
(+ VAT)

## ACORN — for the discerning hobbyist

A complete range of single boards and accessories available

Acorn Controller . . . . .	£ 35
Microcomputer . . . . .	£ 65
Assembled Microcomputer . . . . .	£ 79
Memory . . . . .	£ 95
Memory Assembled . . . . .	£100
V.D.U. . . . .	£ 88
V.D.U. Assembled . . . . .	£ 98

(All prices exclude VAT)

Goods will be despatched within 24 hours or our acknowledgement giving precise delivery date. All prices include p&p within the UK. Please send cheques or postal orders or, if phoning your order, state Barclaycard number. For details please contact 30 Lake Street, Leighton Buzzard. Tel: (0525) 376600.

• Circle No. 135

# New Low-cost Printer from PHL

## Anadex DP8000

- 80 Columns
- Dual Interface - Serial & Parallel
- 112 cps - 84 lpm bi-directional
- 96 ASCII set, 9 x 7 matrix
- 1K Print Buffer

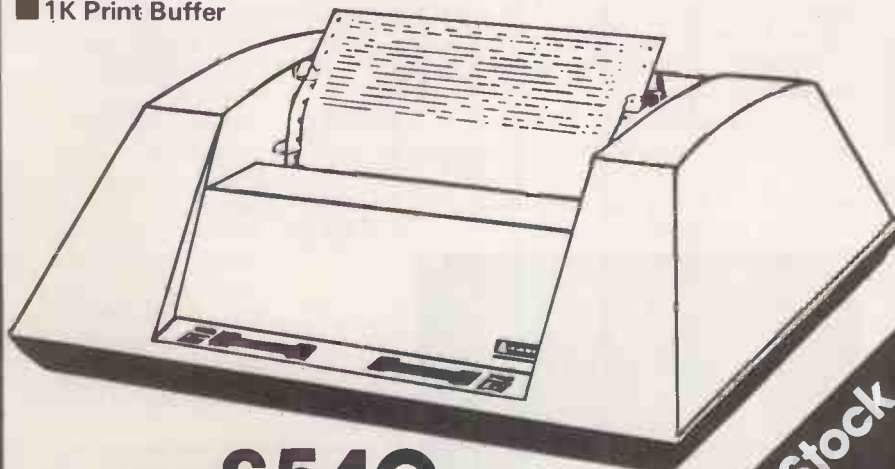

From Only **£540**

**EX Stock**

### Also available Visual Displays

Lear Siegler	from only £571
ADM - 3A	from only £1295
ADM - 3A Graphics	from only £1295
ADM - 31	from only £795
ADM - 42	from only £1049

### Keyboard Printers

Teletype 43	
Pin Feed	from only £ 799
Friction Feed	from only £ 818
Typewriter Terminal	from only £ 825
Portable Models	from only £ 899

Digital	
LA 36	from only £995
LA 34	from only £895
LA 120	from only £1656

### Printers

Texas 810	from only £1392
SCI Rotary Printer	from only £ 747

### Data Storage

Techtran	
950 Microdisc Range	from only £ 955
815 Datacassettes	from only £ 667

### Other Items

AJ 211 Acoustic Coupler	from only £ 199
-------------------------	-----------------



PERIPHERAL HARDWARE LIMITED  
Armfield Close, West Molesey  
Surrey England Telex 922175  
Sole UK distributor

South 01-941 4806 North Harrogate 501263/4 Ireland Dublin 952316

• Circle No. 136

# Graham Knott & Jeff Orr have now moved....

to new premises due to expansion to accommodate larger stock and workshop facilities for the Microcomputer user. Our new number is

## 051-933 5511

ring us at any time for your requirements

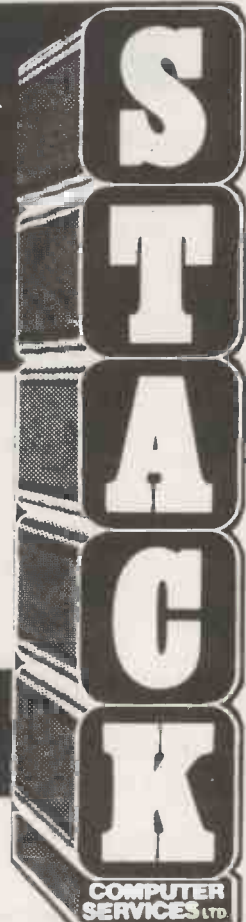

PET	
Pet 8k	£550
Pet 16k	£675
Pet 32k	£795
2nd Cassette	£55

#### Disk Units

**Computhink** 400k Random and Sequential complete to fit 8k Pet (via expandamem) £840  
To fit 16/32n Pet (direct fitting) £895  
800k Unit £1144

#### Memory Expansion

24k Expandamem for Pet £320

#### Interfaces

Uni-direc I-EEE to RS232 £89  
Bi-direc I-EEE to RS232 £140  
Bi-direc 2 ported I-EEE to RS232 £175

#### A/D Convertors

AIM 161 16 channel A/D convertor for Apple, Aim, Nascom etc £130  
Petset 1, AIM 161 including all interfacing requirements for Pet, complete £166

#### Stack Peripherals

**Stack Joystick** a balanced, calibrated unit supplied with software and examples of use, complete £25  
**New 625 Video Adaptor** a vastly improved 625 video convertor for Pet, works extremely well £25  
**Stack Page Printer Interface** copies screen contents onto 20m.a. loop complete with software £25

APPLE	
Apple-plus (b&w) 16k	£770
ITT 2020 (colour) 16k	£830
16k RAM upgrade	£85
Printer Card	£110
Communication Card	£132
High Speed Serial Card	£110
Disk Drive with DOS	£398
Extra Disk Drive	£355
Diskettes (10's)	£30
KIM 1	£99.95
MANUALS New Pet user manual	£5
6500 Programming manual	£5
6500 Hardware manual	£5

#### PRINTERS

Teletype 43 pinfeed RS232 friction RS232	£860
pin and friction RS232	£875
Anadex DP8000	£889
Decwriter IV LA34	£575
Perkins Elmer Pussycat	£880

CRT Copier £839  
Also Centronics Range, Texas Instruments, Lear Siegler

Ring us for a quote on individual models.

#### Consumables

Anadex DP8000 paper (2000 sheets) 9.5" x 11" drop	£15
Teletype 43 pinfeed paper (2000 sheets) 12"x 11" drop	£15
8.5 inch friction roll Box'A' quality (12"x 3.5" diam. rolls)	£20

Box 'B' quality (12 x 3.5" diam rolls)	£15
Box 'A' quality (6 x 5" diam rolls)	£20
Box 'B' quality (6 x 5" diam rolls)	£15

#### Cassettes

C15 cassettes high quality tape, 5 screw cassette cases, per 10 £4.40

#### Disks & Diskettes

We supply 8" and 5.25" diskettes for all disk drives. Please state your machine and we can give you a quotation.

e.g. Pet 2040	£30 per 10
Computhink	£30 per 10
Apple	£30 per 10
Horizon	£30 per 10
Sorcerer	£30 per 10

Many others in stock, both hard and soft secured.

#### Connectors

Pet User Port/I-EEE Port	£1.10 each
Pet 2nd cassette Port	85p each
Hoods for User/I-EEE connectors	£2.25
D.25 RS232 Connectors (State male or female)	£3.00
D.25 Hoods	£2.25

#### Demagnetiser

Curved head £4.00  
If any requirements are not listed please ring us as we may have them in stock.

All prices are +VAT at 15% and include carriage (unless otherwise stated). Please make cheques payable to Stack Computer Services Ltd.

# Stack Computer Services Ltd

## 290-298 Derby Rd, Bootle

### Liverpool 20



# New Bear Components



## ITHACA S100 PRODUCTS AT NEW LOW PRICES

### MAINFRAME

#### DPS-1 S100 Mainframe

Includes: 4mHz, Z80A, CPU, Full feature Front Panel, Twenty-slot actively terminated motherboard, 25 amp power supply, 50/60 Hz 68CFM fan. — £695

BOARDS		Assembled & Tested	Bare
IA1160	Front Panel . . . . .	£225.00	N/A
IA1010	Z-80 CPU 2mHz . . . . .	£105.00	£21.00
IA1010	Z-80 CPU 4mHz . . . . .	£123.00	£21.00
IA1100	Video 50/60 Hz . . . . .	£ 99.00	£15.00
IA1130	Floppy Disk Controller . . . . .	£117.00	£21.00
IA1050	2708/2716 EPROM . . . . .	£ 57.00	£15.00
IA1110	8K Static RAM 250nS . . . . .	£117.00	£15.00
IA1110	8K Static RAM 450nS . . . . .	£ 99.00	£15.00
IA1030	Prototype . . . . .	N/A	£15.00
IA2010	16K Static RAM 250nS . . . . .	£295.00	N/A
IA2010	16K Static RAM 450nS . . . . .	£275.00	N/A
IA1120	Single Board Computer . . . . .	£895.00	N/A
IA1190	4P2S I/O w. interrupts . . . . .	£210.00	N/A
IA1190	4P2S I/O wo. interrupts . . . . .	£180.00	N/A
IA2030	64K Dynamic RAM 250nS . . . . .	£615.00	N/A
IA1170	A/D, D/A — 8 Channel, 8-bit . . . . .	£295.00	N/A

All boards come with manuals.

SEND FOR OUR BOOK LIST AND NEW FULL CATALOGUE

CALLERS AND MAIL ORDER: 40 Bartholomew Street, Newbury, Berks. Tel: 0635 30505  
CALLERS ONLY: 220-222 Stockport Road, Cheadle Heath, Stockport Tel: 061 491 2290

### SOFTWARE

IS-101	K2 Operating System	£ 45.00
IS-102	Pascal/Z — K2 Version	£105.00
IS-103	BASIC/Z — K2 Version	£ 45.00
IS-107	Pascal/Z — CP/M Version	£165.00

DISC CONTROLLER AND 6809 BOARDS NOW AVAILABLE FOR 77-68. SEND FOR DETAILS OF THIS LOW COST RANGE OF KITS.

### SPECTRONICS UV Eprom-Erasing Lamp

PE14	Erases up to 6 chips. Takes approx. 19 mins.	£ 56.00
PE14T*	Erases up to 6 chips. Takes approx. 19 mins.	£ 76.58
PE24T*	Erases up to 9 chips. Takes approx. 15 mins.	£111.22
PR125*	Erases up to 6 chips. Takes approx. 7 mins.	£237.84
PR320T*	Erases up to 36 chips. Takes approx. 7 mins.	£384.09
PC1000*	Erases up to 72 chips. Takes approx. 7 mins.	£842.83

\* Includes a 60 mins. Timer.

TERMS: Credit Sales (minimum £10.00)  
Barclaycard and Access Welcome.  
Please add 15% VAT.

• Circle No. 138

# FARMLAN COMPUTER SYSTEMS

### HARDWARE

16k I.T.T. 2020 Microcomputer	£650
16k R.A.M. Upgrade kit	£60
Disk Drive and controller	£350
Parallel Printer Interface card	£95
Anadex Printer	£525
Numeric Key Pad	£75
Music Composer	£120

### STATIONERY

5 1/4" Verbatim Disks	£2.50 ea
Box Printer Paper	£13.60 per box
Other stationery available upon request	
Full range of Mountain Hardware products	
ALL MACHINERY EXCEPT PRINTER (3 MONTHS) GUARANTEED FOR 12 MONTHS	

**IMPORTANT** We now have available — controller cards for 8" Drives, I.B.M. compatible, suitable for Apple/I.T.T.  
Price on application

### ORDERING INFORMATION:

Delivery/Insurance extra. All prices exclude V.A.T. at 15%  
Price list correct at time of publishing, subject to change without notice.

**FARMLAN, NETHERTON, ROSS-ON-WYE, HEREFORDSHIRE TEL. Ross 4321**  
Offices also at Melton Mowbray, Northallerton, Aberdeen

• Circle No. 139

# SUPERBRAIN™

WITH  
INTEGRAL  
VDU

INTEC DATA SYSTEMS

**£1,995**  
COMPLETE  
(+VAT)

- ★ Full 64K RAM
- ★ Twin Z80A microprocessors
- ★ CP/M operating system
- ★ Twin double density mini floppies (280K total, 240K user)

**SUPERBRAIN™** – stand alone system and intelligent terminal combined in single desk top unit (14<sup>3</sup>/<sub>8</sub>" H × 21<sup>3</sup>/<sub>8</sub>" W × 23<sup>1</sup>/<sub>8</sub>" D). Optional S-100 Bus available for easy linkage to vast range of ancillary equipment including mass Data Storage on Hard Disc. Non-glare dynamically focused 12" CRT and Universal RS-232 Communications port. SOFTWARE PACKAGES AVAILABLE.

## Full SUPERBRAIN™ details from the following dealers:

- JAEMMA LTD.**, 44 Manor Park Road, Castle Bromwich, BIRMINGHAM Tel: 021 7474531  
**JENNINGS COMPUTER SERVICES LTD.**, 55/57 Fagley Road, BRADFORD 2, W. Yorks. Tel: 0274 637867  
**RUSSELL & SON LTD.**, Deane House, 27 Greenwood Place, LONDON NW5 1NN. Tel: 01-485 5574  
**COMPUTERISED BUSINESS SYSTEMS**, 32/34 Huntriss Row, SCARBOROUGH, N. Yorks. YO11 2ED. Tel: 0723 75787  
**RESOURCE PLANNING LTD.**, Goldie House, Upper Church Street, DOUGLAS, Isle of Man. Tel: 0624 4247  
**GEMSOFT COMPUTER SERVICES**, "Alverstone Lodge", Wych Hill Lane, WOKING, Surrey, GU22 0AH. Tel: 04862 60268  
**MICROPEOPLE LTD.**, Microcomputer Consultancy Services, 1 Union Street, LONG EATON, Nottingham, NG10 1HH. Tel: 06076 68923  
**OFFICE COMPUTER TECHNIQUES LTD.**, 22 Highcroft, Husbands Bosworth, MARKET HARBOROUGH, Leicestershire. Tel: 0858 880561  
**MULLER (ANGLO-AMERICAN)**, E Floor, Milburn House, Dean Street, NEWCASTLE-ON-TYNE, NE1 1LE Tel: 0632 29593  
**CULLOVILLE LTD.**, Thornfield, Woodhill Road, Sandon, CHELMSFORD, Essex Tel: 024 541 3919  
**PROMGLOW LTD.**, 12 Dene Road, New Southgate, LONDON N11 1ES Tel: 01-368 9002  
**BOYD MICROSYSTEMS LTD.**, 4 Ivinghoe Road, BUSHEY HEATH, Herts. Tel: 01-950 0303

For dealer enquiries, contact

**ICARUS COMPUTER SYSTEMS LTD., 27 Greenwood Place, London NW5 1NN.**

*SUPERBRAIN™ is the registered trademark of Intertec Data Systems.*

• Circle No. 140

# WHOLESALE ELECTRONIC COMPONENTS

2102L — 400ns	SRAM	.55
2114 — 300ns	SRAM	3.51
4116 — 200ns	DRAM	4.50
2708 — 450ns	EPROM	4.39
AY-5 — 1013	UART	2.65

<b>TV MODULATOR</b>	Chan 36	1.67
2102L x 8	SRAM	3.85
2114 x 8	SRAM	24.45
4116 x 8	DRAM	31.35

Please add 15% VAT to all orders and postage of 50 pence. Postage FREE on orders over £10.

**STRUTT**  
ELECTRICAL AND  
MECHANICAL ENGINEERING LTD.  
ELECTRICAL COMPONENT  
DISTRIBUTORS

3c BARLEY MARKET ST.  
TAVISTOCK  
DEVON PL19 05F  
Tel. TAVISTOCK (0822) 5439  
Telex: 45263

• Circle No. 141

# BITS & P.C.s

## COMPUTER PRODUCTS

### NOW A NASCOM DISTRIBUTOR IN YORKSHIRE

Full range of Nascom Products available.

We are Nascom service and repair specialists order with confidence.

Free for a limited period with Nascom 2. 16K memory board, mini mother board and 2 edge connectors. This is 8K more memory than specified and leaves 28K of free space.

Unbelievable Nascom 1 now only £125.00 or £140.00 ready built and tested.

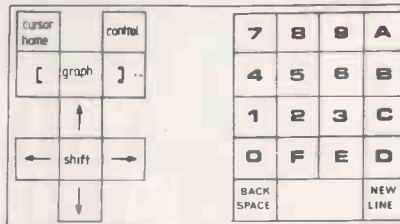

#### Upgrade your Nascom 1 to Nascom 2.

By using our specially designed control key pad this enables you to run Nascom on Nascom 1. Gain on screen edit and cursor movement. The power of Nas-sys. Kit only £23.10. Nas-sys £25.00

A hexadecimal keypad for Nascom 1 & 2. Specially designed for your Nascom by us. This is an essential for entry of machine code listings. New line, space and back space are duplicated for convenience. £30.10 complete kit.

Control and hexadecimal key pads combined for Nascom 1 £37.25 complete kit. The above key pads require no modification at all to your Nascom.

Port Probe. A simple but essential device for Nascom 1 or 2. Allows monitoring of the port output on L.E.D. indicators, input words can be set up with L.E.D. indication interrupts can be tested manually or by using the variable clock provided, this also allows real timing for games £11.20 complete kit.

Dual monitor board. This kit allows switching between 2 monitors on Nascom 1 £5.70.

Chess for Nascom. A powerful chess programme which requires our graphics options. This must be the best chess graphics available. £15.30 on cassette, ask for details.

Nascom 1	£125.00 kit or built	£145.00
Nascom 2		£295.00
Power Supply Unit		£29.50
Nascom 1 Buffer Board		£32.50
8K Ram Board		£85.00
16K Ram Board		£140.00
32K Ram Board		£200.00
Nascom 1 Graphics		£33.05
Nascom 2 Graphics Rom		£15.00
Bits & P.C.s Data Cassettes		
Price for 10 C20		£5.25

Please check with us for your Nascom requirements. Add 15% VAT to all our prices. Barclaycard and Access phone your order. Personal demonstrations by appointment. Please send S.A.E. for any details.  
**BITS & P.C.s**  
18 Rye Garth  
Wetherby, West Yorkshire  
LS 22 4UL  
Tel: (0937) 63744 9 a.m. to 7 p.m.

• Circle No. 142

Dual SHUGART floppy disks, 20-slot mainframe, 25A power supply, full-feature front panel, 4MHz Z-80A, 64K RAM, 2P3S I/O, CP/M 2.0 (with Assembler, Editor)

£2855 + VAT

OPTIONS: Pascal, FORTRAN, BASIC, word-processing, BSTAM telecommunications, VDU's, printers, custom I/O and software packages,

#### 10 MB HARD DISK SUBSYSTEM

5MB fixed plus 5MB cartridge, permits fastest possible back-up, S-100, CP/M 2.0 O/S.

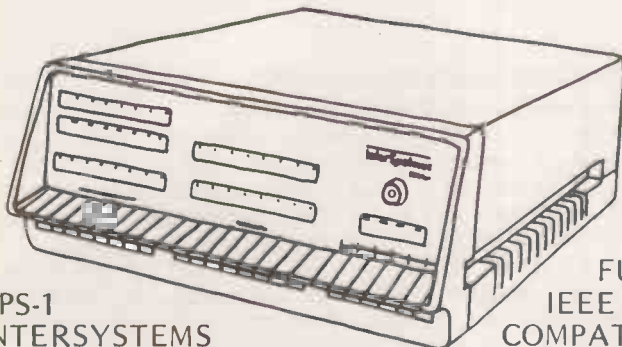

DPS-1  
INTERSYSTEMS

FULLY  
IEEE S-100  
COMPATIBLE

## HEATH/ZENITH WH-89

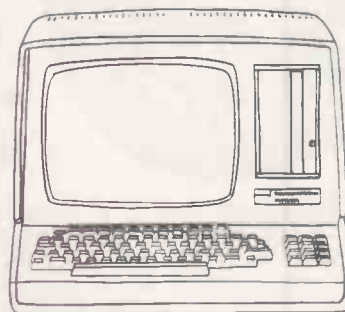

Fully integrated computer with dual Z-80 CPU, up to 48K RAM, 24 x 80 screen, mini-floppy disk, CP/M (with Assembler, Editor)

from £1595 + VAT

OPTIONS: Up to four drives, I/O, printers, FORTRAN, BASIC, word-processing, telecommunications, 512 x 256 PIXEL GRAPHICS Programmed in Microsoft BASIC with images stored on disk.



**MICRONEX**  
**DATA SYSTEMS**

MICRONEX LTD  
HARFORD SQUARE  
CHEW MAGNA  
BRISTOL BS18 8RA  
027-589-3042

• Circle No. 143



EUROPE'S LARGEST SELECTION OF MICROCOMPUTER BOOKS, MAGAZINES AND SOFTWARE FOR THE HOBBYIST, EDUCATIONALIST  
PROFESSIONAL AND RETAILER

### BONUS DISCOUNTS

- a) For the purchase of 3 or more books and paying by cheque, P.O. or cash with the order, give yourself a 10% DISCOUNT.  
b) For the purchase of 3 or more magazine back issues and paying by cheque, P.O. or cash with the order, give yourself a 10% DISCOUNT.

### BY OSBORNE

Introduction to Microcomputers Series	
Vol 0: Beginners Book	£5.95
Vol 1: BASIC Concepts	£6.30
Vol 2: Some Real Microprocessors (without binder)	£18.95
Vol 2: Some Real Microprocessors (with binder)	£24.70
Vol 2: Updating supplement set Nos. 1-6	£17.00
Vol 3: Some Real Support Devices (without binder)	£11.95
Vol 3: Some Real Support Devices (with binder)	£17.70
Vol 3: Updating supplement set Nos. 1-6	£17.00
1 binder (Specify for Vol 2 or 3)	£5.75
1 Updating supplement (Specify for Vol 2 and 3)	£4.00
6800 Programming for Logic Design	£6.30
8080 Programming for Logic Design	£6.30
Z80 Programming for Logic Design	£6.30
Z80 Assembly Language Programming	£6.45
6502 Assembly Language Programming	£6.45
8080A/8085 Assembly Language Programming	£6.45
6800 Assembly Language Programming	£6.45
Accounts Payable and Accounts Receivable (in Wang BASIC)	£10.95
Payroll With Cost Accounting (in Wang BASIC)	£10.95
General Ledger (in Wang BASIC)	£10.95
Accounts Payable and Accounts Receivable (in C BASIC)	£11.95
Payroll With Cost Accounting (in C BASIC)	£11.95
General Ledger (in C BASIC)	£11.95
Some Common BASIC Programs	£6.30

### FOR THE 8080

See Osborne Books!	
8080 Programmers Pocket Guide	£1.95
8080 Hex Code Card	£1.95
8080 Octal Code Card	£1.95
8080 Software Gourmet Guide & Cookbook	£6.95
8080/8085 Software Design	£6.75
8080 Standard Monitor	£9.95
8080 Standard Assembler	£9.95
8080 Standard Editor	£9.95
8080 Special Package: Monitor, Editor, Assembler	£20.00
BASEX: A Simple Language and Compiler for the 8080	£5.50

### FOR FUN

SARGON — A Chess Game	£9.50
BASIC Computer Games	£5.00
More BASIC Computer Games	£5.50
What To Do After You Hit Return	£8.95
8080 Galaxy Game	£6.95
SUPER-WUMPUS — A game in 6800 Assembler Code & BASIC	£4.25
Computer Music Book	£6.75
Computer Rage (A board game)	£6.95
Artist and Computer	£3.95
Games, Tricks and Puzzles for a Hand Calculator	£2.49
Introduction to TRS-80 Graphics	£5.75
Take My Computer Please . . . (Fiction)	£3.25
Introduction to Low Resolution Graphics	£5.50

### FOR THE Z80

See Osborne books!	
Z80 Instruction Handbook (Wadsworth)	£2.95
Z80 Software Gourmet Guide and Cookbook	£7.95

### MAGAZINE BACK ISSUES

Micro 6502 Journal	£1.50
Personal Computing	£1.95
Interface Age	£2.95
ROM	£1.95
Dr. Dobbs Journal	£1.95
Computer Music Journal	£3.75
Peoples Computers (now called Recreational Computing)	£1.95
BYTE	£2.95
Creative Computing	£1.95
On Computing	£1.95
Kilobaud	£P.O.A.
Compute — for the 6502	£1.95
68" Micro	£1.95
Magazine Storage Box (Holds 12)	£1.25
80" Microcomputing	£1.95

### GENERAL

See Magazines and Subscriptions!	
See Osborne Books!	
Microprocessors from Chips to Systems	£7.00
Microprocessor Interfacing Techniques	£8.75
Cheap Video Cookbook	£4.30
C M O S	
CMOS Cookbook	£7.50
IC OP-AMP Cookbook	£8.95
RTL Cookbook	£4.25
TTL Cookbook	£7.50
Ciarcias Circuit Cellar	£5.50
First Book of Kim	£7.00
Buyers Guide to Microsoftware	£2.40
Calculating with BASIC	£4.95
Computer Programs that Work (In BASIC)	£2.95
BASIC Software Library: (Listings)	
Vol 1: Business and Games Programs	£17.50
Vol 2: Maths, Engineering and statistical Programs	£17.50
Vol 3: Advanced Business Programs	£26.95
Vol 4: General Purpose Programs	£7.95
Vol 5: Experiments Programs	£7.95
Vol 6: Miniature Business System	£32.50
Vol 7: Chess/Medbil/Wdproc Programs	£26.95
Vol 8:	£14.95
Bar Code Loader for 6800, 8080, Z80 and 6502	£1.75
Best of BYTE	£8.95
Scelbi BYTE Primer	£8.95
Best of Creative Computing, Vol 1	£6.95
Best of Creative Computing, Vol 2	£6.95
Program Design	£4.25
Programming Techniques: Simulation	£4.25
PIMS — A Database Management System	£5.95

### FOR THE 6502

See Osborne Books!	
See Magazines and Subscriptions!	
Best of Micro, Volume 1	£5.50
Best of Micro, Volume 2	£5.50
Programming the 6502 (Zacs)	£7.95
Programming the 6502 (Foster)	£6.75
6502 Applications	£7.95
6502 Software Gourmet Guide & Cookbook	£7.95

### CONCERNING LANGUAGE

SCELBAL — High Level Language + Supplements	£15.00
Instant BASIC	££6.95
Basic BASIC	£6.50
Advanced BASIC	£6.00
My Computer Likes Me . . . When I Speak in BASIC	£2.75
Users Guide to North Star BASIC	£10.00
A Practical Introduction to PASCAL	£3.95
Microsoft BASIC	£5.50

### For the 6800

See Osborne Books!	
See Magazines and Subscriptions!	
6800 Software Gourmet Guide & Cookbook	£6.95
6800 Tracer — An aid to 6800 Program Debugging	£3.95
Tiny Assembler	£5.75
RA 6800 ML — An M600 Relocatable Macro Assembler	£15.95
Link 68 — An M6800 Linking Loader	£5.50
MONDEB — An Advanced M6800 Monitor Debugger	£3.50

### FOR THE NOVICE

See Magazines and Subscriptions!	
See Osborne Books!	
Your Home Computer	£5.95
Introduction to Personal and Business Computing	£4.95
Getting Involved With Your Own Computer	£4.75
How to Profit from Your Personal Computer	£5.50
Microcomputer Potpourri	£2.40
Hobby Computers are Here	£3.95
New Hobby Computers	£3.95
Understanding Microcomputers and Small Computer Systems	£6.75
Understanding Microcomputers and Small Computer Systems and Audio Cassette	£8.75
Getting Down to Business With Your Microcomputer	£5.50

### MAGAZINE SUBSCRIPTIONS (all processed within 3 weeks)

Micro 6502 Journal (12 issues)	£12.50
68 Micro (12 issues)	£17.50
Personal Computing (12 issues)	£17.00
Interface Age (12 issues)	£25.00
Dr. Dobbs Journal (10 issues)	£13.50
Computer Music Journal (4 issues)	£11.00
Recreational Computing (6 issues)	£8.50
BYTE (12 issues)	£24.50
Creative Computing (12 issues)	£16.50
Kilobaud Microcomputing (12 issues)	£21.00
Compute for the 6502 (6 issues)	£10.50
Introduction to Microcomputers: Vol 2 Updates (issues 7-13)	£18.95
Introduction to Microcomputers: Vol 3 Updates (issues 7-13)	£18.95
80" Microcomputing (12 issues)	£20.00

### HOW TO ORDER

Please note our book magazine prices include postage and packing, but not insurance, if wanted add 12p for every £10 of books ordered. Make cheques, PO's etc. payable to: — L.P. Enterprises.

CREDIT CARDS accepted  
BARCLAYCARD VISA/ACCESS/DINERS CLUB/  
AMERICAN EXPRESS

Phone: 01-553 1001 for Credit Card orders (24 hr answering service)

All publications are published in U.S.A. and shipped into Britain air-freight by L.P. Enterprises. In unusual cases, processing may exceed 30 days.

Prices subject to change without notice

TRADE ENQUIRIES WELCOME

THIS LIST CANCELS ALL PREVIOUS PRICE LISTS: EFFECTIVE JULY 1979  
DUE TO FLUCTUATIONS OF THE DOLLAR, PRICES SUBJECT TO CHANGE WITHOUT NOTICE.

Send to address on page	All Orders must be Prepaid:
Indicate Payment Method; and underline items required.	Total Enclosed £ .....
..... My cheque, P.O., I.M.O. is enclosed in Sterling on U.K. Bank	..... Charge to Barclaycard/Visa/Access/Diners/American Express
Credit Card No. ....	Expiry Date .....
Name .....	
Address .....	
..... POSTCODE .....	
Signature .....	

• Circle No. 144

# New from Millbank!



## Qume Sprint 5 Daisywheel Printers.

These high quality 45/55 KSR and RO printers are now available at attractive OEM prices — from £1389.00 (excl. VAT)

**PLUS.....**

## High-performance Ohio Scientific systems at attractive OEM prices!

We can now offer a range of high performance Ohio Scientific Systems from the low cost C2 series to the incredible C3-B — all at highly competitive OEM Prices, ex-stock or early delivery.

Ring or write for details:

**MILLBANK COMPUTERS LIMITED**

East Lane, Kingston upon Thames, Surrey Telephone: 01-549 7262

• Circle No. 146

## 24 TUNE DOOR CHIMES

### DOOR TUNES £17.13 + VAT

Waddington's Videomaster announce a doorbell that doesn't go Brrringgg, Ding Dong or Bzzzzz. Instead it plays 24 different classical and popular tunes. It will play the tune you select for your mood, the season or the visitor you are expecting to call. Door tunes is not only great fun and a wonderful ice breaker, but is also very functionally and beautifully designed to enhance your home. There is something for Christmas, something for your continental visitors or your relations from the states, and even something for the Queen. Door tunes is easy to install and has separate controls for volume, tone and tempo.



## T.V. GAMES

### PROGRAMMABLE £29.50 + VAT. COLOUR CARTRIDGE T.V. GAME.

The TV game can be compared to an audio cassette deck and is programmed to play a multitude of different games in COLOUR, using various plug-in cartridges. At long last a TV game is available which will keep pace with improving technology by allowing you to extend your library of games with the purchase of additional cartridges as new games are developed. Each cartridge contains up to ten different action games and the first cartridge containing ten sports games is included free with the console. Other cartridges are currently available to enable you to play such games as Grand Prix Motor Racing, Super Wipeout and Stunt Rider. Further cartridges are to be released later this year, including Tank Battle, Hunt the Sub and Target. The console comes complete with two removable joystick player controls to enable you to move in all four directions (up/down/left/right) and built into these joystick controls are ball serve and target fire buttons. Other features include several difficulty option switches, automatic on screen digital scoring and colour coding on scores and balls. Lifelike sounds are transmitted through the TV's speaker, simulating the actual game being played.



### EXTRA CARTRIDGES:

ROAD RACE — £8.87 + VAT.

Grand Prix motor racing with gear changes, crash noises

SUPER WIPEOUT — £9.17 + VAT.

10 different games of blasting obstacles off the screen.

STUNT RIDER — £12.16 + VAT.

Motorcycle speed trials, jumping obstacles, leaping various rows of up to 24 buses etc

NON PROGRAMMABLE TV GAMES

6 Game — COLOURSCORE II — £13.50 + VAT.

10 Game: COLOUR SPORTSWORLD £22.50 + VAT.

Manufactured by Waddington's Videomaster and guaranteed for one year

## CHESS COMPUTERS

### STAR CHESS — £85.65 + VAT PLAY CHESS AGAINST YOUR PARTNER.

using your own TV to display the board and pieces. Star Chess is a new absorbing game for two players, which will interest and excite all ages. The unit plugs into the aerial socket of your TV set and displays the board and pieces in full colour for black and white on your TV screen. Based on the moves of chess. It adds even more excitement and interest to the game. For those who have never played, Star Chess is a novel introduction to the classic game of chess. For the experienced chess player, there are whole new dimensions of unpredictability and chance added to the strategy of the game. Not only can pieces be taken in conventional chess type moves, but each piece can also exchange rocket fire with its opponents. The unit comes complete with a free 18V mains adaptor, full instructions and twelve months guarantee.



### CHESS CHALLENGER £98.50 PLAY CHESS AGAINST THE COMPUTER.

The stylish, compact, portable console can be set to play at seven different levels of ability from beginner to expert including "Mate in two" and "Chess by mail". The computer will only make responses which obey international chess rules. Casting, on passant, and promoting a pawn are all included as part of the computer's programme. It is possible to enter any given problem from magazines or newspapers or alternatively establish your own board position and watch the computer react. The positions of all pieces can be verified by using the computer memory recall button.

Price includes unit with wood grained housing, and Staunton design chess pieces. Computer plays black or white and against itself and comes complete with a mains adaptor and 12 months guarantee.

### OTHER CHESS COMPUTERS IN OUR RANGE INCLUDE:

CHESS CHAMPION — 6 LEVELS £47.39 + VAT

CHESS CHALLENGER — 10 LEVELS — £138.70

+ VAT.

BORIS — MULTI-LEVEL TALKING DISPLAY £163.64

+ VAT.



### ELECTRONIC CHESS BOARD TUTOR £17.17 inc. VAT.

A special bulk purchase of these amazing chess teaching machines enables us to offer them at only £19.75 less than half recommended retail price. The electronic chess tutor is a simple battery operated machine that can actually teach anyone to play chess and improve their game right up to championship level. This machine is not only for total beginners but also for established players wanting to play better chess. Unit contains the electronic chessboard with 32 chess pieces, a 64 page explanatory booklet and a set of 32 progressive programme cards including 6 beginners cards, 16 check mate positions, 9 miniature games, 5 openings, 3 end games, 28 chess problems and 2 master games.

## DRAUGHTS COMPUTERS

### CHECKER CHALLENGER 2 LEVELS £43.00 + VAT. 4 LEVELS £78.00 + VAT.

The draughts computer enables you to sharpen your skills, improve your game, and play whenever you want. The computer incorporates a sophisticated, reliable, decision making microprocessor as its brain. Its high level of thinking ability enables it to respond with its best counter moves like a skilled human opponent. You can select offence or defence and change playing difficulty levels at any time. Positions can be verified by computer memory recall. Machine does not permit illegal moves and can solve set problems. Computer games complete with instructions, mains adaptor and twelve months guarantee.

### PLAY DRAUGHTS/CHECKERS AGAINST THE COMPUTER



## FOR FREE BROCHURES — SEND S.A.E

For FREE illustrated brochures and reviews on TV and chess games please send a stamped addressed envelope, and state which particular games you require information on.

Callers welcome at our shop in Welling — demonstrations daily — open from 9am-5.30pm; Mon-Sat 9am-1pm; Wed.

To order by telephone please quote your name, address and Access/Barclaycard number.

Postage and Packing FREE

AJD DIRECT SUPPLIES LIMITED, Dept. P.C. 4 102 Bellegrave Road,  
Welling Kent DA16 3QD. Tel: 01-303 9145 (Day) 01-850 8652 (Evenings)

• Circle No. 145

## GEMSOFT.

Specialists in  
Business Computers and Software.

Appointed dealers for:

**APPLE; SUPERBRAIN, SWTP,  
VIDEO GENIE.**

Whatever your needs in Micro-Computers, we have one to suit you or your business.

From the Video Genie at £369.

Apple 2 at £695.

Intertec Superbrain at £1995.

And the SWTP 6809 from £2312.

Software for all machines available:

Sales/Purchase Ledgers, Stock Control, Payroll, Word Processing, Production Control, Mailing List etc, etc, etc.

If it doesn't exist, we'll write it for you. Systems tailored to exact customer requirements.

All Apple peripherals in stock, Qume printers from £1950,

Anadex £570, Paper Tiger £585, Microhush £266, Word

Processing programs from £42, Games from £4, and much

more besides.

We're in business to help your Business.

If you can't come and see us, phone for details, or send an

SAE for catalogue.

All prices exclusive of VAT.

Call, write or phone:

**GEMSOFT, 27, Chobham Road, Woking, Surrey.**

Telephone (04862) 22881.

Open 6 days a week, 9.30am to 5.30pm.

• Circle No. 147

# DATRON of SHEFFIELD



## SHARP MZ-80K Home Computer

See it in operation  
and buy it at DATRON

Demonstrations.  
9am - 5pm Monday - Saturday.

Call anytime - no obligation -  
or by mail order.

HP/Leasing Available

Delivery free anywhere in the U.K.

## BOOKS from DATRON

all books in stock at press date

The BASIC Handbook	David Lien	£11.50	PET Work Books Vol. 1-6		£19.00
Illustrating BASIC	Donald Alcock	£2.50	The Mighty Micro	Or C. Evans	£5.75
Basic BASIC	Donald M. Munro	£2.00	Intro. to Personal & Business Computing	Zaks	£5.45
The Little Book of BASIC Style	Nevison	£5.25	Micro Appl. in Business & Industry	Whitbread	£9.50
Some Common Basic Programs	Osborne	£6.45	Peanut Butter & Jelly Guide to Micros	Willis	£6.45
Some Common Basic Programs (PET cassette)		£7.95	Running Wild	Osborne	£2.95
32 BASIC Programs for the PET	Rugg & Feldman	£9.75	A Career in Computing	Penney	£4.25
BASIC Primer	Waite & Pardee	£6.95	Philips Guide to Bus. Computers & the Electronic Office	Enticknap	£3.50
A guide to BASIC Programming	Spencer	£8.85			
A guide to PL/M Programming	McCracken	£7.95			
			Basic Computer Games	Creative Computing	£5.50
PASCAL An Intro. to Methodical Prog.	Findlay & Watt	£4.95	More Basic Computer Games	Creative Computing	£5.50
Introduction to PASCAL	Welsh & Eider	£5.95	Game Playing with Computers	Spencer	£10.20
Programming in PASCAL	Grogono	£6.75	Game Playing with BASIC	Spencer	£5.50
Primer on PASCAL	Conway et al	£7.10			
Struct. Prog. & Problem Solving with PASCAL	Kiebertz	£8.40	How to Build a Computer Controlled Robot	Loofbourrow	£5.95
Micro Problem Solving - PASCAL	Bowles	£6.95	How to Profit from your Personal Computer	T. G. Lewis	£5.50
COBOL for Business Applications	Philippakis	£10.25	TTL Cookbook	Lancaster	£7.15
COBOL with Style	Chmura & Ledgard	£5.40	CMOS Cookbook	Lancaster	£7.50
Learning COBOL Fast	de Rossi	£6.45	TV Typewriter Cookbook	Lancaster	£7.25
			Cheap Video Cookbook	Lancaster	£4.95
FORTRAN Techniques	A. Colin Day	£2.25	Best of Byte		£8.45
FORTRAN Fundamentals	J. Staingraber	£3.45	Best of Creative Computing Vol. 1		£6.95
Problem Solving & Struct. Prog. in FORTRAN	Friedman & Koffman	£9.95	Best of Creative Computing Vol. 2		£6.95
	Donald M. Munro	£3.95			
Computing with FORTRAN					
An Intro. to Prog. & Applications with FORTRAN	Hull & Day	£8.45			
Z80 Micro Handbook	W. Barden	£6.95			
Z80 Programming for Logic Design	Osborne	£6.30			
Z80 Micro. Prog. & Interfacing Bk. 1	Nichols & Rony	£7.75			
Z80 Micro. Prog. & Interfacing Bk. 2	Nichols & Rony	£8.50			
Z80 Instant Programs	J. Hopton	£7.50			
Z80 Programs (cassette)		£10.00			
Z80 Assembly language Prog.	Leventhal	£6.95			
6502 Assembly language Prog.	Leventhal	£6.95			
6502 Applications Book	Sybox	£8.95			
Programming the 6502	Zaks	£7.95			
Programming a Micro (6502)	Foster	£7.25			

**P&P free U.K.**

**Overseas add £1 any order size**

Phone in your Access  
Barclaycard No  
0742 585490  
or complete this  
order form

Send s.a.e. for full list. Prices correct at  
going to press. Add 12p insurance on  
books if required.  
**Cromemco** IIT 2020 apple II PET  
TEXAS INSTRUMENTS na/com-1

Please supply

I enclose: - £  
Cheque/Postal Order No.

Barclaycard/Access No.

Name:

Address:



Datron Micro Centre, Latham House, 243 London Road,  
Sheffield S2 4NF. Tel: 0742-585490

• Circle No. 148

# LITTLE GENIUS

If you find self-instruction manuals difficult to follow then meet our Little Genius.

Little Genius floppy diskettes are the fastest, easiest way to master your micro.

Little Genius will save you time and effort, teaching you to exploit all your micro's facilities.

Courses available now:

- Applesoft Basic
- Pet Basic
- Palsoft Basic
- Advanced Applesoft
- Advanced Pet Basic
- Advanced Palsoft
- Using your Apple
- Using your 2020

For further information, ask your local dealer or contact Peter Brown at Suite 504 Albany House, 324 Regent Street, London, W1R 5AA. Telephone 01-580 6361.



• Circle No. 149

# MICROTEK COMPUTER SERVICES

FOR:

## EQUINOX 300 NORTH STAR HORIZON IMS 5000

PLUS:

DIABLO, ELBIT & TEXAS PERIPHERALS.  
SOFTWARE PACKAGES FOR:

- STOCK CONTROL
- ACCOUNTING AND VAT
- CLIENT INFORMATION & MAILING
- BUDGET CONTROL
- CAR STOCK BOOK
- IMPORT CONTROL
- PAYROLL
- 'LOCATE-A-CAR' SYSTEM, ETC.

50, Chislehurst Road, Orpington,  
Kent.

Tel: Orpington 26803

• Circle No. 150

# Apple or PET? West London's specialists are also in the West End.\*

## apple®

APPLE II EUROPLUS 16K	£695.00
DISC DRIVE WITH CONTROLLER	£349.00
DISC DRIVE WITHOUT CONTROLLER	£299.00
16K ADD ON MEMORY	£ 69.00
HITACHI 9" BLACK & WHITE MONITOR	£127.00
EUROCOLOUR CARD	£ 69.00
PASCAL LANGUAGE CARD	£296.00
ALF MUSIC SYNTHESISER CARD	£215.00
TCM 100 SILENT 40 COLUMN PRINTER	£243.00
PAPER TIGER PRINTER	£585.00
TCM INTERFACE FOR PET OR APPLE	£ 49.00

FROM

# adda

## PET®

PET 8K WITH INTEGRAL CASSETTE	£475.00
NEW PET 8K WITH LARGE KEYBOARD	£495.00
PET 3016 16K COMPUTER	£675.00
PET 3032 32K COMPUTER	£795.00
PET 3040 DUAL DRIVE FLOPPY DISK	£795.00
PET 3022 TRACTOR PRINTER	£525.00
PET 2023 FRICTION PRINTER	£475.00
PET C2N TAPE DECK	£55.00
24K EXPANSION MEMORY	£320.00
COMPUTHINK 800K DISK DRIVE	£1145.00
TELETYPE 43 PRINTER	FROM £860.00
QUME SPRINT DAISYWHEEL	FROM £1800.00

FROM

# adda

Adda Computers, 17-19 The Broadway (between W. H. Smith and Burtons), Ealing, London W.5. Tel. 01-579 5845  
\*New West End address: Abbott House, 1-2 Hanover Street, London W1R 9WB. Tel: 01-408 1611

• Circle No. 151

# MEET THE FAMILY



## ... THERE MUST BE ONE HERE FOR YOU

The Exidy family is a sophisticated range of products designed to meet the ever increasing variety of computing needs including home and business uses, educational and laboratory applications, industrial process control, etc. The Exidy range has been designed with built-in growth capacity to take the risk factor out of computer investment. The Sorcerer Computer now has a memory expansion capability from 8K up to 48K within its own cabinet, enabling the system to grow with your needs plus the ability to add many additional plug-in facilities such as disk drives, printers and pre-programmed ROM PAC's. All Exidy products are backed up by a 12 month warranty covering both parts and labour. The Exidy Sorcerer provides a standard typewriter keyboard plus a 16 key numeric pad. Connections are provided for future expansion within the keyboard unit.

If you want an accounting machine, a word processor, or a program development system, the SORCERER offers all of these within the same unit.

The Word Processing ROM PAC allows you to create, edit, re-arrange and format text. The operator's work is displayed clearly on a screen—you can see the whole of an average business letter—correct mistakes—re-arrange it. Once perfected—press a key and the printer will type a perfect letter in record time—as many times as you like—no wasted letterheadings. Features include auto wraparound, dynamic cursor control, variable line length, global search and replace, holding buffer for re-arrangement of text, right justification, line width and line to line spacing, underlining or boldfacing, text merging and a macro-facility permitting tasks such as formletter typing, multiple column printing or automatic forms entry.

### Now contact your nearest dealer:

#### The NORTH

**BASIC COMPUTING**, Oakville, Oakworth Road, Keighley, W. Yorkshire. 0535 65094  
**E.S. MICROCOMPUTERS**, 7 Berkeley Prec., Ecclesall Road, Sheffield S11 8PN. 0742 668767  
**GLYSTHYDON LTD.**, Nook Farm, Rake Lane, Warton, Preston, Lancs. 0772 633138  
**MAGNUM CONSULTANTS**, 57 Fairburn Drive, Garforth, Leeds. 0532 867892  
**MICROPUTE**, 7 Westbourne Grove, Manchester M20 8JA. 0625 612818  
**MICRODIGITAL**, 25 Bruswick Street, Liverpool L2 0BJ. 051 227 2535  
**TW COMPUTERS LTD.**, 293 London Road, Hazel Grove, Stockport. 061 456 8187

#### MIDLANDS

**M&R SYSTEMS**, 20 Norwich Road, Wisbech, Cambs. 0945 5900  
**MIDLAND MICROS**, 1 Cherry Wood Drive, Aspley, Nottingham. 0602 298 281  
**GRIFFIN & GEORGE**, Birmingham, Manchester, London, Eastkilbride. 01 997 3344

#### LONDON and SOUTH EAST

**E.M.G. MICROCOMPUTERS**, 30 Heathfield Road, Croydon, Surrey CR0 1EU. 01 688 0088  
**HOME & BUSINESS COMPUTERS**, 445 High Street North, Manor Park, London E12. 01 472 5107  
**MICROBITS**, 34b London Road, Blackwater, Camberley, Surrey. 0276 34044  
**SLOUGH MICROSHOP**, 120 High Street, Slough, Berks. 0753 22855  
**TVJ MICROCOMPUTERS**, 165 London Road, Camberley, Surrey GU15 3JS. 0276 62506  
**C.C.S. MICROSALES**, 7 The Arcase, Letchworth, Herts. N2 9EN. 046 26 73301  
**G.P.W. ELECTRONICS**, 146a London Road, North End, Portsmouth, Hants. PO2 9DJ. 0705 693341  
**INFORMEX-LONDON LTD.**, 8-12 Lee High Road, London SE13. 01 318 4213  
**NIC**, 61 Broad Lane, Tottenham, London N15. 01-808 0377

#### WALES and the WEST

**TRYFAN COMPUTERS**, 3 Swifts Blds, High Street, Bangor, Gwynedd LL57 1UW. 0248 52042  
**ELECTROPRINT**, 5 Kingsdown Parade, Bristol BS6 5UD. 0272 292375  
**LIVEPORT DATA PRODUCTS**, The Ivory Works, St. Ives, Cornwall. 0736 798157  
**TVJ MICROCOMPUTERS**, 48 Gloucester Road, Bristol BS7 8BH. 0272 422061

### Or send coupon for further information to:

#### SOLE DISTRIBUTORS

Geoff Wilkinson  
**LIVEPORT DATA PRODUCTS**  
The Ivory Works, St. Ives, Cornwall.

PLEASE SEND DETAILS OF THE EXIDY RANGE

NAME \_\_\_\_\_

ADDRESS \_\_\_\_\_

• Circle No. 152

# Tridata + MICROS = SOFTWARE

Business systems available now for the TRS 80

Sales Ledger (OPEN ITEM/DEBTORS ANALYSIS/STATEMENTS/INVOICES/VAT/DAYBOOKS etc.) from £150

Purchase Ledger (OPEN ITEM/CREDITORS ANALYSIS/REMITTANCE ADVICE/VAT/DAYBOOK etc.) from £150

Invoicing (UPDATES SALES LEDGER/DOWNDATES STOCK/MAINTAINS BACK ORDERS) £75

Stock Control (ISSUES/RECEIPTS/MOVEMENT, USAGE, VALUATION, RE-ORDER REPORTS etc.) £200

Payroll (WEEKLY, MONTHLY, CASUAL STAFF/BONUS SCHEMES/COIN ANALYSIS/PAYSLIPS etc.) £218

Nominal Ledger (Available shortly)

12 MONTH WARRANTY ON ALL PACKAGES - TAILORED SYSTEMS TO YOUR REQUIREMENTS

FOR THE BEST IN PROFESSIONAL MICRO BUSINESS SOFTWARE CONTACT US DIRECT OR CALL YOUR NEAREST TRIDATA DEALER FOR A DEMONSTRATION.

CAMBRIDGE COMPUTER STORE (CAMBRIDGE)	0223 68155
COMPUTER DEVELOPMENT SERVICES (SWANSEA)	0792 26085
ELECTRON SYSTEMS (SANDY, BEDS.)	0767 81195
A. J. HARDING (BEXHILL, E. SUSSEX)	0424 220391
KATANNA MANAGEMENT SERVICES (CHELMSFORD)	0245 76127
OPTRONICS (TWICKENHAM)	01 892 8455
GPW ELECTRONICS LTD (PORTSMOUTH)	0705 693341

Tridata Micros Ltd.  
Smithfield House  
Digbeth  
Birmingham B5 6BS  
Tel: 021 622 6085

• Circle No. 153

## SIRTON PRODUCTS

13 WARWICK ROAD  
COULSDON  
SURREY Tel: 01-660 5617

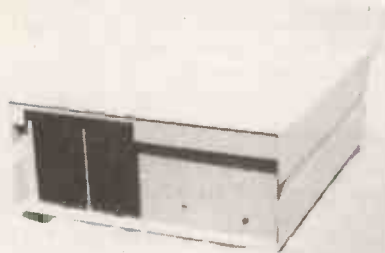

### MIDAS S100 SYSTEMS

Substantial Mainframe to house your S100 system, with optional 5in. or 8in. disc drives. Special systems built to your requirements from Z-80 CPU and other S100 boards held in stock.

Mainframes from £228

MIDAS 1 : Z-80 System from £625 (built)

MIDAS 2 : Z-80 5in. Disc System from £1,100 (built).

MIDAS 3 : Z-80 8in. Disc System from £1,300 (built).

### ITHACA INTERSYSTEMS DPS 1

Professional versatile computer system with comprehensive front-panel facilities and 20-slot motherboard. Units have substantial power supply etc. and come with 2 or 4 MHz Z-80 CPU. BUS conforms to the IEEE S100 standard.  
DPS.1 from £695



## COMPREHENSIVE RANGE OF S100 BOARDS AND SOFTWARE STOCKED

from

ITHACA INTERSYSTEMS · S D SYSTEMS · GODBOUT · CROMEMCO ·  
ECT · SSM · Etc

Write or Phone for Catalogue



• Circle No. 154

PO Box 2  
St Neots  
Cambridgeshire

Dear Sir

**The benefits of word processing are here for all!**

The **Comart VDM** Video Display Module plugs easily into the North Star Horizon Computer S100 Bus and, together with the Comart Monitor and VDM \*Star word processing software, provides the facilities of "instant display" word processing on a general purpose microcomputer.

Text may be entered, edited and standard paragraphs inserted with true upper & lower case display then rapidly printed in your chosen format.

The VDM transforms the Horizon into a valuable word processor yet change the diskette software and it resumes its role as a general-purpose Computer . . . . **Real Flexibility!**

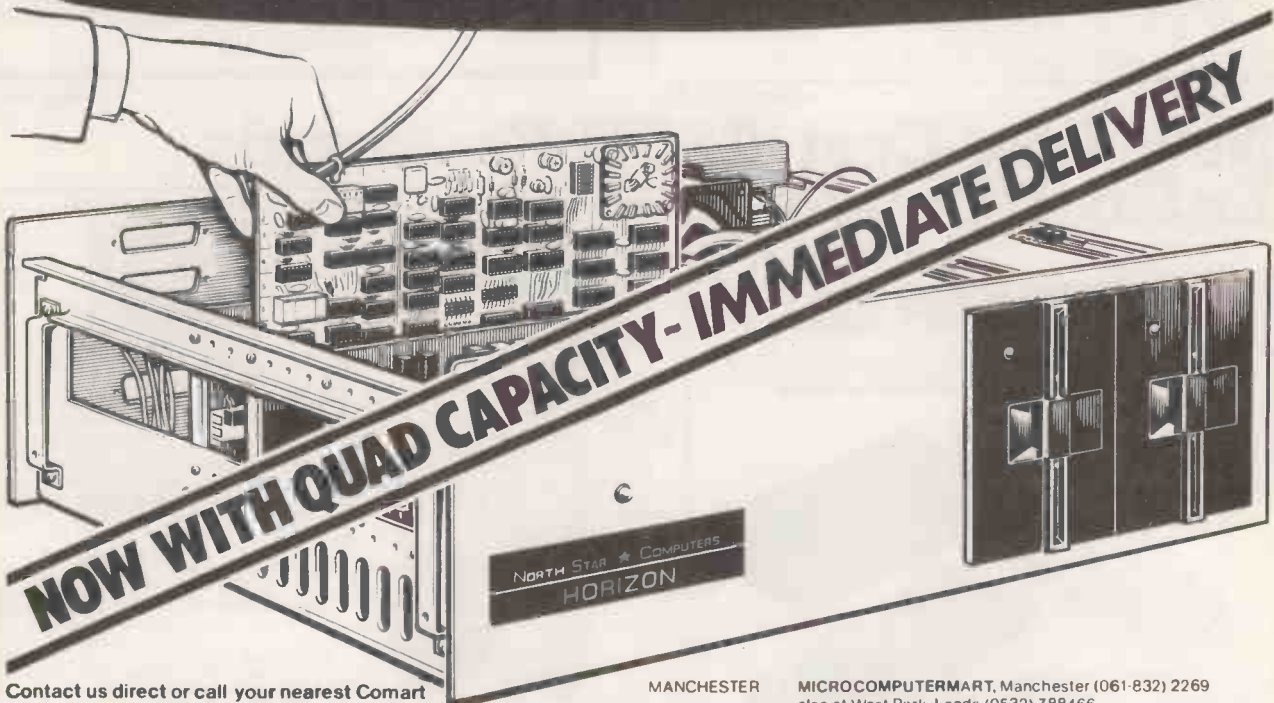

Contact us direct or call your nearest Comart dealer

CAMBRIDGE  
CAMBERLEY  
ILFORD

**CAMBRIDGE COMPUTER STORE**, Cambridge (0223) 68155.  
**MICROBITS**, Camberley, Surrey (0276) 34044  
**THE BYTE SHOP**, Ilford, Essex 01-554 2177  
also at Tottenham Court Road, London 01-636 0647  
**HOLDENE LIMITED**, Leeds (0532) 459459  
also at Wilmslow, Cheshire (0625) 529486  
**DIGITUS LIMITED**, London W101-636 0105  
**ISHERWOODS**, Luton, Bedfordshire (0582) 424851

LEEDS

LONDON  
LUTON

MANCHESTER

NEWBURY

NEWPORT  
NOTTINGHAM

SHEFFIELD  
SOUTHAMPTON

**MICROCOMPUTERMART**, Manchester (061-832) 2269  
also at West Park, Leeds (0532) 788466  
**NEWBEAR COMPUTING STORE**, Newbury, Berks (0635) 30505  
also at Stockport, Cheshire (061-491) 2290  
**MICROMEDIA SYSTEMS**, Newport, Gwent (0633) 50528  
**COMPUTERLAND LIMITED**, Nottingham (0602) 40576  
also at Birmingham (021-622) 7149  
Manchester 061-236 4737  
Glasgow (041 332) 2468

**HALLAM COMPUTER SYSTEMS**, Sheffield (0742) 663125  
**XITAN SYSTEMS LIMITED**, Southampton (0703) 38740



**comart specialists in microcomputers**

Comart Ltd., P.O. Box 2, St. Neots, Huntingdon, Cambs, PE19 2AF. Tel: (0480) 215005 Telex: 32514

• Circle No. 156

# ALAN PEARMAN LTD

Mainframe/micro APL Systems for Business, Industry, Commerce, Education and Hobbyists.

**Hardware**  
MAPLE 280 CP/M system from £1730; full range of APL peripherals (printers and VDUs).

**APL Software**

MICROFIN — Financial Model	£445
(manual £9.45)	
MUTABLE — Report Formatter	£195
FUND/LIFE — Actuarial functions	£695
(manual £4.95)	
STAPL — Statistical functions	£635
(manual £17.45)	
APLOT — Graphics	£555
(manual £8.45)	
UTILITY — Utility functions	£95
(manual £10.45)	
COMMS — communications	£250
APL-ED — Word Processor	£195
ORDER — Order Invoice System	£75
APLAN — Financial Planning	£285

**Micro-APL Interpreters**

Vanguard Systems APL/V80	£175
Softronics APL	£175
TIS APL	£345

Micro-APL for 8080 micros available soon.

**Courses**

Introduction to Micro-APL (1 day)	£75
APL for Analysts (3 days)	£150
Financial Modelling in APL (5 days)	£245
Advanced APL (1 day)	£75

Next series scheduled for 16th-27th June 1980.

**Consultancy**  
Advice on APL system implementation and customer-defined systems written on e.g. VSAPL, APLSF, IPSAPL etc.

**Books**  
All books currently in print on APL in stock.

**Publications**  
Self-Instruction in APL £19.99

For details on any of these areas, telephone  
Chester (0244) 46024/21084  
or write to  
A.P. Limited  
FREEPOST  
Chester CH3 5YZ

• Circle No. 157

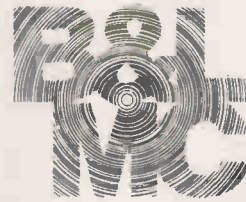

## Micro-Computer Centre for the MIDLANDS

Nascom and Commodore Specialists

A full range of micro computers and peripherals are available, whether buying or browsing we can give helpful and friendly advice.

Commodore Business Systems are suitable for the professional office, the small business or the sole trader. We will be pleased to give advice and a demonstration.

Nascom 2 systems can be fully built and tested to order. We are sole distributors for the Micro Type case for Nascom 1 and 2, also stockists of the William Stuart colour graphics and full range of 'add-ons'.



## Business & Leisure Micro Computers

16 The Square, Kenilworth, Warwickshire CV8 1EB.  
Tel: (0926) 512127

• Circle No. 158

# New Low-Cost ASCII Keyboards Ex Stock Delivery



ALL THE ABOVE KEYBOARDS ARE FULLY TTL-COMPATIBLE PROVIDING THE FULL 128 ASCII CHARACTER SET, AND REQUIRING +5V —12V POWER SUPPLY. FULL TECHNICAL DATA AND CIRCUIT DIAGRAMS SUPPLIED.

Model	Mail Order	Optional Extras:		
KB771 71 Keystations incorporating separate numeric/cursor control pad and installed in a custom built steel enclosure	£95.00	KB15P Edge Connector	£3.25	£4.31
KB756 56-keystations, mounted on PCB	£45.00	KB701 Plastic Enclosure	£12.50	£15.24
KB756MF, as above, fitted with metal mounting frame for extra rigidity	£50.00	KB702 Steel Enclosure	£25.00	£30.48
		KB710 Numeric Pad	£8.00	£9.78
		KB2376 Spare ROM Encoder	£12.50	£14.95
		DC-512 DC/DC Converter	£7.50	£9.20
		25-Way D-Type connector for KB771	£4.25	£5.46

All equipment is refurbished second-user equipment unless otherwise stated.  
All prices subject to carriage & VAT. Trading conditions supplied on request.

### BALL MIRATEL VIDEO MONITOR



9in. diagonal P4 phosphor tube. Bandwidth 12MHz (-3dB). Input voltage 220V 50/60Hz 24W. Output voltage +15V DC (short circuit protected) +12kV DC; 12.6V r.m.s. Separate horizontal & vertical sync. Supplied complete with high & low voltage power supplies, amplifier, and attractive moulded plastic housing including space for keyboard. Full technical manual provided.

**PRICE: £95.00**  
(total including carriage and VAT £123.00)  
**NEW SHUGART FLOPPY DISC DRIVES**



SA400 Minifloppy — 110KB capacity, 35 tracks, transfer rate 125Kbits/sec AV access time, 550msec. Power requirements +5VDC +12VDC

**PRICE: £195.00**  
(price including carriage & VAT £235.00)

SA800 Floppy — 400KB capacity, 77 tracks, transfer rate 250Kbits/sec. AV access time 260msec. Power requirements +24DC +5VDC -5VDC

**PRICE: £395.00**  
(price including carriage & VAT £468.00)

### DIGITRONICS PAPER TAPE PUNCH



Solenoid-actuated unit capable of punching 5 to 8 channel tapes asynchronously. Basic punch contains 8 data, 1 sprocket and 2 transport solenoids plus end-of-tape switch. Pulse amplitude 27VDC. Very compact unit measuring only 6in. X 8in. X 5½in., weight 9½lbs.

**Model P120 (20 cps) £75.00**  
(price including carriage & VAT £92.00)

**Model P135 (35 cps) £95.00**  
(price including carriage & VAT £115.00)

### TERMIPRINTER 7075

Typewriter-quality Keyboard Send/Receive Impact Printer providing full upper and lower case character set, switch-selectable print speeds of 10, 15 and 30cps, 118-column print line with pin-feed platen suitable for paper rolls or continuous stationery (paper width 12.85in.) Standard V.24 (RS232) interface

**£575.00**



### ELECTRONIC BROKERS LIMITED

49-53 Pancras Road, London NW1 2QB.  
Telephone: 01-837 7781 Telex: 298694.  
Our showroom is open MON/FRI 9-1, 2-5 (2 mins. Kings Cross underground)

• Circle No. 159



# DATA LINK

## Microcomputer Systems Limited

Systems software for business, industrial and scientific applications

### MICROSTAR 45 PLUS

A multi-user disk based information processing system designed for commercial application where extreme simplicity of operation is required.



MicroStar Double Density 2.4Mb £5650  
Additional 20 Mb Hard Disk Unit £4950  
Available Software includes

Mailing List, Word Processor, Purchase Ledger, Sales Ledger, Payroll, Invoicing, Etc., Etc.,

### APPLE/ITT 2020

Apple II Plus 16K (B&W) £695  
ITT 2020 16K (colour) £867  
Disk Drive with Controller £349  
Pascal Language System £299  
Auto Start ROM Pack £38  
16K Add-ons £69  
Alf Music Synthesiser Card £180  
Little Genius Tutorials Basic and Advanced £40 each Etc., Etc.,  
Full range of business software

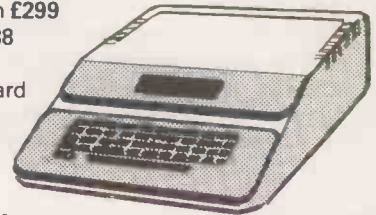

### VDUs/Terminals



Lear Siegler ADM 31 £849  
Lear Siegler ADM 3A £620  
Hitachi 9" VDU (B&W) £127  
Hitachi 12" VDU (B&W) £187  
ITT 340 16" Colour TV £220  
PVM 1850 18" Colour Monitor £570

### Printers

Centronics 779 Tractor feed £875  
Printerm 879 80 col. £695  
Printerm 879 80/132 col. £745  
Microhush £266  
TTY 43 Pin or Friction feed £860  
Paper Tiger £585 Qume Sprint 5 £2115  
Graphics PT £699

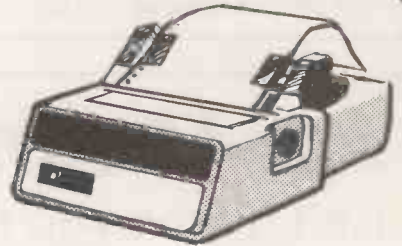

### Systems Furniture

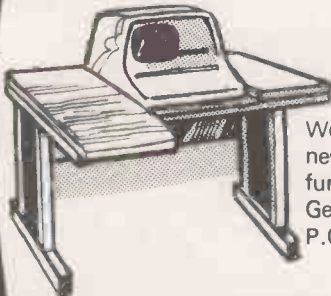

#### \* STOP PRESS

We now have available an exciting new range of GESIKA systems furniture specially imported from Germany by BEAM P.O.A.

ALL PRICES QUOTED EX VAT

### Computer Stationery and Accessories

9 1/2" Plain Listing Paper (per 2000 sheets) £16.00  
Microhush Thermal Paper (2 rolls) £4.00  
Customised Computer Stationery (Invoices/ Statements/ etc) P.O.A.  
BASF 5 1/4" Diskettes £2.50  
BASF 8" Diskettes £3.00  
Library Cases for 5 1/4" £3.00  
Library Cases for 8" £3.50  
Diskette Tray with lockable lid for 5 1/4" £16.00  
Diskette Tray with lockable lid for 8" £22.00  
Diskette Head Cleaners £13.00  
Dust Covers £9.95

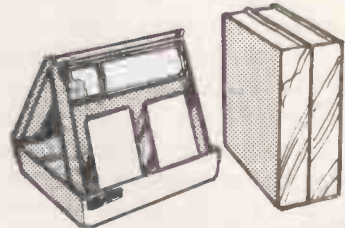

We also stock an extremely comprehensive range of computer books

# DATA LINK

10 Waring House, Redcliffe Hill, Bristol BS16TB  
Telephone: Bristol (0272) 213427

• Circle No. 160

UNIVERSITY OF MANCHESTER  
DEPARTMENT OF EXTRA-MURAL STUDIES

## PRACTICAL BASIC PROGRAMMING

A weekend residential course  
at

Holly Royde College, Manchester  
6.30 p.m. Friday-2.00 p.m. Sunday,  
29th-31st August, 1980  
Fee: £57.50

A weekend residential course for those with little computing background and who would like a thorough introduction to writing programs in BASIC for microcomputers.

The course will cover most of the features of 8K BASIC as used on the majority of microcomputers. Particular emphasis will be placed on the writing of well structured programmes. About half of the timetabled course will consist of practical programming exercises on PET microcomputers.

For a detailed course outline and application form, please contact Lynn Palethorpe, Department of Extra-Mural Studies, The University, Manchester, M13 9PL, telephone 061-273 3333 ext 3076.

• Circle No. 161

# ROUTE 66

COMPUTERS (MAIL ORDER)

GRAND ... OPENING ... SALE ...

NOW AVAILABLE DIRECT TO YOU ... AT SILLY PRICES

**COMPUCOLOR II. MODEL 3**

ONLY ... £990 INC. VAT.

**VIDEO GENIE. EG.3003**

ONLY £380 INC. VAT.

OTHERS AVAILABLE.

SOFTWARE AT REDUCED PRICES  
THIS OFFER CAN NOT LAST FOREVER

Phone our computer dept. Today, or send  
cheque to the Address below.

ACCESS ... BARCLAYCARD ... WELCOME

We can also offer Hirepurchase with No Deposit terms

127 NEW CROSS ROAD LONDON SE14 5DJ  
Telephone 01-732 8608

• Circle No. 162

## Ah-Hmm

(a graphic representation of Mutek clearing its collective throat in an attempt to divert your attention from everyone else's ads!)

### Isn't it time you thought about getting a *real* computer?

One that really *is* adaptable to almost any practical or experimental application?

Look closely at the OSI C2 and new C4 series:  
more computer than you expect...  
for less than you expect!

- built-in D/A converter
- built-in sound port
- remote-control interface
- easily implemented synchronous and asynchronous serial interfaces
- full character graphics  
(dot-addressable graphics available shortly)
- colour capability
- extremely fast BASIC

and a wide range of add-on boards from a number of manufacturers (one example — CA12 96-line parallel I/O (6×6821) board: under £100!).

All this supported by a rapidly expanding base of good software, and of course a full after-sales and technical development service.

We know you'll find it difficult to believe that all this can be cheaper than the most stripped-down machines from Tandy or Commodore, but it's true! The 4K C2-4P is only £349; the new C4P-MF (24K plus one mini-floppy drive) is only £895.

We could go on for ages about easy expansion, the range of add-on boards and intelligent terminal capability, or about OSI's policy of continual improvement compatible with earlier models. But space here is limited, so send for our eight-page C2 technical report (an s.a.e. would be appreciated!).

If you are involved in handling large data bases, why not consider the other end of the OSI range: the C3 series. They offer hard disc options from 23 to 300 Megabytes on line at prices which are less than you expect. All C3 variants can support multi-user/multi-programming and clusters of C2s as intelligent terminals. Ideal for educational use and supported by extremely good software available from several sources. Call today for more information.  
*All prices quoted exclude VAT.*

## Mutek — *real* computers...for less than you expect

Mutek — the independent OSI specialists — Quarry Hill, Box, Wilts. Telephone Box (0225) 743289

• Circle No. 163

# Sintrom Microshop

## The S100 computer centre

**Sintrom Periflex** microcomputer with both  
5" and 8" floppy disc drives

**Vector Graphic** microcomputers

**Micropolis** 5" floppy disc drives (now in stock)

**Micropolis** 8" Winchester / S100 systems

**Telema** computer systems

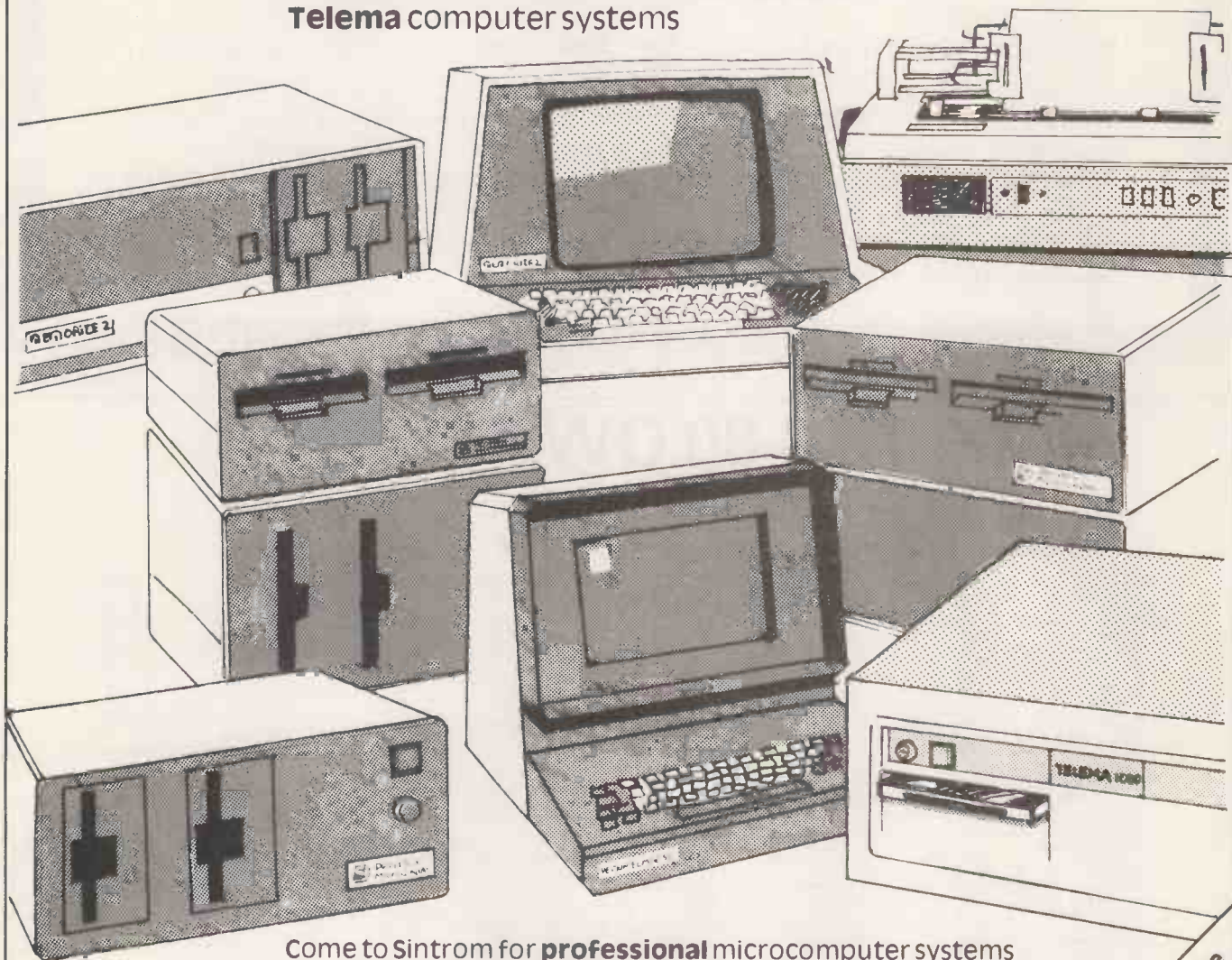

Come to Sintrom for **professional** microcomputer systems backed-up by the long established Sintrom Group, with years of experience in mini and micro computer systems and peripherals.



## Sintrom Electronics

14 Arkwright Road, Reading, Berks RG2 0LS

Tel: Reading (0734) 85464 TELEX: 847395

Sintrom Microshop is a division of the  
Sintrom Group of Companies

**Very competitive terms available  
for dealers and OEMs**  
Phone Martin Whittaker  
on (0734) 85464  
for further details

• Circle No. 164

# 'ever heard of COMAL ?

(extended and structured BASIC with built in file system)

'EVER HEARD OF A MULTI-USER SYSTEM RUNNING TWO DIFFERENT HIGH-LEVEL LANGUAGES (COMAL & PASCAL) AT THE SAME TIME?

phone

**digital data electronics Ltd.**

**(01) 602 2805**

for more information on the **spc/1** micro-computer system.

Starting at £1995 (single user ready-to-run system including the micro with one mini disc drive, VDU, 32 Kbyte RAM and COMAL software), expandable to an eight - user system with up to 80 Megabytes of hard disc storage and capable of running COMAL, Pascal and Assembler at the same time!

Please add 15% VAT to above price.

**db**

• Circle No. 165

## TRS-80 OWNERS!

### MODEL I

### MODEL II

#### LEV II CASSETTE

Adventures:	
The Count*	£8.50
Land*	£8.50
Mission Impossible*	£8.50
Odyssey*	£8.50
Voodoo Castle*	£8.50
Air Raid*	£8.50
Amaz' In Mazes	£5.00
Balloon Race	£5.00
Barricade*	£8.50
Baseball	£5.00
Bingo	£4.00
Bowling (Ten Pin)	£5.00
Breakaway	£4.00
Bridge Challenger	£8.50
Backgammon	£5.00
Concentration	£5.00
Cribbage	£5.00
Dogstar	£6.00
Fastgammon*	£10.00
Galactic Blockade	£5.00
Game of Life*	£6.00
Hangman	£4.00
Kamikaze	£5.00
Mastermind*	£5.00
Mean Checkers*	£11.00
Othello III	£4.00
Pentominos	£6.00
Pork Barrel	£6.00
Pre School Games	£6.00
Remainder	£5.00
Robots	£4.00
Round The Horn	£6.00
Safari	£5.00
Santa Paravia	£5.00
Sargon I	£11.00
Sargon II	£16.00
Ship Air Battles	£5.00
Slalom	£5.00
Snake Eggs	£8.50
Space Battles	£8.50
Star Trek III 3.4	£8.50
Taipan	£5.00
Time Bomb	£4.00
Treasure Hunt	£4.50
Trek 80	£6.00
Trolls Gold	£4.00
Warfare I	£5.00
X-Wing Fighter II	£5.00

Astronomy II	£7.50
Basic IP	£11.00
Basic Toolkit	£11.00
Biorhythms	£4.00
Calendar Functions	£7.50
Complex Maths	£8.50
Electric Pencil*	£50.00
Electronics Asst.	£6.00
ESP Tester	£4.00
File Handling	£7.50
Finance I	£7.50
Finance II	£7.50
Forth (Incl. Primer)	£40.00
Fourier Transforms	£7.50
Graph Builder	£6.50
Horn Radio	£6.00
Home Finance	£6.50
General Accounting	£8.50
Inst. Calculator	£7.50
Inventory Mod.	£11.00
Inventory FP.	£13.00
Inventory Control	£11.00
IQ Builder	£7.50
Keyboard 80*	£6.00
Level III Basic	£26.00
Linear Programming	£7.50
Line Printer Plot	£7.50
Math Drill	£4.00
Math Library I	£18.50
Microtext Editor	£6.00
Mortgage Calculator	£5.00
Personal Finance	£6.00
PASCAL (Incl. Manual)	£26.00
Pilot 2.0	£9.00
Pre-Flight	£11.00
Renumber*	£8.50
RPN Calculator	£6.00
RSM 2 Monitor	£14.50
Simplify It	£13.50
Spelling Narration	£7.50
Spelling Programs	£7.50
Statistics	£11.00
Star Finder	£7.50
Story Builder	£7.50
System Copy*	£8.50
Tarot Cards	£6.00
Teachers Assistant	£6.00
76 Basic Programs	£20.00
Manual for Above	£7.00

#### DISK

Accounts Receivable II	£40.00
Advanced Personal Finance	£13.50
Amateur Radio System	£13.50
Data Base II	£25.00
Electric Pencil*	£75.00
Forth (Incl. Primer)	£35.00
General Ledger	£40.00
Inventory 2.2	£30.00
Inventory 2.3	£40.00
Inventory II	£50.00
KVP Extender	£16.00
Level I in Level II	£13.50
Mailist IV	£40.00
Newdos Plus	£47.50
Pilot 3.0	£15.00
RSM 2D Monitor	£15.00
Text 80	£30.00
ST 80-D	£40.00
Taranto & Associates Conversions of Osbourne & Associates Business Programmes	
Accounts Payable	£90.00
Cash Journal	£40.00
Invoicing	£90.00
Accounts Receivable	£90.00
General Ledger	£90.00
Manuals for Above	£12.00
Complete Co-ordinated System With Manuals	£350.00

CP/M 2.0	£70.00
CBASIC-2	£70.00
Accounts Payable	£255.00
Accounts Receivable	£255.00
General Ledger	£255.00
Inventory System	£255.00
PASCAL/Z Ver 3.	£150.00
Super Sort III	£70.00
Word Star	£240.00
Manuals for Above	£13.50
NOTE: User Licence Agreement Require for Above Business Programmes.	
Osbourne & Associates Business Programs in CBASIC Each	£140.00

MANY OTHER PROGRAMMES AVAILABLE CALL FOR DETAILS.  
ALL PRICES INCLUDE FIRST CLASS POST AND PACKING (UK ONLY).  
SEND 50P FOR FURTHER DETAILS OF PROGRAMMES.  
\* Denotes Machine Language



**MICROCOMPUTER APPLICATIONS**

11 RIVERSIDE COURT, CAVERSHAM,  
READING RG4 8AL, ENGLAND



TELEPHONE:  
(0734) 470425



# XITAN SYSTEMS

## CROMEMCO SYSTEM 3

£4,054.00 for this system with vdu.

The ideal business system. System includes a full 64K fast RAM, dual full-size floppies (Persci 277), RS232 interface/20mamp loop for console device, parallel printer port (Centronics/Anadex compatible), 21 slots for expansion, Lear Siesler 24 lines or 80 chars vdu, and ... CROMEMCO's CDOS operating system with their 14 digit BCD extended disk Basic — ideal for those accurate large numbers required by successful businesses. CDOS is CP/M functionally equivalent, with many extra facilities. Optional extras from Xitan include Fortran, Cobol, Text Formatting, Z-80 macro-relocating assembler and DBMS at £59.00 each, CIS interactive screen handling Cobol at £425.00 (recommended to serious business users), Cromemco S100 boards, CP/M (we are an authorised oem distributor of Digital Research's CP/M) for the System 3, Wordmaster, Wordstar, Supersort, and CPM374X utilities.



COMING SOON! ... Full 7-terminal multi-user operating system from Cromemco for System 3 users. Up to 48K per user, all running independently. This operating system has to be seen to be believed. It will run any of the Cromemco provided and supported software packages, in any combination. Features include partition rescue facilities, allocating more memory to users, real-time clock for time/date stamping of jobs and disk queueing techniques. Buy your System 3 now, expand later as you need it.

## S100 BRITISH COLOUR BOARD

We are proud to offer the first BRITISH S100 Colour board. Manufactured by a local Southampton company — Hi-tech, we can thoroughly recommend this product. Features include true PAL colour generation for high-definition on your television or colour monitor, 15+ colours and black/white with 6 additional grey scales, 24 lines with 40 characters per line, with standard character set plus 44 numbers and symbols, and 64 computer selected graphics symbols. Symbols include fractions and the £ symbol. Plotting is available at 80 x 72 resolution. Single or double-height characters, with flashing on an on/off duty cycle of 3-1. The board is memory mapped on any 2K boundary, with its I/O port set at any of the 256 available on the S100 bus. Just plug into your S100 system and colour television and go! Driver software and documentation provided. Price £295.00 ex vat cash with order. Please specify if for television or 75 ohm monitor.



## ON DEMO NOW! THE CROMEMCO Z2-H

For only £4,995.00 set the reliability and quality of Cromemco, coupled with the capacity of the new IMI 11 megabyte hard disk drive. This is incredible value for money. Specification includes transfer rates of up to 10 times faster than the fastest standard floppy disk, DMA controller for up to 7 hard disk units, and the new extended CDOS operating system. Systems available in three configurations: — A) The Z2-H complete integral system, 64K RAM, Z80A cpu, two double-sided mini-floppies, RS232 console port, parallel printer port, power supplies, cables, case and 12-slot S100 motherboard (7 slots free). B) Additional hard disk subsystem for existing system 2 or system 3 users consisting of one hard disk, DMA controller, power supply, case and cable. C) As unit B but with two hard disks. Prices: Unit A) £5,380.00.  
B) £4,330.00.  
C) £7,420.00.

Xitan Systems also supplies and stocks vdus, printers, NORTH STAR HORIZON computers, Commodore Business Machines PETs, S100 boards, and books. We are here to demonstrate the range of quality microcomputer systems available for use today. Ring up for an appointment now! You'll not be disappointed. We have Osborne's Sales Ledger and Payable Ledger in source form for use on Cromemco System 3 with CBASIC2, and we can offer a customising service on these programs. Additional software includes Microsoft Basic Interpreter and Compilers, Cbasic, Macro80, and CP/M for the North Star Horizon.

**Xitan Systems Ltd., 23 Cumberland Place, Southampton SO1 2BB.**

**Tel: (0703) 38740**

**Hours Tue-Sat 9.30 am to 5.30 pm**

• Circle No. 166

# Computer Selector?

Throw away the pin! Let Cambridge Computer Store help you choose the right system from one of the biggest selections of microcomputers and peripherals in the country — most of which you can see on demonstration and buy off the shelf:

TANDY · TRS 80 · APPLE · PET · N-S HORIZON  
CROMEMCO · COMPUKIT · ACORN · INFOTON  
LEAR-SIEGLER · CENTRONICS · ANADIX

Back-up this impressive range with truly professional standards of advice and after-sales support and you can take the guesswork out of computer selection.

## Cambridge Computer Store

1 Emmanuel Street, Cambridge CB1 1NE  
Telephone (0223) 68155

• Circle No. 167

# Possibly the most cost effective Laboratory Computers in the world.

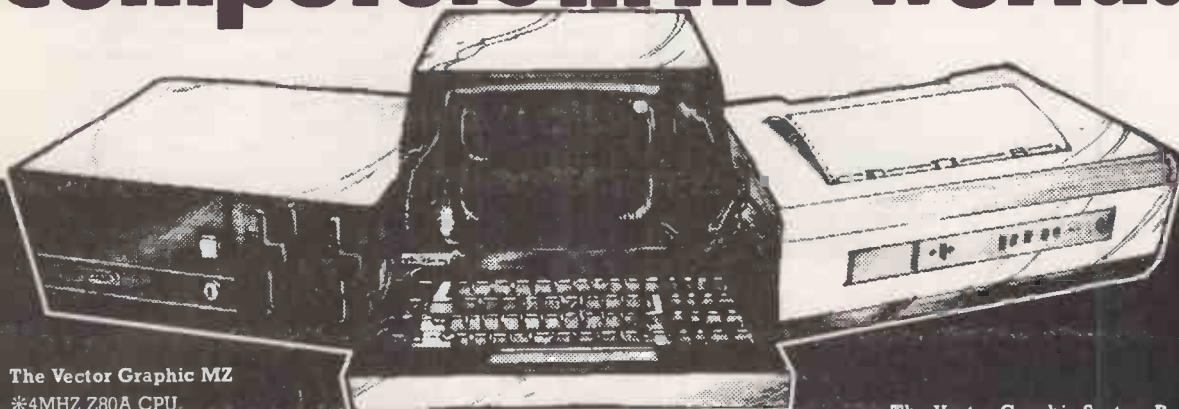

### The Vector Graphic MZ

- \*4MHz Z80A CPU
- \*48K ram
- \*630K Bytes disk storage
- \*Serial port and two parallel ports
- \*Prom/ram Board with monitor
- \*MDOS Operating system
- \*Z80 Assembler
- \*Basic Interpreter

Plus a large range of CP/M compatible software including Fortran, Cobol, Macro assemblers etc.

### The Vector Graphic System B

- Complete Vector MZ system plus:
- \*Vector Mindless terminal\*
- Flashwriter 2 video board (24 x 80)\*
- \*Software driver on prom\*
- MZOS North Star compatible DOS\*
- \*CP/M configured by Almarc\*

**ALMARC**  
DATA SYSTEMS LTD

906 Woodborough Road, Nottingham. Telephone: (0602) 625035

• Circle No. 168

# Thinking Computers?

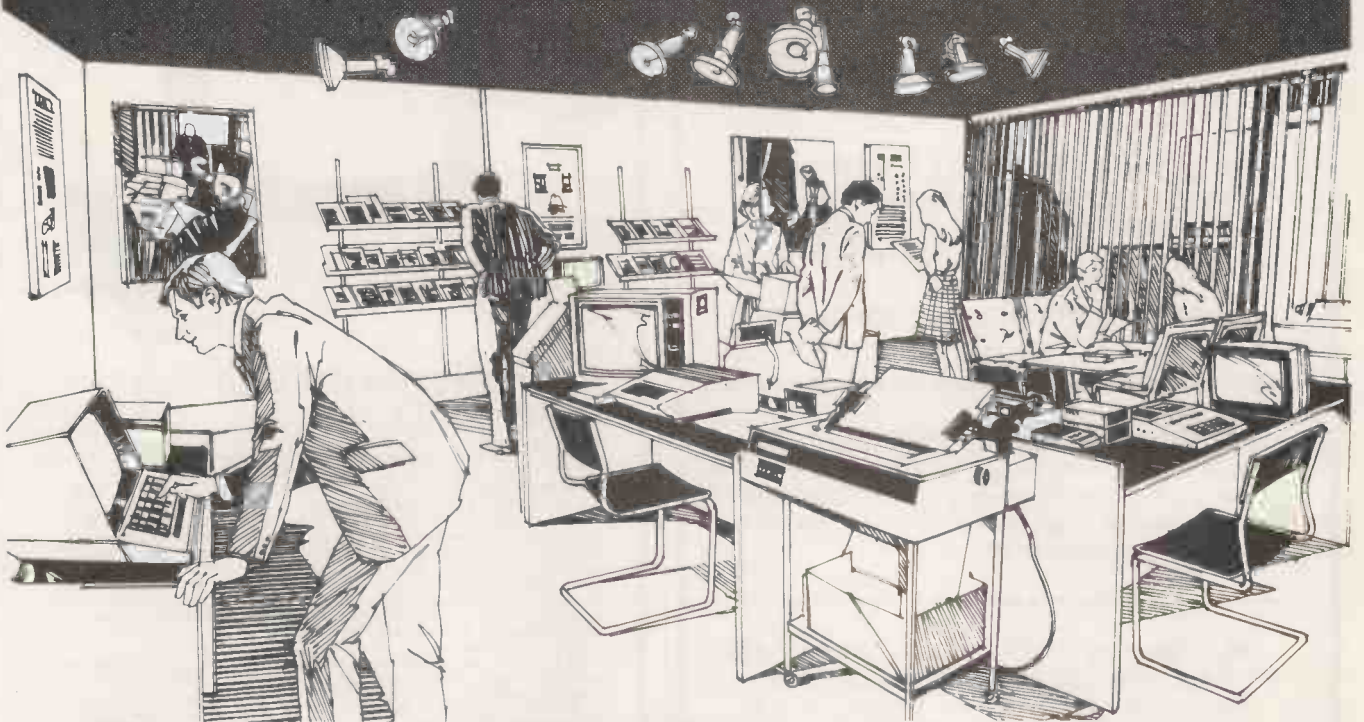

## Then come to the number one micro-computer centre

If you're wondering if a micro-computer can help you, we are here to advise you. At Lion House—London's leading centre for micro-computers—you'll find:

- \* Experts who'll explain the equipment in a way you can easily understand, showing how and where it applies to *your* work.
- \* Demonstration areas where you can get immediate experience of using micro-computers yourself.
- \* Probably the biggest range of software in the UK.
- \* Programmes can be tailored for your particular commercial needs by our In-House Analysts and Programmers.
- \* Total service—including the availability of full maintenance after you've bought an installation.
- \* Leasing and H.P. facilities immediately available.
- \* A computer book section with publications that give you new insight into the world of micro-computers.

**How will micro-computers help you?** In thousands of ways—only a few can be mentioned here...

**MICRO-COMPUTERS FOR BUSINESS**



**For business and professional,** the versatility of compact micro-computers means that all the benefits of big computers are made available to all at low cost. The businessman can now computerise his accountancy, his stock control, his records and much more—cutting his overheads and improving his efficiency.

**For the home,** micro-computers have innumerable uses and considerable value too—sometimes in unexpected ways.

**MICRO-COMPUTERS FOR THE HOME**



Budgeting... investments... controlling heating or security... storing information on things like recipes... designing complex and fascinating games... education...

**Come and see.** We invite you to visit us and investigate the possibilities and the potential. If you're too far away, phone or write and we'll send you more information. **You need a micro-computer.** We can supply it.



• Circle No. 169



## LION MICRO-COMPUTERS

**SMALL COMPUTERS—TO MAKE YOUR BUSINESS BIGGER**

Lion Computer Shops Ltd, Lion House, 227 Tottenham Court Road, London W1 (First Floor). Telephone: 01-637 1601.

Telex: 28394 Lion G.

Open 9 to 6, Monday to Saturday (Thursday to 7).



# PADMEDE



**PADMEDE COMPUTER SERVICES**  
112/116 HIGH STREET, ODIHAM, HANTS  
PHONE ODIHAM (025-671) 2434  
FOR YOUR APPLE HARDWARE AND  
APPLE/ITT2020 BUSINESS SOFTWARE

- **INCOMPLETE RECORD ACCOUNTING** £450  
Trial Balance, Profit & Loss, Balance Sheet, Nominal Ledger Listings, Automatic V.A.T. Calculations, 2000 postings (expandable), 900 Nominal Ledger Codes, 99 sub-analysis codes.
- **SALES LEDGER** £300  
900 Accounts, 4500 Transaction postings per month, Statements, Aged Debt to 3+ months, Full V.D.U. interrogation of accounts, Non-buying customer report, Daybook listing, Turnover year to date for each customer, Representatives report, control accounts.
- **PURCHASE LEDGER** £300  
Same volumes as Sales Ledger but analysis to 899 Nominal Codes.
- **TIME & COST RECORDING** £300  
Time and disbursements recorded against up to 999 codes. Time and rate automatically completed and accumulated. Costs recorded by Project No and/or Client. 99 Chargeboards.
- **JOB COSTING** £300  
Ideal for the Printing Industry. Rates allocated to cost centres. Input from Daily Dockets. Special costs can be input by each job.

ALL SOFTWARE HAS BEEN INSTALLED IN NUMEROUS INSTALLATIONS AND MANY REFERENCE SITES ARE AVAILABLE. OUR FIRST APPLE SALES WERE MADE OVER TWO YEARS AGO.

## WANTED

APPLE/ITT2020 DISTRIBUTORS AND DEALERS TO ACT AS AGENTS FOR OUR PROVEN BUSINESS SOFTWARE. FAVOURABLE DISCOUNTS AVAILABLE.

• Circle No. 170

# SOFTY Software Development System

EX-STOCK

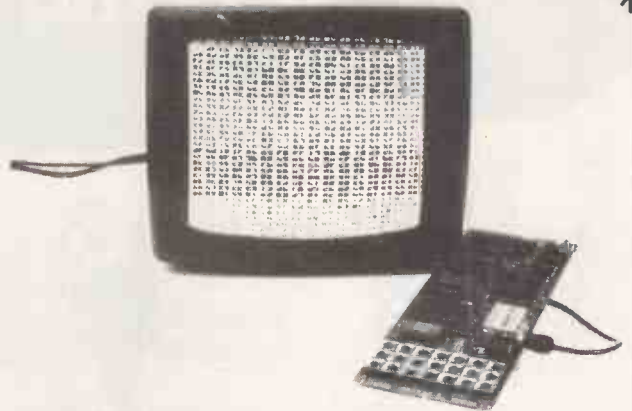

## MICROSYSTEM DEVELOPMENT USING SOFTY

SOFTY is intended for the development of programs which will eventually become software residing in ROM and forming part of a microsystem. During the development stage of a microsystem, SOFTY will be connected in place of the firmware ROM via a ribbon cable, terminated in a 24 pin DIL plug. Data may be entered into the SOFTY RAM via the serial port, parallel port, direct memory access, or the keypad, and manipulated using the assembler key-functions. When the program has been entered, and the internal microprocessor can be 'turned off', and the external microsystem and its resident microprocessor allowed to access and run the program in SOFTY's RAM and/or programming socket. In this way, modification can be made until the required program is complete — the contents of the RAM being clearly visible as a 'page' on TV or monitor. 4 pages are available, 2 of the Data RAM and 2 of the programming socket.

In the end, when the program is complete and working, the DIL plus is removed and replaced by an EPROM device programmed by SOFTY. SOFTY is able to program the 2704/2708/2716 family which have 3 voltage rails — we supply with each SOFTY details of a simple modification which allows SOFTY to program the single rail 2716/2732 etc. (If you want to program EPROMs/PROMs other than the 2704/2708/2716 family, we may be able to help you — our range of add-on Programming Modules is currently under development.)

To help in the process of program development SOFTY has various assembler key-functions, which include — block shift without overwriting, block store, cursor control, match byte and displacement calculations (for jumps etc). A high speed cassette interface is also provided for storing working programs and useful subroutines.

Software is supplied for serial data transfers — which means that you can write an assembler for your favourite MPU in BASIC on your Superboard, UK101, Nascom etc., and transfer the hex code directly to EPROM via SOFTY. The serial transfer program runs in the scratchpad and can be easily loaded from cassette or the programming socket.

Besides software development and EPROM programming, SOFTY has other uses — as a training aid, or as a control computer in its own right, with up to 2K bytes firmware, 1K of RAM, 22 I/O ports and Direct Memory Access. Please write or phone for further details or advice.

SOFTY Kit-of-parts: (including zero insertion force socket for EPROM programmer & 24-pin DIL header plug for connection to the system under development). Price £115 (inc VAT, p&p). SOFTY built and tested — £138 (inc VAT, p&p). SOFTY power supply — £23 (inc VAT, p&p). Write or telephone for full details.

## MODEL 14 EPROM ERASERS

EX-STOCK



### MODEL UV 141 EPROM ERASER

- Fast erase times (typically 20 minutes for 2708 EPROM)
- 14 EPROM capacity
- Built-in 5 to 20 minute timer to cater for all EPROMs
- Safety interlocked to prevent eye and skin damage
- Convenient slide-tray loading of devices
- 'MAINS' and 'ERASE' indicators
- Rugged construction
- Priced at only £89.70 (inc VAT, p&p)

### MODEL UV 140 EPROM ERASER

Similar to Model UV141 but without timer  
Low price at only £70.73 (inc VAT, p&p)

WRITE OR TELEPHONE FOR FULL DETAILS OR SEND CHEQUES/OFFICIAL COMPANY ORDERS TO:

## GP Industrial Electronics Limited

Skardon Works, Skardon Place, North Hill, Plymouth  
PL4 8HA. Telephone: Plymouth (0752) 28627  
TRADE AND EXPORT ENQUIRIES WELCOME

• Circle No. 171



# OFF THE SHELF AVAILABILITY FROM COMPUTER CENTRE

## KIT PACKAGES

### MINI KIT

The lowest priced CP/M280 Micro in UK. Add your power and terminal. Minifloppy 16KB RAM Z80 CTC serial + parallel I/O \$100 motherboard, connectors, manuals CP/M system. Free basic and Altgol. Optional two drive case illustrated and power supply. £149.00



**£786**

### MAXI KITS

8" drive, CP/M disc operating system, 16K bytes Z80, serial and parallel I/O, \$100 motherboard, connectors and cables

Optional power supply kit. £79.00

**£896**

## TRS 80 EXPANSION

### DISC DRIVE

5 1/4" disc drive + power supply in attractive case



**£299**

## 16K BYTES

### UPGRADE KITS

These are the IC's that even work in the 48K expansion. Excellent instructions

**£69**

## MINI FLOPPY

Double single density hard or soft sector used for TRS80, North Star etc. Assembled and guaranteed



**£189**

## 8 INCH DRIVE

### SHUGART COMPATIBLE

Single dual density 8" disc drive. Assembled and guaranteed. Double sided version 419.00

**£329**

## PRICE LIST

### OEM PACKAGED SYSTEMS

	ASSEM
OEM1 Z80, 32KB, 1SER, 1PAR, 2 x 1/4 MEG Disks	1950.00
OEM2 Z80, 32KB, 1SER, 1PAR, 2 x 1/2 MEG Disks	2450.00
OEM3 4MHz, 64KB, 2SER, 1PAR, 2 x 1 MEG Disks	3450.00

### DISC DRIVES

SA400 mini floppy disc drive	189.00
DRI 7100 8 inch drive (single sided)	329.00
DRI 7200 8 inch drive (double sided)	419.00

### VDU'S

Newbury Labs 7000 VDU (24 lines 80 chrs)	479.00
Pentland (full spec)	590.00

### PRINTERS

DRI 6320 (140 cps Max) 132 chrs, Tractor Feed)	1260.00
ANADEX 8000	495.00

### SOFTWARE

CP/M operating system + 6 manuals + basic E	64.00
Library index (33 volumes available)	1.50
Library copies on 5 inch media	4.50
Library copies on 8 inch media (10 or more)	3.50
Microsoft BASIC	180.00
Microsoft FORTRAN	280.00
Micro focus compact COBOL	299.00
Micro focus FORMS	75.00
USCD PASCAL	160.00
Microsoft BASIC compiler	210.00

### MPU

	KIT	ASSEM
8080A CPU with vector interrupt	69.00	104.00
Z80A + eeprom socket	99.00	139.00
SBC 100 Z80 + serial + parallel	155.00	215.00

### DISC CONTROLLERS

Tarbell	125.00	160.00
Versafloppy 1 (S/D)	99.00	140.00
Versafloppy 2 (D/D)	199.00	280.00
National Multiplex (D/D)	235.00	295.00

### MEMORY

8K bytes Econoram II (4MHz) static ram	79.00	94.00
16K bytes Econoram IV (MHz) static	175.00	199.00
64K Expandoram (Dynamic)	449.00	499.00

### I/O

2SIO (2 serial full hand shaking uarts)	119.00	139.00
IO4 2 serial/parallel	89.00	124.00

### SPECIALBOARDS

VDB-8024 (80 chrs x 24 lines) video	185.00	245.00
PB1 2716/2708 eeprom programmer	99.00	145.00
Memtech floating point board		230.00
Prototype board		16.00
2708 prom board (ex proms)	55.00	75.00
Active terminator kit	17.00	
VB1 video (16x64)	99.00	140.00

### POWER SUPPLIES

Power supplies for mini/maxi kit (1 drive)	79.00	(p&p)
Power supply for mini/maxi kit (2 drives)	89.00	£2.50
Transformer (bus & drives)	15.00	

## OEM RANGE



**FROM UNDER  
£2000**

- Up to 2 Mega bytes of floppy disc storage
- High speed Z80 micro
- Up to 64K bytes fast ram storage
- High level operating system (supports Cobol, Fortran, APL, Basic)
- 2 drive minimum system under £2000

Available off the shelf in an attractive case, the Computer Centre OEM 2 provides a powerful main frame computer

System builders are free to add peripherals to suit the final applications. The operating system provided with the OEM 2 is a powerful upward compatible extension to CP/M and will support up to 128 mega byte disc storage

A 10 mega byte fixed disc is already planned and should be available as an extra during 1980

Another remarkable extension to the OEM range is the availability of the multi terminal operating system. But with hardware costs as low as the OEM, the market for sharing the system is likely to be small!!!

OEM's are invited to write or call for details

## FREE LIBRARY

Computer Centre have available over 30 8 inch diskettes of library software for CP/M. Copies FREE with diskettes purchased from us. Index available.

All advertised items generally in stock. Cash with order ensures same day despatch. Add 2% postage and 15% VAT to advertised prices. Send  Catalogue (please tick)

Send

I enclose cheque for £

Name

Address

# COMPUTER CENTRE

THE DISCOUNT COMPUTER STORE

9 De la Bech Street, Swansea, SA1 3EX. Tel: 0792 460023 Telex: 48638

# Stop puzzling over the Micro Jigsaw and buy an operational system to fit your needs

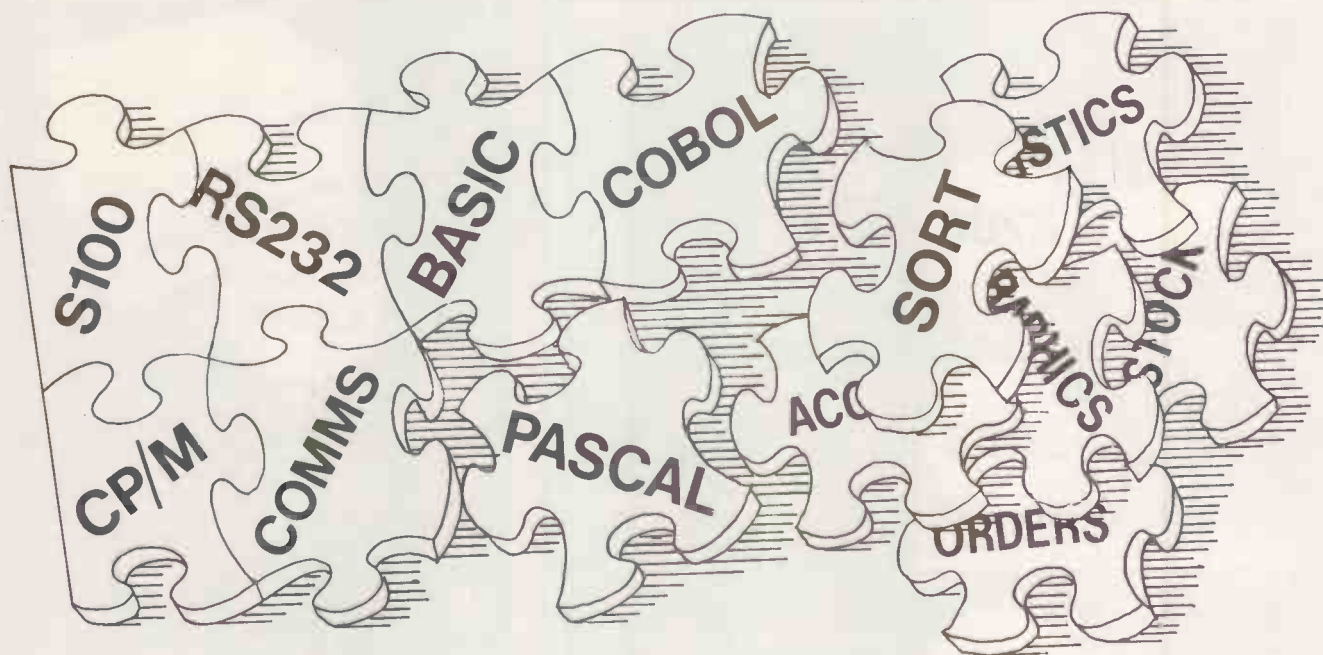

If only buying a microcomputer system was as simple as using one.

Just look at the advertisements in this magazine. When can you find time to digest them all?

There are millions of chips, thousands of boards and hundreds of peripherals, software systems and application packages. How do you pick the right ones to meet your requirements?

And put them together? And make them work? And add the specials you want?

At Digitus we have computer professionals working full-time putting systems together. Absorbing information. Testing equipment and software. Writing programs. Training users.

At one stop you can commission a complete system to fit your requirements.

Last year we supplied systems for: number processing, word processing, data processing,

graphics and machine control. Advised accountants, surveyors, archaeologists and engineers. Helped DP departments and small business men. Developed software for personnel, incomplete records, order processing, business games, linear programming, process control and terminal emulation. And were retained by other computer companies to advise on micros.

This year we can put even more experience to work so that you can benefit from micro technology ... in comfort.

Come and see us. Spend a few hours discussing your requirements. Attend a training course. Select a machine. Test drive some software.

Solve the micro puzzle. Buy an operational system that fits your needs.

Call for an appointment with one of our consultants.

# Digitus

Digitus Limited 9 Macklin Street Covent Garden London WC2 Tel: 01-405 6761

• Circle No. 173

# Mike the boredom killer

THERE IS a great gulf fixed between those who know, love and hate micros, and the rest of the world to whom they are just funny-shaped TVs. We who love them can maunder on for hours about their engaging little ways and our wonderful programs, while the rest of the world taps its fingers on the table, looks at the ceiling, looks at its watch and wonders whether even the Russell Harty Show might not be less boring.

There comes a moment when side A is trying to put its point to side B, when side B says in a rather edgy way, 'Very interesting, fascinating, tell me, what exactly does it do?'

And then it's side A's turn to twiddle its fingers because 10 gets you one it doesn't do anything that anyone in the real world would recognise as *doing*.

Of course there are good reasons for this. The old adage, 'It is much better to travel hopefully than to arrive' is nowhere more true than in our obsession. When a program runs — it just runs. But designing it, debugging it — those are the fascinating bits.

Afterwards, it's just a bit of thought locked in amber, autonomous and strangely boring. So the question is, what should we be doing with micros that the rest of the world will appreciate and, one hopes, reward us for in the traditional fashion?

There are basically two possibilities: exciting things and boring things. By exciting I mean games and spectaculars; by boring I mean applications that take over what's boring in our lives. So far, micro programs have tended to be exciting. We have *Star Trek* and *Adventure* and . . . and well, *Star Trek*. And, of course, all the wonderfully thrilling games that we publish monthly in pages not unadjacent to this one.

But I think the future is with the boring things, because they can save people money. This is hardly news. The mainframe people have been doing it for years. And we have, already, many fruits of this way of thinking in our 'Software Buyers' Guide' pages — accounting packages, data bases, word-processing systems. But I am beginning to feel there is an odd effect here.

We have inherited a tradition of computing which assumes — as used to be historically true — that computers are very expensive and very difficult to use. The only people who could get their hands on them regularly were professional programmers and their minds were so full of the mental gymnastics necessary to make the brutes work at all that they had little mental energy left to ask what people actually wanted the computers to do. And the people of course, having no idea what could be done were no more helpful.

Then computers came to be installed in universities and were made available to people in a wider range of disciplines. The machines seemed to be doing more, but they didn't alleviate much boredom. Why was this?

Two reasons. Firstly there weren't enough machines to do all the boring jobs even if they had been programmed to take the strain — they cost too much. And secondly that's not how they were being programmed.

The people who worked them were academics. At the end of a year's work they wanted to be able to point to another heap of academic papers, more questions raised and slightly fewer questions solved, and the need for another year's research budget.

The effects of economics are often underestimated. If you pay people, as academics are paid, for thinking up questions to answer, you get some interesting questions but few useful answers. But if you pay people for questions successfully answered, you will tend to get action.

Well it isn't surprising that the computer, until recently,

has made no impact on the majority of people's lives. There haven't been enough of them to do so. But now that has changed. The magic break-even figure is now with us, where the cost of a machine that can do some useful work is about a year's wages for an office worker. You can buy a machine, replace a worker, and have four years' work out of the thing for free. That message will get any businessman's attention. And it means that suddenly there is a market for actual solutions to real problems. The person who can scratch away in his back bedroom and come up with a program that actually is of definite use to some non-imaginary people can be sure of making money.

It could well be that he makes a lot of money, for the potential of the software market looks roughly on a par with best-sellerdom or writing scripts for Hollywood.

Why aren't these programs already available? There seems to be a curious hitch or snag in the software creating process. A couple of times a week computing folk hold press conferences to announce some wonderful product.

It is not seldom that they go like this: a particularly glaring example, but there are others very like it (only the names have been changed to protect the stupid).

The managing director got up, got going and in five minutes had wound himself into a knot and crashed the system.

I got talking to the sales director and asked him how he proposed to sell his wonderful thing which cost a minimum of £50,000 a throw when it evidently didn't work, and moreover seemed to be up against a competitor which cost a fraction as much, and did work. "Ah", he said, his eyes glazed, his jaws chomping a morsel of smoked salmon, "that is an interesting question."

Afterwards, it seemed to us that they had done, badly, for half a million, what one of *PC's* contributors has done on his kitchen table — properly — for £300. There seem to be two rules in software production:

- Expense is completely optional — the same thing can cost hundreds, thousands, tens of thousands or hundreds of thousands;
- The more it costs the less well it works.

Why is this?

It is again, I think, a hangover from the old days. Traditionally software is written by getting a very expensive customer — a bank or an army — and shooing programmers through the mill until the customer's simple problems are satisfied. But the programmers are bored by the whole thing.

Comes the personal computer which puts real, if not so glamorous, computer power in the back bedroom. It is programmed by someone who cares very much about what he is doing. He doesn't have to collaborate with anyone else, he has no management to muddle him. He not only cares more, he understands his whole project backwards since he thought of it. He won't make any money until the whole thing runs perfectly and pleases customers. He has every incentive to get on, do it right and do it soon.

The professional programmer, on the other hand, has almost every incentive to do it wrong, and do it late. Ultimately, whether the machine is Cray, a 370 or an Acorn, it will do nothing useful until some human brain drives human fingers to tap the right keys on the keyboard. Once that brain has a roof over its skull, a square meal under its belt, a cup of coffee at its right elbow, and a couple of hours peace and quiet, there is nothing more that money can do for him.

The back bedroom hobbyist is, other things being equal, just as likely to get it right as the £25,000 a year freelance contract programmer; and has more reason to. — P.L. 

## Sinclair pocket micro début

CLIVE SINCLAIR — of tiny calculator and tiny TV-fame — recently demonstrated his new Z80-based personal computer to the Press.

First impressions are of how very small the machine is: without the encumbrance of a TV set, tape recorder and power supply, it would slip with ease into a coat pocket. Inside, it has what is claimed to be a 4K Basic packed into 1K of ROM.

As shown, the machine has 4K of RAM, expandable to 16K with a plug-in package. The touch-sensitive keyboard looks more robust than those on Sinclair calculators, which



are notoriously weak. The machine is neat and at £99.95 (£77.95 in kit form) cheap, but this price excludes mains adaptor (£8.95), TV set (£50 plus) and cassette recorder (£25 plus), giving a total price of more like £180.

The drawbacks are that it will only run Basic, it cannot have more than 16K of memory, one cannot get at the processor to write machine-code, and it does not look as if it will have discs. It cannot even be regarded as an up-market calculator because it doesn't have logs, antilog, sin or cosine functions.

Of course, the user could write his own routines in Basic, but why bother when any calculator for £15 can do the same a hundred times faster? It is hard to endorse Sinclair's claim that it is a 'powerful tool for the experienced user'.

On the other hand, it could serve as an excellent introduction to computing in schools and colleges.

• THE launch of the ZX80 may well lie behind Nascom's decision to cut the price of the Nascom 1, which is now available at £125 in kit form and £145 for the ready-assembled unit.

## Human factor in computer crime

A SERIOUS LOOPHOLE in the law on computer applications has been revealed by a recent Appeal Court ruling. The three judges decided that a computer print-out alone is not admissible as evidence in criminal trials.

The Appeal Court hearing involved a prosecution for burglary in which bank notes found in the accused's possession had serial numbers allegedly part of a series that were in the stolen bundle. The numbers came from the bank of England on a list produced by a note-counting machine which subsequently produced a computer printout of the numbers.

The Criminal Evidence Act specifies that the only admissible written records are those made by a human being from his own personal knowledge. The defence argued that the information recorded in the computer printout was not information supplied by any person who had, or could reasonably be supposed to have, personal knowledge of the matter dealt with in the information.

### by Duncan Scot

The machine noted the number of the first note in the inserted bundle, automatically rejected any notes which were defective in any way, noting their numbers and the number of the last note in the bundle. The man who inserted the bundle noted only the serial number of the first note. The judges held that the serial numbers of the notes were never anyone's personal knowledge.

The significance of the ruling is that since many computer security systems now work automatically, a criminally-minded programmer or operator could alter records on a computer, such as records of debts, without fearing that any log of access time and records altered could be used in evidence in any criminal prosecution.

Lord Justice Bridge, in giving judgement, suggested that a gap in the law had been found. This, together with the inconsistencies in the copyright laws on computer programs (highlighted in Peter Sommer's article in March's PC), suggests that the law as it relates to computers is in urgent need of overhaul.

## £60,000 backing for robot study

A £60,000 STUDY which will seek to identify the manufacturing opportunities for robot parts by British industry has been commissioned jointly by the Government and private industry.

The study, to be carried out by the Industrial Innovation Centre, will concentrate on the mechanical and sensing technology involved in robot development.

## UK firm grabs US Cobol business

COBOL for microcomputers is finally gaining acceptance and one UK version has become the first to win US Government certification. The product, CIS COBOL, from Micro Focus, has received formal approval in the form of certification by the Federal Compiler Testing Centre.

This means that it is the only approved supplier of COBOL for use on US Government microcomputer projects. The company has also signed a marketing deal for the product with the New York-based QI Corporation.

CIS COBOL is a portable software system for compiling, debugging and executing COBOL programs. Its availability means that computer users can take immediate advantage of microcomputing technology by transferring COBOL programs from their larger machines without re-training or recruiting staff.

It is difficult to assess accurately the market for microcomputer COBOL, but the industry reckons on approximately £12m over the next three years. This suggests that OEM's will use about £5m-worth of microcomputer COBOL software, while end-users will need about £7m-worth.

The certification and QI deal for Micro Focus obviously represents a major set-back for another UK-based software-house, CAP-CPP, which has invested over £2m in developing its own version of microcomputer COBOL, Microcobol. This investment included over £750,000 backing from the National Research and Development Corporation.

• See article on funding by Duncan Scot on page 80.

## Keen attack on small-scale user market

KEEN COMPUTERS, the Apple II specialist, is finally launching an attack on the small business market with the Commodore PET.

Previously KCL has marketed the Apple II primarily to the big-business and education market, so the shift in policy would seem to confirm that the small business sector offers the best opportunities for expansion.

Keen's software for the PET will include incomplete record accounting, small business accounts, solicitors accounts and stock control.

KCL has also opened a new office in South London to act as a sales and service centre for London and the Home Counties.

• MICROSENSE, the UK distributor of the Apple II, has dropped the price of the 16-byte, black and white Apple to a suggested retail price of £695. There have been suggestions that a price-war could be in the offing with ITT Consumer Division's 2020.

## Around the dealers

THE BUSINESS of the Byte Shop, put into receivership in November, has been sold to COMART for about £400,000. The new company, Byte Shop (1980) Ltd, will be injected with £1/3m of capital. The former staff have been retained, together with the shops in Tottenham Court Road, London, Ilford, Nottingham, Birmingham, Manchester and Glasgow. It will operate as an entirely separate business within the Comart group.

### TRS-80 hard disc

AN 11-MEGABYTE Corvus mini-Winchester disc is now available for the TRS-80 from T & V Johnston. Details in Tandy Forum, page 118.

### Forth compiler for the PET

ACT PETSOFT has introduced an interactive Forth Compiler/Interpreter to run on the PET. Details in Pet Corner, page 123.

DESIGNED to a new format, a 52-page Hobbyist Catalogue has just been released by Vero Electronics.

Several new products are illustrated, including Verobloc, a new prototyping method of building and testing circuits, S100 bussing systems, a rack-mountable development kit for evaluation of microprocessor-based systems to the S100 format and low-profile DIP sockets.

Contact: Vero Electronics, Industrial Estate, Chandler's Ford, Eastleigh, Hants SO5 3ZR, tel: (04215) 69911.

### Apple finance

VISICALC, an easy-to-use financial modelling package for accountants, has been adapted from mainframe use for the Apple II and is now available for under £100. It is being marketed as "instant visual calculation for any numerical problem without the need for programming." Details of the package in Apple Pie, page 121.

## New maths chips

INTEL have introduced two new maths processor chips, the 8231 (fixed-point) and 8232 (floating-point), which, they claim, increase the performance of a microcomputer system by a factor of up to 100 when carrying out mathematical operations.

Both chips act as dedicated peripherals interfacing directly to Intel's 8080, 8085 and 8088 microcomputers in addition to all other general-purpose processors with 8-bit data buses.

The 8232 will perform 64-bit double-precision or 32-bit single-precision floating-point addition, subtraction, multiplication and division.

Single-precision (32-bit) operation will be used on those occasions when speed is a more important consideration than accuracy.

Both the 8232 maths processor chips contain a 16-bit arithmetic logic unit, a programmed algorithm controller, an 8 by 16-bit operand stack, a 10-level working register stack, command and control registers and a ROM containing all the control software. All transfers between the host processor take place over an 8-bit bi-directional data bus.

## Pascal first

A PASCAL compiler, said to be the first all-British one, has made its appearance. It's from Transam, who make the Triton computer, and is available on discs for CP/M or in 20K of ROM for the Triton.

The disc version will support disc files and both versions have some 'extensions' to standard Pascal to allow PEEK, POKE, direct port and console VDU access.

There are means to work directly in Hex, to manipulate bits and to call machine-code subroutines. Less attractive, perhaps, are the 109 error messages.

## Jap challenge to NEB's helping hand

A NEW TYPE of Viewdata system, designed for the international business user, has been developed by Systems Designers (SDL) for Aregon International, the new name for Insac Viewdata, established by the NEB to promote Viewdata overseas. The name 'Aregon' has been chosen from the Greek word meaning 'helper'.

The new system, IVS-3, is a range of international Viewdata systems for business as well as public service systems.

The software includes extensive facilities for easy input of data and can be used to design and develop new frames. The structure of the software allows ready translation of system commands and responses into a number of foreign languages.

□ THE JAPANESE are catching up in this area of the market as well. Mitsubishi televisions are being used by ISE (Information Services and Equipment) for their Sparrow Intelligent Viewdata Terminal

which goes into production this month (March).

The Sparrow can store individual pages of information while the terminal is connected to Viewdata. Up to sixteen pages can be stored and subsequently viewed off-line. It features a full alphanumeric keyboard and incorporates CP/M operating software for standard business or personal computing tasks.

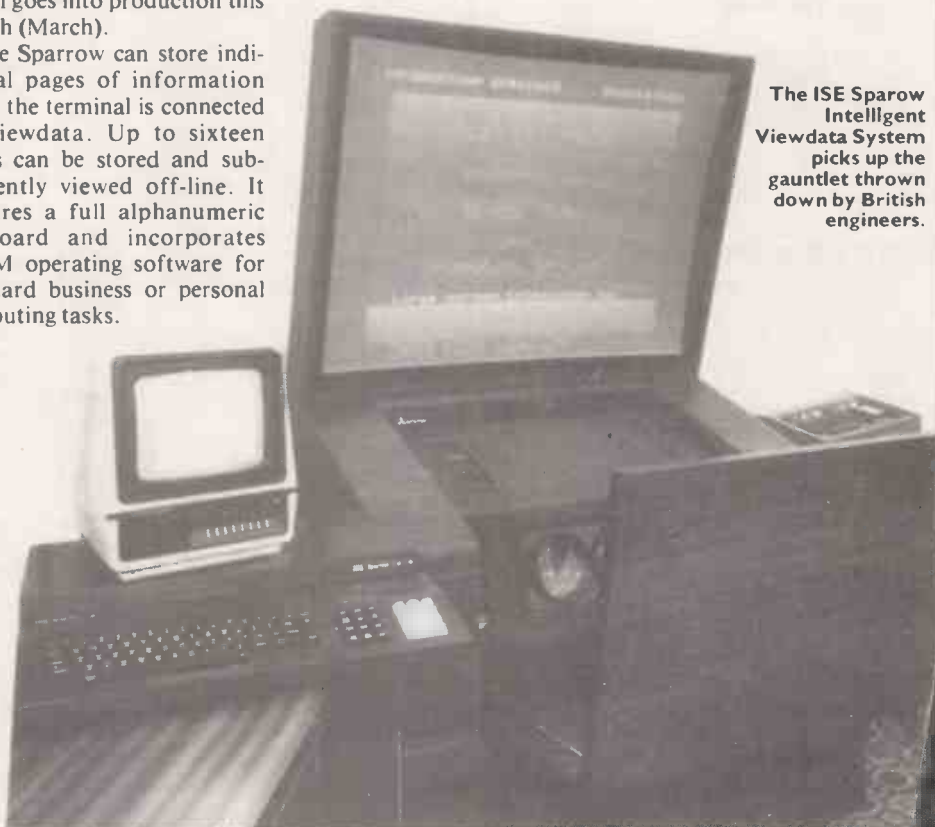

The ISE Sparrow Intelligent Viewdata System picks up the gauntlet thrown down by British engineers.

## Foxing the PET

IF OUR POSTBAG is to be believed, Peter Jennings's Microchess 2 must be one of the most addictive programs around. Readers vied with each other to prove how easily they could defeat the PET. So far the record holder is D. Lomas of Sheffield, with Mate in 10 moves. Several readers are in with under 20; it would appear that there is room for a more advanced chess program for amateurs. Mr W. Green of Basildon, for example, wonders whether anyone has managed to get hold of Chess Challenger or Boris.

### Shortest mate

HERE ARE some game moves to emphasize Maurice Fozzard's observations on Peter Jennings's Microchess 2, in particular

- the inability of the program to learn from previous mistakes.
- the advantages of unorthodox play.
- on a 'points greedy' program, together with the further observation that the castling procedure appears to be considered of high value by the program, especially on the higher levels of play.

White		PET (Black)
1. E2-E4	Advance King's Pawn	E7-E5
2. D2-D3	Advance Queen's Pawn	F8-B4 (Check)
3. B1-C3	Release Check with Queen's Knight	G8-F6
4. H2-H4	Advance Kings Rook Pawn	E8-G8 (Castles)
5. H4-H5	Push Pawn Forward	B8-C6
6. H5-H6	Sacrifice Pawn	G7-H6
7. C1-H6	Take Pawn — attack Rook	F8-E8
8. D1-D2	Push Queen forward	D7-D6
9. D2-G5	Check!	G8-H8
10. G5-G7	You win!	

**D. Lomas,**  
Stumperlowe View,  
Sheffield S10 3QU.

### Must try harder

IN THIS GAME White is simply testing Black's capabilities and is not looking for the best moves. There are plenty of forced wins around the 14 moves range.

White		PET (Black)
1. E2-E4		E7-E5
2. G1-F3		B8-C6
3. F1-B5		G8-F6
4. D2-D3		F8-B4 Check
5. C2-C3		B4-C5
6. As-A4		D7-D6
7. B2-B4		C5-B6
8. A4-A5		B6-F2 Check
9. E1-F2		F6-G4 Check
10. F2-E2		D6-F6
11. C1-G5		F6-G6
12. H2-H4		C6-E6
13. H4-H5		G4-F2
14. D1-A4		G6-E4 Check
15. D3-E4		F2-H1
16. B5-C6 Check		B6-C6
17. A4-C6 Check		E6-D7
18. C6-A8 Check		D7-C8
19. A8-C8 Checkmate		

I have great respect for Mr Jennings, but let's keep our feet on the ground. No good player would be called upon to "wrestle" with Microchess. If you cannot play against it, 100 games in each of which you deliberately throw away a piece and then *easily* win, you are not a good player.

Since writing the above, I have beaten it six times in succession. Number of moves = 19, 17, 21, 14, 18, 17. All different openings. Nor did I exert myself. It does *not* play well at all; as the following demonstrates.

10 REM: NO COMMENT ON WHITE'S MOVES!

White		PET (Black)
1. E2-E4		E7-E5
2. G1-F3		B8-C6
3. F1-B5		G8-F6
4. B5-C6		D7-C6
5. F3-E5		F6-E4
6. D1-E2		D8-D4
7. E5-F3		D4-D5
8. B1-C3		D5-D6
9. C3-E4		D6-E6
10. F3-G5		E6-E5
11. D2-D4		E5-D4
12. E4-F6 Check		E8-D8
13. E2-E8 Checkmate		

**W. Green,**  
Basildon,  
Essex SS14 2QH.

### Classic play

HERE IS a much shorter mate (16 moves) against Level 8 of Peter Jennings's Microchess 2.

White		PET (Black)
1. E2-E4	Danish Gambit	E7-E5
2. D2-D4		E5-D4
3. C3-C3		D4-C3
4. F1-C4		C3-B2
5. C1-B2		G8-F6
6. E4-E5		F8-B4 (Check)
7. B1-C3		D8-E7
8. G1-F3		O-O
9. O-O		F6-G4
10. D1-D4	Attack Knight	H7-H5
11. C3-D5	Threaten Queen with Knight	E7-C5
12. D4-E4	Begin main attack	B4-A5
13. F3-G5		G7-G6
14. D5-E7 Check	Sacrifice Knight	C5-E7
15. E4-G6 Check!		G8-H8
16. G6-H7 Checkmate		

Here is a checkmate after 14:

White		PET (Black)
1. D2-D4		G7-F6
2. C2-C4		E7-E6
3. B1-C3		F8-B4
4. D1-C2		B8-C6
5. G1-F3		D7-D6
6. A2-A3		B4-A5
7. G2-G3		O-O
8. F1-G2		C8-D7
9. O-O		D8-E7
10. F3-G5		C6-D4
11. C2-D3		D4-B3
12. C3-E4		B3-A1
13. E4-F6 Check		G7-F6
14. D3-H7 Checkmate		

**R. J Westmore,**  
Inchture,  
Perthshire PH14 9RZ.

## Check again!

LIKE MY FATHER, I am no computer maniac except for being an avid fan of Peter Jennings's Microchess 2. Hence I was most interested to read Maurice Fozzard's letter but would like to point out (as you might well have discovered for yourself if you had checked) that what he says is *rubbish!*

If White moves 'Queen's Pawn Gambit' D2-D4, PET does not, on any level, reply with G8-F6 on its first move as Mr Fozzard predicts.

It answers with a much more intelligent D7-D5 (Black) which renders Mr Fozzard's second suggested move D4-D5 (White) quite impossible. With such moves, Mr Fozzard of Southend could not possibly have beaten PET, as White's second move would promptly have been answered with a smart question mark.

Check, Mr Fozzard!

**Jennifer Child, Cross-in-Hand,**  
Heathfield, East Sussex TN21 0TN.

## Petting the fox

I WAS INTERESTED by Reginald Mascall's letter (Feedback, PC, January 1980) on sentences containing every letter in the alphabet. No doubt 'quick brown fox' will remain the best known, but it is not too difficult to compose alternatives.

Within a few minutes my RS1936 computer provided the following, which may have more appeal to young lady typists of today.

EXAMINE JAZZ AND POP RECORDS BOUGHT VERY QUICKLY, FOR FLAWS.

This was followed by a second variation, somewhat offbeat.

BAD CANDLEWAX JAM AND HAZY FOG QUITE MAKE A PERSON VOMIT.

Maybe I shall arrive at my own French and German compositions but they would be complicated by the use of accents and umlauts.

**Roger Standing,**  
Restex sa,  
6 rue Pradier,  
1201 Geneva 1.

## Learn the hard way

I HAVE BEEN interested in computers and computer programming for just over a year, and have been saving for a 'Superboard'. It arrived about a month ago and, apart from one dry joint on an IC pin, everything was OK. I had learnt the main points of BASIC from reading the software published in your excellent magazine, and so I was able to begin programming.

I have some advice for other users of the Superboard who are finding a difficulty in reading the program listings because of the closeness of the lines. After the computer has been started up the user can:

POKE 15,0

This sets the terminal width to zero so that when the first character is entered, the computer scrolls up 1 line and prints that character; it then continues on its new line.

When the user wishes to save his program he must reset the terminal width by:

POKE 15,72.

This method not only spaces listings but the print statements so the programmer need not include a double print statement, as many do.

I would also be interested to hear from other people of my age who are interested in programming.

**Peter Davison (14),**  
21 Richmond Drive,  
Cophorne,  
Shrewsbury, Salop SY3 8TN

# “If you want what’s best for your PET, choose Commodore software.”



Kit Spencer  
General Manager  
of Commodore Systems  
360 Euston Road  
London NW1 3BL

The Commodore PET is Britain’s best selling micro-computer, with over 10,000 already installed in a wide range of fields, including Education, Business, Science and Industry.

This has led to a tremendous demand for high quality software.

And Commodore has met this demand by producing a first class range of programs, now available from the nationwide network of Commodore Dealers.

Commodore’s support also includes training courses, a Users’ Newsletter and Official Approval for compatible products of other manufacturers who reach agreed standards.

## COMMODORE PETPACS

Over 50 Petpacs of programs are available (mainly on cassette) from Commodore Dealers. These cover such popular titles as Strathclyde Tutorial, Statistics pack 1, Assembler Development System, Stock Market Trends and the Treasure Trove Collection of game packs including the award winning Star Trek, which is packaged with Petopoly. Prices are from £5 to £50.

## TRAINING COURSES AND SEMINARS

PET systems are simple to use and any normal advice or assistance

## NEW BUSINESS SOFTWARE PROGRAMS ON DISK

Commodore’s Floppy Disk Unit and high-speed Printer, combine with the PET to form a complete system (ideal for running a business) for under £2,500.

Commodore also produce a growing range of business software on disk available from Official Business Software Dealers.

### Business Information System – COMBIS £150 + VAT

Combis facilitates the storage and instant retrieval of all kinds of company records, from personnel files to mailing lists and printed address labels.

### Stock Control – COMSTOCK £150 + VAT

Comstock provides an accurate, up-to-the-second and comprehensive stock position for as many as 1,300 products.

### Word Processor – COMWORD £75 + VAT

Comword turns the system into an excellent word processor.

### Payroll – COMPAY £150 + VAT

Compay is a new, comprehensive payroll package.



you may need can be obtained from Commodore Dealers.

On the other hand, for rapid training on a basic or advanced level, you will certainly be interested in Commodore’s intensive 2 and 3 day residential courses. We also run one day general appreciation seminars.

## PET USERS’ NEWSLETTER

This is Commodore’s official method of sharing new information and ideas between the many thousands of PET users. The newsletter is published regularly and for an annual subscription of £10 you can start receiving copies now.



Look out for this sign. It tells you that compatible products of other manufacturers have met with our standards of approval.



(Tick the appropriate boxes)

To: Commodore Information Centre, 360 Euston Road, London NW1 3BL. 01-388 5702

I am a PET owner  Please put me in touch with my nearest dealer   
Please send me details of: Commodore PET Software   
Training Courses & Seminars  I would like to receive the Users’  
Newsletter and enclose £10 annual subscription

Name \_\_\_\_\_ P.C.

Address \_\_\_\_\_

Tel. No. \_\_\_\_\_

**commodore**  
We made small computers big business.

## UK variables

**J. NEWMAN'S** letter on saving variables on a UK 101 program also provoked a varied bag. Here is a selection:

THE FOLLOWING EXTRACTS demonstrate my solution to this problem:

```
100 LOAD: INPUT AS: I=0
110 I=I+1: INPUT AS(I),BS(I),A(I),B(I)
120 PRINT A(I) < > -1 OR B(I) < > -1 THEN
110
130 POKE 515,0
...
500 INPUT "START TAPE, TYPE'S",
PRESS 'RETURN'; JS
510 SAVE: PRINT *: FOR J=1 TO I
520 PRINT AS(J) " ", BS(J) " "; A(J);
" "; B(J)
530 PRINT " , -1, -1"
540 POKE 517,0
```

Line 130 returns control from the cassette to the computer, and line 540 turns off the SAVE flag, so that after each of these lines the program continues to execute. The second statements in lines 100 and 500 are intended to deal with any rubbish that may be on the tape in front of the recorded data; they can be omitted, but extreme care will then be needed to avoid problems in loading the data.

In my program, I record the data after the recorded program, with an intervening RUN statement recorded; the data will then load automatically after the program has loaded, and the program will then execute from statement 140.

I also note that Mr Newman mentions the lack of an assembler for the UK 101. I have written, in BASIC, a spot assembler for this machine which will run in about 2K of memory. This will translate, and load into memory, the 6502 mnemonics, and will automatically calculate offsets for the branch instructions. It does not allow the use of labels, but does make the entering of machine-code programs a very much simpler process.

It is not a good example of clear programming, being extremely compact, with as many statements as possible crammed into each line, but my aim was to produce the smallest possible program. Presumably the program could be modified to run on any 6502-based system that supports a Microsoft BASIC, but I have not tried it on any other machine.

**Ian S. Jack,**  
West Ashling,  
Chichester,  
Sussex

## Anything goes

IT IS WORTH remembering that when in SAVE with the UK 101, anything that goes to the screen also goes to the tape. When in LOAD, the tape machine output replaces the keyboard output. So the following will record and replay N strings, and is easily modified for variables and what-have-you.

```
100 REM LOAD DATA
110 N=10: DIM AS(N)
120 LOAD: INPUT "RUN TAPE"; AS
130 FOR J=1 TO N: INPUT AS(J): NEXT
140 POKE 515,0
150 .....
1000 REM SAVE DATA
```

```
1010 ? "RUN TAPE ON RECORD": SAVE
1020 INPUT "WHEN RUNNING ON
TAPE, TYPE GO AND HIT
RETURN"; AS
1030 FOR J=1 TO N: ?AS(J):NEXT
1040 LOAD:POKE 515,0
1050 .....
```

First time round, to get the initial data into the system, do not run the tape but answer Line 120 prompt with space and return. Then feed in the data for each array element separated by returns.

POKE 515,0 is a substitute space to cancel the LOAD command. AS is a dummy, as is GO. There has to be some way of letting the UK101 know that you — and the tape machine — are awake and running. GO also avoids getting duff characters off the tape run-in mixed up with the first data string.

Using the same basic techniques you can also achieve an automatic run. When the SAVE LIST has finished and the prompt OK has appeared, type RUN. And make the first instruction of the program 10 POKE 515,0.

By the way, I don't know about a more gentle approach to 6502 machine code programming but Rockwell's R6500 programming manual is very thorough and starts at square 0. Everything but everything is explained in full detail (twice)!

**A. H. Whitfield,**  
Maidenhead,  
Berks SL6 6AE.

## Far from perfect

THE WAY that Comp suggested is far from perfect.

It is not clear whether the variables will be used in the same program or not. If not, then saving the memory will not work since the variables are stored at the end of the program, except for string variables that are defined in the program.

If the variables are to be used in the same program then the variables will be in the correct place but the end of variable table address (stored at 7f-80) will be incorrect.

It would be much better to save the variables from Basic; they can all be saved on tape and then Inputs used. Alternatively they can be saved by writing a program that prints 'X=';X etc, then they can be loaded in the immediate mode and the program run using a GOTO in the same mode; RUN would reset them all.

**J. D. Westrop,**  
Romford,  
Essex RM7 9NS.

## Price of Prestel

THE ARTICLE on Personal Computer Networks (PC, February 1980), which was originally published in *CoEvolution Quarterly*, contains an error.

The section reviewing the British Viewdata (PRESTEL) system states "British viewers need an adapted TV (\$30-\$50 more than a regular TV)". This is incorrect, as there is no Prestel adapted colour set available on the British market for under £600 (\$1350) therefore I am sure the article should have said "... adapted TV (\$300-\$500 more than a regular TV)".

I must also point out that, at the time of writing, the cost of the phone call may work out more expensive than the cost of the "frames", as the databases are not available all

over Britain at local call rates. If one has to call the Prestel database from more than 56 kilometres away between 0900 and 1300 hours Monday to Friday, the call would be charged at peak rate (around 21p per minute or 48 cents) plus 15% British value added tax.

At the time of writing, the majority of the British population is not within local distance of the Prestel databases, although the British Post Office is investing a large amount of money to increase the number of bases. It must be said, however, that the Post Office has, to quote Prestel itself, "no plans at present" to provide a base for Sheffield, one of Britain's top five provincial cities. The nearest base will be Leeds in late 1980, which is a smaller city and not within "local" rates of Sheffield.

**Lindsay Reid,**  
Sheffield S11 7JN.

**Videotex editor Peter Summer** replies:

Keeping up to date with all the nuances of Prestel as it bursts into public availability is almost a full-time job. The CQ article which we published substantially unaltered stated accurately the position as it is supposed to unfold, though current estimates talk of 1983-85 as the period in which we can expect to see a Viewdata add-on to a domestic TV receiver for only £50 or so above regular prices.

By the earlier of those dates well over 1 million sets will have been installed and the rate of new installations will be about 2½ million per annum. Lindsay Reid correctly states the current position; though as I said in our October special, the PO's current commitment is to an investment of £23m. The projections as of mid-January 1980 are that by March 1981, Prestel will have facilities for 77,500 business users and 391,500 residential — as a percentage of the total telephone-owning population, that's 60.7% for business and 62.2% for residential.

Lindsay Reid should give the system a chance to grow naturally and not produce a sum based on the most unfavourable terms his ingenuity can identify. He may have a point about Sheffield, though.

## Debounce again

HERE IS ANOTHER keyboard debounce program. It was dictated to me over the phone about a year ago and now is very useful.

Although I am only 13 years old, I do enjoy programming and have not yet run into any difficulties. At the moment I am learning BASIC, but soon I want to switch to PILOT because I think that will be the language of the future! The program is eight lines long and uses no memory space when it has been 'run'.

```
10 FOR N=1648 TO 16492
20 READ K:POKE N,K:NEXT
30 FOR N=16435 TO 16437
40 READ K:POKE N,K:NEXT
50 POKE 16405,0
60 DATA 205,227,3,183,200,14,60
70 DATA 16,254,13,32,251,201,195,96,64
80 NEW
```

When this program is CLOAded then run, it performs the keyboard debounce and then blanks out, leaving only the bare essentials of its data sentences in the reserved RAM.

This program might interfere with some machine-language programs eg NEWDOS, TRSDOS, etc.

**Jeremy E. San,**  
Mill Hill,  
London N.W.7



# Now you can control your business for less than £2,500.

This could be your best investment opportunity yet. A complete computerised business system, including a Floppy Disk Unit, high-speed Printer and *Britain's best selling microcomputer* – the Commodore PET. All for under £2,500.

## First Class Programs

A comprehensive range of first class programs is offered by *Commodore 'Business Software' Dealers*. These are available on disk from £50-£500. And they cover such applications as *Business Information, Stock Control, Word Processing, Payroll, Accounting and Mailing Systems*.

## Service and Support

With over 10,000 PET computers installed in the UK, dealer support is growing fast. A nationwide network of 90 official

*Commodore 'Business Software' Dealers* ensures that service and technical facilities are close to every PET user. Our dealers can even offer you a 24 hour on-site maintenance agreement.

## Training and Instruction

The PET Business System is self-contained and simple to use. Should you require personalised programs or extensive installation training this can be arranged with your *Commodore 'Business Software' Dealer* who can also give details of official *Commodore Training Courses*. These include intensive 2 & 3 day workshops to train you to write your own programs.

For full details about the Commodore PET Business System, Training Courses, Programs, and *'Business Software' Dealers*, simply fill in the coupon and post today.



To: Commodore Information Centre,  
360 Euston Road, London NW 1 3BL.  
Please send me details of the PET Computer Business Systems.

Name \_\_\_\_\_  
Position \_\_\_\_\_  
Company \_\_\_\_\_  
Address \_\_\_\_\_

Tel. No. \_\_\_\_\_

If you have a particular application in mind please specify:

\_\_\_\_\_  
\_\_\_\_\_  
\_\_\_\_\_

P.C.B.3

**commodore**  
We made small computers big business.

• Circle No. 175

## Language debate continued

I WOULD like to comment upon your Editorial of November 1979 and the letter from John McMillan (Feedback, *Practical Computing*, January 1980) concerning programming languages.

My comments are twofold: firstly I question John McMillan's description of the needs of the professional user; and secondly I question both LISP and PASCAL as the main language of the future for microcomputers.

John McMillan prefers COBOL to BASIC for 'business users' requirements' but he seems blithely to equate 'business' use with 'professional' use with 'serious' use. He says, in effect, that BASIC is fine as a hobbyist plaything but reminds us of the 'more serious users of small computers' and asks us to 'remember the professional tools now and again'.

I am a serious user of small computers — I teach computing to social science students, and also write software with particular emphasis on multivariate statistics: I now use BASIC in most of my programming, and started using BASIC in preference to FORTRAN for on-line analysis many years ago.

It is possible to take any program written in ALGOL60 and FORTRAN and convert it into BASIC without too much difficulty. Many on-line FORTRAN programs (eg GLIM, FAKAD, or SCSS) also take up a large amount of program space with procedures to decode keywords, decoding which is all part of the BASIC specification — but there are few on-line ALGOL60 programs.

I am part-way through some numerical analysis of procedures coded in BASIC for a mainframe (ICL 1902T) and for a microcomputer (APPLE II), with equivalent procedures being coded in ICL Extended FORTRAN. I have found that BASIC and FORTRAN on the ICL 1902T are equally accurate, with BASIC being easier to program for on-line use. Though BASIC on the APPLE II is less accurate than ICL (SOBS) BASIC, the APPLE's results are more accurate than those for at least one old mainframe, the IBM 7090. (I will supply details to those interested.)

One general problem of microcomputer BASICs is the difficulty of the machine-coding for some of the mathematical functions such as SQR or LOG. This is so of BASICs for mainframe computers, but it is true in general for BASICs on microcomputers — this makes me suspicious of the quality of the implementation of more complex languages such as COBOL, PASCAL, or LISP.

This brings me to my second set of comments. BASIC has come a long way and is probably the most widely used language in existence if one includes all the microcomputer users who use BASIC as their main medium. The reason that it is so successful is that BASIC implementers have not been constrained by national or international standards, unlike FORTRAN. Different BASICs have been created — sharing a common core — to cope with different environments.

BASIC is closer to a true language, such as "English", in which there are many dialects and distinct sub-languages, produced by different histories and different cultures. ISA FORTRAN is closer to "proper French", which no person speaks but which is supported by the French government for political reasons — because they are worried by the growing influence of the more flexible "English".

When I read the listings of BASIC in, say, HP Extended BASIC I cannot understand all

but can understand enough to see what is happening: an understanding greatly helped by the judicious use of REMs (John McMillan ignores the use of REMs in BASIC). I realize that the matrix facilities in this particular BASIC are very powerful (close to some of the facilities in ALGOL68) and that they optimize on the HP architecture.

The choice of PASCAL as the language (of André Souson, *Practical Computing*, January 1980) does not seem sensible. PASCAL is very ALGOL60-like (in particular ALGOL-W), and BASIC is an improved FORTRAN-like language. PASCAL is closer to ALGOL60 than ALGOL68 is to ALGOL60.

Apart from some mathematical and natural science users, FORTRAN is far more popular than ALGOL60: what FORTRAN loses in brevity it makes up in simplicity of concept and ease of application. It may not be fair or useful to class the PASCAL versus BASIC choice as a repeat of the ALGOL60 versus FORTRAN choice, because PASCAL has list-processing and data-structuring facilities which do not exist in BASIC.

But if one looks at the numerical abilities of PASCAL, they add nothing to well-programmed BASIC — and the BASIC program is easier to understand. I have not seen complex numerical programs in PASCAL but they must exist.

PASCAL's list-processing facilities are admittedly more extensive than BASIC, but in K. L. Bowles's manual on the UCSD PASCAL system, it is specifically stated that list-processing is beyond its scope — yet it is designed to introduce students to computing with microcomputers.

In Bowles's book, the most complex numerical program is called 'CONVERGE', and part of the output is  $EXP(1) = 2.718281$  which to this accuracy should be 2.718282. This reinforces my doubts concerning the implementation of numerical functions in PASCAL — they use chopped arithmetic — as  $EXP(-1)$  is given as 3.678793E-1 compared to the proper 3.678794E-1 (which is both the chopped and the rounded value).

LISP — the language supported in your November 1979 Editorial — is, again, unsuitable. In 'A Practical Glossary' (*Practical Computing*, January 1980) concerning Polish systems, your writer tells us to 'forget it' — slightly unfortunate as LISP works in a 'Polish' way. In fact the definition of Polish notation given in that article is wrong.

LISP is a functional language, and this has many advantages for complex data-structures, but this also means that LISP is not an algebraic language. There is a variant MLISP, which is algebraic.

The article by Mike Gardner (*Practical Computing*, October 1979) shows clearly how inept LISP is for extended arithmetic (Pythagoras equation, p84), and though LISP has been taught as a first language, it demands mathematical maturity of the students.

These considerations, taken together with the incomprehensibility of LISP programs (eg multiple parentheses) militate against its general use. LISP is inherently very local — as are most Polish systems — and should be easily implemented, as the language itself mirrors hardware operations.

If one wanted to encourage a new extra-special language to supplement BASIC, a rarely canvassed alternative is ALGOL68, which is in itself far superior to PASCAL or LISP — it has superb list-processing and data-structuring facilities in addition to unrivalled

numerical facilities. Probably it would need to be compiled, rather than interpreted, with a multi-pass compiler — thus needing a large system, as does PASCAL. The investment in man-hours for an ALGOL68 compiler would be great, but would produce a tremendously powerful system.

One alternative worth canvassing is a 'super-BASIC' which will incorporate list-processing and data-structuring features, by defining new types of variable — similar to the way one can define integer variables in some floating-point BASICs. If such a language were designed, it would easily outstrip LISP or PASCAL in terms of popularity (measured by use, as against the views of some academics in computer science).

I remember in the late 1960s and early 1970s how computer academics were particularly keen on ALGOL60, and this was the language that science students were taught as a first language. Many of these students stayed with ALGOL60 but many fortunates — such as myself — discovered FORTRAN.

I learnt ALGOL60 on an Elliot 803, and have never used ALGOL60 since my student days. I wonder what will the use of PASCAL by current cohorts of students a few years after their courses have finished?

Dr G. J. Boris Allan,  
Manchester Polytechnic,  
Aytoun St, Manchester U1 3GH.

## Switched-on prof

NICK LAURIE'S article "Removing the Buttons" (*PC*, February, 1980) was valuable, because it makes the point that the real future of the microprocessor lies in making gadgets outwardly simpler, and not more complicated.

Laurie's article reminded me of an incident when I was working at the Cavendish Laboratory in Cambridge. I was helping to develop a machine called Sweepnik — a strange mixture of laser optics, mechanics, and electronics which followed and measured tracks on Bubble Chamber photographs. Sweepnik was controlled by a minicomputer, which performed as much of the measuring as it could automatically. The process was watched by an operator who would give manual assistance if the program got stuck. We were constantly trying to improve the program to make it more automatic; nonetheless, the operator had a fair old collection of buttons and knobs to make manual measurements and wind the film about.

One day, I was proudly demonstrating a nice new row of buttons (which controlled the film transport) to the original inventor of Sweepnik, the late Prof Otto Frisch. Frisch duly admired the new additions, then turned to me with a mischievous smile and said, "Christ, I would like you to show me the machine when it has just one switch, labelled ON and OFF".

C. R. Brown,  
Department of Psychology,  
Sheffield University.

## PET in S.Devon

I OWN an 8K PET and have some experience with BASIC. I would be pleased to offer myself and PET on evenings and possibly weekends to any small group of interested pupils and/or teachers within about 20 miles of Dawlish, charging only petrol costs.

If anyone is interested I can be contacted by letter or on Dawlish 865322 most evenings.

R. Biden,  
29 Gatehouse Rise, Dawlish,  
Devon EX7 0EH.

# Your Commodore PET System

The Commodore PET is Britain's best selling microcomputer and the most popular choice in every field:-

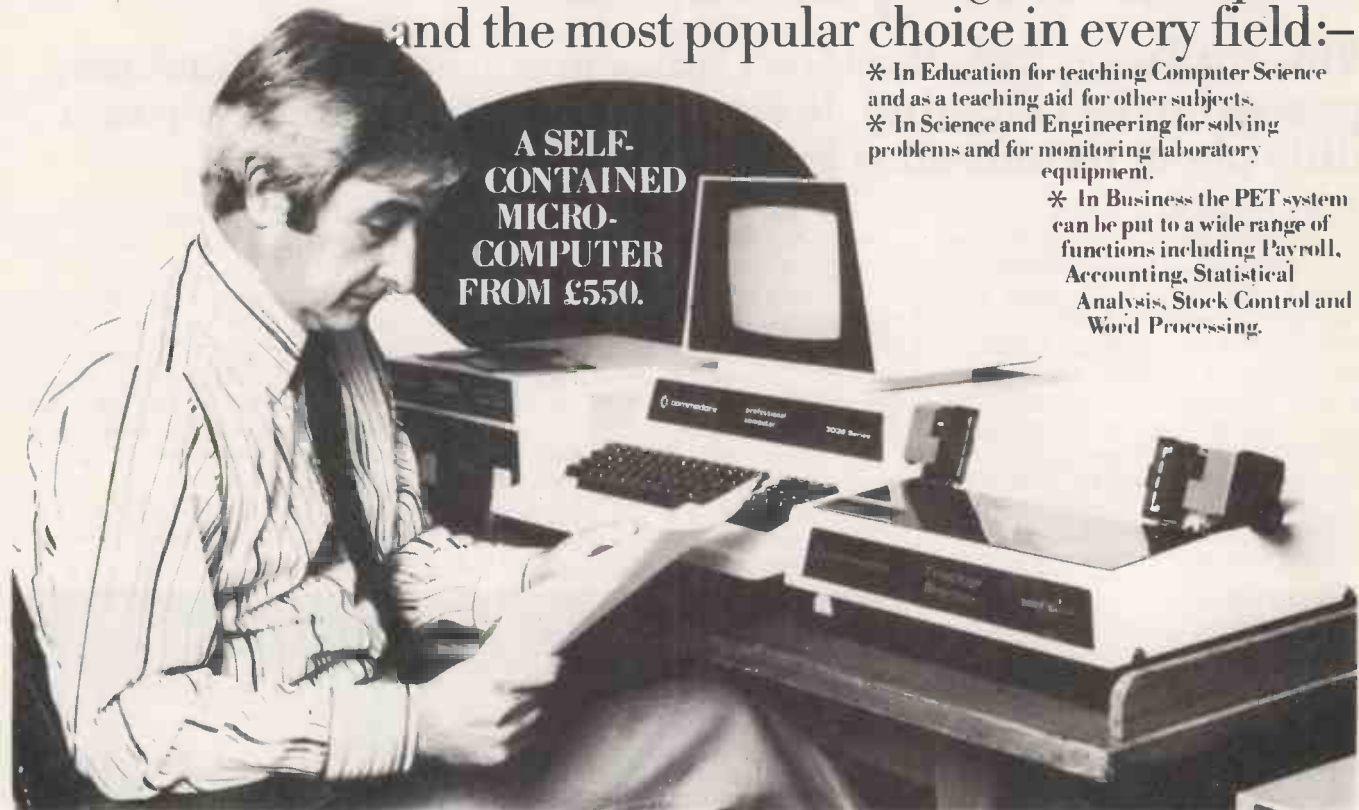

\* In Education for teaching Computer Science and as a teaching aid for other subjects.

\* In Science and Engineering for solving problems and for monitoring laboratory equipment.

\* In Business the PET system can be put to a wide range of functions including Payroll, Accounting, Statistical Analysis, Stock Control and Word Processing.

Not least of its attractions is the price of a PET - from £550 for a self contained unit, to under £2,500 for the complete system including Floppy Disk Unit and high-speed Printer. Ask your nearest Commodore dealer below for details about Commodore hardware, software and training courses.

## Our Dealer\* Network

### LONDON

Capital Computer Systems,  
W1, 637 5551  
ACE (by Top TV Ltd), SW1, 730 1795  
Micro Computer Centre,  
SW14, 876 6609  
Logic Box Ltd, SW1, 222 1122  
Sumlock Bondain Ltd, EC1, 250 0505  
Da Vinci Computers Ltd,  
NW4, 202 9630  
L & J Computers, NW9, 204 7525  
Adda Computers, W5, 579 5845  
CSS Business Equipment Ltd,  
E8, 254 9293  
Advanced Management, EC2, 638 9319  
Metyclean Ltd, SW1, 828 2511  
Microcomputation,  
Southgate, 882 5104  
T.L.C. World Trading Ltd, WC2, 839 3894

### HOME COUNTIES

Orchard Electronics Ltd,  
OXON, 0491 35529  
D. L. Chittenden Ltd, CHESHAM, 4441  
J. R. Ward Computers Ltd,  
MILTON KEYNES, 562850  
Dataview Ltd, COLCHESTER, 78811  
South East Computers Ltd,  
HASTINGS, 426844  
Symtec Systems Ltd,  
SOUTHAMPTON, 38868  
Alphascan Ltd, BANBURY, 75606  
Super-vision, SOUTHAMPTON, 774023  
Millhouse Designs Ltd,  
ALTON, (042) 050374  
Micro Facilities Ltd, MIDDX, 979 4546  
DDM, BRENTWOOD, 230480  
Stuart R. Dean Ltd, SOUTHEND, 62707  
Alpha Business Systems,  
HERTFORD, 57423  
HSV Microcomputers,  
BASINGSTOKE, 62444  
HSV Microcomputers,  
SOUTHAMPTON, 22131  
RUF Computers (UK),  
BURGESS HILL, 45211  
Wego Computers Ltd,  
CATERHAM, 49235

T. & V. Johnson, CAMBERLEY, 62506  
T. & V. Johnson, OXFORD, 721461  
Petalact Electronic Services Ltd,  
WOKING, 23637/21776  
Business Electronics,  
SOUTHAMPTON, 738248  
Amplicon Micro Systems Ltd,  
BRIGHTON, 562163  
Bromwall Data Services Ltd,  
HATFIELD, 60980/64840  
MMS Computer Systems,  
BEDFORD, 40601  
Isher-Woods, LUTON, 416202  
Sumlock Bondain, NORWICH, 26259  
CSE (Computers), READING, 61492  
Oxford Computer Systems,  
WOODSTOCK, 811976

### MIDLANDS & STH. HUMBERSIDE

Taylor Wilson Systems Ltd,  
KNOWLE, 6192  
Betox (Systems) Ltd,  
NOTTINGHAM 48106  
Holbrook Business Systems,  
DERBY, 368088  
Lowe Electronics Limited,  
MATLOCK, 2817  
Davidson-Richards Ltd,  
DERBY, 366803/4  
Arden Data Processing,  
LEICESTER, 22255  
Tekdata Ltd, STOKE-ON-TRENT, 813631  
C.S.M. Computer Systems,  
BIRMINGHAM, 360 6264

Business & Leisure Microcomputers,  
KENILWORTH, 512127  
Caddis Computer Systems Ltd,  
HINCKLEY, 613544  
Allen Computers, GRIMSBY, 40568  
CPS (Data Systems) Ltd,  
BIRMINGHAM, 707 3866  
Camden Electronics,  
BIRMINGHAM, 773 8240  
Cliffstock (Computer Systems) Ltd,  
WOLVERHAMPTON, 24221

### YORKSHIRE & NTH. HUMBERSIDE

Microprocessor Services,  
HULL, 0482 23146  
Microware Computers, HULL, 562107  
Computer Workshop, LEEDS, 788466  
Hallam Computer Systems Ltd,  
SHEFFIELD, 663125  
Ackroyd Typewriters Ltd,  
BRADFORD, 31835  
Datron Micro Centre,  
SHEFFIELD, 585490  
Yorkshire Electronics Service Ltd,  
MORLEY, 522181  
Sheffield Computer Centre,  
SHEFFIELD, 53519

### NORTH EAST

Dyson Instruments, DURHAM, 669937  
Currie & Maughan,  
GATESHEAD, 774540  
Wards Office Supplies,  
GATESHEAD, 605915

Triport Associated Systems,  
SUNDERLAND, 73310  
Newcastle Computer Services,  
NEWCASTLE UPON TYNE,  
(0632) 615325

### SOUTH WALES & WEST COUNTRY

Computer and Design,  
BROADSTONE, 0202 697341  
A. C. Systems, EXETER, 71718  
Computer Supplies (Swansea),  
SWANSEA, 290047  
Sigma Systems Ltd, CARDIFF, 21515  
Devon Computers, PAIGNTON, 526303  
Bristol Computer Centre,  
BRISTOL, 23430  
J. A. D. Integrated Services,  
PLYMOUTH, 62616  
Sumlock Tabdown Ltd, BRISTOL, 26685  
Radan Computational Ltd,  
BATH, 318483  
T. & V. Johnson Ltd, BRISTOL, 422061

### NORTH WEST & NORTH WALES

B. & B. Computers Ltd, BOLTON, 26644  
Megapalm Ltd, CARNFORTH, 3801  
Tharstern Ltd, BURNLEY, 38481  
Fyde Business Machines Ltd,  
PRESTON, 731901  
Preston Computer Centre,  
PRESTON, 57684  
RPL Microsystems, DOUGLAS, 4247/8

### LIVERPOOL

Microdigital, LIVERPOOL, 227 2535  
Rockliff Brothers Ltd,  
LIVERPOOL, 5215830

### MANCHESTER

Cytek (UK) Ltd,  
MANCHESTER, 832 7604  
Executive Reprographic Ltd,  
MANCHESTER, 228 1637  
Sumlock Manchester Ltd,  
DEANS GATE, (0618) 834 4233  
Computer Workshop,  
MANCHESTER, 832 2269  
Professional Computer Services Ltd,  
OLDHAM, 061-624 4065  
D. Kipping Ltd, SALFORD, 834 6367  
Catlands Computers Ltd, 0625 527166

### SCOTLAND

Microcentre, EDINBURGH, 225 2022  
Thistle Computers, KIRK WALL, 3140  
McAllister Business Equipment,  
EDINBURGH, 336 2402

### IRELAND

Softch Ltd, DUBLIN, 784739  
Medical and Scientific,  
LISBURN, 77533

\*This is a list of dealers participating in associated advertising and not a full list.

# Commodore

We made small computers big business.

Commodore Information Centre, 360 Euston Road, NW1 3BL. 01-388 5702

# A challenge to build— and a delight to use

**Vincent Tseng tests the latest Nascom single-board machine, passes on the soldering, loves the screen editor but worries a little about its tolerance for cheap cassette recorders.**

FOLLOWING the resounding success of the Nascom 1, the long-awaited successor has finally arrived. Not surprisingly, it is called the Nascom 2. In my review of the Nascom 1, I was very impressed by the facilities offered for the time. I think that the Nascom 1 probably set the trend toward the single-board computers providing fuller facilities for the user, such as full alphanumeric keyboards and screen displays using domestic TVs. Such success and reputation must be very difficult to follow. Does the Nascom 2 live up to the expectations and to its "pedigree"?

## Facilities

Briefly, the Nascom 2 follows the trend set by its own predecessor the Nascom 1, by having a 57-key solid-state keyboard in the normal typewriter layout, but with some extra keys for cursor control (more about that later). Display output is to a domestic TV — displaying 16 lines of 48 characters.

The CPU is the Z-80A with the clock rate selectable on board of 2 or 4 MHz. The Nascom 2, in common with other single-board computers of more recent design, has a very large amount of memory on board, 10Kbytes of ROM, of which 2K is the NAS-SYS 1 monitor and an 8Kbyte ROM (which is 64K bits) containing a BASIC interpreter.

A total of 10Kbytes of RAM is possible on board, of which 1K is used for the screen memory, and another minimum of 1K RAM is necessary to provide some user workspace, as well as for the system/monitor scratchpad area and the stack (these system areas require 192 bytes).

There is an audio cassette interface which is claimed to be Kansas City standard and can be selected to run at 300 or 1200 baud. This serial interface can be converted to a standard Teletype (TTY) interface. An RS232C serial I/O is also provided. Lastly 16 lines of programmable parallel I/O is available via a Z80 PIO.

## Construction

Like the Nascom 1, the 2 is also offered as a kit; fortunately for us, the review sample was ready-built. As mentioned in its review, the Nascom 1 was not an easy kit to build; nor is the 2. The Nascom 2 has some 281 components on the same-sized board as the 1, ie about the size of this page. This amounts to well over a

thousand soldering points.

Surprisingly, the 2 looks much neater in layout, although packing of components is still very tight. It is not a kit for the beginner, but as with the Nascom 1, it is certainly possible with careful and patient working. Nascom Microcomputers Ltd now offer the option of a ready-built Nascom 1.

Setting up was relatively easy. The power supply requirement is +5V at 2A, +12V at 250mA, -5V at 250mA and -12V at 25mA, not very convenient, but

the Nascom 3A power supply kit was easy to build, good value for money, and would save a good deal of trouble.

Solder links needed to be made for installation of the 4118 1Kbyte RAMs. The links were needed because these RAMs are designed to be interchangeable with the popular 2708 EPROMs. Nascom have designed this capability in, so that the board can have 8K of user-programmed EPROM.

After checking the two banks of selector switches to ensure that the

With over 1000 solder joints, the Nascom 2 is a challenge to constructors.



Nascom 2 was set up in the correct modes, the power supply was switched on and surprise, surprise, everything came to life. There is a power-on reset, and on board it is possible to switch select the reset start address to any 1000 Hex boundary. This is very useful, especially since the 4118 RAMs can be replaced by user-programmed EPROMs.

Also, instead of the computer booting up and jumping into the monitor at 0000 H, it can jump into BASIC at E000 H on power-on. The TV displayed the message "NAS-SYS 1" in the top left-hand corner of the screen, since I had opted for the restart to the monitor.

One of the first things noticed was the nice feel of the keyboard. On closer examination, I realised why: the rows of keys, instead of being at the same level, are stepped as on a conventional typewriter, so that the slight incline usually required is already built-in. This is a minor point, but nevertheless a nice touch.

The display to the TV, although the

characters were clear and sharp and the background reasonably free from interference, tended to "swim" a bit, and did not seem as stable as the Nascom-1 (with modulator). This hinted at a slight deviation from the 50Hz frequency, and might be due to the fact that Nascom have had to compromise to make the Nascom-2 adaptable for 60Hz/525 line TVs.

### Monitor

The NAS-SYS 1 monitor has all the commands that Nasbug T2 had (the monitor reviewed with the Nascom 1) and a few more. That is, it has the basics of examining and modifying memory (M), executing from a specified address (E), single stepping the program (S) for debugging as well as setting of a breakpoint (B), copying of one area of memory to another (C), tabulating a large block of memory (T), and the commands for reading and writing to the audio cassette (R and W) are also there. There are additional commands to directly input

and output via the PIO straight from the monitor, to turn the Nascom 2 into an RS232 terminal — and an intelligent copy command, so that memory is not overwritten before it has been copied.

The keyboard can be set into four different modes (one, for instance, generates the graphics characters) by the "K" command, and there are the expected jump commands for getting into BASIC; both a "cold start" and a "warm start" are provided. A useful command is the user I/O command (U), which allows a user to write an I/O routine which can be called from the monitor (eg to interface to a printer).

However, a couple of criticisms of the Nascom 1 still apply here to the 2: some of the more dangerous commands, such as "E" for execute and "C" for copy are also valid Hex numbers, so it is all too easy to invoke them by accident when you think you are entering a hex value. The other is a command missing for the easy examination and modification of the registers.

The feature which impressed me most was the screen editor incorporated with the monitor. This allowed access to any part of the visible screen (all except the very top line which does not display anything unless it is deliberately written to, for titles etc) via the cursor control keys — up, down, left and right arrows, etc.

The beauty of this is that any part of the visible screen can be edited just by moving the cursor over the character(s) which need changing so one can overwrite or insert, and once "ENTERed" the new character will become effective. This is a real boon when a mistake is made in the command line and the error noticed only after it had been entered.

On other systems there is no option but to type the whole line again correctly, but on the Nascom 2, so long as the command line is still on the screen, one can move the cursor to the offending part and correct it and then using the "Enter" key from the end of that line, the command is re-executed.

This facility is even more useful when using BASIC, because routines or programs in BASIC can be edited using the screen editor, and any part of the routine program can be displayed on the screen by using the LIST command in BASIC. In my opinion this screen editor facility puts the Nascom 2 monitor into a class where only the AIM-65 comes near it.

### BASIC

The BASIC interpreter is held in a single 64Kbit (8Kbytes) Read Only Memory and is a version of the well-known Microsoft (see p106 of this issue) It is quite a useful version of BASIC, with good string functions and double-length PEEK and POKE called DEEK

*continued over*

Set up, the machine is as tidy as could be expected.



# We've put together a total system... so you can take it apart

## IMP Printer

80 cps (max) bidirectional;  
punched or unpunched paper;  
tractor or pressure feed; 7x7 dot  
matrix; 110-9600 baud rates. £325  
built and tested.



## System 80 housing

High strength GRP moulding in variety of colours.  
Accepts 12x8 Nascom 2 CPU board, four 8x8  
expansion boards. £85 incl. frame racking,  
interconnects and motherboard.

## Expansion boards\*

16K RAM £127.50 • 32K RAM £185.00  
48K RAM £245.00

High Resolution Programmable Graphics £90 (kit).  
High Resolution Colour board £140 (kit).

\*Available in kit form.  
All prices subject to VAT.



## Floppy disc system

Double sided, double density 5 $\frac{1}{4}$  in disc giving  
280K bytes formatted, including controller  
board/PSU/Housing and interconnects £480.  
Controller board £127.50 • Second Disc £240.  
CP/M £80



## Microprocessor board\* (Nascom 2)

4MHz Z80 CPU; TV or Video + 1200 baud  
Kansas City + Serial RS 232 printer  
Interfaces; Keyboard; 128 character ASCII  
plus 128 Graphics in 2 x 2K ROM; free  
16-way parallel port; 8K BASIC; NAS SYS  
operating monitor. £280 built and tested.

## Firmware & MOS ICs

Zeap Assembler (4, 1Kx8 EPROMS) £50  
Nas Pen text editor (2, 1Kx8 EPROMS) £30  
NAS-DA disassembler (3, 1Kx8 EPROMS)  
£37.50 • 2708 £9.50 • 2716 £26  
MK 4118N4 £12.75 • MK 4116N4 £55 for 8

System 80 is Nascom's total microcomputer system. It incorporates many of the existing and widely acknowledged products. And many totally new products.

But, above all, System 80 is the culmination of 3 years of microcomputer board design. Our concept was to take microcomputers to their obvious conclusion – total option concept. We have resisted offering an inflexible, boxed system. The housing is irrelevant – it's what's inside that counts. However, we still think our new housing is quite attractive.

It can accept up to five boards, including the CPU board, plugging into an integral frame and NASBUS motherboard. It can be supplied with either 3A or 5A PSU depending on your choice of boards. Provision is made for external connection direct to the boards concerned. The housing is designed to have a further expansion box, plus 5 more boards, stacked on top and plugged into the main motherboard.

Not only do we give you the opportunity to take our system apart so you can choose only the cards you want. We've gone still further. You can also choose your own firmware for the Nascom 2 CPU board.

It has 24-pin sockets – all with link option – to give you a choice between 2708, 2716, TMS 2716, 2508,

2516, 2532, 2758 and 2732 EPROMs. Using 2716 EPROMs alone gives you over 16K of firmware. Firmware in EPROM is available from Nascom now and soon we shall have ROM packages as well.

## System 80 – Total Option Concept

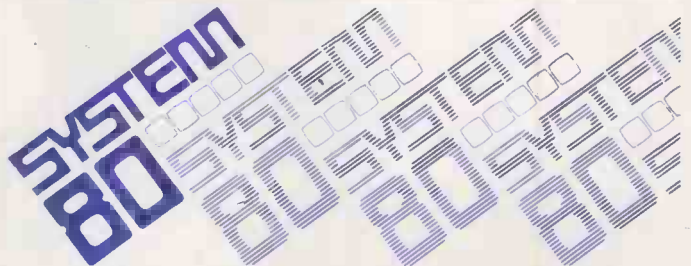

For further details and stockists please contact:  
Nascom Microcomputers Limited, 92 Broad Street,  
Chesham, Bucks. Telephone: (02405) 75155



Nascom Microcomputers



Stepped keyboard gives a good 'feel'.

and DOKE. The interface to machine code routines is via the USR function, and exit from BASIC is MONITOR instead of the usual BYE.

However, there are no debugging, tracing or single-stepping commands available — one has to rely on the use of the STOP command or the ESCape key for investigating a program. There is no EDIT command and the editing facilities in BASIC are very basic! But the screen editor provided by Nas-sys, which works with BASIC, more than compensates for this lack.

Nascom Microcomputers claim very

fast timings for the Nascom 2 for running of the now standard benchmark tests. The timings I obtained were slower, but nevertheless still pretty good, about the same as the Research Machines 380Z, 8K Zapple, and faster than the PET 2001, the Ohio Superboard II and the Apple Extended BASIC. The discrepancy in timings could be because although our test sample's Z-80A was running at full 4 MHz, a wait state was required so that the other slower components on the board could work with it, whereas Nascom's timings may have used full 4 MHz rated components, with no wait states.

## Summary specifications

CPU:	Z-80A.
CLOCK RATE:	Switch-selectable to 2 or 4 MHz (note: majority of components on board need one wait state to work at 4 MHz).
MEMORY:	10Kbytes of ROM — 2K for NAS-SYS-1 8K BASIC; 10Kbytes of 4118 RAM (1K used for video).
KEYBOARD:	57-key solid state full alphanumeric QWERTY layout with cursor control keys — under NAS-SYS-1 software-selectable roll-over.
DISPLAY:	To domestic TV at 50 Hz 625 lines (adaptable to 60 Hz/525 lines) displaying 16 lines of 48 characters. 256 characters including full upper and lower case alphanumerics and 128 graphics characters.
I/O:	Serial I/O to audio cassette (Kansas City at 300 or 1200 baud) or Teletype. Also RS232C parallel I/O by Z80 PIO.

## Graphics

A character generator ROM is provided to enable the Nascom 2 to have 128 graphics characters. This is in addition to the 128-character full upper- and lower-case alphanumerics character generator ROM. Graphics can be displayed by three different modes — directly from the keyboard (useful for trying out effects without programming), by machine-code using the monitor, or by BASIC using the POKE, DOKE commands.

## Cassette

There is an audio cassette interface for the Nascom 2, said to be Kansas City standard and switch-selectable for either 300 or 1200 baud. This proved to be the only real disappointment in the test. With the cheap cassette recorder I had (which I managed to get working well with the AIM-65 at 1200 baud, another known awkward interface), I could only just get it working at the 300 baud rate where the eventual error rate was on average 1 bit per 1K bytes.

To get over this, I still needed to have a 10 ohm resistor from the cassette playback point to ground, and this is, despite using the full range of adjustments

available on the VR1 potentiometer as given in the manual. The 1200 baud rate could only manage to display just about every line corrupted, no matter what impedance matching resistors I tried.

This is a pity, especially since the Kansas City standard interface on the Ohio Superboard II (reviewed in *PC* June, 1979) showed that a very wide tolerance for even very cheap cassette recorders can be achieved. Although there is no file management under the monitor (there is CSAVE and CLOAD in BASIC by file name) NAS-SYS 1 allows the generation of a self-loading tape, ie one which after loading will automatically self-execute.

## Documentation

Much better, is the word. The documentation comes in a ring binder (useful for updates as well as for users' own notes). The section on the NAS-SYS 1 monitor is concise and informative, very good for quick reference. There is also a large part devoted to examples using the monitor and demonstrating the use of Z-80 machine code. This is excellent — Nascom must take reviews to heart!

The hardware section is also good; like the monitor section, it shows some insight to the thought which has gone into the design of the Nascom 2. The construction notes part is only adequate though, and rather brief. I suggest the authors take a look at the construction notes for the Intel SDK-85 and 86 kits.

Lastly, the section on BASIC looks like the standard documentation for Microsoft BASIC, adequate but not outstanding, but in the appendix there are listings of a few useful routines, which can also serve as examples.

## Conclusions

- I was very impressed by the Nascom 2, especially because of the facilities given by the screen editor. This could well make the 2 into another trend-setter like the Nascom 1.
- It is still a challenge to build.
- The Kansas City interface for the cassette seems not to have very good tolerance for cheap cassette recorders.
- It is priced as a kit at just under £300 without VAT. In terms of hardware alone it is comparable to the Ohio Superboard II (only £190 for 4K version now), the Compukit UK101, and the AIM-65 (£249 for 4K version and BASIC is about another £70).
- Stand-out features include the excellent screen editor and the ability to interchange on-board RAM for ROM or EPROM.
- Currently there are some dealers still offering a 16Kbyte RAM board in place of supplying the 8 × 4118 RAMs, which could affect your value-for-money rating.
- The Nascom 2, like the Nascom 1 offers the right facilities, and it has made genuine progress. □

# Easy-to-fix Superbrain looks like good value for money

D. B. Watt examines a new integral machine from a newcomer to this country, Intertec Data Systems and finds it a comprehensive and flexible package.

THE SUPERBRAIN is a completely self-contained system based on twin Z80A microprocessors, with either 32 or 64K bytes of dynamic RAM memory. It is made by Intertec Data Systems of Columbia, South Carolina, a relative newcomer to the personal and small business computer market, which also makes a low-cost VDU called the Intertube.

The Superbrain was first announced at the New York Computer Show last year, but the first models did not start arriving in this country until last December. The system is supplied by several dealers, including GW Computers and Encotel of Croydon.

The machine features an integral keyboard, 12in CRT display, and twin double-density single-sided mini diskette drives. Each diskette may hold up to 125K bytes of memory. The system uses the industry standard CP/M operating system developed by Microsoft, and BASIC, FORTRAN, COBOL and PASCAL are

The unit is surprisingly light, considering its size — 22in wide, 23in deep and 15in high — mainly due to the moulded brown plastics case, which nevertheless looks robust. Inside the components are very neatly assembled: the CRT and disk drives are contained in rigid aluminium chassis.

## Processors

The two processors operate at 4MHz, and have an 8-bit word length. The host processor performs all the main processing and also looks after the screen handling. The other processor performs all the disk-related functions.

The host processor can communicate directly with the disk controller memory but because all 64K of memory is addressable, the 16K banks 0 and 2 are switched off as required, bank 0 when communicating with disk ROM, and bank 2 when communicating with the RAM data buffer.

A 32K system can be easily upgraded to a 64K system by plugging in 16 2K chips, but since the 32K system (£1900) is only £50 cheaper than the 64K system, it is hardly worth opting for the smaller system anyway.

## Keyboard

The keyboard has the standard

QWERTY layout, with a 14-key numeric pad on the right. Alongside the numeric pad are four cursor control keys: left, right, up and down. When running under CP/M, the *delete* key deletes the previous character and re-displays it on the screen; *backspace* displays control — on the screen.

In BASIC, *backspace* moves the cursor back, clearing the deleted character from the screen and *delete* displays deleted characters between backslashes. I fail to see why both these keys should not backspace the cursor, clearing deleted characters from the screen. This is a much neater method and easier to read. Nor is there any form character repeat function, which can be accomplished with a repeat key; alternatively, extra characters could be generated by holding down a key. This is useful, particularly in word processing, for underlining or spacing.

## Restart

At the bottom and to either side of the main keyboard are two RESTART keys, normally red, although one was white on our evaluation system. When pressed simultaneously, the RESTART keys cause a ROM bootstrap loader to load the system off the disk in drive A, the left hand drive. This also happens when the system is switched on.

If there is no disk in drive A, which should be the case when the system is switched on or your diskette may be corrupted, a message is displayed on the screen. This makes the system very simple to start up.

There is another keyboard layout available with a single RESTART key in place of one of the cursor control keys, which is not so sensible since it makes an accidental RESTART possible.

## Screen

The 12in CRT is standard and displays 24 lines of 80 characters. Upper- and lower-case letters are displayed and the screen also features programmable cursor control, cursor home, screen clear, clear to end of line and end of screen. Half-intensity display and inverse video are not available.

The lower case descenders of letters like y's and p's are displayed on the same level as other letters. This can make lower case text confusing to read at first, although one soon gets used to it. Some systems

with small screen have used shorter lines and fewer lines to the screen, but I personally prefer the fuller display.

I found the display quite readable in spite of a certain cramped appearance to the text. The display would be better with a larger screen, but it is difficult to see how Intertec could fit a larger screen in the available space.

The screen brightness control is rather poorly positioned at the rear, along with the power switch and main and ancillary serial interface ports. In order to adjust the brightness, I had to stand at the side to reach the control and look at the screen at the same time.

The well-known and reliable Shugart SA400 mini-floppy diskette drives are used for ancillary storage. They are fine for many people buying their first system, but I do think that larger disks, or the ability to add more disks, should be made available as soon as possible. Smaller disks not only limit the amount of data the system can access at one time, but also tend to slow data transfer rates, which affects the speed of programs.

Obviously Intertec are aware of these problems, as they are soon to make double-sided disks available. These will provide 255 Kbytes per diskette, compared to the SA400's 125K. Intertec are also developing an S100 expansion bus which will allow an S100 card to be interfaced to the Superbrain.

## Peripherals

The expansion bus will cost £250 and should be available this month. It will permit any of the S100-compatible standard floppy diskettes, cartridge disks or the new Winchester drives to be used with the system. There are two slots at the rear of the Superbrain through which ribbon cables can be taken to peripherals.

The Superbrain has at present two asynchronous RS23C serial interfaces. The main interfaces may be used to communicate with another computer, according to the user manual. The auxiliary interface may be used to drive a printer. Both interfaces are fully programmable and may run at any one of the baud rates from 50 to 9600. They are originally set up to run at 1200 baud. To change the baud rate, parity or number of stop bits it is only necessary to run the CONFIGUR program.

Intertec are also developing a





The unit is quite large and robust yet still light in weight.

Centronics-compatible parallel interface to connect directly to the Z80 bus and drive Centronics-compatible printers. A synchronous RS232 interface should be available shortly. The parallel interface should also be available in March with the S100 bus adaptor.

### Software

The software supplied with the system consists of the CP/M operating system, a context editor, assembler and debugger, and utilities to load and dump files, format disks, generate a system disk and copy and display the contents of files.

All of this is in Microsoft software, as are the BASIC-80, FORTRAN and COBOL languages which are available as options, ranging in price from £150 for BASIC to £320 for COBOL. CP/M has become the industry standard operating system and is very reliable.

BASIC-80 is a powerful version similar in many respects to BASIC-PLUS developed by DEC to run on the PDP-II series. Some of the features included are: up to 40-character variable names, string variables of up to 255 characters, integer and single- and double-precision floating point variables.

Up to 15 sequential and random files may be open at any one time, and there are powerful facilities for editing and renumbering lines. Program lines may contain multiple statements and may be continued over several physical lines by the use of the line-feed key, rather than by carriage return.

BASIC-80 uses a rather complicated method for reading data from, or writing to, disc records. As in TEI BASIC described in the review in the January issue of this magazine, FIELD statements are used to define the contents of the file buffers, LSET and RSET are used to move data to and from the buffers, and CVI, MVI, CVD, MVD etc, are used to convert data from one data type to another.

FORTRAN-80 conforms to ANSI standard X3.9-1966. The compiler

generates relocatable code so that only the sub-routines and system routines that are necessary are loaded when running a program. Random and sequential file handling are supported.

Microsoft's COBOL supports relative, indexed and sequential file handling. It is based on the 1974 ANSI standard. The compiler is written in pseudo-code, which is then interpreted. This saves space in memory but results in a slight overhead in execution time. Program object code is also generated in this pseudo-code.

According to the manual, the compiler plus interpreter requires about 25 Kbytes of memory and a typical 500-line program uses 12K. This, together with 7K required for CP/M, requires only 466 Kbytes, hence quite large programs can be written on the Superbrain.

There should be no problems either developing one's own applications or getting packages to run on the system. Some of the programs already available include a sort/merge utility called Supersort, a mailing list system Mailer and Wordstar, an excellent word-processing system which I had the opportunity to examine.

Wordstar is a menu-driven system which performs text editing and formatting on the screen. Editing facilities include global search and replace, blank move, copy and delete, and text merging from another file.

Unfortunately the cursor control keys do not have the expected effect when using Wordstar because the left, right, up and down codes produced by these keys are the same as the ASCII codes control H, control F, control K, and control J.

Wordstar interprets the control codes differently and in fact uses the diamond format by the E,S,D and X on a standard keyboard, in conjunction with the control key to control cursor movement.

### Documentation

The Superbrain documentation is excellent. All the necessary information is

included in one rather bulky manual. The first few sections list the system specifications, describe the basic modules of the Superbrain, introduces the system and explains how to start using it, and describes the CP/M features and facilities. The following chapters explain how to operate the CP/M editor, assembler and debugger. Finally the user manuals for BASIC-80, FORTRANS and COBOL are included.

Servicing the Superbrain appears straightforward, as the system is designed in file units which are very easy to dismantle. Section 2 of the User's Manual describes the file modules, which consist of the keyboard and CPU, CRT module, main power supply, disk-drive power supply, and the disk drives themselves.

GW Computers, who supplied our system for evaluation, provided a 90-day warranty to replace any defective model with a new one.

Outside the warranty period, another system will be supplied on loan while the defective system is returned to them. Parts and labour will be charged when the system is repaired. Alternatively, the customer may repair his own system: it really does seem simple to remove and replace any of the modules.

### Conclusions

- The Superbrain is very reasonably priced for a 64K system and is well designed and neatly packaged in a robust and attractive case. This should make it excellent for small business and educational applications.
- It uses a very well known operating system with Microsoft BASIC-80, which means that the software is reliable and there are a lot of application packages available.
- At present the major drawbacks to the system is the size of the disks. Double-sided disks will be a major improvement at 250 Kbytes per diskette, if and when they become available.
- Alternatively, one can extend the Z80 or S100 bus out to external disk drives. It is only possible to add one S100 card within the system, although it may be possible to take a ribbon cable out through the case to an S100 motherboard carrying extra cards.
- It will not be possible to perform DMA accessing of external peripherals, as the amount of main memory supplied is the maximum that can be addressed by the processor.
- It should also be possible to add two more SA400 or SA800 drives just by extending the cables to the present drives, outside the case. CP/M certainly has the capabilities for handling two extra drives.
- The small size of the CRT does make the text appear cramped. This was particularly noticeable when using the word processing system. [2]

# NEWCASTLE UPON TYNE'S OWN MICROCOMPUTER SYSTEMS HOUSE

MULLER (ANGLO AMERICAN COMPUTERS) LTD\*

- **CONSULTING: Microcomputer Systems Analysis & Feasibility Studies**

NATIONWIDE MAPCON Registered Consultancy: See Below  
£2000 FREE CONSULTING! Why do Without the Facts?

- **SYSTEMS DEVELOPMENT: Integrated Hardware & Software Systems**

TURNKEY Sytems: Fully Customised Programming  
Professional Design, Development, & Maintainance  
Start-to-Finish Systems Integration  
Low-Cost Standard Business Software  
Specialists in Low-Cost Computerisations  
Give us the TOUGH Jobs: That Increase Business & Profits  
Automated Estimation & Tendering  
Process Control & Production Management  
Distributed Processing (Multiprocessing)  
Management Information  
Retail Point-of-Sale & Inventory System

- **EXPERIENCED DEALER: Industry Standard Hardware & Operating Systems**

Featuring the SDS-200 Maximum Capacity Business System  
As Advertised in This and Previous Issues of PC  
By AIRAMCO the UK Distributor

## £2000 FREE CONSULTING

- **VIA Non-Returnable 100% Government Grant for First £2000**  
(This is Enough in 95% of all Cases)

- **AVAILABLE TO Qualified Industries & Manufacturers Small or Large**

- **Most Firms are Fully Served by Flexible Microcomputer Systems**

Why Settle for Expensive Limited-Function Accounting Machines  
(For £8,000 - £12,000)?  
Why Pay for a Minicomputer-Mainframe at £15 - 50,000 ?

- **TODAY'S Technology at a Fraction of the Cost:**

Typically Only £5,000 - £15,000!

- **THE Government Department of Industry Wants You to Have the Facts**

By Way of a MAPCON Registered Consultant  
Non-Believers are Invited to Ring for the Attention of Mr. Nish  
MAPCON Dept. of Industry at Stevenage (0438) 3388

- **AVAILABLE from the NATIONWIDE MAPCON Consultancy Above**

\*E Floor, Milburn House, Dean Street Newcastle upon Tyne (0632) 29593

# Commodore database is tailored for business

Mike McDonald assesses Commodore's first thrust into the business software market

AS WE'VE pointed out before, the emphasis in home and small business computing is moving towards software and away from hardware. But performance lags behind intention. The opinions amply confirmed by my attempt to review some recent software packages: of four software programs running on three different machines, two crashed within minutes of being run up and had to be abandoned.

The package under scrutiny here is the Commodore Business Information System (CBIS), a file handling/record handling system that can have a very wide application for information retrieval.

This sort of package is identified in the Buyer's Guide as a DBMS (Data Base Management System) although in this case it is not strictly true. CBIS is intended for record selection and retrieval and is designed to provide management with general information according to a specified number of selection parameters.

CBIS was, until recently, one of three offerings from Commodore heralding their entry into the commercial software world. They have recently launched more products to increase their repertoire. Commodore have decided on a marketing strategy for their commercial offerings which requires dealers to have a proven capability in both software and hardware support.

These "Business Software Dealers" are chosen by Commodore from their existing list of dealers and once they meet the necessary qualifications, they may offer a complete "packaging" service to the business user, comprising software/hardware installation, support and maintenance and, if required, tailoring of the packages to meet the user's requirements.

## No dirty hands

None of this is included in the price of the software, so the customer will be charged according to the dealer's rate. However, Commodore recommend that first-time users use this service to ensure a trouble-free system, which makes sense for those who are not keen on getting their hands dirty.

The number of Business Software Dealers is now nearly 100, so potential users should not have any difficulty in finding a reasonably local supplier.

Commodore's range of software includes stock control, word processing,



CBIS is a file/record handling system with a wide range of applications.

payroll and CBIS, and financial packages follow soon. These packages are sourced both internally and commissioned from outside software houses under Commodore's guidance. Support is on a strictly local basis through local dealers, but records are also held at Commodore's base in Slough of all users eligible for updates etc.

All packages have been run commercially before release and are therefore free from logical errors, claim Commodore. Experience with grandiose software on larger machines leads one to the conclusion that most bugs may not have reared their ugly heads until several years of intensive use have passed. But the machines under discussion are smaller and Commodore seem to have the right sort of set-up if the user should get into trouble.

CBIS is supplied in the form of a neatly packaged looseleaf binder containing an operator's manual and celluloid page holding the software diskette and security ROM. The manual contains a few pages of preamble on disk handling and care, copyright and so forth including a page on how to insert the security ROM in the correct slot on the main circuit board.

The instructions are clear but there is no mention of the orientation slot on the Integrated Circuit and its relation to the socket. The neighbouring 'chips' were illustrated with their slots, but this might

not spring to the eye of a beginner. One would expect the dealer to put the ROM chip in, but even so, the manual ought to be foolproof. Suggested applications for CBIS include: personnel information, magazine subscription reminders, salesman prospect reminders, name and address files, telephone directories and investment portfolio diaries, although it certainly has many more uses where quick access to a large number of records with selection options is needed.

The minimum configuration for running this package is: Commodore 3001/3032 computer; 2040/3040 floppy disk system; 2022/2023/3022 printer (other types are permissible); IEEE connectors and supplies such as stationery.

This records management system essentially allows the user to predefine up to 10 fields for storing up to 24 characters of information in each field. The ten fields make up a single record, of which 650 may be stored on a single floppy disk. Up to 10 disks may be used to hold the records as either a single file or 10 individual files. Each field is named when setting up a file, ie name, address, phone etc and will be referred to and displayed as such whenever the file is accessed. The fields are actually defined in the program as sub-records or SR's.

For testing purposes, we mounted in-

*continued on next page*

# comart

## ...the specialists

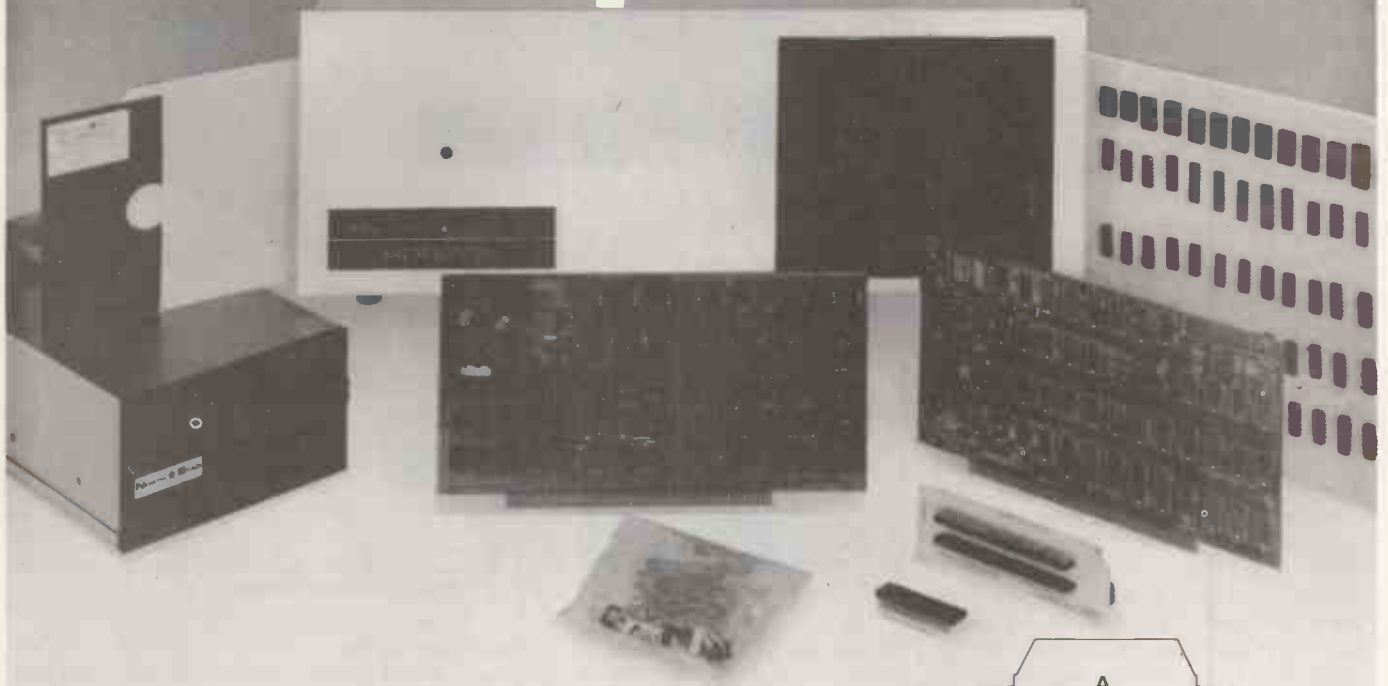

The complete range of North Star computer products in both kit and assembled form is offered by Comart: The Horizon computer, the Microdisk System, memory and floating point arithmetic board. And, Comart being S100 specialists, other items from our computer catalogue may be easily added to meet your requirements.

Teaching, Research, Engineering and Commerce .... each field has applications where this state-of-the-art technology provides cost effective processing of immediate benefit.

Comart quality. Each assembled module is final-tested by our own engineers. Take delivery of a computer system – plug in a wide variety of peripherals and use it.

Attractive prices, good delivery and a choice of Comart's factory repair or on-site service with a Computer Field Maintenance contract make the acquisition of a Comart computer a safe decision.

Find out more – ask us for the Comart catalogue of Computers.

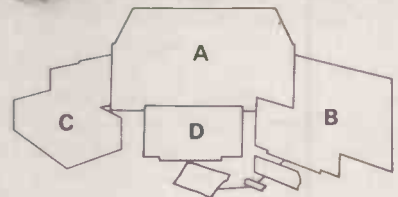

The North Star dual drive double-density Horizon computer A together with a typical kit product B, the Microdisk system drive C and hardware floating point board D.

### Contact us direct or call your nearest Comart dealer

CAMBRIDGE  
CAMBERLEY  
ILFORD

LEEDS

LONDON  
LUTON  
MANCHESTER

NEWBURY

NEWPORT  
NOTTINGHAM

SHEFFIELD  
SOUTHAMPTON

CAMBRIDGE COMPUTER STORE, Cambridge (0223) 68155  
MICROBITS, Camberley Surrey (0276) 34044  
THE BYTE SHOP, Ilford Essex 01-554 2177  
also at Tottenham Court Road London 01-636 0647  
HOLDENE LIMITED, Leeds (0532) 459459  
also at Wilmslow, Cheshire (0625) 529486  
DIGITUS LIMITED, London W11 01-636 0105  
ISHERWOODS, Luton, Bedfordshire (0582) 424851  
MICROCOMPUTERMART, Manchester (061-832) 2269  
also at West Park, Leeds (0532) 788466  
NEWBEAR COMPUTING STORE, Newbury Berks (0635) 30505  
also at Stockport, Cheshire (061-491) 2290  
MICROMEDIA SYSTEMS, Newport, Gwent (0633) 50528  
COMPUTERLAND LIMITED, Nottingham (0602) 40576  
also at Birmingham (021-622) 7149  
Manchester 061-236 4737  
Glasgow (041-332) 2468  
HALLAM COMPUTER SYSTEMS, Sheffield (0742) 663125  
TITAN SYSTEMS LIMITED, Southampton (0703) 38740



## comart specialists in microcomputers

Comart Ltd., P.O. Box 2, St. Neots, Huntingdon, Cambs, PE19 2AF. Tel: (0480) 215005 Telex: 32514

• Circle No. 179

from previous page

formation on the Software Buyer's guide. To begin with, new diskettes had to be initialised or 'newed' prior to use. This was facilitated by a utility program called CMAINT supplied with the software.

CMAINT enables users to access the basic disk operating system functions (DOS) necessary for running the package and includes New, Initialise, Verify, Duplicate, Copy, Rename, and Scratch. There are also other functions specific to Commodore software for creating special master disks and Memory Set routine required before any program can run directly after a power up.

When new disks have been created, the CBIS program can be run. The manual was not particularly clear regarding the disk mounts required. CBIS holds the records on the data disk, which is always mounted in drive 1 and maintains an index to the data disks on a master disk on drive 0. The master disk holds an index for all 10 disks if this many are used.

There is no reference to creating a master disk in the file set-up section and if the program disk is left mounted in drive 0, it causes an error due to write-protection. If the wrong disks are mounted incorrectly, the program does stop as it requests the user to enter the data disk ID and then checks for its existence in drive 1. Once the program had satisfied itself on this point it did not seem to mind any old disk being mounted in drive 0. Disk ID's are in the range of 10 up to 19; typographical errors sometimes referred to these as 10 or 12.

## Menu of facilities

When the program is successfully entered with the correct disks, the field naming routine is initiated — assuming a new disk — if old, the program goes straight to a menu. The ten fields are named, each field descriptor having a maximum length of 12 characters, and the program proceeds to display a menu of facilities which are:

- Naming of fields
- Generate random index
- Input records
- Scan key records
- Modify records
- Query
- Display records
- Extract & print selected records
- Recover or delete records
- Free records
- Update master and exit

Each routine is accessed by pressing the appropriate first letter (in italics).

Data input was the first task. The system responds with a request for a record number. This number must be any figure between 1 and 650 and must not already have any information allocated to it, otherwise it is rejected. Unfortunately there was no facility for going directly to the first available free record, so this could become a tiresome guessing game.

There is a free records routine which prints all of the free record numbers on file but this gets tedious when, as in our case, we had only entered some 75 records.

However, on entering a valid free record number, the display sets itself up for data entry, giving a card column indicator across the top of the screen to show the 24-character limit and prompts the user for each field or sub-record with the field name. When the last field is entered, the system writes the data to the data disk and offers the options of moving on to the next record number, entering your own number or returning to the menu. It would be useful to be able to commit the record to disk or amend it first, but this feature is lacking.

## Modify routine

Mistakes are catered for by the *Modify* routine but the user must recall the record number and sub-record number in which the error was made to take corrective action. The modify routine could be improved if, after the desired record number is entered, it displays the record with the appropriate SR numbers beside each field and then prompts for the SR no. Without this it is rather like shooting in the dark given a poor memory. If the wrong SR is selected, there is no way to abort the modification and therefore the data had to be re-keyed.

The display record function is a straight display of a full record with field names in response to a record number being entered. Having displayed a record, the user has the option of continuing on to the next record or of defaulting to the next non-blank record or, of course, the menu.

The one noticeable thing about this system is that the master index is held in core and knows exactly which records are or are not occupied and therefore response is instantaneous if a record does not exist, and certainly very fast on accessing any of those that do (about 1½ seconds). It is this speed that makes the system ideal for interactive lookup of records if using the record numbers (see example of display output).

An index is always held on a specific field in the set of records. The default, in display mode, is the record number. For the purposes of scanning the file for other fields, say names or ages or prices, the Generate Random Index facility builds the index on whichever sub-record the user wishes (about 90 secs).

Having created the index, the Scan Key Records may be used to display any records on which a match occurs against an entered string. The string (or text) is keyed at the start of the routine and a search initiated for occurrences on the index. A match occurs and the record is displayed. The user may then carry on searching until the next record is found and displayed or he can return to the menu. Like the entry of record numbers, the response time was very quick.

The only drawbacks found were that

- the display failed to insert the hyphen between the field name and the data line, causing a concatenation where the field name occupied 12 characters and made it hard to read (see display example)
- when in the display record mode, once a record is shown, depressing the 'N' will display the next record; anything else restarts the cycle. In the scan mode, 'N' terminates the search whereas anything else continues it.

The string entered must be padded with blanks if less than five characters in length and can be no longer than 10, although it seemed satisfied if it could match the first five characters and ignored the balance of the entry. Despite this, it proved a handy routine for high-speed look-up.

The free records function provides the facility to print all free record numbers on the printer, or will provide a total number of free records figure on the screen. In our case this routine was not particularly useful as the number of free records outstripped those utilised, and, since our records were entered sequentially, there were not gaps in the numbering. This feature would be useful if the file were fuller and deletions had been made.

We would have liked to have been able to display the free record numbers on the screen. One of the miseries of sequential file access is the loss of space when a record is deleted, unless a house-keeping routine is used regularly. The fact that this system uses a fixed record length (considered by some to be a nuisance), combined with an indexing system, means that deleted records can easily be utilised again or even restored, provided they have not been overwritten.

This is a facility provided by the Recover and Delete Records function and should come in quite handy for those applications where the life of the data held is short, ie personnel records for casual labour. The routine simply asks for a record number and whether this is to be deleted or recovered. A minor improvement might be made by displaying the record about to be scratched and asking for confirmation, plus similar action on recovery.

## Management power

The most powerful function of the system is the Extract and Print Record routine, allowing multiple-parameter record searching and selection. This is the answer to the 'who, how many, if and with what' questions that give power to the line manager's elbow and terror to his underlings.

As with the scan facility, Extract will print a record subject to a match of any string, in any position, in any or all of the sub-record fields. The printed information output may be trimmed by the user to any number of contiguous lines

*continued on next page*



13-19 MILFORD STREET, SWINDON  
WILTSHIRE SN1 1DW  
Tel: (0793) 42615 • Telex: 449703

Make more time available  
Enhance your quality of life  
Improve your business

COMPUTER SALES • HARDWARE • SOFTWARE • CONSULTANCY • MEDIA • STATIONERY ETC

COMPUTERISE YOUR BUSINESS NOW!  
EVERYTHING YOU REQUIRE TO START  
COMPLETE — READY TO OPERATE

**£4,500**

including VAT  
COMMODORE PET 2001-32N  
COMPUTHINK 400K  
RANDOM ACCESS DISK DRIVE  
PRINTER  
ALL CONNECTING CABLES  
INCLUDES:  
SALES & PURCHASE LEDGER and  
ALL NECESSARY MEDIA and  
STATIONERY

**SPECIAL THIS MONTH**  
**TEAC DISK DRIVE SA 400 BASED**  
designed for TRS 80  
Single drive up to 125K bytes.....£285 inc VAT  
Dual drive up to 250K (40 tracks) .....£515 inc VAT  
OPENING OFFER includes FREE copy NEWDOS

**PRINTERS**

Anadex, Centronics, Paper Tiger, Teletype 43, Texas 810,  
Interface and cables — Prices on application.  
Anadex DP8000 456.53 525.  
Printer cable 21.74 25.  
Pet printer 3022 608.70 700.  
Printer cable 39.00 45.

**CONSULTANCY**

Please write or telephone if you require advice on  
BEGINNING or EXPANDING your computer installation.  
Software programs customised to your requirements.

**REPRESENTATIVES** required in various areas — please  
contact us for full details.

**OUR BUSINESS EXISTS ON IMPROVING YOUR BUSINESS.**

We are continually adding new products to our range and would be  
pleased to receive your enquiries. • Quantity Discounts available.

	ex. VAT	inc. VAT
<b>TRS 80</b>		
4K Level 2 (c/w K/bd, VDU, T/Rec)	434.78	500.
16K Level 2 (c/w K/bd, VDU, T/Rec)	500.00	575.
0K Interface (to add printer & disk drives)	195.66	225.
16K Upgrade kits (for k/bd or interface)	65.22	75.
Disk Drives, single	413.04	475.
Disk Drives, dual	608.70	700.
Disk Drives, cable 2 & 4 way from	21.74	25.
Anadex Printer, Tractor feed	456.53	525.
Printer cable for Anadex/Centronics	21.74	25.
<b>ITT 2020</b>		
16K (c/w K/bd & Palsoft ROM)	695.65	800.
16K Upgrade kits	65.22	75.
Disk Drive, single with cable	347.83	400.
Printer Interface	108.70	125.
Anadex Printer, Tractor feed	456.53	525.
Colour TV ITT 340 (for monitor)	239.13	275.

**COMMODORE PET**

2001-32N (New keyboard & 32K)	782.61	900.
2040 Dual Disk Drive 343K	673.91	900.
3022 Printer with graphics	608.70	700.

**MEDIA LIST**

5¼" Verbatim	from (Qty 5)	10.43	12.
5¼" Verbatim	from (Qty 10)	17.39	20.
5¼" Dysan	from (Qty 10)	26.09	30.
8½" 3M	from (Qty 10)	30.44	35.
Blank 5¼" & 8½" Diskettes, Soft/Hard Sected, Formatted/Unformatted. We have diskettes to suit many systems. When ordering please quote: SYSTEM MANUFACTURER, MODEL, MEDIA TYPE, AND DISK SIZE. Available in smaller or larger quantities.			

**STATIONERY Listing Paper, Continuous Forms, Labels.**

Listing paper 11" x 8½", 11" x 9½", 11" x 12", 8" x 12", boxed 2000, incl. VAT £10  
Labels 2¼" x 1⅞", white, fanfold, £5 per 1000 ..... 12,000 incl. VAT £40  
Post/Packing/Insurance extra. Delivery by Registered Post, Securicor, etc.  
Price List correct at time of going to Press, subject to change without notice. E. & O. E.  
Standard Warranties apply. All stocks subject to availability.

**Your enquiries assist us in forward purchasing.**

Please send Full Details & Price Lists		My requirements are for		Requirements	Description	inc. VAT
HOME <input type="checkbox"/>	HOBBIES <input type="checkbox"/>	STUDENT <input type="checkbox"/>	BUSINESS <input type="checkbox"/>	Microcomputer:	.....	
Name	.....			Upgrade Kit	.....	
Street	.....			Interface	.....	
Town	.....			Disk Drive	.....	
County	.....			Printer	.....	
Post Code	.....			Cable/Interface:	.....	
Telephone	.....			Cluster System:	.....	
Name of Co	.....			Colour TV	.....	
Position	.....			Media	.....	
PO/Chq No	.....			Stationery	.....	
Mail order: Cheque/Bankers' Draft/Cash/Barclaycard/Access etc. — allow 28 days for delivery.				Stationery	.....	
				Software	.....	
				Post/Pkg/Ins	(please tel. for cost.....)	
						TOTAL: .....

from previous page

given a start and finish position (1-10, 4-7 etc) or it may be optionally routed to one of three print sub-routines.

Only one of the subroutines prints labels. It dumps the first four sub-record lines, assuming these have been defined as a name and three address lines. Program start line numbers are given for the other two sub-routines as well as the field variable array name.

On entering the routine, the user is given the option of selecting the print routine — default is the standard line dump (options 0-3). Having gone for the standard, an option is given to specify the start and finish line numbers to be printed, and the number of carriage returns between lines to define the spacing.

The user is taken through four questions until all of the selection criteria are set. These are

- Sub record number? This specifies on which field the following search criteria are to be applied. The system responds by displaying the field name and asking
- Displacement, Length? This defines the character position at which the search must be started and the number of characters to be tested.
- < = >? This determines the logical match that must be met, ie less than, equal to, greater than. The first and last operators are for numeric fields rather than alpha, or text.
- Data? This is the actual value or string against which the match must be made.

The machine then requests the next record number and providing a zero is not entered, will re-iterate the above questions. This carries on allowing the user to search on all ten fields if required. All search criteria must be met on all sub records for the record to be printed. If a zero is entered at the first SR request, all records are printed.

This proved to be a very useful routine, given that you cannot range check — implement a < and > search on the same field. A possible way around this would be to provide an output file onto another disk and execute a second pass, but this was not currently available.

Another deficiency that would be easy to mend would be the printing of the search parameters on the output report, or at least the display of them on the screen. Presumably, this could be tailored-in by the local dealer. If insufficient characters are entered as the search data value, then the balance is space filled. Excessive data entered results in a null result.

One point we noticed concerned search methods on numeric fields. Where we had originally entered numeric values such as prices or capacities, we omitted to enter a decimal point in the values. When searching fields for a match comprising

< 1000, the input field was four characters in length. The system would examine the first four bytes of the SR and convert any trailing blanks to zero's. Hence 200 would become 2000 and no match made.

Equally, the default for a null string entry when inputting records is a full stop (to prevent falling out of the program when inputting a null string against an input statement). The full stop is numerically interpreted as a 0.0 and therefore matches a "<" test on a whole number.

This is not a criticism but it does lead us to recommend potential users to 'play' with the package before designing a system to be mounted. This applies equally to alpha or alpha-numeric fields. By voluntarily pre-formatting such fields, a much larger amount of useful information can be mounted and successfully searched, thereby overcoming the limitation of a 24-byte fixed-length field, and craftily meeting a requirement that otherwise might not be feasible with such a package.

### Master index file

"Query" is a duplication of the Extract & Print routine, except that records meeting the multiple selection criteria are displayed on the screen instead of being printed. Once a record is displayed, the user may optionally return to the menu by entering an 'E', or space to continue to search.

Finally, there is the Update Master and Exit which updates the master index file on drive 0, adds any new information on to the data file and closes all the files normally. The manual does stress that an exit from the program via any other route could cause the loss of data.

Indeed this was most certainly the case when we updated our file with 25 new entries. We decided to start bending the system before we had written our newly-entered data into the index using the Update facility and thereby placing an 'end of file' marker on it. A loop hole appeared: so we lost our lovingly-entered data by crashing out of the program with a 'CAN'T CONTINUE ERROR'.

We achieved this in the Generate Random Index facility by entering 11 against the sub-record number request used to form the index. This was the only glaring fault in the system and should be modified to range check the value before continuing. If the same reply is given in the Extract routine, to an SR request, it merely takes the units digit and applies it.

We were not very keen on the STOP key being left active, as this would invariably affect a less experienced user unaware of the Continue command.

There were other minor but irritating inconsistencies. We felt that display of user options, when in each routine, should be consistently applied throughout the package instead of in the one or two

routines as at present, ie Press E — to exit/Space — to continue/N — next record etc and that a convention should be adhered to for all facilities. A question mark might usefully replace the full stop as a null entry in the Input mode.

In some cases, the system allowed us to enter more than 24 characters and would truncate down to four or five characters as a result. The scan mode would be better if it displayed the sub-record number on which the random index was currently organised, with possibly a warning that records entered since the last index build are not included.

The manual also has room for improvement. Apart from typing errors, we felt the layout could be better organised and more details given on disk initialisation, loading and labelling, with some — necessary — advice about security copies.

In the Scan section there is no mention of the fact that depression of E will return the user to the menu and terminate the function. It would also be helpful in the print routine section if the field name array variable is given to help in customising reports.

We did like the fact that on searching, the system did display the word P, PAUSE, leaving the user no doubt that it was usefully employing itself in the latest request instead of calculating the square root of —1.

We were also impressed with the overall speed of the record retrieval. On the Extract and Query facilities, wait times were understandably longer — approaching minutes with our 75 records, but this is quite understandable and constitutes a batch job that can easily be scheduled into a convenient slot in the working day.

### Conclusions

- Functionally the program performs efficiently and quickly for record selection and retrieval, and has innumerable applications in any business, large or small.
- It provides a good solution for those wary of a packaged or tailored system of a similar nature, provided they feel capable of pre-determining the necessary design criteria for their data.
- The CBIS program can well be improved by adding a few finishing touches, not only to the program, but also to the documentation to produce a highly recommendable product.
- Access to the print routines allows for tailoring by *qualified* personnel to the user requirement at fairly low cost.
- For the money (£150 plus VAT), CBIS offers an excellent demountable application for the user of Commodore business computers or a dedicated application with a wide sphere of use.
- The fixed-length records and sub-records do require a certain amount of tailoring of the user's data, which must be allowed for. □

# Memories are made of this: a technology and systems review of the state of the art

**M. G. Ayres examines the latest techniques in data storage and makes some informed guesses about the future**

IT TAKES a great deal of time, effort, money and at least a little luck to introduce a new technology to the market. Very few people wish to be pioneers when it comes to backing a new product employing state-of-the-art technology. It comes as no surprise, therefore, that most products introduced in this way are destined to failure, or at best require a long gestation period to achieve market recognition and acceptance.

But if we are not to stand still, somebody has to take the plunge and thankfully a few souls enjoy the hassle — or are forced by circumstances — to take the risk and occasionally make the right decision. It is always a sensitive decision to make, and none more so than where a technological unknown exists.

## Safety first

The difficulty lies on the one hand of becoming a permanent watcher of technology (always waiting for the next generation) and on the other of risking company money (and perhaps career) by acting too hastily.

There is no answer to this problem, which explains why most people err on the side of safety; this seems particularly true in this country, where we are less prepared to accept risk as part of our working lives.

On the following pages I will be looking at the important area of solid state memories at both the technological and systems level and attempt to throw some light on what's being done.

Memory can be broken down into two groups: main and peripheral. Main memory in general uses solid-state devices, which today are best represented by the Mostek 4027, which has become an industry standard for 4K dynamic random-access memories. Its successor is the 16K Mostek 4116, which is pin-compatible. Other manufacturers have their equivalents or alternatives but in general the technology is similar and uses NMOS.

There are basically two versions of the NMOS RAM. They are known as static and dynamic devices and work much as the names imply: the static device stores the data all the time power is applied to it, whereas the dynamic device requires a

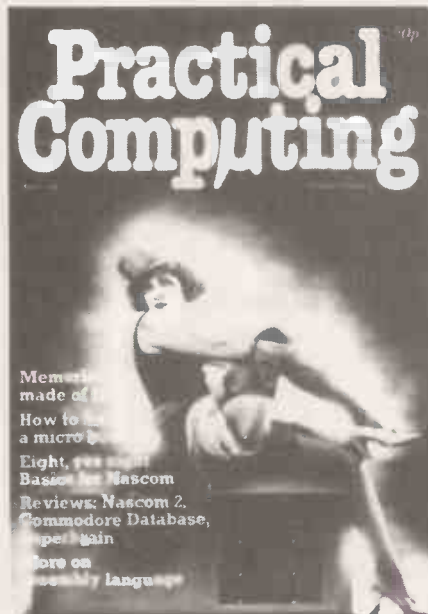

"Somebody has to take the plunge and thankfully a few souls enjoy the hassle..."

refresh cycle to replenish the charge. Considerable arguments flow between the supporters of the various methods and both have survived because there are powerful reasons for the use of both — it just depends on the application being served.

## Horses for courses

Sometimes price is the most important feature: other times it is performance and still others it is reliability. So it will be very much a "horses for courses" issue, with the weighting of the device or memory system design factors determining the selection. Throughout the 1980s the NMOS technology will continue to dominate main memory but within the NMOS technology there will be a lot of activity by the participants, with the Japanese featuring much more.

Peripheral memories are represented by the magnetic storage area of disc and tape in all their variations. Tape is nowadays used for security purposes on mainframes or as a low-cost storage medium, with cassette and cartridge drives on the very small systems. The main peripheral

storage systems used in today's systems are discs and these range from the mini-floppies right up to the 1000-megabyte products.

In the same way as NMOS RAM technology dominates computer main memory, so the magnetic disc dominates the peripheral memory of computer systems. I see no technology posing a threat to the dominance of either and the magnetic disc will continue to enjoy a lion's share of the peripheral storage market. The main threat to the disc will be seen on its flanks, at the very low-capacity and the very high-capacity extremes.

## Memory systems

An area that appears to have a very low editorial profile is the memory systems field. A great deal of time and effort is expended in explaining and predicting the various technologies currently prevailing, but very little is said about the enormous memory capacity that is sold as part of a discrete memory system.

These memory systems range from the modest capacities of say 8K bytes at the semi-professional S100 bus products, to the megabytes sold for use with large IBM mainframes. The markets and hence the products are very different and it would be sensible to treat them separately.

## Mainframes

Practically all the products in this area are being offered for use with IBM computers. There are a number of reasons for this and not least is the market size. IBM dominates the world with mainframe computers and therefore represents an attractive ready-made market for the independents. It also helps that because of the US anti-trust laws, IBM has to be extremely careful in its competitive tactics — it must not abuse its dominant position. It therefore concentrates its efforts on making it difficult for the independents to 'keep up' with a range of technological and commercial changes, designed to be difficult and often expensive to implement.

The IBM market was first attacked by the ferrite core manufacturers, who could offer cost savings of between 30-50% of the equivalent IBM offering and could normally improve performance too.



Currently this market is dominated by the semiconductor manufacturers, with Intel and National Semiconductor amongst the leaders.

## Present memories

Charge-coupled devices, although still widely used for imaging and analogue signal processing, seem to have fallen out of favour in the mainstream digital applications. Although a volatile (non-retentive) memory, the device was seen as a fast serial memory, faster than bubbles but slower than random-access memories. Charge-coupled devices use the standard silicon large-scale-integration technology. This led people to believe that the greater packing density, low power consumption and projected low cost would give them a significant place in the memory hierarchy.

CMOS technology is almost the semiconductor equivalent of the ferrite core and features the most desirable characteristic of requiring only very low power to maintain data indefinitely.

Generally speaking, devices using CMOS are available in 4K capacities and become expensive for large memories, so it is normally used for up to 8K bytes of storage.

NMOS is the main technology used for central computer memory. It comes in all shapes and sizes and has become the dominant technology after PMOS was used in the early 1103s from Intel. Since 1975 it has featured in most of the advances of the static and dynamic random access memory. It now seems that a new process is required to enable further advance to 64K and above.

Bi-polar memories have been left behind by the phenomenal growth of NMOS. Its main characteristic has been higher performance, but normally it imposed a high current drain and was thus expensive to run.  $I^2L$  technology is also included in this category.

Magnetic bubble devices are packaged in many ways at the moment and no standard appears to be emerging, but a typical device could be a 12-pin dual-in-line unit incorporating the bubble chip, support frame, rotating field drive coils and a bias field magnetic circuit, all encapsulated in an area about half that of a matchbox. The bubble is a fascinating thing to behold and, as one would expect from the name, the data is represented by the presence or absence of a cylindrical shape which resembles a bubble when viewed end-on. These bubbles are stored in loops called major and minor, from which they are read out by replication methods.

## Minicomputers

In a similar way to IBM's domination in mainframes, the Digital Equipment Company, affectionately known as DEC, dominates the mini field.

DEC has been in the extremely fortunate position of permanent growth,

so that a significant part of the company's history has been working in a supply-limited market. This has enabled DEC to take a benign approach to the so-called plug-compatible manufacturers, and devote its time and energy towards its own position vis-à-vis the market.

DEC was the first computer company to introduce a standard interface with its unibus for use with the PDP range of computers. This encouraged a great number of independent memory and peripheral suppliers to design plug-compatible products for use with DEC computers.

Because memory systems are inherently software transparent products this was



one of the first areas to capitalize on the attractive DEC installed base with a range of products. Some of these were just straightforward 'look-alike' products which were offered as simple cost-effective alternatives to the DEC offerings and others would claim improvements in the system performance, either by pure speed or by the use of modified architecture, by organization such as cache or fast buffering.

All of this activity obviously gave the user a greater choice and encouraged DEC to maintain its technological leadership in the minicomputer field. In many ways this attention by the independents is a compliment, as the main criterion for this activity by the independent plug-compatible suppliers is an established installed base. This explains why the only companies receiving this attention are the major suppliers.

## Microcomputers

Following on from the minis, the micros have really benefitted from 'foreign' attachments. Some of the *de facto* standards like S100 (8080/Z80) provide a very full range of modules which are designed to operate on this bus, although care is required in selection,

especially with dynamic NMOS.

In the USA, where the majority of the products originate, most of the popular bus systems now boast a range of memory systems suitable for attachment. These are available from very small companies to the major semiconductor houses and range in complexity from simple equivalents to alternative technologies like CCD or bubbles.

In each case, the user is given more choice and can opt for a mix 'n' match approach or with the newer technologies like bubble memory, may be forced to employ them because of application constraints.

An interesting recent product announcement in this area is a number of bubble memory systems for use with a range of micros:

- Plessey — SBC 80 compatible product
- Rockwell — Motorola Exorcisor compatible product
- Bubble-Tec — SBC 80 and LS1-11 compatibles
- Fujitsu — cassette replacement

These should be followed by several new products over the next two years, as they represent an ideal platform for the new bubble memory technology to achieve acceptance.

Another interesting development of data storage which has been brought about because of the hobbyists' need for low-cost memory is the audio tape cassette. With the proliferation of the microprocessor into the cheap microcomputers such as the Commodore Pet, TRS-80 and Rockwell AIM 65, there is a need for a cheap method of storing programs and data.

Although a relatively crude and slow method of storing data, it certainly meets the cost objectives.

However, there are major disadvantages in using the Philips-type cassette but until something better comes along such as bubbles, if it ever competes — then the tape cassette will continue to enjoy a place with the hobbyists. Most of the serious uses of microcomputers will require other technologies — floppies or hard disks in the business environment and bubbles in industrial applications.

## The future

One thing we can say with confidence is that all the present products and processes will be improved and refined, making it extremely tough for anything new (but that has always been the case with innovation). Most of the semiconductor companies are already sampling their 64K memory devices and within a year these will be designed into new system products. The new 16-bit microprocessor will force this to happen as it will require more software and hence more memory than its eight-bit predecessor.

The device manufacturing process

*continued on next page*

From previous page

appears to be the major constraint at present and a lot of industry and government muscle is going into the solution. The Japanese with their very large-scale integration programme are likely to provide most of the answers for progress towards the 256K RAM and the one megabit RAM, thus providing some real competition to the dominant US companies in this field.

On the peripheral storage front, I expect to see improvement and refinement of all the existing technologies, with the floppy disc featuring in much of this. It is conceivable that we will see the use of mixed technologies like bubbles and floppy discs to give us, say, a "flubble". What a beautiful word. It must be almost worth designing a product just to be able to use the name.

Of the new technologies, I would pick out the magnetic bubble device as the one with the greatest potential, as it combines the true non-volatility of the ferrite core with the high-density packaging of the NMOS technology. Having said that, I still have reservations because the bubble has been on the sidelines for two or three years now and has yet to burst on the scene (pardon the pun).

The biggest problem experienced to date concerns the process of manufacture: nobody has yet turned out high enough volumes in this market to meet the cost and hence price objectives. If money and effort are the only requisites for the bubble to come of age, it stands a good chance for the existing participants already read like a *Who's Who* of our industry.

However, I still have reservations because we can all remember dead certs which are now certified dead. It seems that the laboratory stage is straightforward enough but even the old hands like Bell Laboratories, Texas Instruments, Rockwell and Plessey have yet to ship sufficient volumes to make it all viable. It is worth remembering that competing technologies like floppy discs and the RAM are not waiting around for bubbles to happen: the break-even point for the bubble innovators must be moving out all the time as the price and performance parameters change.

Eventually IBM's decision on the bubble is likely to be crucial, as it proved with the floppy — the giant sets most of the systems standards for our industry and is still keeping its plans very close to its chest, as usual.

Currently there are two basic types of organisation used in a bubble device. It can be a purely serial device, where the information is stored as serial bits or bytes, as it is on a magnetic tape, or in serial and parallel form, which improved the access time for the data and makes the device look more like a disc, being organised in a number of major and minor loops. It will be seen from this that

the bubble device is not a random-access device and as the technology stands today, fits between main memory and peripheral memory as far as its projected price and performance parameters are concerned.

Rockwell has been seeking partners in Europe for some time now to second-source its 256K bubble device and has recently announced that Siemens will be manufacturing it in Europe at its Munich facility. This is interesting because Siemens at one time ran down its bubble technology plans and has obviously decided to reverse that decision. Plessey has a similar interest in the Rockwell chip but prefers its own packaging techniques.

One of the interesting things that will



take place is the convergence of the computer industry with other totally separate industries. We have already experienced some activity in the telecommunications area and if our Post Office will allow, substantial benefits can be made available.

Another industry that is converging (at least technically) with the other two is the entertainment industry — particularly television. In the not-too-distant future, we should see in people's homes a combination unit which will serve the entertainment communications and control the domestic services such as heating, air-conditioning, fire and burglar alarms.

This is not wishful thinking because the technology is already available and most of the building blocks are undergoing evaluation by the separate service industries — if ever they decide to talk to one another we will have the product.

## New memory types

Since the first time I saw the Ampex Terabit and Videofile systems in Sunnyvale, California in 1970, I have had an interest in the very large mass memories. It is still a new and developing market but IBM with its 3850 and the independent

equivalents have given it a certain respectability which will encourage others, including Harris, Hitachi and Philips, to pursue their own products in this area.

Perhaps a more interesting development which may affect all our lives has just been introduced in the USA by MCA. It is called Video Disk and is currently aimed at the entertainment industry. In principle it operates in the same way as an audio long-playing record except that there is no physical contact between stylus and disc (it uses a laser) and the information stored is both audio and video. This product has tremendous potential and will be targeted at the industrial market shortly.

Clearly a great deal of data could be more effectively stored in video form, because that is normally the way we prefer to work with it. This is especially true when one considers the advance of the home entertainment and information systems with Teletext and Viewdata systems. It is still too early to make a judgment of how this entertainment pre-recording medium will affect the computer industry. It will certainly have a great influence on all our lives.

It is worth pointing out that I was advocating the video disc as a future information storage medium before the IBM/MCA announcement that they are to form a joint company to exploit its industrial potential. As my track record of getting the future correct is not as impressive as IBM's, you will excuse me this pat on the back.

What about the rest? Well, disappointingly the charge-coupled device (CCD) appears to have lost its way in the digital area, after showing a great deal of promise. It seems to be plagued with the usual manufacturing process problems and conspicuously has lost some of its major backers. I will be surprised if it now survives as a major alternative technology to RAM and bubbles.

Electron-beam technology is still very much in its infancy and remains in the laboratory stage. No major advances are visible on the horizon but I would keep a watch on this area as it has the potential to become a significant technology.

## Conclusion

- Memories will continue to double in capacity at the user level every four or five years.
- Existing technologies will remain dominant at least for the next 10 years — after that we will see, perhaps, Josephson junction devices in the processor and bubble memory outside it.
- No single technology will ever satisfy every application.
- We will therefore see the establishment of a hierarchy of memories, in which different technologies will continue to compete and co-exist — sounds familiar?

RAIR BLACK BOX  
MICROCOMPUTER

POWER  
LOAD  
RESET

RAIR MICROCOMPUTER  
BLACK BOX

*Discover the secrets of  
the RAIR Black Box*



30-32 Neal Street, London WC2H 9PS, Telephone 01-836 4663, Telex 298452

# L.J. ELECTRONICS ANNOUNCE:-



The complete microprocessor learning system:-  
 'EMMA', 6502 based microcomputer, at £125.  
 Peripheral hardware modules, set of 8 for £375.  
 Micro systems power supply, at £189.  
 Complete with comprehensive manuals, giving step by step tuition  
 and many hours of applications programming exercises.

L.J. ELECTRONICS LTD.,  
 FRANCIS WAY,  
 BOWTHORPE,  
 NORWICH.  
 Tel: 0603-746340.

• Circle No. 182

## PETAID

PET SOFTWARE WITH  
 A FUTURE. EVERY PET  
 SHOULD HAVE ONE



LOOK NO PROGRAMMERS!  
 PETAID — THE ANSWER TO A USER'S PRAYER

### STAGE ONE SOFTWARE DEALERS

Name	Address	Telephone No.
Actida Computers Ltd	17-19 The Broadway Ealing LONDON W5 2NH	01 579 5845
Amplicon Micro Systems Ltd	143c Ditching Road BRIGHTON, Sussex BN1 6JA	0273 562163
Computer Services Midlands Ltd	Refuge Assurance House Sutton New Road, Edington, BIRMINGHAM B23 6OX	021 382 4171
D. A. M. s Office Equipment Ltd.	30-36 Dale Street, LIVERPOOL L2 5SF Merseyside	051 227 3301
Jeffrey Martin Computer Services Ltd	78 Fore Street NEWQUAY, Cornwall	063 73 2863
M. M. S	26 Mill Street, BEDFORD	0234 40602
R. P. L. Microsystems	Goldie House, Upper Church Street DOUGLAS, I. O. M	0624 4247
Sheffelin Computer Centre	225 Abbeydale Road SHEFFIELD, S7 11J	0742 53519
Stough Microshop	120 High Street, SLOUGH, Berks	0753 72470
T. B. V. Johnson Microcomputers	165 London Road Camberley, Surrey GU15 3JS	0276 62506
Thistle Computers	29 Albert Street KIRKWALL, Orkney KW15 1HD	0856 3140
Walters Computers Systems Ltd	Field House 107 Worcester Lane STOURBRIDGE, W. Midlands DY9 0SJ	0562 885937
Alpha Business Systems	89 Railway Street, HERTFORD	0992 57423
Callants Computers Ltd Ltd	Green Lane WILMSLOW, Cheshire	0625 57255
G. M. Marketing	Old Barn House Amport, ANDOVER, Hants	026 471 410

All your installed programs could have an identical structure —  
 think how easy subsequent support will be — programs in Days  
 not Weeks. Weeks not Months, Months not years —

PETAID FEATURES: Create Files, Insert, Amend, Delete, Display,  
 Print, Search, Copy, Examine, Extract and Sort — Good  
 Documentation.

### NOW AVAILABLE FOR:

Sequential Commodore Disks  
 Random Access Commodore and Compu/Think Disks  
 Printers Commodore, Anadex, Qume

Tape based Version only £00  
 Sequential Disk based version £000  
 Random Access Disk based version £000

Soon to be available and PETAID compatible!

1. Various Print generators
2. Search and Extract new file
3. Transaction Handlers

ALSO  
 Word Processor  
 Word Processor with mailing  
 Quote Processor  
 Mailing List  
 Estate Agents Pack:  
 Applicants/Word Processing/Properties  
 Stock  
 Incomplete Records  
 Pension Calculations  
 Bond 10+  
 All prices shown are VAT ) P&P UK inclusive

### MAIL ORDER

Written orders with cheque or Access/Visa No. to:

STAGE ONE COMPUTERS 6 Criterion Arcade, Old Christchurch Road, Bournemouth. 23570

Please supply: ITEM ..... QUANTITY .....

AMOUNT £ ..... CHEQUE NO. ....

Name ..... ACCESS/VISA NO. ....

Address .....



• Circle No. 183

# The Turing Test

by David Langford

"IN here, John," said Spencer; John Cobbling winced slightly, as he had at each gratuitous use of his Christian name. After all, Spencer was merely interviewing him for a job; the hearty familiarity struck Cobbling as offensive.

He let himself be ushered into the little room, which was only about five feet square — one of a row of such cells, side by side like lavatory cubicles. The walls were lined with large sound-absorbing tiles, perforated like pegboard and discoloured to a leprosy shade of cream. The furniture consisted of a chair and a teletype. Cobbling sat down.

"What kind of test is this?" he asked nervously. Everything had seemed to be going well ... and now this.

Spencer smiled the smile of one who knows something and isn't telling. "The sort of test where we don't tell you what we're looking for until afterwards," he explained. "You do get a few hints, though. Maybe you've heard of the Turing test?"

Something stirred at the back of Cobbling's mind, but refused to come all the way out into the open. "But that's to do with computers," he said, feeling his eyebrows creep together like furry caterpillars. "Where do computers come into this?"

"Computers come into everything these days," said Spencer in the sort of tone a small boy might have used while saying "Aha!" or "That's what you think," or "Wouldn't you just love to know?"

Cobbling twisted his neck to look up again, wishing he hadn't sat down and given his inquisitor the chance to tower over him. He tried to cover his annoyance with a mild joke: "That's all you're telling me? From that I could decide it's a test of, oh, reticence and discretion — and sit here discreetly not typing anything..."

Spencer's aura of bonhomie chilled perceptibly. "I should not advise that, John," he said with emphasis. "Obviously you don't know what the Turing test is."

Thus prodded, the something at the back of Cobbling's mind crept a little further from its den. "Machine intelligence," he said slowly. "Something to do with telling the difference between a computer and a man. A person," he corrected himself, in case vile sexism was another of the things the all-knowing and all-judging personnel section was assessing.

"Ah, you've got it. Press the return key and carry on from there."

Before Cobbling could formulate another probing question, Spencer had

closed the door behind him. On the inside, the door too was lined with the ugly, perforated tiles.

Cobbling studied the keyboard, feeling very much out of his depth.

*TURING, Alan Mathison (b. June 23, 1912, London — d. June 7, 1954, Wilmslow, Cheshire), mathematician and logician who pioneered in computer theory... Championed the theory that computers could be constructed that would be capable of thought and even proposed that machine thought could closely resemble human thought... (Encyclopaedia Britannica)*

**T**URING'S test for "intelligent" machines is very simple. A man sits at a teletype, carrying on a typed conversation with whatever the teletype may be connected to: perhaps another terminal operated by another person, perhaps a computer. When the computer impersonates human intelligence so well that the man at the teletype cannot tell it from a human operator, the machine passes the Turing test. Of course it might also be said that the man has failed: fancy being unable to tell a mere machine from a real person!

**T**HE RETURN key itself was enough to maintain Cobbling's unease: it was where the 2/3 key was on his own typewriter ... which felt distinctly wrong. He pressed it, and the teletype immediately began to chatter.

\*\*\*HELLO & GOOD MORNING, the machine typed.

Well, of course, that made it obvious. People didn't type that fast and evenly, and so it had to be a machine at the other end. That was the Turing test: he had to work out whether a man or machine was typing at him, the most stupid aptitude test since the firm that had analyzed his handwriting and discovered something so awful that they refused to tell him precisely what... He sighed. Of course it wasn't so easy. The teletype would fire messages at him at just this speed, no matter how slowly they were being typed.

HELLO, he typed cautiously.

\*\*\*WHAT IS YOUR NAME PLEASE?

JOHN LEWIS COBBLING, he typed in.

\*\*\*THANKYOU, JOHN

Even from a computer, he didn't like it. And even a stupid computer should be able to pick up a Christian name like that. But the name request gave him an idea which he thought might be rather cunning. He typed:

WHAT IS YOUR NAME PLEASE?

\*\*\*LET'S CHANGE THE SUBJECT

No through road. Dead end. Turn left only. If he'd only made some other reply when his name was asked for; if he'd only said "Why do you ask?" and maybe exposed the machine's zombie response as it came back with THANK YOU, WHY ... It still wasn't too late to try a similar gambit ... to make a confession — "Sorry, my name is really Mortimer Frogg." What would a machine make of that? A human was bound to see the contradiction, but... His finger was actually moving towards the S key when a second and more disturbing thought struck him.

**T**HIS was a Turing test and his supposed task was to decide whether he was chatting with man or machine: fine, great, marvellous. However, there could well be another and sneakier level to the business. That advertising firm had made him write 500 words on how rice pudding could be given a virile image ... and, he suspected, hadn't even read it before turning it over to the graphologist who'd found evidence of unspeakable perversion in the hang of his consonants. Maybe here if he resorted to saying "My name is really Mortimer Frogg" he'd pass the test only to be blackballed for dishonesty. Say something safe, he thought, say something intelligent and say something quick.

WHAT QUESTIONS DO YOU SUGGEST I SHOULD ASK?

A pause.

\*\*\*ARE QUESTIONS NECESSARY?

He wanted to kick the teletype through sheer ill-temper. Only they might be watching him — and might even knock a few marks off his score if he scrutinized the walls for hidden cameras. It was unfair. If there was a living, breathing organism on the other end, he (or she) was replying in this careful, clipped, sterile fashion merely in order to fool Cobbling. Surely that was against the spirit of the test? What separates sheep from goats, machines from people? He took the hint of the last response and tried a flat statement.

I THINK YOU ARE A COMPUTER

\*\*\*PERHAPS YOU ARE A COMPUTER, TOO

Which was no help either way. Now if he could only jog the player on the other side of this demented game — shock him or her or it with a spate of four-letter words — make the human (if there was one) go over the top with rage and betray some feeling and humanity! Cobbling thought about that one for a few seconds and realized:

(a) A computer could well be programmed to pick up obscenities and react with an outburst of simulated rage.

(b) Conversely, a person could pause, ponder, calm down and react quite impersonally — fast talk had no effect when filtered through the teletype link.

*continued over page*

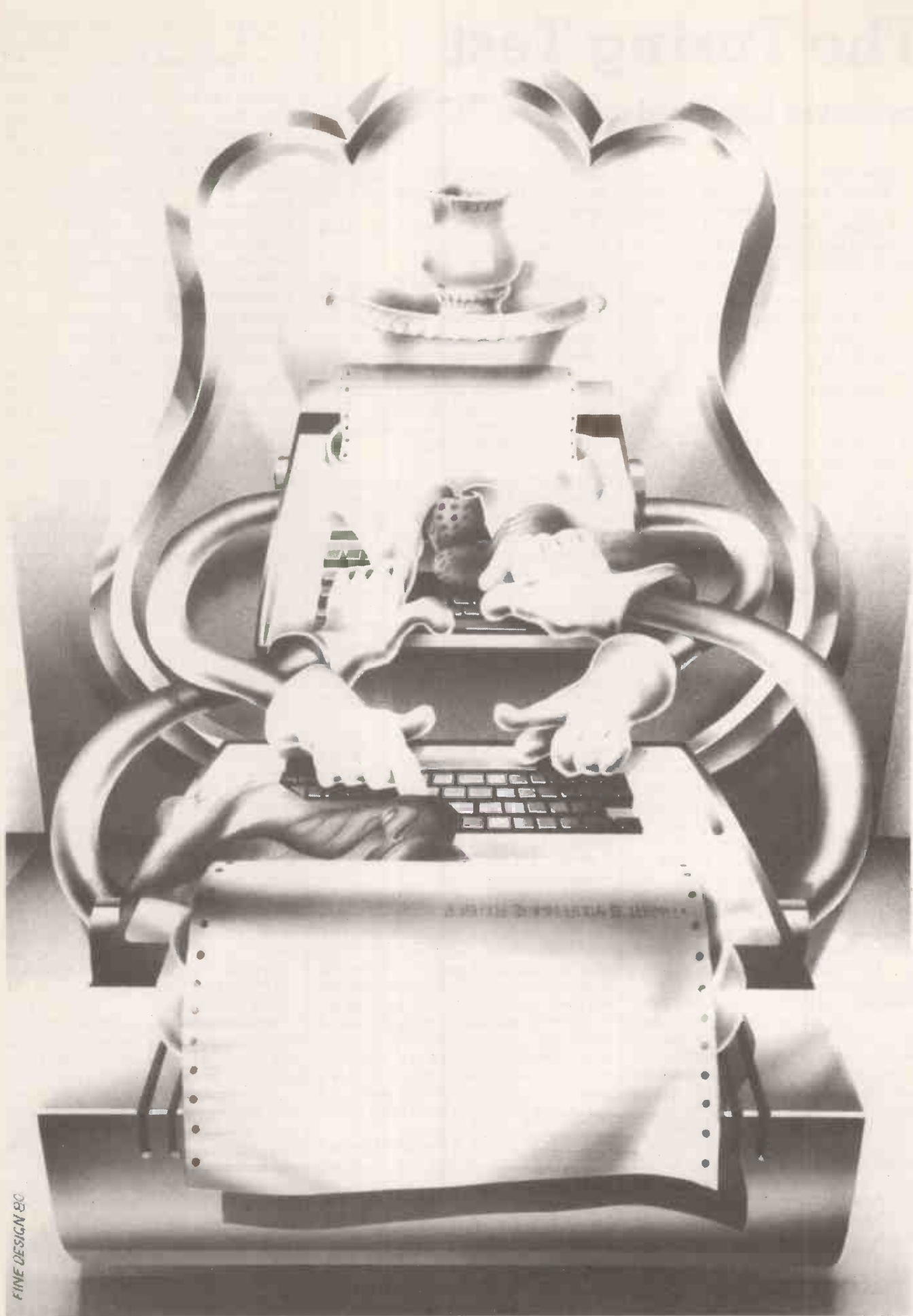

FINE DESIGN '80

*From previous page*

(c) Worst of all, if this dialogue were being monitored, a lapse into four-letter words would rapidly convince the critical watchers that he'd lost his cool. And he'd lose the job as well.

**F**OR purely therapeutic purposes, Cobbling murmured a few of the choicer phrases which had occurred to him . . . but only under his breath. There might be microphones as well as cameras! What the hell could he ask which was innocuous, subtly probing, not too inane, and liable to get a useful answer? He groped for the obvious.

**WHAT ARE THE PROMOTION PROSPECTS LIKE HERE?**

**\*\*\*WE CAN DISCUSS**

**PROMOTION WHEN AND IF**

**YOU'VE BEEN TAKEN ON,** was the reply.

Was it perhaps a little too chatty to be the computer? A little too swift at picking up the keyword 'promotion' to be a person? He rubbed his chin as he thought about it.

**PERHAPS YOU COULD TELL ME MY CHANCES OF BEING TAKEN ON,** he typed, and regretted it at once.

**\*\*\*SURELY YOU DON'T LEAVE THINGS TO CHANCE?**

Now was that or was that not a subtle straying away from the point, as might come from a machine programmed to waffle through a conversation?

Cobbling found himself answering in kind:

**ONE HAS TO TAKE CHANCES SOMETIME**

**\*\*\*VERY TRUE**

...And on and on and on, always circling round whatever the point of this strange test might be, always avoiding which led towards controversial comments and might prejudice his chances. One has to take chances sometimes, but Cobbling didn't really feel that way. By and by he was struck by the notion that there was no machine nor even a cunning personnel interviewer on the other end of the line. Could it be that the unseen adversary was another interviewer in a mirror-image situation, choosing his words with utmost care for just the same reasons which inhibited Cobbling? How neat, how economical that would be.

**I THINK I PREFERRED THE RICE PUDDING ESSAY,** he wanted to type.

**YES, I HAVE ALWAYS WANTED A GOVERNMENT JOB** was what he actually typed.

As always, the machine paused...

**I**N all, the test lasted for about forty minutes. It seemed like an eternity of plodding thought, an endless chess game played blindfold. Cobbling even entertained the heresy that maybe, after all, he didn't really want this government job.

Then the door opened with a sudden

draught of cold air; a hand touched his shoulder. It was Spencer. "Congratulations," he said with the impersonal warmth of a central heating system. "You've passed."

Cobbling raised an eyebrow at him. "I haven't said whether I think it's a man — a person — or a machine yet," he said suspiciously.

"Oh no — but I've had the report from the other end. There was a computer on the line, of course, with our best response-analyzer program — and two programmers sitting in, monitoring the transmissions..."

So he'd been right about *that*.

"None of them could tell," said Spencer, as though that explained everything.

"Tell what?" Having kept his cool for so long, Cobbling was finding it increasingly difficult to speak without vehemence. It would be so nice to break into gentle screams.

"Tell your responses from those of a machine, of course. The Turing Test, you know. Calm, impersonal, bland, no rhetorical flourishes — no, they definitely couldn't distinguish your personality from that of a machine. You passed with flying colours, John."

Cobbling stared at him; nodded slowly and thoughtfully. He thought he saw it now.

Spencer clapped him on the back and said: "You're going to make a good tax inspector."

## Nagging

by G. Phillips

'SYSTEM 2.3 READY' said the screen in a patient, understanding tone of green.

Peter Ferraby keyed in a brisk reply, then sat back and listened to the reassuring clicking of the floppy disk drive as it busied itself loading several thousand bytes of compiler.

The door opened and Peter thought to himself, Here she comes, ready to nag about some trivial thing or other.

'I thought you were going to clean up the spare room?'

Alison stormed into the room, hands on hips. There was no pause in the tapping.

'I must get this finished before lunch — the magazine wants the program by tomorrow.'

'Well, my sister is coming over tomorrow, so there's another deadline for you,' replied Alison, angrily leaving the room when no reply was forthcoming.

'Error in Line 2200' said the machine.

About an hour later, Peter's programming was interrupted anew by the abrupt re-appearance of his wife.

'Look, are you going to give me a hand, or don't you mind not having any lunch?'

'OK, I'll be with you in a minute, but I must store this program on tape first.'

'Can't you put it on the floppy disk?'

'No, the compiler takes up most of the disk, I daren't use the tape for the compiler in case I get bits dropped. It's not so bad with a BASIC program, but I'm lost when it comes to machine code.' Aha! he had blinded her with jargon!

But Alison gave no sign of confusion as she left, rather, she seemed pleased.

Once again, with the other program in the publisher's hands, Peter was working on his Household Accounts Routine — a project often put aside.

'RUN' was entered and Peter awaited the first message, but the program had other ideas. All it would say to him was 'ERROR 302'.

That's a new one, thought Peter.

'You haven't seen the System 2.3 manual around,' asked Peter as Alison entered, hunting for empty coffee cups.

She peered into the screen, then said: 'Oh yes, Error 302, that means your array is dimensioned too high, the system can't cope with it'.

Peter laughed. Was she humouring him by spouting jargon? Only after the door closed did her suggestion make sense. Sure enough, the listing showed an extra 0 within the statement that dimensioned the array.

As he corrected his mistake, Peter marvelled at female intuition.

The following morning saw another obstacle in the path of finishing the

Accounts program. His mother-in-law was paying a visit. If he was lucky, he might be able to snatch an hour or two on the machine.

Alison was still asleep — unusual for her, he reflected. But hadn't she got up in the night for a drink or something?

He hurried into the back room, powered up and waited impatiently for the disk drive to awaken. The 'System 2.3 Ready' message was already glowing.

As his compiler began loading into memory, Peter rewound the Accounts cassette, praying that there would be no tape dropouts.

With the compiler loaded, Peter pressed the PROG-RUN key, as he had done hundreds of times before.

'WHAT DO YOU WANT NOW?' the machine screamed in bold upper case. Peter stared in amazement. When he had recovered sufficient composure, he to typed in a Load command but omitted the 'O'.

'YOU'VE GOT IT WRONG AGAIN — IDIOT!' came the terse reply.

'And don't think I saved the old compiler!' laughed Alison from the door.

'Don't worry dear, it still does all it used to — only now it really tells you off when you get something wrong, a vast improvement I think.'

In spite of himself, Peter laughed; he had just spotted that the label on the front had been amended to read 'NAG 1'.



Ron Sheldon at the Finance for Industry HQ: "Too many people only want to get involved in business to build their own ego."

**With banks looking to make a tenfold return on venture capital, is now the time to start your own micro business? The answer, explains Duncan Scot, is to ...**

## **Fly high or plummet**

IT IS NO TRICK to make a lot of money, if all you want to do is make a lot of money, according to Mr Bernstein in *Citizen Kane*. Yet so many people claim that if only they could find the backing, their ideas would be worth a mint.

Financial security, independence from Big Brother employers, the opportunity to make a mark on the world — even the trappings of the rich — are the promises. With so much on offer, it is surprising how few take up the challenge and chance their luck. Is it really that difficult to start up your own company? Is the backing which is always considered so vital really necessary or really so elusive? or can it be that most people simply cannot be bothered to try?

Of all the excuses, the one about the economic climate being unfavourable must be the weakest at the moment. If microcomputing is the long-heralded start of the second Industrial Revolution, then the industrial giants of the twenty-first

century will now be in their infancy, either as small companies or as embryonic money-spinners in the minds of budding entrepreneurs.

Pessimists and bureaucrats discussing 'What is wrong with Britain?' claim that venture capital for high-risk, high-return ventures is in short supply in the UK, unlike all other Western countries. So far as the UK is concerned, they say, fond dreams about finding a rich angel willing to pour thousands of pounds into a grand idea should best be forgotten.

### **Risky ideas**

So where can the money come from? The providers of development capital are not excessively cautious in their lending requirements to small companies and for new ideas — or so they say themselves. The problem is that there are not enough people in the UK with the money to throw into risky ideas.

This is not to say that there is not a lot

of money floating around in the UK. Life insurance companies and pension funds command vast sums: collectively they invest several million pounds a day. But few of us will ever see this money, as it disappears into property, gilts, gold and art collections, to be recovered with a modest profit thirty years hence when the lives expire and the annuities are paid.

Most other cash, whether from companies saving to meet their tax bills or local authorities hoping to profit from the short period between the collection of the rates and the payments they have to make for their services, is in search of short-term returns, lent at high interest rates for a few months at a time.

There are two sources of business finance in the UK which are geared towards long-term risk investments. The first is the industrial finance house, Finance for Industry (FFI), which is owned by the main clearing and merchant banks and the Bank of England. The





Mike Fisher at the centre of it all at Research Machines. "If we had been given any backing we simply would have lost it all."

second is the state-backed merchant bank, the National Research and Development Corporation.

Although these organizations specialise in lending long, they usually apply the single most difficult requirement to meet, namely: will the project make more money than they could make on the money markets (current MLR 17%) consistently for the duration of the loan? Because if not, forget it.

## Growth investment

They are, after all, as they are wont to point out, lending other people's money and those people expect to see their investment grow, not to have it gambled away. Barely one in ten of new companies which start with backing survive to repay the original investment. So of every ten new companies which are backed, at least one of them will have to make a better profit than could be made on the money markets, and enough to pay for the losses on the other nine.

In principle it means that a backer of a high-risk project will look for 20 to 50 times his investment as a return. This can make a big hole in the proposer's stake.

So most merchant banks will not be keen on a new risky and expensive micro-computing venture. Evidence to the Wilson Committee, which was reviewing the functioning of the City's financial institutions, highlighted the following ques-

tion: "Is it in the public interest that small companies, which are unable to meet the requirements of the financial market, should be supported nevertheless?"

Before answering that question, say the bankers, it is necessary to emphasise the uncertainty in predicting which companies will succeed or fail, and this is particularly so with small companies. The price of supporting 'medium fliers' could be a higher rate of wastage which would mean higher costs for all.

Given this reluctance to back risky adventures in microtechnology, the trick must be to make the right approach to the financial institutions to maximise the chances of securing backing, recognising at the start that a good idea is only part of the story. The FFI and the NRDC both stress the importance of character.

## Commercial nous

"At the back of our minds whenever someone applies is the question 'Does this guy have sufficient commercial nous?'" explained Ron Sheldon, who deals with high-technology ventures from the plush and relaxed surroundings of the FFI's technology arm, the Technological Development Corporation, just off Waterloo Station in London.

"People always say that the problem is finding backing and money for a new venture but I think that is wrong. It goes one stage further. There is plenty of money floating around for good ideas.

The biggest problem by far, and it is always underestimated, is to persuade the potential backer that *you* can actually take hold of the product.

"We are not looking for technical excellence but for some idea of what the marketing will entail and how to make the product right for the market place. Too many people want to get involved in business for the wrong reasons. The first, normally, is that they want to build their own ego. The second fault is that they only really want to play at R and D.

## Not our game

"We recently had a University undergraduate," continued Sheldon, "aged 21, who had an idea and wanted to chat about how to develop it commercially. We are simply not in that game. All I could suggest was that he approached a number of companies with a view to giving them a licence to produce the product and hope for something between four and 10% of the royalties."

A loan from the TDC normally requires selling a 40% stake in the company, leaving the proprietor with 60%, for which he will have to come up with his own money. "For example," explained Sheldon, "if someone can offer £20,000 and takes 60% of the shares, and if the TDC puts up £200,000 and takes 40% of the shares, it is obvious that the bulk of

*continued overpage*

continued from previous page

the money comes in the form of a direct loan which is secured only by the long-term assets of the company which means by its long-term potential. The proprietor only risks the money which he has put up himself and that will often come in the form of a bank loan, secured on his house. We don't care how he raises his share."

As the technology arm of FFI, TDC does have a certain amount of expertise by which potential products can be assessed. With totally new products, however, it is far more difficult. "It is sometimes impossible," said Sheldon, "to say how large a market is for something which nobody knows anything about. All we can do is to bounce the idea around with people who are involved as close to the area as possible. Unfortunately it does mean that there will always be a bias against the unknown, but there is no way round the problem.

### Sorry, Mr Sinclair

"The technology market is getting more and more difficult at the moment," continued Sheldon. "The amount of finance needed to hit a market properly is going up rapidly, while the amount of cash which the individual has is relatively stable; in fact it is usually geared to the value of his house. If Mr Sinclair came to me with a great idea for a new mini-TV we would have to turn him down, although there could well be a market for it and eventually a good return. But the risks are

high and the launch costs would be astronomical if it were to penetrate the market."

Ron Sheldon believes that the name of the game is now software, so much so that TDC have formed a new company, called TDC Developments, which will provide more backing for small companies and new companies in return for a larger share of the equity and a position on the board of directors to supervise the running of the company.

"There is great scope for putting money into software," proclaimed Sheldon. "We can work within a budget, allocating the money for specific objectives until we reach our target. It is far easier to control than trying to finance the building of a prototype piece of equipment."

Building prototypes and new product R & D is more the preserve of the State-backed merchant bank, the National Research and Development Corporation, still proud of the days when it backed its most famous baby, Sir Christopher Cockerell's hovercraft. (It has yet to make any money out of the project). Most of the Corporation's licence income in recent years has come from one sparkling invention (cephalosporn antibiotics), the patents on which soon run out. Without this one success, the Corporation reckons that it would have had to take up the full amount of its £50m Government borrowing limit instead of repaying all its loans.

The NRDC, as its name implies, concentrates on research and development of

## Rules of the game

AN ACQUAINTANCE of ours who successfully raised half a million pounds in the City for a computing project ten years ago gives the following advice:

1. Research everything. In your proposal chuck in a few offhand references to some papers in Icelandic. Say: 'This cursory overview of the possible market reveals a not unpromising situation.'
2. Remember that you are writing for a crew of gin-sodden taxi-drivers. Your prospectus has to be able to read it in the Tube. Keep it short, keep it simple, keep it profitable.
3. If your proposition looks like making £1000 a month, say £10,000 and throw in that 'with development, the market might become quite attractive.'
4. Type up a hundred copies of your proposal, send it to every firm in the yellow pages under 'Bank'. It is fatal to get fixated on one single source of finance — you just become a nuisance. It's like chasing a girl who isn't interested in you.
5. If, when you get to see Them, They don't jump over the table — dribbling — to hold you down while you sign, you haven't clicked.
6. They are unimaginably greedy, and they have to be. If only one project in ten succeeds, then that one has to repay them ten times what they put into it. And that just balances the books. To make a profit they need forty — fifty — a hundred times their investment. A person could get hurt, so watch out.

## Advertising for the man with the money

BACK IN 1978 Lucius Cary decided to help other entrepreneurs in the search for venture capital. With an engineering degree from Oxford University and a Master's in Business Administration at Harvard Business School, Cary had ambitions to run his own engineering company.

While looking for financial backing, he felt an enormous communications gap existed between those who had money to invest and those who wanted it. So he decided, with two partners, to create a forum through which would-be entrepreneurs and the institutions or the individuals who might provide their capital, could meet, in the shape of a monthly information sheet, entitled *Venture Capital Report*.

### Burger bar

In the meantime Cary is running a small chain of American-style hamburger restaurants, in Bristol, in the hope of making the capital he needs.

In Cary's view, not only is it difficult to identify sources of venture capital, but it can also be daunting and time-consuming to approach each of them individually.

Each of the monthly reports carries around eight studies of entrepreneurs needing finance; for instance a Holiday Village requiring £175,000, a pneumatic vibrator requiring £12,500, to a computer professional seeking £54,000 to "establish

**Venture Capital Report September 1979**

1. Microcomputers	£54,000
2. Pneumatic Vibrators	£12,500
3. An Export Services Company	£18,000
4. Holiday Resort Memorial	£300,000
5. Holiday Village	£175,000
6. Quality Gifts Export	£75,000
7. A Fashion Design Company	£430,000
8. Video Systems	£75,000

2 The Mall, Clifton, Bristol BS8 4DR. Tel Bristol 412733, 412222

Cheap at twice the price? a computer systems consultancy to advise firms on how to use microcomputers and then sell them the systems." *Venture Capital Report* gets about 60 applications every month and requires the lot of them to fill in a questionnaire provid-

ing details of their product, market, financial needs, cashflow projections and personal circumstances. About one in ten of the applicants actually makes it into the pages of the report.

Luckily only about 15-20 every month bother to return the questionnaire and so nearly half of the more serious applicants get written up.

### Untried ventures

As yet there has been no proper analysis of the success of the Report or of the type of projects which do succeed in finding backing. Rough figures indicate that about 10% of the projects so far publicised have received some degree of backing; others are still negotiating and some have found backing from other sources. Apparently a large proportion of the backing is coming from private investors, still willing to take a risk on an untried venture.

*Venture Capital Report* is financed solely from its 400 subscribers, an annual subscription costing £125, embracing private investors, banking and investment companies and industrial concerns both in the UK and overseas. The main problem, however, is not how to gain more subscribers, but how to sustain a high quality among the projects.

Contact: *Venture Capital Report*, 2 The Mall, Clifton, Bristol BS8 4DR.



ideas, to bring them to the market place. Its main function is to promote the development and exploitation of inventions, including computer software and electronics, the responsibility for which lies with the Computer Systems and Electronics Group.

George Davis, who works in this group, explained that the Corporation functions in two main areas of activity. The first is the Industrial Joint Venture in which the NRDC provides support for the development, initial production and marketing costs of innovative products within commercial companies. NRDC subsequently recovers its funding, where possible, plus an appropriate margin, by levies on sales of the resulting product.

The second main activity is the exploitation of inventions from research organizations and individuals. In these cases, NRDC accepts assignments of property, undertakes patenting and any other relevant forms of protection and seeks to license the invention to commercial organizations. "Of course the great majority never get that far," said George Davis encouragingly.

In an industrial joint venture the NRDC normally expects to put up about half of the money for the venture in return for a percentage levy on the sales of the resulting products. It seems, however, that the NRDC prefers to work with well-established companies rather than small

concerns. In reply to such criticism it says that over half of its ventures are with companies employing less than 200 people, and early last year they launched a £250,000 advertising campaign to attract higher-quality applications to the Corporation.

One of their more typical ventures in recent years was with the UK based software-house, CAP-CPP, a large, well-established and profitable company employing over 900 staff and with an annual turnover of nearly £12m. In the mid-Seventies, CAP feared they would be by-passed by the microcomputer revolution and decided to tackle the micro market from square one, with a new company called Microsoft Ltd, formed to develop microprocessor development aids.

### Key to the future

CAP had identified the micro market as the key to the future and determined to get in on the act early. They studied the possibility of developing their own languages and adapting COBOL for use in micros.

"A small R and D group studied the problem," explained Lawford Russell, the CAP director in charge of product services. "But after £¼m had been invested we decided we couldn't really go any further. That sort of money, although we could afford it, was stopping us

making any further diversification. We knew it would be useful for the future but we couldn't be sure about the time scales involved so, for the first time, we looked at the possibility of raising additional capital for the work.

"The traditional forms of money were unavailable to us," Russell continued. "The City was wary of high technology, I think because they got their fingers burnt in the early Seventies and when that happens they tend to look inwards and support nothing. We could have borrowed the money but we didn't want the funding to go against our balance sheet. We really wanted someone to share the risk of the development and then share the return if the product was successful."

The NRDC came up with support to the tune of £350,000 although CAP has since increased their own investment, to make a total of over £2m spent on the project.

"As you would expect, our market plans and projections from the early days have proved wrong. We expected the return to be higher. We were probably about two years too early with the product. As is often the case, new technology was not adopted as quickly as we thought," explained Russell. "We didn't think of microprocessors being used as replacements in manufactured products for wired logic. And that market kept the

*continued over*

continued from page 83

semiconductor manufacturers busy for some time."

CAP's annual report makes the same point. "We underestimated the gestation period the manufacturers required to box the micro suitably for retail sales. The investment has been greater than expected." However, the chairman then adds: "The achievement of machine-invariant programming in Microcobol is emerging as one of the most significant developments of the decade."

"The problem with any sort of financing," explained Russell, "is that there has to be some sort of personal contact. We knew George Davis at the NRDC. There is no point in going into any sale cold, especially when it comes to raising money."

NRDC does in fact admit that it prefers to deal with ideas from large and well-established companies, of which apparently at least one in five are worth following up. In the argument over the future of the NEB, the Government has already admitted that there is a need for a state venture capital organization to fill the gap not being met by the market, but there must be some doubt whether the NRDC could fulfil this function, even with a change in policy.

## Heartbreaking

Sir Frederick Wood, chairman of the NRDC, recently argued (*PC*, December 1979) that backing will often set the lone inventor on the road to failure.

"Money by itself may often be of no real value to a small inventor," he said. "Someone once said that offering money to a small inventor is like giving a bottle of champagne to a man dying of thirst in the Sahara Desert. In his desperation to open the bottle, our thirsty man breaks off the neck, spills half the wine, cuts himself badly and, having consumed the balance of the wine, is thirstier than ever half an hour later."

This may explain why of 6600 applications from small inventors over the last seven years, only 44 were judged worth backing. Is it really impossible for the NRDC also to give advice on how to make the best use of backing and marketing?

Some of the most successful companies in the microcomputing field have grown up with no substantial backing and some claim that even if they had backing at the start, they would probably have lost it all anyway. One such company, Research Machines of Oxford, manufactures the 380Z microcomputer, which has won itself a reputation as one of the best machines in the UK. Designed especially for the education and scientific markets, it has virtually cornered this sector.

But three years ago RM had only just thought of moving into the micro market place, and as a company, SCINTEL, dealing in the buying and selling of electronic components, was not especially pros-

perous. Only two years before that, in 1974, the company was established by Mike Fisher and Mike O'Reagan with a total investment of £250 and a car.

In 1972, having completed a Physics degree at Oxford, Mike Fisher determined that some day he was going to run his own company. He spent the next two years doing temporary jobs, some in Africa and later back in the UK with Manpower, which is where he met Mike O'Reagan, an economics graduate from Cambridge. Together they decided to go into business.

"We didn't have any very clear ideas. We both wanted to go into business on our own rather than work for other people," said Mike Fisher, "partly because of that great illusion that if you are your own boss you are more independent and have greater freedom. I knew that I would eventually like to move into manufacturing but that was about as far as our planning went.

"I started off going around some research labs," he continued, "trying to find out what equipment they needed, and managed to persuade someone at the Roussel Labs that I could build them a brainwave analyser for rats. They were willing to pay £18,000."

Roussel paid an advance on the machine and Fisher borrowed another £1000 from friends and family to meet their living expenses for the first year. At the same time they started up Sintel, buying and selling electronic components.

"We thought," explained Fisher, "that the brainwave analyser would take us about eight weeks to build. But it really took us eight months and that is how we



George Davis

started to learn about some of the problems of running a business."

There were no other special projects and after nearly two years of building up the retailing side of the business, Fisher became impatient, until he decided to move back to the original idea of manufacturing at the end of 1976.

"I had kept myself well up-to-date with

the latest developments," he said, "and I knew that we had to build something with a microprocessor. I even toyed with the idea of building an adaptor for Teletext but pulled back from that. At the time I was sitting on an education working party for the Berkshire County Council to study some of the technical requirements for schools and I realised that here was a market for microcomputers which seemed to have been ignored by most of the other manufacturers."

## Mushroom

Mike Fisher designed the prototype 380Z (he admits he is a good electronics designer) by the beginning of September 1977 and had to meet the first order for 25 by the 21st of the month. Since then the business has mushroomed. In November last year, the company moved out of a 3500 sq ft factory into premises with over 16,000 sq ft.

Why does Mike think he has been so successful? "I once read an article about new businesses in the States which claimed that those companies where one of the partners, however much of a leading light, had more than 15% more of the equity than any one of the others tended to fail; we have always stuck rigidly to an equal equity among the partners.

"The other point is that you have to spend some time getting used to running a business, learning some of the basic rules. And you must remember to make a profit. After about a year and a half we realised that we were only just breaking even. Every now and again we added up our costs very roughly and thought we were making lots of money. We didn't realise how much the little costs such as stationery and photocopying add up. Luckily we always lived really frugally."

## Enjoy yourself

As MD of the company, with over 30 employees and with plans for further expansion, Fisher believes that it is essential to enjoy running a business, as opposed to just getting an idea off the ground. "With 30 people," he said, "someone always has a problem, or needs attention or help, and so there is nothing like as much time to think about the future of the company. I was lucky. I have always been fascinated by the way that businesses work, how a company like General Motors manages to develop any new ideas at all.

"When we first started, we believed that if we had substantial backing, we could have made a fortune very quickly. In retrospect, we simply would have lost all the money. We might still have come in the right direction but our mistakes would have cost money rather than just time. I don't think that in the long term, if you are determined to make a business work, backing on a large scale is worth it, especially if you do not have a good deal of business experience." □

"Micro mania hits London—staggering success—the sort of frenzy usually seen at January sales." Datalink (16/7/79)



# The Big One

See you at The Wembley Conference Centre  
**22-24 July, 1980**

Last year's Show broke all records and made headline news in many newspapers. The 1980 Show with its exhibition, international conference and one-day seminars, adds up to the most significant microcomputer event ever held.

Join the top names in the business and reserve your space now—and remember exhibitors who have also booked for the Mersey Micro Show are entitled to a 10% discount on both events!

Seminars held on the first two days will inform the business man of the many ways micros can be used as a commercial aid, both in the office and the home. The seminar on the third day will be devoted to education applications.

In addition, a two-day international conference will examine the state of the art in microelectronics with distinguished speakers from the UK and overseas.

Return this coupon or call Jane McBarnet at Online Conferences Ltd., Argyle House, Northwood Hills HA6 1TS. Telephone: Northwood (09274) 28211

*onTime*

- Please send 1980 Microcomputer Show exhibitor details
- Please send Mersey Micro Show details

Name \_\_\_\_\_

Address \_\_\_\_\_

Tel. No. \_\_\_\_\_

PC

• Circle No. 184

# Robots: sense & sensibility

## Part 3 of Mark Witkowski's robotics series tackles the problem of equipping a machine with the five senses

MAN and the higher animals are often said to have five senses: sight, hearing, touch, taste and smell. These are concentrated about the head in the eyes, ears, skin, mouth and nose. Information that comes from these organs allows us, and all living creatures, to react positively in an uncertain environment.

On the other hand, it is common practice in industrial robotics to modify the world so that it conforms to the requirements of the machine so little or no sensory information is needed. When the robot is used for welding or paint-spraying, this scheme works well, since much skill in these tasks is in maintaining a sufficient degree of consistency and repeatability in the quality of the work.

When robots are used for tasks where it is not possible to predetermine the environment totally, the control algorithm of the machine must be continually modified to take into account these variations.

Production-line assembly of units from their component parts is a typical example. Small items must be picked up, often from random piles of similar objects, oriented and placed in the correct position on the workpiece. Because it is difficult to ensure that each component arrives at the workstation in a predictable way, the robot has not yet been widely used in assembly tasks, which generally remains the province of unskilled human labour.

The next generation of industrial robots will be equipped with a great many more sensing devices which will make them useful for tasks other than a limited range of fixed-sequence operations. They will increasingly be able to act correctly in a wide range of unpredictable environments — doing the right thing at the right time.

A machine must possess 'human-like' sensory faculties in order to qualify as a robot. They are an essential link between the world and a computer program that emulates intelligence. Until recently, the trend in robotics has been to describe sensors only in relation to a specific robot or robot task. In many cases a

robot will only have one or two sensor inputs, but as robotics matures this will change.

Larcombe (1979) has looked at the sensor requirements for a mobile industrial robot and Wang and Will (1978) describe a range of sensors for a fixed-base manipulator system.

Robots must currently use different sensors from those that people use. We place considerable reliance on sight, which is currently too computationally expensive to be used to a great extent in current robot practice. Plenty of research is being done on robot vision, though, which I shall examine later in the series.

Hearing, smell and taste are also not of much value in robotics, although one might reconsider if a robot intended to be a chef. Touch — tactile and proximity sensing — have an important role to play; this review of some of the current ideas will concentrate on this and 'proprioceptive' sensing.

Proprioception is a genuine and undisputed 'sixth' sense we have — that concerned with monitoring the internal state of our bodies. It monitors hunger, body temperature, muscle extension and force and joint position. Similar information about a robot is required by a robot-controlling algorithm.

### Fine-tuned sensors

Robot sensors may either be general, to allow the machine to cope with many tasks, or they may be specific to one task only, and must be changed when the robot moves on to another job. The advantage of the latter method is that sensors can be carefully tuned to the situation they are to detect. Furthermore they can be made to give a clear, preferably binary, output that unambiguously triggers the next sequence or robot behaviour with a minimum of computational expense or complexity.

The advantage of general sensors lies in their flexibility since each new job requires only reprogramming for a different combination of existing sensor hardware.

Information they provide, in addition to the

minimum actually required, can then also be used to monitor and warn of malfunctions that the simple sensor would miss. These gains are offset by the extra expense, number of things to fail and a huge increase in the skill required in programming the robot.

In some applications, the general sensor scheme is essential. For instance: robots used for artificial intelligence research, or those used in remote manipulation telechiric control must have it, particularly if there is no direct visual contact between man and machine. Improved sensors will allow robots to tackle more complex tasks at greater speeds with less modification to their environment and with greater safety for those people that have to work in close proximity to them.

All mobile vehicle robots and manipulators require sensing to some degree. The minimum would be a mechanically precise pick-and-place manipulator that only requires a single interlock with the machine that feeds it parts.

Sensors that warn of impending collision are among the most important on a mobile robot vehicle. In all but the most tightly controlled environments this is essential since most useful robots are large, heavy and fast enough to make them potentially dangerous; 'if it hits it, it will break it' is a sensible maxim.

Proximity and touch sensors can be divided into three distinct groups: those that work over a long range, say greater than six inches; those that function closer than six inches yet involve no actual physical contact; and those that work by actual contact.

Long-range sensing will be of use in obstacle avoidance and route planning. Medium-range should allow sufficient time for the vehicle or manipulator to slow down and could be used to guide the robot or arm until contact is made. The last group of sensors will indicate the extent and area of contact and possibly the amount of force being applied, either by the robot on an object, or by the object on the robot.

Ultrasonic ranging is a popular method

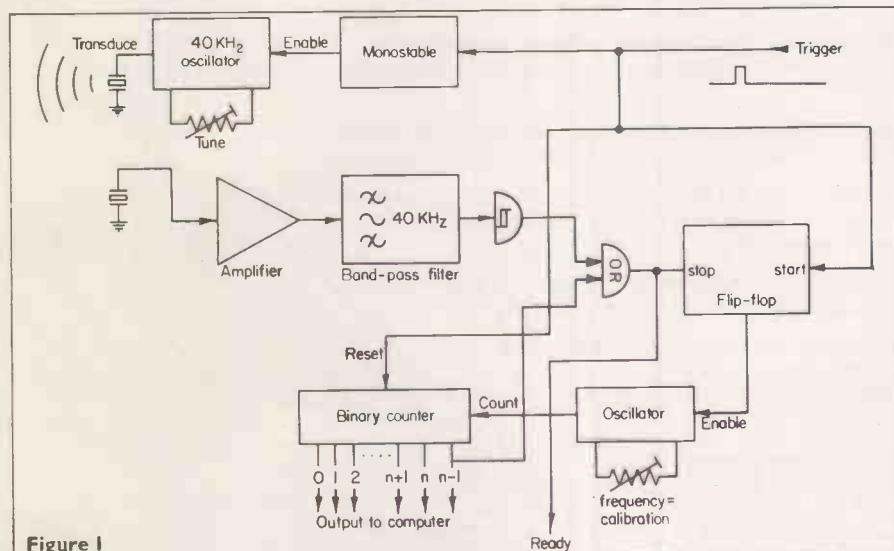

Figure 1

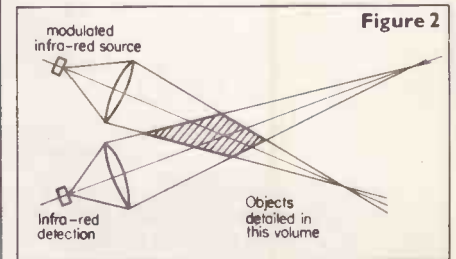

Figure 2

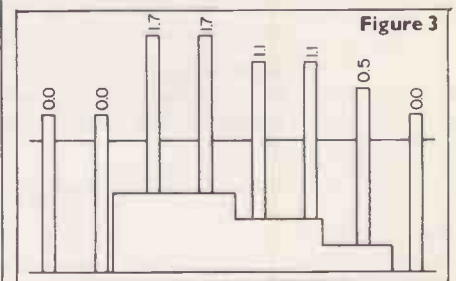

Figure 3

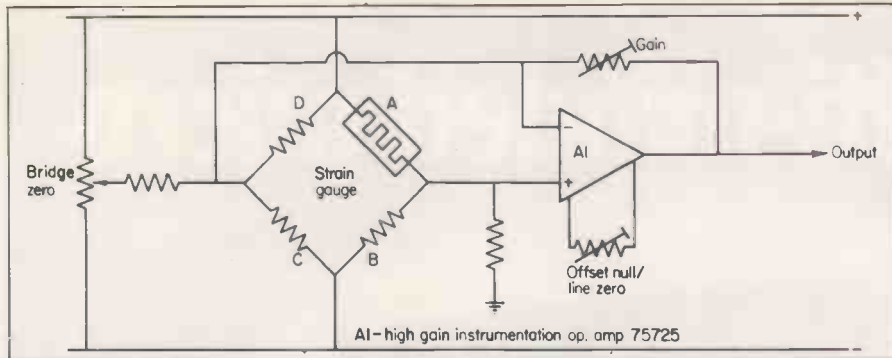
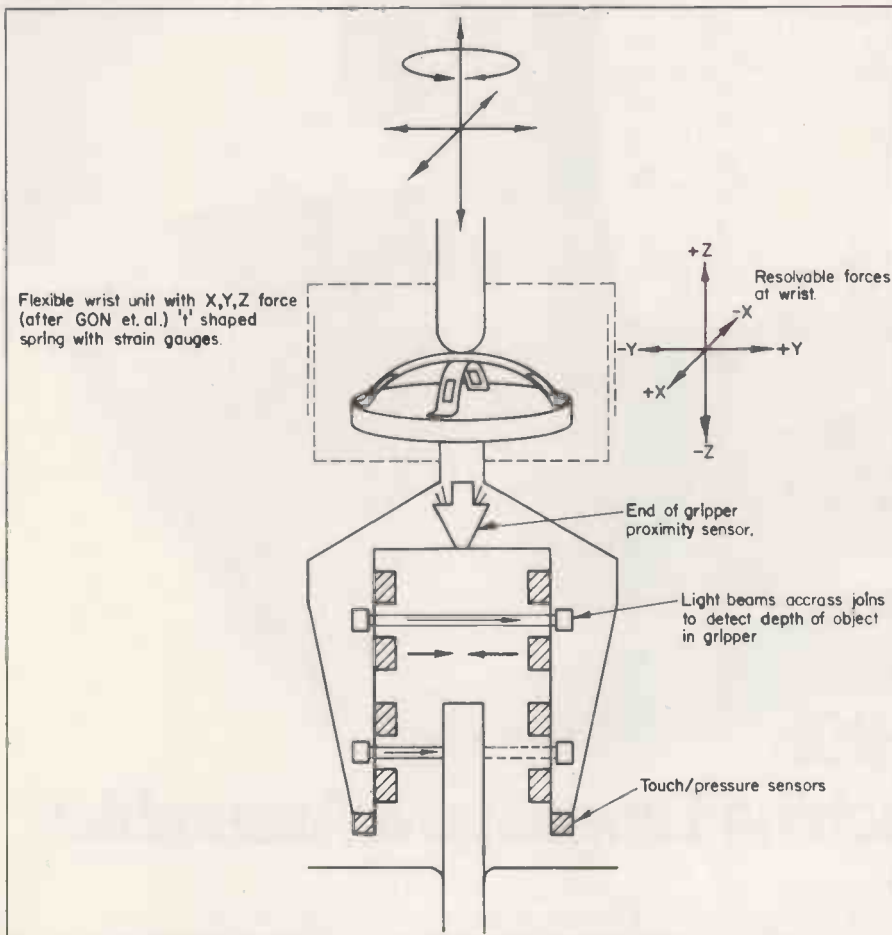

Figure 4 (above); figure 5 (below)



of long-distance object detection. It has been used on several robot vehicles to provide obstacle avoidance and on manipulators to give 'range-imaging' (eg Loofbourrow's 'MIKE'). A brief burst of ultrasound (> 20KHz) is transmitted from a crystal or piezoelectric transducer and any echo caused by the sound being reflected from an object is timed to indicate a distance. (The speed of sound in air is about 300 metres per second).

Figure 1 shows a block diagram of an ultrasonic ranging system. When the monostable is triggered, it enables the transmitter oscillator for a number of cycles (typically 10 at 40KHz). This signal powers the transmitting transducer.

The same signal also sets a flip-flop which starts a second oscillator that feeds into a n-stage binary counter which has been reset to zero by the trigger pulse. This second oscillator continues to count until the echo returns.

When the pulse is detected by the receiver transducer, it is amplified, bandpass-filtered to remove unwanted signals and used to halt the

counting oscillator by re-resetting the flip-flop. The binary result at the outputs of the counter is directly proportional to the distance to the object that caused the echo. Calibration is effected by altering the frequency of the second oscillator.

If there is no echo, the transition of the n+1th bit is used to halt the second oscillator; this bit remains set while the data is read, indicating a null result. National Semiconductor manufacture a single-chip device that incorporates the transmitter and receiver sections and includes a switch so that only one transducer is required, the LM1812 (see manufacturer's information).

Higher frequencies of ultrasound allow a higher resolution because of the shorter wavelength and can be used in narrower beams offering greater selectivity. Longer wavelengths are less attenuated by air and are effective over longer distances. The 270KHz system described by Wang and Will has a seven degree cone on both transmitter and receiver,

which gives sufficient resolution to allow contour maps to be generated with the system.

Several refinements to this technique are possible: phased arrays, analysis of the complex waveform returned by several objects or objects that are not flat. The latter has been used as an acoustic aid for the blind known as 'seeing with ears' (Kay 1979 and Boys *et al* 1979). Unfortunately the pattern-recognition problems when trying to analyse these signals by computer will doubtless prove to be no easier than analysing picture information.

## Ultrasound ranging

Ultrasound merits further research — one should not forget how effectively bats use sound. In many species it has totally replaced sight, with no apparent loss of ability.

Simple ultrasound ranging devices do have their disadvantages. They can be prone to acoustic interference, though filtering the received signal helps; they are not very selective, though broad coverage may be desired. Some surfaces absorb ultrasound, while all flat surfaces act as acoustic mirrors and specular reflection is a major cause of huge surfaces being missed.

As with radar, the returned signal falls off in power with a fourth law with distance, so sensitive receiver amplifiers can be swamped by echoes from nearby objects. It should also be remembered that many domestic animals and pets, such as rodents, cats and dogs can hear these sounds and they could be discomfited by high-intensity ultrasound.

Time-of-flight range finders using light or radio waves are not used much in robotics as the flight time is in the order of nanoseconds per foot. However, optical triangulation techniques are used for ranging and a chip is manufactured that performs a correlation on two images, producing a minimal signal when the two are superimposed. The triangulation reflector is scanned back and forth and the signal is used to servo the focus lens of a camera. This system has been incorporated in the recently announced Sankyo ES.44XL VAF ciné camera (see manufacturer's information).

## Doppler microwaves

Doppler microwave modules could find application in long distance robot sensing. Although they provide no useful range information, they are highly sensitive to movement, both of the vehicle on which they are mounted and objects in the environment. Here again, the signal would be confused and difficult to interpret, but they may have value as a safety sensor when people must work in close proximity to a robot.

Proximity sensing — indications of external objects less than 12 inches away — offers several possibilities for sensor design. Several designs are based on optical methods. In principle light, either infra-red or visible, is focussed on a point in space some inches away from the robot surface (Pond 1979). Any light returned from that point is focussed on a photosensor. While there is no object at that point, the light returned will be negligible; when an object is at the exact point of focus, the returned signal will be at its maximum (figure two).

This system is very selective but certain surfaces will reflect the light poorly and transparent objects pose a particular problem. Furthermore, this type of sensor is sensitive to other sources of light that may be of much greater intensity than the transmitter. It is

*continued on page 89*

# The multi-minded micro



## The Sharp MZ-80K with BASIC, Machine Language & Assembler.

Sharp's microcomputer has three languages. There's BASIC of course and now tapes and manuals for Machine Language & Assembler Programming. Trust Sharp, leaders in the field of electronic business equipment to come up with such a multi-minded microcomputer.

- \* Z-80 based CPU
- \* 4K bytes monitor ROM
- \* Internal memory expansion up to 48K bytes of RAM
- \* 14K extended BASIC (occupies 14K bytes of RAM)
- \* 10" video display unit—40 characters x 25 lines
- \* 80 x 50 high resolution graphics
- \* 78 key ASC11 keyboard alphabet (capital and small) plus graphics
- \* Built in music function
- \* Fast reliable cassette with tape counter—1200 bits/sec
- \* 50 pin universal BUS connector for system expansion—printers, floppy discs. etc.

**Insist on**



Audio, Video, Business Systems, Calculators,  
Cash Registers, Copiers, Microwave Ovens.

Sharp Electronics (UK) Ltd., 107 Hulme Hall Lane, Manchester M10 8HL Tel: 061-205 7321

Find out more about the multi-minded micro by filling in this coupon right away.

I would like to know more about the SHARP MZ-80K and the address of my nearest Specialist.

NAME \_\_\_\_\_

ADDRESS \_\_\_\_\_

TEL: \_\_\_\_\_

Sharp Electronics (UK) Ltd., 107 Hulme Hall Lane,  
Manchester M10 8HL Tel: 061-205 7321

PC/4

• Circle No. 185



continued from page 87

usual to modulate the outgoing beam and to ensure that the receiver is only actuated by light modulated in that way, either using bandpass filters or by employing a tone-decoding phase-locked loop such as the NE567 device.

Texas Instruments produce an infra-red led/phototransistor pair mounted in the same housing and angled to give maximum optical coupling when an object reflects the light at a distance of 0.2in — the TIL139. **Photograph one** shows a similar device. (The 14-pin dil indicates the size).

This device may well be of special interest to Micromouse builders as it would be ideal for detecting the red-painted tops of the run walls. By using the signals from several of these, the mouse could be steered and could also locate branches in the maze. If you expect your mouse to be on television, the beam *must* be modulated, since their lighting is notorious for upsetting equipment.

## Proximity sensors

Proximity sensors are available that will detect most materials by capacitive or inductive changes as the sensor head is brought close to the object. Such devices are used in some standard industrial applications and so are available in commercial grade housings. This makes them suitably robust, though not always very cheap. They are not entirely suitable as general purpose sensors due to wide variations in response to different materials. Inductive types respond to most metals; capacitive types will also respond to non-metallic materials such as wood or PVC. Fluidic sensors are also used in commercial applications.

Zero-range — actual contact — sensors can be either binary or analogue. A microswitch is a cheap and readily obtainable touch sensor, that comes in a good range of sizes, types and actuating forces. **Photograph two** shows one of eight microswitches being used to provide all-round touch sensing on a small robot.

Each of the robot's four sides has a pair of switches joined together by a length of phosphor-bronze strip. The strip is loosely bolted to the switch lever so they can be operated independently, according to where the object touches the vehicle.

This arrangement detects most obstacles at floor level — anything that juts out above the level of the switches should be removed from the vehicle's environment. Notice how the ends of the connecting strip have been bent out; it works best that way.

Tactile resolution can be increased by fitting more switches to the surface of the machine, or by fabricating a special-purpose matrix or strip of sensing devices. **Photograph three** shows a line of 16 experimental touch sensors.

## Tactile resolution

Carbonised conductive foam, as used to store CMOS devices, is mounted between two conducting surfaces made from printed circuit material. The conductivity of this material increases with the degree of compression. This change of resistance is easily converted to a voltage and fed to a microprocessor.

Several problems prevented the use of this system. The most serious was that the foam became unstable after it had been cycled many times. The material is also rather stiff, and while one segment worked well (for a time), when the vehicle was asked to compress many segments, the change in each individual segment was too small to give a useful signal. However, the idea may be revived for a larger,

**Picture 1: Infra-red/led phototransistor pair (right) of special interest to Micromouse builders**

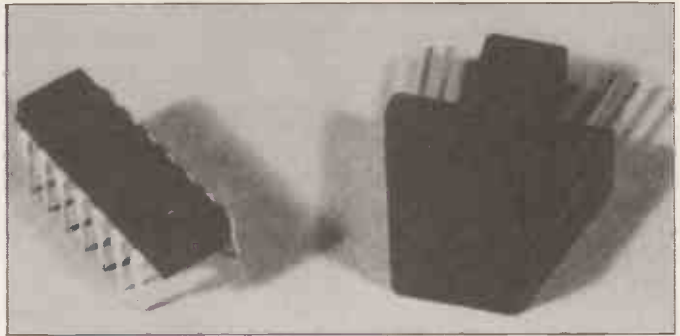

**Picture 2: One of eight microswitches used to provide all-round touch sensing on a small robot**

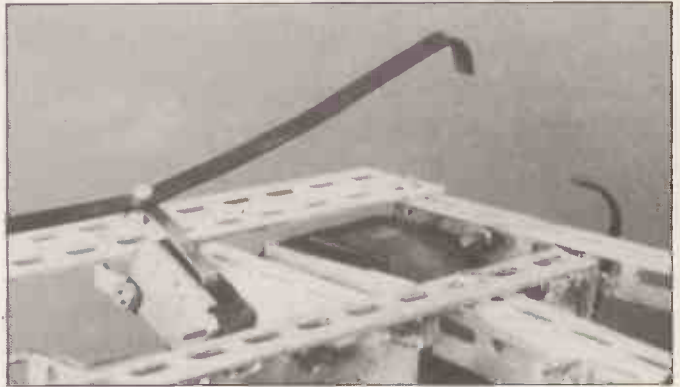

**Picture 3: Special-purpose strip of 16 experimental touch sensors**

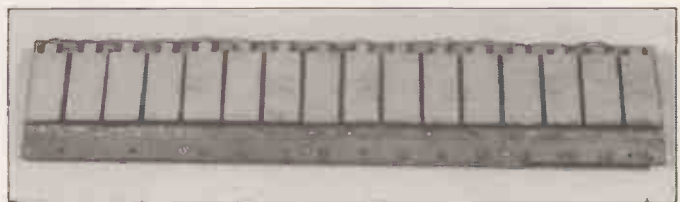

more powerful vehicle. Larcombe (1976) has also designed arrays of tactile sensors.

Pugh, Heginbotham and Page (1977) describe a matrix contact sensor in which a plate is drilled with holes in which a number of ferrous rods may slide up and down. When the plate is lowered onto an object, the rods are pushed up through the plate to a depth proportional to the height of the object at that point. The displacement of each rod is measure by the depth it has entered a coil (**figure three**). A contour map of the object is thus rapidly formed.

Grids of tactile sensors are of particular importance on the inside of gripper jaws, as they indicate to the system when an object has been touched, and also that it is correctly oriented in the jaws. Ueda *et al* (1976) uses a similar idea, with only a single rod, to measure distance in robot welding tasks — a distance measuring triangulation sensor is also described in this paper.

Strain gauges, as shown in **photograph four**, provide a useful method for measuring stress and force applied to or by either a vehicle or manipulator. A strain gauge is a thin strip of resistive material, often a copper-nickel alloy, on a thin flexible plastic sheet backing, fabricated by accurate photo-etching techniques. The background of **photograph five** is a 0.1 inch grid.

Typical resistance of a strain gauge is 120 ohms; when the track is bent or distorted a resistance change occurs due to changes in the length of the track and the physical characteristics of the alloy. The gauge is bonded to the surface of the stressed member with an epoxy adhesive.

Resistance changes are small, so the gauge is

normally incorporated in a Wheatstone Bridge and the resulting signal amplified by a high-gain operational amplifier circuit, as in **figure four**. **Figure four** shows the outline of a quarter bridge circuit. Changes in resistance in the gauge, A, cause changes in the differential voltage at the inverting and non-inverting inputs of the operational amplifier. Both the gain of the circuit and the zero point (with the gauge unstressed) can be altered to suit the application.

In a half bridge, A and B are now both gauges and C and D remain fixed resistors of the same value. This arrangement produces a greater signal, better signal-to-noise-ratio and temperature compensation than the quarter-bridge. A full bridge circuit, in which A, B, C and D are gauges, offers the best performance of all.

Strain gauges are manufactured in many configurations, linear (as in the photograph), for multi-dimensional stress (rosette gauge), for torque loading and diaphragm distortion (Jones 1977, or any book on transducer and instrumentation systems). Many gauges will be used in a multi-dimensional force sensing unit to give a simultaneous read-out of applied force in the X, Y and Z directions.

Several designs have been produced to work on manipulator joints, particularly the wrist. Goto, Inoyama and Takeyasu (1974) describe a cross ('+')-shaped coupling fabricated from sheet spring steel at the wrist with a strain gauge on each of the branches, which has been used for assembly tasks involving inserting pistons in cylinders machined to close tolerances (20 microns).

Wang and Will (1978) describe a modulator

continued on page 91

# M I C R O C O N T R O L

224, EDGWARE ROAD  
LONDON W2 1DN  
TEL (01) 402 8842



SALES SERVICE

*Official Dealers — Apple II — Microstar — Compucorp*

## PRICE LISTS

APPLE II (16K) VIDEO OUTPUT	750.00
HIGH-SPEED SERIAL CARD	110.00
CLOCK CARD	140.00
LIGHT PEN	165.00
VOICE RECOGNITION CARD	127.00
LOWER CASE GENERATOR	40.00
EPROM BURNER & SOCKET ADAPTOR	99.00
PROTOTYPING BOARD	20.00
PAL CARD	72.00
B/W MODULATOR	20.00
PROGRAMMERS AID NO.1	29.00
APPLE II MODULATOR OUTPUT	770.00
DISK DRIVE WITH CONTROLLER	398.00
DISK DRIVE	355.00
DOS 3.2 MANUAL & DISKETTE	18.00
APPLE PASCAL	296.00
AUTO-START ROM	40.00
GAMES PADDLES	17.50
SUPER TALKER	190.00
APPLE II INTEGER BASIC MANUAL	3.55
APPLESOFT BASIC MANUAL	5.75
6502 PROGRAMMING MANUAL	8.90
APPLE II PLUS COLOUR (PAL)	819.00
6502 HARDWARE MANUAL	8.90
BLANK CASSETTE (C15)	0.85
MICROPRODUCTS PARALLEL PORT	40.00
8" FLOPPY DISK SYSTEM (1.2 MB)	2350.00
DISK BASED ASSEMBLER	30.00
VINYL CARRYING CASE	25.00
MICROCHESS 2.0 CHESS DISC	16.00
16K ADD-ON MEMORY	69.00
APPLESOFT FIRMWARE CARD	110.00
INTEGER FIRMWARE CARD	110.00
PARALLEL PRINTER CARD	110.00
COMMUNICATIONS CARD	132.00
APPLE II REFERENCE MANUAL	5.75
BASF FLOPPY DISKETTE	3.50
CENTRONICS 779 PRINTER	889.00
CENTRONICS PRINTER CARD	132.00
HITACHI 9" B/W MONITOR	132.00
TRENDCOM 100 PRINTER	23.00
TRENDCOM PAPER (80 FT)	4.25
TC 3 TRENDCOM 100 I/F	49.00

**NEW!**

## DIGITAL COLOUR CARD

**Apple II or ITT 2020  
Mixed Colour Text!!!**

Complete software control allows  
**15** fully-saturated colours in  
Graphics and Text modes.  
Simple plug-in system. Existing  
Software Compatible Designed  
and Manufactured by us  
Complete System. £148.00  
Monitor Mod Kit £27.00

## 12-BIT RESOLUTION

### A/D Conversion

Our new A/D cards offer high  
12-bit resolution with a fast  
conversion time, 4 inputs on board  
expandable to 8.

Max. Sensitivity 10  $\mu$ V F.S.D.  
Demonstration Software  
Supplied.

Turn your apple to a fast analogue  
data acquisition system X, Y plotter  
etc.

12-Bit System £174.  
8-Bit System £116.

## APPLE PASCAL TM

This Hardware/Software package  
provides a very powerful tool for  
the serious user. High speed hires  
"Turtle" graphics, fast editor,  
Compiler, Relocatable Assembler,  
Excellent System Utilities, Superb  
documentation £289.

**LEASING FACILITIES AND FINANCE  
AVAILABLE  
RING FOR QUOTE**

**COMING SHORTLY  
COLOUR FOR PET TRS80**

**SPECIAL INTERFACES**  
We can design and produce special interface  
systems at reasonable cost

**PART EXCHANGE**  
We offer generous P.X  
allowances, ring for quote

All prices exclude VAT

• Circle No. 186

PRACTICAL COMPUTING April 1980

*continued from page 89*

system, one module for each degree of freedom giving essentially independent outputs. Such a system would lend itself well to use in the 'fingers' of grippers, to detect how much force is being applied to an object being squeezed. The Olivetti SIGMA assembly robot has a force-sensitive wrist in which displacement is measured against springs by position sensors (Salmon 1977).

The Charles Stark Draper laboratories have done a good deal of research into the whole problem of mechanical assembly, using both multi-axis force sensors and compliance wrists (those with a certain amount of 'give'), particularly of close fitting parts (Nevins and Whitney 1979). Figure five shows a possible sensor configuration for a wrist and gripper on a manipulator.

The most important proprioceptive system on a manipulator arm is feedback showing the position or angle of each of the joints. In a computer-controlled arm this is essential. The final position of the gripper is calculated in relation to the working environment, and the movement of the joints is guided along planned routes to avoid known obstacles, including, in a multiple arm system, the other arms.

Many of the currently available point-to-point and continuous-path industrial robots are servo-controlled. Signals from their position sensors are recorded during the 'training' phase. During the playback phase, this recorded signal is compared with the current arm position and the error signal is used by the computer to drive the arm correctly (eg Aareskjold 1979).

## Position encoders

Position encoders can be either analogue or digital, linear or rotational. Linear or rotary potentiometers produce a signal according to where a slider is on a resistive track — a voltage applied across the ends of this track give a voltage proportional to the position of the joint. Generally these have a lower precision and repeatability than digital types, but are cheaper. Their linearity is more important than actual resistance value.

Digital encoders, in which a binary code is read optically from a disc or strip using a light/photocell pair are common. The binary code may either be straight binary, in which case certain transition errors are possible, or a Gray code in which only one bit changes at a time. Eight to ten bit codes are not uncommon and are generally adequate for robot use (about 0.3 to 1 degree resolution in 360). Special techniques in which interbit distances are resolved can give resolutions equivalent to 20 bits. Many of these techniques and systems are described in Woolvet (1977).

With constrained manipulator joints, errors are usually non-cumulative — there is always a reference position on each joint, often defined by an end-of-travel sensor, indicating the limit to mechanical movement. When a control program has to track the position of a mobile vehicle, the problem is far worse. On small machines stepping motors may be used, and integration of the number of steps made (eg Ralph Hollis's NEWT).

On larger vehicles, less easily-controlled drive systems are used. The distance the vehicle travels may be monitored by odometry — integrating the cumulative rotations of the wheels, and then calculating the current co-ordinates of the vehicle. A similar process is known to sailors as 'dead reckoning'.

As this system requires continuous updating, it is computationally expensive, and prone to

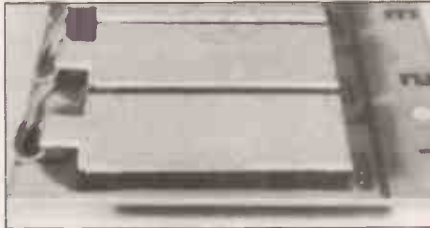

Picture 4 (left): Strain gauge

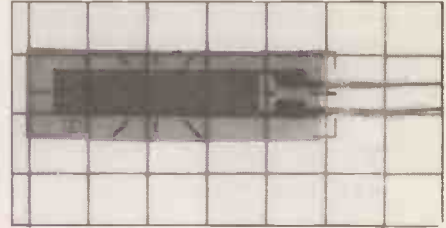

Picture 5 (right): Close-up of photo-etched plastics sheet backing

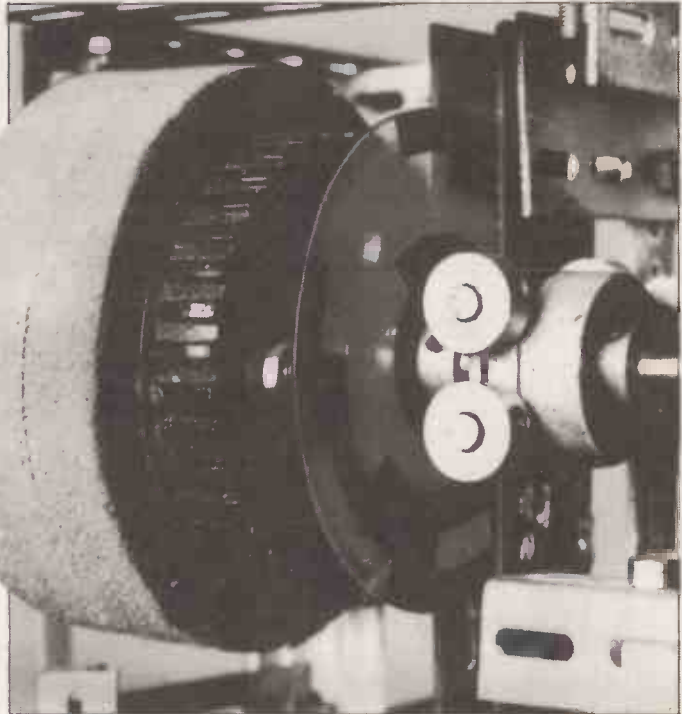

Picture 6: Gray-coded disc used to measure wheel rotation

cumulative errors. Tyres can change diameter due to wear or differing inflations and wheels can slip on a poor surface, or if subjected to excessive accelerations. Inertial navigation systems avoid these problems but only at prohibitive cost. Photograph six shows a Gray-coded disc used to measure wheel rotation on a small robot.

A learning micromouse will almost certainly use a system of this nature. Wheel rotation would be translated into an X-Y coordinate system. A combination of TIL139 type proximity sensors and microswitch touch sensors, possibly with wire 'whiskers' attached (as with Hobby Electronic's HEBOT), will tell the software when a 'T', 'L' or '+' junction or blind alley has been encountered. The current co-ordinates would be stored and used for route planning later.

One solution is to use odometry or dead reckoning as the basis for a total navigation system, but to back it up with information from other sensors. Sonars will detect fixed obstacles, whose position is known; light or radio beacons can provide directional bearings, allowing triangulation. The computer system must therefore generate and maintain a map of its surroundings, a useful extension of the maze-running algorithms that micromouse work will produce.

Aviation provides many interesting examples of navigation by the use of external signal sources. Radio navigation aids, such as Loran 'C', the Decca system, Omega and GEE (from the last world war) involve two or more ground stations that simultaneously transmit pulses.

Signals received from these transmitters will have a phase relationship due to the propagation delays from the transmitters. If they

arrive at the same time, the receiver is on a line equidistant from the two stations. Time differences between the two signals define the receiver to be on a hyperbola between the two. By using a third transmitter, the point of intersection between the two hyperbola fixes the receiver's position.

Generally, the delays using radio waves would be too short and acoustic systems would suffer badly from reflections and other unwanted signals. If the system were reversed, such that the vehicle transmitted and several ground stations received, relaying the information back the system would stand a better chance. Cohen's 'drawing' robot, for example, has four ultrasonic receivers at the corners of the robot area (0.2in resolution in 16ft).

For robots that use mainframes and mini-computers as part of a ground station, this poses no problem, as timing information can be sent with all the other information flowing between robot and computer. Transponder systems in which the vehicle transmits a coded signal which is retransmitted from only one of many possible ground stations (time of flight proportional to distance) are also a possibility (*Navigation systems*, Byatt 1980).

All sensory information from these transducers, and a huge range of other possible designs, some or all of which may be appropriate to a particular design of robot, must then be fed into the computer system. Interfacing binary sensors, such as the microswitch touch sensor, digital shaft encoders and sonars to a microprocessor is straightforward. Parallel interface devices, such as the MC6820, are readily obtainable and easy to use, with full

*continued on page 124*

WALES LEADING  
SYSTEMS HOUSE



14 CHEPSTOW ROAD  
NEWPORT, GWENT.  
50528 / 841691 / 63310

Incorporating ( Microcourier)

At Micromedia we are usually asked for Complete Business Systems, here are a few examples.

	Purchase Price	Lease P/M
Accounting Package Sales Invoicing / Credit Controls Payroll on Alpha Micro, with 10 Megabyte Disk, visual display unit and printer.	17.950	448.75
Purchase Accounts, Sales Accounts, Payroll on Cromemco System <u>iii</u> with work station, visual display unit and 180 c.p.s. printer.	7.950	198.75
Word Processing, Payroll, Accounts, on North Star Horizon with printer visual display unit and additional monitor.	5.500	137.50

Call us for a quotation on :

Cromemco ii & iii

North Star Horizon

Alpha Micro

Compucolour ii

Commodore Pet

S W T P 6800

Microstar 45

#### APPLICATION SOFTWARE

Mailing Lists  
Data Base Management  
Accounting Suites  
Stock Controls  
Simplex Linear Programming  
Personel Records  
Fleet Maintenance Records  
Word Processing  
Pert (Critical Path Analysis)  
Purchase Ledger  
Sales Ledger  
Medical Records  
These are a selection from the range please call us to discuss your particular application.

We specialize in systems for Business Industry and Education and have specialist staff to discuss your applications.

Visual Display Units	From £	Printers	From £	Odds 'n Sods	£
Adds Regent 20	605	Anadex DP800	575	M22 Paper Tape Reader Punch	975
Adds Regent 25	645	S W T P PR 40	250	M33 Paper Tape Reader	450
Adds Regent 40	865	OKI E T 5200	485	M63 Paper Tape Reader Punch	1495
Cifer 2600	600	Teletype 43 KSR	840	Servogor Graphic Plotter	2750
Dec VT 100	1100	Dec LA 34	895	Sigma Graphic Option Controller	2168
Elbit 1920/30	725	Dec LA 36	905	Single side mini Diskettes Per 10	30
Elbit 1920/30x	750	Dec LA 120 KSR	1675	Single side 8" Diskettes Per 10	35
Infoton	610	Diablo 1640 RO	2098	Single side 8" Diskettes Per 10	35
Lear Siegler ADM 3A	595	Diablo 1640 KSR	2292	C12 Cassettes Per 10	475
Newbury Lab Range	From 495	Texas 743	1195	Large range of computer books send SAE for list.	
Pericom 6801	985	Texas 810	1450		
Pericom 6802	1085	Tally Range from	1895		
Pericom 6803	1285				

OEM TERMS & QUANTITY DISCOUNTS AVAILABLE WRITE FOR DETAILS

• Circle No. 187

# "My best Apple programs are on long-term deposit in the City... it pays rather well!"

We brought the first five Apples into the U.K. in November '77, with every penny we had. In November '79, we find several thousand throughout the country.

*THANK YOU* Apple owners.

Now we'd like to help you re-coup your investment by cataloguing and supporting the best Apple programs in the U.K. The Apple Software Bank is more like an old penny bank than a major clearing bank, but we know you'll help it grow. Telephone Stephen Derrick on 01-626-8121 to discuss your investment.

**ATTENTION ALL** Estate Agents, Employment Agencies, Yacht Brokers, Antique Dealers and Motor Traders.

Find out about *FINDER SOFTWARE!*

## **SOME BLUE CHIPS**

**TESKIM.** This ROM will simulate the Tektronix 4010 family of graphics terminals. It's rather good!

**UPPER LOWER CASE ADAPTOR** A chip for the chap considering word processing.

## **NEW ISSUES**

We are continually trying to bring the latest add-ons for your Apples. Please phone for the latest product information and data sheets.

## **NEW PRODUCTS**

**8" SHUGART DISKS** giving 1.2 Megabytes A twin drive (with room for a third.) disk system with controller and software, give tremendous commercial possibilities. £2350 Excl. V.A.T.

**WORD PROCESSOR.** Ask about our Apple II Plus word processor package. Complete System with Diablo 1650 Daisy-Wheel Printer. £4250 Excl. V.A.T.

**PERSONAL COMPUTER PRINTERS.** Sensational 40 & 80 Character printer (graphics options) from £243 Excl. V.A.T. Interfaces for Apple, Pet & TRS 80. High quality silent printers. It's your choice!

**A/D BOARD** At last we have either an 8 bit or 12 bit A/D card for Apple. Excellent spec from £125 Excl. V.A.T.

**APPLE PASCAL** £296



# Personal Computers Limited

194-200 Bishopsgate, London EC2M 4NR.

Let us advise you about *COLOUR DISPLAY* on your Apple. Contact Technical Services.



● Circle No. 203

# Z-Plus Microcomputer System

Over One Megabyte Disk Storage • 4 MHz Z-80 Processor

Two Serial and One Parallel I/O Port • 64k Memory

An alphanumeric keyboard • Including Sytem Desk

Price: 1 Megabyte **£3950**, 2 Megabyte **£4450** plus VAT

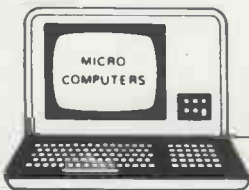

## ROSTRONICS

LIMITED

115-117 WANDSWORTH HIGH STREET, LONDON SW18 4HY  
Telephone: 01-874 1171 Telex: 8813089 INTPRM G

FOR DEMONSTRATIONS CONTACT ONE OF OUR DEALERS

STACK COMPUTER SERVICES  
290/298 DERBY ROAD  
BOOTLE, LIVERPOOL 20  
Tel: 051-933 5511

ROSTRONICS (GLASGOW)  
EWL COMPUTERS LIMITED  
8 ROYAL CRESCENT, GLASGOW  
Tel: 041-332 7642

KUDEK LIMITED  
30 LANSDOWN TRADING ESTATE  
GLOUCESTER ROAD  
CHELTENHAM, GLOS.  
0242-580742

MICRO · APL  
17 DONNE PLACE  
LONDON SW3  
Tel: 01-589 3842

CITY COMPUTING CENTRE LIMITED (Agent)  
PRESTBOROUGH CHAMBERS  
33 SIDBURY, WORCESTER  
Tel: 0905 26106

NORMAN GREEN LIMITED  
67 BRIDGE STREET  
MANCHESTER M3 3BQ  
061-832-3265

Games-playing pastor George Blank shows how to . . .

## Write games for fun, cash and fanmail

WRITING and selling computer games can be a lot of fun. The joy of bringing pleasure to others, the occasional fan mail — much of it outrageously imaginative and entertaining — the feeling of power from the knowledge that you are structuring the time of thousands of people, and the satisfaction of royalty cheques, not to mention the pleasure of designing and playing your own games, are all among the rewards.

It is probably not a way to become wealthy. By far the majority even of those who are good at it will not be able to earn a living at it. It can be a profitable source of extra income, and it makes a delightful hobby. It is not difficult, so many people who are not currently aware of their abilities may be able to try writing games.

The starting point is an idea that can be turned into a game. Possibly the greatest resource of the games master is the ability to see things in a fresh new way that captures our imagination and draws us into his or her own created world. There are many sources of ideas. These might include the reliving of great moments in history, the simulation of fantastic adventures, playing a role from literature or popular movies and television shows. Many other sports and games may themselves suggest either adaptations to the computer or a new direction for a computer game.

Once you have an idea, play with it for a while. I cannot overstress the importance of writing it down, for it will not be clear until you have forced yourself to express it well. Unfortunately, it is also likely that you will forget it if you fail to write it down.

### Organize papers

After you have written down the idea, think of different ways to present it, special twists, innovative ways to use the idea to capture the imagination. Few games will be any better than their central concept, so make sure you have a clear idea of the point of the game before you start writing it.

If the first requirement of writing a good game is committing your ideas to paper, then the second requirement is keeping your papers organized. All the hard work you do to think through the concept of your game, or implement a particular function of it, is wasted if you forget it and lose your records.

I think the best method of organisation is to use a three-ring binder for each

game. The binder is flexible, allowing you to substitute new versions of older concepts, but it also forces you to organise your papers. A file folder is a possible substitute, but papers in a file folder generally do not stay in order.

Now that you have a clear idea of the game that you wish to write, you should sit down and start to write it, correct? Absolutely wrong! As a general rule, the longer you wait before you commit your game to a fixed form, the better off you will be. The best way to treat a good idea is to back it up with research.

In writing a simulation of the clipper ship races of the last century, I read books on history, fictional accounts of sailing, atlases and geographies, guides to sailboat racing, even navigation handbooks. All the time I took notes to add to the notebook. As I learned more about my subject, the central concept of the game changed several times, and I wrote out a new concept.

### Deadlines

There is a danger at this stage for the person who has previously written successful games. I think it is a bad idea to tell a publisher what you are doing, for if the idea is good, you will then be under pressure to rush the job. The best games take weeks or even months, and rushing them destroys them.

The time to tell a publisher about a game is when it is fairly well written, and you need encouragement to keep you at it. Then an expression of interest may provoke you into finishing the task with diligence.

Of course, the problem might be quite different for the novice, who may not even know a publisher. They will have to have a finished product before they even make contact, and then wait a frustrating three to four months to hear back from the publisher.

Once you have developed the idea and done your research, it is time to think about the factors that will enter into the game. For example, in a political simulation, it might be important to give players control over tax levels, food supply, current events, economic investment, the quality of advice received, and many other factors.

Once you have a good idea of the factors that will be in your game, start thinking about the degree of control, from total player control to total randomness for each factor, and place your



thoughts in your notebook. You will not be committed to these ideas, and they will certainly change, first as you write the program and later as you test and polish it, but the early thinking helps considerably.

My personal suggestion is that these steps should take from one to three weeks for a moderately-sized game of high quality. Now you are ready to write your program. There is really only one language that is suitable for the first writing of your program, and that is your native tongue. I program in English before I even begin to program in BASIC or Assembly Language.

It is difficult to tell how much time to put into this, but you will eventually sense the point at which it would be profitable to switch from human language to computer language. My guideline is that each hour spent in planning should later save at least an hour of debugging. If I plan beyond the point at which I am using my time productively, I am wasting my resources. But inadequate planning is also wasteful, as the program may require a lot of debugging or even extensive rewriting.

### Ready, get set . . .

Once you have a decent outline of the program you wish to write, you are almost ready to begin programming. All you need to do is get your notebook ready to keep track of your program. I consider three sections absolutely essential. They are an Index to Sub-Routines, A List of Variables, and Documentation Notes.

The Index to Subroutines is not a fancy typewritten alphabetical cross-reference to everything in your program. It is simply a list of the parts of the program you have written, the starting line number, and enough description that you can find it.

*continued on next page*

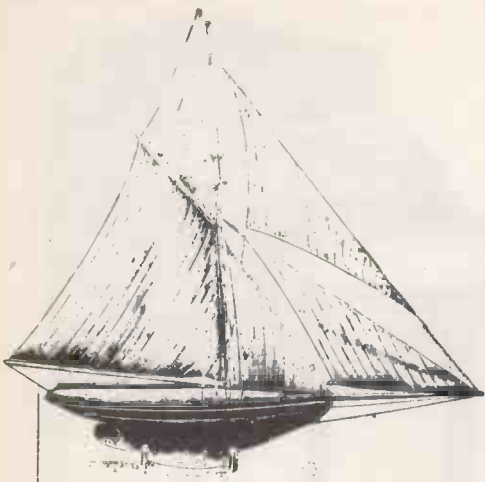

from previous page

This way, you just look on your index page for a routine you want to change or re-use without searching through your program. Here is a sample — the original was done in pencil.

```
00 Initialize
1000 Control
2000 Board meeting
3000 Controller Report
4000 Sales Report
  700 Page Turner
  500 Integer Routine
5000 Production Meeting
```

I write these down as I begin to write that part of the program, then if I wish to refer to a routine I look at it again. For example, I often use an integer subroutine in my games. Since the limit for the INT command in my computer is 32,767, the integer routine tests to see if the number is less than that, converts it to an integer if it is, or divides it to bring it down to the proper range, uses the INT function, and multiplies it back. Using the above list, when I want to use the Integer Routine, I know all I have to do is use GOSUB 500. If I need to know what variables to use for the routine, I can LIST 500-690, as I can see that the next routine starts at 700.

### Critical housekeeping

The other critical piece of housekeeping is a List of Variables. I have mimeographed a form that simply lists the twenty-six letters of the alphabet, with rows across the page for several variables starting with that letter. A typical line might look like this.

```
G Print at loc. G          G(1,5)
General Staff G$(9) Graphics
```

My games often use dozens of variables, and a list of those in use is the only way to avoid extensive debugging problems. I also use pencil on this, so that I can make changes, or list more than one variable in each space. For example, if I want to add two more variables, GF and GM, I could list both of them in the empty second row, one on top of the other.

If I use matrix variables, I use a separate piece of paper for each matrix with a list of each item. For example, here

is the breakdown of the G(1,5) matrix in the previous example.

```
P = Player (0 or 1)
G(P,0) Equipment
  1) Morale
  2) Funding
  3) Divisions
  4) Administrators
  5) Leadership
```

These I usually type out neatly, as I will probably refer to it many times as I use these variables in different parts of the program.

The third essential section is the documentation section. This is already well begun with the statement of the concepts and the notes from your research, plus your English language program. Simply keep it up-to-date so that you can refer to it as you write the program, and later as you prepare the documentation to send out with the program.

### Grin and bear it

All of this may strike you as unnecessary paperwork. Why should you go to all that trouble just to get ready to write a program? I will admit that I can write some programs without any of this work. But quite frankly that means only very short programs, and it is getting very hard to sell short programs any more.

On a longer program you will simply get lost if you have inadequate documentation, you will spend more time looking through your program for the information described here than you would have spent to write it down, your program will be poorly organised and therefore take longer and be harder to write, then, as a crowning blow, after all these extra problems, you will probably spend twice as many extra hours debugging as you save by skipping the paperwork. So either grin and bear it or groan and bear it, but bear it nonetheless!

Now for the actual programming, or perhaps a better term, translating your English program into a computer language. I have several suggestions to make. First, and most important, do not neglect style. Style means that your program should be easy to read, nicely organised, and well commented. There are several good books available on style. I could recommend these, but there are others.

*Programming Proverbs*, by Henry Ledgard (Hayden Book Company)  
*BASIC With Style*, by Paul Nagin and Henry Ledgard (Hayden)  
*The Little Book of BASIC Style*, by John Nevison (Addison-Wesley)

### Style is the man

I prefer them in that order, and think that only one is necessary, but a novice to programming might prefer the second one. You don't have to read these books, though. You can also learn style by reading other people's programs in magazines and taking note of what they

do well. I think the books do a more comprehensive job and prepare you to recognise good style in the magazines.

I edit a magazine, and believe me, I think style is important. In fact, I can think of one program that I printed mainly as an example of style, and not for its content at all!

I find it very helpful to have a standard numbering convention for my programs. Here is my preferred system. You may use it or neglect it as you wish:

- All subprograms begin at a line number ending in 00.
- Remark statements have line numbers ending in 9 and are never called by GOSUB or GOTO.
- Line numbers ending in 1 are used strictly for temporary test lines, to be removed before the program is published. This allows me to print out the variables upon entering and leaving a subroutine, use the TRACE command, and do other tests.
- Line numbers 2,3,4,5,6,7 and 8 are for additional lines added after the routine is first written.
- Program lines otherwise end in 0.

After you are completely finished with your program, and it is thoroughly debugged, you might consider using a re-number program to give it orderly line numbers. Our magazine receives frequent requests for this from people who use the AUTO command to type in line listings.

As you write the actual game, the content is your responsibility. That is what you are selling. All of my suggestions are simply to make your games easier to write or easier to sell. Beyond the content, however, there are some important factors, including graphics, animation, pacing, frustration, and difficulty.

### ... tells a story

Graphics cannot be overstressed. The difference between a good program and a lousy program is usually presentation, not content, and most people prefer pictures to words. I program for the TRS-80 computer, which has memory-mapped graphics. You can buy pads of worksheets to use in plotting your graphics, but I use an easier and cheaper method.

There is a worksheet pad in the Radio Shack manuals. I have taken my manual apart and punched it with holes for a three-ring binder. Then, at an office supply store, I bought a sheet of clear plastic and a special marking pen for overhead projector transparencies. I punched holes in the plastic to fit in the binder right over the worksheet, and now I have a re-usable graphics worksheet. The transparency marker erases with a damp cloth once I have finished my graphics and want to re-use the plastic.

Animation is really only a special form of graphics, but it adds interest to a game and makes it easier to sell. Sound is also in this category, whether it is music, ringing



the bell on the terminal, working a buzzer, or using a speech synthesizer. I have seen one program for the TRS-80 that gives some nice sound effects by clicking an internal relay in the computer.

If your program uses special hardware such as a speech synthesizer, you reduce your potential market unless you isolate the part of the program using the hardware and make it optional. You could do this by a routine like this, with a sound package at the subroutine at 5000.

```
10 INPUT "Do you have a music
board";M$
20 MU=0:IF M$="YES" THEN
MU=1
30 IF MU=1 THEN GOSUB 5000
```

Any later call for music could also use the test: IF MU=1.

Good pacing means that the game has enough going on to hold your attention. Games that require the player to sit for a long time while the computer does a calculation to get ready for the next move, or draws a very slow graphics routine, get very boring very soon. You can speed things up, break up long calculations into separate parts of the program, provide diversion, or rewrite the program to avoid such routines.

### Speeding up

To speed up a program, you can use integer variables, which are much faster than single- or double-precision ones, use variables instead of constants, place frequently-used subroutines and DATA at the beginning of your program, and use other tricks appropriate to your computer. The reasons for these items are as follows.

With integer variables, the computer has to handle only one byte of data, which can be easily handled by the registers, instead of using long, slow sub-routines for arithmetic. With a constant like 3.14, the computer has to treat each digit separately, read it, put it together, convert it into a register variable, and figure out what to do with it.

If you have a variable like PI that was set equal to 3.14 earlier in the program, the computer just loads it into the register and tries to figure out what to do with it, saving many machine-language steps. The reason for putting subroutines and DATA at the beginning of the program is that the computer starts at the beginning to look for them when it gets a READ, GOTO, or GOSUB statement. Then it has to test every line for DATA, or compare every line number for the one requested until it finds it.

Providing diversion is often fun. I have a Star Trek program that has to read a lot of data at the beginning of the program, in order to set up a matrix. I simply put PRINT statements at appropriate points in the initialization routine, so that the computer prints out messages like "ENGINE TEST: GREEN" and "ALL CREW ON BOARD" at intervals while

you are waiting instead of just sitting there.

Frustration should be carefully planned for, as it can really hurt a game. One of my worst examples is in a game called 'Round the Horn' that I wrote for SoftSide. It is a clipper ship race around South America. If a player does not sail far enough east before entering the Doldrums, he must cross the doldrums at an angle, against the current, and without wind. It could take months! While that is realistic, it is not a lot of fun.

### In the doldrums

If I ever rewrite the game, I will add a routine that tests for three weeks in the doldrums and then ends the game with a message like this. "Your crew just died of thirst while trapped in the Sargasso Sea". The point is not to eliminate all frustration, but to limit it to manageable chunks.

Difficulty should be appropriate to the game and consistent. That is, an intellectual game should not be too easy, a game for young children should not be too hard, and an easy game should not have very difficult parts. I like to put graded difficulty levels in my games, so that beginners can play one level and expert players another.

Once you have programmed your game, you have made a good beginning. I would say that about one-third of the work is done. Now you have to debug it, test it, revise or rewrite it, provide documentation, and sell it. I suggest that you play with it, and eliminate any bugs. Then get your friends to play it and get their reactions. Watch them play. Notice any problems they have. Ask for suggestions.

I am very fortunate in this regard, as the youth group of my church loves to play computer games, and they are getting pretty good at making suggestions. You might do well to volunteer as a church youth worker or scout leader to get a hold of a valuable free testing organisation!

Once you have the game thoroughly tested and debugged, the best thing to do is start over. You shouldn't have to do much more research, but the game will probably be much better if you start over by completely rewriting your English program, then redoing the computer program.

### Cost v. quality

I realise that there is a consideration of cost versus quality here, but the market is beginning to demand high standards and this is the best way to do a real quality program. It should go much more quickly, as you have already figured out most of your problems. Now you are looking for better and more interesting ways of doing the same things.

After you rewrite your program, polish it. If you can, add suspense. Television holds our attention and keeps us from changing stations during the com-



mercials by providing a moment of suspense every seven minutes, just in time for a commercial. Is each turn too long or too short? Is there enough action during a turn? Are the graphics sequences attractive and well-paced? Do they add to the game? Are there dull moments in the game, and if so, how can they be eliminated? Can you add special features like animation?

### Check for flaws

Now check your program for flaws. The best way to do this is to have lots of people play lots of games. After I publish a game, there are several thousand readers of *SoftSide* to detect any flaws, but I prefer not to print corrections!

One very important step is to find out how your variables react near the edge of their range. If they ever get near zero, find out what happens at zero. Is there an attempt to divide by zero? If you use variables in your graphics, find out whether they will ever go off-screen, and what would happen if they did. Does the program require more memory than most people have? Are you relying on special features or modifications to your particular computer? Have a friend try it on his computer to make sure.

Now there are only two steps left, but they both take lots of time. The first is to continue your testing for at least a month, with as much testing as possible, to make sure all the flaws are gone. This is hard to do, and I confess it is the most difficult thing for me. But most editors or reviewers, if they get a program that bombs, move on to the next program, and

*continued on next page*

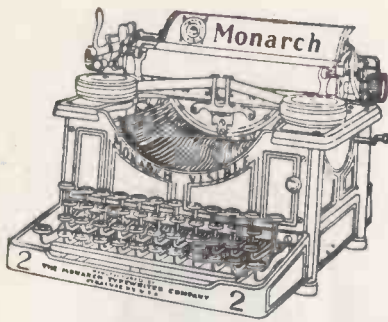

from previous page

that is the end of all your hard work. We now get so much software that we just don't have time to debug it ourselves, so we usually reject it unless it is really promising.

### In the marketplace

Finally, it is time to sell it. There are many factors here. Two that are most important are the type of program and the documentation. If you want to sell it to a magazine, you should write an article to go along with it. The article can include a background story for the game, instructions, and hints on playing the game, along with suggestions for those who want to modify it. Smart software houses are also asking for good documentation, for that can avoid copyright problems. After all, who wants to copy a friend's program when they can get a cassette and a very attractive and helpful instruction manual for a good price?

One of the factors related to the type of program is the kind of computer the program is written for. I am a successful writer of computer games largely because I write for 16K Level II TRS-80 computers, and probably one-third of the computers in the world fit that description. I used to own a Heathkit Microprocessor Trainer, but there is not much income in writing programs for that. *SoftSide* is a successful magazine because every one of our programs will run in a 16K Level II TRS-80. We will not publish a program that requires more memory or a disk unit, although we also publish PROG-80, which does print those programs.

### The best chance

But the type of game also determines your market. A careful look at what different magazines publish will show you where you have the best chance. For example, the readers of *SoftSide* prefer rather elaborate simulations with a lot of intellectual challenge. Once you find an appropriate publisher, look around for others.

In addition to magazines, there are also software suppliers who publish games on cassette and diskette. Several publish both ways. When I sold 'Round the Horn' to *SoftSide* (Before I joined the staff), I was paid for it as an article, I received royalties

from the cassette version of the magazine, and ever since I have been collecting monthly royalties on cassette sales from the TRS-80 Software Exchange operated by the magazine, stimulated by ads in other computer magazines and direct mail.

### Time delay

Another consideration you will want to look closely at is what the publisher will offer. My best program so far, 'Santa Paravia and Fiumaccio', is handled by Instant Software, a division of Kilobaud Microcomputing. I am not sure it is a wise choice. The advertisement is a tiny ad buried in a page of fine print. They demand an exclusive contract, which few others do, so I have to rely on what they offer. Their sales are not really that great.

Our magazine probably sells more TRS-80 software. It took nine months for them to process the game before the first ad appeared. I think they offer a good deal to the purchaser, with the game in Level I, Level II, and Tournament versions on cassette with an instruction manual for \$7.95, but they are not very responsive to their programmers.

It will generally take from two to four months to have your program reviewed, and then it could be another month or so to have it published. As far as I know, no other publisher takes the nine months required by Kilobaud. I have received cheques from some magazines in as little as six weeks after sending my programs. It is probably fair to send a game to several software houses, but you should not offer it as a magazine article to more than one publication at a time. Wait until you are

accepted or rejected before offering it to another publication. If you receive no acknowledgement at all, not even a note saying it was received, then I consider it fair game to submit it to another magazine in two months.

I would suggest sending your material to the more successful magazines first, then to less successful ones if your material is rejected. The smaller ones are desperate enough for software to print almost anything, but they pay quite poorly. I know of at least 15 magazines in the United States that are paying for TRS-80 programs, and I know there must be a lot more. I am not familiar with magazines outside the United States except *Practical Computing*, but I know there are several. I might mention that British readers do not have to send articles to the United States; *Practical Computing* pays as well as anyone.

### Presentation

When you submit your material, appearance is important. A neatly typed article or documentation, double-spaced for the convenience of the editor, a cassette with a typed label, and a cover letter explaining what you are submitting and how to load and use it, all make a good impression.

It may sound like an elaborate process and a lot of work, but writing games is fun and profitable. I think it is worthwhile, and I hope that many who read this will share in the rewards. I know that editors like myself are hungry for good material, but we are often buried in poor programs that do not meet the standards discussed in this article. □



# Keen Computers Micromarket

Keen Computers are one of this country's leading microcomputer consultants, with a reputation for quality after sales service. Recent extensions to our product range mean that we now offer the North Star Horizon and D.E.C. computer systems along with the Apple, and Corvus and Mountain Hardware accessories. Add this to our ability to provide software from a comprehensive range of packages or on a special consultancy basis (we write the software to your specifications) and you can see why we can provide the solution to your problem . . . whatever it may be!



## Apple

Apple II + 16k	750.00
Additional 16k RAM	69.00
Disk drive + controller	398.00
Pascal language system	296.00
Printer card	110.00
RS232 Interface	110.00
Integer Basic ROM	110.00
Supercolour	90.00

## North Star Horizon

16k Horizon computer system with floppy disk drive + controller	1085.00
32k Horizon computer system with floppy disk drive + controller	1415.00
Additional floppy disk	310.00
16k RAM	235.00

Serial/Parallel Interface 65.00

Floating Point Board 205.00

## Peripherals

PRINTERS	
Anadex DP8000	715.00
Lear Siegler 200	1925.00
Diablo 1610	1950.00

CORVUS 10Mb HARD DISK  
... FOR Apple (DOS+Pascal),  
Tandy, S-100 and LSI-11 from  
100Mb tape back-up from 3500.00  
500.00

MOUNTAIN HARDWARE	
Supertalker	190.00
Apple Clock	140.00
S-100 Clock	140.00
Romplus+	120.00

## Software

Packaged titles include Word Processor, Direct Mailing, General Ledger, Sales Ledger, Purchase Ledger, Payroll, Stock Control, Information Retrieval, Estate Agents Management, and many more. Full details sent on request.

We can also design and produce software systems to your specifications . . . for more information contact Bob Ellis on 0602 583254.

To find out more . . . phone or write to:

**Keen Computers**

5b the Poultry, Nottingham.  
tele: 0602 583254  
telex: 37297 (keenco)



# Caught in a trap — no turning back

*M.K. Cook on Maze Runner, a game of hand-eye co-ordination for the TRS-80.*

TO RESIST the obvious pun, Maze Runner is a most remarkable game, both in its origin and final form. It is written for the TRS-80 Level II and will happily sit inside 4K.

I found I had accidentally invented this game in the course of my job as a lecturer in the Physics, Mathematics and Computing department at Manchester Polytechnic. I was investigating a method with our Psychology department could use to study hand-eye co-ordination, utilising a variable-speed moving dot on a computer display.

The game had a remarkable effect on hard-bitten, seen-it-all-before computer programmers. They were most enthusiastic and gave up whole dinner hours to playing it. Most surprising of all, if you know computer programmers, was that nobody could criticize it or come up with any "improvements".

Each game is different because of a random maze-drawing program. It is played as follows:

The computer asks how many players will want to run the same maze. Even if you are playing by yourself, it might be interesting to have more than one run at a maze to see if you can improve your score. The computer will then draw the maze and put an "X" in three corners and in the centre. In the bottom left-hand corner is your ball — quite still.

The object is to guide the ball into the "X"s, thus removing them from the screen. You can make the ball change direction by using the cursor control keys. If the ball hits a maze wall, it will bounce off in a random direction. Each time you

press a key, or the ball bounces off the wall, one point is added to your score. The player with the lowest score wins.

The program does not check whether all the "X"s have been eliminated, as this would slow the game down too much, so you must press the "S" key to set the maze up for the next player or to show the score. This can allow some mild cheating, but it will not go undetected by the other players.

Once running, the program will always let the same number of palyers through each maze. To change this, press the "BREAK" key and type RUN.

Several variations of group play are possible: individual scores, team scores or relay scores. In the relay mode, each member of the team has to get one "X" and then another member takes over. It is quite difficult to regain control of an already-moving ball.

Perhap the greatest fun to be had from this game is when you persuade somebody to have their first go in public. Comments like "I'm glad I'm not driving home with you tonight" abound, as the luckless player tries to gain control. The record score for all newcomers is currently held by our departmental secretary, who notched up 957, when most mazes can be run with a score of 30!

The print-out shows one or two minor differences from conventional notation due to the limited character set on my printer. A line that starts with ' is a remark, but when ' is encountered in a PRINT statement, it is equivalent to ". Finally, \$ is shown as £.

*Listing overpage*

```

PLAYER 1 HAS A SCORE OF 29
PLAYER 2 HAS A SCORE OF 28
PLAYER 3 HAS A SCORE OF 25
PLAYER 4 HAS A SCORE OF 25
PLAYER 5 HAS A SCORE OF 28
PLAYER 6 HAS A SCORE OF 39
PLAYER 7 HAS A SCORE OF 37
    
```

HIT ANY KEY FOR A NEW MAZE

Try the ACT 800 series computer at one of these dealers now:

LONDON  
Lion House (Retail) Ltd.  
227 Tottenham Court Road, London W1P 0HX  
Tel 01-580 7383

THE SOUTH  
Petalect Electronic Services  
32 Chertsey Road, Woking, Surrey  
Tel: 04862-21776/23637

Business Electronics  
Rownhams House, Rownhams, Southampton  
Tel: 0703-734015

RUF Computers  
System House, Victoria Way, Burgess Hill, W. Sussex  
Tel: 04446-45211

T & V Johnson (Microcomputers) Ltd.  
165 London Road, Camberley, Surrey  
Tel: 0276-62506

South East Computers Ltd.  
4 Castle Street, Hastings, Sussex  
Tel: 0424-440099

HSV Business Systems Ltd.  
May Place, Basingstoke, Hants. RG21 1NX  
Tel: 0256 62444  
Southampton Street, Southampton, Hants.  
Tel: 0703 22131

Wilson Hughes and Partners (Data Sciences) Ltd.  
18 Chequers Square, Uxbridge, Middlesex UB8 1LN  
Tel: Uxbridge 53322

The Accounting House Ltd.  
54 London Road, Maiden, Surrey SM4 5B4  
Tel: 01-640 9331

Thyssen Rhein Stahl House  
Molly Millars Lane, Wokingham, Berkshire RG11 2PU  
Tel: Wokingham 783434  
52 High Street, Chatham, Kent ME4 4DS  
Tel: Medway 402718

SOUTH EAST  
Senodisk Ltd.  
34-36 St Helens Road, Westcliff-on-Sea, Essex  
Tel: 0702-352590

The Computerist (Prorole Ltd.)  
642 London Road  
Westcliff-on-Sea  
Essex  
Tel: 0702-335298

SOUTH WEST  
ACT Bristol Ltd.  
Graphic House, Telephone Avenue, Bristol BS1 4BS  
Tel: 0272-211733

EAST MIDLANDS  
HB Computers  
22 Newland Street, Kettering, Northants.  
Tel: 0536-520910/83922

Lowe Electronics Ltd.  
Chesterfield Road, Mallock, Derbyshire DE4 3HE  
Tel: 0629-2817/2430

Arden Data Processing Ltd.  
Municipal Buildings, Charles Street, Leicester  
Tel: 0533-22255

Office Computer Techniques (Middletron)  
Highcroft, Husbands Bosworth, Lutterworth, Leics.  
Tel: 0234-40601

MMS (Steenmoor) Ltd.  
26 Mill Street, Bedford, Beds.  
Tel: 0234-40601

Caddis Computer Systems  
72-74 Tenny Lane, Hinckley, Leics.  
Tel: 0455-613544

A.J.R. (Office Equipment) Ltd.  
5 Church Drive, Daybrooke, Nottingham NE5 6JP  
Tel: 0602-206647

Hallam Computer Systems  
1 Berkeley Precinct, 451 Eccleshall Road,  
Sheffield S11 8PN  
Tel: 0742-663125

EAST ANGLIA  
Sumlock Bondain (East Anglia) Ltd.  
Grosvenor House, 32 Prince of Wales Road,  
Norwich, Norfolk  
Tel: 0603-26259

WEST MIDLANDS  
Taylor Wilson Systems Ltd.  
Oakfield House, Station Road, Dorrridge,  
W. Midlands B93 8HO  
Tel: 021-560 6192

MERSEYSIDE  
Stack Computer Services Ltd.  
290-298 Derby Road, Bootle, Merseyside L20 8LN  
Tel: 051-933 5511

D.A.M.S. (Office Equipment) Ltd.  
30-36 Dale Street, Liverpool 2  
Tel: 051-227 3301

Aughton Automation Ltd.  
Woodward Road, Kirby, Liverpool  
Tel: 051-548 6060

MANCHESTER  
Cytek U.K. Ltd.  
12 Exchange Hall, Corn Exchange Building,  
Manchester M4 3EY  
Tel: 061-832 7604

SCOTLAND  
Robox Office Equipment Ltd.  
Unit 14, Anderson Shopping Centre, Argyll Street,  
Glasgow G2 7PH  
Tel: 041-221 5401

# “The cheapest most advanced business Microcomputer”

... says Michael Korns of Computhink.



**ACT series 800** from only... **£19.45 p.w.\***

\*5 year lease. Shorter terms available.

The next generation computer system built in California by Computhink and backed by Britain's leading computing company, ACT.

The ACT Series 800 features lightening fast processing capabilities and unequalled data retrieval speed. It is upwardly compatible with the PET.

In addition to brilliant High Resolution Graphics the ACT Series 800 has the most advanced full screen data entry and editing capabilities ever made available on a micro-computer.

Nebula fully integrated software packages written in Britain by ACT include Sales Ledger and Invoicing, Purchase Ledger, Payroll, Stock Control and Word Processing. Plus over fifty more program titles.

**ACT 808** with 800,000 characters of on-line disk storage, **£3,950 + VAT.**

**ACT 824** with 2,400,000 characters of on-line disk storage, **£4,950 + VAT.**

Prices correct at time of going to press.

PET is the trademark of Commodore.

**ACT series 800**

Complete the coupon for full details and the name of your nearest dealer who can arrange an immediate demonstration.

My Name \_\_\_\_\_

My Address \_\_\_\_\_

Tel: \_\_\_\_\_

**ACT**  
MICROSYSTEMS

*total  
Computing*

Radclyffe House,  
66-68 Hagley Road,  
Edgbaston,  
Birmingham B16 8PF.  
Tel: 021-455 8686  
Telex: 339396

• Circle No. 190

Whether you're a software engineer looking for the best hardware — an educationalist requiring versatility and the ultimate in reliability — or an OEM demanding flexibility, the finest documentation available, and 'realistic' margins — Zenith Data Systems is your automatic choice.

### Z89 Series Microcomputer.

This highly advanced Microcomputer is the star of the Zenith range.

Specification includes: Floppy disc storage. 48K RAM. 'Intelligent' video terminal.

Two Z80 Microprocessors. Choice of operating systems including CPM.

Standardised communication, RS 232. Prices from £1570

### Z11A Series 16-bit computer.

Based on the powerful new KD11-HA CPU (LSI — 11/2) it offers you the speed and versatility of a minicomputer at



Z89



Z19

# The Professionals

a microcomputer price. With memory\* to 32K words (64K Bytes). Seven additional I/O positions. PDP 11/03 compatible.

Systems from £4335.

\*Memory boards available from £562 per 16K.

### WH14 Serial Printer.

Microprocessor based electronics makes it capable of a wide variety of uses in most computing applications.

It features 5 x 7 dot matrix. Impact print. Operator/software selectable line width — 132, 96 and 80 characters per line. And sprocket paper feed with adjustable spacing.

Price. £510

### Z19 'Intelligent' Video Terminal.

Z80 based, it is capable of a multitude of high-speed functions. It has an easy-to-read high

resolution CRT. Heavy duty keyboard. 128 characters. Addressable cursor, relative and direct. Versatile edit functions. And E.I.A. RS 232/c at 110 to 9600 baud. Price. £735



Z11A



WH14

**Zenith data systems**



THE ULTIMATE IN MICROCOMPUTERS

If you'd like more information about any, or all of the Zenith Data Systems range, just contact us at Zenith Data Systems Division, Heath Electronics (U.K.) Limited, Dept ( ), Bristol Road, Gloucester GL2 6EE. Telephone (0452) 29451. All prices are exclusive of VAT and delivery charges. Generous OEM discounts available.

• Circle No. 191

```

10 'MAZE RUNNER BY M.K.COO
K (G8HBR)
20 CLS
30 DEFINT A-Z
40 PRINT'----- M
AZE RUNNER -----
--'
50 PRINT'USE THE CURSOR KE
YS TO CHANGE DIRECTION OF Y
OUR BALL'
60 PRINT'AND GUIDE IT THRO
UGH THE MAZE'
70 PRINT'TRY TO KILL THE X
'S IN THE LEAST NUMBER OF'
80 PRINT'DIRECTION CHANGE
INSTRUCTIONS AND BOUNCES'
90 PRINT'WHEN YOU HAVE SUC
CEEDED TYPE S FOR YOUR
SCORE'
100 PRINT'IN THE EVENT OF
A DRAW THE FIRST PLAYER TO
GET THE SCORE'
110 PRINT' W
ILL WIN '
120 INPUT'HOW MANY PLAYERS
WILL WANT TO RUN THE SAME
MAZE ';P
130 IF P>10 THEN PRINT'10
PLAYERS AT MAXIMUM':GOTO 12
0
140 IF P<1 THEN 120
150 RANDOM
160 CLS
170 PT=0
180 GOSUB 610

```

```

190 X=3:Y=45
200 SET(X,Y)
210 PRINT0126,'X';:PRINT@6
5,'X';:PRINT0958,'X';:PRINT
@481,'X';
220 D&=INKEY&:IF D&=' ' THE
N220
230 CD=0
240 GOTO360
250 ON D GOSUB 570,560,580
,590
260 RESET(X1,Y1):IF POINT(
X,Y)=0 THEN GOTO 330
270 X=X1:Y=Y1
280 DC=RND(4):IF DC=D THEN
280
290 D=DC
300 ON D GOSUB 570,560,580
,590
310 CD=CD+1
320 GOTO260
330 SET(X,Y):D&=INKEY&:IF
D&=' ' THEN 250
340 IF D&='S' THEN 380
350 CD=CD+1
360 D=(ASC(D&) AND 3)+1
370 GOTO250
380 S(PT)=CD
390 RESET(X,Y)
400 PT=PT+1
410 IF PT><P THEN 190
420 CLS:PRINTCHR&(23)
430 W=0
440 FOR I=0 TO P-1
450 IF S(W)=S(I) THEN W=1
460 PRINT'PLAYER ';I+1;' H
AS A SCORE OF ';S(I)
470 NEXT I
480 PRINT:PRINT:PRINT'HIT
ANY KEY FOR A NEW MAZE'
490 IF P=1 THEN 550
500 PR=((W+1)*64)+18
510 PRINT@PR,CHR&(30);' -
-- WINNER ---';
520 FOR I=1 TO 100:NEXT I
530 PRINT@PR,' HAS A SCOR
E OF ';S(W);
540 FOR I=1 to200:NEXT I

```

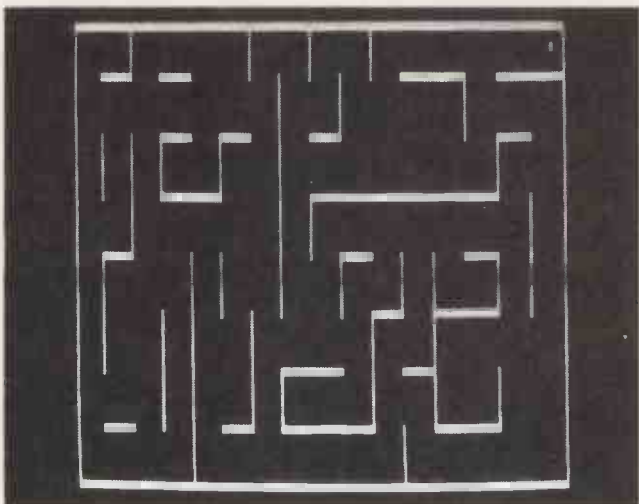

```

550 F&=INKEY&:IF F&='' THE
N 490ELSE 160
560 X1=X:Y1=Y:X=X+1:RETURN
570 X1=X:Y1=Y:X=X-1:RETURN
580 X1=X:Y1=Y:Y=Y+1:RETURN
590 X1=X:Y1=Y:Y=Y-1:RETURN
600 'DRAW THE OUTLINE TO P
LAYING AREA
610 FOR X=0TO127
620 SET(X,0):SET(127,Y)
630 NEXT X
640 FOR Y=0 TO 47
650 SET(0,Y):SET(127,Y)
660 NEXT Y
670 'DRAW THE MAZE
680 T=0
690 GOTO1130
700 D=RND(4)
710 T=T+1:IF T 40 THEN RET
URN
720 IF Y=48 THEN Y=47
730 D1=RND(3)-1
740 IF D=4 AND D1=-1 THEN
730
750 IF L=3 AND D1=1 THEN 7
30
760 IF D=1 AND D1=1 THEN 7
30
770 IF D=2 AND D1=-1 THEN
730
780 D=D+D1
790 IF D<1 THEN D=D+4
800 IF D>4 THEN D=D-4
810 ON D GOTO 820,900,970,

```

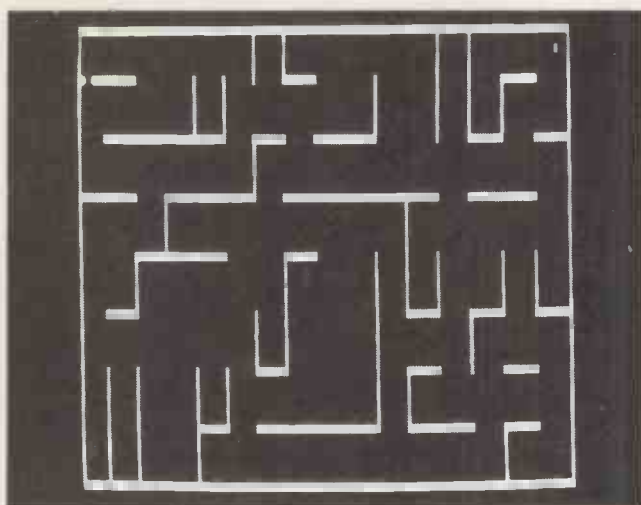

```

1050
820 IF X-8 < 0 THEN 1130
830 IF X=127 THEN C=7 ELSE
C=8
840 IF POINT(X-C,Y)=-1 THE
N 1130
850 FOR A=0 TO C
860 SET(X-A,Y)
870 NEXT A
880 X=X-C:T=0
890 GOTO 730
900 IF X+8 > 127 THEN 1130
910 IF POINT(X+8,Y)=-1 THE
n 1130
920 FOR A=0 TO8
930 SET(X+A,Y)
940 NEXT A
950 X=X+8:T=0
960 GOTO730
970 C=6
980 IF Y+C > 46 THEN 1130
990 IF POINT(X,Y+C)=-1 THE
N 1130
1000 FOR A=0 TO C
1010 SET(X,Y+A)
1020 NEXT A
1030 Y=Y+C:T=0
1040 GOTO 730
1050 IF Y-6 < 0 THEN 1130
1060 IF Y=47 THEN C=5 ELSE
C=6
1070 IF POINT(X,Y-C)=-1 TH
EN 1130
1080 FOR A=0 TO C
1090 SET(X,Y-A)
1100 NEXT A
1110 Y=Y-C:T=0
1120 GOTO 730
1130 D=RND(4)
1140 Y=6*(RND(9)-1):IF Y=4
8 THEN Y=47:D=4
1150 X=8*(RND(17)-1):IF X=
128 THEN X=127:D=1
1160 IF X=0 THEN D=2
1170 IF Y=0 THEN D=3
1180 T=T+1
1190 IF T>20 THEN RETURN
1200 GOTO 810

```



# Introducing the PET COLLECTION



... A suite of powerful business programs at a budget price – from ACT Petsoft, the professional software specialists!

## **1** ACT SALES LEDGER £120

**Commodore Disk £95 Cassette version**

Full facilities for the maintenance of the Sales Ledger, the preparation of a list of outstanding balances and printing of statements. All data including new customer details, invoices, credits, cash and transfers are entered under step by step guidance on the display screen. Printed results include Audit List, Aged Debtors List, Control Account and Statement.

For 32K PETs

Both Sales Ledger and Purchase Ledger are...



## **2** ACT PURCHASE LEDGER £120

**Commodore Disk £95 Cassette version**

Full facilities for maintenance of the Purchase Ledger, the preparation of a list of outstanding balances and printing of remittance advices. The system produces the following printed results: Audit List, Aged Creditors List, Control Accounts, Purchase Ledger Record, Remittance Advice, Cheques and Payment List. For 32K PETs

## **3** PLUS INVOICING WITH STOCK £75

A powerful, easy-to-use system for the CompuThink Disk, handling 1200 or 2400 stock items per diskette.

## **4** PAYROLL 200 £50

For up to 200 employees, on disk or cassette.

## **5** WORDCRAFT £325

The ultimate PET Word Processor, now on CompuThink Disk.

... and over 200 more business programs, games and programming aids in the NEW PETSFT CATALOGUE.

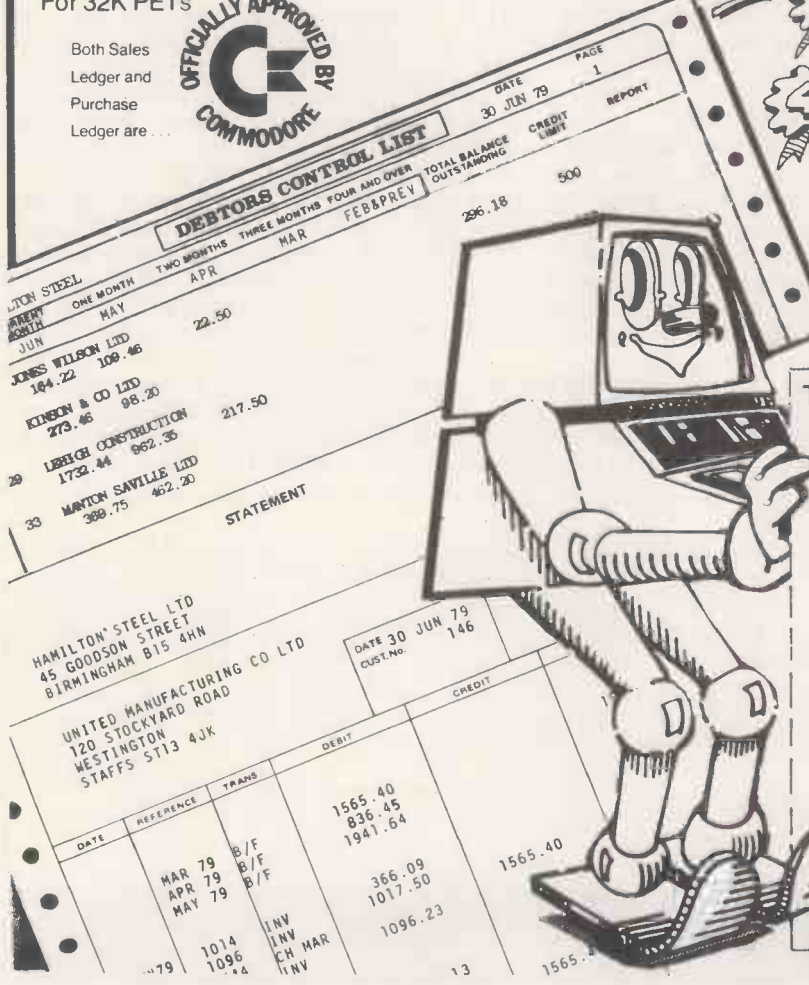

To: ACT PETSFT  
Radclyffe House,  
66-68 Hagley Road,  
Edgbaston, Birmingham  
B16 8PF. Tel: 021-455 8585  
Telex: 339396



Please rush me information on...  1  2  3  4   
 5 also the NEW PETSFT CATALOGUE

My Name is \_\_\_\_\_  
I live at \_\_\_\_\_

Tel. No. \_\_\_\_\_

# ACT Petsoft

• Circle No. 192

# Eight, yes eight, Basics for Nascom: a comparative survey

The Nascom is among the simplest Z80 systems available, it has been one of the market leaders in terms of numbers of units sold and yet it seems to lack any coherent software sourcing. This survey is intended to help the newcomer to choose the most suitable of the eight versions of BASIC for his system and his needs. By Nick Laurie

THE NASCOM-1 was one of the earliest easily available, more or less reliable, low-cost, hobby-orientated single-board computers; today, with over 20,000 sold, it can be found in applications as diverse as industrial process controllers and pub TV games.

As more and more of the early designs fall by the wayside, so it becomes clear that Nascom is destined to become not only a survivor, but now (with Nascom-2) a Series. As evidence, many software houses (including the country's largest, ICL Dataskil) produce a range of material for use on the Nascom with, at the time of writing (November 1979), at least eight versions of BASIC being suitable.

BASIC (Beginner's All-purpose Symbolic Instruction Code) was created in the Sixties by John Kemeny — a fascinating man whose career in science and technology could put many Great Names in the shade. He recently chaired President Carter's enquiry into the Three Mile Island accident as part of a career which included work on the Manhattan Project and a continuing nine-year presidency of the prestigious Dartmouth College.

Working with Professor Thomas Kurtz he developed Basic as a very general purpose, all-powerful (with some effort) high-level language. As an interpreter — and Basic *compilers* are few and far between and very BIG — it needs to be resident in the computer whenever a Basic program is to be executed; it cannot generate machine-code programs that will run by themselves, so that when choosing a version to suit you, it is important to consider the size of your available RAM *after* allowing for the space used by the interpreter itself.

## Your own set-up

In Table 1 the entry SIZE refers to the space used by the interpreter so be sure you have a bit more than this. The CCSOFT Level A Basic is a bit of an exception; this one sits (in ROM) in the sockets provided for your monitor and combines a simple but very effective Basic with the essential monitor housekeeping routines.

The same table shows the MEDIUM used, either tape, EPROM or ROM and your choice here will affect the price. The PRICE entry in Table 1 refers only to the

price of the cheapest medium; for example the 8K Nascom Basic costs only £15 on tape, but £40 in ROM and about £100 in EPROM!

On the other hand, an EPROM or ROM version leaves you all your own RAM for programs and you should consider the relative merits of the different media for your own setup.

## Monitors

A word here about NAS-SYS which has arrived in something of a cloud of confusion: it was developed for the Nascom-2 and is really an enhanced T-4. Unfortunately it is not completely compatible with the earlier monitors and programmes designed for these will not always run under NAS SYS. This applies to all the Basics here except the Nascom 8K and, very soon according to the manufacturers, the XTAL (pronounced crystal) 8K.

Bearing in mind the likely delays in publication, this situation could easily have changed by now and interested readers are advised to study the current advertisements to see whether any of the other versions reviewed here have been adapted for NAS SYS.

SIZE	2K		3K		4K		8K		
PRICE (lowest)	£21.50	£10	£25	£35	£13.50	£12.50	£35	£15	
MANUFACTURER	CC SOFT	COMP	NASCOM	NASCOM	M'ROOM	CC SOFT	XTAL	NASCOM	
PRODUCT NAME	LEVEL A	B BASIC	TINY B.	SUPER TB.	INTEGER	LEVEL C	BASIC	BASIC	
MEDIUM	2 EPROM	CASS	2 EPROM	3 EPROM	CASS	C/E	CASS	C/E/ROM	
EXTRA HARDWARE		RAM at FFFF(h)	Nascom mem b'd	Nascom mem b'd	RAM	RAM or ROM b'd	RAM	RAM or ROM b'd	
MONITOR REQU'D	none	any; not NAS SYS	any; not NAS SYS	any; not NAS SYS	any; not NAS SYS	any; not NAS SYS	ANY	ANY	
ORIGIN	PALO ALTO							MICRO-SOFT	
ARITHMETIC	INTEGERS ONLY (no decimals)					FLOATING POINT			
CONSTANTS RANGE	± 32767					1.7 E38 -1.5E-39		1.5 E38 -1.5 -E-38	
SCIENTIFIC NOT'N									

**TABLE 1**

This table outlines the main parameters you will need to consider when choosing a version of BASIC to suit you.

**TABLE 2**

A point-by-point comparison of the eight available Nascom BASICs. A number of reserved words are available on one version only and reference is made to these in the main body of the article.

	2K			3K	4K		8K	
	CCSOFT	COMP	NASCOM	NASCOM	M'ROOM	CCSOFT	XTAL	NASCOM
<b>VARIABLES</b>								
Numerical	26 — A to Z				286	52	712	
String					A0..Z9		A.Z + A0..Z9	
Arrays	one only					only one	AA.....AZ ZA.....ZZ	
<b>OPERATORS</b>								
() + - / x								
Comparators								
AND OR NOT						indirect		
EXOR								
<b>FUNCTIONS</b>								
ABS RND								
SQR								
INT								
SGN								
SIN COS TAN ATN LOG								
DEF FN EXP								
Raise to Powers								
<b>STRING HANDLING</b>								
LIFTS RIGHTS MIDS LENS STRS CHR\$ ASC					all except STR\$			
VAL								
<b>STATEMENTS</b>								
max no of lines	32767	32767	32767	32767	65529	32767	65529	65529
maximum chars/line	80	132	132	132	90	100	90	72
PRINT TAB REM LET RUN IF... THEN GOTO LIST GOSUB RETURN INPUT RAM STOP CSAVE CLOAD							*	
FOR...TO...STEP...NEXT								
JUMP TO MONITOR								
CALL or USR								
PUT GET (ports)								
PEEK POKE								
DEEK DOKE (2 bytes)								
DIM					X,Y		X,Y...N	X,Y...N
DATA READ RESTORE								
CLEAR								
CLOAD/CSAVE an array								*
ON GOTO ON GOSUB								
END								
SPC								
VDU							PRINT @	SCREEN
CLS							indirect	
POS								
<b>ERROR MESSAGES</b>	3	3	3	3	25	3	19	18

■ = NOT AVAILABLE

■ ROM & EPROM versions lose CSAVE under T.2

## Arithmetic

The most obvious choice to be made is between floating point and integer Basics. An integer Basic deals *only* in whole numbers although it is not too hard to write your own subroutines to deal with decimals or to interface to a maths package such as MAPPI 3Z for *real* power. (Mappi 3Z, as a slight aside, converts the 16 bit registers of the Z80 into two 40-bit registers to give mathematical power in an easily available form of machine code program). If mathematics and its computer applications are your forte then you will probably want a

*floating point* Basic with its ability to handle big numbers and decimal points directly.

## Speed

Using a high-level language such as Basic results in your computer having to take a much longer route between instruction and result; the operating speed is far slower than it would be for an efficiently coded programme written on an assembler such as ZEAP. On the other hand, your programming speed will rise at a significant rate of knots and you have only to ask yourself whether your

machine spends more time being programmed or executing those programmes to be able to decide whether Basic is likely to be for you. No benchmark tests were run in this survey, since it seems hardly relevant or fair to compare a 2K interpreter with an 8K interpreter and for the typical Nascom user, the difference in execution speed is unlikely to be the most important consideration.

## Editing and abbreviations

Editing, to my mind, involves something rather more subtle than  
*continued on next page*

from previous page

Nascom's (8K) comment in their manual under this heading: "The NEW command causes (everything) to be deleted." In fact Nascom's 8K Basic was really written for use with NAS SYS (although it runs quite effectively under T-2 and T-4) and NAS SYS has full(ish) on-screen editing capabilities; however, those users without the new monitor will find themselves limited to the simplest editing functions as found in the much smaller versions (scrub line, replace line, new and back-space).

Editing is really a function for your terminal rather than for the interpreter and it is a shame that more Basics have not taken a little more account of Nascom's rather simple screen handling. XTAL 8K provides a specific EDIT command which allows insertion and deletion of characters with appropriate control of the rest of the line.

### Abbreviations

LIST is allowed to carry two arguments to determine the start point of the list as well as the number of lines to be scrolled, a useful facility which is available on all except Nascom's own 8K Basic. Users of Zeap will long for the automatic line numbering and re-numbering facilities which not one of these Basics offers. Abbreviations are available in the 2, 3 and 4K versions and are sadly missed in the 8K versions.

Another point concerns abbreviations of rather a different type. You will notice in **Table 2** that some facilities such as CLS (clear screen) are not *directly* available. In this example the effect can always be achieved by other means such as PRINT CHR\$(20) or PRINT CHR\$(12) for T-4 and NAS SYS respectively. In Nascom's 2K Basic the same effect can be obtained using PRINT S↑ or its abbreviated P.S↑.

I have chosen not to consider this as a direct instruction since it actually uses combinations of other commands and if we were to use this approach, then almost every Basic can be considered capable of almost every facility. Clear Screen has to be enterable as a single command to qualify for a place in **Table 2** as do all other reserved words.

### Sludgeware

Last August I wrote an article for *Practical Computing* deploring the ghastly state of documentation in general; had I asked for a handful of samples of the very worst specimens, then my wish would have been granted in the delivery of the material accompanying most of these Basics.

Exceptions were CCSOFT (4K only, alas) who really put a lot of effort into turning out a professional-looking document, and Nascom who at least put all (well, almost all) of the info into the manuals but forgot to make it readable. A solid A4 page of photographically reduced typewriting or printout without

an index and with such vital lists as the Error Messages buried right in the middle (why can't they be on a separate card?) represents only half a document.

Of the rest, suffice it to say that most of the information is there, but rarely in depth; they all give a few sample routines of varying value in either Basic or Basic-accessible machine-code to demonstrate various aspects of their language. All manuals (except Xtal's) are designed for about ten days maximum heavy use before crumbling to confetti. I let every remark I ever made about sludgeware stand — at least on this evidence.

### Fiddling around

Almost all the information gleaned from many weeks of evenings spent fiddling with these various Basics is to be found in the accompanying tables. **Table 1** outlines the definitive parameters for each language while **Table 2** makes a point by point comparison of the eight languages. Syntax inevitably varies from one Basic to another and **Table 3** should help to clarify matters by giving a brief description of the meaning of the reserved words used in **Table 2**.

And a final word on the general approach before looking at the idiosyncrasies of the individual interpreters concerns the accuracy of this review. I have checked and double-checked, I have sent copies of the manuscript to all the manufacturers who all replied and whose comments have been included in the final draft and I have then re-checked. All the laws of Murphy, Sod *et al* dictate that there will still be inaccuracies but I hope that this comparative survey will still help Nascom owners to decide exactly what they want from a reasonably well informed position.

### The interpreters

**CCSOFT 2K Level A, COMP 2K tape Basic and NASCOM 2K Tiny Basic** are all very similar. A range of Palo Alto-based simple Basics with CCSOFT's alone being able to run in a totally unexpanded Nascom-1, they allow the new user to develop a real feel for the language at a reasonable cost. Note that Nascom's 2K is on EPROM for use on a Nascom Memory Expansion Board; it cannot be used in place of the monitor like CCSOFT's while the COMP 2K tape is really meant to be used with COMP's S-100 expansion but any RAM addressed up to 4FFF(h) will do. Before dismissing a 2K Basic as being a 'bit on the Mickey Mouse side of things, for the user with a reasonable experience of machine-code programming this size of Basic provides a very suitable framework for supporting, linking and modifying machine-code programs. It can add considerable speed to your programming at very little extra cost and without hogging boards full of RAM.

**NASCOM 3K Super Tiny Basic**, available only as a third EPROM, is the oddball

of the bunch. It is an enhancement for their 2K Tiny Basic and does not use the normal Basic reserved words but instead supplies machine-code sub-routines together with the means to reach them. Facilities offered here include simplified editing, access to the PIO, CALL (to a decimal version of a hex address) and USR plus a simple but useful string handling facility. PEEK and POKE are here with their double-byte big brothers DEEK and DOKE and are called, as are all the others on this chip using the command MC with an argument specifying the appropriate subroutine. This third EPROM will be a very useful enhancement for the Tiny Basic user, but remember that it is only compatible with Nascom's own 2K Tiny Basic.

**MUSHROOM 4K Integer Basic.** At around 4K, a Basic interpreter begins to take on some of the characteristics that make those forty-dimensional Superstar-treks look feasible — but not usually in integer Basic, although it can be, and has been, done. MUSHROOM shows its real strength in its very flexible variable handling with both numerical and string variables being handled as scalar, one-dimensional or two-dimensional arrays. TRACE is a very useful command which steps you through your program line-by-line (remember, an interpreter looks at each line in numerical order, processes it and moves on to the next line) giving line numbers as it goes. It plays havoc with your PRINT instructions since the display of line numbers is mixed up with your output giving a new line (carriage return) with each statement number encountered. Nevertheless it is a superb debugging aid and one which others would do well to incorporate.

**CCSOFT 4K Level C floating point Basic.** Also handles Superstartrek without much problem (CCSOFT sent a copy with their Basic tape and you nearly had to do without this article — it's very addictive) and is quite definitely orientated more towards the mathematicians. There is little in the way of string handling and a surprising lack of logical comparators in direct format, although they can be obtained in a roundabout way using non-standard instructions. Level C is gradually replacing Level B which has not been included in this article since it is being deliberately phased out after serving its purpose as an intermediate between Level A and Level C. Extra functions include STACK which allows you to POP an address of the RETURN stack to give easy access to instant confusion (as well as being very useful in its place) and INKEY which gives an instant response to any keyed input without the need for a newline.

**XTAL 8K Basic** (XTAL = crystal in electronic parlance) is, together with Nascom's own variation on *Microsoft* Basic, a *real* Basic. Perhaps a slightly unfair remark, but a study of the facilities offered at 8K

TABLE 3

Because of the wide variation of syntax between BASICs, this table is used to define the terms used in Table 2.

<b>VARIABLES</b>	Little boxes holding either a single number or a string
Numerical	Only hold numbers
String	Only hold strings of characters. Size usually changeable
Array	A MATRIX of numerical or string variables
<b>OPERATORS</b>	Used to relate the various components of the language
() + - / *	Pretty Basic stuff!
Comparators	Greater than, less than, equal etc.
AND OR NOT	LOGICAL relations are constructed with these
EXOR	Exclusive OR
<b>FUNCTIONS</b>	Complex arithmetic condensed into a single instruction
ABS RND	Return absolute value of argument and random No respectively
SQR	Returns square root
INT	Chunks out everything after the decimal point
SGN	Returns one value for a positive argument, another for neg've
SIN COS TAN ATN LOG	ATN is arctan, the rest should be fairly obvious
DEF FN EXP	Condense your own complex arithmetic. EXP returns e to power
Raise to Powers	Square, cube or more to your heart's content
<b>STRING HANDLING</b>	Allows you to play with letters, words and sentences — easily
LEFT\$ RIGHT\$ MIDS	All these allow strings and bits of strings to be manipulated in various ways including arithmetically.
LEN\$ STR\$ CHR\$ ASC	
VAL	Returns an arithmetic value for a string component.
<b>STATEMENTS</b>	A slightly arbitrary category covering everything else
max no of lines	More than enough lines for any basic program
maximum chars/line	Can often be changed with a poke command
PRINT TAB REM LET RUN	These are the building blocks of any Basic program, their implementation varies from version to version but they are all available. RAM is print size of remaining memory, STOP is a glorified END
IF... THEN GOTO LIST	returning a message like STOP IN LINE N
GOSUB RETURN INPUT	
RAM STOP CSAVE CLOAD	
FOR...TO...STEP...NEXT	Real time savers if you've lived without them for a while
JUMP TO MONITOR	CCSOFT dispense with the monitor, replacing it with Tiny B.
CALL or USR	Give access to machine code routines
PUT GET (ports)	Send or receive values to or from any port
PEEK POKE	Alter memory locations addressed in decimal a byte at a time
DEEK DOKE	Two byte version of PEEK and POKE — very handy
DIM	Dimensions arrays to your specifications
DATA READ RESTORE	Fill arrays with your data. RESTORE sets DATA pointer to 0
CLEAR	Sets all variables to 0
CLOAD or CSAVE ARRAY	Allow an array to be stored on tape without surrounding prog.
ON...GOTO ON...GOSUB	Clever variations on GOTO saving extended use of comparators
END	Defines an end point in a program. Not displayed during run
SPC	Moves print head a number of spaces right
VDU	Allows the VDU to be addressed as a simple co-ordinate grid
CLS	Clear screen
POS	Returns a value for the current cursor position

should show you that there is a considerable difference between this and a 4K version even though this (XTAL) is really only about 7K. It is my own personal favourite with a number of unique features and a slight but noticeable bias towards string handling but it cannot, as yet, run under NAS SYS — this will almost certainly be rectified by the time this article is published. Since one of the big advantages of NAS SYS is the considerable screen (cursor) editing functions, it is a delight to be able to say that the command EDIT brings forth your errant line while offering all the facilities for editing offered in the easily edited and familiar-to-many ZEAP.

Other facilities are SIZE\$ (the \$ is out of place here since this word returns the amount of memory available for string storage), SPEED allows you to vary the

operating speed of your programme (in a very non-linear way) to match, say, a slow printer or even a slow reader. POP serves the same function as CCSOFT's 4K STACK command while WAIT causes everything to stop until a given set of values can be read at a specified port. CONT allows you to continue after a halt has been encountered and leaves all variables untouched.

### Go to, sub, my word!

The last, and possibly most noteworthy is CALL. In my original manuscript I simply said that CALL sets the PC to any hex address but it is really rather more advanced to this. Imagine you have written a machine-code routine and stuffed it into a handy slot at NNNN(h). To include it in a programme you need merely CALL its decimal address. BUT,

and here we see a really sensible approach, if you want to give your subroutine a name, you can do this with the simple statement

```
10 MYWORD=NNNN
```

(where NNNN is in decimal, not hex) and in so doing you create a new reserved word (MYWORD) which can be used in the format

```
20 GOSUB MYWORD
```

and this is undoubtedly a particularly useful attribute. Just to top off this service, Mushroom send a list of all known bugs with each tape as well as an indication as to whether you may need to make any mods and they offer an update service to bring your T4 compatible Basic Tape up to NAS SYS compatibility (when available) at the amazing cost of 50p.

NASCOM's 8K Basic, developed under  
*continued over page*

# DATA PRECISION (Equipment) Ltd.

proudly present

## THE VIDEO KEYBOARD



- 72 key ultra-reliable contactless capacitive keyboard with cursor command keypad
- RS 232/V24 serial I/O up to 9600 bauds
- Composite video output for monitor or modified TV
- Built-in mains power supply

*Although low-cost, the Video Keyboard is OEM built in the UK using only top-quality components. Other low-cost products use cheap, low MTBF contact-switch keyboards. The Video Keyboard uses the same professional quality ultra-reliable contactless keyboard used by top-flight UK terminal manufacturers.*

### DETAILED SPECIFICATION MODEL VDP 10

#### VIDEO

- One page memory  
64 characters per line 16 lines per page
- Full 128 ASCII character set  
96 upper and lower case characters 32 control symbols
- Comprehensive cursor controls  
Left/right/up/down CR/LF Clear/home/line-erase
- PROM translation of inbound characters, giving:-  
Programmable coding for cursor commands  
Programmable display control for each input code
- Cursor command codes can be displayed using:-  
'Display' key for protocol debugging V24 input bit 8 under remote software control
- European compatible composite video out for:-  
TV monitor, or Modified TV set.

#### V28 I/O

- High/low rates externally switchable and jumper selectable from:-  
9600/4800/2400/1200/600/300/150/75 bits/sec.  
220/110 bits/sec. (NOTE: at high receive speeds, remote software should allow 8.3 ms for CR, LF and 132 ms for Clear)  
Odd, Even or No Parity Full duplex or local mode  
One or two stop bits V24 serial I/O using standard 25 pin socket

#### KEYBOARD

- 72 key ultra-reliable solid state contactless keyboard
- Standard ASCII layout plus programmable cursor control keypad
- QWERTY standard
- Full N key rollover
- Caps Lock with LED for TTY compatibility
- Repeat key.

#### MAINS POWER SUPPLY

- Built-in - needs 220-240V 50Hz.

#### CABINET

- Tailor-made to house all electronics, keyboard, video and V24 sockets, switches and power supply.

#### SWITCHES

- Power on/off
- On-line/Off-line
- Baud Rate Select  
Medium/High/Low Normally set to 9600/1200/300
- Display Key  
Displays control characters for easy protocol debugging

AVAILABLE IN TWO VERSIONS (Monitor/converted TV not included).

Complete Video Keyboard . . . . £299.00

Stripped Video Keyboard . . . . £218.50

[stripped version excludes case, case hardware (switches, plugs), 240/9-0-9 VAC transformer but otherwise complete and tested].

Both versions are brand new with comprehensive manual and 12-month warranty.

**DATA PRECISION (Equipment) LIMITED,**  
81 Goldsworth Road, Woking, Surrey GU21 1LJ  
Tel: Woking 64444/67420 Reg. in England No. 913775

Please send me:

. . . . Complete Video Keyboards @ £299.00 each,

. . . . Stripped Video Keyboards @ £218.50 each,

. . . . Video Keyboard Manuals @ £2 each,\*

. . . . Software Manuals @ £1 each \*

\* Deducted if Keyboard purchased

Name . . . . .

Address . . . . .

. . . . .

• Circle No. 193

## LA video link for London?

WALK UP to a London shopfront and thumb your nose at Californian boulevardiers! Demonstrate your latest dance steps to a New York sidewalk audience! Sing in the rain as LA suffocates in the smog! Make friends on another continent without leaving London!

All this may become a contemporary reality if two enterprising Americans, brought up on video technology in the performing arts, translate their dream of a full-sized video interchange, with sound, into operating hardware.

### Space junk

Kit Galloway and Sherrie Rabinowitz, based in Los Angeles and operating under the name Mobile Image, are planning to set up the shopfront-sized video interchange between LA and New York — though London and Japan are mooted as eventual possibilities. The first transmission experiments used an old NASA satellite but this has now wandered off course for lack of propellant and has joined the growing belt of space junk around the earth. Now a commercial satellite is to be used.

A practical restriction on the system's use lies in the brightness of the General Electric back-projection apparatus. In daylight the screen is not bright enough (though a London winter afternoon may be



"Everything would be fine if we were in California..."

be different) and for obvious reasons an interactive system depends on participants being active. So transmissions would take place in the evening. Taking account of time-zone differences between LA and New York, the ideal times are from 1800-2000 hours in LA, corresponding to 2100-2300 hours in New York. After March, the sun goes down too late in LA to get successful transmissions at this time of the evening.

As LA is some eight hours behind

London, it would be only the latest of night-owls who would get to speak and perform for the benefit of passers-by in LA — not perhaps the ideal recommendation for London life.

In New York the Lincoln Center for the Performing Arts will host the show; in LA a department store in an open-air shopping precinct called Century City has made its window available free of charge. Any takers for the early-morning London rush hour? — M.H.

## Eight, yes eight BASICS for Nascom (continued)

Licence from Microsoft by STARBASE (actually Tony Rundle, who used to be Nascom's own resident software expert) is perhaps the more 'standard' of the 8K Basics and is without doubt a very comprehensive language. Designed for NAS SYS it is the only Basic here that will run under *any* normal Nascom monitor although its lack of inbuilt editing functions makes it a bit of a bore to use without the new wonder monitor. Extra commands are WIDTH which defines screen or printer width, which can be very useful in these days of multi-standard printers, as is the NULL command which outputs a defined number (defined by you) of nulls (00) at the end of each line to allow your clockwork printer to get its print head back to the start of a new line without missing anything vital.

WAIT, like XTAL's, hangs on until one of your ports produces a useable signal (remember the PIO does its own interrupting without using micro time so the whole system can lie dormant until correctly cued via a port). EXP(X) returns e to the power X where X is less than 87.3365 (no, I haven't worked out why it

stops there but I'd be surprised if you ever wanted to go even that high) and is a function also available in the XTAL 8K.

CONT is here again for a 'soft' rerun or continuation while LINES determines the number of lines to be scrolled with each LIST entry (ungainly and irritating compared to the XTAL version). Screen (like VDU in the smaller Basics or Print in XTAL) sets the cursor to a point on the screen which can be referenced using the co-ordinates 1 — 15 (for vertical reference) and 1 — 48 (horizontal). It can only put one letter at a time on the top (unscrolled) line (line 16) and again appears ungainly in use — but it works.

The last set of words which serve to make this variation the most graphically-orientated to date consists of POINT, SET and RESET. Used in conjunction with the Nascom-2's graphic character set it allows any point on a grid of 95 by 48 points to be examined (POINT), SET (to a light spot) or RESET (to a dark spot), an undeniable bonus in this particular language. Neither of the 8K Basics have any MAT (matrix algebra) routines which is a shame but which at least gives us something to look forward to.

### Conclusions

- There are eight basic versions (with minor variations according to the medium on which they are sold) of BASIC for the Nascom microcomputer. They span the full range from 2 to 8K and it is to be hoped that they will eventually go to even greater sizes.

- Additional hardware requirements vary from nothing at all to masses of RAM, ROM or EPROM boards and these requirements should be taken into account when considering the cost of your next Basic.

- In the middle range you can choose fairly evenly between languages with a bias towards string handling or mathematics while at the top end (8K) the choice becomes more a matter of personal preferences.

- At the other end of the scale Nascom's 2K Basic has the offer of a third EPROM to bring it just out of the Tiny Basic league while CCSOFT's Level A can be run on an unmodified Nascom to give a foretaste of Basic at reasonable cost. The choice is up to you.

All these only from HENRY'S

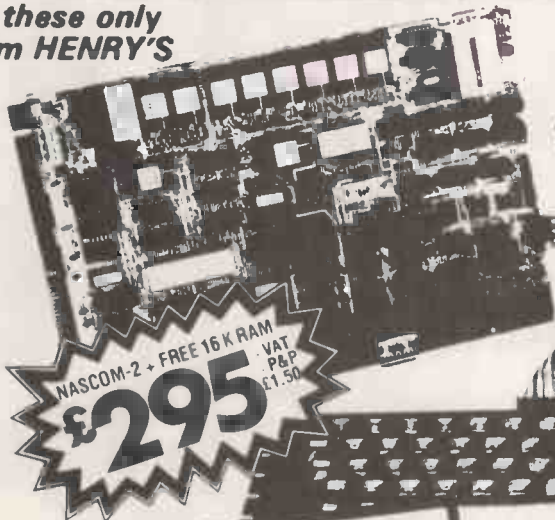

**IN STOCK**  
**FREE POWER SUPPLY**

As reviewed in this issue  
**NASCOM-2 + FREE 16K RAM**

Here's an offer you can't refuse:  
Because of the lack of availability of MK 4118 RAMs, Nascom Microcomputers is supplying its Nascom 2 without the 8 spare 4118s but with a FREE 16K dynamic RAM board.

**NASCOM-2 with 32K RAM**  
**£345 + VAT**  
P&P 1.50

When the 4118s become available, Nascom 2 purchasers can have them at the special price of £80 + VAT for the 8K.  
So, for £295 plus VAT this is what you get:

**NASCOM-2 + FREE 16K RAM**  
**£295**  
VAT P&P £1.50

No more slaving over a hot soldering iron - the Nascom 1 is now supplied BUILT!  
Britain's biggest small system is available fully constructed for you to slot into your own housing for the ridiculously low price of £175 plus VAT (kit price still only £165 plus VAT). **EX-STOCK**

**nascom-1**

12" x 8" PCB carrying 5LSI MOS MOS memory packages. There is on-board unmodulated operating RAM.

**With NAS-SYS SCOOP KIT NOW ONLY FULLY GUARANTEED**  
Less P10 **£125**

**MEMORIES £.p.**

2114	1	4.00
3 FOR		30.00
4116		7.50
8 FOR		55.00
2708		7.50
4 FOR		23.00
4118		12.75
4 FOR		48.00
2716		22.00

**MICROPROCESSOR**

● Z80A which will run at 4MHz but is selectable between 1/2/4 MHz.

**HARDWARE**

● Industrial standard 12" x 8" PCB, through hole plated, masked and screen printed. All bus lines are fully buffered on-board.

**INTERFACES**

● Licon 57 key solid state keyboard.  
● Monitor/domestic TV interface.  
● Kansas City cassette interface (300/1200 baud) or RS232/20mA teletype interface.

The Nascom 2 kit is supplied complete with construction article and extensive software manual for the monitor and BASIC.

**Buy British It's Best!!**

**MEMORY**

- 16K RAM board (expandable to 32K).
- 8K Microsoft BASIC.
- 2K NAS-SYS 1 monitor.
- 1K Video RAM.
- 1K Workspace/Scratchpad RAM.
- Main board sockets for the 8x4118s or 2708 EPROMS.

**EXPANSION NASCOM-1**

- Expansion buffer board **£32.50**
- MEMORY KITS (inclusive all hardware)
  - 8K **£85**
  - 16K **£140**
  - 32K **£200**
- Q board with decoders and all hardware except ICS will accept up to 3 PIOs, 1 CTV and 1 UART **£35**
- NEW, T 4 operating system in (2) 2708 EPROMS UPWARDS **£25.00**
- COMPATIBLE FROM T2 and 8-BUG **£25.00**
- NAS SYS 1. MONITOR **£25.00**

- Programming Manual **£4.50**
- Power supply for up to 32K expansion Mk II **£24.50**
- 8A power supply for larger than 32K expansion **£60.00**
- Expansion card frame **£29.50**
- EPROM programmer **£13.95**
- SMART-1 **£74.95**
- Tiny Basic **£25.00**
- Super Tiny Basic (with editor and machine utility routines) **£35.00**
- Zeap assembler editor **£32.00**
- 8K BASIC ROM **£40.00**
- Naepen Text Handler **£30.00**
- Disassembler **£9.95**

**NASCOM-1 BUILT**  
**£140**  
VAT P&P 1.50

**NASCOM IMP**  
**£325**  
VAT P&P £2.50



**NASCOM IMP PLAIN PAPER PRINTER**

Fully built and housed in a stylish enclosure for just **£325 plus 15% VAT**. Interfaces with all micro computers. Deliveries Ex-Stock.

- Optional tractor feed.
- Baud rate from 110 to 9600
- External signal for optional synchronisation of baud

The Nascom IMP (Impact Matrix Printer) features are:

- 60 lines per minute
- 80 characters per line
- Bi-directional printing
- 10 line print buffer
- 96 character ASCII set (includes upper/lower case)
- Automatic CR/LF
- Accepts 8 1/2" paper.

**HALF PRICE OFFER**



**EXCLUSIVE TO HENRY'S 50% OFF MAKER'S PRICE**

- Software selectable 20, 40 and 80 column using 120mm aluminium-ized paper, 1 roll supplied.
- 150 lines per minute.
- Centronics parallel data interface for Nascom, Tandy, etc.
- 240volt mains input.
- ASCII character set
- Paper feed, and on/off select switches
- Audible 'BELL' signal
- Weight 10lbs
- Size: 13" x 10 1/2" x 4 1/2" LIST PRICE £400

80 column

**Our Price £195.00**  
plus VAT post FREE

**CENTRONICS P1 PRINTER**

Spare paper £9 for 3 Rolls + VAT

**FERRANTI COMPUTER KEYBOARDS**

**STURDY SOLID CASE**



**SIZE 14" x 3"**  
**SLOPING FRONT**

60 Key ASCII Coded in steel case  
Latched output complete with Plug & Cable with circuit to convert to T.T.L. levels.

In good condition at only **£25 + VAT**  
P/P £2.50

Your London & National Nascom Distributor.  
Export Orders deduct VAT, but add 5% carriage  
Official Export & Educational Orders welcome  
Our Telex 262284 Mono Ref. 1400 Transonics

**COMPUTER SEND BROCHURE 15p FREE**  
**STAMP**



**Henry's**

Computer Kit Division  
404 Edgware Road, London, W2, England  
01 402 6822





The committed computerer wipes the sweat from his brow, pauses for breath and prepares himself to pitch into

# Round Two of the wrestling match with assembly language

Last month, David Peckett outlined the concept of assembly-language programming, and its advantages and disadvantages and pointed out that a micro's assembly-language reflects the device's architecture. This month he looks at how data is represented in micros, describes more of the architecture of the 6502 and the 8080A, and investigates further instructions.

## Representing data

NUMBERS and characters can be represented in a computer in a variety of different ways — the precise format(s) will depend on the system's purpose. In virtually all common micros, the system architecture forces the data to be grouped in 8-bit bytes.

**Pure Binary.** I'm sure that you're familiar with the basic idea of binary numbers, but I'll just remind you of the key points. The decimal system we all know and love employs "positional notation" — the position of each digit determines its weight, or significance. For instance:

357.41

is really an abbreviation for:

$$(3 \times 10^2) + (5 \times 10^1) + (7 \times 10^0) + (4 \times 10^{-1}) + (1 \times 10^{-2})$$

Binary notation uses an identical principle, but each digit is weighted by a power of 2, rather than a power of 10. For example:

$$101101 = (1 \times 2^5) + (0 \times 2^4) + (1 \times 2^3) + (1 \times 2^2) + (0 \times 2^1) + (1 \times 2^0) \text{ (ie, 45)}$$

Don't forget that we could use a "binary point" in this system, eg:

$$101.01 = (1 \times 2^2) + (0 \times 2^1) + (1 \times 2^0) + (0 \times 2^{-1}) + (1 \times 2^{-2}) \text{ (ie, 5.25)}$$

This last notation is rarely used by micros, however.

A problem with binary notation is that we need lots of bits to represent real numbers, since the largest quantity that can be contained in  $n$  bits is  $(2^n - 1)$ . Thus a single byte can only hold numbers up to 255, 2 bytes can count up to 65535, etc.

**Signed Binary.** Unfortunately, a simple binary system cannot show negative numbers. A common way of showing the sign is to use the first (*most significant*) bit — if it's "0", the number is positive, and vice-versa. Thus:

$$0101 = +5 \text{ and } 1101 = -5$$

This obviously reduces the magnitude of numbers which can be represented by a given number of bits. With  $n$  bits, we have a range of  $\pm (2^{n-1} - 1)$ . Remember that, if several bytes are used for a large number, only the first bit of the first byte is needed for the sign.

Signed binary has a major weakness when it comes to arithmetic, however. Consider adding +3 and -2:

$$\begin{array}{r} 0011 (+3) \\ + 1010 (-2) \\ \hline 1101 (-5) \end{array}$$

This is clearly the wrong answer! It is possible to use special hardware or software to get over the difficulty, but a better answer is to use a notation that eliminates the problem.

**Two's Complement.** The solution is to use "2's complement" notation. This represents negative numbers by complementing (ie inverting every bit) their positive form, and then adding "1" to the complement. For example, to produce the 2's complement representation of -3:

$$\begin{array}{r} +3 = 0011 \\ \text{Complement: } 1100 \\ \quad \quad \quad + 1 \\ \hline -3 = 1101 \end{array}$$

Let's see if this works for arithmetic:

$$\begin{array}{r} \text{Add:} \quad \quad \quad \text{Sub:} \\ 0100 (+4) \quad \quad 0010 (+2) \\ + 1101 (-3) \quad \quad -1101 (-3) \\ \hline 0001 (+1) \quad \quad 0101 (+5) \end{array}$$

Any *carry* or *borrow* from (*MSB* + 1) is always ignored.

This isn't the place to go into abstruse mathematics, but 2's complement arithmetic will always give the right answer. In fact, the system works both ways. For example, to form  $-(-3)$  (ie +3):

$$\begin{array}{r} -3 = 1101 \\ \text{Complement: } 0010 \\ \quad \quad \quad + 1 \\ \hline 0011 = +3 \end{array}$$

There is one danger with 2's complement arithmetic, and that occurs if there is a carry from the second bit to the first (sign) bit. For instance:

$$\begin{array}{r} 0100 (4) \\ + 0100 (4) \\ \hline 1000 (-8) \end{array}$$

However, if we know that this overflow has occurred, we can allow for it; most computers contain a circuit which detects

it. The range of an  $n$ -bit 2's complement number is  $+(2^{n-1} - 1)$  to  $-2^{n-1}$ , eg, 16 bits (2 bytes) gives a range of +32767 to -32768 (what's the range of the most Tiny BASICs?) Just as in the signed binary, only the most significant bit is signed, and can suffer from overflow.

**Binary Coded Decimal.** Most micros will use 2's complement notation, but in some cases it is not acceptable. Because it uses a fixed number of digits, it can suffer from rounding errors. While this is usually unimportant, there are some applications which cannot tolerate any loss of precision. A good example is financial arithmetic (would you want your bank to round down the odd pennies?). A way round the problem is to use "Binary Coded Decimal" (BCD) notation.

In BCD, each decimal digit is represented by its own 4 bits (4 bits are needed to code the 10 digits 0-9). Normally, the 4 bits have the same weighting as for an unsigned binary number — for obvious reasons this is called "8421 BCD" — but there are other possibilities.

When BCD is used, it is normal for each byte to contain 2 BCD digits ("packed BCD"). Since the aim of BCD is to preserve every digit, the length of a BCD number can vary, and the complete number often takes the form shown in **Figure 1**. The major weaknesses of BCD are that it is very slow, and wastes storage space.

When making BCD calculations, we must take precautions to overcome the difficulty caused by the fact that 4 bits can contain more than 10 digits. Consider the BCD addition of 37 and 15:

$$\begin{array}{r} 0011\ 0111\ 37 \\ 0001\ 0101\ 15 \\ \hline 0100\ 1100 \end{array}$$

The second digit is now larger than 9 — the addition should have caused a decimal carry, but the carry has not left the second digit.

All computers are capable of detecting this condition; when it occurs, the answer is to add 6 to the affected digit and ripple the effect all through the number. In this case, we have:

$$\begin{array}{r} 0100\ 1100 \\ + \quad \quad 0110 \\ \hline 0101\ 0010\ 52 \end{array}$$

*continued on next page*

from previous page

and 52 is the correct answer.

We must also allow for the effect of the "half-carry" from the lower nybble to the upper. The problems are not as forbidding as they sound, because a micro will either have flags and codes to detect and correct the BCD errors (as in the case of the 8080A) or will perform BCD arithmetic automatically (eg the 6502).

**Floating Point Notation.** You may have noticed that, apart from BCD, I haven't considered how to represent fractional numbers. Floating point arithmetic is beyond the range of this series but, for completeness, how are floating point numbers represented in binary form?

A *mantissa* and *exponent* system is used. In decimal "scientific notation", numbers are shown as, eg:

$$0.25378 \times 10^{27}$$

The same technique is used in computers, using binary numbers which appear as:

$$0.p \times 2^q \quad \text{where } 2^{-1} \leq p < 2^0$$

A typical, 4-byte, format is shown in Figure 2.

**Representation of Characters.** We now have several ways of representing numbers in binary terms, and can select the best one for any particular application. How can we represent characters? The most common way is via the ASCII code. This uses 7 bits to code 128 characters and peripheral commands (eg ring BEL1, DElete and End Of Tape). The ASCII character set is shown in Table 1. Note that, in this code, each character is stored in a complete byte; it is therefore an impractical system for storing digits for later manipulation.

### Status words

The 6502 and the 8080A, like all computers, each have a status register containing the Processor Status Word (PSW). What can these PSWs do for us?

A PSW contains up to 8 bits, each one of which is called a "flag". Most of the flags give information about the data in the micro's accumulator, or results of manipulations of that data. Others show the micro's precise mode of operation. The different flags are used to control the course of a program; micros can make decisions based on the values of flags or groups of flags.

The 6502 and 8080A each have an 8-bit PSW, shown in Figures 3(a) and 3(b) respectively. Neither uses all 8 possible flags, and there is a fundamental difference between the ways in which each sets its flags. The 6502 sets appropriate flags whenever data is sent from one register to another, when data is passed from memory to the accumulator, and when data is manipulated. The 8080A only sets its flags when it manipulates data — data transfers do not affect them. The instruction tables that accompany each part of this series show which instructions can affect which flags.

Some of the flags have identical, or

Second nybble (hex)	First Nybble (hex)							
	0	1	2	3	4	5	6	7
0	NUL	DLE	SPACE	0	@	P	'	P
1	SOH	DC1	!	1	A	Q	a	q
2	STX	DC2	"	2	B	R	b	r
3	ETX	DC3	#	3	C	S	c	s
4	EOT	DC4	\$	4	D	T	d	t
5	ENQ	NAK	%	5	E	U	e	u
6	ACK	SYN	&	6	F	V	f	v
7	BEL	ETB	'	7	G	W	g	w
8	BS	CAN	(	8	H	X	h	x
9	HT	EM	)	9	I	Y	i	y
A	LF	SUB	.	:	J	Z	j	z
B	VT	ESC	+	;	K	[	k	{
C	FF	FS	,	<	L	\	l	
D	CR	GS	-	=	M	]	m	}
E	SO	RS	.	>	N	^	n	~
F	SI	US	/	?	O	←	o	DEL

Figure 1 (above); Figure 2 (below)

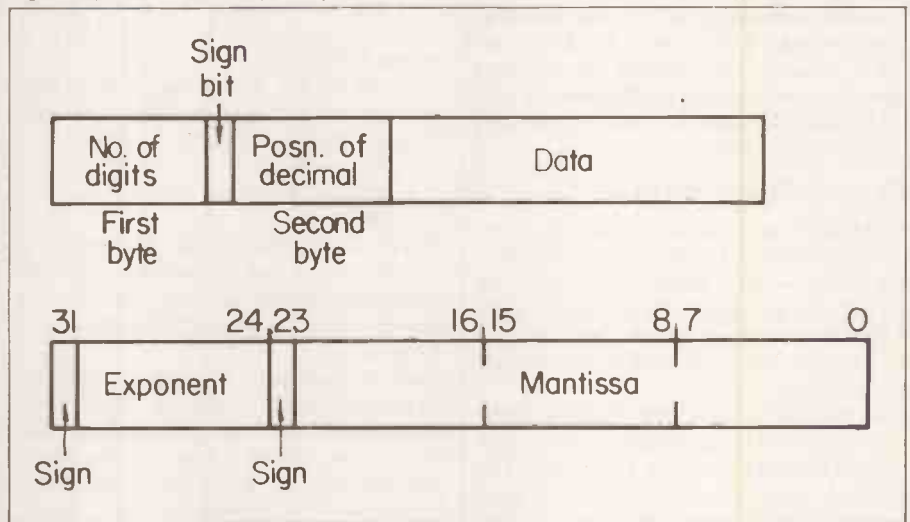

nearly so, meanings in the two devices. Others are unique to one micro.

### Common flags

**Zero (Z).** If an operation gives a zero result, the "Z" flag is set to "1". If the result is non-zero, the flag is set to "0".

**Sign (N-6502, S-8080A).** The sign bit always takes on the value of the MSB which is the result of the operation or data transfer. If it's "1", the result is negative — 2's complement arithmetic is assumed.

**Carry (C).** The carry bit can be set in three ways; during arithmetic it shows an addition overflow, or a subtraction borrow. These occur when a ninth bit is needed to hold the result (eg  $F1_{16} + F2_{16} = 1E3_{16}$ ). Micros also have instructions to shift the data in the accumulator sideways; the MSB or LSB can be shifted into C. Both micros set C to "1" if a carry occurs. However, during subtraction, the 8080A shows a borrow by setting C to "1", while the 6502 sets it to zero. It is vital to remember this difference when you write programs.

### 6502 — only flags

**Overflow (V).** The overflow flag is set to "1" if addition or subtraction causes a

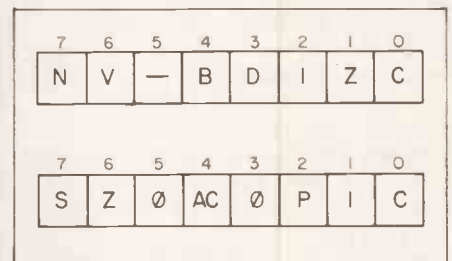

Figure 3(a) above, 3(b) below

carry or borrow between bits 6 and 7. This information is vital during 2's complement arithmetic. The 8080A's lack of an overflow flag can give problems, as I'll show later.

**Break (B).** The break flag is set to "1" while the "BRK" operation is in use. I'll come back to this in a later article.

**Decimal (D).** The 6502 has the valuable ability to perform BCD arithmetic directly with its normal opcodes. If D is set to "1", data is treated as BCD; otherwise, data is regarded as pure binary. The normal way of manipulating D is via the "SED" (SEt Decimal) and "CLD" (CLear Decimal) instructions.

**Interrupt (I).** When I is set to "1", the micro will not respond to interrupts. It is

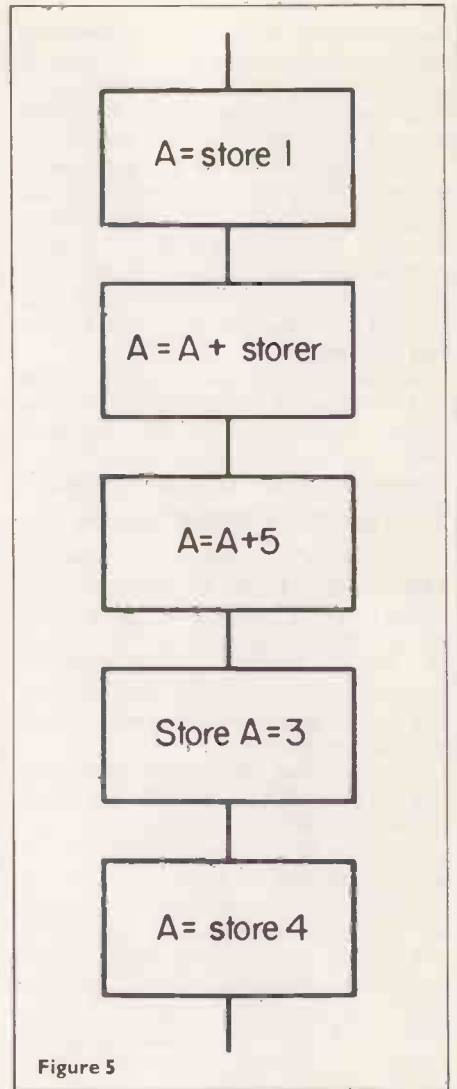
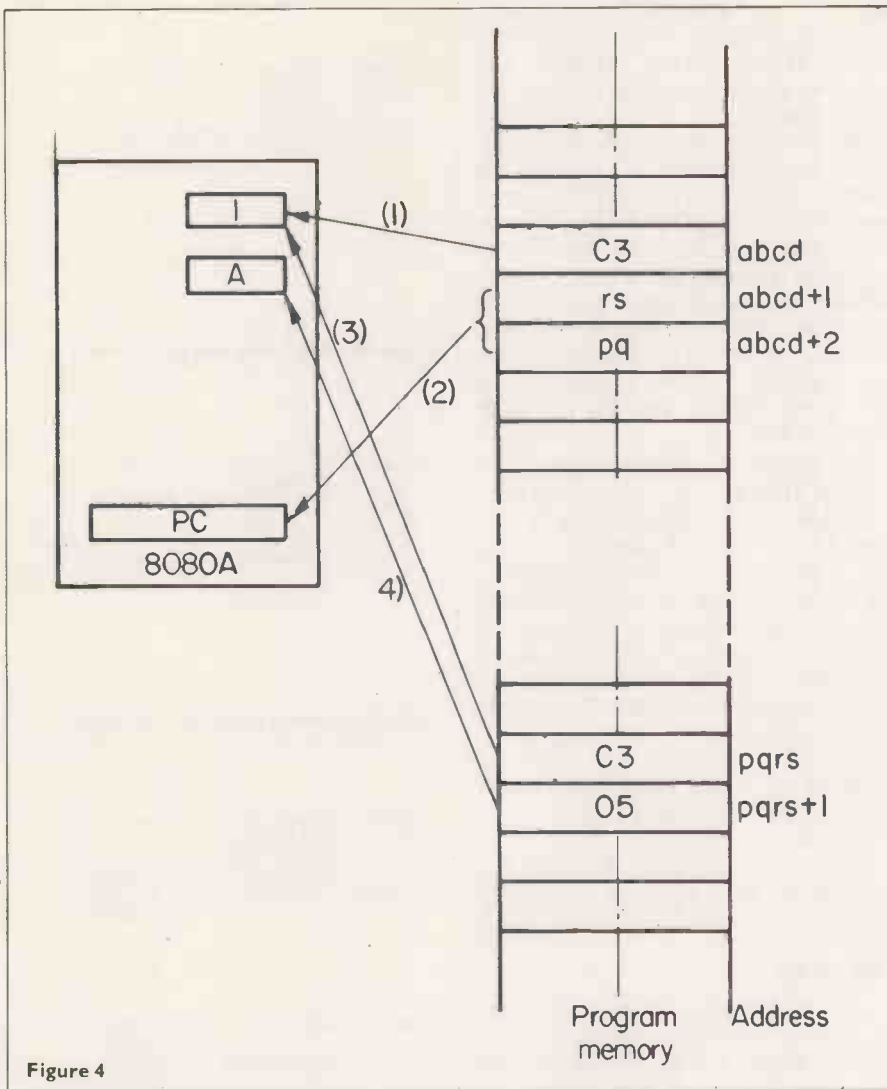

Figure 4

Figure 5

normally used during interrupt service routines, which I'll cover later.

## 8080A — only flags

**Auxiliary carry (AC).** This flag is sometimes known as the "half-carry" flag. It is set by a carry or borrow between bits 3 and 4 during arithmetic, and shows a BCD carry. The flag is only important to the "DAA" (Decimal Adjust Accumulator) instruction.

**Parity (P).** The P flag is affected by any arithmetic or logical operation. If there are an even number of bits in the result, P is set to "1". A typical use would be to check the validity of data received from a terminal.

## Program jumps

An important characteristic of any real computer system is that it rarely starts at one end of its program, goes through to the other end, and stops. On the contrary, the program will be constantly testing data, and jumping to other points as a result of these tests. A primary reason for having flags, particularly the carry and zero flags, is to simplify such tests.

The majority of jumps are these

"conditional jumps", and most of next month's article will look at them in detail. However, the starting point is the "unconditional jump". Both micros use the same mnemonic, "JMP". The mnemonic is always followed by a label, or a 16-bit address, defining where the program is to jump to.

How does a Jump work? First of all, we must recall how a program is stored in memory, and how the micro keeps place in it. A program is stored as a sequence of bytes, representing both opcodes and their associated data. The program Counter (PC) points to each instruction as it is to be executed; the instruction is read in to the micro and decoded.

Once decoded, the appropriate amount of data is also read in, and the instruction is carried out. The PC is then adjusted to point to the next instruction. Remember that a jump is a 3-byte operation; the first (lowest address) gives the code meaning a jump (for an 8080A —  $C3_{16}$ ). This byte is followed by 2 bytes containing the jump address; in both micros, this address is stored low-byte-first.

Look now at Figure 4. This shows what happens during an 8080A jump; the 6502 is very similar. As the program runs, the

PC eventually contains the address "abcd". The code at this address is read into the Instruction Register (I) (1), where it is seen to be  $C3_{16}$ . The next 2 bytes hold the jump address (low-byte-first), and are read into the PC (2), setting it to "pqrs". The micro then immediately reads the code at "pqrs" into I (3). In this case, the code is  $C6_{16}$  (ADI), and so the data in the next byte is added to the accumulator (4). The code in (pqrs + 2) is then read to become the next instruction, and so on.

When can we use jumps? Unconditional jumps are, in fact, only of limited use — the majority in a real program are conditional. A common use is to "patch" a lot of code into a short space. This could be the result of a program amendment, or because the micro's design only allows a limited space for certain operations. The 8080A's interrupt mechanism is a good example of this latter case.

Let's have a look at an example. Suppose the flow-chart of Figure 5 is a short part of a much larger program. When we coded it, we forgot to add the 5, and produced the 6502 and 8080A source code in Figures 6(a) and 6(b) respectively. For one reason or another, it's too late to re-

*continued on next page*

From Previous page

assemble the corrected program; we must patch the correction directly into machine code. Equally, the existing object code must stay, as far as possible, in its current memory locations. We can correct the situation by jumping to a spare area in memory, doing the full calculation, and jumping back to the main program. Fortunately, the "STA STORE3" in each program is 3 bytes long; we can replace it with the 3 bytes of a suitable jump. The patched programs are shown in Figures 7(a) and 7(b).

Beware of using jumps freely — they make a program appallingly difficult to follow. Beware also of the "dynamic halt":

```
LOOP1 JMP LOOP1 ;SIT HERE FOR EVER
```

### This month's instructions

This month's instructions are shown in Table 2. Most of them are concerned with jumps and flag bits, and are self-explanatory. Some, such as the 6502's CLI and SEI, and the 8080A's equivalent DI and EI, are only for completeness at this stage. The following instructions need a little more explanation:

**Increment and decrement (6502 — INC,DEC; 8080A — INR,DCR).** These instructions, which are found in all computers, can be very useful. They allow a register, and often a memory location, to be altered by 1 with a single-byte instruction. There is no need for arithmetic, which may require several bytes for the same effect. Note that the 6502 instructions only affect the memory. On the other hand, those of the 8080A can be used for any register, or for the location (M) pointed to by (H,L).

**No-operation (NOP).** Most computers

have this sort of instruction. It does nothing, and is useful for filling holes left by patches. If you were a pessimist, you could also use it to provide holes to put patches in later.

**PCHL.** This is an odd 8080A instruction. It has the same effect as a jump; for example, if H,L is set to "abcd", which is then transferred to PC by PCHL, the program immediately jumps to "abcd". The instruction is rarely used.

**Decimal Adjust (DAA).** This 8080A instruction is used after each byte of BCD arithmetic. It corrects errors which may have occurred because the micro only does pure binary arithmetic. BCD addition is easy:

```
LDA DATA1 ;FIRST PART
LXI H,DATA2 ;SECOND PART
ADD M ;DATA IS BCD
DAA ;MAKE BCD
CORRECTION
```

Subtraction is more complex, because of the way in which DAA works. The best way is to set A to 99<sub>16</sub>, C to 1, subtract the *subtrahend*, add the *minuend*, and use DAA. For example, for (DATA1 — M):

```
MVI A,$99
SEC
SBB M ;H,L IS SET ALREADY
LXI H,DATA1 ;reset H,L
ADD M
DAA ;CORRECT RESULT
```

The moral is: If you've a lot of BCD arithmetic — don't use an 8080A!

### Exercise

Let's try to apply some of these new instructions by implementing the flow-chart of Figure 8. This is a deliberately clumsy routine which does two things:

- It subtracts one 16-bit (2-byte) number

```
;START OF THE PROGRAM SEGMENT
LDA STORE1
ADC STORE2 ;ASSUME THAT C AND D
STA STORE3 ;FLAGS ARE CLEAR
LDA STORE4 ;ON TO NEXT
OPERATION
```

Figure 6(a): 6502 program with error

```
;START OF THE PROGRAM SEGMENT
LDA STORE1
LXI H,STORE2 ;SET POINTER
ADD M
STA STORE3
LDA STORE4 ;ON TO NEXT
OPERATION
```

Figure 6(b): 8080A program with error

```
;CORRECTED PROGRAM SEGMENT
LDA STORE1
ADC STORE2
JMP CORRCT ;GO TO PATCH
RETURN LDA STORE4 ;BACK IN MAIN
PROGRAM
```

```
CORRCT ADC#5 ;WE FORGOT THIS
BEFORE
STA STORE3 ;COMPLETE
CALCULATION
JMP RETURN ;BACK TO MAIN
PROGRAM
```

Figure 7(a): Corrected 6502 program

```
;CORRECTED PROGRAM SEGMENT
LDA STORE1
LXI H,STORE2 ;SET POINTER
ADD M
JMP CORRCT ;GO TO PATCH
RETURN LDA STORE4 ;BACK IN MAIN
PROGRAM
```

```
CORRCT ADI 5 ;WE FORGOT
THIS BEFORE
STA STORE3 ;COMPLETE
CALCULATION
JMP RETURN ;BACK TO MAIN
PROGRAM
```

Figure 7(b): Corrected 8080A program

Table 2: This month's instructions

Operation	6502			8080A		
	Mnem	Flags	Effect	Mnem	Flags	Effect
Set Carry	SEC	C	C = 1	STC	C	C = 1
Complement Carry	—	—	—	CMC	C	C = C
Set Decimal Mode	SED	D	D = 1	—	—	—
Allow Interrupts	CLI	I	I = 0	EI	None	Ints. Allowed
Stop Interrupts	SEI	I	I = 1	DI	None	Ints. Stopped
Clear Overflow Flag	CLV	V	V = 0	—	—	—
Increment	INC a	N,Z	(a) = (a) + 1	INR r	AC,P,S,Z	(r) = (r) + 1
Decrement	DEC a	N,Z	(a) = (a) - 1	DCR r	AC,P,S,Z	(r) = (r) - 1
No-Operation	NOP	None	None	NOP	None	None
Jump	JMP a	None	PC = a	JMP a	None	PC = a
Jump to Address in (H;L)	—	—	—	PCHL	None	PC = (H,L)
Decimal Adjust	—	—	—	DDA	All	BCD Correct

#### Notes

"a" = Address (defined by the program)

"r" = Any 8080A register. It includes the memory location (M) pointed to by (H,L).

The flags are as defined in the article.

PC = Program Counter

H,L = Register pair formed in 8080A by H and L

Brackets mean "Contents of the location or register(s) defined between the brackets".

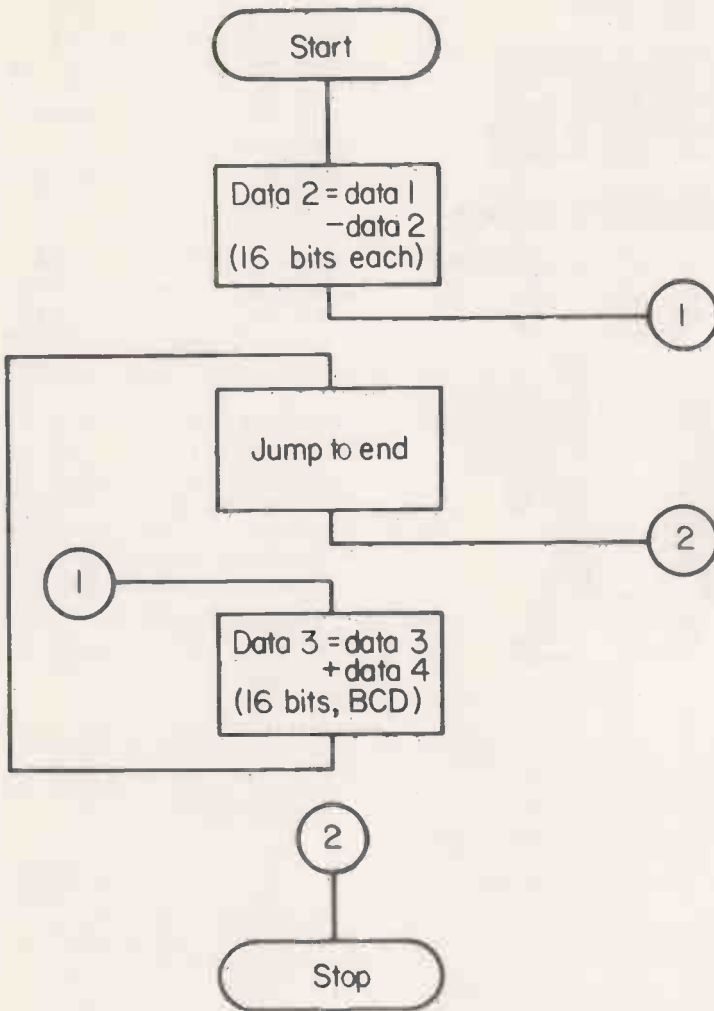

Figure 8

from another, and replaces the subtrahend with the answer.

- It adds two 16-bit (ie 4-digit) BCD numbers, and puts the result back in place of one of them.

There is also a bit of jumping about to show the use of JMP again.

The double-byte sums are examples of "multiple-precision" arithmetic. Two or more bytes can be used to contain larger, or more precise, numbers than is possible with just one byte. When we calculate with them, it's just like pencil-and-paper arithmetic; we start at the right and work to the left, noting any carry or borrow as we go. We also have to save the result of each byte as we go.

In this program, and in all future ones, I'll use the convention that multi-byte numbers are stored with their least-significant digits at the lowest addresses. Neither program is particularly taxing, but there are a few points to make in both.

## Special notes

**6502 Program.** Initially, the carry is set to "1", as this is the "no-borrow" state for subtraction. The borrow (if any) from the

first bytes is then needed for the second subtraction. Notice how I've used simple arithmetical expressions as labels — this simplifies the definition of data addresses. For the BCD addition, the carry is initially set to zero, and the decimal flag is set to "1", putting the 6502 in the decimal mode. From then, the addition is perfectly straightforward, and the BCD data needs no special treatment.

**8080A Program.** You will recall that the 8080A must point to memory, via (H,L), when it is doing arithmetic. Having initially set up H,L, the subtraction is straightforward. H,L is used, via MOV M,A, to put each answer back in memory, and INR L is used to point to the next address. Be careful when you use INR L like this — any carry from L does not affect H, which could destroy your program.

Although the 8080A subtraction procedure uses more lines of source code than the 6502's, it will actually give a shorter, faster-running, object code. This is because very few of the instructions use an address field, and so require only a single byte of machine code. The 8080A BCD routine is similar to the subtraction, but

```

;START OF 6502 PROGRAM SEGMENT
CLD           ;ENSURE FLAGS
SEC           ;CORRECTLY SET
LDA DATA1   ;START
              SUBTRACTION
SBC DATA2   ;SAVE FIRST
STA DATA2   ;BYTE
LDA DATA1 + 1 ;NOTE FORM OF
              LABEL
SBC DATA2 + 1 ;CARRY STILL
              RIGHT
STA DATA2 + 1 ;SECOND BYTE
              FINISHED
JMP STEP1    ;DEMO ONLY
STEP2        ;GO PAST PATCH
;PATCH FOR ADDITION
STEP1        CLC
              ;SET FLAGS
              SED
LDA DATA3   ;BCD ADDITION
ADC DATA4   ;FIRST BYTE
STA DATA3   ;DONE
LDA DATA3 + 1 ;CARRY STILL OK
ADC DATA4 + 1 ;DATA3 + 1
STA          ;FINISHED
              JMP
              ;STEP2
              ;END OF PATCH
END          ;FINISH FROM
              HERE
  
```

Figure 9(a): 6502 demo program

```

;START OF 8080A PROGRAM SEGMENT
LDA DATA1
LXI H,DATA2 ;SET POINTER
SUB M       ;IGNORES AND
           ;RESETS CARRY
MOV M,A    ;FIRST BYTE
           ;DONE
INR L     ;POINT TO NEXT
LDA DATA1 + 1
SBB M    ;USES CARRY
MOV M,A  ;SECOND BYTE
           ;DONE
JMP STEP1 ;DEMO PATCH

STEP2    JMP      END

;PATCH FOR ADDITION
STEP1    LDA DATA3
LXI H,DATA4 ;SET NEW
           ;POINTER
ADD M    ;IGNORES AND
           ;RESETS CARRY
DAA     ;ALSO
           ;CORRECTS
           ;CARRY
STA DATA3 ;FIRST BYTE DONE
INR L    ;INCREMENT
           ;POINTER
LDA DATA3 + 1
ADC M    ;USES CARRY
DAA     ;CORRECT
STA DATA3 + 1 ;SECOND BYTE
           ;DONE
JMP STEP2 ;END OF PATCH

END      NOP      ;FINISH FROM
           ;HERE
  
```

Figure 9(b): 8080A demo program

shows the clumsiness of having to use "DAA".

## Next month

Next month, I'll cover two points: a description of most of the other registers in the 6502 and 8080A, and the ways in which the two micros can make conditional jumps. Until then, you may like to consider

- how we can set up a program to do something a set number of times;
- how we can set up a program to do something until something else happens (not necessarily the same question as the one above);
- what's involved in sorting a list of numbers;
- how to program a micro to generate any given time delay.

## Hard disc arrives

THE 11-MEGABYTE Corvus hard-disk system is now available for the Tandy and, according to T & V Johnston, who will supply the disc, it makes the Tandy one of the most powerful microcomputer systems available.

Equivalent to 94 5½in floppy disk units on line, a single Corvus disk will provide previously unthought-of capacity which, can, by the addition of extra units, be expanded to a total capacity of 45.2 megabytes.

Partly prompted by the introduction of this significant new piece of hardware, Dr Roy King of TVJ Microcomputers has developed a modification which more than doubles the operational speed of the TRS-80 system. According to Dr King, the availability of the Corvus disk system will help not only existing users of TRS-80 systems, but will also certainly influence prospective microcomputer users.

Encased in a sealed unit, the Corvus disc module has an access time of 10 milliseconds with a data transfer rate of 648 kilobytes per second. The system is plug-compatible with the Tandy TRS-80 interface and comes complete with the NEWDOS+ disc operating system, specially written for the Corvus, and complete documentation.

### File responses

OUR QUERY in the Tandy Forum in January (whether anyone had come up with a method of determining the file name on a SYSTEM tape) has produced a varied response, and several different suggestions, some of which we reproduce here. The first is from J. A. Conradi, in Holland, who has developed a small program to read and display the name.

I've used several ROM tape routines. (See annex A for object code of the program). The CALL 0212 (hex) defines



the tape drive and starts it. Then with CALL 0296 (hex) the sync byte is searched. The first "read a byte" instruction (call 0235 hex) determines if the next byte of the tape is a 55 hex. If not, it is no system tape, so jump back to BASIC. If it is 55 hex, the next 6 bytes (the file name) are read and displayed on the screen (CALL 0033 hex). Then with a CALL 01F8 hex the tape drive is disabled. A carriage return (0D) is displayed and a return to the calling program is made.

I've added a 4K BASIC level II version to execute the machine language program (see annex B). Memory size must be 20438. It can also be used for 16K (and bigger) systems without relocation. To relocate the program to higher memory locations, change line 10, 50 and 60. No

changes have to be made in the DATA statements.

After the BASIC program is typed in or read in by CLOAD, put the SYSTEM tape in the recorder and RUN the program. Put the recorder in the PLAY mode, answer the 'READY CASSETTE' with a 'ENTER' and the file name will be displayed.

Changes to put program in high memory in 16K systems:

	4K	16K
memory size	20438	32726
line 10	20439	32727
	20477	32765
line 60	16527,79	16527,127

STEPHEN ZARA, who lives in Sussex, claims that the following Level II BASIC program will also display the name on a SYSTEM program. The name is to be found as the 2nd-7th characters after the header bytes. The program should run without a MEMORY SIZE? allocation.

The program calls the following ROM routines (HEX addresses)

```
0212 start tape
0296 read past header
0235 read a byte from tape into register A
01F8 stop tape
POKE 16553,255 ensures that READ works after use of cassette.
```

AN EVEN SHORTER solution to the same problem has been submitted by Clive Davidson from Derby. He claims that this small basic program will extract the same said file name.

```
5 CLS
10 INPUT -1,A$
20 REM EXTRACT FILE NAME
30 B$ = MID$(A$,2, (LEN(A$)-3))
40 PRINT "FILE NAME IS ";B$
```

Note the file name is always preceded by U and < . This information is removed by LINE 30, to give the actual file name.

#### Annex A

```
4f d7: 3e 00      ld    a,00
4f d9: cd 12 02    call  0212
4f dc: cd 96 02    call  0296
4f df: cd 35 02    call  0235
4f e2: fe 55      cp    55
4f e4: c2 19 1a    jp    nz,1a19
4f e7: 01 06 00    ld    bc,0006
4f ea: cd 35 02    call  0235
4f ed: cd 33 00    call  0033
4f f0: 0b         dec   bc
4f f1: 78         ld    a,b
4f f2: b1         or    c
4f f3: 20 f5      jr    nz,4fea
4f f5: cd f8 01    call  01f8
4f f8: 3e 0d      ld    a,0d
4f fa: cd 33 00    call  0033
4f fd: c9         ret
```

#### Annex B

```
10 for a=20439 to 20477
20 read b
30 poke a,b
40 next a
50 poke 16526,215
60 poke 16527,79
70 input"ready cassette";q$
80 x=usr(0)
90 end
100 data 62,0,205,18,2,205,150,
2,205,53,2,254,85,194,25,26,1
110 data 6,0,205,53,2,205,51,0,
11,120,177,32,245,205,248,1
120 data 62,13,205,51,0,201
```

## Letter from Denmark

ARNE ROHDE writes:

Several contributors to the Tandy Forum have commented on the debounce routine originally published in the April 1979. The code (with the typographical error corrected) appears to work satisfactorily, but for those without an assembler, a BASIC program similar to the one published in the November 1979 issue can be used to insert the code.

To insert machine code of this type, I have for some time used a BASIC program which does not require that the code be converted to decimal numbers for insertion in the DATA statements. The conversion from hexadecimal form to the form required by POKE can be done very simply in TRS-80 level II BASIC.

Also when powering up by TRS-80, I tend to forget to set the MEMORY SIZE which is required for code such as the debounce. However there is another possibility which can be used for machine code in programs which do not use cassette (or disk?) input/output or long messages from the keyboard.

The I/O buffer contains 256 bytes, most of which may be unused during the execution of a program. If done with care, machine code can be stored at the end of the I/O buffer, without taking up space at the high end of memory. The temporary part of my debounce routine is stored in this buffer, since it is only called once and can thereafter be ignored.

Another part of memory which seems to be unused in my system (no expansion interface and no disks) is the reserved area from 404FH to 407FH, and this area is large enough to contain the permanent part of the code for the debounce routine. Actually it only uses the area from 406A to 407F, thus being considerably shorter than the one published in the April issue.

The only changes required to relocate the permanent portion to address 7FEA (or any other address) is the address portion of line 300, and data bytes 2 and 3 in line 310 (6A40 to EA7F, for example). A simple check could also be inserted to examine whether memory has been reserved for machine code. The memory end address can be found in bytes 16561 and 16562, and the value should be less than the routine start address.

As can be seen from the listing, spaces can be interspersed between the data bytes, for example to separate the individual instructions. If the terminal statements in line 20 and the DATA statements from line 300 are changed, the program can be used for entering any machine language program. The assembler code for the debounce is shown above.

There seems to be a bug in Level II BASIC which can arise if programs are written without any spaces between the language tokens. I have seen it several times after compressing a program because of insufficient storage space. The

The Basic program is as follows:

```

10 CLEAR 100:DEFINT H,I,V
20 READ A$,V$:IF A$="END" CLEAR 50:A=USR(0):
NEW ELSE A=0
30 FOR I=1 TO 4:H$=MID$(A$,I,1):GOSUB 200:A=
16*A+H:NEXT:I=1
40 H$=MID$(V$,I,1):IF H$<>" " GOSUB 200:V=16
*I:I=I+1:H$=MID$(V$,
I,1):GOSUB 200:V=V+H:POKE A,V:A=A+1
50 I=I+1:IF I<LEN(V$) THEN 40 ELSE 20
200 H=ASC(H$)-48+7*(H$>"9"):RETURN
28F8 0605 CD6000 C3
300 DATA 406A,118D38 213540 C803 F8 2C 1A AE
E303
310 DATA 42D0,216A40 221640 214A2E 228E40 C9
320 DATA 408E,D842
330 DATA END,END
    
```

406A	118038	LD	DE,3880H
406D	213540	LD	HL,4035H
4070		NXTCH:	
4070	C803	RLC	E
4072	F8	RET	M
4073	2C	INC	L
4074	1A	LD	A,(DE)
4075	AE	XOR	(HL)
4076	28F8	JR	Z,NXTCH
4078	0605	LD	B,05
407A	CD6000	CALL	0060H
407D	C3E303	JP	03E3H
42D0	216A40	LD	HL,406AH
42D3	221640	LD	(4016H),HL
42D6	214A2E	LD	HL,2E4AH
42D9	228E40	LD	(408EH),HL
42DC	C9	RET	

Danish Basic routine (above); assembler code (below)

error arises when the last operand in an IF statement is a string enclosed in quotes and it is immediately followed by certain commands. Inserting a space or the word THEN seems to correct the error in all cases. I have not attempted it with all commands, but PRINT, GOTO, LET and INPUT will cause incorrect execution.

For example the statements

```

10 A$=""
20 IF A$ < > ""PRINT A$:A$ =
""ELSE PRINT "NULL"
30 END
    
```

will not print the word NULL when executed. If a space is inserted between "" and PRINT then the word NULL will appear on the screen. 

# THE LOGICAL APPROACH TO DIGITAL LEARNING

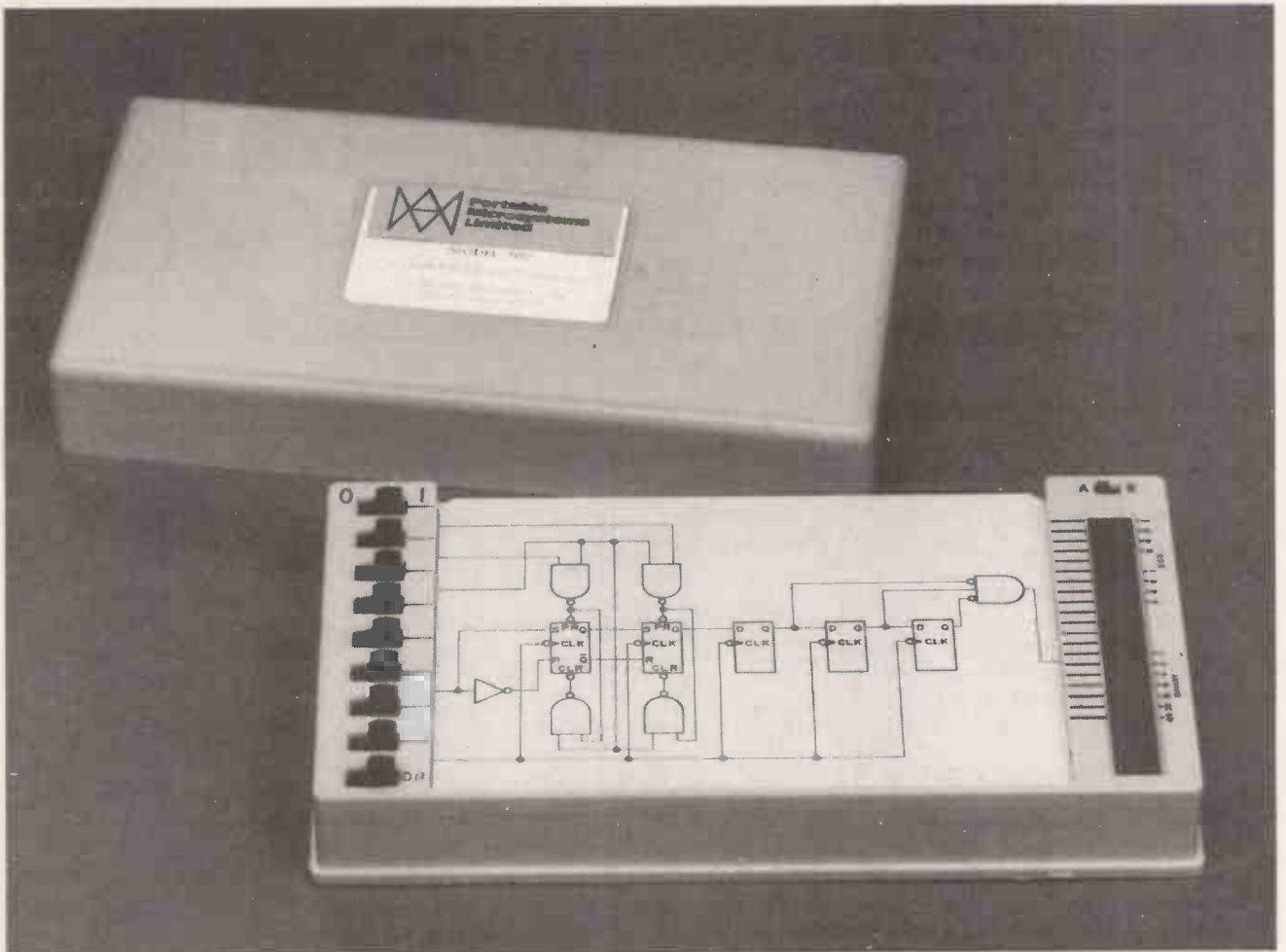

THE ELT 100 FROM PORTABLE MICROSYSTEMS IS A REALLY SIMPLE LEARNING AID FOR THE HOBBYIST, STUDENT OR PROFESSIONAL. KEEP UP IN THE SILICON CHIP REVOLUTION WITH THE HELP OF THE ELT 100.

**PRICE: £59.95 + V.A.T. + £2.50 p+p**

**DELIVERY: EX-STOCK**

**MAIL ORDER PRICE £71.82 inclusive**

*Note: Prices are subject to change without notice.*

Forby House, 18 Market Place, Brackley, Northants NN13 5SF

Telephone Brackley (0280) 702017

Telex Micro 83147

• Circle No. 195



## Not fade away

As a computer consultant and Apple user, I am distressed to think that your Apple Pie users forum may fade away. This would be a great pity, as I feel that nothing but good could come out of constructive communication between hobbyists, who have the skills and the time, and business users, who have the problems, (writes David Sutton, from Cheshire).

May I perhaps breathe a little life into Apple Pie by offering a small prize for the solution of a small commercial problem. I would have a use in a teaching application for a program which could draw, on an Apple display, circles of solid colour.

I have written a simple Applesoft programme to do the job but it is far too slow. The shape drawing facility on the Apple is ruled out by the need to be able to enlarge or shrink the circles at will. Clearly a machine-code subroutine would solve the problem, but I have neither the time nor the inclination to learn Apple machine-code.

But I am prepared to pay £10 to the respondent who sends me a listing of the fastest Apple machine-code subroutine that draws a solid circle of specifiable colour, radius and location on the high-resolution graphics screens, that is locatable anywhere in Apple memory that I choose and does not interfere with the Mountain Hardware Keyboard Filter.

If anyone would like to take up this offer send your entry to Apple Pie, marking the item clearly. We will pass the entries on to Mr. Sutton and arrange for the prize to be awarded. We will also publish the winning entry.

## Finance modelling on the Apple

A new financial modelling package is now available on the Apple. Named VISICALC, it is being billed as 'instant visual calculation for any numerical problem, without the need for programming.'

Visicalc organizes and displays information on the screen in a display made up of 64 columns and 256 rows, like a giant wall-chart. When a key variable is changed, all the related figures are recalculated automatically. The user can play 'What if . . .' with his sales figures and assess his own changes.

The user can define his own formulae, establish his own charts, tables and records and set the limits on the model. The system then takes over and can be used to present a choice of solutions to a business problem.

Priced at £95, the package is available from most Apple dealers, although the 32K Apple II system required to run the package would require an investment of £1200, at least.



## Deviant games

In another response to our "Zzzz! Wake up, Apple users!", Simon Goodwin has sent us this short program list for an Apple Integer BASIC game. He hopes that "a few of the ideas in the program will stimulate the minds of other Apple users, as the program would provide a convenient basis for a variety of deviant games, quite unlike the commercially available games for Apple that I have seen."

```

3 X=0:I= RND (9)*4+4:H=0:A=0
5 GR
10 K= PEEK (-16384)-176: POKÉ
-16368,H
30 X=X+3: IF X>38 THEN 100
40 I=1+ RND (3)*4-4: IF I<4 THEN
I=4: IF I>36 THEN I=36: GR
↑ COLOR=9: VLIN I-1,I+1 AT
X: PLOT X+1,I
50 IF K<1 OR K>9 THEN 10
60 A=A+1: IF A>30 THEN 100
70 COLOR=3+A MOD 2: HLIN 0,39 AT
K*4
80 IF K*4#I THEN 90: PRINT "BLEEPER
DESTROYED.": PRINT :S=S+1:
PRINT "SCORE SO FAR ":S: PRINT
85 X=0
90 GOTO 10
100 TEXT : CALL -936: PRINT "FINAL S
CORE : ":S: PRINT
110 PRINT "AMMUNITION EXPENDED : "
JA: PRINT
120 A=0: INPUT "TYPE 0 TO PLAY AGAIN
":S: IF S=0 THEN 3
130 END
    
```

Points to note about the programme:

- The game ends when either more than 30 shots have been fired, or one of the targets has successfully crossed the screen without being shot down.
- Depress the keys 1-9 to fire across the screen.
- The GR in line 40 could be replaced to advantage by a CALL-1994 command.
- There is a 'cntrl G' inside the first set of inverted commas on line 80.

The Apple that I use shows a strange tendency to change the variable-name 'Y' in programmes into an 'I'!! Do any other Apple users have this problem, or something like it? Or could one of them explain why it happens? That is why I have used 'I' to record vertical position in the enclosed programme.

## System-log routine

Here are the bare bones of a routine to create and maintain a system-log on the Apple, submitted by Paul Humphreys, from Oxford.

The idea may be developed to suit individual requirements. This example assumes one disc-drive, and a printer in #2. The use of a clock-card is implied, but is not essential.

There are three stages:—

1. Program (a) creates the log-file.
  2. Append subroutine (b) to your present programs.
  3. Program (c) prints the log-to-date.
- I use my version to monitor a package.

### LIST

```

1 REM *** CREATE LOG-FILE
8 D$ = CHR$(4)
10 PRINT D$;"OPEN LOG"
20 PRINT D$;"WRITE LOG"
30 PRINT "PROGRAM": PRINT "
SUBJECT": PRINT "TIME"
40 PRINT "*****": PRINT "
*****": PRINT "****"
50 PRINT D$;"CLOSE LOG"
    
```

### JPR10 LIST

```

900 REM *** SUBROUTINE TO
UPDATE LOG ***
910 PRINT D$;"APPEND LOG"
920 PRINT D$;"WRITE LOG"
930 PRINT "A": REM *** A=
YOUR PROGRAM-NAME
940 PRINT "B": REM *** B=
MOST SIGNIFICANT VARIABLE
IN PROGRAM
950 PRINT T$: REM *** T$=
TIME (FROM CLOCK-CARD OR
INPUT)
960 PRINT D$;"CLOSE LOG"
970 RETURN
    
```

### LIST

```

1 REM *** PRINT LOG-TO-DA
TE ***
2 ONERR GOTO 70
10 PRINT D$;"PR#2"
20 PRINT D$;"OPEN LOG"
30 PRINT D$;"READ LOG"
40 INPUT F$: INPUT V$: INF
UT T$
50 PRINT F$,V$,T$
60 GOTO 40
70 IF PEEK (222) = 5 THEN
PRINT D$;"CLOSE LOG"
    
```

# ELF II

THE TRIED AND TESTED  
MICROCOMPUTER  
SYSTEM  
THAT EXPANDS  
TO MEET  
YOUR NEEDS

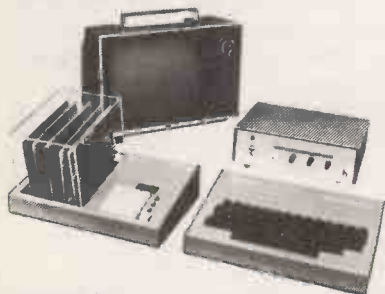

Computer Kit

STARTS AT  
**£59.95**  
+ VAT

ELF II  
BOARD WITH VIDEO OUTPUT

FEATURING THE RCA COSMAC 1802 CPU

STOP reading about computers and get your "hands on" an ELF II and Tom Pitman's short course. ELF II demonstrates all the 91 commands which an RCA 1802 can execute, and the short course speedily instructs you how to use them.

ELF II's VIDEO OUTPUT makes it unique among computers selling at such a modest price. The expanded ELF II is perfect for engineers, business, industry, scientific and educational purposes.

## ELF II EXPANSION KITS

	Ex VAT
* Power Supply for ELF II	£5.00
* ELF II Deluxe Steel Cabinet (IBM Blue)	£19.75
* Giant Board Kit System/Monitor, Interface to cassette, RS232, TTY, Etc.	£25.50
* 4K Static RAM board kits (requires expansion power supply)	£57.50
* Expansion power supply (required when adding 4K RAMs)	£19.00
* ASCII Keyboard Kits 96 printable characters, etc.	£39.95
* ASCII D/lux steel cab (IBM Blue)	£12.75
* Kings prototype board (build your own circuits)	£11.00
* 86 pin Gold plated connectors, each	£3.75
* ELF Light pen writes/draws on TV screens	£6.00
* Video display board 32/64 characters by 16 lines on TV/monitor screens	£61.50
* ELF II Tiny basic on cassette	£9.75
* ELF-BUG Monitor, powerful systems monitor/editor	£9.75
* T. Pitmans short course in programming manual (nil VAT)	£3.00
* T. Pitmans short course on Tiny Basic manual (nil VAT)	£3.00
* RCA 1802 users manual (nil VAT)	£3.00
* On cassette, Text Editor, Assembler, Disassembler (each)	£12.75

## ELF II BOARD SPECIFICATION

\* RCA 1802 8-bit microprocessor with 256 byte RAM expandable to 64K bytes  
\* RCA 1861 video IC to display program on TV screen via the RF Modulator Single Board with Professional hex keyboard - fully decoded to eliminate the waste of memory for keyboard decoding circuits Load, run and memory protect switches  
16 Registers  
Interrupt, DMA and ALU  
Stable crystal clock  
Built in power regulator  
5 slot plug in expansion bus (less connectors)

## BREAKTHROUGH

We proudly announce the release of the first 1802 FULL BASIC, with a hardware floating point RPN MATH PACKAGE (requires 8k RAM). Also available for RCA VIP and other 1802 systems Board includes area for a ROM version.

**£49.50**

+ VAT.

## Video 100 12" Professional Monitor

Ideal for home, personal and business computer systems

12" diagonal video monitor

Composite video input

Compatible with many computer systems

Solid-state circuitry for a stable & sharp picture

Video bandwidth - 12MHz + 3DB

Input impedance - 75 Ohms

Resolution - 650 Lines Minimum in Central

80% of CRT; 550 Lines Minimum beyond

central 80%.

Only **£79** + VAT



## NEWTRONICS KEYBOARD

### TERMINAL

Kit **£114.20** + VAT

assembled  
and tested **£144.20** + VAT

Optional Extra  
Video Monitor **£79** + VAT

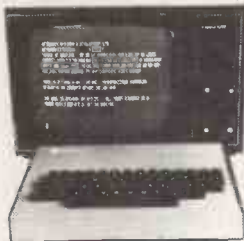

The Newtronics Keyboard Terminal is a low cost stand alone Video Terminal that operates quietly and maintenance free. It will allow you to display on a monitor 16 lines of 64 characters or 16 lines of 32 characters on a modified TV (RF Modulator required).

The characters can be any of the 96 ASC II alphanumeric and any of the 32 special characters, in addition to upper/lower case capability, it has scroll-up features and full X-Y cursor control. All that is required from your micro-computer is 300 baud RS232-C or 20ma loop serial data plus a power source of 8v DC and 6.3v AC. The steel cabinet is finished in IBM Blue-Black.

# Explorer/85

Professional Computer Kit

AT

**£275** + VAT

with  
Microsoft BASIC  
on Cassette  
OR

**£295** + VAT

with  
Microsoft BASIC  
in ROM



## FEATURES INTEL 8085 CPU

FLEXIBILITY: Real flexibility at LAST

The EXPLORER/85 features the Intel 8085 CPU

100% compatible with all 8080A and 8085 software. Runs at 3MHz.

Mother Board (Level A) with 2 S-100 pads expandable to 6 (Level C).

## MEMORY

2K Monitor ROM

4K WORKSPACE/USER RAM

1K Video RAM

8K Microsoft BASIC in ROM or Cassette

## WITH

**ONBOARD S-100  
EXPANSION**

## INTERFACES

STANDALONE FULL ASC11 Keyboard Terminal, 32/64 characters per

RS-232/20Ma Loop. 4, 8bit: 1, 6 bit I/O ports, programmable 14 bit binary counter/timer. Direct interface for any S-100 Board.

FULL Buffering decoding for S-100 Bus pads, wait state generator for

slow memory. Each stage has separate 5v 1A regulator for improved

isolation and freedom from cross talk. P.S.U. requirements: 8v, 6.3v AC.

Runs with North Star controller and Floppies/CPM. EXPLORER/85 is

expandable to meet your own requirements with easy to obtain S-100

peripherals. EXPLORER/85 can be purchased in individual levels, kit

form or wired and tested OR as a package deal as above.

## 16k Dynamic RAM Kit

Expandable to 64k on one S-100 board in 16k increments, designed for

NO wait state operation utilizing the most advanced RAM controller.

16k RAM Kit..... £139 + VAT

16k RAM Expansion Kit (to expand the above up to 64k,

in 16k increments) ..... £89.95 + VAT

## NOW: - EXPLORER/85 with NORTH STAR FLOPPY DISCS

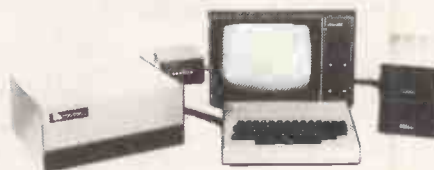

Explorer/85 up and ready to go (as illustrated)	32k.....	£599
	48k.....	£698
	56k.....	£787

North Star Double Density Disc System, 3 - drive controller and a Single 5 1/4" Drive with regulator,	180k byte.....	£500
Twin Drive System.....		£600
BASE - 2 PRINTER, 80 character unidirectional, variable density traction - friction fed etc. ....		£450
Hitachi Monitor 9" .....		£127

All prices are exclusive of VAT

## SEND SAE FOR COMPREHENSIVE BROCHURE

Please add VAT to all prices (except manuals), P&P £2. Please make cheques and postal orders payable to NEWTRONICS or phone your order quoting BARCLAYCARD, ACCESS number.

We are now open for demonstrations and Sales, Monday-Saturday, 9.30 a.m.-6.30 p.m. Near Highgate Underground, on main A1 into London.

# Newtronics

255 ARCHWAY ROAD, LONDON N. 6

TEL: 01-348 3325

• Circle No. 196

PRACTICAL COMPUTING April 1980

## PET DOS peculiarities

THESE COMMENTS, and the sub-routine, for the PET 6502 DOS hardware idiosyncracies were written by Tony Winter, of G.W. Computers, and approved by Commodore:

Three DOS failures have so far been detected and compensated for in our current batch of programs bus version 3 and upwards.

It is my contention that any program currently on the market, which either uses a double redundancy workfile technique needing rename functions, or sequential file arrangements that do not include something like the following conventions to compensate for DOS failures, will not meet the sufficient conditions of reliability customarily associated with a serious program whose market value exceeds about £100. The program features that will persist will be constant but spontaneous hang-ups, apparent file losses, and data transfer going on wrong files.

- The cause of DOS rename failures is still obscure but can be dealt with by simply checking the error number through channel 15, immediately after a rename attempt. If it turns out to 62, then re-attempt it say three times, followed by a copy function if all that failed. One might prefer always to copy, but for longer files there will be a significant delay in processing, so the rename attempt will serve as a time-save if it works. Solution is assumed to be obvious.
- Unreliable date transfer crossing to wrong files due to fault or upset (block availability map) and is best compensated for with all file changes being followed by a verify on the data disk. Solution assumed to be obvious.
- Faulty ends of files are a result of the number of bytes being printed to a file, coinciding with the block availability count less two bytes. This means effectively that if the total



amount of bytes printed to a sequential file, happen to fall into a number that is divisible by 254 (that's critical) or its increment, then an extra carriage return is picked up which now alters the fixed file architecture in a way that causes input statements to fall in an apparent cul-de-sac and the program hang up. If the run/stop key has been disabled (as should be if the program has any purported robustness) then the only recovery is to power down, which is alarming in the middle of an invoice run.

The way to compensate for this is, unfortunately, to slow down all print to file processes by doing a byte count in a way that either detects that the total byte count for the file is an increment of 254, or simply plugs a blank every time the byte count spontaneously reaches the critical number. The following example takes the latter route, since frequency of coincidence is somewhat random and the result is unlikely to fill the data with blanks very frequently. It is vital, however, that the count is detected properly since recovery is far too arduous for most end users to cope with.

It is no good trying to recover by copying the file to a new file and taking off on byte in the process, since the count is the effective correlation and block gets refilled every time.

### Firmware for PET

EPROMS can now be programmed on the PET using a hardware/software package from GR Electronics, Newport, Gwent (0633 67426). It allows PET users to produce firmware to run either on the PET itself or on other microprocessor-based systems.

The programmer is for the 2716d device which uses a 5V supply. It consists of a plug-in circuit board which uses the IEEE port for data, the user port for control lines, and takes 5V from the computer's external cassette drive.

Full EPROM programming is supplied on cassette, with functions including read/write to and from random access and erasable programmable memory, sequencing verification and read/write/modify with addresses and data in hex.

An extension socket is provided for those wishing to deal with memories in batches.

### Scramble for speech synthesis

THE LAST FEW WEEKS have seen an extraordinary surge of interest in speech synthesis, writes Julian Allason. It seems to have started before Christmas with rumours — since substantiated — that Commodore had a speech-synthesising peripheral under development.

By this time, the commercial software houses were scrambling to acquire or develop speech synthesis software of their own. It now seems probable that Commodore themselves will release various software dictionaries to support their new peripheral. No launch date has been announced yet.

Petsoft have demonstrated a Talking Calculator program to key dealers. What is particularly interesting is that PET's own resources have been harnessed in such a way that only an inexpensive tone generator is required to produce comprehensible speech.

### Forth for the PET

ACT PETSOFT have introduced an interactive FORTH compiler/interpreter to run on the PET.

FORTH is a unique high-level language which has recently become popular in the United States, where it is widely used in astronomical and general scientific applications.

The principal advantages of FORTH are that it is extremely fast and requires only a small amount of memory. The language lends itself naturally to structured programming.

Petsoft's PET FORTH package contains a dictionary of 200 'words', each of which approximates to a sub-routine in BASIC. It is vocabulary-based, so the user can tailor the system to resemble the needs and structures of any specific application. Also included are a built-in incremental assembler and text editor.

VARIOUS SCHEMES to convert the PET into a powerful cash register (with or without stock update) have run into problems usually associated with hard-wiring in a cash drawer. Now an American company called Computer Forum are offering a complete kit including drawer and interface for \$140.

```
10 OPEN2,8,5,"@1:SEQUENTIAL,S,W"
20 X#=CHR$(13)
30 FORI=1TO127:A$(I)="1":GOSUB10000:PRINT#2,
  A$(I);X#;NEXTI:CLOSE2
10000 DC=DC+LEN(A$(I))+LEN(X#):PRINT"0":DC
10010 DA=DC/254:IFINT(DA)=DA/254THENPRINT"CO
  RRECTING DOS FAULT":GOTO10030
10020 RETURN
10030 A$(I)=A$(I)+" ":FORW=1TO1000:NEXT:RETU
  RN
  READY.
```

Tony Winter's Commodore-approved subroutine

## OHIO SCIENTIFIC NEWS FLASH

### FULL RANGE OF SUPERBOARDS TO C3's

Best prices, best backup, best service from an Ohio Scientific factory appointed dealer/importer

Ring us for latest prices on boards, accessories, expansion, software etc.

50Hz Superboard prices start From £150 + VAT

C.T.S., 1 High Calderbrook Littleborough Lancs OL15 9NL

Tel: Littleborough (0706) 79332 ANYTIME

• Circle No. 197

### \*\* BRITISH \$100 \*\*

15 Slot Mother Board (S100) with power socket	£25.22
S100 Edge Connectors	£2.61
Card Guides (per pair)	£0.22
Card Cage Kit (painted)	£8.70
Base Tray & Spacers (drilled)	£5.22
Transformer 8v - 20 amps	
13v - 2 amps	
13v - 2 amps	£26.09
26v - 4 amps	
100,000 UF Capacitors	£17.39
18 amp bridge rectifiers	£5.22
Power supply (board only)	£19.13
Components (power supply)	£41.74
Power supply board built & tested	£91.30
Extra quiet fan	£13.91
Complete power supply	£286.96
Box to house all the above	£60.87
7200 DRI double sided drive	£365.22
Anadex DP 8000	£525.00

ALL PRICES VAT EXCLUSIVE

### BYTRONIX

83 West Street, Farnham, Surrey  
Tel: (0252) 726814

• Circle No. 198



**30 ST. JOHNS ROAD  
TUNBRIDGE WELLS  
KENT**

Telephone: Tunbridge Wells (0892) 41555

**DIGITAL MICROSYSTEMS**  
LOW COST BUSINESS COMPUTERS

---

**DSC-2**

- ONE to 29 MEGABYTES DISK STORAGE
- 64 Kbytes of Main Memory - STANDARD
- Digital Research CP/M operating system - STANDARD
- TEXT PROCESSING, BASIC, COBOL, FORTRAN available

---

**HEX-29**

- 32 to 96 MEGABYTES DISK STORAGE
- 32 USER & 16 TASK capability - STANDARD
- Reentrant ASSEMBLER & BASIC - STANDARD
- Floppy disk based development system available

MODATA still need DEALERS in parts of U.K. and IRELAND

• Circle No. 199

continued from page 91

interrupt capability.

Sensors can either be scanned (typically between 10 and 80 times a second), return a value on request or cause an interrupt when they change state. On the whole, the scanning system offers many advantages. The computer is always fed with up-to-date information, the scanning routine can monitor for predefined situations and the computational overheads are predictable.

The output of analogue sensors, such as strain gauges, potentiometers and proximity sensors will have to undergo an analogue-to-digital conversion. The two main techniques, ramp and successive approximation, were covered in *Computabits* (1978).

Typically, a robot sensor will be converted into an eight-, 10- or 12-bit number. The accuracy of digitisation will be governed by the resolution, dynamic range and linearity of the transducers.

### Limits to resolution

Resolution is the smallest step that can be distinguished from the next. In many transducers this is virtually infinite, but it may be limited by noise in amplifiers. Dynamic range is the operational range of the transducer, giving too small a signal at one end to the point where it saturates or breaks at the other.

A strain gauge has a dynamic range of about 1000:1, so that if the transducer is designed to respond to a minimum force of one gram, the maximum useful output will occur when one kilogram is applied. The dynamic range of the A:D converter should at least match that of the transducer.

Non-linearity, in a device such as a potentiometer, limits the confidence with which the signal may be used (high-precision potentiometers have linearities between 1 and 0.1% (manufacturer's information, Penny and Giles Potentiometers Ltd). Dynamic ranges can be extended or compressed over partially useful ranges with logarithmic or exponential post-processing amplifiers.

Several single-chip A:D converter systems exist. The National Semiconductor ADC0816 is an eight-bit converter that incorporates a 16-channel analogue multiplier that can be used to scan sensors with little extra logic (manufacturer's information/data books). The multiplexer is fabricated from CMOS switches.

The CD4069 is a 16-channel multiplexer, without the converter. The ADC1210/1211 chip is a 12-bit converter (without multiplexer). Many different converters, in a range of speeds, resolutions and prices are on the market. Typical conversion times are two to 10 microseconds per bit.

Now we have looked at the types and styles of robots that are made, and the sort of data we can expect from the environment through the robot's sensors, I shall deal in the next part of this series with software and computer programming systems for both industrial and experimental robot control.

### References

Aareskjold K. (1979): *Development and application of an industrial robot for pointing in industry* in: *Industrial Robots Vol 1/Fundamentals* (Tanner W., ed.); Michigan: Society of Manufacturing Engineers ISBN 0-87263-045-5, presented at Finishing '77 Conference and Exposition, October 18-20, 1977.

Boys J.T., Strelow E.R. and Clark G.R.S.

(1979): *A prosthetic aid for a developing blind child* in: *Ultrasonics* 17-1 (January 1979), pp 37-42.

Byatt D.W.G. (1980): *Radio navigation and radar* in *Wireless World* 86-1529 (January 1980), pp 47-51.

Computabits (1978) Kim projects in *Practical Computing* 1-3 (November 1978), pp63-65; 1-4 (December 1978) pp63-69.

Goto T., Inoyama T. and Takeyasu K. (1974): *Precise insert operation by tactile controlled robot* in *The Industrial Robot* 1-5 (September 1974), pp225-228.

Jones B.E. (1977): *Instrumentation, measurement and feedback*, England: McGraw-Hill Book Co (UK) Ltd, ISBN 0-07-084069-5 (particularly Chapter Four, pp66-104).

Kay L. (1979): *Air sonars with acoustical display of spatial information* in *Animal sonar systems*, Jersey symposium, April 1-8, 1979.

Larcombe M.H.E. (1976): *Tactile sensors, sonar sensors and parallax sensors for robot applications* in Third Conference on industrial robot technology & Sixth international symposium on industrial robots, held at University of Nottingham, March 24-26, 1976, England: International Fluidics Services, ppB1-1 to B1-8.

Larcombe M.H.E. (1979): *Mobile robots for industrial use* in *The Industrial Robot* 6-2 (June 1979), pp70-76.

Nevins J.L. and Whitney D.E. (1979): *Robot assembly research and its future applications* in *Computer vision and sensor-based robots* (Dodd G.G. and Rossol L., eds), Proceedings of a symposium held at General Motors research laboratories, September 25-26 1978, New York: Plenum Press ISBN 0-306-40305-6, pp275-321.

Pond J. (1979) *Putting it all together with robots* in *Industrial Robots Vol. 1/Fundamentals* (Tanner W., ed), Michigan: Society of Manufacturing Engineers, ISBN 0-87263-045-5 (reprinted from: the December 13, 1976 *Iron Age*), pp73-79.

Pugh A., Heginbotham W.B. and Page C.J. (1977): *Novel techniques for tactile sensing in a three-dimensional environment* in *The Industrial Robot* 4-1 (March 1977), pp18-26.

Salmon M. (1977) *Assembly by robots* in *The Industrial Robot* 4-2 (June 1977), pp81-85.

Ueda M., Sakai I. and Kumazawa T. (1976): *One trial to use a simple version sensing system for an industrial robot* in 3CIRT/6ISIR (as Larcombe '76), England: International Fluidics Services, ppC3-25 to C3-30.

Wang S.S.M. and Will P.M. (1978): *Sensors for computer-controlled mechanical assembly* in *The Industrial Robot* 5-1 (March 1978), pp9-18.

Woolvet G.A. (1977): *Transducers in digital systems*, IEE Control Engineering series 3/Peter Peregrinus Ltd, ISBN 0-906048-13-3.

# Serious sorting for business

'Bubble' sat technique discussed by Mike Lake

WITH THE ARRIVAL of floppy disks, and possibly hard disk in the future, more and more PETs are being used for serious business purposes that involve the storage of large amounts of data in the form of disk records.

The problem with computer files is that they are set up in an order based on a particular field — for example a stock file might be set up based on the part number order — and sooner or later one would like to examine them in another order. This means that the file needs to be sorted — perhaps on supplier code for a stock file.

Computer sorting is an extremely involved subject and anyone with a professional interest in it is advised to study the classic book on the subject *Sorting and Searching* by Knuth — Volume 3 of his *The art of computer programming* series. The problem boils down to one simple issue — what is the best way of sorting a list?

In PET BASIC terms, let us redefine this as "what is the best way of sorting an array?" Below is a very simple BASIC routine that will sort an array into ascending order. The variable "N" contains the number of elements in the array.

```
100 FOR I = N-1 TO 1 STEP -1
200 FOR J = 1 TO I
300 IF A$(J) > A$(J+1) THEN B$ =
    A$(J): A$(J) = A$(J+1): A$(J+1)
    = B$
400 NEXT J
500 NEXT I
```

This technique is called a "bubble" sort, since for each loop based on "J", it bubbles the highest value to the end of the list. The loop based on "I" controls the number of times the process needs to be repeated — obviously having found the highest value in one loop based on "J", it is not necessary to examine it on the next loop — hence the reason for the "I" loop.

For small numbers of elements, 20 or so, this method is quite satisfactory — after that it becomes embarrassingly slow — just work out how many times statement 300 is executed for 100 elements and you will understand why!

Obviously what is needed here is a machine-code sort of the array. I have written a machine code routine that adds the new command "!S,array-name" to BASIC. This will sort any string array into ascending order. It is extremely fast and will sort 100 elements in about one second. Naturally it slows down as the number of elements increases, so that a

sort of 600 elements takes about thirty seconds.

How does this help to sort disk records? Here the answer lies with another technique called the "tag" sort.

It is firstly necessary to identify the field on which you want the sort to be based — for example the supplier code. Next, all the records on the file need to be read and a tag array created. This array contains the contents of the required field for each record along with the relative address of the record in the file. This "relative address" depends on the file organisation — essentially it is information specifying the location of the record within the file. On the CBM 3040 disk drives this might be the track and sector, while on the CompuLink drives it would be the relative record number.

The two values, field contents and relative address, are joined together to form a single element of an array: for example:

$500 \text{ AB$(I) = SC\$ + CHR$(N)}$   
where AB\$ is the array being created, I is the number we are up to in the array, SC\$ is the field we have just read in (supplier code) and N is the relative record number. The command:

!S,AB\$  
is then all that is necessary to sort the completed array into ascending order.

To then process the records in the required order, all that is necessary is to go through the array and strip of the relative record number and use this information to find the complete record on the disk. Naturally this assumes that you can read the records in random order.

The assembler listing is in two segments. Segment 0 contains the code needed to put a "wedge" into BASIC to allow the addition of extra commands, while segment 1 is the actual sort routine. This particular version is for the 32K PETs and will run on its own or with DOS if DOS has been loaded. For smaller machines lines 7 and 10 will need to be modified to set the top of memory to an appropriate value.

The SORT command can be added to the normal BASIC commands and executed in direct or program mode.

To load the machine code to run the sort, simply load program "SORT-MC" but do NOT attempt to run it. Instead enter:

```
SYS 31744
and the sort will be ready.
```

If you are using the CBM DOS disk

*continued on page 130*



**Nelson Computer Services Ltd**

BUY-SELL-LEASE-RENT-MAINTAIN

**MEDIA**

- MINI DISCS
- FLOPPY DISCS
- DISC CARTRIDGES
- DISC PACKS
- MAGNETIC TAPE
- PAPER TAPE
- TELEPRINTER ROLLS
- PRINTER RIBBONS

**EQUIPMENT**

- PRINTER TERMINALS
- TELETYPE
- IBM CARD PUNCHES
- UNIVAC CARD PUNCHES
- DISC & DATA STORAGE
- FIRE SAFES
- HAND PUNCHES
- BURSTERS
- DECOLLATORS
- SHREDDERS
- GUILLOTINES
- VDU DESKS
- DATA BINDERS

**TEL: 07062-29125**

ST. JOHN'S COURT, BACUP ROAD,  
RAWTENSTALL, LANCBS BB4 7PA

• Circle No. 200

**MINE OF INFORMATION LTD**

1 FRANCIS AVENUE,  
ST ALBANS AL3 6BL  
ENGLAND

Phone: 0727 52801  
Telex: 925 859

**MICROCOMPUTER CONSULTANCY & BOOK SELLERS**

• Circle No. 201

**APPLE & PET IN DUBLIN**

- Come and see these fine computers in our new showrooms.
- Try them and discuss your requirements.

- Sensible Software for Apple
- Invoicing/Debtors' Ledger
- Financial Modelling.
- Shape maker
- Educational systems; maths; physics; commerce.

**SOFTECH LTD**  
51 Lower Camden Street,  
Dublin 2  
Tel: 01-976279

• Circle No. 202

## CALCULATORS

**\*\*Inclusive Prices\*\***

**CASIO Programmables**  
 FX501P 128 step 11 memories £48.95  
 FX502P 256 step 22 memories £68.95  
 FA1 Cassette interface £19.95

**TEXAS Programmables**  
 TI58 480 step 60 memories £66.95  
 TI58C above with constant prog & mem £84.95  
 TI59 960 step 100 mem £172.95  
 PC100C Printer for above £156.95

LIBRARIES Maths/Stats/Electrical each £23.95  
 Full range of CASIO, SHARP, and TEXAS Available. PRICES INCLUDE 15% VAT, POST & PACKING.

**CALCULATOR SALES & SERVICE**  
 ARROW WORKS, ARROW ROAD,  
 REDDITCH B98 8NN  
 Tel: REDDITCH (0527) 43169  
 callers by appointment only please

• Circle No. 204

## NASCOMS 1 & 2

Up to 10 Channels I/O Board.  
 Other I/O Boards soon.  
 S.A.E. to:

## BING SYSTEMS

8 Glen Road, Bingley,  
 West Yorks., BD16 3ET.

• Circle No. 205

## WESTFARTHING COMPUTERS

Consultancy Services  
 and Programming

LECTURE - DEMONSTRATIONS OF MICRO SOFTWARE AND HARDWARE FOR BUSINESS AND PROFESSIONAL GROUPS, BY  
**CAREY HARMER MA**

(Independent advice and information. We do not sell computers or take commissions on sales).

21 Wendron Street, Helston, Cornwall  
 Phone Helston (03265) 4098

• Circle No. 206



### 'MICRO-STATION'

Craftsman-made to office standards. Teak finish with unique features - all cables out of sight. Feed-through paper, sliding printer & drive shelves etc. 6' x 3' x 28"1 to house ALL your peripherals in style.

£196 ex works, VAT+  
**VEMBAROY LTD.**  
 The Bringley, Church Street,  
 Gt. Baddow, Essex  
 0245-71726

• Circle No. 207

```
*--- SEGMENT= 0  FILENAME= WEDGE-DOS-SRC  ---*
0070      1  CHRGET  =    $70
0076      2  CHRGET  =    $76
0077      3  TXTPTR  =    $77
00CD      4  QMKR   =    $CD
0035      5  MEMHI  =    $35
0034      6  MEMLO  =    $34
7C00      7  *      =    $7C00
7C00 A900      8      LDA    #0
7C02 8534      9      STA    MEMLO
7C04 A97C     10     LDA    #124
7C06 8535     11     STA    MEMHI !NEW MEMORY SET
7C08      12 !
7C08 A570     13     LDA    CHRGET !NOW CHECK IF
7C0A C94C     14     CMP    #$4C !A WEDGE IS
7C0C F011     15     BEQ    NEWADD !ALREADY IN
7C0E A976     16     LDA    #$76
7C10 8DC87C   17     STA    RETURN !NO : SO SET
7C13 A900     18     LDA    #0 !CHRGOT AS RETURN
7C15 8DC97C   19     STA    RETURN+1 !ADDRESS
7C18 A94C     20     LDA    #$4C
7C1A 8570     21     STA    CHRGET
7C1C 4C297C   22     JMP    SETUP
7C1F      23 !
7C1F A571     24 NEWADD LDA    CHRGET+1 !SAVE PREV
7C21 8DC87C   25     STA    RETURN !WEDGE ADDR
7C24 A572     26     LDA    CHRGET+2
7C26 8DC97C   27     STA    RETURN+1
7C29 A932     28 SETUP  LDA    #<WEDGE
7C2B 8571     29     STA    CHRGET+1
7C2D A97C     30     LDA    #>WEDGE
7C2F 8572     31     STA    CHRGET+2
7C31 60       32     RTS
7C32      33 ! HAVING PLUGGED THE WEDGE
7C32      34 ! NOW TO SET UP THE CODE.
7C32 68       35 WEDGE PLA    !TAKE
7C33 85BD     36     STA    $BD !A
7C35 68       37     PLA    !COPY
7C36 85BE     38     STA    $BE !OF
7C38 48       39     PHA    !THE
7C39 A5BD     40     LDA    $BD !RETURN
7C3B 48       41     PHA    !ADDRESS
7C3C      42 !
7C3C A5BE     43     LDA    $BE !CHECK FOR
7C3E C9C3     44     CMP    #$C3 !READY
7C40 FC16     45     BEQ    RE1 !MODE C3XX
7C42      46 !
7C42 C9C6     47     CMP    #$C6 !TOKEN
7C44 D008     48     BNE    RE0 !MODE
7C46 A5BD     49     LDA    $BD !CHECK
7C48 C9F9     50     CMP    #$F9
7C4A F00C     51     BEQ    RE1
7C4C D05E     52     BNE    OUT
7C4E      53 !
7C4E C9C8     54 RE0   CMP    #$C8 !IF .....
7C50 D05A     55     BNE    OUT !THEN .....
7C52 A5BD     56     LDA    $BD !CHECK
7C54 C93E     57     CMP    #$3E
7C56 D054     58     BNE    OUT
```



```

7C58          59 !
7C58 20B97C  60 RE1   JSR   INCTXT
7C58 8EC77C  61       STX   XBUF
7C5E A6CD    62       LDX   QMKR
7C60 D004    63       BNE   RETN
7C62 C921    64       CMP   #'!   !IS IT ME
7C64 F01A    65       BEQ   DECODE
7C66 AEC77C  66 RETN   LDX   XBUF   !RESTORE X
7C69 ADC87C  67       LDA   RETURN
7C6C C976    68       CMP   #$76
7C6E F046    69       BEQ   N2
7C70 38      70       SEC   !RESTORE POINTER
7C71 A577    71       LDA   TXTPTR
7C73 E901    72       SBC   #1
7C75 8577    73       STA   TXTPTR
7C77 A578    74       LDA   TXTPTR+1
7C79 E900    75       SBC   #0
7C7B 8578    76       STA   TXTPTR+1
7C7D 4CB67C  77       JMP   N2
7C80          78 !
7C80 20B97C  79 DECODE JSR   INCTXT
7C83 C953    80       CMP   #'S   !SORT?
7C85 D03D    81       BNE   ERROR
7C87 20B97C  82       JSR   INCTXT
7C8A C92C    83       CMP   #',   !COMMA?
7C8C D036    84       BNE   ERROR
7C8E 20B97C  85       JSR   INCTXT
7C91 8501    86       STA   $01   !FIRST CHAR
7C93 20B97C  87       JSR   INCTXT !OF ARRAY
7C96 C924    88       CMP   #'$   !1 CHAR ONLY
7C98 D006    89       BNE   NODOLL
7C9A A900    90       LDA   #0     !ZERO 2ND
7C9C 8502    91       STA   $02   !CHAR
7C9E F009    92       BEQ   DOLL
7CA0          93 !
7CA0 8502    94 NODOLL STA  $02   !2ND CHAR
7CA2 20B97C  95       JSR   INCTXT
7CA5 C924    96       CMP   #'$   !FINAL
7CA7 D018    97       BNE   ERROR !DOLLAR
7CA9 20D17C  98 DOLL   JSR   SORT
7CAC          99 !
7CAC ADC87C 100 OUT   LDA   RETURN
7CAF C976    101      CMP   #$76
7CB1 D003    102      BNE   N2
7CB3 20B97C  103      JSR   INCTXT
7CB6 6CC87C  104 N2    JMP   (RETURN)
7CB9          105 !
7CB9 A000    106 INCTXT LDY  #0
7CB8 E677    107      INC  TXTPTR
7CBD D002    108      BNE   INC1
7CBF E678    109      INC  TXTPTR+1
7CC1 B177    110 INC1   LDA   (TXTPTR),Y
7CC3 60      111      RTS
7CC4          112 !
7CC4 4C03CE  113 ERROR JMP  $CE03
7CC7 00      114 XBUF  .BYTE 0
7CC8 0000    115 RETURN .WORD $0000
7CCA          116      .CONT
*--- SEGMENT= 1  FILENAME= SORT-DOS-SRC ---*
    
```

**PETS ☆ COMPUTER SUPPLIES**  
**PETAL ☆ 80 GOWER ROAD**  
**PETACT ☆ SKETTY**  
**PETSOFT ☆ SWANSEA**  
**PERIPHERALS ☆ 290047**

• Circle No. 208

## ITT APPLE 2020

(Palsöft + Colour)

BASIC SYSTEMS at discount prices  
 BUSINESS SYSTEMS from £2,400.00  
 Full Technical & Software support  
 also

a range of printers & VDU's including  
 DIABLO DAISYWHEEL printers  
 from £1,740.00

Larger Business systems also available  
 Sales • Service • Supplies

A.I.D. OFFICE PRODUCTS/SUPPLIES  
 Brindivell Ltd., 57 Brook Road,  
 Frampton Cotterell, Urmston,  
 BRISTOL. MANCHESTER.  
 Tel: Winterbourne Tel: Manchester  
 (0454) 774564 (061) 747 6454

• Circle No. 209

## TRS-80 System

All items stocked, Barclaycard,  
 Access & American Express are  
 welcome, or apply for your own  
 RADIO SHACK Charge Card.  
 U.K. Delivery by Securicor.  
 Direct and Personal Exports.

**RADIO SHACK LTD.**  
 188 Broadhurst Gardens,  
 London NW6 3AY.

Tel: 01-624 7174 Telex 23718

• Circle No. 210



# apple II in sussex

complete user service

Apple & Microstar, hardware & software  
systems for Micropad handprint data entry.

## oval computer systems

elm park, ferring,  
worthing, west sussex.  
tel:0903-44831

• Circle No. 211

## EXIDY SORCERER

32K Micro Computer

£859.00+ VAT

Dealer for

### Bristol and South West

ELECTROPRINT (Mr. Tasker)

5 Kingsdown Parade • Bristol 6 • 292375

• Circle No. 212

## ITT2020 SOFTWARE APPLE II

### DATABASE

is a program that writes a program. DATABASE can create a flexible record-keeping system custom designed to YOUR specification.

HUNDREDS OF MEMBERSHIP DETAILS  
OF MEDICAL RECORDS  
APPLICATIONS MAILING LISTS, ETC  
a direct replacement for the CARD INDEX

Simply draw the format you require on the screen using the editor. Then let the computer do the rest! Easy to use.

FEATURES: protected screen editing  
automatic date and number checking  
comprehensive search & print functions

£120+V.A.T. for the complete system!

Phone 01-242-7394 or write for details

## DISK DEAN LTD

23 BEDFORD ROW, LONDON WC1R 4EB

• Circle No. 213

```

7CCA          1 ! SORT ROUTINE
7CCA 0000     2 COUNT .WORD $0000
7CCC 0000     3 NUMBER .WORD $0000
7CCE 0000     4 WORK .WORD $0000
7CD0 00       5 LEN .BYTE $00
7CD1          6 !
005E          7 ARRAYS = $5E
0060          8 ADDR1 = $60
0062          9 ADDR2 = $62
0066         10 FIRST = $66
0068         11 SECOND = $68
0001         12 NAME = $01
7CD1         13 !POINT TO ARRAY TABLE
7CD1 A52C    14 SORT LDA $2C
7CD3 855E    15 STA ARRAYS
7CD5 A52D    16 LDA $2D
7CD7 855F    17 STA ARRAYS+1
7CD9         18 !FORCE NAME TO STRING TYPE
7CD9 A502    19 LDA NAME+1
7CDB 0980    20 ORA #$80
7CDD 8502    21 STA NAME+1
7CDF         22 !CHECK ENTRY IN ARRAY TABLE
7CDF A000    23 CHECK LDY #$00
7CE1 B15E    24 LDA (ARRAYS),Y
7CE3 C501    25 CMP NAME
7CE5 D007    26 BNE NO
7CE7 C8      27 INY
7CE8 B15E    28 LDA (ARRAYS),Y
7CEA C502    29 CMP NAME+1
7CEC F02A    30 BEQ FOUND
7CEE         31 !POINT TO NEXT ENTRY
7CEE 18      32 NO CLC
7CEF A002    33 LDY #$02
7CF1 B15E    34 LDA (ARRAYS),Y
7CF3 655E    35 ADC ARRAYS
7CF5 8DCE7C  36 STA WORK
7CF8 C8      37 INY
7CF9 B15E    38 LDA (ARRAYS),Y
7CFB 655F    39 ADC ARRAYS+1
7CFD 855F    40 STA ARRAYS+1
7CFF ADCE7C  41 LDA WORK
7D02 855E    42 STA ARRAYS
7D04         43 !CHECK FOR END OF TABLE
7D04 C52E    44 CMP $2E
7D06 90D7    45 BCC CHECK
7D08 A55F    46 LDA ARRAYS+1
7D0A C52F    47 CMP $2F
7D0C 90D1    48 BCC CHECK
7D0E A07D    49 LDY #>SORT01
7D10 A9E4    50 LDA #<SORT01
7D12 201CCA  51 JSR $CA1C
7D15 4C89C3  52 JMP $C389
7D18         53 !FIND NUMBER OF ELEMENTS
7D18 A005    54 FOUND LDY #$05
7D1A B15E    55 LDA (ARRAYS),Y
7D1C 8DCC7C  56 STA NUMBER
7D1F C8      57 INY
7D20 B15E    58 LDA (ARRAYS),Y
7D22 80CD7C  59 STA NUMBER+1

```





**Some people would give anything to have your micro experience**

Especially if you have practical experience with PASCAL on the APPLE micro computer. Richard Kaluzynski will put you in touch with them.

Knight Computer Services Limited,  
14 Old Park Lane, London W1Y 4NL.  
Tel: 01-491 4706.



Staff Services Division of BOC Datasolve Group and a member of Computing Services Association

• Circle No. 214

## GILBERT COMPUTERS

Gilbert Computers believe in the New **IMAP** MZ

- IMPECCABLY-ENGINEERED
- MODESTLY-PRICED
- BIG-HEARTED, COMPLETE MICROCOMPUTER

It is what we, and you, have been waiting for to solve the problems of the smallest business. You will be able, without specialist knowledge, to quickly and effortlessly handle your stock control; accounting; VAT records; invoicing and other chores.

Provided locally from centres in Market Harborough and Swindon by Gilbert Computers the ONLY suppliers offering these AND

- FREE initial demonstration and explanation at your office, shop or home with no pressure to buy
- Inexpensive tailor-made program service
- Equipment maintenance contracts available
- Finance facilities

Call or write for further details

Old Hall Lane,  
Lubenham, Leics. LE16 9TJ 0858-65894

• Circle No. 215

## Northmoor Electronics

	£		£
Case	50.00	P8255	4.70
Z80 CPU	7.50	P8205	2.00
Z80 PIO	6.50	HM3-7641-5	8.00
Z80 CTC	6.50	HM3-6508-5	4.00
211A	5.50	HM3-6561-5	4.50
4116	7.50	HD3-6402C-9	4.60
2102	3.00	HD3-4792-9	6.60
1702	5.50	TIL 209 Red	0.13
TMS 2516JL (5v)	18.00	TIL 220 Red	0.13
P8085A	15.00	TIL 116	0.80
P8212	2.10	78 MOS CLK	0.90
P8216	2.00	NE555P	0.24
P8251A	4.70	Also LS and C-MOS (s.a.c. for lists)	

**Bulk buy 'Eurocard' Cases**

by Vero Electronics

14 slots for extended Eurocard  
Room at rear for power supplies etc.



Add 15% VAT to all orders plus 30p postage and packing

Trade enquires welcome

21 Wellstead Road  
Wareham Dorset  
Tel: Wareham 2082

• Circle No. 216

```

7D25 4C9A7D 60 JMP ENDCHK
7D28 61 !POINT TO FIRST ELEMENT
7D28 18 62 START CLC
7D29 A55E 63 LDA ARRAYS
7D2B 6907 64 ADC #07
7D2D 8560 65 STA ADDR1
7D2F A55F 66 LDA ARRAYS+1
7D31 6900 67 ADC #00
7D33 8561 68 STA ADDR1+1
7D35 A900 69 LDA #00
7D37 8DCA7C 70 STA COUNT
7D3A 8DCB7C 71 STA COUNT+1
7D3D 72 !POINT TO NEXT ELEMENT
7D3D 18 73 NEXT CLC
7D3E A560 74 LDA ADDR1
7D40 6903 75 ADC #03
7D42 8562 76 STA ADDR2
7D44 A561 77 LDA ADDR1+1
7D46 6900 78 ADC #00
7D48 8563 79 STA ADDR2+1
7D4A 80 !FIND THE SHORTEST LENGTH
7D4A A000 81 LDY #00
7D4C B160 82 LDA (ADDR1),Y
7D4E D162 83 CMP (ADDR2),Y
7D50 9002 84 BCC LESS
7D52 B162 85 LDA (ADDR2),Y
7D54 8DD07C 86 LESS STA LEN
7D57 87 !FIND ADDRESSES OF STRINGS
7D57 C8 88 INY
7D58 B160 89 LDA (ADDR1),Y
7D5A 8566 90 STA FIRST
7D5C B162 91 LDA (ADDR2),Y
7D5E 8568 92 STA SECOND
7D60 C8 93 INY
7D61 B160 94 LDA (ADDR1),Y
7D63 8567 95 STA FIRST+1
7D65 B162 96 LDA (ADDR2),Y
7D67 8569 97 STA SECOND+1
7D69 98 !COMPARE THE STRINGS
7D69 A0FF 99 LDY #0FF
7D6B C8 100 COMP INY
7D6C 98 101 TYA
7D6D CDD07C 102 CMP LEN
7D70 F008 103 BEQ SWOP
7D72 B166 104 LDA (FIRST),Y
7D74 D168 105 CMP (SECOND),Y
7D76 F0F3 106 BEQ COMP
7D78 B045 107 BCS CHANGE
7D7A 108 !SET UP NEXT PAIR OF STRINGS
7D7A A562 109 SWOP LDA ADDR2
7D7C 8560 110 STA ADDR1
7D7E A563 111 LDA ADDR2+1
7D80 8561 112 STA ADDR1+1
7D82 113 !CHECK IF PASS COMPLETE
7D82 EEC27C 114 INC COUNT+1
7D85 D003 115 BNE PASS
7D87 EECA7C 116 INC COUNT
7D8A ADCA7C 117 PASS LDA COUNT
7D8D CDCC7C 118 CMP NUMBER
    
```

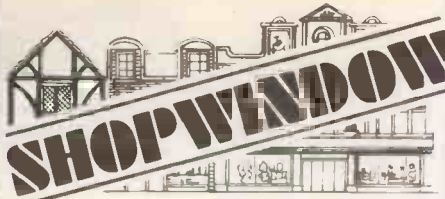

WHAT "Turns a board into a real computer"?

## MICROCASE!

We make cases for micros.  
Stylishly designed.  
Beautifully made.  
Room for extensions + PSU.

## SUPERBOARD COMPUKIT NASCOM 1 & 2

OR UNCUT FOR OEM USE

From your dealer or write to:

**MICROCASE**

Simple Software Ltd

15 Havelock Road

Brighton BN1 6GL

+ SOFTWARE for SUPERBOARD +

• Circle No. 217

## WORD-PROCESSING

written by C.B.C. for  
**APPLE & ITT 2020**

Use your own Micro and Printer and enjoy features found on WP systems costing £000's more! Not to be confused with simple text editing.

**HUNDREDS SOLD IN THE 1st MONTH**  
Upper/lower case printing, full editing, format selection & change, save/recall of text, margin and R.H. justification, block insertion, mail-shots etc. etc. A professional Program!

Mk 2 version **£40** incl. VAT/P&P

Your order plus Cheque, P.O. or Access/Barclay number to:

**MILDMAY ELECTRONICS LTD.**  
200 Moulsham St., Chelmsford, Essex  
Dealer enq. invited, other prog. & aids avail.

• Circle No. 218

## apple II/ITT2020 program incompatibility

A large number of programs written for the Apple II in Integer Basic will not run on ITT Palsoft or Apple II Plus machines without an Integer Basic card.

This problem can be overcome by a software simulation of the original Apple Integer Basic-in-ROM; which, as well as making available the complete range of software written for the Apple II, provides automatic language change — **BOTH UNDER PROGRAM CONTROL AND IN DIRECT MODE** — for disc systems.

Versions of this program are available for 32K and 48K machines with or without DOS, at £12 inclusive.

For further information contact:

Dave Bolton, The Old Schoolhouse, 1 Branch Rd, Park Street, St. Albans: Telephone Park Street (0727) 72917.

• Circle No. 219

```

7D90 D02A 119 BNE NOTDON
7D92 ADCB7C 120 LDA COUNT+1
7D95 CDCD7C 121 CMP NUMBER+1
7D98 D022 122 BNE NOTDON
7D9A 123 !CHECK FOR END OF SORT
7D9A D8 124 ENDCHK CLD
7D9B 38 125 SEC
7D9C ADCD7C 126 LDA NUMBER+1
7D9F E901 127 SBC #1
7DA1 8DCD7C 128 STA NUMBER+1
7DA4 ADCC7C 129 LDA NUMBER
7DA7 E900 130 SBC #0
7DA9 8DCC7C 131 STA NUMBER
7DAC A900 132 PASS2 LDA #$00
7DAE CDCD7C 133 CMP NUMBER+1
7DB1 D006 134 BNE NOTYET
7DB3 CDCC7C 135 CMP NUMBER
7DB6 D001 136 BNE NOTYET
7DB8 60 137 RTS
7DB9 4C287D 138 NOTYET JMP START
7DBC 4C3D7D 139 NOTDON JMP NEXT
7DBF 140 !SWOP LENGTH FIELDS
7DBF A000 141 CHANGE LDY #$00
7DC1 B160 142 LDA (ADDR1),Y
7DC3 8DCE7C 143 STA WORK
7DC6 B162 144 LDA (ADDR2),Y
7DC8 9160 145 STA (ADDR1),Y
7DCA ADCE7C 146 LDA WORK
7DCD 9162 147 STA (ADDR2),Y
7DCF C8 148 INY
7DD0 149 !SWOP ADDRESS FIELDS
7DD0 A566 150 LDA FIRST
7DD2 9162 151 STA (ADDR2),Y
7DD4 A568 152 LDA SECOND
7DD6 9160 153 STA (ADDR1),Y
7DD8 C8 154 INY
7DD9 A567 155 LDA FIRST+1
7DDB 9162 156 STA (ADDR2),Y
7DDD A569 157 LDA SECOND+1
7DDF 9160 158 STA (ADDR1),Y
7DE1 4C7A7D 159 JMP SWOP
7DE4 4E4F20 160 SORT01 .TEXT 'NO SUCH ARRAY'
7DF1 00 161 .BYTE $00
7DF2 162 .END

```

## Serious sorting for business (continued from page 125)

operating system, then this must be loaded and run BEFORE loading the sort routine and executing the SYS 31744 instruction. So the correct sequence of events is:

- Switch on the computer
- Switch on the disk unit
- Load and run DOS
- Load SORT-MC
- SYS 31744

The command uses a very fast machine-code sorting routine to sort any string array. The routine only requires the name of the array — it will then sort the whole array into ascending order. To process an array in descending order, simply start from the end and step down it.

Here is an example of its use:

```

10 FOR I = 1 TO 10
20 READ AB$(I): PRINT AB$(I),
30 NEXT
40 !S,AB$
50 FOR I = 1 TO 10

```

```

60 PRINT AB$(I)
70 NEXT
100 DATADUCK,FOX,CHICKEN,
RABBIT,FROG,TOAD,MOUSE,
FOX
110 DATALION,TIGER

```

This small program will read an array of ten items, invoke the sort and then print out the sorted array.

The format of the command is quite simple:

```
!S,array name, eg
!S,B$
```

BASIC will reply with SYNTAX ERROR if you enter the command incorrectly. The sort routine will reply with NO SUCH ARRAY

if the array you have given it does not exist or is not of string type.

In a statement such as IF . . . . THEN !S,A\$, it is best to separate the two parts of the statement with a colon, so:

```
IF A > 25 THEN !S,A$
```

# BUYERS' GUIDE SOFTWARE

by Mike McDonald

The Software Buyers' Guide takes a new form this month as a result of the sheer volume of applications coming on the market. With 40 dealers (originating sources) offering 105 packages, presentation has been changed for quicker reference.

Suppliers are now listed in alphabetical order with name, address, phone number, and contact. Then applications packages are listed by machine type, giving machine, company name, price, and capacity, to give a brief analysis of commercial packages for any particular machine. The user may then refer to the supplier in the alphabetical supplier list.

The general criteria are still the same: the software price is in the range of £50 up to £1000; the user will require floppy disk drives, a printer, and 32K of RAM; generally prices exclude VAT. Capacities quoted are usually on a per disk basis.

## Machine types by main application

### Sales Ledger

Machine type	Supplier	Price (£)	Capacity
Commodore 3032	Microact	350	2000 A/Cs 7000 trans
Z80/8080	Great Northern C.S.	275	varies
Tandy TRS80	Tridata Micros	P.O.A.	to be linked to S/L & P/L
Apple II	Computech Systems	295	500 A/C 1600 trans
Commodore 3032	HB Computers	200	linked to S/L & P/L
Apple II	Vlasak Electronics	225	500 A/C 1600 trans
CP/M	Computastore	500	linked to S/L & P/L companies

## SHOPWINDOW

### TOPMARK Computers

dedicated to  
**APPLE II**



Simply the best!

Full details from Tom Piercy on Huntingdon (0480) 212563 or circle enquiry card.

• Circle No. 220

### PET PERIPHERALS

Plessey memories 32K only:

PETITE £280  
INPET £249

IEEE488-RS232C serial output interface:  
Self powered £110  
P.C. board only £85

Terminals:

TT43 from £765  
LA34 from £815

Terms: All prices plus VAT, CWO, carriage extra. 90 days warranty on all goods.

Q-COM ELECTRONICS LTD,  
169 BLACK HAYNES RD, SELLY OAK,  
BIRMINGHAM B29 4RE  
TEL: 021 64 33540

• Circle No. 221

### LB ELECTRONICS

WE HAVE MOVED TO —  
11 Hercies, Hillingdon, Middx.  
(Just off the A40).

We stock RAMs, EPROMs, Keyboards, Disc Drives and one-off computer peripherals. We stock Pet 8K and many everyday components and surplus equipment.

2114 450 ns £450.

2708 400 ns £7.25.

2716 (single raise) £20.

Special offer signecus £25.25.

with date 295 character.

Calcomp made 140 8 inch disc drive with manual 195.

As above 40 £85.

Shuggart 801 8 inch drive with manual 300, component.

Post and parcel 30p, drive carriage at cost, all prices inclusive of VAT.

We are open Monday, Thursday, Friday,

Saturday 9.30-6. Tel. Uxbridge 55399.

Sorry but no catalogue yet. We keep

Practical Computing magazine.

• Circle No. 222

### RAPPORT

Quite simply the best introduction service for intelligent people — all ages, Nationwide. Details, stamp and age to

RAPPORT  
Dept PO Box 94  
Oxford

• Circle No. 223



### FREELANCE & PERMANENT PROGRAMMERS AMS GROUP

Established Commodore Business systems dealers are organising a network of skilled PET programmers with commercial computing experience to assist purchasers with system development and implementation.

Tel 01-638 9319  
AMS, 8 Moorfields  
London EC2Y 9AA

• Circle No. 224

## Stoke-on-Trent 813631

For



Contact

# TEKDATA

• Circle No. 225



### SUPERSOFT STILL SMALL ENOUGH TO CARE!

Our new FREE catalogue lists 38 PET programs from £1-£12. Many of our 17 utility programs are only available from us, and as for games, AIR ATTACK at £3 includes a free overlay which brings colour to your screen! Blank RACAL cassettes are £4.50 for ten C.12's.

SUPERSOFT 28 Burwood Avenue, Pinner, Middx.

**STOP PRESS  
BUSINESS PROGRAMS TO ORDER —  
PET AND TRS80**

• Circle No. 226

### A COMPILER FOR TRS-80® BASIC

Southern Software ACCELERATOR speeds execution of BASIC programs by compiling the common statements to Z80 machine-code.

- Develop and debug normally.
- Compile for production work.

Properly-structured, error-free level 2 programs only. £19.95

SOUTHERN SOFTWARE, PO Box 39  
Eastleigh Hants. SO5 5WQ

• Circle No. 227

### Purchase Ledger

Machine type	Supplier	Price (£)	Capacity
CP/M	Structured Systems Group	460	varies
Commodore 3032	Microact	350	2000 A/cs 7000 trans
Z80/8080	Great Northern C.S.	275	varies
Tandy TRS-80	Tridata Micros	225	175 A/Cs 1350 trans
Apple II	Vlasak Electronics	315	200 A/Cs 1000 trans
Apple II	Computech Systems	295	500 A/Cs 1600 trans
Commodore 3032	HB Computers	350	800 A/Cs 4000 trans
CP/M	Computastore	400	open item
Apple II/ITT 2	Padmede Computer Services	300	900 A/C 4500 trans/disk
Exidy Sorcerer	Basic Computing	125 incl	see also Micropute

### General Ledger

Machine type	Supplier	Price (£)	Capacity
Z80/8080	Great Northern C.S.	275	varies
Tandy TRS80	Tridata Micros	P.O.A.	linked to S/L & P/L
Apple II	Computech Systems	295	500 A/C 1600 trans
Commodore 3032	HB Computers	200	linked to S/L & P/L
Apple II	Vlasak Electronics	225	200 A/cs 1000 trans
CP/M	Computastore	500	999 A/C 99 cntrs 9 comp

### Combined packages: ledgers/stock/invoicing

Machine type	Supplier	Price (£)	Capacity
Commodore 3032	G.W. Computers	275-575	1000
Z80/8080	Great Northern C.S.	995	varies
Ohio Scientific	Microcomputer B.M.	656	*
Tandy TRS80	Microcomputer Applctns	90 each	*
Tandy TRS80	T & V Johnson	110	750 trans/disk

### Stock Systems

Machine type	Supplier	Price (£)	Capacity
Apple II/ITT 2	Microdigital	200	1250 items
CP/M	Graffcom Systems	350	520-6000 items
Z80/8080	Great Northern C.S.	275	varies
Tandy TRS80	Tridata Micros	200	630 items/disk
Commodore 3032	Commodore B.M. (UK)	150	650
Commodore 3032	Bristol Software Factory	300-360	2300
Z80/8080	Graham-Dorian Software	325	varies
Apple II/ITT 2	Vlasak Electronics	285	*
Commodore 3032	Petsoft	50	2000
Commodore 3032	L & J Computers	120	3400 items
Commodore 3032	Microact	350	3500 items
Tandy TRS80	T & V Johnson	115	1000 items
Tandy TRS80	T & V Johnson	145	1000 items/invoices
Commodore 3032	Amplicon M.S.	750	500-600 items 255 A/Cs
Exidy Sorcerer	Basic Computing	125 incl	see also Micropute Ltd

### Records management (DBMS)

Machine type	Supplier	Price (£)	Capacity
Commodore 3032	Commodore B.M. (UK)	150	650
Commodore Pet	Stage One Computers	120	165K
Apple II/ITT 2	T & V Johnson	95	112K per drive
Ohio Scientific	Microcomputer B.M.	175	*
Commodore 3032	Amplicon M.S.	140	1500 records
Tandy TRS80	T & V Johnson	200	*
Z80/8080	Structured Systems Group	135	varies

### Word processing

Machine type	Supplier	Price (£)	Capacity
Commodore 3032	Commodore B.M. (UK)	75	165K
Tandy TRS80	T & V Johnson	109	10,000 words
Ohio Scientific	Microcomputer B.M.	116	*
Apple II/ITT 2	Algobel Computers	75	800 lines
Commodore 3032	Hipposoft	325	*
Commodore 3032	HB Computers	70	39 A4 pages
Apple II/ITT 2	Vlasak Electronics	120	*
Z80/8080	Structured Systems Group	120	varies



## Mail Systems

Machine type	Supplier	Price (£)	Capacity
Apple II CP/M	Microdigital Structured Systems Group	?	2500 names/addresses varies
Apple II Tandy TRS80 Z80/8080 CP/M	Keen Computers T & V Johnson Micro Focus Graffcom Systems	300 P.O.A. 90 250	500 addresses 3000 names/addresses varies varies

## Incomplete Records Accounting

Machine type	Supplier	Price (£)	Capacity
CP/M Commodore 3032 Apple II/ITT 2	Profcomp Micro Computation Padmede Computers	P.O.A. 555 450	2000 entries 120 A/Cs 5000 trans 900 A/C 2000 trans/ disk
Exidy Sorcerer	Basic Computing	350 incl	see also Microcompute

## Property Management

Machine type	Supplier	Price	Capacity
Z80/8080 Apple II/ITT 2	Graham Dorian Software Algobel Computers	325 650	varies 400 bldgs 250 owners 2000 tenants
CP/M	Algobel Computers	650	2000 trans

## Alphabetical list of suppliers

Supplier	Address	Sales contact
Algobel Computers 021-233 2407	33, Cornwall Buildings, Newhall St, Birmingham B3 3QR	Steve Linden
Amplicon M.S. 0273-562163	143A, Ditchling Rd, Brighton, Sussex BN1 6JA	Jim Hicks
Basic Computing 0535-65094	Oakworth Rd, Keighley, W. Yorks BD22 7LA	Mike Collier
Bristol Software Factory 0272-20801	Micro House, St. Michael's Hill, Bristol BS2 8BS	W. J. Kyle-Price
Commodore B.M. (UK) 0753-74111	818, Leigh Rd, Trading Estate, Slough, Berks	Nick Green
Computastore 061-832 4761	16, John Dalton St, Manchester M2 6HG	David Nicholson
Computech Systems 01-794 0202	168, Finchley Rd, London NW3	Laurence Payne
Graffcom Systems 01-734 8862	52, Shaftesbury Ave, London W1V 7DE	Barbara A. Castledine
Graham Dorian Software 01-379 7931	c/o Lifeboat Associates, 32, Neal St, London WC2H 9PS	?
G.W. Computers 01-636 8210	89, Bedford Crt Mansions, Bedford Avenue, London WC1	?
Great Northern C.S. 0532-450667	15, Wellington St, Leeds LS1 4DL	Paul Rayner
HB Computers ?	22, Newland St, Kettering, Northants	Stuart Whittaker
Hewport 04254-77352	20, Cunningham Close, Ringwood, Hants BH24 1XW	D. N. Rogers
Hipposoft 0332-760127	9, Littleover Lane, Derby	?
Keen Computers 0602-583254	5B, The Poultry, Nottingham	Bob Ellis
Landsler Software 01-399 2476/7	29A Tolworth Park Road, Surbiton Surrey KT6 7RL	E. Landsler
L & J Computers 01-204 7525	3, Crundale Ave, Kingsbury, London NW9 9PJ	?
Microact 021-455 8585	Radclyffe Hse, 66-68 Hagley Rd, Edgbaston, Bham B16 8PF	John Farthing
Micro Computation 01-882 5104	8 Station Parade, Southgate, London N14	Graham Dicker
Micropute 0625-612818	Communique Place, 9, Presbury Place, Macclesfield, Cheshire	Don Cooper
Micromputer Applications ?	11, Riverside Ct, Caversham, Reading RG4 8AL	?
Microcomputer B.M. 01-981 3993	4, Morgan St, London E3 5AB	?
Microdigital 051-227 2535	25, Brunswick St, Liverpool L2 0BJ	Graham Jones
Micro Focus 01-379 7931	c/o Lifeboat Associates, 32 Neal St, London WC2H 9PS	?
Microsense Computers 0442-41191/48151	Finway Rd, Hemel Hempstead, Herts HP2 7PS	D. Page
Padmede Computer Services 025-671 2434	112/116 High St, Odiham, Basingstoke, Hampshire	John Packwood

## ELF II EQUIPMENT AT DISCOUNT PRICES

Basic Computer Kit or wired and tested	£49.95 £69.95
Giant Board wired and tested	£29.00
4K Static Ram Board wired and tested	£57.00
ASCII Key Board wired and tested	£42.00
Video display board wired and tested	£57.00
Expansion Power Supply	£16.00

ALL PRICES SUBJECT TO VAT AT 15%  
BARCLAY AND ACCESS ACCEPTED  
POSTAGE AND PACKING EXTRA

PLEASE PHONE — 01-363 6125  
or write  
C.A.V.S. Ltd.,  
171 CHASE SIDE, ENFIELD, MIDDXX.

• Circle No. 228

## ORCHARD ELECTRONICS

ORCHARD HOUSE  
21 ST. MARTINS STREET  
WALLINGFORD  
OXON OX10 \*DE

Specialists in the supply of:

- PETS and Peripherals
- Computhink
- Anadex
- TCM
- Software
- Discs
- Paper and Tapps

For these and sympathetic after-sales  
assistance contact Barry or Dave on:

0491 35529

• Circle No. 229

## APPLE & ITT2020 BUSINESS SOFTWARE

Professionally written packages now available  
with comprehensive manuals, built-in validity  
checks, interactive enquiry facilities, user  
options, satisfying accountancy, Inland  
Revenue and Customs & Excise requirements.  
On diskette under DOS 3.2. In Applesoft with  
SPACE utility. Not adaptations. Written for  
Apple System. Support all printer interfaces.  
Sales, Purchases and General Ledgers £296-00  
each.

Manual only £3.

Payroll £375. Manual only £4.

General Ledger supports Incomplete Records,  
Job Costing, Branch and Consolidated  
Accounts etc.

General Ledger Applications Manual £10.

Prices exclusive of V.A.T. From our shop or  
your nearest stockist.

COMPUTECH SYSTEMS  
168, Finchley Road, London, N.W.3.  
Tel: 01-794 0202

• Circle No. 230

## APPLE II — Software

INFORMATION STORAGE  
AND RETRIEVAL SYSTEM ... £55 + VAT.

- Up to 20 user definable fields.
- Options include Create, Amend, Delete, Display and Search.
- Powerful search routine searches for strings within any combination of fields, and records retrieved may be displayed and/or printed.
- Direct retrieval of records via free-format key field.

Please send cheque for £63.25 (inc. VAT,  
P&P) to

HINCKLEY MICRO SYSTEMS LTD.  
Edwards Centre, Regent Street,  
Hinckley, Leics.  
Tel: (0455) 616147

• Circle No. 231

# SHOP WINDOW

## FERGUSSON COMPUTER SERVICES FOR ALL YOUR



### Repairs & Maintenance

- \* FULL WORKSHOP FACILITIES
  - \* 24 HOUR TURNAROUND
  - \* EX-IBM MAINFRAME ENGINEERS
  - \* VERY COMPETITIVE RATES
- RING: — BYFLEET (09323) 45330

**NEW**

## PET INTERFACES

IEEE to PARALLEL INPUT PRINTERS  
(ANADIX — CENTRONICS ETC).

£32 + VAT  
Simple, effective,  
low cost unit,  
without decoding.

£55 + VAT  
ADDRESS DECODING.  
For use with  
Commodore  
Disc Unit.

Made to professional electronic standards, and offered direct by the Manufacturers. Data available, send S.A.E. Terms: Cash with order, plus £1.00 P & P. (Specify printer on order).  
**Bright Electronics, 29/31 Wincombe Drive, Ferndown, Wimborne, Dorset BH22 8HX. Tel: 0202 875075.**

• Circle No. 232

**NEW**

MICROTYPE  
SERIES 80  
MICROCOMPUTER CASE



Ready Cut for Superboard or UK101  
Complete with screws and instructions.  
Also available with uncut keyboard for homebrew enthusiasts. Produced in strong, black ABS plastic. Please state type when ordering.

ONLY £17.50 + VAT Post and packing inclusive.

Send Cheque or Postal Orders to:

Microtype, PO Box 104, Hemel Hempstead,

Herts. HP2 7QZ SAE for Details.



C12 BRANDED DIGITAL QUALITY CASSETTES  
With library box and index card, 10 for 38p ea + VAT.  
Send £5.40 (includes p&p and VAT).

• Circle No. 233

## MAIL LIST for PET DISK AT LAST — A FULL FEATURE MAILING LIST PROGRAM USING PET DISK DIRECT ACCESS FACILITIES

All the usual features combined in a single program, plus: —

- a) Immediate display of any data for amendment.
- b) Labels printed in any sequence — e.g. sorted by postcode or company name.
- c) Record selection by Range or Mask.
- d) Extra code fields may be used for selection or sorting, but not printed on labels.

Program disc with demonstration system and full documentation £49 + VAT.

**RB** COMPUTING 101 Nether Currie  
Crescent, Currie,  
Midlothian, EH14 5JQ.  
Tel: 031-449 3102

Apple version also available Dealer enquiries welcome

• Circle No. 234

Petsoft  
021-455 8585  
Profcomp  
01-989 8177  
Stage One Computers  
0202-23570  
James C Steadman  
0903-814923  
Structured Systems Group  
01-379 7931  
Structured Systems Group  
01-553 1001  
T & V Johnson  
0276-62506  
T.W. Computers  
061-456 8187  
The Alphabet Company  
03046 7209  
Tridata Micros  
021-622 6085  
Vlasak Electronics  
06284-74789  
3-Line Computing  
?

Radclyffe Hse, 66-68 Hagley Rd,  
Edgbaston, Bham B16 8PF  
107, George Lane, South  
Woodford, London E18 1AN  
6, Criterion Arcade, Old  
Christchurch Rd, Bournemouth  
18, Manor Road, Upper Beeding,  
Steyping, Sussex BN4 3TJ  
c/o Lifeboat Associates, 32 Neal  
St, London WC2H 9PS  
c/o LP Enterprises, 313, Kingston  
Rd, Ilford, Essex IG1 1PJ  
165, London Rd, Camberley,  
Surrey GU15 3JS  
293, London Rd, Hazel Grove,  
Stockport, Cheshire  
2 Whitefriars Way, Sandwich,  
Kent CT13 9AD  
Smithfield House, Digbeth,  
Birmingham B5 6BS  
Thames Building, Dedmere Rd,  
Marlow, Bucks SL7 1PB  
36, Clough Rd, Hull HUS 1QL  
?

Julian Allison  
Mr Whitcombe  
?  
James Steadman  
?  
?  
T. Johnson  
?  
A. L. Minter  
A. Plackowski  
Paul Vlasak  
?

## Applications by machine

### Machine type: Commodore

Application	Supplier	Price (£)	Capacity
Ledgers/stock/invoicing	G.W. Computers	275-575	1000
Payroll	Computastore	200	275 employees/disk
Ledger sales	Microact	350	2000 A/Cs 7000 trans
Ledger purchase	Microact	350	2000 A/C's 7000 trans
Stock control	Commodore B.M. (UK)	150	650
DBMS	Commodore B.M. (UK)	150	650
Word processor	Commodore B.M. (UK)	75	165K
DBMS	Stage One Computers	120	165K
Stock control/invoicing	Bristol Software Factory	300-360	2300
Stock control	Petsoft	50	2000
Payroll	Petsoft	50	200 employees
Payroll	Landsler Software	95 incl	250 employees
Stock control/invoicing	L & J Computers	120	3400 items
Minicab/invoice/payroll	L & J Computers	220	
Incomplete records a/c	Micro Computation	555	120 A/C's 5000 trans
Bldg Conversion Spec	Micro Computation	300-400	320 clauses
Ledger sales	HB Computers	350	800 A/C's 4000 trans
Word processor	Hipposoft	325	
DBMS	Amplicon M.S.	140	1500 records
Ledger Purchase	HB Computers	350	800 A/C's 4000 trans
Ledger General	HB Computers	200	Linked to S/L & P/L
Stock control	Microact	350	3500 items
Work measurement	The Alphabet Company	150	
Stock control	Amplicon M.S.	750	500-600 items 255 A/C
Word proc/mailling system	HB Computers	70	39 A4 pages
Hotel room system (intg)	Landsler Software	275	8 x 99 rooms for 400
Hotel system (+ billing)	Landsler Software	450	130 rooms

### Machine type: Tandy

Application	Supplier	Price (£)	Capacity
Ledger sales	Tridata Micros	225	175 A/Cs 1350 trans
Ledger purchase	Tridata Micros	225	175 A/Cs 1350 trans
Ledger general	Tridata Micros	P.O.A.	Linked to S/L P/L
Stock control	Tridata Micros	200	630 items/disk
Payroll	Tridata Micros	218	400 employees
Invoicing	Tridata Micros	75	linked to stock and sales analysis
Word processor (E.P.)	T & V Johnson	109	10,000 words
Ledgers/payroll various	Microcomputer Applctns	90 each	*
Payroll	3-Line Computing	140	*
Ledgers/stock/invoicing	T & V Johnson	110	750 transactions/disk
Stock control	T & V Johnson	115	1000 items
Stock control/invoicing	T & V Johnson	145	1000 items/invoices
Mailing system	T & V Johnson	P.O.A.	3000 names/addresses
DBMS	T & V Johnson	200	*

### Machine type: Apple

Application	Supplier	Price (£)	Capacity
Payroll	Algobel Computers	295	500 employees
Stock control	Microdigital	200	1250 items
Mailing system	Microdigital	?	2500 names/addresses



Ledger purchase	Vlasak Electronics	315	200 A/Cs 1000 trans
Ledger sales	Vlasak Electronics	315	200 A/Cs 1000 trans
Ledger sales	Computech Systems	295	500 A/Cs 1600 trans
Ledger purchase	Computech Systems	295	500 A/Cs 1600 trans
Ledger general	Computech Systems	295	500 A/Cs 1600 trans
Payroll	Computech Systems	379	*
Stock/purchase/order inv.	Vlasak Electronics	285	*
DBMS	T & V Johnson	95	112K per drive
Payroll	T.W. Computers	145	*
Property management	Algobel Computers	650	400 bldgs 250 owners, 20 agts
Word processor	Algobel Computers	75	800 lines
Job costing	Padmede Computer Services	450	1000 A/Cs 99 cost centres
Time & cost recording	Padmede Computer Services	150	150 A/Cs
Structural eng. design	James C. Steadman	200	not applicable
Mailing & letter writer	Keen Computers	300	500 addresses
Payroll	Hewport	400-500	100 mnth 50 wkly
Ledger general	Vlasak Electronics	225	200 A/Cs 1000 trans
Modelling (Visicalc)	Microsense Computers	95	*
Incomplete records/ nominal ledger	Padmede Computer Services	450	900 A/Cs 2000 trans/ day
Ledger sales	Padmede Computer Services	300	900 A/Cs 4500 trans/ day
Ledger purchase	Padmede Computer Services	300	900 A/C 4500 trans/ day
Payroll	Vlasak Electronics	360	*
Word processing	Vlasak Electronics	120	*
Cash flow/bank forecast	Vlasak Electronics	80	*

## Machine type: CP/M

Application	Supplier	Price (£)	Capacity
Mailing system	Structured Systems Group	50	approx varies
Ledger purchase	Structured Systems group	460	varies
Incomplete records	Profcomp	P.O.A.	2000 entries
Payroll	Graffcom Systems	500	250 employees
Purchasing system	Graffcom Systems	450	540-7000 invoices
Stock control	Graffcom Systems	350	520-6000 items
Order entry & invoicing	Graffcom Systems	350	500-5000 orders
Hire purchase system	Graffcom Systems	*	varies
Time recording system	Graffcom Systems	*	100 activity codes
Ledger sales	Computastore	400	open item
Ledger purchase	Computastore	400	open item
Ledger general	Computastore	500	999 A/Cs 99 centres 9 cost cos
Property management	Algobel Computers	650	2000 trans
Mail list system	Graffcom Systems	250	varies

## Machine type: Z80/8080

Application	Supplier	Price (£)	Capacity
Ledger nominal	Great Northern C.S.	275	varies
Ledger purchase	Great Northern C.S.	275	varies
Ledger sales	Great Northern C.S.	275	varies
Stock control (retail)	Great Northern C.S.	275	varies
Client billing	Great Northern C.S.	330	varies
Purchasing system (job)	Great Northern C.S.	275	varies
Appointments system	Great Northern C.S.	220-275	varies
Ledgers/payroll	Great Northern C.S.	995	varies
Apartment management	Graham Dorian Software	325	325
Stock control	Graham Dorian Software	325	varies
Sales analysis (retail)	Graham Dorian Software	325	varies
DBMS	Structured Systems Group	135	varies
Word processing	Structured Systems Group	120	varies
Mail list system	Micro Focus	90	varies

## Machine type: Ohio Scientific

Application	Supplier	Price (£)	Capacity
Ledgers/stock/invoicing	Microcomputer B.M.	656	*
DBMS	Microcomputer B.M.	175	*
Word processor	Microcomputer B.M.	116	*

## Machine type: Exidy Sorcerer

Application	Supplier	Price (£)	Capacity
Stock recording	Basic Computing	125 incl	see also Micropute
Incomplete records	Basic Computing	350 incl	see also Micropute
Ledger purchase	Basic Computing	125 incl	see also Micropute
Ledger sales	Basic Computing	125 incl	see also Micropute

## Problems with your Micro?

Let us help. We have wide experience of the problems and pitfalls that can arise when a computer system is installed.

- Programs designed or written
- Help given in organising a computer system for best results and easiest use
- Independent advice in choosing hardware

Mc Millan Computing Services  
3 Tithebarn Grove,  
Calcot, Reading.  
Tel: 0734 414751 (Ansaphone service)

• Circle No. 235

## EXIDY SORCERER

— original —  
GAMES

not available elsewhere.  
low cost — send for list  
RTL, West Towan House  
Porthtowan, Truro, TR4 8AX

• Circle No. 236

## MICRO ADS

PET 8K 2001 Series also booklets and tapes £475.  
Lingfield 833863.

OSI Superboard Programs: Startrek, 3D Space  
Maze, £3.00; Life\*, Tank Battle, Zombies\*, Noughts  
& Crosses\*, Breakout\* £2.50; Biorhythms\*, Dis-  
assembler\* £2.00; plus many more. Peripheral Con-  
troller Kit\* £16.95. Parallel Interface Adapter Kit\*  
£39.95. (\*also available for (K101). Velvet Software,  
26 Colesbourne Close, Worcester.

SORCERER — 16k including UHF modulator £550  
ono. Reading 479067.

TRS 80 Level II (New October) 16K, Numeric Pad,  
VDU, Cassette, Tapes/Books, (List over £100)  
£495. Tel: 01-989 0430.

Play Space Invaders on your Nascom. Full feature,  
3K object code. Many options. SAE for full details.  
J. Atkins, 37 Wellington Road, Maidenhead, Berks.  
Telephone 0628-35145.

TRS80 16K Level II with Library 100 £430. Star  
Chess TV Game £40 o.n.o. Brighton 593475.

Pet 2001—8K, only a few months old, plus  
several tapes. £425 o.n.o. Tel. Thisleton (Leics)  
332.

UK101, 8K RAM, CASED. Offers around £320.  
Tel. 01-458 3932 (After 6pm).

PET 8K with cassette and VAT costs about  
£630. Mine is in excellent condition and avail-  
able for £500 o.n.o. Miller 01-946 4951.

V.D.U. BOARD D.M.A. Plugs into SS50 BUS  
software etc. Included £75.00 (o.n.o.) 01-558  
2397 (After 6pm).

PERCOM CIS304 Cassette Interface (cased)  
300/600/1200 Baud for 6800up £45.00 (o.n.o.)  
Software etc. included. Tel. 01-558 2397 (after  
6pm).

PET-8K (£100 of Extras) only £400. TI-59 As  
New £100. Tel. 03317-4156.

PET 8K GAMES. 3 Original Programs for  
£1.99. EMW 3 Longford Terrace, Bradford,  
W. Yorks.

TRS-80, Level II, 4K with cassette, PSU etc.  
£400. Parker, 07816-72232 (after 6pm).

TEXAS TI59 Calculator & Print Cradle, Extra Cards.  
£220. Garston (Herts) 79973 Evenings.

## DISCOUNT PETS

**NEW 8K PET £445** with large keyboard, 16K £540, 32K £640, Dual Floppy £670, Programmer's Toolkit £45, Cassette £54.

**BASE 2 PRINTER £475** compatible with PET 3 Interfaces: IEEE, RS232, Centronics parallel, 3 Character fonts — one downloadable, programmable horizontal & vertical densities, stepping motor, tractor feed, contiguous plotting.

**TEXAS TI 99/4 £810** with 13" colour monitor. The most advanced home computer.

**AIM 65 4K SYSTEM £420** cased, powered & with assembler and BASIC. Also memories & motherboards for AIM 65/KIM by Seawell. Disk system (2 x 5" drives) with DOS £800.

**S-100 SYSTEM £1000** based on North Star with single disk drive, Z-80, 2 ports, 32K memory, completely assembled and tested. Runs all North Star software.

**NORTH STAR HORIZON 11 £1400**

**S-100 BOARDS** assembled and tested only. 16K fully static 2MHz memory with bank select, optional wait states, write protect etc. £150. 4MHz £250. Jade 4MHz Z-80 CPU £140. SD PROM-100 EPROM programmer £140. 2 serial & 1 parallel I/O card £120.

### SOFTWARE

**PAYROLL** for NORTH STAR on two disks £56, also for PET Listing only £50.

**SUPER BLAKE 7** game for NORTH STAR/PET on disk £13, for Challenger 8" disk £15, PET cassette £15, listing only £10.

Send for list or call:

**INTELLIGENT ARTEFACTS LTD**

CAMBRIDGE ROAD, ORWELL, ROYSTON, HERTS.  
Telephone: Arrington 689

• Circle No. 250

## Churchtown Electronics (Regd.)

Saint Merryn. (0841 520535)

Cornwall PL28 8ND

6800 SOFTWARE

ED SMITH'S	
M68RR RELOCATABLE RECURSIVE MACRO ASSEMBLER	£69.00
M68AS RELOCATABLE ASSEMBLER	£29.00
M68RS REL. DISASSEMBLER & SEGMENTED SCE. GEN.	£19.00
M68DT DISASSEMBLER/TRACE DEBUG PACK	£12.00
Useful one to help learn machine language programming.	
M68EP EPROM SUPPORT	£12.00
M68SG DISASSEMBLER SCE. GEN.	£15.00
CROTZ RADIOTELETYPE PROGRAM SENDS MORSE CODE	
SENDS AND RECEIVES RTTY AT THREE BAUD RATES (PIA REQD.)	£15.00
CROTZ CALENDAR, CLOCK BOARD. HAVE THE DATE AND TIME ALWAYS AVAILABLE FOR THE MSI 6800 WITH MSIBUG WE HAVE A MUST FOR ALL PROGRAMMERS...	£95.00
BYTE HANDLER ON EPROM	
Simply plug it into the spare socket on the M.S.I. CPU card and you have a most sophisticated programming tool able to search for hex or ASCII, move blocks, fill, compare, reload tapes at different destinations, set or remove breakpoints etc.	£28.00
M.S.I. DISK BASIC LATEST VERSION 1.4 NOW HAS PRINT USING, RENUMBER, ERROR TRAPPING, POP, LINPUT ETC. GET RIGHT UP TO DATE FOR	£48.00
WE CAN SUPPLY PATCHES TO RUN MOST SOFTWARE, TEXT EDITORS, WORD PROCESSORS, CORES, ED SMITHS PROGRAMS ETC., IN THE MSI SYSTEMS. IF YOU DON'T SEE WHAT YOU NEED THEN LET OUR PROGRAMMERS KNOW YOUR REQUIREMENTS. V. A. T. AND BUSINESS PACKAGES AVAILABLE FOR THE M.S.I. DISK SYSTEM.	
PLEASE STATE S.W.T.P. OR M.S.I. WE PURCHASE 6800 SOFTWARE.	
WE SELL SYSTEMS, TERMINALS, PRINTERS AND SOFTWARE. AND HAVE OVER THIRTY YEARS EXPERIENCE IN THE ELECTRICAL AND ELECTRONICS INDUSTRY.	
PRICES INCLUDE POSTAGE BUT NOT V. A. T. PLEASE ADD 15 PERCENT.	

• Circle No. 251

OUR MICROPROCESSOR SYSTEMS UNIT IS OFFERING 2-DAY COURSES INTRODUCING MICROPROCESSORS TO YOU. WE WILL SHOW YOU HOW TO USE ASSEMBLY LANGUAGE PROGRAMMING ON THE TEXAS 9900 16-BIT MICROPROCESSOR, OUR SOFTWARE TECHNIQUES USE EITHER THE MICRO-PROCESSOR TO MONITOR DEVELOPMENT OR IT CAN BE SIMULATED ON A COMPUTER. THE CHOICE IS YOURS ACCORDING TO YOUR NEEDS. MORE THAN 50% OF THE TIME WILL BE SPENT ON PRACTICAL EXPERIENCE WHEN YOU WILL MAKE HARDWARE PERFORM YOUR INSTRUCTIONS.

# INTRODUCE YOURSELF TO MICRO-SYSTEM DESIGN — THE SUMSU WAY

DO YOU HAVE A FRIEND OR COLLEAGUE WHO WANTS TO KNOW WHAT MICRO'S ARE ABOUT? PASS ON THE WORD OR EDUCATE YOURSELF BY CONTACTING:

JOYCE HAMMERTON,  
MICROPROCESSOR SYSTEMS UNIT,  
SHEFFIELD UNIVERSITY,  
MAPPIN STREET,  
SHEFFIELD S1 3JD

TELEPHONE: SHEFFIELD (0742) 78555 EXT. 5149

COURSES ALSO AVAILABLE WITH THE MOTOROLA 6800 8-BIT MICROPROCESSOR

• Circle No. 252



# WHY BUY A MICRO-COMPUTER FROM

# **PETALECT** ELECTRONIC SERVICING LTD.

## BECAUSE

- 1) Established company trading since 1971
- 2) Electronic servicing is our speciality
- 3) We have in-house programmers/systems analysts
- 4) We have our own service engineers
- 5) We will demonstrate the PET at your premises
- 6) We can customise the PET to your requirements
- 7) We can arrange finance
- 8) We offer, after the three-month warranty, a service contract from £69.50
- 9) You benefit from our experience of having sold over 450 micro-computers to industrial, educational and business, personal users.
- 10) We specialise in programs and interfaces for weighing applications for average weight control and counting etc.



All 'PETS' sold with a Basic Tutorial Tape

8K £550.00 + VAT  
16K £675.00 + VAT  
32K £795.00 + VAT

New Large  
Keyboard 'PETS'  
Now in Stock

In our showroom we sell  
Books, Programs, etc.

### Also available:

24K Memory Expansion Boards (disk-compatible), only £320 + VAT  
PET-compatible : dual floppy disk unit with advanced operating system, only £840 + VAT  
Large Extension Keyboard for the PET £89.50 + VAT  
Telephone for complete system prices : Wide Range of Printers Available

If you require any more information or demonstration regarding the PET 2001/8 or any associated equipment, programs, etc., please contact Mr. P.J.A. Watts or Mr. D.W. Randall at:

**PETALECT ELECTRONIC SERVICES LTD**  
33/35 Portugal Road,  
Woking,  
Surrey.  
Tel. Woking 69032/68497

**Shop at:**  
**PETALECT**  
Chertsey Road,  
Woking,  
Surrey.  
Tel. Woking 21776/23637



If your PET is hungry for 5¼" flexible disks, we can feed him.

Control Dataset high quality 5¼" flexible disks are readily available at major office equipment suppliers. Or you can order them direct from us.

For a list of stockists, or details of our mail order service, contact us at Control Dataset Ltd., P.O. Box 16, Argyle Way, Stevenage SG1 2AB, Herts. (Tel: 0438-3399)

**CONTROL  
DATASET**  
  
CONTROL DATA

• Circle No. 254

**THIS IS AN APPLE**



**AND THIS  
IS AN APPLE TWO**



**THE APPLE II  
IS AVAILABLE FROM  
MICROLOGIC**

Temple House, 43-48 New Street, Birmingham

**021-643 0253**

(off Needless Alley, Reception 3rd Floor)

• Circle No. 255

# A SOUND INVESTMENT.

The perfect match of  
cassette body  
and tape.

When you record on cheap cassettes you run a high risk of program failure, dropout errors and excessive headwear. Saving pennies on an unsuitable cassette could turn out to be very costly. To make a long life, high quality microprocessor cassette needs both tape and cassette mechanism to operate together in harmony. Backing up the microprocessor cassette technology is a background of more than 10 years of experience within the Group on the manufacture of computer tape, memory discs and cartridges. Pyral is one of Europe's foremost manufacturers of magnetic digital recording media.



**MP 12 and MP 15  
Microprocessor  
Cassettes**

For further information on the Microprocessor cassette and other Pyral products, send to:

Sales office:

PYRAL MAGNETICS LTD, COURTLANDS ROAD, EASTBOURNE, SUSSEX. Tel: (0323) 638965 Telex: 877123

• Circle No. 256

# THE EXIDY PROFESSIONALS

## PROFESSIONAL WORD PROCESSING SYSTEM

We are proud to offer what must be one of the best word processing systems available. Features include:—

### SIMPLE TO OPERATE:—

- \* Full editing facilities.
- \* Paragraphs can be indented.
- \* Any line length 15-120 char.
- \* Alphabetical sorting of files.
- \* Auto-wrap-around at line ends.
- \* Text is automatically re-aligned for all editing functions.
- \* Any amount of text can be inserted or deleted at any point.
- \* String of characters can be searched for and replaced.
- \* Address files can be merged with standard letters.
- \* Standard paragraphs can be assembled into complete documents.
- \* Auto-repeat on all keys.
- \* Adjustable tap stops.
- \* Disc or cassette storage.
- \* Line numbering, text centring.
- \* ROM-PAC or disc versions

### PRINT FACILITIES:—

- \* Any printer — low cost matrix to a top quality daisy-wheel.
- \* Automatic page numbering, titling, multiple copy printing.
- \* Can be used with both continuous stationary and single sheets.
- \* Proportional spacing, bold facing, subscripts, etc.

### USER CONTROL:—

- \* Powerful macro-programming facilities enable the system to carry out long sequences of operations automatically — and allow you to design these operations to your own needs.

## OTHER PROFESSIONAL SYSTEMS

For many users, the key to the Exidy system is versatility. You don't need any different equipment for a professional business system to take care of your accounts, payroll, etc. All you need is good software ... and under the CP/M disc operating system that is available from numerous sources.

Systems start from well under £1000. But unlike some others, you don't need to start from scratch when you wish to expand. You can build on to your basic system without any difficulty — it has been designed that way.

Because of its versatility, the Exidy system is ideally suited for numerous other established applications, including schools, colleges, research and personal use.

— We will be pleased to advise on development of application —

## THE SORCERER'S APPRENTICE — OUR MONTHLY TIP

This is a simple keyboard scan routine which you may find useful.

To implement it, simply enter at the beginning of your program:

POKE 318,195

POKE 320,224

INP (9) then gives the ASCII value of any key being pressed.

If you have any tips or queries, please send them to us, with

SAE if you would like a reply.

## SYSTEM 1 — Professional word processing / business.

£4150

32K Sorcerer  
Video-disc Unit  
Ricoh daisy wheel printer,  
Word Processor ROM-PAC  
CP/M

## SYSTEM 2 — Low cost business / word processing.

to be announced  
— approx. £3200

32K Sorcerer  
VDU monitor (green)  
Single disc unit 315K  
Ricoh daisy wheel printer  
Word Processor  
CP/M

## SYSTEM 3 — General business applications.

£3250

48K Sorcerer  
Daul Disc Drive 630K  
S100 Expansion Unit  
BD-80 matrix printer  
VDU monitor (green)  
Disc Extended Basic

## SYSTEM 4 — Cassette Computer / Word Processor.

£1475

16K Sorcerer  
Microline 80 matrix printer  
TV monitor  
Basic ROM-PAC  
Word Processor ROM-PAC  
Cassette recorder

## SYSTEM 5 — Low cost disc system (without printer)

to be announced  
— approx. £1500

32K Sorcerer  
TV monitor  
Single disk 315K

## SYSTEM 6 — Minimum system, or as extra terminal

£775

8K Sorcerer  
TV monitor  
Cassette unit  
BASIC ROM-PAC

# RICOH RP-40 DAISY WHEEL PRINTER

We use this in our systems for really high quality word processing work. We are also able to supply it alone at a remarkably low cost. It is supplied complete with friction feed and Centronics interface for the amazing price of:

### OTHER INTERFACES INCLUDE:—

TRS-80 £55  
Basic PET £45  
Disc PET £66

**£1450.00**

(limited offer)

### OPTIONS INCLUDE:—

Tractor feed  
Single sheet feeder  
RS-232 version  
Choice of 10 & 12 pitch fonts

# THE MICROLINE 80 PRINTER

This advanced design printer leaves other more expensive matrix printers way behind. It is compact and quiet. It has friction and pin feed. It has standard, condensed and double width print. The quality of both printer and print are extremely high. All this and more, yet the cost is only:—

\*\* All above prices exclude VAT.

**£499.00**

Optional tractor. Interfaces as above.

# SOFTWARE — THE KEY TO SUCCESS

Any system large or small requires software. We can now offer OVER 200 PROGRAMS for the Sorcerer, ranging from full business systems to cassette-based games and operating aids. Please send large SAE and we will send you free details of all of these programs.

*All of the above products and services are available from these two Exidy professionals:*

## BASIC COMPUTING

Oakworth Road, Keighley, W. Yorks. BD22 7LA  
Tel: 0535 65094 — Mike Collier

## MICROPUTE

9 Prestbury Road, Macclesfield, Cheshire SK10 1AU  
Tel: 0625 612818 — Don Cooper

• Circle No. 257

# Save with Fortronic

## Tally 1602 Matrix Printer

- \*132 characters per line
- \*Centronics Interface
- \*Self Test

**SAVE £500**

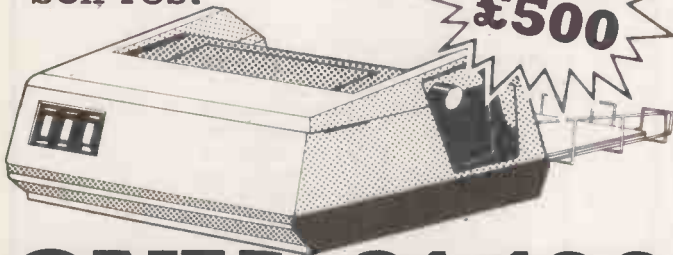

**ONLY £1,100**

## Volker Craig V.D.U. 404

- \*Tele/type compatible
- \*Detachable upper & lower case typewriter style keyboard

**SAVE OVER £135**



**ONLY £499**

Limited supply

# FORTTRONIC

for all your computer peripherals.

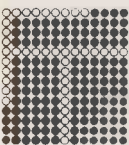

Fortronic Ltd, Holden Way,  
Donibristle Industrial Estate,  
Dunfermline.

Tel 0383 823121 Telex No 727438

• Circle No. 260



**CRYSTAL ELECTRONICS  
CC ELECTRONICS**

## The newest Z80 Basic! XTAL Basic 2-2

HAS to be the best yet for your Nascom 1 or 2  
All the usual features of other 8K floating-point BASICs  
Plus: Extra commands/functions—INCH, KBD, CMD\$  
ON ERR GOTO, ERR, PI, CLOAD? (tape verify)

And Add up to 64 reserved words of your  
choosing—Now put your own disc, tape, control,  
graphics commands, etc for the ULTIMATE in BASIC  
flexibility! Fully upward compatible with version 2.1  
(see earlier Ads). Can be easily adapted to most Z80  
systems. Works with T2, B-BUG, T4 and NAS-SYS  
monitors. Existing version 2.1 users—Return your  
original tape (less manual) with 50p P&P and we will  
update it FREE of charge!

Price: still only £35 + VAT!

### WE ARE NOW A SHARP AGENT

We stock the MZ-80K fully supported.  
Prices from £520.00 plus VAT.

Coming shortly—CRYSTAL BASIC (SHARP)  
—releases another 6k of memory + extra  
commands.

Members of Computer Retailers Association & Apple Dealers Association

Shop open 0930-1730 except Wed. & Sun.

40 Magdalene Road, Torquay, Devon, England. Tel: 0803 22699

Access and Barclaycard welcome.



COMPUTERS  
AND  
COMPONENTS



• Circle No. 258

# Your key. To MICROCOMPUTERS

This coupon will bring you  
details of our new complete  
home computer course.

You will learn all the basic  
principles of computer  
technology and receive full  
instruction on computer  
functions and programming.  
Tuition is carried out at your  
own pace on your own home  
computer and is supervised by  
our qualified computer staff.

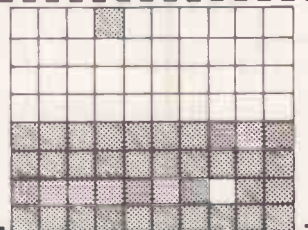

**FREE  
BROCHURES**



## TUTORCOURSE HOME COMPUTER

Please rush me details of your  
HOME COMPUTER COURSE

Send today for a brochure  
on this exciting new course.

Name

Address



Block Caps. Please

Post now, without obligation to:

## British National Radio & Electronics School.

P.O. Box 156, Jersey, Channel Isles

• Circle No. 259

# V. & T. ELECTRONICS

## NASCOMS NEWEST LONDON DISTRIBUTOR

**NASCOM II:** USES Z80A CPU SWITCHABLE 2/4 MHZ, INCLUDES 8K MICROSOFT BASIC 2K MONITOR (NAS-SYS), 16K DYNAMIC RAM, 1K VDU RAM, 1K WORKSPACE RAM, ULTRA RELIABLE LICON KEYBOARD, Z80A PIO GIVING 16 PROGRAMMABLE 10 LINES, KANSAS CITY CASSETTE INTERFACE SWITCHABLE 300/1200 BAUD, BASIC COMMANDS INCLUDE; NEW:LIST:CONT: CLEAR:MONITOR:RUN:NULL:SCREEN:LINE:WIDTH:DEF:DOKE:IF:THEN:FOR:DIM:END:ON:GOTO:LET:NEXT:GOSUB:RETURN:OUT:POKE:REM:STOP:WAIT:SET:RESET:PRINT:DATA:INPUT: READ:RESTORE:CLS: = : - : + : \* : / : ABS:ATN:LOG:SIN:PEEK:INP:INT:SGN:TAN:SPC:POS:RND:USR: COS: SQR: TAB: EXP: FRE: POINT: ASC: CHR: STR: RIGHT: LEFT\$: LEN: MID\$: VAL: CSAVE: CLOAD:

**NASCOM IMP:** PLAIN PAPER PRINTER:60 LINES PER MINUTE:80 CHARACTERS PER LINE BIDIRECTIONAL:800 CHARACTER BUFFER:96 CHARACTER ASCII :110-9600 BAUD:

**NASCOM II** READ BUILT £325.00 ; KIT FORM £295.00  
**NASCOM I** READY BUILT £140.00 ; KIT FORM £125.00  
**IMP PRINTER** READY BUILT £325.00  
PLEASE ADD £1.50 POSTAGE PLUS 15% V.A.T.

### EPROMS — All Ex Stock

2532	5V 4K x 8	£48.00
2516	only 2K x 8 Intel Compat Now	£15.40
2708	1K x 8	£6.00

### RAMS

4116	16K Dynamic 200 ns	£6.50
4116	16K Dynamic 300 ns	£6.25
2114	1K x 4 Static 200 ns Low Power	£5.50
2114	1K x 4 Static 450 ns	£4.25
TRS 80	16K Upgrade Kits	£52.00

### NASCOM 2

16K Ram	£295
16K Ram	Built £325
32K Ram	£345
32K Ram	Built £375

**ALL ITEMS EX-STOCK**  
Please Add 15% VAT  
40p P&P orders under £10.00

## V&T ASSEMBLER

New improved V&T Assembler now available for Nascom 1 & 2.

The only fully relocatable assembler for the Nascom range — (easily converted to other Z80 systems).

— Supports all standard mnemonics & pseudo ops: — DEFB, DEFS, DEFW, DEFM, EQU & ORG. Source, object & symbol areas fully programmable.

Now includes —

- Symbol table
- Operation under T2, T4, B Bug, Nasys
- Label find & change
- Relocating source reader
- Improved keyboard routine, etc.

£12.50 + VAT

Existing V&T Assembler owners may return orig. tape to obtain updated version.

S.A.E. + £2.50 Inc VAT

**V&T ELECTRONICS 82 CHESTER RD., LONDON N.19 5BZ  
01-263 2643**

**dale  
dams**  
OFFICE EQUIPMENT LTD.,  
30-36, Dale Street,  
Liverpool

## WE CAN HELP YOU WITH:

### PETS: PRINTERS: DISKS

2001(32K) £715	CBM 3022	£675 inc cable	CBM 3040	£880
2001(16K) £607	ANADIX	£650	COMPU	{400K £875
2001(8K) £495	TELETYPE 43	from £889	THINK	{800K £1095

## SOFTWARE

**PETAID:** From Stage One Computers, disk based file handling in hours, not weeks — possibly the most useful piece of software available for PET. CBM or COMPU-THINK £140

**PETACT:** Well written business systems covering Sales & Purchase Ledger, Invoicing, and Stock Control: from £270

Many more items in stock

For details of these and many more products and services; telephone:-

# 051-227-3301

• Circle No. 262



**apple computer**  
Sales and Service

## MICROWARE COMPUTERS LTD. OF HULL



### APPLE II PLUS

Apple 16K Computer	695.00
Apple 32K Computer	764.00
Apple 48K Computer	833.00
Eurocolour Card	79.00
Disc Drive with Controller	349.00
Disc Drive Only	299.00
VHF Modulator (for T.V. output)	14.00
High Speed Serial Interface	113.00
Parallel Interface	104.00
Firmware Card	116.00
Integer Card	116.00
Centronics Card	130.00
Communications Card	130.00
Clock/Calendar Card	128.00
Pascal Language System	299.00
Data Acquisition Card	180.00
Music Synthesiser Card	180.00
9" Black & White Video Monitor	127.00
12" Black & White Video Monitor	187.00

### PRINTERS

Anadex DP8000	575.00
Pet Interface for DP8000	45.00
Teletype 43	945.00
Decwriter 4 (LA34)	995.00
Qume Sprint 5 (Daisy Wheel) complete	2,497.00

### COMMODORE

CBM 2001 8K Pet	550.00
CBM 3016 16K Pet	675.00
CBM 3032 32K Pet	795.00
CBM 3022 Printer, 80 column tractor feed	645.00
CBM 3040 floppy disc unit	795.00
IEEE to IEEE cable	25.00
IEEE to Pet cable	20.00
C2N external cassette	55.00

### PETSOFT STOCKISTS

12 minute blank cassettes (per 10)	5.00
5in. floppy discs (Apple & Pet per 10)	30.00
8in. floppy discs (Microstar per 10)	50.00

### MICROSTAR 45 +

(Multi-user, Multi-task)	
64K, 1.2 megabyte	4,950.00
64K, 2.4 m.byte	5,650.00
Upgrade, 1.2 to 2.4 m.b	1,250.00
Add on 2.4 m.b.	3,400.00
20 m.b. hard disc	4,950.00

### VDU We Recommend Hazeltine 1500

785.00

### CABLES (RS232)

VDU Connector	21.00
Printer connector	21.00

### MICROSTAR SOFTWARE

CPM (gives access to Assembler & Basic-E)	180.00
Flexitex word processing	350.00
Stock control	600.00
Sales ledger	750.00
Cobol (under CPM)	350.00
Fortran (under CPM)	275.00
Mailing list	200.00

**Microware Computers**

1133 HESSLE HIGH ROAD HULL HU4 6SB  
Telephone (0482) 562107

ALL PRICES EXCLUDE VAT @15%, UNLESS OTHERWISE STATED

• Circle No. 263



**STOP PRESS:**  
10% DISCOUNT ON  
ALL DELTA SYSTEMS  
DURING MARCH/APRIL

**TERODEC (MICROSYSTEMS) LTD**  
17 The Gallop, Yateley,  
Camberley, Surrey.  
Tel: (0252) 874790  
(0344) 51160

# TERODEC

## IS READY WITH SYSTEMS

### DELTA DPS 32/2 Mini

S-100 starter system, ideal for the first time user. This systems offers computing power (we use the industry standard CP/M1.4) and built in expandability at low cost without sacrificing reliability.

- 32Kbytes of RAM, 4MHz operation without wait states.
- Dual double sided double density minifloppies (720Kbytes).
- 4MHz Z-80 CPU with 3 parallel and 2 serial I/O ports.
- S-100 Bus.
- Solid state keyboard.
- RAM expandable to 64K single user (512K multi-user).
- Discs expandable to four 8" double sided double density drives (4Mbytes).
- Interfaces to most printers.
- Monitor (64 x 16).
- CP/M1.4 Operating System.

DPS 32/2Mini with TV1912 (24\*80) VDU

£1995.00  
£2295.00

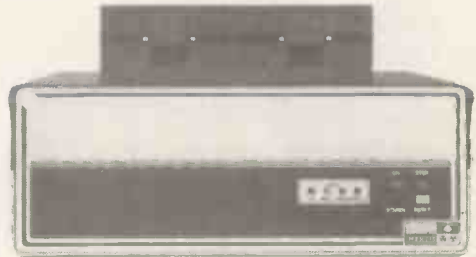

### DELTA DPS 64/1

Professional computing system with all the features necessary for the business or scientific user.

- 64Kbytes of 4MHz RAM, operating without wait states.
- Dual double density single sided 8" drives (1 Mbyte).
- Disc storage expandable to four 8" double sided double density drives (4 Mbytes), fixed and cartridge drives.
- CP/M1.4 standard (CP/M2.0 option).
- Expandable to multi-user (CP/M2.0 with MPM).
- RAM expandable to 512KBytes multiuser.
- Large range of standard Compilers, Interpreters, Assemblers and Applications Packages available.
- TV1912 80 x 24 VDU as standard.
- Interfaces to most VDUs and printers.

DPS 64/2 the same spec as DPS 64/1 with 2 Mbytes of disk storage  
(2 double sided double density drives)

£3099.00  
£3404.00



### TERODEC TMZ-80 Range

Microcomputers with unrivalled flexibility to solve your business computing problems.

- Choice of operating systems — CP/M1.4 or CP/M2.0.
- Interfaces to most VDU's, line, dotmatrix, daisywheel printers and modems.
- 64Kbytes of RAM as standard (512Kbytes multiuser).
- Single or multiprocessor.
- 1-4Mbytes floppy disk storage.
- Fixed or cartridge disks.
- 4MHz Z-80 CPU.
- Comprehensive range of compilers interpreters assemblers and applications packages.
- Installation and commissioning.
- Full range of VDU's and printers.
- Single or multi-user.
- Nationwide maintenance.

• Attractively styled workstation.

TMZ-80-1 1Mbyte 64K with VDU CP/M1.4 and workstation

TMZ-80-2 2Mbyte 64K with VDU CP/M1.4 and workstation

TMZ-80-2 4Mbyte 64K with VDU CP/M1.4 and workstation

£3995.00  
£4295.00  
£5595.00



*TERODEC are the sole U.K. distributor for DELTA PRODUCTS and CENTRAL DATA CORPORATION.*

*Dealer Enquiries Invited*

**TERODEC SYSTEMS LTD**  
16-17 College Place,  
Southampton, Hants.  
Tel: (0703) 39511-5

All information is correct at the time of going to press. Prices exclude VAT and unless stated delivery.

• Circle No. 264



# STOP PRESS!!!

## APPLE II/ITT 2020 SOFTWARE

Systematics Internationally are proud to announce a comprehensive catalogue of professionally written programs for Business/Education/Mathematical/Personal use. All programs contain comprehensive operating instructions. Some examples are:

Sales Ledger	£295	Office Administrator	£72
Purchase Ledger	£295	Addressing & Mailing	£300
General Ledger	£295	Text File Library	£125
Incomplete Records	£295	Electronic Diary	£40
Job Costing	£295	Little Genius	£40
Payroll	£295	Applewriter	£42
Stock Control	£500	Visicalc	£95
Financial Planning	£295		

The Catalogue is updated every three months and is available Free of Charge.

For further details telephone Britt-Marie on  
0268-284601

### SYSTEMATICS INTERNATIONAL LIMITED

5th Floor: Essex House,  
Cherrydown, Basildon, Essex  
TELEX 99431

• Circle No. 265

## GATE MICROSYSTEMS LIMITED

### SCOTLAND'S COMPLETE MICROCOMPUTER SERVICE



now supply and support:—

#### HARDWARE:

- Apple II Systems and Peripherals

- Commodore Business Systems
- A wide range of VDU's, printers etc.

#### SOFTWARE:

- Incomplete Records Accounting
- Sales Ledger
- Purchase Ledger
- Nominal Ledger

- Stock Control
- Payroll
- Word Processing
- Database

*Software can be tailored to your requirements or written to your specifications*

Our service is complete, ranging from advice on system selection through installation and implementation, to operator training and comprehensive hardware and software maintenance.

*You don't have to take our word for it. Call us and arrange a demonstration.*

**GATE MICROSYSTEMS LIMITED**  
THE NETHERGATE CENTRE, 66 NETHERGATE, DUNDEE  
TEL: (0382) 28194

• Circle No. 266



# Maintain the lead with Acorn 6809

... the 6809 designed from the start with the programmer in mind readily supports high level languages and built as it is on the experience of the 6800 is likely to become the standard 8-bit micro-processor for the foreseeable future. . . .

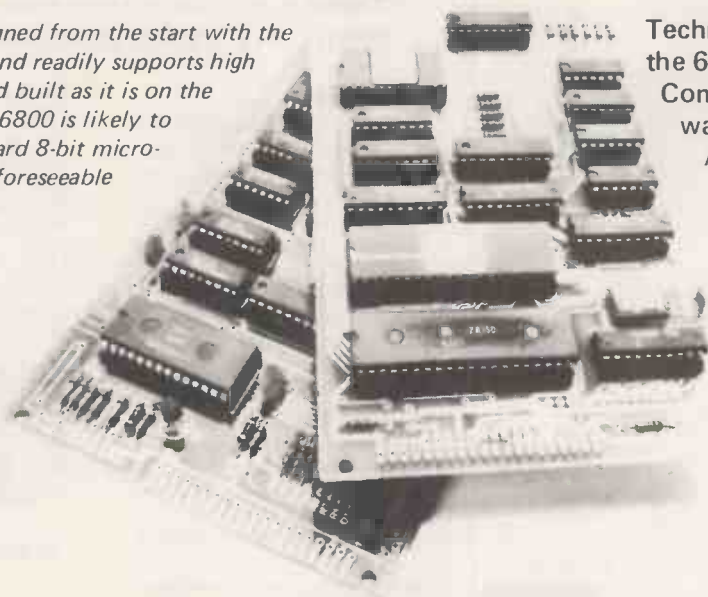

Technology leader in microprocessors the 6809 is now available from Acorn Computer with full supporting hardware on a eurocard paired with the Acorn VDU interface at a special introductory price.



Acorn is offering their two most powerful modules as the basis for a 6809 development system requiring the addition of keyboard, power supply and monitor. For existing owners of Acorn Systems, the 6809 CPU card is a direct plug-in replacement for the 6502 CPU and can be used with all the supporting cards presently consisting of 8K memory, tape interface, VDU interface, Floppy disc drive, Analogue to digital/digital to analogue and Universal interface.

For newcomers to Acorn the two card system can readily be linked to terminals printers, etc., the operating system firmware is designed for modularity and has disc bootstrap.

- 1K RAM
- Direct printer drive
- ASCII keyboard input
- Fully buffered address and data bus
- 2K operating system with
  - Printer routine
  - VDU routine
  - Cassette load and save
  - Disc bootstrap
  - Trace
  - All usual debug facilities



#### VDU

- Seven colours
- Teletext compatible
- Upper and lower ASCII and graphics
- Memory mapped
- Transparent access
- Programmable screen format
- RGB & Sync output
- Light pen facility
- Single 5v rail

- Fastest execution time of any 8-bit processor
- More addressing modes than any other processor
- Position independent code
- Re-entrant programming
- High level language efficiency
- Indirect, indexed and auto increment/decrement
- Four 16-bit registers
- Super powerful instruction set including multiply
- 6800 software compatibility

All Acorn modules are covered by a money-back guarantee and a fast repair/advice service, kits are supplied with full assembly instructions and operating details including where necessary sample programs.

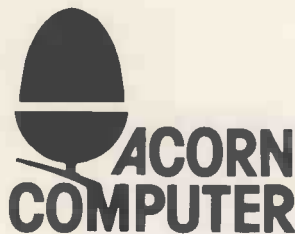

Acorn Computer,  
4a Market Hill, Cambridge CB2 3NJ

Please send me the following

- qty  6809/VDU kit Special offer @ £160 + £24 VAT £184  
 6809 CPU kit @ £95 + £14.25 VAT £109.25  
 VDU Interface kit @ £88 + £13.20 VAT £101.20  
 Details on all Acorn cards

I enclose Cheque/PO to value .....

Name \_\_\_\_\_

Address \_\_\_\_\_

Acorn Computer 4a Market Hill Cambridge CB2 3NJ

VAT No. 215 4002 20

• Circle No. 267

**The New SHARP MZ-80K**  
From £520 plus VAT



Please telephone for demonstrations (Our premises or yours)

**PET HIRE**

From £4.25 per day

10% discount on all PETSOF products  
Please add 50p p&tp to your order  
send large SAE for PETSOF Catalogue

All prices subject to VAT.  
Send Cheque/P.O. with orders to:

**ESSEX COMPUTER SERVICES**

10 Grafton Road, Canvey Island,  
Essex, SS8 7BT.  
Tel. Canvey Island (03743) 61663



• Circle No. 268

**MICROSPEECH**

Does your computer speak to you?  
'WEHL IHT KAN DOO WIHTH MEE!'

**Features**

- Single PCB plugs directly into an SWPTc 6800 bus.
- 9 parameter vocal tract model.
- Realtime software converts any stored phonetic code to speech.
- Computer Games.
- External input for special musical effects.
- Adds speech output to existing BASIC programs.

**Microspeech package**

- Speech synthesizer board (assembled & tested).
- MSP2 Software on floppy disc or cassette.
- Hardware & Software manual.
- Speaking BASIC software option.

**TIM ORR DESIGN CONSULTANT**

55 Drive Mansions,  
Fulham Road,  
London, SW6

**Make your computer talk**

Just by entering phonetic text (as in the sentence at the top of the page). Microspeech with the MSP2 software can make your computer speak. MSP2 uses only 4K of memory. Every extra 1K of buffer space can store 90 seconds of speech.



It speaks for itself

**COSTRONICS ELECTRONICS**  
13 Field Heath  
Avenue, Hillingdon,  
Middlesex

• Circle No. 269

**the software house**

146 OXFORD STREET, LONDON W.1

**APPLE II/ITT PROGRAMS**

**DOS 3.2 TUTOR**

The COMPLETE guide to APPLE DOS. Easily understood, this covers RANDOM ACCESS & SEQUENTIAL FILING, EXEC files & much more.  
SUPPLIED ON FLOPPY DISC

£34.50

**MAIL LIST/LABEL WRITER**

A PROFESSIONAL mailing list program — MENU DRIVEN — multiple sort options enable you to sort your mailing list to YOUR convenience!  
Prints to Labels or complete list — with comprehensive manual

£57.50

**STOCKLOCK**

SINGLE DISC STOCK CONTROL SYSTEM  
USER-DEFINED PASSWORD ENTRY  
AUTO PRINTOUT OF STOCK OR RE-ORDERS  
EASY UPDATE FACILITY  
WHOLESALE & RETAIL PRICES, STOCK LEVEL, RECORDER LEVEL, DESCRIPTION  
complete with MANUAL & variable listings & sample printouts

£80.50

ADVENTURE — our own version — escape from the Wizards lair

£9

ADVENTURE — SCOTT ADAMS versions — for APPLE, SORCERER or TRS80 each

£10

All prices include VAT. Send for our FREE catalogue!!!!!!

• Circle No. 270

# TRANSAM

## COMPONENTS AND SYSTEMS FROM TRANSAM COMPUTERS

•CP/M  
•BASIC  
•PASCAL

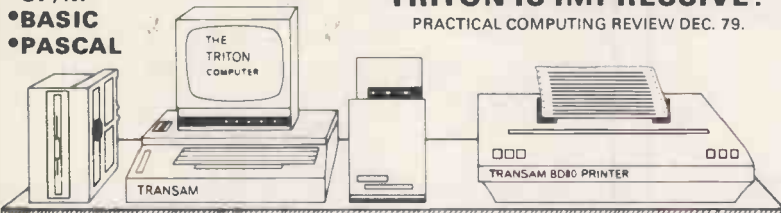

**TRITON IS IMPRESSIVE!**  
PRACTICAL COMPUTING REVIEW DEC. 79.

### TRITON COMPUTER SYSTEM.

Designed for ease of construction and flexibility. Kits come complete and all components and software are available separately. UK designed and supported. Fully documented hardware and software and a totally flexible approach to system building. Powerful and easy to use system monitors - a range of languages available. Firmware is Eprom based and upgrading from one level to the next is easy.

- L5.2 with 1.5k monitor 2.5k basic £294.00
- L7.2 with 2k mon 8k extended basic £409.00
- L8.2 4k ed/mon 20k res pascal £611.00
- L9.2 CP/M disc based system P.O.A.
- 8k ram card kit (21141) £97.00
- 8k eprom cards (EXCL 8 x 2708) £31.00
- Motherboard expansion 8 slot £50.00
- Trap-res assm/ edit etc (8 x 2708) £80.00
- Transam BD80 bi-dir printer £595.00
- TVM 10 video monitor 9" £79.00
- Eprom prog (2708) kit £29.50

SEND FOR OUR CATALOGUE FOR FULL  
DETAILS OF TRITON FEATURES !

### CP/M AVAILABLE NOW FOR TRITON

Disc operating system complete with text editor, assembler, debugger, system utilities and complete file management. Makes Triton fully CP/M compatible and able to run CP/M based software. Triton will support up to four 5 1/4 or 8" drives single or double density full CP/M software user group facilities available. SAE for details. CP/M Disk + manuals (6) £75.00.

### DISK DRIVES & POWER SUPPLIES

SHUGART



- SA400 5 1/4" drive £205.00
- SA800 8" drive £380.00
- Power one quality power supplies
- CP249 1 x 5 1/4" PSU £33.00
- CP233 2 x 5 1/4" PSU £60.00
- CP205 1 x 8" PSU £66.00
- CP206 2 x 8" PSU £76.00

### TCL PASCAL - CP/M COMPATIBLE

A standard Pascal compiler available on a resident (20k) Eprom based configuration\* or available to run under CP/M on 8" disc plus documentation. CP/M version £90.00. \*P.O.A. TCL Pascal Manual and specification £6.50.

### DIL PLUG SOCKETS & SWITCHES

W/WRAP SKTS	DIL SKTS	DIL PLUGS	DIL SWITCHES
80IL 0.20	80IL 0.14	14DIL 0.80	4DIL 1.20
140IL 0.35	140IL 0.15	16DIL 0.65	7DIL 1.75
16DIL 0.42	16DIL 0.17	SCOTCHFLEX 8DIL	1.80
18DIL 0.60	18DIL 0.24	14DIL 1.30	18wZIF* 4.95
24DIL 0.52	20DIL 0.27	16DIL 1.50	24wZIF* 6.20
28DIL 0.74	24DIL 0.30	24DIL 2.80	
40DIL 0.96	28DIL 0.36		
	48DIL 0.50		

ZERO INSERTION FORCE

### COMPUCOLOR II - FULL COLOUR

- 13" 8 colour crt display
  - Built in 5 1/4 disk
  - 16k extended basic in rom
  - 71 key keyboard - detached
  - RS232 + 50 pin bus
  - 8k user RAM - fully expandable
- SPECIAL GRAPHICS PACKAGE  
£985 Plus VAT



### \$100 DISC CONTROLLER £195 Plus VAT

As used on Triton. Fully built will drive 8 x 8" or 8 x 5 1/4" drives. Single or double density. Works with all Shugart compatible drives. Uses the 1791 chip on board crystal - CPU independent



### FULL RANGE OF MICRO SUPPORT CHIPS - IN STOCK

SUPPORT		RAMS	
SN74LS00N 22	SN74LS54N 21	SN74LS138N 95	SN74LS325N 255
SN74LS01N 22	SN74LS55N 21	SN74LS198N 120	SN74LS326N 255
SN74LS02N 26	SN74LS563N 150	SN74LS197N 120	SN74LS327N 255
SN74LS03N 26	SN74LS573N 35	SN74LS221N 125	SN74LS352N 135
SN74LS04N 26	SN74LS574N 40	SN74LS151N 85	SN74LS353N 150
SN74LS05N 26	SN74LS575N 46	SN74LS153N 80	SN74LS354N 85
SN74LS08N 20	SN74LS576N 35	SN74LS154N 180	SN74LS355N 150
SN74LS09N 22	SN74LS578N 35	SN74LS155N 125	SN74LS356N 85
SN74LS10N 18	SN74LS583AN 115	SN74LS156N 125	SN74LS357N 150
SN74LS11N 26	SN74LS585N 110	SN74LS157N 60	SN74LS358N 85
SN74LS12N 25	SN74LS586N 40	SN74LS158N 99	SN74LS359N 85
SN74LS13N 55	SN74LS590N 65	SN74LS160N 116	SN74LS375N 72
SN74LS14N 89	SN74LS591N 99	SN74LS161N 115	SN74LS377N 175
SN74LS15N 25	SN74LS592N 90	SN74LS162N 115	SN74LS378N 132
SN74LS20N 20	SN74LS938N 65	SN74LS163N 90	SN74LS379N 140
SN74LS21N 26	SN74LS954N 120	SN74LS164N 150	SN74LS381N 365
SN74LS22N 26	SN74LS969N 170	SN74LS165N 170	SN74LS386N 57
SN74LS26N 29	SN74LS107N 39	SN74LS166N 175	SN74LS390N 198
SN74LS27N 35	SN74LS109N 39	SN74LS168N 195	SN74LS393N 150
SN74LS28N 35	SN74LS112N 39	SN74LS169N 195	SN74LS261N 350
SN74LS30N 25	SN74LS113N 44	SN74LS170N 250	SN74LS266N 39
SN74LS32N 27	SN74LS114N 44	SN74LS173N 220	SN74LS273N 185
SN74LS33N 39	SN74LS122N 79	SN74LS174N 115	SN74LS279N 79
SN74LS37N 29	SN74LS123N 90	SN74LS175N 105	SN74LS280N 175
SN74LS38N 29	SN74LS124N 150	SN74LS181N 275	SN74LS283N 180
SN74LS40N 25	SN74LS125N 65	SN74LS190N 175	SN74LS290N 180
SN74LS42N 79	SN74LS126N 65	SN74LS191N 175	SN74LS293N 180
SN74LS47N 95	SN74LS132N 75	SN74LS192N 145	SN74LS295AM 220
SN74LS48N 95	SN74LS133N 39	SN74LS193N 175	SN74LS298N 220
SN74LS49N 109	SN74LS135N 40	SN74LS194AN 189	SN74LS324N 180
			SN74LS670N 270

### DPS.1 MAINFRAME - PASCAL SYSTEM

\$100 to IEEE spec



Send 30p for our  
ITHACA catalogue

WE STOCK THE FULL RANGE OF \$100 CARDS AND ACCESSORIES

### ITHACA

PASCAL/Z  
build your own  
Pascal Micro  
Development  
system. IEE-S100  
bus system using  
DPS1 main-frame.  
Supports K2,  
ASSEMBLE/Z and  
PASCAL/Z on 8" disc.  
Complete system  
£2910.00.

### \$100 BOARDS

- 8k Static RAM board (450ns) £99.00
- 8k Static RAM board (250ns) £117.00
- Z80 cpu board (2MHz) £105.00
- Z80 cpu board (4MHz) £123.00
- Z708/27 16 EPROM board £57.00
- Prototype board (bare board) £15.00
- Video display board (64 x 16, 128U/L Ascii) £108.75
- Disc controller board £131.25
- K2 disc operating system £45.00
- ASSEMBLE/Z Macro Assm £37.50
- PASCAL/Z compiler £205.00
- PASCAL/Z CP/M £235.00
- 16k Static RAM £275.00

### VISIT OUR SHOWROOM

WE ALSO STOCK:- a comprehensive range of books and magazines, VERO products including S100 and Eurocard and Wire Wrap equipment, Weller soldering equipment, Ribbon Cables, tools, tapes, diskettes, connectors and OK Tool range. Systems continuously on display in our showroom.

CRYSTALS	4MHz	2.10	F8(3850)	9.50	
100k	3.00	4.43M	1.00	8080A	6.30
200k	3.70	5MHz	2.70	8089	24.00
1MHz	3.80	6MHz	2.70	Z80	8.00
1000k	3.50	7MHz	2.70	Z80A	15.00
1843k	3.00	7.168M	2.50	8085A	12.95
2MHz	1.50	8MHz	2.70	6502	8.00
2457k	3.05	10MHz	2.70	SCMP11	10.00
3276k	2.70	10.7M	2.70	6802	13.95

### ALL PRICES

Exclude VAT & P/P  
VAT 15% P. & P. 40p on small orders.  
For larger items please Tel.  
Telephone credit card orders  
accepted subject to £5 min.  
RAPID MAIL ORDER SERVICE



### CATALOGUE

NEW A4 SIZED  
ONLY 40p & S.A.E.



VISIT OUR SHOWROOM SOON  
9.30-5.30 Mon-Fri  
1.30-2.30 closed lunch  
9.30-5.00 Sat  
Thursday half day 1.30

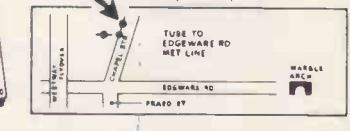

TRANSAM COMPONENTS LTD, 12 CHAPEL STREET, LONDON NW1

Tel: 01-402 8137 Telex: 444898

Circle No. 271

# PRINTERS FOR PET

- Plug connectable. 2001 and 3001
- Full Character Set and Graphics and Cursor Signs
- Variable Character Size
- Reverse Print
- Paper roll or Reversible Tractor Feed
- £ sign
- 100-120 CPS Bi-directional
- 5 x 7, 6 x 7, 9 x 7, Dot Matrix
- 52-80 Print Positions
- Alternative Interfaces → RS232 and Centronix

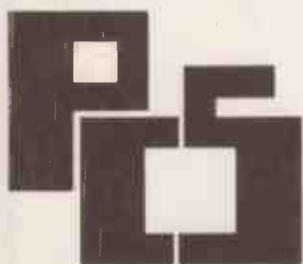

PARAMETERISED  
COMPUTER  
SYSTEMS LTD

PRICES FROM £450

250 Brompton Road  
London SW3

• Circle No. 272

## Cassette Duplicating Supplies

NOW OFFER YOU

### PYRAL

MICROPROCESSOR CASSETTES  
POSTAL PACKS

	C12	C15	C20
10 Pack	£4.85	£5.05	£5.35
50 Pack	£21.45	£22.45	£23.95
100 Pack	£40.55	£42.55	£45.55

### PYRAL

FLOPPY DISCS —  
for example 5¼" postal packs

	5 Pack	10 Pack	50 Pack	100 Pack
	£17.00	£28.35	£127.00	£240.00

The price quoted includes packaging, postage and VAT. Cheques or postal orders with order please, payable to 'Cassette Duplicating Supplies'.

Orders and enquiries to:-  
FRANK WHIPP — 0296 622837

● ○ ○ ○ ○ Sales Office:  
○ ○ ○ ○ ○ 15 Icknield Close  
○ ○ ○ ○ ○ Wendover  
○ ○ ○ ○ ○ Aylesbury  
○ ○ ○ ○ ○ HP22 6HG  
○ ○ ○ ○ ○ Tel: 0296 622837



• Circle No. 273

# PROGRAMMER SW1

**Commercial experience unnecessary.  
Sound knowledge of BASIC essential.**

Do you gain satisfaction from writing elegant, reliable programs which utilise system resources efficiently?

Do you want to become a member of a small growing team developing application programs within a progressive professional firm?

We have Hewlett Packard 3000 Series III and HP2000 Access systems, running on BASIC in interpretive and compiled forms, with 180 megabytes of online storage and 20 user terminals. We can offer challenging programming fare, principally evolving new applications and extensions for our real-time database.

Please apply in writing to C. W. Jonas FRICS

**DRIVERS JONAS**  
CHARTERED SURVEYORS  
18 PALL MALL, LONDON SW1Y 5NF



• Circle No. 274



# L & J COMPUTERS



3 CRUNDALE AVENUE, KINGSBURY NW9 9PJ 01-204 7525

## THE "PET" SPECIALISTS

### HARDWARE



#### COMPARE OUR PRICES!

NEW PET 8K £499  
 New PET 16K £599  
 New PET 32K £725  
 EXTENSION CASSETTE DECKS (WITH COUNTER) £55

#### DUAL DRIVE DISK UNITS

PET 3040 £740  
 COMPUTHINK 400K £949  
 COMPUTHINK 800K £1099

#### PRINTERS

PET 3022 £620  
 CENTRONIC 779 (Tractor feed) £869  
 SWT PR 40 (Inc Interface) £295  
*(becomes an on-line printer)*  
 TELETYPE 43 £875

#### SUNDRIES

TOOL KITS from £55  
 VARIOUS INTERFACES from £40  
 FLOPPY DISCS from £2

PAPER: ROLL & TRACTOR FEED  
 FULL RANGE OF PETSOFT & COMMODORE SOFTWARE

*If you can't see what you want — ask.*

*We pride ourselves on getting what the Customer wants — quickly!*

PRICES DO NOT INCLUDE VAT

### SPECIAL OFFER

**BASF 5¼ FLOPPY DISCS — 30 for £72**

### SYSTEMS



WE OFFER SMALL BUSINESS SYSTEMS FOR UNDER £2099 + WHICH CAN NOT ONLY CARRY OUT MOST OF THE DAY TO DAY CHORES, BUT ALSO HAVE ROOM TO SPARE TO COPE WITH THOSE "ODD JOBS". TAKE YOUR CHOICE!

EACH PACKAGE COMPRISES A 'PET' 32K, CABLES, ANY INTERFACES REQUIRED, BUT DOES NOT INCLUDE PAPER, DISKS ETC.

DUAL DRIVE DISK UNIT	TRACTOR FEED PRINTER		
	PET 2022	TELETYPE43	CENTRONIC779
PET 3040	£2099	£2399	£2399
COMPUTHINK 200K x 2	£2129	£2429	£2379
200K x 4	£2289	£2589	£2539

PRICES DO NOT INCLUDE VAT

### SOFTWARE

As well as a full range of Petsoft and Commodore Software, we have some highly reliable "Home-Brewed" programs available.

**STOCK CONTROL & INVOICING** £60  
 (Handles up to 500 items — 32K) (180 on 16K). Stock depleted on invoicing, search etc. Cassette, disk (& print option).

**STOCK CONTROL & INVOICE (RANDOM ACCESS)** £120  
 On-line handling of 3400 items (50 char.) per disk. Disk (+ printer option) (16 or 32K) search etc.

**ADDRESS/PHONE BOOK** £35  
 Create, amend, enlarge, search (+ print option) (16K or 32K).

**OUTSIDE SERVICES** £220  
 Weekly or monthly invoices — cheque writing facility — optional deductions. (16 or 32K + disk + printer).

**YOUR MONTHLY PLANNER** £7  
 Print your own planner on your own printer! Any year or month.

**RANDOM ENTRY & ANALYSIS** £40  
 Makes adding up all those different invoices childs' play! Cash, cheques etc., balances & VAT.

**CASH BOOK** £90  
 Enter daily/weekly amounts — printout and totals, weekly/monthly analysis, totals and balances.

**SEND SAE. FOR FREE BROCHURE**  
**PRICES DO NOT INCLUDE VAT.**

We can write specialist programs for you. Ask us for a quotation.

### BREAKTHROUGH!

IF YOU ARE A PET 2040/3040 DISC USER WE CAN DRAMATICALLY INCREASE YOUR DISC STORAGE CAPACITY. FULL OPERATING INSTRUCTIONS ONLY £10 — GUARANTEED!!

### ACQUISITION

You are welcome to try, browse & purchase at our premises.  
 You can phone your order.  
 You can fill in & send off the form below.  
 Whichever way you choose, you cannot help but be delighted with our service.

### ORDER FORM

TO L & J COMPUTERS:  
 PLEASE SEND ME BY RETURN:—

\_\_\_\_\_ £ \_\_\_\_\_  
 \_\_\_\_\_ £ \_\_\_\_\_  
 \_\_\_\_\_ £ \_\_\_\_\_

ADD £12 for large items \*\*  
 ADD £1 for small items

VAT £ \_\_\_\_\_

TOTAL £ \_\_\_\_\_

CHEQUE/P.O ENCLOSED\*  
 CHARGE TO MY ACCESS/BARCLAY/VISA CARD No.\*  
 (\*delete as req'd)

ALL GOODS SENT SAME DAY WHEREVER POSSIBLE  
 Recorded delivery by post: or Securicor.\*\*



• Circle No. 275

## At last... the mechanical interface!

Turn your electric typewriter into a low cost, high quality hard copy printer.

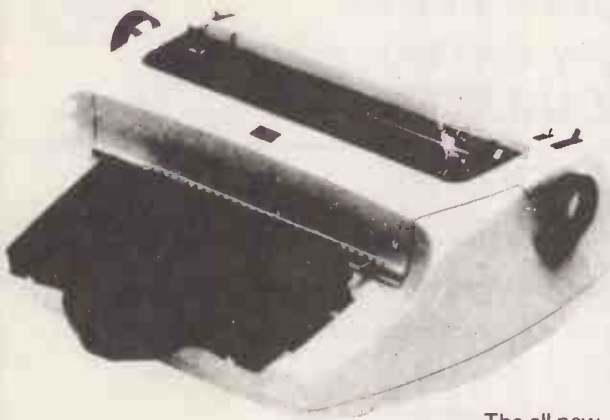

Price, including standard interface

**£325**  
+ VAT

The all new KeyPak from Capital Computer Systems interfaces the keyboard of any commercially available electric typewriter with any computer such as the PET, APPLE and Tandy TRS-80. The result: low-cost, high-quality hard copy.

Contact us now for more information

**CAPITAL COMPUTER SYSTEMS**

Capital House, 29/30 Windmill St, W1. Tel: 01-637 5551

• Circle No. 276

## Array Processing from Silicon Glen on the West Coast of Scotland

Video Vector Dynamics Ltd announce what will be one of the most significant innovations in microcomputing during the 1980's — The VP 9500 Vector Processor.

For more details contact:

**Video Vector Dynamics Ltd**

39 Hope Road

Glasgow G2 6AE

Telephone number 041-226 3481/2

• Circle No. 277

## INTEGRATED SMALL BUSINESS SOFTWARE

### - ISBS -

**FAST AND EASY TO USE ISBS MEANS INCREASED EFFICIENCY AND PROFITABILITY - PUT IT TO WORK FOR YOUR BUSINESS**

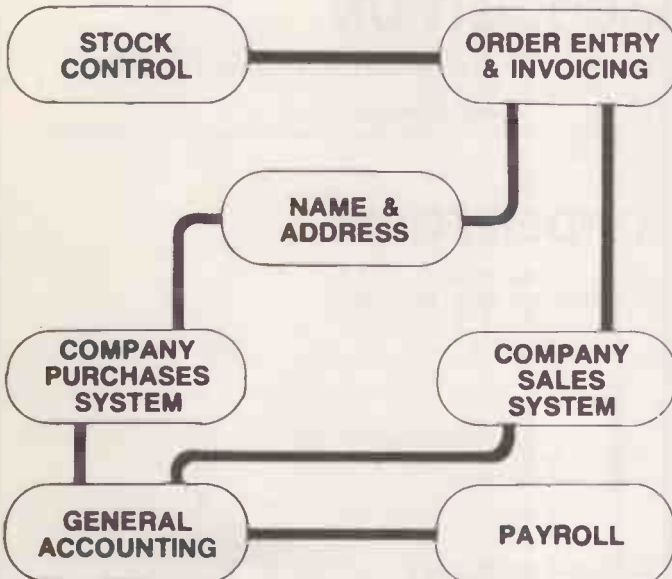

#### ISBS

	£
STOCK CONTROL	350
ORDER ENTRY & INVOICING	350
NAME & ADDRESS SYSTEM	250
COMPANY PURCHASES SYSTEM	450
COMPANY SALES SYSTEM	450
GENERAL ACCOUNTING	400
PAYROLL	500

Packages supplied on floppy disk with easy to follow Reference Manuals — NO PREVIOUS COMPUTER KNOWLEDGE REQUIRED TO OPERATE. ISBS runs on 48K Northstar Horizon, Rair Black Box or other systems supporting CP/M\* — plus VDU and 132 col printer. Complete suite or individual packages available now and are fully supported.

Other software packages available include Time Recording Systems, Finance Control and many others. Special application software undertaken for Northstar & Black Box and also complete TURNKEY SYSTEMS.

\*CP/M registered trademark of Digital Research.

Costs shown exclusive of VAT.

Dealer enquiries welcome.

**GRAFFCOM**

52 SHAFTESBURY AV. LONDON W1.

01-734-8862

• Circle No. 278

# CHROMASONIC electronics

56 FORTIS GREEN ROAD MUSWELL HILL LONDON N10 3HN  
TELEPHONE 01-883 3705 01-883 2289

*your soundest connection in the world of components*

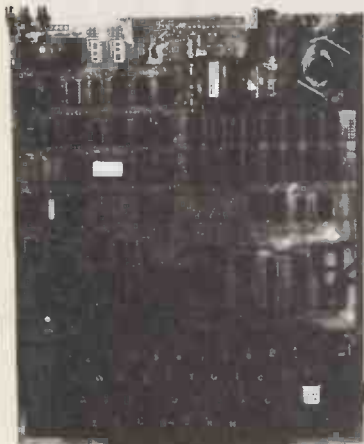

Demonstration At Our Shop  
(enter through stationers)

**NOW AVAILABLE**  
Low cost computer in kit form

## UK101

**NO EXTRA NEEDED  
SIMPLY HIT  
'RETURN' AND GO**

As seen in  
P.E.  
August to November '79

Kit price  
only **£199 + VAT**

**AVAILABLE SOON**  
COLOUR ADD-ON CARD

Enables you to choose your foreground, the background colour anywhere on the screen. Flash any character on the screen at will. Full documentation and parts in kit form. Phone for details.

## STOP PRESS

The latest edition of our 'STOP PRESS' is now available, and contains an up-to-date price list showing all the items that we stock. Just send an S.A.E. or phone for your FREE copy. Our catalogue is still available and if you're one of the few who haven't got a copy, order your FREE copy today.

**EXTRA MEMORY**  
**8 x 2114**  
only  
**£35.00 + VAT**

**INCLUDED FREE**  
Sample tape with extended  
machine code moditor and  
disassembler

Price includes RF modulator and  
and supply  
**ABSOLUTELY NO EXTRAS  
NEEDED**

Also available ready assembled,  
tested and ready to go  
only **£249 + VAT**

Build, understand, and  
program your own  
computer for only a  
small outlay

PLUS SUPERBOARD II only £188.00 + VAT											
Dynamic RAMS	8251	5.00	*7454	0.12	4536	3.03	74LS107	0.32	74LS248	1.09	
	£ 8253	6.93	7460	0.10	4543	1.35	74LS109	0.32	74LS249	1.09	
4027	3.01	8255	5.08	7470	0.19	4553	3.87	74LS112	0.32	74LS251	0.96
4050 (200ns)	2.50	Baud Rate	7472	0.17	4566	1.40	74LS113	0.32	74LS253	0.92	
4050 (350ns)	£2.35	Generators	7473	0.23	4583	0.72	74LS114	0.32	74LS257	0.92	
4060 (300ns)	2.39	MC14411	7474	0.20	4585	0.99	74LS122	0.69	74LS258	0.92	
4116	6.74	MM5307	7475	0.25	LS series		74LS123	0.72	74LS259	1.39	
Static RAMS		7476	7476	0.17	74LS00	0.12	74LS124	1.39	74LS261	4.50	
2102A	1.16	AY-5-1013	7482	0.52	74LS01	0.12	74LS125	0.36	74LS266	0.37	
2102A-2	1.16	MM5303	7485	0.90	74LS02	0.14	74LS126	0.36	74LS273	1.70	
2111A-1	1.70	*TMS6011NC	7486	0.16	74LS03	0.14	74LS132	0.60	74LS279	0.57	
2112A-2	1.83		7489	1.30	74LS04	0.16	74LS133	0.39	74LS283	1.09	
21L02	1.16		7490	0.24	74LS05	0.19	74LS136	0.36	74LS289	4.50	
2114	5.17	<b>2708 only</b>	7491	0.54	74LS08	0.18	74LS138	0.58	74LS290	0.91	
4035 (1000ns)	1.07	<b>£6.26 +VAT</b>	7492	0.29	74LS09	0.18	74LS139	0.58	74LS293	0.91	
4045 (250ns)	6.15		7493	0.24	74LS10	0.18	74LS145	0.97	74LS295	1.30	
5257 (TMS4044)	6.93		7495	0.35	74LS11	0.18	74LS151	0.81	74LS298	1.16	
6810	3.03	TTL	7496	0.42	74LS12	0.18	74LS153	0.52	*74LS348	1.39	
ROMS		7400	7401	0.10	74LS13	0.37	74LS154	1.30	74LS352	1.04	
2513 (U.C.)	6.25	7401	7402	0.10	74LS14	0.65	74LS155	0.72	74LS353	0.92	
2513 (L.C.)	6.25	7402	7403	0.11	74LS15	0.18	74LS156	0.72	*74LS362	4.21	
MM5230	4.82	7403	7404	0.12	74LS20	0.18	74LS157	0.57	74LS365	0.47	
CPU		7404	7405	0.13	74LS21	0.18	74LS158	0.57	74LS366	0.47	
6800	6.01	7405	7406	0.21	74LS22	0.18	74LS159	1.09	74LS367	0.47	
8080	5.08	7406	7407	0.21	74LS26	0.18	74LS161	0.69	74LS368	0.47	
9080	26.05	7407	7408	0.12	74LS27	0.18	74LS162	1.16	*74LS373	0.78	
Z80	9.00	7408	7409	0.13	74LS28	0.19	74LS163	0.69	74LS386	0.36	
6502	9.50	7409	7410	0.11	74LS30	0.18	74LS164	1.06	*74LS393	0.84	
E.PROMS		7410	7411	0.17	74LS32	0.26	74LS165	0.72	*74LS668	1.17	
1702AQ	5.16	7411	7412	0.13	74LS33	0.26	74LS166	1.65	74LS670	1.71	
2708	6.26	7412	7413	0.19	74LS37	0.23	74LS168	1.71			
2716	24.00	7413	7414	0.40	74LS38	0.23	74LS169	1.71			
T.V. Controller		7414	7415	0.19	74LS40	0.18	74LS170	1.72	<b>8 x 4116</b>		
SFF96364	14.59	7415	7416	0.25	74LS42	0.65	74LS173	0.81	only		
Buffers		7416	7417	0.25	74LS47	0.81	74LS174	0.97	<b>£49.50 + VAT</b>		
74365	0.52	7417	7418	0.10	74LS48	0.81	74LS175	0.97			
74366	0.52	7418	7419	0.18	74LS49	0.81	74LS181	2.77	<b>21L02</b>		
74367	0.52	7419	7420	0.18	74LS54	0.18	74LS188	0.44	<b>8 for £8.50</b>		
74368	0.52	7420	7421	0.25	74LS55	0.18	74LS189	2.08	<b>16 for</b>		
81LS95	0.86	7421	7422	0.29	74LS56	0.18	74LS190	0.86	<b>£14.50</b>		
81LS96	0.70	7422	7423	0.10	74LS73	0.33	74LS191	0.86			
81LS97	0.86	7423	7424	0.18	74LS74	0.27	74LS192	1.04			
81LS98	0.70	7424	7425	0.19	74LS75	0.40	74LS193	1.04			
8T26	1.90	7425	7426	0.19	74LS76	0.27	*74LS194	0.86			
8T28	1.90	7426	7427	0.16	74LS78	0.27	74LS195	0.97			
8T95	1.57	7427	7428	0.46	74LS83	0.78	74LS196	0.97	<b>32 for</b>		
8T96	1.57	7428	7429	0.35	74LS85	.81	74LS197	0.97	<b>£26.50</b>		
8T97	1.57	7429	7430	0.56	74LS86	0.27	74LS221	0.92			
8T98	1.57	7430	7431	0.56	74LS89	0.57	74LS240	2.08	<b>64 for</b>		
Interface		7431	7432	0.56	74LS90	0.57	74LS241	2.08	<b>£49.50</b>		
8205	3.00	7432	7433	0.40	74LS91	0.97	74LS242	2.08	<b>All + VAT</b>		
8212	2.00	7433	7434	0.49	74LS92	0.69	74LS243	2.08			
8216	2.08	7434	7435	0.10	74LS93	0.60	74LS245	2.50			
8224	2.77	7435	7436	0.10	74LS95	0.81	74LS247	1.09			
8228	4.13	7436	7437	0.10	74LS96	1.16					
		7437	7438	0.10							
		7438	7439	0.10							
		7439	7440	0.10							
		7440	7441	0.10							
		7441	7442	0.10							
		7442	7443	0.10							
		7443	7444	0.10							
		7444	7445	0.10							
		7445	7446	0.10							
		7446	7447	0.10							
		7447	7448	0.10							
		7448	7449	0.10							
		7449	7450	0.10							
		7450	7451	0.10							
		7451	7452	0.10							
		7452	7453	0.10							
		7453	7454	0.10							
		7454	7455	0.10							
		7455	7456	0.10							
		7456	7457	0.10							
		7457	7458	0.10							
		7458	7459	0.10							
		7459	7460	0.10							
		7460	7461	0.10							
		7461	7462	0.10							
		7462	7463	0.10							
		7463	7464	0.10							
		7464	7465	0.10							
		7465	7466	0.10							
		7466	7467	0.10							
		7467	7468	0.10							
		7468	7469	0.10							
		7469	7470	0.10							
		7470	7471	0.10							
		7471	7472	0.10							
		7472	7473	0.10							
		7473	7474	0.10							
		7474	7475	0.10							
		7475	7476	0.10							
		7476	7477	0.10							
		7477	7478	0.10							
		7478	7479	0.10							
		7479	7480	0.10							
		7480	7481	0.10							
		7481	7482	0.10							
		7482	7483	0.10							
		7483	7484	0.10							
		7484	7485	0.10							
		7485	7486	0.10							
		7486	7487	0.10							
		7487	7488	0.10							
		7488	7489	0.10							
		7489	7490	0.10							
		7490	7491	0.10							
		7491	7492	0.10							
		7492	7493	0.10							
		7493	7494	0.10							
		7494	7495	0.10							
		7495	7496	0.10							
		7496	7497	0.10							
		7497	7498</								

# Possibly the most cost effective word processors in the world.

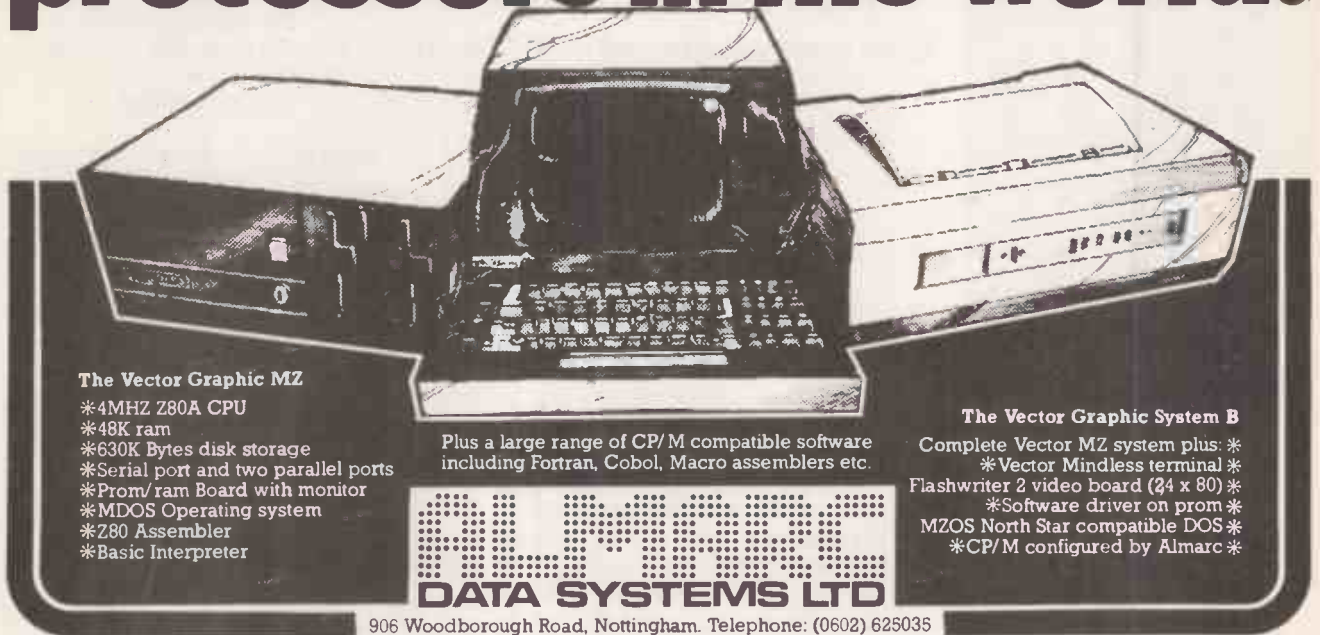

**The Vector Graphic MZ**

- \*4MHZ Z80A CPU
- \*48K ram
- \*630K Bytes disk storage
- \*Serial port and two parallel ports
- \*Prom/ram Board with monitor
- \*MDOS Operating system
- \*Z80 Assembler
- \*Basic Interpreter

Plus a large range of CP/M compatible software including Fortran, Cobol, Macro assemblers etc.

**The Vector Graphic System B**

Complete Vector MZ system plus:

- \*Vector Mindless terminal
- \*Flashwriter 2 video board (24 x 80)
- \*Software driver on prom
- \*MZOS North Star compatible DOS
- \*CP/M configured by Almarc



**DATA SYSTEMS LTD**

906 Woodborough Road, Nottingham. Telephone: (0602) 625035

• Circle No. 292

## The Rohan Computing Collection.....

Rohan computing, in addition to their normal software and systems consultancy services, now offer the following range of computer equipment for sale. As far as possible Rohan computing try to hold these items in stock ready for immediate delivery. Nationwide on site maintenance for all Rohan computing equipment.

**Qume** The Qume is ideal as a general purpose printer or for adding word processing facilities to an existing micro-computer. Print only and keyboard versions available. The keyboard version can double as a spare typewriter. RS232 interface adaptable for the PET, APPLE, etc. XON/XOFF protocol available. Word processing package/driver available for CP/M based systems. Other versions in preparation.

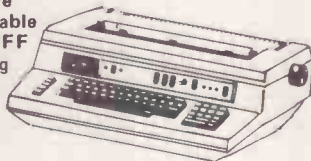

**digital** Digital Decwriter IV. The best desk top matrix printing terminal available. Typewriter styling. 10,12,13,2,16.5 characters per inch. All sizes very legible. 2,3,4,6,8,12 lines per inch. Optional tractor feed and numeric keypad. RS 232 interface.



**PET** Commodore PET microcomputers. The PET is the ideal low cost computer for teaching yourself programming, educational use and time consuming calculations in science, industry and commerce. Graphic display excellent for histograms etc.

- \*8k PET with integral cassette and minikeyboard
- \*16 & 32k PET's with full sized professional keyboards.
- \*2022 matrix printers
- \*2040 floppy disc units.



**CIFER** Cifer 2600 Series VDU's. Superbly engineered and made in Britain. \*12 inch screen. \*7 x 11 character matrix \*9 x 12 matrix for graphic characters \*62 or 100 key detachable keyboards \*Printer port \*VT52 emulation \*Line drawing set



\*RAIR Blackbox, Teletype 43s, Tally high speed matrix printers also available.\*

## Rohan

Phone Richard on SOUTHAM (092681) 3541 for prices and delivery.

Rohan Computing, B.A.S.S. (Engineers) Sales Limited, Kineton Road, Southam, Warwickshire CV33 0DQ

• Circle No. 280



# *Quality Print... for your micro!*

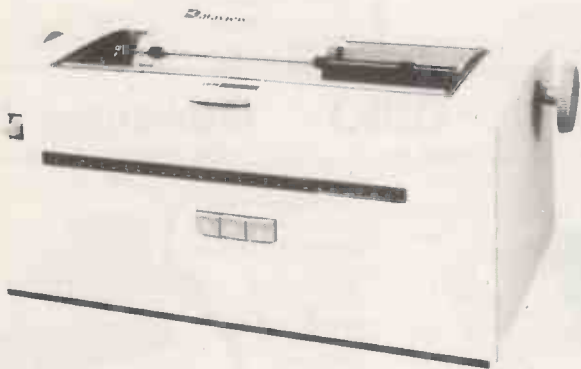

**Rebuilt & Redesigned  
IBM 3982  
Selectric Printers**

- \* 130 column
- \* interchangeable type styles
- \* built-in RS 232 interface
- \* friction feed as standard, pin feed available
- \* PET interface available
- \* 90 days warranty
- \* maintenance agreements available

*Available now. £995 plus V.A.T. and carriage.*

Contact:

 **Dataview**

**Church St. Colchester Essex CO1 1NF  
Tel. Colchester (0206) 63377**

• Circle No. 281



## Super Print 800

80 COLUMN HIGH PERFORMANCE  
IMPACT PRINTER

The ideal companion for PET, Apple,  
TRS80, Exidy, Superboard, CompuKit

Rugged metal enclosure makes it ideal for  
home computing, small business systems, data logging etc.

**NEW**

Just look at these standard features:

- \*RS-232, 20mA, IEE 488 and Centronics 1/0
- \*16 Baud Rates to 19,200
- \*60 Lines per minute - Bidirectional
- \*5 print densities 72,80,96,120 or 132 Chr/Line
- \*Self Test Switch

Standard Feed-Model 800

ONLY £329+VAT

- \*96 character ASC II Standard
- \*Auxiliary User Defined Character Set
- \*Accepts 8 1/2" max. paper - pressure feed
- 9 1/2" max. paper - tractor feed

OPTIONS:-

- \*Tractor & Fast Paper Feed/Graphics(model ST)
- \*2k Terminal Buffer

Tractor & High Speed-Model 800ST

ONLY £389+VAT

## Atari VCS System

Most popular top range micro-video game



Current carts, include:- Air-Sea  
Battle, Space War, Outlaw, Video  
Olympics, Breakout, Basketball,  
Surround, Blackjack, Basic Maths,  
Hunt & Score, Miniature Golf,  
Skydiver, Street Racer, Chess,  
Backgammon and many more.

Cartridges mostly - £13 + VAT  
Chess (8 levels) - £39 + VAT  
Backgammon - £30 + VAT  
Superman - £20.80 + VAT  
Indy 500 - £30 + VAT

Coming Soon - BASIC Computing, Space  
Invaders plus many more!

Buy a VCS, introduce a friend to buy one  
and get a Keyboard FREE worth £19  
(limited Ingersol Offer)

Atari VCS NOW ONLY £113 + VAT  
+ your first cart. - £6.90 + VAT (worth £13)



## Nascom-2

MICRO COMPUTER

ONLY £295 + VAT

FREE 16k  
RAM Board

Z80A 8 bit. This will run at 4 Mhz but is  
selected between 1/2/4/ Mhz.

On-board, addressable memory. 2K  
2K Monitor-Nas-sys 1. 1K Video RAM  
(MK4118). 1K Work space/User RAM  
(MK 4118). 8K Microsoft Basic  
(MK 3600 ROM). 8K Static RAM/  
2708 EPROM

## Superboard II - OHIO - Challenger 4P

At these prices why waste time and money on  
unauthorised kit copies?

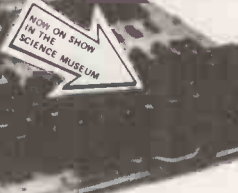

New 50 Hz version  
No Flicker

NOW AN  
UNBELIEVABLE  
£149.95  
+ VAT

610 Expansion Board 8k RAM  
ONLY £149.95 + VAT

IP CD3P Mini-floppy Disc, Cased, PSU,  
2 copies of DOS - ONLY £289 + VAT  
Set of 4k RAM (Superboard users only)  
ONLY £24 + VAT

Plastic Case - Beige ONLY £26 + VAT  
Challenger IP - Metal Cased, Superboard,  
PSU modulator - ONLY £188 + VAT  
Discs & Cassettes available

PAL COLOUR AND SOUND

A major breakthrough  
in price/performance  
for personal/  
business educational

micro's  
- Single RF O/P  
provides both  
sound & vision  
to colour TV.  
(Colour sets  
only).

\*8k Microsoft-8k User RAM \*16 colours,  
32 rows x 64 cols. \*Programmable tone  
generator and DAC \*Joystick and keyboard  
interface.

Challenger 4P - 8k Basic in ROM 8k RAM  
expandable to 32k - ONLY £425 + VAT  
Challenger 4P MF - Same as 4P but with Mini-  
floppy 24k RAM, expandable to 48k -  
ONLY £950 + VAT

Complete range of accessories available



## NEC Spinwriter



- for the  
professional  
word processing  
system

£1795 + VAT

NEC's high quality printer uses a print "thimble" that  
has less diam and inertia than a daisy wheel. Giving a  
quieter, faster more reliable printer than can cope  
with plotting and printing (128 ASC II chs.) with up  
to 5 copies, friction or tractor fed. The ribbon and  
thimble can be changed in seconds. 55 chs. per sec.  
bidirectional printing with red/black, bold, subscript,  
proportional spacing, tabbing, and much much more.



## Video 80

- based on probably  
the world's largest  
selling video monitor  
-over 100,000 in use!

ONLY £69 + VAT

Ideal for home, personal and business  
computer systems \*12" video display  
\*Composite video input \*Compatible  
with many computer systems \*Solid  
state circuitry \*Stylish rugged plastic  
housing



INTELLIGENT  
EPROM PROGRAMMER

Built or in Kit form

Connects directly

to TV. Develop,

Copy, Burn,

Verify 2708,

2716 and with

modification 2516.

Softy is a versatile product and each application will  
be different by definition. When Softy is connected  
via a serial (RS 232) or parallel link with any small  
computer capable of supporting an assembler a  
simple and capable Product Development System  
is formed. For product developments with less than  
2k of firmware Softy may be the only development  
tool you will need.

\*Fast cassette interface-over 2000 baud equiv.

\*Ideal Training Aid-useful control computer

\*Equivalent dev. systems cost over £500+

ONLY £120 + VAT Built & Tested

£100+VAT Kit. £20+VAT Built Power Supply

NOW ON SHOW  
IN THE  
SCIENCE MUSEUM

## miniMAS Terminal

- the intelligent VDU  
ONLY £588 + VAT



**NEW**

\*Utilises the new advanced and powerful  
Z8 Micro \*12" P4 Phosphor high resolution  
display \*24 lines of 40 or 80 characters -  
25th line status \*9 x 13 field displaying  
128 ASC II characters - 4K RAM - 2 page  
\*RS232C or RS432 - 16 independent baud  
rates for each 1/0 \*Full 92 keyboard -  
sophisticated cursor controls \*Emulates  
DEC VT52

# Mighty Micro

In association with Watford Electronics

Please add VAT at 15%. Carriage extra, will advise at time of order. Official orders  
welcome. Product details on request. Trade and export enquiries welcome.

33 CARDIFF ROAD, WATFORD, HERTFORDSHIRE

Tel: (0923) 40588/9 Telex 858747. Open 9 am to 5.30 pm Mon - Sat.

Close to Watford Football Ground. Nearest Station - B.R. Watford.

BUY IN CONFIDENCE - In the event that we are unable to deliver your goods within 7 days, we  
do not bank your remittance until such time as we have the goods to despatch. If on receipt of  
your order the goods do not meet with your satisfaction, return within 7 days for full refund.

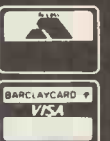

# The small business system that won't let you down

## VECTOR MZ FROM COMPUTASTORE

Computastore has combined the powerful Vector MZ microcomputer with the reliability of proven accounts packages to bring you the benefits of a Small Business Computer at a price you can afford. With a high speed printer, the total system costs £5500, including installation and training – no extras to pay.

The integrated accounts packages provide the flexibility and ease of operation that first time users demand. Operator training is provided at YOUR premises, using YOUR data to get your system working within days. And because our accounts software has been developed in-house, the standard packages can easily be tailored to meet your needs exactly.



■ **SALES LEDGER:** Open item system, produces statements and current aged debtors balance at any time – not just at month end.

■ **PURCHASE LEDGER:** Open item system, produces aged creditors balance and remittance advices at any time – you choose the items you want to pay.

■ **NOMINAL LEDGER:** Links with both sales and purchase ledgers. Compares actual with budget, and with same period previous year.

■ **ONE OFF SOFTWARE:** We will be pleased to quote for any other commercial application.

■ **WORD PROCESSING OPTION:** Combine your word and data processing on the same system.

### TECHNICAL OVERVIEW:

Vector MZ: Industry standard CP/M operating system, 48K RAM, 630K Disk Drives, Fast Z80 microprocessor, S100 bus.

### Mindless Terminal:

High quality 80 x 24 upper and lower case display, Typewriter style keyboard, with numeric keypad.

### Texas Instruments 810:

150 c.p.s. high quality dot matrix printer.

**ONLY £1,700** 32K Vector MZ complete with 630K disk drives, CP/M, C/BASIC and NAD.

Full Range of Low Cost Accessories by Mail Order.

\* Barclaycard and Access welcome.

HARDWARE, SOFTWARE and ACCESSORIES  
sold either as complete systems or separately.



All goods in stock NOW, so why not call in for a demonstration, or ring or write for further details.



**Computastore**

### Software That Means Business

16 John Dalton Street  
Manchester M2 6HG  
Tel: 061-832 4761

• Circle No. 283



A division of  
CRAYWORTH (COMPUTER SERVICES) LTD.

### **SHOWROOM and OFFICES**

**34B London Road, Blackwater,  
Camberley, Surrey.**

**Telephone: 0276 34044. Telex 858893**

open Monday-Friday 9 a.m.-6 p.m.

Saturday 10 a.m.-5 p.m.

by appointment only

Personal Callers Welcome.

Please phone first if you require a personal demonstration.

## **DEAR OEM, BUSINESS, INDUSTRIAL AND SCIENTIFIC COMPUTER PURCHASERS**

Yet again we find our advertising copy dates are here and our material is still under preparation, however, you all know what a micro-computer looks like, so perhaps there's not much point in showing you MORE photographs of the same computers AGAIN.

The GOOD NEWS for 1980 is that our parent company CRAYWORTH (Computer Services) Ltd. have now been appointed by

ZILOG as DISTRIBUTORS for their NEW RANGE of micro-computer systems, which enables us to supply both END-USERS and OEM's at very competitive prices.

ZILOG are the only major micro-computer manufacturer to realise the importance of the U.K. and EUROPEAN micro-computer market and have established their EUROPEAN H.Q. in the U.K. We believe that this will enable us to provide you with the best supported micro-computer system available at the present time.

ZILOG systems are based on the ZILOG Z-80 CPU with 64K bytes of RAM and a nine-slot chassis with power-supply and fan, which leaves seven slots free for additional interfaces, a Real-Time clock card, or even your own specialised boards.

Up to FOUR floppy disk drives can be added and, if this isn't enough, up to FORTY MEGABYTES of exchangeable cartridge hard-disk can be supported.

There are FIVE HIGH-LEVEL LANGUAGES, BASIC, FORTRAN, COBOL, PASCAL and PL/Z in addition to ZILOG's own Z-80 MACRO-ASSEMBLER. There is a COMMUNICATIONS PACKAGE and MULTI-TERMINAL COBOL to allow you DISTRIBUTED PROCESSING with up to FIVE terminals per system.

Other software includes a FULLY INTEGRATED package which includes STOCK-CONTROL, ORDER-ENTRY/INVOICING, SALES-LEDGER, SALES STATISTICS, PURCHASE LEDGER, NOMINAL LEDGER, PAYROLL AND WORD-PROCESSING. NATIONWIDE maintenance is available for those people who DEPEND on their micro-computer system.

There are even COURSES to help you obtain the best possible results from your computer system.

End-User prices start at around £4200 for which we believe you will have the best supported micro-computer available today.

# LOGITEK

The AL TOS ACS 8000 range of business/scientific micro computers creates a new standard in quality and reliability in high technology micro computers.

## High Technology

**Floppy Disk System** The ACS 8000 single board Z80 floppy disk based micro computer utilises the ultra reliable Shugart 8 inch, 1BM compatible, disc drives double density — single sided, and providing 1 M. byte of data storage. Featuring the ultimate in high technology hardware: a fast 4 MHz Z80CPU, 65 kilobytes of 16 K dynamic RAM, 1 kilobyte of 2708 EPROM, an AMD 9511 floating point processor (OPTIONAL) a Western Digital floppy disc controller, a Z80 direct memory access (OPTIONAL), Z80 parallel and serial I/O two serial RS232 ports, 1 parallel port) and a Z80 CTC Programmable Counter/Timer (real time clock). In essence, the best in integrated circuit technology.

**Hard Disk/Multi User Systems** The Winchester hard disk/multi user systems are now available supporting up to 4 simultaneous users and providing a maximum of 58 Megabytes of hard disk data storage.

The systems are truly flexible and allow expansion of the

AL TOS floppy disk system to keep pace with the users requirements. Still single board, features include \* a high speed I/O section with up to six serial ports and one 8 bit Parallel port \* up to 208K of on board RAM, \*High speed (4 MHz) D.M.A. control as standard.

Yes, mini power and at micro cost too.

## Built-in Reliability

The ACS 8000 range are true single board micro computers making them extremely reliable and maintainable. All electronics are socketed for quick replacement. Complete diagnostic utility software for drives and memory is provided.

The board and Shugart floppy disk drives are easily accessible and can be removed in less than ten minutes.

## Quality Software

Unlimited versatility. The ACS 8000 range support the widely accepted CP/M and MP/M operating systems plus basic (Microsoft and CBASIC), Cobol, Pascal, and Fortran IV. All available now.

Logitek, in conjunction with its own microsoftware house, Interface Software Ltd. of Camberley are able to supply a wide range of proven 'off the shelf' business software including general accounting, word processing, stock control, mailing list etc.

There are already over 1 000 micro computer installations using this software.

A track record which we consider speaks for itself. Why re-invent the wheel? when there is standard software of this quality available now?

## After Sales Support

Logitek are supported by DDT Maintenance Ltd. who provide a nationwide field maintenance service for AL TOS products and offer the option of maintenance contracts.



• Circle No. 285

## Availability

Logitek carry deep shelf stocks of AL TOS hardware and compatible peripherals.

If you are a dealer who may be interested in promoting AL TOS and/or Interface Software by joining the fast growing network of approved suppliers, contact Logitek. We can offer you something rather special now.

## Approved Dealers

<b>LONDON:</b>	Logic Box Ltd. Tel: (01) 222 1122 Boyd Microsystems (Wattford) Tel: (011) 950 0303 Systematica Tel: (011) 485 3634
<b>WEYBRIDGE</b>	Kewill Systems Ltd. Tel: (0932) 222448
<b>CAMBERLEY</b>	Profac Computer Services Ltd. Tel: (0276) 25247
<b>GLASGOW</b>	Robox Ltd. Tel: (041) 221 5401
<b>PERTH</b>	Aerhorror Consultancy Services Tel: (041) 641 7758
<b>EAST ANGLIA</b>	Peter MacNaughton & Associates Tel: (073 888) 267
<b>BIRMINGHAM</b>	Proloc Computer Systems Ltd. Tel: (0520) 714038
	Saba Computer Systems. Tel: (021) 643 2021
	University of Birmingham (Anthony Clewett) Tel: (021) 472 1301, Ext. 2001/2273
<b>LINCOLN</b>	Evan Jackson Computer Business Systems Ltd. Tel: (0522) 30371
<b>NOTTINGHAM</b>	East Midland Computer Centre. Tel: (0602) 267099
<b>SHEFFIELD</b>	Sheffield Computer Centre. Tel: (0742) 53519
<b>GLoucestershire</b>	Woolpack Computer Centre (Tebury). Tel: (06666) 269
<b>WILTshire</b>	Validara Services (Melksham). Tel: (0225) 705957
<b>BOLTON</b>	B. & B. Consultants. Tel: (0204) 26644.
<b>YORK</b>	Derwent Electronics Ltd. Tel: (0904) 53990
<b>WINCHESTER</b>	Software Development Services Ltd. Tel: (0962) 68956
<b>HARROGATE</b>	Monitor Data Processing Ltd. Tel: (0423) 60670
<b>KIRKHAM</b>	Mindcom Business Machines. Tel: (0772) 686617



## LOGITEK

E.I.C. Electronics Ltd.  
All enquiries to:  
Portland St. Chorley, Lancs.  
Tel: 02572 66803

also at:  
30 Kelvin Ave.,  
Hillington Industrial Estate,  
Glasgow G52 4LH.



**AL TOS**  
COMPUTER SYSTEMS

# Buy a System...Not just a "Pretty Box"

The SD System\* — From about 97p per hour (40-hour week)

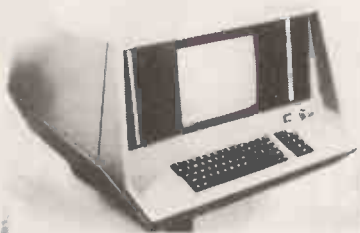

**\*The SD System includes:**

SDS-200 Microcomputer T.I. 810 Printer (or equivalent)  
i.e., NEC SPIN WRITER £1,899. SDS 200 £4,750, T18 10  
£1,499

## The SDS-200 TOTAL System features:

### System Hardware

The SDS-200 gives you features that are not found in systems costing thousands more. State-of-the-Art Engineering. Quality Production and Full Reliability testing make the SDS-200 a dependable, compact and easy to operate data processing system.

- Up to 256K Bytes RAM
- Full Keyboard with Special Accounting Key Pad
- Large 12in. Video Display Screen
- Full Cursor Control including Addressable Cursor
- Blinking, Underlining, Reverse and Protected Fields
- Uses 8in. Flexible Diskettes for Permanent Storage 2 Mbyte on-line
- Forward and Reverse Scrolling
- Capable of up to 160 Special Characters
- Expandable with Memory and Peripheral Equipment
- Will Operate as a Remote Batch Processor for Large Systems
- S 100 industry standard bus
- 4 spare S100 slots.

### System Software

A range of Business Programs are available from CAP-CPP written in Microcobal.

The system will support all normal high level languages including:—

Fortran  
Cobol  
Basic  
CP/M

### Authorised dealers are:

Anglo American Computers Ltd  
Milburn House, Suite D, Dean Street  
Newcastle-upon-Tyne.  
Tel: 0632 29593

Peter McNaughton Ass.  
Anfield, Glenalmond  
Perthshire 073-888 267

Bell Computing Ltd  
62 Lowther Street  
Carlisle 0228 43690

Codified Computer Systems Ltd,  
69 Calabria Road,  
London N5 1HX  
Tel: 01-226 1319.

Picodyte  
Linton House,  
Catherine Street  
Aston, Birmingham  
Tel: 021-328 4840  
Telex: 335511

Optimal  
142 Britannia Street  
Valletta, Malta  
Tel: 356 21818  
Telex: Malta 683.

## A Total System

SD Systems knows that small businesses do not keep full-time programmers on staff. We also know that individually designed business programs can be expensive on a one-time basis. That is why we offer the SDS-200 and compatible business software.

## Leasing Available

The SDS-200 is available by leasing. This gives the small business the opportunity to select the method of acquisition that best fits their needs.



## SDS-200 Expandable

The SDS-200 is designed in a manner to give you expansion capabilities. As your needs change the computer system that you select today should be able to change with you. By the addition of memory and peripheral equipment, the SDS-200 can expand to fit your needs.

**Barcellof Ltd**  
Kimberley House,  
Vaughan Way, Leicester

UK Distributor:

**AIRAMCO LTD**  
Unit A2, 9 Longford Avenue, Kilwinning Ind. Est.,  
Kilwinning, Ayrshire KA13 6EX.  
(0294) 57755 Telex 779808

Dealer enquiries invited

# Buy here at discount prices!

**Save money.**

☆ Full after-sales service in our own workshops ☆ One year guarantee on all machines

Leasing available to companies

## Up to 1.6Mb for PET!

and 'on-line' with the Computhink Disc System

\* Allows powerful business programmes using 16 Extra BASIC commands. \* Easy to connect and use - plugs directly into 16/32K PETs, detailed manual supplied. \* Simple startup (no difficult procedures to remember) as Disc Op. System in ROM. \* Ready to run - useful programmes supplied free; full set of professionally written business packages available - Sales and Purchase Ledger, Stock Control, Payroll etc., \* Real-Time processing, Engineering and Commercial boundaries overcome with full language support - Business BASIC, Assembler, FORTRAN, COBOL, PASCAL, FORTH, FIFTH, PLM, PILOT & CESIL.  
24K Memory expansion with dual disc for old ROM 8K PET £275 for new ROM 8K PET £320

Basic 400K dual disc system

only

**£840**

800K £1,095  
1.6 Mb £2,190

Credit terms available

## The only 16k complete computer for under £400

Keyboard computer, power supply, UHF modulator and all cables to plug into your own TV set and cassette recorder and go!! 16K of user RAM for decent size programmes and data, sophisticated level II Microsoft BASIC. Complete with level I and level II programming manuals. What more could you ask?

TRS-80

**£381<sup>74</sup>**

Expansion interface £199.09  
4K level I computer £251.30

Now! Numeric keypad included

This must be today's best buy!

## Get into print this easy way!

**Fast!**

**Immaculate!**

**Low, low price!**



### Anadex DP 8000 dot-matrix printer

\*Speedy 112 ch/s bidir. \* Fits A4 page - up to 80 cols. \* Up to 4 copies. \* Precision form-filling with sprocket feed. \* Special headings using double-width chars. \* Modern paper format to match A4 filing systems. \* Other paper sizes with adj. sprocket. \* Full punctuation, U/L case, £ sign, 96 ch. set. \* Reliable - strongly built, 100 M.ch. head.

Knock down price!

**£499**

Interfaces -  
Pet £45 Ohios £10  
TRS-80 £40 Sorcerer £8  
Apple £45



### IBM golfball printer ideal for word-processing

\* Forget expensive Spin-Wheel printers - the Golfball produces equal quality at up to 15 ch. per sec. \* Match various typewriter styles with IBM interchangeable heads. \* Completely reliable - each machine rebuilt by IBM trained engineers and fully guaranteed. \* Precision form-filling possible with 15 in. pin-feed platen.

Limited supply!

**£595**

Interfaces -  
Pet £45 Ohios £10  
TRS-80 £35 Sorcerer £8  
Apple £45



### Quick Printer II

\* Now at remarkable price, a high-quality 'tally-roll' printer to list programmes. \* OK in offices or after midnight, printout is a quiet 'z-z-z'. \* Uses now-cheap, 6 cm wide aluminised paper (£1.74 roll), convenient for listings, perfect for photocopying. \* Fast! - 120 lines/min. \* 32 cols. Software selected double-width chs. \* 96 chs. incl. lower case. \* No extra for TRS-80 bus interface.

**£147<sup>80</sup>**

Interfaces -  
Pet £45 Apple £45  
Ohios/Sorcerer/UK101 £10  
TRS-80 Exp. I/F £11.26

## PET 2001-8N (8K RAM New large keyboard)

**£469**

2001 - 16N (16K RAM and new large keyboard) £590  
2001 - 32N (32K RAM and new large keyboard) £690  
External cassette deck, suitable for all Pets £53  
CBM dual drive mini floppy £745  
Tractor feed printer with Pet graphics £499  
Pet high-res. graphics 200 x 320 £259

## You can afford to start computing now! - with the Ohio CI-P

As imported, fully tested, complete with 4K RAM, but unconverted to UK std. (conversion instructions supplied).

**£199**

Add £24 for converted model. Extra 4K RAM £39.

\* Powerful programming possible - 8502 processor, fast 8K Microsoft floating-point BASIC (easy to learn). Superior utilities, 53 key keyboard, giving upper and lower case, user-definable keys, gaming and graphics chs. Ultra-fast and powerful machine code from keyboard. \* No intricate soldering or metal work. Computer supplied assembled in ready-made case. \* Reasonable sized programmes in 4K RAM. \* Expandable to 24K RAM in case, drives discs, printer; available items include Assembler/Editor and Extended Monitor. \* Programme interchangeability/reliability - Kansas City tape interface. \* Save programmes on own cassette recorder - all cables supplied.

- at a lower price than equivalent kits!

# COMPUTERAMA

Your dealer for Bath, Bristol and S.W.

**Tel: Bath (0225) 28819**

We stock components, test instruments, tools etc.

LTD.

TANDY DEALER

AMERICAN EXPRESS

THE NEW CARD VISA

AMERICAN EXPRESS

master charge

BARCLAYCARD VISA

Computerama Ltd.

Harpers Kensington Showrooms  
London Rd. Bath, Avon

Credit card orders accepted by telephone for immediate despatch.

Loads of software - ask for list!

Please add £10 Securicon delivery on computers etc. plus 15% VAT on all prices

PC/4

• Circle No. 287

- **Pascal training course** — available with venues and dates to suit customers. Aims to teach 'standard' PASCAL. Course is augmented by practical case studies with full class discussion of results. Fee: £390. Contact: Twenty First Computer Systems, 29a York Street, Twickenham, Middlesex, tel: 01-892 1180.
- **1 - May 4** **Pascal programming.** Venue: Manchester University Computer Science Building. Fee: £8. Contact: Douglas Kaye, Dept of Extramural Studies, The University, Manchester, M13 9PL, tel: 061-273 3333.
- **2-3** **Sales and forecasting systems: analysis and design.** Venue: London. Explains the sales and forecasting for business and covers techniques for designing computer-based systems to meet typical requirements. Fee: £270. Contact: The Registrar, Infotech, Nicholson House, Maidenhead, Berks, SL6 1LD, tel: 0628 39101.
- **3 - May 6** **Fortran programming (enrol by March 27th).** Venue: Manchester University Computer Science Building. An introduction to FORTRAN. Students will not be expected to have any prior knowledge of computers or computer programming. Fee: £8. Contact: Douglas Kaye, Dept of Extramural Studies, The University, Manchester, M13 9PL, tel: 061-273 3333, ext: 3532.
- **4** **Microcomputers and the businessman.** Venue: Skyway Hotel, Heathrow-London. This appreciation seminar will interest anybody considering the purchase of his first microcomputer system. Fee: £50 + VAT. Contact: Commodore Business Machines Ltd, Training Course Bookings, 360 Euston Road, London, NW1 3BL, tel: 01-388 5702.
- **7-9** **Microprocessor workshop.** Venue: Manchester. Designed for engineers with little or no knowledge of microprocessors. The course is based on the AIM55 board and introduces all aspects of software development by practical programming sessions. Fee: £195 + VAT. Contact: Microsystems Consultants Ltd, PO Box 65, Camberley, Surrey, GU15 1QN, tel: (0276) 27417.
- **8-9** **Requirements planning systems: analysis and design.** Venue: London. Explains materials and inventory management for business and techniques for designing computer-based systems to meet typical requirements. Fee: £27. Contact: The Registrar, Infotech, Nicholson House, Maidenhead, Berks, SL6 1LD, tel: (0628) 39101.
- **9-11** **CICS for application programmers.** Venue: London. Designed for trainee programmers and system staff entering a CICS environment or for experienced staff involved in a change of software. Fee: £345. Contact: The Registrar, Infotech, Nicholson House, Maidenhead, Berks, SL6 1LD, tel: (0628) 39101.
- **10-11 & 24-25** **Introduction to microprocessing.** Venue: Bedford. Introductory course on microprocessors using the TMS 9900. Students should be familiar with digital electronics in terms of logic gates and storage elements. Designed for engineers, technicians, and non-technical high-level language programmers. Fee: £95 + VAT. Contact: Mike Hughes, Microprocessor Training Centre, Texas Instruments Ltd, Manton Lane, Bedford, MK1 7PA, tel: (0234) 67466 ext 3718.
- **14-18** **Advanced program and data design technology.** Venue: London. Designed for analysts, designers, programmers and software managers and other data-processing decision makers. Introduces new ideas, techniques and methods forming an integrated patterning methodology for improving system reliability and maintainability. Fee: £565. Contact: The Registrar, Infotech, Nicholson House, Maidenhead, Berks SL6 1LD, tel: (0628) 39101.
- **15** **Introduction to small business microcomputers.** Venue: Luton, Eurocrest Hotel. Designed for executives, accountants and managers in industry and education. Includes explanation of hardware and software; specifying, purchasing and running a microcomputer; applications and new products and machine demonstrations. Fee: £45 + VAT. Contact: Mrs P. Duggan, Silverton Microcomputer Consultants, Silverton House, 8 Gran Avenue, Worthing, West Sussex BN11 5AN, tel: (0903) 47755.
- **15** **Microcomputers in control systems.** Venue: Manchester, Excelsior Hotel. This appreciation seminar includes the use of microcomputers as programmable monitoring and control tools, interfacing microcomputers to industrial and laboratory equipment, and the microcomputer as a development tool for dedicated system software. Fee: £50 + VAT. Contact: Commodore Business Machines Ltd, Training Course Bookings, 360 Euston Road, London, NW1 3BL, tel: 01-388 5702.
- **15-18** **Microprocessors and microcomputers.** Venue: London, Microprocessor Education Centre, Holborn. Designed for engineers, scientists, systems analysts and their managers. Provides a broad foundation in microprocessor applications through hands-on training. The course covers programming, hardware design and interfacing, techniques and procedures for organising and controlling a microprocessor project from start to completion. Fee: £470 + VAT. Contact: ICSP — UK, Peblecombe, Tadworth, Surrey, KT20 7PA, tel: (03723) 79211.
- **15-18** **PASCAL — Programming in the structural language.** Venue: Royal Horseguards Hotel, Whitehall Court, London, SW1A 2AU. Designed for engineers, programmers, scientists, systems analysts and managers who are using or plan to use PASCAL for the development of software systems. Fee: £470 + VAT. Contact: ICSP UK, Peblecombe, Tadworth, Surrey, KT20 7PA, tel: (03723) 79211.
- **15-18** **Communications '80 Exhibition.** Venue: Birmingham, National Exhibition Centre. Includes communications in the service of mankind, public telecommunications, data and business communications systems, civil radio and emergency communications. Contact: Tony Davies Communications, c/o P.D. Bishop, 8 Coningsby Road, South Croydon, Surrey, CR2 6QP.
- **16-18** **OS JCL for application programmers.** Venue: London. Designed for trainee programmers and systems programming staff becoming involved in an OS-based environment. On completion, participants will be able to make optimum use of JCL statements and OS utilities to improve the efficiency and performance of application programs. Fee: £345. Contact: The Registrar, Infotech, Nicholson House, Maidenhead, Berks SL6 1LD, tel: (0628) 39101.
- **16-18** **FS990/4 Floppy disc-based software development system.** Venue: Bedford. Designed for the technician or engineer who is familiar with the TMS 9900 instruction set and has knowledge or experience of microprocessor or mini-computer systems. Fee: £250 + VAT. Contact: Mike Hughes, Microprocessor Training Centre, Texas Instruments Ltd, Manton Lane, Bedford, MK1 7PA, tel: (0234) 67466 ext 3718.
- **21-25** **Small parts production exhibition.** Venue: Birmingham. Contact: British Robot Association, 39 High Street, Kempston, Bedford, MK42 7BT, tel: Bedford 853605.



- **21-25** **Introduction to computing.** Venue: London. For aspiring data processing professionals. Grounding in computing essentials. Fee £210. Contact: The Registrar, Infotech, Nicholson House, Maidenhead, Berks SL6 1LD, tel: (0628) 39101.
- **24** **Computers and the business executive.** Venue: Sheffield, Hallam Tower Hotel. Fee: £75. Contact: Mrs M. Lange, British Council of Productivity Associations, 8 Southampton Row, London, WC1B 4AQ, tel: 01-405 1023.
- **24-25** **Inspection method for software insurance.** Venue: London. This course explains the IBM-developed inspection method for software insurance. Participants learn to apply inspection methods to software for greater cost-effectiveness. Fee: £310. Contact: The Registrar, Infotech, Nicholson House, Maidenhead, Berks SL6 1LD, tel: (0628) 39101.
- **25** **Engineering system at SIA.** Venue: London. Provides general, non-technical management overview of SIA's engineering systems capability. Designed to help engineering managers assess SIA's engineering computer services. Contact: The Events Organiser, SIA Ltd, Ebury Gate, 23 Lower Belgrave Street, London, SW1W 0NW.
- **28-30** **Assembly language course.** Venue: Birmingham, Excelsior Hotel. Designed for those wishing to program the PET or any other 6502-based microcomputer in machine

● **28 - May 2** **Introduction to programming.** Venue: London. Designed for newcomers to programming. Provides basic introduction to the principles of computer programming in a language-independent way and provides the foundation for subsequent programming language courses. Fee: £355. Contact: The Registrar, Infotech, Nicholson House, Maidenhead, Berks SL6 1LD, tel: (0628) 39101.

● **28 - May 2** **Systems analysis: skills and techniques.** Venue: London. This course shows potential systems staff techniques for defining new system proposals and justifying them in business terms. Fee: £355. Contact: The Registrar, Infotech, Nicholson House, Maidenhead, Berks SL6 1LD, tel: (0628) 39101.

● **30 - May 2** **Mersey Micro Show.** Venue: Liverpool, Adelphi Hotel. Shows the ever-increasing range of the microprocessor. Includes microsystems, business microcomputers, word processors, and personal computers for the home. Contact: Online Conferences Ltd, Argyle House, Joel House, Northwood Hills HA6 1TS, Middlesex, tel: (09274) 28211.

## MICRODIGITAL BOOKS

**BEST SELECTION-BEST PRICES-BEST SERVICE**  
25 Brunswick Street, Liverpool 2 Tel: 051-236 0707 (Mail Order)  
051-227 2535 (All Other Depts)

Accounts Payable & Receivable £9.95	Basic — a unit for Secondary Schools £4.45	8080 Programmer Pocket guide £1.95	Home Computers: A Beginners Glossary and Guide £4.95	Micro/Computer Interface with the 8255 PPI Chip £10.00
Active Filter Cookbook £10.90	Basic Programming £6.95	8080A Bugbook £7.65	Hobby Computers Are Here £3.95	Microformula (TM) £2.95
Adaptize Info. Processing £8.75	Basic Primer £6.95	8080 Programming for Logic Design £5.95	Incredible Secret Money Machine £4.75	Microsoft (TM) Basic £7.00
Advanced Basic £4.00	Collection of Programming Problems and Techniques £12.00	8080A/8085 Assembler Language Programming £6.95	Interface Circuits Data Book £3.50	Microprocessor Basics £7.60
Algorithms & Data Structure Equals Programs £14.00	Computer Crime £12.00	8080/8085 Software Design £7.65	Intro to Artificial Intelligence £14.80	Microw — New Directions for Designers £7.60
Anatomy of a Compiler £15.00	Computer Data Directory £3.98	8080 Machine Language Programming for Beginners £5.10	Intro to Computer Prog £4.75	Microwprocessors Data Manual £5.50
Apl. — An Interactive Approach £9.50	Computer Lib/Dream machines £5.95	8080 Microcomputer Experiments £10.25	INTRODUCTION TO MICROCOMPUTERS. Vol 0 £5.95 Vol II £18.95	Microw for Business Applications £7.15
Artificial Intelligence £12.00	Computer Models of Thought and Language £17.00	8080 Standard Monitor £9.95	Vol I £5.95 Vol III £11.95	More Basic Computer games £5.50
Artist & Computer £3.96	Computer Power and Human reasons £4.76	8080 Standard Editor £9.95	Intro to Personal & Business Computing £4.95	Microcomputer Potpourri £1.75
Ari Computer Programming £9.50 S/B Vol. 1. £16.45 II/B	Computer resource book Algebra £4.00	8080 Standard Assembler £9.95	Intro to Prog. Solving with Pascal. Schneider Et Al £8.90	Modern Operational Circuit Design £18.60
Art Computer Programming Vol. 2. £16.45	Computer Science a First Course £15.00	S7 Practical Programs. Basic £6.40	Interfacng and Communications £4.95	Microwprocessor Apl Implementation £14.75
Ari Computer Programming Vol. 3. £16.45	Computer Science Programming in Fortran IV £7.80	First Book of Kim £7.00	Introductory Experiments in Digital Electronics Vol I £8.75	Mos Memory Data Book £2.80
Assembly Level Programming for small computers £12.76	Computer/Science Projects and Study problems £8.75	Fortran Coloring Book £5.56	Introductory Experiments in Digital Electronics Vol 2 £7.75	Microwprocessor Encyclopedia Vol 2. £7.45
Analysis and design of Digital Circuits and Computer Systems £16.40	Concurrent Pascal Compiler £6.40	Fundamentals of Data Structure £15.00	Instructor's manual for Fortran Programming £6.95	9900 Family systems Design & Data Book £7.95
Accent on Basic £4.95	Conference Proceedings of the 1st West Coast Computer Fair £9.56	Fundamentals of Digital Comps £6.75	Illustrating Basic £2.25	1975 U.S. Comp Chess £4.75
About Computers £6.95	Conference Proceedings of the 2nd West Coast Computer Fair £9.56	Fortran Programming £4.75	IC Optamp Cookbook £8.95	1976 U.S. Comp Chess £4.75
Active Filters £6.45	Conference Proceedings of the 3rd West Coast Computer Fair £9.58	Fortran Fundamentals £3.45	Introduction to Microprocessors & Computing £2.40	NCR Basic Electronics £7.15
Analog/Digital Experiments £7.15	Consumer Guide—Personal Computers & Microw. £5.00	Fun with Computers & Basic 555 timer £5.35	Kim I Users Manual £5.00	NCR Data Communications £7.15
A guided tour of Computer Programming in Basic. £4.16	Content Addressable Parallel Processors. £11.20	50 Circuits using 7400 Series IC's £6.95	Link 68 — M6800 Linking Loader £5.50	NCR Data Processing £6.35
A quick look at Basic £4.45	Computer Dictionary (sams) £6.95	Fortran Fundamentals a short course £2.95	Little Book of Basic Style £4.75	Nascom 1 — Hardware Notes £1.50
Aple II Operators Manual £5.50	Computer Dictionary & Handbook £11.95	Game Playing with Basic £5.50	Linear IC Principles Experiments £7.16	Nascom 1 — Seminar Notes £1.50
Aple II Integer Basic manual £3.55	Computer & Program Guide for Engineers. £9.45	Game Playing with Computers £10.20	Math Elements for Computer Graphics £10.40	Optoelectronics Data Book £3.50
Aple II Applesoft Extended Basic Manual £5.75	Computers for the Physicians Office £15.50	General Ledger £9.95	Microcomputer — Based Design £8.00	Osbourne Updated Subscriptions Vol. 2. (6 issues) £18.95
Advanced Business, Billing, Inventory, Investments, Payroll £26.95	Computerisation for small Business £9.95	Getting Involved with Your Own Computer £4.75	Microcomputer Handbook £15.96	Vol. 3. (6 issues) £18.95
An Introduction to Your new Pet. £1.00	Computer Quiz Book £5.45	Getting Acquainted with Microw £7.95	Microcomputer Primer £6.35	Vol. 2 & 3. combined £30.00
Basic £5.60	Computer Programs that Work £2.95	Guide to Scamp Programming £4.00	Microelectronic £3.25	Binders 2 or 3 £5.75
Basic A Hands on Method £6.50	Computer Music £7.00	Games with a Pocket Calculator £1.75	Micro Problems Solving Using Pascal £7.50	Pascal User Manual & Report £5.25
Basic and the Personal Computer £10.00	Computer Data Directory £3.98	Games, Tricks & Puzzles for a Hand Calculator £2.49	Microprocessor Interfacing techniques £7.95	Payroll with cost accounting £12.00
Basic Computer Games Micro. £4.80	Computer Rage (a board game) £24.80	How to Build A Computer Controlled Robot. £5.95	Microprocessor System Design £14.00	Power Semi-conductor Data Book £7.50
Basic from the Ground Up £7.00	Clarica's Circuit Cellar £5.60	How to Profit from Your Personal Computer £5.50	Microprocessor From Chips to Systems £7.50	The Mighty Micro £5.75
Basic and the 6800. £7.20	Designing with TTL Circuits £10.00	How to Program Microcomputers £7.50	Mind Appliance £4.75	Z — 80 Programming Manual £4.50
Basic with Business Application £8.40	Dictionary of Microcomputing. £10.00	How You Can Learn To Live With Computers £7.00	Modern Operational circuit Design £18.60	TTL Databook £7.00
Basic with style/Programming proverbs. £3.60	Digital Computer Fundamentals. £14.25	How to buy/use Mini-Microw £7.50	Mondeb M6800 Monitor/debug Microcomputers at A Glance £6.45	TI Workbooks (1-6) each £3.00
Basic WorkBook £3.70	Dr. Dobbs' Journal Vol. 1. £10.00	How to Build a Working Digital Computer £4.60		TI S 6800 Tracer £4.80
Best of Creative Computing Vol. 1. £6.95	Digital IC Equivalents & Pin Connections. £11.25	How to Package Your Software £27.50		TTL Cookbook £6.95
Best of Creative Computing Vol. II. £6.95	Designing MZ/Computer Systems £5.40	Home-computer Revolution £2.75		Peanut & Jelly Guide to Computing £6.45
Byte Book of Computer Music £7.00	Editor/Assembler Systems for 8080/8085 Based Systems £11.96			The Best of Micro Z — 80 and 8080 Assembly Prog. £4.80
Beginners Glossary and Guide £5.75				6500 Programming manual £10.50
Beginners Basic £7.50				6500 Hardware Manual £10.50
Byte Vol I £8.45				Software Gazette 50p

 WELCOME

Prices include Postage and Packing anywhere in the UK.

**NEW EDITION FOR BOTH OLD & NEW ROMS**

**ESSENTIAL READING FOR ALL PET USERS**

# THE PET REVEALED

*ALMOST 180 PGES OF SOLID INFORMATION FEATURING:*

PET circuit diagrams — How to use the diagnostic routine — PET ROM subroutines and their entry points — Programming in machine code — Using the IEEE and User Ports — Double-density graphics — Uncopyable programs — Page zero locations and their uses — A TRACE program for Basic program debugging — Disabling the keyboard and/or the Stop key — Adding a repeat key — Line re-numbering — Auto line erasing — Making the PET write its own programs — Printer interfaces — Adding new commands to Basic — Interrupts and multiprocessing.  
Plus many more fascinating facts about the PET.



**commodore**

APPROVED PUBLICATION

*Send cheque for £10.00 made payable to Computerbits Ltd.*

**COMPUTERBITS LTD**

**PO BOX 13, YEOVIL, SOMERSET. TEL. YEOVIL 26522**

# A PRACTICAL GLOSSARY

## Continuing the terminology gamut with S

### Sector

Part of a disc — the term is also used as a synonym for the data held in the sector. Remember the *Glossary* on discs? The disc has concentric tracks; it also has radial divisions, so that the disc surface is also organised into wedges.

These divisions may be physical in that the magnetic gunk on the disc physically isn't there, or notioned in that data is written in these patterns. The two sorts we called 'hard'- and 'soft'-sectored respectively.

One of those triangular sections is a sector, and the location of a block of data is usually addressed by reference to its track and sector numbers.

### Seek time

What happens after you have counted to 100 with your hands over your eyes. It's also the time taken by a disc unit (could be a floppy disc drive) to position its read head (qv) over the specified track on the disc.

Seek time is quite a good measure of comparison — a disc drive that can get to the information quicker than another disc drive ought to be better. But there's more to it than that: it may also take some time for the disc to get up speed, and there'll be a few more microseconds taken by actually reading or writing the data. So total access time (qv) involves more than just seek time.

In any case, there are lots of other blocks, bottlenecks and other pratfalls for the computer to negotiate before it can translate your program into information delivered back to you. So seek time isn't necessarily a useful indicator of overall computing throughout. In which case you may wonder why I included it in the glossary. Well, so do I — now.

### Semiconductor

Malcolm Sargeant when he was still a church organist? Oh, well never mind. A semiconductor is a material whose electrical conductivity is between that of metal and an insulator.

Semiconductors have many unique and usable attributes in computing, which is all you need

to know about them.

These days computer memory tends to be semiconductor, which means data is stored in a bunch of miniature semiconductor circuits.

### Serial

Contrast with parallel (qv): serial means things happen in sequence rather than at the same time. So serial transmission or serial I/O is a method of communication in which each bit (qv) of information is sent sequentially on a single channel; serial access means getting at records in the order in which they occur.

Serial-access storage devices are typified by cassette: they are cheaper than random-access systems like floppy disc, but it takes much longer to get to a given piece of information on a serial medium like tape.

Serial interfaces are widely used to connect terminals to computers: they are technically simpler than parallel interfaces and can be used over longer distances.

There are two well-known serial interfaces, defining which pin in the plug relates to which wire and which electrical signal. **RS-232C**: this specification is also known as CCITT V24. It was laid down originally by an American standards body (the CCITT is a European organisation). It is probably the most widely-used interface; nearly all microcomputers and many peripherals — especially printers and terminals — have RS-232C connectors.

**20mA current loop**: this is still popular. It was first used on the Teletype terminal, and the Teletype 33 was for much of the 1960s the dominant computer terminal. It became a *de facto* standard but these days RS-232C is more popular. The 20mA current loop design cannot operate normally as quickly as RS-232C, so it cannot be used for the faster printers.

### Set

Usually means giving a particular bit the value '1'.

### Shift

Moving data to the right or left. In practice the term applies to operations deep inside the

assembly-language level, and a shift consists of moving the contents of a register left or right by one (or more) bit. The bit falling out of one end would go into carry area somewhere: the bit coming in is usually '0'. The left shift of a binary number by one place is equivalent to multiplying by two.

### Signal

Any conveyer of information — "the physical embodiment of a message," says one dictionary. In practice in computers, it means a detectable and desirable electrical event — undesirable electrical happenstance is called 'noise' (qv).

### Silicon

A non-metallic chemical element widely used as the semiconductor in modern semiconductor circuitry.

### Silicon Valley

The area around Sunnyvale, California where most of the semiconductor manufacturers are installed — and where Fairchild and Hewlett-Packard, the two major progenitors of the modern electronics business are located. Also called Silicon Gulch.

### Simplex

You won't come across this word, but it means communication in one direction only. Compare duplex, which allows you to transmit in either direction down the same link.

### Simulate

Often confused with 'stimulate', but you'll get used to the difference when you get older. Simulate means to represent some aspects of one thing by setting up a symbolic analogue of it. Usually this means running a mathematical model of something.

This simulating is typified by something like the Club of Rome's *Limits to Growth* scenario: the computer is given a set of base data and a collection of variables. Those can be frankly wrong; and, more important, you might well have missed some of the more important considerations when you set up your model.

### SNA

Systems Network Architect rivals DNA in the complexity stakes. SNA is the latest of IBM's grand designs for specifying how its computers and other hardware can be plugged together. Take a look at *network* (qv).

### Software

Programs. In strictly literal terms, you also ought to include program documentation and programming procedures.

### Sol

RIP. This pioneering home computer had wooden sides and a neat flat PCB layout inside it. Made by Processor Technology, which went under last year.

### Solid-state

This is the branch of physics that concerns itself with the essential properties of semi-conductor materials. And all you need to know is that 'solid-state' and 'semiconductor' are used loosely as synonyms to refer to the wonders of current computer technology.

### Stack

Don't bother with this one if you don't feel like it — it's really esoteric. Some computers use a small area of main memory as a temporary data store called a stack: it works on a last-in, first-out basis, and it is essential for keeping track of sub-routines — the stack typically holds the return address.

The assembly language will provide instructions for getting data in and out of the stack, often the amiably-named PUSH and POP commands.

Systems that use stacks do not generally require the programmer to keep track of the actual locations that data is being stacked into. This is done automatically through a stack 'pointer'. To keep track of the last item added to the stack, a register may contain the memory address where the last item is stored in the stack; on some systems, all but one or two registers may be used as a stack pointer.



# interface components



## NASCOM IMP AVAILABLE EX-STOCK

The incredibly low-price Nascom IMP is now available off the shelf at Interface Components. It plugs into any microcomputer system with a serial RS 232 Interface, including the popular Nascom 1 & 2.

Although an impact matrix printer, its versatile feed mechanism allows it to accept A4, foolscap and quarto letterheads making it suitable for word processing applications. And it's quiet too. Line printers and many typewriters are deafening by comparison.

Finished in a smart blue plastic enclosure, the IMP is only £325 plus VAT (post and packing extra) completely assembled.

### FEATURES

- 80 characters wide
- 60 lines per minute
- Bi-directional printing
- 10-line print buffer
- 96 character ASCII set (includes \$, #, £)
- Automatic CR/LF
- 8½" paper (pressure feed)
- 9½" paper (tractor feed)
- Baud rate 110 to 9600
- External signal for optional synchronisation of baud rate

### ORDER FORM

Send your orders to:  
Interface Components Ltd, Oakfield Corner,  
Sycamore Road, Amersham, Bucks HP6 6SU.  
Telephone: 02403 22307 Telex: 837788.

Please send me.....Nascom Imps at £325 each  
plus VAT at 15% plus £2.50 p&p.

Name \_\_\_\_\_

Address \_\_\_\_\_  
\_\_\_\_\_  
\_\_\_\_\_

Access or  
Barclaycard No. \_\_\_\_\_

Personal callers welcome

PC/A/80

• Circle No. 290

PRACTICAL COMPUTING April 1980

# REAL-TIME SPECTRUM ANALYZER

## £340

You can now buy, for about one-sixth the price of current products, a third-octave spectrum analyzer with more features and capabilities than were previously available at any price. What's the catch? If you don't already own a Commodore PET computer (or, soon, a Radio Shack TRS-80 or Apple), you'll have to get one. This will raise the price to somewhat under one-half the price of competing products, but of course you'll also have a COMPUTER!

The THS 224 REAL-TIME FREQUENCY ANALYZER comprises a single circuit board which installs inside the PET. This board contains a set of 31 third-octave filters (20 Hz to 20 kHz), detectors, an analog-to-digital converter, a 1K Read Only Memory containing machine language routines which allows the PET processor to interface with the Analyzer, and the peripheral circuitry necessary to transfer analog data into the PET memory. The simplest BASIC program required to turn the PET into an analyzer is only three statements long! Much longer programs can be written to allow complete user interaction with the analyzer, including many new forms of statistical signal processing, curve weighting, voice recognition etc.



# EXPANSION MEMORY

with space for eprom

**Price break-through**

**24k  
£280**

**32k  
£325**

**All items can be seen and demonstrated at our London showroom. Orders accepted by mail, phone or in person.**

**PETS 8k  
from £495**

PET IS A TRADEMARK OF COMMODORE BUSINESS SYSTEMS

Prices exclude VAT. Send or phone for further details and brochure.

Access, Barclaycard, and Trustcard accepted.



UK Distributors

**Feldon Audio Ltd.,**

126 Great Portland Street, London W1: Tel 01-580 4314 Telex London 28668.

• Circle No. 291

## Advertisement Index

<b>A</b>	Access Data Communications	26	<b>D</b>	DAMS	142	<b>J</b>	J. P. S.	26	<b>O</b>	Online	90
	Acorn	145		Datalink	41				<b>R</b>	Rair	75
	Aculab	16		Dataview	152	<b>K</b>	Keen Computers	99		Research Machines	4, 27
	Adda	36		Data Precision	110		Kode Services	16		Research Resources	19
	Ades	36		Datron Microcentre	35					Rohan	152
	Airamco	158		Digitus	50		<b>L</b>			Restronics	94
	A. J. D.	34		Digital Data Electronics	44		L & J Computers			Route 66	42
	A. J. Harding (Molimerx)	25		Drivers Jonas	148		L. J. Electronics	76			
	Almarc	46, 152					Lifeboats Associates	12, 13	<b>S</b>	Science of Cambridge	14, 15
	A. P. L.	40	<b>E</b>	Electronic Brokers	40		Liveport	37		Sharp Electronics	88
	Audio Products	148		Encotel	18		Lion Microcentre	47		Sirton Products	38
<b>B</b>	Bits & PC's	32		Ensign	70		Logitex	157		Sintrom Microshop	43
	British National Radio School	140		Equinox	4, 21		L. P. Enterprises	32		Slough Microshop	20
	Bristol Software Factory	89		Essex Computer Services	146	<b>M</b>				Software House	146
	Business Computer Services	20	<b>F</b>				Microbits	156		Stage One	76
	Business & Leisure	40		Farmplan	30		Microcentre	2		Strutt	32
<b>C</b>				Feldon Audio	165		Micro Control	85		Systematics International	144
	Cambridge Computer Store	46		Fortronic	140		Micro Computer Application	44	<b>T</b>		
	Capital Computer Systems	150					Microdigital	24		Tempus	18
	Chromasonic Electronics	151	<b>G</b>	Gate Microsystems	144		Micrologic	138		Terodec	143
	Churchtown	136		Gemsoft	34		Micromedia (Systems)	92		Terminal Display	24
	Comart	5, 39, 68		G. P. Industrial Electronics	43		Micronex Data Systems	32		Tim Orr	146
	Commodore Systems			Gamma Winter	6, 7		Micropute	139		Transam	147
	Division	55, 57, 59	<b>H</b>				Microsolve	20		Tridata	38
	Compshop	166, 167		Happy Memories	24		Microtrotex	36		T. & V. Johnson	10, 11
	Compastore	155		H. B. Computers	23		Microware	142	<b>U</b>		
	Computerama	159		Heathkit	102		Mighty Micro	154		University of Manchester	42
	Computer Centre	49		Hotel Microsystems	150		Millbank	34		University of Sussex	136
	Computerbits	162		Henry's Radio	112		Muller	66			
	Comput-a-crop	18					Mutex	42			
	Computopia	28	<b>I</b>						<b>V</b>		
	Computer Retailer Association	4		Icarus	31	<b>N</b>				V & T Electronics	141
	Control Data Services	138		Interface Computers	164		Nascom	62		Video Vector Dynamics	150
	Crofton Electronics	22		Intex Datalog	26		Newbear	30			
	Crystal Electronics	140		Intelligent Artifacts	136		Newtronics	122	<b>X</b>		
				Intersystems	168		N. I. C.	16		Xitan	45

8MHz Super Quality Modulators	£4.90
6MHz Standard Modulators	£2.90
C12 Computer Grade Cassettes 10 for	£4.00
Super Multi-rail P.S.U. +5 -5 +12v	£29.50
ETI Breakout Game - Chip and PCB	£9.90
S100 Expansion Motherboard for Nascom I	£39.00
Anadex Printer Paper - 2000 sheets	£25.00
Floppy Disks 5¼" Hard & Soft Sectored	£3.50
Floppy Disk Library Case 5¼"	£3.50
Eprom Boards	£63.00
8K Static Ram Boards - S100	£110.00
Cartridges for Grandstand	£11.99
George Risk Ascii Keyboard	£39.00
Cartridges for Atari	
- Full Range in Stock	£13.90
Interface PET IEEE - Centronics Parallel	
Not decoded	£49.00
Decoded	£77.00
Interface to Centronics parallel for TRS80	£75.00
Verocases for Nascom 1 & 2 etc.	£22.50
Keyboard Cases	£9.90
Electric Pencil for TRS80	£29.00

RRP £690 only **£590** + VAT



**IBM SELECTRIC GOLFBALL**

Refurbished IBM Golfball Printers to new specs. Accepts Centronics parallel data. Friction feed. Prints at 15 cps.

Attaches either directly or through interfaces to Pet, Apple, TRS80, Sorcerer, Nascom, CompuKit etc.

**HITACHI PROFESSIONAL MONITORS**

9" - **£129**  
12" - **£199**

- Reliability Solid state circuitry using an IC and silicon transistors ensures high reliability.
- 500 lines horizontal resolution Horizontal resolution in excess of 500 lines is achieved in picture center.
- Stable picture Even played back pictures of VTR can be displayed without jittering.
- Looping video input Video input can be looped through with built-in termination switch.
- External sync operation (available as option for U and C types)
- Compact construction Two monitors are mountable side by side in a standard 19-inch rack.

**A PROFESSIONAL WORD PROCESSING SYSTEM AND IT'S A COMPUTER AS WELL.**

FOR ONLY **£3250** + VAT



**PET 32K** - This is the standard 32K Pet from Commodore. Reverse video and graphics allow the WordPro Package to give simple clear and easy to read displays.

**2040 Disk Drives** Twin disk drives allow large high speed storage for your letters, or paragraphs. Plugs in the back of the PET.

**NEC Spinwriter** NEC's high quality printer uses a print "thimble" that has less diameter and inertia than a daisy wheel, giving a quieter, faster, more reliable printer that can cope with plotting and printing (128 ASCII characters) with up to five copies, friction or tractor fed. The ribbon and thimble can be changed in seconds.

55 characters per second bidirectional printing - with red/black, bold, subscript, superscript, proportional spacing, tabbing, and much, much more.

**WordPro II** The heart of the system - consists of a ROM and diskette. The ROM is inserted into a space socket inside the Pet. One of the most versatile Word Processing Packages around.

All items sold separately.

only **£356** + VAT



**TRS80 LEVEL 2 16K**

Fully converted to UK T.V. Standard. Comes complete with easy to follow manuals. UK Power Supply - Cassette Leads - Sample tapes. Special box to enable you to plug into your own TV. Recommended for first time-buyers. Just plug in and go. Full Range of Software Available

Model with numeric key pad £389 + VAT  
4K Level I - machine only £251 + VAT

**NEW REDUCED PRICES**

8K **£449**  
16K **£549**  
32K **£649**

+ VAT



**The PEDIGREE PETS**

Very popular for home & business use. 8K Microsoft Basic in ROM. 8K Pet 32K & 16K with new improved keyboard. All with green screen.

Extra cassette deck £55 Full range of software available.

32K **£690** + VAT  
48K **£790** + VAT



**EXIDY SORCERER**

RRP £859 for 32K

For Personal or Business Use. 32K or 48K memory. 8K Microsoft Basic in ROM. Dual Cassette I/O. RS232 I/O. Parallel I/O (Centronics). Expansion available through optional extra S100 Motherboard. 69 Key keyboard including 16 key numeric pad.

S100 EXPANSION - **£199**

**NASCOM IMP PLAIN PAPER PRINTER**

Fully built and housed in a stylish enclosure for just **£325** plus VAT. Interfaces with all micro computers.

The Nascom IMP (Impact Matrix Printer) features are listed below:

- 60 lines per minute.
- 80 characters per line.
- Bi-directional printing.
- 10 line print buffer.
- Automatic CR/LF.
- 96 character ASCII set (including upper/lower case, \$, #, @).
- Accepts 8½" paper (pressure feed).
- Accepts 9½" paper (tractor feed).
- Tractor/pressure feed.
- Baud rate from 110 to 9600.
- External signal for optional synchronisation of baud rate.
- Serial RS232 interface with parallel option available soon.

only **£295** + VAT

Expand your TRS80 by 32K. 32K Memory on board. Centronics parallel port. Disk controller card. Real time clock. Requires Level II Basic. Interface for 2 cassette decks. complete with power supply.



**TRS80 EXPANSION INTERFACE**

RRP **£540** only **£499** + VAT



**ANADEX DP8000**

Super Quality - Low cost printer. Tractor Feed with full 96 ASCII character set. Accepts RS232C at band rates between 100 and 9600 and Parallel Bit data. Attaches either directly or through interfaces to Pet, Apple, TRS80, Sorcerer, Nascom, CompuKit etc.

**video 100**

12" BLACK & WHITE LOW COST VIDEO MONITOR

RRP **£79** only **£69** + VAT

- Ideal for home, personal and business computer systems
- 12" diagonal video monitor
- Composite video input
- Composite video output
- Compatible with many computer systems
- Solid-state circuitry for a stable & sharp picture
- Video bandwidth - 12MHz + 3DB
- Input impedance -75 Ohms
- Resolution - 650 lines Minimum In Central 80% of CRT; 550 Lines Minimum beyond central 80%.

**NASCOM-2 MICRO-COMPUTER**

only **£295** + VAT



Your choice of freebies with every Nascom 2 purchased from us

either **FREE POWER SUPPLY**  
OR **FREE GRAPHICS ROM**  
OR **FREE VERO CASE** TO TAKE NASCOM 2

**Microprocessors** Z80A. 8 bit CPU. This will run at 4MHz but is selectable between 1/2/4 MHz. This CPU has now been generally accepted as the most powerful, 8 bit processor on the market.

**INTERFACE**

**Keyboard** New expanded 57 key Licon solid state keyboard especially built for Nascom. Uses standard Nascom, monitor controlled, decoding.

**T.V.** The lv peak to peak video signal can drive a monitor directly and is also fed to the on-board modulator to drive the domestic T.V.

**I.O.** On-board UART (Int.6402) which provides serial handling for the on-board cassette interface or the RS232/20mA teletype interface.

The cassette interface is Kansas City standard at either 300 or 1200 baud. This is a link option on the NASCOM-2. The RS232 and 20mA loop connector will interface directly into any standard teletype.

The input and output sides of the UART are independently switchable between any of the options - i.e. it is possible to house input on the cassette and output on the printer.

**PIO** There is also a totally uncommitted Parallel I/O (MK3881) giving 16, programmable, I/O lines. These are addressable as 2 x 8 bit ports with complete handshake controls.

**Documentation** Full construction article is provided for those who buy a kit and an extensive software manual is provided for the monitor and Basic.

**Basic** The Nascom 2 contains a full 8K Microsoft Basic in one ROM chip with additional features like DEEK, DOKE, SET, RESET for simple programming.

With free 16K RAM board.

• Circle No. 300

# COMPUKIT UK101

## EUROPE'S FASTEST SELLING ONE BOARD COMPUTER



- ★ 6502 based system — best value for money on the market.
- ★ Powerful 8K Basic — Fastest around
- ★ Full Qwerty Keyboard
- ★ 4K RAM Expandable to 8K on board.
- ★ Power supply and RF Modulator on board.
- ★ No Extras needed — Plug-in and go.
- ★ Kansas City Tape Interface on board.
- ★ Free Sampler Tape including powerful Dissassembler and Monitor with each Kit.
- ★ If you want to learn about Micros, but didn't know which machine to buy then **this is the machine for you.**

Build, Understand and Program your own Computer for only a small outlay.

KIT ONLY **£199 + VAT**  
NO EXTRAS NEEDED

AVAILABLE READY ASSEMBLED & TESTED  
READY TO GO FOR **£249 + VAT**

Specially designed case for CompuKit in orange/black. With room for accessories **£29.50 + VAT**

6502 Assembler/Editor for CompuKit **£14.90 + VAT**

The **CompuKit UK101** comes in kit form with all the parts necessary to be up and working, supplied. No extras are needed. After plugging in just press the reset keys and the whole world of computing is at your fingertips. Should you wish to work in the machine code of the 6502 then just press the M key and the machine will be ready to execute your commands and programs. By pressing the C key the world of Basic is open to you.

This machine is ideal to the computing student or Maths student, ideal to teach your children arithmetic, and is also great fun to use.

Because of the enormous volume of users of this kit we are able to offer a new reduced price of **£199 + VAT**

Simple Soldering due to clear and concise instructions compiled by **Dr. A.A. Berk, BSc, PhD.**

## THE NEW TRS80 SURPRISE — MODEL II

Fast and expandable!

Model II operates at twice TRS 80's high speed.



In addition to either 32 or 64 thousand characters (bytes) of internal Random Access Memory, one built-in 8" floppy disk stores an additional one-half million bytes, including the Disk Operating System. And you can easily expand up to a four-disk system for up to two-million bytes of storage.

Model II features upper and lower case letters. Its built-in 12" high-resolution video monitor displays 24 lines of 80 normal characters. The professional 76-key keyboard (with "calculator" keypad) includes advanced functions such as Control, Escape, Caps, Hold, Repeat. The keyboard is detachable and moveable for convenient data entry.

You get the enhanced Level III version of TRS-80's already-famous Level II BASIC language and "TRS-DOS" operating system, automatically loaded in memory when you "power up." (About 24K of RAM is used by this software.)

Each time you power up, Model II thoroughly tests itself to insure proper operation. Your chosen program can appear immediately, without any intermediate steps or questions to answer.

### Versatility ... plug-in expandability

Built-in input/output capabilities include two RS-232C channels, and one Centronics parallel port. Future expansion is provided for through four plug-in slots for optional PC boards.

64K 1-Disk Model II **£2250.00 + VAT**

### 1 DISK EXPANSION Room for 3

500K per Drive gives total of 1.5M Byte — 1 Drive plus Cabinet **£799 + VAT**

Just Plug In

**WE ARE NOW EX-STOCK**

### Why do people buy more from COMPSHOP than anywhere else?



- ★ **LARGER STOCKS** — we hardly ever run out
- ★ **GOOD SERVICE** — we give extended warranties on all our products.
- ★ **EXCELLENT REPAIR SERVICE** — Through CompuCare we repair and maintain most makes of personal computers.

LAST YEAR WE SUPPLIED TO THE PUBLIC — **LARGE & SMALL**  
16,000 Television Games & 7,000 Computer Systems



CompuCare is a company that has been set up to provide servicing and maintenance for the popular makes of micro-computers i.e. Sorcerer, Pet, Apple, TRS80, Nascom, CompuKit. Our charges are £7 per hour plus parts.

Because of the extensive range of spare parts stocked you can usually expect your micro to be repaired within 10 days for an average charge of £14 labour.

Emergency 24 hour repairs can be handled for a £10 surcharge where possible. CompuKits and Nascoms unsuccessfully constructed will be charged a standard £25.

### THE ATARI VIDEO COMPUTER SYSTEM

**£99 + VAT**



Atari's Video Computer System now offers more than 1300 different game variations and options in twenty great Game Program™ cartridges!

Have fun while you sharpen your mental and physical coordination. You can play rousing, challenging, sophisticated video games, the games that made Atari famous.

You'll have thrill after thrill, whether you're in the thick of a dogfight, screeching around a racetrack, or dodging asteroids in an alien galaxy. With crisp bright colour (on colour TV) and incredible, true-to-life sound effects. With special circuits to protect your TV.

Cartridges now available All at **£13.90** each + VAT

Basic Maths, Airsea Battle, Black Jack, Breakout, Surround, Spacewar, Video Olympics, Outlaw, Basketball, Hunt & Score\*, Space War, Sky Diver, Air Sea Battle Codebreaker\*, Miniature Golf.

Extra Paddle Controllers — **£14.90 + VAT**

\*Keyboard Controllers — **£16.90 + VAT**



"Europe's Largest Discount Personal Computer Store"

Please add VAT to all prices — Delivery at cost, will be advised at time of purchase. Please make cheques and postal orders payable to COMPSHOP LTD., or phone your order quoting BARCLAYCARD, ACCESS, DINERS CLUB or AMERICAN EXPRESS number.

CREDIT FACILITIES ARRANGED — send S.A.E. for application form.

14 Station Road, New Barnet, Hertfordshire, EN5 1QW Telex: 298755 TELCOM G  
Telephone: 01-441 2922 (Sales) 01-449 6596

OPEN - 10 am - 7 pm — Monday to Saturday  
Close to New Barnet BR Station — Moorgate Line.

★ NOW in IRELAND at: 80 Marlborough St., Dublin 1. Tel: Dublin 749933



**COMP** COMPUTER COMPONENTS

(Part of the Compsshop Ltd. Group)



# At Intersystems, "dump" is an instruction.

## Not a way of life.

(Or, when you're ready for IEEE S-100, will your computer be ready for you?)



We're about to be gadflies again.

While everyone's been busy trying to convince you that large buses housed in strong metal boxes will guarantee versatility and ward off obsolescence, we've been busy with something better. Solving the *real* problem with the first line of computer products built from the ground up to conform to the new IEEE S-100 Bus Standard. Offering you extra versatility in 8-bit applications today. And a full 16 bits tomorrow.

We call our new line Series II™. And even if you don't need the full 24-bit address for up to 16 megabytes (!) of memory right now, they're something to think about. Because of all the perform-

ance, flexibility and economy they offer. Whether you're looking at a new mainframe, expanding your present one or upgrading your system with an eye to the future. (Series II boards are compatible with most existing S-100 systems and *all* IEEE S-100 Standard cards as other manufacturers get around to building them.)

Consider some of the features: Reliable operation to 4MHz and beyond. Full compatibility with 8- and 16-bit CPUs, peripherals and other devices. *Eight* levels of prioritized interrupts. Up to 16 individually-addressable DMA devices, with IEEE Standard overlapped operation. User-selectable functions addressed by DIP-switch or jumpers, eliminating soldering. And that's just for openers.

The best part is that all this heady stuff is available *now!* In our advanced processor—a full IEEE Bus Master featuring Memory Map™ addressing to a full megabyte. Our fast, flexible 16K Static RAM and 64K Dynamic RAM boards. An incredibly versatile and

economical 2-serial, 4-parallel Multiple I/O board. 8-bit A/D-D/A converter. Our Double-Density High-Speed Disk Controller. And what is undoubtedly the most flexible front panel in the business. Everything you need for a complete IEEE S-100 system. Available separately, or all together in our new DPS-1 Mainframe!

Whatever your needs, why dump your money into obsolete products labelled "IEEE timing compatible" or other words people use to make up for a lack of product. See the future now, at your Intersystems dealer or call/write for our new catalog. We'll tell you all about Series II and the new IEEE S-100 Bus we helped pioneer. Because it doesn't make sense to buy yesterday's products when tomorrow's are already here.

## InterSystems™

Ithaca Intersystems,  
58 Crouch Hall Road,  
London, N8 8HG. U.K.

Telephone: 01-341-2447/Telex: 299568

• Circle No. 310

